

UC-NRLF



B 4 113 913

Sam^l H. Hurwitz 2 G.
Harvard University ✓

MEDICAL SCHOOL
LIBRARY

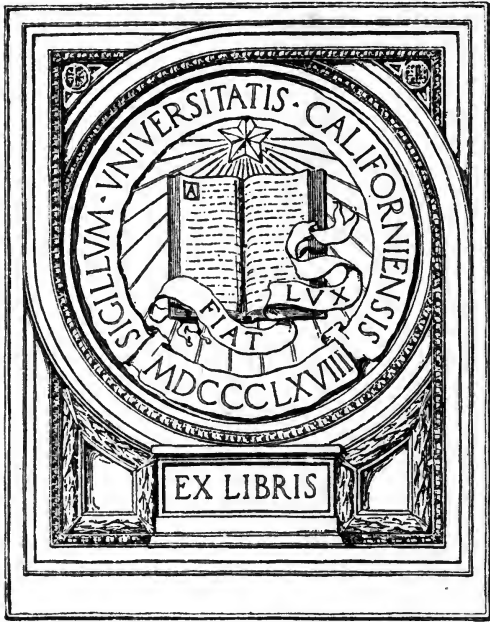

Gift of
Dr. S. H. Hurwitz.

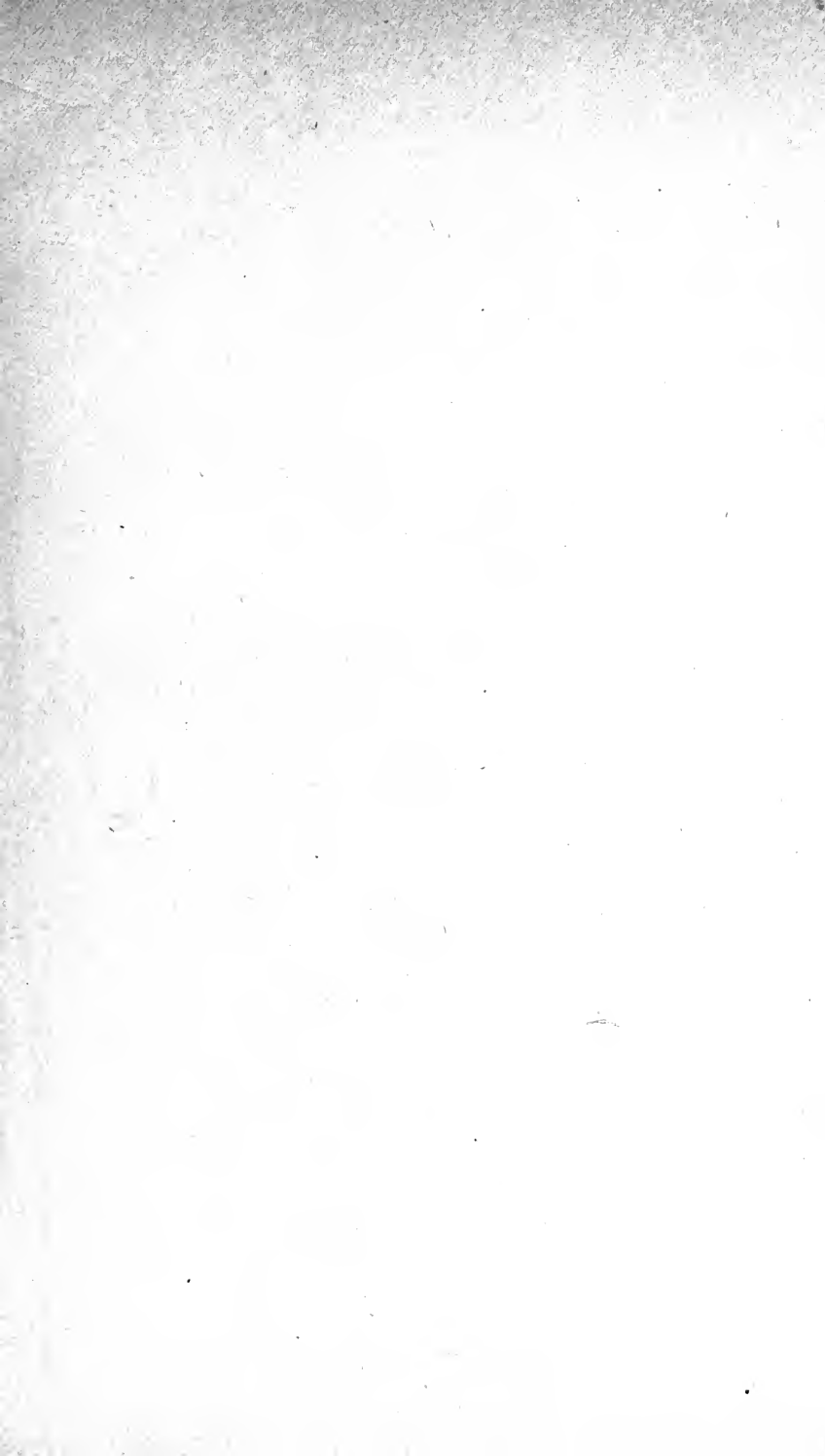

Digitized by the Internet Archive
in 2007 with funding from
Microsoft Corporation

EXPERIMENTAL PSYCHOLOGY

WORKS BY
EDWARD BRADFORD TITCHENER

M. A. (Oxon.), Ph. D. (Leipzig),
LL. D. (University of Wisconsin),

*Member of the Aristotelian Society and of the Neurological Society
of London; Associate Editor of Mind and of the American
Journal of Psychology; Sage Professor of Psychology
in the Cornell University.*

AN OUTLINE OF PSYCHOLOGY

Third edition, revised and enlarged. Cloth, 8vo, \$1.50 net.

A PRIMER OF PSYCHOLOGY

Third edition, revised and enlarged. Cloth, 8vo, \$1.00 net.

EXPERIMENTAL PSYCHOLOGY, QUALITATIVE:

Student's Manual. Second edition, revised. Cloth, 8vo, \$1.00 net.
Instructor's Manual. Cloth, 8vo, \$2.50 net.

TRANSLATIONS

- O. KUELPE, Outlines of Psychology.** Translated by E. B. TITCHENER. Large 8vo, \$2.60 net.
- O. KUELPE, Introduction to Philosophy.** Translated by W. B. PILLSBURY and E. B. TITCHENER. 8vo, \$1.60 net.
- W. WUNDT, Lectures on Human and Animal Psychology.** Translated by J. E. CREIGHTON and E. B. TITCHENER. Second edition, revised. Large 8vo, \$2.60 net.
- W. WUNDT, Ethics: An Investigation of the Facts and Laws of the Moral Life.** Translated by J. H. GULLIVER, E. B. TITCHENER, and M. F. WASHBURN. Vol. I, The Facts of the Moral Life. Large 8vo, \$2.25 net. Vol. II, Ethical Systems. \$1.75 net. Vol. III, The Principles of Morality and the Sphere of their Validity. \$2.00 net.
- W. WUNDT, Principles of Physiological Psychology.** Translated by E. B. TITCHENER. Vol. I, Introduction: The Bodily Substrate of the Mental Life. Large 8vo, \$3.00 net.

THE MACMILLAN COMPANY

66 FIFTH AVENUE, NEW YORK

EXPERIMENTAL PSYCHOLOGY

A Manual of Laboratory Practice

BY

EDWARD BRADFORD TITCHENER

VOLUME II

QUANTITATIVE EXPERIMENTS:

PART I. STUDENT'S MANUAL

*Eine Untersuchung, die an sich nicht schwierig ist,
aber Geduld, Aufmerksamkeit, Ausdauer und Treue
erfordert.*—FECHNER.

New York
THE MACMILLAN COMPANY

LONDON: MACMILLAN & CO., LTD.

1905

All rights reserved

W

QF 357
77 53
1905
v. 2

PREFATORY NOTE: SUGGESTIONS TO STUDENTS

The Psychological Experiment, Qualitative and Quantitative—The Quantitative Experiment in Practice—Laboratory Partnerships—Note Book, Essay Book, commonplace Book—The Modern Languages.

The Psychological Experiment, Qualitative and Quantitative.—The object of the qualitative experiment in psychology is—if we may sum it up in a single word—to *describe*; the object of the quantitative experiment is to *measure*. In the former, we seek to gain familiarity, by methodically controlled introspection, with some type or kind of mental process; we live through, attentively and in isolation, some special bit of mental experience, and then give in words a report of the experience, making our report, so far as possible, photographically accurate. Numerical determinations, formulæ, measurements, come into account only in so far as they are necessary to the methodical control of introspection; they are not of the essence of the experiment. The question asked of consciousness is the question ‘What?’ or ‘How?’: What precisely do I find here, in this attentive consciousness? How precisely is this fusion put together?—In the quantitative experiment, on the other hand, we make no attempt at complete description: it is taken for granted that the mental processes now under examination have become familiar by practice. What we do is to carry out a long series of observations, under the simplest and most general introspective conditions. Then we gather up the results of these observations in mathematical shorthand, and express them numerically by a single value. The questions asked of consciousness are, in the last analysis, two only: ‘Present or absent?’ and ‘Same or different?’ For instance: Do you still hear a tone? or: Is this weight heavier than this other, or lighter than it, or just as heavy? When, as we have said, a great many observations of this sort have been

taken, the whole set of results is thrown into quantitative form. On the average, we can still hear a tone of so-and-so many vibrations ; on the average, we can distinguish two weights if they differ by such-and-such an amount. The question which the quantitative experiment answers is, therefore, some variant of the question 'How much?' Notice, however, that this is not the question asked of consciousness. That question is always the one or other of the two just mentioned: Present or absent? and Same or different? Here, then, is a second difference between the qualitative and the quantitative experiment. The former, aiming at description, comes to an end when introspection has made its report; the latter, aiming at measurement, subjects the results of introspection to mathematical treatment. The experiments are complementary, each sacrificing something and each gaining something. The qualitative experiment shows us all the detail and variety of the mental life, and in so doing forbids us to pack its results into formulæ; the quantitative experiment furnishes us with certain uniformities of the mental life, neatly and summarily expressed, but for that very reason must pass unnoticed many things that a qualitatively directed introspection would bring to light.

The Quantitative Experiment in Practice.—In general, the rules for the conduct of a quantitative experiment are the same as those for a qualitative experiment (vol. I., xiii. f.). There are, however, in practice, certain well-marked differences between the two types of experiment.

(1) In the first place, the quantitative experiment demands much more 'outside' preparatory work than does the qualitative. Most, if not all, of the reading done in preparation for the experiments of vol. I. could be done within the laboratory. This is not the case with the experiments that you are now to perform. The quantitative experiment sums up, in a single representative value, the results of a large number of observations. It is clear, then, that the conditions of observation must be the same throughout: otherwise the results will not be comparable. The observations must be arranged, distributed, timed, spaced, varied, repeated, upon a definite plan; and the plan itself must be laid out with a view to the object and materials of the particular ex-

periment. This means that you must know your *method*; you must have made out a complete scheme of work before you enter the laboratory.

It is not necessary that *O*, as well as *E*, know the method to be employed in a given experiment; if *E* has made out his plan, he can give such instruction to *O* as shall secure the object at which the method aims. It is, indeed, advisable that the members of a laboratory partnership, at the beginning of the term, take two different methods for study, so that each serves as *O* in an experiment with the method of which he is not familiar. For even if these two experiments can be done but once, still, *E* and *O* gain a wider experience than they would obtain from the repetition of one and the same experiment; while if they can be repeated,—as they should be, with reversal of function, whenever time allows,—each student has as *E* the advantage of the experience which he gained as *O*.

(2) Again: the quantitative experiment demands a more sustained attention than the qualitative. Many of the experiments of vol. I. could be dropped, as soon as *O* showed signs of fatigue, and resumed, in the next laboratory session, practically at the point at which they had been left. Some of them actually called for a set of separate observations, so that the work naturally fell into short periods, with rest-pauses between. But we cannot drop a method, half finished, and take it up again at a later time. Once begun, the quantitative experiment must be carried through to its proper end. We make out the plan of the experiment beforehand, in order that our results may be comparable and homogeneous; we must, then, and for the same reason, adhere to the plan in practical work.

(3) Lastly, the service of the apparatus is, in general, a more delicate matter in the quantitative than it is in the qualitative experiment. In some cases, this is due to the greater refinement and complication of the instruments themselves. For the most part, however, we employ simple instruments; and the demands of care and accuracy laid upon *E* derive from that main source of difference between these and our earlier experiments, the obligations of method. The disposition of apparatus in the second, third, fourth series must be exactly as it was in the first series; else the results of the different series cannot be grouped together to yield a single result. But further: method-work in psychology

makes certain claims upon the apparatus which qualitative work does not; claims which we cannot here specify, but which will be pointed out as the experiments proceed.—

In fine, then, there is preparatory work to be done outside the laboratory; and in the laboratory *O* must be steadily and uniformly attentive, while *E* has to carry the plan of the method and at the same time to watch his apparatus. Does not this mean that quantitative experiments in psychology are more difficult than qualitative? On the whole, yes. There are, however, two points that you should keep in mind. The first is that there are degrees of difficulty in quantitative, as there are in qualitative work. Several of the experiments prescribed in this volume are easier than experiments prescribed in vol. I. And the second is that you will bring to bear upon the difficulties of this part of the Course all the experience that you have acquired in the first part. The difficulty of passing from qualitative to quantitative work is, in all probability, nothing like as great as the difficulty which you faced on first beginning the Course,—when you were called upon to renounce popular psychology, to take up an entirely new attitude to mind, to examine consciousness at first-hand by introspection. So that, while the work becomes increasingly difficult, there is nothing to be afraid of.

Laboratory Partnerships.—A few of the following experiments can be performed by a single student; but the great majority require the coöperation of two students, *E* and *O*. It is very desirable that the partnership formed for the qualitative work, if it was congenial, be continued during this second part of the Course. If, however, your former partner is not completing the Course, or if you are yourself resuming the work after an interval, it is desirable that you choose your own partner, rather than leave the choice to the Instructor. *E* and *O* must be in sympathy, and must have full confidence in each other, if the quantitative experiments are to be successfully carried out.

It may be, of course, that you cannot make such an arrangement as is here suggested, and that your partner is selected by the Instructor. If, now, he does not prove to be a congenial associate, see to it that the partnership is promptly dissolved, and an exchange made. Do not hold back for fear of offence, or for

any false shame about making a complaint. You may be pretty sure that, if you do not get on with him, neither does he get on with you. Talk the situation over with him, and part by mutual consent. It is foolish to spoil your work for a scruple.

On your own side, try hard to live up to the terms of the laboratory partnership as described in vol. I., xvi.

Note Book, Essay Book, Commonplace Book.—The note book is to be kept just as for the qualitative experiments (vol. I., xvi. f.), with such minor differences of record as the changed character of the work makes necessary. It should be handed in to the Instructor immediately after the writing up of each separate experiment, so that criticisms and corrections may be made while the performance of the experiment is still fresh in your memory.

From time to time, as the Course proceeds, you will be asked to write an essay upon some general topic connected with the experiments. Write the essays in a second note book, kept specially for them. Write upon one side of the paper only, but enter your references and footnotes upon the other, blank side. If you have occasion to quote a foreign author, give a translation of the quoted sentences in the body of the essay, and write out the original upon the corresponding blank page of the essay book. Never shirk the labour of translation; and, for accuracy's sake, never omit the transcription of the original passage.

If you intend to take a further course in Systematic Psychology at the conclusion of this laboratory work: still more, if you intend to pursue graduate studies in psychology: it will be well worth your while to keep, besides the note book and the essay book, a third book for the recording of miscellaneous psychological notes. This commonplace book might contain, *e. g.*, abstracts of the authors read for an essay, lists of problems that suggest themselves to you in the course of the laboratory exercises, criticisms of current theories, theoretical ideas of your own, lists of references upon topics in which you are interested, odd bits of psychologising that you meet with in your other laboratory and class-room work or in your general reading, apt illustrations of psychological laws that you come across in everyday life, the questions and objections hurled at you by outside critics, etc., etc. To the psychologist, the whole of 'this great and glorious world'

is matter for psychology: and if you keep your commonplace book diligently for a few months, you will be surprised to find how much psychology there is in life, and how close and manifold are the connections between the laboratory and your experiences beyond the laboratory. You will also be surprised to find how naturally and in how real a sense the keeping of the commonplace book leads you to psychologise for yourself.

The Modern Languages.—It has been assumed, throughout this Course, that the student is able to read psychological works in French and German. It is, indeed, necessary to make this assumption, if the Course is to be regarded at all seriously. For experimental psychology was in origin a German science, and has become international. The classical treatises of the earlier period are in German, and have not been translated. Nor have, *e. g.*, those critical essays by J. Delbœuf which suggest the theory of mental measurement adopted in this book.

It is probable, then, that the first essay which you are called upon to write in connection with the Course will demand a reading of French and German, as well as of English, sources. If you are familiar with the foreign languages, well and good. If you are not, do not on that account lose heart, or ask for another assignment. Set to work, on the basis of your school knowledge, and *read* the references. You are not required, by this Course, to become a fluent linguist, or to acquire a literary appreciation of French and German style: you are required simply to read and understand certain prose passages which have a technical and therefore a limited vocabulary. If needs must, take a few private lessons in the less familiar language from some graduate student who knows both the language and psychology. At any rate, make up your mind that by the end of the term you are going to read French and German psychology with accuracy and with some ease. The task is much less formidable than it looks, and every half-hour spent upon its counts.

TABLE OF CONTENTS

INTRODUCTION

MENTAL MEASUREMENT

| | PAGE |
|-----------------------------------------------------------------|---------|
| § 1. Measurement | xix |
| § 2. Mental Measurement | xxi |
| § 3. An Analogy | xxvii |
| § 4. Three Problems of Quantitative Psychology | xxix |
| § 5. Some Technical Terms | xxxvii |
| § 6. The Further Programme of Quantitative Psychology | xxxviii |
| § 7. Questions | xl |

CHAPTER I. PRELIMINARY EXPERIMENTS

EXPERIMENT I

| | |
|-----------------------------------------------------------------------------|---|
| § 8. The Qualitative <i>RL</i> for Tones: the Lowest Audible Tone | I |
|-----------------------------------------------------------------------------|---|

EXPERIMENT II

| | |
|----------------------------------------------------------------------------|----|
| § 9. The Qualitative <i>RL</i> for Tones: Alternative Experiment | 10 |
|----------------------------------------------------------------------------|----|

EXPERIMENT III

| | |
|-------------------------------------------------------------------------------|----|
| § 10. The Qualitative <i>TR</i> for Tones: the Highest Audible Tone | 12 |
|-------------------------------------------------------------------------------|----|

EXPERIMENTS IV-VI

| | |
|------------------------------------------------------|----|
| § 11. The Intensive <i>RL</i> for Pressure | 14 |
|------------------------------------------------------|----|

EXPERIMENTS VII, VIII

| | |
|---------------------------------------------------|----|
| § 12. The Intensive <i>RL</i> for Sound | 22 |
| § 13. Weber's Law | 25 |

EXPERIMENTS IX-XII

| | |
|------------------------------------------------------------------------------------------------------------------------------------------------------------------------|----|
| § 14. Demonstrations of Weber's Law: Fechner's Cloud Experiment; Fechner's Shadow Experiment; Sanford's Weight Experiment; Ebbinghaus' Brightness Experiment | 29 |
|------------------------------------------------------------------------------------------------------------------------------------------------------------------------|----|

CHAPTER II. THE METRIC METHODS

- § 15. The Law of Error 38

EXPERIMENTS XIII, XIV

- § 16. The Method of Limits (Method of Just Noticeable Differences : Method of Least Differences : Method of Minimal Changes) : Determination of the *DL* for Brightness and Tone 55

EXPERIMENT XV

- § 17. Fechner's Method of Average Error (Method of Reproduction : Method of Adjustment of Equivalent *R*) : the Equation of Visual Extents 70

EXPERIMENTS XVI, XVII

- § 18. The Method of Equivalents : Application of the Method to Cutaneous Extents and to Pressure 77

EXPERIMENTS XVIII, XIX

- § 19. The Method of Equal Sense-Distances (Method of Mean Gradations : Method of Supraliminal Differences : Method of Equal-appearing Intervals) : Application of the Method to Intensities of Sound and to Brightness 81

EXPERIMENT XX

- § 20. The Method of Constant *R* (Method of Right and Wrong Cases) : Determination of the Limen of Dual Impression upon the Skin 92

EXPERIMENT XXI

- § 21. The Determination of Equivalent *R* by the Method of Constant *R* : the Comparison of Movements of the Arm . . . 104

EXPERIMENTS XXII, XXIII

- § 22. The Method of Constant *R*-Differences (Method of Right and Wrong Cases) : Determination of the *DL* for Intensity of Sound and for Lifted Weights 106

CHAPTER III. THE REACTION EXPERIMENT

§ 23. The Electric Current and the Practical Units of Electrical
Measurement 120

§ 24. The Technique of the Simple Reaction 141

EXPERIMENT XXIV

§ 25. The Three Types of Simple Reaction 167

EXPERIMENT XXV

§ 26. Compound Reactions: Discrimination, Cognition and Choice . 185

EXPERIMENT XXVI

§ 27. Compound Reactions: Association 192

CHAPTER IV. THE PSYCHOLOGY OF TIME

EXPERIMENT XXVII

§ 28. The Reproduction of a Time Interval 196

LIST OF MATERIALS 199

INDEX OF NAMES AND SUBJECTS 201



INDEX OF FIGURES

| FIG. | PAGE |
|--------------------------------------------------------------------------------------------------|--------|
| 1. Illustration of Mental Measurement | xxxiii |
| 2. Appunn's Lamella | 1 |
| 3. Galton's Whistle | 12 |
| 4. Edelmann's Galton Whistle | 13 |
| 5. Scripture's Touch Weights | 15 |
| 6. von Frey's Hair \mathcal{A} esthesiometer | 16 |
| 7. Application of Hair to the Cutaneous Surface (von Frey) | 16 |
| 8. von Frey's Limen Gauge | 17 |
| 9. Regulating Apparatus for Limen Gauge | 18, 19 |
| 10. Lehmann's Acoumeter | 24 |
| 11. Correlation of Intensive Pressure Sensation with its Adequate Stimulus (Höfler) | 26 |
| 12. Correlation of Tonal Pitch with Vibration Rate (Höfler) | 27 |
| 13. Correlation of S with R under Weber's Law (Wundt) | 29 |
| 14. Arrangement of Apparatus for Fechner's Shadow Experiment | 32 |
| 15. Discs for Kirschmann's Photometer | 36 |
| 16. Cattell's Curve | 42 |
| 17. Curves of Gauss' Law of Error | 43 |
| 18. Mechanical Illustration of Cause of Curve of Frequency (Galton) | 46 |
| 19. Illustration of a Normal Distribution (Galton) | 48 |
| 20. Tuning-forks with Rider Attachments | 68 |
| 21. Tuning-forks with Screw Attachments | 68 |
| 22. Galton Bar | 76 |
| 23. Sound Pendulum | 81 |
| 24. Delbœuf's Disc: First Pattern | 88 |
| 25. Delbœuf's Dark Box | 89 |
| 26. Delbœuf's Disc: Second Pattern | 89 |
| 27. Arrangements of Discs for the Method of Mean Gradations (Wundt) | 90 |
| 28. Wundt's Triple Colour Mixer | 90 |
| 29. Müller's Curve of the Distribution of the RL | 94 |

| | |
|---------------------------------------------------------------------------------------|-----|
| 30. Münsterberg's Apparatus for the Comparison of Movements of the Arm | 109 |
| 31. Müller's Curve of the Distribution of the <i>DL</i> | 107 |
| 32. Carrier Bracket for Lifted Weights | 116 |
| 33. Simple Voltaic Cell | 122 |
| 34. Arrangements of Primary Batteries | 124 |
| 35. Four-frame Nichols Rheostat | 128 |
| 36. Schema of Lamp Battery | 131 |
| 37. Wright-Scripture Lamp Battery | 132 |
| 38. Ammeter (Bottone) | 133 |
| 39. Simple Forms of Ammeter and Voltmeter | 134 |
| 40. Schema of Measurement of Lamp Resistance | 135 |
| 41. Wheatstone Bridge | 135 |
| 42. Metre Bridge (S. P. Thompson) | 136 |
| 43. Schemata of Direct Current and Alternating Current Dynamos (Glazebrook) | 137 |
| 44. Schemata of Series-wound and Shunt-wound Dynamos | 138 |
| 45. The Hipp Chronoscope (front) | 142 |
| 46. The Hipp Chronoscope (back) | 142 |
| 47. Arrangement I of the Simple Reaction Experiment | 145 |
| 48. Arrangement II of the Simple Reaction Experiment | 146 |
| 49. Arrangement III of the Simple Reaction Experiment | 147 |
| 50. Pohl's Commutator | 148 |
| 51. Direction of Currents through Pohl's Commutator | 149 |
| 52. Simple Control Hammer (Wundt) | 152 |
| 53. Noise Stimulator | 153 |
| 54. Sound Hammer (Wundt) | 154 |
| 55. Martius' Arrangement for Simple Reaction to Clangs | 155 |
| 56. Schema of the Wundt-Lange Optical Pendulum | 156 |
| 57. Krille's Interruptor | 157 |
| 58. Cattell's Arrangement for Voice Reactions to Visual Stimuli | 158 |
| 59. Jastrow's Shutter | 159 |
| 60. Scripture's Touch Key | 159 |
| 61. Dessoir's Sensibilometer | 160 |
| 62. Arrangement for Simple Reaction to Electric Stimulation (Dumreicher) | 160 |
| 63. von Vintschgau's Thermophor | 161 |
| 64. Kiesow's Temperature Stimulator | 161 |

| | |
|----------------------------------------------------------------------|-----|
| 65. Moldenhauer's Smell Stimulator | 162 |
| 66. Buccola's Smell Stimulator | 163 |
| 67. Zwaardemaker's Arrangement for Olfactory Reactions | 163 |
| 68. Reaction Key (Telegraph Model) | 164 |
| 69. Jastrow's Reaction Key | 164 |
| 70. Scripture-Dessoir Reaction Key | 165 |
| 71. Cattell's Lip Key | 165 |
| 72. Jastrow's Speech Key | 166 |
| 73. Galvanometer (Peyer et Favarger) | 168 |
| 74. Two-way Switch | 168 |
| 75. Rheochord for Hipp Chronoscope | 168 |
| 76. Distribution of Apparatus in Arrangement II | 169 |
| 77. Distribution of Apparatus in Arrangement I | 174 |
| 78. Frequency Polygon of 'Reaction Times' of Frog (Yerkes) | 179 |
| 79. Frequency Polygon of Reaction Times (Thorndike's data) | 180 |
| 80. Frequency Polygon of Reaction Times (Thorndike's data) | 180 |
| 81. Frequency Polygon of Reaction Times (Alechsieff) | 181 |
| 82. Reading Telescope (Cambr. Inst. Co.) | 188 |
| 83. Five-finger Reaction Keys (Zimmermann) | 189 |
| 84. Roemer's Exposure Apparatus | 193 |
| 85. Vierordt's Lever | 196 |



INTRODUCTION : MENTAL MEASUREMENT

§ 1. **Measurement.**—Whenever we *measure*, in any department of natural science, we compare a given magnitude with some conventional unit of the same kind, and determine how many times the unit is contained in the magnitude. Let P be the magnitude to be measured, and p the unit in terms of which it is to be expressed. The result of our measurement of P is the discovery of the numerical ratio existing between P and p . We state this result always in terms of an equation : $P = \frac{x}{y} p$. The object of measurement, then, is the giving of such values to x and y that the equation may be true.

When we say, *e. g.*, that Mt. Vesuvius is 4200 ft. high, we mean that the given linear magnitude P , the distance from sea level to the topmost point of the volcano, contains the conventional unit of linear measurement, 1 ft., four thousand two hundred times : $P = \frac{4200}{1} p$. When we say that an operation lasted 40 minutes, we mean that the given temporal magnitude, the time occupied by the operation, contained the conventional time unit, 1 min., forty times : $P = \frac{40}{1} p$. When we say that an express package weighs three quarters of a pound, we mean that the package, laid in the scale pan, just balances the sliding weight when this is placed at the twelfth short stroke beyond the first long stroke or zero point of the bar,—the distance between any two long strokes giving the conventional unit 1 lb., and the distance between any two short strokes the conventional sub-unit 1 oz. = $\frac{1}{16}$ lb. : so that $P = \frac{3}{4} p$ in terms of lb., or $P = \frac{12}{1} p$ in terms of oz. In the same way, we might say that the height of Mt. Vesuvius is $\frac{4200}{5280}$ mile ; or that the time of the operation is $\frac{40}{60}$ hr.

These instances show—what must always be borne in mind—

that the unit of measurement is conventional. Its choice is simply a matter of practical convenience. Scientific men are now generally agreed that the unit of space shall be the 1 cm., the unit of time the 1 sec., and the unit of mass the 1 gr. ; so that the unit of mechanical energy is the amount contained in a body of 1 gr. moving through 1 cm. in 1 sec. There is, however, nothing absolute and nothing sacrosanct about these units. Our measurements would be every bit as valid, just as much true measurements, if we took as units the pace or span or cubit, the average time of a step in walking or of a respiratory movement, the ounce or pound. The metric system makes calculation easy, relates the three fundamental quantities in a very simple manner: but that is its sole, as it is its sufficient claim to acceptance.

The prototype of all measurement is linear measurement in space. We can literally superpose one portion of space upon another, for purposes of measurement: we can hold the compared portions together for as long a time as we like; we can shift the one portion to and fro upon the other. The linear space unit is thus the most easily manipulated of all units of measurement. Hence there is a tendency, in natural science, to reduce all quantitative comparisons to the comparison of spatial magnitudes. We compare masses, with the metric balance, by noting the deflections of the pointer. We measure the intensity of an electric current by noting the deflections of the galvanometer needle. We measure rise and fall of temperature by the rise and fall of mercury in the thermometer. We determine the period of a tuning fork by the graphic method. It is, moreover, with spatial measurements that we are chiefly concerned in everyday life. We are all, to some extent, practised in the estimation of space magnitudes, however helpless we may be when called upon to grade weights or to estimate brightnesses.

Finally, it is to be noticed that every measurement implies three terms, expressed or understood. In measuring the height of Mt. Vesuvius we had the zero point, or sea level; the highest point of the mountain; and the point lying 1 ft. above sea level or 1 ft. below the highest point. In measuring the time of the operation, we had the beginning and end of the period occupied by it, and the time point lying 1 min. (or 1 hr.) distant from

the beginning. In weighing our package, we had the zero point upon the scale bar; the limiting point at which the sliding weight was just counterbalanced; and the mark that lay 1 oz. (or 1 lb.) from the zero point. There are various devices—the introduction of submultiples of the unit, the use of the vernier—for increasing the accuracy of measurement; there are other devices for standardising the conditions (temperature, stress) under which a measurement is made; there are mathematical rules for calculating the ‘probable error’ of a given measurement. These are all refinements of the art of measuring. The essential thing is that we have our three terms: the limiting points of the magnitude to be measured, and a point lying at unit distance from the one or the other limiting point.

The third term, without which measurement is impossible, need not, however, be expressed. Suppose that two black strokes are made upon a sheet of paper, and that you are asked to say how far the one is above the other, or to the right of the other. You reply, without difficulty, “Two inches” or “Five centimetres.” But that means that you have mentally introduced a third term: the unit mark, inch or cm., with which you have become familiar in previous measurements. Without this, you could only have said: “The one mark is above the other” or “to the right of the other”; you could not have answered the question “how far.” How long is a given stretch of level road? Two hundred and fifty yards? A quarter of a mile? Most people have no mental unit for such a measurement. Either they say “It looks about as long as from so-and-so to so-and-so,”—comparing it with a familiar distance; or they make a rough determination by pacing the distance itself. How deep is this well? Very few people can say, even if they can see the water. So a stone is dropped in, and the seconds are counted until the splash is heard. The pace or the familiar distance gives a third term for the measurement of the road; and we know that the distance traversed by the stone in falling is the product of the distance traversed in the first second (about 490 cm.—our third term) into the square of the time. Where there is no such third term, there is no measurement. This rule is universal.

§ 2. **Mental Measurement.**—There can be no question but that,

in some way or other, mental processes are measurable. It would be strange, indeed, if the processes of the physical universe, which we know only by means of our sense organs or of instruments which refine upon our sense organs, should be capable of measurement, while the sensations of mental science were not: if all measurement in the physical sciences should tend towards spatial, *i. e.*, visual measurement, while yet the visual sensations themselves were unmeasurable. That apart, however, we have only to appeal to introspection to see that our mental processes furnish the raw material of measurement. Sensations differ more or less in quality: a given tone lies higher in the scale than another, a given green is more yellow than another. They differ in intensity: a noise may be louder than another noise, a brightness stronger than another brightness. They differ in duration: the taste of bitter lasts longer than the taste of sweet, the visual after-image lasts longer than the auditory. They differ in extent: one red is larger, one pressure spread more widely than another. These differences are given with the sensations; they obtain whether or not we know anything of the stimuli which arouse the sensations; we have evidence, in the history of science, that they were remarked and utilised long before the stimuli were known or measured. But if we have differences of more and less, it is only necessary to establish the unit, the third term, in order to convert difference into measured difference.

This establishment of the unit is, however, no small matter. We have said that the units of physical measurement are conventional. On the other hand, the units of modern physics are accurate, objective, universal. It is a far cry to these units—the cm., the sec., the gr.—from such things as the day's journey, the barley-corn, the chaldron. The difficulty of choosing the unit, and of standardising it when chosen, is much greater than might at first thought be supposed, and can be fully appreciated only by one who has followed historically, step by step, the development of scientific theory and practice. What holds in this regard of physics holds also of psychology. Moreover, the psychologist is at a peculiar disadvantage, in that there is no natural unit of mental measurement. The human body affords the natural units of linear measurement: foot, pace, cubit, span. The height of

the sun in the heavens, the alternation of day and night, the changes of the moon,—these are all natural units of time measurement. Units of weight are furnished by convenient natural objects (grain, stone) or by the average carrying power of man or animal (pack, load). There are no such obvious points of reference in psychology. Once more: physics is able to relate and combine its units, to reduce one to another, to express one in terms of another; so that the formula for mechanical work, *e. g.*, has the form $\frac{M.L^2}{T^2}$, where M represents mass measured in gr., L length of path measured in cm., and T time measured in sec. This sort of interrelation is forbidden by the very nature of mental processes, every group of which is qualitatively dissimilar to every other group. Hence there can be no single unit of mental measurement, no generalisation of the units employed in special investigations.

Here, then, are difficulties in plenty. And there can be no question but that these, the intrinsic difficulties, are largely responsible for the tardy advent of measurement in psychology, and for the doubts and controversies and confusions that have arisen since the methods of psychological measurement were formulated. The formulation itself dates only from 1860, when Gustav Theodor Fechner (1801–1887), gathering together scattered observations from physics and astronomy and biology, summing up elaborate investigations of his own, putting his physical, mathematical and psychological knowledge at the service of mental measurement, published his *Elemente der Psychophysik*. Fechner is the founder, we might almost say the creator, of quantitative psychology, and the modern student who will understand the principles and methods of mental measurement must still go to school with Fechner.

There are, however, other and extrinsic reasons for the late development of a quantitative psychology. If we are to have a satisfactory system of mental measurements, we must (as will appear later) rely largely upon the results of physical and physiological research; and, while physics has been securely established for some centuries, modern physiology may be said to date from the second quarter of the nineteenth century. Moreover, there is a sharp line of division in popular thought—a line drawn

for the modern world by Descartes—between the natural and the mental sciences; the former seem to be quantitative and measurable, the latter qualitative and unmeasurable. This ‘common sense’ point of view has all the weight and inertia of a settled tradition. Nay more: at the beginning of the nineteenth century it had received strong reinforcement from the philosophical side. Immanuel Kant (1724–1804)—not a mediæval philosopher, but the author of the *Critique of Pure Reason* and one of the most influential thinkers of modern times—declared roundly in 1786, and found no reason later to change his opinion, that psychology could never attain the rank of a true science. Something was done towards breaking up this dogma by the psychological work of Johann Friedrich Herbart (1776–1841). Herbart is, however, as weak in fact as he is strong in theory. So that, simple as the idea of mental measurement appears to us, who come after Fechner, we need not read far in the psychological literature of the early nineteenth century to realise how difficult it was, before Fechner, even seriously to entertain the idea, to dwell upon it as practicable, as anything more than a bit of daring speculation. The path of scientific progress is littered with brilliant suggestions: it is so easy to suggest, and so hard to grasp the suggestion, to work it out, to invent the methods for turning it into fact! Fechner not only had the idea, the inspiration of mental measurement, but he spent ten laborious years on its actual accomplishment.

There is one mistake, so natural that we might almost call it inevitable, which has sorely delayed the advance of quantitative psychology. It is a mistake with regard to the object of measurement, the mental magnitude. We have seen that every measurement requires three given terms; so that the physical quantity or magnitude is not, so to say, a single term, but rather a distance between terms, a section of some stimulus scale. We are apt to say, carelessly, that we have measured ‘the highest point’ of Mt. Vesuvius, when we have in reality measured, in terms of our arbitrary unit, the distance between its lowest and highest points. It is not the point that is the magnitude, but the distance between points. So with sensations: we are apt to

think of a brightness or a tone of given intensity as a sensation magnitude, as itself measurable. Now the stimulus is measurable: we can measure, in terms of some unit, the amplitude of vibration of the ether or air waves: we have our three terms to measure with. But the sensation, the brightness or the tone, is just a single point upon the sense scale,—no more measurable, of itself, than is 'the highest point' of Mt. Vesuvius. The only thing that we can measure is the distance between two sensations or sense points, and to do this we must have our unit step or unit distance.

Let us take some instances. Suppose that two rooms of equal dimensions are illuminated by two ground glass globes, the one containing five and the other two incandescent lights of the same candle-power. We can say, by eye, that the illumination of the first room is greater than that of the second. How much greater, we cannot possibly say. Even if the globes are removed, so that we can count the lights, we cannot say. The stimuli stand to one another in the ratio 5 : 2. But the corresponding sensations are simply different as more and less, the one a 'more bright' and the other a 'less bright.' The brightness of the lighter room does not contain within it so and so many of the brightnesses of the darker room. Each brightness is one and indivisible. What we have given is rather this: that on the scale of brightness intensities, which extends from the just noticeable shimmer of light to the most dazzling brilliance that the eye can bear, the illumination of the one room lies higher, that of the other room lower. There is a certain distance between them. If we can establish a sense unit for this distance, we shall be able to say that the greater brightness is, in sensation, so and so many times removed from the lesser brightness; just precisely as the top of the mountain, in terms of the 1 ft. unit, is 4200 times removed from the bottom. Neither of the two brightness sensations is itself a magnitude. The magnitude is the distance which separates them on the intensive brightness scale.

Again: we can say by ear that the roar of a cannon is louder, very much louder, than the crack of a pistol. But the cannon roar, as heard, is not a multiple of the pistol crack, does not con-

tain so and so many pistol cracks within it. What we have given is that, on the scale of noise intensities ranging from the least audible stir to the loudest possible crash, the cannon roar lies very high, the pistol crack a good deal lower. Neither noise, in itself, is a magnitude ; both alike are points, positions, upon an intensive scale. The magnitude is the distance between them. With a sense unit of noise distance established, we can measure this given distance, as before.

It was said above that the mistaking of the single sensation for a magnitude is so natural as to be almost inevitable. We are constantly confusing sensations with their stimuli, with their objects, with their meanings. Or rather—since the sensation of psychology has no object or meaning—we are constantly confusing logical abstraction with psychological analysis ; we abstract a certain aspect of an object or meaning, and then treat this aspect as if it were a simple mental process, an element in the mental representation of the object or meaning. What is meant will become clear at once, if we take a few instances. We do not say, in ordinary conversation, that this visual sensation is lighter than that, but that this pair of gloves or this kind of grey note-paper is lighter than this other. We do not say that this complex of cutaneous and organic sensations is more intensive than that, but that this box or package is heavier than this other. We do not even say, as a rule, that this tonal quality is lower than that, but rather that this instrument is flat and must be tuned up to this other. Always in what we say there is a reference to the objects, to the meaning of the conscious complex. It is not grey, pressure, tone, that we are thinking of ; but the grey of leather or paper, the pressure of the box, the pitch of the violin. Now the stimuli, the physical processes, are magnitudes or quantities. What is more natural, then, than to say that the corresponding grey or pressure or tone is also a magnitude or a quantity ? What is more natural than to read the character of the stimuli, of the objects, into the ‘sensations’ with which certain aspects of stimulus or object are correlated ? At any rate, this is what Fechner did. Fechner had an inkling of the truth ; he knew that sense-distances are magnitudes, and every now and

then he seems to look upon the single sensation as merely the limiting point of a distance, *i. e.*, as a position upon some sense scale. But his teaching is that the sensation as such is a magnitude. "In general," he says, "our measure of sensation amounts to this: that we divide every sensation into equal parts, *i. e.*, into the equal increments out of which it is built up from the zero point of its existence, and that we regard the number of these equal parts as determined by the number of the corresponding . . . increments of stimulus, . . . just as if the increments of stimulus were the inches upon a yard-stick." This is wrong. No sensation is a sum of sensation-parts or of sense-increments; no sensation is a measurable magnitude. Fechner has transferred to sensation a point of view that is right for stimulus, but that introspection refuses to recognise in psychology.

§ 3. **An Analogy.**—The passage which we have just quoted from Fechner reads in full as follows: "Our measure of sensation amounts to this: that we divide every sensation into equal parts, *i. e.*, into the equal increments out of which it is built up from the zero point of its existence, and that we regard the number of these equal parts as determined by the number of the corresponding variable increments of stimulus which are able to arouse the equal increments of sensation, just as if the increments of stimulus were the inches upon a yard-stick." Notice that Fechner speaks of the *variable* increments of stimulus which arouse the *equal* increments of sensation. This means, in our own terminology, that equal sense-distances do not correspond always to equal stimulus magnitudes: to obtain equal sense-distances, under different conditions, we must vary the magnitude of the corresponding stimuli. The fact is important: it is also obvious. Go into a small darkened room, and light a candle. There is an immense difference in the illumination of the room. The physical magnitude, the photometric value of the candle, corresponds to a very wide distance upon the scale of subjective brightness intensities. Light a second candle. There is a difference in the illumination, and a marked difference; but it is nothing like so marked as the first difference. The same physical magnitude, then, corresponds now to a lesser sense-distance. Light a third candle, and a fourth, and a fifth. A point will soon come at

which the introduction of another candle makes hardly any appreciable difference in the illumination. The same physical magnitude now corresponds to a minimal sense-distance.

Facts of this sort recur in all departments of sense, and it is part of the business of quantitative psychology to take account of them, and to sum them up in a numerical formula. What precisely the programme of quantitative psychology is in this field, what the facts are with which it has to deal, and how these facts are to be grouped under laws, we shall best understand by help of an analogy from physics. The analogy was first suggested by J. R. L. Delbœuf (1831–1896), late professor in the University of Liège,—a psychologist of great originality, to whom we owe the conception of mental measurement set forth in § 2,¹—and has been worked out in detail by H. Ebbinghaus (b. 1850), professor in the University of Breslau and editor of the *Zeitschrift für Psychologie und Physiologie der Sinnesorgane*.²

If a magnetic needle be suspended at the centre of a circular coil of wire, and an electric current be sent through the wire, the needle is deflected from its position of rest. Suppose that we are seeking to discover the law of this deflection, to find a general expression for the movement of the needle under the influence of currents of different strength. We send a current of so and so many amperes through the coil, and measure the angle of deflection upon a circular scale; then we send through a current of so and so many more amperes, and measure again; and so on. We find that the needle moves farther and farther, as the current is made stronger and stronger. But we find also that the angle of deflection is not simply proportional to the strength of current. If we increase the strength of current by equal amounts, the deflection of the needle becomes progressively smaller and smaller. And however strong we make our current, the needle will never make an excursion of 90°. The mathematical expression of the relation is very simple. If a is the number of amperes in the current, k a constant, and θ the angle of deflection, then $a = k \tan. \theta$.

¹ *Revue philosophique*, v., 1878, 53; *Examen critique de la loi psychophysique, sa base et sa signification*, 1883, 104 f.

² See this *Zeitschrift*, i., 1890, 447 ff.

Let us now, instead of taking determinate strengths of current, change the strength of the current continuously, and let us watch the behaviour of the needle. We find the same law in operation; but it is crossed by a second law. If the needle is hanging steady, whether at the zero point of its scale or at any other point at which it is held by the current in the coil, and we increase the current very slowly, we get at first no movement at all. During this period, while the needle remains stationary, our law of correlation is, apparently, not fulfilled; and the greater the increase of the current before movement sets in, the greater, of course, is the apparent deviation from the law. Presently, however, when the current has been increased by a certain amount, the needle goes with a little jump to the position which the law of correlation requires. And as we continue slowly to increase the strength of the current, the phenomenon is repeated, until the limit of the needle's excursion is reached. The law of correlation is not really in abeyance; it is crossed or masked by another law.

We have, then, two things before us. On the one hand, the needle is a magnetic needle, and the amount of its deflection is a continuous function of the current in the coil. On the other hand, the needle does not move without friction; so that we obtain, under the conditions of our second experiment, not a continuous movement of the needle, but a discrete movement, a series of jerks. It is one and the same needle that moves, and one and the same movement that it makes; but the single needle is at once mechanical and magnetic, and the single movement gives evidence of the operation of two distinct laws.

§ 4. **Three Problems of Quantitative Psychology.**—We cannot argue from the behaviour of a magnetic needle to the behaviour of our sensations. Nevertheless, the analogy serves to give us our bearings in the matter of sense measurement. We will take, first, the facts of sensation that correspond to the phenomena of friction in the needle.

(1) The perfect sensation has four attributes: intensity, quality, duration, extent. Every one of these attributes of sensation is correlated with some property of stimulus. Not every value of stimulus, however, is capable of arousing the correspond-

ing sensation. Just as the current must be increased by a certain amount, whether from zero or from some positive magnitude, to produce a deflection of the stationary needle, so must the stimulus in every case reach a certain magnitude, if it is to set up a sensation.

Take intensity. Some lights are too faint to be seen; there are stars, *e. g.*, that even on the darkest night remain invisible to the naked eye. Some sounds are too faint to be heard; we may be sure, from his gestures, that our friend is shouting to us, but we are too far off to hear his voice. Some pressures are too weak to be sensed; we have no knowledge of the flake of cigar ash that falls upon our hand. Some tastes are too weak to be sensed; a draught of water which proves, on chemical analysis, to hold various salts in solution, may yet be entirely tasteless. Some smells are too weak to be sensed; we get no sensation from an exposure of 1 mm. of black rubber tubing on the olfactometer. One of the things that we have to do, then, is to determine the least intensity of stimulus, in the different sense departments, that will arouse a noticeable sensation. What is the faintest light that we can see? The least sound that we can hear? The lightest weight that we can feel? And so on.

Again: some differences of stimulus intensity are too small to be remarked. If a few lights go out in a brilliantly lighted ball-room, the illumination is not sensibly diminished. If an orchestra is playing, and a belated second violin suddenly joins his fellows, the volume of sound is not sensibly increased. If we lift, blindfold, two glasses of water, from one of which a teaspoonful has been taken, we cannot say which is the heavier. If we put five lumps of sugar into our coffee, we shall hardly make it sweeter by adding a sixth. If we have spilled a bottle of eau de Cologne on the carpet, we shall not notice the little that our guest has poured on her handkerchief. Another thing to do, therefore, is to determine the least increase or decrease of stimulus intensity, in the different sense departments, that will make a noticeable change in the intensity of a given sensation, that will shift it a minimal distance up or down upon the intensive scale.

The same thing holds of quality. There is a lower limit to

the tonal scale and to the band of spectral colours; the air waves and ether waves must reach a certain frequency of vibration before they set up the lowest audible tone and the most extreme spectral red. Moreover, although we can distinguish several tones within the musical semitone, and many more than Newton's seven colours in the spectrum, still, not every change of vibration frequency produces a change of sense quality. We cannot distinguish an a^1 of 440 vs. from one of 440.1 vs.; we cannot distinguish a blue of $465^{\mu\mu}$ from one of $464.5^{\mu\mu}$.

The same thing holds of duration. If a strip of spectral green be exposed, under certain experimental conditions, for a very short time, it is seen merely as a grey. If the time of exposure be made a little longer, it is seen as bluish grey. If the time be still further increased, the bluish grey becomes a distinct blue. Finally, with still greater increase, the green is seen as green. Similarly, if the a^1 be sounded for only $\frac{1}{440}$ sec., so that a single v. reaches the ear, we hear not a tone but merely a noise. As the duration of stimulus is increased, the tonal quality becomes clear. If pairs of clicks are sounded, in rapid succession, a practised observer can distinguish a pair separated by 0.3 sec. from a pair separated by 0.303 sec. But the same observer cannot distinguish a separation of 0.3 sec. from a separation of, say, 0.301 sec.

Finally, the same thing holds of extent. Two stars, whose apparent distance is less than $30''$, are always seen as a single star. Cut a square of blue paper, with sides of 1 mm., and paste it on a white card. Walk backwards from the card: at a distance of about 3 m. the colour of the blue disappears. At certain parts of the skin, pressures of quite considerable area are sensed as mere points. Again: a strip of red, 10 cm. long, cannot be distinguished from a similar strip, 10.05 cm. long, laid in the same straight line with it. In pressure experiments at certain regions of the skin it is necessary to increase the diameter of the stimulus from 2 to 25 mm., in order to obtain a noticeable difference of extent.

(2) Further: our magnetic needle will never make an excursion of 90° , whatever the intensity of current that we employ. In the same way, the sense organs refuse to mediate sensation

when the stimulus has passed a certain maximal value. We cannot hear 'tones' of 100,000 vs. in the 1 sec.; we cannot see 'colours' beyond the extremest violet of the spectrum. Noises of maximal intensity stun or deafen us. If a tone or pressure is continued beyond a certain time limit, we cease to hear and feel; the organ gives out, becomes fatigued and exhausted. If visual stimuli are presented at certain distances from the fovea, they are not seen; the extent of the field of vision is limited. Here, then, is a second principal problem: the determination of the highest value of stimulus that is still effective for sensation.

(3) Thirdly, we will take the facts of sensation that correspond to the law of angular deflection in the tangent galvanometer. Sensation, under all its four aspects, is a continuous function of stimulus. True, a continuous gradation of stimulus will, under certain conditions, give us a discrete sense scale. But that is simply because the nervous structures involved offer resistance to the incoming disturbance, and so produce the phenomena of 'friction.' What, now,—apart from friction,—is the law of correlation of stimulus and sensation?

Let us pause, for a moment, before we try to answer this question, and look back upon the path that we have already travelled. It should be clear that we have not as yet entered upon our proper task of mental measurement. We have talked of measuring the stimulus that can just arouse a sensation; the stimulus that can just evoke a change in sensation, *i. e.*, that corresponds to a minimal sense-distance; and the stimulus that can still just arouse a sensation. All the measurements so far discussed, therefore, are physical, not psychological. Our present problem requires us to measure sensation.

Measurement demands three terms. Suppose, then, that a sense-distance is given: say, a distance of sound intensity. We have two sharply defined noises, of markedly different intensity, chosen from the middle portion of the intensive scale: we are to apply measurement to this noise distance, we are quantitatively to estimate it. How shall we begin? Well, we can measure it, in terms of an arbitrary unit, simply by halving it. We can ask, and seek methodically to answer the question: What noise intensity lies midway, for sensation, between the two given noises?

In other words: At what point, upon the intensive noise scale, is the given noise distance divided into two sensibly equal noise distances? Having determined this point, the middle noise intensity,—which we can do with practice, by help of one of the metric methods,—we may go on to ask: What point upon the scale lies as far above the upper point of our given distance as this lies above the middle point that we have just determined? And again: What point lies as far below the lower point of the given distance as this lies below the middle point? These two new points established, we can say that the whole noise distance which we have so far explored is the fourfold of our arbitrary unit, the half of the original distance. The procedure can then be continued above and below, until a wide range of noise intensities has been measured; *i. e.*, until a considerable section of the intensive scale has been marked off in equal sense divisions.

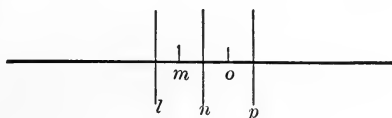

FIG. 1.

A diagram will simplify matters. Let the horizontal line in Fig. 1 represent the continuous scale of sensation intensity in the sphere of noise. We have given the two noises, the two sense points, m and o . Our first task is to determine the noise n that lies midway, for sensation, between m and o . That done, we can take the distance no as given, and increase the intensity of o till we reach a point p such that $no=op$. Again, we can take mn as given, and decrease m till we reach a point l , such that $lm=mn$. The sense-distance lp is then four times the sense unit $lm=mn=no=op$. And we can evidently go on to determine $q, r, . . .$ and $k, j, . . .$ in the same manner.

All that we now have to do, in order to formulate our law of correlation, is to write the corresponding stimulus values by the side of the unit sense-distances. We have already seen that equal stimulus magnitudes do not correspond to equal sense-distances, *i. e.*, that the law of correlation does not take the form of a simple proportionality of the two. We shall now discover what other and less simple relation obtains.

The correlation has been worked out with some degree of fullness for brightnesses, partially for noises, and a formula has been found which satisfies the results in both cases. Where, however, the stimuli must be presented to the observer successively (sounds, lifted weights, temperatures, smells, etc.) the procedure is, naturally much more difficult and uncertain than it is where they can be presented simultaneously (brightnesses). By the time that the third stimulus comes, the observer may have 'forgotten' the distance that separated the second from the first; or the presenting of the second distance may itself drive the first distance out of clear consciousness. Hence we are led to look round for another method. Besides, there is the question of the unit. It is not satisfactory to start out with an arbitrary sense-distance, and take the half of it as our provisional unit. It would be far better if we could find a definite unit, to be employed by all investigators alike. Is there another method of working, and can we discover such an unit?

Suppose that a brightness or a noise is given, and that we seek to determine the just noticeably brighter brightness, or the just noticeably louder noise. The experiment is identical with one of our 'friction' experiments; and its result is the ascertainment of a just noticeable sense-distance. Let us perform it at various points of the sense scale, so that we get the stimulus values corresponding to the distances $l', l'', \dots mm', m'm'', \dots nn', n'n'', \dots$ etc. Now these are all least distances, minima of sensible distance. Are they not, then, equal distances? And, if they are equal, may we not take them as the units of sense measurement?

That least steps, at various parts of the sense scale, should also be equal steps is by no means self-evident. A given difference between sensations might be the least perceptible difference, and yet, when compared with another least perceptible difference from another part of the scale, might be larger or smaller than this other. The equality of just noticeable differences must, then, be proved: it cannot be assumed. The appeal lies, directly, to introspection; indirectly, to the results of experiment. Fechner asserted, on the basis of his own introspections, that all just noticeable differences of sensation are sensibly equal. The state-

ment is made positively, and Fechner was an exceedingly careful and eminently practised experimenter. Still, this evidence needs to be supplemented: judgments of just noticeable difference are far from easy, and one might deceive oneself in the matter. Further evidence is, however, forthcoming. The course of stimulus, over against the least distances of noise and brightness, is precisely the same—is summed up in the same formula—as it is over against the larger sense-distances with which we have been dealing. Moreover, the formula which connects stimulus magnitude with least sense steps has the same form in other sense departments (pressure, lifted weights, tone, smell) that it has in the cases of noise and brightness. We can hardly doubt then, that the proposition “All just noticeable differences of sensation are equal sense-distances” is correct. And so we have our new method and our common unit of sense measurement.

We have our unit of measurement, that is to say, for intensity of sensation: for, so far, we have been speaking only of intensity. Does the same thing hold of quality, duration and extent that holds of intensity?

No: matters are more complicated. In the case of tonal pitch, *e. g.*, it seems that one and the same formula would naturally (in bare sensation) cover both just noticeable differences and the halves of larger tonal sections or distances. Only, when we are asked to bisect a tonal distance, we are not in the domain of bare sensation; we fall under the influence of musical training and tradition, and the results of our experiments are thus obscured. *Æsthetics* has cut across psychology. Again: when we are determining the j. n. d. of visual extent, we get one formula for the correlation of stimulus and sensation; when we are comparing visual extents as wholes, we get another and a different formula. There is good reason for this result: the conditions of judgment are very different in the two cases. Here it is psychology that cuts across psychology; the one set of experiments brings out one law, the other set brings out another. The same thing seems to be true of durations; though in this case the conditions of judgment are still more complicated, and experiments have not been made in sufficient number to allow of any general formulation. The facts will come out later, as we per-

form the experiments. What is important to remember now is that quantitative psychology sets us certain definite problems of mental measurement, and that we are able in theory to solve all these problems—even if they have not yet been all solved in fact—by help of our metric methods and our unit of sense-distance.

There is one point in the above discussion which may have puzzled the reader. We made a sharp distinction between the phenomena of friction (the needle as mechanical) and the phenomena of correlation (the needle as magnetic). Yet, in determining our unit of mental measurement, *i. e.*, our unit of correlation, we have had recourse to one of the friction experiments. There is, however, no real confusion. The fact that the needle remains stationary for a little while, as the strength of current is slowly and continuously increased, is a fact of friction; but when the needle moves, it moves in obedience to the law of correlation, it moves as a magnetic needle. In psychology, we use the fact of friction as a means to our end, which is correlation; we do not use it for its own sake. Suppose that we gave a quickly changing continuous stimulus, like the tone of a siren-whistle, which rises from bass to treble: we should get a corresponding continuous change in sensation; we should hear what we call, loosely, a 'rising tone.' How could this continuously changing sense-continuum help us towards mental measurement? How could it give us a correlation of stimulus with single sensation quality? How could it give us the unit sense-distance? To measure, we must have a discrete series of sensations, in which each term is equidistant from its neighbours before and after. We obtain this series by increasing our stimulus very slowly, so that sensation follows it, not continuously, but in little jerks. We owe the jerkiness of sensation to the fact of friction; but the space moved over at every jerk corresponds to a just noticeable sense-distance, *i. e.*, if our reasoning is correct, to a sensation unit.

That there are gaps and discrepancies, even in this first part of the programme of quantitative psychology, ought not to be surprising. Think of colours and tones. The stimulus magnitudes progress uniformly from less to greater in both sense departments. But tones form one single series, while the colours correlated with homogeneous light form no less than four (three complete, and one incomplete) series.¹ Think, again, of the difference between a duration, say, of 0.5 sec., which we can take in as a whole, as 'a' duration, and a duration of 5 min., which we can estimate only by means of the number and variety of the ideas and perceptions which 'fill' it. Here are differences on the objective side. On the subjective, remember that a science does not advance according to a prearranged logical plan, but unevenly, as the interests of individual workers or the claims of practical utility dictate. Fechner was chiefly interested in the intensive aspect of

¹ See vol. i., S. M., 3, 31; I. M., 7 f. 55.

mental processes, and among mental processes in sensation. His example has led other enquirers to give a disproportionate amount of attention to the laws of sensation intensity. It was a practical question, again, the question of the 'personal equation' in astronomical observations, that put reaction times in the forefront of experimental psychology. Further, at the inception of a science, problems will be wrongly—or, at any rate, inadequately—formulated. Hence much of the work done, *e. g.*, upon what were formerly called the 'space sense' and the 'time sense' is not available for our present purposes. It is concerned rather with perception than with the sensation attributes of duration and extent. All these factors, objective and subjective, combine to make quantitative psychology a ragged group of facts and methods rather than a well-rounded system. The rounding will come with time.

§ 5. **Some Technical Terms.**—The magnitude of stimulus which corresponds to any just noticeable sense-distance is called a *liminal* stimulus. The term *limen* (*Schwelle*, threshold) was introduced into psychology by Herbart in 1811: a liminal stimulus, or liminal stimulus difference, is that which lifts the sensation or the sense-difference over the threshold of consciousness. Our analogy of friction in the galvanometer indicates that all liminal stimuli do the same sort of work, at whatever point of the sensation scale they are operating. The facts that a stimulus must attain a certain magnitude in order to arouse a sensation at all, and that it must attain a certain magnitude in order to effect a noticeable change in sensation, are facts of the same order. Nevertheless, it is customary (and it need not be misleading) to make a distinction. The magnitude of stimulus that just brings a sensation to consciousness is called the *stimulus limen*; the magnitude of stimulus that corresponds to a least sense step from some positive point upon the sense scale we term, with Fechner, the *difference limen*.

The magnitude of stimulus that corresponds to the last noticeable sensation is called the *terminal stimulus*: the expression (*Reizhöhe*) was proposed by Wundt in 1874.

We symbolise 'sensation' by *S* or *s*, and 'stimulus' by *R* or *r*. *R* is the first letter of the German *Reiz*, stimulus. Its use is not unnatural in English, since *r* comes before *s* in the alphabet as stimulus before sensation in the psychological experiment. 'Stimulus limen' thus becomes *RL*; 'difference limen' *DL*; and 'terminal stimulus' *TR*.

Note that all these determinations may be qualitative, intensive, temporal or spatial. Thus the qualitative *RL* for tones is an air wave of some 14 vs. in the 1 sec.; this magnitude of stimulus gives the lowest audible tone; below it, there is no tone, but either silence or noise. The qualitative *DL* in the middle region of the tonal scale is some 0.25 v.; two tones are just noticeably different if their pitch numbers differ by this amount; this magnitude of stimulus corresponds to the least sense step, up or down, from a given tonal quality. The qualitative *TR* for tones is an air wave of some 50,000 vs. in the 1 sec.; this magnitude of stimulus gives the highest audible tone; above it, there is no tone, but either silence or a hissing noise. Similar determinations may be made for intensity, time and space. Theoretically, the fourfold programme can be carried through in all sense departments; practically, however, there are gaps in our knowledge.

Note, further, that the *DL* may be expressed in two ways, as absolute and as relative. If the a^1 of 440 vs. is just noticeably different from a tone of 440.25 vs., then the absolute *DL* is 0.25 v., and the relative *DL* $\frac{0.25}{440}$ or $\frac{1}{1760}$.

§ 6. **The Further Programme of Quantitative Psychology.**— We shall be chiefly occupied, in what follows, with the determination of the two limens, the *RL* and the *DL*, and with the halving of supraliminal sense distances. These are, logically and historically, the fundamental things in mental measurement; they are the first problems to be solved by help of the ‘psychophysical metric methods,’ whose elaboration we owe in the first instance to Fechner. They lead to a generalisation, called by Fechner ‘Weber’s Law,’ in honour of the physiologist Ernst Heinrich Weber (1795–1878). This law, roughly formulated by Weber in 1834, on the basis of experiments in touch and sight, is the first quantitative uniformity established by psychology. It has given rise to a large literature, constructive and controversial, in which all the most important issues of experimental psychology have been threshed out, pro and con, from different points of view. Weber’s Law is thus the natural gateway to quantitative psychology.

It is, however, no more than the gateway. To make Weber’s Law and the metric methods the be-all and end-all of quantitative work would be altogether misleading. For there is no single psychological problem that cannot be attacked on the quantitative as well as on the qualitative side. Every one of the experiments that we have already performed, in vol. I., can be

turned into a quantitative experiment. Let us take some instances.

(1) It has been found by experiment that the increase of brightness which a bright field gains by contrast upon a dark ground is, within limits, directly proportional to the difference between the brightness of field and ground. If b is the objective brightness of the field, B that of the ground, and c the increase of brightness that b gains by contrast, then $c = k(b - B)$: where k is a value that, under the most favourable circumstances, may be $= 1$. This formula yields interesting deductions, which can be experimentally verified; and similar formulæ may be written for colour contrasts.

(2) Of all mental processes, the affective are the most baffling and the least amenable to experiment. Neither of the two affective methods now in use—the methods of impression and of expression¹—is able, as things are, to furnish quantitative results. Nevertheless, an attempt has been made, even in this obscure department of psychology, to formulate in mathematical terms the law that relates affective process to affective stimulus. It is well known that the greater the preëxistent R the more must it be increased if the increase is to produce an appreciable change in the corresponding affection. When one is thoroughly tired out, a little more exertion seems to make no difference; it is the oncoming of tiredness that is distinctly unpleasant. When one is in severe pain, one can easily ‘stand a little more’; it is the lesser pains that show clear degrees of unpleasantness. When one is in full health and vigour, the good things of life are taken as a matter of course; it is in convalescence that health-increments are more and more pleasant. The simplest expression of this law is given by the formula $A = k \log R + \log c$, where A and R stand respectively for affection and stimulus, and k and c are constants.

This law holds only under certain theoretical conditions; in practice, it is cut across by many other laws of the affective life. It would be foolish, therefore, to give it any absolute value; but it would be equally foolish to ignore the amount of truth—and the hint of affective measurement—which it contains.

¹ See vol. 1, S. M., 92 ff.; I. M., 149 ff.

(3) It seems a little paradoxical, at first sight, to say that we can measure our illusions: for will not the same influences that distort perception baffle us in any attempt we may make to estimate the amount of distortion? Yet the problem becomes simple enough if only we regulate its conditions. We can, *e. g.*, measure an extent which, under the conditions of illusory perception, is overestimated, by comparing it with a similar extent seen under normal conditions. Let a be the objective value of the first extent, a' its illusory value, and b the objective value of the second extent which is $= a'$. Then $b - a$ gives us an objective measure of the amount by which a , under the conditions of the illusion, is overestimated. Experimental psychology has been busy of late with this sort of quantitative estimation of the geometrical optical illusions, and the results are of great importance for the theory of space perception.

(4) Finally, we may refer to certain investigations into the laws of memory. We know, from everyday experience, that the longer the time which has elapsed since a given event occurred, the more uncertain and inexact is our recollection of it. Experience does not, however, tell us anything very definite of the nature of the memory curve. We may have noticed, under exceptionally favourable circumstances, that memory weakens at first quickly, and then more slowly; but we shall not have got beyond this observation. Experiment furnishes us with the formula $\frac{m}{f} = \frac{k}{(\log t)c}$: where m stands for memory (amount retained), f for forgetfulness (amount lost), t for time elapsed, and k and c are constants.

It is needless to extend this list. Enough has been said to show that psychology may be treated, from beginning to end, as a quantitative science. True, very little has been done—we might go farther, and say that very little has even been attempted—as compared with what remains to do. But in principle every single problem that can be set in psychology can be set in quantitative form.

§ 7. Questions.—(1) Write the equation $P = \frac{x}{y}p$ in its four possible forms. Are all the forms employed in scientific measurements? Give instances.

(2) Define Psychophysics. Describe briefly the historical conditions under which the science arose.

(3) Discuss the statement: "Sensation, under all its four aspects, is a continuous function of stimulus."

(4) Discuss the statement that least sense steps need not, logically, be equal sense steps. Illustrate.

(5) Throw into quantitative form all the experiments worked out qualitatively in vol. I. State which of these quantitative problems you deem to be the most important, and why.

(6) If two different brightnesses are given, and we are required to find a third brightness that lies for sensation midway between them, we are said to equate two sense-distances. The distance, not the sensation, is the magnitude. How does the distance come to consciousness? What is the material of judgment in the experiment?

(7) Rewrite the affective formula of § 6 (2), in order to make it square with the hypothesis that mental distances, not mental processes, are measurable.

(8) Discuss the hypothesis that the RL and the DL are facts of the same order, phenomena of 'friction.'

(9) Go over the list of quantitative experiments that you have made for Question (5), and separate those in which the measurement is mental from those in which it is physical. What is the relative importance, for psychology, of the two classes of experiments?



CHAPTER I

PRELIMINARY EXPERIMENTS

EXPERIMENT I

§ 8. The Qualitative RL for Tones: the Lowest Audible Tone.—

The object of this experiment is, on the quantitative side, precisely to determine the lower limit of tonal hearing and, on the qualitative, to gain introspective familiarity with the lowest audible tones.

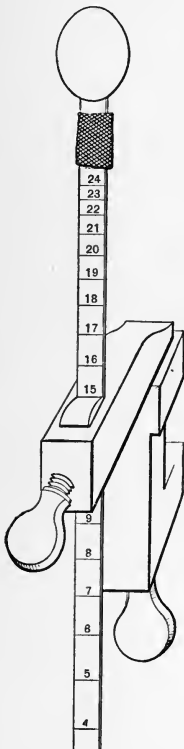

FIG. 2.

MATERIALS.—Appunn's lamella. Scraps of felt or baize. [The Appunn lamella (Fig. 2) is a blade or strip of soft steel, 385 mm. long, 15 mm. wide, and 1 mm. thick. It is clamped in a wooden vise, which is in turn to be screwed to the edge of a table. Along one face is marked a scale, which shows the point at which the strip must be fixed in the vise if it is to make 4, 5, 6, 24 pendular vibrations in the 1 sec. The upper end of the lamella is riveted to a thin steel disc, about 40 mm. in diameter. A cloth ring, 35 mm. in breadth, slides up and down the strip: the purpose of this ring is to eliminate possible overtones, and it is best set, in every experiment, at about one-third of the distance from the upper end of the strip to the scale mark at which it is clamped.]

ADJUSTMENT OF APPARATUS.—The deepest tones are intrinsically weak; and an unpractised *O* finds it difficult to distinguish them from noise. Every precaution should therefore be taken to make the conditions of observation

as favourable as possible. The vise must be clamped firmly to the edge of the table: scraps of felt may be used to prevent

jarring or rattling. The table itself must be higher than usual, and must stand solidly on the floor: pieces of felt or baize should be placed under the legs.

O's chair is so disposed that his better ear is directly opposite the source of sound: *i. e.*, the lamella plays directly into (not past) the opening of the external meatus. The distance from the lamella, in the vertical position of rest, to the orifice of the ear should be measured, and kept as nearly constant as may be throughout the experiment. Since the tones are weak, this distance should be very short. A chin-rest may be used, to ensure a constant position of the head. The orifice of the ear should be 4 or 5 cm. above the upper horizontal surface of the vise.

Whether or not the unused ear shall be stopped depends upon circumstances. If the stopper (which may be a plug of cotton wool and laboratory wax, or a small cork softened in vaseline) render *O* at all uncomfortable, or serve in the least degree to distract his attention, it is best to leave both ears open. The point should be settled in the preliminary experiments.

PRELIMINARY EXPERIMENTS.—*O* must have preliminary practice in the hearing of deepest tones. This is necessary, in order that he may acquire a *standard of judgment*. If we are to determine a valid *RL*, every *R* must be judged in the same way, from the same point of view, by the same criterion, as every other. But if *O*'s preliminary practice is insufficient, he may shift his standard of judgment as the experiment proceeds: he may presently find a tonal element in an *R* which he had formerly taken to be a whirring or puffing noise; or he may, contrariwise, come to demand greater smoothness and volume in the *R* which he reports as tonal. *E* must also have preliminary practice in the manipulation of the lamella. The instrument is awkward, at best; and the experiment will not run smoothly until he has learned to adjust and actuate it by a set of rapid and accurate movements, without effort or bungling.

The limits of the instrument suggest that the *RL* for tones lies above 4 and below 24 vs. in the 1 sec. Now it is a good deal easier, under the conditions of the experiment, to say that one hears a tone than to say that one does not. The quickest vibrations of the lamella give a distinct and unmistakable tonal

quality; the slower vibrations give a deep whir or whiz, which an unpractised *O* may well mistake for a very low tone. Hence it will be advisable to begin *O*'s practice with the highest available tone of 24 vs. By working downwards, from this upper limit, *E* will be able to establish, in a rough and tentative way, the position of *O*'s *RL*. This preliminary knowledge is essential for the further course of the experiment.

Suppose, now, that *O*'s left ear is to be tested. The lamella is clamped to the edge of a high, solid table. The chair (with its chin-rest) is brought up to this edge. *O* seats himself in such a position that the set-screw of the vise lies just above and in front of his left shoulder. *E*, standing behind *O*, actuates the lamella by laying the tip of his left thumb over the upper edge and nearer surface of the disc, and pulling out disc and strip to his left. The amount of pull is determined by the stiffness and elasticity of the lamella; no definite direction can be given with regard to it. He then releases the disc, by a quick and clean lift of the thumb; there must be no catching or dragging. To readjust the lamella, he turns the set-screw (over *O*'s shoulder) with his right hand, and raises or lowers the lamella with his left. It may be necessary for *O* to swing out a little, to his right, while the adjustment is being made: but this is not always the case. If the lamella becomes bent, by a too violent pull, it must be removed from the vise and straightened before the experiment is continued.

O is to know nothing of the result, and as little as possible of the course, of these preliminary experiments. His eyes are closed throughout. He knows that *E* is working from above downwards: but that is all. *E* may sound any particular tone (that of 24, or 22, or 18, etc., vs.) half-a-dozen times over, or may sound it once only. He must make the motions of readjustment at every step, but he need not actually readjust. Hence *O* cannot guess at the value of *R* which corresponds to his *RL*.

METHOD.—*E* knows, in a general way, the position of *O*'s *RL*. He is now to determine its position exactly. To this end, he prepares a set of 20 blank forms, each outlining an experimental 'series.' Ten of these series are 'descending'; in them, *E* works down to the *RL* from above, from a distinct tone. Ten

are 'ascending'; in them, E works up to the RL from below, from a distinctly toneless noise. In the actual experiment, each series is gone through separately. O , that is to say, is first subjected, in regular order, to the R of a descending series, and says at every step whether or not he hears a tone. Then, after a pause, he is subjected in the same way to the R of an ascending series, and again says at every step whether or not he hears a tone. This procedure is continued, until all 20 series have been applied.

We must now look at the Method in a little more detail.

(1) *Construction of the series.*— E found, in his preliminary experiments, that O 's RL lies in the neighbourhood of a certain R : say, an R of x vs. The blank form of a descending series may then contain the R -values $x + 4$, $x + 3$, $x + 2$, $x + 1$, x ; and the blank form of an ascending series the R -values $x - 4$, $x - 3$, $x - 2$, $x - 1$, x . In the actual experiment, O will first be given the R -values $x + 4$, $x + 3$, and then, after a pause, the R -values $x - 4$, $x - 3$, and will inform E at every step whether or not he hears a tone.

(2) *Size of the steps in the series.*—It is clear that our steps must be as small as we can conveniently make them. We are to determine the RL ; and the smaller our steps, the more closely (other things equal) shall we approximate to its real value. In the present instance, we may, for simplicity's sake, take the unit of the lamella (1 v.) as the fixed step for all series alike.

(3) *Starting-point of the series.*—It is unwise to begin every descending and every ascending series with the same R -value. Thus, it would be unwise to begin every descending series with $x + 4$, and every ascending series with $x - 4$ vs. If we do this, O will soon become aware that all the \downarrow and all the \uparrow series are alike. The series are so short, that he will be able to remember, as each fresh series comes, how he judged in preceding series. We want him to pay strict and undivided attention to every R , as it is presented to him. Instead of that, he will very probably be thinking: "This is the fourth step: I heard a tone at that step before,—so that I ought to hear a tone now: yes! I hear a tone!"

If, then, we begin one \downarrow series with $x + 4$, we should begin another with $x + 8$, etc. And if we begin one \uparrow series with $x - 4$, we should begin another with $x - 8$, etc. We may, indeed, begin where we like, provided that we obey three rules. The first is, that the series shall not be so long as to tire O . The second is, that the starting-point of the series shall always be a clear noise or a clear tone: we may not begin with a doubtful R . And the third is, that there shall be (approximately) as many long and short \downarrow series as there are long and short \uparrow series in the total 20. If one of the \downarrow series have 4 steps, one of the \uparrow should have 4 (or 3 or 5) steps;

if one of the \downarrow have 10 steps, one of the \uparrow should have 10 (or 9 or 11) steps. It may not be possible to make the lengths of the \downarrow and \uparrow series strictly identical; but they must be as nearly alike as we can make them.

Within these rules, we may begin where we like. Shall we begin at a different point in every series? Must all our 10 \downarrow series, *e. g.*, be of different lengths? This is not necessary. It may be better for *O*'s attention to have three sorts of series—long, intermediate, short—than to have 10 different series that slide into one another by imperceptible degrees. A good deal depends, too, upon the position of the *RL*. It may be not only inadvisable, but actually impossible, to begin a \downarrow series at 10 different *R*-values. In this matter *E* must use his own judgment.

(4) *The blank forms.*—It should now be clear that *E* cannot fill out all his blank forms beforehand. He makes out his first \downarrow series, we will say, as $x + 4, x + 3, x + 2, x + 1, x$: and he does this on the assumption (warranted by the preliminary experiments) that *O*'s judgment will change from 'tone' to 'no tone' at x . But what if, under the new conditions of the experiment, *O*'s judgment change at $x + 2$? Or what if it do not change till $x - 3$? In such an event, the corresponding \uparrow series would begin, not at $x - 4$, but rather at x or at $x - 10$. And such an event is by no means impossible. In view of this uncertainty, it will be best to enter, on all the 20 blanks, all the possible *R*-values from 4 to 24. The blanks may then be numbered in the order 1 to 20; the direction of the series may be shown by the sign \downarrow or \uparrow in the left-hand margin of the blank: the points at which each series begins and ends will be indicated by the introspections set down opposite the *R*-values employed in the series. The starting-point of a new series may then be chosen in the light of the preceding results.

(5) *Order of the series.*—We have taken it for granted that the whole experiment of 20 series is to begin with a \downarrow series, and that the \downarrow and \uparrow series are to alternate, regularly, throughout the experiment. We begin with the \downarrow series, because *O* is a comparatively unpractised observer, and his first series should therefore be made as easy as possible. His practice will, however, be steadily increasing as the experiment advances; and we must accordingly arrange the later series so that the benefits of this increasing practice shall be shared, as equally as may be, between the \downarrow and the \uparrow series. This end may be reached in various ways. Thus, if we divide the 20 series into four groups of five each, the first group might contain the series $\downarrow\uparrow\downarrow\uparrow\downarrow$, the second $\uparrow\downarrow\uparrow\downarrow\uparrow$; and the third might repeat the second, and the fourth the first. *E* should work out other arrangements for himself.

The relative length of successive series is best determined by chance. If *E* decides to use three lengths—long, moderate, short—he should write these words (6 'long,' 8 'moderate,' 6 'short') on 20 cardboard tickets; shake the tickets in a bag; and draw a ticket for each new series. If he uses four lengths—long, moderately long, moderately short, short—he

writes their titles (5 apiece) on 20 similar cards, and draws as before. And so on.

(6) *Instructions to O.*—We want *O* to be impartial and attentive. It would be best, from this point of view, that he should know absolutely nothing of the method or of the instrument. As a matter of fact, he knows (*a*) that the *R*-values employed cannot fall below 4 or rise above 24 vs. He knows also (*b*) that the unit of the series is 1 v. He knows (*c*) that the first series will be ↓. He does not know what the direction of every subsequent series is to be; there are many patterns of arrangement, any one of which *E* may adopt. At the same time, every series is to begin either with a clear tone or with a clear noise. If it begin with a tone, it must be ↓; if it begin with a noise, ↑. Since we cannot prevent *O*'s finding out, in this way, what the particular series is to be, and since his thinking about the matter might possibly distract or fatigue his attention, we will make a virtue of necessity and (*d*) tell him the direction of each series before we enter upon it.

On the other hand, *O* knows nothing (and is to know nothing) of the length of the series. The series now beginning may be three steps or ten steps long. *O* does not know; and, not knowing, must pay strict attention to each *R* as it is presented.

It need hardly be said that *O* is to know nothing, either, of the numerical results of the experiment until the whole 20 series have been completed.

All these rules and directions may be summed up in a single sentence. *E is to use short, small-stepped series, 10 ↓ and 10 ↑, and is to keep O on the alert by varying the length of the series within the limits of fatigue.*

EXPERIMENT.—*O* is seated in position: his eyes closed, and his unused ear stopped or open, as the case may be. *E* has the blank form of his first ↓ series before him. *E* first says "Ready!" as a signal to *O* that a series is about to begin. He then says 'Now!' and after a short 2 sec. gives the stimulus. *O* says 'Tone!' and *E* enters a + sign opposite the corresponding *R*-value in his blank form. *E* then says 'Now!' and after a short 2 sec. gives the next lower *R*. *O* again says 'Tone!' and *E* enters another + in the record. The series is continued in this way, in a steady and even rhythm, until an *R* is given to which *O* replies either 'Doubtful!' or 'No tone!' *E* enters a ? or — in the record, and the series stops.

A pause, perhaps of 3 min., is now made. Then a second 'Ready!' is given, and a new series begins. *E* starts from an *R* which evokes a decided 'No tone!' and continues the *R* up to the point at which *O* first says, definitely, 'Tone!' There

the series stops. The record may have the form —, —, —, —, + : or possibly —, —, —, ?, + : etc.

When 5 series have been taken, *E* and *O* change places. After another 5 series, they change places again; and so on, until the 20 series have been completed for each.

On no account should the preliminary experiments be made on the same day as the experiment proper. The best plan is to spend one day upon the preliminary experiments and the method, and to work through the regular series (after a few more preliminary tests) at the next laboratory session. If the work proves very tiring, three days may be given to it: the experiment proper is then performed (each time with a few preliminaries) half on the second and half on the third day.

O will naturally employ his better ear for this experiment, whether the unused ear be closed or open. If the Instructor think it worth while, the whole experiment may be repeated for the other ear.

RESULTS.—*E* has his 20 forms, which show the *R*-values employed in the various series and *O*'s introspections. The forms should be pasted, or the full series copied, into the note-book.

These 20 records represent 10 'paired' series: that is, 10 ↓ and 10 (correspondingly long) ↑ series. The ↓ series end with the *R*-value at which the tone has become just unnoticeable (first judgment of ? or —). The ↑ series end with the *R*-value at which the tone has become just noticeable (first + - judgment). Now the *RL* stands on the dividing line between noticeableness and unnoticeableness. Hence we may determine it from any one of our paired series by taking the average of the final terms of the separate (↓ and ↑) series. But we have secured 10 paired series; and we have been at this trouble because there is safety in numbers: the result of a single paired series might be affected by all manner of accidents,—an uncomfortable position on *O*'s part, some outside noise, some temporary lapse of attention, etc. We proceed, accordingly, to determine the average value of all 20 final terms,—of the 10 'just noticeables' and the 10 'just unnoticeables.' This average value fairly represents the *RL* for the particular *O*, under the particular conditions of experimentation, and of health, practice, attention, etc.

It is, however, not enough, when we have measured, to give simply the average result of our measurements. The results of the individual measurements are not identical; all sorts of acci-

dental circumstances have affected the separate tests; the individual results vary through a certain range of values, above and below the average. In the present case, the 20 values which we have averaged are not identical; and the final RL need not be identical with any one of them. This fact of variation must find quantitative expression: and it is expressed in what is termed the 'mean variation' or 'average deviation' of the average result. The MV or AD is the average amount by which the separate measurement-values differ from their average. In the present case, then, it is the average amount by which the separate 'just noticeable' and 'just unnoticeable' differ from the average RL . If we represent these separate values by the symbols $RL_1, RL_2, \dots, RL_{20}$, it is the value determined by the formula:

$$MV \text{ or } AD = \frac{(RL_1 - RL) + (RL_2 - RL) + \dots + (RL_{20} - RL)}{20}$$

The differences in this formula are all to be considered as positive differences, *i. e.*, are to be summed up without regard to sign. A divergence from the average is a real, positive divergence, whether it fall upon the *plus* or *minus* side of the average. Suppose (for the sake of an illustration) that the average value of the RL is 18 vs.; and suppose that the values 16 and 20 occur among the separate determinations. In each case, the difference counts as a positive 'two.' The formula writes 16 — 18 and 20 — 18; but the *minus*-sign is simply the sign of difference.

In general terms, the formula may be written thus:

$$MV \text{ or } AD = \frac{(A-a) + (A-b) + \dots + (A-n)}{N}$$

where A is the average value of the magnitude measured (here the RL); a, b, \dots, n are the values of the successive separate determinations (here the separate 'just noticeable' and 'just unnoticeable'); and N is the number of these determinations (here 20, the number of series taken).

The mode of calculation may be illustrated as follows. Suppose (the numbers are merely fanciful) that we have, to calculate the value of the RL , the six determinations: 22, 20; 21, 22; 19, 18. The RL is the arithmetical mean of these values. Summing them up, and dividing by 6 (the number of determinations), we find $RL=20.3$. Notice that there is no actual determination of this value. Now we have to find the MV , the average difference between the separate determinations and the RL of 20.3. The separate differences are 1.7, 0.3; 0.7, 1.7; 1.3, 2.3. Summing them up, and dividing the sum by 6, we find their arithmetical mean (the MV) to be 1.3. This value does actually coincide with one—but with one only—of the separate differences. The final result of our measurements is then stated

as 20.3 ± 1.3 . This means that, under the conditions of the experiment, the dividing line between noticeableness and unnoticeableness is drawn for *O*, on the average, at 20.3 vs.; and that—again, on the average—it does not fall below 19 or rise above 21.6 vs. The *RL* is thus seen to be a variable, not a constant value. On the average, it lies at 20.3 vs.; but in the individual case it is liable to shift and displacement, up or down, by all sorts of accidental influences affecting *O*'s judgment. The average range of these influences is ± 1.3 .

INTROSPECTIONS.—Regarded simply as an exercise in psychophysics, our experiment is now complete: we have the *RL* and its *MV*. It was, however, one of the objects of the experiment to secure an exact introspective description of the sensations set up at and about the point of the qualitative *RL* for tones. So far, the introspection required of *O* has been of the most meagre kind. He has merely said 'Tone,' 'Doubtful,' or 'No tone;' and his reports have been symbolised in the record by +, ?, and —. How shall we obtain more detailed introspections?

Three courses are open to us. *E* and *O* must decide for themselves which of these courses, or what combination of them, they prefer, and must give their reasons to the Instructor.

(1) We may so remodel the experiment as to require an exact introspective report from *O* at every step of every series. We may instruct him to say, first of all, 'Tone' or 'Doubtful' or 'No tone,' and then to go on with an introspective account of what he has heard. Is this course advisable?
 (2) We may keep the series as they are, and require *O*, in the 3 min. pause between series and series, to sum up the introspective results of the preceding experiments. Is this course adequate? Is it advisable?
 (3) We may work through the 20 series, and then, at the conclusion of the quantitative work, take one or more qualitative series, *i. e.*, series with detailed introspections at every step. Is this course adequate? Is the extra work worth while?

QUESTIONS.—(1) In what sense can an average value be said to 'represent' the results of repeated measurements? What advantage is there in writing 20.3 ± 1.3 for the separate values on p. 8? What disadvantage is there?

(2) Could we use any other representative values, besides the average and the *MV*? How is the experimenter guided in his choice of representative values?

(3) Give, in your own words, a psychological criticism or justification of the method. We have said 'It is best to do this';

'It is inadvisable to do that.' Show why the various courses proposed are, psychologically, advisable or inadvisable.

(4) Indicate the precise point, in the method, at which introspection ends and calculation begins. What reason have we for changing from the one to the other?

(5) Do the series furnish any other values, besides those which we have selected, for the determination of the *RL*?

(6) What sources of error, objective and subjective, have you noticed during your performance of the experiment? Do you think that the method would be adequate to the determination of all sorts of *RL*?

(7) Make out a list of the *RL* (or absolute limens in general) which you think a quantitative psychology should determine. If you are interested in any particular determination, work out the details of experimentation (instrument, method, etc.), and show your plan to the Instructor.

(8) Can you suggest other methods for the determination of the *RL*?

EXPERIMENT II

§ 9. **The Qualitative *RL* for Tones: the Lowest Audible Tone.** Alternative Experiment.—The objects of this experiment are those of Exp. I., p. 1.

MATERIALS, ADJUSTMENT OF APPARATUS, PRELIMINARY EXPERIMENTS: see pp. 1 ff.

METHOD.—*E* knows, in a general way, the position of *O*'s *RL*. He is now to determine it exactly. To this end, he makes out a series of *R*-values such that the highest value will always call forth the judgment 'Tone,' and the lowest the judgment 'No tone.' The length and position of this series must be determined in the light of the preliminary experiments. It may cover all possible values, from 4 to 24 vs. ; it may range between 10 and 24, or between 8 and 20 vs.: everything depends upon the position of *O*'s *RL*.

Having selected the series of *R* to be employed, *E* (1) writes the values of these *R* upon cardboard tickets, and puts the tickets in a small box. He (2) makes out a record-form, by writing the *R*-values in order along a horizontal line at the head of a

sheet of cross-ruled paper. The *R* of a given series are to be employed in haphazard order, and *O*'s judgment is to be entered in its appropriate square upon the record-form.

EXPERIMENT.—*O* is seated in position: his eyes closed, and his unused ear stopped or open, as the case may be. *E* has his record-form and the box of tickets before him. The box is shaken, to mix the numbers. *E* draws a ticket at random, and sets the lamella to the value indicated. Then, after the ready-signal to *O*, he says 'Now;' waits a short 2 sec.; and actuates the lamella. *O*'s judgment is entered, as +, — or ?, under the corresponding *R*-value of the record-blank. *E* draws another ticket; sets the lamella; says 'Now;' waits as before; takes a second experiment; and enters *O*'s judgment in the record. The series is continued until all tickets have been taken from the box.

A pause, perhaps of 3 min., is now made, during which the tickets are replaced in the box and the box thoroughly shaken. Then a second 'Ready!' is given, and a new series begins.

When 5 series have been taken, *E* and *O* change places. After another 5 series, they change places again. Ten series are to be completed by each.

RESULTS.—*E* has his Table of 10 series, which shows the *R*-values employed and *O*'s introspections. The Table should be pasted or copied into the note-book.

The *RL* stands upon the dividing line between noticeableness and unnoticeableness of tone. Hence we may determine it, from any series, by taking the average of the last unnoticeable and the first noticeable (the strongest imperceptible and the weakest perceptible) *R*-values. But we have secured 10 series; and we have been at this trouble because there is safety in numbers: the result of a single series might be affected by all manner of accidents,—an uncomfortable position on *O*'s part, some outside noise, some temporary lapse of attention, etc. We proceed, accordingly, to determine the average value of all 20 terms,—of the 10 'last unnoticeables' and the 10 'first noticeables.' This average value fairly represents the *RL* for the particular *O*, under the particular conditions of experimentation, and of health, practice, attention, etc. We further determine the *MV* or *AD* of the final average. See p. 8.

If the judgment corresponding to the 'first noticeable' is a +, the calculation presents no difficulty. If it is a ?, the question arises whether we shall accept the *R*-value for this ?, or shall go higher in the series and take the first + -judgment as representing the 'first noticeable.' Everything depends upon the general run of judgments within the series. *E* should try to decide the matter for himself, and give reasons for his decision to the Instructor.

INTROSPECTIONS.—See p. 9.

EXPERIMENT III

§ 10. The Qualitative TR for Tones: the Highest Audible Tone.

—The object of this experiment is, on the quantitative side, precisely to determine the upper limit of tonal hearing, and, on the qualitative, to gain familiarity with the highest audible tones.

MATERIALS.—Edelmann's Galton whistle. Heavy standard, with arm and clamp. Small square of felt or baize. [Galton's whistle is a very small stopped labial pipe. It is actuated by the squeeze of a rubber bulb, and closed by a piston, adjustable by a micrometer screw. As the piston is turned inwards, the pipe is shortened, and the tone of the whistle rises in pitch. The number of vibrations for any set of the piston can be calculated from the reading of the screw. The dimensions of the pipe are so

chosen that we can pass from a clear shrill tone to a mere noisy hiss; and the problem is to determine the exact point at which the *R* loses its tonal component, and becomes noise. The original form of the Galton whistle is shown in Fig. 3.

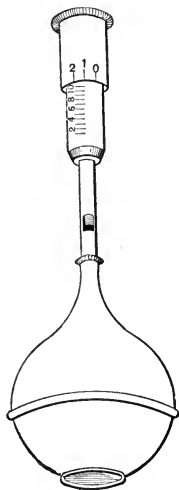

FIG. 3.

The Edelmann whistle (Fig. 4) is composed of two separate and separately adjustable parts: the body of the pipe, with its piston, and the mouth-piece. The pipe is a cylindrical closed pipe, whose open end lies with its sharp circular edge directly over against the mouth-piece. The cylindrical lip suggests the principle of the steam whistle rather than that of the organ pipe. The length of the pipe can be read from the scale of the instrument to tenths, and by the

eye to hundredths, of 1 mm. The mouth-piece is also circular: the air is forced, by pressure on the rubber bulb, through an an-

nular opening or wind-way; impinges on the lip of the pipe; and throws the contained air-column into strong vibration. The width of the mouth of the pipe (the distance separating lip and mouth-piece) can be regulated by a second micrometer screw, reading accurately to tenths of 1 mm. The Edelmann whistle, therefore, allows the tone to be treated as a function, not only of the length of the pipe, but of this and of the width of the mouth as well.]

ADJUSTMENT OF APPARATUS.—*E* wraps the felt about the heavy plate of metal that connects the two halves of the whistle, and clamps it firmly in the arm of the standard. The whistle lies horizontally in the clamp, the body of the pipe to *E*'s left. *O* sits as near the instrument as is convenient (the distance is to

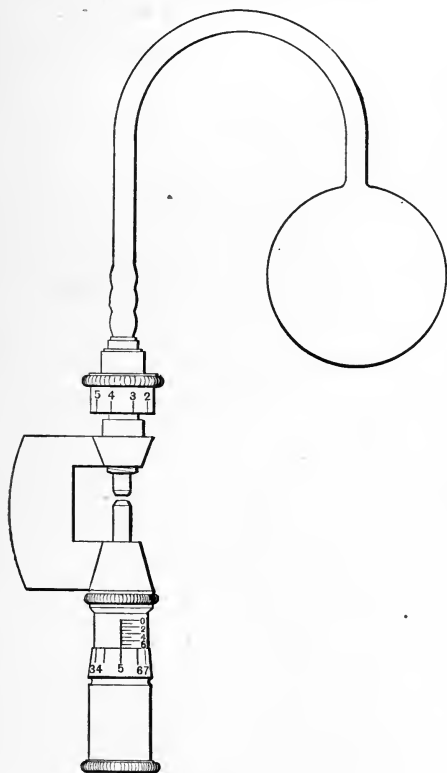

FIG. 4.

be kept constant throughout the experiment), his better ear turned towards it. A chin-rest may be used, to ensure constancy of position. The unused ear may be stopped or open, according to circumstances: see p. 2 above.

PRELIMINARY EXPERIMENTS.—*O* must have preliminary practice in the hearing of highest tones, in order that he may acquire a standard of judgment. *E* must also have preliminary practice in the manipulation of the whistle.

It will be advisable to begin *O*'s practice with an *R* that gives a clear tone. By working upwards, from this lower limit, *E* will be able to establish, in a

rough and tentative way, the position of *O*'s *TR*. *E* sets the whistle by help of a Table furnished by the Instructor: the unit

of change is 1000 vs. *O* knows this; but is to know nothing of the result, and as little as possible of the course of the preliminary experiments. His eyes are closed throughout. He knows that *E* is working from below upwards; but that is all. *E* may advance 1000 vs. at each step, or may sound the same *R* half-a-dozen times over,—going through the motions of readjustment, but not actually readjusting the whistle.

E will probably find that the experiment can be performed with a single width of the mouth of the whistle. The manipulations are then reduced to the setting of the piston with the left hand, and the squeezing of the rubber bulb with the right. The stimulus should be given by a squeeze only, not by squeeze and release of the bulb. The bulb is held in the hollow of the hand, and pressed sharply with the thumb.

METHOD.—See pp. 3 ff., above. The first of the 20 series is, in this case, an \uparrow series.

EXPERIMENT, RESULTS, INTROSPECTIONS.—See pp. 6 ff., above.

QUESTIONS.—(1) What sources of error, objective and subjective, have you noticed during your performance of the experiment? Do you think that the method would be adequate to the determination of all sorts of *TR*?

(2) Make out a list of the *TR* that you think a quantitative psychology should determine. If you are interested in any particular determination, work out the details of experimentation (instrument, method, etc.), and show your plan to the Instructor.

(3) Write out an introspective comparison of lowest and highest tones. Write out a similar comparison of the noises given by the lamella and the whistle, below and above the limits of tonal hearing.

§ 11. **The Intensive RL for Pressure.**—The object of this experiment is to determine the least pressure that can be perceived, under given conditions, by the resting skin.

EXPERIMENT IV

(1) **MATERIALS.**—Scripture's touch-weights. [A full set of touch-weights consists of 20 discs of elder-pith or cork, 3mm. in

diam., suspended by silk threads from short wooden handles. The weights range between 1 and 10 mg. with differences of 1 mg., and between 10 and 30 mg. with differences of 2 mg.]

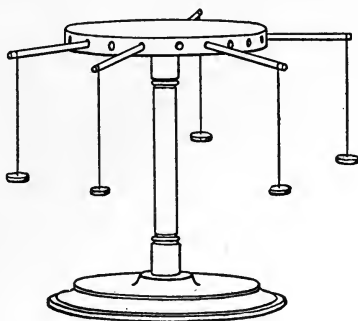

FIG. 5.

MANIPULATION.—Convenient parts of the skin, for this experiment, are temple, middle of forehead, side of nose, inner surface of wrist and forearm, finger-tip. *O* must sit or lie comfortably, in a constant position; the temperature of the room should be kept constant.

E applies the weights normally to the surface to be experimented on. They must be set down steadily and evenly; left for 2 sec.; and then carefully removed. A slight impact will lower the *RL* beyond its proper value. If a weight be set down unevenly, or the thread twitched while the weight lies upon the skin, a tickling will be produced. A jerk away, at the end of the 2 sec., will have the same effect as an initial impact. Some little practice is required before the weights can be applied and removed in a satisfactory manner.

METHOD.—The place of the *RL* is roughly determined in preliminary experiments. The method is that of Exp. II., pp. 10 ff., above.

EXPERIMENT V

(2) **MATERIALS.**—von Frey's hair æsthesiometer. [The instrument consists essentially of a horsehair or human hair, attached to a fine wire, which slides in a metal tube of very small bore. The projecting length of hair can be varied at will, and the tube

clamped at any required point by a screw. A mm. scale, engraved on the tube, makes it possible to set the instrument at the same point in different experiments.]

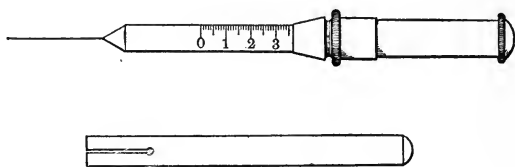

FIG. 6.

PRELIMINARY EXPERIMENTS.—Find a responsive pressure spot, on the back of the hand, and mark its position by a ring of dye. Assure yourself that the spot does not reply to stimulation by the longest length of hair afforded by the aesthesiometer, and that it replies clearly to the shortest length. Determine roughly, in a \downarrow series, the position of O 's RL .

Suppose that a hair is waxed at right angles to the end of a light wooden handle, and that the point of the hair is set down perpendicularly upon some point of the skin (Fig. 7, A). As the handle is lowered, and the

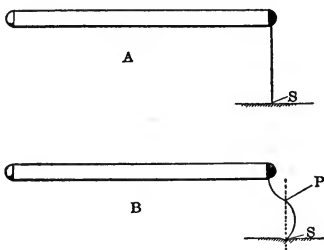

FIG. 7.

Application of a hair to the cutaneous surface. S , skin; P , point of inflection of the S-shaped curve.

pressure consequently increased, the hair bends to form an S-shaped curve (Fig. 7, B). So long as the point of inflection of the curve lies on the perpendicular which passes through the point of stimulation, the hair is pressing vertically upon the skin. As soon as the hair gives to one side, and the point of inflection leaves the perpendicular, a lateral push is added to the vertical pressure.

If, now, the hair is set down upon the pan of a sensitive balance, instead of upon the skin, it is found to exert its maximal pressure (to compensate the heaviest weight) just before it gives. The hair saves itself, so to speak,

by yielding and turning, before the limit of its elasticity is transcended. Moreover, its maximal pressure remains constant over a long period of time, and in spite of much work. These properties render it an admirable instrument for cutaneous stimulation.

In applying the hair to the skin, *E* must, however, be careful not to push the curvature too far. If the curve of flexure is a pronounced *S*, the pressure of the hair will, it is true, be still vertical, but it will not be evenly distributed over the whole surface of the cross-section: the edge of the hair will dig into the skin. Fortunately, the pressure remains constant, at a nearly maximal value, with a very slight curving of the hair; and it is, accordingly, this slight bend which should be employed in practice.

The series may be taken in units of the mm. scale, and the pressure values obtained from the Instructor after the completion of the experiment.

Care must be taken to apply the hair always to the same spot, and (so far as possible) with the same rate of movement. Long hairs quiver and are apt to slip, and stout hairs are apt to spring as they are lifted from the skin, so that careless manipulation will lead to tickling or to the stimulation of neighbouring pressure spots. The hair need not be held on the skin for more than 1 sec. The pressure spots are very readily fatigued; intervals of at least 30 sec. must elapse between stimulations, and *E* and *O* should change places after every one or two series.

METHOD.—The strict serial method of Exp. I. or the haphazard arrangement of Exp. II. may be followed.

EXPERIMENT VI

(3) **MATERIALS.**—von Frey's limen gauge, with discs, springs,

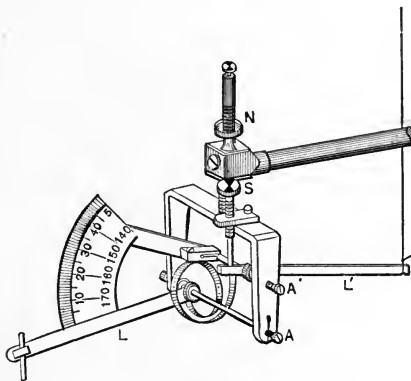

FIG. 8.

and kymograph attachments. [The limen gauge, Fig. 8, consists essentially of two levers, *L* and *L'*, which turn about parallel

axes, A and A' , and are coupled by a clock-spring. The lower lever, L , carries at its extremity a point of horn or bone. This is the stimulus point: it rests upon a small disc of cork or cardboard, which in turn rests upon the skin. Attached to the upper axle, A' , is a paper scale, reading in degrees from 0° to 50° . The horizontal arm is clamped in a standard; the clamp serves for the coarse adjustment of the instrument, while the fine adjustment is effected by the nut N . The intensity of stimulation is regulated by the set-screw S and read off (in degrees) from the paper scale. Six clock-springs of different tension, and discs

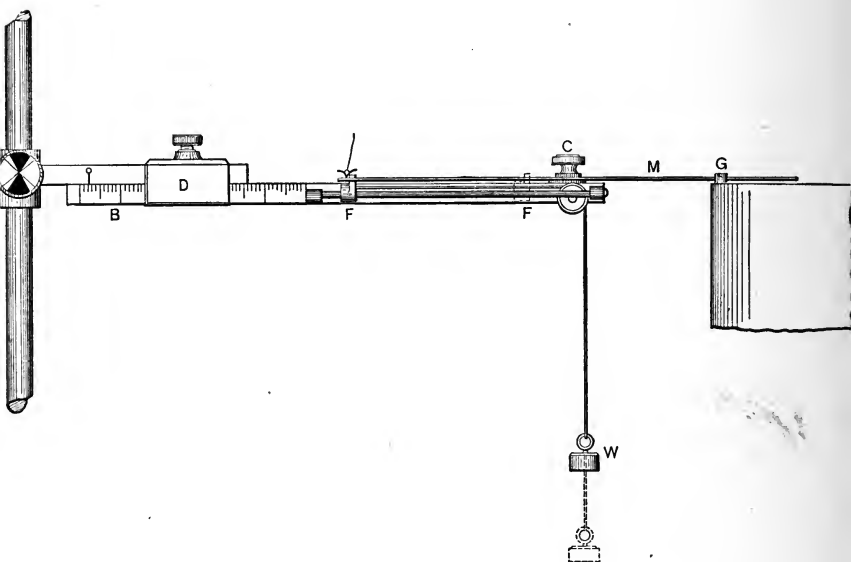

FIG. 9, a.

of three sizes (0.75, 1, 1.5 mm. diam.), are supplied with the gauge.

As thus described, the apparatus permits us to vary the place, the intensity and the area of the stimulus. The RL depends, further, upon its rate of application. To control this factor, we have recourse to the following device (Fig. 9, a, b).

A thread attached to the end of the lever L' is led upwards, over a small and easily running pulley of hard wood, P , to the inner end of the metal strip M . The strip is supported hori-

zontally by the adjustable bar *B*, and turns freely about its vertical axis at *C*. The outer, free end of *M* lies directly over the upper edge of a kymograph cylinder, which carries the rounded pin *G*. It is clear that, if the kymograph is started, the pin *G* will, once in every revolution, strike the free end of *M*, take it a certain distance, and presently release it. So long as *M* is mov-

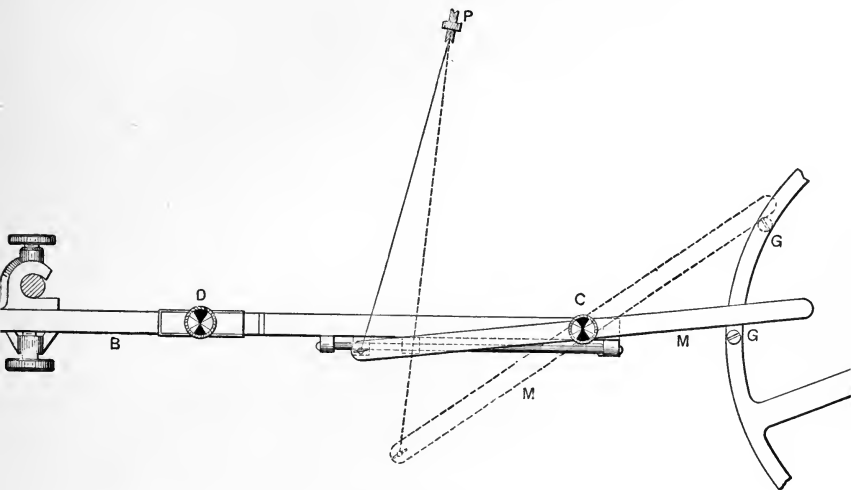
FIG. 9, *b*.

ing, an upward pull is exerted upon the lever *L'*, and the stimulus point of *L* is pressed down upon its disc. As soon as *M* is released, the apparatus must come back with a jerk to its position of equilibrium.

The jerk would, however, be a source of serious disturbance in liminal determinations. To avoid it, we run along the side of *B*, beneath *M*, a metal rod upon which slides the follower *F*. A thread passes from *F*, over a pulley, to the little weight *W*. As *M* moves, *F* (drawn forward by the weight) gently follows it up; so that, when *M* is released by the pin *G*, the apparatus remains in its new position, so to say, as a matter of course, without the least jar or recoil. To reset it, *E* has merely to move *F* back with his finger to its original starting-point.

The bar *B* is adjusted vertically by means of the clamp which holds it to the standard. It consists of two squared rods, fitted with spline and feather, and connected by the broad clamp *D*.

This complication is introduced in order that we may, without manipulating the limen gauge itself, vary the intensity as well as the rate of application of the pressure stimulus. The farther M projects over the kymograph cylinder, the farther, of course, will G take it, and the more severe, accordingly, will be the final pressure of L . First of all, then, in arranging an experiment, we clamp the upper rod of B (which carries a zero-point) at a convenient distance from the kymograph: this is the coarse adjustment. Afterwards, by loosening D , and moving the lower rod of B (which carries a scale) back or forth along the upper rod, we are enabled to take small-stepped pressure series, \downarrow or \uparrow , as the experiment requires: this is the fine adjustment. By changing the rate of revolution of the drum, we change the rate of application of the stimulus; by shifting M in or out, we vary its limiting intensity.]

PRELIMINARIES.—(1) We must know the rate of rotation of the cylinder, at the various speeds of which the kymograph is capable. The drum is covered with smoked paper, and half-a-dozen records are obtained, at short intervals, from a suitable time marker.

Before the paper is varnished, mark upon it (*a*) the setting of the kymograph, (*b*) the date, (*c*) the times of the separate records, and (*d*) the average time of revolution with its MV . If the instrument is well made, the parts kept oiled and free from dust, and the clockwork wound up regularly, this MV will be negligibly small. The test should, however, be repeated at frequent intervals. The dated records are to be kept in a special drawer in the laboratory, where they will be available for comparison.

(2) Preliminary experiments must be made with various combinations of clock-springs and kymograph rates, to determine the approximate position of the RL . The experiments should be conducted with some care, since the skin easily becomes fatigued, and it is therefore essential that the regular experimental series be kept short.

Good places to work upon are the ball of the thumb and the volar surface of the wrist. O must above all things be comfortable: if his arm begins to tingle, or if he feels his position to be in the least degree constrained, the experiment must be broken off. His hand and forearm should rest in a plaster mould, or (what does as well) in a shallow box of sand, covered with a light cloth, and packed to the right shape.

(3) In the actual experiments, all adjustments are made by means of the bar B , but all readings are taken (in degrees) from the scale of the limen gauge. It is necessary, therefore, to work out a correlation of the two scales. To this end, the lever L is set at 0, while the stimulus point rests upon a plate of glass or metal; and B is adjusted, in successive trials, until the required scale of pressure values (degree readings) has been obtained.

If the adjustments of B are accurately made, and if the instrument is kept in good working order, the two scales will remain in perfect correlation; so that E may confidently assume that a given setting of B will reproduce a required scale-reading for L . If by any accident the adjustment of B is inaccurate, the effect is simply to produce a slight irregularity in the size of the steps within a series. Since E takes his readings from the lower scale, the irregularity will be duly entered in the record of the experiment.

METHOD.—The strict serial method of Exp. I., or the haphazard method of Exp. II. may be followed.

RESULTS.—The scale readings of the limen gauge must be translated into terms of pressure. The translation is done, very simply, by substituting for O 's hand the pan of a balance, and finding the weight that will just compensate the pressure of the stimulus point. When the critical values of the series have thus been determined in gr., E calculates the average and its MV in the ordinary way.

The apparatus which we have here employed allows us to vary the application of the R in four different ways. We may vary (*a*) the *intensity* of the R : this is necessary to the liminal determination, and does not come further into consideration. We may vary (*b*) the *place of application*, and so work out a comparative series of limens for different parts of the skin. We may vary (*c*) the *extent* of the R , and so work out a comparative series of limens in terms of the area stimulated. Finally, we may vary (*d*) the *rate of application*, and so work out a comparative series of limens in terms of gr. to the 1 sec., or gr./sec.

As regards (*b*), it is only necessary to say that we have chosen hairless parts of the skin (palm of hand, volar surface of wrist) in order to avoid the complications that arise, even after careful shaving, from the presence of hairs beneath the disc. As regards (*c*), comparative determinations are difficult, owing to the irregular distribution of the pressure spots. E must find an area of O 's skin where there is a sensitive spot surrounded by spots of markedly lower sensitivity. The centre of the disc employed must always cover the sensitive spot. The stimulus point is applied to the

centre of the disc; and the disc itself must lie evenly and smoothly upon the skin.

As regards (*d*) we must go into a little more detail. We are to work out a comparative series of limens in terms of gr. to the 1 sec. We have, then, to take account both of the tension of the clock-spring and of the rate of revolution of the drum. Suppose, first, that the drum, revolving at its slowest rate, makes one revolution in 85.7 sec., *i. e.*, that it travels 4.2° in the 1 sec.; and that, revolving at its fastest rate, it makes one revolution in 9.6 sec., *i. e.*, travels 37.5° in the 1 sec. Here is the one set of data. Now let us bring the stimulus point, with the lever *L* at 0, over the pan of a balance, and lower the limen gauge until the point just touches the pan: let us place a 1 gr. weight in the other pan of the balance: and let us screw down the set-screw *S*, until the pointer of the balance marks 0. We can read off from the scale, in degrees, the tension of the spring for 1 gr. Suppose that, with the weakest of the six clock-springs, the scale reading is 30° , and with the strongest 2.3° . Here is the other set of data. Putting the two together we infer that with the slowest revolution and the weakest spring the stimulus point is applied to the disc at the rate of $\frac{4.2}{30}$ or 0.14 gr./sec.; while with the quickest revolution and the strongest spring it is applied at the rate of $\frac{37.5}{2.3}$ or 16.3 gr./sec. Other determinations are, of course, to be made for the remaining combinations. Variation in the rate of application of the *R* will then be expressed in the results by a column of figures under the rubric gr./sec., which vary (in the supposed case) between the extreme limits 0.14 and 16.3.

QUESTIONS.—(1) What sources of error, subjective and objective, have you noticed during your performance of the experiment? How have you attempted to avoid them?

(2) Compare any one of the three experiments of this Section with Exp. I., II. or III. Which is the more difficult? Answer the Question both on the objective and on the subjective side: *i. e.*, in terms both of manipulation of instruments and of sensory judgment. Give full reasons for your answer.

(3) Suggest method and materials for the determination of the intensive *RL* of pain, warmth, and cold. Try to think yourself into the experiments, and meet the imagined difficulties of the procedure one by one, as they occur to you.

§ 12. **The Intensive RL for Sound.**—The object of this experiment is to determine the least sound that can be perceived by the single ear.

EXPERIMENT VII

(1) MATERIALS.—Watch, in padded box, with (separate) padded front. Wooden uprights and tape (15 m.). Metre rod. Ear plugs. Eye-shade.

ADJUSTMENT OF APPARATUS.—The experiment is to be performed in a corridor or long room, which is free from noise, and whose furniture is always arranged in the same way. *O* sits sidewise to the length of the room: his eyes are shaded, and his unused ear closed. The uprights are placed along the room, in a line with the line that joins *O*'s ears; the tape is stretched across the tops of the uprights, and marked off into 0.5 m. divisions. The watch, lying in the box with its face turned directly toward *O*'s ear, is carried in and out above the tape by *E*; it should be held constantly at the level of the ear, and should be moved in a line a little forward from the line passing through *O*'s two ears. It is convenient to stretch the tape at such a height from the floor that *E*'s elbow just grazes it when the watch is held in the proper position.

PRELIMINARY EXPERIMENTS.—Suppose that *O*'s left ear is to be tested. *E* takes the box in his left, and the box cover in his right hand. Starting from the first metre mark, he moves outwards, by metre intervals. At every stop, the usual 'Now!' is given, and the box uncovered for 5 sec. *O* signals, by a movement of his hand, whether or not he hears the ticking. Blank experiments should be introduced, here and there; all care must be taken that *O* shall not know of their occurrence.

The test is repeated, in the opposite direction. The experiments, outgoing and incoming, are to be continued until the position of *O*'s *RL* has been roughly determined.

METHOD.—The strict serial method of Exp. I. or the haphazard arrangement of Exp. II. may be followed. Unit of change, 0.5 m.

EXPERIMENT VIII

(2) MATERIALS.—Lehmann's acoumeter. [The acoumeter consists of a wooden platform, supported by three set-screws *S* (in Fig. 10 only the lower half of one of the two right-hand screws is shown), at the centre of which a stout mm. screw *M* is set vertically in a screw-nut. The head of the mm. screw is divided

into quarters; a mm. scale stands beside it. A small spring forceps *F* lies upon the head of the mm. screw; it is kept in place by a pin, which fits into a corresponding hole at the centre

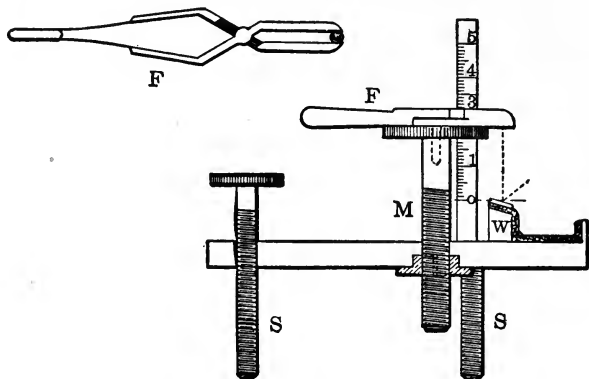

FIG. 10.

of the screw-head. At the front end of the platform is a padded trough; the padding is carried backward over a cross-strip of wood, *W*, whose oblique surface lies directly beneath the jaws of the forceps. A shot, dropped from the forceps, falls vertically upon a square of glass, copper or cardboard, laid upon the surface of the strip, and rebounds into the trough. The noise thus produced constitutes the stimulus; its intensity is expressed as the product of the weight of the shot into its height of fall, *i. e.*, in mg.-mm.]

PRELIMINARY EXPERIMENTS.—*O* sits at a fixed distance of 10 m. from the acoumeter, his unused ear plugged and his eyes shaded. *E* is to determine the position of *O*'s *RL* for this fixed distance and with a shot of known weight. He varies the height of fall by steps of 1 mm., in ↓ and ↑ series, until the critical height has been roughly ascertained.

The zero-point of the vertical mm. scale lies in the same horizontal line as the point of impact upon the square: all three squares have sides of 1 cm. and a thickness of 1 mm. To take the initial scale-reading, *E* turns the forceps round until its jaws strike the scale, and lays a narrow strip of white cardboard against the face of the scale and the lower surface of the forceps. No further reading is necessary, as count can be kept of the turns of the screw-head. The same strip of cardboard is useful for regulating the posi-

tion of the shot. *E* places the shot in the forceps; rests the jaws of the forceps on the card held horizontally; releases the shot, so that it settles down upon the card; and lets the jaws of the forceps close again. He adjusts in this way for every test. An extra forceps is useful, for picking up the fallen shot.

Some little practice is required in the manipulation of the forceps. The pinch of thumb and finger must be firm and uniform; the downward pressure must not be so strong that the forceps scrapes against the screw-head.

METHOD.—The strict serial method of Exp. I., or the haphazard arrangement of Exp. II., may be followed. The unit of change must be determined from the preliminary experiments; it is probable that a step of 0.5 mm. will be small enough.

QUESTIONS.—*O* (1) Sometimes, in the course of these experiments, you are quite sure that you hear the sound; sometimes, you say with confidence that you only 'imagine' it. How do you distinguish between a real and an imagined sound?

O (2) Have you had any similar experience in preceding experiments? Is it present to the same degree in all? Why?

E and *O* (3) Can you suggest experiments that would make it difficult for you to decide whether or not an objective stimulus had been given, and that would therefore bring out clearly the criteria which you apply in distinguishing between a real and an imagined impression?

§ 13. **Weber's Law.**—We said above (p. xxxiv) that the formula of correlation between *R*-magnitude and sense-distance has, in certain sense departments, been worked out with some degree of fullness. We said, also, that the formula has been worked out in terms of two different kinds of sense-distances: in terms of supraliminal distances, arbitrary distance-units that are larger than the *DL*; and also in terms of liminal distances, *i. e.*, of the *DL* or the *j. n. d.* itself (p. xxxv). In the former case, it has been worked out most successfully for brightnesses; in the second, it has been verified for a large number of different sensations. We have now to see what it is and how it is derived.

(1) Suppose that we have before us a series of 50 grey papers, delicately graded from dark to light. We are required to divide up this practically continuous series into 6 equal sense-distances. Keeping the first and the last, the darkest and the lightest papers,

we are to pick out 5 other greys between them, at such points that the sense-distance $\overline{G_1G_2} = \overline{G_2G_3} = \overline{G_3G_4}$, etc. With a little practice, the task is by no means difficult.

Having chosen our 7 papers, $G_1, G_2, G_3, G_4, G_5, G_6, G_7$, we determine their photometric values, their physical light-values or their objective luminosities. We find that these photometric

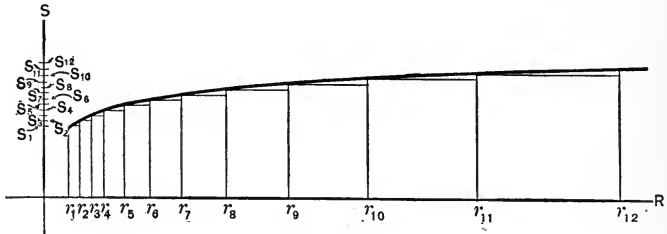

FIG. 11.

Graphic representation of the logarithmic relation obtaining between intensive pressure sensation S and its adequate stimulus R (Weber's Law). From A. Höfler, *Psychologie*, 1897, 138.—For the method of drawing the curve, see § 15 below.

values form (approximately) a series of equal quotients. That is to say, if the sense-distances $\overline{G_1G_2}, \overline{G_2G_3}, \overline{G_3G_4}, \dots$ are equal, then the R -quotients $\frac{G_2}{G_1}, \frac{G_3}{G_2}, \frac{G_4}{G_3}, \dots$ are also equal. An arithmetical series of sense-distances is paralleled by a geometrical series of corresponding R -values.

That is our first general result. Now (2) suppose that we are determining the DL for some given sensation (pressure, or sound, or smell); and that we make our determination at various parts of the intensive scale (*e. g.*, with 25, 50, 100, 200 gr.). We find, again, that the j . n. sense-distances correspond to R -increments that are, approximately, equal fractions of the original R . If we call the R -increments ΔR , then the quotients $\frac{\Delta R_1}{R_1}, \frac{\Delta R_2}{R_2}, \frac{\Delta R_3}{R_3}, \dots$ are approximately equal. So that, in this case also, an arithmetical series of (least) sense-distances is paralleled by a geometrical R -series.

That is our second general result. Putting the two together, we may say that any progressive series of equal intensive sense-distances is paralleled, on the physical side, by an approximately

geometrical series of R -values. Our next problem is to generalise this statement. *If*, we have found, the S -distances form such and such a series, *then* the R -values form such and such another series. But what is the general correlation, that holds irrespectively of 'if' and 'then'?

(3) We can work out our formula, most easily, in terms of supraliminal distances. We know from (1) that the magnitude of any sense-distance is in some way—in what way we have to

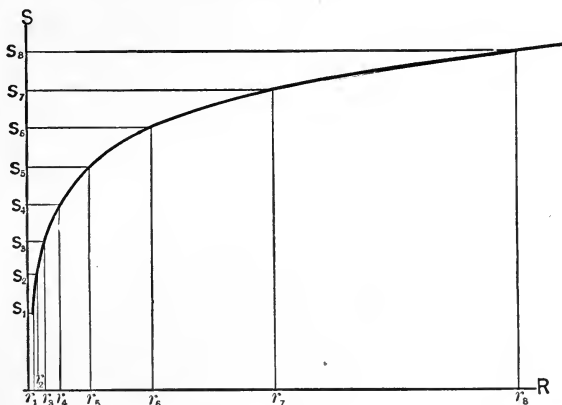

FIG. 12.

Graphic representation of the correlation of tonal pitch (S_1, S_2, \dots are tones an octave apart) with vibration rate (R). If we assume the sensible equality of the octave-distance, at various parts of the tonal scale, the relation is similar to that obtaining between the S and R that fall under Weber's Law. From A. Höfler, *Psych.*, 1897, 135.

discover—dependent upon the quotient of the two R which limit it. Let this unknown dependency be expressed by the mathematical sign of function, f . Then we have, for two successive sense-distances, the equations :

$$\overline{S_1 S_2} = f\left(\frac{R_1}{R_2}\right),$$

$$\overline{S_2 S_3} = f\left(\frac{R_2}{R_3}\right).$$

Adding these equations, we get :

$$\overline{S_1 S_3} = f\left(\frac{R_1}{R_2}\right) + f\left(\frac{R_2}{R_3}\right).$$

But we know from (1) that :

$$\overline{S_1 S_3} = f\left(\frac{R_1}{R_3}\right)$$

and, of course,

$$f\left(\frac{R_1}{R_3}\right) = f\left(\frac{R_1}{R_2} \cdot \frac{R_2}{R_3}\right).$$

We have, then, finally :

$$f\left(\frac{R_1}{R_2}\right) + f\left(\frac{R_2}{R_3}\right) = f\left(\frac{R_1}{R_2}\right) \cdot \left(\frac{R_2}{R_3}\right).$$

Now the only continuous function that can satisfy an equation of this form is (as we learn from the mathematical text-books) a logarithmic function. Hence we may write (inserting a constant factor, c , to indicate our choice of some particular logarithmic system) :

$$\overline{S_1 S_2} = c \log \frac{R_1}{R_2},$$

$$\overline{S_2 S_3} = c \log \frac{R_2}{R_3}.$$

Or, in general, if S_0 and R_0 denote the S and R with which we start, and S and R themselves denote any other sensation and its corresponding stimulus value :

$$\overline{S S_0} = c \log \frac{R}{R_0}.$$

And, lastly, if we denote the intensive S -distances reckoned from an initial S_0 by \mathbf{S} , and the R -intensities calculated in terms of the corresponding R_0 by \mathbf{R} , we have simply :

$$\mathbf{S} = c \log \mathbf{R}.$$

This, then, $\mathbf{S} = c \log \mathbf{R}$, is the general formula required. It represents Fechner's formulation of what is known as Weber's Law (p. xxxviii above). Weber had declared in 1834, on the basis of experiments with weights and visual distances which seemed to establish a constancy of the relative DL , that in the act of comparison of two stimuli the object of perception is not the difference between the stimuli, but rather the ratio of this difference to the given R -magnitudes. Fechner gave this law a precise phrasing and a mathematical derivation, and (as we indicated above, pp. xxiii f., xxxviii) put it to elaborate experimental test.

Although his modesty led him to name it after Weber, we might more correctly term it Fechner's Law or the Weber-Fechner Law.

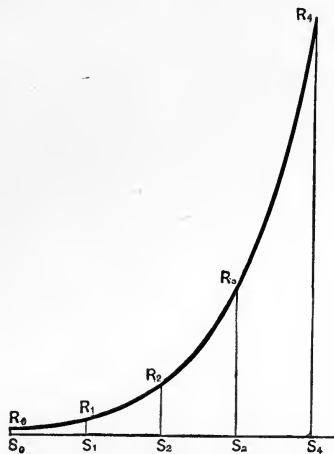

FIG. 13.

Generalised representation of the relation between S and R formulated in Weber's Law. Equal sense-steps are marked off as abscissas, and the corresponding R -values are entered as ordinates. From W. Wundt, *Phys. Psych.*, i., 1902, 497.

Our object in the following experiments is to demonstrate or roughly to verify some of the results which are summed up in Weber's Law.

The formula $S = c \log R$ can be worked out, though not quite so easily, in terms of the DL , of j. n. sense-distances. The derivation has, however, only a mathematical interest, and may therefore be omitted here.

§ 14. **Demonstrations of Weber's Law.**—The object of the following tests is to show (1) that the j. n. d. of brightness is relatively constant, that is, that the difference remains j. n. with very different physical intensities of the component R , provided that these physical intensities stand always in the same ratio to each other; and (2) that a series of equal supraliminal sense-distances is paralleled (approximately) by a set of equal R -quotients.

EXPERIMENT IX

MATERIALS.—Spectacle frame (opticians' trial frame). Three pairs of grey ('smoked') glasses, of different shades, rounded to fit the frame. A partly clouded sky.

Fechner's Cloud Experiment.—Find a place in the sky where the junction of two clouds, or of two parts of the same cloud, shows to the naked eye just a trace of difference in brightness; or where a wisp of cloud is just distinguishable upon the background of sky. Having assured yourself (as well as may be, in the absence of objective test) that the brightness difference in question is really only just noticeable, proceed to observe it (*a*) through the lightest grey glasses, (*b*) through the middle glasses, (*c*) through the darkest glasses, and (*d*) through combinations of the glasses. Make the observations in quick succession, in order that the objective illumination of the sky remain constant throughout the experiment. Does the apparent brightness difference suffer any change under the changing conditions of observation?

Now reverse the experiment. With all three glasses before the eyes, find another place in the sky which shows a barely perceptible brightness difference. Observe this in turn (*a*) through the two darkest pairs of glasses, (*b*) through the darkest alone, (*c*) through the middle pair alone, (*d*) through the lightest, and (*e*) with the naked eyes. Does the apparent difference undergo any change?

By using combinations of coloured glasses, one may reach a degree of darkening which far exceeds that given by the smoked glasses. In this case, however, care must be taken that the two cloud shades, or the brightnesses of cloud and background, are pure greys and show no trace of colour difference.

Since a partly overcast sky is not always at our disposal, we must have further Materials at hand, which shall render us independent of it. The experiment may be performed in various other ways.

EXPERIMENT IX (*a*)

Lay out upon a table, on an uniform black or white background and in clear diffuse daylight, a set of Marbe's grey papers. The pieces of paper must be trimmed accurately to the same size (say, 4 by 1 cm.), and should be covered with a clean strip of plate glass to ensure perfect smoothness of surface. Select two papers that seem to the naked eye, after repeated trial, to be j. n. d. when laid edge to edge. Observe these papers through the grey glasses.

With all three glasses before the eyes, select two other papers that seem to be j. n. d. Observe as in the second part of the preceding experiment.

Repeat, with other pairs of Marbe papers, as often as the series allows.

EXPERIMENT IX (b)

Place upon a colour mixer two greys (mixtures of black and white ; large and small discs) that are j. n. d. Determine the required R -difference, roughly, by a procedure like that of Experiment I. Observe these two greys, in diffuse daylight, through the grey glasses. Fixate some point upon the periphery of the smaller discs.

With all three glasses before the eyes, make another determination of a j. n. d. Observe as in the second part of the cloud experiment.

Repeat the experiment, with at least two other determinations of a j. n. d. under both conditions (six sets of observations in all).

EXPERIMENT X

MATERIALS.—Rumford photometer, with screen of white cardboard. [The photometer consists of a long blackened board, upon which are pasted converging m. scales. A rounded pillar of blackened wood (P, Fig. 14) is set at the centre of the width of the board, a short distance from one end. Behind the pillar and at the edges of the board are placed two upright clips of blackened tin, into which is slipped a piece of white cardboard, S, which serves as screen.] Two sources of light (*e. g.*, a standard candle and a ground glass $\frac{1}{4}$ c. p. incandescent lamp, both set upon low wooden blocks), with curved black screens of cardboard or tin. Grey glasses and frame, as before.

PRELIMINARIES.—The photometer is laid upon a low table in the dark room. The screens of the lights are so adjusted that O , who stands about 1 m. behind the table and a little to one side, can see nothing of candle flame or lamp.

When the lights are suitably placed upon the metre scales, the pillar throws two shadows on the white screen. We are concerned with only one of these : with the shadow cast by the candle. Let L and C represent the two sources of light. The shadow due to C is illuminated only by L ; the rest of the white screen (apart from the second shadow, which does not interest us) is illuminated by both L and C . As we move C farther and farther back, while L remains in position, the amount of light which C sends to the screen becomes smaller and smaller, until presently it is imperceptible. When this point is reached, there is no difference between shadow and ground ; both alike are (for sensation) illuminated only by L . A very slight movement of

C forward or of L backward will now suffice to bring the shadow into view again.

Preliminary experiments are to be made, to determine positions of L and C such that the C -shadow can easily be brought to disappearance.

Fechner's Shadow Experiment.— L is left in its place, and C set at a point where its shadow is clearly seen by O . C is moved backward, step by step,— O closing his eyes between observations,—until the shadow disappears. Now C is moved in, slowly and steadily, until the shadow becomes j. n. C may be shifted to and fro about this point, as O desires, until a positive judgment of j. n. can be passed. No single observation must be long continued, or after-images will arise.

When the point at which the C -shadow becomes j. n. has been finally determined, O makes a series of observations with the grey glasses, as in Exp. IX. Does the difference between shadow and ground suffer any change?

The experiment is now reversed. With all three glasses before his eyes, O determines the point at which the shadow becomes j. n. Observations are then taken, as in the second part of Exp. IX. Does the brightness difference show any change?

RESULTS.— E has a full record of O 's introspections, from Exp. IX.¹, and a similar record, with the scale values of the photometer, from Exp. X. The following Questions arise.

E and O (1) What is the general result of these two experiments? What does it prove?

O (2) Were all your judgments equally certain and unhesitating? If not, can you give reasons for your hesitation, where it occurred? Why do we reverse the first procedure in all the experiments?

O (3) Are you satisfied with the methods employed in the determination of the j. n. d.?

¹ Together with the serial numbers of the Marbe papers, if Exp. IX. (a) was performed; or the values of the disc sectors, if Exp. IX. (b) was done.



FIG. 14.

E and *O* (4) Can you suggest any variations of these experiments that may serve as checks upon their general result, or will show that this result is of special significance?

E and *O* (5) Are the experiments, as performed, rightly called quantitative?

E and *O* (6) Suggest a continuation of Exp. X.

E and *O* (7) Suggest simple alternative experiments.

EXPERIMENT XI

MATERIALS.—Balance, with weights. Set of weighted envelopes, 5 to 100 gr. [The envelopes are heavy 'pay' envelopes, of manilla paper, about 6.5 by 11 cm. They are stiffened by a piece of cardboard (light for the lighter, heavy for the heavier weights), cut to twice the size of the envelopes and then folded. To weight the envelopes, pieces of heavy paper or of card are pasted, or strips of thin sheet lead are sewed, to the inner surfaces of the stiffening card. Scraps of loose paper may be dropped into the fold, to make the weight exact. The weight of the envelope in gr. is written on the inside of the envelope flap, and the flap itself tucked in; the envelopes are not to be sealed. The series consists of 108 envelopes: (*a*) extra standard of 5 gr.; (*b*) extra standard of 100 gr.; (*c*) 26 envelopes, 5 to 10 gr., differing by 0.2 gr. increments; (*d*) 30 envelopes, 10.5 to 25 gr., with 0.5 gr. differences; (*e*) 25 envelopes, 26 to 50 gr., with 1 gr. differences; and (*f*) 25 envelopes, 52 to 100 gr., with 2 gr. differences.]

PRELIMINARIES.—*O* sits at a small, low table, upon which the weighted envelopes are laid. The two extra standards are placed apart; the rest are piled together in a confused heap.

Sanford's Weight Experiment.—*O*'s problem is to arrange the heap of envelopes in five groups, keeping approximately equal sense-distances (intensive differences) between group and group. The envelopes are to be lifted vertically, being taken at the flap end between thumb and forefinger of the right hand. Reference may be made, as often as desired, to the extra standards, which give the extreme range of the series; and *O* may revise his rating, shift envelopes from one group to another, etc., until he is fully satisfied with his result.

Each of the five piles is then weighed in the balance, and the average envelope-weight in each pile determined by division of the total weight by the number of envelopes. Finally, the ratio of these average weights is calculated from group to group.

The experiment should be performed at least twice by both *E* and *O*.

RESULTS.—The numerical results (average weight of the envelopes in each of the five groups, and ratios of group to group) are to be entered in the note-book. The results should also be expressed graphically, by means of a curve: the group-numbers, 1, 2, 3, 4, 5, are taken as abscissas, and the average weights of the envelopes in the groups as ordinates.

EXPERIMENT XII

MATERIALS.—Set of Marbe greys. [This is a series of 44 pieces of grey paper, ranging in brightness from dark grey to white. A convenient size is 3 by 6.5 cm. The pieces are numbered on the back, 1 to 44, in the order light to dark.] Sheet of black or white cardboard. Sheet of plate glass. Kirschmann photometer.

PRELIMINARIES.—*O* sits at a low table, which is uniformly illuminated by diffuse daylight. The cardboard is laid on the table, and the 44 papers placed in order upon the cardboard.

Ebbinghaus' Brightness Experiment.—*O*'s problem is to pick out 3 grey papers at such points that the whole series of greys is divided into four equal sense-distances. He should first select the middle grey of the series, and then proceed to bisect each of the half-series. He may reconsider his choices until he is fully satisfied with his result. He may lay the five terminal greys (nos. 1, 44, and the three chosen) by themselves, cover them with the glass, and estimate the four distances apart from the intermediate terms; he may arrange the four part-series upon the cardboard one above another, etc., etc. The glass should always be used before final choice is made. When he has decided, *E* looks at the backs of the papers and records their numbers.

The experiment is now repeated, with reversal of the order of the papers. If the former order was 1 to 44, from left to right,

it is now 1 to 44 from right to left. The experiment may also be repeated upon a different background ; or the papers may be given to O in a confused heap.

The value of the R which limited the equal sense-distances of Experiment XI. was determined by help of the balance. To determine the values of our five grey papers, in the present experiment, we have recourse to a photometer.

Kirschmann's photometer has three principal parts. (1) The *dark chamber* is formed of two tubes of heavy mill-board, each 50 cm. in length. The one, open at both ends, is 20 cm. in inside diameter ; the other, closed at one end, is just large enough to slip over the first. Both tubes must be painted and repainted and painted again, on the inside, with ivory drop black or some similar dull black paint. The combined tube, varying in length according to circumstances from 60 to 90 cm., is supported horizontally upon the arms of two solid standards. (2) Directly in front of the dark chamber a *colour mixer* is set up. It is necessary that the rotating discs stand close up to the dark chamber. Hence it is advisable to employ a small electric mixer, such as Zimmermann's, which is supported by a vertical rod, vertically adjustable. A semicircular opening is cut from the lower edge of the front tube ; the portion of the vertical rod which projects above this edge, together with the connecting wires, is carefully blackened ; rod and wires are fitted into the opening, so that the discs just pass the edge of the tube ; the edges of the semicircular cut are blackened, and chinks stopped by bits of black cloth. (3) The discs are constructed, as a rule, in three parts ; they differ somewhat, under different conditions. Let us suppose that the paper which we are to test is a black or a very dark grey. The discs will then be as follows.

The *principal disc* is a disc of white cardboard, 21 cm. in diameter. Two opposite quadrants are left entirely white. The other two are left white for a space of 2.5 cm. from the centre, and of 2 cm. from the periphery. The remaining spaces of 4 cm. are divided into two quarter-rings of 2 cm. each. The inner quarter-rings (a in Fig. 15,1) are covered with the dark grey paper to be tested ; the outer (b of the Fig.) are cut out, so

that the black of the dark chamber appears through them. The edge of the disc carries a scale, whose units are 0.5° . The *coarse adjustment* (Fig. 15,2) consists of a disc, 9 cm. in diameter, of the same white cardboard; of a white index sector, extending to the scale of the principal disc; and of a quarter-ring, corresponding to those of the previous Fig., and covered with the same dark grey paper. The *fine adjustment* (Fig. 15,3) is a double sector of white cardboard, corresponding to the two white quadrants of the principal disc. For convenience of manipulation, it is well to leave a tag of, say, 5° in width, projecting some 2 mm. from the two adjustment cards beyond the periphery of the principal disc.

Let the apparatus be set up, the discs so arranged that *a* and *b* of the principal disc have the same angular magnitude. We see upon the white ground, as the discs are rotated, two juxtaposed grey rings, the inner of which is lighter than the outer. These rings are to be equated in sensation. We therefore add more grey to the inner ring, moving the coarse adjustment by means of the index sector. This procedure is repeated until the two greys are approximately equal. We then make use of the fine adjustment, which enables us to increase (or diminish) the brightness of the rings by equal increments of white. Let us assume, *e. g.*, that the greys are approximately equal when their dark components are of 60° and 62° respectively. If we move the fine adjustment back through 0.5° , we change this relation to $61 : 63$. And this means that the ratio of the absolute black to the paper dark-grey has changed by $\frac{2}{62.63}$ or $\frac{1}{1953}$. The fine adjustment must be varied until the two grey rings merge into one, without the slightest trace of difference.

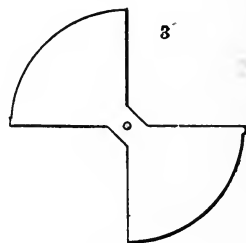
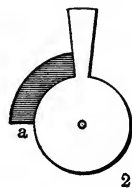
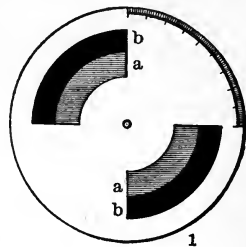

FIG. 15.
Discs of Kirschmann's photometer.

At the conclusion of the experiment, we have the values a° and b° of the paper grey and the chamber black. If we put the reflecting power of the white cardboard = 1, that of the dark grey paper = x , and that of the chamber black = 0, we have the equation:

$$(360 - a) + ax = (360 - b),$$

or

$$x = \frac{a-b}{a}.$$

It is now a simple matter to determine the brightness values of lighter greys. We may retain the dark chamber, reducing the angular value of the b of the principal disc, and increasing the values of a in it and in the coarse adjustment; or we may do away with the chamber, and construct a principal disc whose b consist of our known dark grey paper and whose a are covered by the lighter paper to be tested.

RESULTS.— E has, we will suppose, the numbers of the papers chosen by O in the two space orders of the experiment; he has also determined the photometric values of the papers in terms of the white cardboard of the photometer. All these results, with sample pieces of the papers, are to be entered in the note-book. The photometric values of the two choices are now averaged; the averages, together with their ratios, are entered in the note-book; and a curve is drawn like that of Experiment XI. If time allows of the repetition or variation of the experiment, the additional results are recorded in the same way.

QUESTIONS.— E and O (8) What is the general result of these two experiments? What does it prove?

E and O (9) What are the principal sources of error, objective and subjective, in the experiments as performed?

E and O (10) Suggest further experiments of the same kind.

E and O (11) Suggest a more methodical and reliable way of securing the result aimed at in these experiments.

CHAPTER II

THE METRIC METHODS

§ 15. **The Law of Error.**—Suppose that you are required to measure the length of a rectangular block of wood, and that you are given a mm. scale to measure with. Carefully adjusting the scale, and estimating to tenths of your unit, you find that the length of the block is 112.9 mm. In reporting this measurement, you have no doubt that your result is accurate to 1 mm.; you feel reasonably sure that it is accurate to 0.5 mm. But you are ready to admit that you may, possibly, have made an error of 0.25 mm.; you think it very likely indeed that you are wrong by 0.1 mm. In the interests of accuracy, then, you are tempted to verify your first measurement by another.

Your second measurement may repeat the result of the first. More probably it will not. But if it does, you will not be justified in accepting the 112.9 mm. as the true value of the length you are measuring. For if you repeat the measurement, not once only, but a great many times, you will find that the results vary in a somewhat surprising way. Thus 10 successive measurements, though made with the same scale and apparently under the same conditions of observation, might give you the values: 112.9, 113.0, 112.9, 112.9, 112.9, 112.9, 113.1, 112.9, 113.0, 113.1 mm. It seems natural, perhaps, to lay these discrepancies to the account of the measuring instrument: your unit is 1 mm., and the tenths are estimated. But the same thing would happen if you had a scale that read, with mechanical accuracy, to 0.001 mm. In this case, the actual magnitude of the discrepancies would, of course, be reduced. But the discrepancies themselves would still remain; and, indeed, relatively to the size of the unit would be larger than before,—since, where the unit of measurement is very small, the numerical measure of discrepancies is naturally increased. If you found differences of

1 or 2 tenths before, you will now very possibly find differences of several thousandths.

These facts mean, in brief, that every observation you make is subject to an *error*: the error being defined as the difference (1) between the observed and the true value, if the true value is known, or (2) between the observed and the most probable value, if the true value is unknown. Provided that there is no bias, no constant pressure upon you to err more often in one direction than in another, the 'most probable value' is, evidently, the arithmetical mean or average of all the observed values. The errors are then determined as the differences between this mean and the single measurements. The numerical values represent their magnitude; the sign prefixed to them, *plus* or *minus*, represents their direction.

In the instance taken, of measuring the wooden block, there seems to be no room for an error of bias. Nevertheless, it will be advisable to vary your conditions: to lay the o-point of your scale as often upon the right as upon the left edge of the block, and so to measure from right to left as often as you measure from left to right; and, again, to turn the block round, so that its original right becomes left, and conversely, and to execute both sets of measurements in both positions of the block. The task is so simple, and the change of conditions so slight, that the various sets of measurements will, in all probability, be interchangeable. In this event, the arithmetical mean of all measurements gives, as we have said, the most probable length of the block. If, on the other hand, there is any evidence of what are called 'constant' or 'systematic errors,' these must first be eliminated,—an easy matter, but one which we cannot here discuss,—and the corrected mean employed for the determination of the errors of observation.

Mathematicians regard these 'errors of observation' as the algebraical sum of a very large number of elemental errors, due to various unknown causes. If the cause of an error is known, its result really ceases to be an error, in the present meaning of the word; for, knowing the cause, you can modify your procedure to counteract it, and can thus eliminate its result. The errors of observation, which produce the discrepancies in your measurements, are accidental errors, due to unknown conditions.

It does not follow, however, that because we know nothing of the causes of a set of errors we can say nothing about the errors themselves. On the contrary, mathematical theory has a good

deal to say about the errors of observation ; and part of what it has to say depends—paradoxical as the statement may sound—upon this very fact of our ignorance of the causes of error. The theory tells us, for instance, (1) that smaller errors are more likely to occur than larger. This canon is, undoubtedly, suggested by experience ; we do not make errors of 1 cm.,—at least, the accurate observer does not,—in measuring with a mm. scale. It is also a direct consequence of the mathematical way of regarding the errors : for the elemental errors, of which the resultant errors of observation are made up, may have either direction, and therefore tend to cancel one another ; hence small errors must be more frequent than large, and the smallest error—the error 0—the most frequent of all. The theory tells us further, (2) that, in the long run, *plus* and *minus* errors will occur with the same frequency. This may certainly be assumed, just because we are supposed to know nothing of the causes of the errors ; and it is verified by actual results. The theory tells us, finally, (3) that, while smaller errors are more frequent than larger, the errors as a whole may be regarded as forming a continuously graded series, ranging from 0 to ∞ . This continuous gradation cannot be observed in practice ; if observations were repeated indefinitely upon the same magnitude and under the same circumstances, only a limited number of observed values, all of them exact multiples of the unit of the instrument,¹ would occur. What the theory does, therefore, is to regard the unit of the instrument as reduced without limit. This convention renders a mathematical treatment of results very much easier than it would otherwise be ; we need not hesitate to adopt it. We shall, perhaps, hesitate to accept the statement that, even in an infinitely long series of observations, there must occur an error of infinite magnitude ; but we may comfort ourselves by the thought that it is considered to occur infinitely seldom. Or we may, if we like, say that the errors of observation form a continuously graded series, ranging between 0 and some fixed upper limit of magnitude : the extension of this limit to ∞ is made simply for mathematical reasons, and has no practical significance.

These three rules, we notice, are all concerned with the rela-

¹Or, as in the case of estimated tenths, aliquot parts of the unit.

tion of the *magnitude* of an error to its *frequency*. Small errors are relatively more frequent than large; *plus* and *minus* errors of the same magnitude are of equal relative frequency; all errors, of whatever magnitude, have a certain frequency of occurrence. It is customary to express such a relation between two magnitudes in graphic form, by means of a curve. The curve is, then, a line whose course shows us, at a glance, the relation in which our two variable quantities (here, magnitude and frequency of error) stand to each other.

To construct a curve, we first draw two straight lines XX' and YY' at right angles to each other, causing them to intersect at the point O . The lines XX' and YY' are called the axes of coördinates,¹ and the point O the origin of coördinates. The curve is given, if we know the relation between the two 'coördinates' of any point upon it. Let the point P be given. Its distance from the axis YY' is NP or OM ; this distance is called x , the abscissa of P . Its distance from the axis XX' is ON or MP ; this distance is called y , the ordinate of P . The abscissa and the ordinate are together called the coördinates of P . The relation of x to y , in Fig. 16, is such that $y = \log x$: this is the 'equation' of this particular curve. Knowing it, we can describe the complete curve, or as much of it as we require, as is shown in the Fig.² We do this by assigning successive values to the independent variable x ; computing the corresponding values of the dependent variable y ; then laying down the successive points whose coördinates are (x, y) ; and finally drawing a smooth curve through them.

If we apply these rules of graphic representation to our errors of observation, we obtain a bell-shaped, symmetrical curve of the kind shown in Fig. 17. The point O upon XX' corresponds to an error of the value 0; the magnitude of error, positive or negative, is measured along XX' , to right and left of O ; the relative frequency of an error of a given magnitude is shown by the

¹ The line XX' or XOX' is called the axis of x , the line YY' or YOY' the axis of y .

² We term x positive when it is to the right of O , and negative when it is to the left; we term y positive when it is above O , and negative when it is below. This arrangement of *plus* and *minus* values is, of course, conventional.

height of the corresponding ordinate. Thus, an error of the magnitude o occurs most often; an error of the magnitude OM occurs with the relative frequency ON .

Let us, now, examine the curve in some little detail. We notice, first, that the curve cuts the axis of y perpendicularly; in other words, the curve in that neighbourhood is nearly horizontal: this implies that, in the neighbourhood of the arithmetical mean, there is a group of values that are approximately equal. After a time, the curve begins to slope away rapidly towards the axis of x : this implies that the observed values begin to get less frequent as we depart from the mean; in other words, that larger errors are less frequent than smaller. The curve approaches the

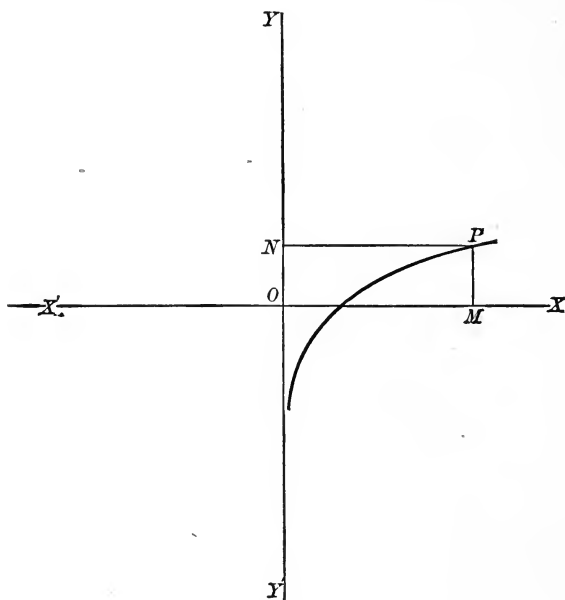

FIG. 16.

From Cattell, art. Curve, in Baldwin's Dict. of Phil. and Psych., i., 1901, 249. If YY' be laid off in units of sensation, and XX' in units of stimulus, the equation $y = \log x$ becomes, specifically, $s = \log r$, Fechner's formula for Weber's Law.

axis of x , in both directions, asymptotically; that is, it comes in course of time indefinitely close to that axis, but never actually touches it: this implies that no magnitude, however remote from the mean, is strictly impossible; every error, however excessive,

will have to occur at length, within the range of a sufficiently long experience. It should, however, be said that no graphic representation can give an adequate idea of the extreme rapidity with which the curve tends toward the axis of x . To the eye, the two appear, after a very short course, to merge into each other. This shows how small is the chance of even a moderate error. Finally, the curve is symmetrical about the axis of y : this implies that equal deviations from the mean, in excess and defect, tend in the long run to appear with equal frequency.

The equation of this error curve is not quite so simple as the equation of the logarithmic curve given above. It is, however, an equation of the same kind. Both alike are 'exponential' equations: that is, equations in which one of the two variables (x, y) appears only as the exponent of some other quantity. Instead of taking the form $y=f(x)$,—where f is the general sign

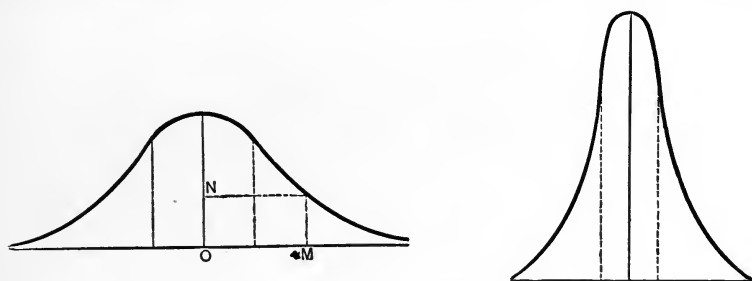

FIG. 17.

Curves of Gauss' Law of Error, for observations of less and greater accuracy.

of function, or functional symbol, and the equation reads " y varies in some determinate way whenever x varies,"—the exponential equation takes the form $y=f(c^x)$, where c is some constant number, and we read " y varies in some determinate way whenever a certain constant quantity raised to the x -power varies." We cannot here follow the mathematical reasoning which leads to this exponential form of equation. We can, however, decide, in the light of a principle already laid down, what the nature of the x -exponent in the equation of the error curve shall be. We have said that positive and negative errors will, in the long run, appear with equal frequency. But, in saying this, we have said that the frequency of error must be a function of

an *even* power of the magnitude: that is, y must be a function of x^2 , or x^4 , or x^6 , etc.: otherwise the frequency of the same amount of error would vary according as the error were positive or negative. The even powers are always intrinsically positive, whether x itself be positive or negative. We shall therefore find, in our exponential equation, not x , but x^2 or x^4 or what not. The use of x^2 rather than x^4 leads to formulæ of comparative simplicity, which can, fortunately, be employed without fear of error.¹

The equation of the error curve is, then, an exponential equation in which the magnitude of error x appears in the form x^2 . The equation is usually written:

$$y = \frac{h}{\sqrt{\pi}} e^{-h^2 x^2}.$$

The symbols are by no means so formidable as they look. The values π and e are numerical constants: π is 3.14, the ratio of the circumference to the diameter of a circle, and e is 2.72, the base of the system of natural logarithms. However they may have got into the equation, then, we can express them in ordinary numbers. So the equation becomes:

$$y = 0.56 h. (2.72)^{-h^2 x^2}, \quad \text{or}$$

$$y = \frac{0.56 h}{(2.72)^{h^2 x^2}}.$$

The only unfamiliar quantity in this equation is now the constant h . This is a value which, while constant for any given set of observations, depends upon the circumstances under which the observations are made. It is a direct measure of the observer's accuracy, of the precision of his measurements. It is thus a value akin to the MV ; only that the MV measures the observer's accuracy inversely,—the larger the MV , the smaller the accuracy, and conversely,—while h measures it directly. Where h is large, the error curve will be tall and narrow; the observed values group closely about the mean; small errors are very greatly in preponderance. Where h is small, the curve is low and broad; the errors are more evenly distributed for a con-

¹The argument may be made clearer, as follows. The requirement is that $y = f(c(-x)^n) = f(c(+x)^n)$. If n is 1, 3, 5, . . . the requirement cannot be fulfilled; if n is 2, 4, 6, . . . the equation holds.

siderable distance on either side of the mean; large errors are relatively common. The two curves of Fig. 17 are, both alike, curves of error; both satisfy the equation which we have just discussed. But the left-hand curve has a small h , the right-hand a large h , in its equation. It is h that determines the special form which the bell-shaped curve assumes, as the graphic representation of the errors made in a particular series of observations.

If we translate our equation into words, it will read somewhat as follows. The relative frequency of a given error (y), in any extended set of observations, is equal to a certain constant value, divided by another constant value raised to the second power of the product of the number representing the magnitude of error (x) and a third constant value. The constants of numerator and denominator are not independent values; both alike are determined by the observer's accuracy (both contain h), and therefore measure his precision. If we know the x and y of any point upon the curve; if we know, that is, the relative frequency of any single error; we can find the value of h , and so construct the whole error curve.

At this point, we are ready to discuss a new term,—the term 'chance' or (what is mathematically the same thing) 'probability.' We have already spoken of the arithmetical mean as the 'most probable' value yielded by a series of observations. Let us now see precisely what probability means.

The probability of a given event, the chance of its occurrence, is defined as the numerical fraction which represents the proportion holding, in the long run, between this particular event and the indefinitely large series of similar events within which it falls. A few illustrations will make the definition clear. (1) What, for instance, is the probability that a certain infant will live to be 80 years old? The particular event here is a life from infancy to 80 years; the indefinitely large series of similar events comprises the life-terms of all infants. Let the proportion of the former to the latter be found, by statistical investigation, to be 1:9; in other words, suppose that 1 infant in 10 does, as a matter of fact, attain the age of 80. Then the chance or probability that our particular infant will reach that age is defined by the numerical

fraction $\frac{1}{10}$. Again, (2) what is the probability that a player will throw a 3 in a given cast of a die? The die has 6 faces; and the probability that he throws any one of them is defined by the numerical fraction $\frac{1}{6}$. This does not mean, of course,

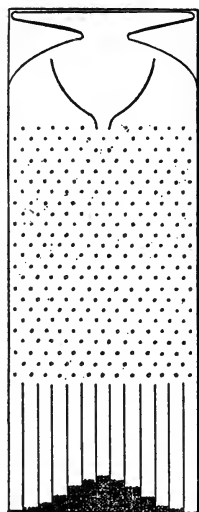

FIG. 18.

Mechanical Illustration of the Cause of the Curve of Frequency: from F. Galton, *Natural Inheritance*, 1889, 63.—“A frame is glazed in front, leaving a depth of about a quarter of an inch behind the glass. Strips are placed in the upper part to act as a funnel. Below the outlet of the funnel stand a succession of rows of pins stuck squarely into the backboard, and below these again are a series of vertical compartments. A charge of small shot is enclosed. . . . The shot passes through the funnel and, issuing from its narrow end, scampers deviously down through the pins in a curious and interesting way; each of them darting a step to the right or left, as the case may be, every time it strikes a pin. The pins are disposed in a quincunx fashion, so that every descending shot strikes against a pin in every successive row. The cascade issuing from the funnel broadens as it descends, and, at length, every shot finds itself caught in a compartment immediately after freeing itself from the last row of pins. The outline of the columns of shot that accumulate in the successive compartments approximates to the Curve of Frequency, and is closely of the same shape, however often the experiment is repeated.”

that in 6 successive throws he will get the 6 faces, 1, 2, 3, 4, 5, 6, once each. It means that, in an indefinitely long series of throws, any particular face will turn up as often as any other. Since there are 6 faces in all, the 3-face must appear in $\frac{1}{6}$ of all the throws made. Once more, (3) suppose that a friend of mine sails on a boat with 19 other passengers, and that I receive the news of the loss of a passenger during the voyage. What is the probability that the lost passenger will prove to be my friend? It is defined by the fraction $\frac{1}{20}$. This does not mean, again, that if my friend planned to take 20 successive journeys, under precisely the same circumstances, he would be planning his death,—for the reason that he would certainly be lost on one of them. It means rather that, if we had data from an indefinitely long series of voyages, undertaken always by 20 passengers carrying the badges A, B, C, . . . , and resulting always in the loss of one man, the carrier of A—which we will assume to the badge

of friendship—would be lost as often as the carrier of B, C, etc.: that is, in $\frac{1}{20}$ of the whole number of cases.

In brief, to say that the chance of a given event's happening in a certain way is $\frac{1}{5}$ or $\frac{1}{100}$, or what not, is only another way of saying that, in the long run, it does tend to happen in that way once in 5 or 100 or so many times. Now we have seen that the y of the equation of the error curve represents the relative frequency of occurrence of a given error in an indefinitely extended set of observations. This means, then, that the y represents the probability of the x with which it is correlated. If we denote the probability of occurrence of an error x , of definite magnitude, by the symbol P_x , we may substitute P_x for y in the equation, and write: $P_x = \frac{h}{\sqrt{\pi}} e^{-h^2 x^2}$. Since, again, the most probable of the observed values is the value of the arithmetical mean, and the error of the arithmetical mean is 0, it follows that the probability of the most probable error (the height of the highest ordinate of the error curve) is $P_0 = \frac{h}{\sqrt{\pi}}$.¹

If we could rest here, our discussion would be comparatively simple. But we cannot. We must, indeed, retrace our steps a little. For, in regarding the equation of the error curve as an ordinary algebraical equation, we have left out of account the fact that the errors are supposed to be continuously graded, that the ordinates of the curve are infinite in number. We have said that y 'represents' the relative frequency of an error of the magnitude x , or the probability of the x with which it is correlated. Such a statement is not strictly correct; we should have said that y is *proportional* to the frequency of x . Since the possibility of error is continuous, the actual number of errors of a particular magnitude must, of course, be indefinitely small. Since an infinite number of ordinates may be drawn, the occurrence of any one definite amount of error is infinitely improbable. What, then, becomes of our derived equations?

Let us remind ourselves, first of all, that the unit of measurement in laboratory work is not a point but a distance. We refer

¹ Because, when $x = 0$, the symbol $e^{-h^2 x^2}$ becomes e^0 , and $e^0 = 1$. This is a direct consequence of the law or convention that $a^x \times a^y = a^{x+y}$. Let $y = 0$: then $a^x \times a^y = a^x$, i.e., $a^y = 1$.

all our measurements, it is true, to a scale mark; but, in doing this, we refer to the mark all the measurements that fall within certain limits. We read to the *nearest* mm., or 0.1 mm., or what

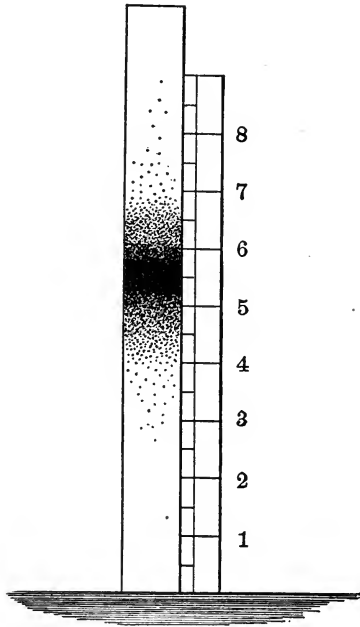

FIG. 19.

Illustration of a Normal Distribution: from F. Galton, *Hereditary Genius*, 1892, 24.—“Suppose a million of the men [of a supposed island race, freely intermarrying, and living for many generations under constant conditions] to stand in turns, with their backs against a vertical board of sufficient height, and their heights to be dotted off upon it. The board would then present the appearance shown in the diagram. The line of average height is that which divides the dots into two equal parts, and stands, in the case we have assumed, at the height of 66 in. The dots will be found to be arranged so systematically on either side of the line of average, that the lower half of the diagram will be almost a precise reflection of the upper. Next, let 100 dots be counted from above downwards, and let a line be drawn below them. According to the conditions, the line will stand at the height of 76 in. Using the data afforded by those two lines, it is possible, by the help of the law of deviation from an average, to reproduce, with extraordinary closeness, the entire system of dots on the board.”

not. If, then, we wish to pass from the continuous to the discrete, from the infinitely numerous ordinates of the error curve to the detached ordinates that we measure in practice, the crucial question is, not ‘What is the relative frequency y of a definite amount of error x ?’ but rather ‘What is the relative frequency of the errors falling between two consecutive divisions of our scale?’ This is given, not simply by the height of the ordinate y correlated with a determinate x , but rather, as we shall see in a moment, by the area of that portion of the curve comprised between the ordinates yy' of the abscissas xx' . To ascertain it, we must sum up all the ordinates of the curve (infinite in number) between the prescribed limits; we must then reduce this

sum to a proportional finite value; and this finite value will represent the probability of an error within the scale unit xx' .

Have we mended matters? Can we sum a portion of an infinite series to a finite result? Yes!—but only by the use of the calculus. Suppose that we have two quantities, like x and y , that are continuously variable. Suppose, again, as is the case with x and y , that we have an equation involving the two quantities. The quantities will, in consequence of the equation, vary together, so that there will be equations between their rates of change. Now let dx or dy stand for an infinitely small increment (a 'differential') of x or y . The differential calculus treats of the ratios of these differentials, and of the fundamental formulæ into which the ratios enter; the integral calculus treats of the summation (integration) of an infinite series of differentials to a finite value. Here, then, in the calculus, is the very instrument of which we are in search.

We write our revised formula as follows. P_x , which we employed for the probability of x , comes to mean the relative frequency of errors within the minimal interval x to $x + dx$. We assume that the ordinate y is constant throughout this small interval; so that P_x must now evidently contain dx as a factor. We have accordingly:

$$P_x = \frac{h}{\sqrt{\pi}} e^{-h^2 x^2} dx.$$

No objection can be taken to our assumption of the constancy of y , if we sum up an infinite number of such terms, and proceed to the limit where dx is made indefinitely small.¹ Doing this,

¹ The above argument will, perhaps, be rendered clearer if we take a geometrical illustration. Consider any portion MN of a curve whose equation is $y = f(x)$. Draw the ordinates MA, NB . Divide the distance AB into n equal parts, and construct upon these a series of inscribed and circumscribed rectangles. The difference between the sum of the inscribed and the sum of the circumscribed rectangles can be seen, by simple inspection, to be = the rectangle ON . But, by increasing n , we can make the area of this rectangle approach 0 as a limit. If, now, the difference between the sum of the inscribed and the sum of the circumscribed rectangles may be made as small as desired, it follows that the difference between the sum of the inscribed rectangles and the area of the curve (which is at once greater than the sum of the inscribed and less than the sum of the circumscribed rectangles) may be made to approach 0 as a limit. Hence the area of the curve can be accurately found by computing the limit to which the sum of the inscribed rectangles tends, when n becomes infinite, and the bases infinitesimal. This, then, is clear warrant for our stating above that y may be treated as constant over the infinitesimal distance or interval dx .

we obtain a more complicated formula for the relative frequency of errors between given fixed limits. For errors, *e. g.*, between the limits 0 and $+x$ it runs :

$$P_{0}^{+x} = \frac{h}{\sqrt{\pi}} \int_{0}^{x} e^{-h^2 x^2} dx,$$

where \int is the sign of summation or integration.¹ Similarly, the relative frequency of all errors larger than this x is :

$$P_x^{\infty} = \frac{h}{\sqrt{\pi}} \int_x^{\infty} e^{-h^2 x^2} dx.$$

If we put $hx=t$, and hence $hdx=dt$, these last two equations may be written in the form :

$$P_{0}^{+x} = \frac{1}{\sqrt{\pi}} \int_{0}^t e^{-t^2} dt, \text{ and}$$

$$P_x^{\infty} = \frac{1}{\sqrt{\pi}} \int_t^{\infty} e^{-t^2} dt.^2$$

Similar formulæ may be written for $-x$ and $-\infty$. Since the error curve is symmetrical, the probability that an error lies between the limits $+x$ and $-x$ is double the probability that it lies between the limits 0 and $+x$ or 0 and $-x$. Hence :

$$P_{-x}^{+x} = \frac{2}{\sqrt{\pi}} \int_{0}^t e^{-t^2} dt.$$

Finally, the probability of all errors whatsoever, between the limits $+\infty$ and $-\infty$ is :

$$P_{-\infty}^{+\infty} = \frac{1}{\sqrt{\pi}} \int_{-\infty}^{+\infty} e^{-t^2} dt.$$

The right-hand member of this equation is given in the text-books as the 'probability integral,' and is generally written $\frac{2}{\sqrt{\pi}} \int_{0}^{\infty} e^{-t^2} dt$. Its value is unity. For, if P be the probability that an event will happen, $1 - P$ is the probability of its fail-

¹ The \int of this and later equations is merely a modification of Σ , the initial letter of the word 'sum.' It denotes 'limit of sum.' The actual sum, before passing to the limit, is denoted by Σ . Thus the sum of the inscribed rectangles of the previous Note is written as $\Sigma y \Delta x$; the limit of this sum, the area of the curve, is written $\int y dx$ or $\int f(x) dx$.

² This expression is tabulated in the mathematical books as the 'error function,' and is denoted by $\text{Erf}(t)$. The right-hand member of the equation immediately preceding is termed the 'error function complement,' and is denoted by $\text{Erfc}(t)$. See J. W. L. Glaisher, Phil. Mag., 4 Ser., xlii., 1871, 296, 421.

ing; if the probability of drawing a prize in a lottery be $\frac{1}{2000}$, the probability of not drawing a prize is $\frac{1999}{2000}$; and $P + (1 - P) = \frac{1}{2000} + \frac{1999}{2000} = 1$. Since the probability integral sums up all the probabilities of occurrence, for and against, we may write

$\frac{2}{\sqrt{\pi}} \int_0^{\infty} e^{-t^2} dt = 1$. This result can be verified independently, if we evaluate the integral by the methods of the calculus.¹

It is not necessary that the reader understand the above formulæ, in the sense that he know how to work with them, to integrate a differential equation, etc.; but it is necessary, if the procedure of the 'error methods' in quantitative psychology is to be anything more than a set of blind rules, that he understand in general terms the reasoning upon which they are based. That reasoning, after all, is not very difficult. The above discussion should become clear after two or three readings. If it does not, if there is an obstinate hitch at some point of the argument, the Instructor must be called upon to smooth things out, or to give references for further reading.—

An illustration will show the close accordance of theory with empirical result, when the observer is skilled and the number of observations considerable. The following Table gives the distribution of errors, observed and calculated, in the case of observations of the differences of right ascension of the sun and two stars, *a* Aquilæ and *a* Canis minoris. The observations were 470 in number, and were made by the English astronomer J. Bradley (1693-1762), whom Laplace called a 'model observer.'

| Magnitude of errors in sec. | Number of errors: | |
|--------------------------------|-------------------|-------------|
| | Observed. | Calculated. |
| 0.0 — 0.1 | 94 | 94.8 |
| 0.1 — 0.2 | 88 | 88.8 |
| 0.2 — 0.3 | 78 | 78.3 |
| 0.3 — 0.4 | 58 | 64.1 |
| 0.4 — 0.5 | 51 | 49.5 |
| 0.5 — 0.6 | 36 | 35.8 |
| 0.6 — 0.7 | 26 | 24.2 |
| 0.7 — 0.8 | 14 | 15.4 |
| 0.8 — 0.9 | 10 | 9.1 |
| 0.9 — 1.0 | 7 | 5.0 |
| Above 1.0 | 8 | 5.0 |
| | 470 | 470.0 |

¹ It is proved, in works on the integral calculus, that $\int_{-\infty}^{+\infty} e^{-t^2} dt = \sqrt{\pi}$.

Hence $\frac{1}{\sqrt{\pi}} \int_{-\infty}^{+\infty} e^{-t^2} dt = 1$. The constant factor in $\frac{1}{\sqrt{\pi}}$ our original formula was, indeed, selected because this factor is necessary to make the total probability unity. Mathematicians worked, at first, with an indeterminate constant *k*.

Three special points remain to be noticed.

(1) We have spoken of the error 0 as the 'most probable' error. Mathematicians use the phrase 'probable error,' in a technical and perhaps somewhat misleading sense, to denote that magnitude of error which is as often exceeded as not reached. We may define the probable error in various ways. Thus, if we were to arrange all the errors in the order of their magnitude, the probable error is that which stands midway in the series. Again, since the probability integral is = 1, the probable error is that magnitude of x for which the integral $\frac{2}{\sqrt{\pi}} \int_0^t e^{-t^2} dt$, in which $t = hx$, has the value 0.5. Or again, it is that magnitude of error for which the chances are even, one to one. Thus, if 5.45 be the arithmetical mean of all determinations of the density of the earth, and the probable error be .20, the meaning is that the probability of the actual density of the earth falling between 5.25 and 5.65 is one to one, *i. e.*, one out of two, or $\frac{1}{2}$. Geometrically regarded, the probable error is the abscissa of that ordinate of the error curve which divides each of the symmetrical halves into two parts of equal area. See Fig. 17.

It should be fully understood that the phrase 'probable error' is conventional. The error designated is not the most probable: that would be the error 0, corresponding to the central ordinate of the curve. Nor is it, in strictness, probable at all; since, as we have seen, the occurrence of any definite, previously assigned error is infinitely improbable. These facts do not, however, impair its practical value.

The probable error may be very simply calculated. We find, from the tables of probability in the text-books, that $P = 0.5$ when $hx = 0.4769$, *i. e.*, when a certain relation obtains between degree of precision and magnitude of error. Hence x , in this case PE_1 , the probable error of the single observation, is $\frac{0.4769}{h}$, or $2.10 PE_1 = \frac{1}{h}$. The measure of precision, h , thus varies inversely as PE_1 .

(2) We must say a word in explanation of the value hx or t . You will presently be required to use a Table, in which various numerical values are assigned to t in the probability integral

$\frac{2}{\sqrt{\pi}} \int_0^t e^{-t^2} dt$. From these values, you will be required to calculate h , the measure of precision, and the corresponding DL . It is essential, then, that you understand what t really is.¹

The value hx is, of course, the product of the measure of precision into a determinate magnitude of error. This product is identical with the ratio $x : \frac{1}{h}$; that is, it is x measured in terms of $\frac{1}{h}$. Now $\frac{1}{h}$ is called, technically, the 'modulus' of the curve of error: a 'modulus' being, in general, any constant coefficient or multiplier whereby a given series or system of quantities may be reduced to another similar series or system. When, therefore, you are looking up a value of t in the Table, you are asking how many times (whole or fractional) the given error x contains the modulus. If $t = 1$, the error is equal to the modulus; if $t = 1.5$, the error is half as great again as the modulus; if $t = 0.5$, the error is half the modulus. In all cases, the modulus is the unit to which you are referring.

To make the idea of the modulus still more concrete, let us call to mind the fact that it is $= 2.1 PE_1$. In looking up t , then, you are also asking how many times the given x contains (approximately) twice the probable error.

(3) Our last point is of a psychological nature. It is tempting to regard the phrase 'degree of probability' as equivalent to 'degree of expectation' or 'amount of belief.' We give expression, in daily life, to various degrees of expectation: we say that an event is 'practically certain,' 'very probable,' 'not unlikely,' 'as likely as not,' 'hardly possible,' 'almost beyond belief.' Do these judgments correspond to certain numerical fractions, representing degrees of objective or mathematical probability? Is the mathematical scale of probabilities simply a more finely graded scale of subjective degrees of expectation?

¹ The following Table illustrates the facts that the integral (which we will term I) varies between the limits 0 and 1, and that it rapidly approaches the latter limit as t increases:

| t | I | t | I | t | I |
|------|-------|------|-------|------|-------|
| 0.00 | 0.000 | 0.75 | 0.711 | 1.50 | 0.966 |
| .25 | .276 | 1.00 | .843 | 1.75 | .987 |
| .50 | .520 | 1.25 | .923 | 2.00 | .995 |

The first thing that strikes us, when we attempt to answer these questions, is that the graduation of the objective scale is incomparably more accurate than that of the subjective. Introspection distinguishes, perhaps, a dozen different degrees of expectation,—though it is more than doubtful if the distances between these degrees are equal, and if the words expressing them convey the same meaning to different persons, or even to the same person at different times. But can we say that the expectation of an event whose probability is $\frac{1}{6}$ differs from that of an event whose probability is $\frac{1}{7}$? Yet these are large numbers! Or have we any expectation at all that corresponds to the probability $\frac{1}{2000}$? Surely, we either drop all thought of the event, or we have a degree of expectation that is far too high,—so high that it cannot be distinguished, say, from the expectation of a probability of $\frac{1}{200}$, ten times as great. It seems absurd, even if it were theoretically justifiable, to correlate two scales of this kind: the one, of extreme and refined accuracy, and the other, as crude and inconstant as a scale can well be.

Nevertheless, it may be objected, there is no disproof of the correlation. It is conceivable that a single degree of expectation corresponds to a zone of degrees of mathematical probability. It is possible, too, that our degrees of expectation may some day be objectively measured, so that we shall be able to equalise the introspective distances between degree and degree, and to assign a numerical value (in terms of some arbitrary unit) to the degree of expectation with which *O* approaches a given series of experiments. We should then have a subjective scale of coarse adjustment, and an objective scale of fine adjustment. Why might not the two be correlated?

The reply is twofold. In the first place, there is no practical ground for believing that the correlation can ever be made out. Expectation is largely a matter of feeling, of temperament: the sanguine mind will confidently expect, positively anticipate, an event which, to the phlegmatic mind, appears exceedingly improbable. It is difficult to see how this typical difference of mental constitution could be overcome. In the second place,

there is no theoretical warrant for the correspondence. On the contrary, the two scales are incommensurable. For it is of the essence of expectation (as it is of the kindred states of attention, practice and fatigue) that it ranges between fixed limits. There is a maximal degree of expectation. Just as we find a terminal stimulus, in the psychology of sensation, such that further objective change has no subjective concomitant, so do we find a certain terminal degree of attention, expectation, practice, beyond which our concentration, certainty, facility, cannot be enhanced. We 'feel sure,' our expectation becomes conviction, long before we have the objective right to be anything more than very moderately expectant. If, then, we are to correlate probability with belief, objective chance with subjective expectation, we can do so only in the sense that we correlate it with a 'rational expectation,' with 'belief as it ought to be.' But this sort of expectation and belief is not the sort that psychology is acquainted with; the attempt at correlation leads, inevitably, to an ideal reconstruction of mind; and therefore, from the psychological point of view, stands self-condemned.

§ 16. **The Method of Limits (Method of Just Noticeable Differences; Method of Least Differences; Method of Minimal Changes).**—Let us suppose that we are to determine the j. n. d. of brightness; that we are to measure the DL at various points upon the brightness scale. All greys, as we know, lie upon a single straight line between the limits B and W (*cf.* the colour pyramid: vol i., 3). We may, then, select any convenient point upon this line as the starting-point of our investigation.

The arrangement of the experiment is simple. We take an ordinary colour mixer, and mount upon it two pairs, large and small, of black and white discs. One disc of each pair must be accurately graduated on the back in 1° units; the graduation may extend, perhaps, over 45° . We are thus able to change the relation of the black and white sectors, over a range of 45° , by units or half units, 1° or 0.5° . Since we are not bound down to any particular point of departure, we may give both of the compound discs an initial value of $180^\circ W$ and $180^\circ B$. If the four discs have been cut from the same

two sheets of card or paper, and if the edges of the smaller pair are accurately trimmed, we shall see on rotation a perfectly uniform lightish grey. How are we to determine the j. n. d.?

The answer appears as simple as the arrangement of apparatus. We have, it would seem, only to lighten the one or other of the greys, adding in white, 1° at a time, in successive observations, until *O* says 'Lighter!' Then we set down in our record the composition of the new grey, which is j. n. lighter than the first grey of $180^\circ W$ and $180^\circ B$,—and the problem is solved.

The quickest way is, however, not always the safest. And a little reflection upon the results of the experiments already performed will suggest that we have here gone to work inconsiderately. We have not tried to get a clear idea, before starting on the experiment, of what the *DL* really is. Is it, *e. g.*, an *S*-distance that has a definite mental equivalent; that we can carry in our heads, as a pattern to go by; that we can remember, from experiment to experiment, so that we shall always obtain the same result, always stop the addition of *W* at the same point? Or is it rather an ideal, calculated value; a distance that has no distinct mental representation, that we are not called upon to estimate or to remember, but that must be established, at the conclusion of each experiment, by mathematical treatment of the results? A very important point! And again: we have not asked ourselves, before starting, whether the arrangement of our experiment closes the door upon all the many errors to which, as preliminary experiments have taught us, psychological observation is liable. For all that we know, it may actually favour certain sorts of error. Another important point; and one that must, surely, be considered before experimental work is begun!

Let *r* represent the standard or normal stimulus in our experiment, *i. e.*, a compound disc of $180^\circ B$ and $180^\circ W$. This is to remain constant throughout. Similarly, let *r*₁ represent the variable stimulus or stimulus of comparison, *i. e.*, a compound disc whose sectors are to be changed, from observation to observation, until the resulting grey is j. n. lighter than the standard grey. The first thing to notice is that *r* and *r*₁ have different positions

in space. If we had performed the rough experiment indicated above, we should probably have put r on the inside and r_1 on the outside, since it is easier to manipulate the large than the small discs. But it makes a difference to our j. n. d., whether r_1 is on the outside or on the inside. Why it should make a difference is not easy to say. If the greys were set up on different mixers, we might suspect differences of physical illumination, or, perhaps, differences in the physiological condition of the retina. Here, however, the two greys are juxtaposed, and can be viewed with strict simultaneity. It may be that the reason for the influence of spatial position lies in the changed attitude of judgment itself, in a different set of the attention over against differently arranged R . However this may be,—and we are compelled to leave the question unsettled,—any single series of observations will, in actual fact, be vitiated by a ‘constant error, the *space error*. Fortunately, the space error can, in this case, be eliminated. If we have determined a DL with r on the inside and r_1 on the outside, we have merely to make a similar determination with r on the outside and r_1 on the inside, and to average the two results. The space errors are opposed, in the two cases, and will cancel out when we average.

The second point to notice is that, when O is called upon to make a series of observations leading to a single result,—*i. e.*, when the experiment is progressive, and requires a certain amount of time for its performance,—his consciousness is apt to take on a definite trend or disposition, which may affect the outcome. Thus, the longer O works, the more *practised* will he become; and the more practised he becomes, the smaller (other things equal) will his DL be, until the limit of maximal practice is reached. On the other hand, the longer he works, the more *fatigued* will he become; and the more fatigued he becomes, the larger (other things equal) will his DL be. Practice and fatigue thus work against each other. Again, if E begins gradually to lighten r_1 , O may be *expecting*, from observation to observation, that the lightening will become apparent in S ; and the farther the series has gone, the greater will this expectation be. But expectation means anticipatory attention, an outrunning of fact by judgment. Hence O will tend to make the difference come too

soon; he will declare that r_1 is lighter than r when, apart from the influence of expectation, he would still have taken the two greys to be alike. Contrariwise, if the series has already progressed a certain distance, and O has been wholly unable to find a difference between r and r_1 , he may be led to think that the coming change is still some few steps away; so far from expecting a difference, he will be expecting a likeness of the two R . His expectation is still an anticipatory attention; but, in this form, it tends to make the observed difference come too late. Finally, and quite apart from expectation, the farther the series has gone, the more *accustomed* has O become to saying 'like,' and the more likely is he to continue to say the same thing. A habit of judgment has been set up; attention lags behind the changes of r_1 . Hence O will again tend, other things equal, to make the difference come too late; he will find two greys alike that he would otherwise see to be different. Habituation is thus opposed to the first form of expectation, while it works in the same direction as the second.

All these sources of error—practice, fatigue, expectation in its two forms, habituation—are *variable*, in the sense that the state or degree of each one of them varies with the progress of the series. What their combined effect would be, in a particular case, we cannot possibly say. But at any rate we cannot count upon their offsetting one another. They are as dangerous and as inevitable as is the 'constant' space error; and we must take account of them, and seek to remove or to minimise them, if our result is to be reliable.

Lastly, the experiment is subject to errors which, like the five just mentioned, vary from point to point of the series, but which, unlike these five, do not vary regularly or continuously with the course of the work. We may call them *accidental* errors. They arise, *e. g.*, from fluctuation or slipping of the attention under subjective influences, from variations in O 's general mood or state of health, from lapse of attention under outside distractions, from errors of manipulation on E 's part, from all sorts of physiological causes. We cannot treat them in the same way that we treat practice and the rest, but we must in some way take account of them.

It follows from this account that the value which we find for the *DL* in a single series of observations is practically worthless. It is vitiated by a constant error; it is affected, on this side or that, by one or more of the variable errors; it is the sport of the accidental errors. The true *DL* is, then, an ideal value, never directly determinable; it is measured by that increment of *R* which, after complete elimination of all errors, constant and variable alike, would make a given r_1 j. n. d. from r in the judgment of an accurate *O*. But we can never, in a single series, eliminate the constant error; we can never, except by the merest chance,—and then we should not know that we had done it!—strike an exact balance among what we have called the variable errors; and we can never wholly rid ourselves of the accidental errors. The *DL* must be calculated from the results of a number of series, carefully planned and disposed; and, even so, its value is only approximative, valid under the total conditions of the experiment.

'Errors of observation' have been treated by mathematicians in what is called the 'theory of probabilities.' From the mathematical point of view, we may measure the true *DL* by that increment of *R* which (after elimination of constant errors) enables *O* correctly to distinguish between r and r_1 in 50% of a long series of observations, while in the remaining 50% his judgment of the relation of r and r_1 is either uncertain or positively wrong. This definition of the *DL* is not different from that given above: only, the former definition regarded the variable errors as ruled out, while the mathematical definition leaves these errors in, and treats them by the laws of probability.

Suppose, now, that we keep to our original idea of changing r_1 by small amounts, in order to make it j. n. lighter than r , but that we work out this idea methodically, with a view to eliminating or minimising the errors of observation. How will our method take shape?

In the first place, we must adapt the method to our revised idea of the *DL*. We have conceived the method to begin with an r_1 that is = and $|||$ ¹ r ; and we have thought of this r_1 as gradually lightened, up to the point at which the first judgment of 'lighter' is given. Should we, by this procedure, determine the true *DL*? Surely not. The *DL* stands on the border-line be-

¹ This symbol means 'subjectively equal to', as = means 'objectively equal to'.

tween noticeable and unnoticeable differences, and we have determined only a least noticeable difference. We must, accordingly, take two determinations, from opposite directions. Starting out from an r_1 that is noticeably lighter than r , we gradually darken it, until its difference from r ceases to be noticeable (until O says 'same', or 'doubtful', or perhaps 'darker'). Then, starting out from an r_1 that is $\lll r$, we gradually lighten it, until O says 'lighter'. Finally, we average the results of the two series,—the $r_1 - r$ which gave r_1 as j . not - n . lighter than r in the first, and the $r_1 - r$ which gives r_1 as j . n . lighter than r in the second,—to obtain a true DL .

Secondly, we must take measures for the avoidance of errors. The elimination of the *constant* space error has already been discussed. Whatever we do with r inside and r_1 outside, we must repeat with r outside and r_1 inside. The whole experiment must be performed twice, with reversal of the space relations of r and r_1 , and the average of the two results taken. The space error just doubles our work. *Variable* errors are reduced to a minimum, partly by directions given to O , partly by a judicious arrangement of the series. *Accidental* errors are compensated by frequent repetition of the paired series. The results of all series are averaged to a final DL , and this, recorded along with a measure of its variability, affords the solution of our problem.

It is clear that we are here applying the method of Exp. I., so modified as to furnish a DL in place of an RL . It is unnecessary to repeat the description of the method in full: the following brief indications will suffice. See above, pp. 4 ff.

Directions to E.

(1) *Preliminary experiments.*—The approximate position of O 's DL must always be determined by preliminary experiments, since it is advisable to begin the experiment with a \downarrow series.

(2) *Size of steps.*—The steps must in every case be small. They should be kept constant within a (paired) series. On the other hand, they may vary, as between one (paired) series and another. Thus, in the illustration taken, they might be made 1° in the one half of the series, and 0.5° in the other. If we were working not with B and W , but with two not very different greys, the range of variation would be much wider.

(3) *Starting-point of the series.*—We have assumed that the \uparrow series starts from the objective and subjective equality of r and r_1 . Now (a), owing to

constant errors, the two do not always coincide. If the two compound discs of $180^\circ B$ and $180^\circ W$ were set up, *e. g.*, on separate mixers, it might very well happen that they did not appear equal to O . In such a case, we must give up the objective and keep to a subjective equality. But again, (*b*) the DL may be so variable that it is impossible to find an r_1 that always appears equal to the standard r . In such a case, we must give up the idea of equality altogether, and start out from an r_1 that either appears uniformly darker than r , or appears (according to circumstances) now darker than r , now equal to it. (*c*) In any event, whether we keep within the limits of subjective equality, or trespass upon the 'darker' r_1 , it is advisable to vary the point of departure of the \uparrow series. The starting-point of the \downarrow series (an r_1 that is always judged lighter than r) should be similarly varied.

(4) *Order of series.*—The experiment, on the analogy of Exp. I., will consist of 40 series: 10 paired series in each of the two space positions. They must be so arranged that the effects of practice are distributed, as evenly as possible, over the whole experiment.

(5) *Length of successive series.*—Series of three lengths are to be used: 3 long, 4 moderate, 3 short in every set of 10. Their order is determined by chance.

Directions to O.

(1) *Direction of judgment.*—Judgment is always given in terms of r_1 . Thus, if O says 'lighter,' he means that r_1 appears lighter than r ; if he says 'doubtful,' he means that he cannot tell whether r_1 is lighter than, equal to, or darker than r ; and so on.

(2) *Variable errors.*—It is essential that O be on his guard against the variable errors of expectation and habituation. He must judge every pair of R , as it comes, with maximal attention and, so far as possible, without any reference to previous judgments. He must not try consciously to correct the errors; he must not, *e. g.*, suspect himself of an expectation error, and try to overcome it by an effort of will: he must simply look attentively at the greys, as they are presented, and make up his mind, without prejudice, as to the relation of r_1 to r .

(3) *The error of bias.*—If O allows his attention to relax, and if E does not sufficiently vary the series, we find a new source of error, introduced into the results by the form and course of the method itself, which we may term the error of bias. The indefinite expectation, which the method presupposes and takes account of, gives place to a definite anticipation of change at some particular step in the series: O looks for a turn of judgment at the fourth, fifth, etc., observation. Should E or O suspect this bias, the haphazard arrangement of the series-lengths must be given up; E must, for a little while, use only the longest and shortest series. If the bias has gone very far, he may introduce, as circumstances suggest, a very long or a very short series. Such a series, it must be remembered, has a disciplinary value only: it is foreign to the method; it interrupts the regular course of the

experiment; its results cannot be counted in with the rest. The prevention of the error of bias is indefinitely better and easier than its cure. And, since *E* already has his directions with regard to variation of the length of the series, its prevention lies in *O*'s hands.—*Cf.* p. 4 above.

The ↓ series furnishes an r_1 which marks the point at which *O*'s judgment changes from 'lighter' to 'same', 'doubtful' or 'darker.' This value of r_1 is recorded as r_d (d = descending). The ↑ series furnishes an r_1 which marks the point at which *O*'s judgment changes from 'same' or 'doubtful' to 'lighter.' This value of r_1 is recorded as r_a (a = ascending). The difference $r_d - r$ is recorded as Δr_d ; the difference $r_a - r$ as Δr_a . The average of Δr_d and Δr_a is written Δr . The final Δr is the average of all the separate Δr_d and Δr_a values. If, as was suggested above, we take 10 paired series, in each of the two positions of space, the final Δr will therefore be the average of 40 determinations.

We have now, if we have worked aright, a value of the *DL* (this final Δr) which is unaffected by any constant error, and is as free from variable and accidental errors as, in the time at our disposal, we can make it. The tale of errors is long; and the reader who has followed the preceding discussion may, perhaps, be inclined to distrust a method that has to move so warily among so many pitfalls. But the sources of error are there: we must either avoid them or fall into them: and that is, surely, the best rule of work which takes account most fully and explicitly of the dangers that beset the path of the experimenter. It is, in reality, an advantage of the method of limits that the errors involved are obvious, can be separately traced and definitely named: for that means that they can, with some little effort, be eliminated. And in spite of the number of errors, the course of the method in practice is comparatively simple. All that *E* has to do is to grade his *R* according to rule; all that *O* has to do is to compare, with maximal attention, every pair of *R* presented.

In conclusion, the information which the method gives may be summed up under the headings: magnitude, course and precision of the *DL*, and magnitude and direction of the constant error.

(1) *Magnitude of the DL.*—The absolute magnitude of the

DL is shown by the value Δr ; its relative magnitude, *i. e.*, its magnitude relatively to the magnitude of the standard stimulus, by the value $\frac{\Delta r}{r}$.

(2) *Course of the DL.*—On this point, we can say nothing. We have, by supposition, determined only one DL at one point upon the R -scale. We may, of course, compare our result with the published results of investigators who have worked under similar conditions. Or, better still, we may compare it with the results of other students who have worked, at different points on the R -scale, in the same laboratory and with the same materials. It is well, however, if time permits, to take at least one other DL , for purposes of comparison.

In a serious investigation, the determination of r_d and r_a would be made, not at one point upon the R -scale (the grey, *e. g.*, of $180^\circ B$ and $180^\circ W$), but at several points between its extreme limits. Thus, in one of the most complete researches that we have, the DL of brightness was determined for 18 intensities of light between the limits 0.5 and 200000: the light unit, 1, corresponding roughly to the illumination of a dull-finish white paper by a stearin candle 75 cm. distant, as viewed through a screen opening of 1 mm². These 18 determinations allow us to plot a curve of the course of the DL from dark to light.—Method work on such a scale is, naturally, out of the question in a laboratory course.

If we decide to make one other determination, we shall do best to work with the same r , but to vary r_1 on the lower (darker) side of it. If we term the Δr already determined the *upper DL* of the r in question, the new Δr will be the *lower DL*. To obtain it, we set out from an r_1 that is noticeably darker than r , and gradually lighten r_1 until O says 'same,' 'doubtful,' or 'lighter.' The value of the r_a is recorded. Similarly, we set out from an r_1 that is subjectively equal to (or, at any rate, not darker than) r_1 , and gradually darken r_1 until O says 'darker.' The value of the r_d is recorded. Finally, the values of $r - r_a$ and $r - r_d$ are averaged to a Δr .

If, now, the absolute DL is constant, we must find, for all the determinations made in the laboratory at different points of the R -scale, that $\Delta r = c$, where c is a constant value. If, on the other hand, the relative DL is constant, we must find, throughout, that $\frac{\Delta r}{r} = k$, where k is a constant. Or again: if we average r_d and r_a to r_m (m = mean), we must find that $\frac{r_m}{r} = C$, where C is

a constant. The value $\frac{r_m}{r}$ is sometimes termed a quotient limit or *QL*.—We thus have, in all, the test-values $\Delta r, \frac{\Delta r}{r}, \frac{r_m}{r}$.

If we have determined the lower as well as the upper *DL*, we have six test-values, as follows (*u* = upper, *l* = lower) :

| | |
|----------------------------------|------------------------------------------------------------|
| the absolute <i>DL</i> | $\Delta r_u, \Delta r_l;$ |
| the relative <i>DL</i> | $\frac{\Delta r_u}{r}, \frac{\Delta r_l}{r - \Delta r_l};$ |
| and the <i>QL</i> | $\frac{r_{mu}}{r}, \frac{r}{r_{ml}}$ |

(3) *Precision of the Observations*.—Psychological practice has usually been content to take the *MV* as the measure of precision for the results of the method of limits. It is, for some reasons, better to give the probable error or *PE*, a variation from the mean of such magnitude that any given variation is as likely to exceed it as to fall below it. The *PE* of a single observation may be calculated from the formula $PE_1 = 0.6745 \sqrt{\frac{\Sigma v^2}{n-1}}$, where Σ is the sign of summation, *n* is the number of observations, and *v* stands for the differences *A*—*a*, *A*—*b*, etc., of the formula on p. 8. The quantity $\sqrt{\frac{\Sigma v^2}{n-1}}$ is termed the error of mean square; it is the error whose square is the mean of the squares of all the errors.¹ In words, then, $PE_1 =$ two-thirds of the error of mean square. The *PE* of the mean (of Δr) may be calculated from the formula $PE_m = 0.6745 \sqrt{\frac{\Sigma v^2}{n(n-1)}}$. Simpler but somewhat less accurate formulæ are :

$$PE_1 = \frac{0.8453 \Sigma v}{\sqrt{n(n-1)}};$$

$$PE_m = \frac{0.8453 \Sigma v}{n \sqrt{(n-1)}}$$

¹This is the general definition of the 'error of mean square.' If we were to follow it strictly, we should have, not $\sqrt{\frac{\Sigma v^2}{n-1}}$, but $\sqrt{\frac{\Sigma v^2}{n}}$. It is, however, shown in mathematical books that, where the number of observations is small, we insure greater accuracy of result by writing *n*—*1* for *n* in the denominator of the fraction. Hence we are not really running counter to our definition; we are simply making the error of mean square the error whose square is the *corrected* mean of the squares of all the errors. See, *e. g.*, M. Merriman, *Least Squares*, 1900, 71.

It follows that, approximately, $PE_1 = 0.85 MV$, and $PE_m = \frac{0.85}{\sqrt{n-1}} MV$. These latter equations are sufficiently accurate for our purposes.

(4) *Magnitude of the Constant Error.*—Let us term the DL obtained with r to the right and r_1 to the left Δr_l , and the DL obtained with r to the left and r_1 to the right Δr_{rl} . Then

$$\Delta r = \frac{\Delta r_l + \Delta r_{rl}}{2},$$

and q , the space error, $= \frac{\Delta r_l - \Delta r_{rl}}{2}$.

If we have determined Δr_l as well as Δr_u , we have

$$\Delta r_u = \frac{\Delta r_{ul} + \Delta r_{ull}}{2}, \quad \Delta r_l = \frac{\Delta r_{ll} + \Delta r_{lll}}{2};$$

whence

$$q = \frac{\Delta r_{ul} - \Delta r_{ull}}{2}, \quad q = \frac{\Delta r_{lll} - \Delta r_{ll}}{2}.$$

Or again: if we regard as negligible the small difference (due to Weber's Law) between Δr_u and Δr_l , we may write

$$\Delta r_l = \frac{\Delta r_{ul} + \Delta r_{ll}}{2}, \quad \Delta r_{rl} = \frac{\Delta r_{ull} + \Delta r_{lll}}{2};$$

whence

$$q = \frac{\Delta r_{ul} - \Delta r_{ll}}{2}, \quad q = \frac{\Delta r_{lll} - \Delta r_{ull}}{2}.$$

In this matter of the constant error, the advantage of the additional determination of Δr_l is obvious.

(5) *Direction of the Constant Error.*—The space error is equivalent, for practical purposes, to a certain algebraical increment of the difference D existing between r and r_1 . In the one arrangement D is increased, in the other diminished, by a small constant amount. Fechner calls the space error *positive* when its effect is to make the left-hand R appear greater than the right; *negative*, when its effect is to make the left-hand R appear less than the right. The distinction is merely conventional, but has remained current since Fechner's time. It is evident that the signs of the formulæ just given presuppose a negative space error: if the error is positive, the signs will be reversed.

EXPERIMENT XIII

Determination of the DL for Brightness.—This experiment may be performed in various ways.

(1) MATERIALS.—Two colour mixers. Four large discs, two black and two white, all slit along one radius, and the latter graduated at the back. Grey screen, of approximately the same brightness as the compound discs employed. Kirschmann photometer. Window screens of white muslin. Metal protractor.

DISPOSITION OF APPARATUS.—The two mixers are set up, side by side, before the grey screen. Discs and screen should be directly illuminated by a high window, which does not admit sunlight during the hours of experimentation; *O* sits with his back to the window. The general illumination of the room should be kept so far as possible constant, from day to day, by the use of muslin screens set in the various windows.

(2) MATERIALS.—Colour mixer. Two large (black and white) and two small (black and white) discs, all slit along one radius, and the white graduated at the back. Grey screen, Kirschmann photometer, muslin screens, protractor, as before. Black observation tube. Eye-shade.

DISPOSITION OF APPARATUS.—The four discs are mounted on the mixer, which stands as before in front of the screen. Observations may be taken binocularly, with the free eyes, or monocularly, through the observation tube. This is of black cardboard, widening at the near end to fit the eye; the reflection of light from its sides must be carefully avoided. The unused eye is shaded.

(3) (4) MATERIALS as in (1) and (2), except that the black and white are replaced by two Hering greys. The advantage of using greys is that the serial steps are shorter, while the actual changes of setting are larger, than they are with black and white, so that the *DL* can be determined with greater accuracy.

GENERAL DIRECTIONS.—Readings should be taken, at the end of every series, both from the scale at the back of the graduated disc, and also from the protractor scale. The latter gives the more accurate value; and a discrepancy between the two results may serve to call *E*'s attention to some error of manipulation during the course of a series.

The photometric value of the brightnesses employed should be determined by the Kirschmann photometer (set up in the same position as the mixers) both at the beginning and at the end of the experiment. Even if the discs are carefully kept in a dark drawer in the intervals between the laboratory sessions, there is danger of fading. The two sets of photometric values are averaged for the final determination of the *DL*.

The results are, of course, entered fully in the note-book in terms of degrees. At the end of the experiment, however, the results of the various series must be translated into photometric values. Suppose, *e.g.*, that a black and a white are used, whose brightness-ratio is given by the photometer as 1 : 40. Then the 'value' of a disc of 180° *B* and a 180° *W* is $180 \times 1 + 180 \times 40$ or 7380 'photometric units.' If the amount of the average *DL* were 5°, the value of the corresponding disc would be $175 \times 1 + 185 \times 40$, or 7575 units. The relative *DL* would then be expressed by the fraction $\frac{195}{7380}$ or $\frac{1}{38}$.

Preliminary experiments are to be made before the experiment proper is begun (p. 60 above). But more than this: *E* should always give *O* a little practice at the beginning of each session, before entering on the series laid out for the day; he should on no account start the series out of hand. The time elapsing between session and session, even if it is no more than 24 hours, is long enough for *O* to get 'rusty'; only after a practice series does he warm up to the work, as one says, or get into the swing of the experiments. This rule must never be broken.

As soon as the conditions of the experiment have been arranged, *E* makes out a plan or Table in which all the constants of the apparatus (distances, heights, etc.) are accurately entered. The plan is rigorously adhered to in the successive series.

EXPERIMENT XIV

Determination of the DL for Tone.—This experiment is best performed by the aid of tuning forks. Two arrangements are in general use.

(1) MATERIALS.—Two forks, the one of which is furnished with riding weights. Piano hammer. Felt. Stop-watch.

Soundless metronome. [The forks are so constructed as to sound in unison when the riders are set a certain distance down

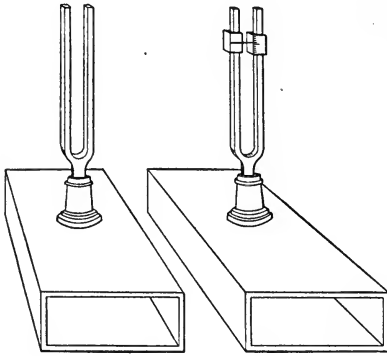

FIG. 20.

the tines of the 'variable' fork; this distance is marked by a light cross-cut on the tines. The one rider carries a horizontal pointer, the other a scale.]

(2) MATERIALS. — Two forks, each furnished with a steel screw, sunk vertically into one of its tines. Piano hammer. Felt. Stop-watch.

Soundless metronome. [The screw is fixed by a thumb-nut, and is turned by its milled head. Just below the milling of the head is a scale, graduated in tenths of a whole turn.]

GENERAL DIRECTIONS.—It is clear that if the riding weights are lowered, or the screw turned down, the pitch of the fork is raised; if the weights are raised, or the screw turned up, the pitch is lowered. Hence it is possible, while the one fork remains constant in tone, to vary the pitch of the other, up or down, as the method requires.

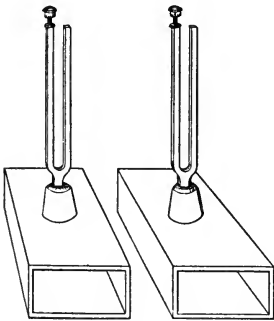

FIG. 21.

Equality of the two vibration-rates in (1) is given by the position of the cross-mark upon the tines of the variable fork: though the setting of the riders should be tested (by listening for beats) before the experiment is begun. Equality of the vibration-rates in (2) must be determined by ear. The screw of the one (the constant) fork is turned down for about half its length. The screw of the other (the variable) fork is then gradually turned down until beats disappear. When this point has been reached, comparative tests are made, (a) by turning the screw a certain number (say, 4) of whole turns up, and then (b) by turning it the same number of whole turns down, below the supposed point of equality; and by counting

the beats in the two cases (10 sec. by the stop-watch). If the point first determined was really the point of equality of vibration-rates, the number of beats in both tests will be the same.

As regards the taking of daily practice series, and the making

out of a plan or Table of the disposition of apparatus, the same rules obtain for this experiment as for Exp. XIII.

The course of the single observation will be as follows. *E* says 'Now!' and after the usual interval strikes the first (standard or variable) fork. When the fork has sounded, say, for 3 sec., he damps it with the felt, and without further signal but after the regular interval strikes the second (variable or standard) fork. This is damped in its turn at the end of 3 sec. *O* then reports or records his judgment.

QUESTIONS.—*E* and *O* (1) What are the main characteristics of the Method of Limits? What is the psychology of the method?

(2) Does the method presuppose a certain method of procedure, *i. e.*, the procedure with knowledge or the procedure without knowledge?

(3) Write out a list of the errors to which the method is subject, indicating in brief the manner of their avoidance.

(4) Make a diagram, showing the course of the method and the way of calculating the *DL*.

(5) Does the method allow of the interpolation of a blank experiment? Suppose, *e. g.*, that *E* observes in *O* a slight tendency towards the error of bias: may he try to check this tendency by the introduction of a blank experiment in the series?

(6) What opportunity for introspection does the course of the method afford?

(7) Suggest modifications of the method.

(8) Discuss the physiology and psychology of the constant error of space.

(9) Give a full explanation of the formulæ on p. 65.

(10) Are the four variable errors (practice, fatigue, expectation, habituation), all on the same psychological level? Why is *O* warned particularly, on p. 61, against the errors of expectation and habituation?

(11) Suppose that you were planning Exp. XIII. or Exp. XIV., not as a laboratory exercise, but as a bit of serious investigation: what improvements or modifications of technique would you suggest?

(12) Suggest further experiments to be made by the Method of Limits.

§ 17. **Fechner's Method of Average Error (Method of Reproduction; Method of Adjustment of Equivalent R).**—In all the experiments which we have hitherto performed, qualitative and quantitative alike, *O*'s part has been reduced, so far as possible, to that of the attentive onlooker; the arrangement of apparatus has been left, as exclusively as might be, in the hands of *E*. In experiments made by the method of average error, this relation of *E* and *O* is changed. *E* plays an entirely subordinate part: all that he has to do is to prepare the apparatus for an experiment, and to record the value at which *O* sets it. The setting, the manipulation and adjustment, are done by *O* for himself.

The reason for this change of relation becomes clear as soon as we state the problem which the method attempts to solve. The problem is that of the equation of two stimuli. A certain stimulus, r , is presented, and *O* is required to make another stimulus, r_1 , subjectively equal to it. Let us take an instance. The r might be a white line of 50 mm. length, shown horizontally upon a black background; and we might ask *O* to lengthen or shorten a similar white line, lying to right or left of the standard r , by pushing a vertical black screen out or in, until the two lines were, in his judgment, of the same length. *E*'s duties would then be confined to setting the movable black screen, at the beginning of each experiment, and to recording the length of r_1 at the end.

What, now, is the point of this whole method? Why is it worth our while to set such a task to *O*?

The point is that, as we saw in § 15, the adjustment of r_1 will never, except by pure accident, be objectively right. The line which *O* judges to be equal to r_1 will, as a rule, prove when measured to be longer or shorter than the standard. From the objective or physical point of view, *O* will be subject to errors of observation, such that his r_1 will almost always differ a little, *plus* or *minus*, from the given r . These 'errors of observation' are, however, of great psychological interest. They depend, in part, upon the uncertainty of *O*'s hand. They depend, in part, upon all those accidental influences, within or without *O*'s organism, which lead him astray in the particular case,—upon the influences whose result we have discussed in § 15. But they depend also

upon the magnitude and variability of the *DL*. This fact alone recommends them to our notice, as students of quantitative psychology.

It is in the 'errors of observation,' therefore, that our problem centres. We must determine them in such numbers that we can deal with them systematically and methodically. We must seek to analyse them, and to refer the results of their analysis to constant or variable conditions. This is what the 'method of average error' sets out to do.

Imagine that *O* is seated before an apparatus of the kind sketched above. In the middle of a vertical black surface is stretched a horizontal white line of 120 mm. A fine black thread, placed vertically, cuts off 50 mm. at the left of the line. We have, then, two continuous white lines, the one of 50, the other of 70 mm. On the right-hand side of the apparatus is a movable black screen, of the same quality as the background. This screen runs in horizontal grooves, above and below, and can be pushed in or out, with uniform movement, by means of a crank placed conveniently to *O*'s hand. The right-hand line can, therefore, be lengthened or shortened at pleasure. From the sides of the black background projects a light framework,—two outstanding arms carrying a horizontal cross-piece,—so constructed that *O*, seated at a comfortable distance for vision and for handling the crank, may rest his forehead against the cross-bar during observations. A mm. scale is attached to the fixed background, so that movement of the smaller screen, in or out, can be accurately measured.

We now have our conditions ready for an experiment. *E* sets the movable screen at such a point on the 70 mm. line that this, the right-hand stimulus, is sensibly larger or smaller for *O* than the standard *r* to the left. *O* settles himself in position, takes the crank in his hand, and proceeds to turn the movable screen inwards or outwards, towards subjective equality of the two lines. His problem is to set r_1 at the length that *best satisfies him* of its equality to the standard *r*. Hence he does not arrest the crank at the first point of apparent equality. Having reached this point, he still continues, very slowly, to shorten or

lengthen r_1 . If he goes too far, as he probably will, he may move the screen out or in again; and he may continue in this way, moving the screen to and fro within narrow limits, until he hits upon the length of r_1 which entirely satisfies him. This value of r_1 is recorded by E , who also sets the apparatus for another experiment.

The experiment is to be repeated 100 times. The method does not lay down any rule for E 's initial setting of r_1 . It will, however, be advisable, on general principles, (1) to begin 50 experiments with $r_1 > r$, and 50 with $r_1 < r$; (2) to vary the initial difference between r and r_1 ,—always, of course, under the restriction that the difference is clear to O at the outset; and (3) to see to it that 'very large' initial differences occur as often as 'very small' differences on both sides (+ and -) of r .

The 100 recorded r_1 will, as we have said, show in the great majority of cases some difference, *plus* or *minus*, from the standard r . The first thing to do is, evidently, to determine the most probable value of r_1 , that is, the r_1 which best represents O 's idea (under the conditions of the experiment) of the distance 50 mm. The formula for the most probable value is, as we know, the formula for the arithmetical mean: $\frac{\sum r_1}{n}$. We calculate the mean value of the 100 r_1 , and enter the result in our record, under the title r_m .

The differences between the single r_1 and this r_m , taken without regard to sign, may now be considered as O 's errors of observation. Or, in other words, the MV or AD of r_m affords a measure of O 's precision. He has had r_m in mind, so to say, as the equivalent of r . He has, on the average, struck it; but in the single case he has struck a little to the one or the other side of it. The MV tells us how accurate or inaccurate, on the average, his adjustments have been. We determine it in the usual way, by summing up the differences found between r_m and the separate r_1 , and dividing the sum by 100, the number of experiments. Let e (error) stand for these differences. Then our formula is $e_m = \frac{\sum e}{n}$. The value e_m is known as the 'average variable error.' It is the most characteristic test-value furnished by the method.

It is natural that we should bring this e_m (or the corresponding PE_1) into relation with the MV (or PE_1) of the method of limits. The two measures of precision cannot, however, be directly paralleled. In the first place, the MV of the method of limits marks the constancy of the point at which O 's judgment changes under the influence of a changing R ; the average variable error marks the constancy of the point at which O finally settles down to a judgment of equality. In the second place, the MV of the method of limits expresses the accuracy of observation only; the e_m expresses the resultant accuracy of observation and adjustment. In the third place, the MV of the method of limits characterises the accuracy of O 's determination of the DL ; the e_m of average error is determined, in part, by the magnitude and variability of the DL itself. Hence, although the two measures belong to the same general class of test-values, we cannot expect them to be numerically the same.

So far, we have spoken, not of r_m itself, but only of its MV . The value r_m , the most probable value of r_1 , may be regarded as free of accidental errors, since these are as likely, in the long run, to fall on the *plus* as on the *minus* side of r , and will therefore cancel out in the average. It will, however, almost certainly be affected by a constant error, if not by a complex of constant errors. The value of the crude constant error may be determined by the formula $c = r_m - r$: the value c being positive or negative according as r_m is $>$ or $<$ r .

The mention of the constant error c suggests, however, that our programme of the method is not yet complete. We have been working, throughout, with r_1 to the right of r . It is probable, then, that at any rate some part of the error c is due to the spatial position of the two stimuli, and that this component can be determined (and therefore eliminated) if our results are combined with those of 100 similar experiments in which r_1 lies to the left of r . E accordingly shifts the movable screen to the left of the apparatus (or the apparatus may be inverted, or a second screen provided), and sets the vertical black thread at a distance of 50 mm. from the right-hand end of the 120 mm. line. The crank is left in its original position; and the experiment proceeds as before.

Our 100 determinations have thus become 200. But now that we see what we have to do, we can also see that the whole experiment has been injudiciously arranged. It would be bad policy

to take our 200 observations in two steady series of 100 each. For one thing, O would be unpractised at the beginning, and highly practised at the end, so that the results of the first and second 100 would not be comparable. For another thing, 100 determinations are too many to take at a single sitting; O would grow fatigued. We shall do well to make out a plan of work beforehand: dividing up our 200 observations into 8 sets of 25 each, and distributing these 8 sets in such a way that each of the four experimental arrangements (smaller r_1 right, greater r_1 right, smaller r_1 left, greater r_1 left), and each of the differences within these four arrangements (r_1 very much smaller, much smaller, distinctly smaller, etc.), receives an approximately equal share of practice. The precise arrangement of the sets need not be given here; E will easily find a plan of distribution in which the effects of practice are properly compensated.

At the conclusion of the experiment, E sorts out the 200 results into two groups of 100 each, which he arranges in columns under the rubrics I (r_1 to the left) and II (r_1 to the right of r). The values r_m , e_m and c are to be determined separately for each group of 100 determinations.

We have said that the value e_m is the most characteristic test-value furnished by the method. We shall want, then, to determine e_m as accurately as possible. Now in any given setting of r_1 , the error e is algebraically added to a constant error c . But a 'constant' error is simply an error whose *conditions* are constant; its *amount* may vary, quite considerably, from stage to stage of a long series of experiments. If our own constant error c has varied in this way, its variation must evidently have affected the value of e_m as determined above. To free e_m of any influence of this sort, we must 'fractionate' the results. We determine Σe , not for the whole group of 100 observations, but for quarter-groups of 25 observations apiece; and we determine e_m , not as $\frac{\Sigma e}{100}$, but as

$$\frac{\Sigma e_1 + \Sigma e_2 + \Sigma e_3 + \Sigma e_4}{100}$$

This value is more accurate than the value $\frac{\Sigma e}{100}$. On the other hand, it is indifferent for the determination of the c of each group whether we work from the group as a whole, or separately from the quarter-groups.

We come now to the consideration of the constant error, in the

interest of which we increased our original 100 to 200 determinations. How are we to analyse it?

We have already suggested that c is made up, in part at least, of the regular space error, q . The q errors are, by hypothesis, equal and opposite; they increase or diminish r_1 , according as the two stimuli are disposed in this way or in that; but they increase and diminish it by equal amounts. If, then, these were the only errors involved in c , we ought to find $\frac{r_{mI} + r_{mII}}{2} = r$. As a rule, the equation does not hold; the average of the two r_m turns out to be distinctly $>$ or $<$ r . Where this is the case, c must have a second component, the sign of which remains unchanged throughout the experiment. We will term it s . Then we have:

$$\begin{aligned} c_I &= -q + s, & r_{mI} - r &= -q + s, \\ c_{II} &= +q + s; & r_{mII} - r &= +q + s; \end{aligned}$$

where the subscript I and II have the same meaning as on p. 65 above (I = r_1 to the left, II = r_1 to the right), and the signs of q are so chosen that a positive or negative q , as found by the equations, corresponds to a positive or negative space error in Fechner's sense (p. 65). From these equations we obtain:

$$\begin{aligned} q &= \frac{c_{II} - c_I}{2}, & q &= \frac{r_{mII} - r_{mI}}{2}, \\ s &= \frac{c_{II} + c_I}{2}, & s &= \frac{r_{mII} + r_{mI}}{2} - r. \end{aligned}$$

Simple as the calculation is, it is well to work out the values of q and s from both sets of equations. Slips in addition and subtraction are commoner than one likes to think!

There is still one more point to be considered. We have been *assuming* that the value c represents a constant error. What right have we to make this assumption? Why may not the occurrence of c be due simply to an irregular distribution of the accidental errors e , itself due to a too small n ? — There are two ways of answering these questions. In the first place, we may have recourse to fractionation. Instead of determining the c_I of column I, and the c_{II} of column II, we may determine four c for each column, — one for every 25 observations. If the four c of each column all have the same sign ($+$ or $-$), we may be sure that c_I and c_{II} represent true constant errors. In the second place, we may compare c_I and c_{II} with the *PE* of the average r_{mI} and r_{mII} , which are also the *PE* of $r_{mI} - r$ and of $r_{mII} - r$. The value PE_m , it will be remembered, gives the limits within which it is

an even chance that the r_m of another set of 100 observations, taken under exactly the same conditions, will lie: it may be determined, approximately, as $= \frac{0.8453}{\sqrt{n-1}} MV$. If, now, c is considerably larger than PE_m , we may be certain that it represents a true constant error.

EXPERIMENT XV

The Equation of Visual Extents.—A very simple set of apparatus for this experiment may be constructed as follows.

MATERIALS.—Galton bar. Black screen. Head-rest. [The Galton bar shown in Fig. 22 consists of a hardwood metre stick, planed smooth upon the surface which carries the scale of inches. Three sliders of blackened metal are fitted to the stick: that in

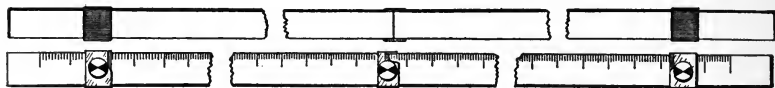

FIG. 22.

the centre shows in front a fine black wire, set precisely at the vertical; those at the ends show larger surfaces, bounded towards the centre by exactly vertical edges. All three sliders may be clamped at the back by set-screws, and are bevelled off to allow of accurate readings from the mm. scale. The screen is a large wooden screen, arranged to stand vertically on a table, and covered with black cloth or cardboard, or painted in dull black.]

DISPOSITION OF APPARATUS.—The screen is set up in a good light, but in such a position that it is not directly illuminated by sunlight. Two small screw-eyes are turned into the back of the metre stick, and two corresponding screw-hooks into the wooden screen: so that the Galton bar is held firmly in the horizontal position at a little distance from the surface of the screen. The central and one or other of the limiting sliders are clamped fast at the standard distance. O sits, with his head in the head-rest, directly facing the central black wire, and at such a distance from the screen that he can conveniently manipulate the movable slider.

After O has made a setting, E gives one of the screw-hooks a

partial turn, thus releasing the end of the bar. Having swung the bar out, and taken his reading, he resets the movable slider and hangs the bar back in position.—

Remember that a few 'practice' settings must be made at the beginning of every session!

Another experiment, made with a somewhat modified form of the method of Average Error, will be assigned in § 21 below.

QUESTIONS.—*E* and *O* (1) What are the main characteristics of this Method of Average Error? What is the psychology of the method?

(2) What criticisms have you to pass upon the method?

(3) Write out a list of the errors to which the method is subject, indicating the manner of their avoidance.

(4) Name and characterise the test-values which the method furnishes.

(5) Summarise the procedure of the method.

(6) Have we, in the text, determined e_m as accurately as is possible? Give reasons for your answer.

(7) Discuss the constant error s .

(8) Suggest modifications of the method.

(9) Discuss the significance of the value e_m , with special reference to the interpretations of Fechner and Müller.

(10) Suggest further experiments by the method.

§ 18. **The Method of Equivalents.**—In Fechner's Method of Average Error, a constant stimulus r is presented, and *O* is required to adjust a variable stimulus r_1 to subjective equality with r . Suppose, now, that the stimuli are applied to a sense organ which, like the skin, is variously sensitive at different places. In such a case, a new problem arises. We may require *O* to adjust an r_1 , applied at one part of the organ, to subjective equality with the standard r , applied at another and more (or less) sensitive part. The standard may, *e. g.*, be applied to the forehead, and the variable to the back of the left hand. We shall then obtain an r_1 -value from the back of the hand, which is 'equivalent' in sensation to the given r -value on the forehead. This is the aim of the Method of Equivalents. The method is, evi-

dently, identical with the Method of Average Error, except that the stimuli are applied to different parts of the organ, or, in some rare cases, to different organs. The same method of calculation may be employed in both cases.

It would, however, in most instances, be very inconvenient to leave the application and adjustment of the stimuli to O . Suppose that he is working with the æsthesiometric compasses. The standard distance is to be given on the forehead, the variable on the back of the left hand. The left hand must lie unmoved upon the table. O , working with the right hand only, must first apply the standard compasses to the forehead (and must apply them, in successive trials, always to the same place and always with the same amount of pressure); must then apply the variable compasses to the back of the left hand, and must vary r_1 , to and fro, until he has obtained the distance that best satisfies him of its equality to r ; and must finally measure off and record this value of r_1 . The whole experiment is awkward, and the results will necessarily be affected by a fatigue error and by errors of manipulation. Besides, O should, by rights, keep his eyes closed during the comparisons.

Conditions may, no doubt, be arranged, which are more favourable to the employment of the principle of average error; but conditions may easily be found that are even less favourable than those we have sketched. On the whole, it would seem better to give up this principle, and to replace it by the principle of the method of limits. The experiment then takes shape as follows.

Let A stand for the forehead, and B for the back of the hand. Let the standard distance be termed a when it is given on A , b when it is given on B .

We begin with the time-order $A-B$. E first applies the standard a , and then the variable b_v , beginning with a b_v that is clearly too large. He gradually reduces b_v , in successive comparisons, until b_v first appears $= a$. There the series stops. E now takes b_v clearly too small, and gradually increases it, until b_v again appears $= a$. There the series stops. The experiment is repeated 10 times, and the average value of b_v is recorded (with its MV) as b_1 .

The time-order is then changed to $B-A$. E first applies the

variable b_v , and then the standard a . The \downarrow and \uparrow determinations are repeated 10 times, and the average value of b_v is recorded (with its *MV*) as b_{11} . The experiment furnishes us with the equivalence $a = \frac{b_1 + b_{11}}{2}$.

To test this result, we repeat the whole experiment, with reversal of standard and variable. Beginning with the time-order $B-A$, E first applies the standard b , and then the variable a_v . The average value of the a_v , \downarrow and \uparrow , is recorded (with its *MV*) as a_1 . Turning to the time-order $A-B$, E first applies the variable a_v , and then the standard b . The average value of the a_v , \downarrow and \uparrow , is recorded (with its *MV*) as a_{11} . The experiment furnishes us with the equivalence $b = \frac{a_1 + a_{11}}{2}$.

If the conditions of practice, etc., have remained constant, we shall find that the ratio $a : \frac{b_1 + b_{11}}{2} =$ the ratio $\frac{a_1 + a_{11}}{2} : b$. We have then obtained the equivalence required.

The constant errors involved in the values b_1 , b_{11} , and a_1 , a_{11} , are plainly the time error p and the principal error s . They may be determined by formulæ similar to those on p. 75 above.

EXPERIMENT XVI

The Method of Equivalents as applied to Cutaneous Extents.
—The only Materials required for this experiment are the æsthesiometric compasses used in Vol. I., Exp. XXXIV.

GENERAL DIRECTIONS.—We may choose, as obvious surfaces to work upon, the volar side of the wrist, the ball of the thumb, and the tip of the forefinger. Since the R with which he is to work must be distinctly supraliminal, E will, first of all, roughly determine O 's two-point limen at these places. That done, he selects separations of the compass points that, while supraliminal, are yet not so large as to prevent serial increase within the limits of the area of stimulation. Thus, if the R are to be applied in the longitudinal direction, he may select distances in the neighbourhood of 5 mm. for the finger, 10 mm. for the thumb, and 20 mm. for the wrist. Finger is now to be equated with both thumb

and wrist, thumb with both finger and wrist, etc. The equivalent extents are roughly determined in preliminary experiments, and the series proper then begin.

As always, a practice series must be taken at the beginning of every laboratory session.

EXPERIMENT XVII

The Method of Equivalents as applied to Cutaneous Pressure.
—MATERIALS.—Cartridge weights. Soundless metronome. Stop-watch. [The weights are paper cartridge cases, 3 cm. in height and 2 cm. in diameter, loaded with shot and stuffed with cotton wool. The top is closed by a wad, and the metal bottom is covered with a layer of blotting paper. There are 10 weights in all, varying by 2 gr. steps from 12 to 30 gr.]

GENERAL DIRECTIONS.—The standard weight is that of 8 gr., applied vertically to the back of *O*'s hand. *E* is to determine the equivalent of this weight, upon the volar surface of the opposite wrist. He first determines the equivalent roughly, in preliminary experiments, and then plans his series. The weights are left upon the skin for 2 sec., and there is an interval of 3 sec. between standard and variable. A pause of 30 sec. is made after each comparison, and a pause of at least 3 min. between series and following series.

In this experiment practice easily wears off, and fatigue easily sets in. To guard against the first source of error, the warming-up series at the beginning of each session must be extended somewhat beyond the usual limits; to guard against the second, the time relations of the experiment must be very strictly observed.

QUESTIONS.—*E* and *O* (1) Write out in full the procedure of the Method of Equivalents, regarded as a form of the method of average error, showing the derivation of the test-values.

(2) Criticise the method (application of the method of limits) as formulated in the text.

(3) Suggest modifications of the method.

(4) Criticise the procedure for the elimination of constant errors.

(5) Criticise Fechner's theory of a proportional constant error.

(6) Under what conditions may equivalents be obtained from two different sense departments? Point out the chief sources of error.

O (7) What complicating factor in judgment does introspection reveal in Exp. XVI. that is absent in Exp. XVII.?

§ 19. **The Method of Equal Sense Distances (Method of Mean Gradations; Method of Supraliminal Differences; Method of Equal-appearing Intervals).**—The method which we are now to discuss is concerned directly with the measurement of sense distances. We have referred to it above, pp. 25 f., and we have had a rough illustration of its use in Exps. XI., XII.

Let us suppose that we are to work with intensities of sound. We require a 'sound pendulum,' such as is shown in Fig. 23. A pendulum rod, suspended from a steel pillar, ends in a hard-rubber ball which strikes, as the pendulum falls, upon a block of ebony.

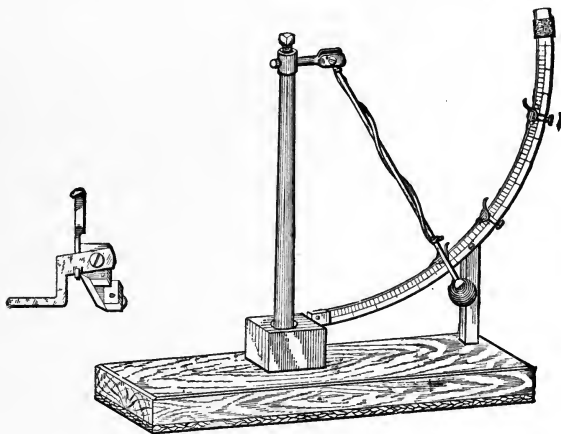

FIG. 23.

A graduated arc, attached to the base of the instrument, shows the angle through which the pendulum falls. Since the intensity of the sound produced is directly proportional to the height of fall, or (what in this case is the same thing) to the square of the sine of half the arc through which the pendulum swings, we can readily calculate the relative intensities of the sounds employed by the formula $i = \sin^2 \frac{\theta}{2}$, where θ is the angle at which the pendu-

lum is set for the experiment. To ensure accuracy of adjustment, the pendulum is not dropped by hand, but released by a mechanical device. The releases (three in number) slide up and down upon the graduated arc, and can be fixed at any height; their manipulation is easy, and they can be turned back, out of use, when not wanted. The sounds must be bright, clear-cut, without resonance. We therefore wind a piece of small rubber tubing round the pendulum rod, push a piece of sponge rubber over the free end of the metal arc, and set the base of the instrument upon layers of thick felt. With these precautions the pendulum ought, if it is well constructed, to give us sounds that vary in intensity, but show no differences of quality and no after-effects.

If we term the sound produced by a fall through 10° the intensity 1, we find by our formula that the sounds produced by a fall through 20° , 30° , 40° , 50° , 60° are roughly 4.0, 8.8, 15.4, 23.5, 32.9. Suppose that we are working between the limits 30° and 60° . We have a stimulus difference of 8.8 to 32.9; or, if we make 30° our unit, a difference of 1 to (approximately) $3\frac{3}{4}$. Corresponding to this stimulus difference is a sense distance, beginning with a relatively weak or faint, and ending with a relatively strong or loud sound. Our problem is, now, to find a stimulus intensity that lies midway, for sensation, between 8.8 and 32.9 or between 1 and $3\frac{3}{4}$. Call the given sense distance \overline{ac} . We are to divide this into the two equal sense distances \overline{ab} and \overline{bc} . There are various ways in which we may seek to accomplish our purpose.

(1) The most natural way, perhaps, is to apply to our present problem the principle of the method of limits. Let r_3 and r_1 , of which r_3 is the greater, represent the two extreme heights of fall. Then we choose an intermediate height of fall, r_v (v = variable), that gives a sound which is clearly too loud. Taking the stimuli always in the order r_3 , r_v , r_1 , we decrease r_v by small steps until we reach the point at which the upper sense distance (the difference between the strongest and the variable stimulus) just ceases to appear smaller than the lower sense distance. The scale value is recorded as r'_d (d = descending), with the corresponding judgment of ? or =. We do not stop the series at this point, but continue to decrease r_v , until we reach the point at

which the upper sense distance first appears larger than the lower. The scale value is recorded as r''_a , with the corresponding judgment of $>$. Here the \downarrow series ends. Now the experiment is reversed. We start with an r_v that gives a sound which is clearly too weak, and (still taking the three stimuli in the order r_3, r_v, r_1) increase r_v by small steps until we reach the point at which the lower sense distance just ceases to appear smaller than the upper. The scale value is recorded as r'_a (a = ascending), with the corresponding judgment of $? \text{ or } =$. The series is continued to the point at which the lower sense distance first appears larger than the upper. The scale value is recorded as r''_a with the corresponding judgment of $>$.

The four values of r_v which we have thus obtained are determined by help of the formula on p. 81. Their average gives us r_2 or the r_v required; the most probable value of the stimulus which lies midway, for sensation, between r_3 and r_1 , — the stimulus whose sensation b bisects the given sense distance \overline{ac} .

So far, however, we have worked only in the time order r_3, r_v, r_1 . To eliminate a possible constant error of time, we must now give the stimuli in the order r_1, r_v, r_3 . We determine the values of r'_a, r''_a, r'_a, r''_a , as before, and average them to an r_2 .

Each of these experiments should be repeated 6 times. The 12 r_2 are averaged to a final value, and the MV is recorded as a measure of precision.

The final value found for r_2 gives us an intermediate stimulus that should be free of constant errors, and is as free of variable errors as we can make it in the time at our disposal. Let its intensity be x . We then have the equation: the sense distance corresponding to $x - 8.8 =$ the sense distance corresponding to $32.9 - x$. Or, with 30° as our unit of stimulus: the distance $x - 1 =$ the distance $3\frac{3}{4} - x$. If x is the arithmetical mean of the two extremes, *i. e.*, if in the last equation it is (approximately) 2.37, we have found that equal sense distances correspond to equal differences of stimulus intensity. If x is the geometrical mean of the two extremes, *i. e.*, if it is (approximately) 1.9, we have found that equal sense distances correspond to relatively equal differences of stimulus intensity.

It need hardly be said that precisely the same rules must be followed here as were prescribed in previous experiments for the method of limits. The single series must be short. The starting-point of the series should be varied; but every \downarrow series should be matched by an \uparrow series of approximately the same length. The size of the steps should be kept constant within each paired series. And so on.

We must take care that practice is evenly distributed, both over the two directions (\downarrow , \uparrow) and over the two time orders. The schema of an experiment thus takes shape somewhat as follows :

| Series | Time order | Direction |
|--------|---------------|--------------|
| 1 | $r_3 r_v r_1$ | \downarrow |
| 2 | $r_3 r_v r_1$ | \uparrow |
| 3 | $r_1 r_v r_3$ | \uparrow |
| 4 | $r_1 r_v r_3$ | \downarrow |
| 5 | $r_1 r_v r_3$ | \uparrow |
| 6 | $r_1 r_v r_3$ | \downarrow |
| 7 | $r_3 r_v r_1$ | \downarrow |
| 8 | $r_3 r_v r_1$ | \uparrow |

Three experiments of this sort furnish the 12 required determinations of r_2 .

(2) We may also employ the method of limits in its alternative form. The essential point in this procedure is that r_v is not varied continuously in one direction, but is taken at haphazard, now weak now strong, now nearer r_3 or nearer r_1 , now precisely midway (arithmetically or geometrically) between r_3 and r_1 . O never knows what to expect, and cannot, therefore, be biassed or expectant. The sounds may come in the order r_3, r_v, r_1 or in the order r_1, r_v, r_3 , and r_v may lie at any point between the extremes. In the particular case, O has to judge of r_v as too high, too low, or middle: the judgment ? is also allowed.

E accordingly makes out a plan of experimentation beforehand. He first determines the limits within which r_v shall be varied. No rule can be given, except that it is better to take the limits too wide than too narrow. He next determines the size of his steps. These may be wider toward the limiting values of r_v , narrower toward the region of the means. Like the values of r_v itself, they should be disposed symmetrically about this region. Then he determines the number of experiments to be made with each value of r_v . He need make but few (say, 5) with the outlying values; he must make more (say, 10) in the middle region, *i. e.*,

from a point somewhat below the geometrical to a point somewhat above the arithmetical mean. Finally, he makes out his haphazard series. Their arrangement is not to be left wholly to chance: for it is important (*a*) that the time order (r_1, r_v, r_3 , and r_3, r_v, r_1) be frequently changed; (*b*) that the values of r_v in two successive observations be not too near together; and (*c*) that the arrangement of the observations in any single series be exactly reversed in some subsequent series. The first two rules explain themselves; the object of the third is to compensate the possible influence upon judgment of the observation (or observations) immediately preceding. These directions are more formidable in statement than they are in actual work.

The results are thrown into tabular form. The first column of the Table shows the values of r_v employed, from the lowest to the highest, as calculated by the formula on p. 81. The next three columns give, under the general rubric \uparrow (time order r_1, r_v, r_3), the number of judgments for l (r_v too low), m (r_v in the middle, or the relation of the two sense distances doubtful) and h (r_v too high). The next three columns give, similarly, under the general rubric \downarrow (order r_3, r_v, r_1), the number of judgments for l, m and h . A final column, headed n , shows the number of observations taken with each value of r_v .

The first thing to do, by way of calculation, is to halve the m cases between the l and h cases of the same horizontal line. We thus obtain $l' = l + \frac{m}{2}$, $h' = h + \frac{m}{2}$. The proceeding is justifiable on the ground that the difference between an m and an h or l judgment is quantitative only, not qualitative; the just discriminable l and h cases are less different from the m cases than they are from one another. The arithmetical means of the h' and l' under the two rubrics \uparrow and \downarrow are then determined, and expressed as percentages. We thus get a second Table, of three columns: the first gives, as before, the values of r_v , the second the percentages of l' judgments, and the third the percentages of h' judgments corresponding to these values.

The subjective mean between r_1 and r_3 lies, evidently, at the value of r_v for which $l' = h' = 50\%$. It is not likely that we shall have struck this precise point in our experiments. In all

probability, we shall find, for two successive values of r_v in the central region, some such relation as this :

| | l' | h' |
|-----------|------|-------|
| $r_v = x$ | 52.5 | 47.5 |
| $r_v = y$ | 40.0 | 60.0, |

from which we can see that the subjective mean between r_1 and r_3 is an r_v that lies between x and y , but cannot tell precisely what value should be assigned to r_2 . If, now, we term the l' respectively l'_x and l'_y , and the h' similarly h'_x and h'_y , we can determine the required r_2 by the formula :

$$r_2 = \frac{x(50 - l'_y) + y(l'_x - 50)}{l'_x - l'_y} = \frac{y(50 - h'_x) + x(h'_y - 50)}{h'_y - h'_x}.$$

We thus obtain, though by a different procedure, the same principal test-value that was afforded by the first form of the method. The second form, unfortunately, does not yield a measure of precision, corresponding to the *MV*.

It was suggested above that 10 observations be taken in the central, and 5 in the outlying regions. If time allow, the experiment should be continued until these numbers have been raised to 50 and 25 respectively.

(3) We said at the outset that there were various ways of attacking the problem of this §. Two of these we have now discussed. Another, though only a preliminary method is, as was remarked at the beginning of the §, the method of group arrangement which we employed in Exps. XI., XII. By this method we are able to determine not only the values of the various intermediate *R*, but also the *MV* of each group.

If we do not possess the instruments required for work with the method of limits, we may equate two sense distances, very simply, by a method of adjustment, *i. e.*, by a method akin to the method of average error. We may, *e. g.*, take squares of black and white cardboard, and seek in a series of trials to paint with Indian ink a grey that shall lie midway for sensation between the two extremes of brightness. The photometric values of the middle greys can then be determined (either directly, or after equation to a grey disc) by the Kirschmann photometer. The simplicity of such a method is, however, offset by its roughness and unreliability.

Finally, we may use for the determination of r_2 a form of the method of constant R -differences which we discuss in § 22. This method furnishes a measure of precision.

EXPERIMENT XVIII

The Application of the Method of Equal Sense Distances to Intensities of Sound.—MATERIALS.—Sound pendulum. Soundless metronome.

GENERAL DIRECTIONS.— E must first of all select his two limiting sensations, above and below. The interval between them should be as wide as possible. At the same time, they must appeal to O as 'going together,' as constituting points upon one and the same sound scale. If the weaker sound seems flat, dull, dead, 'curiously' weak: or if the louder sound seems surprisingly, startlingly loud or emphatic: the limits have, for this O at this stage of practice, been drawn too widely.

When the limiting intensities have been chosen, preliminary experiments are made to determine the region of the sound scale within which, for O 's sensation, the mid-intensity lies. The result will be quite rough.

E may then proceed to the regular series. O sits with closed eyes, about 1 m. from the pendulum, and gives his maximal attention to each triple impression as it comes. The three R are sounded at 1.5 sec. intervals (measured by the metronome). The interval between observation and observation will depend upon E 's handiness with the instrument: it should be kept constant. A pause of some min. is made after each series.

Practice experiments, for warming up, must be taken at the beginning of every laboratory session.

If time permits, both forms of the method should be employed.

EXPERIMENT XIX

The Application of the Method of Equal Sense Distances to Brightnesses.—There are various ways of performing this experiment. We will first of all describe the manner in which it was originally made by Delbœuf.

MATERIALS.—(1) Delbœuf disc. Colour mixer. Metal pro-

tractor. Dark box. Head-rest. [The Delbœuf disc, in its first form, is shown in Fig. 24. The centre piece *A*, 10 cm. in diam., is composed of two discs of cardboard with a cardboard star of

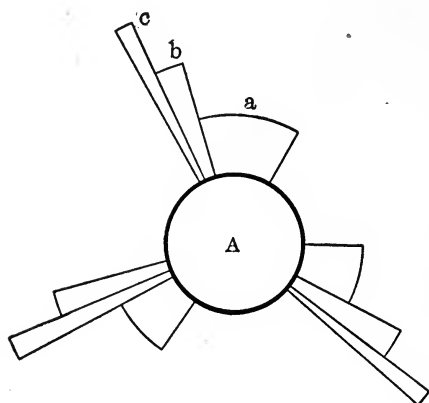

FIG. 24.

the same diam. pasted between them; its edges present a series of slits, in which the sectors *a*, *b*, *c*, etc., may be inserted. The face of *A* is covered with black velvet. The radii of the white cardboard sectors *a*, *b*, *c*, etc., increase, from *A* outwards, in steps of 23 mm.; so that the extreme diameter of the compound disc is 23.8 cm. The sectors themselves have their degree-values

marked on their backs, and a sufficient number of them is cut to produce all the arcs between 1° and 360° of white.

It is, however, not worth while to reproduce the Delbœuf disc in this particular form. A great many sectors must be cut; the sectors become worn and dirty from much handling; and, at the best, a sector is likely to fly out of *A* and get broken during the course of a series. It is better to cut in one piece a cardboard disc composed of *A* and of the *a* and *c* sectors, and in another piece a triple *b* sector, and to mount the latter behind the former on the colour mixer. We then have, if *A* be covered with black and the compound disc rotated before a dark chamber, three grey rings, the inner and outer of which (corresponding to the *a* and *c* sectors) are constant, while the middlemost (corresponding to the *b* sectors) is variable, according as the triple *b* sector is pushed behind the *c* sectors or drawn out from them. Here are the conditions for work with the method of equal sense distances.—We must, of course, have more than one of the *Aac* discs, if we are to vary the limits between which the experiment is taken.

Delbœuf's dark box is shown in Fig. 25. It consists of a

blackened wooden box $ABCD$, $65 \times 50 \times 50$ cm., at the back of which is placed obliquely a board CE faced with black velvet. The box is so disposed that the light from the window at L

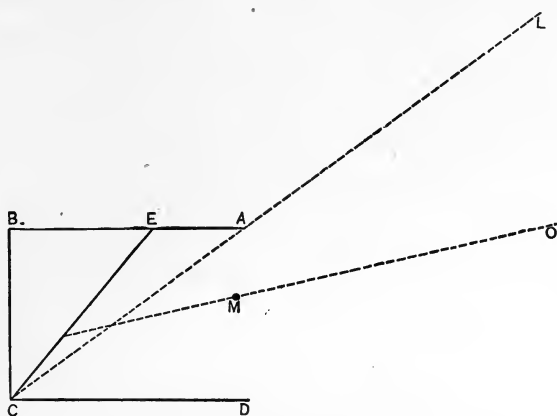

FIG. 25.

does not fall directly upon CE . The disc stands in the opening of the box, with its centre at M ; the observer is at O .—The tube of the Kirschmann photometer will answer the same purpose as this dark box.]

(2) Delbœuf disc. Colour mixer. Protractor. Kirschmann photometer. Head-rest. [The Delbœuf disc may also be constructed as shown in Fig. 26. Upon a disc of white cardboard are pasted two black sectors, corresponding to a and c of Fig. 24. Over the disc is laid a separate black sector, corresponding to b of the former Fig. On rotation, three grey rings appear; the middle-most may be varied.]

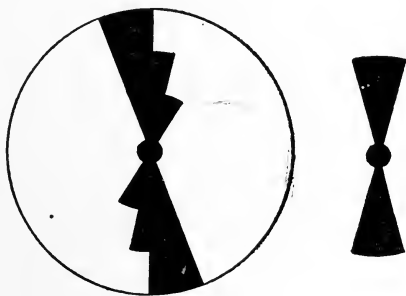

FIG. 26.

The middle sector is shown both separately and in position.

(3) Three colour mixers. Six small discs, three black and three white. Three backgrounds, two constant and one variable. Head-rest with observation tube. Protractor. Kirschmann

photometer. [If one were asked to suggest a procedure for this experiment, it would perhaps seem most obvious to take three mixers; to mount upon each one a compound disc of black and white; to stand the three mixers side by side in the same straight line; and then to set the right and left hand greys at a constant value, and to vary the middle grey as the method requires. The difficulty would, however, at once arise that the three greys must be seen against a background; and that, if the background is the same for all, contrast effects are produced which vary from disc to disc and are not eliminable by any change of position. It is necessary, therefore, that each disc be viewed against a background of its own brightness. An arrangement that fulfils this condition is shown in Fig. 27. The discs are placed in the

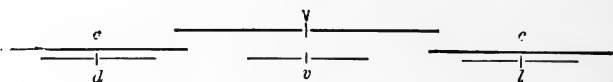

FIG. 27.

order darker (d), variable (v), lighter (l). Behind d and l stand constant backgrounds c of grey paper, matched to the brightness of the discs. Behind v stands the large compound disc V , which is varied as v is varied. In another arrangement, recourse is had to the triple mixer shown in Fig. 28. The three large discs serve as the backgrounds, before which the mixers that carry the small discs are set up.]

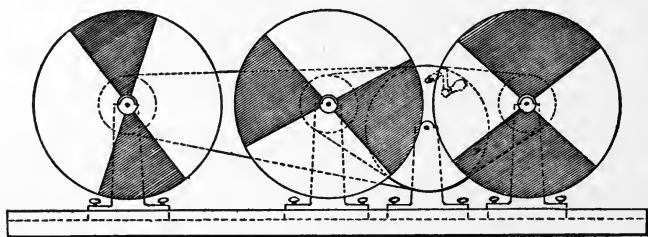

FIG. 28.

GENERAL DIRECTIONS.—As regards choice of limits, preliminary experiments, and warming-up series, the same rules obtain for this exp. as for Exp. XVIII. Note that the time error of Exp. XVIII is here replaced by a space error. We cannot elim-

inate this error with the disc employed in (1), because we cannot put the lightest ring on the outside; we can, however, by a slight modification, bring the darkest ring to the periphery of the disc used in (2); and we can interchange the extreme discs of arrangement (3).

(1) One of the three sectors of the triple piece b is graduated at the back in 0.5° units. The unit of serial change is thus 1.5° . The final reading, at the end of a series, is taken with the protractor.

(2) If we regard the black of the Delbœuf box or the Kirschmann tube as representing the 0 of light intensity, we may report the result of (1) in degrees of white. If, however, we employ the second form of the Delbœuf disc, or the three mixers of (3), we must reduce our results to their photometric values by aid of the Kirschmann photometer: see p. 37 above.

(3) It is very important that the discs and backgrounds of this experiment be uniformly lighted. Hence one has practically no choice but to work in the dark room. O is seated at a low table facing the discs, and observes them through a truncated cone of black cardboard. The source of illumination (*e.g.*, a row of Welsbach burners) is then placed before a white screen upon a stand or table erected above that at which O sits.

The triple mixer of Fig. 28 may be run by an electric motor placed in an adjoining room.

In the observations of (1) and (2), O sits at a distance of about 1 m. from the disc. The distance of O from the three discs of (3) must be regulated by circumstances.

If time permits, both forms of the method should be employed.

QUESTIONS.— E and O (1) Discuss the relative advantages and disadvantages of the two forms of the Method of Limits, as employed for the equation of two sense distances.

(2) What are the principal sources of error in the Method of Equal Distances?

(3) Discuss the validity of rule (*c*), p. 85.

(4) Criticise the method of reduction of l, m, h to l', h' .

(5) Criticise the formula, p. 86.

(6) The second form of the method of limits does not yield a measure of the precision of r_2 . Does it tell us anything at all of the variability of this value?

(7) Discuss the means proposed for the elimination of the constant error of time.

(8) Suggest modifications of the method.

(9) Give a full introspective account of your method of estimating the two sense distances presented.

(10) How would you change the disc of Exp. XIX. (2) for elimination of the space error?

(11) Is there any specific source of error in Exp. XIX. that does not affect the results of Exp. XVIII.?

(12) Which of these exps. is the easier for *O*? Why?

(13) Suggest further experiments by the Method.

§ 20. **The Method of Constant Stimuli (Method of Right and Wrong Cases).**—The method which we are now to discuss, is, in a way, the direct opposite of the Method of Limits. In seeking to determine an *RL* by that method, we vary the *R* until we obtain a certain limiting judgment, the form of which we have settled beforehand. In seeking to determine an *RL* by the Method of Constant Stimuli, we keep the *R* the same, throughout the experiment, and let the judgments vary as they will under the influence of variable and accidental errors. At the end of the experiment, we group the judgments into classes, and from the law of their distribution (the relative number in each class) ascertain, by mathematical means, the amount of *R* which corresponds to the *RL* required. In the one method, then, stimuli vary and judgments are constant; in the other, judgments vary and stimuli are constant.

We may illustrate the procedure by reference to work in æsthesiometry. Suppose that we wish to determine the 'space limen,' or limen of dual impression, for the lower eyelid. The first thing to do is to make out a graduated series of stimuli, *i. e.*, of 'distances,' or separations of the compass-points. The series begins with a distance $D = 0$; that is to say, only one compass-point is employed. It ends with a *D* so large that *O* always (or nearly always) gives the judgment 'two points' when the stimulus is applied. The value of this upper *D* must be ascertained by preliminary experiments. In the particular case before us, the series has been worked out as follows:

| | | | | | | | | | |
|---------------------------------|---|----------------|----------------|----------------|----------------|----------------|---|-----------------|-----------------|
| <i>D</i> in Paris lines | 0 | 0.5 | 1 | 1.5 | 2 | 3 | 4 | 5 | 6 |
| <i>D</i> in mm. (approximately) | 0 | $1\frac{1}{8}$ | $2\frac{1}{4}$ | $3\frac{3}{8}$ | $4\frac{1}{2}$ | $6\frac{3}{4}$ | 9 | $11\frac{1}{4}$ | $13\frac{1}{2}$ |

Other series would do as well: we might take, *e. g.*, 0, 1, 2, 3, 4, 6, 8, 10, 12 mm. The series quoted has, however, been actually employed.

Each one of these 9 stimuli, mixed in haphazard order, is to be set down upon the skin, say, 100 times. *O*'s judgment of the same stimulus will vary, from one observation to another, as the influence of the accidental errors varies. Three forms of judgment are open to him: 'two points,' 'one point,' 'doubtful;'; they are entered upon his record sheet as 2, 1, ?. At the end of the experiment, *E* determines for each stimulus the relative number or percentage of cases in which these three judgments have occurred. Thus, in the investigation already cited, the relative number of two-point judgments was as follows:

| | | | | | | | | | |
|-------------------------|------|------|------|------|------|------|------|------|-------|
| <i>D</i> in Paris lines | 0 | 0.5 | 1 | 1.5 | 2 | 3 | 4 | 5 | 6 |
| Two-point judgments | 0.30 | 0.10 | 0.14 | 0.40 | 0.65 | 0.80 | 0.87 | 0.96 | 1.00. |

This means, *e. g.*, that with a *D* of 3 Paris lines *O* said 'Two' in 80% of the observations, while in the remaining 20% he said 'One' or 'Doubtful.'

These are the results that the Method of Constant Stimuli furnishes. We have now to find some way of turning them to account for a determination of the *RL* and of its variability.

(1) *Inspection of Results: the Course of the Two-point Judgments.*—The limen of dual impression upon the skin, like all other psychophysical limens, is a variable magnitude, subject to the influence of accidental errors. And the values found for it, like the values found for the other limens, obey a certain law of distribution, may be arranged on a certain scheme of frequencies. The precise formulation of this law depends, of course, upon the special conditions of experiment. In general, however, it may be represented graphically by a curve of the form shown in Fig. 29. The values of the abscissas, from 0 onwards, here stand for the various separations *D* of the compass-points. The curve is the curve of distribution of the values found for the *RL*: that is to say, the ordinate drawn vertically to meet the curve from any given point upon the line of abscissas represents the probability (and therefore, in a long series of experiments, the relative fre-

quency) of the case that the RL corresponds to that particular D -value. Hence the area $o D_1 p_1 p_0$ represents the probability (relative frequency) of the case that the RL is $< D_1$, *i. e.*, that the stimulus D_1 evokes the two-point judgment. Similarly, the area $o D_2 p_2 p_0$ represents the probability (relative frequency) of

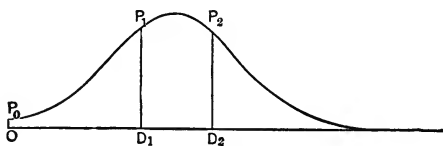

FIG. 29.

the case that the RL is $< D_2$, *i. e.*, that the stimulus D_2 evokes the two-point judgment: and so on. The RL is not a fixed value; it is subject, in the single observation, to the play of all sorts of accidental errors.

The curve drawn in Fig. 29, schematic though it is, enables us to estimate at a glance the value of a series of results obtained by the method now under discussion. We see that, as D increases, the curve first rises to a maximal height, and then gradually falls again to meet the axis of abscissas. This means that our percentages of two-point judgments (p. 93) should increase, at first quickly and then more slowly, with increase of D , until finally a point is reached at which no other judgments are recorded. A really first-rate set of results will, as a matter of fact, evince this uniformity.

The results which we have quoted diverge at two points from the ideal law of distribution. Notice, first of all, that the 30% of two-point judgments for $D=0$ is altogether anomalous. This value of D ought to have given (and in good experimental series does give) a percentage of two-point judgments that is less than the percentage found with the lowest positive value of D . In the present instance, it gave more than twice as many two-point judgments as were recorded for $D=1$ Paris line. A divergence of this sort, where the percentage of two-point judgments for a given D is the same as (or greater than) the percentage value for the next larger D , is termed an *inversion of the first order*. We have every reason to suppose, from the figures,

that the experimental procedure with $D = 0$ varied in some way from the procedure followed with the other, positive D -values: perhaps the pressure of the single point was stronger than that of the two points; perhaps some misleading suggestion was given to O . We cannot say what the error was, but we may be sure that an error was involved; and we must accordingly leave the percentage for $D = 0$ out of account in our later calculations.

Notice, secondly, that the difference between 0.87 and 0.96 ($D = 4$ and 5 Paris lines) is not less, but somewhat greater, than the difference between 0.80 and 0.87 ($D = 3$ and 4). The differences of the successive percentage values, between the limits $D = 0.5$ and $D = 6$, are 0.04, 0.26, 0.25, 0.15, 0.07, 0.09, 0.04. With the one exception of the 0.09 following the 0.07, the sequence is perfectly regular. A divergence of this sort—where, as D increases, the percentage of the two-point judgments increases at first with diminishing and then with increasing rapidity, —is termed an *inversion of the second order*. The inversion is here so slight that we need not reject the results affected by it. At the same time its presence is an indication of some fault of procedure, on the part of E or of O .

Expressed in terms of Fig. 29, an inversion of the second order evidently means that the curve of distribution, instead of running smoothly and evenly, drops down, at some point of its course, towards the axis of abscissas, and then rises again to resume its normal progress. An inversion of the first order means that the curve falls at some point as low as the axis of abscissas (or even below that axis), and then rises again to run its course above it.

(2) *Calculation of the RL: First Procedure.*—The RL corresponds, by definition, to that value of D which calls forth 50% of two-point judgments, and 50% of one-point or doubtful judgments. Our results show that $D = 1.5$ gives 40%, while $D = 2$ gives 65% of two-point judgments. Plainly, then, the liminal D lies somewhere between the limits 1.5 and 2.0 Paris lines. Let us represent by D_a the D that gives the least relative number of two-point judgments > 0.5 ; by D_b the D that gives the greatest relative number < 0.5 ; and by n_a and n_b the corresponding relative numbers of the two-point judgments themselves. We

thus obtain the formula (already employed in a different connection on p. 86):

$$RL = \frac{D_a(0.5 - n_b) + D_b(n_a - 0.5)}{n_a - n_b}.$$

Working this out, we find:

$$RL = 1.7 \text{ Paris lines.}$$

The formula is not altogether adequate, and not entirely free from arbitrariness (see Question 5, p. 91); so that the result must be considered merely approximative.

If we follow this procedure for the determination of the RL , we have unfortunately no means of measuring its variability; the formula does not yield a measure of precision. We may, however, attempt roughly to determine whether the curve of distribution of the accidental values of the RL is symmetrical or asymmetrical. Thus (*a*) we may pick out two D 's that lie at about the same distance above and below the calculated RL , and see whether the corresponding n -values differ by the same or by different amounts from $n = 0.5$. If the differences are approximately the same, the curve of distribution is approximately symmetrical between the D -limits employed; if they are clearly not the same, then the curve is asymmetrical. Thus:

$$\begin{array}{l} \text{for } D = 1.5 = RL - 0.2 \quad \text{and} \quad 2.0 = RL + 0.3, \\ 0.5 - n = \quad +0.10 \quad \quad \quad \text{and} \quad -0.15. \end{array}$$

Or again:

$$\begin{array}{l} \text{for } D = 0.5 = RL - 1.2 \quad \text{and} \quad 3.0 = RL + 1.3, \\ 0.5 - n = \quad +0.40 \quad \quad \quad \text{and} \quad -0.30. \end{array}$$

The first pair of results might stand for symmetry, since the $+0.3$ is slightly greater than the -0.2 . The second term of the second pair, however, is not only not greater,—it is actually smaller than the first term. This means that, in the region of the D 's that are $> RL$, the curve drops toward the axis of abscissas more quickly than it rises from that axis in the region of the smaller D 's. (*b*) The same result comes out if we select two n -values that differ by approximately the same amount, *plus* and *minus*, from 0.5, and compare the differences between the corresponding D -values and the value of the RL . Thus:

$$\begin{array}{l} \text{for } 0.5 - n = \quad +0.40 \quad \text{and} \quad -0.37, \\ RL - D = \quad +1.2 \quad \quad \quad \text{and} \quad -2.3. \end{array}$$

The difference between RL and D in the upper region of the scale is greater (for approximately the same difference between 0.5 and n) than it is in the lower: *i. e.*, again, the curve drops toward the axis of abscissas more quickly in the region of the large D 's than it rises from that axis in the region of the small D 's. Had the $(RL-D)$ -values been approximately the same, we should, on the contrary, have inferred that the curve, between the limits $D = 0.5$ and $D = 4.0$, ran an approximately symmetrical course.

Further than this, towards a knowledge of the variability of the RL , the present procedure cannot take us.

Result (b) is shown still more clearly if we take the two D 's 1.0 and 4.0. We then have:

$$\begin{array}{rcl} \text{for } 0.5 - n & = & +0.36 \quad \text{and} \quad -0.37, \\ RL - D & = & +0.7 \quad \text{and} \quad -2.3. \end{array}$$

Since, however, the value 0.87 for $D = 4.0$ is probably too small (inversion of the second order), it is better to compare it, as we have done, with the value 0.10 for $D = 0.5$.

(3) *Calculation of the RL: Second Procedure.*—We have said that the RL is a variable magnitude. Let us now represent by the same symbol, RL , the median value of the limen of dual impression, and by $\pm \delta$ the magnitude of the accidental variation to which this value is subject; so that the symbol $(RL \pm \delta)$ will stand for the limen of dual impression as affected by accidental errors. A two-point judgment will then be given by O in all cases in which D is $> (RL \pm \delta)$. If we make a long series of experiments with the same D and under the same conditions, we may say that the n corresponding to this D indicates the probability that D is $> (RL \pm \delta)$.

(a) Suppose, now, that D is $> RL$. Then D must be $> (RL \pm \delta)$, first whenever δ is negative, and secondly when it is positive but in absolute magnitude $< (D - RL)$. Since RL is a median value, the probability that δ is negative is = 0.5. The probability that it is positive but $< (D - RL)$ is given by the integral $\int_0^{+(D-RL)} f(\pm \delta) d\delta$, where the term $f(\pm \delta)$ is a general expression for the probability of the occurrence of the magnitude

$\pm \delta$. Hence the probability that D is $>(RL \pm \delta)$ is the sum of these two probabilities: or, in other words, if D is $>RL$ and n consequently >0.5 , the equation holds, for a long series of experiments, that

$$n = \frac{1}{2} + \int_0^{+(D-RL)} f(\pm \delta) d\delta.$$

(b) Suppose, again, that D is $<RL$. Then D will be $>(RL \pm \delta)$ only when δ is negative and in absolute magnitude $>(RL - D)$. The probability of this case is = the probability (0.5) that δ is negative, minus the probability that it is negative and lies between the limits 0 and $-(RL - D)$. In other words, if D is $<RL$ and n consequently <0.5 , the equation holds, for a long series of experiments, that

$$n = \frac{1}{2} - \int_{-(RL-D)}^0 f(\pm \delta) d\delta.$$

(c) Lastly, if $n = 0.5$, D must be regarded as $=RL$.

So far, our equations contain only the indeterminate expression $f(\pm \delta)$. Let us now rewrite them, in terms of Gauss' law of error. We then obtain, as a general formula,

$$n = \frac{1}{2} + \frac{h}{\sqrt{\pi}} \int_0^{(D-RL)} e^{-h^2 \delta^2} d\delta,$$

or, if we make $h\delta = t$,

$$n = \frac{1}{2} + \frac{1}{\sqrt{\pi}} \int_0^{(D-RL)h} e^{-t^2} dt:$$

where the difference $(D-RL)$ is positive, 0 or negative, according as n is $>$, $=$ or <0.5 .

This equation contains precisely the two values which we are seeking to determine: RL , the representative value of the limen of dual impression, and h , the measure of its precision. How are we to solve it?

Let us turn back to our experimental results. We throw out the series for $D=0$, because the $n=0.30$ is anomalous (inversion of the first order). We throw out also the series for $D=6$, because the $n=1$ shows that we have passed beyond the limits of variability of the RL . We are left with the seven D 's 0.5 to

5.0, and with the corresponding n 's. Call the D 's $D_1, D_2, D_3, \dots, D_7$, and the n 's $n_1, n_2, n_3, \dots, n_7$. Our equation enables us to derive from n_1 a definite numerical value t_1 of the product $(D_1 - RL)h$, from n_2 a similar value t_2 of the product $(D_2 - RL)h$, and so on. The following Table gives the values of t for determinate values of n .

FECHNER'S FUNDAMENTAL TABLE

| n | $t = h\delta$ | n | $t = h\delta$ | n | $t = h\delta$ |
|------|---------------|------|---------------|------|---------------|
| 0.50 | 0.0000 | 0.67 | 0.3111 | 0.84 | 0.7032 |
| 0.51 | 0.0177 | 0.68 | 0.3307 | 0.85 | 0.7329 |
| 0.52 | 0.0355 | 0.69 | 0.3506 | 0.86 | 0.7639 |
| 0.53 | 0.0532 | 0.70 | 0.3708 | 0.87 | 0.7965 |
| 0.54 | 0.0710 | 0.71 | 0.3913 | 0.88 | 0.8308 |
| 0.55 | 0.0890 | 0.72 | 0.4121 | 0.89 | 0.8673 |
| 0.56 | 0.1068 | 0.73 | 0.4333 | 0.90 | 0.9062 |
| 0.57 | 0.1247 | 0.74 | 0.4549 | 0.91 | 0.9481 |
| 0.58 | 0.1428 | 0.75 | 0.4769 | 0.92 | 0.9936 |
| 0.59 | 0.1609 | 0.76 | 0.4994 | 0.93 | 1.0436 |
| 0.60 | 0.1791 | 0.77 | 0.5224 | 0.94 | 1.0994 |
| 0.61 | 0.1975 | 0.78 | 0.5460 | 0.95 | 1.1631 |
| 0.62 | 0.2160 | 0.79 | 0.5702 | 0.96 | 1.2379 |
| 0.63 | 0.2347 | 0.80 | 0.5951 | 0.97 | 1.3297 |
| 0.64 | 0.2535 | 0.81 | 0.6208 | 0.98 | 1.4522 |
| 0.65 | 0.2725 | 0.82 | 0.6473 | 0.99 | 1.6450 |
| 0.66 | 0.2917 | 0.83 | 0.6747 | 1.00 | ∞ |

If n is < 0.5 , look in the Table not for n but for $1 - n$, and take t negative. Thus the t for $n = 0.25$ is -0.4769 .

By help of this Table we may write the equations

$$t_1 = (D_1 - RL)h,$$

$$t_2 = (D_2 - RL)h,$$

$$\vdots$$

$$t_7 = (D_7 - RL)h$$

in numerical form, as follows :

$$-0.9062 = (0.5 - RL)h,$$

$$-0.7639 = (1.0 - RL)h,$$

$$-0.1791 = (1.5 - RL)h,$$

$$0.2725 = (2.0 - RL)h,$$

$$0.5951 = (3.0 - RL)h,$$

$$0.7965 = (4.0 - RL)h,$$

$$1.2379 = (5.0 - RL)h.$$

These equations can be solved, for RL and h , by the Method of Least Squares.

So far, so good ! We are not yet, however, out of the mathematical wood. If we were to solve the equations as they stand, we should be making a mistake in theory, and a mistake which is by no means always negligible in practice. We should be proceeding as if t_1, t_2 , etc., were observed values. Now the values really observed are not these t -values, but the n -values. We must, therefore, seek (so to say) to transform the t -values into observed values ; and we may do this by compensating the error which their direct treatment as observed values would involve. We may do it, in other words, by weighting the t -values.

Each of the values n_1, n_2 , etc., has a weight w' proportional to the number of observations upon which it is based. This value w' must for our purposes be multiplied by a coefficient w'' , to be determined from the following Table. Then the products $w'_1 w''_1, w'_2 w''_2$, etc., are the required weights of the values t_1, t_2 , etc.

MÜLLER'S TABLE OF COEFFICIENTS OF WEIGHTS

| n | w'' | n | w'' | n | w'' |
|------|-------|------|-------|------|-------|
| 0.50 | 1.000 | 0.67 | 0.824 | 0.84 | 0.373 |
| 0.51 | 0.999 | 0.68 | 0.803 | 0.85 | 0.342 |
| 0.52 | 0.997 | 0.69 | 0.782 | 0.86 | 0.311 |
| 0.53 | 0.994 | 0.70 | 0.760 | 0.87 | 0.281 |
| 0.54 | 0.990 | 0.71 | 0.737 | 0.88 | 0.251 |
| 0.55 | 0.984 | 0.72 | 0.712 | 0.89 | 0.222 |
| 0.56 | 0.977 | 0.73 | 0.687 | 0.90 | 0.193 |
| 0.57 | 0.969 | 0.74 | 0.661 | 0.91 | 0.166 |
| 0.58 | 0.960 | 0.75 | 0.634 | 0.92 | 0.139 |
| 0.59 | 0.950 | 0.76 | 0.606 | 0.93 | 0.114 |
| 0.60 | 0.938 | 0.77 | 0.578 | 0.94 | 0.089 |
| 0.61 | 0.925 | 0.78 | 0.550 | 0.95 | 0.067 |
| 0.62 | 0.911 | 0.79 | 0.521 | 0.96 | 0.047 |
| 0.63 | 0.896 | 0.80 | 0.492 | 0.97 | 0.029 |
| 0.64 | 0.880 | 0.81 | 0.463 | 0.98 | 0.014 |
| 0.65 | 0.862 | 0.82 | 0.433 | 0.99 | 0.004 |
| 0.66 | 0.843 | 0.83 | 0.403 | | |

The weight of an n which is < 0.5 is the same as the weight of an n which exceeds 0.5 by the same amount. Thus the weights of $n=0.25$ and of $n=0.75$ are both alike = 0.634 .

Since, as a general rule, the values of n are determined from the same number of observations, the weights w' will in most cases all be = 1, and the factor w' in the product $w' w''$ may accordingly be neglected. Let us term this product w . Our equations now become :

$$w_1 t_1 = (D_1 - RL)h,$$

$$w_2 t_2 = (D_2 - RL)h,$$

$$\dots \dots \dots$$

$$w_7 t_7 = (D_7 - RL)h.$$

Or, in numerical form (on the assumption that $w' = 1$),

$$-0.9062 \quad (0.193) = (0.5 - RL)h,$$

$$-0.7639 \quad (0.311) = (1.0 - RL)h,$$

$$-0.1791 \quad (0.938) = (1.5 - RL)h,$$

$$0.2725 \quad (0.862) = (2.0 - RL)h,$$

$$0.5951 \quad (0.492) = (3.0 - RL)h,$$

$$0.7965 \quad (0.281) = (4.0 - RL)h,$$

$$1.2379 \quad (0.047) = (5.0 - RL)h.$$

Treating these equations by the Method of Least Squares, we obtain the normal equations :

$$[D^2 w]h - [Dw]RL.h = [Dtw],$$

$$-[Dw]h + [w]RL.h = -[tw].$$

The squared bracket is here used as the sign of summation : so that

$[D^2 w]$ means $(D^2_1 w_1 + D^2_2 w_2 + \dots + D^2_7 w_7)$; $[Dw]$ means $(D_1 w_1 + D_2 w_2 + \dots + D_7 w_7)$; and so on. A rough solution, with rounding of the fractions to two decimal places, gives :

$$16.05h - 6.37RL.h = 1.96,$$

$$- 6.37h + 3.12RL.h = 0.23;$$

whence we find

$$h = 0.49,$$

$$RL = 1.88.$$

To those who are not mathematically inclined, the last few pages may have appeared somewhat bewilderingly difficult. Let it be said, then, that the *mathematical operations* involved are exceedingly simple. They consist (1) in determining from Fechner's Table the t -values for the given n -values; (2) in determining from Müller's Table the w'' -values for the same n -values; and (3), after the full series of these determinations has been made, in applying the scheme of the Method of Least Squares, as indicated above, to a half-dozen equations that contain two unknown quantities. So far as the calculations go, it is all a matter of simple arithmetic. The *understanding*

of the mathematical argument is another thing. Its general course ought, however, to be intelligible from § 15; and the derivation of the normal equations is explained in detail in the mathematical text-books. Even without an adequate understanding of the argument, the reader should be able to realise the superiority of this second over the first procedure (p. 95). We have determined RL , as we desired; we have also determined h , the measure of precision (p. 44 above); and in so doing, we have utilised not two selected n , but the whole number of n for the different D 's at our disposal, allowing each its proper weight in the final result. The game has been well worth the candle.

EXPERIMENT XX

Determination of the Limen of Dual Impression upon the Skin.

—MATERIALS.—Æsthesiometric compasses. Mm. paper scale.

DIRECTIONS.—Having chosen the part of the skin upon which the RL is to be determined, E ascertains, in preliminary experiments, the value of the upper D . He then makes out a series of R , which should consist of about 10 terms, between the limits 0 and this upper D . The 10 R -values are written upon 10 cardboard tickets; these are shuffled, or shaken in a bag, and the order of their drawing gives the order of the first series of applications.

Each R -value is to be used 50 times over, so that the whole number of applications is 500. E may therefore draught a plan of the complete experiment beforehand. He first makes out 25 series, drawing at haphazard from the bunch of tickets; then inverts these series (writes them backwards); and then shuffles the 50 papers, and works through the series in the resulting haphazard order.

Care must be taken not to fatigue the skin; and warming-up experiments must be given at the beginning of every laboratory session.

QUESTIONS.— E and O (1) Why has this Method of Constant Stimuli received the name of the method of right and wrong cases?

(2) In determining RL and h by our second procedure, we have, after all, used only a part of our results: viz., the two-point judgments. We have done nothing with the one-point and doubtful judgments. Can these outstanding judgments be put to any psychophysical purpose?

(3) At a certain stage of the argument, we assumed that the quantities with which we are dealing were distributed in accordance with Gauss' Law. How can we test this assumption?

(4) In deriving our formulæ for n on pp. 97 f. we spoke of the limen as a variable magnitude, ranging under the influence of accidental errors between the limits $RL - \delta$ and $RL + \delta$; and we regarded D as constant, *i. e.*, as unaffected by the accidental errors. We should arrive at just the same result if we took D as the variable and RL as the constant magnitude. Which is the preferable point of departure for the argument, and why?

(5) We find a certain small percentage of two-point judgments when D is = 0. What is the mathematical expression of this fact?

(6) We have spoken in the text only of the accidental errors $\pm \delta$, whose power to prompt an one-point judgment decreases as D increases. May we suspect the presence of any other kind of accidental errors?

(7) Suggest further experiments by the Method.

§ 21. **The Determination of Equivalent R by the Method of Constant Stimuli.**—We said above (§ 17) that an experiment would presently be assigned in which the Method of Average Error should be employed in a modified form. The problem of that method, it will be remembered, is the equation of two R . A constant stimulus, r , is presented by E , and O is required to make another stimulus, r_1 , subjectively equal to it.

We now undertake the equation of two R by help of the Method of Constant Stimuli. We thus avoid all the complications that arise from O 's active manipulation of r_1 .

MATERIALS.—Münsterberg's apparatus for the comparison of arm movements. [The apparatus, Fig. 30, consists essentially of a car which travels smoothly on three horizontal tracks. The car carries a hollow cylinder of brass for the reception of O 's fore-finger, and a pointer which traverses a scale marked on one of the outer tracks. Two sliding blocks, which can be set at any point along the middle track, mark the beginning and end of the two movements. The stand which supports the tracks is adjustable in height.—Cords run from the two ends of the car,

over pulleys, to weight holders; and the iron standard has a set-screw and slitted arc by means of which the tracks may be set

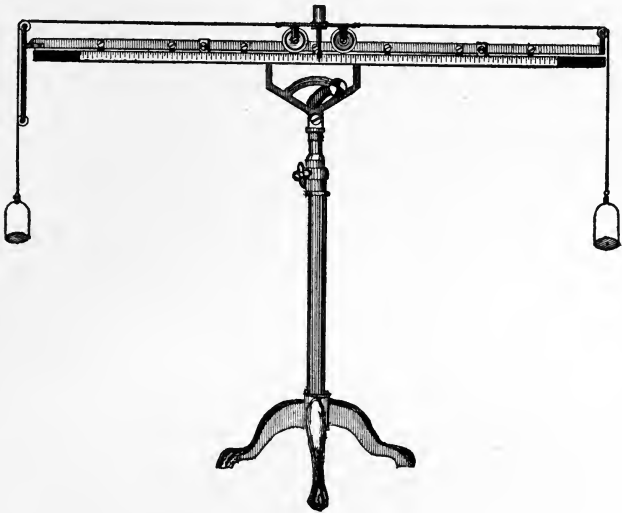

FIG. 30.

obliquely or even vertically. These parts of the apparatus do not now concern us.]

PRELIMINARIES.—*E* adjusts the height of the apparatus so that *O*, standing squarely to it, can move the car without effort. The height of the tracks above the floor is measured, and the position of *O*'s feet and of the feet of the standard is indicated by chalk marks: it is necessary that these determinations remain constant from day to day. The standard distance (say, of 40 cm.) is marked off by the sliders; and the standard stimulus consists always in the movement of the car by *O*, from left to right, between these fixed limits.

EXPERIMENT XXI

Can you now, from what you know of the Method of Average Error and the Method of Constant Stimuli, work out a method for the determination of the subjective equivalent of this standard *r* of 40 cm.-movement? Remember that no adjustments are to be made by *O*. Remember also to guard against constant

errors. Make out a plan of the experiment, as well as you can, and submit it to the Instructor.

QUESTIONS.—*E* and *O* (1) Have you any criticism to offer upon the apparatus?

(2) Is judgment passed purely in terms of kinæsthetic sensations? If not, what other factors enter into it?

§ 22. **The Method of Constant Stimulus Differences (Method of Right and Wrong Cases).**—The object of this Method is to determine the *DL* and its measure of precision, as the object of the Method of Constant Stimuli is to determine the *RL* and its *h*. The procedure in the two cases is strictly analogous. We may illustrate the course of the present method by reference to lifted weights.

We take as our standard, *S*, a weight of, say, 1071 gr. This is the weight whose upper and lower *DL* are to be found. We provide ourselves with a graduated series of weights of comparison, *C*: these may, *e. g.*, be weights of 921, 971, 1021, 1071, 1121, 1171, 1221 gr. One of these is identical with the standard; two differ from it by ± 50 , two by ± 100 , and two by ± 150 gr. The standard weight is to be compared with each of the weights of comparison, taken in haphazard order, 50 times over, and the judgments are to be recorded and classified. *O* judges always in terms of the weight last lifted, or lifted second; and his judgments may take the form 'much greater,' 'greater,' 'doubtful,' 'less,' 'much less.' That is to say, he judges of the second weight lifted in a comparative observation as 'much greater,' 'less,' etc., than the weight first lifted.

The judgments are to be abbreviated on the record sheet as \gg , $>$, $?$, $<$, \ll . If by chance the two weights appear to *O* to be positively equal, the judgment = is to be entered in the record, but the equal-judgments are to be counted with the doubtfuls for purposes of calculation.

Now, however, that we are working with the two *R*, there are two possible time orders: the weight first lifted may be either *S* or one of the *C*'s. If we are to control the constant error of time, the experiment must be performed twice over: once with *S* lifted first, and again with *C* lifted first. Our 50 comparisons

are thus increased, for each C , to 100; we must make in all 700 (not 350) comparisons.—We need not consider here the constant error of space, as it is ruled out by a special arrangement of the apparatus (see p. 116 below).

The results of a complete experiment will resemble those shown in the following Table. The five classes of judgments are here, for simplicity's sake, reduced to three; and the judgments given in the first time order (S first) have been reversed, in order that all judgments alike may refer to S . Thus a $<$ -judgment in the Table means that S was judged as lighter than the C of the same horizontal line; a $>$ -judgment means that S was judged as heavier than the C .

| Weight of Comparison | Standard weight = 1071 gr. | | | | | |
|----------------------|-------------------------------|-----|-----|---------------------------------|-----|-----|
| | Time order I. (S first) | | | Time order II. (S second) | | |
| | $<$ | $?$ | $>$ | $<$ | $?$ | $>$ |
| 921 | 0 | 2 | 48 | 1 | 6 | 43 |
| 971 | 0 | 7 | 43 | 6 | 4 | 40 |
| 1021 | 3 | 18 | 29 | 7 | 19 | 24 |
| 1071 | 13 | 18 | 19 | 17 | 19 | 14 |
| 1121 | 27 | 16 | 7 | 28 | 18 | 4 |
| 1171 | 36 | 11 | 3 | 40 | 9 | 1 |
| 1221 | 47 | 2 | 1 | 43 | 7 | 0 |

(1) *Inspection of Results: the Course of the Judgments.*—The upper and lower DL are variable magnitudes, and the values found for them obey a certain law of distribution, may be arranged on a certain scheme of frequencies. — This law may be

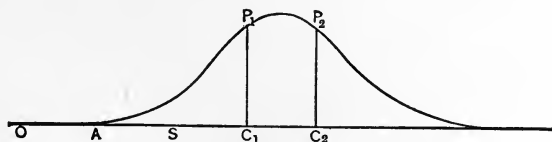

FIG. 31.

represented graphically, for the upper DL , by a curve of the form shown in Fig. 31. The values of the abscissas, from 0 onwards, here stand for the various weights: the line os represents the standard weight or S . The curve is, as we have said, the curve

of distribution of the values found for the upper DL : that is to say, the ordinate drawn vertically to meet the curve from any given point c_1 or c_2 upon the line of abscissas represents the probability (and therefore, in a long series of experiments, the relative frequency) of the case that the DL corresponds to the \pm -difference sc_1 or sc_2 between S and the weight of comparison C . Hence the area $ac_1 p_1$ represents the probability (relative frequency) of the case that a $C=oc_1$ is judged $> S$; and the area $ac_2 p_2$ represents the probability (relative frequency) of the case that a $C=oc_2$ is judged $> S$. A similar construction may be made for the lower DL .

We see that, as C increases, the curve first rises to a maximal height, and then gradually falls again to meet the axis of abscissas. This means that our percentages l of 'less' judgments should increase, at first quickly and then more slowly, with increase of C , until finally a point is reached at which no other judgments are recorded. The figure for the lower DL would show, similarly, that the percentages g of 'greater' judgments should decrease, at first quickly and then more slowly, with increase of C , until finally no such judgments are recorded. If we find that our results show, for some increase of C , no increase of l or decrease of g ,—while the C 's themselves are neither so small that $l=0$ and $g=1$, nor so large that $g=0$ and $l=1$,—we have an *inversion of the first order*. There is no inversion of this kind in the results quoted on p. 107. If we find, under the same conditions, that l increases, or that g decreases, at first with decreasing and then with increasing rapidity, we have an *inversion of the second order*. All four columns of the Table contain an inversion of this second sort.

Let us, first of all, rewrite the Table in percentages. The symbols l (less), u (uncertain), g (greater) replace the original $<$, $?$, $>$. We obtain:

| C | l | u | g | l | u | g |
|------|------|------|------|------|------|------|
| 921 | 0.00 | 0.04 | 0.96 | 0.02 | 0.12 | 0.86 |
| 971 | 0.00 | 0.14 | 0.86 | 0.12 | 0.08 | 0.80 |
| 1021 | 0.06 | 0.36 | 0.58 | 0.14 | 0.38 | 0.48 |
| 1071 | 0.26 | 0.36 | 0.38 | 0.34 | 0.38 | 0.28 |
| 1121 | 0.54 | 0.32 | 0.14 | 0.56 | 0.36 | 0.08 |
| 1171 | 0.72 | 0.22 | 0.06 | 0.80 | 0.18 | 0.02 |
| 1221 | 0.94 | 0.04 | 0.02 | 0.86 | 0.14 | 0.00 |

(1) There is, we said, no inversion of the first order. It is true that we have $l=0.00$ in two cases, in neither of which g is $=1$. This strict parallelism of the course of l and g is, however, not essential. The results are regular when they conform to any one of the three following schemata :

| | | | | | | | | | |
|-------|------|------|------|------|------|------|------|------|-------|
| C | l | u | g | l | u | g | l | u | g |
| $x-y$ | 0.00 | 0.00 | 1.00 | 0.00 | 0.00 | 1.00 | 0.00 | 0.01 | 0.99 |
| x | 0.00 | 0.00 | 1.00 | 0.00 | 0.01 | 0.99 | 0.00 | 0.02 | 0.98, |

the third of which is represented in the Table.—The same thing holds, *mutatis mutandis*, for high values of C that give $g=0.00$. (2) The inversions of the second order become clear as soon as we write out the differences between the successive terms of the four relevant columns. These differences are :

| | | | | | | | | | | | | |
|-----|-----|-----|-----|-----|-----|------|-----|-----|-----|-----|-----|------|
| l | .00 | .06 | .20 | .28 | .18 | .22, | .10 | .02 | .20 | .22 | .24 | .06; |
| g | .10 | .28 | .20 | .24 | .08 | .04, | .06 | .32 | .20 | .20 | .06 | .02. |

The irregularity of the last series is, perhaps, too slight to be properly termed an inversion. The curve rises steeply, drops, and then runs parallel to the axis of abscissas before falling again in the regular manner.

There is a further point which calls for notice. In a perfectly regular set of results, the ?-judgments outlast the <-judgments at the head, and the >-judgments at the bottom of the columns. In this regard, therefore, the Table on p. 107 conforms to rule. In two of the four cases, the < and > judgments have entirely disappeared, while the ? still have the values 7 and 7; in the other two, the ?-judgments have the numerical advantage.

(2) *Calculation of the DL: First Procedure.*—The upper DL corresponds to that value of $D=C-S$ which yields $l=0.5$; the lower DL to that value of $D=S-C$ which yields $g=0.5$. Availing ourselves of the formula given on pp. 86, 96, we find, approximately :

| | | |
|------------------------|--------|--------|
| | DL_u | DL_l |
| Time order I. | 43 | 30 |
| Time order II. | 36 | 53. |

On the basis of these values, we may attempt roughly to determine whether the curves of distribution of the accidental values of the DL are symmetrical or asymmetrical. To this end, we pick out two D -values that lie at about the same distance above and below the calculated DL , and see whether the correspond-

ing l and g values differ by the same amount from l and $g = 0.50$. Thus:

Time order I. The C that gives $0.5 l = 1114$.

$$\text{For } D = 1114 - 1021 = 93, \quad 0.5 - l = .44;$$

$$\text{" } \quad 1221 - 1114 = 107, \quad l - 0.5 = .44.$$

The C that gives $0.5 g = 1041$.

$$\text{For } D = 1041 - 921 = 120, \quad g - 0.5 = .46;$$

$$\text{" } \quad 1171 - 1041 = 130, \quad 0.5 - g = .44.$$

$$\text{For } D = 1041 - 971 = 70, \quad g - 0.5 = .36;$$

$$\text{" } \quad 1121 - 1041 = 80, \quad 0.5 - g = .36.$$

Time order II. The C that gives $0.5 l = 1107$.

$$\text{For } D = 1107 - 971 = 136, \quad 0.5 - l = .38;$$

$$\text{" } \quad 1221 - 1107 = 114, \quad l - 0.5 = .36.$$

$$\text{For } D = 1107 - 1021 = 86, \quad g - 0.5 = .36;$$

$$\text{" } \quad 1171 - 1107 = 64, \quad 0.5 - g = .30.$$

The C that gives $0.5 g = 1018$.

$$\text{For } D = 1018 - 921 = 97, \quad g - 0.5 = .36;$$

$$\text{" } \quad 1121 - 1018 = 103, \quad 0.5 - g = .42.$$

What conclusions are to be drawn from these figures?

(3) *Calculation of the DL: Second Procedure.*—A train of reasoning, precisely analogous to that of pp. 97 f., leads us to the three formulæ:

$$g = \frac{1}{2} - \frac{1}{\sqrt{\pi}} \int_0^{(DL_l \pm D)h_l} e^{-t^2} dt,$$

$$l = \frac{1}{2} + \frac{1}{\sqrt{\pi}} \int_0^{(\pm D - DL_u)h_u} e^{-t^2} dt,$$

$$u = \frac{1}{\sqrt{\pi}} \int_0^{(DL_l \pm D)h_l} e^{-t^2} dt, \\ (\pm D - DL_u)h_u$$

where the sign of D is positive or negative according as C is greater or less than S . The equations contain the four values which we are seeking to determine: DL_u and DL_l , the representative values of the upper and lower difference limens, and h_u and h_l , their respective measures of precision.

Let us write L for DL_p , and U for DL_u ; and let us denote the various measures of precision simply by h . Then we have the equations:

$$\begin{array}{ll} t_1 = (L \pm D_1)h, & t_1 = (\pm D_1 - U)h, \\ t_2 = (L \pm D_2)h, & t_2 = (\pm D_2 - U)h, \\ \cdot & \cdot \\ \cdot & \cdot \\ t_7 = (L \pm D_7)h; & t_7 = (\pm D_7 - U)h; \end{array}$$

which must be worked out twice over, for the time orders I. and II. Referring to Fechner's Fundamental Table (p. 99), we find:

| L_I | U_I |
|------------------------|--------------------------|
| 1.2379 = $(L - 150)h$ | 0.0000 = $(-150 - U)h$ |
| 0.7639 = $(L - 100)h$ | 0.0000 = $(-100 - U)h$ |
| 0.1428 = $(L - 50)h$ | -1.0994 = $(-50 - U)h$ |
| -0.2160 = $(L \pm 0)h$ | -0.4549 = $(\pm 0 - U)h$ |
| -0.7639 = $(L + 50)h$ | 0.0710 = $(+50 - U)h$ |
| -1.0994 = $(L + 100)h$ | 0.4121 = $(+100 - U)h$ |
| -1.4531 = $(L + 150)h$ | 1.0994 = $(+150 - U)h$ |

| L_{II} | U_{II} |
|------------------------|--------------------------|
| 0.7639 = $(L - 150)h$ | -1.4531 = $(-150 - U)h$ |
| 0.5951 = $(L - 100)h$ | -0.8308 = $(-100 - U)h$ |
| -0.0355 = $(L - 50)h$ | -0.7639 = $(-50 - U)h$ |
| -0.4121 = $(L \pm 0)h$ | -0.2917 = $(\pm 0 - U)h$ |
| -0.9936 = $(L + 50)h$ | 0.1068 = $(+50 - U)h$ |
| -1.4531 = $(L + 100)h$ | 0.5951 = $(+100 - U)h$ |
| 0.0000 = $(L + 150)h$ | 0.7639 = $(+150 - U)h$ |

If we weight the t -values, in accordance with Müller's Table (p. 101), these equations become:

| L_I | U_I |
|------------------------------|------------------------------|
| 1.2379(.047) = $(L - 150)h$ | |
| 0.7639(.311) = $(L - 100)h$ | |
| 0.1428(.960) = $(L - 50)h$ | -1.0994(.089) = $(-50 - U)h$ |
| -0.2160(.911) = Lh | -0.4549(.661) = $-Uh$ |
| -0.7639(.311) = $(L + 50)h$ | 0.0710(.990) = $(+50 - U)h$ |
| -1.0994(.089) = $(L + 100)h$ | 0.4121(.712) = $(+100 - U)h$ |
| -1.4531(.014) = $(L + 150)h$ | 1.0994(.089) = $(+150 - U)h$ |

| L_{II} | U_{II} |
|------------------------------|-------------------------------|
| $0.7639(.311) = (L - 150)h$ | $-1.4531(.014) = (-150 - U)h$ |
| $0.5951(.492) = (L - 100)h$ | $-0.8308(.251) = (-100 - U)h$ |
| $-0.0355(.997) = (L - 50)h$ | $-0.7639(.311) = (-50 - U)h$ |
| $-0.4121(.712) = Lh$ | $-0.2917(.843) = -Uh$ |
| $-0.9936(.139) = (L + 50)h$ | $0.1068(.977) = (+50 - U)h$ |
| $-1.4531(.014) = (L + 100)h$ | $0.5951(.492) = (+100 - U)h$ |
| | $0.7639(.311) = (+150 - U)h$ |

From these we obtain the normal equations:

$$\begin{aligned} [D^2w]h - [Dw]DL.h &= [Dtw], \\ -[Dw]h + [w]DL.h &= -[tw]; \end{aligned}$$

which furnish the results:

| | |
|------------------|--------------|
| $L_I = 17.22$ | $h = .0085;$ |
| $L_{II} = 49.82$ | $h = .0094;$ |
| $U_I = 48.38$ | $h = .0094;$ |
| $U_{II} = 28.40$ | $h = .0070.$ |

(1) It is instructive to compare these values with the approximative results on p. 109. We have:

| | |
|-------------------|-----------------------------|
| First procedure: | 30, 53, 43, 36; |
| Second procedure: | 17.22, 49.82, 48.38, 28.40. |

The discrepancy between the two figures that stand for the L_I is startling; but it is accounted for by the fact that the percentages 0.38 and 0.58 selected by the first procedure involve a very distinct inversion of the second order.

(2) If the example given above is worked out, it will be seen that the bracketed sums in the normal equations are always employed as positive values; that is to say, the signs of operation (+, -, +; -, +, -) are retained, no matter whether the sums are intrinsically positive or negative. The measure of precision must, of course, always be a positive quantity (see p. 44 above). Whether the DL be positive or negative depends, not on the outcome of the normal equations, but on the character of the original data. Suppose, e. g.,—the illustration is taken from an experiment actually made,—that we obtained results like these:

| | | | | | | | | | |
|-----|-------|-------|-------|-------|------|-------|-------|-------|-------|
| D | -69.4 | -53.8 | -37.0 | -19.5 | 0 | +20.0 | +39.7 | +60.3 | +80.7 |
| g | 0.99 | 0.95 | 0.88 | 0.73 | 0.51 | 0.31 | 0.16 | 0.05 | 0.01. |

Here the lower DL lies, not in the range of the *minus-D's* at all, but somewhere between $D=0$ and $D=+20$! The normal equations for the data give $L=2.40$, $h=0.0200$; and we read the 2.40 as '*minus 2.40*' because the data show that the liminal D lies on the wrong side of the $D=0$.

(4) *The Fechnerian Time Error.*—Our four DL -values are all affected by the time error. The Fechnerian time error, p , is supposed to be the same in absolute amount, but different in sign, in the two time orders. It is, further, termed ‘positive’ when its effect is to enhance the value of the R first presented, ‘negative’ when its effect is to increase the subjective value of the R last presented. In the case before us, a positive error would accordingly make $U_I > U_{II}$, and $L_I < L_{II}$. This is what we find.

To eliminate p , we write :

$$DL_u = \frac{U_I + U_{II}}{2} = 38.39 \text{ gr.};$$

$$DL_l = \frac{L_I + L_{II}}{2} = 33.52 \text{ gr.}$$

To determine p :

$$\begin{aligned} 2p &= U_I - U_{II} \text{ or } L_{II} - L_I, \\ p &= +9.99 \text{ or } +16.30; \\ \text{av. } p &= +13.145. \end{aligned}$$

(5) *Consideration of the Results.*—Are these results satisfactory? Let us see, first of all, whether the limens conform at all closely to the requirements of Weber’s Law. We have :

$$DL_u = \frac{38.39}{1071} = \frac{1}{27.89};$$

$$DL_l = \frac{33.52}{1071 - 33.52} = \frac{1}{30.95}.$$

The agreement between $\frac{1}{28}$ and $\frac{1}{31}$ is, perhaps, all that we could expect in view of the small number of the experiments. On the other hand, the p -values are suspicious; it is difficult to regard 9.99 and 16.3 as even approximately ‘equal.’ Fortunately, we have a very simple way of finding out whether the average 13.145 adequately represents the time error. For, in terms of this and of the other averages just drawn,

$$L_I = (33.52 - 13.145), \text{ with an } h \text{ of } .0085;$$

$$L_{II} = (33.52 + 13.145), \text{ with an } h \text{ of } .0094;$$

$$U_I = (38.39 + 13.145), \text{ with an } h \text{ of } .0094;$$

$$U_{II} = (38.39 - 13.145), \text{ with an } h \text{ of } .0070.$$

Now, by substituting these figures for the symbols in the right-hand members of the equations on pp. 111f, we shall obtain a

series of t -values whose n may be discovered by reference to Fechner's Fundamental Table. A comparison of the calculated with the observed n will show at once whether our mathematical procedure has been adequate or inadequate. The results of the substitution are as follows :

| n obs. | L_I n cal. | Diff. | n obs. | L_{II} n cal. | Diff. |
|----------|-------------------|-----------|----------|----------------------|-----------|
| 0.96 | 0.94 | -.02 | 0.86 | 0.92 | +.06 |
| 0.86 | 0.83 | -.03 | 0.80 | 0.76 | -.04 |
| 0.58 | 0.64 | +.06 | 0.48 | 0.48 | \pm .00 |
| 0.38 | 0.40 | +.02 | 0.28 | 0.27 | -.01 |
| 0.14 | 0.20 | +.06 | 0.08 | 0.10 | +.02 |
| 0.06 | 0.07 | +.01 | 0.02 | 0.03 | +.01 |
| 0.02 | 0.02 | \pm .00 | 0.00 | 0.01 | +.01 |
| | U_I | | | U_{II} | |
| 0.00 | 0.01 | +.01 | 0.02 | 0.04 | +.02 |
| 0.00 | 0.02 | +.02 | 0.12 | 0.11 | -.01 |
| 0.06 | 0.09 | +.03 | 0.14 | 0.23 | +.09 |
| 0.26 | 0.25 | -.01 | 0.34 | 0.40 | +.06 |
| 0.54 | 0.51 | -.03 | 0.56 | 0.60 | +.04 |
| 0.72 | 0.74 | +.02 | 0.80 | 0.77 | -.03 |
| 0.94 | 0.90 | -.04 | 0.86 | 0.89 | +.03 |

The discrepancies, though obvious enough, are not so large that they may not be accounted for by the small number of experiments.

So far as our analysis has gone, therefore, we have no reason for dissatisfaction. We set out from a small group of data,—not such a group as would be acquired in the progress of an investigation, but rather such a group as might be obtained in a few hours of laboratory work. Despite the small number of the experiments, we have found upper and lower (relative) DL which afford a rough confirmation of Weber's Law, and we have found a value for the positive time error which is at any rate approximately representative of the true value. It should go without saying that these results presuppose extreme care on the part of E , and extreme conscientiousness (together with some preliminary practice in the judgment of weights) on the part of O .

EXPERIMENT XXII

The Determination of the DL for Intensity of Sound.—MATERIALS.—Sound pendulum. Soundless metronome.

PRELIMINARIES.—*E* is to choose his standard, and to make out a list of 7 variable *R*. One of these r_1 is identical with *r*; the remaining 6 are to be distributed symmetrically about *r*, above and below. Their values must be such that the two extreme r_1 , the loudest and the faintest sounds, are hardly ever confused by *O* with *r*, the standard sound. If, *e. g.*, the standard *r* is given by a fall of the pendulum through 45° , the series of variables might perhaps be taken as $60^\circ, 55^\circ, 50^\circ, 45^\circ, 39^\circ, 32^\circ, 24^\circ$.¹ Each of these r_1 is to be compared with *r*, in both time orders, 50 times over; so that the whole number of comparisons will be 700. *E* should make out a plan of the complete experiment beforehand.

The limiting values of r_1 are determined in preliminary experiments, which will therefore take some time, and require to be carefully made. Warming-up series must be given at the beginning of every laboratory session.

EXPERIMENT XXIII

The Determination of the DL for Lifted Weights.—This may be regarded as the classical experiment of quantitative psychology. On the psychophysical side, it has engaged a long line of investigators: Weber himself, Fechner and Hering, all employed it to test the validity of Weber's Law; and a glance at the current magazines will show that the work begun by them has continued down to the present day. On the psychological side it has been made by L. J. Martin and G. E. Müller the vehicle of a qualitative analysis of the sensory judgment, the most elaborate and penetrating that we have. Hence it is fitting that the experiment should have been reserved to the last, and that we should now approach it in the light of everything that we have learned, whether as *E* or as *O*, from the preceding experiments.

MATERIALS.—Fechner's weight holders, with set of weights. Uprights with tape. Carrier bracket. Arm rest. Metronome,

¹ *E* can set the releases to 0.5° . Hence, if this series is actually adopted, *E* should work it out correctly.

soundless or ordinary. Screens. [Fechner's weight holders consist of skeleton cubes of brass wire, covered with a solid brass lid, and lifted by a wooden roller handle (Fig. 32). To the lid is

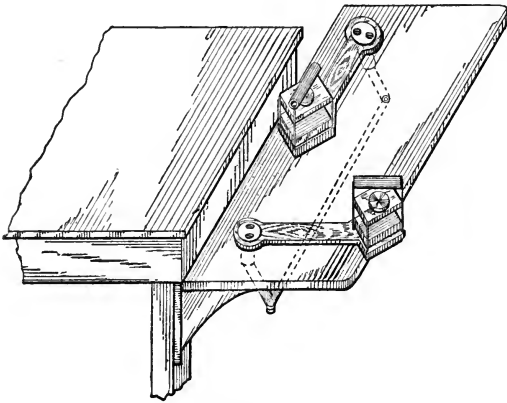

FIG. 32.

soldered a small round box of brass, itself furnished with a cover. The holders may be made to weigh, empty, 300, 400 or 500 gr., according to the dimensions of the materials. The principal weights are squared slabs of lead, zinc, etc., differing in thickness, and cut to lie snugly and evenly in the holders. It is essential that there be no rattling or shifting of the weights, as the holder is lifted. For minor variations of weight, discs of lead, etc., may be dropped into the round boxes carried by the lids.

The carrier bracket (Fig. 32) is a device for the elimination of the space error. Two wooden carriers, turning about vertical axes, are so connected (by the rod beneath the bracket) that either can be swung into the place vacated by the other. The carriers are faced with felt or baize, for the reception of the holders; their movement is arrested by a strip of felt-lined wood placed just beneath the edge of *O*'s table. The weight holders are set, at the proper angle, upon the carriers; *E* swings them in, alternately, to the required position under *O*'s hand: *O* makes the double lift with no change in the spatial relations of his hand and arm.]

PRELIMINARIES.—There are, naturally, various ways in which the experiment may be performed. With the arrangement shown in Fig. 32, *O* is supposed to be seated comfortably at the side of a low table, his forearm lying in the arm rest (plaster mould or sand box), and his hand projecting (back upwards) so far beyond the

edge of the table that he can conveniently grasp the handles of the weight holders, as they are presented. Two upright rods are nailed to the edge of the table, one on either side of *O*'s hand, and a piece of stout tape is stretched across them, at a height of, say, 10 cm. This marks the height of lift.

An alternative arrangement is that *O* stand to the weights: the bracket is fixed at such a height that he can easily grasp the handle with his hand, while the upper arm hangs down by the side of the body and the lower arm (lying in a plane parallel to the median) makes an obtuse angle with the upper. The height of lift may be regulated as before.

Fechner allowed 1 sec. for raising, 1 sec. for lowering, and 1 sec. for changing the weight; so that each observation (double lift) required 5 sec. He allowed the same time, 5 sec., to elapse between observation and observation. Whether these time relations are kept or not will depend upon *O*'s mode of lifting. The weights may be lifted evenly, deliberately, and attention paid to the whole course of the up-down movement; or they may be picked up, as one picks up from the dining table an empty glass that one's neighbour is offering to fill,—lifted all of a piece, with more or less of a jerk, at the best of an initial impulse. *O* must be allowed, after practice, to choose his own manner of lifting; if he decide upon the second mode, the experiments will run their course more quickly than Fechner's.

E and *O* must decide, further, whether they prefer to regulate the experiments by a ticking or a soundless metronome. Sometimes the ticking serves to distract the attention; sometimes it seems, on the contrary, to help towards a better concentration of attention, the metronome taking upon itself (so to say) a part of the responsibility for the conduct of the experiment.

The screens are so arranged that *O* can see nothing of *E*'s operations with the weights.

Having chosen his standard weight, *E* determines, in preliminary experiments, the limiting values of r_1 , above and below r . The determination may take some little time, and must be carefully made. Eight weight holders are then prepared (standard, and 7 variable weights), and marked by *E* with conventional signs. *E* makes out a plan of the complete experiment beforehand.

There is no reason why *O* should look at the weight holders at all, after the first practice series have been taken. He may, however, chance to see them; and it is important that, if he does, they shall present no recognisable differences.

Every r_1 is to be compared with r 50 times, in both temporal orders. These 700 comparisons give plenty of chance for confusion: much more than the corresponding 700 with the sound pendulum, where the r and r_1 are not separate things, but simply different settings of a stationary instrument. Hence it is important for E (1) to make out his programme fully and clearly, series by series; (2) to arrange his weight holders in a certain fixed order, indicated by labels pasted on the table (the labels showing both the actual weight of the holder and its contents, and also the conventional sign with which the particular holder has been marked); and (3) to move the carriers always in a certain order (right first, left second), and to dispose accordingly the weights concerned in a particular comparison.

Warming-up series must be given at the beginning of every laboratory session.

QUESTIONS.— E and O (1) Write out in brief the procedure of the Method of Constant Stimulus Differences, distinguishing carefully the successive stages in the procedure. What is the psychology of the method?

(2) We have done nothing, in our illustration of the method, with the judgments of 'much greater' and 'much less.' To what psychophysical account may these judgments be turned?

(3) In the Table on p. 107 we reversed the judgments given in the first time order (S lifted first), in order that all judgments alike might refer to S . Is this reversal a simple matter of course? Or has it any psychological implications? How would you seek to show that it is psychologically permissible?

(4) What is the psychological ground or introspective basis of the u -judgment?

(5) What advantage is there in using a number of positive and negative D 's for the determination of the DL ? Could not the DL_u be determined by the aid of positive D 's only? And would not the results obtained, say, with two such D 's show with sufficient accuracy whether Weber's Law holds or does not hold for the sense department under investigation?

(6) Criticise Fechner's view of the constant errors of time and space.

(7) Discuss the choice of the five forms of judgment: 'much greater,' 'greater,' 'doubtful,' 'less,' 'much less.'

(8) We said on p. 106: "the S is to be compared with each of the C , taken in haphazard order, 50 times over." What other

arrangements of the experiment are possible? What are their respective advantages and disadvantages?

(9) We also said on p. 106: "*O* judges always in terms of the weight lifted second." What is the reason for this rule? Why should not *O* judge in terms of *C*, or in terms of *S*, irrespective of the time order? Why should he not be left entirely free to judge as he will from one comparison to another?

(10) The *C*'s of p. 106 lie symmetrically to *S*, above and below. Is this the best disposition of the *C*'s? Why?

(11) What are your criteria of judgment in the comparison of lifted weights?

(12) Can you suggest an improvement of the apparatus?

CHAPTER III

THE REACTION EXPERIMENT

§ 23. **The Electric Current and the Practical Units of Electrical Measurement.**—(1) When an insulated substance is charged with electricity, it becomes capable of doing work; in other words, the process of charging is accompanied by the accumulation of potential energy in the substance. In technical terms, we say that the charged substance has a certain *potential*. If, now, we connect by a conductor two bodies of different potential, there is produced in the conductor what is called an electric current. There is a strain or tension between the two points connected, and the electric current tends to transfer this strain through the conductor. A difference of potential or *D. P.* between two points may therefore be defined as that difference in electrical condition which tends to produce a transference of electricity from the one point to the other. We say, conventionally, that the electric current flows from the body at the higher potential to the body at the lower potential.

While, however, a *D. P.* is able to produce, it is not able continuously to maintain an electric current. If the current is to be maintained, the *D. P.* itself must be maintained. The force or agency which keeps up a permanent *D. P.* in any electric generator, primary battery or what not, is termed electromotive force or *E. M. F.* In practice, it is seldom necessary to make the distinction between *E. M. F.* and *D. P.* Thus, for purposes of measurement, the *E. M. F.* of a cell is taken as equal to the maximal *D. P.* between the terminals of the cell on open circuit.

The practical unit of *E. M. F.* or, as it is generally termed, of electrical pressure, is the *volt*. A gravity cell, such as that ordinarily used with a telegraph instrument, gives an *E. M. F.* of about one volt.

(2) Every conductor offers a certain resistance to the passage of an electric current, the amount of resistance varying inversely with its size and directly with its length, and differing also with the material of which it is made. The unit of resistance is

termed the *ohm*. The copper wire ordinarily employed for electric lighting in houses, no. 14 Brown and Sharp gauge, has at summer temperature a resistance of 0.00259 ohm per foot.

(3) We have lastly to consider the current itself,—the current which flows along the conductor under a certain pressure (measured in volts) against a certain resistance (measured in ohms). Current is the rate of flow of electricity. The practical unit of current strength, or the unit rate of flow of electricity, is the *ampere*. An ordinary 16 c. p. 110 volt incandescent lamp requires a current of about half an ampere.

(4) These three fundamental factors, pressure, current and resistance, are present in every active electrical circuit. The flow of electricity along a conductor thus presents a fairly definite analogy to the flow of water through a pipe. When a reservoir supplies a city with water through a long pipe, the rate of flow at the orifice of the pipe depends, first, upon the pressure which drives the liquid through the pipe, *i. e.*, upon the height of the water in the reservoir above the outlet, and, secondly, upon the length and size of the pipe. The quantity of water discharged in the 1 sec., or the rate of flow, here corresponds to the rate of flow of the electric current, measured in amperes; the friction in the pipe corresponds to the resistance of the conductor, measured in ohms; the relationship between *E. M. F.* and *D. P.*, both measured in volts, is the same as the relationship between force of gravity and water pressure or difference of water level.

(5) It is usual to denote the *E. M. F.*, current, and resistance of an active circuit by the letters *E*, *I* and *R* respectively.¹ The connection between them is expressed in what is known as Ohm's Law, which asserts that

$$I = \frac{E}{R},$$

i. e., that

$$\text{amperage} = \frac{\text{voltage}}{\text{ohmage}};$$

in words, that the strength of the current varies directly as the

¹ At the Internat. Elec. Congress of 1893 it was decided that 'current' should be denoted by *I* (intensity) instead of by *C*. The latter symbol is, however, still found in many current editions of works upon electricity.

electromotive force and inversely as the total resistance of the circuit. It follows, of course, that $E = I \times R$, and $R = \frac{E}{I}$. If, then, any two of the three factors are known, we can at once calculate the third. Suppose, *e. g.*, that we have a *D. P.* of 10 volts, and a total resistance of 5 ohms in circuit: then we shall get a current of 2 amperes. Suppose that we desire to send a current of 100 amperes through a resistance of 2 ohms: we shall need a pressure of 200 volts to furnish it. Suppose, finally, that we have a *D. P.* of 50 volts, and that a current of 2 amperes is traversing the circuit: the resistance of the total circuit must be 25 ohms.

The Voltaic Cell.—(1) Voltaic cells exist in a great variety of forms; but in all three parts are present,—two conducting plates,

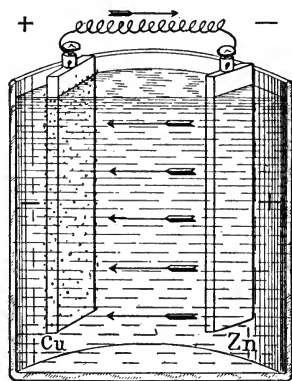

FIG. 33. Simple voltaic cell.

called the elements, and forming together a voltaic couple; and a liquid surrounding the plates, called the electrolyte. A simple cell may be made by putting a strip of copper and a strip of zinc—which must not touch each other—into a glass jar containing dilute sulphuric acid. If such a cell be put on closed circuit, *i. e.*, if the copper and zinc terminals be connected by a copper wire, a continuous current of electricity will flow through the wire

from the copper to the zinc. The copper terminal is thus the positive, the zinc the negative pole of the cell. The circuit is completed, within the jar, by the flow of current through the liquid from the zinc to the copper strip; so that the zinc is the positive, the copper the negative plate or element. The *E. M. F.* of such a cell is measured, as we have said, by the *D. P.* between the positive and the negative poles.

The simple cell, as described, has two drawbacks: polarisation and local action. Polarisation takes place when the bubbles of hydrogen liberated at the surface of the copper plate adhere to it, and so form a resistant film which weakens the current. Local

action takes place when particles of iron, carbon, etc., present as impurities in the zinc plate, form separate voltaic circuits with the zinc itself, thus acting as the negative elements of a number of little voltaic cells; energy is hereby diverted from the main circuit, and the chemicals are quickly wasted. Polarisation is avoided by various means, which are detailed in the larger works on physics and in the special books on primary batteries (*e.g.*, H. S. Carhart, *Primary Batteries*, 1891); local action is prevented by amalgamation of the zinc with mercury.

(2) For laboratory purposes, cells may be divided into two classes: those that should remain normally on open circuit, and those whose circuit should normally remain closed. Cells of the former class are intended for use only for a few minutes at a time; cells of the latter class may be used continuously, until they are practically exhausted. Open circuit cells, of which the Leclanché cell is typical, will probably always be employed in laboratories for the ringing of signal bells, for short-distance telephones, etc. Closed circuit cells, of which the Daniell is typical, may be employed for running small motors, for actuating the Hipp chronoscope, etc., though in most laboratories they are being replaced by storage batteries or by direct current service from the university or city lighting plant.

The open circuit cell must (*a*) be capable of immediate response when the circuit is closed, without previous preparation and for months at a time; and (*b*) must depolarise when left to itself. In the Leclanché cell, the positive plate is a rod of zinc; this is immersed in liquid (an aqueous solution of ammonium chloride) which acts upon it only when the circuit is closed. The negative plate is a hollow cylinder composed of broken carbon and of dioxide of manganese, which latter acts as a slow depolariser. The cell has an *E. M. F.* of about 1.5 volts; its internal resistance is high (as might be gathered from the small size of the zinc rod), varying from 0.4 to 2 ohms.

The closed circuit cell must furnish a strong continuous current over a considerable interval of time. The conditions to be met, therefore, are those of (*a*) low internal resistance and (*b*) prompt depolarisation. We have already referred to the Daniell as a typical cell of this class. The cell is composed of a zinc-copper couple, separated by a porous partition; the zinc plate is immersed in dilute sulphuric acid, the copper plate in a saturated solution of sulphate of copper. During action, the copper plate receives an electrolytic deposit of metallic copper. As ordinarily set up, the Daniell cell has an *E. M. F.* of 1.08 volts, and an internal resistance of 0.85 ohm. The internal

resistance is thus rather large in comparison with the *E. M. F.*; only a moderate current, about an ampere, can be taken from a Daniell as a maximum. On the other hand, the current is extremely constant. This was the cell used, *e. g.*, by Wundt and Dietze in their investigation of the range of consciousness; it is figured by Wundt in the *Physiol. Psychologie*, iii., 1903, 361. The cells figured *ibid.*, i., 1902, 512 are Meidinger cells,—gravity cells of special construction, much used in Germany, with zinc in a solution of magnesium sulphate and copper in a solution of copper sulphate. Another well-known form of the closed circuit cell is the Grenet or bichromate cell. In this, the negative plate (with positive pole!) consists of two parallel slabs of carbon, metallically connected at the top; the positive plate (negative pole) is a plate of zinc, lying between the carbons. The large surfaces of the plates and their close proximity secure a very low internal resistance. The liquid is dilute sulphuric acid in which potassium bichromate has been dissolved. The chromic acid formed in the solution gives up a part of its oxygen to the hydrogen as fast as the latter appears; it thus acts as a very rapid depolariser. The initial *E. M. F.* of the bichromate cell is almost twice as high as that of the Daniell: about 1.9 to 2.1 volts. If furnished with a zinc plate 4 by 3 in., it will yield a current of 2 amperes. The current is, however, less constant than that of the Daniell.

Practical rules for the care and use of these cells must be learned from the special handbooks.

(3) If a number of conductors of equal conductivity be joined

end to end, so as to form one long conductor, the resistance offered to the flow of a current will evidently increase as the number of individual conductors. If the same conductors are placed side by side, so as to form a multiple bridge between the points of highest and lowest pressure, the resistance will evidently fall in proportion to the number of the conductors so placed. The former arrangement is known as arrangement in series, the latter as arrangement in parallel.

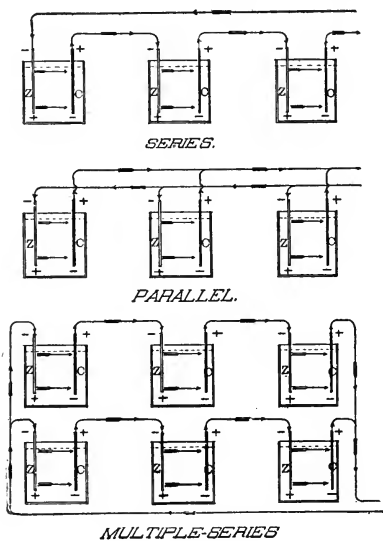

FIG. 34.

These considerations apply to the formation of batteries by the connection of like cells.

First, let the cells be connected in series: the positive terminal of one to the negative terminal of another, the positive terminal of this to the negative of a third, and so on. The battery gives an increase of *E. M. F.*, since the *E. M. F.* of the first cell is added to that of the second, and so on throughout the series. But there is also an increase of internal resistance, by a similar addition of the internal resistances of the separate cells. Hence, if *n* represents the number of cells in the battery, *r* the internal resistance of a single cell, and *R* the resistance of the external circuit, we have

$$I = \frac{nE}{nr + R}.$$

Whether, now, we have increased our available current depends entirely on the value of *R*. If *R* is so small as to be negligible in comparison with *nr*, we have, approximately,

$$I = \frac{nE}{nr} = \frac{E}{r};$$

under such conditions, an infinite number of cells in series cannot maintain a larger current than a single cell on short circuit. If, on the other hand, *r* is negligible in comparison with *R*, increase in the number of cells increases the current in nearly the same ratio. For in that case we have, approximately,

$$I = \frac{nE}{R} = n \frac{E}{R}.$$

Secondly, let the cells be connected in parallel: the positive terminals are all joined together to form the positive, the negative terminals to form the negative terminal of the battery. The *E. M. F.* remains unchanged; but the internal resistance falls to $\frac{1}{n}$ th of that of the single cell. We therefore obtain

$$I = \frac{E}{\frac{r}{n} + R}.$$

What we have done again depends entirely upon the value of *R*. If *R* is negligible in comparison with $\frac{r}{n}$, or even with $\frac{r}{n}$, then

$$I = \frac{E}{\frac{r}{n}} = n \frac{E}{r},$$

or the current is *n*-times greater than can be taken from the

single cell. But as R increases, the gain decreases: until at last, if R is equal to or greater than $\frac{r}{n}$, there is no appreciable advantage in adding to the number of cells in the battery.

In a word, then: to increase our current in face of a *low* external resistance, we must join up a number of cells *in parallel*; to increase it in face of a *high* external resistance, we must join up a number of cells *in series*. We might accomplish the same end, in the first instance, by increasing the size of the cell and so decreasing its internal resistance, and in the second by increasing the *E. M. F.* of the cell. Since, however, the enlarging of the single cell would soon make it unwieldy, and since there is no known cell whose *E. M. F.* exceeds 3 volts, we have recourse in practice to the formation of batteries from small cells.

We may illustrate our formulæ by some numerical instances. Suppose that we have a cell whose *E. M. F.* is 2 volts, and whose internal resistance is 0.1 ohm. Such a cell will, by Ohm's law, give 20 amperes of current on short circuit; it will give 16.6 amperes on a circuit whose external resistance is 0.2 ohm; it will give 0.327 ampere on a circuit whose external resistance is 6 ohms.

Suppose that 6 of these cells are connected *in series*. On short circuit, the *E. M. F.* of the battery is 12 volts, the internal resistance 0.6 ohm. The current is 20 amperes, as with the single cell. If the external resistance is 6 ohms, the *E. M. F.* of the battery is 12 volts, the total resistance 6.6 ohms. The current is now 1.81 amperes, as against the 0.327 of the single cell.

Suppose that 6 of the cells are connected *in parallel*. The *E. M. F.* remains unchanged; but the internal resistance of the battery is only 0.016 ohm. With an external resistance of 0.02 ohm, the current in the circuit is 55.5 amperes, as against the 16.6 of the single cell. With an external resistance of 6 ohms, the current is 0.332 ampere, or practically the same as that of the single cell.

These two methods of connecting cells may be variously combined, and the *E. M. F.* and internal resistance of the battery may thus be variously adjusted. A battery composed of n cells arranged in m series with l cells in each series is said to be grouped in *multiple-series*. For a steady current of maximal value, the cells should be so joined up that the internal resistance of the battery is as nearly as possible equal to the resistance of the external circuit.

Storage Batteries or Accumulators.—A storage battery is an appliance, not for the storage of electricity,—which cannot be

stored,—but for the storage of energy which is delivered to it in the form of electricity, and which it will return in the same form.

The simplest type of storage battery consists of two sets of lead plates immersed in dilute sulphuric acid. If a current of electricity is sent through it, for a certain length of time, peroxide of lead is deposited upon the plates by which the current enters the cell, while the other plates become spongy metallic lead. This process constitutes the charging of the battery. When the charging is completed, the peroxide or brown plates are the positive, the spongy lead or grey plates the negative plates of the cell: if the poles are connected by a conductor, a current will be given, precisely as in the case of the primary battery. When the storage battery is exhausted, it is recharged by a current sent through it from the negative to the positive pole;¹ the discharging current always flows in the opposite direction to that of the charge.

Storage batteries may be used in the laboratory for all purposes for which batteries of closed circuit primary cells can be employed. In general, they are less bulky, more economical, and cleaner than primary batteries. The efficiency of the best types, *i. e.*, the ratio of the energy stored in charging to the energy given out as the battery sinks back to its original condition, is from 70 to 80%; but depreciation is very rapid if the battery is not given proper care. Full instructions as regards time of charging, rate of discharge, care of cells, etc., are given with all purchasable batteries.

Storage batteries are best charged from a direct line; the proper resistance may be inserted into the circuit in the shape of incandescent lamps. Since the charging current must be sent through the battery in a certain direction, and since the dynamo may at any time have been reversed without one's knowledge, it is necessary to test the polarity of the posts to which the battery is to be attached. Pole testers of various kinds are on the market. But the + and - wires may, perhaps, be most simply identified by aid of a pocket compass. One of the effects of the electric current is that it evinces magnetism tangentially to its flow; that is to say, a live wire is magnetic at right angles to the flow of the current. Stretch a wire between

¹ In other words, the positive wire of the source of supply must be led to the positive pole of the storage battery.

the posts that constitute the terminals of the direct line, and hold the compass beneath the wire in such manner that the north pole of the needle would naturally point towards you. If the current is flowing from you, the north end of the needle is deflected to your left,—as if the wire had along its lower surface a bar magnet, at right angles to it, with the south pole to the left. If the current flows toward you, the north end of the needle goes to your right. Conversely, if the compass be held above the wire, the north end of the needle turns to the right when the current flows from you, to the left when it flows towards you. In general: think of yourself as swimming *in the direction* of the current, with your *face* turned to the needle; then the *north pole* of the needle is in every case deflected towards your *left* hand.

The Distribution of Current through the Laboratory.—Wet batteries, whether primary or secondary, have their objectionable

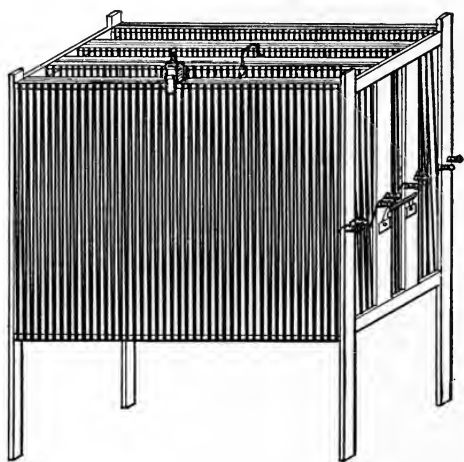

FIG. 35. Nichols rheostat.

features.¹ Their use may be avoided if the laboratory is supplied by a direct line from the university or city power plant. We will suppose that the current delivered is the 110 volt direct current, and that its available maximum has been limited by fuse plugs to some 15 or 20 amperes. We will suppose also that the laboratory consists of one large room, and that the current must be distributed to several pairs of students, working at different parts of it. The distribution may be effected, most simply, by

¹ For open circuit work, the Lechanché cells described above may well be replaced by 'dry' cells, which are light, cheap and clean.

means of a Nichols tinned iron rheostat, or of a set of Wright-Scripture lamp batteries.

(1) To construct the Nichols rheostat, take four or six full-sized sheets of tinned iron, and slit them nearly through from opposite sides at distances of about 1 cm. Mount the zigzag strips thus obtained upon a wooden frame, as shown in Fig. 35. Connect the free ends of each strip to a binding post screwed into the frame, and join up all but the terminal posts by pieces of heavy copper wire, so that the four or six strips represent one continuous strip. The rheostat may now be inserted between the terminals of the direct line; the connecting wires may be so arranged that the whole frame of four or six sheets is in the circuit, or that only one, two, etc., sheets are included. The current strength will be diminished in proportion to the amount of resistance (length of tinned iron strip) introduced.

In a simple circuit, the current strength is the same at all points of the circuit. Suppose, *e. g.*, that the resistance we have put into the main circuit has reduced the current strength to 5 amperes. Then if we attach to the rheostat a pair of wires leading to an apparatus, we shall get a current strength of 5 amperes in the branch circuit, no matter whether the length of strip included between the branch wires is long or short. On the other hand, the *E. M. F.* of a simple circuit is uniformly distributed throughout that circuit. If $I = \frac{E}{R}$, and I is constant, any variation of R

must be accompanied by a corresponding variation of E . Or, concretely: if we have a constant current flowing along a wire of constant cross-section, and we tap this wire at different points, the *drop in volts* along the wire must be uniform and proportional to the resistance between the points. If, with the whole frame in circuit, we get a current of 5 amperes under a pressure of 110 volts, then with half the frame in circuit we must get a current of 5 amperes under a pressure of 55 volts, with a tenth of the frame in circuit a current of 5 amperes under a pressure of 11 volts and so on.¹ We take advantage of this law, for the purposes of distribution of current, in the following way. The two or three longitudinal strips of wood at the top of the rheostat frame are grooved. In the grooves run sliding blocks of wood, which carry a binding post screwed down upon a strip of sheet copper; the end of the strip is bent down and over, so that, as the slider is pushed along, contact is made at cm. intervals with the successive strips of tinned iron. The wires running to the apparatus are now connected, the one with the binding post of a slider, the other with one of the binding posts fixed in the side of the frame and constituting the terminal of one of the separate tinned iron sheets. We thus get, for our apparatus circuit, a current of 5 amperes under a pressure of 5, 10, 15, etc., volts, the voltage varying directly with the proportional distance between the binding posts of the

¹ The strip cut as described in the text from a single sheet of tinned iron offers, in rough average, a resistance of 2 ohms to the passage of the electric current.

rheostat. Half-a-dozen such branch circuits, of various voltages, may be taken off from the one frame. Their current strength may, of course, be still further reduced, where necessary, by the insertion of resistance in series with the apparatus.

Handles should be attached, for convenience of lifting, to the uprights at the ends of the frame. Care must be taken that the tinned iron strip does not become unduly heated; though in the author's experience no danger has ever arisen from this source.

The Nichols frame has other uses in the laboratory. Placed out of the way, under the demonstration table of the lecture room, it may be connected up as resistance with the motor that drives a demonstration colour mixer, or with the arc-light projection lantern. The arc-light, *e. g.*, requires a current of 5 to 10 amperes under a pressure of 40 to 50 volts. Suppose that we have at the terminals of the direct line a 110 volt 20 ampere current. This means that the resistance in the wires leading to the dynamo is 5.5 ohms. By means of the rheostat, we introduce into the circuit a further resistance of 5.5 ohms. A pressure of 110 volts against a resistance of 11 ohms will give a 10 ampere current. We now place the arc-light in the circuit. What voltage is available for it? Since $E = IR$, and the I of the rheostat is 10 amperes, while the R is 5.5 ohms, the pressure employed in sending the current through the tinned iron strip is 55 volts. As we have a *D. P.* of 110 volts between the direct line terminals, we have 110—55 or 55 volts for the arc-light; and a current of 10 amperes under this pressure is, as we have seen, more than enough for it. By varying the rheostat resistance we are able to vary the E and I to meet the requirements of the arc. —

A practical objection to the use of the Nichols rheostat, as a distributing agent, is that it wastes current. Suppose that we have at the direct line terminals a current of 110 volts 15 amperes. The resistance in the wires leading to the dynamo is then 7.3 ohms. To deliver a 5 ampere current at the apparatus table, we put a six-sheet rheostat in the circuit: the total resistance of about 19.5 ohms gives us a current of between 5 and 6 amperes. To get this current, however, we have drawn all the available amperage. The objection does not apply to the use of lamp batteries, next to be described.

(2) The lamp battery, suggested by A. Wright and devised by E. W. Scripture, employs the same principle of distribution as the Nichols rheostat. Two lamps are connected in series with the 110 volt direct current line: a lamp, say, of 110 volts 1 ampere, an ordinary 32 c. p. incandescent lamp; and another, of the same or of higher amperage, but of lower voltage, —say, a 10 volt 1 ampere lamp. The combined resistance of the two lamps corresponds to the total resistance of the tinned iron strip of the rheostat. The resistance of the smaller lamp corresponds to the portion of the tinned iron strip included between the wires of the branch circuit leading to the apparatus. The wires leading to the apparatus from the lamp battery are

accordingly connected in parallel with the terminals of the low voltage lamp.

The larger lamp has a resistance of 110 ohms, the smaller a resistance of 10 ohms. A pressure of 110 volts against a resistance of 120 ohms will

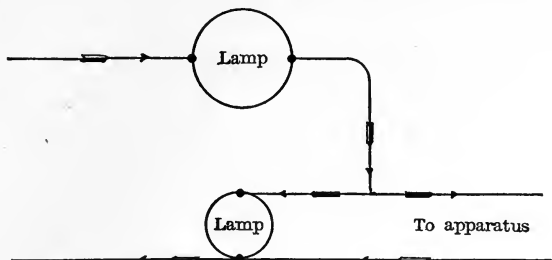

FIG. 36. Schema of lamp battery.

give a current of $\frac{110}{120}$ or 0.916 ampere. Since the resistance of the smaller lamp is $\frac{1}{12}$ of the total resistance of the circuit, it follows that the *D. P.* between the terminals of the smaller lamp must be $\frac{110}{12}$ or 9.16 volts. The two lamps thus make up a battery which delivers, for the apparatus circuit, a current of .916 ampere under a pressure of 9.16 volts.

By varying the combination of large and small lamps, we may vary the pressure and current available for the branch circuit. By arranging a simple switchboard on the wall beneath the terminals of the direct current line, we may provide for the simultaneous use of as many separate lamp batteries as the laboratory requires. Care must be taken that the amperage of the small lamp is at least as high as that of the large: otherwise the small lamp will burn out when the apparatus circuit is opened. For heavier currents, several of the large lamps must be placed in parallel, or a single lamp of higher c.p. employed. The result of various combinations of lamps should be tested out, and a record kept of the efficiency of the batteries.

(3) We said above that $\frac{1}{10}$ of the length of the tinned iron strip in a

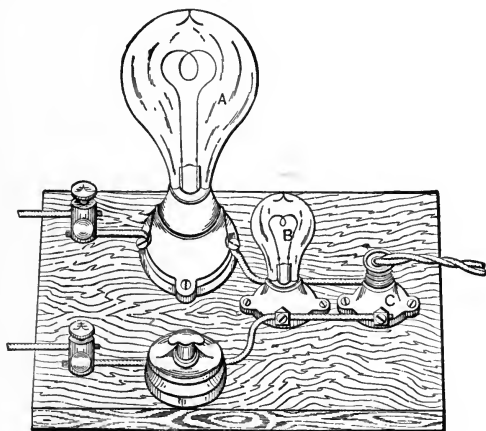

FIG. 37. Lamp battery.

Nichols rheostat might give a current of 5 amperes under a pressure of 11 volts; and we have just said that a lamp battery, made up as directed, will

give a current of 0.916 ampere under a pressure of 9.16 volts. These statements must now be modified. They hold true only under the rather paradoxical condition that nothing is being done with the appliances, that no current is being drawn by the apparatus circuit. As soon as ever we close the branch circuit, we falsify our calculations, because we necessarily decrease the resistance of that part of the main circuit with which it is in parallel. For suppose that the apparatus circuit, which we place in parallel with the smaller lamp of the lamp battery, has a resistance of 3 ohms. The current now goes by two paths: through the 10 ohm resistance of the lamp and through the 3 ohm resistance of the branch circuit. What is the joint resistance? It is found by adding the reciprocals of the several resistances (the conductivities), and by taking the reciprocal of their sum. The sum of the reciprocals is here $\frac{1}{10} + \frac{1}{3}$, or $\frac{13}{30}$: and the reciprocal of this, or the joint resistance offered by the two conductors, is 2.3 ohms. The current in the total circuit is now, not $\frac{110}{120}$, but $\frac{110}{112.3}$ or 0.98 ampere.¹ And since $E = IR$, the tension between the terminals of the lamp battery is 0.98×2.3 or 2.25 volts,—this, instead of the assumed 9.16. Or suppose, again, that the resistance of the branch circuit is 20 ohms. The joint resistance of this and of the smaller lamp is 6.66 ohms. The current in the total circuit is therefore 0.94 ampere;² the tension between the terminals of the lamp battery is 6.26 volts. And what holds of the apparatus circuit in parallel with the smaller lamp of the lamp battery, holds also of the apparatus circuit in parallel with a small length of tinned iron strip in the Nichols rheostat. The closure of an apparatus circuit must always lessen the resistance of the lamp or strip with which it is in parallel, and must therefore alter the current strength of the total circuit and the pressure between the terminals of that part of it which is in parallel with the branch circuit. The higher the resistance of the apparatus circuit, the less, of course, does this interference with the primary circuit become.

The Measurement of Current, Pressure and Resistance.—The preceding Section has made it clear that we cannot work intelligently with electrical appliances in the laboratory unless we are able numerically to determine the I, E and R of our active circuits. Instruments have been devised which make such determinations an easy matter. Current strength is measured by the amperemeter or *ammeter*; pressure by the *voltmeter*; and resistance by the substitution of numerical values (gained by help of the ammeter and voltmeter) for I and E in the equation $R = \frac{E}{I}$. The ammeter and voltmeter belong, both alike, to the class

¹ Of which $\frac{10}{13}$, or 0.75 ampere, is flowing through the apparatus circuit.

² Of which $\frac{10}{30}$, or 0.31 ampere, is flowing through the apparatus circuit.

of instruments known as galvanometers, which measure the strength of an electric current by means of its electromagnetic action. Very many forms, both of ammeter and voltmeter, are on the market; the principles underlying their construction and use are as follows.

(1) *Ammeters.*—We saw above that current electricity evinces magnetism tangentially to its flow; *i. e.*, that a live wire is itself magnetic at right angles to the flow of the current. If, now, we coil the wire in the shape of a helix, we multiply its tangential action, and thus obtain stronger magnetic effects with a given current. Such an arrangement is termed a solenoid, from the channelled or pipe-like form of the conductor. If, again, we insert in the helix a bar of soft iron, the effect of the current passing along the wire, instead of diffusing through space, is concentrated upon the iron core, and the magnetism set up is still further intensified.

In the ammeter shown in Fig. 38, *A* is a curved solenoid wound with coarse wire, and containing a hollow soft iron core. When a current is sent through the wire, the solenoid becomes magnetic, and tends to suck into its interior any small piece of iron placed near it, with a force directly proportional to the strength of the current. This action is exerted upon the scythe-shaped piece of thin iron, *B*, which is accurately pivoted at *C*. To the angle of *B* is attached a light pointer, *D*, travelling over a section of a circular scale. The unit of the scale is 1 ampere.¹ Since the wire of the solenoid is short and coarse, the resistance offered by the ammeter is negligible as compared with the resistance of the circuit into which it is introduced. All that we have to do, then, in order to measure the strength of current in a given circuit, is to break this circuit and insert the ammeter by the binding posts *E, E'*: the deflection of the pointer from zero informs us directly of the strength of current which we are using.

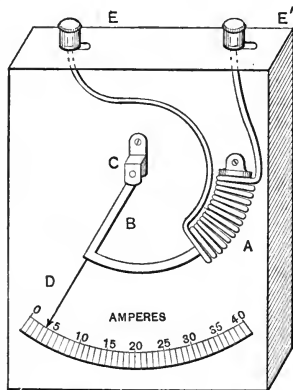

FIG. 38.
Ammeter. From S. Bottone,
Electricity and Magnetism,
1893, 153.

(2) *Voltmeters.*—Suppose that we wind the solenoid of the ammeter shown in Fig. 38 with a very long, fine wire. We shall then have reversed the conditions of its use. So far from the resistance of the ammeter being

¹The ammeter is graded either by means of a constant battery and decomposition cell, or by comparison with another, standard ammeter. Details will be found in the handbooks of electricity and magnetism.

negligible as compared with the resistance of the circuit into which it is introduced, the resistance of this circuit will itself be negligible as compared with the resistance of the ammeter. Let us now connect such a high-

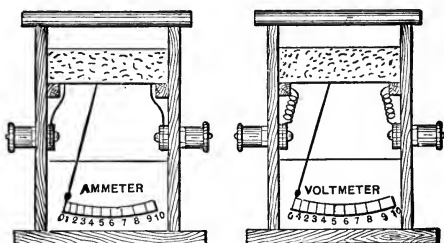

FIG. 39.

Simple forms of ammeter and voltmeter, for ordinary laboratory use.

resistance ammeter in parallel (on a shunt circuit) with the circuit whose voltage we wish to determine. Very little current will pass through the ammeter wire; the voltage of the original circuit will, therefore, remain practically unchanged. Since, however, the resistance of the ammeter is fixed, what little current is drawn by it will, by Ohm's Law, be proportional to the voltage of the circuit. Hence, if the ammeter is provided with a suitable scale, we may read off from it, directly, the *D. P.* between the points of the original circuit at which it was inserted. The ammeter has thus been transformed into a voltmeter.

Let us say, *e. g.*, that the solenoid has a resistance of 500 ohms. A pressure of 1 volt against this resistance would give a current of $\frac{1}{500}$ ampere; a pressure of 2 volts, a current of $\frac{2}{500}$ ampere; a pressure of 100 volts, a current of $\frac{1}{5}$ ampere. Let the unit of the scale be a deflection of the pointer that corresponds to the passage of a $\frac{1}{500}$ ampere current, and let the scale be composed of 100 such units. Then we have a voltmeter that ranges between 0 and 100 volts. If, for example, the pointer of the instrument, in a given case, stands at 21.5, this means that the *D. P.* between the points of the main circuit which the shunt circuit connects is 21.5 volts.

It is customary to allow a resistance of at least 50 ohms, in the voltmeter, for every volt to be measured. That a branch circuit of high resistance, placed in parallel with a main circuit, does not appreciably alter the *D. P.* between the points of the main circuit at which it is attached, has been sufficiently explained in our account of the lamp battery. Hence we need not fear that the voltmeter, any more than the ammeter, will sensibly alter the circuit into which it is introduced.

(3) *Measurement of Resistance.*—The arrangement for measuring resistance by help of ammeter and voltmeter is shown in Fig. 40, where *L* is

a lamp of unknown resistance, A the ammeter, and V the voltmeter. We know, from Ohm's Law, that $R = \frac{E}{I}$. If, then, the ammeter registers 0.5 and the voltmeter 109.5, we know that the resistance of the lamp is $\frac{109.5}{0.5}$, or 219 ohms.—

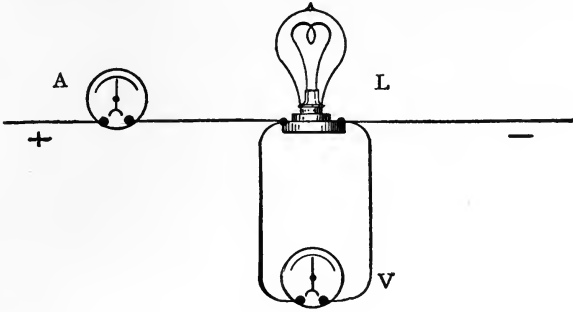

FIG. 40.

There are various methods of measuring resistance in a more direct way. The instrument most commonly employed is some form of the Wheatstone bridge, a schematic representation of which is given in Fig. 41. When the

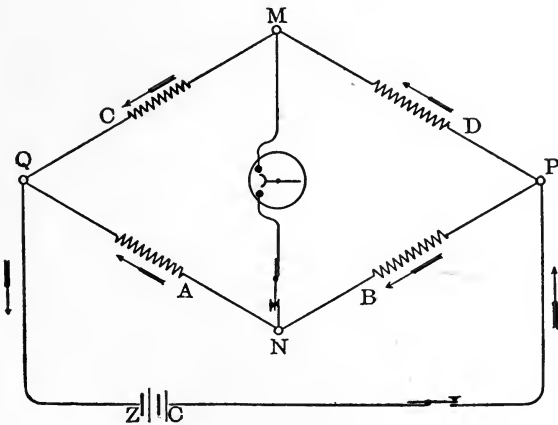

FIG. 41.

Wheatstone bridge. Cf. S. P. Thompson, *Elementary Lessons in Electricity and Magnetism*, 1904, 416.

current which starts from C has reached P , the potential will have fallen a certain value. The current now divides: the potential in the upper branch showing a fall at M , and a further fall at Q , and that in the lower branch

falling similarly at N and Q . Now if N be the same proportionate distance along the resistances PNQ that M is along the resistances PMQ , the fall of potential at N will be identical with the fall at M ; or, in other words, if $A : C = B : D$, M and N will be at equal potentials. A galvanometer placed between M and N will then show no deflection of its needle as the current passes. If, therefore, we have known and variable resistances at A , B , C , and an unknown resistance at D , we have only to adjust the bridge so that the galvanometer needle is not deflected by the current, and we can calculate D from the formula $D = \frac{BC}{A}$.

A simple form of bridge, useful for laboratory purposes, is the metre bridge, shown in schema in Fig. 42. A thin wire ab , 1 m. in length, is

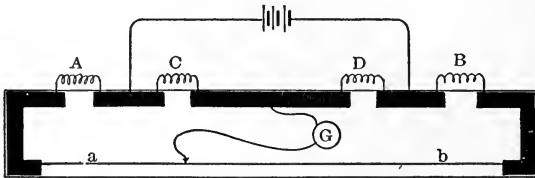

FIG. 42.

Metre bridge. From S. P. Thompson, *Elementary Lessons in Electricity and Magnetism*, 1904, 420.

stretched between stout pieces of copper. A , B , C , D are resistances connected similarly to copper pieces. If the galvanometer wire is slid along ab to the point at which the needle shows no deflection when a current passes, we have $A + a : B + b = C : D$. Since, by hypothesis, all resistances but one are known, the unknown resistance may be calculated. In a simpler form of bridge, A and B are replaced by copper strips of inappreciable resistance; so that $a : b = C : D$. If C is a known and D an unknown resistance, the ratio of the lengths a and b enables us at once to calculate the ohmage of D .—

It is advisable that the resistance of all apparatus in the laboratory, which may be introduced into an electric circuit, be determined, and a tag showing its ohmage attached to each instrument.

Dynamos and Motors.—We know that, whenever a current flows along a wire, a magnetic field is set up round about the wire. It is true, conversely, that if a magnetic field is brought near a wire currents are ‘induced’ in the wire. It is upon this principle of electromagnetic induction that the action of the dynamo depends.

(1) *Simple, direct current dynamo.*—Suppose that we rotate a coil of

wire in the magnetic field between the poles of a magnet (permanent magnet or electromagnet). If the ends of the coil are joined, so that the wire forms a complete circuit, currents will be induced in it,—currents that flow first in one direction and then in the other, according to the direction in which the lines of force of the magnetic field pass through the coil. To convert these alternate currents in the coil or armature into a continuous current in the external circuit, we connect the two ends of the coil to the two halves of a split tube (the commutator). As the coil revolves, the commutator segments revolve also. They are made to turn between two strips of copper, termed

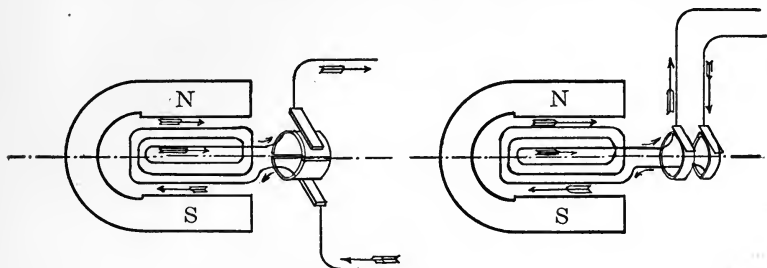

FIG. 43.

Schemata of direct current and alternating current dynamos. From R. T. Glazebrook, *Electricity and Magnetism*, 1903, 392.

the brushes, which are in connection with the external circuit. It is clear that, at every half turn of the armature, its connection with the external circuit is reversed in direction by means of commutator and brushes; and this means that a continuous current flows in the outside circuit. The essential parts of the simple dynamo are, then, the field magnet, the armature, and the commutator and brushes.

(2) *Alternating current dynamo*.—In this form of dynamo, the split ring commutator is replaced by two slip rings (collector rings), to which the ends of the armature wire are attached. The current in the external circuit now changes in direction with the changes of current in the armature.

(3) *Excitation of field coils*.—The field magnet of a dynamo is usually an electromagnet. In the alternating current machine, the coils of the magnet must be supplied with a separate starting current. This is, however, not necessarily the case with the direct current dynamo. For suppose that the field coils are connected with the armature, through the brushes, and that the machine is started. There will be enough residual magnetism in the iron of the machine to set up a small current: this current, passing round the field coils, magnetises them more strongly: the stronger magnetisation of the coils increases the current, which again reacts on the field: and so on. The dynamo is then self-excited.

(4) *Series and shunt winding*.—The field coils of the direct current dynamo may be connected with the brushes and thus with the external

circuit in two ways: in series and in parallel. In the former case, the whole current flows round the field coils, which therefore consist of a few turns of thick wire. In the latter case, the field coils consist of a large number of turns of thin wire. Series wound dynamos are used where a constant current of varying pressure is required (*e. g.*, for arc lighting); shunt wound dynamos where a varying current at constant pressure is demanded (*e. g.*, for incandes-

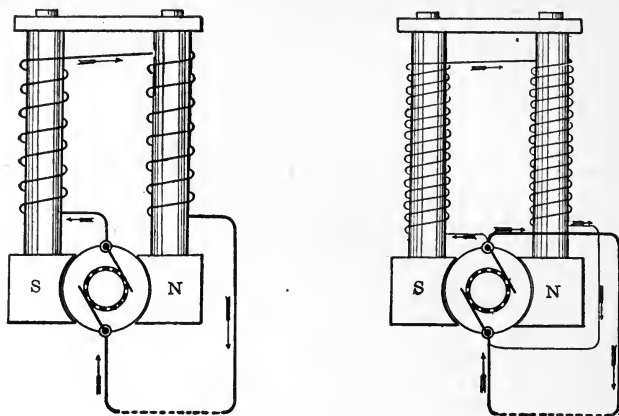

FIG. 44.

Schemata of series-wound and shunt-wound dynamos. Cf. S. P. Thompson, *Elementary Lessons in Electricity and Magnetism*, 1904, 483.

cent lighting). Shunt winding is often replaced by compound winding, where some of the coils are in series with the external circuit, but in addition a number of turns of thin wire are wound on in parallel with the external circuit.

(5) *Direct current motors*.—In the dynamo, mechanical is transformed into electrical energy. In all direct current machines, this transformation is reversible: by supplying a current to the machine, we cause the armature to rotate, and thus transform electrical energy into mechanical. We then have an electromotor. It may be worth while to remember that a series wound motor always rotates in the opposite direction to the series wound dynamo; while a shunt wound motor rotates in the same direction as the shunt wound dynamo, or in the opposite direction, according to its mode of connection with the source of supply.¹ A motor should be started up gradually, by help of an adjustable resistance in the external circuit.

¹ A shunt wound motor, in which both field and armature are connected to a source of like polarity (+ to + and — to —), will rotate in the same direction as the dynamo. To reverse the direction of rotation, the polarity of the source applied to field or armature must be reversed. A compound wound motor will rotate in the opposite direction to the dynamo if the series winding is the more powerful, and will behave as a shunt wound motor if the shunt winding is the more powerful.

A very great variety of direct current motors is on the market. In a laboratory supplied with the direct current, motors of this type are indispensable as colour mixers (vol. i., S. M., 6). They may also be employed to drive kymographs (104); to rotate the Masson disc (111); to turn the rotation apparatus (113); to move the pressure or temperature point of the kinesimeter (i., I. M., 93); to rotate the rhythm apparatus (349); to revolve the barrel and cylinder of the phonograph; and for many other purposes.

(6) *Conversions of the direct current dynamo.*—It is evident that, if we connect the commutator segments of a direct current dynamo with collector rings placed farther out along the shaft, we may draw from it an alternating current. A machine of this sort will produce direct or alternating current, as required; it is termed a double-current generator. If, now, we run the dynamo as a motor, and deliver a direct current to the direct current brushes, we may again draw off an alternating current from the collector rings; direct has been transformed into alternating current, and the machine is an inverted converter. If, finally, after the machine has attained its full speed, we deliver to the collector rings alternating currents of the same periodicity as the dynamo itself will produce, we may draw off direct current from the direct current brushes; alternating has been transformed into direct current, and the machine is a rotary converter. The rotary converter is typical of the class of machines known as synchronous motors.

(7) *Alternating current motors.*—There is, however, another class of alternating current motors, the non-synchronous or induction motors, which is more generally employed in laboratory work. In these motors, an iron ring is supplied with separate windings of wire, to which are delivered alternating currents differing in phase by a known and constant amount. A magnetic field thus travels round the ring with a constant periodicity. If, now, a closed armature coil be mounted within the ring, the travelling magnetic field induces currents in the coil; and these currents in their turn react upon the field of magnetic force and tend to move across it. In other words, the armature is carried round with the magnetic field, and we have an induction motor. Of this type are the 60 cycle 110 volt fan motors, which can be inserted directly into a lamp socket, and are much used in places of business.

Induction motors are simple in construction, have no moving contacts, and do not easily get out of order. They may be so varied as to possess the properties either of the series wound or of the shunt wound direct current motor. Hence a laboratory that is supplied with the alternating, instead of the direct, current may readily procure a set of induction motors suitable to its requirements; though, as a matter of fact, the majority of motors designed for purely psychological purposes have been of the direct current type. For work with other instruments than motors, the alternating must be transformed into direct current,—*e. g.*, by means of the rotary converter mentioned under (6),—which may then be distributed through the laboratory by the Nichols rheostat or by lamp batteries.

Practical Hints for Care of Apparatus.—Many of the small direct current motors on the market are extremely durable if properly cared for, but soon become useless if neglected. A cardinal rule is that the motor must be kept clean and dry; it should be gone over with a cotton cloth, before and after using, to free it of dust and caked oil; and it should never be allowed to stand uncovered in the laboratory. The oil used for lubrication should be of the best quality, and should be carefully applied. The commutator, which is perhaps the most sensitive part of the motor, must be kept smooth by rubbing with fine emery cloth; no emery dust must be allowed to remain upon commutator, brushes or shaft. After cleaning, the commutator should be wiped with an oily rag, not oiled; care must be taken to keep the oil away from the insulation. Before starting, the armature should be turned round slowly by hand, to see that nothing catches, that there are no loose wires adhering to it, etc. The brushes must be carefully adjusted, so that the motor runs without sparking, which is bad both for brushes and for commutator.

If a motor, properly connected and supplied, fails to work, we may suspect one or other of the following five defects: burning out of the armature, due to a jamming of the whole armature or to faulty winding of a coil; short circuit of the armature; defects of the commutator; short circuit of the field magnet; disconnection in the field magnet. Short circuiting and burning out may generally be detected by the heating of the affected coil and the smell of charred varnish. Tests may be made by disconnecting the suspected coil, and connecting it with a primary battery and a current tester or an electric bell. When the seat of the injury has been discovered, the defective part must be returned to the maker or handed over to the laboratory mechanician.

Where alternating current motors are employed, they should be carefully safeguarded by high-resistance fuse plugs, and it should be observed that they start at once when the current is applied. If the armature jams at all, the coils very quickly burn out.

The current tester, spoken of above, does good service in the testing out of long laboratory circuits. It consists of a small, low-resistance electromagnet, boxed in a wooden case resembling that of the push-button of an

electric bell; the armature is drawn down with a click when current passes. Suppose, *e. g.*, that we have a simple Hipp chronoscope circuit, and that the apparatus refuses to work. We have connections at the clock, at the rheochord, at the commutator, at the stimulator, at the key, and at the generator terminals. By aid of the tester, we may work along this circuit, beginning at the generator, and so localise the point of defective connection or of disconnection. The current tester may be replaced by a telephone snapper (Queen pony receiver, $\text{c. } 90$) or by a pocket compass set in a block with a few turns of wire about it.

The rule of cleanliness, which we have laid down for motors, holds for all forms of apparatus in which electricity is employed. Clean mercury, clean binding posts, clean wires,—these are essential. A few minutes' work with sandpaper, at the beginning of the laboratory hour, may prevent the waste of an afternoon.

Practical Exercises.—(1) Measure the resistance in the two magnets of the Hipp chronoscope.

(2) Measure the resistance in a given reaction circuit, including chronoscope magnet, rheochord, stimulator and reaction key.

(3) Given a battery of primary cells arranged for the reaction experiment: measure the *E. M. F.* of the battery, the strength of current delivered, the internal resistance of the cells used.

(4) Test a given lamp battery.

(5) Measure the drop in volts along the strip of a Nichols rheostat.

(6) Measure the resistance in the primary and secondary circuits of an inductorium.

(7) Draw a diagram, showing the change of connections required if a given dynamo is to be employed as a motor. Include some form of resistance.

§ 24. **The Technique of the Simple Reaction.**—In vol. i., 117 ff., we discussed the simple reaction from a purely qualitative point of view. Our unit of measurement was $\frac{1}{50}$ sec., and we used the reaction times solely as a check upon *O*'s introspective record. We have now to repeat the experiment from the quantitative standpoint. Our measurements are to be made, not with the vernier chronoscope, but with an electric chronoscope, whose unit is $\frac{1}{1000}$ sec. The stimulus to reaction will be given, and the reaction movement recorded, by instruments which make or

break an electric circuit. The whole experiment thus becomes more complicated: we must know the errors, constant and variable, of our apparatus, and must take them into account when we seek to determine the representative value and the variability of the reaction times. In the long run, introspection will come to its rights again; but we shall for the present direct our at-

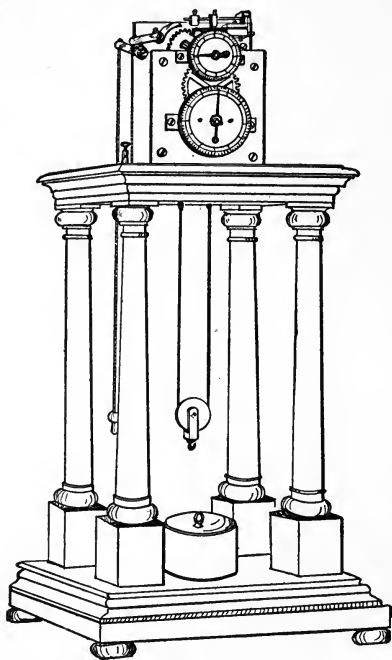

FIG. 45.

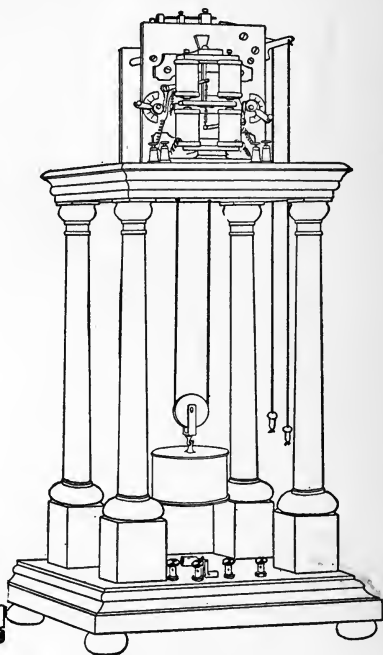

FIG. 46.

tention mainly to the physical and psychophysical aspects of the experiment.

We must consider, in order, the chronoscope, the instruments for its control, the stimulator, and the reaction key.

1. *The Hipp Chronoscope.*—The Hipp chronoscope is an instrument designed for the measurement of short periods of time in units of 1σ or $\frac{1}{1000}$ sec. It consists of three, separate but interconnected parts: the clockwork, the registering apparatus, and the electromagnetic mechanism.

(a) *The Clockwork.*—The clock is driven by a weight, shown in Figg. 45, 46. The cord is wound upon a barrel, the movement

of which is transmitted by a series of gears to the shaft carrying the crown wheel, and to the balance wheel. The latter is shown, behind the upper dial, in Fig. 45. The crown wheel, which has 100 teeth, faces towards the front of the clock; it can readily be seen in the instrument itself. The movement in the balance wheel is regulated by a straight steel spring, whose free end plays between the teeth of the wheel. The spring is adjusted to make precisely 1000 vibrations in the 1 sec. If the clock is running evenly and at its right rate, the balance wheel moves forward one tooth while the spring makes one vibration. The characteristic tone given out by the vibrating spring assures *E* that the clock is running aright.

The clock is started by a pull upon the nearer of the two cords hanging at the left of the instrument. The leverage is so arranged that the pull on the cord not only releases the brake, but also gives a push to the middle gear of the clockwork; hence the chronoscope very quickly acquires its full speed. The motion is arrested by a pull upon the farther of the two cords.

(*b*) *The Registering Apparatus*.—The pointer of the upper dial is fixed to a spindle which passes through the (hollow) shaft carrying the crown wheel, and is altogether independent of it. If the course of the spindle is followed from the front wall of the clock-case through the body of the clock, it will be seen to pass, first of all, through the centre of a second, fixed crown wheel. This wheel is an exact duplicate of the movable crown wheel, which it faces. In the space between the two crown wheels, the spindle carries a cross-bar, one end of which is so shaped as to fit between the teeth of the crown wheels. Then, entering the hollow shaft which forms part of the clockwork, the spindle emerges at the back of the clock-case.

The spindle which carries the upper pointer is connected by gears (visible in the instrument, behind the dial plates) with the short spindle that carries the pointer of the lower dial. Hence, whenever it moves, the lower spindle and pointer must move with it.

It is clear, now, that if the upper spindle is pushed forward, so that the cross-bar engages the teeth of the fixed crown wheel, the clock hands will not move, even if the clockwork is in motion.

If, on the contrary, the spindle is pulled back, so that the cross-bar engages the teeth of the movable crown wheel, the hands will move as soon as the clock begins to run. The former is the normal state of affairs: a brass spring, attached to the back of the upper dial plate, holds the cross-bar forward, between the teeth of the fixed crown wheel. In other words, if E pulls the nearer cord, and so starts the clock, the pointers will not move. But if E , having pulled the nearer cord, puts his hand behind the clock and draws the spindle gently backward, the pointers will begin to revolve.

Both dial plates are graduated in hundredths. A complete revolution of the upper pointer corresponds to a complete revolution of the movable crown wheel; and since this has 100 teeth, and the unit of movement of the clock is $\frac{1}{1000}$ sec., the pointer revolves once in $\frac{1000}{100}$ sec. or $\frac{1}{10}$ sec., and the unit of the dial is $\frac{1}{1000}$ sec. or 1σ . The lower pointer revolves once in 10 sec.; so that the unit of the lower dial is $\frac{1}{10}$ sec. In reading the clock, therefore, the value of the upper dial is simply appended to the value of the lower. If the lower pointer stands at 21+, and the upper at 85, the 'time' is 2185 σ .

(c) *The Electromagnetic Mechanism.*—To the back of the clock case are fastened two electromagnets, with an armature between them (Fig. 46). The lower magnet is connected with the left-hand, the upper with the right-right pair of binding posts on the base of the instrument. The armature is joined to a light, vertical rod, which plays upon the upper spindle at the point where it emerges from the back of the clock-case. The position of the armature between the poles of the magnets is regulated by spiral springs, whose tension is adjustable by means of two eccentric levers, placed to right and left of the magnets, and moving over a circular scale.

If, now, the armature is poised between the two magnets, and the clock is started, the hands will not move. If, however, the two eccentrics are turned up, so that the upper spiral is relaxed and the lower spiral tense; or if a current is sent through the lower magnet, so that the armature is drawn down; then the hands will begin to revolve. And if, on the contrary, the eccentrics are turned down, so that the lower spiral is relaxed and

the upper spiral tense ; or if a current is sent through the upper magnet, so that the armature is drawn up ; then the vertical rod presses forwards against the upper spindle, the cross-bar is forced between the teeth of the fixed crown wheel, and the hands again stand still. In virtue of this twofold regulation of the position of the armature, by spiral springs and by the electric current, the chronoscope is able to register the period of time elapsing between break and make, between break and break, between make and break, and between make and make, of an electric current. The arrangements are as follows.

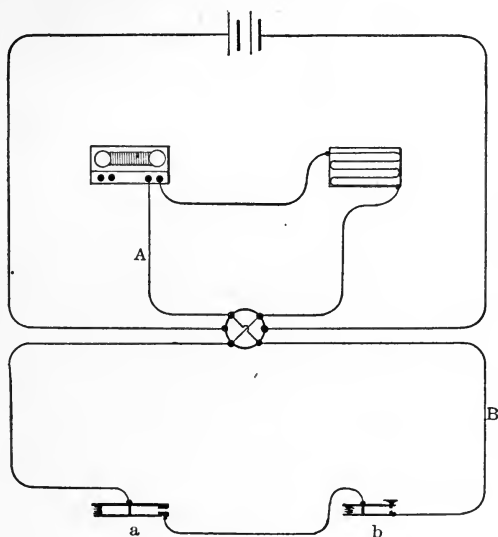

FIG. 47.

Arrangement I. (See p. 147.) The chronoscope is shown in schema, as a pair of electromagnets with their armature. The circuits include rheochord, commutator, sound hammer and reaction key.

(i) *Break to Make*.—A current is sent through the upper magnet, and the eccentrics are turned up. The current is stronger than the spring, so that the armature is held up. If the clock is started, the hands do not move. Now the current is broken. The spring pulls the armature down ; the upper spindle flies back ; the hands move. When the current is made again, the magnet pulls the armature up, against the spring ; the upper spindle is thrust forward ; the hands stop.

(ii) *Break to Break*.—A current is sent through both magnets (the binding posts are connected in parallel with the source of current), and the ec-

centrics are turned down. The armature is held up by the spring. If the clock is started, the hands do not move. Now the current in the upper magnet is broken. The current in the lower magnet is stronger than the spring, and the armature is drawn down; the hands move. As soon as the current in the lower magnet is also broken, the spring pulls the armature up; the hands stop.

(iii) *Make to Break*.—A current is arranged to pass through the lower magnet, and the eccentrics are turned down. Before the experiment begins, the circuit is left open, so that the armature is pulled up by the spring. If the clock is started, the hands do not move. Now the circuit is closed;

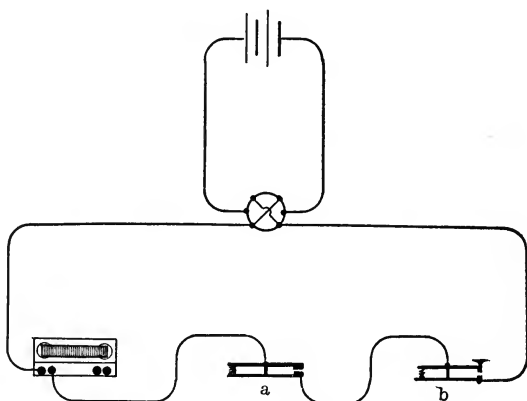

FIG. 48.
Arrangement II. (See p. 147.)

the armature is drawn down; the hands move. As soon as the current is broken, the spring draws the armature up again; the hands stop.

(iv) *Make to Make*.—A current is arranged to pass through both magnets (connections as in ii.), and the eccentrics are turned down. Before the experiment begins, the circuits are left open, so that the armature is pulled up by the spring. If the clock is started, the hands do not move. Now the circuit of the lower magnet is closed; the armature is pulled down; the hands move. As soon as the circuit of the upper magnet is closed, the spring draws the armature up again; the hands stop.

All four arrangements have their uses in the physical laboratory. For purposes of the reaction experiment, we employ only i. and iii. And since the movement of reaction must be a break movement,—for only under this condition can we time it with sufficient accuracy,—we are reduced, in practice, to three dispositions of our apparatus: a shunt circuit with arrangement i.,

and a shunt circuit or direct circuit with arrangement iii. The procedure in the three cases is as follows.

I. *Break to Make: Shunt Circuit.*—The wires from the battery are led to the supply poles of a Pohl's commutator (Fig. 50). With the one side of the commutator is connected a high-resistance circuit *A*, containing chronoscope and rheochord; with the other, a low-resistance circuit *B*, containing the stimulator (a sound hammer: Fig. 54) and the reaction key. At the beginning of the experiment, the hammer *a* is open, the key *b* is closed.

Current is now flowing in *A*. By the conditions of arrangement i., the hands of the clock do not move. When *a* is closed, and the stimulus to reaction thereby given, so much of the current leaves *A* and flows into the circuit of lower resistance *B* that the clock hands move. When *O* reacts,

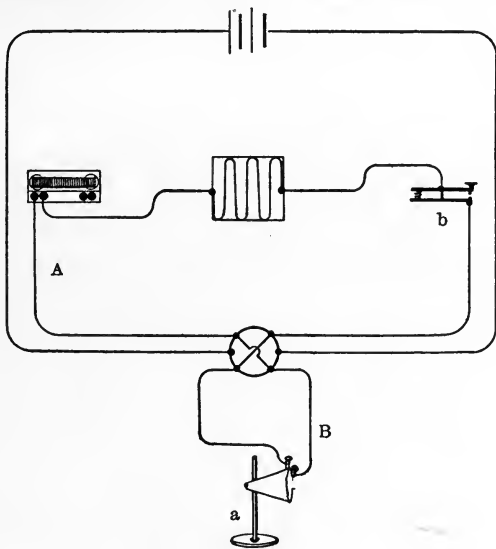

FIG. 49.

Arrangement III. The voice-key is shown in schema, without relay.

by opening *b*, the current is again confined to *A*, and the hands stop.

II. *Make to Break: Direct Circuit.*—The battery wires are led to the commutator as before. Chronoscope, hammer and key are connected in series with the one side of the commutator.

At the beginning of the experiment, *a* is open, *b* is closed. By the conditions of arrangement iii., the hands of the clock do not move. When *a* is closed, current flows through the lower magnet; the clock hands move. When *b* is opened, by the movement of reaction, the current is broken; the upper spring comes into play; the hands stop.

III. *Make to Break: Shunt Circuit.*—The battery wires are led to the

commutator as before. With the one side of the commutator is connected a high-resistance circuit *A*, containing chronoscope, rheochord and key *b*; with the other side, a low-resistance circuit *B*, containing a stimulator which breaks (not makes) its circuit when the reaction stimulus is given. As typical of this kind of stimulator we may take Cattell's voice-key (Fig. 58).

At the beginning of the experiment, both circuits are closed; but so much of the current flows through *B* that the hands of the clock do not move. The calling of the stimulus-word into *a* breaks *B*; the current is confined to *A*, and the hands move. When *b* is opened, by the reaction movement, there is no current in *A*; the upper spring comes into play; the hands stop.

While the electromagnetic mechanism makes the chronoscope available for our reaction experiments, it also introduces certain possibilities of error, which we must carefully guard against.

(1) It is necessary that the *direction* of the current in the electromagnet be *reversed* from test to test; otherwise the cores will become permanently magnetised. The instrument usually employed for this reversal is Pohl's commutator, shown in Fig. 50. When the rocker is brought down towards *E*, the currents in the two connected circuits flow in the directions indicated in Fig. 51, *A*; when it is thrown over, away from *E*, they flow as indicated in Fig. 51, *B*. Better than the ordinary form of the commutator, with mercury contacts, is a form in which the rocker, as it is thrown back and forth, engages either one of two pairs of spring brass edges.

(2) The clock hands record the time elapsing between break and make, or between make and break, of an electric current. But the making and breaking are not instantaneous; they take time. Moreover, they need not by any means take the same time. Consider the simplest possible arrangement of the chronoscope circuit, *i. e.*, arrangement II.; the clock hands move while the current is in the magnet. Now, if the current is strong, the time of magnetisation (make) will be short, and the time of demagnetisation (break)

will be long; if the current is weak, the time of magnetisation will be long, the time of demagnetisation short. Here, then, is the error which we must seek to eliminate. We must take account of the *latent times* of the electromagnetic mechanism: of the time during which the magnet is growing strong enough to pull down the armature against the spring, and of the time

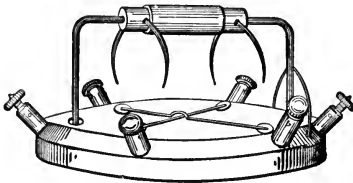

FIG. 50.
Pohl commutator.

during which it is becoming weak enough to allow the spring to pull the armature up. These times may be quite considerable, as compared with the unit of the clock.

As a rule, the times which the clock records are checked or controlled in the following way. The magnet springs are set at a certain tension, and a current is employed of such strength that the armature moves freely and easily under its influence. We then introduce into the chronoscope circuit an adjustable resistance (rheochord), and some control instrument (*e.g.*, a falling hammer) which allows a known interval (*e.g.* 150σ) to elapse between make and break of a current. The clock is allowed to record the times of fall in, say, ten successive trials. If the average time, as recorded, is more than 150σ , the current is weakened, and the tests repeated; until presently the clock records 150σ as the average value of the ten trials. If the average time first recorded is less than 150σ , the current may be strengthened (by the addition of new cells, etc.) or the tension of the springs may be varied. Experience has shown, however, that it is advisable to shift the springs as little as possible. In any case, the average time recorded must be brought up to 150σ . The clock has now no constant error; the slight variation of the recorded times (the *MV* of 10 determinations should not exceed $\pm 1.5\sigma$)

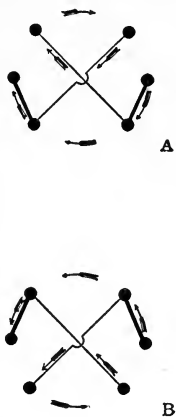

FIG. 51.

enables us to estimate its variable error. So long as the tension of the springs and the strength of the current remain the same we can work with times in the neighbourhood of 150σ , and rely upon the clock to furnish us with correct time values.

Under these circumstances, we know nothing either of the magnitude (absolute or relative) of the latent times of the magnet or of the mechanical accuracy of the clockwork. If, then, we change to the longer times of compound reactions, we must correspondingly change the height of fall of the hammer, and must test the chronoscope over again.—

It is clear that we have here presupposed a test of the control instrument itself. The test is made by the graphic method. Thus, a tuning fork, of known vibration rate, may be allowed to write its curve, during the time of fall, upon a piece of smoked paper attached to the hammer. Or we may have recourse to a more elaborate set of instruments (recording chronograph), and record the moments of make and break upon the surface of a rotating cylinder, alongside of the time-line traced by an electrically driven tuning-fork.

The strength of the current in the chronoscope circuit is regulated, from day to day, by aid of the adjustable resistance and of some form of galvanometer.

It need hardly be said that what holds of arrangement II. holds also, *mutatis mutandis*, for arrangements I. and III.

General Rules for the Use of the Chronoscope.—The chronoscope is furnished with a glass bell-cover, which fits over the

clock-case on the upper platform. The cover should always be kept in place, even during a series of experiments. When the clock is out of use, it should be entirely covered by a wooden or cardboard case. It is essential that the works be kept free from dust.

The clockwork runs only for 1 min. The chronoscope is wound from the centre of the lower dial; the winding is done overhand, from right to left. The newest glass bells have an opening, through which the key may be inserted. If the cover is of the older pattern, it must be lifted with the left hand while the clock is wound by the right. At the end of a series of experiments, the clockwork should be allowed to run down, so that the weight comes to rest upon the base of the instrument.

The clockwork should be started by a quick, firm pull upon the nearer cord. If the pull is hesitating or jerky, the spring will give out a hoarse whirr, instead of its proper clear tone. The whirr may presently pass over into the tone, or the clock may have to be stopped and restarted. In any event, a jerky or hesitating pull is bad for the works. In some clocks, it is possible to pull the cord too far, and so to interfere with the starting. In this case, a cork buffer should be introduced, to limit the extent of pull.

In some instruments, again,—the fault does not seem to be universal,—the tone of the spring is liable, without warning, to drop an octave. The change of rate appears to be due to a loosening of the screws by which the regulating spring is adjusted. *E* must be on the lookout for this source of error; when once its presence has been detected, the tone is easily controlled by ear.

We said above that, if the lower pointer stands at 21+, and the upper at 85, the 'time' is 2185 σ . Now when the upper pointer is between 80 and 100, the lower pointer (at least in all the clocks that the author has seen in use) stands very close indeed to the scale mark that it ought not to reach until the upper pointer has reached 100. *E* thus runs the risk, if he records by first impression, of misreading the time of the clock by 100 σ ; he is likely to write down 2285 instead of 2185. It must be re-

membered that, if the upper pointer has travelled to 85, the lower pointer will have travelled far beyond the scale mark which corresponds with the 0 of the upper dial.

Since the clock-times increase from reaction to reaction, and since the reaction time is found by subtracting the time recorded at the beginning of the experiment from the time recorded at the end, it is advisable to write the column of figures in the record-sheet from below upwards. The lowest figure then shows the time at which the series of reactions began, the next shows the time at which the first reaction was completed, the topmost shows the time at which the last reaction was completed. The figures are in the right position for the successive subtractions, and mistakes are less likely to arise than if the column had been written from above downwards in the ordinary way.

II. *Control Instruments*.—The chronoscope, as we have seen, is tested by the help of some instrument which enables its pointers to record a known and constant period of time. The easiest way of obtaining such a time is to allow a body of constant mass to fall through a constant distance. Since the beginning and end of the time must be marked off by electrical means, the falling body must make or break electrical contacts at two points upon its course. Three types of instrument are now employed for the giving of control times: the gravity chronometer, the pendulum, and the hammer. In the first, a heavy screen falls vertically, and without appreciable friction, between guides to which wheel contacts are affixed. The control time may be varied by varying the height from which the screen drops and the distance between the upper and lower contacts. In the second, a heavy pendulum swings over an arc to which mercury or wheel contacts have been attached. The control time is varied by varying the position of the weight and counterweight of the pendulum, the angle through which it falls, and the distance between the contacts on the base of the instrument. In the third, a bent lever, whose longer arm (the hammer) is heavily weighted, turns about a horizontal axis; as the hammer-head descends, a cross-bar on the shank makes or breaks wheel or sliding contacts. The control time is varied by varying the position of the counterweight on the short arm of the lever, the

height from which the hammer falls, and the distance between the upper and lower contacts.

In arrangement I. (Fig. 47 above) the control instrument is placed in the low-resistance circuit *B*, and is so disposed that the falling body first makes and then breaks a contact. While experiments are being taken, the circuit is closed through the control instrument; when control times are taken *a* and *b* are kept closed. In arrangement II. (Fig. 48 above) the control instrument is introduced into the chronoscope circuit. Experiments and

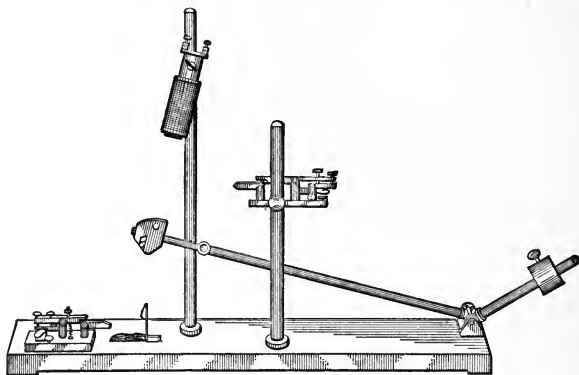

FIG. 52. Simple control hammer.

control times are taken as before. In arrangement III. (Fig. 49 above) the control instrument is connected with both circuits. A first or upper break contact is inserted in *B*, a second or lower break contact in *A*. During experimentation, both contacts are closed. When control times are taken, *a* and *b* are kept closed, and the falling body is allowed (1) to break the first or upper contact in *B*, and then (2) to break the second or lower contact in *A*. The control instrument thus functions first in the low-resistance and then in the high-resistance circuit, taking the place of *a* in the former and of *b* in the latter.

Fig. 52 shows a simple form of the control hammer. The hammer head forms the armature of an electromagnet (actuated by a battery of its own) which can be raised or lowered upon a standard. The control time can thus be varied by varying the height of the magnet; it can also be varied by varying the position of the counterweight, and the height of the upper contact. A cross-bar on the shank strikes the projecting tongue of the upper contact; another on the hammer head strikes that of the lower. The hammer falls upon a rubber cushion, and is prevented from rebounding by a spring catch. The contacts can be set either for make or for break. In arrangements I. and II., the upper is a make, the lower a break contact, and the two are connected by a wire which permits the current to flow when

the instrument is not in use. In arrangement III., both are break contacts, and the connecting wire is removed. The upper limit of height of fall, with this instrument, is 25 cm.

III. *Stimulators*.—(1) For simple reactions to *noise* we may employ the instrument shown in Fig. 53.

A is a spring forceps, of a size to hold, with jaws parallel, an ivory or steel ball of 2.5 cm. diameter. To the lower edge of the one jaw is hinged a plate, *p*, which can be turned up to the horizontal position, and then forms a floor for the ball to rest upon.

To set the ball in place, the handles are lightly squeezed with the right hand, and the jaws opened. Ball and plate are brought up between the thumb and fingers of the left hand, until the plate strikes against the opposite jaw, and the ball rests upon the horizontal floor. The right

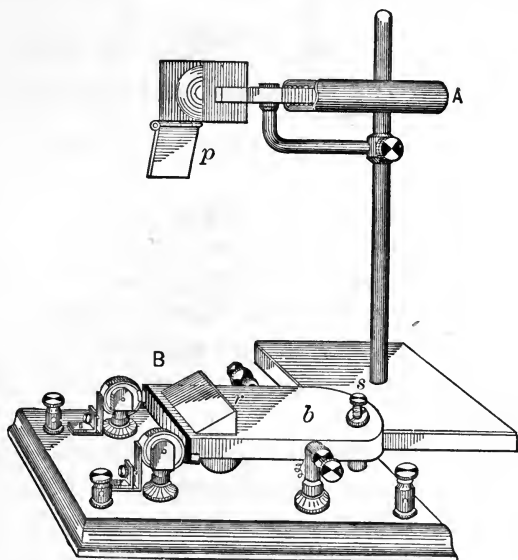

FIG. 53. Sound stimulator.

hand is then relaxed; the ball is firmly held; and the floor, as the left hand is taken away, swings down and out, leaving the ball a free space to fall through. By means of *p* the ball can always be set at precisely the same height.

B consists of a board, *b*, pivoted upon a horizontal axis, and carrying a block of hard rubber, *r*, upon which the falling ball strikes. The front edge of *b* is faced with hard rubber, and rests upon the pins of two wheel-contacts, the one of which is a break, the other a make contact. The current passes from the forward binding post of either side through the wheel-contact, and thence along a wire fastened beneath *b* to the corresponding binding post at the far end of the base. The instrument may thus be used either as a make or as a break stimulator. The stimulus, whose intensity may be varied by varying the height of *A* upon its standard, is the noise caused by the striking of the ball upon *r*: the ball itself is caught on the rebound in a pocket (not shown in the Fig.). The movement of *b* about its axis is regu-

lated by the set-screw *s* and by a block of hard rubber, faced with several thicknesses of felt, set in the wooden base immediately below *r*.

An instrument frequently used as a make stimulator is the sound hammer shown in Fig. 54. The wires of the reaction cir-

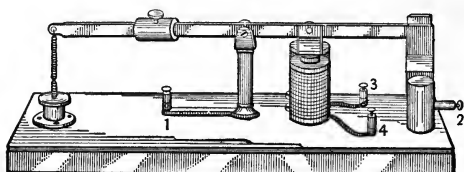

FIG. 54. Sound hammer.

cuit are led to the binding posts 1, 2; the posts 3, 4 of the electromagnet are in connection with a battery and key. When the electromagnetic circuit is closed, the head of the hammer is drawn down upon the block; a sound is thus made at the moment that the reaction circuit through 1 and 2 is completed. The sound may be graduated over a fairly wide range of intensity.

(2) The following arrangement (break stimulator) will serve for simple reactions either to *tone* or to *noise*. We place in the reaction circuit a double key,—a key that will break this circuit at the same instant that it makes a second, independent circuit. The second circuit includes a battery, and the transmitter and receiver of a telephone; the latter is in the reacting room. At the moment that the key is pressed, and the reaction circuit broken, the closure of the telephone circuit makes a click in the receiver. The click serves as noise stimulus to reaction.

If an electric tuning fork is kept vibrating before the transmitter, a tonal stimulus may be given. The pressure of the key breaks the reaction circuit, as before; the simultaneous closing of the telephone circuit means that the fork-tone begins to sound in the receiver.

(3) For simple reactions to *clangs*, we may employ the instrument shown in Fig. 55. A wire is stretched before a sounding box, and is set vibrating by means of a metal pick held in the hand. At the beginning of the experiment, wire and pick

are pressed together; the pluck of the wire breaks the low-resistance circuit. Wires of different cross-section and tension may be used.

The chronoscope circuit of Fig. 55 contains, besides the reaction key, a sound hammer and control hammer. When clang reactions are to be taken,

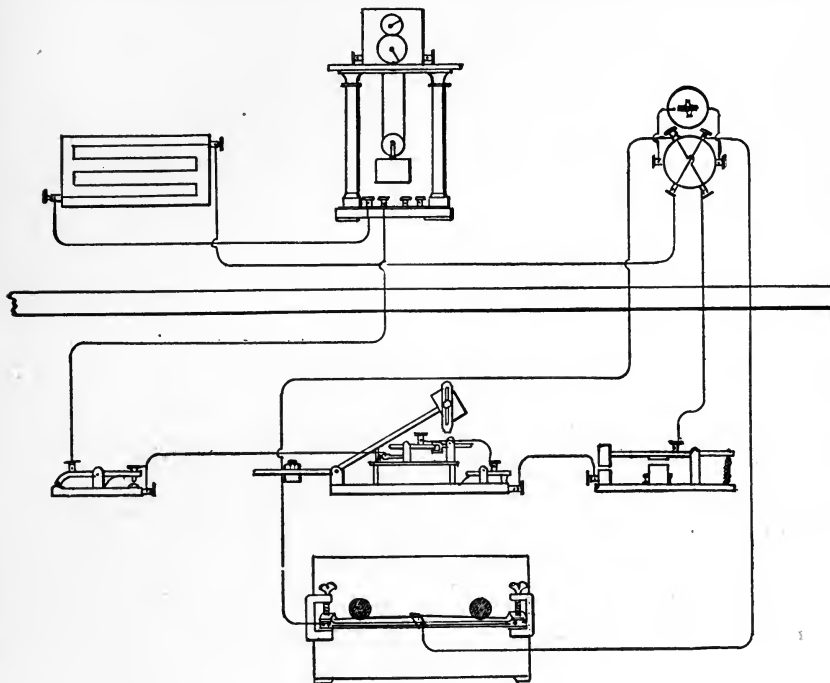

FIG. 55.

See G. Martius, *Philos. Studien*, vi., 1891, 403.

the two hammers are closed. For comparative purposes, noise reactions may be taken with the sound hammer: the control hammer is then closed, and the low-resistance circuit (wire and pick circuit) left open. Control times for the noise reactions may be taken with the control hammer in its present position: key and sound hammer are closed; the low-resistance circuit is open; the hammer makes the high-resistance circuit as it falls past the upper contact, and breaks it again at the lower contact. Control times for the clang reactions are taken by connecting the wires of the low-resistance circuit to an upper break-contact, and the wires of the high-resistance circuit to a lower break-contact on the control hammer: key, sound hammer, and wire-and-pick are closed. As the hammer falls, it first breaks the low-resistance circuit (the clock hands move), and then breaks the high-resistance circuit (the clock hands stop).

(4) *Light* stimuli are usually given by means of a pendulum, a falling screen, or a shutter.

(a) A pendulum stimulator (make) is shown, in schema, in Fig. 56. A

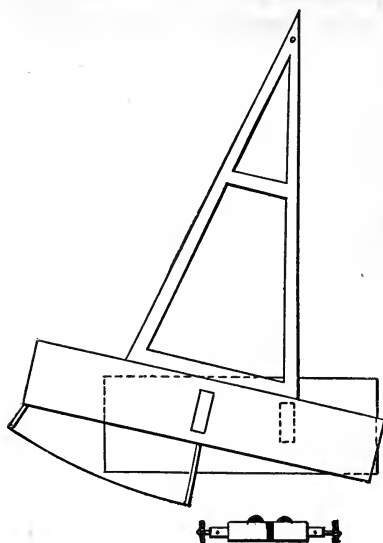

FIG. 56.

Schema of the Wundt-Lange optical pendulum.

The wire is long enough to keep the circuit closed until the movement of reaction has been made.

If the pendulum is to be used as a break stimulator, the mercury cups are placed crosswise to the swing of the pendulum, and are provided with small lateral orifices, between which a delicate bridge of mercury is formed. The pendulum screen now carries, instead of the wire, a plate of mica. As the pendulum falls, the plate severs the mercury bridge, and the contact is broken. The device is shown schematically in Fig. 57.¹

(b) A simple form of the falling screen apparatus, or gravity chronometer, is shown (back view) in Fig. 58. For purposes of experiment, the space between the lateral pillars in front may be filled, *e. g.*, by black cardboard, in which a horizontal slit has been cut. A strip of similar cardboard is placed between the clips at the back of the instrument; so that *O* fixates a black slit in a black surface. The heavy screen, which falls when the electromagnetic circuit is broken, is faced

¹ Here, as everywhere, mercury has its disadvantages, and the wet contacts may well be replaced by wheel contacts of the kind shown above, Fig. 53.

with white paper. At the moment that the white begins to show in the slit, the screen makes or breaks a wheel contact attached to one of the pillars: the contacts are not shown in the Fig. Electromagnet and clips are both adjustable in the vertical direction. The noise made by the drop of the screen upon the base of the instrument comes later than the reaction movement.

The gravity chronometer has been built in various forms, and used for a variety of purposes. If great accuracy is required, the pillars may be made higher, and the screen allowed to fall from a correspondingly greater height. If long exposures are needed, the principle of the Atwood machine may be applied.

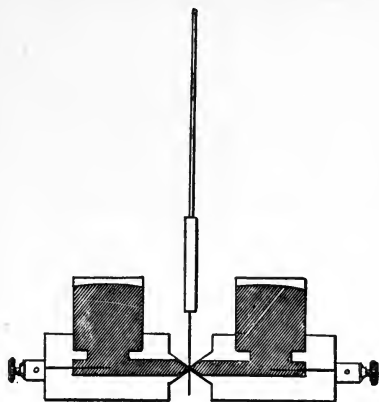

FIG. 57. Krille's interruptor.

The two pointed wires projecting from the lower edge of the screen in Fig. 58 make connection, when the screen drops, between two mercury pools; the closure of the circuit coincides with the exposure, through a slit in the screen itself, of a printed word or other visual stimulus on the card held by the clips. This, and not the arrangement of the apparatus for the simple reaction, is the arrangement represented in the Fig.

(c) The requirements of a shutter for simple reactions are that it shall work noiselessly, and that it shall make or break a circuit at the moment that exposure begins. These requirements are most simply fulfilled if the shutter be pivoted upon a horizontal axle which also carries a wheel contact; the shutter may be opened by means of a weight.

(5) *Pressure* stimulators (areal) for break and make are shown in Figg. 60, 61. In both, the stimulus is given by a rounded hard-rubber surface. The hook at the tip of the make stimulator is made of bone. The distance between the platinum point on the spring and a corresponding platinum plate on the bar (not shown in Fig. 61) is 0.5 mm. It is clear that a short interval must elapse between the giving of the pressure stimulus and the making of the reaction circuit. With practice, this interval becomes constant, and does not exceed 3σ .

For punctual stimulation, the springs should be made very flexible, and the hard-rubber bosses be replaced by stout hairs.

Fig. 62 shows an arrangement for simple reaction to *electrical* stimuli (break shocks of an induced current), the stimulus being applied to the reacting finger. *A* is an Ewald chronoscope, an electromagnetic counter

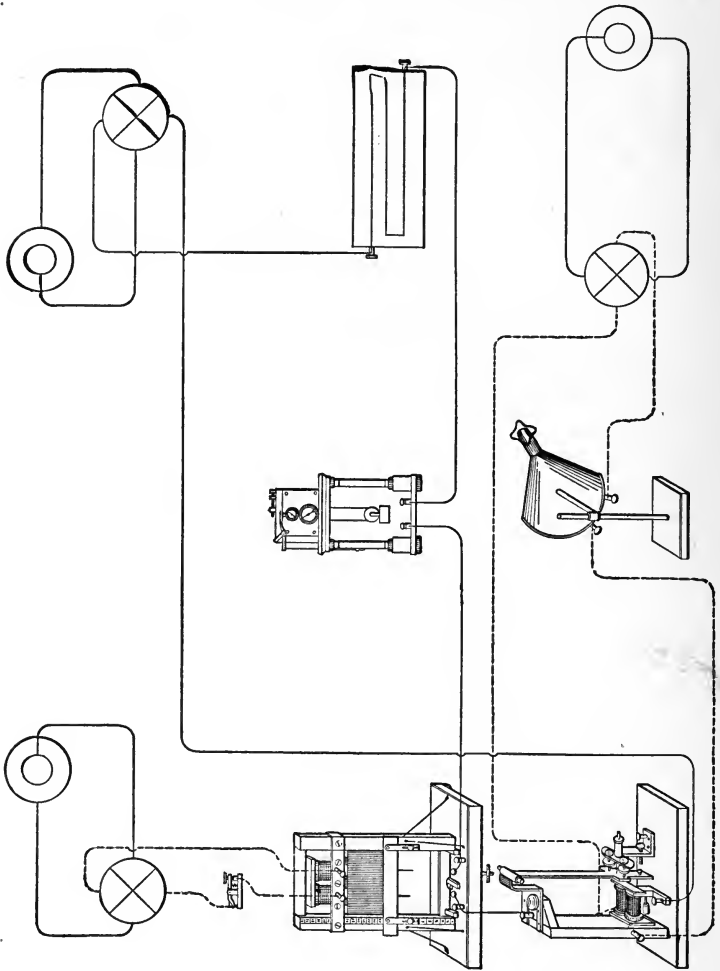

FIG. 58.

See J. McK. Cattell, *Philos. Stud.*, iii., 1886, 315.

carrying a disc graduated in hundredths, and actuated by a 100 vs. electric fork. *B* is the reaction key: the hardrubber button, upon which the finger rests, is pierced by two fine wires, ending above in small plates,

which are connected (by way of binding posts not shown in the Fig.) with the secondary coil of an inductorium. *C* is an electric bell, arranged to give a single short stroke as warning signal. *D* is a rocking key; and *E* is a cardboard disc fitted to the lower surface of a kymograph drum.

The drum is so placed that the periphery of the cardboard disc bears upon the left-hand lever of the rocker. As the disc moves forward, the lever drops into the depression *ab*; at the moment of passing *a*, it assumes the position indicated in the Fig. The current can now flow through bell and inductorium: the signal sounds, and the make-shock is given. This shock is, however, not felt, since it is only after hearing the bell that *O* lays his finger upon *B*. The drum moves on; and at *b* the current in the inductorium is broken. *O* now receives the stimulus of the break-shock. At the same moment, the current through chronoscope, fork and key is made. The counter begins to record the vibrations of the fork, and continues to do so until the circuit is broken by *O*'s reaction. The time of reaction is then read off from the chronoscope disc, in hundredths of a sec., and the pointer is brought back to *o* by a turn of the wheel indicated in the Fig. Meantimé the drum is revolving; at *a'* the signal and make-shock recur, at *b'* the break-shock is given and the clock circuit made; and so on.—The arrangement may be simplified by omitting the bell signal and kymograph, and moving the rocker by hand.

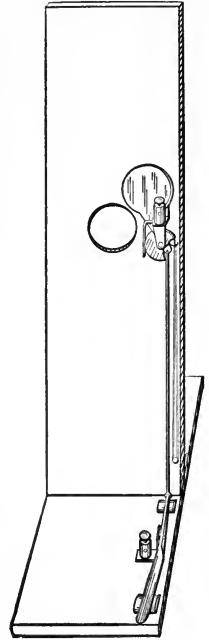

FIG. 59.
Jastrow's shutter.

(6) A make stimulator (areal) for *temperature* is shown in Fig. 63. The rounded cup of metal at the tip, through which the

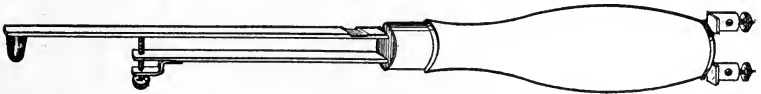

FIG. 60.
Scripture's touch key.

water flows and by which the stimulus is applied, has a diameter of 10 mm. and a height of 13 mm. The receiving vessel on the handle is 14 mm. in diameter and 28 mm. high; it is closed by a cork, through which is passed a small thermometer reading to

0.2°. The receiving tube is supplied from a stationary vessel of hot or cold water, also furnished with a thermometer; this vessel should stand fairly high, in order that the water may circulate freely through the stimulus cup. The error of the apparatus is said to be negligible.

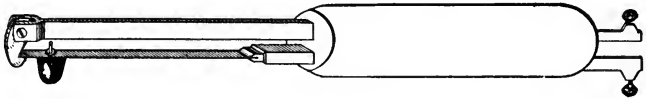

FIG. 61.
Dessoir's sensibilometer.

By inverting the position of the two arms, on the pattern of Fig. 60, the instrument may be changed to a break stimulator.

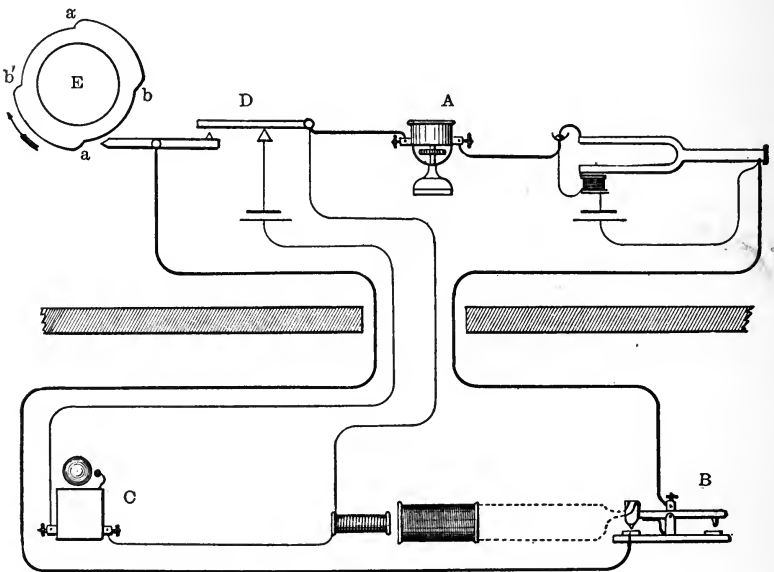

FIG. 62.
See O. Dumreicher, *Zur Messung der Reactionszeit*, 1889, Fig. 2.

All temperature stimulators, except those that employ the principle of radiation (and they are not satisfactory), give a pressure before they give the

required warm or cold stimulus. *O* quickly learns, however, to withhold the reaction movement until he senses the warmth or cold.

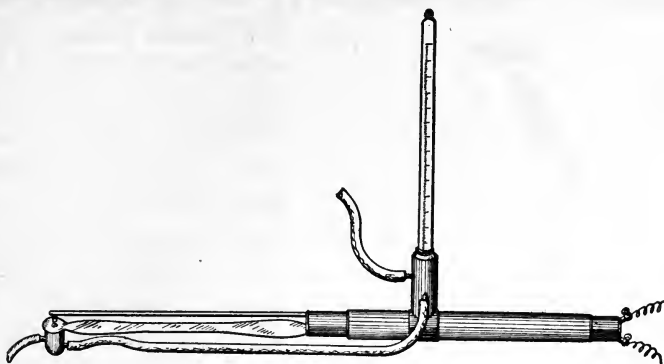

FIG. 63.
von Vintschgau's thermophor.

Punctual stimulation may be effected by the instrument shown in Fig. 64. A hollow tin cone, brought below to a fine point, is closed by a cork, through which pass two glass tubes and a thermometer. The tubes are connected by rubber tubing with tubulated bottles, the one of which contains hot, the other cold water. The temperature of the water in the stimulator may easily be regulated by raising or lowering the one or other of the bottles. To avoid the effects of radiation, the cone is covered, except at its extremity, by a coat of gutta-percha. *O*'s hand and arm rest in a plaster mould, and the skin is covered with a thin sheet of gutta-percha, so pierced as to allow of the stimulation of a marked temperature spot. The stimulator is fixed to a standard, and can be raised or lowered by crank and gears. Arrangements are made whereby a circuit is made or broken as nearly as possible at the moment of application of the temperature stimulus to the skin.

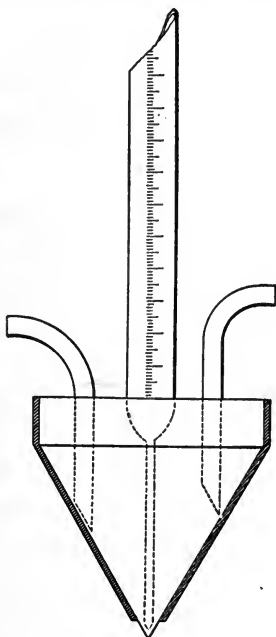

FIG. 64.
Kiesow's temperature stimulator.

(7) It is difficult to find a way of giving *olfactory* stimuli that shall be free of error. Fig. 65 shows a break stimulator. An oval capsule of hard rubber contains the odorous substance. A glass tubule at the lower pole leads by way of rubber tubing to a double rubber bulb, of the sort used with atomisers. Two glass

tubules are introduced symmetrically at the upper pole : the one leads, by way of rubber tubing, to a glass bulb for insertion into

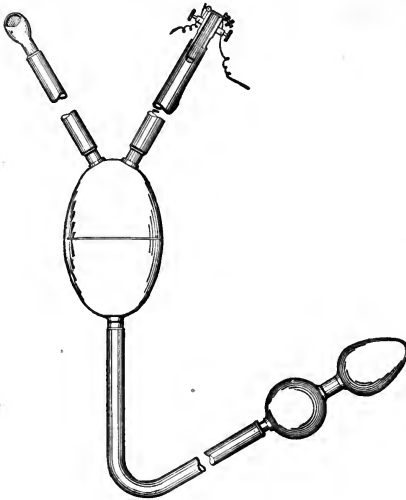

FIG. 65.
Moldenhauer's smell stimulator.

the nostril ; the other, by an equal length of tubing, to a break contact. This latter consists of a plate of aluminium, furnished with a platinum plate which rests upon an adjustable platinum point : the mechanism will be understood from the Fig. The stimulator is clamped to a standard. When the apparatus is ready for use, the rubber bulb is squeezed, and the current of scented air passes out through the two upper tubules, entering the nose at the same moment

that it throws back the aluminium plate and so breaks the reaction circuit.

The inconveniences of the arrangement are as follows. (a) Separate capsules must be provided for different scents. (b) There is no way of grading the intensity of the stimulus with any degree of accuracy. (c) The noise from the rubber bulb is distracting, as is (d) the rush of air into the nostril, which gives a pressure stimulus before the odour is smelled. (e) The smell of the stimulus is complicated by the smell of the rubber tubing. (f) The reaction circuit is broken before (and we do not know how long before) the odorous stimulus reaches the olfactory mucous membrane.

A make stimulator is shown in Fig. 66. A hollow handle of hard rubber carries a small metal cup, *C*. Handle and cup are pierced by the hard rubber rod, *AB*, which terminates above in a metal knob, fitted to close the aperture of *C*. A spiral spring, wound around *AB*, tends to press it downwards, and so to open *C*; this action is prevented by the pin *P*. Two arms, *D*, attached to *AB*, carry platinum points ; and two metal strips, *E*, carrying platinum plates, are connected with binding posts at the base of the handle. At the beginning of an experiment, the

odorous substance (dropped on sponge or cotton wool) is placed in *C*. *O* withdraws the pin *P*; *AB* is driven down by the spring; and contact is made between *D* and *E* at the same time that the smell stimulus is presented. For a second experiment, *B* is pushed up until *P* catches the shoulder of the rod and *C* is closed.

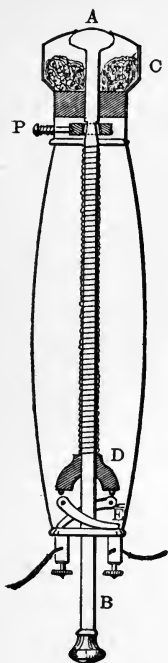

FIG. 66.
Buccola's smell stimulator.

It is clear that this stimulator is open to much the same criticism as has been passed upon the other. Better than either is the arrangement shown in Fig. 67. The flask introduced between the T-piece of the inhaling tube and the rubber tubing that leads to the tambour prevents any admixture of india rubber with the olfactometer stimulus. The writing lever of the tambour records on the kymograph the whole course of *O*'s inspiration. The reaction key is arranged for air transmission; and a 100-fork writes a time line from which the duration of the reaction may be read.

(8) Make and break stimulators for *taste* may be constructed on the analogy of Figg. 60, 61. The spring is made light and flexible, and the hard rubber boss is replaced by a fine camel's-hair brush.

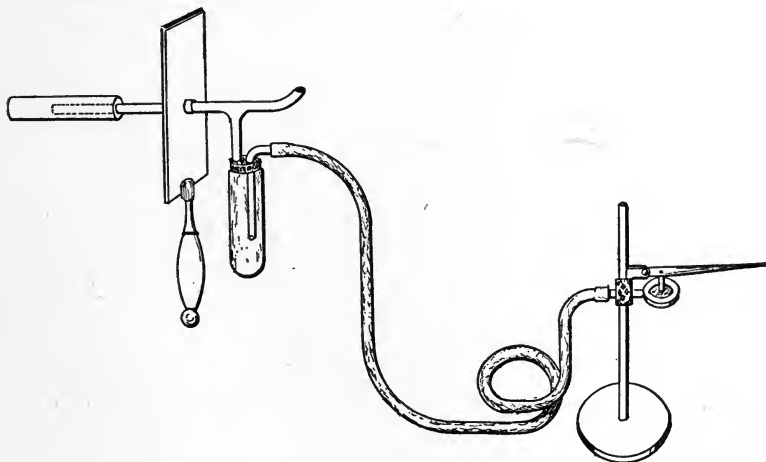

FIG. 67.
Zwaardemaker's arrangement for olfactory reactions.

iv. *Reaction Keys*.—Any form of voluntary movement—movement of hand, foot, lips, jaws, larynx, eyelid—may serve as response to the reaction stimulus. The movement most commonly employed in work upon the simple reaction is a finger movement, and the key is a finger key modelled upon the ordinary telegraph

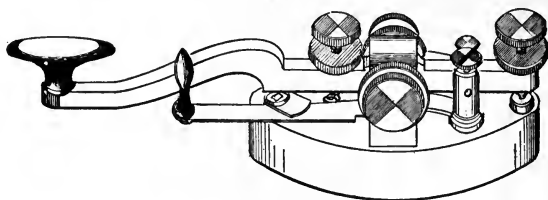

FIG. 68.

key (Fig. 68). The key may be permanently closed (for control experiments) by means of the brass strip and clutch attached to the base. The forefinger of the right hand is laid upon the hard rubber cap, thus holding the key closed; the reaction movement consists in the lifting of the finger and consequent break of contact. The rest of the hand and the arm are supported by a cushion, plaster mould, or what not, placed conveniently upon the table. The movement may be a simple lift of the finger, or may be made laterally (up and to the right), as *O* prefers.

If a downward movement of the finger is preferred, the key has the form shown schematically in Fig. 69. The finger is

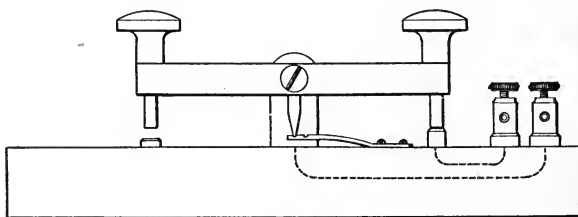

FIG. 69.

Jastrow's reaction key.

laid lightly upon the left-hand cap, a sharp pressure upon which breaks contact. The key remains open, after the reaction movement has been made, since the wedge-shaped point at the centre slips into the second notch in the spring.

Fig. 70 shows a key in which the movement of reaction consists in the opening of the closed thumb and forefinger.

The key consists of two hard-rubber blocks running on steel guides: the lower block may be fixed in any required position by means of a set-screw; the upper moves up or down with the movement of reaction. If the key is held free in *O*'s right hand, the forefinger is inserted in the hole of the upper, the thumb in that of the lower block. If it is fastened to a support, or held in *O*'s left hand, the thumb of the right (the reacting) hand is placed against the projecting hook of the lower block. The three binding-posts enable us to use the key for breaking a circuit by a movement either of flexion (upper and middle) or of extension (middle and lower posts). It may also be used, though less accurately, as a make key: for a movement of flexion, the circuit wires are carried to the middle and lower, for a movement of extension, to the upper and middle binding-posts. The lost time of the make-records may be reduced to a minimum by adjustment of the lower sliding block.

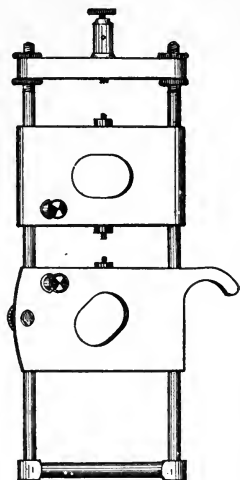

FIG. 70.
Scripture-Dessoir reaction key.

Fig. 71 shows a lip key. The two ivory plates at the ends of

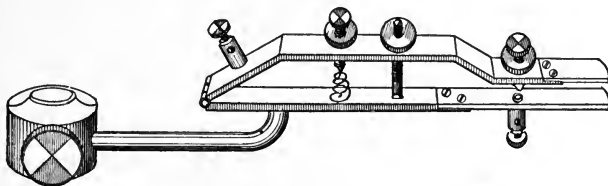

FIG. 71.
Cattell's lip key.

the brass arms are held between the lips, and the key is thus kept closed until the parting of the lips opens it.

A speech key may be constructed as follows. A bit of soft wood, fitted to the teeth, is pivoted at the long end of a metal lever, the short end of which plays between hard rubber and a brass contact. The lever is held against the rubber by a spring. The wood is taken between the teeth, the head exerting such a pull upon it that the lever is held in contact with the brass. The natural movement of separating the teeth in speaking frees the

short end of the lever, which is thus drawn away from the brass contact by the spring.

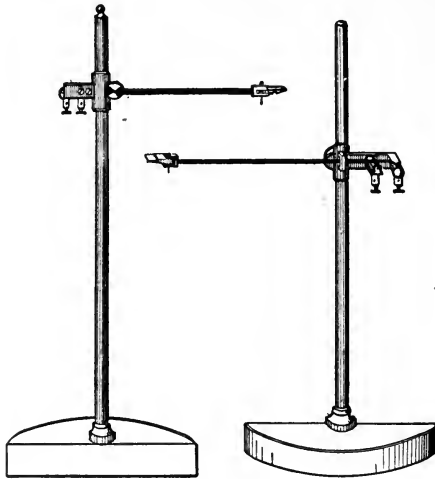

FIG 72.

Jastrow's speech key. The spring, which may be an ordinary elastic band, is not shown in the Fig.

A voice key has been shown in Fig. 58. It consists, first, of a funnel, fitted with a mouthpiece at its smaller and a screw cap at its larger end. The cap is covered with fine leather, carrying at its centre (on the inside) a light platinum contact, connected with a binding post at the periphery. Across the ring of the cap is fixed a bar of metal (also on the inside), connected at one end with a binding post and carrying a platinum point against which the contact of the leather rests. When *O* speaks into the mouthpiece, the leather is driven away from the bar, and the contact is momentarily broken. To make this break permanent, the circuit passing through the cap of the funnel passes also through a relay (a permanent electromagnetic interruptor); as soon as the platinum contact is broken, the armature of the relay magnet is released, and the circuit is definitively broken.

QUESTIONS.— *E* and *O* (1) We have noted certain sources of error in the use of Moldenhauer's smell stimulator. What sources of error are involved in the use of the taste stimulator?

(2) Suggest a stimulator for use in pain reactions.

(3) Work out the details of a temperature stimulator (punctual stimulation) from the directions given on p. 161.

(4) "The Hipp chronoscope has proved itself a most satisfactory time-piece, and perhaps the same principle might be made use of in a chronoscope that would record with an equivalent degree of accuracy the ten-thousandth part of a second" (Witmer, *Psych. Rev.*, i., 1894, 515). What are the chief faults of the Hipp chronoscope as a reaction instrument? What is the significance of the third figure of the recorded times? What would be gained by recording to the nearest ten-thousandth?

(5) Devise a portable reaction outfit, that shall serve for simple reactions to light, sound and pressure.

(6) Devise a pressure stimulator that may be controlled, like the sound hammer or the light pendulum, by an electromagnet.

(7) To what various uses may the Pohl commutator be put?

§ 25. **The Three Types of Simple Reaction.**—Our first task is to measure the time of the simple reaction, in its natural, complete and abbreviated forms. We will begin with reaction to sound; and we will employ, to start with, arrangement II of the reaction circuit.

EXPERIMENT XXIV

MATERIALS.—Constant current of 50–70 milliamperes. Galvanometer. Two-way switch. Hipp chronoscope, new pattern. Rheochord. Commutator. Control instrument. Sound hammer. Break finger-key. Wire (no. 18 B. & S. gauge).—Screen. Cushion or plaster mould.

For magnet of sound hammer. Dry battery. Commutator. Wire.

For magnet of control instrument. Dry battery. Commutator. Wire.

For signal circuit. Dry cell. Two push buttons. Two signals. Wire.

[We may assume that the total resistance of the clock circuit is in the neighbourhood of 100 ohms. We shall accordingly require, for a current of 60 milliamperes, a pressure of 6 volts.

Most of the appliances have been described above. A simple form of *galvanometer*, supplied by the makers of the Hippchron-

oscope, is shown in Fig. 73. It has a range of 0 to 100 milliamperes, and is accompanied by a printed table giving the absolute values of the deflections of the needle.

The two-way *switch* is shown in Fig. 74. The movable arm can be brought over either of the two contact points.

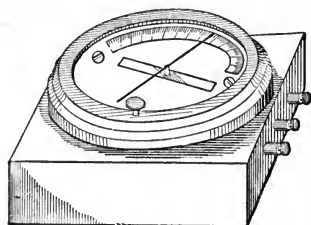

FIG. 73.

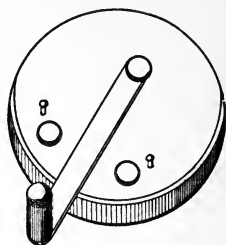

FIG. 74.

The *rheochord* usually supplied with the accessories to the chronoscope is shown in Fig. 75. It consists of a length of fine German silver wire, looped about binding posts, and of two plati-



FIG. 75.

num wires, which pass through a hard-rubber trough filled with mercury. The German silver wire gives the coarse, the platinum wires give the fine adjustment.

The *screen* stands on *O*'s table, between the stimulator and the reaction key. The *cushion* lies on the table, before the key.

The *wire* is 'annunciator wire,' double cotton covered and paraffined.

The two *signals* are actuated by a single cell (three wire connection). The signal in *E*'s room may be an ordinary electric bell. The signal in *O*'s room should be a buzzer or a single-stroke bell. The latter may easily be made from the ordinary bell, by bending the contact-spring so that contact is not broken when the current passes through the magnet. It is well, further, to stick a lump of wax to the inside of the gong; the tone is thus rendered shorter and less resonant.]

DISPOSITION OF APPARATUS.—The instruments must be so arranged that *E* is at the centre of the group, able to control every piece without rising from his chair. They must be so arranged, also, that the manipulations take place in a natural and easily memorised order. Fig. 76 shows a satisfactory disposition of the apparatus in arrangement II.

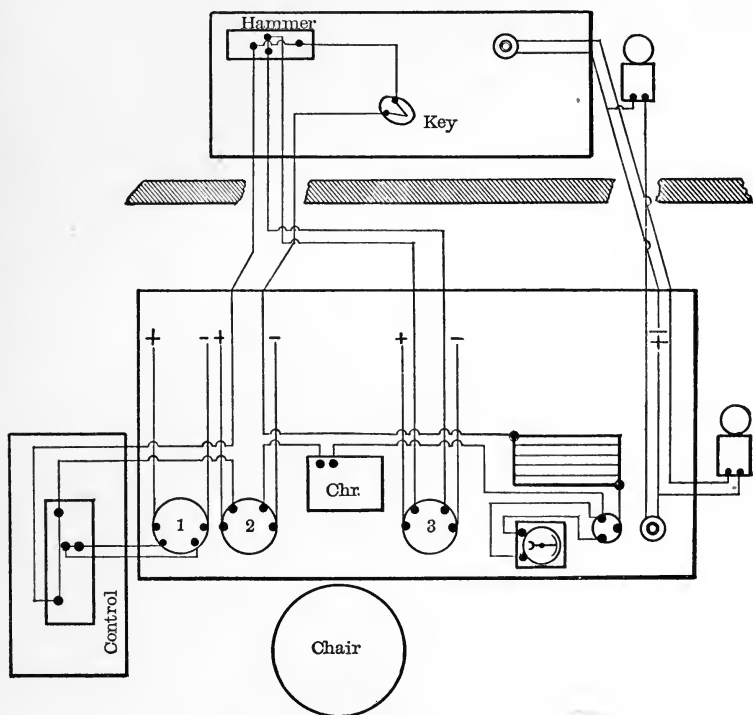

FIG. 76.

E sits on a swivel chair directly facing the chronoscope. The commutator of the reaction circuit (marked 2 in the Fig.) is placed to the left of the chronoscope. Wires running from the farther poles of the commutator connect in series the control instrument, the sound hammer and reaction key, the rheochord, the galvanometer (this only when the switch is so closed as to include the instrument in the circuit), and the chronoscope. Rheochord and galvanometer are placed to the right of the chronoscope, within easy reach of *E*; the control instrument stands

on a separate table to his left ; the sound hammer and key are on a table in an adjoining room. Commutator 3, which controls the magnet of the sound hammer, is placed to the right of the chronoscope ; commutator 1, which controls the release magnet of the control instrument (pendulum, gravity chronometer, or hammer), is placed to the left of commutator 2. The push button of the signal circuit lies to the extreme right of E ; the electric bell is on the wall of the room. The batteries, indicated in the Fig. by the signs + and —, may stand on or under the table. If batteries are not employed, the wires are led to the source of supply, wherever in the room that may be.

The screen (not shown in the Fig.) is set up, on O 's table, between sound hammer and key. The key is fixed in such a position that O , seated at the table in the attitude most comfortable for him, can lay his finger easily and naturally upon the button. The cushion or plaster mould supports his extended arm. To the right of the key is a push button which rings the bell in E 's room. The single stroke bell is on the wall of the room.

COURSE OF AN EXPERIMENT.—We may anticipate a little, in order to illustrate, by help of the Fig., the course of a reaction experiment. Let us suppose that E and O are seated at their respective tables. The three commutators and the reaction key are open ; the control instrument is closed, so that current can flow directly through it ; the galvanometer has been switched out of the reaction circuit ; the clock has been wound, and the time shown by the dials has been recorded. The procedure will then be as follows.

(1) E places his left hand upon the rocker of commutator 2, and pulls it down towards him. The chronoscope circuit is now broken only at the sound hammer and key. (2) With the same hand, E pulls the nearer cord of the chronoscope, and starts the clockwork. The tone of the regulating spring assures him that the clock is running aright. (3) Reaching out with the right hand, he presses the button of the signal circuit, and thus gives warning to O to close the reaction key. (4) After a short 2 sec., he pulls down (with the same hand) the rocker of commutator 3, and thus gives the reaction stimulus. The clock-hands immediately begin to move, and stop only on the breaking of contact

at the reaction key. (5) As soon as they stop, *E* pulls the farther cord of the chronoscope (left hand), and (6) throws open the commutators 2 and 3 (left and right hands). Everything is now as it was before the experiment was taken, except that current has been passed through the chronoscope magnets in a certain direction and that the clock-hands have assumed a different position. (7) *E* then records the time, as shown by the dials. A signal from *O* (coming, probably, just as he is about to take the reading of the clock) assures him that affairs have gone smoothly in the reacting room.

A second experiment exactly repeats the first, except that in it the commutator rockers are thrown over, away from *E*, and the direction of current in the chronoscope magnets is thus reversed. With a little practice, the experiments run their course almost automatically.

The direction of the commutator rockers in the first experiment of a series should always be noted on the record sheet. In the present instance, the word 'in' would be written below the column of figures, since we have assumed that in the first experiment the rockers are pulled down towards *E*. Had they been thrown over, the word 'out' would have been written. This rule is necessary, since *E* may, by some chance, forget the manipulation in a given experiment. If he knows that all the odd-numbered experiments are 'ins,' and all the even-numbered 'outs,' or conversely, the lapse of memory does not matter.

We may now look at the experiment from *O*'s point of view. After seating himself at the reaction table, *O* signals *twice* to *E*, to indicate that he is ready. He then lays his right arm on the cushion. As soon as he hears *E*'s signal, he closes the reaction key, and listens for the sound of the hammer. Having reacted, he ticks off the experiment, by its number, on his record sheet; or, if anything has gone wrong with the apparatus, if his attention has wandered, etc., makes a brief note to that effect. He then signals *once* to *E*. Finally, he replaces his arm on the cushion, and passively awaits *E*'s second signal.

If the preliminary work has been properly done (and it is *E*'s business to do it properly), the apparatus will work without any hitch, and *O*'s signal will simply be an acknowledgment to *E* that an experiment has been made. It is very important that *E* and *O* keep in touch, in this way, from experi-

ment to experiment ; nothing is more annoying than to have, say, 50 experiments recorded in the one room and only 49 in the other.

No more elaborate signalling is necessary, and none should be attempted.

CONTROL EXPERIMENTS.—We must now go back again to the apparatus. Before work upon reaction times is begun, the clock must be regulated. The procedure is as follows.

The contacts of the control instrument are carefully set to some known time : say, 150σ . The reaction key is closed, by the short-circuit switch ; the sound hammer is also closed, either by relaxing the spring or (more conveniently) by slipping a block of wood between the hammer head and the restraining arm that projects above it. The galvanometer is switched out of the clock circuit ; the eccentrics at the back of the clock are turned down.

E pulls down the rocker of 1, and brings up the control hammer (or screen or pendulum) to its magnet. He then pulls down the rocker of 2, and starts the clockwork by a pull upon the nearer cord. The circuit is not yet closed, and the pointers of the chronoscope dials do not move. As soon as the clock gives out its proper tone, *E* opens 1, and the hammer falls. The clock-hands move during the 150σ that elapse between make and break of the control contacts. As soon as they stand still, *E* pulls the farther cord, and stops the clockwork ; he then opens 2. The time recorded by the chronoscope is noted. The experiment is repeated, with reversal of the rockers.

The results of these two trials should be sensibly the same. If the time recorded is more than 150σ , the current must be weakened (more resistance put in the clock circuit) ; if it is less than 150σ , the current must be strengthened (resistance taken out of the circuit, or an extra cell added to the battery). The current is to be regulated, until the clock records an average 150σ in ten successive trials, with an *MV* of not more than 1.5σ . The position of the eccentrics should not be changed, if change can be avoided.

When the right strength of current has been found, the control instrument is closed, and the galvanometer switched into the clock circuit. The reading of the needle, in both directions (both positions of the rocker of 2), is carefully noted. This

reading must be reestablished, by help of the adjustable resistance of the rheochord, for every series of reaction experiments. So long as the tension of the magnet springs and the strength of current remain the same, the clock will record an average 1500 as the equivalent of the control time.

The function of the control instrument, after this initial test, is to keep a check upon the variable error of the chronoscope. There are a good many connections in the circuit, and in course of time some contacts will become defective or some connections wear loose. Or some of the instruments may be required for other experiments in the laboratory, and may have been carelessly replaced. Hence it is possible that the clock times, even with the right strength of current as shown by the galvanometer, will presently become irregular. If this is the case,—if the clock times show an *MV* of more than 1.50,—the circuit must be overhauled, and the defects made good.

PROGRAMME OF WORK.—We are now able to make out the programme of an afternoon's work. (1) At the beginning of the laboratory period, the current is adjusted to its right strength by means of galvanometer and rheochord. (2) Ten control times are then taken; they give an average of 1500, with an *MV* of 1.50 or less. The reaction work proper now begins. (3) In the middle of the period, ten more control times are taken; the result should be as before. The reaction work is then continued. (4) At the end of the period, ten final control times are taken; again, the result should be as before. An increase of the *MV* indicates that the circuit needs inspection: an increase or decrease in the average time recorded means that the current strength has varied. The results of the control experiments must be entered, in full, in the note-book, along with the results of the reaction experiments.

The control experiments look more formidable in print than they are in fact. If the source of supply is constant, the first adjustment of the current takes only a couple of minutes; and the time required for 30 control experiments is quite insignificant.

ANOTHER ARRANGEMENT OF APPARATUS.—Fig. 77 shows a satisfactory disposition of the apparatus in arrangement I of the reaction circuit.

E sits on a swivel chair directly facing the chronoscope. The commutator of the reaction circuit (marked 2 in the Fig.) is placed to the left of the chronoscope. Wires run from the

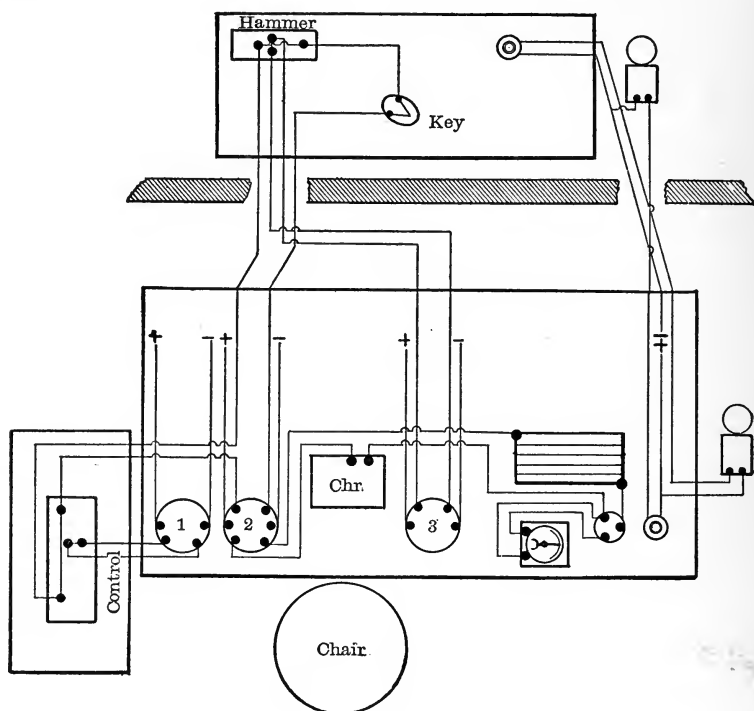

FIG. 77.

nearer poles of the commutator to the chronoscope, rheochord, and (by way of the switch) to the galvanometer: this is the high-resistance circuit *A* of the arrangement. From the farther poles, wires run, by way of the control instrument, to the sound hammer and reaction key: this is the low-resistance circuit *B*. Rheochord and galvanometer are placed to the right of the chronoscope, within easy reach of *E*; the control instrument stands on a separate table to his left; the sound hammer and reaction key are on a table in an adjoining room. Commutator 3, which controls the magnet of the sound hammer, is placed to the right of the chronoscope; commutator 1, which controls the release magnet of the control instrument, is placed to the

left of commutator 2. The remaining details of the arrangement will be understood from the Fig.

The preliminaries for an experiment are as given above, p. 170. The procedure, on *E*'s part, is as follows. (1) *E* places his left hand upon the rocker of 2, and pulls it over towards him. The chronoscope circuit is now closed; the hands of the clock will not move, even if the clockwork is started. (2) With the same hand, *E* pulls the nearer cord of the chronoscope, and starts the clockwork. (3) Reaching out with the right hand, he presses the button of the signal circuit. (4) After a short 2 sec., he pulls down (with the same hand) the rocker of 3, and thus gives the reaction stimulus. The clock-hands immediately begin to move, and stop only on the breaking of contact at the reaction key. (5) As soon as they stop, *E* pulls the farther cord of the chronoscope (left hand), and (6) throws open 2 and 3 (left and right hands). Everything is now as it was before the experiment was taken. (7) He then records the time, as shown by the dials. A signal from *O* assures him that affairs have gone smoothly in the reacting room.—A second experiment repeats the first, except that in it the rockers are thrown over, away from *E*. For *O*'s duties, see above, p. 171.

Adjustment of Current Strength.—Suppose that we take the resistance of *A* to be 200, and that of *B* to be 20 ohms. We know that a current of 60 milliamperes is sufficient for the clock circuit in arrangement II. Let us assume that the same current suffices for the present arrangement. We shall then require, for circuit *A*, a pressure of 12 volts.

It is necessary, now, that the current remain constant both (1) when *A* alone is closed, and (2) when *A* and *B* are closed together. The joint resistance of the two conductors, whose separate resistances are 200 and 20 ohms, is approximately 18.2 ohms. To force a current of 60 milliamperes against a resistance of 18.2 ohms requires a pressure of 1.09 volts. And of the 60 milliamperes, $\frac{20}{220}$ or 5.5 will be in the clock circuit *A*, and $\frac{200}{220}$ or 54.5 in the low resistance circuit *B*. In other words, under the conditions that we have laid down, the closure of both *A* and *B* will mean that we have in the clock circuit a current of 1.09 volts, 5.5 milliamperes.

The following questions now arise. Is our initial assumption (that we can work with a current of 12 volts, 60 milliamperes) correct? How must we arrange our battery, to secure a constancy of the current delivered (1) for *A* alone, and (2) for *A* and *B* together? Is a current of 1.09 volts, 5.5 milliamperes so small as to leave the clock unaffected? Is the ratio of

resistance 200 : 20 a good ratio to choose, or can it be improved upon?—These questions should be answered both theoretically and experimentally.

Control Experiments.—The procedure is as above, p. 172, except that the eccentrics at the back of the clock are turned up. The clock-hands move during the 150σ that elapse between make and break of the control contacts, *i. e.*, between make and break of circuit *B*.

The clock time may be standardised, *mutatis mutandis*, as in arrangement II. It may, however, be simpler first to adjust the current so that the apparatus works well, and then to use the control instrument as a control of both constant and variable errors. Suppose, *e. g.*, that with a given current the clock records 160σ, with an *MV* of 1.5σ or less. We may either adjust the current until the clock records 150σ, or we may leave things as they are, and correct our reaction times after the event for a constant error of +10σ. In the latter case, we use the galvanometer merely to indicate the strength of current employed.—Consult with the Instructor as to which of these alternatives is to be adopted.

PRACTICE, FATIGUE, ETC.—The effect of increasing practice is to shorten the time of reaction, and to reduce its variability. Both *E* and *O* have had so much practice in reaction work as is required by Exp. XXVI., vol. i., 117 ff. Under these circumstances, we may assume that a fairly constant level of practice will be attained if one whole afternoon is devoted to practice experiments. These experiments must be made as carefully and conscientiously as the experiments that are to be used for computation; their results are to be entered in the note-book.

The effect of increasing fatigue is to lengthen the time of reaction, and also to increase its variability. To avoid this source of error, we make the experimental series short, and interpose periods of rest between series and series.

However practised *O* may be, he comes a little strangely or unpreparedly to each new series. One or two experiments must be taken before he ‘warms up’ to the work, or ‘gets into the swing’ of the procedure. This fact, together with what we have said of the influence of fatigue, makes it advisable to begin the work with series of 13 experiments; to leave 5 min. pauses between series and series; and to discard the first 3 experiments of each series for purposes of computation.

The 3 discarded experiments are, of course, to be entered in the note-book. If the work is long continued, so that *O* attains a fairly high level

of practice, the series may be increased to 22, of which only the first 2 experiments are discarded.

TREATMENT OF RESULTS.—(1) The apparatus which we employ in the reaction experiment is to work within certain limits of error ($\pm 1.5\sigma$, in our illustrations), and is to be manipulated in a certain time-order and with a certain time-interval between signal and reaction stimulus. If these rules are infringed, the result of the experiment is worthless, and must be discarded.

It may happen, *e. g.*, that *E* is disturbed, and forgets to give the signal; or that, having given the signal, and noticing that the clock has nearly run down, he curtails the 2 sec. interval in his anxiety to save the experiment; or that a change in the tone of the regulating spring occurs after the signal has been given; etc., etc. Under such circumstances, the faulty experiment is noted, but its result is discarded, and the series is lengthened by one experiment. The case becomes more serious if two or three disturbances of the kind appear in the course of a 13-experiment series. At best, the insertion of the additional experiments required to give 10 valid results is likely to fatigue *O*; and if, further, *O* himself is led to suspect that *E* is careless, the reactions will not be made with the necessary sustained attention. *E*'s wisest plan is to cancel the series; to explain to *O* that something has gone wrong with the instruments; and to inspect the circuits and practice the manipulations over again. It need hardly be repeated that, with decent care, the experiments will run smoothly and mistakes occur but rarely.

Shall we discard, in the same way, the results of experiments which *O* declares by introspection to be worthless? No! We must keep a record of *O*'s introspections, when he gives them; but we must not throw out any of his results. The object of the experiment is to determine, in quantitative terms, *O*'s mode of behaviour under certain fixed conditions. *O* is, for the time being, a psychophysical machine, a reacting machine; and it is a part of our purpose to discover the variations to which such a human machine is liable. We are not now attempting the analysis of the action consciousness; the introspections, valuable as they may be, are only incidental: we are in search of *O*'s reaction time, and of the manner and limits of its variability. The fact that *O* occasionally makes mistakes, disobeys instructions, gives extremely high or extremely low time values, is a feature of his reacting behaviour which we must record, and allow its due place

in our final computation. We must not overemphasise it; but neither must we ignore it.

(2) A complete statement of the results of the reaction experiment includes a list of the different values obtained, and a record of the number of times that each value was found. Such a list and record are called, together, a *table of frequencies* or a *distribution*. The following Table, *e. g.*, shows the distribution of 400 reaction times.

It is important here to recall the fact that in measuring a quantity like reaction time we are measuring to the nearest scale mark,—with the Hipp chronoscope, to the nearest $\frac{1}{1000}$ sec. Thus, the value 158σ means a value that is nearer to 158σ than it is either to 157 or to 159 : means, *i. e.*, a time which lies between 157.5 and 158.5σ .

In constructing a table of frequencies, it is usual to take the unitscale-distances somewhat wider. In the following Table, the unit is 5σ : so that the value 120 includes all recorded times between 120 and 124 ; the value 125 all times between 125 and 129 ; the value 205 , all times between 205 and 209 .

TABLE OF DISTRIBUTION OF REACTION TIMES.

From E. L. Thorndike, *Theory of Mental and Social Measurements*, 1904, 25.

| TIME IN σ | FREQUENCY | TIME IN σ | FREQUENCY |
|------------------|-----------|------------------|-----------|
| 120 | 9 | 165 | 18 |
| 125 | 18 | 170 | 24 |
| 130 | 35 | 175 | 11 |
| 135 | 37 | 180 | 15 |
| 140 | 43 | 185 | 20 |
| 145 | 36 | 190 | 10 |
| 150 | 38 | 195 | 3 |
| 155 | 40 | 200 | 4 |
| 160 | 38 | 205 | 1 |

Such a Table may, evidently, be represented in graphic form.

The times are marked off, along a horizontal line, as abscissæ; the frequencies are denoted by columns of varying height erected upon these abscissæ. The figure thus obtained is termed a *surface of frequency* or a frequency polygon. The contour of the surface—the compound line that connects the tops of the columns, together with the horizontal base line—is termed a *curve of distribution*. Figg. 78–81 show various modes of constructing the frequency polygon from reaction data.

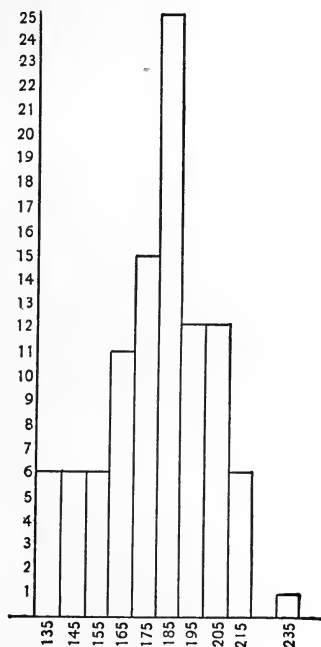

FIG. 78.

Frequency polygon of 'reaction times' of frog to electrical stimulation (method of rectangles). Unit of abscissæ=10σ. Number of experiments=100. From R. M. Yerkes, *Psych. Bulletin*, i., 1904, 140.

Note that the abscissal numbers stand in the *middle* of their unit distances. This means that the class represented by a number extends both below and above it. Thus, 135 is the class number containing all times between 130 and 139.

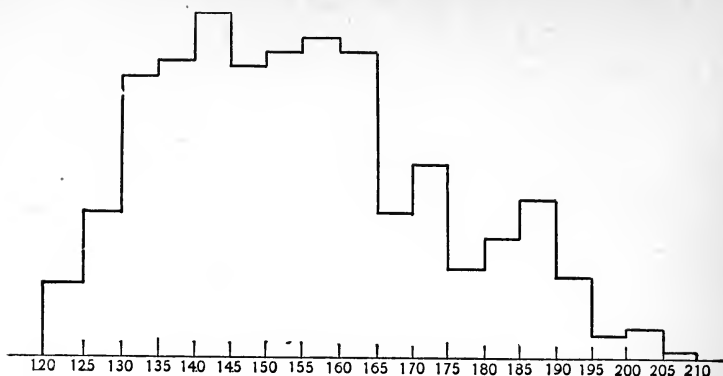

FIG. 79.

Frequency polygon of the reaction times listed in the Table on p. 178 (method of rectangles). Unit of abscissæ=5 σ . Number of experiments=400.

Note that the abscissal numbers stand at the *beginning* of the unit distances.

This means that the class represented by a number extends only above it.

Thus, 120 is the class containing all times between 120 and 124.

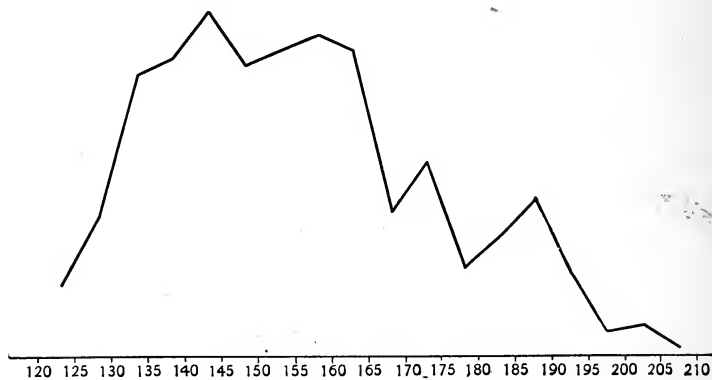

FIG. 80.

Frequency polygon of the reaction times listed in the Table on p. 178 (method of trapezia). Unit of abscissæ and number of experiments as in Fig. 79. The figure is obtained by joining the tops of the middle ordinates of successive contiguous rectangles.

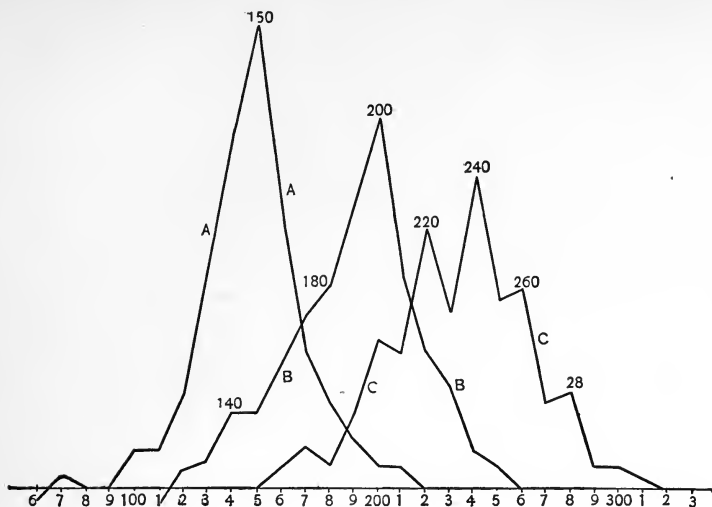

FIG. 81.

Frequency polygons of *A* muscular, *B* central, and *C* sensorial reactions to light. Unit of abscissæ=10σ. Number of experiments in each case=150. From N. Alechsieff, *Philos. Studien*, xvi., 1900, Taf. I.

The abscissal numbers stand at the *beginning* of the unit distances; so that the first class, *e. g.*, comprises all times between 70 and 79σ. Above the abscissal numbers ordinates have been erected, whose successive heights are proportional to the frequency of the classes (method of loaded ordinates). This method of construction applies in strictness only to integral, not to graduated variates: hence the method of Fig. 80 should have been employed.

(3) It has been customary, in psychophysics, to use the arithmetical mean or average, and the mean variation or average deviation, as the representative measures of the reaction time and its variability. The mean of any set of data represented by a frequency polygon of the type of Fig. 78 is determined by the formula $M = \frac{\Sigma(r.f)}{n}$, in which *r* is the reaction-time of any class, *f* its frequency, Σ indicates that the sum of the products for all classes into frequency is to be obtained, and *n* is the number of reactions taken. Thus the mean of the frog reactions represented in Fig. 78 is $(135 \times 6 + 145 \times 6 + 155 \times 6 + 165 \times 11 + 175 \times 15 + 185 \times 25 + 195 \times 12 + 205 \times 12 + 215 \times 6 + 235 \times 1) \div 100 = 180.00\sigma$.

If the frequency polygon have the form of Fig. 79, in which

each abscissal number means 'the numbers from this figure to the next on the scale,' then the mean calculated from it must, if it is to represent an absolute point on the scale, be increased by half the unit of the scale.

The mean variation is determined from the formula $MV = \frac{\Sigma(d.f)}{n}$, where d = deviations of class from mean, and f , Σ , n have the meanings assigned to them in the previous formula. Thus the mean variation of the frog reactions is $(45 \times 6 + 35 \times 6 + 25 \times 6 + 15 \times 11 + 5 \times 15 + 5 \times 25 + 15 \times 12 + 25 \times 12 + 35 \times 6 + 55 \times 1) \div 100 = 17.40\sigma$.

(4) It is important to state, not only the mean and the mean variation, but also the *relative variability* of an experimental series. This is obtained by the formula $rv = \frac{MV \times 100}{M}$. Its importance lies in the fact that the MV depends not only on the deviations of the individual reaction times from the mean, but also on the actual magnitude of the mean itself. Thus an O who reacts to sound in 120σ , with an MV of 10σ , and to light in 180σ , with an MV of 15σ , is reacting with the same degree of constancy in each case, although the absolute values of the MV are different.

The rv of the frog experiments is $\frac{1740}{180}$, or 9.66σ .

(5) Lastly, it is important to state the *range* of the results, *i. e.*, the extreme times between which the series of reactions varies. In the case before us, these times were 133 and 232σ .

The note-book record now includes the following data: (*a*) the crude results, with O 's occasional introspections; (*b*) a table of frequencies, at the head and foot of which stand the extreme values representing (*c*) the range of the series; (*d*) a frequency polygon; and (*e*) the average of the series, with (*f*) its mean variation and (*g*) its relative variability.

A full statistical treatment of the results implies the determination of other representative values. Thus, besides the M , it may be worth while to determine (*h*) the median, and possibly (*i*) the mode of the series. Besides the MV , we may determine (*j*) the standard deviation of the M . Besides the rv , we may

determine (k) the coefficient of variation of the series. And we may also determine the probable error (l) of the mean and (m) of the standard deviation. There is a long list of such values; but these are the most important for psychophysical purposes. The Instructor, if he thinks that you should determine them, will furnish you with definitions of the terms, with the required formulæ, and with references for reading. Be sure that you thoroughly understand the significance of the values before you enter upon their computation. It is a simple waste of time to work out a column of numerical results which you do not comprehend, and which you could not use if opportunity for their use occurred.

FURTHER EXPERIMENTS.—The Instructor will determine the number of sound reactions to be taken. When these have been completed, new series of experiments are to be begun with light and pressure stimuli.

(*a*) A light pendulum, *e. g.*, may replace the sound hammer on *O*'s table: it should stand sidewise to a window, and the light should be reflected through the slit in the screen from a plane mirror. If there is but one electromagnetic release, at the one end of the pendulum arc, so that the pendulum swings back and forth in a single movement and is caught on the return, the rocker of commutator 3 should be thrown completely over in each experiment: the pendulum leaves the magnet at break, while the remaking of the circuit actuates the magnet in time for the return of the bob. If there are two electromagnets, so that the pendulum is caught at the conclusion of a half-swing, and has to be brought back again to its starting-point before a second experiment can be made, the commutator is opened (for release of the pendulum), closed again on the same side (the catch at the end of the half swing), and the rocker is then thrown over (for release and return to starting-point). With a little trouble in the adjustment of current strength, papering of the armature surfaces, etc., the pendulum can be made to work accurately, and practically without noise.

(*b*) The use of the ordinary pressure stimulators implies that a second *E* sit with *O* in the reacting room. If electric stimulation or the stimulator called for by Question 6, p. 167 be employed, this complication is avoided.

The Instructor will decide whether or not smell and taste reactions are to be taken at this stage.

QUESTIONS.—*E* and *O* (1) What is it that we are measuring or determining, in the reaction experiment?

(2) The reaction experiment has more than one claim to be included in a Course in Experimental Psychology. What are the various reasons for its introduction ?

(3) Criticise, in connection, the following statements :

(a) "The variations in the length of the reaction time are most striking in the curves of the sensorial reactions. That is to say, the greater the number of mental processes introduced into the course of the reaction experiment, the greater is the variation which the curve shows. Evidently, then, more weight is to be laid upon these variations than upon the absolute time. For, from the standpoint of psychological analysis, variations that are thus conditioned upon psychological factors are more important than is the establishment of average values" (Alechsieff, 1900).

(b) "Variations in the length of reaction time are usually dealt with merely in their bearing on the trustworthiness of the average value. But if we were better acquainted experimentally with the many elements which enter as determining factors into these variations, we might be able to make a much more extensive use than we can do at present of the reaction process as an index of the activities of the central nervous system" (Smith, 1903).

(c) "Variability, or the degree of constancy with which a reaction occurs, is, for certain purposes, of equal value with the average reaction time. . . . Any or all of these values [the statistical determinations mentioned above, pp. 182 f.] might be useful in a study of the series of [frog] reaction times under consideration" (Yerkes, 1904).

(4) "Es ist nicht entschieden genug zu betonen, dass diese Versuche, wie sie nach ihrer physiologischen Bedeutung die complicirtesten sind, so auch an die psychologische Befähigung und Uebung des *O* die grössten Anforderungen stellen. Sporadisch oder an beliebig ungeübten Personen angestellte Versuche oder aber endlich solche, bei denen man ohne sorgfältige Controle durch die Selbstbeobachtung planlos Reactionszeiten misst, sind daher werthlos" (Wundt, 1903). This criticism would rule out of Experimental Psychology the investigations in which the reaction experiment has been employed as a 'mental test'; a good deal of work done upon *O*'s who are mentally deranged; certain anthropological work (experiments upon Indians, Negroes, etc.); and all experiments performed with the lower animals. Do you subscribe to it? Why?

(5) Suggest other experiments upon action that may lead to psychological results, or to the establishment of psychophysical constants.

§ 26. Compound Reactions; Discrimination, Cognition and Choice.

—If the “reaction consciousness is the laboratory form of the action consciousness of everyday life” (vol. i., 118), it should be possible for us to pass beyond impulsive action (the simple reaction), and to reproduce under experimental conditions the more complex actions that derive from the impulse. This step has, in fact, been taken. ‘Compound reactions,’ as they are termed, were first made by the Dutch oculist F. C. Donders (1818-1889) and his pupils, and have since been studied under very various forms. The principal modes of procedure, looked at from the outside, from the point of view simply of stimulus and movement, may be tabulated as follows.

- I. Experiments with one stimulus and one movement, both known to *O*: the simple reaction (Donders’ *a*-method).
- II. Experiments with more than one stimulus and one movement:
 - (*a*) the stimuli are known beforehand to *O* (sub-form of Wundt’s *d*-method);
 - (*b*) the stimuli are known beforehand to *O* only in the most general way (type of Wundt’s *d*-method).
- III. Experiments with more than one stimulus and more than one movement:
 - (*a*) the stimuli and the correlated movements are known beforehand to *O* (sub-form of Donders’ *b*-method);
 - (*b*) the stimuli and the movements are known beforehand to *O* only in the most general way (type of Donders’ *b*-method).
- IV. Experiments with more than one stimulus and with the alternative of movement and no-movement:
 - (*a*) the stimuli are known beforehand to *O* (sub-form of Donders’ *c*-method);
 - (*b*) the stimuli are known beforehand to *O* only in the most general way (type of Donders’ *c*-method).

These four methods may be illustrated as follows:

Donders’ *a*-method: the stimulus is the spoken syllable *ko*; *O* responds by uttering the same syllable.

- Donders' *b*-method: the stimulus is a spoken syllable made up of *k* and a following vowel; *O* responds by uttering the stimulus-syllable.
- Donders' *c*-method: the stimulus is a spoken syllable made up of *k* and a following vowel; *O* responds *only* to the stimulus *ko* by uttering *ko*.
- Wundt's *d*-method: the stimulus is a spoken syllable made up of *k* and a following vowel; *O* responds to each stimulus, as he apprehends it, by uttering *ko*.

We need say nothing more about the *a*-method, which has been discussed in the previous §§. Nor shall we say anything here of another type of compound reaction, the *reaction on association*, in which the reaction method is turned to account for the study of the associative consciousness (see §27 below). We must, however, look a little more closely at methods II., III., and IV. from the inside, from the point of view of the mental processes involved.

II. (a) *The Discriminative Reaction*.—Suppose that you are giving simple reactions to light. You see a flash of white light, as the pendulum swings, or a bright white disc, as the shutter opens. Every experiment brings back the same stimulus; you know always what to expect. Suppose, on the contrary, that you are told to expect *either* white *or* black. The pendulum screen or the shutter is faced with grey, and *E* may, at his pleasure, place a black or a white card behind the opening. Your reaction has now become a more complicated matter. You take up a different mental attitude to the whole experiment: before, you were definitely expecting a certain stimulus; now, you are expecting one or other of two possible stimuli. You take up a different attitude to the stimulus itself, as it is presented: before, you took its quality for granted; now you have to distinguish it, as 'the black' or 'the white' stimulus. You do not name it, of course: that would introduce a verbal association into the experiment: but you receive it discriminatively. Lastly, you take up a different attitude to the reaction movement: before, the movement followed naturally and inevitably, touched off by the stimulus; now, there is a restraint upon the movement, you dare not lift your finger till you have satisfied yourself of the

quality of the stimulus. Reactions of this sort are called *discriminative* reactions, and the times are called discrimination times (temps de distinction, Unterscheidungszeiten).

SUGGESTIONS FOR WORK UPON DISCRIMINATIVE REACTIONS.—

(1) Two visual stimuli : black and white, or red and green, or blue and yellow. (2) Four visual stimuli : black and white, and two colours. (3) Six visual stimuli : black and white, and four colours. All these experiments can be performed with the visual stimulators described above : pp. 156 f. (4) Two or more light intensities : greys may be used in the fall chronometer or shutter ; various thicknesses of tissue paper in the pendulum. (5) Noise and clang : place a single-stroke bell along with the sound hammer in the reaction circuit, so that either instrument may be switched in at will. (6) Two or three intensities of noise : these may be obtained by regulating the spring of the sound hammer. (7) Two or three clangs of different pitch : use Martius' arrangement of monochord and pick. (8) Mechanical pressure and electrical stimulation : two alternative circuits are arranged, as for noise and clang ; the electrodes are attached permanently to *O*'s hand, and a stimulus is given sometimes by them, sometimes by the sensibilometer. (9) Two intensities of mechanical pressure or of electrical stimulation. (10) Sounds to right and left : the two sound hammers are set to give stimuli of equal intensity. (11) Pressures or electrical stimuli to right and left.

II. (*b*) *The Cognitive Reaction*.—In the discriminative reaction, the stimuli employed are always known beforehand to *O* ; the colours are shown, the sounds presented, before the reactions are taken. In the cognitive reaction, the stimuli are known only in a very general way. *O* is told, *e. g.*, that he will be shown a simple visual impression, a colour or a brightness ; and he is not to react until he has 'cognised,' identified, apprehended the particular quality of the stimulus. The cognitive reaction is thus, in the rough, a more general form of the discriminative reaction. The preliminary expectation is less definite ; the stimulus is received, not discriminatively, but as a familiar object presenting itself for identification ; the movement is restrained until identification is complete. The results of the experiment, on the

objective side, are called cognition times (temps de reconnaissance, Erkennungszeiten).

SUGGESTIONS FOR WORK UPON COGNITIVE REACTIONS.—Visual stimuli offer the best material for these reactions. We may take (1) colours and brightnesses; (2) single letters; (3)

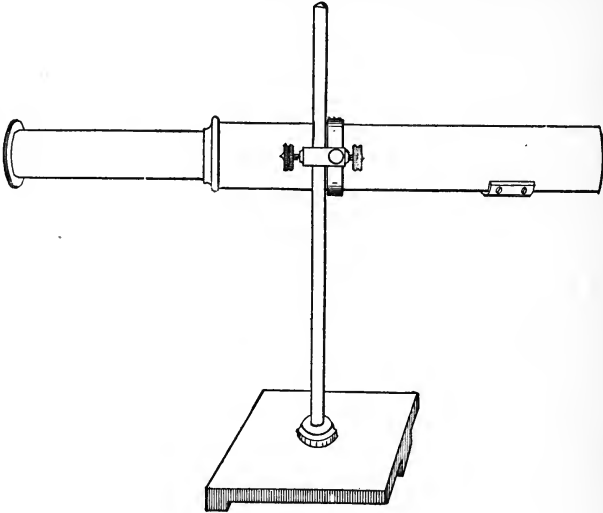

FIG. 82.
Reading telescope.

short words. The type used for the letters and words should be that known as Gothic, grotesque or sansserif (without serifs and hair-lines); the stimulus is observed, not with the naked eye, but through a reading telescope. We may also employ (4) a progressive series of, say, one to six place numbers.

III., IV. The reactions under these two headings are generally grouped together as choice reactions (temps de choix, Wahlzeiten). We may classify them in detail as follows.

III. (a) *The Selective Reaction with Discrimination.*—The reaction is discriminative on the side of stimulus, selective on the side of movement. That is to say, the various stimuli presented to *O* are known to him beforehand; he receives them discriminatively: while he is also called upon to choose between the various movements which, under the instructions given him, are correlated with these stimuli.

SUGGESTIONS FOR WORK UPON SELECTIVE REACTIONS (DISCRIMINATIVE TYPE).—The simplest form of discriminative reaction is that in which two known stimuli are presented to *O* in irregular order. Plainly, then, the simplest form of selective reaction with discrimination will be that in which the two known stimuli are replied to, the one by a right-hand, the other by a left-hand movement. Two reaction keys, placed conveniently for *O*'s two hands, are introduced (in series) into the reaction circuit, and the reacting movement is made with the hand to which the stimulus presented appeals. All the modes of discriminative reaction listed above may thus be transformed into selective reactions.

We are not, however, confined to a choice between two movements. We may use a five-finger reaction key, and react to each one of five known colours by the movement of a particular finger. Or we may take two five-finger keys, adapted to the

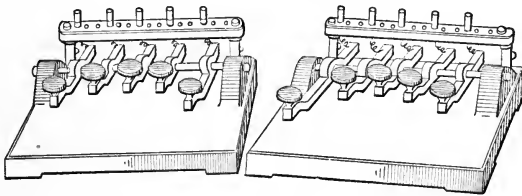

FIG. 83.
Five-finger reaction keys.

right and left hands respectively, and react, say, to the stimuli 1, 2, 3, 4, 5 by movements of the fingers of the right hand, and to the stimuli I, II, III, IV, V by movements of the fingers of the left hand.

III. (b) *The Selective Reaction with Cognition*.—The reaction is cognitive on the side of stimulus, selective on the side of movement. That is to say, the stimuli presented to *O* are not known to him, beforehand, except in a general way; he receives them cognitively: while he is also called upon to choose between the various movements which, by a natural coördination, are correlated with these stimuli.

SUGGESTIONS FOR WORK UPON SELECTIVE REACTIONS (COGNITIVE TYPE).—Since the stimuli are unknown to *O*, we cannot

settle beforehand what reaction movements are to be connected with them; we must rather look about us for a set of movements which are naturally coördinated with various classes of sense impressions. And we find what we require in the movements of articulate speech; it is entirely natural to us to *name* the objects of our surroundings. We accordingly choose as stimuli colours and brightnesses, or letters, or short words, or simple drawings in black-and-white; and we allow *O* to react by speaking the name of the colour, etc., into a voice key.

IV. (a) *The Volitional Reaction with Discrimination.*—The reaction is discriminative on the side of stimulus, volitional on the side of movement. The stimuli are known to *O*; he receives them discriminatively: while the reaction movement is correlated only with certain members of the group, the rest being allowed to pass by unregarded.

SUGGESTIONS FOR WORK UPON VOLITIONAL REACTIONS (DISCRIMINATIVE TYPE).—The conditions for these reactions, in their simplest form, are identical with those of the discriminative reaction. We select two stimuli,—say, black and white; and we instruct *O* to react to the black by lifting his finger from the key, but not to react to white at all. All the modes of discriminative reaction listed above may thus be transformed into volitional reactions.

We are not, however, confined to a choice between a single movement and no-movement. We may, *e. g.*, take two five-finger keys, and react to the stimuli 1, 2, 3, 4, 5 by movements of the fingers of the right hand, and to the stimuli I, II, III, IV, V by movements of the fingers of the left hand, introducing at irregular intervals a stimulus of another kind (+ or Δ) to which no responsive movement is to be made.

IV. (b) *The Volitional Reaction with Cognition.*—The reaction is cognitive on the side of stimulus, volitional on the side of movement. The stimuli are known to *O* only in a general way; he receives them cognitively: while the reaction movements naturally coördinated with the stimuli are in some cases to be made, in others to be suppressed.

SUGGESTIONS FOR WORK UPON VOLITIONAL REACTIONS (COGNITIVE TYPE).—*O* may be told, *e. g.*, that he will be shown

either a colour or a brightness; and that he is to react to all colours by naming them, but not to react to the brightnesses at all. Or he may be told that he will be shown a mixed series of one-syllable verbs and substantives; and that he is to react to the verbs by uttering them, but not to reply to the substantives.

EXPERIMENT XXV

The Instructor will furnish directions for this experiment.

QUESTIONS AND EXERCISES.—*E* and *O* (1) Make a Table, in the form of a genealogical tree, of the more complex types of action and their derivatives. Give an account of the composition of the motive in each case.

O (2) Give a full analysis of the cognition and the discrimination, as mentally experienced, and indicate the place of these complexes in the psychological system.

E (3) Draw a diagram, showing the disposition of apparatus in some *one* of the following experiments. Does the experiment, as you arrange it, require two *E*'s or one? If the former, can you simplify the conditions, or suggest other apparatus, so that but one *E* shall be necessary?

- (a) Discriminative reaction no. 8: mechanical pressure and electrical stimulation; ordinary reaction key.
- (b) Cognitive reaction no. 2: light pendulum (with two release magnets) and reading telescope: ordinary reaction key.
- (c) Selective reaction with discrimination: exposure apparatus for ten figures; two five-finger reaction keys.
- (k) Selective reaction with cognition: exposure apparatus for short words; voice key

O (4) In performing experiments upon compound reactions, you are called upon to introspect. The action consciousness is, however, much more complicated than it was in the simple reaction experiment. Can you suggest any plan whereby the task of introspection shall be simplified?

O (5) In the discriminative reaction (p. 186) you are not allowed to name the stimulus; in the selective reaction with cognition you react by naming. Why is this?

E (6) What preliminary work must be done before selective reactions with discrimination are taken?

O (7) Analyse the process of 'choice,' with reference to selective and volitional reactions.

§ 27. **Compound Reactions: Association.**—In the reaction experiments which we have so far described, *O* reacts after he has sensed, discriminated or cognised the given stimulus. In the *associative* reaction, he does not react to the given stimulus at all; he makes the movement of reaction only after the stimulus has suggested something else, has aroused in consciousness some associated idea. It is this associated idea to which the movement is the response. Suppose, *e. g.*, that we are working with a visual exposure apparatus and with the ordinary finger key. The word *sea* is shown. Instead of reacting as soon as he has cognised the stimulus, *O* waits for the appearance in consciousness of some related idea. Let this be the verbal idea 'shore.' Then *O* lifts his finger from the key as soon as the idea of 'shore' has taken shape.

It is clear that the associative reaction may be varied in a great many ways: as regards stimulus, as regards the rules of association, and as regards response. We will look first at the associations.

I. (1) The obvious procedure to begin with is to leave *O* entirely free in the matter of association. We show him a word; he is to react when the word has suggested something, no matter what. The word *sea* may arouse the idea of land or water or ships or some particular sea or some particular incident at sea,—anything it likes. Associations of this sort are termed, technically, *free* associations. (2) We may, however, limit the range of possible associations. We tell *O* that we shall show him pictures of familiar objects, and that he is to think of a part of the presented object, or of an attribute of it; that we shall show him adjectives, and that he is to think of corresponding substantives; verbs, and he is to think of corresponding adverbs; class-names, and he is to think of instances that fall under them; and so on. Associations of this sort are termed *ambiguous* or partially constrained associations. We ask *O* a question, to which different

answers are possible; but the number of answers is limited, and the association idea must fall within this limit. (3) Or again, we may ask *O* a question that admits of but a single answer. We may show him the names of countries, to which he is to associate the capital cities; words, which he is to translate into French or German; figures, which he is to add or multiply. Associations of this sort are termed *constrained* or univocal associations. (4) Lastly, in the place of simple successive association, we may take more complex mental processes; we may, by our stimulus, ask a question of *O* which requires for its answer a *judgment*. The arrangement of such an experiment is explained under II. (3) below.

II. We turn to the variation of the stimulus. It is usual to employ (1) fairly simple visual stimuli: colours, short words, figures, drawings in black-and-white, etc. These are exposed in the same manner and with the same precautions as in the preced-

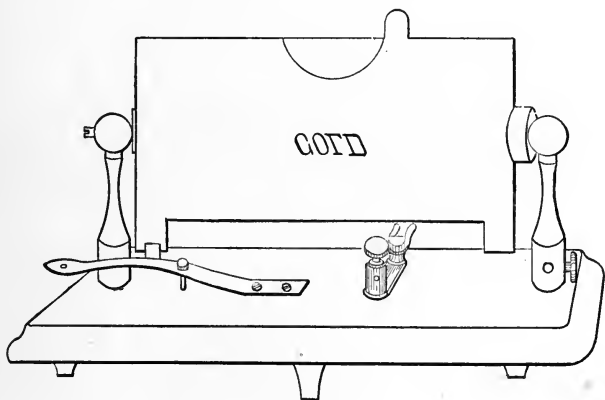

FIG. 84.

Roemer's exposure apparatus.

ing experiments. Sometimes (2) spoken words form the stimuli: *E* may press a finger key at the moment of utterance, and so close the reaction circuit as the stimulus is given, or he may use a lip key, which makes contact at the beginning of the movement of articulation. (3) When a judgment of comparison replaces the association, the stimulus consists of a spoken sentence: *e. g.*, "Which is the greater poet: Tennyson or Browning?" and *E* presses a finger key as he utters the final word.

III. The movement of reaction may be (1) the lift of the finger from the finger key; the associative reaction is then, in outward form, the counterpart of the cognitive and discriminative reactions. It may also (2) be the utterance of the word which names the associated idea: *cf.* the selective reaction (cognitive type). Or again (3) we may tell *O* that he will be shown pictures which represent articles either of dress or of furniture, and that articles of dress are to be answered by the left-hand, and articles of furniture by a right-hand movement; so that the reaction movement implies the subsumption of the given impression under the general category of 'dress' or of 'furniture.' This mode of reaction (*cf.* the selective reaction, discriminative type) may be extended to five or ten correlations of movement and category.

EXPERIMENT XXVI

Make out a plan for an experiment upon the associative reaction, and submit it to the Instructor. The experiment has both a psychophysical and a psychological value: try to allow for both, in the time at your disposal. Remember that some time must be allowed for practice. Use the instruments available in the laboratory.

QUESTIONS.—*O* (1) Give a full analysis of the associative consciousness, under the conditions of your (psychological) experiment. [See Question (4), p.191 above.]

E (2) Suggest apparatus and method for the following problems:

- (a) associative reactions to olfactory stimuli;
- (b) a simple arrangement of the associative reaction, without the Hipp chronoscope and its accessories;
- (c) associative reactions to auditory stimuli other than spoken words.

E and *O* (3) Discuss the importance of the associative reaction for systematic psychology, and its relation to the compound reactions of the foregoing §.

E and *O* (4) What do you mean by a 'judgment,' psychologically regarded? Do the judgment-reactions spoken of above

really imply judgment? What of the reactions with partially constrained association?

E and *O* (5) Discuss the following definitions of association:

- (a) Assoziation ist das, wodurch es erst möglich wird, dass ein Erlebnis von einem andern reproduziert werde.—Watt.
- (b) L'association des idées signifie la liaison, la connexion, l'attraction des idées. L'association, la liaison des idées n'est pas un phénomène de conscience.—Claparède.
- (c) A union more or less complete formed in and by the course of experience between the mental dispositions corresponding to two or more distinguishable contents of consciousness, and of such a nature that, when one content recurs, the other content tends in some manner or degree to recur also.—Dict. of Phil. and Psych.

CHAPTER IV

THE PSYCHOLOGY OF TIME

§ 28. **The Reproduction of a Time Interval.**—The reading of Fechner's *Elemente der Psychophysik* suggested to the Austrian physicist E. Mach (b. 1838) the question whether Weber's Law holds for our estimation of time, as it holds for our estimations of sensible intensity. Mach went to work at once, and between the years 1860 and 1865 made a large number of experiments. His results were negative, but—like all pioneer results—were very far from conclusive. The example which Mach set was quickly followed by other investigators, and experimental studies of the time consciousness came to play a large part in the literature of experimental psychology. As the years have passed, the questions at issue have been differentiated and refined, and methods and instruments have grown correspondingly delicate and accurate. We can do no more here than repeat one of the earlier and cruder experiments,—an experiment described by the physiologist K. Vierordt (1818–1884) in 1868.

EXPERIMENT XXVII

MATERIALS.—Vierordt lever with accessories. Kymograph. Time marker. Arm rest. Soundless metronome. [The Vierordt lever, Fig. 85, is a strip of brass, which turns about a transverse axis, and carries at the end of its shorter arm a flexible writing

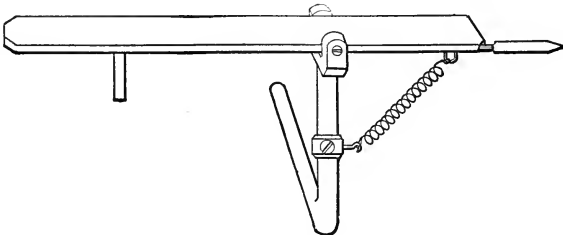

FIG. 85.

point. The lever is held in the horizontal position by a spring,

whose tension is regulated by a collar and set screw adjusted to the support. To the under side of the long arm of the lever is fastened a short brass rod. Beneath the rod is placed a sheet of heavy glass; and above the lever, about midway between the brass rod and the support, an iron rod moves vertically between guides attached to the standard which holds the entire apparatus. Glass, standard and iron rod are not shown in the Fig.]

COURSE OF EXPERIMENT.—*O* is comfortably seated beside the table which carries the apparatus, his eyes closed, his arm supported in the arm rest, and the fingers of his right hand extended just above the end of the long arm of the lever. *E*, taking his time from the soundless metronome, drops the iron rod, twice over, from a constant height. *O* thus hears two sharp sounds of the same intensity, embracing the standard time interval. He is himself to tap the lever when he thinks that an interval has elapsed equal to the interval bounded by the given sounds. The glass plate serves to regulate the excursion of the lever, and also to furnish a third, limiting sound. To avoid complication by the development of a rhythm, the kymograph is stopped and a pause is made between experiment and experiment.

E thus obtains on the surface of the kymograph the record of normal and reaction taps and, just below this, the time record (say, in tenths of a sec.).

PRELIMINARIES.—The experiments should extend, by quarter second intervals, from 0.25 to about 5 sec. *E* must, therefore, practice the production of these intervals by help of the soundless metronome. Even after practice, however, there will be a good deal of variation in the normal times.

O must also have some preliminary practice in the estimation of the times employed. Warming-up experiments must be made at the beginning of every laboratory session.

TREATMENT OF RESULTS.—The normal times are presented (each 25 times over) in haphazard order. At the end of the experiment, *E* may, as circumstances suggest, do either one of two things. He may (1) arrange his normal times in groups, taking first the times up to 0.25 sec., next the times from 0.26 to 0.5 sec., next the times from 0.51 to 0.75 sec., and so on. The times of these groups are averaged; the corresponding re-

production times are averaged; and the two averages are made the basis of further calculation. Thus, the average normal time of the first group might be 0.21 sec., that of the second, 0.36 sec., and so on. Then these times, 0.21 and 0.36 sec., are compared with the averages of *O*'s corresponding times. Or (2) he may sort out the normal times in groups, according to their absolute value, and tabulate only those intervals which were exactly repeated, say, at least 10 times over, in the course of the experiment.

The normal times, in the order lowest to highest, form the first vertical column of a Table. In the second column are entered the average crude errors, *plus* or *minus*, expressed in % of the normal times. In the third are entered the average variable errors, also expressed in % of the normal times. A fourth column shows the percentage of positive crude errors; a fifth gives the number of determinations made with the various normal times.

QUESTIONS.—*E* (1) What conclusions do you draw from the figures of the Table?

O (2) What is the introspective basis of your judgment of equality?

E and *O* (3) Criticise the method employed, and suggest an alternative.

E and *O* (4) Suggest an apparatus for the determination of the *DL* for time intervals.

E and *O* (5) Why should Weber's Law be expected to hold of the discrimination of time intervals? Were Mach's results entirely negative?

E and *O* (6) What are the principal problems of the psychology of time?

LIST OF MATERIALS

The following list includes only those instruments and appliances which have been prescribed for the experiments of the text. Further apparatus will be needed, if the programme of work is to be completely carried out; details of the various instruments available will be found in Part II.

The materials may be obtained from the C. H. Stoelting Co., 31-45 W. Randolph Street, Chicago, Ill.

I. SPECIAL APPLIANCES

- Æsthesiometer, 79, 103.
Appunn's lamella, 1.
Arm-rest, 115, 196.
Bell signals, 167.
Carrier bracket, 115.
Cartridge weights, 80.
Chin-rest, 2, 12.
Colour mixer, Wundt's triple, 90.
Colour mixers, 31, 66, 87, 89.
Control instrument for Hipp chronoscope, 167.
Dark box, 88.
Envelope weights, 33.
Finger-key, break, 167.
Galton bar, 76.
Galton whistle, Edelmann's, 12 f.
Hair æsthesiometer, von Frey's, 15 f.
Head-rest, 76, 88, 89.
Hipp chronoscope, 167.
Kirschmann photometer, 34, 66, 86, 89 f.
Kymograph, with accessories, 19, 20, 196.
Limen gauge, von Frey's, 17; attachments, 18 f.
Lehmann's acoumeter, 23 f.
Metronome, 116.
Metronome, soundless, 68, 80, 87, 115, 196.
Münsterberg's arm-movement apparatus, 104.
Rumford photometer, with white cardboard screen, 31.
Sound hammer, 167.
Sound pendulum, 87, 115.
Time marker, 20, 196.
Touch weights, Scripture's, 14 f.
Tuning forks, one with riding weights, 67.
Tuning forks, with screws, 68.
Vierordt's lever, 196.
Weight-holders, Fechner's, with weights, 115.

II. GENERAL APPLIANCES AND MATERIALS

- Ammeter, 134.
Baize, 1, 12.
Balance, with weights, 21, 33.
Box, cardboard, 10; padded, 23.
Candle, standard, 31.
Commutators, 167.
Current distributors: Nichols rheostat, 129 f.; lamp batteries, 129 ff.
Current tester, 140 f.

- | | |
|-------------------------------------------------------------------------|----------------------------------------------------------------------|
| Cushion, 167. | Plaster mould, 20, 116, 167. |
| Dry cells, 167. | Pole tester, 127. |
| Ear-plug, 2, 12, 23. | Protractor, metal, 66, 87, 89. |
| Eye-shade, 23, 166. | Push buttons, 167. |
| Felt, 1, 12, 67 f. | Rheochord, 167. |
| Forceps, 25. | Rod, iron, 197. |
| Galvanometer, 167. | Sand box, 20, 116. |
| Glass, strip of plate, 30, 34; small plate of, 21; plate of heavy, 197. | Spectacle frame (opticians' trial frame), 29, 31. |
| Glasses, grey ('smoked'), 29, 31; coloured, 30. | Standard, 18; with arm and clamp, 12; with guides for iron rod, 197. |
| Lamp, 4 c.p. incandescent, 31. | Stop-watch, 67 f., 80. |
| Metal, small plate of, 21. | Switch, two-way, 167. |
| Metre bridge, 136. | Tubing, rubber, for gas burners, 91. |
| Metre rod, 23. | Uprights, wooden, 23, 115. |
| Motor, electric, 91. | Voltmeter, 134. |
| Piano hammer, 67 f. | Watch, 23. |
| | Welsbach burners, 91. |
| | Wire, 167. |

III. PAPER, CLOTH, DRAWING MATERIALS, ETC.

- | | |
|---------------------------------------------------------------------------------------|-----------------------------------------------------------------------------------------|
| Cardboard, strip of, 24; sheet of black or white, 34; squares of black and white, 86. | Observation tube, black, 66, 89. |
| Delbœuf disc, 88 f. | Papers, Marbe's grey, 30, 34; Hering's grey, 66. |
| Discs, black and white, 31, 66, 89. | Screens, 116, 167; black, 76; curved black, 31; grey, 66; muslin window, 66; white, 91. |
| Dye, 16. | Tape, 23, 115. |
| Forms, blank, for method work, 3 ff.; record, 10. | Tickets, cardboard, 10. |
| Indian ink, 86. | Wax, 168. |
| Mm. paper scale, 79, 103. | |

IV. LABORATORY FURNITURE

- | | |
|--------------------------|----------------------------------|
| Chair, swivel, 169, 174. | Table, high, 3; low, 33, 34, 91. |
|--------------------------|----------------------------------|

INDEX OF NAMES AND SUBJECTS

- Accumulators, 126 f.
 Acoumeter, Lehmann's, 23 f.
 Action, local, in Voltaic cell, 122 f.
 Adjustment of equivalent R , method of, 70 ff.
 Æsthesiometer, von Frey's hair, 15 f.
 Æsthesiometric compasses, 79, 103.
 Æsthesiometry, illustration from, 92 ff.; experiments in, 79 f., 103 f.
 Affective intensity, quantitative determination of, xxxix.
Alechsieff, N., 181, 184.
 Ambiguous associations, 192.
 Ammeter, 132 ff.
 Ampere, definition of, 121.
Appunn, A., 1.
 Arithmetical mean, as most probable value of a set of observed values, 39, 72, 181.
 Arm-movement apparatus, Münsterberg's, 104 f.
 Association, in reaction experiment, 192 ff.; free, 192; ambiguous or partially constrained, 192; constrained or univocal, 193.
 Average deviation, 8 f.; see *MV*.
 Average error, Fechner's method of, 70 ff.
 Average variable error, 72; and *MV* or *PE*, 73.
 Batteries, primary, how formed from cells, 124 f.; for high and low external resistances, 126; storage, 126 f.; lamp, 129 ff.
 Belief and probability, 53 f.
 Bell, single stroke, 168.
 Bias, error of, in work by method of limits, 61 f.
 Blank experiments, 23.
Bottoné, S., 133.
Bradley, J., 51.
 Brightness, determination of DL for, by method of limits, 66 f. (*cf.* 63).
 Brightness, application of method of equal sense-distances to, 87 ff.
 Brightness experiment, Ebbinghaus', 34.
Buccola, G., 163.
 C , as symbol of current strength, 121.
Carhart, H. S., 123.
Cattell, J. McK., 42, 148, 158, 165.
 Cell, the simple Voltaic, 122 ff.; open circuit and closed circuit, 123; Leclanché, 123; Daniell, 123 f.; Meidinger, 124; Grenet or bichromate, 124; arrangements of cells in batteries, 124 f.; dry, 128.
 Chance, 45.
 Choice reactions, 188.
 Chronograph, recording, 149.
 Chronometer, gravity, 151, 156 ff.
 Chronoscope, Ewald, 158, 160.
 Chronoscope, Hipp, description of, 142 ff.; clockwork, 142 f.; registering apparatus, 143 f.; electromagnetic mechanism, 144 f.; four possible arrangements of, 145 f.; three arrangements of, for reaction experiments, 146 ff.; control of, 149, 151 ff., 172 f., 176; general rules for use of, 149 ff.; current strength required for, 167, 175.
 Clang stimulator, Martijus', 154 f.
Claparède, E., 195.
 Cloud experiment, Fechner's, 30; alternative experiments, 30 f.
 Coefficient of variation, 183.
 Cognitive reaction, 187 f.; see also 189 f., 190 f.
 Commutator, Pohl's, 148 f.
 Compound reactions: discrimination, cognition and choice, 185 ff.; association, 192 ff.

- Conductivity, 124, 132.
 Constant R , method of, 92 ff.
 Constant R -differences, method of, 106 ff.
 Constrained associations, 193.
 Contrast, quantitative determination of, xxxix.
 Control instruments for Hipp chronoscope, 151 ff.; their place in the chronoscope circuit, 152 f., 169, 174; gravity chronometer, 151, 158; pendulum, 151; hammer, 151 f., 155; directions for use of, 172 f., 176.
 Correlation of sense-distance with stimulus magnitude, xxvii., xxxii. ff., xxxviii., 25 ff., 83.
 Current, electric, 121; unit of, 121; rule for determining direction of, 128; distribution of, through the laboratory, 128 ff.; distribution of, in a simple circuit, 129; measurement of, 132 f.
 Current tester, 140 f.
 Curves, construction of, 41; equations of, 41, 43 f.; illustrations of exponential, 42 f. (*cf.* 26 f., 29).
 Cutaneous extents, equation of, 79 f.
- D*, as symbol of distance or difference, 92.
 Dark box, Delbœuf's, 88 f.
Delbœuf, J. R. L., xxviii, 87 ff., 91.
Descartes, R., xxiv.
Dessoir, M., 160, 165.
Dietze, G., 124.
 Difference, just noticeable, as unit of mental measurement, xxxiv. f., xxxvi.
 Difference limen, xxxvii.; fourfold determination of, xxxviii.; absolute and relative, xxxviii.; see *DL*.
 Differential, 49.
 Discriminative reaction 186 f.; see also 188 f., 190.
 Discs, Delbœuf's, 88 f.; Wundt's arrangement of, for work by method of equal sense-distances, 90.
 Disparity of sense-distance and stimulus magnitude, xxvii., xxxiii. f., 25 ff.; analogy of the tangent galvanometer, xxviii. f., xxxvi.
 Distribution, 178 (*cf.* 48); curve of, 179 (*cf.* 43).
DL, as symbol of difference limen, xxxvii.; fourfold determination of, xxxviii.; absolute and relative, xxxviii., 62 f.; a phenomenon of 'friction,' xxxii., xxxvi.; an ideal value, 56, 59; a variable value, 59; definition of, 59; of method of limits, 59 f.; magnitude and course of, as shown by method of limits, 62 f.; curve of distribution of, in method of constant R -differences, 107.
Donders, F. C., 185 f.
Donders' a, b, c methods of reaction, 185 f.
D. P., as symbol of difference of potential, 120.
Dumreicher, O., 160.
 Duration of sensation, problems of, xxxi.
 Dynamos, simple direct current, 136 f.; alternating current, 137; excitation of field coils, 137; series, shunt and compound wound, 137 f.; conversions of direct current, 139.
- e*, numerical constant, 44.
E, as symbol of *E. M. F.* or electromotive force, 121.
Ebbinghaus, H., xxviii., 34.
Edelmann, M. T., 12 f.
 Electromotive force, definition of, 120.
E. M. F., symbol of electromotive force, 120.
 Equal sense-distances, method of, 81 ff.
 Equal-appearing intervals, method of, 81 ff.
 Equations, of curves, 41, 43 f.; normal, in method of constant R , 102; in method of constant R -differences, 112.
 Equivalent R , determination of, by method of constant R , 104 f.
 Equivalents, method of, 77 ff.
 Error, average variable, 72; and *MV* or *PE*, 73.
 Error, Gauss' law of, 33 ff., 97; curve of, 41 ff.; mechanical illustration of cause of curve of, 46; illustration of a normal distribution, 48.
 Error function, 50.
 Error function complement, 50.
 Error of mean square, 64; *cf.* Standard deviation.
 Errors, accidental, 39, 58, 60.
 Errors, constant, 39, 57 f., 39 f., 74 ff.,

- 79, 106, 113, 149; determination of, in method of limits, 65; direction of, in method of limits, 65; determination of, in method of average error, 73, 74 f.; in method of equivalents, 79; in method of constant R -differences, 106 f., 113.
- Errors of observation, 38 ff., 59; mathematical theory of, 40; distribution of, 40 ff., 51; probability of, 47 ff.; in Fechner's method of average error, 70 ff.
- Errors, systematic, 39; see Errors, constant.
- Errors, variable, 58, 60, 61; of chronoscope, 149, 172 f., 176; see Error, average variable.
- Ewald, J. R.*, 158.
- Exercises, practical, in electrical measurement, 141; on the compound reaction, 191.
- Expectation and probability, 53 ff.; dependence of, on mental constitution, 54; limits of, 55; error of, in method of limits, 57 f., 61.
- Experiment, Ebbinghaus' brightness, 34; Fechner's cloud, 30; Fechner's shadow, 32; Sanford's weight, 33 f.; Vierordt's, on reproduction of a time interval, 196 ff.
- Experiments, blank, 23.
- Experiments, preliminary, value of, 2 f., 13 f., 67; disposition of, 7; directions for, 20 f., 68, 77, 80, 87, 103, 115, 116 f., 176, 194, 197; see Practice, Warming up.
- Exposure apparatus, Rømer's, 193.
- Extent of sensation, problems of, xxxi.
- Extents, visual, equation of, 76 f.; cutaneous, equation of, 79 f.
- Fatigue, in serial work, 4, 6; of skin, 20, 103; limits of, 55; in method of limits, 57 f., 60; in method of average error, 74; in method of equivalents, 78, 80; in reaction experiments, 176.
- Fechner, G. T.*, xxiii. f., xxvi. f., xxxiv. f., xxxvi., xxxviii., 28 f., 30, 32, 42, 65, 70, 75, 77, 80, 99, 102, 111, 114, 115 f., 196.
- Fechner's fundamental table, 99, 111, 114.
- Finger keys, 164 f.; five-finger key, 189.
- Formulæ, of measurement in general, xix., xl.; for law of affective intensity, xxxix.; for law of memory, xl.; for MV , 8, 182; for Weber's Law, 28; for Kirschmann's photometer, 37; for error curve, 44; for probability of errors, 47, 49 ff.; for PE , 52 f., 64 f., 76; for error of mean square, 64; for constant errors, 65, 75, 113; for equivalence, 79; for sound pendulum, 81; for r_2 in method of equal sense-distances, 86 (*cf.* 96); for RL , in method of constant R , 96, 97 f.; for DL , in method of constant R -differences, 110; for interrelation of electrical units, 121 f., 125; for arithmetical mean, in reaction experiments, 181; for relative variability, 182.
- Fractionation of results, in method of average error, 74.
- Free associations, 192.
- Frequency polygon, 179.
- von Frey, M.*, 15, 17.
- Galton, F.*, 12, 46, 48, 76.
- Galton bar, 76.
- Galvanometer, 133, 149, 167 f.; analogy of the tangent, xxviii. ff., xxxvi.
- Gauss, K. F.*, 43, 98, 104.
- Gauss' Law, see Error, Gauss' Law of.
- Glaisher, J. W. L.*, 50.
- Glazebrook, R. T.*, 137.
- Grey papers, Marbe's, 30, 34; Hering's, 66.
- h , as measure of precision, 44 f., relation of, to PE , 52; determinations of, 102, 112.
- Habituation error, in method of limits, 58, 61.
- Hair æsthesiometer, 15 f.
- Hairs, as cutaneous stimulators, 16, 157.
- Hammer, control, 151 f., 155; sound, 154.
- Herbart, J. F.*, xxiv., xxxvii.
- Hering, E.*, 66, 115.
- Hipp, M.*, 141 f., 167, 178, 194.
- Höfler, A.*, 26 f.
- I , as symbol of current strength, 121.
- Instructions to O , in serial method work, 6.

- Intensity of sensation, problems of, xxx.; Fechner's interest in, xxxvi. f.
- Interruptor, Krille's, 157.
- Introspection, xxii., xxv. f., xxvii., xxxiv., 141 f.; of lowest tones, 9; questions involving, xli., 10, 14, 22, 25, 32, 37, 69, 77, 81, 92, 104, 106, 118 f., 183 f., 191 f., 194 f., 198.
- Inversion, of the first order, 94 f., 98, 108 f.; of the second order, 95, 108 f.
- J. n. d., as unit of mental measurement, xxxiv. f., xxxvi., 25.
- J. n. d., method of, 55 ff.
- Jastrow, J.*, 159, 164, 166.
- Judgment, direction of, in work by method of limits, 61; standard of, in method work, 2; reaction upon, 193.
- Judgments, nature and direction of, in method of constant *R*-differences, 106; distribution of, in same method, 109.
- Kant, I.*, xxiv.
- Keys, reaction, 164 ff.; telegraph key, 164; *Jastrow's* finger key, 164; *Scripture-Dessoir* finger key, 165; *Cattell's* lip key, 165; *Jastrow's* speech key, 165 f.; *Cattell's* voice key, 147 f., 158, 166.
- Kiesow, F.*, 161.
- Kirschmann, A.*, 34 ff., 66 f., 86, 89, 91.
- Krille, C.*, 157.
- Lamella, *Appunn's*, 1.
- Lamp batteries, 129 ff.
- Lange, L.*, 156.
- Laplace, P. S. de*, 51.
- Least differences, method of, 55 ff.
- Lehmann, A.*, 23.
- Lever, *Vierordt's*, 196.
- Lifting weights, two methods of, 117.
- Limen, definition of, xxxvii.
- Limen gauge, 17; apparatus for regulating, 18 f.
- Limits, method of, 55 ff.
- Limits of sensation, xxx. ff.
- Lip key, *Cattell's*, 165.
- Mach, E.*, 196, 198.
- Marbe, K.*, 30, 32, 34.
- Martin, L. J.*, 115.
- Martius, G.*, 155.
- Masson, V.*, 139.
- Mean gradations, method of, 81 ff.
- Mean variation, 8 f.; see *MV*.
- Measurement, object and result of physical, xix.; units of, conventional, xx., but accurate, xxii., and interrelated, xxiii.; typified by linear measurement in space, xx.; always involves three terms, xx., xxxii.; mental, xxi. f., xxxii. ff.; see *Mental measurement*.
- Median, 182.
- Memory, quantitative investigation of, xl.
- Mental measurement, xxi. ff.; no natural unit of, xxii.; no interrelation of units of, xxiii.; difficulties of, intrinsic and extrinsic, xxiii. f.; *Fechner's* work upon, xxiii. f., xxvi.; material of, not sensation but sense-distance, xxiv. ff.; schema of, xxxii. ff.; just noticeable difference as unit of, xxxiv. f., xxxvi.; fundamental problems of, xxxviii. (*cf.* xxix. ff.).
- Merriman, M.*, 64.
- Method of determination of qualitative *RL* for tones, 3 ff., 10; of determination of qual. *TR* for tones, 14; of determination of intensive *RL* for pressure, 15, 17, 21; of determination of intensive *RL* for sound, 23, 25; of *Fechner's* cloud experiment, 30; of *Fechner's* shadow experiment, 32; of the 'psychophysical series,' 33 f., 34 f.; of photometry (*Kirschmann's* photometer), 36 f.; of least squares, 100, 102; of reaction experiment, 170 ff., 175 f., 185 f.; of *Vierordt's* experiment, 197; see *Metric methods*.
- Metre bridge, 136.
- Metric methods, xxiii., xxxii. f., xxxvi., xxxviii.; method of limits (just noticeable differences, least differences, minimal changes), 55 ff.; illustration from brightness, 55 ff.; sources of error in, 62; test-values of, 62 ff.; method of average error (reproduction, adjustment of equivalent *R*), 70 ff.; illustration from visual extents, 70 ff.; test-values of, 72 ff.; method of equivalents, 77 ff.; illustration from æsthesiometry, 78 f.; formula for

- equivalence, 79; method of equal sense-distances (mean gradations, supraliminal differences, equal-appearing intervals), 81 ff.; illustration from sounds, 81 ff.; formula for calculation of r_2 , 86 (*cf.* 96); method of constant R (right and wrong cases), 92 ff.; illustration from æsthesiometry, 92 f.; inspection of results, 93 ff.; calculation of the RL , first procedure, 95 ff.; formula, 96; second procedure, 97 ff.; formula, 98; application of the method to the determination of equivalent R , 104 f.; method of constant R -differences (right and wrong cases), 106 ff.; illustration of results with lifted weights, 107; inspection of results, 107 ff.; calculation of the DL , first procedure, 109 f., 112; second procedure, 110 ff., 112.
- Metric system, xx.
- Minimal changes, method of, 55 ff.
- Mode, 182.
- Modulus, = $\frac{1}{h}$, 53.
- Moldenhauer, W., 162, 166.
- Motors, direct current, 138 f.; uses of, in psychological laboratory, 139; alternating current or induction, 139; hints for care of, 140.
- Müller, G. E., 77, 101 f., 111, 115.
- Müller's table of coefficients of weights, 101, 111.
- Multiple-series, connection of cells in, 126.
- MV , as measure of variability, 8 f., 11, 44, 64, 73, 78 f., 83, 86, 172 f., 176, 182; and PE , 65; and average variable error, 73.
- Nichols, E. L., 128 ff., 131, 139, 141.
- Ohm, G. S., 121.
- Ohm, definition of, 120 f.
- Ohm's Law, 121, 125, 132, 135.
- Optical illusions, quantitative determination of, xl.; pendulum, 156, 183.
- ρ , as symbol of time error, 79, 113.
- π , numerical constant, 44.
- Parallel, connection of cells in, 125 f.
- PE , as measure of variability, 52, 64, 75 f.; and modulus, 53; of single observation and of mean, 64, 183; and error of mean square, 64; and MV , 65, 76; and average variable error, 73; of standard deviation or error of mean square, 183.
- Pendulum, control, 151; optical, 156, 183.
- Personal equation, xxxvii.
- Photometer, Rumford's, 31; Kirschmann's, 34 ff., 66, 86; formula for Kirschmann's, 37.
- Photometric units, 67.
- Polarisation, in Voltaic cell, 122 f.
- Pole tester, 127.
- Pohl, G. F., 147 f., 167.
- Potential, definition of electrical, 120; difference of, 120 ff.
- Practice, in serial work, 5; limits of, 55; in method of limits, 57; in method of equivalents, 80; distribution of, in method of equal sense distances, 84; in reaction experiments, 176 f.; see Experiments, preliminary, Warming up.
- Preliminary experiments, see Experiments, preliminary.
- Pressure, determination of RL for, by touch-weights, 14 f.; by hair æsthesiometer, 15 ff.; by limen gauge, 17 ff.
- Pressure, electrical, 120; unit of, 120; distribution of, in simple circuit, 129; measurement of, 132 ff.
- Principal error, in method of average error, 75; in method of equivalents, 79.
- Probability, 45 ff., 59; and relative frequency, 47 ff., 93 f., 108; formulæ of, 49 ff.; and expectation or belief, 53 ff.
- Probability integral, 50 f., 52 f.
- Probable error, 52; see PE .
- Psychology, see Mental measurement, Quantitative psychology.
- Psychophysics, xxiii., xxxviii.
- q , as symbol of space error, 75.
- QL , as symbol of quotient limen, 64.
- Quality of sensation, problems of, xxx. f.
- Quantitative psychology, Fechner's service to, xxiii.; attitude of Kant and Herbart to, xxiv.; object of

- measurement in, xxiv. ff., xxxii. f.; problems of, xxviii., xxix. ff., xxxvi., xxxviii. ff.; growth and status of, xxxvi. f.; Weber's Law as gateway to, xxxviii.; coextensive with qualitative psychology, xxxviii. f.; illustrated by reference to brightness contrast, xxxix. f.; to affective intensity, xxxix.; to optical illusions, xl.; to memory, xl.
- Questions, on measurement in general, xl. f.; on *RL* for tones, 9f.; on *TR* for tones, 14; on *RL* for pressure, 22; on *RL* for sound, 25; on Fechner's cloud and shadow experiments, 32f.; on Sanford's weight and Ebbinghaus' brightness experiments, 37; on method of limits, 69; on method of average error, 77; on method of equivalents, 80f.; on method of equal sense-distances, 91 f.; on method of constant *R*, 103 f.; on determination of equivalent *R'* by method of constant *R*, 106; on method of constant *R*-differences, 118 f.; on electrical measurements, 141; on technique of simple reaction, 166 f.; on types of simple reaction, 183 ff.; on compound reactions (discrimination, etc.), 191 f.; on associative reaction, 194 f.; on Vierordt's experiment and the psychology of time, 198.
- Quotient limen, 63 f.
- R*, *r*, as symbol of stimulus, xxxvii.
- R*, as symbol of electrical resistance, 121.
- Range of results, in reaction experiments, 182.
- Reaction, technique of simple, 141 ff.; three arrangements of chronoscope circuit, 146 ff.; experiment on three types of simple, 167 ff.; disposition of apparatus for simple, 169 f., 173 ff., 183; course of experiment, 170 ff.; results, statistical treatment of, 177 ff.; compound, 185 ff., 192 ff.; table of procedures, 185 f.; discriminative, 186 f.; cognitive, 187 f.; choice, 188; selective with discrimination, 188 f.; with cognition, 189 f.; volitional with discrimination, 190; with cognition, 190 f.; associative, types of, 192 ff.; technique of 193 f.
- Reaction times, xxxvii., 141 f., 177.
- Reiz*, xxxvii.
- Reizhöhe*, xxxvii.
- Relative variability, 182.
- Reproduction, method of, 70 ff., 197 f.
- R*-error, nature of, xxvi.; in Fechner, xxvi. f.
- Resistance, electrical, 120 f.; rule for determining joint, 132; measurement of, 134 ff.
- Rheochord, 168.
- Rheostat, Nichols', 129 f., 131 f.
- Right and wrong cases, method of, 92 ff., 106 ff.
- RL*, as symbol of stimulus limen, xxxvii.; fourfold determination of, xxxviii.; a phenomenon of 'friction,' xxxii., xxxvi.; qualitative, for tones, 1 ff., 7, 10 ff.; intensive, for pressure, 14 ff.; fourfold dependency of, 21; intensive, for sound, 22 ff.; distribution of, in method of constant *R*, 94.
- Ræmer E.*, 193.
- Rumford*, 31.
- rv*, as symbol of relative variability, 182.
- S*, *s*, as symbol of sensation, xxxvii.
- s*, as symbol of principal error, 75, 79.
- σ , as symbol of $\frac{1}{1000}$ sec., 142.
- Sanford, E. C.*, 33.
- Schwelle*, xxxvii.
- Scripture, E. W.*, 14, 129 f., 159, 165.
- Selective reaction with discrimination, 188 f.; with cognition, 189 f.
- Sensation, not measurable, xxv., xxvii.; stronger does not contain weaker, xxv. ff.; correlation of attributes of, with properties of stimulus, xxix. ff.; a continuous function of stimulus, xxxvi.; see Duration, Extent, Intensity, Quality.
- Sense-distance, the material of measurement of 'sensation,' xxv., xxxii., 25 ff.; see Correlation, Disparity.
- Sensibilometer, Dessoir's, 160.
- Series, connection of cells in, 125 f.
- Series, construction of, in method work, 4; starting-point of, 4, 60; order of, 5, 61; length of successive, 61.
- Shadow experiment, Fechner's, 32.

- Shutter, Jastrow's, 159.
 Simple reaction, technique of, 141 ff.; experiments on, 167 ff.
 Small stimulator, Moldenhauer's, 161 f.; Buccola's, 162 f.
Smith, W. G., 184.
 Sound hammer, 154.
 Sound pendulum, 81 f., 87; formula for intensity of sound, 81.
 Sound stimulator, 153 f.
 Space, measurement of, typical of all measurement, xx.
 Space error, in method of limits, 57 f.; 60, 65 f.; positive and negative, 65, 75; in method of equal sense-distances, 90 f.
 Standard deviation, 182; see Error of mean square.
 Steps, size of, in serial method, 4, 60.
 Stimulators, in reaction experiment, 153 ff.; noise stimulator (dropped ball), 153 f.; sound hammer, 154; telephone arrangement for tone or noise, 154; clang stimulator, Martius', 154 f.; light pendulum, 156; gravity chronometer, 156 ff.; shutter, 157, 159; pressure (Scripture's touch-key, Dessoir's sensibilometer), 157, 159 f.; electrical, 158 ff.; temperature (von Vintschgau's thermophor, Kiesow's cone), 159 ff.; olfactory (Moldenhauer's, Buccola's, Zwaardemaker's), 161 ff.; gustatory, 163.
 Stimulus limen, xxxvii.; fourfold determination of, xxxviii.; see *RL*.
 Storage batteries, 126 f.
 Sum, limit of, 49 f.
 Supraliminal differences, method of, 81 ff.
 Surface of frequency, 179.
 Switch, two-way, 168.
 $t=hx$, 50 ff.; meaning of the symbol, 53; values of, in Fechner's fundamental table, 99; must be weighted, 100.
 Table, Fechner's fundamental, 99, 111, 114; Müller's, of coefficients of weights, 101, 111; of frequencies, 178.
 Taste stimulators, 163.
 Technical terms, xxxvii. f.
 Telephone snapper, as current tester, 141; stimulator, for tone or noise, 154.
 Telescope, reading, 188.
 Temperature stimulator, Kiesow's, 161; see Thermophor.
 Terminal stimulus, xxxvii.; fourfold determination of, xxxviii.; see *TR*.
 Terms, technical, xxxvii. f.
 Thermophor, von Vintschgau's, 161.
Thompson, S. P., 135f., 138.
Thorndike, E. L., 178.
 Time error, in method of equivalents, 79; in method of constant *R*-differences, 106, 113.
 Time interval, reproduction of a, 197.
 Tone, lowest audible, 1 ff., 10 ff.; highest audible, 12 ff.; determination of *DL* by method of limits, 67 ff.
 Tones, deep, intrinsically weak, 1; introspection of, 9.
 Touch-key, Scripture's, 159.
 Touch-weights, Scripture's, 14 f.
TR, as symbol of terminal stimulus, xxxvii.; fourfold determination of, xxxviii.; qualitative, for tones, 12.
 Tuning forks, 67 f., 154.
 Unit of mental measurement, xxxiv. f., xxxvi.; of measurement a distance, not a point, 47, 178; electrical units, 120 f.; see Metric system.
 Upper limit of sensation, xxxi. f.
 Variability, measures of, see Average variable error, Error of mean square, *h*, *MV*, *PE*.
 Variability, relative, 182.
 Variation, coefficient of, 183.
Vierordt, K., 196.
von Vintschgau, M., 161.
 Visual extents, equation of, 76 f.
 Voice key, Cattell's, 147 f., 158, 166.
 Volitional reaction with discrimination, 190; with cognition, 190 f.
 Volt, definition of, 120.
 Voltmeter, 132 ff.
 Warming up, 67, 68, 77, 80, 87, 90, 103, 115, 118, 176 f., 197; see Experiments, preliminary, Practice.
Watt, H. J., 195.

- Weber, E. H.*, xxxviii., 25 ff., 28 f., 42, 113 f., 115, 195, 198.
- Weber's Law, xxxviii., 25 ff. : Fechner's formulation of, 28; demonstrations of, 29 ff.; curves showing relation of *S* to *R* in, 26 f., 29, 42; test of, by method of constant *R*-differences, 113 f.; for time intervals, 196.
- Weight experiment, Sanford's, 33 f.; in method of constant *R*-differences, 107, 115 ff.; materials for Fechner's 115 f.
- Weights, envelope, 33; cartridge, 80; Fechner's, 115 f.; Fechner's, two methods of lifting, 117.
- Wheatstone, C.*, 135.
- Wheatstone bridge, 135 f.
- Witmer, L.*, 167.
- Wright, A.*, 129 f.
- Wundt, W. M.*, xxxvii., 29, 124, 156, 184.
- Wundt's *d*-method of reaction, 185 f.
- Yerkes, R. M.*, 179, 184.
- Zwaardemaker, H.*, 163.





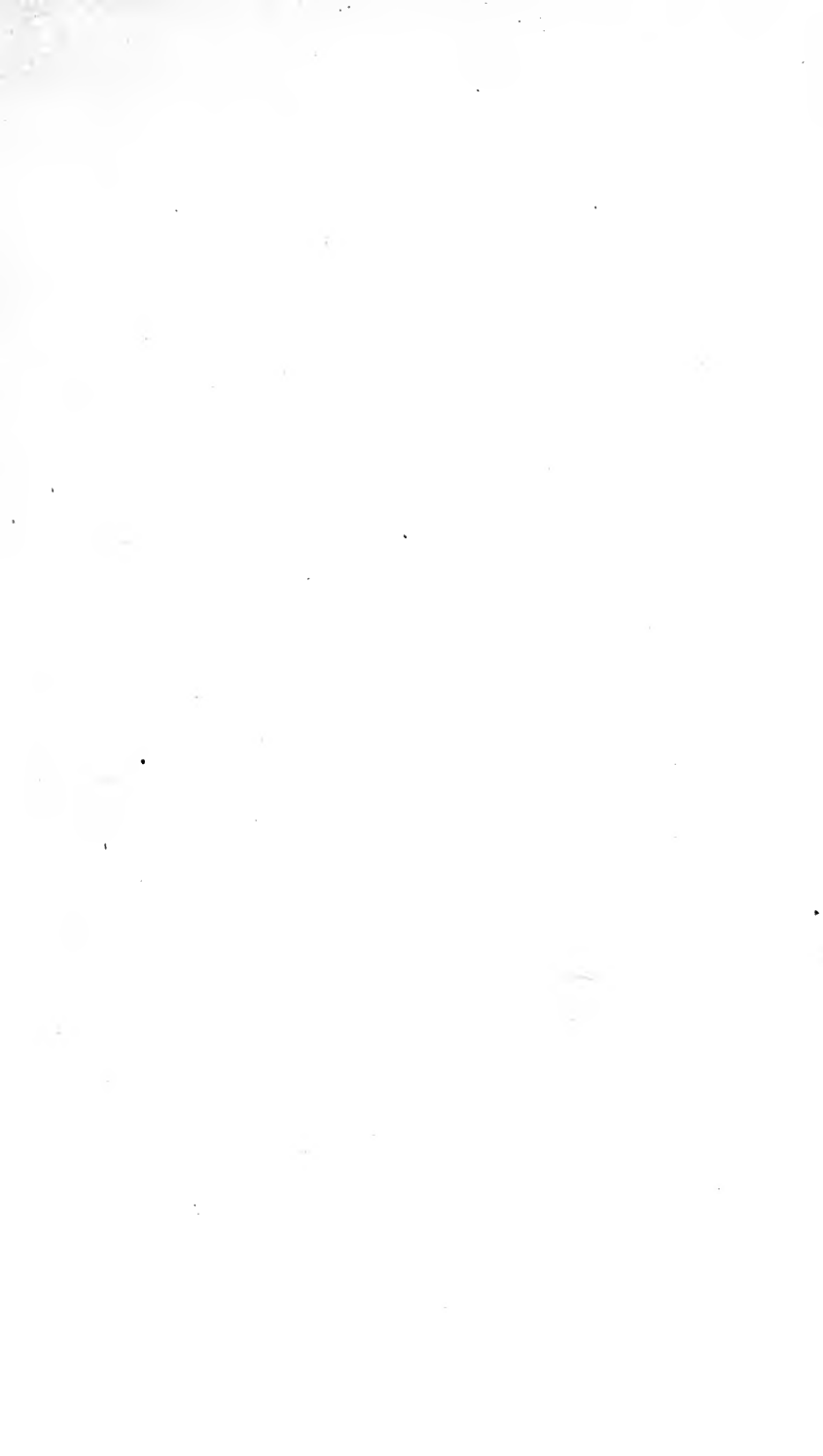

| | | |
|-------|-------------------|------|
| CP557 | Titchener, E.B. | |
| 256 | Experimental psy- | |
| 1905 | chology. | 4199 |
| v.2 | | |
| | | |
| | | |
| | | |
| | | |
| | | |
| | | |
| | | |
| | | |
| | | |
| | | |
| | | |
| | | |
| | | |
| | | |
| | | |

4199

UNIVERSITY OF CALIFORNIA MEDICAL SCHOOL LIBRARY

