

UNIVERSITY OF TORONTO



3 1761 00499093 3



Digitized by the Internet Archive
in 2007 with funding from
Microsoft Corporation

EXPERIMENTAL PSYCHOLOGY

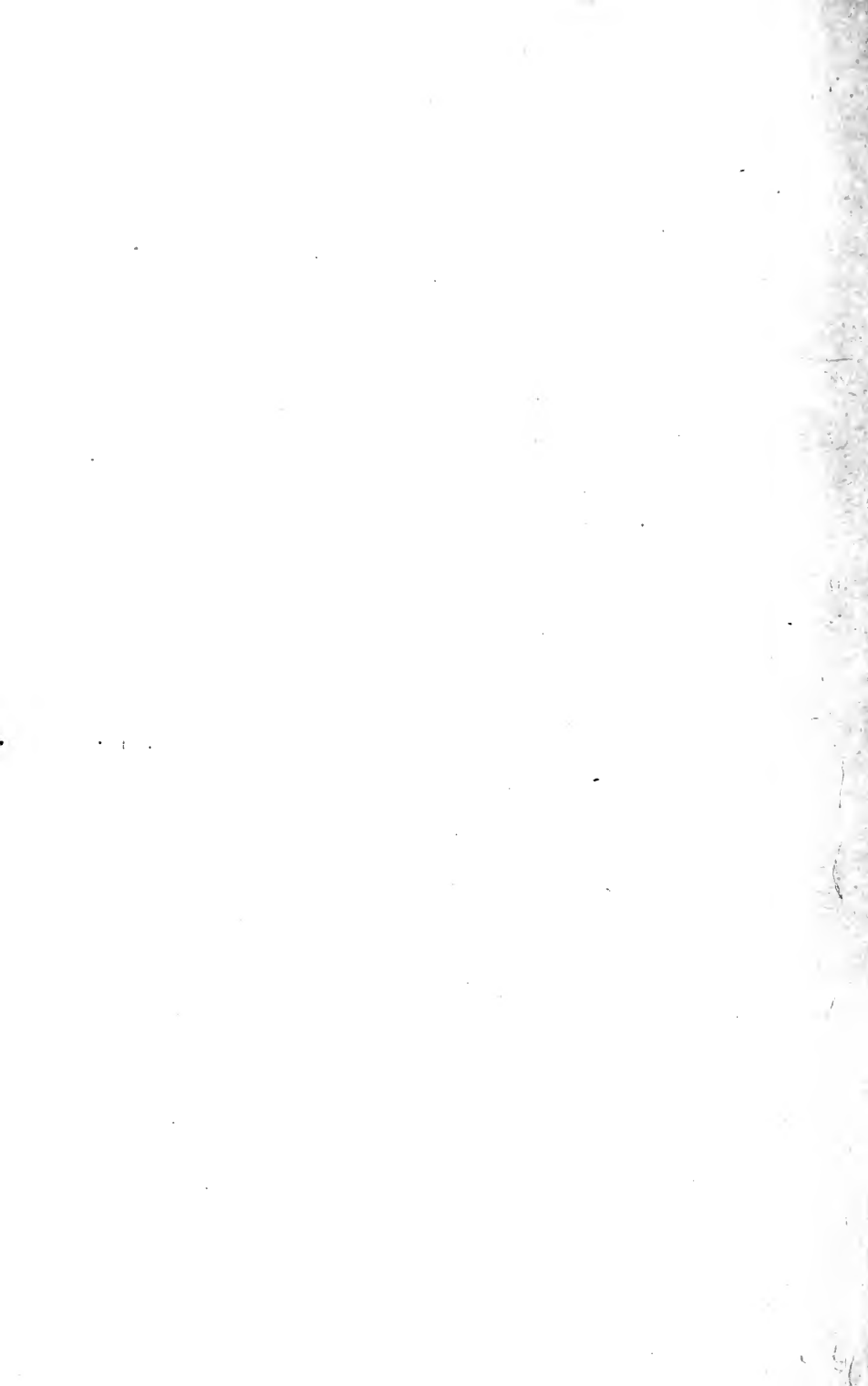

MENTAL PSYCHOLOGY

A Manual of Laboratory Practice

BY

EDWARD BRADFORD TITCHENER

VOLUME II

QUANTITATIVE EXPERIMENTS
PART II. INSTRUCTOR'S MANUAL

177721.
26.1.23

Je pense, quant à moi, et j'affirme que tant qu'un phénomène, quel qu'il soit, physique ou moral, n'a pas été traduit en nombres, il laisse dans l'esprit toujours quelque chose de mystérieux.— DELBŒUF.

New York

THE MACMILLAN COMPANY

LONDON: MACMILLAN & CO., LTD.

1915

All rights reserved

COPYRIGHT, 1905,
By THE MACMILLAN COMPANY.

Set up and electrotyped. Published October, 1905. Reprinted
December, 1915.

Norwood Press:
Berwick & Smith Co., Norwood, Mass., U.S.A.

ELECTRONIC VERSION
AVAILABLE

NO. 96000067

To the Memory of
JOSEPH REMI LÉOPOLD DELBŒUF
1831-1896



PREFACE

THIS second volume follows the plan of the first, with such modifications (noted in their place) as the difference of subject matter has seemed to make necessary.

The major part of the book—in Pt. i., the Introduction, Ch. I., and the expository portions of Ch. II.; in Pt. ii., the Introduction, Ch. I., and the historical and critical Sections of Ch. II.—was written in 1901–1903. In the autumn of 1903, I was obliged to turn aside for a time to other occupations, and did not resume my main task until the spring of 1904. In the meanwhile, Professor G. E. Müller had published his *Gesichtspunkte und Tatsachen der psychophysischen Methodik*, a work of practically the same range as my Chs. I. and II. I had been greatly influenced by Müller's previous writings, and had shaped my account of the Metric Methods in conformity with his standards; I had also, if it may be said without self-praise, carried psychophysical analysis, in various directions, beyond the point at which he had left it. When, therefore, the *Methodik* appeared, I found nothing to alter or amend; though, as I had known before, there was much that might be deepened and broadened. I was sorely tempted to leave my text as it stood, and to take account of Müller's book simply in foot-note references. But the better counsel prevailed: I have gone over again the ground covered by Müller's researches, and have sought to make the new results an organic part of my exposition.

Next after my wife, I owe most, in the preparation of this volume, to Professor E. C. Sanford, of Clark University, and to my colleague Professor I. M. Bentley. I am also heavily indebted to my former assistant, Dr. J. W. Baird, now of the Johns Hopkins University, and to my present assistants, Mr. H. C. Stevens and Mr. C. E. Ferree. The Sections that deal with physical and mathematical questions have been read and revised by Professors

J. MacMahon, E. L. Nichols and H. J. Ryan, of Cornell University: so that, if any errors remain, they have escaped the expert eye. Professor G. E. Müller, of Göttingen, and Dr. G. F. Lipps, of Leipzig, have kindly furnished me with information upon various special points. I must mention, further, Professor J. McK. Cattell, of Columbia University; Mr. W. H. Davis, of Lehigh University; Professor C. H. Judd, of Yale University; Professor W. B. Pillsbury, of the University of Michigan; Dr. H. F. Stecker, late of Cornell University, now of the Pennsylvania State College; Professor G. M. Whipple, of Cornell University; and Mr. L. N. Wilson, Librarian of Clark University: all of whom have rendered me substantial aid. There is, indeed, hardly any one of my American colleagues upon whom I have not called for occasional assistance, which has been willingly granted; and if I do not cite more names in this Preface, it is only because the list, to have significance at all, must end somewhere. I desire to express, in general terms, my sincere gratitude to all—named or unnamed—who have given me of their time and knowledge.¹

I have dedicated this volume to the memory of the late Professor Delbœuf, first, as the author of the 'Reconstruction' which I trace in § 6, but secondly and more personally as the friend who, during the last four years of his life, opened to me a treasure-house of erudition and psychological inspiration.

CORNELL HEIGHTS, ITHACA, N. Y.

April 1st, 1905.

¹ Of my own students, my thanks are due in particular to Mr. B. R. Andrews, Miss G. M. Andrus, Professor J. C. Barnes, Mr. W. A. Frayer, Miss F. Gantt, Mr. R. H. Gault, Miss A. Jenkins, Dr. M. S. Macdonald, Miss M. A. Martin, Miss E. Murray, Miss M. C. Nerney, Miss E. Parry, Miss J. B. Peirson, Mr. G. H. Sabine, Dr. W. D. Scott, Dr. C. R. Squire, Mr. R. B. Waugh, Miss F. M. Winger (Mrs. W. C. Bagley), and the late Mr. O. G. Schumard.

TABLE OF CONTENTS

INTRODUCTION

THE RISE AND PROGRESS OF QUANTITATIVE PSYCHOLOGY

	PAGE
§ 1. Weber's Experiments	xiii
§ 2. Fechner's Interpretation	xx
§ 3. The Reception of the <i>Elemente</i>	xxxviii
§ 4. Criticism	xlvii
(1) The given <i>S</i> not a sum of <i>S</i> -units	xlviii
(2) The equality of the j. n. d.	lxviii
(3) The 'psychophysical law'	lxxxix
§ 5. Our Debt to Fechner	cvii
§ 6. Reconstruction	cxvi
§ 7. Notes on §§ 1-7 of the Text	cxliv
§ 8. Questions and Essay Subjects	clvii
§ 9. The Problems of Sensitivity	clxv

CHAPTER I. PRELIMINARY EXPERIMENTS

EXPERIMENT I

§ 10. The Qualitative <i>RL</i> for Tones ; the Lowest Audible Tone	I
---	---

EXPERIMENT II

§ 11. The Qualitative <i>RL</i> for Tones ; Alternative Experiment	21
§ 12. Determinations of the Lowest Audible Tone	24

EXPERIMENT III

§ 13. The Qualitative <i>TR</i> for Tones ; the Highest Audible Tone	31
§ 14. Determinations of the Highest Audible Tone	41

EXPERIMENTS IV-VI

§ 15. The Intensive <i>RL</i> for Pressure	46
--	----

EXPERIMENTS VII, VIII		PAGE
§ 16. The Intensive RL for Sound		56
§ 17. Weber's Law		61
EXPERIMENTS IX–XII		
§ 18. Demonstrations of Weber's Law		72
CHAPTER II. THE METRIC METHODS		
§ 19. The Law of Error		93
§ 20. The Method of Limits : Historical		99
§ 21. The Method of Limits : Critical		116
EXPERIMENTS XIII, XIV		
§ 22. The Method of Limits : Notes on § 16 of the Text		121
§ 23. The Limits of Continuous Change		137
EXPERIMENT XV		
§ 24. Fechner's Method of Average Error : Notes on § 17 of the Text		143
§ 25. The Method of Average Error : Historical		160
EXPERIMENTS XVI, XVII		
§ 26. The Method of Equivalents : Notes on § 18 of the Text		187
§ 27. The Method of Equivalents : Historical		191
EXPERIMENTS XVIII, XIX		
§ 28. The Method of Equal Sense Distances : Notes on § 19 of the Text		194
§ 29. The Method of Equal Sense Distances : Historical and Critical		210
§ 30. The Psychophysics of Tone : the Tonal DL and Judgments of Tonal Distance		232
EXPERIMENT XX		
§ 31. The Method of Constant R : Notes on § 20 of the Text		248
EXPERIMENT XXI		
§ 32. The Determination of Equivalent R by the Method of Constant R : Notes on § 21 of the Text		258
EXPERIMENTS XXII, XXIII		
§ 33. The Method of Constant R -differences : Notes on § 22 of the Text		263
§ 34. The Method of Right and Wrong Cases : Historical and Critical		275

CHAPTER III. THE REACTION EXPERIMENT

	PAGE
§ 35. Electrical Units and Measurements	319
§ 36. The Technique of the Simple Reaction	326

EXPERIMENT XXIV

§ 37. The Three Types of Simple Reaction	356
--	-----

EXPERIMENT XXV

§ 38. Compound Reactions : Discrimination, Cognition, Choice	375
--	-----

EXPERIMENT XXVI

§ 39. Compound Reactions : Association	381
--	-----

CHAPTER IV. THE PSYCHOLOGY OF TIME

EXPERIMENT XXVII

§ 40. The Estimation of Time	393
--	-----

CHAPTER V. THE RANGE OF QUANTITATIVE PSYCHOLOGY

§ 41. Some Typical Experiments in Quantitative Psychology	405
---	-----

APPENDICES

APPENDIX I. EXAMINATION QUESTIONS	413
APPENDIX II. BOOKS AND PERIODICALS	417
APPENDIX III. FIRMS AND INSTRUMENTS	423

LIST OF MATERIALS	425
-----------------------------	-----

INDEX OF NAMES	429
--------------------------	-----

INDEX OF SUBJECTS	439
-----------------------------	-----

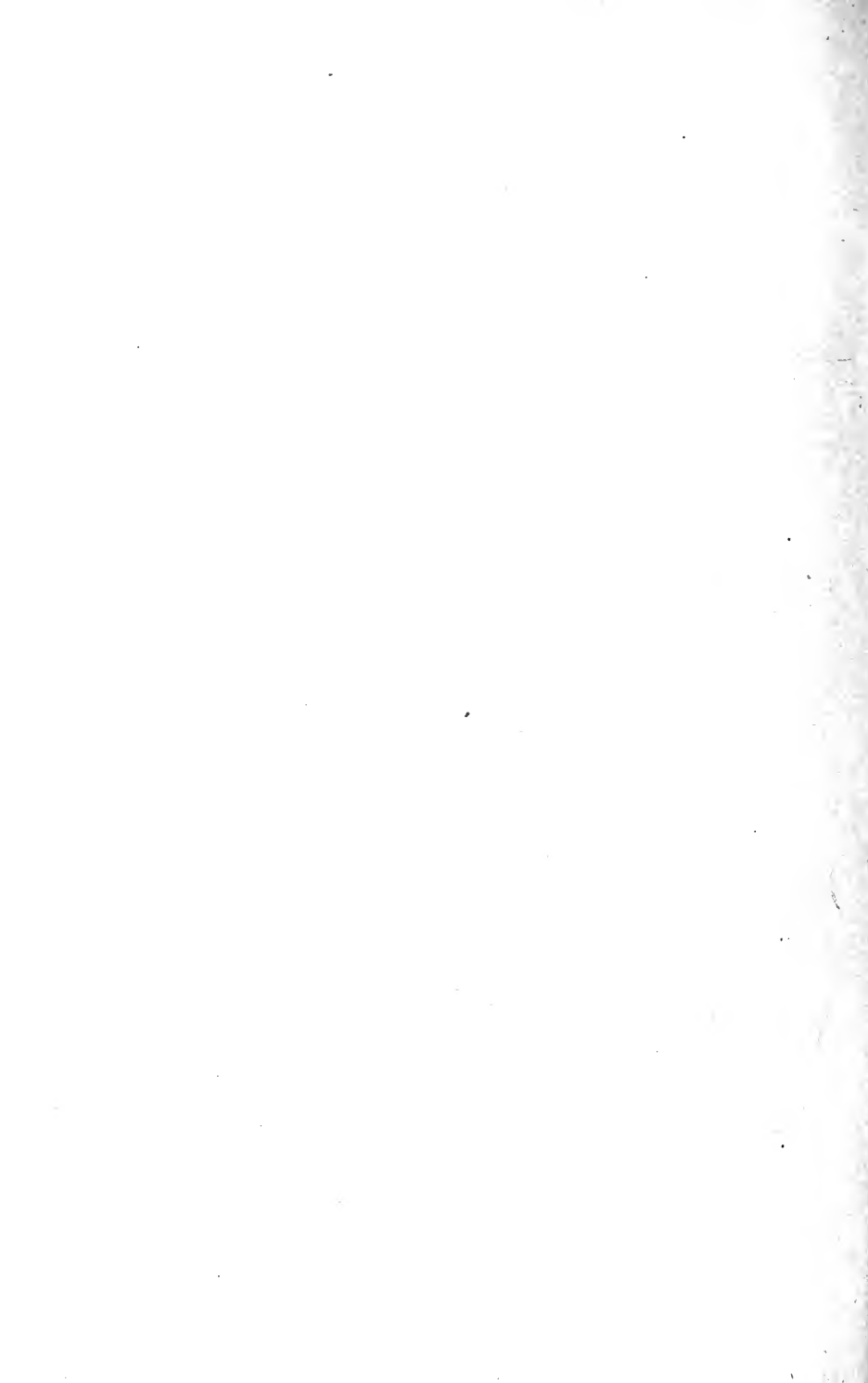

INDEX OF FIGURES

FIG.	PAGE
1. Progression of the <i>DL</i> with increasing <i>R</i> (Ament)	lxxxv
2. Diagram illustrative of the interpretations of Weber's Law	xci
3. Koenig's giant fork	13
4. Appunn's wire fork	14
5. Appunn's series of high forks	31
6. One of Appunn's high forks, with cork attachment	33
7. Politzer's acoumeter	59
8. Zoth's acoumeter	59
9. Seashore's audiometer	60
10. Masson's disc	77
11. Demonstration discs for Weber's Law	78
12. Lehmann's arrangement for the photometry of grey glasses	79
13. Episcotister	79
14. Curves of weight discrimination	83
15. Graphic expression of ratio-series	84
16. Curve of brightness discrimination	86
17. Curve of brightness discrimination	86
18. Martius' disc	87
19. Hering's discs	88
20. Appunn's octave tonometer	91
21. Schema of Method of Limits	130
22. Jastrow's pressure balance	136
23. Marbe's colour mixer	138
24. Stern's tone variator, first model	139
25. Stern's tone variator, latest model	139
26. Schema of Stern's tone variator	139
27. Stern's tone variator with gasometer	140
28. Whipple's double gasometer	141
29. Stratton's æsthesiometer	142
30. Schema of Stratton's æsthesiometer	142
31. Münsterberg's apparatus for the comparison of visual extents	210
32. Wundt's gravity phonometer	221

FIG.	PAGE
33. Wundt's apparatus for memory of visual distances	257
34. Curves illustrating the Method of Right and Wrong Cases (Fullerton and Cattell)	269
35. Curves showing the distribution of r , w and u cases as deter- mined by Gauss' Law of Error (Külpe)	270
36. Weston portable ammeter	322
37. Arrangement for measuring resistance of Hipp magnets	325
38. Old-pattern chronoscope-arrangement for break to break	327
39. Hipp chronoscope, housed, with release key	328
40. Wundt's demonstration chronoscope	331
41. d'Arsonval chronometer	336
42. Mechanism of d'Arsonval chronometer	336
43. Münsterberg's chronoscope	337
44. W. G. Smith's reaction arrangement	339
45. Wundt's large control hammer	341
46. Keys of large control hammer	342
47. Detail of wheel contacts for noise stimulator	344
48. Ewald's reaction key	346
49. Ewald's rocking key	347
50. Kiesow's electroæthesiometer	347
51. Ranschburg's key	350
52. Bryan's apparatus for precision of movement	371
53. Müller's apparatus for memory and association	391
54. Wundt's time-sense apparatus	396
55. Meumann's time-sense apparatus	399
56. Time-sense contacts (Meumann, Schumann)	401
57. Apparatus for brightness contrast (Hess and Pretori)	406
58. Wundt's complication pendulum	408
59. Wundt's complication clock	409
60. Whipple's apparatus for the temporal limen of disparate im- pressions	409
61. Donders' isoscope	410
62. Hering's haploscope (Hillebrand)	410
63. Apparatus for quantitative study of the Müller-Lyer illusion (Heymans)	411
64. Apparatus for quantitative study of the Zöllner illusion (Heymans)	411
65. Memory apparatus (T. L. Smith)	412

LIST OF ABBREVIATIONS

-
- A. J. The American Journal of Psychology, ed. 1887-1895 by G. S. Hall; 1895 ff. by G. S. Hall, E. C. Sanford and E. B. Titchener.
- El. G. T. Fechner, Elemente der Psychophysik. Reprint, 2 vols., 1889. Leipzig, Breitkopf und Härtel.
- G. G. E. Müller, Zur Grundlegung der Psychophysik. 1878. Berlin, T. Grieben.
- I. S. G. T. Fechner, In Sachen der Psychophysik. 1877. Leipzig, Breitkopf und Härtel.
- M. G. E. Müller, Die Gesichtspunkte und die Tatsachen der psychophysischen Methodik. 1904. Wiesbaden, J. F. Bergmann. Off-printed from L. Asher and K. Spiro, Ergebnisse der Physiologie, 2ter Jahrgang, ii. Abt., 266-516.
- P. P. W. Wundt, Grundzüge der physiologischen Psychologie. 1 vol., 1874; 2 vols., 1880, 1887, 1893; 3 vols., with separate index, 1902-3. Leipzig, W. Engelmann.
- P. S. Philosophische Studien, ed. by W. Wundt.
- R. G. T. Fechner, Revision der Hauptpuncte der Psychophysik. 1882. Leipzig, Breitkopf und Härtel.
- Z. Zeitschrift für Psychologie und Physiologie der Sinnesorgane, ed. 1890-1901 by H. Ebbinghaus and A. König; 1902, by H. Ebbinghaus; 1902 ff., by H. Ebbinghaus and W. A. Nagel.

INTRODUCTION : THE RISE AND PROGRESS OF QUANTITATIVE PSYCHOLOGY

Zu einem Werke, wie den *Elementen der Psychophysik*, bedurfte es einer Vertrautheit mit den Prinzipien exakter physikalisch-mathematischer Methodik, und zugleich einer Neigung, in die tiefsten Probleme des menschlichen Seins sich zu vertiefen, wie in dieser Vereinigung nur Fechner sie besass. Und dazu brachte er jene Ursprünglichkeit des Denkens, welche die überkommenen Hilfsmittel frei nach eigenen Bedürfnissen umzugestalten wusste, und kein Bedenken trug, neue und ungewohnte Wege einzuschlagen. . . Die Art, wie er so aus einem zerstreuten und lückenhaften Material klar formulierte und exakt durchgearbeitete Methoden geschaffen hat, ist sicherlich eine der grossartigsten Leistungen, welche die Wissenschaft unserer Tage aufzuweisen hat.—WUNDT.

Fechner's book was the starting point of a new department of literature, which it would be perhaps impossible to match for the qualities of thoroughness and subtlety, but of which, in the humble opinion of the present writer, the proper psychological outcome is just *nothing*.—JAMES.

§ 1. **Weber's Experiments.**—In the years 1829–1834, Ernst Heinrich Weber (1795–1878), then professor of Anatomy in the University of Leipzig, published by installments a long experimental study of cutaneous and kinæsthetic sensation. The monograph is reprinted, under the general title *De tactu*, in Weber's *Annotationes anatomicæ et physiologicæ: programmata collecta*, Leipzig 1851 (fasc. i., 1834, 44 ff.). It falls into two parts: the *De subtilitate tactus diversa in diversis partibus sensui huic dicatis*, and the *Summa eorum quæ experimentis de tactu didicimus*.

In the first part (1831, 90 f.), Weber describes experiments which show that, with a given standard weight of 32 oz., "our observations of the magnitude of weights are rendered more than twice as accurate, if for their estimation we employ the cœnæsthesis of the muscles as well as touch." The fact is interesting, but would, if it stood alone, possess but little importance; tests must be made with other weights, larger and smaller than 32 oz. Weber therefore proceeds to experiment with two standards, of 32 oz. and of $\frac{32}{5}$ oz. or 32 dr. respectively (91, 163). He finds that "a difference of the smaller weights is not less accurately

distinguished by touch than the same difference of the larger weights." The results are as follows:

<i>O</i>	MODE OF JUDGMENT	LEAST PERCEPTIBLE DIFFERENCE
1	Pressure	32 - 17 oz. = 15 oz.
	Lifting	32 - 30.5 oz. = 1.5 oz.
	Pressure	32 - 24 dr. = 8 dr.
	Lifting	32 - 30 dr. = 2 dr.
2	Pressure	32 - 22 oz. = 10 oz.
	Lifting	32 - 30.5 oz. = 1.5 oz.
	Pressure	32 - 22 dr. = 10 dr.
	Lifting	32 - 30 dr. = 2 dr.
3	Pressure	32 - 20 oz. = 12 oz.
	Lifting	32 - 26 oz. = 6 oz.
	Lifting	32 - 26 dr. = 6 dr.
4	Pressure	32 - 26 oz. = 6 oz.
	Lifting	32 - 30 oz. = 2 oz.
	Lifting	32 - 29 dr. = 3 dr.

"Now," he says, "if you compare the differences of the heavier and lighter weights which escape our observation, you will observe that they are almost the same."

For method and sources of error, see 85 f.; for differences of sensitivity, 89 f. Cf. O. Funke, Hermann's Hdbch., iii., 2, 1880, 334 ff.; G. E. Müller, G., 189 ff.; Fechner, El., i., 138 f.; Wundt, P. P., 1874, 313 f.; i., 1902, 530 f. The values of the Table are exceedingly irregular. If we 'mass' the four *O*'s, we get the averages :

	oz.	dr.
Pressure	10.7 ± 2.7	9.0 ± 1.0
Lifting	2.7 ± 1.6	3.2 ± 1.3

Weber does not seem to have worked with weights heavier than 32 oz.

In 1833 (132 ff.) Weber published the results of further experiments, made with a standard weight of 15 half-ounces under varying conditions: with simultaneous and successive application of the weights, with application to the same or to different hand or finger, with the hand supported and unmoved or held

free above the table. Under the most favourable circumstances, the weight of 15 was distinguished from that of 14.5 half-ounces: "we perceive correctly a difference between the weights which is expressed by the numbers 29:30" (133, 135).

In summing up the *De tactu* (171), Weber says that apt and practised *O's* "differentiam duorum ponderum successive una eademque manu librantes" can discriminate a weight of 29 from a weight of 30 oz. or dr., while *O's* less apt or practised discriminate 14 from 15. Here we seem, since there is no evidence of any further experimentation, to have a mixed reference to the two sets of experiments,—those with 32 oz. and dr., and those with 15 half-oz. This supposition is, indeed, raised practically to certainty by a reference on 160 f., where the two sets of experiments are treated together, and where the 15 half-oz. have become, for Weber himself, 15 oz.

It is equally certain that the *DL* of $\frac{1}{30}$ is ascribed by Weber not to pressure alone, but to pressure *plus* the muscle sense. The words "manu librantes," in the passage just quoted, are clear. Moreover, Weber proceeds: "it follows, then, that touch, in hands voluntarily moved (*consulto motis*), is so subtle" that we get a *DL* of $\frac{1}{30}$. And, besides, the words on p. 160 are explicit. Nevertheless, in the *Tastsinn* Weber gives the limen for passive touch as $\frac{1}{30}$ (559), and refers to his older experiments to support his statement (547)! Müller, misled by the *Tastsinn*, cites both it and the *De tactu*, 171, as giving "den eben merklichen Unterschied zweier allein mittels des Drucksinnes wahrgenommener Gewichte" (G., 191).

The primary reason for Weber's confusion lies, probably, in the fact that the *De tactu* is concerned with the difference between skin and skin *plus* muscles, the *Tastsinn* with the difference between skin and muscles alone (546 f.). He must, by lapse of memory or what not, have attributed to skin—now sharply opposed in his mind to muscles—what had in reality belonged to skin and muscles together. His statement that "neuere Versuchsreihen" confirm the previous result, the result, *i.e.*, that weights of 29:30 are discriminated "nur mit der grössten Mühe" by the resting hand, suggests the possibility that he had not even referred to his older work, but found the value $\frac{1}{30}$ in his memory, and (after practice with the muscle sense) made some fresh tests upon passive touch to verify it.

In the second part of the study (1834), we have the first formulation of what is now known as Weber's Law. "In observando discrimine rerum inter se comparatarum," writes Weber,

“non differentiam rerum, sed rationem differentiae ad magnitudinem rerum inter se comparatarum incipimus” (172). In comparing objects and observing the distinction between them, we perceive, not the difference between the objects, but the ratio of this difference to the magnitude of the objects compared. “If we are comparing by touch two weights, the one of 30 and the other of 29 half-ounces, the difference is not more easily perceived than that between weights of 30 and 29 drachms. . . . Since the distinction is not perceived more easily in the former case than in the latter, it is clear that not the weights of the differences but their ratios are perceived. . . Experience has taught us that apt and practised *O*’s sense the difference between weights, if it is not less than the thirtieth part of the heavier weight, and that the same *O*’s perceive the difference not less easily, if drachms are put in the place of half-ounces.

“That which I have set forth with regard to weights compared by touch holds also of lines to be compared by sight. For whether you compare longer or shorter lines, you will find that the difference is not sensed by most *O*’s if the second line is less by a hundredth part. . . The length in which the distinction resides, therefore, although [in the case of lines of 50 and 50.5 mm.] it is twice as small [as it is in the case of lines of 100 and 101 mm.], is nevertheless no less easily apprehended, for the reason that in both cases the difference of the compared lines is one hundredth of the longer line.¹

“I have made no experiments upon the comparison of tones by the ear. [Delezenne, however, determined the *j. n. d.* of the *b* of 240 vs.] As this author does not say that this difference is discriminated less easily in deeper, more easily in higher tones, and as I have never heard that a difference is more easily perceived in higher tones, . . . I imagine that in audition also not the absolute difference between the vibrations of two tones, but the relative, compared with the number of vibrations of the tones, is discriminated.²

“The observation, confirmed in several departments of sense,

¹ On pp. 142 ff., 172, we read only of experiments with a single standard of 100 mm. The line of 50 mm. appears for the first time on p. 173.

² Tones are first mentioned on p. 172, in a reference to W. Weber and to Delezenne: for an account of these experiments, see pp. 235 f. below.

that in observing the distinction between objects we perceive not the absolute but the relative differences, has again and again impelled me to investigate the cause of this phenomenon; and I hope that, when this cause is sufficiently understood, we shall be able to judge more correctly regarding the nature of the senses" (172 ff.).

So much was written in 1834. In 1846 appeared Weber's article *Der Tastsinn und das Gemeingefühl* (R. Wagner's *Handwörterbuch der Physiologie*, iii., 2, 1846, 481; published separately, 1849, 1851), which may be considered the foundation stone of experimental psychology. Weber devotes a brief chapter to the "least differences (*Verschiedenheiten*) of weights which we can distinguish by the sense of touch, of the length of lines, which we can distinguish by sight, and of tones, which we can distinguish by ear" (559). "I have shown," he writes, "that the result in the determinations of weight is the same, whether one takes ounces or half-ounces; for it is not a question of the number of grains that make up the increment of weight, but of the fact that this increment is the thirtieth or fiftieth [should be, fortieth] part of the weight which we are comparing with a second weight.¹ The same thing holds of the comparison of the length of two lines and of the pitch of two tones. It makes no difference whether we compare lines that are, say, two inches or one inch long, . . . and yet the extent by which the one line exceeds the other is in the former case twice as great as in the latter. . . .²

"So too in the comparison of the pitch of two tones, it does not matter whether the two tones are seven tonal steps [*i.e.*, an octave] higher or lower, provided only that they do not lie at the end of the tonal series, where the exact discrimination of small

¹ Weber attempts to reach a pure judgment in terms of the muscle sense by placing the weights in a cloth, which *O* lifts without touching the weights themselves. He finds that weights of 78 and 80 oz. are discriminated. Hence the *DL* is $\frac{1}{40}$: not $\frac{1}{50}$, as he later gives it (547, 560). Curiously enough, Weber seems to have worked with only one standard weight, and to have generalised his result in the light of his earlier experiments. The value $\frac{1}{30}$ has been discussed above. See G. E. Müller, G., 193 ff.; Fechner, *El.*, i., 199.

² Weber worked throughout with very short lines: *De tactu, loc. cit.*; *Tastsinn*, 559, 561. See G. E. Müller, G., 205; Fechner, *El.*, i., 294.

tonal differences becomes more difficult. Here again, therefore, it is not a question of the number of vibrations by which the one tone exceeds the other, but of the vibration ratio of the two tones which we are comparing. . . .¹

“The apprehension of the relation of whole magnitudes, without our having measured the magnitudes by a smaller scale-unit, and without our having ascertained the absolute difference between them, is an extremely interesting psychological phenomenon. In music we apprehend the relations of tones without knowing their vibration rates [*i.e.*, their absolute pitch]; in architecture, the relations of spatial magnitudes, without having determined them by inches; and in the same way we apprehend the magnitudes of sensation or of force in the comparison of weights” (559 ff.).

Weber had, then, first-hand evidence for his law in the spheres of pressure, lifted weights² and visual distances. In the case of tones, he appealed to Delezenne,—mistakenly, as we shall see later (§ 30), since Delezenne made no comparative determinations of the *DL*. On this basis of induction he erected his law. The law itself may be formulated in the equation $\frac{dR}{R} = \text{const.}$, where *dR* represents that change in a given *R* which is just able to produce a change in *S*. Or, in words: the magnitude of the relative *DL* is independent of the absolute magnitude of *R*. Or again, in Fechner's phraseology: the relative differential sensitivity is independent of the absolute magnitude of *R*. A large generalisation for so small a body of fact! Of course, Weber may have performed experiments that he does not report; but the internal evidence of his papers is decidedly against this supposition. One can but wonder, in view of the importance which Weber's Law assumed in Fechner's hands, at the little which Weber has to report, and at the carelessness with which he reports it. The

¹ The reference is again to Delezenne : 559.

² Regarding the pressure experiments, Müller remarks that “[es] lässt sich [daraus] kaum etwas Sicheres betreffs der Gültigkeit des Weberschen Gesetzes im Gebiete des Drucksinnes erschliessen.” From the experiments with lifted weights “lässt sich mit ziemlicher Sicherheit folgern, dass die Empfindlichkeit für relative Unterschiede gehobener Gewichte bei Steigerung der absoluten Gewichtsgrosse gleichfalls etwas zunimmt” (G., 195 f.).

law was, however, to him only one observation among many; interesting and important, but not more important than other facts of sensation. Else he would hardly have failed to carry his experiments farther; to extend them to more than just noticeable *R*-differences; and to mention some of the many everyday experiences which illustrate the law.

See Fechner, *El.*, i., 134 ff., and esp. *Abh. d. k. sächs. Ges. d. Wiss., math.-phys. Cl.*, iv., 1859, 469. It is, perhaps, indicative of Weber's attitude towards his law that the long paper *Ueber den Raumsinn und die Empfindungskreise in der Haut und im Auge* (*Ber. d. k. sächs. Ges. d. Wiss., math.-phys. Cl.*, 18 Decr. 1852, 85 ff.), which refers to the *De tactu* and the *Tastsinn*, says not a word of the constancy or inconstancy of the relative *DL*. And it seems clear, from Fechner's remarks in the *Abh.* of 1859, that he had taken no special pains to press his observations on the notice of his scientific colleagues. Cf. G. Villa, *La Psic. Cont.*, 1899, 245; *Cont. Psych.*, 1903, 137.

A. Höfler (*Psych.*, 1897, 145) writes: "E. H. Weber hatte selbst (mit Euler, Drobisch) die Beziehungen zwischen den Intervallen und den Schwingungszahlen als unter sein Gesetz fallend angesehen; und wenn dies auch nicht zutrifft, . . . so zeigt es doch, dass Weber selbst sein Gesetz nicht auf die eben merklichen Unterschiede eingeschränkt wissen wollte: vgl. auch seine Aeusserung über die Auffassung der Verhältnisse an Bauwerken u. dgl." The author cannot agree with this interpretation. There is nothing in the *De tactu* to bear it out; the title of the relevant section of the *Tastsinn* is against it; Euler and Herbart are nowhere mentioned. If the concluding words of the *Tastsinn* section (the words to which Höfler refers) are carefully read, it will be seen that, while they follow naturally from what precedes, they were not written with an eye to the law. What Weber says, in effect, is simply this. "If you compare weights, lines, tones, you will find a constancy of the relative *DL*. What an interesting thing, psychologically, this comparison of wholes as wholes is! We have it in music, in architecture, and in the estimation of weights." Weber is quite right; it is an interesting thing. But it was suggested to Weber by his work on the *DL*; it is not adduced by him as evidence of his law beyond the realm of the *DL*. Fechner, not Weber, put 'gleich merklich' for 'eben merklich' in the formulation of the law. The extension is warranted by the facts, and is altogether consonant with the spirit of Weber's enquiry; but it was not made by Weber.—Cf. Stumpf, *Tps.*, i., 337 n.; F. Jodl, *Lehrb. d. Psych.*, 1896, 215, 219 f., 233; O. Funke, in *Hermann's Hdbch.*, iii., 2, 1880, 341; and *ct.*, besides Höfler's *Psych.*, Hering, *Sitzungsber. d. kais. Akad.*

d. Wiss. zu Wien, math.-naturw. Cl., lxxii., 1875, 313; A. Grotenfelt, Das Webersche Gesetz, 1888, 118 *n.*; O. Külpe, Arch. f. Gesch. d. Phil., vi., 1893, 181; Stumpf, Beiträge, 1901, Heft 3, 91 f.; F. A. Müller, Axiom d. Psychophysik, 1882, 67; M. Foucault, Psychophysique, 1901, 307; A. Höfler, Vjs., xi., 1887, 368; Wundt, Das Webersche Gesetz u. d. Methode d. Minimaländerungen, 1882, 6 (*cf.* 9, 24); or P. S., ii., 1885, 3 (*cf.* 5, 19).

Weber's predecessors on the experimental side seem to have been occupied, one and all, with brightness intensities: Fechner, El., i., 151 ff.; ii. 548. On the mathematical side, they were concerned with pitch and pitch-number, with the *fortune physique* and the *fortune morale*, and with stellar magnitude and photometry: *ibid.*, i., x., 156, 182, 236; ii., 549 ff.

§ 2. **Fechner's Interpretation.** — If Weber laid the foundation stone of experimental psychology, Gustav Theodor Fechner (1801–1887) may be said to have planned, and in large measure to have erected, a whole building. His work covers a period of full fifty years, from the after-image investigations of 1838 to the Psychische Massprincipien of 1887. We are here concerned only with its quantitative side, *i.e.*, with the writings which led up to and grew out of the Elemente der Psychophysik (1860: reprinted under Wundt's auspices, with notes and bibliography, 1889).

It was on the 22d Oct., 1850, Fechner tells us, as he lay awake in bed before getting up, that the thought came to him of "making the relative increase of bodily energy the measure of the increase of the corresponding mental intensity."¹ The general idea of measuring the intensity of mental activity in terms of the underlying physical activity had long occupied him, but had hitherto led to no fruitful result. The new thought was definite; it gave him a starting point; thrown into mathematical form, it even gave him two formulæ which later on play a large part in the Elemente. But it did not, of course, give him any measure of sensation. The stimuli could be measured; their precise correlation with sensation was a matter of hypothesis. The only thing to do, in default of a sensation measure, was to assume the correctness of the rule, and to put it to empirical test under conditions where measurement was not needed: *e.g.*, in the observa-

¹ El., ii., 554; Fechner sketches, pp. 553–560, the development of his ideas from 1850 to 1860.

tion of simple increase or decrease of sense intensity, of extremes of sensation, of sensations of equal intensity.¹ Fechner therefore contented himself, for the time being, with a brief mention of his new ideas in the *Zend-Avesta* (1851),—a work which, as he gravely remarks, “does not pretend to the character of exact research.”²

The exact research followed, in the shape of the classical experiments on brightnesses and lifted weights, on visual and tactual distances, in many of which Fechner was loyally assisted by A. W. Volkmann. While these were in progress, he lighted upon Weber's generalisation, and his own principle forthwith became Weber's Law.³ Confirmation of the law was sought—and found—in various places: notably in the astronomical classification of the fixed stars by visible magnitude. The fact of the limen, “a datum of everyday experience which has attracted little observation, but on which the whole of the night side of mind depends,”⁴ supplied the last link in the chain of mathematical reasoning. Last, not least, the three psychophysical metric methods, of just noticeable differences, of right and wrong cases, and of average error, were worked out with such care and subtlety as to raise psychology, once and for all, to the dignity of an experimental science.

Of all this work we hear nothing until 1858, when Fechner published a paper on mental measurement,⁵ a sort of author's review of the forthcoming *Elemente*. In 1859 appeared a detailed inquiry into the validity of the law in the sphere of visual intensity,⁶ which furnished material for the discussion in ch. ix. of the

¹ *Zend-Avesta*, ii., 373.

² *El.*, ii., 558; *Zend-Avesta, oder über die Dinge des Himmels und des Jenseits, vom Standpunkt der Naturbetrachtung*, 1851, ii., 312 ff., esp. 334 ff., 341, 373 ff.; *cf.* i., 410 ff.

³ *El.*, i., 64, 134; ii., 558; *Fichte's Zeits.*, N. F., xxxii., 1858, 15; *Abh. d. kgl. sächs. Ges. d. Wiss., math.-phys. Cl.*, iv., 1859, 469, 531.

⁴ *El.*, ii., 558; W. Preyer, *Wiss. Briefe*, 1890, 209.

⁵ *Das psychische Mass*: in *Fichte's Zeitschrift f. Philos. und philos. Kritik*, N. F., xxxii., 1858, 1 ff.

⁶ *Ueber ein psychophysisches Grundgesetz und dessen Beziehung zur Schätzung der Sterngrößen*: *Abh. d. kgl. sächs. Ges. d. Wiss., math.-phys. Cl.*, iv., 1859, 457 ff. *Nachtrag zu der Abhandlung, etc.*: *Ber. d. kgl. sächs. Ges. d. Wiss., math.-phys. Cl.*, xi., 12 Feb. 1859, 58 ff.

Elemente.¹ Finally, in 1860, came the Psychophysik itself. We must devote some little space to its analysis.

Fechner defines Psychophysics as "an exact science of the functional relations or relations of dependency between body and mind."² Its sphere is thus as wide as the sphere of psychology; there will be a psychophysics of sensation, of perception, of feeling, of action, of attention, etc.³ In the present state of our knowledge, however, it will be wise for us to occupy ourselves primarily with sensations, which we may classify as intensive and extensive.⁴ All sensations possess magnitude and form, termed in the intensive domain 'intensity' and 'quality.' We shall be concerned chiefly with their magnitude.⁵

The first step in psychophysical metrics⁶ is the establishment of the metric principle of sensitivity.⁷ Sensitivity is a special form of organic irritability or excitability, the organism's capacity of response to stimulation;⁸ it may be defined as the degree of correspondence between sensation and adequate stimulus. "One and the same stimulus⁹ may, even if applied in the same manner, be sensed more or less strongly by one observer or one organ than by another, or by the same observer or organ at different times; and, contrariwise, stimuli of different magnitude may, under certain circumstances, be sensed equally strongly. We then attribute to the one observer or organ, or to the single observer or organ at one time, a greater or less sensitivity than to the other, or to the same at another time."¹⁰ Now we can measure stimuli; and we are perfectly well able to say whether two given sensations are 'equal' or 'alike.' Hence we can measure sensitivity: it is inversely proportional to the magnitude of the stimuli which

¹ El., i., 139.

² El., i., vii., 8 ff.; Fichte's Z., 1858, 21.

³ El., i., 13 f., 56 f.; ii., 86; I. S., 87; R., 1 ff., 327; Fichte's Z., 1858, 24. Cf. Zend-Avesta, ii., 384 ff.; W. Preyer, *Wiss. Briefe*, 1890, 221.

⁴ El., i., 15, 55; Fichte's Z., 1858, 1, 21; I. S., 61 f.

⁵ El., i., 15 ff.; I. S., 2. Fechner, of course, takes things here too much for granted. He should have defined sensation: not a few of his 'sensations' are, in modern terminology, perceptions. He should also (as we shall see later) have offered evidence of the independent variation of intensity and quality.

⁶ Psychophysische Masslehre: El., i., 21 ff.

⁷ Massprincip d. Empfindlichkeit: El., i., 45 ff.; Fichte's Z., 1858, 4 f.

⁸ El., i., 51. ⁹ For a discussion of stimulus, see El., i., 17 ff. ¹⁰ El., i., 45.

arouse sensations of equal magnitude.¹ Suppose that you can just sense a pressure of 2 gr. at a certain part of the skin, and that I, at the corresponding part, can sense nothing below 4 gr.; then your sensitivity is twice as great as mine. Suppose that (as Weber found) a pressure of 1.5 oz. on the lips is equal to a pressure of 4 oz. on the forehead;² the sensitivities of the two parts stand to one another in the ratio 8:3. It must be understood that, in 'measuring sensitivity,' we are always measuring stimuli, not sensation; we determine what stimuli (or stimulus differences) arouse sensations (or sensation differences) of equal magnitude.³ And it is clear that "the measure of sensitivity, as a measure of mere capacity of sensation, is not to be confused with a measure of sensation itself. Nor does it presuppose any such measure, but only the observation of instances of equal sensations, under like or different conditions of stimulation."⁴

We have to distinguish (1) absolute sensitivity, or S. for absolute *R*-values,⁵ measured by the inverse value of the absolute *R*-magnitudes which evoke a sensation of the same magnitude, and (2) differential sensitivity, or S. for *R*-differences. This latter is measured in two ways: (a) as simple or absolute D. S., by the inverse value of the absolute difference of the *R*-magnitudes, and (b) as comparative or relative D. S., by the inverse value of the ratio of the *R*-magnitudes.⁶ Suppose that you can distinguish a pressure of 18 gr. from one of 24 gr., and that I can distinguish only 16 gr. from the same 24 gr. The absolute D. S. are $\frac{1}{6}$ and $\frac{1}{8}$: yours is to mine as 4:3. The relative D. S. are $\frac{1}{24}$ and $\frac{1}{24}$; yours is to mine as 9:8.⁷

"Since sensitivity is a variable matter, we have not to measure it as we should measure a constant; but we can seek to determine (1) its extreme and (2) its mean values; we can investigate (3) the dependency of its changes upon circumstances; and we can

¹ El., i., 46.² De subt. tactus, 98.³ El., i., 46, 54.⁴ El., i., 54.

S.=sensitivity, R=stimulus. See p. xxxvii. of the text.

⁶ El., i., 50.

⁷ The ratios $\frac{24}{18}$ and $\frac{24}{16}$, to which the D. S. is here made inversely proportional, are known technically as quotient limens (*QL*). The relative *DL* are more commonly expressed in the form $\frac{6}{24}$ and $\frac{8}{24}$, or $\frac{1}{4}$ and $\frac{1}{3}$. The relative D. S. would then be 4 and 3, instead of $\frac{4}{3}$ and $\frac{3}{2}$, respectively. See Fechner, El., i., 244; I. S., 13; R., 397; Stumpf, Tps., i., 298 f.; Külpe, Outlines, 59.

(4) make search for laws which hold throughout its variations. These laws are the most important thing.”¹

Our measurement of sensitivity is a necessary first step, but still only a first step, towards the measurement of sensation.² “The possibility of establishing the equality of small differences of sensation, or small increments of sensation, under changed conditions of stimulation, is the main prerequisite of measurement,”³ but does not guarantee measurement. To measure sensation we must be able to say, not only that our present pain is much more severe than our pain of yesterday, not only that the illumination of two rooms is sensibly the same, but that our pain is 2, 3, 4, . . . times as great as the previous pain, that the brightness of the light is 10, 15, 20, . . . times as great as that of the brightness unit. And we must be able to say this in terms of sensation itself, not merely in terms of the stimulus which arouses sensation.⁴ How are we to arrive at exact statements of this kind?

“The difference between two *R*-magnitudes may always be considered as a positive or negative increment of the one or the other *R*-magnitude; and a total *R* may be regarded, mathematically, as made up by positive increments from zero, increment being constantly added to the sum of former increments, until the full *R* is present. In the same way, a sensation difference may be considered, mathematically, as positive or negative increment of the one or the other sensation, and a total sensation may be regarded as made up of positive increments from zero to its full intensity. If we know the functional relation between the sum of the *R*-increments from zero onwards, and the sum of the corresponding *S*-increments,⁵ we have it *eo ipso* for the total *R* and the *S* which the *R* releases.”⁶ We may, then, get over the difficulty of sense measurement by “having recourse to the relation between the elementary increments out of which we may regard the *R* and *S* as built; this requires no measurement of sen-

¹ El., i., 54; Zend-Avesta, ii., 373.

² El., i., 46, 59 f.; ii., 191.

³ Fichte's *Z.*, 1858, 5: this equality is established by aid of the metric methods; cf. El. i., 171 ff. Our ability to equate sensations at large is presupposed, e. g., in photometry and in the tuning of musical instruments: El., i., 55, 70.

⁴ El., i., 56; ii., 18; I. S., 1; R., 300 ff.: P. S., iv., 218; Delbœuf, *Examen critique*, 1883, 79, 118, 177; Vierordt, *Zeitsinn*, 1868, 9.

⁵ *S*=sensation; see p. xxxvii. of the text. ⁶ El., i., 58 f.

sation, but only . . . a judgment of the equality of *S*-differences or *S*-increments which correspond to given, measurable, variable *R*-increments; from it we derive the functional relation of the sums of the increments, and thus obtain the measure of *S* in terms of the measured *R*." ¹ We mark off an *S*-magnitude in units of its own kind; that is essential to measurement; but the scale which we lay upon the *S*-magnitude is physical, an *R*-scale. "In principle, therefore, our measurement of *S* comes to this: that we split up every *S* into equal divisions, *i.e.*, the equal increments out of which it is built up from the zero-point of its existence, and consider the number of these equal divisions to be determined (as if by the inches of a yard-stick) by the corresponding variable *R*-increments which can produce the equal *S*-increments. . . . We determine the magnitude of the *S*, which we cannot determine directly, as a multiple of the equal parts which we can determine directly; but we read off the number of parts not from the *S*, but from the *R* which brings the *S* with it, and which can be more easily read." ²

So the difficulty is overcome,—in theory. But in practice? Objections are many and insistent. Thus (1) we are to seize an *S* in the act of increase; yet actual *S* are either full-grown, when we meet them, or at least come so quickly to a head that their growth cannot be followed. Now it is true that we cannot measure a full-grown *S*, since such an *S* cannot be divided into parts.³ On the other hand, no *S* is born full-grown; it is fact, not fiction, that every *S* rises gradually to its full height. All that we have to do is to treat this continuous increase of *S* as the infinitesimal calculus treats a curve: for the same *S* in various stages of increase we substitute as many different *S* of the height of these stages.⁴ Again, (2) we are to measure the change of sensation; yet *S* change continuously, the increments running into one another. The same substitution avails us: for an increasing

¹ *El.*, i., 59 f.; *cf.* *Zend-Avesta*, ii., 374.

² *El.*, i., 60; ii., 191 f.; *Fichte's Z.*, 1858, 5 f.

³ These are Fechner's own words. "An die schon erwachsene Empfindung lässt sich kein Mass anlegen, insofern sich keine Theile darin unterscheiden lassen": *Fichte's Z.*, 1858, 8. In the *El.*, i., 61, the last part of the sentence reads: "insofern sich keine quantitative Mehrheit darin unterscheiden lässt."

⁴ *Fichte's Z.*, 1858, 6 f.; *El.*, i., 61 f.; *cf.* *Jodl, Psych.*, 225.

S in the various stages of its intensity we take a number of S of graded intensity. The method of just noticeable differences, *e.g.*, helps us to determine in this way equal S -increments in the higher and lower regions of the R -scale.¹ (3) In saying this we have answered another objection,—namely, that we are to make our successive S -increments all equal, but have no way of ensuring their equality. The metric methods give us a way: the method of *j. n.* differences gives us equal (*i.e.*, just noticeable) S -increments; the method of right and wrong cases gives us S -differences that correspond to the same $\frac{r}{n}$.² Lastly, (4) we are to sum up the S -increments; but their number is infinite, and therefore cannot be summed. The objection holds: we cannot take, all at once, the relative R -increment that corresponds to a given finite S -increment, since the R , in increasing, itself passes through different magnitudes, every one of which has a right to function, in its turn, as divisor. At the same time, the objection can be met by the help of mathematics.³

These are Fechner's objections and Fechner's replies. With them he concludes his general discussion of mental measurement. The remaining chapters of the *Elemente* deal with the subject in detail, under five principal headings: (1) the metric methods; (2) Weber's Law and the sphere of its validity; (3) the limen; (4) formulæ of mental measurement, with corollaries and applications; and (5) the transference of the metric principle from outer to inner psychophysics, from stimulus to excitation.⁴ These topics will occupy us later, in the course of our experiments. A

¹ Fichte's *Z.*, 1858, 6, 9 f.

² *Ibid.*, 10 f.

³ *El.*, i., 63 f.; Fichte's *Z.*, 1858, 6, 13 f.

⁴ The programme of *El.*, i., 68 f. is not strictly carried out; *cf.* ii., v. ff.—The 1889 edition of the *El.* cites the parallel passages from *I. S.*, *R.*, and *Massprincipien* (*P. S.*, iv.).

Two discussions have been omitted from the above list: those of *El.*, i., ch. xii., and ii., chs. xxxiii.—xxxv. (1) The former deals with the Parallel Law, which says that "if two R of different intensity are applied to a sensitive organ for a certain length of time, the absolute S , and therefore the excitations, aroused by the R are diminished by fatigue; the sensed difference, however, remains unchanged, precisely as it would, according to Weber's Law, had the objective R been changed in the same ratio:" *R.*, 180, 241. (2) The latter, entitled 'Special Investigations in certain Departments of Sensation,' deals with the relations of visual and auditory sensations and with the 'extensive' sensitivity.

word must, however, be said regarding the principal formulæ which Fechner employs, and regarding his attitude to Weber's Law.

It is a fact of everyday experience that the increase of a given R which shall effect a noticeable change of the corresponding S depends on the magnitude which R has already attained: the stars give no light in the daytime, but give a good deal of light on a moonless night. Weber found that this increase of R , expressed as a fraction of the total R , remains approximately constant over a wide range of absolute R -intensities. This, so far as Weber himself is concerned, is Weber's Law: this and nothing more. Fechner treats the facts on the hypotheses (1) that the S , as a magnitude, may be regarded as a sum of S -units; (2) that, in investigations which aim at the determination of the j. n. d., these units are conveniently given in the j. n. d. themselves, which as 'sensed differences' or 'difference sensations' are equal at all parts of the R -scale; and (3) that Weber's Law may be transferred from the sphere of 'sensed differences' to that of 'differences of sensation.'¹ On these assumptions mathematical treatment becomes possible.

Let R be the original stimulus, and dR a small increment of R ,—the d not standing for any particular magnitude, but simply indicating that the increment dR is very small: *cf.* its use as the sign of differentiation. Then the relative R -increase is $\frac{dR}{R}$. In the same way, let S be the sensation corresponding to R , and dS

¹ The first two hypotheses we shall discuss later: pp. xlvi. ff., lxviii. ff. The third may be explained as follows.

Not all S -differences are sensed. The two S may be in different minds, or in the same mind but in consciousnesses separated by a long period of time. In such cases, comparison is plainly impossible. But more than this: an S -difference which is sensed by a successive procedure is oftentimes insensible when the R are simultaneously applied. The distinction therefore obtains within a single consciousness. Now Weber's Law is established by aid of sensed differences. But "of all the possible ways in which a difference may be sensed, we may take as extreme or limiting case that in which the very smallest difference which exists should really be sensed, a case which would designate the maximal degree of differential sensitivity. An S -difference can always be identified with such a limiting case," and so Weber's Law can be transferred from the domain of sensed differences to that of S -differences. *El.*, ii., 82 ff.; *I. S.*, 9, 11, 46; *R.*, 183, 330; *P. S.*, iv., 193 ff., 201; Vierordt, *Zeitsinn*, 1868, 154 ff.

the S -increment corresponding to dR . We need a formula which shall satisfy (a) the requirement of Weber's Law, that dS remains constant so long as $\frac{dR}{R}$ is constant, and (b) the mathematical requirement that dS and dR vary proportionally so long as they are very small. The formula is:

$$dS = c \frac{dR}{R}$$

where c is a constant, depending on the unit-values chosen for S and R . This is the *fundamental formula* of mental measurement.¹

From the fundamental formula, together with the fact of the stimulus limen, a second formula may be derived, which "expresses a general quantitative relation between the R -magnitude, summed from R -increments, and the S -magnitude, summed from S -increments."² Consider the fundamental formula as a differential equation, and integrate. Then:

$$S = c \log. \text{ nat. } R + C,$$

where C is the constant of integration. Now introduce the limen; *i.e.*, the determination that S vanishes when R has the liminal value r . The formula becomes:

$$0 = c \log. \text{ nat. } r + C$$

in other words:

$$C = -c \log. \text{ nat. } r$$

and therefore:

$$S = c (\log. \text{ nat. } R - \log. \text{ nat. } r).$$

Translating into the language of common logarithms, we have:

$$S = k (\log. R - \log. r)$$

in other words:

$$S = k \log. \frac{R}{r}$$

¹ Fundamentalformel: El., ii., 9 f.; I. S., 10; R., 184; P. S., iv., 166 ff., 201.
Cf. Zend-Avesta, ii., 374 f.

² El., ii., 10.

where k is a constant including the modulus of the common system. If we make r , the liminal stimulus value, = 1, we may write:

$$S = k \log. R,$$

the form in which the metric formula, as Fechner terms it, usually appears in the text-books.¹ Put into words the formula reads: "the magnitude of sensation (S) stands in relation not to the absolute magnitude of stimulus (R) but to the logarithm of the magnitude of stimulus, when the unit of stimulus is defined as its liminal value (r), *i.e.*, as that magnitude at which sensation appears and disappears."² If we call the value $\frac{R}{r}$ the fundamental stimulus value, we may say that S -magnitudes are proportional to the logarithms of the corresponding fundamental R -values.³ If we make $r=1$, we may say simply that sensation is proportional to the logarithm of stimulus.⁴

The metric formula accords with empirical results: "(1) in the cases of *equality* where an S -difference remains the same with change of the absolute intensity of the R (Weber's Law); (2) in the limiting cases where S itself and where change of S cease to be noticeable or considerable [stimulus limen and neighbourhood of terminal stimulus]. . . ; (3) in the cases of *opposition* between sensations which attain and do not attain to noticeability, in a word, between conscious and unconscious S ."⁵ In it, we have "a relation of dependency that obtains universally, not merely for equal cases of S , between the magnitude of the fundamental R -value and the magnitude of the corresponding S , and which allows us to calculate from quantitative ratios of the former the number of units (das Wievielmahl) in the latter: wherewith the measure of sensation is given."⁶

The above derivation of the metric formula is that which is generally quoted, and that which stands first in Fechner's exposition. The formula may also be derived as follows.

¹ Massformel: El., ii., 33 f.; I. S., 10; R., 184. Cf. Zend-Avesta, ii., 375. The c of the two formulæ are identical.

² El., ii., 13.

³ *Ibid.*

⁴ "Die psychische Intensität ist der Logarithmus der zugehörigen physischen Intensität:" Zend-Avesta, ii., 375.

⁵ El., ii., 16; cf. Zend-Avesta, ii., 377 ff., 385 f.

⁶ El., ii., 17.

Weber's Law tells us that the S -difference remains the same so long as the R -ratio remains the same. That is to say :

$$S - S' = f\left(\frac{R}{R'}\right),$$

where f is the general sign of functional dependency. Let us introduce, as before, the fact of the limen, setting o for S' and r for the corresponding R' . We have :

$$S = f\left(\frac{R}{r}\right).$$

Similarly, the equation

$$S' - S = f\left(\frac{R'}{R}\right)$$

becomes

$$S' = f\left(\frac{R'}{r}\right).$$

This gives the difference

$$S - S' = f\left(\frac{R}{r}\right) - f\left(\frac{R'}{r}\right)$$

which must be equal to the original difference

$$S - S' = f\left(\frac{R}{R'}\right).$$

That is to say :

$$f\left(\frac{R}{R'}\right) = f\left(\frac{R}{r}\right) - f\left(\frac{R'}{r}\right)$$

or

$$f\left(\frac{R}{r}\right) = f\left(\frac{R}{R'}\right) + f\left(\frac{R'}{r}\right).$$

This, however, is an equation of the form $f(xy) = f(x) + f(y)$, of which we can give a general solution only by taking $f(x) = k \log x$, $f(y) = k \log y$, and $f(xy) = k \log xy$: where k is a constant. It follows, then, that we have to take

$$S = f\left(\frac{R}{r}\right) = k \log \frac{R}{r}; \quad S' = f\left(\frac{R'}{r}\right) = k \log \frac{R'}{r};$$

which is the result reached by our previous argument.

We may follow yet a third path. Let there be given three stimuli, R, R', R'' , in descending order of magnitude, together with their corresponding sensations S, S', S'' . We know, by Weber's Law, that

$$S - S' = f\left(\frac{R}{R'}\right); \quad S' - S'' = f\left(\frac{R'}{R''}\right); \quad S - S'' = f\left(\frac{R}{R''}\right).$$

These functions must be of such a nature that

$$(S - S') + (S' - S'') = S - S'',$$

i.e., that the sum of the two partial S -differences is equal to the total S -difference. This means that

$$f\left(\frac{R}{R'}\right) + f\left(\frac{R'}{R''}\right) = f\left(\frac{R}{R''}\right);$$

and as $\frac{R}{R''} = \frac{R}{R'} \cdot \frac{R'}{R''}$, we again have an equation of the form $f(xy) = f(x) + f(y)$, and come to our former result.

There is no need here to follow Fechner farther; to work out the *Unterschiedsformel* and *Unterschiedsmassformel*, to discuss negative sensations, to trace the changes in the metric formula as it is applied outside of its proper sphere of intensity (ii., 21, 58), etc. Some of these things will occupy us later; some lie beyond the scope of the present volume; some, as we shall indicate, may be given to the student as essay subjects. In the meantime, the author cannot too strongly recommend the reading of *El.*, ii., ch. xxxii.; *cf.* *I. S.*, ch. xx.; *G. E. Müller, Z.*, x., 1896, 6 ff.

So far we have been dealing exclusively with outer psychophysics, with the relation of S to R . Fechner's own thinking began, however, as we saw above,¹ with a general question of inner psychophysics; it is here, in the relation of S to E , the excitation, the 'psychophysical process' of his definition,² that his chief interest lies;³ and it is to inner psychophysics that he returns at the end of the *Elemente*. "Are Weber's Law," he asks, "according to which S -increments are constant so long as relative R -increments are constant: and the fact of the limen, according to which S attains a noticeable value only with a certain finite value of R : to be translated for inner psychophysics into a relation between S and E such that R and R -increment are represented by proportional values of E , or not rather into a relation between E and R such that S and S -increment are represented by proportional values of E ? In other words: is the dependency expressed by the fundamental formula and the metric formula a dependency of S upon E or a dependency of E upon R ?"⁴ Fechner decides, on the following grounds, for the former alternative.

¹ *P.* xx.; *El.*, ii., 559; *Fichte's Z.*, 1858, 21. ² *El.*, i., 10: "physical activities which are vehicle or substrate of psychical, and therefore stand in direct functional relation to psychical, we term *psychophysical*:" ii., 377; *I. S.*, 2.

³ *El.*, i., 11 f.; ii., 377; *Fichte's Z.*, 1858, 21; *I. S.*, 56, 213; *Abh.*, 1859, 490; *W. Preyer, Wiss. Briefe*, 1890, 216, 225 f. ⁴ *El.*, ii., 428 f. The term here translated by E is 'psychophysische Thätigkeit;' *cf.* *R.*, 221 ff.

(1) We may say in general that, in view of the disparity of the physical and the psychical, a logarithmic relation between them is entirely conceivable; whereas, in the light of physical and physiological laws, such a relation between R and E is inconceivable. On the other hand, it is, if not a necessary, at least a natural and simple assumption that the relation of R and E , within the limits of the Law's validity, should be that of simple proportion.¹ (2) The magnitude of the sensed difference between two R does not change if our sensitivity to the R be uniformly reduced. It should grow less, if the sensed difference were proportional rather to the absolute than to the relative difference of E ; for if each of the two R , owing to reduced sensitivity, arouses only half as strong an E , the difference of E is also reduced one half.² (3) The same law holds for the pitch of tones that holds for their intensity. If, then, the logarithmic relation is a matter of physiology, it must obtain, in the case of tonal pitch, between vibration rate of E and vibration rate of R : which is inconceivable.³ (4) There can be no doubt that a real difference of E remains unconscious unless it attains a certain magnitude; we do not see the stars in the daytime. And what holds of the DL must hold of the RL : *i.e.*, there must be absolute magnitudes of E which do not as yet arouse an S . But this does away with the hypothesis of equality of E and S .⁴ (5) Finally, it is only by ascribing liminal relations to E as well as to R that we can reach a simple and satisfactory explanation of sleep and waking, consciousness and unconsciousness, attention and inattention.⁵

¹ El., ii., 429 f. The argument from inconceivability is formally withdrawn in I. S., 92 f. Fechner thinks, however, that the cases of logarithmic relation adducible from nerve physiology tell rather in his favour: 72 ff.; *cf.* R., 229 ff. On the naturalness of his own view, see I. S., 65 ff; R., 225 ff., 251 ff. On the value of the arguments, see below, pp. xci. ff.; J. Ward, *Mind*, O. S., i., 1876, 454 ff.; Funke, in Hermann's *Hdbch.*, iii., 2, 1880, 356; W. Dittenberger, *Philos. Monatshefte*, ii., 1896, 89 ff.

² El., ii., 430; this is the Parallel Law, for which *cf.* p. xxvi. above, footnote. *Cf.* R., 240 ff.; Jodl, *Psych.*, 202, 219. ⁸ El., ii., 431.

⁴ El., ii., 431 ff. This argument and its corollary Fechner regards as fundamental: "so dass mir die Frage der Uebertragbarkeit des Schwellengesetzes in die innere Psychophysik eine Lebensfrage nicht nur für meine Ausführung der inneren Psychophysik, sondern für die Möglichkeit einer solchen überhaupt scheint;" I. S., 71; *cf.* 82 ff.; R., 235 ff. (esp. 240).

⁵ El., ii., 435, and following chapters; I. S., 218; R., 242 ff.

Weber's Law, therefore, which, empirically regarded, is the foundation stone of psychophysics,¹ is also in its theoretical significance a fundamental psychophysical law. Approximately valid in the sphere of outer psychophysics,² it holds, we may suppose, without exception or deviation when transferred from *R* to *E*.³ If this be true, Weber's Law will some day prove to be as important and far-reaching in the science of the relations of mind and body as the law of gravitation in general physics.⁴ "Doch sind diess für jetzt allerdings nur Ansichten und Aussichten."⁵

It remains to say a word of Fechner's other systematic contributions to psychophysics: the *In Sachen der Psychophysik*, 1877; the *Revision der Hauptpunkte der Psychophysik*, 1882; and the essay *Ueber die psychischen Massprincipien und das Webersche Gesetz*, 1887 (P. S., iv., 1888). The *In Sachen* is a reply to the principal criticisms of the *Elemente* up to 1877. Fechner had promised in the *Elemente* to publish later a special work "Massmethoden und Massbestimmungen im Gebiete der Psychophysik."⁶ Soon after the publication of the *Elemente*, however, he turned his attention to æsthetics, in which he had been interested as a youth; and the new work on psychophysics was postponed for the *Vorschule der Aesthetik*.⁷ The *In Sachen*, which was necessary in order to clear the ground of objections, is described by Fechner as a sort of first number of the *Massmethoden*: the second number is, if he lives to issue it, to give "Nachträge, . . . Berücksichtigung von Gegenbemerkungen gegen die Ausführungen vorliegenden

¹ *El.*, i., 65 ff.; *Fichte's Z.*, 1858, 18, 24; *I. S.*, 42; *R.*, 292, *n.*; *P. S.*, iv., 187.

² *J. c.*, within the limits of our ordinary usage of the sense-organ; beyond these limits, above and below, occur 'deviations' from the law. *Fichte's Z.*, 1858, 18 ff.; *El.*, i., 65, 67; ii., 430; *I. S.*, 12, 51 ff., 211, 213; *R.*, 147 ff.; *Abh.*, 1859, 464, 530.

³ *Fichte's Z.*, 1858, 23; *El.*, i., 68; ii., 435; *I. S.*, 12, 213; *R.*, 192; *P. S.*, iv., 170, 187.

⁴ *Fichte's Z.*, 1858, 23; *El.*, i., 68; ii., 435; *R.*, 202, 262; *Ber. d. kgl. sächs. Ges. d. Wiss., math.-phys. Cl.*, xvi., 1864, 4 f. *Cf.* the pessimistic tone of James, *Textbook*, 1892, 468; N. von Grot, *Arch. f. syst. Phil.*, iv., 1898, 263, 266; *Ebbinghaus, Psych.*, i., 1, 1897, *Vorbemerkung*.

⁵ *El.*, i., 68. For further remarks on Fechner's attitude to Weber's Law, and on its relation to the general Massprincip. see below, pp. cxiv. f.

⁶ *E. g.*, *El.*, i., 71; *R.*, 105. It was never published.

⁷ The *Zur experimentellen Aesthetik*, i. (all published), appeared in 1871; the *Vorschule* in 1876.

Heftes, . . . manche, von früher her zurückgestellte, Versuchsreihen über extensive und Gewichtsempfindlichkeit, mit Bemerkungen über die Massmethoden."¹ We shall have to take account of the I. S. in § 4 (3), and we shall note from time to time the points at which it marks an advance, in clearness or logical consistency, upon the *Elemente*. It contains nothing that is essentially new: naturally, since (in Fechner's opinion) "kein ausdrücklicher principieller Einwand" has so far been raised against "das in den *Elem. d. Psychophysik* aufgestellte Princip des Empfindungsmasses."²

The Revision is more important. Almost simultaneously with the *In Sachen* appeared G. E. Müller's *Zur Grundlegung der Psychophysik*, 1878. Müller's intention is "die Frage nach der Gültigkeit, Bedeutung und Zweckmässigkeit des von E. H. Weber aufgestellten Gesetzes dem gegenwärtigen Stande unseres Wissens gemäss zu erörtern." The work falls into four parts: the psychophysical metric methods; the facts of Weber's Law; the interpretation of Weber's Law; and the significance of the Law for recognition.³ In the third part, Müller offers a physiological in place of Fechner's psychophysical interpretation; not in any merely controversial spirit, or with an eye to personal reputation, for the physiological interpretation is "weder neu noch erwiesen;" "vielmehr kommt es mir lediglich darauf an, die Angelegenheit des Weberschen Gesetzes gewissermassen in *statum integrum* zurückzuführen und auf einige dieselbe mehr oder weniger berührende, bisher vernachlässigte oder überhaupt unbekannte Probleme . . . die Aufmerksamkeit der Psychophysiker zu lenken."⁴

Here, then, are 'principielle Einwände' in plenty! And the Revision may be considered, in its controversial aspect, as a reply to the *Grundlegung*. The book is, however, not simply polemical. "The principles and methods of psychophysical measurement, the derivation of the psychophysical formulæ, the question of the validity of Weber's Law, the experiments made to confirm it, the controversy between the 'psychophysical' and the 'physiological' interpretations of this law, *i. e.*, between two fundamentally opposed interpretations of psychophysics at large, various principal problems of inner psychophysics, and (by way of introduction) the question of the range of psychophysics in general, all these things have been discussed anew and in detail."⁵ The work may therefore be considered in some sense as a substitute for the *Elemente*; in some sense as a supplement to it; or yet again as prolegomena to a revised *Psychophysics*.⁶ As to the outcome: "ich bin in keiner irgendwie wesentlichen Beziehung dahin geführt worden, die in den '*Ele-*

¹ I. S., iv.² I. S., 211.³ G., v. ff.⁴ G., vi. f.⁵ R., iii. f.⁶ R., iv.

menten' aufgestellten Principien und daraus fließenden Folgerungen und Formeln zu verlassen, sondern im Gegentheil."¹

We must sketch a little more particularly the course of the argument in the essay of 1887.² This, Fechner's latest work, is also in a very real sense his most modern.

Fechner begins with a reference to the astronomical classification of stars by visible magnitude, which proves that it is possible "die Gleichheit empfundener Unterschiede oder auch Unterschiedsempfindungen . . . in verschiedenen Theilen der Helligkeitsscala zu constatiren."³ The same thing may be shown by help of the method of mean gradations and laboratory brightnesses: if the difference $A-B$ is given, we can make a difference $B-C$ that is equal to it; or if $A-C$ is given, we can bisect it at B : in either case, the sensed difference AC is twice the sensed difference AB or BC .⁴ Or again, one may use the method of just noticeable differences. It is entirely possible to estimate the equality of j. n. d. For (1) if we do not assume this possibility, we cannot employ the method as a test of Weber's Law; and the fact that the Law has been verified (within limits) by the method is decisive. (2) In the absence of theoretical or empirical arguments to the contrary, what holds of large sensed differences must hold also of small. (3) Experience proves that, within the limits of an error of observation, the j. n. d. may be made equal in introspection. And (4)—though this is truly not an argument for the equality of the j. n. d. !—if we reject the method of just noticeable differences, we can still fall back upon mean gradations and the equality of supraliminal differences to supply us with a mental measurement.⁵

We can say, then, how many times a smaller difference sensation (correlated with physical values that lie near together) is contained in a larger difference sensation (correlated with physical values that lie farther apart). We have, already, a principle of mental measurement, and one that is of practical value (astronomy). Of course, since all sensations are evoked by stimuli, the measurement of sensations involves a reference to stimuli. If we know that equal difference sensations correspond to equal stimulus ratios, and we take any given difference sensation as unit, we can get n -times as large a difference sensation simply by multiplying the correlated stimulus ratio n -times into itself. This does not, however, by any means imply that the measurability of difference sensations is

¹ R., v.

² For a running criticism of Fechner's arguments, see Wahle, *Das Ganze d. Philos.*, 200 ff., with which cf. Jodl, *Psych.*, 226 ff.

³ P. S., iv., 181. On the 'arithmetical principle' laid down in the opening paragraphs, 179, see Elsas, *Philos. Monatshefte*, xxiv., 1888, 139 f.

⁴ *Ibid.*, 183.

⁵ *Ibid.*, 184 f.

bound up with the validity of Weber's Law. Only, Weber's Law, especially if we regard it as absolutely valid in the sphere of inner psychophysics, affords the simplest basis and the most important body of facts for the application of the principles of mental measurement.¹

But we can pass from the measurement of difference sensations to that of sensation differences. The DL is an error of estimation, akin to the probable error of physical enquiries.² Let us now assume (as we have a right to do) that Weber's Law is valid over a certain portion of the psychophysical scale. "The elimination of constant errors of time and space is already assumed in the validity of Weber's Law for difference sensations; and, on this assumption, Weber's Law obtains for the difference sensations independently of the magnitude of the DL and can accordingly be postulated for the case in which the DL sinks to 0, . . . when the error of estimation dependent on the DL disappears, the difference sensation coincides with the sensation difference, and the same metric procedure that is applicable to difference sensations becomes applicable to sensation differences."³ Both alike are measured in terms of an unit of their own kind; but the units do not correspond,—the difference sensation being always a little larger than the correlated sensation difference, save in the limiting case in which the DL is 0.⁴ Note that, in the change from sensation differences to difference sensations, it is not the S themselves that change; the DL is an error of comparison, of estimation, of memory.⁵

We have measured difference sensations and sensation differences: can we measure sensations? Yes: by help of the RL and arithmetic. Let A, B, C, \dots be stimuli, so chosen that $\frac{B}{A} = \frac{C}{B} = \frac{D}{C}$, etc. Then by Weber's Law the corresponding difference sensations are equal. So also are (as we have shown) the corresponding successive sensation differences $b-a, c-b, d-c$, etc. According to our principle of measurement, the sensation difference $d-b$ is twice $c-b$; if $c-b$ be our unit, $=1$, then $d-b=2$. Now the differences of given values from 0 are identical with the values themselves: $x-0=x$. Let us suppose, then, that b has the S -value 0, so that B is the RL . After as before, $d-b=2(c-b)$: but, since $b=0$, this is the same thing as saying that $d=2c$. Similarly, $e=3c, f=4c$, etc.; and we have the required measurement of sensation.⁶

We have it by grace of the RL : but what is the RL ? May it not be a merely physiological phenomenon? No: remember that, when an R affects the sensorium, in the waking state, it finds the sensorium "not

¹ *Ibid.*, 185 ff. ² *Ibid.*, 188. We return to the point in detail, pp. civ. ff. below.

³ *Ibid.*, 193.

⁴ *Ibid.*, 194.

⁵ *Ibid.*, 195.

⁶ *Ibid.*, 197; cf. *El.*, i., 60; ii., 191.

psychophysically empty, but already occupied by some sort of psychophysical excitations."¹ The incoming R and the corresponding E must, now, transcend this preexistent excitation, pass the 'mixture limen,' "before the S can appear in consciousness with discriminable quality and quantity."² In this sense there is an inner limen, over and above the outer, physiological limen.

Fechner ends the statement of his own views with a discussion of attention,³ and a reference to his psychophysical Weltanschauung.⁴ The rest of the article is taken up with his reply to Elsas⁵ and Köhler.⁶ The only further point that calls for mention here is his insistence on the impossibility of mental measurement without reference to the corresponding R -values. "Let two stimuli of different magnitude r_o , r_n (e. g., two stellar magnitudes) be given; and let us denote the total difference sensation correlated with them by $S(n)$. There is nothing to prevent an experimental determination of the unit, whereby this value is to be measured, either as the just noticeable difference sensation (correlate of the j . n. R -difference) or as an equally noticeable difference sensation (correlate of a given R -ratio) . . . to be found by the method of mean gradations. But if we are to ascertain how many times the unit is contained in $S(n)$, we must (according to Köhler) juxtapose the equal mental steps in consciousness itself,—i. e., without marking off the R between r_o and r_n which correspond to the equal steps,—until we presently attain the total difference sensation designated by $S(n)$. Let the reader try for himself, whether the measurement can be made without the aid of the intervening R ! Without such aid, the mental steps pass indistinguishably into one another; we do not know where one ends and another begins, and therefore cannot fulfil the requirement of determining their n ; it is as if we should attempt to ascertain the height of a tower by mounting the first staircase and then climbing the rest of the way in the air. Besides, there is an initial inconsistency in the argument. While mental measurement is to be attainable, in principle, by itself, without reference to the underlying physical values, yet for the attainment of the mental unit such reference is not only permitted, but expressly demanded."⁷

This survey may fitly conclude with Wundt's words of appreciation. "Diese Arbeit des 86-jährigen ist, wie ich glaube, die klarste und volendetste Darstellung des Problems, die er überhaupt in den beinahe

¹ *Ibid.*, 203.

² *Ibid.*, 204. We return to the question of the RL below, pp. xciv. ff.

³ *Ibid.*, 207 ff.; cf. *R.*, 269 ff.

⁴ *Ibid.*, 211 f.

⁵ A. Elsas, Ueber die Psychophysik, 1886; Fechner, *loc. cit.*, 162 ff.

⁶ P. S., iii., 1886, 573 ff.; Fechner, *loc. cit.*, 212 ff.

⁷ *Ibid.*, 216 ff. Cf. A. Lehmann, Die körperl. Aeusserungen psych. Zustände, ii., 1902, 11.

40 Jahren gegeben hat, während deren er sich mit demselben beschäftigte."¹

§ 3. **The Reception of the Elemente.**— The decade 1850–1860, during which Fechner was at work upon the *Elemente der Psychophysik*, belongs to a confused and depressing period of German political history.² The revolutionary wave of 1848 had spent itself without effect; but the movement towards union, inaugurated by the Frankfort parliament, had also received a serious check at the conferences of Olmütz and Dresden. There followed years of political reaction, such as have occurred again and again in the history of the nations, and such as are almost always characterised by a fruitful growth of science and letters. It is as if the best men of the time, despairing of political progress, had their energies turned perforce into other channels. This may be at any rate a partial explanation of the scientific activity of Germany in the middle of the nineteenth century. We are not here concerned with the advance of the exact sciences; it must suffice to remind the reader that the law of the conservation of energy plays the same part for scientific thinking in the 40's that the origin of species by means of natural selection plays in the 60's.³ We may, however, mention a few of the most important books in the sciences of life and mind. Helmholtz published his *Physiologische Optik*, "one of the four or five greatest monuments of human genius in the scientific line,"⁴ between 1856 and 1866, and his *Tonempfindungen* in 1862; du Bois-Reymond's *Untersuchungen über thierische Electricität* appeared between 1848 and 1860; Ludwig's epoch-making *Lehrbuch der Physiologie* came out in 1852 and 1856; Virchow's *Cellularpathologie* in 1850, and his *Specielle Pathologie und Therapie* in 1854–1862; Lotze's *Medicinische Psychologie* in 1852 and *Mikrokosmos* in 1856–1864: and the list might be largely extended. When, therefore, the *Elemente* entered on the scene in 1860, it found itself at once in good company. We might predict that, as a scientific

¹ P. S., iv., 477 f.

² See B. Gebhardt, *Handbuch d. deutschen Geschichte*, ii., 1892, 540 ff.

³ H. Höffding, *Geschichte d. neueren Philosophie*, ii., 1896, 552 ff., 567.

⁴ James, *Psych.*, ii., 1890, 278.

work by a well-known author, it would be assured of a wide and critically trained audience.

We must, however, enquire a little more closely into Fechner's standing as a scientific writer. His *Massbestimmungen über die galvanische Kette* (1831) had given him a high rank among physicists, and on the death of H. W. Brandes in 1834¹ he was appointed professor of physics in the University of Leipzig.² His work on after-images (1838, 1840) was of the same order as the *Massbestimmungen*, and received its due meed of praise from Helmholtz. "Fechner, der mit einer ausserordentlichen Selbstaufopferung auch gleichzeitig eine grosse Reihe genauer, selbst messender Versuche in diesem Gebiete ausgeführt hat, gab zuerst eine genügende Herleitung der negativen Bilder aus dem Princip der Ermüdung. Diese beiden Arbeiten [Plateaus und Fechners] bezeichnen im Wesentlichen noch den gegenwärtigen Stand der Wissenschaft."³ On the other hand, the publication of *Nanna oder über das Seelenleben der Pflanzen* (1848) and of *Zend-Avesta oder über die Dinge des Himmels und des Jenseits* (1851) must have brought him into disrepute with the main body of contemporary scientific men. "Die Naturforscher zuckten über das Buch [the *Nanna*] die Achsel, und erklärten Fechner für einen unklaren Kopf."⁴ For their philosophy—if they concerned themselves at all with philosophical questions—was the materialism of Moleschott and Vogt and Büchner,⁵ the materialism that Vogt

¹ Not, as Wundt says, "bei dem Weggang W. Webers nach Göttingen" (G. T. Fechner, 1901, 9). Weber went to Göttingen from Halle in 1831, and was forced to vacate his Göttingen chair in 1837. Cf. J. E. Kuntze, G. T. Fechner, 1892, 107; 139.

² For Fechner's life and work, see J. E. Kuntze, G. Th. Fechner (Dr. Mises): ein deutsches Gelehrtenleben, 1892; K. Lasswitz, G. Th. Fechner, 1896; W. Wundt, Zur Erinnerung an G. Th. Fechner, P. S., iv., 471; G. Th. Fechner, Rede zur Feier seines 100-jährigen Geburtstages, 1901; Chronologisches Verzeichniss der Werke u. Abhandlungen G. Th. Fechner's, in *El.*, i., 1889, 337 ff.; O. Külpe, *Arch. f. Gesch. d. Phil.*, vi., 1893, 170, 449; *Vjs. f. wiss. Phil.*, xxv., 1901, 191; A. Elsas, *Grenzbote*, 1888.

³ P. O., 1896, 537; cf. vol. i., I. M., 37 f.

⁴ Lasswitz, 66. We know that the botanist M. J. Schleiden published a violent attack upon *Nanna*, to which Fechner replied in 1856. The *Nanna* was reprinted, under Lasswitz' auspices, in 1899, and again in 1903.

⁵ J. Moleschott, *Der Kreislauf des Lebens*, 1852; L. Büchner, *Kraft und Stoff*, 1855; K. Vogt, *Köhlerglaube und Wissenschaft*, 1855, and *Vorlesungen über den*

upheld against Rudolph Wagner in the famous Naturforscherverammlung at Göttingen (1854): and with this Fechner had nothing in common. It is doubtful, too, if matters were helped by the publication, in 1855, of the work *Ueber die physikalische und philosophische Atomenlehre*. In this book Fechner settles accounts with the speculative Naturphilosophie of Schelling and his school;¹ but he is at equal pains to show that the atomic theory has no connection with materialism.² We may say in general, therefore, that though there were many men of scientific eminence who, like Helmholtz, would take Fechner's work on its scientific merits, irrespective of his philosophical opinions, he would nevertheless be obliged, in 1860, to reconquer his old ground with the rank and file of the scientifically educated public.

What, then, of Fechner's standing as a philosopher, as the author of the *Zend-Avesta*? We have here no interest in Fechner's philosophical views on their own account; the antimaterialistic Grundansicht which forms the background of the *Elemente*, and to which "he has given expression in earlier works,"³ is something that, as psychologists, we might altogether ignore. Only, in that case we could never hope rightly to understand Fechner. For him, Wundt tells us, "die Psychophysik . . . ist nichts anderes gewesen als der umfassendste und gründlichste Versuch, den er unternommen, die in dem *Zend-Avesta* entworfene Weltanschauung nach der Seite der von ihr postulirten Beziehungen zwischen körperlicher und geistiger Welt exact zu begründen und so mindestens innerhalb der durch die Erfahrung gezogenen Grenzen aus der Sphäre des blossen Glaubens in die des Wissens zu erheben."⁴ It is possible to over-emphasise this aspect of the situation. No one, surely, who has read Fechner's psychophysical writings, with the *Vorschule der Aesthetik* (1876) and the *Kollektivmasslehre* (edited by G. F. Lipps, 1897),⁵ can doubt

Menschen, 1863. To mention also are the earlier works of H. Czolbe, *Neue Darstellung des Sensualismus*, 1855, and *Die Entstehung des Selbstbewusstseins*, 1856.

¹ Wundt, G. Th. Fechner, 1901, 63 ff.

² Wundt, G. T. Fechner, 1901, 50: "Aus dem *Zend-Avesta* ist die Atomenlehre . . . hervorgegangen"; Lasswitz, 71 f.

³ *El.*, i., xiii.; *cf.* ii., ix. f.

⁴ Wundt, 44.

⁵ On the relation of these two works to Fechner's philosophy, see Wundt, 50, 74 ff.

that the author has regained much of his prephilosophical interest in scientific work; that he loves analysis and observation for their own sake. On the other hand, no one who knows the *Zend-Avesta* can read through the chapters on inner psychophysics in vol. ii. of the *Elemente* without realising that the issues there raised had been judged, in principle, ten years before. "In Wahrheit kehren alle wesentlichen Ideen des *Zend-Avesta* in der Psychophysik wieder; es sind aber umgekehrt die Grundgedanken der Psychophysik schon im *Zend-Avesta* zu finden."¹ "Mit *Zend-Avesta* hat Fechner die Summe seiner Gedankenwelt gezogen. Alles, was er später geleistet hat, steckt in seinen Keimen schon in diesem Buche."² The *Elemente* is not only a scientific, but also a philosophical work.³

It might seem, at first thought, that the year 1851 would be as favourable for Fechner the philosopher as the year 1860 for Fechner the psychophysicist. There was no reigning philosopher, no dominant philosophical system. Hegel had died in 1831, and the break-up of his school followed almost immediately upon his death. Schelling was called to Berlin in 1841 and proved a failure. Herbart's influence was rather psychological than philosophical. Schopenhauer's work was only just beginning to attract attention. Lotze had not yet made his mark in philosophy; Lange and the cry of 'Back to Kant!' were still fifteen years away. There were many able men in the field, but no great man; the spheres of existing philosophical influence were limited and local. Suppose that a great man should arise, a man with a message to his fellow-men: would not this division of interest give him his opportunity? Might he not do for philosophy what Helmholtz and the rest were doing for science?

Perhaps: though it is an open question whether, in a post-Kantian age, the reign of science is compatible with any profound philosophy, or preoccupation with philosophy compatible with scientific advance. At any rate, Fechner was not the man, and his teaching made but little impression. "Die Zeit," says Wundt, "da Fechners philosophische Schriften zuerst in die

¹ Wundt, 44.

² Lasswitz, 65.

³ Foucault, acquainted with Fechner, as it would seem, only in psychophysical regard (*cf.* list of works, *Psychophysique*, 4 f.), makes the *Weltansicht* of the *El.* derive from the author's psychophysical theories (120)!

Oeffentlichkeit traten, war für ihre Wirkung die denkbar ungünstigste.”¹ Strong words, and, in the light of what we have just been saying, startling words! Yet their truth is apparent. Fechner’s philosophy could never have become academic, a philosophy of the schools. “Wie Fechner seine Philosophie im wesentlichen aus sich selbst geschöpft hat, so wird man auch von ihm sagen können, dass er neueren philosophischen Systemen ein verhältnissmässig geringes Verständniss entgegenbrachte. Für erkenntnisstheoretische Untersuchungen und für geschichtliche Betrachtungen fehlte ihm der Sinn. Natur und Religion—das waren die beiden Pole, um die sich sein philosophisches Denken bewegte.”² In another era, he might have been the philosopher of the people, with a vogue like that of Schopenhauer or von Hartmann or Nietzsche; the pietist and mystic, the poet and the analogist, always find followers,—and, if they are born in due season, a very large number of followers. But the popular philosophy of the 40’s and the early 50’s was the positivism of Feuerbach and the physiological materialism of which we have spoken above; Fechner’s message ran counter to the ‘Zeitgeist’; “für Fechner war das Universum ein Geist, für den Materialismus war es eine Maschine; . . . Fechner galt als Phantast, man misstraute seiner Naturforschung; . . . Fechner war religiös, der Grundzug der Zeit aber war, wenn nicht direkt antireligiös, so doch wenigstens gleichgültig in religiösen Fragen; vor allem war er antikirchlich und antitheologisch; Fechner dagegen hatte einen theologischen Beigeschmack.”³ The Zend-Avesta appealed only to the little circle of readers who were like-minded with its author; it gained no recognition from academic philosophy or from the representatives of natural science, and found no great favour with the general public.⁴

Fechner was fully and painfully conscious of his unpopularity; but he had no intention of giving up the struggle. In the preface to his *Ueber die Seelenfrage* (1861)⁵ he says that he has called four times to a sleeping world,⁶ and the world has not yet awaked.

¹ G. T. Fechner, 1901, 38. ² Wundt, 67. ³ Lasswitz, 66 f. ⁴ Wundt, 42.

⁵ *Ueber die Seelenfrage, ein Gang durch die sichtbare Welt, um die unsichtbare zu finden*, 1861.

⁶ In *Das Büchlein vom Leben nach dem Tode*, 1836; *Ueber das höchste Gut*, 1846; *Nanna*, 1848; and *Zend-Avesta*, 1851.

“Jetzt rufe ich ein fünftesmal, und, wenn ich lebe, werde ich noch ein sechstes und siebentesmal ‘Steh’ auf!’ rufen, und immer wird es nur dasselbe ‘Steh’ auf!’ sein.” And, in point of fact, the call is repeated in *Die drei Motive und Gründe des Glaubens* (1863) and *Die Tagesansicht gegenüber die Nachtsicht* (1879).¹ So far, indeed, is he from giving up, that he tries a new and laborious method of arousing his contemporaries. “In den Hauptwerken, die er in den letzten 30 Jahren seines Lebens veröffentlichte, änderte er, wenn ich mich des Ausdrucks bedienen darf, die *Taktik* seines Verfahrens; ja er änderte diese vornehmlich in dem bedeutendsten dieser Werke, in den ‘Elementen der Psychophysik,’ so sehr, dass für eine oberflächliche Betrachtung der Zweck selber als ein anderer erscheinen konnte.”² “Die exacten Forschungen sind ihm nicht nur durch philosophische Fragen nahe gelegt, sondern die wichtigsten unter ihnen hat er nur zu dem Zweck unternommen, für seine Weltanschauung eine festere Basis und zugleich die Hülfsmittel zu gewinnen, um ihr in der Wissenschaft Eingang zu verschaffen.”³ We have already noted that this view, in its extreme form, may require qualification; that it is substantially true cannot be doubted. How far, then, we may ask, was Fechner successful in his ambition? How well did he succeed, by means of his Psychophysics, in drawing scientific attention to the doctrines of the Zend-Avesta?

Wundt declares that he was entirely unsuccessful. “Als nach dem Erscheinen der ‘Elemente der Psychophysik’ Jahre dahingegangen waren, konnte er sich die Thatsache nicht verschliessen, dass, wenn das letzte Ziel dieses Werkes die Bekehrung der wissenschaftlichen Welt zu seinen philosophischen und religiösen Ueberzeugungen gewesen war, er dieses Ziel abermals nicht erreicht hatte.”⁴ Lasswitz gives a more favourable verdict. “Erst als die Zeitrichtung überhaupt philosophischem Interesse sich wieder zuwandte, als mit dem Rückgang auf Kant⁵ auch in den Kreisen der Naturforscher der Materialismus

¹ To say nothing of *Einige Ideen zur Schöpfungs- und Entwicklungsgeschichte der Organismen*, 1873.

² Wundt, 43.

³ Wundt, 50; Höfding, *op. cit.*, ii., 587 f.

⁴ Wundt, 51.

⁵ To be dated, roughly, from 1866, when F. A. Lange published his *Geschichte des Materialismus*. Cf. also O. Liebmann, *Kant u. d. Epigonen*, 1865.

in seiner Einseitigkeit erkannt wurde, als endlich auch Fechner als der Schöpfer der neuen Wissenschaft der Psychophysik dem naturwissenschaftlichen Zeitgeiste einen neuen Tribut dargebracht und neues Vertrauen errungen hatte, da kamen auch seine philosophischen Schriften wieder über die engeren Kreise seiner Verehrer hinaus zu allgemeiner Geltung.”¹ It is not altogether easy to strike a decision between these two opinions. Wundt, we may remember, was called to Leipzig in 1875, and was therefore in close contact with Fechner during the last twelve years of the latter's life. On this ground, as on many others, his words must carry weight. There are, moreover, two important facts which speak for Wundt's view. The first is that Lotze, a pupil of Fechner's, had worked out a system of philosophy which, having much in common with his master's, was nevertheless calculated both by form and by contents to appeal far more strongly to his fellow philosophers and to men of science.² Compare the *Mikrokosmos* and the *Metaphysik* with the *Zend-Avesta* and the *Seelenfrage!* Lotze, then, would be taken: and Fechner left. The second fact is that Fechner has played a remarkably inconspicuous part in academic literature, in ‘programmes’ and ‘dissertations.’³ On the other hand, we find that the *Atomenlehre* came to a second edition in 1864, and the *Büch-*

¹ Lasswitz, 67 f.

² Lotze's *Logik* appeared in 1874, and his *Metaphysik* in 1879. On the relation of Fechner and Lotze, see Höffding, *op. cit.*, 567 ff., 587 ff.

³ “Das Studium der Fechnerschen Schriften,” says Lasswitz (203), “ist überall in erfreulichem Aufschwunge begriffen.” Of the psychophysical, yes; but of the philosophical? Where are the results? [Since this Note was written, Lasswitz has himself reprinted certain of Fechner's works (noticed in their places in other Notes to this §). There have also appeared four doctorate theses dealing with Fechner: A. Goldschmidt, *Fechners metaphysische Anschauungen*, Würzburg, 1902; E. Stratilescu, *Die physiol. Grundlage d. Seelenlebens bei Fechner u. Lotze*, Berlin, 1903; F. M. Fitch, *Der Hedonismus bei Lotze u. Fechner*, Berlin, 1903; H. Freudenreich, *Fechners psychologische Anschauungen*, Leipzig, 1904. That these events, welcome as they are, represent any general ‘Aufschwung’ of the study of Fechner, the author can hardly believe. Stumpf stood, of course, in intimate relation to Fechner and Lotze; and Külpe, who saw the reprint of the *El.* through the press, has been outspoken in his appreciation of Fechner's work. It is very natural, therefore, that the occasion of Fechner's centenary should call forth theses from Berlin and Würzburg. At any rate, there is no other mention of Fechner in the files of the *Bibliograph. Monatsbericht* since 1890!]

lien vom Leben nach dem Tode to a second in 1866.¹ The latter work is, however, hardly more than a pamphlet; and it is only natural that the interest aroused by the scientific portion of the *Elemente* should bring with it a transient interest in Fechner's other work. The wonder is that it did not bring more; that there was no republication of any part of the *Zend-Avesta*, or of the *Seelenfrage*.² We shall probably be safe, therefore, in following Wundt: just as we may more safely accept Wundt's characterisation of Fechner's system, as "a restoration and completion of the romantic nature philosophy,"³ than Lasswitz' ideas of its relation to the critical philosophy and of the place it is destined to take in modern thought.⁴

As a philosophical work, the *Elemente* failed of its purpose; as a scientific work, it had to overcome prejudice: this is the net result of our discussion. If we look at the preface of vol. i., we see that Fechner has been very careful to propitiate his scientific readers. On the experimental side, he appeals to E. H. Weber, "den ich überhaupt den Vater der Psychophysik nennen möchte"; on the mathematical, to Bernoulli, Laplace and Poisson, to Euler, Herbart and Drobisch, to Steinheil and Pogson. "Das Problem ist . . . der That nach schon von Forschern gelöst, deren Namen eine Gewährleistung der Triftigkeit der Lösung ist." He acknowledges indebtedness to Volkmann, and, after paying a compliment to Herbart, emphasises the essential difference of the *Psychophysik* from the Herbartian mathematical psychology. He admits that his *Grundansicht* is capable of materialistic interpretation, though he himself is diametrically opposed to materialism.⁵ Is not such an introduction admirably

¹ Third, 1887 (the year of Fechner's death); fourth, 1900 (the eve of his centenary); fifth, 1903. Trs. by M. C. Wadsworth, with introd. by W. James, 1904.

² Fechner looked upon the *Seelenfrage* as the most fundamental of his works on nature philosophy: P. S., iv., 212. Lasswitz has now (1901) brought out a second edition of the *Zend-Avesta*.

³ Wundt, 59.

⁴ Lasswitz, 193 ff. Lasswitz' enthusiasm for the subject of his study is natural. We must, however, discount it, when we are trying objectively to estimate Fechner's position in the philosophical world of his day: something very different, be it remembered, from his position in the history of philosophy.

⁵ El., i., ix. ff.; cf. W. Preyer, *Wiss. Briefe*, 1890, 223.

fitted to excite interest and to allay suspicion in the scientific mind?

We have Wundt's word, and we have objective evidence, that the *Elemente*—as a scientific book—“grosses Aufsehen erregte.”¹ In the very year of its publication, Helmholtz (working, of course, on the basis of the *Abhandlung* of 1859) recognised Weber's Law as “eine erste Annäherung an die Wahrheit” and proposed a modification of the fundamental formula, which Fechner gladly accepted.² Mach, in the same year, began a series of experiments to determine whether Weber's Law held for the perception of time;³ and in 1863 published a little volume of *Vorträge über Psychophysik*.⁴ Wundt pays a high tribute to Fechner in 1862, in the introduction to his *Beiträge zur Theorie der Sinneswahrnehmung*;⁵ and again in 1863, in the *Vorlesungen über die Menschen- und Thierseele*. “Fechner verdankt die Psychologie,” he writes, “die erste umfassende Untersuchung der Sinnesempfindungen vom physikalischen Standpunkte, durch die zu einer exakten Theorie der Empfindung der Grund gelegt wurde.”⁶ Volkmann includes psychophysical papers in his *Physiol. Untersuchungen* of 1863.⁷ Aubert challenged the validity of Weber's Law in 1864, on the basis of experiments of his own.⁸ Delbœuf made the acquaintance of the *Elemente* in 1864, and carried out his classical experiments on brightness in 1865–6.⁹ Bernstein published his irradiation theory in 1868.¹⁰ Lotze had said in the *Medicinische Psychologie* of 1852 that he preferred Herbart's mathematical psychology to the formulæ proposed in

¹ G. T. Fechner, 1901, 51.

² P. O., 1867, 314; *cf.* 1896, 390; Fechner, *El.*, ii., 564 ff., esp. 568; I. S., 15, 16 ff.; *Berichte*, etc., 1864, 17 f.

³ *Sitzungsber. d. kais. Akad. d. Wiss. zu Wien, math.-naturw. Cl.*, li., 2te Abth., Sitzung vom 3 Febr. 1865, 133 f.

⁴ Published first in the *Oesterr. Zeits. f. praktische Heilkunde*, 1863.

⁵ See p. xxx.

⁶ See i., pp. viii., 98.

⁷ P. U. im *Gebiete d. Optik*, i., 51, 117.

⁸ H. Aubert, *Physiologie der Netzhaut*, 1865, 49 ff. The first part must have appeared in 1864: see Fechner, *Berichte*, etc., 1864, 1 ff.; I. S., 16 ff., 51 ff., 149 ff.; König in Helmholtz, P. O., 1896, 1215.

⁹ *Examen critique*, 73; *Éléments*, 56, note.

¹⁰ Bernstein, in Reichert u. du Bois-Reymond's *Arch.*, 1868, 388 ff.

the Zend-Avesta,¹—this is, indeed, the one place where the student of modern psychology is likely to run against the Zend-Avesta,—and, no doubt, discussed the *Elemente* with his pupils at Göttingen. Vierordt's *Zeitsinn*, in which much regard is paid to the *Elemente*, came out in 1868.² Höring's work on the time sense appeared in 1866,³ and Keppler's taste experiments in 1869.⁴

Here is evidence enough—and there is doubtless much more—of the interest aroused by the *Elemente* in the 60's. We shall presently find evidence that the interest continued through the 70's and 80's: witness, now, the publication of Müller's *Grundlegung* in 1878, and of the new edition of the *Elemente* (the first "war schon seit mehreren Jahren im Buchhandel vergriffen"⁵) in 1889. Indeed, the interest has never ceased. For the last ten years, it is true, experimental psychology has been growing away from Fechner; qualitative analysis has bulked larger in the literature than quantitative determination.⁶ But we are now, perhaps, entering upon a period in which we can pay adequate regard to both aspects of psychological work, in which we can set numerical values and introspective analyses side by side. And any sort or kind of quantitative psychology must take its stand upon the work of Fechner.

§ 4. Criticism.—We may now discuss some of the principal objections urged against Fechner's psychophysical system. The doctrine of the *Elemente* was attacked from many sides and on many issues. It is therefore inevitable that, in setting forth single objections, we do some violence to the literature. Different men employ the same argument; but they employ it in support

¹ See pp. 210 f.

² K. Vierordt, *Der Zeitsinn nach Versuchen*, 1868.

³ A. Höring, *Versuche über das Unterscheidungsvermögen des Hörsinns für Zeitgrößen*, 1866. I. S., 177.

⁴ F. Keppler, *Das Unterscheidungsvermögen des Geschmackssinnes für Konzentrationsdifferenzen der schmeckbaren Körper*, 1869; *Pflüger's Arch.*, ii., 449. I. S., 161 ff.

⁵ See *El.*, i., v. The author has used the edition of 1889 exclusively, for quotations in this work. The two editions do not tally, page for page; but the difference rarely exceeds two or three lines; so that the fortunate possessors of the first edition will have no difficulty in finding the passages cited.

⁶ See vol. i., I. M., xxii. f.

of different positions, and set it in different contexts. The reader must not be surprised if, on looking up the references which the following discussion brackets together, he find a wide divergence of expression. Nor must he expect that the arguments of which he is in search will be clear-cut and distinct: the very first objection which we take up—the objection that no *S* is a sum of smaller *S*-units—plunges us into controversies about negative *S*-values, about the ‘Unterschiedshypothese’ and the ‘Verhältnishypothese,’ about the qualitative or quantitative nature of intensive differences, about ‘pure sensation’ and ‘apperceived sensation.’ It would be well, if confusion is to be avoided, to preface this Section by the reading (over and above the *Elemente*) of Wundt’s *P. P.*, i., 1902, ch. ix; Ebbinghaus’ *Psych.*, i., §§ 6, 44–46; or Jodl’s *Psych.*, ch. iv. Popular accounts of psychophysics will be found in J. Sully, *Sensation and Intuition*, 1880, 37 ff.; T. Ribot, *German Psych. of To-day*, 1886, 134 ff. (both of these sketches are, unfortunately, to a large extent out-of-date); Wundt, *Human and Animal Psych.*, 17 ff.

(1) *Fechner asserts that the S is a measurable magnitude, or quantity, the sum of a certain number of S-units.*¹

Now it is clear that, in a certain sense, the *S* may properly be termed a magnitude (*Grösse, grandeur*): in the sense, namely, that we can speak of a ‘more’ and ‘less’ of *S*-intensity. Our second cup of coffee is sweeter than the first; the water to-day is colder than it was yesterday; A’s voice carries farther than B’s. On the other hand, the *S* is not, in any sense, a quantity (*messbare Grösse, Quantität, quantité*). For (*a*), as Fechner himself recognised, the verdict of introspection in the case of any single *S* is unhesitating; there is no sign or hint of summation; “an die schon erwachsene Empfindung lässt sich kein Mass anlegen, insofern sich keine quantitative Mehrheit darin unterscheiden lässt.”² Moreover, (*b*) we cannot perform additions and subtractions, with two or more *S*, and obtain sums or remainders. If a weak pressure upon our hand is suddenly doubled, we have a more intensive pressure sensation; but the ‘more intensive’ *S* is a new *S*, not the old *S* with a certain *plus* added to it: the old

¹ See esp. *El.*, i., 60; *P. S.*, iv., 185 f.

² *El.*, i., 61.

S has entirely disappeared. If a source of sound is suddenly withdrawn to a greater distance from us, we hear a weaker sound; but this 'weaker' *S* is not a part of the old *S*; the old has gone, and an entirely new *S* has taken its place.¹

To students of the present generation, this objection appears, perhaps, the most natural and obvious that could have been urged against Fechner's derivation of the 'psychisches Mass.' Yet we search in vain for it in the Table of Contents of the *I. S.* (*cf.* also 3 f., 211). It had, nevertheless, been raised implicitly by Delbœuf in 1873; explicitly by J. Tannery in 1875, and by Delbœuf in 1877.² Fechner, indeed, though without full realisation of the issue, touches the heart of the matter in his reply to Delbœuf (*I. S.*, 32 f.). "Nun kann Delbœuf entgegenhalten," he says, "dass er überhaupt bloß Contrastempfindungen statuirt; indess ich meine, es sei bei einer *S* ihre eigene Stärke, und das Verhältniss des Plus und Minus ihrer Stärke zu anderen *S* zu unterscheiden. Denn wozwischen soll das Verhältniss des Plus und Minus stattfinden, wenn man die *S* an sich selbst eine Stärke versagt; es ist denn nichts dazu da. In der That aber scheint mir Delbœuf das, was bloß Sache der Unterschieds-*S* ist, mit dem, was Sache der absoluten *S* ist, zu verwechseln oder zu vermischen. Ich habe für jenes die Unterschiedsmassformel, für dieses die einfache Massformel. Delbœuf hat für beides bloß eine Formel."³

Whether Delbœuf was at all clearly conscious of the 'quantity objection' in his *Étude psychophysique* (1873)⁴ is, despite his later statements,

¹ It is instructive to compare the following passages. "Sind zwei Töne von verschiedener physischer Stärke gegeben, so kann man sich einen dritten denken, dessen Stärke dem Unterschiede der Stärke jener beiden gleich ist" (Fechner, *El.*, i., 48). "Es ist, soviel ich bemerken kann, unmöglich, den Intensitätsbetrag gesondert vorzustellen, welcher zur niederen Stärke hinzukommen müsste, um die höhere zu ergeben" (Stumpf, *Tps.*, i., 121). See also Wahle, *Das Ganze d. Philos.*, 203; Stout, *Manual*, 30 f.

² It is tempting to read the 'quantity objection' between the lines of certain passages of Hering's criticism: *Sitzungsber. d. kais. Akad. d. Wiss. zu Wien, math.-naturwiss. Cl.*, lxxii., Abth. 3, Sitzung vom 9 Decr. 1875. See esp. the discussion of Weber's experiments, 316 f. On the whole, however, there can be no doubt that Hering failed to urge this objection. *Cf.* A. Meinong, *Z.*, xi., 1896, 387.

Fechner makes no mention of the Tannery letters. It is natural enough that an anonymous correspondence in the *Revue scientifique* should have escaped his notice.

³ *Cf.* *R.*, 200 f., 305.

⁴ Published, with omissions, as first part of the *Éléments de psychophysique générale et spéciale*, 1883. *Cf.* *Examen critique*, 1883, 112 ff.; *Rev. phil.*, v., 1878, 57 ff.; Ebbinghaus, *Z.*, i., 1890, 321, *n.*

very doubtful. The objection was expressly raised by J. Tannery in letters (called forth by articles of Ribot's) published in the *Rev. sci.*, 13 Mars and 24 Avril, 1875.¹ "Sans doute," remarks Tannery, "une sensation peut être plus ou moins vive, mais cela suffit-il pour que la sensation soit une quantité ? . . . Les seules grandeurs que l'on puisse mesurer directement sont celles dont on peut définir l'égalité et l'addition. . . Il ne me semble pas qu'une sensation possède ce caractère d'homogénéité qui appartient essentiellement aux grandeurs mesurables." Delbœuf, who takes up arms on behalf of psychophysics, meets it in terms of his 'Differenzansicht der Empfindung';² *i.e.*, in terms of the Reconstruction of § 6, not of Fechner's *Massformel*. "Nos sens," he declares, "sont des instruments différentiels, c'est-à-dire servant à constater des différences, pas autre chose. Or, quand cette différence est de 2, 3, . . . 10 degrés, la sensation est-elle deux fois, trois fois, . . . dix fois plus grande que lorsqu'elle est de 1 degré" (122). "Supposons que l'on construise une échelle de teintes différentes allant du sombre au clair, et choisies de façon que les contrastes sensibles entre deux teintes voisines soient tous égaux, . . . j'aurais certainement une échelle qui mesurerait la sensation de lumière ou de l'obscurité" (124 f.). "On ne peut pas, en soi-même, prendre isolément deux sensations égales et les ajouter l'une à l'autre, comme on ajoute des poids égaux;" but "un chanteur . . . procède par intervalles de ton, par degrés d'acuité égaux, . . . et il les ajoute comme égaux" (143). The difficulty is thus turned; Delbœuf has rescued his differentials: only, once more, they are not Fechner's. "Les différences de sensation correspondant à ces différences [d'excitation], sont-elles égales; sont-elles de même nature; la sensation est-elle une somme de ces différences" (143)?—this is not Fechner's question; and the 'accroissements égaux' of Delbœuf are equal increments of 'contraste sensible,' not 'gleiche Zuwüchse der Empfindung.'

In the articles written after the Tannery controversy, Delbœuf is quite clear. "La loi de Fechner, disais-je dans l'*Étude psychophysique*, est insoutenable au point de vue mathématique. Elle entraîne des conséquences absurdes, et la manière dont elle est établie ne procure pas à l'esprit une idée bien nette de ce que peut être la quantité d'une sensation, ni comment, par conséquence, elle peut être représentée par un nombre."³ And again, on Fechner's principles "il est impossible de se

¹ Printed (with the author's name) in Delbœuf's *Éléments*: see 111, 113, 136, 138.

² Worked out in the *Théorie générale de sensibilité* (1876; reprinted as second part of the *Éléments*, 1883). Cf. I. S., 113 ff.; Stumpf, *Tps.*, i., 7 ff. Not to be confused with the *Unterschiedshypothese*, the 'difference hypothesis' of Weber's Law.

³ *Rev. phil.*, iii., 1877, 241; *Examen critique de la loi psychophysique*, 1883, 30 f. Repeated in *Rev. phil.*, v., 1878, 35; *Examen*, 72. Yet the reference given is not

faire aucune idée de ce que peut être la quantité de la sensation."¹ Delbœuf himself meets the objection as before.²

Tannery had objected that the intensive *S*-series is not homogeneous. Delbœuf, in the heat of controversy, fails to grasp the situation. "Qu'est-ce que cela prouve," he replies, "sinon que la sensation . . . n'est pas isolable?"³ The objection is, however, very serious. It is taken up independently by J. Ward, *Mind*, i., 1876, 464 ff. "A host of other sensations—to say nothing of images reproduced—accompanies those at the higher end [of the scale], sensations roughly recognised as the stimulating effect of strong light or the strain of heavy weights, and so forth. . . . Could all these be taken into account, a simple enough relation might be found between their intensity and the intensity of the central movement [Fechner's psychophysical process]." Fechner's results are then explained in terms of J. Bernstein's theory of central irradiation; ⁴ "the mistake suspected is that the true intensity has been confused with a possible mode of estimating it, almost with our memory of the chief objects concerned in it—much as people might confound the intensity of a flood or a fire with the ground covered or the number of farms or houses destroyed." The intensive sensation, as Delbœuf admitted, is not isolable, and so the results of measurement are not pure. The objection is put more strongly by R. H. Lotze, who declares that a strong sour does not taste the same as a weak, that a shadow does not look the same as its background: there are "qualitative Veränderungen des Empfindungsinhalts, die von jenen [intensiven] Differenzen der Reize abhängen."⁵ Nevertheless, "ich will," remarks Lotze, "kein grosses Gewicht auf diese Bedenken legen;" only, they must be cleared away before we can admit the *j. n. d.* as the *S*-unit.⁶ Cf. C. Sigwart, *Logic*, ii., 1895, 68.

to the *Étude*, but to the Tannery letters. Cf. the summary of I. S., 1, in *Rev. phil.*, 38 f.; *Examen*, 78 f.

¹ *Rev. phil.*, v., 1878, 61; *Examen*, 120.

² For details, see § 6, below.

³ *Éléments*, 140. Cf. *Examen*, 33, 41; *Rev. phil.*, iii., 1877, 243, 247.

⁴ du Bois-Reymond's *Arch.*, 1868, 388 ff.; *Untersuchungen über den Erregungsvorgang im Nerven- und Muskelsysteme*, 1871, *Absch. iv.*, 166 ff. Cf. I. S., 138 ff.; G. E. Müller, *G.*, 374 ff.; Funke, in *Hermann's Hdbch.*, iii., 2, 1880, 357.

⁵ *Metaphysik*, 1879, § 258; 1884, 511 ff.; *Outlines of Psych.*, (1881) 1886, 17. Cf. *Medicinische Psychologie*, 1852, 208.

⁶ Wundt regards this "geänderte Fassung des Problems" as "kaum mehr als ein Wortunterschied," "sobald man nur die quantitative Messbarkeit jener qualitativen Unterschiede zugesteht": *P. S.*, ii., 12 f.; *P. P.*, i., 1902, 551 f. But whether we say outright that the 'intensive differences' of common speech are in truth qualitative differences, or simply posit a qualitative change along with the

The whole question is discussed by J. von Kries, in the *Vierteljahrsschrift f. wiss. Philos.*, vi., 1882, 273 ff. "Die Gleichartigkeit der Elemente, welche unsere Raum- und Zeitvorstellung auszeichnet, fehlt eben den intensiven Empfindungsreihen." "In dem starken Tone steckt nicht so und so viel mal der schwache, wie im Fuss 12mal der Zoll enthalten ist und in der Minute 60mal die Secunde."¹ Cf. Meinong, *Z.*, xi., 1896, 115 f.; Nagel's *Hdbch. d. Physiol.*, iii., 1, 1904, 23 ff. Other important references are the following.

1878. G. E. Müller, *G.*, 12, seems to imply that the summation of *S* is possible: cf. Stumpf, *Tps.*, i., 42; F. A. Müller, *Axiom*, 116 ff., esp. 121. It should, however, be remembered that Müller explicitly declines to enter upon the question "worin denn nun eigentlich die Merklichkeit oder Deutlichkeit eines Empfindungsunterschiedes bestehe," vii.; cf. 1 ff., 411 ff. In the *Psychophysik der Gesichtsempfindungen*, Müller writes: "man deutet den hier entwickelten Begriff der Empfindungsintensität kurz, wenn auch nicht hinlänglich genau an, wenn man die Intensität der Empfindung kurz als den Abstand derselben vom Nullpunkte definiert;" "[man wird] die Intensität einer Empfindung nach ihrem Verhältnisse zu der als Einheit betrachteten Intensität einer bestimmten Empfindung zu bemessen haben,"—the unit now being an unit-distance: *Z.*, x., 1896, 25 f., 35. Müller further notes the complication of intensive increase by change of quality and of 'insistence' (Eindringlichkeit): 27 f.

1879. S. Exner, in *Hermann's Handbuch d. Physiol.*, ii., 2, 242 f. "Dass die Druckempfindung welche ein Loth hervorruft, von der Druckempfindung, welche ein Pfund hervorruft, nur quantitativ verschieden ist, ist nicht Gegenstand der unmittelbaren Empfindung. Gegenstand der unmittelbaren Empfindung ist nur, dass die beiden Empfindungen verschieden sind."

1880. A. Stadler, *Philos. Monatshefte*, xvi., 583 f. "Die Stärke einer intensive, we are going a long way towards the doubt or denial of any such quantitative measurableness. See Grotenfelt, *Das Webersche Gesetz*, 46 f.; J. L. A. Koch, *Z. f. Phil. u. phil. Kritik*, N. F., lxxix., 1881, 80 f.; lxxx., 1882, 173; Münsterberg, *N. G.*, 6; Jodl, *Psych.*, 1896, 202, 224, 226; Wahle, *Das Ganze d. Philos.*, 1894, 181, 192 f., 195. "Eine Intensität an den Empfindungen selbst ist absolut nicht messbar," says Wahle (193), "denn sie ist nicht vorhanden." A protest against the use of the term 'quality,' in this connection, is raised by Ebbinghaus, *Z.*, i., 324 f., *n.*; Stumpf, *Tps.*, i., 240; ii., 558.

¹ von Kries is criticised by Wundt, *P. S.*, 11 ff.; Grotenfelt, *Das Webersche Gesetz*, 31 ff.; Meinong, *Z.*, xi., 1896, 104 ff., 114 ff.

Empfindung lässt sich nicht auffassen als eine Summe von so und so viel einfachen Empfindungsgraden." Cf. *ibid.*, xiv., 1878, 216, 222; also G. Tarde, *Rev. phil.*, x., 161, 167 f.

1881. E. Zeller, *Abh. d. kgl. preuss. Akad. d. Wiss., phil.-hist. Cl.*, 3 März 1881 (publ. 1882), 5. "Muss man doch einräumen, dass sie [die Bewusstseinserscheinungen] sich uns selbst . . . ausschliesslich als qualitative Veränderungen darstellen." Zeller's paper (*R.*, 332 ff.) was answered by Wundt, *P. S.*, i., 1883, 251; Zeller replied in the *Sitzungsber. d. Berliner Akad.*, 1882, i., 295; and Wundt wrote again in *P. S.*, i., 463.¹

1882. F. Boas, *Pflüger's Arch.*, xxviii., 568 ff. "Man muss demnach wohl annehmen, dass alle Empfindungsintensitäten an ihren qualitativen Unterschieden erkannt werden" (571).

1882. F. A. Müller, *Das Axiom der Psychophysik und die psychologische Bedeutung der Weber'schen Versuche: eine Untersuchung auf Kantischer Grundlage*, *passim: e. g.*, vi., 11, 19, 30 ff., 46 ff. ("Grösse kann nur Objekten beigelegt werden"), 55 f. ("Die Empfindung ist nicht Funktion des Reizes, sondern der Reiz Objekt der Empfindung, und die Empfindung kann somit . . . durch eine Zahl überhaupt nicht dargestellt werden"), 106 ff. ("Wir ersetzen die Contrastempfindung von variabler Intensität durch das Contrastgefühl von variablem Charakter"), 128, 133 f., 137, 143.

1883. Stumpf, *Tps.*, i., 399. "Jede Empfindung präsentirt sich uns als ein Unteilbares." Cf. 42, 121, 350.

1884. P. Tannery, *Rev. phil.*, xvii., 21 f. "Cette hypothèse (à savoir

¹ The sentence quoted from Zeller is definite enough. It is, however, doubtful if he appreciated his own argument; for the reasoning of the paper in general is extremely confused. One might take as unit for a given class of sensations, says Zeller, "the average value of the least perceptible stimulus." But (1) *j. n. S* are "nichts weniger als allgemein bekannte und anerkannte, feste und unveränderliche Grössen;" while (2) "die Aussagen unseres eigenen Bewusstseins . . . sind viel zu unsicher, als dass sich . . . auf sie allein die Annahme gründen liesse, eine gegebene *S* habe, beispielsweise, die fünfzigfache oder hundertfache Stärke der *e. m. S* dieser Klasse" (6). We may reply to the first objection that it is met by Zeller himself, in his reference to 'average value'; to the second, that neither can we tell, without a yardstick, the fiftyfold or hundredfold of, say, $\frac{1}{32}$ inch. Zeller then speaks of Weber's Law, and emphasises the relativity of its measurements. "Wir wüssten vielleicht, dass ein Ton die doppelte Dauer oder Stärke eines anderen gehabt habe, aber wie lange er dauerte und wie stark er war, könnten wir nicht angeben" (10). But to say that the mental must be measured by the mental, and that mental measurement is in so far relative, is merely a truism. If we can say anything at all about "einen Theil oder ein Vielfaches einer Bewusstseinserscheinung" (9 f., 15), we can surely measure, and measure in Fechner's way.

que la sensation d'une différence totale est la somme des sensations des différences partielles) est absolument fondamentale en psychophysique, et elle suppose . . . que les sensations sont susceptibles de mesure, d'addition et de multiplication . . . Ou bien la mesure . . . ne sera au fond qu'une pure convention, ou bien nous possédons un critérium qui nous permettra de contrôler les résultats de cette mesure . . . Or, en thèse générale, le critérium n'existe pas . . . Il y a exception toutefois pour . . . l'ouïe et la vue."

1886. A. Elsas, Ueber die Psychophysik : physikalische und erkenntnisstheoretische Betrachtungen, vi., 49 ff., esp. 56 f. "Und die Empfindung? Sie ist gar kein Objekt wissenschaftlicher Erkenntnis; sie gehört nicht zur Natur; sie hat für den mathematischen Physiker keine Realität; sie lässt sich nicht als ein Quantum mathematisch behandeln" (70). Cf. Philos. Monatshefte, xxiv., 1888, 143.

1888. A. Grotenfelt, Das Webersche Gesetz und die psychische Relativität, 34 f., 37 ff. "Eine Empfindungsintensität ist, nach dem Zeugnisse der inneren Erfahrung, in dem Sinne eine Grösse, dass sie wächst und abnimmt. Jede solche Intensität erwächst aus einer Folge successiver Intensitätszuwüchse; insofern ist es einfach eine Thatsache, dass ein grösserer Intensitätsunterschied die Summe kleinerer, partieller Unterschiede ist, dass sich jede bestimmte Empfindung aus den successiven Intensitätssteigerungen vom Nullpunkte an summirt. Eine Addition derselben findet faktisch statt . . . Freilich hat die Addirung hier nicht vollständig dieselbe Bedeutung wie die Summation extensiver Grössen." Cf., however, 179: "Die Grundannahme, wovon die theoretische Darstellung der Psychophysik überhaupt ausgegangen, nämlich dass ihre Messungen sich auf die psychischen Intensitätsgrössen bezögen, ist durchweg hypothetisch . . . Es bleibt zweifelhaft, ob den psychophysischen Untersuchungen gelungen ist das quantitative Moment des Empfindungsvorgangs herauszugreifen."

1890. W. James, Principles of Psych., i., 546 f. "To introspection, our feeling of pink is surely not a portion of our feeling of scarlet; nor does the light of an electric arc seem to contain that of a tallow-candle in itself."

1890. H. Münsterberg, Beiträge zur exper. Psych., iii., 3 ff. "Die starke Empfindung ist für unser Bewusstsein nicht das Multiplum einer schwachen Empfindung, . . . vielmehr etwas ganz Neues, in gewissem Sinne unvergleichbar."¹ Cf. Grundzüge d. Psych., 1900, 271.

1890. H. Ebbinghaus, Z., i., 324. "Der blosser Eindruck einer Helligkeit besitzt nichts von der Mehrheit von Kerzen, auf deren Vorhandensein er allerdings vielfach beruht; . . . der Eindruck einer grösseren

¹ Münsterberg makes a single exception to this rule, for which see p. cxxxv. below.

Helligkeit ist lediglich etwas Anderes als der einer geringeren." Cf. Psych., i., 1902, 506 f.

1892. J. Sully, Human Mind, i., 89. "We shall never be able to regard a given sensation as made up of so many units, as we can regard a linear length or a mechanical force."

1893. O. Külpe, Outlines [1895], 45 f. We cannot "conceive of sensations as divided into parts;" "this sensation of grey is not two or three of that other sensation of grey."

1894. R. Wahle, Das Ganze d. Philos., 191. "Niemals hat man in einer Empfindung die in ihr stecken sollenden Multipla oder Quanta von Empfindungen bemerkt."

1896. A. Meinong, Z., xi., 97. "Es hätte keinen Sinn, von einem lauten Geräusch zu sagen, es enthalte ein leises von ubrigens genau der nämlichen Qualität als Teil in sich." Cf. 355, 357 f., 374; and see G. F. Stout, A Manual of Psych., 1899, 204, 206.

1897. A. Höfler, Psychologie, 140 f., 228. "Es hat keinen Sinn, eine Empfindung als arithmetische Summe zweier Empfindungen oder als das Vielfache einer anderen Empfindung aufzufassen."

1902. A. Lehmann, Die körperl. Aeusserungen psych. Zustände, ii., 11: "eine *S* lässt sich nicht aus einer Anzahl anderer *S* auf dieselbe Weise aufbauen, wie man z. B. eine Linie hervorbringen kann, wenn man eine Anzahl Längeneinheiten in ihrer Verlängerung absetzt."

Some of these authors (Delbœuf, von Kries, Zeller, F. A. Müller) are answered by Fechner in R. (1882). There can, however, be no doubt that Fechner failed to appreciate the force of the general objection. See esp. the reply to von Kries, R., 322 f.

Wundt's position is, at first, that of Fechner. In the Vorlesungen über Menschen- und Thierseele, i., 1863, 101, he speaks roundly of summing an *S* from *S*-units, "indem wir die Empfindung in ihrem Wachsen allmähig verfolgen." "Es steht uns frei, beliebig grosse Empfindungen durch eine solche Summirung von Einheiten zu messen." In the P. P., 1874, we have the same doctrine. True, there is no definite statement as to the possibility of summation; but the reader feels that the statement is lacking because, to the writer, the fact was obvious. See 287 ff., 295, 302 ff. ("die intensiven psychischen Grössen können schlechterdings nur an ihren Differentialen erster Ordnung gemessen werden"), 306.¹ In the P. P. of 1880, the exposition is changed;

¹ Cf. the letter to the Rev. sci. of April 6, 1875; printed in Delbœuf's *Éléments*, 130 f. Also P. S., i., (1881) 1883, 5 ff., 18 f.

we hear no more of *S*-magnitudes. We are told "dass das Webersche Gesetz auf etwas anderes als auf unsere Schätzung der Empfindungen, d. h. eben auf die Bestimmung des Grades der Merklichkeit derselben, sich unmöglich beziehen kann, weil wir darüber, wie sich die Empfindungen unabhängig von unserer Apperception [von den bei ihrer Schätzung beteiligten Vorgängen der Auffassung und Vergleichung¹] verhalten, überhaupt nichts auszusagen vermögen." Is summation still possible? Apparently,—only that the units of summation are now the Merklichkeitsstufen: "so wird eine dem Reiz *R* entsprechende Empfindung *E* als bestehend aus einer gewissen Anzahl *n* solcher Merklichkeitsgrade von der Grösse $k = \frac{E}{n}$ betrachtet werden können." The *dS* of the fundamental formula are "unendlich kleine Merklichkeitsgrade der Empfindung," instead of 'unendlich kleine Theile' or 'Zuwüchse' of *S*.²

Doubt is, however, cast upon this interpretation by remarks in the essay Ueber das Webersche Gesetz, 1885.³ "Wer einwenden wollte, dass gar nicht die Empfindungen selbst, sondern nur ihre Merklichkeitsgrade gemessen werden, dem würde einfach zu erwidern sein, dass eben die letzteren diejenigen psychischen Elemente sind, die in diesem Falle überhaupt allein messbar sind" (19). The unit of measurement may be any 'bestimmter Merklichkeitsgrad'; its choice is a matter of convenience (19 f., 21 f.).

¹ i., 322. Cf. Logik, ii., 1883, 486.

² i., 332, 352 f., 356, 358, 360. Ebbinghaus thought at first that the change of view was referable to the Tannery controversy of 1875 (misprinted 1878: Z., i., 464, note), but afterwards withdrew this opinion (*ibid.*, ii., 189, 335 f.). If the change is to come from the outside, why should it not come from G. E. Müller (G., I ff., 226, 412)? But the author would ascribe it rather to the intrinsic development of Wundt's doctrine of apperception. This doctrine is itself, in all its far-reaching applications, the psychological successor of Wundt's early doctrine of judgment, which plays so large a part in the Vn. of 1863: see, e.g., i., 57, 303. We return to the point later: p. lxxi., *n*.

Wundt is criticised by Stumpf (Tps., i., 51 f.) on the ground that the aim of investigation is knowledge, not of Unterscheidungsfähigkeit, but of Unterschiedsempfindlichkeit; and by Grotenfelt on the ground that he offers no proof of the measurability of the Merklichkeitsgrade (Das Webersche Gesetz, 47, 64). We shall return to these objections later. Cf. Fechner, R., 268; Meinong, Z., xi., 1896, 124 ff., 256, 263; F. Boas, Pflüger's Arch., xxviii., 1882, 574 f.; Höfer, Z., viii., 1895, 97 f.; Jodl, Psych., 229, 233 ff.

³ P. S., ii., 1 ff.

So far, there is nothing against summation. "Ein Haupteinwand gegen derartige Feststellungen besteht nun aber darin, dass sich die so gewonnenen Einheiten nicht beliebig addiren lassen wie die Theile eines Massstabes, und dass daher vorerst und vielleicht für immer die Ausmessung einer beliebigen concreten Empfindung mittelst der gewählten Einheit ein aussichtsloses Problem zu sein scheint. Ist auch dieser Einwand zunächst gegen das Fechnersche Massprincip [of direct *S*-measurement: 6, 23 ff., 31] erhoben worden, so kann doch nicht geleugnet werden, dass er die Messung der Mercklichkeitsstufen ebenfalls trifft. . . Dem Einwand . . . kann man ruhig mit der Antwort begegnen, dass, so viel bis jetzt sehen lässt, eine solche Messung nicht einmal von besonderem Interesse wäre" (20 f.).

Does Wundt admit the principle of the objection, and make a virtue of necessity? Or does he merely postpone the question until the time shall be ripe for its discussion? "Hier soll nun dem Einwand," he says, "keineswegs, was sehr wohl geschehen konnte, mit dem Hinweis auf die geringe Ausbildung des ganzen Untersuchungsgebietes begegnet werden"; such a mode of reasoning would be in place only if there were some prospect of our ever wanting to sum the Mercklichkeitsgrade. "Jedes Untersuchungsgebiet bringt wieder seine eigenen Probleme mit sich. Mit der Behauptung, dass die sonst im Vordergrund stehenden Aufgaben in einem neuen Fall gegenstandslos sein würden, ist darum hier gar nichts gethan." This looks like admission: *cf.* 21 f.

In 1886, however, appeared a paper by A Köhler—written under Wundt's direction and published in the *P. S.*¹ with the title *Ueber die hauptsächlichsten Versuche einer mathematischen Formulirung des psychophysischen Gesetzes von Weber*—which takes us back to Wundt's standpoint of 1880. "Auf der Empfindungsscala geht man immer um einen eben merklichen Empfindungsunterschied, also die zu Grunde gelegte Masseinheit weiter, und markirt auf der Reizscala den zugehörigen Reizwerth. Ist man also auf der Empfindungsscala 6mal einen eben merklichen Empfindungsunterschied fortgeschritten, so hat man eben die Empfindung um 6 Einheiten vergrössert" (577): this

¹ iii., 572 ff.

is Köhler's view. "Wundt denkt sich die Empfindung, oder besser den Merkleichkeitsgrad einer Empfindung s aus einer Reihe von Merkleichkeitszuwüchsen Δs bestehend, und setzt dem entsprechend die Beziehung $s = n \cdot \Delta s$ an, wo Δs den gleich merklichen Empfindungsunterschied und n die Anzahl derselben bedeutet, welche man successive an einander zu reihen hätte, damit die Empfindung von der Merkleichkeit s entstehe" (595 f.). "Es wird ausdrücklich die Empfindung s aus n gleichen Merkleichkeitsstufen Δs zusammengesetzt gedacht, so dass also Δs die Einheit ist, in welcher die Empfindung s gemessen wird" (597). "Man weiss und kann sich eine klare Vorstellung davon machen, wieviel gleichmerkliche Empfindungszuwüchse Δs man aneinander zu reihen hat, um den Merkleichkeitsgrad der Empfindung zu bekommen, welcher durch k dargestellt wird" (598). Yet Köhler had read Wundt's essay (594, note); and Wundt had read Köhler!

Now Wundt defines the Merkleichkeitsgrad of S , in the P. P. of 1880, as "die Entfernung der Empfindung von jener der Reizschwelle entsprechenden Grenze," whether above (degree of Uebermerkleichkeit) or below (degree of Untermerkleichkeit: i., 356, 358, 361). If this definition is strictly adhered to, the Merkleichkeitsgrade can be summed; one can add distances.¹ If, on the other hand, the Merkleichkeitsgrade are the imaginary unit-magnitudes out of which a single apperceived S is built, then the objection holds against them that holds against Fechner's summation of Empfindungszuwüchse. We can reconcile the P. P. of 1880 with the essay of 1885 if we suppose that Wundt kept, in the former, to the implications of his definition, while he was thinking, in the latter, of a summation in Fechner's sense.² Köhler's exposition (such, at least, is the author's impression) is couched

¹ For a discussion of this point, see § 6, below. Note that the definition meets Grotenfelt's objection, p. lvi. above.

² The supposition is borne out by the fact that Wundt's essay is throughout concerned with Fechner (3 ff.), and is in some sort a reply to Fechner's criticism in the Revision (33 ff.), as well as by the somewhat unusual phrase 'concrete Empfindung' (20). It is worth noting that P. Tannery, who read Wundt's essay with the letter of 1875 in mind, while he finds "de graves concessions aux adversaires de la nouvelle science," i. e., of Fechner, still thinks that "sans doute ces concessions ne sont nullement décisives" (Rev. phil., xvii., 1884, 16, 35).

in terms rather of *Zuwüchse* than of *Entfernungen*; ¹ but Wundt may very well have put his own interpretation upon it.

This reading of the issue would account, further, for the fact that the P. P. of 1887 shows practically no change from the edition of 1880.² In the *Vorlesungen* of 1892, on the other hand, we have, without any doubt, a confusion of the two standpoints, of *Zuwüchse* and *Entfernungen*. "Suppose that we take an *S* which has increased by a *j. n.* magnitude, and that we allow this second *S* to increase again by a *j. n. d.*; the difference between the first and third will be clearer than that between the first and second. And if we proceed in this way, always increasing by a *j. n.* increment, we shall finally arrive at an *S*-intensity which is very much greater indeed than that of the *S* from which we set out. . . . If we wish to learn how much more intensive a second *S* is than a first, our best method will be to analyse the *S* into those elements which are the equivalents of *j. n. d.*"³ These introductory words might be explained in terms of either hypothesis. "One *S* is twice, three times, or four times as intensive as another, when it is made up of twice, three times or four times as great a number of equal *S*-increments. This system of measurement presupposes that we follow up *S* in its gradual increase."⁴ Here we have a return to the position of 1863. "To answer all the questions that come up in any sense-department, then, two measurements are in general sufficient; first, the measurement of the constant relation in which *S*-intensity varies with variations in the intensity of the *R*; and secondly, the measurement of the *j. n. S*. The first measurement enables us to divide up the *S*-scale; by calling in the aid of *R* we can mark it off into equal

¹ Cf. esp. the critique of Delbœuf, 613 ff.

² Cf. i., 340, 349, 378 f., 382, 383, 386 f. with the passages cited p. lvi. above. There is, it is true, a minor complication. Wundt raises the question, in 1885, how far we may go with Fechner beyond Weber, *i. e.*, how far we may argue from 'gleich merklich' to 'gleich.' He finds the argument valid within certain limits (P. S., ii., 29). He accordingly writes in P. P., i., 1887, 340, that "nur die Beziehung zwischen dem *R* und der Empfindungsschätzung bis jetzt unserer Messung zugänglich ist," the words 'bis jetzt' being an addition: cf. i., 1880, 322. He also omits a sentence in 1887 (386) which had in 1880 (360) emphasised the same point. The words 'bis jetzt' disappear in 1893 (i., 333); the missing sentence is not restored,—probably because the author was correcting the edition of 1887.

³ Lectures, 1894 or 1896, 33 f.

⁴ *Ibid.*, 34 f.

parts. The second measurement gives us its 0-point, and thus renders the scale ready for practical use. . . Suppose that we wish to know the intensity of an *S* excited by the pressure of 1 gr. We take our scale, and begin with the 0-point. . . We proceed . . . until we come to a pressure of 1 gr., and then count up how many units of our *S*-scale have been employed up to that point.”¹ This is the position of the P. P. The same position is taken, perhaps somewhat more definitely, in the P. P. of 1893.² It is reassuring to find that the *Vorlesungen* of 1897 omits the passage objected to above, while the remainder of the exposition remains practically unchanged.³

According to the *Logik* of 1895 (ii., 2, 178 ff.), all “psychische Erfahrungsinhalte” are either intensive or extensive magnitudes. Intensive magnitudes are degree of intensity and grade of quality; extensive are temporal and spatial extents. Every process evinces, further, a certain degree of clearness and, as discriminable from other processes, a certain degree of distinctness. Clearness is thus the intensive, and distinctness the extensive aspect of the ‘*Auffassungswert*’ of processes, of their relative value in consciousness, or of their ability to get themselves noticed.

It might be thought, then, that the *Klarheitsgrade* or perhaps rather the *Deutlichkeitsgrade* are the *Merklichkeitsgrade* of *S* taken account of in Weber’s Law. This is, apparently, not the case. All six magnitudes “bilden jedes ein für sich bestehendes Object psychischer Messung.” So far, however,—Wundt says,—intensity and quality of sensation have received most attention: feelings, degrees of clearness, etc., have been “noch so gut wie gar nicht behandelt;” time and space have been treated “in engem Anschluss an die für die Intensitätsmessungen aufgefundenen Principien” (180). Hence his present exposition will be concerned with the measurement of *S*-intensity, as a typical case of mental measurement at large. Nevertheless, when we reach the statement of Weber’s Law, we find that “der Thatbestand der Empfind-

¹ *Ibid.*, 38 f.; cf. the rest of *Lect.* iii.

² Cf. i., 333, 395, 397 f., 400, 402, 404 f., 406 f. with the passages cited pp. lvi., lix., above. Wundt’s acceptance of the quotient hypothesis does not invalidate this statement: see p. lxxx. below.

³ See p. 40. The discovery was especially reassuring to the author, since he had written the criticism of the second edition before seeing the third.—Cf. *Outlines*, (1896) 1897, 252 (where the translator has misleadingly rendered *Grösse* by ‘quantity’ in place of ‘magnitude’).

ungsmessung kann überhaupt nicht als eine Beziehung zwischen Empfindung und Reiz, sondern er muss als eine solche zwischen den Empfindungen und der psychologischen Function der Vergleichung betrachtet werden" (193); and the whole treatment (192 ff.) squares with the treatment of the P. P. This is in itself natural. But what becomes of the measurement of *S*-intensities? And what is the relation of Klarheit to Merklichkeit?

According to the P. P. (ii., 1893, 271), the Klarheit of a process depends partly upon its intensity, partly upon a "möglichst vollständig Anpassung der Aufmerksamkeit" (cf. i., 1902, 552); and this adaptation is in turn very largely dependent upon the adjustment of the sense organ. Deutlichkeit presupposes a certain degree of Klarheit, and also "andere Bedingungen welche die Unterscheidung der einzelnen Vorstellungen beeinflussen." These other influences are associative: Unterscheidung is a special case of associative assimilation (ii., 442 ff.). Vergleichung, on the other hand, is a matter of apperceptive connection or disjunction (476 ff.).

It would seem, then, that both clearness and distinctness are preliminaries to comparison, that both alike are necessary to the determination of Merklichkeitsgrade. The *S* of the *S*-centre has merely intensity (see note, p. lxxxii., below). Passing the limen of attention, and thus involving the apperception centre, it acquires clearness and distinctness, and in doing this undergoes a working-over at the hands of association. If it is to be compared with other *S*, it enters into the specific process of comparative judgment; its functional substrate is a specific distribution of inhibitions within the apperceptive centre. It is, then, only the comparatively judged *S* that has Merklichkeit; the attribute implies that a content of a certain intensity, clearness and distinctness has played its part as one of the terms of comparison in a comparative judgment.

How, now, are intensities and clearnesses to be measured for their own sakes? If the only 'intensity' that we can measure is a judged-clear-distinct intensity (an intensity of a certain Merklichkeit), how can the part-measurements ever become real problems? Two answers appear possible. (1) The measurements may present insuperable difficulties in practice, and yet be theoretically distinguishable; and the distinction may have great methodological, if not practical psychological importance. It is in the Logik, we must remember, that the differentiation is made. (2) As in the essay of 1885 Wundt argued back from Merklichkeit to Intensität, so he may be thinking here of a similar deductive procedure for clearness and distinctness. Which of these two answers is correct, the author cannot attempt to decide. Perhaps both ideas were in Wundt's mind when the paragraph of the Logik was writ-

ten.—For the process of comparison, in logical regard, see *Logik*, i., 1893, 361 ff.

In the P. P., i., 1902, 553, occurs the following sentence. “Der Zuwachs der Aufmerksamkeit, der erfordert wird, damit eine gegebene centrale Sinneserregung um den gleichen Klarheitsgrad (z. B. um ein eben Merkliches) zunehme, ist dem Quotienten aus der Erregungszunahme in die Grösse der Erregung proportional.” That is to say, Ebenmerklichkeit is brought, as a special case, under the general heading of gleicher Klarheitsgrad. Does not this mean that our question is answered: that we may identify, outright, Klarheit and Merklichkeit? In the author's opinion, the passage is not to be pressed. Merklichkeit presupposes Klarheit; and, as we now learn, equal Merklichkeit presupposes equal degree of Klarheit. Moreover, if we take up a Merklichkeitsgrad (so to speak) and look at it out of connection, we shall see simply a clear *S*. It is only functionally, as a term in a judgment of comparison, that the *S* attains Merklichkeit. But Wundt is probably more concerned to indicate by the parenthetical instance that he takes ‘eben merklich’ to mean ‘gleich klar’ or ‘gleich merklich’ than he is to explain in terms of his general system what precisely Merklichkeit may be.¹

In the P. P. of 1902 Wundt is primarily concerned with “die Darstellung eigener Erfahrungen und Ueberzeugungen” (i., ix.), not with compilation. It is, therefore, natural that the question which we are here discussing should have dropped somewhat out of sight. Wundt speaks always and emphatically of Merklichkeitsgrade,² and retains the characteristic phrase “Enternung von der Reizschwelle” as the equivalent of Merklichkeitsgrad.³

¹ A curious turn is given to the doctrine of Merklichkeit by G. F. Lipps, *Massmethoden*, 1904, 33 f.; *Arch. f. d. ges. Psych.*, iii., 185 f. The passage might be made the text of an essay.

² i., 1902, 466 f., 469, 493 f., 497, 505, 541 ff., 551.

³ i., 498, 501; *cf.* 548. On the other hand, the term Enternung does not appear on 497 and 502 (*cf.* i., 1893, 400, 406). It is possible, since the doctrine of sense distances has been steadily growing in favour of late years, that Wundt desired to emphasise, as against it, the adequacy of his own doctrine of Merklichkeit. Such an attitude would be natural; but the fact would remain that the two doctrines are fundamentally the same. *Cf.* note, p. lxxxii. below.

The question then arises as to which of the two formulations offers the greater advantages for systematic purposes. It would be absurd to deny that Wundt has succeeded both in working Merklichkeitsgrade into his system, and in working out his system in terms of Merklichkeit. We must, however, remember that Merklichkeit and apperception, in Wundt's own development, have their roots in

We may suppose, then, in spite of the omission of certain relevant passages, that his view has remained unchanged since 1893.

Two points remain to be noticed. (a) Granted that Fechner's view is wrong, we are still called upon to show how it arose, and whence it derives its seeming naturalness. And again, (b) granted that Fechner's view is wrong, we are called upon to meet the constantly recurring argument that *S* must be measurable because it is a magnitude, because we can speak, intelligently and intelligibly, of 'more' and 'less' of it.

(a) Fechner's principal error lay in that confusion of *S* with *R*, of introspective datum with external condition, to which attention has been called in the text.¹ The error is so natural that even psychologists who have expressly warned their readers against it may themselves fall into the snare.² "Eine Täuschung," says von Kries, "wird hier sehr leicht dadurch hervorgebracht, dass man sich im Allgemeinen bemüht, nach der Empfindung objective (und in objectivem Masse messbare) Werthe zu taxiren. . . Wir übertragen ohne Weiteres auf die Empfindung, was zunächst Gültigkeit hat bezüglich der objectiven Verhältnisse, welche

a faulty doctrine of judgment (see *n.*, p. lvi. above; Stumpf, *Tps.*, i., 90 *n.*). Systematically considered, Fechner's sharp severance of 'sensing' from 'discriminating sensations' (*El.*, ii., 85 f.) would seem to promise a better psychology than Wundt's single set of *Merklichkeitsgrade*: cf. Jodl, *Psych.*, 178 ff., 234. We must remember, also, that Wundt's treatment of apperception has unquestionably been a stumbling-block to very many who have tried to understand his system.

It may be retorted that Wundt himself draws the distinction which is here attributed to Fechner: "die Begriffe 'Empfindungen haben' und 'Empfindungen vergleichen,'" he says, cannot possibly "eins und dasselbe bedeuten" (*P. P.*, i., 1092, 542, *n.*). Granted! But of what avail is it to *have* sensations if, in comparing them, we are brought up short against their *Merklichkeit*? And again: it may be retorted that Fechner is unclear, seeing that he makes our apprehension of an *S*-difference an *Unterschiedsempfindung*, rather than an *Unterschiedsurtheil* or *Unterschiedsschätzung* (cf. Wahle, *Das Ganze d. Philos.*, 198). Again granted! But we spoke of the promise of a psychology, not of its performance. Fechner, as we have seen (p. xxii., above), was not a systematic psychologist.

Cf. Lehmann's critique of Wundt: *Die körperl. Aeusserungen psych. Zustände*, ii., 1902, 17 f.

¹ See Pt. i., xxvi. In the abstract, Fechner was well aware of the danger of confusion; and, indeed, one could hardly set out to write a psychophysics without being aware of it. See, e.g., *R.*, 5.

² Cf. Wundt's rejection of Hering's law, *P. S.*, ii., 8, with the *P. P.*, i., 1887, 356 or i., 1893, 359. *Cz.* i., 1902, 493 f., 541 f.

wir nach den Empfindungen taxiren."¹ The same confusion has been emphasised by many other writers. See, *e.g.*, Brentano, *Psych.*, i., 91 f.; Boas, *Pflüger's Arch.*, xxviii., 568; F. A. Müller, *Axiom*, v. f., 46 ff.; J. Tannery, in *Delbœuf's Éléments*, 138; Ebbinghaus, *Z.*, i., 323 f.; *Psych.*, i., 506 f.; Ward, *Mind*, O. S., i., 1876, 460; Münsterberg, *Neue Grundlegung*, 1890, 5, 11, 116 f.; Exner, *Hermann's Hdbch.*, ii., 2, 1879, 242; J. L. A. Koch, *Z. f. Phil. u. phil. Kritik*, N. F., lxxx., 1882, 174; A. Meinong, *Z.*, xi., 1896, 97, 372 f.; Jodl, *Psych.*, 202; Külpe, *P. S.*, xix., 1902, 549 f.; and *cf.* G. E. Müller, *Z.*, x., 42; R. Wahle, *Das Ganze d. Philos. u. ihr Ende*, 1894, 163 f., 176 f., 208; Wundt, *Völkerpsych.*, i., 2, 1900, 512 ff.

This is the error, and there can be no doubt of its naturalness. Every teacher of experimental psychology knows how difficult it is to dissociate sensation from meaning (*i. e.*, from stimulus) in the beginner's mind.² On the other hand, the 'quantity objection' is also, as we have said, a natural, even an obvious criticism of Fechner's construction. It is interesting to note that this objection had been urged against a mathematical psychology at large long before Fechner's day. Various passages containing it have been collected by G. Itelson, *Arch. f. Gesch. d. Phil.*, iii., 1890, 282 ff. (1) N. Malebranche wrote in 1674: "on ne peut déterminer exactment le rapport qui est entre le vert et le rouge, le jaune et le violet, ni même entre le violet et le violet. L'on sent bien que l'un est plus couvert ou plus éclatant que l'autre. Mais on ne sait point avec évidence, ni de combien, ni ce que c'est qu'être plus couvert ou plus éclatant. . . Si je sais que l'octave est double, . . . c'est que je sais que le nombre des vibrations est double en temps égal ou quelque chose de semblable; . . . on ne peut comparer les sons en eux-mêmes, ou en tant que qualités sensibles et modifications de l'âme." (2) G. Ploucquet, in 1763, is still clearer: "sit gradus lucis datus, qui ponatur vel crescere vel decrescere. Quæritur, num incrementa lucis et ejusdem decrementa exprimi possint quantitativis arithmetice vel geometricis? Respondeo negando. Nam lux obscurior addita obscuriori in se non facit clariorem. . . Id quod percipitur in ipsa visione lucis fortioris non est perceptio lucis debilioris et debilioris. Itaque lucis intensio qua imago non metienda est ex additione minoris et minoris, sed ex intensione unius ejusdemque imaginis." (3) So P. Galluppi, in 1819: if we say that the light of two candles is twice that of one, it is clear that "in questo caso non misuriamo le sensazioni, ma le cause di esse." "La quantità appartiene sempre all'oggette della sensazione, e non mai alla sensazione." *Cf.* F. A. Müller *vs.* Fechner: "Grösse ist nicht der Empfindung und

¹ *Vjs.*, vi., 1892, 275, 286. *Cf.* the whole discussion, 286 ff., 291 ff.

² *Cf.* i., I. M., 4.

ihrem Object, dem Reiz, beizulegen, sondern nur dem Reiz. Nur der Reiz kann durch eine Zahl dargestellt werden" (Axiom d. Ps. ph., 1882, 55); and Lotze (speaking of Vorstellungen, not of Empfindungen!) *vs.* Herbart: "Nun können wir gewiss Das, was wir erinnern, in allen Gradabstufungen vorstellen, deren sein Inhalt fähig ist, aber es ist nicht eben so klar, dass die auf diesen Inhalt gerichtete Vorstellungsthätigkeit dieselben Grössenveränderungen erfahren könnte" (Metaph., 1884, 520). (4) Finally, J. A. Eberhard, in 1776, raises the 'quantity' objection (though somewhat obscurely) in a form that reminds us of Zeller's later arguments. Eberhard speaks of the possibility of a "Verbindung einer gewissen Menge von kleinen Vorstellungen zu einer grössern Hauptperception," and of the "Erhöhung Einer einzelnen Perception zu einem gewissen Grade von Klarheit und Deutlichkeit." He then continues: "die Vergleichung der Grösse dieser Vorstellungen untereinander, nach [dem] Grundstoffe derselben, würde uns zur Mathematik der Seele führen. . . . In der Vergleichung der *S* untereinander, würde [aber] die messende Einheit eine unbemerkbare Vorstellung sein müssen, die eben dadurch zu diesem Gebrauche untüchtig sein wird, weil sie unbemerkbar ist; und in der Vergleichung der *S* mit den Gedanken haben wir ganz ungleichartige Grössen, die gar nicht mit einander commensurabel sind."—*Cf.* M. Dessoir, *Gesch. d. neueren deutschen Psych.*, i., 1902, 365 ff.

(b) "Von vorn herein und im Allgemeinen," says Fechner, "kann nicht bestritten werden, dass das Geistige überhaupt quantitativen Verhältnissen unterliegt. Denn nicht nur lässt sich von einer grösseren und geringeren Stärke von Trieben, es giebt grössere und geringere Grade der Aufmerksamkeit, der Lebhaftigkeit von Erinnerungs- und Phantasiebildern, der Helligkeit des Bewusstseins im Ganzen, wie der Intensität einzelner Gedanken": *El.*, i., 55; *cf.* *I. S.*, 1; *R.*, 325; *W. Preyer, Wiss. Briefe*, 1890, 213. The same idea recurs, *e.g.*, in *Wundt, Essays*, 1885, 155; *Lectures*, 17; letter in *Delbœuf's Éléments*, 130; *P. P.*, i., 1893, 332 (see also 282, 286); i., 1902, 466; *Logik*, ii., 2, 1895, 178; *K. Vierordt, Physiol. d. Menschen*, 1877, 311; *Grottenfelt, Das Webersche Gesetz*, 25 f., 34 f., 54 f.; *J. Tannery, in Delbœuf's Éléments*, 111, 135; *Delbœuf, ibid.*, 3 f., 123; *L. Dauriac, Critique philos.*, xi., 1, 1882, 324; *G. Tarde, Rev. phil.*, x., 1880, 150; *James, Psych.*, i., 489 f.; *A. Elsas, Psychophysik*, 59; *A. Meinong, Z.*, xi., 1896, 87, 95, 97, 110; *F. H. Bradley, Mind, N. S.*, iv., 1895, 1 ff.; *N. von Grot, Arch. f. syst. Phil.*, iv., 1898, 302 ff. How are we to meet it?

So far as the intensity of sensation is concerned, *i.e.*, within the strict limits of Fechnerian psychophysics, there is really no difficulty. All that we have to do is to define 'intensity' from the standpoint of our theory of

mental measurement. From this point of view, the intensity of *S* is an attribute which varies continuously from 0 in a constant direction. It is, therefore, possible for us, after experience of intensities lying at different points upon the intensive scale, to say—whether from memory or in actual perception—that one pressure is stronger, one pain more severe than another, or absolutely that a pressure is unusually strong, a pain extremely severe. We mean, in the first case, that the one pressure or pain lies farther from the 0-point of pressure or pain intensity than the other;¹ in the second, that the pressure or pain lies relatively high up in the scale of intensities that we have experienced. And we imply nothing more than that the distances from the 0-point are in some way, directly or indirectly, measurable.² In reality, the 0-point need not correspond with the total disappearance of *S*-intensity. It may be an arbitrary point, set by habit or by the mean capacity of the sense organ. “*Outre le jugement relatif que nous portons sur le rapport d'intensité de deux causes extérieures agissant sur notre sensibilité,*” says Delbœuf, “*nous portons aussi sur elles un jugement qui a quelque chose d'absolu, en ce que l'unité de comparaison est puisée dans la nature même de notre sensibilité;*” and this is true “*abstraction faite de tout terme de comparaison extérieure.*”³

We have, then, an adequate psychological explanation of the comparative judgments and of the absolute statements of intensity that occur in daily life. “The light to-night is poorer than it was last night”: “What a heavy child!”⁴—the mental attitude involved in such expressions is entirely intelligible. The sensations, points upon the intensive scale, come to us under such circumstances with a rough scale-mark upon them. Otherwise we might, as certain writers do, get over the difficulty by raising the previous question, by challenging the alleged

¹ Cf. A. Lehmann, *Die körperl. Aeusserungen psych. Zustände*, ii., 1901, 10: “unter der gegebenen Stärke *E* einer Empfindung lässt sich überhaupt nichts anderes verstehen, als die Anzahl ebenmerklich verschiedener Empfindungen, die sich zwischen den Grenzen 0 und *E* unterscheiden lassen.”

² See pp. cxxx. ff., below: von Kries, *Vjs.*, 278; G. E. Müller, *Z.*, x., 1896, 2, 25; Lipps, *Logik*, 1893, 122; cf. Meinong, *Z.*, xi., 1896, 357.

³ *Éléments*, 28 f.; cf. G. E. Müller, *G.*, 394. On the comparison of qualitative differences, see von Kries, *Vjs.*, 285 f.; G. E. Müller, *Z.*, x., 35. On comparison in terms of ‘psychological effect,’ see *Vjs.*, 291 ff.; Wundt, *Logik*, ii., 2, 1885, 183; Lipps, *Sitzungsber. d. philos.-philol. und d. histor. Cl. d. kgl. bayer. Akad. d. Wiss.*, 1899, 384 ff.

⁴ Judgments of this sort, judgments by ‘absolute impression,’ play an important part in psychophysical investigations, where they must be analysed in detail. We are here concerned simply with their justification and explanation from the standpoint of a given theory of mental measurement.

facts. Mental processes differ, we might say, but do not differ in degree. If we put a merely quantitative interpretation upon their differences, we are falling into the error signalised above, and confusing *S* with *R*. We may know that two *S* are set up by *R* of the same kind (*e.g.*, by weights), and may, in the light of this knowledge, seek to compare them; but we are then really trying to compare incommensurables, as if we should assert "die Gleichheit einer Schall- und einer Lichtbewegung" or estimate "die Längengrösse einer Secunde" (von Kries, *Vjs.*, 274). The position finds support in the very instances brought against it; for these instances are invariably formulated in terms of *R*.¹

As against Fechnerian measurement, this argument is valid; as against mental measurement in general, it is too radical. Pushed to its logical extreme, it makes a psychophysics impossible.² Moreover, as we have just seen, a correct definition of 'intensity of sensation' removes all difficulty.

On the wider issue, the author has always believed that the experimental method, qualitative and quantitative, is adequate to the whole structure of mind: this belief is intimated in the text.³ It is, of course, by no means universally—perhaps not even generally—held. There are psychologists who maintain that all mental processes are in some sort magnitudes, and that all magnitudes are in some way measurable. "Jeder psychische Thatbestand," writes Wundt, "kann principiell als Grösse betrachtet werden. . . Intensität, Qualität, Klarheitsgrad, räumliche und zeitliche Ausdehnung u. s. w. bilden jedes ein für sich bestehendes Object psychischer Messung."⁴ Bradley, too, says that "all psychical phenomena . . . can, in principle, be measured."⁵ On the other hand, there are psychologists who assert, quite as definitely, that not all mental processes are magnitudes.⁶ Moreover, Wundt after all actually measures only one aspect of one simple process—the intensity of sensation; ⁷ and to say that this particular measurement has been carried out because it is the 'typical' or the 'simplest' form of mental measurement at large, so that all the other measurements not yet made must conform to its pattern, is not an argument that will convince the sceptics. Brad-

¹ See p. xlvi.iii., above. Cf. Wahle, *Das Ganze der Philos.*, 192, 208; Elsas, *Philos. Monatshefte*, xxiv., 1888, 138.—F. Pillon regards all our ideas of mental magnitude as simply metaphorical: ancient physics was dominated by psychological metaphor, modern psychology is in danger of domination by physical. *Critique philos.*, xi., 1, 1882, 389 ff.

² Cf. G. E. Müller's axioms: *Z.*, x., 1896, 1 ff. ⁸ See Pt. i., p. xxxviii.

⁴ *Logik, loc. cit.*, 178 ff. See the discussion, pp. lx. ff. above.

⁵ *Mind, loc. cit.*, 18.

⁶ *E. g.*, Brentano, III. *internat. Congress f. Psych.*, 122 ff.; G. Tarde, *Rev. phil.*, x., 1880, 161.

⁷ *Logik*, 180.

ley, again, declares that his doctrine of the measurableness of 'psychical states' by 'psychical units' has, so far as he is aware, no practical bearing for the psychologist. And lastly, there is, as we have seen, a great difference between 'magnitude' and measurable magnitude or 'quantity.' All mental processes might be magnitudes, and yet no single process might be properly measurable.

In fine, the general question is not ripe for profitable discussion. Opinions upon it are opinions only. In view, however, of the steady advance of the experimental method, and of the steady extension of quantitative treatment to states and processes but lately believed to be beyond the reach of measurement, the author has felt justified in taking the position adopted in the text.

(2) *Fechner assumes that all j. n. d. of S are equal, from whatever part of the intensive scale they may be taken.* To this it is objected, in principle, (a) that 'just noticeable' does not necessarily mean 'equally noticeable,' and (b) that 'equally noticeable' does not necessarily mean 'equal.' The objection, especially in the form (b), is far-reaching, and finds many different expressions.

Let us be clear, in the first place, that Fechner does not identify the S-unit outright with the j. n. d. He maintains, on the contrary, that there is room in his measurement system for any sort of S-unit that the investigator chooses to employ. The j. n. d. is taken as unit simply because it reveals itself introspectively as a constant magnitude in work done by the method of j. n. differences. In this method "fasst man den eben merklichen Unterschied direct als einen für die Empfindung gleichen unmittelbar auf. . . [Es] steht [der Methode] entgegen, dass der Grad des Ebenmerklichseins dem subjektiven Ermessen mehr Spielraum lässt, als bei den anderen Methoden stattfindet. . . Indess lehrt die Erfahrung, dass man sich so zu sagen mit sich selbst über das Gefühl eines kleinen, doch noch sicher genug empfundenen, Unterschiedes verständigen, dieses, wenn nicht absolut, doch nahe genau, bei verschiedenen Versuchen reproduciren und durch Vervielfältigung der Versuche ein gutes Resultat erhalten kann" (El., i., 75; see also R., 120, 122, 303, 318, 323).¹ As for the choice of unit: "nach den von mir aufgestellten und entwickelten Principien," says Fechner, "kann jede beliebige

¹ Repeated in I. S., 43. Fechner seems to have forgotten the passage in the *Elemente*: cf. R., 120, note. The competence of introspection is denied by Funke, in Hermann's *Hdbch.*, iii., 2, 1880, 351; cf. W. Dittenberger, *Philos. Monatshefte*, N. F., ii. (*Arch. f. syst. Philos.*, 1896), 87; Stout, *Manual*, 31. It appears to be acknowledged by C. Wiener, *Wied. Ann.*, xlvii., 1892, 665.

psychische Grösse als eine immer wiederzufindende Masseinheit für psychische Grössen derselben Art gelten, welche einem Reize angehört, der seinen Schwellenwerth in gegebenem Verhältnisse übersteigt"; R., 333; cf. I. S., 44 f.; the course of the argument in P. S., iv., 179 ff., esp. 184 f.; and Wundt, in P. S., ii., 19 f.

So much in fairness to Fechner. We raise, now, our second question,¹ and ask: are the j. n. d. equal? The answer need not necessarily be in the affirmative: we may, e.g., admit the validity of Weber's Law, and yet maintain that the j. n. d. are relatively, not absolutely equal *S*-differences. This belief is, indeed, implicit in a 'metric formula' proposed, in place of Fechner's, by J. A. F. Plateau. "L'idée d'évaluer jusqu'à un certain point les sensations physiques," writes Plateau in 1872, "s'était présentée à moi une vingtaine d'années auparavant [*i.e.*, in the early fifties], et j'avais commencé sur ce sujet une série d'expériences. . . . Comme la méthode que j'ai suivie s'appuie sur un principe absolument différent de celui qui sert de base à la formule de Fechner, et comme, d'ailleurs, le résultat qu'elle m'a donné révèle en nous une faculté particulière d'estimation, je ne crois pas sans intérêt de la faire connaître" (Comptes rendus, lxxv., 1872, 678). Plateau worked by a crude form of the method of mean gradations, and obtained the metric formula $S=c.R^k$, in which *c* and *k* are constants. This implies, not Fechner's fundamental formula, but the equation:

$$\frac{dS}{S} = k \frac{dR}{R},$$

which makes the j. n. d. relatively equal *S*-magnitudes (Pogg. Ann., cl. [ccvi.], 1873, 465 f., 472; Bull. de l'Acad. royale de Belgique, xxxiii., 1872, 376 f., 384; Fechner, I. S., 21). Plateau withdrew his formula after reading Delbœuf's Étude (C. r., 680; Bull., etc., xxxiv., 1872, 261); but the position which he took has been revived, in various forms, by the representatives of the 'quotient hypothesis' of Weber's Law.²

The critical objection, that 'equally noticeable' does not necessarily mean 'equal,' was first raised by F. Brentano, Psychologie vom empirischen Standpunkte, i., 1874. "Richtig und a priori einleuchtend ist nur, dass alle eben merkliche Unterschiede gleichmerklich, nicht aber dass sie gleich sind. Es müsste denn jeder gleiche Zuwachs gleichmerklich, und darum auch jeder gleichmerkliche Zuwachs gleich sein" (9); which remains to be proved. Brentano's "Untersuchung führt zu dem Ergebnisse, dass jeder Zuwachs der Empfindung gleich merklich ist,

¹ This question must, for historical reasons, be first discussed: see p. lxxxviii. below.

² See G. E. Muller, G., 385 f.; Delbœuf, Examen, 91 f.; J. Merkel, P. S., iv., 1888, 543 f.; x., 1894, 140; Grotenfelt, Das Webersche Gesetz, 20, 72, 104, 149; and later references on the Verhältnisshypothese.

welcher zu der Intensität der Empfindung, zu welcher er hinzukommt, in gleichem Verhältniss steht" (88: Plateau's position). So we arrive at the law that "if the intensity of the physical R increases by equal aliquot parts, the intensity of the S also increases by equal aliquot parts" (89), although these parts need not, of course, be the same (90).

Brentano is followed, in quick succession, by J. Tannery, Hering and Ueberhorst. Tannery remarks briefly (Rev. sci., 24 Avril 1875; Delbœuf's *Éléments*, 137): "quant à cette sensation différentielle qui vient servir d'unité, il me semble qu'une unité doit toujours rester la même, et que cette unité-là n'est point assez constante." Hering enters much more deeply into the question: Sitzungsber. d. kais. Akad. d. Wiss. zu Wien, lxxii., Abth. 3, 1876, 310 ff. (session of Decr. 9, 1875). "Wenn nun eine 50 mm. lange Linie um 1 mm., eine 500 mm. lange Linie aber um 10 mm. wüchse, so würden beide Linien einen ebenmerklichen Zuwuchs erfahren, und diese beiden Zuwüchse müssten, nach Fechner's Satze, für unsere Empfindung ganz gleichwerthig sein. Dies ist offenbar paradox, und zwar wird die Paradoxie ganz handgreiflich, wenn man solche, den eben merklichen Unterschieden entsprechende, angeblich immer gleiche Empfindungszuwüchse sich summiren lässt" (321). Let a line of 50 mm. increase by j . n. increments until it is 100 mm. long; and let a line of 50 cm. increase by as many j . n. increments. The second line will be 100 cm. long; and "diese zugewachsenen 50 cm. nun und jene zugewachsenen 50 mm. müssten uns gleich gross erscheinen, denn beide entsprächen [nach Fechner] gleich vielen gleich grossen Empfindungszuwüchsen der beiden ursprünglichen Empfindungsgrössen" (*ibid.*; cf. 323 ff.; Funke, in Hermann's Hdbch., iii., 2, 1880, 352). C. Ueberhorst (*Die Entstehung der Gesichtswahrnehmung*, 1876) believes that "gleichartige Empfindungen, welche noch eben unterscheidbar sind, differiren stets um einen gleichen Bruchtheil ihrer eigenen Stärke von einander" (20: Brentano's position). See also P. Langer, *Die Grundlagen der Psychophysik: eine kritische Untersuchung*, 1876, 19 ff., 59 ff.; C. Sigwart, *Logic*, ii., (1878) 1895, 70 f.; Lotze, *Metaphysik*, (1879) 1884, 542; J. L. A. Koch, *Z. f. Phil. u. phil. Kritik*, N. F., lxxx., 1882, 172 ff., 176.

Fechner replies in the I. S., 45 ff. (cf. R., 198 ff.). "I assume . . . that the magnitude which the difference appears to me to have in the experiment depends upon two different things: first, upon the magnitude of the actual S -difference, and, secondly, upon accompanying circumstances [interval between experiments, attention, mode of application of R , mood, etc., etc.]. To this I add the second assumption . . . that, if the attendant circumstances are kept the same in experiments with variable R -magnitudes, the constancy of the apparent S -difference can

depend only upon a constancy of the true *S*-difference . . . But it is the aim of every good experimental series in this field to keep the secondary conditions . . . as nearly constant as possible." In other words: since we are trying to keep all conditions constant, save the one condition of varying *R*-intensity, it stands to reason that the 'noticeable' or 'apparent' *S*-differences will at least approximate to the 'real' *S*-differences. If we are careless, or if the regulation of certain conditions is out of our power, there will be errors in our results; but such errors, while they may account for deviations from an uniformity, can hardly themselves serve as the basis of an uniformity (47, 51). On Brentano's law, see 24 ff.; on Langer, 39 f.; and *cf.* further R., 268, 327 ff.¹ Fechner's reply is straightforward, and satisfactory—if one can accept Fechner's psychology. But it is a reply made from within the writer's system, and as such does not touch the principle of the objection.

Delbœuf, in the heat of the Tannery controversy, dismisses the objection as irrelevant (*Éléments*, 143). "Il me suffira . . . d'allonger mes phrases, et au lieu d'accroissements égaux, de dire chaque fois des accroissements jugés égaux par le sens intime . . . Que signifie l'expression contraste réel opposée à contraste sensible?" He confesses, later on, that he was more impressed by it than he allowed to appear at the time: *Examen*, 31, note; *Rev. phil.*, 1877, 242.

G. E. Müller (G., 386 ff.) disposes of Brentano's arguments by showing that his appeal to fact is mistaken and his syllogism faulty.² In any case, the question cannot at present be decided by considerations of theory; we must await the further advance of physiology (389). Hering is criticised by Langer, Müller, Exner, Delbœuf and Wundt. Müller (G., 391 ff.) writes: "the metric formula simply declares that with equal relative *R*-increments the *S*-increments are of equal magnitude. It does not by any means declare that the *R*-increments which arouse these equally large *S*-increments must also appear equally large. Hering's objection to the formula is, therefore, no more cogent than an attempt would be, *e. g.*, to refute the statement that the sensation 'red' stands qualitatively nearer to the sensation 'violet' than to the sensation 'blue,' by the counter-statement that we regard the qualitative change of the external *R* as more considerable in the case of transition from red to violet than in the change from red to blue."³ Moreover, on the question of fact, Hering ignores the results of Plateau's method of supraliminal

¹ On Hering's weight experiments, 323 f., see at this time Fechner, I. S., 187; Müller, G., 200 ff., 391 ff., 411 ff.; *Gött. gel. Anz.*, 1878, 808 ff., 815 ff.; Delbœuf, *Examen*, 87 f.; *Rev. phil.*, 1878, 43; and *cf.* Grotenfelt, *Das Webersche Gesetz*, 57 f.

² *Cf.* Meinong, Z., xi., 1896, 386.

³ *Cf.* Meinong, Z., xi., 1896, 386 f.

differences (394 f.). The experiments "stellen ausser Zweifel, dass die Summation gleich vieler eben merklicher Empfindungszuwüchse auf jeder Intensitätsstufe der Gesichtsempfindungen einen gleich deutlichen übermerklichen Empfindungszuwuchs ergibt." Cf. Langer, *Grundlagen*, 24 ff.; though Langer, as we noted above, has his own objections (answered by Müller, G., 96 ff.; restated in the brochure *Psychophysische Streitfragen*, 1893.) Exner (Hermann's *Hdbch.*, ii., 2, 240 ff.) urges that Hering's equation of the R -differences which correspond to j . n. d. of S at different parts of the intensive scale wrenches these differences from their given position, and is therefore unjustifiable. Intensive differences are qualitative, not merely quantitative. They are equal, if you leave them in their place at a certain height (so to say) upon the vertical line which rises from 0 to the terminal R ; they are unequal, if you cut them out of the line and stand them upon the same axis of abscissas. "Die Empfindungen einer bestimmten Gruppe, . . . z. B. die Empfindungen, welche ein allmählich wachsendes Gewicht hervorruft, sind in einer bestimmten Reihe angeordnet. Die Empfindungsgrösse im Fechnerschen Gesetze giebt nun den Ort in jener Reihe an, welche der durch die gegebenen Reize hervorgerufenen Empfindung zukommt" (243).¹ Delbœuf, on the contrary, employs the same argument of qualitative change in support of Hering. "Supposons que sur l'une des mains il y ait 30 disques et sur l'autre 300," and that we find the j . n. d. in the two cases. "Ces deux minima sont-ils égaux? . . . À certains égards on peut répondre oui, puisque en deçà il n'y a pas de sensation; mais à d'autres égards on peut répondre non, parce qu'en fait la main chargée de 30 disques est un autre individu sensible que la main chargée de 300 disques. Vouloir comparer les sensations de ces deux mains, c'est vouloir établir un parallèle entre la manière de sentir de deux personnes différentes; bien mieux, de deux personnes dont l'une serait déjà épuisée et l'autre pleine de vie et de force." Fechner's law is, therefore, not in accordance with the facts: "mais il pourrait se faire qu'elle fût exacte d'une manière abstraite, c'est-à-dire, en tant qu'appliquée à des organes d'une élasticité parfaite et toujours aptes à réagir d'une façon adéquate" (*Examen critique*, 12 f.; *Rev. phil.*, 1877, 231). The objection, then, which once was irrelevant, is now not only relevant, but stronger even than Hering had made it! Delbœuf's position is akin to that of von Kries, *Vjs.*, 1882, 274.

Wundt (*P. S.*, ii., 1885, 8) shows that Hering has substituted for Fechner's law, which asserts that "the difference of two R must increase

¹ Cf. Exner's later exposition: *Entwurf zu einer physiologischen Erklärung der psychischen Erscheinungen*, i., 1894, 174 ff.; Jodl, *Psych.*, 1896, 227; Wahle, *Das Ganze d. Philos.*, 206. f.; James, *Psych.*, i., 1890, 547.

proportionally to the R -magnitudes, if equal differences of S are to be produced," a law to the effect that "the difference of two R must increase proportionally to the R -magnitudes, if the R -difference is to be estimated as equally large;" and remarks that "dieses [Heringsche] Gesetz ist natürlich falsch . . . Immerhin ist es bemerkenswerth, dass selbst dieses . . . im allgemeinen jedenfalls falsche Gesetz . . . in gewissen Sinnesgebieten eine annähernde Gültigkeit zu besitzen scheint" and "mit dem Weberschen Gesetze zusammenfällt." But valid or not, it is not a law which Weber or Fechner had ever thought of formulating, and the objections based upon it are consequently irrelevant.¹

Wundt himself had at first no doubt at all but that the j , n , d . were equal S -magnitudes. "Die eben merklichen Empfindungsunterschiede sind . . . ganz gleich gross, denn wäre etwa der Unterschied im zweiten Fall grösser als im ersten, so wäre er ja grösser als eben merklich, und das geht gegen die Voraussetzung" (Vn., i., 1863, 100 f.). "Die Grenzwerte der Empfindung selbst, nämlich die eben merkliche S und die Maximalempfindung, bleiben überall Grössen von gleichem Werthe . . . Wollte man behaupten, die e , m . S sei grösser oder kleiner als eine andere, so würde man damit sagen, sie sei grösser oder kleiner als eben merklich . . . In jedem Sinnesgebiet ist diejenige S die möglichst grosse, welche das Bewusstsein mehr als jede andere in Anspruch nimmt. Da nun das Bewusstsein für alle Sinne die nämliche ist, so muss auch die Empfindungshöhe überall gleich gross sein . . . Ein . . . ebenmerklicher Intensitätsunterschied ist wieder aus demselben Grunde, wie die e , m . Empfindungsintensität, ein psychischer Werth von constanter Grösse. Denn wäre ein e , m . Unterschied grösser oder kleiner als ein anderer, so wäre er grösser oder kleiner als e , m ., was ein Widerspruch ist" (P. P., 1874, 294 f.). Unfortunately, this argument is circular. "Wenn einer bezweifelt dass alle e , m . Unterschiede einander gleich seien, so gilt ihm das eben-merklich-Sein nicht mehr als charakteristische Eigenthümlichkeit eines constanten Grössenmasses" (Brentano, Psych., i., 9; G. E. Müller, G., 389; Wundt, in Delbœuf's *Éléments*, 130; Funke, in Hermann's Hdbch., iii., 2, 1880, 351; P. Tannery, Rev. phil., xvii., 1884, 21; cf. Grotenfelt, Das Webersche Gesetz, 105). In 1880 we read: "je kleiner diejenige Reizänderung ist, die erfordert wird, um eine gegebene, in den verglichenen Beobachtungen constant erhaltene Empfindungsänderung [*i. e.*, eine nach unserer Schätzung constant erhaltene Empfindungsänderung] hervorzubringen, um so grösser nennen wir die Unterschiedsempfindlichkeit" (P. P., i., 324). "[Bei der Methode der Minimaländerungen] muss man aber eine Voraussetzung machen, welche möglicher-

¹ Cf. M. Foucault, *Psychophysique*, 1901, 185; A. Elsas, *Philos. Monatshefte*, xxiv., 1888, 131 f., *n.*

weise bestritten werden kann und in der That bestritten worden ist: man muss nämlich annehmen, dass die Unterschiedsschwelle stets den nämlichen Werth habe, wie verschieden auch die absolute Intensität der Empfindungen sein mag" (331). Since, however, we can never measure S "unabhängig von den Vorgängen vergleichender Schätzung," "bedarf der Satz, dass jede e. m. Aenderung der anderen gleich ist, keines Beweises." The objection affects the method of mean gradations as much—or as little—as it affects the methods that measure in terms of the j. n. d. "Erst wenn es sich um die Deutung der . . . Resultate handelt, wird die Frage untersucht werden können, welcher Einfluss den einzelnen bei der Vergleichung verschiedener Empfindungen wirk-samen Vorgängen bei den Resultaten zukommt" (332). Weber's law is to be interpreted as a law of apperception (351); and "der Einwand trifft [diese] psychologische Deutung gar nicht" (353). "Es kann für uns ein anderes psychisches Mass der S als das ihrer Merklichkeitsgrade schlechterdings nicht geben" (360).

Nevertheless, the attempt is made, in 1885, to define the limits within which 'gleich merklich' may be identified with 'gleich.' Wundt argues, precisely as Fechner might have done, "dass unsere Beobachtung oder anders ausgedrückt das Merklichwerden der Erscheinungen die einzige Quelle unserer Kenntniss derselben ist, und dass wir daher, so lange die subjektiven Bedingungen unserer Beobachtung constant bleiben, übereinstimmenden Erscheinungen auch eine übereinstimmende Bedeutung heizumessen haben" (P. S., ii., 25). Now the j. n. d. are "ohne Zweifel als gleich merkliche Unterschiede zu statuiren;" and the 'gleich merkliche Unterschiede' of mean gradations are 'selbstverständlich' absolute magnitudes: "wir würden alle Principien der Grössenvergleichung auf den Kopf stellen" if we thought or aimed at anything else;¹ hence the j. n. d. are, under constancy of subjective conditions, equal magnitudes. This constancy is attained "wenn [Constanz der Aufmerksamkeit vorausgesetzt] die mit einander verglichenen Empfindungsunterschiede einer und derselben Reihe einsinniger, unter constanten zeitlichen und räumlichen Bedingungen stattfindender Veränderungen angehören," *i.e.*, when we are dealing with intensities of the same quality, or with continuous qualitative changes at the same intensity (29). Under these conditions we may "unsere Apperception von Empfindungsunterschieden als ein Mass der Empfindungsunterschiede selbst ansehen;" for "die Voraussetzung einer Proportionalität der

¹ G. E. Müller, in his treatment of mean gradations, speaks consistently of the Merklichkeit of übermerkliche Unterschiede (G., 90 ff.). This usage calls down Dittenberger's condemnation (Philos. Monatshefte, N. F., ii., 1896, 84). We can defend it by reference to G., vii.

Apperceptionseffekte mit ihren Ursachen . . . einer jeden, auch physikalischen Massbestimmung zu Grunde liegt" (31).

These quotations have been given at length, because the change of position from 1880 is marked. Nay more: Wundt's concessions to Fechner seem to contradict his present statements that 'Merklichkeitsgrade' of *S* are the only measurable psychical elements (19), and that there can be no "thatsächliche Bestätigung" of Fechner's law because we know absolutely nothing of *S* apart from their apperception (31). We have noted another phase of the inconsistency above (p. lviii.), and have sought to explain it. Grotenfelt (*Das Webersche Gesetz*, 158 ff.) accounts for Wundt's change of ground in very much the same way. "Indem Wundt die Unabweisbarkeit einer psychologischen Deutung aufzeigte und das Webersche Gesetz auf ein allgemeines Gesetz der Beziehung zurückführte, ist er doch bestrebt gewesen, die Fechnersche Theorie so weit wie möglich unangetastet beizubehalten;¹ er hat die mathematischen Formeln Fechners, welche sich alle auf die Unterschiedshypothese gründen, beibehalten, und die Hypothese gegen alle Einwürfe zu vertheidigen versucht" (162). There is no reason to suppose that the parallelism of the two lines of thought ever wrought confusion in Wundt's own mind; but the reader must be constantly alert to the context in which a particular statement is made.

The P. P. of 1887 takes us back to the view of 1880 (i., 349 f., 379).² The reader should cf. further Lectures, (1892) 1894 or 1896, 34, 62; A. Köhler, P. S., iii., 577 f. The discussion of Wundt's present position must be postponed.

We return to G. E. Müller (G., 382 ff.). We have seen that Müller, in replying to Hering, appeals confidently to the method of mean gradations as applied to brightnesses. His final judgment is less definite; but, on the whole, he inclines to accept Fechner's point of view. "The corrected metric formula³ . . . is, it is true, not yet proved to demonstration; at the same time, it is based upon the simplest and most probable assumption regarding the magnitude of equally noticeable *S*-differences.⁴ The attempts so far made to show that this formula, and the principle of psychophysical measurement which underlies it, are certainly invalid, and must be replaced by other formulas, set out from postulates all of which are unproved, and some of which conflict with one another

¹ Cf. Wundt's own statement, P. P., i., 1902, 501.

² With the modifications noted above, p. lix., note. It may be remarked here that Stumpf's note in Z., i., 420 is erroneous; the 'möglicherweise bestreitbar' occurs, as we have seen, in 1880, and not for the first time in 1887.

³ G., 229.

⁴ Cf. Funke, Hermann's Hdbch., iii., 2, 1880, 351; P. Langer, Grundlagen d. Psychophysik, 1876, 20 f., 24; Psychophysische Streitfragen, 1893, 9 ff.

and with experience" (402 f.): cf. 248 ff., 256 ff., 259 ff., 412. On the other hand, Müller is not convinced by Fechner's argument in the I. S. "If we are trying to find out whether equally noticeable *S*-increments, added to *S* of different intensity, are of equal magnitude, then we must first of all raise the question whether the absolute *S*-intensity itself is not to be considered as an 'attendant circumstance' which is of essential importance for the noticeableness of an *S*-increment. . . The point at issue is, whether we are able certainly to decide the question, in what relation the sensed difference stands to the sensation difference; and in particular whether this dependency relation is not influenced, among other things, by the absolute *S*-intensity (or the underlying physical intensity of the *R* or the *E*), which would thus appear as an important 'attendant circumstance'" (Gött. gel. Anz., 1878, 814 f.). The equal magnitude of equally noticeable *S*-differences is thus "zwar nicht unwahrscheinlich, aber doch nicht sicher erwiesen" (819). Cf. Fechner, R., 199 ff.

Stumpf admits the logic of the objection, but thinks that it may be discounted in practice: Tps., i., 51 f. "Wenn ein Unterschied, den wir nicht mehr bemerken, darum doch in der Empfindung vorhanden sein kann,¹ so kann auch ein ebenmerklicher Unterschied in zwei Fällen eine verschiedene Grösse und zwar in der Empfindung besitzen (nicht etwa blos einer verschiedenen Reizgrösse entsprechen). . . Andererseits dürfen gleichmerklicher und gleicher Empfindungsunterschied, wenn nicht begrifflich, doch faktisch unter besonderen Umständen als zusammenfallend oder, dass wir es sogleich vorsichtiger ausdrücken, als proportional angesehen werden. Wenn wir nämlich in bestimmten Fällen berechtigt sind anzunehmen, dass sich die subjektive Zuverlässigkeit² von einer Tonlage, überhaupt von einer Reizregion zur anderen nicht oder nur in verschwindendem Masse ändert, und wir gleichwol die Unterscheidungs-fähigkeit . . . verändert finden, so können wir die Ursache dieser Aenderung nur in einer nach den Reizregionen verschiedenen Empfindlichkeit suchen."

P. Tannery, on the other hand, thinks that Fechner's assumption is logical, but that the appeal must lie to the facts. "[L'hypothèse] que la sensation de la plus petite différence perceptible reste identique à tous les degrés de l'échelle . . . peut être légitime à titre de définition, s'il est vrai que les plus petites différences perceptibles sont jugées égales et que le jugement seul prononce l'égalité ou l'inégalité de deux différences de sensation. Mais on ne peut voir là qu'une définition, légitime,

¹i., 31 ff.; cf. ii., 222. In Z., i., 420, Stumpf writes that "die Frage [nach der Gleichheit der ebenmerklichen Unterschiede] ist experimentell unbeantwortbar," owing to the impossibility of a comparison of least distances.

²i., 23, 31.

je le répète, arbitraire néanmoins dans une certaine mesure" (Rev. phil., xvii., 1884, 20). Unfortunately, the facts appealed to against the hypothesis are the facts of the tonal scale (32 f.).

Is it not time, now, that the objection be put to the test of direct experiment? Fechner had appealed to introspection in support of his position; and Müller and Wundt, Köhler and P. Tannery, have pointed out the agreement in result of the methods of minimal changes and of mean gradations. But no one has so far set to work upon the two methods, deliberately and of set purpose, with the view of discovering their agreement or disagreement. There are, in reality, two possible ways of working. (1) We might take a series of R -values, corresponding to a series, say, of eight successive j . n. d. of S , and thereafter directly compare the two half-distances, of four j . n. d. each, and decide upon their equality or inequality. This would be a direct method of experiment: determine the R -differences as $a-b$, $b-c$, $c-d$, $d-e$, $e-f$, $f-g$, $g-h$, $h-i$, and then see if $a-e$ is equal in S to $e-i$. Or (2) we might determine a few j . n. d. of S , at different parts of the R -scale, in order to establish the constancy of the relative DL , and thereafter work with supraliminal d ., and decide whether the same uniformity holds. This would be an indirect method: it is the method indicated by the authors just cited. Let $a-b$ and $h-i$ be R -differences corresponding to the j . n. d. of S , and let there be constancy of the relative DL , i.e., let $\frac{b-a}{a} =$

$\frac{i-h}{h}$. If the j . n. d. are equal, then the point e , which lies midway for S between a and i , must be such that $\frac{e-a}{a} = \frac{i-e}{e}$, or $e = \sqrt{a \cdot i}$. Either

of these two methods would, presumably, take us to our goal.¹

Yes! but the experimental work would be exceedingly difficult. Liminal determinations are always and intrinsically difficult; and, further, the judgments passed upon j . n. d. and upon supraliminal d . are, even under the most favourable conditions, the expressions of radically different mental attitudes. Nevertheless, the attempt must be made. If the metric methods are to stand at all, they must stand in face of the present appeal. A set of separate methods, yielding incomparable results, would be of small scientific value. Moreover, the attempt has been made. Let us look at the results.

J. Merkel writes, in 1888, that "es fehlt gegenwärtig noch an einer einwürrsfreien experimentellen Prüfung des Weberschen Gesetzes bei denselben Reizstärken unter Anwendung der Methode der ebenmerkli-

¹ For the methods, see W. Ament, P. S., xvi., 1900, 136 f.; cf. also the discussion in Stumpf, Tps., i., 60 ff.

chen Unterschiede und der Methode der mittleren Abstufungen" (P. S., iv., 543). Merkel's own problem is that of the 'dependency between R and S ' as formulated by Fechner and Plateau. Fechner took dS , Plateau $\frac{dS}{S}$, as constant. Which of the two is right? Are we to adopt the 'difference hypothesis' of Fechner or the 'quotient hypothesis' of Plateau? Does S increase in direct proportion to R or as the logarithm of R ? The question of the equality of the j. n. d. is evidently implied in these questions; it is not expressly raised by Merkel.

Merkel worked, by comparative methods, with brightnesses, active pressures and noises. He found in general—our statement is very rough—that the S -mean between two supraliminally different R coincides, within the limits of constancy of the relative DL , not with the geometrical but with the arithmetical mean of the R -values: the ϵ which corresponds to the S -mean = $\frac{a+i}{2}$, not $\sqrt{a.i}$. Merkel expresses this result in terms of the quotient hypothesis.¹ If it be reliable, it means, from our present point of view, that the j. n. d. are not equal, but increase in size with increasing value of R .²

The result is accepted by L. Lange,³ though the conclusion which he draws is not that which we have just drawn. Lange takes the equality of the j. n. d. as a matter of course (132, 136). He infers, therefore, that the outcome of a mental measurement depends upon the magnitude of the unit chosen for the S -scale. If we take a small unit, the j. n. d., we may find, perhaps, that the R -differences $a-e$, $e-i$ are equal for S in the form $a-\sqrt{a.i}$ and $\sqrt{a.i}-i$; whereas, if we take a large unit, seek to bisect the distance $a-i$, we may find that the equal R -differences have the form $a-\frac{a+i}{2}$ and $\frac{a+i}{2}-i$. It is clear that a dependency of this sort, duly substantiated, would force us to revise our whole idea of mental measurement, and ultimately "to work out a new algorithm for the class of magnitudes of which it holds" (139).

Merkel's result is, however, not allowed to pass unchallenged. A. Grotenfelt, also a staunch defender of the quotient hypothesis,—though in a form somewhat different from that given it by Merkel,⁴—suspects that Merkel has been judging R in place of S , and demands at least a suspension of judgment until the work has been repeated: *Das Webersche Gesetz und die psychische Relativität*, 1888, 111 f. On theoretical

¹ P. S., iv., 1888, 541; v., 1889, 245, 499; x., 1894, 140, 203, 369, 507.

² Cf. Grotenfelt, *Das Webersche Gesetz*, 109; Angell, P. S. vii., 421.

³ P. S., x., 1894, 125. The paper was practically completed in 1886.

⁴ See p. 70 below.

and critical grounds, Grotenfelt is convinced that "bei steigenden Intensitäten die Grösse des ebenmerklichen Unterschiedes steigt" (103)¹. Experiments upon noise intensities, by the method of mean gradations, were published in 1892 by F. Angell (P. S., vii., 431 ff.). They were confined within narrower intensive limits than those of Merkel; on the other hand, Angell paid more attention to subjective sources of error and to the introspection of his observers. He nowhere expressly lays it down that all *j. n. d.* are equal; just as Merkel nowhere expressly says that the *j. n. d.* increase with increasing *R*. The belief is, however, evident throughout his paper: he assumes that the two methods of minimal changes and of mean gradations are strictly parallel, and their results directly comparable; he demands that the latter method, if it is to confirm Weber's Law, give the equation $a - \sqrt{a.i} = \sqrt{a.i} - i$; he admits Grotenfelt's contention "dass das Schätzen der Reizintensität 10 als Mitte zwischen dem Reizintervalle 4 bis 16 eine grössere Anzahl von ebenmerklichen Unterschieden zwischen 4 und 10, als zwischen 10 und 16 in sich schliessen würde."² He finds Weber's Law confirmed by his experiments, *i.e.*, obtains the geometrical mean; and declares himself an adherent of the difference hypothesis.³

In the meantime, the question had been discussed afresh by Münsterberg.⁴ "Wir haben durchaus nicht die Berechtigung, zwei eben merkliche Unterschiede ohne weiteres als gleich zu betrachten. . . Die stillschweigende Identifizierung des gleichmerklichen Unterschiedes mit dem gleichen Unterschied ist eben der prinzipielle Fehler der ursprünglichen Psychophysik."⁵ There are, in actual fact, two kinds of *j. n. d.* There is, first, the "eben merkbare Verschiedenheit" of *S*, which does not carry with it a judgment of the direction of change.⁶ This form of the *DL* "gehört völlig in sensorielles Gebiet;"⁷ it is valueless for mental measurement.⁸ There is, secondly, the "eben merkbare Unterschiedsempfindung von bestimmter Richtung."⁹ This least Unterschieds-*S*, like all others of its kind, "bezieht sich auf Spannungsveränderungen, welche den Uebergang von einer *S* zur anderen begleiten,"¹⁰ "stammt

¹ Cf. esp. 40, 62 ff., 95 ff.; also iii., 15 ff., 27, 56, 57 ff., 71, 76, 92, 102, 109, 113, 179 f.; Angell, P. S., vii., 415 ff.; Merkel, *ibid.*, v., 251.

² P. S., vii., 420 f., 431 ff., 449 ff. Ament remarks off-hand (P. S., xvi., 148) that "diese Forderung (of the geometrical mean in mean gradations) ist in der That nur dann berechtigt, wenn man die ebenmerklichen Unterschiede als merklich gleich aufzufassen hat." See, however, Grotenfelt, 104 ff.

³ *Op. cit.*, 468.

⁴ In his *Neue Grundlegung der Psychophysik*, Beiträge, 3, 1890.

⁵ N. G., 58.

⁶ *Ibid.*, 43 f., 49 f., 106 ff.

⁷ *Ibid.*, 107.

⁸ *Ibid.*, 108.

⁹ *Ibid.*, 107.

¹⁰ *Ibid.*, 25.

aus den Muskelspannungen,"¹ and is accordingly measurable.² The question whether the j. n. d. are equal thus becomes a question which may be answered by experiment.³ The answer is affirmative: experiment shows "dass dieselben Verhältnisszahlen, welche für die gleich geschätzten übermerklichen Unterschiede massgebend sind, auch den eben merklichen zukommen."⁴ "[Wenn] unter Unterschiedsschwelle die eben merkbare Unterschiedsempfindung verstanden wird, . . . handelt es sich um gleiche Unterschiede."⁵ For the rest, we find in practice that the "blosse Konstatierung einer Verschiedenheit" and the "Wahrnehmung einer bestimmten Unterschiedsempfindung . . . im allgemeinen sich decken;"⁶ so that, despite the reference of the former to the sensory and of the latter to the motor apparatus,⁷ we are not far from the truth in saying, in found terms, that all j. n. d. of *S* are equal.

We come back to Wundt, and first to the P. P. of 1893. So far as Wundt adheres strictly to his definition of Merklchkeitsgrad, we shall expect him to brush aside the controversy between 'difference' and 'quotient' hypothesis as irrelevant. Distances are neither quotients nor differences.⁸ But we have seen that Wundt, while speaking of Weber's Law as an Apperceptionsgesetz, does not cease to speak of a possible Empfindungsgesetz. His early sympathies are with Fechner; and in the essay of 1885 (P. S. ii., 23 ff.) he places himself, with various reservations, on the side of Fechner and the difference hypothesis. On the other hand, Weber's Law, as Apperceptionsgesetz, is a law of relativity. It was therefore natural for Wundt to write in the P. P. of 1880, when he broke away from Fechner, and again in 1887, that "die Empfindung als solche" might increase, within the limits of Weber's Law, "nach demselben Gesetze annähernder Proportionalität wie die centrale Sinneserregung" (1880, 351; i., 1887, 377, 380); and equally natural that, on the ground of his apperception theory, he should decline to discuss the possibility further. Now, however, he has Merkel's results, and Grotenfelt's advocacy of the quotient hypothesis. If he seeks to penetrate behind the given Merklchkeitsgrad to the pure sensation, shall we not expect him to reject Fechner, and (as relativist) to accept—always under reservation—the quotient theory?

This line of reasoning gives us the key to Wundt's position. "Die

¹ N. G., 108.

² For Münsterberg's theory of mental measurement by concomitant strain sensations, see below, pp. cxxxiv. ff.

³ *Ibid.*, 69.

⁴ *Ibid.*, 90 f., 93; cf. 16.

⁵ *Ibid.*, 108. The experiments are, unfortunately, so rough and unreliable that Münsterberg's conclusion can carry little weight.

⁶ *Ibid.*, 110.

⁷ *Ibid.*, 110 f.

⁸ Grotenfelt, 65, 111; Ebbinghaus, *Psych.*, i., 319 f.

Einführung dieses Gesichtspunktes (*i.e.*, of the doctrine of Mercklichkeitsgrade),” he says, “bietet den Vortheil dar, dass die mathematischen Formulierungen des Weberschen Gesetzes von dem . . . Gegensatz der Unterschieds- und der Verhältnisshypothese nicht berührt werden” (i., 404 f.). After as before, the apperceived S may be conceived of as a sum of Mercklichkeitsgrade, as a point lying at a certain measurable distance from the 0-point of the scale of noticeableness.¹ Formerly, however, he had transferred the notion of ‘gleiche absolute Grösse’ from the differences of R and apperceived S to the differences of R and S in Fechner’s sense. Now that Merkel has brought to light cases in which “an die Stelle des Weberschen Gesetzes ein proportionales Wachsthum der appercipirten Empfindung mit dem Reize treten kann,” he prefers the quotient hypothesis. It is still, remember, only by hypothesis that we can say anything at all about R and S ; what we know are R and the S as “abhängig von den Vorgängen vergleichender Beziehung.” It is, however, readily intelligible that a simple proportionality between R and S might appear, under the influence of these processes of comparison, in more complicated form, as the logarithmic relation of Weber’s Law; whereas the latter could hardly give rise to the former (397 f.). As for the formulas, we can (as was hinted above) keep the $dS = c \frac{dR}{R}$,² if we understand by S the apperceived S , and by R the central sensory excitement or (what is directly proportional to it) the pure S in Fechner’s sense, the S before apperception (405),³

In the P. P. of 1902 this position is carried to its logical conclusion. Wundt insists that the relation of R to S can never be made the object of direct observation or experiment in psychology, but can be discovered “höchstens auf indirecte Weise, etwa durch die Vergleichung der auf verschiedenen Wegen ausgeführten Versuche über die Auffassung der Empfindungen” (i., 467). It is, however, probable, since Weber’s Law is a law of apperception, *i.e.*, of the comparison of S and not of R , that “die Empfindung selbst wachse, ebenso wie die Sinneserregung, . . . annähernd proportional der Stärke der äusseren Reize” (541 f.). Nevertheless, the quotient hypothesis receives historical treatment only; Wundt makes no further attempt to decide, within the sphere of Fechner’s psychophysics, between the difference and the quotient hypotheses (548 ff.).

¹ Logik, ii., 2, 1885, 193. “Nun wird allgemein das ‘Gleichmerkliche’ als eine für die Vergleichung gleich bleibende Grösse, und das ‘Ebenmerkliche’ als das jeder Grössenvergleichung zu Grunde zu legende Mass betrachtet werden können.”

² Cf. i., 1880, 355; i., 1887, 380 f.; i., 1893, 398 f.; i., 1902, 549.

³ Cf. Vn., 1897, 69 f.; Outlines, (1896) 1897, 256.

His own exposition is couched throughout in terms of apperception and *Merklichkeit* (*cf.* the formulæ, 543, 547, 549). Merkel's Law of absolute *S*-estimation (which is in so far as "Ausnahmegesetz, als es an eine bestimmte Methode und an gewisse bei derselben festzuhaltenden Bedingungen geknüpft ist": 505 f.) is set up alongside of Weber's Law (504 ff., 543 ff.), and the conditions of the two forms of sense comparison are worked out in detail (545 ff.). The question of the equality of least degrees of *Merklichkeit* is not discussed, though incidentally it is answered in the affirmative on p. 553.—The impression left upon the reader is that Wundt has definitely turned his back upon the psychophysical problems of *S*-intensity, as they appear in the literature called forth by Fechner's *Elemente*, and that, agreeably to his 'psychological' interpretation of Weber's Law, he is confining himself strictly to psychological analysis.¹

Simultaneously with the fourth edition of the *P. P.* appeared Lipps' *Grundzüge der Logik*. Lipps here takes up a position, as regards the

¹ If we put together the results of the foregoing discussions, we may distinguish three principal stages in Wundt's thought.

(1) The *S* is summed from *j. n. d.* of *S*, which are equal.

(2) The apperceived *S* is summed from equal *Merklichkeitsgrade*. This summation is not a summation of so many little apperceived *S* to make a large apperceived *S*, but rather a summation of unit-distances from the attention limen (i., 1902, 498, 549) along the scale of noticeableness.—The corresponding *d.* of the underlying 'pure' *S* are, within certain limits, absolutely equal (*Unterschiedshypothese*).

(3) The apperceived *S* is summed as before.—The corresponding *d.* of the underlying 'pure' *S* are, probably, relatively equal (*Verhältnisshypothese*: 1893), though this fact is irrelevant for mental measurement (1902).

What, now, of the *S* 'before' apperception? Wundt places the sensory centres and the apperception centre in different parts of the cerebral cortex (i., 1893, 227 f., 230 ff.; i., 1902, 320 ff.). Any *R* which can set up an *E* in a sensory centre arouses *S*, passes the 'limen of consciousness'; the *R* must, however, evoke the reaction of the apperception centre if it is to give rise to an apperceived *S*, to pass the 'limen of attention' (1893, 398; 1902, 553). The *S* before apperception is, therefore, a real mental process, not an 'unconscious' process (*Grotenfelt*, 59 f.); and we are justified, under certain conditions, in arguing to it from the apperceived *S* of our experiments. We experience it in cases of 'Perception' as opposed to 'Apperception' (ii., 1893, 267, 275). When, however, we set to work to estimate and compare *S*, we must even estimate and compare, *i.e.*, we must apperceive.—This is, in effect, Wundt's answer to *Stumpf's* objection, p. lvi. above.

The reader must, of course, decide for himself how far the above summary does justice to the development of Wundt's psychophysical ideas. The question is one of interpretation and evaluation; and the author has, for this reason, given the summary at the end of the discussion instead of taking it as a text to expound from.

j. n. d., which far out-Fechners Fechner. "Alle Massbestimmungen sind relativ, wenn sie nicht schliesslich auf irgend welche in der unmittelbaren Anschauung gegebene Grössen sich stützen, oder ein letztes Element der Messung gefunden wird, das selbst keine weitere Messung mehr zulässt, also als absolute Masseinheit gelten kann. Ein solches letztes Element bildet das eben Merkliche. Die Anzahl des eben Merklichen ist das absolute Mass einer Grösse . . . Das eben Merkliche hat —für die Wahrnehmung nämlich—keine Grösse mehr." Since "das Mass die Anzahl gleicher Theilgrössen ist, durch die eine Grösse ersetzt oder aus der sie zusammengesetzt werden kann," it is clear that the j. n. d. are equal magnitudes. But more than that: they appear to be, for Lipps, the units of all absolute measurement, whether 'physical' or 'mental.' It is not to make our measurement absolute that we have recourse to objective spatial units; it is simply to free the results of measurement from those subjective fluctuations which, 'absoluteness' notwithstanding, attach to our estimation of the just noticeable (120 f.)¹.

We pass to the elaborate study of Weber's Law published in 1896 by A. Meinong (Ueber die Bedeutung des Weberschen Gesetzes: Beiträge zur Psychologie des Vergleichens und Messens, Z., xi., 81, 230, 353). Meinong substitutes for the term 'Unterschied' (eben merklicher, gleich merklicher Unterschied) the word 'Verschiedenheit.' 'Unterschied' means 'difference' in the arithmetical sense, the amount by which one magnitude differs from another: 'Verschiedenheit' means 'differentness,' so to say,—diversity, distinction, unlikeness.² "Darf man," writes Meinong, "im allgemeinen darauf rechnen, dass bei Verschiedenheit der Unterschiedsempfindlichkeit . . . eben merkliche Verschiedenheiten nicht gleich sein werden, so bedeutet im Gegensatze hierzu Gleichheit der Unterschiedsempfindlichkeit eine wohlbegründete Präsomption für Gleichheit der eben merklichen, man kann übrigens ohne weiteres auch sagen:

¹ Later writers seem to have fought a little shy of this Lippsian doctrine. Cf. Meinong, Z., xi., 130, n.

² Cf. B. Russell, Mind, N. S., vi., 1897, 332, 334. "A change of length is itself a length, but a change of temperature or illumination is not itself hot or bright. . . . With intensive quantities, . . . these differences of quantity are not themselves quantities. The difference between two intensive quantities, in fact, differs from each as much as the difference between two horses differs from a horse."

It is noteworthy that Weber, in his first general formulation of Weber's Law, uses the two terms *discrimen* and *differentia*: cf. the translation, p. xvi. above. F. A. Müller (Axiom, 1882, 62) insists that the usage is intentional; that *discrimen*=*Verschiedenheit*, and *differentia*=*Unterschied*. F. Boas (Pfl. Arch., xxviii., 1882, 574) and A. Grotenfelt (Das Webersche Gesetz, 1888, 41) also employ the term *Verschiedenheit*. Stumpf prefers *Unähnlichkeit* (Tps. i., 111, 122 ff.). Ebbinghaus often uses *Verschiedenheit* (Pfl. Arch., xlv., 1889, 113; Z., i., 1890, 328).

der gleich merklichen Verschiedenheiten" (133; *cf.* 260 f.) As regards the relation of Verschiedenheit to Unterschied: "die V. zweier psychischen Daten fällt ihrer Grösse nach weder mit dem absoluten noch mit dem relativen Unterschied dieser Daten zusammen; aber die Beziehung zum relativen Unterschied ist eine ungleich engere" (285). Hence, while he cannot in strictness adopt either the Unterschieds- or the Verhältnisshypothese,—for if you cannot subtract S , you certainly cannot divide them (385),—Meinong finds that the latter position comes very much nearer the truth than the former (387 f., 402). What Weber's Law tells us is that equally distinct or diverse S correspond to equally distinct or diverse R (363, 371, 397): not S -differences, absolute or relative, but S -distinctions (Empfindungsverschiedenheiten) are logarithmically dependent upon R (374 ff.). This view is, it is true, contradicted by the results of Merkel's experiments (261 ff., 388 ff.); but these are readily brought into line "durch die Vermuthung, dass hier statt der Distanzen Strecken verglichen werden, bei denen an Stelle der einfachen Vergleichung die Teilvergleichung eintreten und dadurch der 'Unterschied' im eigentlichen Wortsinne zu seinem Rechte gelangen kann" (396). That is to say, instead of judging in terms of interval, apartness, 'distance' in the proper sense of the word, Merkel judged in terms of that which filled the distance, here the intensive sense-continuum.¹

We appealed to experiment; and the appeal was answered by Merkel and Angell. Nevertheless, these investigators did not raise the precise question that we desired to have raised: and their results are not in accord. Moreover, in discussing Lange and Grotenfelt, Wundt and Meinong, we have come back again to theory and interpretation. In the work next to be mentioned—Ueber das Verhältnis der ebenmerklichen zu den übermerklichen Unterschieden bei Licht- und Schallintensitäten, by W. Ament²—we have an experimental study, undertaken with

¹ The reader should, however, compare Meinong, 264 f., note, 396, with Merkel's statement, P. S., v., 1889, 537, and with his results for wide R -intervals: see, *e. g.*, Ament's combined Table, P. S., xvi., 1900, 142.

On Meinong's general position, *cf.* Höfler, Psych., 1897, §§ 29, 39. "Die einfachste Erklärung der Thatsache, dass die Verschiedenheiten der Empfindungen von 3 g und 4 g , von 3 dkg und 4 dkg gleich merklich, nämlich eben merklich sind, liegt darin, dass diese Verschiedenheiten gleich sind:" 232; *cf.* 141, 249 f. See also Stout, Manual, 1899, 206, 207 f. For the doctrine of 'psychische Arbeit,' *cf.* esp., in the present connection, Höfler, Psych., 249 f.; Z., viii., 1895, 98; Meinong, Z., xi., 1896, 126 ff., 260 f.; T. Lipps, Grundzüge der Logik, 1893, 104, 122; and on the doctrine at large F. Boas, Pflüger's Arch., xxviii., 1882, 574 f.; N. von Grot, Arch. f. syst. Phil., iv., 1898, 266 ff. (with references); Münsterberg, Psych., i., 1900, 277 ff.; V. Henri, L'année psychologique, 3^e année, 1897, 232 ff.

² P. S., xvi., 1900, 135 ff.

the express object of deciding "ob man berechtigt ist, die ebenmerklichen Unterschiede als merklich gleiche aufzufassen, oder nicht" (137).¹ Experiments were made with brightnesses (direct method) and noises (principally, indirect method). The brightnesses consisted of a series of Marbe greys "zwischen einem nicht sehr dunklen Schwarz und einem dunkleren Grau" (49 papers; photometric limits 1:3). The noises were given by a Fechner sound pendulum (intensive limits approximately 1:50).² The result is that, in every case, there is "a divergence between difference determination and difference comparison," *i.e.*, the two subjective halves of a given R -distance do not contain an equal number of *j. n. d.* "This divergence depends upon the magnitude and the position of the compared differences. Hence we must conceive of the DL as a magnitude that increases with increasing R , and must consequently give up Fechner's assumption that it is the unit of measurement within the sphere of S -measurement at large" (195 f.). The result is illustrated by the following Figure.

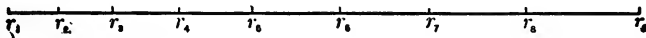

FIG. 1.

The values r_1, r_2, r_3 , etc., are R -intensities, arranged in ascending order: the distance between every pair of successive r represents a DL . The distances r_1-r_2, r_2-r_3 , etc., increase by equal increments. It is clear (1) that the distance r_6-r_9 , though it contains the same number of

¹ Ament sharply separates the two problems of the 'equal noticeableness' and of the 'equality' of the *j. n. d.* We return to the former presently. The disjunction probably accounts for the phrase 'merklich gleich' in the above quotation: 'merklich gleich' is contrasted with 'gleich merklich.' In reality, however, there are three questions. (1) Does 'eben merklich' mean 'gleich merklich'? (2) Does 'eben merklich' mean 'merklich gleich,' in the sense of introspectively equal, sensibly equal, apparently equal? This question was answered affirmatively by Fechner; and if we do not take Fechner's word, we shall not take the word of less experienced observers. It is the question which Ament has in mind at the outset (135); he wishes to know if the *j. n. d.* are on a par with other "unmittelbar als gleich empfundene Unterschiede." (3) If we give this riddle up, we still have the question: Are the *j. n. d.* equal; does 'eben merklich' mean 'psychologisch gleich'? This is the question which Ament actually seeks to answer; 192 ff. In Külpe's account of the investigation (Compte rendu du IVE Congrès de Psychologie, 1901, 160 ff.) the phrase 'merklich gleich' does not occur; though in criticising Fechner's statements Külpe uses the words 'subjectiv gleich.' If we assert that introspection is incompetent to decide question (3), it is (in the author's opinion) best to eliminate question (2) altogether, and to ask simply: Are the *j. n. d.* equally noticeable? and: Are they equal?

² *El.*, i., 176 f. See p. 195 below.

j. n. d., will appear greater than the distance r_1-r_6 ; (2) that the difference decreases, the nearer the compared distances approach to r_5 ,—so that a comparison of r_4-r_5 with r_5-r_6 may even evoke the judgment 'equal;' and (3) that a comparison of r_1-r_2 with r_8-r_9 will evoke a decided judgment of difference, although the two distances are alike j. n. d. See Ament, 193 f.

Are these results to be accepted? This is not the place for detailed criticism: the author must say, somewhat dogmatically, that the investigation has not, in his opinion, proved what Külpe and Ament think it has proved. Concerning the work with brightnesses, it may be pointed out that the *R*-series was discrete, not continuous; that it was very short; and that there are discrepancies in the results from the three *O*'s which Ament does not attempt to explain. If these experiments stood alone, the hostile critic would have an easy task. Concerning the work with noises, which makes a much better impression on the reader, one may at least stress the fact that Külpe and Ament were themselves the sole observers. "Schon bei schwierigeren naturwissenschaftlichen Untersuchungen," writes Ebbinghaus, "wird bekanntlich (unbeschadet der grössten Gewissenhaftigkeit) verwunderlich häufig eben das bestätigt gefunden, was man erwartet hat. Bei psychologischen Dingen ist die Gefahr so gross, dass man fast als Regel aufstellen kann, alle Experimente, die behufs Bestätigung einer eigenen Theorie an dem eigenen Selbst angestellt werden, für verdächtig zu halten" (Psych., i., 88). Ament does not tell us whether the noise experiments were taken up at the conclusion of the experiments with brightness; but even if this is not the case—and it is suggested by the order of presentation—the objection holds that he has left the enquiry unfinished; we must have results from a number of trained *O*'s who are ignorant of the purpose of the work. Moreover, the experimental results offer certain difficulties which are not adequately met by appeal to the corresponding brightness experiments. And finally, we must remember that neither of these sets of experiments stands alone. The value which we place upon Ament's research will depend largely upon our appreciation of previous investigations.¹

¹ Ament's paper contains an unfavourable criticism of Merkel and a favourable review of Angell (139 ff.). Angell's geometrical mean is accounted for by the narrow range of his intensive *R* (179). Ament himself is fully alive to the time error and the error of contrast (166, 184 191), and has availed himself of Angell's introspections in the use of the method of mean gradations (170). But his empirical basis is not solid enough to bear the weight of his conclusions,—still less, that of Külpe's far-reaching deductions: *Compte rendu*, etc., 164 ff. Ament's work is subjected to a severe technical criticism by A. Lehmann,

Ebbinghaus takes similar ground to Stumpf. "Man kann diesen Einwand (*i.e.*, the general objection that 'gleich merklich' does not necessarily mean 'gleich gross') gelten lassen," he says; and he reminds us that the least distances perceived as such in direct and indirect vision, or at different parts of the skin, do not by any means come to consciousness as equal magnitudes. "Trotz aller ungenügenden Begründung aber hat Fechner dennoch sachlich das Richtige getroffen. Obschon es nicht selbstverständlich ist und kaum durch direkte Beobachtung entschieden werden kann, dass ebenmerkliche Verschiedenheiten auch gleiche Empfindungsstufen sind,¹ und obschon sie anderswo, z. B. bei Raumgrössen, nicht als solche betrachtet werden können, hier bei unseren Stärkeverschiedenheiten der Empfindungen muss es notwendig geschehen. Die gegenteilige Annahme würde zu widersinnigen Konsequenzen führen." Ebbinghaus then points out, as Müller and others had done before him, that, in the case of brightness intensities, the results gained by the method of mean gradations are in agreement with those gained by the method of minimal changes. "Die Gleichheit der ebenmerklichen Helligkeitsverschiedenheiten ist also zwar nicht selbst eine unmittelbar zu beobachtende Thatsache, aber eine auf Grund der Uebereinstimmung der beiden Gesetzmässigkeiten kaum zu entgehende Annahme. Ist diese Annahme aber sicher notwendig für Helligkeiten und wahrscheinlich notwendig für Schallstärken, wie soll man sich ihr—wieder² bis zu dem direkten Nachweis ihrer Falschheit—für das Gemeinsame dieser beiden Inhalte, nämlich eben für die Empfindungsstärke überhaupt, entziehen können"?³ Ebbinghaus makes no reference to Ament and Külpe.⁴

What now, of the first part of the general objection: that 'just notice-

Die körperl. Aeusserungen psych. Zustände, ii. (Die psych. Aequivalente d. Bewusstseinserscheinungen), 1901, 105 ff. Lehmann himself maintains, upon experimental evidence, the equality of the *j. n. d.* (12 f., 76 ff., 118). He is answered by Külpe, P. S., xviii., 1902, 328 ff. F. S. Wrinch, *ibid.*, 274 ff., asserts that Külpe's law holds of tone-filled times between the limits 250 and 1200 σ . On Ament's brightness experiments, *cf.* J. Fröbes, Z., xxxvi., 1904, 344 ff.

¹ For this terminology, see § 6 below.

² The *wieder* refers to a similar caution, *supra*, 502.

³ Psych., i., 1902, 501 f. *Cf.* Jodl, Psych., 1896, 226.

⁴ Since the first part of vol. i. appeared in 1897, it may well be that certain sheets of the second part were in print before 1902. There is, however, a reference to the Congress of 1900 on p. 444; and on p. 499 (a page of the sheet that contains our quotation) occurs a reference to a paper of 1901. Hence we may assume that Ebbinghaus, had he been impressed by Ament's work and Külpe's discussion of it, would at least have added these items to the list of titles on p. 495. Ament's article was issued August 7, 1900.

able' does not necessarily mean 'equally noticeable'? It does not require any long discussion. Logically, it is clear, the question: Does 'eben merklich' mean 'gleich merklich'? comes before the question: Does 'eben merklich' mean 'gleich'? Historically, owing to the form of Fechner's exposition, the latter question was raised first; and those who answer it in the affirmative will not hesitate to grant the former also. For those, again, who make 'Merklichkeit' the only possible criterion of intensive *S* and *S*-differences, the two questions become, even logically, one and the same question: things that are 'gleich merklich' are, for psychology, 'gleich.'

All that we have to do, then, is to collect the references. "Wie gross die Merklichkeit ist," says Meinong,¹ "die sich zuerst geltend macht, indem der Unterschiedsschwellenwert eben überschritten wird, darüber ist im Begriffe des 'eben Merklichen' eigentlich noch gar nichts vorgegeben: der Möglichkeit nach könnte die Merklichkeitslinie mit einem hohen wie mit einem niedrigen Merklichkeitsgrade einsetzen, und ob es immer der nämliche Grad ist, darüber kann am Ende nur die Empirie entscheiden." While, that is to say, the 'just' noticeable differences are 'equally' noticeable differences in the sense that they are 'equally just' or 'alike just' noticeable, they need not by any means represent equal degrees of noticeableness: a just noticeable difference might be 'hardly' noticeable in one context and 'easily' noticeable in another. The objection is not organic to Meinong's position, and is not further discussed. Höfler makes the question of 'gleiche Merklichkeit' logically prior to that of 'Gleichheit.'² The assumption that the *j. n. d.* are 'gleiche Verschiedenheiten,' he says, includes the assumption "dass sich unser Merken, d. h. Erkennen (evidentes Beurteilen) der Verschiedenheit, von vorn herein nicht anders gegenüber einer Verschiedenheit zwischen an sich kleineren, als gegenüber einer Verschiedenheit zwischen an sich grösseren Relationsgliedern verhalte. Indem dann das subjektive Moment des Merkens—zwar nicht ganz ausfällt (denn in der That wissen wir ja um Verschiedenheiten eben nur durch das Merken), wohl aber

¹ *Z.*, xi., 1896, 130: *cf.* Ament, *P. S.*, xvi., 135, note. Grotenfelt (*Das Weber'sche Gesetz*, 1888, 9) says: "es scheint einleuchtend zu sein, dass verschiedene so festgestellte ebemerklliche Empfindungsunterschiede auch als gleich merklich bezeichnet werden müssen." *Cf.* Münsterberg, *N. G.*, 58; Jodl, *Psych.*, 223; Dittenberger, *Philos. Monatshefte*, ii., 1896, 77; Wundt, *Das Weber'sche Gesetz*, etc., 1882, 30; *P. S.*, ii., 1885, 25. Köhler (*P. S.*, iii., 1886, 577 f.) clearly distinguishes the two questions of 'gleiche Merklichkeit' and 'Gleichheit.' Under the former head he writes: "es ist schwer, diesen Streit theoretisch zu entscheiden;" fortunately, the results of minimal changes are corroborated by those of mean gradation. Köhler, be it remembered, is speaking in Wundtian terms.

² *Psych.*, 141.

ein für beide Vergleichen constantes Element darstellt, kommt das objektive Moment, nämlich die Gleichheit der beiden Verschiedenheiten rein zum Ausdruck" (232).¹ For the opposite view, see 249 f.

Ament, on the other hand, seems to make the two questions logically co-ordinate.² This is, doubtless, due to the fact that, in his opinion, the *j. n. d.* are not equal magnitudes. For if one has raised the second question first, and has answered it in the negative, the first question comes up at once as a second problem, demanding separate and co-ordinate treatment. Ament confines himself exclusively to the question of equality.³

(3) *Fechner*, as we have seen, regarded *Weber's Law* as a psychophysical law, a law of the functional interdependence of mind and body. He adduces, in the *Elemente*, five distinct, though by no means coördinate arguments for his position: (1) the disparity of *E* and *S*, as contrasted with the homogeneity of *E* and *R*; (2) the parallel law; (3) the validity of *Weber's Law* for tonal pitch; (4) the fact of the limen; and (5) the phenomena of consciousness and unconsciousness, attention and inattention, sleep and waking. The two last are by far the most important and, in *Fechner's* view, are intimately connected.

The arguments of the *Elemente* and of the article *Ueber die Frage des psychophysischen Grundgesetzes mit Rücksicht auf Aubert's Versuche*⁴ (1864) were criticised in detail by G. E. Müller in the *Grundlegung*. The *In Sachen* was reviewed by the same author in the *Göttingische gelehrte Anzeigen* for 1878. Although other writers, before and after Müller, contributed their share to the discussion, it may be said that Müller, a representative of the physiological interpretation of the Law, is mainly responsible for the disappearance of the psychophysical interpretation as a practical issue.

Not that this interpretation had—or has—found adherents! The sole acceptance of *Fechner's* view that is known to the author occurs in *Lipps' Grundtatsachen*, 1883, 76. "Ich weiss," says *Lipps*,—and the whole passage is hardly more than an 'aside,'—"dass der Streit um die Deutung des . . . Gesetzes . . . noch nicht entschieden ist. Ich . . . glaube, der psychophysischen Deutung,

¹ This passage follows immediately upon the sentence quoted above, p. lxxxiv, note.

² P. S., xvi., 135.

³ *Ibid.*, 137.

⁴ Ber. d. kgl. sächs. Ges. d. Wiss., math.-phys. Cl., xvi., 28 Mai 1864, 1 ff.

ich meine derjenigen, die in dem Verhältniss des physischen *R* zum seelischen Vermögen den Grund für den durch das Gesetz bezeichneten Sachverhalt sucht, einstweilen den Vorzug geben zu müssen." Lipps has now withdrawn this opinion. "Das Webersche Gesetz," he writes in 1902, "soweit es ein Gesetz ist, ist ein rein psychologisches Gesetz, nämlich ein Spezialfall des allgemeinen psychologischen Relativitätsgesetzes der psychischen Quantität."¹— G. E. Müller, it is true, looked upon Wundt's Beziehungsgesetz, in the formulation of 1874, as "nicht eine neue Deutung des Weberschen Gesetzes, sondern nur eine Verallgemeinerung der Fechnerschen Auffassung" (G., 375, note). Wundt had written as follows: "Nach seiner psychologischen Bedeutung können wir [das psychophysische Gesetz] ein allgemeines Gesetz der Beziehung nennen. Denn es drückt aus, dass unsere Empfindung kein absolutes, sondern nur ein relatives Mass der äusseren Eindrücke gibt. Reizstärken, Tonhöhen und Lichtqualitäten empfinden wir im allgemeinen nur nach ihrer wechselseitigen Beziehung, nicht nach irgend einer unveränderlich festgestellten Einheit, die mit dem Eindruck oder vor demselben gegeben wäre" (P. P., 421; cf. 315, top). The exposition which concludes with this passage is, without doubt, equivocal;² and Wundt's sympathies were at the time very largely with Fechner. But his later statements leave no question as to its real meaning.

At the risk of repetition, it seems worth while to give in this place the chief arguments urged against Fechner's standpoint.

¹ Sitzungsber. d. philos.-philol. u. d. hist. Cl. d. k. bayer. Akad. d. Wiss., 1902, Heft 1, 46 f. Cf. *ibid.*, 1899, Heft 3, 400. It must be remembered that Lipps' 'psychological interpretation' is couched in terms of his doctrine of 'psychische Vorgänge', and may easily be construed back into a psychophysical interpretation. This Lipps himself admits. "Dies hindert nicht, dass es ein psychophysisches, oder genauer gesagt, psychophysiologisches Gesetz ist für denjenigen, der weiss, dass die psychischen Erregungen oder Vorgänge schlechterdings nichts sind als mechanische, also ganz und gar nach mechanischen Gesetzen begreifliche Gehirnprozesse. Diese Wissenden nun wissen mehr als—man weiss" (1902, 47; cf. 1899, 381).

² Fechner, viewing things through psychophysical spectacles, discusses Wundt's law "wesentlich nur als eine eigenthümliche Modification der physiologischen Ansicht" (R., 264). Cf. Jodl, *Psych.*, 235; Dittenberger, *Philos. Monatshefte*, ii., 1896, 97.

There are three traditional 'interpretations' of Weber's Law.¹ Let us represent the course of events from stimulation to judgment by the following figure :



FIG. 2.

where R denotes stimulus, E excitation, the whole chain of physiological (including psychophysical) processes, S sensation, the mental process corresponding to the excitation in a sensory centre, and C judgment of comparison (*Auffassung und Vergleichung*). We may say, omitting constants, that the physiological interpretation relates the terms as follows :

$$R \parallel E = S = C.$$

The psychophysical view (Fechner's) writes :

$$R = E \parallel S = C.$$

The psychological asserts that :

$$R = E = S \parallel C.$$

It is clear at once that the psychophysical interpretation has a great advantage over the other two : it is precise, definite and unequivocal, whereas the physiological and psychological views are, as formulated, mere classificatory headings, which may cover very different special theories. "The fact of Weber's Law simply asserts a relation between R and reports of the S excited by them, and between these extremes there lies a whole series of mediating processes, all of which, theoretically considered, may cooperate to give the relation its specific character."² Only the psychophysical view is, intrinsically, free from ambiguity : for it declares that the logarithmic relation obtains between the physical as such and the mental as such, and demands nothing further than an understanding of these two terms. Here, then, is an additional reason for disposing of it at this time.

(1) The first of Fechner's arguments was promptly met by the counter argument that "the final stage of the nervous excitation and the sensation, which run strictly parallel to each other, can hardly be anything else than proportional to one another."³ This argument is no less

¹ Cf. Dittenberger, *op. cit.*, 88 f.; Lehmann, *Die körperl. Aeusserungen psych. Zustände*, ii., 1902, 16 ff.

² Külpe, *Outlines*, 163 f. Cf. G. E. Müller, *G.*, 232; Ebbinghaus, *Psych.*, i., 514 ff., 518.

³ E. Mach, *Sitzungsber. d. kais. Akad. d. Wiss. zu Wien, math.-naturw. Cl.*, 2 Abth., lvii., 9 Jan. 1868, 12; Hering, as cited in following note; A. Classen, *Zur Physiol. d. Gesichtssinnes*, 1876, 17; C. Ueberhorst, *Die Entstehung d. Gesichtswahrnehmung*, 1876, 20.

aprioristic than Fechner's; but, as Hering points out,¹ it is one which agrees better than its opposite with Fechner's philosophical interpretation of the relation of mind and body.² Fechner admits, in his rejoinder, that the objection would hold in a case of causal sequence. He denies that it holds in the present case of simultaneous dependency or interdependency, and illustrates this position by instances taken from the natural sciences (length of a pendulum and duration of oscillation, relative length of a curve and its abscissas, etc.).³

In the meantime, Müller had challenged the argument afresh,⁴ reiterating Hering's statement, and adding a further point of his own. If Weber's Law were exact, he says: if it implied, from the physiological standpoint, that E increases exactly as the logarithm of R : then the physiological interpretation might appear less, and the psychophysical more probable. We find, however, as a matter of fact, that the Law holds only approximatively and within certain mean limits.⁵ This fact, that "das Webersche Gesetz nur mit mässiger Approximation gilt," is fundamental.⁶

Fechner is not moved by these arguments.⁷ "What physical principle is there," he asks, "to explain the translation of the *ratio* of the intensity of two physical processes $\frac{R}{R'}$ into a *difference* of the processes $E - E'$ consequent and dependent upon them, so that an n -fold difference $E - E'$ corresponds to an n -fold $\frac{R}{R'}$?"⁸ And again: "when we are considering Weber's Law, the question is whether more weight is to be laid upon the exceptions or upon the rule, so far as the rule is found to hold good. Müller emphasises the exceptions; I emphasise the rule."⁹

¹ Sitzungsber. d. kais. Akad. d. Wiss. zu Wien, math.-naturw. Cl., 3 Abth., lxxii., 1875, 330 f.

² The Identitätsansicht or Zwei-Seiten Ansicht: Zend-Avesta, i., 1851, iii., 410 ff.; ii., 312 ff.; El., i., 5 ff.; ii., 526, 542 f., etc.; R., 1 ff.; K. Lasswitz, G. T. Fechner, 1896, 150 ff.; Wundt, G. T. Fechner, Rede zur Feier seines 100-jährigen Geburtstages, 1901, esp. 42 ff., 83 ff.

³ I. S., 66 ff. Cf. note, p. xxxii. above; R., 227, 256 ff.; G. E. Müller, Götting. gel. Anz., 26 Juni 1878, 819 ff., 830 ff.; 3 Juli 1878, 833 ff.

⁴ G., 233 ff., 366 f.; cf. Jodl, Psych., 232.

⁵ G., 236, 246 f.; Gött. gel. Anz., 1878, 813.

⁶ The argument has been urged by Wundt, *et. g.*, since 1880: P. P., i., 1880, 350 f.; 1887, 376 f.; 1893, 392 f.; 1902, 494, 540. It is now generally accepted: cf. Ebbinghaus, Psych., i., 499; Jodl, Psych., 221; Lehmann, Die körperl. Aeusserungen psych. Zustände, ii., 1902, 66.

⁷ R., v. and *passim*.

⁸ R., 226.

⁹ R., 147 f., 191 f.

Indeed, Fechner's psychophysical system is, as he himself suggests, like a tree, which the winds of criticism must either root more strongly or blow over:¹ in which latter event, we may add, the fallen trunk and scattered branches may be eminently useful for all sorts of purposes, but the tree has ceased to be a tree. Had Fechner given up his argument from *a priori* probability, he would have been forced to revise his whole psychophysical standpoint. To us, who have not to defend this standpoint, the opposing arguments of Hering and Müller must carry conviction. And since, as Ebbinghaus repeats, "die physiologische Auffassung des Weber'schen Gesetzes hätte auch Fechner nach seinem allgemeinen Grundgedanken nahe gelegen,"² we must scrutinise all the more closely his attitude to the fact of the limen,—a fact which is made to help him out of his difficulties, and which may be said to dominate his psychology.³

(2), (3) The next two arguments need not detain us. The parallel law is discussed by Müller, with the result that the question of its validity is indifferent, so far as a choice between the physiological and the psychophysical interpretations is concerned.⁴ Fechner himself confesses, in the light of Müller's critique, that "das Parallelgesetz zwar keinen neuen Gesichtspunct gegen die physiologische Ansicht ins Feld führt; wohl aber kommt ein früher durchschlagend dagegen gefundener [*i. e.*, the aprioristic argument which we have just considered] darin mit zur Geltung."⁵ The parallel law may, then, require examination for its own sake, but does not help us towards an understanding of Weber's

¹ R., v.

² Psych., i., 517.

³ The following points may be further noted. Both Fechner and Müller appeal to the results of current physiological enquiry: I. S., 72 ff.; G., 294 ff.; R., 231 ff. Müller lays stress upon certain psychophysical facts (such as the dependence of the *DL* upon the quality of *R*) which tell, in his opinion, against Fechner's view: G., 246 ff., 334 ff.; *cf.* the reply, R., 248 ff., 142 ff. The position of the G. is not shaken by the arguments of the I. S.: see G., viii., and Müller's review in Göttingische gelehrte Anzeigen, 1878, nos. 26, 801 ff. and 27, 833 ff. On Fechner's position in general, see Grotenfelt, Das Webersche Gesetz, 93 f.; Külpe, Outlines, 164 f., 167; Wundt, P. P., i., 1893, 392 f., 394 ff.; 1902, 540 f., 548; Höfler, Psych., 220 f. Wundt points out that it is impossible "die psychophysische Deutung mit anderen Thatsachen unserer inneren und äusseren Erfahrung in eine innere Verbindung zu bringen." This objection is, however, valid only from the standpoint of the Beziehungsgesetz. Fechner regarded Weber's Law as covering a special class of facts, separate and apart from the facts of physiology and of psychology; but the class was fully wide enough to demand a law its own.

⁴ G., 266 ff.; Götting. gel. Anz., 1878, 824; *cf.* Wundt, P. P., i., 1893, 392; 1902, 540; Dittenberger, Philos. Monatshefte, ii., 1896, 89 f.

⁵ R., 240 ff.

Law.¹ The argument from the musical scale is, as we shall see later, erroneous.²

(4), (5) Fechner regards it as an especial argument in favour of the psychophysical interpretation that his metric formula or logarithmic formula is adequate both to Weber's Law and to the fact or law of the limen. "Aus dem reinen Weberschen Gesetz," he says, "liesse sich überhaupt gar kein endliches Mass für endliche Empfindungen gewinnen, ohne dass man das Schwellenprincip zuzieht."³ The mathematical derivation of the metric formula "würde illusorisch werden, wenn die Thatsache der Schwelle nicht bestände, welche daher mit dem Weberschen Gesetze zusammen erst die zulängliche Unterlage . . . des absoluten Empfindungsmasses bildet."⁴

The RL and the DL in the Elemente.—If we are to appreciate the strength or weakness of this argument, we must know first of all just what Fechner has said about the two limens in the *Elemente*. We come upon the *RL* and *DL* as bare facts, which are rather surprising than otherwise: we should 'naturally' think that the point at which an *S* or *S*-difference begins to be noticeable would coincide with the zero point of the corresponding *R* or *R*-difference.⁵ "In der Thatsache der Schwelle liegt von vorn herein etwas Paradoxes."⁶ However, we are led to the concept of the limen not only by our dealings with *R* and *S*, intensive and extensive, but also by a consideration of the higher and more general conscious states and processes: sleep and waking, attention, thought, etc. This universality of the limen suggests its transference from outer to inner psychophysics.⁷ Both the *RL* and the *DL* have, in spite of their seeming strangeness, a high teleological importance, as securing freedom from interruption and an uniform state of perception.⁸ So much on general grounds. Fechner then proceeds to give the numerical determination of the limens, and the laws of their interdependence, in the various sense departments.⁹ He brings the 'homogeneous' *RL* and *DL* of customary psychophysical discussion under the more general heading of the 'mixture limen' (*ML*), a notion that is destined to play a large part in his system. "Suppose that a stimulus *B* is added to a stimulus or stimulus mixture *A*, and that one seeks to determine the value of *B* at which the increment begins to be

¹ R., 143, 180 f.; Stumpf, *Tps.*, i., 85; J. Ward, *Mind*, O. S., i., 1876, 455 ff.; J. von Kries, *Die Gesichtsempfindungen u. ihre Analyse*, 1882, 109.—On the value of the parallel law as a bridge between outer and inner psychophysics, see Wundt, *G. T. Fechner*, 1901, 47.

² See below, pp. 232 ff.

³ I. S., 88.

⁴ *El.*, ii., 34, 431; *cf.* i., 238 f.; *Berichte*, etc., 1864, 11; I. S., 7 f., 23, 70 f., 87 f., 88, 211.

⁵ *El.*, i., 238.

⁶ *Ibid.*, 246.

⁷ *Ibid.*, 239, 248 f., 251.

⁸ *Ibid.*, 249 ff.

⁹ *Ibid.*, 254 ff.

noticeable as such, or to allow a difference to be felt from the mere effect of *A*. Of all the possible magnitudes that *A* may possess, one may imagine the case in which it is = 0: then we have the instance of the ordinary homogeneous *RL*. Similarly, of all the possible qualities that *A* may evince, one may imagine the case in which it is of the same quality with *B*: then we have the instance of the ordinary homogeneous *DL*.¹ No investigation of the laws of the *ML* proper has as yet been made.²

The *RL* now takes its place in the metric formula;³ the *DL* is included in the Unterschiedsmassformel.⁴ In the important chapter in which he distinguishes sensation differences from sensed differences or contrast sensations, Fechner remarks that the determination of the *DL* implies "einen höheren Bewusstseinsact" than that of the *RL*, though both the higher and the lower are accessible to measurement and comprehensible under a single principle.⁵ Finally, he transfers the limen, along with Weber's Law, from outer to inner psychophysics, where he makes very extended use of it;⁶ and he insists that the physiological interpretation of the *RL* — to the possibility of which he is by no means blind⁷ — is ruled out of court by the parallel fact of the *DL*. "Diese [physiologische] Deutung wird schon dadurch unhaltbar, dass sie nicht auf die Unterschiedsschwelle übertragbar ist, und unstreitig muss dasselbe Erklärungsprincip für beide Schwellen ausreichen."⁸

Such, in brief outline, is the teaching of the *Elemente* as regards the limens.

Müller's Attack upon the RL.—Müller begins his criticism, very pertinently, by raising the previous question. "Dass das Gesetz der einfachen Reiz- oder Empfindungsschwelle . . . für die äussere Psychophysik besteht," writes Fechner, "dafür liegen offenkundige Thatsachen vor."⁹ "Untersuchen wir zunächst," retorts Müller, "ob denn wirklich die sogenannte Thatsache der Reizschwelle als eine in Wahrheit constatirte Thatsache zu betrachten sei."¹⁰ The upshot of his investigation is "dass die Frage nach der Existenz der Reizschwelle eine ziemlich heikle ist."¹¹ This conclusion stands to-day as it stood in 1878. Thus Ebbinghaus, writing in 1902, may be said simply to summarise Müller. "In almost all sense departments," he tells us, "we are constantly receiving, at least during the waking state, weak sensations from what are called

¹ El., i., 331 f.² *Ibid.*, 334 f.³ El., ii., 13, etc.⁴ *Ibid.*, 96 ff.⁵ *Ibid.*, 85 f.; cf. I. S., 84, 99.⁶ El., ii., 428 ff., 437 ff.⁷ *Ibid.*, 431; I. S., 82 ff.; cf. *Berichte*, etc., 1864, 12, 15.⁸ El., ii., 431; I. S., 83 f.⁹ I. S., 82.¹⁰ G., 237. The reader does not need to be reminded that Müller is, in strictness, replying to the El. and not to the I. S.: see G., vii. f.¹¹ G., 239.

internal stimuli (noises of heartbeat and respiration, touch stimuli from clothing, weight of our limbs, idioretinal light). Hence we are dealing in every case simply with small increments of stimuli already present and already in some way operative, only that these stimuli come in the one instance merely from the organism itself, while in the other they come both from the organism and from its external surroundings."¹ If, then, we push the matter to its logical conclusion, we are bound to look upon all limens as *DL*; the separation of the *RL* from the *DL* may be convenient in practice, but will be wrong in theory. Elsewhere, Ebbinghaus draws this conclusion: "es existiert im Grunde nur ein einziges Phänomen, nämlich das der Unterschiedsschwelle, welches sich bei allen möglichen Werten der objektiven Reize in gleicher Weise geltend macht."² The question has been much discussed, and is not easy to settle. We shall review the evidence later.³ In any event, enough has been said to show that the *RL* is precarious ground from which to argue for the psychophysical and against the physiological interpretation of Weber's Law.⁴

Müller on the Relation of the RL to the DL.—We might expect, therefore, that Müller would urge the 'shakiness' of the *RL* as an argument against the metric formula, which presupposes the fact of the limen as well as Weber's Law. This, indeed, he does, when he is working out his own psychophysical formulæ.⁵ At present, he prefers to argue that, "auch wenn die Reizschwelle zu den bestconstatirten Thatsachen der Sinneswahrnehmung gehörte," it would still yield no evidence in favour of the psychophysical interpretation. And, in fact, he has not the least difficulty in showing that the physiological view is adequate, and adequate in more ways than one, to the fact of the limen.⁶ He argues, further, against the bracketing together of the *DL* with the *RL*. "Man sollte meinen, die totale Verschiedenheit der beiden in Rede stehenden Schwellen wäre einleuchtend."⁷ For (*a*) the perception of *S*-differences is, on Fechner's own admission, a conscious act of a higher order than the simple sensing of different *R*; (*b*) the *DL* has to do with the difference of two *S*-intensities, the *RL* not with differences of *S* or of *R*, but with total values of *R*; and (*c*) the *DL* is dependent upon such conditions as lapse of time, of which the *RL* is wholly independent.⁸ We must

¹ Psych., i., 490.² Z., i., 472.³ Pp. cxvii. ff., etc.; cf. in the meantime El., i., 240, 255; I. S., 103 f.; H. Aubert, *Physiol. d. Netzhaut*, 1865, 42 f.; W. Preyer, *Grenzen d. Tonwahrnehmung*, 1876, 65 ff.; Delbœuf, *Éléments*, 34 ff., 166 ff.; Stumpf, *Tps.*, i., 379 ff., esp. 382; Jodl, *Psych.*, 171 ff., 205 ff., 227; O. Funke, in *Hermann's Hdbch. d. Physiol.*, iii., 2, 1880, 327.⁴ G., 239.⁵ G., 227 ff.⁶ G., 239 ff.; Funke, *loc. cit.*⁷ G., 244.⁸ G., 243 ff.

bear in mind that, while Müller is arguing seriously, he is also arguing hypothetically. If there is an *RL* in Fechner's sense, a simple sensing of a least sensation, then this *RL* is something radically different from the *DL*. More than this the argument does not say.

The Limens in the I. S.—We return to Fechner's exposition in the I. S. Here Fechner emphasises the vital importance of an inner limen for inner psychophysics, and discusses certain physiological investigations that seem to bear upon the point.¹ He then declares the physiological explanation of the *RL* to be inadequate, if only for the reason that it is inadequate to the related *DL*.² Two physiological interpretations of the *DL* are proposed, and found wanting.³ Quite apart from the *DL*, however, there are facts of attention that lead directly to the assumption of an inner *RL*.⁴ Fechner next passes on to deal with the *RL* in the light of his negative sensation values,⁵ and finally comes to the *ML*. The *R* and *E* that lie below the *ML* modify consciousness, at the expense (so to say) of their own individuality: "sie gehen unbewusst in einem allgemeinen Bewusstseinsphänomen auf."⁶ "Durch die Thatsache der Mischungsschwelle wird der Schwellenbegriff überhaupt . . . nicht aufgehoben, sondern nur verallgemeinert."⁷ Here is, perhaps, an improvement in detail, but so systematic advance upon the Elements.⁸

The DL in Müller's Review.—Müller's review of the I. S. is concerned with three principal points: the metric methods and the range of validity of Weber's Law; the derivation of the metric formula from Weber's Law; and the interpretation of the metric formula. To Fechner's argument that what holds of the *DL* must also hold of the *RL*, Müller replies as follows. (1) A physiological explanation of the *RL*, implying a proportionality of *S* and *E*, implies absolutely nothing as regards the noticeableness of *S*-differences. In the former case we are talking of the dependence of *S* upon psychophysical activity; in the latter, of the relation of the difference sensation to the *S*-difference. Where is the connection?⁹ (2) If, however, Fechner's argument contains a challenge to the physiological interpretation: 'you must offer some sort of psychophysical representation of the difference sensation,—and then you must make the *S* proportional to the *E*,—and then you run

¹ I. S., 70 ff. Cf. G. E. Müller, Gött. gel. Anz., 1878, 819 ff.

² *Ibid.*, 83 ff.

³ *Ibid.*, 84. An explanation in terms of the *ML* is dismissed, 106.

⁴ *Ibid.*, 85 ff.

⁵ *Ibid.*, 88 ff.

⁶ *Ibid.*, 105 f.; R., 258.

⁷ *Ibid.*, 106. Fechner has forgotten the corresponding passage in *El.*, i., 331; cf. R., 179.

⁸ Pp. 102 f., 104 f. mark, in Fechner's opinion, an advance in clearness of exposition.

⁹ Göttingische gel. Anzeigen, 26 Juni 1878, 826.

against the *DL* : ' we may rejoin that there is, of course, a material substrate of the difference sensation, and that it may best be regarded as akin to that of the difference tone (*cf.* the thermo-electric current in the thermopile). This ' differential process ' will be stronger, the nearer together the primary *R* stand in time ; it will increase with increase of the difference of the two underlying nervous excitations ; but it need not be set up by any and every difference between them. The physiological interpretation is thus fully adequate to the fact of the *DL*.¹ It is true that the adequacy is hypothetical ; but we really know nothing of the psychophysical representation of the *DL*, and must therefore fall back on hypothesis. For this very reason, however, Fechner should not appeal to the *DL* in support of a particular interpretation of Weber's Law. He himself "denkt sich dieselbe als unmittelbar abhängig von dem Logarithmus des (durch die Verhältnisschwelle dividirten) Verhältnisses der beiden Nervenenerregungen : was allerdings eine etwas eigenthümliche Art von psychophysischer Repräsentation eines psychischen Actes ist." ²

The Limens in the R., and Fechner's Reply to Müller.—Fechner, as the reader will have foreseen, holds fast by his own opinions. "Gegen die Thatsache der Unterschiedschwelle," he says, "lässt sich nicht streiten ; aber man kann versuchen, die Reizschwelle durch Rückführung auf die Unterschiedschwelle zu eliminiren. Inzwischen sind die dafür geltend gemachten Erfahrungen durchaus unbeweisend."³ He reviews the sense departments, and argues that, at least in many cases (sound, taste, smell), the organic excitations may be present without arousing sensation. It would be wrong to maintain, in the spirit of the Differenzansicht, that "einfache Empfindungen überhaupt nicht für sich, sondern nur in sofern sie von anderen unterschieden werden, also als Componenten von Unterschiedsempfindungen, bestandfähig sind."⁴ After as before, then, the fact of the limen may play its part in the metric formula.⁵ As regards the physiological interpretation of the *RL*, he writes : "ein schwacher Reiz kann für die Empfindung erstens dadurch verloren gehen, dass er, wegen Erschöpfung durch die äusseren Medien, schon gar nicht bis zum Empfindungsnerven gelangt, zweitens dadurch, dass er wegen Erschöpfung im Nerven selbst nicht bis zum Sensorium gelangt, drittens aber endlich dadurch, dass er, zum Sensorium gelangt, unter der inneren psychophysischen Schwelle bleibt."⁶ That is to say : the existence of an *RL* may be due, in certain cases, to the intervention of

¹ Göttingische gel. Anzeigen, 26 Juni 1878, 827. *Cf.* Stumpf, *Tps.*, i., 104 ; Funke, *Hermann's Hdbch.*, iii., 2, 1880, 346 ff., 349, 359.

² *Ibid.*, 828 f.

³ *R.*, 178 f.

⁴ *Ibid.*, 197.

⁵ *Ibid.*, 183 f., 189, 194, 196 (*cf.* G., 228, note), 204 f., 223.

⁶ *Ibid.*, 235 ff., esp. 240.

physical or physiological obstruction, but there is no evidence that it is always due to such causes. On the contrary, the proof offered is quite inadequate; so that the inner limen, whose existence is vouched for on other grounds (results of physiological enquiry, facts of attention), is at least not imperilled by the physiological arguments. As regards the bracketing of the two limens, Fechner says: "wenn das Princip der inneren Schwelle für Unterschiedsempfindungen besteht, so ist kein Grund, es für einfache Empfindungen abzulehnen. . . . Eine Ansicht, welche das Verschwinden der höheren Unterschiedsempfindung mit dem Verschwinden der niederen einfachen Empfindung unter einen gemeinsamen psychophysischen Gesichtspunct zu fassen vermag, ist in erheblichem Vortheil vor einer gegentheiligen, welche es nicht vermag."¹

Here is a direct rebuttal of Müller's objections. Has Fechner, in the *R.*, worked out his position in greater detail, or with more special reference to the nature of the limen? Let us see.

The *R.* avowedly confines itself to a "Zurückrufung der verschiedenen Modificationen, unter welchen das Schwellengesetz auftritt," and to "Zusatzbemerkungen zu den frühern Betrachtungen."² First comes the review of the senses, in the interest of the *RL*, to which we have already referred. This is followed by an important paragraph on the *ML*. Given a complication of psychophysical conditions, *a, b, c, d, . . .*, and the liminal value of *c* (the value correlated with a qualitative and quantitative discriminability of the mental process γ) will be not absolute but variable, changing with change of the concomitant conditions *a, b, d, . . .*³ Later, we are told that the fundamental psychophysical formulæ take account of the *RL* and the *DL*, but not explicitly of the *ML*. In strictness, the *DL* of the waking state should be translated into a corresponding *ML*, though the more the invading *R* exceed in intensity the preexistent *E*-mixture the more nearly does the pure Unterschiedsmassformel approach to validity. And there has been no need, in practice, to recognise the *DL* as an *ML*.⁴ In the same way, the principle of the *RL* is complicated by the principle of the *ML*, though we can by no means do away with the *RL*. Theoretically or formally, it is a special case of the more general *ML*.⁵

It is clear that Fechner is coming to think more and more of the *ML*. The *RL* and the *DL* appear to be, both alike, limiting cases of the *ML*.

¹ *R.*, 251 ff., esp. 254. Of Müller's 'differential process' Fechner remarks (1) that the analogies of the difference tone and the thermo-electric current are not illuminating; and (2) that any process to which the difference sensation is proportional must = 0 when the sensation = 0: there is no room for a *DL*: 253.

² *R.*, 177.

³ *Ibid.*, 179 f.; *P. S.*, iv., 207.

⁴ *Ibid.*, 192 f.

⁵ *Ibid.*, 193.

The case of the *DL* is simple enough : but would Fechner admit an *RL* in the event of a psychophysically empty sensorium ? Assuredly. Here is an argument which he alleges as a "definitive Erledigung der Frage" of the inner *RL*. "Mathematisch tiefer gehend, hat sich die innere Empfindungsschwelle zur Sicherstellung ihres Daseins gar nicht erst auf die Unterschiedsschwelle zu berufen ; sondern folgt mathematisch daraus, dass zuvörderst eine Reizschwelle, ohne empirisch constatirt zu sein, mathematisch nothwendig aus dem Weberschen Gesetz folgt, und zwar nicht bloss aus dem reinen, sondern selbst aus dem mit seinen Abweichungen nach Müllers Weise zusammengefassten."¹ The argument is none the less characteristic that Müller himself had indicated the reply to be made to it.² But how is the *RL* an *ML* ? The formal reduction is worth very little.

Hering and Müller, be it remembered, had challenged Fechner to show the compatibility of the *RL* with his own system. Fechner now declares that "das Hervortreten des menschlichen Bewusstseins aus dem Allgemeinbewusstsein als einer davon unterscheidbaren Besonderheit eben so an einer hinreichenden Erhebung des ihm unterliegenden psychophysischen Processes über den allgemeinen Process hängt, als das unterscheidbare Hervortreten einer Sonderbestimmung unseres Bewusstseins an einer entsprechenden Bedingung nach dem Princip der Mischungsschwelle hängt."³ Here we have the answer to our question. The *RL* corresponds to the first humanly conscious process differentiated from the processes (of the same or of different kinds) current in the general consciousness. As these processes never sink to the value 0, the *RL* must always be an *ML*,—but an *ML* of what we may call the first order. Since the 'mixture' of the *ML* refers only to the processes of the general consciousness, and the *A* of the Elemente is still = 0, the *RL* may also be considered, as before, a limiting case of the *ML* of the second order, of the human *ML*. The reduction is real as regards the *ML* of the first, formal as regards that of the second order. The argument, then, is straightforward enough : but, of course, the previous question remains,—the question why the differentiation from the general consciousness should involve a limen at all.

The Wider View.—Our last quotation suggests, however, that we may have been unfair to Fechner. May not the final explanation, of which we are in search, be found in his connected treatment of attention, of sleep and waking, of consciousness and unconsciousness ? For he declares in the *El.* that "die Verhältnisse zwischen bewusstem und unbewusstem Vorstellungsleben, Schlaf und Wachen, allgemeinen und

¹ *R.*, 254 ; *cf.* 204, 224, and 262, note.

² *G.*, 373 f. ; *cf.* *R.*, 205 f.

³ *R.*, 256 ff.

besonderen Bewusstseinsphänomenen, kurz die allgemeinsten Verhältnisse des Seelenlebens eine sehr einfache und befriedigende psychophysische Repräsentation auf Grund der Voraussetzung, dass der Schwellenbegriff auf die psychophysische Bewegung übertragbar sei, zulassen. . . Nach all' dem halte ich es nicht für eine unsichere Hypothese, sondern für eine Foderung der ganzen thatsächlichen Sachlage, auf welcher wir zu fussen haben, dass vielmehr die Empfindung von der psychophysischen Thätigkeit, als diese vom Reize im Sinne der Fundamentalformel und Massformel abhängt."¹ These are words of assurance, and it behoves us to consider the evidence upon which the assurance rests.

Fechner appeals, in the first place, to certain facts of attention and inattention. We may become aware, in an after-image, of an object which, as presented, did not come to consciousness; we may not hear a question addressed to us, at the time it is asked, but may recall it to mind when we come out of our brown study; the surgeon may see the blood flow before he has pierced the skin.² All this means that "the psychophysical activity, released and represented by the stimulus, must exceed a certain degree of intensity, if it is to become conscious";³ "es geht etwas in uns fort, die psychophysische Thätigkeit, deren Function sie [Empfindungen, Vorstellungen] sind, und woran die Möglichkeit des Wiederhervortrittes der Empfindung hängt, nach Massgabe als die Oscillation des Lebens oder besondere innere oder äussere Anlässe die Bewegung wieder über die Schwelle heben."⁴ Any nervous organ or structure may be the seat of psychophysical activity; and this activity, provided the excitation attain a certain intensity, must give rise to sensation. Fechner will hear nothing of a special part of the nervous system, a cortex, or sensorium in Müller's sense, to which the excitation must first be transmitted, "Wir können . . . den engeren Seelensitz als den Leibestheil bezeichnen, worin die psychophysischen Thätigkeiten die Schwelle zu übersteigen vermögen."⁵ "Zu jeder Zeit wird es eine Stelle im Nervensysteme, . . . respectiv Gehirn, geben, wo die psychophysische Thätigkeit am stärksten ist, und hier kann man den jeweiligen . . . Seelensitz im engsten Sinne suchen. Von diesem Punkte aus werden die Bewegungen mit abnehmender Stärke durch den ganzen Tract nervöser Fasern im Gehirne, Rückenmarke, Nerven gehen, der damit in Verbindung steht, und in soweit sie über einen gewissen Grad der Stärke, die Schwelle reichen, auch beitragen, das Bewusstsein über die Schwelle zu heben . . . Ob nun Rückenmark und Nerv auch nach Abtrennung vom Gehirne noch psychische Functionen vermitteln können, wird darauf ankommen, ob sie nachher noch psychophysische Bewegungen

¹ El. ii., 435.² *Ibid.*, 432 f. Cf. Wundt, P. P., iii., 1903, 64.³ *Ibid.*, 438.⁴ *Ibid.*, 439.⁵ *Ibid.*, 391.

von hinreichender Stärke, um die Schwelle zu übersteigen, erzeugen können."¹

Is not the circle amazing? Let us quote Müller. "Fechner's theory of the seat of mind is tenable only if Fechner's psychophysical law is tenable; for only on the basis of this law can the theory account for the cases in which excitation is present somewhere in our nervous system, without coming to consciousness in a mental state. On the other hand, his assertion that various facts of the sensory attention, etc., furnish the psychophysical foundation of the *RL*, and so of Weber's Law, rests upon the assumption that his theory of the seat of mind is correct, *i.e.*, that the nature and locality of the nervous organs in which an excitation is set up are entirely irrelevant for the question, whether the nervous excitation shall or shall not give rise to conscious sensation; for only on this assumption can one argue unconditionally, from the cases where nervous excitation is present without a corresponding conscious sensation, that the bodily activities which immediately underlie sensation must exceed a certain liminal value, if they are to arouse conscious sensation at all . . . And yet Fechner thinks himself justified, on the ground that certain facts of the sensory attention appear—if we assume the correctness of a theory of the seat of mind which itself depends upon the correctness of Fechner's psychophysical law—to furnish the psychophysical foundation of the *RL* and of Weber's Law, in making the statement that his psychophysical interpretation of the metric formula is 'not an insecure hypothesis, but a requirement of the whole body of empirical facts upon which psychophysics must be based'!"²

Circularity could hardly go farther. In face of it, we need not follow Fechner through the chapters on sleep and waking, on partial sleep and attention, and on the relation between the general consciousness and its particular phenomena; it is enough to refer again to Müller's criticism.⁴ This is not to say that the chapters in question are not worth reading: on the contrary, they, together with the chapter on the measure of bodily activity which they presuppose,⁵ form one of the most interesting and instructive parts of the *Elemente*.⁶ The circle in Fechner's thinking is far removed from any logical inaccuracy of the vulgar sort. It is rather due—if we may use a favourite word of Fechner's own—to the 'solidarity' of his system, to the organic interdependency of all its parts, to

¹ *El.*, ii., 427.

² *G.*, 350 f.

³ *El.*, ii., 439 ff., 449 ff., 452 ff.; *cf.* 519 ff., 526 ff.

⁴ *G.*, 352 ff.

⁵ *El.*, i., 21 ff.

⁶ Lasswitz refers to the chapters on Energy and on the Seat of Mind as "Beispiele für die meisterhafte Klarheit und Durchsichtigkeit, mit welcher Fechner schwierige Fragen zu behandeln verstand:" *G. T. Fechner*, 82.

the fact that it is a 'tree' and not a bundle of sticks. "Reasoning at every step he treads, Man yet mistakes the way:" the lines might have been written of Fechner.

But did Fechner acknowledge the circle, when it was pointed out? Naturally not. The R. is concerned only to meet Müller's objections, to offer in its turn objections to Müller's positive views, and to repeat, in fuller and more precise form, the exposition of the *Elemente*.¹ The solidity of his system blinds Fechner here, as it blinded him before. Let us take a single instance. Müller had remarked that, on Fechner's theory of the seat of mind, a ganglion which regulates, say, the peristaltic movements of the intestine would, if the excitation transcended a certain liminal value, form part of the "engeren Seelensitz" just as truly as a region of the pons or of the cortex. Fechner replies, a little indignantly, that he has already stated "dass Reize, die durch den weiteren Seelensitz (d. h. den Körper ausser den engeren) verlaufen, nicht eher Empfindung, Bewusstsein erwecken, als bis sie zum engeren Seelensitz gelangt sind."² This is quite true; but it does not meet Müller's objection. For what is the "engere Seelensitz?" Fechner, however, continues. "Mag in einem Darmganglion die psychophysische Erregung über der Schwelle sein, so bleibt sie uns unbewusst, so lange nicht der ganze Tract von Erregungen, der sie mit dem Gehirn verbindet, mit über der Schwelle ist:" and Müller ought to have known this, since it is to be found in the chapter on Psychophysische Continuität und Discontinuität.³ But we find in that chapter that a principal wave (individual consciousness), which runs its course continuously above the principal limen, may carry surface waves, which are discontinuous above and continuous only below their own limen. The discontinuity means simply that the corresponding mental processes are discriminable within one and the same individual consciousness.⁴ How, then, is Müller answered? Indeed, the reader who, checked by Fechner's reproachful words, returns to the inner psychophysics of the *Elemente* with the idea that Müller has done the psychophysical theory injustice, will lay the book down with the renewed conviction that Müller is right. The fact seems to be that Fechner, in 1882, is inclining to draw the limits of the "engeren Seelensitz" more narrowly than he had done in 1860,—while he steadily refuses to admit any change in his general attitude to the question.

The Limens in the Massprincipien.—It remains now to consider the treatment of the two limens in the essay of 1887, *Ueber die psychischen*

¹ See 242 ff., 269 ff., 284 ff.; cf. 218, 266 ff. The I. S. has little to say on these matters: see 26 f., 70 f., 85 ff., 97 f., 218 f.

² R., 243, note; El., ii., 391.

³ El., ii., 526 ff.

⁴ *Ibid.*, 540.

Massprincipien und das Webersche Gesetz.¹ We have already sketched the course of the argument, and shown how Fechner advances from the measurement of difference sensations to that of sensation differences, and from the measurement of sensation differences to that of sensations.² We begin at once, therefore, with the *DL*.

The *DL*, says Fechner, "bedeutet unstreitig" a Schätzungsfehler, an error of estimation. When the *R* upon which *S* of different magnitude depend, and consequently these *S* themselves, do not coincide in time and (or) space, the estimation of their difference is attended by a constant error. The non-coincidence in time and space affects both the direction and the magnitude of the error of estimation. The error of direction can be eliminated, if we take the mean result of series in which temporal and spatial positions have been reversed. The error of magnitude (so to say) cannot be eliminated. If intensive *S* are to be compared at all, they must be compared under conditions of temporal or spatial difference: otherwise, they run together. The existence of the *DL* is accordingly due to the "nicht beseitigbare zeitlich-räumliche Nichtcoincidenz der Reize, mithin psychophysischen Erregungen." The theory is supported by the following arguments.

(a) The fact of constant errors of time and space is universally admitted; the present theory sets these errors in their true light. For, after elimination of errors of direction, it still remains "beiderlei Lagen gemein, dass eine Nichtcoincidenz überhaupt besteht; und hieran hängt auch etwas gemeinsames, dass nämlich eine Abweichung von der wahren Grösse des Unterschiedes stattfindet, worunter die Thatsache der Unterschiedsschwelle nur als Grenzfall begriffen ist." (b) As a matter of experience, the magnitude of the *DL* depends essentially upon the temporal and spatial relations of *R*, increasing (other things equal) with the temporal and spatial difference of *R*. (c) The theory is directly confirmed by the results of experiments upon extensive *S*. Take two rods, the one of 100, the other of 101 space units. Lay them in the same straight line, so that the one forms the extension of the other. You will not be able—such, at least, is the general rule—to tell them apart. Now lay the one over the other: the difference becomes noticeable. The result may be transferred at once to the sphere of intensive *S*, where experiments of the kind are not possible. It may, perhaps, be objected

¹ P. S., iv., 161 ff. The first part of Fechner's essay is, as we have noted, taken up with a criticism of Elsas' Ueber die Psychophysik, 1886. Elsas replies to Fechner in the Philos. Monatshefte, xxiv., 1888, 129 ff. In both works, Elsas strenuously maintains the physiological, or rather the physical character of the *RZ* and the *DL*. See Ue. d. Ps., 41 ff.; Ph. Mh., 145 f., 151 ff.

² See pp. xxxv. ff., above.

that, when we compare the two rods, we are merely uncertain as to which of them is the longer, whereas, when we compare intensive *S*, we pass a positive judgment of equality. But this is not true. There is the same uncertainty of Gleichschätzung in the mental sphere as there is of Gleichheitsbestimmung in the physical.¹

What now of the relation of the two limens? The *DL* is indisputably an inner limen; the two *S* lie before us, for discrimination; and if the *S* are present, their psychophysical conditions must be realised. The same explanation cannot hold for the *RL*, where only one *S* is involved. "Allein es wird sich zeigen lassen, dass, wenn es auch Fälle geben kann, wo der Reiz sich wirklich nicht bis zum Sensorium fortpflanzt (physiological explanation), doch auch in dem Falle, wo er sich bis dahin fortpflanzt, aus einem *anderen* Grunde als dem der zeitlich-räumlichen Nichtcoincidenz eine gewisse Grösse der, durch den Reiz erweckten, ps. ph. Erregung, kurz innere oder ps. ph. Schwelle überstiegen werden muss, un die zugehörige Empfindung bemerklich werden zu lassen."²

The explanation is, in principle, familiar to us from the *R*. When an *R* reaches the sensorium, it finds some sort of psychophysical excitation already in progress. We have therefore to distinguish the pre-existent *E*, the invading *E*, and the concomitant *E*,—the persistence of the first under the action of the second. The pre-existent *E* is a highly complex affair, a resultant of the current train of ideas, of some form of common feeling, of the action of foreign stimuli. If, now, the invading *E* falls below a certain degree of intensity, it "geht unbewusst in dem vorgängigen resp. mitgehenden Bewusstseinszustande auf." The pre-existent consciousness is intensified, or qualitatively modified, but the new *E* is not separately remarked. A band may not be heard amid the clamor of an excited crowd, although the instruments add considerably to the total noise. We may not notice the lighting of a concert hall; nevertheless, our hearing of the music is "etwas modificirt" by the degree of illumination. In this sense, then, *there is no inner limen*: every psychophysical excitation, great or small, serves to enhance the activity of consciousness. Contrariwise, if the *S* that corresponds to the invading *E* is to be "besonders auffassbar," the *E* must transcend a certain liminal intensity. If the band is to be heard, it must play with a certain loudness; the air is then "eine ihrer Qualität nach unterscheidbar gewordene psychische Erregung," although the concomitant *E* (the noise of the mob) may still give the tones a rough and harsh character. In this sense *there is an inner limen*, an *ML*, the passage of which determines the separate effectiveness of the invading *E* for consciousness. As the *S* of Weber's Law and the psychophysical formulæ are always and everywhere "die

¹ P. S., iv., 188 ff.

² *Ibid.*, 202 f.

besonders auffassbaren Empfindungen," the recognition of this inner limen is inevitable.¹

But, if the "Mischungsschwelle an die Stelle der Reizschwelle tritt," the *RL* is a *DL*! Yes: not a *DL* proper, but a *DML*, an Unterschiedsmischungsschwelle.² Different principles are involved in the two cases. The principle of the limen in the *DL* is the temporal or spatial disparity of the two *R* compared. The principle of the limen in the *RL* or *DML* is the necessary competition of the invading *E* with pre-existent *E*. This latter principle holds even in cases where there is no foregoing consciousness: when a child is born, *e.g.*, or when one wakes out of a dreamless sleep. For "soll sich das Bewusstsein des Menschen als Sonderbewusstsein aus dem nie schlafenden Bewusstsein des allgemeinen Geistes, der an das allgemeine [psychophysische] System geknüpft ist, herausheben, so muss die ps. ph. Erregung des Menschen ein gewisses Verhältniss zur ps. ph. Erregung des allgemeinen Systems, worein er eingetaucht ist, übersteigen, welches unter das Princip der Mischungsschwelle tritt."³

And yet the fact of the *RL* is "der Thatsache der Unterschiedsschwelle analog!"⁴ It is surely true, on the contrary, that the two limens are divorced as widely as Müller himself could desire. The determination of a *DL* may be complicated by all manner of pre-existent *E*,—trains of ideas and common feeling and foreign stimuli: yet, in principle, the error of estimation of the *D* depends simply and solely upon the temporal and spatial disparity of the *R*. That is one thing. Every invading *E* has to fight for its separate existence with the rest of consciousness or with the general consciousness, and loses strength in the struggle. That is another thing. The *DL* is pure Fechner.⁵ The *RL* or *DML* is—is it not?—pure Herbart. Remember that it was Herbart who introduced the notion of the limen into psychology.

Summary. (1) *The Limens.*—Here, as so often, Fechner seems to have caught a glimpse of the right path, while he followed the wrong. He felt, from the first, that the two limens should go together; and the feeling persisted to the end. Yet he brackets them in the *El.* in order to prove what cannot be proved, the existence of an inner *RL*,⁶ while he treats them separately, the one in the *Massformel*, the other in the *Unterschiedsmassformel*. When he finds another way of deriving an inner *RL*, he lets the *DL* take its own course, making no more effort to keep it in touch with the *RL* than is expressed in the single word

¹ P. S., iv., 203 ff.; R., 179 f.

² P. S., iv., 207. One might also say, of course, a *QML*, a quotient mixture limen.

³ P. S., iv., 211 f.

⁴ *Ibid.*, 196.

⁵ *Ibid.*, 190.

⁶ Stumpf, *Tps.*, i., 387 f.

'analogous.' On the basis of the *Elemente*, Müller was justified in saying that Fechner had confused things that were totally different. On the basis of the same *Elemente*—and still more on the basis of the subsequent treatises—Ebbinghaus is equally justified in asking: "wie kann man nur, wenn man die Dinge ohne Hintergedanken betrachtet, ganz und gar Zusammengehöriges so auseinanderreißen?"¹ We can say but little for a theory that exposes itself to such contradictory objections.

(2) *The Psychophysical System*.—"When Fechner maintains," says Müller in his recapitulation, "that certain phenomena of the sensory attention and other like facts are compatible only with the psychophysical interpretation of the *RL* and of Weber's Law, we can confidently reply that this assertion rests upon a number of assumptions that are in part untenable, in part at any rate unproved: on the assumption, *e.g.*, that Fechner's theory of the seat of mind and of the significance of the interconnection of all the nutritive processes in the human body² is correct, that during sleep consciousness but not psychophysical activity is wholly in abeyance, etc. With the same right with which Fechner takes his stand upon these assumptions, we might ourselves, on the basis of other assumptions, assert that only the physiological view of Weber's Law affords a satisfactory explanation of the phenomena of the sensory attention, of sleep and waking, etc."³ The reader will not hesitate to subscribe to this criticism. "Kein einziger seiner [Fechner's] Gedanken," says Ebbinghaus, "hat sich als stichhaltig erwiesen."⁴ "Wohlan," Fechner would have answered, "so weit es—the system—eben fehl schlägt, hat man es zu verlassen."⁵

§ 5. *Our Debt to Fechner*.—We have declined to admit Fechner's contention that the *S* is a measurable magnitude, the sum of a number of *S*-units; we have, with some little hesitation, admitted that all *j. n. d.* of *S* are equal, coupling our admission with the proviso that we shall be allowed presently to define the *j. n. d.* in our own way; we have rejected, once and for all, the psychophysical interpretation of Weber's Law. It would seem, then, that the building⁶ which Fechner planned and erected is for us a mere heap of ruins; that the tree to which he likened his system has been rooted up and laid prostrate. Shall we let this inference pass, dismissing the "dear old man . . . with his patient⁷ whimsies" for other and "more nutritious objects of attention"?⁸

¹ *Z.*, i., 472.

² *El.*, i., 21 ff.

³ *G.*, 365.

⁴ *Psych.*, i., 517.

⁵ *Cf. P. S.* iv., 187.

⁶ *I. S.*, 215, Nachwort.

⁷ Patent?

⁸ James, *Psych.*, i., 1890, 549.

In the author's belief, such a course would not only be unjust to Fechner, but would also argue an extreme dimness of scientific vision on the part of the man who followed it. Here are the reasons.

(1) Fechner was the Schöpfer, the originator, the creator of psychophysics. Weber's experiments were there, and would doubtless have borne fruit; Hering, we may suppose, would have written his *Beiträge* and his *Lichtsinn*, Helmholtz would certainly have written his *Optik* and his *Tonempfindungen*, Wundt would in all likelihood have written the *Physiologische Psychologie* and founded his laboratory, if there had been no Fechner. But there can be no doubt whatsoever that, without Fechner's creative work, without his demarcation of the province of psychophysics as a separate science, the progress of experimental psychology, and therefore of psychology at large, would have been sorely delayed. Rightly to appreciate Fechner's originality, one must know the scantiness of the materials that lay to his hand in 1850, and one must realise the inadequacy, practical and theoretical, of Herbart's formulæ. Rightly to appreciate his historical importance, one must remember for how many years he stood at the centre and focus of psychophysical activity.

There is another point. Fechner's work was systematic; psychophysics was born full-armed and mature. The system covered a vast range, swept together a vast body of hitherto disconnected facts. It took account of everything, from the classification of the stars to the phenomena of dreams, from the come-and-go of memory images to the emergence of mind out of the all-pervading world consciousness. But a system invites criticism, not from a few specialists, but from all the workers in every field of the science. We know that the criticism was forthcoming. And no one, surely, will be found to say that the critical work of Wundt and Hering and Müller and Delbœuf has been merely negative in result, that the doctrine of the *Elemente* has not provoked its critics to reconstruction. Their own utterances should be decisive.

In fine, then, we are indebted to Fechner, first, because in founding psychophysics he paved the way for experimental psychology, and, secondly, because he threw his conclusions into

a form that attracted widespread attention and challenged the criticism of men of very varied scientific interests.

It is important that the student, who is naturally influenced by James' estimate of Fechner and of psychophysics, should understand the high esteem in which Fechner is held—even in his own country. We have already quoted Wundt's appreciation in the *Vorlesungen* of 1863.¹ In 1887 Wundt writes: "Fechner . . . ist der Begründer der experimentellen Psychologie geworden. Die Psychophysik, die er anbaute, war nur die erste Eroberung auf einem Felde, dessen weitere Besitznahme erhebliche Schwierigkeiten nicht mehr bieten konnte, nachdem einmal dieser Anfang gemacht war:" P. S., iv., 477; cf. G. T. Fechner, 1901, 49, 54, etc. So Külpe: "wir sehen in der Fechnerschen Behauptung und Durchführung functioneller Verhältnisse zwischen psychischen und physischen Processen die endgültige Begründung einer exacten Psychologie. . . . All' dieser Unvollkommenheit und Unwissenschaftlichkeit [der älteren Psychologie] hat Fechner im Princip ein Ende gemacht. Er hat uns den Weg gezeigt, auf dem allein . . . psychologische Gesetze in der strengen Bedeutung dieses Wortes erreicht werden können:" Arch. f. d. Gesch. d. Phil., vi., 1893, 178 f.; cf. 181 f. and Lasswitz, G. T. Fechner, 84, 89 ff., 191, etc. It is needless to multiply references: Fechner's critics are practically unanimous in their recognition of Fechner's general services to experimental psychology;² and it is to the memory of Fechner, "der von allen verehrte aber von allen auch angegriffene Greis" (Stumpf, Tps., i., 66), that Ebbinghaus dedicates his recent Grundzüge. Even Delbœuf, who writes in a moment of pessimism that "les hypothèses scientifiques reconnues fausses . . . disparaissent presque toujours dans un profond oubli sans laisser plus de traces que les neiges d'antan," even Delbœuf declares that "le mérite de Fechner est au-dessus de toute discussion" (Examen, vii., 2).

James alone refuses to swell the chorus of praise. "The only amusing part of it is that Fechner's critics should always feel bound, after smiting his theories hip and thigh and leaving not a stick of them standing [*sic*], to wind up by saying that nevertheless to him belongs the *imperishable glory* of first formulating them and thereby turning psychology into an *exact science* (!)": Psych., i., 549. This is not precisely what the critics say. That apart, however, we may reply, on the personal side, that German criticism is not remarkable for its amenities, and that, although Fechner's own pupils—like Hering and Lotze—might let their gratitude colour their polemic, other critics would hardly show

¹ See p. xlv. above.

² See e. g., Foucault, *Psychophysique*, 1901, 484.

the respect they show to Fechner unless they meant it; and, on the material side, that the rightness or wrongness of a man's theories does not of itself decide his value for science. We return later on to James' own estimate of Fechner's work.

Let us now consider the value of that work in its systematic aspect. Scientific literature is enriched in two ways: by the writing of monographs and by the writing of systematic treatises. The two activities are, on the average, characteristic of two different types of mind. We expect that so-and-so will turn out, every few years, a new bit of work which will carry our knowledge a step farther into some hitherto unexplored region of fact; we appeal to so-and-so for a correct mapping of the fields already explored; and, as a rule, we do not look to the first for system or to the second for original ideas. Now the monographer has one very obvious advantage over the systematist. Systems, in an age of scientific activity, are out of date almost as soon as they are published; the next month's magazines may necessitate a recasting or rewriting. The investigator, on the other hand, provided that he has followed a critical method, may hope that his contribution to science will be permanent. This advantage is objective, and cannot be done away with. But the monographer has a further, subjective advantage. Ever since the revival of science, the birth of a 'new' physics and biology and psychology, the tendency has been growing to look upon the systematist as a worker at second hand, and to regard the investigator as the true and typical man of science. We may acknowledge, fully and cheerfully, the measure of truth which this idea contains; but we should not let the idea run away with us. A system which is competently written represents as much 'psychische Arbeit' as many monographs, and may be every whit as valuable on the critical and comparative as the monographs are on the constructive side.

The distinction which we have drawn between the two kinds of scientific achievement holds for the main body of scientific workers. The rule admits of many exceptions, and of exceptions of all degrees. The best men, of course, are both investigators and system makers. Fechner himself, and Fechner's successor, Wundt, would have attained scientific eminence by original research, if their systematic work had never been done, or again by the writing of the *Psychophysik* and the *Physiologische Psychologie*, if they had never published their special investigations. What the author wishes to emphasise now, however, is the value of the *Elemente* as a system. We have found that the leading ideas of the system are wrong. Well! a pioneer does not always strike the most practicable path. But suppose that its leading ideas had been right. It must still have been recast within ten years. Does it so much

matter that the ideas have not stood the test of criticism? The important thing is that the system was there to criticise; that Fechner laid his new science before his contemporaries in complete and systematic form, thereby challenging the critical fire of philosophers, psychologists and physiologists, even of physicists and mathematicians. A negative merit? On the contrary. It is idle to speculate on what might have happened if Fechner had been right: we are, perhaps, not so very sure ourselves of what the final 'right' of quantitative psychology may be. But that Fechner's thought was so wide-reaching, its expression so 'solidary,' this was a positive virtue in the representative of novel standpoints and untried methods.¹

So far we have spoken in general terms. To make the matter concrete, let us compare Fechner with Wundt. Fechner's principal object and interest in the *Elemente* is the establishment of an inner psychophysics: "die äussere Psychophysik ist . . . nur die Unterlage und Vorbereitung für die tiefer führende innere Psychophysik" (*El.*, ii., 377). And inner psychophysics is the exact science of the relations of dependency between psychophysical and mental processes,—typically, between *E* and *S*. Wundt, in 1893, describes his physiological psychology as "eine Wissenschaft, welche die Berührungspunkte des inneren und äusseren Lebens zu ihrem Objekte hat," and declares that "alle ihre Untersuchungen werden endlich in der Frage gipfeln, wie äusseres und inneres Dasein in ihrem letzten Grunde mit einander zusammenhängen" (*P. P.*, i., 1; *cf.* 6, and ii., 644 ff.). Is not Wundt's avowed purpose a direct continuation of Fechner's work? Truly, there is a great difference in the manner of execution. Fechner, although he "was gifted with unusual talent for subjective observation,"² was not a psychologist; he has no system of psychology. "Seine ganze Psychologie, so weit sie sich auf eine Interpretation empirischer Thatsachen einlässt, besteht in der Anwendung des Schwellenbegriffs auf die verschiedensten psychischen Vorgänge . . . Das, was die eigentliche Aufgabe der psychologischen Analyse ist, die Aufzeigung der Mannigfaltigkeit und Verschiedenheit der psychischen Vorgänge, bleibt . . . völlig im Hintergrund. . . . Das ganze Interesse Fechners gehört eben nicht der Psychologie als solcher an" (*Wundt, G. T. Fechner*, 83 f.). Wundt, on the other hand, is nothing if not psychological; it is he who introduces the phrase 'experimental psychology' into the literature (*Beiträge*, 1862, vi.); and he is, beyond all question, the first psychologist of the 'new psychology.'³ There is, then, a great

¹ *Cf.* Fechner's own summary of his work (1882) in *W. Preyer, Wiss. Briefe*, 1890, 225.

² See vol. i., I. M., 389.

³ He, and not Lotze! The student who turns from Ladd's preface in *Lotze's Outlines of Psychology* (1886, vi. f.) to Lotze himself, with the hope of finding

difference between the El. of 1860, and the P. P. of 1893; Fechner is driving at nature philosophy and philosophy of religion, Wundt at psychology. None the less, Wundt is indued with Fechner's mantle. The founder of modern psychology is the direct heir and successor of the creator of psychophysics.¹

We must, therefore, take issue with James when he declares that "Fechner's book was the starting point of a new department of literature, which it would be perhaps impossible to match for the qualities of thoroughness and subtlety, but of which, in the humble opinion of the present writer, the proper psychological outcome is just *nothing*" (Psych., i., 534). In the first place, on James' own showing,—for he says that Fechner set out to establish a numerical relation between the mental and the physical worlds,—there is no reason why we should look for any psychological outcome. Fechner was a psychophysicist, not a psychologist. When he founded psychophysics, he did all that he set out to do. Secondly, however, if it be urged that the two sciences are so intimately related that some psychological outcome ought to have resulted, we reply that Fechner rendered essential service to psychology, though a service which it is not easy to estimate in any sort of quantitative way, by the impetus which he gave to psychological experimentation at large.² And thirdly we may point out that James himself recognises one aspect of this service to psychology. "The psychophysics law controversy has prompted a good many series of observations on sense-discrimination, and has made discussion of them very rigorous" (534). "Incidentally to the discussion of it . . . a great many particular facts have been discovered about discrimination which merit a place in this chapter" (539). But the chapter is a chapter of a Psychology, and is headed 'Discrimination and Comparison'!

(2) How much of Fechner's completed work is valuable to us, as experimental psychologists, at the present day? What

the firstfruits of modern psychology, will assuredly be disappointed. Lotze is a factor in the rise of experimental psychology; his influence was favourable, and he made a notable contribution to the science in his theory of local signs. But, on the whole, he is rather surprisingly unmodern. Really, Lotze is a metaphysician with physiological training,—as Herbart is a metaphysician versed in mathematics.

¹ The matter is, in the author's opinion, somewhat overstated by Lasswitz, 90, and not quite correctly stated by Külpe, Arch., etc., 183 f.—The introductory pages of the P. P., i., 1902, are much more distinctly psychological (and therefore less psychophysical) in tone than those of the earlier edition: see esp. 3 f. The change is natural: Wundt is, and has always been, a psychologist; and the riper his genius, the farther does he travel from Fechner. After as before, however, the statement holds that Wundt is Fechner's direct successor.

² Wundt, P. P., i., 1902, 7.

parts of the building still stand? What shoots from the tree are still living?

First and foremost, we owe to Fechner the comprehensive development and theoretical interpretation of the metric methods. The method of just noticeable differences seems to have been employed first by Delezenne (1826); then, much more extensively and successfully, by E. H. Weber (1831 and later). The method of right and wrong cases is due to Vierordt (Hegelmayer, 1852). The method of average error was worked out by Fechner and Volkmann (1856-7). All three methods are discussed in the *Elemente*,¹ with general and special cautions, rules for the elimination of constant errors, formulæ for the mathematical evaluation of results, etc., etc. Much has been done since Fechner's day: we have new methods, new refinements of method, above all, a better understanding of the interrelations of the methods. In principle, however, our current laboratory work is based upon the work of the *Elemente*, and the student who enters upon quantitative psychology is entering the school of Fechner.²

Secondly, we owe to Fechner the concept of the *DL*, and the thorough exploitation of the differential sensitivity. It is, perhaps, hardly too much to say, with Külpe, that "er hat . . . in der Unterschiedsempfindlichkeit die Fähigkeit entdeckt, die uns zu einer allgemein giltigen Analyse unserer inneren Vorgänge anleitet."³ At any rate, the advance which psychological analysis has made in the last forty years—an advance which is unparalleled in the history of psychology—is referable in large measure to the introduction of the *DL* as a working concept.

Thirdly, we owe to Fechner a number of psychophysical investigations, which are important both extrinsically, for their results, but also and more especially intrinsically, as undertaken with an overt psychophysical purpose and carried out by means of the psychophysical metric methods. Fechner employed the method

¹ Plateau's method of mean gradations (worked out, in the rough, about 1852) was unknown to Fechner at this time, though it is in some sort anticipated by Fechner's reference to the classification of the fixed stars. In the I. S., he welcomes the new method, and subjects Delbœuf's experiments to a critical examination: 22, 178 ff.; cf. W. Preyer, *Wiss. Briefe*, 1890, 109.

² Cf. Foucault, *Psychophysique*, 1901, 4, 483 f.

³ *Arch.*, etc., 179.

of just noticeable differences in the spheres of "intensive light sensation, visual measurement and temperature measurement," that of right and wrong cases in his elaborate work with lifted weights, and that of average error in the spheres of visual measurement and tactual measurement.

Fourthly, we owe to Fechner the sole conception of mental measurement that has stood the test of 'inside' criticism: the idea of measuring S by laying-off units of its own kind, and of standardising the units by aid of their correlated R . The thesis that equally noticeable (including 'just' noticeable) differences of S are equal, *i.e.*, may be employed as S -units, is, as we shall presently see, accepted by the majority of experimental psychologists at the present time. We do not, of course,—the point has been made several times in what precedes,—regard the single S as a sum of S -pieces, or the S -unit as a little bit of a larger S -magnitude. Fechner did: though Fechner, too, had floating ideas of 'distance' measurements in psychophysics. But our modern view is simply a reinterpretation of Fechner's Massprincip, not an entirely new view, put in place of Fechner's.

The value of Fechner's work on the metric methods cannot be questioned: see G. E. Müller, *G.*, 45; Wundt, *P. P.*, i., 1893, 341; 1902, 475. We may regret the non-appearance of the Massmethoden, but we probably have its essentials in the *R.* and the Massprincipien. It could hardly have increased our obligations to Fechner in this regard.

The one positive mistake that Fechner made was his overestimation of Weber's Law. There can be no doubt that he exaggerated its psychophysical importance, its range of validity, and the degree of accuracy with which it can be formulated. Let us be clear, however, that in all this Fechner made no error of principle. He was simply wrong in fact. When he said that Weber's Law is a fundamental law of psychophysics, he was guilty of overhasty generalisation, of inadequate induction,—but of nothing worse (Külpe, *Arch.*, etc., 182; Lasswitz, *G. T. Fechner*, 86). And he himself insists, over and over again, that his principle of mental measurement is independent of Weber's Law. See Fichte's *Z.*, 1858, 18 f.; *El.*, i., 65; ii., 33: "[es] lässt sich das ganze Massprincip vom Weberschen Gesetz unabhängig darstellen," and the *Verallgemeinerung*, 191 ff.; *R.*, 333: "dieses Mass setzt keineswegs principiell und wesentlich die Gültigkeit des Weberschen Gesetzes voraus"; *I. S.*, 71; *P. S.*, iv., 181, 187, 193. At the beginning and end of his work, in 1858 and in

1887, he sounds the same note of warning. "Auch hat die Untersuchung im Interesse der möglichsten Verallgemeinerung des Masses hiernach keineswegs wesentlich darauf auszugehen, das Webersche Gesetz möglichst zu verallgemeinern, was leicht eine bedenkliche Neigung mitführen möchte, es über die von Natur gesteckten Grenzen hinaus zu verallgemeinern, oder Bedenken hervorrufen möchte, dass es zu liebe des Masses darüber hinaus verallgemeinert worden sey, sondern man wird ganz unbelangen fragen können und zu fragen haben, wie weit reicht es, wie weit reicht es nicht; denn auch dahin, wohin es nicht reicht, reichen doch die drei Methoden, die dem Masse dienen und somit das Mass" (Fichte's Z., xxxii., 19); cf. P. S., iv., 187. He laid extreme emphasis upon Weber's Law: so that Müller remarks that "[Fechner] vielleicht allzu sehr übersieht, wie wenig sein Name als Begründer der Psychophysik von der Richtigkeit seiner Deutung des Weberschen Gesetzes abhängt" (Gött. gel. Anz., 1878, 836). But he never pinned his Massprinciple to the validity of Weber's Law.

When, therefore, James asserts (Psych., i., 545) that "it is in the theoretic interpretation of Weber's Law that Fechner's originality exclusively consists," he is confusing fact with principle, and thus doing Fechner a palpable injustice. Fechner's originality consists in his endeavour after a psychisches Massprinciple, and he had formulated all his leading ideas before he lit upon Weber's generalisation (El., ii., 558).¹

As for the work that grew out of and clustered round the Elemente, "those who desire this dreadful literature," says James, "can find it; it has a 'disciplinary value'; but I will not even enumerate it in a footnote" (549). Whether or not a literature is 'dreadful' to one depends, of course, on the measure of interest one takes in the subject matter: James does not find the literature of space perception dreadful, and the 150 pp. of his ch. xx. give footnotes galore. Psychophysical literature is far from easy. But it is largely controversial in form, and the average reader enjoys controversy. What is still better: the chief expositors of the science have been endowed with a saving sense of humour. Wundt says of Fechner that "vielleicht hat Niemand in seinem Leben mehr gestritten als er, und gewiss hat Niemand weniger Feinde gehabt als er" (P. S., iv., 476). If we had this single fact to go upon, and knew nothing at all of Dr. Mises, we might be sure that Fechner had humour. One need not read far to find it. Delbœuf had it, too; and Wundt has it, although he was once "le professeur sérieux, qui ne ba-

¹ So far as the author is aware, Fechner never, of his own initiative, refers to Weber's Law as "*the psychophysic law*:" cf. James, 533; Wundt, P. P., i., 1902, 496: though in the heat of controversy he accepts the phrase from Aubert; Ber., etc., 1864, 1 ff.

dine pas." The only man of eminence who, if we may venture to judge in so delicate a matter, is perhaps lacking in humour is Müller: and Müller makes up by thoroughness. Remembrance of this lack, be it noted, will take the sting from a good deal of Müller's criticism.

Small matters! And yet James' Principles is so great a work that its lightest words carry weight;¹ and the author is convinced that the particular words which he has been discussing have done real harm to the cause of experimental psychology in America. Young students *must* be urged to 'plough through the difficulties' of Fechner's books, if they are presently to become psychologists: and James' criticism, which is mainly a criticism of temperament and not of reason, gives them an excuse to shirk these difficulties. *Maxima debetur pueris reverentia.*

§ 6. **Reconstruction.**—The theory of mental measurement which this book accepts has been set forth in Pt. i., pp. xxi. ff. Its cardinal points are (1) the bracketing of the two limens as facts of friction in the neural machine, and (2) the substitution of sense distance for absolute sensation magnitude. The limens thus become irrelevant to Weber's Law,—except in so far as the *DL* is an instrument of analysis at large; and Weber's Law itself becomes a law, not of sensation intensity, but of our estimation of sense separateness within the intensive continuum. It remains now to trace the development of these new ideas, and to see whether any sort of agreement obtains among modern psychologists as regards the general problem of quantitative psychology.

One may say, a little paradoxically, that the work of reconstruction began with Fechner himself. Thus Fechner considers the *j. n. d.* of *S* as differentials in the mathematical sense, as least *S* magnitudes. "Nun haftet aber doch die Differentialnatur weder der einen noch der anderen *S* an, zwischen denen der Unterschied bemerkt wird; auch ist das *S*-Differential sehr wohl zu unterscheiden von dem Unterschied der objektiven *R*, durch den es verursacht wird. . . Als sehr kleine *S*-Grösse wird mithin die *S* einer sehr kleinen Distanz . . . betrachtet. . . Aber . . . die einfache Folgerung z. B., dass, wenn das Differential eines *S*-Wertes die *S* einer sehr kleinen Distanz sei, dass dann notwendigerweise ein endlicher *S*-Wert die *S* einer grösseren Distanz sein

¹ To quarrel with Southey and Old Caspar is, perhaps, merely to break a butterfly on a wheel. The poem is, however, singularly fatuous, and its quotation singularly inapt. See J. R. Seeley, *The Expansion of England*, 1884, 130.

müsse und gar nichts anderes sein könne, findet sich nirgendwo klar und bündig ausgesprochen in den Elementen der Psychophysik.”¹ The idea finds expression of a sort in the third derivation of the metric formula.² It occurs again in a letter to Preyer (22 and 23 Jan., 1874): “in der That fasse ich . . . die positiven *S*-Werthe nicht als daseiende *S* schlechthin, sondern als Entfernungen von dem . . . Nullpunkte des Daseins.”³ It occurs still more clearly in the Massprincipien of 1887, where Fechner begins his exposition with stellar magnitudes and the method of mean gradations:⁴ so clearly, indeed, that even the reader who knows his Fechner experiences something of a shock when the discussion slips back again into the beaten track of the Elemente. “Die bei Fechner unzweifelhaft vorhandene Vorstellung davon, dass *S*-Grössen eben Distanz-*S* sind, ist also gekreuzt und in den Hintergrund gedrängt durch andere Vorstellungen.”⁵ Nevertheless, let us not forget that the idea is ‘unzweifelhaft vorhanden.’

The first positive step on the path to reconstruction was, however, taken by Delbœuf. The limen has, for Delbœuf, no psychological importance whatsoever: the unit of mental measurement is a sense distance, a *contraste sensible*.

(a) *The Limen*.—Delbœuf prefaces his explanation of the *RL* and the *DL* by the following argument. Let us grant, as the limen theory requires, that for the indefinite number of *R* comprised between two points on the *R*-scale the number of *S* is limited. A gas jet, *e. g.*, gives an infinite number of degrees of illumination, according to the position of the plug; but these luminosities, from the bare shimmer of light to the blazing flame, are correlated with a restricted number of distinct *S*. Now suppose that we have passed over a certain number of these *S*, that we have (in other words) determined a certain number of *DL*, and that the plug stands in such a position that we are on the verge of getting a new *S*, of completing another *DL*. At this point we have a determinate *S*-intensity correlated with a flame of a determinate luminosity.

Let us abstract from all the work that has preceded, and start out again from this point. What will happen, when we turn the plug? Will a turn of a hair's breadth give us a new *S*? Surely not: such a

¹ Ebbinghaus, *Z.*, i., 1890, 463 f.

² *El.*, ii., 36 ff.

³ *Z.*, i., 35 f.; W. Preyer, *Wiss. Briefe von G. T. Fechner u. W. Preyer*, 1890, 47.

⁴ *P. S.*, iv., 179 ff.

⁵ Ebbinghaus, *Z.*, i., 465 f.; *Psych.*, i., 511.

result would run counter to our previous experiments, as well as to the theory of the limen. Must we, then, turn the plug afresh through a liminal angle? Surely. But then we can, by repeating the procedure, interpolate as many different S as we like between points which, on the theory, gave room only for a single S ! There is no escape from the dilemma.

Delbœuf argues from this illustration¹ that S is a continuous function of R . "Je pense . . . qu'à chaque excitation déterminée correspond une sensation aussi déterminée. . . Mais, d'un autre côté, je concède que, pour que la conscience fasse une distinction entre deux sensations, il faut qu'il y ait entre elles une différence finie. Or, je n'accorde à ce fait aucune importance."² The explanation of it is, simply, that "l'infiniment petit se conçoit, mais ne peut se percevoir. . . Tout corps en mouvement avance à la façon des aiguilles d'une montre, par petits sauts intermittents. . . Ce que nous disons du mouvement, phénomène extérieur, s'applique exactement au changement, phénomène intérieur. . . Le seuil n'a donc aucune importance psychologique."³ The discontinuity of changes in the physical universe is due, in the last resort, to the atomic constitution of matter (*cf.* the phenomena of molecular cohesion in the thermometer, or the resistance of the air to a moving body).⁴ The discontinuity of changes, under certain conditions of observation, in the mental sphere is explained as follows.

Sensation arises always from a disturbance of organic equilibrium. "L'excitation est une rupture d'équilibre, elle produit une impression sur l'animal. Le phénomène interne correspondant à l'impression est la sensation; c'est donc l'effet sensible provenant d'une rupture d'équilibre."⁵ "Nos sens sont des instruments différentiels; la sensation . . . est due à un phénomène analogue à une rupture d'équilibre."⁶ Let R_i be of the force of the sensitive organism (the movement-process of internal stimulation), and R_e that of the surrounding medium (the movement-process of external stimulation). Then Weber's Law, with constant omitted, becomes $S = \log \frac{R_e}{R_i}$: not, as Fechner wrote it, $S = \log R$. According to Fechner, S increases in arithmetical progression when R

¹ Examen, 127 ff.; Rev. phil., v., 1878, 129. The same reasoning appears in G. E. Müller's *Zur Psychophysik d. Gesichtsempfindungen*, Z., x., 79 f.

² Examen, 129; Rev. phil., 129.

³ Examen, 129 ff.; Rev. phil., 130 ff.

⁴ Examen, 130 f.; Rev. phil., 130 f.

⁵ *Éléments*, 182.

⁶ *Éléments*, 172; *cf.* 36, n. The doctrine of the relativity of S is discussed at length by Stumpf (*Tps.*, i., 7 ff.), who makes great fun of it; Delbœuf's *Differenzansicht* falls under case (*d*), 15 ff. Stumpf gives the most important references up to 1883. See p. clx. below.

increases in geometrical progression. It is rather the case that *S*-increments increase in arithmetical progression, when the corresponding *R*-increments increase in geometrical progression; or, in better phrasing, that successive *S*-contrasts are sensed as equal when the corresponding *R*-differences increase geometrically.¹ At the same time, not every $\frac{R_e}{R_t}$ is capable of arousing a sensation; "le milieu ambiant peut éprouver des variations dont l'être sensible est absolument incapable de s'apercevoir."² There are four cases in which a limen is introduced. (1) The variations in the intensity of *R* may be too slight to arouse *S*: when the temperature of our room is practically constant, we have no sensations of warmth or cold. (2) The variations may take place too slowly: we do not notice, as we sit through a lecture, how bad the air of the hall has become. (3) The organism is flexible, accommodates itself readily to its surroundings: we do not notice the change of atmospheric pressure as we ascend a mountain. (4) In another sense, the organism is not flexible enough. "Pour qu'il y ait sensation distincte, il faut que le mouvement extérieur rencontre des éléments qui aient, par leur nature même, un mouvement harmonique, ou qui soient susceptibles de le prendre. Les organes de sens ne sont rien d'autre que des séries ou des faisceaux de pareils éléments. C'est pourquoi le son n'agit pas sur la main, ni la lumière sur l'oreille.

"Pour que donc la sensation ait lieu, il faut que l'impression ait une certaine importance; mais il faut encore un organe de sens. Au changement physique, en effet, correspond bien un nouveau état sensible; mais la sensation n'est pas identique avec cet état; elle répond à la variation même, c'est-à-dire au changement en tant que *se faisant* et non en tant que *fait*. Or, le changement comprend deux termes, le présent et le passé, et l'être sensible doit les saisir *en même temps* pour sentir. On va voir que l'organe de sens est la condition de la possibilité d'une pareille comparaison."³

The concept of the limen, then, is of no value for psychology. It is possible to realise a continuum of sensation: and this fact alone would prove that the theory of the limen is not rigorously exact.⁴ Yet there are four conditions under which a limen appears. Does Delbœuf mean that the limens, *RL* and *DL* alike, are explicable in terms of physiology, and therefore have no psychological significance? Or does he mean that, though they are mental phenomena, they are irrelevant to the problems of mental measurement?

¹ *Éléments*, 176; *cf.* 45; *Examen*, 143; *Rev. phil.*, v., 138.

² *Éléments*, 195.

³ *Éléments*, 195 ff.; *Examen*, 135; *Rev. phil.*, v., 133.

⁴ *Examen*, 138; *Rev. phil.*, 134 f.

We must remember that Delbœuf gave his views to the world in a series of essays, not in systematic form, and that the views changed somewhat from essay to essay. Hence it is very difficult to answer the questions just propounded. In his note on Müller's G., Delbœuf remarks, à propos of the limen: "quoique les raisonnements de l'auteur soient, en général, autres que les miens, je tiens à noter cette singulière coincidence dans nos sentiments."¹ This looks like the physiological interpretation: only that Müller confines himself, in the G., to the RL , and takes the DL for granted. Again: Delbœuf inclines to a physiological interpretation of Weber's Law.² He would naturally, then, take the RL physiologically. On the other hand, we have passages like this. "Je conçois bien la sensation comme ayant la faculté de s'accroître d'une manière continue; mais les différences finies frappent seules l'esprit, et les différences intermédiaires aussi finies et en nombre indéfini restent non perçues. . . Je veux faire ressortir que les phénomènes sensibles ne diffèrent pas en cela des phénomènes matériels. Ils sont continus, en ce sens que tous les changements s'y tiennent; mais ils sont discontinus, en ce sens que ces changements ne s'y suivent pas d'une manière uniforme et présentent des phases de ralentissement et des phases d'accélération, des phases en puissance et des phases en acte, des phases de préparation et des phases d'action."³ Once more, then: not every $\frac{R_e}{R_i}$ arouses S . Why? Physiologically, because $\frac{R_e}{R_i}$ is so near to unity that no differential excitation reaches the cortex? Or psychologically, because the S corresponding to a particular $\frac{R_e}{R_i}$ is not 'distinct' enough to 'strike the mind'?

In the author's opinion, the latter alternative is that which Delbœuf accepts. Only, he conceives of the discontinuity of S always and everywhere in terms of physical or physiological analogy (helped thereto by his physiological interpretation of Weber's Law), and can therefore declare the two limens to be psychologically valueless, without committing himself to a purely physiological view of them.

(b) *The Sense Unit*.—Delbœuf substitutes for Weber's Law the three laws of degradation, of progression, and of tension. The first declares that "la sensation, à peine produite, s'affaiblit, parce que la différence des forces R_e et R_i tend à devenir nulle"; "la sensation est plus vive à

¹ Examen, 171; Rev. phil., 156.

² Examen, 65, 85; Rev. phil., iii., 1877, 262; v., 1878, 42.

³ Examen, 135 f.; Rev. phil., v., 133. The reader should cf. *Éléments*, 175, *u.*, and the Tannery letters, esp. *Éléments*, 143. See also Stumpf, *Tps.*, i., 34, *u.*; Grotenfelt, *Das Webersche Gesetz*, 5 f., 13, 20 f. *u.*; Fechner, *I. S.*, 27 ff., 94 ff.; *R.*, 178, 303 f.

son début, et va en s'affaiblissant jusqu'à ce qu'elle s'éteigne."¹ The second is the uniformity $S = k \log \frac{R_e}{R_i}$, with which we are already familiar: "la sensation provient d'une différence ou d'un contraste, et les contrastes successifs doivent, pour être sentis égaux, correspondre à des différences réelles de plus en plus fortes: c'est là le fond de la loi de Weber."² The third law says that "il existe pour la quantité R_i un maximum et un minimum où la tension est extrême et touche à la rupture; et la faculté d'accommodation . . . est déterminée en étendue par ces valeurs extrêmes de R_i . . . Cette tension, cette marche vers la rupture est accompagnée d'un sentiment d'épuisement."³

Delbœuf's general theory of sensitivity has not found favour with later psychologists. Müller sharply criticises the law of progression (G., 400 ff.); Stumpf will hear nothing of the law of degradation (Tps., i., 17 f., n.); and Fechner and Stumpf, as we know, reject the *Differenzansicht* of *S* (I. S., 32, 113 ff.; R., 300 ff.). Nevertheless, as regards the subject matter of sense measurement, Delbœuf hits the nail squarely on the head.⁴ *S*-increments are increments of contraste successif, sense distances. Partly, no doubt, this view of mental measurement is suggested by the theory of the relativity of *S* at large ("il n'y a pas de sensation sans contraste");⁵ partly, by the character of Delbœuf's experiments. The method which he employed was Plateau's method of mean gradations; and if one sets out from this method, one naturally tends to think of *S*-distances, or *S*-differences, as the objects of measurement, and to ignore what Fechner calls the absolute values of *S*.⁶

We come to the choice of the unit. "Qu'est-ce à proprement parler que la mesure? C'est . . . une double série des nombres partant de 0 dans les deux sens: . . . 3, 2, 1, 0, 1, 2, 3 . . . , l'intervalle entre les nombres étant rempli par une portion de la chose à mesurer, portion que l'on appelle *unité*. . . . Quand donc on évalue l'intensité d'une sensation, on doit pour cela se servir d'une unité de sensation."⁷

Delbœuf then gives the illustration of the scale of greys,⁸ and concludes: "Il suffit . . . de faire commencer les teintes sombres à une lumière

¹ *Éléments*, 170, 173 ff., 192; *Examen*, 37 f., 143; *Rev. phil.*, iii., 245 f.; v., 139.

² *Éléments*, 42 ff., 171 f., 175 ff., 193; *Examen*, 38 f., 51 f., 141 ff.; *Rev. phil.*, iii., 246, 254 f.; v., 138.

³ *Éléments*, 44, 46 ff., 179 ff., 194; *Examen*, 40 f., 143 f.; *Rev. phil.*, iii., 247; v., 139.

⁴ Cf. Ebbinghaus, Z., i., 1890, 321.

⁵ *Examen*, 161; *Rev. phil.*, v., 151.

⁶ Cf. Fechner's own procedure in the *Massprincipien*, *Phil. Stud.*, iv., 179 ff.

⁷ *Examen*, 99 f., 113; *Rev. phil.*, v., 50, 57.

⁸ Quoted from the Tannery controversy, p. l. above; repeated in *Examen*, 117; *Rev. phil.*, v., 60.

égale à 0, c'est-à-dire à l'obscurité complète, et de prendre pour unité de mesure le contraste entre deux teintes quelconques voisines ou éloignées."¹ "La sensation est, dans ce procédé, mesurée par une unité de sensation."²

This definition of the unit of sense measurement, and the banishment of the limen from the metric formula,³ constitute Delbœuf's two chief services to quantitative psychology.

Next in order⁴ comes Wundt, who in 1880 defines *Merklichkeitsgrad* as "Entfernung der *S* von einer der *R*-Schwelle entsprechenden Grenze" (P. P., i., 358). We have already discussed Wundt's position in detail, and need here say no more of it.⁵

In 1882, the problem of distance measurement was clearly stated by F. Boas (Pfl. Arch., xxviii., 575 f.).⁶ "Die Formu-

¹ Examen and Rev. phil., *loc. citt.*

² Examen, 118; Rev. phil., 60.

³ Examen, 125; Rev. phil., 127.

⁴ Next, if we omit occasional utterances of Preyer's: see *Elemente der reinen Empfindungslehre*, 1877, 20, 43; cf. Ebbinghaus, *Z.*, i., 484 f.

⁵ In the P. P., i., 1902, 549, Wundt says that the Reizschwelle der Empfindung is probably "eine rein physiologische, in den Auslösungsbedingungen der centralen Sinneserregung begründete;" his own formula $\Delta M = C \frac{\Delta S}{S}$, where *M*=Merklichkeit, contains an attention limen, as Fechner's $dS = C \frac{dR}{R}$ contains a stimulus

limen. Cf. 543: the limen, empirically regarded, is made up of two factors, a physiological and a psychological. Similarly, the psychological *DL* is a matter of attention: "the increase of attention which is necessary if a given central sensory *E* is to increase by the same degree of clearness . . . is proportional to the quotient of the *E*-increase into the magnitude of the *E*" (553): there are, however, physiological conditions which affect it in various ways (494, 539 f.). Both the attention-*L* and the attention-*DL* have, of course, physiological substrates: 542, 552 f. Cf. Stumpf, *Tps.*, i., 100 ff.

For Wundt's views of the limens, see P. P., 1874, 283, 291 (the nature of the *DL* is here not discussed, and nothing is said on p. 722 of the attention-*L*); 1880, i., 349, 350, 353, 355, 356; 1887, i., 375, 376, 380 f., 381 f.; 1893, i., 390 f., 392, 398 f., 399 f., 405; ii., 272. Cf. *Lectures*, 63; *Vn.*, 1897, 67; *Outlines*, 1897, 209, 254; P. S., ii., 1885, 34 ff. It is perhaps worth noting that the reader will find nothing about the liminal functions of attention or apperception in O. Staude, *Der Begriff der Apperception in der neueren Psychologie*, P. S., i., 192 ff.; Wundt, *Zur Lehre vom Willen*, *ibid.*, 337 ff.; Külpe, *Die Lehre vom Willen in der neueren Psychologie*, *ibid.*, v., 1889, 427 ff.

⁶ Foucault (*Psychophysique*, 236) gives him first place, chronologically, under the heading 'La mesure de la dissemblance.' This, however, is entirely to miss the significance of Delbœuf's writings.

lirung, welche Fechner der Grundaufgabe der Psychophysik gegeben hat, lässt sich nicht aufrecht erhalten, da seine Voraussetzung des Bestehens von *S*-Intensitäten nicht zutrifft. An Stelle der Beurtheilung von *S*-Intensitäten muss man die von *S*-Qualitäten setzen.¹ . . . Das Problem in seiner correcten Fassung lautet: wie ist die Verwandtschaft zweier *S* abhängig von den *R*-Grössen, welche die *S* verursachen? " 'Relationship' is only 'another expression' for "Grad der Verschiedenheit" (572). The j. n. d. is "die Einheit des Verwandtschaftsgrades" (573). Measurement of Verschiedenheit is rendered possible (1) by the fact that Merklichkeit, the principal characteristic of Verschiedenheit, is constituted of Leichtigkeit and Sicherheit des Urtheiles, and both 'ease' and 'certainty' are measurable magnitudes (574); (2) by the qualitative differences of the single or limiting *S* (575); and (3) by the inaccuracy of recognition,—the more nearly related the *S*, the greater is the probability of their identification, and conversely (*ibid.*).—Beyond this statement of the problem, and sketch of a programme of work, Boas does not go.²

Stumpf in 1883 interprets the metric formula in Delbœuf's way, though without Delbœuf's complications of tension and degradation. "Man kann der Fechnerschen Formel eine Bedeutung wahren, wenn man den Stärkegrad einer *S* durch ihre Distanz vom Stärkeminimum charakterisirt. Das logarithmische Gesetz wird dann zwar nicht ein Gesetz der *S* sondern der *S*-Distanzen sein" (Tps., i., 399).

The early sections of the Tps., i. introduce us to the important concepts of Empfindungssteigerung and Empfindungsdistanz. "Das $>$ Zeichen, will man es auch auf die *S* anwenden, kann als Ausdruck eines Steigerungsverhältnisses benützt werden, aber der Betrag der Steigerung ist nicht abgesondert vorstellbar" (43; *cf.* 121, and Fechner, *El.*, i., 48). "Unter Distanzen verstehen wir . . . nicht bloß räumliche und zeitliche sondern auch qualitative und solche der Intensität, und definiren das Wort durch: Grade der Unähnlichkeit" (57). The section on Analysis and Comparison (96 ff.) treats in detail of the four immanent relations of *S* ("sie sind den Sinnesempfindungen immanent, nicht erst durch das Urteil hineingelegt:" 97): number (Mehrheit), progression (Steigerung),

¹ See p. liii. above.

² In a previous paper (*loc. cit.*, 562 ff.), Boas makes large theoretical claims on behalf of the method of mean gradations.

similarity and fusion. "Fassen wir zunächst das Bemerkte einer Steigerung oder eines Gradverhältnisses in's Auge. Was darunter zu verstehen, lehren zunächst und am deutlichsten die Intensitäten aller S . Zwischen je zwei als ungleich erkannten Intensitäten findet eine Steigerung statt; wir nennen die eine grösser und die bezügliche S stärker. Mit dem Begriffe der Steigerung ist zugleich der einer bestimmten Richtung gegeben, in welcher sie stattfindet" (109 f.). We have already, in vol. i., I. M., 54 f., touched on Stumpf's doctrine of Aehnlichkeit. On the relation of similarity to progression, he has now three things to say. (1) It is tempting to subsume progression to similarity. "Steigerung, könnte man sagen, sei nur da vorhanden, wo ein Inhalt B einen anderen A vollständig in sich enthalte und noch etwas zu demselben hinzufüge, wie die höhere gegenüber der niederen Intensität." But it is not correct to say that the higher intensity 'contains' the lower. Moreover, when we add tone to tone, we get no qualitative progression, although the second impression 'contains' the first, but only a tonal complex (Zusammensetzung) with or without increase of intensity. (2) It would, perhaps, be more nearly true to say that progression is a kind of *simple* similarity. Wherever we have the possibility of progression, we have similarity; and the imperceptibility of progression, in a progressional magnitude, means always the highest degree of similarity. On the other hand, however, not all similars are progressional. Hence it is best, for purposes of exposition, (3) to let the two relations, progression and similarity, stand side by side as separate things (121 f.).

Progression and similarity are, then, to be kept apart; though some similars admit of progression, as does similarity in general (110). Distance is the inverse value of degree of similarity ("der Begriff der Distanz gründet sich darauf, dass Aehnlichkeiten allenthalben graduell abstutbar sind:" 122). In sensation intensity, we have a characteristic which brings all three concepts together.

Defining distance in this widest sense, as degree of dissimilarity, Stumpf goes on to discuss the possibility of distance judgments (122 ff.), the mental mechanism of the estimation of distances (126 ff.: we return to this point later), and the general conditions of the reliability of distance comparisons (128 ff.). The special question of the comparison of qualitative tonal distances (141 ff., 247 ff., etc.) will occupy us in a later Section. Judgments of intensive distances in the sphere of tone and noise are discussed in 392 ff., in the section which gives the reconstruction of Fechner's metric formula.

In the course of his discussion, Stumpf calls attention (i., 124 ff., 251, 395 f.; ii., 560) to Fechner's cutaneous experiments by the method of equivalents (El., i., 132); to Plateau's and Delbœuf's work with degrees

of brightness ; to the suggestions of Hering (Zur Lehre vom Lichtsinne, [1873-4] 1878, 57 ff.) and of F. Boas (Pflüger's Arch., xxviii., 1882, 562 ff.) regarding the method of mean gradations ; to the actual distance comparisons of Helmholtz (Sensations of Tone, 1895, 124 f.) and of R. H. M. Bosanquet (Philos. Mag., 5 Ser., viii., 1879, 299 ff.) ; and to Ebbinghaus' reinterpretation of the metric formula. It is curious that he says nothing of Delbœuf's reconstructive work. Delbœuf was on the right road in 1875, and had become absolutely clear in 1878. —

What, now, of the limens ? We must remember that psychophysics, for Stumpf, is simply a chapter in a "messende Urteilslehre" (Tps., i., 54) ; "die Messung der Beziehung zwischen R und S bildet ein Restproblem," whose solution depends upon the adequacy of our psychology of judgment (53). The primary things for him are, then, the Urteilschwellen of S and of S -distance ; the RL and the DL are secondary matters.

(1) There can be no doubt that we have unnoticed and unnoticeable S . "Es kann in einem Klange oder in einem Geräusche ein Ton enthalten sein, den wir wegen seiner relativ geringen Stärke bei aller Anstrengung der Aufmerksamkeit nicht heraushören können" (i., 34 f. ; Külpe, Outlines, 291). Hence there is a Wahrnehmungs- or Mercklichkeitsschwelle, "eine R -Stärke, unterhalb deren ein Schall selbst bei höchster Aufmerksamkeit und sonst günstigsten Bedingungen nicht mehr wahrgenommen wird" (379). Is there an RL ? Yes : very weak R cannot make their way through the obstacles of the peripheral organ, and there is "Resorption schwächster Erregungen in der complicirteren inneren Leitung" (*ibid.*). Can we ever determine the RL , *i.e.*, "die Wahrnehmungsschwelle durch extrem günstige Bedingungen mit jener ganz oder beinahe zur Coincidenz bringen ?" That depends, mainly, on whether we can ever get absolute attention and absolute freedom from disturbing R (in the present case, absolute silence). "Ersteres ist gewiss nicht, letzteres wahrscheinlich nicht der Fall ; doch wird in beiden Beziehungen unter günstigen Umständen wenig fehlen" (380).

(2) Similarly, there is a judgment-limen for S -differences. "Wäre, wo wir bei höchster Aufmerksamkeit keinen Unterschied mehr finden, auch allemal keiner in den S vorhanden, so ergäbe sich, dass jeder Sinn überhaupt nur *eine* S hätte. Es seien $a, b, c, \dots z$ die sämtlichen Ton- S , welche bei einer allmäligen Erhöhung der Schwingungszahl des Ton- R von der unteren bis zur oberen Hörgrenze auch von den geübtesten und aufmerksamsten Beobachtern eben nicht mehr als verschieden (a nicht von b , b nicht von c , c nicht von d , u. s. w.) erkannt werden : so wäre unter obiger Voraussetzung zwischen allen diesen Ton- S wirklich kein Unterschied, es wären sämtliche Töne vom tiefsten bis zum höch-

sten in der *S* einander gleich, es gäbe nur *einen*. Und weiter, da jene Beobachter factisch *a* von *c* unterscheiden, so wäre $a=b$, $b=c$, und doch $a \neq c$ " (i., 33, 37; cf. ii., 222 f., esp. n.).

There is also a *DL* in the strict sense, "ein Unterschied zwischen zwei *R*, denen kein Unterschied in der *S* entspricht" (i., 32 f.). We cannot, however, directly measure Unterschiedsempfindlichkeit, but only Unterscheidungsfähigkeit (30 n., 49 n.). Hence the determination of the *DL* sensu stricto is always a matter of inference. Given equality of attention and of reproductory conditions, we can argue from variation of the judgment-limen to a parallel or proportional variation in the *DL*: we cannot do more, since there may be a 'constant' in the judgment-limen, *i.e.*, the *S*-difference may have to transcend a certain liminal amount before it can be remarked or judged (37, 52). What the *DL* is, whether a physiological or a mental phenomenon, Stumpf does not say. The reader should cf. i., 100 ff., 183 ff., 351 ff., 357 f.; and the references and cross references under Schwelle, ii., 576.

It is clear, from the above discussion, that there is a good deal of similarity (more, perhaps, than these psychologists themselves would like to admit) between the views of Stumpf and of Wundt. There is an obvious difference in starting-point: Wundt sets out from Fechner's position, from *R* and *S*; Stumpf, twenty years later,¹ sets out from the opposite extreme, from the judgment: and there are very many differences of detail. In general, however, and especially if our interpretation of Wundt's Mercklichkeitsgrade is correct, the attitude of the two men to psychophysical problems is much the same. Cf. Stumpf, i., 66.—

It will be remembered that F. A. Müller (Das Axiom der Psychophysik, 1882, 106) substitutes for Fechner's 'Contrastempfindung (=empfundener Unterschied) von variabler Intensität' a 'Contrastgefühl von variablem Charakter.'² This use of a secondary criterion is criticised by Stumpf, i., 87 ff. Ebbinghaus also points out that *S* of different modalities vary greatly in degree of affective colouring. "Man hat behauptet, verleitet durch die Analogie der Töne, der Bewusstseinszustand beim Anschauen aequidistanter oder nicht aequidistanter Helligkeiten sei ein Gefühl, er gehöre also in das Gebiet, dem Harmoniegefühle, Disharmoniegefühle, Zahnschmerzen, u. s. w. gehören. Offenbar ist nichts weniger der Fall als dies. Gerade das unterscheidet Töne und Helligkeiten, . . . dass jene mit ausserordentlich prägnanten, diese mit ausserordentlich schwachen emotionellen Beimischungen empfunden werden" (Sitzungsber. d. Berlin. Akad., 1887, St. xlix., 1 Decr., 1008).

¹ Wundt was born in 1832; Stumpf in 1848. The Vn. appeared in 1863, the Tps., i. in 1883.

² Cf. F. E. Beneke, Psychol. Skizzen, i., 1825, 47; Stumpf, Tps., i., 177 f.; ii., 84.

So far, then, we have the new idea of mental measurement set forth in Delbœuf's essays, where it is obscured by the writer's theory of sensitivity; in Wundt's *P. P.*, where it is obscured by the author's apperceptive terminology; and in Stumpf's *Tps.*, which is a technical psychological monograph. It has not yet been expounded in such general and generally intelligible terms as to take its place, in the text-books, alongside of Fechner's formulæ.¹ The work of popularisation is now undertaken by Ebbinghaus, in articles of 1887 and 1890, and in the *Grundzüge* of 1897-1902.

"Wann und wodurch," asks Ebbinghaus, "wird . . . das Räumliche numerisch bestimmbar? . . . Zwei Orte sind bloss übereinstimmend oder nicht übereinstimmend in ihrer Lage, sonst nichts. Werden aber drei in Betracht bezogen, so können die zwischen ihnen bestehenden *Ortsverschiedenheiten*, die *Distanzen*, verglichen werden und diese sind nicht mehr nur gleich und ungleich, sondern sie sind auch grösser und kleiner in Bezug zu einander und namentlich können sie als Vielfache voneinander beurteilt werden. . . Ganz dieselbe Art von Messbarkeit, die für das räumliche Empfindungsgebiet besteht, besteht (*im Princip*) auch für alle übrigen Empfindungsgebiete; diejenige Messbarkeit von Empfindungen aber, deren Fehlen man so oft als etwas Besonderes der Farben, Töne, Gerüche u. s. w. hervorhebt, besteht auch für das Räumliche nicht" (*Z.*, i., 1890, 326 ff.). "An und für sich betrachtet hat nicht eine bestimmte, sondern jede beliebige isolierte Empfindung in quantitativer Hinsicht den Wert 0, jede ist als Grösse eine Nullempfindung.² Ganz ebenso wie jeder Ort oder Punkt des Raumes quantitativ gleich Null ist, so auch jede Elementarempfindung; beide haben eben keine Dimension, und Grösse oder Zahl sind dimensionale Gebilde" (468 f.). As to the limen: "wenn die Schwellenempfindung nicht mehr noch weniger den Wert 0 hat wie jede beliebige andere isolierte Emp-

¹ It is noteworthy, *e. g.*, that Grotenfelt—although writing a monograph, although writing in 1888, and although writing from a wide and thorough knowledge of the general literature—says not a word of the *Tps.* Where so much has to be read, one is apt to choose one's books by their titles.

² *Cf.* Wundt, *P. P.*, i., 1893, 407 *n.*; and *cf.* B. Russell, *Mind*, N. S., vi., 1897, 337: "in a quantity, taken in isolation, we cannot discover any of the properties of quantity."

findung, so kann auch die Eigenschaft der logarithmischen Formel, für $R=1$ $S=0$ zu liefern, in keiner besonderen Beziehung zu der Schwellenempfindung stehen sondern muss etwas sein, was zu jeder beliebigen anderen Empfindung in derselben Beziehung steht. . . Es existiert also im Grunde nur ein einziges Phänomen, nämlich das der Unterschiedsschwelle, welches sich bei allen möglichen Werten der objektiven Reize in gleicher Weise geltend macht. Ausserdem aber besitzt für die Empfindung . . . der (angenäherte) Nullwert des Reizes gar nichts besonders Ausgezeichnetes vor anderen Werten. . . Statt mit Fechner grosses Gewicht darauf zu legen, dass die Formel dem Schwellenphänomen in jenem einzigen Falle [*i.e.*, in that of the *RL*] gerecht werden kann, muss man vielmehr über eine so singuläre und dadurch seltsame Leistung stutzig werden" (471 ff.). Ebbinghaus then works out the analogy of the tangent galvanometer, sharply separates the fact of the *DL* from the law of correlation of *S* and *R*, and remodels the logarithmic formula.

In his paper on Die Gesetzmässigkeit des Helligkeitscontrastes (Sitzungsber. d. Berlin. Akad., 1 Decr. 1887, 1006 ff.), Ebbinghaus describes an experiment with grey papers. "Ich habe ein Gebiet von Helligkeiten, welches alles umfasst, was uns in gewöhnlichem Leben bei diffuser Tagesbeleuchtung von Helligkeiten vorkommt, in 7 möglichst gleiche Theile getheilt. . . Die Quotienten von je 2 auf einander folgenden objectiven Helligkeiten bilden nun von unten nach oben folgende Reihe :

2.25 ; 2.11 ; 2.05 ; 1.77 ; 1.72 ; 1.68 ; 1.98.

Es gilt also . . . für jeden mässig grossen Ausschnitt . . . der Satz : wenn mehrere Helligkeiten von uns subjectiv als æquidistant gesehen werden, so bilden die objectiven Helligkeitszahlen annähernd eine geometrische Progression. . . Die Anschaulichkeit einer solchen Reihe æquidistanter Helligkeiten scheint mir noch in einer . . . principiellen Beziehung von einem gewissen Interesse zu sein. Sie gestattet, Jedermann in verständlicher Weise zu demonstrieren, was eigentlich gemeint ist mit einer subjectiven Empfindungsdistanz und mit dem Messen solcher Distanzen."¹ These brightness distances are not apprehended as differences : "die Anschauung der Helligkeitsdistanzen verhält sich zu derjenigen der einzelnen Helligkeiten sehr ähnlich wie die Anschauung einer räumlichen Strecke zu derjenigen der einzelnen Orte" (1008). Still, one may regard

¹ Delbœuf here has his revenge ; for if Stumpf does not mention him, neither does Ebbinghaus mention Stumpf ! See Pfüger's Arch., xlv., 122 n.

them as differences, if one hopes that anything will come of such an interpretation. "Will ich z. B. die Resultate der obigen Beobachtungen . . nicht nur in Worten aussprechen, sondern in eine Formel verdichten, so komme ich sehr leicht zu einer derartigen Fiction" (1009). Cf. also Pflüger's Arch., xlv., 1889, 113, 121 f.

We have already drawn largely upon the article of 1890 Ueber negative Empfindungswerte (Z., i., 320, 463). It will be remembered that Ebbinghaus here brackets the RL and the DL as alike instances of the DL ; deprecates Fechner's separation of the two in two different formulæ (the Massformel and the Unterschiedsmassformel); and parallels the DL with the facts of friction in the galvanometer, so that "die Hereinziehung der Schwelle in eine Empfindungsformel irrig ist" (477). How does he himself derive the metric formula?

Fechner's formula (see p. xxviii. above) is

$$S = c \log. \text{ nat. } R + C.$$

Now S is not a measurable magnitude. To make it measurable, we must make it a sense distance, refer it to some wholly arbitrary (not necessarily liminal!) S_0 . Then we have the formula (the stroke above the line being the sign of distance):

$$\overline{SS_0} = c \log. \text{ nat. } R + C.$$

To determine C , we have recourse to the fact that every isolated S as such, every S compared not with another S but with itself, = 0. Then

$$\overline{S_0S_0} = 0$$

and, if R_0 be the R corresponding to S_0 ,

$$0 = c \log. \text{ nat. } R_0 + C,$$

$$C = -c \log. \text{ nat. } R_0.$$

Substituting, we have for our original formula

$$\overline{SS_0} = c \log. \text{ nat. } \frac{R}{R_0}$$

or in other words (see pp. xxviii. f.)

$$\overline{SS_0} = k \log \frac{R}{R_0}.$$

"Die Bestimmung der Einheiten, in denen die R -Größen R und die S -Größen $\overline{SS_0}$ gemessen werden sollen, bleibt hier noch vorbehalten; die Wahl der R -Einheit ist gleichgültig für die Formel, durch die Festsetzung der S -Einheit wird k bestimmt" (479). Only in one case can an apparent difficulty arise: in the case that, having to choose a zero-point of the S -scale in a purely arbitrary way, we should place it at the liminal S . Even so, however, we have but to remember that "die logarithmische Formel für kleine Werte der objectiven Reize notorisch ungiltig

ist und längst, ehe die Reize dem sog. Schwellenwert nahekommen, aufgehört hat, auch nur annähernd ein Spiegel des sachlichen Verhaltens zu sein. Was daher für kleine *R*-Werte überhaupt und speziell für den *R*-Schwellenwert aus ihr folgt, ist sachlich vollkommen bedeutungslos, es ist eine rein analytische Konsequenz" (482 f.; *cf.* 471).

See further Psych., i., 61 ff., 488 ff., esp. 509 ff.; Wundt, P. P., i., 1893, 405; 1902, 549. With G. E. Müller, Z., x., 80 n., *cf.* Ebbinghaus, Psych., 494 f.

James in 1890 endorses Stumpf's idea of distance measurement. "When we take a simple sensible quality like light or sound, and say that there is now twice or thrice as much of it present as there was a moment ago, although we seem to mean the same thing as if we were talking of compound objects, we really mean something different. We mean that if we were to arrange the various possible degrees of the quality in a scale of serial increase, the *distance*, *interval* or *difference* between the stronger and the weaker specimen before us would seem about as great as that between the weaker one and the beginning of the scale. It is these *relations*, these *distances*, which we are measuring and not the compositions of the qualities themselves, as Fechner thinks. . . Introspection shows, moreover, that in most sensations a new *kind* of feeling invariably accompanies our judgment of an increased impression; and this is a fact which Fechner's formula disregards" (Psych., i., 546 f.).¹

The discussion enters on a new stage with the work of Meinong (1896). We have so far taken it for granted that 'distance' can be measured. We have sought to save the principle of mental measurement by setting in place of Fechner's *S* Delbœuf's 'degree of sensible contrast'; not the former, but the latter, is the divisible and therefore the measurable mental magnitude. Are we, however, right in calling distance (separation, apartness, distinction, diversity) a measurable magnitude? A magnitude it unquestionably is: but a divisible magnitude?

Meinong decides without hesitation that distance is not divisi-

¹ *Cf.* ch. vi., esp. 158 ff. Since James will not quote the dreadful Fechnerian literature, even in a footnote, one might expect that he would be particularly careful to cite the authors who have been active in the work of reconstruction. Yet he gives no reference to the Delbœuf essays of 1877 and 1878; to Wundt's remarks of 1880 and 1887; or to Ebbinghaus' paper of 1887.

ble. Think of two space points: the path or way that lies between them is divisible into parts; not so their distance. "Hält man also Distanz und Strecke wohl auseinander, dann erkennt man mit unmittelbarer Evidenz, dass eine Verschiedenheit, eine Distanz, in Verschiedenheiten teilen ganz denselben Ungedanken bedeutet, als die Tonstärke in Teile zerlegen. Distanz ist eine unteilbare Grösse."¹ But how can we measure a magnitude that is not divisible?

We are familiar, in physics, with the distinction of direct and indirect measurement: we are measuring directly when we lay the metre rod upon the object of measurement, indirectly, when we tell the time by reference to the space-units of the clock-face. Besides these two forms of measurement, which may be termed measurement proper, we have, however, what we may call surrogate measurement or measurement by deputy. "Bei Messung der Distanz wird eigentlich nicht diese gemessen, sondern die zugeordnete Strecke, bei Messung der Temperatur nicht diese, sondern der Quecksilberstand, bei Messung der Geschwindigkeit nicht diese, sondern eine aus Weg und Zeit gebildete neue Complexion. An Stelle des eigentlich zu messenden Gegenstandes, des Messobjektes, . . . ist ein Surrogat getreten, das eigentlich gemessen wird; ich stelle daher Messungen dieser Art als surrogative Messungen den früher betrachteten als eigentlichen Messungen gegenüber."² The sanction of surrogate measurement lies in the fact that "mit Hülfe des Surrogates die Vorteile, um deren Willen Teilvergleichung und Messung bei teilbaren Grössen vorgenommen werden, sich unter günstigen Umständen zum grössten Teile auch unteilbaren Grössen zuwenden lassen."³

We breathe again: all that we have to do, apparently, is to substitute Tonstrecke, Farbenstrecke, etc., for Tondistanz and Farbandistanz; we measure distance surrogatively in terms of path. But wait! "Das anschauliche Erfassen solcher unräumlicher oder unzeitlicher Strecken," says Meinong, "ist, soweit überhaupt ausführbar, nichts weniger als leicht; noch schwerer dürfte es sein, derlei Vorstellungen zur Grundlage eines praktischen Massverfahrens zu machen, das vor einer direkten Vergleichung der Distanzen irgend etwas voraus hätte. So hat das Bestehen der

¹ *Z.*, xi., 98.² *Ibid.*, 243 f.³ *Ibid.*, 245.

betreffenden Strecken zwar jedenfalls den Wert, dem Gedanken der halben oder doppelten Distanz einen festen Sinn unterzulegen: als Messungssurrogate leisten aber Strecken, soweit sie nicht Raum- oder Zeitstrecken sind, weiter keine Dienste." ¹

This is a serious check. Fortunately, it is of a practical, not of a theoretical nature. In theory, mental measurement is possible. In practice, we meet with the difficulty that "sich zu jenen Operationen, welche der physischen Messung eigentlich erst den Charakter der Exaktheit verleihen, auf psychischem Gebiete keine Gelegenheit findet. . . Es giebt darum keine eigentliche psychische Messung, die unmittelbar wäre, und keine surrogative psychische Messung, bei der das psychische Surrogat eine unmittelbare Messung gestattet." What then is to be done? "Psychische Grössen können nicht anders gemessen werden, als unter Vermittelung physischer Grössen: die Feststellung des funktionellen Verhältnisses zwischen physischen und psychischen Grössen wird dadurch zum unabweislichen Bedürfnis,—die Befriedigung dieses Bedürfnisses die unerlässliche Voraussetzung aller psychischen Messung." ² In a word, we find in the *R*-Strecke the possibility of surrogate measurement of the *S*-Distanz. The functional connection of *R*- and *S*-magnitudes is given by Weber's Law, which shows that equally diverse *S* correspond to equally diverse *R*. The logarithmic dependence of the Massformel obtains not between *R* and *S*, but between *R* and *S*-distinction (Verschiedenheit): so that we have in this formula, as restated and reinterpreted, the required determination of magnitude of distance (mental) by magnitude of the distant terms (physical). ³

Meinong's views are expounded in three articles, Ueber die Bedeutung des Weberschen Gesetzes, in *Z.*, xi., 1896, 81 ff., 230 ff., 353 ff. The articles are not easy reading: partly because of the subtlety of the reasoning, partly because Meinong is more interested in his subject than in his reader, and makes no apparent effort to say what he has to say in its simplest and briefest form, partly again because there are many references, expressed or understood, to previous work either of Meinong himself or of those who think with him. A good idea of the general situation may be obtained from A. Höfler's *Psychologie*, 1897, §§ 29. 39.

¹ *Ibid.*, 250 f.

² *Ibid.*, 360.

³ *Ibid.*, 374 ff.

A popular account is given by G. F. Stout, *Manual of Psych.*, 1899, 19) ff.; cf. 31. Meinong's summary, 399 ff., should be read over two or three times before the reading of the whole is attempted.

On distance and path (*Distanz* and *Strecke*) see pp. 98 f., 239 f., 245, 247 f., 250 f., 264, 277, 356, 370, 376, 379; on the interrelation of the various forms of measurement, 244; on the continuity of *S*, 249 f., 365. For characteristic statements of Meinong's own position, see 127 ff., 255 f., 359, 396.

Meinong has nothing to say of the psychological significance of the *RL*. According to Höfler (236), his view is "dass eine nur eben merklich gewordene *S* nicht ihrerseits auch noch den Nullwert der *S*, sondern schon eine endliche Grösse darstelle": so the proportionality of *R* and *S* is saved. Höfler adds on his own account (248) that it is not necessary to assume "dass *allen R* von der *R*-Schwelle bis hinab zum absoluten *R*-Nullpunkt noch *S* entsprechen müssen" [for physiological reasons?]. The *RL* is thus assimilated to Stumpf's *Urteilschwelle* (*Tps.*, i., 33 f.) and Wundt's *Aufmerksamkeitsschwelle* (*P. P.*, ii., 1893, 272). In his section on the *DL* (120 ff.) Meinong remarks: "was verschieden erscheint, *ist* auch verschieden; was hingegen verschieden ist, erscheint als verschieden nur bis zu einer Grenze, jenseits welcher der Schein der Gleichheit eintritt. Die Grenze heisst bekanntlich *DL*." He then emphasises the epistemological importance of the uncertainty of 'equal' judgments; but offers no psychological explanation, further than to say that Fechner has overestimated the factor of 'zeitlich-räumliche Nicht-Koincidenz' (*P. S.*, iv., 192). Höfler (248) ascribes the *DL* to a "Mangel der Unterscheidungsfähigkeit," and refers again (as does Meinong) to Stumpf, *Tps.*, i., 33.

We find, then, that in one form or another, in whole or in part, with more or less of consistency and of agreement in details, the view of mental measurement as distance measurement has found advocates in Delbœuf, Wundt, Boas, Stumpf, Ebbinghaus, James, Meinong, Höfler, Stout, and G. E. Müller.¹ It is a good omen for the future of quantitative psychology that men of such varied training and tradition should set about the work of reconstruction in substantially the same way.

It is, perhaps, unnecessary to say that there are still psychologists of the first rank who have so far withheld their assent to the doctrine of mental measurement here advocated.² It should, however, be expressly

¹ *Z.*, x., 1897, 25 f., 35.

² Thus it is worth noting that Jodl, whose *Lehrbuch* (1896, 210 ff.) gives a long

stated that there are some whose systematic teaching is incompatible with it. We may refer, in particular, to certain authors whose names have figured in previous discussions.

(1) Külpe remarks (Outlines, 45 f.): "We cannot measure *S* by reference to or by means of other *S*. Neither can we, as things are, measure them by their functional relations to bodily processes. . . . But the objections which hold against the measurability of *S*, at any rate at the present time, fall to the ground when urged against *S* and *D. S*." He therefore confines himself to the measurement of sensitivity.¹ The author regards this position as needlessly conservative.

In the Outlines, Külpe does not attempt to decide between the physiological and the psychological interpretations of Weber's Law; he therefore leaves the nature of the limens undetermined: 165 ff. In the article of 1901 (Ive Congrès international de psychologie, *Compte rendu*, 162, 167 f.), he accepts the psychological interpretation, and explains the limens in terms of attention (Merken as Konstatieren, Auffassen, Beurteilen).

(2) The position taken by Münsterberg, in his *Neue Grundlegung der Psychophysik*,² is in effect a compromise between the view of Fechner, that

and well-considered account of psychophysics, makes no mention of distance measurements, and does not even cite (744, 746) the relevant articles of Delbœuf and Ebbinghaus. Jodl's criticism of the metric formula (228 f.) meets Fechner on his own ground. Renouvier, again, is unable to see any essential difference between the mental measurements of Fechner and Delbœuf: *Critique philos.*, vii., 1, 1878, 183, 186. Cf. Foucault's criticism, *Psychophysique*, 1901, 248 ff.

¹ Cf. Fechner, *El.*, i., 45, 54. Külpe, in effect, returns to the standpoint of Weber and Vierordt, who were also concerned with the measurement of sensitivity, not of sensation,—with capacity, not with process. More recently, this position has been represented by F. Galton, in England, and by the French and American psychologists who have taken up the subject of 'mental tests.' The following are some of the more important references. F. Galton, *Inquiries into Human Faculty*, 1883, 34 ff., 370; *Anthropometric Laboratory, Notes and Memoirs*, i., 1890; *Journ. Anthropol. Inst.*, May, 1889, 401 ff.; J. McK. Cattell, *Mind*, O. S., xv., 1890, 373; Cattell and L. Farrand, *Psych. Rev.*, iii., 1896, 618; H. Münsterberg, *Centralbl. f. Nervenheilk. u. Psychiatr.*, xiv., 1891, 196; J. Jastrow, *Chicago Exposition: Ethnology, Section of Psych.*, 1893; E. Kraepelin, *Psych. Arbeiten*, i., 1895, 1 (with several articles, by various hands, in the same periodical); J. A. Gilbert, *Stud. Yale Psych. Lab.*, ii., 1894, 40; A. Binet and V. Henri, *Année psych.*, ii., 1896, 411 ff. (with other articles); S. E. Sharp, *Amer. Journ. Psych.*, x., 1899, 329; J. McK. Cattell *et al.*, *Psych. Rev.*, iv., 1897, 132; v., 1898, 176; vi., 1899, 174; viii., 1901, 165; L. W. Stern, *Ue. Psych. d. individuellen Differenzen*, 1900 (with bibliography). It is, perhaps, needless to say that one may both recognise the value of 'mental tests' and, at the same time, push beyond sensitivity to a measurement of mental process.

² *Beiträge z. exper. Psych.*, Heft 3, 1890.

all *S* may be regarded as sums of *S*-increments, and the views of writers like von Kries, who deny the possibility of mental measurement. Münsterberg insists, at the outset, that 'intensive' differences of *S* are differences not of degree but of kind. "Wir müssen unbedingt daran festhalten, dass die stärkere und die schwächere *S* zwei ganz verschiedene einfache Bewusstseinsinhalte sind, von denen wir zunächst nichts anderes aussagen können, als dass sie verschieden, d. h. nicht identisch sind."¹ "Die stärkere *S* ist nicht gleich der schwächeren *S* plus einem Zuwachs, sondern beide sind völlig verschiedene Bewusstseinsinhalte, genau so wie zwei qualitativ verschiedene *S*. Es [ist] damit die Trennung zwischen qualitativem und intensivem Unterschied aufgehoben."² It would, however, be premature to argue from this fact that *S* and *S*-differences are unmeasurable. "Es wäre ja vielmehr denkbar, dass bei den Intensitätsänderungen zu den *R*-Wahrnehmungen noch irgend etwas zweites hinzukäme, was bei den Qualitätsänderungen nicht vorhanden ist, dass also die Trennung auf Grund eines accessorischen Elementes eintritt und somit einerseits in der That nicht auf den *S*-Unterschieden selbst beruht, und andererseits dennoch, alle Erfahrung vorangehend, naturgemäss überall eintreten müsste."³ The accessory element required is found in the muscle sensation. "Alle physikalische Messung beruht auf der Konstatierung resp. Herstellung gleicher Muskel-*S*; meiner Ansicht nach ruht auf genau derselben Grundlage alle Messung der psychischen Grössen, der *S*-intensitäten, und eben weil die Grundlage dieselbe ist, kommt der psychischen Intensitätsmessung auch dieselbe Berechtigung zu wie allen physikalischen Messungen."⁴ The muscle sensation is qualified for its task in two ways. (1) A Spannungsempfindung is a constant accompaniment of change in *S*-intensity. "Jeder *R* löst reflektorisch Muskelspannungen aus, deren Stärke von der Stärke des *R* abhängt. Jede *R*-Änderung ruft demnach eine Spannungsänderung hervor und diese tritt als Spannungsempfindung ins Bewusstsein . . . Wir nennen einen *S*-Unterschied gleich einem anderen, wenn in beiden Fällen gleiche Spannungsänderungen vorliegen."⁵ (2) The muscle sensation is a Fechnerian sensation. "Den Muskel-*S* kommt eine völlig exceptionelle Stellung zu, die schwache Muskel-*S* ist in der That in der starken enthalten und beide sind nicht qualitativ von einander verschieden, sondern nur durch ihre zeitliche Dauer und räumliche Ausdehnung."⁶

¹ N. G., 5, 91, 98 f.; cf. Psych., i., 1900, 263 f., 271, 281 f.

² N. G., 14, 56; Psych., i., 373.

³ N. G., 13, 17.

⁴ N. G., 23 f.

⁵ N. G., 92, 109; Psych., i., 284.

⁶ N. G., 22 f., 30, 32, 34, 56, 92; Psych., i., 282.

It follows that the single *S*, though itself a qualitative datum prompting merely the comparative judgment of 'like' or 'different,' is by indirection a measurable magnitude, in so far as the correlated muscle-*S*, a simple more or less of content, has a determinate place upon a true quantitative scale. *S* becomes indirectly measurable by way of its constant muscular accompaniment.¹ It follows also that any sense distance can be measured, whose limiting terms are correlated with muscle-*S* (so intensive distances, distances of tonal pitch); and that equations can be set up between distances taken from different sense departments. Direct distance measurements are as impossible for Münsterberg as direct *S*-measurements are for Delbœuf;² *S*-measurements are as easy for him, by way of muscle, as they were for Fechner by help of the theory of *S*-increments.

This theory is repeated, with all its details,³ in the *Grundzüge der Psych.*, i., 1900, except that Münsterberg will now hear nothing of mental measurement, whether direct or indirect. He declares that "das Psychische als solches im letzten Grunde . . . überhaupt nicht quantitativ bestimmbar sei."⁴ Fechner's system is untenable, for the reason that it makes the *S*-difference an "addierbare Grösse."⁵ Measurements of the *D.S.* may be made, and may be valid; but that is because "in den abgeleiteten Wert nicht *S*, sondern *R*, also physische Grössen, als bestimmende Faktoren eintreten."⁶ Ebbinghaus' distance measurements are not measurements at all. "Das Räumliche, das die Naturwissenschaft zu messen hat, sind . . . gar nicht 'Ortsverschiedenheiten' oder 'Ortsdistanzen,' sondern zwischen den Orten liegende Objekte. Die 'Ortsverschiedenheit' ist eine Gestaltqualität . . . Thatsächlich bleiben Helligkeitsdistanzen wie Ortsdistanzen unteilbar, während physikalische Objekte, von denen allein die Naturwissenschaft handelt, teilbar und deshalb messbar sind . . . Die Lehre von der Distanzvergleichung ist sicher ein sehr entwickelfähiges und wichtiges Gebiet der Psychologie; sie steht aber prinzipiell in denkbar schärfstem Gegensatz zur

¹ There are certain passages in the *N. G.* which seem to show that only *S*-distances or *S*-differences, not *S* themselves, are thus indirectly measurable; in general, however, Münsterberg teaches that *S* can be measured. *Cf.* 2, 53, 71 with 32, 56, 92, 122.

² *N. G.*, 4, 35, 45, 56, 117; *Psych.*, i., 276 f.

³ See, e.g., what is said of distance comparison, 272, 275, 276 f.: the Abstands-empfindung or Kontrastgefühl is represented in consciousness by charakteristische Spannungsempfindungen. *Cf.* also the parallel references in the foregoing notes.

⁴ i., 263, 280, 385. *Cf.* esp. the discussion of the unit, 268 ff.

⁵ *Ibid.*, 271.

⁶ *Ibid.*, 272 f.

Lehre von der physikalischen Messung."¹ The reasons for this change of position are epistemological, not psychological, and cannot here be discussed.²

In criticism of the *Neue Grundlegung*, it is perhaps enough to say that the 'muscle' sensation is not by any means a Fechnerian sensation, but a content of precisely the same kind as other sensation contents, blue or pressure or sour.³ In the matter of mental measurement, we may admit, with Meinong and Münsterberg, that "Distanzen sind niemals addierbar,"⁴ and yet maintain—as, indeed, Meinong does—that mental processes are, in principle, measurable.⁵

(3) G. F. Lipps, like Külpe, halts on the hither side of mental measurement. It is, however, only fair to say that his problem is not strictly psychological. It is rather psychophysical: the quantitative formulation (Bestimmungsweise) of psychophysical parallelism.⁶ How is the numerical correlation (Zuordnung) of *R* and *S* to be carried out?

Any given manifold of *S* may be transformed, by a purely psychological procedure, into one or more discrete series, each of whose terms is *j. n. d.* from the terms immediately preceding and following. There are three possible series: intensive, qualitative, and intensive-qualitative. Every *S*, as member of a series, has its own determinate place, its own ordinal number; while, as member of the total manifold which the combined series represent, it may have a system of ordinal numbers.⁷ The problem before us is twofold: to delimit the *R*-sphere with which a given *S*-series is correlated, *i.e.*, to determine the *RL* and *TR*, and then to connect each ordinal number of *S* with the corresponding measurement-

¹ *Ibid.*, 273 ff. A similar position is taken by Wahle (*Das Ganze d. Philos.*, 189, 206, 208). "Das kann man wohl sagen, diese und diese *S* hat, bis sie ihr gegenwärtiges Aussehen erlangte, sich durch so viele neue Formen durchgearbeitet, als bei einem Wachsen des *R* Neuheiten constatiert wurden, aber das ist auch nicht im Entferntesten eine Messung dieser *S*."

² For a summary of Münsterberg's reconstruction, see *ibid.*, 429 f. Münsterberg makes the relation of *S* and *R* the basis of his descriptive, that of *S* and *E* the basis of his explanatory psychology.

³ The opposite extreme to Münsterberg is found in Jodl, who asserts that the Bewegungsempfindungen "in eine Vielheit verschiedener Inhalte auseinanderfallen, von welchen jeder sui generis ist" (*Psych.*, 197).

⁴ *Ibid.*, 275. The reader must never lose sight of the fact that Münsterberg is arguing from an epistemological standpoint. It makes no difference, in laboratory work, whether we speak of Distanzvergleichung or of Empfindungsmessung.

⁵ For criticism of Münsterberg, see G. E. Müller, *Göttingische gel. Anzeigen*, 1 Juni 1891, 426 ff.; Stumpf, *Tps.*, ii., 558 f.; Jodl, *Psych.*, 212; Meinong, *Z.*, xi., 1896, 119.

⁶ *Grundriss d. Psychophysik*, 1899, 39.

⁷ *Ibid.*, 40 ff.

value of R .¹ Since the S -series is discrete, and the R -values are continuously variable, it follows that the ordinal numbers m, n of S will correspond not only to the 'normal' R -values R_m, R_n , but to these values \pm their DL .²

We have, now, to distinguish two empirical cases. (a) If the absolute DL is constant, we get the equation $R_n - R_m = 2(n - m)DL$: the differences of the ordinal numbers of any pair of S are directly proportional to the differences of the corresponding R -values.³ (b) If, on the other hand, the relative DL is constant, as is in general the case with intensively graduated S -series, we get the equation $n - m = k(\log R_n - \log R_m)$: the differences of the ordinal numbers of any pair of S are directly proportional to the differences of the logarithms of the corresponding R -values; or, more generally, equal differences of the ordinal numbers of S correspond to equal quotients of the correlated R -values.⁴ Finally, if we write $m = 0$, we have $n = k \cdot \log R_n$: the ordinal number of S increases proportionally to the logarithm of the corresponding R -value.⁵ This is Fechner's law, freed from objections. Not S is regarded as a mathematical function of R : we cannot write S_n for n in our last equation: but the ordinal number of S , its numerical place in a series, is brought into functional relation with measurable R -values.

This deduction is, without doubt, ingenious. It cuts all the difficulties. It is, *e.g.*, in many respects identical with the doctrine of distance measurements: but, whereas the distance-psychologist has to face the question of the equality of the *j. n. d.*, Lipps can shelve this question altogether; the difference between the ordinal numbers 1 and 3 is the same as that between 18 and 20, whatever be the psychological relation of the *j. n. d.* distances 1-2, 2-3, 18-19 and 19-20. If, then, we could remain poised in psychophysics, as the "Grenzwissenschaft zwischen der Psychologie und der Physik (im weitesten Sinne des Wortes),"⁶ without slipping over into psychology or physiology, we might be tempted to accept Lipps' formulæ.

But, alas! we have—Lipps himself has—psychologically to explain Weber's Law. This means that we have to account both for the existence

¹ *Ibid.*, 45 ff. The psychophysical problem is similarly envisaged by C. Henry (Comptes rendus, cxxii., 1896, 951, 1139, 1283). Henry, however, more cautious than Lipps, makes no attempt at interpretation.—*Cf.* the Fechnerian formula of C. Wiener (Wied. Ann., xlvii., 1892, 661): "the measurement value [Maasszahl: not Ordnungszahl, numéro d'ordre] of an S -intensity is given with the number of weaker S -intensities that can be interpolated, with just noticeable distinguishableness, between the given S and the absence of all S , plus one."

² *Ibid.*, 47 ff., 50.

³ *Ibid.*, 50.

⁴ *Ibid.*, 52.

⁵ *Ibid.*, 53.

⁶ *Ibid.*, 7.

and for the relative constancy of the DL .¹ Now (a) when we speak of the 'intensity' of a mental process, we have in mind its hold over us, its power to absorb or occupy us. The greater this power, the stronger, of course, must be the stimulus that can distract us, that can noticeably increase the given 'intensity'. "Demgemäss tritt in der DL nichts anderes als die Intensität der S zu Tage, und man wird die Intensität als um so grösser anzusehen haben, je grösser das zu der S gehörige R -Intervall ist. . . Zwei Empfindungen S_n und S_m der Reihe S_1, S_2, S_3, \dots mit den R -Intervallen $R_n \pm DL_n$ und $R_m \pm DL_m$ verhalten sich hinsichtlich ihrer Intensität wie $DL_n : DL_m$." ² Again, (b) "die physische Energie des R ist die objektive Grundlage für die subjektiv empfundene Intensität. Da man nun bei stetig und gleichmässig sich änderndem R eine stetig und gleichmässig sich ändernde S vorauszusetzen hat, so wird auch die R -Energie der S -Intensität proportional zu setzen sein."³ In other words $S_n : S_m$ as $R_n : R_m$.⁴—Putting the two results together, we have $DL_n : DL_m = R_n : R_m$, and therefore $\frac{DL}{R}_n = \frac{DL}{R}_m$. "Hierdurch wird aber die Gültigkeit des Weberschen Gesetzes gefordert."⁵ Yes! and herewith are precisely those old difficulties raised which the psychophysical deduction had avoided.⁶

It remains, now, to answer certain questions and to meet certain objections that arise in face of Delbœuf's theory of mental measurement. The first question is this. (1) Can we in strictness speak of a mental measurement, when our quantitative result is not sanctioned by introspection? Suppose that we have divided a sense distance \overline{ae} into four equal distances, $\overline{ab}, \overline{bc}, \overline{cd}, \overline{de}$. Have we any right to say that $\overline{ae} = 4 \overline{ab}$, when an introspective examination of the two distances would not reveal the fact that the one is the fourfold of the other?

This question is answered, by implication, in Fechner's defence of his principle of mental measurement (El., i., 56). "Die S theilt sich nicht von selbst in gleiche Zolle oder Grade ab, die wir zählen und summiren könnten. Aber erinnern wir uns dass das bei physischen Grössen nicht anders ist. Zählen wir denn die

¹ *Ibid.*, 54.

² *Ibid.*, 54 f.

³ *Ibid.*, 48, 55; cf. Jodl, *Psych.*, 229.

⁴ *Ibid.*, 56.

⁵ *Ibid.*, 56. It should be said that Lipps is here writing with all possible brevity, and that his two principles of explanation are avowedly popular.

⁶ Lipps' position is now worked out, in greater detail, in his *Die Massmethoden der experimentellen Psychologie*, 1904; *Arch. f. d. ges. Psych.*, iii., 123 ff.

Zeitabschnitte direct an der Zeit ab, wenn wir die Zeit messen, die Raumabschnitte direct an dem Raum ab, wenn wir den Raum messen? Vielmehr wir legen eine äusserlichen Massstab an. . . Dass man doch das Mass des Psychischen immer im *reinen* Gebiete des Psychischen gesucht hat, mag ein Hauptgrund sein, dass man es bisher nicht finden könnte."

It is, indeed, clear that all measurement would be superfluous, if we could tell beforehand and without the procedure of measurement how many times our unit is contained in the given magnitude. The equation $P = \frac{x}{y} \rho$ is the *result* of measurement. "Beim Messen kommt es gerade darauf an, den eigenthümlichen Mängeln menschlicher Vergleichungsfähigkeit nach Thunlichkeit nachzuhelfen" (Meinong, 123). We give below, p. cxliv., references to the topic of measurement in general. The reader may now *cf.*, on this special point, Zeller, *Abh. d. Berlin. Akad.*, 1881, 6; ¹ *Sitzungsber.*, 1882, 298; Wundt, *P. S.*, i., 465; Ebbinghaus, *Z.*, i., 327; *Psych.*, i., 507; *Sitzungsber. d. Berlin. Akad.*, 1887, 1007; Delbœuf, *Éléments*, esp. 125; Jodl, *Psych.*, 225. The objection is stated very clearly, in Fechnerian terms, by Wahle (*Das Ganze d. Philos.*, 186 ff.). "Wenn das Bewusstsein nicht weiss, dass eine *S* zwei, zweieinhalb, dreimal so gross ist, als eine andere, oder dass sie um ein bestimmtes *S*-Quantum grösser ist, als eine andere, so kann so etwas auch nicht in die Psychologie eingeführt werden. . . Sollte die Entscheidung über ein Vielfaches der *S*-Stärke nicht mehr in dem Bereiche der menschlichen Beurtheilungskraft liegen? Das ist doch nicht zu glauben." *Cf.* F. Boas, *Pfl. Arch.*, xxxiii., 1882, 573 f.

(2) How does the *S*-distance come to consciousness? What is the material of the distance-judgment of equality, or of 'greater' or 'less'? We will take the authors in order.

For Fechner, this question did not arise. Fechner's sensed difference = difference sensation = contrast sensation is a true sensation, for 'sensed difference' means simply 'sensed *S*-increment' or 'partial sensation' (see *El.*, ii., 83; *cf.* i. 48, 75, etc.). There are, it is true, passages in Fechner's writings which could hardly be reconciled with this interpretation; but there can be no doubt that, on the whole, it represents Fechner's opinion.²

¹ See footnote, p. liii., above.

² The 'Bewusstsein einer Beziehung' is, for Fechner, a conscious act of a higher order than the mere 'Auffassung einer *S*'; *El.*, ii., 86. Since the comparison of two *S* falls under the heading of a 'Vergleich zwischen einer Mehrheit

Nor did the question arise for Delbœuf. Since sensation at large "provient d'une différence ou d'un contraste," it is the most natural thing in the world that change of *S* should consist in change of sensible contrast. See esp. Examen, 93, 117, 143, 154 f.

Stumpf, it will be remembered, defines the distance between two *S* as the inverse value of their degree of similarity. Direct judgments of equality of distance (equal degree of dissimilarity)—judgments "rein auf die bezüglichlichen Empfindungen, Qualitäten, Intensitäten, etc., gestützt"—are theoretically probable and practically possible (i., 122 ff.; cf. 97). "Ist es zur Schätzung einer Distanz notwendig," Stumpf goes on to ask, "die *S*, welche zwischen den beiden die Distanz bildenden *S* liegen, oder den Uebergang in der Phantasie vorzustellen?" In that event, comparison of distances would resolve itself into comparison of the magnitude of 'Uebergangs-*S*.' Now this magnitude may mean either the *time* that the transition takes, or the *number of S* that are passed over. The time is variable, and must therefore be ruled out. As for the number of *S*: "zählen können wir nur Unterschiedenes." If the discriminated *S* are the *j. n. d. S*, then our comparison of two distances involves a very large number of extremely difficult judgments. If more widely separated *S* are chosen, then these must themselves be placed at equal distances,—and our task is multiplied. And if small distances can be directly compared, why not large distances?

"Ein Uebergang mag im Bewusstsein in manchen Fällen in kontinuierlicher Form *stattfinden*; es mag auch oft *nützlich* sein, eine gegebene grosse Distanz in mehrere kleinere zerlegt zu denken; aber innerhalb einer jeden von diesen ist dann der Uebergang zum anderen nicht unbedingt und allgemein zur Distanzschätzung *notwendig*; er gehört nicht zu den essentiellen Bedingungen des Distanzurtheiles. Zu diesen gehört nichts weiter als 3 oder 4 *S* einer gewissen Gattung." We ought, therefore, to be able in some measure to estimate distances of *S*, in cases where intermediate *S* either do not exist or at least have never been experienced. "Bei Geruch und Geschmack dürfte dies sogar wirklich vielfach zutreffen" (i., 126 ff.; cf. 62).

Ebbinghaus does not scruple to employ the term 'Distanzempfindung' interchangeably with 'Empfindungsdistanz.' "Die räumlichen Bestimmung von *S*', this 'higher act' is involved in the apprehension of a sensed difference. There is, no doubt, a certain obscurity here: cf. footnote, p. lxiii. above. Fechner, as we have often insisted, was not a systematic psychologist. Nevertheless, his instinctive use of *Empfindung* in place of *Merklichkeit* is sound and sane: While, therefore, the author agrees with Angell in his polemic against the term 'difference *S*' as employed by later writers (P. S., vii., 417; cf. i., I. M., 378), he regards Fechner's usage as (for Fechner) correct. Cf. Langer, Grundlagen d. Psychophysik, 1876, 17; Grotenfelt, Das Webersche Gesetz, 1888, 57 f.

mungen bilden wie Farben, Töne, u. s. w. ein eigentümliches Empfindungsgebiet und nichts anderes" (Z., i., 325); so that one may speak of 'Raumempfindungen' (328). This usage may be condoned, if one has it at heart to emphasise the immediacy, the directness of the distance judgment. In strictness, it must be condemned: for a tone-distance is a mental formation of a different order from the tone, and the colour-distance a formation of a different order from the simple colour. Ebbinghaus himself, when he is writing within a psychological system, talks not of 'Empfindungen' but of 'Anschauungen.' Distance consciousnesses "gehören dahin, wo man die Raumanschauungen unterbringt"; so that the Anschauung of brightness distances stands to that of the separate brightnesses very much as the Anschauung of a spatial distance (Strecke) stands to that of the separate positions (Orte): Sitzungsber. d. Berlin. Akad., 1887, 1008. Even here, an objection may be raised: for is there an Ortsempfindung, comparable with the Helligkeitsempfindung? Or can we, in strictness, speak of a Helligkeitsanschauung?

In the Psychology, a distinction is made between the 'spezifische' and the 'gemeinsame Eigentümlichkeiten' of *S*. Colour-tone and brightness are specific properties of visual *S*, pitch differences of auditory, warmth and cold of temperature *S*. Spatial extent, on the other hand, is common to the *S* from eye and skin, temporal duration to all *S* alike (i., 168 f.). The two groups of properties are discussed in two different chapters (169 ff., 409 ff.).

"Haben wir *S* beliebiger Art," says Ebbinghaus (411), "so kommt uns an ihnen ausser den . . . spezifischen Eigentümlichkeiten *ohne weiteres und unvermittelt durch Reflexion* noch vielerlei anderes zum Bewusstsein: . . . räumliche Bestimmungen; . . . zeitliche Bestimmungen; . . . Veränderung; Mehrheit und Einheit; Identität, Aehnlichkeit und Verschiedenheit." The specific *S* have, as a rule, several of these general properties attached to them, and can be cut free only by a process of abstraction. Conversely, the general properties never occur alone, but always in connection with specific *S*. The properties themselves are Erlebnisse, Inhalte. As there is no general name for them in current psychology, and no generally accepted theory of their origin (Meinong's phrases 'consolidated contents' and 'ideas of higher order' imply a special theory), Ebbinghaus borrows for them—without theoretical implication—the Kantian term Anschauung. He then points out that the Anschauungserlebnisse—what shall we call them: receipts?¹—may be approached, psychologically, from two different directions, may be met

¹ If the term must be translated, 'recept' would seem to be a better word than 'intuition,' although Romanes, who first employed it, would hardly have sanctioned the usage: see *Mental Evolution in Man*, 1888, 36 ff.

by one or other of two psychological attitudes : those of genesis (412 ff.) and of nativism (418 ff.). He himself decides in favour of a nativistic view (esp. 420 f.).¹

We should, now, expect to find the *S*-Distanz (Stufe, Intervall, Abstand, Grad des Abstechens gegen einander : 64) mentioned in the section on *Aehnlichkeit und Verschiedenheit* (474 ff.). As there is no such reference (and as Stumpf's § 6, not § 7, is referred to : 474), we must suppose that Ebbinghaus is reserving the topic for further treatment. Besides the passage quoted from the *Sitzungsber.*, we have the fact that in the *Psych.* (502) and in Pflüger's *Arch.*, xlv., 113, the *S*-Distanzen are termed *S*-Verschiedenheiten. There can, then, be no question as to their place in Ebbinghaus' system.

James thinks that, in equating distances, "we mean that if we were to arrange the various possible degrees of quality in a scale of serial increase" the interval or difference "between the stronger and the weaker specimen before us would seem about as great as that between the weaker one and the beginning of the scale" (i., 546). This is measuring *Distanz* by *Strecke* : cf. Stumpf's criticism, above. James' remark need not be taken literally, since he has, in his feelings of relation (i., 243 ff.), an adequate nativistic basis for direct distance comparisons.

Meinong's treatment in the articles before us is largely epistemological : the reader, may, however, cf. § 6, 104 ff., § 10, 124 ff., and the footnote, 358,—this to be taken in connection with Dittenberger, *Philos. Monatshefte*, ii., 1896, 82 f. For Meinong's psychology of relations ("Distanz ist eine Relation : " 98) see the references given in his introductory sections, 81 ff., and I. M. Bentley, *The Problem of Mental Arrangement*, *Amer. Journ. of Psych.*, xiii., 1902, 269 ff.

Finally, we may call attention once more to Lipps' *Logik*, 122. "The magnitude of the qualitative distance between two colours, say, red and green, or the degree of their dissimilarity, is determined primarily, for my immediate consciousness, by the certainty with which I keep them distinct even with slight energy of application (*Festhalten*) or slight attention to their particularity." Here is that theory of 'mental work' to which we have referred above, p. lxxxiv. *n.* "The same . . . degree of dissimilarity is also determined conceptually, and therefore indirectly, . . . by the number of *j. n. d.* colours into which the total distance divides for me." Here is indirect measurement in terms of *Strecke*. "The absolute measure of a given . . . *S*, that is, the degree in which . . . it itself is given, consists in the number of *j. n. d.* into which the qualitative distance of this *S* . . . from its zero-point divides." Here we have justice done to the Fechnerian distinction of *S* and *S*-difference : cf.

¹ Cf. Lipps' criticism, *Z.*, xxviii., 1902, 166 ff.

above, pp. xxxvi., xlix., lxvi. "Qualities and qualitative differences ['intensities' and 'intensive' differences included] are measurable as such; only one must remember that measurement in this case is never anything else than the becoming-conscious of numbers of the just noticeable."—The whole passage, § 239, offers an admirable essay subject.

There are, then, various ways of answering our question, according as one inclines towards a 'genetic' or towards a 'nativistic' theory of mental function; or, again, according as one lays the greater stress upon introspective or upon logical analysis. In any event,—and this, for our present purpose of reconstruction, is the important point,—the current psychological systems are all alike able to meet the question without difficulty.

§ 7. Notes to §§ 1-7 of the Text.—The following notes cover points that have not been raised, or at least not raised in the same context, in the foregoing Sections.

§ 1. *Measurement*.—On measurement in general, see Helmholtz, *Zählen u. Messen*, in *Philos. Aufsätze* E. Zeller gewidmet, 1887, 17; W. S. Jevons, *The Principles of Science*, 1887, bk. iii.; Fechner, *El.*, i., 45 ff., 56; P. S., iv., 217 f.; Delbœuf, *Éléments*, 111, 134; *Examen*, 99; Wundt, P. S., ii., 1885, 10; *Logik*, ii., 1, 1894, 403 ff.; ii., 2, 1895, 179; von Kries, *Vjs.*, vi., 1882, 257; M. Radakowic, *ibid.*, xiv., 1890, 1 ff.; Münsterberg, N. G., 1890, 14; Ebbinghaus, Z., i., 1890, 325; Meinong, Z., xi., 1896, 232, 237, 239; E. W. Scripture, *The New Psychol.*, 1897, 30; B. Russell, *Mind*, N. S., vi., 1897, 326; T. Lipps, *Logik*, 1893, 120 ff. Especially interesting, in psychological regard, is Meinong's statement (Z., xi., 117): "[es] scheint mir das qualitative Moment nirgends deutlicher erfassbar als beim Raume"; cf. Höfler, Z., x., 1896, 223 ff.

To avert misapprehension, it may be said that the definition of the unit of mechanical energy on p. xx. is phrased to suit the exposition, and differs from that usually offered. Energy is ordinarily defined either in terms of mass and velocity or in terms of the equivalent amount of work. Where the energy is kinetic, it is made $= \frac{1}{2} mv^2$, and its unit (the erg) is defined in terms of the work done by unit force (the dyne) in moving a body through a distance of 1 cm. We set out with the expression $W=fs$, where W is the work, f the force, and s the distance through which the force acts. Since $f=ma$, where m is the mass of the body moved and a the acceleration produced,

we have the equation $W=mas$. Here $s=\frac{1}{2}at^2$; so that W may be written $=\frac{2ms^2}{t^2}$. (Cf. the statement of the dimensions of work or energy,

p. xxiii.) Since, again, the absolute v is $=2s$, and therefore $\frac{v^2}{t^2}=\frac{4s^2}{t^2}$, we may put $W=\frac{1}{2}mv^2$: this is, as was said above, the usual expression for the kinetic energy.

§ 2. *Mental Measurement*.—See esp. Fechner, *El.*, i., ch. vii. (quotation, p. 60) and Wundt, *Die Messung psychischer Vorgänge*, in *Essays*, 1885, 154. The statement that sense differences were early remarked and utilised refers to the classification of the stars by visible magnitude: Fechner, *P. S.*, iv., 1887, 181.

On units of measurement, see the art. *Weights and Measures*, by W. M. F. Petrie, *Encyc. Brit.*, 1888; on the qualitative dissimilarity of groups of mental processes, see Wundt, *Logik*, ii., 2, 1895, 179 f. (cf. *P. S.*, ii., 20 ff.); Höfler, *Psych.*, 1897, 236.

Fechner gives two reasons for the tardy advent of a quantitative psychology: (1) dass man das Mass des Psychischen immer im reinen Gebiete des Psychischen gesucht hat; (2) dass (so to say) ungleiche Abtheilungen des Massstabes gleichen Abtheilungen des zu messenden Gegenstandes entsprechen: *El.*, i., 56, 62.

For Kant's position, see the *Metaphysische Anfangsgründe der Naturwissenschaft*, 1786, x. f.; and cf. the author's article on *Psychol.* in the 19 Cent., *Internat. Year Book*, 1900, 978. Those who are interested in the matter from the standpoint of Kant's own psychology should cf. J. B. Meyer, *Kant's Psychologie*, 1870, 214 ff., 267 ff.; G. Itelson, *Philos. Monatshefte*, N: F., ii., 1890, 285 f.; M. Dessoir, *Gesch. d. neueren deutschen Psych.*, i., 1902, 366 f.

On Herbart's 'theory,' cf. Wundt, *P. P.*, 1874, 6; i., 1902, 7: "dem Unternehmen Herbarts, Mathematik auf Psychologie anzuwenden, kann, was man über seinen sonstigen Inhalt urtheilen möge, das *eine* Verdienst nicht bestritten werden, dass es die Möglichkeit einer Anwendung mathematischer Betrachtungen in diesem Gebiete deutlich in's Licht gesetzt hat." On his 'fact,' cf. *ibid.*, 1874, 798; i., 1893, 486: "treffend sagt Herbart selbst von seiner Psychologie, sie construire den Geist aus Vorstellungsreihen, ähnlich wie die Physiologie den Leib aus Fibern. In der That, so wenig es jemals gelingen wird, aus der Reizbarkeit der Nervenfasern die physiologischen Functionen zu erklären, so fruchtlos ist das Unternehmen aus dem Drücken und Stossen der Vorstellungen die innere Erfahrung abzuleiten." For a special instance, see Stumpf, *Tps.*, ii., 185 ff. A popular account of Herbart's psychology is given by T. Ribot, *German Psych.*, 1886, 24 ff.

§ 3. *An Analogy*.—For the tangent galvanometer, see W. Watson,

Text Book of Physics, 1899, 684; fuller treatment will be found in A. Wüllner, Lehrbuch d. Experimentalphysik, iii., 1897, 579; E. Mascart et J. Joubert, Leçons sur l'électricité et le magnétisme, ii., 1897, 213.

The precise behaviour of the galvanometer needle will, of course, depend upon the nature of the mechanical restraint under which it suffers. The Analogy presupposes that the needle is not free, but restrained by a considerable friction. The conditions are perfectly realised in certain instruments of an older pattern: modern galvanometers are practically so free that those accustomed to their performance will, perhaps, fail to get the point of the illustration until they reach the end of the \S . Again: if we have a galvanometer which 'sticks,' but whose construction is such that the needle becomes entirely free when the friction is overcome, we find that the needle swings by the proper point, instead of following the increasing current, and perhaps sticks again at some too high a reading. But these and similar objections mean simply that the analogy is no more than an analogy, useful up to a certain limit, and not to be pressed beyond it.

Non-mathematical students are sometimes puzzled by the statement that the needle will never make an excursion of 90° . Since $\tan 90^\circ = \infty$, it is clear that nothing short of an infinite force will produce the deflection. Or again: since the movement of the needle is always the resultant of the pulls of the current in the coil and of the earth's magnetism, the influence of the latter will always be apparent with anything but an infinite amount of current in the coil.

\S 4. *Three Problems.*—Some of the instances of this \S will be familiar to the student from vol. i. Many of them will be discussed in the course of this vol. In the meantime, the following references may be useful for lecture purposes. For the *DL* of tones, E. Luft, P. S., iv., 1888, 528; *DL* of colours, P. Mentz, P. S., xiii., 1898, 538; extensive *RL*, Helmholtz, P. O., 1896, 256, 374; temporal *RL* of colours, A. Kunkel, Pflüger's Arch., ix., 1874, 219 f. See also Külpe, Outlines, §§ 15, 18, 19, 24, 25, 56, 65.

"Sensation . . . is a continuous function of stimulus." The author has taken the truth of this proposition for granted throughout his discussion. For one thing, it seems (apparently) to the majority of present-day psychologists to be more probable than its opposite; for another, it affords, true or false, a perfectly good working hypothesis. Nevertheless, it has not found universal acceptance; and we must here consider some of the arguments brought against it.

In his *Metaphysik* (1884, 513), Lotze asks the question "why a continuous curve of increase of *R*-intensity is not followed continuously by the more slowly ascending curve of *S*-intensity; why there rather remains an interval, during which *R* increases without effect, producing a noticeable change in *S* only with the attainment of its final value." He proposes three answers, of which the first appears to be the most satisfactory. (1) "It is not an insoluble task for mechanics, to construct a system of material parts in such a manner that a continuously impelling force can still, by reason of internal checks, exert its effect only with intermissions, at determinate moments; on this analogy we should have to think of the nerve as so constructed that, whatever the degree of excitation from which we start, a certain further accumulation and increase is required to produce a movement that can serve as stimulus for the arousal of a new sensation. . . . However, we have not the remotest idea of how such a mechanism should be conceived and where in the nervous system it should be placed." (2) Less probable is the hypothesis that makes *E* proportional to and continuous with *R*, and seeks the ground of discontinuity "in der Natur des Empfindens"; "eben in dem Begriffe des Empfindens liegt Nichts, was mit Wahrscheinlichkeit die hier unmögliche Zwischenmaschinerie ersetzen könnte." (3) Nor is it allowable to make a distinction between *Empfindung* and *Wahrnehmung*, and to say that the former is continuous with *R* and *E*, "aber die Wahrnehmung bringe die wirklich gewachsene Intensität der *S* in anderem Verhältniss und un stetig zum Bewusstsein."—The fact that we have a discrete series of *S*-intensities over against the continuous curve of *R*-intensity is due, therefore, not to anything intrinsic to *S* itself, and not to the processes of discrimination and comparison involved in our estimates of *S*-intensity, but rather to the discrete character of *E*, of the nervous substrate of *S*.—*Cf.* the less positive discussion in *Outlines of Psych.*, 1886, 19 f.

Funke (in *Hermann's Hdbch.*, iii., 2, 1880, 358 f.) admits that Lotze's physiological conception is possible, and cites as parallel the intermittent innervation of the nerves of inspiration that goes along with continuous stimulation of the respiratory centre. He thinks, however, that the hypothesis in the present

case is by no means probable: we cannot imagine the nature of the inhibitory mechanism required, and the fact of the *DL* is more readily explained "aus der Unvollkommenheit des Auffassungsvermögens für verschiedene *S*-Intensitäten" (*ct.* 349). Moreover, there are two counter-arguments. If the hypothesis be correct, then (1) continuous increase of *R* must give in consciousness an intermittent increase of *S*; and (2) at a certain lower limit of rapidity of the *R*-increase, the corresponding *S* must show pauses, interruptions of continuity. Neither of these consequences is realised in fact.

Stumpf (*Tps.*, i., 351 ff.) points out that the second of these arguments is not binding. While *R* proceeds from *a* to *b*, *E* might remain at *a*; while *R* goes on from *b* to *c*, *E* might stay at *b*; and so forth. The first argument, again, is valid only on the assumption (common to both Lotze and Funke) that "any the least change in *S* must be perceptible." If we reject this assumption, then the *R*-zone *a—d*, corresponding to a j. n. d. of *S*, may really give rise, say, to the four *S* *a*, *b*, *c* and *d*,—these *S* being discrete, but so little different that their difference cannot be perceived. "Lotze's view is, then, possible and defensible,—but only if one gives up the principle from which its necessity would follow." Stumpf, it is needless to say, does not accept the principle. He is, nevertheless, non-committal in his conclusion: "mir scheint einstweilen weder pro noch contra ein trifftiges Argument möglich."

In his discussion of quality (183 ff.) Stumpf remarks that the Helmholtz theory of audition favors a discrete tone series. He also suggests (himself employing Funke's second argument) that an extremely slow *R*-change might even render the discrete nature of the *S*-series perceptible. As for the continuity of tonal idea (as distinguished from tonal sensation), that might be real enough; we might fill out the breaks in sensation "durch Acte unwillkürlich productiver Phantasie": *cf.* the blind spot of the eye. A similar "unwillkürliches Hinarbeiten der Phantasie" is possible in the case of intensity (353).

So Stumpf leaves the question. It is one that peculiarly suits his somewhat scholastic temperament; and if he does no more with it,—if he leaves it in this way, with merely academic *pro*

and *con.*—we may ourselves, without hesitation, choose the orthodox view.¹ Readers who desire to pursue the topic farther may consult: Aubert, *Phys. Optik*, 1876, 595; Preyer, *El. d. reinen Empfindungslehre*, 1877, 6, 62 f. (these writers think that we are “inclined *à priori* to attribute continuity to objects, and to hold fast to this assumption for so long as sensation and perception do not directly contradict it”); Wundt, *P. S.*, ii., 1885, 7; *P. P.*, i., 1893, 325, 458, 484 f.; i., 1902, 441; Höfler, *Psych.*, 242 ff.; G. E. Müller, *G.*, 380 f.; *Z.*, x., 79 ff.; Delbœuf, *Examen*, 127 ff., 135 f.; Stout, *Manual*, 1899, 203; C. Renouvier, *Critique philosophique*, vii., 1, 1878, 180 f.; A. Stadler, *Philos. Monatshefte*, xiv., 1878, 219 ff.; F. A. Müller, *Axiom*, 1882, 23; J. Ward, *Mind*, O. S., i., 1876, 461 f.; A. Elsas, *Psychoph.*, 1886, 38 ff.; A. Grotenfelt, *Das Webersche Gesetz*, 1888, 169 ff.; C. S. Peirce and J. Jastrow, *Mem. Nat. Acad. Sci.*, iii., 1, 1884, 75, 82; Jastrow, *Amer. Journ. of Psych.*, i., 1888, 277; P. Tannery, *Rev. phil.*, xvii., 1884, 22, 25 ff.; xxv., 1888, 194 ff.; A. Köhler, *P. S.*, iii., 1886, 583; A. H. Pierce, *Journ. Ph. Psych. Sci. Meth.*, ii., 1905, 150.

§ 5. *Technical Terms.*—The term *Schwelle* appears to occur for the first time in Herbart's *Psychol. Bemerkungen zur Tonlehre*, 1811; *Werke*, ed. G. Hartenstein, vii., 1889, 10. *Cf.* the *Lehrbuch zur Psych.*, 1816; *Werke*, v., 1886, 18; and the *Psychol. als Wissenschaft*, 1824; *Werke*, v., 341. The term *Unterschiedsschwelle* was introduced by Fechner, apparently in 1860 (*El.*, i., 239). For *Reizhöhe*, see Wundt, *P. P.*, 1874, 282.

A humorous critic has remarked, *à propos* of experimental psychology, that “the success of a modern science depends largely, if not wholly, on the elaboration of a technical terminology and the generous provision of instruments for a laboratory.” The remark raises the smile that it was meant to raise: but it may be taken seriously as well. For both instruments and terms are necessary; and yet we meet with a sort of contempt for both, even within the science itself. We are often told, for instance, that ‘the best work has always been done with the simplest instruments,’² and that we are in danger of making our labor-

¹ Fechner, *El.*, ii., 84; *P. S.*, iv., 172 ff.

² The idea is sanctioned by no less a psychological authority than J. McK. Cattell: see *Psych. Rev.*, v., 1898, 658.

atories too pretentious, and losing sight of the end in our interest in the means. But this is mere nonsense. The best work has always been done by the best men; and the best men have, all too often, been forced to content themselves with poor instruments. Their work would have been still better, had they had adequate appliances. The most reliable investigation into the differential sensitivity for visual sensations that we possess—the work of A. König and E. Brodhun, *Sitzungsber. d. Berl. Akad. d. Wiss.*, 26 Juli 1888, 917; 27 Juni 1889, 641—was made with an extremely elaborate and expensive dioptrical apparatus. The more generously we are supplied with such instruments of precision, the better shall we work.¹

Similarly, the importance of a good terminology can, from the point of view of teacher and student, hardly be overestimated.² A rose by any other name would smell as sweet; but we do not teach botany by smell. The teacher of psychology is required, in a very limited time, to bring his pupils within the circle of the science; to start them psychologising, to train them in method, to give them facts and uniformities. How much of his success must depend upon his choice of words, and how completely is the beginner at the mercy of his phrasing!

Experimental psychology was, in origin, a German science; and the German technical terms must be translated. One great difficulty is that the terms already current in English psychology—the psychology of ‘associationism’: see *i.*, I. M., 404, 419—are all surcharged with functional meaning; they refer to mind in use; whereas the characteristic terms of experimental psychology avoid functional reference, and imply nothing more concerning mind than its existence. Take, *e.g.*, the word *Unterschiedsempfindlichkeit*. It is tempting to reduce this to familiar English by translating it ‘sensible discrimination.’³ But—‘sensible

¹ Provided, that is, that we are already psychologists! *Cf.* *i.*, I. M., vii.

² *Cf.* Scripture’s remarks, *New Psych.*, 39, — in which naïveté would seem to reach its limit.

³ As, *e.g.*, the author did in his translation of Külpe’s *Outlines*, 1895. Sully and James use the phrase ‘discriminative sensibility,’ *Human Mind*, i., 1892, 89; *Psych.*, i., 1890, 533; Stout and Baldwin recommend ‘sense discrimination,’ *Dict.*, i., 1901, 284; Foucault uses ‘sensibilité différentielle,’ *Psychoph.*, 11.

discrimination' is rather the equivalent of sinnliche Unterscheidungs-fähigkeit, or Unterscheidungs-fähigkeit im Empfindungs-gebiet; and the student of psychophysics is called upon to distinguish sharply between Unterschiedsempfindlichkeit and Unterscheidungs-fähigkeit. Nothing remains but to take the ugly collocation 'differential sensitivity,' and to make it passable by the abbreviation D. S.

It would be wearisome to follow out, in this way, the history of every technical term employed in the book. And it would also be useless: for technical terms, however good the reasons which prompt to their suggestion, must fight their own way in the world, and stand or fall by their own merit or demerit. The author may, however, quote the most important maxims which have guided him in his choice. (1) The first rule has been negative: that one should not try to satisfy the requirements of psychology at large, but be content with terms that 'work' well in experimental psychology. For psychology is a vast subject, and its departments are as yet imperfectly co-ordinated. It is out of the question to secure, as things are, terms that shall serve interchangeably, say, in the genetic psychology of Stanley Hall and Baldwin, in the functional psychology of James and Stout, and in an experimental course. Contexts, even postulates, are widely divergent. Ultimately, we may hope, there will be a *rap-prochement* of the various psychologies. In the meantime, it is the part of modesty and of common sense to let each psychology work out its own verbal salvation. (2) A good terminology should be absolutely transparent, letting the facts be seen through the words. Constructive thought runs its course, for the most part, in symbols, which may be arbitrarily defined; though the story of the *Kritik der reinen Erfahrung* shows, clearly enough, that arbitrariness may go too far. But the beginner thinks imitatively, not constructively. For his use, technical terms should do more than symbolise the facts: they should, so far as possible, suggest, recall, indicate, relate, clarify, quicken the facts. It follows that the terms chosen for use in experimental psychology should cover, as literally as may be, the corresponding German terms to which the student will be constantly referred. Almost all

of the classical literature is in German, and very little has been translated.¹ It follows, further, that the terms chosen must neither be familiar terms which would bring with them misleading associations, nor terms so unfamiliar that their assimilation would itself be difficult. Sometimes it is possible to take a current word, and to change or restrict its meaning, for scientific purposes, without loss of the warmth and intimacy that go with its use. Sometimes one must have recourse to a neologism; but then one must see to it that the novel term is not wholly novel, but exists already in some derivative or cognate form. And it follows, finally, that the terms chosen must be terms that fall naturally into groups, that allow of adjectival formations, that lead easily to or from other terms and groups: in a word, that they must be both adequate and self-consistent.

So much for rules. Having formulated them, let us admit frankly that they cannot be strictly followed, that every working terminology is a compromise. Technical terms are a matter partly of individual authority, partly of organic growth, partly of inertia of attention, partly of accidental factors,—training, association, chance likes and dislikes. They are too important to neglect: but he who meddles with them should be endowed with a vast deal of patience and a plentiful supply of humour.

Cf. F. Tönnies, *Mind*, N. S., viii., 1899, 289, 467; ix., 1900, 46; Baldwin's *Dict. of Phil. and Psych.*, i., 1901, vii. f.; ii., 1902, 677 ff.; Titchener, *Amer. J. of Psych.*, vii., 1895, 78; viii., 1896-7, 584.

‡ 6. *Quantitative Psychology*.—On contrast measurements, see A. Lehmann, *Phil. Stud.*, iii., 1886, 497; H. Ebbinghaus, *Sitzungsber. d. Berl. Akad.*, xlix., 1887, 995 (our illustration is drawn from this paper: for the law of contrast darkening, cf. *ibid.*, and *Psych.*, i., 223); A. Kirschmann, *P. S.*, vi., 1890, 417; C. Hess and H. Pretori, *Arch. f. Ophthal.*, xl., 4, 1894, 1; H. Pretori and M. Sachs, *Pfl. Arch.*, lx., 1895, 71.

On the law of the fortune morale, see D. Bernoulli, *Comment. Acad. scient. imp. Petropolit.*, v., 1738, 177, 181 f.; P. S. de Laplace, *Théorie analytique des probabilités*, (1812) 1847, 187, 432; cf. the *Essai philoso-*

¹ It is to be hoped that we shall some day have an Englished series of psychophysical classics, in which such things as Weber's *Tastsinn*, the constructive parts of Fechner's *Elemente*, Hering's *Lichtsinn*, etc., will be accessible to all English-speaking students.

phique (1814), trs. by F. W. Truscott and F. L. Emory, 1902, 22 ff., 189; S. D. Poisson, *Recherches sur la probabilité*, etc., 1837, 72; Fechner, *El.*, i., 65, 236; ii., 549 f.; *I. S.*, 59; Wundt, *Beiträge*, 1862, xxx. f.; *P. S.*, i., 1883, 252; *P. P.*, 1874, 434; i., 1880, 469, 494; i., 1887, 512, 537; i., 1893, 563, 591; ii., 1902, 317 f.; A. Grotenfelt, *Das Webersche Gesetz*, 1888, 87 ff.; F. Kirchner, *Psychologie*, 1883, 147; J. Merkel, *P. S.*, iv., 1888, 591; G. A. Lindner, *Psych.*, 1880, 30, 134 f.; F. C. Müller, *Arch. f. Physiol.*, 1886, 311; Delbœuf, *Examen*, 42 f.; Höfler, *Psych.*, 418 f.; Jodl, *Psych.*, 213 f., 394; Zeller, *Abh. d. Berl. Akad.*, 1881, 11 ff.; J. Ward, *Mind*, O. S., i., 1876, 457 f.; A. Lehmann, *Hauptgesetze d. menschl. Gefühlslebens*, 1892, 256 ff.

The first quantitative determination of an optical illusion was made by H. W. Knox and R. Watanabe (Oppel's lines: i., *S. M.*, 157), in *A. J. of Psych.*, vi., 1893-5, 413, 509. Since this time the quantitative method has been widely used: one of its latest applications will be found in A. H. Pierce, *Studies in Auditory and Visual Space Perception*, 1901, 224. Stout refers to it (*Manual*, 1899, 32 f.) as one of the standard illustrations of quantitative work in psychology.

For the memory formula, see H. Ebbinghaus, *Das Gedächtnis*, 1885, 106; H. K. Wolfe, *P. S.*, iii., 1886, 554. Quantitative work on memory has continued, almost without interruption, down to the present; but interest has also attached, in recent years, to the qualitative questions of the mechanics of association and reproduction, and of the course and employment of the memory-image. *Cf.* the bibliography published by I. M. Bentley, *A. J. of Psych.*, xi., 1899-1900, 4 ff. A good account of current doctrine is given by Ebbinghaus, *Psych.*, i., 1902, 606 ff. It is now becoming possible to combine the qualitative and quantitative procedures: *cf.* G. M. Whipple, *A. J. of Psych.*, xii., 1901, 401; xiii., 1902, 219; and the introspective records in Müller and Pilzecker, *Gedächtnis*, 1900.

See, further, § 41 below.

The Instructor must recognise, at the outset, that method work is, to the average student, very much more difficult than qualitative work. A parallel has often been drawn between qualitative and quantitative work in psychology and qualitative and quantitative work in chemistry. In the main, and so far as analogies are accustomed to go, this analogy holds: but elementary quantitative work in psychology is, in the author's judgment, relatively much harder than the corresponding work in chemistry. This fact alone, quite apart from the difference in mental attitude involved, justifies the separation of the two fields, and the putting of quality

before quantity in a psychological training course. The average student, on entering the laboratory, is simply not competent to do quantitative experiments. And more than that: it will happen, time and time again, that even one's best students, after the fullest directions and the most careful explanations, will hand in results of a laborious experimental series which—owing to some slip in method, some irregularity of procedure, some too facile interpretation, some unforeseen and undetected prepossession, some lapse of attention—are altogether worthless from the standpoint of the experiment. A method is not an easy thing to grasp: the Instructor, who has gone over it hundreds of times, step by step, bringing out and insisting upon the psychological importance of each determination, has it ingrained in his mental constitution: but the student must assimilate it, by a sustained effort of attention. Practice in method work itself can alone give the surety of manipulation and the discriminating judgment that method work requires. We can, however, shorten the term of practice by giving a preliminary training on the qualitative side.

Hence the author cannot agree with those psychologists who advise that qualitative and quantitative experiments be intermingled, from the first, in class work.¹ In his own experience, the result of such mixture is that the qualitative experiments are slighted as rough and indeterminate tests, which ought by rights to be made quantitative; while the quantitative experiments are performed—largely through sheer ignorance of their true difficulty—in a slovenly and intermittent fashion.² It is well, of course, to throw one's qualitative exercises, so far as possible into quantitative form: that ensures accuracy: but it does not turn quality into quantity. On the other hand, there are a few really quantitative experiments that do not take much time, and that can be performed roughly, in a sort of qualitative way, without previous training: so the determination of certain *RL*, and the sorting into groups of given weights or brightnesses. But these are the very experiments that should be used as an introduction to quantitative work. Their tendency to slip into 'quality'

¹ See, e.g., J. Jastrow, *Science*, xiii., 10 May 1901, 742 f.; O. Külpe, *Z.*, xxx., 1902, 436.

² Cf. with this vol. i., I. M., xx. ff.

of the wrong kind makes them admirable warning examples; and their comparative easiness does not at all disprove the difficulty of quantitative work at large. Moreover, even they are meaningless to the student unless prefaced by a pretty full account of the aims and limits of quantitative psychology.¹

Over and above the greater difficulty of quantitative work, we must keep in mind the change of mental attitude which it demands. It is not easy for the student to turn, in qualitative work, from experiments upon sensation, which require the keenest attention, to experiments upon affective process, which require a passive, as it were a listless frame of mind. It is not easy, again, for him to turn from sensation or affection to perception, where the problem is far more complex, and where he is called upon, so to say, to drive several observations abreast. The change from qualitative to quantitative work is greater than either of these changes. The student is conscious that, once an experiment is started, there is no release. The series must be gone through with, or the time will have been just wasted. To put the matter in simile: the student is not now rehearsing a set speech, but arguing to prove his case; and if there be one weak spot in his argument, the whole case breaks down. He is not playing the part written for a single instrument, but directing the orchestra; and if he make a slip, the whole performance is thrown into confusion. He is not working out an illustration to a known mathematical rule, but going through an elaborate set of computations; and if he make a mistake, the whole work will be to do over again. Or, to phrase it more directly: the student becomes, by practice, a manipulating machine, making a long series of adjustments at regular intervals and with great accuracy; at the same time, his attention ranges ahead, he has the

¹ The proof of the pudding is in the eating; and the author writes from sad experience. If it is objected that other people may do better,—that qualitative and quantitative experiments have, *e.g.*, already been intermixed, with good result, in Sanford's Course, why, let Sanford himself supply the answer. "Most of the experiments," he says (p. iv.), "are demonstrational in character, and aimed at qualitative rather than quantitative results, even where for convenience they have been given a quantitative form. Precautions necessary for results of the latter sort have therefore been lightly touched upon." Besides, Sanford puts at the *end* of the Course his special chapter on Weber's Law and the psychophysical methods.

whole course of the method in mind, he is quick to note lapse or error on the part of *O*, he decides promptly on doubtful points, he is alert to the total 'situation.' As *O*, he is required to make a succession of maximal efforts of attention; to judge quickly and accurately, relapsing into passivity as soon as the judgment is passed; and, at the end of the series, to give account of his manner of judging. Indeed, there is no need to search for similes. If method work were not intrinsically difficult, if it did not demand its own special mental attitude, the greater part of the literature of psychophysics, constructive and destructive, would not have been written.

It is, then, even more important here than it is in qualitative work (see i., I. M., xx.) that the Instructor shall teach from first-hand knowledge of the methods. One error may ruin an experiment, and the possibilities of error are legion. Yet if advice and criticism are to be helpful, they must be definite, detailed. Fortunately, the Instructor acquires, after a few years of teaching, a sort of instinctive familiarity with the methods: so that he can, as a rule, lay his finger accurately upon a weak point of procedure, and say: "Here your pauses must have been irregular," or "Here you were getting inattentive, and the habituation error came in." As a rule,—not invariably; for students and methods are slippery things. However, the human mind is mainly impressed by positive instances, and the student, after a few such criticisms, gains a wholesome respect both for the methods and for the Instructor. This is the reward of first-hand work. But if the Instructor does not know how precisely to shape his directions, so that *E* and *O* shall understand just what they have to do; and if he is not able to check and control the results handed in to him, so that *E* and *O* shall realise the psychological importance of the method they have employed: then psychophysics becomes as foolish and worthless as its worst enemies could desire.

And if the student, after all, go wrong,—as, in the light of this somewhat pessimistic discussion, he may almost be expected to do? Has he then wasted his time? Not at all: there is nothing like making a blunder to keep one straight in later work. It is always better to have worked wrongly—if you know afterwards

where your mistake lay—than not to have worked at all. In the present case, it is not seldom better to have worked wrongly than to have worked rightly at the first attempt; the reconsideration of the method stamps its psychological necessity more firmly on the student's mind; the problem becomes luminous; the difficulties, now fully realised, are seen to be surmountable. *Cf.* i., S. M., xv.—

So far, then, as training is concerned (the author is not speaking of original work), quantitative experiments are far more difficult than qualitative, and should be postponed till some general practice has been had in a psychological laboratory; while the attitude of mind in the two cases is so widely different that a beginner will find it impossible to turn successfully from the one to the other.

§ 7. *Questions.*—(1) See W. S. Jevons, *The Principles of Science*, 1887, 285 ff. (2) Answer from § 2. (3) Answer from pp. cxlvi. ff., above. (4) Answer from § 4 (2). (5) Answer on the lines of § 6 of the text. (6) Answer from § 6. (7) Answer on the lines of Ebbinghaus' formula, § 6, p. cxxix. above. (8) Answer from § 4 (3) and references there given. (9) Answer from § 4 of the text. The second part of the question is not set in order that the Instructor may strike a decision, but rather that he may hold the balance between two equally important departments of psychology. The interested student will 'take sides:' just as, when one begins the study of literature, one is very sure that lyric poetry is of a higher order than dramatic, or vice versa. If he is for psychology and nothing but psychology, he will cry up the mental measurements; if he is an enthusiast for natural science, he will find no sure ground outside of physics. In either case, the Instructor is in opposition.

§ 8. **Questions and Essay Subjects.**—The following are suggested as essay subjects. Materials for their treatment will be found in the foregoing discussions and references; a few new references are here added. The essay should, whenever the subject allows, be both historical and critical. It is advisable to assign a topic to each pair of students, at the beginning of the quantitative laboratory work, and to allow a considerable time (say, two months) for its study. The Instructor will decide whether reports of progress are to be handed in separately by the students, and privately discussed with them, or whether a number

of topics shall be dealt with in informal seminary meetings. As the essays approach completion, it will probably be worth while to have them read and discussed in seminary.

(1) The doctrine of mental measurement.

This topic may be subdivided in various ways: *e.g.*, (a) Fechner's view of mental measurement (the *Elemente* and the *Massprincipien*); (b) the difference between the teaching of Fechner and the Reconstruction (say, Fechner's *Massprincipien* and Ebbinghaus' *Psychologie*); (c) physical and mental measurements: their resemblances and differences. The field may, again, be narrowed by the assignment of special books or articles for critical review: thus, (a) Fechner's *El.*, i., chs., i., ii., iv., vi., vii.; (b) selected chapters of the *Elemente* with Delbœuf's *Examen* or Ebbinghaus' articles in *Z.*, i.; (c) Cattell, *Philos. Rev.*, ii., 1893, 316 ff. with Scripture, *The New Psychology*, 1897. A good deal of psychology may be learned by a critical study of some author who gives, in brief compass, a 'personal,' perhaps a heterodox statement of the psychophysical problem and its solution: *e.g.*, (d) Münsterberg, *Beiträge*, Heft iii.; (e) Tarde, *Rev. phil.*, x., 1880, 150, 264 (restricts measurement to belief and desire); (f) Foucault, *Psychophysique*, ch. vi. (the "quantité qui est en jeu dans les mesures psychophysiques" is "la clarté des perceptions").

(2) The doctrine of *Merklichkeit*.

Wundt, P. P., and Meinong's criticism, *Z.*, xi., 124 ff. A good text for this essay may be found in the following sentences (C. Wiener, *Wied. Ann.*, xlvi., 1892, 661). "[Es] drängt sich uns als Maasseinheit der Zunahme der *S*-Stärke und damit der *S*-Stärke selbst die *Merklichkeit* dieser Zunahme auf, sodass wir sagen, zwei *S*-Stärken sind um eine *S*-Einheit verschieden, wenn ihr Unterschied gerade bemerkt oder empfunden (!) werden kann . . . Die *S*-Einheit ist also gegeben durch die eben merkbare Unterscheidbarkeit (!) zweier *S*." Or, again, in these words (W. Dittenberger, *Phil. Monatshefte*, N. F., ii., 1896, 102): "der Unterschied zweier appercipirter Empfindungsintensitäten ist psychologisch betrachtet von der *Merklichkeit* des zugehörigen Reizunterschiedes grundverschieden."

It is interesting to compare Wundt's doctrine of *Merklichkeit* with Foucault's doctrine of *clarté*.

(3) The sources of Fechner's psychophysics.

This essay has two parts: (a) the course of Fechner's own thinking (*El.* ii., 553 ff.), and (b) his relation to predecessors (especially Herbart) and contemporaries.

(4) The relation of Fechner to Herbart.

Fechner owed to Herbart three things: the general idea of mental measurement, *i.e.*, of the application of mathematics to psychology; the concept of the limen; and the ideal of mental analysis, for which the *DL* proved to be so effective an instrument. On the two former counts, see Wundt, *G. T. Fechner*, 1901, 66 f.; *P. P.*, i., 1902, 7 *n.* On the third, Wundt, *Logik*, ii., 2, 1895, 162; *P. P.*, i., 1902, 357; L. W. Stern, *Z. f. paed. Psych. u. Path.*, ii., 1900, 334. It is possible, too, that Fechner's preponderant interest in sensation was due, in part, to the 'intellectualistic' trend of Herbart's psychology.

(5) The relation of Wundt to Fechner.

A text may be found in O. Külpe, *Arch. f. Gesch. d. Phil.*, vi., 1893, 183; or in G. F. Lipps, *Massmethoden*, 1904, 15 f., 33; *Arch. f. d. ges. Psych.*, iii., 167 f., 185.

(6) The sources of the 'new' psychology.

This essay would include a review of Lotze, of whom we have said very little. Lotze is, indeed, indefinitely less modern (on the purely psychological side) than those who know him only by his theory of local signs would be apt to suppose. *Cf.* Stern, *loc. cit.*, 345; and *n.*, p. cxi. above.

(7) The question of 'mental work' and 'mental fatigue.'

This essay should connect with Höfler's definition of attention (see i., *S. M.*, 117; *Psychologie*, 263) and with his article on *Psychische Arbeit*, *Z.*, viii., 1895, 44, 161. See above, p. lxxxiv. *n.* Höfler's discussions may be taken together with Lehmann's criticism: *Die körperl. Aeusserungen psych. Zustände*, ii., 1901, 192 ff.

(8) Psychophysical parallelism.

This is an exceedingly difficult topic, and should not be assigned without especial reason. Usually, with enthusiastic students, there is a special reason: men take sides, as if temperamentally, with parallelism or interactionism. It is then best to give them something solid to bite on. The best popular accounts known to the author are: for interaction, James, *Psych.*, i., ch. v. (*cf.* 67 ff.); ii., 584, 591 f.; for parallelism, Ebbinghaus, *Psych.*, i., 27 ff. Good essay texts are: (1) Fechner, *El.*, *Einleitendes*, i., ii.; (2) Fechner, *Ueber die Seelenfrage*, 1861; (3) F. Paulsen, *Introd. to Philos.*, (1892) 1898, 74 ff.; (4) C. Stumpf, *Eröffnungsrede*, in *Bericht ü. d. III. internat. Congress f. Psych.*, 1897, 3 ff. (for interaction); (5) G. Heymans, *Zur Parallelismusfrage*, *Z.*, xvii., 1898,

62 ff. ; (6) O. Külpe, Ue. d. Beziehungen zw. körperlichen u. seelischen Vorgängen, *Z. f. Hypnotismus*, vii., 1898, 97 ff. ; (7) W. Wundt, *Die psych. Causalität u. d. Princip d. psychophysich. Parallelismus*, P. S., x., 1894, 47 ff. ; (8) A. Riehl, *Der philosophische Kritizismus*; ii., 2, 1887, 176 ff. (epistemological) ; (9) J. Rehmke, *Allgemeine Psych.*, 1894, 35 ff. (polemic against parallelism) ; (10) J. von Kries, *Ue. d. materiellen Grundlagen d. Bewusstseinserscheinungen*, 1898 ; (11) C. Hauptmann, *Die Metaphysik in d. Physiologie*, 1893 ; (12) C. A. Strong, *Why the Mind has a Body*, 1903. The literature of the subject is very wide, and of all degrees of value.

(9) The teleological significance of the logarithmic law.

For Fechner, J. J. Müller, *Ber. d. kgl. sächs. Ges. d. Wiss., math.-phys. Cl.*, xxii., 1870, 328 ; against him, Hering, *Sitzungsber. d. kais. Akad. d. Wiss. zu Wien, math.-naturwiss. Cl.*, lxxii., 1875, 318, 321 ff., 332 ff. See also Fechner, *I. S.*, 57, 75 ; G. E. Müller, *G.*, 1878, 403 ff., 408 ff. ; A. Grotenfelt, *Das Webersche Gesetz*, 1888, 128 f. ; P. Langer, *Grundlagen d. Psychophysik*, 1876, 15 f., 27 ff. ; J. Delbœuf, *Examen*, 15 f., 63 f. ; J. von Kries, *Vjs.*, vi., 1882, 287 f. ; A. Gruenhagen, *Physiologie*, ii., 1886, 128 ff. ; A. Meinong, *Z.*, xi., 1896, 387 ; H. Ebbinghaus, *Psych. i.*, 1902, 512 ff. ; Külpe, *Outlines*, 168 ; A. Elsas, *Philos. Monatshefte*, xxiv., 1888, 149.

(10) The doctrine of relativity.

See esp. Stumpf, *Tps.*, i., 1883, 3 ff., 76 ff. ; Ward, *Mind*, O. S., i., 1876, 457 ff. ; Grotenfelt, *Das Webersche Gesetz*, 76 ff., 174 ff. ; Meinong, *Z.*, xi., 383 ff., 398 ; Ebbinghaus, *Psych.*, i., 518 ff. ; Wundt, *P. P.*, i., 1893, 393 ff., 397, 399, 416, 591 ; i., 1902, 541 ff., 551 ; iii., 1903, 784 ; T. Lipps, *Sitzungsber. d. kgl. bayr. Akad. zu München, phil.-philol. Kl.*, 1902, 3 ff. ; *Leitfaden d. Psych.*, 1903, 74 ff. Stumpf, Grotenfelt and Wundt give many further references.

(11) Fechner's psychology.

A general sketch in Wundt, *G. T. Fechner*, 1901, 83 ff. Special criticisms will be found scattered in the literature : thus, on Fechner's psychology of 'sensation' see Ward, *Mind*, O. S., i., 1876, 464 ff. ; Hering's letter quoted by Fechner, *I. S.*, 49 f. ; Delbœuf, *Examen*, 43 f., 87, to be taken with *I. S.*, 61 *n.* and *El. i.*, 15, ii., 336 ; Foucault, *Psychophysique*, 1901, 9 f., 175 ff., with refs. to Fechner, 229, 269 ; Lipps, *Massmethoden*, 1904, 15 ; *Arch. f. d. ges. Psych.*, iii., 167.

(12) Wundt's psychophysics.

Two things should, in the author's opinion, be emphasised : (1) the development of the doctrine of apperception on the basis of that of un-

conscious inference (see, besides refs. already given, Stumpf, Tps., i., 90, n.), and (2) the essential similarity of Wundt's Merkllichkeitsgrade to the 'distances' and 'contrasts' of the Reconstruction.

(13) Stumpf's psychophysics.

This essay requires a careful study of the first three §§ of the Tps., i. Stumpf sets out from the fact of the universality of the sensory judgment: "dem Erwachsenen bietet sich keine Sinnesempfindung, die nicht in einem gewissen Masse beurteilt, in irgend einer Beziehung aufgefasst würde" (7): "das Vorhandensein einer *S* im Bewusstsein ist fast ausnahmslos mit gewissen Urteilen über ihr Verhältnis zu anderen Vorstellungen verbunden" (22).¹ Moreover, these 'judgments, apprehensions, apperceptions' can, if not alter the contents of *S*, at least bring about a confusion between a present *S* and other contents not now sensed. This effect of judgment is, then, Stumpf's point of departure.

By the *reliability* of a judgment is meant the degree of confidence that may be placed by others in the truth or accuracy of the judgment as expressed. Since, in general, objects are judged along with their sensations (*cf.* our discussion of the *R*-error), we may speak of the *objective reliability* of judgment, in cases where "mit den *S* zugleich Objektives" or "über *S* als Zeichen äusserer Vorgänge beurteilt wird" (23). Questions accordingly arise as to the factors which condition obj. rel., and as to methods of measuring it.

Before answering these questions, Stumpf distinguishes two classes of judgments. The first class consists of those in which every one of the possible answers to a given question may (according to circumstances) be either right or wrong. For instance: "How many tones do you now perceive?" "Which of these two different tones is the higher?" The second class contains judgments in which the affirmation is always right and the negation always wrong, or vice versa. For instance: "Is this tone the same as that you heard just now?" "Is this interval pure?" (24). The obj. rel. of judgments of the first class is identical with their degree of *probability*, *i. e.*, the ratio of the chances for the rightness and wrongness of the assertion made; that of judgments of the second class is identical with the degree of *accuracy* of the affirmative statement (likeness or purity), or with the degree of its approximation to the truth, —this being determined by the *j. n.* or just unnoticeable unlikeness or impurity (26 f.).

Objective reliability, now, is conditioned upon two general factors:

¹ We omit the discussion of the law of relativity, on which see Question (10).

(1) *sensitivity*, the degree in which our *S* correspond to the adequate *R* which arouse them; and (2) *subjective reliability*, the reliability of a judgment with regard to the correct apprehension of sensations as such, and without regard to their correct reference to external objects (28, 31). In general, defects of sensitivity are responsible for errors in judgments of the second class, and defects of subj. rel. for errors in those of the first class (38).

Passing to our second question, we find three things to measure: obj. rel., and its two factors, sensitivity and subj. rel. (1) Obj. rel. may be measured directly, without reference to (or even knowledge of) its factors. "All 'psychophysical' experimental series furnish, as *direct* results, measurements of this kind. They tell us what the difference or ratio of two *R* must be that shall call forth, under certain definite conditions, *judgments* of a definite degree of probability (first class) or of accuracy (second class) . . . The means to this end are *series* of judgments, from which we calculate the ratio of the right to the total number of answers, or the average error of the wrong statements" (43 f.). (2) Measurement of subj. rel. is "usually accomplished by examination of a series of judgments taken from the same *O* with constancy of adequate external *R* and with the introduction of circumstances that may affect the judgment. Judgments of the first class are here the more useful, since they show more plainly the effect of the disturbing circumstances" (45). (3) "Measurement of sensitivity presupposes knowledge of subj. rel. It can be based only upon *O*'s statements, and these are dictated, in the first instance, not by his *S* but by his apprehension of them. Sensitivity itself is given, when we have subtracted from obj. rel., which alone is directly measurable, everything that should be laid to the account of subj. rel. Here, judgments of the second class are the more available, since they give the greater prominence to sensitivity" (49).—

This is the framework of Stumpf's argument. It is clear that his psychophysics is Fechner upside-down. Fechner began with sensitivity, and looked upon differences of subj. rel. as disturbing factors that should, so far as possible, be eliminated. Stumpf begins with the obj. rel. of judgments, and in so doing sets subj. rel. in the forefront of interest; the measurement of sensitivity thus becomes a 'Restproblem,' a remainder of work that is left us when we have taken the one of our known quantities, the subj. rel., from our total, the obj. rel. "Die Psychophysik tritt so ihrem ganzen Inhalte nach als ein Capitel und zwar, was den Lauf der Forschung betrifft, als das letzte, in eine *messende Urteilslehre* ein" (54).

Here is material in plenty for the exercise of the student's critical acumen! What are we to say of this doctrine of the *Sinnesurtheil*?

Whence did Stumpf get it? What is its validity? Is it true that we never have a sensation without at the same time 'judging' it? What is the psychological mechanism of 'apprehending in connection,' of 'judging about relation to other ideas'? What precisely does Stumpf do (*i. e.*, what does he do for psychology) in measuring obj. rel.? What is the measurable magnitude (or what are the magnitudes) involved? What is the psychological value of his discrimination of two types of judgment? Can the same distinction be couched in terms of direction and preparation of attention? What are the psychological factors that make up subj. rel.? Are they measurable? Can Stumpf's position be worked out in associationist terms? The position has extreme value as a reasoned statement from premisses the direct opposite of Fechner's: has it positive, permanent value on its own account? In detail: are Stumpf's definitions clear-cut, 'workable'? are the methods which he suggests themselves reliable? does he offer us a definite programme of work? is there any close connection between his psychophysical principles and his doctrine of distance measurements? is he consistent in his view of psychophysics (*cf.*, *e. g.*, the definition, 54 *n.* with 55, last paragraph)?

All these queries are to be answered, primarily, on the basis of the first three §§ of the 'Tps. A complete answer demands, of course, familiarity with the whole of Stumpf's psychophysical work. See also Wundt, *Lectures*, 115 ff.; P. P., iii., 1903, 579 ff.; H. Böhmer, *Die physiol. Theorie d. Sinneswahrnehmung vom Standpunkte d. Psychophysik*, 1865, 355 ff.; A. Riehl, *Der philos. Kritizismus*, ii., 1, 1879, 187 ff.; James, *Psych.*, ii., 1 ff.; Jodl, *Psych.*, 1896, 178 ff.

(14) The doctrine of negative sensations.

Fechner, *El.*, ii., 39; I. S., 88; R., 206; P. S., iv., 218; Preyer's *Wiss. Briefe*, 1890, 111; Z., i., 29, 108 (also in Preyer's *Wiss. Briefe*); Delbœuf, *Éléments*, 20, 177; *Examen*, 37, 105, 154; Langer, *Grundlagen d. Psychophysik*, 1876, 49; *Psychophysische Streitfragen*, 1893, 12; G. E. Müller, G., 368; *Göttingische gel. Anz.*, 3 Juli 1878, 835; A. Nitsche, XXX. *Programm d. k. k. Staats-Gymnasiums zu Innsbruck*, 1879, 22; C. Gutberlet, *Natur und Offenbarung*, xxvi., 1880, 114; A. Elsas, *Ue. d. Psychophysik*, 1886, 47; G. Tarde, *Rev. phil.*, x., 1880, 162; Wundt, *Lectures*, 42; *Vn.*, 1897, 47; P. P., i., 1893, 402, 406; i., 1902, 498, 501; A. Köhler, P. S., iii., 1886, 588, 598, 615; W. Preyer, *El. d. reinen Empfindungslehre*, 1877, 20, 43, 45; letters in *Wiss. Briefe*, 1890; H. Ebbinghaus, Z., i., 1890, 320, 463; *Psych.*, i., 1902, 511 f.; M. Foucault, *Psychophysique*, 1901, 150; F. Jodl, *Psych.*, 1896, 218 f.

(15) The physiology and psychology of Wundt's doctrine of apperception.

This essay involves a comparison of P. P., i., 1893, 230 ff., with *ibid.*, 398 f. and ii., 275 f.; or of i., 1902, 324 ff., with *ibid.*, 552 f. and ii., 1903, 341. The former comparison has been made, in detail, by W. Dittenberger, *Philos. Monatshefte*, N. F., ii., 1896, 97 ff. Dittenberger's discussion may itself be taken as text for the essay.

(16) The relation of Fechner's psychophysics to his experimental aesthetics.

A text will be found in Lipps, *Massmethoden*, 22; *Arch.*, iii., 174. The student should read Fechner's *Zur experimentalen Aesthetik*, i. (all published), in *Abh. d. kgl. sächs. Ges. d. Wiss., math.-phys. Cl.*, ix., no. vi., 1871, 564 ff., and portions of the *Vorschule d. Aesthetik*, 2 vols., 1876.

(17) G. E. Müller's psychophysical axioms.

See Z., x., 1896, 1 ff. Cf. Külpe, *Z. f. Hypnotismus*, vii., 1898, 114 ff.

The classical literature of psychophysics abounds in mathematical discussions. To the early workers a quantitative millennium seemed near at hand; even in 1879 Fechner could say to Wundt, *à propos* of the founding of the Leipzig laboratory, "Wenn Sie die Sache so im Grossen betreiben wollen, dann werden Sie in ein paar Jahren mit der ganzen Psychophysik fertig sein."¹ The present generation tend, on the contrary, to fight rather shy of mathematical formulations: at any rate, the author has not found among his students any considerable interest in this aspect of the science, and it is hardly probable that his experience is singular. A few essay subjects which imply mathematics are, however, subjoined. The points involved are, in every case, points of psychophysical, not simply of mathematical importance.

(1) A criticism of Fechner's use of the 'mathematical auxiliary principle,' *El.*, ii., 6 ff.

See W. Dittenberger, *Phil. Monatshefte*, 1896, 78 f.; A. Elsas, *ibid.*, xxiv., 1888, 133 ff.; A. Stadler, *ibid.*, xiv., 1878, 219 f.; M. Radakowic, *Vjs.*, xiv., 1890, 7 ff.

(2) A criticism of Wundt's formula $\Delta S = k \frac{\Delta R}{R}$, where ΔS is "eine eben merkliche oder gleich merkliche Aenderung der

¹ Lasswitz, G. T. Fechner, 1896, 90.

S ," k is a constant, and ΔR is the "Zuwachs, der zu einer centralen Sinneserregung R hinzukommen muss" in order to effect a ΔS .

See P. P., i., 1887, 382 ; i., 1893, 400 ; i., 1902, 497 ; P. S., ii., 1885, 6 ; A. Elsas, Ueber d. Psychophysik, 1886, 7 f., 17 ; Phil. Monatshefte, xxiv., 1888, 132 ; W. Dittenberger, *ibid.*, 1896, 80 ; A. Köhler, P. S., iii., 1886, 585 ; Fechner, *ibid.*, iv., 1887, 167, 201, 227 ; A. Grotenfelt, Das Webersche Gesetz, 1888, 17 f. ; A. Höfler, Vjs., xi., 1887, 355 ff.

(3) "The most important ameliorations of Fechner's formula are Delbœuf's in his *Recherches sur la mesure des sensations*, 1873, and Elsas' in his pamphlet *Ueber die Psychophysik*, 1886."—James, *Psych.*, i., 1890, 539. Give a critical estimate of the mathematical work of Delbœuf and Elsas ; note the points (if any) in which it marks an advance upon Fechner ; compare Delbœuf and Elsas as mathematical psychophysicists.

Delbœuf, *Éléments*, 32 ff. ; *cf.* 164 ff., and *Examen*, 51, 140 ff. ; Elsas, *Psychophysik*, 10 ff. ; *cf.* Phil. Monatshefte, xxiv., 1888, 131 ff. Fechner replies to Elsas in P. S., iv., 1887, 165 ff., and to Delbœuf in I. S., 27 ff., etc. G. E. Müller heads § 124 of the G. (400 ff.) with the words : "auch Delbœuf's Correctur der Fechner'schen Maassformel muss für eine wenig glückliche erachtet werden" (xv.). See also Köhler, P. S., iii., 1886, 604 ff. ; F. A. Müller, *Axiom*, 1882, 129 ff. ; M. Foucault, *Psychophysique*, 1901, 197 ff. ; A. Höfler's review of Elsas, in Vjs., xi., 1887, 351 ff.

(4) Criticise, in the light of the Reconstruction, Stadler's proposal of a Massformel that shall recognise the fact of the *DL*.

A. Stadler, *Phil. Monatshefte*, xiv., 1878, 220, 223.

(5) "Fechner's Unterschiedsmassformel . . . widerspricht [der dritten Ableitung der Massformel] geradezu." Criticise this statement, and estimate the psychophysical importance of the Unterschiedsmassformel.

M. Radakowic, *Vjs.*, xiv., 1890, 19 f.

§ 9. **The Problems of Sensitivity.**—The author has avoided, in the text, any mention of 'that blessed word' Sensitivity. The student will soon run against the word, or some English or foreign equivalent, in his reading of the literature ; and it is advisable to give a lecture upon it, early in the present Course. But the

term is probably better out of the way in a first introduction to quantitative experiments.

What does Sensitivity—*Empfindlichkeit*—mean? “One and the same R ,” says Fechner (*El.*, i., 45), “may, even if applied in the same way, be sensed more or less strongly by one person or one organ than by another, or by the same person or organ at different times; and contrariwise, R of different magnitude may, according to circumstances, be sensed equally strongly. We then attribute to the one person or organ, or to the given person or organ at one time, a greater or less sensitivity than to the other, or to the same at another time.” “We regard sensitivity as inversely proportional to the magnitude of the R which evoke . . . an S of equal magnitude” (46). “In general, the term sensitivity covers the same ground as the terms stimulability, excitability, sensibility” (51). “The measure of sensitivity is, as measure of mere capacity of S , not to be confused with a measure of S itself. Nor does it, as thus understood, presuppose any such measure, but only the observation of equal cases of S , partly under the same, partly under different conditions of stimulation” (54). “Since sensitivity is variable, we need not seek for any hard and fast measure of it; but we can determine (1) its limiting values and (2) its mean values; we can investigate (3) the dependence of its changes upon circumstances; and we can (4) establish laws which remain valid through all its mutability” (*ibid.*).

Fechner thus regards Sensitivity, response to stimulus by sensation, as a property of organised matter, of the living individual. In measuring it, we are always measuring R , not S (54): we determine what R are sensed or not sensed, what R or R -differences are sensed as same or different. It is, however, the necessary basis of S -measurement (46, 59 f.). The three metric methods of the *Elemente* (just noticeable differences, right and wrong cases, average error)—methods for the measurement of sensitivity, not of S —furnish the data upon which our measurement of S depends (i., 71; ii., 191).

Fechner's views of S -measurement have not found acceptance. The concept of sensitivity has, however, taken a permanent place in psychophysics, irrespectively of what may lie beyond it. And,

like many other general terms in psychology, it vacillates between two meanings, or two aspects of meaning. It is employed, on the one hand, to denote a psychophysical function, the organism's capacity of sense-response to stimulation; it is employed, on the other, as the logical representative of a great group of facts, statically taken,—as the *Inbegriff* of all determinations made by the metric methods. In vol. i., I. M., xxi., the distinction between qualitative and quantitative work was drawn, for convenience' sake, in functional terms. Fechner undoubtedly thought of sensitivity in this way: so do the 'mental test' psychologists. Külpe, who dispenses altogether with *S*-measurement, at least in the present stage of our knowledge, and accordingly makes the measurement of sensitivity the be-all and end-all of psychophysics, defines liminal sensitivity as "the bare capacity of experiencing and communicating *S*," and differential sensitivity as "the introspection of different contents and the report of their difference" (Outlines, 31 f., 33). Here we seem to stand halfway between the functional and the logical definitions: the word 'capacity' emphasising the former, while the warning against the assumption of a 'faculty of comparison' (31) suggests the latter. Wundt, who measures not *S* but degrees of *S*-Merklichkeit, defines sensitivity, formally, as $\frac{I}{RL}$ or $\frac{I}{DL}$ (more generally, in the second instance, as the inverse value of the *R*-change necessary to a determinate change of *S*): P. P., i., 1893, 333 f., 336; i., 1902, 468, 470. Stumpf, who regards psychophysics as the final chapter of a 'messende Urteilslehre,' defines sensitivity as "the degree to which our *S* correspond with the adequate *R* which arouse them" (Tps., i., 28, 54). This last is, in the author's judgment, the best, because it is the least committal definition.

We may classify the departments of sensitivity, at least provisionally, as follows:

Modal sensitivity (M. S.): . . .	$\left\{ \begin{array}{l} \text{Liminal sensitivity (L. S.);} \\ \text{Terminal sensitivity (T. S.).} \end{array} \right.$
Differential sensitivity (D. S.):	

These forms must be briefly discussed.

We measure L. S. by determining the least value of R (qualitative, intensive, spatial, temporal) that can arouse an S . We measure T. S., similarly, by determining the highest value of R that can still arouse an S . These two measurements, therefore, give us the RL and TR of the text. We measure D. S. (in the narrower sense) by equating and differentiating two supraliminal S , and noting the R -values which correspond to sensible equality and to *j. n.* difference. We obtain either the DL , or some value which is conditioned upon the DL . Finally, we measure S. S. by equating and differentiating two supraliminal sense distances, two sections cut from the whole sense continuum. We obtain a sectional DL , or some value that is conditioned upon it. It is clear that, in the last two cases, there are eight part-problems (equation and differentiation for all four S -attributes).

We must go into a little more detail as regards the M. S. (1) Fechner distinguishes between S . for absolute R -values, which he calls Absolute S ., and S . for R -differences, which he calls D. S. Absolute S . is measured by the inverse value of the R -magnitudes which arouse an S , liminal or supraliminal, intensive or extensive, of the same magnitude. Apart, then, from supraliminal and extensive R , it may be said that Fechner's A. S. corresponds to our L. S. and T. S., although Fechner is naturally preoccupied with the L. S. (El., i., 45, 50; *cf.* 130 ff., 238 ff., 254 ff.). (2) Wundt's terminology is different. The 'minimal' S corresponds, for him, to the RL , whose value is an inverse measure of R. S. (Reizempfindlichkeit). The 'maximal' S corresponds to the TR , whose value is a direct measure of R -capacity (Reizempfanglichkeit). The portion of the R -scale lying between RL and TR is the range of R (Reizumfang). Its investigation is a matter of the D. S. (P. P., i., 1893, 334 ff.; i., 1902, 468 ff. The terminology is worked out only for intensity: *cf.* ii., 1893, 6 with i., 450, 483). Wundt's R. S. and R -capacity thus correspond to our L. S. and T. S. Whether or not his range of R be included in the M. S. is a matter of definition; the usage of the different authors differs. (3) Stumpf uses the term M. S. (Umfangsempfindlichkeit) for "the extent of the S -sphere as compared with the sphere of R ." It includes our L. S. and T. S. In the case of the partial series of vision (R-G, B-Y, Bl-W), its

investigation is, in practice, identical with that of the D. S. In the case of taste and smell, where we cannot arrange the *S* in series, we determine the M. S. by listing the *R* which do and do not arouse *S* (Tps., i., 28 f.). (4) Külpe distinguishes M. S., "measured by the number of *S* given with or possible to a particular sense," from 'sensibility,' "measured in terms of the attributes predicable of the separate *S*." M. S. is thus partly concerned with the determination of upper and lower limits, our L. S. and T. S. (though these cannot be determined save in terms of the *S*-attributes!), and partly with the work which properly falls to the D. S.

In two special cases, Külpe's distinction seems to lead him into error. The M. S. of the skin, he says, is determined when we have counted up all the possible cutaneous *S*. But these are not qualities of a single sense: they proceed rather from four senses. Further, it "would be a test of qualitative sensibility to enquire how many air vibrations are necessary for the perception of the pitch of tone to which their period corresponds." But this is a determination of a temporal tone limen. The *RL* of pitch are the vibration rates correlated with the highest and lowest audible tones: see Stumpf, Tps., i., 28; Fechner, El., i., 258; Külpe, Outlines, 33 f.

The ambiguity of usage and the crossing of definitions are intelligible enough when we remember (*a*) that the *DL* is a fact of 'friction,' and as such strictly co-ordinate with the *RL*, while (*b*), on the other hand, there is evidence that the least sense distances correlated with the *DL* may be regarded as equal, and thus taken as the units of *S*-measurement. The *DL* is called upon (as we noticed in the text: p. xxxvi.) to play two different parts. Since we have ourselves decided to look upon all *j. n. d.* of *S* as equal distances, it seems best to take the *DL* from the sphere of the M. S., and to make this simply a collective name for the L. S. and T. S. The statement of the qualitative M. S. for tones would then be: "About 14 to 50,000 vs." The statement of the extensive M. S. for a certain blue would be: "Nasal, 53°; temporal, 37°, upper, 51°, lower, 24°": together with a table of its *minima visibilia* in direct and indirect vision. And so on.

And now what of the two sorts of *j. n. d.*? Are we justified in bracketing together, as D. S. in the wider sense, the D. S.

proper and the S. S.? Let us take some instances. In the one case, perhaps, we seek to determine the grey which is j. n. lighter than a given grey; in the other, to find a visual point-distance that is j. n. larger than a given point-distance. In the one case we seek to equate the brightness of a point, directly seen, with the brightness of a point shown in indirect vision; in the other, to equate a tonal distance in the bass with a tonal distance in the treble.¹ In all such experiments we obtain formally like results: a j. n. d., or some error value that is conditioned upon the j. n. d. May we bracket the two sets of determinations, differential and sectional, under a common heading?

There is only one assumption upon which the bracketing is justified: the assumption that two sensibly equal distances of the S. S. contain equal numbers of least sense steps (intensive, qualitative, etc.). The truth of this assumption is, of course, by no means evident. The decisive appeal lies to experiment: but, as we have seen, such appeal has been made in very few instances, and then under conditions that are not wholly free from objection.² In the absence of direct experiments, it will, however, be rendered probable, if we find that the *R*-distances which are equated in sensation differ with difference of the *DL*,—being smaller where the *DL* is smaller, and larger where it is larger; if we find, *e. g.*, that a small tonal difference in the middle region of the scale (small *DL*) is the equivalent of a large difference low in the scale (larger *DL*); or if we find, conversely, that a given space distance (separation of compass points) is sensed as larger on a part of the skin where the *DL* for space distance is small, as smaller on a part where the *DL* is large. Since this is what we actually do find, the assumption may be regarded as entirely reasonable. Stumpf, *Tps.*, i., 60 ff.

It is, nevertheless, impossible to identify the D. S. and the S. S. For investigations of D. S., only two *R* are employed; for those of S. S., at least three. The conditions in the latter case are, therefore, more com-

¹ Here belong the experiments made by Fechner's method of equivalents, and referred by him to the A. S.: the equation of pressure intensities, *e.g.*, at different parts of the skin, or of visual distances (Fechner's extensive *R*) in different regions of the retina.

² See above, p. lxxxiv.

plicated ; the danger of judgment by secondary criteria is much greater. Moreover, we have said in the text that, in certain instances, the general conditions of judgment are different as we pass from determination of the *DL* to comparison of *S*-distances (Ebbinghaus, *Psych.*, i., 504 f.): in these instances there can be no argument whatsoever from the *D. S.* proper to the *S. S.*, or conversely.

So, on the whole, our classification may stand. Like most classifications of complex material for pedagogical ends, it is a compromise. Things are put together, from one point of view, which from another should be kept apart: so the *L. S.* and the *T. S.* Things are set apart, from one point of view, which from another would be brought together: so the *L. S.* and the *D. S.* But the schema will serve, at any rate, for lecture purposes, for giving the student his bearings in the vast tangle of facts that constitutes psychophysics.

Essay Subject.—A complete programme of the investigation of *S.*, showing the method to be employed for every attribute of *S* in every *S*-department.

This essay may most profitably be written after the student has gained a general knowledge of the methods and of their interrelation (see pp. 93 ff., below), and understands the significance of the test-values which they furnish. The lacunæ in the programme are especially instructive, and the reasons for their existence should be fully discussed. Some hints are given by Stumpf, *Tps.*, i., 57 f.

Müller, at the opening of the *M.* (1 f.), says that the applications of the metric methods *äusserlich betrachtet* are fourfold: to *RL* and *DL*, and to equal-appearing *R* and *R*-differences. An advanced student may be asked the question: What, then, are the applications, *innerlich betrachtet*? Does the doctrine of sensitivity furnish a satisfactory 'internal' point of view?

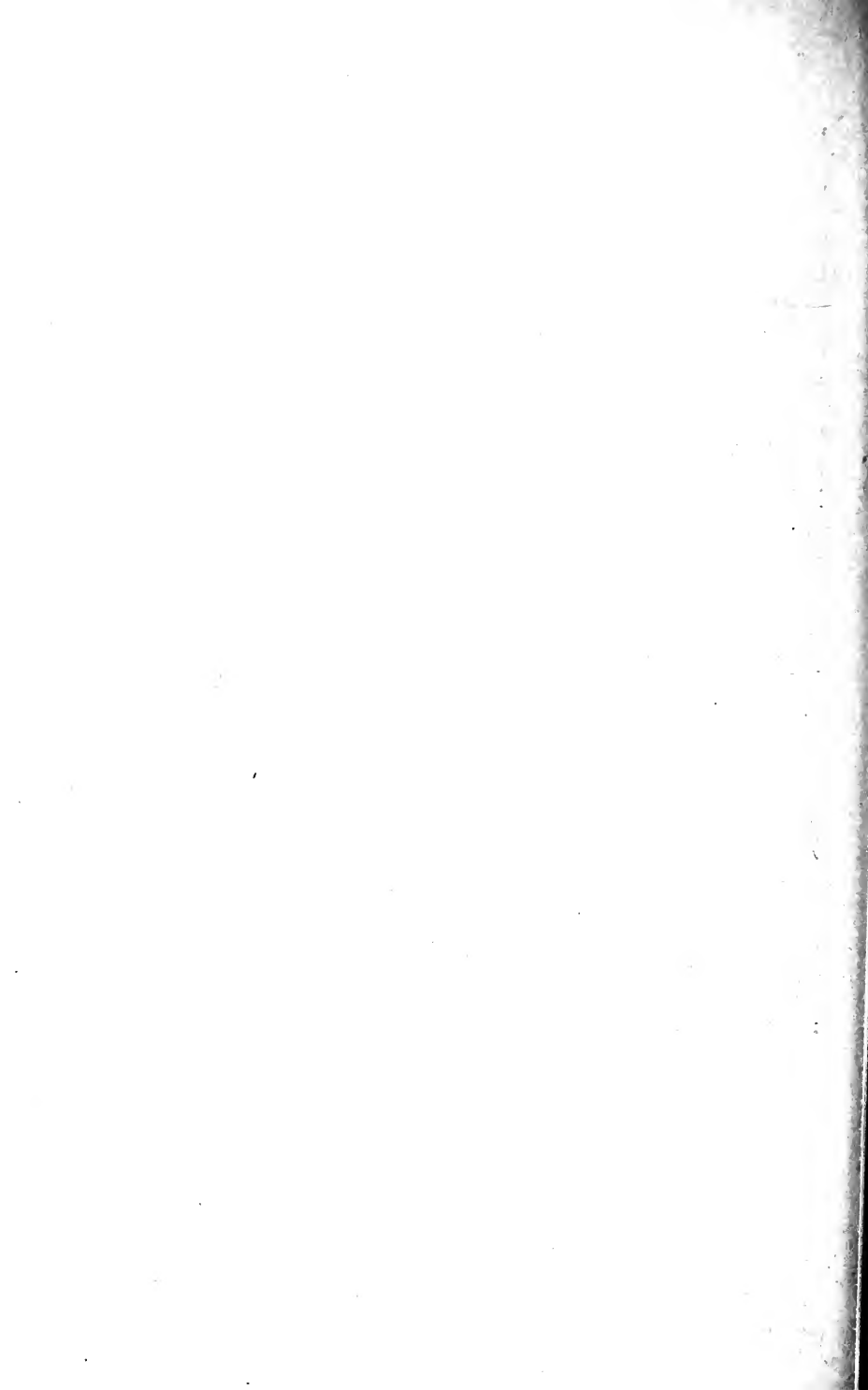

CHAPTER I

PRELIMINARY EXPERIMENTS

My desire and aim are to arouse interest as well as to impart instruction. Labour is not to be shirked in the study of a great question; but it may be lightened in two ways: first, by the diminution of its absolute amount; and, secondly, by calling forth an energy which shall diminish it relatively. The true teacher, with the discipline of his pupil in view, will, I apprehend, always invoke the positive in preference to the negative force.—TYNDALL.

EXPERIMENT I

§ 10. **The Qualitative RL for Tones; the Lowest Audible Tone.**—**MATERIALS.**—The dimensions given for the lamella are those of the author's instrument. Zwaardemaker (*Z.*, vii., 1894, 20) makes the strip 420 mm. long and 12 mm. wide, and the cloth ring 15 mm. broad; the range of vs. is the same.¹

The metal disc is always pulled from above; so that, in course of time, its lower edge works away from the strip. When this happens, it is apt to rattle for a moment after the lamella has been released. The fault is easily corrected by the mechanician. But if the accident occur in the course of an experiment, a wisp of cotton wool should be introduced between disc and strip.

ADJUSTMENT OF APPARATUS.—The distance between lamella and ear should be determined as the least distance at which the lamella, making the maximal excursion required by the series, fails to strike *O*'s ear or head.

¹ According to a note in Wundt, *P. P.*, i., 1893, 450, the lamella was described by A. Appunn in a pamphlet published in 1889 (*Ueber Wahrnehmung tiefer Töne: Hanau*). The author has not seen this paper. Neither, as may here be remarked, has he been able to procure the papers by G. [and A. ?] Appunn in the Wetterau. *Ges. Nat. Ber.*, 1863-7, 73 ff.; 1887-8.

In all demonstrations of the use of the lamella that the author has seen, the instrument is clamped to a high support, and *O* stands sidewise to it,—holding himself erect, or bending his head, in such a manner that the disc is always directly opposite the opening of the meatus. This arrangement answers well enough for a quick (say, a two-series) determination of the *RL*. For a methodical determination, it is not advantageous. If *O* keep his eyes open, he is apt to connect the appearance or disappearance of the tone with a certain length of the lamella. If his eyes are closed, and his head is brought into position by *E*, he is apt to connect the appearance or disappearance of the tone with a certain set of head and shoulders. Judgment is thus passed, not in terms of hearing, but in terms of sight or of 'muscular' sensation. Moreover, *O*'s attitude soon becomes fatiguing, and the distance between his ear and the lamella may vary within pretty wide limits.

Some laboratories will, doubtless, possess a stand, which can be raised or lowered without noise. Where this is the case, the lamella should be clamped to the stand, and its height varied as the experiment demands. But the money required to build such a stand may be more profitably invested in a set of wire forks.

Those who are unfamiliar with psychophysical work may be inclined to underestimate the danger from 'secondary criteria' of judgment (sight, muscular sensations, etc.). It is, however, a lamentable fact that the human mind shows in this regard an unflinching ingenuity. Even the trained worker is constantly surprised by the protean forms which the secondary criteria may assume. One may give definite instructions; one may have an honest, fairly practised and entirely well-intentioned *O*; one may hedge the introspections about with all sorts of conditions: yet, if there *is* a way out or a way round, that way will sooner or later be taken. With a practised *O*, the secondary criteria will also, sooner or later, make their appearance in the introspective reports. With a comparatively unpractised *O*, there is no guarantee that they will ever be recorded.

The psychology of the matter, looked at in the abstract, is somewhat as follows. *O* is called upon to give a series of maximal attentions to an unfamiliar and intrinsically uninteresting *R*. The outcome of this series of attentions is to be a quantitative determination. *O* is therefore on his mettle; he wishes to pass stable and accurate judgment. He is also

anxious : for he has no means of knowing how accurate and stable his judgment really is,—he has nothing to ‘go by.’ If, then, there is any half-way constant or familiar concomitant of his first few judgments (a visual pattern, a muscular set, or what not), he almost instinctively takes advantage of it, and uses it as a standard of reference in later judgments.

Brief as this statement is, it may serve to show the naturalness and, if one may say so, the reasonableness of the recourse to secondary criteria. No abstract statement could do justice to their insidiousness and universality. The author has known a student to compare distances, on Münsterberg’s apparatus for arm movement, by noting the place at which his hand struck his thigh as he dropped it from the finger-carriage!—and this was done quite innocently, without suspicion that it was wrong or even unusual. Nothing, indeed, seems too far-fetched or improbable to serve as secondary criterion of judgment in psychophysical method work. The Instructor should collect and classify instances, as the experiments proceed.

E must be very careful always to release the disc by the same movement. Otherwise, the sound of the pluck may be made the criterion of judgment.

As the disc of the lamella swings to and from the ear, air-waves are set up, whose impact upon the concha produces distinct sensations of pressure and temperature. Some *O* disregard these accessory sensations; others are distracted by them; still others make use of them, often unwittingly, as secondary criteria of judgment. The author has made experiments, on a single practised *O*, to determine the effect (*a*) of interposing a thin Bristol-board screen between ear and disc, and (*b*) of allowing the lamella to play past (instead of into) the opening of the auditory meatus. In both cases, the *RL* was shifted only 1 v. : in (*b*) it lay one v. higher, in (*a*)—curiously enough—one v. lower, than in the regular experiments. The particular results must be regarded as accidental : but the fact seems to be established that such a change of experimental conditions does not materially affect the position of the limen. It would be worth while to make comparative tests in some numbers.

An objective source of error in the lamella, under the prescribed conditions of usage, is that the initial amplitude of vibration increases as the rate of vibration decreases. Zwaardemaker suggests a numerical correction of the results (*op. cit.*, 21). It would also be possible to regulate the amount of pull from test to test, say, by means of a vertical rod hinged to the table. But the author doubts if either procedure is worth while. For one thing, the difference in amplitude is insignificant over the critical portion of the scale, which (in the author’s experience) rarely

covers more than 3 vs. and usually lies in the region 13 to 17 vs. For another, the strip is not uniformly elastic ; it warps and bends, vibrating much more freely from some points than from others. It should, of course, be pulled as often in the one direction as in the other (it may be changed about after every series) ; but even so this source of error is inevitable.

As a rule, the cloth ring serves satisfactorily to cut off the overtones. Occasionally, however, by some accident or by careless manipulation, a shrill overtone will be heard. It need not interfere with *O*'s judgment.

For the temporal regulation of the series, a noiseless metronome may be constructed. A screw-eye is turned into a wooden upright, or into a block of wood fastened to the wall ; and a pendulum is made from a length of cotton thread and a weight. The thread is adjusted to the required frequency of oscillation by the help of a stop-watch. An instrument of this kind is useful for many laboratory purposes.

On the value of practice and 'warming-up' experiments, see Müller, M., 33.

METHOD.—The method is Müller's Method of Least Differences as applied to the determination of an absolute *L*. It will be discussed in detail later. The following points may now be noted.

(1) *Interruptions of series*.—Any single test may be nullified by a lapse of attention, an outside noise, the presence of an overtone, etc. The question then arises whether the series shall be continued, or the test in question repeated. The answer depends upon circumstances. If the test come at the beginning or end of a series, no notice need be taken of its failure ; if it occur at a critical part of the series, it must be repeated. In either event, *E* must face the situation in a perfectly matter-of-fact way ; he must not allow *O* to be disturbed. In the former case, e.g., *E* might say : 'All right ! Makes no difference ! Now !' ; in the latter : 'All right ! Take it again ! Now !' The repetition should be noted in the record, but the series may be counted in with the rest. The important thing is that the full 20 series be worked through, evenly and steadily, without departure from the plan of arrangement.

(2) *Length of series*.—A 'moderate' series has 6 to 8 steps. A long series should not go above 12 ; a short series should not fall below 4.

(3) *Order of series*.—If *O* has attained a fair constancy of judgment in the preliminary experiments, the order of the series (as well as the length of successive series) may be determined by chance.

(4) *O's attitude*.—The chief subjective sources of error in this method

are two : expectation and habituation. The effect of the latter is seen in a tendency on *O*'s part to go on judging as he has been judging : *e.g.*, after he has said 'Tone' a few times, to go on saying 'Tone' beyond the point at which a change of judgment would normally occur. The effect of the former is usually seen in a tendency towards a too early change of judgment : *O* knows that the *RL* is coming nearer at every step, and therefore grows increasingly expectant of a marked change in the character of the *R*. In this form, the error of expectation makes against the error of habituation. Sometimes, however, the two play into each other's hands. *O* knows that the steps are small. Hence, if the given *R* is a clear tone or a clear noise, he may expect that the following *R* will be equally clear as tone or noise. This expectation may also carry him beyond the point at which a change of judgment would normally occur, and so reinforce the error of habituation.

In view of these sources of error, *O* should be carefully instructed to judge every *R* independently, as it is presented. If his series show signs of a subjective error, the nature of the dangers to which his judgment is exposed should be pointed out to him. If they do not, the discussion of these sources of error may be postponed.

(5) *Size of steps*.—In order not to introduce too many variables in a first experiment, we have kept the steps constant at 1 v. If, however, the method is to be strictly followed, the size of the steps as well as the length of the series should be varied. There are two principles of variation. (a) The steps may be made larger at the beginning of a series, where judgment is prompt and certain, than they are towards the end, when we are approaching the limen. Thus, a 6-step series might have the form 3, 2, 1, 1, 0.5, 0.5. Theoretically, no objection can be urged against this principle of series formation. Practically, the principle cannot be carried very far, if we are to keep to the rule of correspondence between \downarrow and \uparrow series. A \downarrow series with constant steps may be matched, within a step or two, by an \uparrow series. But it is very difficult to construct an \uparrow series that shall match a \downarrow series with variable steps. Hence it would seem better, on the whole, to keep to a single step within each series. (b) On the other hand, the absolute size of the steps should vary from series to series. The lamella, *e.g.*, can easily be scaled to half-vs. We may then employ units of 0.5 v., 1.0 v., and 1.5 vs., in different series. *O* should be left in ignorance of the size of the step used from one series to another. It need hardly be said that every unit must be taken as often in a \downarrow as in an \uparrow series. It is not necessary, however,—it is not even advisable,—that the two members of a paired series be always taken in immediate succession ; the distribution of series may be planned beforehand, or may be left to chance.

RESULTS.—The following Table shows the complete results of an experiment taken under the conditions laid down in the text.¹

SERIES.	↓ 1	↑ 2	↓ 3	↑ 4	↓ 5	↑ 6	↓ 7	↑ 8	↓ 9	↑ 10	↑ 11	↓ 12	↑ 13	↓ 14	↑ 15	↓ 16	↑ 17	↑ 18	↑ 19	↓ 20	
Vs. 24	+																				
23	+																				
22	+		+														+				
21	+		+											+			+				+
20	+		+						+					+			+				+
19	+		+				+		+					+			+		+		+
18	+		+		+		+		+					+			+		+		+
17	+		+		+		+		+			+		+			+		+		+
16	+	+	+		+		+		+			+	+	+			+		+	+	?
15	+	-	+	+	+	+	+		+	+	+	+	-	-	+	?	+	-	-		
14	-	-	-	-	?	-	?	+	?	-	-	-	-	-	-	-	-	-	-	-	-
13	-	-	-	-	-	-	-	-	-	-	-	-	-	-	-	-	-	-	-	-	-
12	-	-	-	-	-	-	-	-	-	-	-	-	-	-	-	-	-	-	-	-	-
11	-	-	-	-	-	-	-	-	-	-	-	-	-	-	-	-	-	-	-	-	-
10	-	-	-	-	-	-	-	-	-	-	-	-	-	-	-	-	-	-	-	-	-
9	-	-	-	-	-	-	-	-	-	-	-	-	-	-	-	-	-	-	-	-	-
8	-	-	-	-	-	-	-	-	-	-	-	-	-	-	-	-	-	-	-	-	-
7	-	-	-	-	-	-	-	-	-	-	-	-	-	-	-	-	-	-	-	-	-
6	-	-	-	-	-	-	-	-	-	-	-	-	-	-	-	-	-	-	-	-	-
5	-	-	-	-	-	-	-	-	-	-	-	-	-	-	-	-	-	-	-	-	-
4	-	-	-	-	-	-	-	-	-	-	-	-	-	-	-	-	-	-	-	-	-

Notice, in the first place, that there is a fair degree of correspondence in the length of the ↓ and ↑ series. If we tabulate the series, in order of length, we obtain the following figures :

↓	11	9	8	7	7	6	6	5	5	4,
↑	12	9	8	8	7	7	6	6	5	4.

¹ O had worked through the experiments of Pt. i., but had had no special practice beyond the preliminary experiments. His left ear was stimulated. The unused ear was open.

Now for the calculation! Summing up the final terms of all series, and dividing by 20, we find $RL=14.85$ vs. Summing up the differences between this average RL and the separate determinations, and dividing by 20, we find $MV=.595$ v. This is as far as the text takes us. We may, however, make the results the basis of various other computations.

(1) In our determination of the arithmetical mean of the numerical results (the average RL), we have accepted the figures yielded by the Table. These figures it must be remembered, represent limits,—limits of steps of 1 v. Suppose that, in a \downarrow series, O says 'Tone' at 15 and 'No tone' at 14. The value 14 is entered in the Table. In reality, O might have said 'No tone' at any point between the limits 15 and 14. Hence the fairest value from which to calculate is not 14, but 14.5. Suppose, again, that in an \uparrow series, O says 'No tone' at 13 and 'Tone' at 14. The fairest value to record is 13.5. Wherever the change of judgment takes this positive form, we should add .5 to the final terms of the \downarrow and subtract .5 from the final terms of the \uparrow series. Under such conditions, our average RL would be identical with the RL as determined above: we add as much to the 10 \downarrow series as we subtract from the 10 \uparrow series. The MV would be a little smaller: .555 instead of .595.

There is, however, a slight complication, due to the fact that the final term of some \downarrow series corresponds to a ?, not to a — judgment. In these cases, the recorded figure may stand. If O says 'Tone' at 15 and 'Doubtful' at 14, we may assume that he would say 'No tone' at 13. The fairest value to calculate from is then 14. On this basis, we determine our RL as $14.72 \pm .54$ vs. This is a more accurate value than the $14.85 \pm .59$.

(2) We may calculate (from the revised figures) the separate values of the $RL\downarrow$ and the $RL\uparrow$. For the former we find $14.75 \pm .6$; for the latter, $14.7 \pm .48$. The difference is insignificant.

(3) We may 'fractionate' the experiments, and calculate the RL for each separate group of 5 determinations. Using the revised figures, we find:

$$RL(1) = 14.6 \pm .36,$$

$$RL(2) = 14.1 \pm .32,$$

$$RL(3) = 14.9 \pm .44,$$

$$RL(4) = 15.3 \pm .44.$$

The differences are slight. It is, however, noteworthy that the steady ascent of the RL from (2) to (4) tallies with O 's introspections. O declared that he had given his best attention in group (2), and that he became increasingly tired and inattentive in (3) and (4). He even doubted whether the values of group (4) could be counted in with the rest of the determinations.

(4) We may give a graphic representation of the results by constructing what is called a 'surface of frequency.' If we turn to the Table, we see that the value

14 occurs 7 times,
 15 " 9 "
 16 " 4 times.

If, now, we represent the values 14, 15, 16 each by a distance of 0.5 cm. marked off along a horizontal line, and if we represent each time that the value occurs by a height of 1 mm. above this line, we obtain a figure which shows at a glance the magnitude and variability of *O*'s *RL*. Rules for the construction and interpretation of surfaces of frequency are given the student under Exp. XXIV. (simple reaction).

(5) A set of measurements may be represented by many other single values, besides the average or arithmetical mean. One of the most important of these values is the median (*Zentralwert*, *Wertmitte*). The median is, literally, the middlemost value of a series. It may be defined as the magnitude above and below which one-half of the results appear, when they are arranged in ascending or descending order. Like the average, it need not coincide with any one of the actual results. Indeed, it is nearly always an interpolated value. In long series, however,—series of one or two hundred upwards,—the difference between the middlemost determination and the median is insignificant.

We may determine the median, from our revised figures, as follows. We have 20 determinations. Grouping them, we find :

	Result	13.5	14	14.5	15	15.5	16
Frequency of its occurrence	}	1	3	9	1	5	1

The median value (the value above and below which 10 determinations occur) evidently lies among the group of 14.5. Now there are 4 values below 14.5. This means that there are 6 more values to be taken before we reach the median. The value 14.5 itself occurs 9 times. According to the simplest principle of interpolation, then, we have to take $\frac{2}{9}$ of the interval covered by the value 14.5, and to add it to the lower limiting value of that interval. The interval is 14.25—14.75. If we add $\frac{2}{9}$ or .66 of this interval (*i.e.*, of 0.5) to the lower limiting value 14.25, we obtain 14.58, the value of the median.

The calculation may be reversed, and our result tested, in this way: There are 7 values above 14.5. This means that there are 3 more values to be taken before we reach the median. We must therefore subtract $\frac{3}{9}$ of the interval covered by the value 14.5 from the upper limiting value of that interval. And 14.75—17 is, again, 14.58, the value of the median.—

This procedure may be formulated as follows. Divide the results into three lots : those less than the middle class, whose total number is a ; those of the middle class, b ; and those greater, c . Then $a + b + c = n =$ the whole number of results. Let l' = the lower, and l'' = the upper limiting value of the middle class. Let x = the distance of the median above l' or below l'' , according as x is positive or negative. Then :

$$\frac{n}{2} - a : b = x : l'' - l', \text{ when } x \text{ is positive ;}$$

$$\frac{n}{2} - c : b = x : l'' - l', \text{ when } x \text{ is negative.}$$

Grouping our 20 determinations, as the rule requires, we have :

Below middle	Middle class	Above middle
4	9	7

The first equation reads, accordingly :

$$10 - 4 : 9 = x : 14.75 - 14.25,$$

$$x = .33.$$

Similarly, the second equation reads :

$$10 - 7 : 9 = -x : 14.75 - 14.25,$$

$$-x = .17.$$

Hence the median is $14.25 + .33$ or $14.75 - .17$, *i. e.*, 14.58.

(6) Yet another representative value of a series of measurements is found in the mode (*dichtester Wert, Dichtigkeitsmitte*), which is the commonest single value, the single value that appears most frequently in the records. The mode of our *RL* determinations is, evidently, 14.5 : this is the value that appears most frequently (9 times) in the revised figures.¹

Putting these results together, we have :

Average	Median	Mode
14.72	14.58	14.50 vs.

(7) As with the representative value, so with the measure of variability : we are not by any means confined to the *MV*. We may, *e. g.*, determine what is called the standard deviation or error of mean square. This is the square root of the average of the squares of all the individual differences between the final *RL* and its separate determinations. In other words, it is the difference whose square is the average of the squares of all the differences. If v represent the single differences (residuals), and n be the number of determinations, then the formula for the standard

¹ This is, in reality, only the empirical mode, or mode as determined by inspection ; it corresponds roughly to the determination of the median as lying within the group of 14.5. The precise calculation of the mode is more laborious than that of either the average or the median. We need not enter into details here : see Fechner, *Kollektivmasslehre*, 1897, 182 ff.

deviation is $\sqrt{\frac{\sum(v^2)}{n}}$. When, however,—as in the present case,—the number of determinations is small, it is customary to introduce a correction by writing $n-1$ for n in the denominator of the fraction. The formula thus becomes : $\sqrt{\frac{\sum(v^2)}{n-1}}$.

Let us determine the standard deviation of the average 14.72. The individual differences or v are as follows :

Difference	.22	.28	.72	.78	1.22	1.28
Frequency of occurrence	9	1	3	5	1	1

The sum of the squares is therefore $.0484 \times 9 + .0784 + .5184 \times 3 + .6084 \times 5 + 1.4884 + 1.6384 = 8.238$. The fraction $\frac{\sum(v^2)}{n-1}$ or $\frac{8.238}{19} = .4335$. Then $\sqrt{.4335} =$ approximately .66, is the standard deviation required.¹

Theoretically, and practically in series of sufficient length, the *MV* of the average stands in a constant numerical relation to the *SD*, as follows :

$$MV \text{ or } AD : SD = 1 : 1.2533, \text{ or} \\ AD = 0.7979 SD.$$

(8) Another measure of variability is given by the 'probable error' of the representative value. In any series of errors, the probable error has such a value that the number of errors which exceed it is the same as the number which fall short of it. In other words, it is an even wager that an error taken at random will be greater or less than the probable error. For a discussion of it, see p. 52 of the text.

The formula for the probable error of the mean ² is :

¹ It may be noted, for the benefit of the student, that the terminology of 'errors' and 'deviations' is somewhat confused. The term 'mean variation' has become established in psychophysics, English and German alike. It is identical with the 'average deviation' of statistics and the 'mean error' of physical science. The 'error of mean square' is called by Merriman (Least Squares, 1900, 204) the 'mean error,' by Sanford (Lab. Course, 359) the 'average error.' This phrase is a translation from the German (*cf.* Külpe, Outlines, 67, and the German text-books generally). In statistical work it is known as the 'standard deviation.' On the other hand, the terms 'average error' (Fechner, *El.*, i., 72), 'average crude error,' 'average variable error,' when they occur in discussions of the metric method of average error, often (perhaps usually) denote *MV*'s of one sort or another. *Cf.* Cattell, art. Errors of Observation, in *Dict. of Phil. and Psych.*, i., 340.

² Notice the implication of the formula : that the trustworthiness of an average is proportional, not to the number of determinations made, but to the square root of that number. Other things equal, an average of 25 determinations is five times as trustworthy as is the single determination.

$$PE_m = 0.6745 \frac{SD}{\sqrt{n}}$$

or, in full :

$$PE_m = 0.6745 \sqrt{\frac{\Sigma(v^2)}{n(n-1)}}$$

In our own case, this becomes :

$$PE_m = 0.6745 \frac{.66}{4.47}, \text{ or } 0.6745 \sqrt{\frac{8.238}{380}}$$

In other words, $PE_m = 0.099$.

For general purposes we may use, instead of the above formulæ, the approximate formula :

$$PE_m = \frac{0.8453}{\sqrt{n-1}} MV.$$

In our own case, this becomes :

$$PE_m = \frac{0.8453}{4.36} 0.54.$$

In other words, $PE_m = 0.1$.

(9) Lastly, there is, of course, a 'probable error' of the single observation, as well as a probable error of the mean. Its formula is :

$$PE = 0.6745 \sqrt{\frac{\Sigma(v^2)}{n-1}}$$

or $PE = 0.6745 SD$. In our own case, it amounts to 0.44.

Calculated from series of sufficient length, $PE : MV : SD = 1 : 1.18 : 1.48$. Even with our few results and approximative determinations, this ratio gives 0.44 : 0.52 : 0.65.

(10) Putting all these results together, and adding some new determinations on the same lines, we have :—

<i>Average</i>	14.72 vs.	$MV = \pm .54$ $SD = \pm .66$
<i>Median</i>	14.58 vs.	$MV = \pm .50$ $SD = \pm .67$
<i>Mode</i>	14.50 vs.	$MV = \pm .47$ $SD = \pm .70$
$PE = \pm .44$		$PE_m = \pm .099$

(11) It is needless to say that many other things may be done with the figures. Thus we may determine the median error of the median : either by the method given above, and now applied to residuals instead of to determinations, or simply by arranging the determinations in order, writing the residuals under them, counting off a quarter of the residuals from either end, and averaging to obtain the median. In our own case, the median error is 0.5. We may then determine the probable error of the

median¹ itself as $\frac{0.5}{\sqrt{n}}$ or 0.11. Again, we may determine the uncertainty (the probable error) of the *PE*. Or, once more, we may calculate (by the aid of Tables in the mathematical text-books) the relative chances that the true average of our measurements lies within certain, continually widening limits. And so on.

Now all these determinations are valuable in their own place. But it is foolish to run to extremes, and to make a fetish of numerical values.² The statistical treatment of variations is very much 'in the air' just now, and there is a temptation to carry it too far. For all practical purposes, it is enough in these experiments to know the values of the average and the *MV* (Müller) or the values of the average and the *PE* (Scripture).³ It would be well if every student of quantitative psychology understood the Kollektivmasslehre; occasions arise when *O* finds a knowledge of the meaning and computation of the ordinary measurement values exceedingly useful, if not indispensable. But it must be remembered—we shall have more to say upon the matter later—that ideal curricula cannot be imposed upon undergraduates. And the student who desires to gain a limited acquaintance with psychophysical methods and quantitative results should not be burdened with a mass of preliminary work which he will forget as soon as he leaves the laboratory.⁴ With graduates the case is different.

INTROSPECTIONS.—With unpractised *O*, there can be no question but that it is best to take extra, separate series for the introspections. It is essential that the series run smoothly; and the introspective requirement means continual interruption.⁵

¹ One of the disadvantages of the median is that it is a more uncertain value, for a given set of determinations, than is the average. It is necessary to make 249 determinations to secure the same accuracy for the median as is given by 114 determinations for the average.

² Cf. what is said below of the treatment of reaction-time results: pp. 362 ff.

³ Scripture simplifies calculation by writing $\frac{2}{3}$ for the factor 0.6745. Yale Studies, iv., 1896, 91 ff.

⁴ The author was glad to run across a somewhat similar remark in Müller (M., 162). After discussing various values derived from the method of constancy (right and wrong cases) with a full series of *V*'s, Müller says: "Es gibt natürlich noch zahlreiche andere Operationen, die man mit den . . . Resultaten vornehmen kann. . . . Aber die Mitbewerter weiterer Operationen—man kann hier das ganze Rüstzeug der Kollektivmasslehre hervorholen—wird im Grunde nichts Neues von Wesenheit zutage fördern." It is true that Müller knows his Kollektivmasslehre, while the average student of psychology does not!

⁵ It may mean a total change of mental attitude. Take an unpractised *O*, in

Something may be done in the pauses. But *E* has his coming series to arrange, and *O* has only his memory to rely upon. Still, *O* should be encouraged to volunteer remarks at the end of the series; *E*'s attention may thus be called to sources of error, factors in judgment, etc., which would otherwise escape notice.

With practised *O*'s, the qualitative and quantitative procedures may be combined to an extent that the older psychophysics would have deemed impossible. Even so, however, it is in general safer to duplicate the series. See Müller, M., 33 ff.

INSTRUMENTS.—The following are the most available instruments for undergraduate use.

(1) *Lamella*. This is the cheapest and simplest instrument for the work. Its defects have been discussed above: cf. also F. Bezold, *Funktionelle Prüfung des menschlichen Gehörorgans*, 1897, 130. According to Zwaardemaker (*Z.*, vii., 13) it was first described by A. Appunn in 1887–8; Wundt (*P. P.*, i., 1893, 450) dates Appunn's paper 1889.

(2) *Giant fork*. Helmholtz and Wolf worked with a giant Koenig fork in 1870, and Preyer with Appunn forks in 1879. The Koenig fork (Fig. 3) is still listed by L. Landry (Koenig's successor) and by Kohl. The specimen in the Cornell laboratory gives, by means of sliding weights, the tones 16 to 25 vs. The fork may be actuated by pinching with the gloved hand, or by striking with the two fists or with rubber-faced mallets. It is a good demonstration instrument, but not very satisfactory for

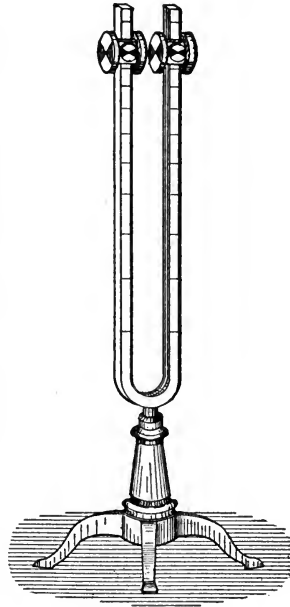

FIG. 3.

the sense of this book, and determine the *RL* (1) by a paired series without and (2) by a paired series with step-for-step introspections. The discrepancy in the results is startling.

laboratory purposes. If no resonance box is made, the accompanying noises and overtones are confusing. The resonance box itself fills up the whole side of a room (Preyer, *Ak. Unt.*, 4).

(3) *Edelmann fork*. Bezold's set of instruments for a 'continuous tonal series' contains a low fork of 11 to 18 vs. The fork is light enough to be held before the ear with the hand. This and the fork next above it could probably be bought separately: the author has not worked with the Bezold instruments. See *Z.*, xiii., 1897, 162.

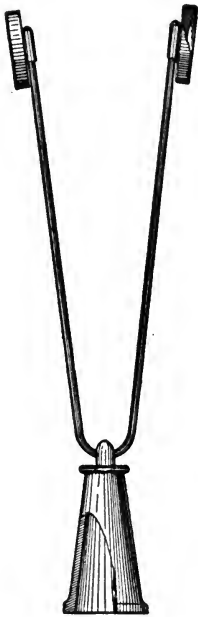

FIG. 4.

(4) *Wire forks*. The Appunn wire forks (Fig. 4) were apparently introduced by S. Moos (*Z. f. Ohrenheilk.*, xxiv., 1893, 151). They range from 8 to 24 vs., by 2 vs. intervals; higher forks, of 32, 48, 56, etc., vs. are furnished for practice work. The material is a wire (4 mm. in diam.) of soft steel or of some alloy; the weights are brass discs. There are no perceptible overtones.

The author greatly prefers these forks to the lamella; though it should be said that they are brittle, and soon break in two at the bend. He has had the set reproduced in medium grade (spring Bessemer) steel wire. The new forks give shrill overtones, which must be damped by cloth rings sewed round the wire.

QUESTIONS.—(1) A discussion of this point will be found in J. Venn, *The Logic of Chance*, 3d edn., 1888, 444 f., 448 f., 460 f., 474 ff. The student may also cf. W. S. Jevons, *The Principles of Science*, 1900, 357 ff.

(2) The student may be referred to Venn, *Logic of Chance*, chs. xviii., xix.; K. Pearson, *Grammar of Science*, 1909, 381 ff.; C. B. Davenport, *Statistical Methods*, 1899 (an extremely useful

little book for practical purposes) ; M. Merriman, *A Textbook on the Method of Least Squares*, 1900, esp. 41 ff., 208 ff. (the book is admirably clear, and may be understood in good part even by the non-mathematical reader) ; E. W. Scripture, *Yale Studies*, 1894, 1 ff. (an unnecessarily technical paper, and not to be followed in all of its conclusions) ; E. L. Thorndike, *Educational Psychology*, 1903, 3 ff., 166 ff. ; *Mental and Social Measurements*, 1904, esp. 71 ff. ;¹ F. Galton, *Natural Inheritance*, 1889, 35 ff. (median) ; J. McK. Cattell, art. *Errors of Observation*, and W. R. F. Weldon, art. *Variation, Statistical Treatment of*, in *Dict. of Phil. and Psych.*, i, ii. ; Fechner, *Ueber den Ausgangswerth der kleinsten Abweichungssumme*, *Abh. d. kgl. sächs. Ges. d. Wiss., math.-phys. Kl.*, xi., 1878, 1 ff. (esp. for the median) ; Fechner, *Kollektivmasslehre*, ed. G. F. Lipps, 1897, 8, 17, 160 ff. (average) ; 13, 17, 165 ff. (median) ; 12, 17, 170 ff., 182 ff. (mode) ; 14, 172 ff. (other representative values) ; 18 ff., 92 ff. (measures of variability).

The student should be led fully to realise what it is that the various representative values represent. He should, *e.g.*, understand why it is that the average is the best representative value of the experiments that he has just been making. It is a good plan for the Instructor to have a collection of examples, so chosen as to indicate the relative importance for different purposes of the three values discussed above. The collection may easily be formed from the literature.

(3) A good answer to this Question implies a psychological theory of the method. Some few points (mostly in relation to sources of error) will be brought out by an intelligent student. The Instructor may discuss these, and may anticipate the historical and critical discussion of the methods (pp. 99 ff.) so far as he judges advisable. Hints of theory should be thrown out as early as possible in quantitative work ; on the other hand, it is bad pedagogy to load the student's mind at first with too much detail.

(4) Introspection ends when the series end. Psychology goes farther : for the *RL*, though an ideal value, lying midway between the final introspective data of corresponding (↓ and ↑) series, is

¹ On these two works, see p. 98 below.

a psychological value. Calculation thus begins for psychological purposes, and for those only. Once begun, it naturally follows the rules peculiar to it as a special mathematical operation.

The student must clearly understand that the calculation is *psychological* calculation. It is a common mistake, at first,—and it may be reinforced later by interest in the calculative processes for their own sake,—to suppose that there is a sharp dividing line between the psychological work of the experiment and the mathematical work of calculating its result. If that were true, the calculation might be dispensed with.

(5) In the Exp., as made, every \downarrow and every \uparrow series has given us a single *RL*-value: the \downarrow series, the value of the first or just unnoticeable *R*; the \uparrow series, the value of the first or just noticeable *R*. If we represent these values in two typical series, by the letters *b* and *a'*, our average *RL* (as determined from any paired series) is $\frac{a'+b}{2}$.

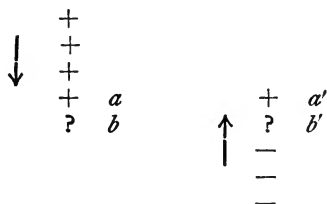

It is clear, however, from inspection of the series, that they furnish two other values, whose average has an equal claim to represent the *RL*. These values are *a*, the last noticeable *R* of a \downarrow series, and *b'*, the last unnoticeable *R* of an \uparrow series. The average of the last 'noticeable' and the last 'unnoticeable' is as truly a liminal value as the average of the first 'unnoticeable' and the first 'noticeable.' In other words, *RL* may be made $=\frac{a+b}{2}$. Or, if we combine all four critical values, $RL = \frac{a+a'+b+b'}{4}$.

METHOD.—As thus employed, the method is Higier's extension of Müller's Method of Least Differences. It will be discussed in detail later. In the present instance, precisely the same

series may be made the basis of either mode of calculation. The extension of the method becomes of importance only when we apply it to the determination of the *DL*. Nevertheless, it is worth while at this stage to call the student's attention to the significance of the values *a* and *b'*.

RESULTS.—Instead of working out the combined *RL* from our former Table (p. 6), we may take another set of results. The following Table shows the complete results of an experiment made under the conditions laid down in the text, except that 12 (not 20) series were taken.¹

SERIES	↓ 1	↑ 2	↓ 3	↑ 4	↓ 5	↑ 6	↓ 7	↑ 8	↓ 9	↑ 10	↓ 11	↑ 12
Vs. 23							+					
22							+					
21							+					
20	+						+					
19	+				+		+					+
18	+		+		+		+					+
17	+		+		+		+		+			+
16	+		+		+		+		+			+
15	+	+	+	+	+	+	+	+	+	+	+	+
14	+	-	+	-	+	-	?	?	+	?	+	?
13	-	-	-	-	-	-	-	-	-	-	-	-
12		-		-		-		-		-		-
11		-		-		-		-		-		-
10		-		-		-		-		-		-
9		-		-		-		-		-		-
8		-		-		-		-		-		-
7		-		-		-		-		-		-
6		-		-		-		-		-		-

¹ *O* and conditions as before (p. 6). The table shows the effects of increasing practice.

The series correspond, fairly well, as follows :

↓	10	8	7	7	6	5
↑	10	8	8	7	5	4.

The separate averages, as drawn from the Table, are :

<i>a</i> last noticeable	14.2 ± .3 ;
<i>b</i> first unnoticeable	13.2 ± .3 ;
<i>a'</i> first noticeable	15.0 ± 0 ;
<i>b'</i> last unnoticeable	14.0 ± 0.

The *RL*, calculated as $\frac{b+a'}{2} = 14.1 \pm .92$;

“ $\frac{a+b'}{2} = 14.1 \pm .17$;

“ $\frac{a+a'+b+b'}{4} = 14.08 \pm .53$.

If we undertake a revision of the figures of the Table (see p. 7, above), we find (1) that in all but one of the ↓ series *a* and *b* coincide. Thus, in series 1, the last noticeable and the first unnoticeable fall with equal probability upon 13.5. Only in series 7, *a* falls upon 14.5 and *b* upon 14.0. Again, (2) in the first 3 ↑ series *a'* and *b'* coincide. In the last three, we must put *a'* at 14.5 and *b'* at 14. Averaging all values, we obtain $RL = 14 \pm .42$.

The determination of other representative values and measures of variability may be assigned to the student, if the Instructor see fit, as an exercise in computation.

If the student fail to answer the Question, he may be asked to criticise some bit of work in which Higier's method (or an approximation to it) has been employed. Higier's own account is to be found in P. S., vii., 1892, 265 ff. If it be thought too difficult, take Scripture's Exercise on the Threshold of Touch (Yale Studies, iv., 1896, 92 ff.). The following criticisms will occur to the reader :

(a) It is not advisable to place the hand on the knee. Apart from the fact that constancy of position cannot be guaranteed, complicating pressures are introduced which may distract the attention.

(b) The interval between the ready-signal and the application of *R* is to be "about 2 to 5 sec." It should be kept constant at a short 2 sec. ; otherwise, *O*'s attention may lapse and wander. It is advisable to vary the conditions of an exp. ; it is oftentimes advisable to vary them irregularly. But the degree of attention is the very last thing that should vary in a liminal determination ! Notice that nothing is said in the

Specimen Record of the times elapsing between the Ready! and the application of *R*. Some of the more startling irregularities in series 4, 7, 10 may be due to their variation; although

(c) errors of manipulation play a large part in any exp. with the touch-weights.

(d) The exp. is performed only in the \uparrow direction. The series have all the same length and all the same size of step.

(e) The value chosen to represent the 'lower' limen (our *RL*) is *a'*. This is correct, although in strictness 1 mg. (half the unit interval) should be subtracted from every recorded value before the average is drawn.

(f) Another value ("the number of the disc beyond which all were felt") is selected to represent the 'upper' limen. This may suggest to *O* the possibility of determining upper and lower limiting limens¹ or *LL*, in addition to the *RL* proper; or—since he knows nothing so far of *LL*—may suggest to him the use of the value *a* in the \downarrow (and therefore also of *b'* in the \uparrow) series for the determination of the *RL* itself.² At any rate, the procedure is so different from our own as to set him thinking.

¹ The author proposes this term for the German 'Schwelle der Unentschiedenheit' and 'obere Grenze der zufälligen Werte der *RL*.' The former, according to Müller (who is speaking of the Raumschwelle der Haut), "ist dadurch charakterisiert, dass jedes *D*, das kleiner ist als die *S*. der *U*., den Eindruck der einfachen Berührung erweckt, hingegen jedes *D*, das grösser ist als dieselbe, entweder das Urteil 'unentschieden' zufolge hat oder den Eindruck der Doppelberührung hervorruft" (M., 44). The definition may be applied, *mutatis mutandis*, to the determination of any absolute *L*. The latter is "der geringste von allen denjenigen *D*-Werten, die stets das Urteil 'doppelte Berührung' ergeben" (*ibid.*): the definition may be similarly extended. It is this upper *LL* that Scripture seeks to determine. While, however, the lower *LL* may be ascertained, the value of the upper *LL* is always very dubious; see Müller, *in loc.*; Ebbinghaus, *Psych.*, i., 1902, 492. What holds of the *RL* in this regard holds also of the *DL*; see Müller, M., 44, 55; and cf. his critique of Fechner and Volkmann, G., 56 ff. There may, of course, be exceptional circumstances which suggest the determination of the upper *LL*: cf. Meumann, P. S., ix., 1893, 277 ff.; xii., 1896, 152 ff.—These *LL* must be sharply differentiated from the overlimens or *OL*. "Man kann neben der oberen und der unteren *DL* noch eine obere und eine untere Ueberschwelle unterscheiden, welche dadurch charakterisiert sind, dass *V* nur dann für viel grösser bzw. viel kleiner erklärt wird als *H*, wenn der Unterschied zwischen *V* und *H* die obere bzw. untere Ueberschwelle überschreitet": Müller, M., 55, 171; E. Mosch, P. S. xiv., 1898, 542.

² Müller remarks (M., 184) that Scripture noted "bei dem aufsteigenden Verfahren neben dem ersten merkbaren *R*-Werte auch noch den letzten unmerkbar." This would represent the ascending half of Higier's method. What Scripture really does, however, is to record the disc first felt (the first noticeable *R*) and the disc beyond which all were felt, *i.e.*, the upper limiting value of the ascending *RL*. The 'last unnoticeable' does not appear at all in his directions.

(6) For sources of error, see the discussion of the method, pp. 4 f.— In some cases, the effects of expectation, habituation, suggestibility, etc., are so great as to prevent the determination of the limen by the serial method. Thus Kiesow, in his determination of the qualitative *RL* for taste, found it impossible to employ the \downarrow series: *P. S.*, x., 1894, 358 f. Stratton devised the method of 'serial groups,' for the determination of the visual movement-limen, because "certain excellent though suggestible subjects" proved refractory to the method of minimal changes; they "persisted in seeing the light move on every occasion, whether there was any actual movement or not": *Psych. Rev.*, ix., 1902, 444 ff. Müller, in determining the limen for the visual sensation aroused by electrical stimulation, repeated his *R* 5 times at every step, and averaged the *R*-values at which the five-fold perception was 'still just possible' and 'just no longer possible': *Z.*, xiv., 1897, 372: *cf.* 364, 367. Gamble gave up the \downarrow series for smell, as Kiesow had done for taste: "it is often impossible, on account of adhesion in the tube or in the nasal passages, or on account of memory after-images, or cumulative stimulation, to move from a point of intensive stimulation to a point at which sensation entirely disappears." *O* was allowed to move to and fro, back and forth, about the first final point of an \uparrow determination: *A. J.*, x., 1898, 106. Some instance or instances of this sort will probably be suggested to the student by his qualitative work.

(7) The student should think of certain perception limens (limens of movement, visual, cutaneous, articular, etc.; the two-point limen of the skin) as well as of the *RL* proper.

(8) The student will almost invariably suggest modifications of the serial method, *i.e.*, ways of varying the *R* so as to bring out the same judgment of 'just noticeable.' This gives the Instructor an opportunity to introduce the idea of the method of constancy (right and wrong cases), where the *R* are kept the same and the judgment of *O* varies under the influence of accidental errors. As was said above, theoretical hints of this kind cannot be thrown out too early in quantitative work.

EXPERIMENT II

§ 11. **The Qualitative RL for Tones: the Lowest Audible Tone. Alternative Experiment.**—The method is a form of Kraepelin's combined method of limits and differences (*i.e.*, of min. ch. and right and wrong cases): see P. S., vi., 1891, 499 f. The object of the haphazard order of the *R* is to avoid the errors of expectation, habituation, etc., incident to the former method.

On the score of psychological analysis, it may be doubted whether the results of this and of the first method are ever strictly comparable. For one thing, (*a*) the standard or criterion of judgment is likely to differ in the two cases. In the method of least differences (method of limits), the standard is fixed by the character of the series. *O* begins every new series with the knowledge that 'this is a tone; this is the sort of thing that a very low tone is,' or that 'this is a noise; this is the sort of thing one hears before one reaches the tonal limit.' He need not trouble to memorise tone or noise; he is constantly reminded of what tone and noise 'sound like.' In the combined method, on the other hand, he has nothing to help him but his memory of the preliminary experiments. As the several *R* are presented, he has to ask himself afresh: Is there tonality in this impression? does this sound like a low tone? If he has a standard, it is either an ideal, memory standard, or a standard improvised from the immediately preceding experiments. In both events, it is likely to vary from series to series, even from one part to another of the same series. Again, (*b*)—perhaps as a result of this difference of criterion—there is apt to be a marked difference in degree of attention. In the method of least differences, *O*, after a very little practice, inclines to take things easily for the first few steps of a series. In the combined method, attention is strained to the utmost at every step; so that it is, at times, almost comic to note the relief with which the judgment 'Nothing' is passed on an *R* of 6 vs., or the judgment 'Tone' on an *R* of 22. The combined method is thus by far the more fatiguing of the two. Besides, (*c*) the method of least differences has its own pitfalls of expectation, etc., which the combined method aims to avoid.

Despite this difference of psychological motivation, the quantitative results yielded by the two methods in laboratory practice are, to all intents and purposes, the same,—equal degree of practice being presupposed. The *RL* is a variable value: variable not only for different *O*, at different stages of practice, with different degrees of attention, but intrinsically variable. Nevertheless, the results of the two methods tally surprisingly well. How are we to explain this fact?

We might, perhaps, shelter ourselves behind the roughness of our work. *O* is not an investigator. And we know, from the analogy of physical weighings and measurings, that the rough determinations are those most likely to agree. With a better instrument, with smaller steps, with more refined introspections, the variability of the *RL* would come out more plainly,

All this is true. It is also true, however, that the representative values of the *RL* for tones, as determined by different methods, agree very well even under the most accurate conditions of observation. This can only mean that the *RL* corresponds to a real and definite change in the character of the sensations aroused by the instrument employed. There are certain *RL* whose position is so masked by physiological and psychological disturbances that their determination, whether by the method of least differences or by the combined method, is out of the question. But the *RL* for tones, the ideal dividing line between tone and no-tone, the first critical point upon the tonal scale, is so clearly marked for introspection that we find it (within certain closely drawn limits of variation) by whatever psychological road we approach it. No liminal determination is easy; but this particular determination is certain. It is for this reason that the experiment is well fitted to serve as introduction to quantitative work in psychology.

RESULTS.—The following Table¹ shows the complete results of an experiment taken under the conditions laid down in the text.

Vs.	8	9	10	11	12	13	14	15	16	17	18	19	20	21
Series 1	—	—	—	—	+	+	+	—	+	+	+	+	+	+
" 2	—	—	—	—	—	—	+	+	+	+	+	+	+	+
" 3	—	—	—	—	—	—	—	+	—	?	+	+	+	+
" 4	—	—	—	—	—	—	+	+	+	+	+	+	+	+
" 5	—	—	—	—	+	—	+	?	+	+	—	+	+	+
" 6	—	—	—	—	—	?	+	+	+	+	+	+	+	+
" 7	—	—	—	—	—	+	+	+	+	+	+	+	+	+
" 8	—	—	—	—	—	—	+	+	+	+	—	+	+	+
" 9	—	—	—	—	—	—	+	+	+	—	+	+	+	+
" 10	—	—	—	—	—	+	+	—	+	?	+	+	+	+

¹ *O* and conditions as before, pp. 6, 17. *O* has now reached his first steady level of practice. A renewed determination by the method of least differences gave *RL*=13, with an *MV* of less than 0.5. It is possible that further practice would reduce this value by a vibration; but, according to the author's experience, it is not probable.

(1) The first question that arises is the question of the treatment of the ? -judgments. Müller thinks that "bei der etwas prekären Beschaffenheit" of these judgments, their R should not be counted either as perceptible or as imperceptible (M., 185). He is, however, evidently thinking of results in which (owing to the smallness of the unit) ? -judgments are quite common; for his immediate problem is, whether the arithmetical mean of all the ? - R can be regarded as a 'characteristic value representing the RL .' In the case before us, we have only one ? -judgment to consider: that of series 6. This series is quite regular; and there is no reason to think that the ? -judgment stands on any other level than that of the b of a \downarrow or the b' of an \uparrow series (method of least differences). We may therefore assume that the critical values of series 6 are 13 and 14, not 12 and 14.

(2) Since the R have been given in haphazard order, the interval covered by any value y is not the interval $y-z$, but the interval $x.5-y.5$. In other words, we may calculate our averages from the figures as they stand, without revision.

(3) The irregularities of judgment which occur with this method are always a little puzzling to the student. In some cases we may, of course, suspect an objective source of error. Thus the two — under 18, and the two ? and one — under 17, may with some show of reason be attributed to a warp of the lamella, which prevented its oscillations attaining their full amplitude or maintaining their normal duration. Unfortunately, the instrument was not examined at the conclusion of the experiment. It should, however, be said emphatically that irregularities of judgment are characteristic of the method; they are due to all sorts of accidents, which the keenest observation will be unable to identify in detail. It will be remembered that the determination of an upper LL is vitiated by their occurrence. An experiment that gave only regular series of the type of series 6 would be open to the suspicion either that its units were far too large or that O had not judged in terms of audition.

(4) If we average the last unnoticeables, we find $RL=12.5 \pm 0.8$; if we average the first noticeables, $RL=13.5 \pm 0.8$. If we take the average of both values, we have $RL=13 \pm 0.8$.

It is possible to treat the results by the procedures of the method of constancy (right and wrong cases). Such a course is, perhaps, hardly advisable at this stage; though the Instructor may take the results as a text in answering Question (8), p. 20 above.

(5) Müller (M., 185) recommends the introduction of blank experiments. With the lamella, however, they are usually failures. The strip must be plucked, or *O* will miss the sound of actuation. If, now, the lamella be arrested immediately after the pluck, *O* misses the impact of the air-waves upon his ear and hair. If a screen be interposed between lamella and ear, the impact is again cut off, while supraliminal tones are still heard. On the whole, therefore, it seems best to dispense with the blank experiment in this particular case.

§ 12. **Determinations of the Lowest Audible Tone.**—The following Table brings together the most important historical statements. A few other references are given in the Remarks appended.

I. PROPER TONES OF VARIOUS INSTRUMENTS.

	Observer	Date	Instrument	Vs.
(1)	Sauveur	1700	40 ft. pipe	12.5
(2)	Chladni	1802	32 ft. pipe	About 16
	"	"	Stretched string	About 16
(3)	Biot	?1817	32 ft. pipe	16
	"	"	Weighted string	16
(4)	Wollaston	1820	(Organ)	Below 33
(5)	Savart	1831	Rotating spoke	7 or 8
(6)	Despretz	1845	Rotating spoke	Between 16 and 48
(7)	Helmholtz	1863	Weighted string	37
	"	1870	Koenig fork	28 to 30
(8)	Wolf	1871 (1870)	Koenig fork	28
(9)	Preyer	1876	Loaded reeds	16 to 24
	"	1879	Appunn fork	About 18.6
(10)	Ellis	1877	Loaded reeds	15 or 16
(11)	McKendrick	1878	—	About 30
(12)	Wundt	1887	Appunn fork	14 or less
	"	1893	Appunn lamella	8 to 10
	"	1902	Wire forks	Below 16
(13)	Melde	1891	—	24
(14)	Cuperus	1894	Appunn lamella	10.1 to 12.95
(15)	Bezold	1897	Edelmann fork	11 or less

II. DIFFERENCE TONES.

(16)	Wundt	1874	Large pipes	8
(17)	Preyer	1876	Reeds	18 to 20
(18)	Schaefer	1899	Edelmann Galton whistles, forks, blown bottles	30 or less (once 14)

III. INTERRUPTION TONES.

(19)	Schaefer	1899	Siren discs, wood and metal	16
------	----------	------	--------------------------------	----

REMARKS.—I. *Proper Tones of Various Instruments.*

(1) J. Sauveur, *Histoire de l'académie royale des sciences*, Année MDCC. Avec les mémoires de mathématique et de physique, pour la même année. Tirés des Registres de cette Académie. 2 edn., Amsterdam, MDCCXXXIV., 190. Second Paris edn., 1761, 134. The account is not from Sauveur's own hand.

(2) E. F. F. Chladni, *Die Akustik*. Leipzig, 1830, 2. Unveränderte Ausgabe. The preface is dated 1802 (so Preyer, *Gr. d. Tw.*, I). With the stretched string, "wird man ungefähr von 32 (einfachen Schwingungen) an eine Wirkung auf das Gehör bemerken." The 32-ft. *C* of 16 vs, is "der tiefste Ton von dem man Gebrauch zu machen pflegt" (27). Again, experience shows that "bei den tiefsten Tönen, von denen man Gebrauch macht, wenigstens 30 (einfache) Schwingungen in einer Secunde geschehen" (230).

(3) J. B. Biot, *Précis élémentaire de physique expérimentale*, 3d edn., 1824, i., 344, 356. "Cette limite . . . n'est au reste qu'une indication approchée qui n'est point susceptible de rigueur." The first edn. of the *Précis* appeared in 1817.—The same limit, of 16 vs., is accepted by K. Vierordt, *Physiol. d. Menschen*, 1877, 365.

(4) W. H. Wollaston, *Philos. Trans*, for the year 1820. Pt. ii. London, 1820, 313. Wollaston writes that the lowest note of the organ (by which he means the contra-*C* of 33) is distinctly perceptible by most ears. But (310) "there does not seem to be any

strict limit to our power of discerning low sounds. . . We may doubt at what point tones suited to produce any musical effect terminate; yet all [normal] persons . . . continue sensible of vibratory motion, until it becomes a mere tremor, which may be felt and even almost counted."

(5) F. Savart, Ueber die Grenze der Hörbarkeit tiefer Töne, Pogg. Ann., xxii. (xcviii.), 1831, 596; Ann. chim. phys., xlvii., 1831, 69. Savart cut down his toothed wheel to a single diameter, *i.e.*, to two spokes. At the extremities of the diameter he held two cards or thin boards; these were laid close to the ends of the spokes, in a plane at right angles to the plane of the wheel. As the spokes drove by, a "series of little explosions" was produced. A low tone was heard when the strokes came 7 to 8 times in the 1 sec. Savart assumes that this tone is directly due to the stroke, and that each stroke represents 1 complete vibration.—Criticised by Despretz, 444; Helmholtz, Sens. of Tone, 175 (also in Lehre von d. Tonempf., 1863, 266); Wolf, Sprache u. Ohr, 244; Preyer, Gr. d. Tw., 3 f. Wundt (Phys. Psych., 1874, 362) gives an erroneous description of the instrument.

In 1830 (Pogg. Ann., 301) Savart reports that a wheel with a single tooth, rotated against a card more than 32 times in the 1 sec., gives "a peculiar steady tone, whose pitch rises with increase of the number of revolutions." There is no indication that Savart is here seeking to determine the lowest audible tone, although Preyer (31) so interprets the passage.¹

(6) C. Despretz, Pogg. Ann., lxx. (cxli.), 1845, 442 ff.; Comptes rend., xx., 1845, 1214 ff. Despretz used Savart's instrument, and also a similar apparatus in which the spokes revolved between four pairs of boards. At 16 strokes in the 1 sec., he heard no tone; the lowest tone given by either instrument was the contra-G of 48. He remarks that the apparatus gives a number of tones and noises, and that neither Marloye nor Cagniard-

¹ Which has been otherwise unfortunate! Savart says that, if the toothed wheel be struck against the card, we hear a tone — of a quality altogether different from the qualities of the tones produced by two or more teeth — which does not vary, however rapidly the single stroke be made. Whereupon Poggendorff remarks that, if two single strokes follow each other as rapidly as the successive strokes of the two-toothed wheel, we ought to hear the same tone. Of course! But Savart is speaking of *one* (quick or slow) stroke.

Latour had referred the low tone heard in Savart's experiments to the shocks of the rotating rod. See Preyer, 4.

(7) Helmholtz (*Sens. of Tone*, 176) used a thin brass piano wire, weighted with a copper coin, stretched over a sounding box. The string was chosen because it had only high harmonic overtones, which could not be confused with the fundamental. The contra-*D* gave "a very weak sensation of tone, and even this was rather jarring"; at the subcontra-*B* "there was scarcely anything audible left." Helmholtz' statements concerning the vibration-rates of his string vary somewhat: see Preyer, *Akust. Unt.*, 9 f.; Schaefer, *Z.*, xxi., 1899, 161.

Subsequently (1870) Helmholtz obtained two Koenig forks, giving the tones from 24 to 35, and from 35 to 61, respectively. "For 30 vs. I could still hear a weak drone; for 28 scarcely a trace."

In his *Popular Lectures on Scientific Subjects*, Helmholtz remarks that the contra-*C* of 33 is "very nearly the limit of audibility," and that for the subcontra-*C* of $16\frac{1}{2}$ "the ear can scarcely separate the tone from an obscure drone." The lower limit is finally set at "about 20." See *Populäre wiss. Vorträge*, 1865, Heft, i., 64; 1876, i., 64; *Pop. Lect. on Sci. Subj.*, New York, 1885, [First series] 64, 69; new edn., London, 1884, 1st. ser., 56, 61. The lecture was first printed in 1857.

(8) O. Wolf, *Sprache und Ohr*, 1871, 245. "Bei grosser Anstrengung und Aufmerksamkeit konnte ich noch [einen Ton] von 28 Schw. unterscheiden." The observation was made in Helmholtz' company, with the forks mentioned under (7).

Wolf also describes an Appunn 'lower limit apparatus,' consisting of 4 reed pipes: the lowest reed, with variable weight, made 4 vs., the second 8 vs., the third 16, the fourth 32 in the 1 sec. (*op. cit.*, 245 ff.). The third reed gave an overtone of 32 vs., and 'einzelne Luftstösse.' The fourth gave a clear fundamental. Why there were no reeds between 16 and 32—in the critical region—Wolf does not explain. The contra-*C* of 33 is heard as continuous tone from a 16-ft. stopped labial pipe.

(9) Preyer used an Appunn 'fundamental tone apparatus,' a series of loaded harmonium reeds, giving the vibration-rates 8, 9, 10, . . . 32, 34, 36, 38, 40. The fundamental was heard as the

reed rang off. See Table, Gr. d. Tw., 10 f. Criticised by Helmholtz (who thinks that reed pipes were employed): Sens. of Tone, 176: cf. Ellis, *ibid.*, and Preyer, Akust. Unt., 5 ff.

Later, Preyer obtained two Appunn forks, the one of which vibrated approximately 18.6, the other 13.7 times in the 1 sec. The tone of the former could be heard, with or without resonance box; the latter gave no audible tone. Akust. Unt., 1879, 1 ff.—

J. K. Love (Glasgow Thesis: abstract in Journ. of Anat. and Physiol., xxiii. [N. S., iii.], 1889, 336) accepts Preyer's determination of 15 to 16 vs. "Many ears cannot hear notes caused by less than 24 vs."

(10) A. J. Ellis (Preyer's Akust. Unt., 6 ff.; in extract, Helmholtz' Sens. of Tone, 176 f.) used a duplicate of Preyer's fundamental tone apparatus. Results:

Nominal pitch of reed	Actual pitch	Introspections
8	7.91	Sishing of escape of wind from reed, and beats from upper partials.
9 to 15	8.89 to 14.91	Sishing and beats; faint low tone like a differential. Octave of lowest partial?
16	15.91	"Quite an organ tone; nothing like a hum or differential; but the sish and beats remain. I must have heard the lowest partial."

(11) J. G. McKendrick, *Encycl. Brit.*, 9th edn., vii., 393.

(12) W. Wundt, *Physiol. Psych.*, i., 1887, 423: a large fork by A. Appunn allows the tone of 14 to be heard "vollkommen deutlich." *Ibid.*, i., 1893, 450: the Appunn lamella gives a tone at 8 to 10 vs. *Ibid.*, ii., 1902, 90: the Appunn wire forks give a clear tone, gradually lowering in pitch, down to 14 vs. At 12 to 10 vs., 9 practised observers heard a tone, but of indeterminate pitch. Five of the 9 heard an indefinable tone at 8 vs. Some of

the observers declared the tones from 12 to 8 vs. to be higher than the tone of 14 vs. Nothing is said of the lamella.

(13) F. Melde, in A. Winkelmann's Hdbch. d. Physik, i., 764.—E. W. Scripture (New Psych., 324) puts the lower limit at "somewhere around 12 complete vibrations."

(14) See H. Zwaardemaker, Z., vii., 1894, 21. Cuperus' results are as follows:

Age of <i>O</i>	Average vs.
10 to 20	10.10
20 to 30	10.54
30 to 40	10.85
40 to 50	11.00
50 to 60	12.33
Over 60	12.95

The number of *O*'s was 190. The variability of four-year averages is determined as $\frac{PE}{\sqrt{n}}$: see 21, 23. The error of the instrument is that it gives a larger initial amplitude of oscillation for lower than for higher tones: 21. Moreover, we do not know how it rings off at different lengths and with different initial amplitudes of oscillation: 24.

(15) F. Bezold, Z., xiii., 1897, 162, 166. The tone of 11 vs. "wird nur mehr von einem Theil sonst normalhöriger Gehörorgane perzipiert." Bezold regards his low forks as free from overtones: but an argument from pathology is rebutted by Schaefer, *ibid.*, xxi., 1899, 164 f.—*Cf.* the earlier paper, Z., f. Ohrenheilkunde, xxiii., 1892, 254 ff.; reviewed by Schaefer, Z., v., 1893, 356.

II. *Difference Tones.*

(16) Wundt declares (Phys. Psych., 1874, 362) that two large stopped labial pipes, sounding the *C* and *D* of the great octave, gave a difference tone $C_3=8$ vs., "die man sehr deutlich als einzelne Luftstöße wahrnimmt." Yet very different persons, musical and unmusical, recognised difference tones of 8 to 16 vs. as deeper in pitch than the primaries. The tone of 8 vs. is also heard on large organs, while the two primaries are almost completely annulled by interference, if the pipes stand near together.

In 1880 (i., 393 f.) Wundt remarks that tones "somewhat lower than 16" can be heard as difference tones from labial pipes. In 1887 he accepts the 8, if the vibrations are strong enough. The limit 8 to 10 recurs in the edn. of 1893, i., 450. In 1902 (ii., 90), he regards the tone heard as a Zwischenton (96, 103, 111, 129), whose pitch is masked (*a*) by the general uncertainty of pitch-estimates of 'stossende Töne,' especially in the lower regions of the scale, and (*b*) by the subjective impression of greater depth made by these tones as compared with continuous tones of the same objective pitch. — See (17) below, and *cf.* C. Stumpf, *Vjs. f. Musikwiss.*, 1888, 540 f.; *Tps.*, ii., 1890, 551.

(17) Preyer says (*Gr. d. Tw.*, 15): "I hear plainly the difference tone of 24, but I am doubtful at 18, and at 12 there is no trace of any fusion." The Appunn tonometer, which furnishes beats of 4, 8, 12, . . . in the 1 sec., gave a "sudden continuity of sensation at 20." Preyer worked with metal tongues, apparently within the limits 100 and 1000. He notes that a deep tone, heard with reeds of 500 and 512, is not the tone of 12 vs., but the difference tone of the octaves, 1000 and 1024 vs. Schaefer (166) agrees, and explains in the same way Wundt's difference tone of 8 vs., and an observation of his own in which the tonometer appeared to give a difference tone of 10 vs.

(18) K. L. Schaefer (*Z.*, xxi., 1899, 166 ff.) sought to determine the limen of perception of difference tones, in the different regions of the musical scale, with primaries that were free of overtones. At 9000 to 10000 vs. (whistles), the limen was generally 30, sometimes rather less. From 8000 to 200 (whistles, forks, bottles), a difference tone was always found above 30, "in der Regel schon viel früher." In one case (fork of 200 and bottle), it appeared "bereits spurweise bei 14." From 100 down, the method became unreliable.

III. Interruption Tones.

(19) Schaefer, *op. cit.*, 170 ff. Results:

Instrument	Principal tone	Deepest interruption tone
Wooden disc	<i>b</i> (247.5) to <i>a</i> ¹ (440)	24, 25
Metal disc	<i>e</i> ³ (1320) to <i>g</i> ³ ₇ (1520.64)	22, 23, 25
Wooden disc	<i>d</i> ² (594) to <i>d</i> ³ # (1237.5)	16, 18

Four series were taken, in this order, with each disc,—12 series in all. The reduction from 25 to 16 vs. may be referred to practice. The author thinks it possible that, under especially favourable conditions, the lowest limit might be still further lowered.

It should be noted that Schaefer (161 ff.) looks with suspicion upon all the determinations of pt. I. of the Table, since there is no guarantee in any case that “man es nur mit dem Grundton zu thun hat.”

EXPERIMENT III

§ 13. **The Qualitative TR for Tones: the Highest Audible Tone.**—We require for this experiment an instrument that shall give physical ‘tones,’ beyond the range of hearing, whose intensity is at least as great as that of the highest audible tones. The instrument most commonly found in psychological laboratories, for the determination of the upper limit of tonal hearing, is the Galton whistle (Cambridge Instr. Co., Hawksley, Koenig or Edelmann). Many laboratories possess also the Appunn or Koenig series of small forks, or the Koenig series of steel cylinders.

The Galton Whistle.—Galton seems to have first described his whistle in 1876: “Whistles for determining the Upper Limits of Audible Sound,” S. Kensington Conferences (in connection with the Loan Exhibition of Scientific Instruments), 1876, 61. “I contrived a small whistle for conveniently ascertaining the upper limits of audible sound in different persons, which Dr. Wollaston had shown to vary considerably. He used small pipes” (Inquiries into Human Faculty and its Development, 1883, 38, 375; Nature, xxvii., 1883, 491; cf. W. H. Wollaston, Philos. Trans. Royal Soc. London, cx., 1820, pt. ii., 310, 312; Sanford, Lab. Course, 379 ff.).

High Forks.—The first set of very high forks was apparently that

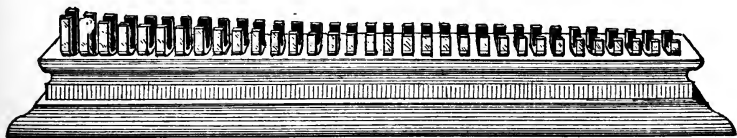

Fig. 5.—Appunn's series of high forks, for the determination of the qualitative TR. The forks are actuated by bowing across the tops of the tines.

made by Marloye, and used in 1845¹ by C. Despretz (Comptes rendus, xx., 1845, 1214; Pogg. Ann., 3te Reihe, v. [cxli.], 1845, 445). Koenig made his first set of high forks in 1874 (Wied. Ann., N. F. lxi. [ccc.], 1899, 627). The forks with which Preyer worked in 1875 were furnished by G. Appunn (W. Preyer, Ueber die Grenzen der Tonwahrnehmung, Jena, 1876, 20, 23): the pattern-set was kept in the Appunn workshop (A. Appunn, Wied. Ann., N. F. lxiv. [ccc.], 1898, 411.)

Cylinders.—Koenig showed a series of steel cylinders at the Paris Exhibition of 1867 (R. Koenig, *ibid.*, lxix. [ccc.], 1899, 627).

These instruments have been thoroughly tested, of late years, by different methods. As their reliability is a matter of great importance, the author here brings together the principal literary references.

(1) R. Koenig: Catalogue des appareils d'acoustique. Paris, 27 Quai d'Anjou. 1882, no. 47; 1889, no. 50. "Série de 18 diapasons pour les notes de $ut_7 = 8192$ v. s. à $fa_9 = 43690.6$ v. s. [in our notation, $c^5 = 4096$ vs. to $f^7 = 21845.3$ vs.] avec étui, et un support en fonte de fer. . . . Déjà avec les trois derniers diapasons, au-dessus de ut_9 , la production de ces sons et leur observation deviennent assez difficiles, aussi ai-je préféré arrêter cette série au fa_9 , pour qu'on ne puisse me reprocher d'entrer dans la domaine de la phantasie." Cf. also Quelques expériences d'acoustique, Paris, 1882, 108.

1889, no. 51. "Série de 22 cylindres en acier pour les notes de ut_7 à ut_{10} [$c^5 = 4096$ to $c^8 = 32768$ vs.] avec marteau en acier."

(2) Spezialitäten welche in dem akustischen Institut von A. Appunn . . . angefertigt werden. Three catalogues. (a) No date: 1892? No. 15. Eine Reihe von 33 Stimmgabeln auf einem Fuss, $4\frac{1}{2}$ Octaven Tonleiter darstellend von $c^4 = 2048$ bis $g^8 = 49152$ Schwingungen, zur Ermittlung der höchsten Hörgrenze. No. 17. Hörprüfungs-Apparat nach Professor Kessel-Jena; enthält 11 Stimmgabeln von 2000 bis 50000 Schwingungen. (b) No date: 1894? Nos. 13, 14 as nos. 15, 17 above. No. 42. Stimmgabeln nach jeder Angabe; Einstimmung derselben auf jede beliebige Schwingungszahl, mit Garantie für absolute Genauigkeit. (c) 1898-99. No. 13 (c). 62 Metallpfeifchen in Etui, eine Tonreihe von 1500 bis 50000 Schwingungen darstellend, aufsteigend von Halbton zu Halbton. Unter Garantie für Richtigkeit der angeführten Tonhöhen. No. 14 as nos. 17, 14 above. No. 42 as no. 42 above. The special set of 33 highest forks is not mentioned.—Other advertised series of high forks and pipes are here omitted.

(3) A descriptive list of instruments manufactured and sold by the Cambridge Instrument Company, Cambridge, 1892. Sec. 28, Anthropometric apparatus; 119 ff., Hearing highest audible note. Cf. F. Galton, Inquiries into Human Faculty,

¹Not 1848, as Koenig says (probably by a printer's error) in Wied. Ann., N. F. lxi. [ccc.], 1899, 626.

1883, 375 ff. "The number of vibrations in the note of a whistle may be found by dividing 13440 by four times the depth, measured in inches, of the inner tube of the whistle. This rule, however, supposes the vibrations of the air in the tube to be strictly longitudinal, and ceases to apply when the depth of the tube is less than about one and a half times its diameter." Sanford remarks of the

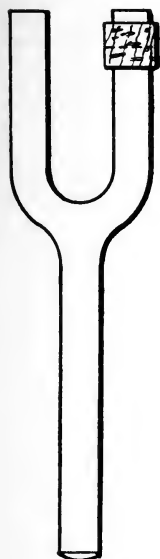

FIG. 6.*

Cambr. Inst. Co.'s form of the Galton whistle: "All that the instrument can safely show, except when handled with elaborate precautions, is the general character of very high tones and the fact that some persons can still hear tones that others cannot. . . It is hardly likely that [the makers] would contend for a high degree of certainty of the values given, especially at the upper end of the scale" (Course in Exp. Psych., 1898, 379 ff.).—See also F. Galton, On the Anthropometric Laboratory at the late International Health Exhibition, Journ. Anthropol. Inst., 11 Nov. 1884, xiv., 1885, 216.

(4) Illustriertes Verzeichniss no. iii. der medicin. Präcisions-apparate . . . von Dr. M. Th. Edelmann. München, 1895. No. 31 (13). Galton-Pfeifchen neuer Construction. Tonumfang g^5 bis über die obere Gehörgrenze hinaus. [This is the pipe tested by Stumpf and Meyer; it is not the new Edelmann instrument recommended in the text for experiment.]

(5) H. Zwaardemaker: Das presbyakustische Gesetz. Zts. f. Ohrenheilk., xxiv., 1893, 1. Also: Der Einfluss der Schallintensität auf die Lage der oberen Tongrenze. *Ibid.*,

303. [Gives a subjective method for standardising the Galton whistle.]

(6) F. Melde: Ueber einige Methoden der Bestimmung von Schwingungszahlen hoher Töne. Wied. Ann., N. F. li. (cclxxxvii.), 1894, 661; lii. (cclxxxviii.), 1894, 238. [Melde's two objective methods, the optical-graphic and the method of resonance, take him to the c^7 . Appunn's small forks are entirely unreliable: "die Abstimmung . . . ist . . . vollkommen unzuverlässig" (259). Koenig's forks, on the contrary, are extremely accurate.]

(7) C. Stumpf u. M. Meyer: Schwingungszahlbestimmungen bei sehr hohen Tönen. *Ibid.*, N. F. lxi. (ccxcvii.), 1897, 760. [Test of Edelmann's whistles, Koenig's forks, and Appunn's pipes and forks, by the difference-tone method. The method reached approximately to the c^7 . The Appunn pipes and forks are inaccurate; the Koenig forks accurate. The whistles are accurate only over the lower portion of their scale.]

(8) A. Appunn: Schwingungszahlenbestimmungen bei sehr hohen Tönen. *Ibid.*, N. F. lxiv. (ccc.), 1898, 409. [Reply to Melde, and to Stumpf and Meyer.]

* Fig. 6.—One of Appunn's small forks (no. 10), full size. Such a fork may be separately actuated by means of the cork attachment shown in the Fig. The tine is lightly brushed with shellac varnish, and the cork affixed by means of a morsel of warmed rosin. The concave surface of the cork is then moistened with dilute acetic acid, and a glass tube (say, 11 mm. in diam., and 24 cm. long) drawn across it. The cork will, of course, slightly lower the pitch of the fork; thus, a tone of 2048 may be reduced by 5 vs. See K. Antolik, Math. u. naturw. Ber. aus Ungarn, viii., 1890, 295; F. Melde, Wied. Ann., N. F. li. (cclxxxvii.), 1894, 683; lii. (cclxxxviii.), 1894, 244.

(9) C. Stumpf u. M. Meyer: Erwiderng. *Ibid.*, N. F. lxxv. (ccci.), 1898, 641.

(10) F. Melde: Erwiderng gegen Ant. Appunn's Abhandlung: Ueber Schwingungszahlenbestimmungen bei sehr hohen Tönen. *Ibid.*, 645.

(11) F. Melde: Ueber einen neuesten A. Appunn'schen Hörprüfungsapparat. Pflüger's Arch., lxxi., 1898, 441. [Test of a Kessel apparatus by the resonance method. The forks are, again, quite unreliable.]

(12) F. Melde: Ueber Stimmpfatten als Ersatz für Stimmgabeln, besonders bei sehr hohen Tönen. Wied. Ann., N. F. lxxvi. (cccii.), 1898, 767. [With these plates, the resonance method reaches to 28000 vs.]

(13) A. Appunn: Ueber die Bestimmung der Schwingungszahlen meiner hohen Pfeifen auf optischem Wege. *Ibid.*, N. F. lxxvii. (ccciii.), 1899, 217. [The pitch is determined by a photographic method. The pipes prove to be fairly accurate.]

(14) A. Appunn: Warum können Differenztöne nicht mit Sicherheit zur Bestimmung hoher Schwingungszahlen angewandt werden? *Ibid.*, 222. [Objects to the method of Stumpf and Meyer.]

(15) F. Melde: Ueber die verschiedenen Methoden der Bestimmung der Schwingungszahlen sehr hoher Töne. *Ibid.*, 781. [Classifies and outlines the various methods so far employed.]

(16) A. Zickgraf: Ueber Melde's neueste Methode zur Bestimmung sehr hoher Schwingungszahlen. Marburg, 1899. Diss. [Test of Appunn's forks with the pendulum vibrograph: the forks are inaccurate.]

(17) C. Stumpf: Ueber die Bestimmung hoher Schwingungszahlen durch Differenztöne. Wied. Ann., N. F. lxxviii. (ccciv.), 1899, 105. [Defence of the method against Appunn; new observations with Appunn's pipes.]

(18) F. A. Schulze: Bestimmung der Schwingungszahlen Appunn'scher Pfeifen für höchste Töne auf optischem und akustischem Wege. *Ibid.*, 99. [Test of Appunn's pipes by his photographic method, as well as by the methods of Kundt (dust figures) and Quincke (interference tubes). Further test, by Stumpf, with his difference-tone method. The results of all four methods tell against Appunn.]

(19) F. A. Schulze: Zur Bestimmung der Schwingungszahlen sehr hoher Töne. *Ibid.*, 869. [Discussion of Kundt's and Quincke's methods; test of Koenig and Edelmann whistles, and of Appunn's forks. The latter are inaccurate.]

(20) A. Schwendt: Experimentelle Bestimmungen der Wellenlänge und Schwingungszahl höchster hörbarer Töne. Mit Benutzung von Herrn Dr. Rudolph König brieflich mitgetheilte praktischer Anleitungen ausgeführt. Pflüger's Archiv, lxxv., 1899, 346. [Kundt's method. Koenig's high forks are "ausserordentlich zuverlässig;" his cylinders¹ proved to be correct up to $c^7 = 16384$. Test of Galton's whistles: Koenig, earlier Edelmann, later Edelmann. The method reaches to the $a^7 = 27361$, or even higher.]

(21) A. Schwendt: Ergänzung zu meiner Abhandlung: Experimentelle Bestimmungen, etc. *Ibid.*, lxxvi., 1899, 189. [Appunn's pipes, tested by Kundt's method, are inaccurate.]

(22) R. Koenig: Ueber die höchsten hörbaren und unhörbaren Töne von $c^5 = 4086$ Schwingungen ($ut_7 = 8192$ v. s.), bis über f^9 (f_{111}), zu 90000 Schwingungen (180000 v. s.), nebst Bemerkungen über die Stosstöne ihrer Intervalle, und die durch sie erzeugten Kundt'schen Staubfiguren. Wied. Ann., N. F. lxxix. (cccv.), 1899,

¹ On these cylinders, cf. Stumpf and Meyer, no. (7), 769; Melde, no. (12), 768.

626, 721. [The series of high forks, c^5 to f^7 ,—which, as we have seen above, are extremely accurate,—were tuned by difference tones. The cylinders were tuned by difference tones to the middle of the octave c^5 - c^6 ; from this point on, their length was determined by calculation. The shorter cylinders now prove to be slightly too long (Schwendt found the e^7 to be approximately a d^7): but the error is easily corrected. By Kundt's method, the author attains to 90000 vs.: a limit lying far beyond the range of hearing.]

(23) M. Th. Edelmann: Fortschritte in der Herstellung der Galton-Pfeife (Grenzpfefe). Zts. f. Ohrenheilk., xxxvi. (4), 1900, 330.

(24) M. Th. Edelmann: Studien über die Erzeugung sehr hoher Töne vermittelt der Galton-Pfeife (Grenzpfefe). Drude's Ann. d. Physik, 4te F., ii., 1900, 469. [Pitch-determinations in the case of the earlier Galton whistles were clumsy and uncertain. Description of the newest whistle. Kundt's method reaches to 170000 vs.]

(25) A. Schwendt; Tonhöhenbestimmungen höchster Töne. Verhandl. d. Ges. deutscher Naturf. u. Aerzte, ii., 2, 1900, 369.

(26) A. Schwendt: Ergänzende Untersuchungen über Tonhöhenbestimmungen sehr hoher Töne mittels der Kundtschen Staubfiguren. Verhandl. d. deutsch. otol. Ges., 1900, 55.

(27) A. Schwendt: Einige Beobachtungen über die hohe Grenze der menschlichen Gehörwahrnehmung. Arch. f. Ohrenheilk., xlix. (1), 1900, 1. [The upper limit, for young persons tested with the Edelmann whistle, lies at e^8 to f^8 .]

(28) C. S. Myers: On the Pitch of Galton Whistles. Journ. of Physiol., xxviii., 1902, 417. [In all forms of Galton whistle, pitch varies with wind pressure, the alteration of pitch with change of pressure being usually greatest when the pressure is relatively low. A point is reached near the TR where a tone is heard only as the blast enters or leaves the whistle: at these moments the pressure is low, and tones of lower pitch are sounded. A whistle tone of 50000 vs. is inaudible.]

We may summarise the results of these investigations as follows. (1) The Koenig forks are accurate; the Appunn forks are worthless for the purpose for which they are intended. (2) The Koenig cylinders require correction; but the error is important only in the upper portion of the series, and the set can be employed, as it stands, after redetermination of pitch by the Kundt method. (3) The Appunn pipes are no more reliable than the forks. So far as the author is aware, these pipes have not made their way into psychological laboratories. (4) All the older forms of the Galton whistle (Cambr. Instr. Co., Hawksley, Koenig, Edelmann) must be retested by the Kundt method. Even the new Edelmann whistle, with its accompanying Table, must be used with caution. At times, the tone may disappear, giving place (as the movement of the piston is continued) to a new tone, produced under quite different conditions. At

times, also, one may hear deep secondary tones (from the cavity of the piston cap?): *cf.* Stumpf and Meyer, 1897, 764 f., 779; Edelmann, 1900, 473. According to Myers, the pitch is largely dependent upon wind pressure, though Edelmann declares that in whistles of the steam-whistle pattern "die Tonhöhe *schr* wenig abhängig vom Winddruck ist." Myers, with Stumpf and Meyer, objects to the rubber bulb (Myers employs a water-driven air blast); Edelmann prefers it, as free from concomitant noises and productive of tones which are readily discriminable and not fatiguing.

It is, of course, only a matter of time for the mechanical difficulties to be overcome and the differences of opinion reconciled. In the meanwhile, we must just accept the Edelmann instrument and the Edelmann Table, unless the Instructor find time to repeat Myers' experiments upon his own whistle.

For the original dust-method, see Monatsber. d. kgl. preuss. Akad. d. Wiss. zu Berlin, Sitz. d. phys.-math. Cl., 22 Mai 1865 (vol. dated 1866, 244 ff.: report of Kundt's paper by H. G. Magnus); A. Kundt, Pogg. Ann., cxxvii. [cciii.], 1866, 497. Schwendt asserts, justly, "dass man mit dieser Methode die Tonhöhe der zur Bestimmung der hohen Hörgrenze dienenden Instrumente in absolut sicherer und äusserst genauer Weise bestimmen kann. Es ist jeder Physiologe und Arzt in Stand gesetzt, mit einigen Glasröhren und etwas Lycopodiumstaub die Tonhöhe seiner Instrumente, hoher Stimmgabeln und Galtonpfeifen, ohne grosse Mühe zu bestimmen. Fehlerhafte Construction und falsche Tonhöhenbestimmung der betreffenden Instrumente sind mittelst dieser Methode mit absoluter Sicherheit nachweisbar" (Pfl. Arch., lxxv., 1899, 361). It may be added that the cost of instrument and controls is very small: Edelmann lists the boxed whistle at Mk. 45, and a set of control materials at Mk. 8. On the other hand, 'ohne grosse Mühe' is a very relative term; and the Instructor should not attempt to standardise his instrument unless he has plenty of patience and free time.

METHOD.—See above, pp. 4 f., 20.

RESULTS.—It is not necessary to print full Tables of results. The following is a typical series taken from an *O* in the middle stage of practice.

Length of pipe	↑ Series. Introspection	Length of pipe	↓ Series. Introspection
3.63	+ Sharp, clear tone; fills hiss well up	0.53	— Swish very tonal
		0.66	— Hiss only
2.93	+ Smaller tone	0.78	— Hiss only
2.40	+ As before	0.84	— Hiss only
2.00	+ As before	0.92	— Hiss only
1.87	+ Tone just at beginning	1.02	— Hiss only
1.74	+ As before	1.12	? Perhaps suggestion of tonal element in mass?
1.62	+ Point of tone somewhere	1.22	+ Tone at beginning
1.52	+ At beginning		
1.42	+ Very thin		
1.30	? Do not think there is a suggestion of tone		

This experiment was made with Edelman's Galton no. 423. Constant width of mouth, 0.7. Unit 1000 vs. Averaging the results, we have:

$$\begin{array}{ccc} \uparrow 1.30 = 28000 : & & \downarrow 1.22 = 29000 : \\ & \text{Av. } 28500 \pm 500 \text{ vs.} & \end{array}$$

O's TR was finally determined as 31000 ± 1000 vs.

The following Table shows an experiment taken, under the same objective conditions, for qualitative purposes. The (2) after the figure indicating length of pipe means that a repetition of the R was called for. The effect of fatigue is clearly shown.

Length of pipe ¹	↑ Series. Introspection	Length of pipe	↓ Series. Introspection
3.63	Tone, clearly different from the hiss	0.43	Suggestion of tone in the wish itself, but all alike
3.27	Tone, cloudier and more muffled	0.47	As before
2.93	Tone: muffled, weaker, shorter	0.53	Hiss less tonal
2.63	Tone more distinct from hiss	0.60	As before
2.40	Tone an instant, faint	0.66	Mere hiss
2.18 (2)	Tone just distinguishable in hiss, faint and brief	0.72	As before
2.00	Tone clearer and longer	0.78	As before

¹ 3.63=16000; 0.43=40000 vs. Unit of change=1000 vs.

1.87	Tone almost engulfed; a pinch; not thin but small	0.84 (2)	As before
1.74 (2)	Very faint; still more engulfed	0.92	As before
1.62	Only hiss	1.02 (2)	As before
1.52	Just a point of tone?	1.12	As before
1.42	Clearer tone	1.22	Tone, small, at beginning?
1.30	Tone and instant at beginning?	1.30	Perhaps tone at beginning?
1.22	As before	1.42 (2)	As before
1.12	Only hiss	1.52	Tonal
1.02	As before	1.62 (2)	Tone, very faint and brief
0.92	As before	1.74	Tone, distinct but muffled
0.84 (2)	As before	1.87	Tone sharp and prominent
0.78 (2)	As before	2.00	As before
0.72	Hiss is a whish, tonal all through	2.18	As before
0.66 (2)	As before	2.40	As before
0.60	As before	2.63	As before
0.53	As before	2.93	As before
0.47	As before	3.27	As before
0.43	As before	3.63	As before

As the *TR* is approached, the introspective phrases all point in the same direction. This *O* uses the terms 'muffled,' 'engulfed,' 'a pinch of tone': others report a bead, or button, or drop, or point of tone in the general hiss. The tone is like a clear glass bead, set upon a monotone background of noise, which appears to extend both before and after. It is noteworthy that these descriptive terms do not appear in Myers' introspections (1902, 419, 421), unless possibly in the single entry "a trace of high note." On the other hand, Myers frequently records a 'quivering' tone. We may suspect that the introspective differences are due to the difference in the mode of actuation of the whistle.

¹ Scripture and Smith speak of the passage "from silence to tone" and "from tone to silence": Yale Stud., ii., 1894, 111. There is no 'silence' with the rubber bulb. In the \uparrow series, the tone, which at first is clear and dominant, shrinks in duration and in 'volume' till it dies out. The search for the tone, in the region of doubt, is like the search for a pinhead upon a rough cloth surface. *O* never doubts whether the sound of the whistle, as a whole, is tone or noise; he doubts whether he can still make out the 'drop' of tone in the hoarse rush of the air. In the \downarrow series, the whistle at first gives out a shrill, piping hiss, which of itself inevitably suggests a very high pitch. There presently appears, upon or within this total hiss, a tiny point or bead of tone. The \downarrow introspection is consequently more difficult than the \uparrow ; even a practised *O* may need two or three repetitions of the *R* before he is able to pass a confident judgment.

With the lamella, the introspections point towards a merging of the discrete air-puffs into a smooth, hollow, rounded tone, of indefinable quality. One *O* remarks, at the critical point of a \downarrow series: "the smooth, continuous tonal quality is giving place to a rumbling. It is a question of which predominates, and not of tone *within* noise, as it is with the Galton whistle."

QUESTIONS.—(1), (2) The *TR* is neither so important for theory nor so easily determinable in practice as the *RL*. In examinations for colour blindness it is important to know the extreme limits of the spectrum for the eye under investigation. These limits may be determined by the method of least differences: a black screen with a vertical slit is drawn over the spectrum, until the colour just appears or disappears. We may term the extreme limit of red and the extreme limit of violet both alike *TR*, since the *RL* for colour is ordinarily interpreted to mean the least amount of objective colour necessary to tinge a grey, *i.e.*, the lower limit of colour saturation. In mapping the retinal field into zones, by campimetry, we also determine (spatial) *TR*. It may be, again, that when we understand more of the chemical basis of the olfactory series we can determine qualitative *TR* for smell.

The determination of intensive *TR* is, as Wundt says (*P. P.*, i., 1902, 469), "überhaupt sehr unsicher." We can approach the *TR*, in most cases, only in the \uparrow direction; and, even so, the fatigue error is enormous. But for this, the *TR* of tastes and smells might be attempted.

Müller evidently attaches little importance to the *TR*; he does not mention it in his list of psychophysical problems (*M.*, 1 f.).

(3) Answered above, pp. 38 f.

FURTHER EXPERIMENTS.—The four values *a*, *b*, *a'*, *b'* may be employed for the determination of the *TR* as well as for that of the *RL*. The *TR* may also be determined by the haphazard arrangement of Exp. II.

If a constant air-blast is available, the *TR* as determined by its means may be compared with the *TR* as determined with the rubber bulb. Or the *TR* may be determined by Scripture's method of regular and continuous variation: the piston is screwed

up, at a slow constant rate, until the tone ceases, and unscrewed at the same rate until a tone appears. The difference between the \uparrow and \downarrow results will probably be greater in this than in the former cases.

For the method, see Scripture, A. J. P., iv., 1891, 577 ; Z., vi., 1894, 472 ; Scripture and Smith, Yale Studies, ii., 1894, 108. On constant blasts, and their advantages and disadvantages, see Scripture, A. J. P., iv., 1892, 582 ; Stumpf and Meyer, Wied. Ann., N. F. lxi. (ccxcvii.), 1897, 762, 773 f. ; Edelmann, Drude's Ann., 4te F., ii., 1900, 475 ; Myers, J. of Physiol., xxviii., 1902, 422.

Just as the extent of the campimetrical zones is dependent upon the magnitude and brightness-value of the R employed, so is the range of hearing dependent upon the intensity of the tones. This fact can be demonstrated only by help of a continuous and accurately variable air-blast.

The fact has long been known : *cf.* F. Savart, Ann. chim. phys., xliv., 1830, 337 ; Pogg. Ann., xx. (xcvi.), 1830, 291, 293, 296. An attempt to put the matter on a quantitative basis was made, almost simultaneously, by Zwaardemaker (Der Einfluss der Schallintensität auf die Lage der oberen Tongrenze, Zts. f. Ohrenheilk., xxiv., 1893, 304) and by Scripture and Smith (*op. cit.*, 1894). These investigators worked with a Galton-Koenig whistle, whose tones they deduced from physical formulæ (106), —an inadmissible procedure (Stumpf and Meyer, Wied. Ann., lxi., 760). “The general result for all O 's indicates that the pitch of the highest audible tone varies directly and almost proportionately with the intensity” (111). The Study seems to have been unknown to the later German writers. Zwaardemaker determined the distance-limen by help of a Galton whistle, connected by a piece of thick-walled rubber tubing with a glass funnel, to the rubber membrane of which a cuff-button was attached. The button was pressed down upon the table : “der Druck wurde ganz von der Schnelligkeit, mit welcher das Andrücken des Trichters gegen die feste Unterlage geschah, bestimmt” (305). He concludes that “die Schärfe des Ohrs in der höchsten Octave unserer Tonleiter schnell abnimmt. In Folge dessen, wechselt letztere ihre Lage je nach der Schallintensität. Die Unterschiede in dieser Hinsicht umfassen das Intervall einer Terz, wenn die Schallintensität von einer gewissen Grösse auf das Tausendfache derselben steigt. Die Zone relativer Unempfindlichkeit dehnt sich eine Strecke weit in die Scala hinein aus, aber keineswegs ferner als $f \sharp^4$ ” (306, 310, 313).

See further, Preyer, Gr. d. Tw., 1876, 20, 24; Melde, Wied. Ann., li., 1894, 662; Stumpf and Meyer, *op. cit.*, 778; Melde, Pfl. Arch., lxxi., 1898, 452; Stumpf, Wied. Ann., lxxviii., 1899, 115 *note*; Schulze, *ibid.*, 879; Schwendt, Pfl. Arch., lxxv., 1899, 362; Koenig, Wied. Ann., lxxix., 1899, 732, 738 (limit depends on duration, as well as on vibration-rate and intensity); Edelmann, Drude's Ann., ii., 1900, 476.

ESSAY SUBJECTS.—(1) The development and the relative validity of methods for the determination of high frequencies of vibration.

(2) Determinations of the highest and lowest audible tones, and their validity.

§ 14. **Determinations of the Highest Audible Tone.**—The following Table brings together the most important determinations and inferences regarding the upper limit of tonal hearing.

	Observer	Date	Instrument	Vs.
(1)	Sauveur	1700	Pipes, strings	6400
(2)	Chladni	1802	$\frac{1}{8}$ -ft. organ pipe	8192
(3)	Biot	?1817	Pipe	4096
(4)	Wollaston	1820	Pipes	21120 or higher
(5)	Savart	1830	Toothed wheel	24000 or higher
(6)	Despretz	1845	Forks	36850
(7)	Turnbull	1874	Koenig's cylinders	20000
(8)	Preyer	1876	Appunn's forks	40960
(9)	Blake	1878	Koenig's cylinders, Tisley Galton whistle	20000
(10)	McKendrick	1878	—	35000
(11)	Love	1889	Open pipes	20000-25000
(12)	Melde	1891	—	40000
(13)	Scripture & Smith	1894	Koenig Galton whistle	10000-53000
(14)	Zwaardemaker	1894	Galton whistle	8875-20480
	Cuperus	"	"	8533-21845
(15)	Stumpf and Meyer	1897	Edelmann Galton whistle	20000
(16)	Bezold	1897	Edelmann Galton whistle	55000 or higher
(17)	Schwendt	1899	Edelmann Galton whistle	27361 or higher
(18)	Edelmann	1900	Edelmann Galton whistle	50000 or higher
(19)	Myers	1902	Hawksley and Edelmann Galton whistles	20000-25000
(20)	Jones	1902	Edelmann Galton whistle	45000-50000

REMARKS.—(1) J. Sauveur, *op. cit.*,¹ 190. The length of the

¹ For works here referred to as *op. cit.*, see above, pp. 25 ff.

pipe which gave him the highest audible tone was 64 times as small as his standard pipe of 100 vs.

(2) E. F. F. Chladni, *op. cit.*, 28. The tone "wird kaum können deutlich hervorgebracht und unterschieden werden": it is a c^6 . Despretz (*op. cit.*, 445) gives Chladni's limit as 11000.

(3) J. B. Biot used an open pipe of 18 lines (40.6 mm.) length: *op. cit.*, i., 356; so Savart, *Pogg. Ann.*, 1830, 291. Preyer (Gr., 18), quoting Fechner's German edition of 1829, makes the pipe 9 lines (20.3 mm.) long, and the tone 8192 (identical with Chladni's determination).

(4) W. H. Wollaston writes (*op. cit.*, 313 f.): "the range of human hearing comprised between the lowest notes of the organ and the highest known cry if insects includes more than 9 octaves, although the vibrations of a note at the higher extreme are 600 or 700 fold more frequent than those which constitute the gravest audible sound." The upper limit is set at more than 6 octaves above the middle *E* of the piano, *i.e.*, at a point not far above the $e^7 = 21120$. Scripture and Smith (105) give it as 25000. Savart, misunderstanding Wollaston, puts his limit (291) at 9000 to 10500. Despretz, by a similar misunderstanding (444), puts it at 9500 to 11000.

(5) F. Savart used a wheel of brass, 82 cm. in diameter, with 720 teeth. A card or a wedge of thin wood was held against the teeth by the hand. Other determinations were:

Glass cylinder (longitudinal vibration)	15500 to 16500 ;
Steel rod (transverse vibration)	15000 to 16000 ;
Pipe (not considered reliable)	10000.

See *Pogg. Ann.*, 1830, 292 ff., 295. Savart thinks that a larger wheel, with the same number of teeth, rotated more rapidly, would make still higher tones audible (296).

(6) C. Despretz sought to determine the limit at which the ear becomes unable, not to hear, but to compare tones. His forks ceased to sound at 36850 vs. Up to 36500 the ear can, with more or less difficulty, "entendre, apprécier, classer" the tones heard. *Pogg. Ann.*, 1845, 447.

(7) L. Turnbull used Koenig cylinders (10000 to 30000 vs.).

and steel hammer; the cylinders were suspended at a distance of 35 ft. (10.66 m.) from the observing ear. The Table of results is:

Age 15 to 18	. . .	20000 ; ¹
21	. . .	17500 ;
25	. . .	15000 ;
30 to 50	. . .	12500 (=g ⁶) ;
60	. . .	10000.

In one instance, a tone of 30000 was heard by a trained musical ear.—Proceed. A. A. S., [1874] 1875, pt. i., 137 f. As the cylinders require correction, the results cannot be taken at their face value. The distance from the ear appears needlessly great: cf. Koenig, Catalogue of 1889, 24.

(8) W. Preyer employed three sources of tone. (a) With the large Appunn siren (1024 holes), the tone of 24000 was faintly audible in the windrush. (b) With the Koenig cylinders, the highest tone of the series, $c^8=32768$, was heard by Preyer himself and by one other O. (c) With the Appunn forks, the $e^8=40960$ could easily be heard. Preyer thinks that with suitable apparatus the limit might be pushed somewhat higher, though not far. See Gr. d. Tw., 19 ff.—Determinations (b) and (c) are, of course, incorrect.

Helmholtz seems to have made no independent determination of the highest audible tone. He writes in 1877 (Sens. of Tone, 1895, 18, 151) that "the experiments of Koenig with short sounding rods, and those of Preyer with Appunn's tuning-forks, have established the fact that very high tones from 4000 to 40000 vs. in a sec. can be heard." Koenig says (Catalogue, 1889, 24) that "le cylindre *sol*, [$g^7=24576$] ne fait déjà plus entendre de son perceptible"; cf. Wied. Ann., N. F. lxxix. (cccv.), 1899, 724 f., and (17) below.—In the Pop. Lect. on Sci. Subjects, Helmholtz gives the Despretz limit of approximately 32000: New York, 1885, [First ser.] 69; London, 1884, new ed., 1st ser., 61.

Wundt, in 1893, accepts Preyer's result: P. P., i., 450 f. (the

¹ Stumpf (Tps., i., 263), apparently misled by the reviewer in Knapp's Arch., gives Turnbull's upper limit at 20000-22500 vs. K. Vierordt (Physiol. d. Menschen, 1877, 365) puts the average upper limit at 24000.

number of vs. is misprinted in the edns. of 1880 and 1887). In 1902 he writes that the Appunn forks give a "fortwährende Erhöhung des Tons" up to the fork marked (approximately) 50000. He puts the upper limit (with Schwendt) at 37000-48000; there are, however, considerable individual differences: P. P., ii., 90 f. We may repeat that the Appunn forks are wholly unreliable.

(9) C. J. Blake, Knapp's Arch., ix., 1879, 170; Amer. Journ. Otol., i., 1878, 267. "The average of a series of tests of over 100 persons, from 12 to 60 years of age, gave the average upper limit as a tone of about 40000 v.s. (single vibrations)." The limit of audibility varied with age: cf. F. Galton, Sci. Conferences, S. Kensington Museum, 1876, 62. Patients with defects of the tympanic membrane could hear tones of 80000 to 100000 v.s. (cf. Stumpf, Tps., i., 264).—The cylinders were 17 in number, ranging by 5000 v.s. intervals between the limits 20000 and 100000 v.s. The Galton whistle was made by S. C. Tisley and Co., London.

See also C. J. Blake, Summary of Results of Experiments on the Perception of High Musical Tones, Trans. Am. Otol. Soc., 1872.

(10) J. G. McKendrick, *op. cit.*, 593. The limit lies between 30000 and 35000.

(11) J. K. Love (*op. cit.*, 336) used small pipes, which "give distinct notes of from 20000 to 25000 vs. per sec."

(12) F. Melde, *op. cit.*, i., 764.—The same rough limit of 40000 is accepted by A. Höfler, Psychol., 1897, 97, 101.

(13) E. W. Scripture and H. F. Smith employed a Koenig whistle, with variable air-blast. The wide differences of range are conditioned upon differences in the intensity of the tone. With greater intensity, still higher tones might be heard. Yale Stud., ii., 1894, 110 f.; Scripture, New Psych., 1897, 321 ff.—The whistle was not standardised, and the figures therefore require correction.

(14) H. Zwaardemaker (Z., vii., 14) investigated the upper limit of tonal hearing regarded as a function of age. He and his collaborator, N. J. Cuperus, worked with a Galton whistle (older type). Their results in summary are as follows.

Age	Zw. (219 obs.)	Cu. (190 obs.)
Under 10	e^1	—
10 to 20	$d^1 \sharp + \frac{1}{4}$ tone	f^1
20 to 30	Same	$e^1 + 2$ commas
30 to 40	$d^1 \sharp - 2$ commas	$e^1 + 1$ comma
40 to 50	$c^1 \sharp + \frac{1}{4}$ tone	$d^1 \sharp + \frac{1}{4}$ tone
50 to 60	$b^6 - 1$ comma	$c^1 \sharp$
Over 60	$c^6 \sharp + \frac{1}{4}$ tone	$c^6 \sharp$

The limits are averages. All ears examined were normal. The air pressure was approximately the same for all experiments.

(15) C. Stumpf and M. Meyer, *Wied. Ann.*, N. F. lxi. (ccxcvii.), 778. The limit is set by the Edelmann whistle, older form. The authors expressly state that this physical tone-limit is not necessarily the physiological hearing limit: to determine the latter, we must have better sources of sound.—The requirement has, to some extent at least, been met by the newer pattern of the Edelmann whistle.

(16) F. Bezold, *Z.*, xiii., 166. The whistle resembled that used by Stumpf and Meyer.—An earlier paper appeared in *Z. f. Ohrenheilkunde*, xxiii., 1892, 254 ff.

(17) A. Schwendt, *Pfl. Arch.*, lxxv., 362. The limits, with various instruments, are:

Koenig cylinders	e^1	20480 (really 18432);
Koenig forks	f^1	21845;
Koenig Galton whistle	f^1	21845 or somewhat higher;
Edelmann Galton whistle	a^1	27361 or somewhat higher.

“Instruments which demonstrably give 40000 vs. have not as yet been constructed. Nor have tones of this pitch ever been heard.”

(18) M. Th. Edelmann, *Drude's Ann.*, 4te F., ii., 476. “With these improved whistles, it can easily be shown that the extreme limit of hearing extends for many persons to 50000 vs., or even somewhat higher.”

(19) C. S. Myers, *Journ. of Physiol.*, xxviii., 425. “A whistle tone of 50000 vs. per sec. is inaudible. The highest audible tone from the Hawksley Galton whistle for young adults is one of from 20000 to 25000 vs. per sec.” See the same author,

Arch. of Otolaryngology, xxxi., 1902, 284; Reports of Cambridge Anthropol. Exped. to Torres Straits, ii., pt. 2, 1903, 150, 154.

(20) H. M. Jones, Edinburgh Med. Journ., N. S., xi., 355. "A small proportion [of persons with assumed normal hearing] can reach from 45000 to 50000 vs. per. sec., and a very large number from 37000 to over 40000." The paper gives illustrations of the various parts of the whistle, and describes Schwendt's application of Kundt's dust-method of testing pitch.

EXPERIMENT IV

§ 15. **The Intensive RL for Pressure.**—(1) *The Touch-Weights.* Sets of these weights were made, a few years ago, by Willyoung; so that they are probably to be found in a good number of American laboratories. Were it not for this fact, and for Scripture's recommendation of the use of the weights in laboratory practice (Yale Stud., iv., 1896, 92 ff.; New Psychol., 284), the author would hardly have described the experiment. In his own experience, it has generally proved unsatisfactory.

Scripture (Thinking, Feeling, Doing, 1895, 104) gives the *RL* for an average *O* as 2 mg. for forehead, temples and back of forearm and hand; 3 mg. for inner side of forearm; 5 mg. for nose, hip, chin and abdomen; 5 to 15 mg. on inner surface of fingers; and 1000 mg. on heel and nails. The last determination can hardly have been made with the touch-weights! Indeed, the list is simply that of Aubert and Kammler (A. Kammler, *Exper. de var. cutis region. minim. pond. sentiendi virtute*, Diss., 1858; H. Aubert and A. Kammler, *Moleschott's Untn. zur Naturlehre d. Menschen*, v., 1858, 141). In the *New Psych.*, 284, Scripture finds the figures quoted "quite too low for most people." The *RL* for the tip of the index finger in his Specimen Record (Yale Stud., 93) is 11.2 mg.

The author has made experiments on temple, side of nose, eyelid, finger tip, palm, wrist, forearm and knee. From these it would seem that the haphazard arrangement of Exp. II. is decidedly preferable to the strict serial method. This is due, in large measure, to the construction and mode of application of the weights, which are apt to roll and waver as they settle upon

the skin, and so to produce a tickling before they arouse the pressure sensation proper. With the serial method, which puts a premium upon suggestion, this tickling may be wrongly interpreted as pressure.

The following may serve as an illustrative series. The weights were applied to the left side of *O*'s nose. The place of stimulation was marked in blue dye, and the times were regulated by a noiseless metronome: time of application, 2 sec.; interval between applications, 30 sec. *O* recorded his introspections; *E* recorded, independently, his judgment of the manipulation of the weights.

Mg.	Introspection	Manipulation
2	—	Good
4	—	Good
6	+	Weight dropped
8	—	Good
10	—	Fair
12	Light pressure or tickling	Weight rolled
14	—	Fair
16	—	Very good
18	+	Fair

The following results, taken by Scripture's method (Yale Stud., 93) and by the strict serial method, are offered as warning examples. In Scripture's method, a definitely directed expectation plays a very large part. In the serial method, expectation is also at work, though its direction is less definite. If *O*'s expectation is disappointed, he is apt to 'go to pieces' in the remainder of the series.

O_1	O_2	O_3	O_4	O_5
Right temple	Right knee	Tip of right index	Tip of right index	Palm (over metacarpal of right index)
a_1 2.1 ± .36	3.5 ± 1.7	5.7 ± .98	9.2 ± .32	10.3 ± .62
a_2 3.9 ± 1.7	9.8 ± 2.24	5.7 ± .98	9.4 ± .56	11.0 ± 1.0
<i>RL</i> 4.5 ± 1.0	6.0 ± 1.6	10.7 ± .52	10.3 ± .71	12.5 ± 1.0

The a_1 and a_2 are averaged from ten series.¹ The *RL* of the first, second and fourth columns is averaged from six, that of the third and fifth columns from ten paired series. The variation is given throughout in terms of the *MV*.

In the light of these and of many similar results, the author strongly

¹ For the meaning of the symbols, see Note 2, p. 19 above; or Scripture, *loc. cit.*

recommends the employment of the haphazard method.¹ He has not, however, sufficient confidence in the touch-weights to quote figures.

Disturbing factors in the experiment are cutaneous after-images, fatigue of the stimulated area (due, perhaps, to changes of blood-supply), and distracting sensations arising from the constant position of arm, leg or head. The temperature of the room must be kept reasonably constant; an interval of at least 30 sec. must elapse between stimulations; and *O* must be allowed to change his attitude after every series.

Since this is not a punctual but an areal limen, and the cutaneous response is a function both of weight and of area of the *R*, the results must be stated in terms of the hydrostatic pressure, *i.e.*, not in gr. but in gr./mm².

EXPERIMENT V

(2) *The Hair Æsthesiometer*.—This instrument was described by von Frey in 1896 (Abh. d. kgl. sächs. Ges. d. Wiss., math.-phys. Cl., xxiii., no. 3, 46 [214]). It is sold by Zimmermann (with horsehair or woman's hair) for Mk. 6. If the laboratory possesses von Frey's double bristle-æsthesiometer (Zimmermann, Mk. 45: not a satisfactory instrument!), two hair æsthesiometers can easily be made of it by taking the tubes from the cross-handle, and replacing the bristles by horsehairs. von Frey promises (*op. cit.*, 215) that "Herr Dr. R. Berger an einer anderen Stelle über eine grössere Zahl praktischer Erfahrungen berichten wird"; but, so far as the author knows, this promise has not been kept.

On the use of stimulus-hairs in general, see von Frey, Ber. d. kgl. sächs. Ges. d. Wiss., math.-phys. Cl., 2 Juli 1894, 185 ff.; *op. cit.*, 208 ff. A somewhat similar arrangement for the determination of the *RL* was employed by A. M. Bloch, Arch. de physiol., (5) iii., 2, 1891, 322 ff.; von Frey, *op. cit.*, 215 f.; and after Bloch by H. Griffing, On Sensations of Pressure and Impact, Psych. Rev. Mon. Suppl., 1, Feb. 1895, 17.

On the standardising of the hairs by the balance, see von Frey, Ber., 186; Abh., 209 ff. The diameter of the hair may be measured by aid of the microscope, as explained by von Frey, Abh., 209. Horsehairs are approximately circular in cross-section (diam. 160 to 250 μ), and can be measured (after practice with the instrument) by a Brown and Sharpe micrometer caliper,

² Blank experiments should be introduced: see p. 24 above.

reading to $\frac{1}{100}$ mm.¹ Great care must be taken to keep the caliper free of dust.

The disc values of the preceding experiment were measured in pressure units of 1 gr./mm². von Frey found that this mode of measurement is not applicable to stimulus hairs. If area and force (= maximal weight lifted by the hair) are different, the hairs are not physiologically equivalent, even though their pressure value is the same. Thus hairs whose constants are 3020 μ^2 and 22 mgr., and 15400 μ^2 and 110 mgr., respectively, have the same pressure value of 7 gr./mm.²; and hairs whose constants are 4150 μ^2 and 82 mgr., and 18100 μ^2 and 360 mgr., have the same pressure value of 20 gr./mm.²; but, in each case, the hair of greater force and area is the more effective stimulus. Physiological equivalence is attained if force is made proportional, not to area, but to radius; the unit is then 1 gr./mm. As the dimensions of this magnitude are those of a surface tension, von Frey terms the corresponding values of the stimulus hairs their tension values. Thus hairs whose constants are 73.5 μ and 150 mgr., 39 μ and 78 mgr., and 20 μ and 40 mgr., all have the same tension value 2 gr./mm., and are all physiologically equivalent stimuli. — According to Abh., 230 f., the critical area (the areal magnitude at which we must change from the tension to the pressure unit) lies between the diameter values $\frac{1}{4}$ and 2 mm. See the theoretical discussion by M. von Frey and F. Kiesow, Z., xx., 1899, 146 ff.; Arch. per le scienze mediche, xxiii., 1899, 263 ff.; and references there given.

von Frey determined the hair *RL* for 73 pressure spots on the calf and 303 on the wrist. The values varied between 0.5 and 4 gr./mm., with an average of 1.44 for the calf and 1.28 for the wrist. Very similar results were obtained by Kiesow: *Giornale della reale accad. di medicina di Torino*, vi., 1900, 7 f. [of off-print]. Kiesow has, however, shown in further experiments that this average limit of 1 to 2 gr./mm. must be extended, both above and below: *Phil. Stud.*, xix., 1902, 307 f.; *cf. ibid.*, xiv., 1898, 573.

The author has had a good many experiments made with the hair *æsthesiometer*, and has no hesitation in saying that the experiment can be successfully performed by patient and careful students. It is, however, an experiment of much greater difficulty, objective and subjective, than are the experiments of the foregoing Sections. The application of the hair is a deli-

¹ The spring of the instrument may with advantage be replaced, for present use, by a weaker spring.

cate matter; the pressure spot readily tires; and judgments of intensity are intrinsically more trying, require a greater strain of attention, than judgments of quality. Hence it may be doubted whether the æsthesiometer will ever be of service, as von Frey supposes, in the regular course of medical practice. Indeed, Berger's failure to publish his results points directly to some such conclusion.

The standardising of the hair, at the different lengths furnished by the experimental series, may be entrusted to an enthusiastic student, but is (in the author's experience) better performed by the Instructor or the mechanician. It is not difficult; but it is slow and tiresome, and demands undivided attention. A good chemical balance is needed, preferably of the type that allows the application of the hair to a flat pan placed above the beam. The æsthesiometer is clamped vertically to the arm of a standard, and (the back or top glass of the balance having been removed) is set at such a height that the point of the hair just rests upon the surface of the pan. Small weights are then placed in the other pan, and the æsthesiometer is lowered, little by little, until the balance is poised with the hair at the right curvature.¹

The following results were obtained from the same *O* at the interval of a week. The spot stimulated was a highly sensitive spot on the back of the hand. *O* had had, previously, one afternoon's practice and one afternoon's regular work. The first set of results was worthless, owing to *E*'s inability to manipulate the hair. The second and third (here quoted) show what may be accomplished under rather unfavourable conditions; for a hair of 60 to 70 mm. is too long for easy handling. See von Frey, *Abh.*, 213.

(1) Length of hair employed, 63—71.5 mm.

mgr. ↓	mgr. ↑	
118	114	
120	112	
109	112	Av. 114.1 ± 3.2 mgr.

¹ It is advisable, for the sake of comparison and control, to determine in a certain proportion of cases the maximal force exerted by the hair,—von Frey's 'hair constant': see *Abh.*, 211 ff.

(2) Length of hair employed, 62–70 mm.

mgr. ↓	mgr. ↑	
120	111	
122	114	Av. 116.7 ± 4.2 mgr.

More frequent are results like these (another spot on the back of the hand) :

Length of hair employed, 42–46 mm.		
mgr. ↓	mgr. ↑	
213	191	
174	174	
174	191	Av. 186.1 ± 12.1 mgr.

We have now to convert these values into gr./mm. The hair may be measured (as was said above : p. 48) either by the microscope or by the caliper. One soon comes to have a very delicate 'feel' for the caliper, so that there is little or no danger of crushing the hair. Still, it is best to watch the hair through a lens, as the setting is made, and so to control the measurement by eye as well as by touch.

In order to compare the results of the two methods of measurement, the author had the stimulus hair of the preceding experiments measured independently by two skilled observers. The microscopical measurement was made by Mr. R. E. Sheldon, of the Dept. of Neurology in Cornell University (Leitz stand and objective ; condenser and diaphragm removed ; Zeiss ocular micrometer and stage micrometer). The report was that the hair was sensibly circular in cross-section, and that the diameter was 170μ . The caliper measurement was made by Mr. F. A. Stevens, the mechanician of the Psychological Laboratory. Six successive readings gave 17.2, 17.2, 17, 17, 17, 17.1 hundredths of a mm. : av. 170.8μ .¹ We may call the two determinations 170μ and 171μ and the radii accordingly 85 and 85.5.

Calculating from Series (1), we have $RL = \frac{114.1}{85}$ or $\frac{114.1}{85.5}$, *i.e.*, 1.34 or 1.33 gr./mm. From Series (2), we have $RL = 1.37$ or 1.36 gr./mm. The RL for this spot will then be 1.35 or 1.34 gr./mm. Calculating from Series (3), we have $RL = 2.2$ gr./mm.

¹ The hair was remeasured by the microscope, and the original result obtained. Indeed, the danger of crushing is so vividly present, as one uses the caliper, that the errors tend invariably to fall on the hither side of the true reading. A hair of 208μ diam. will be measured, *e.g.*, as 21, 21.1, 21.2, not as 20 hundredths. The measurement quoted was, of course, made by an exceedingly practised *O* ; but the author, who is far less skilled, made the av. diam. only 17.2.

EXPERIMENT VI

(3) *The Limen Gauge*.—This instrument is figured and described by von Frey, *Abh.*, 188 ff. Although the essential points of procedure are given in the text, the Instructor should carefully read von Frey's ch. ii. before entering on the experiment. The gauge (without attachments) is listed by Zimmermann at *Mk.* 32.¹ The arrangement figured in Fig. 9 of the text was devised as an improvement of von Frey's arrangement, *Abh.*, 193; it works very smoothly and accurately.

von Frey used a Baltzar kymograph (*Abh.*, 192); and the author has used a Zimmermann kymograph of the same pattern. These instruments are exceedingly constant in their function. If a cheaper clock must be employed, and its regularity cannot be depended on, there is nothing for it but to smoke the drum, and to take time records simultaneously with the experiments proper.

The pin *G* should be screwed into the cylinder, and should have a cross-cut in its head, so that it may easily be removed by the screw-driver. For slow rates of rotation, it is worth while to have two such pins in the cylinder, at the two ends of a diameter. The rounding of *G* and of the end of *M* constitutes a distinct improvement upon von Frey's *D* and *L* (*Abh.*, 193).

For the recording of the curves of *R*-application, see *Abh.*, 196; for results, *ibid.*, 199, 201, 205; *Z.*, xx., 1899, 138 f.; for the confinement of the experiment to hairless areas, *Abh.*, 196; *Z.*, 131, 135; for general cautions as to choice of area, *Z.*, 135 f.

So far as apparatus and manipulation are concerned, this is the most elaborate experiment that we have so far undertaken. If it is performed for all three variables—place, area, rate of application—it is also an experiment that demands a good deal of preliminary work, and that itself takes a good deal of time. Once the conditions are arranged, however, it is easier, for both *E* and *O*, than the preceding experiment. The Instructor must use his discretion as regards what shall be done by and what for *E*, and as regards the programme of the general experiment. It may be advisable, *e.g.*, to put the apparatus entirely in the hands

¹ For some slight modifications, see M. von Frey and F. Kiesow, *Z.*, xx., 1899, 134 f.

of an assistant or of a graduate student; circumstances will decide.

The disposition of the apparatus is of some consequence. Since *E* has to set *B*, to read off from the scale of *L*, and to watch the application of the stimulus point, he must have a good light. Since he has to start and stop the clock at frequent intervals, he should carry a pair of wires over pulleys from the brake to a handle at his own end of the table: he can hardly reach round the apparatus, or behind *O*'s back, to the kymograph; and the constant getting up and sitting down again are very disturbing. The clock must be wound at the end of every series. Under certain conditions, *O* may wind with his unstimulated hand without leaving his chair, provided that (as should always be done) a crank has been substituted for the cross-handle usually given to the clock key. Generally, however, it is good for *O* to take his arm from the mould between series, and to stroll about the room for a few minutes; so that the winding is easily arranged for.

The place of application of the disc should, of course, be permanently marked (as pressure spots are marked) during the progress of the experiment.

RESULTS.—The following is the only extended series of results that the author has at his disposal. It is quoted here at some length, since lessons may be learned from it as to the character of the results obtainable in regular laboratory practice.

Disc no. 1: diam., 5 mm.; area, 19.6 mm.²: weight, 3 mgr.

Spring: tension value for 1 gr.=9° of scale.

Rate of drum: 5.7°, 4.0°, 3.6° in the 1 sec.

Rate of application of R: 0.63, 0.44, 0.4 gr./sec.

Series 1. 0.63 gr./sec.

↓		↑
6° = 650 mgr.		7.5° = 850 mgr.
6.75° = 762 "		8° = 900 "
Av. 790 ± 84 mgr.		

Series 2. 0.44 gr./sec.

↓		↑
9° = 1000 mgr.		11° = 1350 mgr.
8° = 900 "		9.5° = 1090 "
Av. 1085 ± 135 mgr.		

The *RL* has increased with the slowing of the rate of application. The

high *MV* shows lack of practice.—Had *E*, now, proceeded at once to the slowest rate of 0.4 gr./sec., the *RL* would in all probability have increased still further. Instead of doing this, however, he went on to practise *O* at the given rate of 0.44 gr./sec. The results obtained in the subsequent series were :

↓ 9.5°,	8.75°,	7°,	6°,	5° ;
↑ 10°,	8.5°,	7.5°,	6°,	6° .

If we take the last four values, we have :

Series 3. 0.44 gr./sec.

↓	↑
6° = 650 mgr.	6° = 650 mgr.
5° = 550 "	6° = 650 "

Av. 625 ± 37 mgr.

E then proceeded (after a practice series) to the slowest rate of 0.4 gr./sec., and obtained the values :

Series 4. 0.4 gr./sec.

↓	↑
8° = 900 mgr.	8° = 900 mgr.
8.5° = 950 "	6.5° = 725 "
7° = 800 "	6.5° = 725 "
7° = 800 "	8° = 900 "

Av. 837 ± 75 mgr.

The *RL* has increased. Continuing *O*'s practice, *E* gave ten more series at this rate, and the average *RL* finally settled down at 525 ± 56 mgr. (4 paired series).

The author quotes these details for what they are worth. von Frey emphasises the effect of practice in lowering the *RL* within a single long series (*Abh.*, 203). It appears from the above that practice is similarly effective in experiments made, as these were, at 3 or 4 days' intervals. The moral would then be that, if *E* desires to demonstrate the influence of *R*-area, of place of stimulation, or of rate of *R*-application, he should distribute his experiments from the first so as to secure an equal measure of practice to every variable. With the short time at his disposal, he must expect a large *MV*; but his results will be relatively significant. If, on the other hand, he desires accurately to determine a single *RL*, he must be prepared to take a fairly large number (say, 25) paired series : a tedious business, when one considers the necessity of long pauses between *R* and *R* !

NOTES.—(1) The above results were gained by the strictly serial method : a few series were too long, but on the whole the plan of the experiment was good. The

slow rates of rotation were forced upon *E* by the method: the spring employed was the weakest of the set, and any increase of rate beyond the limit quoted meant that the ↓ series could not be paired by like ↑ series.—It must, of course, remain for the present an open question, how far the steady decrease of the *RL* with 'practice' is an artifact of the method. The author can only say that the experiments were made with great care. (2) The disc was of cardboard, and was applied to the back of the hand (area described in vol. i., *S. M.*, 54). No exploration was made for pressure spots: this was an oversight.—For evaluating the scale degrees in mgr., it is a help to use a balance whose pan remains stationary during the weighing, so that *E* has merely to screw down *S* to the required reading.—*E* had intended to work with a series of discs, but the experiments reported took so long a time that the original plan could not be carried out. (3) 'Practice,' as we shall see later (p. 307), is a slippery term. In the present case, it undoubtedly covers a change in standard of judgment. (4) We cannot compare our results directly with those of von Frey (*Abh.*, 199): method, place of stimulation, area of *R*, rate of drum, were all different. On the whole, the *RL* above quoted appear somewhat smaller than von Frey's. It should be noted, however, that although von Frey's method does not furnish him with *MV* his Table shows great variability in successive determinations. Thus the same *O*, working under exactly the same experimental conditions, gives the following results in mgr.:

Jan. 22, '96.	Jan. 25, '96.
1500	500
1000	410
600	250.

QUESTIONS.—(1) and (2) may be answered from the foregoing. (3) On pain, see, *e.g.*, von Frey, *Abh.*, 246 ff.; S. Alrutz, *Undersökningar öfver Smärtsinnet*, Upsala, 1901 (gives bibliography); on warmth and cold, Goldscheider, *Ges. Abh.*, i., 1898, 107; Kiesow, *P. S.*, xiv., 1898, 583; C. S. Sherrington, in Schaefer's *Physiol.*, ii., 1900, 948.

ESSAY SUBJECTS.—(1) The results of experimentation upon the intensive cutaneous *RL* (pressure, warmth, cold, pain).

(2) The theory of cutaneous stimulation (pressure, warmth, cold, pain).

(1) See, *e.g.*, Wundt, *P. P.*, i., 1893, 382 ff.; i., 1902, 532 ff.; C. S. Sherrington, in Schaefer's *Physiol.*, ii., 920 ff. (2) See, *e.g.*, von Frey and Kiesow, *Z.*, xx., 1899, 126 ff.; Sherrington, *loc. cit.*¹

¹The author may repeat, à propos of these references, that it is never his intention to furnish a complete bibliography of the topics treated in the present work. He has chosen rather to send the student to sources (often to secondary sources) from which he may find his way for himself to the earlier literature. [Reviewing vol. i. in *Mind*, N. S., x. 1901, 540, W. McDougall writes: "In the section on

§ 16. **The Intensive RL for Sound.**—(1) *The Watch Test.* It is almost as difficult to justify the inclusion of this time-honoured experiment in a psychological text-book as it would be to exclude it. The author has admitted it for two reasons. In the first place, it can be performed, at a pinch, by help simply of a watch, a bit of chalk, and a yardstick; and even in this guise it serves to illustrate the method. Secondly, the watch-tick is so familiar a sound that a careless *O* is likely to imagine it, and to signal that he hears it when he really has only its memory-image in consciousness. Hence the use of the watch legitimates the introduction of blank experiments in the regular serial method. This fact, as well as the introspective differentiation of minimal sensation from memory image, is worthy of the student's attention.

The result is, of course, not an *RL* in any strict sense of the term; watches tick at different intensities, and we have no measure of the intensity of the particular watch employed. The objections to the use of the watch-tick in tests of acuity of hearing are fully stated by Bezold in *Arch. of Otology*, xv., 1886, 79; *cf.* the same author, *Schuluntn. über d. kindl. Gehörorgan*, 1885, 9, and plate opp. 94; B. R. Andrews, A. J., xv., 1904, 43. It is useless to give results, as the range of hearing varies with the size of the room, nature of walls, etc., and nature and disposition of furniture. The customary statement is that the tick may be heard by normal ears at 2.5 to 4.5 m., though in certain circumstances the distance may rise as high as 9 m. In the room and with the watch used by the author, the normal range is about 12 m. See Sanford, *Lab. Course*, 55; Andrews, *loc. cit.*, 43 f.

(2) *The Lehmann Acoumeter.* The instrument is described

localisation of sources of sounds there is no mention of Prof. Münsterberg's method. To some this omission will seem a serious defect." Yet in *I. M.*, 372, attention is called to the references given by Matsumoto, and among these (*Yale Stud.*, v., 1897, 53, 73) are those to Münsterberg! Had the author written a catalogue raisonné of the complete literature, this same or some equally well-disposed reviewer would have pointed out the futility of sweeping together Matsumoto's footnotes. Another critic, N. Vaschide, objects to the inclusion of Bain's works in the list recommended to the student for his private library (i., *I. M.*, 431), and thinks that they were better replaced by the *Arch. ital. de biologie!* Are French undergraduates in the habit of buying sets of periodicals, as they enter upon their various courses?]

by A. Lehmann, P. S., xi., 1895, 494 f. It is simple to manipulate, and may easily be adapted to the space limits of the ordinary laboratory. The Politzer acoumeter, on the other hand, has a normal range of 15 to 20 m. Lehmann's results, with an average *O* at 10 m. distance, are as follows:

Glass square	540 mg.-mm.
Copper " "	1110 "
Cardboard " "	225 "

The *RL* obtained by the author are considerably lower: with the copper square he has, *e.g.*, obtained a value as low as 500 mg.-mm. Again, however, it is useless to give results, as the range of hearing is constant only for the particular room in which the experiment is made.

The Lehmann acoumeter is apparently a modification of the instrument described by Vierordt, *Die Schall- und Tonstärke*, 1885, 28 ff., which in its turn derives from that of Schafhäütl.

Other Apparatus and Determinations.—The following are some of the more important determinations. Speech-tests are not included in the list.

(1) C. E. Schafhäütl found that the noise made by the fall of a cork pellet, weighing 1 mgr., from a height of 1 mm. upon a glass plate was just perceptible by the normal ear at a distance of 91 mm. See *Abh. d. bayr. Acad. d. Wiss.*, vii., 1855, 517; *Fechner, El.*, i., 257.

(2) L. Boltzmann and A. J. I. Toepler found that a pipe tone of 181 vs. in the 1 sec. (*f*♯) became imperceptible to a good ear, under certain conditions of experimentation, at a distance of 115 m. See *Pogg. Ann.*, cxli. (ccxvii.), 1870, 349; *Stumpf, Tps.*, i., 384 f.; and *cf.* nos. (4) 189, (7) 396, (9) 407.

(3) C. Nörr (*Z. f. Biol.*, xv., 1879, 297), using small iron balls dropped upon an iron plate, puts the *RL* for a distance of 50 cm. at 1500 mg.-mm.

(4) C. K. Wead (*Am. Journ. of Sci.*, 3 Ser., xxvi., 1883, 177 ff.) determined the *RL* with a series of 6 tuning forks. See *Table*, 188, and comparison with the results of Boltzmann and

Toepler and of Rayleigh (first paper), 189. See also *ibid.*, 3 Ser., xli., 232 ff.; and *cf.* nos. (7) 393, (8) 50, (9) 407.

(5) M. Wien made an artificial ear-drum by stretching the membrane of an aneroid barometer across the mouth of a resonator. The membrane was thrown into vibration by a tuning-fork of the same pitch as the resonator ($a^1 = 440$ vs.), actuated by an electromagnet and inserted in a telephone circuit. See Ueb. d. Messung d. Tonstärke, Diss., 1888; Wied. Ann., xxxvi. (ccxxii.), 1889, 835, 838, 849 f.; and *cf.* nos. (7) 393, (8) 3, 33, 46, 49, (9) 407.

(6) Rayleigh, using forks and resonators, determined the amplitude of aërial vibration for a liminal tone of $c^1 = 256$ vs. See Phil. Mag., 5 Ser., xxxviii., 1894, 370; and *cf.* the writer's earlier paper, Proc. Roy. Soc., xxvi., 1878, 248; and nos. (4) 189, (7) 393, 396, (8) 5, 33, (9) 407.

(7) H. Zwaardemaker and F. H. Quix (Arch. f. Physiol., 1902, Suppl. Bd., 367 ff.) determined the *RL* for a long series of tuning forks (392 and Taf. vii.). For comparison of their results with those of Rayleigh, Wien and Wead, see 393.

(8) M. Wien (Pfl. Arch., xcvi., 1903, 1 ff.) used a series of telephone tones: for results, see 32; for critique of no. (7), 48 ff.

(9) H. Zwaardemaker (Z., xxxiii., 1904, 407) gives a comparative Table of the results of nos. (2), (4)–(8). *Cf.* Ann. psych., x., 1904, 161 ff.

We turn now to instruments. (1) Politzer's acoumeter consists of a steel cylinder, 28 mm. long and 4.5 mm. in diam., set at right angles in a vertical rod of hard rubber which terminates above and below in half-rings intended for the reception of thumb and forefinger. Just above the cylinder, and parallel with it, is a percussion hammer of steel; the head lies upon the cylinder, the handle extends through the hard rubber upright, and the hammer moves about a transverse axis driven through the rod. An elbow of hard rubber, carrying a plate of soft rubber or cork, is attached to the hard rubber upright just below the handle of the hammer. The upright is held between the thumb and forefinger, the handle of the hammer pressed down upon the plate by the second finger, and the head then allowed to fall upon the cylinder. The height of fall is thus constant; the tone of the cylinder is a c^2 .

See A. Politzer, *Lehrbuch d. Ohrenheilkunde*, 1893, 107 f.; *Arch. f. Ohrenheilkunde*, vi., 1873, 35; xii., 1877, 104. The instrument is listed by Meyrowitz at \$2.75.

(2) O. K. M. Zoth's acoumeter is of the same kind as Lehmann's. It consists of a prismatic upright, giving a height of fall up to 50 mm.; mechanical and electrical devices for releasing small steel balls, of 3.2, 6.4 and 9.6 mm. diam.; and a block of steel, placed in a round padded trough, upon which the balls fall. The instrument is listed by Zimmermann, 1903, at Mk. 145.

(3) Many attempts have been made to adapt electrical devices as testing instruments. The general plan has been to use a telephone click, which varies in intensity according to the amount of electrical energy employed in producing it. Most of the instruments have proved unsatisfactory: Politzer, *Lehrbuch*, 110, 606; J. Gruber, *Diseases of the Ear*, trs. 1902, 131. See, however, Wien, no. (8) above.

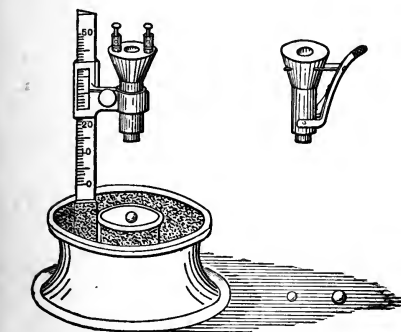

FIG. 8.—Zoth's acoumeter.

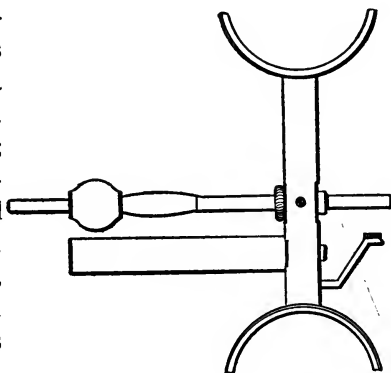

FIG. 7.—Politzer's acoumeter. There is supplied with the instrument a small metal disc, attached to a pin, which can be inserted in the upright above and at right angles to the hammer. The disc may be pressed against the opening of the external auditory meatus, or may be applied to temple, mastoid process, etc., while the ear passages are closed.

A recent instrument of this type is the audiometer of C. E. Seashore. The complete apparatus consists of an induction coil, a battery, a galvanometer, a resistance coil, switches and a telephone receiver, all except the receiver being built into one compact and portable piece. A scale, reading in units from 1 to 40, indicates the number of

sections involved in the secondary circuit. The corresponding values of sound intensity vary from 1 to 1079: "as it is most convenient to vary the R in a

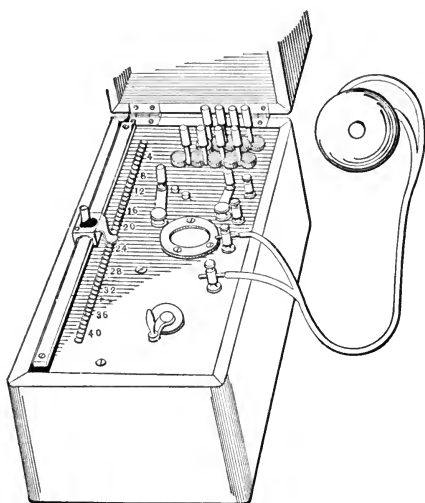

FIG. 9.—Seashore's audiometer. Sold by the C. H. Stoelting Co.; price about \$50.

geometric ratio according to the psychophysical law, this principle has been taken as a guide in determining the scale intensities of the sound"; "the 40 steps in the series are, as nearly as can be determined, psychologically equal." The average RL for normal ears lies near the middle of the scale. Provision has been made for the production of tones in the audiometer. See Iowa Stud., ii., 1899, 158.

The author has not worked with this instrument. Andrews (A. J., xv., 1904, 45) remarks that "the two sounds produced by the Seashore audiometer [*i. e.*, the sounds of the double telephone click] are not, at least not always, alike in quality. This objectionable feature could doubtless be eliminated by a modification of the apparatus." The author is informed, further, by those who have used the instrument, that the objective unit-values differ quite considerably from day to day (with temperature?). It would appear, then, that the apparatus is not altogether reliable in its present form.

Much work has been done, of recent years, upon the measurement of objective sound intensity. Into this the author cannot, for reasons of space, here enter.

QUESTIONS.—The Questions arise out of the remarks made above, p. 56, regarding the watch test. For the criteria of subjectivity and objectivity, see O. Külpe, P. S., vii., 1892, 399; viii., 1892, 313 f.; xix., 1902, 508 ff., esp. 538, 546 ff.; Outlines, 184 (*cf.* with P. S., xix., 528). Some of these experiments of Külpe's might well be repeated by an interested student. See

also C. E. Seashore, Yale Stud., iii., 1895, 1 ff. On Question (2), see p. 22 above.

ESSAY SUBJECTS.—(1) Determinations of the *RL* for sound, and their validity.

(2) The technique of physical measurements of the intensity of sound. (*Cf.*, by way of orientation, W. Altberg, Drude's Ann., 4te F., xi. [cccxvi.], 1903, 405.)

§ 17. **Weber's Law.**—The mathematical derivation of Weber's Law is taken from Ebbinghaus, Psych., i., 509; it should be compared with Fechner's derivations, p. xxx. above. The formulation of the Law in terms of the *DL* may now be given: *cf.* p. cxxix. above.

We know that the *DL* are, in some unknown manner, a function of the *R*-quotients; and we regard all intensive *DL* as sense steps of equal magnitude. If we denote the *j.* n. sense distance by ΔS , the corresponding *R*-increment by ΔR , and the required function by *f*, we have the equation:

$$\Delta S = f\left(\frac{\Delta R}{R}\right).$$

Fechner assumed, now, that the values ΔS and ΔR may be regarded, without serious error, as mathematical infinitesimals, or differentials. The advantage of the assumption is this: that the relation between two variables so connected as are *S* and *R*, whatever it may be when *S* and *R* are taken in the large, may be considered as a relation of simple proportionality when *S* and *R* are taken in the small. By help of this reduction we can determine the character of the function *f*. Writing for the former equation

$$dS = c\left(\frac{dR}{R}\right),$$

we have by integration

$$S = c \log R_0 + C.$$

C, the constant of integration, is now determined from the equation

$$\bar{S}_0 - S_0 = c \log R_0 + C$$

as

$$C = -c \log R_0.$$

Substituting this value of *C* in the former equation, we finally obtain

$$\bar{S} - S_0 = c \log \left(\frac{R}{R_0}\right),$$

the formulation desired. See Ebbinghaus, *op. cit.* 510 ff.; and *cf.* Meinong, Z., xi., 1896, 364 ff.; Höfler, Psych., 1897, 135 ff.

Interpretations of Weber's Law.—The question of the *interpretation* of Weber's Law has been touched upon at various points of our introductory discussion (see, *e.g.*, pp. xxxi. ff., xci. ff.). Students of quantitative psychology are often puzzled to understand why an interpretation is necessary, and how it differs from ordinary psychological explanation. It will, therefore, be worth while to devote a few words to the subject.

(1) We explain a psychological uniformity in one of two ways. Either we refer the mental to the physiological, as when we explain the laws of contrast from a physiological theory of vision, or the laws of difference tones from a physiological theory of audition; or we refer the mental phenomena in question to other mental phenomena, as when the facts of recognition are explained by an acquired mental disposition. Since the mental processes or states or dispositions which bear the burden of explanation in the latter case have themselves a physiological substrate, we may always (provided that our physiological knowledge is adequate) substitute the physical for the mental, the physiological for the psychical disposition, etc., and so explain throughout in physiological terms. When the physiological (or the parallel physiological-mental) conditions of a psychical occurrence have been made out and formulated, our psychological explanation is complete. From this point of view, then, an explanation of Weber's Law would consist, first, in the psychological analysis of the mental processes involved in our sense judgments (the phrase is used without prejudice), and secondly in the reference of these constituent processes to their physiological (or parallel physiological-mental) conditions. Further than this, psychological explanation does not need to go.

(2) This was, however, not the way in which the facts of Weber's Law were approached. Weber's Law, with its logarithmic correlation of S and R , offered itself to Fechner and his contemporaries as a sort of riddle or mystery. The riddle must be read, the mystery cleared up, before quantitative psychology could pursue its farther course with any intelligent hope of success. The Law called for 'interpretation,' in the sense that the logarithmic break in the chain of causal equivalents must be localised, and its presence accounted for. Fechner, as we know, car-

ried the law of causation from the stimulus to the sensorium, and exchanged it for Weber's Law at the line of demarcation between physical and psychical. Mach, on the other hand, thought that E and S , which run strictly parallel to each other, can hardly be anything else than proportional to one another, and accordingly placed the break between R and E . Interpretation does not, of course, actually oust explanation from the field; Bernstein's irradiation theory is an explanatory theory; but it cuts across explanation, obscures the real psychological issue, and stumbles at a difficulty which is of its own making.

(3) There is another aspect of the difference between interpretation and explanation, which it is less easy to describe. Explanation is satisfied when it has established an uniformity of correlation. The R come in at the periphery in a geometrical series. Somewhere between sense-organ and final cortical excitation (where, precisely, it is the business of physiology to tell us), the geometrical progression is transformed, we will suppose, into an arithmetical. This arithmetical series of E is paralleled by a progressive series of equal S -distances. When we have established these facts, in detail, our explanation is finished. We have a correlation of R -quotient with E -difference, and a one-to-one correlation of equal E -differences with equal S -distances.

Notice, now, that nothing is said of the *value* of the S -distances relatively to the E -differences. The S -distances are equal, among themselves; the E -differences are equal, among themselves; there is a one-to-one correlation of S -distance and E -difference. That is all. But in the days when the single S was regarded, not as a point upon a sense-scale, but as itself a quantity, there was, naturally, a tendency to evaluate the S in terms of its conditioning E . On the psychophysical interpretation, there was a shrinkage, so to speak, in the transformation of E into S ; on the physiological, there was a loss of energy between R and E , or at E itself, so that only a part of R or of E found representation in S . And this representation was a matter of quantitative equivalence: the S was equal to the available fraction of R or E , the S -difference equal to the difference of the available fractions of physical or physiological energy. Here, then, in the speculations regarding the values of S and S -differences relatively to R and E and their

differences, is something that 'interpretation' superadds to explanation. We have our one-to-one correlation: that is explanation. We may most easily 'interpret' the correlation as a correlation of equals. But the addition is not necessary: for we may have, in *E*-difference and *S*-distance, things that are wholly incommensurable, and our explanation will still stand.

This attempt of interpretation to transcend explanation was doubtless prompted by Fechner's erroneous view of the character of the single *S*. But errors die hard; and the list of interpretations figures as largely in the psychologies of to-day as it did in the books of twenty years ago. What we should now do is to discard interpretation, and confine ourselves to explanation. We must analyse the processes concerned in the consciousnesses which the Law covers, and seek their physiological conditions. Then Weber's Law will 'interpret' itself: for it will depend upon the result of our analysis whether we put it under the heading of sensation, or of apperception, or of judgments of comparison, or what not.

(4) This position is not by any means new. The psychological attitude which it implies comes out, more or less clearly, in several of the 'interpretations' familiar to us from psychological literature. Thus Wundt, while he insists that the interpretation of Weber's Law must be psychological,—while, in other words, he puts the logarithmic relation between *S* and apperception of *S*,—has consistently maintained that the psychological interpretation is to be paralleled by a physiological explanation, and has worked out the mechanics of a hypothetical 'apperception centre' to suit his psychological analysis. The difficulty of this view is, precisely, that it is two-sided. Let us take a not improbable case: the case that physiology some day offers positive reasons for placing the loss of energy involved in the logarithmic relation between sense-organ and nerve-fibre, and at least negative reasons for denying such loss between sense-centre and apperception centre. How is Wundt to reply? He has committed himself to a psychological 'interpretation'; and yet, here is physiology playing havoc with the supposed intricacies of the apperception centre! There cannot be two courts of final appeal. Surely, the thing to do is to throw interpretation overboard: to carry one's psychologi-

cal analysis as far as it will go, but then to accept from the physiologists, without question, what they have to say about the physiological substrate of the uniformity.

Meinong, again, seems to have a clear understanding of the fact that interpretations are irrelevant; though his treatment, in the last resort, is nothing less than satisfactory. "Was die That-sachen, die das Webersche Gesetz in sich fasst, besagen," he says, "ist einfach dies, dass gleichen R -Verschiedenheiten gleiche S -Verschiedenheiten, grösseren R - V grössere, kleineren R - V kleinere S - V zugehören. Das ist nichts weiter als der denkbar einfachste Sachverhalt. . . Zu 'deuten' ist an diesem Sachverhalte nichts" (Z., xi., 397: cf. 253 ff.). Grant this, for a moment. We are still not freed of physiology. The numerical fractions that represent the DL in the different sense departments differ exceedingly; and the explanation of their difference must be physiological. And if "das Webersche Gesetz die theoretische Norm bedeutet," and "man auf das Deuten erst dort und in dem Masse angewiesen ist, wo und in dem sich Abweichungen von dem Weberschen Gesetze Anerkennung erzwingen," this Deuten must be a simple explanation in physiological terms: there is no change of mental attitude as one passes from the middle of the sense-scale towards either extreme. Physiological considerations are thus mixed in with the "denkbar einfachste Sachverhalt" from the very first; and, in so far, they suggest the advisability of a thorough-going physiological explanation. But now challenge the formulation itself: is it not an interpretation when one says that a given correlation is the 'simplest conceivable'? What does simplicity matter, if we are in search of fact? The "relations-theoretische Deutung" is an interpretation; and it is an interpretation which breaks down in face of facts. There is no change of mental attitude as one passes from the judgment of liminally different weights to that of liminally different tones: and yet the DL corresponds in the one case to a quotient, in the other to an arithmetical difference. Difficulties of this sort are bound to arise, upon any kind of 'psychological interpretation' of Weber's Law.

To repeat, then: the moral of all this discussion is—Get rid of interpretations! Make your correlation: analyse both terms of

the correlation, as minutely as psychological and physiological methods allow. Then state your results, and be satisfied. You have explained; and that is all that psychology requires of you.

ESSAY SUBJECTS.—If the author hopes that psychophysics may gradually purge itself of interpretations of Weber's Law, this does not mean that the literature of interpretation is not worth reading and studying. Both on the physiological and on the psychological side, it furnishes admirable texts for essay-writing. The principal references are as follows.

I. PHYSIOLOGICAL INTERPRETATION.

- E. Mach : Sitzungsber. d. kais. Akad. d. Wiss. zu Wien, math.-naturw. Cl., 2 Abth., lii., 1865, 308; *ibid.*, liv., 1866, 131, 393; *ibid.*, lvii., 1868, 11; Analyse der Empfindungen, 1900, 60.—See Müller, G., 307 f.
- J. Bernstein : Reichert's Arch., 1868, 388; Untersuchungen über d. Erregungsvorgang im Nerven- u. Muskelsysteme, 1871, 166.—See Wundt, P. P., 1874, 425; Müller, G., 374.
- E. Hering : Sitzungsber. d. kais. Akad. d. Wiss. zu Wien, math.-naturw. Cl., 3 Abth., lxxii., 1875, 337 f.—Müller, G., 307 f.; E. Kraepelin, P. S., ii., 1885, 652 ff.; J. Merkel, P. S., iv., 1888, 593.
- J. Ward : Mind, i., 1876, 452.—Müller, G., 380 f.
- G. E. Müller : G., 224 ff.—Wundt, P. P., i., 1902, 550; W. Dittenberger, Arch. f. syst. Phil., ii, 1896, 92 ff.
- J. Delbœuf : Éléments, 1883, 172 ff.; Examen, 1883, 38 f., 65 f., 85, 143, etc. [In the author's opinion, there can be no doubt that Delbœuf tended definitely towards a physiological interpretation. Wundt, however, claims him for the psychological interpretation, apparently on the simple ground of his Differenzansicht of sensation : P. P., i., 1887, 380; i., 1902, 551. Reference is made to Théorie générale, 1876, 28 (Éléments, 175) : why, the author fails to see. Grotenfelt writes, very sanely : "die Gesichtspunkte, von denen die psychologische Erklärung des W. G. ausgeht, scheinen Delbœuf nicht ganz fremd zu sein; das Gesetz erscheint ihm überhaupt als ein leichtverständliches, vernunftmässiges Verhältniss; andererseits sucht er aber auch die Grundzüge einer physiologischen oder physikalischen Erklärung desselben zu entwerfen. Die psychologischen Rücksichten treten bei ihm jedoch überhaupt sehr zurück, sie werden nur hier und da schwach angedeutet; die Behandlung der Frage ist im grossen und ganzen geeignet das Gesetz als ein durchaus physiologisches erscheinen zu lassen." Das W. G., 13.]

- T. Ribot : *Psych. allemande contemp.*, 1885, 207 ff.
 A. Elsas : *Ueber die Psychophysik*, 1886, 38 ff.
 H. Lotze : *Outlines of Psychology*, 1886 (1881), 19.
 H. Ebbinghaus : *Pflüger's Arch.*, xlv., 1889, 113 ; *Z.*, i., 1890, 476 ;
Psych., i., 514 ff.
 L. M. Solomons : *Psych. Rev.*, vii., 1900, 234 ff.—Müller, M., 109.
 A. Lehmann : *Die körperl. Aeuss. psychischer Zustände*, ii., 1901, 179.
 We may refer, also, to the physiological work of J. Dewar and J. G. McKendrick, *Trans. Roy. Soc. Edin.*, xxvii., 1873, 141 ; *Nature*, viii., no. 193, 10 July 1873, 204 ; W. Pfeffer, *Untn. aus d. botan. Inst. zu Tübingen*, i., 1881–5, 363 ; *Pflanzenphysiol.*, ii., 1904, 625 ; F. C. Müller, *Arch. f. Physiol.*, 1886, 270 ; A. D. Waller, *Brain*, xviii., pts. 70, 71, 1895, 200 ; E. Steinach, *Pflüger's Arch.*, lxiii., 1896, 495 ; H. S. Jennings, *Journ. Comp. Neurol. and Psychol.*, xiv., 1904, 465 f. ; J. W. Salomonsohn, *Pfl. Arch.*, c., 1903, 455 ; J. W. Langelaan, *ibid.*, cvii., 1905, 94.

II. PSYCHOLOGICAL INTERPRETATION.

- W. Wundt : *Vorlesungen*, i., 1863, 133 ff. ; 1897, 62 ff. ; *Lectures*, 1896, 59 ff. *P. P.*, 1874, 421 ff. ; i., 1902, 538 ff. *P. S.*, ii., 1885, 31 ff. *Essays*, 1885, 162 f. *Logik*, ii., 2, 1895, 192 ff. *Grundriss*, 1896, 299 ff. ; *Outlines*, 1897, 254 ff.—Grotenfelt, *Das Webersche Gesetz*, 153 ff. ; Ebbinghaus, *Psych.*, 518 ff. ; Stumpf, *Tps.*, i., 8, 337 ff. ; ii., 558 ; H. Münsterberg, *Beitr.*, i., 1889, 42 ff. ; iii., 1890, 91 ff.
 A. Grotenfelt : *Das Webersche Gesetz und die psychische Relativität*, 1888, 71 ff.—Wundt, *P. P.*, i., 1902, 552.
 J. Merkel : *P. S.*, iv., 1888, 590 ff. *Cf. ibid.*, 541 ; v., 1889, 290 f. ; x., 1894, 153 f.—Foucault, *Psychophysique*, 223.
 A. Meinong : *Z.*, xi., 1896, 396 ff.
 G. Heymans : *Z.*, xxi., 1899, 321 ; xxvi., 1901, 305 ; xxxii., 1903, 38 ; xxxiv., 1904, 15.—F. S. Wrinch, *P. S.*, xviii., 1903, 309.
 O. Külpe : *iv. Congrès internat. de psychologie*, 1901, 167 f. ; *cf. W. Ament*, *P. S.*, xvi., 1900, 194 ; *Külpe*, *Outlines*, 167 f.
 T. Lipps : *Sitzungsber. d. philos.-philol. u. d. hist. Cl. d. k. bayer. Akad. d. Wiss.*, 1902, Heft 1, 46 f. ; *Leitfaden d. Psych.*, 1903, 74 ff.

III. GENERAL DISCUSSIONS.

- H. Lotze : *Medicinische Psych.*, 1852, 206 ff.
 W. James : *Psych.*, i., 1890, 545 ff. (Inclines to a physiological interpretation.)
 A. Grotenfelt : *Das Webersche Gesetz*, 1888, 11 ff. (Expository.)

- A. Seth : Weber's Law, in *Encycl. Brit.*, 9th edn., xxiv., 1888, 469. (Non-committal.)
- G. T. Ladd : *Elements of Physiol. Psych.*, 1889, 379 ff. (Accepts Wundt's twofold position, without attempting a mediation.) *Psych., Descr. and Explan.*, 1894, 140. (Appears to emphasise, if anything, the physiological explanation.)
- F. Jodl : *Psych.*, 1896, 230 ff. (Refuses to decide between the physiological and the psychophysical interpretations : rejects Wundt's view.)
- A. Höfler : *Psych.*, 1897, 145 f., 220 ff. (Follows Meinong's interpretation, in terms of 'theory of relations.')
- O. Külpe : *Outlines of Psych.*, 1895, 163 ff. (Does not attempt to decide between the physiological and the psychological interpretations.)
- W. Dittenberger : *Arch. f. syst. Phil.*, ii., 1896, 82 ff. (Critical.)
- T. Ziehen : *Leitfaden d. physiol. Psych.*, 1900, 39 ff. ; Introduction, 1895, 54 ff. (The Law is, in the first instance, a law of association of ideas.)
- M. Foucault : *La psychophysique*, 1901, 207 ff., 215 ff. (Critical.)
- W. Wundt : *P. P.*, i., 1902, 538 ff. (Psychological interpretation.)
- H. Ebbinghaus : *Psych.*, i., 1902, 514 ff. (Physiological.)
- J. Royce : *Outlines of Psych.*, 1903, 264 ff. (The Law is "a law of our reactions.")

Hypotheses of Weber's Law.—If the theory of mental measurement which this book represents is correct, the question of the *Unterschiedshypothese* *vs.* the *Verhältnisshypothese* of Weber's Law falls to the ground. Since, however, it still plays a part in certain views of mental measurement which we have assimilated to our own (*e.g.*, in Wundt's doctrine of *Merklichkeit*), and since it is of great historical importance in the development of psychophysical opinion, we must give some account of it.

As generally understood, the difference hypothesis correlates equal *S*-differences, the ratio hypothesis equal *S*-ratios, with equal *R*-ratios. Meinong, however, points out (*Z.*, xi., 389 f.) that this twofold division is neither logically complete nor adequate to the views actually held. There are four possible hypotheses :

- (1) that equal *R*-ratios correspond to equal *S*-differences,—the orthodox difference hypothesis of Fechnerian psychophysics : the *R-D* hypothesis ;¹

¹ *R*, in these hyphenated expressions, = ratio ; *D* = difference. The symbol *R*, standing by itself, means stimulus.

- (2) that equal *R*-ratios correspond to equal *S*-ratios,—the ratio hypothesis of Grotenfelt, etc. : the *R-R* hypothesis ;
- (3) that equal *R*-differences correspond to equal *S*-differences,—a *D-D* hypothesis, to which we must refer presently in our discussion of Merkel ; and
- (4) that equal *R*-differences correspond to equal *S*-ratios,—a conceivable *D-R* hypothesis.

Further distinctions may, of course, be made, according as the object of mental measurement is regarded as *S*, *S*-distance or diversity, or the noticeability of *S*. To work these out in the present connection would, however, mean needless repetition of previous discussions.

The *formula-system* of the *R-R* hypothesis lagged far behind that of the *R-D* hypothesis. The reader should consult : Plateau, *opp. citt.*, p. lxxix. above ; Müller, G., 382 ff. ; Fechner, I. S., 24 f. ; P. S., iv., 178 f. ; Köhler, P. S., iii., 616 ff. ; Merkel, P. S., iv., 543 f., 573 ff. ; v., 538 ff. ; x., 140 ff., 518 ff. *Cf.* also the generalised formulæ of P. Langer, *Grundlagen d. Psychophysik*, 1876, 58 ff.

The *R-R* hypothesis was first propounded by Plateau (1872), who was followed by Brentano (*Psych.*, i., 1874, 88 f.), Hering (*op. cit.*, 1875, 314, etc.), and Langer (1876). A discussion of these authors is to be found in Müller, G., 382 ff. ; Müller's conclusion we already know. Köhler rejects the *R-R* hypothesis (P. S., iii., 619) ; Elsas (*Psychophysik*, 1886, 73) regards it as wholly hypothetical (*cf.* however, the formulæ of pp. 20 ff.) ; Fechner thinks it worthy of impartial consideration (P. S., iv., 175 ff.). Delbœuf does not give it serious attention¹ (*Examen*, 12 f. ; *cf.* Grotenfelt, 73 f.). Wundt, in 1887, writes his formulæ in accordance with the *R-D* hypothesis, and avoids reference to its rival by taking refuge in his doctrine of *Merklichkeit* (P. P., i., 377 ff.).

The discussion enters on a new stage with the work of Grotenfelt (*Das Webersche Gesetz*, 76 ff., etc.) and Merkel (P. S., iv., 541 ff., 589). Both alike are representatives of the *R-R* hypothesis ; but their interpretations are somewhat different. See Grotenfelt, 65, 108 ff. ; Merkel, P. S., v., 245 ff., 537, 541, 547 f. Angell is now drawn into the controversy (P. S., vii., 1892, 414 ff.), and declares for the *R-D* hypothesis (468). Merkel returns to the charge in 1894 and 1896 (P. S., x., 140 ff., 203 ff., 376 ff., 514, 517 ; Z., xii., 233 ff.), and attempts (as Meinong shows : Z., xi., 392) to reconcile the *D-D* with the *R-R* hypothesis. Angell ripostes in A. J., xii., 1900, 76 f.

In 1893 Wundt goes over to the *R-R* hypothesis, though with the customary reservations regarding *Merklichkeit* and apperception (P. P., i.,

¹ It will be remembered that Delbœuf's results induced Plateau to withdraw his formula.

esp. 397 f.). In 1902 he accepts Merkel's distinction of judgment 'nach Unterschieden' and judgment 'nach Verhältnissen' (P. S., vii., 560 ff.; x., 150, 223, etc.), sets Merkel's Law alongside of Weber's, and writes as their respective formulæ :

$$C_a = k \cdot \Delta S, \text{ and } C_r = k \cdot \frac{\Delta S}{S},$$

where C_a means comparison of S by absolute, C_r their comparison by relative differences, and ΔS is the change in S -intensity corresponding to some determinate degree of noticeability (P. S., i., 547 ff.; cf. Logik, ii., 2, 1896, 193 ff.). Müller characterises this last position as "jene, eine solide Basis durchaus entbehrende und von einer empirischen Psychologie himmelweit verschiedene, Konstruktion" (M., 243). The difference in mode of judgment was, indeed, noticed neither by Angell's nor by Ament's O 's (P. S., xvi., 144). Ament himself inclines to the R - R hypothesis (194), and Külpe, on the basis of Ament's work, formally accepts it (iv. Congrès, 1901, 167). Meinong also accepts it, in the form of a Verhältnissverschiedenheitshypothese (Z., xi., 391). Ebbinghaus remarks that "die viel diskutierte Frage, ob das, was man bei der Vergleichung zweier S erlebt, als ihre Differenz oder ihr Verhältnis aufzufassen ist, völlig in der Luft steht; sie ist ebenso sinnlos, wie die andere, ob man bei der Vergleichung zweier Punkte im Raum eine Differenz oder ein Verhältnis empfinde" (Psych., i., 519 f.; cf. Foucault, Psychophysique, 227). And Müller concludes his M. (243) with the sentence: "Unter denjenigen Faktoren, von denen zur Zeit feststeht, dass sie bei Versuchen der hier in Rede stehenden Art unter diesen oder jenen Umständen die Urteile zu bestimmen vermögen, lässt sich . . . gerade einer vermissen, nämlich die Fähigkeit, S -Unterschiede oder S -Verhältnisse im eigentlichen Sinne des Wortes miteinander vergleichen zu können."—

If the above historical sketch is both summary and imperfect, the author's excuse is to be found in § 6. In his own opinion, both the 'interpretations' and the 'hypotheses' regarding Weber's Law may, apart from their place in the general chain of argument and experiment that has led up to the Reconstruction, be dismissed from consideration by a quantitative psychology. A knowledge of them will save us from doing over again work that has already been done; it is also indispensable, if we are to find our way through the literature to an understanding of the present status of psychophysics. This granted, their only remaining usefulness is for purposes of instruction: an appreciation of the Grotenfelt-Merkel controversy, *e. g.*, involves certain points in systematic psychology, and may thus conduce to the psychological training of the student. But, at the best, the subject-matter of the foregoing paragraphs must be adjudged one of the least fertile fields of psychophysical controversy.

Range of Weber's Law.—The data concerning the range of Weber's Law are, for the most part, easily accessible in the text-books: we may therefore content ourselves with a brief summary. It should be remembered that the Law obtains, in any case, only over a certain middle section of the intensive scale, and that even here it is, in all probability, rather approximately than exactly valid. Within these limits, its range is wide. The facts are, in the rough, as follows.

I. Audition.

- (1) *Noise.* In the case of minimal *S*-distances, there is no difference of opinion. As regards supraliminal *S*-distances, we can only say (in the light, *e. g.*, of Merkel's results) that the Law is probably valid under the right conditions of judgment.—Wundt, *P.*, i., 1902, 509 ff.
- (2) *Tone.* The Law holds, so far as has been investigated, for minimal *S*-distances.—Ebbinghaus, *Psych.*, i., 286; M. Wien, *Wied. Ann.*, xxxvi., 1889, 845 ff.

II. Vision.

- (3) *Brightness.* The same remarks apply here as for Noise.—Wundt, 517 ff.; Ebbinghaus, 208, 496 ff.
- (4) *Colour.* The Law appears to hold for minimal *S*-distances.—Wundt, 529 f.; A. Koenig and E. Brodhun, *Sitzungsber. d. Berliner Akad.*, 26 Juli 1888, 917; 27 Juni 1889, 641.

III. Pressure.

- (5) *Pressure (passive).* The Law holds for minimal *S*-distances.—Wundt, 530 f.; Ebbinghaus, 499.

IV. Kinæsthetic Complexes.

- (6) *Lifted weights.* The Law holds for minimal *S*-distances. As regards supraliminal *S*-distances, there is the regular difference of opinion.—Wundt, 531 ff.; Ebbinghaus, 370 ff.
- (7) *Arm Movements.* The Law appears to hold for minimal *S*-distances.—Ebbinghaus, 499, 504; F. Kramer and G. Moskiewicz, *Z.*, xxv., 1901, 114 ff.
- (8) *Eye Movements.* The Law holds for minimal *S*-distances in the sphere of Augenmass.—Ebbinghaus, 451, 504; Wundt, ii., 1902, 541 ff. *Cf.* the results of experiments upon ocular convergence: Wundt, 594 ff.; J. W. Baird, *A. J.*, xiv., 1903, 183, 191.

V. *Smell.*

- (9) *Smell.* The Law appears to hold for minimal *S*-distances, so far as investigated.—E. A. McC. Gamble, A. J., x., 1898, 137; *cf.* Wundt, ii., 49.

VI. *Taste.*

- (10) *Taste.* Results are few, and show some discrepancy. Wundt leaves the question open (ii., 41); Ebbinghaus inclines to regard the Law as valid for minimal *S*-distances (499).

VII. *Organic Sensations.*

No investigations have been made upon the organic sensations proper. If we regard the simple feelings as, genetically, derivative from organic sensations, we may instance:

- (11) *Feelings.*—Wundt, ii., 317 f. (*mensura sortis*; law of the fortune physique and fortune morale): *cf.* the references, pp. clii. f., above.

EXPERIMENTS IX, X

§ 18. **Demonstrations of Weber's Law.**—Exp. IX., the cloud experiment, is described by Fechner in *El.*, i., 140 ff.; Exp. X., the shadow experiment, *ibid.*, 147 ff. *Cf.* also *Abh. d. kgl. sächs. Ges. d. Wiss., math.-phys. Cl.*, iv., 1859, 457 ff., 465 ff.

MATERIALS.—Opticians supply 6 shades of grey glass, numbered 1 to 6 in the order light to dark. How far these shades are meant to be constant, from maker to maker, the author does not know; there is a slight variation even in those supplied by the same firm. Marbe's photographic greys may be procured from G. Glock, Kaiserstr. 9, Würzburg (the standard sets are 72 pieces in album, each 3 by 6.7 cm.; and 44 sheets, ca. 16.5 by 25.5 cm.) and from E. Zimmermann, Emilienstr. 21, Leipzig (*Helligkeitsskala* of 25 pieces in two sizes; more qualities to be had by special order): they are described in *Z.*, xii., 1896, 62 f. A set can be made, without great difficulty, in the laboratory, or the preparation may be entrusted to any skilled photographer. Excellent greys may be obtained, further, by painting white paper with a mixture of zinc white and ivory drop black (for directions, see Lehmann, *Die körperl. Aeusserungen psych. Zustände*, ii., 1901, 23): these have the advantage that they fit in well with the greys of the Hering series (set of 50 shades, now procurable from the C. H. Stoelting Co. of Chicago). Or finally, and most simply, a series

of extreme nicety can be worked out by help of Indian ink—and patience! Fechner, *El.*, i., 147; Ebbinghaus, *Sitzungsber. d. Berliner Akad.*, 1 Dezr. 1887, 995.

The preservation of whites, blacks and greys, for laboratory purposes, is a much more difficult matter than would appear from the literature. There is also little uniformity whether in the manufacture of sets or in the coating of any single sheet. Thus it is often impossible to cut from a single sheet of Hering grey two discs that look precisely alike when placed on the colour mixer; and importations of blacks and whites made at a few months' interval may differ so greatly as to render the direct continuation of an experiment already begun out of the question. The discs also deteriorate by handling more quickly than do colour discs.¹ These statements may seem exaggerated; they are, however, the fruit of unhappy experience.—

The Rumford photometer, as sold in cheap form for school purposes, has a baseboard of 20 by 120 cm. The pillar is 13 cm. in height, and stands about 18 cm. from the end of the board. The cardboard screen is 15 cm. square. The instrument serves fairly well with a candle and a ground glass 16 c.p. lamp. It is listed at \$4.25 by the C. H. Stoelting Co.

Shadow Exp.: Cautions not noted in the Text.—The arrangement given in the Text is, perhaps, the most practical and the most generally available. The experiment is, however (as we shall see presently), very rough. It would be better to work with lights of equal luminosity (say, with two standard candles whose light had been photometrically tested) and with longer distances: *cf.* Wundt, *Lectures*, 28 ff.

G. E. Müller (G., 107 ff.) lays down the following rules for the experiment. (1) The lights must be kept steady. Hence draughts, changes of temperature, jerky movements of the candlestand, are to be avoided. (2) Candle and lamp must always sit squarely upon the m. scales. (3) *E* must be careful to avoid lateral movements of *C*, as he pushes the stand back and forth; *O* must be careful, in the same way, not to move his head. (4) Lateral reflections must be avoided; *O* must not be able directly

¹ The Hering velvet black—a black of high 'saturation'—may fade noticeably in the course of a single day's work, if the daylight illumination is strong.

to see *C* and *L*. (5) The penumbra is larger, (*a*) the more extended the flame of *C*, (*b*) the farther the pillar from the white screen, and (*c*) the nearer the pillar to *C*. As the penumbra is a source of error, the dimensions of the apparatus must be chosen with regard to it. (6) The apparent size of the shadow influences its perceptibility. *C* must therefore be so placed that its movement does not appreciably affect the size of the shadow. For the same reason, the position of *O*'s eyes must remain constant throughout the experiment. (7) Regard must be had to such conditions as adaptation, fatigue, attention, etc.—Under this last heading, the reader may be reminded of the fluctuations of attention to minimal stimuli and stimulus differences, discussed in vol. i., I. M., 194 ff. It is essential that the observations be brief and discontinuous.

QUESTIONS.—(1) The general result of the experiments is that a very slight difference of brightness (estimated by *O* to be *j. n.*) remains equally noticeable (*j. n.*) when increased or decreased by the removal or the interposition of the grey glasses, provided that it bear always the same relation to its components, that these are themselves increased or decreased in the same degree (Abh., 458 f.; El., i., 141). This proves “that the magnitude which a brightness difference evinces in sensation depends far more upon the relative than upon the absolute magnitude of the difference; where we understand by ‘relative’ magnitude of the difference its ratio to the magnitude of its components” (Abh., 459; El., i., 134 f., 141). In other words, the result of the experiments is a confirmation of Weber's Law.

(2) The usual judgment, promptly given, is to the effect that the brightness difference has undergone no change. In some cases, however, (*a*) *O* will declare that the difference, as observed with the darker glasses, is greater than it appeared when viewed with the naked eye (Abh., 461 f., 464; El., 143 f., 146). See G. E. Müller, G., 104; Aubert, Phys. d. Netzhaut, 81. (*b*) There may be hesitations due to lack of adaptation: in passing from dark to light, the eye may be dazzled, in passing from light to dark, it may be momentarily blinded (Abh., 462; El., 144). (*c*) If very light or very dark fields are employed, the brightness difference may be perceived only uncertainly, or may definitely disap-

pear.—In experiments roughly made, after Fechner's model, with the coloured glasses ordinarily used in the laboratory, the author has not observed those differences of D. S. which Müller thinks ought to appear: G., 103; *cf.* Fechner, R., 165.

Fechner reverses his procedure in order to meet a possible objection arising out of (*a*). If a difference, estimated as *j. n.* without glasses, can be seen at all with the darkest glasses; and if, similarly, a difference, estimated as *j. n.* with the darkest glasses, can be seen at all with the naked eyes: "so liegt hierin eine Art *objectiver* Beweis, dass der Unterschied durch die Gläser in keinem irgends erheblichen Grade an Mercklichkeit gewinnen oder verlieren kann." Abh., 463; El., 145: *cf.* Müller, G., 105.

(3) The differences used in the cloud experiment are pretty certainly supraliminal: Müller, G., 56, 102 ff.; Helmholtz, P. O., 1896, 386. It would seem that Fechner was disposed in general to overestimate the magnitude of the *j. n. d.*; *cf.* his statements as to their introspective equality, p. lxviii., above. In the shadow experiment, the position of *C* ought to be settled by methodical procedure in both directions. But the distances of the lights from the screen are, in any case, too small to allow of accurate result: Aubert, Phys. d. Netzhaut, 57; Müller, G., 113 f.

(4) Fechner speaks of three 'principal cases': (*a*) the case realised in the experiments, "dass nämlich der Lichtunterschied bei seiner Abschwächung ein ungeändertes Verhältniss zu seinen, in demselben Verhältnisse mit abgeschwächten, Componenten behält" (El., 141); (*b*) the case in which the stronger component alone is weakened, or the weaker alone intensified,—so that the brightness difference, while it is diminished absolutely, is also diminished relatively to its components; and (*c*) the case in which both components are increased by a certain *plus* or diminished by a certain *minus* of intensity: this is the direct opposite of (*a*), inasmuch as the brightness difference remains absolutely the same, but is relatively changed. El., 141 f.

The second case is obtained, in the shadow exp., if we move the one of the lights, while the other stays in place, nearer to or farther from the white screen, or if we increase the intensity of the one without altering the other; the third is obtained, in the same exp., if we illuminate the bright field and the *j. n.* shadow

by a third light of considerable intensity (150 f.). In neither event does the brightness difference remain unchanged for sensation. The third case is also illustrated by the fact that "we can all see the stars at night, while in broad daylight we cannot see even Sirius and Jupiter. Nevertheless, the absolute difference of brightness between the parts of the sky where the stars are and the surrounding parts is just as great as it is by night. All that the daylight does is to add an equal *plus* to the intensity of both" (142). Cf. *Abh.*, 460.

(5) No. We have not properly determined the magnitude of the *j. n. d.*, in the cloud exp.; and, if we had, we have not the photometric values of the component *R*. Our shadow exp. has been made under unfavourable conditions; and we know nothing accurately of the values of the lights employed. Moreover, we have not determined the photometric values of the grey glasses. On the other hand, the aim or design of the exps. is quantitative, and they could easily be so modified as to fulfil the requirements of quantitative work.

There are, however, various reasons why they should be left in the rough. If we are to work accurately upon the question of the validity of Weber's Law for brightnesses, we shall not take clouds or shadows to work with, but shall appeal rather to the colour mixer or to some dioptrical apparatus. The value of these experiments lies elsewhere. They are of extreme historical importance, as the first experiments made by Fechner himself: *El.*, i., 140; ii., 558. They offer an admirable exercise in criticism: and we have models of criticism in the comments of G. E. Müller (*G.*, 102 ff., 106 ff., 112 ff.) and of Aubert (*Phys. d. Netz.*, 57). And, lastly, although as they stand they prove too much,—since Weber's Law is nowhere more than approximately valid: p. 71 above,—their result is, to the beginner, very surprising, and brings home to him, in a most effective way, the reality of the logarithmic relation.¹ Cf. Höfler, *Psych.*, 141 f.

¹ This, then, is the introduction to Weber's Law by way of surprise. From another point of view, the relation expressed in the Law may be made to appear as a matter of course: Müller, *G.*, 393 *n.*; A. Nitsche, *Progr. d. k. k. Staatsgymnasiums in Innsbruck*, 1879, 12; Meinong, *Z.*, xi., 1896, 397 *n.*; Höfler, *Psych.*, 230. This naturalness of the Law may be brought out in lecture after the present exps. have been done.

(6) "Instead of weakening the two components in the same degree by dark glasses, one can effect the same weakening by moving the two sources of light, *C* and *L*, farther and farther out from the white screen, while keeping their mutual relation undisturbed": *El.*, i., 148 ff. The brightening may be effected, similarly, by moving the two lights in from the extreme distance.

(7) (a) *Materials*.—A photographic negative, or a photograph on glass (window transparency), that shows some very faint shadows or some very faint differences of shading. Half-sheet of black cardboard, with circular opening of 1 cm. diam. at its centre.

Observe a *j. n. d.* of brightness in the photograph through the opening in the cardboard (this mode of observation helps to do away with surface reflections), projecting it against variously illuminated backgrounds.—Helmholtz, *P. O.*, 1896, 385 f.; Sanford, *Course*, 334 f. This exp. may be employed for demonstration of the 'upper' and 'lower limits' of the Law: *cf.* Fechner's exp. with the sun spots, *El.*, i., 145; *Abh.*, 464.

(b) *Materials*.—Masson disc (see vol. i., *S. M.*, 111). Grey glasses.

The Masson disc may well replace the twofold grey disc recommended for Exp. IX. (b), p. 31 of the text.

(c) *Materials*.—Colour mixer with Delbœuf disc.

Delbœuf (*Éléments*, 82 ff.) describes demonstration discs which give a geometrical decrease of intensity from centre to circumference. A Kirschmann and E. C. Sanford have constructed the discs here illustrated (Fig. 11): nos. 1 and 2 increase, no. 3 decreases in intensity towards the periphery. No. 4 is a 'control' disc, whose brightness increases outwards in arithmetical progression. See Kirschmann, *Am. J. of Psych.*, vii., 1895-6, 386 ff.; ix., 1897-8, 346 ff.; Sanford, *Course*, 1898, 335 f., 412 f.

Literature.—These two exps. were original with Fechner (*Abh.*, 469). He had, however, as he himself discovered, been anticipated by other

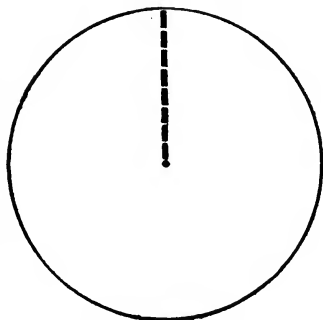
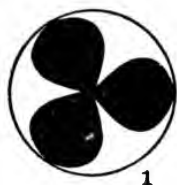

FIG. 10.—Masson's disc.

observers. Thus the shadow exp. is described, in essentials, by the French mathematician P. Bouguer (1698-1758), in his *Traité d'optique*



1



2



3



4

FIG. 11.

sur la gradation de la lumière, etc., ed. by N. L. de Lacaille, 1760, 51 ff.¹ For other references to the work of Fechner's predecessors, see *El.*, i., 151 ff.; *Abh.*, 470 ff.; G. E. Müller, *G.*, 110 f., 121 ff.; Helmholtz, *P. O.*, 1896, 386 ff., 478; Aubert, *Phys. d. Netz.*, 1865, 52 ff.; *Phys. Optik*, 1876, 487 ff.

On the *cloud exp.* see Müller, *G.*, 102 ff.; Aubert, *P. d. N.*, 80 f.; Helmholtz, *P. O.*, 386; Fechner, *R.*, 165 f.

Shadow exps. have been performed by:

- (1) A. W. Volkmann: *El.*, i., 146 ff.; *Abh.*, 467 ff.; also Volkmann, *Phys. Unt. im Gebiete d. Optik*, i., 1863, 56 ff. See G. E. Müller, *G.*, 112 ff.; Aubert, *P. d. N.*, 52 ff.; *P. O.*, 487 f.; Helmholtz, *P. O.*, 386, 478; Fechner, *R.*, 157 ff.
- (2) H. Aubert: *P. d. N.*, 1865, 54 ff.; *P. O.*, 1876, 488 f. See Müller, *G.*, 117 ff.; Fechner, *Ber. d. k. sächs. Ges. d. Wiss., math.-phys. Cl.*, xvi., 1864, 1 ff.; *I. S.*, 151 ff.; *R.*, 154 ff.
- (3) W. Camerer, *Zehender's Monatsbl. f. Augenheilk.*, xv., 1877, 56 f. See Fechner, *I. S.*, 155 f.; Müller, *G.*, 117.

Exps. with Masson's disc have been performed by:

- (1) Helmholtz, *P. O.*, 390 f. See Müller, *G.*, 124 f.; Aubert, *P. d. N.*, 70 f., 81 f.; *P. O.*, 492; Fechner, *El.*, ii., 564 ff.; *Ber.*, 1864, 17 f.; *I. S.*, 150 f.; *R.*, 154 f.
- (2) Delbœuf, *Éléments*, 76 ff. See Müller, *G.*, 125 f.
- (3) Aubert, *P. d. N.*, 70 ff.; *P. O.*, 489 ff. See Müller, *G.*, 126 ff.; Fechner, *Ber.*, 1864, 1 ff.; *I. S.*, 151 ff.; *R.*, 154 ff.
- (4) E. Kraepelin, *P. S.*, ii., 1885, 306 ff., 651 ff. See Wundt, *P. P.*, i., 1902, 519 f., 526 f.
- (5) O. Schirmer, *Arch. f. Ophth.*, xxxvi., 4, 1890, 121 ff. See Wundt, *op. cit.*, 520, 526.

¹ Cited in *Abh.*, 470, as 81.

Other references to quantitative investigations of brightness sensations are given below : pp. 124, 138, 199. For a general summary, see Wundt, P. P., 1874, 310 ff. ; i., 1880, 335 ff. ; i., 1887, 357 ff. ; i., 1893, 367 ff. ; i., 1902, 517 ff.

Additional Experiment.—The absorptive power of the grey glasses may be measured by Lehmann's method (P. S., iv., 1888, 234 ff.) as follows.

MATERIALS.—White screen. Two lights, of equal intensity, with black hemicylindrical screens. Black observation screen, with two openings and shutter. Episcotister. Grey glasses. Lateral and overhead black screens or curtains.

The arrangement of the materials is shown in Fig. 12. The

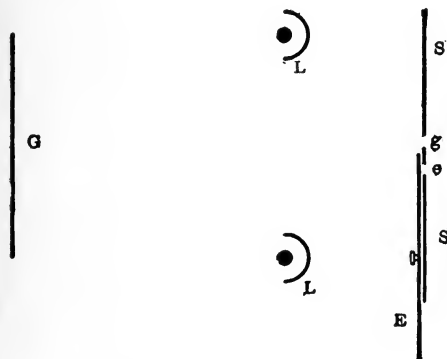

FIG. 12. *SS*, black screen ; *E*, episcotister ; *LL*, lamps ; *G*, ground glass screen ; *e*, observation hole for episcotister ; *g*, observation hole for grey glass.



FIG. 13. Episcotister. Zimmermann, 1903, Mk. 38-50.

materials themselves may be varied within wide limits. The following are those used by the author.—White screen of ground milk glass, 102 by 76 cm. Two Welsbach gas-burners, supplied from the same wall-fixture by tubes of equal length and lumen. Observation screen of blackened wood, 90 by 90 cm. : observation holes circular, 2 cm. in diam., 1.5 sm. apart from edge to edge. Episcotister of blackened metal : a circular frame, 16 cm. in diam., with four openings of 78°, graduated in degrees ; 6 double sectors, of 90°, 90°, 40°, 30°, 20° and 10° respectively ; frame and

sectors mounted upon an electric colour mixer. Readings can readily be made to 0.5° .

The episcotister is placed as close as possible to the screen S , in such a position that the sectors cover the opening e , while the rim of the circular frame is entirely concealed by the screen. The opening g is covered by the glass to be tested: the glass may be slipped into a paper or cardboard pocket, pasted or tacked to S .

The distances separating the various parts of the apparatus are regulated by O 's convenience and by the size of the dark room.

PRELIMINARIES.— O must sit in the dark room for some 15 min. before the experiment, in order to ensure adaptation to dark. The openings e and g must be covered by the shutter in the intervals between observations.

METHOD.—The object of the experiment is to equate the luminosities of e and g . The method employed is that of least differences.

The method is, in outline, as follows. A glass is placed behind g . The episcotister sectors are given such a value that e is distinctly darker than g . Then e is gradually lightened, until O says 'equal.' Now the procedure is reversed. E begins with an e that is distinctly too light, and gradually darkens it, until O says 'equal.'

The same two procedures are followed with the stimuli interchanged: the glass is placed behind the opening e , the episcotister behind g . The results of the four series are averaged to give the required equation.—For the mode of calculation, see pp. 7 ff. of the text; attention must be paid to the distribution of practice, since a number of glasses are to be tested.

Let us suppose that an equation has been made; and let a° be the mean value of the open sectors of the episcotister. Through every areal unit of the opening e (the opening covered by the episcotister) there has passed a quantity of light, i , determined by the formula

$$i = \frac{a}{360} \cdot I,$$

where I is the amount of light passing through the opening when unobscured. Again: if we denote by a the coefficient of absorption of the glass employed, there has passed through every areal unit of the opening g a quantity of light, i , such that

$$i = (1 - a)I,$$

where I has the same value as before. Since the two luminosities e and g are equal, we have

$$\frac{a}{360} = 1 - a = b,$$

where b is the photometric value of the glass.

RESULTS.—The following results were obtained with a set of 6 Meyrowitz glasses. No attempt was made to eliminate the space error, since the close agreement of found and calculated¹ values in the series taken showed that it was negligible. Only the average of the \uparrow and \downarrow series is given; with the darker glasses, the MV was usually = 0, and in no case did it exceed 1° . With an unpractised O , it would be advisable to bring the two openings e and g nearer together, and to give them an oval form (long axis vertical).

Glass.....	1	2	3	4	5	6
Open sector of episcotister: av. of \uparrow and \downarrow series.....	163°	152°	146°	88°	41°	18°

Glasses.....	1+5	2+4	3+ 4	3+5	4+ 6	5+6
Open sector of episcotister: av. of \uparrow and \downarrow series.....	18.25°	37.5°	36°	17°	4°	2.25°

From this we have :

Glasses.....	1	2	3	4	5	6	1+5	2+4	3+4	3+5	4+6	5+6
b found.....	.453	.422	.406	.244	.114	.050	.050	.104	.100	.047	.011	.0062
b calc.052	.103	.099	.046	.012	.0057

¹ If we term the brightness-values of two glasses b_1 and b_2 , then (under like conditions of illumination) the former will transmit a quantity of light $i_1 = Ib_1$, the other a quantity $i_2 = Ib_2$. The two together will, by the law of absorption, transmit

These results, with calculation of other combinations of glasses, give *very roughly* the series :

Glasses	1	4	1+2	2+3	5	1+4	3+4	6	4+5	3+6	4+6	5+6
<i>b</i>	1/2	1/4	1/5	1/6	1/8	1/9	1/10	1/20	1/40	1/50	1/100	1/200

EXPERIMENTS XI, XII

Exp. XI. is described by Sanford, Lab. Course, 340 f., 413 f. Specimen results from four *O*'s (118 envelopes, 5 to 100 gr.) are given on p. 341. As regards the choice of differences, "some such arrangement . . . is necessary if the heavier classes are not to be very much larger numerically than the lighter" (413 f.).

In weighting with lead, care must be taken that the strips are sewed to the card at the lower end of the envelope, *i.e.*, below the turned-in flap.

There can be no doubt, from the author's experience, that the choice of differences recommended by Sanford brings with it a source of error. There is a marked tendency, as well with *O*'s who are ignorant of the purpose of the experiment as with those who know it, to make the piles equal, if possible. Many of the envelopes are so weighted that it is difficult to decide whether they shall be assigned, *e.g.*, to pile 2 or pile 3. Almost invariably, *O* will tend to put them on the pile which contains the smaller number of envelopes. The error cannot be eliminated: it may, in some degree, be counteracted by requiring *O* to revise his first grouping before the measurements are made. The requirement suggests that the Instructor does not like the look of the piles, as they stand, and so leads to a more objective estimation of the weight of the envelopes.

RESULTS.—The following are typical of the results obtained from entirely unpractised *O*'s.

Group	<i>O</i> ₁ . First trial.				
	I	II	III	IV	V
Av. weight of single envelope in gr.	11.6	23.8	38.2	55.5	85.0
Ratio		2.0	1.6	1.4	1.5
		<i>O</i> ₁ . Second trial.			
Av. weight, etc.	11.6	23.0	40.6	53.5	85.0
Ratio		1.9	1.7	1.3	1.6

a quantity $i_3 = Ib_1b_2$. If we term the brightness-value of the two glasses, taken together, b_3 , we must therefore find $b_3 = b_1b_2$. This equation gives us a check upon the results of our actual determinations.

	O_2 . First trial.				
Av. weight, etc.	11.3	27.2	36.8	62.2	86.2
Ratio	2.4	1.4	1.7	1.4	

	O_3 . First trial.				
Av. weight, etc.	6.6	10.7	17.9	44.5	82.1
Ratio	1.6	1.7	2.5	1.8	

The ratios become much more nearly equal after half-a-dozen trials.—
The four sets of results are expressed in graphic form in Fig. 14.

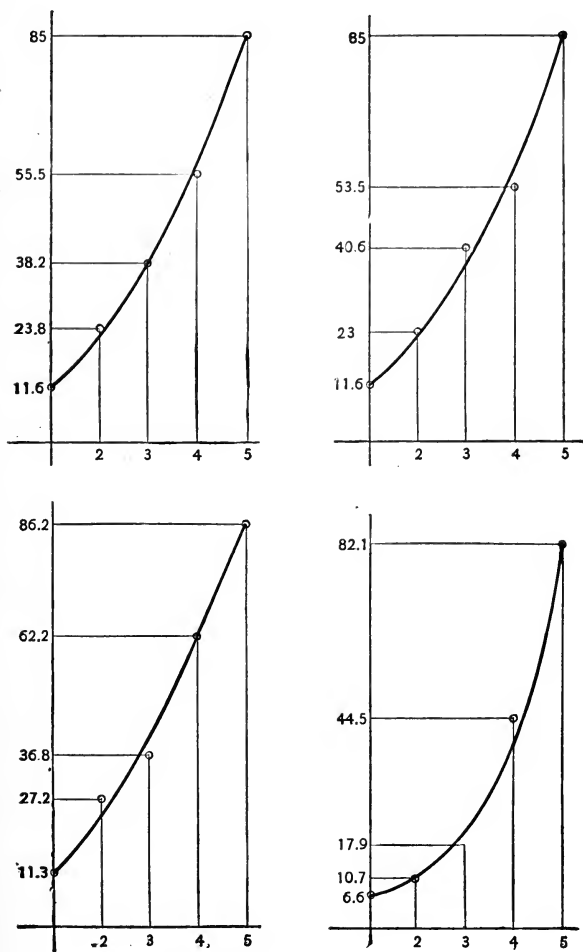

FIG. 14.

The curves in this Fig. have been 'smoothed' in the ordinary way. The question, however, naturally arises: what is the geometrical progression to which the results most nearly approximate? what is the equation of the exponential curve that most nearly agrees with the line connecting the highest points of the ordinates? The answer is that the equation $y = M^x$, where M is the arithmetical mean of the observed ratios, is an approximation accurate enough for all practical purposes.

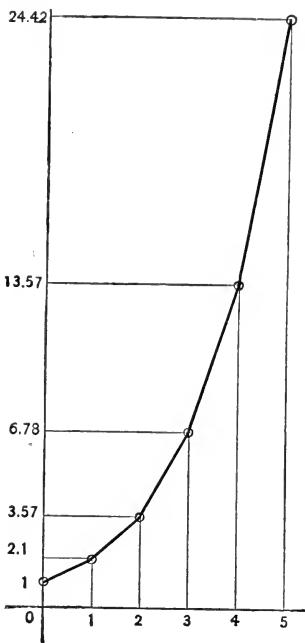

FIG. 15.

Take, e.g., the observed ratios,
 2.1, 1.7, 1.9, 2.0, 1.8.

From them construct the series

1, 2.1, 3.57, 6.78, 13.57, 24.42.

Express this series graphically, as in Fig. 15. Join the successive points by straight lines. The area (obtained by adding up the areas of the quadrangles) is 38.73.

The average ratio is 1.9. For trial, consider the curve $y = (1.9)^x$, and compare its area with the area found above. The area between $x=0$ and $x=5$ is

$$\int_0^5 (1.9)^x dx = \frac{(1.9)^x}{\log 1.9} \Big|_0^5 = \frac{(1.9)^5 - 1}{\log_e 1.9} = \frac{23.76}{.64185}$$

or 37.02, an area a trifle less than 38.73. For another trial, consider the curve $y = 2^x$. Its area is

$$\int_0^5 2^x dx = \frac{2^x - 1}{\log_e 2} = \frac{31}{.693147}$$

or 44.72. This gives an excess of 6, while the former trial gave a defect of 1.7. Say, then, as $6 + 1.7 : 1.7 :: 2 - 1.9 : \text{correction}$. The correction = .022. Hence, instead of 1.9 we should use 1.922.

Thus the exponential curve $y = (1.922)^x$ gives an area which is the same as the area formed by the broken line of Fig. 15. But this curve is, to all intents and purposes, identical with $y = M^x$.

The equation can also be put in the form $y = e^{ax}$, if we find a such that $e^a = 1.922$; that is,

$$a = \log_e 1.922 = .653.$$

Hence the equation of the exponential curve with constant ratio that comes closest to the given tracing is $y=e^{.653x}$; and it gives a constant ratio of $e^{.653}$, which is 1.922.¹

Experiment XII. is described by Ebbinghaus, *Psych.*, i., 1902, 496 f.; *Die Gesetzmässigkeit des Helligkeitscontrastes*, Sitzungsber. d. Berlin. Akad., 1887, 994. Ebbinghaus had a set of 50 shades; his quotients for 8 equidistant brightnesses are given above, p. cxxviii.

The following are the first six determinations made, with the Marbe papers, by an unpractised *O*:

Space order	1 — 44					44 — 1				
Papers	1	14	25	35	44	44	41	26	12	1
	1	12	24	35	44	44	35	24	13	1
	1	14	25	34	44	44	34	24	12	1

The photometric values for the series

44 34 24 12 1

were .063 .13 .25 .49 1.11;

which give the ratios

2.0 1.9 1.96 2.26.

Another *O* took as his first choice the papers

44 31 24 11 1

whose photometric values were

.063 .16 .25 .54 1.11;

which give the ratios

2.5 1.56 2.1 2.0.

The two sets of results are expressed in graphic form in Figg. 16, 17.

Kirschmann's photometer is described in *P. S.*, v., 1889, 292 ff.¹ An improved form is figured by W. G. Smith, *Toronto Stud.*, ii., 2, 1904, 31 [113]. For determinations see, *e.g.*, Kirschmann, *P. S.*, vi., 1891, 424; K. Marbe, *ibid.*, ix., 1893, 390. As com-

¹ All this is, of course, mathematics by 'rule of thumb.' The student who desires to pursue the subject farther might begin, *e.g.*, with ch. iii. of C. B. Davenport's *Statistical Methods*, 1899, 16 ff.

² *Cf.* the somewhat similar arrangement of F. Hillebrand, *Sitzber. d. kais. Akad. d. Wiss. in Wien, math.-naturw. Cl.*, xcvi., Abth. 3, Feb. 1889, 96. Hillebrand's experiments on the white valence of coloured papers (95 ff.) are instructive, and may be repeated without difficulty.

pared with the photometers of modern physics, the instrument is very rough; but it suffices for the purposes of the present Course.

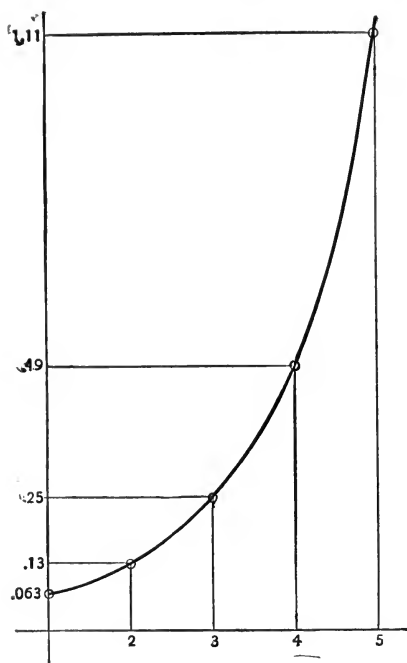

FIG. 16.

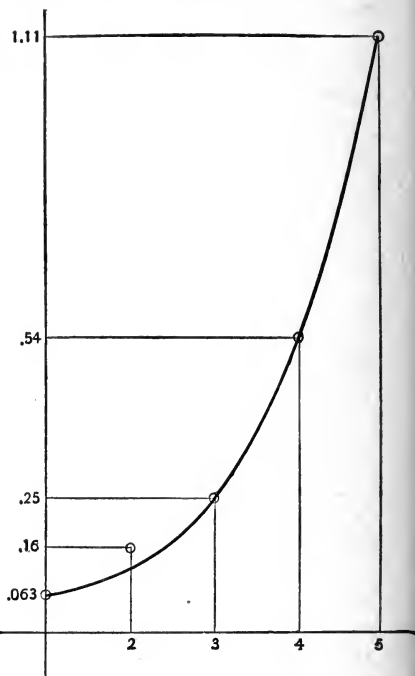

FIG. 17.

Historically, the problems of photometry were of great importance for psychophysics: see, *e.g.*, G. F. Lipps, *Arch. f. d. ges. Psych.*, iii., 1904, 154 ff. And from the point of view of their intrinsic importance, photometric experiments are, perhaps, unduly neglected in psychological laboratories; their technique has grown to be so refined, and the instruments required are so expensive, that one is tempted to cast the burden of training and outlay upon the physical laboratory, and to appeal to the physicist to standardise one's papers or glasses. The author was, at first, disposed to include a § on photometry in this book, but decided after consideration that not much more could be done by the student than is called for in Exps. IX. and XII. The Instructor will, of course, recommend the reading of Helmholtz, *P. O.*, 1896, 416 ff., 428 ff., 473 ff. A useful little book is W. M. Stine's

Photometrical Measurements, 1900; *cf.* refs. in Baldwin's Dict., ii., 298. If the students in the Course are taking a concomitant course in experimental physics (vol. i., I. M., xxv.), special arrangements may be made with the Instructor in Physics to introduce the typical photometric exercises.

Some Experiments on Colour Photometry.—The following experiments may be assigned to interested students.

(1) *Martius' Method.* Two similar rings are cut from the coloured paper to be investigated, and are pasted with great care upon black and white discs of the same size. The two ringed discs are then mounted upon a colour mixer. If, now, the coloured paper is brighter than the surrounding grey, the grey of the inner disc will, under steady fixation, darken; if it is darker, the inner grey will lighten. If the brightnesses of grey and colour are equal, the *O* will say 'equal' or 'doubtful'.—For full account of method¹ and apparatus, see G. Martius, *Beitr. z. Psych. u. Phil.*, i., 1896, 104 ff.; *cf. ibid.*, 1897, 161 ff.; iii. *Internat. Congress*, 1897, 183 ff.

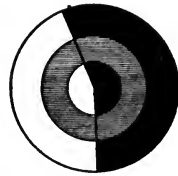

FIG. 18. Martius' disc.

(2) *Rivers' Method.* If a compound disc of two colours or of a colour and a grey be set into such rapid rotation that mixture is complete, and a light wooden rod be passed across the surface of the disc, the rod will ordinarily leave behind it on the disc a number of parallel bands in the colours of the original components (or of the one colour component and of the complementarily tinged grey) alternately arranged. This phenomenon is called the Münsterberg-Jastrow effect (Jastrow, A. J., iv., 1891, 201; Sanford, *Course*, 167; E. B. Holt, *Harvard Stud.*, i., 1903, 167). When, however, the grey and the colour of such a compound disc are of equal brightness, the bands do not appear.—For method and materials, see W. H. R. Rivers, *Journ. Physiol.*, xxii., 1897, 137 ff.

(3) *Flicker Photometry.* The general principle or postulate which underlies flicker photometry is that the point at which intermittent *R* give rise to a continuous *S* depends on brightness and not on colour tone. A good deal of work has been done in recent years, and the method bids fair to supplant the other methods proposed for colour photometry. So far, however, the results have not been properly co-ordinated, and theory has not settled down to anything like universal acceptance. The literature is easily accessible; and the author therefore lists the

¹ Note the remark, 109 f., that the pairing of the series is not necessary.

principal papers, leaving the Instructor or the student to pick out for himself observational series that he deems worth repeating.

1893. O. N. Rood, Amer. Journ. Sci., 3 Ser., xlv., 173.

1896. A. Pabst, Ueb. d. Bestimmung d. Helligkeit farbiger Papiere durch intermittierende Netzhautreizung. Diss., Würzburg.

F. Schenck, Pfl. Arch., lxiv., 165.

F. P. Whitman, Phys. Rev., iii., 341.

1897. O. F. F. Grünbaum, Journ. Physiol., xxi., 396.

J. B. Haycraft, *ibid.*, xxi., 126.

W. H. R. Rivers, *ibid.*, xxii., 137.

C. S. Sherrington, *ibid.*, xxi., 33.

F. Schenck, Pfl. Arch., lxxviii., 32.

F. L. Tufts, Trans. N. Y. Acad. Sci., xvi., 190.

1898. O. F. F. Grünbaum, Journ. Physiol., xxii., 433.

O. N. Rood, Science, N. S., vii., 757, 785.

1899. W. de W. Abney, Proc. Roy. Soc. Lond., lxx.,

282; Phil. Trans., A. cxliii., 259.

O. Polimanti, Z., xix., 263.

O. N. Rood, Amer. J. Sci., 4 Ser., viii., 194, 258.

F. Schenck, Pfl. Arch., lxxvii., 44.

1900. W. de W. Abney, Proc. Roy. Soc., lxxvii., 118.

1902. M. Schaternikoff, Z., xxix., 241.

F. Schenck and W. Just, Pfl. Arch., xc., 270.

1903. J. von Kries, Z., xxxii., 113.

1904. H. Kruss, Physik. Z., v., 65.—*Cf.* Baldwin's Dict., ii., 298.

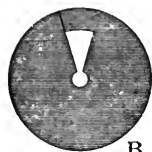

B

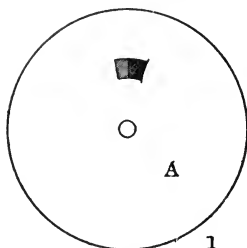

A

1

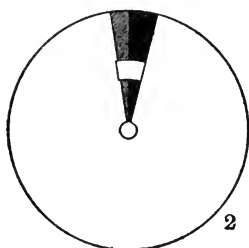

2

FIG. 19.

(4) *Hering's Method.* A large coloured disc *A* has a short slit in the middle of a radius. Smaller grey discs are cut to the form *B*. One or more of these are placed on a mixer behind *A*, and the free part of the peripheral ring or rings is thrust through the slit. Fig. 19, 1 shows a compound disc in which two *B*, the one distinctly lighter, the other distinctly darker than *A*, have been used. On rotation, we have a coloured background, on which is seen a less saturated ring. The projecting portions of *B* are varied until no difference in brightness between ring and background can be made out. Fig. 19, 2 shows the converse arrangement. Two large grey discs are slit along a radius and mounted on the mixer; then comes a coloured small disc, of the form *B*; in front stands a large disc of the same colour, slit along a radius.

The course of the exp. is indicated by the Fig.—See A. Brückner, Pfl. Arch., xcvi., 1903, 90 ff. (gives an imperfect review of other methods.)

QUESTION (8).—The general result of the experiments is that equal sense distances correspond to approximately equal R -quotients; “dass für eine gleichmässig, d. h. in gleichen Abstufungen fortschreitende Steigerung der S -Stärken die zugehörigen R -Intensitäten annähernd eine geometrische Progression bilden” (Ebbinghaus, Psych., i., 497). In other words, the result is, again, a rough confirmation of Weber's Law.

(9) We have spoken of a source of error lying in the choice of weights, p. 82 above. In Exp. XII., an objective source of error is found in the small number of brightness values at O 's disposal; the series is very far from being continuous. The chief source of subjective error, in all experiments of this kind, is the confusion of S with R of which we have spoken above, pp. lxiii. ff.

(10) Jastrow worked in 1888 with visual extents. “A very large number [500] of thin sticks, varying arbitrarily in length from a few mm. up to about 300 mm., were mixed together in a random order; and the problem of the O was to arrange these sticks according to length in a given number [6 or 9] of classes. . . . But one stick at a time was seen, and as soon as it was thrown into the bag it was lost from the O 's view.” The results approximated to arithmetical, not to geometrical series. A. J., iii., 1890, 44 ff.

In 1889 Jastrow, with L. M. Hanks and J. B. Kerr, made a similar investigation with kinæsthetic extents. There were about 360 sticks, ranging in length from a few mm. to about 275 mm. “The sticks were not seen by the O . The latter simply felt their lengths by moving his forefinger along them and announcing the compartments in which he wished them placed.” The sticks were sorted into 6 classes. The result “is in every respect essentially similar to that with visual magnitudes.” *Ibid.*, 47 ff.

Jastrow notes that one of the 4 O 's in this experiment, and one of the 9 in the former, showed a marked tendency to give a geometrical series of R . We must suppose that the outstanding O of the visual experiment judged in terms, not of total visual impression, but of eye movement. We may also suppose that the 3 ‘arithmetical’ O 's of the kinæsthetic

experiment were visualisers, and judged in terms, not of feel, but of mental vision. These hypotheses may appear gratuitous. But they serve to bring the experimental results into line, and Jastrow himself gives us no data for a critical judgment. He merely remarks that obedience to Weber's Law in the visual experiments "may be an individual matter" (46), and that "the *O* who follows the geometric series [in the kinæsthetic experiments] would be one who did not consciously state the problem to himself, but went on a general impressionist view of the matter" (49).

In 1891 Jastrow and W. B. Cairnes published an investigation of time-intervals. *O* was allowed to listen to the slowest (40 in the 1 min.) and fastest (208 in the 1 min.) beats of a metronome, and was required to imagine this range of rates divided up into 6 grades or magnitudes. The *R* varied by 2 beats per min. from 40 to 120; by 3, from 120 to 144; and by 4, from 144 to 208: 63 intervals were thus employed. *O* sat with his back to the metronome, and called out the number of the class to which he assigned the given *R*. Three sets of 189 observations each were obtained from one *O*, two from two others, and one from three others: 10 in all. The average results show "a decided approximation to a geometrical series." *A. J. P.*, iv., 1892, 213 ff.

In the same year, Jastrow and A. A. Lee "experimented with a form of movement in which, with the forearm supported at the elbow as a pivot, the hand moved laterally for practically any distance from 5 to 190 mm." The results "roughly approximate an arithmetical series." *Ibid.*, 217 ff.

In the interval experiment, Jastrow notes the error of the serial limits, the error of absolute judgment, and the *R*-error: 216 f. As regards the movement experiments, we must say, as we said of the other kinæsthetic experiments, that there is no evidence of judgment in terms of 'motor sense' apart from visualisation. For the rest, the conditions of such experiments at large are extremely complicated; see, at this stage, Ebbinghaus, *Psych.*, i., 1902, 369 f.

In 1892 Jastrow and W. D. Brown published a series of experiments with lifted weights. Sixty cylindrical weights, from 12 to 795 gr., were arranged in 6 classes by lifting in the palm of the hand; two sets (120 judgments) were taken with 7, four

sets with 3 *O*'s. The result is "a coarsely approximate geometric series." A. J. P., v., 1893, 245 ff.

In the following year, J. H. Leuba worked with artificial stars. His two instruments are figured *ibid.*, 371, 376. "Complete uniformity of ratio is not shown. The deviations, however, are not extremely great, and the series of magnitudes is very much more nearly a geometrical series than an arithmetical" (384).—

This 'classification method,' or 'method of the psychophysical series,' might be still further extended in various directions. In any form, it serves to bring out subjective attitudes and subjective and objective sources of error. For our present purpose, however, the two experiments of the text seem to be by far the best. An interested student might be allowed to construct Leuba's simpler apparatus, and to work out the problem of stellar classification in the light of Jastrow's paper, A. J., i., 1887, 112 ff. If the laboratory contain a tonometer or piano, some student will

FIG. 20. Ap-
punn's tonometer.
Cf. Wundt, P. P.,
i., 1893, 461; ii.,
1902, 84. The Cor-
nell instrument has
129 reeds, varying
by steps of 4 vs.
between the limits
512 and 1024 vs.

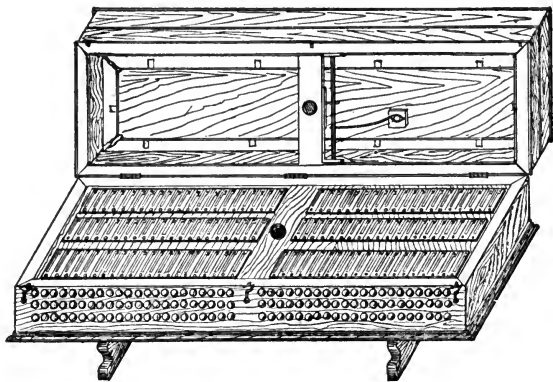

almost certainly suggest the extension of the method to tonal intervals; the Instructor may then anticipate something of § 30.

(11) Exp. XII. is, of course, a modification of Plateau's experiment, for which see below, p. 211. It is not improbable that a student, who has already determined certain *RL* by the method of limits, will think of applying this method to the present problem, and will so hit upon a method of 'mean gradations.'

ESSAY SUBJECTS.—(1) The range and validity of the method of classification.

(2) The history of photometrical methods (brightness photometry).

(3) The history of colour photometry, and the relative validity of the methods employed.

CHAPTER II

THE METRIC METHODS

In aller Naturwissenschaft ist allerdings nur so viel exakt, als Mathematik in ihr anzutreffen ist, aber ebenso ist auch in aller Mathematik nur so viel exakt, als sie Naturwissenschaft enthält. Nicht die reine Mathematik, sondern die mathematische Naturwissenschaft ist der grösste Triumph des menschlichen Geistes.—GOLDSCHIED.

Es ist wirklich nicht schwer, noch diese oder jene neuen Modifikationen der psychophysischen Methoden auszudenken. Aber man schafft nur Verwirrung und Umständlichkeiten, wenn man ganz ohne Zweck und Nutzen von den traditionellen Verfahrensweisen abweicht.—MÜLLER.

§ 19. **The Law of Error.**—The placing of this quasi-mathematical discussion at the head of the Sections that deal with the metric methods does not mean that it must necessarily be read before the methods are attacked. The method of limits, *e.g.*, may be taken up without regard to it. The author would rather suggest that practical work be begun at once, and that the Section be assigned as collateral reading, so that its contents will be familiar to the student when he comes to deal with the 'error' methods.

The problem set by these 'error' methods is one of the most difficult problems that the teacher of experimental psychology has to face. There is no precedent that can guide him in its solution; for, few and incomplete as are the published Courses of laboratory instruction, they represent diametrically opposite views on the question. We have, on the one hand, psychologists who reduce the metric methods to rule of thumb, and leave the understanding of the formulæ to students who already possess a sufficient knowledge of mathematics. We have, on the other hand, psychologists who speak of little else than computation and the adjustment of observations, and so make the methods the vehicle rather of applied mathematics than of psychology. The author has attempted in the text to strike a middle course between these extremes: not because the *via media* is here the safest,—it is, on the contrary, the most perilous of the three,—but because it promises to lead most directly to psychological results.

Undoubtedly, both of the extreme positions may be supported

by strong arguments. "It is a pedagogical mistake," a representative of the first direction might say, "to have anything in the Student's Manual that the student cannot work with. Describe the method: that the student can follow. Then let him work blindly with the formulæ, whose derivation he cannot follow. Put your mathematical discussion, a real and full mathematical discussion, in the Instructor's Manual: the quasi-mathematical discussion in the Student's Manual will only make the student feel that there is something mysterious involved in the formulæ, something that he cannot master; and that is a definitely bad result. Would it not be better to send a student direct to the calculus, if the matter is to be treated in any extended way? Can he be said, no matter how well he may be able to put the formulæ in words and to catch the ideas that underlie them, really to get at what the thing would mean to him if he understood the calculus as calculus?" Similarly, a representative of the mathematical direction might say: "You cannot get psychological results that shall be worth anything out of six months' method-work. It took Frankl three semesters to find his confirmation of Martin and Müller's *generelle Urteilstendenz*;¹ and unless you get something of this qualitative analysis from your record sheets, the psychology of the methods is not worth while. What you can do in half a year is to give your students training in general scientific method: you can tell them something about octiles and deciles, and irregular distributions, and Pearson's law of correlation. Give them this; make the methods a lesson in the elementary applications of mathematics. Then, when they come to work at psychology for themselves, they will at least have solid ground to work from."

The author hopes that he has stated these positions fairly, and that he appreciates the weight of the arguments. The difficulty that he finds in both is that they do not meet the present exigencies of psychological instruction. It is regrettable, on general principles, that any third-year University student, be he mathematically minded or not, should be unable to read such a book, say, as Merriman's Least Squares. It is very regrettable: but it is true, in the author's experience, that the great majority of the

¹ Z., xxviii., 1902, 2.

students who come into the psychological laboratory cannot. Now these students come into the laboratory for psychology, and for nothing else. They cannot use the methods intelligently without a minimum of mathematical insight; they cannot be taught mathematics—any more than they can be taught neurology or physics—in the time spent upon psychology. What the author has tried to do, therefore, is, first and foremost, to treat the methods psychologically; to show in every case where introspection stops and where mathematical manipulation begins, and to hold in view throughout the psychological end to which calculation is the means. Secondarily, he has tried to say enough about mathematics for the student to realise how necessary an ally mathematics is, when one is working at psychology from the quantitative standpoint, and to understand at least the general trend of the arguments put forward, *e.g.*, by Fechner and Müller in the classical psychophysical treatises. If the student desires to continue his psychological work after graduation, he can be advised to give some time to pure mathematics in his senior year,—and he will take the advice, now that he has learned that such a course is the *sine qua non* of farther advance. If his psychological interest stops short with undergraduate work, as in most cases it must do, he has at least been led to see that mathematics is an indispensable auxiliary of advanced scientific thought; he has gained some little outlook upon mathematical modes of expression; and he may be tempted to devote some portion of his energies to mathematics, for the purposes of his general education, before leaving the University. The author suggested in vol. i. (I. M., 52) that qualitative experiments upon tonal sensation might serve the cause of music. In the same way, these quantitative experiments may serve the cause of mathematics. If one is a psychologist, music and mathematics are useful handmaids of psychology. Whatever one is, they are parts of a liberal education.

This is the author's *apologia*. Teachers of psychology have to meet existing conditions, and the existing conditions are, all too often, those of teaching quantitative psychology to non-mathematical students. We can insist that our graduate students shall know a certain amount of mathematics; we cannot, as things are,

make the same requirement for undergraduates. For while there are a few Universities where courses of instruction in methods of measurement and the adjustment of observations are given within the department of Psychology, or where circumstances allow the professor of Psychology to require such courses as a preliminary to his own work, this state of things is the exception, and not the rule. And while the professor himself knows the value of the mathematical attitude for investigation, and realises how vast and important a literature is thrown open by a working knowledge of the fundamental conceptions of mathematics, he cannot say that the results of the application of mathematics to psychology are, at the present day, such as to warrant the exclusion of the non-mathematical student from his laboratory. It is, indeed, doubtful whether such exclusion will ever be warranted.

This is, at the same time, the author's excuse for not inserting in the text a special Section on correlation, another on irregular distribution, etc.¹ He is concerned with mathematics only in so far as mathematics is necessary for practical psychological work and for an understanding of the literature. If the student's collateral reading goes beyond the classical treatises—which he *must* read—he will very soon learn, under the Instructor's guidance, what it is desirable for him to know. For the rest, the Instructor must decide, here as elsewhere, how far he will supplement the text by mathematical essays or exercises, as he must decide in general what to expand, modify, substitute, omit, to suit the special needs of his classes.

As for the pedagogical objection, that must give way, if the results of practice are against it. Many eminent mathematicians have attempted to set forth the principles of mathematical thinking in non-mathematical language, and their attempts have been found useful. The author is not a mathematician, but ought for that very reason to have some feeling for the difficulties that beset the beginner. He may add that the paragraph under discussion, like all the other paragraphs of the text, has stood

¹ Thorndike (*Ment. and Soc. Meas.*, 70) regards it as an open question whether students of mental measurement should not from the beginning be taught to put the 'normal' distribution in its proper place as simply one amongst an endless number of possible distributions. The question cannot, however, arise for the teacher who considers the historical development of psychophysical theory.

the test of practice. Not every student who drifts into the laboratory will gain from it; not every student gains from the Course at large. But it has helped serious students in the past, and may therefore reasonably be expected to help others in the future. In which hope let it be committed to the critics!

The following books will be found useful in connection with the text:

Airy, G. B. : *On the Algebraical and Numerical Theory of Errors of Observations and the Combination of Observations.* 1861.

Bowley, A. L. : *Elements of Statistics.* 1900.

Comstock, G. C. : *An Elementary Treatise upon the Method of Least Squares, with Numerical Examples of its Applications.* 1890.

Davenport, C. B. : *Statistical Methods, with Special Reference to Biological Variation.* 1899. (Gives, pp. 40-42, a selected bibliography of works on the quantitative study of organisms.) Cf. the writer's *Statistical Study of Biological Problems*, *Pop. Sci. Mthly.*, lix., 1901, 447.

Ebbinghaus, H. : *Das Gedächtnis.* 1885, §§ 7, 8, 10.

Galton, F. : *Natural Inheritance.* 1889.

Galton, F. : *Hereditary Genius, an Inquiry into its Laws and Consequences.* 2d. edn., 1892.

Jevons, W. S. : *The Principles of Science, a Treatise on Logic and Scientific Method.* (Reprint) 1900.

Johnson, W. W. : *The Theory of Errors and Method of Least Squares.* 1892.

Merriman, M. : *A Text-Book on the Method of Least Squares.* 8th edn., 1900. (Indispensable !)

Merriman, M., and Woodward, R. S. (editors) : *Higher Mathematics, a Text-book for Classical and Engineering Colleges.* 1896.

Proctor, R. A. : *Easy Lessons in the Differential Calculus.* 1889.

Venn, J. : *The Logic of Chance, an Essay on the Foundations and Province of the Theory of Probability, with especial reference to its Logical bearings and its application to Moral and Social Science and to Statistics.* 3d edn., 1888.

Vivanti, G. : *Complementi di matematica ad uso dei chimici e dei naturalisti.* Milan, 1903.

Whitworth, W. A. : *Choice and Chance, with 1000 Exercises.* 5th edn., 1901.

The Instructor will naturally refer, also, to the mathematical text-books used in his own University, and to the psychophysical

applications of the law of error worked out by Fechner, Müller, Wundt, Merkel, Fullerton and Cattell, G. F. Lipps, etc.¹ The logic of the theory of probabilities is best discussed, perhaps, by G. Boole, *An Investigation of the Laws of Thought*, on which are founded the Mathematical Theories of Logic and Probabilities, 1854; by J. Venn, in the *Logic of Chance*; and by B. Bosanquet, *Logic, or the Morphology of Knowledge*, 1888 (against Venn). A History of the Mathematical Theory of Probability was published by I. Todhunter in 1865. Useful and easily accessible articles are those on Probability by M. W. Crofton (mathematical) in the *Encyc. Brit.*, 9th edn., and by E. W. Davis and F. Franklin (largely logical and historical) in Baldwin's *Dict. of Philos.*, ii. Both articles give references to the literature. The serious student will, of course, go back to Laplace's *Théorie analytique des probabilités* (first published in complete form in 1812), and the more popular *Essai philosophique sur les probabilités* (1814: very poorly translated by F. W. Truscott and F. L. Emory, 1902) which serves as introduction to it in the *Oeuvres*, 1843-7, vol. vii., and to Gauss' *Theoria combinationis observationum erroribus minimis obnoxia* (1812-26).²

¹ We may here mention a series of articles by E. W. Scripture that bear more or less closely upon the matter in hand: *The Method of Regular Variation*, A. J. P., iv., 1892, 577; *Psychological Measurements*, *Philos. Rev.*, ii., 1893, 677; *Accurate Work in Psychology*, A. J. P., v., 1894, 427; *Some Psychological Illustrations of the Theorems of Bernoulli and Poisson*, *ibid.*, 431; *On Mean Values for Direct Measurements*, *Yale Stud.*, ii., 1894, 1 (gives many references); *Adjustment of Simple Psychological Measurements*, *Psych. Rev.*, i., 1894, 281; *Practical Computation of the Median*, *ibid.*, ii., 1895, 376; *Elementary Course in Psychological Measurements*, *Yale Stud.*, iv., 1896, 89; *Computation of a Set of Simple Direct Measurements*, *ibid.*, viii., 1900, 109. The articles contain much useful material, but are of varying merit, psychologically and mathematically. See also *The New Psychology*, 1897, chs. ii., iii., and App. i., ii., iii., vii.; and V. Henri, *Le calcul des probabilités en psychologie*, *Année psych.*, ii., 1896 (1895), 466 ff.; v., 1899, 153 ff.—Useful books to have in the laboratory are F. Castle, *Workshop Mathematics*, pts. i. and ii., 1900.

² At the end of this Section, as originally written, the author had said: "Now that mathematical methods are being widely applied to the study of organic evolution, we shall doubtless have text-books of applied mathematics for biologists and psychologists, as we already have them for mechanical and civil engineers. In that event, the purely mathematical deduction of formulæ may be banished from works upon psychology." Since the writing of these words two books, of especial interest to experimental psychology, have appeared from the pen of E. L. Thorn-

On the psychology of expectation, see two articles by Aars, *Z.*, xix., 1899, 241; xxii., 1900, 401; and the (not very satisfactory) monograph by C. M. Hitchcock, *Psych. Rev. Mon. Suppl.* 20, 1903.

§ 20. **The Method of Limits (Method of Minimal Changes): Historical.**—A scientific method naturally undergoes many transformations before it settles down into its definitive form. For method grows up concomitantly with observation: some observations, already made, may suggest the means of refining upon observation, while conversely the making of an observation implies, of itself, that the observer knows more or less how to observe.

dike: *Educational Psychology*, 1903, and *An Introduction to the Theory of Mental and Social Measurements*, 1904. The former applies quantitative (statistical) methods to a number of educational problems; the latter aims "to introduce students to the theory of mental measurements;" though "the book may with certain limitations be used as an introduction to the theory of measurement of all variable phenomena."

The books represent a step, and a long step, in the right direction. Both alike, unfortunately, are marred by a general carelessness of exposition, which (in the author's experience) makes it wellnigh impossible for untrained students to read them with profit, or even with understanding. They are primarily intended for the writer's own use with his classes; and with a lecturer behind them they should do admirable service. But what shall we say, *e. g.*, of two and a half pp. of Tables, each with rows of figures headed by such mysterious symbols as *H*, *T*, *F*, *Tu*, *Tp*, *Ea*, *Ep*, not a single one of which is explained in the text (*Ed. Psych.*, 98 ff.)? The reader must either find vol. ii. of the *Yale Stud.*, from which the Tables are taken,—or must let these pages go. Instances of the sort are all too common. Again, it is unfortunate, from the psychologist's point of view, that in the second work "the author has had in mind the needs of students of economics, sociology and education, possibly even more than those of students of psychology, pure and simple." The 'possibly' is over-modest: for apart from some psychophysical illustrations, most of them of the 'mental test' type, and all given without any exact statement of conditions, we do not come within sight of 'psychology, pure and simple.' Moreover in the 'references for further study' (164 f.), we find under *Psychology*,—besides two of Galton's books, a statistical paper by Cattell, and Wissler's work on the correlation of mental and physical tests (this last characteristically mistitled),—only Fullerton and Cattell's *Small Differences*: recommended as "the best introduction to the special problems in mental measurement which confront the student of psychophysics!"

The critic's irritation at these defects is, perhaps, greater than it would be, were the general tendency of the books less sound. A careful revision, for misprints and omissions, and a steady resolve on the writer's part to be clear, even at the cost of a little more space, would make a second edition indefinitely more valuable than the first. In any event, however, a mathematics for the psychologist has still to be written.

In the special case before us, there can be no doubt that attempts to determine the *j. n. d.* of *R* by direct observation were made, many times over, before the birth of psychophysics. The problem has a personal or competitive side, which renders it interesting; and the materials for its rough solution (two strings, a set of weights, two basins of warm water) are easily procurable and easily regulated. Fechner (El., i., 73) dates the first beginnings of the method of *j. n. d.* from Delezenne (1826); Lipps (Massmethoden, 2 ff., 40, 50; Arch. f. d. ges. Psych., iii., 154 ff., 192, 202), from Lambert and Bouguer (1760). They might, with equal right, have pushed it back to Sauveur (1700),—and many brave men lived before Sauveur!—or have referred it forward, as Wundt does, to E. H. Weber (1829). Everything depends upon what we mean by a ‘method.’

Apart from the difficulty of laying one’s finger upon the first man who made a relevant observation, there is the further difficulty of disentangling the inessential observations of the earlier literature from the essential. We call our method the ‘method of limits’ or the ‘method of minimal changes,’ and the name must mean something. Yet how are we to give it a definite meaning without deciding, at the outset, what the essential point of the method is? And how can we do this without dogmatism? We find, as a matter of fact, that two main strands are interwoven in the history of the method of *j. n. d.*; and we find, further, that the one of these strands ravel out again into threads of two kinds, psychophysical and psychological. We have, as the first strand, the more obvious procedure of the *adjustment of R to a j. n. d.*; as the second, the method of determination of the *j. n. d.* by *carefully graded approach* from a subliminal or supraliminal *R*-difference. The former presupposes that *O* will know a *j. n. d.* when he sees it; that he can carry the *j. n. d.* in his head, and set his *R* by this mental pattern. The latter does not call for any sort of estimate or mental pattern of the *j. n. d.*; *O* gets his *DL* only indirectly from his own introspections, directly from *E*’s calculations. Introspection furnishes the data for calculation; but the introspection is not directed upon a *j. n. d.* So modern a psychologist as Ebbinghaus, now, recognises both of these methods as legitimate, and brackets them both under the same

general heading (Psych., i., 67). The *DL* which they yield are, however, different, both psychologically and in *R*-value. If they are to be treated together, the one must simply make way for the other. And so we find that Ebbinghaus, forced to a choice, regards the method of adjustment, with its preconceived "Idee einer gleichen Stufengrösse," as the typical method (75 f.). In the author's opinion, this is a step backward. He assumes with Müller (G., 61), who first insisted upon the point, that the second of the two procedures represents the true method of limits.¹ The justification of this choice must be sought in the whole of the following discussion.

So much for the strands: now for the threads! The method of limits, as here characterised, takes on two forms. In the one form (Wundt's method of minimal changes) it is *par excellence* a psychological method. It presupposes—nay more, it rather encourages—certain variable errors, notably the error of expectation; and it cuts its procedure to fit these errors. Its part-series are arranged upon a normal or ideal plan; the *R* submitted to observation, within a series, are selected with overt regard to the factors of expectation, habituation, etc.; and the procedure with knowledge is prescribed, in order that these factors may operate constantly and uniformly. The psychology of the method is the psychology of serial stimulation: every judgment is passed under the cumulative influence, physiological and psychological, of the previous experiments in the series. A procedure without knowledge would render the influence of the variable psychological errors sporadic, fluctuating, incalculable.—This is the logic, expressed or understood, of the strict Wundtian method.

The psychophysicists, on the other hand, seek to bring the method into line with the 'error' methods. They point out that the psychological errors are—variable errors; that no procedure can take fair account of them; that expectation, *e.g.*, may work backward as well as forward. The thing to do, then, with these errors, is to rule them out. Give *O* such instruction that he is *not* under the influence of foregone judgments; forbid him to 'expect'; if he insists on expecting, take the *r* in haphazard, not

¹ Wundt (P. P., i., 1902, 475 f.) dismisses the method of adjustment as an "approximative Verfahrensweise." Müller gives a more definite criticism in M., 2 f., 8, 9, 187 ff.

in serial order. This modification of the method of limits is recommended by Müller (M., 179 ff.). Kraepelin's combined method (P. S., vi., 1891, 499 f.) takes us half-way towards it. Foucault (*Psychophysique*, 1901, 352 f., 356 ff.) employed it in experiments upon visual distances. Wundt himself (*op. cit.*, 478 f.) offers it as a *pis aller*; though he seems, in doing so, to betray a confusion with regard to the underlying principles of his own method. A choice between the two forms is not so easy as was the choice between the method of adjustment and the method of minimal gradation. There is a good deal to be said—from the point of view of the Instructor, who has to train beginners in the way they should go, there is a very great deal to be said—for Wundt's envisagement of the method. On the other hand, the *DL* of the Wundtian method, taken strictly, is incomparable with the *DL* of the 'error' methods. From the psychophysical standpoint, therefore, we must rank ourselves with Foucault and Müller.

Returning now to the original distinction between the method of adjustment and the true method of *j. n. d.*, the method from which our method of limits derives, we find the first beginnings of a relevant procedure in the work of E. H. Weber. Hence the method itself has sometimes been termed 'Weber's method' or, in *æsthesiometry*, 'Weber's first method.' As applied in the latter field, it dates from 1829 (*Annot. anat. et physiol.*, 1851 [1829], 47). As applied to the determination of the *DL*, it requires that two like *R* shall be presented to *O*, and the one very gradually increased (or diminished) until a difference becomes noticeable. "In plurimorum hominum manibus," writes Weber, "mensa quiescentibus, pondera duarum librarum collocavi. . . Postea, insciis illis, pondus alterutrum imminui, manusque pondera ferentes mutavi. . . Tum si homo iteratis periculis et mutatis saepe manibus gravius pondus a leviori recte discernerebat, notavi" (*ibid.*, 1851 [1831], 86; *cf.* Wagner's *Hdwbch.*, iii., 2, 1846, 546). Here we have the *j. n. d.* of pressure determined by the gradual reduction of the one *R*, with elimination of a space error. Fechner (*El.*, i., 72) recommends approach to the *j. n. d.* from both possible directions. "Im Allgemeinen ist bei dieser Methode zweckmässig, den Unterschied eben so oft von einem

übermerklichen auf den Grad des eben merklichen herabzubringen, als von einem unmerklichen zu diesem heraufzubringen, und das mittlere Resultat zu nehmen": *cf.* I. S., 53, 153; R., 121.

Nevertheless, Fechner did not at all recognise the fact that a carefully graded approach to the *j. n. d.* is the key-note of the method. Müller points out (G., 56 ff.) that certain of the earlier investigations referred by Fechner to the method of *j. n. d.* were really performed by quite different methods. Thus (1) Fechner's own experiments with grey glasses (p. 72 above) and with temperatures (El., i., 202 ff.), Masson's disc experiments (Ann. de chim. et de phys., xiv., 1845, 150; El., i., 152 ff.; Helmholtz, P. O., 1806, 386; Müller, G., 121 ff.), etc., fall in strictness under a rudimentary form of the method of supraliminal differences (Müller) or of equal-appearing intervals (James), the classical form of which we shall presently discuss as the method of mean gradations (Wundt): while (2) Volkmann's experiments with sound intensities (El., i., 176 ff.) and a part of Fechner's work upon ocular measurement (El., i., 233 f.) were done by a similarly imperfect form of *r.* and *w.* cases (disputed by Wundt, *Das Webersche Gesetz*, 1882, 40; P. S., i., 557; Fechner, R., 124). It must be remembered, when we are passing criticism of this sort, that Fechner did not set out from our definition of the *DL*. He, like Weber, overestimated its value, regarding the *j. n. d.* as that *R*-difference which could always be remarked by a practised *O*, but any the least diminution of which would prevent discrimination (*cf.* El., i., 128; Wundt, *Das Webersche Gesetz*, 9; P. S., ii., 5). We have seen above (p. lxxviii.) that he strenuously defends the position that the *j. n. d.* is a definite psychological magnitude that may be definitely ideated. At the same time, the criticism is not unjust: in 1882, when Fechner has Müller's and Wundt's procedures before him, he still prefers his own (R., 119 ff.).

We come back to Weber and his method. Co-ordinate with this, the method of *j. n. d.*, is a method of *j. not-n. d.*, such as was used by Bouguer in his shadow-experiment of 1760. The two partial methods seem to have been first employed together for aesthesiometric determinations; R. Lichtenfels, in 1851, took a 'just one-point' limen as well as Weber's 'just two-points' (Sitz-

ungsber. d. kais. Akad. d. Wiss. zu Wien, math.-naturw. Cl., vi., Abth. i., 340). As applied to the determination of the *DL*, this method of disappearing differences requires that two sensibly different *R* be presented to *O*, and the one gradually increased (or diminished) until the original difference becomes unnoticeable.

Is there, now, any way of combining these two methods, with elimination of constant and variable errors, for the determination of a *DL* in Müller's sense? Fechner recommends the averaging of the ascending and descending *j. n. d.* This procedure gives us a value which is greater than our own *DL*, but which has psychological validity: the average value is a Fechnerian *DL* freed from certain errors. To average *j. n. d.* and positive equality (on the analogy of Lichtenfels' combined method) is quite another matter. Is it psychologically justifiable? And, if justifiable, is it psychologically valuable?

Lichtenfels, we note, did not do it; he left his two series side by side. Judged from the standpoint of Müller's *DL*, he was right. The average of *j. n. d.* (ascending) and of positive equality (descending) will yield a value smaller than our *DL*, as Fechner's method yields a value that is larger.¹ Nevertheless, the two partial methods can be combined. The suggestion comes from Delbœuf. "On fait d'abord croître la différence *d*," says Delbœuf in 1873, "jusqu'à ce qu'elle devient perceptible; puis on la fait décroître jusqu'à ce qu'elle cesse de l'être."² The descending series extends, not to positive equality, but only to lapse of difference. Müller, in 1878, works out this idea of Delbœuf's in his own method of 'least differences' (G., 63 f.),—the first instance of methodical combination of *j. n. d.* with *j. not-n. d.* in order to the determination of a true *DL* by minimal changes.³ According to Müller's method, we set out from a clearly supra-liminal difference of *r* and *r*₁, and diminish *r*₁ uniformly and very

¹ We assume, for purposes of the argument, that judgments of 'positive equality' are possible. See Müller, M., 12 f.

² *Éléments*, 9. Müller (G., 66 f., n.) is mistaken in identifying this suggestion with that of Fechner.

³ Lipps, *Massmethoden*, 51 f. (Arch., 203 f.). Lipps evidently underestimates the complexity of the problem which the history of the method presents: cf. 57, 72 (Arch., 209, 224).

slowly until "der Unterschied beider *R* nicht mehr merklich erscheint." There we stop; and either repeat the determination or reverse the procedure. In the latter event, we start from a subliminal difference, "etwa von der Grösse 0," and gradually increase it until it becomes *j. n.* The two liminal values are determined in a large (and equal) number of series, and the average of all determinations is taken. The resulting value—with constant errors eliminated—is the *DL* required. Müller offers a quasi-mathematical proof (64 ff.), in terms of the "zufällige Fehlerursachen," of the necessity of the combined procedure.¹

Müller's method, despite its psychophysical advantages, seems to have remained a mere paper-method—in part, perhaps, owing to Fechner's criticism in the *R.*—until the method of 'minimal

¹ In the *Arch. f. d. ges. Psych.*, iii., review section, 1904, 42, Lipps expresses a belief that Müller's method is a method of *continuous* variation of the variable *R*: "die Methode der kleinsten Unterschiede ist demnach eine *Herstellungsmethode* im Sinne des Verfassers (Müllers)." There can be no doubt that Müller's phrasing in *G.*, 63, taken out of its context, is ambiguous. But Lipps' interpretation is little less than ridiculous. For (1) Müller cautions *O*, in *G.*, 62, against a long-drawn-out and reflective judgment of likeness or difference. How could *O* find opportunity for such a judgment, if the variable *R* were continuously varying? The words "ganz allmählich und mit möglichst gleichförmiger Geschwindigkeit" (63) refer to the elimination of this error of reflective judgment; they do not recommend a continuous procedure. (2) In *G.*, 69, Müller says that the verschiedene Abstufungen des *R*-Unterschiedes may be replaced by eine grössere Anzahl abgestufter *R*-Unterschiede prepared beforehand and exhibited in the proper order. In this the language of continuous variation? (3) Müller is bettering Fechner's method of *j. n. d.* And Fechner, in *El.*, i., illustrates that method by reference to lifted weights, *i. e.*, to a discrete procedure. (4) The whole tenor of the discussion in *G.*, 61 ff., presupposes the discrete procedure, although the same word 'allmählich' occurs in it. (5) Although the shadow-experiments of the authors cited on p. 64 may have been in so far continuous that the moving light was moved out at a sweep to the neighbourhood of the limen, yet about that point it was moved to and fro by limited steps. And Aubert's Masson-disc experiments, Delbœuf's experiments, and Helmholtz' disc experiments (*G.*, 69, 124) distinctly presuppose a discrete procedure. (6) The technique of continuous change (see § 23 below) was but little developed at the time that the *G.* was written. (7) In *M.*, 164 ff., Müller brackets together his own method of least differences and the Wundtian method of minimal changes, without a hint of this essential difference between them. In mentioning the method of continuous change (168 *n.*), he refers to Stern, Stratton and Seashore,—not to his own *G.* If the 'spezielle Gesichtspunkte und Massregeln' that the continuous procedure requires were to be found in the *G.*, its author would surely have said as much. (8) The word 'allmählich' occurs in *M.*, 166, where the procedure is overtly discrete.

changes' was worked out and brought into use by Wundt. In 1880, Wundt accepted the principle of combination, and introduced the name *Methode der Minimaländerungen der Empfindung*.¹ At the same time, however, he exchanged Müller's psychophysical point of view for the psychological: the essentials of the method are, for him, steady serial advance upon the *j. n. d.*, and its determination under the cumulative influence of foregone judgments. In 1882, Wundt published an elaborate essay upon the revised method (*Das Webersche Gesetz und die Methode der Minimaländerungen*, *Dekanatsschrift d. Univ. Leipzig*, 39 ff.; reprinted in the *P. S.*, i., 556 ff.), which is now generally known as 'Wundt's method of minimal changes.' The method was reviewed at length by Fechner, in *Abh. d. kgl. sächs. Ges. d. Wiss., math.-phys. Cl.*, xiii., 1887 [1884], 7 ff.—

All of the psychophysical metric methods have been subjected, ever since their formulation, to a running fire of criticism. But, out of them all, minimal changes has, perhaps, made the most determined enemies. And even among those investigators who accept the principle of careful graded approach to the *DL*, there is the widest possible divergence of opinion regarding the procedure to be followed. We must, therefore, defend in some detail the position adopted in the text; and, to do this, we must have a clear understanding of the Wundtian method. Wundt sought, long ago, to give the method complete and final form; Müller, until 1904, had given nothing but suggestions. Hence Wundt's rules, and not Müller's, have generally been obeyed in practice; and his account is thus the natural starting-point for criticism.

Wundt's method, in brief, is as follows. The principal points are taken from *P. P.*, i., 1902, 476 ff.

We set out from $r_1 \parallel r$, and increase r_1 by unnoticeable increments until r_1 appears just $> r$. This point is marked: but, to be on the safe side, we increase r_1 by a few more steps. Then we decrease r_1 , in the same gradual way, until we have reached (and passed a little beyond) the point at which $r_1 \parallel r$. This point is marked. The two resulting

¹ *P. P.*, i., 326, 328, 332, 334. In 1874 (*P. P.*, 295) Wundt uses the phrase "*Minimalveränderung der Empfindung*" as the equivalent of 'eben merklicher Empfindungsunterschied.'

values, r'_o and r''_o are averaged to r_o .¹ We now set out again from r_1 \parallel r , and decrease r_1 , proceeding by unnoticeable gradations to the point at which r_1 appears just $< r$. This point is marked, and the series continued for a few steps farther. Then we increase r_1 , in the same gradual way, till we reach (and pass) the point of apparent equality of r_1 and r . This point is marked. The two resulting values, r'_u and r''_u , are averaged to r_u .²

We thus obtain two liminal values: the *upper DL*, $r_o - r = \Delta r_o$, and the *lower DL*, $r - r_u = \Delta r_u$. These values are determined several times over, with the view of increasing the accuracy of the final result and of eliminating constant errors.

If, now, $\Delta r_o = \Delta r_u = \text{const.}$, we have a constancy of the absolute *DL*, and need go no farther. If we find, on the other hand, that variation of the magnitude of r brings with it variation of Δr_o and Δr_u , we must take new test-values. Since the Δr_o and the Δr_u determined for any particular r are neighbouring *DL*, they will differ but very little in absolute amount. Whatever, then, the course of the *DL* may be, we shall commit at most a negligible error in writing $\frac{\Delta r_o + \Delta r_u}{2} = \Delta r$, the

mean DL. By help of this Δr , and of the original r_o and r_u , we obtain a value r_e , such that

$$r_e = r_o - \Delta r = r_u + \Delta r = r + \frac{\Delta r_o - \Delta r_u}{2}.$$

Further, by help of r_e and r , we obtain a value Δ , such that

$$\Delta = \pm (r_e - r) = \frac{\Delta r_o - \Delta r_u}{2}.$$

The former of these values is called the *estimation value* of r : if it is $> r$, then r has been overestimated; if it is $< r$, r has been underestimated; if it is $= r$, r has been correctly estimated. The latter value, Δ , is termed the *estimation error* or the *estimation difference*. If it is positive, r has been by so much overestimated; if it is negative, r has been by so much underestimated; if it is $= 0$, r has been correctly estimated. Or again: if $r_e = r$, and $\Delta = 0$, *i.e.*, if $\Delta r_o = \Delta r_u$, we have found a constancy of the absolute *DL*; if $r_e > r$, and Δ is positive, *i.e.*, if $\Delta r_o > \Delta r_u$, we have found an increase of the absolute *DL* with increasing r ; and, finally, if $r_e < r$, and Δ is negative, *i.e.*, if $\Delta r_o < \Delta r_u$, we have found a decrease of the absolute *DL* with increasing r .³

¹ The subscript o means 'upper.' The symbol r_o might accordingly be read 'oberer Grenzreiz.'

² This symbol may be read 'unterer Grenzreiz.' The subscript u means 'lower.'

³ Just as the course of the *DL* may make it necessary, in strictness, that we should write $\Delta r = \sqrt{\Delta r_o^2 + \Delta r_u^2}$ instead of $\Delta r = \frac{\Delta r_o + \Delta r_u}{2}$, so (says Wundt)

Once more, if the relative DL is constant, we must have

$$\frac{\Delta}{r} = \text{const.}, \quad \frac{r_o}{r} = \frac{r}{r_u} = \text{const.}$$

If we make $\frac{r_o}{r} = q_o$, the upper quotient limen, and $\frac{r}{r_u} = q_u$, the lower quotient limen, we have the equation $\sqrt{q_o \cdot q_u} = \sqrt{\frac{r_o}{r_u}} = q$, the *mean QL*.

We thus obtain, in all, the test values $\Delta r_o, \Delta r_u, \Delta r; \frac{\Delta r}{r}; r_e, \Delta, \frac{\Delta}{r}; q_o, q_u, q$.

To these may be added $\frac{\Delta r_o}{r}, \frac{\Delta r_u}{r}$, which are sometimes useful;¹ they require no explanation. It is to be remembered that all and several of these test-values are derived from the three values r, r_o and r_u , of which the first is presupposed, and the two later given by the method.²

What is to be said by way of comment on this method? It is, evidently, a method that Wundt has worked out as a labour of love; it is *totus, teres atque rotundus*; it provides a wide range of test-values, suitable to all sorts of R , for the calculation of the DL . Why may we not accept it as it stands?

we may have, under certain circumstances, to make $r_e = \sqrt{r_o \cdot r_u}$ and $\Delta = \sqrt{r_o \cdot r_u} - r$. In general, however, the error will be negligible.—The author cannot but suspect a mistake in these statements. If the magnitude of the DL is determined by Weber's Law, and $r_o = \sqrt{r_o \cdot r_u}$, then r must also = $\sqrt{r_o \cdot r_u}$: in other words, Δ must = 0! See Müller, M., 172.

¹ It would seem more correct to write $\frac{\Delta r_o}{r}, \frac{\Delta r_u}{r_u}$: see, however, Külpe, *Outlines*, 59; and *cf.* the following note.

² For the QL , see Külpe, *Outlines*, 59; and esp. Fechner, *Abh. d. kgl. sächs. Ges. d. Wiss., math.-phys. Cl.*, xiii., 1887 [1884], 12 f., 79 ff. The numerical relation of the relative DL to the QL works out as follows:

$$q_o = \frac{r_o}{r} = \frac{r + \Delta_o}{r} = 1 + \frac{\Delta r_o}{r}; \text{ therefore } \frac{\Delta r_o}{r} = q_o - 1;$$

$$q_u = \frac{r}{r_u} = \frac{r_u + \Delta r_u}{r_u} = 1 + \frac{\Delta r_u}{r_u}; \text{ therefore } \frac{\Delta r_u}{r_u} = q_u - 1;$$

$$q = \sqrt{\left(\frac{\Delta r_o}{r} + 1\right) \left(\frac{\Delta r_u}{r_u} + 1\right)}.$$

Wundt, however, in the value $\frac{\Delta r}{r}$, refers Δr_u not to r_u but to r . We then have:

$\frac{\Delta r_u}{r_u} = q_u - 1$; therefore $\frac{\Delta r_u}{r} = (q_u - 1) \frac{r_u}{r} = \frac{q_u - 1}{q_u} = 1 - \frac{1}{q_u}$: whence we obtain

$$\frac{\Delta r}{r} = \frac{\Delta r_o + \Delta r_u}{2r} = \frac{1}{2} \left(q_o - \frac{1}{q_u} \right).$$

(1) The first point that strikes us is that the method has definite psychological implications, which make a comparison of its results with the *DL* of an 'error' method impossible. Why should the series be continued "zur Sicherstellung" beyond the point at which *O*'s judgment changes? Sanford tells us. "It is considered better to increase the variable *R* once or twice more in order to guard the *O* against a merely accidental impression that a perceptible difference has been reached, though no record is made of the difference used *unless it is evident that his previous success was accidental*," and so on (Course, 344: italics not in the original). But the *DL* is always subject to 'accidental' errors, and the object of a 'method' is to take account of them! Besides: suppose that the first change of judgment is followed by a second judgment of the same kind; does that prove that the first was not 'accidental'? Suppose that it is followed by a judgment of the opposite kind; may not this second judgment itself be 'accidental'?¹ What is really implied in the method is that the *DL* can be correctly determined by *one* paired series; variable errors are provided for, by choice of stimuli and reversal of series; and accidental errors are ruled out by the stealthy caution of the approach to the *DL*. The reply must be: not proven.

(2) The second point that strikes us is that Wundt does not accept the Müllerian definition of the *DL*; so that, again, the results of his method are incomparable with the results of the 'error' methods. Wundt averages, not the *j. n. d.* and the *j. not-n. d.*, but the *j. n. d.* and the *R*-difference that corresponds to subjective equality. Wundt's *DL* is accordingly, on the whole, smaller than Müller's. For the 'first change of judgment' does not by any means necessarily coincide with a positive change of introspection; we may not assume that, if we are working from 'lighter' towards 'equal,' the first change of judgment will be indicated by a definite 'equal.' True, this will happen, perhaps as a rule, with unpractised *O*'s, and will happen occasionally, as the result of accidental errors or of too large a step, with *O*'s that are practised. But it is not necessary. *O* may be unable to say: "Yes! this time again the grey is lighter!" and yet may be equally unable to say, "It is now positively equal to the stand-

¹ This point has now been made by Müller, M., 164 f., *n.*

ard grey." The point to be marked, on Müller's definition,—in the instance taken, the representative of Wundt's $\Delta r''_0$,—is the point at which the original difference ceases to be noticeable: the point at which *O*'s judgment first hesitates or changes, no matter what the form of *O*'s report may be. See Müller, *G.*, 63; *M.*, 164; V. Henri, *Ueber die Raumwahrnehmungen des Tastsinnes*, 1898, 12; and *ct.* Wundt, *P. S.*, i., 558 f.; Külpe, *Outlines*, 58; Foucault, *Psychophysique*, 341, 343.

What led Wundt to make this change from Müller's prescription? One is tempted to say, at first thought,—simple inadvertence. For in transcribing Müller's method (*P. S.*, i., 558) Wundt writes 'gleich' where he should, according to his text, have written 'nicht mehr merklich verschieden'; and such a mistake, if one were thinking out a method prior to actual work with it, might easily be made. But there must be a set or trend of consciousness behind such inadvertence; and it is not difficult to see how this trend might be set up. Consider the origin of the combined procedure. The photometric method of disappearing difference, and Lichtenfels' one-point series in æsthesiometry, undoubtedly suggest a positive reversal of judgment in the reversed series. Consider also Fechner's account of the relation of the three methods of the *Elemente*. "Diese drei Methoden führen auf verschiedenen sich ergänzenden Wegen zu demselben Ziele. Bei der *M.* der eben merklichen Unterschiede wird die Gränze zwischen übermerklichen und untermerklichen Unterschieden als eben merklicher Unterschied beobachtet; bei der *M.* der *r.* und *f.* Fälle werden übermerkliche Unterschiede gezählt (die nach Zufälligkeiten bald in richtigem, bald falschem Sinne ausfallen); bei der *M.* der mittleren Fehler werden untermerkliche Unterschiede gemessen" (*El.*, i., 73). Here the *j. n. d.*, as the limit between subliminal and supraliminal difference, is brought perilously near the upper limit of subjective equality: practically, to the point at which Wundt's average puts it. We return to this matter again. Consider also Wundt's own account of the interrelation of the methods, written in 1880. The *j. n. d.* is "eine eben die Grenze unserer Auffassung erreichende Aenderung der Empfindung." The method of *av. error* derives directly from that of *j. n. differences*, "wenn man sich bei derselben auf die Feststel-

lung der *eben untermerklichen* R -Unterschiede beschränkt." Similarly, the method of r . and w . cases, despite its difference of procedure, derives indirectly, through the "Verfahren der *eben übermerklichen* R -Unterschiede," from that of mean gradations (P. P., i., 326, 328). Remember finally that Volkmann, who first suggested the averaging of Δr_o with Δr_u , worked by a form of minimal changes which is closely analogous to *av. error*. Here we have, surely, an array of influences which might well have blinded Wundt to the *differentia* of Müller's suggestion. Yet we cannot doubt that Müller's definition of the DL is the only definition that can bring together the results of the various methods.

(3) What, now, of the values r_e and Δ ? How did Wundt arrive at them? Are they important?

Note, in the first place, that the prefix 'estimation' comes into the method from work upon the 'time sense.' The first investigation by minimal changes published in the P. S. is Kollert's *Untersuchungen ü. d. Zeitsinn*; of the two illustrations given by Wundt in his first exposition of the revised method (*Das Weber'sche Gesetz*, 46; P. S., i., 562), that from Kollert's work stands in the first place; Wundt declares that the two values in question have an especial significance in time sense problems (*opp. citt.*, 48, 565). Now the question of the validity of Weber's Law for time judgments is a complicated question (Wundt, P. P., 1903, iii., 49 f.). Issues were not so clear in 1882 as they are twenty years later, and it was natural that the two topics—of time sense and of S -intensity at large—should be thrown together. Nevertheless, the mixture has bred a good deal of confusion.

Note, in the second place, how the idea of the DL as (practically) the upper limit of subjective equality, the border-line between 'equal' and 'greater,' helps towards the derivation of the two values. We quote Fechner (*Abh.*, 1887 [1884], 11). "In the procedure of minimal changes, we at one time estimate r as (approximately) equal to r_o at other times, — and equally often, of course, — as equal to r_u ; on the average, therefore, as equal to $r_e = \frac{r_o + r_u}{2}$; and the deviation of this average estimation value from the r to be estimated gives us the average estimation error Δ . Nothing, then, could appear more rational than

this terminology,"—which Fechner at once proceeds to attack for reasons that do not at the moment concern us. But, from our own point of view, nothing could well be more irrational than this whole argument. What we set out to do is to calculate the DL of r . We do this by determining what descending value of r_1 is just no longer noticeably $> r$, and what ascending value is first judged $< r$. We do not estimate r as equal or approximately equal to anything. Wundt's conception of the nature of the DL , whether due to inadvertence or not, is fatal to the method here as it was fatal before.

But the values themselves?—we do not want, as the Germans say, to pour off the baby with the bath-water. The admissibility of the values themselves depends, primarily, upon the admissibility of the equation $\Delta r = \frac{\Delta r_o + \Delta r_u}{2}$, or its equivalent, which we discuss below. That question apart the values have, confessedly, very little importance for a characterisation of the DL . "Während bei den Zeitsinnsversuchen," says Wundt, "der mittlere Schätzungswert r_e der Vergleichszeit und sein Unterschied Δ von der Normalzeit r das Hauptinteresse beanspruchen, steht bei der Prüfung des Weberschen Gesetzes [we may add, of the course of the DL in general] selbstverständlich die Bestimmung der Unterschiedsschwellen Δr_o und Δr_u im Vordergrund" (*loc. cit.*), and with the latter part of the sentence Fechner (*Abh.*, 12) heartily agrees. It is, perhaps, tempting, if we retain the general Wundtian procedure, to retain with it the value Δ (half the difference of Δr_o and Δr_u , as Δr is half their sum), and to give this value some such name as the 'discrimination constant' of the particular r for which the upper and lower DL have been determined. But, in practice, the value Δr does us every necessary service.¹

(4) What, lastly, of the equation $\Delta r = \frac{\Delta r_o + \Delta r_u}{2}$? Is the averaging of the upper and lower to a mean DL permissible?

We might, evidently, conceive of the DL as a mean value, representing the j. n. d. (for a given R) in all directions or dimensions in which a differential determination is possible. We

¹ On Schätzungsfehler and Schätzungsdifferenz, see Wundt, *Das Webersche Ges.*, 44; P. S., i., 561; Fechner, *Abh.*, 11 f.; Mehner, P. S., ii., 550.

might, e.g., conceive of the R in question as the centre of a circle, and of the DL as the distance, in any direction, from this centre to its circumference. As there are but two possibilities of actual determination,—the two radii forming the up-down diameter,—we should be reduced, in practice, to the determination of the Δr_o and the Δr_u . Our mean radius would then be the average of these two values. From this point of view the DL would be, not the j . n. increment of R , but the mean of all possible j . n. increments and j . n. decrements. It would be an ideal value, not only in the sense in which we have hitherto called it ideal, but in the further sense that it takes up into itself two values (themselves already ideal) and combines them into a resultant value which is one degree more remote from psychological reality. The j . n. increments and the j . n. decrements would be symbolised by a single value which is referred to a single R .

This generalised definition of the DL presupposes, of course, a precisely equal range of variation for Δr_o and Δr_u . If this assumption be granted, or if the error involved be considered negligible, it is defensible, though the measure which it introduces differs from the measure accepted in our definition. Whether it played any part in the Wundtian formulation of the method, we cannot say. Probably, however, it did not. The key to that method seems to be the desire to eliminate constant errors.

The combination of the Δr_o with the Δr_u appears first in certain experiments of Volkman's upon ocular measurement (*Physiol. Unt. im Geb. d. Optik*, i., 1863, 129 ff.). "Das Verfahren," says Volkman, "ist folgendes. Es wird eine Normaldistanz unter abwechselnd linker und rechter Raumlage dazu benutzt, eine Fehldistanz herzustellen, welche, wiederum abwechselnd, *um ein Minimum* grösser oder kleiner erscheint. Durch das Wechseln der Raumlagen einerseits, und des Vorzeichens der Unterschiede andererseits, wurde der Einfluss der constanten Fehler ausgeglichen." We need not cavil, for the present, at the inclusion of this method under the rubric of j . n. differences. We have rather to notice the facts (*a*) that Volkman is, in reality, introducing a new, generalised measure of the DL (see G., 207, *n.*), and (*b*) that the reason assigned for the novel procedure is the elimination of constant errors.

Given Volkmann's method, and the procedure naturally follows. The method is, clearly, modelled upon or at least closely related to the method of av. error, which Volkmann had previously employed (120 ff.: cf. the term *Fehldistanz* in our quotation). Working by that method, Volkmann had found "Ursachen, welche den Irrthum nach einer bestimmten Seite hindrängen" (119),—sources of constant error, residing in the one-sided conditions of manipulation or of attention. It cannot, then, surprise us that he should, as it were instinctively, make allowance for these sources of error when he comes to work by the second method.

Wundt, apparently, did the same thing; though there is, curiously, no evidence that he was influenced by Volkmann. In 1880 (P. P., ii., 93) he refers to Volkmann's experiments; but, while he criticises Volkmann's use of av. error, says not a word in criticism or approval of his method of j. n. differences. In the description of minimal changes, again, nothing is said of a combination of Δr_o and Δr_u (i., 326 ff.). Since in the *Dekanatschrift* of 1882 this combination is recommended as a matter of course, Wundt's attention (if our interpretation be correct) must have been called to the existence and importance of constant errors between the years 1880 and 1882.

It is significant that F. Boas, in 1881 (Pflüger's Arch., xxvii., 214), published a paper *Ueber d. verschiedenen Formen des Unterschiedsschwellenwerthes*, which deals explicitly with constant errors, and which Wundt had certainly read (*Das Webersche Gesetz*, 42; P. S., i., 559). It is true that there is nothing in the paper which bears directly upon the form to be given to a method of minimal changes. But we shall not be passing the limits of reasonable conjecture if we suppose that Wundt's attention was strongly turned, by Boas' work, to the question of constant errors in general, and that he was thus led—with or without conscious reference to Volkmann—to the formulation of his double procedure.

What, then, is the constant error that we take to be aimed at by this double procedure? The aim of the method is "durch Combination der Versuche nach Oben und Unten die von einseitiger Vergleichsrichtung abhängigen Fehler zu eliminiren" (Fechner,

Abh., 10). In the one half of the method our standard of reference is always behind us, lower than our variable R ; in the other it is always before us, higher than the variable. The constant direction of comparison brings with it a constant error in each case; and we eliminate this error by averaging.

Well! but *do* we eliminate the error? Are we just reversing the same procedure?—Make the questions concrete. What are we to do with Δr_u ? Shall we, with Tischer (P. S., i., 509), refer it to r ? Shall we, with Wundt, refer it to r_u (P. S., i., 565), while at the same time we refer Δr to r (564)? Shall we, with Müller, refer it to r_u , and say nothing at all about Δr (G. 207)? Shall we, with Fechner, refer Δr_u to r_u , and then make the relative $DL = \sqrt{\frac{\Delta r_o \cdot \Delta r_u}{r \cdot r_u}}$, thus basing it upon an R that we have not used (Abh., 13)? Shall we, with Merkel, refer Δr_o and Δr_u to the stimuli r and r_u as upper DL , and to the stimuli r_o and r as lower DL , thus making two values play four parts (P. S., iv., 254)? Whether or not these difficulties amount to anything in practice, they show plainly enough that, from the theoretical standpoint, the combination of the two procedures is not satisfactory.¹

It is a little curious that no one has suggested the employment of Wunt's double procedure for the determination of a single DL . There is one case—the case of Wundt's Δr_u —in which the procedure would seem to be unexceptionable. The experiment would take shape as follows. Set out from $r \parallel r_1$, and reduce r_1 ; the series gives r'_u . Set out again from an r_1 noticeably $< r$, and increase r_1 ; the series gives r''_u .

¹ Fechner's praise of the Wundtian procedure (Abh., 107) must be attributed to the fact that it sets free the values q_o and q_u , and thus allows us to work out the numerical relations of the QL and the relative DL . And indeed, if we could but get an errorless r_o and r_u , the method would have a good deal more to say for itself.

In work upon tactual measurement by the method of av. error, Fechner discovered a constant error due to the mere fact that the constant K in a series remained constant, afforded a one-sided standard of reference (EL, ii., 140, 151, 347). He seeks to eliminate this (and other possible errors) in the case of Wundt's method by multiplying r_o and r_u into a factor of correction, which he determines as

$\frac{r}{\sqrt{r_o \cdot r_u}}$. Since, however, this determination presupposes Weber's Law (presupposes that a purified q_o must be equal to a purified q_u), it is clear that the correction cannot lay claim to general significance. Cf. Abh., 79 ff., 97 ff. (esp. 85); and, for the probable conditions of the error in question, Müller, M., 196 f.

Calculate Δr_u . Now set out from $r_u \parallel r_1$, and increase r_1 ; the series gives r'''_u . Set out again from an r_1 noticeably $> r_u$, and decrease r_1 ; the series gives r''''_u . Calculate $\Delta r'_u$. Average Δr_u with $\Delta r'_u$ to a final Δr . This is the *DL* of the stimulus r_u .

The only objections that the author can see to this procedure are: (1) that it tends to mask the fact that the *DL* is the j. n. *increment* (not decrement) of R ; (2) that it starts us upon our investigation without knowledge of our r , our point of final reference; and (3) that it is unnecessarily cumbrous. The first objection is entirely, the second mainly pedagogical. The third raises the whole question of the advisability of the double procedure.

It is clear that the double procedure cannot be applied, in this way, above r , for the determination of Δr_o . The choice of r_o as constant R in the third and fourth series involves an error, in so far as the $\Delta r'''_o$ and the $\Delta r''''_o$ must be referred roundly to r , instead of to that slightly different R -value which (except by chance) will always form their real standard of reference.

So far, we have been considering Wundt's test-values as he has defined them, without seeking to penetrate more deeply than he has done into the psychology of the method. There can, however, be no doubt that the judgments of minimal changes are affected by factors akin to those discovered by Martin and Müller in their study of lifted weights by the method of constant R -differences or r . and w . cases (*Zur Analyse der Unterschiedsempfindlichkeit*, 1899). We return to this point in § 22, where we also continue the history of the method by reference to Müller's *M*.

§ 21. **The Method of Limits (Method of Minimal Changes): Critical.**—It is unnecessary to review here the criticisms passed upon the method of minimal changes, as minutely as we have reviewed the development of the method itself. We have accepted a definition of the *DL*; we know something of the influence of type (i., I. M., xxv. ff.); we keep sharply distinct the measurement of magnitude and of precision of the *DL*. Moreover, as will appear presently, psychophysicists are beginning to get a clear idea of the interrelations of the four classical methods. It would, therefore, be waste of time to work over criticisms which show these definitions and distinctions in the making. We may confine ourselves to certain 'standard' criticisms, which still hold their place in the modern literature of the method.

(a) It has often been objected that no O can properly estimate the *j. n. d.* As brought against Weber and Fechner, the objection (as we saw just now: p. 75) is well taken. And we can have no doubt that the *j. n. d.* (greater and less) of Volkmann's experiments on ocular measurement was a difference greater than the true DL . That the objection should survive the year 1878, however, is only one more proof of the longevity of misunderstandings in general. Müller's method is not a method of adjustment: it does not require O to estimate anything. Two R are presented, either markedly different or sensibly alike. If they are different, the difference is slowly decreased, and O has to say, at each step of the procedure, what their subjective relation now is; whether they are still different in S , whether their difference is problematical, whether they are sensibly the same. If the original R are alike, the course of judgment is reversed. Where, then, in the experiment, is O called upon to 'estimate' the *j. n. d.*? The point rather is that, at some place in each series, his judgment will fluctuate, hesitate, change, reverse. Then, the critical values of r_1 having been noted, the DL is calculated. Nevertheless, we find the objection repeating itself in Jastrow, A. J. P., i., 1888, 275 f.; James, Psych., i., 1890, 540; Fullerton and Cattell, Small Differences, 1892, 10, 36 f.; Sanford, Course, 1898, 349. Cf. Ebbinghaus, Psych., i., 67, 75 f.

We note the most serious effects of this misunderstanding in the work of Fullerton and Cattell. Müller's suggestion, say these authors, "may, in some cases, be an improvement in technique, but does not seem to us to alter the fundamental assumptions of the method" (10 *n.*). The assumptions are that the *j. n. d.* is a constant value, and that it can be correctly ideated. Yet Müller declares the DL to be a variable value, and devises a method to replace that of ideation (*i. e.*, of adjustment)!—Their own procedure closely resembles that of Volkmann, to which we have alluded above. They gave "a single stimulus, and required the experimentee to fix upon another *j. n.* greater or less" (37). "In this form, it will be seen that the method is analogous to that of average error; and as the numbers of right and wrong cases were recorded ['wrong cases' being attempts at greater which resulted in less and *vice versa*], the three psychophysical methods have been combined." Confused, rather! For, in the first place, the true method of limits does not ask O to estimate any R or R -difference whatsoever; it supersedes the

method of adjustment. In the second place, while it has been maintained that the method of average error can be applied, and applied with psychological result, to any *S*-distance (Merkel, P. S., ix., 184), we must remember that the mathematical theory of the method is still very imperfect (Müller, M., 213: *cf.* pp. 166 ff. below), and that the present use of it implies just that estimation of a notoriously uncertain *S*-distance (the *j. n. d.*) which it is the purpose of the method of limits to avoid.¹ In the third place, the *r.* and *w.* cases of the method of that name are obtained under psychological conditions so different from those here prevailing that intercomparison of results is impossible. These are not pedantic objections, due to any purism as regards the traditional methods: they are based upon the obvious fact that a psychophysical method is not an indifferent tool, to be used under all conditions upon all sorts of mental material, but a tool whose successful use demands clear and consistent definition of the problem to be attacked. We cannot compare results on the mere ground that two columns of figures carry the same heading ‘% of *w*-cases.’ We must have, in every instance, a full statement of the trend and composition of the observing consciousness. We may, of course, take the method psychophysically, and aim at psychophysical uniformities: but we must still make sure that the psychological conditions are constant from set to set of the compared results.²

(*b*) Again, we often meet the statement that the method of limits introduces an *error of expectation*, whereby the value of the *DL* is falsified, if, indeed, a *DL* can be honestly determined at all. This objection must be carefully considered.

We distinguished just now between a psychological and a psychophysical view or theory of the method of limits. Now the objection is generally urged against an extreme psychological interpretation of the method. It is urged against that point of view which, so to say, puts a premium upon the variable errors of expectation and habituation; which proposes to eliminate them, so far as that is possible, much as if they were constant errors,—by reversal of series; which despairs of any serial work that shall not be cumulative in its influence upon the final judgment. The

¹ Fechner himself, as is too often forgotten, recommended the method of *j. n. d.* only for rough tests in which time was a consideration: *El.*, i., 75.

² For an uncertainty of result which is really to be attributed, not to the method, but to misunderstanding of the method, to divergence of type of the *O*'s examined, or to the writer's confusion of magnitude and precision of the *DL*, see Fullerton and Cattell, *op. cit.*, 11, 17, 36 f., 150; Jastrow, A. J. P., i., 1888, 273, 302.

tendency of such a view is, naturally, to set up too rigid conditions for expectation and habituation. In reality, the limits of the errors are elastic, and vary considerably with degree of practice, and from individual to individual. The psychological theory of the method would not deny these facts; but its tendency is to overlook them. The Wundtian method, *e.g.*, has always presupposed an expectation of change, an expectation that in both series makes the turn of judgment come too soon. As a matter of fact, *O* may expect, according to circumstances, either change or no-change (M. Meyer, *Z.*, xvi., 1898, 371).

It would, perhaps, be difficult to find this psychological view expressed in the extreme form which we have given it. Wundt, from whom it derives, is less strenuous than some of his followers: for he declares that highly practised *O*'s may overcome the error of expectation (P. P., i., 1902, 479, 491). Nevertheless, the logic of the traditional or orthodox view of the method of minimal changes is as we have stated it. See Wundt, P. P., i., 1893, 357; Külpe, *Outlines*, 54, 62 ff.; Ebbinghaus, *Psych.*, i., 79; Sanford, *Course*, 348; Foucault, *Psychophysique*, 341. Münsterberg (*Beitr.*, ii., 1889, 155) asserts that *Selbsttäuschung* is a 'chronisches Leiden' of the method; and the procedure without knowledge is strongly recommended by Fullerton and Cattell, *op. cit.*, 11; Henri, *Raumwahrnehmungen*, 9, 11 f.; *cf.* Wundt, P. P., i., 1902, 478 f.

The psychophysical view of the method, on the other hand,—Müller's view, as opposed to Wundt's,—simply enjoins upon the experimenter an extreme care in the choice and instruction of his *O*'s. The psychological errors are to be banished, ruled out; not allowed for. "Man muss die *O*'s in eindringlicher Weise anweisen, sich beim Urteilen jedesmal möglichst nur durch die beiden zu vergleichenden Eindrücke bestimmen zu lassen, und vor einer Beeinflussung durch die oben angegebenen Fehlerquellen warnen" (M., 175). To examine the influence of expectation is one thing; to use the method of limits for psychophysical purposes is another and quite a different thing.

What, then, of the objection? We again distinguish, first of all, between objective and subjective *O*'s. Objective *O*'s will take their instruction and follow it,—subject to certain errors

which we shall mention presently. Subjective *O*'s, especially in the earlier stages of practice, are likely to be misled: they wish to shine, they wish to satisfy *E*, they wish to do these things while at the same time they maintain a strictly objective attitude to the *R*: and the result is chaos (Meyer, *loc. cit.*, 372; Washburn, P. S., xi., 1895, 218 f.). Oftentimes, however, they may be brought into line by an imperative repetition of instructions or by the introduction of a very long or very short series; sometimes, they settle down to a better attitude in the mere course of practice. On these points the author's experience is fairly decisive. If the method is used as directed, it takes a very clumsy *E* and a very poor *O* to vitiate it altogether. The difference between the objective and the subjective *O* remains, and for work of research Müller's cautions are entirely in place. But the author believes that the 'psychological' atmosphere with which the method has been surrounded is very largely responsible for its wholesale condemnation.

Granted, however, that we are working with objective *O*'s: there are still very many sources of error. We have mentioned practice, fatigue, the two forms of expectation, and habituation. Instances of the latter are to be found in G. Lorenz, P. S., ii., 1885, 434; E. Meumann, *ibid.*, xii., 1896, 157. It is, of course, not peculiar to the method of limits: *cf.* E. Meumann, *ibid.*, ix., 1893, 265; M. F. Washburn, *ibid.*, xi., 1895, 222. The danger of slip comparisons (of which we have more to say later on) is also common to the method of limits and the method of constant *R*-differences: Z. Radoslawow, *ibid.*, xv., 1899, 411. All this, however, simply means (what we knew well enough before) that the *DL* may be influenced by a great variety of factors; "dass überall, wo man mit dem psychologischen Standpunkte Ernst macht, die Complicirtheit des Psychischen zu Tage tritt" (Martin and Müller, U. E., iii.). All the more reason, then, that we should not force our method into a hard and fast psychological schema! We must rather seek to determine the *DL* under standard psychophysical conditions; trust to a comparison of introspections and numerical results for a first knowledge of the psychological influences; and then examine these latter in new investigations, quantitative and qualitative. Psychophysics and

psychology thus play into each other's hands. The more we know of variable errors, the greater will be the refinement of our method; and the more refined our method, the better will be our opportunities for increased knowledge of errors.

Having said so much on behalf of the method of limits, we must admit that there are certain outstanding cases where, for psychological or physiological reasons, its employment in the regular serial form is not advisable. Some of these cases we have already mentioned, p. 20 above. For others, see V. Urbantschitsch, *Ueber Hörübungen*, 1895, 35 f.; Pflüger's *Arch.*, xciv., 1903, 357; G. Heymans, *Z.*, xxvi., 1901, 309 f. How far this disability extends, we cannot say; the range of psychophysical work, at the present day, is very far from being coextensive with the range of psychophysical problems. In any event, we should not expect a single method to cover the whole field of enquiry. "Es ist eben die eine Methode unter gewissen Umständen, für gewisse Zwecke, nach gewissen Ausführungsweisen, vorteilhafter als die andere" (Fechner, *R.*, 111).¹

§ 22. **The Method of Limits: Notes on § 16 of the Text.**—The method, as described in the text, is Müller's method (*G.*, 63 f.; *M.*, 164 ff.), though the errors have been worked out rather in Wundt's way. The name *Grenzmethode* was suggested by Kraepelin (*P. S.*, vi., 1891, 494) and has been accepted by Müller (*M.*, 3). It is better than the name 'minimal changes,' since it brings out the fact that the series stop short at a boundary, at the turning-point of judgment.

The general procedure of the method has been sufficiently explained. A word must be said, however, about the assumption, tacitly made in the text, that the space error will be simply a Fechnerian error.

The Fechnerian formulæ, made out for time only, are given by Müller, *M.*, 169 f. The reader may *cf.* the general discussion, 63 ff., though we shall ourselves take up the whole question of constant errors later on (pp. 302 ff.). Besides the Fechnerian error, we have the two factors (Martin and Müller, *U. E.*, 29 ff.,

¹ On the question of the 'best' method, see Fechner, *El.*, i., 133; *I. S.*, 44; Külpe, *Outlines*, 73; Ebbinghaus, *Psych.*, i., 78; Müller, *M.*, 10; Wundt, *P. P.*, i., 1893, 356 ff.; i., 1902, 490 ff.

64 ff.) of *general* and *typical* tendency of judgment. The general tendency of judgment is:

- (a) *positive* when the *DL* is smaller in the first mode of spatial arrangement (*r* to the right) than it is in the second;
- (b) *negative* when the *DL* is smaller in the second mode of spatial arrangement (*r* to the left) than it is in the first;
- (c) *indifferent* when there is no difference between these *DL*.

Similarly, the typical tendency of judgment is:

- (a) *positive* when the *DL* is smaller for $r > r_1$ than it is for $r < r_1$;
- (b) *negative* when the *DL* is smaller for $r < r_1$ than it is for $r > r_1$;
- (c) *indifferent* when there is no difference between these *DL*.

We repeat, for the sake of completeness, that the Fechnerian space error is:

- (a) *positive* when its effect is to make the left-hand *R* appear greater than the right;
- (b) *negative* when its effect is to make the left-hand *R* appear less than the right;
- (c) *indifferent* (i.e., = 0) when neither effect is produced.

Now let us apply these rules to our formulæ. Suppose that Δr_u is considerably larger than Δr_l (p. 64): we say 'considerably' larger, because there will be a certain difference due to Weber's Law. In that case the typical tendency of judgment is *positive*. Contrariwise, if Δr_u is smaller than Δr_l , then the typical tendency is *negative*. In either event, the equations

$$q = \frac{\Delta r_{uI} - \Delta r_{lI}}{2}, \quad q = \frac{\Delta r_{lII} - \Delta r_{uII}}{2}$$

do not give us the true value of *q*, but furnish two essentially different values, whose difference is both a consequence and a proof of the existence of a typical tendency in *O*'s judgments.

Suppose, again, that the Δr_I of the last group of equations (p. 65) is smaller than the Δr_{II} . In that case, the general tendency of judgment is *positive*. Contrariwise, if Δr_I is larger than Δr_{II} , the general tendency is *negative*. In either event, the equations

$$q = \frac{\Delta r_{uI} - \Delta r_{uII}}{2}, \quad q = \frac{\Delta r_{lII} - \Delta r_{lI}}{2}$$

do not give us the true value of q , but furnish two essentially different values, whose difference is both a consequence and a proof of the existence of a general tendency in O 's judgments.

These considerations serve to emphasise the statement of the text, that in the matter of constant errors the advantage of the additional determination of Δr_I is obvious. For we cannot test the validity of the first pair of q -equations without knowing the relation of Δr_I and Δr_{II} ; and we cannot test the validity of the second pair, without knowing the relation of Δr_u and Δr_l .—Müller, M., 170 f.; Külpe, P. S., xviii., 1902, 338 f.

EXPERIMENTS XIII, XIV

The principal questions which the author was called upon to decide, in writing this part of the Course, were the following: How full and explicit shall be the directions given to E and O ? How many experiments shall be recommended under each method? and: How far shall the results obtained in the Cornell laboratory be quoted?

(1) The directions given to E and O are purposely made as brief and curt as possible. For one thing, both students have already had the practice in psychological experiment afforded by the exercises of vol. i. They should now be prepared to apply the knowledge acquired in qualitative work. For another thing, the essential matter at this point of their training is that they understand the methods. The author has therefore sought to direct their attention to the scheme of the whole experiment rather than to the details of manipulation and observation. There are, as he well knows, many directions of detail that must, sooner or later, be given; but these may safely be left to the supervision of the Instructor.¹

¹ A critic already quoted (W. McDougall, *Mind*, N. S., x., 1901, 540) remarks of vol. i. that "to English readers the directions to the student will seem unnecessarily and even undesirably minute, for the following of directions so thorough and minute as those here given must tend to prevent the development of initiative and self-confidence in the students." The answer is, of course, that it was the author's intention to photograph each experiment in words up to the point at which introspection (the pith of the whole matter) was reached, and from that point onwards to leave the student to fend for himself. The critic has failed to distinguish between the conditions of observation and observation itself. Nevertheless, the author is now prepared for the objection that 'the directions to the student seem unnecessarily and even undesirably brief.'

(2) As regards the number of experiments, it seemed best to the author that he should recommend only those which he knew, from personal experience, could properly be performed in the time at the student's disposal. For this reason all experiments, *e.g.*, on odorimetry are banished from the book, although the author has a distinct partiality for them. And even within the limits thus prescribed, he has made his choice rather narrow than wide; for it is extremely important that a laboratory establish its own traditions in quantitative work, that it acquire a large stock of comparable results, that its officers be keenly and as it were instinctively alive to the difficulties which confront the beginner: and all these results are most quickly and surely obtained by the restriction of method work to a small number of often-repeated experiments. For the rest, the Instructor must use his discretion in extending the methods to other than the prescribed fields.

(3) Lastly, it seemed to the author that the results of his own experiments should either be transcribed in complete detail or reduced to the compass of a bare numerical mention. As a rule, at any rate, there is no useful half-way house between these extremes. Now the important thing about method work is, as was said just now, the understanding of the method itself. The numerical *DL* determined by the students of this Course are worthless. They are valid only under the conditions of the experiment: and these are neither the conditions under which psychophysical constants are established nor the conditions under which clinical or anthropological norms are obtained. That is to say, the *DL* represent only a certain stage of psychological training; they are intrinsically valueless whether for theory or for practice. Under these circumstances, it would surely be a waste of space to quote in full the data from which they are calculated. To the author, as an individual teacher of psychology, the loss of the thirteen years' records of the Cornell laboratory would be well-nigh irreparable. Every one has its own set of associations, its own warning, its own encouragement, its own suggestion. Every one has contributed, in greater or less measure, to the exposition of the methods in the text. But in the great majority of cases it appears unnecessary and useless to print any particular specimen.

For determinations of the *DL* for brightness, see Wundt, P. P., i., 1893, 367 ff.; i., 1902, 517 ff.; Ebbinghaus, Psych., i., 1897, 208; i., 1902, 499 f.; Helmholtz, P. O., 1896, 384 ff.; von Kries, in Nagel's Hdbch. d. Physiol., iii., 1, 1904, 249 f. In the author's experience, laboratory determinations vary, with observers and conditions, from 1/40 to 1/70.

Attention may be called to a source of error in Exp. XIII. (2) and (4). The two *R* are here mounted on the same mixer. It is essential, now, that the direction of regard be kept constant throughout. A shift even to a neighbouring quadrant may throw a series into entire disorder. If the observation tube is used, *O* should be directed to fixate a point upon the line of junction of the two *R* that fill the field.

For determinations of the *DL* for tone, see § 30 below, where the general questions of the psychophysics of tone are discussed.

The Instruments.—Forks with riders have generally been used for experiments upon the j. n. d. of tone since the publication of Luft's investigation in 1888 (P. S., iv., 511). Kohl lists a pair of a^1 -forks on resonance boxes with sliders at Mk. 33, and a similar pair of c^1 -forks at Mk. 40 (Cat. no. 12, 239): the author does not know how accurately these instruments can be adjusted. He himself uses a pair of Appunn forks ($c = 128$ vs.) made especially for psychophysical work. The forks give a full round tone, accompanied for perhaps 1 sec. by a shrill overtone which, however, soon ceases to be disturbing to *O*.

The screw-forks were introduced by M. Meyer in 1898 (Z., xvi., 353). Experiments were made with tones of 100, 200, 400, 600 and 1200 vs. "Die eine Zinke jeder veränderlichen Gabel wurde—je nach der Grösse der Gabel—1.5 bis 3.5 cm. tief angebohrt und eine entsprechend lange, durch eine Gegenmutter feststellbare *Stahlschraube* eingesetzt, die bei der Gabel 1200 hohl, bei den übrigen massiv war und bei 100 einen schweren, bei 200 einen etwas leichteren Messingkopf als Belastung trug." The author happened to have a pair of c^1 -forks (tines about $140 \times 7 \times 5$ mm.) that were not in use, and after reading Meyer's account instructed his mechanician to sink a solid steel screw (32 mm. long; diam. of head 12 mm.) into a tine of one of them. The result was not very satisfactory: the tone of the screw-fork was not lasting and resonant, but rang off dully after a few sec. Meyer says nothing of this change; and his 200 forks sounded for so long a time that three observations could be made before their tones rang off (355). Probably, therefore, there is something wrong with the dimensions of the author's forks and screw: the tines, *e. g.*, are rather unusually slender. The author then had a similar screw let into a tine of the second fork (see Fig. 21 of the text). With care in manipulation (finding of the optimal region for striking, of the optimal length of screw), the forks are now available for method work. The tones still weaken very quickly, though fully 3 sec. may be allowed for observation, and it is possible to count beats up to 10 sec. So far as the author knows, Meyer's forks are not on the market; they could doubtless be obtained from Oehmke.

To actuate his three highest forks, Meyer used a mechanical spring-hammer (354). In the author's experience, this is a perfectly unnecessary complication; *E* very soon acquires the knack of striking evenly and at the same place upon the tine. The author has not either used a conduction tube (354), but places the two forks symmetrically to *O*'s ear at a distance chosen by *O* himself.

The value of the *DL* (absolute) as obtained under the described conditions has never exceeded 2 vs. for either set of forks, and has fallen as low as .75 v.

The experiments may be made by the strict serial method, by the method of complete series (Question 7, below), or with haphazard arrangement of *R*. The standard *R* (as in all method work in which the apparatus and conditions make it possible) should be changed from student to student.

QUESTIONS.—(1) It is characteristic of the Method that we vary the *R* until we have obtained a certain, predetermined type of judgment. In the \downarrow series, we stop short at the judgment 'same,' 'doubtful' or 'darker,' as the case may be; in the \uparrow series, we stop short at the judgment 'lighter.' The former is the judgment of 'just no longer lighter,' the second the judgment of 'now first lighter.' In other words, we have *variability of R and constancy of judgment*. In another type of method (of which the method of r. and w. cases is representative) we have, contrariwise, constancy of *R* and variability of judgment. See Ebbinghaus, *Psych.*, i., 75 f., and later refs. on classification of methods (p. 315 below).

The 'psychology' of the method differs, according as we look at the method itself psychologically (method of minimal changes) or psychophysically (method of limits). In the latter case, the important point is that the constant judgment marks the limit or boundary of an experiment; and the psychology of the method is the *psychology of limiting judgments*. In the former, the important point is that we make a gradual approach to the required liminal determination; the final judgment of each series is obtained under the cumulative influence, physiological and psychological, of all the earlier judgments and stimulations of the series. The psychology of the method is then the *psychology of serial stimulation*. From Müller's point of view, the serial gradation

of the R is merely an accident of procedure: you cannot get to your boundary, with accuracy, unless you approach it by small steps: and the serial stimulation, as such, must not be allowed to influence judgment.

(2) The phrases 'with knowledge' and 'without knowledge' are very loosely used in current psychophysical investigations,—perhaps for the reason that each of them is capable of various qualifications and restrictions. Fechner distinguishes three procedures: with knowledge, with half-knowledge, without knowledge (*Abh. d. k. sächs. Ges. d. Wiss.*, xiii., 1884, 125). In the last, O knows nothing at all save that a certain sense-organ is being stimulated. In the second, he is told after every test what the precise character of the stimulation was. In the first, he knows beforehand what the nature of the coming stimulation is to be. Müller accepts the definitions of the procedures with knowledge and with half-knowledge, but differentiates three forms of the procedure without knowledge. It is a procedure wholly without knowledge when employed in Fechner's sense. It is without knowledge as regards the R -difference when O knows which of the two R is r , and which is r_1 , but knows nothing of the magnitude or direction of the difference between them. It is without knowledge as regards temporal or spatial-position when O knows the magnitude and direction of the R -difference, but does not know which of the two given R (first or second, left or right) is r , and which is r_1 (*M.*, 22 f.; Martin and Müller, *U. E.*, 195). The latter procedure is termed by Kämpfe (*P. S.*, viii., 1893, 543) and Wundt (*P. P.*, i., 1902, 492) a procedure with half-knowledge.

In the method of limits, as described in the text, O knows the direction (towards difference or towards equality, up or down) in which the series is to take him. He knows, also, which of the two R is r and which is r_1 . He knows nothing, however, of the starting-point of the series, or of the size of the steps which it will contain. The procedure is therefore a sub-form of Müller's second 'procedure without knowledge.'

It is possible to follow Müller's second procedure more strictly. E may employ the schema of the method given in the text, but may refrain from informing O as to the direction of the series. Nothing is gained,

however, by this reticence. An objective O will take the first two R at their face value, and will decide off-hand that the present series is to move up or down. A subjective O will feel comfortable only when he is introspectively certain of the direction in which he is working; he will be anxious and worried, at the beginning of every series, even if the original difference (or likeness) of r and r_1 is glaringly evident. In his case, E has gratuitously introduced a source of distraction. The matter would be altogether different if the serial character of the experiment at large could be kept from O 's knowledge. But we take 40 or 80 series; and if O is not an imbecile, he will very soon grasp the fact that the initial difference or likeness of r and r_1 determines the character of the immediately following observations.

It is generally stated that the method of minimal changes implies the procedure with knowledge (*e.g.*, Külpe, 62 f.). The Wundtian method, indeed, seems to presuppose O 's knowledge of the starting-point as well as of the direction of the series. The procedure without knowledge (haphazard order of the r_1) is then recommended as a 'check' upon the results of the regular method (Külpe, 40 f.; Wundt, P. P., i., 1902, 478 f.): how the check is to be applied does not appear. The Müllerian method may employ, indifferently, either of the two modes of stimulation, the serial or the haphazard, apart from the exceptional circumstances in which serial stimulation is ruled out of court (p. 121 above).—

The points here involved are so important that the author may be pardoned for insisting upon them. When Fullerton and Cattell (*Small Diffs.*, 11) recommend the procedure without knowledge, they do so under stress of their difficulties with the *j. n. d.* These difficulties are, however, imaginary. The *j. n. d.* is *not* the psychophysical *DL*. It may be an interesting thing *per se* to discover what is O 's idea of a *j. n. d.*, and how precise is his determination of it in practice: just as it may be interesting, for psychological reasons, to employ Kämpfe's procedure, or to introduce any other variation of the regular methods. But if we are talking psychophysics, it makes no difference whatever (with good O 's) whether we supply the amount of knowledge required for the serial method, or whether we present our R in haphazard order. Henri, again (*Raumw.*, 11 f.), despairs of the irregularity of a series taken without knowledge—though he prefers this procedure—and finds salvation only in the law of numbers. In point of fact, he ought to have stopped his series at 30 mm., and repeated it, unless his object was just to see what would happen if the series were continued; and in that case there is nothing puzzling or irregular about the results. Psychophysics is difficult enough, without our adding to it difficulties of our own making!

Bibliography.—On the relative advantages of the procedures see Fechner; *El.*, i., 118 f.; *R.*, 58 ff.; *Abh.*, xiii., 1884, 125 ff.; Wundt, *P. S.*, i., 17 f.; *P. P.*, i., 1893, 357 f.; ii., 9; i., 1902, 491 ff.; ii., 446; Külpe, *Outlines*, 40 f.; Martin and Müller, *U. E.*, 6, 16, 178 f., 195 f.; Müller, *M.*, 22 ff., 54; Henri, *Raumwahrn.*, 9. 66; Kämpfe, *P. S.*, viii., 550 ff.; Fullerton and Cattell, *Small Diff.*, 11, 152; Ebbinghaus, *Psych.*, i., 79 f.; Jastrow, *A. J. P.*, i., 288; Sanford, *Course*, 15, 348, 356; Meyer, *Z.*, xvi., 362 ff.

(3) The answer should take some such form as this:

(a) The constant *space* error is eliminated by performing the whole experiment twice, with reversal of the spatial position of r and r_1 . (b) The variable error of *expectation*, in its first form, is ruled out by instruction to O ; if it persists, it is minimised by a threefold variation of the length of the series. *Habituation* is prevented, on the one hand by instruction to O , and on the other by the comparative shortness of the series. The same thing holds of expectation in its second form. *Fatigue* is avoided, partly by the shortness and variety of the series, partly by the interposing of rest-periods between series and series. If *practice* is not maximal at the outset (as it should properly be), it is equalised, so far as possible, by a fitting distribution of the series in time. (c) Attention should be maximal and constantly directed in every observation. Fluctuation of attention and other *accidental* errors are minimised by a tenfold repetition of all the series. (d) The error of *bias* is fatal to the method. It can, however, be introduced only by carelessness on the part of E or O .

The Wundtian method recognises only the first form of the error of expectation. This and habituation are thought to be minimised by averaging the results of two series, of approximately equal length but of opposite direction: Külpe, 54; Wundt, 491 f.; Sanford, *Course*, 348.

(4) A diagram is given by Külpe (*Outlines*, 58), which shows a narrowing of the steps as the DL is approached (see p. 5 above). Another mode of representing the method is that followed in Fig. 21. The vertical axis is the scale of R -intensities. The short horizontal lines indicate the values of r_1 , in two series. The oblique lines connecting these with the point r indicate the successive comparisons of r_1 and r . The value Δr is the mean of the values $(r_a - r)$ and $(r_a - r)$. The Fig. would, perhaps, be more instructive—but would also require much more

to be noticeable. The value of r_1 is noted. The series is continued, until r_1 first appears lighter than r ; this value of r_1 is also noted. At the conclusion of the experiment, r_u is determined as the arithmetical mean of all r_1 that have appeared 'just lighter' and 'just no longer lighter' than r , and r_l as the mean of all r_1 that have appeared 'just darker' and 'just no longer darker' than r . Then

$$\Delta r_u = r_u - r, \quad \Delta r_l = r - r_l.$$

If it should happen that the judgments in a \downarrow series change directly (without the interposition of = or ?) from $>$ to $<$, then the first $<$ must be counted twice, both as a 'just no longer lighter' and as a 'just darker' judgment. Similarly with an \uparrow series: the first $>$ must be counted both as a 'just no longer darker' and as a 'just lighter.' Again, if it should happen that all the judgments of an experiment have the form $>$ or $<$, so that no 'equals' or 'doubtfuls' occur, then the DL must simply be determined as the dividing-line between the r_1 that appear $> r$ and the r_1 that appear $< r$; *i.e.*, it must be averaged from the first $<$ of the \downarrow and the first $>$ of the \uparrow series.—See Müller, M., 169, 187; *cf.* 57 f.

The method of complete series (*cf.* p. 16 above) may be made to yield 8, not 4, critical values. These are as follows:

\downarrow Series.	\uparrow Series.
a r_1 last $> r$	a' r_1 first $> r$
b r_1 first not $> r$	b' r_1 last not $> r$
c r_1 last not $< r$	c' r_1 first not $< r$
d r_1 first $< r$	d' r_1 last $< r$

The regular method makes

$$\Delta r_u = \frac{b+a'}{2} - r, \quad \Delta r_l = r - \frac{d+c'}{2}.$$

It is, however, legitimate to write

$$\Delta r_u = \frac{a+b'}{2} - r, \quad \Delta r_l = r - \frac{c+d'}{2};$$

for if, *e.g.*, the value $\frac{b+a'}{2} - r$ is the arithmetical mean of the first \downarrow unnoticeable and the first \uparrow noticeable difference, above r , the value $\frac{a+b'}{2} - r$ is the mean of the last \downarrow noticeable and the last \uparrow unnoticeable difference in the same direction. We have, accordingly,

$$\Delta r_u = \frac{a+b+a'+b'}{4} - r, \quad \Delta r_l = r - \frac{c+d+c'+d'}{4}.$$

See Müller, M., 176 f.; H. Higier, P. S., vii., 1892, 266 ff.

These 4 or 8 values are the values to be used if the results of the method of limits are to tally, psychophysically, with the results of the other methods. It is, however, only natural, in view of the various interpretations of the method, that different investigators should choose different values as a basis of calculation. Thus Scripture (New Psych., 291) determines the upper DL as $\frac{a+a'}{2}-r$, and the lower as $r-\frac{d+d'}{2}$ (generalised by Müller, M., 178 f.). Foucault (Psychophysique, 347) determines, in \downarrow and \uparrow series, the upper and lower limits of the zone of 'equal' judgments, securing uniformity of results by widening his steps (352). His upper j. u. d. (or upper 'mean error of recognition': 348) thus corresponds to our $\frac{b+b'}{2}-r$, and his lower j. u. d. to our $r-\frac{c+c'}{2}$. These values "stehen in einem durchaus schwankenden Verhältnisse zu den nach der üblichen Grenzmethod bestimmten DL " (Müller, M., 177 f.). Lastly, Merkel on one occasion uses only the values d and a' (P. S., ix., 1893, 415), while on another occasion he uses b and c' (*ibid.*, 409; cf. Münsterberg, Beitr., ii., 1889, 155 f.; Higier, P. S., vii., 1892, 236). These latter procedures, however, refer us to a form of the method of average error, discussed below, pp. 156 ff., 176. ff.

(b) Another form of the method of limits has been mentioned above (p. 21): it is that in which complete series are employed, but the r_1 of each series are presented *in haphazard order*.

The values afforded by the method are :

- a the smallest r_1 that appears $> r$;
- b the greatest r_1 that does not appear $> r$;
- c the smallest r_1 that does not appear $< r$; and
- d the greatest r_1 that appears $< r$.

From them, we obtain :

$$\Delta r_u = \frac{a+b}{2} - r, \quad \Delta r_l = r - \frac{c+d}{2}.$$

Kraepelin's combined method (p. 102 above) presents the r_1 in serial order, and treats the results by the principles both of minimal changes and of r . and w . cases. It has been employed by M. Falk, Raumschätzung mit Hilfe von Armbewegungen, Diss., 1890; H. Higier, P. S., vii., 265 ff., 283 f. A method somewhat similar to that under discussion was employed by C. E. Seashore (Yale Stud., iv., 1896, 47 ff.) in work upon

the D. S. for weights. Foucault (*Psychophysique*, 352) determines, not the values a , b , c , d , but only the largest and smallest r_1 that still appear= r .—Müller, M., 179 ff.

(8) It is very difficult to introduce the student to the constant errors at this stage without taking him more deeply into psychophysics than his knowledge warrants. For this reason, no discussion of the Martin-Müller factors has been given in the text. The Fechnerian space error may, of course, be due to some such psychological condition as preference by the attention; it may be due to physiological causes (Martin and Müller, U. E., 185); it may be due to a conjunction of the psychological and the physiological. There is no elementary analysis known to the author; and there is very little analysis of any sort in the literature. The text-books are in general content to leave the question as Fechner left it (*cf.* Külpe, *Outlines*, 51 f.; Sanford, *Course*, 347 f., 352 f., 355 f., 360; Wundt, P. P., i., 1902, 476, 480; iii., 1903, 52).

The student should, at any rate, read and analyse Fechner's section in *El.*, i., 88 ff. The Instructor may also recommend, according to the capacity of the student, certain of the following passages: Fechner, *El.*, i., 112 ff.; R., 130 ff.; Müller, G., 46 ff.; M., 24, 59, 63 ff., 113 ff., 126 ff., 136 ff., 169 ff., 232 ff.; Martin and Müller, U. E., 58 ff., 116 ff., 179 ff.; Müller and Schumann, *Pflüger's Arch.*, xlv., 1889, 92 ff., 100 ff.; Merkel, P. S., iv., 1888, 135 f., 288 f.; v., 1889, 521 f.; vii., 1892, 603 ff.; x., 1894, 244 f., 376 ff.; Lehmann, *Körperl. Aeuss.*, ii., 1901, 122 ff.; Külpe, P. S., xviii., 1902, 337 ff. It will be clear from these quotations that the Fechnerian time error has fared better than the space error.

The other Fechnerian errors and the Martin-Müller factors will be discussed later.

(9) In explaining the formulæ, E and O should work out the influence of a (positive or negative) error upon the effective magnitude of D , and derive the equations from the resulting course of judgment.

(10) So far as this method is concerned, there is a marked difference between practice and fatigue, on the one hand, and expectation and habituation, on the other. The two former can be governed by E ; there is no need to give O instructions regarding them. The two latter are checked, hindered, by E 's conduct of

the experiment; but it depends, in the last resort, upon *O*'s attitude to the *R* whether or not they shall exert an influence upon judgment. Expectation is amenable to introspection; it is always, in the author's experience of the method, accompanied by a feeling. Habituation, on the contrary, may very well escape *O*'s notice; it is due either to inattention or (possibly) to some physiological 'set.' Hence it is a more insidious error even than expectation.

Analytical or structural studies of the practised, expectant, etc., consciousness are sadly to seek. Habit has been treated, from this point of view, by B. R. Andrews (A. J. P., xiv., 1903, 121 ff.); practice by Martin and Müller (U. E., 128 ff.; cf. Müller and Schumann, Z., vi., 1894, 327). From the side of mental function, a very great deal has been written upon practice, habit and fatigue; less upon expectation. The literature is easily accessible, and need not be brought together here. We may refer, *e. g.*, for practice and habit, to W. L. Bryan and N. Harter, Psych. Rev., iv., 1897, 27; vi., 1899, 345: for practice and fatigue, to the work of Kraepelin and his school, as quoted by Wundt, P. P., iii., 1903, 623; for expectation, to the authors cited above, p. 99.

The following illustrations may serve to show the effects of the variable errors in experimental work.

(1) *Expectation*. We take an instance from æsthesiometry (M. F. Washburn, P. S., xi., 1895, 221 f.). The compasses were applied to the wrist, and *O* was required to say whether the direction of stimulation was horizontal or vertical (longitudinal). *H*=horizontal, *V*=vertical, *I*=one point (blank experiment).

Stimulus	<i>H</i>	<i>H</i>	<i>H</i>	<i>H</i>	<i>H</i>	<i>H</i>	<i>H</i>	<i>H</i>	<i>I</i>	<i>I</i>	<i>I</i>	<i>H</i>	<i>H</i>
Judgment	<i>V</i>	<i>H</i>	<i>V</i>	<i>H</i>	<i>V</i>	<i>H</i>	<i>V</i>	<i>H</i>	<i>V</i>	<i>H</i>	<i>I</i>	<i>V</i>	<i>I</i>

All the regularly applied *R* were *H*. The first two judgments, however, chanced to be *V*, *H*. *O* was thus led to expect an alternation of direction, and judged *V*, *H* in the 6 following observations. *E* then had recourse to blank experiments. The first two were judged *V*, *H*, in accordance with expectation. The third broke up the tendency to alternation of judgments,—but also broke up the series; for the two final *H* were judged *V* and *I*.

(2) *Practice*. S. Thorkelson (1885: see E. Meumann, P. S., viii., 1892, 435 f.) distinguishes five or six stages of practice in work upon the D. S. for tone-filled intervals. The times investigated varied in arithmetical

progression ($D=1.5$ sec.) between the limits 1.5 and 12 sec. The relative DL of the Table represent averages from the whole series.

<i>Practice</i>	<i>DL</i>
None	$\frac{1}{10}$
General, increasing	$\frac{1}{12}$ to $\frac{1}{15}$
General, attained	$\frac{1}{15}$ to $\frac{1}{18}$
Special, increasing	$\frac{1}{18}$ to $\frac{1}{20}$
Special, attained	$\frac{1}{20}$ to $\frac{1}{25}$
? Maximal	? Above $\frac{1}{25}$

(3) *Fatigue*. Local fatigue can be illustrated at any time by repeated stimulation of a pressure spot. "Man kann die Ermüdung eines Punktes so weit treiben," so von Frey (rather Irishly) remarks, "dass er erst auf Reize anspricht, welche bereits auf benachbarte Punkte übergreifen, also für isolirte Erregung zu stark sind" (Abh., 1896, 221). In the case of areal stimulation, it often happens that the RL , instead of being raised, is lowered to 0; hyperæsthesia sets in, and subjective S arise to distract the attention. Thus the judgment + was returned at every step of the following series, taken under the conditions described above (p. 55) with the von Frey limen gauge (values given in degrees of the scale): 17, 15, 14, 11.5, 10.5, 10, 9, 8.25, 7.5, 7, 6, 5.5, 4, 3, 3, 1.5, .75, 0, 0!

The effect of fatigue is well shown in certain time-sense experiments by M. Ejner (Zeitsinn, 1889, 28). O was required to reproduce, 25 times in succession, each of the standard times 0.5, 1, 2, 3, 4 min. Two experiments of this sort, a and b , were taken at the same sitting, whatever the standard time employed. There are thus two chances for fatigue to show itself: (1) in the b as compared with the a series, (2) in the a and b series of the long as compared with those of the short times. The figures of the following Table are averages of the last 5 out of the 25 reproductions: for the sake of easy comparison, they are all reduced to a normal time of 0.5 min. or 30 sec.

Times reproduced	0.5 min.	1 min.	2 min.	3 min.	4 min.
Reprod. of 30 sec. in a	38.54	39.64	36.37	28.11	29.41
" " b	35.24	36.85	31.37	26.83	28.70.

It is clear that (1) the subjective 0.5 min. is shorter in b than in a , and (2) that it is shorter for the long than for the short times. Both results are due, at least in large measure, to fatigue.

(4) *Habituation*. The influence of habituation is evident in the Rohtabelle of tonal DL published by E. Luft, P. S., iv., 1888, 524: it will be noticed that in one \uparrow series ($<$ to $=$) the difference $r-r_1$ actually becomes 0. Cf. the writer's remarks, 526 f. A similar instance is given by M. F. Washburn, P. S., xi., 1895, 222.—

Series which show the effect of the variable errors in approximately pure form should be preserved by the Instructor. A concrete illustration will do more for the student than any amount of merely verbal explanation. At the same time, very careful notes should be kept of the precise conditions under which the error has operated. We tend to speak of 'practice,' etc., as if there were but one factor involved in the result. As a matter of fact, 'practice' is merely a general name for a large number of co-operating influences, physiological and psychological (*cf.* Martin and Müller, *loc. cit.*; Whipple, A. J. P., xiii., 1902, 225 ff.); and the same thing is true of the other terms.

(11) An improvement that is almost constantly suggested is the transference of Exp. XIII. to the dark room and the use there of a steady source of illumination. To which the Instructor has his answer!

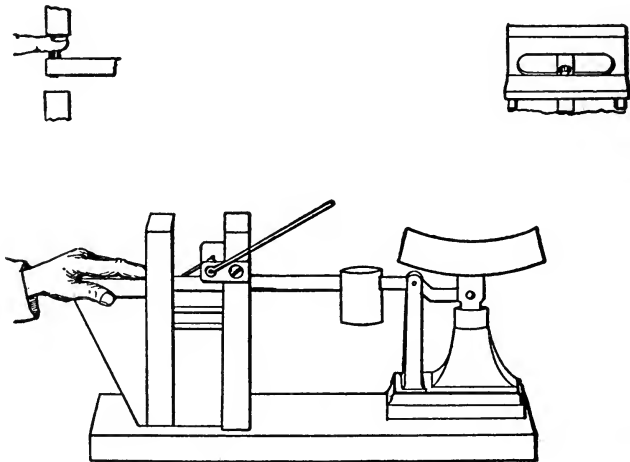

FIG. 22.

(12) It is, of course, impossible to foresee the answer to this Question. In some cases, the Instructor may accept the suggestion offered, and allow *E* and *O* to carry out their experiment (see p. 124 above); in others, he will simply refer them to some published investigation in which the proposed application of the method has been attempted.

For determinations of the *DL* of areal pressure, Sanford (Course, 345, 417 f.) recommends Jastrow's pressure balance (A. J., iii., 1890, 54 ff.). The instrument is shown in Fig. 22; the author has not worked with it.

ESSAY SUBJECTS.—(1) The psychological presuppositions of the method of limits, as it is described by various authors.

(2) The validity of the *DL* determined by the method of limits.

(3) The physiology and psychology of the variable errors: practice, fatigue, expectation, habituation.

(4) A statement, with critical estimate, of the various forms that the method has assumed in experimental work.

(5) A critical account of the conditions which favour, and of those which make against the application of the method of limits to a psychophysical problem.

The fourth essay will demand reading far beyond the limits of citation drawn for this book, and should result in the compilation of a working bibliography of the method. The fifth should be made as comprehensive as possible; its aim is to encourage the student to look for definite reasons, internal and external, that may explain the breakdown of the method in particular cases.

(6) Determinations of the *DL* for colour tone and brightness: historical and critical.

(7) Determinations of the *DL* for tone and noise: historical and critical.

(8) The question of the intensity of visual sensations.

On the last subject, see G. E. Müller, *Z.*, x., 1896, 2 f., 6 ff., 25 ff., with refs.; Külpe, *Outlines*, 113 f.; *ct.* P. S., xix., 1902, 509.

§ 23. **The Limens of Continuous Change.**—If one asks a student, who is innocent of psychophysical knowledge, to devise a method for the determination of the *DL*, he is very likely to suggest a continuous change of r_1 . A standard grey, *e.g.*, is to be shown; and another grey, at first precisely like it, is to be slowly lightened or darkened, until a difference becomes apparent; or a tone is to be sounded for a few sec., and then gradually raised or lowered in pitch until a change becomes noticeable; and so on. Now here is a real problem. The determination of the least noticeable continuous change of r , and of its dependence upon the direction and rate of the objective change, upon the value of r itself, etc., is both important and interesting. Moreover, the problem has, of late years, attracted a good deal of attention; it is dealt with, monographically, by L. W. Stern, in his *Psycho-*

logie d. Veränderungsauffassung, 1898. At the same time, it can hardly be made the subject of set experiments in a book like the present. The work is difficult; the time required for anything like a satisfactory result is long; questions of method and of evaluation still remain unsettled; and the student must, in any case, learn the regular methods first. All that the author can do, therefore, is to give some account of apparatus, and references to the investigations so far made. If there are students in the laboratory who have completed the prescribed course, and who desire to take up a bit of work that shall occupy them, say, for three months, they may very well be recommended to one or other of the following problems.

(1) *Visual Sensation.* The best instrument for ordinary laboratory use is the Marbe colour mixer (Fig. 23), which allows *E* to vary the rela-

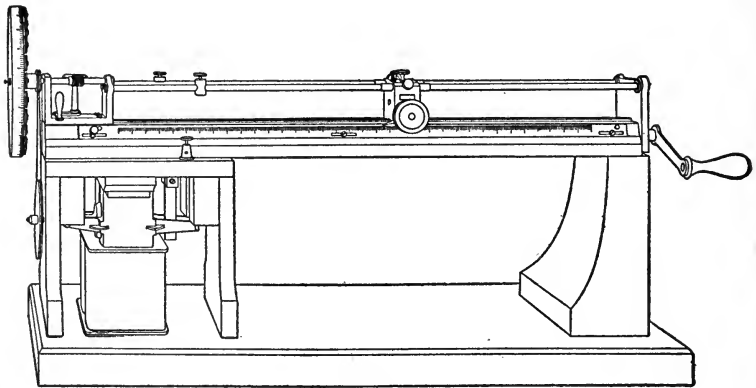

FIG. 23.

tion of two disc-sectors during rotation. A set of directions may be obtained from E. Zimmermann. The mixer is made in two forms, costing respectively (without motor) Mk. 115 and Mk. 155.

For instruments, methods, etc., cf. A. Koenig and C. Dieterici, *Z.*, iv., 1892, 244; L. W. Stern, *Z.*, vii., 1894, 249 ff., 395 ff.; K. Marbe, *Physiol. Centralblatt*, 1894, no. 25, 811; C. E. Seashore, *Yale Stud.*, iii., 1895, 38 ff.; O. Lummer and E. Brodhun, *Z. f. Instrumentenkunde*, xvi., 1896, 305. Cf. vol. i., I. M., 17.

(2) *Visual Movement.* Lines, points, figures, etc., may be drawn or pasted upon an 'endless' strip of paper travelling between two kymograph drums.

E. von Fleischl, Ber. d. Wiener Akad., lxxxvi., 3 Abth., 1882, 17 ff.; H. Aubert, Pflüger's Arch., xxxix., 1886, 347; xl., 1887, 459; L. W. Stern, Z., vii., 1894, 321 ff. (gives further refs. and apparatus); G. M. Stratton, Psych. Rev., ix., 1902, 433 ff.

(3) *Auditory Sensation.*—The Stern variator consists essentially of a blown bottle, whose pitch may be varied by the continuous introduction or withdrawal of mercury. Since the pitch of the bottle tone changes more quickly in the higher than in the lower regions, and uniformity of tonal change

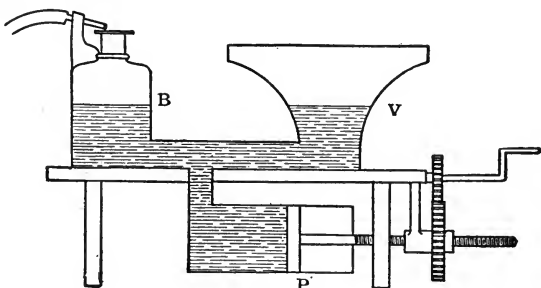

FIG. 24.

is required, the bottle is connected with a properly constructed 'variator' which furnishes the necessary correction. The principle of the instrument will be understood from Fig. 24, in which *B* is the

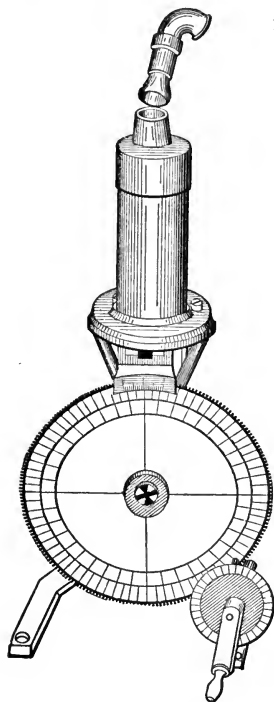

FIG. 25.

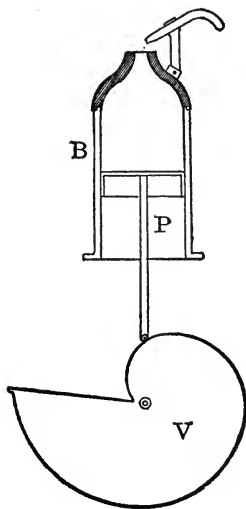

FIG. 26.

blown bottle, *V* the variator, and *P* the piston by means of which the height of the mercury column is regulated. The latest form of the apparatus is shown in Fig. 25; its construction is indicated in Fig. 26, where again *B* is the bottle, *V* the variator (a metal disc, cut to the shape of the required curve), and *P* the piston. A three-bottle apparatus, covering, *e.g.*, the vs. 150-300, 300-600, 600-1200, and furnished with graduated discs, reading directly in vs., a table and an air-tank (Fig. 27), can be procured from Kohl for Mk. 485. The same apparatus, without

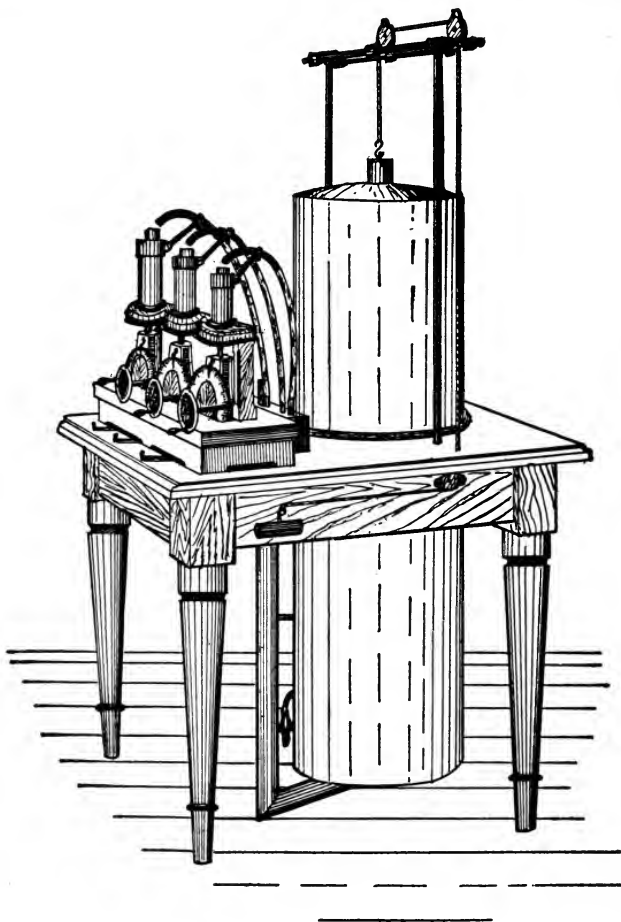

FIG. 27.—The bottles shown in this Fig. are of an older pattern than that represented in Fig. 25.

the table and air-tank, and consequently without the graduation by vibrations, costs Mk. 335. Seven bottles, ranging (with some overlapping) from the G of 100 to the d^3 of 1200 vs., are supplied by the maker.—See L. W. Stern, *Verh. d. physik. Ges. zu Berlin*, xvi. Jahrg., 1897, no. 4, 42 ff.; *Z.*, xi., 1896, 1 ff.; xxi., 1899, 360 ff.; xxx., 1902, 422 ff.; *Verh. d. deutsch. otolog. Ges. zu Breslau*, 1901, 135; G. M. Whipple, *A. J. P.*, xiii., 1902, 219 ff. *Cf.* E. W. Scripture, *A. J. P.*, iv., 1892, 579 f.; W. Preyer, *Z.*, vii., 1894, 241.

A serviceable laboratory instrument for acoustical work is Whipple's double gasometer, shown in Fig. 28. For description, see G. M. Whipple, *A. J. P.*, xiv., 1903, 107; E. B. Titchener, *ibid.*, xv., 1904, 57. An apparatus for producing continuous change in the intensity of a tone is described by Seashore, *op. cit.*, 51; criticised by Stern, *Psych. d. Ver.*, 84f. *Cf.* Scripture, *A. J. P.*, iv., 580.

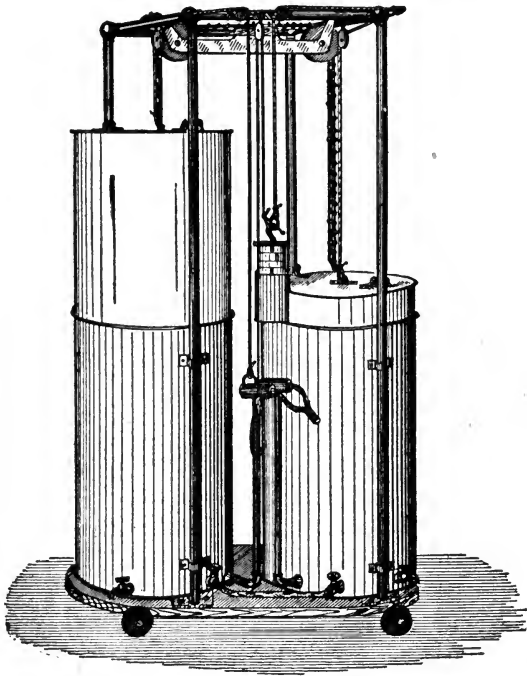

FIG. 28. Whipple's double gasometer. About \$75.

(4) *Auditory Localisation*.—No investigation, so far as the author knows, has been carried out. It would, however, be easy to regulate the movement of the semicircles of the sound-cage (i., *S. M.*, 179) so that the receiver (giving, *e.g.*, the tone of a tuning fork) should be carried at a uniform rate in various directions.

(5) *Pressure Sensation*.—von Frey's limen gauge has already been described (*Pt. i.*, pp. 17 ff.). Stratton's three lever apparatus (Fig. 29) has a wide range of usefulness; it permits of increase or decrease of pressure, instantaneous or gradual, for any required value of r . The principle of the apparatus will be clear from Fig. 30; the hydrostatic balance is employed only for gradual pressure changes.

G. S. Hall and Y. Motora, A. J. P., i., 1887, 72 ff. ; M. von Frey, Abh., 1896, 188 ff. ; G. M. Stratton, P. S., xii., 1896, 525 ff. ; H. Griffing, Psych. Rev. Mon. Suppl., I., 1895, 77 f. ; C. E. Seashore, Yale Stud., iv., 1896, 28 ff., 39 ff.

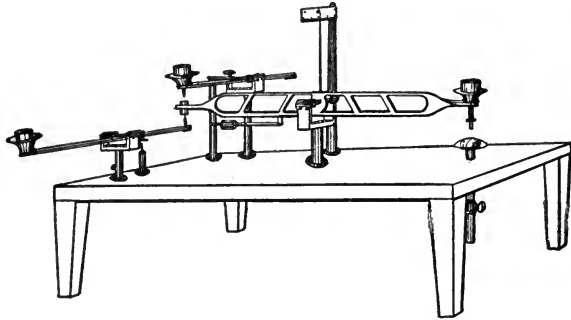

FIG. 29. Zimmermann, 1903, Mk. 280.

(6) *Temperature Sensation.* Seashore (Yale Stud., iii., 30) used a heated wire ; Stern (Psych. d. Ver., 89) suggests a modification of the method of A. Heinzmann, Pflüger's Arch., vi., 1872, 222 (cf. C. Fratscher, Jenaische Z. f. Naturw., N. F. ii., 1875, 130 ; W. T. Sedgwick,

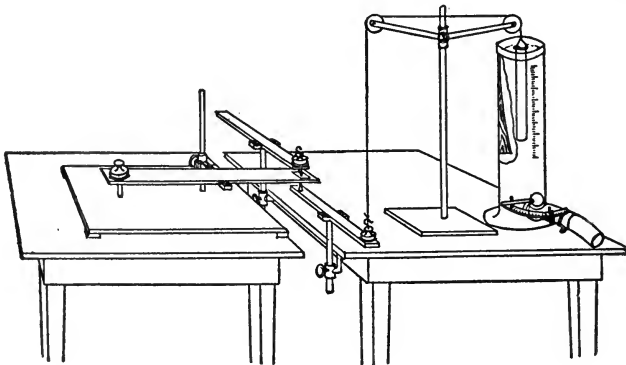

FIG. 30.

Biol. Stud., Johns Hopkins Univ., ii., 1883, 385). Cf. E. W. Scripture, Science, xi., 1892, 258 ; Z., vi., 1894, 473 ; W. Preyer, Pflüger's Arch., vi., 1872, 236 ; Z., vii., 1894, 241.

(7) *Cutaneous Movement.*—The kinesimeter (i., I. M., 93 f.) may be employed. See G. S. Hall and H. H. Donaldson, Mind, O. S., x., 1885, 557.

(8) *Taste Sensation*.—Seashore (Yale Stud., iii., 57 f.) used the acid taste set up by the electric current. It is conceivable that the same method might be employed for tests of the intensive D. S.

(9) *Smell Sensation*.—The standard olfactometer (i., I. M., 142) may be used for the production of continuous intensive change.

(10) *Lifted Weights*.—An apparatus is described by Seashore, Yale Stud., iv., 41 ff.—

For method, *cf.* (besides the investigations cited) J. Jastrow, A. J. P., i., 1888, 302; E. W. Scripture, *ibid.*, iv., 1892, 577; Z., vi., 1894, 472; L. W. Stern, Psych. d. Veränderungsauf., 1898, 90 ff. For a general account of the experiments, *cf.* Ebbinghaus, Psych., i., 466 ff., 472 ff.; Wundt, P. P., i., 1902, 524 f., 529, 533 f., 538; ii., 92 f., 577 ff.

ESSAY SUBJECTS.—(1) The question of 'movement sensations,' 'sensations of difference,' etc. See i., I. M., 377 ff. To the references there given, add Fechner, R., 44; Scripture, New Psych., 372 f.; Preyer, Gr. d. Tonw., 36 f.; Stern, Psych. d. Ver., 45 f., etc.; Vierordt, Z. f. Biol., xii., 1876, 226 ff.; Ebbinghaus, Psych., i., 410 ff., 466 ff.; S. Exner, Ber. d. Wiener Akad., lxxii., 3te Abth., 1875, 156 ff.; M. F. Washburn, P. S., xi., 1895, 201; G. M. Whipple, A. J. P., xii., 1901, 445.

(2) Stern's Uebergangsempfindungen (sensations of transition). Stern, *opp. citt.*; Stumpf, Tps., ii., 340; Stratton, P. S., xii., 542 ff., 570 ff.; S. Witasek, Z., xiv., 1897, 401 ff.; F. Schumann, Z., xvii., 1898, 117, 128 ff.; Wundt, P. P., ii., 92 f.; Ebbinghaus, *loc. cit.*

(3) The methodology of continuous *S*-change.

§ 24. **Fechner's Method of Average Error: Notes on § 17 of the Text.**—The method is described by Fechner in El., i., 120 ff.; ii., 148 ff., 343 ff.; I. S., 216 f.; R., 104 ff. The rules of calculation adopted in the text are, in principle, those of Külpe (Outlines, 76 ff.), Sanford (Course, 358 ff.), Lipps (Grundriss d. Psychophysik, 66 f.), Müller (M., 192 ff.). Wundt prefers to work from the crude errors and not from the r_m : see P. P., i., 1887, 352; i., 1893, 346; i., 1902, 481. The imaginary apparatus was suggested by Münsterberg, Beiträge, ii., 1889, 151 f.

Whether one works from the r_m or from the crude error, one's e_m must, of course, be the same: it would be absurd to get different values for the average variable error from the two procedures. But, if the results are to tally, the crude errors must be summed up (and their

variations from the average determined) with regard to sign. If the *MV* of the average of any quantities a, b, c, \dots is to be equal to the *MV* of the average of the quantities $a-k, b-k, c-k, \dots$, then these latter quantities must be signed. Wundt says nothing of the signs of his crude errors in 1887, but in 1893 and 1902 introduces the misleading parenthesis "ohne Rücksicht auf deren Vorzeichen."

Take an illustration: Sanford's first series, 358. The standard is 150; the settings are 147, 145, 145, 147, 149, 145, 149, 142, 147, 151. The r_m is accordingly 146.7, and its *MV* is 1.96. If we follow Wundt's procedure, we have the average crude error as 3.5 and its *MV* as 1.8! Allow for signs, on the other hand, and the average crude error is -3.3, and its *MV* 1.96.

It may, perhaps, be noted that Sanford has made a slip in calculation, 359. From his four sets of results (standard left, ascending and descending; standard right, ascending and descending), he obtains a variable error of 2.11 as the *MV* of the average of all forty trials, 147.8. He should have found the *MV* separately, for the four sets, from the r_m 146.7, 148.2, 147.2, 149.1, and then averaged them to an average variable error. The value of this is not 2.11 but 2.02.

Finally, it may be pointed out that Wundt's formula, P. P., 1874, 297 *n.* and i., 1880, 328 *n.*, is not applicable where the one of the two errors is a constant error. See Fechner, R., 109 f.; Müller, M., 201 f.

On fractionation (the division of results into small groups for separate mathematical treatment) and its advantages, see Fechner, *El.*, i., 83 f., 120, 124 ff., 212, 219; ii., 319 ff., 346, 358; R., 107 ff., 337; Volkmann, *Phys. Unt.*, 120; Münsterberg, *Beitr.*, ii., 156 f.; Higier, P. S., vii., 236 f., 243; Merkel, P. S., ix., 405; Müller, M., 77 f., 192 f.

On formulæ for the *PE* see Fechner, *Pogg. Ann.*, Jubelband, 1874, 66 ff.; *El.*, i., 123 f.; Merkel, P. S., ix., 58; Henri, *Ann. psych.*, ii., 1896 (1895), 496 ff.; Müller, M., 193 f.

The Number of Experiments.—It has generally been assumed that the method requires a large number of experiments. Indeed, in view of its psychological implications, it is hard to see what other assumption can be made.¹ There are, however, a few dissentient voices.

Sanford works out his illustration of average error on the basis of 40

¹ "In psychologischer Hinsicht ist der einzige Masswert bedeutungslos": Lipps, *Massmethoden*, 47 (*Arch.*, iii., 199).

observations (Course, 358 ff.). His explanations are, however, hampered by the small number of results (36, *n.*), and some of the values of his Table are puzzling to the beginner,—who tends always to regard the figures of a short Table as representing qualitative tests, each to count for one, rather than as hit-or-miss shots, valuable only in quantity. In general, Sanford declares that “the number of tests will vary with the purpose of the experiments. The formulæ for the *PE* apply more exactly as the number of observations increases, but the number necessary in this method is much less than in the method of *r.* and *w.* cases” (362). It is, unfortunately, a common thing in psychophysical literature to find an author declaring that a certain method, which he likes, requires less work and fewer tests than another method which he dislikes or likes less well.

Fullerton and Cattell assert that “a single experiment by the method of average error indicates the observer’s accuracy of discrimination, and half-a-dozen give a result sufficiently reliable for clinical and anthropometric purposes” (Small Diff., 18). Here the method is actually reduced to a qualitative test. *E* says to *O*: “Here is something for you to do; let us see, now, how well you can do it!”—and the crude error is taken as a rough numerical expression of the quality of the performance. There can be no question of the elimination of constant errors; there is no guarantee of the compensation of accidental errors. The coefficients of the PE_1 and PE_m of 6 observations ($\frac{0.6745}{\sqrt{5}}$ and $\frac{0.6745}{\sqrt{30}}$ respectively) are 0.3 and 0.12. This clinical and anthropometric method is, then, to be sharply distinguished from the psychophysical.

Witmer (Analyt. Psych., 217) fails to draw the distinction. “Ten experiments, in some cases even a single test, suffice satisfactorily to establish an exact measure of the sensitivity of a given subject. The method is therefore most serviceable and sufficiently exact for comparative measurements in statistical and child psychology.” Of course, a method which is exact is sufficiently exact for any psychology. Witmer has, apparently, read Fullerton and Cattell, and ‘gone them one better.’¹

The Characteristic Test-Value.—We have given the chief place to the e_m , the *MV* of *O*’s settings of r_1 , as the typical test-value of the method of average error. The PE_1 has been men-

¹ To guard against misconception, the author may remark that for certain purposes of statistical treatment a single setting made by a large number of different persons may be of real value. A group of such results would, indeed, be more valuable than a group obtained in the way suggested by Fullerton and Cattell; since the taking of half-a-dozen tests introduces the variable error of practice.

tioned only incidentally.¹ The choice was made, partly for historical reasons, partly for the sake of simplicity in exposition. We may, of course, use, as a measure of *O*'s precision, this *MV*, the PE_1 , or the error of mean square, *SD* or $EMS = \sqrt{\frac{\sum(e^2)}{n-1}}$; Fullerton and Cattell (*Small Diff.*, 87) suggest also the use of the crude error itself. The first three values are numerically related, in the rough, as follows:

$$\begin{aligned} PE_1 &= 0.85 MV; \\ SD \text{ or } EMS &= 1.48 PE_1; \\ SD \text{ or } EMS &= 1.25 MV. \end{aligned}$$

The statement that it is possible to extract from the *MV* and the *EMS* combined a true *h* and a value akin to the *DL* (Lipps) is discussed in § 25.

The Significance of O's Adjustments.—Writers upon average error have not said much of the importance of *O*'s adjustment of r_1 . Fechner remarks in the *El.*: "bei allen drei Methoden spielen unregelmässige Zufälligkeiten, welche theils den Manipulationen anhaften, theils in subjectiven Verhältnissen der Auffassung der verglichenen Grössen begründet liegen, eine grosse Rolle."² He does not seem, however, to have drawn any distinction between average error and the other two methods; we should, perhaps, hardly expect the distinction from one who worked so much by himself. At any rate, when Müller makes the e_m dependent in part, upon the 'uncertainty of hand,'³ Fechner replies that he does not understand what Müller means.⁴

Stumpf, in 1883, distinguishes sharply between "Activität und Passivität des Urteilenden bei Herstellung der *R.* . . Die äussere Action, z. B. das Stimmen einer Saite zum Gleichklange mit einer anderen, zieht notwendig einen Teil der Aufm. auf sich. Verschiedene Elemente der subjectiven Zuverlässigkeit⁵ gewinnen sofort grösseren Einfluss und zwar oft solche, an deren Wirkung man im Voraus kaum gedacht hätte."⁶ . . Bei der activen Versuchsweise wird es von vorn herein Niemand einfallen, anders

¹ That the e_m is subject to Gauss' law is shown by Fechner, *El.*, i., 123 f.; *Henri*, *Année psych.*, ii., 1896, 496 ff.

² *El.*, i., 77; *cf.* *R.*, 25 ff.

³ *G.*, 80.

⁴ *R.*, 113, *n.*

⁵ *Tps.*, i., 22 ff.; *cf.* pp. clxi. ff., above.

⁶ *Ibid.*, 303 ff.

vorzugehen als durch bloß einseitige *R*-Veränderung—schon der Bequemlichkeit halber, und um die Aufm. nicht noch mehr, als es ohnedies durch die Selbstbethätigung des Urteilenden der Fall ist, abzulenken. So führt die active Methode natürlicherweise die Möglichkeit feinerer mathematischer Behandlung mit sich, wodurch der oben erwähnte Nachteil ausgeglichen wird.”¹

Jastrow calls average error the “most natural” of the methods,² and Sanford is apparently expanding this remark when he says that av. error “requires discrimination not by itself alone, but in its natural relation to action.”³ It might be replied that discrimination, in all the methods, is naturally related to action, seeing that *O* is always required to express his judgment in words, and that such expression is a perfectly natural mode of motor reaction upon presented stimuli. Still, when this has been said, the difference between av. error and the other methods remains: in the latter, the motor discharge of the discriminating consciousness is a movement of the larynx; in the former, a continuous movement of hand and arm, with or without verbal accompaniment. It is a question, now, whether the presence of ‘muscular sensations’ in consciousness is to be regarded as a psychological complication, which renders the results of av. error incomparable with those of the other methods, or whether attention is so strongly directed to the visual stimuli, and so strongly diverted from the muscular sensations, that the uncertainty of *O*’s hand merely replaces the uncertainty of *E*’s settings. In the author’s experience, everything seems to depend upon the convenience of the apparatus. If *O*’s adjustments are simply and easily made, they soon become automatic; the muscular sensations drop out of consciousness; while *O*’s feeling of power or control induces a favourable disposition.⁴ One of the baffling features of the other methods—especially of *r.* and *w.* cases—is that the two *R* are out of reach; one longs at times for a shade more or a shade less of difference; one resents the compulsion of judgment. If, on the other hand, the apparatus is awkwardly or variably disposed, the muscular sensations do, undoubtedly, serve to distract the attention. In Sanford’s illustration, a Galton bar,

¹ Tps., i., 63 f.

² A. J. P., i., 292.

³ Course, 362.

⁴ Cf. M. Mehner, P. S., ii., 1885, 601.

with r set, "was handed the subject, with the request that he set the other slide at exactly the same distance from the centre line."¹ This procedure is faulty. There is no guarantee that O will grasp or hold the bar in precisely the same way, that he will make his adjustment by use of the same muscles, that he will hold the instrument at the same distance from the eyes, in the same plane of vision, etc. The method may be demonstrated upon a roughly made instrument, with a large measurement unit; but the conditions of use must be kept constant.²

Fullerton and Cattell, taking the suggestion from Müller, seek to analyse the variable error into an error of perception and an error of movement. In work upon force of movement (dynamometry), they proceed as follows. "The O was told to give a pull of (say) 2 kg. As might have been expected, his error in estimating a standard magnitude was usually very great. He was then told the direction and approximate amount of his error and allowed to try again. This was repeated until he had made 5 trials, by which time he could usually give the standard without great variation."³ A series of 10 judgments was then made, the O giving in each trial first the standard pull from memory, and then a pull as nearly as possible equal to it. A series of 5 trials preceded each series of 10 judgments, and if in the course of the series the first pulls varied greatly from the standard, the O was told to make his pulls less or greater as the case might be" (Small Diffs., 68). "After the O had made the force of his second movement as nearly as possible equal to that of his first, we did not consider the experiment complete, . . . but required the O to decide or guess which of the two movements had been the greater, in spite of his attempt to make them exactly alike; and to assign a degree of confidence to his decision" (91). A Table of the % of r . cases in these decisions, for r_1 greater and r_1 less, is given, and the conclusion reached that the variable error "is complex, being partly due to an error of perception, and partly to an error of movement" (92). The two components are mathematically calculated (93 ff.).

Let us see what this analysis amounts to. O is told to make his second pull as nearly as possible equal to his first. How is he to judge of their equality? By muscular sensations. Having made his two pulls, he is

¹ Course, 358.

² This discussion presupposes that the method of average error is put to the same general purposes as the other metric methods. We may, of course, be interested to determine the accuracy of O 's movement for its own sake (p. 370 below); but that is another matter.

³ This is the regular procedure with half-knowledge: p. 127 above.

asked whether the two were really equal, and, if not, how the second is related to the first. How is he to decide? By muscular sensations. Where, then, is the antithesis between 'error of movement' or 'uncertainty of hand', and 'error of perception'? The fact is, simply, that the dynamometer is an instrument whose error of 'too great' cannot be corrected by *O*. The registering pointer is not attached to the spring-bar; the extreme limit of *O*'s pull is always registered; if he pulls too far, he has no remedy (67).

We should expect, under these circumstances, that *O* would pull timidly when *r* was small,—fearing to overshoot the mark,—and more confidently when *r* was large. In terms of the Table of % of *r*. decisions, we should expect, with small *r*, a greater % of *r*. cases for "*r*₁ smaller," and with large *r* an approximately equal distribution for "*r*₁ smaller" and "*r*₁ greater." Averaging for all *O*'s, we get:

	<i>r</i> ₁ smaller	<i>r</i> ₁ greater	
2 kg.	69.4	59.7	% of <i>r</i> . answers
4 kg.	69.0	56.1	
8 kg.	59.8	57.1	
16 kg.	62.5	62.8.	

The figures must be taken for what they are worth. Unfortunately, the authors do not give the actual number of determinations upon which the two sets of % are based. We should expect the "*r*₁ smaller" to be more numerous, as well as more accurate, with small *r*. We should expect, also, a different interpretation of "small *r*" from the men and the women. We should expect, finally, that the number of *minus* errors with small *r* would (always under limitations of *O*'s type) decrease steadily with practice. There are no data by which we can verify these hypotheses.

Our conclusion is, then, that, while the *O*'s were told to make *r*₁ as nearly as possible equal to *r*, by muscular sensation, they were given an apparatus which allowed them to control the magnitude of *r*₁ only in one direction. They thus worked under pressure, and were able, subsequently, to correct their adjustment,—still in terms of muscular sensation. Had it been possible to shift to and fro at the conclusion of movement; or had the *O*'s known that the registering pointer could be set anywhere, by push and pull alike; the error of timidity might have been eliminated, and the error of movement, Müller's 'uncertainty of hand,' would have been (other things equal) no greater than it is in experiments with Augenmass. An error that can be detected by introspection is certainly not an error of manipulation in Müller's sense.

A similar analysis is attempted by Fullerton and Cattell for the variable error in *time* of movement. A movement of the hand through 50

cm. is executed at four rates of speed : maximal, 0.25, 0.50 and 1 sec. The time-standard is made by *O* for himself in five trials, as before (106).

In this case, we must sharply distinguish between the experiments made with maximal speed and those made at prescribed rapidities. If *O* is told to move as quickly as he can, and then to repeat his movement, he has, evidently, no opportunity for introspective control during the experiment. Whether or not the maximal rate has been a (subjectively) constant rate must be decided, introspectively, after the event. We should expect, from what we know both of the effects of 'warming up' or 'getting into swing' and of the influence of competition in muscular performances, that the second movement would tend to be quicker than the first. We should expect also, that *O* would tend to judge the second movement to be quicker; the warming up might come to consciousness by way of several secondary criteria. The Table of % of r. cases (111) gives us, as an average from all *O*'s :

	r_1 quicker	r_1 slower
Maximal rate	82.7	30 % of r. answers.
"The second blow seemed far quicker and more powerful than the first. It was, in fact, quicker, but less so than it seemed." Surely, we are very far here from an error due to 'uncertainty of hand'!		

The remaining experiments may be interpreted in the same way as the experiments on force of movement. If *O* has a short time to move in, he will adjust r_1 hurriedly, anxiously, and may be introspectively aware, after the experiment, that he has moved too fast. If he has plenty of time, his " r_1 quicker" and " r_1 slower" will be more evenly distributed. We find from the Table :

	r_1 quicker	r_1 slower
0.25 sec.	72.5	63.7 % of r. answers
0.50 sec.	73.2	60.7
1.00 sec.	68.0	67.5.

The result bears out our expectation.

The 'errors of movement' of Fullerton and Cattell are thus reduced to errors arising from timidity, warming up,¹ and anxiety. This reduc-

¹ On Anregung and Antrieb, see various articles in Kraepelin's *Psychol. Arbeiten*; e. g., E. Kraepelin, i., 1895, 51; E. Amberg, *ibid.*, 374 ff.; A. Hort and E. Kraepelin, *ibid.*, 460 ff.; G. Aschaffenburg, i., 1896, 613; W. H. R. Rivers and E. Kraepelin, *ibid.*, 634 ff.; W. Weygandt, ii., 1897, 125, 184, 196 ff.; L. Cron and E. Kraepelin, *ibid.*, 284 ff., 318 f.; G. von Voss, ii., 1898, 405, 436 ff., 440, 448; W. Weygandt, ii., 1899, 702 ff.; E. H. Lindley, iii., 1900, 502 ff., 509 ff.; A. Oseretzkowsky and E. Kraepelin, iii., 1901, 658 ff., 675 ff.; J. P. Hylan and E. Kraepelin, iv., 1902, 490 ff.; G. Heumann, iv., 1904, 569 ff., 598 ff. Cf. Martin and Müller, *Zur Analyse der U. E.*, 117; Kraepelin, P. S., xix., 1902, 459 ff.; Wundt, P. P., iii., 1903, 618, 623 f.

tion is, of course, tentative. And, even if correct as far as it goes, it is doubtless incomplete. Had the authors given their numerical data in greater fulness, we might have tested it more rigidly. Had they given introspective data, we might have rounded it out. The essential points of the above discussion are (1) that the error of manipulation, in any field of work, cannot be an error that is traceable by introspection, and (2) that the effects ascribed by the writers to the error of manipulation may be explained, with some reasonableness, as due to conditions imposed upon consciousness by the arrangement of the experiments.

The Time Error.—The method of average error offers unfavourable conditions for the elimination of the Fechnerian time error. In the case of ocular measurement, as we have presented it, there is no temporal constant error. Fechner suggests that a time error could be introduced, and eliminated, if in one set of determinations r , in another r_1 , were first fixated and estimated. But it is difficult to see how O could be kept, after the initial fixation, from giving priority of reference to r . We might introduce a time error, in another way, by removing r , in one series, before r_1 is shown, and by removing r_1 , in another, before r is presented. How far this procedure would be satisfactory, the author does not know. It hardly seems to square with the principle of the method, which requires that the pattern be shown before the copy is made.

Fechner meets the difficulty, in aesthesiometric work, by using discrete steps and himself applying both the normal and the variable compasses to the part stimulated. It is clear, however, that—if fatigue is to be avoided— O 's knowledge of r must come into play for the initial setting of r_1 ; so that, even if r_1 be given before r , r is held in mind throughout the experiment as a standard of reference. Hence it seems improbable that the reversal of procedure really alters nothing else than the time-relations of stimulation, or that the averaging of the two sets of determinations really eliminates a time error.—See Fechner, *El.*, ii., 149; *Abh.*, xiii., 1884, (*Zeitsinn*) 80 f.; *Abh.*, xiii., 1884, (*Raumsinn*) 288; Müller, G., 72 f.; M., 191 f.

The Constant Error of Direction.—Sanford (*Course*, 360) determines the error of direction, *i.e.*, the constant error due to the fact that r_1 is sometimes increased, sometimes decreased, to

equality with r . Fechner, discussing Camerer's work with the method of equivalents, remarks: "auch bei meinem Verfahren kann es nützlich sein, diesen Fehler zu berücksichtigen; doch geht wenigstens voraussetzlich bei dem wiederholten Hin und Wieder vor der definitiven Einstellung die Beziehung auf den ersten Ausgang merklich verloren, und gestehe ich, daher auf diesen Fehler keine besondere Rücksicht genommen zu haben" (Abh., xiii., 1884, 291). The author has, accordingly, made no mention of this source of error. Müller in M. says nothing of it.

EXPERIMENT XV

The Galton Bar.—The instrument described in the text works very well. The unhooking of the bar by E , in order to take the reading from the mm. scale, is not so clumsy a matter as might be supposed; the whole process requires only a few sec. If, however, the apparatus is to be set up permanently in the laboratory, the following improvements may be suggested.

A horizontal slit, slightly wider than the bar and just long enough to hold it firmly in place, is cut in the wooden screen. When the bar is in position, the screen is faced with black cloth; the slit in the cloth is cut narrower than that in the screen, so that the cloth edges overlap the bar a little, above and below. Further: since O may, if the central slider is actually at the centre of the bar, judge the equality of r and r_1 by the aid of the projecting end-pieces of the bar,—the pieces that extend to right and left beyond the limiting sliders,—instead of confining his attention to the extent of r and r_1 themselves, the limiting sliders are made much longer than in Fig. 22 of the text, and are furnished with a fan-shaped extension of heavy wire, over which black cloth (of the same kind as covers the screen) is smoothly drawn. O now has nothing to judge by except the limiting edges of the black bands of metal; he cannot tell whether the line of wire is at the centre of the bar or far to one side of the centre. A small black pin is set in the front surface of the limiting sliders, some distance back from the edge, for greater convenience of handling. E 's readings are made, of course, from the back of the screen. Under these conditions, the apparatus is, apart from any possible irregularity of the mm. scale, as accurate as one could wish.

These arrangements are sufficient for the equating of *short* visual extents. If long distances are employed, O must sit farther back from the screen. Handles of blackened wood are then hinged to the lower

edges of the limiting sliders, and O works with these instead of directly with the sliders. It need hardly be said that the results are comparable only if O is seated always at the same distance from the screen and makes his manipulations always in the same way.—

A still simpler set of materials is mentioned by Sanford, Course, 358 f. Strips of mm. paper, 200 mm. long and 5 mm. wide, are presented to O , with the blank side uppermost, and he indicates by a sharp cut with a penknife the point which he judges to be the middle of the strip. It is clear, however, that the conditions here are different from those laid down for the method in the text. The same thing is true of the Galton bar proper, sold by the Cambridge Sci. Instr. Co. for 18/- : see Sanford, Course, 402. This Company also makes an Angular Division Testing Apparatus for £2. 0. 0. For another home-made form of the bar, see Sanford, 414. For other and more elaborate instruments, see the experimental refs. of the following §; also Scripture, *New Psych.*, 396.

QUESTIONS.—(1) The method is a method of adjustment. In the method of limits, E takes O by the hand, and leads him slowly up to the required determination; in the method of average error, O is his own master, and makes his determination for himself, by any procedure that he prefers. The psychology of the method is, therefore, the psychology of *precision of adjustment*.

(2) The principal criticism to be passed on the method is that it is fundamentally *unmethodical*. The instruction "Set r_1 to the value that *best satisfies you* of its equality to r " fails to impose upon O any determinate form of procedure: the given observation cannot be exactly repeated, the course of the method can never be exactly reconstructed. This criticism really restricts the use of the method of average error to cases in which the number of different r_1 that may be judged equal to r is very small. See Müller, *M.*, 187 ff. Lipps (*Massmethoden*, 49 f.; *Arch. f. d. ges. Psych.*, iii., 43 f., 201 f.) appears not to have understood Müller's objection. His own account of his experiments with greys is curiously schematic (*Massmethoden*, 71; *Arch.*, 223).

Other and more special criticism would deal with the elimination of constant errors (especially with the time error, and with the same-signed error s), with the psychophysical significance of the value e_m , etc.

(3) The Question may be answered somewhat as follows.

(a) The gross constant error c may be determined directly from the results of a single set of observations. It may be analysed, by further work, into the two components q , the space error (eliminated by performing the whole experiment twice over, with reversal of the spatial position of r and r_1); and s , the principal error. (b) The variable error of *practice* can be minimised by a fitting distribution of the various sets of determinations in time. *Fatigue* is prevented, partly by the shortness of the sets (25 observations), partly by the interpolation of rest-periods between set and set. (c) The value r_m is freed of *accidental* errors by the performance of a sufficiently large number of experiments. (d) O 's adjustment of r_1 may give rise to an *error of manipulation*, akin to the error of bias in the method of limits (see C. Bohn, Pogg. Ann., Ergbd. vi., 1874, 397; and cf. E. A. Gamble, A. J. P., x., 109). The danger must be met by instruction to O to maintain a maximal degree of attention throughout the experiment.

(4) We have, first, the 'average error stimuli' r_{mI} and r_{mII} . These represent the most probable values of O 's settings, in the two spatial positions. If we average them to r_m , we have a value freed of the constant error q and containing only the constant error s .

We have, secondly, the 'average variable errors' e_{mI} and e_{mII} . These are the *MV* of r_{mI} and r_{mII} respectively. Since the adjustments which O has made are, one and all, adjustments to equality with the same r , we may assume that the play of accidental errors has remained the same in both experimental arrangements, and may average these two *MV* to a single e_m . We must, however, be on our guard against supposing that this final e_m is the *MV* of the average r_m !

We have, thirdly, the values of the constant errors q and s . It was in order to an analysis of the gross constant error c that we raised the number of our experiments from 100 to 200.

(5) The answer may run, briefly, as follows.

Set out from an r_1 that is $|\gt|$ (or $|\lt|$) r . Decrease (or increase) r_1 until you reach the point at which $r_1 \parallel r$. Proceed with the movement, and shift back and forth, about the zone of equality, until you find the length of r_1 that best satisfies you of its equality to r . Repeat 100 times.—Repeat the experiment, with reversal of the spatial position of r and r_1 .

(6) No: we have not applied the factor of correction, necessary for a small number of observations (see p. 64 of the text). Since

$$\frac{\Sigma x}{\sqrt{n}} = \frac{\Sigma v}{\sqrt{n-1}}$$

(Merriman, *Least Squares*, 93), the fraction $\frac{\Sigma e}{n}$ should in strict-

ness be written $\frac{\Sigma e}{n} \cdot \sqrt{\frac{n}{n-1}}$. In other words, $e_m = \frac{\Sigma e}{\sqrt{n(n-1)}}$.

This formula should be used in calculation. See Müller, M., 192; and *cf.* Fechner, *El.*, i., 125 f.; *Ber.*, 1861, 57 ff.; *I. S.*, 216 f.; *R.*, 110 f.

(7) Fechner referred the principal error, s , to the simple fact that r is constant, in every observation, and r_1 variable. The two R are never presented under precisely the same conditions: r is settled, given, a standard of reference, while r_1 is unsettled, dependent on O 's judgment, a magnitude always referred to another magnitude. The antithesis of 'stimulus referred' and 'stimulus to-be-referred-to' cannot, of course, be eliminated by any change of procedure; so that the error s is same-signed throughout the experiment. See Fechner, *El.*, ii., 140, 151, 355 ff.; *Abh.*, xiii., 1884, (*Zeitsinn*) 79 f.; *Abh.*, xiii., 1884, (*Raum-sinn*) 282.

Müller analyses the principal error into two components. The first is due to a lack of uniformity in the adjustment of r_1 . It may happen, whether by accident or as the result of special tendencies in manipulation, that O sets r_1 more frequently at one of the higher than at one of the lower values within the zone of subjective equality, or conversely. Such an hypothesis explains Fechner's results, *El.*, ii., 363 f. The second component is due to the difference between the upper and lower DL of r . Suppose that Weber's Law holds: then the lower DL will be slightly smaller than the upper, and r_m must be slightly larger than r . Any other influences that serve to differentiate the two DL must affect the value of r_m in this way. See Müller, M., 196 ff.

Let us assume that the principal error is entirely due to the difference between the two DL . Then it may be affected by the general and the typical tendencies of judgment (p. 122 above).

Suppose, *e.g.*, that O is positive in type. This means that his DL are smaller for $r > r_1$ than they are for $r < r_1$. Then the lower DL , which

we have taken to be (by Weber's Law) slightly smaller than the upper, becomes still more reduced, and r_m must be quite considerably larger than r . If Weber's Law does not hold, but there is a constancy of the absolute DL , the effect of the positive type will still be apparent. And conversely, if O 's type be markedly negative.

Or put the same thing in another way. The positive type is the type which receives the absolute impression of 'weak' ('small,' etc.) more often than it receives the absolute impression of 'strong' ('large,' etc.). That is, the errors of setting below r will be smaller than the errors of setting above r ; r_m will be larger than r . And conversely, if the type be negative.

Suppose, again, that the general tendency of judgment is positive: *i.e.*, that the impression of 'weak' is received most often when r_1 lies to the left of r . This means that the positive difference $r_m - r$ (due, by hypothesis, to Weber's Law and positive type) will be greater in the first spatial position of the stimuli (r_1 to the left) than in the second.—Or suppose that there is no general tendency, but that the attention of the O goes predominantly to the right-hand stimulus. This will mean that the positive difference $r_m - r$ is greater in the second spatial position of the stimuli (r_1 to the right) than in the first.—Similar results may be worked out for other admixtures of general and special tendency, under the influence of a constant direction of attention.

When we remember, further, that the value of s is not solely due to the difference of the two DL , but is also dependent, to an unknown degree, upon O 's tendencies of manipulation, we realise that Fechner's assumption of its constancy throughout the experiment has no stable basis. For a discussion of the possibilities, see Müller, M., 196 ff.

(8) The modification that will most naturally suggest itself to the student, at this stage, is (a) a combination of Fechner's method with the method of limits. We have been seeking to determine the point at which the two lines are most certainly, most satisfactorily equal; we have been transforming ourselves, so to speak, into instruments of precision. The result is not encouraging. Objectively, we can never repeat our procedure; subjectively, we can never be sure that we have really done the best that is in us to do. Now the method of limits helped us over the difficulty of Fechner's method of *j. n. d.*,—the difficulty of adjusting a variable stimulus to a value liminally different from the value of a constant stimulus: why, then, should it not help us here,—help us to overcome the difficulties involved in the adjustment of

a variable stimulus to equality with a constant stimulus? Why should we not seek to make r_1 , not positively equal to r , but rather unnoticeably different from it, and then combine the values of unnoticeable difference, ascending and descending, to a single 'error of observation'? The judgment of disappearing difference is a judgment with which the method of limits has made us familiar; we know that we can pass it, and pass it with but little variation.

The method would then take shape as follows. We first make r_1 , say, on the right, $|\rangle|r$, and decrease r_1 until we reach the point at which r_1 ceases to appear $> r$. There we stop. We then make r_1 , still on the right, $|\langle|r$, and increase r_1 to the point at which it ceases to appear $< r$. There we stop. The procedure is repeated with r_1 on the left. If we take 50 observations of each kind, we have at the end of the experiment 200 determinations of the j. u. d. between r and r_1 .

The calculation of the test-values runs parallel to that of the Fechnerian method. In place of r_{mI} and r_{mII} , we determine the four values r_{uI} r_{lI} r_{uII} r_{lII} (where $u =$ upper, $l =$ lower, and I and II refer to the two spatial arrangements). In place of e_{mI} and e_{mII} , we determine e_{uI} e_{lI} e_{uII} e_{lII} . If, however, the values of e_l and e_u are but little different, we may average them to a single value: so that, after all, the four e_m -values become the familiar e_{mI} and e_{mII} .¹ The four r_m -values are averaged, similarly, to the two, r_{mI} and r_{mII} .¹ With these values in hand, we may proceed to a consideration of the constant errors.

Let us see, however, whether we have really gained by our change of method. At first sight, everything seems in order. There are series in the method of limits which end, precisely as O 's present adjustments end, with a judgment of disappearing difference. If we think of the grey of Exp. XIII. as changing, not discretely by steps of 1° or 0.5° , but continuously, by uniform change of the black and white sectors during rotation,—and, as we have seen, this continuous change is not difficult to effect,—the resemblance becomes still closer. Nevertheless, the two methods are, in reality, very different. In the method of limits, the

¹ It will, of course, be understood that the values thus symbolised are parallel to, not identical with, the values similarly symbolised in the Fechnerian method. Müller, M., 203, 214 f.

gradation (or the rate of continuous change) of r_1 is regulated by E ; O knows nothing of it. Moreover, the nature of the gradation is exactly recorded, so that the series can be repeated under precisely the same conditions. In our combined method, O adjusts r_1 for himself, and there is no guarantee that he can reproduce his adjustment in any later test. The psychological conditions of the judgment of disappearing difference are thus widely divergent in the two cases; and with the difference in conditions goes a difference in psychological value.

Again, our new method is, at the best, an incomplete application of the method of limits. For the method of limits determines not only the point of disappearing difference, but also the point of just noticeable difference. While, therefore, the method of limits can give us the values e_u and e_l ,—if those values are desired,—the combined method is unable to furnish the values Δr_u and Δr_l , characteristic of the method of limits. The advantage is all on the side of the latter method; the combined method has no *raison d'être*.

'Not even as affording a measure of the j. u. d.?' No! For we do not really determine the r_1 that is j. u. $>$ or $<$ r . Starting from $r_1 |<| r$, we determine the *lower* limit of j. u. d. Starting from $r_1 |>| r$, we determine the *upper* limit of j. u. d. But these are not the upper and lower limits of one and the same j. u. d. The lower limit is the lower limit of an *ascending* j. u. d.; the difference $r - r_1$ is referable, not to r , but to r_1 . The upper limit is the upper limit of a *descending* j. u. d.; the difference $r_1 - r$ is referable, not to r_1 , but to r . We ought by rights, in our \uparrow adjustments, to determine the first point of equality and the last point of equality of r and r_1 , and then to strike the average. Similarly, we ought, in our \downarrow adjustments, to determine both the first and the last points of equality, and to average. As the j. n. d. is the mean between first difference and disappearing difference, so is the j. u. d. the mean between disappearing difference and last equality. Why, then, do we not seek to determine this mean? Simply because the determination is impracticable. We can, without too great difficulty, arrest the moving screen at the point where r_1 first seems equal to r . But if we try to find the point at which r_1 last seems equal to r , we either stop timidly at some point within the zone of equality, or we overshoot the mark and stop only at some point of positive difference.

This latter criticism may, perhaps, be discounted in practice. The two j. u. d. will, very probably, overlap; and the averaging of the \uparrow and \downarrow values would not lead to any considerable error. Still, the theoretical error remains. And in view of the imperfections of the method, taken as a whole, we may surely say, without hesitation, that it is not worth preserving. If one is forced for any reason to work by oneself, the combined

method may be of some service. If one desires to repeat the experiments of certain published investigations (discussed in § 25), it must necessarily be adopted. But under ordinary laboratory conditions, its employment is a waste of time.—See Müller, M., 201 ff.; and *cf.* Wundt, P. P., i., 1902, 481 f.

(b) Another form of the method that is intrinsically faulty is the form which it assumes in certain investigations of the 'time sense.' A normal time is given, say, by two hammer strokes; and *O* makes a third stroke, or arrests the wheel of the time-sense apparatus, when a time has elapsed that, in his judgment, is equal to the normal time. The defects of the method are patent: only one arrangement of the times is possible; the r_1 include, besides the time error, the value of an ascending (lower) *j. u. d.*; the determination is complicated by a reaction time. For rough work with large times the method is convenient;¹ for delicate work it is wholly to be condemned. See K. Vierordt, *Zeitsinn*, 1868, 34 ff.; *Z. f. Biol.*, xviii., 1882, 397 ff.; Buccola, *Le Legge del Tempo nei Fenomeni del Pensiero*, 1883, 374 ff.; R. Glass, *P. S.*, iv., 1888, 436 ff.; H. Münsterberg, *Beitr.*, ii., 1889, 54 ff.; M. Ejner, *Zeitsinn*, 1889, 10 ff.; F. Schumann, *Z.*, iv., 1893, 60 ff.; H. C. Stevens, *A. J. P.*, xiii., 1902, 1 ff. The method was also used, with various modifications, by L. T. Stevens, *Mind*, O. S., xi., 1886, 393 ff.; H. Nichols, *A. J. P.*, iv., 1891, 60 ff.; F. Martius, *Z. f. klin. Med.*, xv., 188, 536 ff.; J. Paneth, *Centralbl. f. Physiol.*, iv., 1890, 81 ff.

For criticism of the method, see Wundt, P. P., ii., 1880, 290; i., 1902, 482; iii., 1903, 505 f.; Glass, *P. S.*, iv., 442; Schumann, *Z.*, iv., 22 f., 65; Müller, M., 204 f.

(c) A third form of the method, an application of the method of constant *R* or *R*-differences will be discussed later: see § 32.

(9) This is a difficult Question. It may be answered summarily from Fechner, *R.*, 18 ff., 114 f.; Müller, *G.*, 80 *n.*; M., 210 ff. If possible, it should be assigned as an essay subject (see § 25), but in no case should it be omitted.

(10) The student who knows his Fechner will think at once of the æsthesiometric experiment, with self-application of the compasses, described in *El.*, ii., 343 ff. The author cannot recom-

¹ We employ it for this purpose in Exp. XXVII. below.

mend the introduction of the experiment into this Course: it is tedious, and makes greater demands on the interest and attention of the student than do the experiments so far included.¹ On the other hand, a very pretty experiment, and one that *should* be introduced into the Course in every laboratory that possesses a Marbe mixer (p.138 above), is the application of the Fechnerian method to greys or colour saturations. The standard grey or colour is set up on an ordinary mixer, the variable on the Marbe instrument: the latter, of course, being fitted with a series of bands and pulleys so that the control of r_1 lies with O .

§ 25. **The Method of Average Error: Historical.**—The method of average error is, evidently, a free gift to psychophysics from the exact sciences of physics and astronomy (Fechner, R., 114; Merkel, P. S., ix., 55). It was a favourite method with Fechner; one connects his name with it as naturally as one connects the name of E. H. Weber with the method of *j. n.* differences; and it is to Fechner's occupation with physics that we owe its elaboration in the interests of psychophysics.

The method is usually referred, in its historical beginnings, to the German physicist and astronomer K. A. Steinheil,—better known by his work on the telegraph (1838). Steinheil published in 1837 a paper entitled *Elemente der Helligkeitsmessungen am Sternenhimmel* (Abh. d. k. bayr. Akad. d. Wiss., math.-phys. Cl., ii., esp. 76), in which he describes an "Ocularapparat zur Vergleichung der Helligkeit erleuchteter Flächen." We are told nothing of his mode of procedure, except that the two bright surfaces to be compared were set to subjective equality. The same thing is true of the work of P. A. E. Laugier (*Expériences sur la sensibilité de l'oeil dans les pointés astronomiques*, Comptes rendus, xlv., 1857, 841). Fechner himself gives us, in the *El.*, a general characterisation of the method, rules for the calculation of the test-values, and illustrations of its use in the spheres of ocular and tactual measurement (i., 71 ff., 76 ff., 88 ff., 120 ff., 211 ff.; ii., 148 ff., 311 ff., 343 ff.; *cf.* corrections in the *I. S.*, 216 ff.). The derivation of test-values is also discussed in two arti-

¹ If the experiment is performed, it is best to use an æsthesiometer of the Jastrow or Ebbinghaus type, in which the two points may be separated by turning a thumb-screw set transversely between them (Cat. of Garden City Model Works, 1894, \$5.00; Zimmermann, 1903, Mk. 60). See below, p. 258.

cles of 1861 and 1874.¹ It is not, however, until we come to the R., that we find any detailed account of procedure. This account is worth quoting in full: it forms the basis of the method of the text. "A certain distance, *e.g.*, between compass points or parallel threads, is presented. This I call the normal distance. I am to make another distance, the error distance, as nearly equal to this as it can be made by eye. First of all, starting from an error distance that is too large or too small, I adjust it roughly, in an irresponsible sort of way, to apparent equality with the normal. Then I consider whether or not it really corresponds to sensible equality, and I shift the boundary of the error distance, thread or compass point, to and fro,—all the time watching closely for the effect upon sensation,—until I seem, with a definitive adjustment, to have touched equality as closely as I may" (R., 105). Here,—apart from the reference to the change of starting-point, which shows an investigator alive to the danger of constant errors,—we have the method of average error in its naive and original form. O is required to make an r_1 equal to a given r . Very well, then! Let him take his time, and push his limit back and forth until he has fully satisfied himself that the two R are equal!

Müller, who in 1878 had not this statement before him, is compelled to think out a procedure for himself. "If," he says, "one is attempting to set a distance r_1 as *nearly as possible* to equality with a given distance r , it would seem that one must proceed as follows. First of all, one takes a distance that is clearly larger (or smaller) than r , and gradually shortens (or lengthens) it until the point is reached at which the difference between the two distances ceases to be noticeable." The procedure must not, however, be arrested at this point. "One must continue to change r_1 , and must try approximately to ascertain the extent of that range of magnitude within which the distance r_1 may move without necessarily appearing larger or smaller than r ."

¹ Ueber d. Correctionen bezüglich d. Genauigkeitsbestimmung d. Beobachtungen: Ber. d. k. sächs. Ges. d. Wiss., 1861, 57; Ueber d. Bestimmung d. wahrsch. Fehlers eines Beobachtungsmittels durch d. Summe d. einfachen Abweichungen: Pogg. Ann., Jubelband, 1874, 66; *cf.* also Ueber d. Ausgangswerth d. kleinsten Abweichungssumme: Abh. d. k. sächs. Ges. d. Wiss., math-phys. Cl., xi., 1878 [1874], 1 ff., 50 ff.

Then one must seek, by shifting thread or compass point to and fro, to determine, as accurately as may be, the mean value of these magnitudes of r_1 that are not necessarily distinguishable from r " (G., 73 f.). Fechner, in criticism, expresses the pious wish that Müller had tried himself, or had persuaded some one else to try, a single experimental series by this method, in order to see if it were practicable or could lead to practically useful results! At any rate, he says, no such toil and misery are contemplated by *his* method (R., 114).¹ We may remark at once that Merkel, in 1893, tested Müller's procedure in the field of ocular measurement, and found it 'unsuitable' (P. S., ix., 177). He adds, with true scientific caution, that the "method may possibly prove more useful in other departments."

The author, also in 1893, tested Müller's method in the same sphere of ocular measurement, and found it impracticable. The instrument employed was rough, and need not be described. What happened, as regards judgment, was this.

The first determination, which makes r_1 first or just equal to r , offers no great difficulty. But, now, one is to go farther, and to determine the *last* point at which r_1 is equal to r . The tendency is almost irresistible to pass this point, and suddenly to bring oneself up with a positive judgment of 'less' or 'greater.' What is then to be done? If one moves the limit of r_1 back, one is really starting upon a new experiment, taken from the contrary direction. If one throws out the observation, and begins over again, one works with a bias in favour of stopping too soon, and has an uneasy consciousness that one probably *has* stopped too soon. The best thing to do is to be satisfied with the result, and to take the positive judgment of 'less' or 'greater' as marking the lower or upper limit required. This assumption made, one has to move the limiting line to and fro, within the zone of equality, until one hits upon the most satisfactory 'equal.' But how is one to remember the zone of equality? If the two limiting points had been marked, one could, of course, bisect the zone by eye. Marking, however, is out of the question. Now the zone of equality is not so wide as a church door: that one knows: but how wide it is one does *not* know,—provided that one has, in making the second determination, been maximally attentive to the problem in hand, and has not cast repeated backward glances to the former determination. And

¹ The above quotations have been in so far simplified that only one boundary-line of r_1 is supposed to be moved. Fechner and Müller leave it open whether one or both shall be shifted. Cf. Stumpf, Tps., i., 63 f.

that would ruin the second determination, which is already sufficiently difficult. No! what one really does is to fall back upon the naïve Fechnerian method, neglecting one's two limiting determinations; one shifts the boundary of r_1 back a little, hesitatingly, then forward a little, then back again, and so on, and the memory of the zone of equality vanishes into thin air.¹

As Müller makes no mention of this procedure in the M., we may infer that he, too, has now satisfied himself of its impracticability.

The experiments of Fechner and Volkmann on ocular and tactual measurement, reported in the El. (i., 211.; ii., 343), were, we may suppose, made as Fechner describes such experiments in the R. In 1863, however, long before the appearance of the R., Volkmann had himself given an account of his procedure (Physiol. Unt. im Gebiete d. Optik, i., 117 f.). "A determinate distance, Fechner's normal distance, is given, and one tries to make another, Fechner's error distance, equal to it. In doing this, one is, in general, subject to a certain error. . . . If we are rightly to comprehend the significance of this error, we must remember that it . . . represents the magnitude of a difference which has remained unnoticed. If we bear in mind, further, how the problem of equality has been solved,—by the reduction of a noticeable difference to the point at which it passes the limit of the unnoticeable,—we see at once that, in careful experimentation, the unnoticeable (*verkennbare*, confusable) difference can be only minimally smaller than the just noticeable." Müller (G., 82 ff.) interprets this passage to mean that Volkmann worked, not by Fechner's procedure, but by a form of the method of just unnoticeable differences; that he sought to determine, not the point of complete subjective equality of r and r_1 , but the outer limit of their just unnoticeable difference, *i.e.*, of their confusability. Volkmann's 'average variable error' would therefore represent "the average deviation from the mean value of the *j.* unnot. d." (G., 84). Wundt, in 1874 (P. P., 555), accepts Volkmann's method without question; in 1880 (P. P., ii., 93), he refers to it, citing Müller in a footnote, as "a sort of combination of the

¹ On the substitution of discrete for continuous adjustment; see below, p. 180.

methods of minimal changes and of average error": *cf.* ii., 1887, 116. In 1893, he admits the two methods of the text, as both falling under the rubric of average error (P. P., i., 347), but still thinks that Volkmann "did not apply the principle of the error method in entirely pure form" (ii., 133). The criticism must now be based upon the supposition that Volkmann worked only from greater to equal, and never from less. There is no evidence to the contrary in Volkmann himself. At the same time, the fact, if it were a fact, would be curious; since Fechner, in the R. account, expressly mentions approach from the two directions, and Volkmann was a careful experimenter. Wundt repeats his criticism, a little more sharply, in 1902 (P. P., ii., 542).

Volkmann's statements would certainly be interpreted, by a reader who had no further evidence in the matter, as Müller interprets them. Müller, be it noted, assumes that Volkmann worked in both directions (G., 83): his objection is that a method of average error aims to make r and r_1 "wirklich gleich" for sensation, and that Volkmann's method deals with j . unnot. (*i.e.*, practically, with j . n.) differences (89, 83). Fechner, however, disputes the interpretation. Volkmann's paragraph, he says, contains not so much a description of procedure as a theory of method. Had Volkmann worked as Müller supposes, he would assuredly have made explicit mention of the ascending and descending series, as he does of the spatial position, right or left, of his standard distance. Moreover, in a brief characterisation of the method, occurring in an earlier passage (Physiol. Unt., 97), Volkmann explains that his apparatus allows "die zweite (Fechner's Fehldistanz), . . . soweit es das Augenmass gestattet, der ersten gleichgemacht [zu] werden."—It is difficult to strike a decision. The author inclines to the belief that Fechner is right. But, however that may be, the mediate or combined form of the method is now, by Müller's criticism, brought into full light.

We turn to the derivation of test-values. In the El. (i., 72), Fechner describes the application of the method to lifted weights, as follows. You to take a certain weight, accurately weighed, as your normal, and are to attempt to make a second or error weight equal to it "nach dem blossen Urtheil der Empfindung." When you have satisfied yourself of the equality of the two

weights, you determine your error by weighing the second weight. The experiment is repeated many times over, and the errors averaged (without regard to sign) to an average error. "Die Empfindlichkeit der Gewichtsunterschiede wird der Grösse des mittleren Fehlers, den man so erhält, reciprok zu setzen sein."

Details of procedure are given in the R., 105 ff. Let r and r_1 represent the normal and the error stimuli. The differences $r_1 - r = E$ are then the crude errors: they contain, in general, a constant error c . The mean error stimulus, r_m , is determined as $\frac{\sum r_1}{n}$. The differences $r_m - r_1 = e$ are the pure variable errors. Their average, determined without regard to sign, is $\frac{\sum e}{n} = e_m$. "der reine Mittelfehler, dessen reciproken Werth ich als Mass der Unterschiedsempfindlichkeit betrachte."

There are two ways of readily determining the required values c and e_m . (1) In the procedure sketched above, r_m is calculated from the separate r_1 ; the e are determined in absolute value as the differences $r_m - r_1$; and $c = r_m - r$,—a value that will be positive or negative, according as $r_m > r$ or $r_m < r$. The calculation of e_m , in this way, is, however, clumsy and liable to error. We therefore short-cut, as follows. (a) Add together all the r_1 that are $> r_m$. Let their sum be G , their number g . Subtract r_m , taken g -times, from G . The remainder is the positive sum of pure errors, $G - g \cdot r_m = P$. (b) Add together all the r_1 that are $< r_m$. Let their sum be K , their number k . Subtract K from r_m taken k -times. The remainder is the negative sum of the pure errors, $k \cdot r_m - K = Q$. (c) The value $P + Q$ —the addition being made without regard to sign—gives the total sum of pure errors, Σe .

(2) The first method of calculation avoids all reference to E . The second starts out with their determination: the positive and negative E are entered in separate columns. All positive r_1 are now summed up to P , and all negative (by absolute value) to Q' . We then have $c = \frac{P - Q'}{n}$. To determine e_m , we make use of those E that gave the same sign as c . Let t be the number, T the sum, of the same-signed E that exceed c in magnitude. Then we get Σe by subtracting tc from T and doubling the remainder: $\Sigma e = 2(T - tc)$. The reason is clear. The sum of the same-signed pure errors is $\frac{\Sigma e}{2} = T - tc$. But the sum of the other-signed must, by theory, be the same as that of the same-signed. Hence if we double the right hand member of the equation, we get the total sum of pure errors.—If we find instances of $E = c$, the E may be counted at

will either to the same-signed or to the other-signed c , provided that this reference be made to affect both t and T .

Since c is eliminated by the reduction of E to e , there is no intrinsic necessity for repeating the experiments with changed spatial or temporal position of r . Such repetition is, however, necessary if c is to be resolved into its components (R., 109; *cf.* El., i., 122; Müller, G., 72 f.).

The average crude error E_m falls into two components, c and e_m . The latter value Fechner uses as a measure of the D. S. If his position be sound, the method of average error may claim to accomplish (though less accurately: p. 153 above) what is accomplished by the methods of limits and of constant R -differences. If the position be unsound, the method is simply a method for the equation of stimuli, and the e_m is its characteristic measure of precision. The psychophysical value of the e_m , as compared with other measures of precision, will then depend upon the constancy and transparency of its conditions.

Now it is just this position of Fechner's that Müller attacks in the G. Nobody, he says, has so far raised the fundamental question whether one really has the right "to consider the average value of the pure variable errors as a magnitude proportional to the value of the DL " (73). After full examination, he himself concludes that "of all the various modifications that can be proposed of the method of average error, there is not one which is capable of an exact mathematical analysis. They are, one and all, more or less dependent upon factors the influence of which is insufficiently known, and they are far too complicated to allow any theoretical determination of the relation in which the mean value of the pure variable errors stands to the value of the DL ." The appeal lies to experimental results, and the experiments will demand "sehr grosse Ausdauer und Sorgfalt" (79).

Fechner replies, in the R., that Müller has unduly narrowed his conception of mental measurement. The DL is only one out of many possible units. Müller admits the method of supraliminal differences; he should, therefore, be ready to admit a method of (average) subliminal differences (R., 18 ff.). But Fechner has missed the real issue.

There are two values that a metric method furnishes: the principal measure, and the degree of its variability. The method of

limits, e.g., furnishes as principal measure the magnitude of the *DL*, and as measure of variability the *MV* of that magnitude. To which of these classes of measures, now, does the average of the pure variable errors belong? Fechner himself has no hesitation in classing it as a measure of precision, of the same general sort as *MV* or PE_1 or *h*. He uses the phrases 'precision of observations,' 'accuracy of physical and astronomical observations,' in *El.*, i., 74; and speaks in *R.*, 114, of the e_m as a measure of 'subjective accuracy.'¹ Yet he has no hesitation, either, in making it proportional to the magnitude of the *DL*.

Müller is evidently right: the question at issue is fundamental, and Fechner has not argued it out. What is, as a matter of fact, the relation of the e_m to the *DL*? Historically, from the point of view of the method as it has actually developed, we may divide this question into two. The first is this: Does the method of average error, which gives us an e_m , provide us also, directly or indirectly, with any acknowledged measure of a sense distance; and, more particularly, of a distance that may be definitely related to our chosen distance unit, the *DL*? If it does, then we may examine the e_m in the light of this other test-value, and so decide, in terms of the method itself, whether the course of the e_m reflects the course of the *DL*. If it does not: if no amount of mathematical torture will wring an affirmative answer from the method: then the second question presents itself. May not the e_m , whether by theory or by empirical result, be somehow brought into relation with the magnitude of our distance unit, the *DL* (otherwise determined) of the *r* employed? If it may, then we shall be able to condone the original sin of omission. If not,—if the second question must also be answered in the negative, then the Fechnerian method has no claims to be regarded, *sensu stricto*, as a method of mental measurement.

Fechner, as we know, raises only the second of these questions, and answers it by saying that the e_m is proportionally related to the *DL*. Müller, to whom we are indebted for the *DL* of *r*, and

¹ On the relation of e_m to *h*, see Fechner, *El.*, i., 129; *R.*, 114 f.; Müller, *G.*, 80; *M.*, 211; Fullerton and Cattell, *Small Diff.*, 18; Higier, *P. S.*, vii., 263; G. F. Lipps, *Gundriss d. Psychophysik*, 68; cf. *Massmethoden*, 49 (*Arch. f. d. ges. Psych.*, iii., 201).

w. cases, makes no attempt in the G. to find a *DL* or any analogous value in average error. He, like Fechner, addresses himself exclusively to the second question; and his answer is,—negative, as regards theory: not proven, as regards practice. Nevertheless, many subsequent writers assume, apparently as a matter of course, that Fechner's interpretation is correct.¹ We return to this point later. On the other hand, certain authors have raised the first question, with affirmative result. We will now look at their arguments.

(1) In 1887, Wundt pointed to the value *s*, the Fechnerian principal error or error of reference, as in some sort a representative of the *DL* of minimal changes and of *r.* and *w.* cases.² Wundt has been followed, *e.g.*, by Külpe.³

In introducing the value *s*, Wundt refers to Fechner (*R.*, and *Pogg. Jubelband*). Now it is true that Fechner, in the *R.*, distinguishes, as Wundt does, between an 'apparent' and a 'true' constant error. But the two distinctions are by no means the same. Fechner's apparent constant error is an error due, not to any constant condition, but rather to a lack of compensation of accidental errors, which in turn is due to a too small *n*. His true constant error is the error of temporal and spatial position (*R.*, 107 ff.). Wundt's apparent constant error, on the other hand, is the error of time and space,—called 'apparent,' one must suppose, merely for the reason that it may be eliminated by reversal of procedure. His true constant error is the error of overestimation or underestimation of *r*; and it is this, our value *s*, which (if smaller than the PE_m) is to be referred to lack of compensation of accidental errors (*P. P.*, i., 1893, 347). Wundt makes the true constant error, *s*, the analogue of the value Δ of his method of minimal changes. This Δ , it will be remembered, is half the difference of the upper and lower *DL*: Wundt terms it the 'estimation error' or 'estimation difference': the author has proposed for it the name 'discrimination constant' (p. 112,

¹ Sanford, *e.g.*, writes (Course, 359): "the *MV* of the single settings from the average . . . is . . . the average limen as given by this method." Witmer asserts that the av. variable error "establishes an exact measure of the sensitivity" (*Analyt. Psych.*, 217). Elsewhere, however, he says that "the av. variable error records the constancy with which the subject approximates to the standard weight" (206). It records, of course, the constancy with which *O* approximates to the most probable value of the variable weight, the value which represents the standard in his idea.

² *P. P.*, i., 352.

³ *Outlines*, 77.

above).—Wundt, then, did not find the value s in the R. Still less did he find it in the essay in Poggendorff's Jubelband. He found it rather in El., ii., which he does not cite.

We noted above (p. 155) that Fechner discovered, in work with av. error, a constant error, which he ascribed to the simple fact that the r of every series remains constant, affords a one-sided standard of reference, while r_1 is variable. “[Es kann] bei der Methode der mittleren Fehler ein constanter Fehler darauf beruhen, dass wir stets die Fehlgrösse, aber nicht die Normalgrösse der Abänderung bis zur scheinbaren Gleichheit mit der anderen unterwerfen” (El., ii., 140). Let p and q stand for the errors of time and space respectively, and s for the constant error which we are now discussing. Then the four possibilities for average error are :

$$\begin{aligned} c_I &= +p - q + s; & c_{III} &= +p + q + s; \\ c_{II} &= -p - q + s; & c_{IV} &= -p + q + s. \end{aligned}$$

Whence we have :

$$p = \frac{c_I - c_{II}}{2} = \frac{c_{III} - c_{IV}}{2};$$

$$q = \frac{c_{III} - c_I}{2} = \frac{c_{IV} - c_{II}}{2};$$

$$s = \frac{c_I + c_{IV}}{2} = \frac{c_{II} + c_{III}}{2}.$$

See El., ii., 151 f.; cf. 347 f.—Here, then, is the Wundtian s . Wundt was working out his method of minimal changes, with a keen eye for constant errors, between 1880 and 1882. When he came to revise his account of average error in 1887, he remembered Fechner's s (forgetting, or at least neglecting to state, the place of its discussion, whether in El., ii., or in the second Abh. of 1884), and incorporated it in the method, with a general reference to Fechner's av. error discussions in the R. and in Pogg. Jubelband. His originality consists, not in the introduction of s as a test-value of the method: Fechner had used it in 1860: but rather in its interpretation, as a value akin to the liminal values of minimal changes and right and wrong cases.

The Δ of minimal changes, with which Wundt parallels the value s , is half the difference of Δr_u and Δr_l . It is, therefore, strictly dependent upon the magnitude of the DL (Fechner, Abh., 1884, 10; cf. Estel, P. S., ii., 48). On the other hand, the s of the Fechnerian method is dependent, as we have seen above (p. 155), both upon the relative magnitude of Δr_u and Δr_l and upon O 's tendencies of manipulation. There can, then, be

no exact parallelism between Wundt's Δ and Fechner's s . If we turn to the combined or mediate method of average error, then, it is true, the Wundtian r_e (the estimation value of r) is analogous to $r_m = \frac{r_u + r_l}{2}$ and the Wundtian Δ to $r_m - r$. But we have already decided that the mediate method is both incomplete and lacking in transparency, and we have questioned the usefulness of the Wundtian values r_e and Δ in the method of limits itself. In fine, therefore, what we obtain from the Wundtian suggestion is merely an analogy to values whose utility in their own proper sphere is dubious. See Müller, M., 204.

(2) In 1899, G. F. Lipps employed the MV and the ME together to determine a true h and a mean D (just unnoticeable difference). The argument is as follows.

Suppose that a stimulus $r_m + \varepsilon$ is judged $= r$. One cannot say that, in passing this judgment, O has made an error of ε . For the judgment 'equal' belongs, not to r_m only, but to $r_m \pm D$. All that one can say is, therefore, that O has committed an error that lies somewhere between the limits $\varepsilon + D$ and $\varepsilon - D$. The probability of such an error, expressed in terms of Gauss' law, is :

$$P_\varepsilon = \frac{h}{\sqrt{\pi}} \int_{\varepsilon - D}^{\varepsilon + D} e^{-h^2 \varepsilon^2} d\varepsilon,$$

or, if $\Phi [h\varepsilon]$ represent the integral

$$\frac{2}{\sqrt{\pi}} \int_0^{h\varepsilon} e^{-h^2 \varepsilon^2} d[h\varepsilon],$$

$$P_\varepsilon = \frac{1}{2} \Phi [h(\varepsilon + D)] - \frac{1}{2} \Phi [h(\varepsilon - D)].$$

Where the theory of errors in physics and astronomy uses the formula

$P_\varepsilon = \frac{h}{\sqrt{\pi}} e^{-h^2 \varepsilon^2}$, the theory of errors in psychophysics must use this more complicated formula. Substituting in the regular equations for ε_m (i.e., for $MV = \frac{\Sigma \varepsilon}{n}$) and for $ME \left(= \frac{\Sigma(\varepsilon^2)}{n} \right)$, we obtain :

$$\frac{\Sigma \varepsilon}{n} = \frac{1}{h\sqrt{\pi}} + \frac{D}{2} \cdot A,$$

$$\frac{\Sigma(\varepsilon^2)}{n} = \frac{1}{2h^2} + \frac{D^2}{3},$$

where A is an abbreviation for :

$$\left(1 + \frac{1}{2(hD)^2}\right) \cdot \Phi[hD] + \frac{1}{hD\sqrt{\pi}}(e^{-h^2D^2} - 2).$$

“Diese Bestimmungen,” says Lipps, “gestatten die Berechnung der DL zusammen mit dem Präzisionsmasse h ganz ebenso wie bei der Anwendung einer Zählmethode” [*e.g.*, of *r.* and *w.* cases].¹ If we work out his formulæ we obtain the following result.

Write x for h , and y for hD : then the equations become

$$(1) \quad \lambda x = a + y \cdot A,$$

$$(2) \quad \lambda_1 x^2 = b + y^2,$$

$$(3) \quad A = 1 + \frac{1}{2y^2} \cdot a \int_0^y e^{-v^2} dy + \frac{a}{2y} [e^{-v^2} - 2];$$

where $\lambda = \frac{2}{n} \Sigma \varepsilon$; $\lambda_1 = \frac{3}{n} \Sigma \varepsilon^2$; $a = \frac{2}{\sqrt{\pi}}$; $b = \frac{3}{2}$.

From (1) and (2)

$$A = \frac{\lambda \sqrt{\frac{b+y^2}{\lambda_1}} - a}{y}.$$

This value of A , substituted for A in the identity (3), gives, after multiplying through by $2y^2$:

$$2\lambda y \sqrt{\frac{b+y^2}{\lambda_1}} - 2ay = 2y^2 + a \int_0^y e^{-v^2} dy + ay [e^{-v^2} - 2].$$

Differentiate both sides of this identity in y :

$$2\lambda \sqrt{\frac{b^2+y^2}{\lambda_1}} + \frac{4\lambda y^2}{\sqrt{\frac{b^2+y^2}{\lambda_1}}} - 2a = 4y + ae^{-v^2} + a[e^{-v^2} - 2] - 2ay^2 e^{-v^2}.$$

Cancel $-2a$, unite terms, and multiply by $\sqrt{\frac{b^2+y^2}{\lambda_1}}$. Then :

$$2\frac{\lambda}{\lambda_1}(b^2+y^2) + 4\lambda y^2 = \sqrt{\frac{b^2+y^2}{\lambda_1}} [4y + 2ae^{-v^2} - 2ay^2 e^{-v^2}],$$

or $\frac{2\lambda b^2}{\lambda_1} + \left(\frac{2\lambda}{\lambda_1} + 4\lambda\right)y^2 =$ “ “

say : $p + qy^2 = \sqrt{\frac{b^2+y^2}{\lambda_1}} [4y + 2ae^{-v^2}(1-y^2)].$

¹ Grundriss d. Psychophysik, 67 ff. Lipps gives intermediate formulæ.

Square both sides :

$$(4) \quad p^2 + 2pqy^2 + q^2y^4 = \frac{\frac{3}{2} + v^2}{\lambda_1} \left[4y + \frac{4}{\sqrt{\pi}} e^{-y^2} (1 - y^2) \right]^2,$$

where
$$p = \frac{3\Sigma\epsilon}{\Sigma\epsilon^2}; \quad q = \frac{4}{3} \frac{\Sigma\epsilon}{\Sigma\epsilon^2} + \frac{4}{n} \Sigma\epsilon; \quad \lambda_1 = \frac{3\Sigma\epsilon}{n}.$$

A value of y given by equation (4), when substituted in equation (2), would give at once the value of x , or h . Then the relation $hD=y$ would give D . But equation (4) is transcendental in y (because of the factor e^{-y^2}); hence h and D cannot be expressed exactly, in terms of the quantities given, from the data furnished. However, we may write

$$e^{-y^2} = 1 - y^2 + \frac{y^4}{2} \dots$$

in equation (4), and collect the powers of y^2 (of which there will be an infinite number). All powers above y^4 will have numerical coefficients independent of $\Sigma\epsilon$, $\Sigma\epsilon^2$, and n . The first four powers of y are :

$$(5) \quad \left\{ 16 + \frac{331}{2\pi} - \frac{3}{n} \Sigma\epsilon^2 \left(\frac{4}{3} \frac{\Sigma\epsilon}{\Sigma\epsilon^2} + \frac{4}{n} \Sigma\epsilon \right)^2 \right\} y^4 - \frac{112}{\sqrt{\pi}} y^3 + \left\{ 36 - \frac{128}{\pi} - \frac{18}{n} \Sigma\epsilon \left(\frac{4}{3} \frac{\Sigma\epsilon}{\Sigma\epsilon^2} + \frac{4}{n} \Sigma\epsilon \right) \right\} y^2 + \frac{72}{\sqrt{\pi}} y + \frac{36}{\pi} - \frac{9\Sigma\epsilon}{n} = 0.$$

This is equation (4) correct to five terms. Equation (5) can be solved, although the work is laborious. A first approximation gives

$$hD = \frac{\sqrt{\pi}}{72} \left[\frac{36}{\pi} - \frac{9\Sigma\epsilon}{n} \right],$$

$$h = \frac{1}{\Sigma\epsilon^2} \sqrt{\frac{1}{3} n \left[\frac{2}{3} + \frac{\pi}{72^2} \left(\frac{36}{\pi} - \frac{9\Sigma\epsilon}{n} \right) \right]},$$

$$D = \frac{\sqrt{\pi \Sigma\epsilon^2}}{72} \frac{\left[\frac{36}{\pi} - \frac{9\Sigma\epsilon}{n} \right]}{\sqrt{\frac{1}{3} n \left[\frac{2}{3} + \frac{\pi}{72^2} \left(\frac{36}{\pi} - \frac{9\Sigma\epsilon}{n} \right)^2 \right]}}$$

Hardly a satisfactory result!—

Since the above was written, the author has received the following solution from Dr. Lipps himself.

“ Write f for $\frac{1}{n} \Sigma\epsilon$ and g^2 for $\frac{1}{n} \Sigma\epsilon^2$: then equations (1) and (2) become :

$$(1) \quad f = \frac{1}{h\sqrt{\pi}} + \frac{D}{2} \cdot A,$$

$$(2) \quad g^2 = \frac{1}{2h^2} + \frac{D^2}{3};$$

whence directly :

$$fh\sqrt{\pi} = 1 + \frac{Dh\sqrt{\pi}}{2} \cdot A; \quad 2g^2h^2 = 1 + \frac{2D^2h^2}{3};$$

or, if hD is replaced by t :

$$fh\sqrt{\pi} = 1 + \frac{t\sqrt{\pi}}{2} \cdot A; \quad 2g^2h^2 = 1 + \frac{2t^2}{3}.$$

Hence we obtain, as equation for t :

$$\frac{f\sqrt{\pi}}{g\sqrt{2}} = \frac{2 + t\sqrt{\pi} \cdot A}{2\sqrt{1 + \frac{2}{3}t^2}}$$

If t is found, h can be calculated at once from

$$fh\sqrt{\pi} = 1 + \frac{t\sqrt{\pi}}{2} \cdot A, \text{ or from } gh\sqrt{2} = \sqrt{1 + \frac{2t^2}{3}}$$

(provided that the value of A in the first equation has been determined), by division by $f\sqrt{\pi}$ or $g\sqrt{2}$. To determine t from the equation

$$\frac{f\sqrt{\pi}}{g\sqrt{2}} = \frac{2 + t\sqrt{\pi} \cdot A}{2\sqrt{1 + \frac{2}{3}t^2}}$$

or, if the value for A be written out, from

$$\frac{f\sqrt{\pi}}{g\sqrt{2}} = \frac{e^{-t^2} + \sqrt{\pi}(t + \frac{1}{2}t)\Phi(t)}{2\sqrt{1 + \frac{2}{3}t^2}}$$

employ the following Table. (For smaller intervals of t a fuller Table must be constructed, if interpolation does not furnish sufficiently accurate values.)

t	$\frac{f\sqrt{\pi}}{g\sqrt{2}} = \frac{2 + t\sqrt{\pi} \cdot A}{2\sqrt{1 + \frac{2}{3}t^2}}$	A
0	1.000	0
0.5	1.001	0.1835
1	1.010	0.343
2	1.041	0.560
3	1.061	0.679
4	1.070	0.749
5	1.075	0.794
6	1.078	0.826
10	1.0825	0.892
100	1.085	0.989
1000	1.085	0.999
∞	1.085	1.000

You see that the value of $\frac{f\sqrt{\pi}}{g\sqrt{2}}$ increases very slowly; you see also that the empirical values $\frac{\Sigma e}{n}$ and $\frac{\Sigma e^2}{n}$, from which $\frac{f\sqrt{\pi}}{g\sqrt{2}} = \frac{\Sigma e\sqrt{\pi}}{\sqrt{\Sigma e^2} \sqrt{2n}}$ is

to be calculated, must range within narrow limits (1 to 1.085) if a real positive value is to be found for t . It follows that there will be many occasions when the assumption that the observational series obey the ordinary (Gauss') law of error will not hold water The methods of experimental psychology must be grounded anew, independently of any assumption of a determinate law of error Hence I look upon the formulæ which presuppose the ordinary law of error as nothing more than a temporary expedient.

"Let me give an illustration of the use of these equations. Suppose that with $n=240$ observations we have found: $\Sigma \varepsilon=38.64$; $\Sigma \varepsilon^2=8.68$; so that $\frac{f\sqrt{\pi}}{g\sqrt{2}}=\frac{38.64\sqrt{\pi}}{\sqrt{8.68}\sqrt{480}}=1.061$. Then we have, from the above

Table, $t=3$, and from $fh\sqrt{\pi}=1+\frac{t\sqrt{\pi}\cdot A}{2}$ or from $gh\sqrt{2}=\sqrt{1+\frac{2}{3}t^2}$

the same result, $h=9.83$. Since $t=Dh$, we have finally: $h=9.83$, $D=0.31$. Suppose, again, that with $n=240$ we have found: $\Sigma \varepsilon=76.85$; $\Sigma \varepsilon^2=40.42$; so that $\frac{f\sqrt{\pi}}{g\sqrt{2}}=\frac{76.85\sqrt{\pi}}{\sqrt{40.42}\sqrt{480}}=0.978$. In this case, there is

no real positive value of t that satisfies the equation $\frac{f\sqrt{\pi}}{g\sqrt{2}}=\frac{2+t\sqrt{\pi}\cdot A}{2\sqrt{1+\frac{2}{3}t^2}}$

(We might, it is true, replace the value 0.978 by 1.000, and take $h=\frac{1}{f\sqrt{\pi}}=\frac{1}{g\sqrt{2}}=1.76$; but this procedure does not recommend itself.)

Nor is there any guarantee that longer observational series will furnish other values for f and g that shall lead to usable values of t . In my opinion, the only way out of these difficulties is to be found in a revision and new foundation of the psychophysical methods."

Lipps' solution thus cuts the difficulty which makes itself apparent in the first set of formulæ. There can be no doubt that it follows the right path: if the mathematicians are bent upon revising the metric methods, they must hand down to psychophysicists numerical Tables of the complex functions which they employ. The construction of such Tables is a thankless task, and it seems a pity that men of ability should spend their time upon it. Still the cry for the Tables rises both from psychology and from biology; and though computers can do a good deal of the work, they can do it at best only under the direct supervision of a competent mathematician. We must therefore hope that the *Neue Grundlegung* which Lipps promises will meet this practical requirement, and not confine itself to the simple explication of formulæ.

What are we to say of this derivation? In the first place, it is evidently inapplicable to Fechner's method. On that method,

it is impossible to predict or to determine the relative frequency with which the various values of r_1 that lie within the zone of equality are chosen by O . The derivation applies rather to a form of the method of av. error which we have not yet discussed,—the form in which it is combined with the method of constant R or R -differences.¹ Secondly, Lipps' j. u. d. is assumed to be of the same magnitude on either side of r .² The assumption may be allowed, of course, for the first establishment of formulæ; but it cannot be admitted as a general principle. Thirdly, it is a criticism rather of the method than of Lipps' treatment of the method that the test-value furnished is not the DL but a j. u. d.: we have accordingly represented it throughout by D . As regards the DL itself, Lipps is inconsistent. He defines it (a) as the "grösstmögliche Zu- und Abnahme, die unbemerkt bleibt,"³ and (b) as "denjenigen Betrag der zu R hinzutreten muss, um eine eben merkliche S -Aenderung zu bedingen."⁴ It is clear that the two definitions conflict.—In spite of these objections, the formulæ may do good analytical service, provided that they are mathematically correct.⁵

¹ This point has been made by Müller, M., 219.

² Grundriss, 48.

³ *Ibid.*

⁴ *Ibid.*, 49 f.

⁵ Müller remarks of Lipps (M., 219): "seine mathematische Entwicklung ist unrichtig." Lipps, however, declares that his formula is identical with that given by Müller himself in M., 217 (Massmethoden, 64; Arch., iii., 216), and shows their coincidence in full in Arch. f. d. ges. Psych., iii., 44 f. In a letter to the author, Professor Müller acknowledges the correctness of Lipps' reply. As regards the formula itself, he writes as follows: "Die von mir angegebene Formel beruht, wie in meiner Abhandlung angegeben, (1) auf der Voraussetzung dass die Konstanzmethode benutzt worden sei. Ist die Grenz- oder Herstellungsmethode angewandt worden, so ist schon über die 'Häufigkeiten des Hergestelltwerdens' der verschiedenen Fehlreize nichts sicheres zu sagen, und es ist dann sogar bei Zugrundelegung der nachstehenden Voraussetzungen theoretisch nichts zu machen. (2) Jene Formel beruht auf der Voraussetzung, dass die untere und obere Unterschiedsschwelle einander gleich seien (Lipps setzt die untere und obere Unterschiedsschwelle beide gleich dem einen Werthe i_0), dass also nicht bloss die durch das Webersche Gesetz bedingte Verschiedenheit beider Schwellen zu vernachlässigen sei, sondern auch kein eine grössere Differenz beider Schwellen bedingender positiver oder negativer Typus vorhanden sei. Man kann in praxi unmöglich diese Voraussetzung ohne Weiteres als erfüllt ansehen. (3) Es wird ferner vorausgesetzt, dass für die zufällige Variabilität der Schwellen das Gauss'sche Fehlergesetz gelte. Wiederum eine Voraussetzung die man nicht ohne Weiteres der Verarbeitung von Versuchsergebnissen zu Grunde legen darf. (4) Dasselbe gilt

We pass now to the combined or mediate form of the method,¹ which is employed in Münsterberg's work on ocular measurement (Beitr., ii., 1889, esp. 155 ff.). Münsterberg accepts Müller's view of Volkmann's procedure: unlike Müller, he charges Volkmann with working only in one direction, from greater to less (129, 155). He himself is careful to avoid this source of error. "Wenn wir . . . systematisch abwechseln, jedesmal in 5 Reihen von erheblich grösseren, in 5 Reihen von erheblich kleineren Werten ausgehen und den gesammten Durchschnitt berechnen, so repräsentieren die Abweichungen von diesem Durchschnitt wirklich den eben unmerklichen Unterschied; . . . der Durchschnitt aus diesen Abweichungen ohne Rücksicht auf die Vorzeichen ergibt dann den variablen Fehler" (156). The detailed procedure is as follows.

Let r denote the normal distance, and r_1 the variable (Fechner's error) distance. Then the average r_1 is determined separately, in each series of 20 observations, for the 10 values in which r_1 lay to the left (r_{mI}), and for the 10 in which it lay to the right (r_{mII}). The \pm difference between r_{mI} or r_{mII} and r represents the constant error. This is referred to r , as a certain percentage, by the formula $c_I = \frac{100 (r_{mI} - r)}{r}$ and $c_{II} = \frac{100 (r_{mII} - r)}{r}$. The percentages are calculated for all the r employed (1, 2, 3, . . . 20 cm.), and the general average is taken.

The average of the pure variable errors (*i. e.*, the average of the positive or negative variations of the 10 values from their average value, taken without regard to sign) is, for Münsterberg, "als der eben unmerkliche Unterschied der reciproke Wert der Empfindlichkeit." First of all, the average variable error is calculated separately for r_1 left and

von der vierten Voraussetzung, dass die zufällige Variabilität der unteren und der oberen Unterschiedsschwelle ganz dieselbe sei, dass man also z. B. bei Voraussetzung des Gauss'schen Gesetzes für die Variationen der oberen und unteren Schwelle einen und denselben Werth von k anzusetzen habe.—Nach Vorstehendem ist es mir sehr begreiflich, dass eine Anwendung jener Formel auf vorliegende Versuchsergebnisse sich nicht bewährt hat."

Lipps' book, in spite of the favourable review by P. Mentz (Z., xxv., 1901, 204 f.), has been curiously neglected in the literature. This neglect may be due to its extreme brevity, or to the writer's fondness for mathematical exposition, or to his general views of psychophysics; perhaps to all these things in combination. His standpoint is worked out in greater detail in the *Massmethoden* of 1904.

¹ Cf. above, p. 132.

right, as e_{mI} and e_{mII} . Then the average of these two values is determined : $\frac{e_{mI} + e_{mII}}{2} = e_m$.¹ This is calculated in percentage of r as $\frac{100e_m}{r}$.

There are 20 such percentage values, one for each of the 20 R employed. The 20 are averaged to a general average, and, finally, the MV of the general average is offered as the value which "orientiert uns unmittelbar über die Gültigkeit des Weberschen Gesetzes" (157, 178).

We cannot, in the light of principles already laid down, accept these values or the interpretation that Münsterberg puts upon them. It is of the essence of the method of limits that it makes separate determinations, ascending and descending, and averages the results. Münsterberg should accordingly have determined his $\downarrow e_m$ and $\uparrow e_m$ separately, in each spatial arrangement; and then, if the two determinations in the same space order were nearly enough alike, have taken their average. These separate e_m would have been clear of complication by the magnitude of the upper and lower DL , whereas Münsterberg's composite e_m depends upon the magnitude, as well as the variability, of the two limens. The reference of this e_m to the standard R shows that, in the writer's opinion, the upper and lower DL are sensibly the same; but the assumption cannot be made without evidence. Lastly, we may note that Münsterberg makes no attempt at an analysis of the constant error.

In 1890, W. Higier published an *Experimentelle Prüfung der psychophysischen Methoden im Bereiche des Raumsinnes der Netzhaut* (Dorpat dissertation: revised reprint in P. S., vii., 232 ff.). In work with average error, Higier made 500 determinations for each of 7 standard distances, 250 in either space order; the experiments were made in series of 25 determinations, alternately \downarrow and \uparrow . The pure errors are determined from the separate series by help of the crude errors E ; their average is then taken from all the series, right, left, ascending, descending; and the inverse value of the average is made the measure of the D. S. (237). The average pure error, thus determined, is referred to r , in Münsterberg's way; and the $\downarrow e_m$ and $\uparrow e_m$, when

¹On this mode of computation, see Müller, M., 202, 214.

treated by themselves (240), are averaged from the two space orders. Hence much the same general criticism may be passed upon Higier that we have already passed upon Münsterberg.

The constant error is analysed into its I, II, ↓ and ↑ components, and recourse is had to the control of the *PE*. Two same-signed constant errors are found: the r_1 are in every case $>$ the r , and the r_1 of the second spatial arrangement (r_1 to the right) are $>$ the r_1 of the first. The former is explained as a time error; r is apprehended first, and "in der Reproduktion verlängert" (270). It would, therefore, correspond to Fechner's positive time error in work with lifted weights (El., i., 115; cf. Müller and Schumann, Pfl. Arch., xlv., 1889, 94). But why is it not Fechner's s ?¹ The latter is referred to the experimental conditions of monocular observation (269 ff.). It, too, may perhaps be otherwise accounted for, as due, e.g., to a preferential attention.

In 1893, J. Merkel published an elaborate study of the method: Die Methode der mittleren Fehler, experimentell begründet durch Versuche aus dem Gebiete des Raummasses (P. S., ix., 53, 176, 400). He first discusses the application of Gauss' theory of errors of observation to the variable errors furnished by the method; then describes the procedure to be followed, with critical reference to Müller (176 ff.), Münsterberg (178 ff., 202 ff.) and Higier (178 ff., 201 f.); next reviews the previous literature, from Kundt onwards (199 ff.); and finally gives the results of experiments of his own. Merkel insists that the r_1 of the descending ($r_1 > r$) and the ascending ($r_1 < r$) series must not be averaged, if Gauss' formulæ are to be employed. Let R_a represent the average r_1 ascending, R_d the average r_1 descending, PE_a the probable error of the single r_a , and PE_d the probable error of the single r_d . Then Merkel's criterion of the validity of Weber's Law is:

$$\frac{PE_a}{R_a} = \frac{PE_d}{R_d} = \text{const.}$$

Again, if R represents the mean value of R_a and R_d (determined

¹ See Müller, M., 202. Not only does Higier omit reference to Fechner's s : he identifies the 'true' and 'apparent' constant errors of Wundt and Fechner! See 243 ff.; cf. 261 ff.

either as $R = \sqrt{R_a R_d}$, or, if R_a and R_d are but slightly different, as $R = \frac{R_a + R_d}{2}$, then $\epsilon = R - r$ is the value of the constant error affecting R .

In his test of Weber's Law, Merkel has simply substituted the more accurate PE_1 for the MV or ϵ_m of other investigators. The substitution makes, of course, no difference in principle. Hence we need not go further into detail as regards his procedure.¹

We come, finally, to the exposition of the method by M. Foucault (*Psychophysique*, 1901, 347 ff.). The procedure is as follows.

"Let r represent the standard stimulus, We take, first, an r_1 that is too small, and increase it, by short equal steps, until it appears equal to r : the value is noted as r'_a . We continue to increase r_1 , in the same way, and record the last value at which it appears equal to r : this value is r''_a . Then we take an r_1 that is too large, and decrease it, noting first the value r'_d , the largest at which it appears equal to r , and finally the value r''_d , the least value which appears equal to r . Averaging r'_d and r''_d , on the one hand, and r'_a and r''_a , on the other, we obtain the values r_d and r_a as the upper and lower r_1 that appear equal to r . These values are, both alike, independent of any influence exerted upon judgment by the order in which r_1 is varied."

Errors of time and space are, of course, to be taken account of. Let us suppose that r_d and r_a have been freed from them. Then we have:

$$r_d - r = D_d, \text{ the 'upper error of recognition';}$$

$$r - r_a = D_a, \text{ the 'lower error of recognition'; and}$$

$$\frac{D_d + D_a}{2} = \frac{r_d - r_a}{2} = D_m, \text{ the 'average pure error of recognition'}$$

The last is the most important test-value which the method furnishes (353). Again, "the r_1 which lies at the centre of the zone of equality is that which appears on the average to be equal to r . Call this magnitude

r_m . Then we have: $r_m = \frac{r_d + r_a}{2}$. Finally, if we make $r_m - r = D$, the

¹ The reader may be reminded that Merkel in one series of experiments follows Volkman's method, of adjustment to a j. n. d.: P. S., ix., 415 ff.; cf. p. 132 above. It may also be noted that Merkel proposes to eliminate the error of habituation (found in the combined method by Münsterberg: *Beitr.*, ii., 156) by setting out in every case from an r_1 that is only just noticeably $>$ or $<$ r : *ibid.*, 179, 411.

magnitude D corresponds to Wundt's error of estimation ; it denotes, according as it is positive or negative, the value by which we overestimate or underestimate r ."

The author proceeds to discuss the value of averaging, for the elimination of accidental errors ; the influence of practice ; and the size of the steps to be employed. The error of expectation is counteracted either by irregular variation of the magnitudes chosen for r_1 , or (with reliable O 's) by simple reversal of the regularly varied series. "On note chaque fois la plus forte et la plus faible des excitations qui paraissent égales à la normale" (352). It need hardly be pointed out that the use of discrete in place of continuous r_1 avoids a difficulty mentioned above,—the difficulty of determining the r_1 which is *last* equal to r . At the same time, the knot is cut rather than untied.

In conclusion, Foucault turns to the constant and variable errors. (1) The absolute constant error, or estimation error, may be attributed "au moins hypothétiquement, à la présence de l'image constitutive dans la perception." The 'constitutive image' is "l'image générale qui (on the author's theory) est contenue dans la perception" (129). Its presence is difficult of proof: "sur ce point, l'observation subjective ne nous donne pas d'information précise ; la combinaison de l'image constitutive avec la sensation est trop intime pour que nous puissions l'analyser directement : aussi l'analyse que j'ai donnée sur ce point est hypothétique" (132). Nevertheless, indirect evidence of its existence is found in normal illusions and in the genesis of perception in the child. At any rate, we may explain the estimation error, hypothetically, by assuming that the pure datum of sensation is obscured by the hypothetical constitutive image. (2) The constant errors of time and space may be eliminated by averaging. (3) The variable errors of r_d and r_a "mesurent la stabilité du jugement sensoriel, et l'on y pourrait voir peut-être une mesure de la régularité de l'attention. . . Mais l'erreur variable dépend en même temps de causes accidentelles" (355).

Appended are the results of an investigation, by this method, into the visual perception of lines (356 ff.).

Foucault's method is open to criticism on various counts (*cf.* p. 132 above). Its chief point of interest lies in its close resemblance to Wundt's method of minimal changes. We began with Fechner's method of average error, the aim of which is to make an r_1 "wirklich gleich," for sensation, to a given r . Out of this came—perhaps by way of an incautious statement of Volkman's—the combined or mediate method of average error, in which O stops short at the outer limits of equality. The combined method

is used, in fancied security, by Münsterberg and Higier. It is also used by Merkel, who, while correcting mistakes of theory in the work of his predecessors, himself offers an equivalent of the Fechnerian e_m as the measure of the D.S. In the meantime, Wundt has been at work upon both forms of the method. His result is a compromise. He finds in the e_m (or in the average of $\downarrow e_m$ and $\uparrow e_m$) an inverse measure of the D.S.; he also finds, in Fechner's principal error, a value which represents the value Δ of minimal changes. Now comes Foucault, and frankly assimilates the combined method of average error to the method of minimal changes. "La méthode des petites variations donne la différence juste perceptible, la méthode des erreurs moyennes donne, sur le nom de l'erreur pure de reconnaissance, la différence juste imperceptible. . . C'est dire que les deux méthodes sont presque identiques, ou plutôt que la méthode des différences juste perceptibles, déjà transformée considérablement par Wundt, se résout dans la méthode des erreurs moyennes. . . Au point de vue des résultats numériques des expériences, la différence entre la méthode de Wundt et la méthode des erreurs moyennes est peu considérable. . . En revanche, la différence est notable au point de vue de l'interprétation psychologique des expériences" (356). That is to say: Wundt measures the noticeability of sensation by help of his 'psychological' DL ; Foucault measures the clearness of perception (285 ff.) by help of his 'pure error of recognition.' In schema, however, Foucault's method might be laid, term for term, over the Wundtian method of minimal changes, and the only difference would be the difference in the choice of limiting values.

This result may, of course, be variously appreciated. To the author, it seems the *reductio ad absurdum* of the combined method. If we gained anything by it,—if the method gave us any test-value that should serve our psychophysical purposes better than the DL of the method of limits,—the case would be different. But nothing is gained. We have simply wandered back from the Fechnerian method of average error to the place from which we started: the method of limits. Only, the place has changed its name, and is not so well surveyed as it was when we left it.—

We have still left it an open question whether or not the e_m may be regarded as proportional to the DL . Let us look at some opinions.

We have seen that Fechner, Volkman (P. U., 118), Wundt, Münsterberg, Sanford, Higier and Merkel regard the e_m as inversely proportional to the magnitude of the D . S. Müller, who first insisted on the distinction between measures of magnitude and measures of precision, finds in the G . that this assumption has no theoretical support, and awaits the issue of further experimentation for a practical decision of the question. Külpe (Outlines, 77) makes the e_m a measure of delicacy (precision) of discrimination, and of that only. We turn now to some other authorities.

James (Psych., i., 541) sides with Fechner. "There will in general be an error whose amount is large when the discriminative sensibility called into play is small, and *vice versa*. . . It should bear a constant proportion to the stimulus, no matter what the absolute size of the latter may be, if Weber's Law hold true."¹ Ebbinghaus, like Müller, takes a middle position. "An dieser [Fechnerschen] Betrachtung ist jedenfalls soviel richtig, dass Unterschiedsschwellen und mittlere Fehler nicht völlig voneinander unabhängige Dinge sind. Der jeweilige Wert des einen hängt mit ab von dem jeweiligen Wert des anderen und wird im Allgemeinen wohl mit diesem steigen und fallen müssen. Allein gleichzeitig hängt jede der beiden Grössen doch auch noch von sonstigen Umständen ab, und dass also ihre Zusammengehörigkeit bis zu einer wahren Proportionalität gehe, ist keineswegs erforderlich." Ebbinghaus then points out that the reduction of the time allowed for judgment means a large increase of the e_m , and a much smaller increase of the DL ; while the interpolation of a time-period between r and r_1 means a large increase of the DL , and a much smaller increase of the e_m . Hence "mittlere Fehler und Unterschiedsschwellen haben neben einer gewissen Beziehung zueinander auch eine gewisse Unabhängigkeit voneinander" (Psych., i., 69 f.).² Jastrow is more radical. For him

¹ So G. Sergi, *Psych. physiologique*, 1888, 21.

² Cf. Müller, M., 213, 218 f.

there is no *DL*: "sensation and stimulation each forms a continuum, and it leads to hopeless confusion to apply discrete conceptions to them" (Amer. J., i., 1888, 276 f.). Hence the only thing we can do is to measure sensibility, whether as between one *O* and another, one sense and another, or what not. The e_m (or, as Jastrow prefers, the probable error) "is the gauge of variation in sensibility from day to day, in different individuals, and so on. . . If A is a better observer than B, the complete significance of this fact is expressed by saying that his probable error is less than B's. . . To say that one sense is finer than another is to say that its probable error is less. . . The probable error furnishes a quantitative estimate of sensibility. If A has twice the sensibility of B, this means that his probable error will be one half that of B" (293 f., 298). If this point of view could be made out, there would be no such thing as quantitative psychology, and our present question would be meaningless, a question raised upon an unreal issue. But Jastrow's polemic against the *j. n. d.* seems, as we have seen, to be based upon a misconception, and he has given us no discussion of the measurement of sense distances.

Fullerton and Cattell in the main follow Jastrow. "If a series of trials be made and the average error taken, the observer's accuracy of discrimination is directly measured" (Small Differences, 1892, 18). "All the experiments made by the three methods [of *j. n. d.*, *r.* and *w.* cases, and *av. error*] . . . seem to us to determine the error of observation under varying circumstances, and not to measure at all the quantity of sensation. . . The experiments . . . show that the error of observation usually increases as the stimulus increases, but more slowly. . . We believe that the error of observation tends to be related to the magnitude of the stimulus in a simple manner; namely, that the error of observation (and the so-called least noticeable difference) is proportional to the square root of the stimulus" (23 f.: Fullerton gives a qualified assent, 26).¹ The *DL* is here assim-

¹ Fullerton and Cattell put their law forward as a new substitute for Weber's Law, without reference to the literature (25 f.). A 'parabolic law,' with the equation $S = \sqrt{\frac{R}{c}}$, was, however, formulated by P. Breton in 1885 on the basis of experiments with brightness (Ass. franç. pour l'avancement des sciences, 226 ff.;

lated to the e_m , as an error of observation. We are thus—rather paradoxically—reminded of Fechner, who used the DL and the h , indiscriminately, as measures of the D. S., and who in 1887 termed the DL a ‘Schätzungsfehler.’ And again, we are reminded of Müller. In their law of the square root, the authors provide us,—not, of course, with that empirical correlation of the DL and the e_m which Müller desiderates,—but at least with a substitute. We are not measuring sense distances, quantities of sensation, they say, but errors of observation. Now, if with a stimulus r we make an error x , then with a stimulus $2r$ we shall make an error $x\sqrt{2}$. Whether we term the error an ‘average variable error’ or a ‘just noticeable difference’ depends simply on the method employed. The e_m is not a determinate function of the DL ; but the e_m and the DL are quantities of the same order, and are both alike determinate functions of r .

There is nothing in the passage cited to warn the reader against its generalisation. The first hint that the writers are putting a restricted meaning upon the term ‘just noticeable difference’ is given by the statement that their method of j. n. d. “is analogous to that of average error” (37). That the meaning must be restricted is clear, however, from Cattell’s later article, in *A. J. P.*, v., 1893, 285 ff. “Researches in which the method of j. n. d. has been used do not of necessity measure the error of observation at all. The variation in adjusting the j. n. d. would roughly measure the error of observation, but this has been neglected” (290 f.). The j. n. d. is either a supraliminal difference—of stimuli, not of sensations (291, 293); or it is an artifact of method, due perhaps to the obliteration of objective differences by the mechanism of the eye, perhaps to the temporal and spatial relations of the stimuli (291).—If, now, we read the Small Diffs. in the light of this later discussion, we see plainly that the DL which represents an error of observation is not the DL at large, but the DL of the writers’ own method of j. n. d.

In any event, neither Fullerton and Cattell, nor Cattell alone, allows any place to a quantitative psychology, in the sense in which we have employed the word ‘quantitative’ in this book. “I entirely question the

Comptes rendus de l’acad. des sciences, ciii., 1887, 426). Its validity has lately been denied by C. Henry (*ibid.*, cxxii., 1896, 951). Again, if we write the new law $S = c\sqrt{R}$, we have in it merely the special form of Plateau’s formula examined by A. Stefanini, *Atti d. R. Acc. Lucc. di Sci. Lett. ed Arti*, xxv., 188, 383 ff.; *cf.* *Il Nuovo Cimento*, 3, xxxi., 1892, 235; Merkel, *P. S.*, v., 540 ff.; vii., 562.

application of the error of observation to the measurement of the intensity of sensation. . . We cannot measure the intensity of sensation and its relation to the energy of stimulus either by determining the error of observation or by estimating amounts of difference" (A. J. P., 292 f.). It is impossible here to enter into detailed criticism. We note, however, that the reasoning in the Small Diffs. has not fully convinced one of the writers; that the evidence for the limen and for Weber's Law is far too strong to be thus lightly set aside; that the authors do not distinguish sharply between 'magnitude' and 'precision' of the *DL*,—the concepts should have been discussed, even if their difference or their validity were denied; and that the experiments leave a good many loopholes for criticism. The sort of psychophysics—we might term it 'physical psychophysics'¹—represented by Jastrow and by Fullerton and Cattell is a definite and fairly consistent body of doctrine, which has the advantage of a relatively great simplicity. Its leading ideas were formulated in the sterile period of psychophysics, when Fechner's theories were in disrepute,² and experimental psychology had not yet entered upon the qualitative stage. For these reasons, and because of the authority of its propounders, it has exercised a very considerable influence upon American students. We shall have more to say about it presently, when we are reviewing the method of constant *R*-differences (*r.* and *w.* cases). The author may, however, express his opinion here that several of its underlying assumptions are erroneous, and that its simplicity is gained only at the expense of psychological facts. See F. Schumann, *Z.*, vi., 1894, 475 ff.; E. B. Titchener, *Mind*, N. S., i., 1892, 557 ff.; Müller, *M.*, 14 f., 22, 58 f., 102, 211.

Müller recurs to the question in the *M.* (210 ff.). We saw above that Fechner had not hesitated to class e_m with h as a measure of precision. Müller, in the *G.*, was content to remark that e_m depends, not only upon the accidental error processes, but also upon the magnitude of the *DL*, upon the uncertainty of manipulation, etc.; so that an $h = \frac{1}{e_m \sqrt{\pi}}$ cannot possibly be identified with the h of right and wrong cases (*G.*, 80). He now declares, categorically, that the simplest of the e_m values,—that which we obtain in the purest form of the method of average error, the form (not yet discussed) in which it is combined with the method of

¹ A. J. P., v., 292 f.

² And yet the germs of it, like the germs of so many other things, are to be found in Fechner himself! See above, pp. xxxvi., civ.

constant R or R -differences,—is in principle neither an average DL nor a measure of the precision of the DL , “sondern in komplizierter Weise sowohl von den Mittelwerten als auch von den Streuungsmassen der beiden DL abhängig” (223).¹ In the Fechnerian method, it depends (a) upon the relative frequencies with which O selects the various possible values of r_1 , and (b) upon the probability accruing to each such value of r_1 that it be allowed to stand after selection; more briefly, it depends upon the ‘Häufigkeiten des Hergestelltwerdens’ and upon the ‘Wahrscheinlichkeiten des Zugelassenwerdens.’ Assuming the validity of Gauss’ Law for the accidental variations of the DL , we may translate the latter phrase to mean a dependency upon the values of the upper and lower DL and upon their h or measures of precision. The influence of relative frequency of selection (an influence superadded upon the other, in the Fechnerian method) cannot be exactly determined: 211 ff., 220, 223. Lastly, the $\downarrow e_m$ and $\uparrow e_m$ of the combined method depend, not at all upon the magnitude of the DL , but only upon their variability; while they are further dependent upon the relative frequency with which the various possible values of r_1 are selected by O . In view of the difference in the conditions under which the adjustment is made, there is, however, no reason to identify this latter dependency with the influence exerted by (a) above upon the Fechnerian e_m : 213 ff., 223 f.

Now we know—though this point has not yet been discussed—that, under certain experimental conditions, the product of the average DL into the average measure of precision is approximately constant. If, under these conditions, experiments are made by the combined method of average error and of constant R or R -differences, we shall accordingly expect to find the course of the e_m reflecting the course of the DL . We have an instance in A. Wreschner, *Methodologische Beiträge*, 1898, 66. Again, if experiments are made by Fechner’s method under such conditions that frequency of adjustment is uniformly distributed over the whole range of the r_1 employed, we shall find a similar parallelism. We have an instance in Fechner’s work upon ocular measurement, *El.*, i., 214 f. Once more: we know that $\downarrow e_m$ must (other

¹ Cf. A. Kleiner, *Pfl. Arch.*, xviii., 1878, 562 ff.

things equal) be greater, the greater the variability of the upper DL , *i.e.*, the smaller the h or measure of precision. If, then, the product $\Delta r_u \cdot h_u$ is constant, then increase of r must be accompanied by increase both of Δr_u and of $\downarrow e_m$, though the growth of the two magnitudes need not be strictly proportional. A similar argument holds for $\uparrow e_m$. We can thus understand that the course of $\downarrow e_m$ and $\uparrow e_m$ may also reflect the course of the DL ,—as it does in the work of Higier (P. S., vii., 237 ff.) and Merkel (P. S., ix., 409 ff.). If, on the other hand, conditions are introduced (as in Ebbinghaus' experiments) whereby DL and h are led to vary disproportionately, then there must also be a disproportionality between the courses of the DL and the e_m .

We are thus able, at the end of our discussion, to return a fairly definite answer to the question whether or not the method of average error is a true method of mental measurement. Fechner was not wholly in the wrong; but the solution of the problem afforded by the e_m is indefinitely more complicated than he supposed.

ESSAY SUBJECTS.—(1) The value of Fechner's method of average error as a psychophysical method; its claims to qualify as a method of S -measurement.

(2) A statement, with critical estimate, of the various forms that the method has assumed in experimental work.

(3) The significance of the e_m .

(4) The physiology and psychology of *Anregung* and *Antrieb*.

(5) The general psychophysical value of methods of adjustment.

(6) Experiments upon the estimation of visual extents: historical and critical.

General discussions will be found in Wundt, P. P., ii., 1893, 131 ff.; ii., 1902, 541 ff.; O. Zoth, in Nagel's Hdbch. d. Physiol., iii., 2, 1905, 380 ff.

§ 26. **The Method of Equivalents: Notes on § 18 of the Text.**
—The rules given for the conduct of the method are those found in the text-books: see, *e.g.*, Külpe, *Outlines*, 56 f.; Wundt, P. P., ii., 1902, 448; Müller, M., 207 (201). It would, of course, be possible to determine two critical values \uparrow , and two \downarrow , as in the method of equal sense distances: see p. 82 of the text.

EXPERIMENT XVI

For this experiment, see M. F. Washburn, P. S., xi., 1895, 196 ff., 219. It is advisable to have the points of the æsthesiometer sharper than in vol. i., Exp. XXXIV.; the author reduces them to a diam. of $\frac{1}{8}$ mm.

It should go without saying that, in order to an equal distribution of the effects of practice (p. 79 of the text), *E* must make out beforehand a plan of the complete experiment.

EXPERIMENT XVII

As this experiment is a little unusual, and yet may be performed easily and with uniform result, the author here departs from his regular custom, and transcribes a full set of determinations.

SCHEME OF EXPERIMENT,

without regard to distribution of series for equality of practice.

A_r =back of right hand ; A_l =back of left hand.

B_{rr} =right wrist, right of centre line ; B_{rl} =right wrist, left of centre line ; B_{lr} =left wrist, right of centre line ; B_{ll} =left wrist, left of centre line.

Subscript I, standard first on *A* ; subscript II, standard second on *A*.

$A_{rI} \uparrow$	B_{ll}	$A_{rII} \uparrow$	B_{ll}	$A_{lI} \uparrow$	B_{rr}	$A_{lII} \uparrow$	B_{rr}
$A_{rI} \downarrow$	B_{ll}	$A_{rII} \downarrow$	B_{ll}	$A_{lI} \downarrow$	B_{rr}	$A_{lII} \downarrow$	B_{rr}
$A_{rI} \uparrow$	B_{lr}	$A_{rII} \uparrow$	B_{lr}	$A_{lI} \uparrow$	B_{rl}	$A_{lII} \uparrow$	B_{rl}
$A_{rI} \downarrow$	B_{lr}	$A_{rII} \downarrow$	B_{lr}	$A_{lI} \downarrow$	B_{rl}	$A_{lII} \downarrow$	B_{rl}

RESULTS of 32 series taken under the above scheme, but distributed with regard to the effects of practice :

 O_1

20, 20	20, 22	20, 20	22, 22
20, 20	22, 22	20, 20	22, 22
22, 20	22, 22	20, 16	22, 22
16, 20	20, 22	20, 18	20, 21

 O_2

20, 20	22, 18	24, 24	24, 24
22, 20	20, 18	22, 20	21, 24
24, 22	22, 24	28, 20	24, 24
22, 16	18, 20	24, 20	20, 22

The experiment was now reversed (see Question 3, below). A weight of 20.5 gr. on the wrist was taken as standard for O_1 , a weight of 21.5 gr. as standard for O_2 . Variable weights, 4–13 gr., with steps of 1 gr. Twelve series were taken as follows (scheme as above, *mutatis mutandis*):

		O_1		
8	9		9	—
8	—		8	7
8	8		9	—
9	—		8	8
		O_2		
8	11		8	—
8	—		6	7
9	10.5		8	—
7	—		6	6

In this reversed experiment, O remarked more than once that his right wrist was 'more sensitive' than his left. No reason could be given. The fact appears in the figures (though not in the introspections) of the principal experiment.

Generalising, we may say that a weight of 8 gr. on the back of the hand is the equivalent of a weight of 21 gr. on the volar surface of the wrist : or, in other words, that the sensitivity of the back of the hand : the sensitivity of the wrist :: 21 : 8. It is not necessary here to work out the results in detail.

The cartridge weights were first suggested by Galton (*Inquiries*, 1883, 373: *Sanford, Course*, 365, 367), who, however, used them for experiments with lifting (*Inquiries*, 34 ff., 374). We shall speak of Galton's set again, in § 33. The cartridge cases should be marked on the side 1, 2, 3, . . . , in the order light to heavy. It is advisable that the gr.-values to which these marks correspond remain unknown both to E and to O until the whole experiment is completed: in other words, it is advisable that the set recommended in the text be varied (extended, steps reduced to 1.5 gr., etc.), or that equivalence be determined upon other cutaneous areas than back of hand and volar surface of wrist.

QUESTIONS.—(1) This question should be answered from § 17 of the text.

(2) See the criticism passed on the application of the method of limits to the problem of average error in § 25.

(3) Fechner distinguishes two different procedures, which he terms G_1 and G_2 . That of the text is the G_1 -procedure. It is characterised by the fact that the standard stimulus remains constant throughout, whether it is applied to A or to B : in other words, $a = b$. The alternative or G_2 -procedure is characterised by the variation of the standard stimulus. Suppose that in the time order $A-B$ we obtain the equivalence $a = b_I$, and in the time order $B-A$, the equivalence $a = b_{II}$. Instead, now, of setting b ($= a$) on B , in the reversed experiment, we use b_{II} in the time order $B-A$, and b_I in the time-order $A-B$. In other words, having first determined b_I and b_{II} as the equivalents of a , we now seek to redetermine a as the equivalent of b_{II} and b_I . We thus obtain the values a_{III} and a_{IV} . Continuing the experiment, we first revert to the original procedure, and determine a new b_I and b_{II} ; then these are made the standards upon B , and we determine from them a new a_{IV} and a_{III} . And so on. Finally, we determine b_e ($e =$ equivalent) as the average of all b_I and b_{II} , and a_e as the average of all a_{III} and a_{IV} .¹

The G_2 -procedure offers no special advantages: see Fechner, *Abh.*, xxii. (xiii.), 1884, 280 ff.; Müller, *M.*, 210; *cf.* 76 f.²

(4) It must, as usual, be left in the discretion of the Instructor to rest content with the exposition of the text or to take the student more deeply into the question of the eliminability of the constant errors. For the facts in the case, see Müller, *M.*, 205 f.

(5) On the hypothetical Verhältnissfehler, see Fechner, *Abh.*, 1884 (Raumsinn), 281 ff.; Müller, *M.*, 207 ff.

(6) Experiments involving the comparison of visual and tactual distances were made by Wundt in 1858 (*Beiträge*, 1862, 34 ff.; Fechner, *El.*, ii., 315). Fechner, who made experiments of his own, thinks (*a*) that comparison is possible only "durch Erfahrungen, die wir früher beim beziehentlichen Gebrauche der beiderlei Sinnesorgane gemacht haben," *i.e.*, that it is associative,

¹ Subscript *I* means standard first on A ; *II*, standard second on A ; *III*, standard first on B ; *IV*, standard second on B .

² Besides these procedures, the problem of equivalence may be attacked by the method of constant R .

and not direct; and suspects (*b*) "dass (on occasions) man sich eine Art Vergleichsmassstab dabei in der Phantasie willkürlich macht, und den einmal gemachten dann ungefähr einhält": 318 ff. The reader will be reminded of similar sources of error in the method of equal sense distances (p. 203 below). The author has not made experiments in this field, but has no doubt that visualisation of the tactual distance plays a great part in the case of visually minded *O*'s.

If we regard the attribute of extension as identical in touch and sight, as implying a simple quantitative 'more' or 'less' of one common space, direct intercomparison of visual and tactual areas, distances, etc., should be possible. The same thing would hold, *mutatis mutandis*, of time. But this identity of the spatial and temporal attributes is by no means proved. Consider the fate of the attribute of intensity! It may very well be the case that extension and duration are going the same road. Meinong says, *e.g.*, that to him "das qualitative Moment nirgends deutlicher erfassbar scheint als beim Raume" (*Z.*, xi., 117), and M. F. Washburn has sounded a like note of warning as regards duration (*Psych. Rev.*, x., 1903, 416).

The idea of a cross-comparison between intensive differences in disparate sense departments occurs in Münsterberg, *Beitr.*, iii., 1890, 56 ff. "Soweit tastende Vorversuche mirch orientierten, schien es mir möglich, den Unterschied zwischen schwachem Schall und starkem Gewicht so einzustellen, dass er gleich dem Unterschied zwischen schwachem Gewicht und starkem Schall geschätzt wird" (98). The mechanism of such comparison is, for Münsterberg, the *Spannungsempfindung*,—the one Fechnerian sensation, built up of increments: see § 6. This theory has not received serious consideration. No doubt, judgments of intensive equivalence as between different sense departments are possible. But they are, without any question, judgments based upon association and experience, and not judgments of direct comparison.

(7) Visualisation. *P. S.*, xi., 195, 196 ff.; *cf.* Fechner, *El.*, i., 132.

§ 27. **The Method of Equivalents: Historical.**—The method of equivalents seems to have been first employed in 1831 by E.

H. Weber, in the sphere of passive pressure (Ann. anat. et physiol., 1851, 97 ff.; Fechner, El., i., 132; Abh., 1884 [Raumsinn], 278). Weber found, e.g., that a pressure of 4 oz. on the forehead is approximately equal in sensation to a pressure of 1 oz. on the lips. The method, still unnamed, was next employed by Wundt in 1858 for the intercomparison of visual and tactual distances (Beitr., 1862, 34 ff.; Fechner, El., ii., 315 ff.). Fechner, who introduced the title 'method of equivalents' (El., i., 131), appears to have worked out the method, on the analogy of the method of average error, without knowledge of its previous use by Weber. A preliminary account of procedure is given in El., i., 131 ff. "Das Verfahren, was man bei der Methode der Aequivalente einschlägt, ist wesentlich dasselbe, als bei der Methode der mittleren Fehler, nur dass man die Ausgleichung der beiden Zirkeldistanzen für die *S* nicht auf derselben, sondern auf verschiedenen Hautstellen bewirkt, und nicht auf den Unterschied, sondern das Verhältniss der verglichenen Grössen acht hat" (133). Fechner insists, however, that the calculations of average error may be applied directly to the method of equivalents (*ibid.*; cf. Müller, M., 207 n.). In El., ii., 318 ff. he gives the results of experiments made by him upon Wundt's problem. In Abh., 1884 (Raumsinn), 273 ff. he discusses the procedure of the method of equivalents in greater detail, compares it with the method of r. and w. cases, and cites results.

The application to equivalents of the principle of the method of limits is due to W. Camerer. The results of Camerer's investigations were not published until 1887 (Z. f. Biol., xxiii., 509 ff.), though the work was in progress in 1884 (Fechner, Abh., 281). Fechner is inclined to prefer the new procedure to his own (*ibid.*).

Camerer's conclusions are discussed by M. F. Washburn, Ueber den Einfluss von Gesichtsassociationen auf die Raumwahrnehmungen der Haut, 1895, 23 ff.: cf. Fechner, Abh., 277, 310; Z. f. Biol., xxi., 1884, 567. Washburn's results (obtained with special reference to the error of visualisation) are given *ibid.*, 30 ff., 39, 52 ff.; also P. S., xi., 196 ff., 206, 218 ff.

Henri (Raumwahrnehmungen, 1898, 24, 59 ff.) derives the method of equivalents from Weber's observation that the sub-

jective distance between two compass-points widens and narrows as the compasses are drawn from finger-tips to elbow or across the face from ear to ear (Ber. d. sächs. Ges. d. Wiss., 1852, 94). Fechner, it is true, cites in *El.*, ii., 311, 322, the paper in which the observation is reported. We have, however, seen that in *El.* i., 131 he seems to claim the method as his own, and that in referring to Weber he quotes the experiments made, not with tactual distances, but with passive pressure.

Wundt's problem of the comparison of visual and tactual distances is taken up and extended (apparently without knowledge of Wundt's work) by Jastrow (*Mind*, O. S., xi., 1886, 539 ff.), who compares linear distances as estimated by the resting eyes, by span of forefinger and thumb, and by free arm-movement. *Cf.* Washburn, 37 f. (*P. S.*, xi., 204); Goldscheider, *Ges. Abh.*, i., 1898 (1885), 182, 196; Henri, 61; Helmholtz, *P. O.*, 1896, 704.

J. N. Czermak remarked in 1857 (*Sitzungsber. d. Wien. Akad.*, math.-naturw. Cl., xxiv., 231) that the seconds-hand of a watch appears to move faster in direct than in indirect vision. He suggested that there might be an analogue to this phenomenon in the sphere of touch; that a given rate of movement may be perceived as faster upon more sensitive than it is upon less sensitive parts of the skin. The suggestion was experimentally confirmed by K. Vierordt: *Zeitsinn*, 1868, 119 f.; *cf.* Hall and Donaldson, *Mind*, O. S., xi., 1885, 571. Here are, plainly, two problems for the method of equivalents. On movement in direct and indirect vision, see S. Exner, *Pflüger's Arch.*, xxxviii., 1886, 217 f.; H. Aubert, *ibid.*, xxxix., 1886, 362 ff.; F. B. Dresslar, *A. J. P.*, vi., 1894, 312; L. W. Stern, *Z.*, vii., 1894, 341 ff., 362; *Psych. d. Ver.*, 1898, 181 ff.

We may also think of the equation of brightnesses in direct and in indirect vision (*Wundt*, *P. P.*, i., 1902, 521); of the equation of visual distances under the same conditions (*Helmholtz*, *P. O.*, 1896, 704); of the equation of horizontal and vertical lines (*cf.* vol. i., *S. M.*, 160; *I. M.*, 315); of the equation of weights lifted, *e.g.*, by hand and foot; of the equation of distances traversed by different limbs or segments of limbs; of the equation of differently filled time-intervals (*Wundt*, *P. P.*, iii., 1903, 58); etc., etc.—

It is a little surprising that the method of equivalents has not made more impression upon the practice and the literature of experimental psychology. It finds no mention in Baldwin's Dictionary and in Sanford's Course; Wundt says nothing of it in the *Logik* (ii., 2, 1895, 185 ff.), or in the first volume of the *P. P.* (*cf.* ii., 1893, 11 f.; ii., 1902, 448); Stumpf gives it but a passing glance (*Tps.*, i., 60); Ebbinghaus quotes an equivalence from Camerer, but says nothing of the method (*Psych.*, i., 445 f.; *cf.* 66 ff.); Foucault passes it by without reference. Now it is true that the method of equivalents is not a special method; Fechner, in *El.*, i., insists upon this point as strongly as does Müller in the *M.* It is true, also, that the results are not susceptible of straightforward mathematical treatment, and that Fechner's discussion in the *Raumsinn* has a somewhat forbidding appearance. Nevertheless, the method is intrinsically interesting; it is always a favourite method in laboratory practice; and the few investigations made by it have been fully as fruitful as, on the average, are investigations carried out by the other methods. The reason for its neglect is, in all probability, the fact that it has no direct bearing upon Weber's Law.

ESSAY SUBJECTS.—(1) The contributions made by the method of equivalents to our knowledge of the factors involved in sensory judgments.

(2) A programme of work to be accomplished by the method of equivalents.

(3) A statement, with critical estimate, of the forms which the method has taken in experimental work.

(4) The position to be taken by a systematic psychology as regards the possibility of direct intercomparison of disparate *S* (*S*-attributes, *S*-distances).

(5) The place of experiments upon ocular measurement and æsthesiometry (*Augenmass* and *Raumsinn d. Haut*) in a systematic exposition of psychophysics. [We have spoken of 'visual extents' and 'cutaneous extents': is this correct? And how far have we anticipated, in these experiments, the problem of mean gradations? Text in Stumpf, *Tps.*, i., 57 ff.]

§ 28. **The Method of Equal Sense Distances: Notes on § 19 of the Text.**—The sound pendulum was first constructed by Volk-

mann, whose model is described by Fechner, *El.*, i., 176 f.; *cf.* K. Vierordt, *Die Schall- und Tonstärke*, 1885, 106 ff. It may have been suggested by the pendulum acoumeter of J. E. M. G. Itard (J. S. T. Gehler's *Physikalisches Wörterbuch*, Art. *Gehör*, iv., 2, 1828, 1217; *El.*, i., 179). Fechner later had a double pendulum built for his own use (*ibid.*). It has now become a standard laboratory instrument, and is figured, *e.g.*, by Wundt, *P. P.*, i., 1893, 361; i., 1902, 511; Sanford, *Course*, 374; Kämpfe, *P. S.*, viii., 522. Kämpfe gives dimensions and materials (523; *cf.* Sanford, 376).¹ The releases used with the Leipzig instrument are figured and described by Kämpfe, 524; those shown in Fig. 23 of the text are identical with Sanford's, figured and described in *Course*, 375 f. *E* very soon gains control of them; after a couple of hours' practice, he becomes able to slide his hand up and down the arc, setting and releasing, with automatic precision. The chief differences between the Cornell instrument and those in use at Leipzig and Clark Universities are: (1) that the pendulum is one-armed only, (2) that an additional wooden upright is introduced to support the metal arc, and (3) that the base-key, intended to catch the pendulum after its first rebound and so to prevent secondary sounds, has been omitted. The one-armed model is recommended by Kämpfe (522), Sanford (374, *n.*) and Ament (*P. S.*, xvi., 170); the extra stay avoids resonance effects, which the sponge rubber cannot wholly eliminate; and the pendulum can be caught with the finger as effectively as with the key, and much more conveniently.

The following Table shows the relative intensities of the sounds when the pendulum falls through any angle between 10° and 60°, the sound at 10° being taken as unity.² For the formula, see Fechner, *El.*, i., 179 ff.; Kämpfe, 526 ff.

¹ Note, in particular, that the ebony block must be glued, not screwed, to the wooden base. It will work loose once or twice a year; and then one must simply glue it on again.

² Ament's pendulum differed in its dimensions from the pendulum here prescribed, so that his intensive values are also different: *P. S.*, xvi., 176.

ANGLE 10° = INTENSITY 1.00.

Angle.	Intensity.	Angle.	Intensity.
11°	1.21	36°	12.57
12	1.44	37	13.25
13	1.69	38	13.95
14	1.95	39	14.66
15	2.24	40	15.40
16	2.55	41	16.14
17	2.88	42	16.90
18	3.22	43	17.68
19	3.59	44	18.47
20	3.97	45	19.28
21	4.37	46	20.10
22	4.79	47	20.92
23	5.23	48	21.78
24	5.69	49	22.64
25	6.17	50	23.52
26	6.66	51	24.40
27	7.17	52	25.30
28	7.70	53	26.21
29	8.25	54	27.13
30	8.82	55	28.07
31	9.40	56	29.01
32	10.00	57	29.97
33	10.62	58	30.94
34	11.25	59	31.92
35	11.90	60	32.92

The experimental schema on p. 84 of the text is modelled upon that of W. Ament, P. S., xvi., 174. The order of the 8 series should, of course, be varied in the second and third experiments. The description of the alternative method is taken from F. Angell, P. S., xi., 455 ff. The arrangement of the Tables will be understood by reference to pp. 459, 461.

Direction and Expression of Judgment.—Different *O*'s differ widely in the formulation of their judgments. Some express themselves, from the first and as it were instinctively, in terms of the second interval; the last distance given strikes them as equal, greater, etc. Others refer always to the first interval; the first distance given is less, equal, etc. Yet others judge in terms of the middle *R*: r_v is too high, too low, middle. This last is, in the author's experience, the most common form of expression with unpractised *O*'s. Indeed, in the alternative method, it

is practically universal, and has therefore been presupposed in the text. The *O*'s who express their judgment in terms of distance usually estimate the second interval in relation to the first (second greater, etc.), though several instances of the opposite direction of judgment have fallen within the author's knowledge.

It might be supposed that expression of judgment in terms of r_v would put a premium on the *R*-error. It might also appear desirable, in view of the theory of mental measurement which this book represents, that *O* should be instructed always to formulate his judgment in terms of interval or distance. The author, speaking with great reserve and only on the basis of his own experience, cannot find that the formulation or direction of judgment exercises any determinate influence upon the results. To put it crudely: one may get the geometrical mean with judgment given in terms of r_v , and the arithmetical with judgment given in terms of distance, about as often as one gets the reverse. A judgment expressed in terms of r_v need not by any means be passed in those terms; it may be a true distance judgment, which has found easiest and most natural expression in terms of r_v . No doubt, all these matters must some day be worked out in detail. In the meantime, however, the author is of the opinion that *O* should be left free to express himself in what terms he will.

See under Question (9), below; and *cf.* Ament, P. S., xvi., 172; Müller, M., 225 f.; J. Fröbes, Z., xxxvi., 1904, 243 f., 358.

EXPERIMENT XVIII

MATERIALS.—The success of this experiment depends largely upon the care with which the pendulum is set up. It is hardly possible to be too scrupulous about the levelling of the table, the laying of the felt base, etc., etc. The furniture of the room and its arrangement should remain the same throughout the experiment. Very slight differences in setting-up and in position may make the difference between clean sounds that vary only in intensity, and sounds that are variously complicated by resonance, after-effects, clang-tint.

DIRECTIONS TO *O*.—In the experiments taken by the author, *O* has always been instructed, in general terms, to compare the two *S*-distances, to say whether S_2 lies nearer to S_1 or to S_3 ,

etc. In the light of Müller's and Fröbes' work, it would seem advisable, in some cases and for the sake of comparison, to instruct *O*, specifically, to use the criterion of degree of cohesion. The instruction, once given, must be repeated—emphatically, not perfunctorily—at frequent intervals during the experiment.

'Degree of cohesion' is a little abstract. Perhaps one might give an illustration: sound r_1, r_2, r_3 , with r_2 lying fairly close to r_1 , and let *O* 'hear' how the two weak sounds class themselves together, form a natural group, while the loud sound is left outstanding. One must insist, however, that *O* listen for the sounds, not separately, but in their mutual relation; that he hear how the pair (r_1, r_2) go together, while the pair (r_2, r_3) refuse to go together,—not that he hear simply two like 'weaks' and one unlike 'strong.'

Whether *O* shall be specially warned, from the outset, against the *R*-error is a matter for the Instructor to decide. Even with the few students who have a distinct natural aptitude for experimental psychology, the error (in greater or less degree) is practically inevitable. It is easily brought out by questioning, at the end of the first day's work. The author's experience is that it is worth while to let *O* blunder, and then to pull him up sharply after the event; having once fallen into the error, he recognises any recurrent tendency towards it.

Introspective notes on the factors that influence judgment should be made at the end of every two or four series.

RESULTS.—In the author's experience, it is possible, with a pendulum of the dimensions quoted, to use the full range of values given in the Table, p. 196 above. It is better, however, to draw the limits rather narrowly in the first experiment made. The author finds that, after warning for the *R*-error, the haphazard method gives the geometrical mean with about 5 out of 10, the regular serial method only with about 2 out of 10 *O*'s. The remaining mid-values lie in the neighbourhood of the arithmetical mean. It must be remembered that the *O*'s in question are but little practised. But in any case the diversity of result is fully intelligible in the light of § 29.

EXPERIMENT XIX

MATERIALS.—Delbœuf's disc and box are described in *Éléments*, 1883, 58 f. The second form of disc is figured by Wundt,

P. P., i., 1880, 339 (and later editions). The arrangement with three discs is discussed by A. Lehmann, P. S., iii., 1886, 497 ff.; H. Neiglick, *ibid.*, iv., 1888, 28 ff.; cf. J. Fröbes, Z., xxxvi., 1904, 354 ff. The large triple mixer is recommended by Wundt, P. P., i., 1893, 373 (and later).

The limits should not be made too wide, at any rate in the first experiment. Delbœuf was unable to find a satisfactory *S*-mean between black and white (*Éléments*, 59, 62 f.), and there is no doubt that the absolute apartness of black and white for *S* puts a premium on the *R*-error.

Some judgment must be used by *E* in cutting his *b*-sectors. Nothing is more annoying than to find that the *b*-sector mounted on the disc is not wide enough for the completion of a series. Where there is the least doubt about the sufficiency of its range, two *b*-sectors should be mounted, the one behind the other, and the second drawn out if needed. The card of which the disc and sectors are cut must be as thin as possible.

RESULTS.—Experiments with the Delbœuf discs give, almost invariably, a middle value which lies near the geometrical mean. Here are the results of some series with the first form of the disc and the dark box (regular method).

- (1) O_1 . Limiting values, in degrees of *W*, $3 \times 13 = 39$ and $3 \times 67 = 201$. Arith. mean, 120. Geom. mean, 88.5.

Av. of 6 paired series	98.75 ± 3.83
Diff. from arith. mean	21.25
Diff. from geom. mean	10.25
Ratio of diffs.	1:2

- (2) O_2 . Limits 24, 243. Arith. mean, 133.5. Geom. mean, 76.4.

Av. of 3 paired series	90.25 ± 6.66
Diff. from arith. mean	43.25
Diff. from geom. mean	13.85
Ratio of diffs.	1:3.1

- (3) O_3 . Limits, 15, 300. Arith. mean, 157.5. Geom. mean, 67.

Av. of 4 paired series	95.60 ± 5.45
Diff. from arith. mean	61.90
Diff. from geom. mean	28.60
Ratio of diffs.	1:2.1

These are average results: sometimes the approximation to the geometrical mean is closer, sometimes the MV is higher.

Lehmann (P. S., iii., 498) gave up Delbœuf's arrangement on account of the disturbance of judgment by contrast effects. "Wie es den O möglich gewesen ist," he says, "sicher zu schätzen, ist mir eigentlich ein Räthsel." This riddle he seeks to read later on (513) by the guess that "bald der Contrast gegen den hellen, bald der Contrast gegen den dunklen Ring hervorgetreten ist." Now it is true that, if O gets it into his head that he *ought* to be bothered by contrast, the determinations will scatter, and the MV of the single r_2 be very high. As a rule, however, O takes the experiment for granted, and does not think of contrast, except perhaps to wonder as the series progress that contrast has not entered as a disturbing factor into judgment. The fact is that, even with the illumination regulated as carefully as may be, the brightness of a grey disc or grey ring seen in daylight is a very average matter: hence the importance of constant direction of fixation in work upon the DL for brightness. If O is on the lookout for differences of brightness, he can find them, contrast or no contrast; if he is judging the distances from ring to ring by general impression, they do not matter.¹ Contrast is, no doubt, there, in an objective way: but it and its effects need not at all come to mind in the passing of a judgment.

More important is the fact that the Delbœuf disc, in its first form, does not permit us to vary the space relations of the rings; we cannot put the largest white sectors on the outside. With the second form of disc, the interchange may be effected in various ways. Thus, the cc' sectors (wide) may be pasted at the periphery of the disc only to the depth of their rings, and the aa' sectors (narrow) may be carried up from the centre of the disc to meet cc' . Then slits of the width of bb' are cut at the right distances along two opposite radii; a b disc is cut with two annular tongues, on the analogy of the Hering disc of Fig. 19; and the tongues are thrust through the slits. The bb' sectors can then be varied from the width of the aa' sectors up to any required value.—

¹ What holds of rings seen in daylight holds still more of total discs, whether viewed in daylight or by artificial light. Fröbes, taking the suggestion from an introspective report by Müller, offers much the same explanation of Delbœuf's experiment as is given here. Müller, however, was judging in terms of his positive criterion of degree of cohesion (*Z.*, xxxvi., 371).

The arith. and geom. means of two given limiting values may be calculated in degrees from their photometric values as follows. Suppose that the limiting discs are made up of $50^\circ W + 310^\circ B$ and $250^\circ W + 110^\circ B$ respectively, and that in photometric value $B:W=1:50$. The value of the first disc is 2810, the value of the second is 12610 photometric units. The arithmetical mean is 7710, the geometrical 5953. Let x stand for the number of white, y for the number of black degrees in the corresponding discs. Then we have:

$$\begin{array}{ll} x+y=360, & x+y=360, \\ 50x+y=7710 & 50x+y=5953 \end{array}$$

whence

$$\begin{array}{ll} x=150^\circ, y=210^\circ; & x=114^\circ, y=246^\circ. \end{array}$$

The author has not succeeded in getting uniformly satisfactory results with (3). It is a difficult matter, even with artificial illumination, to set up three separate discs that with the same proportions of black and white shall all look exactly alike in the six possible spatial arrangements. If E is satisfied, O may still find a difference; and if O is called upon to decide for himself, he is likely to become finical, to demand, *e.g.*, the elimination of brightness differences from part to part of one and the same disc. Sometimes, it is true, the experiment will run quite smoothly: a good deal depends upon the type of the students. It is, however, not an experiment that one can rely upon to furnish results in a given time, and should not be assigned indiscriminately to any E and O .

Fröbes (*Z.*, xxxvi., 356 f.) used a single background (a light grey curtain) and varied r_2 by help of the Marbe mixer; the contrast effects were measured after the event (375). This arrangement simplifies the conditions of the experiment. The use of the large triple mixer makes the observations tedious and long drawn out, and prevents the employment of the Marbe mixer.

QUESTIONS.—Some of these Questions are too difficult for any but fairly advanced students. In any case, the Questions should not be attempted until E and O have had practical work with the method.

(1) There can be no doubt that the haphazard form of the method is more reliable, for beginners, than the regular form with serial gradation of r_v .

First of all, we must make a distinction, according as the stimuli in the regular method are simultaneously or successively presented. Suppose, on the one hand, that we are working with three greys, all mounted upon the same colour mixer, or at any rate standing side by side upon the same table before us. Suppose, on the other hand, that we are working with sounds, which must be given in succession. In both cases, we are working between fixed limits, r_3 and r_1 . Every change of r_1 must, therefore, affect both $r_3 - r_v$ and $r_v - r_1$. O has the limits in mind from the first. He may not have definitely in mind the corollary that every increase of $r_3 - r_v$ means a corresponding decrease of $r_v - r_1$, and conversely; but in some sort or other the fact will soon be borne in upon him. He is thus almost compelled to expect short series; he is in imminent danger of an error of bias. In the case of the greys, simultaneously presented, the error is corrected by the presence of the extremes along with the variable mean; if O is constantly fearing to go too far, he is as constantly reassured by seeing how long a distance he has still to travel. In the case of sounds, the error of bias has full play. It is hardly an exaggeration to say that, with an O of the subjective type, E may, by variation of the starting-point of his series and the size of his steps, bring out any r_2 that he chooses, over a wide range of middle values. If O is objective, and the experiment is conducted with extreme care, the results of the regular method may tally with those of the alternative, or with those of the modified method of constant R -differences. But when successive R are employed and O is unpractised, very little reliance can be placed upon the results of the regular method taken alone.

Secondly, however, and quite apart from the error of bias, the author's experience puts it beyond question that the regular method, as used in ordinary laboratory work, is more exposed than the alternative to the errors which inhere in the problem of mean gradations at large, and which are discussed under (2) below. The reason seems to be that the regular method throws the greater responsibility upon O . It does not require him to ideate the mean, and to keep this idea in mind throughout an experiment; but it does definitely suggest such ideation. The alternative method, on the other hand, presents each threefold group

of R for itself, to be judged and done with. If this analysis be correct (and it is borne out by introspections), the regular method suffers from something of the same disability that attaches to the first crude form of the method of just noticeable differences. Again, therefore, little reliance can be placed upon the results of the regular method taken alone; and the statement now holds of simultaneous as of successive R , and of objective as of subjective O 's,—provided that these latter have had only so much experience in method work as a training-course affords.

This is not by any means to say that the regular form of the method is worthless. On the contrary, a comparison of its results with the results of the alternative method, or with those of the modified method of constant R -differences, may be extremely instructive. No errors are so real to one as those that one has oneself fallen into; and without an understanding of the errors, the history of the method of mean gradations is full of sound and fury, signifying nothing.

(2) The besetting difficulty of the method of equal sense distances (at least, in such a Course as the present) is, without question, the error which we have designated above (p. lxiii.) the R -error.¹ The error consists, in general terms, in a substitution of R for S ; O ideates the objective R -magnitudes, in some way or other, and then compares, not the S -distances which he should compare, but rather these ideated R . He may, *e.g.*, visualise the pendulum, and choose his r_2 as that sound which corresponds, in his idea, with the middle height of fall: this case has occurred more than once in the author's experience. Or he may set up, in the light of his own past experience, an arbitrary mental scale of sounds, placing r_1 (estimated absolutely, for itself alone) at one point, r_3 at another, the ideal r_2 at another, and then trying to fit the real r_v to the ideal: cases of this sort have also fallen within the author's knowledge. It must be remembered that the grading of successive sounds is an unfamiliar and an intrinsically difficult task. It is, therefore, not surprising that O should be tempted to judge, not in terms of sound intensity, as the experiment requires, but in terms of some secondary criterion. And it is obvious that various criteria are afforded by the R themselves,

¹ Cf. J. von Kries, in Nagel's Hdbch. d. Physiol., iii., 1, 1904, 28.

—whether as the slight differences of quality or resonance that occur with all but the best-made and most carefully manipulated instruments, or as the associative recognition-marks furnished by *O*'s past experience. It is, perhaps, difficult for those who have not worked with the method to realise the nature of the secondary criteria; still more difficult to realise their great diversity and their coercive power over judgment. They form, as we have remarked before, a peculiarly dangerous source of error. Unfortunately, too, the more painstaking and conscientious the *O*, the more likely is he in the first stages of practice—from his intensive occupation with the experiment and his attentive examination of the stimuli—to fall a victim to them. Οὐκ ἔστι γῆρας τοῦδε τοῦ μᾶσματος.

The occurrence of visual schemata, and their influence upon judgment in sound work, have been noted by Angell (P. S., vii., 438, 446), Ament (*ibid.*, xvi., 173) and Müller (M., 241).¹ H. Neiglick remarks in 1888 that “[bei der Methode] trügerische Associationen mitwirken, gegen welche man wohl nie gänzlich gesichert werden kann” (P. S., iv., 41); and the *R*-error plays a large part in the controversy arising out of Merkel's experiments (see § 29). Cattell goes so far as to say: “the question here is whether we do in fact judge differences in the intensity of *S*, or whether we merely judge differences in the *R* determined by association with their known objective relations. I am inclined to think that the latter is the case. . . I believe that my adjustment is always determined by association with the known quantitative relations of the physical world” (A. J. P., v., 1893, 293). In so far as this is a bit of first-hand introspection, it is undoubtedly correct. When, however, the writer attempts to generalise it, he is flying in the face of other, equally positive introspections, as we shall see later under (9). Foucault says, in the same spirit: “quand on demande au sujet de ranger trois excitations de manière à former deux différences égales de sensation, il fournit ordinairement une série qui forme deux différences égales d'excitation. . . La comparaison psychophysique porte sur l'intensité des excitations, et non pas des sensations” (Psychophysique, 237.) Again: “l'égalité qui est en jeu dans ces jugements et qui les rend possibles ne peut être qu'une égalité objective, l'égalité des deux différences qui existent entre les excitations” (251: *cf.* 292 f.). All this is overstatement. The insidiousness of the *R*-error may be granted.² But it remains an error, an error

¹ Cf. Fröbes, Z., xxxvi., 258 (lifted weights).

² See discussion of Fröbes' investigation at the end of § 29.

of attitude on the part of O ; different O 's are differently liable to it; it may be headed off by fitting instruction or by fitting variation of the method. In making themselves and their own introspections the measure of all other observers, Cattell and Foucault are falling into the mistake of which Stricker was guilty in his *Sprachvorstellungen*, and are thus neglecting one of the first lessons of the laboratory. See Müller, M., 241 f.

For the influence of expectation and habituation, see Angell, 447 f.; Ament, 171, 185 f. The remarks of these authors point clearly towards an error of bias. For expectation, see also Fröbes, Z., xxxvi, 259.

The error of judgment by absolute impression is considered below, under (7). The error introduced by musical knowledge into tonal work is discussed at length in § 30.

(3) The rule appears in Angell, P. S., vii., 456. The argument by which he supports it is correct; but the rule itself is sadly inadequate to the requirements: Müller, M., 29, *n*. Materials for criticism will be found *ibid.*, 24 ff.

(4) See C. Lorenz, P. S., vi., 1891, 69 ff.; Angell, *ibid.*, vii., 460 ff.; Müller, M., 227 ff.

(5) The formula was proposed by Wundt: see Angell, P. S., vii., 464; Wundt, P. P., i., 1902, 480; Müller, M., 42, 226. It presupposes that the curve of sensation change runs in a straight line parallel to the axis of abscissas between the limits $r_v = x$ and $r_v = y$. This assumption is, of course, arbitrary. Moreover, the formula employs only two (x and y) of the r_v -values used in the experiment. The selection is again arbitrary.—A mathematical way of removing these objections is indicated by Lipps, Arch. f. d. ges. Psych., iii., review section, 38 f.

(6) Something, but not much. See Müller, M., 42 f.; or pp. 96 f. of the text.

(7) Wundt (P. P., i., 1902, 480) assumes, with the text-books in general, that we have to do here with a Fechnerian time error, which may be eliminated by a simple reversal of the order of the three R . Müller has, however, shown (we have not as yet referred to his argument) that, even when but two R are employed, the Fechnerian time error is (approximately) eliminable only if the difference between them is slight. In the present case we have three R , and the differences between them are large! The time error is, therefore, not eliminable. Suppose that the stimuli are

presented in the first time order, as r_1, r_v, r_3 : time errors (call them b_1 and c_1) will affect our estimation of r_v and r_3 . Suppose again, that the stimuli are presented in the second time order, as r_3, r_v, r_1 : time errors (call them a_{II} and b_{II}) will affect our estimate of r_v and r_1 . We have, now, no means of ascertaining the relation of the four values a_{II}, b_{II}, b_1, c_1 . We may not even be able to say whether the sign of b_{II} is the same as the sign of b_1 or is its opposite.

This criticism does not mean, however, that we are to be content with a single time order in our experimentation. We have to consider the possible influence of typical and general tendencies of judgment. That the results of a single time order might give a very one-sided view of the facts is shown by Müller, M., 234;¹ cf. Fröbes, Z., xxxvi., 265.

For an instance of a small time error, see Ament, 183 ff.; Külpe, P. S., xviii., 1902, 342; for a large time error, Merkel, *ibid.*, v., 521 f. On the general question of elimination, see Merkel, *ibid.*, x., 244 f., 376 f., 382 f.; Lehmann, *Körp. Aeuss.*, ii., 1901, 122 ff.; Külpe, P. S., xviii., 337 ff.; Müller, M., 232 ff. For instances of judgment by absolute impression, see Angell, 438; Ament, 178; Müller, M., 239 f.; and discussion of Fröbes, end of § 29 below.

(8) It is not likely that the student will suggest any such procedure as we find in Müller, M., 226 ff. He may, however, very well suggest the importance of making r_1 (or r_3) the variable,

¹ Suppose, Müller says, that O is negative in type and is at the same time influenced by the absolute impression of the last sound heard: then it would never do to rely upon the results of the single time-order r_1, r_v, r_3 .—The reason is this. The effect of absolute impression in the time-order r_1, r_v, r_3 will be to make r_2 too loud; the given interval $r_3 - r_v$ will be unduly extended by the impression of extreme loudness produced by r_3 . Conversely, the effect of absolute impression in the time-order r_3, r_v, r_1 will be to make r_2 too faint. These tendencies might be equal, as well as opposite. Now, however, let a negative type supervene. The O of negative type is the O who has the smaller DL when the standard (in a two-stimulus method) is less than the variable (M., 116); that is, he is an O who receives the absolute impression of loudness more often than he receives the absolute impression of faintness (118). This means, then, that the loud-setting of r_3 in the order r_1, r_v, r_3 will be more uniform and regular than the faint-setting of r_2 in the order r_3, r_v, r_1 ; the absolute impression and the negative type play, in the first order, into each other's hands. Under these conditions, it would evidently be misleading to offer only the results obtained in the order r_1, r_v, r_3 .

while r_2 and r_3 (or r_1 and r_2) remain constant. He may also hit upon the expedient of using four stimuli, r_1, r_2, r_3 and r_4 , for the equating of the two distances $r_1 - r_2$ and $r_3 - r_4$. In this latter case any one of the four stimuli may be made the variable.

See Angell, 438; Münsterberg, Beitr., iv., 1892, 167 ff.; Ament, 166 ff.; Müller, M., 230 f.

(9) In view of the errors to which the method of equal sense distances is exposed, and in view more especially of the *R*-error, it is of the utmost importance that the modes of judgment adopted by different *O*'s should be carefully analysed by introspection. We have already noted the part played by visual schemata, which may take the form either of a mental picture of pendulum and arc, or of a mere line upon which r_v shifts to and fro while the points r_1 and r_3 are fixed. We have also noted the influence of an empirical sound scale, to which the given stimuli are referred. The question still remains: what is the normal process of judgment in cases where *O* exactly follows instructions,—where he escapes the *R*-error, and has no visual schema or associations from past experience to guide him?

Müller records his own introspection, with simultaneously presented colours or brightnesses, as follows. "Dasjenige, was mein Urteil bestimmt, ist allgemein gesprochen die Leichtigkeit, mit der sich einerseits das Reizpaar $r_1 r_v$ und andererseits das Reizpaar $r_v r_3$ kollektiv, d. h. als ein einheitlicher Komplex auffassen lässt. Ich will diese Leichtigkeit des Kollektivaufgefasstwerdens . . . kurz als den *Kohärenzgrad* des betreffenden *R*-Paares oder der betreffenden *R* bezeichnen. . . Wie man sieht, beruht mein Urteil nicht auf einer direkten Vergleichung der *S*-Unterschiede, wenn es auch von den vorhandenen *S*-Unterschieden insofern abhängig ist, als der Kohärenzgrad zweier Eindrücke von dem Unterschiede der beiden *S* abhängt" (M., 237 f.). The degree of cohesion of simultaneous visual impressions depends upon the differences of quality and insistence (*Eindringlichkeit*) of the sensations, upon their extension and spatial relations (proximity, symmetry of position), and upon the presence or absence of a common contour. It depends further upon habit and upon definitely directed expectation. In the case of successive

impressions, the influence of spatial relations is replaced by that of temporal succession and limitation (length of intervals, rhythm, etc.).

Müller does not make the mistake of Foucault and Cattell, and declare that this mode of judgment is the only possible, or even the customary mode. He does, however, offer confirmatory evidence from other observers (239), and refers particularly to his experiments upon the comparison of qualitative differences of colours of the same brightness (Z., x., 1896, 69 ff.).

The author has had striking proof of the influence of 'degree of cohesion' in the sphere of sounds. If, e.g., r_v is noticeably too weak, it often happens that the three sounds, in the order r_1, r_v, r_3 , form two groups of this kind: (weak, weak)—*strong!* And conversely, if r_v is noticeably too loud. In some cases, the grouping is clearly motivated throughout by absolute impression; the sounds come, singly, as *weak, weak, strong*:¹ in others, the grouping is effectuated without reference to absolute impression, and simply in terms of cohesion. There appear, moreover, to be two fairly distinct ways of employing this criterion of cohesion. Müller evidently employs it in a positive way; his effort is to get two R together, and to hold them together (237). The introspective records at the author's disposal indicate that attention goes rather to the gulf or gap that separates the R . Judgment is based, not so much upon the fact that the one R -pair holds together, as upon the fact that the other R -pair definitely falls apart. Müller says in Z. (70): "der Unterschied zwischen dem Rot und dem Gelb erscheint gewissermassen wie eine weite Kluft in Vergleich zu dem Unterschiede zwischen mittlerem Gelbrot und mittlerem Gelbgrün." This sort of judgment is surely different from Müller's judgments as described in M. The striking thing for introspection is not that reddish yellow and greenish yellow fit together, while red and yellow can be bracketed, if at all, only with considerable effort; it is rather that red and yellow stand out, apart from each other, while reddish yellow and greenish yellow stand nearer together, are less clearly distinct and apart. Müller's criterion is positive cohesion; that of the passage quoted from the Z. and of the author's students is negative cohesion, or positive apartness. While, therefore, the author would not deny the complexity of the factors that govern judgment in the particular case (M., 238), he is inclined to think that, at least in many instances, the judgments of the method of equal distances represent true judgments of sense distance, and that the method is consequently better fitted than Müller allows (M., 234

¹ See Fröbes, Z., xxxvi., 257 f., 262.

f., 242 f.) to furnish information regarding 'the relation of *S* to *R*.' See, however, the conclusion of § 29.

Müller has not yet published the details of his investigation with colours. It may be said, however, that the question "ob sich die kollektive Auffassung des Rot und des neben ihm befindlichen Gelb leichter, gleich leicht oder weniger leicht vollziehen lasse als die kollektive Auffassung des Gelbrot und des neben ihm befindlichen Gelbgrün" (M., 239) is a question which still leaves the door open to associative influences, whether direct (the Gelbrot and Gelbgrün both suggest the name Gelb, both look yellowish, etc.) or indirect (knowledge of 'primary' colors, etc.). Indeed, it seems to the author that this question is more favourable to associations than was the instruction to the *O*'s "die subjektiven Unterschiede, welche den beiden ihnen gleichzeitig vorgeführten Farbenpaaren entsprechen, miteinander zu vergleichen;" and that the helplessness of the *O*'s, in face of the latter instruction, may be ascribed, in part at least, to the fact that its psychophysical phrasing seems definitely to prohibit a recourse to associative criteria. We are not told how long this instruction was continued, how many *O*'s were tested, what training they had had in psychophysical work, etc., etc. Details will, no doubt, be published later on.—

Since the foregoing paragraphs were written, further introspective results have been published by J. Fröbes (*Z.*, xxxvi., 1904, 257 ff., 368 ff.: see end of § 29). In experiments with lifted weights, Müller as *O* notes the effects of absolute impression of the third weight and of all three weights, of verbal characterisation, of visual schemata, of visual ideas of the objective *R*, of the 'slip comparisons' with which we shall presently become familiar (§ 34), of expectation, of forgetfulness of the first (or first and second) *R*, of motor disposition, of the attitude and intention of *O*, etc. (257 ff.). In experiments with brightnesses, in which *O* was instructed beforehand to judge in terms of degree of cohesion, Müller gives an analysis of his positive procedure (368 f., 370 f.), and enumerates certain criteria which suggested themselves, but which he did not employ (verbal characterisation, absolute impression, surprise, etc.: 369 f.). Another *O* appears to employ both the positive and the negative forms of the criterion of cohesion, as circumstances suggest (372). Another gives up all idea of a 'kollektive Auffassung,' and passes from disc to disc (dark to light) with "einem gewissen Ruck, einer Gefühlswirkung": "beim Hinübergehen vom einen zum anderen ist der Stoss ein verschieden grosser" (372 f.). All *O*'s except Müller were greatly influenced by the affective value and attention-compelling power of the brightest disc (373 f., 376).

(10), (11) See above, p. 200.

(12) Exp. XIX. is the easier. Partly, the grading of greys is intrinsically easier than the grading of sound intensities; partly, the simultaneous presentation of the three *R* in Exp. XIX. offers better conditions for judgment.

(13) The method may obviously be applied to the estimation of visual extents. An instrument often employed for this purpose is Münsterberg's Augenmassapparat, shown in Fig. 31. See

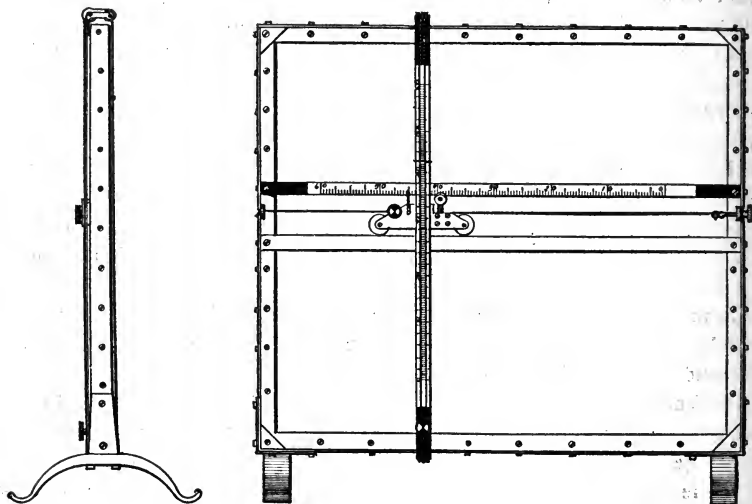

FIG. 31. Münsterberg's apparatus for the comparison of visual extents; back and side views. Elbs, §22.

Ebbinghaus, *Psych.*, i., 1902, 505; Kraepelin, *P. S.*, vi., 1891, 513; Jastrow, *A. J.*, 1890, 44 ff.; Foucault, *Psychophysique*, 1901, 373 f.; S. Witasek, *Z.*, xi., 1896, 321 ff.; F. Schumann, *Z.*, xxx., 1902, 241 ff.

§ 29. **The Method of Equal Sense Distances: Historical and Critical.**—The method of mean gradations was first employed in psychophysics by the Belgian physicist J. A. F. Plateau (1801–1883). Plateau made experiments in the early fifties, but published nothing until 1872.¹ The experiments were very simple.

¹ For the original references, see p. lxxix. above. Cf. also G., 90 f., 101 f.; I. S.,

Plateau prepared two squares of paper, the one pure white, the other intensely black, and requested eight observers, all of whom were artists, to paint a grey that should lie for sensation exactly midway between the two extremes of brightness. The eight greys proved to be very nearly the same. The central value, photometrically determined, was about $\frac{1}{8}$, the white being taken as unity. Plateau drew the tentative conclusion that our sensation of brightness increases as the cube root of the stimulus.¹ He proposed to continue the procedure, first bisecting the two equal 'contrasts' already given, then subdividing the four equal distances into eight, and so on, until a working scale of brightness sensations (with corresponding stimulus values) should be established. This intention was not carried out. We may, however, fairly credit to Plateau the proof that *O* is able, under certain conditions, to compare supraliminal distances with a fairly high degree of accuracy.

At Plateau's suggestion, Delbœuf undertook, in 1865-6, a systematic study of brightness sensations by the method of mean gradations.² The memoir was published in 1873.³ We have already described Delbœuf's experimental procedure,⁴ and may give at once a specimen Table of his results.⁵

O a young woman. Series I., diffuse daylight; grey sky. Series II., apparatus lighted by a candle, surrounded by a white paper re-

22; Delbœuf, *Éléments*, 56 f.; Examen, 91; Wundt, *P. P.*, i., 1880, 325; i., 1887, 344, 348 f.; i., 1893, 337, 341; i., 1902, 471, 475; Stumpf, *Tps.*, i., 1883, 60, 124 ff., 395.

¹ Plateau, that is, regarded the sensations 0—1—2 as correlated with the stimuli 0—1—8. If we put the ratio of the brightnesses of the extreme stimuli at 1: 60—70 (Kirschmann, *P. S.*, v., 1889, 299 f.), we get for $\frac{1}{8}$ the proportions 1: 7.5: 60, 1: 8.75: 70, *i. e.*, approximately geometrical series.

² *Éléments*, 56 f.

³ *Étude psychophysique: recherches théoriques et expérimentales sur la mesure des sensations, et spécialement des sensations de lumière et de fatigue; in Mémoires de l'Acad. royale de Belgique*, xxiii., 1873. Offprints: Bruxelles, Hayez; Liège, Desoer. Abridged reprint in: *Éléments de psychophysique*, Paris, 1883.

⁴ Pp. 88 f. of the text.

⁵ *Éléments*, 61; *G.*, 96; *I. S.*, 182; *A. Lehmann, P. S.*, iii., 1886, 514; *Körp. Aeuss. psych. Zustände*, ii., 1901, 77.

flector, at about 25 cm. distance. Sector values given in 1° units. Values for inner (variable) sector, averages of 5 determinations.

No. of exp.	Outer sector	Middle sector	Inner sector		<i>MV</i>	
			I.	II.	I.	II.
1	9	47	237.6	243.4	37.3	14.3
2	13	27	54.4	55.2	.9	3.4
3	13	36	98.8	94.8	6.6	1.4
4	13	41	129.2	123.4	13.4	5.3
5	13	56	247.8	235.8	27.2	13.1
6	21	60	169.4	157.0	7.3	6.8
7	21	64	200.0	175.8	8.0	17.9
8	22	36	57.6	56.8	2.1	1.8
9	22	51	119.8	107.4	11.8	7.4
10	22	58	153.2	139.2	5.0	15.9
11	22	66	194.8	183.2	27.0	9.4
12	43	64	97.4	94.0	3.9	5.2
13	43	72	130.0	119.8	12.4	4.6
14	43	87	176.8	168.8	16.6	9.3

It is to be noted that Delbœuf varied the inner sector only, instead of varying either both outer and inner (in different series) or the more sensitive middle sector.¹ It is to be noted, further, that he worked always with the darkest grey on the outside, instead of alternating the spatial arrangement of his darkest and lightest rings;² and that he did not make allowance for the effect of contrast.³ On the other hand, he was on the alert to secure

¹ Why Delbœuf varied his inner sector is difficult to see. Perhaps the reason is purely mechanical: it would be an advantage, with his apparatus, that the sectors to be varied (pulled out and pushed in) should be short and broad. Plateau, as we have seen, varied the middle stimulus. The same idea is implicit in Hering's discussion, *Lichtsinn*, 57 ff. Wundt, in 1880 (P. P., i., 325), speaks of the constancy of the extremes as a matter of course. Lehmann (P. S., iii., 1886, 514) varied his middle stimulus, and remarks that his procedure is in this respect different from Delbœuf's; but he gives no explanation, though (from 499, 502 f., 504 ff., 506 ff.) one would have expected him to demand a variation of all three stimuli. Fechner (I. S., 180) says that Delbœuf should have varied his outer as well as his inner ring, but does not suggest a variation of the middle ring. See Question (8), p. 206 above.

² Lehmann, *op. cit.*, 504 f.

³ In the *Éléments*, Delbœuf remarks that he found, on returning to his experiments of 1865-6 for purposes of publication, "qu'il fallait tenir compte de l'effet dit de contraste" (56). Nothing more definite is said. In the original

constancy of external and internal conditions; ¹ he combined ascending and descending series to a single result; ² and he was especially concerned to avoid fatigue.³

The results are interpreted, not by Fechner's formula $S=k \log R$, but by the formula $S = k' \log \frac{c+R}{c}$, where k' is a constant, and c is "le minimum d'excitation nécessaire à la sensibilité de l'organe." By taking as R -unit the value that gives $k' = 1$, Delbœuf transforms this formula into $S = \log \frac{c+R}{c}$.⁴

Delbœuf had at first attempted to repeat Plateau's experiments and "obtenir des teintes intermédiaires entre le noir considéré comme absolu . . . et des teintes blanches quelconques."⁵ The attempt proved unsuccessful, "à cause de la présence de la quantité c , et des modifications considérables que subit le jugement à ces limites extrêmes, à la suite d'un faible changement de lumière."⁶ He did, however, on the basis of his own experiments with lesser distances, construct a 'curve of stimuli' corresponding to the 'scale of sensations' from white to black.⁷ A figure can easily be cut to the shape of the curve from white cardboard, and rotated before the opening of a blackened box. One then obtains, as Delbœuf says, "une belle figure lumineuse dont les teintes vont en s'affaiblissant d'une manière insensible du centre . . . vers la circonférence."⁸

Fechner, in 1874, wrote at Preyer's suggestion a review of Delbœuf's *Étude* for the *Jenaer Lit. Zeitung* (reprinted in Preyer, *Wiss. Briefe*, 1890, 108 ff.). Here he says: "ich lege grosses Gewicht auf seine experi-

paper, he remarks further that "il est facile de remédier en partie à cet inconvénient, en découpant le carton de manière à donner au fond, tant intérieur qu'extérieur, le même éclat qu'à l'anneau moyen"; *Mémoires*, 59, 71.

¹ See, e.g., *Éléments*, 64 ff.

² *Ibid.*, 65.

³ *Ibid.*, 65 f., 67. Cf. the discussions 41 ff., 92 ff.

⁴ *Ibid.*, 15, 34, 42, 61. On the value c , see *Éléments*, 70 ff., 79 ff.; I. S., 34 f., 178 ff.; R., 162 ff., 304; A. Köhler, P. S., iii., 1886, 607 ff.; A. Stefanini, *Il Nuovo Cimento*, 3, xxxi., 1892, 235.

⁵ *Éléments*, 59, 62. Here is indirect evidence that the variation of the inner ring in the disc experiments was, as has been suggested above, a matter of convenience and not of principle. ⁶ *Ibid.*, 59. ⁷ *Ibid.*, 81 ff.; G., 92, 163 f.

⁸ *Ibid.*, 85. Demonstration discs have been made by Kirschmann: see A. J. P., vii., 1896, 401 ff.; ix., 1898, 346 ff. Cf. Sanford, *Course*, 335 f., and p. 78 above.

mentale Durchführung einer . . . wesentlich neuen Methode, das Abhängigkeitsgesetz der *S* vom *R* zu untersuchen" (109). In the I. S. (22 f., 34 f., 178 ff.) he again admits the claims of the new procedure to rank as a psychophysical method (remarking that "schon die Sternengrössenschätzungen im Grunde unter diess Princip treten"), and discusses Plateau's and Delbœuf's results. He does not, however, give the method a special rubric in the R., though the "Princip der Vergleichung übermerklicher Unterschiede" is recognised (164). In the *Psychische Massprincipien* of 1887 his exposition begins with the classification of stellar magnitudes, and passes directly to the "Verfahren der mittleren Abstufungen" (P. S., iv., 1888, 182 ff.).¹

Müller subjects the method itself, as well as Delbœuf's experiments, to a searching criticism.² He first notes that the *MV* of Delbœuf's Table increases with increase of the values of the middle sector. This may be due either to the greater magnitude of the sense distances compared, or to the greater absolute intensities of the component brightnesses (G., 95 ff.).³ Müller decides in favour of the latter alternative, and explains the result by the assumption "dass das dem mittleren Werthe der zufälligen Beobachtungsfehler reciproke Maass der Präcision, mit welcher eine Lichtintensität aufgefasst wird, bei Steigerung letzterer einen ähnlichen Gang nehme wie die absolute D.S." (97 ff.). From the Table at large he draws the conclusion that "the relative D.S. increases, over a wide range of light intensities, with increase of the absolute light intensity; the law being that for equal increments . . . and even for equal multiples . . . of *R*-intensity the increase is less, the greater the pre-existent *R*-intensity" (162 f.). The great advantages of the method are "dass sie verhältnissmässig am schnellsten zum Ziele führt," and "dass man . . . sicher geht, dass die Zulänglichkeit der Versuchsergebnisse nicht durch den Einfluss der sog. Adaptation der Netzhaut beeinträchtigt wird" (100, 185 ff.). Its chief defects are three. (1) "Ist ein Unterschied von bestimmter Uebermerklichkeit gegeben, so lässt sich eben nur dann unter veränderten Versuchsumständen ein U. von ganz derselben Uebermerklichkeit herstellen, wenn man den neu herzustellenden U. fortwährend mit dem ursprünglich gegebenen vergleichen und so lange abändern kann, bis er gleich merklich erscheint wie jener." Such a comparison is often impossible; one cannot, *e.g.*, determine the influence of fatigue. (2) The method does not allow us to compare the

¹ We may note that, if *a*, *b*, *c* are three brightnesses, arranged in ascending order, the method consists for Fechner *either* in varying *c* while *a* and *b* are constant, *or* in varying *b* while *a* and *c* are constant: 183.

² The passages here cited from the G. (90 ff., 161 ff.) must be read in connection with M., 224 ff.

³ Cf. the parallel argument, M., 238.

D.S. of different individuals, since "man durchaus keine Gewähr dafür hat, dass derjenige Grad der Uebermerklichkeit, welchen der eine *O* bei seinen Versuchen zu Grunde legt, auch von den anderen benutzt worden sei." This is a cardinal point for Müller (2, 101); but it is an objection which may, surely, be got over by the numerical relation of a given supraliminal distance to the *j. n. d.*¹ (3) The method does not allow us to formulate the course of the D.S. with increasing intensity of *R*, since the formula will again vary "je nach dem Grade der Uebermerklichkeit, den man bei den betreffenden Versuchen zu Grunde legt." When we add to these the further fact that the method is of very doubtful application to any but visual stimuli, we must admit that it cannot compare, for general psychophysical usefulness, with the methods of min. changes and of *r.* and *w.* cases (100 f.).

In 1874, Hering made theoretical use of the principle of the method of mean gradations for "die Bezeichnung der Lichtempfindungen durch Zahlen- oder Grössenverhältnisse" (Zur Lehre vom Lichtsinne, 1878, 57 ff.): he was not acquainted with Plateau's previous work. In the same year, Wundt, also without knowledge of Plateau, came very near to a practical formulation of the method. He took a Helmholtz contrast disc of black and white (P. O., 1896, 545), and observed the contrasts under different conditions of illumination (through grey glasses, etc.). Within wide limits, "der Unterschied der *S* bleibt derselbe, solange das Helligkeitsverhältniss der einwirkenden Licht-*R* constant erhalten wird. . . Somit ist der Helligkeitscontrast nur eine besondere Form des psychophysischen Gesetzes, nach welchem der Unterschied zweier *S* der Differenz ihrer Logarithmen proportional ist." On the basis of these observations, Wundt derived the psychophysical law as Fechner had done in *El.*, ii., 35 f.: changing the general equation $S - S' = f(R/R')$ by help of the limen into the special equation $S - S' = k \log(R/R')$, where *S* and *S'* are the sensations set up along the boundary of the two brightnesses *R* and *R'*, and *k* is a constant. Had it occurred to Wundt to equalise his contrasts, by adjustment, before submitting them to observation,—a procedure which must have appeared to him entirely practicable, since he was able to judge of contrasts as equal whether they obtained between dark or light components,

¹ Cf. H. Neiglick, P. S., iv., 1888, 52.

—he would have worked out the method of mean gradations. See P. P., 1874, 420; i., 1880, 339, 459; i., 1887, 478 f., 498 f.; i., 1893, 519 ff., 540 f.; ii., 1902, 218 ff.; and *cf.* Vn., i., 1863, 198 f.; P. S., iv., 101, 112 ff.

In 1882, F. Boas suggested that the method had wider applications than Müller supposed.¹ In music, we are able to judge of the uniformity of a crescendo or diminuendo, and we have themes or figures (structures involving differences of tonal intensity) repeated forte and piano. We are also able to judge of the regularity or irregularity with which a succession of tactual, auditory or visual impressions slows or quickens. Finally, experiments of his own have shown that supraliminal distances of passive pressure "sehr wohl vergleichbar sind."²

The method has two forms. Either one may take two constant R , and seek to determine a third, intermediate R , equally distant from the two extremes; or one may take a certain distance $r - r'$, and seek to determine an equal distance $R - R'$ between stimuli of greater or less absolute intensity. "Die letzte Abart der Methode ist die vollkommeneren." Its results should be treated by formulæ akin to those used in r. and w. cases.³ It should then enable us (1) "die Merklichkeiten der Verschiedenheiten von R -Unterschieden zu bestimmen," (2) "die Abhängigkeit der Merkbarkeit eines Unterschiedes von seiner Grösse festzustellen," and (3) "gleich merkliche Unterschiede bei verschiedenen R -Stärken aufzufinden."⁴

In 1885, just twenty years after Delbœuf began his experiments at Ghent, the experimental study of Weber's Law by the method of mean gradations was resumed at Leipzig.⁵ From 1885 to the present time there has been no large break in the literature of the method. This literature, if not very difficult, is extremely involved. The method has led, one might almost say, to consistently contradictory results, and has brought out much detailed criticism and counter-criticism. It is impossible for us here to work through the problems point by point and argument

¹ Pflüger's Arch., xxviii., 1882, 562 ff.

² *Ibid.*, 563.

³ *Ibid.*, 564 f. Müller remarks (M., 228) that Boas' attempt to establish these formulæ is "sehr wenig glücklich."

⁴ *Ibid.*, 566.

⁵ See Neiglick, P. S., iv., 1888, 29.

by argument, from Lehmann's first attempts at the elimination of contrast to Wundt's formulation of 'Merkel's Law.' This, the most satisfactory procedure, would require a book. We can merely mention the salient points in order, taking result and criticism of result alike as matters of fact.

We begin, then, with Lehmann, who sets out to test Delbœuf's method and to reconcile his results, if possible, with those of Aubert.¹ This aim is not realised. Lehmann becomes involved at once in an attempt to eliminate contrast,² and at the end of his paper can do no more than hand over a fairly promising method to his successor.³ This method—that of three separate discs rotating before three identical backgrounds—is taken up by Neiglick:⁴ the procedure is serial and with knowledge.⁵ An idea of the results can be obtained from the following Table.

White : Black = 68 : 1.⁶ R_1, R_3 , constant ;
 R_m , estimated mean ; R_a , arithmetical and
 R_g , geometrical mean.

R	R_3	R_m	R_a	R_g
1.00	27.8	6.24	14.4	5.27
3.97	27.8	11.33	15.9	10.46
4.53	27.8	11.70	16.1	11.22
5.93	27.8	12.91	16.8	12.91
6.39	27.8	13.36	17.0	13.32
8.44	27.8	15.55	18.1	15.32
15.14	27.8	20.91	21.4	20.51
21.84	27.8	24.54	24.8	24.64
27.8	34.5	30.23	31.1	30.96
27.8	42.31	34.59	35.0	34.29
27.8	44.99	36.68	36.3	35.30
27.8	54.22	40.79	41.0	38.82
27.8	65.02	43.66	46.4	42.50
27.8	68.00	43.62	47.9	43.47

¹ P. S., iii., 1886, 497 ; Aubert, *Physiol. d. Netzhaut*, 1865, 63.

² *Ibid.*, passim, esp. 498, 513, 528.

³ *Ibid.*, 533.

⁴ P. S., iv., 1888, 28 ff.

⁵ In the Wundtian sense of this phrase : see p. 127 above. Cf. P. S., iii., 503.

⁶ *Ibid.*, iii., 510 ; iv., 36. For the Table, see iv., 63, Taf. vi. ; Wundt, P. P., i., 1893, 378 ; i., 1902, 528. Wundt describes the apparatus, *ibid.*, 1893, 373, 377 f. ; 1902, 527.

The Table shows a pretty close approximation of R_m to the geometrical mean, within the brightness limits 1 to 68. Neiglick further discusses the relation of Weber's Law to contrast, and finds the law best satisfied when the contrast of the component brightnesses is maximal.¹ His interpretation is at once challenged by Wundt,² and need not occupy us here.

Merkel declares the work of Delbœuf, Lehmann and Neiglick to be inconclusive,³ and himself obtains different results. His procedure is still serial and with knowledge; but his stimuli are presented successively.⁴

Photometric limits (determined as distances
of lamp from ground glass), 0.5 — 1536.⁵
Column headings as before.

R_1	R_3	R_m	R_a	R_g
0.5	2	1.17	1.25	1.00
0.5	8	3.56	4.25	2.00
0.5	32	10.44	16.25	4.00
0.5	96	24.8	48.25	6.92
0.5	384	68.5	192.95	13.85
0.5	1536	149.9	768.25	27.70

For these wider distances, the R_m falls between R_a and R_g , but lies nearer the former.

Grotenfelt, in 1888, interprets the results of Delbœuf and Neiglick, and the classification of stellar magnitudes, as follows. "Diese Schätzungen werden so ausgeführt . . . dass sich der O immer *nur* auf den unmittelbaren, subjektiven Eindruck, welchen die S machen, stützen kann. Bei den Versuchen mit grauen Flächen fehlen beinahe vollständig alle Erfahrungen und Associationen, welche möglicherweise unbewusst zu einer vergleichenden Schätzung der R , statt der unmittelbaren Vergleichung der S , verleiten könnten. Nun gilt es überhaupt in anderen Fällen anerkanntermassen, dass wir in dem unmittelbaren Eindruck kein absolutes Mass für unsere S besitzen."⁶ Diese Umstände führen

¹ P. S., iv., 84 ff.

² *Ibid.*, 112 ff.

³ *Ibid.*, 550 ff.

⁴ *Ibid.*, 553; *cf.*, however, x., 1894, 222.

⁵ *Ibid.*, 568, Table xiii.; Wundt, P. P., i., 1893, 379; 1902, 528. Table ix., 567; is criticised by Lehmann, *Körp. Auss. psych. Zustände*, ii., 1901, 79.

⁶ Das Webersche Gesetz, 26 f.

auf den Gedanken, dass es sich auch hier nur um gleiche Mercklichkeitsgrade der Unterschiede handeln mag, um S , welche gegen einander gleich fühlbar kontrastiren, und nicht um eine direkte vergleichende Schätzung der Unterschiede." ¹ From this point of view, the R_m must coincide with the R_o . "Wo die Methode . . . rein hervortritt, d. h. wo der O gezwungen ist die S ausschliesslich nach dem unmittelbaren Eindruck zu beurtheilen, da müssen die festgestellten Unterschiede nur gleich merkliche Unterschiede sein; als allgemeines, principiell gültiges Verhältniss muss erwartet werden, dass die Ergebnisse dieser Methode mit denjenigen der M. d. e. m. U. auf demselben Sinnesgebiete stimmen." ² What, then, is to be said of Merkel's results? We may appeal to his procedure: successive, not simultaneous. Or we may appeal to the results themselves: "eine in ziemlich regelmässiger, aber doch sehr schwer erklärbarer Weise fortschreitende und in den Mittelraum zwischen R_a und R_o fallende Reihe." Or we may appeal to his standpoint, as evidenced by his method of doubled stimuli. It is entirely possible "dass bei seinen Versuchen . . . theilweise eine Schätzung der R eingetreten ist statt der unmittelbaren Vergleichung der S ." If other investigators confirm his results, the question will arise "ob das nicht darauf beruhen mag, dass man auf dem betreffenden Gebiete Erfahrungen über die objektive Stärke der R gesammelt hat, welche Erfahrungen nun auch bei der Vergleichung nach der Methode der mittl. Abst. unvermeidlich mitbestimmenden Einfluss gewinnen, indem der O dazu verleitet wird die R zu schätzen." ³ In a word, the probability is that Merkel's results are not pure results, but depend upon complicating conditions, and more especially upon associative influences which have led him to judge in terms not of S but of R .

Merkel, of course, repudiates this suggestion. ⁴ He had in the meantime extended his investigation to pressure stimuli, ⁵ and now gives an account of his procedure and results; these accord with the results for brightnesses. ⁶

¹ *Ibid.*, 106 f.

³ *Ibid.*, 111 f.

⁵ *Ibid.*, 253.

⁶ *Ibid.*, 255, 269. Cf. Wundt, P. P., i., 1893, 382; i., 1902, 536.

² *Ibid.*, 111.

⁴ P. S., v., 1889, 245 ff.

Active pressure with the finger. Weights 1 to 5000 gr.
Column headings as before.

R_1	R_3	R_m	R_a	R_g
1	10	4.689	5.5	3.162
2	20	9.801	11.0	6.325
5	50	21.97	27.5	15.81
10	100	46.36	55.0	31.62
20	200	92.37	110.0	63.25
50	500	215.3	275.0	158.1
100	1000	430.7	550.0	316.2
200	2000	948.3	1100.0	632.5
500	5000	2435.0	2750.0	1581

This paper is closely followed by another, in which Merkel—it is noteworthy that he never seems to have doubted the value of the method as applied to successive stimuli—records his work with sound intensities.¹ The procedure is, as before, serial and with knowledge. The sounds were obtained by dropping steel balls, of different weight, from a varying height upon a plate of hard wood.²

R_1	R_3	R_m	R_a	R_g
2.025	6.075	4.060	4.050	3.508
4.993	14.98	9.911	9.986	8.648
9.886	29.66	19.88	19.77	17.12
39.73	119.2	80.39	79.46	68.81
77.89	233.7	155.0	155.8	134.9
146.6	439.8	305.4	293.2	253.9
260.8	782.4	524.6	521.6	451.7
795.2	2386	1600	1591	1377
1234	3702	2461	2468	2137

We have here precisely the same tendency of judgment that is shown in the two preceding Tables.³

We come now to the vexed question of the bisection of tonal distances. Stumpf, in 1883, had granted the theoretical possibility of distance judgments, more especially of the equation of supraliminal distances in the various sense departments, but had denied the applicability of the method of mean gradations to tonal

¹ P. S., v., 518 ff.

² *Ibid.*, 506 ff.

³ *Ibid.*, 519, Table xvi.; Wundt, P. P., i., 1893, 367; i., 1902, 516.

distances.¹ In 1890, the question was approached experimentally by C. Lorenz² and Münsterberg.³ A controversy between Wundt and Stumpf followed, the course of which we trace elsewhere.⁴ Whether we side for Stumpf or for Wundt, there can be no doubt that Weber's Law fails of validity in the sphere of tonal qualities.

The next paper⁵—that of Angell, 1891—takes us back to sound intensities. Angell worked with Wundt's gravity phonometer,

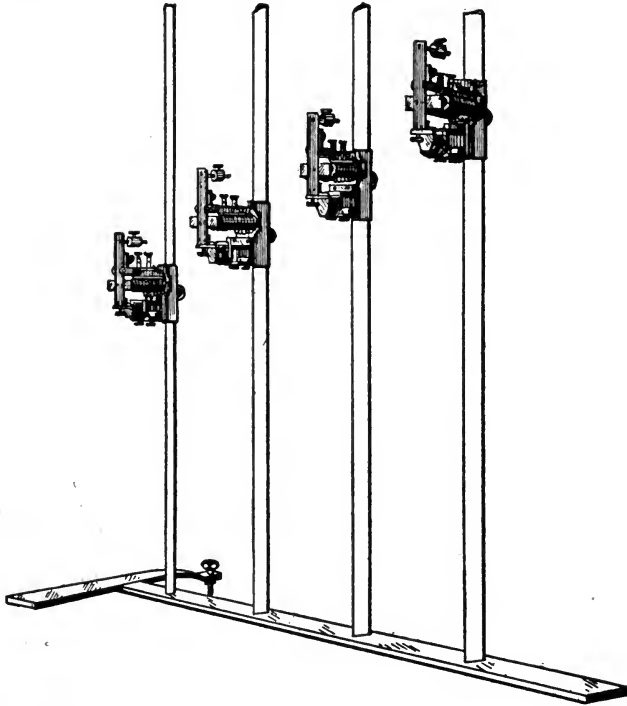

FIG. 32.—Wundt's gravity phonometer, latest form, without plates or trough: Zimmermann, 1903, Mk. 385. A cheaper form (§25), built in the Cornell Laboratory, works fairly satisfactorily.

¹ Tps., i., 123 f., 247 ff.

² P. S., vi., 1891, 26 ff.

³ Beiträge, iii., 1890, 37, 41; cf. iv., 1892, 147 ff. On Münsterberg's equations of disparate *S*-differences (iii., 56 ff., 98), see Angell, P. S., vii., 434; Müller, M., 235 f.

⁴ See p. 242.

⁵ Kraepelin (P. S., vi., 502 f.) and his pupil Higier (P. S., vii., 289) had, in the meantime, assimilated the method of mean gradations to Merkel's method of doubled stimuli. Cf. Münsterberg, Beiträge, iii., 1890, 118; Angell, P. S., vii., 423; Wundt, P. P., i., 1893, 346; i., 1902, 480.

using ivory balls, of the same weight, which fell from different heights upon hard-wood plates.¹ He employed both the serial procedure with knowledge and the irregular procedure without knowledge: the latter had already been employed by Lorenz.² With the former procedure, he found it possible (if we may speak in round terms) to bring out any R_m that he wanted; O 's judgments, under constant conditions, were uniform enough, but the point of subjective equality varied regularly with the initial value of R_v and the size of the steps.³ With the latter, he obtained the following results (two observers):

R_1	R_3	R_m		R_a	R_g
10	40	19.62	20.49	25	20
20	60	35.00	35.75	40	34.6
15	60	28.60	32.33	37.5	30
20	80	41.61	43.71	50	40
20	100	43.77	51.11	60	44.7

i.e., a close approximation to the geometrical mean.⁴ Angell finds several technical flaws in Merkel's procedure, and pronounces his conclusions in general "höchst bedenklich."⁵

In 1892, Fullerton and Cattell published the results of experiments upon the extent and force of movement done by the method of 'estimated amount of difference.' They believe that "the O probably does not estimate quantitative relations in S , but quantitative differences in the R learned by association."⁶ They thus attribute to the method at large the fault which Angell charges to Merkel's investigations. They seem, indeed, to have set out with this view: for we read that the O is directed to "mark off on the scale the half of 500 mm., . . to double 300 mm., . . to find

¹ P. S., vii., 414 ff. For the apparatus, see P. S., iii., 269; Wundt, P. P., i., 1893, 362; i., 1902, 512; G. A. Hoefler, Z., xxxvi., 1904, 270 f.

² *Ibid.*, vi., 45 ff.

³ *Ibid.*, vii., 443 ff.

⁴ *Ibid.*, 465; Wundt, P. P., i., 1893, 367; i., 1902, 516.

⁵ *Ibid.*, 465 ff.; cf. 432 f. Wundt remarks that Angell's result with the serial method, "da es nur bei Versuchen, in denen eine Erwartungstäuschung mitwirkte, erhalten wurde, liefert keinen entscheidenden Beweis gegen das von Merkel gewonnene Ergebnis" (P. P., i., 1902, 517; cf. i., 1893, 367). But Angell suspects precisely this source of error in Merkel: 467.—Ebbinghaus' classification of brightnesses and Merkel's experiments with light and sound are interpreted in accordance with the Spannungstheorie by Münsterberg, Beiträge, iii., 113 ff. Merkel replies in P. S., vii. 1892, 560 ff. He discusses *ibid.*, viii., 1892, 120 ff. the results of C. Lorenz.

⁶ Small Diffs., 152, 19 f. Cf. A. J. P., v., 293.

the mean between 300 and 700 mm.”; and again “to double 3 kg., to halve 12 kg., and to find a mean between 2 and 4 kg. and 4 and 8 kg. respectively.”¹ This is the language of *R*, not of *S*; the problem of the method has been changed. It is small wonder that “the method of estimated amount of difference—in which an *O* judges the definite quantitative relations of *R*, as in making one difference equal to or double another—gives variable results.”² As Fullerton and Cattell use it, it simply measures *O*’s familiarity with the *R*.

Merkel replies to Angell, by argument and by new experiments, in 1894. His chief points are: that Angell was bound, from the outset, to discover the geometrical mean, whether this mean would be discovered or not; that he should have begun his serial experiments with $R_v = R_1$ or R_3 ; that his experiments with irregular variation of R_v cover too small a range of stimulus intensities to be decisive; and that, in this procedure, attention is unduly concentrated upon R_v .³ At least the second and third of these are good arguments. When, however, Merkel meets Angell’s suggestion of the influence of association, expectation, etc., by the statement: “ich wie kein anderer bin von dem Bestreben geleitet, die psychophysischen Methoden so zu gestalten, dass diese Einflüsse völlig ausgeschlossen werden,”⁴ we are reminded that he is, by mental constitution, a physicist rather than a psychologist; that he had, in the previous year, protested energetically against the admission of qualitative factors into method work;⁵ and that his work as a whole is exceedingly poor in introspective data. No one can read Merkel’s papers without recognising the fact that he is strongest upon the side of mathematical physics, and weakest upon the side of introspection and psychological theory.⁶

¹ *Ibid.*, 42 ff., 99 ff. The authors apparently made some preliminary tests on themselves, since they say: “the writers agree in finding that they cannot estimate such quantitative differences in sensation in a satisfactory manner” (20), and then formulated their instructions to *O* in terms of *R*. But they must have had in mind the Fechnerian notion of quantitative differences in *S*.

² *Ibid.*, 152. The work is criticised by Merkel, *P. S.*, x., 1894, 225 ff.

³ *P. S.*, x., 210 ff., 377 f.

⁴ *Ibid.*, 221.

⁵ *Ibid.*, ix., 1893, 196 f.

⁶ See esp. *Die Aufgaben und Methoden der Psychologie in der Gegenwart, Jahresber. d. kgl. Realgymnasiums in Zittau für 1894-5, 1895, 1 ff.* Cf. Müller, *M.*, 242.

The new experiments are made with sound intensities by the method of mean gradations in combination with that of r. and w. cases or of e. and u. cases.¹ Merkel concludes that, if the after-effect of the stimuli (due to a too rapid succession, and varying with variation of the limiting *R*) and the effect of contrast are ruled out, the revised method gives between the limits 10 and 110 a direct proportionality of *R* and *S*.² The same result follows from the older work on sound, in which these disturbing effects were not eliminated,³ and also from his own work on light and pressure.⁴

Meinong suggests in 1896 that Merkel may have judged in terms of *Strecke* rather than in terms of *Distanz*. "Handelt es sich . . . um die Mittenschätzung bei psychischen Strecken, und es kommt dabei . . . zu einem Verfahren, das der Superposition physischer Strecken einigermaßen analog ist, so ist dann sehr natürlich, dass das zuletzt Verglichene der Unterschied der grössten von der mittelgrossen, und der Unterschied der mittelgrossen von der kleinsten Strecke ist. Handelt es sich . . . um ähnliche Schätzungen bei Schallstärken, so geschieht es, wenn ich an mir gemachten Beobachtungen trauen darf, thatsächlich, dass man beim Uebergang von der einen Schallstärke zur anderen, wie sie [er?] dem Abgeben des Urtheils voranzugehen, dem Wahrnehmen der Schalle aber nachzufolgen pflegt, statt Sprünge zu machen, den Weg zwischen den betreffenden Schallstärken wenigstens manchmal in der Einbildung ausfüllt; von hier aus könnte dann wieder ein Quasi-Superpositionsverfahren zu Differenzen statt Verschiedenheiten führen."⁵

This suggestion is, perhaps, confirmed by the results of Witasek's experiments on angular divergences (*Winkelverschiedenheiten*), published in the same year.⁶ The experiments cover a wide range of angular magnitude, and were performed both passively and actively. The passive procedure gives the arithmetical mean; the active gives the arithmetical in about 80%, the geometrical in about 20% of the trials.⁷ Witasek

¹ *Ibid.*, x., 228 ff., 369 ff.

² *Ibid.*, 514.

³ *Ibid.*

⁴ *Ibid.*, 517.

⁵ *Z.*, xi., 1896, 263 f., 396. Cf. Stumpf, *Tps.*, i., 126 ff.; C. Lorenz, *P. S.*, vi., 1891, 92. Angell replies briefly to Merkel's criticisms in *A. J. P.*, xii., 1900, 76 f. On Merkel's formulæ in *P. S.*, vii., 613 ff. and x., 229 ff., see Müller, *M.*, 228.

⁶ *Z.*, xi., 1896, 321 ff.

⁷ *Ibid.*, 330.

remarks that the required judgment is difficult, and that *O* has recourse, where possible, to secondary criteria. Very likely, therefore, "der *O* legt in der Phantasie den kleinsten Winkel auf den mittleren, merkt sich den Unterschied beider, legt dann den mittleren auf den grössten und macht nun den *Unterschied* gleich dem des ersten Paares." And *Unterschied* is not *Verschiedenheit*. "Eine derartige Verschiebung der Frage zu vermeiden, ist eigentlich ganz und gar subjektive Sache des *O*." Why in the world, then, did not Witasek ask his *O*'s how they judged? "Man kann es ja dem *O* nicht ansehen, ob er *Unterschiede* oder *Verschiedenheiten* vergleicht."¹ No! But one can ask for introspections; and one can make control experiments, explaining the differences of judgment-attitude to *O* after the event, and requiring him to judge in this way or in that, or at least to say whether the two attitudes are possible for him.

Merkel replies that a superposition of *Strecken* not only did not occur in his experiments, but is "bei intensiven *S* gar nicht denkbar." "Ich lasse die drei *R* aufeinander folgen, beurteile jeden einzelnen für sich und entscheide dann möglichst rasch, ob der Reiz R_m dem einen oder anderen Grenzreize näher lag, oder ob er die Mitte einzunehmen schien."² It is noteworthy that he calls the method "die Methode der mittleren Reize."³

Ament in 1900 goes carefully over the ground in dispute between Merkel and Angell, deciding (except on the question of range of *R* employed) in favour of the latter.⁴ Ament points out that Merkel's work with mean gradations was done after his work with the method of doubled stimuli, and that his results differ characteristically from those which Angell obtained by the serial procedure;⁵ he strongly suspects the presence of secondary criteria.⁶ He himself works with brightnesses (limits 1-3) and sounds (1-47), and finds that "die gefundene Mitte zwischen zwei Grenz-*R* von dem geometrischen Mittel derselben . . . nach R_3 hin um so mehr abweicht, je grösser das Verhältniss der Grenz-*R* zu einander ist und je grösser die absoluten Intensitäten derselben sind."⁷ This is in accord with Angell's serial results. The conclusion is drawn from experiments performed (with sounds) both by the serial and by the irregular procedure, though

¹ *Z.*, 332.² *Ibid.*, xii., 1896, 237.³ *Ibid.*, 236.⁴ *P. S.*, xvi., 139 ff., 145 ff.⁵ *Ibid.*, 146.⁶ *Ibid.*, 143.⁷ *Ibid.*, 180. Müller, M., 243.

the former is so modified, to meet the idiosyncrasies of *O*, that its serial nature is much obscured.¹ Ament believes that Angell, had he extended his range of experimentation, would have reached a similar result.²

In 1901, G. Heymans attempts a re-interpretation of the results of Merkel, Angell and Ament. According to Heymans, the law of proportionality between *R* and *S* is crossed by the law of mental inhibition, whereby weak *S* are forced from consciousness by strong proportionally to the intensity of the latter.³ The *DL* thus becomes a phenomenon of inhibition, and Weber's Law a limiting case of the law of inhibition.⁴ The upper and lower deviations from Weber's Law, as well as the systematic deviations from the arithmetical mean found by Merkel and Ament, are explicable on the same principles.⁵ Angell's geometrical mean (irregular procedure) and the geometrical series of stellar intensities are accounted for by the narrow range of the intervals.⁶ These hypotheses "gestatten die Vielheit der vorliegenden Erscheinungen in einfacherer und übersichtlicherer Weise, als bis jetzt möglich war, zu beschreiben. Ausserdem weisen sie auf eine innere Zusammengehörigkeit dieser Erscheinungen hin, und fordern einen gemeinsamen Erklärungsgrund für dieselben."⁷

In the same year, Lehmann published a detailed criticism of Ament's results, and suggested the use of certain factors of correction which brought them into the neighbourhood of the geometrical mean.⁸ Külpe replied, in still greater detail, in 1902.⁹ F. S. Wrinch had, in the meantime, attacked the problem for tone-filled times,¹⁰ and found results that accorded in the main with those of Merkel and Ament.¹¹ The method of mean gradations was employed between the limits 250 and 20000.¹² We may re-

¹ *Ibid.*, 171.

² *Ibid.*, 179.

³ *Z.*, xxi., 1899, 321 ff.; xxvi., 1901, 305 ff., 381. Cf. *Int. Congr. Exp. Psych.*, 1892, 109 ff.

⁴ *Ibid.*, 344.

⁵ *Ibid.*, 357 f., 358 ff.

⁶ *Ibid.*, 378.

⁷ *Ibid.*, 381. That Külpe (who was responsible for Ament's paper) does not accept Heymans' theory is clear from Wrinch, *P. S.*, xviii., 1902, 309 ff. Müller makes no mention of Heymans' work in the *M.*

⁸ *Körp. Aeuss. psych. Zustände*, ii., 1901, 105 ff.

⁹ *P. S.*, xviii., 1902, 328 ff.

¹⁰ *Ibid.*, 274 ff. Some experiments were also made with 'empty' intervals, limited by sounds : 290 ff. The work was done in Külpe's laboratory.

¹¹ *Ibid.*, 308 ff., 326.

¹² *Ibid.*, 278.

mark, without prejudicing the validity of Wrinch's conclusions, that the conditions of judgment are radically different for short and long times, and for the determination of the *DL* and the halving of temporal distances. It is, therefore, possible that some such relation obtains here, between the methods of limits and of mean gradations, as obtains in the sphere of ocular measurement.¹

We saw that Wundt, in 1874, came very near to an independent formulation of the method of mean gradations. In 1880, he remarks that Plateau's method has, so far, been applied only to brightnesses, *S* which "annähernd simultan mit einander verglichen werden können. Doch würde die Methode," he continues, —perhaps in reply to Müller,—“in etwas veränderter Form wahrscheinlich auch auf die Schallempfindungen anwendbar sein.”² In 1887, nothing is said of restriction to particular sense departments;³ brightnesses and noises are given as illustrations of the constant errors of space and time.⁴ In 1893 all three forms of the method (serial procedure, irregular procedure, combination with *r.* and *w.* cases) are discussed.⁵ “Unbedingt ist die unregelmässige Variation des mittleren *R* zu bevorzugen, welche die Erwartungseinflüsse ausschliesst oder sie in zufällige variable Fehler verwandelt, die in einer grossen Zahl von Versuchen sich ausgleichen.”⁶ Merkel's results are passed over rather lightly. In the case of sounds, it is suggested that the serial procedure,⁷ in the case of brightnesses that the effect of contrast and the successive procedure⁸ may be responsible for the deviation from the geometrical mean. In the case of pressure, it is stated that we do not know the part played by sensations of passive pressure and of movement; “ebenso ist der Einfluss der zeitlichen Veränderungen dieser *S*-Componenten während der Ausführung der Bewegung nicht sicher zu bestimmen.”⁹ Nevertheless, Wundt admits that the method of mean gradations is ‘unfavourable’ to Weber's Law, save on the condition that R_m be irregu-

¹ Ebbinghaus, *Psych.*, i., 1902, 505.

² *P. P.*, i., 1880, 325 f.

³ *P. P.*, i., 1887, 344. It was, doubtless, this passage (overlooked by Angell) that led Merkel to apply the method, as a matter of course, to sounds and pressures.

⁴ *Ibid.*, 351 f.

⁵ *P. P.*, i., 1893, 344 f., 355 f.

⁶ *Ibid.*, 357.

⁷ *Ibid.*, 360.

⁸ *Ibid.*, 371, 379.

⁹ *Ibid.*, 382.

larly varied and the time-order constantly changed.¹ The chief point of difference between the favourable and the unfavourable methods or procedures is that, in the former, "der Normal-*R* wechselt, zu dem ein bestimmter Vergleichs-*R* in Beziehung gebracht wird," while in the latter "der Normal-*R* in einer grösseren Anzahl zusammengehöriger Verfahren constant bleibt."² But this statement surely underestimates the length of series and number of experiments required for min. ch. and r. and w. cases! —The difference is later turned to account for the psychological interpretation of Weber's Law.³

The P. P. of 1893 evidently represents a half-way house in Wundt's thought. He is ready to grant that Merkel's results were not obtained under pure conditions; at the same time, he thinks that there is enough in them to warrant their citation on behalf of his own interpretation of Weber's Law. In 1902, his position has become definite. There are now two laws, Weber's and Merkel's.⁴ The latter, it is true, is a law of exceptions; it is bound to a certain method, and to certain determinate conditions within the method; but these conditions and the contents to which they apply are sufficiently important to warrant the erection of a special law. "Da die übrigen Bedingungen der Beobachtung bei der Auffindung beider Gesetze, abgesehen von der Grösse der Intervalle und der Vergleichung von je drei, nicht bloss von zwei *R*, vollkommen übereinstimmen können, so wird dadurch die Coexistenz dieser so wesentlich abweichenden Gesetze zu einer psychologisch sehr interessanten Erscheinung. Denn es lässt sich . . . kaum denken, dass es andere Einflüsse als solche, die selbst den Vorgängen der Vergleichung und Schätzung der *S*-Stärken angehören, also psychologische Momente sind, aus denen diese Unterschiede entspringen."⁵ Weber's Law presupposes a relative, Merkel's an absolute estimation, or "Gleichschätzung gleicher absoluter Unterschiede."⁶ The coexistence of these two modes of estimation is "eine entscheidende, nahezu einem ex-

¹ P. P., i., 1893, 388.

² *Ibid.*, 389.

³ *Ibid.*, 394. On Wundt's 'absolute' and 'relative' estimation, see W. Dittenberger, Arch. f. syst. Phil., N. F., ii., 1896, 101; Meinong, Z., xi., 1896, 265; Ament, P. S., xvi., 1900, 144.

⁴ P. P., i., 1902, 494, 496, 504 ff.

⁵ *Ibid.*, 506.

⁶ *Ibid.*, 545.

perimentum crucis gleich zu achtende Bestätigung" of the psychological interpretation of Weber's Law.¹

Wundt's argument, in brief, is as follows. Weber's Law holds when the *S*-differences are minimal, and only two *S* are compared. The two conditions are closely related; for, if differences are minimal, a distribution of attention over three *S* would lead to inaccurate results. The course of the *DL* must thus be determined by a number of entirely independent single comparisons. But that is the prime condition of a *relative* estimation. For one can bring the two values *a* and *b* of one comparison into a relation of correspondence with the values *c* and *d* of another, only by marking the ratio $\frac{a}{b}$ and then noting that the ratio $\frac{c}{d}$ is identical with it. Merkel's Law holds, on the other hand, when the *S*-differences are large and three *S* are compared. Again, the two conditions are closely related: for two widely different *S* of one experiment cannot be compared with two widely different *S* of another; if two wide intervals are to be compared, they must be embraced between three *S* in one experiment. One then marks the intensity of one limiting *S* (the first presented), and measures off from it the intensities of the mean and of the other extreme. But that is the prime condition of an *absolute* estimation: one compares, not $\frac{a}{b}$ with $\frac{b}{c}$, but *b* — *a* with *c* — *b*. It is necessary that the *a*, *b*, *c*, be presented only once in ascending or descending order; since only so do the three *S* form a single aggregate idea, which we can divide into two equal intervals. This means that *a*, *b*, *c* must be given successively. If they are given simultaneously, the attention wanders back and forth between them. Moreover, contrasts arise; and we compare contrasts by relative estimation. This explains the difference in result of experiments with simultaneous and successive brightnesses. It is advisable, also, to vary *b* regularly. One then holds the three *S*, so far as possible, together in consciousness; whereas, if one has merely to say whether a given distance *ab* is greater than a *bc*, one is greatly tempted to compare $\frac{a}{b}$ with $\frac{b}{c}$.²

Wundt finds the first hint of Merkel's Law in Hering's weight experiments (Sitzungsber. d. k. Akad. d. Wiss. zu Wien, lxxii., 3te Abth., 9 Decr. 1875, 323 f.). He thinks that Fechner's reply to Hering (I. S., 187 f.) is insufficient; but he says nothing of the criticisms of Langer (Grundlagen, 1876, 24 ff.) and Müller (G., 391 ff., 411 ff.). Lehmann's objection, that Merkel's results do not bear out the equation $R_1 = 2 R_m$ —

¹ P. P., i., 1902, 544 f.

² *Ibid.*, 545 ff.

R_3 is met by the counter-objection that "diese Umrechnung die Abweichungen doppelt so gross erscheinen lässt, als sie wirklich sind."¹

Most readers of the P. P.—at any rate, most of those who have had personal experience in method work—will probably feel that Wundt's explanation is too schematic.² That there are typically different modes of judging, in mean gradations, is beyond question. There is, first, the main difference of reference to S and reference to R : the latter attitude is by far the easier. Within each of these, there is the further difference of objective and subjective type. Suppose that two O 's, an objective and a subjective, were trained to judge in terms of S rather than of R : still, the serial procedure would, in all likelihood, prove worthless in the hands of the latter. But in speaking of R and S , objective and subjective, we are giving merely the crude outline of differences; we ignore the colouring and shading, that vary almost from individual to individual. The name of the secondary criteria in mean gradations is legion.

In the author's judgment, it is probable that Weber's Law holds for supraliminal differences in the sense departments and in the region of the intensive scale where it holds for liminal differences. The positive evidence is too strong to be overthrown by the negative,—especially as the negative evidence is often equivocal, and is variously estimated even by those who would gladly accept it. At the same time, the author regards this point as of relatively minor significance. What we now need is an introspective reconstruction of the method, a full analysis of the conditions of judgment for different O 's, in different sense-departments, for different magnitudes of sense distance. When we have this, we may come back to Weber's Law—or to whatever more complicated formula the facts may require—and speak once more in quantitative terms. The work on this, as on all the metric methods, is preëminently work that demands coöperation. We want a large number of O 's, we want O 's of all types and degrees of training, we want tests of the method by men who are prejudiced or pre-

¹ P. P., i., 1902, 506 ff.

² Wundt's distinction of Weber's and Merkel's Laws and his theory of judgment in mean gradations are severely criticised by Müller, M., 243.

possessed both for and against, we want a volume of introspective reports, we want the analysis and critical judgment of those who see the method from within, in the light of their own introspection, and of those who see it merely from without, as a piece of applied logic.¹

A word must be said of Fröbes' recent investigation (*Z.*, xxxvi., 1904). Fröbes' avowed aim is "die Urteilsfaktoren aufzuklären" (241). Suspecting the influence upon judgment of *absolute impression*, he therefore begins with the classical field for absolute impression,—lifted weights. The method is the modified form of the method of constant *R*-differences.² In four series, r_1 and r_2 were constant at 600 and 1200 gr., while r_3 was varied; in one, r_1 and r_3 were constant at 600 and 2360 gr., while r_2 was varied. The space error was eliminated by disposition of apparatus. Owing to motor *Einstellung*, only one time order, r_1, r_2, r_3 , was found practicable, and even so it was necessary to interpolate two extra lifts of r_1 between observation and observation. The instruction to *O* was "to compare the *S*-differences," "to say whether r_2 lay for *S* nearer to r_1 or to r_3 " (242 ff., 248). The results of Müller's two series (r_3 and r_2 variable) shown a fairly close approximation to the arithmetical mean: unfortunately, the interplay of time-order, motor *Einstellung*, absolute impression, and *R*-error³ forbid any attempt at interpretation (265). Those of the remaining series show a steady rise, from a value well below the arithmetical mean to a value approximating Müller's; they are explained by absolute impression and the course of practice (257, 265, 266 ff.).

Fröbes next proceeds to a repetition (with minor variations) of Ament's experiments with brightnesses (methods of *j. n. d.* and mean gradations): Müller served as *O*, and judgment by degree of cohesion was prescribed. The results speak for the equality of the *j. n. d.* Suggestions are offered in explanation of the opposed results (2 out of 3 *O*'s) gained by Ament; but no final conclusion can be reached, since the determining factors in the judgments of Ament's *O*'s are unknown (344 ff.).

¹ This conclusion agrees in the main with Müller's remarks, *M.*, 242 f., though the author is less sceptical than Müller in the matter of distance judgments.—The author has not devoted a special paragraph to the *M.*, in this §, since the contents of Müller's discussion (224 ff.) have already been utilised in § 28.

² *M.*, 199 ff. To find Fröbes' refs. to the *M.* in the off-printed and newly paginated edition, subtract 272 from his figures. His treatment of the numerical results (*Z.*, 248 ff.) affords a pretty illustration of the course of procedure laid down in the *M.*

³ This is apparently an interpretation of Müller's introspections, 259, which in themselves are not quite clear.

Finally, Fröbes reports a study of mean gradations made with rotating discs (dark room with artificial light ; mixed adaptation). The method was a form of the method of limits ; r_2 was varied ; judgment by degree of cohesion was prescribed (356 ff., 376). The results were as follows :

- (1) $r_1 = 30^\circ W$, $r_3 = 230^\circ W$. Two series were taken. The first, and more reliable, gives a middle value that lies very much closer to the geom. than to the arith. mean ; the second, and less reliable, gives a middle value that lies about midway between these means.
- (2) $r_1 = 30^\circ W$, $r_3 = 140^\circ W$. Four *O*'s (of whom Müller is one) give a middle value that lies much closer to the geom. than to the arith. mean.
- (3) $r_1 = 140^\circ W$, $r_3 = 250^\circ W$. The same four *O*'s give a middle value which exceeds the arith. mean by some $9^\circ W$.
- (4) $r_1 = 250^\circ W$, $r_3 = 360^\circ W$. The same four *O*'s give a middle value which exceeds the arith. mean by some $20^\circ W$!

The two latter results are explained by the fact that three of the *O*'s declared that r_3 "bei den mittleren und höheren Intensitäten blendend hell schien und isoliert stand" (375) ; while the fourth (Müller), although he did not find any of the *R* 'dazzling,' nevertheless declared that "bei den Versuchen in den beiden intensiveren Helligkeitsgebieten die lichtstärkste Scheibe infolge ihrer Eindringlichkeit eine besonders hohe Tendenz, sich isoliert zu stellen, besessen hat" (375 f.). "Man sieht," moralises Fröbes in conclusion, "won welchem Einfluss in diesem ganzen Gebiete der sogen. Vergleichung übermerklicher *S*-Unterschiede der Versuchsmodus ist, und wie weit die Dinge hier davon entfernt sind, so einfachen Deutungen zuzulassen, als man bisher für angezeigt gehalten hat" (379).

ESSAY SUBJECTS.—(1) The value of the method of equal sense distances to a quantitative psychology ; the general relation of the method to methods that furnish a *DL*.

(2) A statement, with critical estimate, of the various forms that the method has assumed in experimental work.

(3) Merkel's Law.

(4) The psychology of the comparison of sense distances.

(5) The *R*-error.

§ 30. **The Psychophysics of Tone : the Tonal *DL* and Judgments of Tonal Distance.**—In the early days of psychophysics, when evidence for Weber's Law was being sought in all possible directions, nothing seemed more natural than to appeal to the musical scale. The vibration ratios of the intervals are constant : which surely means that equal differences of sensation are paral-

leled by relatively equal differences of stimulus. Weber himself, with this estimation of intervals in his mind, writes as follows. "When we are comparing two tones, it makes no difference whether they are seven steps [an octave] higher or lower, unless indeed they lie at the end of the tonal series, where the exact discrimination of small tonal differences is more difficult. It is here not a question of the number of vibrations by which the one tone exceeds the other, but of the relation of the number of vibrations of the two tones that we are comparing."¹ And Fechner says, in just the same spirit: "There is no need of special experiments to confirm the law under this heading, since it is the simple and, if one may say so, the notorious judgment of the musical ear, that tonal differences which are equal in sensation correspond in different octaves to equal ratios of vibration rates; so that we may consider the law as proved more directly here than anywhere else, and, further, as proved for large differences."² Helmholtz

¹ E. H. Weber, *Tastsinn u. Gemeingefühl*, in R. Wagner's *Handwörterb. d. Physiol.*, iii., 2, 1846, 560. A few sentences before, Weber cites the work of Delezenne (see p. 235, below); but this is irrelevant (see Fechner, *El.*, i., 137, 181 f., 261 ff.). Farther on, Weber writes (561): "The apprehension of the relations of whole magnitudes, without measurement of the magnitudes by a smaller standard and without knowledge of their absolute difference, is an extremely interesting psychological phenomenon. In music, we apprehend the relations of tones, without knowing their vibration rates; in architecture, the relations of spatial magnitudes, without having determined them by inches; and in just the same way we apprehend the magnitudes of sensation or the magnitudes of force in our comparison of weights." Hering regards this last sentence as the "Kern der ganzen Auseinandersetzung" (*Sitz.-ber. d. Wiener Akad., math.-naturwiss. Cl.*, lxxii., 3 Abth., 1875, 313). He is therefore at some pains to point out that the phrase 'apprehend relations' is used in different senses; what we apprehend, in the case of tones, is interval, or relation of tonal sensation, not vibration rate. Stumpf, however, thinks that the 'vibration rates' is merely a lapsus calami, and that we should read: "In music, we apprehend the relations of tones, without knowing their absolute pitch." This interpretation is borne out by a remark of Weber's (560): "If our mind counted the vibrations of the two tones, then we might suppose that it would take account only of the number of vibrations by which the one tone exceeds the other." It therefore seems plausible. The statement which Hering criticises is then off the point of the present discussion. See Tonps., i., 337; and *cf.* the exposition in § 1.

² *El.*, i., 182. Fechner has already remarked (138) that Weber gives no evidence for his law in the sphere of tones, beyond the 'general statement' of its validity; but he thinks that, in view of Weber's unconditional accuracy as observer, we may allow this statement the weight of 'observed facts.' Yet, as Fechner himself sees,

declares, in the first edition of the *Physiologische Optik*, that "differences of tonal pitch, in particular, appear equally great when the differences in period of vibration amount to equal parts of the total period of vibration."¹ Vierordt is no less emphatic: "The law holds in widest extent and with strict accuracy in the sphere of discrimination of tonal pitch."² And Wundt writes, in 1874: "We sense directly only the relations of the vibration rates, not their absolute differences; and equal absolute differences of sensation correspond to equal ratios of vibration rates. . . We find always in octave and fundamental, fifth and fundamental, etc., the same differences of sensation, whatever the absolute pitch of the tones."³ This was, indeed, the general psychological belief.

The change of opinion, when it came, was radical. In 1876

Weber's appeal to Delezenne is irrelevant (181). As additional evidence, Fechner cites the fact that Euler, Herbart and Drobisch have based their mathematical treatment of tonal relations upon the sensible equality of the musical intervals at different parts of the scale (65, 182: *cf.* L. Euler, *Tentamen novæ theoriæ musicæ*, 1739, 73; J. F. Herbart, *Werke*, ed. G. Hartenstein, vii., 1889 [1839], 216; M. W. Drobisch, *Abh. d. kgl. sächs. Ges. d. Wiss., math.-phys. Cl., ii.*, 1855, 35). The reader should also consult *El.*, ii., 179 ff., esp. 187 ff., and the general discussion, 198 ff. For Fechner's later position, see below, p. 237. He makes theoretical use of the supposed equality of the musical intervals in *El.*, ii., 430 f., and *Ber. d. kgl. sächs. Ges. d. Wiss., math.-phys. Cl.*, 1864, 11.

¹ P. O., 1867, 312. In 1896, 387, the passage reads: "appear *musically* equally great." The following reference to our "measurement of pitch by logarithm of the vibration number" remains unchanged. *Cf.* and *cf.* the related passages in the *Sensations of Tone*, 256 a, 264 f., 363 c, all of which date back at least to the edition of 1870.

² K. Vierordt, *Der Zeitsinn nach Versuchen*, 1868, 161.

³ P. P., 1874, 363, 364 f. In 1880, 395, 397, the two sentences are repeated; but the paragraph containing the second goes on to say that the musical scale has its own laws of harmony. "This and this only can be inferred here from the existence of the musical scale and its applicability to simple tones, that we possess in our sensation a measure for the qualitative gradation of tones, and that this measure follows Weber's law with regard to objective tonal relations. But this inference might have been drawn equally well, if music had chosen quite different intervals." In 1887, i., 425 f., the statement of the sensible equality of intervals is withdrawn, and the question left open for experimental investigation. We shall return later to the treatment of 1893, i., 452 ff.; ii., 1902, 72 ff. *Cf.* also the *Vorlesungen über Menschen- und Thierseele*, i., 1863, 174 f.; 1892, 87 (*Human and Animal Psych.*, 1896, 81); 1897, 88; *Essays*, 1885, 159 ff.; Grotenfelt, *Das Weber'sche Gesetz*, 81 f.; Delbœuf, *Éléments*, 119, 143; *Examen*, 3, 21, 171.

appeared Preyer's paper, *Die Unterschiedsempfindlichkeit für Tonhöhen*. In the same year appeared Langer's *Die Grundlagen der Psychophysik*. Preyer urged factual, Langer theoretical objections to the prevailing belief. Thus Langer writes: "The assumption that, in the hearing of octaves, equal sensation differences are marked off is an arbitrary assumption, which is merely an expression of a periodicity based upon certain relations of the vibration rates. Until the sensation of the n -fold pitch has been brought into relation to the n -fold sensation of the simple pitch, the agreement with the law lies in the definition of 'pitches,' which also signify the sensations of the pitches."¹ Two years later came the elaborate criticism of Müller's *Grundlegung*, the keynote of which is that 'equal interval' is by no means identifiable with 'equal distance for sensation.' The musical scale was not constructed in sensibly equal steps, but was "determined by musical requirement and æsthetic principles."² Finally, Stumpf published in 1883 the first volume of the *Tonpsychologie*, accepting Müller's criticism, and offering experimental proof that "the same interval represents a different distance in different regions."³

We must pass in brief review the various contributions, critical and experimental, which have been made to a psychophysics of tone: only in this way can we gain a judgment upon present issues. We begin with the determination of the tonal *DL*.

The J. N. D. of Pitch: (a) Successive Tones.—(1) C. É. J. Delezenne found, in 1826, that the tones given by the two parts of a metal string stretched over a bridge could be distinguished by practised ears when their vibration ratio was 239.58 : 240.41. In other words, the j. n. d. for the tone $b=240$ vs. was 0.83. Unpractised *O*'s remarked a difference between the tones 241.68 and 238.33; *i.e.*, the j. n. d. in the same region was 3.35.

Delezenne's string of 1147 mm. gave the "lower octave of the tone *B* on the fourth string of the cello," *i.e.*, the *B* of 120 vs. See Stumpf, *Zts.*, xviii., 1898, 373. Fechner seems to have understood Delezenne aright: *El.*, i., 261 ff. Later writers give the pitch of the string as that of 60 vs., taking Delezenne's 'vibrations' to mean 'single vibrations': see Preyer, *Gr. d. Tonw.*, 26 f. (Delezenne

¹ P. Langer, *Die Gr. d. Ps.*, eine kritische Untersuchung, 72 ff., esp. 79.

² *G.*, 276 ff.

³ *i.*, 337 ff., 247 ff. We return to these passages later.

appears to have miscalculated his results, and Preyer is also guilty of minor errors), and the further references, p. 237.

J. Sauveur (1700) perceived a difference between the tones of two monochord strings, tuned to unison, when the length of the one was reduced $\frac{1}{200}$. The pitch of the strings is not stated. Preyer suspects a change of tension.—W. Weber writes: "I can say from experience that the ear senses delicately enough, under favourable conditions, to determine the tones unaided so accurately that the error never amounts to more than 1 vibration in 200" (Pogg. Ann., xiv. [xc.], 1828, 398, 400).—J. H. Scheibler (1840: quoted by Preyer) failed to distinguish a difference of 0.5 v. in the λ of 230.4 vs.

(2) A. Seebeck found, in 1846, that practised ears could distinguish with certainty between the tones of two forks of 440 and 439.636 vs. That is, the j. n. d. for the tone $a^1=440$ was 0.363.—Pogg. Ann., lxxviii. (cxliv.), 1846, 462. Cf. Preyer, 27; O. Wolf, Sprache u. Ohr, 1871, 248. Misquoted by Fechner, El., i., 260.

(3) W. Preyer worked, in 1876, with Appunn's 'tone-difference apparatus': a refined form of the reed tonometer, giving the tones 500, 500.1, 500.2, . . . 501, 504, 508, 512, and 1000, 1000.2, . . . 1000.8, 1001, 1008, 1016, 1024, 2048, 4096. Highly practised *O*'s distinguished with certainty between the tones 500 and 500.3, and 1000 and 1000.5 (under extremely favourable conditions, 1000.4: Preyer must have had extra reeds to give the tones 1000.25 and 1000.5; see p. 31). Unpractised *O*'s invariably recognised a difference of 16 vs. within the limits c to c^3 ; little practised *O*'s a difference of 8 vs. between c and c^2 , and a slightly greater difference in the region of the c^3 .

For the low tones below 40, Preyer sets the j. n. d. at 1 v. or more for practised, and at 2, 3 or more vs. for unpractised *O*'s. For the tones between 40 and 120, he thinks that a j. n. d. of 0.5 v. may be attained with practice, though unpractised *O*'s require a difference of 2 or more vs. These statements appear to rest upon personal observation, though not upon systematic experiments. For the region above the c^3 , he cites only a few observations with high forks.—Gr. d. Tonw., 28–36.

A. von Dommer (1862; Preyer, 33) asserts that the extreme limit of tonal discrimination, throughout the musical scale, may be set at 0.002 octave. Cf. the belief of E. H. Weber and Fechner, p. 233, above.—Volkmar v. Volkmann (Lehrbuch d. Psychol., ed. H. Cornelius, 1884, i., 233) allows the ear a range of 10 octaves divided into quarter tones, or 280 qualities.

Wundt (P. P., 1874, 369) says that he found the fork tone $a^1=435$ vs. j. n. d. from the tone of 432,—a difference of 3 vs. The observation is not found in later editions.

Following Preyer's example, we may put the above results together in the form of a Table.

	<i>n</i>	<i>J. n. d.</i>	<i>Abs. D. S.</i>	<i>Rel. D. S.</i>
<i>B</i>	120	0.418	2.39	287 ¹
<i>a</i> ¹	440	0.363	2.75	1212
<i>b</i> ¹	500	0.300	3.33	1666
<i>b</i> ²	1000	0.500	2.00	2000

where *Abs. D.S.* = $1/j.n.d.$, and *Rel. D.S.* = $n/j.n.d.$

For criticism and discussion, see: Fechner, *El. i.*, 260 ff.; *I. S.*, 168 ff.; *R.*, 173 f.; Müller, *G.*, 290 ff. (answered by Preyer, *Ak. Unt.*, 1879, 64 ff.); *Gött. gel. Anz.*, 26 Juni 1878, 824; Wundt, *P. P.*, i., 1893, 454 (*cf. i.*, 1887, 426 f.); ii., 1902, 74; Stumpf, *Tps.*, i., 298 ff.; *E. Luft*, *P. S.*, iv., 1888, 512 ff.; *I. Schischmanow*, *ibid.*, v., 580 ff. It must, of course, be admitted that the Table brings together observations made by different men, with different methods, at different parts of the scale, and on different tone sources. How much all this matters, we shall be better able to judge presently. In the meantime, Fechner's attitude is interesting and characteristic. In the *I. S.*, he accepts Preyer's results; he regrets that a "wichtige Stütze" of Weber's Law "wegfällt," and comforts himself as best he may with a threefold *jedoch*. But one of the *jedoch*'s,—a "Vermuthung" on which in 1877 "kaum Gewicht zu legen sei,"—appears five years later, in the *R.*, to be so strong that the question of Weber's Law "bleibt hienach bis auf weiteres ganz unentschieden." Briefly put, the 'Vermuthung' is that, as Weber's Law in the sphere of intensity has so far been verified 'im Allgemeinen' with constancy of quality, so it may possibly hold in the sphere of quality if intensity (here, amplitude of vibration) be kept constant. The conjecture is demolished by Stumpf and Luft.

(4) *E. Luft* published in 1888 (*P. S.*, iv., 511) an extended series of experiments made with tuning-forks by the method of minimal changes. The forks had the pitch-numbers 64, 128, 256, 512, 1024 and 2048; later, forks of 32 vs. were added. One member of each pair was supplied with riders. The results for Luft himself may be tabulated as follows:

	<i>n</i>	<i>J. n. d.</i>	<i>Abs. D. S.</i>	<i>Rel. D.S.</i>
<i>C</i> ₁	32	0.44	2.27	72.7 ²
<i>C</i>	64	0.149	6.711	430
<i>c</i>	128	0.159	6.289	805
<i>c</i> ¹	256	0.232	4.310	1103
<i>c</i> ²	512	0.251	3.984	2040
<i>c</i> ³	1024	0.218	4.587	4697
<i>c</i> ⁴	2048	0.362	2.762	5657

At first sight, the small values of the *j. n. d.* may be surprising. But we must remember (*a*) that Preyer sought to determine the least value that was *invariably* noticed by a practised *O*, whereas Luft's limens represent

¹ The first line of this Table gives Delezenne's results in the erroneous form in which they are cited by the following writers. The line should read:

<i>b</i>	240	0.83	1.20	289.
----------	-----	------	------	------

² Not 727, as Stumpf says (*Tonps.*, ii., 553).

the mean between just noticeable difference and subjective equality of the tones ; and (b) that Preyer himself and one other highly practised *O* were able to discriminate tuning-fork tones of 440 and 439.75, *i.e.*, found a j. n. d. of 0.25 v. in the once accented octave (Gr. d. Tonw., 28). Moreover, (c) Luft's values for the c^3 show the greatest fluctuation, and are therefore the least reliable ; so that the 0.218 is in all probability too small (see Stumpf, Tonps., ii., 552 f.).¹

It is, then, hardly correct to say (as Wundt does ; P. P., i., 1893, 454 ; ii., 1902, 75) that Luft's *DL* is "nur etwa halb so gross als in Preyer's Versuchen." We have :

Luft	c^1	0.232
Preyer	a^1	0.250
Preyer	b^1	0.300
Luft	c^2	0.251
Preyer	b^2	0.400
(Luft)	c^3	0.218
Luft	c^4	0.362

When we remember what the values mean in the two investigations, we find, on the contrary, a very close agreement. The figures given by Seebeck and, more especially, by Delezenne, appear to be too large.

As regards *delicacy* of the D. S. (variability of the *DL*), Preyer's experiments tell us nothing ; his limens represent the magnitude of the D. S. at a given (just maximal) delicacy. Luft finds (530) that the certainty of judgment for tones of 64 to 512 "ziemlich constant ist, oder sich wenigstens nur in geringem Grade vermindert" as the vibration rate increases. It shows a marked decrease at 1024 and 2048. Both these tones are 'sharp' and 'penetrating,' and 'readily fatigue the ear.' Nevertheless, as was remarked above, the extreme uncertainty at 1024 seems to point to some experimental error.

Luft also made experiments by the method of r. and w. cases, of which more presently. His work by minimal changes is sharply criticised by Meyer, Z., xvi., 1898, 362 ff. ; see Wundt, P. P., ii., 1902, 86 *n.*

(5) M. Meyer, 1898, worked with forks by the method of right and wrong cases. The order was always N-V, and each test was repeated 3 times or oftener. Massed results :

Diff.	% 6 O's			% Stumpf	
	r	w	d	r	w
600 ±					
0.37	60	21	19	84	16
0.63	71	18	11	90	10
1.10	85	6	9	—	—

% r-cases : Stumpf					
Diff.	100	200	400	600	1200
0.35	71	83	80	84	67
0.65	74	91	92	90	70

¹ How an increase of the value 0.218 should lead to a corresponding increase of the value for the rel. D. S., so that (as Stumpf conjectures) this might actually decrease somewhat from c^3 to c^4 , the author is unable to understand. Tonps., ii., 553.

We may infer that the j. n. d. is approximately the same for tones of 200, 400 and 600; somewhat less (and again approximately the same) for tones of 100 and 1200. This agrees with Luft's conclusion, for the middle and upper parts of the scale; but disagrees with his results for 64 and 128.—Z., xvi., 352; Wundt, P. P., ii., 1902, 86 n.

Luft made experiments by r. and w. cases with the tone of 64. The results (not mentioned by Meyer) are:

Diff.	% r-cases	
	O_1	O_2
0.30	74.5	60.5
0.28	54	59
0.27	56	61
0.26	67	68
0.25	52	57
0.22	44	54

The values for 0.26 are ascribed to chance.—Meyer, on his side, made some minimal-change series with the tone of 600, from which he declines to draw inferences. But the method was followed only in part, and each step was repeated 3 times or oftener.—Neither Luft nor Meyer seeks further to evaluate the results from r. and w. cases.

(6) Seashore published in 1899 (*Iowa Studies*, ii., 55) a statistical study of students and school children. The *DL* of the former varied from 2 to 30+ vs. The method was a combination of minimal changes (\downarrow) and r. and w. cases. The instruments were forks, struck in rapid succession and held close to the ear. See also C. Wissler, *Psych. Rev. Mon. Suppl.* 16, June 1901, 6, etc.; C. S. Myers, *Arch. of Otol.*, xxxi., 1902, 283 ff.; *Cambr. Anthrop. Expedn. to Torres Straits*, ii., 155 ff.; G. M. Whipple, *A. J.*, xiv., 1903, 295 f.; C. Spearman, *A. J.*, xv., 1904, 228 ff., 243 f., etc.

We may mention here Stumpf's experiments upon unmusical O 's: *Tps.*, i., 313; *cf.* ii., 552 f. Musical intervals were played, at various parts of the scale, and the question asked, which of the two tones was the higher. Stumpf finds that "the reliability of judgment increases greatly from the low to a middle region (probably e^2), and beyond this shows a slight decrease within the limits of the musical scale" (326). Practice, even in the case of unmusical O 's, must favour the middle region (332). The probable inference to be drawn from the results is that the relative D. S. increases with pitch up to about e^3 (333). The point of maximal D. S. apparently lies somewhat higher than that of maximal reliability (334).—We must remember Stumpf's definition of 'objective reliability' (23), and its dependence upon two sets of factors: sensitivity (28), including both modal

and differential S., and subjective reliability (31), including relative accuracy and certainty of reproduction, degree of attention, feeling, present contents of consciousness. For introspective reports in the above-mentioned experiments, see 326 f. —See also Whipple, A. J., xiv., 1903, 299 ff.

A note of Wundt's (P. P., ii., 1902, 75) is of such great educational importance that it may be reproduced entire. "Musikalisch geübte und ungeübte *O* verhalten sich in dieser Beziehung (as regards the magnitude of the *DL*), nachdem erst die unerlässliche Versuchsübung vorübergegangen ist, vollkommen gleich, abgesehen natürlich von Fällen abnormer Unempfindlichkeit. Der grosse Werth, der in früheren Beobachtungen auf das Moment der musikalischen Uebung gelegt wurde, hat hier wie in anderen Fällen lediglich in der Art der Ausführung derselben, bei der es zu einer erheblichen Versuchsübung nicht kommen konnte, seinen Grund." The author's experience bears out these statements. An unmusical *O* will often balk at an experiment upon the tonal *DL*, until he is assured that the determination of the *DL* has nothing at all to do with musical training or ability. Then, having attempted the experiment, he will give values identical (within the error limits) with those of musical *O*'s. Cf. also C. Spearman, A. J. P., xv., 1904, 270 f. Wundt would not deny, of course, that a certain interest attaches to the unpractised *DL* of unmusical *O*'s.

The J. N. D. of Pitch : (b) Simultaneous Tones.—Wundt considers it impossible to establish the j. n. d. of simultaneous tones, since the beats which arise when the tones are sounded must betray their pitch differences : P. P., i., 1893, 453 f. ; ii., 1902, 74. Stumpf, however, has made determinations of two kinds. (1) Two forks may be held to the two ears, and struck so weakly that their beats are inaudible or at least unobtrusive. The one of two c^2 forks, sounded in this way, might be lowered 8 vs. (or, when the natural difference of the two ears is taken into account, 12 vs.), while the tones still remained single in sensation. With a difference of 16 vs. (*i.e.*, with the pitch-difference of the ears, 20 vs.), the impression was decidedly impure. The full results were :

Lower half of great octave (66–132 vs.),	about 8 vs. (whole tone) ;
Upper half " " " " " "	8 vs. (half tone) ;
c^1	" 8 vs. (quarter tone) ;
c^2	12 to 20 vs. (quarter tone) ;
Thrice accented octave	about 100 vs. ($\frac{3}{4}$ tone).

(2) The tones may affect the same ear. We must then train ourselves to disregard beats, to make our judgment before the beat is completed, etc. Stumpf distinguished the organ tones *C* and *E* (66 and 82.5 vs.) ; but not A_1 and *C* or F_1 and A_1 (55 and 66, 44 and 55 vs.). The *DL* thus lies, at this part of the scale, between 11 and 16 vs. For unmusical *O*'s, the j. n. d. in the thrice accented octave may amount to a third.—Tps., ii., 319 ff. ; cf. 63, 162 (top), 163 f., 396, 480 ff. ; i., 138.

See also the observations of R. H. M. Bosanquet, Phil. Mag., (5) xi., 1881, 420 f. ; F. Krueger, P. S., xvi., 1900, 324 f., 366, 624 ff. ; and the more comprehensive paper by K. L. Schaefer and A. Guttman, Z., xxxii., 1903, 87 ff.

According to Stumpf in Z., xviii., 373, Delezenne found that the j. n. mistuning of the $b=240$ vs. (simultaneous tones) was 2.5 vs.

We pass now to the investigations made by the method of equal sense distances, which connect this with the preceding § 29. Results and interpretations in this field are still *sub judice*. Finally, we have to consider the work done upon the 'interval sense,' *i.e.*, upon the j. n. d. of tonal distances.

Supraliminal Tone Differences : Judgments of Distance.—We have seen that, up to about 1875, it was the general belief that the same musical interval represents a constant tonal distance or pitch difference, from whatever part of the scale it may be taken.

(1) In 1878, G. E. Müller, "speaking from his own experience," declares that this is not the case. He gives no particulars of his observations.¹

(2) Stumpf (1883) lays down the rule, though with great reserve, that intervals in the upper region of the scale represent wider distances than corresponding intervals in the lower region. He bases the rule upon personal observation.²

(3) Systematic experiments were published in 1890 by C. Lorenz.³ They were made with Appunn tonometers, giving the five octaves from 32 to 1024 vs. The unit of difference in the two lowest octaves was 2, in the three upper, 4 vs. The method employed was a combination of Mean Gradations with Right and Wrong Cases. Two tones, an upper and a lower, were kept constant, and a variable middle tone interpolated between them. The three tones were sounded in the order $u-m-l$ or $l-m-u$, and the observer was required to say, in each case, whether the middle tone lay nearer u , or nearer l , or midway between u and l . The distances $u-l$ ranged from the double octave (1:4) to the minor second (15:16), and included unmusical as well as musical intervals. Musical and unmusical O 's took part in the investigation. The general result is stated by Lorenz as follows. "We possess the capacity of comparing finite pitch-differences with one another, and measuring them by one another, independently of clang-relationship. This measure of pitch-differences, directly inherent in sensation, does not accord with Weber's Law: the same harmonic intervals do not represent equal absolute differences of sensation; on the contrary, an almost perfect proportionality obtains between the absolute differences of tone sensation and the differ-

¹ G., 287, 289.

² Tps. i., 247 ff.; cf. 141 ff., 339, and Wundt, P.S., vi., 1891, 611; vii., 1892, 302. Stumpf thinks that the same rule holds for simultaneous as for successive tones: Tps. ii., 403 ff., 406. On distance judgments as complicated by fusion, see *ibid.*, 385, 397 f.; Külpe, Outlines, 1895, 394.

³ P. S., vi., 1891, 26 ff.

ences of vibration-rates.”¹ That is to say, the sense-mean for tonal differences not exceeding the double octave is given with the arithmetical (not the geometrical) mean between the corresponding pitch-numbers. The result agrees admirably with the values of the *j. n. d.* for successive tones.²

(4) In his *Neue Grundlegung der Psychophysik*, 1890, Münsterberg gives a brief account of extended experiments upon the estimation of tonal distances. He found that musical *O*'s divide a given distance at the tone whose pitch-number is the geometrical mean between the extremes, while unmusical *O*'s divide at the arithmetical mean. The former, being unable to abstract from their musical knowledge, are of little value for the enquiry.³

No further report upon these experiments has been published.⁴ In

¹ *Ibid.*, 103.

² The publication of Lorenz' experiments gave rise to an angry controversy between Wundt and Stumpf. The references are: Wundt, *P. P.*, i., 1887, 428 ff.; i., 1893, 455 ff., 462 f.; ii., 1902, 75 ff., 85 f.; *P. S.*, vi., 1891, 605; vii., 1892, 298, 633; Stumpf, *Tps.*, i., 1883, 250 f.; ii., 1890, 551, 557 f.; *Zts.*, i., 1890, 419; ii., 1891, 266, 426, 438. The author read the articles as they appeared; read them through again early in 1893; and reread them at the end of 1901. In the first reading he was biased in favour of Wundt; in the second, somewhat in favour of Stumpf. His judgment, however, has been the same in every case: that Stumpf's criticism is too sweeping. Lorenz' results are, of course, open to modification or correction by later work. That is the fate of all pioneer inquiries. But Stumpf's interpretation is surely one-sided. The article by G. Engel, *Z.*, ii., 361 (written apparently in support of Stumpf), is interesting from the musical standpoint, but almost comically inadequate from the standpoint of psychophysics. Wundt, we may remark, is so thoroughly convinced of the accuracy of Lorenz' results that he has made them the basis of a demonstration experiment: *P. P.*, ii., 1902, 85 f. Stumpf, on the other hand, is so thorough a believer in the efficacy of his own criticism that he writes in 1901: "die Theorie der arithmetischen Mitte scheint noch todter wie die der geometrischen" (*Beitr.*, 3, 93). Müller (*M.*, 230, 241) finds unmistakable evidence that Lorenz' judgments were influenced by musical associations, and demands a careful analysis of the different factors concerned.

In the *P. S.*, vi., 634; vii., 300, Wundt says that experiments upon pure tones are in course in his laboratory; and in the *P. P.*, i., 1893, 460; ii., 1902, 82, he figures the necessary arrangement of tuning-forks. The experiments were made, as the author remembers, by P. Krüger (*P. S.*, vii., 1892, 56, 442), but so far as he is aware have never been published.

³ H. Münsterberg, *Beiträge zur experimentellen Psychologie*, iii., 1890, 37, 39, 41; iv., 1892, 149; *cf.* Stumpf, *Tonps.*, ii., 551. Münsterberg interprets the results in terms of his muscle-sense theory: "in jedem Falle also basiert auch die Messung der Tondistanzen ausschliesslich auf den Aussagen des Muskelsinns" (iii., 44).

⁴ Münsterberg was induced by Stumpf's criticism of Lorenz to undertake new experiments: *Beitr.*, iv., 154; *Zts.*, ii., 443.

1892, however, Münsterberg described a second investigation, carried out by a different method.¹ Lorenz had sought to determine the tone *m* that lay midway between the given *u* and *l*: Münsterberg sounds four tones, *a*, *b*, *x*, *y*, and requires his *O*'s to compare the two distances *a—b* and *x—y*. The experiments were made with the tonometer. First, certain of Lorenz' series were repeated, by the original method (musical and unmusical *O*'s and intervals); the results agree with those of Lorenz. Secondly, the same method was employed with intervals wider than the double octave (Lorenz' limit); in this case, *m* did not correspond to the arithmetical mean, but the upper half of the total distance invariably appeared larger than the lower.³ After this preliminary work, the four-tone method was introduced. "The point at which judgments of equality reached their maximum lies between the point of equal vibration ratio and the point of equal vibration difference, shifting from the former to the latter with increasing magnitude of the normal distance."⁴ Thus, within the limits 256 and 456 vs., we have :

Normal distance	Equal vib. ratio	Equal vib. diff.	Jdgt. of equality
20 vs.	422.9	436	424-428
40	394.3	416	404-408
60	369.4	396	388
80	347.4	376	372-376.

Two further variations of method were tried: the duration of the tones was increased, and the tonal distances 'filled' with intermediate tones. In some cases, the distance bounded by the longer tones seemed to be wider than the same distance as previously heard; in all cases, the 'filled' distance seemed greater than the 'empty.'⁵ It should be added that the results of the four-tone method in general show considerable individual differences.⁶

(5) Stumpf's study of Siamese music in 1901 (Beitr., 3, 69 ff.) attempts to give a backward swing to the pendulum. "Thatsachen wie die der siamesischen Leiter, auch die der javanischen, können nun wirklich benutzt werden, um die ältere Anschauung Weber's und Fechner's zu rehabilitieren. . . Innerhalb der mittleren Tonregion, . . . die zu gleichen Schwingungsverhältnissen gehörigen Tonabstände verändern sich für die *S* nicht oder nur um einen sehr geringen, unmerklichen Betrag. Bei grösseren Intervallen (vielleicht schon von der Quinte an) und bei Vergleichen von Intervallen aus verschiedenen Tonregionen kann der Betrag der Veränderung immerhin merklich werden; und ich meine

¹ Beitr., iv., 147 ff.

² *Ibid.*, 164.

³ *Ibid.*, 167. The individual differences were large.

⁴ *Ibid.*, 170, 176. Müller, M., 231.

⁵ *Ibid.*, 172, 176.

⁶ *Ibid.*, 170 ff. Cf. Wundt, P. P., i., 1893, 463.

nach eigenen früher erwähnten Beobachtungen, dass dies auch wirklich der Fall ist. . . . Während unsere Intervalle, auf die Fechner seinen Beweis stützte, im Grunde nur zufällig mit den Forderungen des [Weberschen] Gesetzes zusammentreffen, da sie einen principiell anderen Ursprung haben, lassen sich die Intervalle gleichstufiger Leitern, von welchen Fechner keine Ahnung hatte, allem Anschein nach nicht ohne solche Voraussetzung begreifen" (94 f.).¹ Of all this we can only say that it works out, on the whole, for the material at hand, but that it is admittedly hypothetical, and that the next following study may compel us to modify or correct the hypotheses in important particulars. It would, therefore, be equally foolish either to ignore Stumpf's work or to admit at once the validity of his position. See F. Krüger, *Z.*, xxvii., 1901, 210 ff.,—a review which makes brief mention of new observations on tonal psychophysics.

We may say, in summary, that there is great need of further investigation. It seems, however, to be established that comparisons of tonal distances (supraliminal tone differences) are possible, both for unmusical and for musical *O*'s. The former must be trained, for the special purposes of the enquiry; the latter must abstract from their musical knowledge and associations. Even so, the sources of error peculiar to mean gradations recur, with modifications due to the shift from intensity to quality: it may be, too, that new sources of error are introduced. It is possible that, within certain limits, equality of tonal distance is given with equal difference of vibration rate: there is, in the author's judgment, some positive ground for this belief, and the analogy of the *DL* must be allowed to count for something. In any case, the same musical interval does not necessarily represent the same tonal distance at different parts of the scale.

The J. N. D. of Tonal Distances: 'Interval Sense:' (a) *Successive Tones*.—Several determinations have been made of the j. n. mistuning of musical intervals, *i.e.*, of fixed tonal distances. Theoretically, enquiries of this sort form the natural complement of the foregoing investigations. As we may seek, by mean gradations, to find the central point of a visual distance, and then proceed by minimal changes to ascertain the

¹ Stumpf is careful to point out (95 *n.*) that the Siamese scale does not, in strictness, fall under Weber's Law, but under another Law of the same name. Musical intervals can, of course, fall under Weber's Law, *sensu recentiore*, only if they are based upon intensities of *S*, *i.e.*, upon muscular adjustments of the vocal organs. As samples of the discussion upon this issue, see Stumpf, *Tps.*, i., 1883, 153 ff.; the papers by E. Storch, A. Bernstein and A. Samojloff in *Z.*, xxvii., 1902, 361; xxviii., 1902, 261; xxix., 1902, 121, 352; C. H. H. Parry, *Evolution of the Art of Music*, 1896, ch. ii.

j. n. lengthening or shortening of each half of this distance, so in the case of tones: we may supplement our judgments of tonal distance by experiments in which the one of two sensibly equal distances is gradually increased or diminished, until it becomes j. n. greater or less than the other, constant distance. Moreover, the j. n. d. of pitch may itself be regarded as the j. n. mistuning of a musical interval, *i.e.*, of the prime. So we find that Fechner says: "the case in which we determine the j. n. deviation from the purity of an unison may be regarded as a special instance of the general case in which we determine the deviation from a zero difference of two tones."¹

Practically, however, the issue is complicated, even more seriously than in the previous investigations, by musical influences; it is, to a great extent, taken out of the hands of psychology and given over to æsthetics. The musical *O* has his own intervals, subjective equivalents of the objective interval ratios, stamped indelibly upon his consciousness; and these subjective intervals are æsthetic values rather than psychological facts. Here is a source of confusion at the very outset. Schischmanow, *e.g.*, practised his *O*'s, before a series of experiments was taken, upon the mathematically pure interval, in order that this, the standard distance, might be "gut eingeprägt."² And Stumpf exclaims: "Dadurch ist ja ein Hauptzweck der ganzen Untersuchung vereitelt!"³ Not at all! It depends upon what your 'Hauptzweck' is. If you are going to work psychophysically, as you would work upon visual distances, Schischmanow's procedure is justified; if you are working with musicians, or with musical *O*'s who are not under bond to abstract from æsthetic influences, the determination of subjective purity is important and even necessary.

It is natural, then, that the literature should be controversial in tone and that the conclusions drawn from the experiments should be individual rather than general. We may touch briefly upon the principal papers.

¹ *El.*, i., 261; see, however, Wundt, *P. P.*, ii., 1902, 88.

² *P. S.*, v., 576.

³ *Z.*, xviii., 378; *cf.* Wundt, *P. P.*, ii., 1902, 88 *n.*

INVESTIGATOR	DATE	INSTRUMENT	REGION	O's	FORM OF QUESTION	REFERENCES	REMARKS	ORDER OF INTERVALS
C. E. J. Delezenne ¹	1826	Monochord	$g-f^1 \sharp$ (192-355.5)	Musical and unmusical	Is the given interval too large or too small?	Fechner, <i>El.</i> , i., 261; Preyer, <i>Gr. d. Tonw.</i> , 38, 58; Schischmanow, <i>P. S.</i> , v., 563; Stumpf, <i>Z.</i> , xviii., 321, 373.	The tones of a monochord ring off quickly, and it is difficult to manipulate the instrument with accuracy — It is to be remembered that Preyer and Schischmanow mistake the region from which Delezenne's tones were derived.	5th (—0.45 v.), major 3d (+0.94), 8 (+1.4), major 6th (+1.2, —1.3).
A. Cornu and E. Mercadier	1869	Various instruments (violin, cello, organ, etc.)	Once accentuated octave?	Musical	Play (or sing) the interval as accurately as possible.	Comptes rendus, lxxviii., 301, 424, etc.; Stumpf, <i>Z.</i> , xviii., 322, 375.	The experiments are insufficiently reported. Stumpf suspects individual, local or national differences. ²	5th : av. ratio 1.501 (physical = 1.500), major 3d : 1.266, (physical [Pythagorean] = 1.2656).
W. Preyer	1876	Tonometer	Chiefly, ⁸ small octave (127.6-255.3)	Musical and unmusical	Is the given interval pure or impure?	<i>Gr. d. Tonw.</i> , 45; Stumpf, <i>Z.</i> , xviii., 322, 376; Schischmanow, <i>P. S.</i> , v., 570, 593.	The results are gained from two O's and the experiments are not very numerous. The instrument was defective as regards mistuned fifths.	O ₁ : 8, 5, major 2, 4, major 3, major 6, minor 3, minor 6. O ₂ : 8, 5, 4, major 2, major 3, minor 3, major 6, minor 6.
J. Schischmanow (incl. O. Kùlpe and Peisker)	1889	Forks	c^1-c^2 (256-512)	Musical and unmusical	As Delezenne	<i>P. S.</i> , v., 558; Stumpf, <i>Z.</i> , xviii., 322, 377.	The two O's were alternately O and E; the steps (minimal changes) were few in number, and the unit of change was known to both O's.	(1) Peisker and Kùlpe, O ₁ : 8, 5, major 6, major 3, 4, 5, major 3, 4, major 6, (2) Schischmanow, O ₁ : 8, 5, 4, major 3, major 6, major 2, minor 3, minor 6, minor 7, major 7. O ₂ : 8, 5, 4, major 6, major 3, minor 3, major 2, minor 6, minor 7, major 7.
C. Stumpf and M. Meyer	1898	Tonometer, forks	d^1-d^2 (300-600); d^1-d^3 (300-750)	Musical	Is the given interval pure, too large or too small?	<i>Z.</i> , xviii., 321; <i>Beitr. z. Ak. u. Musikkwiss.</i> , ii., 1898, 84.	The results are based upon the subjectively (not objectively) pure intervals : 369-372.	8, 5 and major 3 are all three judged with equal certainty. ³

¹ Delezenne's original paper is published in the *Recueil des travaux de la Société des Sciences de Lille*, 1826-27, 1 ff.; the author has not seen it. Schischmanow credits Delezenne with work upon the fourth (593); but Fechner (263), Preyer (38) and Stumpf (373) make no reference to this interval. On the psychophysical value of the experiments, see Foucault, *Psychophysique*, 28; F. A. Müller, *Axiom*, 70 ff., 93 ff.

² Cornu and Mercadier are concerned to prove that intervals are played melodically in the Pythagorean, harmonically in the pure or natural scale. The refs. are: *Comptes rendus de l'Acad. des Sciences*, lxxviii., 1869, 301, 424; lxx., 1870, 1168; lxxiii., 1871, 178; lxxiv., 1872, 321; lxxvi., 1873, 431. Results for melodic intervals:

	ut	ré	mi	fa	sol	la	si	ut
1871 (p. 178)	1000	1124	1264	1335	1503	—	1902	2002
1882 (p. 322)	1000	1127	1265	1329	1500	1686	1907	—
Pyth.	1000	1125	1266	1333	1500	1687	1898	2000
Nat.	1000	1125	1250	1333	1500	1666	1875	2000

	la	si	ut	ré	mi	fa	sol [#]	la
1873 (p. 432)	1000	1124	1186	1334	1501	1582	1901	2002
Pyth.	1000	1125	1185	1333	1500	1580	1898	2000
Nat.	1000	1125	1200	1350	1500	1600	1875	2000

³ Preyer gives (61 ff.) the results of some experiments in the highest and lowest tone regions, 4096-20480 and 16-64.

⁴ This result, together with the slight advantage of the fifth in simultaneous intervals (p. 248), is extremely important. The idea that the *corruptio optimi* (i. e., of the best consonance, or the best fusion degree) was not only *pessima* but also *facillima* seemed to be borne out by the work of Preyer and Schischmanow, and had found practically universal acceptance (Külpe, *Outlines*, 286; Stumpf, *Tps.*, ii., 137; Wundt, *P. P.*, i., 455). The present result negatives it (Stumpf, 369, 384, 401 ff.). We may say, however, (1) that Stumpf's reliance upon Delezenne (374) is misplaced, partly because Delezenne sets the major 3 as well as the 5 in advance of the 8, and partly because his 5 determinations were inaccurate (Preyer, 39, 58); (2) that his quotation from D. G. Türk (384) is mistaken: it is not Türk who is speaking, but a 'practical tuner' whose views are opposed to those of Türk (Schischmanow, 562); and (3)—what is vastly more important than these things—the atmosphere of Stumpf's whole enquiry is rather æsthetical than psychological: cf. esp. 392 ff. It is by no means proved that the j. n. deviation from the octave, as a tonal distance, is no less than the j. n. deviation from the fifth, similarly considered. In other words, if we could go behind the æsthetic 'feeling of purity,' and judge of distance as distance, we might conceivably find the uniformity at which Preyer and Schischmanow arrived. Of course, again, we might not. But the chapter is very far from closed. Cf. Wundt, *P. P.*, ii., 1902, 86 ff.

Stumpf's notes on the introspections of his *O*'s (384 ff.) are to be read with especial care.

The J. N. D. of Tonal Distance: (b) Simultaneous Tones.—Delezenne found that the j. n. d. for intervals (8, 5, major 3, major 6) simultaneously sounded was without exception greater than that for the same intervals sounded successively: Stumpf, Z., xviii., 374.

Cornu and Mercadier (1869) give as average ratio for the major third 1.251 (physical ratio, 1.250), for the fifth 1.499 (physical 1.500). The result is inexplicable: Stumpf, 375. In 1873 they give, similarly, for the minor third the average ratio 1.200, which is identical with the physical.

Stumpf and Meyer find that the j. n. d. of the simultaneous octave and major third is considerably greater than that of the successive. In the case of the fifth, the difference points in the same direction, but is extremely slight (366 f.). As regards the order of intervals, the fifth stands slightly in advance of the other two (372).

Cf. 383 (ref. to Faist); 399 (explanation of increase of limen); 400 (use of simultaneous fifths in tuning); 360 (Table for fork tones).

§ 31. **The Method of Constant Stimuli (Method of Right and Wrong Cases): Notes on § 20 of the Text.**—The general exposition of the method and the derivation of the formulæ are modelled upon Müller's treatment: Pflüger's Arch., xix.,¹ 1879, 191 ff.; M., 12 ff., 35 ff. The formula for the first procedure was suggested by Wundt: see Angell, P. S., vii., 1892, 464. Fechner's Fundamental Table may be found in El., i., 108; R., 66; Wundt, P. P., e.g., i., 1902, 484; Sanford, Course, 351; Scripture, New Psychology, 490. The following additional Tables are given by Fechner (El., i., 110; R., 66 f.):

FECHNER'S FUNDAMENTAL TABLE, CONTINUED: I.

<i>n</i>	<i>t</i>	<i>n</i>	<i>t</i>	<i>n</i>	<i>t</i>
0.8300	0.6747	0.8800	0.8308	0.9300	1.0436
0.8325	0.6817	0.8825	0.8397	0.9325	1.0569
0.8350	0.6888	0.8850	0.8488	0.9350	1.0706
0.8375	0.6960	0.8875	0.8580	0.9375	1.0848
0.8400	0.7032	0.8900	0.8673	0.9400	1.0994
0.8425	0.7105	0.8925	0.8768	0.9425	1.1145
0.8450	0.7179	0.8950	0.8864	0.9450	1.1301
0.8475	0.7253	0.8975	0.8962	0.9475	1.1463
0.8500	0.7329	0.9000	0.9062	0.9500	1.1631
0.8525	0.7405	0.9025	0.9164	0.9525	1.1806
0.8550	0.7482	0.9050	0.9267	0.9550	1.1988
0.8575	0.7560	0.9075	0.9373	0.9575	1.2179

¹ Wrongly cited as xi. in Müller, G., viii.

0.8600	0.7639	0.9100	0.9481	0.9600	1.2379
0.8625	0.7719	0.9125	0.9591	0.9625	1.2590
0.8650	0.7800	0.9150	0.9703	0.9650	1.2812
0.8675	0.7882	0.9175	0.9818	0.9675	1.3048
0.8700	0.7965	0.9200	0.9936	0.9700	1.3297
0.8725	0.8049	0.9225	1.0056	0.9725	1.3569
0.8750	0.8134	0.9250	1.0179	0.9750	1.3859
0.8775	0.8221	0.9275	1.0306	0.9775	1.4175

FECHNER'S FUNDAMENTAL TABLE, CONTINUED: II.

<i>n</i>	<i>t</i>	<i>n</i>	<i>t</i>	<i>n</i>	<i>t</i>
0.970	1.3297	0.980	1.4522	0.990	1.6450
0.971	1.3404	0.981	1.4672	0.991	1.6728
0.972	1.3513	0.982	1.4828	0.992	1.7032
0.973	1.3625	0.983	1.4991	0.993	1.7375
0.974	1.3740	0.984	1.5164	0.994	1.7764
0.975	1.3859	0.985	1.5345	0.995	1.8214
0.976	1.3982	0.986	1.5537	0.996	1.8753
0.977	1.4110	0.987	1.5742	0.997	1.9430
0.978	1.4242	0.988	1.5961	0.998	2.0352
0.979	1.4380	0.989	1.6195	0.999	2.1851

Müller's Table of weight coefficients is taken from Pflüger's Arch., xix., 204, except that the w'' for $n = 0.96$ and 0.98 have been interpolated by the author. The following additions are given by Müller:

MÜLLER'S TABLE OF COEFFICIENTS OF WEIGHTS, CONTINUED.

<i>n</i>	w''	<i>n</i>	w''
0.900	0.193	0.962	0.043
0.905	0.180	0.966	0.036
0.910	0.166	0.970	0.029
0.915	0.152	0.973	0.024
0.920	0.139	0.976	0.020
0.925	0.126	0.979	0.016
0.930	0.114	0.982	0.012
0.935	0.101	0.985	0.009
0.940	0.089	0.988	0.006
0.945	0.078	0.990	0.004
0.950	0.067	0.992	0.003
0.954	0.059	0.994	0.002
0.958	0.050	0.996	0.001

If other values of t or w'' are required, the student can readily find them by interpolation.

Tables of values of the probability integral $\frac{2}{\sqrt{\pi}} \int_0^\gamma e^{-t^2} dt$ for the argument γ may be found in most works upon probabilities. If we term this integral $\Phi(\gamma)$, it is clear that our final equation on p. 98 of the text will read

$$n = \frac{1}{2} + \frac{1}{2}\Phi(\gamma),$$

or

$$2n - 1 = \Phi(\gamma);$$

that is to say, any one of these general Tables may, in case of need, take the place of Fechner's Fundamental Table. For a compact form of the general Table see Merriman, *Least Squares*, 1900, 220; *Scripture, New Psychology*, 475; for an extended four-place Table, Kämpfe, *P. S.*, ix., 147; five-place, A. Meyer, *Wahrscheinlichkeitsrechnung*, 1879, 545; seven-place, M. B. Weinstein, *Physikalische Maassbestimmungen*, i., 1886, 519; seven and eleven-place, E. Czuber, *Wahrscheinlichkeitsrechnung*, 1903, 569; J. L. F. Bertrand, *Calcul des probabilités*, 1889, 329. It need hardly be said that, for anything short of research, Fechner's Tables are amply sufficient.

On the rule for calculating the coefficient w'' , see Müller, *Pflüger's Arch.*, 204 ff. On the formation and solution of normal equations, see, *e. g.*, Merriman, *Least Squares*, 45 ff., 56 f., 175 ff.

The results quoted on p. 93 of the text were obtained by A. Riecker, a member of the group who worked under Vierordt's direction at Tübingen: see *Zeits. f. Biologie*, x., 1874, 190; Fechner, *Raumsinn* (*Abh.*, 1884), 115 f. They have been rounded off, somewhat arbitrarily, for purposes of exposition. The actual figures are shown in the following Table, where N = the number of observations made:

D	0	0.5	1.0	1.5	2	3	4	5	6
n	0.302	0.102	0.140	0.402	0.652	0.800	0.877	0.964	1
N	126	116	100	90	86	100	105	103	97

The assumption that, between the limits $D = 0.5$ and $D = 5.0$, $N = \text{const.}$ was also made arbitrarily, for the sake of simplicity in exposition.

The determination of the RL logically precedes that of the DL ; and the procedure to be followed in its case is, intrinsically, the simpler. Nevertheless, the student will do well, for historical reasons, to approach the development of the method of right and

wrong cases from the side of the *DL*. Hence the author would advise that the references given below be passed over, for the present, and that the student return to them later on, after he has mastered the argument of the Fechner-Müller formulæ for the *DL*.

Bibliography.—A. W. Volkmann, Ber. d. k. sächs. Ges. d. Wiss., math.-phys. Cl., x., 1858, 47 ff.; R. Kottenkamp and H. Ullrich, Z. f. Biol., vi., 1870, 37 ff. (arm); A. Paulus, *ibid.*, vii., 1871, 237 ff. (leg); A. Riecker, *ibid.*, ix., 1873, 95 ff. (leg); x., 1874, 177 ff. (head); G. Hartmann, *ibid.*, xi., 1875, 79 ff. (trunk and neck); O. Gärtner, *ibid.*, xvii., 1881, 56 ff. (finger, chin, forearm); E. Schimpf, *ibid.*, 62 ff. (leg); K. Vierordt, Pflüger's Arch., ii., 1869, 297 ff.; Z. f. Biol., vi., 1870, 53 ff.; Grundriss d. Physiol. d. Menschen, 1877, 342; Physiol. d. Kindesalters, 1881, 458; G. E. Müller, Pflüger's Arch., xix., 1879, 191 ff.; Fechner, R., 423 ff.; Raumsinn (Abh., xxii. [xiii.]), 1884, 111 ff.; W. Camerer, Z. f. Biol., xvii., 1881, 1 ff.; xix., 1883, 280 ff.; V. Henri, Raumwahrnehmungen, 1898, 12 ff. (general bibliography, 215 ff.); G. E. Müller, M., 35 ff.

EXPERIMENT XX

This is a straightforward experiment, and should yield clean and instructive results. The only danger is that *E* and *O* take it too easily, and become careless; hence it is well to impress upon them that slips of manipulation or attention are faithfully mirrored in the distribution of the 'cases.'

The inversion of haphazard series has been discussed above, Question (3), p. 205.

QUESTIONS.—(1) We noted above (p. xxvi. of the text) that there is a strong tendency, in every-day life, to think of the *objects* to which mental processes refer, rather than to turn the attention upon mental process itself. Psychologists are by no means free from this tendency; and the name which the present method usually bears is a good instance of it. The method is known as the 'method of right and wrong cases,' and the judgments are classified as 'right' or 'wrong' according as the response to a positive *D*-value is 'two points' or 'one point.' Psychologically, the judgment is simply a judgment of two impressions or of one impression; and psychologically, if the judgment has been conscientiously given, it is always 'right.' Logically, in

terms of the objective separation of the compass points, the judgment is 'right' or 'wrong.'

There can be no great objection to this mode of classification, —to the substitution of meaning for process, of logic for psychology,—if only it covers the facts, and if we ourselves understand what it means, and do not let the reference to stimulus obscure the real problem of the method. As a matter of fact, however, the classification does not cover the facts. For (a) psychologists have added to the right and wrong judgments a third category, of 'doubtful' judgments. Now this is a purely psychological division. The name 'doubtful' is illogical, because there is never any doubt as to the objective separation of the compasses; logically, the doubtful judgments are wrong judgments. It is only because the method is, after all, a psychological method, and because the doubtful judgments constitute a special psychological class, that psychologists have at this point ranked 'doubtful' alongside of 'right' and 'wrong.' The original logical classification is cut across by a psychological.

It is, however, confusing and misleading to call a method the 'method of right and wrong cases,' and nevertheless to admit three classes of judgments, right, wrong and doubtful. The name of the method seems to imply that the right and wrong judgments are alone important, the doubtful judgments something insignificant or superfluous. Indeed, this opinion is, as we shall see, actually held by certain psychophysicists. But natural as the view may be, it is altogether mistaken. The doubtful cases are as inevitable to the judging mind as are the wrong cases, and there is a certain range of positive D -values which yields right and doubtful judgments, but no wrong judgments at all (Müller, M., 38). Hence it was a step in the right direction when Wundt (*Logik*, ii., 2, 1895, 189) proposed the name of 'method of three cases' for the traditional 'method of right and wrong cases.'

(b) Quite apart, however, from the doubtful cases, the usual name of the method becomes illogical as soon as we deal with a D that is $= 0$. Here the one-point judgments are objectively right, and the two-point judgments objectively wrong. Yet we are compelled, in our determination of the RL , to count the two-point judgments as right, and the one-point as wrong! The ab-

surdity disappears at once with the disappearance of the title 'method of right and wrong cases.'

The above criticism holds, *mutatis mutandis*, for determinations of the *DL*. Thus, when D is = 0, judgments of 'greater' and 'less' are both objectively wrong, and only the rarely occurring judgment of positive equality is right. Yet the greater (less) judgments are classed as right, the less (greater) as wrong, and the equals and doubtfuls go together as doubtful! If the name of 'right and wrong cases' is to be kept at all, it can be kept only as the historical designation of Fechner's method, whereby the *DL* is determined from a single D . See below, pp. 268 ff.¹

(2) Yes: we may determine, not only the *RL* proper, but a lower *RL* or limen of uncertainty, such that every $D < UL$ evokes the judgment of one point, while every $D > UL$ evokes the judgment 'doubtful' (this when D is $> UL$ but $< RL$) or 'two points' (this when D is $> UL$ and also $> RL$). The *UL* is a variable magnitude, whose median value is identical with the D that gives $n + u = 0.5$; where n represents, as before, the relative number of two-point judgments, and u the relative number of doubtful judgments. The formula for the *UL* is:

$$n + u = \frac{1}{2} + \frac{1}{\sqrt{\pi}} \int_0^{(D-UL)h} e^{-t^2} dt.$$

The h of this formula is the measure of precision for the *UL*.— See Müller, M., 43 f., 46, 49; and *cf.* p. 19 above.

On the determination of the *upper limit* of the *RL* or *DL*, *cf.* Müller, M., 44, 55, with Lipps, Arch. f. d. ges. Psych., iii., review section, 39.

¹ English-speaking psychologists have only gradually come to the conclusion that the translation of the German terms 'richtig' and 'falsch,' in this connection, is 'right' and 'wrong.' A. Seth, in his article on Weber's Law (Encycl. Brit., 9th ed., xxiv., 1888, 470) speaks of the method of 'correct and incorrect instances'; Ladd (Physiol. Psych., 1889, 364), of 'correct and mistaken cases'; James (Psych., i., 1890, 540), of 'true and false cases'; the translator of Sigwart's Logic (ii., 1895, 71), of 'true and false instances'; the translator of Ribot's German Psych. of To-day (1886, 144), of 'true and false cases'; the translators of Ziehen's Physiol. Psych. (1892, 63, 73; 1895, 64, 74), of 'correct and false (mistaken) cases'; M. Maher (Psychology, 1900, 56), of 'correct and mistaken cases.'

(3) We found by our first procedure (p. 96 of the text) that the curve of distribution of the RL is not symmetrical. In that case, however, we took the median value of the RL to be 1.7 Paris lines. The derivation in terms of Gauss' Law gave 1.88. We have now to examine the course of the curve in the light of this value, 1.88, and of its measure of precision, $h = 0.49$.

The method is simple. We replace the value RL and h by the numbers 1.88 and 0.49 in all the seven expressions $(D - RL) h$, and then look up in Fechner's Fundamental Table—paying regard to sign!—the seven n -values that correspond to the resulting t -values. We thus obtain:

D	0.5	1.0	1.5	2	3	4	5
Observed n	0.10	0.14	0.40	0.65	0.80	0.87	0.96
Calculated n	0.17	0.27	0.40	0.53	0.78	0.93	0.985.

Our previous inference is confirmed: within the limits taken, the curve of distribution of the RL drops towards the axis of abscissas in the region of the higher D 's more quickly than it rises from that axis in the region of the lower. Nevertheless, there is nothing to suggest that our assumption of the validity of Gauss' Law was wrong,—that some other law of distribution holds in its place. The results show a distinct tendency to approximate towards the values required by Gauss' Law; and those that diverge from it diverge sporadically, and thus bear upon their face the marks of experimental inaccuracy.

(4) It is better to make RL the variable magnitude, for the following reasons. (a) The source of the accidental errors may be physical, physiological or psychological. In so far as it is psychological, we may more naturally refer the variation to the limen than to the objective D . (b) The limen does, as a matter of observed fact, vary from experiment to experiment, whereas it is of the essence of good experimental work that D remain constant throughout the series in which it is employed. When, therefore, we say that the limen = $RL \pm \delta$, we are stating a fact; when we say that the compass distance = $D \pm \delta$ we are introducing a mathematical fiction. (c) In most experiments, we seek to determine more than one type of limen. Thus, in the present instance we may determine both the RL and the UL : in work by the method of constant stimulus differences we may determine,

besides the upper and lower DL , the upper and lower overlimens or OL .¹ If, now, we regard these two (or four) limens as constant, and only the D 's as subject to accidental variation, then it follows that the values assigned to h in the two (or four) formulæ must be the same; for the D 's employed are the same, and it is to the variability of these D 's that the h 's are to be referred. Contrariwise, if we regard the two (or four) limens as variable, and the D 's as constant, then we have every reason to expect that the h 's, which are now to be referred to the limens, will themselves vary. Experiment shows that, in actual fact, the h 's differ, and sometimes widely: so that, from this point of view also, an assumed variability of the limens is to be preferred to an assumed variability of the objective D 's.—See Müller, M., 59 f.

(5) If we make the RL variable, and the D 's constant, we must say that the accidental value of the limen, *i.e.*, the value ($RL \pm \delta$), may at times be < 0 , or negative. The value $-\delta$ is, in such instances, $> RL$, the median value of the limen. If, on the other hand, we make RL constant and the D 's variable, we must say that the accidental value of D , *i.e.*, the value ($D \pm \delta$), may at times be $=$ or $> RL$, even if D itself be $= 0$. The value $+\delta$ is, in such instances, > 0 by an amount that is at least $= RL$. Practically, the two statements come to the same thing. Theoretically, there is little to choose between them, since the δ of either formulation may be interpreted physiologically as the condition of a concomitant sensation, or as some sort of central irradiation. In general, however, as we saw just now, it is better to regard the RL as the variable magnitude.—See Müller, M., 45.

We said in the text (p. 94) that, in a first-rate experimental series, the n for $D=0$ would be smaller than the n for any positive D -value. We may illustrate this statement from the work of Riecker himself. Thus (*Z. f. Biol.*, x., 188 f.):

¹ In the method of constant stimulus differences, O has the choice of 5 judgments with regard to the two R presented to him in each experiment. The one R may be 'much smaller,' 'smaller,' 'larger,' 'much larger' than the other; or the relation of the two may be 'doubtful.' The upper (lower) OL marks the point which must be transcended if the larger (smaller) R is to be judged much larger (much smaller) than the smaller (larger) R . Cf. p. 19 above.

Red part of lower lip			Red part of upper lip		Tip of nose	
<i>D</i>	0	0.5	0	0.5	0	0.5
<i>n</i>	0.00	0.084	0.00	0.043	0.024	0.063
<i>N</i>	106	109	96	116	86	94

(6) We must always face the possibility that our final percentages are made up, in small part, of results that run counter to the rubric. *O* may have said 'two' when he meant to say 'one,' or conversely; *E* or *O* may have written 1 for 2, or 1 for ?, or what not, in the experimental record; *E* may have set the compasses to a wrong *D*; *O* may have been wholly inattentive in a given observation, and have allowed himself to pass a 'snap' judgment; and so on. These *errors of contravention* will occur even with the most careful workers. They will, of course, affect all *D*'s in the same manner. They do more harm, however, in the region of the lowest and the highest *D*'s. Suppose, *e.g.*, that we are working with a *D* that should give 0.45 of two-point and 0.45 of one-point judgments. The chance that 2 is recorded for 1 is equal to the chance that 1 is recorded for 2; the general result is not materially affected. Suppose, on the other hand, that we are working with a *D* that should give 0.99 two-point judgments. Here the chances are all in favour of a record of 1 for 2. Or suppose that we are working with a *D* that should give only 0.10 two-point judgments. Here the chances are all in favour of a record of 2 for 1.

In the middle *D*-regions, then, the presence of errors of contravention will be apt to escape our notice. In the highest and lowest regions we may hope to discover it. If we find, *e.g.*, that a set of results, whose course is otherwise regular, ends in this way:

<i>D</i>	5	5.5	6	6.5	7	7.5
<i>n</i>	0.96	0.99	0.97	1.00	0.97	0.99,

we have every right (other things equal) to argue to the concurrence of these errors. And the same thing holds of similar irregularities in the lowest *D*-region.—See Müller, M., 39.

A word may be added with regard to the degree of coincidence to be expected between the observed *n* and the *n*-values required by Gauss' Law. Beginners in quantitative psychology are disposed to regard the conditions of experimentation as more rigid than they actually are, and so to look for a degree of coincidence that the more experienced worker

will not demand. It must be remembered that, where the number of observations is relatively small, the grouping of the *D*'s (even though it be determined by 'chance') may very well lead to a variation in concentration of attention, in *O*'s standard of judgment, etc., which is not compensated from one set of experiments to another. It must be remembered also that, in the special case of æsthesiometry, different *D*'s may bring into play pressure spots or cutaneous areas of varying sensitivity, while the rounding of the skin may make an exact setting of the higher *D*'s almost impossible. In view of the manifold sources of error, only the very best series, obtained with highly practised *O*'s, can come into consideration for the question whether or not Gauss' Law furnishes an adequate representation of the variability of the limen.—Müller, M., 62.

(7) Pressure (touch-weights or limen gauge); passive movements (see Wundt, P. P., i., 1902, 533, with refs.); dual impression for vision (*ibid.*, iii., 1903, 492); etc.

FIG. 33.—The apparatus here shown consists of a square wooden frame, 70 x 70 cm., faced with clear glass, and set vertically in a grooved slide, in which it may be moved to or from the *O*. Directly behind the glass is an equally large sheet of white cardboard, fastened on the left-hand side to a micrometer screw, itself attached to the wooden frame. The one of the two black dots is painted on the inner surface of the glass, the other on the white cardboard; this latter, the movable dot, may be moved to or from the other by a turn of the micrometer screw. The coarse adjustment is effected by help of a metric scale, laid horizontally behind the screw; the fine adjustment by help of the scale divisions marked on the head of the screw itself. A single turn of the screw shifts the cardboard a distance of 0.5 mm., and the screw-head is divided into hundredths, so that the unit of the instrument is $\frac{1}{200}$ mm. To avoid disturbance by reflections from the glass, the face of the apparatus is covered, except for the quadrangular opening shown in the Fig., by dull brown paper. See Z. Radoslawow-Hadji-Denkow, P. S., xv., 1899, 324.

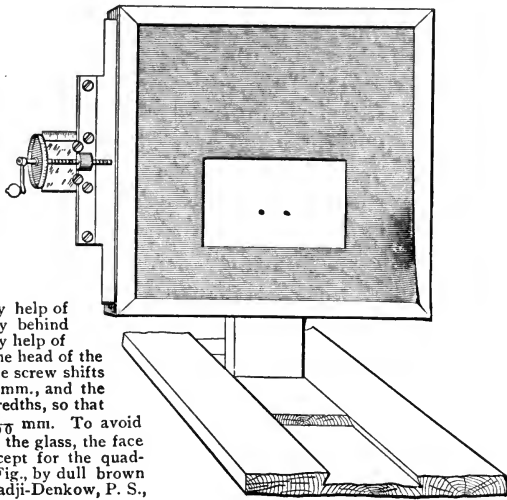

EXERCISES.—If the Instructor see fit, the student may be given a set of figures from some completed investigation for the calculation of the *RL* or *UL* and the corresponding *h*. Such work is good practice; and if the tally sheets are preserved in the laboratory, the checking of the results takes but little time. Here, *e.g.*, is Riecker's Table from Z. f. Biol., x., 1874, 190:

Paris lines	0	0.5	1	1.5	2	3	4	5	6
2-pt. jdgts.	.302	.102	.140	.402	.652	.800	.877	.964	1.000
1-pt. jdgts.	.634	.864	.800	.531	.302	.160	.076	.027	—
?-jdgts.	.064	.034	.060	.067	.046	.040	.047	.009	—
<i>N</i>	126	116	100	90	86	100	105	103	97

ESSAY SUBJECTS.—(1) The procedure of various investigators with regard to the subject of Question (4) above.

(2) A critique of the work and conclusions of A. Binet, in *Ann. psych.*, ix., 1903, 89 ff., 247 ff.

(3) Determinations of the limen of dual impression on the skin: historical and critical.

References in Henri, *Raumw.*, 1898. Special attention should be paid to the various forms of æsthesiometer employed (or a special essay may be written upon the development of the instrument since Weber's time). Among recent models we may mention that of Ebbinghaus (*Zimmermann's cat.*, 1903, 115), which combines the advantages of Griesbach's and Jastrow's instruments (Mk. 60); and that of von Frey (*ibid.*, 115 f.; Mk. 170), which guarantees absolute simultaneity of impression, where this is desired (*Z.*, xxvi., 1901, 34), or may be used for the successive stimulation of isolated pressure spots (*Z.*, xxix., 1902, 163). The author has not seen the æsthesiometer of C. Spearman (*R. Sommer, Ausstellung von exper.-psych. App. u. Methoden*, 1904, 37).

§ 32. **The Determination of Equivalent R by the Method of Constant Stimuli: Notes on § 21 of the Text.**—The Münsterberg apparatus is described by E. B. Delabarre, *Ueber Bewegungsempfindungen*, 1891, 74 ff.; *cf.* Münsterberg, *Beitr.*, iv., 1892, 183 ff. It is made by Elbs, with two finger cylinders of different sizes, for \$45. A home-made substitute would consist of two hardwood tracks (preferably of cherry) screwed along the edge of a table, and a car with boxwood wheels. If the tracks are rubbed with dry soap, the car runs smoothly and with very little noise. The sliders, of strip brass, should extend across both tracks.—*Cf.* the apparatus of Fullerton and Cattell, *Small Diff.*, 34.

EXPERIMENT XXI

METHOD.—The method is given by Müller, *M.*, 199 ff. *E* must prepare a 'complete series' of variable stimuli, a series, *i.e.*, which extends from a movement so small that *O* will always judge it

'less' to a movement so large that *O* will always judge it 'greater.' The stimuli range by short steps between these limits. These variable stimuli, taken in haphazard order, are presented to *O* in an equal number (say, 100) of cases, and in all possible temporal and spatial positions, for comparison with the standard. *O* judges $>$, $<$, or $?$ ($=$). At the end of the experiment, *E* determines, for each temporal and spatial order involved, the arithmetical mean r_m of all the r_1 that evoked the judgment of doubtful (equal), and the arithmetical mean e_m of all the (positive or negative) differences between this r_m and the original r_1 . The difference $r_m - r = c$ then represents the total constant error, made up of principal error, time error and space error: *cf.*

§ 17 of the text. Questions then arise concerning:

- (1) the analysis of c : Müller, M., 199 f.;
- (2) the determination of *O*'s type: M., 200 f.; and
- (3) a more extended use of the results of the experiment: M., 201.

For examples of this form of the method, see M. Falk, *Versuche üb. d. Raumschätzung mit Hilfe d. Armbewegungen*, Diss., Dorpat, 1890, 9 ff.; H. Higier, P. S., vii., 1892, 265 ff., 283 f.; A. Wreschner, *Method. Beitr.*, 1898, 66 f., 86.

Delabarre (105) recommends an interval of 4 sec. between r and r_1 . So far as his experience goes, the author can make the same recommendation.

QUESTIONS.—(1) The moving car makes a good deal of noise; and this noise may serve as a secondary criterion in judgment. The danger can be obviated by stopping *O*'s ears.

There is no guarantee of constancy of *O*'s position. It is tiresome to stand continuously in one attitude; and even if the feet are in the same place, the weight of the body may be shifted from side to side. Sometimes *E* will notice a tendency of the whole body to follow up the arm movement. The angles at shoulder, elbow and wrist may all vary within the limits of a single series. *O*'s manner of holding the car must be constantly controlled by *E*.

O is likely to change his rate of movement from observation to observation, or from series to series. If he desires to be particu-

larly accurate, he will move slowly. The results obtained from different *O*'s may also be incomparable by reason of differences of force of movement. The qualitative impression produced by a bang against the slider is very different from that produced by a gentle push against it.

The movement is rectilinear; and this means that the qualitative difference between (relatively) large and small movements is exaggerated.

(2) With some *O*'s, judgment appears to be passed exclusively or almost exclusively in terms of kinæsthetic sensations. Others, however, depend obstinately upon visual criteria. Thus one *O*, whom the author was trying to educate into reliance upon kinæsthesia, gave the following visual schemata in order,—the one cropping up as its predecessor was banished: a portion of a yardstick, a portion of a ruler, the space occupied by the ruler but with no ruler there, the space between 'positions in space,' black line with brass posts, brass car in motion, black car in motion, black car in motion between two brass posts, two black rails, two black rails with the brass car in motion, upper arm and its angle with the body, lower arm in motion, position of fingers in the different stages of the movement, the line which the arm follows in falling (this was extremely constant), triangle described by arm (rest to start, start to finish, finish to rest). The series is interesting. The first simple schema is almost gone when the image of the apparatus takes its place; and again, when this image has been forced out of consciousness, *O*'s own arm and body supply the required criterion. Several times in the course of the experiment *O* reported a "dizzy feeling" when by chance the visual image had been entirely suppressed. Usually, the kinæsthetic sensations were not noticed at all; and to the end of the experiment *O* 'felt strange' when the judgment was mainly or exclusively couched in kinæsthetic terms.

Visualisation is, then, the principal disturbing factor: *cf.* p. 191 above. Surprise also plays its part in the judgments: *cf.* Fröbes, *Z.*, xxxvi., 263, 370, 373 f.

Cf., on these two Questions, Delabarre, *op. cit.*, 69 ff., 79 ff., 81 ff.; Meumann, *Z.*, vi., 1893, 391; Wundt, *P. P.*, i., 1893, 428 f.; ii., 1902, 38; G. W. Störring, *P. S.*, xii., 1896, 489 f.; L. W. Stern, *Psych. d. Veränd.*

erungsauffassung, 1898, 35. The author can confirm the observations recorded by Delabarre under (10), 106 f.

In the author's experience, this experiment is particularly fruitful in slip comparisons (see p. below).

ESSAY SUBJECTS.—(1) The psychophysics of kinæsthetic sensation, apart from experiments with lifted weights.

(2) A criticism of Delabarre's *Bewegungsempfindungen*.

(1) See Delabarre; F. Kramer and G. Moskiewicz, *Z.*, xxv., 1901, 101; R. S. Woodworth, *Psych. Rev.*, viii., 1901, 440 (all with the refs. cited).

(2) On method, see Schumann, *Z.*, v., 1893, 297, and utilise the discussion of § 25.

ALTERNATIVE EXPERIMENT.—An experiment which, in the author's experience,¹ works out very prettily, although the materials required are somewhat cumbrous, is that of G. Martius on the apparent size of objects at different distances from the eye (*P. S.*, v., 1889, 601 ff.). A rod of standard length is hung on a screen, at a constant distance from *O*, and is compared with other rods hung on a similar screen at other distances.

MATERIALS.—Standard rods of 20, 50 and 100 cm. in length. Complete series of variable rods: differences 0.5 cm. for the rod of 20 cm., 1 cm. for the rods of 50 and 100 cm. Two screens. Head-rest. [The rods are cut of hardwood, 5 mm. square. They may be left in their natural colour or (better) painted a very light dull-finish brown. The screens may be made of ordinary brown denim; the variable screen must be much the larger of the two. Double-pointed pins are thrust, somewhat obliquely, into the back of the rods, at a distance of about $\frac{1}{3}$ of their length from what is to be the upper end; the pins can be pushed through the denim without leaving a mark. The middle point of the variable distances is indicated by a cross-mark upon the back of each rod, and *E* has a private mark upon the variable screen, with which this middle point is made to coincide: so that the centres of standard and variable rods lie always in the same horizontal straight line.]

PRELIMINARIES.—The two screens are set up in a large room;

¹ This experience extends, it is true, only to some half-dozen trials.

if the room cannot be cleared of its ordinary furniture, it may be necessary to set up lateral screens as well. Care is taken that the two screens are evenly lighted, so that the nearer passes over into the more remote without any distinct break along the overlapping edge. *O*'s chair and head-rest are so placed that his eyes in the primary position are directed approximately upon the centre of the standard rod; and the variable screen is so adjusted that the variable rod can be viewed by a simple turn of the eyes to one side, without movement of the head. The experiment must be made in both spatial arrangements (variable to right and left of standard).

The distances employed in Martius' experiments were: normal, 50 cm., variable, 5.75 and 3 m., from *O*'s eyes. Other distances should be used, if time permits; but the experiment should begin with these two, for the sake of comparison of results.

Martius used the method of minimal changes; he appears not to have allowed for the space error. He notes the influence of the *R*-error, and suggests a method for minimising it (605 f.); and he points out the change in mode of judgment as one passes from the two smaller to the largest normal length (609).

The author's students have all, with some amount of individual variation, confirmed the general results of Martius' paper.

See, besides the refs. given by Martius, B. Bourdon, *Perception visuelle de l'espace*, 1902, 128 f.; J. McCrea and H. J. Pritchard, *A. J.*, viii., 1897, 503 f.

In the Clark University laboratory, Martius' apparatus has been put into permanent form, as follows. Two quadrangular screens of blackened wood are mounted on wooden feet, and turn (like revolving bookcases) about their vertical axes. The one, narrower screen has mounted upon its four faces four vertical strips of white paper, which serve as the standard lengths. The other, broader screen carries upon its four faces the four corresponding series of variable paper strips, arranged from left to right in the order less to greater, with their tops in the same straight line. *O* may thus select from a whole series of variables, simultaneously exposed, the length which appears to him to be equal to the standard length upon the nearer screen; or a shutter may be moved over the strips upon the farther screen, and the variables

exposed one by one, in any required order.—It is, undoubtedly, a great convenience to have the apparatus in a compact and permanent form; but the author is inclined to think that sources of error are introduced by this arrangement which the use of the more cumbersome materials avoids.

QUESTIONS.—(1) What are the factors that influence or determine judgment in this experiment?

(2) Criticise and compare the two forms of Martius' apparatus described above.

(3) Criticise the work of McCrea and Pritchard, with special reference to their comments on Martius' results.

ESSAY SUBJECT.—The theory of Apparent Magnitude.

The literature is extensive, and an answer to the question really involves a psychology of visual space. The student may read Bourdon, *Perc. vis. de l'espace*, 1902, 109 ff., 392 ff. Among recent theoretical articles may be mentioned those of E. Mach (*Anz. d. kais. Akad. d. Wiss. in Wien*, 1901, 165) and F. Hillebrand (*Denkschr. d. kais. Akad. d. Wiss. in Wien, math.-naturw. Kl.*, lxxii., 1902, pp. 53: reviewed by von Kries, in *Z.*, xxxiii., 1903, 366).

§ 33. **The Method of Constant Stimulus Differences (Method of Right and Wrong Cases): Notes on § 22 of the Text.**—The exposition of the method is modelled upon Müller's treatment: *M.*, 50 ff. The illustrative series will be found in Pflüger's *Arch.*, xlv., 1889, 93. It will be noted that Müller and Schumann (*ibid.*, 109) give the DL as 40.3, and the h as 0.0139. The reason for this discrepancy is, first, that Müller and Schumann, in view of the small number of judgments, massed the results of all four principal cases (both time and both space orders) for every D , and then calculated the DL and h by the formulæ of *G.*, 19 ff. (not 53 ff.): in other words, that they employed the procedure with *incomplete* elimination of the constant errors (*El.*, i., 112 ff.; *R.*, 130 ff.; *G.*, 46 ff.; Martin and Müller, *U. E.*, 58 ff.; *M.*, 63 ff.). Even, however, if they had employed the alternative procedure, with complete elimination of the constant errors,—if, *i.e.*, they had determined a DL and h for all four principal cases, and had then combined these partial values to a final value,—their results would have differed from those of the text, seeing that the author

has there paid regard only to the time error, and has ignored the space error altogether. This neglect simplifies the exposition, and is not misleading to the student, since the space error is ruled out by the apparatus of Fig. 32 of the text.

After this explanation, it goes without saying that the Table on p. 114 of the text is an impossible Table, inserted simply and solely for the sake of carrying the exposition through to its natural end.

A more elaborate set of results (from Merkel, P. S., iv., 141) is worked out by Müller, M., 52, 71; only the time error is involved. Our somewhat cavalier treatment of this error should be compared with Müller's remarks, *ibid.*, 72, 122, 142.

If two constant errors (time and space) are involved, the procedure becomes more complicated. It is given in detail by Müller, M., 63 ff. In essentials, it is as follows. Suppose that the average values of (4) of the text (p. 113) are unsatisfactory, and that their unsatisfactoriness is confirmed by the test of (5), p. 114. There are then two possibilities to be considered. Either we have done wrong in interpreting the constant errors as simple Fechnerian errors; or we have done wrong in assuming that Gauss' law of distribution applies to the results in hand. There is chance for error at these points: the constant errors may be due to conditions which do not operate as equal and opposite in the different temporal and spatial orders, or the results may be distributed according to some other law than Gauss': there is no chance for error at any other point. To test the applicability of Gauss' law, we discard the average values of (4) altogether, and go back to the individual values of (3), pp. 110 ff. Substituting these values for the symbols in the right-hand members of the equations on p. 111, we obtain (from Fechner's Fundamental Table) a series of calculated n for the various D 's which we may compare with the n of our original data. If Gauss' law is applicable to these data, the two series will show a satisfactory agreement; if it is not, the two series will diverge. In the former case, we must proceed to a stricter analysis of the constant errors. In the latter, we must either look about for some other law of distribution, or must rest content with the rough determination of the First Procedure (p. 109).

EXPERIMENT XXII

Rules for setting up the apparatus, etc., have been given above, p. 197. They must be scrupulously followed. The interval between the two sounds of an observation may be conveniently set at 1.5 sec. (*cf.* Exp. XVIII.).

The series of R indicated in the text works very well. With the extremes of $r_1 = 60^\circ$ and $r_1 = 24^\circ 30'$ the author has never obtained less than 92% of r . cases.

EXPERIMENT XXIII

MATERIALS.—Fechner describes his weight holders in *El.*, i., 97 f. They are preserved in the Göttingen laboratory, but have (so far as the author is aware) never been figured.

The elimination of the space error is effected in the Göttingen laboratory, very simply, by standing the weight holders upon a padded board, set parallel to the edge of the table, and pushing the board along under O 's hand: L. Steffens, *Z.*, xxiii., 1900, 279; J. Fröbes, *ibid.*, xxxvi., 1904, 243. The carrier bracket shown in Fig. 32 of the text has been in use at Cornell since 1899. A possible source of error lies in the fact that with a light weight the carrier moves easily, while with a heavy weight it tends to drag across the bracket; O may thus judge of the heaviness of the weight by the sound of the moving holder. The difficulty can be obviated either by covering the bracket with cloth, and fastening metal runners to the under side of the carriers, or by leaving the bracket smooth, and gluing a thick layer of felt to the under side of the carriers. E very soon learns to swing the carriers in and out at the prescribed rate, and with a force proportioned to the weight of the loads.

Various kinds of weight-holder have been employed for this experiment. We have mentioned Galton's cartridge weights (p. 189 above). A permanent set is sold by the Cambr. Instr. Co. for £5: see *Inquiries*, 34 ff., 370 ff.; C. I. Co.'s cat., 1892, 121 f. Jastrow in 1892 used cylindrical cases of a somewhat larger size (*A. J.*, v., 245). The Garden City Model Works advertised in 1894 a set of 9 hard rubber cylinders, $1\frac{1}{2}$ in. in diam. and 4 in. high, weighted with shot to 300, 305, 310, 315.25, 320.3, 331, 341.5, 364.1 and 388.4 gr. respectively, and packed in two

wooden cases, for \$8.50. The weights were to be lifted in the palm of the hand. Fullerton and Cattell used round wooden boxes, about 6 cm. in diam. and 3 cm. high; "the weight was lightly grasped on the side with the thumb and fingers" (Small Diff., 118 f.). Frankl had "gleiche Blechbüchsen, entsprechend mit Schrotkügelchen angefüllt" (Z., xxviii., 1902, 2). This is, of course, the simplest type of weight-holder,—a shell, into which the weight is packed, and which forms with the weight a single solid block.¹ Next in order comes the weight-holder with separate handle. Hering's² *O*'s used, for one series, a light wooden handle, to which was hung a scale-pan of cardboard; the handle was taken between thumb and forefinger. Fechner's weight-holder is of this type. So, too, is the box and ring employed by E. Claparède in his study of the rate of lift with weights of different volume (Arch. de psych. de la suisse romande, i., 1901, 74; ii., 1902, 24). A somewhat different principle is introduced with Weber's³ plan of laying the weight in a cloth, the corners of which are gathered up and held by *O*. Hering's *O*'s, in another series, grasped the two ends of a towel which supported a wooden scale-pan. An extension of this principle is found in Wreschner's apparatus (Methodol. Beitr., 1898, 8), where the weight-holder hangs by a cord carried over pulleys from a wristlet attached to *O*'s forearm. Of the same type is the arrangement described by A. J. Kinnaman, A. J., xii., 1901, 242.

Merkel (P. S., v., 1889, 254 f.) and C. Jacobi (Arch. f. exp. Pathol. u. Pharmakol., xxxii., 1893, 49 ff.) replace the weight-holder by a form of active pressure balance.—

The dimensions of the author's holders are approximately 8.5 × 8.5 × 15 cm.⁴ The wooden handle is 10 cm. in length; its diameter for men's hands is 2.9, for women's, 2.6 cm. The principal weights form the series 1000, 900, 800, 700, 600, 500, 400 gr. (4 of each); the minor weights (4.6 cm. in diam.) the series 200 (4), 100 (4), 50 (4), 20 (8) gr. The weights and holders can be so cheaply made that it is worth while to have at least 3 sets (24 holders) in the laboratory.

It is very important that the instructions given to *O* for these two exps. be clearly worded. *E* and *O* come to the exps. to—

¹ Cf. the weights used in the study of the size-weight illusion: F. B. Dresslar, A. J., vi., 1894, 343; J. A. Gilbert, Yale Stud., ii., 1894, 43; C. E. Seashore, *ibid.*, iii., 1895, 2; *ibid.*, 1896, iv., 62; Scripture, New Psych., 1897, 274; etc. Other refs. will be found in these papers: see also Claparède, first ref. in text below. With Yale Stud., iii., 18, cf. Iowa Stud., ii., 1899, 36 ff.

² See above, p. lxxi.

³ See above, p. xvii.

⁴ The wire frames are here made needlessly high (7.1 and 7.3 cm.). It would be better to lower the frames, and to increase correspondingly the length of the handle supports.

wards the end of the Course, after they have been referred at various points to Martin and Müller's U. E., and when they know something of the complexity of the process of 'comparison.' Hence they are apt to sit down with the idea that *O* will perform certain acrobatic feats of judgment, and that the results will show the effect of all manner of tendencies and influences. The Instructor must, therefore, insist that the work is to be taken in the same spirit as all the preceding exps.: attentively, but still with a sort of detached interest; not self-consciously, not with any undue scrupulosity.¹ The effect of *O*'s training should come out in his introspections, at the end of the series; but he must not, so to say, be on the lookout for opportunities of introspection, still less make such opportunities for himself. What *O* has to do is to say what is there; not to reflect on what, in the light of his knowledge, he thinks may be there. The exps. are neither Chinese puzzles nor occasions for 'showing off.' And the conditions for judgment are, as a matter of fact, a good deal easier than they are in some of the foregoing exps.

With *O*'s of the subjective type, it is as difficult to ensure this attitude of attentive indifference as it is, in the reaction experiment, to banish the idea of the time factor. The Instructor will do well, therefore, to pay regard to type, and in certain cases to place the exps. earlier in the Course. Exp. XXII. is a good deal easier than Exp. XXIII. The comparison of lifted weights is not an elementary process, even if the weights are lifted 'ruckweise,' in Müller and Schumann's way.

QUESTIONS.—(1) The aim of this Question is simply to ensure the student's understanding of the text. It must be answered from the text itself, with reference also made to the account of the Method of Constant Stimuli. A more detailed treatment may be based upon the following § 34.

(2) The judgments may be turned to account for the determination of the overlimens or *OL* (see pp. 19, 255 above, footnote): cf. E. Mosch, P. S., xiv., 1898, 498; Müller, M., 58. They are also valuable in the analysis of the constant errors: Müller, M., 114 ff., 132 ff.; cf. the following § 34.

¹ See above, pp. clv. f., 204.

(3) See Müller and Schumann, Pflüger's Arch., xlv., 42; A. Wreschner, Methodologische Beiträge, 1898, 15, 87 ff.

(4) It is to be remembered that the term 'u-judgment' covers judgments both of 'doubtful' and of 'positively equal.' See Müller, M., 12 f., and the references there cited: Kraepelin, P. S., vi., 505; Martius, *ibid.*, v., 606; Angell, *ibid.*, xix., 18, 20; Whipple, A. J., xii., 412, 432, 442; xiii., 264 ff.; Münsterberg, Psych. Rev., i., 49; Martin and Müller, U. E., 197 ff., 204; Schumann, Z., iv., 5 ff., 13 f., 55, 64 (this last reference applies to estimation of intervals). We may add: Müller and Schumann, Pfl. Arch., xlv., 40 f.; Boas, *ibid.*, xxvi., 1881, 494; Wreschner, Methodol. Beitr., 12, 40. Other material may be gathered from § 34. The Question may, indeed, be easily expanded into an essay: in any event, the student should bring his own introspective experience to bear upon it.

(5) See Müller, M., 24 f., 28 f., 58 f., 78 f., 83, 138, 144 n, etc. It is very improbable that experimental psychology will return to the Fechnerian manner of employing only one or two D 's. On the contrary, we may suppose that the norm of future work will be the Vollreihe or complete series (*ibid.*, 25). This has been employed by Wreschner, in his Methodol. Beitr., 1898; less rigidly by Meumann in work upon the time consciousness (P. S., ix., 1893, 281 f.; xii., 1896, 152 ff.), and by Ebbinghaus (Psych., i., 492 ff.). Cf. also the formulation of Kraepelin's combined method, P. S., vi., 1891, 499 f.; Müller, M., 181.—Nevertheless, it may be worth while, for historical and didactic reasons, to write out the procedure of the method when but two R are employed.

Let the two stimuli, r_1 and r_2 , be proportional to the two straight lines xo and XO of Fig. 34. Their difference, D , is then proportional to the distance PO . With both stimuli, O is liable to errors of observation. We will assume that h , the measure of precision, is the same for both stimuli, so that the two curves of error have precisely the same form. The curves may then be drawn as vyu and VYU . For convenience of demonstration, we draw the ordinates mn , pq , MN , PQ , for the $\pm x = PE_1$, thus dividing each curve into four equal areas. In a number of successive comparisons of r_1 and r_2 , various things may happen: we will look at a few of the possibilities. (1) O may sense the first

stimulus as xv , the second as XU . This will happen very rarely; but it may happen. Then xo , the smaller stimulus, is judged to be very distinctly smaller than XO . (2) More often, xo will be

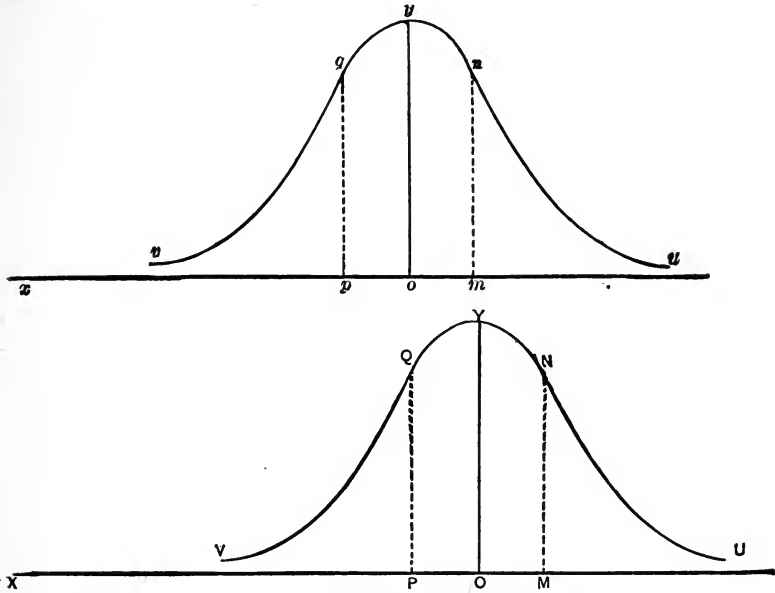

FIG. 34.

From Fullerton and Cattell, *On the Perception of Small Differences*, 1892, 13.

sensed as xp , and XO as XM . Here, again, the difference will be rightly distinguished, though not so clearly as before. (3) The two R may be sensed as xo and XP , or as xm and XO : they will then appear alike. (4) They may be sensed as xm and XP , xm and XV , or even as xu and XV ; in these cases the subjectively greater R will be taken for the smaller. In a word, the existence of the errors of observation affords a satisfactory explanation of the occurrence of the three sets of 'cases' in judgment, —the cases r (right), w (wrong) and u (uncertain or equal). A constant difference D is given; but positive and negative errors are algebraically added to it, so that it becomes for sensation now a $+D$, now a $D = 0$, and now a $-D$.

If, however, we may regard every judgment passed in the experimental series as an observation affected by the normal error

of observation; and if every error of observation may be expressed in terms of D , may be considered as a *plus* or *minus* or zero difference between r_1 and r_2 ,—in brief, is the equivalent of some D -magnitude; then the error curves of the r , w and u cases may be drawn as if hD and not hx were the t for the relative number of cases in question. Let us see what data we require for the drawing, and what the form of the curves is.

We know that $\frac{r}{n} + \frac{w}{n} + \frac{u}{n} = 1$; and that $\frac{r}{n} = \frac{1}{2}$ when $D = DL$. Now (1) for $D = 0$, we have to assume an equal probability of r and w , so that $\frac{r}{n} = \frac{w}{n}$. The terms r and w are, in this case, wholly arbitrary; but the assumption is the simplest and most reasonable that can be made. (2) For a $-D$, the present w -cases become r -cases, and conversely. It follows that the relative frequency of w for a negative D obeys the same law of distribution as the relative frequency of r for a positive D . The curves for r and w will therefore intersect at $D = 0$, taking symmetrical paths in opposite directions. (3) The number of u -cases may be determined by the equation $\frac{u}{n} = 1 - \frac{r+w}{n}$.

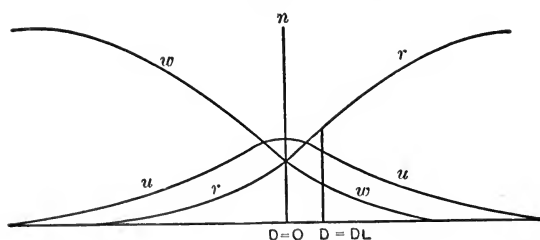

FIG. 35.—Curves showing the distribution of r , w and u cases as determined by Gauss' Law of Error. From Külpe, Grundriss d. Psych., 1893, 73.

With these data to guide us, we may draw the three curves as shown in Fig. 35. The ordinates represent the numbers of the special cases, whose total number is n ; the abscissas are the values of $t = hD$ given in Fechner's

Fundamental Table. Ordinates are shown for $D = 0$ and $D = DL$.

We now have no difficulty in constructing formulæ whereby we may calculate the DL from our results with a given D . These formulæ will contain h , which is our required measure of accuracy or precision.

(1) Suppose that D is $> DL$: the relation is evidenced at once

by the fact that $\frac{r}{n}$ is $> \frac{1}{2}$. For O, D is $= D \pm x$, where x denotes the positive or negative error which occasions the various judgments. An r -case will occur whenever x is positive, and also when it is negative but in absolute magnitude $< D - DL$. The relative frequency of the r -cases is, therefore, = the probability of all positive x , plus the probability of those negative x that are smaller than $D - DL$. In formula:

$$\frac{r}{n} = \frac{1}{2} + P \circ^{D-DL} = \frac{1}{2} + \frac{1}{\sqrt{\pi}} \int_0^{h(D-DL)=t_1} e^{-t^2} dt.$$

(2) A w -case will occur whenever x is negative and in absolute magnitude $> D + DL$. The relative frequency of the w -cases is, therefore, = the probability of all negative x , minus the probability of those negative x that are smaller than $D + DL$. In formula:

$$\frac{w}{n} = \frac{1}{2} - P \circ^{D+DL} = \frac{1}{2} - \frac{1}{\sqrt{\pi}} \int_0^{h(D+DL)=t_2} e^{-t^2} dt.$$

(3) Finally, an u -case will occur whenever x is negative and in absolute magnitude $> D - DL$ but $< D + DL$. The relative frequency of the u -cases is, therefore, = the probability of negative x within the limits $D - DL$ and $D + DL$. In formula:

$$\frac{u}{n} = P \circ_{D-DL}^{D+DL} = \frac{1}{\sqrt{\pi}} \int_{h(D-DL)=t_1}^{h(D+DL)=t_2} e^{-t^2} dt.$$

In Fechner's Fundamental Table, the appropriate $t = hD$ is given for every $\frac{r}{n}$ that is $> \frac{1}{2}$. For $\frac{w}{n}$, the value of t for the equivalent $\frac{r+u}{n}$ must be sought in the Table. If the first t be written t_1 , as in equation (1) above, and the second t be written t_2 , as in equation (2), we have:

$$\begin{aligned} h(D-DL) &= t_1, \\ h(D+DL) &= t_2, \end{aligned}$$

whence we obtain

$$\begin{aligned} h &= \frac{t_1 + t_2}{2D}, \text{ and} \\ 2DL - \frac{t_2 - t_1}{h}, \text{ or } DL &= \frac{(t_2 - t_1)D}{t_2 + t_1}. \end{aligned}$$

But DL , the difference limen, and h , the measure of precision, are the two values required of the method.—Külpe, Grundriss,

73 f.; Outlines, 71. For a discussion of this h , see the following § 34.

We turn to the Fechnerian *constant errors* of time and space. There are four possibilities with lifted weights:

- I. S is lifted first and stands on the right;
- II. S " second " right;
- III. S " first " left;
- IV. S " second " left.

Further: a time error is positive, in Fechner's sense, when it adds to the weight first lifted; negative, when it subtracts from the weight first lifted. Similarly, a space error is positive when it adds to the left-hand weight; negative, when it subtracts from the left-hand weight.

The values h and DL must be determined separately for I., II., III. and IV. The final h is then averaged from the four partial h , and the final DL from the four partial DL . To determine the values of the constant errors, we proceed as follows.

Let T_1, T_2, T_3, T_4 stand for the $\frac{t_1+t_2}{2}$ of the four h -formulæ, and p and q (as is usual) for the Fechnerian errors of time and space. Then, if we make p and q positive in I., we have:

$$\begin{aligned} T_1 &= h(D+p+q), & T_2 &= h(D-p+q), \\ T_3 &= h(D+p-q), & T_4 &= h(D-p-q). \end{aligned}$$

A fitting combination of these equations, by addition and subtraction, gives us:

$$hp = \frac{T_1 - T_2 + T_3 - T_4}{4},$$

$$hq = \frac{T_1 + T_2 - T_3 - T_4}{4}.$$

Since we know that $hD = \frac{T_1 + T_2 + T_3 + T_4}{4}$, we may write these equations:

$$p = \frac{T_1 - T_2 + T_3 - T_4}{T_1 + T_2 + T_3 + T_4} \cdot D,$$

$$q = \frac{T_1 + T_2 - T_3 - T_4}{T_1 + T_2 + T_3 + T_4} \cdot D.$$

values that we can determine numerically.

In this account, the values p and q are always thought of as increasing or decreasing the given D ; so that the effective difference between r_1 and r_2 is not this given D itself, but rather a $D \pm p \pm q$. What sign shall be prefixed to p and q in the particular case depends on the results. The signs used above indicate (1) that we find more r -cases (the effective D is greater) in the time order SC than in the time order CS , and (2) that we find more r -cases with S to the right than we do with S to the left. This means (1) that p subtracts from the weight first lifted: the error of time is negative; and (2) that q adds to the left-hand weight: the error of space is positive.

(6) The references to Fechner himself have already been given. The criticism should follow Müller, G., 49 ff.; M., 64 ff. There are two principal points to notice. (a) Fechner's assumption of the equality of p and q in the opposed time and space orders is valid only in cases where $\pm D$ is small in comparison with S . For only in such cases is it possible that, *e.g.*, the fatigue set up by the R lifted first to the disadvantage of the R lifted second is approximately the same whether S or C be first taken. It follows, of course, that p and q are independent of the absolute magnitude of $\pm D$ only when all the D 's employed are small as compared with S . (b) Again, this equality of the opposed p and q with small D 's presupposes *complete* opposition of the orders. It presupposes, *i.e.*, either that the time (or space) error is the sole constant error involved in the experiment, or that the results compared are obtained under opposite conditions both of time and of space. If the opposition is incomplete (opposite times but same spaces, or different spaces but same times), the Fechnerian assumption need not be valid. Thus, in order I. S to the right, in order II. C to the left, is first lifted. We cannot here assume equality of the two p , even for $D = 0$; for the processes upon which p depends may differ, both in amount and in consequence, according as the weight first raised lies to the right (or is lifted by the right hand) or lies to the left (or is lifted by the left hand). Contrariwise, in order I. S to the right, in order IV. C to the right, is first lifted. Here, if S and C are but little different, the conditions underlying the time and space errors must be approximately the same.

(7) The principal references are: Müller and Schumann, Pfl. Arch., xlv., 41 f.; Martin and Müller, U. E., 7 ff.; Müller, M., 12

ff., 114 ff., 132 ff., 160; Wreschner, *Method. Beitr.*, 11 f.; Mosch, *P. S.*, xiv., 493 f.; Ebbinghaus, *Psychol.*, i., 74, 492 ff.

(8) This Question may be answered directly from Müller, M., 25 ff. The classification of the practical possibilities is a little difficult, since the arrangement of the *D*'s is cut across by the arrangement of the whole experiment. The unit of the latter may be the series (a set of observations, as many as there are *D*'s, in which every *D* occurs once), the group (a set of repeated, *e.g.*, 25 observations with a single *D*), or the division (a quarter, eighth, etc. of the total experiment). Bearing these units in mind, we have the following:

- (a) *Haphazard* arrangement of the *D*'s. These are given in chance order :
 - i. within the single series (the order of the series being otherwise determined);
 - ii. from group to group: the order of the groups is determined by chance, and each *D*, as it turns up, is employed, say, 25 times over;
 - iii. within a division of the experiment, or even throughout the whole experiment (every *D*, *e.g.*, being written down on cards 50 times over, for both temporal and both spatial positions, and the whole number of cards shuffled).
- (b) *Regular* arrangement. The *D*'s are presented in regular, ascending-descending order, either
 - i. within the single series (every ascending being paired by a descending series), or
 - ii. within the division; the ascending series, *e.g.*, being taken in groups, and paralleled by a descending series of similar groups.
- (c) *Systematic* arrangement. The experiment is so planned, from the outset, that every *D* is preceded, with the same (or approximately the same) frequency, by large, moderate and small, positive and negative *D*'s.

Müller and Schumann, and Martin and Müller have employed the plan of haphazard variation within the series; Fechner has used the group arrangement; and Camerer (*Z. f. Biol.*, xxi., 1885, 577) has used (c).

(9) The question of direction of judgment is discussed by Müller, M., 16 ff.

(10) See Müller, M., 25.

(11) This Question should bring to light the factors of visual-

isation, various forms of ideation of the *R*, absolute impression, expectation, surprise, Einstellung, etc. See § 34.

(12) See above, pp. 265 f.

ESSAY SUBJECTS.—(1) The psychophysics of kinæsthesis (active pressure and lifted weights).

The principal references are given in these two §§. A partial bibliography is printed by A. J. Kinnaman, A. J., xii., 1901, 259 ff.

(2) The weight experiments of Fechner and Hering.

(3) The weight experiments of Müller and Schumann, and the writers' formulation of Weber's Law. (Refs. in § 34.)

§ 34. **The Method of Right and Wrong Cases: Historical and Critical.**—(1) *Fechner and Müller.* The idea of measuring the D.S. by means of the right, wrong and doubtful judgments passed upon a constant small *R*-difference seems to have originated with the Tübingen physiologist K. Vierordt (1818–1884). In 1852 F. Hegelmayer, a pupil of Vierordt's, published an investigation Ueber Sinnengedächtniss, in which he sought to determine the effect of lapse of time upon the discrimination of lines. Hegelmayer finds that the D.S. is greater for horizontal than for vertical lines, and asserts a constancy of the relative *DL* for linear extents. His method is a crude form of *r* and *w* cases: a total of 257 judgments is distributed over no less than 166 different experimental arrangements; and no attempt is made to go behind the bare statement of the *r*, *w* and *e* cases obtained.¹

In 1856, T. Renz and A. Wolf, also pupils of Vierordt's, published experiments by the new method upon the D.S. for intensity of sound. Renz and Wolf pay regard to the constant error of time; otherwise, they show no great advance upon Hegelmayer. Their experiments are limited in number, and they, like Hegelmayer, are content with the mere statement of *r*, *w* and *e* judgments.²

¹Vierordt's Arch. f. physiol. Heilkunde, xi., 1852, 844. The year is given wrongly as 1859 in König's bibliography of physiological optics: see Helmholtz, P. O., 1896, 1274 (no. 6900). Cf. Fechner, El., i., 74, 211; Abh. d. kgl. s. Ges. d. Wiss., math.-phys. Cl., xiii. (Abh., xxii.), 1887 (1884), 111, 113; Müller, G., 25 f.; Vierordt, Der Zeitsinn, 1868, 25 (gives Hegelmayer's date as 1853); G. F. Lipps, Massmethoden, 1904, 21 (Arch. f. d. ges. Psych., iii., 1904, 173.)

²Vierordt's Arch., xv., 1856, 185; Pogg. Ann., xcvi. (clxxiv.), 1856, 595. Cf. Fechner, El., i., 74, 175 f., 90 n.; Müller, G., 26.

If, then, the merit of originating the method belongs to Vierordt, it is a merit that stops short where it began. The establishment of the method of r. and w. cases as an instrument of psychophysical analysis is the work of Fechner. Not only did Fechner elaborate the method on its theoretical side; he made an experimental investigation of the D.S. for lifted weights, all in the interests of the method, which extended over the years 1855-1859 and involved no less than 67072 comparisons.¹ Müller writes of him in 1878: "in unvergleichlich eingehenderer Weise als seine Vorgänger hat sich Fechner mit der Methode der r. und f. Fälle beschäftigt. Die Gewichtsversuche, die er nach dieser Methode angestellt hat, sind wohl die genauesten und sorgfältigsten aller auf das Webersche Gesetz bezüglichen Experimentaluntersuchungen. . . Ich halte es für überflüssig, die gewaltigen Fortschritte hervorzuheben, die . . . das psychophysische Massverfahren und die Analyse und Ausbildung der psychophysischen Massmethoden in Folge der theoretischen und experimentellen Arbeiten Fechners gemacht hat, und betrachte selbstverständlich Alles das, was etwa meine eigenen Entwicklungen Richtiges enthalten sollten, nur für eine durch Fechners Arbeiten angeregte, kritische Ergänzung derselben."² And Fullerton and Cattell declare, in 1892, that "Fechner's research with lifted weights . . . has, perhaps, never been surpassed in extent and accuracy by any investigation in any science."³ It is well that opinions of this sort should be borne in mind. We are compelled to dissent from Fechner's interpretation of the method; but we should make a great mistake if we belittled his work.

¹ *El.*, i., 93, 183, 195; *R.*, 59.

² *G.*, 26, 45.

³ *Small Diffs.*, 116. Witmer, after increasing Fechner's comparisons to 76072 (*Analyt. Psych.*, 1902, 218), asserts that "Fechner prejudged the results of the experiments before he had lifted a single weight." Taken as it stands, the statement is ridiculous. Did Fechner prejudge the results of experiments with colour or with tones? In *El.*, i., 175, he admits that Weber's Law does not hold for colours; in *I. S.*, 169, he withdraws his former opinion that it holds for tonal pitch. If his weight experiments had yielded results contrary to Weber's Law, he would have said so. It is true that Fechner "combined the man of science and the ardent mystic;" it is also true that he held preconceived theories of a "necessary relation between mind and matter" (see p. xli., above). It is not true that he allowed his mysticism and his theories to falsify or prejudice his experimental results.

The aim of the method of *r.* and *w.* cases, according to Fechner, is to measure the *R*-increment which is required, in the various circumstances in which sensitivity is to be compared, to produce the same ratio of *r* and *w* cases (or of *r* cases) to *n*, the total number of cases. The magnitude of sensitivity, under these various circumstances, is made inversely proportional to the magnitude of the *R*-increment in question.¹ There are several ways in which we might seek to realise the aim of the method. Thus (1) we might work empirically, varying the *R*-increment under the different conditions until we actually found the same $\frac{r}{n}$. Such a procedure would, however, be extremely tedious, and no multiplication of experiments could render it exact. (2) Again, we might determine the $\frac{r}{n}$ under different conditions; repeat the work, until we came upon approximately the same ratio; and then interpolate. In this way we should gain something on the score of time and tedium. Nevertheless, the procedure would still be circumstantial and inexact. (3) Fortunately, mathematics shows us a short cut to the desired end. Consider the character of the method: the repeated comparison of two slightly different *R*, the nature of the judgments passed. Errors of observation and the law of probability suggest themselves of their own accord. Since, now, in experimental series that are otherwise comparable, the precision of *O* depends only upon the sensitivity which he brings to bear upon the *R*-difference, we seem to be led to the conclusion that "the measure of the D.S. may be represented by the value, ordinarily denoted by *h*, which in Gauss' Law furnishes the measure of precision of observations." It seems reasonable, too, that "between the $\frac{r}{n}$ yielded by experiment and the product of *h* into the *R*-increment *D* for which the particular $\frac{r}{n}$ has been found (*i.e.*, between $\frac{r}{n}$ and *hD*), there must obtain a mathematical relation, such that *hD* may be derived from the given $\frac{r}{n}$, and then *h*, the measure of sensitivity, determined by division of *hD*

¹ *El.*, i., 72. *Cf.* Müller, M., 94 ff.

by D ." It remains, then, to prove these assumptions: to establish the mathematical relation from the theoretical side, to verify it by experiment, and to make it practically available for purposes of the method.¹

Fechner first of all reduces all cases to r and w cases, by counting the e and d half to r and half to w .² Next, by a mathematical argument which we need not here reproduce, he finds the formulæ:³

$$\frac{r'}{n} = \frac{1 + \theta}{2}; \quad \frac{w'}{n} = \frac{1 - \theta}{2}; \quad \theta = \frac{2r'}{n} - 1 = 1 - \frac{2w'}{n},$$

where r' and w' are the revised numbers of r and w cases respectively, and θ is the probability integral:

$$\frac{2}{\sqrt{\pi}} \int_0^t e^{-t^2} dt.$$

Finally, he makes out the Table which correlates $\frac{r'}{n}$ with $t = hD$ (Fundamental Table for the Method of r . and w . cases: see p. 99 of the text) between the limits $\frac{r'}{n} = 0.50$ and $\frac{r'}{n} = 1.00$.⁴ The calculation of the test-value h is now simple. Having obtained a certain $\frac{r'}{n}$, one looks up in the Table the corresponding value of hD , and determines h by division of this value by D . The demands of theory and of availability are satisfied; the demand for experimental verification is met by Fechner's weight experiments.

The principal objection which Müller raises against Fechner's treatment of the method is that Fechner has failed to distinguish between a measure of precision and a DL . The DL is that average value of D which gives 50% of r -judgments; the measure of precision characterises the uncertainty, the limits of variation, of our apprehension of the stimuli r_1 and r_2 .⁵ Both values are important; both may be derived from the method. But they must be kept distinct. Müller accordingly works out the formulæ for the r , w and e cases which we have given (in somewhat sim-

¹ El., i., 101 ff.; R., 24. On Fechner's h , see R., 48, 50 n., 51 f., 97 f.

² El., i., 72, 94; R., 67 ff.

³ El., i., 104 ff. For A. F. Möbius' line illustration, see El., i., 105 ff.; G., 36 ff., 42 ff.; R., 101 ff.

⁴ El., i., 108, 110 f.; R., 66 f.

⁵ Or, as we take it (see below), of our apprehension of this average D .

plified form) in the preceding § 33.¹ These formulæ yield others, by means of which DL and h may be determined. The formula² for the DL is $DL = \frac{(t_2 - t_1)D}{t_2 + t_1}$; that is, it agrees with the DL -equation given above.³ On the other hand, our h and Müller's h are somewhat different.⁴ We may explain this difference at once.

Let h be the measure of precision for our observation of r_1 , the smaller weight: the h of the upper curve of Fig. 34 (p. 269). Similarly, let h' be the measure of precision for our observations of r_2 , the heavier weight: the h of the lower curve of the same Fig. We assumed, in drawing these curves, that $h = h'$. This is not strictly true, since the measure of precision changes with the absolute R -intensity (G., 22). Let $h = h'(1 + \theta)$. Then the resultant measure of precision, the measure of precision not for the accidental variations of r_1 and r_2 but for the accidental variations of the difference D , is $\frac{hh'}{\sqrt{h^2 + h'^2}}$, or, in terms of θ ,

$\frac{h}{\sqrt{2 + 2\theta + \theta^2}}$: G., 16. This resultant measure of precision is our (and Fechner's) simple h , the h that is equal to $\frac{t_1 + t_2}{2D}$ by the formulæ of § 33.

If we employ Müller's own formulæ, we have :

$$t_1 = \frac{h(D - DL)}{\sqrt{2 + 2\theta + \theta^2}},$$

$$t_2 = \frac{h(D + DL)}{\sqrt{2 + 2\theta + \theta^2}},$$

and consequently

$$h = \frac{(t_1 + t_2)\sqrt{2 + 2\theta + \theta^2}}{2D}$$

(G. 20). If we neglect the difference between h and h' , and so make $\theta = 0$, the factor $\sqrt{2 + 2\theta + \theta^2}$ becomes simply $\sqrt{2}$, and we have :

$$h = \frac{(t_1 + t_2)\sqrt{2}}{2D}.$$

In other words, to determine Müller's h , the measure of precision of either of the curves of Fig. 34, we have simply to multiply Fechner's h , the measure of precision of our apprehension of D , by $\sqrt{2}$.⁵ If, on the other hand, we do not wish to neglect the difference between h and h' ,

¹ See G., 18, form. (6), (7); 19, form. (9).

² G., 20.

³ P. 271.

⁴ G., 19 f.

⁵ Cf. G. E. Müller u. F. Schumann, Pflüger's Arch., xlv., 1889, 109.

we must seek to find the value of θ by a procedure given by Müller, G., 22 f. (*cf.* Fechner, R., 20, 24, 48 f., 51, 85 *n.*, 98 ff.; J. Merkel, P. S., iv., 1888, 130).

The simplified formulæ of the text are given by Fechner : R., 96. We return to their derivation presently. They are adopted by Külpe (*Outlines*, 71), who, however, says nothing of the difference between Müller's and Fechner's h . The same formulæ for DL and h are given by Sanford, *Course*, 351. Scripture has, apparently, failed to recognise the justice of Müller's criticism. At least, he treats the method from the original Fechnerian standpoint, without mentioning Müller (*New Psych.*, 489 f.; *cf.* the general ref., 268).

Müller devotes three chapters of his G. to the method. The first deals with the errors of observation made in the apprehension of r_1 and r_2 , and with the 'resultant' errors of observation arising from their combination; applies the law of probability to the determination of these resultant errors; gives the formulæ for DL and h ; and discusses the time error, the relative value of direct and reflective judgments, etc.¹ The second is mainly occupied with a detailed criticism of Fechner's El.² The third treats of the elimination of constant errors.³ Müller's style is not easy at best; and, in the present instance, most readers will agree with Fechner that "Müller selbst es nicht eben bequem gemacht hat, ihm in dieser Hinsicht zu folgen." At the same time, the argument is straightforward, rather formally than materially difficult, and will well repay thorough reading. Indeed, the understanding of it is essential. If the non-mathematical student, who has followed the elementary explanations of this book, will sit down to read the El., the G. and the R. systematically, in that order, he will find at the end that he really knows something of the issues involved, and has a much better grasp of the arguments than from first inspection of the pages he would have thought possible.

Fechner was at first inclined to accept Müller's criticism, and actually recast the results of his weight experiments in the light

¹ G., 11-25; *cf.* El., i., 94 f. On the Fehlvorgänge, see El., i., 76 ff.; G., 334 ff.; R., 25 ff.; Merkel, P. S., iv., 156, 289; vii., 1892, 575.

² G., 25-45.

³ G., 46-55; *cf.* Fechner's discussion of complete and incomplete compensation of constant errors, El., i., 113 ff.

of Müller's formulæ.¹ On further consideration, however, he convinced himself that Müller was wrong. The main object of the method, he insists, is the ascertainment not of DL but of h .² The reason that he halves the e cases between the r and w cases is not that he looks upon them as an "unliebsame Beigabe," to be cleared out of the way as soon as possible,³ but that "das [Gauss'sche] Gesetz . . . nicht auf die S , sondern die zu Grunde liegenden scheinbaren Unterschiede zwischen den R , welche in die S fallen, angewandt wird; den vielen Null- S , welche die Methode liefert, entsprechen aber nicht Nullwerthe der scheinbaren Unterschiede, sondern es gehen nur nach dem Schwellengesetz kleine positive und negative scheinbare Unterschiede der R in Nullwerthe für die S zusammen, indess sie selbst diesseits und jenseits eines einzigen Nullwerthes vertheilt zu denken sind."⁴ We will trace briefly the course of the argument.

Fechner begins by showing that his method, no less than Müller's, can furnish both DL and h . We may conceive of the e -cases, or no-difference cases, he says, as forming a continuous zone or region, bounded on the one side by positive or r cases, and on the other by negative or w cases. This zone of no-differences, taken as a whole and without regard to the sign of the constituent judgments, may be termed the *total limen* or TL . TL thus covers all those apparent differences which disappear for perception. It falls into two divisions, extending above and below the point of ideal equality of the two sensations corresponding to r_1 and r_2 . Let us call the positive division, the part of TL which lies above the ideal point of separation, the upper *partial limen* or PL_u : then this division includes all cases in which D has been reduced by a value equivalent to the magnitude PL_u . Similarly, let us call the negative division, the part of TL which lies below the ideal point of separation, the lower partial limen or PL_l : then this division includes all cases in which D has been augmented by a value equivalent to the magnitude PL_l . Since in Fechner's procedure the e cases are given half to the r and half to the w cases, so that $\frac{e}{2}$ values are sensed on the positive and $\frac{e}{2}$ on the negative side as if D were 0, this means that in the former instance r' loses $\frac{e}{2}$, while in the latter w' loses (or r' gains) the

¹ R., 72, 81.² R., 48: cf. 24 f.³ G., 37; P. S., iv., 131.⁴ R., 45, 68. On the phrase 'apparent difference,' see R., 40 ff.

same number. The relation between the magnitudes $D-PL_u$ and $D+PL_l$, on the one hand, and the r' and w' cases on the other, can now be expressed in formulæ.

We had in the El. the equation :

$$\frac{r'}{n} = \frac{1}{2} + \frac{1}{\sqrt{\pi}} \int_0^{\hbar D=t} e^{-t^2} dt.$$

Applying our new principles, we have further :

$$\frac{r' - \frac{e}{2}}{n} = \frac{r}{n} = \frac{1}{2} + \frac{1}{\sqrt{\pi}} \int_0^{(\hbar D - PL_u)=t_1} e^{-t^2} dt,$$

$$\frac{r' + \frac{e}{2}}{n} = \frac{r+e}{n} = \frac{1}{2} + \frac{1}{2\sqrt{\pi}} \int_0^{(\hbar D + PL_l)=t} e^{-t^2} dt.$$

From the three equations

$$\begin{aligned} t &= \hbar D, \\ t_1 &= \hbar(D - PL_u), \\ t_2 &= \hbar(D + PL_l) \end{aligned}$$

we have the results :

$$\begin{aligned} \hbar &= \frac{t}{D}, \\ PL_u &= \frac{(t-t_1)D}{t}, \\ PL_l &= \frac{(t_2-t)D}{t}, \\ TL &= \frac{(t_2-t_1)D}{t} = \frac{t_2-t_1}{\hbar}, \\ DL &= \frac{TL}{2} = \frac{(t_2-t_1)D}{2t}. \end{aligned}$$

See R., 49 f., 91 f.; and *cf.* Kämpfe, P. S., 518 f.; Müller, M., 102 n.

Müller¹ objects that Fechner's division of the e cases is valid only when D is 0 or very little different from 0. This condition, however, is in general not fulfilled. Instead of halving the e cases to the r and w cases, therefore, Müller regards them as equally distributed about the ideal point of separation which divides the zone TL into PL_u and PL_l . Fechner's treatment of the e cases gives PL_l larger than PL_u ; Müller's treatment, of course, gives $PL_u = PL_l = \frac{TL}{2} = DL$.

Müller's \hbar , the measure of precision for the error curve of r_1 or r_2 ,

¹ R., 51, 97 ff.

can be found from G., 19 f., form. (10) and (12). Fechner's h , the h of our apprehension of D , becomes by Müller's procedure :

$$h = \frac{t_1 + t_2}{2D}$$

Further :

$$TL = 2DL = 2 \frac{(t_2 - t_1)D}{t_2 + t_1} = \frac{t_2 - t_1}{h} ;$$

$$DL = \frac{TL}{2} = \frac{(t_2 - t_1)D}{t_2 + t_1}.$$

These are the h and DL formulæ adopted in the preceding Section.

Fechner goes on to point out that "die Massbestimmungen je nach dem Theilungsprincip I. oder II. nicht sehr verschieden ausfallen können." Thus, for $r=70$, $w=20$, $e=10\%$ we have :¹

	I. (Fechner)	II. (Müller)
h	0.4769/ D ,	0.4830/ D ;
DL	0.2352 D ,	0.2322 D .

He shows in detail later that "die Verhältnisse der Masswerthe h , TL , auf die es bei Massvergleichen ankommt, wirklich in keinem nennenswerthen Grade verschieden ausfallen, mag man die betreffenden Masswerthe nach I. oder nach II. ableiten, wonach selbst wenn II. einen theoretischen Vortheil hätte, man doch nach II. keine Vergleichsresultate gewinnen würde, die irgends erheblich von den, nach I. zu gewinnenden, abweichen."² The proof is couched in terms of his own extensive experiments with lifted weights.³

There follow practical rules for calculation when r or r' is < 0.5 (the formulæ quoted above hold only for r or $r' > 0.5$),⁴ and when $r = n$, or h is infinitely large.⁵ Fechner advises against the introduction of blank experiments : "kurz, man führt durch Einschaltung von Vexirversuchen in die Hauptversuche eine Complication ein, für die bis jetzt keine Elimination gefunden ist."⁶ The most favourable D for practical work is, he says, a D which yields 84% of r (or, in his formulation, of r') cases.⁷

¹ R., 52.

² R., 80, 82.

³ R., 82 : cf. p. 276, above.

⁴ R., 53 f.

⁵ R., 54 f.

⁶ R., 58 ff., esp. 63. Fechner's defence of the procedure with knowledge rests upon one subjective and five objective grounds : 60 f. Fullerton and Cattell (Small *Diffs.*, 117) ignore the former, and cite only one of the latter.

⁷ R., 65. In 1880, Wundt advised a D which should give $r = 50\%$; P. P., i., 331 : so in P. S., i., 1881, 9. In 1887, the method of minimal changes is recommended, in general terms, as a control for "ein angemessenes Verhältniss r . und f. Fälle : " P. P., i., 348. In 1893, the same control is proposed, since D must lie between 0 and the DL , or at greatest be only minimally $> DL$: P. P., i., 356. In 1902 the question is not raised.

As regards the treatment of ϵ -cases, Fechner offers four possibilities.¹ They may be equally divided between r and w (his own procedure I.); they may be separately treated, as disposed uniformly about the ideal centre of TL (Müller's procedure II.); they may be proportionally divided, $\frac{re}{r+w}$ going to the one and $\frac{we}{r+w}$ to the other side; or they may be left out of account altogether.² The two latter modes of distribution need not be seriously considered.³ In the last resort, we must decide for I. and against II.: "es ist ein aprioristischer, ein mathematischer, ein empirischer, und dazu sind es praktische Gründe, welche zum Vorzuge von I. vor II. zusammenstimmen."⁴

The discussion ends with a chapter on the theory of the method. Three ways of deriving the test-values are given. The first is that incorporated by Wundt in the last three edns. of the P. P.;⁵ the second is the simplified Müllerian way;⁶ the third is the way of Müller himself in the G.⁷ Fechner also defends the mathematical exposition of the El. against Müller's attack.⁸—

A word may be said here of the early editions of the P. P. In 1874, Wundt treats the method very briefly. The D. S. is made directly proportional to the value $\frac{1}{D}$, where D is the average R -difference required to give in all cases the same $\frac{r}{n}$. This value, $\frac{1}{D}$, is however not determined in practice. In its place we take the value h , which is "jenem R -Zuwachs D reciprok, also der D. S. direct proportional." The ϵ -cases are distributed in Fechner's way.⁹ In 1880, the text remains substantially

¹ R., 67 ff.² R., 69.³ R., 83 f.

⁴ R., 69 ff. Stumpf remarks (Tps., i., 25): "wenn gefragt wird: sind zwei vorliegende S gleich, ein Intervall rein oder nicht, so ist die Affirmation allemal falsch, die Negation wahr; und wenn sich der Urteilende nach diesen allgemeinen Principien richtete, würde er getrost immer negiren dürfen, um nie fehlzugehen." So Kraepelin (P. S., vi., 495 f.): "rein logisch genommen sind die scheinbaren ϵ -Fälle allerdings 'falsche' Fälle." G. Lorenz (P. S., ii., 1885, 464) actually grouped his ϵ with his w cases: cf. Fechner, P. S., iii., 1885, 35 ff.; Merkel, *ibid.*, iv., 266 ff.; Higier, *ibid.*, vii., 1891, 286. Stumpf and Kraepelin, however, at once go on to say that logic is not psychology. "Wir setzen bei Sinnesurteilen voraus, dass der Urteilende durch den concreten Sinneseindruck determinirt wird. Da wird denn factisch bald auf Gleichheit bald auf Ungleichheit erkannt" (Tps., *loc. cit.*). Stumpf regards Fechner's distribution of the 'unentschiedene' (presumably, then, the d and ϵ) cases, at least under certain conditions of judgment, as "nicht incorrect": *ibid.*, 44.

⁵ R., 86 ff.; Wundt, P. P., i., 1887, 353 ff.; i., 1893, 348 ff.; i., 1902, 483 ff.⁶ R., 94 ff.⁷ R., 97 ff.⁸ R., 101 ff.⁹ P. P., 298 f.

unchanged, except that nothing is said of Fechner's treatment of the e -cases.¹ The proportionality of h to the D. S. is justified by the remark that "durch die D. S. eben nichts anderes als die Genauigkeit der S -Schätzung gemessen werden kann:" experience has also fully borne out the assumption. Müller's procedure is mentioned, and offered as a simple alternative to Fechner's.² In 1887, while the text is still unchanged,³ we have a derivation of Fechner's TL (the first of the three in the R.) and a fuller reference to Müller. The use of h (now replaced by Müller's DL) as a measure of the D. S. is declared to be "wenngleich mit den Beobachtungen in zureichendem Einklang stehend, doch einigermaßen hypothetisch." Müller's treatment, however, "setzt unbedingt eine zureichende Anzahl von e -Fällen voraus, was durchaus nicht in allen Untersuchungsgebieten verwirklicht zu sein pflegt. Fehlen die e -Fälle, so ist übrigens selbstverständlich auch bei der Fechnerschen Behandlungsweise das Gewinnen von DL -Werthen unmöglich."⁴

(2) *Simplified Forms of the Method.*—There are two simplified forms of the method of r . and w . cases: the method of r . and w . answers (Jastrow, Kraepelin), and the method of equal and unequal cases (Merkel).

Fechner had made the suggestion in 1882⁵—and had himself rejected it⁶—"die e -Fälle ganz von der Berechnung auszuschließen und die Berechnung so zu führen, als wenn es bloss r und w gäbe, wonach auch die Totalzahl n der Fälle nicht zu setzen wäre $n = r + w + e$ sondern $n = r + w$." Merkel wrote in 1888: "es würde übrigens nichts hindern, bei den Versuchen zu verlangen, nur die Urtheile r und w abzugeben; die Fechnersche Methode der r und w Fälle mit ihren Schlüssen auf Grund des Präcisionsmasses würde dabei bestehen bleiben, das Müllersche Criterium für die Gültigkeit des Weberschen Gesetzes sich dagegen als völlig nutzlos erweisen."⁷ This proposal is, clearly, different from Fechner's, though it makes towards the same end. Merkel would bar out the e -judgments not only from calculation but also from the record, and so far as might be from consciousness. The same idea was put into practice by Kraepelin. "Alle diese [Vertheilungs-] Schwierigkeiten können . . . nur dadurch, und zwar endgültig, beseitigt werden, dass man die Methode ein

¹ P. P., i., 328 ff. The distribution of e -cases in the El. is mentioned casually in the new paragraph, 333.

² *Ibid.*, 333 f.

³ P. P., i., 346 f.

⁴ *Ibid.*, 353 ff.

⁵ R., 69.

⁶ R., 83 f.

⁷ P. S., iv., 131.

einheitliches Princip, und zwar dasjenige der Ungleichschätzung zu Grunde legt. . . Dieses von mir schon lange angewendete . . . Verfahren läuft darauf hinaus, dass dem *O* die Aufgabe gestellt wird, unter allen Umständen einen der beiden verglichenen *R* als grösser zu bezeichnen. . . Auf diese Weise erhalten wir thatsächlich nur *r* und *w* Fälle, deren weiterer Verwerthung keinerlei theoretische Bedenken mehr im Wege stehen." ¹ H. Higier, working under Kraepelin's direction, published an elaborate investigation of visual distances (bright lines), made in part by the new method, in 1890.²

In the meantime, Peirce and Jastrow had, in 1884, carried out an investigation of pressure by aid of the method of *r.* and *w.* answers. "We have experimented with the pressure sense, observing the proportion of errors [wrong answers] among judgments as to which is the greater of two pressures, when it is known that the two are two stated pressures, and the question presented for the decision of the *O* is, Which is which? From the probability, thus ascertained, of committing an error of a given magnitude, the *PE* of a judgment can be calculated according to the mathematical theory of errors." ³ In 1888, Jastrow gave a full account of the new method, with theoretical discussion and practical illustrations: ⁴ it is now usually called by his name. Fullerton and Cattell employed it, in their work on Small Differences, in 1892.⁵

The great object of the method of *r.* and *w.* answers is to avoid the mathematical complications which arise from the presence of *e*-judgments. "Einen rechnerischen Ausweg," says Kraepelin, ". . . gibt es schlechterdings nicht. Alle vorgeschlagenen Vertheilungsmethoden beruhen auf Voraussetzungen, die bisher nicht bewiesen oder nachweisbar falsch sind und im günstigsten Falle den Effect haben, dass die unbequemen Fälle schliesslich durch einfache Umtaufung aus den Berechnungen verschwinden."⁶ He and Jastrow therefore take the bull by the horns, and instruct *O* that he is not to judge 'equal.' The *R* presented will always be different, though *O* does not know, perhaps, what this *D* is, and certainly does not know in which order the two *R* will be given. If *O*

¹ P. S., vi., 496.

² Diss., Dorpat. Also P. S., vii., 247.

³ C. S. Peirce and J. Jastrow, Small Differences of Sensation: Mem. Nat. Acad. Sci., iii., 1, 1885 (1884), 76.

⁴ Amer. Journ. Psych., i., 277 ff., 305 ff.

⁵ *Op. cit.*, 15 f.

⁶ P. S., vi., 496.

cannot perceive a D , he is to make a guess: there must be no e -cases. Neither, Jastrow insists, must there be any d -cases.¹ Higier follows Jastrow on this point:² Fullerton and Cattell halve their occasional d -cases between r and w .³ Sanford approves this procedure "if for any reason a few d -answers cannot be avoided," but he thinks it better "not to allow them at all."⁴ "Wie ich aus eigener Erfahrung versichern kann," declares Kraepelin, "stösst die praktische Durchführung solcher Versuche bei einiger Uebung auf keine nennenswerthen Schwierigkeiten."⁵

What, now, of the measure of the D.S.? Jastrow says that "there is no characteristic point on the curve [of errors] evidently appropriate for the standard of sensibility; hence the choice of such a point must be made on grounds of convenience and simplicity. The standard of sensibility that I now propose is that ratio of the two R (or rather that ratio less one) with which, one-half of the answers being correct by chance, one-half of the remaining one-half of the answers will also be correct,—*i. e.*, when *one* error occurs in every *four* answers. The reason of this choice is that this ratio measures the PE ."⁶ Thus, let $r_1=1$, and $r_2=1+x$. Then "if I find as the result of 1000 experiments with two weights 200 and 210 gr. that 250 of the answers are w (or calculate from an equivalent set of experiments that at this ratio of R that proportion of answers would be w), the sensibility of the pressure sense in this case is $\frac{1}{2^0}$." For the ratio $1:1+x$ is here 200:210 or $1:1+\frac{1}{2^0}$; hence $x=\frac{1}{2^0}$. "If in a following series of experiments I find 250 mistakes when the R -values are only 200 and 208, then the sensibility has improved from $\frac{1}{2^0}$ to $\frac{1}{2^5}$."⁷ Fullerton and Cattell accept this suggestion of the PE as the measure of the D.S. afforded by the method, and work out the correlation of $\frac{r}{n}$ with $\frac{D}{PE}$ from the formula:⁸

$$\frac{r}{n} = \frac{1}{2} + \frac{1}{\sqrt{\pi}} \int_0^{t=\frac{D}{PE}} e^{-t^2} dt.$$

Since $PE = \frac{0.4769}{h}$, the correlation is given at once by division of the value of $t = hD$ in Fechner's Fundamental Table by 0.4769. We thus obtain:⁹

¹ A. J. P., i., 282 ff.

² P. S., vii., 247.

³ Small Diffs., 59 ff., 120 ff., 138 ff.

⁴ Course, 357.

⁵ P. S., vi., 496, 505; Higier, *ibid.*, vii., 276.

⁶ *Loc. cit.*, 286.

⁷ *Ibid.*, 286 f.

⁸ Small Diffs., 15 f.

⁹ Small Diffs., 16. The Table is also printed by Sanford, Course, 354.

$\frac{r}{n}$	$\frac{D}{PE}$	$\frac{r}{n}$	$\frac{D}{PE}$	$\frac{r}{n}$	$\frac{D}{PE}$	$\frac{r}{n}$	$\frac{D}{PE}$	$\frac{r}{n}$	$\frac{D}{PE}$
0.50	0.00	0.60	0.38	0.70	0.78	0.80	1.25	0.90	1.90
0.51	0.04	0.61	0.41	0.71	0.82	0.81	1.30	0.91	1.99
0.52	0.07	0.62	0.45	0.72	0.86	0.82	1.36	0.92	2.08
0.53	0.11	0.63	0.49	0.73	0.91	0.83	1.41	0.93	2.19
0.54	0.15	0.64	0.53	0.74	0.95	0.84	1.47	0.94	2.31
0.55	0.19	0.65	0.57	0.75	1.00	0.85	1.54	0.95	2.44
0.56	0.22	0.66	0.61	0.76	1.05	0.86	1.60	0.96	2.60
0.57	0.26	0.67	0.65	0.77	1.10	0.87	1.67	0.97	2.79
0.58	0.30	0.68	0.69	0.78	1.14	0.88	1.74	0.98	3.05
0.59	0.34	0.69	0.74	0.79	1.20	0.89	1.82	0.99	3.45

Fullerton and Cattell employ the method of r . and w . answers in experiments on extent¹ and force of movement,² lifted weights³ and lights.⁴

Kraepelin discusses Jastrow's proposal of the PE as measure of the D.S., without committing himself to its adoption.⁵ Higier says nothing at all of the proposal. He utilises his results⁶ to examine (1) the influence of various eliminable sources of error (practice, fatigue, spatial position, etc.); (2) the constancy of the $r\%$ with relatively equal D ; (3) the deviations of his hD -curve from that of Fechner's Fundamental Table; (4) the constancy of the product of D into Fechner's h , and of r_1 and r_2 into Müller's h and h' ; (5) the course of the PE of the different R and D ; (6) the amount of agreement with the variable and constant errors of the method of av. error, which he also employed; (7) the possibility of a calculation of the j . n. and j . u. R -difference; and (8) the probable sources of the constant errors. Higier also made experiments by the classical method of r , w and e cases, in order (9) to gain an experimental basis for the distribution of the e -judgments. He considers the principles of proportional, equal (Fechner) and unequal (Müller) distribution, and decides, on the whole, in favour of the second.⁷

We turn now to some criticisms of the method. Merkel, who had

¹ *Ibid.*, 59 ff. A few d -cases occurred.

² *Ibid.*, 77 ff. Results from the method of j . n. d. are transformed into r and w cases.

³ *Ibid.*, 120 ff. The d -cases are halved between r and w .

⁴ *Ibid.*, 138 ff. The d -cases are treated as before.

⁵ P. S., vi., 510 f. Merkel condemns it: P. S., vii., 629.

⁶ P. S., vii., 233, 246, 248. Higier combined Jastrow's method of r . and w . answers with the Wundtian principle of minimal changes, and from the resultant method derives two test values, "einen Procentsatz r -Fälle resp. sein Präcisionsmass und einen eben merklichen R -Unterschied." For the test-value of av. error he uses the mean variable error: 233, 237.

⁷ *Ibid.*, 274 ff.—It may be remarked that another pupil of Kraepelin's, E. Löwenton, employed Jastrow's method in his *Versuche über das Gedächtniss im Bereiche des Raumsinnes der Haut*; Diss., Dorpat, 1893, 25. See A. Wreschner, Z., viii., 1895, 142 ff. The method is also approved by Foucault (*Psychophysique*, 387 f.), whose reasoning, however, can hardly be taken seriously.

suggested it in 1888, is strongly opposed to it in 1892. He gives three reasons. (1) "Wir werden auch bei Ausschluss der ϵ -Fälle trotz angestrengter Aufmerksamkeit in einzelnen Fällen einen D nicht wahrnehmen, aber gezwungen einen solchen festzustellen werden wir bald r , bald w urtheilen. Wir überlassen also die ϵ -Urtheile dem Gesetz der Wahrscheinlichkeit. Da dasselbe nur bei grösseren Zahlen zutrifft, so unterliegt der Ausschluss dieser Urtheile Bedenken." (2) "Angenommen, wir stellen Versuche mit positiven Zulagen an. In diesem Falle wird die Zahl der r -Fälle mit der Zunahme der Zulage wachsen. Gestattet sind nur die Urtheile r und w . . . Wie leicht wird man da geneigt sein, einen Fall, in welchem ein D nicht erkannt wird, zu den falschen zu zählen!" (3) "Bei Ausschluss der ϵ -Fälle ist man geneigt, bei kleinen D , bei denen ja die Auffindung des Unterschieds schwieriger ist, mit verstärkter Aufmerksamkeit zu beobachten. Man erhält dann bei den kleinen Zulagen relativ zu viel r -Fälle." Merkel finds these objections confirmed by his own and Higier's experimental results.¹

There are other dissentient voices. Ebbinghaus terms the Jastrow method a "Vergewaltigung des Urtheils." "Natürlich ist es von Wert, dass neben manchen anderen Modalitäten gelegentlich auch einmal untersucht werde, wie sich das Urteil verhält, wenn ihm die Gleichheitsaussagen untersagt werden, aber zu einer Verallgemeinerung dieses die Brauchbarkeit der Resultate vermindern und dazu als Zwang empfundenen Verfahrens besteht nicht die mindeste Veranlassung."² Wundt remarks that "dieses Verfahren unterwirft das Urtheil einem Zwang, der die Gleichmässigkeit der Beobachtungen in unberechenbarer Weise stören muss:" he also repeats Merkel's objection that a very large number of experiments is necessary.³ Wreschner writes in 1898: "nun mag ja die Verwertung der ϵ -Fälle . . . einige Schwierigkeiten bieten; aber nicht diese, sondern eine den thatsächlichen Verhältnissen der inneren Wahrnehmung entsprechende Beurteilung darf doch allein massgebend sein."⁴ Müller declares, in the *M.*: "Dieses Verfahren ist durchaus verwerflich, weil es Aussagen der Versuchsperson erzwingt und in Rechnung stellt, die dem psychischen Sachverhalt (der tatsäch-

¹ P. S., vii., 569, 586 f. 629. Cf. P. S., ix., 1893, 197. "Handelt es sich . . . um die Vergleichung zweier S hinsichtlich ihrer Intensität, so muss man die Fähigkeit haben, dieselbe als gleich oder verschieden zu bezeichnen, wenn der unmittelbare erste Eindruck dieses oder jenes Urtheil nahelegt." The whole passage, 195-198, is interesting, and might well be made the subject of an essay.—On the first objection, cf. also Külpe, *Outlines*, 64, 73.

² *Z.*, ii., 1891, 450. So Kämpfe, P. S., viii., 1893, 513, 554, 578.

³ P. P., i., 1893, 354. The method is not mentioned in 1902.

⁴ *Methodologische Beiträge zu psychophysischen Messungen*, 1898, 31 f. Cf. the author, in *A. J. P.*, ix., 1898, 593.

lichen Unentschiedenheit des Falles oder dem vorhandenen Eindruck der Gleichheit) direkt widersprechen, und die Versuchsperson statt zur Gewissenhaftigkeit zur Gewissenlosigkeit erzieht."¹

We are here in face of one of those dilemmas that so often confront and puzzle the beginner in experimental psychology. Kraepelin, Jastrow, Cattell and Sanford approve the simplified method; they declare that it offers "verhältnissmässig sehr geringe subjective Schwierigkeiten." Merkel, Ebbinghaus, Wundt and Müller disapprove it; they declare that it puts a constraint upon judgment. And all eight are honourable men. What is one to do? Well! The crucial questions are: What is the motive that prompted the simplified method? and: What object does the method propose to itself? Now (*a*) there seems to be no doubt that the motive underlying the formulation of the new method is the desire to avoid the necessity of a choice between the Fechner and Müller formulæ. The *u*-judgments (*e* and *d* cases) are regarded as offering insuperable difficulties to mathematical treatment. So the knot is cut, and the tangled bits of the rope are simply thrown away. A little more patience would have brought out the fact that the upper and lower *DL* and their corresponding *h* may be determined, and accurately determined, without any mathematical or other manipulation of the *u*-judgments (Müller, M., 57 *u.*). Hence the motive to the simplified method must be characterised as unscientific. It is a motive that, in default of their own confession, we should hardly venture to ascribe to scientific psychologists. (*b*) The object of the method seems equally clear: it is intended to replace the regular method of *r.* and *w.* cases in general psychophysical procedure. This, however, it cannot possibly do. Doubtful and equal judgments do naturally occur; they are attested by introspection, and by the introspection of competent *O*'s. If, then, we are dealing with mind as mind presents itself to us for examination, we cannot ignore these judgments. We smile at the constructions of the older associationist psychology, for which, *e.g.*, recognition meant always the revival of a memory image and the comparison of that image with the datum of perception. Yet the mind of the simplified method is every whit as artificial, every whit as schematic. Our primary task, as psychologists, is to discover the processes of consciousness, not to force those processes into our own ready-made channels.

If the reader accept these arguments, he is still (be it noted) at full liberty to consider the Jastrow method as, under certain circumstances, a valuable method. It is of the essence of an experiment to vary the conditions of observation. When we have recorded and quantified the natural course of mind, it may be of great interest to put consciousness

¹ M., 15, 57 ff., 84.

in a strait-waistcoat, and see what happens. In a word, there may well be room in psychophysics for the method of *r.* and *w.* answers, alongside of (and subsidiary to) the method of *r.* and *w.* cases, as there is surely room for many another method as yet unthought of. No weight of authority can banish the one and exalt the other; the questions that they answer are different questions.¹ Only, in the author's opinion, the Jastrow method meets but one of several special cases of restricted judgment, and can lead to valid results solely by way of comparison with the rest. At any rate, since the Vierordt-Fechner-Müller method fulfils general introspective requirements, it must always take the precedence in a general exposition of the psychophysical methods.²

Merkel, impressed (as were Kraepelin and Jastrow) by the difficulties arising from the *e*-cases of the regular method,³ proposed in 1888 his alternative method of equal and unequal cases.⁴ He first employs the method of minimal changes for the determination of a *DL* (Wundt's Δr_0). The two stimuli *r* and $r + \Delta r_0$ are then taken as the r_1 and r_2 of the regular method of right and wrong cases. *O* is required to say whether r_2 is greater than r_1 or not. In the former case, his judgment is registered as *u*, in the latter as *e*. If *d*-judgments occur, they are divided proportionally between *u* and *e*.⁵ It is clear that the resultant *u* correspond to the *r* cases, and the *e* to the *e* and *w* cases of the original method. The principal object of the method of equal and unequal cases is to furnish a *DL*. For this end, one set of determinations is not sufficient. Either one makes a number of experiments with different *D*, and then finds the $D = DL$, *i.e.*, the point at which $\frac{u}{n} = \frac{1}{2}$, by graphic interpolation; or one uses two different values of *D*, and calculates the value of $D = DL$ by a special

¹ Cf. Stumpf, *Tps.*, i., 44 *n.*; and the general statement of the object of psychophysical experiments, 55.

² There is no justification whatever for saying, as Witmer does (*Anal. Psych.*, 215), that "the amount of difference sufficient to give 75% of *r* judgments is usually regarded as the *j. n.* amount of difference."

³ *P. S.*, vii., 587.

⁴ *P. S.*, iv., 257 ff.; vii., 606 ff.; *Z.*, v., 1893, 99 f.; *Aufgaben u. Methoden d. Psychologie in d. Gegenwart*, 1895, 16 ff. See also Wundt, *P. P.*, i., 1893, 354 f.; i., 1902, 489; Kraepelin, *P. S.*, vi., 497 f.

⁵ *P. S.*, vii., 607. Foucault (*Psychophysique*, 1901, 395) makes Merkel halve them: but this is the earlier procedure of *P. S.*, iv., 259.

formula. The measure of precision is found by the procedure followed in the regular method.

Merkel's method has not been taken seriously by later experimenters.¹ Indeed, it had no real reason for existence, when once Merkel had satisfied himself that the ordinary method of *r.* and *w.* cases could be handled mathematically,²—unless, of course, we raise the previous question regarding the method at large.³ We need do no more here, therefore, than give the derivation of the test-values in Merkel's own words.

"The method of *r.* and *w.* cases leads at times, even with comparatively small values of *D*, to miscarriages, in which either the *r* or the *w* cases fail to appear. If we try to avoid such miscarriages by decreasing the *e*-cases or by increasing the concentration of attention, we alter the value of the *DL*. These considerations impelled me to work out the method or *e.* and *u.* cases. The method allows us to experiment under normal conditions of attention, and affords the simplest and least objectionable means of determining the *DL*. . . The probable errors and the measures of precision of r_1 and r_2 are to be found by the preceding formulæ.⁴ If we have made experiments with a series of *D*-values, we determine the value $D=DL$ most simply by graphic representation of the results and interpolation; the value corresponds to the point $\frac{u}{n}=\frac{1}{2}$. We thus

obtain the differences $D-DL$. By help of the formulæ $h=\frac{t_1}{D-DL}$ and $h'=\frac{t_2}{D-DL}$, where t_1 and t_2 correspond to the number of *u*-cases, we also obtain the values of h and h' . If we make experiments with two different *D*-values ($r_2=r_1+D_1$, $r_3=r_1+D_2$), we can employ the approximative value $A=\frac{h_1}{h_2}=\frac{r_1+r_3}{r_1+r_2}$ to calculate the *DL* from the formula: $DL=\frac{At_2D_1-t_1D_2}{At_2-t_1}$. The determination of the *DL*, which is to be looked upon as the principal problem of this method, and which can be carried

¹ Kraepelin, P. S., vi., 501; Merkel, P. S., vii., 569. Müller (M., 94) calls it "eine verkrüppelte Form der Methode der konstanten Unterschiede, der eine falsche Auffassung dieser letzteren Methode zu grunde liegt."

² P. S., vii., 585 ff.

³ As Külpe does, *Outlines*, 74. "This modification of Merkel's is, psychologically regarded, an improvement upon the method of *r.* and *w.* cases as ordinarily understood. Besides which, it does away with the inappropriate and misleading terms 'right' and 'wrong' . . . Unfortunately, the procedure is not worked through with logical consequence. . . It still leaves open the question of the relation of the direct to the indirect sensitivity and sensible discrimination, and so fails to meet the objections urged against the applicability of the law of error." Cf. Stumpf, *Tps.*, i., 64 f.

⁴ Z., v., 99.

out with great accuracy, corresponds to the determination of the point of equality in the method of *r.* and *w.* cases."¹

For applications of the method, see Merkel, P. S., iv., 1888, 261 ff., 275 ff.; viii., 1892, 110 ff. The method itself, with Müller's critique (M., 93 f.), may be made the subject of an essay.

(3) *Merkel.* In 1892, Merkel revives the whole question of the validity of the method of *r.* and *w.* cases. He discusses in detail the nature of the elementary errors, their magnitude, the relative frequency of their occurrence and coincidence, and the general problem of the application of probability formulæ to judgments of *D* passed under the conditions of the method.² The merit of the discussion is that it justifies and makes explicit the principle of distribution of the *e*-cases which in Müller's formulæ is merely implicit, and which had been rejected by Fechner in the *R.* We must not, with Fechner, halve the *e*-cases, assigning them in equal numbers to *r* and *w*, but must halve the zone or region over which, according to Gauss' Law, they are distributed. Merkel accordingly looks up in Fechner's Fundamental Table the t_1 corresponding to $\frac{r}{n}$ and the t_2 corresponding to $\frac{r+e}{n}$, and determines the arithmetical mean $\frac{t_1+t_2}{2}$. He then looks up the value of $\frac{r'}{n}$ corresponding to this average *t*, and finds $n\left(\frac{r'}{n}-\frac{r}{n}\right) = r'-r=e'$, the number of *e*-cases that are to be counted to the *r*.³

Merkel rejects Müller's $DL = \frac{(t_2-t_1)D}{t_2+t_1}$, on the ground that it varies with the value of *D*.⁴ He puts in place of it:

$$PL_u = \frac{r_1 \cdot DL}{r_1 - c},$$

$$PL_l = \frac{r_1 \cdot DL}{r_1 + C + D},$$

¹ *Ibid.*, 99 f.; P. S., iv., 289. The *h* and *h'* are the Fechnerian measures of precision for two different *D*; the h_1 and h_2 are Müllerian measures of precision for different *r*. Cf. *ibid.*, 130, 148.

² P. S., vii., 571 ff. It is unfortunate that Merkel, in the derivation of his formulæ, throughout assumes the validity of Weber's Law.

³ P. S., vii., 598; Wundt, P. P., i., 1893, 352 f.; i., 1902, 487.

⁴ P. S., vii., 594; Z., v., 98. Cf. Wundt, *opp. citt.*, 353 and 488. The point here at issue might be given as a question to a student with mathematical interests.

where C is the range of distribution of the positive, c that of the negative errors, and DL is Müller's value $\frac{(t_2 - t_1)D}{t_2 + t_1}$. These equations may be written, approximatively:

$$PL_u = \frac{2r_1 \cdot DL}{2r_1 + D - DL}$$

$$PL_l = \frac{2r_1 \cdot DL}{2r_1 + D + DL}$$

Finally, h , the measure of precision, is determined as $\frac{t_1 + t_2}{2D}$.

The derivation of these equations will be found in P. S., vii., 585 ff.; see esp. 593 and 599. The way in which they are to be used, for the verification of Weber's Law, is indicated in P. S., viii., 1892, 100 ff.

Merkel's distribution of the e -cases is accepted by Kämpfe: P. S., viii., 1893, 520. Kämpfe employed the procedures with knowledge, with part-knowledge, and without knowledge (536). He finds that Müller's DL is available as a test-value only in the procedure with knowledge (563 ff.), and therefore has recourse to Fechner's h as a general measure of the D.S. (566 ff., 571), though he recognises the fact that h is a measure of the delicacy, DL of the magnitude, of the D.S. (571 f.: cf. 589). Müller shows, however, that Kämpfe's abnormal series are due simply to his conduct of the experiment, which carried a false suggestion to the O : L. J. Martin und G. E. Müller, Zur Analyse der Unterschiedsempfindlichkeit, 1899, 178 f.; cf. Müller, M., 54, 85 f., 89, 100 ff., 107; Lipps, Massmethoden, 61 f. n. (Arch., iii., 213 f.).

(4) *Bruns, Mosch.*—Bruns¹ remarks, in 1893, that there is an obvious disparity between the amount of experimental material collected by Kämpfe² and his mathematical treatment of the results. The fact is that psychophysicists have not availed themselves of the standard methods for adjusting measurements that are regularly employed in physics and astronomy. If this defect is made good, "die vielerörterte Frage, wie man die e -Fälle auf die beiden anderen Urtheilsklassen zu vertheilen habe, ist . . . von vorn herein abgeschnitten. Die ganze Frage ist übrigens lediglich dadurch entstanden, dass man von zwei möglichen Wegen immer nur den einen und zwar den weniger zwackmässigen eingeschlagen hat."³ Bruns accordingly works out a new

¹ P. S., ix., 1.

² P. S., viii., 511 ff.

³ P. S., ix., 50.

set of formulæ, which "den Ansatz für die Methode der r. und f. Fälle enthalten."¹ We cannot here reproduce the derivation of these formulæ. We may, however, lessen the strangeness of their appearance by throwing the formulæ of Fechner and Müller into similar form.

Fechner's original formula is, as we have seen :

$$\frac{r + \frac{e}{2}}{n} = \frac{1}{2} + \frac{i}{\sqrt{\pi}} \int_0^{hD} \frac{e^{-t^2}}{\pi} dt.$$

From it he determines hD , and thence h , which he regards as the measure of the D.S. Now let $r = Rn$, $e = En$, $w = Wn$, and

$$\frac{2}{\sqrt{\pi}} \int_0^x e^{-y^2} dy = \Phi(x),$$

so that R , E and W denote the relative frequencies of the three judgments $D > 0$, $D = 0$, $D < 0$. Then Fechner's formula reads :

$$R + \frac{1}{2}E = \frac{1}{2} + \frac{1}{2}\Phi(hD),$$

or

$$2R + E - 1 = \Phi(hD).$$

Müller, on the other hand, arrives at the formulæ :

$$2R - 1 = \Phi[h(D - DL)],$$

$$2(R + E) - 1 = \Phi[h(D + DL)],$$

from which he calculates h and DL , the difference limen which measures the D.S. Bruns, now arranges the three judgments $>$, $=$, $<$ upon an axis of abscissas upon which the values of D in both directions from 0 are also represented. The $>$ -judgments then occupy a certain upper zone from $+\infty$ to x_0 , the $=$ -judgments a certain middle zone from x_0 to x_u , and the $<$ -judgments a lower zone from x_u to $-\infty$. If the law of error is denoted in general by $\phi(x)$, and if we make

$$\psi(x) = \int_0^x \phi(y) dy,$$

Bruns finds, by the laws of the calculus of probabilities, the three formulæ :

$$R = \psi(\infty) - \psi(x_0 - D),$$

$$E = \psi(x_0 - D) - \psi(x_u - D),$$

$$W = \psi(x_u - D) - \psi(-\infty),$$

which are not independent of one another, but connected by the

¹ *Ibid.*, 49.

relation $R + E + W = 1$. The form of the law of error is, so far, left entirely indeterminate. If we assume, with Fechner and Müller, that Gauss' Law is here valid, and employ our former symbol $\Phi(x)$, we may write these equations:

$$\begin{aligned} 2R - 1 &= \Phi[h(D - x_o)], \\ 2E &= \Phi[h(D - x_u)] - \Phi[h(D - x_o)], \\ 1 - 2W &= \Phi[h(D - x_u)], \end{aligned}$$

one of which, however,—let it be the middle one,—is superfluous. If the remaining two are compared with Müller's formulæ, it will be seen that these can be derived from them by the substitution of x_o and x_u for DL and $-DL$. Bruns has therefore brought us, by a path which avoids the difficulty of the distribution of e -judgments, to the point to which we were led by Müller and Merkel.¹ His procedure has the further advantage that it does not commit us to Gauss' Law; if the formulæ do not work in practice, Gauss' Law may be replaced by some form of the law of error which is adequate to the results of experiment.

The formulæ were tested by Mosch, in 1898, with negative result.² Unfortunately, the character of Mosch's work is not such that the test can in any way be regarded as conclusive.³ It is, indeed, one of the most puzzling as well as one of the most regrettable features of this whole psychophysical development that the material amassed since 1878 for the empirical verification of Müller formulæ is altogether inadequate.⁴ At the same time, the question whether Gauss' law is valid under the conditions of r . and w . cases, or whether we are to find some more general law of the distribution of errors, which shall take its place, is a question which, once asked, must be borne in mind by all future investigators.⁵

¹ Bruns, P. S., ix., 7, 46 ff.; Mosch, P. S., xiv., 494 ff.

² P. S., xiv., 517 f., 519.

³ Müller, M., 87 ff., 107.

⁴ *Ibid.*, 88 f. Formulæ in this field must (1) be logically correct, *i. e.*, must be logically deducible from the presuppositions of the method, so that the values h and DL to which they lead shall really possess the significance ascribed to them. In this sense, Fechner's formulæ are incorrect, Müller's correct. The formulæ must also (2) be correct in the sense that they are adequate to the empirical data; that their application leads to a sufficient agreement between calculated and observed values. It is the latter point that is now under discussion. See M., 102; and *cf.* Lipps, *Massmethoden*, 59 (*Arch.*, 211); *Arch.*, 40 f.

⁵ M., 89. *Cf.* Pfl. *Arch.*, xix., 1879, 209.

Fechner himself, in his posthumous work *Kollektivmasslehre*,¹ had found it necessary to generalise and extend Gauss' law, in order to cope with cases of asymmetrical distribution of deviation from the mean. Bruns, in 1898, attacks the same problem with better mathematical equipment, and develops a generalised law of distribution which takes the form of a sum of derivations of Gauss' transcendental, multiplied by certain unknown constants.² This law is employed by Mosch.³ "Es zeigte sich dass dieses Gesetz in der That in Stande ist, jenen regelmässigen Verlauf der Widersprüche zu einem unregelmässigen zu gestalten, dass also das verallgemeinerte Vertheilungsgesetz den Thatsachen der Beobachtungen besser Rechnung trägt als das einfache Gauss-sche."⁴ Nevertheless, the outcome of Mosch's investigation is, on the psychological side, very scant. He thinks that the measure of precision, h ,—or, as he prefers to put it, the measure of uncertainty, U , = $\frac{1}{h}$ or the modulus,—has nothing at all to do with the D.S.: it is, however, probably conditioned by psychological factors, chief among which is the fluctuation of attention.⁵ Whether the values x_o and x_u can be employed to measure the D.S., he leaves altogether undecided.⁶

(5) *Back to the Cases!* It could hardly be said, in the light of the foregoing paragraphs, that in the late nineties the outlook for the method, mathematical or psychological, was very promising. The statement made confidently by Ebbinghaus in 1891: "mit den Gleichheitsurtheilen ist . . . alles in bester Ordnung"⁷ would certainly not have commanded any general assent. The method stood in sore need of reconstruction: there was no recognised norm of procedure; the constant errors lay very much as Fechner had left them; the new formulæ proposed from the mathematical side were too complicated for use by non-mathe-

¹ Ed. by G. F. Lipps, 1897, 55 ff.

² P. S., ix., 355 ff. Müller, M., 90 ff.

³ *Ibid.*, 527.

⁴ *Ibid.*, 549.

⁵ *Ibid.*, 542, 546 f., 549.

⁶ *Ibid.*, 545 f., 547 f., 549. For criticism, see Müller, M., 86 ff., 91. In a later paper (P. S., xx., 1902, 218) Mosch declares that "das Gauss'sche Fehlergesetz in der Psychophysik mit grosser Annäherung gilt."

⁷ Z., ii., 450.

maticians; the psychological interpretation of the test-values was regarded, by competent workers, as very uncertain.¹ Interest in the method had never died out; but the student with an ordinary psychological equipment might well have been pardoned for avoiding it.

There are, now, certain writers who have confined themselves to a simple statement of the r , w and e cases, which are presented for the reader's inspection without any sort of mathematical treatment. This procedure is followed, *e.g.*, by Stumpf, in his work on the cognition of tonal pitch.² We find it employed also by Luft³ in 1888, by Meyer⁴ in 1898, and by Stumpf and Meyer⁵ in 1898.

It is probably in the same spirit that Ebbinghaus, in 1897, proposes to assimilate the problem of r . and w . cases to the problem of *min. ch.* "We must not merely ask: is this R , as compared with this other, greater, equal or smaller? but, more exactly: is this R *j. n.* different from this other, or indistinguishable from it, or is the difference so large and clear that it seems capable of further reduction before disappearing altogether? The judgments that O has at his disposal must therefore be: equal, *j. n.* greater, clearly greater, and—if we work with values below the normal R —*j. n.* smaller and clearly smaller: in this last case, then, five in all. If the judgments are couched in these more accurate terms (and there is no particular difficulty in giving them), and if further the $\pm D$ employed in the experiments are increased by constant increments up to the point at which judgments of *j. n. d.* cease to occur, so that the extreme D are clearly cognised, then the determination of the *j. n. d.* from the recorded judgments is an easy matter. We take the total number of e and the total number of *j. n. >* (or *j. n. <*) judgments, find the average values of the corresponding R , and determine their difference. This is the *j. n. d.* required. The judgments 'clearly $>$ ' and 'clearly $<$ ' do not come into account, by reason of their inde-

¹ It is worth remarking that Wundt, in 1902, closes his psychological account of the method with a reference to Kämpfe. Bruns and Mosch are mentioned only in connection with the 'theory' of the method (P. P., i., 475, 482 ff.). This seems to mean that Wundt does not regard the generalised law of Bruns as ripe for discussion, on the psychological side.

² P. S., iv., 355 ff.

⁴ Z., xvi., 356 ff.

² Tps., i., 1883, 313 ff.

⁵ Z., xviii., 333 ff.

terminateness; they simply serve to delimit the judgments of j. n. d. above and below.”¹

In 1898, Wreschner published the results of an investigation with lifted weights, which he carried out by a method closely resembling this of Ebbinghaus. Fifteen standard weights were employed, lying between the limits 200 and 8000 gr. Each of these was compared with as many variable weights as sufficed to bring out judgments ranging from ‘much greater’ to ‘much less.’ The variables differed from their standard W by 0.05 W or multiples of 0.05 W . Ebbinghaus’ requirement of continuous and uniform gradation of the $\pm D$ is thus fulfilled. The recorded judgments were ‘equal,’ ‘less,’ ‘greater,’ ‘much less’ and ‘much greater.’ At first, four other classes were admitted: ‘equal or less,’ ‘equal or greater,’ ‘nearly much less’ and ‘nearly much greater.’ In practice, however, the five proved to be sufficient.

Wreschner uses his results, in the first place, to measure the ‘reliability’ of judgment, *i. e.*, “die Aussichten, welche eine einmalige S oder deren Beurtheilung hat, in einem Wiederholungsfall, der unter möglichst gleichen Versuchsbedingungen stattfindet, bestätigt zu werden.” Reliability is expressed “durch das gegenseitige Verhältniss von Bestätigungen und Nichtbestätigungen oder, bei stets gleicher Wiederholungszahl, durch die Anzahl der Bestätigungen der einmaligen S bzw. ihrer Beurtheilung.” Within a given category of judgments, maximal reliability corresponds to the maximal ordinate of a curve whose abscissas are the variable weights which evoked the judgment in question, and whose ordinates are proportional to the number of judgments passed.² Secondly, in order to trace the course of the D.S., Wreschner proposes “die Zuverlässigkeit in ihrer Beziehung zu dem objektiven D zu betrachten, also die Schwere der zu den einzelnen Graden der Zuv. gehörigen Fehlgewichte, ferner die Differenzen in den Bestätigungszahlen je zweier der Schwere nach benachbarter Fehlgewichte zu berücksichtigen.”³ Namentlich jedoch wird es sich empfehlen, alle zu einer Kurve gehörigen Einzelwerte auch einmal durch einen einzigen Wert auszudrücken, und daraufhin die Wandlungen der D.S. zu verfolgen. Ein derartiger Wert aber ist der *Zentralwert*, d. i. das arithmetische Mittel aus allen Urteilen einer bestimmten Art [more correctly, of all the variable weights corresponding to these judgments], der noch genauer als der Maximalwert dasjenige Fehlgewicht

¹ Psych., i., 74.

² Methodologische Beiträge zu psychophysischen Messungen, 25 f., 46 ff., 91 ff., 184 ff., 213 ff.

³ *Ibid.*, 26, 54 ff., 95 f., 192 ff., 217 ff. The procedure is approved by Marbe, Z., xx., 1899, 184.

angiebt, welches die meisten Chancen hat, im Sinne einer betreffenden Urteilsart beurteilt zu werden."¹ Thirdly, Wreschner seeks to determine, by comparing the ascending and descending branches of the curves representing the distribution of the various classes of judgments, the clearness or distinctness with which these classes are discriminated.²

Wreschner's work was done under Ebbinghaus' direction, and Ebbinghaus "gab für die Methode der Verrechnung sehr viele und wertvolle Anregungen."³ It is clear, therefore, that Ebbinghaus must have had this investigation in mind when he wrote the passage quoted from the *Psych.* It is true that Wreschner does not use the forms of judgment 'j. n. greater,' 'j. n. less.' He did, however, at the beginning of his experimentation, call for judgments of 'equal or greater' and 'equal or less.' These categories were presently dropped, since the *O*'s had less and less recourse to them as the experiment advanced, and since with *D*'s of 0.05 *W* the five principal categories answered all the demands of introspection.⁴ It is true, again, that Wreschner does not calculate the *DL* in Ebbinghaus' way. He takes what he calls the 'central value,' divides it by the number of hundreds in the standard weight, and enters the quotient in the Table of values which he employs to test the validity of Weber's Law.⁵ Still, these 'central' values are Ebbinghaus' average *R*, and the required subtractions are easily performed. Indeed, we find Ebbinghaus himself asserting, later in the *Psych.*, that Wreschner found a constancy of the relative *DL*, between the limits 2000 and 6000 gr., at approximately $\frac{1}{3}$ (i., 1902, 371 f.). There can be no doubt, then, that Wreschner's method of 'fields of judgment' is identical with Ebbinghaus' reformed method of r. and w. cases. The keynote of the method is the return from mathematics to psychological empiricism.

Ebbinghaus' procedure is discussed by Müller, M., 160 ff. Müller appears to think that the method given by Wundt, P. P., i., 1902, 478 f. is a transcript of Ebbinghaus' method. This cannot, however, be the case, since the passage occurs also in the P. P. of 1893, i., 344. Müller's criticism (162) remains valid.

Wreschner's monograph is subjected to a severe criticism by Martin and Müller, U. E., 3 f., 140 ff. The points urged against Wreschner are, no doubt, well taken, though it would have been more generous had the writers also emphasised the good features of the research (*Scripture, Psych. Rev.*, v., 1898, 441 f.; *Titchener, A. J.*, ix., 1898, 591 ff.). Further criticism is given in Müller, M., 155 f., 162 f.

We have, lastly, to mention in this connection the work Zur

¹ *Ibid.*, 26 f., 221 f.

² *Ibid.*, 27, 61 ff., 96 ff., 195 ff., 219 ff.

³ *Ibid.*, 227.

⁴ *Ibid.*, 11 f.

⁵ *Ibid.*, 222.

Analyse der Unterschiedsempfindlichkeit, by L. J. Martin and G. E. Müller.¹ These authors admit that "trotz des psychologischen Charakters, den alle Untersuchungen nach der Methode der constanten Unterschiede in mehr oder weniger hohem Grade besitzen, eine sachgemässe Auffassung und Behandlung der Versuchsergebnisse nicht anders möglich ist als auf Grund einer gewissen fehlertheoretischen Einsicht."² They themselves, however, dispense with any "nähere fehlertheoretische Ausprägung mancher Konsequenzen und Vorschriften, die sich aus den . . . gewonnenen Resultaten und Anschauungen ergeben," partly because their qualitative methods and results are novel, and, being novel, are necessarily incomplete, partly also because they do not think their readers would understand them.³ It would, however, be a great mistake to suppose "dass die psychologische Complicirtheit dieses Erscheinungsgebietes das fehlertheoretische Denken ausschliesse; sie schiebt das letztere nur etwas zurück."⁴ First of all, we must have qualitative analysis: we must raise the questions "ob es neben dem bekannten Einflusse der Raum- und Zeitlage nicht noch andere constanten Faktoren giebt, welche die Resultate in einseitiger Weise bestimmen; ob der Maassstab, der beim Urtheilen über die gegebenen Eindrücke angewandt wird, hinlänglich constant bleibt, d. h. ob die Anforderungen, denen die zu vergleichenden *S* entsprechen müssen, damit ein bestimmtes Urtheil . . . gefällt werde, im Laufe einer Versuchsreihe annähernd unverändert bleiben; ob ferner das Urtheil wirklich stets das Resultat einer Vergleichung zweier *S* oder *S*-Complexe ist oder wenigstens in manchen Fällen thatsächlich nur auf Grund der einen der beiden *S* abgegeben wird; ob man dieselben Resultate erhält, wenn man das Urtheil das eine Mal hinsichtlich des ersten, das andere Mal aber hinsichtlich des zweiten *R* abgeben lässt; was für einen Unterschied in den Resultaten es bedingt, wenn man die verschiedenen Haupt-*R* das eine Mal neben einander, das andere Mal aber jeden derselben in bestimmten Abtheilungen der Versuchsreihe ausschliesslich zur Anwendung bringt;"⁵ and so on. When these and similar questions have been answered, the time will be ripe for mathematical interpreta-

¹ Zur Analyse der U. E.: Experimentelle Beiträge, 1899.

² *Op cit.*, 229.

³ *Ibid.*, 115, 229.

⁴ *Ibid.*, 116.

⁵ *Ibid.*, 1 f.

tion.—Let us see, now, in brief outline, what it is that Martin and Müller have accomplished.

The experiments were performed with lifted weights; the arrangements accorded, in general, with those described in the text, pp. 115 ff.¹ Besides the standard weights, which lay for the most part in the neighbourhood of 500 and 1000 gr.,² there were seven variables: one of these was equal to the standard weight of the series, the other six were disposed at equal intervals above and below the standard.³ Four 'principal cases' were distinguished: (1) standard right, first; (2) standard right, second; (3) standard left, first; (4) standard left, second.⁴ The judgments allowed were: less (clear), less, undecided, greater, greater (clear), and—in case of obvious disturbance—bad.⁵ The 'bad' experiments were repeated.⁶ The judgment 'equal' was ruled out.⁷ In general, *O* was required to judge in terms of the second weight, and the procedure was without knowledge.⁸ Five men and six women took part in the experiments.⁹

(1) *Anomalous Differences and Type*.—Assume that the time error is negative, the space error positive, in Fechner's sense. Then we have, as values of the 'effective difference' between the two weights in the four principal cases:

Standard > Variable	Standard < Variable
1. $D - p - q$	1. $D + p + q$
2. $D + p - q$	2. $D - p + q$
3. $D - p + q$	3. $D + p - q$
4. $D + p + q$	4. $D - p - q$

Assume, again, that the time error is negative, the space error also negative. We have:

Standard > Variable	Standard < Variable
1. $D - p + q$	1. $D + p - q$
2. $D + p + q$	2. $D - p - q$
3. $D - p - q$	3. $D + p + q$
4. $D + p - q$	4. $D - p + q$

¹ *Ibid.*, 2 ff.; cf. Müller u. Schumann, Pflüger's Arch., xlv., 1889, 37 ff.

² *Ibid.*, 22 f., 34 ff., 82 ff., etc.

³ *Ibid.*, 5 f.; M., 24 ff.

⁴ *Ibid.*, 6; Pfl. Arch., xlv., 105; M., 64.

⁵ *Ibid.*, 7 ff., 13; cf. Pfl. Arch., xlv., 40 ff.; M., 13.

⁶ *Ibid.*, 13; Pfl. Arch., xlv., 39 f.

⁷ *Ibid.*, 11 f.; M., 12 f.

⁸ *Ibid.*, 6 f. Pfl. Arch., xlv., 40, 42; M., 16 ff., 22 ff.

⁹ *Ibid.*, 15. Use was also made of the results of the Pfl. Arch. investigation.

Assume that the time error is positive, the space error also positive. Then we have :

Standard > Variable	Standard < Variable
1. $D + p - q$	1. $D - p + q$
2. $D - p - q$	2. $D + p + q$
3. $D + p + q$	3. $D - p - q$
4. $D - p + q$	4. $D + p - q$

Assume, lastly, that the time error is positive, the space error negative. Then we have :

Standard > Variable	Standard < Variable
1. $D + p + q$	1. $D - p - q$
2. $D - p + q$	2. $D + p - q$
3. $D + p - q$	3. $D - p + q$
4. $D - p - q$	4. $D + p + q$

If we designate 'standard > variable' by (A), and 'standard < variable' by (B), we have in every case the equations :

$$(A)1. = (B)4. \quad (A)2. = (B)3. \quad (A)3. = (B)2. \quad (A)4. = (B)1.$$

If, finally, we denote by $a_1, a_2, \dots, b_1, b_2, \dots$ the relative numbers of r -cases corresponding to the effective differences (A)1., . . . (B)1., . . . we obtain :

$$a_1 - b_4 = 0 \quad a_2 - b_3 = 0 \quad a_3 - b_2 = 0 \quad a_4 - b_1 = 0$$

or, in sum :

$$\Sigma a - \Sigma b = 0.$$

Apart from the slight correction required by Weber's Law, this equation must hold, if Fechner's constant errors of time and space are alone concerned in the results.¹

The event shows that the equation does not hold. We find, first, that in general :

$$a_1 > b_4, a_3 > b_2, a_2 < b_3, a_4 < b_1,²$$

i. e., "with equal effective difference, more r -cases are obtained when the variable is lifted second than when it is lifted first."³ We find, secondly, a marked difference between the observers. One group gives $\Sigma a > \Sigma b$: this means that O has a tendency to give more r -cases when the standard is > the variable than when it is < the variable. This same group shows the expected positive values for the anomalous differences $a_1 - b_4, a_3 - b_2$, but occasionally replaces negative by positive values for the differences $a_2 - b_3, a_4 - b_1$. The result is due to the interaction of the two tendencies, general and special, just remarked. The O 's are referred to a 'positive' type.⁴ The second group gives $\Sigma a < \Sigma b$: this

¹ *Ibid.*, 17 ff.; M., 113 f.

² *Ibid.*, 24.

³ *Ibid.*, 25; M., 115.

⁴ *Ibid.*, 29 ff.

means that *O* has a tendency to give more *r*-cases when the variable is greater than the standard. This same group shows the expected negative values for the anomalous differences $a_2 - b_3$, $a_4 - b_1$, but occasionally replaces positive by negative values for the differences $a_1 - b_4$, $a^3 - b_2$. The result is again due to the interaction of the general and special tendencies. The *O*'s are referred to a 'negative' type.¹ There are also, in all probability, individuals who must be accounted to a third, 'indifferent' type.²

The authors' explanation of these discrepancies is both simple and convincing. "[Es] lassen sich die anomalen Differenzen und ihre besonderen Verhaltensweisen, insbesondere auch ihre Abhängigkeit vom Typus, in völlig befriedigender Weise erklären, wenn man von der schon durch die Selbstbeobachtung constatirbaren Thatsache ausgeht, dass unser Urtheil über die Gewichte vielfach von dem *absoluten Gewichtseindrucke* bestimmt wird, und ferner berücksichtigt, dass das Vergleichsgewicht selbstverständlich den absoluten Eindruck der Leichtigkeit oder der Schwere nach Maassgabe des Betrags von $\pm D$ häufiger macht als das Grundgewicht; dass ferner der absolute Eindruck des Vergleichsgewichtes das Urtheil selbstverständlich leichter bestimmt, wenn das Vergleichsgewicht zuzweit gehoben ist, als dann, wenn es zuerst gehoben ist [since in the latter case the impression 'nur durch die Erinnerung auf das Urtheil zu wirken vermag'³]; und dass endlich, wiederum selbstverständlich, *kräftige Heber* innerhalb der in Betracht kommenden Grenzen von den Gewichten leichter den Eindruck der Leichtigkeit als denjenigen der Schwere erhalten, hingegen *wenig kräftige Heber* sich umgekehrt verhalten."⁴ The validating of these two influences—the influence of the absolute judgment and the influence of type (*i. e.*, in the last resort, of differences of muscular strength)—would itself form a sufficient justification of the method of qualitative analysis.⁵

¹ *Ibid.*, 31 f.

² *Ibid.*, 33. On the relativity of type, see M., 115 f.

³ *Ibid.*, 45.

⁴ *Ibid.*, 57 f. Italics not in the original. Cf. 38 f., 40 ff., 43 ff., 50 ff.; M., 116 ff.

⁵ On the psychology of the judgment by absolute impression, see further *ibid.*, 225; Witasek, Z., xxiv., 1900, 149 ff.; Müller, M., 125 f., 240. The influence of such a judgment has been noted by Schumann for time intervals (Z., xviii., 1898, 38 f.) and for visual distances (Z., xxx., 1902, 255 ff., 262, 280 f., 326 f., 338); by Washburn for æsthesiometry (P. S., xi., 1895, 220); by Fullerton and Cattell for memory of weights and lights (Small Diffs., 1892, 149); by Bentley for greys (A. J., xi., 1899, 36); by A. J. Kinnaman for lifted weights (A. J., xii., 1901, 251); by F. Angell for clangs (A. J., xii., 1900, 69 f.), sound intensities (P. S., vii., 1892, 438) and greys (P. S., xix., 1902, 7 f., 15, 21); by Ament and Külpe for sound intensities (P. S., xvi., 1900, 178, 184; xviii., 1902, 338 f.); by Fröbes for lifted weights

(2) *Influence of Temporal Position.*—Fechner had regarded the time error as a constant error, which could be eliminated by reversal in time of the experimental procedure. In other words, he had assumed "dass bei hinlänglich kleinen Werthen von D der Einfluss der Zeitlage einem Zuwuchse äquivalent sei, der bei den beiden Zeitlagen mit gleichem absoluten Betrage, aber entgegengesetztem Vorzeichen zu D hinzutrete."¹ Martin and Müller accept this assumption, with the proviso that such a time error must be interpreted physiologically (by fatigue or by warming-up and facilitation).² At the same time, the physiologically conditioned error is only one of three components in the total influence exerted on judgment by temporal position. We have, secondly, a 'general tendency of judgment,' resulting from the effect of absolute impression. We have seen that the absolute impression made by the variable weight frequently (and much more frequently than that of the standard) determines our judgment of the relation of the two R presented for comparison; and we have seen, further, that this influence is more readily exercised when the variable is lifted second than when it is lifted first. We thus acquire a tendency to give more r -cases when the standard is lifted first than when it is lifted second. This 'general tendency of judgment' appears in all observers.³ We have, thirdly, a 'typical tendency of judgment,' resulting from differences of type. If the influence of type is superimposed upon an existing general tendency and Fechnerian time error, it "modificirt das Verhalten des Einflusses der Zeitlage im gleichen oder entgegengesetzten Sinne wie der Fechnersche Zeitfehler, je nachdem das Vorzeichen des Typus mit dem Vorzeichen des Fechnerschen Zeitfehlers übereinstimmt oder nicht."⁴ Neither the general nor the special tendency

(Z., xxxvi., 1904, 257, 262) and greys (370, 373). Martin and Müller suspect it in various unrecorded instances (U. E., 230 ff.; M., 122 ff.). It has long been recognised by psychophysicists as a possible source of error in the method of r and w cases; the author remembers that it was mentioned in the Einführungscursus given at Leipzig by Külpe in 1890. The 'general tendency of judgment' may, indeed, as we shall see later, be overcome by fitting instructions to O .

It is to be noted that the 'absoluteness' of impression shows a certain relativity: see L. Steffens, Z., xxiii., 1900, 260 ff.; Müller, M., 125. And it should go without saying that, if evidence of the Martin-Müller factors is found in other sense departments (e.g., in judgments which do not involve active movement) and in the use of other methods, all such instances must be carefully scrutinised for their own sakes; we must not be overhasty in applying the Martin-Müller schemata. This caution may be exemplified by reference to Whipple, A. J., xii., 1901, 438; xiii., 1902, 234, 241, f., 252.

¹ *Ibid.*, 58 ff.; M., 69 ff.

² *Ibid.*, 63, 117 ff.; Pfl. Arch., xlv., 92 ff.

³ *Ibid.*, 64 ff.; M., 115. Cf. W. Frankl, Z., xxviii., 1902, 1 ff.

⁴ *Ibid.*, 64, 69 ff., 73 f.; M., 115 f., 127, 137.

is an eliminable error, of the same kind as Fechner's time error.¹ The former may, however, be ruled out by suitable direction of the attention. "War die Aufmerksamkeit bei der zweiten Zeitlage [standard second] in besonders hohem Grade dem Vergleichsgewichte zugewandt, so kann sich die generelle Urtheilstendenz ganz vermissen lassen. . . Ebenso . . . wenn in Folge besonderer Instruction sich die Aufm. der *O* bei der ersten Zeitlage in hohem Grade dem Grundgewicht zuwendet."²

The authors describe two procedures which enable us to determine the presence, the direction, and the (approximate) relative magnitude of the three components. The first works by way of the series of $\pm D$ and the anomalous differences ;³ the second, allowable only under the conditions of these experiments, is termed the 'summary' procedure.⁴ "Man zählt ohne besondere Berücksichtigung der einzelnen Werthe von *D* alle Fälle zusammen, in denen bei der 1. Zeitlage $G < V$ erschien, ebenso alle Fälle, in denen bei der 1. Zeitlage $G > V$ erschien, und ebenso alle Fälle, in denen bei dieser Zeitlage das Urtheil *u* (oder *e*) abgegeben wurde. In gleicher Weise verfährt man betreffs der 2. Zeitlage. Alsdann stellt man die in dieser Weise bei beiden Zeitlagen für die Urtheile $<$, *u* (*e*) und $>$ erhaltenen Summenwerthe neben oder unter einander und bestimmt nach dem gegenseitigen Verhältnisse der bei beiden Zeitlagen für $<$ erhaltenen Werthe und nach dem gegenseitigen Verhältnisse der bei beiden Zeitlagen für $>$ erhaltenen Werthe die Richtung und die Stärke des Einflusses der Zeitlage."⁵ They find that the positive type admits both directions of the Fechnerian time error, while the negative type allows only a negative error.⁶ This result agrees excellently with their views of the nature of type and of the Fechnerian error: "denn es versteht sich fast von selbst, dass die weniger kräftigen Heber stets ein Ueberwiegen des Einflusses der Ermüdung über den Einfluss der Bahnung oder Anregung zeigen, während es sich gleichfalls leicht begreift, dass bei den kräftigeren Hebern bald der eine bald der andere dieser beiden Einflüsse überwiegt."⁷

¹ *Ibid.*, 65, 73; M., 136 f.

² *Ibid.*, 150 ff., 183 f., 223; M., 118 f., 120. Witasek thinks that the typical tendency might be headed off in a similar way: Z., xxiv., 152.

³ *Ibid.*, 81 ff., 97; M., 135.

⁴ *Ibid.*, 98 ff.; Pfl. Arch., xlv., 95; M., 126 ff. This § 24 of the M. should be carefully read by the student.

⁵ *Ibid.*, 98. G = Grundgewicht, V = Vergleichsgewicht; $< = G < V, > = G > V$.

⁶ *Ibid.*, 97, 107.

⁷ *Ibid.*, 119. The result is not mentioned in M., 126 ff. The reader should note the emphasis laid in the latter work upon direction of attention: see 132 n., 117 n., 121.

(3) *Influence of Certain Factors on Type and on Fechner's Time Error.*—Further confirmation of the authors' standpoint is found in the effect upon type and upon the Fechnerian error of the number of immediately preceding experiments. In general, "[es] erfährt im Verlaufe der Sitzung sowohl der Typus als auch der F. Zeitfehler eine negative Aenderung. Dieses Verhalten lässt sich ohne weiteres durch den Einfluss der Ermüdung erklären. Die Erm. bewirkt, dass der absolute Eindruck der Leichtigkeit immer seltener, hingegen der absolute Eindruck der Schwere immer öfter auftritt: und . . . dass bei jeder Doppelhebung der zweite Impuls in den späteren Runden mehr hinter dem ersten zurücksteht als in den früheren, bezw. dass an die Stelle eines Ueberwiegens des zweiten Impulses über den ersten das gegentheilige Verhalten tritt."¹ Similar evidence is afforded by the influence of the magnitude of the standard weight. "Der F. Zeitfehler zeigt eine Tendenz, bei zunehmendem Grundgewichte sich in negativer Richtung zu ändern." For the fatigue set up by the lifting of the first weight must be greater, the greater the *G* and consequently the *V* of the series.²

Practice may operate in no less than five different ways, "die sämtlich mehr oder weniger im Stande sind, eine oder mehrere der drei Componenten des resultirenden Zeitfehlers direkt oder indirekt zu beeinflussen." It may work purely physiologically, increasing *O*'s strength for lifting the weights; it may render the lifts more and more uniform; it may enable *O* to concentrate his attention more and more definitely upon the experiments; it may change the effect for judgment of the absolute impression of the single weight; or, finally, it may alter the scale of judgments, shift the subjective standard for the application of a determinate judgment-category.³

(4) *Slip Comparisons.*—It happens, on occasion, that one or other of the weights to be compared is really compared, not with its present twin, but with some preceding weight. "Wenn bei einer Doppelhebung eines der beiden Gewichte mit einem Gewichte verglichen wird, das bei einer der vorausgegangenen Doppelhebungen gehoben worden ist, so bezeichnen wir diese Vergleichung als eine Nebenvergleichung." These 'changelings' were investigated in a special set of experiments, in which "einerseits Vexirversuche, bei denen $V = G$ war, und andererseits sog. Hauptversuche, bei denen *V* um einen constanten, pos. oder neg., Betrag von *G* abwich, in zufälliger Weise mit einander gemischt angestellt wurden."⁴ "Bei zunehmendem *V* der Hauptversuche nimmt bei den Vexirversuchen in allen vier Hauptfällen die Zahl für $>$ ab, hingegen die Zahl für $<$ zu."⁵ This means that "bei den Vexirversuchen das zuzweit

¹ *Ibid.*, 126; M., 116.

² *Ibid.*, 136.

³ *Ibid.*, 128 ff.; M., 27 ff.

⁴ *Ibid.*, 157; M., 27.

⁵ *Ibid.*, 159.

gehobene Gewicht mehr oder weniger oft mit dem Vergleichsgewichte der Hauptversuche verglichen wurde."¹ The slip comparisons have little effect upon the general tendency of judgment,² but may influence *O*'s scale of judgments.³ The experimenter must seek, so far as possible, to avoid them,⁴

(5) *Miscellaneous Points*.—The first section of this final chapter is devoted to the space error.⁵ The second discusses the question to which of the two weights of an experiment *O*'s judgment shall refer, and decides in favour of the second.⁶ The third gives the times of the various judgments, as measured by the metronome. "Die Urtheilszeit fällt unter sonst gleichen Umständen bis zu gewisser Grenze um so kürzer aus, je deutlicher das psychische Moment . . . ist, das Veranlassung giebt, das eine der beiden Gewichte für kleiner oder grösser zu erklären als das andere; den höchsten Durchschnittsbetrag erreicht sie in denjenigen Fällen, wo ein Unterschied der beiden Gewichte nicht oder wenigstens nicht mit Sicherheit behauptet werden kann."⁷ The fourth treats of the Müller-Schumann theory of the comparison of lifted weights.⁸ The fifth offers a brief review of the work, and suggestions for future investigation.⁹ "Die sog. D.S. beruht auf der Wirksamkeit einer ganzen Anzahl verschiedener psychologischer Factoren, die unter versch. Bedingungen in versch. Weise an der Bewirkung des Urtheils betheiligt sein können. . . . Für die Psychologie ist nicht die Untersuchung jener irgendwie defi-

¹ *Ibid.*, 160.

² *Ibid.*, 167 ff.

³ *Ibid.*, 170 ff.

⁴ Suggestions are given, 175 ff. See also Witasek, *Z.*, xxiv., 154 f. Instances will be found in Meumann, *P. S.*, xii., 1896, 253; *Z. Radoslawow-Hadji-Denkow*, *ibid.*, xv., 1899, 411; Whipple, *A. J.*, xii., 439; Fröbes, *Z.*, xxxvi., 1904, 259, 264, 373.

⁵ *Ibid.*, 179 ff. The error is investigated by the summary procedure. A fuller and amended account of this treatment is given in *M.*, 131 ff.

⁶ *Ibid.*, 185 ff., 190; *Pfl. Arch.*, xlv., 42. The procedure with partial knowledge is discussed, 195 f., 204. See *M.*, 16 ff., 22 ff.

⁷ *Ibid.*, 196 ff., esp. 197; *M.*, 15 f.; Boas, *Pfl. Arch.*, xxvi., 1881, 499; Münsterberg, *Psych. Rev.*, i., 1894, 45 ff.; Whipple, *A. J.*, xii., 445 f.; *F. Angell*, *P. S.*, xix., 18; *Cattell*, *P. S.*, iv., 1888, 250; *Proc. Amer. Psych. Ass.* 1893, 26; *P. S.*, xix., 63 ff.

⁸ *Ibid.*, 206 ff.; *Pfl. Arch.*, xlv., 55 ff.; cf. Witasek, *Z.*, xxiv., 155 ff. The section includes a critique of Fullerton and Cattell (214 ff.), as a previous section (140 ff.) is devoted to a critique of Wreschner. In *Z.*, xxiii., 1900, 108 f., Cattell publishes a brief reply to Müller's criticism of Fullerton and Cattell, and protests against the tone of Müller's polemics, esp. as directed against Wundt. It cannot be denied that Müller's criticisms, although they are generally well founded, show a certain brutality—at any rate, a certain lack of humanity—which must make against their acceptance, and must therefore hinder the very cause that Müller desires to further. Cf. above, p. cxvi. Müller replies, characteristically, in *Z.*, xxiv., 1900, 142 ff.

⁹ *Ibid.*, 222 ff.

nirten D.S. die letzte Aufgabe, sondern die Untersuchung der Factoren, auf deren Wirksamkeit die Urtheile über die zu vergleichenden Sinneseindrücke und die Besonderheiten dieser Urtheile beruhen. Jeder jener Factoren ist, so weit es eben geht, hinsichtlich seiner Natur und Wirkungsweise und hinsichtlich seiner Abhängigkeit von den Versuchsumständen zu untersuchen. Und was wir mit dieser unserer Untersuchung gegeben haben, ist eben ein Versuch, auf den drei hier zu Gebote stehenden Wegen, nämlich erstens durch ein Studium der numerischen Ergebnisse (der anomalen Differenzen u. s. w.), zweitens durch die Selbstbeobachtung und drittens durch die Untersuchung der Urtheilszeiten einige Auskunft über die das Urtheil bestimmenden Factoren und ihre Wirkungsweise zu gewinnen."¹ What we now need is a further psychological discussion of 'absolute impression'; an exact description of the limits within which judgment is determined by such absolute impression (a requirement not satisfied by knowledge of the general and special tendencies of judgment); and an analytical study of the process of comparison (or slip comparison).²

There can be no doubt that the work of Martin and Müller will stand as a landmark in the history of experimental psychology,—comparable, perhaps, with such books as Hering's *Lichtsinn* or Ebbinghaus' *Gedächtnis*. It has answered certain difficult questions of psychological analysis; it suggests a method for the solution of many further problems. On the other hand, it does not profess to do much for the method of r. and w. cases as a psychophysical method. And our imaginary student of psychology, who balked at Bruns' mathematics in 1898, was probably not encouraged to try his hand at the method by this new publication in 1899. All the more welcome is Müller's *M.*, to which we now turn our attention.

We add a few notes on the last two edns. of the P. P. In 1893, reference is made in the text to Fechner's mode of distribution of the *e*-cases.³ The use of *h* as a measure of the D. S. is defended.⁴ Merkel's derivation

¹ *Ibid.*, 225. Cf. *M.*, 6 f.

² *Ibid.*, 225 f. Some methodological suggestions follow: 227 f. A study of the process of judgment in the discrimination of clangs and tones has since been published by Whipple, *A. J. P.*, xii., 1901, 409 ff; xiii., 1902, 219 ff. Cf. Kraepelin, *P. S.*, vi., 503; Stumpf, *Tps.*, i., 44, 46. See also J. Fröbes, *Z.*, xxxvi., 1904, 241 ff., 344 ff.

³ *P. P.*, i., 1893, 339.

⁴ *Ibid.*, 352. Cf. Stumpf, *Tps.*, i., 43, 56.

of *DL*-formulæ, and his method of e. and u. cases, are treated in some detail.¹ A new paragraph deals with the relative values of the methods, with the error of expectation, and with the three procedures (those with knowledge, with partial knowledge, and without knowledge).²—The exposition of 1902 is unchanged, except that the expression ‘Fehlermethoden’ is replaced by ‘Abzählungsmethoden,’³ and that references are given to recent articles in the *P. S.*⁴

(6) *Müller’s M.*—It has always been a source of difficulty to the student of Fechnerian psychophysics that the systematic literature of the science stopped short in 1882. The *El.* finds its counterpart in *Müller’s G.*; the *I. S.* was reviewed at length by *Müller* in the *Gött. gel. Anz.* But the *R.*, which is a restatement of Fechner’s belief in face of the *G.*, seems never to have been adequately reviewed; nor do we, for a long time to come, find any general work that deals with mental measurement and the metric methods. Psychophysics entered, in the early eighties, upon a period of monographs and special studies; and although Fechner’s positions were attacked again and again, yet the attacks were themselves made from standpoints so diverse, and the contexts in which they occur are so varied, that it is far from easy to obtain a synthetic view of the struggle, or to appreciate its outcome. The *P. P.*, it is true, we have had always with us; *Külpe’s* sections on the methods are valuable; there have recently appeared *Lipps’* little *Grundriss der Psychophysik* (1899) and *Foucault’s Psychophysique* (1901). These and other aids to psychophysical study should not be undervalued. No one of them, however, properly fills the gap of which we have just spoken.

Nor is this gap wholly closed in the year 1904. A complete history of psychophysics has still to be written. At the same time, it would be difficult to overestimate the value, whether to teacher or to student of quantitative psychology, of *Müller’s* work: *Die Gesichtspunkte und die Tatsachen der psychophysischen Methodik.* It is true that *Müller* does not discuss the formulæ of the *R.*;⁵ but he gives “eine zusammenfassende und

¹ *Ibid.*, 352 ff.

² *Ibid.*, 356 ff.; cf. 351, and our remarks above, p. 127.

³ *P. P.*, i., 1902, 470 f.

⁴ *Ibid.*, 475.

⁵ *M.*, 102 n.

zugleich kritische Uebersicht über alle Verfahrensweisen und Gesichtspunkte, die seit dem Auftreten Fechners . . . zutage gekommen sind";¹ and he moves throughout within the lines drawn by Fechner.² Moreover, he has attempted "unter möglicher Anknüpfung an vorliegendes empirisches Material die vorhandenen Lücken auszufüllen und einen gewissen Abschluss der psychophysischen Methodik zu erreichen,"³—so that the methods are presented fully and concretely, in such form as to admit of direct test and application. Müller's work has been reviewed by G. F. Lipps (*Arch. f. d. ges. Psych.*, iii., 1904, 33 ff.), who also published, shortly after its appearance, an independent study entitled: *Die Massmethoden der experimentellen Psychologie* (Leipzig, 1904; also in *Arch. f. d. ges. Psych.*, iii., 153 ff.).

We have paid such constant regard to the M., in our account of the psychophysical methods, that it is unnecessary to give any detailed analysis of its contents.⁴ There are, however, several points in the treatment of r. and w. cases that must still be briefly touched on.

Part i. of the M., devoted to the Konstanzmethode, contains four chapters. The *first* (pp. 12 ff.) discusses the general experimental procedure of the method: its various sections have been made the subjects of Questions in § 22 of the text. The *second* (35 ff.) treats of the determination of the limens and of their variability. A word must be said here of its three concluding sections.

§ 19 (94 ff.) raises a fundamental issue between Fechner and the writer, as regards the method of r. and w. cases. Müller looks to the method to furnish "den Hauptwert der betreffenden Schwelle . . . und den Wert des zugehörigen Streuungsmasses." On the other hand, "man hat gelegentlich die Meinung geäußert, die absoluten S. oder die D. S., welche zwei verschiedenen Versuchskonstellationen zugehörten, liessen sich einfach dadurch vergleichen, dass man die Werte von r (der relativen Zahl der richtigen Fälle), welche ein und dasselbe D bei beiden Konstellationen ergebe, miteinander vergleiche. . . . Vor allem aber ist man nach dem Vorgange von Fechner, Vierordt u. a. von der Ansicht ausgegangen, die absoluten S. oder D. S., welche verschiedenen Versuchskonstellationen zugehörten, seien einfach den D -Werten rezip-

¹ *Ibid.*, iii.

² *Ibid.*, i ff.; Lipps, *Arch.*, iii., 33 f.

³ *Ibid.*, iii. f.

⁴ On the relation of the preceding §§ to the M., see Preface to the present volume.

rok zu setzen, welche bei den verschiedenen Konstellationen einen und denselben Wert von r (z. B., $r=0.84$)¹ ergeben." The discussion starts out from Henri's paradox (Raumw., 18 ff.), and concludes with the proof that Fechner's assumption is valid neither for the RL (98) nor for the DL (101). A positive justification for Müller's definition of the limens is given on p. 101.²

On the relation of RL and h , Müller remarks that "in vielen Fällen, wo RL grösser ist, h den kleineren Wert besitzt. Es kommt aber gar nicht selten auch vor, dass dem grösseren RL zugleich auch das grössere h zugehört." There can, therefore, be no question of the constancy of the product $RL \cdot h$ (99; Pfl. Arch., xix., 233). § 20 (104 ff.) deals with the relation of DL and h (G., 334 f.). "Wenigstens unter gewissen Bedingungen zeigt das Produkt von DL und dem mittleren h bei variiert-er R -Stärke und vielleicht auch bei variiert-er Intensität der Aufmerksamkeitskonzentration eine Tendenz zur Konstanz. . . Aber nicht einmal eine ungefähre Konstanz dieses Produktes darf behauptet werden, wenn verschiedene Versuchsweisen, verschiedene O 's oder weiter voneinander getrennte Versuchsperioden in Vergleich zu einander gestellt werden." The reason for the approximate constancy of $DL \cdot h$, under certain conditions, cannot at present be given (108). "Solange unser Wissen über das tatsächliche Verhalten dieses Produktes noch so sehr an Unbestimmtheit leidet, ist es verfrüht, in Untersuchungen über die Ursachen dieses Verhaltens einzutreten."³

§ 21 attempts a classification of the zufällige Fehlervorgänge. We have four main types of error process: (1) errors due to the character of the R applied (*e.g.*, varying intensity of the two compass points; varying quality or tint of the sounds made by dropped balls); (2) errors due to the receiving organ (*e.g.*, varying width of the pupil); (3) errors due to processes directly affecting the excitability or state of excitation of the sensory nerve-structures (*e.g.*, varying blood supply); (4) errors due to psychological conditions (*e.g.*, varying degree of attention). To these may be added, in certain cases, (5) errors due to manipulation (*e.g.*, varying energy of lift or varying grasp of the holder, in work with lifted weights).

¹ See R., 65.

² Questions may be set upon the reference to Fechner (98 *n.*; Abh. Raumsinn, 141 f., 183 ff.), to Stumpf (102 *n.*; Tps., i., 40 ff.), to Jastrow (*ibid.*; A. J., i., 280), and to L. M. Solomons (109; Psych. Rev., vii., 1900, 234 ff.). The question of the interrelation of the RL (or DL) and h , and of its significance, forms an admirable essay subject. So also (if the student is ripe for it) does the question, brought up by these sections of the M., of the relative fertility or suggestiveness of Fechner's and Müller's formulæ.

³ Cf. Lipps, Massmethoden, 56 (Arch., iii., 208).

The psychological factors are given as (a) varying degree and direction of attention; (b) variation of the constituent process in the given complex by which judgment is determined (instances are given in detail: 111 f.); (c) degree and direction of expectation and imagination; (d) influence of chance order of preceding experiments. This last has been analysed (27 ff.) into four distinct sources of error: slip comparisons, shift of standard of judgment, change in concentration of attention, and inertia or habituation of judgment. "Das Vorstehende zeigt hinlänglich, wie gross die Variabilität des psychischen Verhaltens bei Versuchen der in Rede stehenden Art ist. Es zeigt zugleich auch, worin zum Teil die Erziehung zu einem konstanteren Verhalten besteht, welche die *O* durch eine längere Ausdehnung der Versuchsreihe erhält."¹

The *third* chapter (113 ff.)—Die Mitwirkung des absoluten Eindruckes—represents a serious attempt at the analysis of constant errors. The *fourth* (143 ff.) discusses the treatment of results obtained with a complete series (Vollreihe) of *D*'s.² Its subject matter lies almost wholly beyond the sphere of laboratory drill, and within that of research.—The same thing is true of the concluding portion of Lipps' *Massmethoden*. Where this latter work bears upon the topics dealt with in the present volume, it is referred to incidentally in footnotes and occasional citations. Lipps is rather irritatingly silent about the literature of the methods, and seems sometimes, in his effort after brevity, to ignore the psychological complexity of the subjects under consideration.³

Further Applications of the Method.—We have spoken more than once of the possible solution, by the method of constant *R* or *R*-differences, of problems set primarily to other methods. The following are the cases in point.

(1) *Average Error*: see (c), p. 159 above.—A constant stimulus *r* is given. It is required to equate to this a variable *r*₁. Cf. § 32.

¹ An essay should be set upon the importance of *instruction* (definite phrasing of the object of the experiment) to *O* in psychophysical work: a matter which, in view of the whole course of the *M.*, it would be difficult to stress too heavily. See 8 f., 34 f., 112, 118, etc.; and cf. p. 372 below.

² Cf. Lipps, *Massmethoden*, 68 (Arch., 220 n.).

³ The following suggest themselves as essay subjects. (1) How far is Lipps' criticism of Müller's psychophysical standpoint justified? *M.*, iii., 1 ff.; Arch., *loc. cit.*, 33 ff., 37; *Massmethoden*, 38 (Arch., 190). (2) Lipps' criticism of Müller's use of the Hauptwert and its Streuungsmass: *M.*, 5 ff.; Arch., 35 f.; *Massmethoden*, 13 f., 46 f., 48 (Arch., 165 f., 198 f., 200). (3) Müller's and Lipps' estimate of the work of Bruns: *M.*, 57, 63, 90 f.; Arch., 39 ff.; *Massmethoden*, 59 (Arch., 211); P. S., ix., 1893, 1 ff. (4) The validity of Lipps' four methodological principles: *Massmethoden*, 39, 41, 44, 46 f. (Arch., 191, 193, 196, 198 f.).

(2) *Mean Gradations*: see (8), p. 206 above.—A sense distance ac is given; it is required to determine the stimulus b_m which leads to the judgment $ab=bc$.

(a) Suppose that we are applying the method of limits in its alternative or haphazard form. We may then employ the formula given on p. 86 of the text. But we may also, assuming the validity of the reduction of l , g and m to the (relative) values l' and g' , use the formula:¹

$$g' = \frac{1}{2} + \frac{1}{\sqrt{\pi}} \int_0^{(b-b_m)h} e^{-t^2} dt,$$

and by its means determine b_m and its h precisely as we determine the RL and its h by the method of Constant Stimuli: see pp. 97 ff. of the text.

In reality, however, there is not a single b_m , but a number of b_m . Moreover, the limits of this zone of middle values are themselves variable. We shall, therefore, do better to determine, first, the representative value of the *upper* zonal limit, b_g , as that R -value which gives $g=0.5$; next, the representative value of the *lower* zonal limit, b_l , as that R -value which gives $l=0.5$; and finally the representative b_m , as $b_m = \frac{b_g + b_l}{2}$.

The determinations of b_g and b_l may be made by either of the formulæ discussed above. If the first formula is employed, the resulting values of b_g and b_l ,—if the second, these values with their corresponding h ,—must be stated along with the value of the final b_m .—See Müller, M., 226 ff.

(b) Instead of following the haphazard form of the method of limits, we may work with a complete series of b -values. These values, separated by a small constant interval, are so chosen that at least the lowest always evokes the judgment $\overline{ab} < \overline{bc}$, and at least the highest the judgment $\overline{ab} > \overline{bc}$. All the b -values are presented with the same frequency; the order is either haphazard or systematic. The representative b_m is then determined simply as the arithmetical mean of all b -values for which the judgment m is recorded.—It is, of course, possible to determine, further, values that correspond with the b_g and b_l of the previous method, as well as an average variable error or e_m .

See Müller, M., 229 f., for procedure and references. The further evaluation of the results may be studied in Müller's ch. iv., 143 ff.,—a chapter which we have not discussed in the present work (see p. 313 above).

(3) *Equivalents*: see (3), p. 190 above.—The problem of the method

¹ The symbol g (greater) here replaces the h (higher) of the text, for the avoidance of confusion with the h as denoting the measure of precision.

of equivalents may be attacked by any one of the three fundamental methods, of adjustment, limits or constant stimuli (Müller, M., 206). For the procedure in the latter instance, *cf.* what has been said above with regard to average error.

ESSAY SUBJECTS.—Besides the subjects suggested in the footnotes to pp. 312, 313, the following may be selected for treatment.

- (1) The method of r. and w. cases as developed by Fechner.
- (2) The method of r. and w. cases as developed by Müller.
- (3) The method of r. and w. cases as developed by the Leipzig school. (This essay would discuss the various editions of the P. P., and the series of relevant articles in the P. S.).
- (4) Merkel's contributions to psychophysics.
- (5) The development of psychophysics in America.
- (6) A critique of Fullerton and Cattell's Small Differences.
- (7) The methodological implications of Lipps' distinction between correlation and measurement (Massmethoden, 39; Arch., iii., 191; *ibid.*, review section, 36 f.).
- (8) A critique of Wreschner's Methodologische Beiträge.
- (9) A critique of Martin and Müller's Unterschiedsempfindlichkeit.
- (10) The function of the attention in Müller's M. (see footnote, p. 306 above).
- (11) Müller aims, in the M., "einen gewissen Abschluss der psychophysischen Methodik zu erreichen." Has he succeeded?
- (12) The interrelations of the methods; a classification of the methods.

This subject should be treated historically. It is a subject of great interest and some difficulty, and might with advantage be made the topic of a seminary conference.

To Fechner, who envisaged his three methods from the physical point of view, their relationship appeared extremely simple. The principal passage is El., i., 128 f.¹ A similar position is at first adopted by Wundt: P. P., 1874, 300 f. The P. P. of 1880 (i., 328, 330 f.) represents a transition period in Wundt's thought. That of 1887 repeats the statements of the previous edition, almost without modification (i., 345 f., 347 f.), but

¹ *Cf.* El., i., 73, 133; R., 47, 64.

contains also the distinction between error and gradation methods (343).¹ In 1891 Kraepelin published his article *Zur Kenntniss der psychophysischen Methoden* (P. S., vi., 493 ff.), in which he bracketed the methods of minimal changes, mean gradations and average error as 'methods of limits,' while the methods of r. and w. cases (with one or more *D*'s), of r. and w. answers and of equal and unequal cases are denominated 'methods of difference' (494, 498). Wundt, in 1893, adheres to his own classification, saying nothing of Kraepelin (P. P., i., 336, 340 ff.). Külpe, in the same year, makes the Wundtian distinction the basis of a systematic treatment of the methods (*Grundriss*, 54 ff.).² In the *Logik* of 1895 (ii., 2, 185) Wundt introduces the new terms 'methods of adjustment' (*Einstellungsmethoden*) and 'methods of enumeration' (*Abzählungsmethoden*), including under the former the method of adjustment to equality (av. error), the method of adjustment of minimal differences (minimal changes), and the method of adjustment of equal distances (*Strecken*: method of mean gradations), and under the latter the methods of two cases (equal and unequal, positive and negative cases), the method of three cases (r. and w. cases), and the method of five, etc. cases (r. and w. cases with several possibilities of judgment and several *D*'s).³

Ebbinghaus in 1897 declares that it is the aim of the psychophysical methods to "determine those *R*-magnitudes which are correlated with equal-appearing psychological magnitudes, *i.e.*, with equal *S*-steps." Now (1) there are two possibilities as regards the *magnitude* of the *S*-steps involved. These may be liminal or supraliminal. In the former event, one carries the idea of the normal distance in one's head, and judges whether a presented *R*-pair corresponds with the norm; in the latter, one cannot memorise the distance, but must compare two presented *R*-

¹ First made, apparently, in P. S., i., 1883, 555.

² A classification of Merkel's (P. S., vii., 1892, 563, 566, 568) may find mention here, though it is not important. Merkel distinguishes between ratio methods (av. error, minimal changes, equal and unequal cases, and 'equal ratios' — the last a method whereby an *n*-fold stimulus or the *n*th part of a stimulus is determined) and difference methods (mean gradations). At the same time (567 f.) he retains Wundt's division into error methods and gradation methods.—The relation of the test-values of various methods (a phase of the present subject which might be worked out for itself, and on which we have given references in preceding paragraphs) is discussed by Merkel, P. S., iv., 1888, 129, 131, 148 f., 270, 289; vii., 601.

³ In the *Einstellungsmethoden*, the *R* are 'set' in various ways, and judgment is passed upon them; in the *Abzählungsmethoden*, the judgments passed upon constant *R* are 'told off,' and their count is turned to some psychophysical use. A *Herstellungsmethode* implies, as distinct from an *Einstellungsmethode*, active adjustment of stimuli by *O*.

pairs. Again, (2) there are two possibilities as regards the *mode of judgment*. Either we may vary the *R* until our preconceived idea is suited; or we may present selected *R*-pairs and vary our judgments (within prearranged limits) to suit the impression. This difference leads to a distinction between methods for the determination of stimulus (*Verfahren mit R-Findung*) and methods for the determination of judgment (*V. mit Urtheilsfindung*).¹—A method is thus sufficiently characterised when one has stated whether liminal or supraliminal distances were involved, and whether stimulus or judgment was determined (*Psych.*, i., 74 ff.).

Lipps, in 1899, divides the methods into methods of enumeration (typified by *r.* and *w.* cases) and methods of measurement (minimal changes and *av. error*). In the *Zählmethoden*, one presents a constant *R*-pair, and notes how often the three possible judgments are recorded; in the *Massmethoden*, one measures the *R* which corresponds to "eine irgendwie bestimmte *S*."² In 1904, Lipps identifies his *Massmethoden* with Wundt's *Einstellungsmethoden* and Ebbinghaus' *Verfahren mit R-Findung*, and his *Zählmethoden* with Wundt's *Abzählungsmethoden* and Ebbinghaus' *V. mit Urtheilsfindung*.³ In the *P. P.* of 1902, Wundt subsumes the methods of mean gradations and minimal changes under 'gradation,' and *r.* and *w.* cases and *av. error* under 'enumeration methods' (i., 470 ff.). Average error is, however, still given as closely connected with *min. changes* (472 f.).⁴

We come finally to Müller. Fechner's simple co-ordination of the methods was proved erroneous by the criticism of the G. Müller himself, however, gave no classification of methods until the publication of the *M.* He there distinguishes: (1) a method of best-possible active adjustment, a *Herstellungsmethode*; (2) a method of limits or *Grenzmethode*; and (3) a method of constant stimuli or constant stimulus differences, a *Konstanzmethode*. As applied to the four psychophysical problems—the determinations of *RL* and *DL*, and of subjectively equivalent *R* and *R*-

¹ This distinction was drawn by Wundt in 1880. The method of *r.* and *w.* cases 'weicht von den drei vorangegangenen Methoden dadurch wesentlich ab, dass bei ihr nicht die *R* nach der *S* abgestuft werden, sondern dass man umgekehrt die *R*-Unterschiede constant lässt und untersucht, wie sich in zahlreichen Beobachtungen die *S* verhalten die solchen constanten *R*-Unterschieden entsprechen': *P. P.*, i., 328.

² *Grundriss d. Psychophysik*, 61 f., 64.

³ *Massmethoden*, 63 f.; *Arch. f. d. ges. Psych.*, iii., 215 f.; *ibid.*, review section, 43.—Foucault (*Psychophysique*, 1901, 326) denies the validity of Wundt's distinction, and asserts that all the psychophysical methods are 'error methods.'

⁴ In the *Logik*, it will be remembered, *av. error* is an *Einstellungsmethode*.

differences—these three types cover “alle zur Zeit vorliegenden psychophysischen Methoden.”^{1, 2}

(13) The assignment of ‘degree of confidence’ to judgments passed in method-work.

Peirce and Jastrow, Mem. Nat. Acad. of Sci., iii., 1884, 75; Jastrow, A. J., i., 1888, 302 ff.; Fullerton and Cattell, Small Diffs., 1892, 14, 61, 124 ff., 143 ff.; H. Griffing, Pressure and Impact, Psych. Rev. Mon. Suppl. 1, 1895, 31; G. M. Whipple, A. J., xii., 1901, 417, 435, 437, 439, 440, 443, 445 f.; xiii., 1902, 228 f., 242 f., 250; Müller, M., 21 f.; cf. also Stumpf, Tps., i., 22 ff.

(14) The place of the metric methods in quantitative psychology at large; their relation to the methods employed, *e.g.*, in the investigation of attention or memory; their claim to rank as the ‘typical’ methods of experimental psychology.

A text may be found in Müller, M., 11. Or the question may be made concrete in this way. Lipps takes the same wide view of quantitative psychology and its problems that we have ourselves taken in this book: is, then, his Massmethoden (Arch., iii., 153 ff.) adequately written? Has he the right to stop short where he does, without discussing the methods of experimental æsthetics, of memory investigation, etc.?

¹ M., 1 ff. A criticism of the Wundtian distinction is given, 10 f. A section (182 ff.) is devoted to the relation of the *DL* determined by the method of limits to that determined by the method of constant *R*-differences.—To the previous references on the interrelation of test-values add G. Lorenz, P. S., ii., 1885, 465; E. Mosch, *ibid.*, xiv., 1898, 545; xx., 1902, 215 ff.; Lipps, Massmethoden, 84; Arch., iii., 236. Materials for this essay will also be found in Stumpf, Tps., i., 22 ff.

² Add, now, E. B. Holt, The Classification of Psychophysic Methods, Psych. Rev., xi., 1904, 343 ff. The range of this paper is so wide, that it might be assigned to the student, separately, for discussion and criticism.

CHAPTER III

THE REACTION EXPERIMENT

I think these experiments show that it is possible to apply scientific methods to the investigation of mind. We have determined the times required for those processes which make up a great part of our mental life, and found these times to be constant: they are no more arbitrary, no less dependent on fixed laws than, for example, the velocity of light.—CATELL.

Zu wissen, wie viel Tausend- oder Hundertheile einer Secunde irgend ein mehr oder minder fest abzugrenzender Process braucht, ist an und für sich eine ziemlich gleichgültige Sache. Einen gewissen Werth erhalten solche Messungen erst dadurch, dass man die verschiedenen Resultate mit Rücksicht auf ihre abweichenden psychologischen Bedingungen vergleicht; und ihr Hauptwerth liegt, wie bei allen psychologischen Versuchen, in der mit dem Experiment sich verbindenden Selbstbeobachtung.—WUNDT.

§ 35. **Electrical Units and Measurements.**—It should go without saying that the Sections in the text are no more intended for physicists or electricians than were the mathematical Sections for mathematicians. It should also go without saying that, in the ideal curriculum, no student would enter the psychological laboratory without a fair knowledge of the facts and laws of electricity and magnetism, or, indeed, of physics at large. But 'it is a condition, not a theory, that confronts us': and, so long as students come into the laboratory who have received the greater part of their academic training in language, literature, history and philosophy, so long will it be necessary to give instruction in elementary science.

It will be observed, further, that the Sections are written rather for small and, so to say, makeshift laboratories than for laboratories of large size and resources. In other words, they are written for the majority of laboratories, as these are situated at the present time. A laboratory director who has at his command the services of a practical electrician and a sufficient sum of money will be able to install his electrical equipment much more conveniently and much more elegantly. He will be able to install it in such fashion that the students in the various rooms

may get what power they want, and as they want it, without necessarily understanding the principles of supply and distribution: though this, in the author's opinion, is a doubtful advantage.

(1) *Elementary Works upon Current Electricity*.—Several of these have been mentioned in the text. The most generally useful of those that have come to the author's notice is S. P. Thompson's *Elementary Lessons in Electricity and Magnetism*, 1894 (reprint, 1904). The *Electrical Engineering Leaflets (Elementary Grade)* by E. J. Houston and A. E. Kennelly, New York, 1897, are serviceable at many points. There is, indeed, a long series of manuals of electricity: from A. A. Kent's *Electrical Units for Boys* (1900) through J. A. Beaton's *Practical Compend of Electricity* (1901) to works like that of S. P. Thompson, or W. E. Ayrton's *Practical Electricity* (1896); and thence again to monographs on special topics,—P. Benjamin, *The Voltaic Cell*, 1893; W. R. Cooper, *Primary Batteries*, 1901; A. Treadwell, *The Storage Battery*, 1898; T. A. L. du Moncel and F. Gerdal, *Electricity as a Motive Power*, trs. C. J. Wharton, 1883,—and to the most elaborately technical or theoretical treatises. Information may be obtained, further, from the articles in standard cyclopædias; from text-books of physics and physiology;¹ from the columns of *Nature*,—to say nothing of technical periodicals; and from trade catalogues. Some day, we may hope, there will be a volume on electricity and magnetism, written by a psychologist for the benefit of students of psychology.

(2) *Primary Batteries*.—Among the older forms of primary cell, reference should perhaps be made here to those of Grove and Bunsen; among the newer, to the Edison-Lalande. The former give a powerful and uniform current, but are inconvenient in use. The latter has a comparatively low voltage, but very little internal resistance. Once set up, it requires practically no attention, and all in all is probably the most convenient primary battery extant for laboratory purposes.

¹ A good deal is said about electrical measurements in the text-books of electrotherapeutics. The author has read the introductions to several such works, and has found them generally reliable. A curious mistake occurs in one of the best (C. W. Jacoby, *Electrotherapy*, 1901, 94, Fig. 66): a mistake which, however, need not be enlarged on here, as it is implicitly corrected in the text.

The Grove and Bunsen cells are described by Thompson, *Elem. Lessons*, 168 ff., 174; Ayrton, *Pract. Elec.*, i., 438 ff., 443 f., 484, 486; Carhart, *Prim. Batt.*, 43 ff., 46 f. Grove cells were used, *e.g.*, by Kraepelin, *P. S.*, i., 425. The Edison-Lalande cell (now sold as the Edison Primary Battery) is described by Thompson, 172, 174 (Lalande); Ayrton, 462 ff.; Carhart, 58 ff. See also catalogue of Edison Manufacturing Co., New York City. Nine types of cell are made: the most generally useful is perhaps Type S, which has an *E. M. F.* of 0.7 volt, and an average internal resistance of 0.025 ohm. This cell will deliver 6 amperes of continuous current; a battery of 4 cells runs the Edison motor-phonograph for 100 hours with a single charge, and the Edison \$13.50 fan-motor for 150 hours. The cell is listed at \$3.00.—The Meidinger cell, familiar to readers of the *P. S.*, is figured and described by Ayrton, 431 ff. The Grenet cell is ordinarily made in 'plunge' form, since even on open circuit the zinc is constantly affected by the acid.

On the rule for obtaining maximal current with cells grouped in multiple series (p. 126 of the text) see *e.g.*, Carhart, 160 f. On the rule for finding the total resistance of a divided conductor (p. 132 of the text), see Thompson, *Elem. Lessons*, 409 ff. On the magnetic effects of the current (p. 127 of the text), see *ibid.*, 181 ff.

(3) *Storage Batteries.*—The best secondary battery known to the author is the chloride accumulator, made by the Electric Storage Battery Co., Philadelphia. Thirty-one forms of portable battery are regularly listed. Useful for general laboratory work are Type C (3 plates), 5 cells (10 volts), 1.25 amperes, list price \$19.00; and Type E (5 plates), 1 cell (2 volts), 10 amperes, list price 14.50 (this battery will drive the Edison motor-phonograph). The batteries are encased in hard-wood boxes with handles.

(4) *Distribution of Current.*—As regards the two modes of current distribution described in the text, the author, who has tried both, inclines to recommend the rheostat above the lamp battery: chiefly on the ground that its use is more intelligible to the average student. The psychological laboratory, as compared, *e.g.*, with the physical, draws current so seldom and for such short periods of time that the wastage which the use of the rheostat implies need hardly be considered. Doubtless, however, a laboratory tradition in favour of the lamp battery could soon be established,—as appears now to be the case at the Yale laboratory. The battery is fully described by Scripture, *Yale Studies*,

iv., 1896, 76 ff.; cf. *ibid.*, iii., 1895, 109; New Psychology, 1897, 483 f. The small lamps specified by Scripture may be obtained from the Bryan-Marsh Co., New York City. The values assigned to the ordinary commercial lamps of low c. p. are, as might be expected, somewhat unreliable. For that matter, all lamp batteries must be tested out, on open circuit, before they are used for laboratory purposes.—The rheostat is described by E. L. Nichols, *Outlines of Physics*, 1897, 442 f.

It will be noticed that the objection urged against the rheostat on the score of waste is a *practical* objection; as things work out in practice, the rheostat is more wasteful than the lamp battery. Both alike are resistance devices; and a single 32 c. p. lamp placed across the terminals of the 110 volt circuit draws all the current that there is, as surely as does the rheostat. But one can string a large number of lamps between the terminals, where one uses only a single rheostat.

(5) *Measuring Instruments*.—By a curious infelicity, so far as instruction to the student is concerned, two of the measuring in-

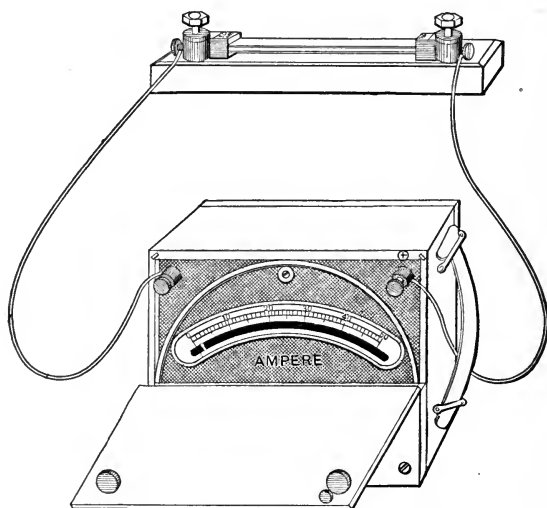

FIG. 36. Weston portable ammeter: \$25.

struments that are best suited to the requirements of the psychological laboratory,—the Weston portable voltmeter and ammeter,

—appear precisely to reverse the statements of the text. The ammeter comes supplied with a shunt: and the unpractised student, having connected up the ammeter in parallel, tends almost irresistibly to join up the voltmeter in series. The explanation of this seeming anomaly is, fortunately, not difficult. The *ammeter* is, in reality, a voltmeter; but a voltmeter graduated, not for volts, but for amperes. It will be remembered that the voltmeter, as described in the text, is a high-resistance ammeter; only a fraction of the current flows through it, but this fraction is directly proportional to the *D. P.* between the points of the main circuit with which it is connected. Evidently, then, instead of graduating the scale for volts, we may graduate it for amperes. We supposed (p. 134 of the text) a resistance in the ammeter of 500 ohms, and a scale unit corresponding to the passage of $\frac{1}{500}$ ampere. This unit meant a pressure of 1 volt. Suppose, now, that we give the ammeter such a resistance as that $\frac{1}{500}$ of the current in the main circuit flows through it, while $\frac{499}{500}$ flows through a low-resistance conductor (a shunt) with which it is in parallel. In this case, the scale unit corresponding to the passage of $\frac{1}{500}$ ampere means a flow in the main circuit of 1 ampere. This is the principle of the Weston instrument. The advantage of the shunt, *i.e.*, of the retransformation of voltmeter into ammeter, is that, since only a fraction of the total current flows through the ammeter coils, the instrument may be used to measure very much stronger currents than would be possible without the shunt. On the other hand, the Weston *voltmeter* is what we have described all voltmeters as being,—a very high resistance ammeter. To supply a shunt with the voltmeter would be absurd, since the portion of the main circuit which we connect up in parallel with the voltmeter is itself the (variable) shunt whose resistance, as compared with the resistance of the voltmeter, is negligible, and the *D. P.* between whose terminals is the object of our measurement. To place the voltmeter in series would simply mean an enormous increase of the resistance, and therefore a reduction of

the current, in the main circuit; the reading of the voltmeter scale would be meaningless.

A clear account of ammeters and voltmeters is given by Ayrton, *Practical Electricity*, i., 1896, 127 ff., 179-183, 188 f. The mirror beneath the scale in the Weston instruments is introduced to avoid the error of parallax. In taking a reading, *O* should hold his head so that the pointer exactly hides its reflection in the glass.

(6) *Electromotors*.—The best advice that can be given with regard to the selection of motors for laboratory work is probably this: that the Instructor should settle, very definitely, what it is that he wants the motors to do, and should then consult with his colleague of Physics. The author may venture the assertion, from his own experience, that it is false economy to buy the cheaper sort of small motors; they are usually little more than toys, and will not stand the wear and tear of laboratory requirements.

The Edison fan-motors (Edison Mfg. Co., New York City: \$9.25, \$13.50, \$17.50) are reliable instruments. The motor supplied with the Edison phonograph is exceptionally good, and may be used for a great variety of purposes. The Ziegler Electric Co.'s \$9.00 combination motors are serviceable, but need overhauling by the mechanic once a year. The motors of the small Zimmermann colour-mixers are too light, and need overhauling at least twice a year. The Helmholtz motor (employed by F. Schumann with his time-sense apparatus, *Z.*, xvii., 1898, 259 f.; figured by E. Cyon, *Atlas zur Methodik der physiol. Experimente u. Vivisectionen*, 1876, Taf. xlix.), though admirable for certain purposes, is probably not worth its cost to the laboratory. For heavier work, the Crocker-Wheeler motors may be recommended.

As typical of the use of the rotary converter, we may mention the employment of a Holzer-Cabot dynamotor in the laboratory of the Univ. of Michigan. The instrument, it will be remembered, is essentially a motor and dynamo on the same shaft. The motor in question is built for the lighting circuit (alternating current) of 220 v., and the dynamo gives a 10 v. direct current. The dynamotor thus replaces primary batteries; the current can be carried to as many rooms as require it.

Practical Exercises.—In the author's experience, it is advisable that the student perform one or two practical exercises of the kind indicated in the text, before he proceeds to the reaction ex-

periment. What precisely the exercises shall be will depend upon the equipment of the laboratory, as well as upon the student's previous knowledge: the half-dozen suggested by the author are merely suggestions, to be varied from and improved upon by the Instructor. A long list of questions will be found at the end of Thompson's *Elementary Lessons*.

The Hipp magnets.—The resistance of the clock magnets is stated by the makers to be 50 ohms. Tests of 4 magnets in the author's laboratory gave resistances of 56, 56.7, 58, 57 ohms (results accurate to 0.5 ohm); and tests in the Clark Univ. laboratory gave similar values (55 to 60 ohms). Fig. 37 shows the method employed: the substitution of a known for the unknown resistance, and variation of the former to secure the same deflection of the ammeter. The battery is a 3-cell storage battery, yielding about 5.4 volts; *A* is the Weston ammeter with shunt attachment; *R* is a resistance box, 0.1 to 110 ohms. By means of the switch, either *R* or the magnet may be thrown into circuit. The number of plugs pulled from *R* is varied until the ammeter gives the same reading for both positions of the switch.

Conversion of a Generator into a Motor.—Directions will, of course, have been supplied with any machine that the laboratory happens to possess;

but the student should be able to work out the connections theoretically for himself. A good instrument, for illustrative purposes, is the C. H. Stoelting Co's dissectible hand-power dynamo (listed at \$40.00). It is wound for shunt or series connections, and is arranged for either constant or alternating current. As a motor, for regular laboratory use,

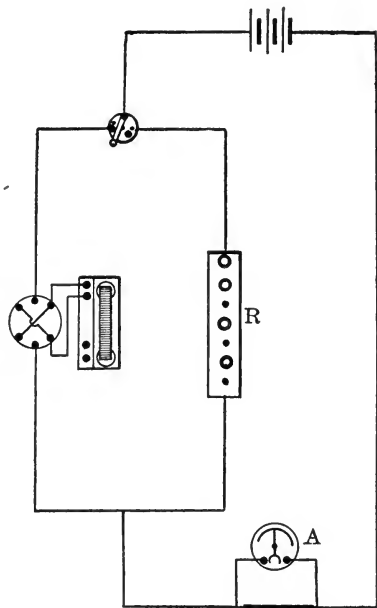

FIG. 37.

¹ If the ammeter on this arrangement is not sensitive enough, the circuit wires may be led direct to the ammeter posts, the shunt remaining in place. The deflections of the needle will now, of course, be much greater than before. What the unit of the scale stands for is immaterial, since all that we require is equality of deflection for the two branches of the circuit.

it is less satisfactory, since it requires 16 volts and 5 to 6 amperes (80 to 100 watts), and has only a two-pole armature. Another useful machine is the model dynamo no. 1 (\$20.00) or no. 2 (\$30.00) made by the Elbridge Electr. Mfg. Co. This is wound according to specifications. The author has used it, for various purposes, during the last six years, and has found it durable and serviceable. Either of the above-mentioned machines can be supplied with resistance.

§ 36. **The Technique of the Simple Reaction.**—The instruments employed, at one time or another, for the simple reaction experiment are fairly bewildering in their variety. The author has sought here to bring together and discuss the most important. Some he has omitted as out-of-date, or as obviously inaccurate; others, no doubt, have been omitted through ignorance.

I. *The Hipp Chronoscope.*—The Hipp chronoscope,¹ a modification of the Wheatstone electric chronoscope introduced by M. Hipp of Reutlingen, and now made by Peyer, Favarger et Cie. of Neuchâtel, exists in two forms, the older and the newer.² The chief difference between the two, apart from the larger size and stronger construction of the newer form, is that the older chronoscope has one, the newer two electromagnets.³ The clock-hands of the former move, therefore, only during the interruption of a current flowing through the magnet. It may replace the newer pattern in arrangement I. (make to break of a shunt circuit). It may also be used in the manner shown in Fig. 38: the chronoscope circuit is broken by the break of the voice-key in *A*, and is made again, through the high-resistance circuit *C*, when the reaction key is opened in *B*.—For description of the instrument, see W. Oelschläger, *Pogg. Ann.*, lxxiv. (cl.), 1849, 589; A. Hirsch, in *J. Moleschott's Untersuchungen*, ix., 1863, 183 ff.;

¹ In the Einführungscursus which the author attended at Leipsic, the chronoscope was always referred to, by the lecturer, as "das Hippsche Chronoskop." A fellow student, a German by birth, remarked once that the instrument was, no doubt, 'hübsch,' but that there seemed to be no reason for the constant repetition of the adjective. The story illustrates the wisdom of introducing a little historical or biographical detail into scientific courses.

² Only the newer form can now be purchased; but many laboratories possess and use the older pattern.

³ In the newest clocks, there are no binding-posts upon the base of the instrument, but only upon the platform of the clock-house.

C. Kuhn, *Angewandte Elektrizitätslehre*, 1866, 1185 f. 1228 ff.; H. Schneebeli, *Pogg. Ann.*, clv. (ccxxxi.), 1875, 619; and esp. Wundt, *P. P.*, ii., 1893, 322 ff.; iii., 1903, 387 ff.¹ The author has

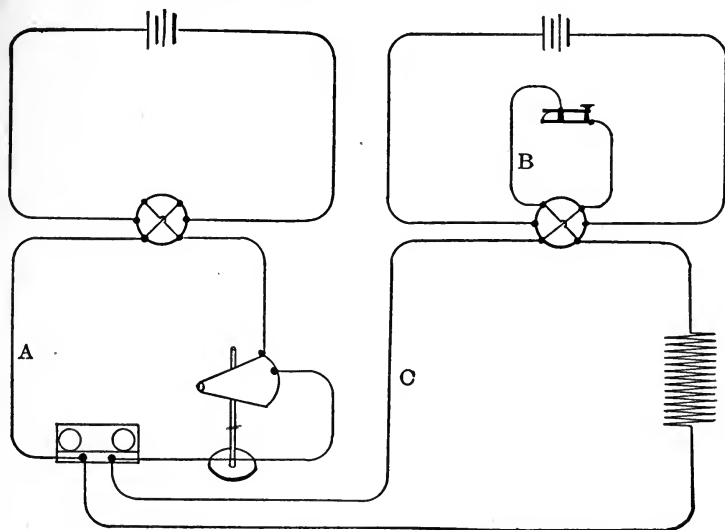

FIG. 38.—Old-pattern chronoscope, break to break. Kraepelin, *P. S.*, i., 574. The voice-key is shown without relay.

not thought it worth while to reproduce from Wundt the four figures which show the working of the various mechanisms. For use in the Cornell laboratory, he has had these figures enlarged (on sheets 10.5 by 8 in.); has typewritten, in translation, the accompanying explanatory text; and has framed each figure with its text as a wall-chart. The four charts may thus be examined, and compared with the clock itself, by any interested student.²

To keep the works free of dust, and at the same time to deaden the noise of the spring (an important matter, if the instrument stands in the reacting room), the chronoscope may be permanently housed in a glass-fronted wooden case; the clock is wound through a hole in the glass, or

¹ No descriptive pamphlet is issued by the makers, who, however, furnish on request type-written instructions regarding the use of the chronoscope at large or the function of the special mechanisms.

² A simple diagram, corresponding to Wundt's first figure, will be found in A. Binet, *Introd. à la psych. expér.*, 1884, 109.

by opening the upper glass door. To avoid injury from carelessness or inexperience in starting and stopping, the cords may be replaced by

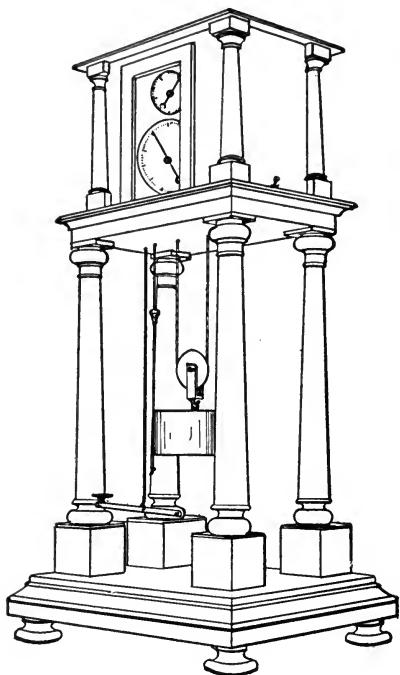

FIG. 39.

Dolley (Mem. Nat. Acad. Sci., 400) it amounted to 7σ ; in a clock known to the author, it amounts to 10σ .

All in all, the Hipp chronoscope is an excellent instrument; very durable, and almost surprisingly reliable. It may be safely recommended, and there is little likelihood that it will be superseded, in the near future, by other types of chronoscope. The author would not himself have ventured to write "*Le meilleur instrument pour mesurer le temps de réaction est le chronoscope de*

metal bars, connected at the base with levers, depression of which starts and stops the clock; the levers project through an opening at the bottom of the wooden house. This alteration is of great advantage when the chronoscope is to be tested by means of a stop-watch. To prevent loosening of the screws which adjust the vibrating spring, a clamp may be screwed upon the carriage of the spring.—For these and other possible improvements, see J. McK. Cattell and C. S. Dolley, *Memoirs of Nat. Acad. of Sciences*, vii., 1896, 395 f.¹

When all other faults of the chronoscope have been corrected,² there sometimes remains a constant error, due to irregularity of the teeth of the crown wheel. This error will, of course, make itself felt only occasionally. In the clock used by Cattell and

¹ The catalogue of Jastrow's instruments, issued in 1894 by the Garden City Model Works, Chicago, Ill., shows a chronoscope housed in the manner described; the cords pass, under pulleys, through holes in the side of the house.

² Both of the author's chronoscopes show the tendency, mentioned in the text, to drop an octave, *i.e.*, to record five-hundredths for thousandths of a sec. The change is quite sporadic and irregular.

Hipp,"—but he is glad that a fellow psychologist has found the courage to do so.¹

Control of the Chronoscope.—The method of control described in the text is, so far as the author can discover, the method usually employed. There is another method, which does not require the clock to give absolute times. The magnet springs are set at a certain tension, and a current is employed of such strength that the armature moves freely and easily under its influence. Tension and current are kept constant from experiment to experiment, the latter by aid of the adjustable resistance of the rheochord. A control instrument, of known time-value, is introduced into the circuit, and the average time recorded by the clock, with its variation, is noted. We may then work with any chronoscope times that lie in the neighbourhood of this recorded time. The (positive or negative) difference between clock-time and control-time represents the constant error of the chronoscope, whose times must accordingly be corrected at the conclusion of the experiments.—This method of control is to be recommended especially in cases where the chronoscope is used, in quick succession, with different kinds of stimulator (visual, auditory, tactual). For the current required to furnish absolute times with any one set of apparatus will not serve with another; and it is easier to keep the current constant, and correct the times, than it is to readjust the current for every series of experiments.

The method of control described in the text may be further elaborated as follows. Think of the processes of magnetisation and demagnetisation as represented by curves, the abscissæ being units of time counted from 0 (from the moment of make or break), and the ordinates denoting degree of magnetisation. In the case of a strong current, *e. g.*, the curve of magnetisation would rise steeply from 0 and would soon be running high above the abscissæ, while the curve of demagnetisation would fall (from the height of maximal magnetisation) slowly and gradually towards the abscissæ. If these two curves are drawn from the same 0-point of time, they will intersect at some part of their course. That is to say, there will be a certain moment of time (a certain point upon the abscissæ) at which, in the two reverse processes, the degree of magnetisa-

¹ R. S. Woodworth, *Le Mouvement*, 1903, 346. *Cf.* Scripture, A. J., vi., 1894, 428 f.; Binet, *Ann. psych.*, ii., 1895 (1896), 774.

tion (height of ordinate) will be the same. If, then, the tension of the spring be so adjusted that it is overcome by the magnet at a point of time inappreciably later, while it in turn overcomes the magnet at a point of time inappreciably earlier, than this particular moment, the two latent times will be sensibly equal, and the chronoscope reading (provided that the clockwork is mechanically accurate) will be free of error.

Given the mechanical accuracy of the clock, the adjustment of current to equality of the two latent times will be no more difficult than the adjustment required in the text. The accuracy of the chronoscope times may be tested by help of a stop-watch whose constant error is known. It is, of course, impossible to start and stop chronoscope and stop-watch with absolute simultaneity; but the error is small. Moreover, since the two chronometers may be allowed to run together for a period of 50 sec., it is distributed over a comparatively long time. The variable error of the test may be eliminated by making a number of determinations, and the constant error may be partly eliminated by using different observers. If, now, the unit of the chronoscope is more or less than 1σ , the regulating spring is adjusted until it makes 1000 vs. in the 1 sec. We then introduce into the chronoscope circuit a control instrument which allows a known interval (say, 1500) to elapse between make and break of a current. We set the magnet springs at a given tension and vary our current strength, by help of resistance, until the chronoscope records, on the average, 1500 for every control experiment. The two latent times are then equal; the clock has no constant error; the slight variation of the recorded times enables us to estimate its variable error. So long as the tension of the springs and the strength of current remain the same, we can work with times in the neighbourhood of 1500, and rely upon the clock to furnish us with correct time values.

Have we gained anything by this extra work,—the work involved in the regulation of the clock mechanism? May we, *e. g.*, regard our control by 1500 as adequate for other times? Will the durations of the two opposite processes of magnetisation and demagnetisation, made equal in this one case, remain equal in other cases? If they do not, the simpler method of the text will be preferable.

Let us look a little more closely at the processes of magnetisation and demagnetisation. At the beginning of the time to be measured, let a constant external *E. M. F.*, E_e , act upon the magnet coil: this will correspond to the steady current $I_e = \frac{E_e}{R}$. To the immediate establishment of this current there is, however, an impediment, in the form of a self-induced counter *E. M. F.*, E_i (where the subscript *i* denotes 'internal'). The actual current flowing at any moment, before inductance has been

overcome, is accordingly $I = \frac{E_e - E_i}{R}$. And the relation of E_e to E_i is a function of the time elapsed since the making of the external current.¹ It is clear, then, that if the period during which the current traverses the magnet is shorter than the time required to overcome the inductance, the

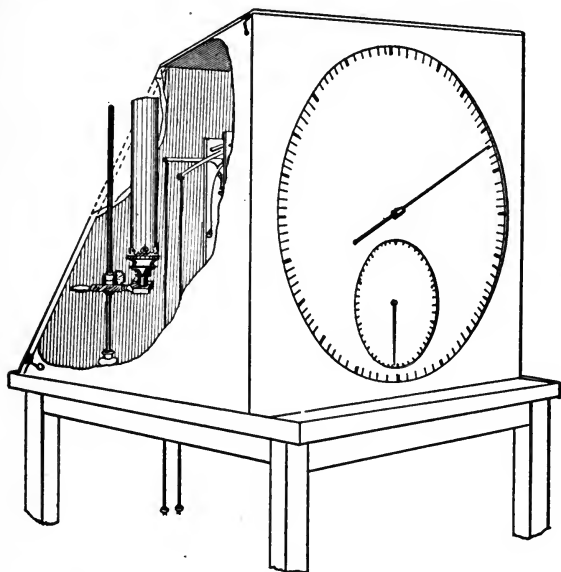

FIG. 40. Wundt's demonstration chronoscope; see P. P., ii., 1893, 330; iii. 1903, 395. Zimmermann, 1903, Mk. 440.

current will never act at its full intensity : the time of magnetisation will be relatively long, that of demagnetisation relatively short. It is precisely as if, under the schematic conditions laid down in the text (where nothing is said of inductance), we were using a current of weaker intensity. There will still be a certain adjustment of current and of magnet springs which will equalise the two latent times, and thus standardise the readings of the chronoscope ; but it would be absurd to suppose that the readings remain correct for longer times, during which the

¹ See, e.g., H. du Bois, *The Magnetic Circuit in Theory and Practice*, 1896, 236 f. ; Thompson, *Elementary Lessons*, 468 ff. Nothing is said in the following discussion of the effect of inductance upon the process of demagnetisation. Since inductance tends to oppose any change in the strength of the current, it will delay demagnetisation just as it delays magnetisation.

The other factors concerned in the establishment of a magnetic circuit may also, so far as the author is able to judge, be neglected in the present discussion.

inductance has been fully overcome and the current acts at its full intensity.

What, then, of these longer times themselves? Will a control by any one of them be adequate for all the rest?—The times of magnetisation will, of course, all be the same; the same intensity of current is at work. For the times of demagnetisation, there are two theoretical possibilities. Either the residual magnetism will increase as the time of passage of current increases; or a limit will be reached, a state of saturation akin to that which is reached with increase of the intensity of current. In the former case, the process of demagnetisation will last longer and longer, as the times to be measured are taken longer and longer; in the latter, there will be a certain length of time for and beyond which the period of demagnetisation remains constant. This is what, under certain conditions, we seem actually to find. The evidence is as follows.

(1) In the old-pattern chronoscope, the hands move at *break* and stop again at *make* of a current. Hence, at the beginning of an experiment, the current is in the magnet. Now, however regularly the experiment is conducted, it is clear that there will be some variation of the time, before the reaction stimulus is given, during which the circuit is closed. Nevertheless, Berger found that, with a given intensity of current, the error of the chronoscope remained constant for readings between 200 and 400 σ (P. S., iii., 93). Müller and Schumann obtained the same result for times between 106 and 3800 σ (in Müller and Pilzecker, *Exper. Beiträge z. Lehre v. Gedächtniss*, 1900, 292 ff., 297): Külpe and Kirschmann for times between 56.6 and 598 σ (P. S., viii., 170 f.).¹ Since, if complete demagnetisation be presupposed, the times of magnetisation must be the same, we are forced to the conclusion that the magnet had, so to say, become saturated during the preliminary closure of the circuit, and hence that the times of demagnetisation were also alike in all cases.

(2) We need not, however, rely exclusively upon this hypothetical variation of the times of closure. Kraepelin (*Ueber die Beeinflussung einfacher psych. Vorgänge*, etc., 1892, 15) varied the times in special experiments, the time of closure averaging 1 sec. in a first, and 5 sec. or more in a second series of 50 tests. The times recorded by the clock (gravity chronometer control) were 164 and 162 σ respectively, with *PE* of ± 3 and $\pm 2.5\sigma$. That is to say, the maximal effect which we can ascribe to the additional residual magnetism stored up in the extra 4 or more sec.

¹ Müller and Schumann remark (297) that "gelegentliche Versuche" put a lower limit at 88 σ : *i.e.*, at this interval demagnetisation is not complete. Various reasons might be offered for the discrepancy between this result and those of Külpe and Kirschmann, but the data are not sufficient to support any positive conclusion.

is a reduction of the measured time by 2σ ; and it is highly probable that this reduction is not attributable to residual magnetism at all, but merely to the variable error of the apparatus employed.¹

We conclude, therefore, that under these conditions the time of demagnetisation does *not* sensibly increase with increase of the time during which the magnetic circuit is closed. If only the current is closed long enough for the overcoming of inductance, the times of magnetisation and demagnetisation will remain constant, and a single time-control will serve for all experiments with the chronoscope.

Unfortunately, we have no experimental data for the new pattern clock.² It would seem, *a priori*, that the argument of the foregoing paragraphs ought to hold for our arrangement II. In that arrangement, the magnet circuit is first definitively made, then definitively broken. Provided, then, that the closure of the circuit lasts long enough for the overcoming of inductance, we have apparently the same conditions as before, only in reversed time order. We do not know, of course, *how* long the closure must last: that must be determined by special tests.³ In arrangement I., there is a minimal current in the magnet during the period of the experiment. This state of affairs has been investigated (in the old-pattern clock) by Külpe and Kirschmann. They find (P. S., viii., 169) a variable error which ranges between the limits -10.8 for a time of 56.6σ and $+61.9$ for a time of 677.9σ . The rate of the clock was known, and the times are absolute.⁴ In this case, therefore, there can be no

¹ Cf. R. Sommer, *Psychopathologische Untersuchungsmethoden*, 1899, 161.

² Decisive experiments have, apparently, been made by N. Ach: see E. Claparède, *Archives de Psych.*, iii., 1904, 324; N. Ach, *Bericht üb. d. I. Kongress f. exp. Psych. in Giessen*, 1904, 123. The reports so far published are, however, exceedingly meagre.

³ The application which (if the author has read him aright) Kraepelin would make of his control experiments is wholly unjustified. See Ueber die Beeinflussung, etc., 14 ff. A paper by R. Sommer (*Correspondenzblatt f. d. ärztl. Vereine im Grossh. Hessen*, 1899, Heft 12, 185) which, according to Müller and Schumann (*Gedächtniss*, 299), bears out the inference of the text, has not been seen by the author.

⁴ Müller and Schumann (in *Gedächtniss*, 300) raise the question whether these times are absolute. The constant error of the clock was known: it had, as the writers rather quaintly put it, "eine Geschwindigkeit von 1024σ in der Secunde" (P. S., viii., 168). But there is no express statement that the times of Table V., p. 169, are corrected.—The author, who had felt the same doubt, asked Professor Külpe for the facts. Professor Külpe replied that he had no notes, and no definite recollection, although he inclined to think that the times were corrected. The matter is, however, put beyond dispute by the chronoscope times given under *B* in the Table. These are so nearly identical with the chronograph times that they must have been corrected: and if they, then also the times given under *A*.

question of one control doing duty for a series of increasing or decreasing reaction values. In arrangement III., there is a minimal current in the magnet before, and a full current during, the experiment. The conditions are again complicated, and we may probably expect a variable error with recorded times of different length.

On the whole, then, and in default of any thorough test of the new-pattern chronoscope, we shall do best to keep to the method of control laid down in the text. In the present state of our knowledge, there is no certain return for the labour involved in standardising the clockwork.

NOTES.—(1) The method of control by the stop-watch was employed by Cattell and Dolley. Professor Cattell writes to the author: "It is my impression that the final error is not much more than 0.1 sec., which would be only an error of $\frac{1}{3000}$ of the total time measured."

Külpe and Kirschmann say (P. S., viii., 168) that the pitch of the regulating spring in the clock tested by them was 1024 vs. Professor Kirschmann informs the author that, to the best of his recollection, the pitch was determined by comparison with Koenig forks and counting of beats. It is probable that the writers used the regular $\mu\frac{1}{5}$ fork of the Koenig series (2048 v. s.), and that this fork happened to possess the exact pitch of the clock spring. The upper fork of the Bezold series (Z., xiii., 1897, 162, 165) appears to be admirably adapted for use in this method of control. Indeed, the method is so simple and takes so short a time that, if the clock is to be standardised, it might be worth while to have a 1000 vs. fork, with riders and a scale graduated to 2 vs., made especially for control purposes.¹

(2) The position of the regulating spring of the chronoscope is fixed, in the horizontal direction, by coincidence of a file-mark with the right-hand vertical edge of the carriage. The spring may be tilted down and towards, or up and away from, the teeth of the balance wheel, by rotation of the carriage about its transverse axis: change of position is effected by the screwing in and out, respectively, of two regulating screws. In the right position, the extremity of the spring just fails to touch the teeth of the balance wheel when this is slowly turned by hand; the spring is set in motion by the vibration of the thin layer of air between it and the wheel. The angle made by the spring and the radius drawn from the centre of the wheel to the point of contact with the spring should be $90^\circ + 45^\circ = 135^\circ$. The pitch of the spring may be changed (within narrow limits) by adjustment of the damper and riding weight. The damper

¹ For an indirect method of standardisation, see Müller and Schumann, in *Gedächtniss*, 294 ff.

acts as the bob of a pendulum, varying the rate of vibration as its position along the spring is varied; the rider serves as a sort of fine adjustment for the damper, enabling us to keep the latter well out of the way, towards the butt of the spring. The damper will also limit an excessive amplitude of excursion, due to any small irregularity in the teeth of the balance wheel (Wundt, P. P., ii., 1893, 326; iii., 1903, 391).

The Instructor should thoroughly understand this mechanism, and should not be afraid to readjust if readjustment seems called for. It can, of course, hardly ever become *necessary* to make a change in the setting of the spring, since a clockwork whose error is known is as useful as a clockwork which gives absolutely accurate times.

(3) In prescribing the use of the control instrument as a check upon the *variable* error of the chronoscope, we have given as limit of accuracy an *MV* of 1.5σ for a time of 150σ and for 10 trials. Külpe and Kirschmann (P. S., viii., 169) found for chronoscopic times between 45.8 and 502.1σ (large control hammer; old pattern clock, shunt circuit; 10 or more trials) mean variations of 0.42 to 1.1σ , irregularly distributed. The highest time, of 677.9σ , had an *MV* of 2.74σ . Witmer (Psych. Rev., i., 508) regards his apparatus as reliable if the *MV* of 100σ in 10 trials is not more than 1σ : he gives (*ibid.*, 512) the *MV* of 27 test series of 20 trials for times ranging between 18.9 and 3589.8σ (new pattern clock; arrangement II.; pendulum control). Other determinations will be found in Hill and Watanabe, A. J., vi., 243 (new pattern clock, arrangement II.; large control hammer); M. Dessoir, Arch. f. Physiol., 1892, 308 (new pattern clock, arrangement III.; Siemens-Pflüger hammer);¹ R. Sommer, Psychopathol. Untersuchungsmethoden, 1899, 158 ff. (details of circuit not given; Hipp gravity control); etc.

II. *Some Other Chronoscopes.*—(1) The chronometer of A. d'Arsonval (Fig. 41) is an electric clock, reading to the two-hundredth of a second, whose pointer moves when the current in the magnet is broken, and comes to a standstill as soon as the current is remade. The mechanism will be understood from Fig. 42; the forward pull of the armature severs the continuity of the central spindle, so that the pointer with its attachments is out of connection with the clockwork. The instrument to the right in

¹ Dessoir measured his reaction times by arrangement II., and took his controls by arrangement III. His whole discussion (306 ff.) shows but little familiarity with the technique of the experiment.—The hammer of W. Siemens and E. F. W. Pflüger (the source of all psychological control hammers) is figured by E. Cyon, Atlas, 1876, Taf. xxxvii., Fig. 2.

Fig. 41 is a pressure stimulator or sound hammer (break); that to the left is the reaction key (make). The chronometer is port-

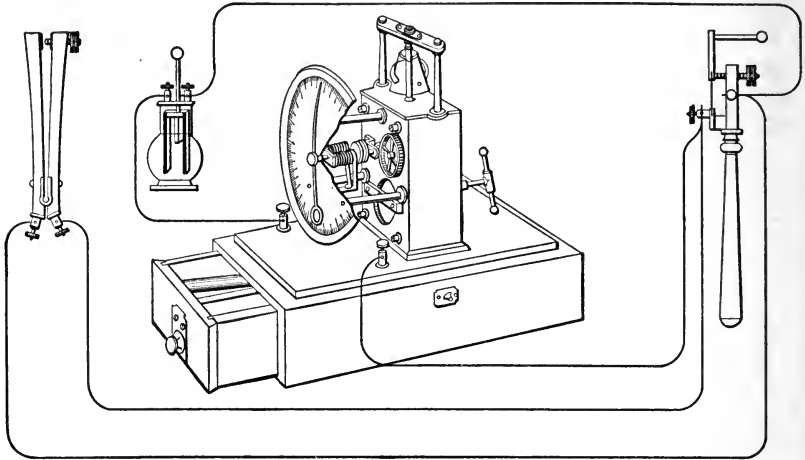

FIG. 41. d'Arsonval chronometer, with sound-hammer and reaction key.

able, comparatively noiseless, and runs at uniform speed for nearly 15 min.; it was originally intended for use in medical practice. It is made by C. Verdin, Paris, for Fr. 350, and is de-

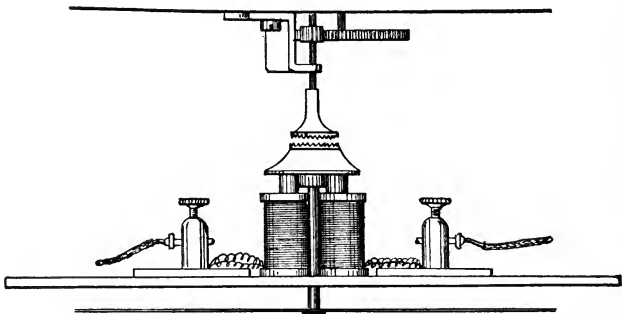

FIG. 42. Mechanism of d'Arsonval chronometer (Philippe).

scribed in Verdin's Catalogue, [1896?] 131 ff. See also A. d'Arsonval, *Soc. de Biol.*, 15 Mai 1886; A. Binet, *Introd. à la psych. expér.*, 1894, 110 f.; *Presse médicale*, 24 Juin 1896; J.

Philippe, *Technique du chronomètre de d'Arsonval*, 1899 (gives full directions for testing and using the instrument).

(2) Münsterberg's chronoscope (Fig. 43) is a spring clock-work, without electrical attachments of any sort, reading to the one-hundredth of a second. The crown wheel, which revolves once in 5 sec., has 500 teeth; and the main dial has, accordingly, 500 divisions. The unit of the smaller dial is 5 sec., and the scale is graduated in 36 (later, 60) divisions, so that the clock will register a continuous time of 3 (or 5) min. Once wound, the chronoscope will run uniformly for over 10 min. The pointers can be brought back to 0 after every experiment. The two push-buttons at the top of the Fig. are for starting and stopping the clock; pressure on the lever to the left connects the pointer with the clock gears. See *Beitr.*, iv., 1892, 128 f. The chronoscope is made by H. Elbs, Freiburg i. B., for \$60.

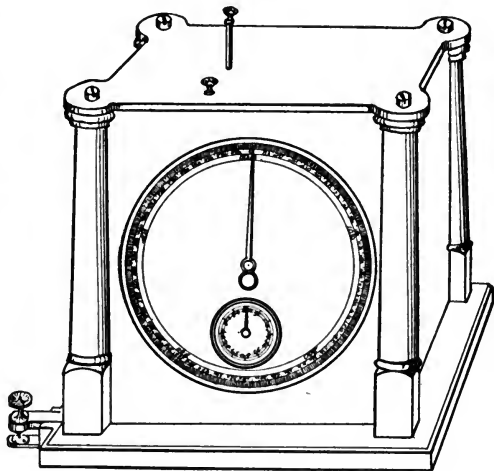

FIG. 43. Münsterberg's chronoscope.

(3) The chronoscope of J. R. Ewald is shown in Fig. 62 of the text. It consists essentially of a little electromagnet, whose armature moves to and fro in the rhythm of a 100-fork. The armature plays between the teeth of a cog-wheel, to which the pointer is directly attached. Since this wheel has 100 teeth, the unit of dial and chronoscope is $\frac{1}{100}$ sec. A catch prevents the cog-wheel and pointer from slipping back, and the armature from skipping a tooth of the wheel. The pointer can be returned to 0 after every experiment: for, while the dial is fixed, magnet, cog-wheel and pointer may be revolved about the axis of the pointer by the milled wheel shown below the clock-case in the Fig.; a second catch makes it possible to set the pointer with accuracy. The

fork may be driven by a Bunsen aspirator (Ewald, Pflüger's Arch., xliv., 1889, 556) or by an electromagnet. The chronoscope is made by F. Maier, Strassburg: the price of chronoscope and fork, according to the catalogue of the Psychological Laboratory of Harvard University (1893, 12), is \$40. The chronoscope alone is listed by Peyer and Favarger at Fr. 185. J. Philippe (Technique du chronomètre de d'Arsonval, 10) remarks that the chronoscope, "très simple mais fragile, eut peu de succès." It was used by J. A. Gilbert in his *Researches on the Mental and Physical Development of School Children* (Yale Stud., ii., 1894, 46).

(4) A pendulum chronoscope, in which the index attached to a weighted pendulum plays over a circular scale graduated empirically (by means of a falling weight) in hundredths of a sec., was described in 1895 by G. W. Fitz. See *Psych. Rev.*, ii., 39.

(5) A more elaborate instrument of the same type, whose scale is graduated to half-hundredths by comparison with tuning-fork records, and whose mean variable error is given as not greater than 2σ , was described in the same year by E. W. Scripture. See *Yale Studies*, iii., 99; *New Psychology*, 1897, 157, 159; *Année psych.*, iii., 1897, 659.

Other pendulum chronoscopes have been described (6) by C. E. Seashore, *Iowa Studies*, ii., 1899, 153 ff., and (7) by J. A. Bergström, *Psych. Rev.*, vii., 1900, 483 ff. A wheel chronoscope (8) is described by J. McK. Cattell, *Psych. Rev.*, vii., 1900, 333.

III. *The Chronographic Method.*—Reaction times may be recorded graphically; the moments of stimulation and reaction are marked upon the smoked surface of a rotating cylinder, upon which a tuning-fork of known vibration rate is also writing a time line. See Wundt, *Lectures*, 1896, 274.

(1) The arrangement for recording reaction times in even hundredths of a sec., shown in Fig. 44, was devised by W. G. Smith (*Proc. Physiol. Soc.*, Novr. 17, 1894). The current from *A* flows through the 100-fork *B*, and returns through one of the circuits *CKD*, *CTD*, *CRD*. The circuit *CTD* is always closed, so that *B* never ceases to vibrate; owing, however, to the high resistance of the time-marker *T*, the current flows freely in this circuit only when the others are broken. *K* is a break key, which

remains closed until the stimulus is given: it may be opened, *e.g.*, by the swing of a pendulum, the click serving as a sound stimulus. *R* is the reaction key, which remains open until the move-

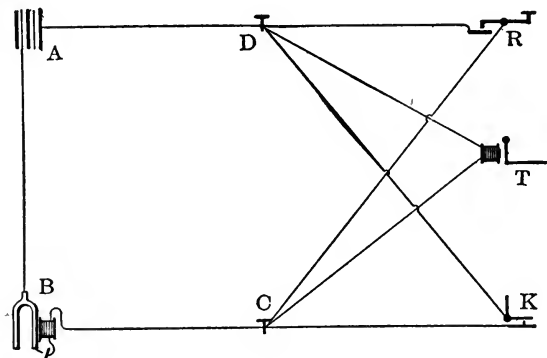

FIG. 44.

ment of reaction is made. At the beginning of the experiment, *CKD* and *CTD* are closed. With the breaking of *K*, *T* begins to record. With the closing of *R*, by the lift of *O*'s finger, the current is drawn off into the low-resistance circuit *CRD*. It is clear that *K* may be replaced by any other form of break stimulator.¹

(2) The chronographic method has been brought to a high degree of accuracy in the Yale laboratory. The reaction records consist of tuning-fork curves marked with dots at the moments of stimulation and reaction. The 'spark method,' as it is termed, is described by C. B. Bliss, *Yale Studies*, i., 1893, 2 ff.; see esp. the fig. on p. 13. See also Scripture, *ibid.*, 97 ff.; iv., 1896, 80 f., 124 ff.; *New Psychology*, 83 ff., 135 ff.

The author has not worked with the spark method, and can therefore judge of it only by the printed reports. It seems to be admirably adapted to the recording of simple reaction times. For compound times, Bliss (*op. cit.*, 8 f.) suggests a modification of the method; Scripture (*N. P.*, 155) prefers to substitute the chronoscope for the chronograph. In *Yale Stud.*, iv., 124 the spark method is recommended for both simple and complex (discrimination and choice) reaction times; only 10 of the latter, however, are to be taken, and the times, under the conditions prescribed, would not be of the longest. If, then, the spark method is available only

¹ On other simple tuning-fork arrangements, see vol. i., I. M., 227; P. C. Colls, *Proc. Phys. Soc.*, Decr. 1895 (*Ann. psych.*, ii., 1896, 770).

for the simple experiment, and another set of instruments has to be provided for the compound, it would seem better to have recourse from the outset to some form of chronoscope. On the other hand, the spark method has uses beyond the limits of the reaction experiment: see Scripture, N. P., 98 f., 126; Yale Stud., iv., 113, 121, 127.

On the chronographic method in general, and the spark method in particular, see O. Langendorff, *Physiol. Graphik*, 1891, 119 ff., esp. 142 ff.; É. J. Marey, *Méthode graphique*, 1878, 133 ff., 322 f., 456 ff.

Wundt's chronograph, which is ordinarily employed by users of the Hipp chronoscope to determine the constants of their control apparatus, is described by L. Lange, P. S., iv., 1888, 457 ff.; cf. Wundt, P. P., ii., 1893, 338 ff.; iii., 1903, 405 ff.; Cattell, A. J., iv., 1892, 597; Wundt, P. S., viii., 1893, 653; Külpe and Kirschmann, *ibid.*, 162. References to the earlier literature will be found in Wundt, P. P., ii., 1887, 282; ii., 1893, 343. The chronograph of R. Dodge is described in Z., x., 1895, 414 ff.; Sommer, *Ausstellung*, etc., 1904, 64; cf. B. Erdmann and R. Dodge, *Psych. Unt. üb. d. Lesen*, 1898, 105 ff. The spark chronograph of W. von Beetz (*Pogg. Ann.*, cxxxv., 1868, 126) is listed by Kohl (without inductorium) at Mk. 180. Schumann's chronograph (which closely resembles Wundt's) is described in Z., iv., 1893, 51; xvii., 1898, 260.

IV. *Control Instruments.*—It has seemed to the author, in reviewing this field, that practically every laboratory of any consequence has its own control apparatus. It seems, too, that the psychologist who uses a given form of control is apt to become a partisan of that form: doubtless because the apparatus, being an apparatus of precision, requires constant oversight, and everyone prefers to employ the instrument whose difficulties he has overcome for himself. In reality, it is a matter of no moment which of the three current forms of control one adopts, provided only that the instrument is well constructed, and has a sufficiently large range of times.

(1) *Gravity Chronometers.* To mention here are the Hipp gravity apparatus (p. 344 below) and the Cattell gravity chronometer (p. 345). A new gravity apparatus has recently been described by Ebbinghaus (*Z.*, xxx., 1902, 292 ff.); the instrument has a range of 0.1 to 0.4 sec., and is accurate to the $\frac{1}{1000}$ sec. It is made by E. Schultz (successor to F. Tiessen) of Breslau; the price is Mk. 160-180. See R. Sommer, *Ausstellung von exper.-psych. App. u. Methoden*, 1904, 64 ff.

A gravity apparatus, in which a ball drops from a height of 7 feet, was described by Jastrow in *A. J.*, iv., 1891, 208 ff.; cf. Bergström, *Psych. Rev.*, vii., 1900, 487. The author is informed that similar apparatus are in use in the laboratories of Michigan and Nebraska Universities.

(2) Control pendulums are described by L. Witmer, *Psych. Rev.*, i., 1894, 506 ff., and by H. J. Watt, *Theorie d. Denkens*, 1904, 10 ff. Witmer remarks (514) that Cattell's pendulum stimulator is employed for control purposes at Columbia University. The catalogue of the Harvard laboratory (1893) includes a Münsterberg pendulum—a combined stimulator and con-

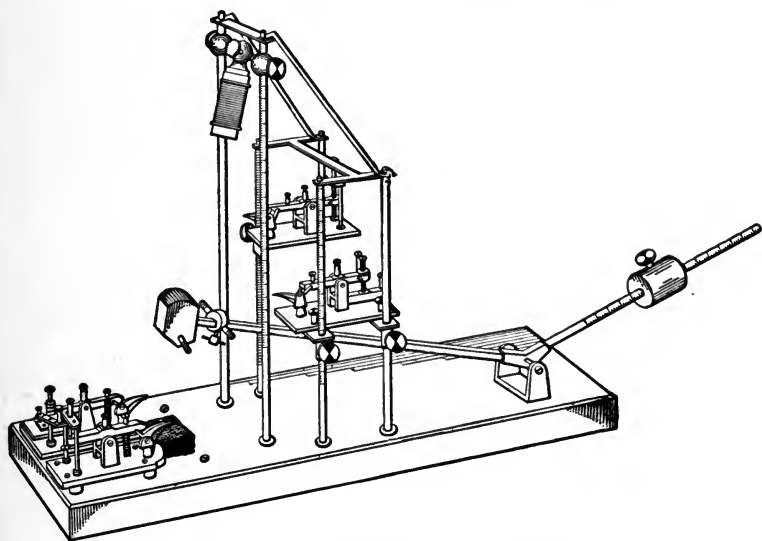

FIG. 45.—Wundt's large control hammer.

trol—made by Elbs; the price is not stated (12, no. 127). Pendulum controls are also employed, e.g., at the Clark and Michigan laboratories; in the Giessen Psychiatr. Klinik (R. Sommer, *Ausstellung von exper.-phys. App. u. Methoden*, 1904, 66 f.); and, apparently, at the Göttingen laboratory (*ibid.*, 67).

(3) Four hammers are made by Zimmermann: the original Krille hammer (G. O. Berger, *P. S.*, i., 45; L. Lange, *ibid.*, iv., 482; Wundt, *P. P.*, ii., 1887, 276: Mk. 78), the large hammer shown in Fig. 45, the simple hammer shown in Fig. 52 of the

text (Mk. 145), and the Lange control for the chronograph (P. S., iv., 458; Wundt, P. P., ii., 1893, 339; iii., 1903, 406: Mk. 95). The large hammer costs Mk. 340; it is described by Külpe and Kirschmann, P. S., viii., 1892, 145 ff., and by Wundt in the last two edns. of the P. P. The instrument has a range of 0.1 to 0.6 sec. It will do everything that is asserted of it; but it is unnecessarily complicated (see Fig. 46) and extremely sensitive (Külpe

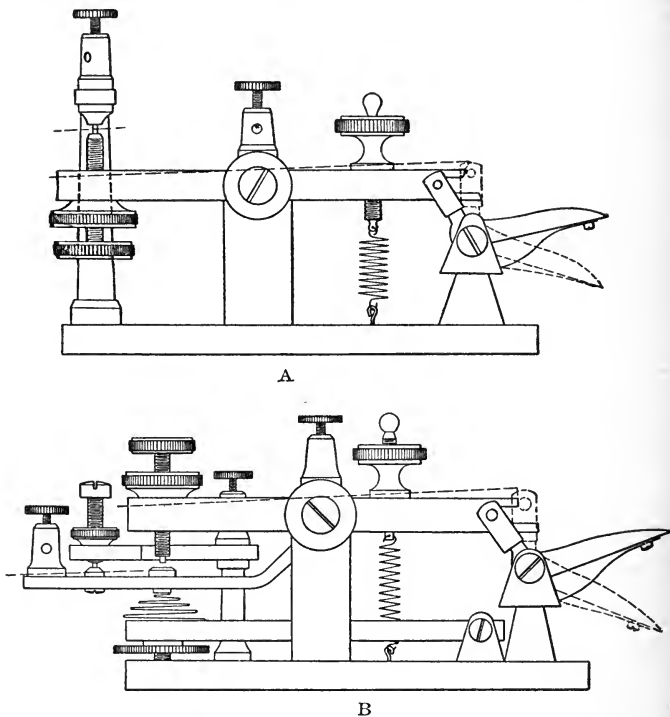

FIG. 46.—*A* break, *B* make or break mechanism of the large control hammer. See Wundt, P. P., ii., 1893, 332 f.; iii., 1903, 398 f.

and Kirschmann, 170). The author can by no means recommend it for general laboratory use.¹

¹ Cf. F. Kiesow, Z., xxxv., 1904, 9.—In response to an enquiry concerning the time-limits of the simplified control hammer, figured in the text, Herr Zimmermann very kindly made a series of experimental tests, with the result "dass bei demselben die längste Zeitdauer des Falls 600σ beträgt," *i.e.*, that the limits are identical with those of the large control hammer.

A hammer built upon the same general principle, but differing in details of construction, is described by E. T. Dixon, *Journ. of Physiol.*, xx., 1896, 78 ff. The instrument gives times up to 400 σ and the author believes that "there would be no difficulty in making a small hammer to give reliable results up to 1 sec."

The author has himself used the large Wundt control hammer at intervals for the past twelve years, and has naturally acquired a liking for the instrument and some skill in its manipulation. In his own or in other experienced hands, it works admirably. But he has never ventured to entrust it to undergraduate students. All things considered, he has little doubt that, for ease of manipulation and range of usefulness, a heavy pendulum with wheel contacts is the form of control to be recommended to new laboratories. This does not at all mean that the other controls are unreliable; as was said above, it is indifferent for accuracy of result what form one employs, provided that the instrument is good and that one works sympathetically with it. That Külpe and Kirschmann, *e. g.*, obtained poor results with the gravity chronometer (148) means simply that the machine was poorly made, or that it was too new to work smoothly, or that the writers did not acquire sufficient practice in its manipulation. The off-hand judgment of Dessoir (*Arch. f. Physiol.*, 1892, 307) is not to be dignified by the name of criticism. Professor Wundt once informed the author that the hammer had proved, in practice, a much better type of control apparatus than the pendulum. But this would seem, after all, to be merely a matter of care in construction and usage.¹

On the *technique and results* of control experiments with the hammer, see G. O. Berger, *P. S.*, iii., 1886, 44 ff., 93; L. Lange, *ibid.*, iv., 1888, 483; Münsterberg, *Beitr.*, i., 1889, 68; iv., 1892, 40 ff.; Müller, *Gött. gel. Anz.*, 1 Juni 1891, 398; *Z.*, iv., 1893, 404 ff.; O. Külpe and A. Kirschmann, *P. S.*, viii., 1892, 145 ff. On experiments with gravity apparatus, see J. Jastrow, *A. J.*, iv., 1891, 208 ff.; J. McK. Cattell and C. S. Dolley, *Mem. Nat. Acad. Sci.*, vii., 1896, 397 ff. (*cf.* Cattell, *P. S.*, iii., 1886, 97, 307 ff.; *Mind*, O. S., xi., 1886, 223; *Brain*, viii., 1885, 295); H. Ebbinghaus, *Z.*, xxx., 1902, 292 ff.; Witmer, as cited below. On the pendulum control, see L. Witmer, *Psych. Rev.*, i., 1894, 506 ff.; H. J.

¹ Both Wundt (*P. P.*, iii., 1903, 399, 410) and Müller and Pilzecker (*Gedächtniss*, 1900, 5) speak as if the direct control of the hammer by a tuning-fork were a simple matter of course. In the author's experience (it is true that his hammer has not the special attachment shown in Zimmermann's 1903 catalogue), the operation requires a good deal of patience and some little skill.

Watt, *Theorie d. Denkens*, 1904, 13. Hints of procedure are, of course, given time and again in the literature of reaction experiments: so, *e.g.*, by G. Martius, *P. S.*, vi., 1891, 407 f.

Among other instruments that have been used for control purposes we may mention the Schumann 'time sense' apparatus (F. Schumann, *Z.*, xvii., 1898, 253 ff.; Müller and Schumann, in *Gedächtniss*, 289 ff.). Külpe's chronoscope attachment (listed by Zimmermann for Mk. 15) enables one to dispense with a control instrument, and to record the chronoscope times directly upon the chronograph. It is described by H. J. Watt, *Theorie des Denkens*, 1904, 9 ff.

V. *Stimulators*.—(1) *Noise*. The stimulator shown in Fig. 153 of the text was suggested by the gravity apparatus formerly sup-

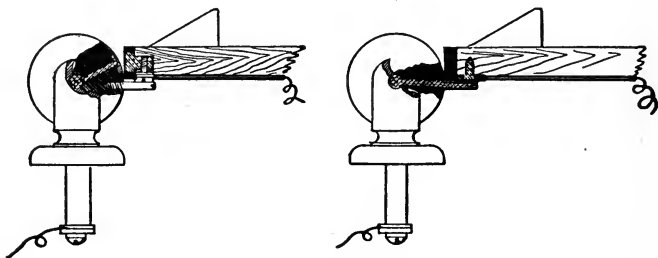

FIG. 47. Detail of wheel contacts of noise stimulator.

plied by Hipp with the chronoscope. The older model of this apparatus (which had serious defects¹) is figured, *e.g.*, by Wundt, *P. P.*, ii., 1893, 322; iii., 1903, 388; a new model is listed and figured by Zimmermann, *Cat.* 1903, 33 f. The wheel contacts were suggested by Cattell and Dolley, *Mem. Nat. Acad. Sci.*, vii., 1896, 399. They are shown in detail in Fig. 47.²

¹ See, however, Sommer, *Psychopath. Untersuchungsmethoden*, 1899, 158 ff. The apparatus is sold by Peyer and Favarger for Fr. 75.

² The use of the instrument, as shown in Fig. 53 of the text, implies that *E* and *O* are in the same room, and that the stimulator stands upon *E*'s table. If the ball is of steel, the forceps may be replaced by an electromagnet, controlled by *E* in the instrument room, and the ball may be set in position, after every experiment, by *O* in the reacting room. The base may also be made larger, and the standard erected upon it, so that the entire apparatus is constructed in one piece. The author has sought, however, to render it as cheap and simple as possible.

The sound hammer appears to have been devised by W. Hankel (Ber. d. kgl. sächs. Ges. d. Wiss., math.-phys. Cl., xvi., 1864, 51, 58; Pogg. Ann., cxxxii. [ccviii.], 1867, 139, 147 f.), and to have been brought to its present form by Wundt: see P. P., 1874, 732; ii., 1880, 224. Fig. 54 of the text is from Zimmermann's Cat., 1903, 31. Other models are shown, *ibid.*, 53, and Wundt, P. P., ii., 1893, 423; iii., 1903, 503.

(2) *Tone or Noise*. For this arrangement, see Bliss, Yale Stud., i., 1893, 13.

A tone stimulator is described by von Kries and Auerbach, Arch. f. Physiol., 1877, 323 f. (Taf. ix., Fig. 5). A steel spring or lamella is clamped above the pole of an electromagnet. The current in the magnet is not so strong that the lamella is pulled down, but is strong enough to enable the magnet to hold the lamella if it is bent down by hand. At the moment of break, the lamella is released, and vibrates at its proper frequency, thus giving a tonal stimulus.

(3) *Clang*. See G. Martius, P. S., vi., 1891, 403. The clangs employed gave fundamental tones of 33, 264, 1056 and 2112 vs. The heaviest wire was not actuated by the pick, but was held with the gloved finger against a brass plate until the moment of stimulation arrived.

Reactions to musical chords were taken in 1891 by E. Tanzi, who connected the keys of a pianoforte with the chronoscope circuit. See Riv. di Filos. scient., x., Decr. 1891, 747 ff.

Hankel (Ber., 60; Pogg. Ann., 150) substituted a gong for the ambos of his sound-hammer, and obtained "einen kurzen und scharfen Ton."

(4) *Light*. (a) Fig. 56 of the text is taken from L. Lange, P. S., iv., 1888, 482. The pendulum is described in detail by Wundt, P. P., ii., 1893, 334 ff.; iii., 1903, 400 ff. It is figured by Zimmermann, Cat. 1903, 23. Krille's device for breaking the circuit is figured by O. Langendorff, Physiol. Graphik, 1891, 123.—The pendulum is a good and reliable instrument, but is too complicated for use in a drill course.

Another form of pendulum stimulator is figured and described by Fullerton and Cattell, Small Diffs., 1892, 135 ff.

(b) The gravity chronometer shown in Fig. 58 of the text was

devised by Cattell, and is described in P. S., iii., 1886, 97 f., 307 ff.; Mind, O. S., xi., 1886, 223 ff. The Fig. itself is from P. S., iii., 315: or Wundt, P. P., ii., 1887, 327. A more elaborate instrument is described by Cattell and Dolley, Mem. Nat. Acad. Sci., vii., 1896, 397 ff. An arrangement for tachistoscopic purposes is figured by J. Zeitler, P. S., xvi., 1900, 381. Wundt's demonstrational form of the instrument (Lectures, 242) is well known: the author has made it more manageable by using, in place of the falling screen, a black cloth shutter wound upon spring rollers.

(c) A serviceable shutter is described, though with insufficient detail, by E. T. Dixon, Journ. of Physiol., xx., 1896, 77 f. Jastrow's shutter was formerly sold by the Garden City Model Works, Chicago, Ill., for \$8.50; it is furnished with vertical guides and a spring lever (not shown in Fig. 59 of the text) whereby a series of cards may be exposed in quick and regular succession. The instrument is not solidly built, and has a rather large error, depending in part on the tension of the elastic band; but the principle is correct.

(4) *Pressure.* The areal make stimulator was devised (primarily for taste reactions) by von Vintschgau (M. v. Vintschgau and J. Hönigschmied, Pflüger's Arch., x., 1875, 2 ff., 28; J. M. Dietl and M. v. Vintschgau, *ibid.*, xvi., 1878, 318).¹ M. Dessoir's sensibilometer is figured and described in Arch. f. Physiol.,

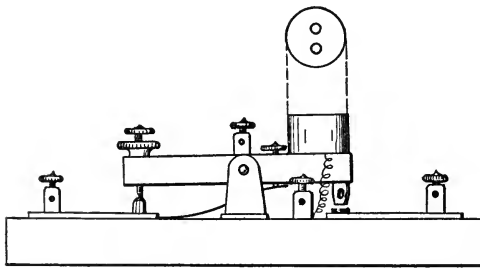

FIG. 48. Ewald's reaction key. See Dumreicher, Zur Messung d. Reactionszeit, 1889, Fig. 3.

1892, 308 ff., 313. The break stimulator is a slightly modified form of Scripture's touch key (Yale Stud., iii., 1895, 107 f.; New Psych., 135), which remakes the circuit immediately after break. Ewald's instruments are described by O. Dumreicher, Zur Messung der Reactionszeit, 1889, 32 ff.; Fig. 62 of the text is from Dumreicher's Fig. 2. The accompanying Figg. 48, 49 show Ewald's reaction key and rocker.

¹The instrument is figured by G. Buccola, Legge del Tempo, 1883, Tav. i., Fig. 10; G. Sergi, Psych. physiol., 1888, 295.

The punctual stimulator ('electroaesthesiometer') called for by Question (6) is described by F. Kiesow, *Z.*, xxxv., 1904, 10.

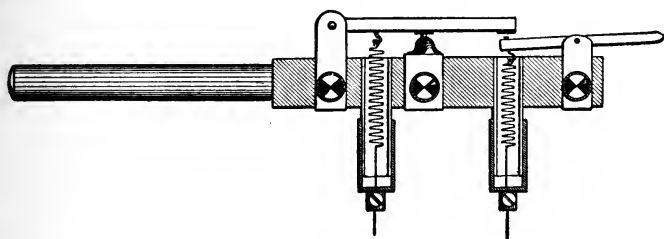

FIG. 49. Ewald's rocking key. See Dumreicher, *Zur Messung d. Reactionszeit*, 1889, Fig. 5.

There seems to be no reason why von Frey's apparatus for the 'space limen' (*Z.*, xxvi., 1901, 34; xxix., 1902, 162) should not be adapted to reaction work.

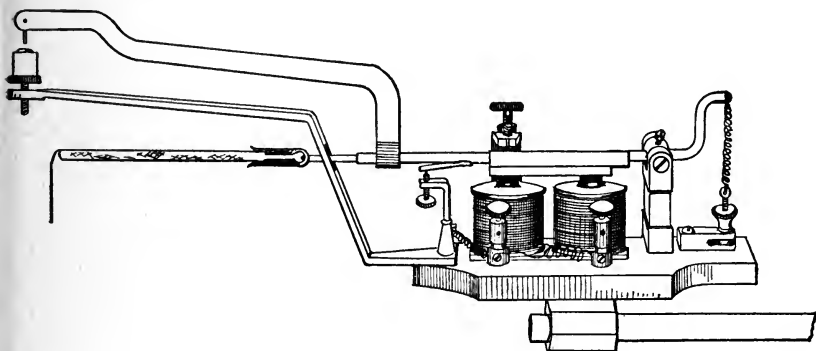

FIG. 50. Kiesow's electroaesthesiometer.

The induction shock has been a favourite form of cutaneous stimulation. For another arrangement see, *e.g.*, J. von Kries and F. Auerbach, *Arch. f. Physiol.*, 1877, 308 ff.; *Taf. viii.*, Fig. 4.

The earliest experiments with light, sound and electrical cutaneous stimuli are those reported by A. Hirsch in 1862 (*Bull. de la soc. des sciences naturelles de Neuchâtel*, vi.: reprinted in *Moleschott's Untn.*, 1863). It was Hirsch, also, who proposed the phrase 'physiological time' in place of the older 'personal equation.' The earliest cutaneous experiments with mechanical stimulation are those of W. Hankel (*Ber.*,

67 f.; Pogg. Ann., 158 f.). T. C. Mendenhall (Am. Journ. Sci. and Arts, 3 Ser., ii. [cii.], 1871, 158) appears to have used a rough form of sensibilmeter.

(5) *Temperature*. The thermophor is figured and described by M. von Vintschgau and E. Steinach, Pflüger's Arch., xliii., 1888, 153 ff. Other temperature stimulators are described by A. Goldscheider, Ges. Abh., i., 1898, 316 (Arch. f. Physiol., 1888, 424); A. Rémond, Recherches exp. sur la durée des actes psychiques les plus simples, 1888, plate following p. 12. The arrangement for punctual stimulation was suggested by the apparatus of F. Kiesow, P. S., xiv., 1898, 589.¹

For a report of experiments with diffused stimulation, see J. Pollitzer, Journ. of Physiol., v., 1884, 143; E. Tanzi, Riv. sperim. di Freniatria, xvi., 1890, 385.

(7) *Smell*. The break stimulator is described by W. Moldenhauer, P. S., i., 1883, 607 f. The break mechanism is shown *ibid.*, 421, Fig. 1 (Kraepelin's voice key).² The make stimulator is figured and described by G. Buccola, La Legge del Tempo nei Fenomeni del Pensiero, 1883, 44 f.; Tav. i., Figg. 8, 9, 9 (bis);³ G. Sergi, Psych. physiol., 1888, 294. The olfactometric arrangement was suggested by H. Zwaardemaker, Physiol. d. Geruchs, 1895, 198. See also N. Vaschide, Trav. du Lab., Asyle de Villejuif, 1902.

(8) *Taste*.—See M. von Vintschgau and J. Hönigschmied, Pfl. Arch., x., 1875, 2 ff.; C. Henry, Compt. rend. de la soc. de biol., Oct. 27, 1894. The earliest experiments were made by W. H. von Wittich and A. Grünhagen, Z. f. rationelle Medicin, 3te Reihe, xxxi., 1868, 113.

(9) *Pain*. Practically nothing has been done with the sense

¹ The results of some experiments with punctual stimulation have been published by A. Lehmann (Hauptgesetze d. menschl. Gefühlslebens, 1892, 40), who, however, does not describe his procedure.—The earliest experiments in this field were made by A. Herzen, Lo Sperimentale, xliv., Oct. 1879, 354.

² A somewhat similar instrument had been employed by H. Beauais, Gazette méd. de Paris, no. 6, 10 Fév., 1883; Comptes rendus, xcvi., 1883, 387; Recherches expér. sur les conditions de l'activité cérébrale, 1884, 49. Cf. Buccola, 109 f.; Zwaardemaker, 197.

³ It may be worth remarking that the priority of work in this field belongs to Buccola: see Arch. ital. per le malattie nervose, no. 6, Nov. and Dec., 1882, 416; Riv. di filos. sci., ii., 1883, 453; Arch. ital. de biol., v., 1884, 289.

of cutaneous pain, although there is no reason why experiments should not be made with a punctual stimulator, on the model of Kiesow's electroæsthesiometer. See E. H. Weber, Wagner's *Hdwbch.*, iii., 2, 1846, 572 ff.; S. Exner, *Pfl. Arch.*, vii., 1873, 623; O. Rosenbach, *Deutsche medicin. Wochenschrift*, x., 1884, no. 22, 338; xv., 1889, no. 13, 248; E. Tanzi, *Riv. di Filos. scient.*, v., April 1886, 215 ff.; M. Dessoir, *Arch. f. Physiol.*, 1892, 323 ff.

VI. *Reaction Keys*.—Reaction keys in the various psychological laboratories are as leaves in Vallombrosa; but, until recently, very little attention has been given to the reacting movement. We will take the keys first.

A perfectly good break key may be made of two pieces of spring brass, laid end to end with some overlap upon a wooden base, and fastened at their outer ends with binding posts: the inner end of the lower strip is fixed to the base, while that of the upper is left free, and carries a hard rubber button. Pressure on the button holds the key closed; when the finger is lifted, the button springs up, and contact is broken. The key ordinarily employed for reaction work, however, is a modified form of the telegraph key; an early form is shown in Wundt, *P. P.*, 1874, 770. Zimmermann makes a simple key for Mk. 12.50; the ordinary form is listed by him at Mk. 28, but the regular \$3.00 telegraph key will answer very well. A standing objection to this type of key is that *E* must rely upon *O* to maintain contact, by pressure of the finger, until the moment of reaction arrives. In the author's experience, the objection is not serious; with a very little practice, *O*'s handling of the key is rendered automatic. The press-key is described by Jastrow in *A. J.*, iv., 1891, 210; another form, in which there are three binding posts and the restraining spring is concealed in the central upright, was listed by the Garden City Model Works in 1894 for \$3.50. The thumb-and-finger key was introduced by Dessoir in 1892: in its original form, it consisted of two hard rubber rings, fitted with contacts and binding posts, and shaped to slip over *O*'s thumb and finger; the range of movement was limited by two inelastic bands fastened to the rings on either side (*Arch. f. Physiol.*, 1892, 309). Scripture's modification is described in *Yale Stud.*, i., 1893, 88. Zimmermann lists it at Mk. 30.

Cattell's lip key is figured, *e.g.*, in *Mind*, O. S., xi., 1886, 225; P. S., iii., 1886, 312. Zimmermann lists it at Mk. 25. Meumann's biting key is listed by Zimmermann at Mk. 12.50. A speech key, of the same general pattern, is described by Kraepelin, *Ueber d. Beeinflussung einf. psych. Vorgänge*, etc., 1892, 17; *cf.* E. Roemer, *Psych. Arbeiten*, i., 1896, 568 ff. Jastrow's speech key (*A. J.*, iv., 1892, 201, 412) was advertised by the Garden City Model Works at \$3.50.

An eyelid key (stimulation of the one eyelid and reaction by the other) is listed by Zimmermann at Mk. 39.

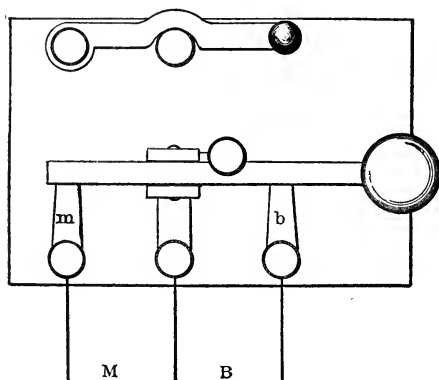

FIG. 51.—Ranschburg key. The contact tongues *m*, *b* can be swung in or out, as make or break is required. *M*, make circuit; *B*, break circuit.

There are numerous keys whereby two contacts may be made, or two broken, at the same moment; and others which may be used either for make or for break, as occasion demands. Typical of this latter class is the key supplied with the Ranschburg apparatus (Fig. 51), which has also an arrangement for short-circuiting. More important are the keys which serve to make and break instantaneously. Ewald's rocker is shown in Fig. 49 above. Jastrow has a key, built in the regular telegraph form, which answers the same purpose (listed by Garden City Model Works at \$7.00). The most elaborate key of this sort is Scripture's multiple key (*Yale Stud.*, i., 12, 98, etc.), supplied by the Yale Laboratory for about \$25.00.

Cattell's voice key is described in *Mind*, *l. c.*, 226; P. S., *l. c.*, 313 f.; Wundt, P. P., ii., 1893, 337; iii., 1903, 403.¹ A more compact form, in which the diaphragm and electromagnet are set up upon a single base, is described by E. Roemer, *Psych. Arbeiten*, *l. c.*, 578; *Année psych.*, iii., 1897, 657. Wundt's original

¹ *Cf.* H. J. Watt, *Theorie d. Denkens*, 1904, 9 f.; Erdmann and Dodge, *Psych. Unt. üb. d. Lesen*, 1898, 111. Erdmann and Dodge (283) also attempted to construct a chin-key, but without success.

voice key, in which a plate of aluminium is thrown back (and contact thus broken) when an explosive consonant is spoken into the funnel, is described by Kraepelin, *P. S.*, i., 1883, 421 (*cf.* the figure of Moldenhauer's smell stimulator, p. 162 of the text). The 'Libbey-Baldwin key,' referred to in the *Dict. of Phil. and Psych.*, i., 1901, 614 (*cf.* H. C. Warren, *Psych. Rev.*, iv., 1897, 580) appears to be of this latter type.

There are occasions when the ordinary apparatus of the reaction experiment cannot be used, and it is necessary to devise new instruments to suit the novel conditions. A good illustration is found in the pendulum employed by R. Dodge to determine the reaction time of the eye,—a pendulum which is at once pendulum chronoscope, stimulator, and reaction key. See *Psych. Rev.*, vi., 1899, 477 ff.; *cf.* B. Erdmann u. R. Dodge, *Psych. Untn. über das Lesen*, 1898, 121 ff.

VII. *The Reaction Movement*.—In the *P. P.*, iii., 1903, 390, Wundt speaks decidedly in favour of the finger key. "Ueberall, wo es frei steht, die Art der Reaktionsbewegung zu wählen, ist die combinirte Bewegung von Hand und Arm wegen der natürlichen Uebung, die ihr zu statten kommt, vorzuziehen, weil sie sich nicht nur am gleichförmigsten und schnellsten, sondern namentlich auch am längsten ohne Ermüdung ausführen lässt." The author has never felt any inclination to move the arm, in reaction experiments; nor is it clear to him that the movement of the hand is quicker or more practised than the movements of speech. However, the finger key is the key that has been most used, and it is therefore necessary to consider the character of the reaction movement, as performed with this key.

In the first bit of systematic work upon reactions that he undertook (*P. S.*, viii., 138 ff.), the author found that the lift of the finger from the button of the key was by no means so simple and easy as had been reported. There was a tendency, especially in muscular reactions, to cramp the finger upon the key; and there was a tendency, when the moment for reaction arrived, to heighten this form of innervation, *i.e.*, to increase the downward pressure, before the lift was executed. The result was an undue lengthening of the reaction times. In view of this source of error, Professor Wundt suggested that the reacting finger be laid upon

the side of the button, and slipped or snapped off by a downward movement to the table, instead of raised. This mode of reaction was accordingly adopted in the P. S. investigation, and in the early work of the Cornell laboratory (A. J., vi., 1894, 242 f.).

So the matter rested, until in 1900 W. G. Smith published his *Observations on the Nature of Human Reaction Movements* (Proc. Physiol. Soc., Oct. 20; Journ. of Physiol., xxv., p. xxvi.). Smith found that 8 of his 13 O's lifted the finger with no appreciable hesitation, while 5 began the reaction movement by pressing the finger downward. The reaction key was an inverted transmission sphygmograph, connected with a Marey tambour and writing lever. The mode of reaction was not appreciably affected by the direction of attention.

In 1903 Smith published results obtained from 33 O's. Of these, 5 gave fairly constant evidence of the 'antagonistic' mode of reaction; 5 showed this form intermittently; 18 lifted the finger without hesitation; 5 furnished doubtful records. The preliminary antagonistic movement (which seems, in Smith's experiments, to have been unremarked by the O's) averaged .04 to .05 sec. When this period is subtracted from the total time of the record, it appears that the true reaction time is often shortest in the 'antagonistic' form of reaction. This result may mean either one of two things. Either a greater intensity of muscular innervation has actually shortened the time of reaction; or the 'ordinary' reactions are usually lengthened by an inner conflict of nervous impulses, which are not strong enough to manifest themselves in the graphic tracing. Smith did not in all cases obtain the sensorial-muscular difference, and did not attempt to train his O's to give it; he declares, however, that "difference in the adjustment of attention has no marked influence on the mode of reaction." He advises that the reaction curve of each O be analysed, graphically, before recourse is had to the chronoscope (Mind, N. S., xii., 47 ff.).

It is obvious that we have here by no means reached a full understanding of the antagonistic reaction. What, *e.g.*, is the effect of practice upon the antagonistic movement? Smith was able to make but a limited number of experiments (49), and does not answer the question. He remarks that, in one instance, the effect of fatigue was a return to the

'ordinary' form of reaction. This "may perhaps be interpreted as meaning that the reaction movement was made in a less energetic way" (55). Practice might bring about a similar change. So might a definite instruction to *O*.

Again, it is regrettable that Smith made no attempt to estimate the value of introspective control. Some of his *O*'s knew, some did not know, the purpose of the experiments (49); yet the opportunity for comparative introspection was not taken. "One subject was inclined to believe that the antagonism was more frequent in the muscular reaction, but the curves do not show any decided difference" (55). This sentence points to an introspective difference between the sensorial and muscular forms, which is not improbable *a priori*, since in the sensorial form attention is directed upon the stimulus.¹ At the same time, it might be urged that the sensorial reaction gives abundant scope for introspection during its course. The question should be submitted to a systematic test. For if we find that, after practice, the introspective verdict is reliable, we may dispense with the graphic analysis of the reaction curves. The same thing will hold, of course, if we find that the antagonistic movement disappears with practice, or with suggestion from *E*. Smith's *O*'s were, perhaps, insufficiently practised for the introspective task.

Quite recently, a more elaborate study of reaction movements has been published by C. H. Judd, C. N. McAllister and W. M. Steele (*Yale Stud., N. S., i., 1905, 141 ff.*). A special reacting key was devised, and the reaction records were both graphic and chronoscopic; 51 *O*'s gave 964 graphic records of simple (sound) and 523 records of discriminative (colour) reaction. The general results are as follows.

Only 19 records in the whole group of simple reactions appear simple throughout; and the simplicity is, in all likelihood, illusory. (1) Fully one third of the records are 'wavy,' *i.e.*, show a periodic relaxation and pressure; here "a rhythmical balance is maintained between the tendency to react and its antagonistic." (2) The 'antagonistic' type tends to prepare for the reaction by gradually or suddenly moving in the opposite direction; here, instead of a balance, "the antagonistic tendency is for the time being in the ascendancy." (3) Another type "is that in which a partial reaction, either sudden or gradual, precedes the true reaction"; there is "preponderance of the preparation for reaction over the checking

¹ Moreover, it was in work upon the muscular form that the author first lit (by introspection) upon the fact of the antagonistic movement.

antagonistic strain."—Of the 51 *O*'s, 10 regularly show the antagonistic tendency when preparing for a reaction; 2 are clearly predisposed towards partial reaction; 4 give the characteristic wavy or balanced records; and 2 "maintain by voluntary strain even a better balance than is exhibited in the wavy form of record" (166 ff.).

In these experiments, *O* held down a long strip of spring brass, and reacted by lifting his finger (143). In another series, *O* "pressed upward against an additional spring during the period of preparation, and when he received the stimulus made a strong enough movement to pass the additional spring completely, and thus executed the required upward movement of complete reaction." Under these conditions, the *O*'s of the antagonistic type gave up the antagonistic movements: "there appeared in their places either level lines, or wavy lines, or gradually downward sloping lines, more commonly the last." *O*'s of the non-antagonistic type showed a marked tendency "to abandon all other forms of movement in favour of the gradual upward preparation" (173 f.).

The writers further discuss the influence of the warning signal (148, 164, 168), the time values of the reactions (168 ff., 174 f.), the significance of the form of key employed (176 f.), the nervous habits of the *O*'s (177 ff.), the question of sensory and motor reactions¹ and of 'reaction types' (179 f.), and the relation of the various phases of reaction to consciousness (180 ff.).—

There can be no doubt that this work marks a distinct step in advance beyond that of Smith. Criticism is largely disarmed, both by the positive content of the investigation and by the admissions and promises of the writers (142, 168, 176 f., 179 f.). It must, however, be remembered that, so far, the results obtained hold only for the particular *O*'s under the particular conditions of the experiment.² We do not know what would have happened had the *O*'s been longer practised; had trained reactors been taken; had a key been employed that more nearly approached the regular telegraph form; had the work been done by *O*'s accustomed introspectively to report upon the reaction consciousness; had the instruction to react "as quickly as possible" been modified or omitted. Not

¹ The confusion that still obtains in reaction work is illustrated by the fact that the writers, having directed their *O*'s "to move the hand as quickly as possible after receiving the stimulus" (142), nevertheless feel called upon to raise the sensory-motor issue.

² The failure of T. V. Moore (*Psych. Rev. Mon. Suppl.*, 24, 1904, 55) to obtain evidence of the antagonistic reaction movement is sufficiently explained by the Yale experimenters (*op. cit.*, 175 f.). Moore's paper is devoted to a consideration of the time required for the reaction movement under different conditions: see summary, 55 ff. Some literary references are given, 4 ff.

until these and similar questions have been answered can we bring the recorded variations in the reacting movement into fruitful relation with the reaction times and their variability.

No work has been published, to the author's knowledge, upon the downward or pressing movement. It is not unlikely that this is preceded, in a certain percentage of cases, by an antagonistic lift.¹

Practically all those who have worked with the lip key have noted a tendency to premature reactions; the lips are often opened before the reaction proper is made. Cf. Cattell, P. S., iii., 313; A. R. Hill and R. Watanabe, A. J., vi., 244 f.; E. Roemer, Psych. Arbeiten, i., 568 ff.; Müller and Pilzecker, Gedächtniss, 1900, 7. Dessoir remarks (Arch. f. Physiol., 1892, 311) that his thumb-and-finger key "in jeder Beziehung sehr bequem ist." Hill and Watanabe (*l. c.*, 246) found, however, that one of their 5 *O*'s had great difficulty in handling the key (a copy of Dessoir's instrument).

Zimmermann lists a pneumatic key (Mk. 35) which, with a slight modification, may be employed in practice experiments either with lift or with pressure of the finger.

QUESTIONS.—(1) See, *e.g.*, Kiesow, Z., xxxiii., 1904, 453 ff. (2), (3), (6) Answer from the foregoing §§. (4) It may be worth while to point out that Wundt (P. P., iii., 1903, 382) sets the lower limit of accuracy for the recording instrument at $\frac{1}{100}$ sec. The student may also be referred to E. Leumann, P. S., v., 1889, 620. (5) This Question is meant to refer the student to the literature: he should have some idea of the great variety of devices that have been employed in the reaction experiment. See, *e.g.*, B. Lewis, Journ. of Ment. Sci., xxxix., 1893, 505. (7) If cross-wires and rocker are retained, it may be used to reverse the direction of current in a single circuit. If cross-wires are re-

¹ The author has made some experiments upon this question, and has found no trace of the antagonistic lift, even in the case of *O*'s who gave (intermittently) the antagonistic pressure in the lifting reaction. The tests were, however, too few to serve as the basis of a generalisation.—On the force and rapidity of reaction movements, see E. B. Delabarre, R. R. Logan and A. Z. Reed, Psych. Rev., iv., 1897, 615.

moved, and rocker retained, it will serve as two simple keys, making and breaking two circuits alternately. If cross-wires are removed, rocker retained, and connection made to two adjacent binding posts (the one of which is a rocker post), it will serve as a simple make or break key.

§ 37. **The Three Types of Simple Reaction.**—The literature of the reaction experiment is very extensive. No attempt is made, in this Chapter, to present a bibliography; but the references that are given incidentally will enable the student to find his way to other investigations.

The history of the experiment falls, roughly, into the following four periods.

(1) The astronomical period: the 'personal equation.'

This period opens with the tragic dismissal of D. Kinnebrook, in 1796, by the British astronomer-royal, N. Maskelyne; and extends to about 1865. For an account of it, see E. C. Sanford, *A. J. P.*, ii., 1888-9, 3 ff., 271 ff., 403 ff.

(2) The physiological period: the 'velocity of the nervous impulse.'

This period begins with the work of A. Hirsch, in Moleschott's *Untersuchungen*, ix., 1863, 183 ff. Its positive conclusion is, perhaps, given with S. Exner's paper in *Pflüger's Arch.*, vii., 1873, 601 ff.¹ Criticism of the method was kept up, pretty continuously, till 1880. See O. Dumreicher, *Zur Messung d. Reactionszeit*, 1889, 14 ff.

(3) The psychophysical period: the 'duration of simple mental processes.'

This period may, perhaps, be dated from the work of Donders and his pupils (J. J. de Jaager, *Over den physiologischen tijd der psychische processen*, Utrecht, 1865; F. C. Donders, *Arch. f. Anat. Physiol. u. wiss. Med.*, 1868, 657 ff.). It has continued to the present time, though it seems to culminate in the late seventies and the eighties of the last century. See J. Jastrow, *The Time Relations of Mental Phenomena*, 1890 (selected bibliography of 57 titles); K. Fricke, *Biol. Centralbl.*, viii., 1889, 673; ix., 1889, 234, 437, 467.

A psychophysical sub-period (the period of mental tests) may be dated from Galton's introduction of the reaction experiment into the anthropometrical laboratory in 1889. This period also continues to the present time, though it seems to culminate towards the end of the nineties.

¹ Exner introduced the term 'reaction time,' to replace the older 'physiological time': see Hermann's *Hdbch.*, ii., 2, 1879, 262.

(4) The psychological period: the 'analysis of the action consciousness.'

The first definite expression of the psychological attitude towards the reaction experiment occurs, so far as the author can discover, in Külpe's *Grundriss*, 1893, 421. "Die Reactionen sind . . . nichts Anderes als exacte Typen dessen, was man in der Psychologie des gewöhnlichen Lebens als *Handlungen* bezeichnet Dadurch erhalten die Reactionen eine weit über ihre blosse Dauer hinausreichende Bedeutung."¹ Wundt gives it emphatic endorsement in *P. S.*, x., 1894, 498, as the right attitude to assume in all reaction work; and again in *Logik*, ii., 2, 1895, 226; *P. P.*, iii., 1903, 305, 383, 452. The author attempted in 1896 a detailed comparison of the various types of action and the various forms of the reaction experiment: *Outline of Psych.*, 1896, ch. xiv., esp. 333; *cf.* *Primer of Psych.*, 1898, 179 ff., 258 ff.

It must be understood that these periods are roughly dated, and that they are periods in the history of the reaction experiment as considered from the psychological point of view. Thus, astronomical work on the personal equation by no means ceased with 1865. And again: Cattell and Dolley, in 1896, are still interested in the determination of the velocity of the nervous impulse, and Alechsieff, in 1900, in the question of transit observations. Yet again: the beginnings of the psychological period might possibly be set back to Wundt's systematic exposition of 1874, or to the discovery of Orschansky and L. Lange (1887, 1888). In the rough, however, the periods seem to the author to be distinguishable as successive shifts of interest from one aspect of the experiment to another.

At present, the reaction experiment has a twofold value,—psychophysical and psychological. As we shall see later, psychological analysis is a more crying need, just now, than is psychophysical determination. Nevertheless, there can be little doubt that future psychophysical investigations will play into the hands of psychology. It was, *e.g.*, a distinct gain when the use of the frequency polygon led Alechsieff to the conclusion (*P. S.*, xvi.,

¹ There is no hint of this, *e.g.*, in Lange's paper of 1888, or in Dwelshauvers' of 1891. And although the author has made a careful search for anticipations of Külpe's position, he has not found them elsewhere. Fricke's general remarks (*Biol. Centralbl.*, viii., 1889, 677; ix., 1889, 256, 479) were doubtless inspired by Külpe (*cf. ibid.*, viii., 678).

23) that the variation of the reaction time is of more consequence than its absolute duration, "denn für die psychologische Analyse sind solche von den psychologischen Bedingungen verursachte Variationen wichtiger als die Feststellung von Mittelwerthen." And it is surely a sign of the times that much the same thing should be said—in ignorance, apparently, of Alechsieff's work—by W. G. Smith (*Mind*, N. S., xii., 1903, 58) and—in ignorance, apparently, of the statements of both Smith and Alechsieff—by R. M. Yerkes (*Psych. Bulletin*, i., 1904, 137 ff.; *cf.* *Harvard Psych. Studies*, i., 1903, 623 ff.). We may confidently expect that what has happened to the metric methods will also happen to the reaction experiment. With greater accuracy of execution, more regard to the instruction of *O*, and better knowledge of the statistical treatment of results, will come a more penetrating analysis of the conscious processes involved.

EXPERIMENT XXIV

MATERIALS.—It may be repeated that any source of constant current whatever may be employed to actuate the Hipp chronoscope: gravity cells, storage battery, dynamotor, terminals of lighting system,—anything from a little group of Meidingers to the 220 v. circuit with a high lamp resistance.

In a reaction circuit (arrangement II.) measured by the author, the resistance was about 80 ohms. Hence 100 ohms is an outside limit, even for cases where the clock and reacting rooms are somewhat widely separated.

The interval between the ready-signal and the reaction stimulus may be exactly regulated by means of a pendulum (L. Lange, *P. S.*, iv., 1888, 484; Wundt, *P. P.*, iii., 1903, 404 f.). Experience has shown, however, that this further complication of the apparatus is not necessary.

A convenient substitute for the padded plaster mould is the sand-box mentioned in the text, p. 20.

DISPOSITION OF APPARATUS.—If the experiment is conducted in a single room, the bell circuits are dispensed with, and *E* gives the ready-signal to *O* by saying "Now!" before the stimulus is applied. The stimulator may also be transferred to *E*'s table, so

that *O* has nothing before him but the reaction key. Otherwise, the disposition of the apparatus remains the same.

The position of the push button on the reacting table requires *O* to move his right arm for the signal after every reaction. The button might, of course, be brought over to the left of the key, and the signal be given by *O*'s left hand. On the whole, however, the use of the right hand is preferable: fatigue is thus avoided, while the experiment is not delayed.

A somewhat different arrangement of apparatus is figured by Cattell in *Mind*, xi., 1886, 227. No connections are shown in the Fig. The drawing-in of the wires, on a diagrammatic reproduction of the Fig., may be assigned as an exercise to the student. A similar use may be made of the arrangement figured by Cattell and Dolley, *Mem. Nat. Acad. Sci.*, vii., 1896, 399.

As regards arrangement I., Külpe and Kirschmann advise "einen grösstmöglichen Unterschied der in beiden Stromkreisen gesetzten Widerstände" (*P. S.*, viii., 171).

PRACTICE, FATIGUE, ETC.—The time of reaction, like all other psychophysical 'constants,' varies with the conditions under which it is determined; an accurate result presupposes—as it does with the *DL* or with the measure of time discrimination—maximal practice. The attainment of this level of practice is, unfortunately, out of the question in a drill course: partly because but a short time can be devoted to the reaction experiment, partly because the work is not done every day, but suffers interruption from one laboratory period to another.

Wundt has recently laid great stress upon the necessity of maximal practice for the final determination of representative values and of their variability. He gives as practised norms: for simple reactions to light, muscular 150 σ , sensorial 240 σ (N. Alech-sieff); and for simple reactions to sound, muscular 100 σ , sensorial 128 σ (R. Bergemann: see *P. P.*, iii., 1903, 417 ff.). The previously accepted norms have been: for sight, 180 σ and 270 σ , for sound, 120 σ and 230 σ : *cf.* vol. i., I. M., 216. In estimating these results, we are sadly hampered by lack of introspective detail. We know that, in ordinary life, the impulsive action is merely a temporary phase—a poise or balance—of the action consciousness; that

it tends constantly to slip over into ideomotor or even into secondary reflex action. The same thing is eminently true of the reaction experiment. Unless instructions are continually renewed, and unless the introspective control is of the sharpest, all three of the prescribed reaction forms tend to lapse into simpler types (*cf.* the author's *Primer of Psychology*, 1902, 181). Hence, until we have definite and generally accepted analyses of the reaction consciousness, we cannot say at what point maximal practice has been attained, and at what point the given form has begun to degenerate. 'Effect of practice' is thus an ambiguous term: the sensorial time of 128 σ may not be a sensorial time at all, but the time of a reaction that has run down-hill towards the sensorimotor type. Wundt, it is true, gives an elaborate analysis of the reaction consciousness; but it is an analysis based upon and possibly coloured by theory, and not an analysis in terms of a large collection of introspective data. A thorough-going introspective study of action is, as the author has remarked elsewhere (*Science*, xx., 1904, 793; *A. J.*, xvi., 1905, 217), one of the great desiderata of experimental psychology.

The factor of 'warming up' or *Antrieb* has already been mentioned: see p. 150 above.

NUMBER OF EXPERIMENTS.—As regards the number of experiments made, the Instructor must use his discretion. If the students are to continue psychological work beyond the limits of this Course, it will be worth their while to spend some time upon the apparatus, even if the number of reactions taken is thus reduced, say, to 100 for each of the three types. If, on the other hand, the students do not intend to go farther into experimental psychology, it may be better to prepare the apparatus for them, and to let them make, say, 250 experiments of each kind.

The instructions should be repeated, in the same terms, at the beginning of every session, and at the end *O* should be asked—not as a matter of form, but as a matter of vital importance—whether or not they have been obeyed. Carelessness, indifference, tedium,—any one of these things means a change in the character of the reaction.

TREATMENT OF RESULTS.—We will, first of all, work out the

additional representative values for the frog experiments by the rules given above, pp. 8 ff.

Median. The classes and their frequencies are:

135	145	155	165	175	185	195	205	215	225	235
6	6	6	11	15	25	12	12	6	0	1

The median value evidently lies between 180 and 190. There are 44 values below 180, and 31 above 190. There are thus 6 determinations to be taken from below, and 19 from above, before we reach the median. The value 185 occurs 25 times. According to the simplest principle of interpolation, then, we have to take $\frac{6}{25}$ of the 10σ interval and add it to the lower limiting value of that interval, to 180σ; or to take $\frac{19}{25}$, and subtract it from 190. We thus obtain 182.40 as the median value required.

Mode. The empirical mode can be seen, by inspection, to lie at 185σ.

Standard Deviation. The *SD* or *EMS* of the mean is found by the formula $\sqrt{\frac{\sum (v^2 \cdot f)}{n}}$. The sum of the v^2 in the present case is $2025 \times 6 + 1225 \times 6 + 625 \times 6 + 225 \times 11 + 25 \times 15 + 25 \times 25 + 225 \times 12 + 625 \times 12 + 1225 \times 6 + 3025$ or 47300; and n is 100. Hence we have $\sqrt{473}$ or 21.75σ as the *SD*.

Coefficient of Variation. This value, of which we have not yet spoken, is determined by the formula $\frac{SD \times 100}{M}$. In the present case it is, accordingly, $\frac{21.75}{180}$ or 12.08σ.

Probable Error of Mean. The formula $0.6745 \frac{SD}{\sqrt{n}}$ gives us $\frac{0.6745 \times 21.75}{10}$ or ± 1.467σ.

Probable Error of SD. The formula is $0.6745 \frac{SD}{\sqrt{2n}}$. This gives us $\frac{0.6745 \times 21.75}{14.14}$ or ± 1.037σ.

A complete Table of significant values will accordingly read as follows:

	Range : 133—232σ.			
Mean	180.00 ± 1.467	<i>MV</i> 17.40		<i>rv</i> 9.66
Median	182.40	<i>SD</i> 21.75 ± 1.037		<i>cv</i> 12.08
Mode (emp.)	185.00			

This illustration is taken from R. M. Yerkes, *Psych. Bulletin*, i., 1904, 140 f. The student may be recommended to work out a parallel series of values from Yerkes' Fig. 2, p. 140,—without reference, of course, to the writer's Table on p. 141.¹ On the *rv* see C. S. Myers, *Rep. Cambr. Anthropol. Exped.*, ii., 2, 1901, 212; C. B. Davenport, *Proc. Amer. Acad. Arts and Sciences*, xxxii., 1897, 272 *n.*; Yerkes, *Amer. Journ. Physiol.*, ix., 1903, 291 f.² On the *cv*, see K. Pearson, *Trans. Roy. Soc. London*, clxxxvii. A, 1896, 277.

Whether, in the present state of our knowledge, these various determinations have any particular psychophysical value is a question that will be differently argued from different points of view. It is, perhaps, one of those not infrequent questions upon which the Instructor should be prepared to take either side, as against a pronounced bias on the part of the student. The main topics for discussion are suggested in the essay subjects given below.—

In refusing to strike out the times which *O*'s introspection declares to be invalid, the author is apparently at issue with Alechsieff (*P. S.*, xvi., 13). It must be remembered, however, that Alechsieff's problem was psychological, not psychophysical (5): *cf.* the author's directions in vol. i., I. M., 217 f.

QUESTIONS.—The author has put these topics in the form of Questions, in order that the attention of all students—even of those who have not the time for more than a summary consideration of them—may be called to some of the disputed issues in this portion of systematic psychology. They are, however, much better treated as essay subjects.

(1) We are measuring, primarily, the duration of certain excitatory processes in the living organism, the time taken by certain physiological events. What these processes are, we know only schematically. Nor do we know at all accurately what the variability of the reaction time signifies: whether the addition of extra processes to (or the subtraction of normally constituent processes from) the complex of typical processes, with the substitution of paths that this addition (or subtraction) involves; or a

¹ Dr. Yerkes informs the author that the range of Fig. 2 is 131—296σ.

² *Cf.* also the author's *Primer*, 1898, 186; and Jastrow, *A. J.*, iv., 414.

variation of some or other of these typical processes themselves, under the varying influences of connected centres or organs. It is perhaps safe to say, in the rough, that both factors are at work in the ordinary course of the reaction experiment. At any rate, the representative values and the measures of variability stand, primarily, for physiological processes.

Some of these processes, now, are psychophysical, *i.e.*, have conscious concomitants. Hence the temptation to say that the 'reduced' reaction time (the reaction time *minus* the time of those physiological events which are not psychophysical) measures the duration of certain mental processes. It is, of course, by no means an easy matter to determine this reduced time, even approximately. But that apart, the question has been raised whether we have any right at all to speak of the 'duration' of mental processes in terms of objective time: see M. F. Washburn, *Psych. Rev.*, x., 1903, 416 ff. It is a question which, however worthy of consideration, cannot be gone into here. The author will only point out that the view attacked does no more than represent a 'copy theory' of psychological time, for the simplest mental processes, and that the copy theory is, almost inevitably, the first theory of the relation of objective and subjective which suggests itself when that relation is presented as a scientific problem.

(2) We have noted that the reaction experiment has both a psychological and a psychophysical interest (p. 357 above). These points should be worked out in detail. It may be remarked also that the experiment (like certain experiments on movement) affords a *method* for the study of very varied problems: see the author's *Outline*, 350 ff.; H. Münsterberg and W. T. Bush, *Psych. Rev.*, i., 1894, 45; Cattell, *P. S.*, xix., 1902, 63 ff.

(3) See above, pp. 12, 357 f., 362.

(4) Wundt, *P. P.*, iii., 1903, 386. Wundt expressly rules out the experiments of G. Buccola on the mentally deranged (*La legge del tempo*, 1883, 203 ff.), though he accepts the work of G. Aschaffenburg (*Psych. Arbeiten*, iv., 1902, 235 ff.); those of R. M. Bache, *Psych. Rev.*, ii., 1895, 475 ff.; and those of E. M. Weyer, *Yale Stud.*, iii., 1895, 96 ff. *A fortiori*, he would rule out the more recent work on still lower organisms. Now some of

these studies (that of Bache, *e.g.*) may be criticised on general scientific grounds. But the answer to the Question implies, of course, an estimate of Wundt's position, in *P. P.*, iii., Sect. 2, 377 ff.

(5) This Question raises the whole issue of a 'motor' psychology and psychophysics. The author's attitude to the subject is, in brief outline, as follows.

(a) We have no warrant for speaking of a "motor side of consciousness."¹ Consciousness is not two-sided, sensory and motor. Whether we are dealing with consciousness as perception or as action, we are dealing with mental material of the same kind. The elementary processes of which consciousness is composed are always and everywhere the same, though they may be patterned or disposed in this way or that, given in this or that state of clearness or obscurity. It is true that "movement enters consciousness not only as perceived, but as intended." The 'conscious intention' is, however, not a new type of mental process: not a sensation of innervation or an unique Willensimpuls: it is a complex formation of sensations and affection, requiring for its analysis precisely the same sort of introspective work that is done upon perception or memory or imagination.

In general terms, the psychology of movement has to deal with the conscious antecedents of movement, the 'motive' to action; and with the conscious concomitants or consequences of movement,—the formations to which movement is the adequate stimulus. These are specific complexes, and therefore demand special study, as emotion does, or recognition: but there is nothing *sui generis* about their constituent processes. The psychophysics of movement has to find representative values and measures of variability for the force, rapidity, extent, etc., of movements, themselves definitely prescribed, which are correlated with definite conscious concomitants or consequences. Both movements and consciousnesses will, of course, be taken as simple as possible.²

¹ R. S. Woodworth, *Accuracy of Voluntary Movement*, 1899, 1 f.; *Le Mouvement*, 1903, 1 f.

² So far as the author can judge, these definitions are valid for all the forms of movement that fall within the sphere of psychology or psychophysics; for the sustained serial movements that constitute 'work' (*Arbeit und Leistung*, *travail*), for the expressive movements, etc., as well as for the single voluntary action. And again, so far as he can judge, the definitions must remain valid, however radical be the change in the approach to and exposition of the psychological system induced by the adoption of a 'motor' theory of consciousness. So long as 'motor

(*b*) So much in general. Approaching the matter historically, now, we can hardly fail to see that experimental psychology has been enlarging its ideas, of late years, with regard to the bodily substrate of mental processes and formations. On the whole, and apart from special theories, the new psychology has tended to one-sidedness in its references to the body; it has been too easily satisfied with appeal to the organs of sense and to the doctrine of cerebral localisation. This state of things is changing, and changing rapidly. Along with the analysis of the kinæsthetic complexes has come the recognition that consciousness is limited, shaped, directed, modified by physiological factors hitherto neglected by physiological psychology. We are coming, *e.g.*, more and more to think and speak in terms of such concepts as *Einstellung*, *Bahnung*, *Bereitschaft*; and we are beginning to realise that our knowledge of the motor mechanisms of the organism must be as detailed and exact as our knowledge of the sensory. If to explain the phenomena of beats we must venture on a functional interpretation of the minute structure of the internal ear, so to explain the sensory judgments of likeness and difference in the comparison of lifted weights we must have recourse to subcortical preadjustments and to dispositions of the motor apparatus. The result of this change of attitude is the opening up of a new set of problems, and the writing of a new chapter in psychophysics.

We are not concerned, for the moment, with the study of central psychology' is confined to general sketches of procedure, with illustrations in the large, it may seem to lie worlds apart from such an analytical psychology as is represented by this book. But just as soon as its expositors grapple with the facts in detail, they must take the psychological description of these facts from the analytical psychologists, as they must take their physiology from the physiologists.

As indicative, in very different ways, of the trend of 'motor' theorising, see J. M. Baldwin, *Mental Development*, 1895 and later; J. Dewey, *The Reflex Arc Concept in Psych.*, *Psych. Rev.*, iii., 1896, 357; W. McDougall, *Improvement in Psych. Method*, *Mind*, N. S., vii., 1898, 364; Münsterberg, *Aktionstheorie*, *Gründzuge*, i., 1900, 525; T. L. Bolton, *Biol. Theory of Perception*, *Psych. Rev.*, ix., 1902, 537; C. H. Judd, *Yale Stud.*, N. S., i., 1905, 199 ff. It is, perhaps, not fanciful to bring this general movement in psychology into connection with the pragmatic tendencies of current philosophy. As for its outcome in special psychological problems, we have so far only vol. i. of the *Harvard Psych. Studies*, 1903, to go by. Although the *Aktionstheorie* controlled the selection of the work here reported, the contents of the volume present no marked *differentia*; the most that can be said is that the writers appear to be, generally, on the lookout for motor factors and influences. But the same thing is true, *e.g.*, of the contents of the *Yale Studies*, and in large measure of the *Année psychologique*: even the 'typical' study of the reaction-time of the frog had been anticipated in principle by E. M. Weyer's experiments on the dog (*Yale Stud.*, iii., 1895, 96). *Cf.* Bentley, *Phil. Rev.*, xiv., 1905, 257.

factors,¹ but only with the peripheral motor mechanisms. What are we to say of the work that has been done?²

(c) We shall do well to remind ourselves, in the first place, that its novelty is only relative. Novelty there is: change of attitude, shift of emphasis. But as early as 1826 Johannes Müller pointed out the importance of eye movement for the apprehension of visual form.³ Wundt was writing on eye movements in 1859,⁴ and S. Lamansky in 1869.⁵ Camerer's thesis of 1866 (*Versuche üb. d. zeitl. Verlauf d. Willensbewegung*) was conceived quite in the spirit of the modern 'motor' school. Only, as we have said in another connection, a science does not advance with even front; its course is narrowed and directed by special interests.⁶ And there can be no doubt that psychophysics has paid undue attention to the reaction experiment, while it has left untouched other and at least equally important aspects of the action problem. From this point of view, the recent work upon voluntary and involuntary movement is altogether commendable; it attempts to make good a defect, to fill a gap, in the structure of the science; it reopens a path of investigation which, save at particular points, has been allowed to fall into disuse.

(d) Under these circumstances, we should expect to find that the new work had profited by the lessons to be learned from the old. No one would nowadays set to work upon the time consciousness, or complication, or fluctuations of attention, in the manner of the original investigators. But more than that: psychology is not a mere bundle of serial studies, but a science, with standards, norms, methods, concepts, that are applicable in every field of enquiry. We should expect, then, to find the new work pervaded by the new psychological spirit. In particular: since the study of the motor apparatus must fall into three main divisions,

¹ It may, however, be worth while to bring together some recent references on motor Einstellung. See A. Binet, *Rev. philos.*, xxix., 1890, 143, 149 ff.; E. B. Delabarre, *Ueber Bewegungsempfindungen*, 1891, 109 f.; L. Solomons and G. Stein, *Psych. Rev.*, iii., 1896, 492 ff.; G. Stein, *ibid.*, v., 1898, 294 ff.; Martin and Müller, *U. E.*, 1899, 136 ff.; L. Steffens, *Z.*, xxiii., 1900, 241 ff.

² Typical investigations in this field are: W. L. Bryan, *Development of Voluntary Motor Ability*, A. J., v., 1892, 125 ff.; Fullerton and Cattell, *Small Diff.*, 1892; R. S. Woodworth, *Accuracy of Vol. Movement*, 1899; E. B. Delabarre and E. B. Huey, on a method of recording eye movements, A. J., ix., 1898, 572, 575; R. Dodge, a series of papers in *Psych. Rev.*, vi., 1899, ff.; *Amer. J. Physiol.*, viii., 1903, 307; C. H. Judd, *Writing Movements*, P. S., xix., 1902, 243; G. M. Stratton, *Aesthetics of Visual Form*, *ibid.*, xx., 336; C. H. Judd, C. N. McAllister and W. M. Steele, *Stud. of Eye Movements by means of Kinetoscopic Photographs*, *Yale Stud.*, N. S., i., 1905, 1 ff. The list might easily be extended.

³ *Zur vergl. Physiol. d. Gesichtssinnes*, 262 f.

⁴ *Beiträge*, 1862, 140 ff.

⁵ *Pfl. Arch.*, ii., 418 ff.

⁶ See p. xxxvi. of the text.

physiological, psychological and psychophysical, we should expect to find the investigator keenly conscious of the specific character of his problem, —to find him changing his methods and his attitude as he crossed the line from any one of these sciences to any other.

There are, now, many investigations with which, on their own account, criticism can find no fault. The methods are ingenious, the results accurate. Where, on the contrary, the work touches upon more general issues, we too often find confusion of thought. We find appeals to popular psychology. We find biological conceptions thrust, fit or no fit, upon psychological material. We find a sort of pride taken in the inability to say where physiology ends and psychology begins: the investigator is above all such scholastic distinctions. We find an abrupt dismissal of views and theories prior to the view or theory that the writer himself adopts. In a word, we find just that lack of clean thinking which, combined with definite achievement, is the characteristic of pioneer work. And we cannot but reflect that it is late in the day for pioneering, and regret that the dearly bought experience of the past has not been drawn upon for guidance in the present.

(e) The author must leave these criticisms in general terms: the reader need not go far to discover their substantial accuracy. There is, however, one point that calls for more extended comment. It is nothing less than the proclamation of an objective psychological method; and here are its terms:

“ We cannot tell from introspection what guides our movements. . . . We have to rely on a quantitative determination of the degree of accuracy obtained under different conditions. Here we have a method of psychology which does not depend upon introspection. And it seems undeniable that this method ought to be applied in as many fields as possible. . . . Give the ‘subject’ some difficult task to perform under certain conditions from which he cannot escape (much as in a game); then vary the conditions, and measure and compare the success of his efforts, and you have a method which permits in the subject a direct and naive attitude toward the problem that is set him, and which enables the experimenter to analyse at his leisure the factors which contributed to the given end. Undoubtedly, this method might be skilfully adapted to various departments of psychological research. It is readily, almost inevitably, applied to the problem of the accuracy of movement.”¹

Not a novel method, surely! Not a method whose previous application has been restricted to “memory and some problems of perception!” Rather, the method of the earlier work on the ‘time sense’; the method of the earlier work upon reaction time; the method which, in the domain of Fechnerian psychophysics, has led—among other lamentable results—

¹ Woodworth, *Acc. Vol. Movement*, 25.

to the distinction of Weber's and Merkel's Laws. The old, bad method of arguing out a psychology on the basis of psychophysical determinations: of inferring, speculating, deducing,—always in terms of popular psychology, pure and simple, or of some theoretical prepossession: of putting logical schema for psychological fact. A method that experience has discredited. Give the subject a difficult task under conditions which he cannot escape? Allow him to take a direct and naive attitude to the problem? This is simply to say: Give a free rein to secondary criteria. Let the experimenter analyse at his leisure the factors in the results? But these factors are either physiological or psychological; and, if they are psychological, the experimenter must identify them either by his own introspection or by some logical substitute. Truly, it was an irony of fate that the year in which these words were written should be the year of Martin and Müller's *Unterschiedsempfindlichkeit*!

Let us look at the classical instance of successful work with this objective method,—at Ebbinghaus' *Gedächtnis*. Ebbinghaus began his experimental work in 1879, and ended it in 1884; the plan of it was made out in 1879. What, now, was the atmosphere of experimental psychology at this date? What were the available researches, the available books? Psychophysical, through and through. And Ebbinghaus had been especially influenced by Fechner, to whom he has recently dedicated his *Psychologie*. The natural consequence is, then, that the *Gedächtnis* is itself psychophysical. The book contains psychological matter, just as Wundt's writings in the psychophysical period contain psychological matter,—and for the same reason. But its aim and scope and intention—read the headings of the sections!—are all psychophysical. Further: read what Ebbinghaus has to say in 1897 of psychological method (*Psych.*, i., 56 ff.). There is one general method, which has two inseparable phases, observation of self and observation of others: “alle Beobachtung anderer is nichts, wenigstens für die Psychologie nichts, ohne die stete Belebung und Durchgeistigung vermittelt der Resultate der Selbstbeobachtung” (56 f., 59). This method may be made quantitative (60 ff.). And its quantitative results are at once turned to psychophysical account by the metric methods (66 ff.). Finally, we have various methods of ‘indirect mental measurement,’ dependent upon our capacity to judge of impressions as ‘like’ and to aim, under various circumstances, at the production of ‘like’ effects (82 f.): here belong the memory experiments (85). The methods in question are, essentially, psychophysical methods,—only that, in general, the psychophysical laws of the phenomena investigated are not yet made out (86 f.). Their results are of psychological import, because it is “die Gleichheit der seelischen Eindrücke und des seelischen Wollens” that constitutes “den eigent-

lichen Nerv und den Angelpunkt" of the whole procedure (86).¹ But all these quantifications—psychological measurement, psychophysics, indirect mental measurement—reduce in the last resort to the double-faced method of observation of self and observation of others. "Wer lediglich an anderen messend experimentiert, ohne einmal an dem eigenen Selbst zu erleben, was alles innerlich vorgeht bei solchen Experimenten, der gewinnt zwar Zahlen, die irgend etwas bedeuten mögen, aber was sie bedeuten, bleibt ihm verschlossen. Er ist nicht Herr der Resultate und der Fülle von komplizierenden Momenten, die in ihnen zusammenwirken mögen" (88).

Not much here of a psychological method without introspection! The best that we can say for the proposed method is that, in skilful hands, it may subserve the diagnosis—perhaps, under certain circumstances, the prognosis—of psychological problems. But any one who builds a psychology upon it, reasoning where he should have observed, is foredoomed to failure.²

(f) Still, when criticism has done its worst, there is much in this 'motor' work—as was said above under (d)—which the student of psychology may study with great profit: there are many experiments that might with advantage be introduced, did time allow, into such a Course as the present. The author gives below a number of literary references, under the headings of rapidity and precision of movement. He has purposely thrown together investigations of the most varied kind, investigations in which movement has been studied (under various aspects) for its own sake, and investigations in which it has been used as a means to some psychological or psychophysical end. The first thing that the student should be asked to do, if the Instructor deems it proper for him to enter upon this field, is to sort out the problems under their general headings. An admirable exercise in systematic psychology!

¹ Cf. Stumpf, *Tps.*, i., 55.

² Two supplementary remarks! (1) It may be urged that the author is inconsistent in this appraisal, since he has himself included Ebbinghaus' work in a quantitative psychology (see p. xl. of the text; p. cliii above). But a quantitative psychology includes both psychology proper and psychophysics. What the author criticises is the attempt to argue a psychology, *sensu stricto*, out of psychophysical data. And that this is what Woodworth proposes to do is clear from the opening sentence of the quotation on p. 367, in which he declares introspection to be impossible. Now where introspection is impossible, there we can have only a psychophysics. But (2) the extension of Ebbinghaus' work in the hands of Müller and Schumann (1894) and Müller and Pilzecker (1900) is at the same time an extension of the field of introspection. And the author has no doubt in the world that a rigorous application of the introspective method to Woodworth's problems would also yield psychological result.

Then some problem of special interest may be selected, and worked out in the laboratory,—worked out with all the care and caution that are bestowed upon the regular experiments of the Course. It need hardly be said that so heterogeneous a list as the following could not be made complete, even if completeness were aimed at.

i. *Rapidity of a Single Movement*.—W. Camerer, *Versuche üb. d. zeitl. Verlauf d. Willensbewegung*, Tübingen, 1866 (Vierordt, *Zeitsinn*, 1868, 88 ff., 104 ff., 110 f.); F. Galton, *On the Anthropometric Laboratory*, 1885, 13; *Anthrop. Lab., Notes and Memoirs*, 1890, 23; *Journ. Anthr. Inst.*, xix., 1890, 28; J. von Kries, *Arch. f. Physiol., Suppl.*, 1886, 2 ff.; J. Loeb and A. von Korányi, *Pfl. Arch.*, xlv., 1890, 101 ff.; Fullerton and Cattell, *Small Diff.*, 1892, 114 f.; A. Binet and J. Courtier, *Rev. philos.*, xxxv., 1893, 664 ff.; C. Jacobi, *Arch. f. exp. Pathol. u. Pharmakol.*, xxxii., 1893, 82 ff.; E. B. Delabarre, *Psych. Rev.*, iv., 1897, 615 ff.; C. N. McAllister, *Yale Stud.*, viii., 1900, 21 ff.; T. V. Moore, *Psych. Rev. Mon. Suppl.*, 24, 1904.

ii. *Rapidity of Repeated Movements*.—G. Valentin, *Physiol. d. Menschen*, ii., 1, 1847, 204; J. von Kries, *Arch. f. Physiol., Suppl.*, 1886, 6 f.; F. B. Dresslar, *A. J.*, iv., 1892, 514 ff.; W. L. Bryan, *ibid.*, v., 1892, 137 ff.; C. B. Bliss, *Yale Stud.*, i., 1893, 45 ff.; J. A. Gilbert, *ibid.*, ii., 1894, 48; J. M. Moore, *ibid.*, iii., 1895, 92; W. L. Bryan and N. Harter, *Psych. Rev.*, iv., 1897, 34; J. A. Gilbert, *Iowa Stud.*, i., 1897, 8; A. Binet and N. Vaschide, *Ann. psych.*, iv., 1898, 81, 88, 221, 267; J. B. Haycraft, *Journ. of Physiol.*, xxiii., 1898, 1; W. W. Davis, *Yale Stud.*, vi., 1898, 7 ff.; W. S. Johnson, *ibid.*, 51 ff.; E. W. Scripture, *ibid.*, vii., 1899, 102; C. E. Seashore, *Iowa Stud.*, iii., 1899, 69 ff.; R. S. Woodworth, *Accuracy of Vol. Mvt.*, 1899, 108 f.; W. W. Davis, *Yale Stud.*, viii., 1900, 81; O. Raif, *Z.*, xxiv., 1900, 352 ff.; E. A. Kirkpatrick, *Psych. Rev.*, vii., 1900, 274 ff.; C. Wissler, *Correl. of Mental and Phys. Tests*, *Psych. Rev. Mon. Suppl.* 16, 1901, 8; W. C. Bagley, *A. J.*, xii., 1901, 195; F. W. Smedley, *Chicago Pub. Sch. Child Stud. Rep.*, iii., 1902, 41; I. Miyake, *Yale Stud.*, x., 1902, 1 ff.; C. R. Squire, *Psych. Rev.*, x., 1903, 251 ff.; D. Awramoff, *P. S.*, xviii., 1903, 533 ff.; T. L. Bolton, *A. J.*, xiv., 1903, 618.

iii. *Accuracy of Movement*.—H. P. Bowditch and W. F. Southard, *Journ. of Physiol.*, iii., 1880-2, 232; M. Blix, *Neurol. Centralblatt*, 1884, 83; W. L. Bryan, *A. J.*, v., 1892, 177 ff.; Fullerton and Cattell, *Small Diff.*, 1892, 65 ff.; E. W. Scripture and C. S. Lyman, *Yale Stud.*, i., 1893, 92 ff.; E. W. Scripture and T. L. Smith, *ibid.*, ii., 1894, 115 ff.; E. W. Scripture, *ibid.*, 122 ff.; E. W. Scripture, *ibid.*, iv., 1896, 69 ff.; C. S. Parrish, *A. J.*, viii., 1897, 265 ff. (with references); W. L. Bryan and N. Harter, *Psych. Rev.*, iv., 1897, 36 ff.; G. M. Whipple, *A. J.*, ix., 1898, 568;

W. W. Davis, *Yale Stud.*, vi., 1898, 29 ff.; W. S. Johnson, *ibid.*, 64 ff.; R. S. Woodworth, *Accuracy of Vol. Mvt.*, 1899; C. Wissler, *Mental and Phys. Tests*, 1901, 8; W. C. Bagley, A. J., xii., 1901, 196; C. H. Sears, *ibid.*, xiii., 1902, 28 ff. (with references); E. J. Swift, *ibid.*, xiv., 1903, 201 ff.; T. L. Bolton, *ibid.*, 618.

No special heading is made here for Extent of Movement, since references have been given above, p. 261. Nor do the four headings together make any pretence to cover the whole ground. Experiments of high psychological interest may be taken from the investigations of Work (Binet, Kraepelin) in all its phases. The paper on normal motor automatisms by Solomons and Stein¹ is a mine of suggestion. Instructive, too, are such studies as those of W. S. Johnson, *Yale Stud.*, vi., 1898, 75 ff.; G. E. Partridge, A. J., xi., 1900, 244 ff.; J. H. Bair, *Psych. Rev.*, viii., 1901, 474 ff.; E. J. Swift, A. J., xiv., 1903, 230 ff.; E. Schultze, *Z. f. Phil. u. Päd.*, vi., 1899, 1 ff.

A word of caution may be added, to the effect that the Instructor will do well not to introduce any problem from this literature into the Course until he has himself worked it through, and satisfied himself that it will yield psychological results in a limited time. The late Dr. J. O. Quantz worked for a year in the author's laboratory on the psychological aspects of Camerer's thesis, and the study was still incomplete when he was compelled to relinquish it. The author once made a sort of reaction experiment of the setting-up and taking-down of an inductorium: the student went through the manipulations under time control, and gave his introspections at the end of each experiment. This investigation, too, though it bore good psychological fruit for those engaged upon it, was in so ragged a state at the end of a year that it was not publishable. *Ex uno disce omnes!*

The following Essay Subjects cover, in part, the ground already-traversed in the Questions.

(1) The history of the reaction experiment (simple reaction).

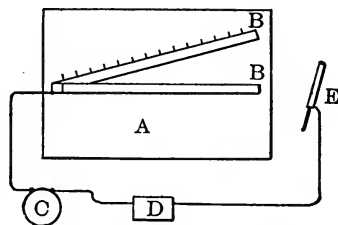

FIG. 52.—Bryan's apparatus for measuring precision of movement. *A*, plate of glass, upon which are fastened *BB*, two strips of platinum foil; *C*, battery; *D*, sounder; *E*, stylus. Problem: to draw a straight line between the arms *BB* as near as possible to their intersection, without making contact. A. J., V., 178.

¹ Cited among the works on motor Einstellung, note, p. 366 above.

(2) The analysis of the simple reaction; the constituent processes, physiological, psychophysical, psychological: an historical study.

The basis of this essay would be a collection of the analyses of the reaction offered by various investigators of the third and fourth periods. The essay will require some bibliographical work from the student; but enough references have been given to start him well on his way. In the fourth period, a distinction should be drawn as sharply as possible between those who look mainly at the contents of the reaction consciousness, and those who lay stress upon the character of the preceding psychophysical disposition. On the latter point, see, *e.g.*, Külpe, P. S., vi., 1891, 514 ff. (Titchener, *Mind*, N. S., i., 1892, 220); *Monist*, xiii., 1902, 48 ff.; *Outlines*, 407 f.; G. E. Müller in A. Pilzecker, *Sinnliche Aufmerksamkeit*, 1889, 78 ff.

(3) The range of instruction to *O* permitted by the conditions of the reaction as a psychological or psychophysical experiment.

This essay would, *e.g.*, bring into clear light the difference between instructions which demand 'as quick as possible' a response to the reaction stimulus, and the instructions which carefully avoid all temporal reference. Texts for it may be found in plenty: *e.g.*, "Einseitig die Aufmerksamkeit entweder auf den Reiz oder auf die Bewegung zu richten, das vermag man selbstredend bei jeder Aufgabe und mit jedem Apparat. . . Ich darf aber nicht dem *O* die verkehrte Zumuthung stellen, er solle den einen oder den anderen Theil des Gesamtvorganges willkürlich bevorzugen. . . Von einer Reaction verlange ich, dass sie sicher und schnell geschehe" (*Dessoir*, *Arch. f. Physiol.*, 1892, 312 f., partly transposed): or the more general counter-statement of Müller, "Wir müssen durch eine geeignete, eindringliche und nachhaltige Instruktion des *O* eine . . . Einengung des psychologischen Verhaltens . . . anstreben" (*M.*, 8 f.).

In the author's judgment, the case stands as follows. Given a competent *O*, what you get out of a psychological or psychophysical experiment depends very largely upon what you put in. Certain limits are set, of course, by the type of the *O*, by the temporary disposition of consciousness, and by the physical constitution of the organism. Within these limits, however, it is as true as the worst enemies of experimental psychology could wish—though true in a different sense from theirs—that you can 'get what results you like.' The author has been able in his

own person to reproduce Tokarsky's reactions of 5 or 10σ:¹ at the same time, his sensorial reaction to light, repeated yearly in laboratory practice, has remained the same since it was first determined in 1889. Everything depends upon 'what you want,' *i.e.*, upon the rubrics under which you are working.

Now there can be no doubt that, as a matter of fact, reaction times have in the past been taken under instructions of the most diverse kinds. We know this in part from explicit statements; in part, from the general tone of the investigations and the writers' remarks on theory. The result has been, on the one hand, a good deal of rather acrimonious dispute about time values, and on the other a series of controversies about the nature of the reaction experiment, which have led to little or no result simply because the disputants were not talking about the same thing. 'The reaction experiment' does not exist: under one set of instructions, the experiment is one thing; under another, it may be another and quite a different thing. The reaction experiment as applied in mental tests on school children: the reaction experiment as applied to the mentally deranged; the reaction experiment as applied to dogs and frogs and medusæ: the reaction experiment as applied to a group of Filipinos or Indians or Murray Islanders: is it one and the same experiment throughout? Nay, more: the reaction taken in one laboratory for purposes of analytical psychology: the reaction taken in another laboratory under the influence of the type theory: the reaction taken in yet a third

¹ A. A. Tokarsky, III. internat. Congress f. Psych., 1897, 172. The method of reproduction was this. The interval between signal and reaction stimulus (the latter a sound) was exactly regulated by the use of a pendulum, which in the course of its swing touched off both. The author sought to adapt himself to the interval, and to press the reaction key simultaneously with the sounding of the stimulus. The tendency towards automatism was encouraged. There were premature reactions (not so many as might have been expected; for the bias of adaptation was towards the allowance of its full value to the interval); but there were plenty of reactions of the Tokarsky type.—To the outside observer, now, this was a carefully regulated reaction experiment, which gave curiously short times. In reality, it showed the effects of a certain self-instruction, or self-suggestion, and was not a 'reaction experiment' of the recognised kind at all. And it is surely intelligible that a self-instruction of the same kind, not at all expressly formulated or recognised by *O*, but still definitely operative, might grow up in the course of a regular 'reaction' experiment, where stress was laid on quickness of reaction, where no other instructions were given by *E*, where the desire of the *O*'s was to please *E* by short times, where they had no interest in the analysis of the reaction consciousness, but tried to get through the work creditably with a minimum of trouble, where they had had no experience or warning of the change of mental attitude due to secondary criteria, of the tendency towards automatism, and so on.

laboratory as a psychophysical datum to be treated presently by statistics along with so many thousand more: are these one and the same thing? It is an exaggeration, but an exaggeration justified by the present chaos, to say that every laboratory, every group of workers, has a specific interpretation and application of the reaction experiment. And nothing but a thorough-going and unprejudiced study of the respective spheres of 'type'¹ and 'instruction' will bring us to order and agreement.²

(4) Wundt's interpretation of the simple reaction: historical and critical.

(5) The validity of the three 'types' of simple reaction: the sensorial, muscular (Lange), and central (Martius).

(6) The value of the reaction experiment to the student of mental pathology.

(7) The scientific value of the results of reaction experiments made upon children or upon the lower races of mankind.

(8) How far are the 'reactions' of man and of the lower animals comparable?

(9) What do we know of the physiological processes involved in the reaction experiment?

(10) The adequacy of introspection to the action consciousness, as indicated by comparison with the time-values.

(11) The value to astronomy of the investigations of reaction time made in the psychological laboratory.

(12) The effect of practice on the simple reaction.

A few references may be given, by way of orientation, though the student should by this time find no difficulty in discovering materials for the essays. (5) L. W. Stern, *Psych. d. indiv. Differenzen*, 1900, 103 ff., 142 f. (6) Besides the ref. to Aschaffenburg already given, see E. Kraepelin, *Psych. Arb.*, i., 1895, 8; M. Walitzsky, *Rev. philos.*, xxviii., 1889, 582; P. Janet, *Névroses et idées fixes*, i., 1898, 77, etc.; F. Raymond and P. Janet, *ibid.*, ii., 1898, 51, etc. (7) G. M. Whipple, *A. J.*, xv., 1904, 489; C. S. Myers, *Cambr. Anthropol. Expedn. to Torres Straits*, ii., 1903, 189; G. Grijns, *Arch. f. Physiol.*, 1902, 1. (8) Yerkes, Harvard

¹ Taken in the widest sense, to include mental constitution, more or less impermanent dispositions, tendencies to reproduction, etc., etc.

² A trained student, working with historical knowledge but without bias, could, in the author's opinion, unravel the whole tangle in a couple of years. A suggestion for the Carnegie Institution!

Stud., i., 1903, 598; *cf.* with ref. already given to Wundt. (9) E. A. Schaefer, *Physiology*, ii., 1900, 608 ff. (10) S. Exner, *Pfl. Arch.*, vii., 1873, 644 ff.; G. Martius, *P. S.*, vi., 1891, 199 ff.; G. Dwelshauvers, *ibid.*, 222; A. Binet, *Rev. phil.*, xxxiii., 1892, 650; C. B. Bliss, *Yale Stud.*, i., 1893, 33 ff.; R. Watanabe, *A. J.*, vi., 1894, 408. Distinguish here between subjective estimates of the reaction *time* and introspective analysis of the reaction consciousness. (11) P. Stroobant, *Compt. rend.*, cxiii., 1891, 457; cxv., 1892, 1246; N. Alechsieff, *P. S.*, xvi., 1900, 48; Wundt, *P. P.*, iii., 1903, 436. The essay may be extended beyond the reaction experiment to psychophysics at large: *cf.* H. Leitzmann, *P. S.*, v., 1889, 79; K. Pearson, *Phil. Trans. Roy. Soc. Lond.*, cxviii. A, 1902, 235 ff. (criticise the experimental procedure in this paper). (12) G. O. Berger, *P. S.*, v., 1889, 174; L. Lange, *ibid.*, iv., 1888, 489; Fricke, *Biol. Centralbl.*, ix., 1889, 254; *cf.* Wundt, *P. P.*, iii., 1903, 417 f.

§ 38. **Compound Reactions: Discrimination, Cognition and Choice.**

—The psychology of the compound reactions discussed in Section 26 of the text is, perhaps, in even less satisfactory a state than is the psychology of the simple reaction. The first classification presented is, of course, purely external. It is useful to the student as a bit of mnemotechnics, but it has no psychological significance.¹ The second classification is psychological: but it is schematic in the extreme, and so far as the assimilative complexes ‘discrimination’ and ‘cognition’ are concerned it implies a certain system of psychology (Wundt, *P. P.*, ii., 1893, 442; iii., 1903, 536). It was put forward by the author in 1898 (*Primer*, 260 ff.).

There can be no doubt that the plan of the compound reaction may be widely varied beyond the limits of this second classification. There can be little doubt, either, that the classification groups together problems of very various degrees of psychological complexity, problems which are therefore, in reality, different problems. Nevertheless, Wundt has made this field of experimental work so peculiarly his own that it seems unwise, on the basis of the material at hand and in a work like the present, to undertake any more detailed analysis.

¹ A somewhat similar classification, in which, however, psychological factors play a part, was proposed by Jastrow, *Time Relations*, 1890, 27. The author’s table was made out independently of Jastrow’s work.

Attention may be called to a point in which the language of the text differs from current terminology. It is customary (though the usage is not universal) to give the names 'cognition times,' 'choice times,' etc., to the remainders obtained by subtracting certain partial times from the total times of reaction. In the author's opinion, this subtraction method is extremely precarious: we return to the matter later on (p. 390). In any event, however, the remainders should be termed 'reduced choice times,' etc., and not 'choice times' without qualification. The 'choice time' is the total time of the choice reaction. In the same way, if we write 'impulsive action' for 'simple sensorial reaction,' the 'impulse time' would be the reaction time, and the 'reduced' reaction in Exner's sense would give us the 'reduced impulse time.' It is true that the subtraction method is theoretically justified in the case of the simple reaction as it is not in the case of the compound. But those who apply the method in the latter instance are tacitly assuming that the analogy holds from the simple to the complex.

Nothing is said in the text of the important question of 'automatic co-ordination' (Wundt, P. P., ii., 1893, 382; iii., 1903, 471),—for the same reason that nothing has been said in the previous Sections of external and internal influences affecting the simple reaction (Wundt, *opp. citt.*, 344; 433): it is impossible to take account of everything in a drill course. As regards co-ordination, the author has no doubt that Wundt is right in his main contention. For one thing, von Kries' reply (Vjs. f. wiss. Philos., xi., 1887, 15 f.) practically concedes Wundt's point. For another, the author has been able, by continued practice and by encouraging the tendency towards automatism, himself to reproduce von Kries' times; while he is also able to reproduce the cognition times of P. S., viii., 1892, 138.¹

EXPERIMENT XXV

If the compound reactions of this Section are made in a laboratory course, it is best to begin with some form of the choice reaction. The difficulty of discriminative and cognitive reactions has been pointed out, experimentally by Cattell (P. S., iii., 1886, 452), theoretically by von Kries (Vjs., xi., 1887, 10 ff.). It

¹ An instructive experiment is described by L. M. Solomons, *Psych. Rev.*, vi., 1899, 376 ff. It is unfortunately too long to be included in this Course.

consists, as Wundt says (P. P., ii., 1893, 365; and esp. iii., 1903, 453, 459 f.), in the fact that the control of these reactions is not objective, but only introspective, whereas the control of the choice reactions is, at any rate in part, objective. *O* is to react when a certain assimilation is completed; but he must live the process through, and demarcate it, for himself. Hence he should come to the experiment with a fluid consciousness, without any fixed and ingrained habit of reacting; he should come with goodwill, and with expectation of success,—scepticism is as fatal here as it is in the case of the temperature spots; and he should come with a certain solidity or serenity that will not be discouraged by initial failures ('objective' type). Under these conditions, and indeed under any moderate approach to them,—for they constitute only a counsel of perfection,—the experiment will succeed after a brief practice. But the choice reactions are easier.

Every form of compound reaction has, to be sure, its own intrinsic difficulties and sources of error. These vary so greatly, however, with the nature of the problem and the training of the *O*'s that no definite advice can be given. The Instructor should select the mode of reaction and the apparatus that he means to employ in the Course, and should then work through the experiment, beforehand, for himself. With this preparation he will be able, especially after the work has been taken by a few pairs of students, either to give the necessary cautions by word of mouth or to make up a written set of instructions for use in the laboratory.

The technique of the compound reaction is not difficult to one who has used the Hipp chronoscope in the various arrangements possible for the simple reaction. The experiment should, wherever the conditions allow, be restricted to two students. Not only is the work of the second *E* monotonous and wasteful, but his presence in the reacting room is also a positive source of disturbance to *O*. It is far better to assign a few simple manipulations, over and above the movement of reaction, to *O* himself.

Suggestions for the arrangement of the compound reactions of this Section (to be taken critically!) will be found in M. Friedrich, P. S., i., 1881, 45; Kraepelin, *ibid.*, 1883, 421; E. Tischer, *ibid.*, 518; J. Merkel, *ibid.*, ii., 1885, Taf. I.; G. O. Berger, *ibid.*, iii., 1886, Taf. I.; Cattell,

ibid., 315; Mind, O. S., xi., 1886, 227; Titchener, P. S., viii., 1892, 138 f.; F. C. Donders, Arch. f. Anat., Physiol. und wiss. Med., 1868, 665 ff., 675 ff.; J. von Kries and F. Auerbach, Arch. f. Physiol., 1877, 302 ff., Taff. VIII., IX.; R. Tigerstedt and J. Bergqvist, Z. f. Biol., xix., 1883, 5 ff.; J. A. Gilbert and G. C. Fracker, Iowa Stud., i., 1897, 63 ff.; C. E. Seashore, *ibid.*, ii., 1899, 64 ff.; E. Roemer, Psych. Arb., i., 1896, 566 ff.

QUESTIONS.—(1) This Question is the continuation of Question (3), vol. i., S. M., 118. It may be answered most directly from the author's Primer, 258.

(2) Wundt, P. P., iii., 1903, 528 ff., 535 ff.; B. Erdmann and R. Dodge, Psych. Unt. üb. d. Lesen, 1898, 214 ff. (critique of Wundt and Cattell).

(3) It is clear that most of these compound reactions may be taken with the apparatus already described for the simple reaction experiment. (a) The student should be able to suggest the apparatus for the electrical-stimulation circuit. He should also be able to suggest means for keeping the resistance of this circuit equal to the resistance in the pressure-circuit. A two-way switch upon the table in the clock-room will enable *E* to throw in either circuit at pleasure. If the sensibilometer is used, a second *E* will be necessary, and the order of the experimental series must be prearranged by the two *E*'s. If Kiesow's electroæsthesiometer is used, there seems to be no reason why the whole experiment should not be controlled by the single *E* in the clock-room. The author, however, has not employed this instrument, and does not know how far the adjustment of *O*'s hand or of the stimulus hair itself may require supervision. (b) The telescope is set up on *O*'s table, at a convenient distance from the table that carries the pendulum. *O* sits on a high chair, so adjusted that he can hold his eye to the telescope without falling into a constrained attitude, while his right hand rests on the reaction key. Although the movement of the pendulum is governed from *E*'s room, a second *E* is needed to change the stimuli. The only alternative is to let *O* leave his place, after each experiment, and put in a fresh card from a pack lying (back uppermost!) on the pendulum table. (c) As exposure apparatus we may employ, not any of the instruments so far mentioned, but an Ach card changer. The instrument is described in Psych. Arb., iii., 1900, 267, and

was used by H. J. Watt (*Theorie des Denkens*, 1904, 9 ff.; *Arch. f. d. ges. Psych.*, iv., 1905, 291 ff.). It is a card-feeding apparatus, which is used without the telescope, and may thus be set up within easy reach of *O*. *E* exposes a card by pulling a cord, which runs over pulleys to a lever at the base of the instrument; at the end of an experiment, *O* trips a second lever, which brings down a screen over the word or figure already exposed; *E* then exposes the next card by a pull on the cord; and so on. The action required of *O* is exceedingly simple, and does not necessitate his leaving his seat.¹—The wires from the five-finger keys should be brought together at a multiple switch on *E*'s table. *E*, who has already placed the cards in the card-changer and therefore knows the succession of figures, can then switch into circuit that finger and that finger only which *O* is to move in response to the particular figure next to be exposed. Should *O*, by any chance, move the wrong finger, no time can be recorded by the chronoscope; the clock hands will continue to move until *E* pulls the cord. (*d*) The connections for the Ach card changer and a voice key are figured by Watt (*Theorie*, 10; *Arch.*, 292).² *E* should redistribute the apparatus in accordance with the scheme of Figg. 76, 77 of the text; only the sound-funnel and the card changer are to go into *O*'s room.

The arrangement suggested for the five-finger keys presupposes that the current is led in at one place for all five levers, and may be led out from each lever separately. If this condition is not realised in the keys at hand, a slight modification of the contacts will secure it. Merkel

¹ The exposure apparatus shown in Fig. 84 of the text is described by E. Roemer, *Psych. Arb.*, i., 1896, 572 ff.; *Année psych.*, iii., 1897, 656. When the lever is pressed, the card-holder flips over, making contact as its projecting boss strikes the spring clutch on the base. There is, of course, some noise as the card-holder strikes, and there is a constant error of exposure (Ziehen thinks the error variable: *Z.*, xiv., 1897, 286). The author has not seen the apparatus. Ach's card changer is a modification of that devised by A. Alber (*Arch. f. Psychiatr.*, xxx., 1898, 641; figured by E. Claparède, *L'association des idées*, 1903, 265). It is said to be comparatively noiseless; and it apparently works well, since Watt makes no criticism of it. The constant error of Watt's instrument was 22.1σ, *MV* 0.3σ. Cf. R. Sommer, *Ausstellung von exper.-psych. App. u. Methoden*, 1904, 70 f.

² The slate resistance (*Tellerwiderstand*) shown in Watt's figure is made by Elektrizitäts-Ges. Gebr. Ruhstrat, Göttingen, for Mk. 65. Cf. R. Sommer, *Ausstellung*, etc., 1904, 74.

(P. S., ii., 1885, 86, and Taf. I. Fig. 2 : Zimmermann, Mk. 65) passed the current through all ten levers, and judged of the correctness of the reaction by the movement of an index wire. For us, however, this would mean the presence of a second *E* in the reacting room.—Jastrow's five-finger key, which may be used either for make or break, and is suited to either hand, was listed by the Garden City Model Works in 1894 at \$7.50.—The keys shown in Fig. 83 of the text are listed by E. Zimmermann at Mk. 110 the pair. Plug contacts enable *E* to confine the current to a particular lever or set of levers. For us, however, this would again mean the presence of a second *E* in *O*'s room.

(4) Fractionate the reaction consciousness! In the discriminative reaction, *e.g.*, take a special short series of experiments for introspection of the preparation (attitude of expectation); another for the introspection of consciousness from the appearance of the stimulus to the completion of the discriminative assimilation; and a third for the introspection of the final (movement) stage of the whole process. In this way you secure a fuller introspective record, and make the experiment a much easier and less anxious matter for *O*.

The author applied this method of fractionation—whether or not at the advice of Professor Wundt he cannot now say—to some of his own cognition reactions in 1892 (P. S., viii., 138): unfortunately, however, he was then intent rather on the times than on the introspection, and so gave but little attention to the contents of the cognitive consciousness.¹ He has since used the method, time and again, in reaction work,—applying it even to the simple reaction, in the case of students who find unusual difficulty in the analysis of the impulse. Yet it has never occurred to him to mention it in print; and, very likely, it would not have occurred to him now, but for the express recommendation of the method by Watt (Theorie d. Denkens, 35; Arch., 317). All the older established laboratories have, no doubt, their special rules of this sort, which have become traditional in the routine of instruction; but they are so much a matter of course that they are the last things one remembers in describing an experiment. Here, then,—thanks to Watt,—is this rule, which should have been in vol. i. Better late than never!²

¹ "Optimus est portus pœnitenti mutatio consilii."

² The general rule of introspective fractionation is, of course, not new. The earliest recommendation which the author remembers is that of H. Aubert, Moleschott's *Untn.*, v., 1858, 285.

(5) In the discriminative reaction, the reacting movement is a finger movement, and the naming of the stimulus would therefore interpolate an associative process between discrimination and response. In the selective reaction with cognition, the vocal utterance is itself the reacting movement agreed upon in advance by *E* and *O*.

(6) Either the hands (or fingers) must be practised to the same mechanical readiness of reaction, or the simple reaction times of the different hands (or fingers) must be determined. *O* easily learns to react left-handedly with the ordinary telegraph key. If the five-finger keys are used, it is advisable to take simple reactions (all ten levers separately) in the course of the choice reactions.

(7) See Donders, 1868; von Kries, 1887; refs. under (3), p. 384 below; Erdmann and Dodge, 228 ff.; C. M. Hill, A. J., ix., 1898, 587 (*Z.*, xx., 1899, 448).

§ 39. **Compound Reactions: Association.**—It is customary, in the literature of the reaction experiment, to distinguish between simple reactions, discriminative and cognitive reactions, choice reactions, and associative reactions. This fourfold division has been suggested partly by the course of controversy, partly by the special developments and systematic relations of the associative reaction. It is possible, now, to give this form of reaction a place in the classification of the preceding Section; and it may be worth while to show what that place is, even although the classification as a whole be not accepted.

Wundt's account of the associative reaction (P. P., iii., 1903) is, *e.g.*, by no means clear apart from some classificatory context. He tells us, at first, that association may be superimposed upon the act of cognition as the process of choice is superimposed upon the act of discrimination (452, 455). But is the choice reaction necessarily discriminative? No! For Cattell's choice reactions with naming (462) are, by definition, cognitive, though Wundt calls them discriminative; and Wundt himself, speaking of such experiments in general terms (455), says that they include "eine *Erkennungs-* und eine *Wahlhandlung.*" We must say, then, that association may be added to cognition as choice is added to cognition or discrimination. But may not association be superimposed upon discrimination? *O*'s preparation would be different; but the ex-

periment could be carried out. Wundt says nothing of this. He proceeds rather to distinguish a second type of associative reaction. In the first, association is added to cognition; in the second, in which *O* reacts by naming an associated word, association and choice are successively superimposed upon cognition (455). So we have cognition-association contrasted with cognition-association-choice. The rest of Wundt's exposition is taken up with the various classes of association (free, constrained, etc.).

To understand this account, we may make out a Table, keeping the same main divisions as in the preceding Section. We then have :

- II. (1) Reactions after simultaneous association :
- (a) the discriminative reaction ;
 - (b) the cognitive reaction.
- (2) Reactions after successive association :
- (a) discrimination followed by association (*e.g.*, show one of 5 known colours, and associate to the colour presented some object of that colour) ;
 - (b) cognition followed by association (Wundt's associative reaction of the first type).
- III. (1) Selective reactions after simultaneous association :
- (a) selective reaction with discrimination ;
 - (b) selective reaction with cognition.
- (2) Selective reactions after successive association :
- (a) discrimination followed by association (*e.g.*, show one of 2 known colours ; associate to the colour presented some object of that colour ; react with the right hand if it is a natural, with the left, if it is a manufactured object) ;
 - (b) cognition followed by association (Wundt's associative reaction of the second type).
- IV. (1) Volitional reactions after simultaneous association :
- (a) volitional reaction with discrimination ;
 - (b) volitional reaction with cognition.
- (2) Volitional reactions after successive association :
- (a) discrimination followed by association (*e.g.*, show either one of 5 known colours or a black ; react to the colours after having associated with them objects of their colour ; do not react to the black at all) ;
 - (b) cognition followed by association (*e.g.*, show a mixed series of one-syllable verbs and substantives ; to the substantives associate adjectives, and react by naming the adjectives ; do not react to the verbs).

This, be it understood, is not a programme of work, but a logical schema. It shows that Wundt's two types of associative reaction are rightly distinguished, if his classification of the remaining forms of compound reaction is correct. Whether it would be worth while to make experiments of the types II. (2) (a) and III. (2) (a) the author cannot say, though he inclines to an affirmative answer. There would, so far as he can see, be nothing to be gained by attempting the volitional reactions.

Theoretically, the judgment reactions would form a third class (c) under each of the headings II. (2), III. (2), IV. (2). The experiments would, however, be difficult to arrange; and the psychology of judgment—a very disputed matter—is best attacked by other means. The Table, once more, is not intended as a programme of work.

EXPERIMENT XXVI

The best arrangement for the associative reaction, in a Course like the present, is the combination of visual-verbal stimulus (card changer) and spoken-verbal associate (voice key). Two things may be done. (1) Series of reactions (say, 50 each) may be taken with free, ambiguous and constrained association, and the times and their variability compared both with one another and with the published results in the literature. (2) Short series of reactions with partially constrained association may be made the basis of an introspective examination of the associative consciousness. Here it will be worth while to employ the forms of partially constrained association already used by Watt, and to make Watt's analyses a standard of comparison. The forms are six in number: association of a superordinate, subordinate or co-ordinate idea; of a whole, a part, and another part of a common whole. If we fractionate the consciousness into four stages, as Watt does, and make our series consist of 5 reactions each, we shall have $5 \times 6 \times 4$ or 120 experiments, as against the 150 of the former exercise. See *Theorie d. Denkens*, 7, 16 ff., 34 ff.; *Arch. f. d. ges. Psych.*, iv., 1905, 289, 298 ff., 316 ff.; and for comparative figures Wundt, *P. P.*, ii., 1893, 376 ff.; iii., 1903, 466 ff.

On the technique of the associative reaction, see F. Galton, *Brain*, pt. vi., 1879, 149; *Inquiries into Human Faculty*, 1883, 185 (stop-watch); cf. A. Thumb and K. Marbe, *Exper. Untn. üb. d. psych. Grundlagen d.*

sprachl. Analogiebildung, 1901, 18 f.; A. Mayer and J. Orth, *Z.*, xxvi., 1901, 2; F. Schmidt, *Z.*, xxviii., 1902, 65); M. Trautsholdt, *P. S.*, i., 1883, 231; J. McK. Cattell and S. Bryant, *Mind*, *O. S.*, xiv., 1889, 230 f.; M. de Manacéine, *Le surmenage mental*, 1890, 165, 183 (association box); C. Féré, *Pathol. des Émotions*, 1892, 330 (d'Arsonval chronometer); Kraepelin, *Beeinfl. einf. psych. Vorgänge*, 1892, 17 ff.; G. Aschaffenburg, *Psych. Arb.*, i., 1895, 214 f.; E. T. Dixon, *Journ. of Physiol.*, xx., 1896, 77; T. Ziehen, *Neurol. Centralbl.*, xv., 1896, 290 (Münsterberg's chronoscope: see E. Roemer, *Z.*, xii., 1896, 133); R. Sommer, *Psychopath. Untn.-Methoden*, 1899, 344 f.; A. Wreschner, *Allg. Z. f. Psychi- atr.*, lvii., 1900, 241 (metronome); H. J. Watt, *Arch. f. d. ges. Psych.*, iv., 1905, 292.

QUESTIONS.—(1) Use Watt's analyses; and *cf.* Cattell's *O's*, *Mind*, *O. S.*, xiv., 1889, 244 ff.

(2) (a) It is best, perhaps, to use the chronographic method, with Zwaardemaker's stimulator. Or, if this is too cumbersome a method, let *O* press the knob of a stop-watch as he inhales from the olfactometer, and press it again when the association has formed. The experiments are very interesting in qualitative regard. (b) Use stop-watch or soundless metronome. (c) The author has long desired to make experiments with musical stimuli, but has not yet been able to do so. On the mechanical side, it would be easy to register the final note or chord of a phrase or motif, played on the piano, either electrically (Tanzi: p. 345 above) or pneumatically (A. Binet and J. Courtier, *Ann. Psych.*, ii., 1896, 202). The times would, however, be of less value than the introspections. When one thinks of the extreme suggestiveness of musical phrases to musical minds, one cannot but believe that such experiments would throw a good deal of light on the processes of association.

(3) The latter part of the Question has already been answered. The first part may bring out several points. There is, *e.g.*, the importance of the experiment as affording a means of exact analysis of the associative consciousness; knowing precisely what association is, as experienced, we are able to 'place' it in the psychological system. There is, also, its importance for the classification of associations: see, besides the refs. in vol. i., *I. M.*, 417, E. Claparède, *L'association des idées*, 1903, 209 ff.; J. Orth,

Z. f. päd. Psych., iii., 1901, 104; Watt, Arch. f. d. ges. Psych., iv., 407; Th. d. Denkens, 125; Titchener, Outline, ch. viii. There is, further, the problem of the relation of association to judgment, which forms the topic of the next Question. Indeed, the customary fourfold division of reaction experiments would seem to depend (p. 381 above) upon the two facts, first, that from the beginning controversy raged about the nature of the process of choice; and secondly that, also from the beginning, the associative reaction was looked upon rather as contributing to the doctrine of association than as extending the range of mental chronometry.

(4) This is a very difficult Question: and the answer to it depends upon an initial definition of 'judgment.' In P. P., ii., 1893, 381, Wundt thinks that the course of consciousness in certain partially constrained association experiments is practically the same with its course in the simplest acts of logical judgment: cf. 478; Trautscholdt, P. S., i., 245; Cattell, *ibid.*, iv., 1888, 249 f.; Mind, O. S., xii., 1887, 74 (see also Cattell and Warren, under Essay no. 9, p. 392 below). In iii., 1903, 470, this position is modified; 'logically determined associations' are distinguished from the 'judgment proper': cf. 575, 580 f. Wundt's definition of judgment will be found in Logik, i., 1893, 154 ff.: "eine Zerlegung einer Gesamtvorstellung in ihre Bestandtheile" (156), "die Zerlegung eines Gedankens in seine begrifflichen Bestandtheile" (158); cf. the author's Outline, 215 ff.¹ Very different is the attitude, e.g., of K. Marbe, Exper.-psych. Untn. üb. d. Urteil, 1901. "Urteile," says Marbe, "nenne ich Bewusstseinsvorgänge, auf welche die Prädikate richtig oder falsch eine sinngemässe Anwendung finden" (9 f.); and he concludes "dass es unseren experimentellen Untersuchungen zufolge kein psychologisches Kriterium des Urteils giebt" (94). Judgment thus becomes a function which, as such, belongs not to psychology but to logic (Wundt, P. P., iii., 581). Watt accepts Marbe's results, without reservation, but supplements them by his own doctrine of preparation (Aufgabe: Th., 128 ff.; Arch., 410 ff.). Royce (Psych. Rev., ix., 1902, 113 ff.) objects to them that "it

¹ The account of the 'association after disjunction' here given is intended as an account of the psychology of judgment at large, not of that of the analytic judgment. Cf. M. W. Calkins, Introd. to Psych., 1901, 236.

was the experimenter and not the subject in whom the process that was to be studied went on." Watt replies, a little condescendingly, that "von einem Denken zu sprechen, das mechanisch eingeübt ist, im Gegensatz zu einem aktiven, neuen, wertvollen Denken, ein vulgärer Unterschied ist, der die psychologische Analyse und das Experiment wenig angeht" (Th., 62; Arch., 344); and Whipple remarks that, in experimental work, one has to take what is there,—psychological facts rather than logical schemata (A. J., xiii., 1902, 261). Well! It is foolish to quarrel about terms. If *A* says that the word 'judgment' belongs to psychology, while *B* restricts it to logic; or if *C* says that the judgment, as psychological experience, always implies active attention, while *D* says that it does not; we have, first of all, to ask 'Is the issue an issue of fact, or an issue merely of words?' and, if it is the latter, to keep our tempers. The question of fact now before us is something like this: Is the judging consciousness, as Wundt looks at it, a distinct form of consciousness, characteristically stressed and patterned? Think of the student sitting down to this essay. He has to assimilate the data and arguments quoted above: he has to acquire a *Gesamtvorstellung*, an aggregate idea, of the psychological status of the Question: then he has to let his active attention play upon the aggregate idea, until, with redistribution of clearness-values, there forms the logical sentiment of truth or of agreement. The course of consciousness is, surely, well-marked and characteristic: and whether we name it 'association after disjunction,' in an effort to keep within the accepted terms of psychology, or whether we call it 'judging,' outright, or whether we avoid psychologising in terms of attention and appeal to the reproductive tendencies of the psychophysical organism, is a matter of relatively small moment. This kind of consciousness is there, and is radically different in introspection from "ein Denken, das mechanisch eingeübt ist." So much is fact.

According to Münsterberg, now, all associations are *Urteilsakte*, while conversely all *Urteilsakte* are 'schliesslich nur Associationen' (Beitr., i., 91 ff., 123 ff.). According to Marbe, all those conscious processes are judgments to which one may properly apply the predicate right or wrong: the category is so

far narrowed.¹ According to Wundt, "der Vollzug der Urtheilsfunction besteht, psychologisch betrachtet, darin, dass wir die dunkeln Umrisse des Gesamtbildes successiv deutlicher machen, so dass dann am Ende des zusammengesetzten Denkactes auch das Ganze klarer vor unserm Bewusstsein steht": the category is still farther narrowed. The student must discuss these views, and exercise his — judgment.

(5) Watt, *Th.*, 126; *Arch.*, 408. Claparède, *L'association des idées*, 1903, 6 f. (the sentences are put together from different contexts). J. M. Baldwin and G. F. Stout, *Dict. of Phil. and Psych.*, i., 1901, 78. The *Question* refers back to vol. i., I. M., 402 f. For psychology, association is the associated complex, the associative consciousness; and the problem of psychology, in its regard, is the analysis and synthesis of this particular form of consciousness, and the statement of its physiological conditions. For psychophysics, the problem of association is the establishment of such formulæ as Ebbinghaus seeks in his *Gedächtnis*. In other words, the division of problems here is precisely what it was in the case of the metric methods.

The author knows the difficulty of definition, which is the difficulty of constructive work at large; and he has no wish to offer a carping or meticulous criticism. He cannot but think, however, that many of the definitions of the *Dict. of Phil. and Psych.*, in the field of what may be termed general psychology, are needlessly loose and carelessly articulated. Thus, in the definition of Association, mental dispositions are said to 'correspond to' conscious contents. If we look up Disposition (i., 287) we find it defined, by the same two writers, as "an effect of previous mental process, or an element of original endowment, capable of entering as a co-operative factor into subsequent mental process." We are not now concerned with elements of original endowment; so that the first and third clauses constitute the definition required.² But then a dis-

¹ Marbe, of course, does not stand (so to say) in the same straight line with Münsterberg and Wundt. Watt's definition of judgment (*Th.*, 134; *Arch.*, 416) comes nearer to being a psychological intermediary.

² The "elements of original endowment" are, of course, ruled out by the phrase "formed in and by the course of experience." Why the words should have been inserted in the definition of Disposition is difficult to see; for the writers mark off Disposition (1) from Disposition (2)=Predisposition, and later on make Predisposition the technical name for congenital disposition. If we turn to Predisposition itself (ii., 329), we find that it is an "inherited disposition."

position should not be said to 'correspond to' a conscious contents, but to 'be produced' or to 'be left behind' by it. Association accordingly becomes (if we abbreviate a little) an union, formed by experience, between the mental traces left behind by two conscious contents, such that when the one content recurs the other tends to recur also. Very well! but *do* 'contents' recur? Of course not: meanings recur; contents never (Baldwin, Handbook, i., 1890, 165; Stout, Manual, 1899, 84). Pass this, however, and consider the mechanics of association. Two ideas have been together in consciousness; they have set up two mental dispositions, which form an union. At a later date, the one idea recurs. Recurring, it realises its own disposition. But this disposition is attached to the other disposition. The other disposition, therefore, tends to share in the realisation of the first; and the idea which originally produced it tends itself to recur. The work is done by the dispositions.

Now consult Stout's Manual (82 ff.). "On seeing a flower, I am told that it has a certain name. Afterwards, I hear this name again: it may then call up to my mind a mental picture of the flower, although no flower is actually present . . . The actual perception of the flower occurred as part of the same continuous conscious process as the hearing of the name. Hence, when the name occurs again, it may re-excite the mental disposition left behind by the perception, and re-excite it in such a way that the mental image of the flower rises before the mind although no actual flower is present to the senses." Here it is not the name

[What the 'prefix of the latter term' may be (329, col. 2., ll. 13, 14), the author cannot discover. Is the latter term $\xi\xi\zeta$? or habit?] It looks, then, as if the definition of Disposition should have had three sub-headings; (1)=acquired+congenital disposition; (2)=acquired disposition (the usage recommended); and (3)=congenital disposition (Predisposition recommended).

If we seek, further, to replace the other terms of the definition of Association by their definitions, we get into more difficulty. What is experience? "Consciousness considered as a process taking place in time" [i., 360. The (1) on 361, col. 1, l. 12, should be (2)]. And what is consciousness? "The distinctive character of whatever may be called mental life" (i., 216). "Formed in and by the course of experience" thus becomes "formed in and by the course of the distinctive character (considered as temporal process) of the mental life." And "contents of consciousness" becomes "contents of the distinctive character of whatever may be called mental life." Yet, if we turn to 'content,' we find (i., 223): "whatever in any way forms part of a total consciousness," etc. Here 'consciousness' is employed, against its definition, in the sense in which the experimentalists employ it.

The fact would seem to be that the writers took the terms, as they came up, and approached them with very different 'dispositions' or 'associations.' Natural enough! But suppose that an experimental psychologist were guilty of similar looseness: would there not be a certain Schadenfreude in the other camps?

which realises the name-disposition, which is united to the perception-disposition, which thus tends toward realisation and hence to the reinstatement of the perception contents: it is rather the name-presentation which acts directly upon the perception-disposition. The work is done jointly by presentation and disposition. *Cf.* *Analytic Psych.*, i., 1896, 23 f.

It is not a very hard matter to 'reconcile' these accounts. The point is, however, that no reconciliation should be necessary. A writer who deals as freely as Stout does with such slippery phrases as 'conative process' and 'mental disposition' ought above all things, for the student's sake and for the sake of his own doctrine, to be clear.

ESSAY SUBJECTS.—(1) The history of the reaction experiment (compound reaction exclusive of the associative reaction).

Most of the refs. will be found in Wundt, *P. P.*, ii., 1893, 362 ff.: iii., 1903, 450 ff.; in Jastrow, *Time Relations*, 1890; and in K. Fricke, *Biol. Centralbl.*, ix., 1889, 437, 467. Add G. Valentin, *Physiol. d. Menschen*, ii., 2, 1848, 191; G. Buccola, *Legge del tempo*, 1883, 249 ff.; Münsterberg, *Beitr.*, i., 1889, 64 ff.; Jastrow, *A. J.*, iv., 1891, 198, 411; G. Aschaffenburg, *Psych. Arb.*, ii., 1897, 71; G. T. W. Patrick and J. A. Gilbert, *Iowa Stud.*, i., 1897, 42; J. A. Gilbert and G. C. Fracker, *ibid.*, 42; C. E. Seashore, *ibid.*, ii., 1899, 64; B. Erdmann and R. Dodge, *Psych. Untn. üb. d. Lesen*, 1898, 203 ff., 280 ff.; P. Ranschburg, *Allg. Z. f. Psychiatr.*, lvii., 1900, 689.

(2) The history of the associative reaction.

See, besides refs. already given, Jastrow, *Time Relations*, 47 ff.; Fricke, *Biol. Centralbl.*, ix., 474; Buccola, *Legge del tempo*, 307; C. Féré, *C. R. Soc. Biol.*, xxv., April 1890, 173; T. Ziehen, *Abh. aus. d. Geb. d. päd. Psych.*, iii., 1900; H. Piéron, *Rev. de psychiatr.*, vii., 1903, 515

(3) The analysis of the compound reaction (cognition, discrimination, choice): historical and critical.

The essay would begin with Donders (1868), and discuss the views of von Kries and Wundt. It would, more particularly, distinguish between the schools of 'content' and of 'preparation.' See esp. Wundt, Kraepelin and Merkel, *P. S.*, x., 1894, 485, 499; Wundt, *P. P.*, iii., 1903, 452; Külpe, *Outlines*, 410 ff.; Watt, *Th. d. Denkens*, 78; Arch. f. d. ges. *Psych.*, iv., 360.

(4) The significance for the experiment of the instruction given to *O*.

This point has been worked out for the associative reaction by Watt, Th. d. Denkens, 16 ff.; Arch., 298 ff. Cf. the method described in vol. i., I. M., 411; S. Witasek, Z., xii., 1896, 185 ff.; Müller and Pilzecker, Gedächtniss, 1900, 13 ff.

(5) Wundt's interpretation of the compound reaction (discrimination, cognition, choice), and the relation it bears to his theory of action: historical and critical.

P. S., i., 1881, 27; x., 1894, 485; the various editions of the P. P.; Logik, ii., 2, 1895, 209, 224.

This essay implies a critique of the *procedure with subtraction*,—itself, perhaps, a subject important enough for separate treatment. See, e.g., G. O. Berger, P. S., iii., 1886, 49; Cattell, *ibid.*, 452; Fricke, Biol. Centralbl., ix., 439; Külpe, Outlines, 410 ff.; Erdmann and Dodge, Psych. Untn. üb. d. Lesen, 1898, 211 ff.; Müller and Pilzecker, Gedächtniss, 1900, 19 ff.; Watt, Th., 121 ff.; Arch., 403 ff. The author subscribes to Watt's conclusion: "obgleich es nicht ausgeschlossen ist, dass das Subtraktionsverfahren schliesslich anwendbar wäre, meinen wir, dass seine bisherige Anwendung den Wert der in dieser Weise berechneten Resultate eher vermindert und den späteren Forschern den Zugang zu den experimentellen Daten und irgendeinen sicheren Vergleich der Resultate fast unmöglich gemacht hat."

(6) The validity of Münsterberg's distinction of 'sensorial' and 'muscular' attitudes toward the compound reaction.

Beitr., i., 1889, 64 ff.; G. Martius, P. S., vi., 1891, 167 ff.; Jastrow, A. J., iv., 1891, 200; G. E. Müller, Gött. gel. Anz., no. 11, 1 Juni 1891, 397 ff. (use this ref. also for Essays 3 and 4 above).

(7) The effect of practice on the compound reaction.

See the refs. given above to Wundt (1893 and 1903) on automatic coordination; Cattell, P. S., iii., 486; Kraepelin, St. Petersburg. med. Wochenschr., xiv., 1889, 1 ff. It would be interesting to compare the effects of practice with those of definite instruction (associative preparation).

(8) The comparative value of compound reactions taken from

(a) children, (b) the lower races, (c) the mentally defective or deranged.

This essay should consider all those 'mental tests' in which the processes of discrimination, choice, etc., are introduced under time control: it should not be restricted to formal 'reaction' experiments. The validity of the test itself, its mode of administration, the uniformity of the standard of judgment involved, the comparability of the results with those of compound reactions, etc., should be discussed.

See also C. S. Myers, *Cambr. Anthropol. Expedn. to Torres Sts.*, ii., 1903, 189 ff.; G. T. W. Patrick and J. A. Gilbert, *Iowa Stud.*, i., 1897, 45; C. Rossi, *Riv. speriment. d. Frenat.*, xxvii., 1901, 399 ff.; N. Vaschide and C. Vurpas, *C. R. soc. Biol.*, 20 Juli 1901 (F. Krüger, *Z.*, xxx., 1902, 232); W. G. Smith, *Brit. J. Psych.*, i., 1905, 244, 253; refs. to Aschaffenburg, Kraepelin, Wreschner, etc.

(9) The extension of the reaction method to complexes other than discrimination, cognition, successive association.

We have taken the terms 'cognition' and 'discrimination' from Wundt's classification of the intellectual processes. The question then arises, whether other terms of this classification may be made the subject of reaction experiments.

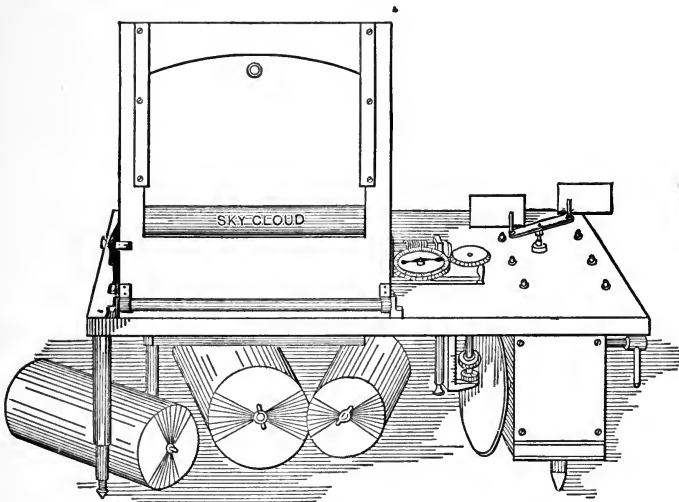

FIG. 53. Müller's kymographic apparatus for the study of memory and association. Zimmermann, 1903, *Mk.* 540. See *Z.*, vi., 1894, 89 f.

See also H. C. Warren, *Psych. Rev.*, vi., 1897, 569 (Cattell, *ibid.*, vii., 1898, 70); Jastrow, *ibid.*, v., 1898, 279; A. J., iv., 1892, 415; Müller and Pilzecker, *Gedächtniss*, 118; W. G. Smith, *loc. cit.*; and the discussion of 'judgment' above.

(10) The psychological results of the memory studies of Ebbinghaus (1885), Müller and Schumann (*Z.*, 1894) and Müller and Pilzecker (1900).

Cf. the classification of psychological methods in Ebbinghaus, *Psych.*, i., 1897, 56 ff.

CHAPTER IV

THE PSYCHOLOGY OF TIME

Also kurz, das Zustandekommen des Zeiturtheils aus der inneren Wahrnehmung zeitlicher Verhältnisse und die Abhängigkeit dieser letzteren von den allgemeinen psychischen Phänomenen, das bezeichne ich als Forschungsgegenstand der Zeitsinnpsychologie.—MEUMANN.

In der That haben die verschiedenen Untersuchungen über den Zeitsinn zu sehr differierenden Ergebnissen geführt, und die Behauptung, dass gerade die neuesten im Recht sind, die früheren falsch waren, ist offenbar unbegründet, so lange für die älteren Resultate keine Erklärung gefunden ist.—MÜNSTERBERG.

§ 40. **The Estimation of Time.**—There is, perhaps, in the whole literature of experimental psychology, no body of work that better repays the reader for minute and critical study than the sequence of investigations upon what, at Czermak's suggestion, was long termed the 'time sense.' The work began some twenty years before the founding of the first psychological laboratory; it suffered, in its earlier phases, from a pronounced and typical attack of psychophysics; recovering from this, thanks more especially to Meumann, it attained to psychological maturity; and it has a long lease of life yet to run. Moreover, the investigations are not only coextensive with experimental psychology, but they form also an unitary and coherent group, which can be studied by and for itself. Test of method, growth of technique, refinement of analytical procedure, differentiation of problems, shift of interest from the accidental to the essential,—all these things are shown, as in a microcosm perfect to the last detail. And still more: the writers have waged a civil war of criticism, not more ruthless, truly, than some of the others that we have recorded in our account of the metric methods, but surely more continuous: there is no definite break in the history, as there is in psychophysics at large after the publication of Fechner's R.¹ At the same time, criticism is now hard pressed to keep

¹ See p. 310, above.

at the heels of production; so that the reader need by no means fear a lack of opportunity for the exercise of his own critical acumen. In a word, the student who knows his 'time sense,' while from this alone he obtains a very imperfect knowledge of the range of experimental psychology and of the sphere of application of the psychophysical methods, has, nevertheless, a good idea of what experimental psychology has been and of what it has come to be.

For purposes of exposition, as for purposes of study, the work done upon the estimation of time intervals divides, prettily enough, into well-marked periods. The author has tried to furnish, in what follows, a fairly complete bibliographical guide to the whole literature. He suggests that the student who has become familiar with the metric methods, their development and their validity, during the year in which this Course is taken may, in the following year, work through the literature of the time sense, period by period, for himself,—abstracting, summarising, criticising, relating, appreciating. The value of such work to the beginner he can confidently attest. Only, of course, the work must be done thoroughly: there must, *e.g.*, be no scamping of the formula-disputes of the psychophysical period. A threshing of old straw? Well! one may learn better to wield the flail on that than if one had new wheat,—from which one could not fail, however clumsy, to beat out a few grains.

I. *The Preliminary Period.*

This period contains three names:¹ those of J. N. Czermak, who in 1857 published a programme of work to be done upon the 'time sense'; of E. Mach, who made experiments during the years 1860–1865 with the purpose of testing the validity of Weber's Law; and of K. Vierordt, whose book *Der Zeitsinn nach Versuchen* (1868) aims "to work out the various functions of the time sense as they are exhibited in at least the most important

¹ An incidental experiment of Thomas Reid's (*Essays on the Intellectual Powers of Man*, iii., 1785, ch. v., *sub. fin.*) may be brought into connection with the work of F. Martius, *Z. f. klin. Medizin*, xv., 1889, 536 ff.; *cf.* E. Kraepelin, *Deutsche med. Wochenschrift*, 1888, no. 33, 669 ff.

sense departments, in the execution of voluntary movements and, finally, in the simple ideation of temporal magnitudes." All three men make definite contributions to their subject. Vierordt's work, in particular, is of high importance. Indeed, if (to use Tyndall's figure¹) Vierordt stands erect in his year and Meumann in his; and if a straight line is drawn from Vierordt to Meumann, tangent to the heads of both; there is no investigator in the intervening period whose head would touch the line.

See Czermak, *Ideen zu einer Lehre von Zeitsinn*, Wiener Sitzungsber., math.-naturw. Cl., xxiv., 1857, 231; Moleschott's *Untn.*, v., 1858, 65; *Ges. Schriften*, i., 1879, 417 ff.; Mach, Wiener Sitzungsber., math.-naturw. Cl., li., Abth. 2, 1865, 133; Moleschott's *Untn.*, x., 1866, 181; Vierordt, *Der Zeitsinn*, 1868 (A. Höring, *Versuche üb. d. Unterscheidungsvermögen d. Hörsinnes für d. Zeitgrößen*, Diss., Tübingen, 1864; W. Camerer, *Versuche üb. d. zeitl. Verlauf d. Willensbewegung*, Diss., Tübingen, 1866; *Z. f. Biol.*, xvii., 1881, 17).

Add Wundt, *P. P.*, 1874, 784 ff.; ii., 1880, 284 ff.; ii., 1887, 355 f.; ii., 1893, 420 ff.; iii., 1903, 102 ff., 500 f.; *P. S.*, i., 1881, 13, 37 f.; Kollert, *ibid.*, 1882, 78; Vierordt, *Z. f. Biol.*, xviii., 1882, 397; Estel, *P. S.*, ii., 1884, 44 f., 49, 60 ff., 478; Fechner, *I. S.*, 1877, 174 ff.; *Abh. d. kgl. sächs. Ges. d. Wiss.*, math.-phys. Cl., xiii., 1884, 57 ff.; Mehner, *P. S.*, ii., 1885, 565, 580, 590 ff.; R. Glass, *ibid.*, iv., 1887, 437; Stevens, *Mind*, O. S., xi., 1886, 402 f.; Ejner, *Exper. Stud. üb. d. Zeitsinn*, 1889, 1 ff.; Leumann, *P. S.*, v., 1889, 630; Munsterberg, *Beitr.*, ii., 1889, 4 ff., 49 f.; Nichols,² *A. J.*, iii., 1891, 503 ff., 528; Schumann, *Z.*, iv., 1892, 2, 20 ff., 48; xviii., 1898, 3; Meumann, *P. S.*, viii., 1892, 456 ff., 472 ff., 482, 501; ix., 1893, 267; Merkel, *ibid.*, ix., 1893, 193; Hüttner, *Martius' Beitr.*, i., 1902, 367 ff.

See further Herbart, *Psych. Untn.*, Heft 1, 1839, §§ 56, 57; *Werke*, ed. Hartenstein, vii., 1889, 309 ff.; R. Mauritius, *Progr. d. Gymnas. Casimirianum, Coburg*, 1870, 24 ff. (Wundt, *P. P.*, 1874, 786; Estel, *P. S.*, ii., 50, 62 f.); G. Buccola, *La legge del tempo*, 1883, 374 ff. (Schumann, *Z.*, iv., 42).

II. *The Psychophysical Period.*

This, which is sometimes known as the Leipsic period, covers seven principal publications: five from the Leipsic Laboratory

¹ On Light, 1885, 49 f.

² Nichols is not always accurate: thus, Vierordt's "experiments with intervals of sight" are in reality experiments on "die Wahrnehmung von Geschwindigkeiten mittelst des Sehnsinns" (*Zeitsinn*, 86); and the indifference point for "eye" is in reality that for "Getast" (112).

(Kollert, Estel, Mehner, Glass) and two from the pen of Fechner. The work of Wundt's pupils centres about the problem of the accuracy of our reproduction of time intervals (problems of the constant error, of the indifference point, of the 'periodicity of the time sense'); Fechner, on the contrary, is mainly interested in the question of the validity of Weber's Law. The seven papers

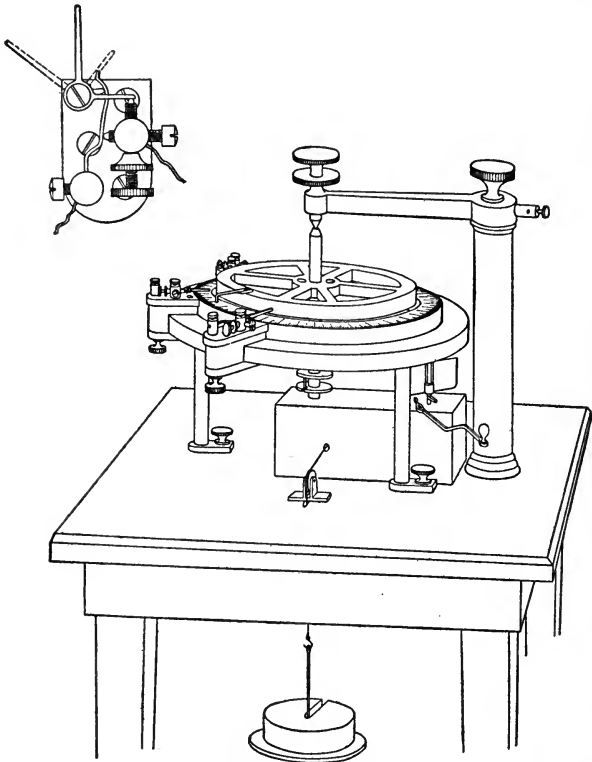

FIG. 54. The older form of the Leipzig 'time sense' apparatus. See Wundt, P. P., ii., 1893, 421 f.; iii., 1903, 502 f.; Estel, P. S., ii., 1885, 38.

constitute a well-defined group. There is, however, evidence of a gradual change in the laboratory work,—change in point of view, as well as in method and technique. Thus, the mathematical tendencies of Kollert and Estel disappear or are greatly modified in Mehner and Glass. Kollert and Estel hardly mention the reports of their *O*'s; Mehner and Glass are largely influenced

by the introspections. The work begins with the method of r. and w. cases, which is promptly given up for minimal changes; it ends with the exclusive use of the method of av. error. So with apparatus: Kollert employed a pair of metronomes, while Estel and Mehner had a crude form of what is now the standard time sense instrument.

See J. Kollert, P. S., i., 1882, 78; V. Estel, *ibid.*, ii., 1884, 37; Fechner, Abh. d. kgl. sächs. Ges. d. Wiss., math.-phys. Cl., xiii., 1884, 3; Estel, P. S., ii., 1885, 475; M. Mehner, *ibid.*, 546; Fechner, *ibid.*, iii., 1885, 1; R. Glass, *ibid.*, iv., 1887, 423.

Add Wundt, P. P., ii., 1880, 290; ii., 1887, 350 ff.; ii., 1893, 415 ff.; iii., 1903, 498 ff.; P. S., i., 1883, 562 f.; Trautscholdt, *ibid.*, 249; Vierordt, Z. f. Biol., xviii., 1882, 397; Fechner, R., 1882, 174 f.; Stevens, Mind, O. S., xi., 1886, 403 f.; Wolfe, P. S., iii., 1886, 556; Ejner, Zeitsinn, 1889, 6 ff., 16 ff., 35 f.; Leumann, P. S., v., 1889, 630; Münsterberg, Beitr., ii., 1889, 6 ff., 50 ff.; Müller, Gött. gel. Anz., 1 Juni 1891, 412; Nichols, A. J., iii., 1891, 507 ff., 528; Schumann, Z., iv., 1892, 24 ff., 56; xviii., 1898, 3, 37 f.; Meumann, P. S., viii., 1892, 432, 434, 438, 440, 454, 457, 464, 466, 494 f.; ix., 1893, 278; Merkel, *ibid.*, 205, ff., 411; Wrinch, *ibid.*, xviii., 1902, 300, 302 ff.; Hüttner, Martius' Beitr., i., 1902, 371 ff.; Nelson, Psych. Rev., ix., 1902, 458; Müller, M., 171 f., 191.

III. *The Intermediate Period.*

At the end of the psychophysical period, the time sense may be said to have gone into commission. The outlook was, indeed, not very encouraging. There had been several experimental investigations, but each, as it came, seemed only to increase the number of new results, without confirming the old; it would be difficult to find two consecutive papers whose points of difference are not more striking than their points of agreement. We have now a group of papers dealing with problems suggested, indeed, by the previous work, but for the most part off the straight line of psychophysical enquiry. We have, also,—what was perhaps to be expected at this stage,—a rather rank growth of theory.

(1) S. Thorkelson, Undersøgelse af Tidssansen, Christiania, 1885. (Quoted above, p. 134, for practice. Summary and criticism in Meumann, P. S., viii., 1892, 432 ff., 457 f. Add Wundt, P. P., ii., 1893, 414 f., 426; iii., 1903, 498, 505; Wrinch, P. S., xviii., 1902, 307; Hüttner, Martius' Beitr., i., 1902, 374.)

(2) G. S. Hall and J. Jastrow, *Mind*, O. S., xi., 1886, 61 f. (Wundt, P. P., ii., 1893, 411; Nichols, A. J., iii., 1891, 524 ff.; Schumann, Z., iv., 1892, 42 f.; xviii., 1898, 18 ff.; Meumann, P. S., viii., 1892, 446, 458, 473.)

(3) L. T. Stevens, *Mind*, O. S., xi., 1886, 393. (Nichols, A. J., iii., 1891, 516 ff., 528; Münsterberg, *Beitr.*, ii., 1889, 12; Schumann, Z., iv., 1892, 43 f.)

(4) H. Münsterberg, *Beiträge*, ii., 1889, 1 ff.; iv., 1892, 89 ff. (Wundt, P. P., ii., 1893, 429; Nichols, A. J., iii., 1891, 519 ff., 528; Schumann, Z., i., 1890, 129 f.; iv., 1892, 35 ff.; Meumann, P. S., viii., 1892, 434, 441 ff., 481, 488, 501 f.; xii., 1896, 134, 140 f., 159, 183, 212; Z., vi., 1893, 390; Müller, *Gött. gel. Anz.*, 1 Juni 1891, 411 ff.; Robertson, *Mind*, O. S., xv., 1890, 524 ff.; Hüttner, *Martius' Beitr.*, i., 1902, 374.)

(5) M. Ejner, *Exper. Studien üb. den Zeitsinn*, Dorpat Diss., 1889. (Wundt, P. P., ii., 1893, 414 f.; iii., 1903, 498; Nichols, A. J., iii., 1891, 518 f., 528; Wrinch, P. S., xviii., 1902, 307; Kraepelin, *Ueb. d. Beeinflussung*, etc., 1892, 32 f., 98 f., 146 f.)

(6) J. Paneth, *Centralbl. f. Physiol.*, iv., 1890, 81 ff. (Ebbinghaus, Z., i., 1890, 224; Schumann, Z., iv., 1892, 46 f.; Meumann, P. S., viii., 1892, 458; Kennedy, *Psych. Rev.*, v., 1898, 490.)

(7) H. Nichols, A. J., iii., 1891, 452 ff.; iv., 1891, 60 ff. (Wundt, P. P., ii., 1893, 420; iii., 1903, 500; Schumann, Z., iii., 1892, 72 f.; iv., 1892, 44 f.; Meumann, P. S., viii., 1892, 444, 502 f.)

(8) E. Kraepelin, *Ueb. d. Beeinflussung einfacher psych. Vorgänge durch einige Arzneimittel*, 1892, 32, 96, 144. Cf. R. Sommer, *Psychopath. Untns.-Meth.*, 1899, 282 f.

(9) J. Jastrow and W. B. Cairnes, A. J., iv., 1892, 213 ff.

(10) H. Münsterberg and A. R. T. Wylie, *Psych. Rev.*, i., 1894, 51 ff.

(11) J. A. Gilbert, *Yale Stud.*, ii., 1894, 52 ff., 85 ff.

(12) M. A. Shaw and F. S. Wrinch, *Toronto Stud.*, ii., 1899, 105 ff. (Wrinch, P. S., xviii., 1902, 300, 307.)

(13) M. L. Nelson, *Psych., Rev.*, ix., 1902, 447 ff. (Meyer, Z., xxxii., 1903, 304.)

(14) H. C. Stevens, A. J., xiii., 1902, 1 ff. (Wrinch, P. S., xviii., 1902, 307; Dürr, Z., xxxvi., 1904, 303 f.; Miner, *Psych., Rev.*, ix., 1902, 530 f.)

(15) B. Edgell, A. J., xiv., 1903, 418 ff. (C. N. McAllister, *Psych. Bulletin*, i., 1903, 439 f.)

(16) A. Aliotta, *R. Istituto di Stud. sup. di Firenze, Ricerche di Psicologia*, i., 1905, 1 ff.¹

¹ The author has included in the fourth and last period only the longest and most systematic studies of recent years. In spirit and conception, however, certain of the articles cited above would seem properly to belong to it. The problem of rearrangement is left to the student.

Add to these refs. E. Leumann, P. S., v., 1889, 619 f.; Mach, Beitr. z. Analyse d. Empfindungen, 1886, 103 ff.; 1900, 157 ff.; K. Groos, Z., ix., 1896, 321 ff.; Sanford, A. J., vii., 1896, 450 f.; A. Binet, Rev. philos., xxix., 1890, 138 ff. (Ebbinghaus, Z., i., 1890, 150; Nichols, A. J., iii., 1891, 527); Arch. de psych., ii., 1902, 20 f.; M. Thury, *ibid.*, ii., 1903, 182 ff.; James, Psych., i., 1890, ch. xv.; Delbœuf, II. Internat. Congress, 1892, 156 ff.; J. M. Bramwell, III. Internat. Congress, 1897, 417 ff.; L. W. Stern, Psych. d. indiv. Differenzen, 1900, 115 ff.—This supplementary list is made up of very heterogeneous items; it may, however, serve to direct the reader's attention to various outlying problems. The author has avoided any reference to the absolute temporal limen, the range of attention and consciousness, the results of complication experiments, the perception of change, the 'specious present,' and other cognate subjects. References to experiments on the estimation of reaction times have been given above, p. 375.

IV. *The Modern Period.*

The characteristic writer of the modern period—the period marked by a combination of psychological analysis with psycho-

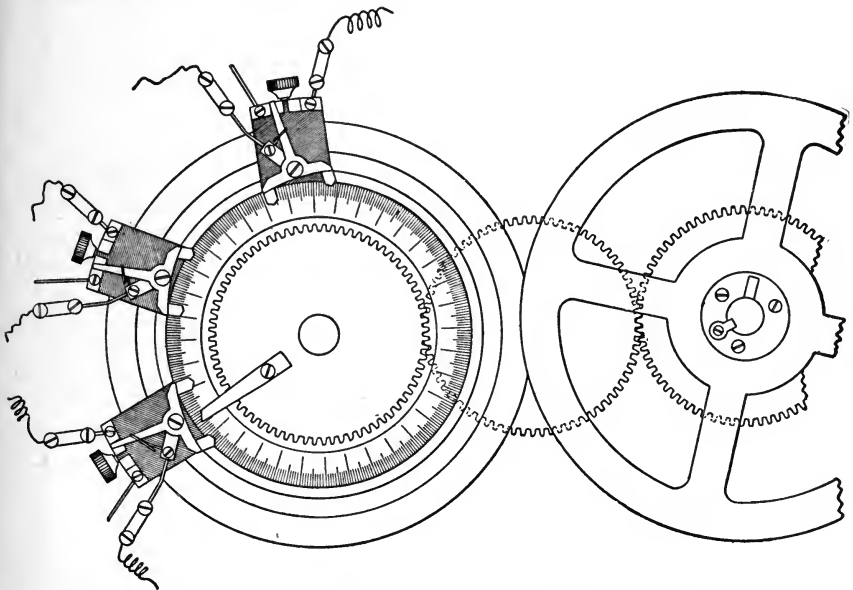

FIG. 55. Schema of the new Leipzig 'time sense' apparatus. See Wundt, P. P., ii., 1893, 424; iii., 1903, 362 f.; Meumann, P. S., ix., 1894, 270. The instrument will serve any purpose for which a series of accurately timed electrical contacts is required.

physical method—is E. Meumann. See the series of articles in the P. S., viii., 1892, 431 ff. (read the programme, 503 ff.!) ; ix., 1893, 264 ff. ; xii., 1896, 127 ff. ; Z., x., 1896, 158 ff.¹

To this period belong also (1) the investigations of F. Schumann, *Nachr. v. d. kgl. Ges. d. Wiss. zu Göttingen*, 1890, no. 20 ; Z., iv., 1892, 1 ff. ; ix., 1895, 297 ff. ; x., 1896, 318 ff. ; xvii., 1898, 106 ff. (contains an outline of Müller's theory of time perception), 253 ff. ; xviii., 1898, 1 ff. ; (2) the study of F. S. Wrinch, P. S., xviii., 1902, 274 ff. ; and (3) that of M. Hüttner, *Martius' Beitr.*, i., 1902, 367 ff.

Add Wundt, P. P., ii., 1893, 408 ff. ; iii., 1903, 47 ff., 53 ff., 86 ff., 362 ff., 493 ff. ; Külpe, *Outlines*, 385 ff. ; Nichols, *Psych. Rev.*, i., 1894, 638 ff. ; Tawney, *ibid.*, iii., 1896, 700 ff. ; Judd, *ibid.*, vi., 1899, 208 ff. ; Merkel, P. S., ix., 1893, 192 ff., 208 ; Mentz, P. S., xi., 1895, 115 ; Kiesow, Z., xxxiii., 1903, 148 f. ; Nelson, *Psych. Rev.*, ix., 1902, 447 f. ; von Kries, Z., viii., 1894, 23 ; A. Grünhagen, *Jahresber. üb. d. ges. Medizin*, xxvii., 1892, 226 ; F. Jodl, *Psych.*, 1896, ch. ix., § 1 ; Scripture, *New Psychology*, 1897, 170 ff. ; M. Foucault, *Psychophysique*, 1901, 464 ff. ; Müller, M., 55, 124, 204 f.

EXPERIMENT XXVII

The experiment is described by Vierordt, *Zeitsinn*, 1868, 34 ff.² In Vierordt's experiments, *E* marked the normal time by pressing the brass rod down upon the glass plate. This arrangement ensures the qualitative likeness of the three sounds ; but, in the author's experience, *E*'s pressures are likely to vary in force, so that the two limiting sounds of the normal interval may differ in intensity. Hence the arrangement of the text seems preferable. Vierordt's results are shown in Table A, p. 36. The following set was obtained, under the conditions laid down in the text, in the Cornell laboratory.

¹ Cf. the articles on rhythm : P. S., x., 1894, 249, 393.

² Vierordt (*Zeitsinn*, 31) says merely that the short arm of his lever measured about 3, the long arm 7 inches. The author's instrument measures 254×9×4 mm ; the short arm is 95 mm. long. The support, of soft iron bent at a right angle, extends downward for 70 mm. and out (towards the standard) for 130 mm. The brass rod, 35 mm. in length, is screwed into the under side of the lever at a distance of 75 mm. from the end.—On the calculation of test values, see *Zeitsinn*, 20 ff.

NT	E_m	e_m	$+E$	n
0.48	+ 12.9	10.2	83.3	17
0.67	+ 11.1	9.6	47.6	26
0.72	+ 12.5	10.0	62.5	10
0.78	+ 9.0	5.2	60.6	24
0.80	+ 6.2	6.6	52.5	38
0.90	+ 3.3	5.3	37.0	29
0.91	+ 3.1	4.2	43.3	15
1.00	- 3.8	7.1	13.3	15
1.20	- 6.6	10.8	12.5	40
2.08	- 2.6	11.6	7.6	13
2.86	- 11.9	15.3	6.0	15

NT =normal time in sec.; E_m =average crude error in % of NT ; e_m =average variable error in % of NT ; $+E$ =percentage of positive crude errors; n =number of experiments.

The Table is very irregular: partly, O was insufficiently practised at the outset; partly, the number of observations was oftentimes too small. Nevertheless, by comparison with Vierordt's Table, the following uniformities emerge.

(1) The time of reproduction is longer than NT when this is short, shorter than NT when this becomes longer. The values of E_m are at first positive; they decrease, as NT increases; finally they swing over into minus values; and these values promise to increase as NT further increases.

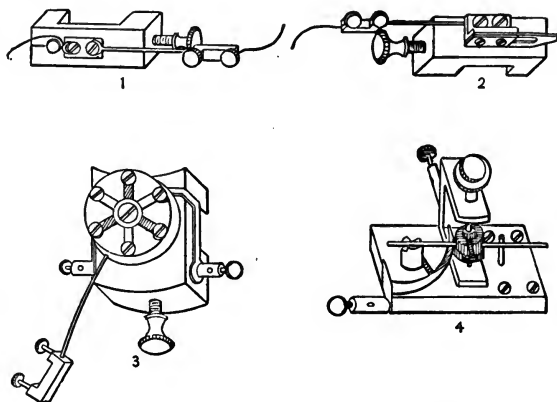

FIG. 56. Contacts for the time-sense disc. Nos. 1, 2, 3 from E. Meumann, P. S. xii., 1896, 145, 147; no. 4 from F. Schumann, Z., xvii., 1898, 257.

(2) When NT is short, $+E$ is large; *i.e.*, there is a marked numerical preponderance of reproduction times that are too long; while, when NT is long, there is a similar numerical preponderance of reproduction times that are too short, $-+E$ becomes small.

(3) As NT increases, the absolute value of the av. var. error increases also. As expressed in the Table (in % of NT) the e_m at first decreases,

presently reaches a minimum, and then increases,—at first quickly, then more slowly.

The actual points of change in the above Table do not coincide with those of Vierordt's Table. Indeed, very little dependence can be put upon the figures of either Table. The three uniformities, however, come out pretty constantly, with a careful *O*.

Introspection.—The following introspections were given in the course of the first 30 experiments taken from the *O* of the Table. *O* has not yet settled down to any one criterion, but is groping amongst the possibilities. For the sake of simplicity in exposition, the *NT* are arranged in descending (not in haphazard) order. *E* is the crude error, in % of *NT*.

<i>NT</i>	<i>E</i>	<i>Introspection</i>
0.70	+14.3	Great uncertainty of attitude. Combination of visual, auditory and kinæsthetic imagery. <i>O</i> thinks that the first two taps were made by himself. Thinks of motion of eccentric on fly-wheel.
0.80	+ 6.2	Rate busy, lively, forcible. <i>O</i> visualised 3 dots on a line.
0.90	-11.1	Gave too short an interval. Was trying to get 3 equal sounds. Did not think of content of interval.
0.98	+ 8.1	Did not count. Felt some contrast with preceding experiments. [Two times in the neighbourhood of 0.75 sec. had been given.] Interval not so favourable to judge as the preceding.
1.05	-10.3	Intensity of normal sounds was disturbing. Consciousness mainly auditory. Wanted to make large excursion with hand. Unpleasant feeling; worry; thought he was going too slow.
1.20	+ 7.5	Strong expectation. Did not feel sure; thought he tapped too soon. Feels surer if he makes a loud tap. Feels surer also if he thinks that his tap is the first of another interval. Does not like the division 1-2-3; prefers 1-2-3-4. No rhythm. Did not count.
1.20	+ 9.0	Thought he made an error of expectation. Judgment was 'one — one,' like the beating of a pendulum. Strict attention to stimulus. Carries mental standard; thinks of filling the interval.
2.01	+ 3.0	Sickening rhythm; too slow. Filled interval with subjective accentuation as 1 . . 2 . . 3. Perceived the times as distinct things.
2.86	- 5.7	Measured intervals by changes in intensity of resonance of table [!]. Tried to use breathing, but gave that up; then tried to measure by other means, as visualising machine. Filling partly auditory, partly kinæsthetic.

ADDITIONAL EXPERIMENT.—If time allows, the experiment described by Vierordt in § 16, 62 ff., deserves repetition.

QUESTIONS.—(1) and (4) have been answered in what precedes. No definite answer can here be given to (2): *cf.*, however, the Table of introspections cited above. For (3), see above p. 159. (5) We have pointed out more than once (*e.g.*, p. 232) that in the early days of psychophysics Weber's Law was expected to hold of much more than the mere intensity of *S*. It has now become a law of that, and of that only: where Weber's Law obtains, there what we call intensity of *S* is the material of judgment. Hence, if Weber's Law does hold for the 'time sense,' or for any limited range of time intervals, our judgment of the times must be based upon sensible intensities. The Question then becomes: How far is our judgment of time intervals thus based? And what are the intensive *S* involved?—On the second part of the Question, see, as a first reference, Fechner, I. S., 174 ff. (6) See, *e.g.*, Wundt, P. P., iii., 1903, 1 ff., 492 ff.

ESSAY SUBJECTS.—It has already been suggested that a careful study of the whole literature be made in the year after that in which this Course is taken. The following, among others, may be chosen as topics for essays.

(1) Czermak's programme: how far is it adequate, and how far has it been carried out?

(2) Vierordt's Zeitsinn: criticism and appreciation.

(3) The theories of 'time sensation.'

(4) The Leipsic work (psychophysical), and the validity of the periodic law.

(5) Fechner, Estel, and the method of minimal changes.

(6) Schumann's theory of time perception and time estimation.

(7) Meumann's programme, as compared with Czermak's; Meumann's work, as compared with Schumann's; the general significance of Meumann's position.

(8) Weber's Law and time.

(9) Outstanding problems in the investigation of the temporal D. S.

(10) Wrinch's conclusion regarding the inequality of the *j. n. d.* of time.

We referred to Wrinch, p. lxxxvii. above, in connection with Külpe and Ament. His paper merits serious consideration. Criticism should be based not only on the sources of error in the investigation itself but also upon the results gained in other fields by the method of mean gradations (see esp. Fröbes, p. 231 above). The author is not convinced that Wrinch has made the point raised by the subject of the essay.—Much the same thing may be said also of Edgell's investigation.

(11) The importance of practice in experiments upon the temporal D. S.

(12) A review of the work done upon cognate problems, and a comprehensive programme of the experimental study of the time consciousness.

CHAPTER V

THE RANGE OF QUANTITATIVE PSYCHOLOGY

Es fehlt der Psychologie von vornherein die Möglichkeit einer Verallgemeinerung der Masseinheiten, wie sie der physikalischen Messung eigen ist. Doch hindert dies nicht dass die *Principien* hier ebenso allgemeingültig sind wie dort. Denn diese Principien sind auch hier von der besonderen qualitativen Eigenthümlichkeit der Phänomene ganz unabhängig: sie gründen sich einzig und allein darauf, dass alle psychischen Elemente und ihre Verbindungen, wie beschaffen sie im übrigen auch sein mögen, *stetig veränderliche Grössen sind, deren jede sich auf eine eindimensionale Grösse zurückführen lässt.*—WUNDT.

Supposons que l'expérimentation puisse s'étendre à l'ordre entier des phénomènes psychologiques, et permette d'isoler ces phénomènes les uns des autres, comme on isole les gaz qui composent l'air. Le psychologue serait encore loin de posséder une science semblable à celle que peut acquérir le chimiste ou le physicien, et qui lui assurât les mêmes avantages. Ce qui fait la valeur scientifique de la chimie, c'est l'analyse *quantitative* des substances; ce qui fait la valeur scientifique de la physique, c'est qu'on peut y fixer par des *nombres* les rapports des antécédents et des conséquents. Or, les phénomènes psychologiques *ne sont pas mesurables.*—RABIER.

§ 41. **Some Typical Experiments in Quantitative Psychology.**
—In § 6 of the text it was explained that this Course covers only a limited part of the field of quantitative psychology. In principle, it was there affirmed, every problem set in psychology can be set in quantitative form; in practice, the range of quantitative work is already very wide. We have, now, been obliged, partly by the historical development of the science, partly by the intrinsic importance of the questions involved, to confine ourselves for the most part to work upon the metric methods and upon the reaction experiment. It therefore seems necessary to add in this place a few references to outlying problems. It must be said, and said emphatically, that the selection here made is a selection from a very large number of possibilities, and that it is therefore an individual selection on the part of the author. Another experimental psychologist, facing the same issue, might choose an entirely different set of illustrations.

I. *Sensation.*—(1) Fig. 57 shows the arrangement used by C. Hess and H. Pretori in their *Messende Untn. üb. d. Gesetzmässigkeit d. simultanen Helligkeits-Contrastes* (Arch. f. Oph-

thal., xl., 4, 1894, 1 ff.; see p. clii above). Two vertical white surfaces, SS' , meet at an angle of 90° , and can be separately

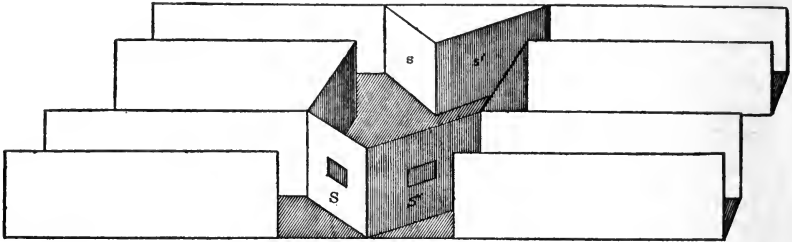

FIG. 57.

illuminated. Each surface contains a window, through which O views the similar surfaces ss' ; these can also be separately illuminated. The anterior surfaces are thus the inducing, the projections of the windows upon the posterior surfaces are the induced fields. For further details, see the original paper: *cf.* also A. Tschermak, in L. Asher and K. Spiro, *Ergebnisse d. Physiol.*, ii. Jahrg., ii. Abth., 1904, 752 ff.

(2) In the sphere of auditory sensation, we may single out F. Krüger's *Beobachtungen an Zweiklängen*, P. S., xvi., 1900, 307 ff., 568 ff., together with the later papers *Zur Theorie der Combinationstöne*, *ibid.*, xvii., 1901, 185 ff., and *Differenzttöne und Konsonanz*, *Arch. f. d. ges. Psych.*, i., 1903, 205 ff.

Directions for simple quantitative experiments upon difference tones are given in an article by M. Meyer, A. J., xvi., 1905, 293 ff.

II. *Affection*.—The experimental study of the affective processes by psychological methods is still in a very backward state. Mention may be made here of two recent investigations, in which the method of impression has been extended to meet new problems. The work is only roughly and crudely quantitative.

The first paper is that of Titchener (P. S., xx., 1902, 382 ff.), who attempts to apply the method of paired comparison (vol. i., I. M., 158) to the six affective categories of Wundt's pluralistic theory. The results, so far as they go, speak in favour of the dualistic theory of affection.

The experiments are, however, not very numerous, and each set of stimuli was tested only for two (not for three) of the Wundtian dimensions.

The second investigation, made by K. Gordon (Arch. f. d. ges. Psych., iv., 1905, 437 ff.) in Külpe's laboratory, is directed upon the question "ob die Annehmlichkeit bzw. Unannehmlichkeit gewisser visueller Erlebnisse einen Einfluss auf die Genauigkeit der Erinnerung an diese Erlebnisse hat." The results are negative (443, 447). Again, however, the experiments are not very numerous. Moreover, the writer says nothing of a point of high systematic importance. In theory, the impressions were all viewed with maximal attention. Nevertheless, they are classified as pleasing, displeasing—and *indifferent*. Yet Külpe (Outlines, 273 ff.) apparently approves of Wundt's definition of feeling as "the mode of reaction of apperception upon sensations." How then can an apperceived perception be indifferent? And even if we waive this point, of the relation of affection to attention, the possibility would remain that the *O's* attended with peculiar concentration to the indifferent impressions, just because they were indifferent. In a commentary upon the work (Arch., 459 ff.) Külpe remarks that the results speak against the extreme pluralistic theory.

The technique of the ergograph (vol. i., I. M., 170) has, perhaps, touched high-water mark in Bergström's apparatus (A. J., xiv., 1903, 253, 268). The new instrument is adapted for various forms of work, and is apparently (in good hands) exceedingly accurate. It costs, however, some \$125, and is probably too complicated for anything but original investigation.

Reference may be made, further, to R. Müller's critique of the Mosso ergograph (P. S., xvii., 1901, 1 ff.), and to Binet's instrument (Année psych., iv., 1898, 304).

III. *Attention*.—(1) Complication experiments were first made by Wundt in 1861. Although the list of experimental investigations is not long, the early results have been much discussed, and the experiment has exercised a determining influence upon Wundt's psychological system. The original apparatus is figured in Lectures, 270; the first instrument of precision in P. P., 1874, 778; ii., 1880, 277; ii., 1887, 345; ii., 1893, 405; iii., 1903, 82. Fig. 58 shows this instrument in improved form. A third model is figured by M. Geiger, P. S., xviii., 1902, 350; Zim-

mermann, *Cat.* 1903, 22; Sommer, *Ausstellung*, etc., 1904, 37; and, schematically, by Wundt, *P. P.*, iii., 1903, 68. Fig. 59 shows an instrument built for the author by Zimmermann in 1905; it differs in various minor details from Geiger's apparatus.

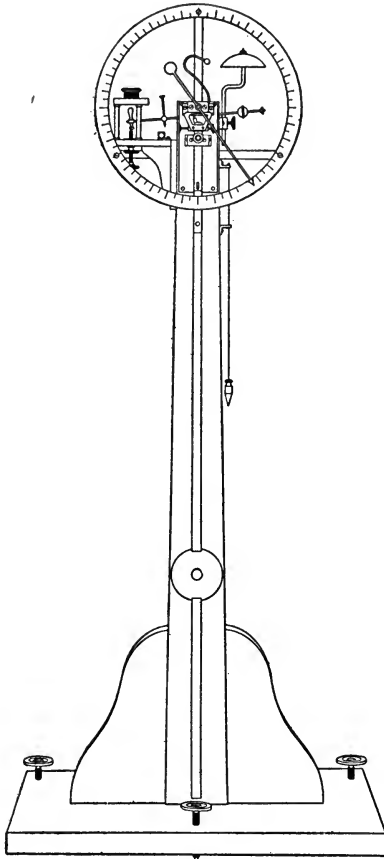

FIG. 58.

that of E. M. Weyer, *P. S.*, xiv., 1898, 616 ff.; xv., 1899, 67 ff.; cf. Wundt, *P. P.*, iii., 1903, 45 ff. Weyer's apparatus is figured in *P. S.*, xiv., 627. Fig. 60 shows the instrument employed by G. M. Whipple, *A. J.*, x., 1899, 280 f.

The experimental references are: W. von Tschisch, *P. S.*, ii., 1885, 603 ff.; J. R. Angell and A. H. Pierce, *A. J.*, iv., 1892, 528 ff.; J. Jastrow and G. W. Moorehouse, *A. J.*, v., 1892, 239 ff.; C. D. Pflaum, *P. S.*, xv., 1899, 139 ff.; Geiger, *loc. cit.* See also James, *Psych.*, i., 1890, 411 ff.; Lipps, *Grundtatsachen*, 1883, 658 ff.; Ebbinghaus, *Psych.*, i., 1902, 592 ff.; Wundt, *loc. cit.*; *P. S.*, i., 1881, 34 f.; xv., 1900, 579 ff.; Titchener, *Mind*, *N. S.*, ix., 1900, 287 ff.; H. C. Stevens, *A. J.*, xv., 1904, 581.

(2) Another experiment of first-rate importance for the theory of attention is that on the temporal limen of homogeneous and disparate *S*. The work was begun by Exner in 1875¹ (*Pfl. Arch.*, xi., 403 ff.), and the latest study is

¹ If we admit the method of frequency (Külpe, *Outlines*, 380, 382 ff.), the experiments go back at least 10 years earlier.

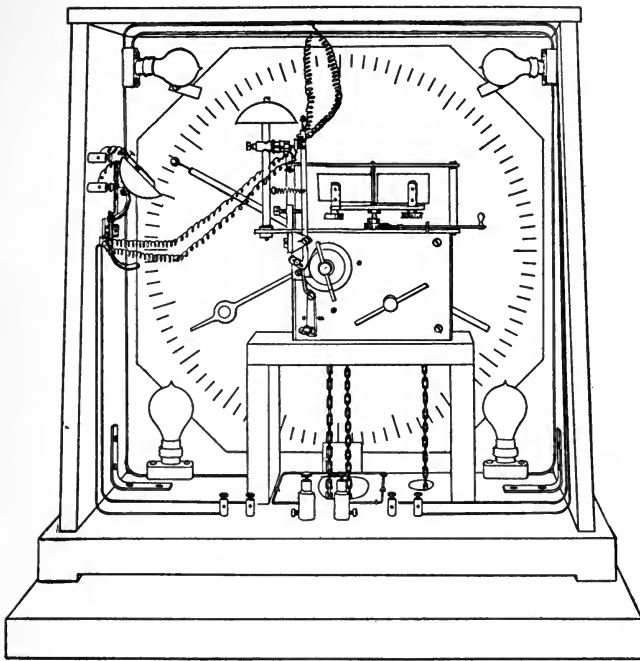

FIG. 59.

IV. *Visual Space Perception*.—(1) Fig. 61 shows an instru-

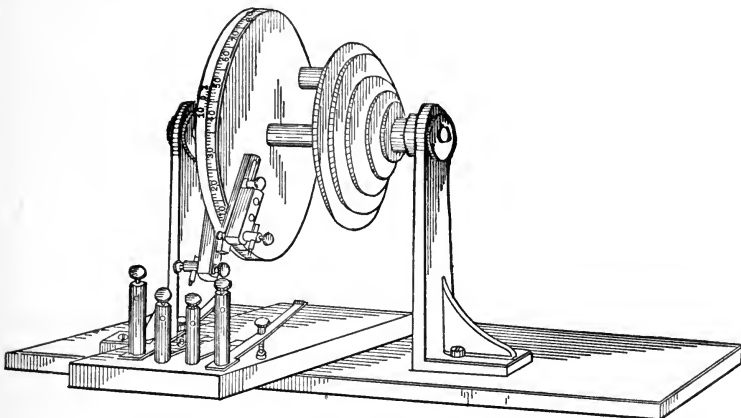

FIG. 60.

ment (isoscope) employed by F. C. Donders for the determination of the subjective retinal vertical. See Arch. f. Ophthal.,

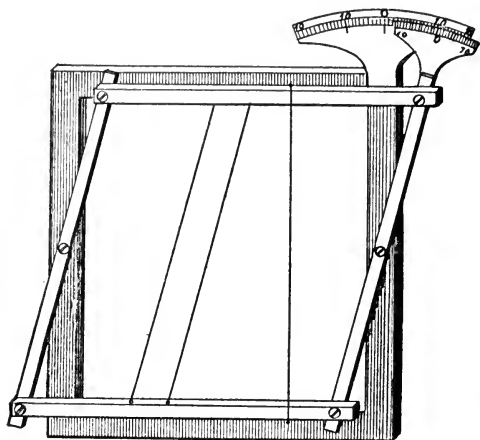

FIG. 61.

xxi., 3, 1875, 107; Aubert, P. O., 1876, 650; Hering, in Hermann's Hdbch., iii., 2, 1879, 355 ff., 468 ff., 496 ff.; Sanford, Course, 266 ff.

(2) Fig. 62 shows the modification of Hering's haploscope (itself a modification of Wheatstone's mirror stereoscope) em-

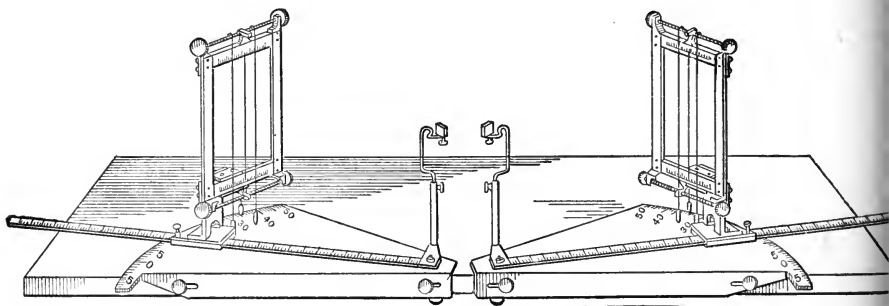

FIG. 62.

ployed by F. Hillebrand, in his paper on Die Stabilität d. Raumwerte auf d. Netzhaut (Z., v., 1893, 38 ff. and Taf.). Cf. Hering, in Hermann's Hdbch., 393 f.

(3) A great deal of work has been done, of recent years, on the quantitative determination of various optical illusions. Fig. 63, 64 show two apparatus employed by G. Heymans: the one in a study of the Müller-Lyer (Z., ix., 1895, 223), the other in a

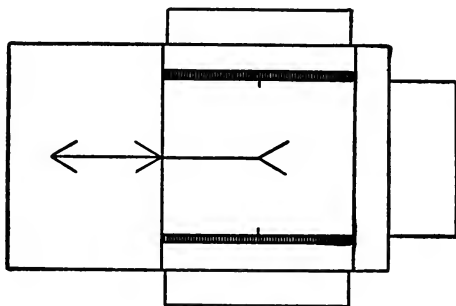

FIG. 63.

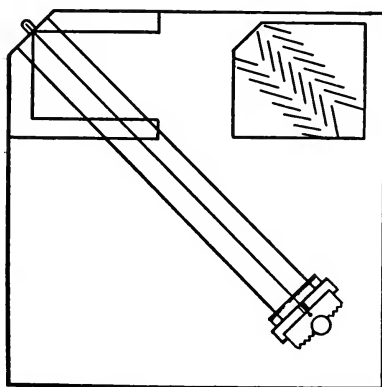

FIG. 64.

study of the Zöllner figure (Z., xiv., 1897, 102). Both are easily made, and are sufficiently accurate for the purposes of this Course.—References to further work may readily be found in the current bibliographies.

V. *Rhythm*.—The apparatus figured and described by R. MacDougall and R. H. Stetson, in *Harvard Stud.*, i., 1903, 313 ff., 417 f., mark a distinct advance in experimental technique. Cf. *Wundt's Taktirapparat*, P. P., iii., 1903, 38.

VI. *Memory*.—Experiments upon memory (deriving from Ebbinghaus' *Gedächtnis* of 1885) are as characteristic of the present epoch as are the 'motor' studies mentioned above (pp. 364 ff.). We have figured Müller's memory kymograph (p. 391). Fig. 65 shows the exposure apparatus and pendulum employed

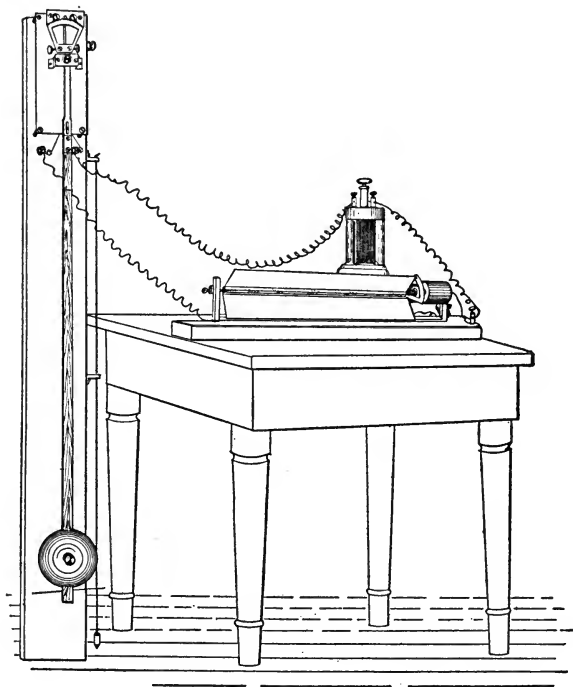

FIG. 65.

by T. L. Smith, *A. J.*, vii., 1896, 457 f. Zimmermann, *Cat.* 1903, advertises Wirth's rotation apparatus (Mk. 345), Ranschburg's apparatus (complete outfit, Mk. 192.50; *cf.* p. 350 above), and Wirth's memory apparatus (two forms: Mk. 105, and—complete outfit—Mk. 324: these instruments may be combined with the rotation apparatus). See P. Ranschburg, *Monatsschr. f. Psychiatr. u. Neurol.*, x., 1901, 321 ff.; W. Wirth, *P. S.*, xviii., 1903, 701 ff.; *ibid.*, xx., 1902, 639 ff.; F. Reuther, *Beiträge z. Gedächtnisforschung*, 1905, 33; R. Sommer, *Ausstellung von exper.-psych. App. u. Methoden*, 1904, 27 ff., 57 ff.

APPENDIX I

EXAMINATION QUESTIONS

A written examination held at the end of the qualitative work of this Course is of real value, since it enables the Instructor to judge how far the student has wrought his experimental results into a systematic psychology (vol. i., S. M., xviii.), and how far he has gone in his collateral reading. An examination held at the end of the quantitative work is less valuable; indeed, the author has, of late years, relied entirely upon the laboratory exercises and the assigned essays for an estimate of the student's progress. Since, however, there may be colleges and universities which require an examination, or teachers of psychology who lay greater weight upon the comprehensive terminal review, the author gives below a number of questions selected from papers set to his classes.

1. Discuss the attributes of sensation. How is the method of introspective analysis employed in their investigation? Give the general rules for the use of this method, and show how it is related to memory and language.

2. Describe (under three headings) Herbart's services to modern psychology. Discuss the (four) principal external influences under which modern psychology has developed.

3. What is Stumpf's position as regards the intensive summation of unlike tonal qualities? Give A. M. Mayer's ratio for the limen of suppression with tone and noise. Give G. Heymans' formula for suppression, in terms of an 'active' and a 'passive' stimulus.

4. Discuss the problem of the connection of mind and body, (*a*) as treated by some author to whom you have been referred, and (*b*) from your own point of view.

5. Do auditory sensations obey Weber's Law? Write fully, with historical references.

6. Describe H. Zwaardemaker's experiments upon tonal limits. What

instruments were used? What were the general results? What explanations have been put forward to account for the phenomena?

7. Describe E. Luft's experiments upon the D. S. for tones. What was the instrument, and what the method employed? What is the important feature of the results? Give Külpe's table for the *DL*.

8. What is meant by 'double hearing'? What is its bearing upon experiments on the D. S.? What are the possible explanations of double hearing?

9. Describe H. K. Wolfe's experiments upon pitch memory. Give his results, with criticism.

10. How can we determine the minimal duration of stimulus at which tone can be cognised? What results did R. Schulze obtain? Criticise. Give five results of the experiments of Abraham and Brühl.

11. What is the scope, and what the meaning of Weber's Law?

12. How do you eliminate constant errors in Wundt's method of minimal changes?

13. Describe Fechner's method of average error.

14. How would you measure the D. S. of pitch by means of two forks of 512 vs., provided with riders? Illustrate by a diagram of the method.

15. Indicate in outline how you would apply the method of r. and w. cases to temperature discrimination.

16. What are the fundamental postulates of psychophysics? What are the main arguments *against* parallelism? What hypothesis is best able to replace it?

17. In what different senses has the term 'apperception' been employed, and in what systems does it play a conspicuous part?

18. How does modern psychology deal with the fact that a mental process may convey the meaning of extension, *i.e.*, stand for a spatially extended 'object'? Quote authors.

19. What is the psychological basis (or what the psychological explanation) of the 'meaning' or 'value' that logic and ethics attach to various conscious processes?

20. Estimate the value and validity of Weber's Law.

21. "In the case of sensational intensity, there is a tendency toward constancy of the relative D. S.; in that of sensational quality, a tendency toward constancy of the absolute D. S." Is this statement true? Discuss and explain.

22. How would you apply the method of mean gradations to an investigation of active pressure (lifted weights)?

23. Discuss the application of Weber's Law to the affective processes.

24. Describe the method to be employed in some particular series of liminal determinations (upper and lower limits of tonal sensation, or

minimal pressure, or just audible intensity of sound). What are the peculiar difficulties of such work, *i.e.*, of work near the limen of sensation ?

25. Describe and criticise the principal odorimetric methods.
26. How would you examine the D. S. of sound ?
27. Give some account of photometric methods.
28. Describe a typical chronometric experiment, giving a diagram of the apparatus. What is the psychological value of such an experiment ?
29. Explain the following : transition sensation, differential sensitivity, noticeableness, *Anschauung*.
30. What is the primary object of the psychophysical metric methods ? What difference in principle is there between 'gradation' and 'error' methods ? Illustrate.
31. When we stop a child's crying by calling its attention to 'something else,' has the child ceased to *feel* the pain, or has it merely ceased to *notice* ? Explain fully.
32. What are the elementary conscious processes ? Under what aspects may they be regarded by psychology ? How do you account for the fact that 'red,' 'cold,' etc., *mean* something to us ?
33. How can we determine and measure our 'illusions' ?
34. What is the popular view of 'mind' and 'consciousness' ? How does the scientific view differ from this ? What are the reasons which lead the psychologist to reject the popular view ? Are they good reasons ? Why ?
35. Suppose that we had determined a sense-distance that was the 10-fold of a given distance from the same sense-continuum. Introspection could tell us nothing of the ratio 1 : 10. Is this fact an argument against the validity of mental measurement ?
36. Translate and comment upon the following passages.

(a) Principiell also wird unser Mass der Empfindung darauf hinauskommen, jede Empfindung in gleiche Abtheilungen, d. s. die gleichen Incremente, aus denen sie vom Nullzustand an erwächst, zu zerlegen, und die Zahl dieser gleichen Abtheilungen als wie durch die Zolle des Massstabes durch die Zahl der zugehörigen variablen Reizzuwächse bestimmt zu denken, welche die gleichen Empfindungszuwächse hervorzubringen im Stande sind; wie wir ein Stück Zeug messen, indem wir die Zahl der gleichen Abtheilungen desselben durch die Zahl der Elle bestimmen, welche sie zu decken vermögen; nur dass statt des Deckens hier das Hervorbringen steht.

(b) Jede Grösse kann nur auf eine Masseinheit ihrer Art bezogen werden; und insofern, kann man allerdings sagen, lässt sich Raum nur durch Raum, Zeit nur durch Zeit, Gewicht nur durch Gewicht messen; aber ein Anderes ist es mit den Massmitteln und den Massmethoden. Insofern die zu messenden Grössen nicht abstract in der Natur der Dinge bestehen und sich nicht von einander abstrahiren und abstract voneinander handhaben lassen, kann man auch die abstracte Mass-

einheit und ein Massverfahren damit nicht in der Natur der Dinge finden ; und es kommt nur darauf an, das praktische Massverfahren mit den concreten Massen der Wirklichkeit so einzurichten, dass die Grössenbeziehung des zu Messenden zur Masseinheit sich doch rein herausstelle.

(c) Von vorn herein kann man das Bedenken hegen dass bei der grossen Veränderlichkeit der Empfindlichkeit nach Verschiedenheit der Individuen, der Zeit und unzähliger innerer und äusserer Umstände es ganz fruchtlos sei, sich um ein Mass desselben zu bemühen, einmal, weil ein stets Veränderliches keiner scharfen Messung zugänglich sei, zweitens, weil die Resultate keine Constanz und hiemit keinen Werth haben, sofern die an gewissen Individuen, zu gewisser Zeit, unter gewissen Umständen beobachteten Resultate sich doch anderwärts und anderemale nicht wiederfinden würden. In der That ist nicht in Abrede zu stellen dass in dieser Hinsicht für das Mass auf unserem psychophysischen Gebiete Schwierigkeiten bestehen.

(d) Die vermittelten functionellen Beziehungen zwischen Körper und Seele erfüllen den Begriff der functionellen Beziehung nur insofern vollständig, als man die Vermittelung in das Verhältniss mit eingehend denkt, da bei Wegfall der Vermittelung die Constanz oder Gesetzmässigkeit in der Relation des Körpers und der Seele wegfällt, die unter Zutritt der Vermittelung besteht. So löst ein Reiz nur insofern gesetzlich Empfindung aus, als es zum lebendigen Gehirne auch nicht an lebendigen Nerven fehlt, welche die Wirkung des Reizes zum Gehirne überpflanzen. Insofern das Psychische als directe Function des Physischen betrachtet wird, kann das Physische der Träger, die Unterlage des Psychischen heissen. Physische Thätigkeiten, welche Träger oder Unterlage von psychischen sind, mithin in directer functioneller Beziehung dazu stehen, nennen wir psychophysische.

(e) Möge nun Jeder die Idee und den Spielraum der inneren Psychophysik so weit und so lange beschränken, als ihn der Zwang und das Band der Thatsachen nicht nöthigt, die Beschränkung aufzugeben. Nach meinem Glauben giebt es in dieser Hinsicht keine Gränze. In der That, bedenke ich, dass die Empfindung der Harmonie und Melodie, die unstreitig einen höheren Charakter als die der einzelnen Töne trägt, der Verhältnisse derselben Schwingungszahlen als Unterlage bedarf, die einzeln den einzelnen Empfindungen unterliegen, und dass sie sich nur in genauem Zusammenhange mit der Weise, wie diese zusammenklingen und sich folgen, ändern kann ; so scheint mir hierin eine Andeutung nur für ein höheres, aber kein fehlendes speciellcs Abhängigkeitsverhältniss zwischen höherem Geistigen und physischer Unterlage zu liegen, und Alles wohl mit dieser, leicht weiter auszuführenden und zu erweiternden Andeutung zu stimmen.

See also vol. i., I. M., 424 (Question VII., 5), 426 (Questions IX., 3, 8; X., 2, 4, 6), 427 (Questions XII., 4 [c]; XIII., 5), 428 (Questions XIV., 5; XV., 5, 6), 429 (Questions XV., 8, 9; XVI., 3).

APPENDIX II

BOOKS AND PERIODICALS

The list of necessary periodicals stands as it stood in 1901, with the following corrections and additions:

- (1) The *Année psychologique* now has A. Binet as its sole chief editor, and has apparently given up the publication of the annual bibliography. Vol. x., 1904, contains the bibliography for 1903.—Masson et Cie., 120 Boulevard Saint-Germain, Paris.
- (2) The *Philosophische Studien* (20 vols. and separate index) passed out of existence in 1903, and was succeeded by the *Archiv für die gesammte Psychologie*, edited 1903-1905 by E. Meumann, 1905 by E. Meumann and W. Wirth. The *Archiv* publishes reviews of books, as well as large topical reviews of progress in various departments of psychology.—W. Engelmann, Leipzig.
In 1905, Wundt began the publication of *Psychologische Studien, Neue Folge der Philosophischen Studien*, which is to serve as medium of publication for the Leipzig Laboratory.—W. Engelmann, Leipzig.
- (4) Since 1904, the *Psychological Review* has appeared in two sections: a bimonthly article section, edited by J. M. Baldwin and H. C. Warren (C. H. Judd is added, in the same year, as editor of the Monograph Series), and a monthly literary section, the *Psychological Bulletin* (same editorship). The Monograph Series continues the monograph supplements of the older issue; the bibliography is still sold separately.—The Macmillan Co., 66 Fifth Avenue, New York City.
At the same time that this change was made in the management of the *Review*, F. J. E. Woodbridge began the publication of a fortnightly *Journal of Philosophy, Psychology and Scientific Methods*.—Sub-station 84, New York City.
- (5) The *Zeitschrift* was edited to 1901 by H. Ebbinghaus and A. König, and in 1902 by H. Ebbinghaus; since 1902 it has been edited by H. Ebbinghaus and W. A. Nagel. The annual bibliography is continued.

- (6) Add *The British Journal of Psychology*, edited (since 1904) by J. Ward and W. H. R. Rivers.—University Press, Cambridge; The Macmillan Co., New York City.

As even this brief revision shows, there has been a strong tendency in the past few years toward the multiplication of psychological journals. Indeed, the number of serial publications is now so large, and their contents so specialised, that they will hardly be found all together in a single institutional library,—to say nothing of a private library. While one heartily welcomes anything that makes for the extension and diffusion of the science, this scattering of psychological matter is in so far to be regretted as that the individual psychologist becomes more and more strictly confined to his special field of knowledge and investigation. The larger libraries are, as a rule, very willing to lend their books; but it takes time and effort to apply for these, and to read them when they have been sent; and the psychologist, busy in his own department, is thus likely to overlook many things that he would have taken cognisance of, had they been more easily accessible. Under these circumstances, the value of the yearly bibliographies can hardly be overestimated. While they are rarely, if ever, complete, they rarely miss a publication of serious importance.—

The following list of 50 works completes the tale of what are, in the author's judgment, the 'hundred best books' for the private library of the student taking this Course.

51. H. Aubert, *Physiologie der Netzhaut*. Breslau, E. Morgenstern. 1865.
52. A. Binet, *L'Étude expérimentale de l'intelligence*. Paris, Schleicher Frères et Cie. 1903.
53. É. Claparède, *L'Association des idées*. Paris, O. Doin. 1903.
54. J. Delbœuf, *Éléments de psychophysique, générale et spéciale*. Paris, Germer Baillièrre et Cie. 1883.
55. J. Delbœuf, *Examen critique de la loi psychophysique : sa base et sa signification*. Paris, Germer Baillièrre et Cie. 1883.
56. H. Ebbinghaus, *Ueber das Gedächtnis : Untersuchungen zur experimentellen Psychologie*. Leipzig, Duncker & Humblot. 1885.
57. R. Eisler, *W. Wundt's Philosophie und Psychologie in ihren Grund-
lehren dargestellt*. Leipzig, J. A. Barth. 1902.
58. A. Elsas, *Ueber die Psychophysik : physikalische und erkenntniss-
theoretische Betrachtungen*. Marburg, N. G. Elwert. 1886.

59. S. Exner, Physiologie der Grosshirnrinde, in L. Hermann's Handbuch der Physiologie, ii., 2, 1879. Leipzig, F. C. W. Vogel.
60. G. T. Fechner, Ueber ein psychophysisches Grundgesetz und dessen Beziehung zur Schätzung der Sterngrössen. Leipzig, S. Hirzel. 1859.¹
61. G. T. Fechner, In Sachen der Psychophysik. Leipzig, Breitkopf und Härtel. 1877.
62. G. T. Fechner, Revision der Hauptpunkte der Psychophysik. Leipzig, Breitkopf und Härtel. 1882.
63. G. T. Fechner, Ueber die Frage des Weberschen Gesetzes und Periodicitätsgesetzes im Gebiete des Zeitsinnes. Leipzig, S. Hirzel. 1884.
64. G. T. Fechner, Ueber die Methode der richtigen und falschen Fälle in Anwendung auf die Massbestimmungen der Feinheit oder extensiven Empfindlichkeit des Raumsinnes. Leipzig, S. Hirzel. 1884.
65. M. Foucault, La psychophysique. Paris, F. Alcan. 1901.
66. G. S. Fullerton and J. McK. Cattell, On the Perception of Small Differences, with special reference to the extent, force and time of movement. Philadelphia, University of Pennsylvania Press. 1892.
67. F. Galton, Natural Inheritance. London, Macmillan & Co. 1889.
68. A. Grotenfelt, Das Webersche Gesetz und die psychische Relativität. Helsingfors. J. C. Frenckell & Sohn (G. W. Edlunds Buchhandlung). 1888.
69. J. F. Herbart's Schriften zur Psychologie : vols. v., vi., vii. of Sämmtliche Werke, ed. G. Hartenstein. Hamburg and Leipzig, L. Voss. 1886, 1888, 1889.
70. J. Jastrow, The Time-Relations of Mental Phenomena. New York, N. D. C. Hodges. 1890.
71. W. S. Jevons, The Principles of Science : a Treatise on Logic and Scientific Method. London, Macmillan & Co. ; New York, The Macmillan Co. (1874) 1900.
72. F. Jodl, Lehrbuch der Psychologie. Stuttgart, J. G. Cotta'sche Buchhandlung. 1896. Second edn., 1903.
73. P. Langer, Die Grundlagen der Psychophysik. Jena, H. Dufft. 1876. With the pamphlet Psychophysische Streitfragen. Ohrdruf, C. Grapenthin. 1893.

¹ This essay is dated 1859 in the bibliography appended to *El.*, i., 1889. It was published (without separate dating) in the 1859 volume of the *Abh.* of the Kgl. Sächs. Ges. d. Wiss. The author has therefore referred to it, in the text, as the 'Abhandlung of 1859.' According to the advertisements of S. Hirzel, it must, however, have been printed at the end of 1858.

74. K. Lasswitz, Gustav Theodor Fechner. Stuttgart, F. Frommanns Verlag (E. Hauff). 1896.
75. G. F. Lipps, Grundriss der Psychophysik. Leipzig, G. J. Goschen'sche Verlagshandlung. (Neudruck) 1903.¹
76. T. Lipps, Leitfaden der Psychologie. Leipzig, W. Engelmann. 1903.
77. R. H. Lotze, Outlines of Psychology. Trs. G. T. Ladd. Boston, Ginn & Co. 1886.
78. L. J. Martin und G. E. Müller, Zur Analyse der Unterschiedsempfindlichkeit: experimentelle Beiträge. Leipzig, J. A. Barth. 1899.
79. M. Merriman, A Text-Book on the Method of Least Squares. New York, J. Wiley and Sons. 1900.
80. F. A. Müller, Das Axiom der Psychophysik und die psychologische Bedeutung der Weberschen Versuche. Marburg, N. G. Elwert. 1882.
81. G. E. Müller, Zur Grundlegung der Psychophysik. Berlin, Th. Grieben. 1878.
82. G. E. Müller, Die Gesichtspunkte und die Tatsachen der psychophysischen Methodik. Wiesbaden, J. F. Bergmann. 1904.
83. G. E. Müller and A. Pilzecker, Experimentelle Beiträge zur Lehre vom Gedächtniss. Leipzig, J. A. Barth. 1900.
84. H. Münsterberg, Grundzüge der Psychologie, i. Leipzig, J. A. Barth. 1900.
85. W. Preyer, Ueber die Grenzen der Tonwahrnehmung. Jena, H. Dufft. 1876.
86. W. Preyer, Akustische Untersuchungen. Jena, G. Fischer. 1879.
87. W. Preyer, Wissenschaftliche Briefe von Gustav Theodor Fechner und W. Preyer: nebst einem Briefwechsel zwischen K. von Vierordt und Fechner, sowie neun Beilagen. Hamburg and Leipzig, L. Voss. 1890.
88. E. A. Schäfer, Text-book of Physiology, ii. Edinburgh, Y. J. Pentland; New York, The Macmillan Co. 1900.
Or W. Nagel, Handbuch der Physiologie des Menschen, iii. Braunschweig, F. Vieweg & Sohn. 1905.

¹ Lipps' Massmethoden will be found in Meumann's Archiv. The student may be reminded that many of the more important magazine articles—articles which it is a good thing to possess separately, even if the magazines themselves are accessible—may be procured either in pamphlet form (so this Massmethoden) or in the form of off-prints (so, e.g., G. E. Müller's Psychophysik der Gesichtsempfindungen).

89. L. W. Stern, *Psychologie der Veränderungsauffassung*. Breslau, Preuss und Jünger. 1898.
90. G. F. Stout, *A Manual of Psychology*. New York, Hinds and Noble. 1899, 1901.
91. C. A. Strong, *Why the Mind has a Body*. New York, The Macmillan Co. 1903.
92. C. Stumpf, *Leib und Seele: Der Entwicklungsgedanke*. Zwei Reden. Leipzig, J. A. Barth. 1903.
93. S. P. Thompson, *Elementary Lessons in Electricity and Magnetism*. New York, The Macmillan Co. (1894) 1904.
94. E. L. Thorndike, *An Introduction to the Theory of Mental and Social Measurements*. New York, The Science Press. 1904.
95. J. Venn, *The Logic of Chance: an essay on the foundations and province of the theory of probability, with especial reference to its logical bearings and its application to moral and social science, and to statistics*. London, Macmillan & Co.; New York, The Macmillan Co. Third edn., 1888.
96. K. Vierordt, *Der Zeitsinn nach Versuchen*. Tübingen, H. Laupp. 1868.
97. A. W. Volkmann, *Physiologische Untersuchungen im Gebiete der Optik*. Leipzig, Breitkopf und Härtel. Heft i., 1863; Heft ii., 1864.
98. E. H. Weber, *Annotationes anatomicæ et physiologicæ*. Leipzig, C. F. Koehler. 1851.
99. R. S. Woodworth, *Le Mouvement*. Paris, O. Doin. 1903.
100. W. Wundt, *Gustav Theodor Fechner; Rede zur Feier seines 100-jährigen Geburtstages*. Leipzig, W. Engelmann. 1901.

The following additions and corrections should be made to the list given in 1901 (vol. i., I. M., 431 ff.).

6. The first vol. of Ebbinghaus' *Psychologie* is now complete: 1902.
20. A second edition of Höfler and Witasek's *Schulversuche* appeared in 1903.
26. Add II. *Die physischen Äquivalente der Bewusstseinserscheinungen*. 1901.
30. A second and enlarged edition of the *Beiträge zur Analyse der Empfindungen* was published in 1900 under the title *Die Analyse der Empfindungen und das Verhältniss des Physischen zum Psychischen*. Jena, G. Fischer.
43. Add the art. *Psychology* in *Encyc. Brit.*, xxxii., 1902, 54 ff.
44. E. H. Weber's *Der Tastsinn und das Gemeingefühl* was published separately, as off-print, in 1849 and 1851. It is possible to buy, very cheaply, the whole set of R. Wagner's *Handwörterbuch der Physiologie mit Rücksicht auf physiologische Pathologie* (Braunschweig, F. Vieweg und Sohn, 1842-1853: four, usually bound as five volumes), in which (vol. iii., 2, 1846, 481-588) Weber's article was published. The *Handwörterbuch* contains other articles of psychological interest and importance: e.g., Lotze's *Leben, Lebenskraft*;

Instinct ; Seele und Seelenleben ; Purkinje's Wachen, Schlaf, Traum und verwandte Zustände ; Listing's Zur Dioptrik des Auges.

45. Fifth edition, 3 vols., with separate index, 1902-3. Vol. i. of translation (E. B. Titchener), London, Swan Sonnenschein & Co.; New York, The Macmillan Co. 1904.
47. Sixth German edn., 1904.

APPENDIX III

FIRMS RECOMMENDED FOR THE SUPPLY OF PSYCHOLOGICAL INSTRUMENTS

The following corrections are now to be made in the list printed in vol. i., I. M., 434 f. :

5. C. H. Stoelting Co. (Address, etc., as before.) This firm has now undertaken to furnish complete sets of the apparatus required for the present Course.
14. L. Landry, successor to R. Koenig. (Address, etc., as before.)
15. M. Kohl, Adorferstr. 20, Chemnitz i. S. (Manufacturer of the Stern variator.)
18. This firm (like the Garden City Model Works, which formerly manufactured Jastrow's instruments) has now gone out of business.

Add to the list the following firms :

30. Baird and Tatlock, Ltd., 14 Cross St., Hatton Garden, London, E. C. (General supplies ; optics, acoustics.)
31. F. E. Becker & Co., Hatton Wall, London, E. C. (General supplies ; optics, acoustics.)
32. Bryan-Marsh Co., 136 Liberty Street, New York City. (Lamps of low voltage, for lamp batteries.)
33. Crocker-Wheeler Co., 731 O. C. S. Bank Building, Syracuse, N. Y. (Motors.)
34. M. Th. Edelmann, Physikalisches-mechanisches Institut, München. (Physical and physiological instruments of precision.)
35. Edison Manufacturing Co., 83 Chambers St., New York City. (Edison primary batteries and fan-motors.)
36. Elbridge Electric Manufacturing Co., Elbridge, N. Y. (Dynamos and motors.)
37. Electric Storage Battery Co., Allegheny Avenue and 19th St., Philadelphia. (Chloride accumulators.)
38. Electrizitäts-Gesellschaft Gebr. Ruhstrat, Göttingen. (Electrical instruments.)

39. Wm. Gaertner & Co., 5347-5349 Lake Avenue, Chicago, Ill. (General laboratory supplies.)
40. G. Glock, Kaiserstr. 9, Würzburg. (Marbe's grey papers.)
41. Harvard Apparatus Co., 47 Pearl St., Brookline, Mass. (Simple physiological instruments.)
42. W. Oehmke, Dorotheenstr. 35, Berlin N. W. (Certain of Stumpf's and Meyer's instruments.)
43. Peyer, Favarger et Cie., Neuchâtel. (Hipp chronoscope; Hipp gravity apparatus; galvanometers, etc.)
44. E. Schulz (successor to F. Tiessen), Optisches Institut, Breslau. (Ebbinghaus' gravity apparatus.)
45. Spindler & Hoyer, Göttingen. (Schumann's time-sense apparatus; etc.)
46. F. A. Stevens, Cornell University Laboratory. (Certain of the author's instruments.)

LIST OF MATERIALS

Since this list must include all the appliances discussed or recommended in the book, it will necessarily err by excess, as the corresponding list of Pt. i. errs by defect. If further information is desired as regards the relative merits of alternative instruments, the author—so far as his experience allows—will gladly supply it.

I. SPECIAL APPLIANCES

- Acoumeter, Lehmann's, 56; Politzer's, 57, 58 f.; Zoth's, 59.
- Æsthesiometer, 159, 188, 251; Stratton's, 141 f.; Jastrow's, 160, 258; Ebbinghaus', 160, 258; von Frey's, 258, 347; Griesbach's, 258; Spearman's, 258. See Hair æsthesiometer.
- Angular division testing apparatus, 153.
- Apparent magnitude, Martius' apparatus for determination of, permanent form, 262.
- Arm-movement apparatus, Münsterberg's, 3, 258; cheaper form, 258.
- Artificial star apparatus, Leuba's, 91.
- Association box, Manacéine's, 384.
- Audiometer, Seashore's, 59.
- Campimeter, 39.
- Carrier bracket, 265.
- Chronograph, von Beetz', 340; Dodge's, 340; Schumann's, 340; Wundt's, 340.
- Chronometer, d'Arsonval's, 335 f., 384.
- Chronoscope, Hipp's, 325, 326 ff., 358, 377; housing of, 327 f.; Külpe's attachment for, 344; Wundt's demonstration, 351; Ewald's, 337; Münsterberg's, 337, 384; Fitz' pendulum, 338; Scripture's pendulum, 338; Seashore's pendulum, 338; Bergström's pendulum, 338; Cattell's wheel, 338.
- Colour mixer, 77, 87 f., 125, 198 f.; Marbe's, 138, 160, 201; Wundt's triple, 199.
- Complication pendulum, 408; clock, 409.
- Contrast apparatus, Hess and Pretori's, 406.
- Control instruments: (1) Hipp's gravity apparatus, 340, 344; Cattell's gravity chronometer, 340, 345 f.; Ebbinghaus' gravity apparatus, 340; Jastrow's, 341; (2) Witmer's pendulum, 341; Külpe's, 341; Cattell's, 341; Münsterberg's, 341; (3) Krille's hammer, 341; Wundt's large and small, 341 f.; Lange's, 342; Dixon's, 343.
- Cylinders, Koenig's, 32, 35.
- Dark box, Delbœuf's, 198.
- Disparate *S*, Whipple's apparatus for temporal limen of, 409.
- Episcotister, 79.
- Ergograph, Bergström's, 407; Binet's, 407.
- Forks, Appunn's wire, 2, 14; giant, 13; Bezold's lowest (Edelmann), 14; Appunn's high, 31, 55; Koenig's high, 32, 35; with riders, 125; with screw attachments, 125; Koenig's 1024 vs., 334; Bezold's highest, 334.

- Galton bar, 152.
- Galton whistle, 31, 35 f.; with Zwaardemaker's funnel, 40.
- Gravity chronometer, demonstration, Wundt's, 346; Titchener's, 346. See Control instruments; Stimulators.
- Hair æsthesiometer, von Frey's, 48.
- Haploscope, Hillebrand's, 410.
- Interruptor, Krille's, 345.
- Isoscope, Donders', 410.
- Key, Ewald's reaction, 346; Ewald's rocking, 347, 350; home-made break, 349; telegraph, 349; Jastrow's pressing, 349; Dessoir's thumb-and-finger, 349; Scripture's modification, 349; Cattell's lip, 350; Meumann's biting, 350; Jastrow's speech, 350; eyelid, 350; Ranschburg's make or break, 350; Jastrow's, 350; Scripture's multiple, 350; Cattell's voice, 350; Roemer's voice, 350; Wundt's voice, 350 f.; Libbey-Baldwin voice, 351; Smith's sphygmograph, 352; Judd's spring, 354; Zimmermann's pneumatic, 355; Merkel's five-finger, 379 f.; Jastrow's, 380; Zimmermann's, 380.
- Kinesimeter, 142.
- Kymograph, with accessories, 52 f.; with endless paper strip, 138.
- Lamella, Appunn's, 1 f., 3 f., 13.
- Lever, Vierordt's, 400.
- Limen gauge, von Frey's, 52, 141, 257; attachments for regulating, 52 f.
- Memory apparatus, Müller's, 391, 412; Smith's, 412; Ranschburg's, 350, 412; Wirth's, 412.
- Olfactometer, 143, 384.
- Optical illusions, Heymann's instruments for measuring, 411.
- Passive movement, apparatus for measuring limen of, 257.
- Pendulum, Dodge's reaction, 351; signal, 358.
- Phonometer, Wundt's gravity, 221.
- Photometer, Kirschmann's, 85; Rumford's, 73.
- Pipes, Appunn's high, 35.
- Precision of movement, Bryan's apparatus for determining, 371.
- Pressure balance, Jastrow's, 136; Merkel's, 266; Jacobi's, 266.
- Reaction times, Smith's arrangement for measuring, 339; spark-method for measuring, 339 f.
- Rhythm apparatus, MacDougall's, Stetson's, Wundt's, 411.
- Rods, for Martius' experiment on apparent magnitude, 261.
- Sound cage, 141.
- Sound pendulum, 194 f., 197, 265.
- Spectroscope, 39.
- Stimulators: (1) *sound*: noise (Hipp), 340, 344; (Titchener), 344; sound hammers, 345; tone or noise (Bliss), 345; tone (von Kries and Auerbach), 345; clang (Martius), 345; (Hankel), 345; chord (Tanzi), 345, 384 (*cf.* Binet and Courtier, 384); (2) *light*: pendulum (Lange), 345, 378; (Fullerton and Cattell), 345; gravity chronometer (Cattell), 345 f.; shutter (Jastrow), 346; (Dixon), 346; card-changer (Ach), 378; (Roemer), 379; (Alber), 379; (3) *pressure*: von Vintschgau's stimulator, 346; sensibilometer (Dessoir), 346, 378; touch-key (Scripture), 346; electroæsthesiometer (Kiesow), 347, 378; æsthesiometer (von Frey), 347; Ewald's electric key, 346; electric stimulator (von Kries and Auerbach), 347; (4) *temperature*: thermophor (von Vintschgau), 348; Goldscheider's stimulator, 348; Rémond's, 348; Kiesow's cone, 348; (5) *smell*: Moldenhauer's stimulator, 348; Buccola's, 348; Beaunis', 348; Zwaardemaker's, 348; (6) *taste*: von Vintschgau's stimulator, 348.

- Tachistoscope, Zeitler's, 346.
 Time-sense apparatus, Schumann's, 344;
 Wundt's older, 396; Meumann's newer,
 399; contacts for Schumann's and
 Meumann's, 401.
 Tone variator, Stern's, 139; with table
 and gasometer, 140.
 Tonometer, Appunn's, 91.
 Touch-weights, Scripture's, 46, 257.
 Visual distances, Wundt's apparatus for
 memory of (used to determine limen
 of dual impression), 257.
 Visual extents, Münsterberg's apparatus
 for comparison of, 210.
 Weight-holders, Fechner's, 265 f.; Her-
 ing's, 266; Claparède's, 266; Weber's,
 266 (*cf.* xvii.); Wreschner's, 266;
 Kinnaman's, 266.
 Weights, envelope, 82; cartridge, 188 f.,
 265; Galton's, 265; Jastrow's, 265;
 Fullerton and Cattell's, 266; Frankl's,
 266; for size-weight illusion, 266.
 Weights, Seashore's apparatus for grad-
 ual lift of, 143.

II. GENERAL APPLIANCES AND MATERIALS

- Ammeter, Weston portable, 322, 325.
 Balance, with weights, 48.
 Bow, violin, 31.
 Caliper, B. & S. micrometer, 48 f., 51.
 Cells, Grove, 320 f.; Bunsen, 320 f.;
 Edison, 320 f.; Meidinger, 321; Grenet,
 321.
 Chloride accumulator, 321.
 Commutator, Pohl's, 355 f.
 Conduction tube, 126.
 Dynamo, Stoelting's dissectible, 325;
 Elbridge El. Co.'s, 226.
 Dynamotor, 324, 358.
 Gasometer, Whipple's double, 141 (*cf.*
 39).
 Glasses, coloured, 75.
 Glasses, grey, 72, 79.
 Head-rest, 261.
 Lamp battery, 321 f.
 Lights, two equal, with black hemicylin-
 drical screens, 79.
 Mallet, rubber faced, 13.
 Metronome, 384.
 Metronome, soundless, 4, 384.
 Microscope, 48, 51.
 Motors, Edison fan, 324; Ziegler com-
 bination, 324; small Zimmermann, 324;
 Helmholtz', 324; Crocker-Wheeler,
 324.
 Nichols rheostat, 321 f.
 Piano, 91.
 Plaster mould, 358.
 Resistance box, 325; slate resistance,
 379.
 Resonance box, for giant fork, 14.
 Rod, 87.
 Sand box, 358.
 Spring hammer, for actuating forks, 126.
 Stand, adjustable, for lamella, 2.
 Stop-watch, 4, 330, 334, 384.
 Switch, two-way, 325, 378.
 Telescope, reading, 378.
 Voltmeter, Weston portable, 322.
 Watch, 56.
 Wire, 142.

III. PAPER, CLOTH, DRAWING MATERIALS, ETC.

Bristol board, 3.	Mm. cross-ruled paper, 153.
Cardboard, half-sheet of black, with circular opening, 77.	Paper, black and white, 73; Hering's velvet black, 73.
Cloth ring, for lamella, 4; for wire forks, 14.	Papers, Marbe's grey, 72, 85; painted grey, 72 f.; Hering's grey, 72 f.
Cotton wool, 1.	Penknife, 153.
Discs, Masson's, 77; Delbœuf's, 77, 198 f., 200; Kirschmann's and Sanford's, 77 f.; Martius', 87; Münsterberg-Jastrow, 87; Hering's (Brückner's), 88, 200.	Photographic transparency, 77.
Dye, 47.	Screen, black, with vertical slit, 39; white, 79; black observation, with two openings and shutter, 79.
	Screens or curtains, 79, 201, 261 f.

INDEX OF NAMES

- Aars, K. B.-R., 99.
 Abney, W. de W., 88.
 Ach, N., 333, 378 f.
 Airy, G. B., 97.
 Alber, A., 379.
 Alechsieff, N., 357 ff., 362, 375.
 Aliotta, A., 398.
 Alrutz, S., 55.
 Altberg, W., 61.
 Amberg, E., 150.
 Ament, W., lxxvii., lxxix., lxxxiv.-
 lxxxviii., 70, 195 ff., 204 ff., 207, 225 f.,
 228, 231, 304, 403.
 Andrews, B. R., 56, 60, 134.
 Angell, F., lxxix., lxxxiv., lxxxvi., cxli.,
 69 f., 196, 204 ff., 207, 221-227, 248,
 268, 304, 308.
 Angell, J. R., 408.
 Antolik, K., 33.
 Appunn, A., 1, 13, 32 ff.
 Appunn, G., 1.
 d'Arsonval, A., 335 ff., 384.
 Aschaffenburg, G., 150, 363, 374, 384,
 389, 391.
 Aubert, H., xlv., xcvi., cxv., cxlix., 46,
 74 ff., 78, 105, 139, 193, 217, 380, 410.
 Auerbach, F., 345, 347, 378.
 Avenarius, R., cli.
 Awramoff, D., 370.
 Ayerton, W. E., 320 f., 324.

 Bache, R. M., 363 f.
 Bagley, W. C., 370 f.
 Bair, J. H., 371.
 Baird, J. W., 71.
 Baldwin, J. M., cl. ff., 87 f., 194, 365, 387
 f., 407.
 Beaton, J. A., 320.
 Beaunis, H., 348.
 von Beetz, W., 340.
 Beneke, F. E., cxxvi.

 Benjamin, P., 320.
 Bentley, I. M., cxliii., cliii., 304, 365.
 Bergemann, R., 359.
 Berger, G. O., 332, 341, 343, 375, 377,
 390.
 Berger, R., 48.
 Bergqvist, J., 378.
 Bergström, J. A., 338, 341, 407.
 Bernoulli, D., xlv., clii.
 Bernstein, A., 244.
 Bernstein, J., lxvi., li., 63, 66.
 Bertrand, J. L. F., 250.
 Bezold, F., 13 f., 24, 29, 41, 45, 56.
 Binet, A., cxxxiv., 258, 327, 329, 336, 366,
 370 f., 375, 384, 399, 407.
 Biot, J. B., 24 f., 41 f.
 Blake, C. J., 41, 44.
 Bliss, C. B., 339, 345, 370, 375.
 Bloch, A. M., 48.
 Boas, F., liii., lvi., lxiv., lxxxiii. f., cxxii.
 f., cxxv., cxxxiii., cxl., 114, 216, 268, 308.
 Böhmer, H., clxiii.
 Bohn, C., 154.
 du Bois, H., 331.
 du Bois-Reymond, E., xxxviii., 240.
 Bolton, T. L., 365, 370 f.
 Boltzmann, L., 57.
 Boole, G., 98.
 Bosanquet, B., 98.
 Bosanquet, R. M. H., cxxv., 240.
 Bouguer, P., 78, 100.
 Bourdon, B., 262.
 Bowditch, H. P., 370.
 Bowley, A. L., 97.
 Bradley, F. H., lxv., lxvii. f.
 Bramwell, J. M., 399.
 Brandes, H. W., xxxix.
 Brentano, F., lxiv., lxvii., lxix. ff., lxxxiii.,
 69.
 Breton, P., 183.
 Brodhun, E., cl., 71, 138.

- Brown, W. D., 90.
 Brückner, A., 89.
 Bruns, H., 294 f., 297 f., 309, 313.
 Bryan, W. L., 134, 366, 370.
 Bryant, S., 384.
 Buccola, G., 159, 346, 348, 363, 389, 395.
 Büchner, L., xxxix.
 Bush, W. T., 363.
- Cairnes, W. B., 90, 398.
 Calkins, M. W., 385.
 Camerer, W., 78, 152, 192, 194, 251, 274,
 366, 370 f., 395.
 Carhart, H. S., 321.
 Castle, F., 98.
 Cattell, J. McK., cxxxiv., cxlix., clviii.,
 10, 15, 98 f., 117 ff., 128 f., 145 f., 148,
 150, 167, 183 ff., 204 f., 208, 222 f., 258,
 266, 269, 276, 283, 286 ff., 290, 304, 308,
 315, 318, 328, 334, 338, 340 f., 343-346,
 350, 355, 357, 359, 363, 366, 370, 376 ff.,
 381, 384 f., 390, 392.
 Chladni, E. F. F., 24 f., 41 f.
 Claparède, É., 266, 333, 379, 384, 387.
 Classen, A., xci.
 Colls, P. C., 339.
 Comstock, G. C., 97.
 Cooper, W. R., 320.
 Cornu, A., 246 ff.
 Courtier, J., 370, 384.
 Crofton, M. W., 98.
 Cron, L., 150.
 Cuperus, N. J., 24, 29, 41, 44.
 Cyon, E., 335.
 Czermak, J. N., 193, 393 ff., 403.
 Czolbe, H., xl.
 Czuber, E., 250.
- Dauriac, L., lxxv.
 Davenport, C. B., 14, 85, 97, 362.
 Davis, E. W., 98.
 Davis, W. W., 370 f.
 Delabarre, E. B., 258-261, 355, 366,
 370.
 Delbœuf, J. R. L., xxiv., xlv., xlix. ff.,
 lv., lix., lxxv. f., lxxix., lxxi. f., xcvi.,
 cviii. f., cxiii., cxv., cxvii.-cxxxii., cxxxiv.
 f., cxxxvii. f., cxxx., cxxxiii. f., cxxxvi.,
 cxxxix. ff., cxliv., cxlix., cliii., clviii.,
 clx., clxiii., clxv., 66, 69, 77 f., 104 f.,
 198 ff., 211-214, 216 ff., 234, 399.
 Delezenne, C. É. J., xvi., xviii., cxiii., 100,
 234 f., 237 f., 240, 246 ff.
 Despretz, C., 24, 26, 32, 41 f.
 Dessoir, M., lxxv., cxlv., 335, 343, 346,
 349, 355, 372.
 Dewar, J., 67.
 Dewey, J., 365.
 Dieterici, C., 138.
 Dittenberger, W., xxxii., lxxviii., lxxv.,
 lxxxviii., xc. f., xciii., cxliii., clviii.,
 clxiv. f., 66, 68, 228.
 Dixon, E. T., 343, 346, 384.
 Dodge, R., 340, 350 f., 366, 378, 381,
 389 f.
 Dolley, C. S., 328, 334, 343 f., 346, 357,
 359.
 von Dommer, A., 236.
 Donaldson, H. H., 142, 193.
 Donders, F. C., 356, 378, 381, 389, 410.
 Dresslar, F. B., 193, 266, 370.
 Drobisch, M. W., xix., xlv., 234.
 Dürr, E., 398.
 Dumreicher, O., 346 f., 356.
 Dwelshauvers, G., 357, 375.
- Ebbinghaus, H., xxxiii., xlvi., lii., liv.,
 lvi., lxiv., lxxx., lxxxiii., lxxxvi. f., xcii.
 ff., xc. f., cvii., cix., cxvii., cxxi. f.,
 cxxv.-cxxx., cxxxiii. f., cxl.-cxliv.,
 clii. f., clvii.-clx., clxiii., clxxi., 19, 61,
 67 f., 70-73, 85, 89 f., 97, 100 f., 117,
 119, 121, 124, 126, 129, 143, 160, 182,
 187, 194, 210, 222, 227, 258, 268, 274,
 289 f., 297-300, 309, 316 f., 340, 343,
 368 f., 387, 392, 398 f., 408, 412.
 Eberhard, J. A., lxxv.
 Edelmann, M. T., 33, 35 f., 40 f., 45.
 Edgell, B., 398, 403.
 Ejner, M., 135, 159, 395, 397 f.
 Ellis, A. J., 24, 28.
 Elsas, A., xxxv., xxxvii., xxxix., liv., lxxv.,
 lxxvii., lxxiii., civ., cxlix., clx., clxiii. ff.,
 67, 69.
 Engel, G., 242.
 Erdmann, B., 340, 350 f., 378, 381, 389 f.

- Estel, V., 169, 395 ff., 403.
 Euler, L., xix., xlv., 234.
 Ewald, J. R., 337 f., 346 f., 350.
 Exner, S., lii., lxiv., lxxi. f., 143, 193, 349, 356, 375 f., 408.

 Faist, A., 248.
 Falk, M., 132, 259.
 Farrand, L., cxxxiv.
 Fechner, G. T., xiv., xix. f., xx.-xxxvii., xxxviii.-xlvii., xlviii.-li., lv. f., lviii. f., lxiii. ff., lxviii.-lxxi., lxxiv.-lxxviii., lxxx.-lxxxiii., lxxxv., lxxxix.-civ., cvi.-cxviii., cxx.-cxxxiv., cxxxix. f., cxxxiv., cxxxvi., cxxxix. ff., cxliv. f., cxlix., clii., clviii. ff., clxii.-clxviii., clxx., 9 f., 15, 19, 57, 61 f., 64, 69, 72 f., 75 ff., 78, 98, 100, 102-106, 108, 110 ff., 114 f., 117 f., 121, 127, 129, 133, 143 f., 146, 151 f., 155 f., 159 f., 162 ff., 166-170, 174, 178, 182, 184-187, 190 ff., 194 f., 212 ff., 229, 233, 234-237, 245-251, 253 f., 264 ff., 270, 272-285, 287 f., 290 f., 293-297, 302 f., 305 ff., 309 ff., 315, 317, 368, 393, 395 ff., 403.
 Féré, C., 384, 389.
 Feuerbach, L. A., xlii.
 Fitch, F. M., xlv.
 Fitz, G. W., 338.
 von Fleischl, E., 139.
 Foucault, M., xx., xli., lxxiii., cix., cxiii., cxvii., cxxxiv., cl., clviii., clx., clxiii., clxv., 68, 70, 102, 110, 119, 132 f., 179 ff., 194, 204 f., 208, 210, 247, 288, 291, 310, 317, 400.
 Fracker, G. C., 378, 389.
 Frankl, W., 94, 266, 305.
 Franklin, F., 98.
 Fratscher, C., 142.
 Freudenreich, H., xlv.
 von Frey, M., 48 ff., 52, 55, 135, 141 f., 258, 347.
 Fricke, K., 356 f., 375, 389 f.
 Friedrich, M., 377.
 Fröbes, J., lxxxvii., 197-201, 204 ff., 208 f., 231 f., 260, 265, 304, 308 f., 403.
 Fullerton, G. S., 98 f., 117 ff., 128 f., 145 f., 148, 150, 167, 183 ff., 222 f., 258, 266, 269, 276, 283, 286 ff., 304, 308, 315, 318, 345, 366, 370.
 Funke, O., xiv., xix., xxxii., li., lxviii., lxxiii., lxxv., xcvi., xcviiii., cxlvii. f.

 Gärtner, O., 251.
 Galluppi, P., lxiv.
 Galton, F., cxxxiv., 15, 31 ff., 44, 97, 99, 189, 265, 356, 370, 383.
 Gamble, E. A. McC., 20, 72, 154.
 Gauss, K. F., 98, 178.
 Gebhardt, B., xxxviii.
 Geiger, M., 407 f.
 Gerald, F., 320.
 Gilbert, J. A., cxxxiv., 266, 338, 370, 378, 389, 391, 398.
 Glass, R., 159, 395 f.
 Goldscheider, A., 193, 348.
 Goldschmidt, A., xlv.
 Gordon, K., 407.
 Griesbach, H., 258.
 Griffing, H., 48, 142, 318.
 Grijns, G., 374.
 Groos, K., 399.
 von Grot, N., xxxiii., lxv., lxxxiv.
 Grotenfelt, A., xx., lii., liv., lvi., lviii., lxv., lxix., lxxi., lxxiii., lxxv., lxxviii. ff., lxxxiii. f., lxxxviii., xciii. cxx., cxvii., cxli., cxlix., cliiii., clx., clxv., 66 f., 69 f., 218, 234.
 Gruber, J., 59.
 Grünbaum, O. F. F., 88.
 Grünhagen, A., clx., 348, 400.
 Gutberlet, C., clxiii.
 Guttmann, A., 240.

 Hall, G. S., cli., 142, 193, 398.
 Hankel, W., 345, 347.
 Hanks, L. M., 89.
 Harter, N., 134, 370.
 Hartmann, G., 251.
 von Hartmann, K. R. E., xlii.
 Hauptmann, C., clx.
 Haycraft, J. B., 88, 370.
 Hegel, G. W. F., xli.
 Hegelmayer, F., cxiii., 275.
 Heinzmann, A., 142.
 von Helmholtz, H. L. F., xxxviii. ff., xlv., cviii., cxxv., cxliv., cxlvi., cxlviii.,

- 13, 24, 26 ff., 43, 77 f., 86, 103, 105, 124, 193, 215, 233, 275, 324.
 Henri, V., lxxxiv., cxxxiv., 98, 110, 119, 128 f., 144, 146, 192 f., 251, 258, 312.
 Henry, C., cxxxviii., 184, 348.
 Herbart, J. F., xli., xlv. f., lxxv., cvi., cviii., cxii., cxlv., cxlix., clix., 234, 395.
 Hering, E., xiv., xix., xlix., lxiii., lxx.-lxxxiii., xci. ff., c., cix., cxxv., clii., clx., 66, 69, 72 f., 88, 200, 212, 215, 229, 233, 266, 275, 309, 410.
 Herzen, A., 348.
 Hess, C., clii., 405.
 Heümann, G., 150.
 Heymans, G., clix., 67, 121, 226, 411.
 Higier, H., 16, 18 f., 132, 144, 167, 177 f., 181 f., 187, 221, 259, 284, 286 ff.
 Hill, A. R., 335, 355.
 Hill, C. M., 381.
 Hillebrand, F., 85, 263, 410.
 Hipp, M., 326, 329, 340, 344.
 Hirsch, A., 326, 347, 356.
 Hitchcock, C. M., 99.
 Hoefler, G. A., 222.
 Höföding, H., xxxviii., xliii.
 Höfler, A., xix. f., lv. f., lxxxiv., lxxxviii., xciii., cxxxii. f., cxliv. f., cxlix., cliii., clix., clxv., 44, 61, 68, 76.
 Hönigschmied, J., 346, 348.
 Höring, A., xlvii., 395.
 Holt, E. B., 87, 318.
 Hort, A., 150.
 Houston, E. J., 320.
 Hüttner, M., 395, 397 f., 400.
 Huey, E. B., 366.
 Hylan, J. P., 150.
 Itard, J. E. M. G., 195.
 Itelson, G., lxiv., cxlv.
 de Jaager, J. J., 356.
 Jacobi, C., 266, 370.
 Jacoby, C. W., 320.
 James, W., xxxiii., xxxviii., xlv., liv., lxx., lxxii., cvii., cix. f., cxii., cxv. f., cxxx., cxxxiii., cxliii., cl. f., clix., clxiii., 67, 103, 117, 182, 253, 399, 408.
 Janet, P., 374.
 Jastrow, J., cxxxiv., cxlix., cliv., 87, 89 ff., 117 f., 129, 136, 147, 160, 182 f., 185, 193, 210, 258, 265, 285-291, 312, 318, 328, 341, 343, 346, 349 f., 356, 362, 375, 380, 389 f., 392, 398, 408.
 Jennings, H. S., 67.
 Jevons, W. S., cxliv., clvii., 14, 97.
 Jodl, F., xix., xxv., xxxii., xxxv., xlvi., lii., lvi., lxiii. f., lxxii., lxxxvii. f., xc., xcii., xcvi., cxxxiii. f., cxxxvii., cxxxix. f., cliii., clxiii., 68, 400.
 Johnson, W. S., 370 f.
 Johnson, W. W., 97.
 Jones, H. M., 41, 46.
 Joubert, J., cxlvi.
 Judd, C. H., 353, 365 f., 400.
 Just, W., 88.
 Kämpfe, B., 127 ff., 195, 250, 282, 289, 294, 298.
 Kammler, A., 46.
 Kant, I., xli., xliii., cxlv.
 Kennedy, F., 398.
 Kennelly, A. E., 320.
 Kent, A. A., 320.
 Keppler, F., xlvii.
 Kerr, J. B., 89.
 Kiesow, F., 20, 49, 52, 55, 342, 347 ff., 355, 378, 400.
 Kinnaman, A. J., 266, 275, 304.
 Kinnebrook, D., 356.
 Kirchner, F., clii.
 Kirkpatrick, E. A., 370.
 Kirschmann, A., clii., 77, 85, 213, 332-335, 340, 342 f., 359.
 Kleiner, A., 186.
 Knox, H. W., cliii.
 Koch, J. L. A., lii., lxiv., lxx.
 Köhler, A., xxxvii., lvii. f., lxxv., lxxvii., lxxxviii., cxlix., clxiii., clxv., 69, 213.
 König, A., xlvi., cl., 71, 138, 275.
 Koenig, R., 32, 34, 41, 43.
 Kollert, J., 111, 395 ff.
 von Korányi, A., 370.
 Kottenkamp, R., 251.
 Kraepelin, E., cxxxiv., 21, 66, 78, 102, 121, 134, 150, 210, 221, 268, 284-288,

- 290 ff., 309, 316, 327, 332 f., 348, 350 f.,
371, 374, 377, 384, 389 ff., 394, 398.
- Kramer, F., 71, 261.
- von Kries, J., lii, lv., lxiii., lxvi. f., lxxii.,
xciv., cxxxv., cxliv., clx., 88, 124, 203,
263, 345, 347, 370, 376, 378, 381, 389, 400.
- Krille, C., 345.
- Krüger, F., 244, 391, 406.
- Krüger, P., 242.
- Kruss, H., 88.
- Külpe, O., xx., xxiii., xxxix., xlv., lv.,
lxiv., lxxxv. ff., xci., xciii., cix., cxii. ff.,
cxxxii., cxxxv., cxxxiv., cxxxvii., cxlvi.,
cl., cliv., clix. f., clxiv., clxvii., clxix.,
10, 60, 67 f., 70, 108, 110, 119, 121, 123,
128 f., 133, 137, 143, 182, 187, 206, 226,
241, 246 f., 270 f., 280, 289, 292, 304, 310,
316, 332-335, 340, 342 ff., 357, 359, 372,
389 f., 400, 403, 407 f.
- Kuhn, C., 327.
- Kundt, A., 34 f., 36, 46.
- Kunkel, A., cxlvi.
- Kuntze, J. E., xxxix.
- Ladd, G. T., cxi., 68, 253.
- Lamansky, S., 366.
- Lambert, J. H., 100.
- Lange, F. A., xli., xliii.
- Lange, L., lxxviii., lxxxiv., 340-343, 345,
357 f., 374 f.
- Langelaan, J. W., 67.
- Langendorff, O., 340, 345.
- Langer, P., lxx. ff., lxxv., cxli., clx.,
clxiii., 69, 229, 235.
- Laplace, P. S. de, xlv., clii., 98.
- Lasswitz, K., xxxix. f., xli.-xlv., xcii.,
cii., cix., cxii., cxiv., clxiv.
- Laugier, P. A. E., 160.
- Lee, A. A., 90.
- Lehmann, A., xxxvii., lv., lxiii., lxvi.,
lxxxvi. f., xci. f., clii. f., clix., 56 f., 67,
72, 79, 133, 199 f., 206, 211 f., 217 f.,
226, 229, 348.
- Leitzmann, H., 375.
- Leuba, J. H., 91.
- Leumann, E., 355, 395, 397, 399.
- Lewis, B., 355.
- Lichtenfels, R., 103 f., 110.
- Liebmann, O., xliii.
- Lindley, E. H., 150.
- Lindner, G. A., clii.
- Lipps, G. F., xl., cxxxvii. ff., clix. f.,
clxiv., 15, 86, 98, 100, 104 f., 143 f.,
153, 167, 170 ff., 174 ff., 253, 275, 294,
296 f., 310-313, 315, 317 f.
- Lipps, T., lxvi., lxxxii. ff., lxxxix. f.,
cxliii. f., clx., 67, 408.
- Loeb, J., 370.
- Löwenton, E., 288.
- Logan, R. R., 355.
- Lorenz, C., 205, 221 f., 224, 241 ff.
- Lorenz, G., 120, 284, 318.
- Lotze, R. H., xxxviii., xli., xlv., xlvi., li.,
lxv., lxx., cix., cxi. f., cxlvii. f., clix., 67.
- Love, J. K., 28, 41, 44.
- Ludwig, C., xxxviii.
- Luft, E., cxlvi., 135, 237 ff., 298.
- Lummer, O., 138.
- Lyman, C. S., 370.
- MacDougall, R., 411.
- Mach, E., xlvi., xci., 63, 66, 263, 394 f.,
399.
- Magnus, H. G., 36.
- Maher, M., 253.
- Malebranche, N., lxiv.
- de Manacéine, M., 384.
- Marbe, K., 72, 85, 138, 160, 201, 299, 383,
385 ff.
- Marey, É. J., 340.
- Martin, L. J., 94, 116, 120 f., 127, 129,
133 f., 136, 150, 263, 267 f., 273 f., 294,
300 ff., 305, 309, 315, 366, 368.
- Martius, F., 159, 394.
- Martius, G., 87, 261 ff., 268, 344 f., 374 f.,
390.
- Mascart, E., cxlvi.
- Maskelyne, N., 356.
- Masson, V., 77 f., 103.
- Matsumoto, M., 56.
- Mauritius, R., 395.
- Mayer, A., 384.
- McAllister, C. N., 353, 366, 370, 398.
- McCrea, J., 262 f.
- McDougall, W., 55, 123, 365.
- McKendrick, J. G., 24, 28, 41, 44, 67.

- Mehner, M., 112, 147, 395 ff.
 Meinong, A., xlix., lii., lv. f., lxiv. ff.,
 lxxi., lxxxiii. f., lxxxviii., cxxx.-cxxxiii.,
 cxxxvii., cxl., cxliii. f., clviii., clx., 61,
 65, 67-70, 76, 224, 228.
 Melde, F., 24, 29, 33 f., 41, 44.
 Mendenhall, T. C., 348.
 Mentz, P., cxlvi., 176, 400.
 Mercadier, É., 246 ff.
 Merkel, J., lxix., lxxvii.-lxxxii., lxxxiv.,
 lxxxvi., cliii., 66 f., 69 f., 98, 115, 118,
 132 f., 144, 160, 162, 178 f., 181 f., 184,
 187, 204, 206, 217-220, 222-230, 264,
 266, 280, 284 f., 288-294, 296, 309, 315
 f., 368, 377, 379, 389, 395, 397, 400.
 Merriman, M., 10, 15, 94, 97, 250.
 Meumann, E., 19, 120, 134, 260, 268, 308,
 350, 393 ff., 397-401, 403.
 Meyer, A., 250.
 Meyer, J. B., cxlv.
 Meyer, M., 33 f., 36, 40 f., 45, 119 f., 125
 f., 129, 238 f., 246, 248, 298, 406.
 Miner, J. B., 398.
 Mises, Dr., cxv.
 Miyake, I., 370.
 Möbius, A. F., 278.
 Moldenhauer, W., 348, 351.
 Moleschott, J., xxxix.
 du Moncel, T. A. L., 320.
 Moore, J. M., 370.
 Moore, T. V., 354, 370.
 Moorehouse, G. W., 408.
 Moos, S., 14.
 Mosch, E., 19, 267, 274, 294, 296 ff., 318.
 Moskiewicz, G., 71, 261.
 Matora, Y., 142.
 Müller, F. A., xx., lii. f., lv., lxiv., lxxxiii.,
 cxxvi., cxlix., clxv., 247.
 Müller, F. C., cliii., 67.
 Müller, G. E., xiv. f., xvii. f., xxxi., xxxiv.,
 xlvi., li. f., lxiv., lxvi. f., lxix., lxxi.-
 lxxvii., lxxxix.-xciii., xcvi.-cii., cvi. ff.,
 cxiv. ff., cxviii., cxx. f., cxxx., cxxxiii.,
 cxxxvii., cxlix., cliii., clx., clxiii. ff.,
 clxxi., 4, 12 f., 16, 19 f., 23 f., 39, 66 f.,
 69 f., 73-76, 78, 94, 98, 101, 103-106,
 108-111, 115-121, 123, 126 f., 129-134,
 136 f., 143 f., 148-153, 155, 157, 159,
 161-164, 166 f., 170, 175-178, 182, 184
 f., 187, 190, 194, 197 f., 200, 204-209
 214 ff., 221, 223-227, 229-232, 235, 237,
 241 ff., 248-253, 255-259, 263 f., 267 f.,
 273-285, 289-297, 300 ff., 304 f., 309-
 315, 317 f., 332 ff., 343 f., 355, 366, 368
 f., 372, 390 ff., 397 f., 400, 412.
 Müller, J., 366.
 Müller, J. J., clx.
 Müller, R., 407.
 Münsterberg, H., lii., liv., lxiv., lxxix. f.,
 lxxxiv., lxxxviii., cxxxiv.-cxxxvii., cxliv.,
 clviii., 56, 67, 87, 119, 132, 143 f., 159,
 176-179, 181 f., 191, 207, 210, 221, 242
 f., 258, 268, 308, 337, 341, 343, 363, 365,
 384, 386 f., 389 f., 395, 397 f.
 Myers, C. S., 35 f., 38, 40 f., 45, 239, 362,
 374, 391.
 Neiglick, H., 199, 204, 215-218.
 Nelson, M. L., 397 f., 400.
 Nichols, E. L., 322.
 Nichols, H., 159, 395, 397-400.
 Nietzsche, F. W., xlii.
 Nitsche, A., clxiii., 76.
 Nörr, C., 57.
 Oelschläger, W., 326.
 Orschansky, S., 357.
 Orth, J., 384.
 Oseretzkowsky, A., 150.
 Pabst, A., 88.
 Paneth, J., 159, 398.
 Parrish, C. S., 370.
 Parry, C. H. H., 244.
 Partridge, G. E., 371.
 Patrick, G. T. W., 389, 391.
 Paulsen, F., clix.
 Pearson, K., 14, 362, 375.
 Peirce, C. S., cxlix., 286, 318.
 Peisker, —, 246.
 Petrie, W. M. F., cxlv.
 Pfeffer, W., 67.
 Pflaum, C. D., 408.
 Pflüger, E. F. W., 335.
 Philippe, J., 337 f.
 Pierce, A. H., cxlix., cliii., 408.

- Piéron, H., 389.
 Pillon, F., lxvii.
 Pilzecker, A., cliii, 332, 343, 355, 369, 372, 390, 392.
 Plateau, J. A. F., xxxix., lxix., lxxviii., cxliii., cxxiv., 69, 91, 184, 210-214, 227.
 Ploucquet, G., lxiv.
 Pogendorff, J. C., 26.
 Pogson, N. R., xlv.
 Poisson, S. D., xlv., cliii.
 Polimanti, O., 88.
 Politzer, A., 57 ff.
 Pollitzer, J., 348.
 Pretori, H., clii., 405.
 Preyer, W., xxi. f., xxxi., xlv., lxxv., xcvi., cxi., cxliii., cxvii., cxxii., cxlix., clxliii., 13 f., 24-28, 30, 32, 41 ff., 141 ff., 213, 235-238, 246 f.
 Pritchard, H. J., 262 f.
 Proctor, R. A., 97.

 Quantz, J. O., 371.
 Quincke, G. H., 34.
 Quix, F. H., 58.

 Radakowic, M., cxliv., clxiv. f.
 Radoslawow-Hadji-Denkow, Z., 120, 257, 308.
 Raif, O., 370.
 Ranschburg, P., 350, 389, 412.
 Rayleigh, 58.
 Raymond, F., 374.
 Reed, A. Z., 355.
 Rehmke, J., clx.
 Reid, T., 394.
 Rémond, A., 348.
 Renouvier, C., cxxxiv., cxlix.
 Renz, T., 275.
 Reuther, F., 412.
 Ribot, T., xlviii., cxlv., 67, 253.
 Riecker, A., 250 f., 255, 257.
 Riehl, A., clx., clxlii.
 Rivers, W. H. R., 87 f., 150.
 Robertson, G. C., 398.
 Roemer, E., 350, 355, 378 f., 384.
 Romanes, G. J., cxlii.
 Rood, O. N., 88.
 Rosenbach, O., 349.

 Rossi, C., 391.
 Royce, J., 68.
 Rumford, 73.
 Russell, B., lxxxiii., cxxvii., cxliv.

 Sachs, M., clii.
 Salomonsohn, J. W., 67.
 Samojloff, A., 244.
 Sanford, E. C., clv., 10, 31, 33, 56, 77, 82, 87, 109, 117, 119, 129 f., 133, 136, 143 f., 147, 151, 153, 168, 182, 189, 194 f., 213, 248, 287, 290, 356, 399, 410.
 Sauveur, J., 24 f., 41, 100, 236.
 Savart, F., 24, 26, 40 ff.
 Schäfer, E. A., 375.
 Schaefer, K. L., 25, 29 ff., 240.
 Schafhäutl, C. E., 57.
 Schaternikoff, M., 88.
 Scheibler, J. H., 236.
 Schelling, F. W. J. von, xli.
 Schenck, F., 88.
 Schirmer, O., 78.
 Schischmanow, I., 237, 245 ff.
 Schleiden, M. J., xxxix.
 Schmidt, F., 384.
 Schneebeli, H., 327.
 Schopenhauer, A., xli. f.
 Schultze, E., 371.
 Schulze, F. A., 34, 41.
 Schumann, F., 133 f., 143, 159, 178, 185, 210, 261, 263, 267 f., 273 ff., 279, 302, 304, 324, 332 ff., 340, 344, 369, 392, 395, 397 f., 400 f., 403.
 Schwendt, A., 34 ff., 41, 44 ff.
 Scripture, E. W., cxliv., cl., clviii., 12, 15, 18 f., 29, 38, 40 ff., 44, 46 f., 98, 132, 141 ff., 153, 248, 250, 266, 280, 300, 321, 329, 338 ff., 346, 349 f., 370, 400.
 Sears, C. H., 371.
 Seashore, C. E., 59 ff., 105, 132, 138, 141 ff., 239, 266, 338, 370, 378, 389.
 Sedgwick, W. T., 142.
 Seebeck, A., 236, 238.
 Seeley, J. R., cxvi.
 Sergi, G., 182, 346, 348.
 Seth, A., 68, 253.
 Sharp, S. E., cxxxiv.
 Shaw, M. A., 398.

- Sherrington, C. S., 55, 88.
 Siemens, W., 335.
 Sigwart, C., li., lxx., 253.
 Smedley, F. W., 370.
 Smith, H. F., 38, 40 ff., 44.
 Smith, T. L., 370, 412.
 Smith, W. G., 85.
 Smith, W. G., 338, 352 ff., 358, 391 f.
 Solomons, L. M., 67, 312, 366, 371, 376.
 Sommer, R., 258, 333, 335, 340 f., 344,
 379, 384, 398, 408, 412.
 Southard, W. F., 370.
 Spearman, C., 239 f., 258.
 Squire, C. R., 370.
 Stadler, A., lii., cxlix., clxiv. f.
 Staude, O., cxxii.
 Steele, W. M., 353, 366.
 Stefanini, A., 184, 213.
 Steffens, L., 265, 305, 366.
 Stein, G., 366, 371.
 Steinach, E., 67, 348.
 Steinheil, K. A., xlv., 160.
 Stern, L. W., cxxxiv., clx., 105, 137 ff.,
 141 ff., 193, 260, 374, 399.
 Stetson, R. H., 411.
 Stevens, H. C., 159, 398, 408.
 Stevens, L. T., 159, 395, 397 f.
 Stine, W. M., 87.
 Störing, G. W., 260.
 Storch, E., 244.
 Stout, G. F., xlix., lv., lxviii., cxxxiii.,
 cxlix. ff., cliii., 387 ff.
 Stratilesco, E., xliv.
 Stratton, G. M., 20, 105, 139, 141 ff., 366.
 Stricker, S., 205.
 Strong, C. A., clx.
 Stroobant, P., 375.
 Stumpf, C., xix. f., xlix.-liii., lvi., lxiii.,
 lxxv. ff., lxxxii. f., xciv., xcvi., xcvi.,
 cvi., cix., cxviii., cxx.-cxxxviii., cxxx.,
 cxxxiii., cxxxvii., cxli., cxliii., cxlv.,
 cxlviii., clx.-clxiii., clxvii.-clxxi., 30,
 33 f., 36, 40 f., 43 ff., 57, 67, 143, 146,
 162, 194, 211, 220 f., 224, 233, 235, 237-
 248, 284, 291 f., 298, 309, 312, 318,
 369.
 Sully, J., xlvi., lv., cl.
 Swift, E. J., 371.
 Tannery, J., xlix. ff., lvi., lxiv. f., lxx. f.,
 cxx. f.
 Tannery, P., liii., lviii., lxxiii., lxxvi. f.,
 cxlix.
 Tanzi, E., 345, 348 f., 384.
 Tarde, G., liii., lxx., lxxvii., clviii., clxiii.
 Tawney, G. A., 400.
 Thompson, S. P., 320 f., 331.
 Thorkelson, S., 134, 397.
 Thorndike, E. L., 15, 96, 98.
 Thumb, A., 383.
 Thury, M., 399.
 Tigerstedt, R., 378.
 Tischer, E., 115, 377.
 Titchener, E. B., cxlv., clii., 141, 185,
 300, 357, 360, 372, 375, 378, 385, 406,
 408.
 Todhunter, I., 98.
 Tönnies, F., clii.
 Toepler, A. J. I., 57 f.
 Tokarsky, A. A., 373.
 Trautscholdt, M., 384 f., 397.
 Treadwell, A., 320.
 Tschermak, A., 406.
 von Tschisch, W., 408.
 Türk, D. G., 247.
 Tufts, F. L., 88.
 Turnbull, L., 41 ff.
 Tyndall, J., 395.
 Ueberhorst, C., lxx., xci.
 Ullrich, H., 251.
 Urbantschitsch, V., 121.
 Valentin, G., 370, 389.
 Vaschide, N., 56, 348, 370, 391.
 Venn, J., 14, 97 f.
 Vierordt, K., xxiv., xxvii., xlvi., lxx.,
 cxiii., cxxxiv., 25, 43, 57, 143, 159, 193,
 195, 234, 251, 275 f., 291, 370, 394 f.,
 397, 400, 402 f.
 Villa, G., xix.
 von Vintschgau, M., 346, 348.
 Vivanti, G., 97.
 Virchow, R., xxxviii.
 Vogt, K., xxxix.
 Volkmann, A. W., xxi., xlv., cxiii., 19,
 78, 103, 113 f., 117, 144, 163 f., 176,
 179 f., 182, 194, 251.

- von Volkmann, V., 236.
 von Voss, G., 150.
 Vurpas, C., 391.
- Wagner, R., xl.
 Wahle, R., xxxv., xlix., lii., lv., lxiii. f.,
 lxvii., lxxii., cxxxvii., cxl.
 Walitzsky, M., 374.
 Waller, A. D., 67.
 Ward, J., xxxii., li., lxiv., xciv., cxlix.,
 cliii., clx., 66.
 Warren, H. C., 351, 385, 392.
 Washburn, M. F., 120, 134 f., 143, 188,
 191 ff., 304, 363.
 Watanabe, R., cliii., 335, 355, 375.
 Watson, W., cxlv.
 Watt, H. J., 341, 344, 350, 379 f., 383-
 387, 389 f.
 Wead, C. K., 57 f.
 Weber, E. H., xiii. ff., xvii. ff., xxiii.,
 xxxiv., xlv., lix., lxxxiii., cxiii., cxxxiv.,
 clii., 100, 102 f., 117, 192 f., 233 f., 236,
 258, 266, 349, 368.
 Weber, W., xvi., xxxix., 236.
 Weinstein, M. B., 250.
 Weldon, R. F., 15.
 Weyer, E. M., 363, 365, 408.
 Weygandt, W., 150.
 Wheatstone, C., 410.
 Whipple, G. M., cliii., 136, 141, 143, 239 f.,
 268, 305, 308 f., 318, 370, 374, 386, 397, 408.
 Whitman, F. P., 88.
 Whitworth, W. A., 97.
 Wien, M., 58 f., 71.
 Wiener, C., lxviii., cxxxviii., clviii.
 Wirth, W., 412.
 Wissler, C., 99, 239, 370 f.
 Witasek, S., 143, 210, 224 f., 304, 306,
 308, 390.
 Witmer, L., 145, 168, 276, 291, 335, 341,
 343.
 von Wittich, W. H., 348.
- Wolf, A., 275.
 Wolf, O., 13, 24, 26 f., 236.
 Wolfe, H. K., cliii.
 Wollaston, W. H., 24 f., 31, 41 f.
 Woodward, R. S., 97.
 Woodworth, R. S., 261, 329, 364, 366 f.,
 369 ff.
 Wreschner, A., 186, 259, 266, 268, 274,
 288 f., 299 f., 308, 315, 384, 391.
 Wrinch, F. S., lxxxviii., 67, 226 f., 397 f.,
 400, 403 f.
 Wüllner, A., cxlvi.
 Wundt, W. M., xiv., xxxvii., xxxix.-xlvi.,
 li. ff., lv.-lxiii., lxiv. ff., lxvii., lxxi.-
 lxxv., lxxvii., lxxx. ff., lxxxiv., lxxxviii.,
 xc., xcii. ff., ci., cviii.-cxii., cxiv. f.,
 cxxii., cxxvi. f., cxxx., cxxxiii., cxl.,
 cxliv. f., cxlix., cliii., clvii. ff., clxiii. f.,
 clxvii. f., 1, 13, 24 ff., 28 ff., 39, 43, 55,
 64, 66-69, 71 ff., 78 f., 91, 98, 100-103,
 106-112, 114 ff., 119, 121, 124, 127 ff.,
 133 f., 143 f., 150, 159, 163 f., 168 ff.,
 178, 180 ff., 187, 190, 192-195, 198 f.,
 205, 211 f., 215, 217-222, 227-230, 234,
 236-243, 245, 247 f., 252, 257, 260, 283
 f., 289 ff., 293, 298, 300, 308, 315 ff.,
 327, 331, 335, 338-346, 349 ff., 355, 357
 ff., 363 f., 366, 368, 374-378, 380-383,
 385 ff., 389 ff., 395-400, 403, 406 ff.,
 411.
- Wylie, A. R. T., 398.
- Yerkes, R. M., 358, 362, 374.
- Zeitler, J., 346.
 Zeller, E., liii., lv., lxv., cxl., cliii.
 Zickgraf, A., 34.
 Ziehen, T., 68, 253, 379, 384, 389.
 Zimmermann, E., 342.
 Zoth, O. K. M., 59, 187.
 Zwaardemaker, H., 1, 3, 13, 29, 33, 40 f.,
 44, 58, 348, 384.

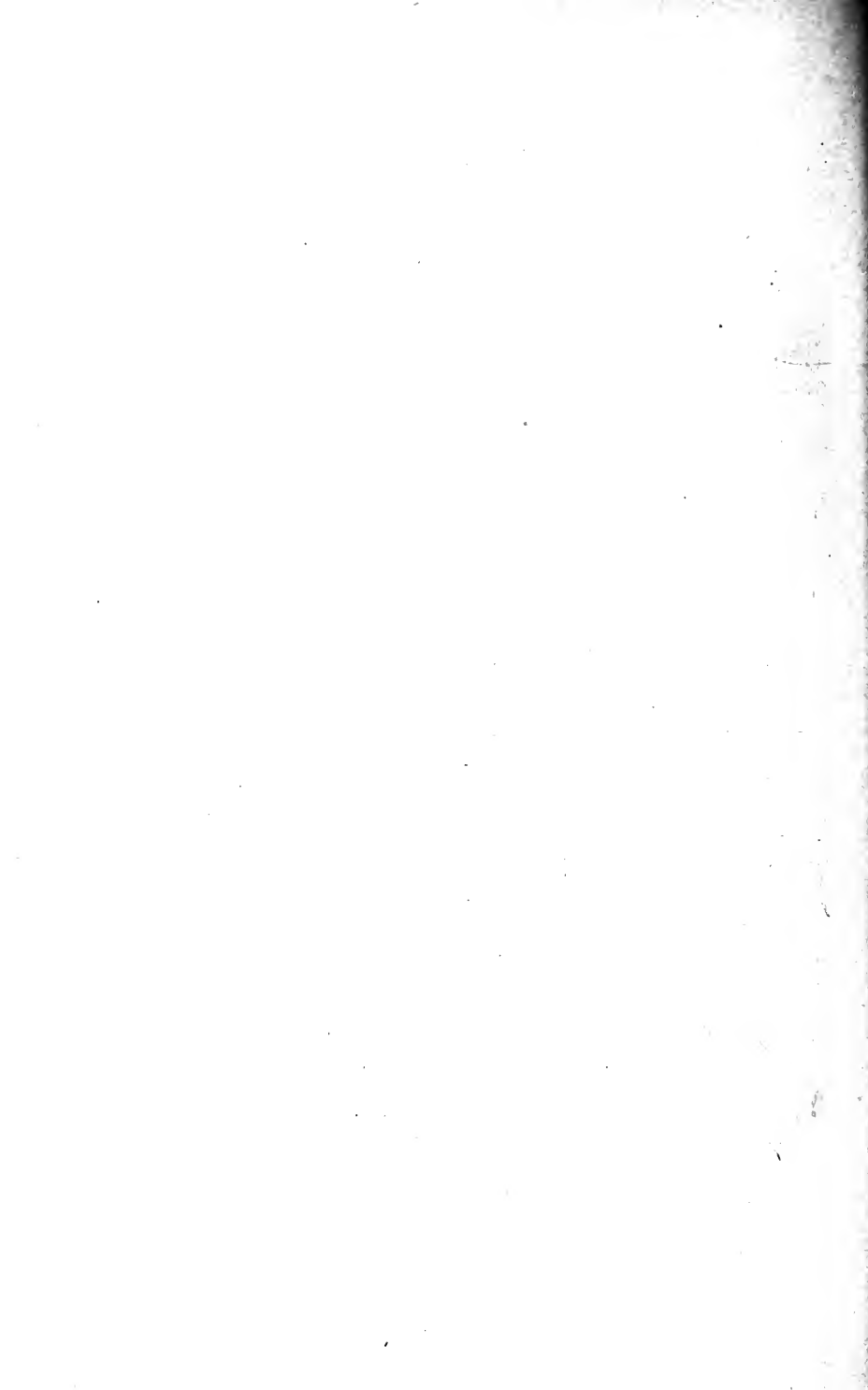

INDEX OF SUBJECTS

- Absolute impression, judgment by, lxvi., 205 f., 231, 275, 304 f., 307, 309, 313.
- Absolute sensitivity, xxiii.
- Accumulator, chloride, 321.
- Acoumeter, Lehmann's, 56 f.; Politzer's, 57 ff.; Zoth's, 59.
- Action consciousness, analysis of, 357 f., 360, 372, 374 f.
- Additional experiments: on tonal limits, 39 ff.; on R/L for pain and temperature sensation, 55; on differentiation of S and memory-image, 60 f.; on demonstrations of Weber's Law, 77; on absorptive power of grey glasses, 79; on white valence of coloured papers, 85; on colour photometry, 87 ff.; on classification of artificial stars, 91; on average error, with the Marbe mixer, 160; on equal sense distances, with visual extents, 210; on determination of equivalent R by method of constant R (Martius' expt.), 261 ff.; on psychology and psychophysics of movement, 370 f.; on psychology of time, 403.
- Adjustment, methods of, 316 f.; see Average error, method of.
- Adjustment of R to a j. n. d., the procedure typical of one form of the method of j. n. d., 100, 102, 117 f.
- Adjustment, significance of O 's, in method of av. error, 146 ff.
- Æsthesiometer, Ebbinghaus', 160, 258; Griesbach's, 258; Jastrow's, 160, 258; Spearman's, 258; Stratton's, 142.
- Æsthesiometry, work upon, by method of equivalents, 188; references to, by method of constant R , 255; regularity of results, in work by method of constant R , 255 ff.
- Æsthetics, experimental, xxxiii., clxiv., 318.
- Affective processes, and Weber's Law, xx., clii. f., 72; quantitative investigation of, 406 f.; see Feeling.
- Ammeters, 322 ff.
- Anomalous differences, 302 ff., 306.
- Anschauung*, cxlii. f.
- Answers to questions, on mental measurement, clvii.; on the qualitative R/L for tones, 14 ff.; on the qualitative TR for tones, 39; on the intensive R/L for pressure, 55; on the intensive R/L for sound, 60 f.; on Fechner's cloud and shadow expts., 74 ff.; on Sanford's weight and Ebbinghaus' brightness expt., 89 ff.; on method of limits, 126 ff.; on method of av. error, 153 ff.; on method of equivalents, 189 ff.; on method of equal S -distances, 201 ff.; on method of constant R , 251 ff.; on determination of equivalent R by method of constant R , 259 ff.; on method of constant R -differences, 267 ff.; on technique of simple reaction, 355 f.; on three types of simple reaction, 362 ff.; on compound reaction (discr., cogn., choice), 378 ff.; on associative reaction, 384 ff.; on psychology of time, 403.
- Antagonistic reactions, 352 ff.
- Anregung* and *Antrieb*, 150, 305 f., 360.
- Apparent magnitude, Martius' expt. on, 261 ff.; theory of, 263.
- Apperception, in Wundt's system, lvi., lxii. f., lxxiv. f., lxxx. ff., cxxii., clx. f., clxiv., 69, 407.
- Arm-movement apparatus, 258; sources of error in work with, 259 f.
- Association, psychology of, 387 ff.

- Associative reaction, 381 ff.; see Reaction, Reaction expt.
- Attention, in Fechner's psychophysics, xxxii., lxxxix., c., ci. ff., cvii.; should be maximal in method-work, 18; in method of least differences and Kraepelin's combined method, 21; direction of, in av. error, 156, 178; in method of constant R (æsthesiometry), 257; in method of constant R -differences, 306, 312 f.; quantitative expts. on, 407 ff.
- Attention limen, in Delbœuf, cxx.; in Wundt, cxxii.; in Stumpf, cxxv. f.; in Meinong, cxxxiii.; in Külpe, cxxxiv.
- Audiometer, Seashore's, 59 f.
- Average error, method of, xxi., cxiii., 111, 115, 118, 143 ff., 156, 160 ff., 180, 186, 192, 316; how related to the method of j. n. d. (Wundt, 1880), 110; rules of calculation in, 143; number of expts. required by, 144 f.; significance of O 's adjustments in, 146 ff.; criticism of, 153; procedure of, 154; combination of, with method of limits, 156 ff., 170, 176 ff.; as used in work on the time sense (method of reproduction), 159, 400 ff.; as application of method of constant R or R -differences, 159, 175, 185 f., 313; first employment of, cxiii., 160; Fechner's account of, 160 f.; Müller's rules for (1878), 162 ff.; as used by Volkmann, 163 f.; questions on, 153 ff.; essays on, 187.
- Average error, combined or mediate form of method of, 132, 156 ff., 176 ff.; Münsterberg, 176 f.; Higier, 177 f.; Merkel, 178 f.; Foucault, 179 ff.
- Axioms, Müller's psychophysical, clxiv.
- Batteries, primary, 320 f.; storage, 321; lamp, 321 f.
- Bereitschaft*, 365, 389.
- Bias, error of, in av. error, 154, 162; in method of equal S -distances, 202, 205.
- Bibliographies, psychological, 417 f.
- Books, the best fifty, for work with this Course, 418 ff.
- Brightness, determination of DL of, by method of limits, 125; Ebbinghaus' expt. on, 85; Fechner's expts. on, xxi., cxiv.; Delbœuf's expts. on, 211 ff.; of grey rings and discs, not uniform, 200; work upon, by method of equal S -distances, 199 ff.
- Carrier bracket, 265.
- Cartridge weights, 189, 265.
- Cells, Grove, 320 f.; Bunsen, 320 f.; Edison (Edison-Lalande), 320 f.; Meidinger, 321; Grenet, 321.
- Change, limens of continuous, 137 ff.; visual sensation, 138; visual movement, 138 f.; auditory sensation, 139; auditory localisation, 141; pressure sensation, 141 f.; temperature sensation, 142; cutaneous movement, 142; taste, 143; smell, 143; lifted weights, 143; essays on, 143.
- Chronographic method, for reaction expts., 338 ff., 384.
- Chronographs, 340.
- Chronometer, d'Arsonval's, 335 ff.
- Chronoscopes, Ewald's, 337 f.; Hipp's, 326 ff.; arrangement for break to break (old-pattern clock), 327; housing of clock-case, 327 f.; control of, 329 ff.; Wundt's demonstration, 331; Münsterberg's, 337; pendulum, 338, 351; wheel, 338.
- Clearness, in Wundt's system, lx. ff., lxvii.; Foucault's measurement of, clviii., 181.
- Cloud expt., Fechner's, 72, 76, 78; sources of error in, 74 f.
- Coefficient of variation, 361.
- Cohesion, degree of, in work with method of equal S -distances, 198, 207 f., 232.
- Colour mixer, Marbe's, 138, 160, 201.
- Complete series, method of, 126, 130 ff.; with haphazard arrangement of R , 132; see Limits and differences, method of.
- Complication expts., 407 f.
- Constant R , method of, 248 ff., 258 ff.;

- essays on, 258; see Right and wrong cases, method of.
- Constant R -differences, method of, 116, 120, 231, 263 ff.; essays on, 275, 312 f., 315 ff.; see Right and wrong cases, method of.
- Continuity of S as function of R , cxviii., cxlvi. ff.
- Contrast, sensible, in Delbœuf's theory of mental measurement, xlix. f., lxxi., cxxi., cxxx.
- Contrast, visual, measurement of, clii., 405 f.; in Delbœuf's brightness expts. by method of equal S -distances, 200, 212 f.; Wundt's observations on, 215 f.
- Control instruments, for Hipp's chronoscope, 340 ff., 343 f.; gravity chronometers, 340 f.; pendulums, 341; hammers, 341 ff.; other instruments, 344.
- Co-ordination, automatic, 376, 390.
- Correction, factor of, in min. changes (Fechner), 115; for small number of observations, 155.
- Criteria of judgment, secondary, 2 f., 150, 203 ff., 225, 231 f., 368.
- Current, distribution of electric, 321 f.
- Curve, determination of exponential, which most nearly agrees with results of expt., 84 f.
- Curves, of results from Sanford's weight expt., 83; from Ebbinghaus' brightness expt., 86; of distribution of errors of observation, 269; of distribution of r , w and u cases, 370.
- Cylinders, Koenig's steel, for determination of highest audible tone, 32.
- D , arrangement of, for work with method of constant R -differences, 274; most favourable, for work with Fechner's method of r . and w . cases, 283.
- Degradation, Delbœuf's law of, cxx. f.
- Delbauf, J., on the doctrine of the summation of S -units, xlix. ff.; author of the Reconstruction of the theory of mental measurement, cxvii., cxxi.; declares the limens to be psychologically irrelevant, cxvii. ff., though he does not commit himself to a physiological interpretation of them, cxx.; his three laws of degradation, progression and tension, cxx. f.; his services to quantitative psychology, cxvii.; gives no systematic exposition of his views, cxx., cxvii.
- Difference hypothesis of Weber's Law, xlvi., lxxviii. f., lxxx ff., lxxxiv., 68 ff.
- Difference, methods of, 316.
- Difference S , material substrate of (Fechner and Müller), xcvi. f.; Fechner's use of term, cxli.
- Difference tones, 29, 406.
- Differential sensitivity (D. S.), xxiii., cli. f., clxvii. ff., clxxi.; simple or absolute and comparative or relative, xxiii.; analysis of (Martin and Müller), 301 ff., 308 f.
- Differenzansicht der Empfindung*, xlix. f., cxxi.; see Relativity.
- Direction of comparison, error of, in minimal changes (Fechner), 115; in av. error, 151 f., 178.
- Disappearing differences, method of, 103 f., 110.
- Discrimen* and *differentia*, xiv. f., lxxxiii.
- Discrimination constant, of method of minimal changes, 112, 168.
- Discs, Masson's, 77; expts. performed with, 78; Delbœuf's (Kirschmann and Sanford), 77 f.; Martius', 87; Hering's (Brückner), 88; Delbœuf's, 198 ff., 212.
- Distance between S -points replaces absolute S -magnitude as material of mental measurement, cxvi.; but distance is not a divisible magnitude, cxxx. f.; hence *S-Distanz* is measured by *R-Strecke*, cxxxii.; how represented in consciousness, cxl. ff.
- Distribution, normal and irregular, 96; Bruns' generalised law of, 297.
- DL , Fechner's teleological view of, xciv.; subsumed in *El.* to *ML*, xciv.; separated by Müller from the Fechnerian *RL*, xcvi. f.; bracketed with

- the *RL* in I. S., xcvi.; physiologically interpreted by Müller, xcvi.; subsumed in R. to the *ML*, xcix. f.; in Massprincipien is an error of estimation, civ. f. (*cf.* xxxvi.); relation of, to the *RL* in Massprincipien, cvi.; in Fechner's psychophysics at large, cvi. f.; value of concept of, to modern psychology, cxiii., cxvi.; regarded by the Reconstruction as a fact of friction, cxvi. (*cf.* Delbœuf, cxvii. ff.); magnitude and precision of, 116, 118, 238, 278, 311; of method of limits, 104 f., 111, 117, 120; advantage of determination of upper and lower, 123; of minimal changes, 107 f., 109 f., 111; and *QL*, 108, 115; validity of average of upper and lower, 112 ff.; generalised definition of, 112 f.; employment of Wundt's double procedure for the determination of a single, 115 f.; of method of complete series, 131; incorrect determinations of, 132 f.; as found by Lipps' formulæ in method of av. error, 170 ff., 175; relation of, to av. variable error, 166 ff., 182 ff., 185 ff.; of method of r. and w. cases, 270 f.; of method of equal and unequal cases, 291 f.; relation of, to *h*, 312; see J. n. d.
- DL*, of areal pressure, determination of, 136; of brightness, 124; direction of regard must be constant in expts. on, 125; of colours (Mentz), cxlvi.; for pressure and lifted weights (Weber), xiv. f.; of tones, successive, cxlvi., 125 f., 235 ff.; for unmusical *O*'s, 239; and musical training, 240; of tones, simultaneous, 240; of time intervals, lxxxvii., 403 f.
- DL* or *Unterschiedsmischungsschwelle*, cvi.
- Doubled stimuli, method of, 219, 225; *cf.* 222 f.
- Doubtful judgments, in Kraepelin's combined method (lowest audible tone), 23; in method of r. and w. cases, 268, 278 ff., 285 ff. (290), 293, 295 f., 297.
- D. S., see Differential sensitivity.
- Dual impression, limen of visual, 257; limen of tactual, see *Æsthesiometry*.
- Duration, attribute of, 191.
- Dust method, Kundt's, of determining frequency of vibration, 36.
- Dynamometers, experimental, 325 f.
- Ebbinghaus, H.*, part taken by, in the Reconstruction, cxxvii. ff.; his use of the phrase 'distance sensation,' cxli. f.; his use of 'recept' (*Anschauung*), cxlii. f.
- Einstellung*, motor, 231, 275, 365 f.
- Electricity, works dealing with, 320.
- Energy, definition of mechanical, cxlix. f.
- Enumeration, methods of, 316 f.
- Envelope weights, 82.
- Episcotister, 79 f.
- Equal-appearing intervals, method of, 103; see Equal *S*-distances, method of.
- Equal and unequal cases, method of, 291 f., 310, 316.
- Equal judgments, in method of r. and w. cases, see Doubtful judgments.
- Equal *S*-distances, method of, 191, 194 ff.; two procedures in, 201 ff., 225 f.; use of four *R* in, 207, 216; first employment of, cxiii., 210 f.; Delbœuf, 211 ff.; Müller's criticism of, 214 f.; Hering and Wundt, 215 f.; Boas, 216; Lehmann and Neiglick, 217; Merkel, 218 ff., 223 ff.; Fullerton and Cattell, 222 f.; Meinong, 224 f.; Ament, 225 f.; Heymans, 226; Wundt's account of, 227 ff.; Fröbes, 231 f.; expts. with tones, 241 ff.; essays on, 232.
- 'Equality' and 'lapse of difference,' 104, 109 f.
- 'Equally noticeable' and 'equal,' lxi. ff., lxxxv.
- Equivalent *R*, determination of, by method of constant *R*, 258 ff., 313; essays on, 261, 263.
- Equivalentals, method of, clxx., 187 ff.; two procedures in, 190, 192; applications of, 190, 193; first employment

- of, 191 f.; as a mode of av. error, 192, 194; as combined with method of limits, 192, 315; as combined with method of constant R , 314 f.; essays on, 194.
- Ergographs, 407.
- Error, average variable, 145, 154, 165, 176 f., 180; is it proportional to the DL ? 166, 182 ff.; Fechner and Müller on, 166 ff.; Wundt on, 168 ff.; Lipps on, 170 ff.; Fullerton and Cattell on, 183 f.; Müller on, in *M.*, 185 ff.
- Error, Gauss' law of, 96; works upon, 97 f.; agreement of observed and calculated values in æsthesiometrical work, 256 f.; curves showing distribution of errors of observation, 269; curves showing distribution of r , w and u cases, 270; question of validity of, in *r.* and *w.* cases, 295 ff.
- Error methods, 93, 101 f., 109, 316.
- Error of mean square, 9 f.; see *SD*.
- Error of recognition, Foucault's, 179 f., 181.
- Error, principal, in av. error, 154 ff., 168 ff., 178, 181; in method of constant R , 159.
- Error, sources of subjective, in Müller's method of least differences, 4 f., 20; in method of limits, 133 ff.; in method of equal S -distances, 201 ff., 208 f., 242 ff.; in method of constant R , 256; in method of constant R -differences, 267; in expts. on compound reaction, 377; in Vierordt's expt., 402; sources of objective and subjective, in use of lamella, 3 f.; in use of instruments for determination of tonal TR , 35 f.; in use of touch-weights, 46 ff.; in use of hair æsthesiometer, 49 f.; in use of limen gauge, 55; in watch test, 56; in shadow expt., 73 f.; in use of envelope weights, 82; in use of sound pendulum, 197, 265; in use of greys, 73, 200, 212 f.; in use of arm-movement apparatus, 265; in use of Hipp chronoscope, 328; in use of lip key, 355; in use of Vierordt's lever, 400, 402.
- Errors, accidental, 109, 145, 154, 312 f.
- Errors, constant, 102, 105, 115, 118, 133, 145, 151 f., 154, 165 f., 177 f., 180, 190, 259, 263 ff., 267; DL explained by Fechner in terms of, civ. (*cf.* xxxvi.); aimed at, in the combination of the upper and lower to a mean DL , in Wundt's method of minimal changes, 114 ff.; true and apparent, 168, 178; complete and incomplete elimination of, in method of constant R -differences, 263 f.; in method of *r.* and *w.* cases (two R), 272 f., 302 ff., 313.
- Errors, crude, 143 f., 146, 165 f.
- Errors of contravention, 256.
- Errors, terminology of, 10.
- Errors, variable, 101, 118 ff., 149 ff., 154.
- Essay subjects, on rise and progress of quantitative psychol., clviii. ff.; on sensitivity, clxxi.; on highest and lowest tones, 41; on intensive RL for pressure, 55; on intensive RL for sound, 61; on interpretations of Weber's Law, 66 ff.; on demonstrations of Weber's Law, 92; on method of limits, 137; on continuous R -change, 143; on av. error, 187; on equivalents, 194; on method of equal S -distances, 232; on method of constant R , 258; on determination of equivalent R by method of constant R , 261, 263; on method of constant R -differences, 275, 312 f.; on this and on the metric methods in general, 315 ff.; on three types of simple reaction, 371 f.; on compound reactions, 389 ff.; on psychology of time, 403 f.
- Estimation difference or error, in Wundt's method of minimal changes, 107, 111 f., 168, 180 f.
- Estimation of *j. n. d.*, not called for by method of limits, 117.
- Estimation value, in Wundt's method of minimal changes, 107, 111 f.
- Examination questions, 413 ff.
- Exercises, mathematical, 18, 257 f., 293;

- practical, in electrical measurements, 324 ff.; in reaction technique, 359.
- Expectation, error of, 5, 20, 47, 101, 129, 133 f., 205, 222, 275, 310, 313; studies of, 99; in minimal changes, 118 ff.; instance of effect of, 134.
- Experiments, blank, 24, 48, 56, 130, 307.
- Experiments, typical, in quantitative psychol., 405 ff.
- Experiments, Weber's, with pressure, lifted weights and ocular measurement, xiii. ff., xvii. f.; Fechner's, with brightnesses, lifted weights, temperatures, visual and tactual distances, xxi., cxiv., 276; Hering's, with lifted weights, lxxi., 229; Martin and Müller's, with lifted weights, 302 ff.; Delbœuf's, with brightnesses, 211 f.; Vierordt's, on the time sense, 400 ff., 403.
- Explanation, psychological, of Weber's Law, 62, 65 f.
- Extension, attribute of, 191.
- Facilitation, 306, 365.
- Fatigue, error of, 39, 120, 129, 133, 151, 154, 273, 305, 307; studies of, 134; illustrations of effect of (time sense and cutaneous stimulation), 135.
- Fechner, G., T., early interested in inner psychophysics, xx., xxxi.; adopts Weber's Law, xxi.; publishes the *El.*, xxii.; the *I. S.*, xxxiii.; the *R.*, xxxiv.; the *Massprincipien*, xxxv.; his scientific standing, xxxix.; his standing as a philosopher, xl. ff.; his success as a philosopher, xliii. ff.; as originator and systematizer of psychophysics, xlv. ff.; his psychophysical beliefs, lxviii. ff., lxviii. ff., lxxxix. ff., 62 f., 68, 276; vouches for the introspective equality of the *j. n. d.*, lxxxv., 75, 103; his services to psychology, (1) as the founder of psychophysics, cviii. f.; (2) as systematist, cviii., cx. f.; (3) by his completed work, cxiii. ff., 276 (metric methods, *DL*, experimental investigations, theory of mental measurement, cxiii. ff.); his overestimation of Weber's Law, cxiv. f.; his relation to Wundt, cxi. f., clix.; to Herbart, clix.; his psychology, xxii., lxiii., xc. f., cxi. f., cxl. f., clx.
- Fechner's contemporaries, in science, xxxviii.; in philosophy, xxxix. ff.
- Feeling, as substitute for sensible contrast in method work, liii., cxxvi.; use of, as criterion of judgment, in method of equal *S*-distances, 209; see *Affective processes*.
- Fields of judgment, Wreschner's method of, 300.
- Five cases, method of, 316.
- Flicker photometry, 87 f.
- Forks, Edelmann's, for determination of qualitative *RL*, 14; giant, for determination of qualitative *TR*, 13 f.; Appunn's wire, 14; Koenig's and Appunn's high, 31 f., 35; with riding weights, 125; with screw attachments, 125 f.
- Formulæ, Fechner's fundamental, xxviii.; Fechner's metric, xxix.; Plateau's fundamental, lxix.; Ebbinghaus' metric, cxxix.; of measurement at large, cxl.; Wundt's fundamental, cxliv. (*cf.* 70); for determination of median, 9; for *SD*, 10; for *PE* of mean, 11; for *PE* of single observation, 11; for determination of photometric values of grey glasses, 80 f.; of Wundt's method of minimal changes, 107 f.; for space error, in method of limits, 122; of method of complete series, 131; Wundt's, for av. error, 144; for calculating arith. and geom. means of limiting brightness values, 201; Wundt's, for determination of subjective mean in method of equal *S*-distances, 205; Delbœuf's metric, 213; of probability integral, 250; for *UL*, 253; for method of *r.* and *w.* cases (two *R*), 271; for constant errors, 272; for *r.* and *w.* cases (Fechner), 278; for *h* (Fechner and Müller), 279, 282 f.; for *r.* and *w.* cases (Fechner's reconstruction), 279, 282 f.; for correlation of $\frac{r}{n}$ with $\frac{D}{PE}$,

- 287; for *DL* of equal and unequal cases, 292; for r. and w. cases (Merkel), 293 f.; (Bruns), 295 f.; for Fechnerian constant errors in r. and w. cases, 302; for anomalous differences (Martin and Müller), 303 f.; for application of r. and w. cases to problems of mean gradations, 314.
- Fractionation, of experimental series, 7, 144; of action consciousness, 380.
- Frequency, surface of, 8.
- Fundamental formula, Fechner's, xxviii., ci.; Plateau's, lxix.; Wundt's, cxliv., 70.
- Galton bar, 152 f.
- Galton whistle, 31, 35 f., 37.
- Galvanometer, analogy of the tangent, cxlv. f.
- Gradation methods, 316.
- Graded approach to j. n. d., typical of one form of the method of j. n. d., 100, 102 f., 106, 109.
- Greys, for demonstration of Weber's Law, 72 f.
- h*, as measure of precision, 167, 185 ff., 257, 268, 270 f., 279, 281 ff., 290; regarded by Fechner as a measure of sensitivity, 297 f. (*cf.* 285, 294, 309); Fechner's and Müller's, 279 f., 282 f.; conditioned by fluctuation of attention (Mosch), 297; relation of, to *RL* and *DL* in method of constant *R* and *R*-differences, 312.
- Habit, psychological analysis of, 134.
- Habituation, error of, 5, 20, 118 ff., 129, 133 f., 179, 205, 313; illustrations of, 135.
- Hair æsthesiometer, von Frey's, 48 f.; sources of error with, 49 f.
- Hairs, as stimulators, 48 f.; measurement of (microscope and caliper), 48 f., 51; standardising of, 48, 50.
- Haploscope, Hillebrand's, 410.
- Herbart, J. H.*, relation of, to Fechner, xlv. ff., clix.
- Highest audible tone, determinations of, 41 ff.
- Hypotheses of Weber's Law, 68 ff.; see Difference hypothesis; Quotient hypothesis.
- Inhibition, Heymans' law of, 226.
- Inner psychophysics, xx., xxvi., xxxi. ff., xxxvi., xciv. f., xcvi., xcix. f., cv., cxi.
- Instruction to *O*, significance of, 5, 313, 360, 372 ff., 390.
- Instruments, psychological, cxlix. f.; for determination of lowest audible tone, 13 f.; of highest audible tone, 31 ff.; for demonstrations of Weber's Law, 77 f.; Lehmann's photometer, 79 f.; for work on colour photometry, 87 ff.; Appunn's tonometer, 91; Jastrow's pressure balance, 136; for limens of continuous change, 138 ff.; Scripture's Galton bar, 152; Münsterberg's apparatus for ocular measurement, 210; Wundt's gravity phonometer, 221; Wundt's apparatus for memory of visual extents, 257; weights and weight holders, 265 f.; Merkel's and Jacobi's pressure balance, 266; for work upon the time sense, 396, 399, 401; for study of visual contrast (Hess and Pretori), 406; ergographs, 407; complication pendulum, 408; clock, 409; for temporal limen of homogeneous and disparate *S*, 409; isoscope, 410; haploscope (Hillebrand), 410; for study of optical illusions, 411; for study of memory, 391, 412; manufacturers of, 423 f.; see Reaction; Reaction expt.
- Intensity of *S*, definition of, lxx. ff.
- Intensity of tone, a condition of range of hearing, 40 f.
- Intensive *S*, not homogeneous, xlvi., li. ff., 191.
- Interpretations of Weber's Law, xxxiv., lxxxix. f., xci. ff., cxx., cxxiv., 66 ff.; how different from explanations, 62 ff., 70; essays on, 66 ff.
- Interval sense, 244 ff.

- Introspections, in method of least differences, 7, 12 f., 15; in determination of tonal *RL*, 22, 39; of tonal *TR*, 37 ff.; of difference between *S* and memory-image (watch test), 56; in method of equivalents (cutaneous pressure), 189; in comparison of visual and tactual distances, 190 f.; in method of equal *S*-distances, 203 f., 207 ff., 225, 230 ff.; in expts. on musical intervals, 245, 247; in work with arm-movement apparatus, 260; in method of constant *R*-differences, 267; of 'doubtful' and 'equal' judgments, 268; in reaction expt., 360, 362; in 'motor' work at large, 367 ff., 374 f.; in Vierordt's expt. on the reproduction of a time interval, 402.
- Isoscope, Donders', 410.
- J. n. d., method of, xxi., xxvi., xxxv.; first employment of, cxiii., 102, 160; two lines of development of, 100; two forms of typical, 101; Fechner's, employs \uparrow and \downarrow series, 102 f., 104; how related to av. error (Wundt, 1880), 110; recommended by Fechner for preliminary work, 118; see Least differences, method of; Limits, method of; Minimal changes, method of.
- J. n. d. of *S*, are they equal? lxviii. ff., lxxv.; progressive increase of (Ament and Külpe), lxxxv. f.; overestimated by Fechner, 75, 103; the psychophysical, cannot be ideated, 117 (*cf.* 316 f.); Fechner's, not the psychophysical *DL*, 128; of tones, 235 ff., 240; of tonal distances, 244 ff., 248; see *DL*.
- J. not-n. d., method of, 103 f., 110.
- J. u. d., as determined by combined method of limits and av. error, 158.
- Judgment, two classes of, in Stumpf's psychophysics, clxi. ff.; irregularities of, in Kraepelin's combined method (lowest audible tone), 23; standard of, in method of least differences and Kraepelin's combined method, 21, 55; in aesthesiometry, 257; in method of constant *R*-differences, 313; confidence of, in method-work, 318; direction and expression of, in method of equal *S*-distances, 196 f.; direction of, in method of constant *R*-differences, 274; general tendency of, 94, 122 f., 155 f., 206, 303 f., 305 f.; typical tendency of, 122 f., 155 f., 206, 303 f., 305 f.; time of, in work with constant *R*-differences, 308; psychology of, 385 ff.
- Judgment determination, methods of, 317.
- 'Just noticeable' and 'equally noticeable,' lxxxvii. ff.
- Keys, for use in reaction expt., 349 ff., 379 ff.
- Lamella, Appunn's, 1 f., 13; adjustment of, 1 f., 3 f.; sources of error in, 3 f.
- Law, Breton's parabolic, 183 f.
- Law, Fechner's parallel, see Parallel Law.
- Law, Fullerton and Cattell's, that the error of observation is proportional to the square root of *R*, 183 f.
- Law, Merkel's, 70, 228 ff.
- Law, Weber's, see Weber's Law.
- Least differences, Müller's method of, as applied to the determination of the *RL* (qualitative for tones), 4 f.; specimen table of results, 6; as extended by Higier, 16, 18; table of results, 17; as employed by Scripture, for pressure limen, 18 f.; not universally applicable, 20; compared with Kraepelin's combined method, 21 f.; as applied to the determination of the *TR* (qualitative for tones), 36; specimen table of results, 37; as extended by Higier, 39 f.; results of, with hair aesthesiometer, 50 f.; with limen gauge, 53 f.; as applied to the equation of luminosities, 80; combines the j. n. d. with the j. not-n. d. to a *DL*, 104; in Müller's account, implies discrete procedure, 105; see Limits, method of; Minimal changes, method of.
- Lifted weights, Weber's expts. with,

- xiii. f., xvii. f., 266; Fechner's expts. with, xxi., cxiv., 265 f., 276; Hering's expts. with, lxxi., 229; Martin and Müller's expts. with, 302 ff.
- Limen, temporal, of homogeneous and disparate S , 408.
- Limen gauge, von Frey's, 52 ff.; disposition of apparatus, 53.
- Limens, teleological importance of, in Fechner's view, xciv.; in Fechner and Müller, xciv. ff.; significance of, for the Reconstruction, cxvi.; in Delbœuf, cxvii. ff.; in Wundt, cxvii.; in Stumpf, cxxv. f.; in Ebbinghaus, cxxviii.; in Meinong, cxxxiii.; of continuous change, 137 ff.; see *DL*, *DML*, Inner psychophysics, *LL*, *ML*, *QL*, *QML*, *RL*.
- Liminal sensitivity (*L. S.*), clxvii. ff., clxxi.; cf. xxix.
- Limits, method of, 93, 99 ff., 116 ff., 121 ff., 156 ff., 167, 177, 192, 316; differentiated from method of minimal changes as psychophysical from psychological, 101 f.; two procedures, serial and haphazard, 101 f., 128; combines the *j. n. d.* with the *j. not-n. d.* to a *DL*, 104 f.; does not demand estimation of the *j. n. d.*, 117; not universally applicable, 121, 128; named by Kraepelin, 121; implies a sub-form of the procedure without knowledge, 127; diagrammatic representation of, 130; essays on, 137.
- Limits and differences, Kraepelin's method of combined, 21, 46 ff., 102, 132; specimen table of results, 22.
- LL* or limiting limens, 19, 23, 253.
- Lotze, *R. H.*, a rival of Fechner, in philosophical regard, xliv.; prefers Herbart's mathematics to Fechner's, xlvi.; his significance for modern psychology, cxi. f., clix.; on continuity of S as function of R , cxlvii. f.
- Lowest audible tone, determinations of, 24 ff.; proper tones of various instruments, 25 ff.; difference tones, 29 f.; interruption tones, 30 f.
- Magnitude and quantity, xlvi. ff., lx., lxiv. ff., lxxvii. f., clxxiii.
- Manipulation, errors of, 19, 146 ff., 154, 251, 312; tendencies of, 155 f.
- Mathematical essays and exercises, clxiv. f., 18, 257 f., 312.
- Mathematics, place of, in a psychological course, 93 ff.; list of works on, useful in this Course, 97 f.
- Mean gradations, method of, xxxv., lxix., lxxxvi., cxiii., 91, 103, 194, 210, 225 f., 231, 241, 316; how related to *r.* and *w.* cases (Wundt, 1880), 111; see Equal S -distances, method of.
- Mean stimuli, method of, 225.
- Measurement, Delbœuf's definition of, cxxi.; Meinong's distinction of direct, indirect and surrogate, cxxxi.; formula of, cxl.; references on, cxliv.
- Measurement methods (Lipps), 317.
- Median, 8 f., 361; *PE* of, 12.
- Memory, quantitative investigation of, cliii., 318, 368, 392, 412.
- Mental measurement, Fechner's principle of, xxiv. f., xxxvi., cxiv. (the S a sum of S -units, xlvi. ff.; the principle independent of Weber's Law, cxiv. f.); as viewed by the writers of the Reconstruction, cxvi.; and introspective sanction, cxxxix. f. (cf. liii.); Münsterberg's theory of, by concomitant strain sensation, lxix. f., cxxxiv. ff., 191, 222, Meinong's view of (*S-Distanz* measured by *R-Strecke*), cxxxii.; notes on the exposition of the text, cxlv.; essays on, clviii.
- Mental tests, cxxxiv., 356.
- Mental work, lxxxiv., clix.
- Merkel's law, 70, 228 ff.
- Merklichkeit*, in Wundt's system, lvi. ff., lxxiv., lxxx. ff., cxxii., clviii., clxvii., 68 f.; and *Klarheit*, lxi. f.; in Müller's *G.*, lii., lxxiv., lxxvi.
- Method of average error; average error, combined or mediate form of; complete series; constant R ; constant R -differences; disappearing differences; doubled stimuli; equal-appearing

- intervals; equal and unequal cases; equal *S*-distances; equivalents; five cases; j. n. d.; j. not-n. d.; limits; limits and differences, combined; mean gradations; mean stimuli; minimal changes; r. and w. answers; r. and w. cases; supraliminal differences; three cases; two cases; see Average error, etc.
- Methods for determination of the limens of continuous change, 138 ff., 143.
- Metric formula, Fechner's, xxix., xlix., xcvi., xcvi., ci.; Ebbinghaus', cxxv., cxxix., 61; Plateau's, lxix., 184.
- Metric methods, in Fechner, xxi., xxvi., cxiii. f., clxx., 110; in Fullerton and Cattell, 117 f.; how interrelated, 315 ff.; two types of, 126, 317; two characteristic values furnished by, 166; as the typical methods of quantitative psychology, 318; question of the best method, 121, 147, 310; essays on, 315 ff.
- Metric principle of sensitivity, Fechner's, xxii.
- Minimal changes, method of, 99, 105, 116 ff., 164, 180 f., 298; a psychological, as distinct from a psychophysical method, 101, 106, 109; worked out by Wundt, 105 f.; Wundt's derivation of test values, 106 ff.; implies procedure with knowledge, 128; see Least differences, method of; Limits, method of.
- ML*, general heading for *RL* and *DL* in *El.*, xciv.; in *I. S.*, xcvi.; in *R.*, xcix. f.; in *Massprincipien*, cv. f.
- Modal sensitivity (*M. S.*), clxvii. ff.
- Mode, empirical, 9, 361.
- Motor psychology, 364 ff.; no warrant for speaking of a 'motor side of consciousness,' 364; problems of psychology and psychophysics of movement, 364; relatively neglected by the older experimentalists, 365 ff.; typical investigations in, 366; characteristics of recent work in, 366 f., 369; offers a psychological method that is independent of introspection, 367 ff.; list of works on rapidity of movement, 370; on accuracy of movement, 370 f. (*cf.* extent of movement, 261); expts. on force of movement, 148 ff.; sources of variable error in dynamometry, 149; expts. on time of movement, 149 ff.; sources of variable error, 150 f.
- Motors, electric, 324.
- Movement, of reaction, significance and analysis of, 351 ff.; general psychology and psychophysics of, see Motor psychology.
- Müller, G. E.*, publishes the *G.*, xxxiv., xlvii.; on the summation of *S*-units, lii.; on the equality of the j. n. d., lxxi., lxxv. f.; insists on the approximative character of Weber's Law, xcii.; criticises Fechner's doctrine of the *RL*, xcvi. f.; criticises the relation of the *RL* to the *DL* in Fechner's system, xcvi. f., cvii.; suggests a material substrate for the difference-*S*, xcvi. f.; criticises Fechner's view of the seat of mind, of attention, etc., cii. f., cvii.; publishes the *U. E.* (with L. J. Martin), 300; publishes the *M.*, 310.
- Münsterberg-Jastrow effect, 87.
- MV*, as measure of variability, 145 f., 154, 167, 179, 361; in method of least differences, 7, 37, 47; in Higier's extended method, 18; in Kraepelin's combined method, 23; in Scripture's modified method, 47; and *SD*, 10, 146; and *PE*, 11, 146; course of, in Delbœuf's expts. by method of equal *S*-distances, 214.
- Ocular measurement, Weber's expts. upon, xvi., xvii. f.; Fechner's expts. upon, xxi., 163; Volkmann's expts. upon, 163; Münsterberg's apparatus for study of, 210.
- OL* or overlimens, 19, 255, 267.
- Optical illusions, measurement of, cliii., 411.
- Papers, black, white, and grey, care of, 73.
- Parallel law, Fechner's, xxvi., xxxii., xciii. f.

- Parallelism, psychophysical, clix. f.
PE, definition of, 10; of mean, 10 f., 361; and *MV*, 11; of single observation, 11; and *SD*, 11; of median, 12; uncertainty of, 12; as measure of variability, 12, 29, 145 f., 167, 179, 287 f., 361; formulæ for, 144; of *SD*, 361.
- Perception limens, 20, 138 f., 142.
- Periodicals, psychological, 417 f.
- Personal equation, 356.
- Phonometer, Wundt's gravity, 221.
- Photometer, Kirschmann's, 85; Rumford's, 73; Hillebrand's, 85.
- Photometry, xx., 86 f., 103, 110; of colours, 87 ff.; Martius' method, 87; Rivers' method, 87; Rood's flicker method, 87 f.; Hering's method (Brückner), 88 f.; Lehmann's method, for grey glasses, 79 ff.
- Pipes, Appunn's high, 35.
- PL* or partial limen, of right and wrong cases, 281 ff., 293 f.
- Positive and negative cases, method of, 316.
- Practice, 120, 129, 133, 145, 154; effect of, in work with limen gauge, 54 f.; in time sense, 134 f.; in work with lifted weights, 307; studies of, 134, 136; in reaction expt., 359 f., 374 f., 376, 390.
- Pressure, Weber's expts. on, xiii. ff., xvii. f.; hydrostatic unit of, 48; and unit of tension, 49; work upon cutaneous, by method of equivalents, 188 f.; essays on intensive *RL* for, 55.
- Pressure balance, Jastrow's, 136; Merkel's and Jacobi's, 266.
- Probability, logic of, 98; references on, 98.
- Probability integral, values of, 250.
- Procedures with and without knowledge, 127 ff., 217 f., 294, 310; cf. 21.
- Progression, Delbœuf's law of, cxx. f.; in Stumpf's psychophysics, cxxiv. f.
- Psychology, of method of least differences, 15 f.; of method of minimal changes, 101, 126; of method of limits, 121, 126; of method of av. error, 153.
- Psychophysical metrics, xxii.; series, method of, 82 ff., 89 ff.
- Psychophysics, Fechner's definition of, xxii.; physical, 185, 285 ff.
- Quantitative psychology, range of, lxxvii. f., 318, 405 ff.; essays on, clviii. ff.
- Quantitative work in psychology, difficulties of, cliii. ff.
- Questions on determination of equivalent *R* by method of constant *R*, 259, 263; on method of constant *R*-differences, 312; on psychology of time, 403; examination, 413 ff.
- QL*, xxiii.; and relative *DL*, 108, 115.
- QML*, cvi.
- Quotient hypothesis of Weber's Law, lxi., lxxviii., lxxx. ff., lxxx. ff., lxxxiv., 68 ff.
- Range, of reaction times, 361 f.
- Reaction, antagonistic, 352 ff.; history of simple: the astronomical period, 356; the psychophysical period, 356; the psychological period, 357; analysis of, 372; varieties of, with differences of instruction, 373 f.; Wundt's interpretation of, 374; validity of the three types of, 374; range of possible *O*'s, 374; range of method, 374; compound (discr., cogn., choice), psychology of, 375, 390; classification of, 375; relative difficulty of the different forms, 376 f.; technique of, 377 ff.; history of, 389; analysis of, 389; sensorial and muscular attitudes in, 390; associative, classification of, 381 ff.; technique of, 383 f.; history of, 389; judgment, 383, 385 ff.; range of *O*'s for compound, 390 f.; range of method, 391 f.; essays on, 371 f., 389 ff.
- Reaction expt., value of, 357 f., 363, 384; disposition of apparatus in, 358 f.; number to be taken, 360; treatment of results, 360 ff.; instructions to *O*, 372 ff.; physiology of, 374 f.
- Reaction time, what it measures, 362 f. (cf. 374 f.); reduced, 363, 376.
- Reconstruction, general trend of, cxvi.;

- initiated by Delbœuf, cxvii.; course of, before popularised by Ebbinghaus, cxxvii.; representatives of, cxxxiii.
- Reference, Fechner's constant error of, 115.
- Relative variability, 361.
- Relativity of *S*, doctrine of, lxxv., xc., xciii., cxviii., clx.; see *Differenzansicht der Empfindung*.
- Reliability of judgment, in Stumpf's psychophysics, clxi. ff.
- Reproduction of a time interval, expt. on, 400 ff.
- R*-error, in Fechner, lxiii. ff.; in Hering, lxxii. f.; suspected in Merkel by Grotenfelt, lxxviii.; in method of equivalents, 190 f.; in method of equal *S*-distances, 198 f., 203 ff., 207, 219 (Merkel), 222 f. (Fullerton and Cattell), 230 f.; shown in name 'right and wrong cases', 251; in Martius' expt. on apparent visual magnitude, 262; in work with method of constant *R*-differences, 275.
- Resistance, measurement of electrical, in Hipp magnets, 325.
- Retinal vertical, determination of subjective, 409 f.
- Rheostat, Nichols', 321 f.
- Rhythm, quantitative investigation of, 411.
- Right and wrong answers, method of, 285 ff.; object of, 286, 290; correlation of $\frac{r}{n}$ with $\frac{D}{PE}$, 287 f.; criticisms of, 288 ff.
- Right and wrong cases, method of, xxi., xxvi., cxiii., 20, 24, 103, 116, 118, 241, 248 ff., 263 ff., 316 f.; how related to mean gradations (Wundt, 1880), 111; criticism of name, 251 ff.; procedure of, with two *R*, 268 ff.; originated with Vierordt, cxiii., 275; worked out by Fechner, 276 ff.; Müller's criticism, 278, 311 f., and reconstruction, 279 ff.; Fechner's reconstruction, 281 ff.; simplified forms of (right and wrong answers, equal and unequal cases), 285 ff.; Merkel's view of, 293 f.; Bruns and Mosch, 294 ff.; assimilated by Ebbinghaus to min. changes, 298 f.; and Wreschner's method of fields of judgment, 299 f.; Martin and Müller's qualitative analysis of judgments passed in (lifted weights), 301 ff.; Müller's *M*., 310; application of, to av. error, 313; to mean gradations, 314; to problem of equivalents, 314 f.; see Constant *R*, method of; Constant *R*-differences, method of; Equal and unequal cases, method of; Right and wrong answers, method of.
- RL*, Fechner's interpretation of, xxxvi. f.; teleological importance of, xciv.; subsumed in *El.* to *ML*, xciv.; attacked by Müller in *G.*, xc. f.; the Fechnerian, marked off by Müller from the *DL*, xcvi. f.; bracketed with *DL* in *I. S.*, xcvi. f.; various conditions of, in *R.*, cxviii. f.; subsumed in *R.* to *ML*, xcix. f.; relation of, to the *DL*, in *Massprincipien*, cv. f.; relation of, to the *DL*, in Fechner's psychophysics at large, cvi. f.; regarded by the Reconstruction as a fact of friction, cxvi.; a psychophysical value, 15 f.; a variable magnitude, 255 f.
- RL*, extensive (Helmholtz), cxlvi.; temporal, of colours (Kunkel), cxlvi.; determination of intensive, for sound, by watch test, 56; by Lehmann acoumeter, 57; by other apparatus, 57 f.; for pressure, 46 f., 49, 50 f., 54 f.; for tone, qualitative, 7, 18, 22 f., 24 ff.; shows but little variability from method to method, 21 f.; essays on, 41; distribution of, in method of constant *R*, 254.
- SD*, 9 f., 146, 361; and *MV*, 10, 146; and *PE*, 11, 146; *PE* of, 361.
- S*-difference, apparent and real, lxx. f.
- S*-distance, how represented in consciousness, cxl. ff.
- Seat of mind in Fechner's psychophysics, and Müller's criticism, ci. ff.

- Sectional sensitivity (S. S.), clxvii.; relation of, to the D. S., clxx. f.
- Sensation, not a measurable magnitude, *i.e.*, not a sum of S -units, xlvi. ff.
- Sensations, negative, xlvi., clxiii.
- Sensed differences and differences of sensation, xxvii., xxxvi.
- Sensitivity, xxii. ff., clxv. ff.; measurement of, the first step towards mental measurement (Fechner), xxiv.; restriction of mental measurement to (Külpe), cxxxiv.; (Lipps), cxxxvii. ff.; Delbœuf's theory of, cxxi.; definition of, clxv. f.; departments of, clxvii.; problems of, clxviii.; essays on, clxxi.; see Differential sensitivity; DL ; RL .
- Series, in method of least differences, interruptions of, 4; length of, 4, 6; order of, 4.
- Shadow expt., Fechner's, 73 ff., 78; sources of error in, 73 f.
- Similarity, in Stumpf's psychophysics, cxxiv.
- Slip comparisons, 120, 209, 307 f., 313.
- Sound, work with, by method of equal S -distances, 197 f.; essays on intensive RL for, 61.
- Sound pendulum, 194 ff., 265.
- Space error, 102, 121 f., 129, 133, 180, 259, 262, 263 ff., 272 f., 302 ff., 308.
- Spark method, for reaction time expt., 339 f.
- Standard deviation, see SD .
- Stars, classification of, by visible magnitude, xx. f., xxxv., cxlv.
- Statistical treatment of results, value of, 12, 14 f., 362.
- Steps, size of, in method of least differences, 5.
- Stimulators, for reaction expt., 344 ff.; sound, 344 f.; light, 345 f., 351, 378 f.; pressure, 346 ff., 378; temperature, 348; smell, 348; taste, 348; pain, 348 f.
- Stimulus determination, methods of, 317.
- Stumpf, C., on the summation of S -units, xlix., liii.; on the equality of the j. n. d., lxxvi.; his place in the Reconstruction, cxxiii. ff.; compared with Wundt, cxxvi.; on continuity of S as function of R , cxlviii.; his psychophysics, clxi. ff.
- Subtraction method, in reaction expt., 390.
- S -unit, Fechner's, not necessarily the j. n. d., lxviii.; Delbœuf's, cxx. ff.; Ebbinghaus', cxxix. f.
- Supraliminal differences, method of, 103, 166; see Equal S -distances, method of; Mean gradations, method of.
- Table, of Weber's results with pressures and lifted weights, xiv.; of results from method of least differences (lowest audible tone), 6; of results from this method as extended by Higier (lowest audible tone), 17; of results from Kraepelin's combined method (lowest audible tone), 22; of results from method of least differences (highest audible tone), 37; of results from this method and from Scripture's modified method (intensive RL for pressure), 47; of results with von Frey's hair æsthesiometer, 50 f.; of results with von Frey's limen gauge, 53 f.; of determination of photometric values of grey glasses, 81 f.; of results of Sanford's weight expt., 82 f.; of Ebbinghaus' brightness expt., 85; Lipps', for method of av. error, 173; of results from method of equivalents (cutaneous pressure), 188 f.; of intensities furnished by the sound pendulum, 196; of results for brightness from method of equal S -distances, 199; of Delbœuf's results from method of equal S -distances, 212; of Neiglick's results, 217; of Merkel's results, 218, 220; of Angell's results, 222; combined, of DL for successive tones, 237; Luft, 237; Luft and Preyer, 238; Meyer, 238; Luft, 239; of work upon interval sense, 246; Fechner's fundamental, continued, 248 f.; Müller's, of coefficients of

- weights, continued, 249; of Riecker's results from method of constant R , 250, 256, 258; for method of r . and w . answers (Fullerton and Cattell), 287; of results of Vierordt's expt. on reproduction of a time interval, 401; of introspections, 402.
- Tactual measurement, Fechner's expts. on, xxi., cxiv., 163; Volkmann's, 163.
- Taste, expts. on, xlvi.
- Technical terms, cxlix. ff.
- Temperature, Fechner's experiments on, cxiv.
- Tension, Delbœuf's law of, cxx. f.; unit of, with hair stimulator, 49; and unit of hydrostatic pressure, 49.
- Terminal sensitivity (T. S.), clxvii. ff., clxxi.; cf. xxix.
- Test-values, of Wundt's method of minimal changes, 108; of Fechner's method of av. error, 145 ff., 154; of combined method of limits and differences, 157, 160 f., 164 ff.; of r . and w . cases, 271 f., 278 f., 281, 293 f.; interrelation of, 318.
- Three cases, method of, 316.
- Time error, 133, 151, 178, 180, 205 f., 259, 263 f., 302 ff.; as analysed by Martin and Müller, 305 f.; influenced by number of preceding expts. and by magnitude of standard R , 307.
- Time sense, xlvi. f., 111, 134 f., 226, 272 f.; so termed by Czermak, 393; value of historical study of, 393 f.; periods in work upon; preliminary, 394 f.; psychophysical, 395 ff.; intermediate, 397 ff.; modern, 399 f.; bibliography of, 395, 397 ff., 400; essays on, 403 f.
- Time sense apparatus, 396, 399, 401.
- TL or total limen, of r . and w . cases, 281 ff.
- Tonal distances, j. n. d. of successive, 244 ff.; of simultaneous, 248; equation of, 220 f., 241 ff.
- Tone, determination of DL for, by method of limits, 125 f.; of RL for, by method of least differences, 6; by Higier's extended method, 17; by Kraepelin's method, 22; quantitative investigation of, 406; essays on qualitative RL and TR for, 41.
- Tones, appealed to, in support of Weber's Law, xvi. ff., 232 ff.; criticism, 234 f.; appeal renewed by Stumpf, in study of Siamese music, 243 f.
- Tone variator, Stern's, 139 ff.; gasometers for, 140 f.
- Tonometer, Appunn's, 91.
- Touch-weights, Scripture's, 46 f.; sources of error with, 46 f., 48.
- TR for tone, qualitative, 37, 41 ff.; importance of determinations of, 39; essays on, 41.
- Two cases, method of, 316.
- Types, Martin-Müller positive and negative, 122, 155 f., 302 ff.; objective and subjective, 119 f., 128, 230, 267; vs. instruction, 374.
- UL or limen of uncertainty, the lower LL , 253, 257.
- Unmusicalness, 239 f.
- Values, critical, of method of least differences, as extended by Higier, 16.
- Velocity of nervous impulse, 356.
- Visual extents, equation of, by method of av. error, 152 f.
- Visualisation, 191, 260, 274 f.
- Voltmeters, 322 ff.
- Warming up, see *Anregung* and *Antrieb*.
- Watch test, for intensive RL of sound, 56.
- Weber, E. H., first formulated Weber's Law, xv. f.; regards the Law as of wide range, xvi. ff., but takes no great pains to make it known, xviii. f.; does not extend it beyond the j. n. d., xix. f.; on the apprehension of relations, xix. f., 233; his expts., xiii. ff., 266.
- Weber's Law, not presupposed by Fechner's metric principle, cxiv. f.; teleological significance of, clx.; approxi-

- mative only, xcii., 71, 76; demonstrations of, 73 ff., 78, 82 ff.; possible either by way of surprise or as a matter of course, 76; essays on, 92; range of, 71 f., 230; Fechner's view of, as a law of intensity and quality, 257; is a law of intensity only, 244, 403; Delbœuf's interpretation of, cxx.; Ebbinghaus' formulation of, in terms of the *DL*, 61; Fechner's interpretation of, xxxi. ff., lxxxix. ff., cxiv. f.; Heymans' interpretation of, 67, 226; Meinong's interpretation and explanation of, 65; Müller's interpretation of, xxxiv., xcii. ff.; Wundt's interpretation and explanation of, lvi., lx. f., xc., xciii., 64 f., 228 ff.
- Weber's method, Weber's first method, 102.
- Weight expt., Sanford's, 82; sources of error in, 82.
- Weight-holders, 265 f.
- Weights, 265 f.; see Cartridge weights; Envelope weights.
- Wundt, W. M.*, on the summation of *S*-units, lv. ff.; on the equality of the *j. n. d.*, lxxiii. ff., lxxx. ff.; compared with Fechner, cxi. f., clix.; his part in the Reconstruction, cxxii., clxi. (*cf.* lviii., lxii.); his view of the limens, cxxii.; compared with Stumpf, cxxvi.; his definition of sensitivity, clxvii.; see Apperception; Clearness; *Merklichkeit*.

(96)

273



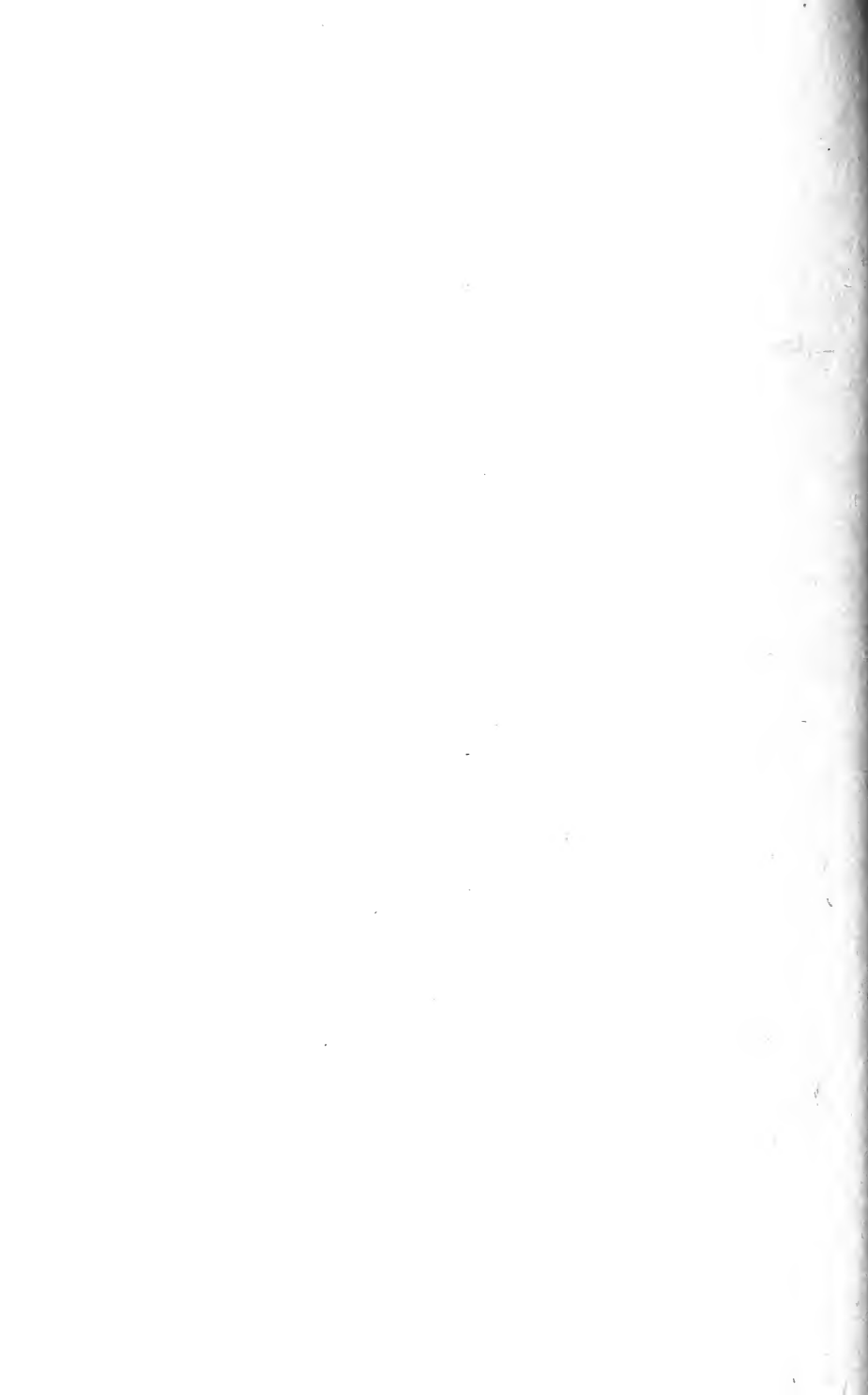

AUG 10 1987

**PLEASE DO NOT REMOVE
CARDS OR SLIPS FROM THIS POCKET**

UNIVERSITY OF TORONTO LIBRARY

