

UMASS/AMHERST



312066005066796

LIBRARY

OF THE

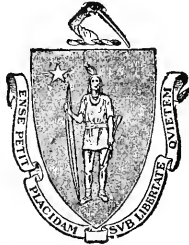

MASSACHUSETTS
AGRICULTURAL
COLLEGE

SOURCE. S 675 funds...
B6

AUG 19 1991
3070041



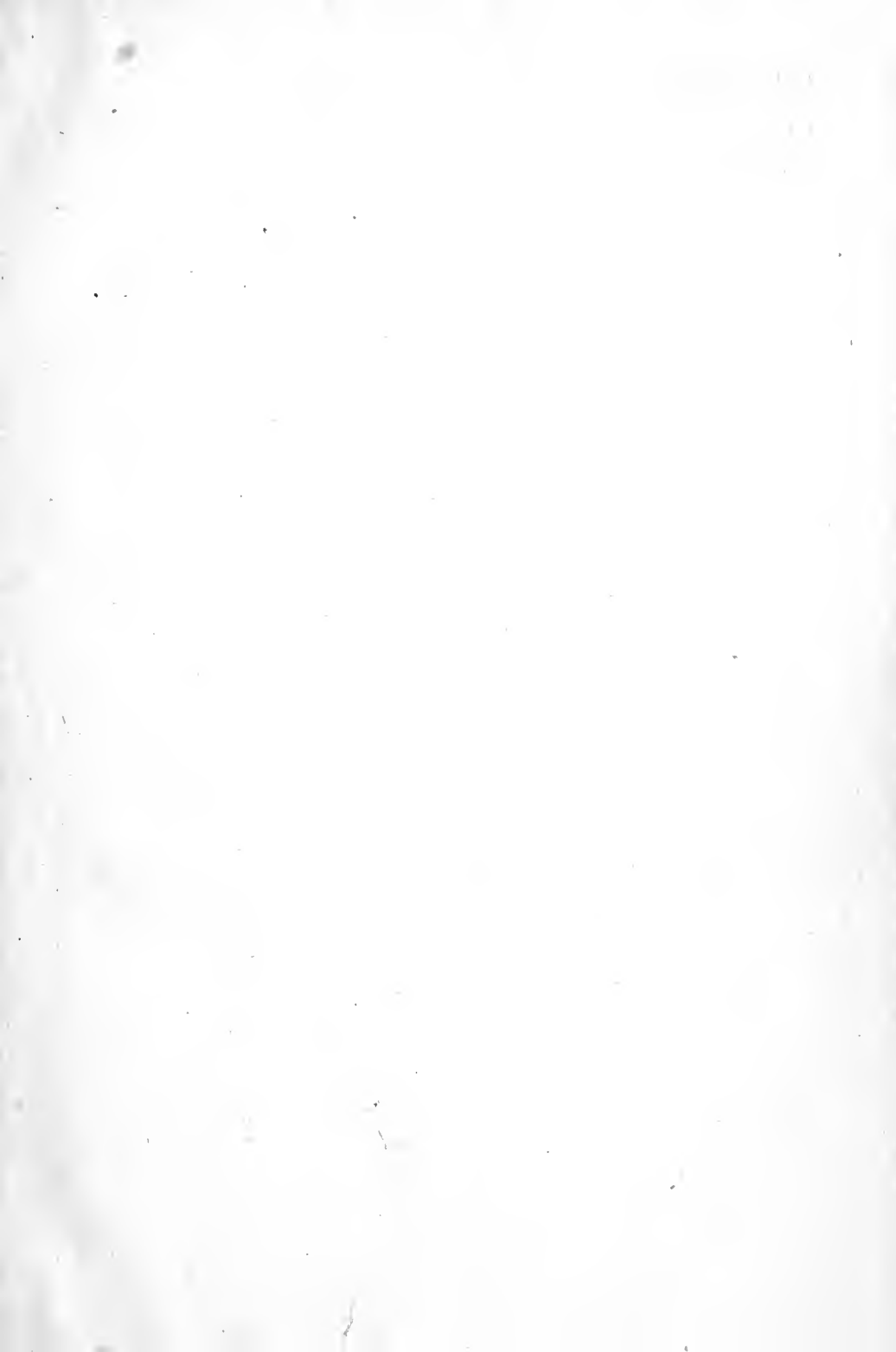

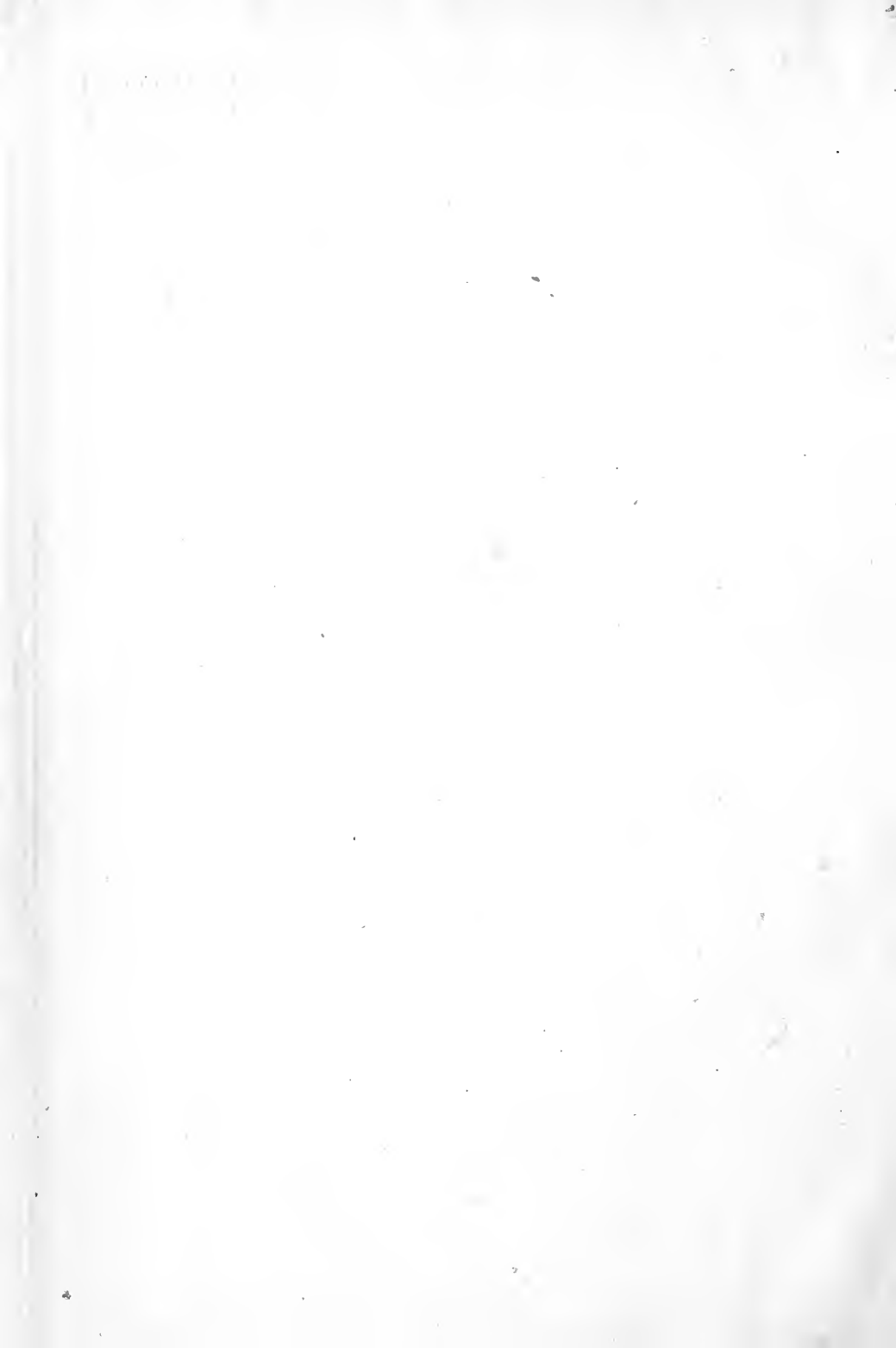

THE
CORRESPONDENCE COLLEGE
OF AGRICULTURE

FARM ENGINEERING

PART I.

FARM STRUCTURAL ENGINEERING

BY

H. BOYDEN BONEBRIGHT, B. S. A. Memb. A. S. A. E.

Department of Agricultural Engineering, Montana Agricultural College, Bozeman, Montana

This is the first of a series of three books giving a complete course of instruction in

FARM ENGINEERING

COPYRIGHT, 1911
THE CORRESPONDENCE COLLEGE OF AGRICULTURE
FORT WAYNE, INDIANA

47

630.62
1364

NOTE TO STUDENTS

In order to derive the utmost possible benefit from this paper, you must thoroughly master the text. While it is not intended that you commit the exact words of the text to memory, still there is nothing contained in the text which is not *absolutely essential* for the intelligent farmer to know. For your own good never refer to the examination questions until you have finished your study of the text. By following this plan, the examination paper will show what *you* have learned from the text.

This lesson book is not intended to be a "book of plans" for farm buildings.

It is designed to give in a practical way, the fundamental, scientific knowledge which should enable the student to plan farm buildings, which will exactly fit the purpose for which they are built. It is also designed with a view to putting the student into closer touch with the Experiment Stations and the Agricultural Colleges, that he may derive therefrom such information as he may need from time to time.

No attempt has been made to repeat information which may be *obtained for the asking*, from the Colleges and Experiment Stations.

The student should write for the list of free bulletins given below at once, in order that he may get them in time to avoid all delays in his studies.

LIST OF FREE BULLETINS—SEND FOR THEM.

Bulletins No. 100 and 117, Agricultural Experiment Station, Iowa State College, Ames, Iowa.

Farmers' Bulletin No. 3, Montana Experiment Station, Bozeman, Montana.

Bulletin No. 1, Extension Dept., Iowa State College, Ames, Iowa.

Sewage Plants for Private Houses, Engineering Experiment Station, Iowa State College, Ames, Iowa.

FARM ENGINEERING

PART 1

DEVELOPMENT OF FARM STRUCTURAL ENGINEERING.

It is impossible to go into the history of the early development of farm buildings because the most primitive of men had rude forms of caves, huts, etc., which served as a protection from the elements, from savage beasts and from more savage men.

In fact, within the last century, the farm buildings in many parts of the United States were used as shelters for man and beast and as forts or block houses to protect our pioneers from the Indians. Some of the buildings are still in use in the Rocky Mountain region.

Thus we see that military influence had much to do with the early development of our farm structures. This may explain to some extent the heavy framing of some types of the farm buildings of today.

A careful investigation is not necessary to prove to the student of modern times that the development of farm structures has not kept pace with the marvelous growth and development of city structures.

The needs of the most up-to-date of farmers, are so simple when compared with the needs of a great manufacturing concern that the designs of the farm buildings are comparatively simple.

This fact leads in too many cases to the substitution of guesswork in place of design. The inevitable results are; unnecessary expense, a lack of useful qualities, unsanitary, inconvenient and unsightly buildings which are likely to last but a short time.



Plates 1 and 2---SMALL BARN AND POLE SHED

A neat little barn such as is shown in Plate 1, has real value on the farm aside from its usefulness for storage purposes. Its attractiveness adds to the value of the farm.

Such a "shack" as is shown in Plate 2, is a disgrace to any farm, and its value is nearly always a minus quantity.

In order to properly understand Farm Structural Engineering it is necessary to have certain parts of several different sciences and arts clearly in mind. The following are the principal sciences and

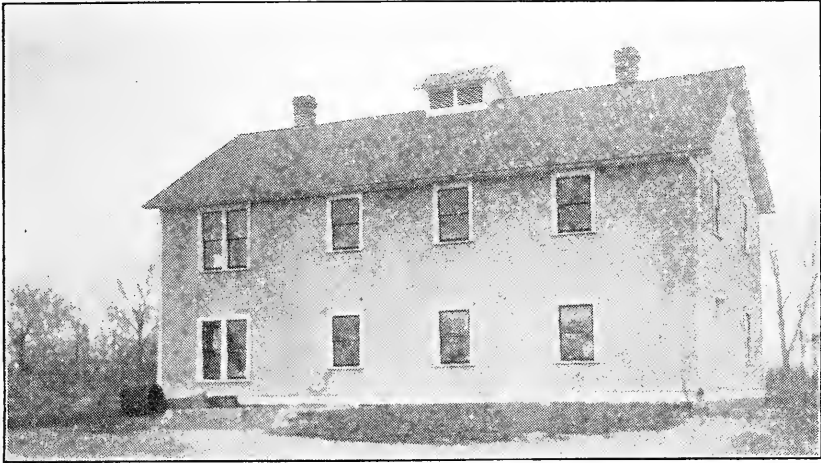

Plate 3—SEED HOUSE

A carefully designed seed house makes an excellent building in which to place the farm office.

arts which need to be considered. They are enumerated alphabetically, and not in order of importance.

- | | |
|--------------------------|---------------------|
| * Agronomy | ** Masonry. |
| * Animal Husbandry. | a. Brick masonry. |
| ** Architecture | b. Stone masonry |
| ** Carpentry | ** Painting |
| ** Concrete Construction | * Poultry Culture |
| * Farm Management | * Sanitary Science. |
| * Horticulture | |

While it is impossible to take up all of these subjects completely, those of most importance, from the designer's standpoint, will be treated at some length.

Agronomy.—The seed houses, granaries, hay sheds, corn cribs, etc., should be designed with a clear understanding of the require-

* Factors governing types of structures.

** Factors directly connected with the actual construction of the structure.

ments of each building. In general all of these buildings should be well ventilated. In most cases the contents of the building require some ventilation and in all cases a fair supply of fresh air adds to the comfort of the men who must work in the buildings. The seed houses should be provided with plenty of light, and in the colder climates it is advisable to have some means of heating the work room.

On large ranches the seed house is a very suitable building in which to have the ranch office.

Animal Husbandry.—In order to design the barns, stables, hog houses, silos, etc., properly, it is necessary for the student to have a very definite understanding of the requirements of the live stock.

First, it is commonly conceded that all live stock requires ventilation. This is taken up under each different plan of structure designed for the housing of animals.

Farm Management.—If the designer of farm structures is to work intelligently, he must know where and how his buildings are to be located. He must also know the relative positions of the other buildings.

From the farm management standpoint there are many factors which govern the location of the farm plant. The principal points are:

Nearness to Farm Land.—In the case of large ranches it is often advisable to place the buildings as near the center of the land as sanitary conditions will permit. While this system often calls for a good road from the buildings to the main road, the extra expense is often more than counterbalanced by the time which is saved in going to and from the fields.

Nearness to Roads and Markets.—In the case of smaller farms, care should be taken to locate the buildings as near to the market as possible, and near the best possible thoroughfares. In case a distinct advantage is to be derived by locating on a bad road, it will often be found profitable to improve a short section of public road at the farm owner's expense, rather than to locate the farm building in an undesirable place.*

Location of Buildings With Respect to Each Other.—The two systems of locating farm buildings are known as: First, centralized plan; Second, distributed plan.

* The subject of road building and improvement is taken up in another book of this series.

In the extreme cases of the central plan, the dwelling, the stables and out buildings are all under one roof. In some parts of the United States such farm buildings are to be found at the present time. In the more up-to-date of centralized plans the house is separate from the other buildings. The hogs and chickens have separate houses and the horses, sheep, cattle, grain, hay and machinery are all sheltered in one large barn.

The distributed plan calls for separate buildings for the different species of farm animals, and special buildings for grain, hay and machinery. In many cases however, the necessary grain and hay is stored in each of the buildings which shelters animals. Thus in some cases the granary and hayshed are eliminated from the list.

We have every sort of variation from the extreme centralized plan to the completely distributed plan. As the designer must choose his own plan of location, it may be well to look into some of the advantages and disadvantages of the two systems.

The **centralized plan** has the advantage, in that feed is always handy to the stock to which it is to be fed. Less material and labor is necessary in the building and less ground is taken up by it.

Its disadvantages lie largely in the danger from fire, for in case a large farm building takes fire, it is almost impossible to save the building or its contents.

Again, a large percentage of the authorities are now insisting that the different species of live stock should not be housed in the same stables.

In case a contagious or infectious disease gets a foothold in a large centralized plant it is usually very hard to stamp out. A case was brought to the attention of the author in which the cost of cleaning the yards and an old fashioned barn, together with the disinfecting after a siege of tuberculosis cost over \$1,700.00.

The Distributed Plant.—The smaller barns of the distributed plant, are easy to disinfect. The animals of different species are housed in separate buildings. In case one of these buildings burns it is, in most cases, possible to save the other buildings. These are all distinct advantages.

The cost of the distributed plant is somewhat greater on account of the extra amount of material and labor required to construct the

smaller buildings. More of the farm land is taken up by the buildings as they are usually some distance apart and land between them is seldom cultivated.

It is possible, however, for the man who is starting with small capital to use one of the small buildings for several purposes at first and later add such buildings as may be necessary.

With these points clearly in mind and with the aid of a thorough knowledge of the different agricultural subjects, the student may choose intelligently which plan is best suited to his needs.

Horticulture.—It is often necessary to build special buildings for the purpose of storing roots, potatoes, fruits, cider, etc. The construction of these buildings will differ greatly in different climates, but the general principles of construction should govern the design of all buildings for horticultural purposes.

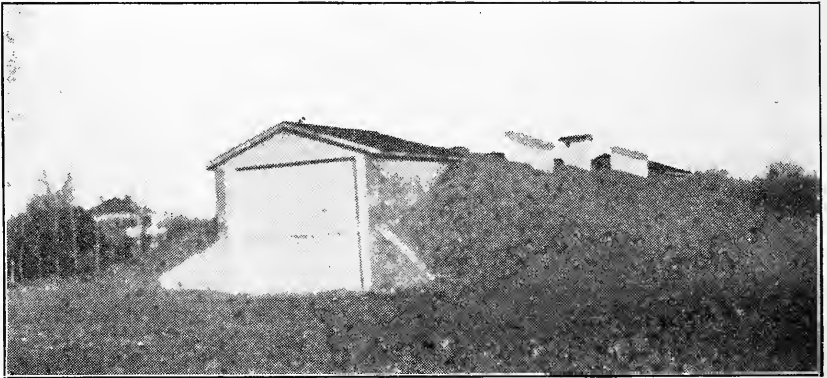

Plate 4—ROOT CELLAR

Root cellars must be designed for the particular conditions which prevail in each locality. A typical Greely* potato cellar is shown in Plate 4.

Poultry Culture.—Nearly every authority on poultry has some special form of poultry house which he recommends above all others. As the general climatic conditions govern, to a great extent, the design of the coops and houses it is quite impossible to make a single design fit all conditions.

Incubator and brooder rooms also need special attention as a uniform temperature is almost necessary in these apartments. The

*Greely, Colorado, is noted throughout the United States for its famous potatoes.

detail work of poultry house design can be taken up to better advantage in connection with the plans of the various buildings.

SANITARY SCIENCE.

So much of the design of up-to-date farm structures must depend upon sanitary science that several important headings must be taken up. We know that at present there is a tendency for the contagious diseases of man and beast to spread rapidly over large area. This is in many cases because the conditions under which the animals exist are abnormal. In many cases even the lower animals abhor these conditions, but they are so confined as to make it impossible to escape them. The structures of the farm should be so built as to promote a natural, healthy existence, not only in the lower animals, but in man as well. That these ends may be accomplished let us take up a few of the most important sanitary considerations.

To begin with, in the choice of a building site, one must never overlook the sanitary or unsanitary qualities of the chosen spot. If the desired site be unsanitary, and this condition cannot be remedied, then the site should by all means be no longer considered as a suitable place for the buildings. **Health must take precedence in the choice of building sites.**

From the sanitary standpoint the building site must fulfill the following conditions:

First: The slope must be such as to insure surface drainage *away* from the buildings and well. In the very level regions it is sometimes necessary to grade up the building site to some extent. If what little natural drainage there is, be augmented by a little grading it is often possible to improve the sanitary conditions of a site one hundred per cent.

Second: In case the soil is of such a nature as to be damp or marshy any considerable portion of the year, there must be some outlet into which sub-surface drainage may be emptied. Tile drains should be laid so as to thoroughly drain the yards and the soil under the different buildings. The outlet of these drains should be located so that none of the impure drainage water can possibly get to the well. It should never be used as drinking water for the farm animals.

In case the buildings are located on a steep slope, a large open ditch should pass around the yards above the building. This will

prevent flood water from running into the yards, buildings and wells. Make the ditch large enough to carry away the water of a *flood*, not of a gentle rain.

Third: Too many people are not aware of the fact that *air drainage* is just as essential as water drainage. A site for the farm buildings is often chosen in a deep ravine, or in a dense grove. The currents of air are not allowed to pass about the buildings and yards, because the "wind break" is too dense. There should be a free circulation of pure air about all the buildings. The wind dries the damp soil, removes the noxious odors, and helps very materially in the sanitation of the farmstead.

The above statement must not be taken as an objection to wind

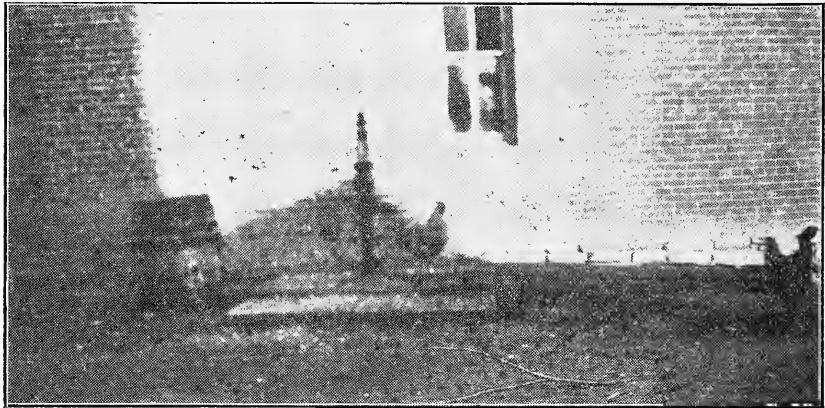

Plate 5—SURFACE WELL

A low well platform, surrounded by mud and surmounted by chickens is a sure sign that sickness will visit those who must drink water from the well.

breaks or to trees. Trees are essential to the beauty of the farms, and when properly arranged *aid*, rather than interfere with sanitation.

Fourth: Near the building site there must be some good source of pure wholesome water. The principal source of farm drinking water is the farm well.

The wells may be classified and described as follows:

Surface Wells.—Those wells which are shallow and receive their water from surface drainage are called surface wells. They are usually unsanitary because the surface drainage water gathers so much

filth before entering the well, that the water is rendered unwholesome and dangerous.

Shallow Wells.—The shallow well draws its water from sub-surface drainage, and often in times of flood from the surface. The shallow well does not receive its water supply from beneath a layer which is impervious to water.

The shallow well has to be placed on the “doubtful” list from a sanitary standpoint, because, although the water may be pure, it stands a chance to be contaminated with dirt and disease germs.

The Deep Well.—The deep well has its source of water supply beneath an impervious layer. The well should be cased water tight from the curb to the impervious layer. This keeps out all surface impurities. While the water of such a well may contain mineral impurities, it is almost sure to be free from disease germs.

Artesian Wells.—The artesian well is a “deep well” which furnishes a continual or intermittent flow of water without the use of a pump.

Wells may be further classified as open, bored, drilled and driven. In general, the ground about the well should be higher than the surrounding ground. This causes surface water to drain away.

The casing, whether of stone, brick or steel should be tight to a point several feet below the curb. This keeps out surface water, small animals, such as mice, rats and rabbits, as well as insects and worms.

Some authorities lay down the rule that a well should be a distance equal to twice its depth from any source of contamination, such as privies, cess pools, stables, etc. This rule is in general, a good one, but in some instances, the distance must be greater than twice its depth. Again, if the well is cased water tight to an impervious layer a short distance beneath the surface, it is not always necessary to have the distance to sources of contamination so great.

Springs.—In general, springs are sources of pure water. But if flood waters sweep over the spring occasionally, there is great danger of contamination.

The farm buildings should never be located in inconvenient,

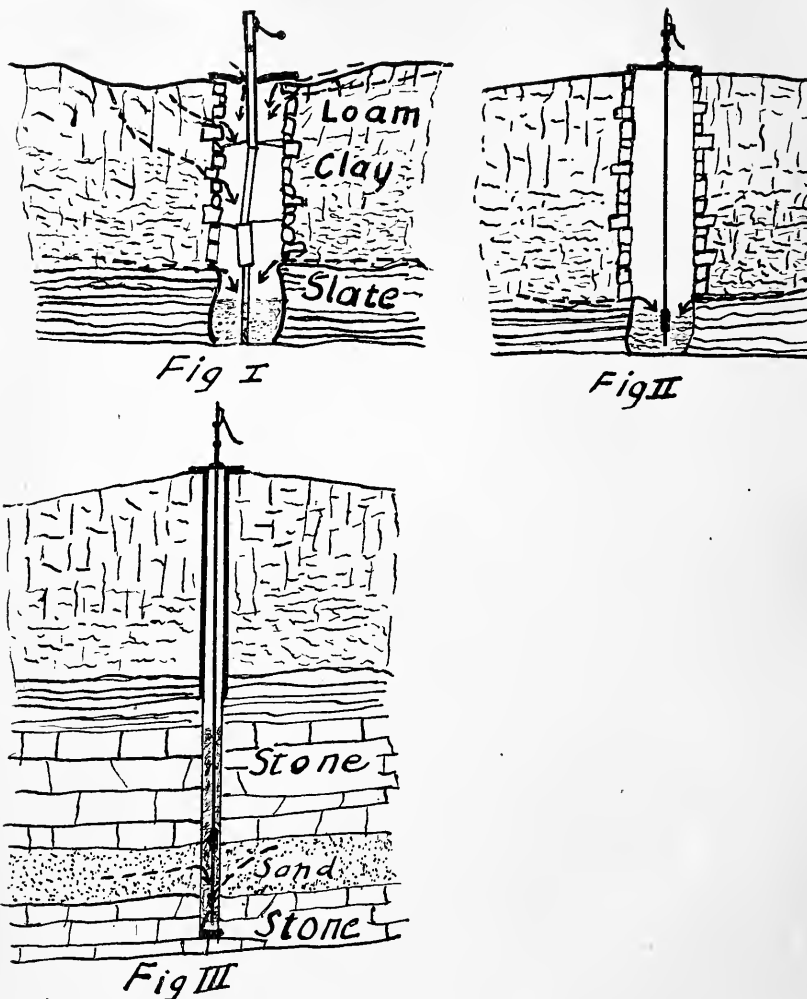

Plate 6—WELLS

These three cross sections show the surface well (Fig. 1); the shallow well (Fig. 2), and a deep well (Fig. 3)

The dotted arrows show the points where the water supply may enter. Notice the sunken condition of the ground about the surface well. Surface water, insects and small animals can enter at will.

The shallow well is constructed in a much better manner. All surface water drains away from the top of the well. The platform is tight and the pump fits the platform.

The deep well is still better. It is cased water-tight down to the slate, so that it draws all its water from below the layers of slate and stone. Such a well may always be considered a safe source of drinking water, unless by some means impurities are introduced into the well by artificial means.

Dug wells may be cased with concrete or with large glazed tiles cemented at the joints. Drilled wells are cased with riveted sheet iron tubing or with gas pipe. The latter is the better by far.

unsanitary places just because of a spring. The water should be piped to a good location, even though it becomes necessary to use a hydraulic ram.

Streams.—In mountain regions and on the sparsely settled plains of the west, it is often possible to find streams which are safe sources of drinking water. In the thickly settled states, however, this is seldom the case. Under these conditions, whenever it is possible to avoid the use of creek or river water for drinking purposes, it should always be done.

After the site has been chosen, the proper drainage systems put in, and a good water supply established, there are several sanitary conveniences which are indispensable.

Sewage Disposal.—The common system of disposing of night soil upon most farms is by the old privy vault method. In general this system is to be condemned as filthy and very unsanitary. It is possible to catch the night soil in some form of box or scraper and haul it into some distant field, where it should be buried at once. In case it is not buried the dogs and other animals are likely to become covered with it and in this way they carry disease germs from place to place. In case quick lime is added to the soil in the scraper from time to time the latter method is found to be fairly satisfactory.

Cess Pools.—It is often convenient to drain the sewage from the sinks, bathtub and inside closet to a cess-pool. If the cess-pool be located far enough from the well, and in such a position that all the drainage is *from the well toward the cess-pool*, it is altogether possible to establish a sanitary sewage system.

In case the cess-pool is in porous soil, it is seldom necessary to provide an outlet drain. The seepage is usually sufficient to provide ample drainage.

In case the cess-pool is located in soil which is impervious to water, it sometimes becomes necessary to provide a drain which will carry away the water after it has risen to a height of from four to six feet from the top of the cess-pool.

The sewage, after having dropped from the inlet into the cess-pool moves slowly, and in consequence allows the solid portions to settle out. The remaining fairly clear water flows out of the drain. In some cases, dams are placed across the cess-pool between the in-

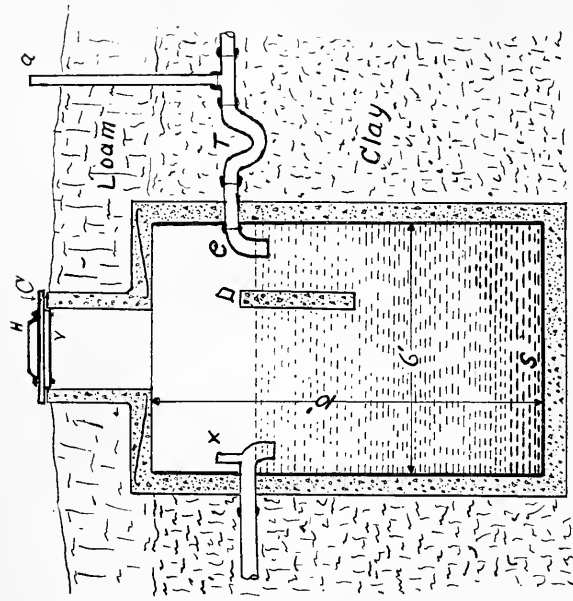

Fig. 2.

Plate 7—CESS POOLS

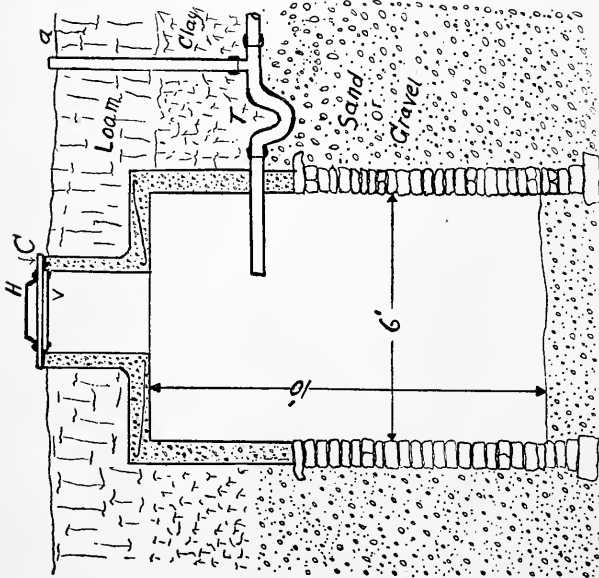

Fig. 1

The cess pool shown in Fig. 1, Plate 7, is designed for a medium sized farm house. The cess pool must be located in soil which will readily absorb moisture. The lower part may be built of stone or brick laid without mortar. The top part should be of stone or brick laid in mortar, or of concrete. In case of brick or stone, the top should be arched. In case of concrete, there should be some reinforcement in the horizontal cover which joins the sides to the neck. Three or four rings of barbed wire are sufficient. The top or lid may be made of cast iron, reinforced concrete, or planks. There should be a hole in the lid for ventilation.

The cess pool in Fig. 2, Plate 7, is designed for clay soils which will not absorb water readily. The section Z is a darn extending from side to side. It prevents the water flowing across, and out of O, without first losing the suspended sewage.

This cess pool is water tight, and must be cleaned from time to time. The water which flows out of O, must be taken care of as per instructions in Field Engineering. The outlet O, should extend down into the sewage about two inches, to prevent the scum getting into the pipe. It should have a vent x, to prevent siphoning. The outlet should be below frost line.

A cess pool should never be placed where it can contaminate by seepage, any source of drinking water.

a, Vent to trap and house pipe; c, cover or lid; h, handle to lid; t, trap to prevent gases passing back to house; v, vent; x, outlet vent to prevent siphoning; e, elbow to turn sewage down.

let and outlet. The dam prevents the sewage from flowing directly across the surface of the water and out of the drain.

A ventilator should always be provided to carry off all noxious gases from the cess-pool.

The Septic Tank and Sewage Disposal Plants.—In this book, a thorough discussion of sewage disposal plants is impossible. In general, it may be stated that the sewage is carried into a tank, which should be dark and almost unventilated. The contents are allowed to stand for some time.

The solid matter settles out, and anaerobic bacteria decompose the solid part of the sewage.*

The liquid, teeming with billions of germs, then passes out and is distributed upon filter beds, where the aerobic bacteria finish the purifying process. The liquid from the filter beds is almost pure water.

So many theorists have written exhaustive articles upon the subject of private sewage disposal plants, that the student is likely to become confused, unless he clearly understands the *whole truth* in regard to these plants.

The student should write to The Iowa State College Engineering Experiment Station, at Ames, Iowa, for the bulletin on Sewage Disposal Plants for Private Houses.

The author of this bulletin, Professor Marston, (American Society of Civil Engineers) is an authority on sewage disposal plants. No Agricultural library is complete without this bulletin.

Blue print plans are furnished by Professor Marston to those who wish to build plants.

The Cremating Pit.—A great many ignorant or thoughtless farmers drag animals which have died of contagious diseases, some distance from the yards and leave the carcasses to decay, and be eaten by dogs and vultures.

What is still worse, some people sell the carcasses to the representatives of soap factories. Thus the germs are spread wherever the wagon load of carcasses is hauled.

The carcasses should be removed at once, to a cremating pit and

* Anaerobic bacteria work when oxygen is present in very small quantities, if at all. Aerobic bacteria work in the presence of oxygen.

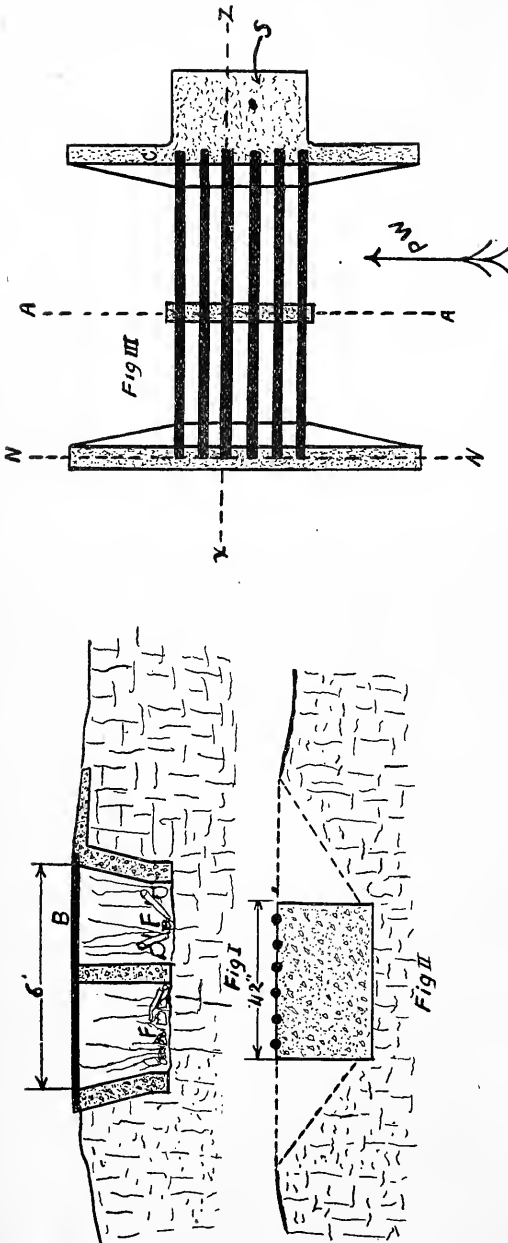

Plate 8—CREMATING PIT

The drawing Fig. 3, Plate 8, gives an excellent idea of the top view of the cover for a cremating pit. The heavy bars may be gas pipe or solid iron. In case railroad rails are used, no center support is necessary. The skidway **S**, makes it easy to haul the carcasses upon the grid.

Fig. 1, is a section as **xz**. The fire **F**, is shown in place. Fig. 2, is a section at **aa**, with the outlines of concrete wall **nn** in dotted lines. The arrow **PW**, indicates the direction of prevailing winds. The pit should be located so that the wind passes down the incline to the fire **F**.

The pit shown is expensive, but one can easily be made which will do the work and cost much less.

burned. The fire destroys all germs, and thus all possibilities of other animals becoming diseased from the carcass are eliminated.

In case the cremating pit is not used, the carcasses should be removed to a deep grave and buried in quick lime which will destroy the germs.

However a cremating pit is so cheap and so easy to build, that no up-to-date farm is completely equipped without one.

The Hospital Stall.—The hospital stall is the farm “pest house.” It should be so located that all drainagé from it, runs away from the other farm buildings. It should be at least three hundred feet from the nearest yards in which uninfected animals are kept. On the small farm, the stall may be built to accommodate a sick horse or cow, or several sick hogs or sheep.

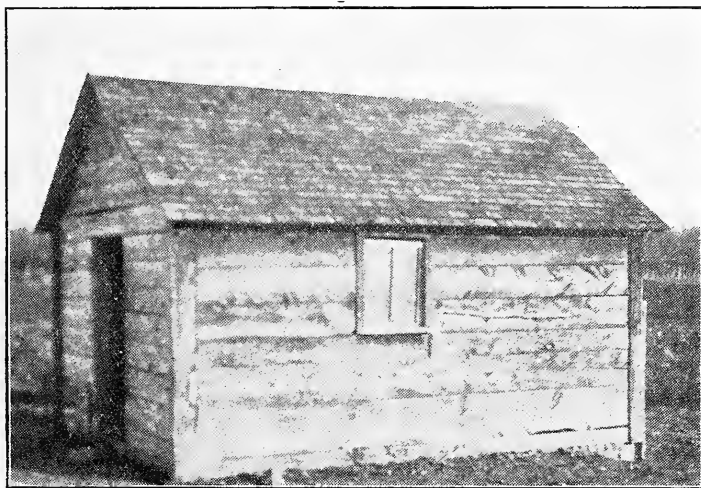

Plate 9—HOSPITAL STALL

A hospital stall or shed costs but little, but it is often the means of saving many hundreds of dollars.

While the building should provide protection and comfort to the patient, it should easily be disinfected throughout.

As soon as an animal is dead or cured, all litter from the stall should be buried, and the stall disinfected inside and out with some powerful disinfectant such as crude carbolic acid or corrosive sublimate. It should also be thoroughly whitewashed from time to time.

Sanitary Science Governs Building Materials.—To some extent we must choose our materials for farm buildings from a sanitary standpoint. The materials used for floors and sides of stalls should be impervious to moisture, easily cleaned, and strong enough not to become displaced.

In general, the material and workmanship should be such as to produce a building which will not harbor vermin, which will be strong and which will be easy to clean and disinfect.

ARCHITECTURE.

In order that a building may be properly constructed, it is necessary to have the parts correctly designed from two standpoints.

First: From the standpoint of beauty. No man can lay down rules which will govern all the proportions of a building from the standpoint of beauty. A few suggestions are offered below.

a. Avoid low, "squatty" buildings. The artistically designed bungalow is an exception to the rule.

b. Sky-scrapers appear beautiful in a city, but on the farm, high buildings which cover little ground are unsightly. They are also more easily blown over.

c. Large buildings with very small windows are likely to appear out of proportion.

d. A small barn with a large cupola shows poor taste on the part of the designer.

e. A large barn should never be fitted with very small cupolas. Use ventilator stacks. They do not appear out of proportion.

f. The cornice of a building should project at least as many inches, as the building is feet high, (from ground to plate.)

g. Never use gaudy paints upon farm buildings. They are unsightly, and usually fade quickly.

h. Remember that lean-tos and odd shaped out-buildings detract much from the symmetry of the general building plan. (See Plates 10 and 11.)

Second: The more important consideration in the design of a farm structure is **strength**. The term strength is too often misconstrued to mean massiveness. The farm architect should aim to combine *real strength* with beauty. He must know that the crude fastening together of huge timbers does not always indicate strong con-



Plate 10

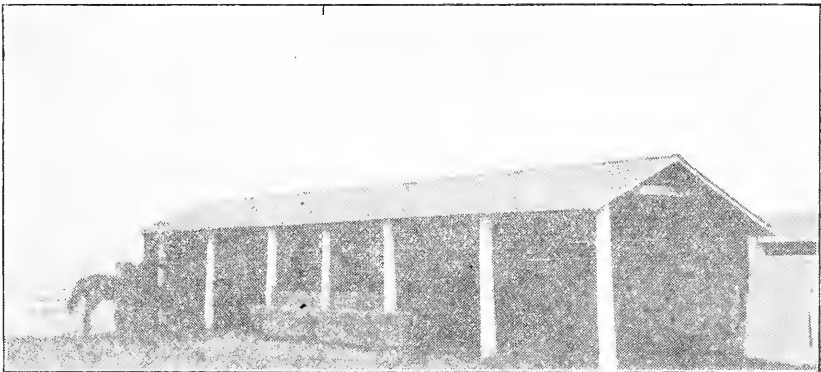

Plate 11

A neat little open feed shed, such as is shown in Plate 10, is very serviceable and looks in place on any farm. But such a shed as is shown in Plate 11, is unsightly wherever it may be located.

struction. In farm practice, it seldom indicates a thorough knowledge of the requirements of the structure. The various parts of the frames of structures are called **members**.

Members are subjected to one or more of five stresses.

A. Tension is the stress which tends to pull the particles of a member apart. Example: The wires of a telephone line are subjected to tension.

B. Compression is the stress which tends to crush the particles or molecules of a body together. Example: The stones in a wall are subjected to compressive stresses.

C. Torsion is the stress which tends to twist a member. Example: A screw is subjected to torsion when it is being screwed into a piece of wood.

D. Bending Stress. When a member is subjected to transverse stresses which tend to bend or distort it, it is said to be subjected to bending stress. Example: The wagon evener is subjected to bending stress.

E. Shear. The stress known as shear, tends to slip the molecules of a member over each other. Example: Tin is subjected to shearing stress when cut with the tin snips or shears. The torsion and shearing stresses do not enter into this work to any great extent.

In taking up the work of design, we shall first consider the column. No part of the farm structure receives less real thought than the columns. In order to design the columns correctly, we must allow a "factor of safety". In case a member would just carry a certain load, if we were to make the member two, three, or four times as strong, we would be using the factor of safety of two, three, or four respectively. The factor of safety must be determined by the judgment of the designer.

For wood, it is common to use a factor of four or more.

For steel or wrought iron, three or more.

For cast iron in tension, ten or more.

For cast iron in compression, six or more.

For good stone in compression, ten or more.

For poor stone in compression, very large.

Columns are divided into two general classes: A, short columns; B, long columns.

A short column is shorter than ten times its least lateral dimension. Such a column will be crushed without bending or breaking. All that is necessary in the design of a short column is to determine the total load which it must carry. Multiply this by the factor of safety, divide by the compressive strength of the material in the column. This will give the number of square inches of cross section of the column.

If the column is to be square, simply extract the square root of the area of the column, and choose a timber of that dimension, or in case it proves to be an odd size, choose the next size larger.

Example: Design a soft pine column three feet long to carry ten tons with a factor of safety of five. (short column.)

10 tons = 20,000 lbs. 20,000 lbs. \times 5 = 100,000 lbs.

100,000 lbs. \div 3000* = $33\frac{1}{3}$. The square root of $33\frac{1}{3}$ = 5.7 +
Use a 6"x6". As 6 is more than $\frac{1}{10}$ of 36", the column is "short."

In case the column could be only four inches thick, then we would divide $33\frac{1}{3}$ by 4. Result, $8\frac{1}{3}$. Use a 4x10. As 4 is more than $\frac{1}{10}$ of 36, this column is also a "short one."

In case of long columns, (columns whose length is more than ten times the least lateral dimension) it is common to use a special formula. These formulas vary greatly. In designing columns for farm buildings, it is seldom necessary to apply any special formula, as it is nearly always possible to brace the columns so that the rule for short columns applies. In general, use only square or round columns. Use a large factor of safety, and be sure that no side thrust is overlooked. In case the column receives heavy side thrusts, design first as column, and then see that the timber is strong enough to bear the side thrust by the use of the rules for simple beams.

BEAMS.

The design of beams is much harder than the design of columns.

Beams are divided into three general classes, as follows:

- **Cantilever Beams.**—Those beams which are held rigidly at one end with the load applied at the free end, or at some point between the fastening and the free end are termed cantilever beams. (See K and A, Plate 12.)

Simple Beams.—This type of beam is supported at each end and the load is applied between the supports. (See B and C, Plate 12.)

The Combined Cantilever and Simple Beam in which the beam is rigidly fastened at each end while the load is applied between the rigidly fastened ends.

When a cantilever beam is subjected to the stress of a weight, the upper part of the beam is in tension while the lower part is in compression. At some point between the top and bottom of the beam there is a point at which there is neither tension nor compression. This point is the **neutral axis**.

If material in a beam is placed at a greater distance from the neutral axis, the beam is made very much stronger.

In the case of most woods, the neutral axis is near the center of the beam.

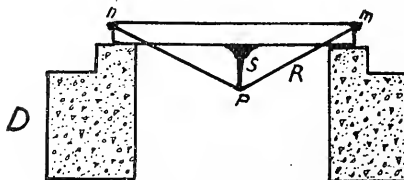
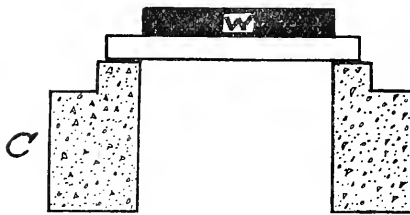
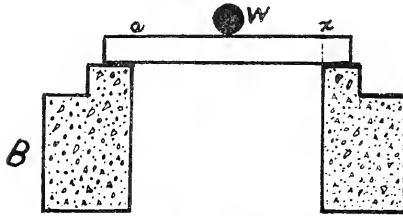
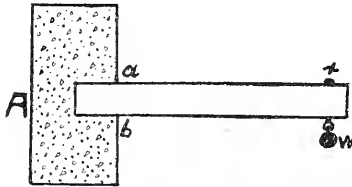
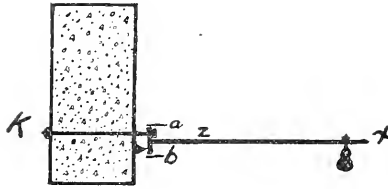

Plate 12—BEAMS

In case a 4x8 is laid upon its side, the greatest distance that any of the wood is from the neutral axis is about two inches. While if the beam is placed upon edge, the greatest distance is four inches. The average distance in the first case is one inch, and in the latter case it is two inches.

As the strength of a beam depends upon the distance which the material is from the neutral axis, we find: Rule 1. The strength of a beam varies as the **square of its depth**.

As the leverage of a beam varies directly as the length, we obtain the following rule. Rule 2. The strength of a beam varies **inversely as its length**.

Rule 3. The strength of a beam varies directly as it thickens.

By using the above rules in connection with table 2, the strength of an ordinary beam can be easily determined. (Fig. B, Plate 12, is loaded with concentrated load, W. Fig. C, Plate 12, is loaded with distributed load, such as hay, grain, etc.)

In Fig. D, Plate 12, the rod $n P m$ is called a truss rod. The beam nm , is designed as a column first, later it is designed as a beam, the length being the distance from the center of the strut S , to the points n or m . The rod must carry *all* of the load.

Never use more than two struts between a beam and a rod.

The trussed beams are not very common in farm buildings.

Rafters are designed as beams, with this exception; the beam is considered to be the **length of the run of the rafters**, not the length of the rafter itself. A very large factor of safety must be allowed on account of the wind which exerts terrific force upon the roofs of buildings in some localities.

TABLE 1.
SAFE STRENGTH OF MATERIAL IN POUNDS PER SQUARE
INCH OF CROSS SECTION.

MATERIAL	COMPRESSION
Brick (in cement)	200 lbs.
Brick (in lime)	75 to 125 lbs.
Good Granite	500 lbs.
Good Limestone	400 lbs.
Rubble Work (in lime)	100 lbs.
Concrete (one part cement, two parts sand, clean and sharp, two parts gravel, clean and rough.	150 lbs.

MATERIAL	COMPRESSION	TENSION
Yellow Pine	1,000 lbs. lengthwise 125 lbs. crosswise	2,000 lbs. lengthwise crosswise
Wrought Iron	10,000 lbs.	10,000 lbs.
Cast Iron	2,000 lbs.	1,000 lbs.

White pine is about $\frac{5}{8}$ as strong as yellow pine.

Hemlock is about $\frac{3}{4}$ as strong as yellow pine.

Oak is about as strong as yellow pine.

TABLE 2.
BEST YELLOW PINE BEAMS.

In the following table the beam is considered to be **one full inch** thick, and **free from knots, holes**, etc.

The loads are *safe for perfect beams only*.

To compute the strength of a 2x4, one would have to remember that a stock 2x4 is only $1\frac{1}{2}$ inches thick. Consequently, multiply by $1\frac{1}{2}$. If there are any knots make allowance for them.

The table is made for uniformly loaded beams. See Fig. C, Plate 12.

For beams with concentrated load, divide the figures of the table by two, (2).

For cantilever beams uniformly loaded, divide by four, (4).

For cantilever beams with load at the outer end, divide by eight (8).

Width of beam 1 inch. (Full inch.)

Depth of beam in inches	Length of beam in feet						
	6	8	10	12	14	16	18
2	150	120					
4	600	480	380	300			
6	1400	1080	850	700	600	490	
8	2500	1920	1500	1250	1100	960	
10	4000	3000	2400	2000	1700	1500	1300
12		4300	3400	2800	2450	2150	1900
14				3900	3300	2900	2500

White pine is about $\frac{5}{8}$ as strong as yellow pine.

Hemlock is about $\frac{3}{4}$ as strong as yellow pine.

Oak is about as strong as yellow pine.

Spruce is about $\frac{5}{8}$ as strong as yellow pine.

TABLE 3
LOADS.

The following table gives the weights of the different materials per square foot. In case of roofs, the square foot of roof surface (not horizontal surface) is used.

MATERIAL.	WEIGHT PER SQUARE. FOOT
$\frac{3}{4}$ -in. Sheathing	2 to 2 lbs.
Lath and Plaster	7 to 10 lbs.
Shingles	2 lbs.
1-Inch Flooring	About 4 lbs.
Oats	22 to 25 lbs. per foot in depth.
Corn	40 lbs. per foot in depth.
Barley	35 lbs. per foot in depth.
Wheat.	40 to 45 lbs. per foot in depth.
Hay, (loose)	4 to 5 lbs. per foot in depth.
Hay, (bales)	15 to 25 lbs. per foot in depth.

Table of cubic feet of space needed for different animals.

A horse	600 to 800 cubic feet.
A cow	500 to 600 cubic feet.
A hog	150 to 300 cubic feet
A sheep	150 cubic feet.
A hen	15 to 25 cubic feet.

The above is merely an estimate and does not have to be adhered to strictly.

MECHANICAL DRAWING.

The student does not need to be an "artist" at mechanical drawing. He should, however, be able to express his thoughts by means of drawings. The necessary instruments and equipment are:

Drawing Board.—A flat board 12" by 14". A larger board is often desirable for larger drawings.

"T" Square.—A flat, thin, straight edge fastened at right angles to a short thick piece of wood ($\frac{3}{4}$ "x2"). The "T" square is placed with the cross piece against the end of the drawing board and all horizontal lines are drawn along its upper edge.

The Triangles.—The triangles are usually made of hard rubber or celluloid. To draw perpendicular lines place the triangle upon the

“T” square and draw lines along the edge of the triangle. Triangles usually have one right angle and two angles of 45 degrees. The latter angles on some triangles are 60 degrees and 30 degrees. A “45 degree triangle” is sufficient for this work.

Right Line Pen.—The blades of a right line pen can be adjusted to any width of line which the draftsman wishes to use. In most cases a pencil drawing is all that is necessary for the farm buildings.

Dividers.—The ordinary dividers are so made that either pen or pencil may be fitted into them. They are used for drawing circles.

Scale.—The Scale is often called a “rule.” The “Mechanical triangular” scale is suited for this work. The inches are divided into $\frac{1}{2}$, $\frac{1}{4}$, $\frac{1}{8}$, etc., whereas in the engineer’s scale the inches are divided into tenths.

The outlines of a structure should be shown in heavy *solid* lines. Any part inside the building which could not be seen from the outside may be put in in *dotted lines*. In some cases a portion of the outside may be “cut away” and the framing shown in light solid lines. (See individual hog house.)

The student should draw each floor, the roof, and at least one view of a side and an end. For correct system of drawing see plate of machinery shed. **Never try to draw perspective drawings such as is shown in the lower figure of the individual hog house. They are difficult to make and they are satisfactory only for those who cannot understand mechanical drawing of the ordinary kind.**

Dimension lines should be supplied wherever necessary. They are light, solid lines with arrows at each end, showing the exact termination of the line. Feet and inches are placed near the middle of the line. 8' indicates eight feet, while 8" indicates eight inches. 3' 6" is the mechanical way of writing three feet six inches.

EXCAVATION:

In case it becomes necessary to remove earth or stone in order to locate the foundation of a building, the student should understand the system of laying out the work. He should also know how to estimate the quantity of material which must be moved.

The lines of the excavation should be at least three inches

outside of the side line of the wall. The space between wall and natural earth is filled in with sand, gravel or earth.

The quantity of material to be removed is estimated in **cubic yards**.

It is often cheaper to excavate a runway at one side or end of a basement in order to allow the use of teams and scrapers in place of hand labor.

The estimating of such work is very easy.

Example.—Find the number of cubic yards of earth to be removed for a basement 33'x64'. Average depth, 4 feet.

(In this case a team and scraper should be used. The runway would be about eight feet wide and ten feet long.)

Body of excavation: 32' plus 6"=32.5'. 64' plus "=64.5'
 $64.5' \times 32.5' \times 4' = 8,424$ cubic feet. $8,424$ cubic feet $\div 27 = 312$ cubic yards. (27 cubic feet=1 cubic yard.)

Runway excavation: (2'=average depth of runway.)

$10' \times 2' \times 8' = 160$ cubic feet $\div 27 = 5.9$ cubic yards. (6 cubic yards.)

Total, 312 cubic yards plus 6 cubic yards equals 318 cubic yards.

MASONRY.

While a large book might be written on the subject of masonry, a few simple statements will give the student a clear understanding of the points to be observed.

In both brick and stone work, the walls should have all joints **broken**. In Plate 13, *R* indicates "Rubble" stone work with the joints properly broken; *r* is a wall of the same type with the joints improperly broken at the points indicated by arrows.

C and *c* represent properly and improperly laid walls of "Course work."

B and *b* show properly and improperly laid brick walls.

All walls should be "bonded" by means of stone or bricks which join the outer and inner layers of the wall. In case of brick work, the layers of "bonding brick" should not be more than seven layers apart.

Fig. N of Plate 13, shows a top view of a 16-inch brick wall bonded with ordinary brick.

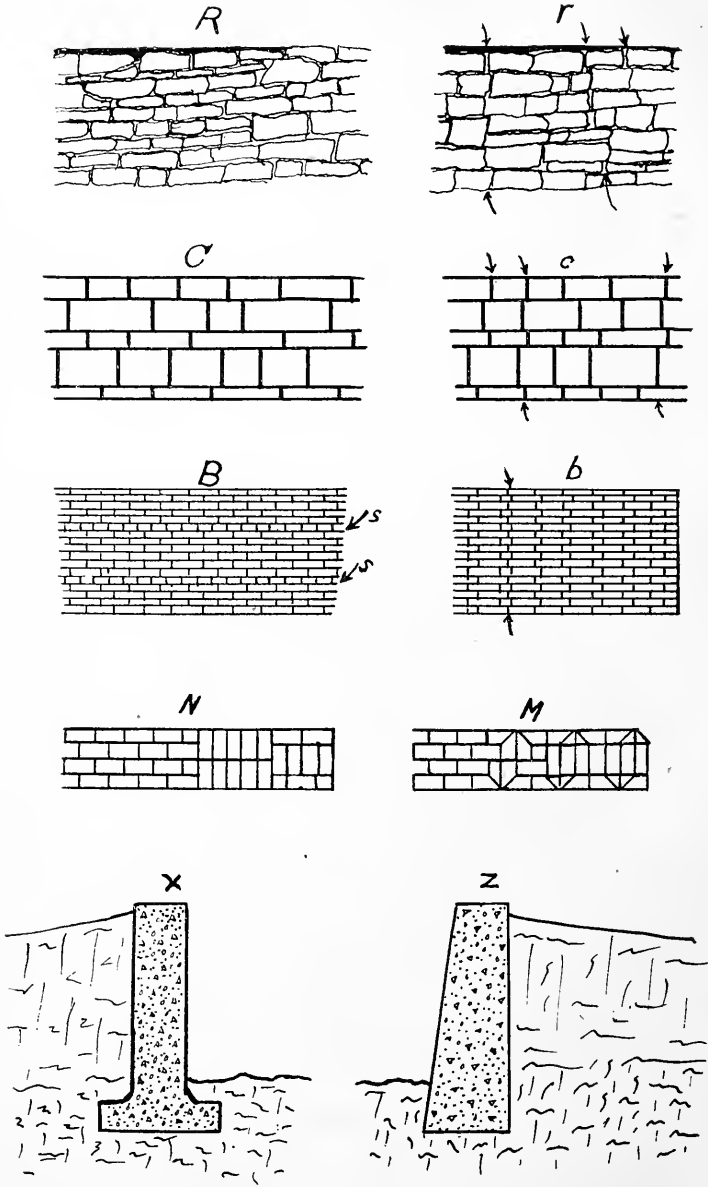

Plate 13—WALLS

Fig. M, Plate 13, shows a special type of invisible bonding brick. Strips of iron with hooked ends are sometimes used for bonding purposes.

In case walls do not cover sufficient ground to carry the weight, the bottom of the wall is made wider in order to increase the bearing surface. The extension at the foot of the wall is called a "Footing."

Fig. X, Plate 13, shows a concrete wall with footing.

Fig. Z, Plate 13, is a tapered wall which gives the desired results in many cases. The openings for all doors and windows should be arched, or provided with a stone cap. The cap should be of ample size and should extend out into the walls far enough to have ample bearing surface.

All angles of a cement or concrete wall should be rounded and the wall reinforced at the angle to prevent cracking.

Mortar.—Lime mortar consists of calcium oxide (quick lime) which has been slacked in sufficient water to make a thick paste. The paste, when mixed with sand and exposed to air takes up carbon dioxide and becomes limestone.

As limestone is soluble in water containing carbon dioxide, the lime mortar is subject to rapid disintegration. It is, however, cheap and very satisfactory for rough work. Most farm houses are plastered with lime mortar, the first coat containing plastering hair, the second coat containing no hair, and the third coat, (in case one is applied) being made of nearly clear lime plaster.

Cement mortar is made of cement and sand. When the cement takes up water, it recrystallizes and forms stone. The mortar requires plenty of moisture for the completion of the setting process. As the cement mortar is very hard and insoluble, it is preferred for outside work and for "Pointing up" walls.

"Pointing up" consists of digging out all loose mortar at the outer edge of the joints and completely filling in the joint with mortar. The mortar, when rounded with a special trowel is said to be "beaded."

CARPENTRY.

Several volumes of very good material have been written on the subject of carpentry.*

* "The Steel Square," by Fred. T. Hodgson, and "The Builder and Wood Worker," by F. T. Hodgson, are published by Sargent & Co., 94 Center Street, New York.

The day of the "old fashioned" carpenter who spent much time putting in complicated sill joints, and numberless mortices is nearly past. The increase in the price of lumber, and the enlightenment of the designers have reduced the size of the timber a great deal. This makes it imperative that all unnecessary mortices should be done away with. Consequently, the joints of up-to-date farm buildings are now almost exclusively held together by spikes. The free use of spikes in the proper places, proves to be a great help in securing strength and rigidity in our buildings.

The pitches of roofs and the length of rafters are considered by many to be hard problems for the amateur carpenter.

The common system of computing pitches is by number of inches which the rafter rises in passing over one foot of horizontal distance.

The distance the rafter rises in passing over one foot of surface, is termed the "Rise". The horizontal distance over which it passes is termed the "Run".

The pitch is named according to the fraction of the total width of the building which the regular gable roof rises above the level of the plate.

Example.—On a building twelve feet wide, if the gable were three feet above the plate, the pitch would be $\frac{1}{4}$. (6" rise to 1 ft. run). If the gable were 4 feet above the plate, the pitch would be $\frac{1}{3}$. (8" rise to 1 foot run.) If the gable were 6 feet above the plate, the pitch would be $\frac{1}{2}$. (12" rise to 1 foot run.)

The Plate shows how to lay off a rafter by means of the ordinary steel square. (See Plate 14.)

Fig. A, Plate 14, shows a 12-ft. building with 6-ft rise or $\frac{1}{2}$ pitch.

Fig. B, Plate 14, shows a 4-ft. rise, or $\frac{1}{3}$ pitch.

Fig. D, Plate 14, shows the old method of laying off rafters. The square is moved along upon the rafter so that the corner comes first at *b*, second above *c*, third above *d*, etc.

The distance *ah* is marked off for each foot of run and the final position of *h* will be directly above one of the small letters, *c*, *d* or *e*.

By marking down along the edge of the tongue *Th*, the top cut of the rafter is given. By marking along the edge of the square *ab* in its present position, the heel cut of the rafter is given.

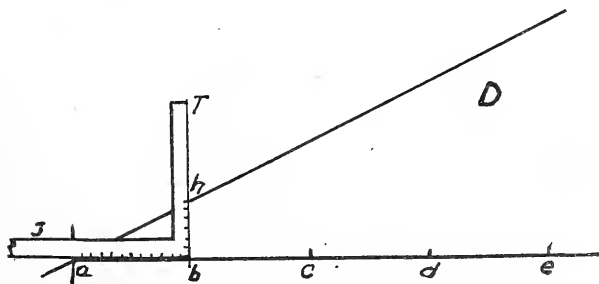
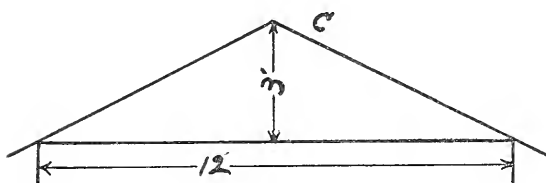
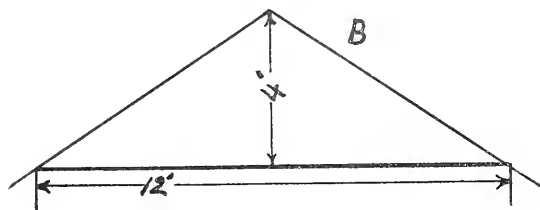
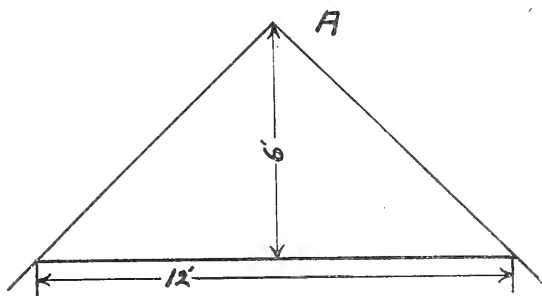

Plate 14—FRAMING RAFTERS

The Author is a firm believer in the use of the framing square, and consequently does not dwell upon the use of the old-fashioned square.

By means of the tables upon the side of the Nicholas framing square, all rafter cuts may be laid out by simply consulting the table. The results are accurate, and as the framing square costs no more than the old board rule square, there is no reason why it should not be used by every student.

The handling of carpenter tools cannot be taken up here, but a few hints on selecting carpenter tools are not out of place.

Buy good tools of a Standard make.

In buying planes, get those which have blades adjustable up and down and sidewise. The throat should also be adjustable.

Saws should be fine for fine work; 12 teeth to the inch is not too fine. For coarse work, such as framing, a cross cut saw should be as fine as 8 teeth to the inch. A rip saw should have 4 or 5 teeth to the inch.

For finishing work, a hammer should have a round face, while for rough work the square face is preferred by many. *Don't* buy freak tools for plain work.

PAINTING.

Out-side paint for barns, fences, etc., should be made of ground burned clay, and raw linseed oil. The common colors are yellow, red and brown.

For house painting, lead oxide (white lead) and zinc oxide should be mixed with raw linseed oil. The so-called boiled linseed oil, is raw oil with some drying agent added.

The inside finish should be bought ready-prepared, and used according to directions.

In general, paint should be applied in thin coats, well rubbed in.

The student must choose the colors and types of finish according to his own particular taste in the matter.

PLUMBING.

When putting in closets, sinks, etc., remember that every fixture must have a trap, to prevent the back flow of noxious gases from the sewer. The trap should be **vented** directly to a ventilator stack, which must open through the roof: The stack should be the same size as the sewer pipe.

The traps should be directly connected to the fixtures. The fact that a trap is placed at the entrance of the cess pool, in no way does away with the necessity of the fixture traps in the house.

All plumbers' supply houses have drawings and specifications for the installation of their fixtures.

Caution: No lead pipe should be used in the water line from which drinking water is obtained. The water acts upon the lead and a *slow* poison is likely to be found in that part of the water which has been standing in the lead pipe.

It is nearly always advisable to have plumbing done by a competent plumber, rather than to attempt the work without experience.

ESTIMATING QUANTITIES.

The student can become proficient in estimating quantities of material by actual practice only.

A few simple rules are here given for the guidance of the student in making estimates.

1. Begin by estimating excavations.
 2. Finish foundations and chimneys.
 3. Work out first floor, sides, second floor and roof in order.
 4. Complete plastering estimate.
 5. Complete inside finishing estimate.
 6. It is customary to put all materials of a kind, such as 2x4's, siding, laths and shingles together in the final estimate. But it is advisable to keep a copy of the estimate of each part separate, for the benefit of the builder.
 7. Lumber is estimated by the thousand feet.
 8. Shingles are estimated by the thousand.
- 1 bunch = $\frac{1}{4}$ of 1,000.

(If shingles are laid 4 inches to the weather, 1,000 shingles will cover about 1 square.—100 square feet. At five inches $1\frac{1}{4}$ squares.)

9. In estimating flooring, add about $\frac{1}{3}$ the total number of surface feet to the estimate to make up for tongues in 3" or 4" flooring. In case of 6" or 8" flooring or ship lap, add $\frac{1}{4}$ the original estimate.

For narrow siding $\frac{1}{3}$ must be added to the original estimate.

10. Good paint should cover from 200 to 300 square feet of new lumber per gallon for the first coat. Second coat, 300 to 400 square feet.

11. When the necessary number of nails has been determined, consult the following table. Divide by number of nails per pound to find number of pounds required.*

It takes about $2\frac{1}{2}$ pounds, of 3d nails, or about $3\frac{1}{2}$ pounds of 4d nails to lay 1,000 shingles. *d* indicates the penny of the nail.

d	length in inches	Number per lb.	
2d	1	1100 to 1200	Sometimes used, for lathing.
3d	$1\frac{1}{4}$	700 to 750	Shingle and lath nails.
4d	$1\frac{1}{2}$	400 to 450	Shingle nails.
6d	2	250 to 275	Thin siding.
8d	$2\frac{1}{2}$	125 to 140	For siding, sheathing and flooring.
10d	3	75 to 90	Sheathing and flooring.
12d	$3\frac{1}{4}$	65 to 70	Toe-nailing rafters, etc.
16d	$3\frac{1}{2}$	45 to 50	Toe-nailing rafters, etc.
20d	4	30 to 35	Framing work.
30d	$4\frac{1}{2}$	25 to 30	Framing work.
40d	5	15 to 20	Framing work.

Casing and finishing nails run about $\frac{1}{3}$ to $\frac{1}{4}$ more per pound than do the common nails listed above.

CHICKEN COOPS.

The student cannot do better than to obtain "Farmers' Bulletin No. 3" of the Montana Experiment Station at Bozeman, Montana. As the Bulletin contains a reprint of "Farmers' Bulletin No. 357" of the United States Department of Agriculture, the knowledge imparted is very complete, both in general poultry culture, and in the details of poultry houses construction.

HOG HOUSES.

As differences in latitude and general weather conditions influence the type of hog house which is desirable for different localities, the student will necessarily have to investigate local conditions before designing a hog house or "piggery."

The individual hog house shown in Plates 15 and 16, is very desirable for brood sows. It is suitable for all the central and northern states.

* As nails are cheaper by the keg than by the pound, it often pays to buy a keg rather than a large fraction of a keg.

All hog houses should be well lighted, provided with plenty of fresh air, and a clean, warm floor.

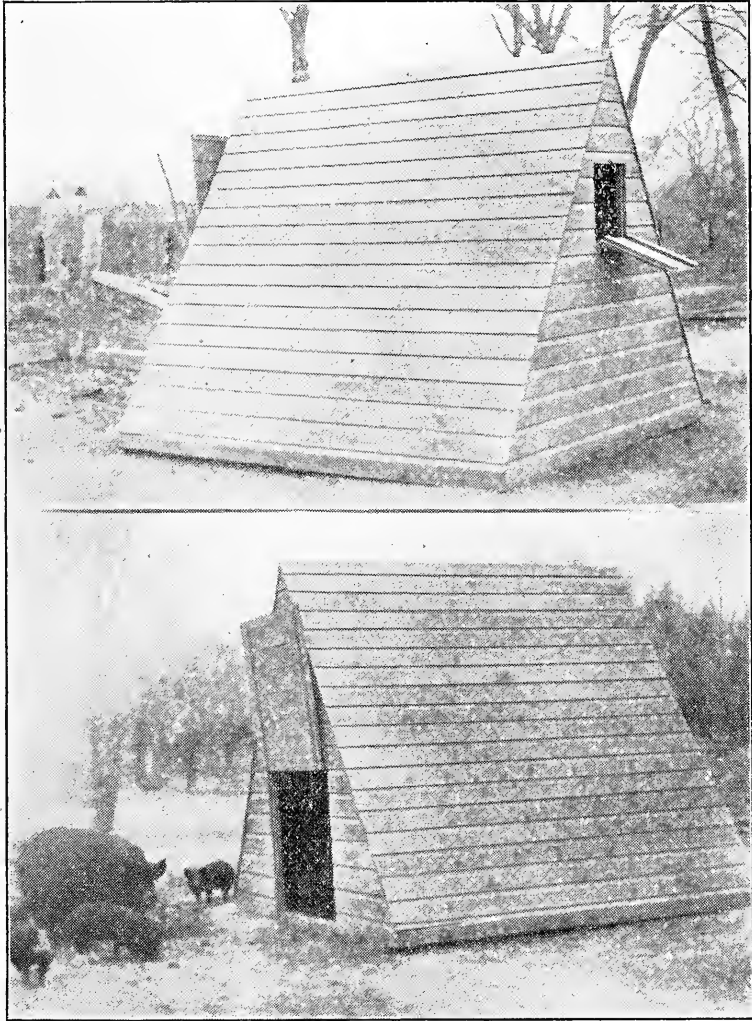

Plate 15—INDIVIDUAL HOG HOUSE

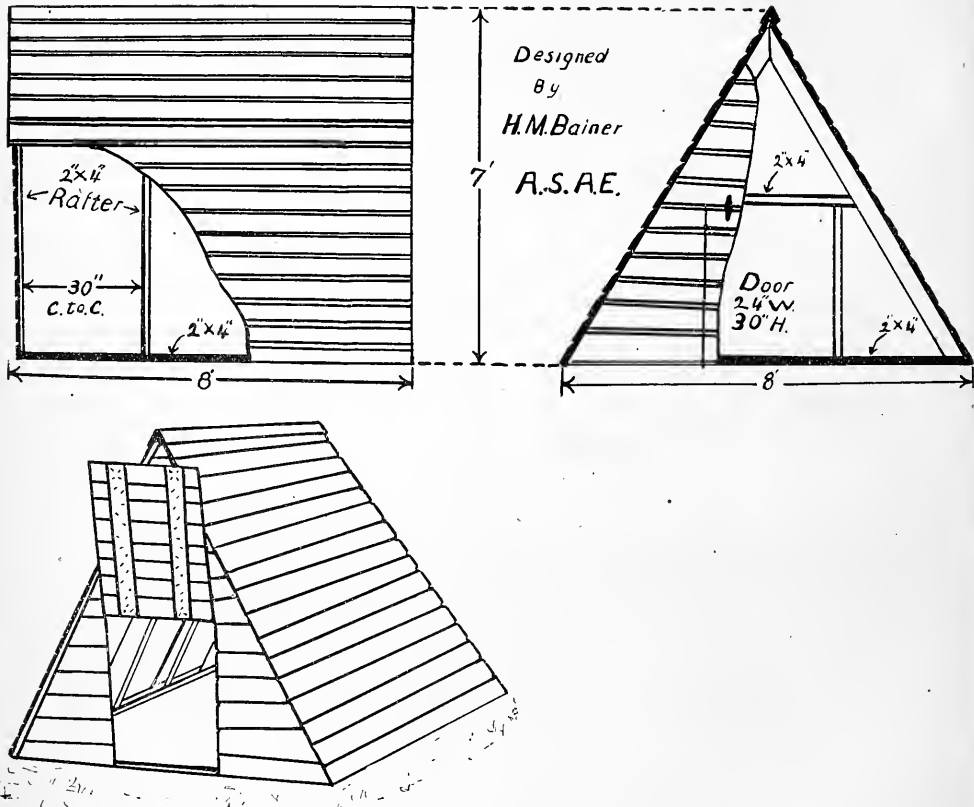

Plate 16- INDIVIDUAL HOG HOUSE

It is essential that a sow should be quiet during her farrowing period. The individual hog house fills the bill exactly.

It is built with a two by four frame. The frame is covered with drop siding or ship lap. The house is easily moved from place to place.

A small door about a foot square should be put in the end opposite the large door. The small door should be near the top. It provides ventilation, and allows the herdsman to drive out ugly sows. The drawings and the picture explain how the individual hog house is built.

COW BARN.

Cow barns, above all, should be well ventilated and lighted. The most practical system of lighting and ventilating consists of placing windows rather high in the sides of the barn. The windows should be hinged at the bottom, so as to swing inward at the top. At the

sides, there should be boards set in such a manner that when the window is open, the in-coming air must come over the top of the windows. Cold drafts are thus eliminated.

The floors may be of paving brick or concrete. In case of very smooth, cement floors, no ice should be allowed to collect upon the floor. Cows are likely to slip upon this film of ice and become disabled.

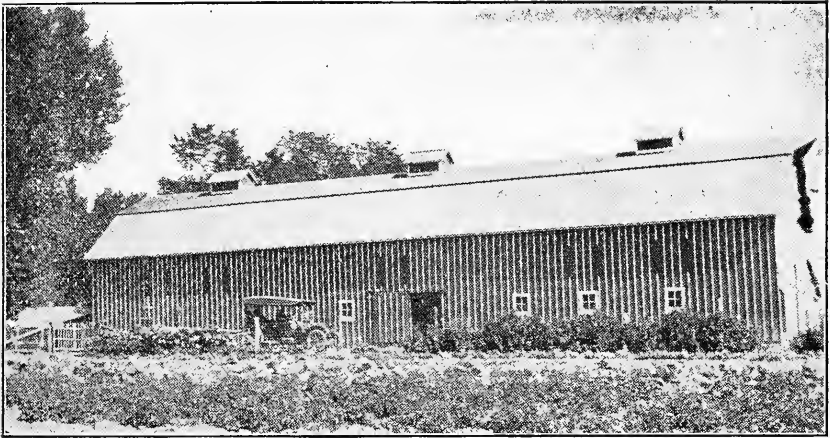

Plate 17--A BARN OF EXCEPTIONAL DESIGN

From the standpoint of arrangement, there is practically no improvement that could be made. The surroundings are sanitary, and in summer, the flower beds in the fore-ground are very beautiful.

For the ground plan, see Plate 18.

The dairy room should be some distance from the barn, in order to exclude all contaminating odors from the stored milk, butter or other products.

A silo may be located near the cow barn, and connected to the feed way by a covered alley way.

THE SILO.

The student should make a careful study of the most up-to-date silos. See Bulletins 100 and 117, Iowa State College Experiment Station, Ames, Iowa. These Bulletins are so clear and concise, that further discussion would be fruitless.



Plate 19--IOWA SILO

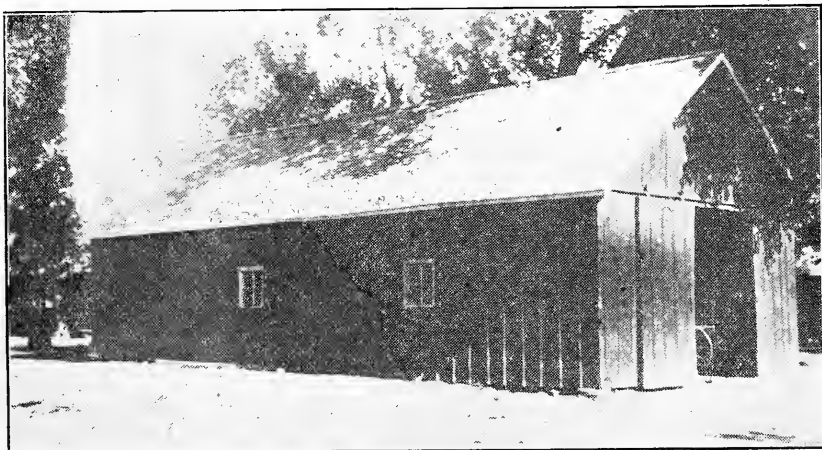

Plate 20--MACHINE SHED

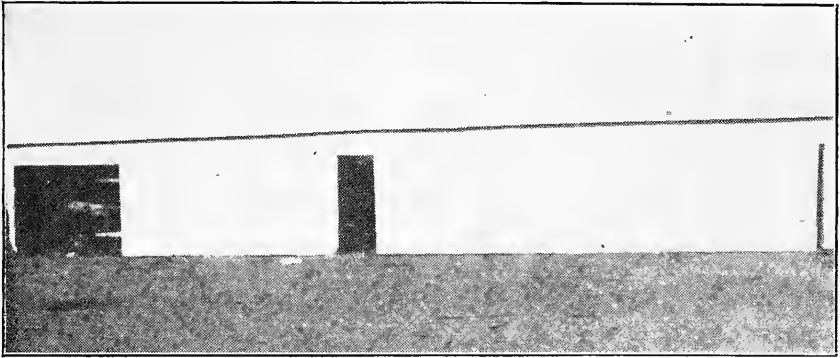

Plate 22—MACHINE SHED

In spite of many theories to the contrary, the author has learned by actual field investigations, that only closed machine sheds are satisfactory. The shed in Plates 20 and 21 is considered very satisfactory.

The long, narrow shed in Plate 22, is also very satisfactory.

HORSE BARN.

The horse barn should be separated from the cow barn if possible. The wagon, carriage, and harness rooms should also be separated from the horse stalls by tight partitions. The ammonia arising from the stalls will eventually ruin paint and leather.

The system of ventilating the horse stable should be the same as in the case of the cow barn. For size of stalls see table.

TABLE OF SIZE OF STALLS.

Horse (single), 3' 8"x10' or 4'x10'. (From front of manger.)

*Horse (single), 5'x10'. (From front of manger.)

Horse (double), 7'x10' or 8'x10'.

Horse (single, box stall) 10'x10', or 10'x12'.

Cow (single stall), 3' 6" to 4'x7'. (From front of manger to front of gutter.)

Total length of stall from front of manger to back wall.

For horses, 14'. 16' is better.

For cattle, 11' to 13'.

*Horse stalls between 4 and 5 feet wide are often found to be unsatisfactory, owing to the fact that when a horse lies down he may get his feet above him in a stall wider than four feet, and not be able to get them under him again in a stall narrower than five feet. This often requires the pulling of the horse out of the stall in order to allow him to get up.

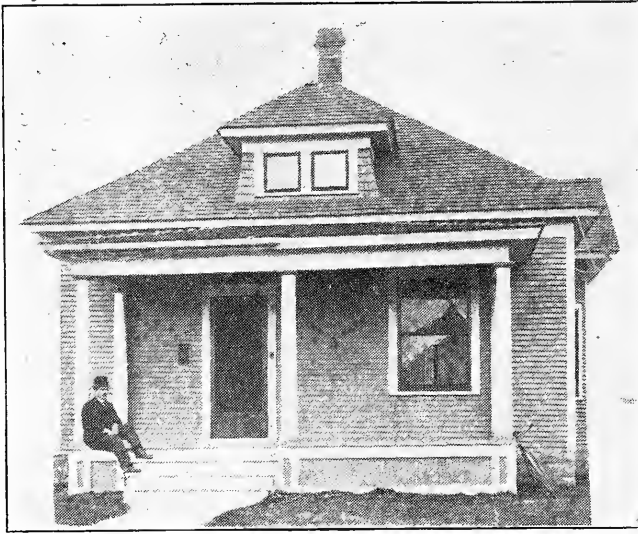

Plate 23—A NEAT FARM COTTAGE

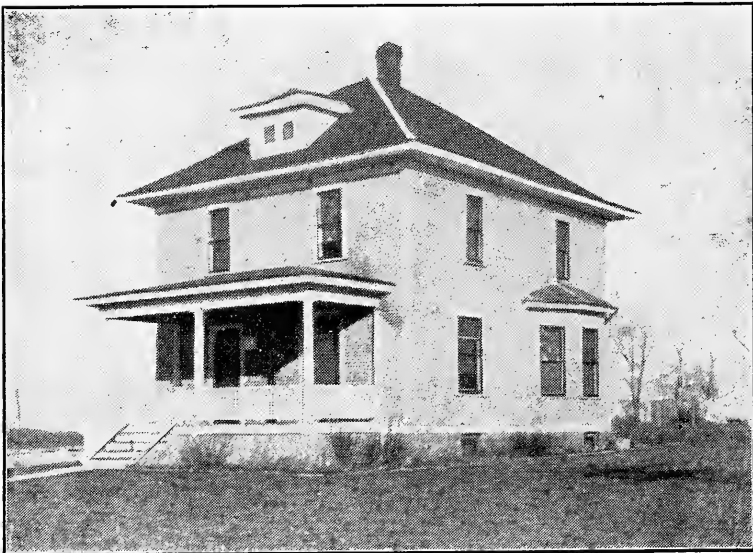

Plate 24—FARM HOUSE

DWELLING HOUSES.

As the location of the farm, the climate, the special weather conditions, the size of the family, and the taste of the people who dwell in farm houses, are all factors which govern the design of farm houses, no plans are included in this volume.

The student should work out plans to exactly suit the conditions and no one else can do this for him.

Procure from the Extension Dept., Bulletin No. 1, "Healthful Homes," Iowa State College, Ames, Iowa.

EXAMINATION

Note to Student—These questions are to be answered independently. Never consult the text after beginning your examination. Use thin white paper about 6"x9" for the examination. Number the answers the same as the questions, but never repeat the question. Mail answers promptly when completed.

QUESTIONS FOR EXAMINATION.

1. Give two reasons why farm buildings used to be built of such heavy material.
2. In what ways does "guess work" cause buildings to be unsatisfactory?
3. Name three advantages of the centralized or single barn plan for farm buildings.
4. Tell why the "distributed" plan of building is more satisfactory than the centralized system.
5. What factor takes precedence over all others in choosing a building site?
6. What is meant by "air drainage"?
7. Name the three principal classes of wells.
8. How far from a well should all sources of contamination be kept?
9. How should a well be lined or cased?
10. What is a cess pool?
11. What dangers are likely to attend the installation of a cess pool?
12. Why is a trap placed between the cess pool and the house sewer pipe?
13. What is a "septic tank"?
14. Of what use is a hospital stall?
15. What is a cremating pit?
16. What qualities should building material possess to be sanitary?
17. Give the three rules governing the strength of beams.
18. How are rafters designed?
19. Why must rafters have such a large factor of safety?

20. If a plain beam 12 feet long will bear a 1000-pound load concentrated in the middle, what evenly distributed load would it carry?
21. A roof has a rise of 6" to a run of 1-foot. What is its pitch?
22. What rise must a roof have per foot of run, if it is a $\frac{1}{2}$ pitch roof?
23. Where should the fixture traps be placed with respect to plumbing fixtures in a house?
24. Is a column 4"x4" (full size) two feet long, a "long" or a "short" column?
25. What points should be observed in designing a hog house?
26. How much paint should "first coat" one side of a barn 40 feet long, by 20 feet high?
27. What points must be observed in designing a cow barn?
28. Where should the dairy or milk room be placed with reference to the cow barn?
29. What do we mean by the "bonding bricks" in a brick wall?
30. What do we mean by the term "footing" as applied to walls?
31. A. The student shall choose a location for a building site, describe its location from standpoints of roads, nearness to fields and market and its sanitary qualities.
B. Decide what type of farming is to be done, whether grain, hay, dairy, or general farming. State the size of farm and number of horses, cattle, sheep, hogs and chickens to be kept (approximate).
C. Decide whether the centralized or distributed type of buildings are to be used.
D. Draw a rough sketch of farmyard roads, etc., locating to scale the well, cesspool, or closet, and the buildings. Be SURE to show slope of land by an arrow. Make the drawing as a map not in perspective.
E. *From here on the student may use all data available.* Make at least TWO drawings of each building; see that they are designed CORRECTLY, and estimate quantities of material and labor required for ONE of the larger buildings. (Note. The student should take plenty of time to this question. The author would not attempt to answer question 31 in less than five days of eight hours each.)

WRITE THIS AT THE END OF YOUR EXAMINATION.

I hereby certify that the above questions were answered entirely by me.

Signed

Address

.....



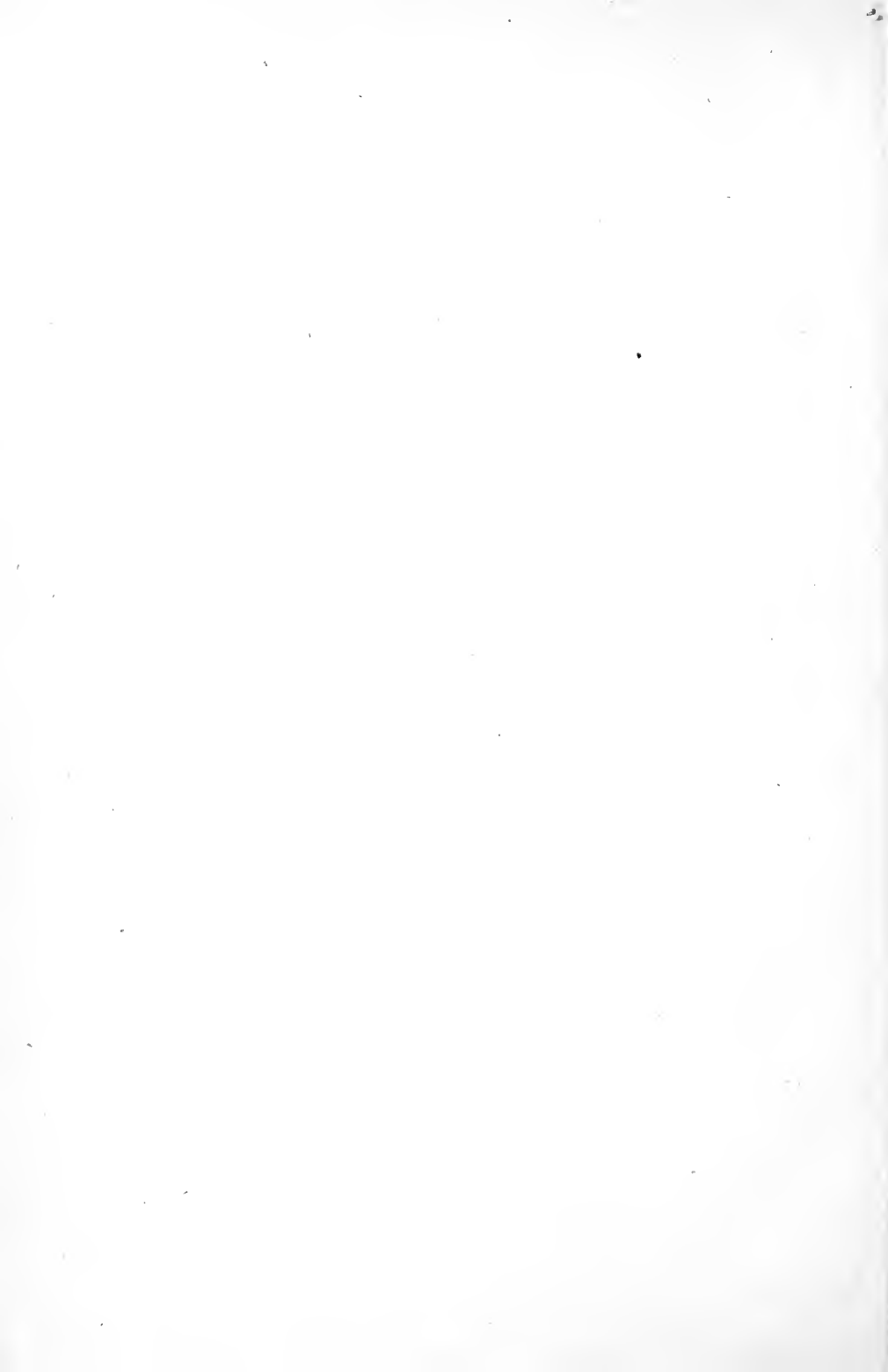

THE
Correspondence College
of Agriculture

FT. WAYNE, INDIANA

FARM ENGINEERING—Part II

Field Engineering

By H. BOYDEN BONEBRIGHT, B. S. A., A. S. A. E.

Dept. of Agricultural Engineering
Montana Agricultural College

This is the Second of a Series of these Books giving a Complete Course of Instruction
in Farm Engineering.

COPYRIGHT, 1912

The CORRESPONDENCE COLLEGE OF AGRICULTURE

NOTE TO STUDENTS

In order to derive the utmost possible benefit from this paper, you must thoroughly master the text. While it is not intended that you commit the exact words of the text to memory, still there is nothing contained in the text which is not absolutely essential for the intelligent farmer to know. For your own good, never refer to the examination questions until you have finished your study of the text. By following this plan, the examination paper will show what you have learned from the text.

When the student takes up the work of Field Engineering he should not labor under the impression that he is to learn "Civil Engineering at a Glance." A Four Year Course in Civil Engineering in any good college would only fit the student for beginner's work as a civil engineer.

For this reason the author will endeavor to set forth in a clear practical way those points which are absolutely necessary in Farm Field Engineering.

The student can at the cost of a few minutes' time and the expenditure of a few cents for postage secure bulletins from various experiment stations which will be very broadening so far as results of field engineering work are concerned. These bulletins do not however tell how to go about the work and many ridiculous failures are attributed to the so-called "errors" in these valuable little books which are in fact due only to the lack of true principles of Farm Field Engineering.

The student who studies these bulletins must always ask himself this question: Do the conditions under which I am working check with the conditions under which the results set down in this bulletin were obtained? Do not jump at conclusions! Be Sure!

LIST OF FREE BULLETINS. SEND FOR THEM.

1. "Land Drainage by Means of Pumps."—Bulletin 243, U. S. Dept. of Agriculture.
2. "Duty of Water."—Bulletin 56, Agricultural College, N. M.
3. "Measurement of Water for Irrigation."—Bulletin 53, Wyoming Experiment Station, Laramie, Wyoming.
4. "Drainage Conditions in Iowa."—Bulletin 78, Experiment Station, Ames, Iowa.
5. "Drainage of Farm Lands."—Farmer's Bulletin 187, U. S. Dept. of Agriculture.
6. "Land Drainage."—Bulletin 138, Experiment Station, University of Wisconsin.
7. "Drainage of Irrigated Lands in San Joaquin Valley, California."—Bulletin 217, U. S. Dept. of Agriculture.
8. "Drainage of Irrigated Lands."—Farmer's Bulletin 371, U. S. Dept. of Agriculture.
9. "Selection and Installation of Machinery for Small Pumping Plants."—Circular 101, U. S. Dept. of Agriculture.
10. "Current Wheels."—(Their use in lifting water for irrigation), Bulletin 146, U. S. Dept. of Agriculture.
11. "The Use of Windmills for Irrigation in the Semi-arid West."—Farmer's Bulletin 304, U. S. Dept. of Agriculture.
12. "Practical Information for Beginners in Irrigation."—Farmer's Bulletin 263, U. S. Dept. of Agriculture.
13. "The Right Way to Irrigate."—Bulletin 86, Utah Agricultural College Exp. Station, Logan, Utah.
14. "The Construction of Concrete Fence Posts."—Farmer's Bulletin 403, U. S. Dept. of Agriculture.
15. "Cement Pipes for Small Irrigation Systems."—Agricultural Exp. Station, Tucson, Arizona.
16. "Cement Mortar and Concrete," (For Farm Use)—Farmer's Bulletin 235, U. S. Dept. of Agriculture.

17. "Cement and Concrete Fence Posts."—Bulletin 148, Colorado Agricultural College Exp. Station, Ft. Collins, Colo.
18. "The Destruction of Hydraulic Cements by Alkali."—Montana Agricultural College Exp. Station, Bozeman, Mont. (Bulletin 81.)
19. "Restoration of Lost Corners and Subdivisions of Sections."—U. S. Gen. Land Office, Dept. of the Interior, Washington, D. C.

In order to properly understand the typical surveyor's instruments, drawing instruments, etc., the student should secure the following catalogues. When he studies in the text about a level, a compass, a transit, a planimeter or other "Instrument of Precision" he should turn to these catalogues and carefully study the details of construction of the instrument. The information will be of untold value to the student who expects to put his knowledge into practice. By the careful study of the various makes of instruments he will broaden his understanding of the work as well as of the instruments, for the makers give detailed information as to the **adjustments** of their instruments and the **method of using each instrument**.

Gurley's Manual, of American engineers' and surveyors' instruments, W. & L. E. Gurley, Troy, N. Y., or Seattle, Wash.

Catalogue of surveyors' instruments, C. L. Berger & Sons, Boston, Mass.

Catalogue of Keuffel & Esser, Keuffel & Esser, New York.

The Frederick Post Catalogue, Frederick Post Co., Chicago, or San Francisco.

Catalogue of Drawing Materials, Eugene Dietzgen Co., Chicago, or New York.

Blasting of Ditches, E. I. Dupont & Co., Wilmington, Delaware.

If the student establishes an Engineering Library he cannot do better in the way of field engineering books than to purchase the following:

Engineering for Land Drainage (Elliot), John Wiley & Sons, New York.

Mechanical Engineers' Pocket Book (Kent), John Wiley & Sons, New York.

Physics of Agriculture (King), F. H. King, Madison, Wisconsin.

Theory and Practice of Surveying (Johnson), John Wiley & Sons, New York.

FARM ENGINEERING

PART II.

Many attempts at Farm Engineering have been made since the history of agriculture. The results of the best work have been handed down to us and by far the greater number of failures have been lost sight of. Broadly speaking, the failures have all been due to ignorance, but this by no means indicates that those who made the blunders were not well educated. It is easy for a man who is a good scholar in the true sense of the word to make ridiculous errors in drainage. These errors might readily be detected by a practical ditch-digger who could neither read nor write. In case of failures, you will find that the educated and the illiterate invariably **jumped at conclusions**, with disastrous results.

While the higher mathematics are of great assistance in doing very accurate engineering work, there is no good reason why by far the greater part of the farm field engineering cannot be accomplished by the man who has a thorough knowledge of arithmetic and plane geometry. The following named subjects are so interwoven, however, that he who hopes to succeed as an agricultural engineer, must of necessity understand the underlying principles upon which they are based:

- Agronomy.
- Animal Husbandry.
- Concrete Construction.
- Farm Management.
- Masonry.

Physics.

Sanitary Science.

In the following discussion the subjects are taken up alphabetically, and not in order of most importance.

Agronomy.—Few people realize that the agronomist must know (not guess) the exact needs of the plants which are to be grown. This often makes for success or failure on the part of the engineer, as his work may be condemned upon the basis that his system of drainage or irrigation did not permit of the raising of a certain crop upon a given field, when as a matter of fact, the crop is in no way suited to the conditions, even though the engineering be done perfectly. The engineer should be able to find out in regard to rainfall, temperature, length of seasons, etc., so that he may not make ridiculous errors in his claims for the improvements which are contemplated.

The United States Government has a weather bureau in each state, and from these, the student may obtain for the asking, statements of maximum, minimum, and average temperature for the months, together with a statement of the amount of precipitation for each month. Now, if the student is armed with such a statement, and has a clear knowledge of the requirements of plants, he is in a position to advise with some degree of accuracy. What is more, he is able to foresee failures, which, if allowed to occur, might be attributed to the work, rather than to the right cause.

The soil is another important branch of Agronomy which governs very directly the growth of plants, the handling of drainage or irrigation water, and even the building of fences. A system which may prove effective upon some kinds of soil, may fail upon another kind. Later in the work, the student will have ample opportunity to observe these points.

Animal Husbandry.—It is necessary to have a knowledge of the needs of the different farm animals in order to make the designs of fences fill all the needs and not merely a part of them. The student who has observed valuable horses ruined by wire cuts will realize that the loss of one horse would have

paid well for the building of a properly designed fence in the place of the barbed wire contraption which ruined the horse. But perhaps the same fence which ruined the horse was an excellent hog, sheep and cow fence. It merely needed completion before it could be justly called a horse fence.

Animals also influence the physical condition of the soil and its chemical richness as well. The drainage of tramped stock yards is a much harder problem than the drainage of an untramped field. It often occurs that the engineer can accomplish more by prescribing a correct method of tillage, than could be accomplished by any other means. Study the habits of animals, and what is required for them, and you will soon learn that much of the field engineering which you encounter has been poorly done.

Concrete Construction.—Unless the student has done much work in concrete construction, he should be forewarned against the “contractor” who claims to have “unlimited experience.” Anyone can start out as a concrete contractor and get away with the money if one is so inclined. The student should KNOW what is right and what is wrong and insist on the work being done to his specifications. He will be told many things by the contractor, but he should remember that it usually costs less to do poor work than it does to do good work. This often gives much color to the statements of the man who has taken a concrete contract. Know your subject, specify plainly and exactly, and insist upon the work being done right.

Farm Management.—The engineer must be able to compute the cost of contemplated improvements and to estimate in a fairly accurate way whether or not they will be profitable. Not all highly scientific improvements are necessarily profitable. Striking examples of unsuccessful engineering projects are to be seen in the irrigated countries. Not that the discarded systems were unsuccessful from the engineers’ standpoint, but in so many cases the water did not do sufficient good when delivered, to justify even one-half the original expense. The same is sometimes true of drainage projects, but the relative percentage of failures is comparatively small.

The laying out of a farm in the first place is something that is too often overlooked. It is often better economy to chance present fences, tear down some old buildings and generally rearrange the whole farm than to improve upon the original plan. It often happens that the most undesirable spot on the farm has been chosen as a building site simply because of a spring being near it. The extra expense of drilling a deep well in a more healthful location could often be saved in a season in doctor bills alone, to say nothing of the other advantages to be derived from a really desirable location.

Masonry.—The subject of masonry has been thoroughly treated in Part One of Farm Engineering. An engineer may make a very good design, and if this design be submitted to a bungling mason, the engineer stands a fair chance to be blamed for the failure which is almost sure to follow. Masonry, like concrete work, is a field often invaded by those who have been marked failures in other lines of work.

Physics.—The student should have a knowledge of elementary physics. The careful study of any high school textbook will give the fundamental knowledge necessary. Many laws of physics will be given in this book, but they will not be listed as such.

Sanitary Science.—As in the case of Farm Structural Engineering, sanitary science is one of the most important factors in the work. The student should become thoroughly acquainted with the laws of his state which govern sanitary conditions. It may be mentioned here that in many cases where people have, for selfish reasons, refused to allow drainage ditches to pass through their lands were declared a menace to public health, and the drainage projects were subjected to no further hindrance. A thorough knowledge of these laws and rulings will enable the engineer to put through projects which seem to be opposed by hopeless odds. One should never give up until he has exhausted all recourses to laws upon sanitary matters. Likewise, be sure that the project in hand is not of such a nature as to make it possible for some other party to ruin the

usefulness of the work by having it declared a menace to the public health.

The author has in mind the case of a small town which installed a sewage system which emptied into a small creek. This creek had previously been dammed to make a reservoir for drinking water by a farmer who lived a short distance down the stream. No sooner was the system ready for operation than an injunction was granted prohibiting the emptying of sewage into the creek. And it looks at present as though the injunction would remain active permanently. Even a slight knowledge of law should have warned an engineer not to empty sewage in a creek immediately above the source of drinking water of this farmer.

Cases are on record in which large hotels in the mountain summer resorts have been forbidden to empty sewage into creeks which were sources of water supply for towns at least 30 miles down stream. The student need have no trouble upon this score if he will give careful attention to the matter before beginning a project.

Land Survey.—The science of surveying is as old as history. To be sure, the first systems were crude, but in their time they answered the purpose. In the history of our own country we find that lines were often run by driving to or from the rising sun, and that the length of these same lines was often determined by computing the circumference of the rear wagon wheel and then counting its revolutions until the desired distance had been covered.

Later the land was laid off by means of the surveyor's chain and the compass. This method was far more nearly exact, but there still remained much room for improvement. The use of the steel tape in measuring lines and the transit in determining their directions is at present the most nearly exact method of determining distances and directions which is open to the agricultural engineer. In order to determine the length of a line accurately, one must not only know how to use a surveyor's tape, but one must practice using it until he is able to

measure a line 1,000 feet long any number of times and make each answer check within .05 of one foot. This is no easy task, but practice will accomplish the task to the satisfaction of all concerned.

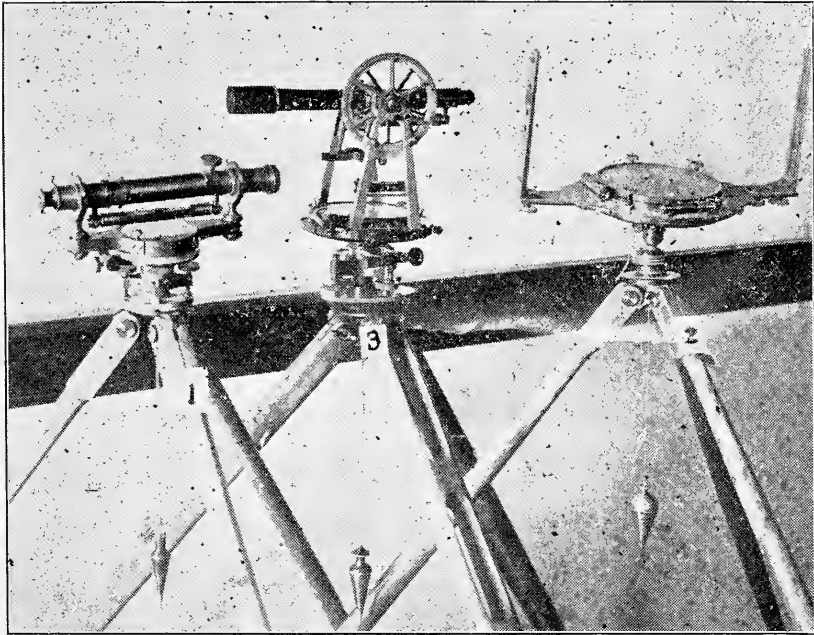

PLATE I.—No. 1. Architects level tilted to one side to show compass box.
No. 2. Large compass. The needle of this instrument can be seen.
No. 3. The surveyors transit with Vertical circle.
(The plumb bobs of these instruments have been drawn up so as to be included in the photo.)

The Tape.—The tape is usually 100 feet long, although 50-foot tapes and 200-foot tapes are not uncommon. At each end of the tape one foot of the distance is marked off into ten equal divisions or into tenths of a foot. In some cases the tenths are subdivided into ten parts, or into hundredths of feet. The tape usually has detachable wire handles. It is usually advisable to replace the handles with a rawhide thong about $\frac{3}{8}$ of an inch wide by one foot long. The thong makes a convenient handle and never catches trash as the tape is dragged about. In order

to measure straight, it is necessary to know two points on the line (usually the ends) and then see to it that all measurements are made exactly on that line. The "rear chainman" (the man who attends to the rear of the tape) must signal to the "head chainman" to move left or right until he has the front end of the tape exactly in line with the stake at the further end of the line. Then the tape is pulled clear of all obstructions and the rear chainman holds the zero point at the front side of the stake or "pin." The head chainman then sticks a pin so that its front side is just even with the one hundred foot mark, or such other mark as he chooses to measure to.

The pins are generally made of about No. 6 wire, with a loop at the top, and a pointed bottom. They are about one foot long. In case the measurements are made through grass or underbrush, a piece of red flannel should be tied in the loop of each stake, as they are then much easier to see. Eleven stakes or pins are commonly used. "One to start with," and then when ten are picked up by the rear chainman there have been ten measurements made, 500 feet in case of the 50-foot tape, 1,000 feet in case of the 100-foot tape, or 2,000 feet in case of the 200-foot tape. In this way it is easy to keep track of the distance.

Be sure to properly line in the chainman, or the measurements will be ridiculously incorrect. The lining in may be done wholly by motions or by word (in case of short tapes). Never try to do field work accurately without the use of a METAL tape.

"Poles" are usually set at the ends of the line to aid in "lining in." The poles consist of wood (sometimes gas pipe), about one inch in diameter and six feet long. They are painted red and white to assist the eye in seeing them. In some localities blue is easier to see than red. The pole is set upright when the line has been determined, and it proves a great help to the "chainmen."

In measuring curved lines it is often necessary to use very short measurements. There are other methods of measuring

these lines, but unless the operator is familiar with higher mathematics it is better to use a tape. When a line runs up or down hill a plumb-bob should be used to determine the point at which the line should be held so that it is brought exactly above the pin. The tape **MUST** be held **HORIZONTAL**, not parallel to the earth's surface. Small grades, such as $\frac{1}{2}$ foot in one hundred, need not be considered in tape work.

Errors.—By the time the student has tried the 1,000-foot line a few times he will become interested in errors. For this reason let us look into the matter. If your tape is too long by $\frac{1}{2}$ inch, then each measurement will add to the error of the last measurement. If the tape is too short, then there will be an ever increasing error in the other direction. Such an error is a **cumulative** error. It is a very bad type of error and **MUST** be avoided. Suppose that you are using pins $\frac{1}{4}$ inch in diameter and the head chainman places the pin so that its **REAR** side is at the 1,000-foot mark instead of placing the pin so that its front side is at the 100-foot mark. Then $\frac{1}{4}$ inch will be added to the one hundred feet at every measurement. $10 \times \frac{1}{4} = 2\frac{1}{2}$ inches.

Now when coming back, if the head chainman corrects his error and the rear chainman brings the zero point to the rear of the stake each time, this cuts off $\frac{1}{4}$ inch each time and the line will be $2\frac{1}{2}$ inches too short. Now you will fail to check by just 5 inches. By this time the cumulative error will be perfectly apparent.

The **compensating** error is not so bad. Such an error as missing the placing of a pin by $\frac{1}{1000}$ of a foot is not so bad because in one case it may be in one direction and in the next case it will be in the other. By the law of chance it is as likely to be one way as the other. But do not think that it is a good plan to depend on this law. It often proves the undoing of the one who depends on it. **Try to abolish all errors, both compensating and cumulative**, and in spite of your best efforts there will be plenty of errors and some to spare.

Remember that it is easier to make a mistake of 100 feet

than of one foot, and that in your figures it is as easy to make a mistake of 1,000 as of 1 or .01.

How to Turn Off a Right Angle With a Tape.—It often becomes necessary to turn a line at right angles, in order to pass an object while measuring a line or in order to find the direction of a “right line” from a point in the line. To do this one should measure back 8 feet on the line from the point at which the line is to be turned off. At the point, 8 feet back from the turning point, set a pin exactly on the line. Now, with the zero point held at the turning point or stake, scratch the arc at the 6-foot point at what you believe to be right angles to the main line. Make the arc cover several degrees, in order to avoid any delays. Now, with the zero point held at the point 8 feet back on the main line find the point in the scratched arc where the 10-foot mark crosses the scratch. The point is in a line which is at right angles to the main line at the original turning point. The foregoing is based upon the fact that the square of the base plus the square of the side of a right angle triangle is equal to the square of the hypotenuse. $8 \times 8 = 64$; $6 \times 6 = 36$;
 $10 \times 10 = 100$; $64 + 36 = 100$.

In case of long lines, one may use 60 feet, 80 feet and 100 feet. This gives greater accuracy. In case the transit is handy it is usually advisable to turn off the angles with it. It is quicker. By bisecting the right angle one is able to turn off the 45 degree angle with little trouble.

INSTRUMENTS BY WHICH DIRECTIONS ARE DETERMINED.

The Compass.—(See Plate 1, Fig. 2.)—In the preliminary surveys of land the compass is often used to determine the direction in which lines should be run. The fact that the same end of a magnetized needle always points approximately north enables the instrument makers to design an instrument which can be used to determine the direction of lines. The magnetic

needle is balanced upon a pivot in the middle of a glass covered cavity. Around this cavity are the degree marks, by which one is able to read the number of degrees the line varies from the approximate north and south line. The engineer who wishes to do good work with a compass must exercise great care for the following reasons:

1. The "North magnetic pole" lies east of due north, and consequently at different points on the earth's surface the "declination" or "variation" from the true north and south line is different in extent. And what is more, the North magnetic pole does not remain in exactly the same place all the time. All good instrument makers give directions in their catalogues for the finding of the declination of the needle for different points in the U. S. at different times. By the use of these tables one is able to determine fairly accurately the direction of a line. (See Gurley's Manual.)

2. Local attractions often interfere with the needle of the compass, as for example, a bar of iron held near the instrument will draw the needle away from the true line. The presence of large bodies of iron ore are likely to draw the needle out of line and make the readings entirely wrong.

From the foregoing it will be seen that the compass, while an excellent instrument for rough work, is likely to prove of little value to the agricultural engineer who must do accurate work. For these reasons but little emphasis is laid upon the instrument here. The makers of good compasses furnish catalogues telling how to adjust the individual instruments and how to determine the North and South line, or the declination of the needle. (See Plate 1, Fig. 3.)

The Transit.—Transits are provided with a compass needle and graduated circle so that they may be used as a compass in case one so wishes. But they are also provided with circles so graduated that angles may be accurately measured with them. (See Plate 1, Fig. 1.)

The Architect's Level.—The architect's level is often provided with a magnetic needle and graduated circle by which

one may determine the direction of the given line. The same general rules which govern the errors in compass observations hold true when applied to the magnetic needle readings of the transit or the architect's level.

The Plumb Line.—By means of a weight called a “plumb-bob,” attached to a “plumb-line,” lines can be determined which are vertical to the earth's surface. As the center of gravity of the earth is presumed to be its center, then all plumb lines will naturally hang with the lower ends pointing toward the center of the earth. For this reason no two plumb lines can be exactly parallel. For by geometry we learn that two parallel lines will never meet, no matter how far they are extended. Now, as all plumb lines meet at the center of the earth, it stands to reason that they are not parallel. The best plumb-bobs are made of steel or brass, hollowed out on the inside. The cavity is filled with mercury. This is done to give the greatest possible weight for the size. (The wind does not bother such a bob nearly so much as a lighter one.)

The plumb-bob is an instrument which the surveyor must constantly use. It is simple, and under most conditions it is very accurate. It is sometimes influenced by the presence of great bodies of earth at one side of it, but for all practical purposes one need not hesitate to use the plumb-bob with absolute confidence.

Bubbles and Bubble Tubes.—The direction of lines is also determined by means of glass tubes nearly filled with ether. The tubes are not straight on the inside, but they are slightly bent. Thus, when the tube lies on the side the ether seeks the lowest level and the bubble of ether gas is forced to the highest point in the tube. As one end of the tube is raised the ether flows to the other end and the bubble seeks the higher end. In cheap levels the glass tubes are not accurately made and consequently are not sensitive to slight movements of the tube, but in the high-grade instruments the tubes are so ground that the slightest alteration in the position of the tube is instantly shown by the position of the bubble. The two principal uses

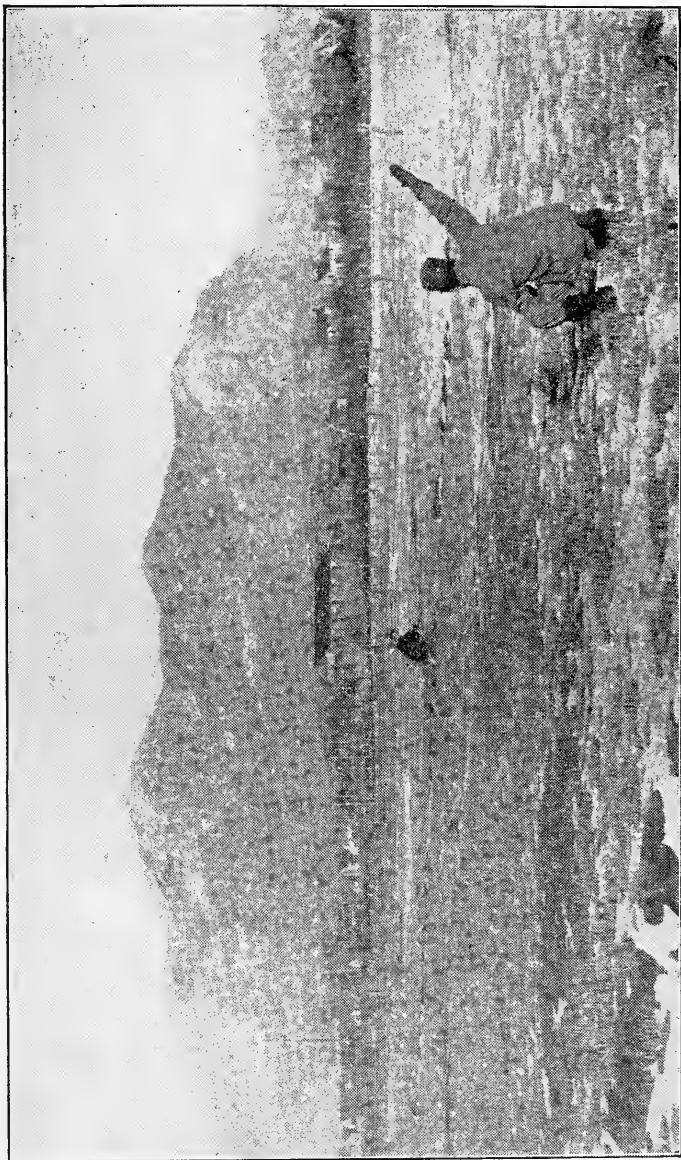

PLATE II. The engineer (in the foreground) is "Lining in" the head chainman. The engineer is signaling the head chainman to move the peg or pin slightly to the right before sticking it. The thin narrow steel tape is invisible in the picture. Bozeman, Montana, in the background. In the distance, nine miles away, towers Mt. Baldy.

of the bubble tubes are to determine (a) plumb lines; (b) horizontal lines.

General Principles Governing the Adjustment of Bubble Tubes.—It stands to reason that a glass tube so delicately ground as a bubble tube must be accurately set in an instrument in order to secure accuracy. Nearly all tubes are surrounded by a brass tube which is held by adjusting screws. The system used in setting the bubble tube consists of bringing the tube into such a position that the center of the bubble is directly under the center of the bubble tube. Then the position of the tube is reversed and if the instrument is in perfect adjustment the center of the bubble again comes under the center mark of the tube.

Examples.—To Adjust a Carpenter's Level.—First, lay the level on a solid base and block up the lower end until the bubble comes to center. Now carefully change ends with the level. If the bubble again comes to center the level is correctly adjusted. If it does not, then adjust for one-half the difference and repeat the trial until the correct adjustment is arrived at. **To Adjust the Plumb Bubble.**—Draw a line on a vertical wall along the side of the level when the plumb bubble is in center of the tube. Now turn the level on the other side of the line with the same edge (the bottom of level) to the line. If the bubble centers then the plumb tube is in correct adjustment. If not, adjust for one-half the difference as before.

In the first place we make the axis of the bubble tube parallel to the bottom of the level. In the second place we make the axis of the bubble tube at exactly right angles to the bottom of the level. Thus we can determine a horizontal or "level line" and a vertical or plumb line by the same instrument (the carpenter's level).

In the case of the small bubble tubes on the compass and transit bases, the object is to make it possible to adjust the base of the instruments so that they will be level. In the case of those tubes beneath the telescopes, the object is to make the "line of sight" level, or parallel to the axis of the bubble tube.

Thus, in the eye level the axis of the bubble tube may be parallel to the line of sight and accurate work may be done, even though the wyes are out of adjustment. But in case the wyes are out of adjustment the instrument must be leveled up each time the tube is revolved upon the vertical axis.

*All makers of good instruments furnish directions for adjusting their instruments, and these directions should be followed carefully. All instruments which are so made that their accuracy depends upon bubble tubes should be handled with great care and frequent trials should be made in order to be absolutely sure that none of the adjustments are "off." For it must be remembered that the engineer's reputation often depends upon the accuracy of his instruments. It is much easier and **by far** more satisfactory not to make errors than it is to try to explain how the errors were made.

PHOTOGRAPHY.

While it is not absolutely necessary for an Agricultural Engineer to be able to take photographs, yet in no other way can he so plainly describe and show his work as by a photo. The United States Government requires photos of the different federal enterprises, as they progress. This not only gives a clear and definite idea of the rate of progress, but it serves as a record of the work after it is done. If the Engineer is able to photograph his work it helps him in many ways. It shows up the work to the best advantage. It saves a great deal of time and labor which would be required in making drawings to show progress. And in case of legal proceedings the photo is absolute evidence. The photos are also useful in showing prospective clients the work which you have accomplished.

For the above reasons it is well to have a camera and to be able to take photos with it. (See Plate 3, Fig. 6.)

*See Gurley's Manual. It is a good text book of American Surveyors' Instruments. Also Burger's Catalogue.

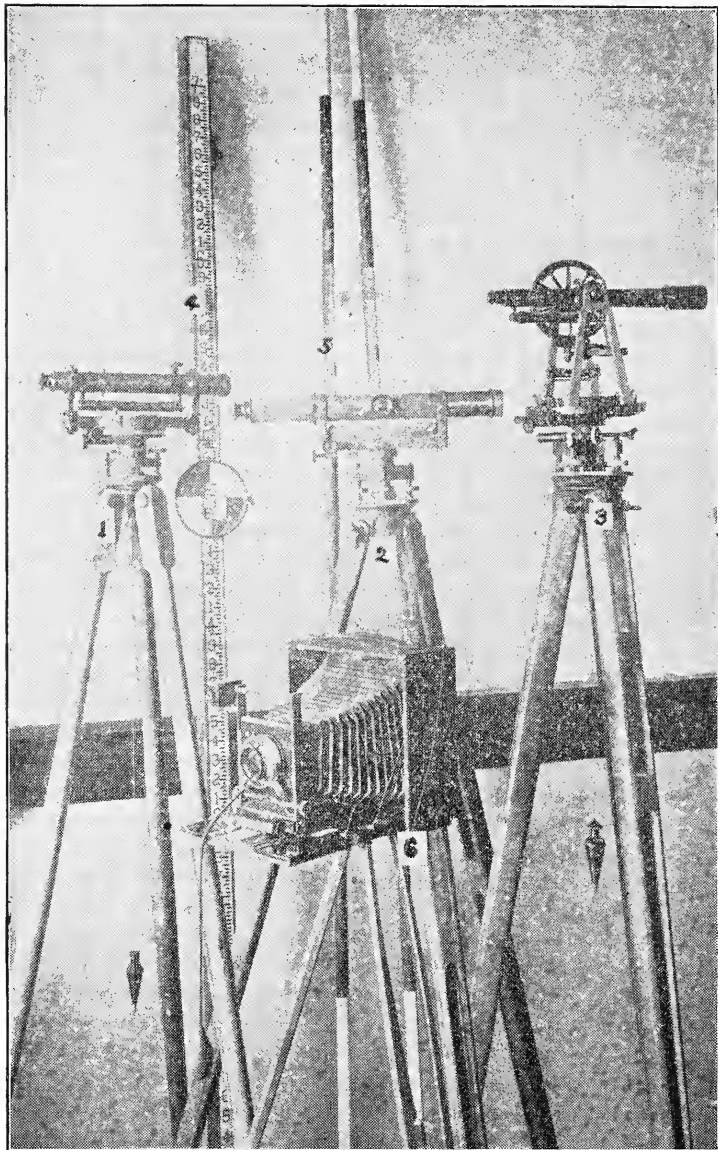

PLATE III.—No. 1. Architect's level. This level is of the Wye type with Compass box and circle graduated in degrees.

No. 2 is a regular type of Dumpy level. Notice the absence of Wyes.

No. 3. A transit with vertical circle.

No. 4. A Philadelphia rod with target.

No. 5. Two steel flag staffs, or "range poles."

No. 6. A 5 in. by 7 in. camera valued at \$180.00 with which most of the pictures in this book were taken. (A cheaper camera could have been made to do better work where water is shown.)

The Camera.—From the standpoint of the Engineer, the most expensive is not always the most desirable camera. The most of the pictures in this book were taken with a \$180.00 camera. Yet in those pictures which show movement there is a blur which would not have been shown by a camera of the Rapid Rectilinear type, which could have been bought for \$15.00. A simple, easily adjusted camera with a lens which can be depended upon to take instantaneous exposures in bright light is the most suitable for the Engineer. The author has had in his charge cameras ranging in price from \$5.00 to \$200.00, and for field work there is no doubt that the simple camera with a simple lens and shutter is more suitable for the Agricultural Engineer. An Engineer cannot take the time necessary to do "artistic photography" as the term is understood by the photographer. What is needed is clear pictures bringing out plenty of contrast and detail, regardless of the artistic blending of light and shade, so necessary to portrait work.

Every company furnishes directions for the manipulation of the cameras. A few simple solutions, two or three granite iron pans, a printing frame and a dark closet provided with a simple "ruby" light will often take the place of a wheelbarrow load of patent developers, fancy automatic devices and expensive apparatus which some people think they must have in order to do photographing.

The detail of the work cannot be taken up here, however. The student will find that photography, as the Engineer needs it, is simple, and he will find that every day new cases arise which enable him to save time and add to the efficiency of his work by the use of a camera.

LAND SURVEYING.

Land surveying is done for one of two general purposes. In the first place, the surveying was done to establish the boundary lines of townships, sections, etc. The boundaries were supposed to be marked permanently by so-called "monu-

ments," constructed of stones, pegs, stumps, trees, holes in the ground or holes filled with charcoal. The stone and the charcoal monuments lasted pretty well but the holes in the ground filled up, the pegs, stumps and trees rotted away, and the second use of land surveying becomes apparent.

It is to locate the old corners, re-establish them or if need be, locate new ones. In order to do this work correctly one must do it according to United States regulations. These rules are very clearly given in the little circular entitled "The Restoration of Lost or Obliterated Corners and Sub-divisions of Sections." Write to the United States Land Office, Department of the Interior, Washington, D. C., for this circular. Follow

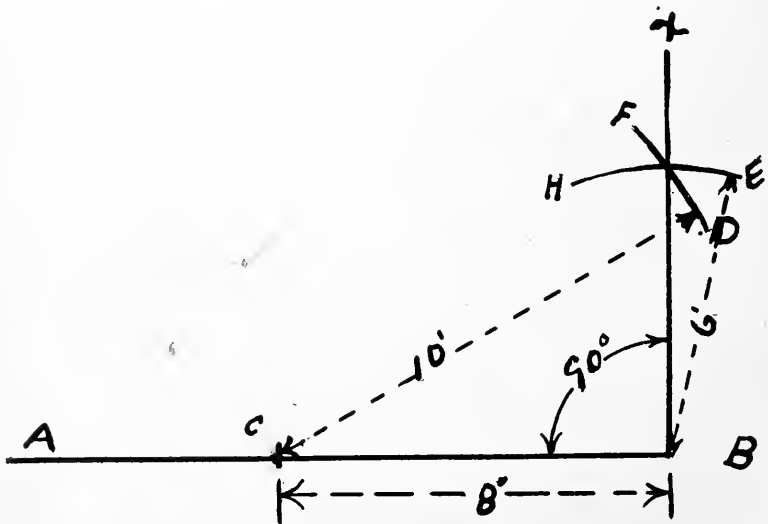

PLATE 4. In running the line AB, the engineer found it necessary to turn a right angle at B. He measured back 8 ft. to C, and struck the arc FD, 10 ft. from C. Then he struck the arc HE, 6 ft. from B. By drawing the line from B through the intersection of arcs FD and HE, he obtained the line BX, which is at exactly 90 degrees to AB.

its directions and do not try to do the work according to any other method. Where a question of law is concerned, do not permit theoretical considerations to interfere with the rules which are so plainly laid down.

It is often necessary to determine the area of irregular fields. For the surveyor who has not had higher mathematics this work requires more field work than for the surveyor who has a thorough knowledge of higher mathematics. However, the work can be done, by dividing the fields into right angled triangles, and applying the formula. The area of a right angle triangle is equal to $\frac{1}{2}$ the product of the perpendicular and base.

With a compass, a transit, or an architect's level set up at a point on a boundary line which in your judgment will be the point at which a perpendicular from a certain corner will meet your boundary line. Turn off 90 degrees and by repeated trials locate the desired point. Now with a tape measure the base and the perpendicular lines of the triangle. Multiply one by the other and divide by two to get the area of the triangular part of the field. Continue until the field has been divided into right triangles and all of these have been measured. Now add the areas of all and the sum will be the area of the irregular field.

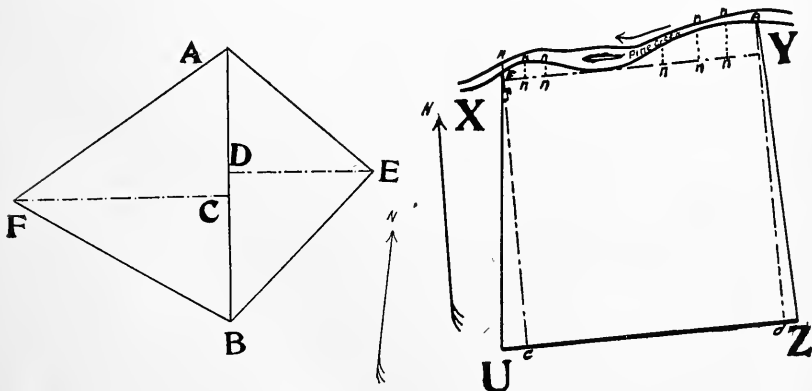

PLATE 5. Fig. 1. In figure 1 the field AFBE is first divided by line A D, then each of the fields is divided into two right angle triangles. The area is equal to the sum of the four triangular fields.

Fig. 2. In figure 2 a field of irregular shape is bounded on one side by a crooked line (Pine Creek). After the right triangles Uce and Zda have been laid off, the line X Y is laid off at right angles to ce and d B. Then the short lines N N N N etc., are measured and the small pieces of land calculated. The sum of all the subdivisions will equal the area of the field.

Example: (See Plate 5, Fig. 1.) In this example it happens to be easier to establish a new line A B upon which to set up the instrument.

The line A B is first established. Then the point C is located by trials. The area of A C F is equal to $(AC \times FC) \div 2$.

Now locate D by trials so that E D is at right angles to AB, then the area of ADE will equal $(AD \times DE) \div 2$, and the area of DEB will be equal to $(DB \times DE) \div 2$. Now all the different parts of the field have been measured and all that remains is to add the areas of the four triangles and the result will be the exact area of the field.

When the lines of a field are curved, as by a creek bank, it often becomes necessary to use ingenuity in determining the area. It is usual to lay off as much of the land as possible in fields having straight lines and then determine the area of the remainder, as in example given below. (See Plate 5, Fig. 2.) The area of C F B is equal to $(FC \times CB) \div 2$.

Determine area of U X Y Z, as in case of field having straight lines for boundaries. You will have to lay out X Y. Now at frequent intervals measure the distances n, n, nn, nn, etc., and compute the small areas as accurately as possible. Add them all to the area of XYZU and the area of the field is obtained.

Caution.—Always use the same units of measure on the field and when the results are obtained in the same units one may then change these units to any other units as desired. Do not measure one triangle in feet and inches, another in feet and tenths and still another in rods, feet and inches. **Stick to one unit of measure.**

To Determine the Area of An Irregular Field by Means of the Polar Planimeter.—If the student has an accurate drawing outfit, including a good and accurate protractor, the work of calculating the area of an irregular field is not so difficult.

Measure the sides of the field accurately and the angles exactly. Now draw a map of the field to some scale, taking great care to make each angle and line exactly at the right

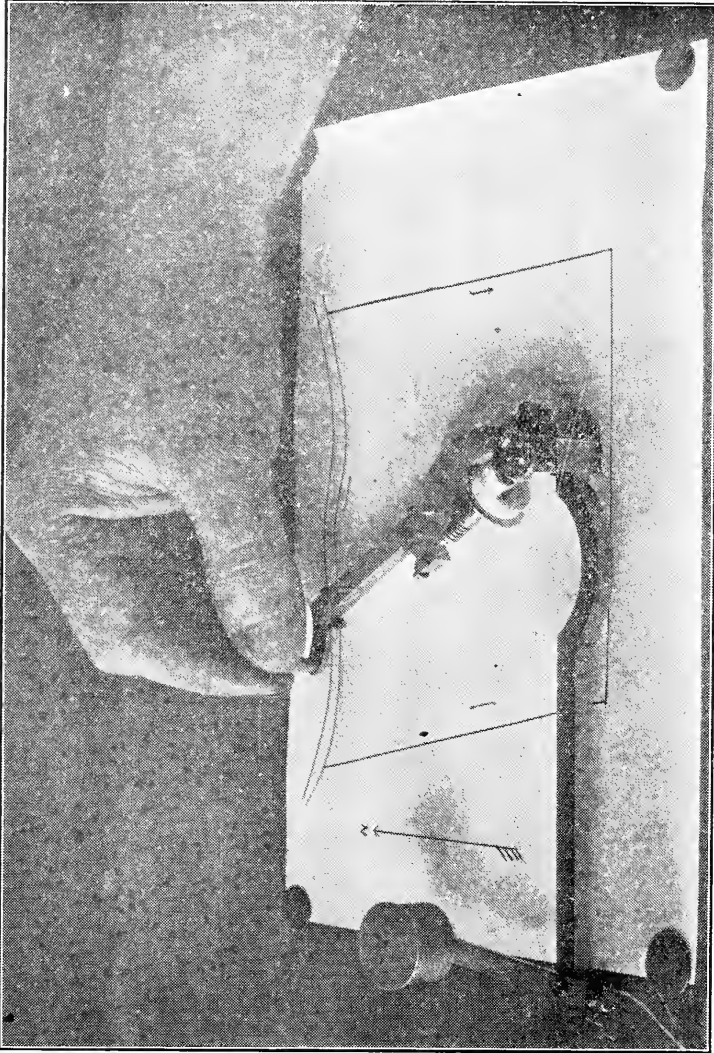

PLATE 6. Cut 6 is a photo of a hand carefully tracing the point of a Polar Planimeter over the boundaries of the field shown in the map. The point was moved in the direction indicated by the small arrows. When the point has been moved around the field the planimeter indicates the number of square inches in the map. (See catalogue of makers for detailed instructions.)

angle and of exactly the right length. By means of the Polar Planimeter the **exact** area of the field as mapped may be determined in square inches. Now suppose that we let each rod of the field (a small field) be represented by one inch. After measuring the map we find that it has exactly 92.65 square inches of area included inside the boundary lines. Then by dividing the total number of square inches of area by 160 (the number of square rods in an acre) we get .5790 of an acre.

This is all right for a small field, but suppose the field to be larger. Then we may let one-tenth inch equal a rod and then each square inch will equal 100 square rods. So after the number of square inches in the map has been determined we multiply by 100 and divide by 160 to get the number of acres. Any scale may be used, but when a very small map is made for a very large field the error is likely to amount to too great an area.

The planimeter should be used with great care and the area of the map should be measured not less than **three** times. If the answer varies more than one one-hundredth of an inch the work should be repeated until the answer checks within one one-hundredth of a square inch.

The different styles of planimeters vary so much that no exact rules can be given here, which will govern the use of the individual instrument, but a few general rules are not amiss.

1. Never try to run a planimeter when excited or nervous, as the shaking of the hand will spoil the accuracy of the work.

2. Always draw the map on a **good, strong** paper and do not let it become wet after the map is made. The swelling and the distortion of the paper will spoil the accuracy of the result.

3. Never draw the map with a blunt pencil. Always use a sharp pencil of **hard** lead. The error of the width of a thick line is often great.

4. Be careful to get all lines **the right length**.

5. Be sure to lay all angles off **exactly right**. In general, **be accurate**.

To Run a Division Line Through an Irregular Field Cutting Off a Certain Number of Acres.—The Line to Be Parallel to Another Straight Line.

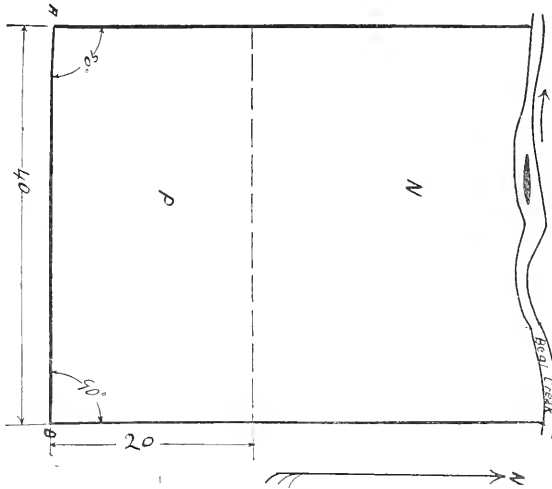

PLATE 7. Example. Run a line through the field in Cut 7 so as to leave seven acres next Bear Creek's. The line to run parallel to the line A B. First we find that the side A B is 40 rods long. The angles are right angles (90 degrees). The field contains exactly 12 acres. We now subtract 7 from 12 leaving 5. Then as field N must contain seven acres we know that field P will contain five acres. Dividing the total number of square rods in five acres by forty (the length of A B) we get twenty rods as the width of the field P. $160 \times 5 = 800$ square rods in five acres. $800 \div 40 = 20$. We now measure off twenty rods along each side and establish line which divide the field at exactly the desired point, and at the same time it is parallel to the line A B.

It often happens that a field has but one irregular side. If the corners are exactly 90 degrees and the three sides straight, then all that is necessary is to subtract the required number of acres from the total number of acres. Measure off the necessary distance along the side lines and establish the line.

But suppose the line must join the irregular side of the field. The question becomes harder. Now by higher mathematics one could calculate the location of the line. But with the planimeter the Agricultural Engineer can locate it in a

short time. First, calculate the area into the units of the map, (square inches). Now draw in a light line parallel to the desired line at the place where you estimate the line should be drawn. Try with the planimeter. Keep trying new lines until the desired area is cut off. Be sure that the line is parallel to the desired line. Now measure off the distance which this line is from the line to which it is parallel, change to rods and proceed to measure off the distances in the field.

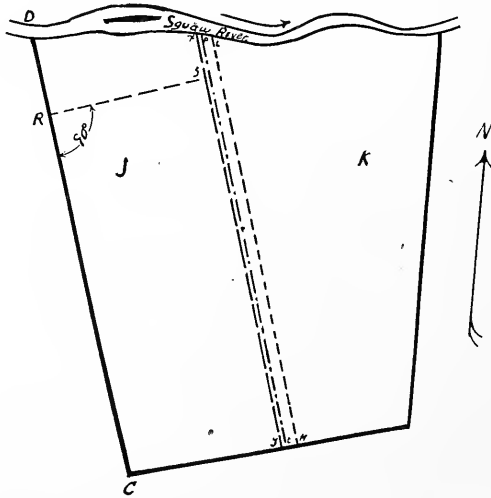

PLATE 8. Example. Run a line parallel to C D to cut off four acres from the field next Squaw River. The field has no angle of 90 degrees. The field is first found to contain 9 acres. This is found by making the map, but it is not absolutely necessary information. It does however guard the engineer from trying to cut off more than the field contains. The map is drawn to scale and a trial line L M is drawn (lightly). Field J is measured with the Polar Planimeter. It is too large. Second trial line P T proves nearly correct. Line X Y proves to be right. The distance C Y is measured on the map and the units changed to rods. A right line from some point on D C near the river end of the line is now measured and its length changed to rods. Now go to the field and lay off the distance C Y and R S and establish line X Y in the field. Field J contains the correct area and X Y is parallel to C D.

By the use of an accurate map and the planimeter the Engineer can perform all of the divisions of irregular fields which may come up. But in all this work he **must be accurate.**

Caution.—It is not safe to take a farmer's word for the

size of an irregular field. The engineer is likely to find that a field has a much greater or less area than the farmer tells him the field contains. One is likely to find himself trying to cut ten acres off a seven acre field if one does not first determine the area of the field.

MAPS AND DRAWINGS.

Instruments.—While it is very desirable to have a large and expensive mechanical drawing set, it is by no means necessary to good work.

A board, 12" x 14", with one end planed until it is straight and smooth is all that is necessary for ordinary work.

(For planimeter work, a large board 30" x 36" should be used.)

A "T" square for horizontal lines.

A 45 degree triangle. (About 6".)

A 30-60 degree triangle. (About 5".)

A right line pen.

A set of combination dividers, which carry either points, pencil or pen, for circular drawing.

A triangular scale with the inches divided into tenths, twentieths, thirtieths, etc., is necessary for this work.

A protractor with which to lay off angles is also very desirable.

Plain drawings should be made on heavy paper. These drawings should be made in pencil first, then inked in with black waterproof ink.

The title of the drawing should describe the land which it portrays, and the scale, 1 inch equals 1 rod, or 1 inch equals 10 rods, etc., should be placed in plain sight.

An arrow pointing north should also be placed in some conspicuous place on the drawing.

In case of creeks, arrows should be placed either in the creek or along the bank to show direction of flow. In case of tile drains or irrigation ditches, this is also necessary.

In the drawing of maps remember to use the sign (') to represent feet and the sign (") to represent tenths of feet, not inches. It is well to write out the dimensions in full if the drawing is of great importance. Thus 9 feet or 17.8 feet. This excludes all possibility of error. Many do not use the sign (") at all. Thus they write 17.8', which is all very well unless the point happens to be rubbed out.

In general, make the drawings accurate rather than artistic, plain rather than flowery, simple rather than technical.

Fences.—After the boundaries of a field have been decided upon it becomes necessary to fence it. The fencing of fields has been practiced to some extent since the history of agriculture began. In the first place the methods were crude. Lines of stones were laid upon the ground and more stones were piled on top of them until a kind of barrier was formed. Tree trunks and brush were also used as fences. These methods of fencing, though crude, are used in some parts of the United States today. Later boards were brought into use as fencing material. They are used today in many parts of the country, especially where tight board fences are built. These serve as wind-breaks, as well as fences. Pole fences have also been used a great deal in the United States for confining live stock and for protection from the attacks of hostile Indians.

By far the greater part of the modern fencing in this country is now done with wire. The wire may be smooth or barbed. It may be strung upon poles in single strands or it may be woven into the form of wire netting. The latter is much the better for use in the fencing in of horses and well-bred, valuable cattle. It is also to be preferred as a hog or sheep fence, because it renders it next to impossible for the animals to escape.

It is to be preferred to single strand fence because it is more effective as a barrier and at the same time it turns the

stock without injuring the animals in the slightest. Many a farmer could well afford to take down his barbed wire fence and replace it with the best grade of wire net fence. The loss caused by the old barbed wire fences has in many cases run into the hundreds of dollars in a single night. (Night thunder storms often frighten horses into the wire fence which cannot be seen in the darkness.)

For the fencing of hogs and cattle a wire net fence of about 36" to 40" surmounted by two or three well stretched barbed wires makes an excellent barrier, both from the efficiency and the humane standpoints. For horses it is well to use a netting fence not less than 48" inches high with one or two No. 8 smooth wires tightly stretched above the netting.

The question of wire has already been settled very satisfactorily. We can buy fence that will hold out mosquitos, stronger fence that will resist chickens or small pigs, still stronger fence that is capable of turning hogs, cattle and horses, and some companies now build fence that will turn Buffalo, elk and the fierce lions of the African frontier.

But the post question has not been so successfully answered. Wood posts are becoming scarce, and the price is constantly going up while the quality and the size of the posts are just as rapidly going down. So far no iron posts have been built which are sufficiently cheap and strong to justify their extensive use on the farm. The logical solution now seems to be the substitution of **strongly reinforced cement posts** for the wooden ones.

Many companies have built molds for the manufacture of cement posts. These molds have almost invariably molded a post which does not contain sufficient cement and sand to withstand the pressure, no matter what shape or form was given to the post. Furthermore no matter how much reinforcement was used the cement could not stand the pressure. And it should be clearly understood that the reinforcement in posts should be of **iron** and placed in the **corners** of the posts. In case the posts must resist animals upon both sides of the fence the posts should be **round** or **square**, not of the triangular

type. **Wood reinforcements** for posts are not satisfactory. The wood swells and bursts the post. Then it shrinks and is loose in the cement. Some salesmen claim that water cannot pass through the cement and moisten the wood, but experience does not support the theory.

Some companies are now building very good cement posts but the cost is not so low as to meet the competition of good wood posts. The engineers and salesmen of many companies set up the claim that their posts are strong enough to withstand the wind load and that that is all that is required. Posts built upon this theory are as a rule not sufficiently strong to provide a suitable rubbing post for a small cow. Should a hunter climb over such a fence he almost invariably cracks the post upon which his weight comes. This kind of theoretical design has put the cement posts into disrepute in many localities. The claim that "Our cement post is as strong as any wood of the same size," is usually not backed by actual tests.

"The Bulletin on Concrete and Cement Fence posts," (Colorado Bulletin 148), by H. M. Bainer and the Author of this work gives the results of actual tests with both Cement and Concrete fence posts. The best cement and a good grade of sand were used. The posts were well made and properly cured. Yet in no case did they approach in strength a new wood post of their size. As this bulletin is free and gives the results of tests on several hundred cement and concrete posts, the student should by all means avail himself of the information. The theory of the reinforcing material and the placing of it in the post is thoroughly taken up in the bulletin.

There is no doubt that a very good concrete or cement post can be built which will last longer and look much better than the wood posts which are now being sold.

Setting the Posts.—There is no rule which can be given as to the depth which a post should be set. In some soils a post need not be set more than 18 inches deep while in others the depth must be from 3 feet to 4 feet. The post should be

set sufficiently deep that it may resist a side thrust sufficient to break it at the ground line.

“How strong should a line post be?” is a frequent question.

This is a question which must be answered according to the local conditions. A post which projects four feet from the ground should stand a side thrust at the top, of at least 300 pounds. This is less than a $3\frac{1}{2}$ " x $3\frac{1}{2}$ " new spruce post will stand.

Before the engineer contracts for a quantity of cement posts he should test several samples according to the following directions: (See Plate 9.)

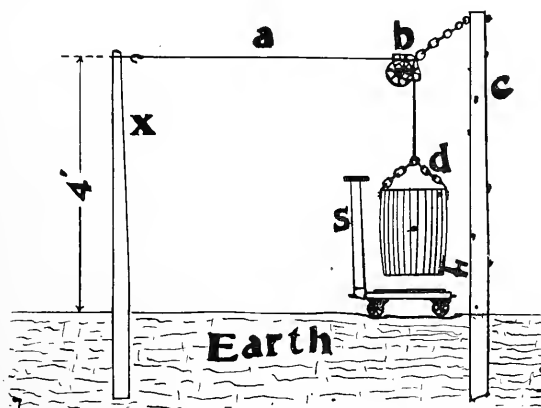

PLATE 9. The drawing Plate 9 shows how a cement post may be tested. The hitch of the rope a is just 4 ft. above the ground. b is an easy running pulley. d is a barrel which is supported above the scales. s. c. is a wooden post firmly set in earth. The weight of barrel plus the water which must be added to break the post is the breaking strength of the post. After the post breaks the water may be taken from the spigot and used in the testing of the next post. The water should be added slowly until post breaks. In case the scale platform cannot be held off the knife edges which it rests on while weighing, the barrel should be caught by a cross plank and let slowly down to the scales. Many other pieces of apparatus may be built to do this testing.

Corner posts and gate posts must be much stronger than line posts. It would be necessary to know the type of fence before the size of post could be determined. This subject is

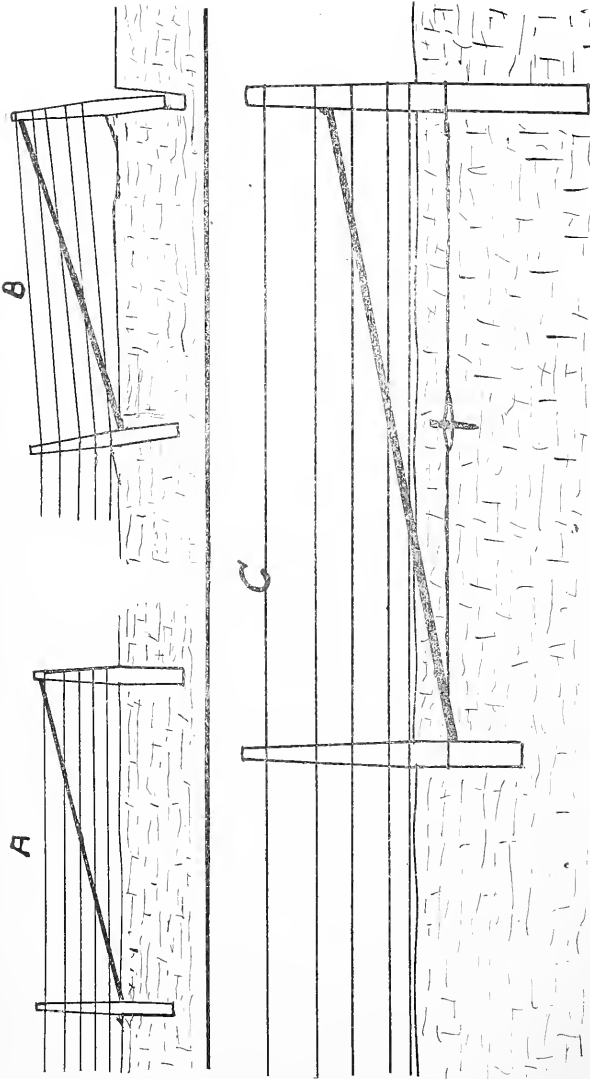

PLATE 10. The drawing A, Plate 10, shows the wrong method of bracing a gate post or corner post. The pole or pipe brace rests against the top of the gate post and against the "corner post" at the ground line. Now if the top of the posts is moved by the wires the ground has little chance to resist the action of the posts which act as levers. Only that portion of the earth near the top has any chance to resist the action of the wires and the surface is nearly always comparatively soft. Then, too, the brace tends to lift the gate or corner post. The shorter the brace the worse the lifting effect. Drawing B shows the effect of the wrong system of bracing. The larger drawing C shows a much better system. The brace is one foot lower at the brace post and about two feet lower at the gate post. The large (No. 5 or 6) galvanized wires which join the brace post and corner or gate posts have been twisted by the iron peg until the corner is rigid. The gate post, or corner post and the brace post are so united that a complete resisting unit is formed. The brace post cannot give because it is attached to the corner post. The corner post cannot give because the brace post supports it by means of the brace. It cannot lean over because the brace pushes it back at the top and the wire holds it vertical at the bottom. All that is left is to stand erect or move along in its present position. The lower layers of earth are so solid that it is almost impossible for it to move. (See the results of corner and gate tests at Colorado Experiment Station in Bulletin No. 148.)

also thoroughly taken up in the cement post bulletin above mentioned.

Treatment of wood posts to lengthen the period of usefulness. There are many ways in which a wood post may be treated in order to preserve it. Coal tar when smeared upon the post, from the ground line down will prevent rot. A good oil paint will also do good work as a preservative.

If an iron tank is available it is a good plan to dip the bottom of the post (up to 4" above ground line) in boiling linseed oil. But the cost of linseed oil is such as to make this expensive. Perhaps the most effective way of preserving wood posts is by means of the creosote treatment. The wood is treated **under pressure** with creosote and this renders the wood unfit for habitation of the myriads of tiny insects, fungi and bacteria which cause wood to decay. This treatment requires expensive apparatus and is consequently not in general use so far as fence posts are concerned. It is used extensively for the treatment of railroad ties and salt water piling.

For the bracing of corner posts and gate posts, see drawing 10.

BRIDGES AND CULVERTS.

In many fields we find creeks and ditches. In order to cross these creeks or ditches, some farmers resort to piling in brush and then covering the brush with manure or dirt. By so doing they often cause more damage to be done than the price of a new and permanent culvert would have amounted to in the first place. The brush culvert is likely to work all right for a while, and then at the most inopportune moment it may break down or clog up, and the surrounding field is inundated. This not only destroys the crops but it is likely to cause ditches to be washed in the land. Another point which is often overlooked is the fact that the size of the loads which are hauled over these improvised affairs is often limited by them. The teamster often unconsciously lightens the load

rather than run the risk of "sticking" his team in the ditch. Again the fact that teams of young horses are so often unable to pull through these ditches causes a great many otherwise good horses to be balky, and consequently next to useless. The subject of Bridges and Culverts will be taken up under Farm Engineering Part III.

It should be mentioned, however, that all bridges and culverts should be made strong enough to carry more than the load to which the hauling of grain will subject them. If there is any possibility that a threshing machine and engine will have to pass over the bridge it should be designed to carry not less than twenty-five (25) tons. The up-to-date traction engines are being made larger and heavier and at present many have passed the twenty-ton mark.

The culverts should be placed where they will give the most service with the least travel, and at the same time offer no hindrance to the free flow of the water in the ditch or creek.

The size of the water-way beneath the culvert should be large enough to allow the water to pass under the culvert, even in time of heavy rains. The foundation should be strong enough to prevent the washing out of the culvert or bridge by swiftly moving flood water, or the jamming out of the culvert or bridge by rapidly moving ice.

In order to properly design such a bridge for a large stream the engineer must often do a great deal of field work and calculation. But for the smaller creeks, drainage ditches and irrigation ditches the work can be accomplished by the exercise of a little common sense.

In case the bridge must span a mountain torrent, however, there is need for care no matter how small the normal stream may be. The student should carefully study bridge and culvert design in Part III of Farm Engineering.

DRAINAGE AND IRRIGATION.

When the field has been laid out and fenced, the field engineering work is by no means complete.

In nearly all of the fertile sections of the United States, and in fact in nearly all of the fertile sections of the globe, the yield of desirable crops is governed, not by the abundance or scarcity of plant food in the soil itself, but by temperature and moisture conditions in the air and in the soil.

It is almost impossible to influence to any extent the temperature or the moisture content of the atmosphere, but we can govern to a large extent the moisture content of the surface layers of the soil to a depth of from four to six feet. The principal means of controlling the moisture content of the soil are:

- A. Drainage.
- B. Irrigation.
- C. Combined drainage and irrigation.
- D. Scientific cultivation.

Drainage.—While we hear a great deal of talk, and read a great many well written articles on the subject of irrigation, we must admit that the greater part of the work of reclamation and improvement comes under the head of Drainage. Not only do we need drainage in the naturally wet lands, but in many irrigated sections, drainage must be resorted to in order to keep the soil in a fit condition for crop production.

Topography.—In order to determine the lowest or the highest portion of a field, the grade of ditches or the proper location for ditches, either drainage or irrigation, we must be able to make a map of a field, which will show just what points are the highest, the lowest, and what points are on a uniform grade from the highest to the lowest.

The map will describe not only the boundaries of the field, but it will show at a glance the "lay of the land."

1. **Stadia Surveying.**—This is done by means of a transit and a stadia rod. The three cross wires of the transit enable

the surveyor to tell how far the stadia rod is from the instrument. At the same time he can read the elevation on the rod by means of the center cross wire. He then reads the vertical circle, and by higher mathematics the exact relative elevation is obtained. This method, when used by experienced surveyors enables them to make rapid progress in the work, but the work when completed, is not absolutely accurate. In the preliminary work of railroad location, or in the running of large canals for long distances, it is a very good method of mapping the contour of the land. Then, after the map is made, the railroad or the ditch may be located on the map and later on it may be laid out in the field. As stadia work is not necessary for ordinary field engineering, no further attention will be given it here.

2. Level and Rod Surveying.—The surveyor's level and rod may be used intelligently, easily, and very accurately by anyone who understands plain, ordinary Arithmetic.

Before going into the field, the engineer should see that his level is in adjustment. Do not guess at this. Do not assume that the maker has adjusted the instrument before sending it out. Beyond a doubt the instrument was in adjustment when it left the factory, but a railroad journey often puts a level out of adjustment. If the level sets in its case or on the tripod during a rough wagon journey, it is likely to be put out of adjustment. Be sure of the adjustments before you begin to "Run Levels" over your field. The few minutes of time required to check adjustments are always well spent.

The Philadelphia Rod is one of the most satisfactory levelling rods for the Agricultural Engineer. (See Plate 3, Fig. 4.) Do not make the mistake of thinking that only an Architect's rod will work with an Architect's level. This is not the case. The Philadelphia Rod reads to feet, tenths of feet, and hundredths of feet without the use of the target, while by using the target we may, (by means of the Vernier) read to thousandths of a foot.

Now that we have a properly adjusted level, and a suitable rod, we will proceed to run levels over a certain field.

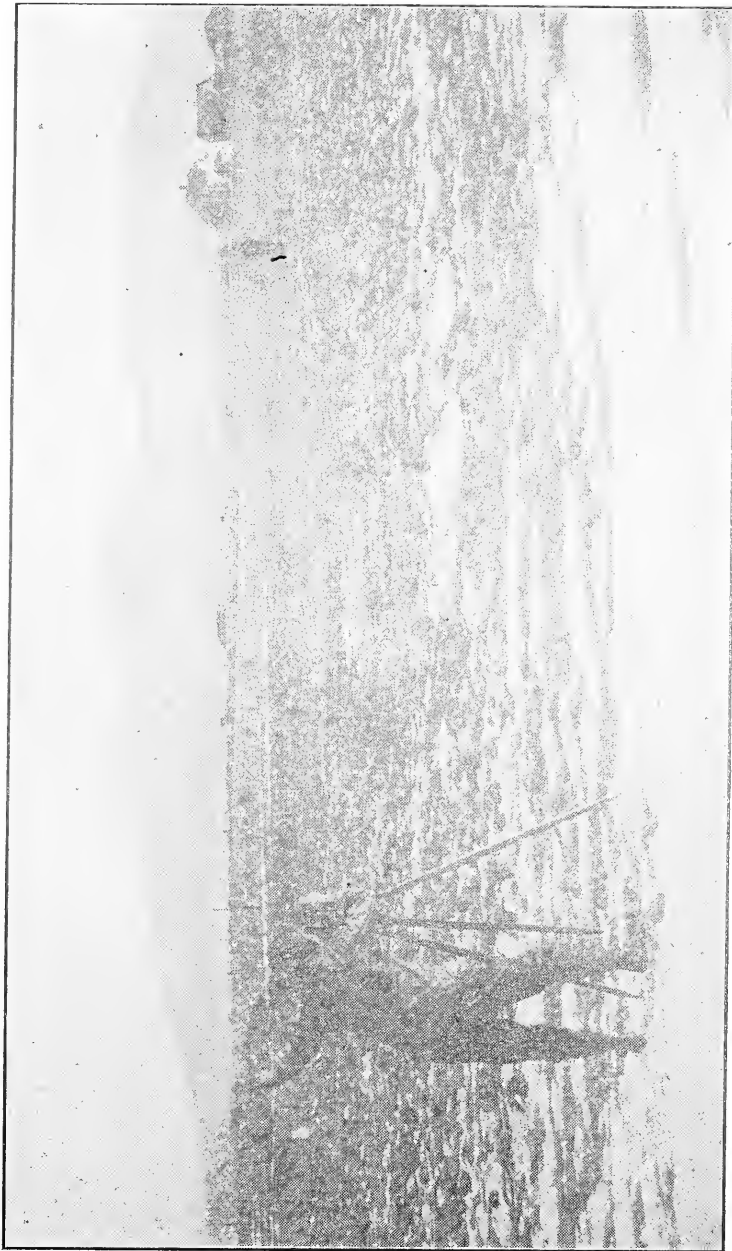

PLATE 11. The man in the foreground is sighting at the target of the Philadelphia rod which the rodmán (in the background) is holding. The levelman is adjusting the focus of his instrument with his right hand while he motions to the rodmán to move the top of the rod to the left. The target (seen slightly below the rodmán's knees) is level with the instrument. (The ground rises towards the mountains.)

and the rod is placed upon the newly driven stake. The stake will be known as the "Bench Mark." We usually assume that its elevation is ten feet. After the level is firmly set and levelled, the engineer looks through the level, and after having directed the rodman to hold the rod perfectly vertical,* he carefully reads the number of feet, tenths and hundredths which the cross wire indicates on the distant rod. of sight from the level to the rod is level.

The reading is added to the original (assumed) 10', and the total recorded as the "height of instrument" (H. I.). The reading of the rod is recorded as the "Back Sight" (B. S.). Do the recording at once with a hard, smooth, pointed pencil. (See specimen notes, Plate 13.)

Now it is apparent that the center of the level lens is just as many feet, tenths and hundredths above the top of the "Bench Mark" as the reading indicates, because the line

Now the rodman changes location and places the rod upon the ground. The level is turned so as to bear upon the rod and another reading is taken.

The "Bench Mark" is designated as Station 0 (zero), and the new station is called Station 1. Whatever the reading of Station 1 happens to be, it is recorded under foresight (F. S.), and this subtracted from the H. I., will give the relative elevation of Station 1. The elevation is computed and recorded in the column under elevation (Elev.) and on the line given to Station 1.

The student will not notice that if the F. S. reading is greater than the B. S. reading, station 1 is lower than 0, and that if the reading is less than the B. S. reading, station 1 is higher than station 0. This point often fools the beginner.

Again the beginner often imagines that the height of instrument is obtained by measuring from the center of the

* The vertical wire enables the engineer to see whether or not the rod is being correctly held. The rod should "line up" with the vertical wire.

10 Acre Field of T. Jones.

Sta	Topog. Levels				Elev
	BS	HI	FS		
0	5.91	15.91		10	
1			5.39	10.52	
2			5.37	10.54	
3			4.86	11.05	
4			4.52	11.39	
5	5.05	16.40	4.54	11.37	
6			4.67	11.75	
7			4.17	12.25	
8			4.35	12.07	
9			3.90	12.52	
10			3.40	13.02	
11			2.40	14.02	
12			1.40	15.02	
13	5.41	7.61	4.22	12.20	
14			5.09	12.52	
15			5.01	12.60	
16			4.56	13.05	
17			4.66	12.95	

PLATE 13. The notes shown in Plate 13 are the notes which the engineer took in mapping the ten acre field of Mr. T. Jones shown in Plate 12. Notice that Station O is given an assumed elevation of 10'. This is done so that if a lower point is found it will not have a "Minus elevation." The three dots inside a circle indicate where the level was set up. Notice that it is not over a station. By going over the map one can trace the movements of the engineer as he proceeded up the field. The student will notice that a Foresight is not necessarily on the opposite side of the instrument from the station upon which the Backsight was taken. The stations may be within a foot of each other, but the one with the known elevation is used for the back sight while the one with the unknown elevation calls for the Foresight. The above process is known under the term of *Differential Levelling*. The length of the Backsight and the Foresight to the turning point should be nearly the same distance. This must be remembered or errors are likely to creep in. It is not necessary if the instrument is in perfect adjustment.

tube to the ground. This is not the case. The height of the instrument is the distance which it is higher than the elevation of the station upon which the last backsight was taken.

The engineer is now able to "prospect" for a lower point of outlet for the drain. If it is found, he marks the place and turns his attention to the rest of the field. When he has taken a reading with the rod about as far up the field from the instrument, as the 0 station was down the field from the instrument, he signals the rodman to "hold the point."* He then proceeds to pick up the level and go to a point some distance beyond the rodman, sets up his level, and sights back at the rod. The reading is recorded under column B. S., and on the line given to the last station. Now, by adding the B. S. reading to the elevation of the last station. (which the rodman is "holding"), the new height of instrument is obtained.

More foresights are taken and the elevation of the new stations obtained. In this way the engineer proceeds to get the elevation of the chosen points. (Not the elevation above sea level, but the elevation above the bench mark.) Now he can figure out how much grade (drop or rise) per hundred feet he has, and where he will locate the drain.

Suppose that in a proposed drain of 4620 feet he finds that the total fall is 17' and 3" (seventeen and three-tenths feet). He divides the drain into 100 foot stations and thus finds that he has $46 \frac{1}{5}$ stations.

If the grade is uniform, he divides the total fall into 46 parts (ignoring the $\frac{1}{5}$ station) and finds that he may give each 100' of the drain $17.3 \div 46$ or .376 of a foot fall to the hundred.

He now decides on the depth of his drain at the outlet, and if the depth is the same at the head of the drain, he is now ready to compute the elevation of the bottom of the ditch at each 100 ft. station.

* The rodman must **make sure** that he does not sink the rod into the ground or raise it after the last F. S. is taken until the new B. S. is read. The station is known as the "Turning Point," T. P.

Starting at 0 he subtracts the depth of the drain from the elevation of 0 (10' was assumed) and adds to this reading the .376 foot for each station above. By continuing to add, he obtains the elevation of the bottom of the ditch at each station of the ditch.

P33

Ditch Grade of 10A. Field P31.

Sta	BS	HI	FS	Elev	Grade	Cut.
0	4.920	14.920		10.000	8.000	2.000
100'			4.420	10.500	8.375	2.125
200'			4.015	10.905	8.750	2.155
300'			3.755	11.165	9.125	2.040
400'	5.150	16.625	3.445	11.475	9.500	1.975
500'			4.852	11.773	9.975	1.897
600'			4.425	12.200	10.250	1.950
700'			3.902	12.723	10.625	2.098
800'			3.623	13.002	11.000	2.002

PLATE 14. Plate 14 is a page (33) of an engineer's note book. It shows how he laid out the ditch after the Topography map had been roughly made. He laid out his grade and then recorded the "cut" as he went along. The figures should be made with a hard lead pencil, so that they will appear neat and remain plain. (For Engineers' pocket field books see Frederick Post Catalogue.) Select what you want before ordering. See also Eugene Dietzgen catalogue.

He then proceeds to lay off his station points with a tape. A stake is driven into the earth and the number of the station is plainly written on the stake with a crayon or soft pencil. These stakes locate the ditch. Now at a distance of 2, 3, or 4 feet, (depending upon the size of the ditch) to

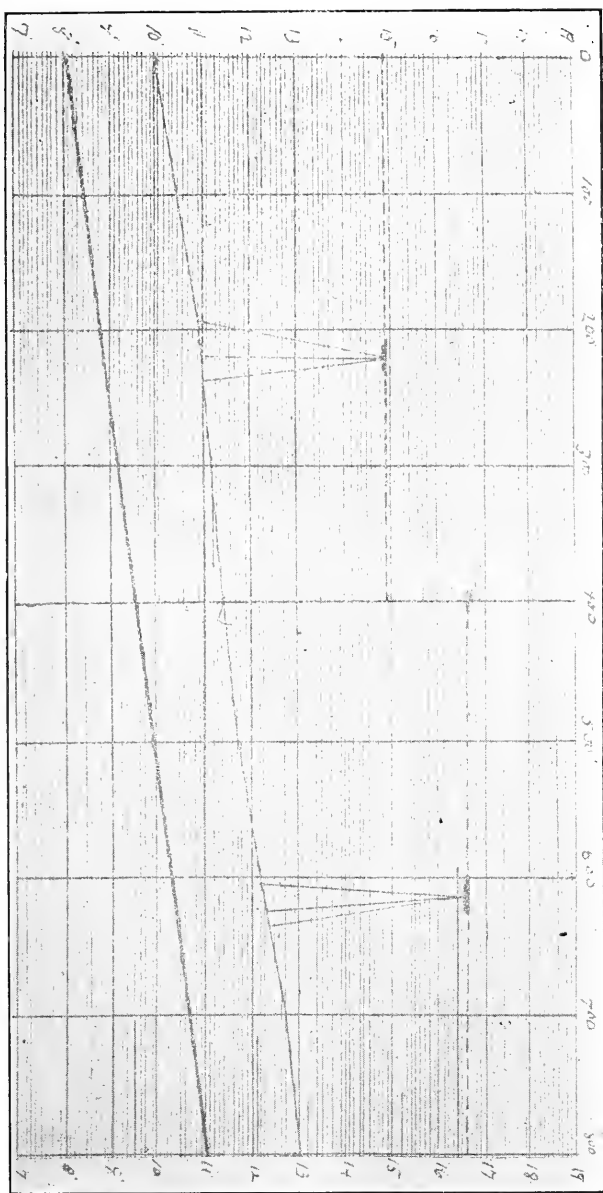

PLATE 15. Plate 15 is a section through the earth following the 840 ft. of ditch laid out in Plates 12 and 13. Each of the heavy horizontal lines indicates one foot of elevation. Each light line represents 1-10 of a foot. The vertical lines represent 100'. Notice that this is not a mechanical drawing in the true sense of the word. It is not in true proportions. It would be impracticable, as well as unnecessary, to make the map long enough to be in proportion. The line running from 8' to 11' is the bottom of the ditch. The line running from 10' to 13' (13.992') is the surface of the ground. It is not straight as is the bottom of the ditch. The location of the level and the sights which were taken is shown. 400' is the turning point. (For Profile map paper see Frederick Post catalogue.)

one side of each stake is placed another, the guide stake. This is done so that the location of the first is not lost in case it is knocked over. The engineer now goes over the ground with the level and rod and by subtracting the computed elevation of the bottom of the ditch from the elevation of the top of the ditch stakes, (he obtains these elevations as he goes, by reading the rod when placed upon the stakes), he obtains the depth of the ditch below the top of the stake. He then writes "the cut" on each stake. "The cut" is the depth which the ditch must be "cut" or dug below the top of the stake.

When the levels are all taken, the cuts determined, and the width of the ditch decided upon, stakes are driven beside the ditch. Then a notch is sawed in the side of each stake a certain distance above the bottom of the ditch. A heavy string, or what is better, a fine wire (No. 15 or 16) is drawn tight along the ditch. It is tied into each notch and if the ditch is on even grade, the wire will be straight when tied in. The ditch digger needs only to gauge the bottom of his ditch from the wire and this is easily done by means of a "gauge stick."

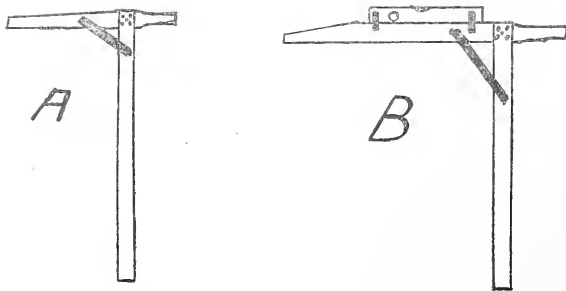

PLATE 16. Plate 16 shows a side view of two "gauge sticks." Fig. A is of a stick used for narrow ditches and as the side arm is short the digger is able to hold the stick nearly plumb and thus get the ditch on even grade.

Fig. B is of a stick for wider ditches. There is a carpenter's level fastened to the top of the cross arm and the stick is so held that the bubble comes to center. The student can readily see how the use of the string stretched an exact distance above the bottom of the ditch, and one of these gauge sticks, will enable a digger to get an even grade.

The stakes which hold the wire need not be set at interval of less than 25 feet. In case of string, they should be set every 10 feet.

When the ditch is dug, the engineer should run levels on it with the rod set on the bottom of the ditch at frequent intervals (every 10, 15 or 20 ft.). In this way he can make

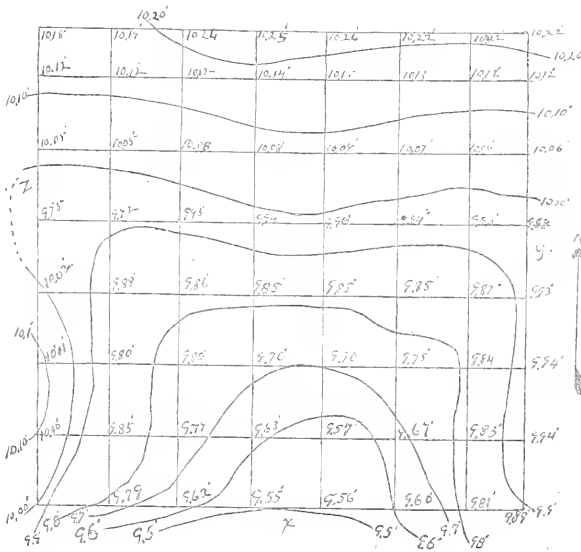

PLATE 17. When the engineer began work on the ten acre field in Plate 17 he found that the field was nearly level. He began at the S. W. corner and ran lines of levels North and South at intervals of 100'. He made his stations 100 feet apart. The narrow "left over" was at the North side and the East side. When he had finished he drew a map and giving station at S. W. corner an elevation of 10' he proceeded to write the elevation of each station at the intersection of the hundred foot lines. Then he was able to draw in the contour lines. He found the point X to be lowest, but he had less than a foot of fall in that direction. If he could get an outlet near X then he could by deepening the lower portion of the ditch, drain the field. Now suppose that a deep ravine runs along one of the other sides of the field. The engineer can drain this field to the East, North, or South, by using a shallow drain near X and deepening it enough to cut the banks near Y or Z. This is not an exaggerated case. Many fields give the engineer more trouble than this one. If a "cross section" paper has been used for the map the lines might have been more accurately drawn, but they would not have developed any outlet, or higher grade. (For cross section paper see Frederick Post catalogue.)

sure that the stakes and line were not molested, and that the ditch is properly dug.

Method for Nearly Level Fields.—In case of fields which are nearly level, the work must be done with more attention to detail. It is best to run parallel lines of levels about 100 feet apart. The stations should not be more than 100 feet apart. Thus the field is divided into a series of 100 feet squares. (Checkerboard style.) When the exact elevation of each station is obtained, draw map and put in the contour lines on each 1/10 ft. (Ten lines to 1 ft. elevation.) The lines now show the lay of the land. The drain can be plotted on the map, and laid off in the field.

When the drains have been located, the engineer should indicate on his map the number of degrees each bend throws the ditch from the straight line. He should also show the distance from each bend to the next bend.

The drain, near its foot, will form an angle of a certain number of degrees with a line fence, a road, or a section line. This angle must also be recorded. Thus, a person who later wishes to know how the drain runs, has only to consult the map. In case of hidden tile drains, the map is of great importance.

The angle between the ditch and some permanent line should **always** be used, rather than the compass bearing. Compasses vary, and the North Magnetic Pole also varies, but a section line is finally established.

Change of Grade.—Sometimes the land lies so that it is impossible to run the ditch on "even grade," that is, with the same fall to each 100 ft. In such a case we "change grade," but whenever it is possible the grade should grow greater (or steeper) as we proceed **down** the ditch. If the top of the ditch is steep, and the change causes the water to flow into a more nearly level ditch, the water will not be carried away fast enough, and there will be flooding at the point of change. If the lower ditch is made larger, it will take care of the water, but the water will flow slower in the large ditch of less grade.

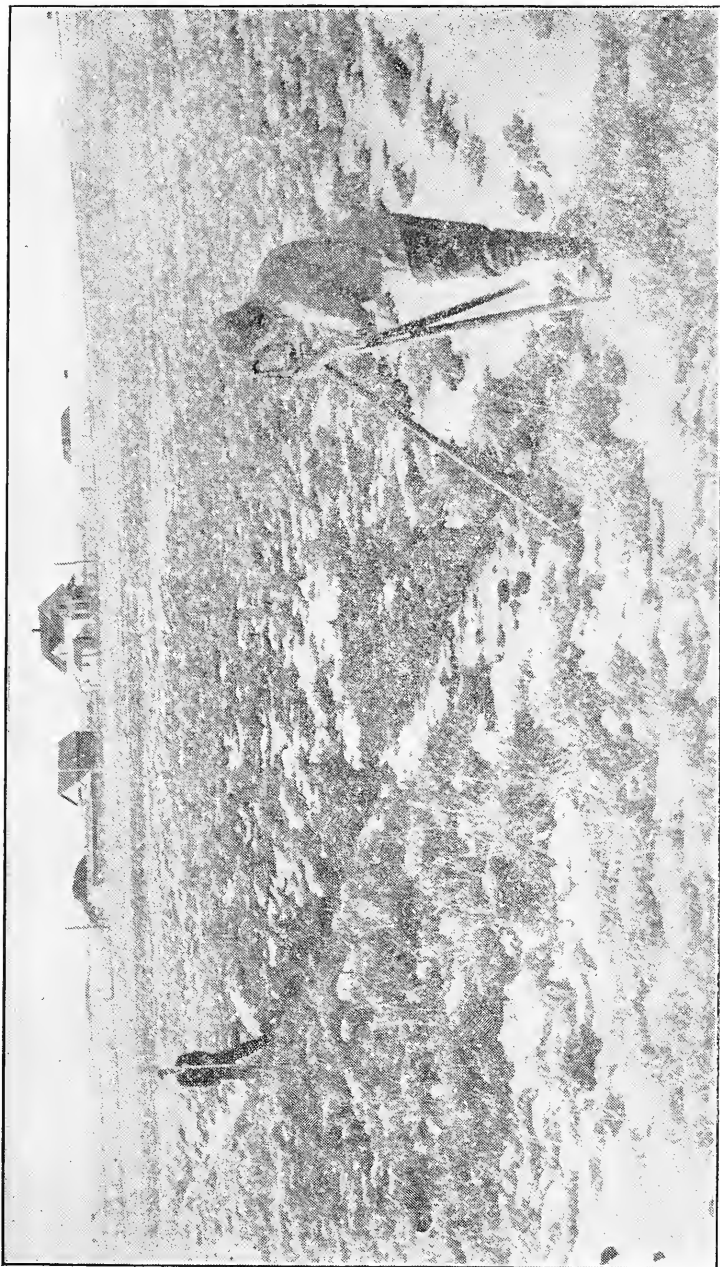

PLATE 18. The engineer (in the foreground) is determining the number of degrees which the creek bends beneath his instrument. He first takes a backsight along that part of the ditch now passed over and then by revolving his transit he is able to determine the number of degrees which the ditch or creek deviates from the straight line. He can also take the bearing of the creek and the azimuth. He could accomplish the same on fairly level ground by means of the Arheifeit's level.

Right here the student must know that the **faster water flows, the greater the size of soil particles it will carry.** Sand will settle out of slowly moving water, while larger stones are carried along by a torrent.

So, when the swiftly moving water of the upper ditch of high grade comes into the larger ditch of lower grade, the water slows down, and deposits sand and silt in the ditch bottom. This soon fills up the ditch or tile and the ditch proves a failure. But, if the grade of the ditch be increased rather than decreased, the water **gains speed**, and there is no tendency to fill up the ditch with deposits of sand or silt. If it is absolutely necessary to change the grade of the lower part of the ditch to a lower grade, the point of change of grade should be carefully watched.

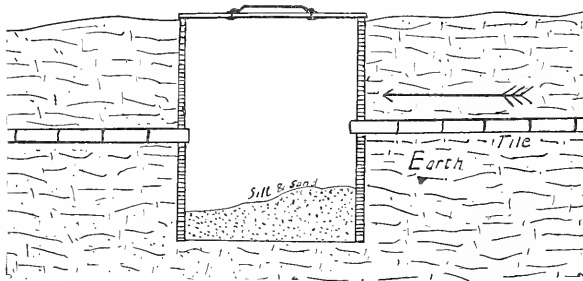

PLATE 19. Plate 19 is a cross section of a "silt basin." Viewing the basin from the top it would appear round. It would be simply a shallow round well loosely walled up with brick or stone or perhaps with a concrete wall about 4 inches thick. The tile comes in at one side. The water is slowed up and as it slowly flows across the well or basin the silt and sand settles to the bottom. The water passes out the other side into the tile of lower grade. If the basin had a grated top and were a little lower in the ground it would be a "Catch Basin" or "Sump." The water might then enter from the top. The Arrow shows the direction of flow.

In case of tile drains a "silt basin," see Plate 19, should be placed at the point of change of grade. This may be cleaned out from time to time.

So-called "practical ditchers" will tell the engineer that this is not necessary, but after the credulous engineer spends a few days locating a tile drain that has not been mapped,

and is now useless, digs up the tile, and pokes the solid sediment from the clogged tile with a stick, and finds in many places that the tile has been completely clogged by deposited sediment, he will realize that the laws of Nature work exactly the same whether the engineer sees the process or not. Such an experience will do more to instill a true appreciation of the effect of change of grade in ditches, into the mind of a student than a volume of sermons upon the subject.

If the student wishes to take up the work of tile draining, he should, if convenient, procure "Engineering for Land Drainage," by Elliot, from John Wiley & Sons, New York. This large volume contains all detailed information which the engineer will need. It is reliable.

Outlets of Drains.—It is usually advisable to wall up the outlets of drains to prevent the washing away of the adjoining land. In case of tile drains a cross wall should be built so that the tile projects through the wall. There should be a chance for the water to flow freely away from the mouth of the tile.

Drainage by Pumping Plants.—In Holland, the drainage water is lifted over the protecting dykes by large windmills, (the Dutch windmills we so often see in pictures).

In this country, the steam engine, the gasoline engine, and the electric motor are now being used in connection with centrifugal pumps to raise drainage water from low lands and throw it into a drain which is higher than the land itself. See Bulletin 243, U. S. Dept. of Agriculture.

DIGGING THE DITCHES.

The condition of the earth, the kind of soil, and the relative cost of labor, will determine largely the methods to be employed in digging the ditches.

Immense plows, drawn by capstans are often used for open ditches. A quicker way is to place sticks of dynamite.

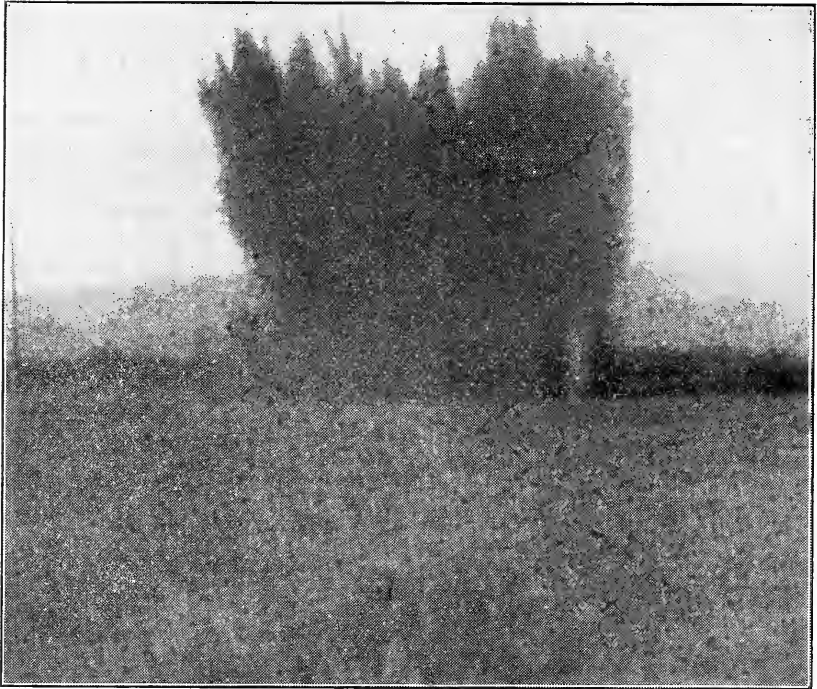

PLATE 20. Plate 20 is an instantaneous photo of a dynamite explosion which dug 200 feet of ditch in about ten seconds. The sticks of 75 per cent dynamite weight $\frac{1}{4}$ lb. each and were placed two feet apart in holes three feet deep. The ditch is about four feet deep. It is about two feet wide at the bottom and four feet wide at the top. The man who shot the charge and the photographer were under a load of straw, 200 feet away. Rocks the size of a man's head flew as much as 400 feet from the ditch. The ditch was left smooth, straight and in fine condition without any further labor.

(at least 75% strength) in holes about two feet apart along the line of the ditch. By means of an electric current all the sticks are set off at once. The earth is blown from the ditch and falls upon the banks and in the nearby fields. A half mile of ditch is sometimes made at a single explosion. For information (free) write to E. I. Dupont Co., Wilmington, Delaware.

A great many ditching machines are now built by various companies. These machines dig the ditch by means of steam

or gasoline power. They are successful under favorable conditions.

IRRIGATION.

We have discussed the method by which we are able to reduce the moisture content of the soil, now let us consider how we may increase the moisture content. A few years ago we might have been led to believe that the so-called "Rain Makers" could, by the explosion of bombs at high elevations, cause rain to fall at will. Now we have definitely settled upon Irrigation as the system which must be used if we are to add water to the soil by artificial means.

Irrigation has been practiced for many hundreds of years in some of the older countries. It is now being practiced in the United States, both on semi-arid lands and the lands of the humid sections. In fact, the sprinkling of a lawn, or the watering of garden truck is, in a way, irrigation. But, as the Agricultural Engineer considers irrigation, the term refers to the addition of great quantities of water to tracts of considerable size.

Sources of Irrigation Water.—Rivers are the principal sources of irrigation water. The water is diverted by dams into ditches and thus conveyed to the fields, or to storage reservoirs. The rights to use water from these rivers are secured by legal process, and when once secured, are valuable property. The amount of water which may be secured for a certain tract of land is usually limited by law. The student must look up these matters for himself, as the State laws vary so much that no exact data can be given in this work.

After all the water available during the irrigation season has been appropriated, companies are formed for the purpose of building storage reservoirs. By placing a dam across some narrow outlet to a large natural basin, a lake is formed. The river water is then diverted into a ditch which leads to the reservoir. The water is stored during the winter season and

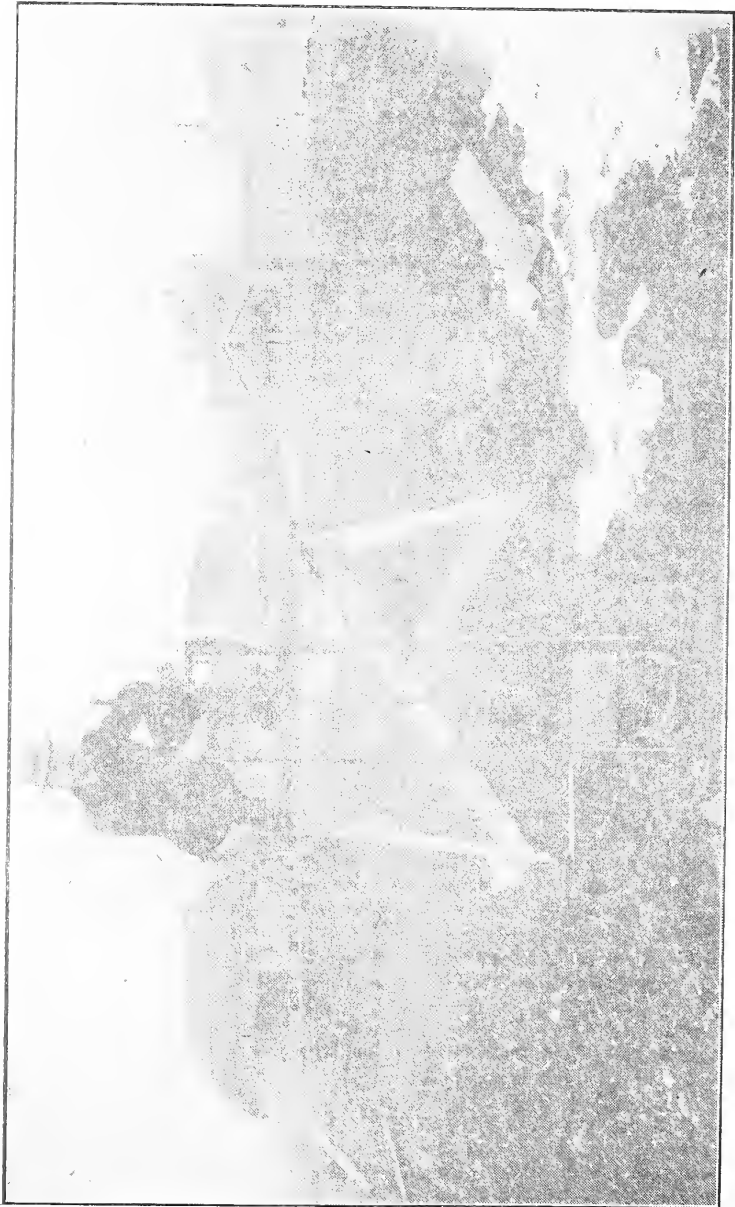

PLATE 21. The ditch rider has just set the steel headgate to turn out the correct amount of water. He is now locking the wheel so that no one can change it. When the water appears in the main ditch the water will flow through the tile until shut off by the ditch rider. This solves the problem of water division, and water stealing in a most satisfactory manner. (The Montana Agricultural College Barns are seen in the background.)

at the time of floods.

The water remains in the reservoir until needed for irrigation. The size of these reservoirs varies from a few acres to several square miles. Sometimes natural lakes are tapped by ditches and they then become reservoirs. The outlet of a reservoir is governed by a headgate, such as is shown in Plate 21. These headgates are often large enough to open a hole four feet square. In some cases, several gates are placed side by side.

If the student will imagine water under a head of 20 or 30 ft., spouting from two, three, or four of these great headgates, he will get an idea of the immense amount of water which some of these water storage companies use on the fields below the reservoir.

River water is often pumped to land which lies at a height which makes it impossible to bring the water to the land by ditches. These plants are much like the drainage plants except that the water is pumped into large flumes and carried to the fields. Sometimes the cost of a flume would be so great that the "Inverted Siphon" is used. This consists of a water-tight pipe with the ends bent up until the intake end is high enough to cause water pumped in at this end to run out the outlet end. Again we sometimes see the pump directly connected to a pipe which runs up the hill side to the higher ground.

Wells.—In some parts of the country, the land is underlaid with a stratum of water bearing gravel or sand. If this stratum is within 40 to 50 feet of the surface, and if it carries water in sufficient quantity, a pumping plant may be used for irrigation. The wells are usually large in diameter (12 to 20 feet). The casing must allow the water to pour in without difficulty. By the proper installation of the right kind of machinery, these wells are made to be excellent sources of irrigation water.

Do not confuse a well of this kind with a small farm well which has a capacity of $\frac{1}{2}$ cubic foot per minute. Some of

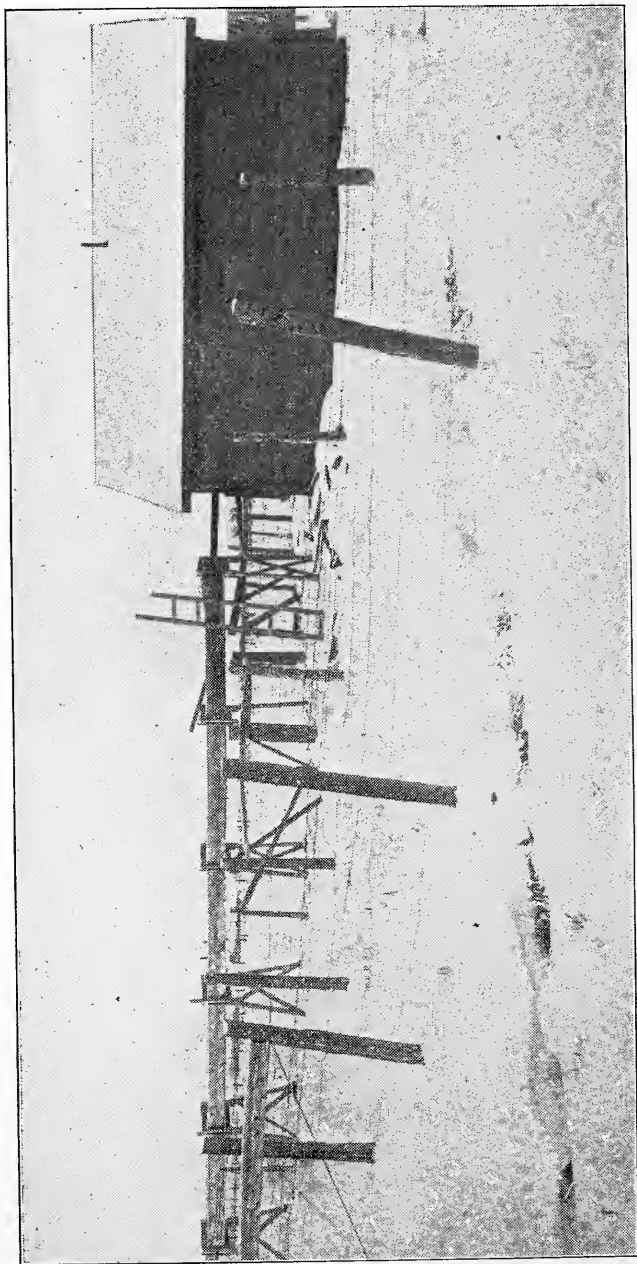

PLATE 22. This stream will fill a thrasher's tank in from 30 to 45 seconds. The flume carries the water to a small reservoir where it is stored for a few days. The water from the creek runs into a "Stump" and is pumped by centrifugal pump through the pipe and into the flume at the rate of $\frac{3}{4}$ cubic foot per second. The water is stored in sufficient quantity the irrigator starts to irrigate. He uses $1\frac{1}{2}$ to 2 cubic feet per second. When the water is stored in sufficient quantity the irrigator starts to irrigate. The water from the creek runs into a "Stump" and is pumped by centrifugal pump through the pipe and into the flume at the rate of $\frac{3}{4}$ cubic foot per second. This stream will fill a thrasher's tank in from 30 to 45 seconds.

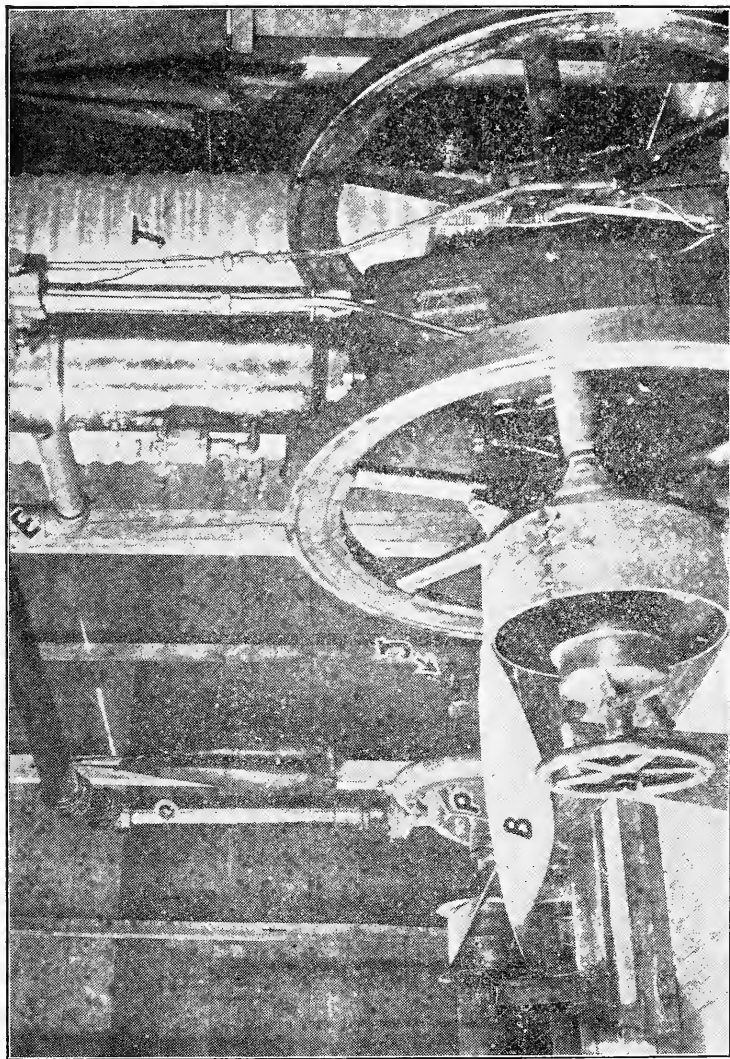

PLATE 23. Plate 23 is inside view of plant shown in Plate 22. It shows a 5 H P International Harvester Co. engine in the foreground. The 6" drive belt B running to the No. 3 (3") Gould Horizontal Centrifugal pump P. Notice that the size of the outlet pipe is increased from 3" to 4" just above the pump. This reduces friction, thus making it possible to run with less Gasoline. J is the priming pump. This type of pump must be primed every time it becomes empty. A submerged vertical pump does not need priming, any more than a blacksmith's fan blower. It is always ready to take up the load when the shaft is started. T is the cooling tank. E is the exhaust pipe leading through the roof.

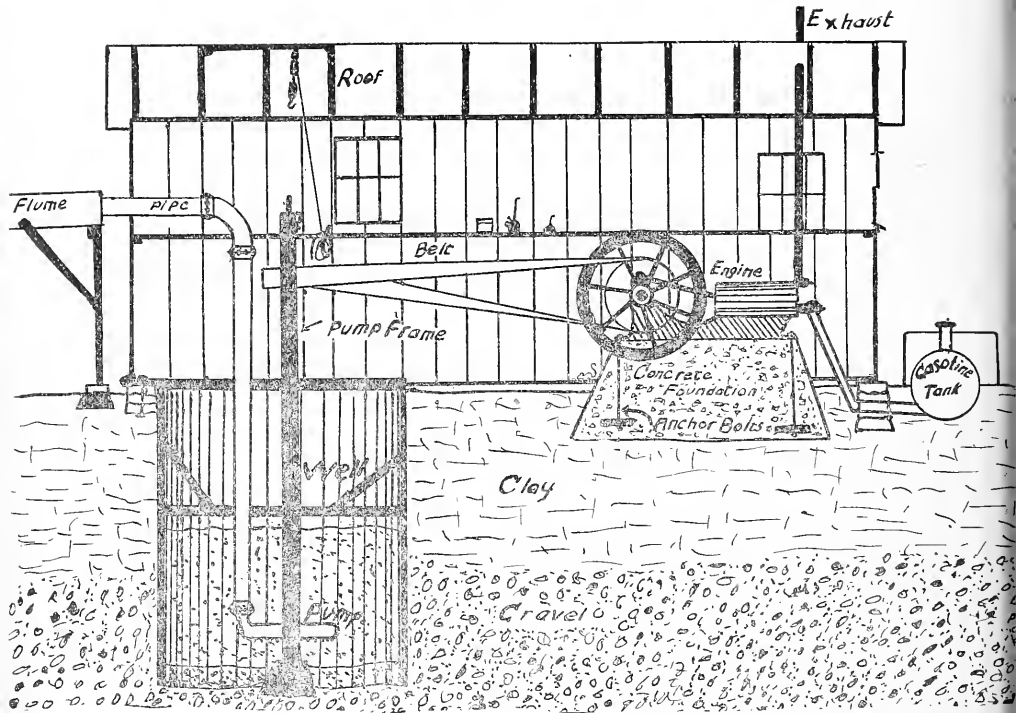

PLATE 24. In order to understand Plate 24 the student must imagine that the shed of the pumping plant has been cut by a plane which passes through the ridge, the ends and the soil beneath the plant. The plane does not cut the engine, the pump frame, or the flume. The engine sets on a concrete foundation and is fastened by anchor bolts. The Gasoline tank is outside the building and is covered by a box. The suction and overflow pipes run from engine to tank. (No cooling device is shown.) The well is large, and is cased with rough planks which allow water to flow through readily. The pump is of the Vertical centrifugal type and is fastened in a frame which slides inside the frame which we see. If the operator wishes to fix the pump he attaches the tackle (suspended from the roof) to the loop on the frame and after having loosened the pipe elbow he arises the inside sliding frame, with pump attached, until the pump comes to the platform half way down in the well. He then makes repairs, drops the pump, connects elbow, puts on the bolt and goes ahead. As this type of pump is always in the water *it is always primed*. If the belt is crossed the wrong way little or no water is pumped. The student must remember to run the centrifugal pump in the *right direction*. Notice that the pipe is enlarged just above the pump. It is thus made easier for the pump, the engine and all connections. The enlarging of the pipe reduces friction and thus saves gasoline. The end of the flume is seen at the left of the pumphouse. If a ditch or creek enlarged water into the well it would then be termed a "Sump."

these wells furnish as much as three or four cubic feet **per second**.

Amount of Water Needed.—It is generally considered that water to a depth of from one to two and one-half feet must be added in order to properly irrigate the average soils. The amount varies with the amount of rainfall during the growing season, the temperature of the locality, the amount of wind, the type of soil, and the kind of crop to be grown. So we see that no hard and fast rule can be laid down, which will determine the amount of water needed.

Units of Measure for Irrigation Water.—There are many units of measure for irrigation water. Many of these units are not standardized, and are, therefore, unreliable units.

The “miner’s inch” refers to the amount of water which will pour through an opening one inch square in the side of a box, when under a head of six inches. But whether the head is to be measured from the top of the opening or the bottom is not generally stated. Therefore, the actual head is an unknown quantity and the quantity of water which represents a miner’s inch is unknown.

The “inch.” This is a term that completely fools many people. It may mean one inch of water covering an area of one acre. It may mean the amount of water which will flow over a weir one foot wide, with a depth of one inch at the crest. It may mean a “miner’s inch.” It may mean almost anything, and yet people talk about the “inch” of water as though they really knew what the term really means. No more space will be given to inaccurate units.

Accurate Units.—The cubic foot per second. This unit is accurate because a cubic foot is a cubic foot and a second is a second. Both are **standard** units. So when a man says, “I own three cubic feet per second for a 90-day season, beginning June 1st,” we could figure just how many cubic feet of water he has a right to use each year.

$$60 \times 3 = 180 \text{ cubic feet per minute.}$$

$$180 \times 60 = 10,800 \text{ cubic feet per hour.}$$



PLATE 25. The engineer in Plate 25 is measuring the flow of water in the canal by means of a current meter. There is a turbine wheel at the end of the tube which he is holding. This wheel whirls at a speed in proportion to the rate of flow of the water. As the wheel revolves it is made to give a clicking sound which is heard through the tube. The number of clicks per minute is taken and then by consulting a chart which accompanies the meter the observer is able to determine the rate of flow of the various parts of the current. The engineer in the plate is using an "Acoustic Current Meter."

$10,800 \times 24 = 259,200$ cubic feet per day.

$259,200 \times 90 = 23,280,000$ cubic feet per season.

The Acre Foot.—We often use the term "acre foot," and by it we mean that quantity of water which will cover one

acre of land to a depth of one foot. As the area of an acre is 43,560 square feet, the acre foot is equal to 43,560 cubic feet, or a stream of one second foot would have to flow 43,560 seconds, or 726 minutes, or 12 hours and 6 minutes to deliver one acre foot.

How Irrigation Water is Measured.—There are two principal methods of measuring irrigation water. 1. By means of the current meter, and (2), by means of “weirs.”

In case of large streams, the engineer holds a current meter for a certain period of time in each square foot of an imaginary cross section of the stream. He does the timing by means of a stop watch. Now, when he has the number of revolutions per second or per minute, he consults a table which accompanies the meter, and thus computes the number of feet of flow per second of that given foot of cross section. When he has measured all the square feet, he adds the total number of second feet and thus gets the number of second feet in the stream.

One must measure each square foot because there are different rates of flow in different parts of the stream. Generally speaking, the water flows more rapidly in the center, than at the sides, and it flows more rapidly near the surface than near the bottom. The rough banks retard the flow.

Special “flumes” are sometimes built and each inch or tenth foot of depth is computed with a meter. These flumes are called “rating flumes.” The ditch rider can tell at a glance at the gauge rod, how many cubic feet per second are passing through the rating flume.

The “Weir.”—By bringing water to a standstill, and then allowing it to pour over a clean cut notch in the side of the pool, we are able to compute accurately, just how many cubic feet per second go over the notch. Several forms of weirs are used, but the cippoletti weir is the most practical. The notch is cut in the weir board, so that the bottom of the notch (“the crest”) is at least twice as high from the bottom of the box as the depth of water which will flow over the crest. The ends of the crest should be twice as far from the sides of the box as the depth of water over the crest.

The sides of the notch slope outward at the rate of 1 inch on each side to 4 inches in height, (1 to 4). The edges of the notch are sharp and the bevel of the edge is on the down stream side of the board. The board may be set in a weir box, (see Plate 27), or in the straight run of a turnout box. (see Plate 28). The board may also be set in a concrete cross wall which dams up the current of a stream and forms a little lake. The board should be at right angles to the stream, and the stream should jump over the notch and drop clear of everything into the stream below. It should "jump over air." The water as it comes to the pond or box should be brought to a standstill and allowed to pass over the

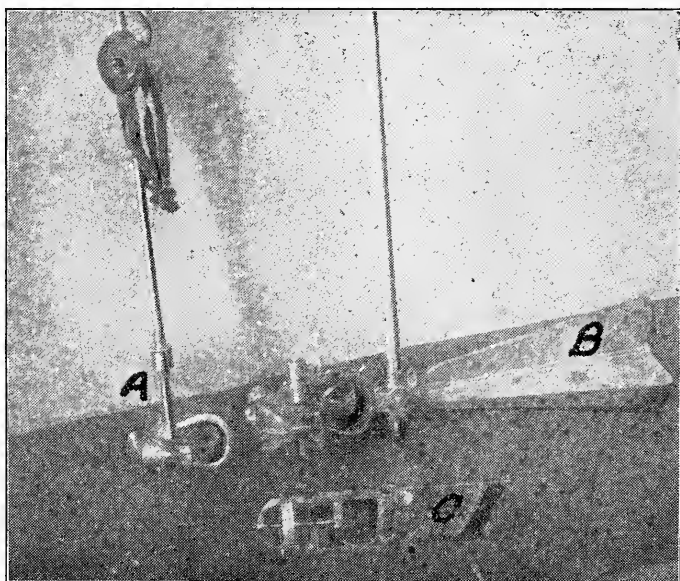

PLATE 26. Plate 26 is a photo of three current meters. Fig. A is an Acoustic Meter such as the engineer is using in Plate 25. Fig. B is a current meter which is fitted with an electric sounder which gives a buzz at each recording stroke. (See Gurley's manual for description and for the reduction tables for use with these meters.) Fig. C is a very small, yet accurate, current meter. It is for use in small streams and ditches. It is not supplied with "staff." It has electric recording device. (See Keuffel & Esser Catalogue for detailed information.) This is a collection of strictly high grade current meters.)

weir as from a large, quiet lake. This abolishes "speed of approach" and makes the weir a very accurate water meter.

The height of the water on the crest is measured **not** directly over the crest, but back in the box at least 6 feet from the weir. A stake is driven until its top is **exactly** level with the crest. The rod is placed on the stake, and the depth of the water above the top of the stake is the **depth over the crest**. This is done to do away with the "sink" of the water as it comes to the crest. **Don't forget** to measure back from the weir at least six feet, (see Plate 29).

The following table, tells how much water flows over weirs from 1 foot wide, to 10 feet wide for each 1/100 foot in depth. The unit is cubic foot per second.

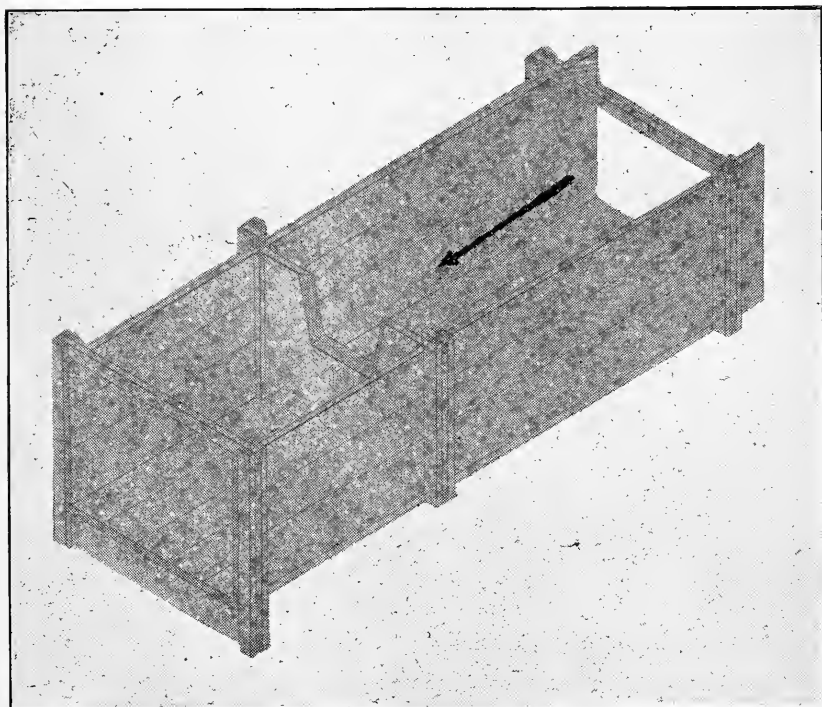

PLATE 27. A weir box made of planks and timbers. The weir is of the type known as the Cippoletti weir. Notice that the sides of the notch slant out at the rate of one inch on each side to four inches in height of the notch. The arrow shows which way the current passes through the box.

The following table is taken from Bulletin 72 of Montana Experiment Station: (This bulletin is now out of print.)

Depth of water on crest--	1-foot well--		1½-foot well--		2-foot well--		3-foot well--		4-foot well--		5-foot well--		6-foot well--		7-foot well--		8-foot well--		9-foot well--		10-foot well--	
	Cu. ft. p'r sec	Cu. ft. p'r sec	Cu. ft. p'r sec	Cu. ft. p'r sec	Cu. ft. p'r sec	Cu. ft. p'r sec	Cu. ft. p'r sec	Cu. ft. p'r sec	Cu. ft. p'r sec	Cu. ft. p'r sec	Cu. ft. p'r sec	Cu. ft. p'r sec	Cu. ft. p'r sec	Cu. ft. p'r sec	Cu. ft. p'r sec	Cu. ft. p'r sec	Cu. ft. p'r sec	Cu. ft. p'r sec	Cu. ft. p'r sec	Cu. ft. p'r sec	Cu. ft. p'r sec	Cu. ft. p'r sec
0.01	0.0034	0.0051	0.0067	0.0101	0.0135	0.0168	0.0202	0.0236	0.0269	0.0303	0.0337	0.0371	0.0405	0.0439	0.0473	0.0507	0.0541	0.0575	0.0609	0.0643	0.0677	0.0711
0.02	0.0095	0.0143	0.0190	0.0286	0.0381	0.0476	0.0571	0.0667	0.0762	0.0857	0.0952	0.1047	0.1142	0.1237	0.1332	0.1427	0.1522	0.1617	0.1712	0.1807	0.1902	0.1997
0.03	0.0175	0.0262	0.0350	0.0525	0.0700	0.0875	0.1050	0.1225	0.1400	0.1575	0.1750	0.1925	0.2100	0.2275	0.2450	0.2625	0.2800	0.2975	0.3150	0.3325	0.3500	0.3675
0.04	0.0269	0.0404	0.0539	0.0808	0.1077	0.1347	0.1616	0.1885	0.2155	0.2424	0.2693	0.2963	0.3232	0.3501	0.3770	0.4039	0.4308	0.4577	0.4846	0.5115	0.5384	0.5653
0.05	0.0376	0.0565	0.0753	0.1129	0.1506	0.1882	0.2258	0.2635	0.3011	0.3388	0.3764	0.4141	0.4517	0.4894	0.5270	0.5647	0.6023	0.6400	0.6776	0.7153	0.7529	0.7906
0.06	0.0495	0.0742	0.0990	0.1484	0.1979	0.2474	0.2969	0.3464	0.3958	0.4453	0.4948	0.5443	0.5938	0.6433	0.6928	0.7423	0.7918	0.8413	0.8908	0.9403	0.9898	1.0393
0.07	0.0624	0.0935	0.1247	0.1871	0.2494	0.3118	0.3741	0.4365	0.4988	0.5612	0.6235	0.6859	0.7482	0.8105	0.8728	0.9351	0.9974	1.0597	1.1220	1.1843	1.2466	1.3089
0.08	0.0762	0.1143	0.1524	0.2285	0.3047	0.3808	0.4570	0.5331	0.6092	0.6853	0.7614	0.8375	0.9136	0.9897	1.0658	1.1419	1.2180	1.2941	1.3702	1.4463	1.5224	1.5985
0.09	0.0909	0.1364	0.1818	0.2727	0.3636	0.4545	0.5454	0.6363	0.7272	0.8181	0.9090	0.9999	1.0908	1.1817	1.2726	1.3635	1.4544	1.5453	1.6362	1.7271	1.8180	1.9089
0.10	0.1065	0.1597	0.2129	0.3194	0.4259	0.5323	0.6388	0.7452	0.8517	0.9582	1.0646	1.1710	1.2774	1.3838	1.4902	1.5966	1.7030	1.8094	1.9158	2.0222	2.1286	2.2350
0.11	0.1228	0.1842	0.2457	0.3685	0.4913	0.6141	0.7370	0.8598	0.9826	1.1054	1.2282	1.3510	1.4738	1.5966	1.7194	1.8422	1.9650	2.0878	2.2106	2.3334	2.4562	2.5790
0.12	0.1399	0.2099	0.2799	0.4198	0.5598	0.6997	0.8397	0.9796	1.1196	1.2595	1.3995	1.5394	1.6794	1.8193	1.9593	2.0992	2.2392	2.3791	2.5191	2.6590	2.7990	2.9389
0.13	0.1578	0.2367	0.3156	0.4734	0.6312	0.7890	0.9468	1.1046	1.2624	1.4202	1.5780	1.7358	1.8936	2.0514	2.2092	2.3670	2.5248	2.6826	2.8404	2.9982	3.1560	3.3138
0.14	0.1764	0.2645	0.3527	0.5201	0.7054	0.8818	1.0581	1.2345	1.4108	1.5872	1.7635	1.9398	2.1161	2.2924	2.4687	2.6450	2.8213	2.9976	3.1739	3.3502	3.5265	3.7028
0.15	0.1956	0.2934	0.3912	0.5668	0.7823	0.9779	1.1735	1.3691	1.5647	1.7603	1.9559	2.1515	2.3471	2.5427	2.7383	2.9339	3.1295	3.3251	3.5207	3.7163	3.9119	4.1075
0.16	0.2155	0.3232	0.4309	0.6464	0.8619	1.0773	1.2928	1.5083	1.7237	1.9392	2.1547	2.3702	2.5857	2.8012	3.0167	3.2322	3.4477	3.6632	3.8787	4.0942	4.3097	4.5252
0.17	0.2360	0.3540	0.4720	0.7079	0.9439	1.1799	1.4159	1.6519	1.8878	2.1238	2.3597	2.5957	2.8316	3.0676	3.3035	3.5395	3.7754	4.0114	4.2473	4.4833	4.7192	4.9552
0.18	0.2571	0.3857	0.5142	0.7713	1.0284	1.2855	1.5426	1.7997	2.0568	2.3139	2.5710	2.8281	3.0852	3.3423	3.5994	3.8565	4.1136	4.3707	4.6278	4.8849	5.1420	5.3991
0.19	0.2788	0.4182	0.5576	0.8365	1.1153	1.3942	1.6731	1.9520	2.2309	2.5098	2.7887	3.0676	3.3465	3.6254	3.9043	4.1832	4.4621	4.7410	5.0199	5.2988	5.5777	5.8566
0.20	0.3011	0.4517	0.6022	0.9034	1.2045	1.5056	1.8068	2.1079	2.4090	2.7101	3.0112	3.3123	3.6134	3.9145	4.2156	4.5167	4.8178	5.1189	5.4200	5.7211	6.0222	6.3233
0.21	0.3240	0.4860	0.6480	0.9720	1.2960	1.6199	1.9439	2.2679	2.5919	2.9159	3.2399	3.5639	3.8879	4.2119	4.5359	4.8599	5.1839	5.5079	5.8319	6.1559	6.4799	6.8039
0.22	0.3474	0.5211	0.6948	1.0422	1.3896	1.7370	2.0844	2.4318	2.7792	3.1266	3.4740	3.8214	4.1688	4.5162	4.8636	5.2110	5.5584	5.9058	6.2532	6.6006	6.9480	7.2954
0.23	0.3714	0.5570	0.7427	1.1141	1.4854	1.8568	2.2281	2.5995	2.9709	3.3423	3.7137	4.0851	4.4565	4.8279	5.1993	5.5707	5.9421	6.3135	6.6849	7.0563	7.4277	7.7991
0.24	0.3958	0.5938	0.7917	1.1875	1.5834	1.9792	2.3750	2.7709	3.1667	3.5625	3.9584	4.3542	4.7501	5.1459	5.5418	5.9376	6.3335	6.7293	7.1252	7.5210	7.9169	8.3127
0.25	0.4208	0.6312	0.8417	1.2625	1.6833	2.1042	2.5250	2.9458	3.3666	3.7875	4.2083	4.6292	5.0500	5.4708	5.8917	6.3125	6.7333	7.1542	7.5750	7.9958	8.4167	8.8375
0.26	0.4463	0.6955	0.9227	1.3390	1.7853	2.2317	2.6780	3.1243	3.5707	4.0170	4.4633	4.9096	5.3559	5.8022	6.2485	6.6948	7.1411	7.5874	8.0337	8.4800	8.9263	9.3726
0.27	0.4723	0.7085	0.9447	1.4170	1.8893	2.3617	2.8430	3.3063	3.7787	4.2510	4.7233	5.1956	5.6679	6.1402	6.6125	7.0848	7.5571	8.0294	8.5017	8.9740	9.4463	9.9186
0.28	0.4988	0.7482	0.9976	1.4964	1.9952	2.4941	2.9929	3.4917	3.9905	4.4893	4.9881	5.4869	5.9857	6.4845	6.9833	7.4821	7.9809	8.4797	8.9785	9.4773	9.9761	10.4749
0.29	0.5258	0.7887	1.0515	1.5773	2.1031	2.6289	3.1546	3.6804	4.2062	4.7320	5.2578	5.7836	6.3094	6.8352	7.3610	7.8868	8.4126	8.9384	9.4642	9.9900	10.5158	11.0416
0.30	0.5532	0.8298	1.1064	1.6596	2.2128	2.7660	3.3192	3.8724	4.4256	4.9788	5.5320	6.0852	6.6384	7.1916	7.7448	8.2980	8.8512	9.4044	9.9576	10.5108	11.0640	11.6172
0.31	0.5811	0.8716	1.1622	1.7433	2.3244	2.9054	3.4865	4.0676	4.6487	5.2298	5.8109	6.3920	6.9731	7.5542	8.1353	8.7164	9.2975	9.8786	10.4597	11.0408	11.6219	12.2030
0.32	0.6094	0.9141	1.2189	1.8283	2.4377	3.0472	3.6566	4.2660	4.8754	5.4848	6.0942	6.7036	7.3130	7.9224	8.5318	9.1412	9.7506	10.3600	10.9694	11.5788	12.1882	12.7976
0.33	0.6382	0.9573	1.2764	1.9147	2.5529	3.1911	3.8293	4.4675	5.1058	5.7440	6.3822	7.0204	7.6586	8.2968	8.9350	9.5732	10.2114	10.8496	11.4878	12.1260	12.7642	13.4024
0.34	0.6674	1.0012	1.3349	2.0023	2.6698	3.3372	4.0047	4.6721	5.3395	6.0069	6.6743	7.3417	8.0091	8.6765	9.3439	10.0113	10.6787	11.3461	12.0135	12.6809	13.3483	14.0157
0.35	0.6971	1.0457	1.3942	2.0913	2.7884	3.4556	4.1827	4.8798	5.5769	6.2740	6.9711	7.6682	8.3653	9.0624	9.7595	10.4566	11.1537	11.8508	12.5479	13.2450	13.9421	14.6392
0.36	0.7272	1.0908	1.4544	2.1816	2.9088	3.6390	4.3682	5.0904	5.8175	6.5446	7.2717	7.9988	8.7259	9.4530	10.1801	10.9072	11.6343	12.3614	13.0885	13.8156	14.5427	15.2698
0.37	0.7577	1.1366	1.5154	2.2731	3.0308	3.7885	4.4563	5.3040	6.0617	6.8194	7.5771	8.3348	9.0925	9.8502	10.6079	11.3656	12.1233	12.8810	13.6387	14.3964	15.1541	15.9118
0.38	0.7886	1.1830	1.5773	2.3659	3.1545	3.9432	4.7158	5.5204	6.3091	7.0977	7.8863	8.6749	9.4635	10.2521	11.0407	11.8293	12.6179	13.4065	14.1951	14.9837	15.7723	16.5609
0.39	0.8200	1.2300	1.6399	2.4599	3.2799	4.0998	4.9198	5.7398	6.5597	7.3797	8.1996	9.0195	9.8394	10.6593	11.4792	12.2991	13.1190	13.9389	14.7588	15.5787	16.3986	17.2185
0.40	0.8517	1.2776	1.7034	2.5551	3.4068	4.2585	5.1102	5.9619	6.8137	7.6654	8.5171	9.3688	10.2205	11.0722	11.9239	12.7756	13.6273	14.4790	15.3307	16.1824	17.0341	17.8858
0.41	0.8838	1.3258	1.7677	2.6515	3.5354	4.4191	5.3031	6.1869	7.0708	7.9546	8.8384	9.7222	10.6060	11.4898	12.3736	13.2574	14.1412	15.0250	15.9088	16.7926	17.6764	18.5602
0.42	0.9164	1.3746	1.8328	2.7491	3.6655	4.5819	5.4983	6.4146	7.3310	8.2474	9.1638	10.0802	10.9966	11.9130	12.8294	13.7458	14.6622	15.5786	16.4950	17.4114	18.3278	19.2442
0.43	0.9493	1.4239	1.8968	2.8479	3.7972	4.7465	5.6958	6.6451	7.5944	8.5437	9.4930	10.4423	11.3916	12.3409	13.2902	14.2395	15.1888	16.1381	17.0874	18.0367	18.9860	19.9353
0.44	0.9826	1.4739	1.9622	2.9478	3.9304	4.9180	5.8966	6.8782	7.8608	8.8434	9.8260	10.8086	11.7912	12.7738	13.7564	14.7390	15.7216	16.7042	17.6868	18.6694	19.6520	20.6346
0.45	1.0168	1.5244	2.0326	3.0489	4.0652	5.0815	6.0978	7.1141	8.1303	9.1466	10.1629	11.1792	12.1954	13.2117	14.2279	15.2442	16.2604	17.2767	18.2929	19.3092	20.3254	21.3417
0.46	1.0504	1.5755	2.1007	3.1511	4.2014	5.2518	6.3021	7.3														

FARM ENGINEERING

Depth of water on crest--	FARM ENGINEERING										
	1-foot well--	1½-foot well--	2-foot well--	3-foot well--	4-foot well--	5-foot well--	6-foot well--	7-foot well--	8-foot well--	9-foot well--	10-foot well--
Feet	Cu. ft. p'r sec	Cu. ft. p'r sec	Cu. ft. p'r sec	Cu. ft. p'r sec	Cu. ft. p'r sec	Cu. ft. p'r sec	Cu. ft. p'r sec	Cu. ft. p'r sec	Cu. ft. p'r sec	Cu. ft. p'r sec	Cu. ft. p'r sec
.61	2.4059	3.2079	4.8119	6.4159	8.0198	9.6238	11.2278	12.8317	14.4357	16.0396	
.62	2.4654	3.2871	4.9307	6.5743	8.2178	9.8614	11.5050	13.1486	14.7921	16.4357	
.63	2.5252	3.3670	5.0505	6.7340	8.4175	10.1009	11.7844	13.4679	15.1514	16.8349	
.64	2.5856	3.4475	5.1712	6.8949	8.6187	10.3424	12.0661	13.7899	15.5136	17.2378	
.65	2.6464	3.5286	5.2929	7.0572	8.8215	10.5857	12.3500	14.1143	15.8786	17.6429	
.66	2.7077	3.6103	5.4155	7.2206	9.0258	10.8310	12.6361	14.4413	16.2465	18.0516	
.67	2.7695	3.6927	5.5390	7.3854	9.2317	11.0781	12.9244	14.7707	16.6171	18.4634	
.68	2.8317	3.7757	5.6635	7.5513	9.4392	11.3270	13.2148	15.1027	16.9905	18.8783	
.69	2.8944	3.8593	5.7889	7.7185	9.6481	11.5778	13.5074	15.4370	17.3667	19.2963	
.70	2.9576	3.9435	5.9152	7.8869	9.8586	11.8304	13.8021	15.7738	17.7456	19.7173	
.71	3.0212	4.0283	6.0424	8.0565	10.0706	12.0848	14.0989	16.1130	18.1272	20.1413	
.72	3.0852	4.1137	6.1705	8.2273	10.2842	12.3410	14.3978	16.4547	18.5115	20.5683	
.73	3.1497	4.1997	6.2965	8.3993	10.4992	12.5990	14.6988	16.7989	18.8985	20.9983	
.74	3.2147	4.2863	6.4294	8.5725	10.7156	12.8588	15.0019	17.1450	19.2881	21.4313	
.75	3.2801	4.3734	6.5601	8.7469	10.9336	13.1203	15.3070	17.4937	19.6804	21.8671	
.76	4.4612	6.6918	8.9224	11.1530	13.3836	15.6142	17.8447	20.0753	22.3059		
.77	4.5495	6.8243	9.0991	11.3728	13.6486	15.9233	18.1981	20.4729	22.7476		
.78	4.6384	6.9577	9.2769	11.5961	13.9153	16.2345	18.5538	20.8730	23.1922		
.79	4.7279	7.0919	9.4559	11.8198	14.1838	16.5477	18.9117	21.2757	23.6396		
.80	4.8180	7.2270	9.6360	12.0450	14.4539	16.8629	19.2719	21.6809	24.0899		
.81	4.9086	7.3629	9.8172	12.2715	14.7258	17.1801	19.6344	22.0887	24.5430		
.82	4.9998	7.4997	9.9996	12.4995	14.9993	17.4992	19.9991	22.4990	24.9989		
.83	5.0915	7.6373	10.1830	12.7288	15.2746	17.8202	20.3661	22.9118	25.4576		
.84	5.1838	7.7757	10.3676	12.9595	15.5514	18.1433	20.7322	23.3271	25.9191		
.85	5.2767	7.9150	10.5533	13.1916	15.8300	18.4683	21.1066	23.7449	26.3833		
.86	5.3700	8.0551	10.7401	13.4251	16.1101	18.7952	21.4802	24.1652	26.8502		
.87	5.4640	8.1960	10.9280	13.6599	16.3919	19.1239	21.8559	24.5879	27.3199		
.88	5.5585	8.3377	11.1169	13.8961	16.6754	19.4546	22.2338	25.0131	27.7923		
.89	5.6535	8.4802	11.3069	14.1337	16.9604	19.7872	22.6139	25.4406	28.2674		
.90	5.7490	8.6235	11.4980	14.3726	17.2470	20.1216	22.9661	25.8706	28.7451		
.91	5.8451	8.7677	11.6902	14.6128	17.5353	20.4579	23.3804	26.3030	29.2255		
.92	5.9417	8.9126	11.8834	14.8543	17.8251	20.7969	23.7669	26.7377	29.7096		
.93	6.0389	9.0583	12.0777	15.0971	18.1166	21.1360	24.1554	27.1748	30.1943		
.94	6.1365	9.2048	12.2730	15.3414	18.4096	21.4778	24.5461	27.6143	30.6826		
.95	6.2347	9.3520	12.4694	15.5867	18.7041	21.8214	24.9388	28.0561	31.1735		
.96	6.3334	9.5001	12.6668	15.8335	19.0002	22.1669	25.3336	28.5003	31.6670		
.97	6.4326	9.6489	12.8662	16.0815	19.2979	22.5142	25.7305	28.9468	32.1631		
.98	6.5323	9.7985	13.0647	16.3309	19.5970	22.8632	26.1294	29.3956	32.6617		
.99	6.6326	9.9489	13.2652	16.5815	19.8978	23.2141	26.5303	29.8467	33.1629		
1.00	6.7330	10.1000	13.4667	16.8333	20.2000	23.5667	26.9333	30.3000	33.6667		
1.01					20.5038	23.9211	27.3384	30.7556	34.1729		
1.02						20.8090	24.2772	27.7454	31.2135	34.6817	
1.03						21.1158	24.6351	28.1544	31.6737	35.1930	
1.04						21.4240	24.9947	28.5654	32.1361	35.7067	
1.05						21.7338	25.3561	28.9784	32.6007	36.2220	
1.06						22.0450	25.7192	29.3933	33.0675	36.7417	
1.07						22.3577	26.0840	29.8103	33.5365	37.2628	
1.08						22.6719	26.4505	30.2291	34.0078	37.7864	
1.09						22.9875	26.8187	30.6499	34.4812	38.3124	
1.10						23.3045	27.1886	31.0727	34.9568	38.8409	
1.11						23.6230	27.5602	31.4974	35.4346	39.3717	
1.12						23.9430	27.9335	31.9240	35.9145	39.9050	
1.13						24.2644	28.3084	32.3525	36.3965	40.4406	
1.14						24.5872	28.6850	32.7829	36.8808	40.9786	
1.15						24.9114	29.0633	33.2152	37.3671	41.5190	
1.16						25.2370	29.4432	33.6494	37.8556	42.0617	
1.17						25.5641	29.8248	34.0854	38.3461	42.6068	
1.18						25.8925	30.2079	34.5234	38.8388	43.1542	
1.19						26.2224	30.5928	34.9631	39.3335	43.7039	
1.20						26.5536	30.9792	35.4048	39.8304	44.2560	
1.21							31.3672	35.8483	40.3393	44.8103	
1.22							31.7569	36.2936	40.8303	45.3670	
1.23							32.1481	36.7407	41.3333	45.9250	

In case the engineer wishes to measure the depth in inches rather than in hundredths, he may consult the following table. He can find the number of miner's inches which will pass over the weirs. Each miner's inch in this particular table is equal to $1/40$ of a cubic foot per second. So, by dividing the number of miner's inches by 40, we get the number of cubic feet per second.

The following table is taken from Bulletin 72 of Montana Experiment Station: (The supply of this bulletin has been exhausted.)

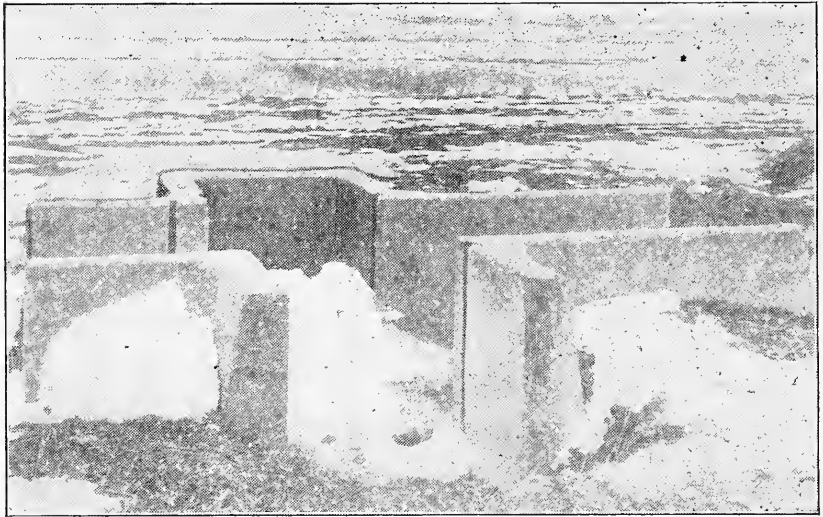

PLATE 28. A concrete turn-out box. The ditch brings the water in at the right. It may flow straight through, or by putting tightly fitting boards in the slots of the main channel the water can be turned to right and left. Then by putting boards in the left wing the water can be turned to the right. If boards be placed in the left slots then the water runs into the right (closed) wing. In this case the water is delivered into a tile which enters the bottom of the right wing. If the side slots be closed to the top and a low board with a weir slot in its upper edge be inserted in the main channel of the box, then the turn-out box is converted into a weir box. The gauge peg should be located at least six feet upstream from the weir. Its top should be level with the crest of the weir.

Depth of water on crest...	1-foot well...	1½-foot well...	2-foot well...	3-foot well...	4-foot well...	5-foot well...	6-foot well...	7-foot well...	8-foot well...	9-foot well...	10-foot well...
Inches	Miners' inches	Miners' inches	Miners' inches	Miners' inches	Miners' inches	Miners' inches	Miners' inches	Miners' inches	Miners' inches	Miners' inches	Miners' inches
1/8	1/8	1/4	5-16	7-16	9-16	11-16	7/8	1	1 1/8	1 1/4	1 7-16
1/4	3/8	5/8	3/4	1 3-16	1 9-16	2	2 5-16	2 3/4	3 1/8	3 1/2	4
3/8	3/4	1 1/8	1 1/2	1 1/4	3	3 3/4	4 1/2	5 1/4	6	6 3/4	7 1/2
1/2	1 1/8	1 3/4	2 1/4	3 1/2	4 5/8	5 3/4	6 7/8	8	9 1/8	10 3/8	11 1/2
5/8	1 1/2	2	3	5	6	8	10	11	13	14	16
3/4	2	3	4	6	8	11	13	15	17	19	21
7/8	3	4	5	8	11	13	16	19	21	24	27
1	3	5	6	10	13	16	19	23	26	29	32
1 1/8	4	6	8	12	15	19	23	27	31	35	39
1 1/4	5	7	9	15	18	23	27	32	36	41	45
1 3/8	5	8	10	16	21	26	31	37	42	47	52
1 1/2	6	9	12	18	24	30	36	42	48	54	60
1 5/8	7	10	13	20	27	34	40	47	54	60	67
1 3/4	7	11	15	22	30	38	45	52	60	67	75
1 7/8	8	12	17	25	33	42	50	58	67	75	83
2	9	14	18	27	37	46	55	64	73	83	92
2 1/8	10	15	20	30	40	50	60	70	80	90	100
2 1/4	11	16	22	33	44	55	66	77	87	98	109
2 3/8	12	18	24	36	47	59	71	83	95	107	119
2 1/2	13	19	26	38	51	64	77	90	102	115	128
2 5/8	14	21	28	41	55	69	83	97	110	124	138
2 3/4	15	22	30	44	59	74	89	103	118	133	148
2 7/8	16	24	32	47	63	79	95	111	126	142	158
3	17	25	34	51	68	85	102	119	136	152	169
3 1/8	18	26	36	54	72	90	108	125	143	161	179
3 1/4	19	28	38	57	76	95	114	133	152	171	190
3 3/8	20	30	40	60	80	100	121	141	161	181	201
3 1/2	21	32	42	64	85	106	127	149	169	191	212
3 5/8	22	34	45	67	89	112	134	157	179	201	224
3 3/4	24	35	47	71	94	118	141	165	188	212	235
3 7/8	25	37	49	74	99	124	148	173	198	222	247
4	26	39	52	78	104	130	155	181	207	233	259
4 1/8	27	41	54	81	109	136	163	190	217	244	271
4 1/4	28	43	57	85	114	142	170	199	227	255	284
4 3/8	30	44	59	89	119	148	178	207	237	267	296
4 1/2	31	46	62	93	124	155	185	216	247	278	309
4 5/8	32	48	64	97	129	161	193	226	258	290	322
4 3/4	34	50	67	101	134	167	201	235	268	302	335
4 7/8	35	52	70	105	139	174	209	244	279	314	349
5	36	54	72	109	145	181	217	254	290	326	362
5 1/8	38	56	75	113	150	188	225	263	301	338	376
5 1/4	39	58	78	117	156	195	234	273	312	350	390
5 3/8	40	61	81	121	161	202	242	282	323	362	404
5 1/2	42	63	84	125	167	209	251	292	334	376	418
5 5/8	43	65	86	130	173	216	259	303	346	389	432
5 3/4	45	67	89	134	179	223	268	313	357	402	447

FARM ENGINEERING

Inches	Depth of water on crest...											
	1-foot weir...	1-foot weir...	1½-foot weir...	2-foot weir...	3-foot weir...	4-foot weir...	5-foot weir...	6-foot weir...	7-foot weir...	8-foot weir...	9-foot weir...	10-foot weir...
	Min- ers' Inches	Min- ers' Inches	Min- ers' Inches	Min- ers' Inches	Min- ers' Inches	Min- ers' Inches	Min- ers' Inches	Min- ers' Inches	Min- ers' Inches	Min- ers' Inches	Min- ers' Inches	Min- ers' Inches
5 ⁷ / ₈	46	69	92	138	185	231	277	323	369	415	461	
6	48	71	95	143	190	238	286	333	381	429	476	
6 ¹ / ₈	49	74	98	147	196	246	295	344	393	442	491	
6 ¹ / ₄	51	76	101	152	202	253	304	354	405	455	506	
6 ³ / ₈	52	78	104	156	209	261	313	365	417	469	521	
6 ¹ / ₂	54	81	107	161	215	269	322	375	429	483	537	
6 ⁵ / ₈	55	83	110	166	221	276	331	387	442	497	552	
6 ³ / ₄	57	85	114	170	227	284	341	398	454	511	568	
6 ⁷ / ₈	58	88	117	175	234	292	350	409	467	525	484	
7	60	90	120	180	240	300	360	420	480	540	600	
7 ¹ / ₈	62	92	123	185	246	308	370	431	493	554	616	
7 ¹ / ₄	63	95	126	190	253	316	379	443	506	569	632	
7 ⁵ / ₈	65	97	130	195	260	324	389	454	519	584	649	
7 ¹ / ₂	67	100	133	200	266	333	399	466	532	599	665	
7 ⁵ / ₈	68	102	136	205	273	341	409	477	546	614	682	
7 ³ / ₄	70	105	140	210	280	349	419	489	559	629	699	
7 ⁷ / ₈	72	107	143	215	286	358	430	501	573	644	716	
8	73	110	147	220	293	367	440	513	586	660	733	
8 ¹ / ₈	75	113	150	225	300	375	450	525	600	675	750	
8 ¹ / ₄	77	115	154	230	307	384	461	537	614	691	768	
8 ³ / ₈	79	118	157	236	314	393	471	550	628	707	785	
8 ¹ / ₂	80	120	161	241	321	401	482	562	642	722	803	
8 ⁵ / ₈	82	123	164	246	328	410	492	574	656	739	821	
8 ³ / ₄	84	126	168	252	335	419	503	587	671	755	838	
8 ⁷ / ₈	86	128	171	257	343	428	514	599	685	771	856	
9	87	131	175	262	350	437	525	612	700	788	875	
9 ¹ / ₈	--	134	179	268	357	446	536	625	714	804	893	
9 ¹ / ₄	--	137	182	273	364	456	547	638	729	820	911	
9 ³ / ₈	--	139	186	279	372	465	558	651	744	837	930	
9 ¹ / ₂	--	142	190	285	379	474	569	664	759	854	949	
9 ⁵ / ₈	--	145	193	290	387	484	580	677	774	861	967	
9 ³ / ₄	--	148	197	296	394	493	592	690	789	888	986	
9 ⁷ / ₈	--	151	201	302	402	503	603	704	804	905	1005	
10	--	154	205	307	410	512	615	717	820	922	1024	
10 ¹ / ₈	--	157	209	313	417	522	626	731	835	939	1044	
10 ¹ / ₄	--	159	213	319	425	532	638	744	850	957	1063	
10 ³ / ₈	--	162	217	325	433	541	650	758	866	974	1083	
10 ¹ / ₂	--	165	220	331	441	551	661	771	882	992	1102	
10 ⁵ / ₈	--	--	224	337	449	561	673	785	898	1010	1122	
10 ³ / ₄	--	--	228	342	457	571	685	799	913	1027	1142	
10 ⁷ / ₈	--	--	232	349	465	581	697	813	930	1046	1162	
11	--	--	236	355	473	591	709	827	946	1064	1182	
11 ¹ / ₈	--	--	240	361	481	601	721	841	962	1082	1202	
11 ¹ / ₄	--	--	244	367	489	611	733	856	978	1100	1222	
11 ³ / ₈	--	--	249	373	497	621	746	870	994	1119	1243	
11 ¹ / ₂	--	--	253	379	505	632	758	884	1011	1137	1263	
11 ⁵ / ₈	--	--	257	385	514	642	770	899	1027	1156	1284	
11 ³ / ₄	--	--	261	391	522	652	783	913	1044	1174	1305	

FARM ENGINEERING

Depth of water on crest.	1-foot well.	1½-foot well.	2-foot well.	3-foot well.	4-foot well.	5-foot well.	6-foot well.	7-foot well.	8-foot well.	9-foot well.	10-foot well.
Inches	Min-ers' inches	Min-ers' inches	Min-ers' inches	Min-ers' inches	Min-ers' inches	Min-ers' inches	Min-ers' inches	Min-ers' inches	Min-ers' inches	Min-ers' inches	Min-ers' inches
11 7/8	---	---	265	398	430	663	795	928	1060	1193	1326
12	---	---	269	404	539	673	808	943	1077	1212	1347
12 1/8	---	---	---	410	547	68-	821	958	1094	1231	1368
12 1/4	---	---	---	417	556	694	833	972	1111	1250	1389
12 3/8	---	---	---	423	564	705	846	987	1128	1269	1410
12 1/2	---	---	---	430	573	716	859	1002	1145	1289	1432
12 5/8	---	---	---	436	582	726	872	1017	1162	1308	1454
12 3/4	---	---	---	442	590	737	885	1032	1180	1328	1475
12 7/8	---	---	---	449	599	748	898	1048	1197	1348	1497
13	---	---	---	456	607	759	911	1063	1215	1368	1518
13 1/8	---	---	---	462	616	770	924	1078	1232	1389	1541
13 1/4	---	---	---	469	625	781	938	1094	1250	1409	1563
13 3/8	---	---	---	475	634	792	951	1109	1268	1429	1585
13 1/2	---	---	---	482	643	803	964	1125	1286	1449	1607
13 5/8	---	---	---	---	652	815	978	1140	1303	1469	1629
13 3/4	---	---	---	---	661	826	991	1156	1321	1489	1652
13 7/8	---	---	---	---	670	837	1005	1172	1340	1509	1675
14	---	---	---	---	679	849	1019	1189	1359	1530	1699
14 1/8	---	---	---	---	688	860	1032	1207	1376	1550	1721
14 1/4	---	---	---	---	697	871	1046	1220	1394	1570	1743
14 3/8	---	---	---	---	706	883	1059	1236	1412	1590	1766
14 1/2	---	---	---	---	715	894	1073	1252	1431	1610	1789
14 5/8	---	---	---	---	725	906	1087	1268	1449	1631	1812
14 3/4	---	---	---	---	734	918	1101	1285	1468	1652	1835
14 7/8	---	---	---	---	743	929	1115	1301	1487	1673	1859
15	---	---	---	---	753	941	1129	1317	1506	1694	1882
15 1/8	---	---	---	---	---	953	1143	1334	1524	1715	1906
15 1/4	---	---	---	---	---	965	1158	1351	1543	1736	1929
15 3/8	---	---	---	---	---	977	1172	1368	1562	1757	1953
15 1/2	---	---	---	---	---	989	1186	1385	1580	1778	1977
15 5/8	---	---	---	---	---	1001	1201	1402	1600	1801	2001
15 3/4	---	---	---	---	---	1013	1215	1419	1620	1822	2025
15 7/8	---	---	---	---	---	1025	1229	1437	1639	1844	2049
16	---	---	---	---	---	1037	1244	1455	1659	1866	2073
16 1/8	---	---	---	---	---	1049	1259	1472	1678	1888	2098
16 1/4	---	---	---	---	---	1061	1273	1489	1698	1910	2122
16 3/8	---	---	---	---	---	1073	1288	1506	1717	1932	2147
16 1/2	---	---	---	---	---	1086	1303	1523	1737	1954	2171
16 5/8	---	---	---	---	---	1098	1318	1539	1757	1976	2196
16 3/4	---	---	---	---	---	1110	1333	1556	1777	1999	2221
16 7/8	---	---	---	---	---	1123	1348	1572	1797	2021	2246
17	---	---	---	---	---	1135	1363	1589	1817	2044	2271
17 1/8	---	---	---	---	---	---	1378	1607	1837	2066	2296
17 1/4	---	---	---	---	---	---	1393	1625	1857	2089	2321
17 3/8	---	---	---	---	---	---	1408	1642	1877	2112	2346
17 1/2	---	---	---	---	---	---	1423	1660	1897	2134	2372
17 5/8	---	---	---	---	---	---	1438	1678	1918	2157	2397
17 3/4	---	---	---	---	---	---	1454	1696	1938	2181	2423
17 7/8	---	---	---	---	---	---	1469	1714	1959	2204	2448
18	---	---	---	---	---	---	1484	1732	1979	2226	2474

Ditches.—In order to carry irrigation water or drainage water, we need ditches. The laying out of irrigation ditches is done in the same way as drainage ditches, except that we sometimes use dykes to carry the water over the low places. So we get "Fill" in the place of "Cut" if the grade happens to have a greater elevation than the elevation of the land.



PLATE 29. Measuring the depth of the water over a weir. The rod stands upon a solid post, the top of which is exactly the same height as the crest of the weir. This measurement must be made in the nearly still water at least six feet back from the weir. (The water pitches down as it approaches the weir. There are just four-tenths of a foot of water going over their weir.)

Sometimes we carry water past low places by the inverted siphon. Some "Practical Drainage" men believe they can use a true siphon made of tile drain to draw water over a hill. Their drainage projects usually fail because the tile are not air tight. Tile drains should be run "on grade."

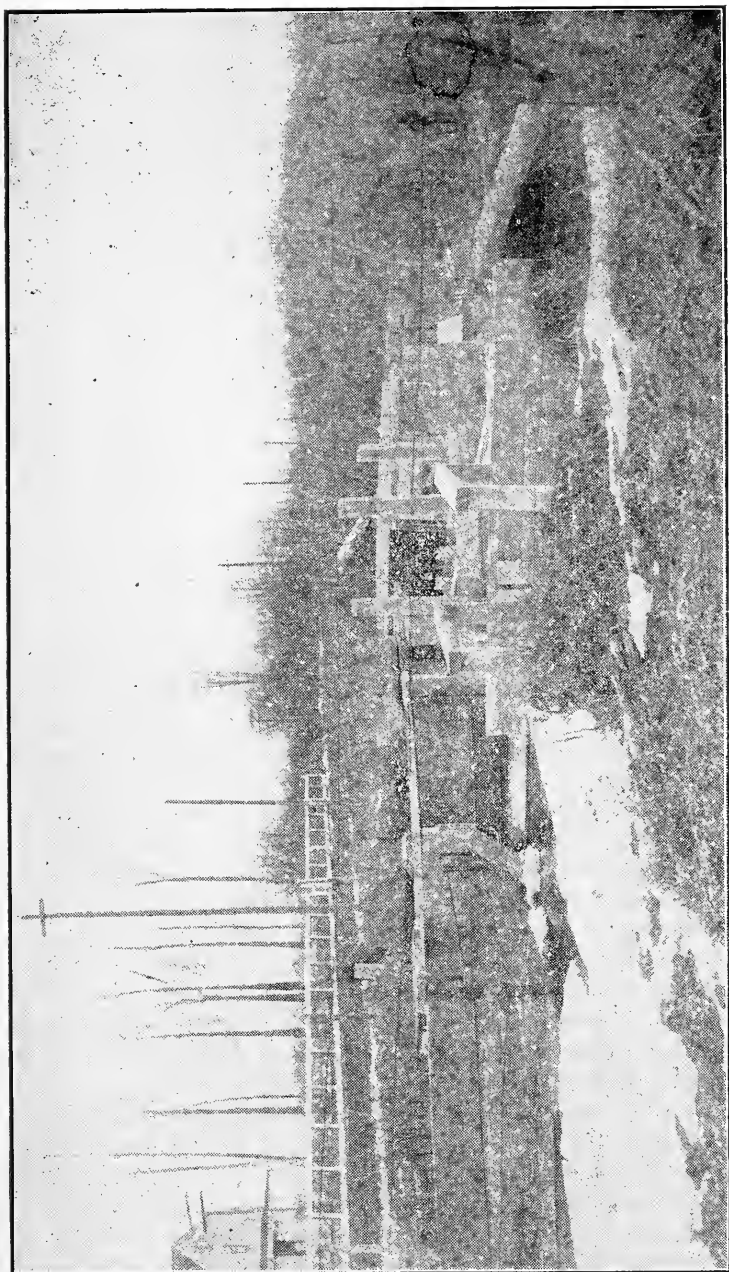

PLATE 20. A type of turn-out box which is rapidly being displaced by the permanent and attractive concrete boxes. Such a device as is shown in the cut is not only unsightly, but it is the source of a great deal of injustice as a ditch rider cannot measure out the water with any degree of accuracy. Such boxes are often the cause of bloody quarrels.*

*In some of the counties of the irrigated sections, more murders have been caused by unjust water divisions than were committed by the Indians, the outlaws, and in all the saloon brawls combined. A good ditch rider, and a system of lock headgates, or properly set weir boxes and turn-out boxes would have prevented most of the trouble.

Open Ditches.—The sides of the open ditches usually slope out about 1 or $1\frac{1}{2}$ feet on each side to each foot of depth. The banks are thus kept from falling in and clogging the ditch. In general, wide ditches are preferable because they do not wash so deep, or change courses so often.

Drain Tile.—Drain tile are of three general classes: square end tile, bevel end tile, and bell end tile. They may be classified according to material into the following classes: 1. Common red tile; 2. Vitriified or glazed tile; and 3. Cement tile.

The common red tile often disintegrates and causes trouble.

The glazed tile are expensive but last well.

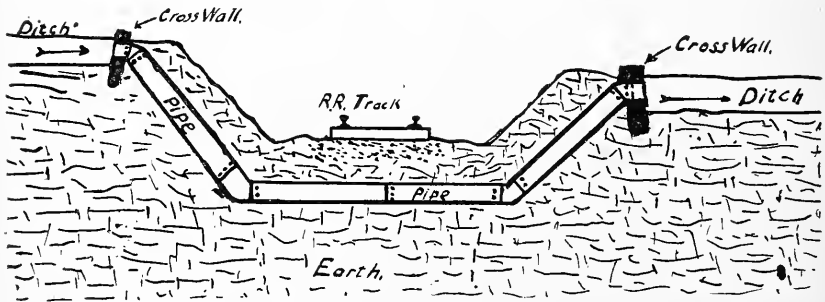

PLATE 31. In Plate 31 is shown a cross-section of a railroad track with an "inverted siphon" running across under the cut and the track. The ditch comes in at the left, (as shown by arrow), and the water runs in at the open end of the pipe which projects through the cement cross-wall. It runs under the track and the force of the water behind drives it up and out of the other end of the pipe, which is a little lower than the in-take end. The siphons are now being built as large as eight feet in diameter and several miles in length. A great ditch is thus carried clear across the "Bitter Root Valley" in Montana.

The cement tile are all right if rightly made, and laid where no alkali water runs through them. (See Bulletin 81 of the Montana Experiment Station.) The cement tile should be of a rich mixture and made very wet. Otherwise the flowing water will soon wear holes through the loose, crumbly cement sides.

After irrigation water has been measured and brought to the field by the ditches, it is turned out into small ditches

by means of turnout boxes. These are made of cement, concrete or wood. See Plates 28 and 30. In case of deep ditches, many prefer the steel head gate. See Plate 21.

The methods of handling the water on the land vary so much that it is impossible to go into detail for each system. In some localities, the water is brought into tiles, and fed to the soil from below, "sub-surface irrigation." In some locali-

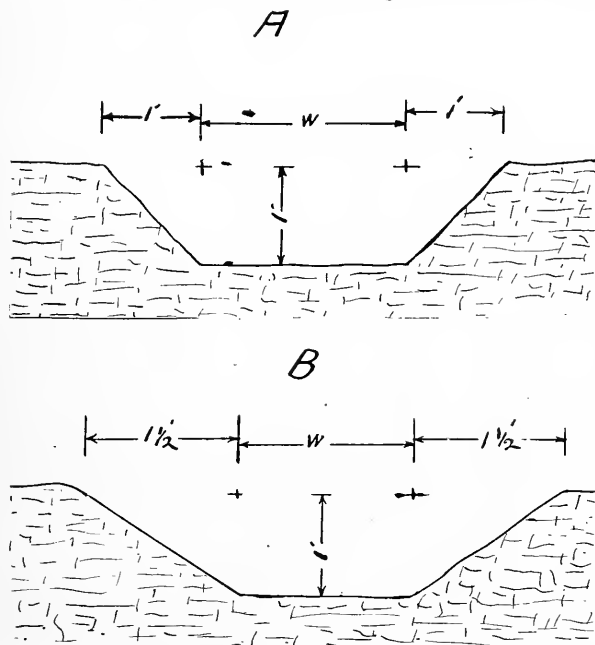

PLATE 32. This gives an idea of desirable cross-sections for drainage or irrigation ditches. Figure A has a slope of 1 to 1. That is, each side slopes out one foot to each foot of depth. Figure B is of a ditch with a 1 to $1\frac{1}{2}$, that is, each side slopes out one foot and six inches or one foot and five tenths to each foot of depth. A is satisfactory for ditches through hard soil, heavy clay, etc., while B should be used for sandy soil or any easily washed soil.

ties, little furrows are made, two, three or four feet apart, and a little water allowed to run down each furrow. This is called "corrugated irrigation." Again, in some parts of the country, dykes are built at the lower sides of the fields, and the water is allowed to flood the fields, "flooding." And so

we find all of these systems changed, and combined until we have no end of special methods of irrigation.

The Preparation of Land for Irrigation.—It is necessary

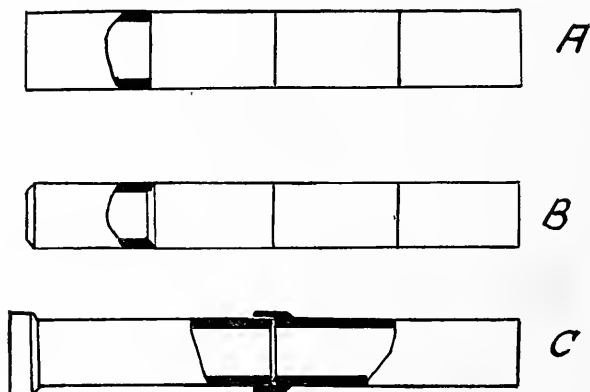

PLATE 33. This shows a side view of the three different types of tile. Fig. A is the ordinary "square-end" tile. Fig. B is a "bevel-joint" tile. Fig. C is a "bell-end" tile. In each figure the side of the tile has been cut away to show a section of a joint. The bell-end tiles are usually made two, three, or four feet long, while the others are usually one foot long in small sizes and two feet long in large sizes.

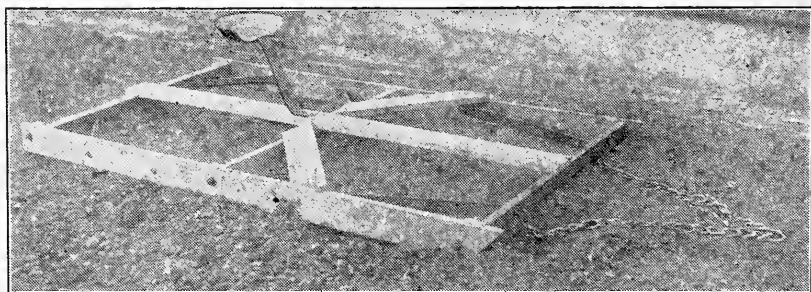

PLATE 34. This is a photo of the latest and most approved type of irrigation leveler. It is sixteen feet long by eight in width. If it is to be used on light soil the members are 2"x6"; if it is to be used on medium soil, 2"x8"; if on heavy soil, 2"x10" or even 2"x12". The braces are of old wagon tire and the chain by which it is pulled is a log chain. From two to six horses are required to drag it. It rubs off the high spots and carries the soil to the low spots and there drops it automatically. As no company builds these useful machines, the farmer builds them himself.

to get the surface of the field free from little high spots and low spots, before irrigation can be properly done. This is accomplished by plowing the ground, and then going over it with an irrigation leveller.

Control of Moisture, and Temperature of the Soil by Means of Scientific Tillage.—If wet ground is rolled with a heavy roller, the moisture near the top is readily evaporated from the surface. The evaporation cools the soil, just as the evaporation of sweat cools the human body. Thus we remove moisture and cool the soil by rolling.

If we establish a surface mulch by surface tillage, we are able to prevent evaporation, and thus keep the soil moisture from evaporating. This also brings the fine particles in such a position that they can absorb heat from the sun's rays, and as they are not cooled by rapid evaporation, the soil is warmed.

Thus we control the temperature and moisture by drainage, irrigation and scientific tillage.

TILE LINES.

The general use of drain tile both for the purpose of carrying drainage water and irrigation water as well as sewage makes it necessary to study the matter carefully before venturing to install a tile system of carrying water or sewage.

Capacity of Tile Drains.—No attempt is made here to go into the infinite detail of the carrying capacity of drain tile. It is well for the student to know that the capacity of a tile, drain or conduit varies according to the smoothness of the flow also depends upon the depth of water in the soil above the tile.

The following table gives somewhere near the flow which we might expect from a six-inch tile system if everything was in good working order and the work of laying the tile had been properly done:

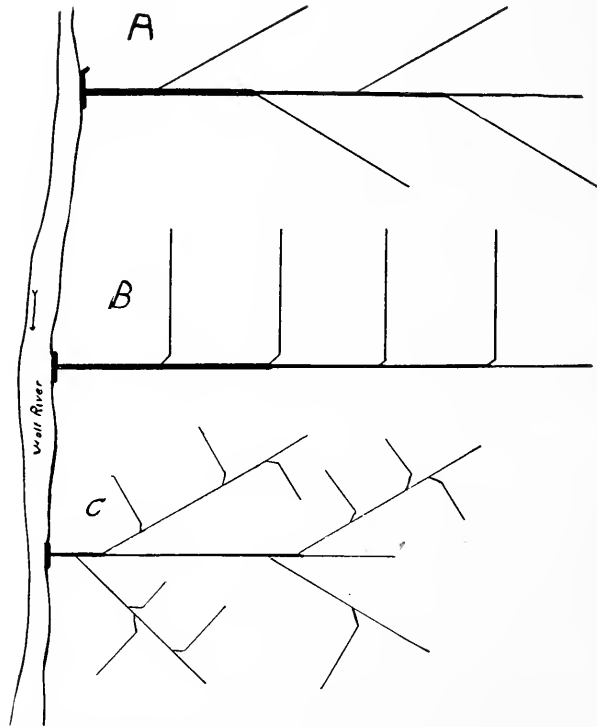

PLATE 35. This shows three systems of laying out tile drains or open drains. Fig. A is the branch system. The main line goes up the main hollow or low ravine. The branches may extend up small low places or they may be extended into the level land on each side of the main ditch. This system works very well on very fiat land as well. Notice the cross-wall at the mouth of the drain. An "upstream wing" protects the bank from washing out. Fig. B is a side branch method which resembles a gridiron. In case one wishes to drain a side hill the main line may extend along the base of the hill and the branches may extend up the side of the hill. Notice that the tile bends downstream in each case before the branches are allowed to enter the main tile. Also notice that a larger tile is used below the branches than above. If the grade of Fig. B were reversed, then this system would be suitable for the discharge of sewage water from a water tight cess-pool. In case there is danger of the outlets (which would then be at the ends of the branches) clogging by freezing, the water should be drawn from the cess-pool by an intermittent siphon. See Farm Engineering, Part I and Iowa Engineering Experiment Station bulletin on Sewage Plants for Private Houses. Fig. C shows a combination of systems shown in A and B. This is good in case a large ravine has many smaller side ravines which are separated by ridges through which it is impracticable to dig the ditches.

Inches of drop per hundred ft.	Number of second feet discharged from tile.
30	$\frac{3}{4}$
24	$\frac{5}{8}$
18	$\frac{1}{2}$
12	$\frac{3}{8}$
6	$\frac{5}{16}$
3	$\frac{1}{4}$

As the number of cubic feet of discharge will vary approximately as the square of the diameter of the tile one might figure the capacity of the different sizes of tile from the above table. To get the discharge of a three-inch tile, $6 \times 6 = 36$, $3 \times 3 = 9$, $36 \div 9 = 4$. Then a three-inch tile will carry approximately $\frac{1}{4}$ as much as a six-inch tile.

To find the capacity of a twelve-inch tile, $6 \times 6 = 36$, $12 \times 12 = 144$, 144 is four times as great as 36 so we might expect four times as much discharge from the larger pipe. This is based on the fact that the area of a circle increases as the square of the diameter.

As there is more resistance per unit of area of cross section in the small tile the increase in discharge will be greater in proportion to the cross section in large tile than it will be in small tile.

Systems of Laying Tile.—There are a great many systems of laying out tile drains. The student must apply some one of these systems and make such combinations as he sees fit.

TILE DRAINAGE.

In different parts of the country the people hold widely different opinions in regard to the proper methods of draining land. In general it may be said that they do not really understand the advantages to be derived from drainage.

Many believe that when they have removed the **surface**

water they have properly drained the field. In a large majority of cases the idea is absolutely wrong. Again we often meet those who really believe that all the water should remain on the land in order to produce a crop. Such people have little or no idea of the detrimental effects which result from a "high water table." By a high water table we mean the height of the free water in the soil.

The student should understand that there are **three** types of water in the soil:

1st—Free water, that type of water which may flow from place to place. Such water flows into a well or cellar which penetrates below the water table.

2nd—Capillary water. This type of water is in the form of a thin film which covers the surface of each particle of moist soil.

3rd—Hygroscopic moisture. This form cannot be seen but when soil which is apparently very dry is heated, it loses weight. This is due to the loss of water which we cannot see.

In all three cases the water is of the same composition, but its effects on plant growth are very different. Both hygroscopic and capillary moisture promote plant growth, while the free moisture causes the plants to actually drown. Of course many aquatic plants can live with their roots in free water, but we must remember that such plants as corn, oats, wheat, barley, rye, clover, timothy, alfalfa, etc., are **not aquatic**. The roots reach into the soil for plant food and moisture, but when they reach a very high water table they often perish.

In the light of the above facts, it is easy to understand why subsurface or "under drainage" often causes land, which has previously been unproductive, to produce abundant crops.

The author has never met with a case where a thorough system of under drainage really caused the land to "dry out" as some people imagine it would.

As a matter of fact, neither capillary or hygroscopic moisture can be drawn from the land by an underground drain.

It is only the **free water** that is really affected.

Systems of underdraining:

Mole Ditches.

Some years ago a machine was devised which forced a bullet shaped piece of iron through the soil, at a depth of from one to three feet. The ditch worked much as a modern tile drain works, but it soon caved in on nearly level land, while in hilly land the water tore out deep gullies where the ditch had been.

Brush or Stone Drains.

Many people dug ditches, filled them partly full of brush or loose stones and filled the top of the ditch with earth. These ditches often cave in and fill up or wash out until gullies are formed. However, many people still believe that such drains **must** be used. Such a belief rapidly dies out when a thorough knowledge of the advantages of tile drainage is acquired.

By means of tile drainage the engineer may regulate the height of the water table to suit conditions. By so doing he allows the soil to become aerated, and thus the roots of plants may penetrate to a great depth.

The absence of the free water near the surface allows the soil to warm up earlier in the spring, and to maintain a better tilth throughout the season.

In laying out and digging ditches for tile drains the general directions should be followed carefully. The bottom of the ditch should be smoothed by means of a tiling hoe or spoon. The tiles are then laid end to end in the ditch and a little fine soil is carefully tramped on top of them.

The ditch may now be filled with a slip scraper or by

hand. The earth should be tamped thoroughly over the tiles, in layers not more than six inches in thickness; this will prevent washouts.

It must be remembered that the water enters the tile drain **between the ends of the tiles**. Some think that the water soaks through the tile. The latter idea is incorrect.

One need not hesitate to use either cement tile or vitrified clay tile for drainage purposes, and even though the ends are placed close together, the water finds no difficulty in rushing in and filling the line. In fact great care must be taken to have the ends of the tile forced close together. This prevents dirt entering the tile. Many prefer to use bell end tile in place of square end tile for drainage purposes. This makes the work more expensive, and at the same time of no more real value.

In those localities where alkali is prevalent the vitrified tile should always be used, as the alkali "eats up" or destroys the ordinary tile. The cement tile is rapidly destroyed by alkali unless it is especially treated to prevent the action of alkali.

Size of Tiles.

In theory we might be able to use two and three inch tile for our short drains, but in actual practice we have ceased to use drains smaller than four inches in diameter. It is hard to say just what size tile should be used, but the following data will prove advantageous to those who wish to use tile drainage:

- A four-inch tile will drain from ten to fifteen acres.
- A five-inch tile will drain from twelve to twenty acres.
- A six-inch tile will drain from twenty to forty acres.
- A seven-inch tile will drain from forty to sixty acres.
- An eight-inch tile will drain from sixty to eighty acres.

The above data must be used with judgment or the student may find that he is putting in smaller tile than he should put in. He seldom finds that he has put in larger tile than he should put in.

It should be remembered that the carrying capacity of a tile is approximately proportional to the square of the diameter. Consequently one should not expect two four-inch tiles to fill one eight-inch tile, etc., etc.

Joints.

In bringing the laterals into the mains we should always be careful to see that the water does not approach the main at right angles. It should gradually approach the direction in which the water is flowing in the main tile, and the axis of the branch should be level with the axis of the main tile. In other words, the bottom of the tiles should not be level.

The Tiling Hoe.

The tiling hoe is made especially to smooth the bottom of the ditch, leaving a round for the tile to lay in. All ditches should be smoothed with a tiling hoe.

Ditch Digging Machines.

Many good companies are now building machines which dig ditches for tile drains at exactly the right level, and in some cases these machines smooth up the bottom, leaving it round for the tile. The Buckeye ditcher is an example of this type of machine.

In running levels for tile drains, we must follow the same rules as we use in digging ditches for drainage or irrigation. The same method of measuring off and staking out is used as in drainage and irrigation ditching.

EXAMINATION

Note to Students—These questions are to be answered independently. Never consult the text after beginning your examination. Use thin white paper about 6 in. x 9 in. for the examination. Number the answers the same as the questions, but never repeat the question. Mail answers promptly when com-

1. Explain how a lack of knowledge of Agronomy may prevent an Agricultural Engineer from doing successful work.
2. Explain how an Agricultural Engineer must be governed by the principles of Farm Management.
3. Describe **accurately** the construction of a surveyor's level of the "Y" type.
4. Discuss errors in tape measurements, treating of Cumulative and Compensating Errors.
5. Explain how to turn off a right angle by means of the tape and pins.
6. If the surveyor runs a line at 90 degrees to the direction of the compass needle, will the line be an east and west line? Why?
7. Explain how to bring the level bubble tube parallel with the bearings of the "Y" rings.

8. Tell how the area of a field with straight sides of irregular length, and angles other than 90 degrees, may be determined.
9. Tell how the area of an irregular field may be determined with a planimeter.
10. Explain how to cut off a certain number of acres from an irregular field, and still have two sides of the new field parallel to each other.
11. Why is the price of wood fence posts increasing from year to year?
12. Tell how to make a cement fence post.
13. Tell how to test the strength of a cement fence post.
14. Why are god culverts and bridges necessary on the farm?
15. Why is it desirable to govern the temperature and moisture conditions of the soil?
16. In what three principal ways can the agricultural engineer govern the temperature and moisture conditions of the soil?
17. What is a topography map? How does it help in drainage and irrigation projects?
18. Explain the principles of differential leveling.
19. The student will now prepare a map of field shown in Plate 17, and with a cut of three feet at X, draw in dotted lines a proposed drainage system. He will show, (1) direction of drains; (2) length of drains ;(3) angles turned off. This map should enable any engineer to locate tile drains, laid according to the map.
20. The student will now fill in the following page of notes, giving the grade and cut at each 100-foot station. The ditch is to be 2 feet deep at each end, and run on even grade.

Sta.	S. B.	H. I.	F. S.	Elev.	Grade	Cut
0	4.50	11.50	10.00	8.00	2.00
100	5.21
200	4.02
300	3.65
400	3.46
500	3.21
600	2.84	2.00

21. The student will make a profile map showing bottom of ditch and top of ground.
22. Tell the two main sources of irrigation water.
23. Describe an inverted siphon and tell how it works.
24. Define the second foot and the acre foot as units of measure of irrigation water.
25. Describe the cippoletti weir and tell how it should be made and set.
26. Consult Plate 29 and weir tables. The rod reading is exactly .4 foot. The crest of the weir is 1 foot long. How many cubic feet, or what part of a cubic foot per second is passing over the weir?

Write this at the end of your Examination

I hereby certify that the above questions were answered entirely by me.

Signed -----

Address -----

THE
CORRESPONDENCE COLLEGE
OF AGRICULTURE

FARM ENGINEERING,—Part III

HIGHWAY ENGINEERING

and

FARM CONCRETE CONSTRUCTION

by

H. BOYDEN BONEBRIGHT B. S. A. MEMB. A. S. A. E.

Agricultural Engineer

Montana State College and Experiment Station
BOZEMAN, MONTANA

This is the third of a series of three books giving a complete course of instruction in

FARM ENGINEERING

NOTE TO STUDENTS

In order to derive the utmost possible benefit from this book you must thoroughly master the text. It is not intended that you should commit the exact words to memory, but there is nothing contained in the text which is not absolutely essential for the intelligent farmer to know.

For your own good never refer to examination questions until you have finished the study of the text. By following this plan the examination will show what you have learned from the text.

This lesson book is not intended to be a book of plans for the building of roads or for the construction of concrete structures. It is designed to give in the most practical possible way, the fundamental scientific knowledge which the student must have if he is to successfully build roads, or concrete work. With the information given in this book the student should be able to design for himself such roads or concrete work as will best fit the conditions under which they are to serve.

Should the student wish to buy some books on the subject of Roads and Pavements he will find "Roads and Pavements" by Ira Osborn Baker to be an excellent addition to any engineering library. "Highway construction," by T. Byrne, is also an excellent reference book. These books are published by John Eiley & Sons, New York. Cost five dollars each.

The student can secure for the asking "Concrete Construction about the Home and Farm" from the Atlas Portland Cement Co., 30 Broad St. N. Y. "Concrete Silos" and "Concrete in the Country" from The Universal Portland Cement Co., Chicago, Ill.

Farm Engineering Part III

Highway engineering in its crudest forms has been practiced since the earliest history of man.

When man learned the fact that it was easier to walk around a hill in a gradually ascending line than to climb directly up one side, he began putting into practice some of the principles which are now so scientifically worked out by our high salaried railroad and highway engineers.

And it is not at all improbable that man first learned the principles of rounding the hills from the game which he pursued, for the trails of many wild animals show that even the beasts of the forests understand something of laying out roads on a reasonable grade.

Later when the ass and the ox were used by man as beasts of burden the trails had to be widened and the steepest grades had to be removed from the trails.

Then the crude forms of carts and sleds appeared and the trails were widened into roads. While thousands of years have elapsed since these crude roads began to scar the face of the earth, yet, it remained for this generation to witness the entrance of the most destructive vehicle, which roads have ever been made to carry. Heavily loaded wagons and traction engines may crush the road's surface, but in so doing they only serve to make the surface harder. But the automobile with its round soft tires does little packing, and in fact when driven at a moderate speed it scarcely injures the road at all. But when the speed is increased to twenty miles an hour the dust, the sand, and even the small pebbles, fly from beneath the wheels with sufficient force to carry them several feet from the center of the road.

When the auto's speed increases to fifty or sixty miles per hour the material is literally blown from beneath the tires and it falls many feet from where it originally lay.

Consequently many systems of road-building which served the purpose perfectly for thousands of years, have become impractical within the last decade, for as fast as the road surface is loos-

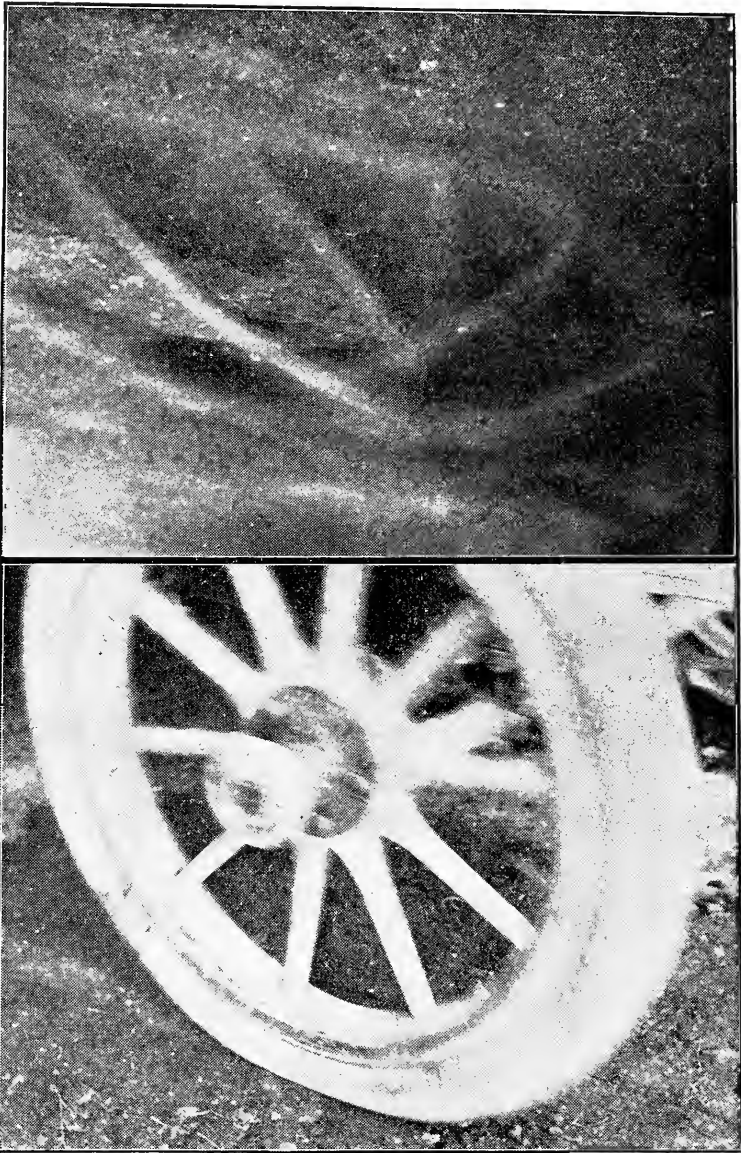

Plate 1. In plate 1 at the top is shown an automobile wheel traveling at slow speed. Notice that no dirt is being thrown from beneath the tire. The lower part of the plate shows a wheel (traveling to left) at high speed. Notice the particles of earth and the pebbles falling from beneath the tire in the direction of camera. (Of course this picture shows a blurred wheel owing to the speed at which the wheel passed).

ened by the calks of horses and the wheels of slow moving vehicles, it is knocked to the road-side or blown into an adjoining field by the swiftly moving automobiles.

And we must figure that the automobile has come to stay. While it is to be hoped that the extreme speed of some of our reckless drivers will be a passing fad, we must reckon with the swiftly moving machines as among the worst destroyers of old-fashioned good roads.

In order to properly understand the subject of highway engineering, we must have very definite knowledge of several sciences.

Surveying.

In order to properly lay out a road one must understand the use of the level and transit, or at least the use of the highway or architect's level. With these instruments the highway engineer lays out the line of the road, and determines the grades. He is also able to stake out the cuts and fills, and to locate the side ditches and the crown in the middle of the road.

Drainage.

One of the most essential points in road construction is proper drainage of the land through which the road runs, and especially that land directly under the travelled portion of it.

Soils.

For the following reasons it is essential that the engineer be able to judge the type of soil over which he lays out a road.

1st. He must know how to drain the road, and the type of soil has much to do with the problem of drainage.

2nd. He must be able to tell what treatment will best fit the surface for heavy or light traffic, as the case may be.

3rd. He must be able to foretell what effect the climate will have upon the soil over which he lays out a road.

4th. He must be able to determine the effect of swiftly running water, not only on the road's surface, but its effect upon the side ditches, and the culverts and bridges along the way.

Animal Husbandry.

The student should have a fair idea of the pulling ability of horses, and of the effect of different road surfaces upon the feet of horses.

Sanitary Science.

In some cases roads either add to or detract from the sanitation of a district. The engineer should be able to so construct the roads that they will aid in keeping a district sanitary, or at least, not in any way hinder the work of sanitation.

Concrete Construction.

The student should have a fair idea of the principles of concrete construction and masonry, in order that he may design and build small culverts and bridges in an economical and satisfactory manner.

Materials of Construction.

The student should have a fair knowledge of the materials of construction used in bridges and culverts.

Sufficient material is found in Part 1 to enable the student to figure strengths sufficiently accurately for all ordinary work. The student must always figure on giving road structures a **large factor of safety**, as traction engines and herds of farm animals often subject a structure to from 10 to 20 times the normal load.

LAYING OUT ROADS

In the laying out of a good road the engineer must first consider what purpose the road is to serve. If it is to be a pleasure road, then he need not seriously consider the problems which relate to shortening distances between points, but aim rather at cutting down grades by means of contours, rather than cuts and fills.

In the case of tonnage roads he should aim to have the shortest possible road from point to point, and at the same time cut all grades as low as possible.

In many states it has become a habit to put all highways upon section lines. This is often very bad practice, as it often lengthens the distance between points, while not infrequently, it places the road in such a position that deep gulches must be crossed, and high ridges must be surmounted. Such construction is very faulty from the standpoint of tonnage roads.

The main thoroughfares into our larger towns and cities often carry as much tonnage as some of the less important railroads, and there is no good reason why the most direct route should not be

taken by them, even though some land had to be acquired by condemnation proceedings.

Again, by properly laying out a road we can avoid steep grades and thus increase the efficiency of the road a great deal, for as "a chain is no stronger than its weakest link," so the efficiency of a tonnage road must be measured by its steepest grades or by its poorest bridges.

It is unnecessary to take up here the subject of running levels over the projected highways as the work of running levels is dealt with thoroughly in Part II, of Farm Engineering.

Grade of Roads.

In laying out a road one of the most essential points is the grade. A perfectly level road, while desirable from the standpoint of draft of vehicles, is not desirable from the drainage standpoint. It is likely to become a mire during wet seasons of the year, and when it once becomes a mire it is very slow about drying out.

On the other hand, a very steep grade is undesirable, not only on account of the increased draft of ascending vehicles, but also on account of the difficulty of maintaining a good road surface during wet weather. The washing effect of hard rains, upon the steep grades is very hard to overcome.

How Grades Are Computed.

Many authorities speak of the grade of a road in terms of feet rise per hundred feet of travel. For instance, a rise of one foot in traveling one hundred feet is spoken of as "a grade of one to the hundred."

Another way of designating the amount of grade is in per cent. That is, if the rise is one foot in a hundred feet the rise is said to be one per cent. Five feet rise per hundred feet of travel is a five per cent. grade, etc., etc.

In both the above cases the **actual distance** traveled is taken as the basis of length of travel, while in theory the distance should be taken on a level, yet the error is so slight that most authorities do not take it into account. Hence, we simply measure the distance on the road surface and divide it into the feet of rise in order to get the grade.

Effect of Grade on Draft of Vehicles.

When a loaded wagon is pulled up an incline the power re-

quired to move it becomes greater, due to the fact that the load, the wagon, and the source of power, be it team, or engine, must be elevated bodily as the load proceeds.

Some people believe that the actual pull required to move a load up a grade varies exactly as the per cent of the grade. This is not the case, because there are other factors which enter into the total pull of a loaded vehicle.

Axle Friction.

A certain amount of power is required to cause the wheels to revolve upon the axles, or in case of sleds, power is required to cause the runners to slip upon the snow or ice.

The amount of axle friction is generally from five to ten per cent of the total pull of a vehicle when running upon a level road.

Rolling Friction.

What really causes by far the greater part of the draft of vehicles, is the fact that the wheels actually crush into the surface of the earth and thus as they proceed they keep smashing down the earth in front of the wheels. In general rolling friction accounts for about 90 per cent to 95 per cent of the total draft of vehicles on level roads.

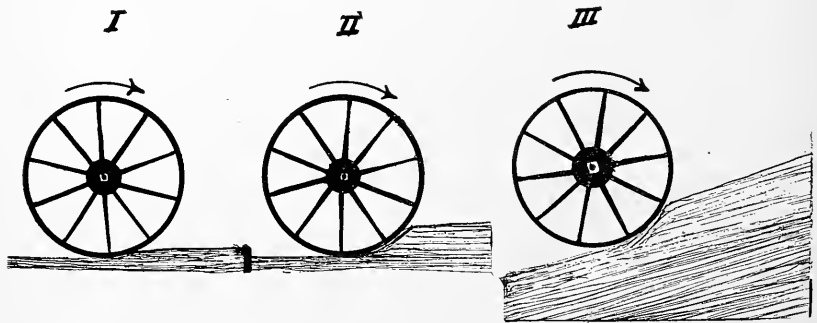

Plate 2. Figure 1 represents lightly loaded wagon wheel running upon a hard road. Figure 2 represents heavily loaded wagon wheel running upon a soft level road. Figure 3 represents a heavily loaded wheel running up a steep grade upon a soft road. Notice the marked increase in "rolling resistance" shown of 2 over 1 and added to the rolling resistance of 2 we find grade resistance in 3.

Of course, on hard roads the axle friction remains nearly the same, while the rolling friction decreases. Thus the per cent of the axle friction is greater on hard roads and smaller on soft roads,

while the total draft of the vehicles is smaller on hard roads and greater on soft roads.

This explains the fact that a good team often has great difficulty in moving a two-ton load over a soft earth road, while an equally good team can easily haul a four or five ton load over a hard paved street.

Now when the student realizes that the axle friction and the rolling friction do not diminish when a vehicle is drawn up a grade, he will readily understand why so much power is required in hauling heavy loads over steep grades.

The following table gives approximately the draft of loaded wagons over different types of roads.

Pull in pounds per ton of weight moved:

Good macadam road.....	75 to 110
Sandy road with hard bottom.....	150 to 200
Good hard earth road.....	75 to 150
Soft earth road.....	150 to 300
Plowed ground hard bottom.....	500 to 800

This may increase to nearly the weight of the load in case the road becomes soft enough.

The student should understand clearly that **nearly every type of road offers a different rolling resistance**. Hence, no **exact** data can be given which can be used in all cases. And what is more, the rolling resistance will vary in the same soil under different climatic conditions.

Not only do we look to the grade resistance, the rolling resistance, and the axle resistance to interfere with the progress of a team, but the horses must lift their own weight at a disadvantage. As the muscular effort of a horse while pulling is nearly all in the hind legs and loin, the front of the horse is only of sufficient weight to keep the front feet from leaving the ground. When the horse attempts to pull up a steep grade, the front feet leave the ground before his best effort can be made.

The same is true of traction engines. In many types of engines there is great danger of the front end rising from the ground while ascending steep grades.

Were it possible to select grades of any desired pitch the average engineer would probably select a grade of from one-tenth foot

to one-half foot per hundred. This affords good drainage and does not increase the grade resistance to a point where it will become troublesome. We find a great many long and troublesome hills which have grades as steep as eight feet per hundred feet. Generally they are not considered serious impediments to traffic. A ten per cent grade is generally considered practical if not too long. A fifteen to twenty per cent grade should never be tolerated in a tonnage road unless the length of pull can be restricted to less than 100 yards. In such cases it is usually possible to reduce the grade by cut and fill or by making the road to follow a contour around the hill.

Grades of fifteen to twenty per cent are not only hard to ascend but they are very dangerous of descent as well.

However, in mountainous parts of the country we find roads in which grades as steep as twenty per cent are not infrequent.

In such localities vehicles are usually of stronger construction than those used upon the more nearly level roads.

We have the "mountain wagon" in place of the surrey, and the "mountain gear" in place of the lighter "valley gear" in our lumber wagons.

Special automobiles with low gears suitable for mountain roads are now furnished by many companies.

Traction engines, as a rule, have no trouble in ascending grades too steep for travel by horses which are pulling heavy loads.

Regarding the descent of steep grades in mountainous sections of the country, each vehicle, even to the lightest buggy, is equipped with a powerful brake. The sleds are equipped with "rough-locks" and of course the traction engines and automobiles have the reverse gear as a last resort in case the brakes do not serve the purpose.

The above facts are not intended as excuses for extremely steep grades in mountain roads. The engineering is faulty, but in many cases the roads do not carry sufficient tonnage to warrant cutting the grades at great expense.

Width of Highways.

In general the width of highways is determined by the laws of the state rather than by the judgment of the engineer. Many states require the highway to be 66 feet or 4 rods wide between fences.

In a great majority of cases the roads need not be this wide. The actual graded surface is nearly always decided by the highway engineer. While many roads of little importance are built from 20 to 24 feet wide it is a general practice to use about 30 to 34 feet



Plate 3. "Four-wheeled drive" tractor ascending 64 per cent. grade. In general, tractors have little difficulty in climbing a steep hill which affords a good foothold or grip.

for the graded portion. That is, from the center of one ditch to the center of the other. The matter of width must be left to the judgment of the engineer.

Crown of the Road Surface.

In order that moisture may be made to run off the traveled portion of a road the center is usually raised higher than the sides. The height of the crown above the bottom of the side ditches varies from 4 to 18 inches. From 5 inches in a narrow road to 10 inches in a wide road is considered good practice for earth roads.

The crown should be rounding, not sharp, and the side ditches should have slanting sides. Nature tends to destroy the sharp angles of earth surfaces and the sharp banks of a road ditch are no exception to the rule.

Besides the natural agencies which tend to cave in the banks, we also have a very great action from animals and vehicles. By smashing the sharp banks into the ditch they fill up that portion wherein the drainage water should move freely. Thus, the sharp banks prove very faulty in road construction. The rounded ditches with sloping banks are little harder to make and serve the purpose much better. In every case in which the slope of the land is not excessive the dirt which is used to make the crown of the road

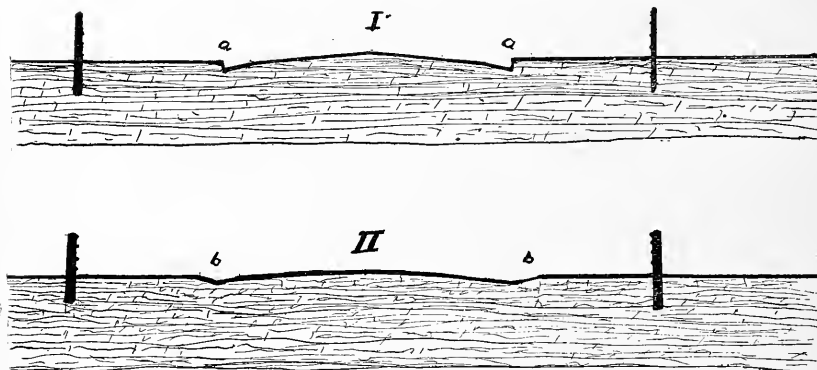

Plate 4. In the case of Fig. 1, Plate 4, the side ditches have sharp angles at *a* and *a*. Such ditches soon crumble in and become useless. In Fig 2, Plate 4, we see sloping ditches at *b* and *b*. These sloping ditches remain in good condition for a long time. They do not hinder the dragging or the grading of the road.

should be equal in quantity to that removed from the ditches. Thus, no dirt need be moved lengthwise upon the road. In other words the cut in the ditches equals the fill of the crown.

Drainage of Roads.

One of the serious factors which must be considered by the highway engineer is the drainage of roads.

It is not a hard matter to keep roads reasonably dry during favorable seasons of the year by having properly constructed side ditches. Many people attempt to drain roads by putting tile drains under the middle of the road's crown. The ditch which is dug for the tile drain usually proves troublesome for several years. And as it becomes hard, packed and puddled, the efficiency of the tile is diminished. As a matter of fact the real efficiency of such a tile is never very high.

If the tile be placed under one or both of the side ditches the results are much better. This is true for two reasons.

1st. The crown of the road tends to cause the surface water to run to the side ditches where it soaks directly down to the tile drain.

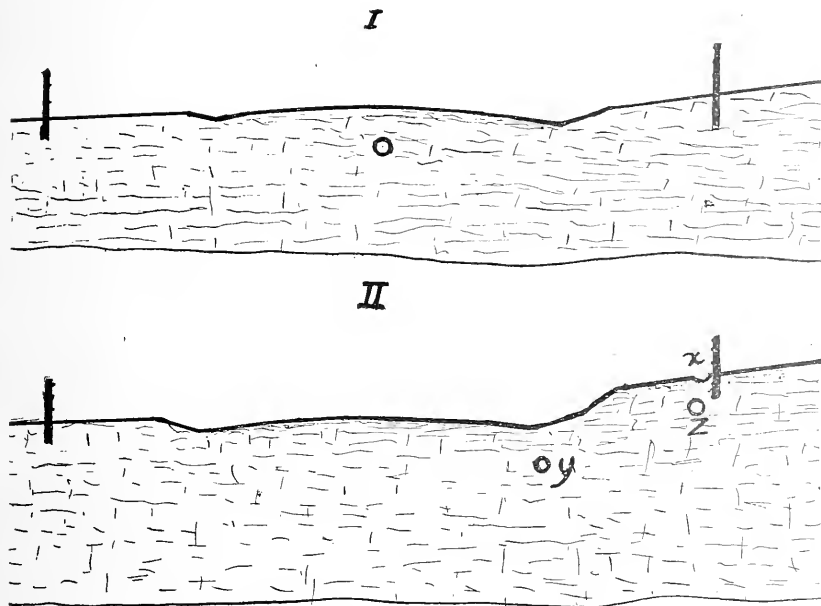

Plate 5. In Fig. 1, Plate 5, is shown a useless attempt to drain a road by means of a tile running in the center of the road. As the soil is puddled and as the center of the road is high, the water must run to the side ditch and soak through the ground to the tile. In Fig. 2, Plate 5, we see a tile placed under side ditch where the water can easily reach it. The auxiliary open ditch "x" and the tile "z" are sometimes used to cut off washing and seepage on side hills. The open drain "x" is very valuable for catching the wash of severe rains while the tile "z" serves to drain the soil in case the side hill has wet seepy spots or springs in it.

2nd. Because the earth in the ditches is not packed so hard as the earth on the crown of the road.

In case of side hills it is well to do all the tile draining on the upper side of the road. This prevents water from rushing upon the crown of the road during the heavy rains and it also prevents seepage water from keeping the surface of the road wet between rains.

A large ditch near the fence on the upper side of the road often

proves of great value, as it catches flood waters which come down from the adjoining hillside.

In case of wet, seepy, or springy hillsides a tile drain laid along the upper fence often intercepts the flow of ground water and thus keeps the road dry.



Plate 6. A little scientific road drainage would have prevented this condition of the road shown in the plate.

In rare cases it becomes necessary to secure permission to put drains into adjoining fields in order to keep roads dry, but this is seldom the case.

Culverts.

“Where does all this drainage water, of which we have been speaking, go to?” we ask.

In each locality there is a general drainage system that must be made use of. A creek, a branch of a river or, perhaps a river. The drainage water must be conducted to some such outlet.

In case the road crosses a low spot or an undrained marsh, it is usually advisable to build an embankment upon which the road may be located.

It often pays to investigate the nature of the soil beneath these sink holes. If "hard pan" or an impervious layer of clay is found a few feet below the surface and below this "hard pan" a layer of gravel, or loose earth is located, it is often possible to "shoot the hard pan" with dynamite and thus allow the drainage water to seep down into the subsurface soil and flow away.

In draining a piece of road in this way the engineer often drains much valuable land by the road side. In many cases it is better practice to build a road around a swamp rather than to dyke it. The land is seldom very valuable in the neighborhood of a swamp, and the road bed is cheaper and often far more satisfactory when located on the banks about the swamp. It is always advisable to place culverts under the roads which traverse low swampy ground. While there may be no apparent movement of water in the swamp yet rains and seepage are likely to cause water movements from one side to the other. Thus, the culvert often saves washouts and much trouble.

Culverts.

The side ditches or the tile drains bring the water down the grades of a road to the lower places. It often becomes necessary to conduct the water from one side of the road to the other. This is done by means of culverts. A culvert is simply a small bridge. It must be **sufficiently strong** to carry the **heaviest loads**, and **sufficiently large** to carry the water from one side of the road to the other without allowing any of the water to flow across the road bed.

Culverts are made of various materials.

1st. Stone culverts are of two general types.

A. The box culvert which consists of two parallel walls built across the road. On top of these and reaching from one wall to the other large flat stones are laid. The whole is covered with dirt and the culvert is complete. These culverts are "laid up dry" (that is, without mortar), with lime mortar, or cement mortar. The latter is by far the best of the three types.

B. The arch culvert consists of two walls which are put parallel to each other at the base and the tops are so laid as to form nearly a semi-circle at the top. There are many types of arches but they all embody the one principle. Each stone is so laid that it resists **compression stress**, and not bending stress.

As in the case of the box culvert the arches are laid "dry", with lime mortar, or with cement mortar. When it comes to carrying heavy traction engines the arch usually proves superior to the box type of stone culvert, as these heavy motors often exert a pressure of many tons upon one "lug" or "grouter". If this stress be exerted upon the middle of one of the flat stones of a box culvert, there is likely to be a smashed culvert. While stone is very strong in com-

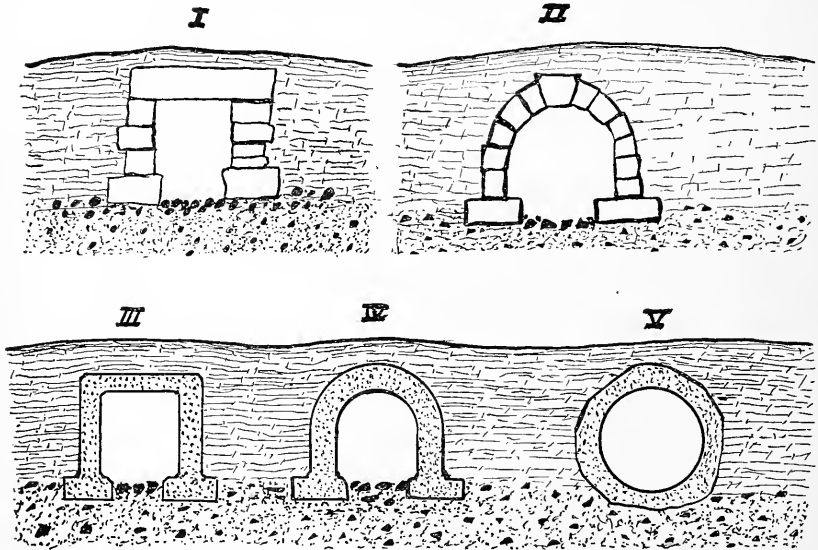

Plate 7. In Plate 7, Fig. 1, is shown section of stone box culvert. Notice that the top stone acts as a common beam; Fig. 2 is a section of an arch culvert or stone repression; Fig. 3 a box concrete culvert; Fig. 4 an arch concrete culvert; Fig. 5 a monolithic round culvert made without the use of regular outside forms. In the cases of 1, 2, 3 and 4 the side walls have footings and the bed of the stream is covered with stones to prevent washing.

pression it is not very strong or very reliable when subjected to bending stresses. For this reason the arch culvert is generally more satisfactory than the box culvert.

Concrete Culverts.

One of the most satisfactory materials for the building of culverts is concrete. It is easily made in the right shape, it is not extremely expensive and it is probably the most durable material now available for culverts.

Types of Concrete Culverts.

The box type of culvert has met with favor in some sections. The side walls usually have an extension or "footing" at the bottom. The top must be **heavily reinforced** in order to prevent it from breaking down. The heavy slab of concrete which forms the top has bars extending from side to side of the culvert, cast into the concrete. The bars are usually about one inch to one and one-half inches from the lower surface of the slab. Thus, the iron bars' pull and the concrete material at the top of the slab must take on equal stress in compression.

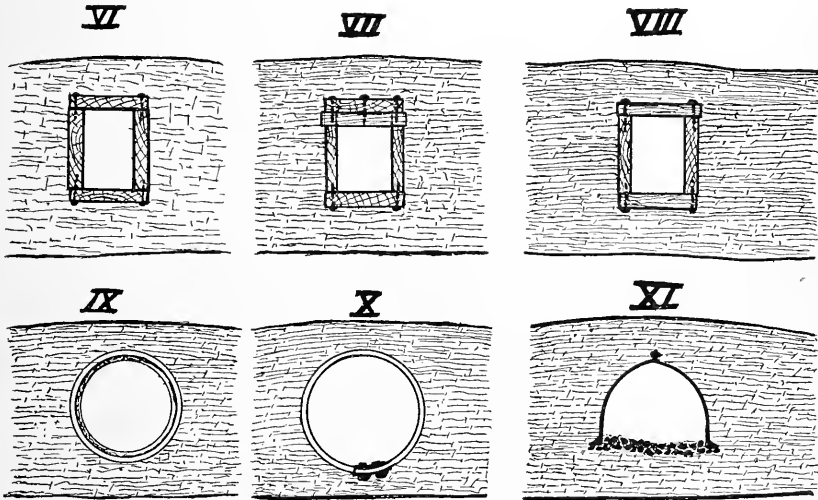

Plate 8. In Plate 8, Fig. 6, we see a section of a plank box culvert. The plank needs but to be split to render the culvert worthless. Fig. 7 shows how cross timbers may be mortised into the side planks in order to give the top plank support from beneath. Fig. 8 shows how the top and bottom planks may be cut into three pieces and laid across the culvert. This is the best of the three types but at that, it is a rather short-lived culvert. Fig. 9 is a tile culvert with bell and tile. Fig. 10 is a corrugated sheet steel culvert. Fig. 11 is a cast iron or sheet steel arch. Notice that all of these culverts are placed well down beneath the surface of the road.

A far more popular culvert is the concrete arch. The material is so placed that each part is in compression. In theory, the smaller arches do not require reinforcement, but in actual practice it is a good plan to reinforce the work throughout with steel reinforcing bars or with heavy woven wire fence. Such fence as "The Electric Weld" and the "Page" fence give excellent results when used as reinforcing material for small arches.

Probably the cheapest, the most easily made and one of the most satisfactory concrete culverts is the round monolithic culvert. This is a culvert of one piece of concrete. In most cases the ground is prepared, and a heavy layer of concrete is thrown into the trench. The form, which is nothing more than a round, collapsible sheet-iron tube, is then laid upon the fresh concrete. The concrete is placed about the sides of the mold and over the top. In a few days the concrete sets, and by some patent device the mold is made to become smaller in diameter. It is then withdrawn and earth is placed over the culvert. Such culverts should be reinforced with rods or woven wire.

All cement culverts should be coated with neat cement (pure cement) mixed in water. Some call this material "cement paint", "cement whitewash" or "cement wash". It is applied with a brush and it renders the surface of the work water-proof.

Small Wooden Culverts.

For a great many years wooden culverts were more popular than any other type. This is no doubt due to the fact that they were cheap and quickly constructed.

In case of the box culvert a common system is to spike four



Plate 9. The large culvert or bridge shown in this plate had poor wooden wing walls which allowed the water to leak through and wash out the dirt back of the side walls. The "cave-in" came at the first heavy rain after the installation. Proper wing-walls and a proper tamping and puddling of the soil back of the side walls, would have made a good job out of a bad one.

planks together in such a way that one plank lies upon the earth, two others set upon edge, rest upon the first plank and form the sides of the culvert. Another is then laid upon the two side planks in such a manner as to form a top. Now all that is necessary to break down such a culvert is to split the top plank. The weight of traction engines will do this regularly unless there be plenty of dirt over the culvert.

In some cases heavy hard wood cross pieces are laid under the upper plank and mortised into the side planks. This improves the culvert about 100 per cent.

A still better system is to cut the top and bottom planks into short pieces and lay them crosswise on the ground for the bottom and on top of the side planks for the top.

All the above mentioned wood culverts are all right **when new** if they be properly made and set. But when they become slightly rotted, they are poor excuses for culverts.

Large Wooden Culverts.

In the building of the larger types of wood culverts it is common to drive posts or piles into the creek bottom. Planks are then

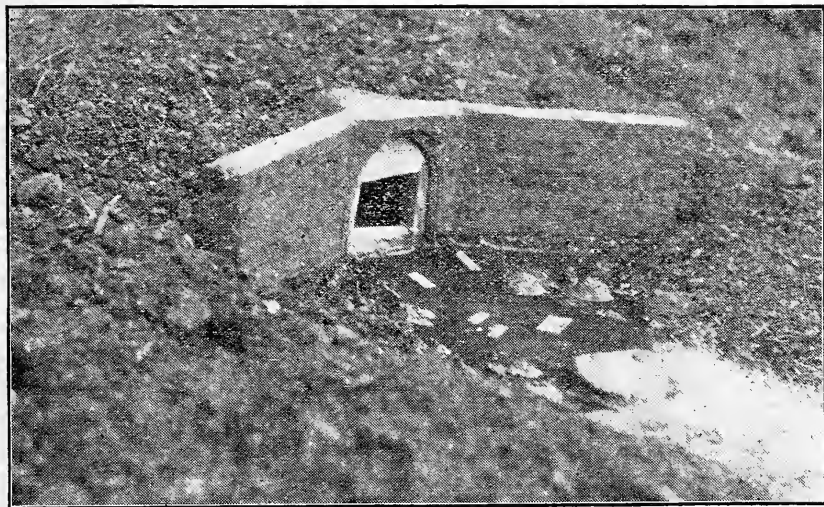

Plate 10. An arch culvert and wings made in one piece (monolithic) of concrete. When the workmen are ready to remove the inside forms, they will move the lower cross beam after which they can remove the sides and top of the arched form.

spiked to these piles on the outsides and some wooden stringers are placed upon the tops of the piles. Planks are then laid upon the stringers and after the earth work is filled in against the sides of the bridge it is complete. It is much better to substitute two or three of the round concrete culverts placed side by side for these larger wooden culverts.

It is quite possible to so build the two or three monolithic culverts that they are all made of one large piece of reinforced concrete. Such a culvert does not wash out easily and it will last a life time.

Steel and Iron Culverts.

It has become common of late years to substitute a piece of "corrugated steel pipe" for the concrete or stone culvert. The price

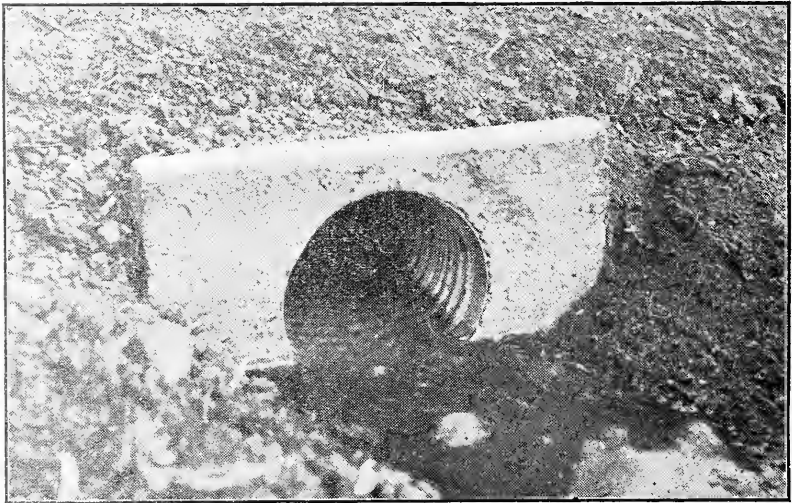

Plate 11. A very large corrugated steel culvert installed under a high fill. Notice the very heavy retaining wheel.

of these steel culverts is reasonable and they are easy to locate. They last a long time when properly made and galvanized. A good method of setting such a culvert is to build the wings of concrete and to cover the entire iron culvert with concrete. Such a combination makes a good culvert after the iron has rusted out.

Many types of steel and cast iron arch culverts are now on the

market. When properly set they give excellent satisfaction, but it too often happens that they are not given a good foundation. Thus, eventually they warp and in some cases give away. It is a good plan to cover such an arch with a heavy wall of concrete. Thus you will get a concrete backing to the sheet metal.

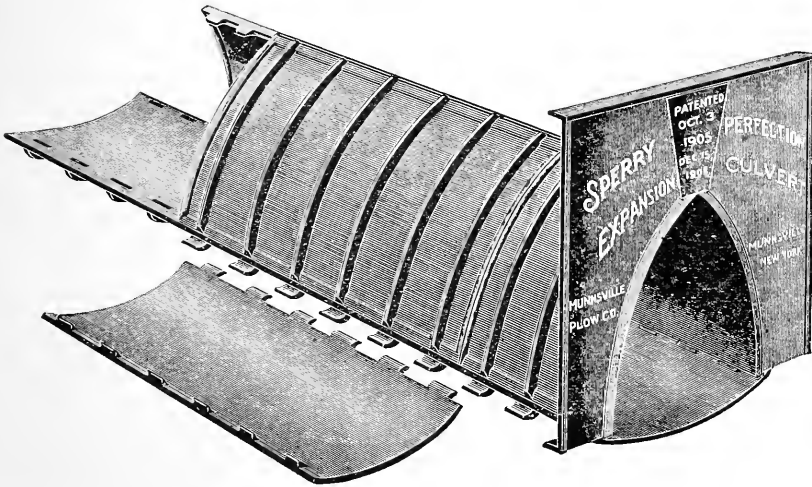

Plate 12. A cast-iron sectional culvert in process of erection. Notice that a metal wing-wall and a metal bottom are provided.

Tile Culverts.

Culverts are often built of tiles. These tiles are sufficiently large and strong to carry the weight of all types of vehicles and motors. The proper setting is absolutely necessary if tile culverts are to be successful. This is taken up more fully under "setting of culverts."

Perhaps the poorest kind of tile for culverts is the red, unglazed clay tile. As this type readily absorbs water it is very likely to disintegrate when subjected to freezing and thawing. Concrete tile, when made porous, is also inclined to disintegrate in the same manner as unglazed clay tile. Well glazed "bell end" clay tile are very satisfactory for culverts, as are water-proof cement tile.

Cast iron tile are now being used extensively by railroads and they make a most excellent culvert.

SETTING CULVERTS

It is one thing to select a good type of culvert, and it is very decidedly another thing to set it as it should be set.

The author has ample opportunity to study poor methods of setting culverts and in most cases the opportunities are less welcome than instructive. A few of the most common faults are:

1. Wrong location.
2. Culvert too small.
3. Culvert not set deep enough.
4. Culvert not protected by wings.
5. Culvert not properly tamped and puddled when set.



Plate 13. The culvert shown in Plate 13 was not protected by wing-walls. It was not tamped or puddled on the sides. A few days after the photo was taken, it was washed out and down stream.

Wrong Location.

It would seem rather foolish to lay down a law requiring road commissioners to place the culverts where the water could flow through them, yet we often find culverts so far up on the side of a hill that the water must seep through or run over the road way, or else run up hill to get to the culvert. This trouble is usually due to some so-called practical man "using his eye" to locate the lowest point in the hollow or ravine. The use of a level would eradicate the difficulty. It is needless to say that drainage culverts should

be placed so that drainage water will flow to and through them. Irrigation ditch culverts must be placed at such points as will preserve the proper grades of the ditches. Thus, in some parts of the country we find nearly all the irrigation ditch culverts on the highest parts of the roads.

Culvert Too Small.

It is a foolish custom among some road supervisors to choose a size of culvert and use it regardless of the amount of water it must carry. It is next to impossible to tell an engineer how large a culvert should be, because of the fact that the culvert must carry floods. Whenever possible it is well to measure the sectional area of a stream at its highest flood and then design the culvert to carry from one and one-half to two times the amount.

By using this method it is often found necessary to use culverts which seem very large, but when such a culvert is once installed properly it eradicates future trouble once for all.

To determine the cross section of a flood stream it is not necessary to get into the water during the flood. Simply mark the points to which the water reaches upon the banks, then after the flood subsides, determine by level how deep the water was. Then the width of the stream at the flood time may be determined with a tape and the approximate number of square feet of its cross section may be determined.

It is often possible to get from some neighbor a rather accurate statement of how far the stream overflows its banks at flood time. From this a fair estimate can be obtained of the cross section of the stream.

The cross section should be determined at or near the location of the new culvert, otherwise it is of little use. After the area is determined the size of the culvert may be determined. For rectangular box culverts the approximate height may be assumed and the cross section area divided by the height will give the width. Now if an allowance of one and one-half is used, simply add one-half the width of the culvert to its computed width and the result will be the actual width of the culvert. In case an allowance of twice the cross section is used, simply multiply the cross section of the stream at flood by two and divide by the height of the culvert. In case of round culverts, the cross section area should first

be divided by three and one-seventh. By extracting the square foot of the answer, we get the radius, or one-half the diameter of the culvert.

In case the round culvert would be too large, the cross section may be divided into two, or three parts and the culverts may be laid side by side.

In case of arch culverts all that is necessary is to consider that portion of the cross section which has parallel walls as a rectangle and the arched portion as a semi-circle. The sum of the areas of the semi-circle and the rectangle will be the total area of the culvert.

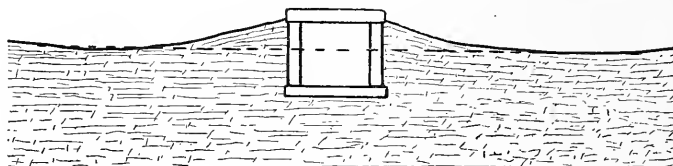

Plate 14. In Plate 14, we see a cross section of a culvert which was not placed deep enough to be satisfactory. Notice that the top of the opening is far above the low spots in the road as indicated by the dotted line. The top plank is exposed to traffic. The top of the culvert should have been lower than the dotted line.

Not all arches are semi-circles but the result will be near enough for satisfactory results in case of culverts.

Culverts not set deep enough.

Many people fail to place culverts low enough in the ground to allow the water to run through the culvert without passing over the road bed. This is poor practice. In case of a deep fill it is generally good practice to put the culvert at the bottom of the embankment so that no water is allowed to collect on the upper side of the embankment.

Culvert Not Protected by Wings.

It is good practice to protect the culvert by "retaining walls" or wings at both the upper and lower ends. These wings should be **nearly water tight**, in order to prevent the water running in and cutting away the earth at the sides of the culvert. It is well to have the wings extend at an angle up the stream at the upper end and down stream on the lower end of the culvert. Reinforced concrete walls, eight or ten inches thick make very satisfactory retaining

walls for small culverts. They should have a solid foundation and be well backed by thoroughly tamped earth. Culverts which are

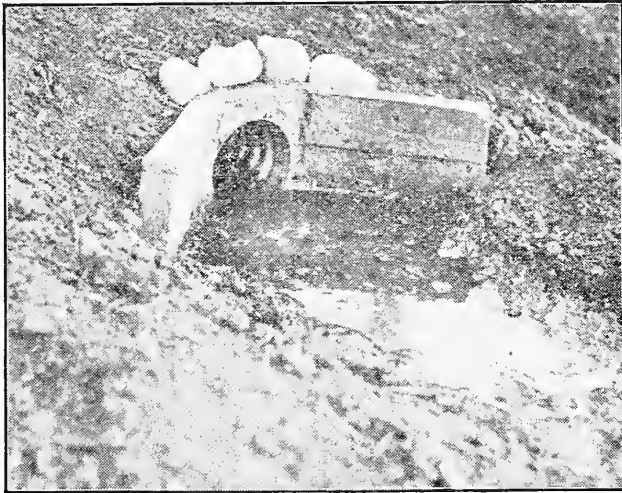

Plate 15. Corrugated steel culvert with concrete wing walls. The water gets no chance to strike the embankment as the walls guide it into the culvert. A very good installation.

not provided with wings or retaining walls are very likely to be washed out by floods. In case of large or deep culverts the retaining wall should always be surmounted by a guard wall or railing.



Plate 16. A corrugated steel culvert being poorly installed. Notice the lack of wing walls. The large clods are being dumped loosely about the culvert. The first heavy rain will probably wash out the culvert.

to prevent teams from attempting to cross the ditch rather than the culvert.

Culvert Not Tamped and Puddled.

It is a bad practice to dump loose dry earth in beside a culvert by means of a scraper or shovel unless the earth be thoroughly tamped. It is better not only to tamp the earth but to wet it as well. This "puddles" the soil and when it dries it becomes hard and solid, not hard and loose.

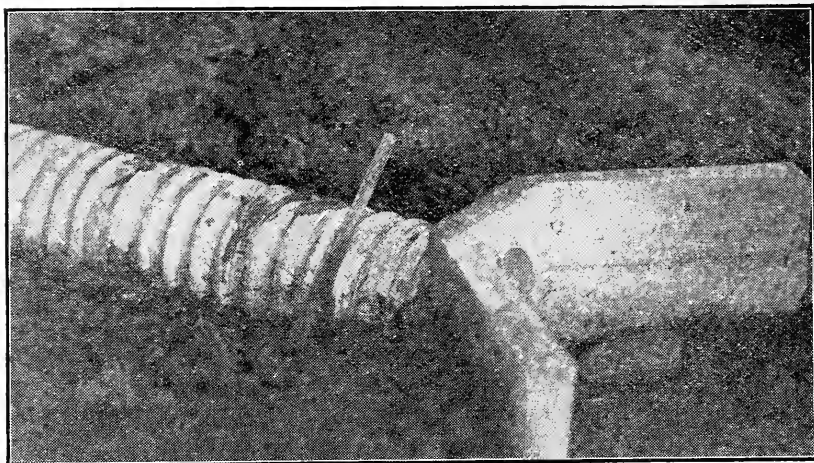

Plate 17. A corrugated steel culvert being properly installed. The concrete wing walls are in place and the earth is being tamped and puddled as it is filled in.

The dry, loose earth crumbles away easily when subjected to the action of running water, while the hard tamped puddled earth resists the action of the water. The lack of thorough tamping and puddling of the soil about the culverts often explains why they wash out at every heavy flood.

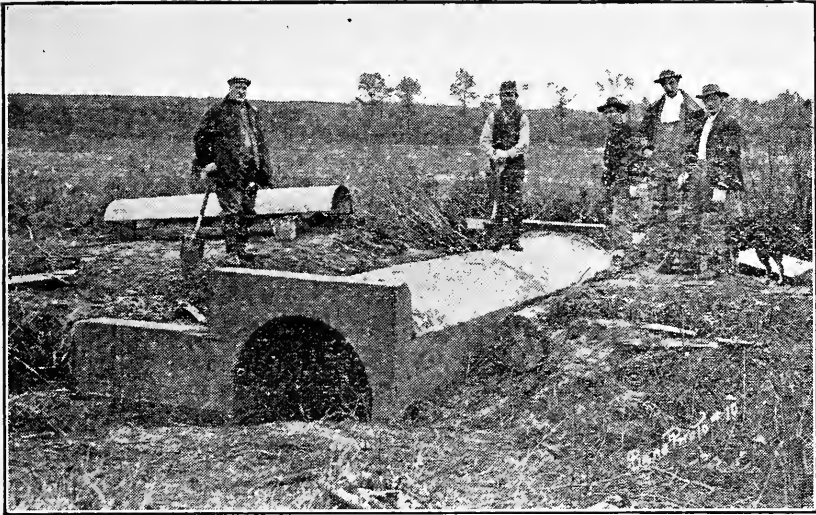

Plate 18. An arch culvert made by the use of a patent steel form. The log which is shown at the right should not be allowed to remain as it will serve to allow water to cut its way along the side of the culvert. Unless this grade is built higher, the culvert will be subjected to great strains from passing engines.

SURFACES OF ROADS

Now that we have taken up the subject of road drainage let us consider the matter of the road's surface. A road surface must have several qualities in order to be considered good.

1st. It must be hard enough to prevent the wheels of passing vehicles and motors from cutting into it.

2nd. It must be of such a nature as to furnish a "foot-hold" or "grip" for animals and motors.

3rd. It must be as nearly dustless as possible.

4th. It must be tough enough that it will not crumble under heavy traffic.

5th. It must shed water and dry off quickly after rains.

6th. It must be of such a nature that freezing and thawing will not ruin it.

7th. It must not be too expensive.

The student will realize at once that such a road surface is rather hard to find, and as matter of fact, the soil of each locality

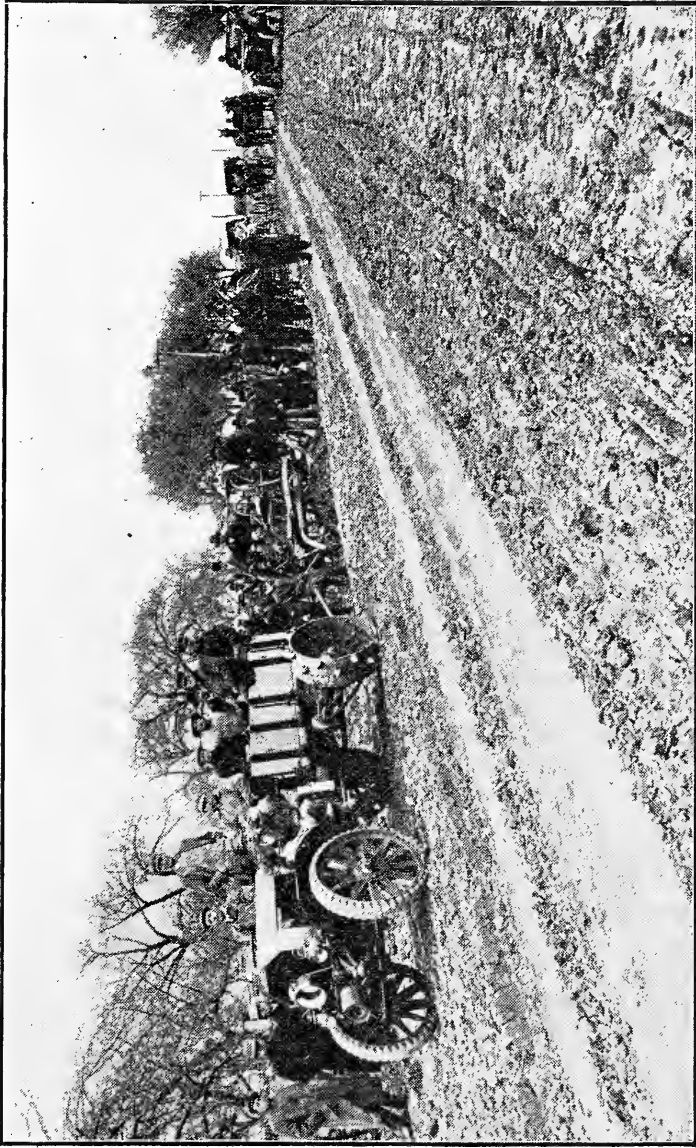

Plate 19. This gives an excellent idea of how to use a reversible grader. In the foreground is a large furrow which has been moved over toward the middle of the road by the previous round of the grader. It will be moved to the center at the end of the present round. Such a combination as is here shown, is a very desirable one for rapid road work.

is to a greater or less extent responsible for the type of road surface found there. This is true because the cost of putting on some other type or road surface is, in a great many cases, too expensive.

Earth Roads.

In the building of an earth road after it has been laid out and the part to be graded has been staked out, it is common to use what is known as a "reversible grader." That is, a grader with a blade which can be set to throw the earth to either side. If the soil is hard and tough several furrows may be plowed on the lines where the ditches will be. Then with the grader the earth is moved toward the center of the road until the proper crown is obtained. The graders should be driven **along the road and not across it**. The blade, when set on an angle of about forty-five degrees, pushes the earth sidewise and thus, by repeated operations lands it at or near the center of the road.

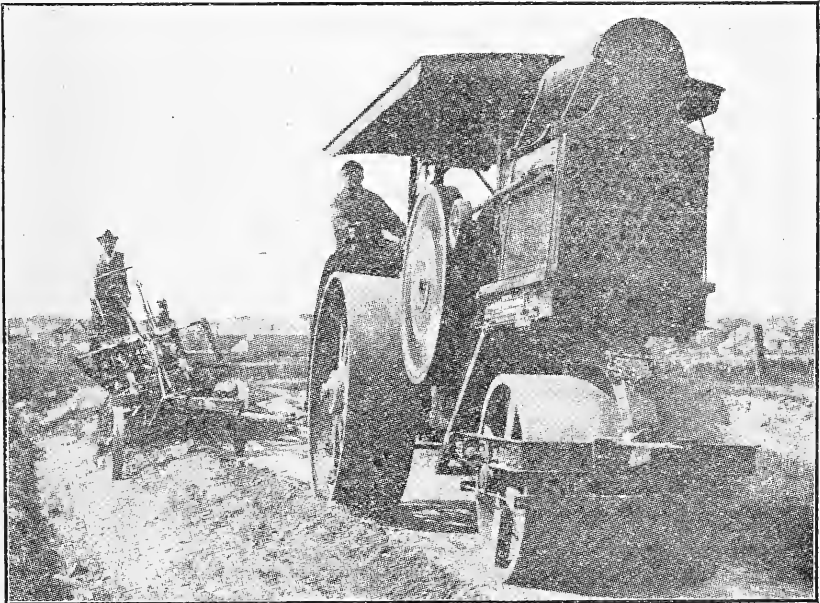

Plate 20. A gasoline road roller rolling a road as it is being graded by reversible grader. This is an excellent scheme for making a hard well-packed road.

The road should then be rolled with a heavy roller. Few of the horse drawn rollers are heavy enough to accomplish the desired

result. A ten to fourteen ton steam roller is very satisfactory. If the soil is moist at the time of rolling, so much the better.

In case of high grades with deep side ditches, an elevator grader is often used. This type of machine is equipped with a plow which throws the earth upon a moving apron. The apron carries the earth up to the desired height and deposits it upon the bank. It is later levelled to its proper position by the reversible grader. Such a bank should be rolled, and packed thoroughly before it is put into service as a road. Otherwise "pot holes" or "chuck holes" are likely to form within a few days.

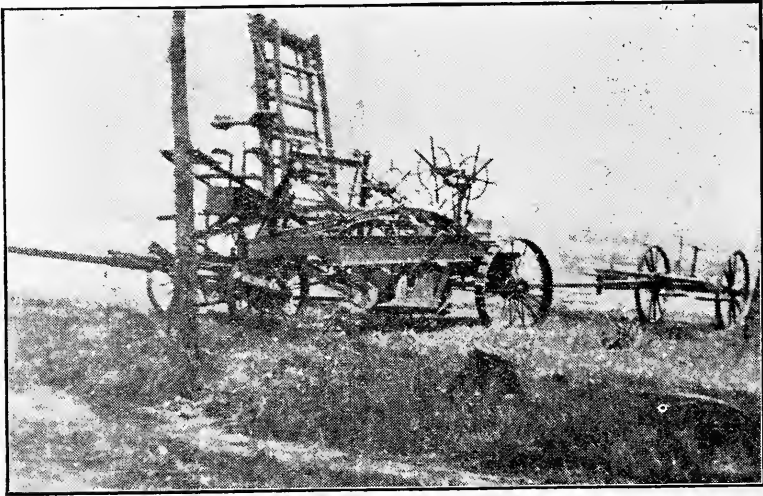

Plate 21. An elevator grader or "excavator". This machine is equipped with push-cart to which four horses are hitched. Such a machine attached to a good traction engine makes a very good rig for rapid excavation.

The elevator grader is often used for the purpose of loading dump wagons when the earth must be moved some distance as in the making of cuts and fills.

Cuts and Fills.

In case it becomes necessary to cut down a portion of a hill in order to give a road the proper grade, it is usually found advisable to move the earth to the adjoining low spot in the road and thus make what is known as a fill. In this way less earth needs to be moved.

In case but little earth needs to be moved "slip scrapers" are used. These little scrapers are so common that they need no description.

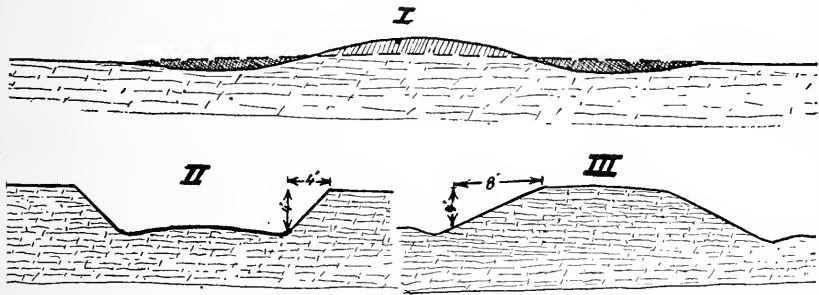

Plate 22. Fig. 1 shows longitudinal section of road through a hill. The dark-shaded portions are fill and the light-shaded portion is cut. By hauling dirt from a cut to the low places and thus making the fills the amount of labor was greatly lessened; Fig. 2 is a cross section of the cut showing banks with 1 to 1 slope; Fig. 3 is section of fill with banks made 2 to 1 (8 to 4) slope. **Note:** The longitudinal section is not made to the same scale as the two cross sections.

For hauls of a hundred feet or more it is common to use wheel scrapers or "wheelers". These scrapers are provided with wheels and are so designed that after the scraper has been filled with earth it is raised clear of the ground by means of a lever. It is then hauled to the desired location and dumped much the same as the slip scraper.

For long hauls, and for rapid work an elevator grader drawn by a traction engine and several dump wagons drawn by horses make an ideal outfit.

Only the best of traction engineers and expert elevator grader men should be employed on such an outfit, as a few hours lost in "tinkering" means a great loss of time and money.

The side banks of a cut should not be left perpendicular as such banks crumble in, and fill up the side ditches. The slope should be at least "one to one". That is, they should recede one foot to each foot in height.

Fills should slope about one and one-half to one or two to one. This is, they should recede one and one-half or two feet to each foot of rise. The earth work is usually figured in cubic yards of earth moved. Prices vary with the kind of earth, the length of haul, and local prices of labor, etc.

In case of hard earth, or rock, dynamite proves to be a very cheap and efficient excavator.

Maintenance of Earth Roads.

The best method of caring for or maintaining the earth road is by the use of the King drag or some other implement of like nature.

The drag consists of two planks, each about six or seven feet long, these planks set upon edge and are dragged along the road, thus acting as a pair of scrapers, one following the other. The rear



Plate 23. Front view of a home-made King drag. The lower planks are 3"x8"x6'; top planks are 2"x10"x4'.

plank is about three feet behind the front one. The hitch is so arranged that the end of the drag nearer the center of the road is behind the outer end. Thus, the loose earth is moved toward the middle of the road. The right time to use a King drag is just as the mud is beginning to dry enough to harden. When the mud is thin and soft the drag does little good, and when the earth is dry and hard it does little or no good.

The King drag, when properly used: Fills the ruts, maintains the crown, keeps the side ditches open, and so puddles and packs the soil as to give a hard, firm, even road surface.

In many rural communities each farmer drags that portion of the road which adjoins his farm. Such public spirit is commendable, and profitable as well. For we must remember that "A community is judged by the quality of its roads." Good roads indicate that the community is up-to-date, prosperous and intelligent; bad roads indicate that the opposite conditions prevail.

Stone Roads.

For centuries it has been the custom to build roads with stone surfaces. Many roads were built with the surfaces of large flat



Plate 24. A patent road drag or "surfacer" dragging a road at the proper time to give a smooth, hard finish to the surface. Such a machine coupled to a strong tractor makes a very good combination as the work of dragging can be done with great rapidity at exactly the right time.

stones. Such roads are unsatisfactory for the following reasons:

They do not allow the horses' feet to secure a good grip.

When wet or muddy the stones are very slippery.

Such a road is very expensive.

When smaller stones are properly set they make an excellent paving for city streets, but this system of road making is rarely found in country districts in the United States.

Macadam Roads.

The term macadam applies to broken stone roads which are prepared by putting a thick layer (10 or 12 inches) of broken stone on the earth surface of the road. This may be rolled in by steam or gasoline rollers or left to be rolled down by traffic. Such roads are readily destroyed by a combination of team and automobile traffic. The maintenance of such a road under both team and auto traffic is a hard proposition and a most expensive one.

Telford Roads.

In case of Telford roads a layer of large rough stones is laid in the bottom of the traveled portion of the road. On these a four-inch layer of crushed stones is placed and rolled in by roller or by traffic. This layer is in turn covered by a layer of fine broken stones which is rolled into the coarser bottom material.

The macadam and Telford roads, when made of a good tough wear-resisting stone are very good for roads which have team traffic only. They wear well and the slow-moving vehicles roll the material, thus making it hard and firm. But when the auto with its soft tire speeds over the road at 35 to 50 miles an hour, the maintenance of one of these roads becomes a puzzling matter for the best of highway engineers.

NEW TYPES OF ROADS.

Had this book been written ten years ago many pages would have been taken up in minute directions for the building of stone roads, but since the advent of the automobile the subject of hard road surfaces is a matter for experiment.

Some authorities took to petroleum which has an asphalt base, as the solution of the problem. This asphalt is worked into an earth road and then rolled. It gives a hard, smooth surface which is impervious to water. It does not allow large ruts to form, and

there is little or no loose dirt for the auto wheels to kick into the adjoining fields. Other authorities believe that the coming road will be made of concrete.

Some new materials are now being used which form a soft

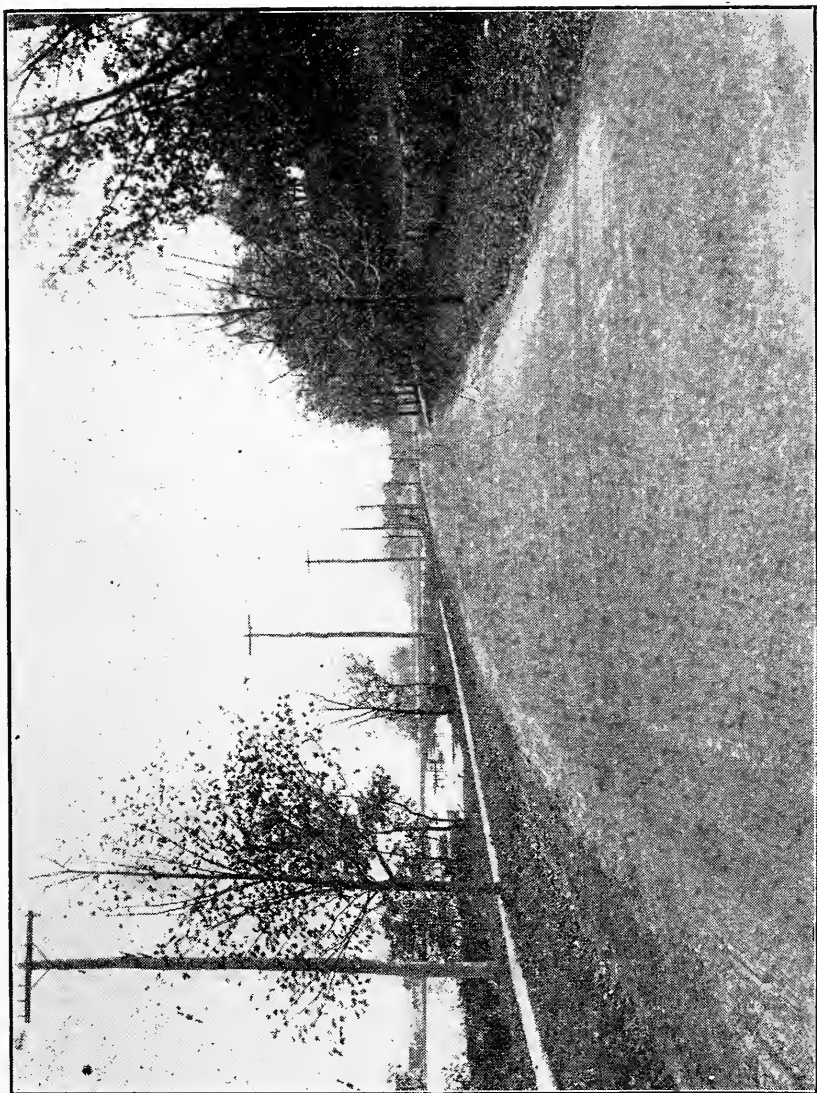

Plate 25. A type of commercial pavement which the company claims will withstand team and automobile traffic,

road surface that is water-proof and nearly dustless. They are, as a rule, very expensive.

Some companies now use asphalt, tar, and other materials for the holding of crushed stone in place. These are known as bituminous concretes, or bitrolithic pavements. They are very expensive and should be cautiously experimented with. Of one thing we are certain and that is that we have the question of a good, cheap, and satisfactory combination tonnage and auto road to solve. We now have good roads which are very expensive, and cheap roads which are not good.

With the best efforts of our high grade highway engineers concentrated upon the subject, we should look for pretty positive results within the next decade. In the meantime let us make the best possible earth roads by careful attention to grading, draining and dragging them.

Bridges are now as much a commercial article as are engines, or road graders, so that in deciding upon a type of bridge the engineer needs but to ascertain the length and width of the bridge which is needed, and submit the specifications of length, width and maximum load to the bridge building firms for bids. These companies have standard designs which fit nearly every requirement, and as they make and erect the bridges on a large scale they are, as a rule, able to underbid any small contractor.

The subject of bridge selection and bridge design should be left to an engineer who devotes his whole attention to the subject of bridges.

The day of wooden bridges is past. It is now a matter of steel or concrete, with here and there a stone arch.

All modern highway bridges should be able to carry a moving load of twenty-five tons with safety.

CHAPTER

ROAD MACHINERY.

A few special points will be taken up under this head although many of the more important points have been brought out in previous paragraphs.

Slip Scrapers.

One of the simplest of road machines is the slip scraper. It has been defined as a "horse scoop." The scraper should be pro-

vided with strong, smooth, wood handles, a rigid steel bail with swivel, and a pair of steel runners on the bottom of the scraper. The slip is suitable for moving earth short distances. It should not be used where a reversible grader can be made to operate.

Wheel Scrapers.

Wheel scrapers should be strongly and simply built. The tongue of the scraper should be provided with a loop or hook to which the "snap team" or "helper" may be attached during the loading. It often happens that two horses can, with little effort, haul a load of earth, which requires the best efforts of four horses to load.

The wheels of wheel scrapers are often made too light. One should always see to it that the scrapers are provided with strong wheels.

Wheel scrapers are often used in hauling earth from one hundred feet to several hundred yards.

Buck Scrapers.

Buck scrapers are much like slip scrapers except that they have greater width, and they are provided with shoes, so that as they turn over in dumping, they scatter the earth over considerable area instead of dumping it in a pile.

Reversible Graders.

A good reversible grader has many adjustments which should be easily made by the operator. A seat is usually provided at the front of the grader for two drivers.

The rear wheels should be mounted on extension axles so that the wheels may be set out to one side or drawn in near the grader. By this means the wheels are adjusted so that they always run on hard ground. The blade should be adjustable so that it may be made to throw earth to either side.

The two ends of the blade should be supplied with separate adjustments so that they may be raised or lowered at will.

Many other adjustments are found on up-to-date graders, but the above are the principal ones. The grader should be strongly built of steel.

The Elevator Grader (Excavator).

The elevator grader requires a very great tractive effort in

order to keep moving. For this reason we find that many of the best makes have push carts attached to the rear of the machine. From six to ten horses are attached in front and four or six are attached behind. The rear driver simply guides his horses by means of a wheel which controls the direction of the travel of the cart wheels. The plow of the elevator should be very strong and well braced. The conveyor is usually made of a wide piece of rubber belting. The carrier or conveyor should be adjustable at all points. All bearings should be as nearly dust-proof as possible. The bearings should be equipped with hard oiling devices.

The Grader Hitch.

When traction engines are used to draw reversible or elevator graders an adjustable hitch should be used, by means of such a hitch the grader may be steered separately, without it following directly behind the engine.

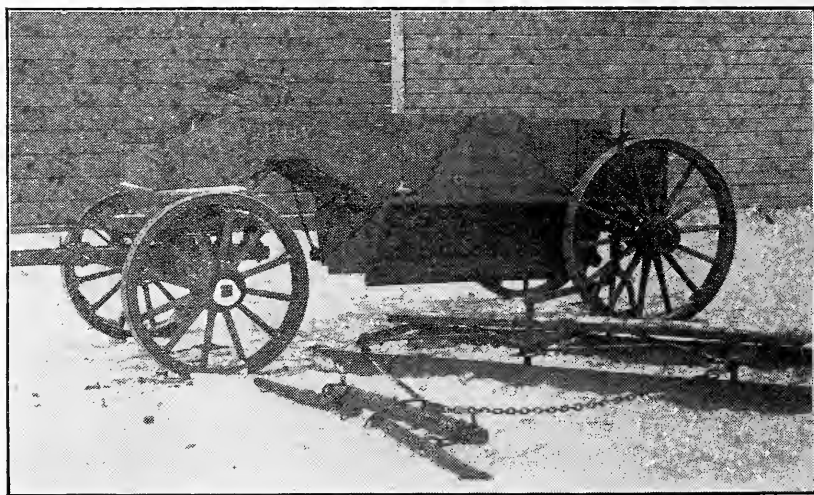

Plate 26. A good type of dump wagon showing how the bottom doors drop down to discharge the load. Beside the wagon is a patent steel King drag. It is equipped with lever by which the blades may be set at any desired angle. The picture also shows how not to store road machinery.

Dump Wagons.

Good dump wagons are now being built by many companies. The front wheels should be so hung that they can turn at an angle of at least ninety degrees to the body. This makes short turns pos-

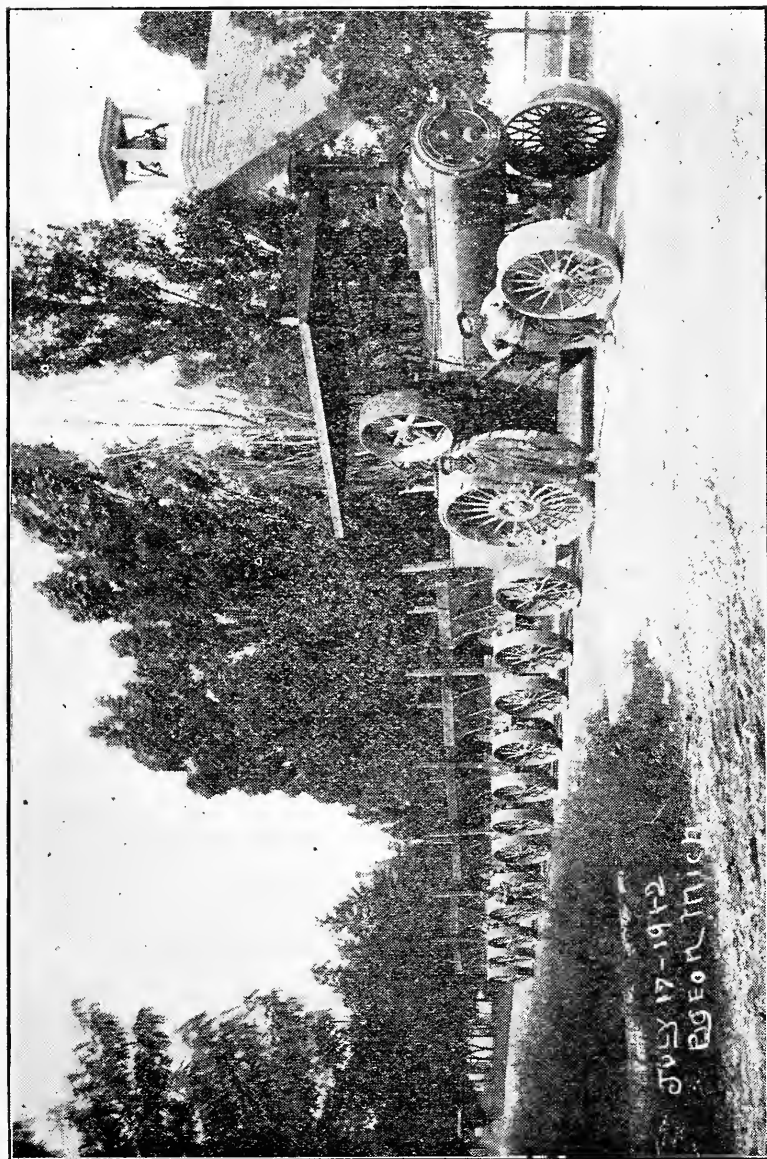

Plate 27. A good type of modern tractor and a train of up-to-date dump wagons. This train will follow around a corner in such a way that all the wheels will follow very nearly in the same track.

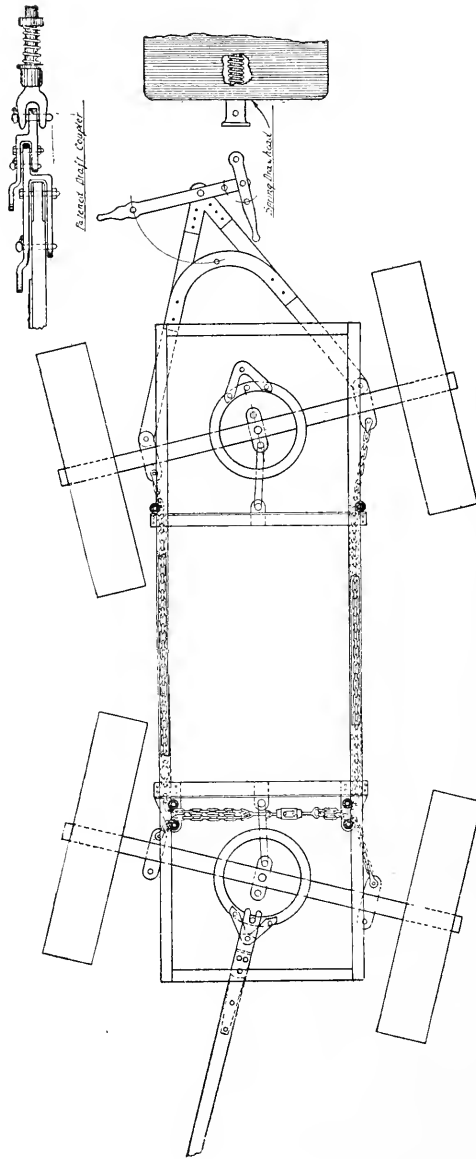

Plate 28. This plate shows how the wheels of an engine dump wagon are so hitched as to make the wagons follow the engine around a corner instead of **cutting** across the corner. This is a very important point in dump wagons for engine use.

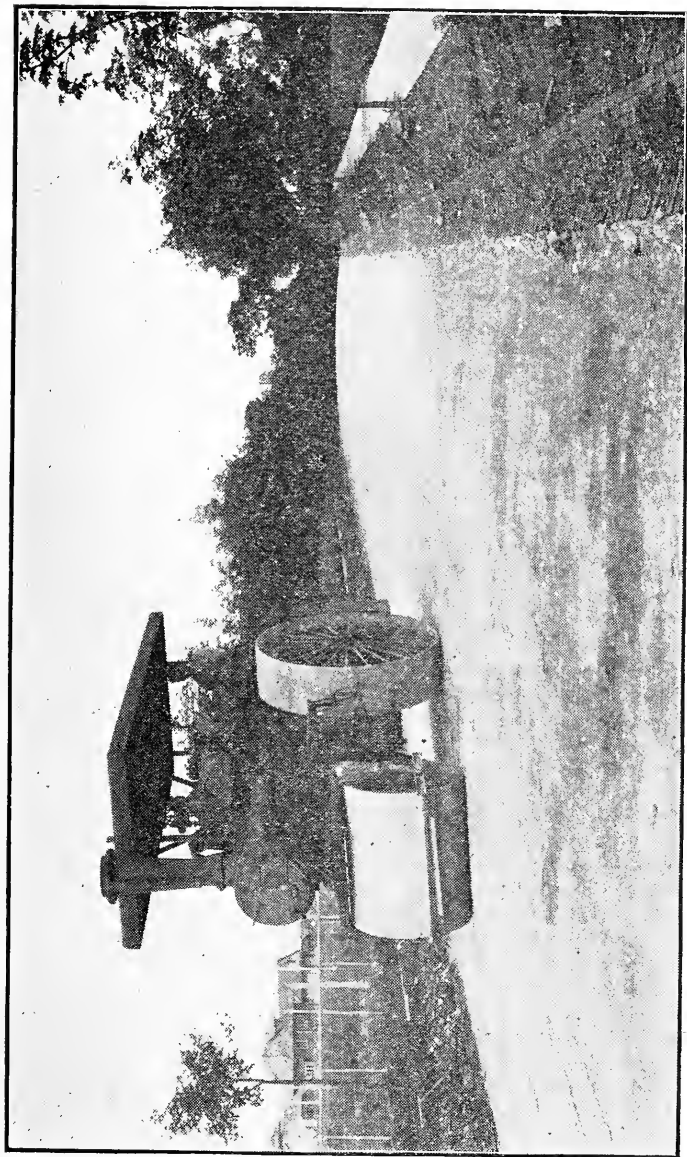

Plate 29. A good type of steam roller working down the surface of one of the new patent pavings.

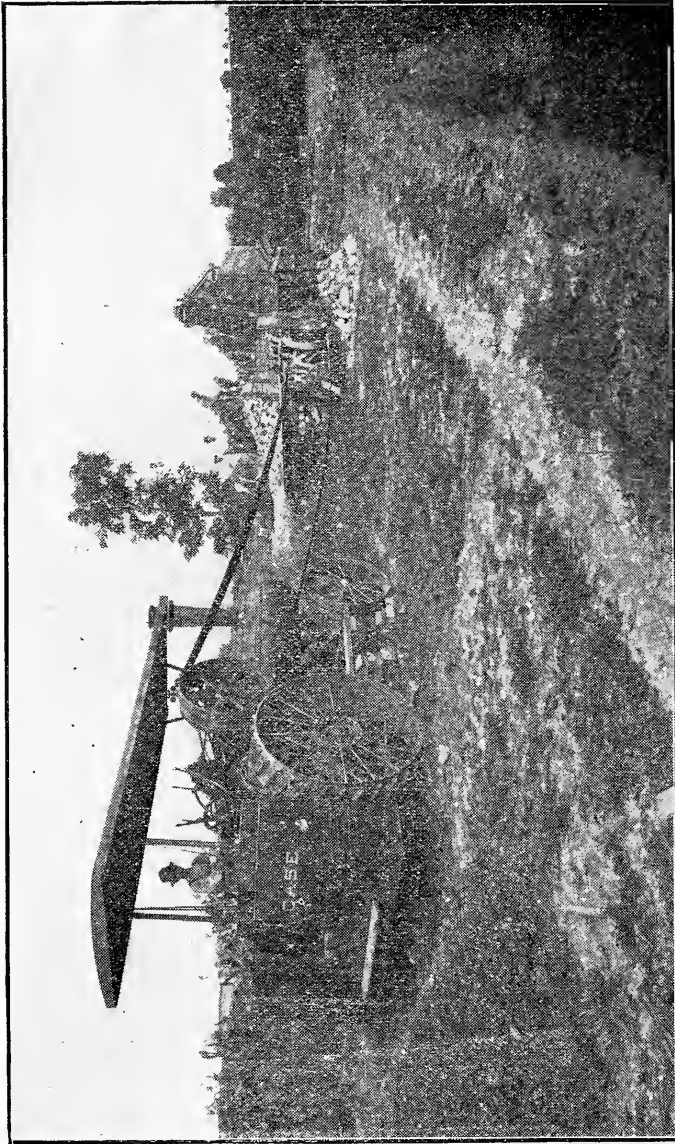

Plate 30. Tractor and portable stone crusher and sifter at work by the roadside. This makes it possible to deliver crushed stone to the nearby road with a very short haul.



Plate 31. Stretch of concrete road near Red Oak, Iowa. There is no doubt that such a road as this is satisfactory for teams and autos, but one must realize that it is by no means a cheap road.

sible. The rear wheels and axle should be very strong as they must carry most of the load. The dumping boards or doors should be so hung that they may be let down slowly, for it often happens that it is desirable to allow the load to sift out over considerable area, rather than to have it all dumped in a pile.

Road Rollers.

In general, road rollers are of two types, steam and gasoline. Steam rollers give good service, but water and coal must be hauled to them, and in many states a licensed engineer must be hired. The wheels should have flat tires so made that spikes or "grouters" may be attached in case of heavy pulls, or in case it is necessary to "roughen up" an old piece of road. This is often done when a road surface is being refinished. The rollers should be provided with a differential or compensating gear so as to make the drive wheels each pull an equal amount, both on straight roads and on curves.

Gasoline or kerosene engines are now mounted on forms and are made to act as road rollers. When they are built sufficiently strong and heavy they make excellent rollers. They may also be used to operate stone crushers when standing in the belt.

Portable Stone Crushers.

Some companies now build stone crushing plants which may be moved from place to place, in the same way as threshing machines are moved. These machines are operated by traction engines or road rollers. They give excellent results when they are operated by competent men.

All road machinery should be stored in a closed shed. It should have all bright parts greased when not in use.

FARM ENGINEERING—PART III, A.

Farm Cement Work or Concrete Construction.

Each year sees the structures of the farms being made less of wood and other materials which do not possess the quality of great durability.

Concrete is rapidly taking the place of wood in our farm structures, and it is fitting that we give the subject of concrete construction careful attention.

Cement.

We have two general classes of cement: Natural and Portland. In the natural cement the "cement rock" is used as it comes from the earth. It is simply converted into cement by a baking and grinding method. Now if the cement rock happens to be good the resultant cement will be good, and if the rock is bad the cement will also be bad. For this reason natural cement is generally considered to be unreliable. It is, as a rule, slightly cheaper than Portland cement. Portland cement is made of chemically analyzed rocks mechanically mixed in chemically correct proportions. This renders the strength and setting qualities of good grades of Portland cement very uniform.

(Some people foolishly believe that Portland cement is made in Portland, Maine or Oregon. The name refers to the process, not to the city where it is made.)

Setting of Cement.

When cement sets the powdered rock takes up its water of crystallization and again becomes a stone. It adheres to the sand or stone which it touches and then we get concrete. There are some intricate chemical processes in the setting of cement, but if we remember that cement work must be kept moist while setting and that the setting process continues for several weeks, we will have the main part of the practical side of the process in hand.

Cement and Concrete.

When we speak of cement work we refer to a cement and sand mixture which is free from gravel or broken stone. Thus, when we say a post is made of a one, three mixture, we mean that one part

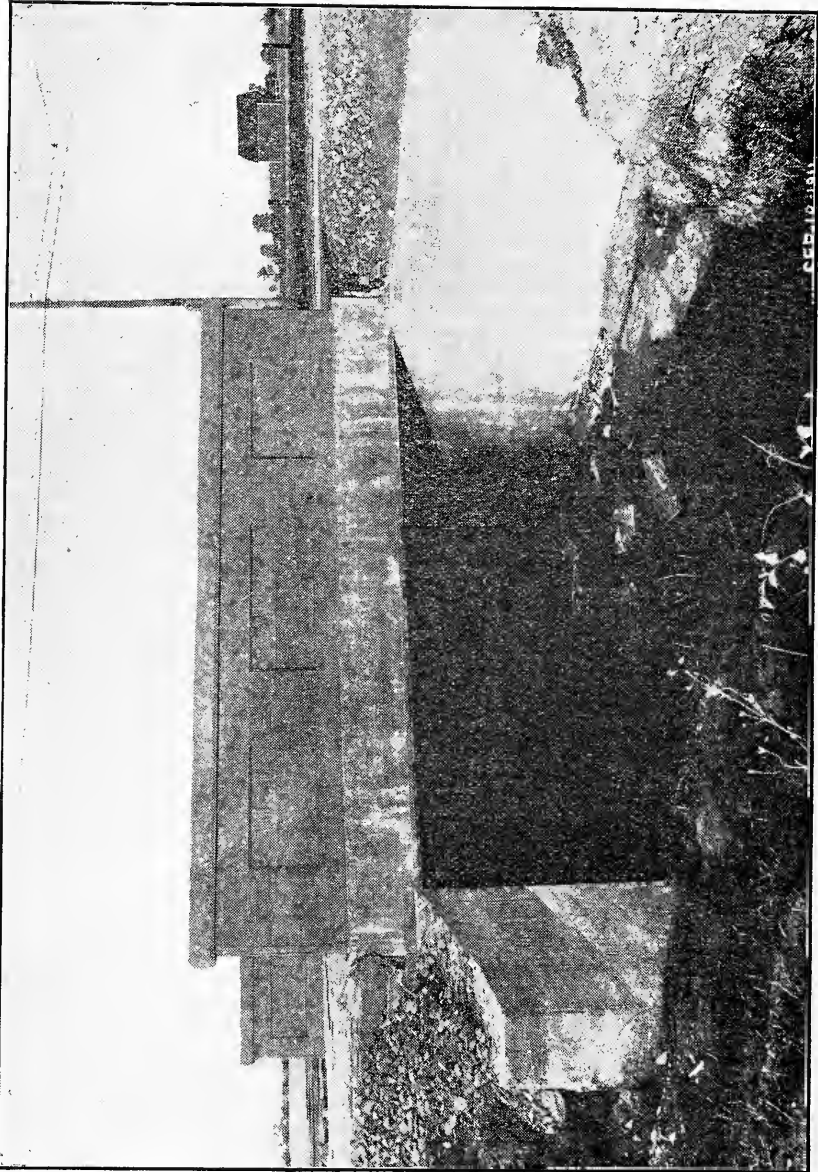

Plate 32. A concrete culvert of the box type, showing a good installation. Notice the heavy wing walls projecting at an angle of the side walls of the culvert.

by measure of cement has been added to three equal parts of sand. In speaking of concrete we refer to the mixture as 1, 2, 2 or 1, 2½, 2½, or 1, 3, 3, etc. Thus, we mean that one part of cement has been added to two parts of sand and two parts of stone (all proportions by measure, not by weight.)

Thus the first number indicates cement, the second sand, and the third gravel or broken stone.

Sand.

Sand for good cement or concrete work should be free from dirt, sticks, leaves, etc. It should have sharp angular grains, not smooth rounded particles.

Gravel.

Gravel should be clean and angular. Smooth glassy pebbles usually make poor concrete.

Broken Stone.

Crushed stone is generally much better for concrete than gravel, as the particles are rough and freshly broken the cement gets a better grip on them than on smooth gravel.

Proportion to Use.

Neat Cement is used for the purpose of giving water-proof coatings to cement or concrete work. Neat cement is pure cement as it comes from the sack. It is mixed with water and applied as a paint or wash to the surfaces of walls, etc., for the purpose of filling the pores of the cement or concrete. It does the work very well when properly applied.

A 1-3 mixture is a very rich mixture. It is used for the purpose of making cement fence posts, and for top-coating cement floors, sidewalks, etc.

A 1-4 mixture is used for the building of posts, troughs, sidewalks, floors, engine bases, sills, etc.

A 1-5 mixture is not very desirable as it could be greatly strengthened by substituting some gravel or broken stone for part of the sand.

A 1, 2, 2, mixture makes a very strong concrete, suitable for almost any kind of work which requires a dense, hard concrete.

A 1, 2½, 2½, mixture is also strong and hard. It is used for the building of silos, walls, floors and side walks, but care should be

taken to give the walks and floors a top dressing of 1-3 cement mixture. This top dressing should be from one-half to one inch thick. It should be applied **immediately** after the body of the floor is laid.

1, 3, 3 mixtures and 1, 3½, 3½ mixtures are often used for the building of walls, blocks and side-walks, but it is a practice of doubtful economy to use a mixture weaker than 1, 3, 3 for farm purposes.

Mixing Cement or Concrete.

Proportioning. It is common to measure out the cement, sand and gravel in boxes or pails, so as to get the right proportions. Thus we use one box cement, three boxes sand and three boxes gravel for a 1, 3, 3 mixture.

Now we do not get seven boxes of concrete, because the sand settles in among the gravel, and the fine cement sifts in among the sand and gravel. Thus when the setting is complete we get a solid rock.

One authority has computed the amounts of cement, sand and stone necessary to make a yard of rammed concrete as follows:

Mixtures		
cement	sand	stone

Stone
1 inch and under

1	2.0	4.0
1	2.5	5.0
1	3.0	5.0

Stone
2½ inch and under

1	2.0	4.0
1	2.5	5.0
1	3.0	5.0

Amounts		
cement bbls.	sand cu. yds.	stone cu. yds.

Clean
Materials

1.46	0.44	0.89
1.19	0.46	0.91
1.11	0.51	0.85

Clean
Materials

1.48	0.45	0.90
1.21	0.46	0.92
1.14	0.52	0.87

Mixing.

Hand mixing is very common in farm practice. The gravel and sand are spread upon a large board platform and then the ce-

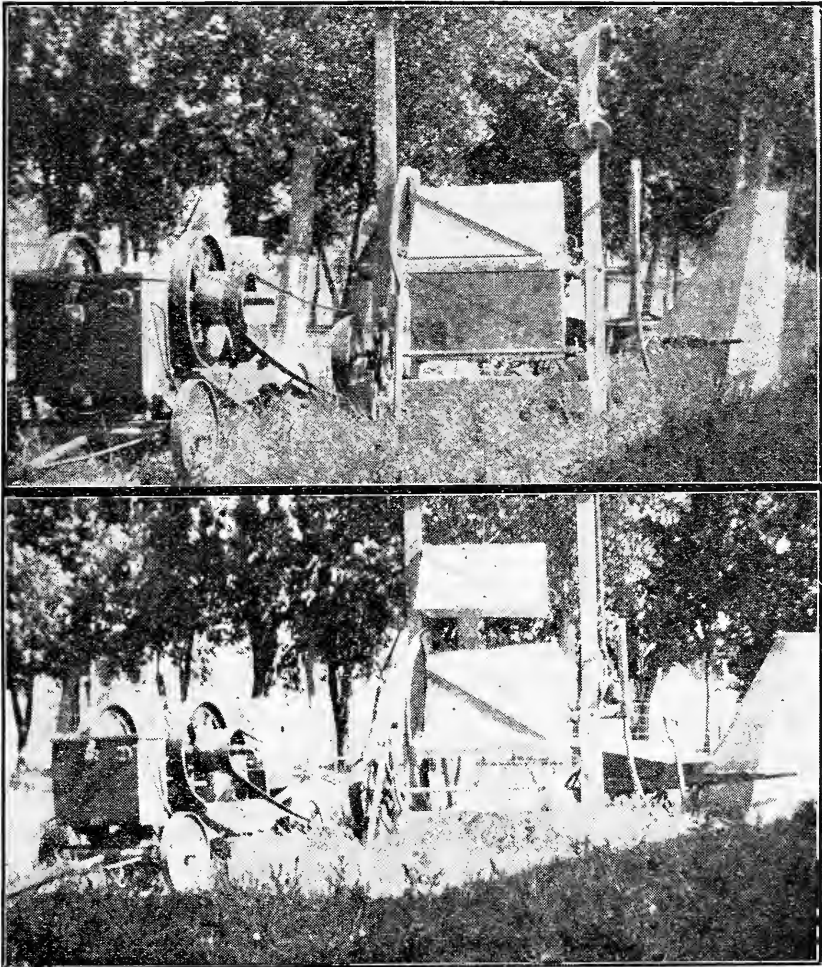

Plate 33. At the top is shown a home-made concrete mixer at work. The engine is geared by jack-shaft and rope-belt to the square box. The right amount of sand, cement and gravel is put in the box, the lid is put on, and the box is then revolved. When the dry mixing is complete, the water is added through the axle which is a pipe with perforated bottom. When the wet mixing is complete, the clutch is released, the lid of the box is loosened and raised to the position shown in the bottom picture. The concrete is then dumped by revolving box one-half turn. Two men can thoroughly mix a yard per hour with this simple machine. It costs about \$6.00.

ment is spread over the pile of sand and gravel. The whole is "dry mixed" twice by shoveling from one part of the platform to the other. Water is then added and the whole mass is wet mixed two or three times by thoroughly shoveling it.

Machine Mixing.

Batch mixers are very popular because the right proportions of cement, sand and gravel are thrown into a steel box, and this is revolved until the material is thoroughly dry mixed. Then water is added while the machine is in motion and the wet mixing is done without trouble. The whole is then dumped to the floor or to a waiting wheel-barrow.

Continuous Mixers.

Continuous mixers are so built that the right amounts of cement, sand and gravel are continually dropped into the mixing drum or trough. The material is dry mixed at one end of the drum or trough and as it is moved to the other end water is added.

Unless these mixers are used by careful workmen there is likely to be an uneven proportioning of the mixture due to clogging of one of the feeding devices.

Should the cement feed remain clogged for any great length of time the resultant concrete would be a mixture of sand, gravel and water. Thus a whole job of concrete work may be spoiled by one minute's carelessness on the part of the operator.

Reinforced Concrete.

When concrete work is subjected to bending stresses, as in the case of fence posts or beams the side of the member which is subjected to tension should be reinforced with steel or iron wires or roughened rods.

This is done because cement or concrete is very strong in compression, but it is rather weak in tension.

For flat slabs such as the sides of tanks, arch culverts, etc., a piece of heavy woven wire fence makes excellent reinforcing material.

For such pieces of work as fence posts, roller wheels, engine bases, etc., barbed fence wire is very good.

In case a lot of old barbed wire is available, it is possible to twist two or more strands together to make a rough, wire cable. This, when twisted, is straight and strong.

The twisting process is easily accomplished by twisting the ends of wires about the spokes of a wagon wheel and the other end to a post. Raise the wagon wheel from the ground and turn it until the wires are tightly twisted into a cable. If the wires are kept **tight** while the twisting is being done the resultant cable will be straight, and therefore easily placed in any type of cement or concrete work. Cables are often made as much as 200 to 300 feet long and then cut up into pieces of desired length. This provides an excellent way of getting some desirable service out of old barbed wire.

Dry Mixtures.

When we add but sufficient water to moisten the cement or concrete we speak of it as a dry mixture. Such a mixture may be tamped into a mold and the mold may be immediately removed. While this is a desirable feature, yet it is more than offset by the fact that such cement or concrete is nearly always very porous.

As these porous concretes permit water to soak through very readily they are not very desirable for tanks, floors, etc. When alkali is present in the water they are very readily destroyed, as the alkali water gets all through the concrete and causes it to disintegrate.

Wet Mixture.

When sufficient water is added to concrete to cause it to flow from the shovel like soft batter it is said to be a wet mixture. This type of mixture forms a hard and dense concrete which will, when properly made, be nearly water-proof.

As the wet mixture will not stand up when placed in the molds, it becomes necessary to leave the molds in place for some time. The molds may be removed as soon as the work is hard enough to stand, but it is better to leave them on for a week at least.

As the wet mixture is being poured into the molds it is well to move the large pebbles back from the sides of the molds by means of a flat shovel or a crowder. The crowder is nothing more than a large hoe with the goose neck straightened out.

As the shovel or crowder pushes back the large stones or gravel, water carrying sand and cement rushes in between the wall and the shovel. Thus a coating of cement and sand is given to the concrete work. This improves its appearance and at the same time renders it more nearly water-proof.

Silos.

Silos are built of monolithic cement work, of monolithic concrete and of cement blocks. In all cases they must be strongly reinforced. See Atlas Portland Cement Bulletin.

Houses.

The foundations for houses are often made of solid concrete while the portions of the walls above the foundation are made of cement blocks, laid up like stones or bricks. Unless the blocks are made of a rich mixture they absorb water readily. This often causes the walls of cement houses to be damp and unhealthy.

Sidewalks.

In building a side-walk we use about four inches of 1, 3, 3 mixture and put on a top dressing of about $\frac{1}{2}$ inch of 1, 2 or 1, 3 mixture.

The side walk should be made in sections not more than five feet long. The edge of one section should be greased with oil or axle grease before the other section is laid. In this way the joint forms a line of cleavage, or what is known as an "expansion joint." This joint becomes small in summer as the walk expands, and wide in winter when the walk contracts.

Concrete Floors.

The floors are made the same as walks but the blocks may be as large as 10 feet square.

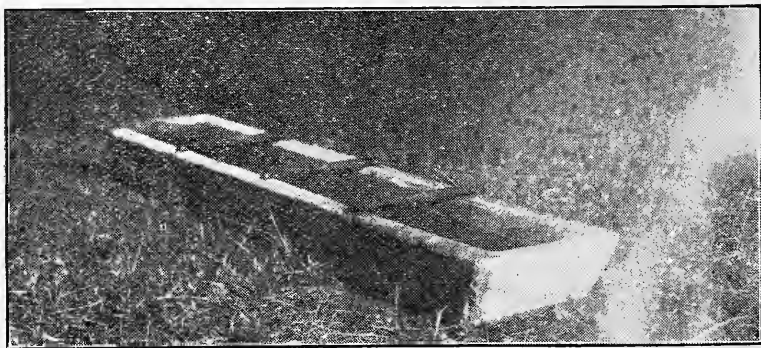

Plate 34. A very desirable hog trough can be made of cement. This trough cost 90 cents and labor. The trough weighs about 450 pounds. It is needless to say that the hogs do not root it over.

Fence Posts.

Strong durable fence posts can be made by the use of a wet 1-3 mixture in molds which make line posts **not less than five inches square** and corner posts **not less than eight inches square** at the ground line.

The line posts should be reinforced by two strands of barbed wire in each corner while the corner posts should have not less than six strands in each corner.

Pig Troughs.

Pig troughs should be made with the insides sloping outward in order to make it easy for the pig to drink, and in order to prevent the ice which may form in the trough from breaking the sides of the trough. Pig troughs should be well reinforced.

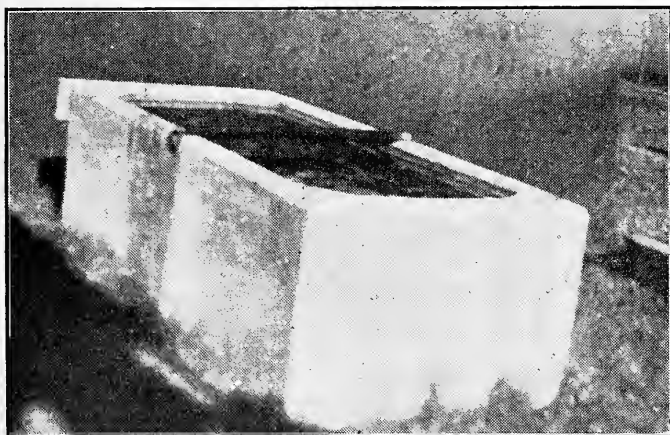

Plate 35. A concrete watering trough made of 2, 2½, 2½. The mixture was poured in the moulds and all coarse material worked back from the surface by means of a grader. Sixteen pounds of reinforcing wire was used in the tank. It stood filled with water for three seasons during winter and summer. At times the mercury fell to 29 below zero, but the trough showed no signs of giving way. The inside walls of the tank slope outward as they approach the top, thus preventing the ice from bursting them.

Large Troughs.

Large troughs, for cattle and horses may be made with walls six or more inches thick at the top. The walls should become thicker toward the bottom of the trough so that the inside of the trough slopes outward toward the top. This prevents ice from

breaking the sides of the tank. The ends, sides and bottoms of all tanks should be strongly reinforced. All sharp angles should be rounded or filleted, as cement work usually cracks from some sharp internal angle.

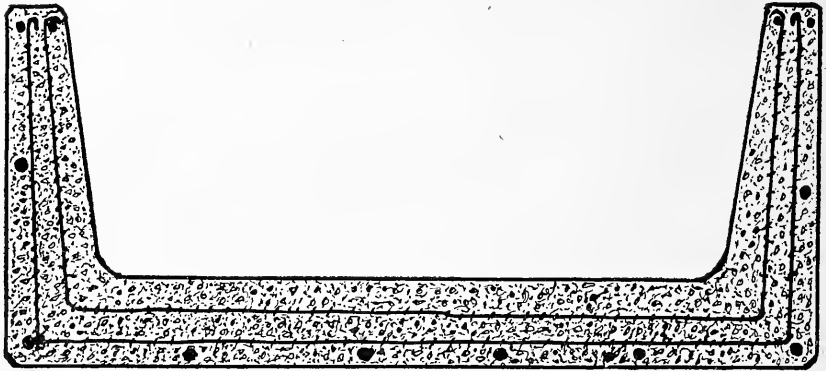

Plate 36. Cross section of a watering trough showing, "a", sloping internal side walls; "b", filleted or rounded corners or angles; "c", the placing of reinforcing wires. The large dots represent the ends of the side and bottom wires. The position of the wires which reach from the top at one side around the bottom and up to the top at the other side, is also shown.



Plate 37. Very desirable land rollers are now being made by casting cement wheels in patent rims. The rims remain on the wheels and form a steel tire for them. These rollers are heavy, but due to the fact that the weight is in the wheels, they are not very hard to pull.

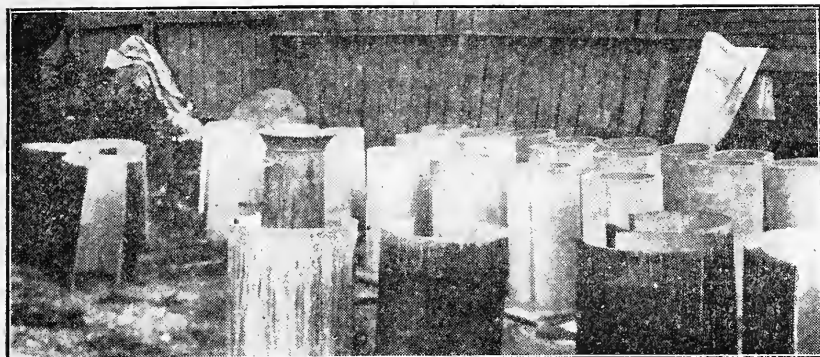

Plate 38. Cement contractor's yard where cement tiles are being constructed by pouring the cement in tile moulds. These tiles are hard and almost impervious to moisture.

The field of farm cement construction is spreading daily, and the ingenious farmer may make nearly any of the farm buildings of concrete if he but applies his ingenuity to the task.

Examination

Note to Student—These questions are to be answered independently. Never consult the text after beginning your examination. Use thin white paper about 6x9 in. for the examination. Number the answers the same as the questions, but never repeat the question. Mail answers promptly when completed.

-
- 1—Explain how the automobile affects the old types of road surfaces.
 - 2—What is axle friction of vehicles?
 - 3—Tell how the hardness of a road surface affects the rolling friction.
 - 4—Why is the pull required to move a vehicle not exactly proportional to the grade?
 - 5—How may we drain roads which run along side hills?

- 6—Why is the “arch type” of stone or concrete culvert superior to the “box type”?
- 7—Of what use are wing walls when used with culverts?
- 8—Tell how to set a corrugated steel culvert properly.
- 9—What qualities must a road surface have if it is to be considered as good?
- 10—Tell how to grade a road with a reversible grader.
- 11—Tell how and in what cases elevator graders are used.
- 12—Tell under what conditions wheel scrapers are used.
- 13—What is the object of rolling a new road surface?
- 14—How heavy should a good road roller be?
- 15—Why should the banks of cuts and fills be sloping?
- 16—Tell how to maintain the surface of an earth road.
- 17—What is a King drag? How is it used?
- 18—What adjustments should we look for in a good reversible grader?
- 19—Tell some of the good points to be looked for in an up-to-date road roller.
- 20—What is Portland Cement?
- 21—What is meant by 1, 3 mixture?
- 22—What is meant by a 1, 3, 3 mixture?
- 23—What kind of sand and gravel should we select for concrete work?
- 24—Tell how to properly mix a batch of concrete.
- 25—Tell how to build troughs in such shape as to prevent the freezing of water in the trough from bursting it.

Write This at the End of Your Examination.

I hereby certify that the above questions were answered entirely by me.

Signed

Address

.....

**The Correspondence College
of Agriculture**



FARM ENGINEERING---PART ONE

