

The D. H. Hill Library



North Carolina State College

SB46

B2

NORTH CAROLINA STATE UNIVERSITY LIBRARIES



S01116125 H

This book is due on the date indicated below and is subject to an overdue fine as posted at the circulation desk.

EXCEPTION: Date due will be earlier if this item is RECALLED.

FARM AND GARDEN RULE-BOOK

The Rural Manuals



MANUAL OF GARDENING — *Bailey*

MANUAL OF FARM ANIMALS — *Harper*

FARM AND GARDEN RULE-BOOK — *Bailey*

MANUAL OF HOME-MAKING — *In preparation*

MANUAL OF CULTIVATED PLANTS — *In preparation*

FARM AND GARDEN RULE-BOOK

A MANUAL OF READY RULES AND REFERENCE

WITH RECIPES, PRECEPTS, FORMULAS, AND TABULAR INFORMATION FOR THE USE OF GENERAL FARMERS, GARDENERS, FRUIT-GROWERS, STOCKMEN, DAIRYMEN, POULTRY-MEN, FORESTERS, RURAL TEACHERS, AND OTHERS IN THE UNITED STATES AND CANADA

BY

liberty yde
L. H. BAILEY

NINETEENTH EDITION

New York

THE MACMILLAN COMPANY

1929

All rights reserved

COPYRIGHT, 1911,
BY THE MACMILLAN COMPANY.

Set up and electrotyped. Published November, 1911. Reprinted
August, 1912; June, 1914.

New edition, with corrections, November, 1915; July, 1917.

Norwood Press
J. S. Cushing Co. — Berwick & Smith Co.
Norwood, Mass., U.S.A.

PREFACE

THE first edition of this manual was published late in 1889, and the second early in 1892, both by the Rural Publishing Company, publisher of the "American Garden" and "Rural New-Yorker." The third edition, much remodeled, was published by The Macmillan Co., May, 1895. The book has been reprinted, February, 1896; May, 1897; August, 1898; August, 1899; June, 1901; October, November, 1902; February, 1904; July, 1905; January, 1907; May, June, 1908; August, 1909.

The old form of the book, under the title "The Horticulturist's Rule-Book," is now to be discontinued, having served its place and day. So far as I know, it was the first compilation of its kind in this country, and therefore it was very imperfect and incomplete. The intervening years, covering nearly a quarter century, have also seen a vast enlargement of the farmer's horizon, so that the little book that I prepared in my novice days can no longer represent the situation.

I am sure that I have more misgiving in putting out this larger and completer book than I had in the small first effort. The field is wider, and therefore more difficult to cover; and knowledge has grown so uninterruptedly that one knows scarcely where to begin and what to compass. The only definite point is where to end, for publishers fortunately set limits to sizes of books; and when this limit was reached I discarded three or four chapters and prepared the index.

For myself, I am conscious of the many good things that have not been printed in the book; but I hope that my consultant—I cannot expect to have a reader for a book of this sort—will find some satisfaction in the things that are included. Every

care has been taken to choose reliable sources of information, but I can scarcely hope to have escaped errors; and of course I cannot hold myself responsible for the value of the many diverse varieties of information and advice that are here collected. Any user of the book will do me a kindness if he reports to me any error that he may discover. If the new book should meet with the favor that fell to the old, I shall need these suggestions in the making of new editions; but I can hardly hope that such continued favor will come to it, for this would mean that the two would span a half century, and in these rapidly enlarging days this is too much to expect of any fascicle of facts.

I am indebted to many good persons for the information contained in the book, as the names in the proper places testify; but I am specially under obligation to Professor A. R. Mann for much help.

L. H. BAILEY.

ITHACA, N. Y., September 1, 1911.

CONTENTS

CHAPTER I

	PAGES
THE WEATHER	1-23
<i>How to use the Weather Map</i>	2
The storm-tracks, 2 — The weather map, 4 — The weather indications, 5.	
<i>Weather Bureau Forecasts</i>	6
Signals of the United States Weather Bureau, 7 — Canadian signals, 8.	
<i>Barometer and Wind Indications</i>	9
<i>Popular Weather Signs</i>	11
<i>Frosts, and Methods of Protection</i>	12
How frost forms, 12 — To find the dew-point, 14 — Table for determining temperature of dew-point, 15 — Methods of protection against frost, 16.	
<i>Phenology</i>	17
<i>Climate and Crop Production; keeping Records</i>	19
Climatic records compiled by the weather services, 20 — How climatic data may be secured, 21 — Making local observations, 23.	

CHAPTER II

THE ELEMENTS AND THE SOIL	24-39
<i>Distribution of the Elements</i>	25
The atmosphere, 25 — The elements essential to the life and growth of plants, 25 — Ultimate composition of a wheat plant, 26 — Ultimate composition of human body, 26.	
<i>The Ash and Mineral Parts of Animals and Plants</i>	26
Mineral elements in animal bodies, 27 — Composition of ash of human body, 27 — Composition of the ash of leading farm crops, 28.	
<i>Chemical Compounds</i>	28
<i>The Soil</i>	29
Classification of soils in respect to origin, 29 — Classification of	

	PAGES
soil constituents, 29 — Weight of soils, 30 — Texture of the soil, 32.	
<i>Soil Water</i>	32
Amount of water used by various crops in producing a ton of dry matter, 32 — Mean volume of water held by different soils, 33 — Water evaporated by growing plants for one part of dry matter produced, 33 — Water needed under arid conditions, 34.	
<i>Plant-food in the Soil</i>	34
Plant-food in surface soil, with calculations to pounds in an acre, 34.	
<i>Alkali Lands</i>	35
The normal condition of arid lands, 35 — Percentage composition of alkali, 36 — Quantity of gypsum required to neutralize sodium carbonate, 37.	
<i>Tillage, and Soil Management</i>	37
Objects of tillage, 37 — Jordan's rules of fertility, 38.	

CHAPTER III

CHEMICAL FERTILIZERS; AND LIME	40-80
<i>Some of the Sources of Chemical Fertilizers</i>	41
Composition of materials used as sources of nitrogen, 41 — Composition of materials used as sources of phosphoric acid, 41 — Marketed production of phosphate rock in United States, 41 — World's production of phosphate rock, 1905-1907, 42 — Average composition of Stassfurt potash salts, 42 — Potash salts produced in the United States, 1850 to 1905, 43 — Importation of potash salts, 43 — Potassic materials produced by the aid of electricity, 44 — Principal potash material used in United States, 45.	
<i>Fertilizer Formulas and Guarantees</i>	45
<i>Methods of Computing Value of Fertilizers</i>	47
Trade-values of plant-food elements in raw materials and chemicals, 1910, 47 — Valuation and cost of fertilizers, 48 — Valuation, and agricultural value, 48 — Rule for calculating approximate commercial valuation of mixed fertilizers, 48 — Computing the trade value, 49 — How to figure the trade value, in greater detail, 50.	
<i>Home-Mixing of Fertilizers</i>	52
General advice, 52 — Incompatibles in fertilizer mixtures, 53 — Table for calculating raw materials required per ton by mixtures of given composition, 53.	

	PAGES
<i>Soil Analysis and Fertilizer Tests</i>	54
Field tests to determine fertilizer needs, 56.	
<i>Analyses of Various Chemical Fertilizer and Related Materials</i>	57
Dissolved bone-black, 57 — Bone charcoal, 57 — Ground bone, 57 — Dried blood, 58 — Dry ground fish, 58 — Sulfate of ammonia, 58 — Sulfate of potash, 58 — Sulfate of magnesia, 58 — Nitrate of Soda, 58 — Muriate of potash, 58 — German potash salts, 58 — Kainit, 59 — Land-plaster or gypsum, 59 — Ashes, unleached, 59 — Ashes, leached, 59 — Coal ashes, bituminous, 59 — Coal ashes, anthracite, 59 — Gas-lime, 59 — Seaweed, 60.	
<i>Fertilizer Formulas for Various Crops</i>	60
Formulas suggested by Maine Experiment Station, 60 — Specific mixtures for different crops, 63.	
<i>Lime for the Land</i>	77
To determine whether a soil is acid, 77 — Application of lime, 78 — Forms of lime, 78 — Fineness of division, 79 — Classification of lime for agricultural purposes, 79 — Other tests for lime, 80.	

CHAPTER IV

FARM MANURES, AND SIMILAR MATERIALS	81-91
<i>Composition and Characteristics of Manures</i>	81
Cattle manure, 81 — Stable or horse manure, 81 — Sheep manure, 82 — Hog manure, 82.	
<i>Composition of Manure from Different Animals</i>	82
Composition of fresh excrement of farm quadrupeds, 83 — Composition of drainage liquors, 83 — Composition of litter, 84 — Poultry manures, 84.	
<i>Utilization of Manures</i>	85
Rate of production, 85 — Use of manures, 86 — Commercial value, 86 — Losses by leaching, 87.	
<i>Further Analyses of Animal Excrements</i>	88
Common barnyard manure, fresh, 88 — Common barnyard manure, moderately rotted, 88 — Same, thoroughly rotted, 88 — Cattle-feces, fresh, 88 — Cattle-urine, fresh, 88 — Horse-feces, fresh, 88 — Horse-urine, fresh, 89 — Sheep-feces, fresh, 89 — Sheep-urine, fresh, 89 — Swine feces, fresh, 89 — Swine-urine, fresh, 89 — Peruvian guano, 89 — Human feces, fresh, 90 — Human urine, fresh, 90 — Sewage, 90.	
<i>Analyses of Fruit and Garden Products, with reference to their Fertilizing Constituents</i>	90

CHAPTER V

	PAGES
SEED-TABLES	92-105
<i>Quantity of Seed required per Acre</i>	92
<i>Hay and Pasture Seeds</i>	94
Permanent meadows, 94 — Permanent pastures, 94 — Number and weight of grass seed, and another estimate of quantity to sow, 94 — Examples of seed mixtures that would furnish 20,000,000 grass seeds per acre, 95 — Testing grass seed, 96.	
<i>Number of Tree-Seeds in a Pound</i>	96
Fruit trees, 96 — Forest trees, 96.	
<i>Weights and Sizes of Seeds</i>	97
Seedmen's customary weights per bushel, 97 — Weight and size of garden seeds, 98.	
<i>Figures of Germination and Purity</i>	100
Testing seeds, 100 — High average percentage of purity and of germination of high-grade seeds, 101 — Average time required for garden seeds to germinate, 102.	
<i>Longevity of Seeds</i>	102
Vilmorin's tables, 102 — Haberlandt's figures, 104 — Vitality of seeds buried in soil, 104.	
<i>Average Yields of Garden Seed-Crops</i>	105

CHAPTER VI

PLANTING-TABLES	106-123
<i>Dates for Sowing or Setting Kitchen-Garden Vegetables in Different Latitudes</i>	106
Lansing, Michigan, 106 — Boston, 106 — New York, 107 — Norfolk, 107 — Georgia, 108 — Tender and hardy vegetables, 108.	
<i>Date-Tables</i>	109
Vegetable-gardener's planting-table, 109 — Usual planting dates for field crops, 110 — Flower-planting table, 116.	
<i>Distance-Tables</i>	119
Usual distances apart for planting fruits, 119 — Usual distances apart for planting vegetables, 119 — Orange trees, 119 — Number of plants required to set an acre of ground at given distances, 120 — Quincunx planting, 123.	
<i>Plan for a Home Garden</i>	123

CHAPTER VII

	PAGES
MATURITIES, YIELDS, AND MULTIPLICATION	124-132
<i>Maturity-Tables</i>	124
Time required for maturity of different garden crops, reckoned from the sowing of the seeds, 124 — Time required, from setting, for fruit-plants to bear (for northern and central latitudes) 124 — Average profitable longevity of fruit-plants under high culture, 125.	
<i>Yield-Tables</i>	125
Average full yields per acre of various horticultural crops, 125 — Yields of farm crops, 127.	
<i>Propagation-Tables</i>	130
Tabular statement of the ways in which plants are propagated, 130 — Particular methods by which various fruits are multiplied, 130 — Stocks commonly used for various fruits, 131 — How vegetable crops are propagated, 131 — How farm crops are propagated, 132.	

CHAPTER VIII

CROPS FOR SPECIAL FARM PRACTICES. HOME STORAGE AND KEEP- ING OF CROPS	133-149
<i>Forage Crops</i>	133
Roughage, 133 — Fodder, 133 — Soiling, 133 — Silage, 134.	
<i>Soiling Crops</i>	134
Soiling crops adapted to northern New England, 135 — Time of planting and feeding soiling crops, 135 — Soiling crops for Pennsylvania, 136 — Crops for partial soiling for Illinois during mid-summer, 136 — Succession of soiling crops for dairy cows for Wisconsin, 136 — Mississippi, 137 — Kansas, 137 — Dates for planting and using soiling crops in western Oregon and western Washington, 137 — Dairyman's rotation in middle latitudes, 137.	
<i>Cover-Crops</i>	138
<i>Catch-Crops</i>	139
<i>Nurse-Crops</i>	140
<i>Field Root-Crops</i>	140
<i>Methods of Keeping and Storing Fruits and Vegetables</i>	141
Apples, 141 — Cabbage, 142 — Celery, 142 — Crystallized or glacé fruit, 143 — Figs, 144 — Gooseberries, 144 — Grapes, 144 — Onions, 146 — Orange, 147 — Pears, 147 — Quince, 147 — Roots, 147 — Squash, 147 — Sweet-potato, 148 — Tomato, 149.	
<i>Cold Storage</i>	149

CHAPTER IX

	PAGES
COMMERCIAL GRADES OF CROP PRODUCTS. FRUIT PACKAGES	150-171
<i>Cotton Grades</i>	150
<i>Grades of Hay and Straw</i>	151
Hay, 151 — Alfalfa, 152 — Straw, 152.	
<i>Grades of Grain</i>	153
White winter wheat, 153 — Red winter wheat, 154 — Hard winter wheat, 154 — Northern spring wheat, 154 — Spring wheat, 155 — White spring wheat, 155 — Durum wheat, 155 — Velvet chaff wheat, 156 — Pacific Coast wheat, 156 — Mixed wheat, 157 — Rye, 157 — White oats, 157 — Mixed oats, 158 — Red or rust-proof oats, 158 — White clipped oats, 158 — Mixed clipped oats, 159 — Purified oats, 159 — Corn, 159 — White corn, 160 — Yellow corn, 160 — Mixed corn, 160 — Milo-maize, 160 — Kaffir corn, 161 — Barley, 161 — Winter barley, 162 — Sample grades, 163.	
<i>Fruit Packages</i>	163
California deciduous fruits, 163 — Chautauqua grape figures, 164 — California citrus fruits, 164 — Apple boxes, 164 — Canadian fruit packages, 167 — Proposed United States standards, 168.	
<i>Packages for truck crops, including strawberries</i>	169

CHAPTER X

THE JUDGING OF FARMS, CROPS, AND PLANTS. EXHIBITION AND NOMENCLATURE RULES. EMBLEMATIC PLANTS AND FLOWERS	172-186
<i>Farms and Farm Practices</i>	172
The agricultural virtues, 172 — Loudon's rules for gardeners, 173 — Essential points to consider in the organization of a farm, 174 — Points of a good farm, 174 — Score-card for farms, 175.	
<i>Corn and Potatoes</i>	177
Score-card for dent corn, 177 — For use in the plant selection of seed corn, 177 — Card for use in judging varieties of corn at husking time, 177 — Score-card for potatoes, 177.	
<i>Standards for Judging Fruits at Exhibitions</i>	177
Apples and pears, 177 — Peaches, 177 — Plums, 178 — Cherries, 178 — Grapes, 178 — Collections, 178 — Barrel apples, 178 — Box apples, 179.	
<i>Flowers and Plants</i>	179
The American Rose Society scale of points, 179 — Standardization of roses, 179 — Carnations, 179 — Gladiolus, 180 — Chrysan-	

	PAGES
themum, 180 — Sweet pea, 180 — Scale of points of florists' plants, 180.	
<i>Sample Rules to Govern Exhibitions</i>	181
Massachusetts Horticultural Society rules, 181.	
<i>Nomenclature Rules</i>	183
Rules for naming kitchen-garden vegetables, 183 — American Pomological Society rules of nomenclature, 183.	
<i>Emblematic Plants and Flowers</i>	185
State flowers, 185 — National and regional flowers, 186 — Party flowers, 186.	

CHAPTER XI

GREENHOUSE AND WINDOW-GARDEN WORK	187-201
<i>Greenhouse Practice</i>	187
Potting earth, 187 — Suggestions for potting plants, 188 — Watering greenhouse and window plants, 188 — Liquid manure for greenhouses, 188.	
<i>Lists of Plants</i>	189
Twenty-five plants adapted to window-gardens, 189 — Vegetable-growing under glass, 190 — Twenty-five useful aquatic and sub-aquatic plants for outdoor use, 191 — Commercial plants and flowers, or "florists' plants," 191.	
<i>The Heating of Greenhouses</i>	192
Methods of proportioning radiating surface for heating of greenhouses, 192 — Size of pipes connecting radiating surface and the boiler or heater, 194 — Table of dimensions of standard wrought-iron pipe, 194 — To design heating surface, 195.	
<i>Other Information relating to Heating</i>	195
Diameters for chimney flues, 195 — Effects of wind in cooling glass, 196 — Table of radiation for glass, 196 — Radiating surface of pipes, 197 — Method of finding boiler capacity for cast-iron pipe, 198 — Customary temperatures in which plants are grown under glass, 198.	
<i>Various Estimates and Recipes</i>	198
Percentage of rays of light reflected from glass roofs at various angles of divergence from the perpendicular, 198 — Angle of roof for different heights and widths of house, 199 — Standard flower-pots, 199 — To prevent boilers from filling with sediment or scale, 200 — To prepare paper and cloth for hotbed sash, 200 — Paint for hot-water pipes, 200 — Liquid putty for glazing, 201 — Paint for shading greenhouse roofs, 201 — To keep flower-pots clean, 201.	

CHAPTER XII

	PAGES
FORESTRY AND TIMBER	202-220
<i>Planting Notes</i>	202
Nursery planting-table for forest trees, 202 — Forest planting, 203.	
<i>Hardness of Common Commercial Woods</i>	204
<i>Forest Yields</i>	204
Approximate time required to produce wood crops, 204 — Yield of white pine, 205.	
<i>Life of Fence-Posts and Shingles</i>	207
Durability of fence-posts in Minnesota, 207 — Prolonging the life of fence-posts, 207 — Prolonging the life of shingles, 209 — Suggestions for community action, 210.	
<i>Board Measure</i>	210
<i>Cord Measure</i>	211
<i>Log Measure</i>	212
Scribner decimal log rule, 214.	
<i>U. S. Forest Service Log-Scaling Directions</i>	214
Allowances for taper, 216.	
<i>Cubic Log Measure</i>	216
Method by measurement of length and middle diameters, 217 — By length and end diameters, 217 — Solid cubic contents of logs, 218.	
<i>Cubic Contents of Square Timber in Round Logs</i>	218
The two-thirds rule, 219 — The inscribed-square rule, 220.	

CHAPTER XIII

WEEDS	221-233
<i>General Practices</i>	221
Annual weeds, 221 — Biennials, 222 — Perennials, 222.	
<i>Chemical Weed-killers or Herbicides</i>	223
Salt, 223 — Copper sulfate (blue vitriol), 223 — Iron sulfate, 223 — Kerosene, 223 — Carbolic acid, 224 — Sulfuric acid (oil of vitriol), 224 — Caustic soda, 224 — Arsenical compounds, 224.	
<i>Application of Herbicides</i>	224
Gravel roadways, gutters, tennis courts, walks, 224 — List of weeds that may be controlled by means of chemical sprays, 225 — List of weeds on which present spraying methods are not effective, 225 — Rhode Island experience with iron sulfate, 225 — South Dakota experience with iron sulfate, 226 — Ohio experi-	

	PAGES
ence, 226 — Cornell experience, 227 — Various experiences, 227 — When to apply weed sprays, 228.	
<i>Treatment for Particular Weeds</i>	229
Poison ivy, 229 — Prickly lettuce, 229 — Bracted plantain, 229 — Horse nettle, 229 — Buffalo bur, 229 — Spiny amaranth, 229 — Spiny cocklebur, 229 — Chondrilla, 230 — Wild carrot, 230 — Wild oats, 230 — False flax, 230 — Mustard, 230 — King-head, 230 — Canada thistle, 230 — Dandelion, 231 — Sow thistle, 231 — Quack-grass, 231 — White daisy, 231 — Black mustard, 232 — Orange hawkweed and chickweed, 232.	
<i>Lawns</i>	232
Weeds in lawns, 232 — Moss on lawns and walks, 233.	
<i>Moss or Lichen on Trees</i>	233

CHAPTER XIV

PESTS AND NUISANCES	234-251
<i>Mice and Rats</i>	234
To prevent mice from girdling trees in winter, 234 — Washes to protect trees from mice, 235 — Carbonate of baryta for rats and mice, 235 — Tartar emetic, 235 — Strychnine for mice, 235 — Camphor for rats and mice, 236 — French paste, 236 — Phosphorus, 236 — To protect seed-corn from burrowing animals, 236.	
<i>Rabbits</i>	236
Wash for keeping rabbits, sheep, and mice away from trees, 236 — Blood for rabbits, 236 — To drive rabbits from orchards, 237 — Another wash, 237 — California rabbit-wash, 237 — California rabbit poisons, 237 — Sulfur for rabbits, 237 — Cow-manure, 237 — Asafoetida, 238 — Kansan method of protecting trees from rabbits, 238 — To remedy the injury done by mice, rabbits, and squirrels, 241.	
<i>Ground Squirrel or Spermophile Remedies</i>	241
<i>Moles</i>	242
<i>Prairie-dogs</i>	242
<i>Woodchucks or Ground-hogs</i>	243
<i>Pocket-gophers</i>	243
<i>Wolves and Coyotes</i>	243
<i>Muskrats</i>	243
<i>Pestiferous Birds</i>	243
Bird poisons, 243 — Poison for English sparrows, 244 — To pro- tect fruits from birds, 244 — To protect newly planted seeds, 244	

	PAGES
— To protect corn from crows, 245 — To protect young chickens, 245.	
<i>Mosquitoes</i>	245
Kerosene for mosquitoes, 245 — Fishes available for destruction of mosquito larvae, 246 — Hibernating mosquitoes, 246 — Rules for mosquito extermination and prevention, 247.	
<i>The House-Fly</i>	249
The typhoid fly, or house-fly, 249 — Control, 250.	
<i>Slime on Ponds</i>	251

CHAPTER XV

GERMICIDES AND GERMICIDES FOR PLANT DISEASES	252-258
<i>Practices</i>	252
Destroying affected parts, 252 — Rotation of crops, 253 — Sterilizing by steam, 253.	
<i>Substances</i>	253
Bordeaux mixture, 253 — Ammoniacal copper carbonate, 255 — Copper carbonate, 255 — Corrosive sublimate, 255 — Formalin, 256 — Lime, 256 — Lime-sulfur, 256 — Potassium sulfid, 258 — Resin-sal-soda sticker, 258 — Sulfate of copper, 258 — Sulfate of iron, 258 — Sulfur, 258.	

CHAPTER XVI

PLANT DISEASES	259-285
<i>Certain General or Unclassified Diseases</i>	260
Damping-off, 260 — (Edema or dropsy, 260 — Smut of cereals, 260 — Storage rots, 262.	
<i>Diseases of the Different Plants or Crops</i>	262
Alfalfa, 262 — Almond, 263 — Apple, 263 — Apricot, 265 — Asparagus, 265 — Barley, 265 — Bean, 265 — Bean, Lima, 265 — Beet, 266 — Blackberry, 266 — Brussels sprouts, 266 — Cabbage, 266 — Carnation, 267 — Cauliflower, 267 — Celery, 267 — Cherry, 267 — Chestnut, 268 — Chrysanthemum, 268 — Corn, 268 — Cotton, 269 — Cranberry, 269 — Cucumber, 270 — Currant, 270 — Ginseng, 270 — Golden-seal, 271 — Gooseberry, 271 — Grape, 271 — Hollyhock, 273 — Lettuce, 273 — Muskmelon, 274 — Nectarine, 274 — Nursery stock, 274 — Oats, 274 — Onion, 274 — Pea, 275 — Peach, 275 — Pear, 277 — Plum, 279 — Potato, 279 — Pumpkin, 280 — Quince, 280 — Radish, 280 — Raspberry, 281 —	

Rice, 281 — Rose, 281 — Spinach, 281 — Strawberry, 282 — Sweet-potato, 282 — Tobacco, 282 — Tomato, 283 — Violet, 283 — Wheat, 283.	
<i>Seed and Soil Treatments</i>	284

CHAPTER XVII

INSECTICIDAL MATERIALS AND PRACTICES	286-300
<i>General Practices</i>	286
Cleanliness, 286 — Hand-picking, 286 — Promoting growth, 286	
Burning, 286 — Banding, 286 — Fumigation, 287 — Fungous diseases as insecticides, 290.	
<i>Insecticidal Substances</i>	290
Arsenic, 290 — Arsenicals, 291 — Bait, 293 — Bran-arsenic mash, 293 — Bisulfid of carbon, 293 — Carbohc acid materials, 293 — Criddle mixture, 293 — Distillate emulsion, 294 — Hot water, 294 — Kerosene emulsion, 294 — Lime-sulfur, 294 — Miscible oils, 297 — Pyrethrum, 297 — Resin and fish-oil compounds, 298 — Soaps, 298-299 — Soda and aloes, 299 — Sulfur, 299 — Tangle-foot, 299 — Tar, 299 — Tobacco, 299 — White hellebore, 300.	

CHAPTER XVIII

INJURIOUS INSECTS, WITH TREATMENT	301-336
<i>General or Unclassified Pests</i>	301
Angleworm, 301 — Aphides, 301 — Bag-worm, 301 — Blister-beetle, 302 — Brown-tail moth, 302 — Cutworm, 302 — Flea-beetle, 303 — Four-striped plant-bug, 303 — Gipsy-moth, 303 — May-beetle, 303 — Mealy-bug, 303 — Nematode root-gall, 303 — Red-spider or mite, 304 — San José scale, 304 — Scale-insects, 304 — Snails, 305 — White ants, 305 — Wire-worm, 305.	
<i>Insects classified under the Plants they chiefly Affect</i>	305
Apple, 305 — Apricot, 310 — Asparagus, 310 — Aster, 311 — Bean, 311 — Birch, 311 — Blackberry, 311 — Cabbage, 311 — Carrot, 312 — Cauliflower, 313 — Celery, 313 — Cherry, 313 — Chestnut, 313 — Chrysanthemum, 313 — Clover, 313 — Corn, 314 — Cotton, 316 — Cranberry, 317 — Cucumber, 318 — Currant, 318 — Dahlia, 319 — Egg-plant, 319 — Elm, 319 — Endive, 320 — Gooseberry, 320 — Grape, 320 — Hollyhock, 322 — House-plants, 322 — Lawns, 322 — Lettuce, 322 — Melon, 322 — Mushroom, 323 — Onion, 323 — Orange and lemon, 323 — Parsley, 324 — Parsnip, 324 — Pea, 324 — Peach, 325 — Pear, 326 — Pecan, 327 — Per-	

simmon, 328 — Pineapple, 328 — Plum, 329 — Poplar, 329 — Potato, 329 — Privet or Prim, 330 — Quince, 330 — Radish, 330 — Raspberry, 330 — Rhubarb, 331 — Rose, 331 — Squash, 331 — Strawberry, 332 — Sugar-cane, 333 — Sumac, 334 — Sweet-potato, 334 — Tobacco, 335 — Tomato, 335 — Violet, 335 — Wheat, 336 — Willow, 336.

CHAPTER XIX

LIVE-STOCK RULES AND RECORDS	337-364
<i>Determining the Age of Farm Animals</i>	337
Cattle, 337 — Sheep, 338 — Swine, 339 — Horses, 339.	
<i>Gestation and Incubation Figures</i>	342
Number of young at birth, 343 — Number of eggs in brood, 343.	
<i>Other Characteristics</i>	344
Average temperatures of farm animals, 344 — The pulse of farm animals, 344 — Period of heat, 344 — Quantity of blood in the bodies of farm animals, 345.	
<i>Temperatures for Cold Storage of Animal Products</i>	345
<i>Advanced Registry</i>	345
Schedule of charges for supervising records of cows, 348 — Holstein-Friesian records, 349 — Ayrshire records, 350 — Guernsey records, 351 — Jersey records, 354.	
<i>Fast Horse Records</i>	357
Trotters, 358 — Pacers, 358 — Fastest records for one mile, 358 — Fastest records for two miles, 359 — Fastest records for three miles, 359 — Fastest records for four miles, 359 — Fastest records for five miles, 359 — Fastest records for six miles, 359 — For ten miles, 359 — For eighteen miles, 359 — For twenty miles, 360 — For thirty miles, 360 — For thirty-two miles, 360 — For fifty miles, 360 — For one hundred miles, 360 — For decades, 360.	
<i>Profit-and-Loss Figures</i>	360
Profit or loss in dairy cows, 360 — Profit or loss in fattening steers, 362 — In fattening sheep, 362 — In fattening swine, 362.	
<i>Cow-testing Associations</i>	362
Apparatus required, 364 — Value of cow-testing associations in Virginia, 364.	

CHAPTER XX

POULTRY	365-382
<i>Standard Weights of Poultry in Pounds</i>	366
<i>Descriptive Score-Card for Standard Poultry</i>	367

	PAGES
<i>Eggs</i>	368
Scoring and judging one dozen eggs, 368 — Students' score-card for a dozen eggs, 369.	
<i>Rules for Machine Incubation</i>	370
<i>Feeding</i>	372
Cornell ration for egg-production, 372 — Relation of food-consumption to egg-production, 372.	
<i>Preparing Fowls for Market by Bleeding</i>	374
<i>Care of Feathers and Eggs</i>	375
Feathers, 375 — General care of eggs, 375 — Preserving eggs, 376.	
<i>Parasites of Fowls</i>	377
Hen louse, 377 — Chicken mite, 377 — Scaly leg, 378 — Depluming scabies, 378 — Hen fleas, 378 — Chicken tick, 378.	
<i>Sample Rules and Regulations for the Exhibition of Poultry</i>	378
<i>Outline for Critical Examination of a Poultry Farm</i>	381

CHAPTER XXI

EXHIBITING AND JUDGING LIVE-STOCK. MARKET GRADES	383-408
<i>General Rules and Regulations governing Exhibits of Live-Stock</i>	383
<i>Score-Cards for Farm Animals</i>	392
Draft-horse, 392 — Light-horse, 393 — Students' card for proportions of horse, 395 — Beef-cattle (female), 395 — Beef-cattle (bull), 397 — Dairy-cattle, 398 — Mutton sheep, 399 — Breeding-sheep, 401 — Fat-hog, 402 — Bacon-hog, 404.	
<i>Market Classes and Grades</i>	404
Beef, 404 — Veal, 405 — Mutton and lamb, 406 — Pork, 406 — Swine, 407.	

CHAPTER XXII

COMPUTING THE RATION FOR FARM ANIMALS	409-428
<i>Computing by Energy Values</i>	409
<i>Computing on Basis of Quality and Quantity of Milk</i>	410
<i>Computing the Balanced Ration by the Wolff-Lehmann Standards</i>	413
<i>The Feeding Standards</i>	414
Feeding standards per day and 1000 lb. live weight, 414 — Per day per head, 415 — Proteid requirements for cattle, sheep, and swine, 416 — Average weights of different feeding stuffs, 417 — Sample rations, 417.	
<i>Composition Tables</i>	419

Composition tables, 419 — Digestion tables, 424 — Fertilizing constituents, 426.

CHAPTER XXIII

EXTERNAL PARASITES OF ANIMALS	429-441.
<i>Handling the Cattle-tick or Texas-fever Tick</i>	429
Dips for cattle-ticks, their preparation and use, 429 — Method of spraying, 433 — Disinfectant for ticks in infested stables, 434 — Eradication of ticks by rotation of fields, 435.	
<i>Other External Parasites of Farm Animals</i>	434
Lime-and-sulfur dips, 434 — Nicotine solutions, 434 — Commercial dips, 436 — Crude oil emulsion, 436 — Lice powder, 436 — Cresol disinfecting soap, 436 — The kinds of parasites (cattle, 437; horse, 439; sheep, 440; swine, 441).	

CHAPTER XXIV

MILK AND MILK PRODUCTS; DAIRY FARMS	442-472
<i>Composition of Milk</i>	442
Composition of cow's milk, 442 — Average composition of milk of various kinds, 443 — Average composition of typical cow's milk, 443 — The milk of different breeds, 444 — Milk solids of different breeds, 444 — Ash in cow's milk and its products, 444 — Mineral constituents in milk, 444 — Variation in average composition of 574 samples of market butter samples, 445 — Nutrients and energy in one pound of food materials as compared with milk, 445 — Average composition of milk products and other food materials, 446.	
<i>Milk, Butter, and Cheese Tests</i>	446
Babcock test for butter-fat, 446 — Computing total solids, 447 — Test for acid, 447 — Test for boiled milk, 448 — The lactometer test for specific gravity, 448 — Test for boric acid or borax, 449 — Test for formaldehyde in milk, 450 — Standardizing milk, 450 — Butter moisture-test, 451 — Salt in butter, 453 — Salt in cheese, 453 — Over-run in butter-making, 454 — Spoon-test for oleomargarin and renovated butter, 455 — Moisture in cheese, 455 — Babcock test for fat in cheese, 456 — Casein in milk, 456 — Wisconsin curd-test, 457.	
<i>Propagation of Starter for Butter-Making and Cheese-Making</i>	458

	PAGES
<i>Farm Butter-Making</i>	458
Bitter milk and cream, 459 — Why butter will not "come," 460 — Old cream makes poor-flavored butter, 461 — White specks in the butter, 461 — Mottled butter, 461 — Effect of feed on butter-fat, 461.	
<i>Butter from Whey</i>	461
<i>Milk, Butter, and Dairy-farm Scores</i>	462
Score-card for market-milk, 462 — Butter score-card, 463 — Cheese score-card, 464 — University of Wisconsin score-cards, 465.	
<i>Butter Classifications and Grades</i>	465
Definitions, 465 — Grades, 465 — Specials, 465 — Extras, 466 — Seconds, 466 — Thirds, 467 — No. 1 packing stock, 467 — No. 2 packing stock, 467 — No. 3 packing stock, 467.	
<i>Dairy Establishment Scores and Rules</i>	467
Score-card for production of sanitary milk, 467 — Milk inspection of farm dairies, 469 — Rules for the production of clean milk, 471 — Sanitary inspection of city milk plants, 472.	

CHAPTER XXV

CONSTRUCTION, FARM ENGINEERING, MECHANICS	473-503
<i>Silos</i>	473
Least number of dairy cows for silos of given diameters, 473 — Feeding capacity of silos, 473 (Approximate quantity of silage required per day — Necessary diameter of silos for feeding given numbers of cows) — Other silo figures, 476 (Weight of silage-capacity of cylindrical silos).	
<i>Barn Figures</i>	477
<i>Wire Fence</i>	477
Dimensions of 1-, 2-, 3-, 4-acre lots and fence required to inclose them, 478 — Gauges, sizes, and weights of plain wire, 479 — Barb-wire, 479 — Galvanized coiled spring-steel wire, 479 — Rods of fence required for fields of different sizes, 480.	
<i>Tensile Strengths of Ropes</i>	481
<i>Tile Draining</i>	481
Number of feet of tile per acre, 481 — Limit of size of tile to grade and length, 481 — Number of acres drained by given sizes of tile, 482 — Price-list of tile, 483 — Cost of laying tile, 483 — Drainage points, 484 — Don'ts in land drainage, 484.	
<i>Road-Drags</i>	485
Use of the King road-drag, 485 — The split-log road-drag, 487.	

	PAGES
<i>Data on Water</i>	489
Rules, 489 — Feet-head and pressure, 489 — Pressure and feet-head, 490 — Equivalents for moving water, 490 — Foot-loss of water through pipes by gravity, 491 — Friction-loss of water in pipes (pounds), 492 — Friction-head (feet), 493 — Barometric pressure at different altitudes as affecting pumps, 494.	
<i>Windmill Figures</i>	494
Windmills for pumping, 494 — Power of mill, 495 — Speed of mill, 496 — Loading and speed, 497 — Sizes and cost of circular reservoirs for irrigation by windmills, 497 — Cost of mills, 498.	
<i>Machinery and Motors</i>	498
Widths of belting, 498 — Size and speed of pulleys or gears, 498 — Calculated capacity of piston pumps, 499 — Power required to operate triplex pumps, 500 — Horse-power required to raise water to different heights, 501 — Horse-power of steel shafting, 501 — Electric appliances on the farm, 502 — The motor power of a stream, 502 — Hydraulic rams, 503 — Hot-air engines, 503.	

CHAPTER XXVI

MASON WORK. CEMENTS, PAINTS, GLUES, AND WAXES	504-515
<i>Building or Mason's Cement; Gravel and Pitch</i>	504
Approximate estimates of mason-work, 504 — Floors, borders, walks, and foundations, 505.	
<i>Mending Cements</i>	507
Cements for iron, 507 — Boiler cements, 507 — Tar cement, 508 — Copper cement, 508 — Fire-proof or stone cement, 508 — Earthenware cement, 508 — Cement for glass, 508 — Sealing cements, 508.	
<i>Paints and Protective Compounds</i>	509
Home-made washes for fences and outbuildings, 509 — Fire-proof paint, 509 — For damp walls, 509 — Water-proofing paint for leather, 510 — For cloth for pits and frames, 510 — For paper, 510 — To prevent metals from rusting, 510 — To prevent rusting of nails, hinges, etc., 510 — To remove rust, 511 — Amount of paint required for a given surface, 511.	
<i>Glues</i>	511
Liquid glue, 511 — Flower gum, 511 — Gum for labels and specimens, 512.	
<i>Waxes for Grafting and for Covering Wounds</i>	512
Common resin and beeswax waxes, 512 — Alcoholic wax, 513 —	

Pitch wax, 513 — Waxed string and bandages, 513 — Covers for wounds, 514.

PAGES

CHAPTER XXVII

COMPUTATION TABLES	516-542
<i>Tables of Regular American Weights and Measures</i>	516
Avoirdupois weight, 516 — Troy or jewellers', 516 — Apothecaries', 516 — Comparative weights, 517 — Dry measure, 517 — Liquid measure, 517 — Apothecaries' fluid measure, 517 — Line or linear measure, 517 — Surveyors' or chain measure, 518 — Square measure, 518 — Surveyors' square measure, 518 — Solid or cubic measure, 518 — Paper and book denominations, 519.	
<i>Metric Weights and Measures</i>	519
Weight, 519 — Capacity, 520 — Length, 520 — Surface, 520 — Cubic, 520 — Equivalents in metric and American measures, 521.	
<i>Money Tables</i>	521
English money, 521 — French, 522 — German, 522 — Dutch, 522 — Italian, 522 — Spanish, 522 — Russian, 522 — Austrian, 522 — Monetary units of American countries, 522 — Other money equivalents, 523 — Money table, 524 — Legal rates of interest, 524.	
<i>Wage-Tables</i>	526
Day wages, 526-527 — Month wages, 526.	
<i>Thermometer Scales</i>	527
<i>Miscellaneous Measures, Weights, and Estimates</i>	528
Measures and dimensions of many kinds, 528 — Weights of various varieties of apples per bushel, 529 — Dried fruit and cider, 529 — Various estimates, 529 — To find bushels in bins, 530 — To find tons of hay in mow or stack, 530 — To figure cost of hay by the ton, 530.	
<i>Capacities of Pipes and Tanks</i>	531
Quantity of water held by pipes of various sizes, 531 — Number of gallons in circular tanks and wells, 531 — Approximate contents of cylinders, 531 — Gallons in square-built tanks, 532.	
<i>Legal Weight of the Bushel</i>	533
List of products for which legal weights have been fixed in but one or two states, 533, 540 — Legal weights (in pounds) per bushel in the United States, 534 — Other articles, 540 — Legal weights of seeds and grains in Canada, 540.	
<i>Government Townships</i>	541

CHAPTER XXVIII

	PAGES
COLLECTING AND PRESERVING SPECIMENS FOR CABINETS OR EXHIBITION PERFUMERY. LABELS	543-558
<i>Collecting and Storing Samples of Soil</i>	543
<i>Samples of Seeds and Grains</i>	544
<i>Collecting and Preserving Plants for Herbaria</i>	545
<i>Preserving, Printing, and Imitating Flowers and Other Parts of Plants</i>	546
<i>Collecting and Preserving Insects</i>	551
<i>Making Perfumery at Home</i>	551
<i>The Preservation of Fruits for Exhibition Purposes</i>	552
Six Canadian recipes, 552 — A California method, 556.	
<i>Labels</i>	556
<i>Jars for Specimens</i>	558

CHAPTER XXIX

DIRECTORIES	559-567
<i>Institutions and Agencies making for a better Rural Life</i>	559
<i>Agricultural and Forestry Colleges, Schools, and Experiment Stations in Canada</i>	561
<i>Agricultural Colleges and Experiment Stations in the United States</i>	561
<i>Forestry Schools in the United States</i>	564
<i>North American Veterinary Colleges and Departments</i>	565
<i>Home Economic Institutions and Departments</i>	566
<i>Institutions teaching Landscape Architecture (or Landscape Gardening) of College Grade</i>	567

FARM AND GARDEN RULE-BOOK

FARM AND GARDEN RULE-BOOK

CHAPTER I

THE WEATHER

THE farmer lives with the weather. Therefore he should understand it; and he should be able to follow the indications of the weather maps, and should be provided with good thermometers and barometers of his own.

It is important that the thermometer should indicate the temperature correctly, and for this one must rely on the maker. Most reliable instrument-makers place the firm name on their instruments as a guarantee of accuracy. When purchasing, it is therefore well to see that the instrument bears the name of the maker. A reliable thermometer of the ordinary pattern costs \$1 to \$3, depending on the size and style of the case. Probably the most satisfactory instrument for farm use is "Six's" pattern of self-registering maximum and minimum thermometers. This instrument is but little larger than the ordinary thermometer, and arranged with two scales, one of which shows the highest and the other the lowest temperature since the instrument was "set." To "set" the thermometer, the small steel index in the tube is pulled down to the end of the column by a magnet that accompanies the instrument. The current temperature is indicated by this instrument in the same way as by the ordinary thermometer. Thermometers that cost from 25 ¢ to 50 ¢ are usually inaccurate through a part of the scale.

The same rule as to maker should be observed in the purchase of an aneroid barometer, although there are probably fewer worthless barometers on the market than worthless thermometers. A good aneroid barometer costs \$10 to \$15, depending on the size and make. As these instruments depend for accuracy on the mechanical construction, the cheaper grades are usually unsatisfactory. A pocket

aneroid barometer (about the size of a watch) costs about \$12. These instruments are arranged to determine elevations as well as to give weather indications.

Mercurial barometers are more expensive, costing \$25 to \$40. As the mercury in the column of a mercurial barometer changes its length with changes of temperature just as the column of mercury does in a mercurial thermometer, it is necessary to correct the reading at each observation. Tables, giving the amount to be added or subtracted from the reading for each degree of temperature, should be secured when the instrument is purchased.

Thermometers should be exposed in the shade, and where there is a free circulation of air. Barometers should not be exposed to full sunshine for any great length of time. Any convenient place in the house will give proper exposure for barometers.

How to use the Weather Map

(Weather Bureau, U. S. Dept. Agric.)

The first impression of a student of the weather maps, as they present their seemingly endless forms and combinations of the temperature and pressure lines, is often one of confusion. This feeling is likely to be attended by one of discouragement, and the impulse to abandon the task of seeking an underlying plan is more powerful with many persons than the incentive, which depends upon curiosity, to know what it all really means.

The storm-tracks.

The storms of the United States follow, however, year after year a series of tracks, not capricious, but related to each other by very well-defined laws.

The positions of these tracks have been determined carefully for the United States by studies made in the Forecast Division of the Weather Bureau, on the long series of maps that have been made during the past twenty years. The track that the central point of a high area or that the center of a storm follows in passing over the country from west to east is laid down on individual charts, these are collected on a group chart, and from this the average track pursued can be readily described. The chart herewith (see fig. 1) shows the general result of

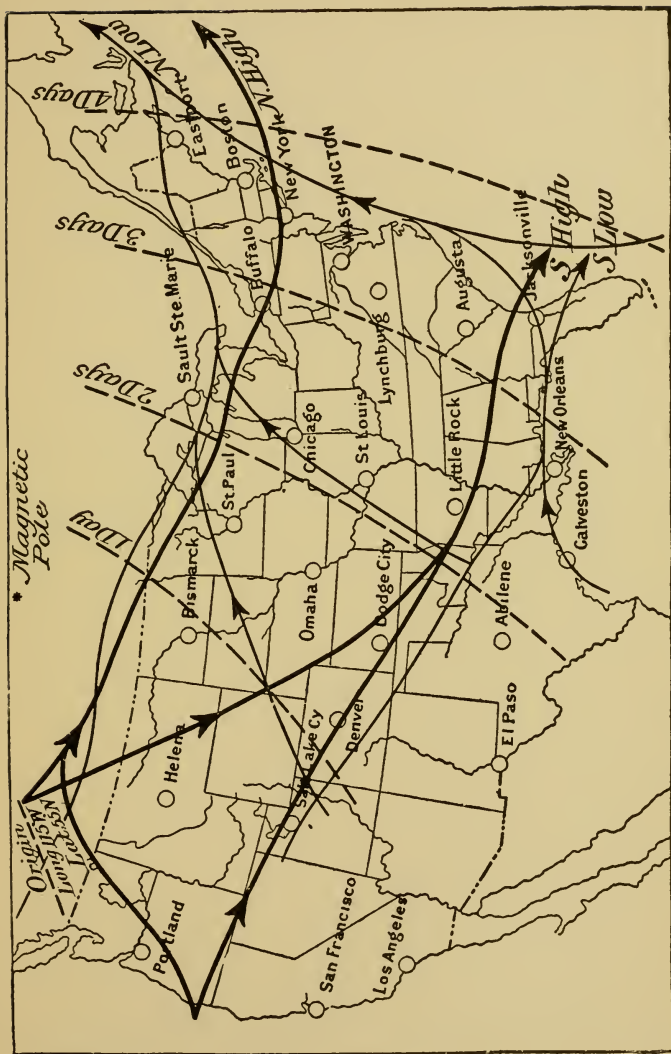

Fig. 1. — Weather map, showing mean tracks and average daily movement of storms.

a study of tracks of storms in the United States. It indicates that, in general, there are two sets of tracks running westerly and easterly, one set over the northwestern boundary, the Lake region, and the St. Lawrence Valley; the other set over the middle Rocky Mountain districts and the Gulf States. Each of these is double, with one for the "highs" and one for the "lows." Furthermore, there are lines crossing from one main track to another, showing how storms pass from one to the other. The transverse broken lines show the average daily movement. On the chart the heavy lines all belong to the tracks of the "highs," and the lighter lines to the "lows." Let us trace them somewhat in detail. A "high" appearing on the California coast may cross the mountains near Salt Lake, and then pass directly over the belt of the Gulf States to the Florida coast; or it may move farther northward, cross the Rocky Mountains in the State of Washington, up the Columbia River Valley, then turn east, and finally reach the Gulf of St. Lawrence. The paths are determined by the laws of the general circulation of the atmosphere and the configuration of the North American continent. This movement of the "highs" from the middle Pacific coast to Florida or to the Gulf of St. Lawrence is confined to the summer half of the year — April to September, inclusive.

In the winter months, on the other hand, the source of the "highs" is different, though they reach the same terminals. In the months October to March, inclusive, many "highs" enter the United States near the one hundred fiftieth meridian and move south along the Rocky Mountain slope into the southern circuit, and thus reach the South Carolina coast; or else they turn more abruptly eastward and move in the northern circuit over the Lakes to Newfoundland. The chief difficulty in the art of forecasting is to decide which of these paths will be pursued and the probable rate at which the movement will take place.

The weather map.

The daily maps of the Weather Bureau show stations in the United States and Canada that make telegraphic reports of the weather each day at 8 a. m. and 8 p. m., seventy-fifth meridian time. The reports consist of observations of the barometer and thermometer, the velocity and direction of the wind, amount, kind, and direction of movement of clouds, and amount of rain or snow, and the 8 a. m. reports

are furnished to nearly one hundred stations of the Weather Bureau for use in the preparation of maps and bulletins.

On the weather maps solid lines, called *isobars*, are drawn through points that have the same atmospheric pressure, a line being drawn for each one-tenth of an inch in the height of the barometer. Dotted lines, called *isotherms*, are drawn through points that have the same atmospheric temperature, a line being drawn for each ten degrees of temperature. Heavy dotted lines are sometimes used to inclose areas where decided changes in temperature have occurred during the preceding twenty-four hours. The direction of the wind at each station is indicated by an arrow which flies with the wind. The state of the weather — clear, partly cloudy, cloudy, rain, or snow — is indicated by symbols. Shaded areas are used on the maps issued at Washington, and at several stations, to show areas within which precipitation in the form of rain or snow has occurred during the preceding twelve hours. The tabular data give details of maximum and minimum temperatures, and 24-hour temperature changes, wind velocities, and amount of precipitation during the preceding twenty-four hours. The text printed on the maps presents forecasts for the state and the station, and summarizes general and special meteorological features that are shown by the lines, symbols, and tabulated data.

The weather indications.

The centers of areas of low barometric pressure, or general storms, are indicated on the map by the word "low," and the centers of areas of high barometric pressure by the word "high." The general movement of "lows" and "highs" in the United States is from west to east, and in their progression they are similar to a series of atmospheric waves, the crests of which are designated by the "highs" and the troughs by the "lows." These alternating "highs" and "lows" have an average easterly movement of about six hundred to seven hundred miles a day. The "lows" usually move in an easterly, or north of east, direction, and the "highs" in an easterly, or south of east, direction.

In advance of a "low" the winds are southerly or easterly, and are, therefore, usually warmer. When the "low" passes east of a place, the wind shifts to westerly or northwesterly with lower temperature. The eastward advance of "lows" is almost invariably preceded

and attended by precipitation in the form of rain or snow, and their passage is usually followed by clearing weather. The temperature on a given parallel west of a "low" may be reasonably looked for on the same parallel to the east when the "low" has passed, and when the night is clear and there is but little wind, frost is likely to occur along and north of an isotherm of 40°. A "low" is generally followed by a "high," which in turn is followed by another "low."

By bearing in mind the usual movements of "lows" and "highs" and the general conditions referred to that attend them, coming weather changes may be frequently foreseen. "Lows" often move south of east from the Rocky Mountains to the Mississippi Valley, and then change direction to north of east. "Lows" of tropical or subtropical origin often move in a westerly direction to our south Atlantic and Gulf coasts, and then recurve to the northeastward. The centers of "lows" do not as a rule cross isotherms, but generally follow the general trend of the isothermal lines. Cold waves are always accompanied by, and forerun, "highs."

When isotherms run nearly east and west, no decided changes in temperature are likely to occur. When isotherms directly west of a place incline from northwest to southeast, the temperature will rise; when from northeast to southwest, the temperature will fall.

Southerly to easterly winds prevail west of a nearly north and south line passing through the middle of a "high," and also east of a like line passing through the middle of a "low." Northerly to westerly winds occur west of a nearly north and south line passing through the middle of a "low," and also east of a similar line passing through the middle of a "high."

An absence of decided and energetic "lows" and "highs" indicates that existing weather conditions will continue until later maps show a change, which usually appears in the west.

Weather Bureau Forecasts

Forecasts of the weather expected during the ensuing thirty-six hours are issued by the United States Weather Bureau daily at about 10 A.M. and 10 P.M. and are distributed to all parts of the country by telegraph, telephone, mail, and by means of flag and whistle signals.

Nearly all telephone companies cooperate or are willing to cooperate

with the Weather Bureau in making the information available to the public in general. It is thus possible to obtain the official weather forecast by calling the central exchange of almost any telephone one may be using.

Signals of the United States Weather Bureau.

Flag Signals (Fig. 2)



FIG. 2. — United States flag signals.

No. 1, square white flag, alone, indicates fair weather, stationary temperature.

No. 2, square blue flag, alone, indicates rain or snow, stationary temperature.

No. 3, square, white above, blue below, alone, indicates local rain, stationary temperature.

No. 4, triangular black, refers to temperature.

No. 5, square white, with black center, cold wave.

No. 1, with No. 4 above it, indicates fair weather, warmer.

No. 1, with No. 4 below it, indicates fair weather, colder.

No. 2, with No. 4 above it, indicates warmer weather, rain or snow.

No. 2, with No. 4 below it, indicates colder weather, rain or snow.

No. 3, with No. 4 above it, indicates warmer weather with local rains.

No. 3, with No. 4 below it, indicates colder weather with local rains.

No. 1, with No. 5 below it, indicates fair weather, cold wave.

No. 2, with No. 5 below it, indicates wet weather, cold wave.

Whistle Signals

The warning signal, to attract attention, will be a long blast of from fifteen to twenty seconds' duration. After this warning signal has been sounded, long blasts (of from four to six seconds' duration) refer to weather, and short blasts (of from one to three seconds' duration) refer to temperature; those for weather to be sounded first.

BLASTS	INDICATE
One long	Fair weather.
Two long	Rain or snow.
Three long	Local rains.
One short	Lower temperature.
Two short	Higher temperature.
Three short	Cold wave.

Interpretation of Combination Blasts

One long, alone	Fair weather, stationary temperature.
Two long, alone	Rain or snow, stationary temperature.
One long and short	Fair weather, lower temperature.
Two long and two short	Rain or snow, higher temperature.
One long and three short	Fair weather, cold wave.
Three long and two short	Local rains, higher temperature.

By repeating each combination a few times, with an interval of ten seconds between, possibilities of error in reading the forecasts will be avoided, such as may arise from variable winds, or failure to hear the warning signal.

Canadian signals (Fig. 3)

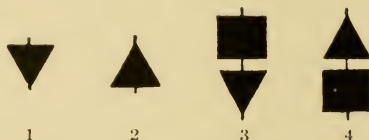

FIG. 3. — Canadian storm warnings.

No. 1, gale at first from an easterly direction.

No. 2, gale at first from a westerly direction.

No. 3, heavy gale at first from an easterly direction.

No. 4, heavy gale at first from a westerly direction.

The night signal corresponding to Nos. 1 and 3 is a red light.

Night signal corresponding to Nos. 2 and 4 is a white light above a red light.

Barometer and Wind Indications

(W. M. Wilson)

The mercurial barometer is the instrument used for all observations when great accuracy is required, but an aneroid barometer is more convenient, less liable to injury, and will answer all practical purposes.

Attention need not be given to the legends fair, changeable, stormy, etc., that usually appear on the face of the instrument, because changes in pressure are much more important indications of approaching weather than the actual pressure at a given time.

To forecast the weather accurately, the force and direction of the wind should always receive equal consideration with the changes of pressure as indicated by the barometer.

The following general statements may aid in showing the relation of wind, pressure, and weather:—

The atmosphere may be compared to an ocean of air that rests upon the earth just as the water rests upon the bed of the oceans. There are great currents of air in the atmosphere, just as there are great currents or rivers of water in the oceans.

Storms are eddies in the atmosphere, and float along in the currents or rivers of air very much like the eddies often seen floating on the surface of a river.

All of the United States and Canada, except the southern part of Florida, lies at the bottom of a great river of air that flows from west to east around the world with the north-pole at the center. It is called the circumpolar whirl. And as the storms in this latitude are eddies in the north-circumpolar whirl, they float along from west to east in the current of this river of air.

The air always whirls about the center of every storm-eddy in the same direction—counter-clock-wise in the northern hemisphere and clock-wise in the southern hemisphere. Therefore, if a storm-eddy in the latitude of the United States is approaching, the winds will first be from a southerly direction, and when the center of the storm has passed, the wind will come from a northerly direction.

If the center of the storm passes north of the observer, the wind will change from S.E. to S., then to S.W., and finally to W. or N.W. as the storm passes on its way eastward.

If the center of the storm passes south of the observer, the wind

will start in from the S.E. and gradually "back" to the N.E., then to the N. and finally to the N.W.

To locate the center of the storm, stand with your face squarely to the wind, and extend your arms from your sides. Your right hand will then point in the direction of the center of the storm. For example, if one faces a wind from the south, his extended right hand will point toward the west; if one faces a west wind, his extended right hand will point north.

A study of the daily weather maps, printed in many daily papers, will be of much help in becoming familiar with the movements of these storm-eddies.

The pressure of the atmosphere at the center of the storm-eddy is always less than at a distance from the center; therefore, as the storm approaches, the pressure will decrease and the barometer will fall. Thus a falling barometer indicates the approach of a storm-eddy, and the direction of the wind will give approximately the location of the center.

If the barometer is falling and the wind square from the south, the indications are that the storm is approaching from the west and will probably pass near the observer.

If the barometer is falling and the wind from the southwest, the center of the storm will probably pass north of the observer.

If the barometer is falling and the wind N.E., the center of the storm is approaching from the southwest, and will probably pass south of the observer. If the barometer is rising and the wind S.W. to W., the center of the storm will pass north of the observer, and clearing weather follow soon.

The following barometer and wind table is condensed from Professor Garriott's more extended compilation, and is the result of many years of study and experience:—

Barometer steady; wind, S.W. to N.W.; fair weather, with slight changes in temperature for 1 or 2 days.

Barometer falling slowly; wind, S.W. to N.W.; warmer, with rain in 24 to 36 hours.

Barometer falling rapidly; wind, S.W. to N.W.; warmer, with rain in 18 to 24 hours.

Barometer falling slowly; wind, S. to S.E.; rain within 24 hours.

Barometer falling rapidly; wind, S. to S.E.; wind increasing in force with rain within 12 to 24 hours.

Barometer falling slowly; wind, S.E. to N.E.; rain in 12 to 18 hours.

Barometer falling rapidly; wind, S.E. to N.E.; increasing wind and rain in 12 hours.

Barometer falling rapidly; wind, E. to N.E.; in summer rain probable within 24 hours; in winter rain or snow with increasing winds, probably continuing 24 to 48 hours.

Barometer rising slowly; wind, S. to S.W.; clearing and cooler within a few hours, and probably continued fair weather for several days.

Barometer rising rapidly; wind, S. to W.; clearing and cooler. In winter cold wave probable.

Should the barometer continue low when the sky becomes clear, expect more rain within 24 hours. (C. L. Prince.)

Rapid changes in the barometer indicate early and marked changes in the weather. (E. B. Garriott.)

If the thermometer and barometer rise together,
It is a very sure sign of coming fine weather.

If the barometer falls two or three tenths of an inch in four hours, expect a gale of wind. (C. L. Prince.)

In summer, when the barometer falls suddenly, expect thunderstorms; if it does not rise again when the storm ceases, there will be several days of unsettled weather.

The barometer falls lower for high winds than for heavy rains.

Popular Weather Signs (Wilson)

When it is evening, ye say, It will be fair weather: for the heaven is red. And in the morning, It will be foul weather to-day: for the heaven is red and lowering. — *Matthew*, xvi, 2, 3, Rev. version.

When ye see a cloud rising in the west, straightway ye say, There cometh a shower; and so it cometh to pass. — *Luke*, xii, 54, Rev. version.

After fine, clear weather the first signs in the sky of coming changes are usually light streaks, curls, wisps, or mottled patches of white, distant clouds, which increase and are followed by an overcasting

of murky vapor that grows into cloudiness. Usually the higher and more distant the clouds seem to be, the more gradual but general the coming change of weather will prove. — *Fitzroy*.

If cirrus clouds form in fine weather with a falling barometer, it is almost sure to rain. — *Howard*.

If cirrus clouds dissolve and appear to vanish, it is an indication of fine weather. — *Garriott*.

When cloud streamers point upward, the clouds are falling or descending, and rain is indicated; when cloud streamers point downward, the clouds are ascending, and dry weather is indicated. — *Garriott*.

Clouds flying against the wind indicate rain.

If in hot weather two strata of clouds appear to move in opposite directions, thunderstorms are indicated.

Well-defined cumulus clouds forming a few hours after sun-rise, increasing toward the middle of the day, and decreasing toward evening are indicative of settled weather; if instead of subsiding in the evening, leaving the sky clear, they keep increasing, they indicate wet weather. — *Jenyns*.

Birds fly high in fair weather and low in foul weather. The explanation is that in fair weather the barometer is usually high, the air heavier and denser and capable of sustaining a given weight at a greater elevation than when less dense during the passage of a storm.

Frosts, and Methods of Protection

How frost forms (Wilson).

In the day, plants usually receive more heat from the sun than they give off (radiate), and consequently become warmer; but at night the process is reversed, and they radiate more heat than they receive and thus grow colder. When the surface of a plant has lost (radiated) sufficient heat to cause its temperature to fall to 32° or below, frost forms. Any condition that causes increased radiation will increase the liability of frost, and conversely, whatever checks radiation or supplies additional heat to the air will tend to ward off frost.

A clear night is favorable for frost because radiation or loss of heat from the surface of the earth proceeds most rapidly under a clear sky. Clouds act as a blanket. The heat rays do not penetrate them easily, but are reflected back toward the earth, thus checking radiation by confining the heat to the strata of air between the earth and the clouds.

A quiet air is favorable for frost. Radiation proceeds more rapidly from the surface than from the air above the surface. This is shown by the fact that a thermometer placed in the grass on a quiet, clear night will read 10° or even 15° below one suspended three or four feet above the surface. If there is much wind, this difference will not occur, because the wind mixes the colder air at the surface with the warmer air above, thus giving a more uniform temperature.

A moderately dry atmosphere is favorable for frost, because when the air is humid only a slight fall of temperature will occur before the temperature at which dew begins to form (*dew-point*) is reached, and when the vapor in the air begins to change into water (dew), the heat that was used originally to change the water into vapor is no longer required and is said to be liberated, and tends to raise the temperature of the air, or at least to retard the fall.

The effect of the liberation of heat in the process of the formation of dew may be appreciated when it is said that the heat added to the air in the formation of a pint of dew is sufficient to raise the temperature of more than five pints of water from the freezing to the boiling point.

Under ordinary conditions, when the dew-point is 10° or more above the frost-point, 32° , a frost is not likely to occur, but if the dew-point approaches 32° , frost is likely to occur.

In a cranberry marsh near Mather, Wis., during the season of 1906, Cox found that the minimum temperature averaged 8.2° below the temperature of the dew-point as observed the previous evening, and in extreme cases the difference was as much as 20° and 22° . On a marsh near Berlin, Wis., on the night of September 27, 1906, at 11 P.M. the dew-point was found to be 43° , yet frost began to form in parts of the marsh at 1 P.M. when the temperature had fallen to 28° ; frost became general at 2 A.M., and the following morning a minimum temperature of 24.4° was observed.

The dew-point of the previous evening cannot, therefore, be regarded as a safe guide for the minimum temperature of the following night.

The chief value of dew-point observations of the previous evening appears to be in the fact that they indicate the temperature at which the heat from the condensing vapor will begin to be poured into the air, and if this temperature is much above the frost-point, this addition of heat may be reasonably expected to check the fall of temperature and thus ward off a frost.

To find the dew-point.

The dew-point is determined by the wet- and dry-bulb thermometer (or psychrometer). The instrument may be made as follows: For the frame find a board eighteen inches long, two inches wide, and one half inch thick; bore a hole in one end so as to hang the apparatus on a nail when not in use. Get two all-glass thermometers with cylindrical bulbs, and the degrees Fahrenheit engraved on the stem. Cover the bulb of one thermometer with a thin piece of cotton cloth, fastening it securely by a thread. When this cloth covering is wet with water and exposed to evaporation in the air, it constitutes the "wet-bulb thermometer"; the other thermometer has no covering on its bulb, is not wet at any time, and constitutes the "dry-bulb thermometer."

The range of temperature of the open air in the following table is from 36° Fahrenheit to 75° Fahrenheit, and of depression of temperature in the wet bulb, from 1° to 13° Fahrenheit, giving a range in both directions of sufficient scope for the needs of northern farmers during the growing season. The temperature of the dry-bulb (or open-air temperature) is found in the left-hand column of the table; the difference in degrees between the readings of the dry- and wet-bulb is entered in the horizontal line at the top, from 1° to 13°. To find the temperature of dew-point at any observation, find in left-hand column the temperature of dry-bulb, then follow the horizontal line opposite that figure till you reach the perpendicular column under the difference between dry- and wet-bulb readings, and the figures at the meeting of these two columns will give the temperature of dew-point. For example, suppose the dry-bulb stands at 65° and wet-bulb at 55°: the difference is 10°. Pass across the page in the line of 65° till you intersect the vertical column under 10°, and you read 47°, which is dew-point under these conditions. If the dew-point is 10° or more above frost-point (32° Fahrenheit), there is little danger of killing frost; but if the dew-point is less than 10° above 32°, danger may be apprehended. If a line is drawn from the intersection of 43° — 1° and 67° — 13°, of the table, this may be called the danger line, and all dew-point temperatures below this line indicate danger of frost, and are printed in *italics*. This margin of 10° is taken because the temperature on a still night will often sink several degrees below the first dew-point, and the temperature of the air at five feet above the ground is

several degrees above that at ground level. For these reasons combined, a margin of 10° may be safely assumed as the limit of safety.

Table for determining the temperature of dew-point from the readings of the dry-bulb and wet-bulb thermometers (Hazen)

DRY-BULB THERMOMETER	DEPRESSION OF THE WET-BULB THERMOMETER												
	1°	2°	3°	4°	5°	6°	7°	8°	9°	10°	11°	12°	13°
75°	74	72	71	69	68	66	64	63	61	59	57	56	54
74°	73	71	70	68	67	65	63	62	60	58	56	54	52
73°	72	70	69	67	66	64	62	61	59	57	55	53	51
72°	71	69	68	66	64	63	61	59	58	56	54	52	50
71°	70	68	67	65	63	62	60	58	56	55	53	51	48
70°	69	67	66	64	62	61	59	57	55	53	51	49	47
69°	68	66	64	63	61	59	58	56	54	52	50	48	46
68°	67	65	63	62	60	58	57	55	53	51	49	46	44
67°	66	64	62	61	59	57	55	54	52	50	47	45	43
66°	64	63	61	60	58	56	54	52	50	48	46	44	
65°	63	62	60	59	57	55	53	51	49	47	45	42	41
64°	62	61	59	57	56	54	52	50	48	46	43		40
63°	61	60	58	56	55	53	51	49	47	44	42	41	38
62°	60	59	57	55	53	52	50	48	45	43		39	37
61°	59	58	56	54	52	50	48	46	44	42	41	38	35
60°	58	57	55	53	51	49	47	45	43		39	36	33
59°	57	56	54	52	50	48	46	44		40	38	35	32
58°	56	55	53	51	49	47	45	42	41	39	36	33	30
57°	55	54	52	50	48	46	44		40	37	35	31	28
56°	54	53	51	49	47	44	42	41	39	36	33	30	26
55°	53	52	50	48	46	43		40	37	34	31	28	25
54°	52	50	49	46	44	42	41	39	36	33	30	27	23
53°	51	49	47	45	43		40	37	34	31	28	25	20
52°	50	48	46	44	42	41	38	36	33	30	27	23	18
51°	49	47	45	43		40	37	34	31	28	25	21	16
50°	48	46	44	42	41	38	36	33	30	27	23	19	14
49°	47	45	43		40	37	34	31	28	25	21	17	11
48°	46	44	42	41	38	36	33	30	27	23	19	14	9
47°	45	43		40	37	35	32	29	25	22	17	12	6
46°	44	42	41	39	36	33	30	27	24	20	15	10	3
45°	43		40	37	35	32	29	26	22	18	13	7	-1
44°	42	41	39	36	33	30	27	24	20	16	11	4	-5
	✓	40	37	35	32	29	26	23	19	14	8	1	-9
43°	41	39	36	34	31	28	25	21	17	12	6	-2	-15
42°	40	38	35	33	29	26	23	19	15	9	3	-6	-22
41°	39	36	34	31	28	25	22	17	13	7	0	-11	-32
40°	38	35	33	30	27	24	20	16	11	4	-4	-16	-74
39°	37	34	32	29	26	22	18	14	8	2	-8	-23	
38°	36	33	31	28	24	21	17	12	6	-1	-12	-35	
37°	35	32	29	26	23	19	15	10	4	-5	-17		
36°	34	31	28	25	22	18	13	8	1	-8	-25		

Methods of protection against frost (Wilson).

Protection against frost is not only possible, but practicable. The method to be employed depends on the kind of crop, the expense its value will justify, and the facilities at hand. But whatever method is chosen, it must be carried out systematically, intelligently, and with thoroughness if satisfactory results are to be obtained.

Progressive cranberry growers resort to three expedients to ward off light frosts, aside from flooding, which is practiced in the spring and autumn and also when exceptionally severe frosts are expected. These methods are cultivation, drainage, and sanding. By cultivating the marsh and keeping it free from weeds, moss, and other vegetation, the heat from the sun more easily penetrates the soil, and there is, therefore, more heat to be given off when needed to prevent frost during the night. Good drainage decreases the effect of cooling by evaporation, and a dry soil becomes warmer under sunshine than a wet soil, and therefore radiates heat more freely into the air at night when needed to ward off frost. A covering of sand lowers the specific heat of the soil, and thus stores up a large amount of heat during the day to be given to the air at night. In the Cape Cod marshes it is the practice to spread about half an inch of sand over the surface of the marsh each year. These methods, when systematically and carefully carried out, are usually effective in warding off light frosts that are liable to occur between early spring and autumn.

Smudging has been practiced for many years in the trucking sections of the Southwest, as well as in the fruit-growing districts of California and Florida. The object is to cover the garden or orchard with a thick blanket of smoke and vapor, with a view to checking radiation. The success of this method depends upon the care and thoroughness with which it is carried out. The cloud of vapor or smoke must cover the garden or orchard, and be dense. A thin blanket will not be sufficient. The fire should be built on the windward side of the orchard, and such material used as damp straw, prunings, manure.

If the fire burns briskly, it may be sprayed with water to increase the cloud of vapor.

Portable smudges have superseded the stationary smudge in many places. They possess the advantage of being moved from place to place, thus overcoming the effect of a change of wind, which often ren-

ders the stationary smudge ineffective. Any sort of a fire-box that can be placed on a stone-boat or sled will answer the purpose.

The most effective method, and the one now practiced by the large fruit-growers of Colorado and California, is the distribution of a large number of small fires, about forty to the acre, throughout the orchard. In this case dependence is placed in the direct heat given off by the fires as well as in the cloud formed from the smoke. Coal is the fuel most generally used in California, while oil is coming into use in Colorado. When coal is used, it is the practice to suspend wire baskets a few feet from the ground, containing ten to twenty pounds of coal, which is lighted when frost threatens. Forty such baskets will raise the temperature of the orchard three or four degrees. The cost depends upon the price of the fuel. In California a ton of soft coal that costs \$2.50 was considered sufficient for one acre each night.

Some orchardists have replaced the coal baskets with oil burners. This method is more expensive to install, as the burners are more costly than the baskets, and tanks must be provided for the storage of the oil; but it is said to be much more convenient, and quite as efficient. At the Hamilton fruit ranch, near Grand Junction, Col., the temperature in an orchard of twenty acres was maintained at 33° by the use of oil burners, while a minimum temperature of 27° was registered in surrounding localities. The cost of the protection of this orchard for four nights when frost occurred in the vicinity was approximately ten per cent of the value of the crop. Methods less systematic than the above are usually disappointing. (For another discussion, see Paddock and Whipple, "Fruit-Growing in Arid Regions.")

Phenology

Phenology (contraction of *phenomenology*) is that science which considers the relationship of local climate to the periodicity of the annual phenomena of nature. It usually studies climate and the progression of the seasons in terms of plant and animal life, as the dates of migrations, of blooming, leafing, ripening of fruit, defoliation, and the like. If observations are to have permanent value, they must be taken with a definite purpose. The particular objects of phenological observations are the following:—

1. To determine the general oncoming of spring.
2. To determine the fitful or variable features of spring.
3. To determine the epoch of the full activity of the advancing season.
4. To determine the active physiological epoch of the year.
5. To determine the maturation of the season.
6. To determine the oncoming of the decline of fall.
7. To determine the approach of winter.
8. To determine the features of the winter epoch.
9. To determine the fleeting or fugitive epochs of the year.

Good phenological observations upon plants should satisfy the following tests, as given by Hoffmann:—

1. They should represent as broad a distribution as possible of the given species, selected for observation.
2. Ease and certainty of identifying the definite phases which are to be observed.
3. The utility of the observations as regards biological questions, such as the vegetative periods, time of ripening, etc.
4. Representation of the entire vegetation period.
5. Consideration of those species which are found in almost all published observations, and especially of those whose development is not influenced by momentary or accidental circumstances, as is the dandelion.

The epochs of vegetation that should be observed for most phenological purposes are these:—

1. Upper surface of the leaf first visible or spread open.
2. First blossoms open.
3. First fruit ripe.
4. All leaves, or more than half of them, colored.

Typical and average plants should always be selected for observation, and they should be few in number. A dozen well-selected species will afford more satisfactory records year by year than observations made at random upon a great variety of plants. For the sudden moods of spring, the peach and dandelion are useful for observation, but such plants—those which respond quickly to every fitful variation of the

early season — are not reliable for the staple records of the years. Useful plants for study are the following:—

Apple.	Cultivated Strawberry.
Pear.	Lilac.
Quince.	Mock Orange (<i>Philadelphus</i>).
Plum.	Horse Chestnut.
Sweet Cherry.	Red-pith Elder
Sour Cherry.	Common Elder.
Peach.	Flowering Dogwood.
Choke Cherry.	Native Basswood.
Wild Black Cherry.	Native Chestnuts.
Japanese or Flowering Quince.	Privet or Prim.
Cultivated Raspberry.	Red Currant.
Cultivated Blackberry.	Cultivated Grape.

Climate and Crop Production; keeping Records (Wilson)

Every farmer understands that a very intimate relation exists between climatic conditions — the average temperature, rainfall, and sunshine — and the growth of plants ; but not all farmers appreciate the full significance of the climatic factor in crop production.

An officer of a state college of agriculture recently asked five members of the faculty to assign respective values to the three main factors affecting the average yield of corn under the climate of the forty-second parallel. The factors considered were: soil, including texture, fertility, and cultivation ; climate, including temperature, rainfall, and sunshine ; and seed. The average of the five estimates on the basis of 100 were for soil, 46 ; climate, 36 ; and seed, 17. Three out of the five gave to climate a value of 40, one 35, and one 25, and two out of the five gave climate and soil equal values.

If these estimates are near the truth, it becomes apparent that climate is nearly, if not quite, as important a factor in crop production as soil, and much more important than seed ; yet it receives but scant attention from the average agriculturist, probably because climate, unlike soil and seed, is beyond the control of man.

The weather is a variable factor, because it changes from day to day, from week to week, and from season to season. But climate is a permanent factor ; for climate, which is the average of all the weather,

does not change, except possibly through long geological periods. When the climate of a locality has been once determined, it may be counted on absolutely. What the climate is for this generation it will be for the next, and the next, so far as we can see. It could not be otherwise, for climate in the large is the result of the sun's heat, modified by the topography of the earth's surface — the mountains, the valleys, the oceans; and "so long as the sun shines with his accustomed vigor and the hills and the seas abide in their places," so long will the climate of every locality remain unchanged. The fact that crops now are grown successfully in what are considered arid regions, and are being pushed farther and farther into the frosty north, has been cited in support of the contention that the climate is changing; but these changes in the area of successful production have not been brought about by an increase of rainfall on the one hand, or of temperature on the other, but by new methods of cultivation and seed selection, and better adaptation of human practices to natural conditions.

We may rely, therefore, upon the permanency of the climatic factor in crop production. The weather may vary by a small margin from year to year, or from one season to the next, but the average temperature, rainfall, and sunshine for so short a period as ten years will depart so little from the true normal climate that the departure may be neglected in actual practice.

Climatic records compiled by the Weather Services.

As it requires about ten years of careful observation to determine approximately the average or normal temperature of a locality, and perhaps twenty years to determine the normal rainfall, few farmers would feel that they had the time or skill to devote to so serious an undertaking; nor is it necessary that they should. This work has been done already in the United States, and with great accuracy and care. The Weather Bureau of the United States Department of Agriculture has collected and tabulated all records of temperature and rainfall that have been made in the United States. Some of these records cover a period of more than a hundred years, many of them more than fifty years, and the work still is going on. At present, observations are being made at about 4000 places. With this number of records, distributed more or less evenly over the entire country, it is possible

to determine very accurately the normal temperature and rainfall for almost any locality in the United States.

A similar system is in operation by the Canadian Government, and information as to the climate of almost any inhabited locality in the Canadian provinces may be had on application to the Director of the Canadian Meteorological Service, Toronto.

The data are usually compiled by months. For example, the normal temperature and rainfall by months for Ithaca, N. Y., are as follows: Normal or average temperature, 31 years record: January, 24°; February, 25°; March, 32°; April, 44°; May, 57°; June, 66°; July, 71°; August, 68°; September, 61°; October, 50°; November, 38°; December, 28°; Annual, 47°. Normal or average precipitation in inches and hundredths of inches, including melted snow: January, 2.07; February, 1.84; March, 2.42; April, 2.30; May, 3.39; June, 3.73; July, 3.51; August, 3.06; September, 2.89; October, 2.96; November, 2.50; December, 2.30; Annual, 32.97.

These values would be considered approximately correct for a radius of twenty to fifty miles, depending principally on the topography, whether mountainous or level, and the proximity of large bodies of water and the prevailing wind direction. It is recognized that there may be an appreciable difference between the climate of a valley and that of an adjacent hill, or, on account of differences of soil character, between one farm and another in the same locality. Such local variations are usually small, although important, particularly in such matters as air drainage and frost, and can be determined only by observations made on the spot. The averages, compiled by the Weather Bureau, include observations made on hill-tops as well as in valleys, and, therefore, represent strictly average conditions. They have been carefully computed, and may be relied upon with confidence.

How climatic data may be secured.

The Climatological Service of the U. S. Weather Bureau is organized by sections, each section embracing a single state, except in the case of some of the smaller states, which are included in one section. The New England States make up one section; also Delaware, Maryland, and the District of Columbia. The work of each section is under the supervision of a section director, in whose office are kept all records pertaining to his section. The accompanying list gives the city in

which the office of each section director is located, and the section under his charge. A request for climatic data should show clearly (1) the locality for which the data are desired, and (2) the character of the data, and should be addressed, Section Director, Local Office, Weather Bureau, followed by the appropriate city and state:—

CITY	SECTION	CITY	SECTION
Atlanta	Georgia	Louisville	Kentucky
Atlantic City	New Jersey	Milwaukee	Wisconsin
Baltimore	Maryland and Delaware	Minneapolis	Minnesota
Bismarek	North Dakota	Montgomery	Alabama
Boise	Idaho	Nashville	Tennessee
Boston	New England	New Orleans	Louisiana
Cheyenne	Wyoming	Oklahoma	Oklahoma
Chicago	Illinois	Parkersburg	West Virginia
Columbia	Missouri	Philadelphia	Pennsylvania
Columbus	Ohio	Phoenix	Arizona
Denver	Colorado	Portland	Oregon
Des Moines	Iowa	Raleigh	North Carolina
Grand Rapids	Michigan	Reno	Nevada
Helena	Montana	Richmond	Virginia
Honolulu	Hawaii	Salt Lake City	Utah
Houston	Texas	San Francisco	California
Huron	South Dakota	San Juan	Porto Rico, W. I.
Indianapolis	Indiana	Santa Fe	New Mexico
Ithaca	New York	Seattle	Washington
Jacksonville	Florida	Springfield	Illinois
Lincoln	Nebraska	Topeka	Kansas
Little Rock	Arkansas	Vicksburg	Mississippi

Probably the most important information for the general farmer concerning the climate of his locality is the average temperature and rainfall by months, but the following data are available for practically all parts of the United States, having been compiled in 1906 and published in Bulletin Q, to which reference should be made when making request: Temperature by months; mean or average; mean of maxima; absolute maximum; mean of minima; absolute minimum; highest monthly mean; lowest monthly mean; precipitation, including melted snow; mean or average; number of days with .01 inch (one hundredth of an inch) or more; total amount for the driest year; total amount for the wettest year; dates on which the extreme temperatures for the locality occurred. For northern states the dates are given generally when the minimum temperature fell to -10° (10° below zero) or below, and the maximum rose to 90° or above; for southern states, when the minimum fell to 32° or below, and the maximum rose to 95° or above.

Making local observations.

The value of climatic information, supplied by the Weather Bureau, may be enhanced greatly by observations of temperature and rainfall made on the farm, particularly if made in connection with phenological observations suggested on pages 17-19. Such a record is a valuable asset to a farm, and its value increases as each year's record is added. A suitable equipment need not be expensive, nor the work made laborious. The highest and lowest temperature may be obtained at a single reading, made preferably about sunset, by use of Six's pattern of maximum and minimum thermometers, mentioned on page 1. The average of the two thermometer readings gives the daily mean. This is the method used by the Weather Bureau, and will make the record strictly comparable with any data obtained from that source.

A serviceable rain-gauge may be constructed by the use of any vessel having straight sides. A tomato-can, placed two feet above ground, and fifty feet from buildings or trees, will give good results. The depth of the water caught may be measured with an ordinary rule, but to make the record comparable with those made by the Weather Bureau, the fractions of an inch should be reduced to decimals. Perhaps it would be better to make a rule graduated in inches and tenths. Ten inches of average snow will make, when melted, one inch of water.

A convenient method for recording and preserving weather observations is important. A book is preferable, having at least thirty-four ruled lines. Use one page for each month. Rule the page into eight columns, leaving ample margin on the right for phenological notes. Beginning at the left, head the columns as follows : date ; highest temperature ; lowest ; mean ; rainfall ; snowfall ; wind direction (every farm should have a good weather-vane) ; weather ; phenology. Enter each day's record on line with appropriate date. Under phenology full notes should be made, showing the condition and advancement of the various crops, for here is the point of contact between current weather and plant growth. All this may be combined with a diary of farm work. At the end of each month the temperature columns should be averaged and the total rainfall set down ; and when these values are compared with the normal, the importance of the climatic factor in crop production will be more fully understood. (For thermometer scales, see Chap. XXVII.)

CHAPTER II

THE ELEMENTS AND THE SOIL

THE mass of the earth (and the atmosphere) is at present assumed to be composed of certain elementary or indivisible substances, and of combinations of these substances. The number of elements now recognized by chemists is eighty-three. The names of these elements, with the symbols that are used for convenience and brevity in expressing the combinations into which they unite, are given in the table:—

The elements and their symbols

Aluminum	Al.	Iron	Fe.
Antimony	Sb.	Krypton	Kr.
Argon	A.	Lanthanum	La.
Arsenic	As.	Lead	Pb.
Barium	Ba.	Lithium	Li.
Beryllium	Be.	Lutecium	Lu.
Bismuth	Bi.	Magnesium	Mg.
Boron	B.	Manganese	Mn.
Bromin	Br.	Mercury	Hg.
Cadmium	Cd.	Molybdenum	Mo.
Cæsium	Cs.	Neodymium	Nd.
Calcium	Ca.	Neon	Ne.
Carbon	C.	Nickel	Ni.
Cerium	Ce.	Niobium	Nb.
Chlorin	Cl.	Nitrogen	N.
Chromium	Cr.	Osmium	Os.
Cobalt	Co.	Oxygen	O.
Columbium	Cb.	Palladium	Pd.
Copper	Cu.	Phosphorus	P.
Dysprosium	Dy.	Platinum	Pt.
Erbium	Er.	Potassium	K.
Europium	Eu.	Praseodymium	Pr.
Fluorin	F.	Radium	Ra.
Gadolinium	Gd.	Rhodium	Rh.
Gallium	Ga.	Rubidium	Rb.
Germanium	Ge.	Ruthenium	Ru.
Glueinum	Gl.	Samarium	Sm.
Gold	Au.	Scandium	Sc.
Helium	He.	Selenium	Se.
Hydrogen	H.	Silicon	Si.
Indium	In.	Silver	Ag.
Iodin	I.	Sodium	Na.
Iridium	Ir.	Strontium	Sr.

Sulfur	S.	Tungsten	W.
Tantalum	Ta.	Uranium	U.
Tellurium	Te.	Vanadium	V.
Terbium	Tb.	Xenon	Xe.
Thallium	Tl.	Ytterbium	Yb.
Thorium	Th.	Yttrium	Y.
Thulium	Tm.	Zinc	Zn.
Tin	Sn.	Zirconium	Zr.
Titanium	Ti.		

Distribution of the Elements

Oxygen, hydrogen, nitrogen, and some of the rarer elements exist in the atmosphere in a pure or free state as well as in combinations in animal and plant and earthy substances; but most of the elements are present in nature only in combination with other elements. The larger number of the eighty-three known elements are very rare. Nearly 99 per cent of the earth's crust (including the water) is made up of eight elements, as follows (according to Clark):—

Oxygen	47.02
Silicon	28.06
Aluminum	8.16
Iron	4.64
Calcium	3.50
Sodium	2.63
Magnesium	2.62
Potassium	2.32

No other element is estimated to contribute as much as 1 per cent to the composition of the crust of the globe. Hydrogen is estimated to comprise .17 per cent, and carbon .12.

The atmosphere is a mixture (by volume) of seventy-nine parts of nitrogen and twenty-one parts of oxygen, with small quantities of argon, carbon dioxid, vapor of water, ammonia, and organic gases in addition.

The elements essential to the life and growth of plants, so far as known, are ten: calcium, magnesium, potassium, phosphorus, iron, sulfur, from the soil; carbon, hydrogen, oxygen, nitrogen, from the atmosphere. Combinations formed by the vital processes of plants and animals — as starch, sugar, acetic acid — are known as organic compounds; all others are inorganic compounds. The different elements making up a compound are calculated in terms of their atomic weights.

The elements of which plants are composed, are largely oxygen, carbon, and hydrogen. The younger and more succulent the plant, the

greater the proportion of oxygen and hydrogen, because the proportion of water is greater.

Ultimate composition of a wheat plant at maturity, containing 10 per cent moisture. The hydrogen and oxygen of the water are included in the statement

Carbon	42.87
Hydrogen	6.04
Oxygen	45.26
Nitrogen	0.94
Potassium	0.36
Calcium	0.33
Phosphorus	0.11
Other ash constituents	4.09
	100.00

Ultimate composition of human body. The proportion of C varies greatly with the amount of fat, also the O and ash to a less extent. The statement includes the oxygen and hydrogen of the water

	KIRK	VOLEMAN
O	72.0	65.7
C	13.5	18.4
H	9.1	10.0
N	2.5	2.6
Ca	1.3	
P	1.15	
S	0.15	
Na	0.1	
Cl	0.08	
F	0.08	
K	0.03	
Fe	0.01	
Mg	0.001	
Sc	trace	

The water is about 65 per cent, which makes the dry-matter in the animal much less than in the mature plant, the moisture content of which is shown to be 10 per cent in the preceding table.

The Ash and Mineral Parts of Animals and Plants

When a plant is oven-dried, the free or uncombined water passes off. When it is completely burned, the carbon, hydrogen, nitrogen and most of the oxygen are driven off. What remains is *ash*, containing the mineral elements. Incomplete burning of plant material results in *coals* and ash; the coal is mostly carbon. Charcoal is carbon.

Mineral elements in animal bodies

(Calculated from Results of Lawes and Gilbert)

	OX		CALF	SHEEP			LAMB	PIG		
	Half fat	Fat	Fat	Thin	Half fat	Fat	Very fat	Fat	Thin	Fat
	%	%	%	%	%	%	%	%	%	%
Fat	19.1	30.1	14.8	18.7	23.5	35.6	45.8	28.5	23.3	42.2
Nitrogenous matter . .	16.6	14.5	15.2	14.8	14.0	12.2	10.9	12.3	13.7	10.9
Minerals	4.66	3.92	3.8	3.16	3.17	2.81	2.9	2.94	2.67	1.65
Water	51.5	45.5	63.0	57.3	50.2	43.4	35.2	47.8	55.1	41.3
Content of stomach, etc.	8.2	6.0	3.2	6.0	9.1	6.0	5.2	8.5	5.2	4.0
Total	100.0	100.0	100.0	100.0	100.0	100.0	100.0	100.0	100.0	100.0
MINERALS										
Phosphorus803	.677	.670	.488	.524	.454	.484	.492	.465	.286
Calcium	1.508	1.281	1.177	.944	.965	.846	.886	.915	.771	.455
Magnesium051	.037	.048	.034	.031	.029	.033	.031	.032	.019
Potassium170	.146	.171	.144	.140	.123	.131	.138	.163	.115
Sodium108	.094	.109	.090	.077	.072	.096	.076	.082	.054
Iron028	.017	.015	.026	.029	.024	.021	.018	.015	.009
Sulfur015	.013	.016	.021	.014	.012	.011	.016	.021	.012
Live weight, lbs. . . .	1,232	1,419	258.8	97.6	105.1	127.2	239.4	84.4	93.9	185.0
Age	4 yr.	4 yr.	9.5 wk.	1 yr.	3¼ yr.	1¼ yr.	1¼ yr.	½ yr.		

Composition of ash of human body (Beaunis)

TISSUE	BONE	CALF MUSCLES	BRAIN	LIVER	LUNGS	BLOOD	MILK	LYMPH
Analyst	Heintz	Staffel	Breed	Oidt-mann	C. Schmidt	Verdeil	Wilden-stein	Dahn-hardt
Sodium chlorid	—	10.59	4.74	—	13.0	58.81	10.73	74.48
Sodium oxid	—	2.35	10.69	14.51	19.5	4.15	—	—
Potassium oxid	—	34.40	34.42	25.23	1.3	11.97	21.44	10.35
Calcium oxid	37.58	1.99	0.72	3.61	1.9	1.76	18.78	3.25
Magnesium oxid	1.22	1.45	1.23	0.20	1.9	1.12	0.87	0.97
Ferric oxid	1.66	—	—	2.74	3.2	8.37	0.10	0.26
Chlorin	—	—	—	2.58	—	8.37	—	0.05
Fluorin	—	—	—	—	—	10.23	—	1.09
Phosphorus pen- toxicid	53.31	48.13	48.17	50.18	48.5	10.23	19.00	—
Sulphur trioxid	—	—	0.75	0.92	1.4	1.67	2.64	8.20
Carbon dioxid	5.47	—	—	—	—	1.19	—	—
Silicic oxid	—	0.81	0.12	0.27	—	—	—	—
Potassium chlorid . . .	—	—	—	—	—	—	26.33	—

Composition of the ash of leading farm crops (Snyder)

SEEDS	DRY-MAT-TER	PURE ASH	COMPOSITION OF 100 PARTS OF THE PURE ASH								
			K ₂ O	Na ₂ O	CaO	MgO	Fe ₂ O ₃	P ₂ O ₅	SO ₃	SiO ₂	Cl
Wheat	Approximately 90 per cent	2.03	30.24	0.65	3.50	13.21	0.60	47.92	—	0.73	—
Oats		3.12	17.90	1.66	3.60	7.03	1.18	25.64	1.79	39.20	0.94
Barley		2.61	20.92	2.39	2.64	8.83	1.19	35.10	1.80	25.90	1.02
Rye		2.09	32.10	1.47	2.94	11.32	1.24	47.74	1.28	1.37	0.48
Corn		1.45	29.8	1.10	2.17	15.52	0.76	45.61	0.78	2.10	0.91
Flax		3.67	26.27	2.22	9.61	15.86	1.11	42.48	—	0.88	—
Clover		4.50	35.35	0.95	6.40	12.90	1.70	37.93	2.40	1.30	1.23
Peas		2.73	43.10	0.98	4.81	7.99	0.83	35.90	3.41	1.91	1.60
Beans		3.63	41.48	1.10	4.99	7.15	0.46	38.86	3.40	0.65	1.80
FODDERS											
Clover	Air dry, approximately 87 per cent	7.02	27.25	0.80	29.26	8.32	0.57	10.66	—	6.18	—
Timothy		6.82	34.69	1.83	8.05	3.24	0.83	11.80	2.80	32.17	5.20
Brome grass		6.55	27.65	0.89	7.59	4.32	1.83	5.84	—	4.37	—
Corn		8.72	27.18	0.85	5.70	11.42	0.85	9.14	—	40.18	—
STRAWS											
Flax	Air dry, approximately 87 per cent	2.86	34.07	4.37	24.81	15.04	3.67	6.24	—	6.70	—
Buckwheat		6.15	46.60	2.20	18.40	3.60	—	11.19	—	5.50	—
Pea		4.80	21.40	5.70	38.80	7.20	1.40	7.10	—	5.40	—
Bean		6.10	32.70	8.70	25.30	7.30	1.70	7.90	—	5.50	—
Wheat		5.37	13.65	1.38	5.76	2.46	0.61	4.81	—	67.50	—
Oat		7.17	26.42	3.29	6.97	3.66	1.20	4.59	3.20	46.70	4.40
Barley	5.35	23.26	3.54	7.22	2.58	1.13	4.24	3.80	51.00	3.20	
ROOTS											
Potatoes	24	3.80	60.00	2.96	2.64	4.93	1.10	16.86	6.50	2.10	3.40
Sugar-beets	15	3.80	53.10	8.92	6.10	7.86	1.14	12.20	4.20	2.28	4.80
Turnips	12	8.00	45.40	9.84	10.60	3.69	0.81	12.71	—	1.80	5.00

Chemical Compounds

The chemist uses initials (or other letters) to designate the elements, when he makes a formula to express the composition of any compound; and he adds a figure to each symbol when more than one part or atom (by atomic weight) enters into the make-up of the molecule. Thus H₂O represents a compound in which the molecules are two parts hydrogen and one part oxygen; in common language, this particular compound is known as water. K₂O is potash (or potassium oxid) — two parts potassium and one part oxygen. Gypsum or land-plaster is calcium sulfate, — CaSO₄, which means calcium one part, sulfur one part, oxygen four parts. Quartz is SiO₂. Quicklime is CaO.

Phosphoric acid is P_2O_5 . Common table salt is $NaCl$ (sodium and chlorin).

Following are the formulas for various common substances:—

Acetic acid	$C_2H_4O_2$	Nitric oxid	NO
Ammonia	NH_3	Nitric peroxid	NO_2
Aniline	$NH_2(C_6H_5)$	Nitrous oxid	N_2O
Arsenious oxid	As_2O_3	Saltpetre	KNO_3
Carbon dioxid	CO_2	Starch	$C_6H_{10}O_5$
Carbonic oxid	CO	Strychnine	$C_{21}H_{22}N_2O_2$
Chloroform	$CHCl_3$	Sugar, cane	$C_{12}H_{22}O_{11}$
Ferric oxid (iron rust)	Fe_2O_3	Sugar, grape or glucose	$C_6H_{12}O_6$
Ferrous oxid	FeO	Sulfate of potash	K_2SO_4
Hydrochloric acid	HCl	Sulfuretted hydrogen	H_2S
Mercuric oxid	HgO	Sulfuric acid	H_2SO_4
Nitrate of soda	$NaNO_3$	Sulfuric oxid	SO_3
Nitric acid	HNO_3	Sulfurous oxid	SO_2

The Soil

The soil, as the farmer understands it, is the soft tillable covering or epidermis of the earth. It is derived primarily from disintegrated rock, but all productive soils contain organic remains, or materials derived directly from these remains. Some soils, as those in swamps, are very largely organic.

Classification of soils in respect to origin (Merrill)

The Regolith (loose earth covering)	Sedentary	Residual deposits	Residuary gravels, sands, clays, wacke, laterite, terra rossa, etc.
		Cumulose deposits	Peat, muck and swamp or palludal soils, in part.
	Transported	Colluvial deposits	Talus and cliff debris, material of avalanches.
		Alluvial deposits, including the aqueo-glacial .	Modern alluvium, marsh and swamp deposits, estuarian clays. Loess and adobe in part.
		Æolian deposits .	Wind-blown material, sand-dunes. Adobe and loess in part.
		Glacial deposits .	Morainal material, either lateral, terminal, or ground moraines, drumlins, etc.

Classification of soil constituents (U. S. Dept. Agric.)

NAME	SIZE OF PARTICLES (diameters in millimeters)
1. Gravel	2.0 to 1.0
2. Coarse sand	1.0 to 0.5
3. Medium sand	0.5 to 0.25
4. Fine sand	0.25 to 0.1
5. Very fine sand	0.1 to 0.05
6. Silt	0.05 to 0.005
7. Clay	0.005 to 0.0000

Weight of soils.

Soils vary widely in weight according to their composition and the size of the particles. Humus soils are the lightest, and sandy soils are the heaviest. Clay soils weigh less per cubic foot than arable soils or sandy soils. The larger the amount of organic matter in a cubic foot of soil, the less it weighs. For this reason, surface soils are lighter, as a rule, than subsoils (Stevenson).

The weight of a cubic foot of dry soil is given by Shubler as follows:—

	LB.
Silicious sand	110
Half sand and half clay	96
Common arable soil	80 to 90
Heavy clay	75
Garden mold rich in vegetable matter	70
Peat soil	30 to 50

Warrington gives the following data regarding the weight of soil per acre:—

1. *Old pasture, Rothamsted, loam with clay subsoil*

	ORIGINAL WET SOIL	DRY SOIL			
		Total	Stones	Fine soil	Roots
	lb.	lb.	lb.	lb.	lb.
First 9 inches . .	3,294,380	2,328,973	174,091	2,144,470	10,412
Second 9 inches . .	3,867,780	3,098,939	353,322	2,744,715	902
Third 9 inches . .	4,091,620	3,273,324	217,515	3,055,501	308
Fourth 9 inches . .	4,139,420	3,343,787	280,730	3,063,057	

2. *Arable land, Rothamsted, loam with clay subsoil*

	ORIGINAL WET SOIL	DRY SOIL			
		Total	Stones	Fine soil	Roots
	lb.	lb.	lb.	lb.	lb.
First 9 inches . .	3,288,553	2,919,689	340,656	2,578,634	399
Second 9 inches . .	3,688,115	3,044,615	141,861	2,902,682	72
Third 9 inches . .	3,882,285	3,215,285	213,190	3,002,095	
Fourth 9 inches . .	3,995,723	3,313,563	197,400	3,116,163	

3. Arable land, Woburn, sandy soil

	ORIGINAL WET SOIL	DRY SOIL			
		Total	Stones	Fine soil	Roots
	lb.	lb.	lb.	lb.	lb.
First 9 inches . . .	3,835,104	3,157,448	93,763	3,063,074	611
Second 9 inches . . .	3,947,640	3,381,804	201,527	3,180,277	
Third 9 inches . . .	4,046,364	3,462,498	170,443	3,292,055	
Fourth 9 inches . . .	4,014,432	3,501,466	274,239	3,227,227	

These tables show: (1) That each of these classes of soil is lighter at the surface; (2) that in each case the weight increases with an increase in depth. This increase in weight of the lower zones is due: (1) to the increase of pressure to which the lower zones are subjected; (2) to the fact that the surface soil is more loose and porous; (3) to coarser texture of subsoil. This condition is brought about by the removal of the finest soil particles from the surface into the sub-soil by the action of rain; by the accumulation of organic matter in the surface soil; and, in the case of arable soils, by tillage.

The specific gravity of a soil indicates its weight as compared with the weight of an equal volume of water. An English authority has published the following table, which gives the *specific gravity* of the more common soil constituents:—

Water	1.00	Dolomite	2.8-3.0
Humus	1.2-1.5	Mica	2.8-3.2
Clay	2.50	Hornblende	2.9-3.4
Quartz	2.62	Augite	3.2-3.5
Feldspar	2.5-2.8	Limonite	3.4-4.0
Talc	2.6-2.7	Hematite	5.1-5.2
Calcite	2.75		

Schöne gives the following for the specific gravity of soils:—

Clay soil	2.65
Sandy soil	2.67
Fine soil	2.71
Humus soil	2.53

The true specific gravity of an arable soil varies from about 2.5 to 2.7.

Texture of the soil.

The size and shape of the particles of which the soil is composed determine its *texture*. The arrangement of the particles determines its *structure*, as "loose," "open," "mealy," "friable," "cloddy," "porous," "hard," "compact," "retentive," "leachy."

The texture determines the amount of soil-surface exposed to roots, and to a great extent the quantity of moisture that the soil may hold.

The size and form of the particles determine the number in a given volume of soil. It has been estimated by Whitney that a gram of soil contains 2,000,000,000 to 20,000,000,000 soil particles. The number of particles per gram of different soil types is approximately as follows:—

Early truck	1,955,000,000
Truck and small fruit	3,955,000,000
Tobacco	6,786,000,000
Wheat	10,228,000,000
Grass and wheat	14,735,000,000
Limestone	19,638,000,000

Owing to the fact that a soil is made up of particles, there is between them a certain amount of space that is occupied by air or water; this is known as the "pore space." In ordinary soils the pore space varies from a little over 50 per cent in the finest clay soils to about 25 or 30 per cent in coarse sands of uniform texture.

Soil Water

Water occurs in the soil in three forms: (1) Gravitational or hydrostatic water; (2) capillary water; (3) hygroscopic water.

Amount of water used by various crops in producing a ton of dry-matter (Stevenson)

	NO. OF TRIALS	WATER USED PER TON OF DRY-MATTER	WATER USED	DRY-MATTER PER ACRE	ACRE-INCH OF WATER PER TON OF DRY-MATTER (KING)
		tons	in.	tons	
Barley	5	464.1	20.69	5.05	4.096
Oats	20	503.9	39.53	8.89	4.447
Maize	52	270.9	15.76	6.59	2.391
Clover	46	576.6	22.34	4.39	5.0899
Peas	1	477.2	16.89	4.009	4.212
Potatoes	14	385.1	23.78	6.995	3.339
Average		446.3	23.165	5.987	3.939

Mean volume of water held by different soils, in laboratory tests in columns 45 inches high, with calculations to field conditions (Lyon and Fippin)

	I DRY POROSITY PER CENT	II FINAL MEAN WATER CONTENT PER CENT	III APPROXIMATE PER CENT OF MOIS- TURE AT WHICH CROPS WILL WILT	IV PER CENT OF AVAILABLE MOISTURE	V WEIGHT OF DRY SOIL PER CUBIC FOOT	VI VOLUME OF AVAIL- ABLE WATER PER CUBIC FOOT	VII INCHES OF AVAIL- ABLE WATER TO DEPTH OF FOUR FEET
1. Dune sand . . .	52	10.7	3	7.7	80	cu. in. 166 CC. 2,720	4.60
2. Coarse sand . . .	51	10.6	3	7.6	81	170 2,790	5.20
3. Fine sandy loam	50	18.0	5	13.0	83	300 4,900	8.50
4. Light silt loam . .	50	20.9	10	10.9	83	250 4,100	6.90
5. Clay	59	30.4	17	13.4	68	252 4,140	7.03
6. Muck soil	80 ¹	250.0	80	170.0	15	740 11,550	20.50

¹ Estimated.

Water taken from the soil by evaporation is a loss additional to that transpired by the crop. The following results were secured at the Iowa Experiment Station in an experiment to determine the total amount of water removed from the soil by evaporation and transpiration:—

ONE TON	TONS OF WATER LOST	ACRE-INCH OF WATER LOST
Clover hay	1560	13.7
Air-dried corn fodder	570	5.0
Oats and straw	1200	11.0

One inch of water covering an acre of land weighs about 226,875 pounds, or more than 113 tons.

Water evaporated by growing plants for one part of dry matter produced, in pounds (Lyon and Fippin)

LAWES AND GILBERT ENGLAND		HELLRIEGEL GERMANY		WOLLNY GERMANY		KING WISCONSIN	
Beans . . .	214	Beans . . .	262	Maize . . .	233	Maize . . .	272
Wheat . . .	225	Wheat . . .	359	Millet . . .	416	Potatoes . .	423
Peas . . .	235	Peas . . .	292	Peas . . .	479	Peas . . .	447
Red clover .	249	Red clover .	330	Rape . . .	912	Red clover .	453
Barley . . .	262	Barley . . .	310	Barley . . .	774	Barley . . .	393
		Oats . . .	402	Oats . . .	665	Oats . . .	557
		Buckwheat .	371	Buckwheat .	664		
		Lupine . . .	373	Mustard . .	843		
		Rye . . .	377	Sunflower .	490		

Water needed under arid conditions.

Under dry-farming conditions, Widtsoe calculates that

1 acre-inch of water will produce	2½ bu. wheat
10 acre-inches of water will produce	25 bu. wheat
15 acre-inches of water will produce	37½ bu. wheat
20 acre-inches of water will produce	50 bu. wheat

if all the water could be saved and be fully utilized in plant growth. Under average cultural conditions in arid regions, he concludes that approximately 750 pounds of water are required for the production of one pound of dry matter.

Plant-Food in the Soil

In estimating plant-food, chemists usually catalogue only the three elements (or combinations of them) that are likely to be much depleted by the growing of crops, — nitrogen, phosphorus, potassium. (These determinations were made by the solution-in-hydrochloric-acid method, sp. gr. 1.115. Other analytical methods in use would give higher readings, particularly in phosphorus and potash, as stronger acids are used to make the soil solutions.)

Plant-food in surface soils, with calculations to pounds in an acre (Roberts)

No.	NITROGEN N., %	PHOS. ACID P ₂ O ₅ , %	POTASH K ₂ O, %	LB. N. IN 1ST 8 IN. SOIL	LB. P ₂ O ₅ IN 1ST 8 IN. SOIL	LB. K ₂ O IN 2D 8 IN. SOIL
1	.379	.059	.062	8,310	1,294	1,360
2	.293	.056	.034	6,250	1,194	725
3	.195	.196	.183	4,218	4,240	3,959
4	.282	.267	.866	6,436	6,094	19,766
5	.245	.05	.232	5,364	1,095	5,079
6	.26	.052	.348	5,700	1,140	7,630
7	.26	.029	.182	5,635	628	3,945
8	.26	.15	.903	5,700	3,289	19,800
9	.109	.032	.149	2,321	681	3,173
10	.334	.038	.056	7,224	822	1,211
11	.14	.051	.047	2,971	1,082	997
12	.295	.037	.130	6,312	792	2,782
13	.04	.23	.23	872	5,016	5,016
14	.09	.019	.019	1,912	404	404
15	.12	.23	.9	2,548	4,884	19,113
16	.07	.13	.83	1,512	2,808	17,929
17	.03	.22	.65	635	4,659	12,812
18	.09	.3	2.1	1,958	6,526	45,686
19	.07	.29	1.19	1,497	6,202	25,448
20	.12	.44	1.96	2,571	9,428	42,000
				000,000	000,000	000,000

No.	NITROGEN N., %	PHOS. ACID P ₂ O ₅ , %	POTASH K ₂ O, %	LB. N. IN 1ST 8 IN. SOIL	LB. P ₂ O ₅ IN 1ST 8 IN. SOIL	LB. K ₂ O IN 2D 8 IN. SOIL
				000,000	000,000	000,000
21	.10	.33	1.8	2,153	7,105	38,752
22	.11	.15	.83	2,343	3,195	17,682
23	.11	.28	1.95	2,455	6,250	43,526
24	.04	.13	.89	850	2,759	18,890
25	.07	.21	1.1	1,484	4,451	23,314
26	.08	.18	.98	1,701	3,846	20,833
27	.08	.19	.86	1,699	4,034	18,260
28	.03	.15	.54	636	3,180	11,447
29	.22	.49	1.85	4,746	10,571	39,910
30	.16	.36	1.9	3,509	7,895	41,670
31	.04	.14	.73	848	2,967	15,480
32	.06	.14	.92	1,272	2,969	19,510
33	.17	.38	1.18	3,599	8,046	24,984
34	.1	.2	1.13	2,143	4,285	24,212

Alkali Lands

In countries of heavy rainfall, the alkaline materials are leached out in the drainage waters. In arid countries there is very little or no leachage; the water passes off by evaporation, and the alkaline and other materials in solution are left at or near the surface of the ground.

The normal condition of arid lands is illustrated in the table below (Means). The first part gives the percentage of total soluble salts in two soils from central Montana, where neither soil originally contained enough alkali within the zone of root action to be detrimental. The second part shows the condition of these soils after a few years of judicious irrigation, and the third part displays the condition after a few years of irrigation without drainage:—

Table showing percentage of alkali in soils

DEPTH	UNIRRIGATED		IRRIGATED		OVER-IRRIGATED	
	Sandy Loam	Clay	Sandy Loam	Clay	Sandy Loam	Clay
First foot04	.04	.04	.10	.79	.76
Second foot04	.04	.05	.07	.92	.71
Third foot03	.05	.04	.08	.94	.63
Fourth foot03	.20	.05	.08	.79	.61
Fifth foot05	.33	.06	.08	.52	.59
Sixth foot06	.34	.05	.16	.52	.19
Seventh foot06	.25	.06	.21	.36	
Eighth foot17	.25	.07		.36	
Ninth foot24	.28	.05		.29	
Tenth foot24		.05			
Eleventh foot21		.07			
Twelfth foot12		.07			

Percentage composition of alkali in arid soils¹ (Lyon and Fippin)

	YAKIMA CO., WASH. MEADOWLAND			BOISE VAL- LEY, IDAHO		BILLINGS, MONTANA		CALIFORNIA		
	Sur- face 12 in.	2d 12 in.	3d 12 in.	Sur- face 12 in.	Sur- face Depo- sit	Crust 0-1 in.	Sur- face 10 in.	Tu- lare Exp. Sta.	Mo- jave Pla- teau	Im- perial Des- ert
Potassium chloride, KCl	—	5.61	7.82	8.08	1.84	—	—	—	—	1.15
Potassium sulfate, K ₂ SO ₄	—	—	—	—	—	1.60	21.41	3.95	.92	—
Potassium carbonate, K ₂ CO ₃	8.74	9.73	8.64	—	—	—	—	—	—	—
Sodium sulfate, Na ₂ SO ₄	—	—	—	16.54	67.70	85.57	35.12	25.28	43.34	—
Sodium nitrate, NaNO ₃	—	—	—	—	—	—	—	19.78	—	8.21
Sodium carbonate, Na ₂ CO ₃	66.94	13.86	6.58	41.55	.10	trace	7.28	32.58	15.38	.58
Sodium chloride, NaCl	—	—	—	—	17.56	.55	trace	14.75	39.34	28.83
Sodium phosphate, Na ₂ HPO ₄	—	—	—	—	—	—	—	2.25	1.02	—
Magnesium sulfate, MgSO ₄	—	—	—	.82	6.15	8.90	4.06	—	—	—
Magnesium chloride, MgCl ₂	13.30	—	—	—	—	—	—	—	—	2.81
Calcium chloride, CaCl ₂	1.90	—	—	—	—	—	—	—	—	58.42
Sodium bicarbonate, NaHCO ₃	—	36.72	45.28	31.27	.72	.67	22.06	—	—	—
Calcium sulfate CaSO ₄	9.12	1.87	6.17	.64	5.93	2.71	10.07	—	—	—
Calcium bicarbonate, Ca(HCO ₃) ₂	—	16.48	13.17	—	—	—	—	—	—	—
Magnesium bicarbon- ate, (Mg(HCO ₃) ₂	—	12.57	12.34	—	—	—	—	—	—	—
Potassium bicarbon- ate, KHCO ₃	—	—	—	1.10	—	—	—	—	—	—
Ammonium carbon- ate (NH ₄) ₂ CO ₃	—	—	—	—	—	—	—	1.41	—	—

¹ Compiled from analyses made by the Bureau of Soils of the United States Department of Agriculture and by the California Experiment Station.

The following table shows the *quantity of gypsum required to neutralize sodium carbonate* in an acre-foot of soil:—

PER CENT SODIUM CARBONATE	GYPNUM PER ACRE-FOOT ¹	PER CENT SODIUM CARBONATE	GYPNUM PER ACRE-FOOT ¹
Per cent	Pounds	Per cent	Pounds
.01	640	.06	3840
.02	1280	.07	4480
.03	1920	.08	5120
.04	2560	.09	5760
.05	3200	.10	6400

¹ An acre-foot of soil weighs 4,000,000 pounds.

Very often the black alkali is accompanied by other soluble salts, and the change in kind of salt brought about by the gypsum leaves more white alkali than plants will stand. The economic use of gypsum is therefore restricted to localities having only small amounts of total soluble salts. As a general rule, drainage can be properly applied, and the land freed of both black alkali and white alkali at less expense than by the application of gypsum. Gypsum costs \$4 to \$10 per ton in the regions where it is needed in black alkali reclamation, and when it becomes necessary to apply sufficient to neutralize 0.1 per cent of sodium carbonate in two or three acre-feet of soil per acre, the cost is seen to be prohibitive.

Tillage, and Soil Management

Tillage is the preparing and stirring of the soil with the object to make it more congenial to the growth of plants. On the wise management of the soil depends the perpetuation of the human race.

Objects of tillage (King).

Stated in the broadest and briefest way, the purpose of tillage is to develop and maintain beneath the surface of the field a commodious and thoroughly sanitary home and feeding ground for the roots of crops and for the soil organisms that help to transform the organic matter and the less soluble forms of the mineral plant-food materials of the soil into more soluble and suitable conditions adapted to the immediate needs of plants. But to make the habitable part of the soil

of a field commodious and sanitary, and at the same time to maintain within it a sufficiently rapid development of readily water-soluble plant-food materials so conditioned as to be highly available to the crop, requires careful attention to many essential details. Some of the chief objects of tillage are: —

(1) To secure a thorough surface uniformity of the field, so that an equally vigorous growth may take place over the entire area.

(2) To develop and maintain a large effective depth of soil, so that there shall be ample living room, an extensive feeding surface and large storage capacity for moisture and available plant-food materials.

(3) To increase the humus of the soil through a deep and extensive incorporation of organic matter, so that there may be a strong growth of soil micro-organisms and the maintenance of a high content of water-soluble plant-food materials.

(4) To improve the tilth and maintain the best structural condition in the soil, so that the roots of the crop and the soil organisms may spread readily and widely to place themselves in the closest contact with the largest amount of food materials.

(5) To control the amount, to regulate the movement, and to determine the availability of soil moisture, so that there shall never be an excess or a deficiency of this indispensable carrier of food materials to and through the plant.

(6) To determine the amount, movement, and availability of the water-soluble plant-food materials present in the soil, so that growth may be both rapid, normal, and continuous to the end of the season.

(7) To convert the entire root zone of the soil into a commodious sanitary living and feeding place, perfectly adapted to the needs of the roots of the crop and to the soil organisms, — adequately drained, perfectly ventilated, and sufficiently warm.

(8) To reduce the waste of plant-food materials through the destruction of weeds, and the prevention of their growth, through prevention of surface washing and drifting by winds.

Jordan's rules of fertility.

1. Thorough tillage, with efficient machinery, to be given if possible when the moisture conditions of the soil admit of satisfactory pulverization.

2. Frequent surface tillage at times of scanty rainfall, in order to conserve the supply of soil moisture.

3. A sufficiently rapid rotation of crops to insure good soil texture, to allow the necessary frequency of applying fertilizing material, and as a main result to secure a paying stand of crops.

4. The introduction into the soil at frequent intervals of an amount of organic matter necessary to proper soil texture and water holding power, either by application of farm manures, by plowing down soiling crops, or by the rotting of the turf.

5. The scrupulous saving of all the excrement of farm animals, both solid and liquid.

6. The purchase of plant-food with due reference to the needs of the farm and to the system of farm management prevailing.

7. The maintenance in the soil of those conditions of drainage and aeration which promote the growth of desirable soil organisms, and the introduction into the soil when necessary, of such organisms as are essential to the growth of particular plants.

CHAPTER III

CHEMICAL FERTILIZERS; AND LIME

A *fertilizer* is a material added to the soil for the purpose of supplying food for plants.

An *amendment* is a substance or material that modifies the physical, mechanical and chemical nature of the soil.

Stable manure is both fertilizer and amendment. Lime is used mostly as an amendment, since it is not often necessary to supply it for the plant-food that it contains. On sandy soils it may be needed as a fertilizer.

The extent of the fertilizer industry is indicated by the following figures of complete fertilizers manufactured in the United States in two given years :—

	1900	1905	INCREASE	PER CENT OF INCREASE
Quantity in tons of 2000 lb.	1,478,826	1,603,847	125,021	8.5
Value	\$26,318,995	\$31,305,057	\$4,986,062	18.9

Fertilizer discussions are concerned mostly with nitrogen, phosphorus, and potassium (always in combination with other elements, never used in their elemental form), since these are the elements most likely to be deficient in the soil. To be economically usable as a fertilizer, a material must not only contain some one or more of these three elements in available form, but it must be relatively low in price and obtainable in large quantities. Nitrate of potash (saltpetre) is a good fertilizer, but it is impossible to use it because of the cost. Many of the fertilizer materials, — as bone-black, blood, ashes, — are waste products or by-products.

Some of the Sources of Chemical Fertilizers

Percentage composition of materials used as sources of nitrogen (German Kali Works, N.Y. City)

	NITROGEN	EQUIVALENT TO AMMONIA	POTASH K ₂ O	PHOS. ACID TOTAL
Nitrate of soda . . .	15 to 16	18 to 19½	—	—
Sulfate of ammonia . .	19½ to 21	24 to 25½	—	—
Dried blood (high grade)	13 to 14	16 to 17	—	2 to 3
Dried blood (low grade)	10 to 11	12 to 13	—	1½ to 2
Tankage	5 to 9	6 to 11	—	9 to 16
Dried fish scrap . . .	9 to 10	11 to 12	—	5½ to 7
Cottonseed meal . . .	6½ to 7½	7½ to 9	1½ to 2	2 to 3
Castor pomace	5 to 6	6 to 7	1 to 1½	1½ to 2
Tobacco stems	2½ to 3	3 to 3½	2 to 10	½ to 1

Composition of materials used as sources of phosphoric acid (Kali Works)

	TOTAL	AVAILABLE	INSOLUBLE	NITROGEN	EQUIVALENT TO AMMONIA	POTASH K ₂ O
Acid phosphate . . .	16 to 19	14 to 17	1 to 2	—	—	—
Carolina phos. rock	26 to 27	—	26 to 27	—	—	—
Dissolved bone black	17 to 20	16 to 18	1 to 2	—	—	—
Bone meal	20 to 25	5 to 8	15 to 17	1 to 4½	1¼ to 5½	—
Dissolved bone . . .	15 to 17	13 to 15	2 to 3	2 to 3	2½ to 3½	—
Thomas slag	22 to 24	—	22 to 24	—	—	—
Peruvian guano . . .	12 to 15	7 to 8	5 to 8	6 to 10	7¼ to 12	1½ to 4

Marketed production of phosphate rock in the United States, from the beginning of the industry in 1867 to 1909, in long tons (Van Horn, U.S. Geol. Surv.)

YEAR	QUANTITY	VALUE	YEAR	QUANTITY	VALUE
1867-1887	4,442,945	\$23,697,019	1900	1,491,216	\$5,359,248
1888	448,567	2,018,552	1901	1,483,723	5,316,403
1889	550,245	2,937,776	1902	1,490,314	4,693,444
1890	510,499	3,213,795	1903	1,581,576	5,319,294
1891	587,988	3,651,150	1904	1,874,428	6,580,875
1892	681,571	3,296,227	1905	1,947,190	6,763,403
1893	941,368	4,136,070	1906	2,080,957	8,579,437
1894	996,949	3,479,547	1907	2,265,343	10,653,558
1895	1,038,551	3,606,094	1908	2,386,138	11,399,124
1896	930,779	2,803,372	1909	2,330,152	10,772,120
1897	1,039,345	2,673,202			
1898	1,308,885	3,453,460	Total	33,924,431	139,487,246
1899	1,515,702	5,084,076			

World's production of phosphate rock, 1905-1907, by countries, in metric tons
(Van Horn)

COUNTRY	1906		1907		1908	
	Quantity	Value	Quantity	Value	Quantity	Value
Algeria . . .	333,531	\$965,600	373,763	\$2,183,404	452,060	\$2,639,940
Aruba (Dutch West Indies) . . .	26,138	1	36,036	1	29,061	1
Belgium . . .	152,140	282,612	182,230	332,114	198,030	355,897
Canada . . .	521	4,024	748	6,018	1,448	14,794
Christmas Islands (Straits Settle- ments)	92,010	1	112,147	1	110,849	1
France . . .	469,408	1,872,000	431,237	1,876,736	485,607	1,896,606
Norway . . .	3,482	46,524	2	—	—	—
Spain . . .	1,300	7,592	2	—	—	—
Tunis . . .	796,000	2,304,400	1,069,000	4,547,842	1,300,543	5,531,624
United King- dom . . .	—	—	33	224	9	68
United States	2,114,252	8,579,437	2,301,588	10,653,558	2,424,453	11,399,124

Average composition of Stassfurt potash salts (German Kali Works)

NAME OF SALTS IN 100 PARTS ARE CONTAINED	SULPHATE OF POTASH	MURIATE OF POTASH	SULPHATE OF MAGNESIA	CHLORIDE OF MAGNESIA	CHLORIDE OF SODIUM	SULPHATE OF LIME	SUBSTANCES IN- SOLUBLE IN WATER	WATER	CALCULATED TO PURE POTASH K ₂ O	
	K ₂ - SO ₄	KCl	Mg- SO ₄	Mg- Cl ₂	NaCl	Ca- SO ₄			Average	Guar- anteed
A. Crude Salts (Natural Products)										
Kainit	21.3	2.0	14.5	12.4	34.6	1.7	0.8	12.7	12.8	12.4
Carnallit	—	15.5	12.1	21.5	22.4	1.9	0.5	26.1	9.8	9.0
B. Concentrated Salts (Manufactured Products)										
Sulfate of Potash {96% 90%	97.2 90.6	0.3 1.6	0.7 2.7	0.4 1.0	0.2 1.2	0.3 0.4	0.2 0.3	0.7 2.2	52.7 49.9	51.8 48.6
Sulfate of potash-magnesia	50.4	—	34.0	—	2.5	0.9	0.6	11.6	27.2	25.9
Muriate of {90-95% Potash {80-85%	— —	91.7 83.5	0.2 0.4	0.2 0.3	7.1 14.5	—	0.2 0.2	0.6 1.1	57.7 52.7	56.8 50.5
Manure salt, min. pot- ash 20%	2.0	31.6	10.6	5.3	40.2	2.1	4.0	4.2	21.0	20.0
Manure salt, min. 30% potash	1.2	47.6	9.4	4.8	26.2	2.2	3.5	5.1	30.6	30.0

¹ Value not reported.

² Statistics not yet available.

Potash salts produced in the United States, 1850 to 1905¹ (Phalen, U.S. Geol. Survey.)

CENSUS	NUMBER OF ESTABLISHMENTS	PRODUCT		AVERAGE PRICE PER POUND
		Quantity	Value	
		lb.		
1850	569	—	\$1,401,533	—
1860	212	—	538,550	—
1870	105	—	327,671	—
1880	68	4,571,671	232,643	\$0.051
1890	75	5,106,939	197,507	0.039
1900	67 ²	3,864,766	178,180	0.046
1905	39 ²	1,811,037	104,655	0.058

¹ Munroe, C. E., Bull. 92, Census of Manufactures, Bur. Census, 1905, p. 38.

² Includes establishments engaged primarily in the manufacture of other products.

There was a time when the United States produced a large part, if not all, of the potash it consumed. The burning of wood and the lixiviation of the resulting ash to extract the potash, though of minor importance so far as the monetary value of the product is concerned, is one of the oldest of the purely chemical industries in this country. Cognizance was taken of it in the census reports as early as 1850, so that data are available for comparing the condition of the industry for each decade since that year. The above table gives the quantity and value of potash produced in the United States from 1850 to 1905.

Potash salts are used extensively in the United States. They are essential to numerous industries that are vitally connected with the welfare of the American people—the most notable being the fertilizer industry. They are used also in the manufacture of glass, in certain kinds of soap, in some explosive powders, and in the chemical industries, including the manufacture of alum, cyanides, bleaching powders, dyestuffs, and other chemicals. (Phalen.)

Importation of potash salts

The potash industry has not been revived in the United States thus far, and the great bulk of the potash salts now used are imported. The following table (by Phalen) shows the magnitude of the importation of potash salts for the years 1900, 1905, and 1910:—

Imports of potash salts for the calendar years 1900, 1905, and 1910, in pounds.
[Figures from Bureau of Statistics]

	1900		1905		1910	
	Quantity	Value	Quantity	Value	Quantity	Value
	lb.		lb.		lb.	
Chlorate	1,243,612	\$68,772	—	—	—	—
Chloride	130,175,481	1,976,604	214,207,064	\$3,326,478	381,873,875	\$5,252,373
Nitrate (crude and refined)	10,545,392	276,664	9,911,534	304,596	11,496,904	333,854
All other, including carbonate (crude and refined), bicarbonate, caustic (crude and refined), chromate and bichromate, cyanide, hydriodate, iodide, iodate, permanganate, prussiate (red and yellow), sulfate (crude and refined)	54,904,088	1,407,303	82,935,532	1,891,081	116,820,873	2,777,396
Total	196,868,573	3,729,343	307,054,130	5,522,155	510,191,652	8,363,623
Increase	—	—	110,185,573	1,792,812	203,137,522	2,841,468
Percentage of increase	—	—	55.96	48.07	66.15	51.45
Kainit, "kyanite," and kieserite, and manure salts ²	520,605,120	1,508,217	830,903,360	3,116,884	1,288,199,360	3,251,511

¹ This table is based on total imports for the calendar year, not on imports for consumption for the calendar year.

² These figures are for the fiscal years.

Potassic materials produced by the aid of electricity

Among the chemicals produced by the aid of electricity are potassium chlorate and potassium hydroxid. The following table gives the quantity and value of the potassium salts made electrolytically at the censuses of 1900 and 1905, with the amount and percentage of increase (Phalen) : —

	1900	1905	INCREASE	PER CENT OF INCREASE
Quantity, tons	1,900	3,908	2,008	105.7
Value	\$80,097	\$200,008	\$119,911	149.7

Principal potash materials used in fertilizers in the United States, 1900 and 1905

	1900	1905	INCREASE	PER CENT OF INCREASE
Kainit :				
Quantity, tons	54,700	190,493	135,793	248.3
Value	\$520,833	\$1,891,073	\$1,370,240	263.1
Other potash salts :				
Quantity, tons	—	122,107	—	—
Value	\$3,098,400	\$3,606,701	\$508,301	16.4
Nitrate of potash				
Quantity, tons	884	1,160	276	31.2
Value	\$32,156	\$39,039	\$6,883	21.4
Wood ashes :				
Quantity, bushels	—	17,083	—	—
Value	—	\$2,050	—	—

Fertilizer Formulas and Guarantees (Voorhees)

Probably more than nine-tenths of the fertilizers used in this country are purchased in the form of mixtures containing all three of the essential constituents, nitrogen, phosphorus, and potassium. The various brands are prepared from formulas designed to be especially suitable for different crops and soils. This method of purchase saves labor and thought on the part of the farmer, but the cost of the constituents is greater than if the fertilizer materials are bought and home-mixed; besides, in the mixtures the farmer does not always obtain such proportions of the constituents as are best adapted to his conditions. These mixed fertilizers, as a rule, are, and should always be, accompanied by a statement of guaranteed composition. This is very essential, because purchasers are unable to tell, by mere visual inspection, what kinds and proportions of fertilizing materials have entered into the mixture. In many states the laws require that the source of the materials also shall be distinctly stated, in order to insure the use of good products, as the mixing permits the disguising of poor forms, especially of those containing the element nitrogen.

Guarantees, however, sometimes confuse the purchaser, because the method of stating the guarantee is such as to mislead, provided he does not understand the meaning of the terms, or is unable to convert the percentages into their equivalents. It is entirely legitimate, when there are no laws forbidding, for the manufacturer to guarantee ammonia,

instead of nitrogen; bone phosphate, instead of phosphoric acid; and sulfate of potash, instead of actual potash. The statement of the guarantee of the constituents in combination increases the percentage, thus leading ignorant purchasers to think that they are obtaining a larger percentage of the constituents than is really the case.

In the case of raw materials, a guarantee based on the purity of the chemical salts is very frequently used. That is, a substance when pure contains 100 per cent of the specific salt, and the guarantee which accompanies this product is merely a statement that indicates its purity. For example, when nitrate of soda is guaranteed to contain 95 per cent nitrate, it means that it is 95 per cent pure nitrate, or that 5 per cent of the total substance consists of impurities. The same is true in the case of sulfate of ammonia, sulfate of potash, muriate of potash, and other potash salts that may be offered. In order that the farmer may have a simple method of determining the actual content of the constituents, however guaranteed, the following tables are given to show the terms that are used, their equivalent of actual elements, and the factors to use in converting the one into the other:—

To convert the guarantee of Ammonia Nitrogen Nitrate of soda Bone phosphate Phosphoric acid Muriate of potash Actual potash Sulfate of potash Actual potash	} into an equivalent of	Multiply by Nitrogen 0.8235 Ammonia 1.214 Nitrogen 0.1647 Phosphoric acid 0.458 Bone phosphate 2.183 Actual potash 0.632 Muriate of potash 1.583 Actual potash 0.54 Sulfate of potash 1.85
--	----------------------------------	---

The following statements show the methods of stating guarantees on the basis of purity, in the case of many *raw materials*, and the equivalent percentage on the basis of actual constituents:

Guarantee on basis of purity:—

- Nitrate of soda, 95 per cent, or containing 95 per cent pure nitrate.
- Muriate of potash, 80 per cent, or containing 80 per cent pure muriate.
- Sulfate of potash, 98 per cent, or containing 98 per cent pure sulfate.
- Kainit, 25 per cent, or containing 25 per cent pure sulfate.

Guarantee on basis of actual constituents:—

- Nitrate of soda, total nitrogen 15.64 per cent.
- Muriate of potash, actual potash 50.50 per cent.
- Sulfate of potash, actual potash 53.00 per cent.
- Kainit, actual potash 13.50 per cent.

The following illustration shows a guarantee of the same *mixed fertilizer*, on the basis of equivalents in combination, and on the basis of actual constituents:

Guarantee on basis of equivalents in combination:—

Nitrogen (equivalent to ammonia), 2 to 3 per cent.
 Available phosphoric acid (equivalent to bone phosphate of lime), 16 to 20 per cent.
 Potash (equivalent to sulfate of potash), 6 to 8 per cent.

Guarantee on basis of actual constituents:—

Nitrogen (total)	1.65 to 2.50 per cent.
Phosphoric acid (available)	7.00 to 9.00 per cent.
Potash (actual)	3.25 to 4.25 per cent.

It will be observed that the guarantee in the one case means the same as in the other. Different methods of stating guarantees should not mislead those who will familiarize themselves with the terms used, and with the conversion factors.

In the case of the mixed fertilizers, the percentage of the constituent elements that are given on the basis of equivalents represents the amounts when they exist in combination with other elements, viz., nitrogen, as ammonia; phosphoric acid, as bone phosphate; and potash, as sulfate.

Methods of Computing Trade Value of Fertilizers

Trade-values of plant-food elements in raw materials and chemicals, 1910.

The trade-values in the following schedule have been agreed upon by the Experiment Stations of Massachusetts, Rhode Island, Connecticut, New York, New Jersey, and Vermont, as a result of study of the prices actually prevailing in the large markets of these states.

These trade-values represent, as nearly as can be estimated, the average prices at which, during the six months preceding March, the respective ingredients, in the form of unmixed raw materials, could be bought at retail for cash in our large markets. These prices also correspond (except in case of available phosphoric acid) to the average wholesale prices for the six months preceding March, plus about 20 per cent in case of goods for which there are wholesale quotations.

	cts. per lb.
Nitrogen in ammonia salts	16
Nitrogen in nitrates	16
Organic nitrogen in dry and fine-ground fish, meat and blood and mixed fertilizers	20
Organic nitrogen in fine-ground bone and tankage	20
Organic nitrogen in coarse bone and tankage	15
Phosphoric acid, water-soluble	4½
Phosphoric acid citrate, soluble (reverted)	4
Phosphoric acid in fine-ground fish, bone and tankage	4
Phosphoric acid in cottonseed meal, castor-pomace and ashes	3½
Phosphoric acid in coarse fish, bone and tankage	3½
Phosphoric acid in mixed fertilizers, insoluble in ammonium citrate or water	2
Potash as high-grade sulfate, in forms free from muriates (chlorides), in ashes, etc.	5
Potash in muriate	4¼

Valuation and cost of fertilizers.

The total cost (to the farmer) of a ton of commercial fertilizer may be regarded as consisting of the following elements: (1) Retail cash cost, in the market, of unmixed trade materials; (2) cost of mixing; (3) cost of transportation; (4) storage, commissions to agents and dealers, selling on long credit, bad debts, etc. While the total cost of a fertilizer is made up of several different elements, a commercial valuation includes only the first of the elements entering into the total cost, that is, the retail cash cost in the market of unmixed raw materials.

Valuation, and agricultural value.

The agricultural value of a fertilizer depends upon its crop-producing power. A commercial valuation does not necessarily have any relation to crop-producing value on a given farm. For a particular soil and crop, a fertilizer of comparatively low commercial valuation may have a higher agricultural value; while, for another crop on the same soil, or the same crop on another soil, the reverse might be true.

Rule for calculating approximate commercial valuation of mixed fertilizers on basis of trade-values for 1910.

Multiply the percentage of nitrogen by 4.0.

Multiply the percentage of available phosphoric acid by 0.8.

Multiply the percentage of insoluble phosphoric acid (total minus available) by 0.4.

Multiply the percentage of potash by 1.0.

The sum of these 4 products will be the commercial valuation per ton on the basis taken.

Illustration. The table of analyses shows a certain fertilizer to have the following composition: Nitrogen 2.52 per cent; available phosphoric acid 6.31 per cent; insoluble phosphoric acid .89 per cent; potash 6.64 per cent. According to this method of valuation, the computation would be as follows:—

Nitrogen	2.52 × 4.0 =	\$10.08
Available phosphoric acid	6.31 × 0.8 =	5.05
Insoluble phosphoric acid	0.89 × 0.4 =	0.36
Potash	6.64 × 1.0 =	6.64
		\$22.13

This rule assumes all the nitrogen to be organic and all the potash to be in the form of sulfate. If a considerable portion of nitrogen exists in the fertilizer as nitrate of soda or as sulfate of ammonia, and potash is present as muriate, the results are somewhat less.

Farmers should be warned against judging fertilizers by their valuations. A fertilizer, the cost of which comes chiefly from the phosphoric acid present, would value much lower commercially than a fertilizer with a high percentage of nitrogen, and yet the former might be the more profitable for a given farmer to purchase.

Table for converting the fertilizer elements into their usually reported forms, and vice versa (J. P. Stewart) Corrected

(a) CONVERTING ELEMENTS INTO COM- POUNDS	(b) CONVERTING COMPOUNDS INTO ELE- MENTS
K × 1.2043 = K ₂ O. (Atomic wts. based on O = 16)	K ₂ O × .8303 = K.
P × 2.2903 = P ₂ O ₅ .	P ₂ O ₅ × .4366 = P.
N × 1.2154 = NH ₃ .	NH ₃ × .8228 = N.
Mg × 1.6568 = MgO.	MgO × .6036 = Mg.
Ca × 1.3990 = CaO.	CaO × .7148 = Ca.

Computing the trade value.

*A simple way of figuring the value of a commercial fertilizer*¹ (Cavanaugh)

EXAMPLE NO. 1. GUARANTEED ANALYSIS

Nitrogen	1.60 to 2.00 per cent
Phosphoric acid available	7.00 to 8.00 per cent
Potash	2.00 to 3.50 per cent
Cost per ton	\$29.00

¹ In these and the succeeding examples, it happens that the trade values per lb. of chemicals are not those of 1910, given on pp. 47-48; but it is intended only to explain the method.

Multiplying the lowest figure representing the per cent of the given element by 20, and calculating the value from the price per pound, we have in No. 1 (remembering that 1 per cent means one pound in a hundred, or twenty pounds in a ton):—

Nitrogen	1.60 × 20 =	32 lb. @ 15¢ =	\$4.80
Phosphoric acid	7 × 20 =	140 lb. @ 5¢ =	7.00
Potash	2 × 20 =	40 lb. @ 5¢ =	2.00
Commercial value per ton			<u>\$13.80</u>

EXAMPLE NO. 2. GUARANTEED ANALYSIS

Nitrogen	3.30 to 4.00 per cent
Phosphoric acid available	8.00 to 10.00 per cent
Potash	7.00 to 8.00 per cent
Cost per ton	\$38.00

Its value is calculated the same as No. 1:—

Nitrogen	3.30 × 20 =	66 lb. @ 15¢ =	\$9.90
Phosphoric acid	8.00 × 20 =	160 lb. @ 5¢ =	8.00
Potash	7.00 × 20 =	140 lb. @ 5¢ =	7.00
Commercial value			<u>\$24.90</u>

The cheapest fertilizer is the one in which one dollar purchases the greatest amount of plant-food. In No. 1, \$29 obtained \$13.80 worth, which is at the rate of forty-eight cents worth for \$1. In No. 2, \$38 buys \$24.90 worth of plant-food, or at the rate of sixty-five cents worth for the dollar. The difference between the commercial value, as calculated, and the selling price, is to cover expenses of manufacture, bagging, shipping, commission fees, and profits.

How to figure the trade value of a fertilizer in greater detail (Voorhees)

It is assumed that the mixed fertilizer is guaranteed to contain

Ammonia	4 per cent
Available phosphoric acid	8 per cent
Total phosphoric acid	9 per cent
Potash	6 per cent

and that the nitrogen exists in three forms, as nitrate, as ammonia, and as organic; the phosphoric acid in three forms, soluble, reverted, and insoluble; and potash in two forms, sulfate and muriate. The 4 per cent ammonia would be equivalent to 3.28 per cent nitrogen, 1 per cent of which is nitrate-nitrogen, $\frac{1}{2}$ per cent sulfate of ammonia-nitrogen,

The first column of figures in Table B shows the percentage, or pounds per hundred, of the constituents, which is multiplied by the percentage of fineness, which gives the percentage or pounds per hundred of fine or coarse in the third column. The calculation is then finished, as in the case of complete fertilizers.

Home-Mixing of Fertilizers

General advice (Kentucky Station).

The farmer may mix his own fertilizers in a satisfactory manner. He should first determine how many pounds of phosphoric acid, nitrogen, and potash he wishes to use per acre, then determine how much of each of the materials used will be required to furnish the desired amounts of the ingredients. This having been done, it is easy to figure to any number of acres. It does not matter about figuring out what per cent there will be of each ingredient, the important thing being to know how many pounds of each ingredient are being applied. The foregoing points having been determined, the next step is the mixing. Prepare a tight floor of sufficient size. Put down the bulkiest material first in an even layer, following with the others in order of their bulk. See that all lumps are well broken up. Potash salts and nitrate of soda may be lumpy. Take a shovel and begin at one end of the pile and shovel the materials back, turning and mixing each shovelful as much as possible. Repeat the operation until well mixed. There is no doubt that fertilizers may be well mixed at home, but it is advised only when it can be done more cheaply and when fertilizers of the desired composition cannot be purchased.

The function of the fertilizer factory is to mix fertilizers cheaper and better than the farmer can do it himself. That the factory can do this there is no doubt. That they are not doing so, as a rule, is evident.

In some states, the farmer decides what he wants to use on his land and submits his formula to the manufacturer, who mixes his goods for him and charges the retail price for the *singles* or *simples* used, and a reasonable profit on the actual cost of mixing.

It is gratifying that some of the largest manufacturing concerns advocate the exclusive use of high-grade fertilizers and the unit or pound basis of purchase.

Incompatibles in fertilizer mixtures (U. S. Dept. Agric.).

The danger of indiscriminate mixing of fertilizing materials should be understood, and a diagram (Fig. 4) is given to indicate what combinations may be safely made of some of the more common materials.

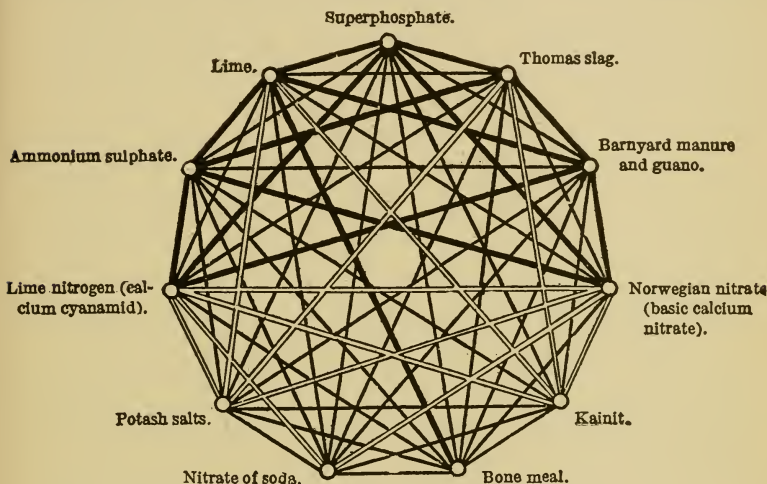

FIG. 4. — Incompatible combinations in fertilizers.

In this diagram the heavy lines unite materials which should never be mixed, the double lines those which should be applied immediately after mixing, and the single lines those which may be mixed at any time.

Table for calculating raw fertilizer material required per ton by mixtures of given composition

FERTILIZER MATERIAL AS CALLED FOR IN A FORMULA	PER CENT OF NITROGEN (N) IN THE FORMULA	EQUIVALENT TO AMMONIA (NH ₃) PER CENT	FACTOR FOR CALCULATING FERTILIZER MATERIAL FROM NITROGEN	FACTOR FOR CALCULATING FERTILIZER MATERIAL FROM AMMONIA
Nitrate of soda	15.0	18.2	Multiply by 133	Multiply by 110
Dried blood	12.4	15.0	161	133
Sulfate of ammonia	20.0	24.3	100	86.4
Cotton-seed meal	7.0	8.5	286	235

Table for calculating raw fertilizer material required per ton by mixtures of given composition.—Continued

FERTILIZER MATERIAL AS CALLED FOR IN A FORMULA	PHOSPHORUS (P) PER CENT	PHOSPHORIC ACID (P ₂ O ₅) PER CENT	FACTOR FOR CALCULATING FERTILIZER MATERIAL FROM PHOSPHORUS	FACTOR FOR CALCULATING FERTILIZER MATERIAL FROM PHOSPHORIC ACID
Acid phosphate	6.1	14.0	Multiply by 328	Multiply by 143
Basic slag	7.0	16.0	285	125
	POTASSIUM (K) PER CENT	POTASH (K ₂ O) PER CENT	FACTOR FOR CALCULATING FERTILIZER MATERIAL FROM POTASSIUM	FACTOR FOR CALCULATING FERTILIZER MATERIAL FROM POTASH
Muriate of potash	41.5	50	Multiply by 48	Multiply by 40
Kainit	10	12	200	167
Sulfate of potash	40	48	50	42

To mix a 2-8-6 fertilizer, *i.e.* a fertilizer containing 2 per cent nitrogen, 8 per cent phosphoric acid and 6 per cent potash, the quantities of raw material may be calculated as follows:—

$$\begin{aligned}
 2 \times 133 &= 266 \text{ lb. nitrate of soda} \\
 8 \times 143 &= 1144 \text{ lb. acid phosphate} \\
 6 \times 40 &= 240 \text{ lb. muriate of potash} \\
 \hline
 &1650 \text{ lb. mixture}
 \end{aligned}$$

If dried blood were used instead of nitrate of soda, it would be necessary to use 322 lb. of it to secure the required amount of nitrogen ($2 \times 161 = 322$) in the ton. If the formula called for ammonia rather than nitrogen, the multiple would be 110 or 133 respectively.

Soil Analysis and Fertilizer Tests (Cavanaugh)

A chemical analysis of a soil consists in finding the amounts of nitrogen, phosphoric acid, potash, lime, magnesia, and humus that it contains. It may be carried further, and the other constituents determined. These materials, except the humus and nitrogen, are extracted from the soil by strong acids. The action of these acids is many times stronger than is ever brought to bear on the soil in its normal con-

dition in the field. It is therefore impossible at present to draw any certain conclusions from the results of such an analysis that are applicable to field conditions.

If, however, an analysis shows only a very small amount of nitrogen, then one may conclude that the soil is deficient in this element and will probably be benefited by its application. But this may be as easily told by a simple inspection of the field while plants are growing. A soil deficient in nitrogen is constantly showing its condition in the plants. Short growth of straw and vine, failure to develop a full, dark-green color, and the growth of sorrel and ox-eye daisy, all tell as accurately as the chemist with all his skill that the soil lacks nitrogen. And it is the same with the other constituents. It is only when a soil is extremely deficient in certain plant-foods that an analysis shows the cause of the trouble.

The great majority of all soils, good and poor agriculturally, differ only in narrow limits as to their composition. Every soil that yields well does not contain more plant-food than one that yields less; on the other hand, many soils that give poor yields are often rich in plant-food.

Two samples of soil were recently examined in the chemical laboratory. On one of the soils alfalfa grows readily, on the other it has failed. It might seem that the cause could be discovered by analyzing the two samples. Following are the results:—

No. 1, that does not grow alfalfa

No. 2, that grows alfalfa

Nitrogen (N)	0.07 per cent	Nitrogen (N)	0.07 per cent
Phosphoric acid (P ₂ O ₅)	0.12 per cent	Phosphoric acid (P ₂ O ₅)	0.12 per cent
Potash (K ₂ O)	0.14 per cent	Potash (K ₂ O)	0.13 per cent
Lime (CaO)	0.17 per cent	Lime (CaO)	0.20 per cent
Magnesia (MgO)	0.24 per cent	Magnesia (MgO)	0.22 per cent
Organic matter (humus)	3.45 per cent	Organic matter (humus)	3.15 per cent

Soils have an average weight of 2,000,000 lb. per acre for a depth of eight inches, and the composition of the two soils by weight is as follows:—

<i>No. 1</i>		<i>No. 2</i>	
.07 N	= 1,400 lb. per acre.	0.07 N	= 1,400 lb. per acre.
.12 P ₂ O ₅	= 2,400 lb. per acre.	0.12 P ₂ O ₅	= 2,400 lb. per acre.
.14 K ₂ O	= 2,800 lb. per acre.	0.13 K ₂ O	= 2,600 lb. per acre.
.17 CaO	= 3,400 lb. per acre.	0.20 CaO	= 4,000 lb. per acre.
.24 MgO	= 4,800 lb. per acre.	0.22 MgO	= 4,400 lb. per acre.
3.45 humus	= 69,000 lb. per acre.	3.15 humus	= 63,000 lb. per acre.

It will be seen that in chemical composition these soils are practically identical, and yet one grows good alfalfa and one does not.

This shows that the chemical composition is not always the deciding factor in fertility. As a matter of fact, it is rarely the deciding factor. A soil that showed higher amounts of plant-food than in the cases cited above gave very low yields. A good system of tile drains was put in this field, and three years later the crops were very large. The draining produced no differences in the chemical content, but it brought success. Failure may be due in other cases to poor tilth, acidity, bad rotations, and various physical causes.

Chemical analyses of soils are valuable mainly to assist in conducting investigations of a scientific character. With the present methods they are of little use as a means of deciding what fertilizer should be applied. The farmer should experiment with different fertilizers, and not depend on a chemical examination of his soil, unless he has reason to think that he has a very special problem. The widespread notion that chemical analyses of soil and of plant will tell what fertilizers to add and what crops to grow is erroneous.

Field tests to determine fertilizer needs may be made as follows:—

The field should be plowed before the plats are laid out. Then use substantial stakes at the corners of the plats and mark them well. It would be well to leave a space of 4 feet between each two plats, to be sure that the plants on one plat cannot feed on the fertilizer each side of it.

Do not lay out the plats on land that has been manured within one year. If you made fertilizer experiments last year, do not use the same set of plats again this season.

The following diagram shows the arrangement of the plats, with the spaces between, each plat containing $\frac{1}{16}$ of an acre:—

1. Plat K.	15 lb. Muriate	potash	100 lb. lime on this half
2. Plat N.	15 lb. nitrate	soda	100 lb. lime on this half
3. Plat P.	30 lb. super	phosphate	100 lb. lime on this half

Each plat one rod wide.	4. Plat Blank.	No fer	tilizer	100 lb. lime on this half
	5. Plat KN.	15 lb. muri	ate potash	100 lb. lime on this half
		15 lb. nitra	te soda	
	6. Plat KP. (mixed)	15 lb. muriate 30 lb. superph	potash	100 lb. lime on this half
			osphate	
	7. Plat NP.	15 lb. nitrate	soda	100 lb. lime on this half
		30 lb. superp	hosphate	
	8. Plat NPK. (mixed)	15 lb. nitra	te soda	100 lb. lime on this half
		15 lb. muri	ate potash	
	30 lb. super	phosphate		
9. Plat S.		stable	manure	100 lb. lime on this half

Eight rods long.

Analyses of Various Chemical Fertilizer and Related Materials

DISSOLVED BONE-BLACK

This material is a superphosphate prepared by treating refuse bone-black from sugar refineries with oil of vitriol, which renders nearly all the phosphoric acid soluble in water.

Soluble phosphoric acid	14.55
Reverted phosphoric acid	2.39
Insoluble phosphoric acid	0.20

BONE CHARCOAL

Moisture at 100° C.	18.16	Reverted phosphoric acid	5.18
Ash	72.24	Insoluble phosphoric acid	20.02
Total phosphoric acid	25.58	Insoluble matter	0.69
Soluble phosphoric acid	0.38		

GROUND BONE. (Two samples)

	I	II
Moisture at 100° C.	3.97	12.43
Ash	49.35	64.21
Total phosphoric acid	19.49	25.67
Reverted phosphoric acid	3.80	6.20
Insoluble phosphoric acid	15.69	19.34
Nitrogen	4.04	2.68
Insoluble matter	0.78	0.42

DRIED BLOOD

Moisture	15.02	Nitrogen	8.24
--------------------	-------	--------------------	------

DRY GROUND FISH

Moisture at 100° C.			8.34
Ash			37.76
Total phosphoric acid			8.23
Soluble phosphoric acid			0.10
Reverted phosphoric acid			3.81
Insoluble phosphoric acid			4.32
Nitrogen			6.81
Insoluble matter			0.82

SULFATE OF AMMONIA

This article, now manufactured on a large scale as a by-product of gas-works, usually contains over 20 per cent of nitrogen, the equivalent of from 94 to 97 per cent of sulfate of ammonia. The rest is chiefly moisture.

Nitrogen	20.02	Equivalent ammonia	24.30
--------------------	-------	------------------------------	-------

SULFATE OF POTASH. (Two samples)

The double sulfate of potash and magnesia is usually sold as "sulfate of potash."

	I.	II.
Actual potash	27.76	51.28
Equivalent sulfate of potash	51.3	94.80

SULFATE OF MAGNESIA

Moisture at 100° C.	29.01	Sulfuric acid	30.35
Magnesium oxide	15.87	Insoluble matter	6.29

NITRATE OF SODA

Nitrate of soda is mined in Chile and purified there before shipment. It usually contains about 16 per cent of nitrogen, equivalent to 97 per cent of pure nitrate of soda. It contains, besides, a little salt and some moisture.

Moisture	0.35	Sulfate of soda	0.21
Salt (sodium chloride)	0.23	Pure nitrate of soda	99.21

MURIATE OF POTASH. (Two samples)

Commercial muriate of potash consists of about 80 per cent of muriate of potash (potassium chloride); 15 per cent or more of common salt (sodium chloride), and 4 per cent or more of water.

	I.	II.
Actual potash	50.0	52.82
Equivalent muriate	79.2	83.70

GERMAN POTASH SALTS — Average of 11 Analyses

Moisture at 100° C.	13.14	Magnesium oxide	9.25
Potassium oxide	21.63	Sulfuric acid	10.85
Sodium oxide	13.76	Chlorine	35.63
Calcium oxide	0.85	Insoluble matter	2.08

KAINIT — Average of 3 Analyses

Moisture at 100° C.	9.26	Magnesium oxide	8.97
Potassium oxide	14.04	Sulfuric acid	21.05
Sodium oxide	21.38	Chlorine	32.38
Calcium oxide	1.12	Insoluble matter	0.89

LAND-PLASTER OR GYPSUM

Hydrated sulfate of lime	74.88
Matters insoluble in acid	1.23
Moisture	1.18
Other matters, chiefly carbonate of lime	22.66

ASHES (WOOD), UNLEACHED

Moisture at 100° C.	15.72
Calcium oxide	28.61
Magnesium oxide	3.00
Ferric oxide	1.03
Potassium oxide	8.72
Phosphoric acid	0.32
Insoluble matter, before calcination	18.49
Insoluble matter, after calcination	12.12

ASHES (WOOD), LEACHED

Moisture at 100° C.	13.72
Calcium oxide	26.90
Magnesium oxide	6.06
Ferric oxide	0.68
Potassium oxide	1.92
Phosphoric acid	1.79
Insoluble matter, before calcination	5.49
Insoluble matter, after calcination	2.57

COAL ASHES, BITUMINOUS

Water	5.0	Soda	0.4
Organic substance	5.0	Magnesia	3.2
Ash	95.0	Phosphoric acid	0.2
Potash	0.4	Sulfuric acid	8.5

COAL ASHES, ANTHRACITE

Water	5.0	Soda	0.1
Organic substance	5.0	Magnesia	3.0
Ash	90.0	Phosphoric acid	0.1
Potash	0.1	Sulfuric acid	5.0

GAS-LIME — Average of 4 Analyses

Moisture at 100° C.	22.28	Sulfur	20.73
Calcium oxide	42.66	Insoluble matter	6.05

	SEAWEED. (Two samples)	
	I	II
Moisture at 100° C.	12.05	14.96
Nitrogen	1.66	1.28
Phosphoric acid	0.44	0.17
Potassium oxide	3.81	0.36
Calcium oxide	2.73	3.86
Magnesium oxide	1.48	1.30

Fertilizer Formulas for Various Crops

There is no exact method of determining the fertilizer or plant-food needs of the various crops. Certain guides have been established, however, from analyses of the plants and other means, and some of these block formulas are given here for the information of the consultant. The careful grower will make tests of his own (see p. 56), and use formulas only as guides.

Formulas suggested by the Maine Experiment Station.

It is to be borne in mind in using these formulas that they are only suggestive and that different conditions of soil make such different treatment essential that a formula which may prove successful on one farm may not be equally so on another. In no case is it to be expected that fertilizers will take the place of good tillage and care of crops.

CROP AND FERTILIZING MATERIALS	WEIGHT USED PER ACRE	NITROGEN	PHOSPHORIC ACID		POTASH
			Available	Total	
CORN on sod land or in conjunction with farm manure:	lb.	lb.	lb.	lb.	lb.
Nitrate of soda	100	16	—	—	—
Acid phosphate	400	—	52	56	—
Muriate of potash	150	—	—	—	75
Total	650	16	52	56	75
Percentage composition	—	2.5	8.0	8.6	11.5
Nitrate of soda	100	16	—	—	—
Screened tankage	200	11	15	32	—
Acid phosphate	300	—	39	42	—
Muriate of potash	150	—	—	—	75
Total	750	27	54	74	75
Percentage composition	—	3.6	7.2	9.9	10.0
Nitrate of soda	100	16	—	—	—
Cottonseed meal	200	14	—	3	4
Acid phosphate	400	—	52	56	—
Muriate of potash	150	—	—	—	75
Total	850	30	52	59	79
Percentage composition	—	3.5	6.1	7.0	9.3

CROP AND FERTILIZING MATERIALS	WEIGHT USED PER ACRE	NITROGEN	PHOSPHORIC ACID		POTASH
			Available	Total	
GRASS — spring seeding with oats as a nurse crop in conjunction with liberal applications of farm manure: ¹	lb.	lb.	lb.	lb.	lb.
Nitrate of soda	50	8	—	—	—
Acid phosphate	200	—	26	28	—
Muriate of potash	200	—	—	—	100
Total	450	8	26	28	100
Percentage composition	—	1.8	5.8	6.2	22.2
GRASS — spring seeding with oats without farm manure:					
Nitrate of soda	100	16	—	—	—
Screened tankage	500	28	36	80	—
Acid phosphate	200	—	26	28	—
Muriate of potash	250	—	—	—	125
Total	1050	44	62	108	125
Percentage composition	—	4.2	5.9	10.3	11.9
GRASS — summer or fall seeding with farm manure (at seeding):					
Acid phosphate	100	—	13	14	—
Muriate	75	—	—	—	38
Total	175	—	13	14	38
Percentage composition	—	—	7.4	8	22
The following spring apply —					
Nitrate of soda	100	16	—	—	—
Acid phosphate	200	—	26	28	—
Muriate	200	—	—	—	100
Total	500	16	26	28	100
Percentage composition	—	3.2	5.2	5.6	20.0
GRASS — summer or fall seeding without farm manure (at seeding):					
Nitrate of soda	100	16	—	—	—
Screened tankage	400	22	29	64	—
Muriate of potash	100	—	—	—	50
Total	600	38	29	64	50
Percentage composition	—	6.3	4.8	10.7	8.3
The following spring apply —					
Nitrate of soda	100	16	—	—	—
Acid phosphate	200	—	26	28	—
Muriate	200	—	—	—	100
Total	500	16	26	28	100
Percentage composition	—	3.2	5.2	5.6	20.0

¹ If desired to apply by machinery, it would be necessary to mix with about 200 pounds of some fine, dry material, as muck or loam.

CROP AND FERTILIZING MATERIALS	WEIGHT USED PER ACRE	NITRO- GEN	PHOSPHORIC ACID		POTASH
			Avail- able	Total	
GRASS—spring top-dressing grass land, suggested by the Rhode Island Experiment Station: ¹	lb.	lb.	lb.	lb.	lb.
Nitrate of soda	350	54	—	—	—
Acid phosphate	400	—	52	56	—
Muriate of potash	250	—	—	—	125
Total	1000	54	52	56	125
Percentage composition	—	5.4	5.2	5.6	12.5
CLOVERS, OR ALFALFA, without other manure and on land carrying the proper root tu- bercle organisms :					
Nitrate of soda	50	8	—	—	—
Acid phosphate	400	—	52	56	—
Muriate of potash	250	—	—	—	125
Total	700	8	52	56	125
Percentage composition	—	1.1	7.4	8.0	17.9
BEANS OR PEAS without other manure on soil carrying the proper root tubercle organ- isms :					
Nitrate of soda	50	8	—	—	—
Acid phosphate	400	—	52	56	—
Muriate of potash	150	—	—	—	75
Total	600	8	52	56	75
Percentage composition	—	1.3	8.7	9.3	12.5
MANGOLDS OR OTHER BEETS, based upon experiments at the Rothamsted (England) Experiment Station (to be used in conjunction with a liberal dressing of farm ma- nure) :					
Nitrate of soda	400	64	—	—	—
Muriate of potash	400	—	—	—	200
Common salt ²	200	—	—	—	—
Total	1000	64	—	—	200
Percentage composition	—	6.4	—	—	20.0
MANGOLDS OR OTHER BEETS without farm manure :					
Nitrate of soda	200	32	—	—	—
Screened tankage	800	44	58	128	—
Sulfate of ammonia (or 300 pounds high-grade dried blood)	200	40	—	—	—
Acid phosphate	200	—	26	28	—
Muriate of potash	400	—	—	—	200
Common salt	200	—	—	—	—
Total	2000	116	84	156	200
Percentage composition	—	5.8	4.2	7.8	10.0

¹ Rhode Island Sta. Bul. 90. ² Beets are successfully grown in Maine without salt.

It is of the utmost importance in purchasing materials for these home mixtures to buy only on a guaranty of composition and to insist that the materials shall be of standard high-grade quality.

Specific mixtures for different crops (Agric. Exp. Sta. Geneva, N.Y., 14th Rept.).

In the following tables (pages 64 to 77), Van Slyke gives formulas for various crops as an illustration of the kinds of mixtures that are ordinarily advised. He is convinced, however, that practically all purposes would be satisfactorily served by the use of not more than a half dozen different formulas. We should work toward the more or less independent handling of nitrogen, phosphorus and potassium compounds, using them separately or together as special conditions and the results of observation and experience may suggest. This is possible, of course, only with the student farmer. For the mass of farmers, the formal recipe or the commercial mixture must yet form the basis of fertilizer applications. As a broad statement to guide the careful farmer, Van Slyke suggests the following:—

For leguminous crops, a formula of 1-8-10 (in the order of nitrogen, available phosphoric acid and potash).

For cereals, 3-8-5.

For all kinds of garden crops, 4-8-10.

For grass and forage crops, 4-6-9.

For orchards, 2-5-10.

For root-crops, 3-8-7.

The materials that are given for use in the succeeding tables are assumed to have a fairly definite composition, and the calculations are based on the following conditions of composition:—

(1) Nitrate of soda, 95 to 96 per cent pure, containing 16 per cent of nitrogen.

(2) Dried blood, containing 10 per cent of nitrogen.

(3) Sulfate of ammonia, containing 20 per cent of nitrogen.

(4) Stable manure, containing .5 per cent of nitrogen.

(5) Bone-meal, containing 20 per cent of total phosphoric acid, one-half being calculated as available during first season on application; also containing 4 per cent of nitrogen.

Whenever bone-meal is used in a mixture, allowance should be made for its nitrogen, and so much less of other forms of nitrogen-materials used.

(6) Dissolved bone, containing 15 per cent of available phosphoric acid and 3 per cent of nitrogen.

(7) Dissolved bone-black, containing 15 per cent of available phosphoric acid.

(8) Dissolved rock, containing 12 per cent of available phosphoric acid.

(9) Muriate of potash, 80 per cent pure, containing 50 per cent of potash.

(10) Sulfate of potash, 90 to 95 per cent pure, containing 50 per cent of potash.

(11) Kainit, containing 12 to 13 per cent of potash.

(12) Wood-ashes, containing 5 per cent of potash.

ALFALFA

	PER CENT	POUNDS FOR ONE ACRE	POUNDS OF DIFFERENT MATERIALS FOR ONE ACRE
Nitrogen	1	5 to 10	{ (1) 30 to 60 lb. nitrate of soda : or (2) 25 to 50 lb. sulfate of ammonia ; or (3) 50 to 100 lb. dried blood ; or (4) 1000 to 2000 lb. stable manure.
Available phosphoric acid .	8	30 to 60	{ (1) 300 to 600 lb. bone-meal ; or (2) 200 to 400 lb. dissolved bone-meal or bone-black ; or (3) 250 to 500 lb. dissolved rock.
Potash	10	40 to 80	{ (1) 80 to 160 lb. muriate ; or (2) 80 to 160 lb. sulfate ; or (3) 325 to 650 lb. kainit ; or (4) 800 to 1600 lb. wood-ashes.

APPLES

	PER CENT	POUNDS FOR ONE ACRE	POUNDS OF DIFFERENT MATERIALS FOR ONE ACRE	POUNDS OF DIFFERENT MATERIALS FOR ONE TREE
Nitrogen	2	8 to 16	{ (1) 50 to 100 lb. nitrate of soda ; or (2) 40 to 80 lb. sulphate of ammonia ; or (3) 80 to 160 lb. dried blood ; or (4) 1600 to 3200 lb. stable manure.	{ (1) 1 to 2 lb. nitrate of soda ; or (2) $\frac{3}{4}$ to 1 $\frac{1}{2}$ lb. sulfate of ammonia ; or (3) 1 $\frac{1}{2}$ to 3 lb. dried blood ; or (4) 35 to 70 lb. stable manure.
Available phosphoric acid .	8	30 to 60	{ (1) 300 to 600 lb. bone-meal ; or (2) 200 to 400 lb. dissolved bone-meal or bone-black ; or (3) 250 to 500 lb. dissolved rock.	{ (1) 6 to 12 lb. bone-meal ; or (2) 4 to 8 lb. dissolved bone or bone-black ; or (3) 5 to 10 lb. dissolved rock.
Potash	12	50 to 100	{ (1) 100 to 200 lb. muriate ; or (2) 100 to 200 lb. sulfate ; or (3) 400 to 800 lb. kainit ; or (4) 1000 to 2000 lb. wood-ashes.	{ (1) 2 to 4 lb. muriate ; or (2) 2 to 4 lb. sulfate ; or (3) 8 to 16 lb. kainit ; or (4) 20 to 40 lb. wood-ashes.

ASPARAGUS

	PER CENT	POUNDS FOR ONE ACRE	POUNDS OF DIFFERENT MATERIALS FOR ONE ACRE
Nitrogen . . .	5	20 to 40	{ (1) 120 to 240 lb. nitrate of soda; or (2) 200 to 400 lb. dried blood; or (3) 4000 to 8000 lb. stable manure.
Available phosphoric acid .	7	30 to 60	{ (1) 300 to 600 lb. bone-meal; or (2) 200 to 400 lb. dissolved bone-meal or bone-black; or (3) 250 to 500 lb. dissolved rock.
Potash . . .	9	35 to 70	{ (1) 70 to 140 lb. muriate; or (2) 70 to 140 lb. sulphate; or (3) 300 to 600 lb. kainit; or (4) 700 to 1400 lb. wood-ashes.

BARLEY

	PER CENT	POUNDS FOR ONE ACRE	POUNDS OF DIFFERENT MATERIALS FOR ONE ACRE
Nitrogen . . .	4	12 to 24	{ (1) 75 to 150 lb. nitrate of soda; or (2) 50 to 120 lb. sulfate of ammonia; or (3) 125 to 250 lb. dried blood; or (4) 2500 to 5000 lb. stable manure.
Available phosphoric acid .	7	20 to 40	{ (1) 200 to 400 lb. bone-meal; or (2) 150 to 300 lb. dissolved bone or bone-black; or (3) 175 to 350 lb. dissolved rock.
Potash . . .	8	25 to 50	{ (1) 50 to 100 lb. muriate; or (2) 50 to 100 lb. sulfate; or (3) 200 to 400 lb. kainit; or (4) 500 to 1000 lb. wood-ashes.

BEANS

	PER CENT	POUNDS FOR ONE ACRE	POUNDS OF DIFFERENT MATERIALS FOR ONE ACRE
Nitrogen . . .	1	5 to 10	{ (1) 30 to 60 lb. nitrate of soda; or (2) 25 to 50 lb. sulfate of ammonia; or (3) 50 to 100 lb. dried blood; or (4) 1000 to 2000 lb. stable manure.
Available phosphoric acid .	7	30 to 60	{ (1) 300 to 600 lb. bone-meal; or (2) 200 to 400 lb. dissolved bone or bone-black; or (3) 250 to 500 lb. dissolved rock.
Potash . . .	9	35 to 70	{ (1) 70 to 140 lb. muriate; or (2) 70 to 140 lb. sulfate; or (3) 300 to 600 lb. kainit; or (4) 700 to 1400 lb. wood-ashes.

BEETS

	PER CENT	POUNDS FOR ONE ACRE	POUNDS OF DIFFERENT MATERIALS FOR ONE ACRE
Nitrogen . . .	5	20 to 40	{ (1) 120 to 240 lb. nitrate of soda ; or (2) 100 to 200 lb. sulfate of ammonia ; (3) 200 to 400 lb. dried blood ; or (4) 4000 to 8000 lb. stable manure.
Available phosphoric acid .	6	25 to 50	{ (1) 250 to 500 lb. bone-meal ; or (2) 175 to 350 lb. dissolved bone or bone-black ; or (3) 200 to 400 lb. dissolved rock.
Potash . . .	9	35 to 70	{ (1) 70 to 140 lb. muriate ; or (2) 70 to 140 lb. sulfate ; or (3) 300 to 600 lb. kainit ; or (4) 700 to 1400 lb. wood-ashes.

BLACKBERRIES

	PER CENT	POUNDS FOR ONE ACRE	POUNDS OF DIFFERENT MATERIALS FOR ONE ACRE
Nitrogen . . .	3	15 to 30	{ (1) 100 to 200 lb. nitrate of soda ; or (2) 75 to 150 lb. sulfate of ammonia ; or (3) 150 to 300 lb. dried blood ; or (4) 3000 to 6000 lb. stable manure.
Available phosphoric acid .	6	30 to 60	{ (1) 300 to 600 lb. bone-meal ; or (2) 200 to 400 lb. dissolved bone or bone-black ; or (3) 250 to 500 lb. dissolved rock.
Potash . . .	8	40 to 80	{ (1) 80 to 160 lb. muriate ; or (2) 80 to 160 lb. sulfate ; or (3) 300 to 600 lb. kainit ; or (4) 800 to 1600 lb. wood-ashes.

BUCKWHEAT

	PER CENT	POUNDS FOR ONE ACRE	POUNDS OF DIFFERENT MATERIALS FOR ONE ACRE
Nitrogen . . .	4	15 to 30	{ (1) 90 to 180 lb. nitrate of soda ; or (2) 75 to 150 lb. sulfate of ammonia ; or (3) 150 to 300 lb. dried blood ; or (4) 3000 to 6000 lb. stable manure.
Available phosphoric acid .	8	30 to 60	{ (1) 300 to 600 lb. bone-meal ; or (2) 200 to 400 lb. dissolved bone or bone-black ; or (3) 250 to 500 lb. dissolved rock.
Potash . . .	9	35 to 70	{ (1) 70 to 140 lb. muriate ; or (2) 70 to 140 lb. sulfate ; or (3) 300 to 600 lb. kainit ; or (4) 700 to 1400 lb. wood-ashes.

CABBAGE

	PER CENT	POUNDS FOR ONE ACRE	POUNDS OF DIFFERENT MATERIALS FOR ONE ACRE
Nitrogen . . .	4	40 to 80	{ (1) 250 to 500 lb. nitrate of soda ; or (2) 200 to 400 lb. sulfate of ammonia ; or (3) 400 to 800 lb. dried blood ; or (4) 8000 to 16,000 lb. stable manure.
Available phosphoric acid .	7	70 to 140	{ (1) 700 to 1400 lb. bone-meal ; or (2) 500 to 1000 lb. dissolved bone or bone-black ; or (3) 600 to 1200 lb. dissolved rock.
Potash . . .	9	90 to 180	{ (1) 180 to 360 lb. muriate ; or (2) 180 to 360 lb. sulfate ; or (3) 700 to 1400 lb. kainit ; or (4) 1800 to 3600 lb. wood-ashes.

CARROTS

	PER CENT	POUNDS FOR ONE ACRE	POUNDS OF DIFFERENT MATERIALS FOR ONE ACRE
Nitrogen . . .	3	15 to 30	{ (1) 90 to 180 lb. nitrate of soda ; or (2) 75 to 150 lb. sulfate of ammonia ; or (3) 150 to 300 lb. dried blood ; or (4) 3000 to 6000 lb. stable manure.
Available phosphoric acid .	7	35 to 70	{ (1) 350 to 700 lb. bone-meal ; or (2) 250 to 500 lb. dissolved bone or bone-black ; or (3) 300 to 600 lb. dissolved rock.
Potash . . .	8	40 to 80	{ (1) 80 to 160 lb. muriate ; or (2) 80 to 160 lb. sulfate ; or (3) 300 to 600 lb. kainit ; or (4) 8000 to 16000 lb. wood-ashes.

CELERY

	PER CENT	POUNDS FOR ONE ACRE	POUNDS OF DIFFERENT MATERIALS FOR ONE ACRE
Nitrogen . . .	5	40 to 80	{ (1) 250 to 500 lb. nitrate of soda ; or (2) 200 to 400 lb. sulfate of ammonia ; or (3) 400 to 800 lb. dried blood ; or (4) 8000 to 16,000 lb. stable manure.
Available phosphoric acid .	6	50 to 100	{ (1) 500 to 1000 lb. bone-meal ; or (2) 350 to 700 lb. dissolved bone or bone-black ; or (3) 400 to 800 lb. dissolved rock.
Potash . . .	8	65 to 130	{ (1) 130 to 260 lb. muriate ; or (2) 130 to 260 lb. sulfate ; or (3) 500 to 1000 lb. kainit ; or (4) 1300 to 2600 lb. wood-ashes.

CAULIFLOWER

Same as for cabbage.

CHERRIES

	PER CENT	POUNDS FOR ONE ACRE	POUNDS OF DIFFERENT MATERIALS FOR ONE ACRE	POUNDS OF DIFFERENT MATERIALS FOR ONE TREE
Nitrogen . . .	2	10 to 20	(1) 60 to 120 lb. nitrate of soda; or (2) 50 to 100 lb. sulfate of ammonia; or (3) 100 to 200 lb. dried blood; or (4) 2000 to 4000 lb. stable manure.	(1) $\frac{1}{2}$ to 1 lb. nitrate of soda; or (2) $\frac{1}{2}$ to 1 lb. sulfate of ammonia; or (3) 1 to 2 lb. dried blood; or (4) 20 to 40 lb. stable manure.
Available phosphoric acid . .	7	35 to 70	(1) 350 to 700 lb. bone-meal; or (2) 250 to 500 lb. dissolved bone, etc.; or (3) 300 to 600 lb. dissolved rock.	(1) $3\frac{1}{2}$ to 7 lb. bone-meal; or (2) $2\frac{1}{2}$ to 5 lb. dissolved bone, etc.; or (3) 3 to 6 lb. dissolved rock.
Potash	9	45 to 90	(1) 90 to 180 lb. muriate; or (2) 90 to 180 lb. sulfate; or (3) 350 to 700 lb. kainit; or (4) 900 to 1800 lb. wood-ashes.	(1) 1 to 2 lb. muriate; or (2) 1 to 2 lb. sulfate; or (3) $3\frac{1}{2}$ to 7 lb. kainit; or (4) 9 to 18 lb. wood-ashes.

CLOVER

Same as for alfalfa.

CORN

	PER CENT	POUNDS FOR ONE ACRE	POUNDS OF DIFFERENT MATERIALS FOR ONE ACRE
Nitrogen . . .	2	10 to 20	(1) 60 to 120 lb. nitrate of soda; or (2) 50 to 100 lb. sulfate of ammonia; or (3) 100 to 200 lb. dried blood; or (4) 2000 to 4000 lb. stable manure.
Available phosphoric acid . .	7	35 to 70	(1) 350 to 700 lb. bone-meal; or (2) 250 to 500 lb. dissolved bone, etc.; or (3) 300 to 600 lb. dissolved rock.
Potash	6	30 to 60	(1) 60 to 120 lb. muriate; or (2) 60 to 120 lb. sulfate; or (3) 250 to 500 lb. kainit; or (4) 600 to 1200 lb. wood-ashes.

For sweet corn, somewhat larger amounts of nitrogen may be applied.

CUCUMBERS

	PER CENT	POUNDS FOR ONE ACRE	POUNDS OF DIFFERENT MATERIALS FOR ONE ACRE
Nitrogen . . .	4	30 to 60	{ (1) 180 to 360 lb. nitrate of soda ; or (2) 150 to 300 lb. sulfate of ammonia ; or (3) 300 to 600 lb. dried blood ; or
Available phosphoric acid .	6	50 to 100	{ (4) 6000 to 12,000 lb. stable manure. (1) 500 to 1000 lb. bone-meal ; or (2) 350 to 700 lb. dissolved bone, etc. ; or (3) 400 to 800 lb. dissolved rock.
Potash . . .	8	65 to 130	{ (1) 130 to 260 lb. muriate ; or (2) 130 to 260 lb. sulfate ; or (3) 500 to 1000 lb. kainit ; or (4) 1300 to 26,000 lb. wood-ashes.

CURRANTS

	PER CENT	POUNDS FOR ONE ACRE	POUNDS OF DIFFERENT MATERIALS FOR ONE ACRE
Nitrogen . . .	2	10 to 20	{ (1) 60 to 120 lb. nitrate of soda ; or (2) 50 to 100 lb. sulfate of ammonia ; or (3) 100 to 200 lb. dried blood ; or (4) 2000 to 4000 lb. stable manure.
Available phosphoric acid .	5	25 to 50	{ (1) 250 to 500 lb. bone-meal ; or (2) 175 to 350 lb. dissolved bone, etc. ; or (3) 200 to 400 lb. dissolved rock.
Potash	8	40 to 80	{ (1) 80 to 160 lb. muriate ; or (2) 80 to 160 lb. sulfate ; or (3) 320 to 640 lb. kainit ; or (4) 800 to 1600 lb. wood-ashes.

EGG-PLANT

	PER CENT	POUNDS FOR ONE ACRE	POUNDS OF DIFFERENT MATERIALS FOR ONE ACRE
Nitrogen . .	4	40 to 80	{ (1) 240 to 480 lb. nitrate of soda ; or (2) 200 to 400 lb. sulfate of ammonia ; or (3) 400 to 800 lb. dried blood ; or (4) 8000 to 16,000 lb. stable manure.
Available phosphoric acid .	5	50 to 100	{ (1) 500 to 1000 lb. bone-meal ; or (2) 350 to 700 lb. dissolved bone, etc. ; or (3) 400 to 800 lb. dissolved rock.
Potash	9	90 to 180	{ (1) 180 to 360 lb. muriate ; or (2) 180 to 360 lb. sulfate ; or (3) 700 to 1400 lb. kainit ; or (4) 1800 to 3600 lb. wood-ashes.

FLAX

	PER CENT	POUNDS FOR ONE ACRE	POUNDS OF DIFFERENT MATERIALS FOR ONE ACRE
Nitrogen . . .	3	10 to 20	{ (1) 60 to 120 lb. nitrate of soda ; or (2) 50 to 100 lb. sulfate of ammonia ; or (3) 100 to 200 lb. dried blood ; or (4) 2000 to 4000 lb. stable manure.
Available phosphoric acid .	8	25 to 50	{ (1) 250 to 500 lb. bone-meal ; or (2) 175 to 350 lb. dissolved bone or bone-black ; or (3) 200 to 400 lb. dissolved rock.
Potash	9	30 to 60	{ (1) 60 to 120 lb. muriate ; or (2) 60 to 120 lb. sulfate ; or (3) 250 to 500 lb. kainit ; or (4) 600 to 1200 lb. wood-ashes.

GOOSEBERRIES

Same as currants.

GRAPES

	PER CENT	POUNDS FOR ONE ACRE	POUNDS OF DIFFERENT MATERIALS FOR ONE ACRE
Nitrogen . . .	2	8 to 16	{ (1) 50 to 100 lb. nitrate of soda ; or (2) 40 to 80 lb. sulfate of ammonia ; or (3) 80 to 160 lb. dried blood ; or (4) 1600 to 3200 lb. stable manure.
Available phosphoric acid .	8	30 to 60	{ (1) 300 to 600 lb. bone-meal ; or (2) 200 to 400 lb. dissolved bone, etc. ; or (3) 250 to 500 lb. dissolved rock.
Potash	11	45 to 90	{ (1) 90 to 180 lb. muriate ; or (2) 90 to 180 lb. sulfate ; or (3) 350 to 700 lb. kainit ; or (4) 900 to 1800 lb. wood-ashes.

GRASS FOR PASTURES

	PER CENT	POUNDS FOR ONE ACRE	POUNDS OF DIFFERENT MATERIALS FOR ONE ACRE
Nitrogen . . .	2	15 to 30	{ (1) 90 to 180 lb. nitrate of soda ; or (2) 75 to 150 lb. sulfate of ammonia ; or (3) 150 to 300 lb. dried blood ; or (4) 3000 to 6000 lb. stable manure.
Available phosphoric acid .	8	30 to 60	{ (1) 300 to 600 lb. bone-meal ; or (2) 200 to 400 lb. dissolved bone, etc. ; or (3) 250 to 500 lb. dissolved rock.
Potash	10	40 to 80	{ (1) 80 to 160 lb. muriate ; or (2) 80 to 160 lb. sulfate ; or (3) 275 to 550 lb. kainit ; or (4) 800 to 1600 lb. wood-ashes.

GRASS FOR LAWNS

	PER CENT	POUNDS FOR ONE ACRE	POUNDS OF DIFFERENT MATERIALS FOR ONE ACRE
Nitrogen . . .	5	20 to 40	{ (1) 120 to 240 lb. nitrate of soda ; or (2) 100 to 200 lb. sulfate of ammonia ; or (3) 200 to 400 lb. dried blood ; or (4) 4000 to 8000 lb. stable manure.
Available phosphoric acid .	6	25 to 50	{ (1) 250 to 500 lb. bone-meal ; or (2) 175 to 350 lb. dissolved bone, etc. ; or (3) 200 to 400 lb. dissolved rock.
Potash . . .	8	30 to 60	{ (1) 60 to 120 lb. muriate ; or (2) 60 to 120 lb. sulfate ; or (3) 250 to 500 lb. kainit ; or (4) 600 to 1200 lb. wood-ashes.

As a more specific mixture, we suggest the following : 100 lb. nitrate of soda, 100 lb. bone-meal, 100 lb. acid phosphate (dissolved rock) and 100 lb. muriate of potash an acre.

GRASS FOR MEADOWS

	PER CENT	POUNDS FOR ONE ACRE	POUNDS OF DIFFERENT MATERIALS FOR ONE ACRE
Nitrogen . . .	4	15 to 30	{ (1) 90 to 180 lb. nitrate of soda ; or (2) 75 to 150 lb. sulfate of ammonia ; or (3) 150 to 300 lb. dried blood ; or (4) 3000 to 6000 lb. stable manure.
Available phosphoric acid .	7	30 to 60	{ (1) 300 to 600 lb. bone-meal ; or (2) 200 to 400 lb. dissolved bone, etc. ; or (3) 250 to 500 lb. dissolved rock.
Potash . . .	9	35 to 70	{ (1) 70 to 140 lb. muriate ; or (2) 70 to 140 lb. sulfate ; or (3) 275 to 550 lb. kainit ; or (4) 700 to 1400 lb. wood-ashes.

HOPS

	PER CENT	POUNDS FOR ONE ACRE	POUNDS OF DIFFERENT MATERIALS FOR ONE ACRE
Nitrogen . . .	3	20 to 40	{ (1) 120 to 240 lb. nitrate of soda ; or (2) 100 to 200 lb. sulfate of ammonia ; or (3) 200 to 400 lb. dried blood ; or (4) 4000 to 8000 lb. stable manure.
Available phosphoric acid .	6	35 to 70	{ (1) 350 to 700 lb. bone-meal ; or (2) 250 to 500 lb. dissolved bone, etc. ; or (3) 275 to 550 lb. dissolved rock.
Potash . . .	12	100 to 200	{ (1) 200 to 400 lb. muriate ; or (2) 200 to 400 lb. sulfate ; or (3) 800 to 1600 lb. kainit ; or (4) 2000 to 4000 lb. wood-ashes.

HORSE RADISH

	PER CENT	POUNDS FOR ONE ACRE	POUNDS OF DIFFERENT MATERIALS FOR ONE ACRE
Nitrogen . . .	4	15 to 30	{ (1) 90 to 180 lb. nitrate of soda; or (2) 75 to 150 lb. sulfate of ammonia; or (3) 150 to 300 lb. dried blood; or (4) 3000 to 6000 lb. stable manure.
Available phosphoric acid . . .	6	25 to 50	{ (1) 250 to 500 lb. bone-meal; or (2) 175 to 350 lb. dissolved bone, etc.; or (3) 200 to 400 lb. dissolved rock.
Potash	9	35 to 70	{ (1) 70 to 140 lb. muriate; or (2) 70 to 140 lb. sulfate; or (3) 275 to 550 lb. kainit; or (4) 700 to 1400 lb. wood-ashes.

LETTUCE

	PER CENT	POUNDS FOR ONE ACRE	POUNDS OF DIFFERENT MATERIALS FOR ONE ACRE
Nitrogen	5	40 to 80	{ (1) 250 to 500 lb. nitrate of soda; or (2) 200 to 400 lb. sulfate of ammonia; or (3) 400 to 800 lb. dried blood; or (4) 8000 to 16,000 lb. stable manure.
Available phosphoric acid . . .	6	50 to 100	{ (1) 500 to 1000 lb. bone-meal; or (2) 350 to 700 lb. dissolved bone, etc.; or (3) 400 to 800 lb. dissolved rock.
Potash	9	75 to 150	{ (1) 150 to 300 lb. muriate; or (2) 150 to 300 lb. sulfate; or (3) 600 to 1200 lb. kainit; or (4) 1500 to 3000 lb. wood-ashes.

MILLET

Same as for meadow grass.

MUSKMELONS

Same as for cucumbers.

NURSERY STOCK

	PER CENT	POUNDS FOR ONE ACRE	POUNDS OF DIFFERENT MATERIALS FOR ONE ACRE
Nitrogen	3	10 to 20	{ (1) 60 to 120 lb. nitrate of soda; or (2) 50 to 100 lb. sulfate of ammonia; or (3) 100 to 200 lb. dried blood; or (4) 2000 to 4000 lb. stable manure.
Available phosphoric acid . . .	6	25 to 50	{ (1) 250 to 500 lb. bone-meal; or (2) 175 to 350 lb. dissolved bone, etc.; or (3) 200 to 400 lb. dissolved rock.
Potash	7	30 to 60	{ (1) 60 to 120 lb. muriate; or (2) 60 to 120 lb. sulfate; or (3) 240 to 480 lb. kainit; or (4) 600 to 1200 lb. wood-ashes.

OATS

	PER CENT	POUNDS FOR ONE ACRE	POUNDS OF DIFFERENT MATERIALS FOR ONE ACRE
Nitrogen . . .	4	12 to 24	{ (1) 75 to 150 lb. nitrate of soda ; or (2) 60 to 120 lb. sulfate of ammonia ; or (3) 120 to 240 lb. dried blood ; or (4) 2500 to 5000 lb. stable manure.
Available phosphoric acid .	6	20 to 40	{ (1) 200 to 400 lb. bone-meal ; or (2) 140 to 280 lb. dissolved bone, etc. ; or (3) 160 to 320 lb. dissolved rock.
Potash	9	30 to 60	{ (1) 60 to 120 lb. muriate ; or (2) 60 to 120 lb. sulfate ; or (3) 250 to 500 lb. kainit ; or (4) 600 to 1200 lb. wood-ashes.

ONIONS

	PER CENT	POUNDS FOR ONE ACRE	POUNDS OF DIFFERENT MATERIALS FOR ONE ACRE
Nitrogen . . .	5	45 to 90	{ (1) 270 to 540 lb. nitrate of soda ; or (2) 225 to 450 lb. sulfate of ammonia ; or (3) 450 to 900 lb. dried blood ; or (4) 9000 to 18,000 lb. stable manure.
Available phosphoric acid .	6	55 to 110	{ (1) 550 to 1100 lb. bone-meal ; or (2) 385 to 770 lb. dissolved bone, etc. ; or (3) 450 to 900 lb. dissolved rock.
Potash	9	80 to 160	{ (1) 160 to 320 lb. muriate ; or (2) 160 to 320 lb. sulfate ; or (3) 650 to 1300 lb. kainit ; or (4) 1600 to 3200 lb. wood-ashes.

PARSNIPS

	PER CENT	POUNDS FOR ONE ACRE	POUNDS OF DIFFERENT MATERIALS FOR ONE ACRE
Nitrogen . . .	3	20 to 40	{ (1) 120 to 240 lb. nitrate of soda ; or (2) 100 to 200 lb. sulfate of ammonia ; or (3) 200 to 400 lb. dried blood ; or (4) 4000 to 8000 lb. stable manure.
Available phosphoric acid .	9	55 to 110	{ (1) 550 to 1100 lb. bone-meal ; or (2) 375 to 750 lb. dissolved bone, etc. ; or (3) 450 to 900 lb. dissolved rock.
Potash	8	50 to 100	{ (1) 100 to 200 lb. muriate ; or (2) 100 to 200 lb. sulfate ; or (3) 400 to 800 lb. kainit ; or (4) 1000 to 2000 lb. wood-ashes.

PEACHES

	PER CENT	POUNDS FOR ONE ACRE	POUNDS OF DIFFERENT MATERIALS FOR ONE ACRE
Nitrogen . . .	2	15 to 30	{ (1) 90 to 180 lb. nitrate of soda ; or (2) 75 to 150 lb. sulfate of ammonia ; or (3) 150 to 300 lb. dried blood ; or (4) 3000 to 6000 lb. stable manure.
Available phosphoric acid .	5	40 to 80	{ (1) 400 to 800 lb. bone-meal ; or (2) 280 to 560 lb. dissolved bone, etc. ; or (3) 320 to 640 lb. dissolved rock.
Potash . . .	7	55 to 110	{ (1) 110 to 220 lb. muriate ; or (2) 110 to 220 lb. sulfate ; or (3) 450 to 900 lb. kainit ; or (4) 1100 to 2200 lb. wood-ashes.

PEARS

Same as for apples.

PEAS

Same as for beans.

PLUMS

Same as for cherries.

POTATOES

	PER CENT	POUNDS FOR ONE ACRE	POUNDS OF DIFFERENT MATERIALS FOR ONE ACRE
Nitrogen . . .	4	30 to 60	{ (1) 180 to 360 lb. nitrate of soda ; or (2) 150 to 300 lb. sulfate of ammonia ; or (3) 300 to 600 lb. dried blood.
Available phosphoric acid .	6	40 to 80	{ (1) 400 to 800 lb. bone-meal ; or (2) 275 to 550 lb. dissolved bone, etc. ; or (3) 325 to 650 lb. dissolved rock.
Potash . . .	9	65 to 130	{ (1) 130 to 260 lb. muriate ; or (2) 130 to 260 lb. sulfate ; or (3) 520 to 1040 lb. kainit.

PUMPKINS

Same as for cucumbers.

QUINCES

Same as for apples.

RADISHES

	PER CENT	POUNDS FOR ONE ACRE	POUNDS OF DIFFERENT MATERIALS FOR ONE ACRE
Nitrogen . . .	3	15 to 30	{ (1) 90 to 180 lb. nitrate of soda ; or (2) 75 to 150 lb. sulfate of ammonia ; or (3) 150 to 300 lb. dried blood ; or (4) 3000 to 6000 lb. stable manure.
Available phosphoric acid .	7	35 to 70	{ (1) 350 to 700 lb. bone-meal ; or (2) 250 to 500 lb. dissolved bone, etc. ; or (3) 280 to 560 lb. dissolved rock.
Potash . . .	9	45 to 90	{ (1) 90 to 180 lb. muriate ; or (2) 90 to 180 lb. sulfate ; or (3) 350 to 700 lb. kainit ; or (4) 900 to 1800 lb. wood-ashes.

RASPBERRIES

	PER CENT	POUNDS FOR ONE ACRE	POUNDS OF DIFFERENT MATERIALS FOR ONE ACRE
Nitrogen . . .	2	12 to 24	{ (1) 75 to 150 lb. nitrate of soda ; or (2) 60 to 120 lb. sulfate of ammonia ; or (3) 120 to 240 lb. dried blood ; or (4) 2400 to 4800 lb. stable manure.
Available phosphoric acid .	7	40 to 80	{ (1) 400 to 800 lb. bone-meal ; or (2) 280 to 560 lb. dissolved bone, etc. ; or (3) 320 to 640 lb. dissolved rock.
Potash . . .	10	60 to 120	{ (1) 120 to 240 lb. muriate ; or (2) 120 to 240 lb. sulfate ; or (3) 480 to 960 lb. kainit ; or (4) 1200 to 2400 lb. wood-ashes.

RYE

Same as for oats.

SORGHUM

Same as for corn.

SPINACH

	PER CENT	POUNDS FOR ONE ACRE	POUNDS OF DIFFERENT MATERIALS FOR ONE ACRE
Nitrogen . . .	2	15 to 30	{ (1) 90 to 180 lb. nitrate of soda ; or (2) 75 to 150 lb. sulfate of ammonia ; or (3) 150 to 300 lb. dried blood ; or (4) 3000 to 6000 lb. stable manure.
Available phosphoric acid .	7	55 to 110	{ (1) 550 to 1100 lb. bone-meal ; or (2) 375 to 750 lb. dissolved bone, etc. ; or (3) 450 to 900 lb. dissolved rock.
Potash . . .	5	40 to 80	{ (1) 80 to 160 lb. muriate ; or (2) 80 to 160 lb. sulfate ; or (3) 320 to 640 lb. kainit ; or (4) 800 to 1600 lb. wood-ashes.

SQUASHES

Same as for cucumbers.

STRAWBERRIES

	PER CENT	POUNDS FOR ONE ACRE	POUNDS OF DIFFERENT MATERIALS FOR ONE ACRE
Nitrogen . . .	3	25 to 50	{ (1) 150 to 300 lb. nitrate of soda ; or (2) 125 to 250 lb. sulfate of ammonia ; or (3) 250 to 500 lb. dried blood ; or (4) 5000 to 10,000 lb. stable manure.
Available phosphoric acid .	7	55 to 110	{ (1) 550 to 1100 lb. bone-meal ; or (2) 375 to 750 lb. dissolved bone, etc. ; or (3) 450 to 900 lb. dissolved rock.
Potash . . .	9	70 to 140	{ (1) 140 to 280 lb. muriate ; or (2) 140 to 280 lb. sulfate ; or (3) 550 to 1100 lb. kainit ; or (4) 1400 to 2800 lb. wood-ashes.

TOBACCO

	PER CENT	POUNDS FOR ONE ACRE	POUNDS OF DIFFERENT MATERIALS FOR ONE ACRE
Nitrogen . . .	4	30 to 60	{ (1) 180 to 360 lb. nitrate of soda ; or (2) 150 to 300 lb. sulfate of ammonia ; or (3) 300 to 600 lb. dried blood ; or (4) 6000 to 12,000 lb. stable manure.
Available phosphoric acid .	6	50 to 100	{ (1) 500 to 1000 lb. bone-meal ; or (2) 350 to 700 lb. dissolved bone, etc. ; or (3) 400 to 800 lb. dissolved rock.
Potash . . .	10	80 to 160	{ (1) 160 to 320 lb. sulfate ; or (2) 1600 to 3200 lb. wood-ashes.

TOMATOES

	PER CENT	POUNDS FOR ONE ACRE	POUNDS OF DIFFERENT MATERIALS FOR ONE ACRE
Nitrogen . . .	4	25 to 50	{ (1) 150 to 300 lb. nitrate of soda ; or (2) 125 to 250 lb. sulfate of ammonia ; or (3) 250 to 500 lb. dried blood ; or (4) 5000 to 10,000 lb. stable manure.
Available phosphoric acid .	6	35 to 70	{ (1) 350 to 700 lb. bone-meal ; or (2) 250 to 500 lb. dissolved bone, etc. ; or (3) 280 to 560 lb. dissolved rock.
Potash . . .	7	40 to 80	{ (1) 80 to 160 lb. muriate ; or (2) 80 to 160 lb. sulfate ; or (3) 320 to 640 lb. kainit ; or (4) 800 to 1600 lb. wood-ashes.

TURNIPS

Same as for beets.

WATERMELONS

Same as for cucumbers.

WHEAT

	PER CENT	POUNDS FOR ONE ACRE	POUNDS OF DIFFERENT MATERIALS FOR ONE ACRE
Nitrogen . . .	4	12 to 24	{ (1) 75 to 150 lb. nitrate of soda ; or (2) 60 to 120 lb. sulfate of ammonia ; or (3) 120 to 240 lb. dried blood ; or (4) 2400 to 4800 lb. stable manure.
Available phosphoric acid .	7	20 to 40	{ (1) 200 to 400 lb. bone-meal ; or (2) 140 to 280 lb. dissolved bone, etc. ; or (3) 160 to 320 lb. dissolved rock.
Potash . . .	4	12 to 24	{ (1) 25 to 50 lb. muriate ; or (2) 25 to 50 lb. sulfate ; or (3) 100 to 200 lb. kainit ; or (4) 250 to 500 lb. wood-ashes.

Lime for the Land

Of late years the old custom of liming the land has been revived. It is now found that lime, or other alkali, is needed to neutralize the acidity of certain soils.

To determine whether a soil is acid, and therefore probably in need of lime (Wheeler).

By litmus paper (to be secured at drug store). — To half a cup of soil add water until it is like thick porridge, and then insert blue litmus paper without handling the end introduced into the soil. After an hour or two, remove and rinse only the lower end. If this end is intensely reddened, liming is probably desirable. The color is pinkish if much acid vegetable matter is present; but if it is not present, the color may be brick-red.

By ammonia water. — To a tablespoonful of soil in half a glass of water add a teaspoonful or more of dilute ammonia water; if the liquid

becomes intensely brown after standing for some hours, and especially if it becomes black, the probable presence of acid vegetable matter is indicated.

When a soil test indicates only slight acidity, lime may not be needed for most plants.

Application of lime.

On sandy soils, 500 lb. of lime to the acre may be sufficient. On soils very rich in acid organic matter, as much as 5000 to 6000 lb. may be needed. Under usual conditions, about one ton to the acre is a good dressing (20 to 40 bu., with 30 bu. perhaps the average). The legal weight per bushel of lime is 70 lb. in some states and 80 lb. in others.

Some persons apply lime after plowing and mix it into the soil with the harrow; others apply in fall and follow by spring plowing.

Forms of lime (Fippin).

In a pure form, the calcium equivalent in 100 lb. of lime is about as follows (Ca is calcium; O, oxygen; H, hydrogen):—

	CALCIUM IN 100 LB.	EQUIVALENT IN COMPOSITION TO 100 LB. LUMP LIME
(a) CaO, Lump lime, freshly burned lime, quicklime	71	100
(b) Ca(OH) ₂ , Hydrated lime, water-slaked lime	54	132
(c) CaCO ₂ , Lime carbonates, air-slaked lime, ground limestone, marl	40	180
(d) CaSO ₄ + 2H ₂ O, Gypsum, land plaster	23	310
(e) Ca ₃ (PO ₄) ₂ , Lime phosphate, ground phosphate rock	38	Pure 187
(f) CaH ₄ (PO ₄) ₂ + CaSO ₄ , Acid phosphate (15% P ₂ O ₅)	39	25% CaCO ₃ 181
(g) (CaO) ₄ P ₂ O ₅ , Basic slag, Tomas phosphate powder	23	310
(h) Ashes (containing quicklime)	43	165
	15 to 30	450

Strictly speaking, the lime manufacturers are concerned with only the first three forms, but these must compete to some extent with other forms. Phosphate fertilizers may sometimes owe their benefits to their lime contents. The same result might then be secured at much less cost from lime.

Fineness of division of lime (Fippin).

The finer the lime (the smaller the particles) the greater its availability. Considering the calcium content, first cost, freight, and fineness, it is often better to use the lump or hydrated or ground lime than the ground limestone or marl; the lump quicklime slakes into very fine particles when applied to the soil. It is impossible to attain the same degree of fineness by grinding that is attained by burning and slaking. Seventy-five per cent, at least, of the ground material should pass a 100-mesh screen. The larger the percentage of coarse material, the larger the amount necessary to get the same net effect. Considering composition and fineness as commonly found on the market, 50 lb. of lump lime is equivalent approximately to

- 60 lb. hydrated lime.
- 100 lb. air-slaked lime.
- 250 lb. ground limestone or marl.

Classification of lime for agricultural purposes.

Agreement between the Directors of the New England and New Jersey Experiment Stations and the Special Committee of the National Lime Manufacturers' Association of Boston, March 3, 1909.

LIME	{	(1) High Calcium	{	(1) Hydrate	{	(1) Spraying	{	Must contain 93% combined oxides and hydrates and all pass a standard 100-mesh sieve.
				(2) Land				
		(2) Caustic	{	(1) Lump	{	Must contain 90% combined oxides and carbonates, of which not more than 10% shall be carbonates, excepting Ground, which may contain 20% carbonates.		
				(2) Fines				
(3) Ground								
(2) Dolomitic or High Magnesium	{	(3) Ground Limestone . . .	{	(4) Kiln Slaked	{		{	Must contain 90% combined carbonates and pass 50-mesh sieve.

All shipments except Kiln Slaked shall be accompanied by a statement showing (1) proper class name and (2) guaranteed analysis, in which the respective percentages of calcium and magnesium oxides are given.

Package shipments to show class and analysis on each package.

Bulk shipments to have class and analysis statement attached either to invoice or inner side of the car.

All lime to be sold by weight cwt. or ton.

Analyses to be those at kiln, and guaranteed.

Other tests for the need of lime (Fippin).

There is no simple method for accurately determining the need of lime. The use of strips of blue litmus in the wet soil and their distinct change to a pink color in a half-hour is one common test that is indicative of such need. Strips of blue and red litmus paper may be placed in the bottom of a drinking glass and covered with white filter paper or blotting paper on which is placed the soil to be tested. The soil is then moistened with clear rain water until the paper becomes damp. This is a more exact test than the direct application of litmus paper to the soil.

Another method of determining the presence of free bases is to put on the soil a drop of muriatic acid diluted four or five times. If there is any perceptible bubbling, or effervescence, this indicates the presence of sufficient lime. Should lime be shown in the subsoil but none in the soil, a moderate application of lime is likely to be beneficial.

The best indication of the need for lime is the type of plant growth that the soil bears. The vigorous growth of lime-loving plants, such as alfalfa, clover, and the scab of potatoes, indicates the presence of sufficient lime; while the absence or weak growth of plants of this kind, and the predominance of such plants as horse sorrel, white daisy, and redtop, indicate a need for lime.

CHAPTER IV

FARM MANURES, AND SIMILAR MATERIALS

ANIMALS are among the most essential agents in the maintaining of the fertility of the land. Farm manures are of great value, not only for the plant-food they contain, but for the humus that they contribute and the organisms that they carry.

Composition and Characteristics of Manures (Brooks)

Cattle manure.

For practical purposes, one will be sufficiently accurate in estimating well-kept barnyard (or cattle) manure to contain one-half of one per cent each of nitrogen and potash, and one-third of one per cent of phosphoric acid. On this basis, a ton of manure would contain 10 lb. each of nitrogen and potash, and $6\frac{2}{3}$ lb. of phosphoric acid. A cord of well-preserved manure kept without loss of urine and without exposure to the weather will weigh a little more than three tons. A cord of such manure, therefore, should contain about thirty pounds of nitrogen and potash and twenty pounds of phosphoric acid.

Stable or horse manure.

The manure from horses is generally more valuable than that from the other larger domestic animals, excepting sheep, provided it has been well kept. It is richer in nitrogen, and usually also in phosphoric acid and potash, than the manure of either cattle or hogs. It contains relatively little water, and ferments rapidly.

Experiments at the Cornell Experiment Station showed horse manure to have the following composition: water, 48.69 per cent; nitrogen, 0.49 per cent; phosphoric acid, 0.26 per cent; potash, 0.48 per cent. Plaster was very freely used in this experiment, and this doubtless reduced the percentages, so that the figures are undoubtedly below the average.

Sheep manure.

Sheep manure is generally accumulated under the animals with sufficient litter to keep the latter dry and clean. Under these conditions, there is commonly no appreciable loss either of urine or of ammonia because of excessive fermentation. The amount of urine voided by sheep is relatively small, and the elements of value in sheep manure ordinarily suffer less loss than is common in the case of other kinds of farm manure. When sheep manure is finally removed from the pens and put into loose piles, as is often the case, in order that it may be worked into suitable mechanical condition to spread, it very rapidly undergoes decomposition, and heats quickly. It is then likely to lose a part of its nitrogen in the form of ammonia. To prevent this, it is well to scatter kainit or land-plaster as the pile is built up. The average of four analyses of sheep manure made at the Massachusetts Experiment Station showed it to contain: water, .2922 per cent; nitrogen, 1.44 per cent; phosphoric acid, .92 per cent; potash, 1.17 per cent. Sheep manure is now sometimes collected, dried, and ground, and put on the market as sheep guano. In this form it is a concentrated manure, especially valuable for dressing lawns, for use in hothouses, and like purposes.

Hog manure.

The manure made from swine undoubtedly varies more widely than that from the other domestic animals, because of the wider variations in the nature of their food and the conditions under which they are kept. The excrements of swine on most farms are not kept by themselves but are mixed with other manures, and this in general would seem to be the better system of management. Hog manure, if kept by itself, is relatively watery, and is usually poor in nitrogen and rich in phosphoric acid. It decomposes slowly, and must be ranked as a cold manure.

Comparison of Manure from Different Animals (Brooks)

Having made separate statements on the qualities and characteristics of the manure from cattle, horses, sheep, and swine, we may now compare these manures in tabular form:—

Composition of fresh excrement of farm quadrupeds.

One thousand pounds of fresh dung contain:—

	WATER	NITROGEN	PHOSPHORIC ACID	ALKALIES
Horse	760	5.0	3.5	3.0
Cow	840	3.0	2.5	1.0
Swine	800	6.0	4.5	5.0
Sheep	580	7.5	6.0	3.0

One thousand pounds of fresh urine contain:—

	WATER	NITROGEN	PHOSPHORIC ACID	ALKALIES
Horse	890	12.0	0.0	15.0
Cow	920	8.0	0.0	14.0
Swine	975	3.0	1.25	2.0
Sheep	865	14.0	0.5	20.0

The potash of both the dung and the urine is included with lime, magnesia, and other elements, to make up the so-called "alkalies."

Composition of drainage liquors.

One thousand pounds contain:—

	WATER	NITROGEN	PHOSPHORIC ACID	POTASH
Drainage from gutter behind milch cows	932	9.8	2.4	8.8
Drainage from manure heap	820	15.0	1.0	49.0

The figures presented in this last table are based on analyses made at the Hatch Experiment Station, Amherst, Mass. It will be noticed that these liquors are richer both in nitrogen and in potash than the average of farm manures.

Composition of litter.

One ton contains in pounds:—

	NITROGEN	PHOSPHORIC ACID	POTASH
Wheat straw	9.6	4.4	16.4
Rye straw	11.2	5.1	18.1
Oat straw	14.4	3.6	23.0
Barley straw	11.4	5.0	23.5
Pea straw	20.8	7.0	19.8
Soy bean straw	14.0	5.0	22.0
Buckwheat straw	13.0	7.1	24.2
Millet straw	14.0	3.6	34.0
Marsh hay	17.2	10.6	54.0
Ferns	00.0	7.4	37.2
Leaves	15.0	3.2	6.0

Poultry manures.

Poultry manures are richer than the other farm manures when well preserved. There are two principal reasons for this: First, the food is richer, as a rule; and second, the excretion corresponding to the urine of the larger domestic animals is semi-solid, voided with the dung, and not subject to direct loss. Poultry manures as a rule are rich in nitrogen and phosphoric acid, because the foods given the fowls are rich in these elements. These manures are relatively poor in potash, although they may contain a larger percentage of this element than do the other farm manures. The composition is subject to wide variation. The table shows the results of analyses:—

	WATER	NITROGEN	PHOSPHORIC ACID	POTASH
	Per cent	Per cent	Per cent	Per cent
Hen manure, fresh, according to Storer . .	56.00	1.60	1.50-2.00	0.80-0.90
Hen manure, fresh, analysis by Goessmann	52.35	0.99	0.74	0.25
Hen manure, dry, average two analyses, Goessmann	8.35	2.13	2.02	0.994
Duck manure, fresh, according to Storer . .	56.60	1.00	1.40	0.62
Goose manure, fresh, according to Storer . .	77.10	0.55	0.54	0.95
Pigeon manure, according to Storer	52.00	1.75	1.75-2.00	1.0-1.25

Poultry manure ferments very quickly, and, as frequently handled, loses much of its nitrogen in the form of compounds of ammonia, which are rapidly formed and which escape into the air unless means to prevent are taken. The mixture of poultry manures with such materials as land-plaster, kainit, acid phosphate, or superphosphate plaster is almost imperative for satisfactory preservation. Often dry earth or powdered dry muck or dry sawdust are also excellent materials to mix with it. If kainit alone is used, poultry manure remains very moist, and will be found difficult of application. As a result of experiments in the Massachusetts Experiment Station, it is concluded that the annual excreta collected beneath the roosts per adult barnyard fowl will amount to about 30 to 45 lb., according to the breed.

Utilization of Manures

Rate of production (Roberts and Brooks).

Extended investigations at the Cornell Experiment Station showed that the following amounts of excrements were produced daily for each 1000 lb. of live weight of animal:—

	Lb.
Sheep	34.1
Calves	67.8
Pigs	83.6
Cows	74.1
Horses	48.8
Fowls	39.8
Total excrements	348.2
Total manure	388.0

If straw bedding be added, which is nearly or quite equal to excrements in potential manurial value, it will be seen how large a quantity of manure is produced from 6000 lb. of mixed live-stock. A dairy of twenty 1000-lb. cows comfortably fed would produce, in the six winter months, 133½ tons of excrement, or 146½ tons of manure. Animals fed a highly nitrogenous ration, say 1 : 4 (as were the pigs in the above investigation), consume large quantities of water, and hence produce large quantities of excrements, especially liquid, the weight of which usually exceeds the weight of food consumed ; while those fed on a wide ration, say 1 : 9, consume comparatively little water, and hence produce less weight of excrements.

The experienced farmer will know from the results of earlier years

about the quantity of manure that will be made from a given number of animals. For a beginner, some rule whereby the amount to be made can be estimated with reasonable accuracy will be useful. As the result of careful experiments, German investigators give the following rules to determine the quantity of manure that will be made: Multiply the dry matter in the food consumed by the different classes of farm animals by the following factors: for the horse, by 2.1; for the cow, by 3.8; for the sheep, by 1.8. To the product, in any case, add the weight of the bedding used. The horse of average size consumes daily about 24 lb. of dry matter, and makes, therefore, 2.1 times 24 lb., or 50 lb., of manure daily. The cow of average size consumes daily about 25 lb. of dry matter, and makes 3.8 times 25 lb., or 95 lb., of manure daily. A 125-lb. sheep consumes about 3 lb. of dry matter daily, and makes 1.8 times 3 lb., or 5.4 lb., of manure daily.

Use of manures.

A thousand pounds of wheat, 16 $\frac{2}{3}$ bu., and 2000 lb. of straw (an average crop per acre) require 27 lb. of nitrogen, 12.4 lb. of phosphoric acid, 17.9 lb. of potash. Ten tons of fresh unrotted manure from horses and cattle fed a moderate grain ration contain 136 lb. of nitrogen, 44 lb. of phosphoric acid, 120 lb. of potash. In farm practice it is estimated that the first crop grown after manuring may utilize, under favorable conditions, one-half of the plant-food contained in the manure applied. The plant-food available in ten tons of good fresh manure is: nitrogen 68 lb., phosphoric acid, 22 lb., potash, 60 lb. Thirty bushels of wheat and 2600 lb. of straw require, approximately, 46 lb. of nitrogen, 21 lb. of phosphoric acid, and 27 lb. of potash (*Roberts*).

Manures are frequently wasted by being applied too liberally. It is not economical, except for special crops or special conditions, to apply as much as thirty to forty two-horse loads or tons per acre at one time. For usual farm purposes, ten to twenty tons, or ten to twenty two-horse loads, is a liberal application per acre. It is best to apply it as it is made, if the land is not in a growing crop. The manure should be spread directly from the wagon, or a manure-spreader be used.

Commercial value (Roberts).

The value of manure in the following tables is determined by investigation during the winter months, and the nitrogen, phosphoric

acid, and potash are computed at 15, 6, and 4½ cents per pound, respectively (see prices, p. 47). The indirect benefits of manures may be considered an equal offset for the slightly less availability of their plant-food constituents as compared with fertilizers:—

KIND OF MANURE	VALUE PER TON
Sheep	\$2.30
Calves	2.17
Pigs	2.29
Cows	2.02
Horses	2.21

Limited amounts of bedding were used in the tests from which the above figures were made. The plant-food in straw is not so quickly available as it is in the excrement of animals.

The following table exhibits the value of manure from different animals of average or aggregate weight of 1000 pounds:—

KIND OF ANIMALS	VALUE PER YEAR
Fowls	\$51.10
Sheep	26.09
Calves	24.45
Pigs	60.88
Cows	29.27
Horses	27.74

Manurial value of a ton of the usual bedding material computed as above:—

	NITROGEN	PHOSPHORIC ACID	POTASH	TOTAL
Barley straw	\$1.65	\$0.34	\$1.74	\$3.73
Oats	1.38	0.33	1.59	3.30
Rye	1.47	0.30	0.77	2.54
Wheat	1.44	0.26	0.57	2.27

Losses by leaching (Roberts).

Manures exposed at Ithaca in loose heaps of two to ten tons for six months showed loss of values as follows:—

	PER CENT
1889 horse manure	42
1890 horse manure	62
1890 cow manure	30
1889 mixed manure (compacted)	9

In other cases, when small quantities of gypsum were mixed with the manure, the losses were notably diminished.

Further Analyses of Animal Excrements

Common barnyard manure, fresh

Water	710.0	Lime	5.7
Organic substance	246.0	Magnesia	1.4
Ash	44.1	Phosphoric acid	2.1
Nitrogen	4.5	Sulfuric acid	1.2
Potash	5.2	Silica and sand	12.5
Soda	1.5	Chlorine and fluorine	1.5

Common barnyard manure, moderately rotted

Water	750.0	Lime	7.0
Organic substance	192.0	Magnesia	1.8
Ash	58.0	Phosphoric acid	2.6
Nitrogen	5.0	Sulfuric acid	1.6
Potash	6.3	Silica and sand	16.8
Soda	1.9	Chlorine and fluorine	1.9

Common barnyard manure, thoroughly rotted

Water	790.0	Lime	8.8
Organic substance	145.0	Magnesia	1.8
Ash	65.0	Phosphoric acid	3.0
Nitrogen	5.8	Sulfuric acid	1.3
Potash	5.0	Silica and sand	17.0
Soda	1.3	Chlorine and fluorine	1.6

Cattle-feces, fresh

Water	838.0	Lime	3.4
Organic substance	145.0	Magnesia	1.3
Ash	17.3	Phosphoric acid	1.7
Nitrogen	2.9	Sulfuric acid	0.3
Potash	1.0	Silica and sand	7.2
Soda	0.2	Chlorine and fluorine	0.2

Cattle-urine, fresh

Water	938.0	Lime	0.1
Organic substance	35.0	Magnesia	0.4
Ash	27.4	Sulfuric acid	1.3
Nitrogen	5.8	Silica and sand	0.3
Potash	4.9	Chlorine and fluorine	3.8
Soda	6.4		

Horse-feces, fresh

Water	757.0	Lime	1.5
Organic substance	211.0	Magnesia	1.2
Ash	31.6	Phosphoric acid	3.5
Nitrogen	4.4	Sulfuric acid	0.6
Potash	3.5	Silica and sand	19.6
Soda	0.6	Chlorine and fluorine	0.2

Horse-urine, fresh

Water	901.0	Lime	4.5
Organic substance	71.0	Magnesia	2.4
Ash	28.0	Sulfuric acid	0.6
Nitrogen	15.5	Silica and sand	0.8
Potash	15.0	Chlorine and fluorine	1.5
Soda	2.5		

Sheep-feces, fresh

Water	655.0	Lime	4.6
Organic substance	314.0	Magnesia	1.5
Ash	31.1	Phosphoric acid	3.1
Nitrogen	5.5	Sulfuric acid	1.4
Potash	1.5	Silica and sand	17.5
Soda	1.0	Chlorine and fluorine	0.3

Sheep-urine, fresh

Water	872.0	Lime	1.6
Organic substance	83.0	Magnesia	3.4
Ash	45.2	Phosphoric acid	0.1
Nitrogen	19.5	Sulfuric acid	3.0
Potash	22.6	Silica and sand	0.1
Soda	5.4	Chlorine and fluorine	5.5

Swine-feces, fresh

Water	820.0	Lime	0.9
Organic substance	150.0	Magnesia	1.0
Ash	30.0	Phosphoric acid	4.1
Nitrogen	6.0	Sulfuric acid	0.4
Potash	2.6	Silica and sand	15.0
Soda	2.5	Chlorine and fluorine	0.3

Swine-urine, fresh

Water	967.0	Soda	2.1
Organic substance	28.0	Magnesia	0.8
Ash	15.0	Phosphoric acid	0.7
Nitrogen	4.3	Sulfuric acid	0.8
Potash	8.3	Chlorine and fluorine	2.3

Peruvian guano

Moisture at 100° C.	12.17	Total nitrogen	5.13
Total phosphoric acid	18.45	Actual ammonia	3.94
Soluble phosphoric acid	1.54	Organic nitrogen	0.86
Reverted phosphoric acid	5.92	Nitrogen as nitric acid	0.33
Insoluble phosphoric acid	10.99	Insoluble matter	13.64
Potassium oxide	3.46		

Human feces, fresh

Water	772.0	Lime	6.2
Organic substance	198.0	Magnesia	3.6
Ash	29.9	Phosphoric acid	10.9
Nitrogen	10.0	Sulfuric acid	0.8
Potash	2.5	Silica and sand	1.9
Soda	1.6	Chlorine and fluorine	0.4

Human urine, fresh

Water	963.0	Lime	0.2
Organic substance	24.0	Magnesia	0.2
Ash	13.5	Phosphoric acid	1.7
Nitrogen	6.0	Sulfuric acid	0.4
Potash	2.0	Chlorine and fluorine	5.0
Soda	4.6		

Sewage (Samuel Rideal)

1000 tons of London crude sewage

	LB.
Ammonia	219
Phosphoric acid (soluble)	28
Phosphoric acid (insoluble)	24
Potash	51

Analyses of Fruit and Garden Products, with Reference to their Fertilizing Constituents (Wolff and Goessmann)

One thousand parts of the plants contain in pounds:—

NAME	WATER	NITRO-GEN	ASH	POTASH	LIME	PHOS- PHORIC ACID
Corn, kernels	144	16.0	12.4	3.7	0.3	5.7
stalk and leaves	150	4.8	45.3	16.4	4.9	3.8
Potato, tubers	750	3.4	9.5	5.8	0.3	1.6
vines	770	4.9	19.7	4.3	6.4	1.6
Peas, seed	143	35.8	23.4	10.1	1.1	8.4
vines	160	10.4	43.1	9.9	15.9	3.5
Beans, seed	150	39.0	27.4	12.0	1.5	9.7
vines	160		40.2	12.8	11.1	3.9
Carrots, roots	850	2.2	8.2	3.0	0.9	1.1
leaves	822	5.1	23.9	2.9	7.9	1.0
Sugar beet, roots	815	1.6	7.1	3.8	0.4	0.9
leaves	897	3.0	15.3	4.0	3.1	0.7
White turnip, roots	920	1.8	6.4	2.9	0.7	0.8
leaves	898	3.0	11.9	2.8	3.9	0.9
Swedish turnip, roots	870	2.1	7.5	3.5	0.9	1.1
leaves	884	3.4	19.5	2.8	6.5	2.0
White cabbage, head	900	3.0	9.6	4.3	1.2	1.1
roots	890	2.4	15.6	5.8	2.8	1.4

Analyses of Fruit and Garden Products—*Continued*

NAME	WATER	NITRO- GEN	ASH	POTASH	LIME	PHOS- PHORIC ACID
Savoy cabbage, head	871	5.3	14.0	3.9	3.0	2.1
Cauliflower	904	4.0	8.0	3.6	0.5	1.6
Horseradish, roots	767	4.3	19.7	7.7	2.0	2.0
Spanish radish, roots	933	1.9	4.9	1.6	0.7	0.5
Parsnip, roots	793	5.4	10.0	5.4	1.1	1.9
Artichoke, roots	811	—	10.1	2.4	1.0	1.1
Asparagus, sprouts	933	3.2	5.0	1.2	0.6	0.9
Common onion, bulb	860	2.7	7.4	2.5	1.6	1.3
Celery	841	2.4	17.6	7.6	2.3	2.2
Spinach	923	4.9	16.0	2.5	1.9	1.6
Common lettuce	940	—	8.1	3.7	0.5	0.7
Head lettuce	943	2.2	10.1	3.9	1.5	1.0
Roman lettuce	925	2.0	9.8	2.5	1.2	1.1
Cucumber	956	1.6	5.8	2.4	0.4	1.2
Pumpkin	900	1.1	4.4	0.9	0.3	1.6
Rhubarb, roots	743.5	5.5	28.8	5.3	5.0	0.6
stem and leaves	916.7	1.3	17.2	3.6	3.4	0.2
Apples	831	0.6	2.2	0.8	0.1	0.3
Pears	831	0.6	3.3	1.8	0.3	0.5
Cherries	825	—	3.9	2.0	0.3	0.6
Plums	838	—	2.9	1.7	0.3	0.4
Gooseberries	903	—	3.3	1.3	0.4	0.7
Strawberries	902	—	3.3	0.7	0.5	0.5
Grapes	830	1.7	8.8	5.0	1.0	1.4
seeds	110	19.0	22.7	6.9	5.6	7.0

For analyses of fertilizer ingredients in forage crops and feeding-stuffs, see Chap. XXII. Consult, also, Cover-crops and Catch-crops, Chap. VIII.

CHAPTER V

SEED-TABLES

THE farm practice of the particular person greatly modifies the quantity of seed to be used to the acre, as also the purpose for which the given crop is to be grown; but the average quantities are to be found about midway between the extremes given in these tables.

Quantity of Seed Required per Acre

Alfalfa (broadcast)	20-25 lb.	Chick-pea	30-50 lb.
Alfalfa (drilled)	15-20 lb.	Chicory (and by cuttings)	1-1½ lb.
Artichoke, Jerusalem	6-8 bu.	Clover, alsike (alone, for forage)	8-15 lb.
Asparagus	4 or 5 lb., or 1 oz. for 50 ft. of drill	Clover, alsike (on wheat or rye in spring)	4-6 lb.
Barley	8-10 pk.	Clover, Egyptian or berseem	½-1 bu.
Barley and peas	1-2 bu. each	Clover, Japan (lespedeza)	12 lb.
Bean, dwarf (in drills)	1½ bu.	Clover, mammoth	12-15 lb.
Bean, pole (in drills)	10-12 qt.	Clover, red (alone, for forage)	16 lb.
Bean, field (small varieties)	2-3 pk.	Clover, red (on small grain in spring)	8-14 lb.
Bean, field (large varieties)	5-6 pk.	Clover, sweet (melilotus)	2 pk.
Beet	4-6 lb.	Clover, white	10-12 lb.
Beggarweed (for forage)	5-6 lb.	Clover, yellow (for seed)	3-5 lb.
Beggarweed (for hay)	8-10 lb.	Clover, yellow (in mixture)	1 lb.
Bent-grass	1-2 bu.	Corn	6 qt.-1 bu.
Berseem	½-1 bu.	Corn (for silage)	9-11 qt.
Blue-grass	25 lb. (pure)	Cotton	1-3 bu.
Brome-grass (alone, for hay)	12-15 lb.	Cowpea	1-1½ bu.
Brome-grass (alone, for pasture)	15-20 lb.	Cowpea (in drill, with corn)	½-1 bu.
Brome-grass (in mixture)	2-5 lb.	Cowpea (for seed)	3 pk.
Broom-corn	3 pk.	Cress, upland (in drills)	2-3 lb.
Broom-corn (for seed)	1 pk.	Cress, water (in drills)	2-3 lb.
Buckwheat	3-5 pk.	Crimson clover	12-15 lb.
Bur-clover	12 lb.	Cucumber (in hills)	2 lb.
Cabbage	¾-1 lb.	Durra. See Kafir and Milo	
Carrots (for stock)	4-6 lb.		
Cassava	By cuttings		
Cauliflower	1 oz. for 1000 plants		
Celery	1 oz. for 2000 plants		

Eggplant	1 oz. for 1000 plants	Red-top (re-cleaned)	12-15 lb.
Field-pea (small varieties)	2½ bu.	Rescue-grass	30-40 bu.
Field-pea (large varieties)	3-3½ bu.	Rice	1-3 bu.
Flax (for fiber)	1½-2 bu.	Rutabaga	3-5 lb.
Flax (for seed)	2-3 pk.	Rye (early)	3-4 pk.
Grass, for lawns	3-5 bu.	Rye (late)	6-8 pk.
Guinea-grass	Root cuttings	Rye (forage)	3-4 bu.
Hemp (broadcast)	3½-4 pk.	Rye-grass	2-3 bu.
Hungarian-grass (hay)	2 pk.	Sage (in drills)	8-10 lb.
Hungarian-grass (seed)	1 pk.	Sainfoin (shelled seed)	40 lb.
Johnson-grass	1-1½ bu.	Salsify (in drills)	8-10 lb.
Kafir (drills)	3-6 lb.	Sand lucerne (broadcast)	15 lb.
Kafir (for fodder)	10-12 lb.	Serradella (alone, in drills)	40-50 lb.
Kale	2-4 lb.	Sheep's fescue	2½-3 bu.
Kohlrabi	4-5 lb.	Sorghum (forage, broadcast)	1½-2 bu.
Lespedeza	12 lb.	Sorghum (for seed or syrup)	2-5 lb.
Lettuce	1 oz. for 1000 plants	Sorghum, saccharine (for silage or soiling, drills)	6 lb.-½ bu.
Lupine	1½-2 bu.	Sorghum and peas	3-4 pk. each
Mangels	5-8 lb.	Soybean (drills)	2-3 pk.
Meadow fescue	12-15 lb.	Soybean (broadcast)	1-1½ bu.
Melon, musk (in hills)	2-3 lb.	Spinach (in drills)	10-12 lb.
Melon, water (in hills)	4-5 lb.	Spurry	6-8 qt.
Millet, barnyard (drills)	1-2 pk.	Spurry (for seed)	4 qt.
Millet, foxtail (drills)	2-3 pk.	Squash, bush (in hills)	4-6 lb.
Millet, German (seed)	1 pk.	Squash, running (in hills)	3-4 lb.
Millet, Aino (drills)	2-3 pk.	Sugar-beets	15-20 lb.
Millet, pearl (for soiling)	4 lb.	Sugar-cane	4 tons of cane
Millet, pearl (for hay)	8-10 lb.	Sunflower	10-15 lb.
Millet, proso or panicle (drills)	2-3 pk.	Sweet clover	2-4 pk.
Milo	5 lb.	Sweet-potato	1½-4 bu.
Mustard, broadcast	½ bu.	Teasel	1-1½ pk.
Oat-grass, tall	30 lb.	Teosinte	1-3 lb.
Oats	2-3 bu.	Timothy	15-25 lb.
Oats and peas	{ oats 2 bu., peas ½ bu.	Timothy and clover	{ timothy 10 lb. clover 4 lb.
Onion (in drills)	5-6 lb.	Tobacco	{ 1 tablespoonful to 100 sq. yd. to set out 6 acres
Onion seed for sets (in drills)	30 lb.	Tomato (to transplant)	¼ lb.
Onion sets (in drills)	6-12 bu.	Turnip (broadcast)	2-4 lb.
Orchard-grass	12-15 lb. (pure)	Turnip (drills)	1-2 lb.
Para-grass	Cuttings	Turnip (hybrid)	3-5 lb.
Parsnips	4-8 lb.	Velvet bean	1-4 pk.
Peas, garden (in drill)	1-2 bu.	Vetch, hairy (drilled)	{ 1 bu. + 1 bu. small grain
Popcorn	3 lb.	Vetch, hairy (broadcast)	{ 1½ bu. + 1 bu. small grain
Potato (Irish) average	10-14 bu.	Vetch, kidney	18-22 lb.
Potato, cut to 1 or 2 eyes	6-9 bu.	Vetch, spring	{ ⅝ pk. + 1 bu. small grain
Potato, recommended by many for best yields	15-20 bu.	Wheat	6-9 pk.
Pumpkin	4 lb.		
Radish (in drills)	8-10 lb.		
Rape (in drills)	2-4 lb.		
Rape (broadcast)	4-8 lb.		

Hay and Pasture Seeds

<i>Permanent meadows:</i>		<i>Permanent pastures:</i>	
Timothy	12 lb.	Timothy	3 lb.
Red clover	4 lb.	Orchard-grass	2 lb.
Alsike	2 lb.	Red-top	2 lb.
Timothy	16 lb.	Kentucky blue-grass	2 lb.
Red-top	16 lb.	Italian rye-grass	1 lb.
Red clover	4 lb.	Meadow fescue	2 lb.
Red-top	13 lb.	Red clover	4 lb.
Orchard-grass	18 lb.	White clover	2 lb.
Meadow fescue	9 lb.	Kentucky blue-grass	8 lb.
Red clover	4 lb.	White clover	4 lb.
Tall oat-grass	28 lb.	Perennial rye-grass	9 lb.
Red clover	8 lb.	Red fescue	3 lb.
Timothy	8 lb.	Red-top	8 lb.
Red clover	4 lb.	Red-top	14 lb.
Alsike	2 lb.	Alsike	8 lb.
Kentucky blue-grass	2 lb.	Creeping bent	6 lb.
Red-top	2 lb.	Perennial rye-grass	12 lb.
Orchard-grass	10 lb.	Red fescue	20 lb.
Red-top (re-cleaned)	5 lb.	Red-top	10 lb.
Red-top (in chaff)	12 lb.	Kentucky blue-grass	8 lb.
Tall meadow oat-grass	12 lb.	White clover	2 lb.
Red clover	8 lb.		
Alsike clover	4 lb.		

} 20-24 lb. per acre

} Wet pasture

} Light sandy soil

Timothy, red-top, Kentucky blue-grass and red clover, equal parts, 8 to 20 lb. pounds per acre of the mixture.

For quantity of seed for cover-crops, see Chap. VIII.

Number and weight of grass seeds, and another estimate of quantity to sow (Fraser).

The following table has been adapted from "The Best Forage Plants," by Stebler and Schroeter, and from it calculations may be made. The actual number of grains in a pound will frequently vary 20 per cent either way; for example, in re-cleaned fancy seed there are fewer grains to the pound, while in an uncleaned sample free from chaff, but containing many small seeds, the number will be greater. The re-cleaned seed weighs heavier per bushel. The uncleaned seed may contain a large proportion of chaff, and in such case the number of seeds per pound of material may be very low. The numbers given are per pound of pure seed. The percentage of germination of average samples of seed is frequently but half, and even less than half, of that given in the table. The germination of the rye grasses given in the table is a little higher than ordinarily found in the United States, even with imported seed. Low germinating power may be due to lack of uniformity in ripening the seed; to part of the seed on a plant being mature before

the remainder, frequently seen in meadow foxtail; or to poor methods of harvesting, as in Kentucky blue-grass:—

NAME	NUMBER OF GRAINS IN ONE POUND OF PURE SEED	AMOUNT TO SOW PER ACRE, IF SOWN ALONE, STANDARD QUALITY	GOOD PERCENTAGE OF GERMINATION	WEIGHT PER ENG- LISH BUSHEL	WEIGHT OF 10,000,- 000 GRAINS, SIZE AS PER COLUMN 1
		<i>Pounds</i>		<i>Pounds</i>	<i>Pounds</i>
Awnless brome grass	137,000	30-50	75-90	13-14	72.99
Kentucky blue-grass	2,400,000	15-20	80-90	14-32	4.17
Orchard-grass	579,000	20-35	80-95	12-23	17.25
Perennial rye-grass	336,800	25-40	95-98	18-30	29.7
Italian rye-grass	285,300	30-45	95-98	12-24	35.1
Meadow fescue	318,200	30-35	75-95	12-30	31.42
Sheep's fescue	680,000	25-30	60-75	10-25	14.85
Tall oat-grass	159,000	20-30	80-90	10-16	62.89
Meadow foxtail	907,000	20-25	60-90	6-14	11.02
Red-top	6,030,000	8-16	90-95	12-40	1.65
Timothy	1,170,500	10-16	95-98	45-48	8.54
Alsike clover	707,000	10-13	95-98	60-64	14.14
Red clover	279,000	10-16	95-98	60-64	35.8
White clover	740,000	10-12	95-98	60-64	13.51
Alfalfa	209,500	15-30	95-98	60-64	48.56

Examples of seed mixtures that would furnish 20,000,000 grass seeds per acre, and the weight of same (Fraser)

	No. of Seeds	Weight of Pure, Viable Seed. Lb.
<i>For hay and fall pasture. Heavy land. Brief duration.</i>		
Timothy	13,400,000	11.44
Alsike	3,300,000	4.66
White clover	3,300,000	4.46
	<u>20,000,000</u>	<u>20.56</u>
<i>For hay and pasture.</i>		
Timothy	10,000,000	8.54
Kentucky blue-grass	2,000,000	0.82
Orchard-grass	1,400,000	2.42
Alsike	3,300,000	4.66
White clover	3,300,000	4.46
	<u>20,000,000</u>	<u>20.90</u>
<i>For hay and pasture.</i>		
Timothy	8,000,000	6.84
Kentucky blue-grass	2,400,000	1.00
Orchard-grass	2,000,000	3.46
Meadow foxtail	1,000,000	1.10
Alsike	3,300,000	4.66
White clover	3,300,000	4.46
	<u>20,000,000</u>	<u>21.52</u>

Examples of seed mixtures — Continued

	No. of Seeds	Weight of Pure, Viable Seed Lb.
<i>For hay.</i> Heavy loam.		
Red clover	2,790,000	10.00
Alsike	2,121,000	3.00
Timothy	7,089,000	6.06
Red-top	8,000,000	1.32
	20,000,000	20.38

Testing grass seed (Fraser).

In testing the seed for germination power and purity it is more satisfactory to weigh out a sample of the seed, separate the chaff and inert matter, weigh it, and then proceed to make a germination test of the remainder. For example, if a sample of awnless brome grass contain 10 per cent of dirt and chaff, and 75 per cent of the pure seeds are viable, the actual germination power of the sample is 67.5 per cent, or

$$\frac{75 \times 90}{100} = 67.5.$$

Number of Tree-Seeds in a Pound

FRUIT TREES

	About
Apple	12,000
Cherry pits	1,000
Peach	200
Pear	15,000
Plum	600
Quince	15,000
Mulberry	200,000

FOREST TREES

	By count
Butternut	Juglans cinerea 15
Black walnut	Juglans nigra 25
American horse-chestnut	Æsculus glabra 36
Hickory (shellbark)	Carya alba 78
American sweet chestnut	Castanea vesca, var. 90
Silver-leaved maple	Acer dasycarpum 2,421
Honey-locust	Gleditschia triacanthos 2,496
Black cherry	Prunus serotina 4,311
Black ash	Fraxinus sambucifolia 5,629
American basswood	Tilia Americana 6,337
Norway maple	Acer platanoides 7,231
Sugar maple	Acer saccharinum 7,488
Barberry	Berberis vulgaris 8,183
Red cedar	Juniperus Virginiana 8,321
Rock elm	Ulmus racemosa 8,352
American white ash	Fraxinus Americana 9,858
Osage orange	Maclura aurantiaca 10,656

FOREST TREES—Continued

		By count
Silver fir	Abies pectinata	12,000
Box elder	Negundo aceroides	14,784
Hardy catalpa	Catalpa speciosa	19,776
Ailanthus	Ailanthus glandulosus	20,161
White pine	Pinus Strobus	20,540
Scarlet maple	Acer rubrum	22,464
Green ash	Fraxinus viridis	22,656
Black locust	Robinia Pseudacacia	28,992
Red elm	Ulmus fulva	54,359
American white elm	Ulmus Americana	92,352
American mountain ash	Pyrus Americana	108,327
White birch	Betula alba	500,000

Figures vary greatly in different counts, the variation probably amounting to as much as 20 per cent. It is usually estimated that white pine seeds run about 30,000 to the pound, and red cedar 20,000.

Weights and Sizes of Seeds

Seedsmen's customary weights per bushel of seeds (Edgar Brown)

KIND OF SEED	Pounds per bushel	KIND OF SEED	Pounds per bushel
Alfalfa	60	Cowpea	56-60
Amber cane	45-60	Crested dog's-tail	14-30
Bent-grass :		Fescue :	
Creeping	10-20	Hard	12-16
Rhode Island	10-15	Meadow	14-24
Bermuda-grass	24-36	Red	12-15
Bird'sfoot clover	60	Sheep's	12-16
Bitter vetch		Tall	14-24
Blue-grass :	60	Various leaved	14-18
Canada	14-20	Flat pea	50-60
Kentucky	14-30	Flax	48-56
Texas	14	Hemp	40-60
Broad bean	50-60	Japan clover :	
Brome, awnless	10-14	Hulled	60
Broom corn	45-60	Unhulled	18-25
Bur clover :		Johnson-grass	14-28
Hulled	60	Kafir	50-60
Unhulled	8-10	Lentil	60
Spotted	60	Lupine, white	50-60
Castor bean	46-60	Meadow foxtail	7-14
Clover :		Meadow-grass	
Alsike	60	Fowl	11-14
Crimson	60	Rough-stalked	14-20
Egyptian	60	Wood	14-24
Mammoth	60	Millet :	
Red	60	Barnyard	30-60
White	60	Broom corn	45-60

Weights and Sizes of Seeds—Continued

KIND OF SEED	Pounds per bushel	KIND OF SEED	Pounds per bushel
Millet—continued		Rye-grass:	
Common	48-50	English	10-30
German	48-50	Italian	14-25
Golden Wonder	48-50	Saintoin	14-32
Hungarian	48-50	Serradella	28-30
Pearl	48-56	Soybean	58-60
Milo	50-60	Spelt	40-60
Oat-grass:		Sunflower	24-50
Tall	10-14	Sweet clover:	
Yellow	7-14	Hulled	60
Orange cane	45-60	Unhulled	33
Orchard-grass	10-18	Sweet corn (according to	
Pea:		variety)	36-56
Field	60	Sweet vernal, perennial	6-15
Garden, smooth	60	Teosinte	40-60
Garden, wrinkled	56	Timothy	45
Peanut	20-30	Velvet bean	60
Rape, winter	50-60	Vetch:	
Red-top:		Hairy	50-60
Chaff	10-14	Spring	60
Fancy	25-40	Water-grass, large	14
Rescue-grass	12-28	Wild rice	15-28
Rice	43-45	Yellow trefoil	60

For *legal* weights of seeds, grains, fruits, and other products, see Chap. XXVII.

Weight and size of garden seeds (adapted from Vilmorin's tables)

	Weight of a qt. of seeds in oz.	Number of seeds in 1 grain
Angelica	5.827	11.02
Anise	11.65	12.96
Asparagus bean (<i>Dolichos sesquipedalis</i>)	29.91	32.40 to 42.12 in 100 gr.
Balm	21.36	129.60
Basil	20.59	51.84
Bean	24.27 to 33.02	4.86 to 51.84 in 100 gr.
Beet	9.71	3.24
Borage	18.65	4.21
Borecole	27.19	19.44
Broccoli	27.19	24.30
Cabbage	27.19	19.44
Caper	17.87	10.37
Caraway	16.31	22.68
Cardoon	24.47	1.62
Carrot with the spines	9.32	45.36
Carrot without the spines	13.98	61.56

Weight and size of garden seeds—Continued

	Weight of a qt. of seeds in oz.	Number of seeds in 1 grain
Catmint	26.42	77.76
Cauliflower	27.19	24.30
Celery	18.65	162.00
Chervil	14.76	29.16
Chervil sweet-scented	9.71	2.59
Chervil turnip-rooted	20.98	29.16
Chicory	15.54	45.36
Chick-pea	30.30	1.94 in 10 gr.
Coriander	12.43	5.83
Corp. salad	10.88	64.80
Cress, American	20.98	61.56
Cress, common garden	28.36	29.16
Cress, meadow (cuckoo-flower)	22.53	97.20
Cress, Para	7.78	220.32
Cress, water	22.53	259.20
Cucumber, common	19.42	2.27
Cucumber, globe	19.42	6.48
Cucumber, prickly-fruited gherkin	21.36	8.42
Cucumber, snake (<i>Cucumis flexuosus</i>)	17.48	2.59
Dandelion	10.49	77.76 to 97.20
Dill	11.65	58.32
Egg-plant	19.42	16.20
Endive	13.20	38.88
Fennel, common or wild	17.48	20.09
Fennel, sweet	9.13	8.10
Gumbo, see OKRA.		
Good King Henry	24.28	27.86
Gourds, fancy	17.48	1.29
Hop	9.71	12.96
Horehound	26.42	64.80
Hyssop	22.34	55.08
Kohlrabi	27.19	19.44
Leek	21.37	25.92
Lettuce	16.70	51.84
Lovage	7.78	19.44
Maize, or Indian corn	24.86	2.59 to 3.24 in 10 gr.
Marjoram, sweet	21.37	259.20
Marjoram, winter	26.22	777.60
Martynia	11.26	1.29
Muskmelon	13.98	2.27
Mustard, black or brown	26.22	45.36
Mustard, Chinese cabbage-leaved	25.64	42.12
Mustard, white, or salad	29.13	12.96
Nasturtium, tall	13.20	4.54 to 5.18 in 10 gr.
Nasturtium, dwarf	23.30	9.7 in 10 gr.
Okra	24.08	9.7 to 11.66 in 10 gr.
Onion	19.42	16.20
Orach	5.44	16.20
Parsnip	7.78	14.25
Parsley	19.42	22.67
Pea	27.19 to 31.08	1.29 to 3.56 in 10 gr.
Pea, gray or field	26.41 to 31.08	3.24 to 5.18 in 10 gr.

Weight and size of garden seeds — Continued

	Weight of a qt. of seed in oz.	Number of seeds in 1 grain
Peanut	15.54	1.29 to 1.94 in 10 gr.
Pepper	17.48	9.72
Pumpkin	9.71	1.94 in 10 gr.
Purslane	23.70	162.00
Radish	27.19	7.77
Rampion	31.08	1620.00
Rhubarb	3.10 to 4.66	3.24
Rocket Salad	29.13	35.64
Rosemary	15.54	58.32
Rue	22.53	32.40
Sage	21.37	16.20
Salsify	8.93	6.48
Savory, summer	19.42	97.20
Savory, winter	16.70	162.00
Scorzonera	10.09	5.83
Scurvy-grass	23.30	97.20 to 116.64
Sea-kale	8.16	9.72 to 11.66 in 10 gr.
Spinach, prickly-seeded	14.57	5.83
Spinach, round-seeded	19.81	7.13
Spinach, New Zealand	8.74	6.48 to 7.77 in 10 gr.
Strawberry	23.30	51.84 to 162.00
Strawberry blite (<i>Blitum</i>)	31.08	324.00
Strawberry tomato (<i>Physalis</i>)	25.25	64.80
Sweet Cicely	9.71	2.59
Tansy	11.65	453.60
Thyme	26.41	388.80
Tomato	11.65	19.44 to 25.92
Turnip	26.03	29.16
Valerian, African	4.27	16.20
Watermelon	17.87	3.24 to 3.88 in 10 gr.
Wax gourd	11.65	1.36
Welsh onion, common	18.65	19.44
Welsh onion, early white	22.92	32.40
Wormwood	25.25	745.20

Figures of Germination and Purity

Seed testing.

The testing of seeds is of two purposes, — to determine whether the sample is adulterated, and to determine the viability or germinating power.

Adulteration or impurity is discovered by examining the sample under a lens.

Viability is determined by sprouting the seeds under favorable conditions. Mix the sample well, and choose 100 seeds as they come, eliminating only the foreign seeds. Place them between folds of moist Canton flannel, and keep moist (not soaking wet) by covering

with a plate. Keep at living-room temperature. As rapidly as the seeds sprout, remove them. See that the seeds do not touch each other, or mold may spread.

High average percentage of purity and of germination of high-grade seed (Duvel)

SEED	PURITY PER CENT	GERMINA- TION PER CENT	SEED	PURITY PER CENT	GERMINA- TION PER CENT
Alfalfa . . .	99	95	Millet, hog . .	99	90
Asparagus . .	99	85	Millet, pearl .	99	90
Barley . . .	99	98	Mustard . . .	99	95
Beans . . .	99	98	Oats	99	96
Beet, garden .	99	150 ¹	Okra	99	80
Beggarweed . .	99	90	Onion	99	96
Bermuda-grass .	98	90	Orchard-grass .	95	90
Blue-grass, Can- ada	95	85	Parsley	99	80
Blue-grass, Ken- tucky	95	85	Parsnip	98	85
Brome, awnless .	90	90	Peas	99	98
Buckwheat . . .	99	96	Pumpkin	99	96
Cabbage	99	95	Radish	99	97
Caraway	98	90	Rape	99	96
Carrot	98	85	Red-top	96	90
Cauliflower . .	99	85	Rice	99	95
Celery	98	85	Rye	99	96
Clover, alsike .	98	95	Rye-grass, Ital- ian	98	90
Clover, crimson .	98	97	Rye-grass, Eng- lish	98	90
Clover, red . . .	98	95	Salsify	98	85
Clover, sweet . .	98	90	Sainfoin	99	95
Clover, white . .	96	90	Sorghum	98	95
Collard	99	95	Soybean	99	95
Corn, field . . .	99	99	Spinach	99	90
Corn, sweet . . .	99	94	Spurry	99	90
Cotton	99	90	Squash	99	96
Cowpea	99	95	Sugar-beet (large balls) .	99	175 ¹
Cress	99	90	Sugar-beet (small balls) .	99	150 ¹
Cucumber	99	96	Sunflower	99	90
Eggplant	99	90	Sweet-pea	99	90
Endive	99	85	Teosinte	99	90
Fescue, meadow .	98	90	Timothy	99	96
Fescue, sheep's .	96	85	Tomato	99	94
Flax	99	95	Tobacco	99	90
Hemp	99	90	Turnip	99	98
Kafir corn . . .	99	97	Velvet bean . .	99	90
Kale	99	95	Velvet grass (hulled)	97	85
Lettuce	99	98	Vetch	99	93
Melon, musk . .	99	96	Wheat	99	98
Melon, water . .	99	96			
Millet, common .	99	90			

¹ Each beet fruit, or "ball," is likely to contain two to seven seeds. The numbers given in the table represent the number of sprouts from one hundred balls.

Average time required for garden seeds to germinate

	DAYS		DAYS
Bean	5-10	Lettuce	6-8
Beet	7-10	Onion	7-10
Cabbage	5-10	Pea	6-10
Carrot	12-18	Parsnip	10-20
Cauliflower	5-10	Pepper	9-14
Celery	10-20	Radish	3-6
Corn	5-8	Salsify	7-12
Cucumber	6-10	Tomato	6-12
Endive	5-10	Turnip	4-8

Longevity of Seeds

Vilmorin's tables

	AVERAGE YEARS	EXTREME YEARS
Angelica	1 or 2	3
Anise	3	5
Asparagus bean (<i>Dolichos sesquipedalis</i>)	3	8
Balm	4	7
Barley	3	—
Basil	8	10 +
Bean	3	8
Beet	6	10 +
Borage	8	10 +
Borecole	5	10
Broccoli	5	10
Buckwheat	2	—
Cabbage	5	10
Caraway	3	4
Cardoon	7	9
Carrot, with the spines	4 or 5	10 +
Carrot, without the spines	4 or 5	10 +
Catmint	5	6 +
Cauliflower	5	10
Celery	8	10 +
Chervil	2 or 3	6
Chervil, sweet-scented	1	1
Chervil, turnip-rooted	1	1
Chicory	8	10 +
Chick-pea	3	8
Clover	3	—
Coriander	6	8
Corn-salad, common	5	10
Cress, American	3	5
Cress, common garden	5	9
Cress, meadow (cuckoo-flower)	4	(?)
Cress, Para	5	7 +
Cress, water	5	9 +
Cucumber, common	10	10 +
Cucumber, globe	6	(?)

Longevity of Seeds—Continued

	AVERAGE YEARS	EXTREME YEARS
Cucumber, prickly-fruited gherkin	6	7+
Cucumber, snake (<i>Cucumis flexuosus</i>)	7 or 8	10+
Dandelion	2	5
Dill	3	5
Egg-plant	6	10
Endive	10	10+
Fennel, common or wild	4	7
Fennel, sweet	4	7
Flax	2	—
Gumbo, see OKRA.		
Good King Henry	3	5
Gourds, fancy	6	10+
Hop	2	4
Horehound	3	6
Hyssop	3	5
Kohlrabi	5	10
Leek	3	9
Lentil	4	9
Lettuce, common	5	9
Lovage	3	4
Maize, or Indian corn	2	4
Marjoram, sweet	3	7
Marjoram, winter	5	7
Martynia	1 or 2	(?)
Millet	2	—
Muskmelon	5	10+
Mustard, black or brown	4	9
Mustard, Chinese cabbage-leaved	4	8
Mustard, white or salad	4	10+
Nasturtium, tall	5	5
Nasturtium, dwarf	5	8
Oats	3	—
Okra	5	10+
Onion	2	7
Orach	6	7
Orchard-grass	2	—
Parsnip	2	4
Parsley	3	9
Pea, garden	3	8
Pea, gray or field	3	8
Peanut	1	1
Pepper	4	7
Pumpkin	4 or 5	9
Purslane	7	10
Radish	5	10+
Rampion	5	10+
Rape	5	—
Rhubarb	3	8
Rocket salad	4	9
Rosemary	4	(?)
Rue	2	5

Longevity of Seeds—Continued

	AVERAGE YEARS	EXTREME YEARS
Rye	2	—
Sage	3	7
Salsify	2	8
Savory, summer	3	7
Savory, winter	3	6
Scorzonera	2	7
Scurvy-grass	4	7
Sea-kale	1	7
Soybean	2	6
Spinach, prickly-seeded	5	7
Spinach, round-seeded	5	7
Spinach, New Zealand	5	8
Squash, bush-scallop	6	10+
Strawberry	3	6
Strawberry, tomato (<i>Physalis</i>)	8	10+
Sweet Cicely	1	1
Tansy	2	4
Thyme	3	7
Timothy	2	—
Tomato	4	9
Turnip	5	10+
Valerian, African	4	7
Watermelon	6	10+
Wax gourd	10	10+
Welsh onion, common	2 or 3	7
Welsh onion, early white	3	8
Wheat	2	7+
Wormwood	4	6

Haberlandt's figures of longevity (Quoted in Johnson's "How Crops Grow")

	PERCENTAGE OF SEEDS THAT GERMINATED IN 1861 FROM THE YEARS							
	1850	1851	1854	1855	1857	1858	1859	1860
Barley	0	0	24	0	48	33	92	97
Maize	0	not tried	76	56	not tried	77	100	96
Oats	60	0	56	48	72	32	80	100
Rye	0	0	0	0	0	0	48	96
Wheat	0	0	8	4	73	60	84	89

Vitality of seeds buried in soil (W. J. Beal).

In the fall of 1879, fifty fresh seeds of each of twenty-one kinds of plants (mostly weeds) were mixed with moderately moist sand and placed in uncorked bottles that were buried twenty inches below the surface, with the mouths slanting downward. Acorns were buried near the bottles. Six tests have been made of these seeds. The crosses (+) indicate germinations:—

NAMES OF SEEDS TESTED AS KNOWN IN 1879	5TH YEAR	10TH YEAR	15TH YEAR	20TH YEAR	25TH YEAR	30TH YEAR
Amarantus retroflexus	+	+	+	+	+	+
Ambrosia artemisiæfolia	0	0	0	0	0	0
Brassica nigra	?	+	+	+	+	+
Bromus secalinus	0	0	0	0	0	0
Capsella Bursa-pastoris	+	?	+	+	+	+
Erechtites hieracifolia.	0	0	0	0	0	0
Euphorbia maculata	0	0	0	0	0	0
Lepidium Virginicum	+	+	+	+	+	+
Lychnis Githago.	0	0	0	0	0	0
Maruta Cotula	+	+	+	0	+	0
Malva rotundifolia	+	0	0	+	0	0
Oenothera biennis	+	+	+	+	+	+
Plantago major	0	0	+	0	0	0
Polygonum Hydropiper	0	+	+	+	+	possibly
Portulaca oleracea	0	+	+	+	+	0
Quercus rubra	0	0	0	0	0	0
Rumex crispus	+	?	+	+	+	+
Setaria glauca	+	+	+	0	+	+
Stellaria media	+	+	+	+	+	+
Thuja occidentalis	0	0	0	0	0	0
Trifolium repens	0	0	0	0	0	0
Verbascum Thapsus	+	?	+	+	0	0

In all of the six tests, eight species out of twenty-two failed to germinate; and of the remaining fourteen species, seeds of eight, possibly nine, germinated often when they had been buried thirty years. The acorns (*Quercus rubra*) buried near the bottles of seeds were all dead at the end of two years.

Average Yields of Garden Seed-Crops

	WHEN CROP IS AS GOOD AS 20 BU. OF WHEAT PER ACRE WOULD BE	WHEN CROP IS VERY HEAVY
	lbs. of seed per acre	lbs. of seed per acre
Bean	600	1500
Pea	900	2500
Squash, summer	100	700
Squash, winter	100	400
Sweet corn	1000 to 2500 (according to variety)	2500 to 4000
Cucumber	150	700
Muskmelon	125	600
Watermelon	150	1000
Tomato	100	400
Cabbage	250	800

The average crop is probably 10 to 20 per cent less than the figures given in the first column.

CHAPTER VI

PLANTING-TABLES

THE novice always wants exact advice as to dates, depths, and distances. It is impossible to give such advice that is reliable in all times and places; it must be given only for suggestion and guidance, not for exact and absolute application. Accepted in this spirit, planting-tables may be very useful, even for the experienced planter.

Dates for Sowing or Setting Kitchen-Garden Vegetables in Different Latitudes

Lansing, Michigan

(Average of 4 and 5 years.)

Bean, bush	May 16.
Bean, pole	May 30.
Beet	April 20.
Broccoli	May 10.
Brussels sprouts	May 10.
Cabbage, early, under glass	March 15.
Cabbage, late	May 20.
Carrot	May 7.
Cauliflower, under glass	March 15.
Celery, under glass	March 18.
Celery, in open ground	May 20.
Corn	May 19.
Cucumber	May 23.
Egg-plant, under glass	March 15.
Kale	May 9.
Kohlrabi	May 9.
Lettuce	May 5.
Melon	May 30.
Okra	May 15.
Onion	April 17.
Parsnips	May 7.
Peas	April 15.
Pepper under glass	March 15.
Potato	May 3.
Pumpkin	May 31.
Radish	April 26.
Salsify	May 7.
Spinach	April 10.
Squash	May 28.
Tomato, under glass	March 13.
Turnip	April 15.

Boston (Rawson)

Asparagus	About the end of April.
Bean, bush	About the first week in May.

Bean, pole	From about the middle of May to the 1st of June.
Bean, lima	About the 1st of June.
Beet	About the middle of April.
Borecole, or Kale	About the middle of April; plant out in June.
Brussels sprouts	In March or April in hotbed.
Cabbage	Transplant the last week in April or the 1st in May.
Carrots	Last of May or 1st of June.
Cauliflower	From the 1st of May until the 1st of July.
Celery	The 1st week in April to the 2d in July.
Corn, sweet	About the 1st of May.
Cucumber	For 1st crop, about the middle of March.
Egg-plant	About March 15 in hotbed.
Endive	June or July.
Kohlrabi	May or June.
Okra	About the 10th of May.
Peas	During the last of April up to the 1st of May.
Pepper	Put out of doors about the 1st of April.
Radish	From the 1st of April to the middle of June.
Spinach	About the 1st of September.
Tomato	About the 25th of May set plants outdoors.
Turnips, for fall use	Any time from July 1 to August 20.
Watermelon	About the middle of May.

New York (Henderson)

Plants to sow from the middle of March to the end of April. Thermometer in shade averaging 45 degrees.

Beet	Cauliflower	Parsley
Carrot	Endive	Peas
Cress	Kale	Radish
Celery	Lettuce	Spinach
Cabbage	Onions	Turnip
	Parsnip	

From the middle of May to the middle of June. Thermometer in the shade averaging 60°.

Bean, bush	Bean, runner	Nasturtium
Bean, cranberry	Corn, sweet	Okra
Bean, lima	Cucumber	Pumpkin
Bean, pole	Melon, musk	Squash
Bean, scarlet	Melon, water	Tomato

Norfolk, Virginia

Months in which different crops are planted or sown, or set out in the open air.

Kale and Spinach	sown during August, September, and October.
Cabbage	The seeds are sown in August and September, and the plants are transplanted in the open air in November and December.
Onions	Sown in August, September, January, and February.
Leeks	The same as onions.
Lettuce	Sown in September and January.
Radish	Sown in every month in the year.
Peas	December, January, February, March, April, August, and September.
Beans	March and April.
Egg-plant	April and May.
Tomatoes	April and May.

Squash	April.
Cauliflower . . .	March and April.
Potatoes	February, March, and July.
Sweet-potatoes .	May.
Beets	February and March.
Corn	April, May, June, and July.
Oats	September, October, November, December, February, and March.
Millet	June and July; after potatoes.
Grass-seed	September, October, November, February, and March.
Carrots	February and March.
Celery	April and May.
Cucumbers	April.
Watermelons . . .	April.
Cantaloupes . . .	April.
Peanuts	May.

Georgia (Oemler)

Asparagus	From December 1 to the middle of March.
Bean, bush	From the 1st to the middle of March.
Beet	Through November and December.
Cabbage	From the 1st of October to the 15th. Transplant about November 1 and later.
Cauliflower	From May to September.
Cucumber	About March 1 to the 15th.
Egg-plant	To prick out, about the middle of January, otherwise ten or fifteen days later.
Lettuce	About the middle of September.
Onion	About January 1.
Pea	About December 1.
Potato	The 1st of February.
Radish	From Christmas to the last of February.
Spinach	From September 10 until October 15.
Squash	About the last of February up to the middle of March.
Sweet-potato . . .	In cold frames, about the 1st of January.
Tomato	About January 1.
Watermelon	About the 15th of March.

Tender and hardy vegetables

Vegetables injured by a slight frost, and which should therefore be planted only after the weather has settled.

All Kidney, Lima, and Common Beans	Egg-plant	Pumpkin
Corn	All melons	Squash
Cucumber	Okra	Sweet Potato
	Pepper	Tomato

Vegetables which, when properly handled, will endure a frost.

Asparagus	Corn-salad	Parsley
Bean, Windsor, Broad or Horse	Cress	Parsnip
Beet	Endive	Pea
Borecole	Horseradish	Radish
Broccoli	Kohlrabi	Rhubarb
Brussels sprouts	Kale	Salsify
Cabbage	Leek	Sea-kale
Carrot	Lettuce	Spinach
Cauliflower	All Onions	Turnip
Celery		

Date-tables

Vegetable-gardeners planting-table (U. S. Dept. Agric.)

See also separate table of distances on p. 119.

	SEEDS OR PLANTS REQUIRED FOR 100 FEET OF ROW	DISTANCE FOR PLANTS TO STAND			DEPTH OF PLANTING
		Rows apart		Plants apart in rows	
		Horse cultivation	Hand cultivation		
Artichoke, globe . . .	½ ounce	3 to 4 ft.	2 to 3 ft.	2 to 3 ft.	1 to 2 in.
Artichoke, Jerusalem . . .	2 qt. tubers	3 to 4 ft.	1 to 2 ft.	1 to 2 ft.	2 to 3 in.
Asparagus, seed . . .	1 ounce	30 to 36 in.	1 to 2 ft.	3 to 5 in.	1 to 2 in.
Asparagus, plants . . .	60 to 80 plants	3 to 5 ft.	12 to 24 in.	15 to 20 in.	3 to 5 in.
Beans, bush . . .	1 pint	30 to 36 in.	18 to 24 in.	5 or 8 to ft.	½ to 2 in.
Beans, pole . . .	½ pint	3 to 4 ft.	3 to 4 ft.	3 to 4 ft.	1 to 2 in.
Beets . . .	2 ounces	24 to 36 in.	12 to 18 in.	5 or 6 to ft.	1 to 2 in.
Brussels sprouts . . .	¼ ounce	30 to 36 in.	24 to 30 in.	16 to 24 in.	½ in.
Cabbage, early . . .	¼ ounce	30 to 36 in.	24 to 30 in.	12 to 18 in.	½ in.
Cabbage, late . . .	¼ ounce	30 to 40 in.	24 to 36 in.	16 to 24 in.	½ in.
Cardoon . . .	½ ounce	3 ft.	2 ft.	12 to 18 in.	1 to 2 in.
Carrot . . .	1 ounce	30 to 36 in.	18 to 24 in.	6 or 7 to ft.	½ in.
Cauliflower . . .	¼ ounce	30 to 36 in.	24 to 30 in.	14 to 18 in.	½ in.
Celeriac . . .	¼ ounce	30 to 36 in.	18 to 24 in.	4 or 5 to ft.	⅞ in.
Celery . . .	¼ ounce	3 to 6 ft.	18 to 36 in.	4 to 8 in.	½ in.
Chervil . . .	1 ounce	30 to 36 in.	18 to 24 in.	3 or 4 to ft.	1 in.
Chicory . . .	¼ ounce	30 to 36 in.	18 to 24 in.	4 or 5 to ft.	½ in.
Citron . . .	1 ounce	8 to 10 ft.	8 to 10 ft.	8 to 10 ft.	1 to 2 in.
Collards . . .	¼ ounce	30 to 36 in.	24 to 30 in.	14 to 18 in.	½ in.
Corn salad . . .	2 ounces	30 in.	12 to 18 in.	5 or 6 to ft.	½ to 1 in.
Corn, sweet . . .	¼ pint	36 to 42 in.	30 to 36 in.	30 to 36 in.	1 to 2 in.
Cress, upland . . .	½ ounce	30 in.	12 to 18 in.	4 or 5 to ft.	½ to 1 in.
Cress, water . . .	½ ounce	Broadcast			On surface
Cucumber . . .	½ ounce	4 to 6 ft.	4 to 6 ft.	4 to 6 ft.	1 to 2 in.
Dandelion . . .	¼ ounce	30 in.	18 to 24 in.	8 to 12 in.	½ in.
Eggplant . . .	⅓ ounce	30 to 36 in.	24 to 30 in.	18 to 24 in.	½ to 1 in.
Endive . . .	1 ounce	30 in.	18 in.	8 to 12 in.	½ to 1 in.
Horseradish . . .	70 roots	30 to 40 in.	24 to 30 in.	14 to 20 in.	3 to 4 in.
Kale, or borecole . . .	¼ ounce	30 to 36 in.	18 to 24 in.	18 to 24 in.	½ in.
Kohlrabi . . .	¼ ounce	30 to 36 in.	18 to 24 in.	4 to 8 in.	½ in.
Leek . . .	½ ounce	30 to 36 in.	14 to 20 in.	4 to 8 in.	1 in.
Lettuce . . .	½ ounce	30 in.	12 to 18 in.	4 to 6 in.	½ in.
Melon, muskmelon . . .	½ ounce	6 to 8 ft.	6 to 8 ft.	Hills 6 ft.	1 to 2 in.
Melon, watermelon . . .	1 ounce	8 to 12 ft.	8 to 12 ft.	Hills 10 ft.	1 to 2 in.
Mustard . . .	¼ ounce	30 to 36 in.	12 to 18 in.	4 or 5 to ft.	¼ in.
New Zealand spinach . . .	1 ounce	36 in.	24 to 36 in.	12 to 18 in.	1 to 2 in.
Okra, or gumbo . . .	2 ounces	4 to 5 ft.	3 to 4 ft.	24 to 30 in.	1 to 2 in.
Onion, seed . . .	1 ounce	24 to 36 in.	12 to 18 in.	4 or 5 to ft.	½ to 1 in.
Onion, sets . . .	1 quart of sets	24 to 36 in.	12 to 18 in.	4 or 5 to ft.	1 to 2 in.
Parsley . . .	¼ ounce	24 to 36 in.	12 to 18 in.	3 to 6 in.	⅞ in.
Parsnip . . .	½ ounce	30 to 36 in.	18 to 24 in.	5 or 6 to ft.	½ to 1 in.
Peas . . .	1 to 2 pints	3 to 4 ft.	30 to 36 in.	15 to ft.	2 to 3 in.
Pepper . . .	⅓ ounce	30 to 36 in.	18 to 24 in.	15 to 18 in.	½ in.
Physalis . . .	⅛ ounce	30 to 36 in.	18 to 24 in.	18 to 24 in.	½ in.
Potato, Irish . . .	5 lb. (or 9 bu. per acre)	30 to 36 in.	24 to 36 in.	14 to 18 in.	4 in.
Potato, sweet . . .	3 lb. (or 75 slips)	3 to 5 ft.	3 to 5 ft.	14 in.	3 in.
Pumpkin . . .	½ ounce	8 to 12 ft.	8 to 12 ft.	Hills 8 to 12 ft.	1 to 2 in.
Radish . . .	1 ounce	24 to 36 in.	12 to 18 in.	8 to 12 to ft.	½ to 1 in.
Rhubarb, seed . . .	½ ounce	36 in.	30 to 36 in.	6 to 8 in.	½ to 1 in.
Rhubarb, plants . . .	33 plants	3 to 5 ft.	3 to 5 ft.	3 ft.	2 to 3 in.
Rutabaga . . .	¼ ounce	30 to 36 in.	18 to 24 in.	6 to 8 in.	½ to 1 in.
Salsify . . .	1 ounce	30 to 36 in.	18 to 24 in.	2 to 4 in.	½ to 1 in.
Spinach . . .	1 ounce	30 to 36 in.	12 to 18 in.	7 or 8 to ft.	1 to 2 in.
Squash, bush . . .	½ ounce	3 to 4 ft.	3 to 4 ft.	Hills 3 to 4 ft.	1 to 2 in.
Squash, late . . .	½ ounce	7 to 10 ft.	7 to 10 ft.	Hills 7 to 9 ft.	1 to 2 in.
Tomato . . .	⅓ ounce	3 to 5 ft.	3 to 4 ft.	3 ft.	½ to 1 in.
Turnip . . .	½ ounce	24 to 36 in.	18 to 24 in.	6 or 7 to ft.	¼ to ½ in.
Vegetable marrow . . .	½ ounce	8 to 12 ft.	8 to 12 ft.	Hills 8 to 9 ft.	1 to 2 in.

Usual planting dates for field crops (Cyclo. Amer. Agric.)

	MARITIME PROVINCES	QUEBEC ¹	NEW ENGLAND	CENTRAL NEW YORK	GEORGIA AND ALABAMA	INDIANA (LAFAYETTE)
Alfalfa	May 10-July	May	May-July	May-Aug. 15	Feb., 20-Mar., October	April-August
Artichoke	—	May	—	May, June	March	—
Asparagus	—	May	April	—	Feb., March, Nov. 20-Dec. 10	April 15
Barley	May	May, June	April, May	April, May 15	Sept. 20-Oct.	April 1
Beans	June 1-15	May 15-30	May 15-25	May 15-June 25	April-June	May 20
Broom-corn	—	May 15-30	—	—	April, May	May 20
Buckwheat	June	May-July	June 1-20	June 15-July 5	March 15-30	June 1
Cabbage	May 1-15	Hotbed April	March-June 15	May	Jan.-March 2	Apr. 10-June 1
Carrot	May	May	May	March-August	Mar. 20-April	April 15
Clover	May	May	Mar. 15-Sept. 1	—	Mar., Sept., Oct.	Feb.-April
Cotton	—	—	—	—	Mar. 20-May 15	—
Cowpea	May	May	May 15-June 1	May 15-June 25	May-August 1	May 15-25
Field-pea	May	May	March 15-May	April-June	Feb., April	April 1
Flax ³	May	May	—	—	—	—
Kafr	—	Hotbed April	April	May	April-June	May 20
Kohlrabi	—	—	—	May	March	April 15
Lespedeza	—	—	—	—	March 1-15	—
Lupine	—	—	—	—	March	—
Maize	May 20-June 1	May	April-May 12	May	March-July 1	May 1-20
Mangels	May 1-20	May	April 15-May 20	May	March, Aug. 1	May 1-20
Melilotus	—	May	July	March-Sept.	Feb., March	—
Millet	June	May-July	May 10-June 20	May 15-July 10	April-July	June 1

	May	May, June	April	April	April	Feb., March, Sept.-Nov.	Mar. 15-Apr. 10
Oats	May	May, June	April	April	April	Feb., March, Sept.-Nov.	Mar. 15-Apr. 10
Parsnip	May	May	April, May	April, May	May	Mar. 25-Nov.	April 25-30
Peanut	May 15-June 1	May	April 15-May 10	April 15-May 10	March-July 5	May, June Feb. 15-March, July 1-10	April-June
Pumpkin	June 1	May 15-30	May 5-31	May 5-30	May, June	May	May 15
Rape	June	May-July	April	April	May-July	March, October March-May	May-July
Rice	—	May, June	June 5-30	June 5-30	May, June	July	April 20-25
Rutabaga	May	May or Sept.	Apr., May, Sept.	Apr., May, Sept.	August-October	Mar., Sept.-Nov. Sept., Oct.	Sept. 20-Oct. 10
Samfoin	—	—	May 10-30	May 10-30	May 15-June 25	March 15-June	May 20-31
Sorghum	—	—	May	May	May, June	April 10-June	May 15-25
Soybean	May 10-June 1	May 15-30	May 15-June 15	May 15-June 15	May, June	April 5-30	May 1-10
Squash	May 15	May	—	—	May	—	May 1-20
Sugar-beet	—	May	—	—	—	Mar. 21-Apr. 5	—
Sugar-cane	—	May	—	—	—	May 1-July ²	May 10-15
Sweet-potato	—	May	—	—	—	March-October	Sept., October
Timothy	—	May	—	—	—	—	—
Tobacco	—	Hotbed April, plant June 1	Apr. 15-May 15, Aug.-Oct.	Apr. 15-May 15, Aug.-Oct.	March-Sept.	May	—
Turnip	May 15-June 30	May-July	April, May, July-August	April, May, July-August	Seed-bed March, April, June 1 May-July	Feb.-April 25, July 1-10	May-August
Vetch	May	May, June	July	July-August	May-August	Feb. 25-Mar. 10, Sept., Oct.	April 1
Wheat	May	May	April	April	April-Sept.	Oct., Nov.	Sept. 20-Oct. 10

¹ District of Quebec; District of Montreal about twelve days earlier.
² Transplanting.
³ For others, see article on flax.

Usual planting dates for field crops — Continued

	WISCONSIN	MANITOBA	MISSOURI (COLUMBIA)	OKLAHOMA	NEW MEXICO	COLORADO	MONTANA 1
Alfalfa . . .	April 10-July 1	May 15-June 1	Apr. 15-May 15 Aug. 15-Sept. 15	Mar. 15-May 15 Aug. 15-Oct. 1	March, April, Aug. 15-Oct. 1	Mar. 15-Apr. 20	Apr. 15-May 10
Artichoke . . .	May, June	May 18	April 1-30	_____	_____	April	May 15
Asparagus . . .	_____	Shoots May 6	Mar. 20-May 1	_____	_____	March 15-30	May 5
Barley . . .	April 10-25	May 10-25	Mar. 20-Apr. 10	Feb. 15-Mar. 15	_____	May 15-June 1	May 20
Beans . . .	May 10-30	June 11	April 15-mid- summer	_____	_____	_____	_____
Broom-corn . . .	_____	_____	May 10-25	April 1-May 15	April, May	May 15	April 10
Buckwheat . . .	June 20-July 10	May 1	Not grown	_____	_____	June 15-July	_____
Cabbage . . .	Tr. May 15-30	April 25	Mar. 15-July 15	Apr. 1-June 1	_____	April 15	May 20
Carrot . . .	Apr. 25-May 15	May 7-16	Mar. 20-Apr. 15	_____	_____	April 1-15	May 1
Clover . . .	Apr. 15-May 10	May 15-June 1	Feb. 1-Apr. 1	_____	_____	Mar. 15-Apr. 20	May 10
Cotton . . .	_____	_____	June 1-10	Apr. 15-May 15	_____	_____	_____
Cowpea . . .	May 20-31	June 11	June 1-July 10	May 15-July 15	Spring and summer	June 15	_____
Field-pea . . .	_____	_____	Mar. 1-April 1	March 1	March-June	April 1	May 1
Flax 2 . . .	April 20-30	May 4-8 May 16-June 15	_____	_____	_____	_____	April 10
Kafir . . .	_____	_____	May 1-25	April 1-July 1	March-June	May 15	April 10
Kohlrabi . . .	_____	_____	Mar. 1-April 30	_____	_____	April 15	_____
Lespedeza . . .	_____	_____	_____	_____	_____	_____	_____
Lupine . . .	_____	_____	_____	_____	_____	_____	_____
Maize . . .	May 15-30	May 21-June 1	May 1-25	Mar. 15-June 15	April, May	Mar. 15-April	May 12
Mangels . . .	May 1-15	May 16	May 5	April 1-May 1	May, June	May 15	May 1

Melilotus . . .	April 15-30	April, May	Mar. 1-June 1	June, July	May 15
Millet . . .	May 20-July	June, July	Feb. 15-Mar. 15	Feb.-July	May 10
Oats . . .	April 10-30	March 15-31	Mar. 1-June 1	Feb.-July	May 10
Parsnip . . .	April 10-30	Apr. 1-April 1	Apr. 15-June 15	April-May ³	May 25
Peanut . . .	May 1-30	Apr. 15-May 1	Feb. 15-Mar. 15,	_____	_____
Potato . . .	May 1-June 30	Mar. 15-Apr. 30	June 15-July 15	_____	_____
Pumpkin . . .	May 10-30	May 1-June 1	April 1-May 1	_____	May 20
Rape . . .	May 1-Aug. 1	March-May	Feb. 15-Apr. 1	_____	Up to July 10
Rice . . .	May 1-30	May 25	April 1-May 1	_____	May 5
Rutabaga . . .	Aug. 25-Sept. 10	Sept., October	Aug. 15-Nov. 15	Jan.-July	Apr. 1-May 10
Rye . . .	_____	_____	_____	Sept., Oct.	_____
Sainfoin . . .	May 10-20	May 1-25	Mar. 1-Aug. 1	March-June	May 10
Sorghum . . .	May 15-30	June 1-July 10	May 15-July 15	_____	May 20
Soybean . . .	May 10-30	May 1-June 1	Apr. 1-May 15	_____	May 20
Squash . . .	May 20-June 10	May 5	_____	_____	May 1
Sugar-beet . . .	May 1-30	May 1-25	_____	_____	_____
Sugar-cane . . .	_____	May 15-June 15	April 1-May 1	_____	_____
Sweet-potato . . .	April-Sept.	April, Sept.	_____	_____	May 10
Timothy . . .	Tr. May 1-June 1	May 1-25	_____	_____	_____
Tobacco . . .	_____	_____	_____	_____	_____
Turnip . . .	May 16-21	March-August	July 15-Aug. 31	_____	May 5
Vetch . . .	May 15-June 1	April, August	Sept. 10-Nov. 30	Jan.-April 15,	May 1
Wheat . . .	April-August	Sept. 15-Oct. 30	_____	Sept. 1-Oct. 15	_____

¹ For irrigated crops; for non-irrigated crops, as soon after March 25 as conditions allow.

² For others, see article on flax.

³ Grown only at high elevations.

⁴ If there is enough moisture.

Usual planting dates for field crops—Continued

	ARIZONA ¹ (PHOENIX)	NEVADA	CALIFORNIA	OREGON	WASHINGTON	ALASKA
Alfalfa	Jan., Feb., 10 Sept. 20–Nov. 10	March–August	October–Feb.	March–May 15	Apr. 20–May 15	—
Artichoke	Jan.–March, Oct., Nov., Sept.–March 1	—	Dec.–March	March–May 15	April 1–May 1	—
Asparagus	—	April	Dec.–March	March–May 15	Mar. 10–May 15	—
Barley	March–April 15, Aug. 15–Sept. 15	May 20	April, May	March–May 15, Oct.–Dec.	April 20	May 1–15
Beans	—	April 20–May 20	April, May	March–May 15	April 25–May 25	—
Broom-corn	—	May 1–10	April, May	May 15–June 1	May 10–20	—
Buckwheat	Tr., Jan., Feb., Sept. 15, Oct. 20	May 15	May	March–May 15, Oct.–Dec.	May 10–20	May 10
Cabbage	Jan., Feb., Aug. 20–Oct. 15	May 15	Sept.–April	March–May 15	Mar. 15–Apr. 1 (under glass)	—
Carrot	—	March, April	Sept.–April	March–May 15	April 15–May 15	May 1
Clover	—	—	April, May, Oct.–Feb.	March–May 15, Oct.–Dec.	Mar., Apr., Sept.	April 1
Cotton	April	—	April, May ²	—	—	—
Cowpea	April–August	—	April, May	—	—	—
Field-pea	Jan., Feb., Aug. 20–Nov. 20	April, May	Sept.–May	March–May 15	Mar. 15–May 15	April 15
Flax ³	—	May 1–20 (not grown)	Dec.–April	March–May 15	May 1–15	May 1
Kafir	—	April 20–May 10 (not grown)	April–June	March–May 15	May 1	—
Kohlrabi	April–June	May 15	Dec.–April	March–May 15	May 15–April 1 (under glass)	Tr., June 1
Lespedeza	—	—	—	—	—	—
Lupine	Feb. 20–Mar. 15, July 10–Aug. 5	April 20–May 20	October–Feb. April, May	March–May 15	April 15–May 1	—
Maize	—	—	April, May	March–May 15	May 1–15	—

Mangels	—	April 15—May 15	October—June	March—May 15	April 1—June 1	April 15
Melilotus	—	—	—	March—May 15	March—May	—
Millet	August	Early April	April, May	May 15—June 1	April 10	—
Oats	October—Dec.	Early April	Dec.—April	March—May 15,	—	April 20—May 15
Parsnip	—	May 15	April, May	Oct.—Dec.	April 1—May 1	April 15
Peanut	—	—	April, May	March—May 15	April 1—May 1	—
Potato	Jan. 15—Feb. 15, Aug. 20—Sept. 10	April 15—May 15	Sept.—May	March—May 15	—	May 1
Pumpkin	March—June	May 10	April, May	May 15—June 1	May 1—15	—
Rape	—	Early April (not grown)	—	March—August	April 1—June 1	May 1
Rice	—	—	—	—	—	—
Rutabaga	—	May 1—10	Sept.—April	March—May 15	May 1—June 1	Apr. 15—May 15
Rye	—	Feb.—April, Sept.—Nov.	Dec.—Feb.	Oct.—Dec.	Mar., Apr., Sept.	Winter, July; Spring, May 1
Sainfoin	—	—	—	March—May 15	—	—
Sorghum	May, June	April 20—May 10	April—June	March—May 15	May 1—15	—
Soybean	—	—	Feb.—April	March—May 15	April 1	—
Squash	—	May 20	April, May	May 15—June 1	May 1—20	—
Sugar-beet	Jan. 15—Feb. 28, Sept. 20—Oct. 10	April 20—May 10	January—May	March—May 15	May 1	—
Sugar-cane	—	—	—	—	—	—
Sweet-potato	March—May	—	May	—	May 1—15	—
Timothy	—	—	April, May	October—Dec.	Mar., Apr., Sept.	—
Tobacco	—	March, April	Sept.—May	March—May 15	March 20	—
Turnip	Jan., Feb., Aug.—Oct.	May 15	Sept.—May	March—May 15,	(under glass)	April—July 31
Vetch	—	—	Sept.—Feb.	Oct.—Dec.	April—June	—
Wheat	—	Early April	Dec.—March	March—May 15, Oct.—Dec.	April—Sept.	—

¹ From Bull. No. 48, Part III, Arizona Agricultural Experiment Station.

² No commercial product.

³ See article on flax.

⁴ Grown only in extreme northern part.

Flower-planting table (Suburban Life)

It is a wise plan to grow enough extra plants in a reserve bed or in pots during the summer, so that any gaps in the bed may be filled as the occasion requires. This table includes some perennials and biennials, as well as annuals. It is made for about the latitude of New York.

VARIETY	WHEN TO SOW SEED		THIN OR TRANS- PLANT TO (Inches)	HEIGHT (Inches)	SEASON OF BLOOM	COLOR OF FLOWERS
	Indoors	Outdoors				
Abronia	March	May	12	½ to 1½	July to frost	Yellow, pink, rose White
Achillea (Sneezewort)	—	June- Sept. 1	12	1 to 1½	July- October	White
Adonis	March	April	—	1	June- August	Crimson
Ageratum	March	May	6	½ to ¾	June to frost	Blue, white
Agrostemma (Rose- of-Heaven)	April	May	6	1 to 1½	July to frost	Rose, white
Alonsoa	April	May	6 to 12	1 to 3	July to frost	Scarlet, white
Amaranthus	April	—	18	5 to 6	August	Red, purple, yellow, white
Aquilegia (Colum- bine)	—	July-Sept. 1	8	2½	June-Sept. 1	Yellow, white, red, blue
Argemone (Mexican Poppy)	April in pots	May	12	1½ to 2	July, August	Yellow, white
Asperula	April	May	6	1	Aug., Sept.	Blue
Aster (China)	March, April	May	9	1 to 3	July- October	Yellow, white red, blue
Aster (Perennial)	—	July- Sept. 1	12	1 to 3	Sept., Oct.	White, pink, blue
Balloon Vine	April	May	6	10	Aug., Sept.	White
Balsam	April	May	24	2 to 2½	July to frost	Yellow, white, pink, red
Bartonia	—	May	—	1 to 3	July-Sept.	Yellow
Beets	April	—	6	1 to 2	—	Ornamental foliage
Black Dahlia	March	May	12	1 to 1½	July, August	Dark red
Brachycome (Swan River Daisy)	April	May	6	½ to 1	—	Blue, white
Cacalia (Emilia)	—	May	6	1 to 2	July to frost	Scarlet, yellow
Calandrina	—	May	6	¼ to 1	—	Rose, purple
Calendula (Pot Mari- gold)	March	Late April	6	⅔	June-Oct.	Orange, yellow
Calliopsis (Coreopsis)	March	April	10	1½	June to frost	Yellow
Callirhoe (Poppy Mallow)	April	May	9	1 to 3	July to frost	Purple, lilac, red, cherry
Campanula (Canter- bury Bell)	—	July- Sept. 1	12	2 to 3	June- August	Blue, white, pink
Candytuft	April	May	4 to 12	½ to 1½	June-Oct.	White
Cannabis (Giant Hemp)	—	—	—	10	—	Inconspic- uous
Cardinal Flower	March	—	9	1 to 2½	Aug., Sept.	Scarlet
Castor bean (Ricinus)	April	May	3	4 to 8	—	Grown for foliage
Catananche	March	—	6	2 to 3	June- August	Blue, white
Celosia (Cockscomb)	March, April	May	6	½ to ¾	June to frost	Red

Flower-planting table — Continued

VARIETY	WHEN TO SOW SEED		THIN OR TRANS-PLANT TO (Inches)	HEIGHT (Inches)	SEASON OF BLOOM	COLOR OF FLOWERS
	Indoors	Outdoors				
Carnation (Marguerite)	March	—	6	1 to 1¼	June to frost	White, pink, red
Centaurea (Blue Bottle)	—	April	6	2 to 3	June to frost	Blue, white, pink
Centranthus	April	May	9	1 to 2	July to frost	Red, white
Chrysanthemum, Annual	March, April	May	8	1 to 1½	June-Oct.	White, red, yellow
Cleome (Spider Plant)	April	May	8	2	July, August	Purple
Cobœa	March, April	—	8	10 to 20	Aug., Sept.	Violet, greenish purple
Collinsia	April	May	8	1 to 1½	July, August	White, lilac, violet
Convolvulus	—	April	2	½ to 1	July to frost	Blue
Cosmos, Early	April	May	12	4	July, August	White, pink
Cosmos, Late	April, May	May	24	6 to 8	Sept. to frost	White, pink, red
Dahlia	March, April	—	3	4	Aug. to frost	White, red, yellow
Dianthus (China Pink)	March, April	May 5	6	1 to 1¼	July to frost	White, pink, red
Digitalis (Foxglove)	—	July-Sept. 1	9	3 to 4	July, August	Pink, white
Eschscholzia (California Poppy)	—	May	4	¾	July-Sept.	Orange, yellow, white
Evening Primrose	—	—	20	1 to 1½	July-Sept.	Yellow
Flax	—	May	8	2 to 2½	July-Sept.	Red, blue
Four O'clock	April	May	8	1½ to 2	July to frost	White, yellow, red
Gaillardia	April	May	6	¾ to 1	July to frost	Yellow, red
Gilia	—	May	3 to 12	¼ to 2½	July-Sept.	Blue, red, white
Globe amaranth (Gomphrena)	April	May	6	1	July to frost	Red, white, blue
Golden-tuft (Alysum)	—	July-Sept. 1	6	½	July-October	Yellow
Gourds	March, April	May	12	15	September	White
Gypsophila	April	May	8 to 12	1 to 2	July-Sept.	Rosy
Hawkweed	—	April, May	6	½ to 1	Aug., Sept.	Yellow, red
Helianthus (Sunflower)	April, May	May	12 to 36	3 to 6	July to frost	Yellow
Hibiscus	March, April	July-Sept. 1	15 to 24	5 to 7	August	White to red
Hollyhock	March, April	July-Sept. 1	15	5 to 7	August	White to red
Honesty (Lunaria)	March, April	May	12	1½ to 2½	June, July	Pink, purple
Hop	—	April, May	12	20 to 30	—	Ornamental foliage
Ipomœa (Morning-Glory)	March	April	6	10 to 15	June to frost	Blue, red, white
Kochia	—	April	9 to 12	2 to 2½	—	Grown for foliage

Flower-planting table — Continued

VARIETY	WHEN TO SOW SEED		THIN OR TRANS- PLANT TO (Inches)	HEIGHT (Inches)	SEASON OF BLOOM	COLOR OF FLOWERS
	Indoors	Outdoors				
Larkspur (Annual)	March,	May 5	6	1 to 1½	June-Sept.	Blue, white, red, pink
Lobelia	April Feb.- April	May	4	½	June to frost	Blue, white
Lupinus	—	May	6	2	July, August	Pink, blue, white
Madia (Tarweed)	—	May	12	1 to 2	July-Oct.	Yellow
Marigold	April	May	6	½ to 3	July to frost	Yellow
Martynia (Unicorn plant)	April	May	24	1	July	Yellow, purple, white
Matthiola bicornis	—	April	6	½ to 1	Aug. to frost	White
Mignonette	March, April	May 10	6	1	July to frost	Greenish yellow
Myosotis (Forget-me not)	April	May	6	½	June- August	Blue, pink, white
Nasturtium	April	May 1	6	1 to 10	June to frost	Yellow, red, orange
Nicotiana (Tobacco)	April	May 10	9	3	July to frost	White, pink, red, yellow
Pansy	March	April, July, August	4	⅓	April to frost	Various
Petunia	Feb., March	May	6	1	June to frost	Red, white, pink
Phlox (Annual)	March, April	May	12	1	July to frost	Red, white, pink, yellow
Poppy (Annual)	—	April, Sept., October	6	1 to 2	June- August	Pink, red, yellow, white
Poppy, Iceland	—	April-Sept.	6	1	June- August	Red, yellow, white
Pyrethrum	—	July-Sept.	12	2	July, August	White, pink, red
Portulaca	—	May	6	1	July to frost	Red, white
Salpiglossis	April	May	6	2 to 2½	Aug. to frost	Yellow, white red, brown
Salvia	Feb., March	May	18	2 to 3	Aug. to frost	Scarlet
Scabiosa (Mourning Bride)	April	May	9	2	July to frost	White, purple, yellow
Silene (Catchfly)	March	April	6	1 to 1½	July-Sept.	Red, white,
Snape dragon	March	—	6 to 12	½ to 3	July to frost	Yellow, white, pink, red
Stocks (Ten Weeks)	March, April	May	12	1 to 1½	July-Sept.	Pink, scarlet white, yellow
Sweet Alyssum	—	April, May	4	¼ to ½	June-Oct.	White
Sweet Pea	—	Mar., April	3	6	July-Sept.	All colors
Sweet William	March	July- Sept. 1	6	2	June, July	Red, white pink
Venus' Looking-glass (Speccularia)	—	April	6	¾	Aug., Sept.	White, blue
Verbena	Feb.- April	May	6	1	June to frost	White, pink, red, blue
Zinnia	March, April	May	6	1½ to 2	June-Oct.	Red, yellow, pink, white

Distance-Tables

Usual distances apart for planting fruits

Apples	30 to 40 feet each way.
Apples, dwarf (Paradise stocks)	8 to 10 feet each way.
Apples, dwarf (Doucain stocks)	12 to 25 feet each way.
Pears	20 to 30 feet each way.
Pears, dwarf	10 to 15 feet each way.
Plums	16 to 20 feet each way.
Peaches	16 to 20 feet each way.
Cherries	16 to 25 feet each way.
Apricots	16 to 20 feet each way.
Nectarines	16 to 20 feet each way.
Quinces	8 to 14 feet each way.
Figs	20 to 25 feet each way.
Mulberries	25 to 30 feet each way.
Japanese Persimmons	20 to 25 feet each way.
Loquats	15 to 25 feet each way.
Pecans	35 to 40 feet each way.
Grapes	8 to 12 feet each way.
Currants	4 × 5 feet.
Gooseberries	4 × 5 feet.
Raspberries, black	3 × 6 feet.
Raspberries, red	3 × 5 feet.
Blackberries	4 × 7 to 6 × 8 feet.
Cranberries	1 or 2 ft. apart each way.
Strawberries	1 × 3 or 4 feet.
Oranges and Lemons	25 to 30 feet each way.

Distances recommended for orange trees in California

Dwarfs, as Tangerines	10 to 12 feet.
Half-dwarfs, as Washington Navel	24 to 30 feet.
Mediterranean Sweet, Maltese Blood, Valencia	24 to 30 feet.
St. Michael	18 to 24 feet.
Seedlings	30 to 40 feet.

Usual distances apart for planting vegetables (see also table, p. 109)

Artichoke	Rows 3 or 4 ft. apart, 2 to 3 ft. apart in the row.
Asparagus	Rows 3 to 4 ft. apart, 1 to 2 ft. apart in the row.
Beans, bush	1 ft. apart in rows 2 to 3 ft. apart.
Beans, pole	3 to 4 ft. each way.
Beet, early	In drills 12 to 18 in. apart.
Beet, late	In drills 2 to 3 ft. apart.
Broccoli	1½ × 2½ ft. to 2 × 3 ft.
Cabbage, early	16 × 28 in. to 18 × 30 in.
Cabbage, late	2 × 3 ft. to 2½ × 3½ ft.
Carrot	In drills 1 to 2 ft. apart.
Cauliflower	2 × 2 ft. to 2 × 3 ft.
Celery	Rows 3 to 4 ft. apart, 6 to 9 in. in the row; "new celery culture," 7 × 7 in., each way.
Corn-salad	In drills 12 to 18 in. apart.
Corn, Sweet	Rows 3 to 3½ ft. apart, 9 in. to 2 ft. in the row.
Cress	In drills 10 to 12 in. apart.
Cucumber	4 to 5 ft. each way.
Egg-plant	3 × 3 ft.
Endive	1 × 1 ft. to 1 × 1½ ft.
Horseradish	1 × 2 or 3 ft.

Kohlrabi	10 × 18 in. to 1 × 2 ft.
Leek	6 in. × 1 or 1½ ft.
Lettuce	1 × 1½ or 2 ft.
Melons, musk	5 to 6 ft. each way.
Melons, water	7 to 8 ft. each way.
Mushroom	6 to 8 in. each way.
Okra	1½ × 2 or 3 ft.
Onion	In drills from 14 to 20 in. apart.
Parsley	In drills 1 to 2 ft. apart.
Parsnip	In drills, 18 in. to 3 ft. apart.
Peas	In drills; early kinds, usually in double rows, 6 to 9 in. apart; late kinds, in single rows, 2 to 3 ft. apart.
Pepper	15 to 18 in. × 2 to 2½ ft.
Potato	10 to 18 in. × 2½ to 3 ft.
Pumpkin	8 to 10 ft. each way.
Radish	In drills, 10 to 18 in. apart.
Rhubarb	2 to 4 ft. × 4 ft.
Salsify	In drills, 1½ to 2 ft. apart.
Sea-kale	2 × 2 to 3 ft.
Spinach	In drills, 12 to 18 in. apart.
Squash, bush	3 to 4 ft. × 4 ft.
Squash, late	6 to 8 ft. each way.
Sweet Potato	2 ft. × 3 to 4 ft.
Tomato	4 ft. × 4 to 5 ft.
Turnip	In drills, 1½ to 2½ ft. apart.

Number of plants required to set an acre of ground at given distances

This table is computed by dividing 43,560 (the number of square feet in an acre) by the product of the two distances, in feet: $43,560 \div 6$ (2 ft. × 3 ft.) = 7260. This assumes that the acre is full to the margin. A square acre is a little less than 209 ft. on all sides.

PLANTS		PLANTS	
1 in. × 1 in.	6,272,640	3 in. × 6 in.	348,480
1 in. × 2 in.	3,136,320	3 in. × 7 in.	298,697
1 in. × 3 in.	2,090,880	3 in. × 8 in.	261,360
1 in. × 4 in.	1,568,160	3 in. × 9 in.	232,320
1 in. × 5 in.	1,254,528	3 in. × 10 in.	209,088
1 in. × 6 in.	1,045,440	3 in. × 11 in.	190,080
1 in. × 7 in.	896,091	3 in. × 12 in.	174,240
1 in. × 8 in.	784,080	4 in. × 4 in.	392,040
1 in. × 9 in.	696,960	4 in. × 5 in.	313,632
1 in. × 10 in.	627,264	4 in. × 6 in.	261,360
1 in. × 11 in.	570,240	4 in. × 7 in.	224,022
1 in. × 12 in.	522,720	4 in. × 8 in.	196,020
2 in. × 2 in.	1,568,160	4 in. × 9 in.	174,240
2 in. × 3 in.	1,045,440	4 in. × 10 in.	156,816
2 in. × 4 in.	784,080	4 in. × 11 in.	142,560
2 in. × 5 in.	627,264	4 in. × 12 in.	130,680
2 in. × 6 in.	522,720	5 in. × 5 in.	250,905
2 in. × 7 in.	448,045	5 in. × 6 in.	209,088
2 in. × 8 in.	392,040	5 in. × 7 in.	179,218
2 in. × 9 in.	348,480	5 in. × 8 in.	156,816
2 in. × 10 in.	313,632	5 in. × 9 in.	139,392
2 in. × 11 in.	285,120	5 in. × 10 in.	125,452
2 in. × 12 in.	261,360	5 in. × 11 in.	114,048
3 in. × 3 in.	696,960	5 in. × 12 in.	104,544
3 in. × 4 in.	522,720	6 in. × 6 in.	174,240
3 in. × 5 in.	418,176	6 in. × 7 in.	149,348

PLANTS		PLANTS	
6 in. × 8 in.	130,680	20 in. × 36 in. or 3 ft.	8,712
6 in. × 9 in.	116,160	20 in. × 42 in.	7,467
6 in. × 10 in.	104,544	20 in. × 48 in. or 4 ft.	6,534
6 in. × 11 in.	95,040	20 in. × 54 in.	5,808
6 in. × 12 in.	87,120	20 in. × 60 in. or 5 ft.	5,227
7 in. × 7 in.	128,013	1 ft. × 1 ft.	43,560
7 in. × 8 in.	112,011	1 ft. × 2 ft.	21,780
7 in. × 9 in.	99,562	1 ft. × 3 ft.	14,520
7 in. × 10 in.	89,609	1 ft. × 4 ft.	10,890
7 in. × 11 in.	81,462	1 ft. × 5 ft.	8,712
7 in. × 12 in.	74,674	1 ft. × 6 ft.	7,260
8 in. × 8 in.	98,010	1 ft. × 7 ft.	6,223
8 in. × 9 in.	87,120	1 ft. × 8 ft.	5,445
8 in. × 10 in.	78,408	1 ft. × 9 ft.	4,840
8 in. × 11 in.	71,280	1 ft. × 10 ft.	4,356
8 in. × 12 in.	65,340	1 ft. × 11 ft.	3,960
9 in. × 9 in.	77,440	1 ft. × 12 ft.	3,630
9 in. × 10 in.	69,696	2 ft. × 2 ft.	10,890
9 in. × 11 in.	63,360	2 ft. × 3 ft.	7,260
9 in. × 12 in.	58,080	2 ft. × 4 ft.	5,445
10 in. × 10 in.	62,726	2 ft. × 5 ft.	4,356
10 in. × 12 in.	52,272	2 ft. × 6 ft.	3,630
10 in. × 15 in.	41,817	2 ft. × 7 ft.	3,111
10 in. × 18 in.	34,848	2 ft. × 8 ft.	2,722
10 in. × 20 in.	31,363	2 ft. × 9 ft.	2,420
10 in. × 24 in. or 2 ft.	26,136	2 ft. × 10 ft.	2,178
10 in. × 30 in.	20,908	2 ft. × 11 ft.	1,980
10 in. × 36 in. or 3 ft.	17,424	2 ft. × 12 ft.	1,815
10 in. × 42 in.	14,935	3 ft. × 3 ft.	4,840
10 in. × 48 in. or 4 ft.	13,068	3 ft. × 4 ft.	3,630
10 in. × 54 in.	11,616	3 ft. × 5 ft.	2,904
10 in. × 60 in. or 5 ft.	10,454	3 ft. × 6 ft.	2,420
12 in. × 15 in.	34,848	3 ft. × 7 ft.	2,074
12 in. × 18 in.	29,040	3 ft. × 8 ft.	1,815
12 in. × 20 in.	26,136	3 ft. × 9 ft.	1,613
12 in. × 30 in.	17,424	3 ft. × 10 ft.	1,452
12 in. × 42 in.	12,446	3 ft. × 11 ft.	1,320
12 in. × 54 in.	9,680	3 ft. × 12 ft.	1,210
15 in. × 15 in.	27,878	4 ft. × 4 ft.	2,722
15 in. × 18 in.	23,232	4 ft. × 5 ft.	2,178
15 in. × 20 in.	20,908	4 ft. × 6 ft.	1,815
15 in. × 24 in. or 2 ft.	17,424	4 ft. × 7 ft.	1,556
15 in. × 30 in.	13,939	4 ft. × 8 ft.	1,361
15 in. × 36 in. or 3 ft.	11,616	4 ft. × 9 ft.	1,210
15 in. × 42 in.	9,953	4 ft. × 10 ft.	1,089
15 in. × 48 in. or 4 ft.	8,712	4 ft. × 11 ft.	990
15 in. × 54 in.	7,744	4 ft. × 12 ft.	907
15 in. × 60 in. or 5 ft.	6,969	5 ft. × 5 ft.	1,742
18 in. × 18 in.	19,360	5 ft. × 6 ft.	1,452
18 in. × 20 in.	17,424	5 ft. × 7 ft.	1,244
18 in. × 24 in. or 2 ft.	14,520	5 ft. × 8 ft.	1,089
18 in. × 30 in.	11,616	5 ft. × 9 ft.	968
18 in. × 36 in. or 3 ft.	9,680	5 ft. × 10 ft.	871
18 in. × 42 in.	8,297	5 ft. × 11 ft.	792
18 in. × 48 in. or 4 ft.	7,260	5 ft. × 12 ft.	726
18 in. × 54 in.	6,453	6 ft. × 6 ft.	1,210
18 in. × 60 in. or 5 ft.	5,808	6 ft. × 7 ft.	1,037
20 in. × 20 in.	15,681	6 ft. × 8 ft.	807
20 in. × 24 in. or 2 ft.	13,068	6 ft. × 9 ft.	806
20 in. × 30 in.	10,454	6 ft. × 10 ft.	726

		PLANTS			PLANTS
6 ft. × 11 ft.		660	18 ft. × 42 ft.		57
6 ft. × 12 ft.		605	18 ft. × 48 ft.		50
7 ft. × 7 ft.		889	18 ft. × 54 ft.		44
7 ft. × 8 ft.		777	18 ft. × 60 ft.		40
7 ft. × 9 ft.		691	20 ft. × 20 ft.		108
7 ft. × 10 ft.		622	20 ft. × 24 ft.		90
7 ft. × 11 ft.		565	20 ft. × 30 ft.		72
7 ft. × 12 ft.		518	20 ft. × 36 ft.		60
8 ft. × 8 ft.		680	20 ft. × 42 ft.		51
8 ft. × 9 ft.		605	20 ft. × 48 ft.		45
8 ft. × 10 ft.		544	20 ft. × 54 ft.		40
8 ft. × 11 ft.		495	20 ft. × 60 ft.		36
8 ft. × 12 ft.		453	24 ft. × 24 ft.		75
9 ft. × 9 ft.		537	24 ft. × 30 ft.		60
9 ft. × 10 ft.		484	24 ft. × 36 ft.		50
9 ft. × 11 ft.		440	24 ft. × 42 ft.		43
9 ft. × 12 ft.		403	24 ft. × 48 ft.		37
9 ft. × 14 ft.		345	24 ft. × 54 ft.		33
9 ft. × 15 ft.		322	24 ft. × 60 ft.		30
9 ft. × 18 ft.		268	30 ft. × 30 ft.		48
9 ft. × 20 ft.		242	30 ft. × 36 ft.		40
10 ft. × 10 ft.		435	30 ft. × 42 ft.		34
10 ft. × 12 ft.		363	30 ft. × 48 ft.		30
10 ft. × 15 ft.		290	30 ft. × 54 ft.		26
10 ft. × 18 ft.		242	30 ft. × 60 ft.		24
10 ft. × 20 ft.		217	36 ft. × 36 ft.		33
10 ft. × 24 ft.		181	36 ft. × 42 ft.		28
10 ft. × 30 ft.		145	36 ft. × 48 ft.		25
10 ft. × 36 ft.		121	36 ft. × 54 ft.		22
10 ft. × 42 ft.		103	36 ft. × 60 ft.		20
10 ft. × 45 ft.		96	38 ft. × 38 ft.		30
10 ft. × 48 ft.		90	38 ft. × 40 ft.		28
10 ft. × 54 ft.		80	38 ft. × 42 ft.		27
10 ft. × 60 ft.		72	38 ft. × 48 ft.		23
12 ft. × 12 ft.		302	38 ft. × 50 ft.		22
12 ft. × 15 ft.		242	38 ft. × 54 ft.		21
12 ft. × 18 ft.		201	38 ft. × 60 ft.		19
12 ft. × 20 ft.		181	40 ft. × 40 ft.		27
12 ft. × 24 ft.		151	40 ft. × 42 ft.		25
12 ft. × 30 ft.		121	40 ft. × 48 ft.		22
12 ft. × 36 ft.		100	40 ft. × 50 ft.		21
12 ft. × 42 ft.		86	40 ft. × 54 ft.		20
12 ft. × 48 ft.		75	40 ft. × 60 ft.		18
12 ft. × 54 ft.		67	42 ft. × 42 ft.		24
12 ft. × 60 ft.		60	42 ft. × 48 ft.		21
15 ft. × 15 ft.		193	42 ft. × 54 ft.		19
15 ft. × 18 ft.		161	42 ft. × 60 ft.		17
15 ft. × 20 ft.		145	48 ft. × 48 ft.		18
15 ft. × 24 ft.		121	48 ft. × 54 ft.		16
15 ft. × 30 ft.		96	48 ft. × 60 ft.		15
15 ft. × 36 ft.		80	50 ft. × 50 ft.		17
15 ft. × 42 ft.		69	50 ft. × 54 ft.		16
15 ft. × 48 ft.		60	50 ft. × 60 ft.		14
15 ft. × 54 ft.		53	54 ft. × 54 ft.		14
15 ft. × 60 ft.		48	54 ft. × 60 ft.		13
18 ft. × 18 ft.		134	60 ft. × 60 ft.		12
18 ft. × 20 ft.		121	70 ft. × 70 ft.		8
18 ft. × 24 ft.		100	80 ft. × 80 ft.		7
18 ft. × 30 ft.		80	90 ft. × 90 ft.		5
18 ft. × 36 ft.		67	100 ft. × 100 ft.		4

Quincunx planting.

To find the number of plants required to set an acre by the quincunx method, ascertain from the above tables the number required at the given rectangular distances, and then increase the number by one-half.

The real quincunx planting places a tree in the center of the square. The trees cannot all be equal distance apart. The so-called quincunx that places all trees at equal distances is only the square method running diagonally across the field.

Plan for a Home Garden (Fig. 4)

Many plans may be found in books and periodicals for home gardens. They are not to be accepted literally, but as suggestions of the problems involved.

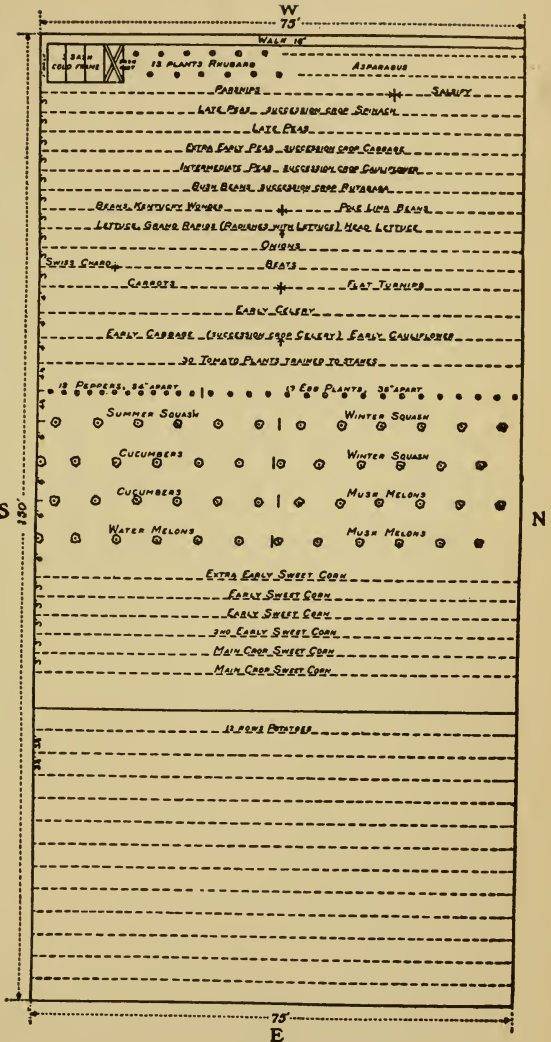

FIG. 4.—A garden for a family of six persons (Suburban Life).

CHAPTER VII

MATURITIES, YIELDS, AND MULTIPLICATION

ANY figures of dates of maturity of the various plants or crops and of yields must necessarily be only approximately or averagely correct; but methods of multiplication allow of more definite statement.

Maturity-Tables

Time required for maturity of different garden crops, reckoned from the sowing of the seeds

	DAYS FROM SEED
Beans, string	45-65
Beans, shell	65-70
Beets, turnip	65
Beets, long blood	150
Cabbage, early	105
Cabbage, late	150
Cauliflower	110
Corn	75
Egg-plant	150-160
Lettuce	65
Melon, water	120-140
Melon, musk	120-140
Onion	135-150
Pepper	140-150
Pumpkin	100-125
Radish	30-45
Squash, summer	60-65
Squash, winter	125
Tomatoes	150
Turnips	60-70

Time required, from setting, for fruit-plants to bear. (For northern and central latitudes)

Apple — 3 to 5 years. Good crop in about 10 to 18 years.

Apple, on paradise stocks, good crops in 4 to 5 years.

Blackberry — 1 year. Good crops in 2 and 3 years.

Citrous fruits (oranges, lemons, etc.) — 2 to 3 years. Good crop 2 or 3 years later.

Cranberry — 3 years gives a fair crop.

Currant — 1 year. Good crops in 2 and 3 years.

Gooseberry — 1 year. Good crops in 2 and 3 years.

Grape — Fair crop in 4 years.

Peach — 2 years. Good crop in 4 and 5 years.

Pear — 3 or 4 years. Fair crop in 6 to 12 years; dwarfs in 5 to 7 years.

Persimmon, or Kaki — 1 to 3 years.

Quince — 2 years. Good crop in 4 years.

Raspberry — 1 year. Good crop in 2 and 3 years.

Plum — 3 years. Good crop in 5 or 6 years.

Strawberry — 1 year. Heaviest crop usually in 2 years.

Average profitable longevity of fruit-plants under high culture

Apple	35-50 years	Peach	8-12 years
(Less in parts of the prairie states and more in northeastern states.)		Pear	50-75 years
Blackberry	6-10 years	Persimmon, or Kaki, as long as an apple-tree.	
Currant	20 years	Plum	20-25 years
Gooseberry	20 years	Raspberry	6-10 years
Orange and Lemon	50 or more	Strawberry	1- 3 years

When serious trouble from diseases is to be apprehended, the plantation may be brought into early fruiting and then destroyed before the disease makes great headway. This is particularly applicable to blackberries, raspberries, and strawberries.

Yield-Tables

Average full yields per acre of various horticultural crops

The yields of those crops in which the salable products are equal in number to the number of plants per acre, and in which the product is sold by the piece, are to be calculated from the planting-tables in Chap. VI — such as cabbage, celery, and the like. Usually the profits are secured from yields above the average. The statements here given are growers' estimates rather than census figures.

Apples — A tree 20 to 30 years old may be expected to yield from 25 to 40 bushels every alternate year.

Artichoke — 200 to 300 bushels.

Beans, Green or Snap — 75 to 120 bushels.

Beans, Lima — 75 to 100 bushels of dry beans.

Beets — 400 to 700 bushels.

Carrots — 400 to 700 bushels.

Corn — 50 to 75 bushels, shelled.

Cranberry — 100 to 300 bushels. 900 bushels have been reported.

Cucumber — About 150,000 fruits per acre.

Currant — 100 bushels.

Egg-plant — 1 or 2 large fruits to the plant for the large sorts like New York Purple, and from 3 to 8 fruits for the smaller varieties.

Gooseberry — 100 bushels.

Grape — 3 to 5 tons. Good raisin vineyards in California, 15 years old, will produce from 10 to 12 tons.

Horseradish — 3 to 5 tons.

Kohlrabi — 500 to 1000 bushels.

Onion, from seed — 300 to 800 bushels. 600 bushels is a large average yield.

Parsnips — 500 to 800 bushels.

Pea, green in pod — 100 to 150 bushels.

Peach — In full bearing, a peach tree should produce from 5 to 10 bushels.

Pear — A tree 20 to 25 years old should give from 25 to 45 bushels.

Pepper — 30,000 to 50,000 fruits.

Plum — 5 to 8 bushels may be considered an average crop for an average tree.

Potato — 100 to 300 bushels.

Quince — 100 to 300 bushels.

Raspberry and blackberry — 50 to 100 bushels.

Salsify — 200 to 300 bushels.

Spinach — 200 barrels.

Strawberry — 75 to 250 or even 300 bushels.

Tomato — 8 to 16 tons.

Turnip — 600 to 1000 bushels.

For yields of *seeds* in various garden crops (by seed-growers), see p. 105.

Yields of field crops (Cyclo. Am. Agric.)

As reported by observers in several parts of the continent

	QUEBEC	NEW YORK		NORTH CAROLINA		ALABAMA	
	Average	Average	Best	Average	Best	Average	Best
Alfalfa	3 tons	2.3 tons	7 tons	1.7 tons	5 tons	3.5 tons	7 tons
Barley	25 bu.	23.9 bu.	50 bu.	10 bu.	25 bu.	12 bu.	45 bu.
Beans, field	20 bu.	10.5 bu.	45 bu.	10 bu.	—	—	—
Broom-corn	—	565 lb.	1000 lb.	455 lb.	—	400 lb.	600 lb.
Buckwheat	25 bu.	16.9 bu.	40 bu.	10 bu.	30 bu.	—	—
Cabbage	12 tons	10 tons	40 tons ¹	100 crates	200 crates	5 tons	10 tons
Carrots	12 tons	10 tons	20 tons	—	—	—	—
Clover	2 tons	1.1 tons	4 tons	1-2 tons	3 tons	2 tons	3 tons
Cotton	—	—	—	½ bale	2 bales	200 lb. ²	1000 lb.
				10 bu.	30 bu.		
				1.5 tons	5 tons	10 bu.	30 bu.
Cowpeas	—	—	—	1-2 tons	—	—	—
Field-pea	25 bu.	17.1 bu.	45 bu.	—	—	—	—
Flax	15 bu.	8.5 bu.	15 bu.	—	—	—	—
Kohlrabi	—	—	—	—	—	—	—
Lespedeza	—	—	—	1.25 tons	2 tons	—	2 tons
Maize	25 bu.	32 bu.	100 bu.	13 bu.	100 bu.	14 bu.	75 bu.
Mangels	20 tons	24 tons	40 tons	—	—	—	—
Melilotus	—	—	—	2 tons	—	2 tons	3.5 ton ³
Millet	—	1.7 tons	5 tons	1.5 tons	4 tons	1 ton	3 tons
Oats	35 bu.	32 bu.	80 bu.	10 bu.	50 bu.	15 bu.	70 bu.
Parsnips	—	335 bu.	1000 bu.	—	—	—	—
Potatoes	150 bu.	79 bu.	500 bu.	70 bu.	—	60 bu.	300 bu.
Pumpkin	—	—	—	—	—	—	—
Rape	20 tons	—	—	—	—	—	—
Rice	—	—	—	360 lb.	—	12 bu.	30 bu.
Rutabaga	10 tons	14 tons	30 tons	100 bu.	—	—	—
Rye	15 bu.	16 bu.	35 bu.	5.5 bu.	20 bu.	7 bu.	20 bu.
Sorghum	—	—	—	5-6 tons	10 tons	2.5 tons	7 tons
				12 bu.	40 bu.	15 bu.	25 bu.
				1.7 tons	4 tons	1.7 tons	4 tons
Soybean	—	—	—	—	—	—	—
Sugar-beets	15 tons	7.8 tons	30 tons	7-8 tons	12 tons	200 ³	600 ³
Sugar-cane	—	—	—	85 bu.	—	80 bu.	400 bu.
Sweet-potatoes	—	119 bu.	200 bu.	—	—	—	—
Timothy	2 tons	1.1 ton	4 tons	1-2 tons	4 tons	—	—
Tobacco	1000 lb.	1155 lb.	—	650 lb.	—	500 lb.	1000 lb.
Turnips	10 tons	12 tons	28 tons	100 bu.	—	—	—
Vetch	2 tons	—	—	1-2 tons	3 tons	1.5 tons	3 tons
Wheat	15 bu.	18.9 bu.	60 bu.	7-8 bu.	30 bu.	8 bu.	30 bu.

¹ Including varieties grown for stock-feeding.² Lint.³ Gallons of syrup.

Yields of field crops — Continued

As reported for this volume by observers in several parts of the continent

	INDIANA		WISCONSIN		MANITOBA		EASTERN TEXAS	
	Average	Best	Average	Best	Average	Best	Average	Best
Alfalfa . . .	3-4 tons	6 tons	3 tons	6 tons	3 tons	4 tons	3 tons	7 tons
Barley . . .	25 bu.	40 bu.	30 bu.	65 bu.	30 bu.	75 bu.	—	—
Beans, field . .	—	—	18 bu.	30 bu.	—	—	150 bu.	200 bu.
Broom-corn . .	—	—	—	—	—	—	—	—
Buckwheat . . .	—	—	15 bu.	35 bu.	—	—	—	—
Cabbage . . .	—	—	—	—	—	—	4000 lb.	6000 lb.
Carrots . . .	—	—	10 tons	18 tons	300 bu.	800 bu.	9000 lb.	12,000 lb.
Clover . . .	1.5 tons	2.5 tons	3 bu. seed 1.5 tons	5 bu. seed 4 tons	2 tons	4 tons	—	—
Cotton . . .	—	—	—	—	—	—	½ bale	2 bales
Cowpeas . . .	18 bu.	30 bu.	8 bu.	15 bu.	—	—	1.5 tons	3 tons
Field-pea . . .	—	—	10 bu.	25 bu.	40 bu.	65 bu.	40 bu.	60 bu.
Flax . . .	—	—	13 bu.	25 bu.	18 bu.	—	—	—
Kohlrabi . . .	—	—	—	—	—	—	1200 lb.	2000 lb.
Lespedeza . . .	—	—	—	—	—	—	—	—
Maize . . .	40 bu.	100 bu.	41 bu.	100 bu.	—	—	30 bu.	90 bu.
Mangels . . .	18 tons	25 tons	25 tons	60 tons	800 bu.	1200 bu.	5 tons	6 tons
Melilotus . . .	—	—	2.5 tons	4 tons	—	—	—	—
Millet . . .	1.7 tons	4 tons	30 bu. seed 2 tons	65 bu. seed 4 tons	2 tons	4 tons	1 ton	2 tons
Oats . . .	30 bu.	80 bu.	36 bu.	97 bu.	40 bu.	110 bu.	35 bu.	85 bu.
Parsnips . . .	—	—	8 tons	15 tons	300 bu.	600 bu.	9000 lb	12,000 lb.
Potatoes . . .	100 bu.	200 bu.	92 bu.	400 bu.	300 bu.	800 bu.	60 bu.	150 bu.
Pumpkin . . .	—	—	—	—	—	—	6 tons	8 tons
Rape . . .	—	—	15 tons	35 tons	10 tons	—	—	—
Rice . . .	—	—	—	—	—	—	50 bu.	100 bu.
Rutabaga . . .	—	—	12 tons	40 tons	500 bu.	1000 bu.	6 tons	8 tons
Rye . . .	14 bu.	50 bu. ¹	16 bu.	40 bu.	20 bu.	40 bu.	—	—
Sorghum . . .	9 tons	15 tons	15 bu. seed	25 bu. seed	—	—	2.5 tons	6 tons
Soybean . . .	20 bu.	35 bu.	15 bu.	35 bu.	—	—	—	—
Sugar-beets . .	14 tons	20 tons	12 tons	30 tons	300 bu.	800 bu.	4 tons	6 tons
Sugar-cane . .	—	—	—	—	—	—	25 tons	40 tons
Sweet-potatoes	—	—	—	—	—	—	100 bu.	400 bu.
Timothy . . .	1.5 tons	2 tons	1.5 tons	3.5 tons	1.5 tons	4 tons	—	—
Tobacco . . .	—	—	1280 lb.	1800 lb.	—	—	800 lb.	1200 lb.
Turnips . . .	—	—	10 tons	35 tons	600 bu.	1100 bu.	6 tons	8 tons
Vetch . . .	—	—	8 tons ²	12 tons ²	2 tons	3 tons	—	—
Wheat . . .	14 bu.	45 bu.	12 bu.	35 bu.	27 bu.	56 bu.	12 bu.	48 bu.

¹ Winter rye.² Green feed.

Yields of field crops — Continued

As reported for this volume by observers in several parts of the continent

	NEW MEXICO		WYOMING		WASHINGTON		BRITISH CO-LUMBIA
	Average	Best	Average	Best	Average	Best	Range
Alfalfa . .	3 tons	7 tons	3 tons	8.5 tons	6 tons ¹	10 tons ¹	—
Barley . .	40 bu.	70 bu.	35 bu.	—	29.7 bu.	80 bu.	35 bu. to 105 bu.
Beans, field .	600 lb.	1000 lb.	—	—	13 bu.	—	15 bu. to 25 bu.
Broom-corn .	—	—	—	—	3000 lb.	—	—
Buckwheat .	—	—	—	—	19.4 bu.	—	13 bu. to 41 bu.
Cabbage . .	—	—	—	16,150 lb.	2855 heads	—	3 tons to 25 tons
Carrots . .	—	—	12,000 lb.	21,107 lb.	476 bu.	—	4 tons to 85 tons
Clover . .	—	—	—	—	2.2 tons	5 tons	1.5 tons to 4.5 t.
Cotton . .	—	—	—	—	—	—	—
Cowpeas . .	—	—	—	—	—	—	—
Field-pea . .	—	—	18 bu.	34.7 bu.	26 bu.	—	25 bu. to 106 bu.
Flax . .	—	—	—	16 bu.	5.7 bu.	—	—
Kohlrabi . .	—	—	—	15,475 lb.	—	—	10 t. to 16 tons
Lespedeza . .	—	—	—	—	—	—	—
Maize . .	22 bu.	60 bu.	—	—	21 bu.	40 bu.	10 t. to 45 t. ⁵
Mangels . .	—	—	—	—	600 bu.	—	13 t. to 50 t.
Melilotus . .	—	—	—	—	—	—	—
Millet . .	—	—	—	—	1.5 tons	—	1 ton to 6 tons
Oats . .	35 bu.	85 bu.	40 bu.	137 bu.	42 bu.	150 bu.	35 bu. to 125 bu.
Parsnips . .	—	—	—	8200 lb.	377 bu.	—	—
Potatoes . .	—	—	75 bu.	972 bu.	142 bu.	500 bu.	8 t. to 28.5 t.
Pumpkin . .	—	—	—	—	1384 pumpkins	—	—
Rape . .	—	—	—	—	—	—	—
Rice . .	—	—	—	—	—	—	—
Rutabaga . .	—	—	15 tons	—	—	—	20 t. to 63 t.
Rye . .	—	—	18 bu.	34 bu.	14.6 bu.	—	15 bu. to 32 bu.
Sorghum . .	—	—	—	—	—	—	—
Soybean . .	—	—	—	—	—	—	4.5 tons
Sugar-beets .	11.5 tons	19.5 tons	10 tons	28.7 tons	3.3 tons	18 tons ²	6 tons to 23 tons
Sugar-cane .	—	—	—	—	2.9 tons	—	—
Sweet-potato	10,000 lb.	18,000 lb.	—	—	90 bu.	—	—
Timothy . .	—	—	1.5 tons	—	3.7 tons	irrigated	2 t. to 5.5 tons
Tobacco . .	—	—	—	—	1.5 tons	dry land	—
Turnip . .	—	—	—	40 tons	236 lb.	—	—
Vetch . .	—	—	—	—	3 tons	—	—
Wheat . .	30 bu.	63 bu.	25.5 bu.	50 bu. ³ 78 bu. ⁴	25 bu.	100 bu.	11 bu. to 43 bu.

¹ Under irrigation. On dry land, 2.5 tons and 4 tons, respectively.² Under irrigation.³ Field culture.⁴ Garden culture.⁵ For silage.

Propagation-Tables

Tabular statement of the ways in which plants are propagated¹

A. BY SEEDS — Seedage

I. On their own roots	I. By undetached parts — Layerage	{	1. Root-tips.
			2. Stolons and runners.
B. BY BUDS	II. By detached parts	{	3. Layers proper. Simple. Serpentine. Mound or Stools. Pot or Chinese.
			1. By undivided parts. — Separation. (Bulbs, corms, bulblets, bulb scales, tubers, etc.)
II. On roots of other plants — Graftage	I. By detached scions	{	2. By divided parts — Cuttage
			Division. Cuttings proper. Of stems. Growing wood. Ripened wood. Of tubers. Of roots. Of leaves.
	II. By undetached scions. — Inarching.		1. Budding: Shield, flute, veneer, ring, annular, whistle or tubular. 2. Grafting: Whip, saddle, splice, veneer, cleft, bark, herbaceous, seed, double, cutting.

Particular methods by which various fruits are multiplied

Barberry	Cuttings of mature wood; seeds.
Orange	Seeds; seedlings budded or grafted.
Figs	Cuttings, either of soft or mature wood.
Mulberry	Cuttings of mature wood. Some varieties are root-grafted, and some are budded.
Olive	Cuttings of mature or even old wood. Chips from the trunks of old trees are sometimes used.
Pomegranate	Cuttings, layers, and seeds.
Apple and Pear	Seeds; seedlings budded or grafted.
Peach and other stone-fruits	Seeds; seedlings budded. Peach-trees are sold at one year from the bud, but other stone-fruit trees are planted when two or three years old.
Quince	Cuttings, usually; the cuttings often grafted.
Grape	Cuttings of from one to three buds; layers.
Currant and Gooseberry . .	Cuttings; gooseberry oftener by mound-layers.
Raspberries, red	Suckers from the root; root-cuttings.
Raspberries, black and purple	Layers from tips of canes; root-cuttings.
Blackberry	Root-cuttings; suckers from the root.
Dewberry	Layers of tips of the canes; root-cuttings.
Dwarf Juneberry	Sprouts or suckers from the root.
Cranberry	Layers or divisions.

¹ Modified from a synopsis prepared by B. M. Watson, Jr., Bussey Institution.

- Strawberry Runners; tip-cuttings.
 Banana Suckers from the crown.

Stocks commonly used for various fruits

- Almond Peach, hard-shell almond, plum.
 Apple Common apple seedlings, Paradise and Doucin stocks, crab-apple and wild crab. "French crab" stocks are common apple seedlings reared in France and imported.
 Apricot Apricot and peach in mild climates, and plum in severe ones; Marianna.
 Cherry Mazzard stocks are preferred for standards; Mahaleb stocks are used for dwarfing. The wild pin-cherry (*Prunus Pennsylvanica*) is sometimes used as stock in the Northwest, on account of its hardiness. Seedlings of Morelio cherries are also used there.
 Medlar Hawthorn, medlar, quince.
 Mulberry Seedlings of white and Russian mulberry; cuttings of Downing.
 Orange Seedlings; Otaheite orange, shaddock; *Citrus trifoliata*, particularly for dwarfs.
 Peach and Nectarine Peach. Plum is often used when dwarfs are wanted, or when the peach must be grown in a too severe climate or upon heavy soil.
 Pear Pear (seedlings of common pear and the Chinese type). Quince (rarely mountain ash, or thorn) for dwarfs. Apple temporarily.
 Persimmon, Japanese Native persimmon.
 Plum Plum, myrobalan plum, peach; Marianna.
 Quince The finer varieties are sometimes grafted upon strong-growing kinds like the Angers. When cuttings are difficult to root, they are sometimes grafted upon apple roots, the foster-root being removed upon transplanting, if it does not fall away of itself.

How vegetable crops are propagated

By seeds

- | | |
|---|-------------------------|
| Artichoke, globe also by offsets (see p. 132) | Kohlrabi |
| Asparagus | Leek |
| Beans of all kinds | Lettuce |
| Beet | Martynia |
| Borecole or kale | Muskmelon |
| Brussels sprout | Mustard |
| Cabbage | Onion (see also p. 132) |
| Carrot | Parsley |
| Cauliflower and broccoli | Parsnip |
| Celeriac | Pea |
| Celery | Pepper |
| Chicory | Pumpkin |
| Corn | Salsify |
| Corn-salad | Spinach |
| Cress | Squash |
| Cucumber | Tomato |
| Dandelion | Turnip |
| Egg-plant | Watermelon |
| Endive | |

By other means than seeds

Artichoke, globe; by seeds, but many worthless plants may be secured; by suckers about the crown of the old plant, if particular strains are to be perpetuated.

Artichoke, Jerusalem; by tubers, or divisions of the tubers.

Horseradish, cuttings of side roots.

Mushroom, by spawn (or dried and prepared mycelium); latterly also by spores.

Onion, the "black seed" or usual onions, by seed; potato or Egyptian onions, by "tops" or bulblets borne in the place of flowers; multipliers, by the natural divisions of the bulbs. Onion "sets" are small dry onions that renew their growth when planted.

Potato, cuttings of the tubers.

Rhubarb, or pie-plant; by seeds, but these give variable progeny; preferably by division of the roots into strong eyes.

Sea-kale; by seeds, but better by root-cuttings from the best plants.

Yam, Chinese. Bulblets from the axils of the leaves; division of the root.

How farm crops are propagated

By seeds

Alfalfa	Peanut
Barley	Pumpkin and Squash
Bean	Rape
Broom-corn	Rice
Buckwheat	Root-crops
Cabbage	Rubber, Para (Hevea), seeds in nursery beds.
Clover	Rubber, Panama (Castilloa), seeds in nursery beds.
Coffee, seeds started in beds, and transplanted.	Rubber, Ceara (Manihot), seeds and cuttings.
Corn	Rye
Cotton	Sorghum
Cowpea	Sugar-beet
Flax	Tea, in nursery beds
Ginseng	Teasel
Grasses	Tobacco
Hemp	Vetch
Kafir	Wheat
Millet	
Oats	

By other parts than seeds

Arrow-root, division of underground parts.

Cassava, mostly by cuttings of the seed-canes, as for sugar-cane; early varieties sometimes by seeds.

Hop, cuttings of the underground stems or "roots."

Potato, cuttings of the underground stems or tubers.

Sugar-cane, cuttings of the canes; rarely by seeds for production of new varieties.

Sweet-potato, sprouts from the potatoes, in seed-beds.

CHAPTER VIII

CROPS FOR SPECIAL FARM PRACTICES. HOME STORAGE AND KEEPING OF CROPS

DIFFERENT systems or plans of farming are expressed in the character of the cropping scheme; and some of these schemes are so special that they may be thrown together in a reference advice-book.

Forage Crops

Forage is herbage food, whether green or cured. The forage crops are grasses (whether utilized in meadows, pastures, or otherwise), all coarse natural grazing crops such as animals are likely to find provided in nature, and miscellaneous roots and vegetative parts grown specifically for feeding purposes. They are distinguished from the threshed grains and all manufactured products. It will be seen at once that there are two cultural groups comprised in the class of forage crops, — the group occupying the land for a series of years (meadows and pastures), and the group comprising the annual-grown or biennial-grown plants (as maize, cowpea, pea, millet, roots). These groups overlap, however, so that no hard and fast line can be drawn between them.

The word *roughage* is applied to the coarser forage products, as maize, cowpeas, kafir; sometimes it is used as equivalent to forage.

Fodder is practically equivalent to the word "forage," but is less specific; it is by some restricted to dried or cured forage. The word is commonly used for the coarser kinds, in distinction from hay.

Some of the leading forage crops are alfalfa, cabbage, the various cereals, clovers, cowpea, kafir, maize or Indian corn, mangels, millet, rape, soybean, sorghum, vetches.

Soiling is the feeding of green harvested forage direct from the field to the animals. The feed is carried to them. This system is distinguished from pasturing. The animals are kept in small inclosures or in stalls, and thereby their feed is regulated and the standing crop is not injured by them. The term is probably derived from that use or origin of the verb "to soil" that indicates to satisfy or to fill.

A species of pasturing is sometimes known as soiling. By means of movable fences, the animals are allowed to graze a part of the crop clean and then to move on at the next feeding to fresh foraging. This use of the term is allowable, since the object is the same, — to supply the animal with a given amount of succulent food; the animal does the harvesting. This practice may be known as *pasture soiling*.

It would not do to allow animals to roam at will and to gorge themselves in such crops as maize, growing grain, heavy alfalfa, clover, or cowpeas; consequently the animals are *soiled* on these crops in one way or another.

Silage is green or uncured forage that is preserved, or ensiled, in a tight receptacle or silo (see Chap. XXV). The following crops have at various times been recommended for ensiling: corn, clovers, alfalfa, meadow-grasses, cowpeas, soybeans, Canada field peas, sorghum, sunflower, millet, apple pomace, beet pulp, canning house refuse.

Soiling Crops

The more important soiling crops are: winter grains (cut before blooming), peas and oats, alfalfa, clover, vetch, soybeans, millet, cowpeas, corn, sorghum, and rape.

If it is desired to feed green crops throughout the entire season, the following rotation is suggested (Woll): —

- (1) Winter wheat or rye, ready to cut and feed during May;
- (2) Green clover, for feeding during the early part of June;
- (3) Oats and peas, sown as early as possible in the spring, and later two or three times at weekly intervals; available for feeding during the remainder of June and July;
- (4) Corn, or corn and sorghum, planted at the usual time, for feeding in August and September;
- (5) The land occupied by oats and peas when cleared may be sown to millet or barley, for feeding during the fall months.

The following crops for partial soiling are recommended by Jordan:

Three sowings of peas and oats in May and early June, and two plantings of corn, one at the usual time, the other two weeks later. These crops will furnish a supply of green feed when this is most likely to be needed. Quincy included four crops in his system, viz. early clover (for feeding during May and June), oats (for July), corn (for August), second growth of clover or grass (September to October 15), tops of carrots and turnips, cabbages (October 15 to November).

Special rotations for soiling crops have been recommended by various authorities, and the farmer has the choice of a variety of crops that may be grown for this purpose. The rotations suitable for soiling included below are given as guides for farmers living in the states mentioned, or under similar agricultural conditions (collected by Woll) :—

Soiling crops adapted to northern New England (Lindsey)

(For 10 cows' entire soiling)

KIND	SEED PER ACRE	TIME OF SEEDING	AREA	TIME OF CUTTING
Rye	2 bu.	Sept. 10-15	$\frac{1}{2}$ acre	May 20-May 30
Wheat	2 bu.	Sept. 10-15	$\frac{1}{2}$ acre	June 1-June 15
Red clover	20 lb.	July 15-Aug. 1	$\frac{1}{2}$ acre	June 15-June 25
Grass and clover	$\left\{ \begin{array}{l} \frac{1}{2} \text{ bu. red-top, 1 pk.} \\ \text{timothy, 10 lb. red} \\ \text{clover} \end{array} \right\}$	September	$\frac{2}{3}$ acre	June 15-June 30
Vetch and oats	3 bu. oats, 50 lb. vetch	April 20	$\frac{1}{2}$ acre	June 25-July 10
Vetch and oats	3 bu. oats, 50 lb. vetch	April 30	$\frac{1}{2}$ acre	July 10-July 20
Peas and oats	$\left\{ \begin{array}{l} 1\frac{1}{2} \text{ bu. Canada peas,} \\ 1\frac{1}{2} \text{ bu. oats} \end{array} \right\}$	April 20	$\frac{1}{2}$ acre	June 25-July 10
Peas and oats	$\left\{ \begin{array}{l} 1\frac{1}{2} \text{ bu. Canada peas,} \\ 1\frac{1}{2} \text{ bu. oats} \end{array} \right\}$	April 30	$\frac{1}{2}$ acre	July 10-July 20
Barnyard millet	1 pk.	May 10	$\frac{1}{3}$ acre	July 25-Aug. 10
Barnyard millet	1 pk.	May 25	$\frac{1}{3}$ acre	Aug. 10-Aug. 20
Soybeans (medium green)	18 qt.	May 20	$\frac{1}{3}$ acre	Aug. 25-Sept. 15
Corn	May 20	$\frac{1}{3}$ acre	Aug. 25-Sept. 10
Corn	May 30	$\frac{1}{3}$ acre	Sept. 10-Sept. 20
Hungarian	July 15	$\frac{1}{2}$ acre	Sept. 20-Sept. 30
Barley and peas	$\left\{ \begin{array}{l} 1 \text{ bu.} \\ 1\frac{1}{2} \text{ bu. peas, } 1\frac{1}{2} \text{ bu.} \\ \text{barley} \end{array} \right\}$	August 5	1 acre	Oct. 1-Oct. 20

Time of planting and feeding soiling crops (Phelps)

The dates given in the table apply to central Connecticut and regions under approximately similar conditions

KIND OF FODDER	AMOUNT OF SEED PER ACRE	APPROXIMATE TIME OF SEEDING	APPROXIMATE TIME OF FEEDING
1. Rye fodder	2½ to 3 bu.	September 1	May 10-20
2. Wheat fodder	2½ to 3 bu.	Sept. 5-10	May 20, June 5
3. Clover	20 lb.	July 20-30	June 5-15
4. Grass (from grass-lands)			June 15-25
5. Oats and peas	2 bu. each	April 10	June 25, July 10
6. Oats and peas	2 bu. each	April 20	July 10-20
7. Oats and peas	2 bu. each	April 30	July 20, Aug. 1
8. Hungarian	1½ bu.	June 1	Aug. 1-10
9. Clover rowen (from 3)			Aug. 10-20
10. Soybeans	1 bu.	May 25	Aug. 20, Sept. 5
11. Cowpeas	1 bu.	June 5-10	Sept. 5-20
12. Rowen grass (from grass-lands)			Sept. 20-30
13. Barley and peas	2 bu. each	Aug. 5-10	Oct. 1-30

Soiling crops for Pennsylvania (Watson and Mairs)

CROP	AREA FOR 10 COWS	WHEN TO BE FED
Rye	½ acre	May 15-June 1
Alfalfa	2 acres	June 1-June 12
Clover and timothy	¾ acre	June 12-June 24
Peas and oats	1 acre	June 24-July 15
Alfalfa (second crop)	2 acres	July 15-Aug. 11
Sorghum and cowpeas (after rye)	½ acre	Aug. 11-Aug. 28
Cowpeas (after peas and oats)	1 acre	Aug. 28-Sept. 30

Crops for partial soiling for Illinois during midsummer (Fraser)

KIND OF FODDER	AMOUNT OF SEED PER ACRE	APPROXIMATE TIME OF SEEDING	APPROXIMATE TIME OF FEEDING
1. Corn, early, sweet, or dent	6 qt.	May 1	July 1-Aug. 1
2. Corn, medium, dent	5 qt.	May 15	Aug. 1-Sept. 30
3. Cowpeas	1 bu.	May 15	Aug. 1-Sept. 15
4. Soybeans	1 bu.	May 15	Aug. 1-Sept. 15
5. Oats and Canada peas	1 bu. each	April 15	July 1-July 15
6. Oats and Canada peas	1 bu. each	May 1	July 15-Aug. 1
7. Rape (Dwarf Essex)	4 lb.	May 1	July 1-Aug. 1
8. Rape, second sowing	4 lb.	June 1	Aug. 1-Sept. 1
9. Rape, third sowing	4 lb.	July 1	Sept. 1-Oct. 1

Succession of soiling crops for dairy cows for Wisconsin (Carlyle)

CROP	POUNDS OF SEED PER ACRE	TIME FOR SOWING	APPROXIMATE			DEGREES OF MATURITY	PALATABILITY	
			Time of Cutting	Days from Sowing to Harvest	Daily Feed per Cow			Acres for Ten Cows
Fall rye	168	Sept. 10	May 15-June 1	248	38	½	Before blooming	Poor
Alfalfa	20	Mar. 20	June 1-15	72	36	½	Before blooming	Fair
Red clover	15	—	June 15-25	—	36	½	In bloom	Fair
Peas and oats	{ P 60 O 48	April 16	June 25-July 5	70	32	½	In milk	Average
Peas and oats	{ P 60 O 48	April 26	July 5-15	70	32	½	In milk	Average
Oats	80	May 5	July 15-25	70	32	½	In milk	Average
Alfalfa (second crop.)	—	—	July 15-30	—	36	—	Before blooming	Average
Rape	2.5	May 26	Aug. 1-15	67	42	½	Mature	Good
Flint corn	—	May 20	Aug. 15-25	86	40	½	In silk	Very good
Sorghum	50	June 1	Aug. 25-Sept. 10	86	39	½	When well headed	Very good
Evergreen sweet corn	—	May 31	Sept. 10-25	102	39	½	In silk	Very good
Rape	2.5	July 20	Sept. 25-Oct. 10	67	42	½	Mature	Good

Remarks. — Feed in stable during day and turn cows on pasture at night, or feed carefully in the pasture, spreading the forage. After cutting rye, use same ground for the rape, flint corn, and sorghum, and after cutting peas and oats, use same ground for evergreen sweet corn and rape. After oats, sow peas and barley. In this way a single acre only is required (except alfalfa, which is permanent), and the forage produced is ample succulent feed for ten cows for nearly half the year.

Mississippi. — “One of the best, surest and safest crops for soiling is sorghum, planted thick, and with the rows not over two feet apart. The sorghum may follow a crop of oats or some other early crop, and will withstand dry weather better than most other plants. Cowpeas are good, and corn may be used satisfactorily on land that will produce fair to large yields.” (Moore.)

Kansas. — Dates when soiling crops are available: Alfalfa, May 20 to September 30; wheat, June 1 to June 15; oats, June 15 to June 30; sweet corn, July 15 to July 31; field corn, August 1 to September 15; sorghum, August 1 to September 30; kafir, August 1 to September 30; wheat and rye pasture, until the ground freezes. (Otis.)

Dates for planting and using soiling crops in western Oregon and western Washington (Hunter)

CROPS	WHEN PLANTED	WHEN USED
Rye and vetch	September 1-15	April 1-May 15
Winter oats and vetch	September and October	May 15-July 1
Winter wheat and vetch	September and October	May 15-July 1
Red clover	May 15-July 1
Alfalfa	During June
Oats and peas	February	During June
Oats and vetch	February	June 15-July 15
Oats and peas	April	During July
Rape	May 1	During July
Oats and peas	May	During August
Rape	June	During August
Corn	May 10-20	During August, September, and October.
Turnips	July 1	Late fall and early winter
Thousand-headed kale .	March 15 and trans. June 1	October 15-April 1
Mangels, carrots and rutabagas	April	Oct. 15-April 1 (fed from bins, pits, or root-houses).

Rotation used successfully by practical dairymen in the middle latitudes (40° N.)

CROP	SEEDING TIME	SEED PER ACRE	IN PRIME FEEDING CONDITION
Rye and vetches . . .	September	2 bu. rye, $\frac{1}{2}$ bu. vetch	April 25 to May 10
Wheat and vetches . .	September	2 bu. rye, $\frac{1}{2}$ bu. vetch	May 10 to June 1
Red and alsike clover	April or August	25 to 30 lb.	June 1 to June 25
Oats and Canada peas	April	2 bu. oats, 2 bu. peas	June 25 to July 10
Very early sweet corn	May	8 qt.	July 10 to July 25
Late sweet corn . . .	May and June	6 qt.	July 25 to Aug. 25
Sorghum and cowpeas	June	10 qt. sorghum, 50 qt. peas	Aug. 25 to frost

Cover-Crops

A cover-crop is one that is grown for its effect as green-manure or protection, or otherwise, rather than for its value as a product of itself. Cover-crops are used

1. To prevent the loss of soluble plant-food, which occurs when the lands are left uncovered during the late fall and winter;
2. To prevent the galling or surface erosion of hillsides or slopes by winter rains;
3. To prevent root injury by excessive freezing of orchard lands;
4. To supply humus;
5. To improve the physical condition of the land.

Legumes used as cover-crops: red clover and Canada field-peas, widely useful in the northern tier of states; alfalfa in the western states and California; soybeans, cowpeas, and crimson clover in the central and southern states; velvet bean and beggarweed, especially useful only in the South; hairy vetch and spring vetch, most successfully used in the South, though rather generally grown in the northern states; sweet clover and, for peculiar conditions, serradella.

Non-legumes used as cover-crops: rye, wheat, oats, and barley, of the cereals, are more commonly used; rape and turnips, which are not hardy in the northern sections; buckwheat, white mustard, and spurry under special conditions.

Some of the leading cover-crops mentioned or recommended for fruit plantations (the leguminous or nitrogen-gathering species being starred): —

Living over winter: —

* Clovers.

* Hairy or winter vetch (*Vicia villosa*).

* Sweet clover (little used).

Winter rye.

Winter wheat.

Killed by freezing: —

* Cowpea.

* Soybean.

* Velvet bean.

* Pea.

- * Bean.
- * Beggarweed.
- * Spring vetch (*Vicia sativa*). } 1 qt. of spring or winter
vetch (seed) weighs
 $1\frac{3}{4}$ lb.
- Rape.
- Turnip.
- Oats.
- Barley (little used).
- Buckwheat.
- Maize.
- Millet (little used).

Average quantities of seed per acre for heavy cover-crops in fruit plantations

Barley	2-2½ bu.
Beans	1½-2 bu.
Beggarweed	5-8 lb.
Buckwheat	1½ bu.
Clover, red	10-15 lb.
Clover, mammoth	15-20 lb.
Clover, crimson	15-20 lb.
Cowpea	1½-2 bu.
Maize	2-3 bu.
Millet	1½ bu.
Oats	2-3 bu.
Pea	2-3 bu.
Rape	2-5 lb.
Rye	1½-2 bu.
Soybean	2-4 pk.
Sweet clover	10-12 lb.
Turnip	4 lb.
Velvet bean	1-4 pk.
Vetch	20 lb. to 1½ bu.
Wheat	2-2½ bu.

Alfalfa (20 to 24 lb. to the acre) is sometimes used as a cover-crop in orchards, being plowed a year from sowing or allowed to remain for a longer period. Various combinations or mixtures are also used: as mammoth clover, 6 lb., alfalfa, 10 lb., turnip, 2 to 3 oz.; alfalfa, 6 lb., crimson clover, 6 lb., alsike clover, 3 lb., strap-leaf turnip, 2 to 3 oz., all sown in midsummer. Cowpeas in drills and cultivated, and rye, rape, or turnips added at the last cultivation. Winter vetch, 1 bu., rye, ½ bu. Cowpea, 1½ bu.; red clover, 6 lb. Oats, 2 bu.; peas, 2 bu.

Catch-Crops

Catch-crops are those crops that occupy the ground for short intervals between the growing of other crops, in order to secure more products within a given time.

Nitrogen-consuming catch-crops: rye, wheat, buckwheat, turnips, dwarf Essex rape.

Nitrogen-gathering catch-crops: red clover, 15 lb. per acre; mammoth clover, 15 lb.; alsike clover, 5 lb. with 5 lb. red clover; crimson clover, 12-15 lb.; alfalfa, 25-35 lb. broadcast or 15-25 lb. drilled; Canada field-pea, $\frac{1}{2}$ -2 bu.; cowpea, 1-1 $\frac{1}{2}$ bu., broadcast; soybean, 1-1 $\frac{1}{2}$ bu. broadcast, or 2-3 pk. drilled; velvet bean, 1 bu.; sand or winter vetch, 1 $\frac{1}{2}$ -2 bu.

The amount of nitrogen contained in various crops:—

	TONS PER ACRE GREEN	NITROGEN LB.	ORGANIC MATTER LB.
Cowpeas	6	48	1920
Soybeans	6	60	2640
Crimson clover	6	60	2160
Alsike clover	6	60	2640
Red clover	6	60	2400
Canada field-peas	5	50	2200

Nurse-Crops

Plants used to aid, shield, or shade other plants, until the other plants become established, are nurse-plants. Grain is a nurse-crop when it is used as an aid to seeding to grass. Nurse-cropping is practiced in forestry, also.

Field Root-Crops (Minns)

Seeds of the mangel may be sown in central New York from May 1 to June 1, with expectation of a good crop. Late frosts do not endanger the young plants; and if the ground is in good condition the earlier they are sown in the month of May, the longer the growing season will be. They are not seriously affected by dry weather if given good tillage. They are mature enough to harvest by October 1, and may be allowed to remain in the ground until November 1 with safety. Hard freezing weather damages the part of the root that stands above ground, and therefore it is safe to have them harvested before November.

Seeds of carrots are slow to germinate, and must be planted near the surface of the ground. It is essential to have the best of soil and weather

conditions for them. From May 20 to June 20 inclusive would be the proper time for sowing carrots in this latitude. They do not make much growth until the heat of summer is past. The seedlings are very feeble, and require much hand tillage; but after harvest time is over, and especially after August and September rains, carrots make vigorous growth until late in the autumn. As the root grows mainly below the surface of the ground, they need not be harvested as early as mangels. They may remain out of doors, and will continue to increase somewhat in size until the ground begins to freeze. It is better to harvest them before bad weather sets in.

Rutabagas do not require as long a season in which to mature as do carrots or mangels. They are also sensitive to drought during mid-summer. In order to have them mature at a time in the autumn when they are wanted for feed or to store away for winter use, it is best to plant the seed from June 1 to 20 inclusive. The seed germinates readily, and the plants soon become large enough to till easily. From seed sown in June, the crop will usually mature by October 1, which is early enough for stock-feeding purposes. They may be left out of doors until cold weather comes, in November.

White turnips of different sorts will mature in a comparatively short time. They also are sensitive to summer drought, and therefore it is best to sow the seed from July 20 to 30 inclusive. Even then their success is dependent very largely on the amount of moisture in the soil at the time of sowing and during the month that follows. If conditions are favorable, they will mature by November 1, and as they are not easily damaged by frost, they can be allowed to remain out of doors until freezing weather sets in.

White turnips are frequently sown as a catch-crop after a crop of early potatoes has been removed, or at the last cultivation of a field of corn which has been planted early. Sown in this way, the cost of growing them is low and consistent with their value for feeding purposes.

Of the four types of root-crops named, the mangels are the most reliable in this locality, and the carrots the most expensive to grow.

Methods of Keeping and Storing Fruits and Vegetables

Apples.

1. Keep the fruit as cool as possible without freezing. Choose only normal fruit, and place it upon trays in a moist but well-ventilated

cellar. If it is desired to keep the fruit particularly nice, allow no fruits to touch each other upon the trays, and the individual fruits may be wrapped in tissue paper. For market purposes, pack tightly in barrels after the apples have shrunk, and store the barrels in a very cool place.

2. Some solid apples, as Spitzenburgh and Newtown, are not injured by hard freezing, if they are allowed to remain frozen until wanted and are then thawed out very gradually.

3. Many apples, particularly russets and other firm varieties, keep well when buried after the manner of pitting potatoes. Sometimes, however, they taste of the earth. This may be prevented by setting a ridge-pole over the pile of apples in forked sticks, and making a roof of boards in such a way that there will be an air space over the fruit. Then cover the boards with straw and earth. Apples seldom keep well after removal from a pit in spring.

4. Apples may be kept by burying in chaff. Spread chaff — buck-wheat-chaff is good — on the barn floor, pile on the apples and cover them with chaff and fine broken or chopped straw 2 feet thick, exercising care to fill the interstices. They may be covered in leaves or moss.

Cabbage.

The most satisfactory method of keeping cabbages is to bury them in the field. Choose a dry place, pull the cabbages, and stand them head down on the earth. Cover them with soil to the depth of 6 or 10 inches, covering very lightly at first to prevent heating — unless the weather should quickly become severe — and as winter sets in, cover with a good dressing of straw or coarse manure. The cabbages should be allowed to stand where they grew until cold weather approaches. The storing beds are usually made about 6 or 8 feet wide, so that the middle of the bed can be reached from either side, and to prevent heating if the weather should remain open. Cabbages quickly decay in the warm weather of spring.

Cabbage for family use is most conveniently kept in a barrel or box half buried in the garden. Cabbages and turnips should never be kept in the house cellar, as when decaying they become very offensive.

Celery.

For market purposes, celery is stored in temporary board pits, in sheds, in cellars, and in various kinds of earth pits and trenches. The

points to be considered are, to provide the plants with moisture to prevent wilting, to prevent hard freezing, and to give some ventilation. The plants are set loosely in the soil. There are several methods of keeping celery in an ordinary cellar for home use. The following methods are good: —

Secure a shoe or similar box. Bore one-inch holes in the sides, four inches from bottom. Put a layer of sand or soil in the box, and stand the plants, trimmed carefully, upon it, closely together, working more sand or soil about the root part, and continuing until the box is full. The soil should be watered as often as needed, but always through the holes in the side of the box. Keep the foliage dry.

Celery may also be stored and well blanched at the same time, in a similar way, by standing it in a barrel upon a layer of soil. Some roots and soil may be left adhering to the plants. Crowd closely, water through holes near the bottom, as in case of box storage, and keep the plants in the dark.

Blanched celery can also be preserved for a long time by trimming closely and packing upright in moss inside of a box. A large quantity of the vegetable may thus be stored in a small space.

Crystallized or glacé fruit.

The principle is to extract the juice from the fruit and replace it with sugar syrup, which hardens and preserves the fruit in its natural shape. The fruit should be all of one size and of a uniform degree of ripeness, such as is best for canning. Peaches, pears, and similar fruits are pared and cut in halves; plums, cherries, etc., are pitted. After being properly prepared, the fruit is put in a basket or bucket with a perforated bottom and immersed in boiling water to dilute and extract the juice. This is the most important part of the process, and requires great skill. If the fruit be left too long, it is over-cooked and becomes soft; if not long enough, the juice is not sufficiently extracted, and this prevents perfect absorption of the sugar. After the fruit cools, it may again be assorted as to softness. The syrup is made of white sugar and water. The softer the fruit, the heavier the syrup required. The fruit is placed in earthen pans, covered with syrup, and left about a week. This is a critical stage, as fermentation will soon take place; and when this has reached a certain stage, the fruit and syrup are heated to the boiling-point, which checks the fermenta-

tion. This is repeated, as often as may be necessary, for about six weeks. The fruit is taken out of the syrup, washed in clean water, and either glacéd or crystallized, as desired. It is dipped in thick syrup, and hardened quickly in the open air for glacéing, or left to be hardened slowly if to be crystallized. The fruit is now ready for packing, and will keep in any climate.

Figs.

After the figs are gathered and dried in the same way as peaches or apricots, wash to remove all grit, and spread in shallow pans, and set them in the oven to become thoroughly heated, taking care to prevent scorching. Then roll in powdered sugar, which has been rolled to remove all lumps. When cold, pack away, preferably in paper bags. They make a delicious lunch with a bowl of milk. They are also excellent for the dessert.

Gooseberries keep well if kept tight in common bottles filled with pure water. Be sure that none but perfect berries are admitted, and keep in a cool place. The berries should be picked before they are ripe, or edible from the hand, — in the stage at which they are used for culinary purposes.

Grapes.

1. The firm grapes usually keep best — as Catawba, Vergennes, Niagara, Diana, Jefferson, etc. Thickness of skin does not appear to be correlated with good keeping qualities. Always cut the bunches which are to be stored on a dry day, when the berries are ripe, and carefully remove all soft, bruised, and imperfect fruits and all leaves. Keep the fruit dry, cool, and away from currents of air. Many varieties keep well if simply placed in shallow boxes or baskets and kept undisturbed in a cool, rather moist place.

2. Pack the bunches in layers of dry, clean sand.

3. Pack in layers of some small grain, as wheat, or oats, or barley.

4. Cork-dust is also excellent for use in packing grapes. This cork can be had from grocers who handle the white Malagas, which are packed in this material.

5. Pack the bunches in finely cut, soft, and dry hay, placing the grapes and hay in consecutive layers.

6. Dry hardwood sawdust is also good for packing.

7. Place on shelves in a cool, airy room. After a few days wrap the bunches separately in soft paper, and pack in shallow pasteboard boxes, not more than two or three layers deep. Keep in a cool, dry room that is free from frost.

8. Cut the bunches with sharp scissors, place in shallow baskets, but few in a basket, and after reaching the house dip the cut end of stems in melted wax. Now take tissue paper or very thin manila paper cut just to the right size, and carefully wrap each cluster of grapes. Secure shallow tin boxes; place a layer of cotton-batting at the bottom, then a layer of grapes, then batting; three layers of grapes are enough for one box, alternating with cotton-batting, and topping with batting; then gently secure the lid to each box, and when done place in cold storage for use in April, or even later. If cold storage cannot be had, put in a dry, cool room, and when cold weather approaches, cover in an interior closet with just sufficient covering to prevent freezing; warmth will cause over-ripening and deterioration.

9. Roe's method. — In a stone jar place alternate layers of grapes and straw paper, the paper being in double thickness. Over the jar place a cloth, and bury below frost in a dry soil. The grapes will keep until New Year's.

Keeping grapes for market (W. M. Pattison, Quebec).

It is the generally received opinion that the thick-skinned native seedlings are the only keepers. This is correct as regards preserving flavor, but several hybrids of foreign blood are the best keepers known. Before giving results of this and former trials, instructions in packing may be of service. The varieties intended to be laid up for winter use should be those alone which adhere well to the stem and are not inclined to shrivel. These should be allowed to remain on the vines as long as they are safe from frost. A clear, dry day is necessary for picking, and careful handling and shallow baskets are important. The room selected for the drying process should be well ventilated, and the fruit laid out in single layers on tables or in baskets where the air circulates freely, the windows being closed at night and in damp weather. In about ten days the stems will be dried out sufficiently to prevent molding when laid away. When danger from this is over, and the stems resemble those of raisins, the time for packing has arrived. In this, the point to be observed is to exclude air proportionately with their

tendency to mold. I have used baskets for permanent packing, but much prefer shallow trays or boxes of uniform size to be packed on each other, so that each box forms a cover for the lower, the uppermost only needing one. Until very cold weather, the boxes can be piled so as to allow the remaining moisture to escape through a crevice about the width of a knife-blade. Before packing, each bunch should be examined, and all injured, cracked, and rotten berries removed with suitable scissors. If two layers are packed in a box, a sheet of paper should intervene. The boxes must be kept in a cool, dry room or passage, at an even temperature. If the thermometer goes much below freezing-point, a blanket or newspaper can be thrown over them, to be removed in mild weather. Looking over them once in the winter and removing defective berries will suffice, the poorest keepers being placed accessibly. Under this treatment the best keepers will be in good edible order as late as February, after which they deteriorate.

The following is a list of grapes worth noticing, that have been tested for keeping:—

DESCRIPTION		LIST OF GRAPES TO BE RECOMMENDED
VARIETIES KEEPING WELL UNTIL—	Nov. 1	Lady, Antoinette, Carlotta, Belinda.
	Dec. 1	Lady Washington, Peter Wylie, Mason, Worden, Senasqua, Romell, Ricketts No. 546, Concord, Delaware.
	Jan. 1	Duchess, Essex, Barry, Rockland, Favorite, Aminia, Garber, Massasoit, Dempsey, Burnet, Undine, Allen Hybrid, Agawam, Gen. Pope, Francis Scott.
	Feb. 1	Salem, Vergennes, Eldorado.
	Jan. 15	Wilder, Herbert, Peabody, Rogers No. 30, Gaertner, Mary, and Owosso.

Onions demand a dry cellar, and the bulbs should be thoroughly dried in the sun before they are stored. All tops should be cut away when the onions are harvested. If a cellar cannot be had, the bulbs may be allowed to freeze, but great care must be exercised or the whole crop will be lost. The onions must not be subjected to extremes of temperature, and they should not thaw out during the winter. They can be stored on the north side of a loft, being covered with two

or three feet of straw, hay, or chaff to preserve an equable temperature. They must not be handled while frozen, and they must thaw out very gradually in the spring. This method of keeping onions is reliable only when the weather is cold and tolerably uniform, and it is little employed.

Orange.

Aside from the customary wrapping of oranges in tissue paper and packing them in boxes, burying in dry sand is sometimes practiced. The fruit is first wrapped in tissue paper, and it should be buried in such manner that the fruit shall not be more than three tiers deep.

Pears.

Pears should be picked several days or even two weeks before they are ripe, and then placed in a dry and well-ventilated room, as a chamber. Make very shallow piles, or, better, place on trays. They will then ripen up well. The fruits are picked when full grown but not ripe, and when the stem separates readily from the fruit-spur if the pear is lifted up. All pears are better for being prematurely picked in this way. Winter pears are stored in the same manner as winter apples.

Quinces are kept in the same way as winter apples and winter pears. Some varieties, particularly the *Champion*, may be kept until after New Year's in a good cellar.

Roots of all sorts, as beets, carrots, salsify, parsnips, can be kept from wilting by packing them in damp sphagnum moss, like that used by nurserymen. They may also be packed in sand. It is an erroneous notion that parsnips and salsify are not good until after they are frozen.

Squashes should be stored in a dry room in which the temperature is uniform and about 50°. Growers for market usually build squash houses or rooms and heat them. Great care should be taken not to bruise any squashes which are to be stored. Squashes procured from the market have usually been too roughly handled to be reliable for storing.

Sweet-potato.

In the North. — Dig the potatoes on a sunny day, and allow them to dry thoroughly in the field. Sort out the poor ones, and handle the remainder carefully. Never allow them to become chilled. Then pack them in barrels in layers, in dry sand, and store in a warm cellar. They are sometimes stored in finely broken charcoal and wheat-chaff.

Sometimes they are kept in small and open crates, without packing-material, the crates being stacked so as to allow thorough ventilation. The Hayman or Southern Queen keep well in this way.

A warm attic is often a good place in which to store sweet-potatoes. A tight, warm room over a kitchen is particularly good.

In the South (Berkmans). — Digging the tubers should be delayed until the vines have been sufficiently touched by frost to check vegetation. Allow the potatoes to dry off in the field, which will take but a few hours. Then sort all those of eating size to be banked separately from the smaller ones. The banks are prepared as follows: Make a circular bed six feet in diameter, in a sheltered corner of the garden, throwing up the earth about a foot high. Cover this with straw and bank up the tubers in shape of a cone, using from 10 to 20 bushels to each bank. A triangular pipe made of narrow planks to act as a ventilator should be placed in the middle of the cone. Cover the tubers with straw 6 to 10 inches thick, and bank the latter with earth, first using only a small quantity, but increasing the thickness a week or ten days afterwards. A board should be placed upon the top of the ventilating pipe to prevent water from reaching the tubers. Several banks are usually made in a row, and a rough shelter of boards built over the whole. The main point to be considered in putting up sweet potatoes for winter is entire freedom from moisture and sufficient covering to prevent heating. It is therefore advisable to allow the tubers to undergo sweating (which invariably occurs after being put in heaps) before covering them too much; and if the temporary covering is removed for a few hours, a week after being heaped, the moisture generated will be removed and very little difficulty will follow from that cause. If covered too thickly at once, the sweating often endangers rapid fermentation, and loss is then certain to follow. Sand is never used here in banking potatoes. Some varieties of potatoes keep much better than others. The Yellow Sugar yam and the Pumpkin yam are the

most difficult to carry through; while the Trinidad potato keeps as readily as Irish potatoes, only requiring to be kept free from frost and light by a slight covering of straw, if the tubers are placed in a house. Next in keeping quality come Hayti yam, Red-skinned, Brimstone, Nigger Killer; and last of the potato section is the Nansemond.

Tomato.

Pick the firmest fruits just as they are beginning to turn, leaving the stems on, exercising care not to bruise them, and pack in a barrel or box in clean and thoroughly dry sand, placing the fruits so that they will not touch each other. Place the barrel in a dry place.

In the autumn when frosts appear, tomatoes, if carefully picked and laid on straw under the glass of cold frames, will continue to ripen until near Christmas. Green but full-grown tomatoes may be gradually ripened by placing them in cupboards or bureau drawers.

The ripening of tomatoes may be hastened ten days by bagging them as grapes are bagged.

Cold Storage

Storing under refrigeration is mostly a business by itself, and is therefore out of reach of a general book of rules. However, a few figures drawn from experience may be useful to the farmer:—

Temperature for fruits and vegetables in cold storage (Rochester Cold Storage Co.). P. 345

GOODS	TEMPERATURE	GOODS	TEMPERATURE
Apples ¹	30-33°	Lemons	36°
Berries	36°	Maple Syrup	35°
Canned goods	35°	Nuts	35°
Celery	32° with care	Oranges	36°
Cherries	36°	Pears	32° with care
Cranberries	33°	Peaches or plums	35°
Dried berries	30-32°	Prunes	35°
Dried apples	30°	Quinces	30°
Dried corn	30°	Raisins	35°
Dates	35°	Vegetables	35°
Evaporated apples	30°	Wine	40°
Figs	33°	Watermelons	35°
Grapes	36°		

¹ Apples are often carried as low as 30°, in a dry-air circulating room; the heavier-skinned apples may be carried as low as 29°. With pears and celery, which contain much water, care should be taken that they do not go below freezing.

CHAPTER IX

COMMERCIAL GRADES OF CROP PRODUCTS. FRUIT PACKAGES

THE market grades or classes of some products have been very carefully standardized. This is particularly true of grains, hay, and straw, and to a less extent of fruit. In prepared animal products there has been very little standardizing by societies or committees.

Cotton Grades

No printed rules have been formulated for the official grading of cotton, as this work proceeds upon the basis of a *set of types* of actual cotton, adopted as standard on the recommendation of a committee representing the entire cotton industry. These sets of cottons are made up by the United States Department of Agriculture and furnished to all applicants at the cost of their preparation. The samples are put up in specially prepared boxes.

In the Cotton Grades, as now being issued by the Department of Agriculture, several new ideas have been embodied, conspicuous among which is the protection of the grades by photographs. Each of the nine grade boxes contains twelve samples of cotton, separately packed, representing as nearly as possible the range of diversity in the grade represented. The boxes are twenty inches square; inside the lid of each is a full-size photograph showing the appearance of the cotton when certified by the Secretary of Agriculture. As each particle of trash and each material unevenness in the surface of the cotton is shown in the photograph, it is evident that any material change in the appearance of the cotton itself can easily be detected by comparison with the photograph. Of course these photographs make no pretension to show the grade of the cotton, — only the position of the trash and fiber. The seal of the Department of Agriculture and the signature of the Secretary, together with a seal-impress certifying the grade of the cotton, appear on the photograph. Experts of the highest class have

been employed in the preparation of the Official Cotton Grades, and each set is a correct copy of the original types promulgated by the Secretary of Agriculture on the recommendation of Committee.

Grades of Hay and Straw (Established by the National Hay Association, Inc.)

Hay.

Choice Timothy Hay — Shall be timothy not mixed with over one-twentieth other grasses, properly cured, bright, natural color, sound, and well baled.

No. 1 Timothy Hay — Shall be timothy with not more than one-eighth mixed with clover or other tame grasses, properly cured, good color, sound, and well baled.

No. 2 Timothy Hay — Shall be timothy not good enough for No. 1, not over one-fourth mixed with clover or other tame grasses, fair color, sound, and well baled.

No. 3 Timothy Hay — Shall include all hay not good enough for other grades, sound, and well baled.

Light Clover Mixed Hay — Shall be timothy mixed with clover. The clover mixture not over one-fourth, properly cured, sound, good color, and well baled.

No. 1 Clover Mixed Hay — Shall be timothy and clover mixed, with at least one-half timothy, good color, sound, and well baled.

No. 2 Clover Mixed Hay — Shall be timothy and clover mixed with at least one-third timothy. Reasonably sound and well baled.

No. 1 Clover Hay — Shall be medium clover not over one-twentieth other grasses, properly cured, sound, and well baled.

No. 2 Clover Hay — Shall be clover, sound, well baled, not good enough for No. 1.

No Grade Hay — Shall include all hay badly cured, stained, threshed, or in any way unsound.

Choice Prairie Hay — Shall be upland hay of bright, natural color, well cured, sweet, sound, and may contain 3 per cent weeds.

No. 1 Prairie Hay — Shall be upland and may contain one-quarter midland, both of good color, well cured, sweet, sound, and may contain 8 per cent weeds.

No. 2 Prairie Hay — Shall be upland, of fair color, and may contain one-half midland, both of good color, well cured, sweet, sound, and may contain $12\frac{1}{2}$ per cent weeds.

No. 3 Prairie Hay — Shall include hay not good enough for other grades and not caked.

No. 1. Midland — Shall be midland hay of good color, well cured, sweet, sound, and may contain 3 per cent weeds.

No. 2 Midland — Shall be fair color, or slough hay of good color, and may contain $12\frac{1}{2}$ per cent weeds.

Packing Hay — Shall include all wild hay not good enough for other grades and not caked.

No Grade Prairie Hay — Shall include all hay not good enough for other grades.

Alfalfa.

Choice Alfalfa — Shall be reasonably fine, leafy alfalfa of bright green color, properly cured, sound, sweet, and well baled.

No. 1 Alfalfa — Shall be coarse alfalfa of natural color, or reasonably fine, leafy alfalfa of good color, and may contain 5 per cent of foreign grasses; must be well baled, sound, and sweet.

No. 2 Alfalfa — Shall include alfalfa somewhat bleached, but of fair color, reasonably leafy, not more than one-eighth foreign grasses, sound, and well baled.

No. 3 Alfalfa — Shall include bleached alfalfa, or alfalfa mixed with not to exceed one-fourth foreign grasses, but when mixed must be of fair color, sound, and well baled.

No Grade Alfalfa — Shall include all alfalfa not good enough for other grades, caked, musty, greasy, or threshed.

Straw.

No. 1 Straight Rye Straw — Shall be in large bales, clean, bright, long rye straw, pressed in bundles, sound, and well baled.

No. 2 Straight Rye Straw — Shall be in large bales, long rye straw, pressed in bundles, sound, and well baled, not good enough for No. 1.

No. 1 Tangled Rye Straw — Shall be reasonably clean rye straw, good color, sound, and well baled.

No. 2 Tangled Rye Straw — Shall be reasonably clean; may be some stained, but not good enough for No. 1.

No. 1 Wheat Straw — Shall be reasonably clean wheat straw, sound and well baled.

No. 2 Wheat Straw — Shall be reasonably clean; may be some stained, but not good enough for No. 1.

No. 1 Oat Straw — Shall be reasonably clean oat straw, sound and well baled.

No. 2 Oat Straw — Shall be reasonably clean; may be some stained, but not good enough for No. 1.

The above grades of hay and straw have been adopted by Exchanges in the following markets: —

Minneapolis, Minn.	Richmond, Va.	St. Paul, Minn.
Jacksonville, Fla.	Buffalo, N.Y.	Nashville, Tenn.
Washington, D.C.	Saginaw, Mich.	St. Louis, Mo.
Philadelphia, Pa.	Atlanta, Ga.	Chicago, Ill.
New Orleans, La.	Savannah, Ga.	Pittsburg, Pa.
Indianapolis, Ind.	Columbus, O.	Louisville, Ky.
Kansas City, Mo.	Baltimore, Md. ¹	State of Minnesota
Norfolk, Va.	Cleveland, O.	New York City
Duluth, Minn.	Birmingham, Ala.	
Toledo, O.	Cincinnati, O. ¹	

¹ Using grades in part only.

Grades of Grain (Adopted by the Grain Dealers' National Association, 1909)

White winter wheat.

No. 1 White Winter Wheat — Shall include all varieties of pure soft white winter wheat, sound, plump, dry, sweet, and clean, and weigh not less than 58 lb. to the measured bushel.

No. 2 White Winter Wheat — Shall include all varieties of soft white winter wheat, dry, sound, and clean, and shall not contain more than 8 per cent of soft red winter wheat, and weigh not less than 56 lb. to the measured bushel.

No. 3 White Winter Wheat — Shall include all varieties of soft white winter wheat. It may contain 5 per cent of damaged grains other than skin-burnt wheat, and may contain 10 per cent of soft red winter wheat, and weigh not less than 53 lb. to the measured bushel.

No. 4 White Winter Wheat — Shall include all the varieties of soft white winter wheat, not fit for a higher grade, in consequence of being of poor quality, damp, musty, or dirty, and shall not contain more than 10 per cent of soft red winter wheat, and weigh not less than 50 lb. to the measured bushel.

Red winter wheat.

No. 1 Red Winter Wheat — Shall be pure soft red winter wheat of both light and dark colors, sound, sweet, plump, and well cleaned, and weigh not less than 60 lb. to the measured bushel.

No. 2 Red Winter Wheat — Shall be soft red winter wheat of both light and dark colors, sound, sweet, and clean, shall not contain more than 5 per cent of white winter wheat, and weigh not less than 58 lb. to the measured bushel.

No. 3 Red Winter Wheat — Shall be sound, soft red winter wheat, not clean or plump enough for No. 2, shall not contain more than 8 per cent of white winter wheat, and weigh not less than 55 lb. to the measured bushel.

No. 4 Red Winter Wheat — Shall be soft red winter wheat, shall contain not more than 8 per cent of white winter wheat. It may be damp, musty, or dirty, but must be cool, and weigh not less than 50 lb. to the measured bushel.

Hard winter wheat.

No. 1 Hard Winter Wheat — Shall include all varieties of pure, hard winter wheat, sound, plump, dry, sweet, and well cleaned, and weigh not less than 61 lb. to the measured bushel.

No. 2 Hard Winter Wheat — Shall include all varieties of hard winter wheat of both light and dark colors, dry, sound, sweet, and clean, and weigh not less than 59 lb. to the measured bushel.

No. 3 Hard Winter Wheat — Shall include all varieties of hard winter wheat of both light and dark colors, not clean or plump enough for No. 2, and weigh not less than 56 lb. to the measured bushel.

No. 4 Hard Winter Wheat — Shall include all varieties of hard winter wheat of both light and dark colors. It may be damp, musty, or dirty, and weigh not less than 50 lb. to the measured bushel.

Northern spring wheat.

No. 1 Hard Spring Wheat — Shall be sound, bright, sweet, clean, and consist of over 50 per cent of the hard Scotch Fife, and weigh not less than 58 lb. to the measured bushel.

No 1 Northern Spring Wheat — Must be northern-grown spring wheat,

sound, clean, and of good milling quality, and must contain not less than 50 per cent of the hard varieties of spring wheat, and weigh not less than 57 lb. to the measured bushel.

No. 2 Northern Spring Wheat — Shall be northern-grown spring wheat, not clean enough or sound enough for No. 1, and must contain not less than 50 per cent of the hard varieties of spring wheat, and must weigh not less than 56 lb. to the measured bushel.

No. 3 Northern Spring Wheat — Shall be composed of inferior shrunken northern-grown spring wheat, and weigh not less than 54 lb. to the measured bushel, and must contain not less than 50 per cent of the hard varieties of spring wheat.

No. 4 Northern Spring Wheat — Shall include all inferior northern-grown spring wheat that is badly shrunken or damaged, and must contain not less than 50 per cent of the hard varieties of spring wheat, and shall weigh not less than 49 lb. to the measured bushel.

Spring wheat.

No. 1 Spring Wheat — Shall be sound, plump, and well cleaned, and weigh not less than 59 lb. to the measured bushel.

No. 2 Spring Wheat — Shall be sound, clean, of a good milling quality, and weigh not less than 57½ lb. to the measured bushel.

No. 3 Spring Wheat — Shall include all inferior, shrunken, or dirty spring wheat, and weigh not less than 53 lb. to the measured bushel.

No. 4 Spring Wheat — Shall include all spring wheat damp, musty, grown, badly bleached, or for any cause unfit for No. 3, and weigh not less than 49 lb. to the measured bushel.

White spring wheat.

White Spring Wheat — The grades of Nos. 1, 2, 3, and 4 White Spring Wheat shall correspond with the grades of Nos. 1, 2, 3, and 4 Spring Wheat, except that they shall be of the white variety.

Durum (Macaroni) wheat.

No. 1 Durum Wheat — Shall be bright, sound, dry, well cleaned, and be composed of durum, commonly known as macaroni wheat, and weigh not less than 60 lb. to the measured bushel.

No. 2 Durum Wheat — Shall be dry, clean, and of good milling

quality. It shall include all durum wheat that for any reason is not suitable for No. 1 Durum, and weigh not less than 58 lb. to the measured bushel.

No. 3 Durum Wheat — Shall include all durum wheat bleached, shrunken, or for any cause unfit for No. 2, and weigh not less than 55 lb. to the measured bushel.

No. 4 Durum Wheat — Shall include all durum wheat that is badly bleached or for any cause unfit for No. 3, and weigh not less than 50 lb. to the measured bushel.

Velvet chaff wheat.

No. 1 Velvet Chaff Wheat — Shall be bright, sound, and well cleaned, and weigh not less than 58 lb. to the measured bushel.

No. 2 Velvet Chaff Wheat — Shall be sound, dry, clean, may be slightly bleached, or shrunken, but not good enough for No. 1, and weigh not less than 57 lb. to the measured bushel.

No. 3 Velvet Chaff Wheat — Shall include all wheat that is bleached, smutty or for any other cause unfit for No. 2, and weigh not less than 55 lb. to the measured bushel.

No. 4 Velvet Chaff Wheat — Shall include all wheat that is very smutty, badly bleached and grown, or for any other cause unfit for No. 3.

Pacific Coast wheat.

No. 1 Pacific Coast Red Wheat — Shall be dry, sound, clean, and free from smut, and weigh not less than 59 lb. to the measured bushel.

No. 2 Pacific Coast Red Wheat — Shall be dry, sound, clean, and only slightly tainted with smut and alkali, and weigh not less than 58 lb. to the measured bushel.

No. 3 Pacific Coast Red Wheat — Shall include all other Pacific Coast red wheat. It may be smutty or musty, or from any other reason unfit for flouring purposes, and weigh not less than 54 lb. to the measured bushel.

Pacific Coast white wheat shall be graded according to the rules for Pacific Coast red wheat. In case of a mixture of Pacific Coast wheat with our home-grown wheat, red or white, such mixture shall be graded "Pacific Coast Mixed Wheat."

The grades of Pacific white and Pacific red wheat are to include all such wheats as are grown in the extreme Northwest and on the Pacific slope from either spring or winter seeding.

Mixed wheat.

Mixed Wheat — In case of an appreciable mixture of hard and soft wheat, red and white wheat (except as provided in the rule of red winter, white winter, and northern spring wheat), durum, and spring wheat, any of them with each other, it shall be graded according to the quality thereof, and the kind of wheat predominating, shall be classed as No. 1, 2, 3, and 4 Mixed Wheat, and the inspector shall make notation describing its character.

Rye.

No. 1 Rye — Shall be dry, sound, plump, sweet, and well cleaned, and shall weigh not less than 57 lb. to the measured bushel.

No. 2 Rye — Shall be dry, sound, and contain not more than 1 per cent of other grain or foreign matter, and weigh not less than 55 lb. to the measured bushel.

No. 3 Rye — Shall include inferior rye not unsound, but from any other cause not good enough for No. 2, and weigh not less than 53 lb. to the measured bushel.

No. 4 Rye — May be damp, musty, or dirty, and weigh not less than 50 lb. to the measured bushel.

White oats.

No. 1 White Oats — Shall be white, dry, sweet, sound, bright, clean, free from other grain, and weigh not less than 32 lb. to the measured bushel.

No. 2 White Oats — Shall be 95 per cent white, dry, sweet, shall contain not more than 1 per cent of dirt and 1 per cent of other grain, and weigh not less than 29 lb. to the measured bushel.

Standard White Oats — Shall be 92 per cent white, dry, sweet, shall not contain more than 2 per cent of dirt and 2 per cent of other grain, and weigh not less than 28 lb. to the measured bushel.

No. 3 White Oats — Shall be sweet, 90 per cent white, shall not contain more than 3 per cent of dirt and 5 per cent of other grain, and weigh not less than 24 lb. to the measured bushel.

No. 4 White Oats — Shall be 90 per cent white, may be damp, damaged, musty, or very dirty.

Notice. — Yellow oats shall not be graded better than No. 3 White Oats.

Mixed Oats.

No. 1 Mixed Oats — Shall be oats of various colors, dry, sweet, sound, bright, clean, free from other grain, and weigh not less than 32 lb. to the measured bushel.

No. 2 Mixed Oats — Shall be oats of various colors, dry, sweet, shall not contain more than 2 per cent of dirt and 2 per cent of other grain, and weigh not less than 28 lb. to the measured bushel.

No. 3 Mixed Oats — Shall be sweet oats of various colors, shall not contain more than 3 per cent of dirt and 5 per cent of other grain, and weigh not less than 24 lb. to the measured bushel.

No. 4 Mixed Oats — Shall be oats of various colors, damp, damaged, musty, or very dirty.

Red or rust-proof oats.

No. 1 Red Oats or Rust-Proof — Shall be pure red, sound, bright, sweet, clean, and free from other grain, and weigh not less than 32 lb. to the measured bushel.

No. 2 Red Oats or Rust-Proof — Shall be seven-eighths red, sweet, dry, and shall not contain more than 2 per cent dirt or foreign matter, and weigh 30 lb. to the measured bushel.

No. 3 Red Oats or Rust-Proof — Shall be sweet, seven-eighths red, shall not contain more than 5 per cent dirt or foreign matter, and weigh not less than 24 lb. to the measured bushel.

No. 4 Red Oats or Rust-Proof — Shall be seven-eighths red, may be damp, musty, or very dirty.

White clipped oats.

No. 1 White Clipped Oats — Shall be white, clean, dry, sweet, sound, bright, free from other grain, and weigh not less than 35 lb. to the measured bushel.

No. 2 White Clipped Oats. — Shall be 95 per cent white, dry, sweet, shall not contain more than 2 per cent of dirt or foreign matter, and weigh not less than 32 lb. to the measured bushel.

No. 3 White Clipped Oats — Shall be sweet, 90 per cent white, shall not contain more than 5 per cent of dirt or foreign matter, and weigh not less than 30 lb. to the measured bushel.

No. 4 White Clipped Oats — Shall be 90 per cent white, damp, damaged, musty, or dirty, and weigh not less than 30 lb. to the measured bushel.

Mixed clipped oats.

No. 1 Mixed Clipped Oats — Shall be oats of various colors, dry, sweet, sound, bright, clean, free from other grain, and weigh not less than 35 lb. to the measured bushel.

No. 2 Mixed Clipped Oats — Shall be oats of various colors, dry, sweet, shall not contain more than 2 per cent of dirt or foreign matter, and weigh not less than 32 lb. to the measured bushel.

No. 3 Mixed Clipped Oats. — Shall be sweet oats of various colors, shall not contain more than 5 per cent of dirt or foreign matter, and weigh not less than 30 lb. to the measured bushel.

No. 4 Mixed Clipped Oats — Shall be oats of various colors, damp, damaged, musty, or dirty, and weigh not less than 30 lb. to the measured bushel.

Note — Inspectors are authorized, when requested by shippers, to give weight per bushel instead of grade on Clipped White Oats and Clipped Mixed Oats from private elevators.

Purified oats.

Purified Oats — All oats that have been chemically treated or purified shall be classed as Purified Oats, and inspectors shall give the test weight on each car or parcel that may be so inspected.

Corn.

The following maximum limits shall govern all inspection and grading of corn: —

Grade	Percentage of Moisture	Percentage cob rotten. Exclusive of bin burnt or mahogany corn	Percentage dirt and broken grains
1	15	1	1
2	16	5	2
3	19	10	4
4	22	See No. 4 Corn rule, all colors.	

White corn.

No. 1 White Corn — Shall be 99 per cent white, sweet, and well matured.

No. 2 White Corn — Shall be 98 per cent white, and sweet.

No. 3 White Corn — Shall be 98 per cent white, and sweet.

No. 4 White Corn — Shall be 98 per cent white; but shall include damp, damaged, or musty corn.

Yellow corn.

No. 1 Yellow Corn — Shall be 99 per cent yellow, sweet, and well matured.

No. 2 Yellow Corn — Shall be 95 per cent yellow, and sweet.

No. 3 Yellow Corn — Shall be 95 per cent yellow, and sweet.

No. 4 Yellow Corn — Shall be 95 per cent yellow; but shall include damp, damaged, or musty corn.

Mixed corn.

No. 1 Mixed Corn — Shall be corn of various colors, sweet and well matured.

No. 2 Mixed Corn — Shall be corn of various colors, and sweet.

No. 3 Mixed Corn — Shall be corn of various colors, and sweet.

No. 4 Mixed Corn — Shall be corn of various colors; but shall include damp, damaged, or musty corn.

Milo-maize.

No. 1 Milo-Maize — Shall be mixed milo-maize of choice quality, sound, dry, and well cleaned.

No. 2 Milo-Maize — Shall be mixed milo-maize, sound, dry, and clean.

No. 3 Milo-Maize — Shall be mixed milo-maize, not dry, clean, or sound enough for No. 2.

No. 4 Milo-Maize — Shall include all mixed milo-maize that is badly damaged, damp, musty or very dirty.

Milo-maize that is wet or in heating condition shall not be graded.

*Kaffir corn.*¹

No. 1 White Kaffir Corn — Shall be pure white of choice quality, sound, dry, and well cleaned.

No. 2 White Kaffir Corn — Shall be seven-eighths white, sound, dry, and clean.

No. 3 White Kaffir Corn — Shall be seven-eighths white, not dry, clean or sound enough for No. 2.

No. 4 White Kaffir Corn — Shall be seven-eighths white that is badly damaged, damp, musty, or very dirty.

No. 1 Red Kaffir Corn — Shall be pure red corn, of choice quality, sound, dry, and well cleaned.

No. 2 Red Kaffir Corn — Shall be seven-eighths red, sound, dry, and clean.

No. 3 Red Kaffir Corn — Shall be seven-eighths red, not dry, clean, or sound enough for No. 2.

No. 4 Red Kaffir Corn — Shall be seven-eighths red that is badly damaged, damp, musty, or very dirty.

No. 1 Kaffir Corn — Shall be mixed kaffir corn of choice quality, sound, dry, and well cleaned.

No. 2 Kaffir Corn — Shall be mixed kaffir corn, sound, dry, and clean.

No. 3 Kaffir Corn — Shall be mixed kaffir corn, not dry, clean, or sound enough for No. 2.

No. 4 Kaffir Corn — Shall include all mixed kaffir corn that is badly damaged, damp, musty, or very dirty.

Kaffir corn that is wet or in heating condition shall not be graded.

Barley (Barley Association of the United States).

No. 1 Barley — Shall be sound, plump, bright, clean, and free from other grain, and not scoured nor clipped, shall weigh not less than 48 lb. to the measured bushel.

No. 2 Barley — Shall be sound, of healthy color (bright or straw color), reasonably clean and reasonably free from other grains and seeds, and not scoured nor clipped, shall weigh not less than 46 lb. to the measured bushel.

¹ By some writers now spelled kafir, and written without the word "corn." See *Cyclo. Amer. Agr.* ii. 384, where the word "maize" is also dropped from milo. "Kafir" is used in this book by preference.

No. 3 Barley — Shall include slightly shrunken or otherwise slightly damaged barley, not good enough for No. 2, and not scoured nor clipped, shall weigh not less than 44 lb. to the measured bushel.

No. 4 Barley — Shall include barley fit for malting purposes, not good enough for No. 3.

No. 1 Feed Barley — Shall test not less than 40 lb. to the measured bushel, shall be cool and reasonably free from other grain and seeds, and not good enough for No. 4, and may include barley with a strong ground smell, or a slightly musty or bin smell.

Rejected Barley — Shall include all barley testing under 40 lb. to the measured bushel, or barley which is badly musty or badly damaged, and not good enough to grade "feed" barley, except that barley which has been chemically treated shall not be graded at all.

Bay Brewing Barley — The grades of Nos. 1, 2, and 3 Bay Brewing Barley shall conform in all respects to the grades of Nos. 1, 2, and 3 Barley, except that they shall be of the Bay Brewing variety, grown in the far West and on the Pacific Coast.

Chevalier Barley — The grades of Nos. 1, 2, and 3 Chevalier Barley shall conform in all respects to the grades of Nos. 1, 2, and 3 Barley, except that they shall be of the Chevalier variety, grown in the far West and on the Pacific Coast.

Bay Brewing Mixed Barley — In case of admixture of Bay Brewing barley with barley of other varieties, it shall be graded according to the quality thereof, and classed as 1-2-3 Bay Brewing Mixed Barley.

Chevalier Mixed Barley — In case of admixture of Chevalier barley with barley of other varieties, it shall be graded according to the quality thereof, and classed as 1-2-3 Chevalier Mixed Barley.

Winter Barley.

No 1 Winter Barley — Shall be plump, bright, sound, and clean, free from other grain, and weigh not less than 48 lb. to the measured bushel.

No. 2 Winter Barley — Shall be sound, plump, may be stained, shall contain not more than 3 per cent of foreign matter, and weigh not less than 46 lb. to the measured bushel.

No. 3 Winter Barley — Shall include all shrunken, stained, and dirty barley, shall contain not more than 5 per cent of foreign matter, and weigh not less than 44 lb. to the measured bushel.

No. 4 Winter Barley — Shall include all barley not fit for a higher grade in consequence of being poor quality, damp, musty, or dirty; shall contain not more than 10 per cent of foreign matter, and weigh not less than 40 lb. to the measured bushel.

Sample grades — General rule.

All wheat, barley, oats, rye and corn that is in a heated condition, souring, or too damp to be safe for warehousing, or that is badly bin-burnt, fire-burnt, fire-smoked, or badly damaged, mixed with garlic, onions, or containing live weevil, exceedingly dirty, or where different kinds of grain are badly mixed with one another, shall be classed as Sample Grade, and the inspector shall make notations as to quality and condition.

Fruit Packages

Sizes and weights of packages for deciduous fruits (California Fruit Distributors)

Weights in first table, sizes in second

Cherries	11	pounds per box
Peaches	21½	pounds per box
Pears	50	pounds per box
Pears for export to Europe	24	pounds per box
Prunes	26	pounds per single crate
Apricots	26	pounds per single crate
Nectarines	25	pounds per single crate
Plums	26	pounds per single crate
Grapes	26	pounds per single crate
Grapes	56	pounds per double crate

	IN INCHES		
	Depth	Width	Length
Cherries, box	2¾	9	19¾
Peaches, box	5	11¾	19¾
Pears, box	9	11¾	19¾
Pears, for export to Europe, box	4½	11¾	19¾
Apricots, single crate	5	16	17½
Nectarines, single crate	5	16	17½
Prunes, single crate	5	16	17½
Plums, single crate	5	16	17½
Grapes, single crate	5	16	17½
Grapes, double crate	11¼	16	17½

Chautauqua, N. Y., grape figures.

The grapes are shipped in 8-pound Climax baskets, which weigh, when not filled, 20 ounces. A carload is 2800 to 3000 baskets. A girl will pack from 100 to 150 baskets per day. One and one-fourth cents per basket is paid for picking and packing. An average acre of Concord grapes yields about 500 baskets. The average annual cost of cultivating the vineyard up to picking time is \$8. The expense of picking, packing, packages, and carting is about \$28 for the 500 baskets. In bulk, the grapes are shipped in crates of 38 lb. capacity; cost of picking in crates is about 2 cents for quantity representing 2½ baskets. The bunches are cut from the vines with shears made for the purpose. In the packing house the bunches are trimmed.

Citrus fruits.

The specifications of the boxes used in the packing of California oranges are shown in the railroad tariffs with an estimated weight, and the box so shown is the only one used. The inside dimensions are 11½ in. × 11½ in. × 24 in., the slats are 26 in. long, but the thickness of the ends and center-pieces is 2 in., making the inside length 24 in. No. 2 Jumbo orange-box, 11½ in. × 12½ in. × 24 in.

The California box for lemons shown in the tariff is 10½ in. × 14 in. × 25 in. Recently, the lemon shippers adopted a new-sized box which packs lemons to better advantage, and this new box will be used as soon as the accumulation of old stock is exhausted, and the tariffs will be changed to show its dimensions, which are, 10¾ in. × 13½ in. × 25 in. inside. Old box, 3675 cu. in.; new box, 3501 $\frac{9}{16}$ cu. in.

Florida orange-box, 12 × 12 × 24½ in. inside. Half-box, 5 $\frac{5}{8}$ × 12 × 24½ in.

Apple boxes (W. A. Taylor).

The memoranda following (p. 165) show legal weights to the bushel of apples and legal sizes of apple-boxes and barrels; also the usual standard (not legal) sizes of apple-boxes and the heaped-bushel expressed in cubic inches in such states as have expressed the capacity of the heaped-bushel in that form.

All these boxes when actually used are subject to considerable variation in capacity, resulting from the use or non-use of cleats under the covers.

Apple legislation (Box and barrel sizes and weights per bushel)

STATE	POUNDS PER BU.	BOX SIZE	BARREL SIZE
Arkansas . . .	"Green apples" 50	20" × 12" × 9" "lawful bu. measure"	
Connecticut . . .	"Apples" . . . 48		2160 cu. in.
Florida	"Apples, green" 48		
Iowa	"Apples" . . . 48		
Kansas	"Green apples" 48		
Maine	"Apples" . . . 44	20" × 11" × 10" 2250 cu. in. (1) "stand. bu. box"	Head 17 $\frac{1}{8}$ " Stave 28 $\frac{1}{2}$ " Bulge 64" } 3 bu
Maryland		2212 cu. in.	6253 $\frac{3}{4}$ cu. in.
Massachusetts . . .	"Apples" . . . 48		
Michigan	"Apples" . . . 48		Heads 16 $\frac{1}{2}$ " Stave 27" or four bbl. size
Minnesota	"Apples, green" 50		
Missouri	"Apples" . . . 48		Heads 17 $\frac{1}{4}$ " Stave 28 $\frac{1}{2}$ " Diam. center inside 20 $\frac{1}{4}$ "
Nebraska	"Green apples" 48		
New Jersey	"Apples" . . . 50		
New York	"Apples" . . . 48		Head 17 $\frac{1}{8}$ " Stave 28 $\frac{1}{2}$ " Bulge 64" 100 qt.
North Carolina . . .	"Green apples" 48		
North Dakota	"Apples" . . . 50		
Ohio	"Apples" . . . 50		Head 17 $\frac{1}{8}$ " Stave 28 $\frac{1}{2}$ " Bulge 66"
Oregon "stand- ard box"	"Apples" . . . 45	18" × 11 $\frac{1}{2}$ " × 10 $\frac{1}{2}$ "	2173 $\frac{1}{2}$ cu. in.
Oregon "special box"		20" × 11" × 10"	2200 cu. in. 2 $\frac{1}{2}$ bu.
Tennessee	"Apples, green" 50		
Texas	"Apples" . . . 50		
Vermont	"Apples" . . . 46		
Virginia	"Apples" . . . 45		Head 17 $\frac{1}{8}$ " Stave 27 $\frac{1}{2}$ " Bulge 64
Washington	"Green apples" 45	18" × 11 $\frac{1}{2}$ " × 10 $\frac{1}{2}$ "	
Wisconsin	"Apples" . . . 48		100 quarts

Other apple-box sizes

California (40 lb.)	20 $\frac{3}{4}$ " × 10 $\frac{3}{8}$ " × 9 $\frac{1}{8}$ "	1965 " "
California (50 lb.)	20 $\frac{3}{4}$ " × 11 $\frac{1}{4}$ " × 10 $\frac{3}{4}$ "	2393 " "
Canadian (legal)	20" × 11" × 10"	2200 " "
Colorado	18" × 11" × 12"	2376 " "
Washington "special"	20" × 11" × 10"	2200 " "
Norwestern special	20" × 12" × 10"	2400 " "

¹ Printed 2250 cu. in. in the law, but the dimensions figure 2200 cu. in.

Legal heaped-bushel capacities (Apples)

Connecticut (heaped bu.)	2564 cu. in
Kansas (heaped bu.)	2564 " "
Washington (heaped bu.)	2564 " "

Box packing of apples in Washington and Oregon (C. S. Wilson).

Boxes. — (a) Standard, 10½ in. × 11½ in. × 18 in. inside measurement.

(b) Special, 10 in. × 11 in. × 20 in. inside measurement.

Material. — Ends, ¾ in.; sides, ¾ in.; tops and bottoms, two pieces each, ¼ in. thick. There should be two cleats for each top and bottom. The sides of the box should be nailed with four nails at each end of each side. The cleats should be put neatly on the box, and four nails driven through them and through the top or bottom into the ends. Five-penny cement-coated nails are preferable.

Wrapping paper. — Any of the following grades may be used: Light Manila, heavy-weight tissue, or "white news." The size of the wrapper will vary somewhat, according to the size of the apple. Two sizes should be ordered, 8 in. × 10 in. and 10 in. × 10 in. The approximate cost of this wrapping paper would be, light Manila and heavy-weight tissue, 4½ or 5 cents per pound, or about 35 cents per thousand sheets; "white news," 3½ cents per pound, or about 30 cents per thousand sheets.

Lining paper. — The lining paper is made from "white news," size 18 in. × 24 in. The approximate cost of this paper would be 3½ cents per pound, or about \$1.15 per thousand sheets.

Layer paper. — In some cases it is necessary to use layer paper to raise the pack in order to come out right at the top. For this purpose use colored tag-board, size 17¼ in. × 11 in., or 19½ in. × 10½ in., according to the box. The approximate cost of this paper would be about \$7.50 per thousand sheets.

Packing. — Before placing the apples on the packing table they are usually graded into different sizes. This facilitates very much the work of the packers. A sizer may be used at the beginning, but one soon trains the eye to recognize the different grades. The diagonal pack is preferable, although one is forced to use the straight pack for a few sizes.

The following table was used at Hood River, Oregon, in the fall of 1910 (C. I. Lewis, in "Better Fruits"):

Table of commercial box packs

SIZE — EXPRESSED IN NO. APPLES PER BOX	TIER	PACK	NO. APPLES IN ROW	NO. LAYERS IN DEPTH	BOX USED
45	3	3 St.	5-5	3	Standard
54	3	3 St.	6-6	3	Special
63	3	3 St.	7-7	3	Special
64	3½	2-2 Diag.	4-4	4	Standard
72	3½	2-2 Diag.	4-5	4	Standard
80	3½	2-2 Diag.	5-5	4	Standard
88	3½	2-2 Diag.	5-6	4	Standard
96	3½	2-2 Diag.	6-6	4	Special
104	3½	2-2 Diag.	6-7	4	Special
112	3½	2-2 Diag.	7-7	4	Special
120	3½	2-2 Diag.	7-8	4	Special
128	4	4 St.	8-8	4	Special
144	4	4 St.	9-9	4	Special
150	4½	3-2 Diag.	6-6	5	Standard
163	4½	3-2 Diag.	6-7	5	Standard
175	4½	3-2 Diag.	7-7	5	Standard
188	4½	3-2 Diag.	7-8	5	Special
200	4½	3-2 Diag.	8-8	5	Special

Fruit packages in Canada (Fruit Marks Act).

The minimum legal limit of apple barrel is a barrel having a dimension of not less than $26\frac{1}{4}$ inches between the heads, inside measure, and a head diameter of 17 inches, and a middle diameter of $18\frac{1}{2}$ inches, representing as nearly as possible 96 quarts.

When apples are packed in Canada for export, for sale by the box, they shall be packed in good strong boxes, of seasoned wood, the inside dimensions of which shall not be less than 10 inches in depth, 11 inches in width, and 20 inches in length, representing as nearly as possible 2200 cubic inches.

The Inspection and Sale Act, dealing with fruit baskets (May, 1907), reads as follows:—

“2. Every basket of fruit offered for sale in Canada, unless stamped on the side plainly in black letters at least three-quarters of an inch deep and wide, with the word ‘Quart’ in full, preceded with the minimum number of quarts, omitting fractions, which the basket will hold when level-full, shall contain, when level-full, one or other of the following quantities:—

“ (a) Fifteen quarts or more.

"(b) Eleven quarts, and be $5\frac{3}{4}$ inches deep perpendicularly, $18\frac{3}{4}$ inches in length, and 8 inches in width at the top of the basket, $16\frac{3}{4}$ inches in length, and $6\frac{7}{8}$ inches in width at the bottom of the basket, as nearly exactly as practicable, all measurements to be inside of the veneer proper, and not to include the top band.

"(c) Six quarts, and be $4\frac{1}{2}$ inches deep perpendicularly, $15\frac{3}{8}$ inches in length, and 7 inches in width at the top of the basket, $13\frac{1}{2}$ inches in length, and $5\frac{7}{8}$ inches in width at the bottom of the basket, as nearly exactly as practicable, all measurements to be inside of the veneer proper, and not to include the top band: Provided that the Governor in Council may by proclamation exempt any province from the operation of this section.

"(d) Two and two-fifths quarts, as nearly exactly as practicable."

Proposed United States standards (Provisions in the Lafean Bill, now before Congress, 1911).

First. The standard box package for apples is a box having a capacity of not less than 2342 cubic inches when measured without distention of its parts.

Second. The standard basket package for apples is a basket having a capacity of not less than 2342 cubic inches, when measured level-full, without distention of its parts.

Third. The standard barrel package for apples is a barrel of the following dimensions, when measured without distention of its parts: Length of stave, $28\frac{1}{2}$ inches; diameter of head, $17\frac{1}{8}$ inches, distance between heads, 26 inches; circumference of bulge, 64 inches, outside measurement.

Section 3. That the standard grade for apples which shall be shipped or delivered for shipment in interstate or foreign commerce, or which shall be sold or offered for sale within the District of Columbia or the Territories of the United States, are as follows:—

Apples of one variety, which are well-grown specimens, hand-picked, of good color for the variety, normal shape, practically free from insect and fungus injury, bruises, and other defects, except such as are necessarily caused in the operation of packing, or apples of one variety, which are not more than 10 per centum below the foregoing specifications, are standard grade "U. S. Size A," if the minimum size of the apples is two and one-half inches in transverse diameter: or are stand-

ard grade "U. S. Size B," if the minimum size of the apples is two and one-fourth inches in transverse diameter; or are standard grade "U. S. Size C.," if the minimum size of the apples is two inches in transverse diameter.

Packages for truck crops, including strawberries (L. C. Corbett).

Potatoes.—Truck crop potatoes are shipped from the Atlantic seaboard points in ventilated barrels holding $2\frac{3}{4}$ bushels; from the Mississippi Valley and Gulf States in sacks holding 190 pounds; from Maine in sacks holding 165 pounds; and from the California and Colorado sections in sacks holding 100 pounds (everything in this region being sold by net weight rather than by bushel). In northern sections of Vermont, New York, Michigan, Wisconsin, potatoes are largely sold in bulk by weight at so much per bushel.

Cabbages from the Atlantic seaboard states south of Baltimore are shipped either in crates or ventilated barrels holding $2\frac{3}{4}$ bushels. These crates are usually flat, about 3 feet long. At the North, crates 3 feet square are often used for shipment of cabbage, but the general crop grown for storage and for the manufacture of kraut is sold in bulk by the ton (heads trimmed).

Cauliflower from the Southern fields is almost universally shipped in ventilated barrels, packed in excelsior, barrels being standard truck-crop-barrel of $2\frac{3}{4}$ bushels. California package is a flat carrier holding 1 dozen or $1\frac{1}{2}$ dozen heads.

Brussels sprouts are packed in quart cups, in crates holding 32 cups.

Tomatoes from Eastern States in crates holding about 1 bushel, similar to those used for the shipment of muskmelons, dimensions about 12 in. \times 12 in. \times 22 in. Some fruits arrive from Florida in this type of package, but most tomatoes come in 6-basket carriers similar to those used for peaches. In Texas a flat, 4-basket carrier, which is only one tier deep, is almost universally used.

Onions of the winter sorts are shipped either in ventilated barrels or standard sacks holding about $2\frac{3}{4}$ bushels. The Texas Bermuda crop is universally shipped in slatted bushel crates, 20 inches long, 12 inches wide, and 12 inches deep.

Celery from the Florida section is packed in flat crates usually 11 in. \times 20 in. \times 24 in. The California package is a cubical crate,

24 in. × 24 in. × 20 in. Most Eastern sections use the California type of package.

Muskmelons from most sections arrive in a veneer crate very similar in shape to the orange-box but somewhat smaller, the dimensions being approximately 12 in. × 12 in. × 22 in. Some sections ship melons in 60-quart and 32-quart berry crates, while a small percentage of the crop arrives in flat carriers arranged to hold a single layer of melons. These carriers usually contain 18 to 24 melons.

Eggplants are usually wrapped in paper and forwarded in 60-quart berry crates.

Peas are shipped largely in $\frac{5}{8}$ standard Delaware baskets with ventilated wood covers, or in barrel-high Delaware baskets with ventilated wood covers.

Sweet-potatoes are shipped in ventilated barrels holding $2\frac{3}{4}$ bushels, covered with burlap.

Asparagus is shipped in carriers made to accommodate 8 to 12 bunches.

String beans (snap) are shipped either in $\frac{1}{2}$ -bushel or barrel-high Delaware baskets.

Beets are usually pulled when 2 or $2\frac{1}{2}$ inches in diameter and tied in bunches of 3 to 6 beets and packed in 60-quart berry crates, ventilated barrels, or barrel-high Delaware baskets, depending on the market to which they are consigned.

Water-cress is either marketed in bunches or in bulk in iced barrels, or in iced barrel-high Delaware baskets.

Cucumbers are marketed from the trucking region either in ventilated barrels, barrel-high, or $\frac{1}{2}$ -bushel Delaware baskets; and in the pickle-growing districts they are marketed in bulk by the hundred-weight.

Lettuce from the truck-farming districts is marketed in either $\frac{1}{2}$ -bushel or barrel-high, Delaware baskets or in ventilated barrels. The barrel package is not, however, generally used.

Spinach is almost universally marketed from the truck-farming sections in ventilated barrels. A small quantity is received in barrel-high Delaware baskets.

Okra is marketed either in 6-basket carriers or in a special flat carrier without baskets, in which the pods are carefully arranged one layer wide. These packages are usually about 2 feet long.

Green peppers are almost universally marketed in 6-basket carriers.

Radishes are tied in bunches and packed in 1-bushel or barrel-high Delaware baskets, as a rule. A few are marketed in ventilated barrels.

Strawberries are offered in quart cups, either in 60-quart crates from the Carolina and Norfolk region, or in 24- or 32-quart crates from other regions, the 32-quart being more universally used than any other.

Dimensions.

The truck barrel is 28 inches high and has 16-inch heads.

The eggplant and squash crate has a head 11 in. \times 14 in., and is 24 inches long.

The half-barrel basket commonly used in the Norfolk region is 20 inches high, $9\frac{1}{2}$ inches at the bottom and 17 inches at the top.

The asparagus-box has heads 10 in. high, 15 inches at the top and 17 inches at the bottom, and slats 26 inches long, outside measure, making it 10 in. \times 15 in. \times 17 in. \times 24 in. inside.

The one-half barrel lettuce basket, called the "Delaware barrel-high basket," is 16 inches inside diameter at the top, 9 inches inside diameter at the bottom, and 27 inches high.

The cabbage crate which comes from Norfolk is $11\frac{1}{2}$ in. \times 18 in. on the heads, and is 36 inches long with a partition in the middle.

The three-peck basket which is used early in the season for shipping peas, beans, cucumbers, and crookneck squashes is 20 inches high, 14 inches inside measure at the top, and $8\frac{1}{2}$ inches inside measure at the bottom.

The flat onion crate with partition in the center has 16 in. \times 7 in. heads, and is 24 inches long.

CHAPTER X

THE JUDGING OF FARMS, CROPS, AND PLANTS. EXHIBITION AND NOMENCLATURE RULES. EMBLEMATIC PLANTS AND FLOWERS

IN recent years there has been great development of the desire to standardize knowledge in agriculture; and to this end many formal plans have been devised to enable one to set numerical measures to the various attributes of an object or an establishment or an operation. One is thereby able "to judge," and to score the object by comparison with an ideal scale of points rather than with other objects like itself. Good scoring eliminates the old method at fairs, for example, of giving a first prize to the best of several competitors: it gives it only to those that score sufficiently high in a scale of grades of perfection.

The making of score-cards has now come to be a popular practice in the colleges of agriculture, in fairs, and in societies, and the number of published cards is very large. In this chapter only a few representative scores can be given; score-cards for animals are given in Chap. XXI. If the reader wants score-cards of the different breeds of animals, he may find them in Vol. III of the *Cyclopedia of American Agriculture*.

Farms and Farm Practices

The "agricultural virtues" (Pearson).

Better prices, more than anything else, have put new life into our agriculture, and have brought about a disposition on the part of some farmers to adopt better methods, and have emphasized the greater opportunity open to all farmers and the need of the general adoption of the best methods, such as are well known to the few. These best methods include the following:—

1. Conservation of fertility.
2. Thorough cultivation.

3. Drainage.
4. Growth of leguminous crops.
5. The use of cover-crops.
6. The proper use of lime and commercial fertilizers.
7. Crop rotation.
8. Selection of seed.
9. Spraying for fungous and insect pests.
10. Disposal of poor cows.
11. Use of pure-bred sires.
12. Feeding economical rations.
13. Protection against bovine tuberculosis.
14. Production of clean milk.
15. Keeping of farm business accounts.
16. Use of mechanical power and machinery.
17. Employment of labor throughout the year.
18. Maintaining a reputation for honesty.
19. The providing of home comforts.
20. Reading reliable agricultural publications.
21. Membership in active agricultural organizations.

Loudon's rules for gardeners.

1. Perform every operation in the proper season and in the best manner.
2. Complete every operation consecutively.
3. Never, if possible, perform one operation in such a manner as to render another necessary.
4. When called off from any operation, leave your work and tools in an orderly manner.
5. In leaving off work, make a temporary finish, and clean your tools and carry them to the tool-house.
6. Never do that in the garden or hothouses which can be equally well done in the reserve ground or in the back sheds.
7. Never pass a weed or insect without pulling it up or taking it off, unless time forbid.
8. In gathering a crop, take away the useless as well as the useful parts.
9. Let no plant ripen seeds, unless they are wanted for some purpose, useful or ornamental, and remove all parts which are in a state of decay.

Essential things to consider in the organization of a farm.

It is difficult to state principles underlying the proper layout and organization of a farm, since the plan must conform to the person and to local conditions. The leading points to consider are perhaps the following:—

The adaptation of the plan to the kind of farming that is to be pursued.

The best utilization of the different soils and exposures and natural features on the place.

The economizing of time and labor in reaching all parts of the farm.

The best location of buildings with reference to efficiency of administration.

Such layout as will best provide for rotation and the maintenance of fertility.

A proper proportion between the different parts, as between tilled and untilled land, forest and open, meadow and pasture, forage crops and grazing, orchards and annual crops.

Provision for the necessary live-stock.

Such shape and size of fields as will best lend them to economical working.

Provision for the more personal parts of the place, as gardens, yards, and ornamental features.

Development of the artistic or attractive appearance of the entire estate.

Points of a good farm.

In looking for a farm, the inquirer should consider the question primarily from a business point of view. He should know what are the "points" of a good farm. It is well to make a list of the points, to study the place with reference to them, and to score it under each, as one would score a horse or a cow. The points or attributes are of two classes: those that are internal, or part of the farm itself; and those that are external, or have to do with geographical location, neighborhood, and the like. Some of the points may be mentioned:—

Internal

External

Lay of the land, or topography	Climate
Size of the farm	Healthfulness
Shape of the farm	Neighborhood
Kind of soil	Distance from town or railway station
Condition of soil as regards fertility and physical properties	Shipping facilities
Drainage	Means of communication
Water-supply	Labor supply
State of cultivation	Markets in which to buy and sell
Crops now standing, and their condition	School and church privileges
Woodland	Character of the farming in the community
Character of fields and of fences	Rural organizations
Buildings and other improvements	Likelihood of increase or decrease in value
Kind of farming to which place is adapted	

Score-card for farms (Warren)

	STANDARD
SIZE	
1. Adapted to kind of farming	20
FIELDS	
2. Shape and size	30
3. Nearness to farmstead	30
TOPOGRAPHY	
4. As affecting ease of cultivation	30
5. As affecting production	10
6. As affecting erosion and loss of fertility	15
7. As affecting air drainage	5
FERTILITY	
8. Natural	80
9. Condition	40
PHYSICAL PROPERTIES OF THE SOIL	
10. As affecting economy of cultivation	} 90
11. As affecting number of days of labor	
12. As affecting loss of soil fertility	10
13. As affecting kinds of possible crops	20
DRAINAGE	
14. Natural	} 50
15. Artificial	
CONDITION	
16. Freedom from stumps, stones, weeds, waste land, etc.	50
CLIMATE	
17. As affecting animal and crop production	
18. As affecting number of days of labor	
HEALTHFULNESS	
19. As an economic factor	40
LOCATION	
20. Distance to market	40
21. Roadways	50
22. Local markets	30
23. Shipping facilities	20
24. Neighbors as an economic factor	40
25. Labor supply of neighborhood	10
26. R. F. D., telephone, trolleys, etc.	30
27. Churches, school, grange, etc., as economic factors	30
TAXES	
28. Per cent on cash value	10

Score-card for farms—Continued

SIZE	STANDARD
WATER-SUPPLY	
29. Running water, wells	40
IMPROVEMENTS	
30. Site of farmstead	10
31. House as adapted to needs of farm	60
32. Other buildings	60
33. Fences, kind, condition, arrangement	30
34. Timber, orchards, vineyards, etc.	20
TOTAL	
Deductions for	
SCORE	
Area in acres	
Price asked	
Price per acre	
Price per acre (excluding waste land)	
Estimated value	
Which farm would you prefer to buy?	

The number of points assigned in the foregoing score-card is not the limit, but is suggestive. For example, if the water-supply is exceptionally good, give it more than forty points. Any other exceptional values may be scored more than the points assigned. In some cases, a deduction of all the points assigned is not sufficient. Distance to market may absolutely disqualify a farm for the sale of milk. If the score-card is followed exactly, this farm may score higher than a fairly good farm near market. In all such cases, deduct additional points from the total score. It is only by this flexibility that scores can be made that are truly comparable. The best farm for the purpose should have the highest final score. The chief purposes of a score-card are to make the examination systematic and to prevent the forgetting of important items.

If the points are not properly distributed for the kind of farming to be followed, a new distribution of points should be made before comparing farms. For example, for truck farms, all points that have to do with ease of tillage should be given a higher rating, while fertility is of less importance. In irrigated sections, water right, alkali, and ease of application of water must be included.

No points are assigned for climate. This should be considered when judging farms in different regions or at different altitudes, or when topography or proximity to water makes a difference in the climate of the farms that are being compared. This would be specially important near sea-coasts and in little understood climatic situations.

Corn and Potatoes

*Score-card for dent corn (Ohio Improvement Association)**For use in the final selection of seed ears*

1. Adaptability	25
2. Seed condition	15
3. Shape of kernel	15
4. Uniformity and trueness to type	15
5. Weight of ear	10
6. Length and proportion	10
7. Color of grain and cob	5
8. Butts and tips	5
	<hr/>
	100

For use in the plant selection of seed corn

1. Adaptability	35
2. Vigor	25
3. Height of plant, and height and angle of ear	15
4. Uniformity and trueness to type	10
5. Weight of ear (estimated)	15
	<hr/>
	100

Card for use in judging varieties of corn at husking time

1. Bushels per acre (uniform moisture test)	50
2. Maturity	25
3. Uniformity and trueness to type	15
4. Color	10
	<hr/>
	100

Score-card for potatoes

Uniformity	20 points
Symmetry	15 points
Trueness to type	20 points
Freedom from disease and insects	15 points
Commercial value	30 points
	<hr/>
	100 points

Standards for Judging Fruits at Exhibitions (Ontario, Canada,
Fruit-Growers' Association, 1911)

Apples and Pears. — Single Plates

Form	15
Size	15
Color	25
Uniformity	25
Freedom from blemish	20
	<hr/>
	100

Peaches. — Single Plates

Form	15
Size	20
Color	25
Uniformity	20
Freedom from blemish	20
	<hr/>
	100

Plums. — Single Plates

Form	10
Size	25
Color	15
Uniformity	25
Freedom from blemish	25
	<hr/> 100

Cherries. — Single Plates

Form	10
Size	20
Color	20
Uniformity	25
Freedom from blemish	25
	<hr/> 100

Grapes. — Single Plates

Form of bunch	10
Size of bunch	15
Size of berry	10
Color	10
Bloom	5
Freedom from blemish	20
Flavor	25
Firmness	5
	<hr/> 100

Collections of Apples, Pears, Plums, Peaches, Cherries, and Grapes on Plates

Freedom from blemish	20
Color	15
Uniformity	10
Size	10
Form	10
Commercial value	10
Quality	10
Nomenclature	5
Arrangement	5
Season	5
	<hr/> 100

Barrels. — Apples

<i>Fruit: —</i>	
Size	10
Color	20
Uniformity	15
Freedom from blemish	15
Texture and flavor	15
	<hr/> 75
<i>Package: —</i>	
Material	4
Finishing	6
	<hr/> 10
<i>Packing: —</i>	
Facing	6
Tailing	2
Racking	3
Pressing	4
	<hr/> 15
	<hr/> 100

<i>Fruit: —</i>	Boxes. — Apples, Pears, Peaches	
Size		10
Color		20
Uniformity		15
Freedom from blemish		15
Texture and flavor		15
		75
<i>Package and packing: —</i>		75
Material		3
Finishing		4
Fullness or bulge		4
Solidity or compactness		5
Attractiveness and style of pack		5
Alignment		4
		25
	Flowers and Plants	25
		100

The American Rose Society scale of points

All exhibits will be judged by points in accordance with the following official scales: —

POINTS OF VALUE	COM- PETITIVE CLASSES	NOVELTIES FOR CER- TIFICATES, ETC.	POINTS OF VALUE	COM- PETITIVE CLASSES	NOVELTIES FOR CER- TIFICATES, ETC.
Size	15	10	Foliage	15	15
Color	20	20	Fragrance (for novelties only)	—	5
Stem	20	15	Distinctiveness	—	10
Form	15	15		100	100
Substance	15	10			

Standardization of the grading of roses (American Rose Society, 1911).

Nine-inch, twelve-inch, fifteen-inch, eighteen-inch, and twenty-four-inch, and higher as necessary. Such a grading should be appreciated by both the commission men and retailers.

Scale of points for judging carnations (American Carnation Society)

This scale shall be employed in judging all seedlings for Certificate of Merit, or for any special prize, and in all classes where competition is close, it shall be used to arrive at a decision: —

Color	25
Size	20
Calyx	5
Stem	20
Substance	10
Form	15
Fragrance	5
Total	100

Scale for gladioli (American Gladiolus Society)

Resistance to disease	5
Texture of flower	10
Duration of bloom	10
Size of bloom	10
Color of bloom	15
Form of flower	10
Form of spike	10
Stem (length and stiffness)	10
Number of flowers on spike	15
Vigor (aside from disease resistance)	5

Chrysanthemum (Official Scale of Chrysanthemum Society)

<i>Commercial</i>		<i>Exhibition</i>	
Color	20	Color	10
Form	15	Stem	5
Fullness	10	Foliage	5
Stem	15	Fullness	15
Foliage	15	Form	15
Substance	15	Depth	15
Size	10	Size	35
	<u>100</u>		<u>100</u>

<i>Single varieties</i>		<i>Pompon varieties</i>	
Color	40	Color	40
Form	20	Form	20
Substance	20	Stem and foliage	20
Stem and foliage	20	Fullness	20
	<u>100</u>		<u>100</u>

Single varieties to be divided into two classes, large-flowered and small-flowered.

Scale of points to govern judges of sweet peas (National Sweet Pea Society of America)

Length of stem	25	Substance	15
Color	20	Number of flowers on a stem	15
Size	25	Total	100

The sweet pea or other foliage can be used with the flowers unattached, and flower stems must be free of wood, unless otherwise specified. Wiring of flowers or stems will disqualify.

Scale of points of florists' plants adopted by National Flower Show of the Society of American Florists

No. 1. Single Specimen Foliage Plants

Size of plant	25	Rarity	15
Cultural perfection	35	Form	10
Distinctiveness	15		

No. 2. Single Specimen Flowering Plants

Size of plant	20	Floriferousness	15
Cultural perfection	35	Color	10
Rarity	10	Foliage	10

No. 3. Collections or Number of Flowering Plants

Size of group or collection	15	Arrangement or staging	10
Distinctiveness	15	Color harmony	10
Cultural perfection	20	Rarity	10
Number of varieties	20		

No. 4. Collections or Number of Foliage Plants

Size of group or collection	15	Number of varieties	20
Rarity	15	Arrangement or staging	20
Cultural perfection	30		

No. 5. Group of Foliage Plants

Size	10	Rarity	10
Distinctiveness	20	Arrangement or staging	30
Cultural perfection	20	Color effect	10

No. 6. Group of Flowering Plants

Size of group	10	Arrangement	35
Rarity	10	Quality of flowers	20
Cultural perfection	15	Foliage	10

Sample Rules to Govern Exhibitions

Massachusetts Horticultural Society rules (1911).

Special rules of the plant and flower committee. — 1. All named varieties of Plants or Flowers exhibited for premiums or other awards must have the name *legibly* and correctly written on stiff card, wood, or some other permanent substance; and each separate plant or flower must have its name attached.

2. All exhibits shall be marked by a *card* on which shall appear the *name* and *address* of the exhibitor and inclosed in an envelope on which shall appear only the *number* of Prize as listed in the Schedule.

3. Plants in Pots, to be entitled to Prizes, must evince skillful culture in the profusion of bloom or decorative foliage, and in the beauty, symmetry, and vigor of the specimens.

4. No awards will be made on other than regular prize days, except for objects of special merit.

Special rules of the fruit committee.—All fruits offered for premiums must be correctly named. Indefinite appellations, such as “Tippin,” “Sweeting,” “Greening,” etc., will not be considered as names.

2. All Fruits offered for premiums must be composed of exactly the number of specimens or quantity named in the Schedule. A “dish” of Apples, Pears, Peaches, Plums, Nectarines, Quinces, Figs, Apricots, etc., is understood to contain twelve specimens, and this number will be required of all Fruits when not otherwise specified.

3. The whole quantity required of any one variety of Fruit must be shown in a single dish or basket except in collections.

4. Contributors of Fruits for Exhibition or Prizes must present the same in the Society’s dishes. All Small Fruits must be shown in baskets of uniform size, which will be furnished to exhibitors by the Superintendent at cost.

5. No person can compete for more than one Prize with the same variety or varieties of Fruit; except that a single dish of the same variety, but not the same specimens of fruit, may be used by an exhibitor for both Special and Regular Prizes.

6. The Fruit Committee, in making its awards, will consider the flavor, beauty, and size of the specimens, comparing each of these properties with a fair standard of the variety. The adaptation of the variety to general cultivation will also be taken into account. Other things being equal, specimens most nearly in perfection as regards ripeness will have the preference. Score-cards may be used at the discretion of the Committee.

Special rules of the vegetable committee.—1. The specimens offered must be well grown and placed on the tables clean and correctly labeled.

2. All exhibits of Vegetables offered for premium must be composed of exactly the number of specimens or quantity named in the Schedule.

3. At all exhibitions of Fungi distinctively colored cards, having the word “Poisonous” plainly printed thereon, shall be provided, and all persons exhibiting Fungi not known to be edible shall be required to use these cards in labeling all such exhibits.

4. All collections of vegetables will be judged on merit, giving consideration, first, to quality; second, to arrangement; and third, to variety. Not more than two varieties of one kind of vegetable admissible in collections.

Nomenclature Rules

Rules for naming kitchen-garden vegetables, adopted by the Committee on Nomenclature of the Association of American Agricultural Colleges and Experiment Stations (1889, and still in force).

1. The name of a variety shall consist of a single word, or at most of two words. A phrase, descriptive or otherwise, is never allowable; as, *Pride of Italy, King of Mammoths, Earliest of All.*

2. The name should not be superlative or bombastic. In particular, such epithets as *New, Large, Giant, Fine, Selected, Improved*, and the like, should be omitted. If the grower or dealer has a superior stock of a variety, the fact should be stated in the description immediately after the name, rather than as a part of the name itself; as, "*Trophy, selected stock.*"

3. If a grower or dealer has secured a new select strain of a well-known variety, it shall be legitimate for him to use his own name in connection with the established name of the variety; as, *Smith's Winnigstadt, Jones's Cardinal.*

4. When personal names are given to varieties, titles should be omitted; as *Major, General*, etc.

5. The term "hybrid" should not be used except in those rare instances in which the variety is known to be of hybrid origin.

6. The originator has the prior right to name the variety, but the oldest name which conforms to these rules should be adopted.

7. This Committee reserves the right, in its own publications, to revise objectionable names in conformity with these rules.

Code of nomenclature of the American Pomological Society.

Priority.—Rule 1. No two varieties of the same kind of fruit shall bear the same name. The name first published for a variety shall be the accepted and recognized name, except in cases where it has been applied in violation of this code.

A. The term "kind" as herein used shall be understood to apply to those general classes of fruits which are grouped together in common usage without regard to their exact botanical relationship, as apple, cherry, grape, peach, plum, raspberry, etc.

B. The paramount right of the originator, discoverer, or introducer

of a new variety to name it, within the limitations of this code, is recognized and emphasized.

C. Where a variety name through long usage has become thoroughly established in American pomological literature for two or more varieties, it should not be displaced nor radically modified for either sort, except in cases where a well-known synonym can be advanced to the position of leading name. The several varieties bearing identical names should be distinguished by adding the name of the author who first described each sort, or by adding some other suitable distinguishing term which will insure their identity in catalogues or discussions.

D. Existing American names of varieties which conflict with earlier published foreign names of the same or other varieties, but which have become thoroughly established through long usage, shall not be displaced.

Form of Names. — Rule 2. The name of a variety of fruit shall consist of a single word.

A. No variety shall be named unless distinctly superior to existing varieties in some important characteristic, nor until it has been determined to perpetuate it by bud propagation.

B. In selecting names for varieties the following points should be emphasized: Distinctiveness, simplicity, ease of pronunciation and spelling, indication of origin or parentage.

C. The spelling and pronunciation of a varietal name derived from a personal or geographical name should be governed by the rules which control the spelling and pronunciation of the name from which it was derived.

D. A variety imported from a foreign country should retain its foreign name, subject only to such modification as is necessary to conform it to this code or to render it intelligible in English.

E. The name of a person should not be applied to a variety during his life without his express consent. The name of a deceased horticulturist should not be so applied, except through formal action by some competent horticultural body, preferably that with which he was most closely connected.

F. The use of such general terms as seedling, hybrid, pippin, pearmain, beurre, rare-ripe, damson, etc., is not admissible.

G. The use of a possessive noun as a name is not admissible.

H. The use of a number, either singly or attached to a word, should

be considered only as a temporary expedient while the variety is undergoing preliminary test.

I. In applying the various provisions of this rule to an existing varietal name which has through long usage become firmly embedded in American pomological literature, no change shall be made which will involve loss of identity.

Rule 3. In the full and formal citation of a variety name, the name of the author who first published it shall be given.

Publication. — Rule 4. Publication consists (1) in the distribution of a printed description of the variety named, giving the distinguishing characters of fruit, tree, etc., or (2) in the publication of a new name for a variety which is properly described elsewhere; such publications to be made in any book, bulletin, report, trade catalogue, or periodical, providing the issue bears the date of its publication and is generally distributed among nurserymen, fruit-growers, and horticulturists; or (3) in certain cases the general recognition of a name for a propagated variety in a community for a number of years shall constitute publication of that name.

A. In determining the name of a variety to which two or more names have been given in the same publication that which stands first shall have precedence.

Revision. — Rule 5. No properly published variety name shall be changed for any reason except conflict with this code, nor shall another variety be substituted for that originally described thereunder.

Emblematic Plants and Flowers

State flowers adopted by the vote of the public schools, sometimes by the legislatures (*), sometimes by choice of the people.

Alabama	Goldenrod
Alaska	Forget-me-not
Arkansas	Apple blossom
California	California poppy (<i>Eschscholzia</i>)
Colorado	Columbine
Connecticut	Mountain laurel
* Delaware	Peach blossom
Florida	Orange blossom
Idaho	Syringa
Illinois	Violet
Indiana	Corn
* Iowa	Rose
Kansas	Sunflower
Kentucky	Trumpet-flower
Louisiana	Magnolia

* Maine	Pine cone and tassel
Maryland	Goldenrod
* Michigan	Apple blossom
Minnesota	Moccasin-flower
Mississippi	Magnolia
Missouri	Goldenrod
* Montana	Bitter-root (<i>Lewisia</i>)
* Nebraska	Goldenrod
Nevada	Sage-brush
New York	Rose
North Dakota	Wild rose
Ohio	Scarlet carnation
Oklahoma	Mistletoe
* Oregon	Oregon grape (<i>Berberis</i>)
Rhode Island	Violet
State tree	Maple
South Dakota	Pasque (<i>Anemone</i>)
Tennessee	Daisy
Texas	Blue bonnet
Utah	Sego lily (<i>Calochortus</i>)
* Vermont	Red clover
Washington	Rhododendron (<i>R. Californicum</i>)
West Virginia	Rhododendron
Wisconsin (State tree)	Maple

National and regional flowers

Canada	Sugar maple
China	Narcissus
Egypt	Lotus (<i>Nymphaea Lotus</i>)
England	Rose
France	Fleur-de-lis (<i>Iris</i>)
Germany	Corn-flower (<i>Centaurea Cyanus</i>)
Greece (Athens)	Violet
Ireland	Shamrock (<i>Trifolium</i> , usually <i>T. repens</i>)
Italy	Lily
Japan	Chrysanthemum
Nova Scotia	Mayflower (<i>Epigaea</i>)
Prussia	Linden
Saxony	Mignonette
Scotland	Thistle
Spain	Pomegranate
Wales	Leek

Party flowers

Beaconsfield's followers	Primrose
Bonapartists	Violet
Orleanists	White daisy
Ghibellines	White lily
Guelphs	Red lily
Prince of Orange	The orange
Parnellites	Ivy
Jacobites	White rose

CHAPTER XI

GREENHOUSE AND WINDOW-GARDEN WORK

GREENHOUSE production has now passed beyond the stage of exclusive amateurism, and has become a recognized form of agriculture. It is farming under glass. The area is small, but the investment is high and the skill is great.

Greenhouse Practice

Potting earth.

Loam (decomposed sod), leaf-mold, rotted farm-yard manure, peat, and sand afford the main requirement of the plants most commonly cultivated. Seedlings, and young stock generally, are best suited by a light mixture, such as one part each of loam, leaf-mold, and sand in equal parts. The older plants of vigorous growth like a rich, heavy compost, formed of equal parts of loam and manure; and a sandy, lasting soil, made up of two parts each of peat and loam to one part of sand, is the most desirable for slow-growing sorts. A little lumpy charcoal should be added to the compost for plants that are to remain any great length of time, say a year, in the same pot. The best condition of soil for potting is that intermediate state between wet and dry. Sphagnum (moss), or fibrous peat and sphagnum in mixture and chopped, should be used for orchids and other plants of similar epiphytal character.

Cow-dung is highly prized by many gardeners for use in potting soil. It is stored under cover and allowed to remain until dry, being turned several times in the meantime to pulverize it. Manure water is made either from this dried excrement or from the fresh material. When made from the fresh material, the manure-water should be made weaker than in the other case.

Suggestions for potting plants.

The pots should be perfectly dry and clean, and well drained. However one-sided a plant may be, it is advantageous to have the main stem as near the center of the pot as possible, and the potted plant is usually in the best position when perfectly erect. Soft-wooded plants of rapid growth, such as coleus, geraniums, fuchsias, and begonias, thrive most satisfactorily when the soil is loose rather than hard about the roots. Ferns should have it moderately firm, and hard-wooded stock, azaleas, ericas, acacias, and the like, should be potted firmly. In repotting plants, more especially those of slow growth, the ball of soil and roots should never be sunk to any great extent below the original level, and it is always preferable to pot a plant twice, or even three times, rather than place it in a pot too large.

Watering greenhouse and window plants.

Plants cannot be satisfactorily watered just so many times a day, week, or month. All plants should be watered when necessary — when they are dry. This is indicated by a tendency to flag or wilt, or by the hollow sound of the pots when tapped. The latter is the safest sign, as, after a prolonged period of dull weather, many plants wilt on exposure to bright sunshine, although still wet at the roots. But a growing plant should not be allowed to become so dry as to wilt, nor should the soil ever reach a condition as dry as powder. This is a condition, however, which is essential to some plants, more particularly the bulbous and tuberous kinds, during their resting period. Incessant dribbling should be avoided; water thoroughly, and be done with it until the plants are again dry. Plants under glass should not be sprayed overhead while the sun is shining hot and full upon them. The evening is the best time of the day for watering in summer, and morning in winter. In watering with liquid manure, the material should not come in contact with the foliage. Plants recently potted should not be watered heavily at the roots for a week or ten days; spray them frequently overhead.

Liquid manure for greenhouses.

Most of the artificial fertilizers may be used in the preparation of liquid manure, but a lack of knowledge as to their strength and char-

acter lessens their value in the minds of gardeners. Clean cow manure, which varies little in stimulating property, is considered by gardeners to be the safest and most reliable material to use for a liquid fertilizer. A bushel measure of the solid manure to 100 gallons of water makes a mixture which can be used with beneficial results on the tenderest plants; and for plants of rank growth the compound may be gradually increased to thrice that strength with safety. Soot may be added with advantage, using it at the rate of 1 part to 10 parts of the manure. The mixture should stand for a few days, being stirred occasionally, before application.

Lists of Plants

Twenty-five plants adapted to window-gardens

POTS

Adiantum cuneatum, particularly the form known as <i>A. gracillimum</i> .	Fuchsia, varieties.
Aloysia citriodora.	Mahernia odorata.
Begonia metallica, and many others.	Myrtus communis.
Cocos Weddelliana.	Pelargoniums, in variety.
Ficus elastica.	Primrose, Chinese.
Freesia refracta.	Pteris serrulata.
	Vallota purpurea.

BASKETS

Epiphyllum truncatum.	Saxifraga sarmentosa, beefsteak geranium.
Fragaria Indica.	Sedum Sieboldii.
Fuchsia procumbens.	Tradescantia zebrina, wandering Jew (<i>Zebrina pendula</i>).
Othonna crassifolia (<i>O. Capensis</i>).	
Oxalis violacea.	
Pelargonium peltatum.	

WATER

Eichhornia crassipes (<i>E. speciosa</i>).	Narcissus Tazetta, var. orientalis,
Hyacinths.	Chinese sacred lily.

In selecting plants for a window-garden or house conservatory, those plants should be omitted that are much subject to the attacks of aphid and mealy-bug. Amongst the common plants which are much infested are coleus, German ivy (*Senecio scandens*), calla, Vinca variegata, Cyperus alternifolius, fuchsia, cineraria, and carnation. Those that are nearly exempt are most kinds of geraniums, begonias, wandering Jew, and most ferns. Palms are very liable to scale infestation. (For insects, see p. 301.)

Vegetable-growing under glass

	NIGHT TEM. °F.	DAY TEM. °F.	MATURITY FROM SEED OR ROOTS	ADVICE
Asparagus . . .	45-55	60-70	3-4 wk.	Roots are taken from field, 3-5 years old; use only strong roots.
Beans	60-65	70-80	6-8 wk.	Little grown commercially and then as incidental crop.
Cauliflower . . .	50-55	60-65	4-5 mo.	Transplant once; give abundance of air; requires much water, yet good drainage. Avoid checking growth of plants. Commonly matured under glass, as a late spring crop.
Cucumber	60-65	70-75	10-14 wk.	Often follows winter tomatoes, in ground beds, making a spring and early summer crop. Sometimes grown on benches. There are two types of forcing cucumbers, the common, or White Spine, type and the English or frame varieties.
Lettuce	45-50	55-65	7-12 wk.	Grown mostly on the ground.
Mushrooms . . .	50-60	50-60	6-8 wk.	Grow under benches, or in cellars; an uncertain crop.
Muskmelon	65-70	70-85	10-14 wk.	Not commonly forced. When grown, usually as a late fall or late spring crop.
Parsley	45-50	55-65	8 wk.	Transplant in the fall from the field, and cut back.
Peas	45-50	55-65	70-80 d.	Little grown under glass, as the yield is light. Must be off before hot weather of spring.
Radishes	45-50	55-65	5-6 wk.	Rapid growth should be secured; use no old manure.
Rhubarb	45-50	55-60	3-5 wk.	Roots dug in fall, frozen and planted under benches or in frames. After cropping, replant in field.
Spinach	45-50	55-65	8-10 wk.	Grown as an incidental or secondary crop; does well in solid beds.
Tomato	60-65	75	4-5 mo.	Transplant into pots, hand pollinate in winter and dark weather, but most growers depend on shaking the plants. Now widely grown in ground beds.

Beets, cress, sweet herbs (particularly spearmint), are also grown under glass.

Twenty-five useful aquatic and sub-aquatic plants for outdoor use

t denotes those that do not endure the winter (tender).

Acorus gramineus, variegated.	Ouvirandra fenestralis (<i>Aponogeton fenestrale</i>); <i>t</i> .
Aponogeton distachyum.	Papyrus (<i>Cyperus Papyrus</i>); <i>t</i> .
Azolla Caroliniana.	Pistia Stratiotes; <i>t</i> .
Caltha palustris.	Pontederia cordata.
Cyperus alternifolius; <i>t</i> .	Sagittaria Montevidensis; <i>t</i> .
Eichhornia crassipes or azurea (properly <i>E. speciosa</i>); <i>t</i> .	Salvinia natans.
Limnanthemum Indicum; <i>t</i> .	Sarracenia purpurea.
Limnanthemum nymphoides.	Scirpus Tabernæmontanus zebrina (<i>Juncus effusus</i> , variegated).
Limnocharis Humboldtii (<i>Hydrocleys Commersonii</i>).	Trapa natans.
Myriophyllum proserpinacoides; <i>t</i> .	Typha latifolia.
Nelumbium (<i>Nelumbo</i>). Many species and varieties. Some <i>t</i> .	Victoria regia; <i>t</i> .
Nuphar advena.	Zizania aquatica.
Nymphæa. Many species and varieties. Some <i>t</i> .	

Commercial plants and flowers, or "florists' plants"

The following are chiefly grown by florists in this country: —

Adiantum.	Heliotrope.
Alyssum.	Hyacinth.
Anemone.	Hydrangea.
Antirrhinum	Iris.
Asparagus plumosus.	Lilac.
Aster, China.	Lilium Harrisii (<i>L. longiflorum</i> , var. <i>eximium</i>).
Azalea.	Lily of the Valley.
Begonia.	Marguerite, or Paris Daisy (<i>Chrysanthemum frutescens</i> , and <i>C. fœniculaceum</i>).
Bougainvillea.	Mignonette.
Bouvardia.	Narcissus.
Calla.	Nephrolepis (fern).
Carnation.	Nymphæa.
Cattleya.	Pansy.
Chrysanthemum.	Peony.
Cineraria.	Phlox.
Coreopsis.	Poinsettia.
Cyclamen.	Rhododendron.
Cypripedium.	Rose.
Dahlia.	Smilax (<i>Asparagus medeoloides</i>).
Daisy (<i>Bellis perennis</i>).	Spirea (<i>Astilbe</i>).
Deutzia.	Stevia (<i>Piqueria trinervia</i>).
Dracena.	Swainsona.
Freesia.	Sweet pea.
Gaillardia.	Tuberose.
Gardenia.	Tulip.
Genista (<i>Cytisus</i>).	Violet.
Gladiolus.	
Gypsophila.	
Helianthus.	

The Heating of Greenhouses (R. C. Carpenter)

Methods of proportioning radiating surface for heating of greenhouses.

Radiating surface, whether from steam or hot-water pipes, is estimated in square feet of exterior surface. All projections, ornaments, etc., on the exterior of pipes or radiators are counted as efficient surface. Formerly, cast-iron pipe of about 4 inches in diameter was used almost altogether for greenhouse work; it is still used to some extent for hot-water heating, but the great majority of houses are now piped with wrought iron or steel pipe, which is made of standard size and thickness, and is a regular article of trade.

The *heating surface* in a boiler or hot water heater is that portion of the boiler, or heater, which is exposed to the direct heat of the fire or of the heated gases.

Grate surface is the number of square feet of grate in the boiler or heater.

In estimating the heat required for greenhouses, the area expressed in square feet of glass in the roof and walls is taken as the basis from which computations are made. Certain rules of practice have been adopted, and appear to give fairly good results in proportioning radiating surface, grate surface, and heating surface. The ratio of heating surface to grate surface in heaters will depend upon the kind of coal to be burned and the economy desired. The more heating surface provided per unit of grate surface, the higher the economy, but the greater the first cost of the heater. The usual practice in large boilers is to employ 40 square feet of heating surface to 1 of grate surface for hard coal, and 80 feet of heating surface to 1 of grate surface for soft coal.

In small cast-iron heaters the proportion of heating surface to grate is frequently one-third to one-fourth that given above.

If the greenhouse is maintained at 70° when the outside temperature is zero, one square foot of radiation will supply 5 square feet of glass surface, if steam is used at 5 pounds pressure, or 4 square feet of glass surface if water at a temperature of 180° F. is used. The following table gives the ratio of radiation to glass surface for various temperatures:—

(A) Table showing relation of glass surface, radiating surface, and heating surface¹

Temperature of radiating surface . . .	HOT-WATER HEATING			STEAM HEATING	
	160°	180°	200°	(5 lbs. Pressure) 220°	(10 lbs. Pressure) 240°
	Square feet of glass for 1 square foot radiating surface.				
Temp. 100° F. above surrounding air . .	2.3	2.7	3.2	3.5	4.2
Temp. 90° F. above surrounding air . .	2.55	3.0	3.55	3.9	4.66
Temp. 80° F. above surrounding air . .	2.75	3.38	4.0	4.37	5.25
Temp. 70° F. above surrounding air . .	3.2	4.0	4.5	5.0	6.0
Temp. 60° F. above surrounding air . .	3.8	4.5	5.25	5.85	7.0
Temp. 50° F. above surrounding air . .	4.5	5.4	6.4	7.0	8.4
Temp. 40° F. above surrounding air . .	5.7	6.7	8.0	8.7	10.5
Temp. 30° F. above surrounding air . .	7.7	9.0	10.6	11.6	14.0
Radiation per pound of coal	56.2	47.7	40.9	40	36
Heat units given off 1 square foot radiating surface B.T.U. ² for 70° Temp. diff. . .	160	190	220	225	250

For instance, to maintain the temperature of a greenhouse 70° at zero weather, there should be 1 square foot of radiating surface for 4.0 square feet of glass for hot-water heating, in which the maximum temperature of the water is maintained at 180°; or there should be 1 square foot of radiating surface for 5 square feet of glass for low-pressure (under 5 pounds) steam. These numbers are given somewhat greater by some authorities, and there is no doubt that if the house is not much exposed, higher proportions will give satisfactory results.

The preceding table gives more exact values for these quantities, and will be found to accord with the best practice in heating of greenhouses, either by steam or hot water. Each pound of coal burned on the grate will transfer to the water or steam in the heater about 9000 B.T.U. As the amount of coal consumed can be varied with the draft or firing conditions, it is evident that no fixed rule can be given for the proportion of grate to radiation.

¹ From Carpenter's work on "Heating and Ventilating Buildings."

² British Thermal Unit, — heat required to raise 1 lb. of water 1 degree.

Size of pipes connecting radiating surface and the boiler or heater.

Various empirical rules have been given for proportioning main-supply and return pipes, which have proved quite satisfactory in practice. George A. Babcock gives the following rule, which will be found very satisfactory for greenhouse heating, whether with low-pressure steam or with water:—

The diameter of main pipe leading to the radiating surface should be equal in inches to 0.1 the square root of radiating surface in square feet. The main pipes should not be less than 1½ inches in diameter, return pipes for water heating the same size as mains, and, for steam heating, one size less than mains, but never less than ¾ inch in diameter. The following table shows the radiating surface supplied by various sizes of main pipe.

(B) SIZE OF PIPES	RADIATING SURFACE SUPPLIED
1¼ inches	155 square feet
1½ inches	225 square feet
2 inches	400 square feet
2½ inches	620 square feet
3 inches	900 square feet
3½ inches	1220 square feet
4 inches	1600 square feet

(C) *Table of dimensions of standard wrought-iron pipe— For steam and water*

1 inch and below, butt-welded; proved to 300 pounds per square inch, hydraulic pressure.

1¼ inch and above, lap-welded; proved to 500 pounds per square inch, hydraulic pressure.

TABLE OF STANDARD SIZES

INSIDE DIAMETER NORMAL	INTERNAL AREA IN ONE LINEAL INCH	CIRCUMFERENCE OF PIPE IN INCHES	LENGTH OF PIPE PER SQUARE FOOT OF RADIATING SURFACE-FEET	NUMBER SQUARE FEET IN ONE FOOT OF PIPE	CONTENTS IN GALLONS, PER FOOT	NO. OF THREADS PER INCH OF SCREW
½	0.3048	2.652	4.502	0.221	0.0102	14
¾	0.5333	3.299	3.637	0.274	0.0230	14
1	0.8627	4.134	2.903	0.344	0.0408	11½
1¼	1.496	5.215	2.301	0.434	0.0638	11½
1½	2.038	5.969	2.010	0.497	0.0918	11½
2	3.355	7.461	1.611	0.621	0.1632	11½
2½	4.783	9.032	1.328	0.752	0.2550	8
3	7.368	10.99	1.091	0.916	0.3673	8
3½	9.837	12.56	0.955	1.044	0.4998	8
4	12.730	14.13	0.849	1.178	0.6528	8
4½	15.939	15.70	0.765	1.309	0.8263	8
5	19.990	17.47	0.629	1.656	1.0200	8

The preceding table gives the standard sizes and principal dimensions of wrought-iron pipe. From this table the amount required for a given amount of radiating surface can be readily computed. This pipe can be purchased of any dealer.

To design heating plant.

1. Find radiating surface by dividing area of glass in square feet by results in table A. Hot water pipes can be kept at a temperature of 180° F. if desired.

2. Find the size of grate by multiplying amount of radiating surface by number of pounds of coal per square foot of grate per hour divided by "radiation per pound" in table A.

3. Find size of main pipes by table B, using size next larger when radiating surface comes between numbers given. It is usually better to have several main and return pipes, and divide the radiating surface in sections.

Other Information relating to Heating

Diameters for cylindrical chimney-flues, for given heights and boiler capacities (R. C. Carpenter)

Four-cornered chimneys are considered to be equivalent to cylindrical chimneys when the sides equal the diameter.

HEIGHT OF CHIMNEY IN FEET		30	40	50	60	80	100
Steam { Sq. Ft. Rated Boiler Capacity	Water { Sq. Ft. Rated Boiler Capacity	Diameter in Inches	Diameter in Inches	Diameter in Inches	Diameter in Inches	Diameter in Inches	Diameter in Inches
		250	375	7.0			
500	750	9.2	8.8	8.2	8.0		
750	1,125	10.8	10.2	9.6	9.3	8.8	8.5
1,000	1,500	12.0	11.4	10.8	10.5	10.0	9.5
1,500	2,250	14.4	13.4	12.8	12.4	11.5	11.2
2,000	3,000	16.3	15.2	14.5	14.0	13.2	12.6
3,000	4,500	18.5	18.2	17.2	16.6	15.8	15.0
4,000	6,000	22.2	20.8	19.6	19.0	17.8	17.0
5,000	7,500	24.6	23.0	21.6	21.0	19.4	18.6
6,000	9,000	26.8	25.0	23.4	22.8	21.2	20.2
7,000	10,500	28.8	27.0	25.5	24.4	23.0	21.6
8,000	12,000	30.6	28.6	26.8	26.0	24.2	23.4
9,000	13,500	32.4	30.4	28.4	27.4	25.6	24.4
10,000	15,000	34.0	32.0	30.0	28.6	27.0	25.4

Effects of wind in cooling glass (Leuchars)

Velocity of Wind per hour	Time Required to lower Temperature from 120° to 100° F.
3.26 miles	2: 58 minutes
5.18 miles	2: 16 minutes
6.54 miles	1: 91 minutes
8.86 miles	1: 66 minutes
10.90 miles	1: 50 minutes
13.36 miles	1: 25 minutes
17.97 miles	1: 08 minutes
20.45 miles	1: 00 minutes
24.54 miles	: 91 minutes
27.27 miles	: 81 minutes

Table of radiation for glass (Dean¹)

STEAM						HOT WATER					
Table of amount of steam radiating surface necessary to heat a given amount of glass exposure to various temperatures in zero weather.						Table of amount of hot-water radiating surface necessary to heat a given amount of glass exposure to various temperatures in zero weather.					
Square feet of exposure	Number of square feet of radiation required at					Square feet of exposure	Number of square feet of radiation required at				
	40°	45°	50°	60°	70°		40°	45°	50°	60°	70°
25	2½	3¼	3¾	4½	5	25	4½	5	6¼	7½	8½
50	5½	6¼	7½	8½	10	50	8	10	13	14	16
75	8	9	10	13	15	75	13	15	19	21	25
100	11	13	14	17	20	100	17	20	25	29	33
200	23	25	30	33	40	200	33	40	50	57	67
300	34	38	43	50	60	300	50	60	75	86	100
400	45	50	57	67	80	400	67	80	100	114	133
500	56	63	72	83	100	500	83	100	125	143	167
1,000	112	125	143	167	200	1,000	167	200	250	286	333
2,000	223	250	286	333	400	2,000	333	400	500	572	667
3,000	334	375	429	500	600	3,000	500	600	750	857	1,000
4,000	445	500	571	667	800	4,000	667	800	1,000	1,143	1,333
5,000	556	625	714	833	1,000	5,000	833	1,000	1,250	1,429	1,667
10,000	1112	1250	1429	1667	2,000	10,000	1667	2,000	2,500	2,857	3,333
20,000	2223	2500	2857	3333	4,000	20,000	3333	4,000	5,000	5,714	6,667
30,000	3334	3750	4286	5000	6,000	30,000	5000	6,000	7,500	8,573	10,000
40,000	4445	5000	5714	6667	8,000	40,000	6667	8,000	10,000	11,429	13,333
50,000	5556	6250	7143	8333	10,000	50,000	8333	10,000	12,500	14,286	16,667

¹ From Dean's "Greenhouse Heating," by permission of "Domestic Engineering."

Radiating surface of pipes of different lengths and diameters

LENGTH OF PIPE (Ft.)	¾ IN. PIPE	1 IN. PIPE	1¼ IN. PIPE	1½ IN. PIPE	2 IN. PIPE	2½ IN. PIPE	3 IN. PIPE	3½ IN. PIPE	4 IN. PIPE
10	2.7	3.5	4.3	4.9	6.2	7.5	9.1	10.5	11.8
11	3.0	3.8	4.8	5.4	6.8	8.3	10.0	11.6	13.0
12	3.3	4.1	5.2	5.9	7.5	9.0	11.0	12.6	14.1
13	3.6	4.5	5.6	6.4	8.1	9.8	11.9	13.7	15.3
14	3.8	4.8	6.1	6.9	8.7	10.5	12.8	14.7	16.5
15	4.1	5.2	6.5	7.4	9.3	11.3	13.7	15.8	17.6
16	4.4	5.5	6.9	7.9	10.0	12.0	14.6	16.9	18.8
17	4.7	5.9	7.4	8.4	10.6	12.8	15.5	17.9	20.0
18	5.0	6.2	7.8	8.9	11.2	13.5	16.5	19.0	21.2
19	5.2	6.6	8.3	9.4	11.8	14.3	17.4	20.0	22.3
20	5.5	6.9	8.7	9.9	12.5	15.0	18.3	21.1	23.5
21	5.8	7.3	9.1	10.4	13.0	15.8	19.2	22.1	24.7
22	6.0	7.6	9.6	10.9	13.7	16.5	20.2	23.2	25.9
23	6.3	8.0	10.0	11.3	14.3	17.3	21.1	24.3	27.0
24	6.6	8.3	10.4	11.9	14.9	18.0	22.0	25.3	28.2
25	6.9	8.6	10.9	12.3	15.6	18.8	22.9	26.3	29.3
26	7.2	9.0	11.3	12.8	16.2	19.5	23.8	27.4	30.5
27	7.4	9.4	11.7	13.3	16.8	20.3	24.7	28.5	31.7
28	7.7	9.7	12.2	13.8	17.4	21.0	25.6	29.6	32.9
29	8.0	10.0	12.6	14.3	18.0	21.8	26.6	30.6	34.1
30	8.3	10.4	13.0	14.8	18.7	22.5	27.5	31.6	35.3
31	8.5	10.7	13.5	15.3	19.3	23.3	28.4	32.7	36.4
32	8.8	11.1	13.9	15.8	19.9	24.1	29.3	33.7	37.6
33	9.1	11.4	14.3	16.3	20.5	24.8	30.2	34.8	38.8
34	9.4	11.7	14.7	16.8	21.2	25.6	31.1	35.8	40.0
35	9.6	12.1	15.2	17.3	21.8	26.3	32.0	36.9	41.1
36	9.9	12.5	15.6	17.8	22.4	27.0	33.0	38.0	42.3
37	10.2	12.8	16.1	18.3	23.0	27.8	33.9	39.0	43.5
38	10.5	13.2	16.5	18.8	23.7	28.5	34.8	40.1	44.6
39	10.7	13.5	16.9	19.3	24.3	29.3	35.7	41.1	45.8
40	11.0	13.8	17.4	19.8	24.9	30.1	36.6	42.2	47.0
41	11.3	14.2	17.8	20.5	25.5	30.8	37.6	43.2	48.2
42	11.6	14.5	18.2	20.8	26.1	31.6	38.5	44.3	49.4
43	11.8	14.9	18.7	21.3	26.8	32.3	39.4	45.3	50.6
44	12.1	15.2	19.1	21.8	27.4	33.1	40.3	46.4	51.7
45	12.4	15.6	19.5	22.4	28.0	33.8	41.2	47.4	52.9
46	12.7	15.9	20.0	22.8	28.6	34.6	42.2	48.5	54.0
47	12.9	16.3	20.4	23.2	29.2	35.3	43.0	49.6	55.2
48	13.2	16.6	20.8	23.7	29.9	36.1	43.9	50.6	56.4
49	13.5	17.0	21.3	24.2	30.5	36.8	44.8	51.7	57.6
50	13.8	17.3	21.7	24.7	31.1	37.6	45.8	52.8	58.7

Method for finding boiler capacity for cast-iron pipe

Table showing how to get at the amount of 3½-inch east-iron pipe necessary to heat greenhouse to temperature wanted, when outside temperature is at zero, Fahrenheit (Lord & Burnham Co.)

- For 10° below zero, add 10 per cent. ; for 20° add 20 per cent., and so on.
 For 70° to 75° divide square feet of glass and equivalent by 1.8.
 For 65° to 70° divide square feet of glass and equivalent by 2.28.
 For 60° to 65° divide square feet of glass and equivalent by 2.62.
 For 55° to 60° divide square feet of glass and equivalent by 3.
 For 50° to 55° divide square feet of glass and equivalent by 3.46.
 For 45° to 50° divide square feet of glass and equivalent by 4.
 For 40° to 45° divide square feet of glass and equivalent by 4.67.
 For 35° to 40° divide square feet of glass and equivalent by 5.5.

For 2-inch work, use same table and same example and multiply the amount of 3½-inch pipe obtained by 1.68.

In proportioning glass surface, all wall surface must be figured in ; about 5 feet of wall equals 1 foot of glass.

Customary temperatures in which plants are grown under glass

	DAY	NIGHT
Asparagus plumosus	70°	60°
Azalea, Indian	65°	50°
Bulbs (hyacinth, tulip, etc.)	60°	45°
Carnation	60°	50°
Calla	70°	60°
Chrysanthemum	55°	45°
Cineraria	65°	50°
Cyclamen	65°	50°
Ferns, as maiden hair	75°	60°
Lily (Easter)	65°	55°
Lily of the valley (forcing)	90°	90°
Palms, house	75°	60°
Primulas	65°	50°
Rose	65°	55°
Smilax	60°	50°
Stocks	65°	50°
Sweet pea	60°	50°
Violet	50°	40°

Various Estimates and Recipes

Percentage of rays of light reflected from glass roofs at various angles of divergence from the perpendicular (Bouguer)

1°	2.5 per cent
10°	2.5 per cent
20°	2.5 per cent
30°	2.7 per cent
40°	3.4 per cent
50°	5.7 per cent
60°	11.2 per cent
70°	22.2 per cent
80°	41.2 per cent
85°	54.3 per cent

Angle of roof for different heights and widths of house (Taft)

HEIGHT FEET	4 Ft.	5 Ft.	6 Ft.	7 Ft.	8 Ft.	9 Ft.
WIDTH FEET	o /	o /	o /	o /	o /	o /
6	33 21	39 48	45	49 24	53 8	56 18
7	29 44	35 32	40 36	45	48 49	52 07
8	26 33	32	36 52	41 11	45	48 22
9	23 57	29 3	33 5	37 52	41 38	45
10	21 48	26 33	30 58	35	38 39	41 59
11		24 26	28 36	32 28	36 2	39 17
12		22 57	26 33	30 15	33 41	36 52
13		21 2	24 47	28 18	31 36	34 42
14			23 12	26 34	29 44	32 44

Among greenhouse builders, 32° is the pitch of roof that has practically been established for all houses up to 25 feet in width; beyond that width, 26° is commonly used for the slope or pitch of the roof.

Standard flower-pots.

American

The Society of American Florists has adopted a standard pot, in which all measurements are made inside, and which bears a rim or shoulder at the top. The breadth and depth of these pots are the same, so that they "nest" well.

English. — Chiswick Standards

	DIAM. AT TOP	DEPTH
	<i>In.</i>	<i>In.</i>
Thimbles	2	2
Thumbs	2½	2½
60's	3	3½
54's	4	4
48's	4½	5
32's	6	6
24's	8½	8
16's	9½	9
12's	11½	10
8's	12	11
6's	13	12
4's	15	13
2's	18	14

To prevent boilers from filling with sediment or scale.

(1) Exercise care to get clean water and that which contains little lime. (2) Blow it out often. It can be blown out a little every day, and occasionally it should be blown off entirely. (3) Put slippery-elm bark in the boiler tank. Or, if slippery-elm is not handy, use potato-peelings, flax-seed, oak-bark, spent tan, or coarse sawdust. (4) Put in, with the feed-water or otherwise, a small quantity of good molasses (not a chemical sirup), say one-half to one pint in a week, depending upon the size of boiler. This will remove and prevent incrustation without damage to the boiler. These vegetable substances prevent, in a measure, by mechanical means, the union of the particles of lime into incrustations.

To prepare paper and cloth for hotbed sash.

1. Use a sash without bars, and stretch wires or strings across it to serve as a rest for the paper. Procure stout but thin manila wrapping-paper, and paste it firmly on the sash with fresh flour paste. Dry in a warm place, and then wipe the paper with a damp sponge to cause it to stretch evenly. Dry again, and then apply boiled linseed oil to both sides of the paper, and dry again in a warm place.

2. Saturate cloth or tough, thin manila paper with pure, raw linseed oil.

3. Dissolve $1\frac{3}{4}$ pounds white soap in one quart water; in another quart dissolve $1\frac{1}{2}$ ounces gum arabic and 5 ounces glue. Mix the two liquids, warm, and soak the paper, hanging it up to dry. Used mostly for paper.

4. 3 pints pale linseed oil; 1 ounce sugar of lead; 4 ounces white rosin. Grind and mix the sugar of lead in a little oil, then add the other materials and heat in an iron kettle. Apply hot with a brush. Used for muslin.

Paint for hot-water pipes.

Mix lampblack with boiled oil and turpentine. It is harmless to plants.

Liquid putty for glazing.

Take equal parts, by measure, of boiled oil, putty, and white lead. Mix the putty and oil, then add the white lead. If the mixture becomes too thick, add turpentine. Apply with a putty-bulb.

Paint for shading greenhouse roofs.

Make a paint of ordinary consistency of white lead and naphtha. It is removed from the glass by the use of a scrubbing-brush. Make it thin, or it is hard to remove.

Ordinary lime whitewash is good for temporary use. If salt is added, it adheres better. It may be applied with a spray pump.

To keep flower-pots clean.

When the pots are cleaned, soak them a few hours in ammoniacal carbonate of copper (recipe, page 255). Soak them about once a year. This fungicide kills the green alga upon the pots, and prevents a new growth from appearing.

CHAPTER XII

FORESTRY AND TIMBER

FORESTRY is the raising of timber crops. It is not the planting of shade trees or ornamental trees, or even of groves, but the planting and rearing of forests. The primary product of the forest is timber; usually the timber is sawed into boards, known collectively in North America as lumber (*lumber* is properly and differently used in England); some timber is used for fire-wood, some for wood-pulp, and some for other uses. In the trades, *timber* usually means the squared or heavy sawed product used in framework.

Planting Notes

Nursery planting-table for forest trees (Farmer's Bulletin)

SPECIES	WHEN TO COLLECT SEEDS	HOW TO STORE SEEDS	PER CENT WHICH SHOULD GERMINATE	WHEN TO PLANT SEEDS	DEPTH TO PLANT SEEDS	SPACING OF SEEDS IN ROWS	HEIGHT OF 1-YEAR-OLD SEEDLINGS
Ash, green . . .	Oct. "	Bury in sand	35-50	Spring	$\frac{1}{2}$ in.	Scatter thickly	6-9
Ash, white . . .	" "	" "	35-50	"	$\frac{1}{2}$ in.	"	6-10
Basswood . . .	Sept. or Oct.	Sow at once	5-50	Fall	$\frac{1}{2}$ in.	"	6-12
Beech . . .	Fall	Bury in sand	70-80	Early spring	$\frac{3}{4}$ in.	2 in. apart	3-6
Butternut ¹ . . .	Sept. or Oct.	"	75-80	"	1 in.	3 to 6 in. apart	10-18
Box elder . . .	" "	"	40-60	Spring	$\frac{1}{2}$ in.	Touching in rows	10-14
Catalpa, hardy	Oct. or Nov.	Cool, dry place	40-75	"	1 in.	$\frac{1}{2}$ in. apart	14-30
Cherry, black .	Aug. or Sept.	Bury in sand	75-80	"	1 in.	2 to 3 in. apart	4-6
Coffee tree, Kentucky .	Sept. or Oct.	Cool, dry place, or bury in sand	70-75	"	1 in.	"	3-6
Cottonwood ² . .	June or July	Sow at once	75-95	Summer	$\frac{1}{2}$ in.	1 in. apart	20-30
Elm, slippery .	May or June	"	50-75	Late spring	$\frac{1}{8}$ in.	Scatter thickly	15-18
Elm, white . . .	" "	"	50-75	"	$\frac{1}{8}$ in.	"	5-10
Hackberry . . .	Oct.	Bury in sand	70-80	Spring	$\frac{1}{2}$ in.	1 to 2 in. apart	6-12
Hickory, pignut ¹	Sept. or Oct.	"	50-75	"	1-2 in.	3 to 6 in. apart	2-6
Hickory, shag-bark ¹ . . .	" "	"	50-75	"	1-2 in.	"	2-6
Hickory, shell-bark . . .	" "	"	50-75	"	1-2 in.	"	2-6

¹ Difficult to transplant on account of tap root. Advisable to sow seeds in permanent sites in field whenever possible.

² Easily grown from cuttings. Not necessary or advisable to attempt growing from seed.

Nursery planting-table for forest trees—Continued

SPECIES	WHEN TO COLLECT SEEDS	HOW TO STORE SEEDS	PER CENT WHICH SHOULD GERMINATE	WHEN TO PLANT SEEDS	DEPTH TO PLANT SEEDS	SPACING OF SEEDS IN ROWS	HEIGHT OF 1-YEAR-OLD SEEDLINGS
Locust, black .	Oct.	Cool, dry place, or bury in sand	50-57	Spring	In. 1	2 to 3 in. apart	In. 18-20
Locust, honey .	"	"	50-75	Fall or spring	½	"	6-14
Maple, red . .	May or June	Sow at once	25-60	Late spring	1	½ in. apart	6-10
Maple, silver .	"	"	25-50	"	1	"	12-20
Maple, sugar .	Oct.	Sow at once, or bury in sand	30-50	Fall or spring	1	"	6-12
Mulberry, Russian . . .	July or Aug.	Cool, dry place	75-95	Spring	½	Scatter thickly	8-10
Oak, bur ¹ . . .	Sept. or Oct.	Sow at once, or bury in sand	75-95	Fall or spring	1½	3 to 6 in. apart	5-9
Oak, red ¹ . . .	"	"	75-95	"	1½	"	6-20
Oak, white ¹ . . .	"	"	75-95	"	1½	"	5-9
Osage orange .	"	Cool, dry place	60-95	Spring	½	1 in. apart	10-15
Poplar, yellow	"	Sow at once	5-10	Fall	¼	Scatter thickly	4-6
Walnut, black ¹	"	Bury in sand	75-80	Spring	1½	3 to 6 in. apart	10-18

For number of tree seeds in a pound, see Chapter V.

¹ Difficult to transplant on account of tap root. Advisable to sow seeds in permanent sites in field whenever possible.

Note on the conifers (Mulford).—White pine, Scotch pine, and Norway spruce seed should be collected as soon as it is ripe, in September. The cones should be dried, allowing the seed to fall out. The seed should be stored for the winter in bags hung in a dry, cool place, and should be sown thickly in the spring, covering with about one-eighth inch of soil. From 60 to 90 per cent of the seed should germinate. One-year-old seedlings are from one and one-half to three inches high.

Forest planting (Mulford).

Forest planting is usually done with the mattock (grub hoe). A space about twelve to sixteen inches square should be cleared of all growth, and a hole dug in the middle of this large enough to receive the roots comfortably. Another method is to plow and harrow the ground, mark out with a corn marker, and simply set the tree in a slit pried open with a common spade, the slit being closed by a second thrust of the spade. By the former method, from 250 to 600 trees per day per man can be planted; by the latter method, from 800 to 2000 trees. Forest trees are ordinarily planted 4 × 4, 5 × 5, or 6 × 6 feet (*i.e.* about 2700, 1750, and 1200 trees per acre, respectively), the closer spacing being more necessary with slow-growing trees and on poor soils.

Hardness of Common Commercial Woods

Shellbark hickory	100	Black walnut	65	Yellow pine	54
Pignut hickory	96	Black birch	62	Chestnut	52
White oak	84	Yellow oak	60	Yellow poplar	51
White ash	77	White elm	58	White birch	43
Scrub oak	73	Hard maple	56	Butternut	43
Red oak	69	Red cedar	56	White pine	30
White beech	65	Wild cherry	55		

Forest Yields

Approximate time required to produce different wood crops (U. S. Forest Service)

SPECIES	LOCALITY	AV. DIAM. 6 IN. (POSTS)	AV. DIAM. 8 IN. (HANDLE, PULP, SPOOL, OR FUEL WOOD, PROPS)	AV. DIAM. 11 IN. (TIES)	AV. DIAM. 14 IN. (POLES AND PILES)	AV. DIAM. 18 IN. (SAW TIMBER)
		Years	Years	Years	Years	Years
<i>Northern forests</i>						
Aspen	Me.	30	40	60	—	—
Beech ¹	Mich.	—	80	100	—	200
Birch, paper	Me.	—	50	—	—	—
Hemlock ¹	Mich.	—	100	130	—	—
Maple, sugar ¹	Mich.	—	90	—	—	200
Pine, red	Wis.	32	40	55	75	100
Pine, white	N.Y.	32	40	55	—	90
<i>Central hardwood forests</i>						
Chestnut ²	Md.	20	25	40	55	85
Oak, red	Ky.	25	30	45	—	100
Oak, white	Ky.	35	45	80	—	160
Poplar, yellow	Tenn.	—	45	—	—	110
<i>Farm timber plantations</i>						
Catalpa ²	Ill.	20	—	—	—	—
Larch, European ²	Ill.	23	—	—	—	—
Maple, silver ²	Ill.	—	25	—	—	—
Walnut, black ²	Ill.	25	35	—	—	—
Cottonwood ²	Nebr.	—	18	—	—	—
<i>Southern forests</i>						
Ash, white	Ark.	—	30	45	—	85
Cottonwood	Miss.	—	15	—	—	30
Cypress	Md.	40	—	65	75	90
Gum, red	S.C.	—	—	30	—	55
Pine, loblolly	S.C.	20	25	40	55	70
Pine, longleaf	S.C.	—	—	75	100	130
<i>Pacific coast forests</i>						
Fir, Douglas	Wash.	25	35	45	50	75
Hemlock, western	Wash.	—	50	70	—	125
Pine, sugar	Cal.	40	50	65	—	100
Pine, western yellow	Cal.	25	35	45	55	80
Redwood	Cal.	20	25	35	50	70

¹ Species tolerant of shade which should show better results in second growth.

² Species growing under favorable conditions when measured.

Yield of white pine per acre in southern New Hampshire (Margolin)

QUALITY I

AGE	NUMBER OF TREES	BASAL AREA	MEAN HEIGHT	VOLUME	CURRENT ANNUAL INCREMENT	MEAN ANNUAL INCREMENT
<i>Years</i>		<i>Square ft.</i>	<i>Feet</i>	<i>Cubic ft.</i>	<i>Cubic ft.</i>	<i>Cubic ft.</i>
25	2,430	190	33	3,100	124	124
30	1,840	215	41	4,367	253	145
35	1,250	230	48	5,850	296	167
40	870	238	56	7,033	236	176
45	640	243	64	8,000	193	177
50	510	246	70	8,767	153	175
55	430	249	75	9,475	141	172
60	380	252	80	10,100	125	168
65	340	255	84	10,633	106	164
70	310	258	87	11,100	93	158
75	280	261	90	11,567	93	154
80	260	263	93	12,000	86	150
85	240	266	95	12,383	76	146
90	220	268	97	12,767	76	142

QUALITY II

25	2,430	163	31	2,700	108	108
30	1,840	183	38	3,700	200	123
35	1,250	195	45	4,850	230	139
40	870	212	52	5,800	190	145
45	640	221	59	6,600	160	147
50	510	228	65	7,300	140	146
55	430	233	71	7,925	125	144
60	380	236	76	8,500	115	142
65	340	238	80	9,000	100	138
70	310	241	84	9,450	90	135
75	280	244	87	9,900	90	132
80	260	247	89	10,300	80	129
85	240	250	91	10,650	70	125
90	220	253	93	11,000	70	122

QUALITY III

25	2,430	150	28	2,300	—	92
30	1,840	165	35	3,033	146	101
35	1,250	176	42	3,850	163	110
40	870	185	48	4,567	143	114
45	640	191	54	5,200	126	116
50	510	197	60	5,833	126	116
55	430	201	66	6,375	108	116
60	380	205	71	6,900	105	115
65	340	208	75	7,367	93	113
70	310	211	79	7,817	90	112
75	280	213	83	8,233	83	110
80	260	216	85	8,600	73	107
85	240	218	88	8,917	63	105
90	220	221	89	9,233	63	103

Second growth

AGE		VOLUME		
		Quality I	Quality II	Quality III
Years		Board feet	Board feet	Board feet
20	.	4,600	3,150	1,700
25	.	8,400	5,900	3,450
30	.	15,100	10,800	6,550
35	.	24,950	18,050	11,200
40	.	33,550	25,000	16,450
45	.	40,750	31,450	22,150
50	.	47,450	37,800	27,650
55	.	52,350	42,550	32,750
60	.	57,300	47,400	37,500
65	.	61,850	51,850	41,850
70	.	65,900	55,800	45,700
75	.	69,750	59,500	49,250
80	.	73,300	62,850	52,400
85	.	76,700	66,000	55,300
90	.	80,050	69,000	57,950

Volume in board feet is round-edged box board material.

White pine thinnings

AGE	QUALITY I			QUALITY II			QUALITY III		
	Total Thinning per Acre		Trees under 5 Inches in Diameter Breast-high	Total Thinning per Acre		Trees under 5 Inches in Diameter Breast-high	Total Thinning per Acre		Trees under 5 Inches in Diameter Breast-high
	Cubic feet	Board feet	Cubic feet	Cubic feet	Board feet	Cubic feet	Cubic feet	Board feet	Cubic feet
25	1,350	2,000	830	900	750	750	600	—	600
30	1,730	4,500	660	1,380	3,300	600	1,090	2,200	500
35	1,980	6,800	480	1,680	5,600	450	1,440	4,300	400
40	2,120	8,700	270	1,900	7,500	300	1,640	5,800	300
45	2,240	10,100	60	2,040	8,900	150	1,750	6,900	200
50	2,280	11,200	—	2,100	9,900	—	1,800	7,600	80
55	2,280	12,000	—	2,100	10,400	—	1,780	8,100	—
60	2,260	12,300	—	2,000	10,600	—	1,700	8,300	—
65	2,200	12,300	—	1,850	10,300	—	1,590	8,200	—
70	2,100	11,900	—	1,630	9,500	—	1,420	7,800	—
75	1,950	11,100	—	1,300	8,000	—	1,200	6,900	—
80	1,700	9,500	—	860	5,000	—	920	5,600	—
85	—	—	—	200	1,200	—	650	4,000	—
90	—	—	—	—	—	—	370	2,300	—

Life of Fence-Posts and Shingles

Durability of fence posts in Minnesota (Green).

	YEARS
Red cedar	30
White cedar (quartered 6 in. face)	10-15
White oak (6 in. round)	8
Red and black oak	4
Tamarack (red wood)	9
Elm	6-7
Ash, beech, maple	4
Black walnut	7-10

Prolonging the life of fence-posts (Willis).

Measures for posts named in ascending order of efficiency:—

Peeling and seasoning.

Charring.

Painting.

At best, surface brush paintings are not very durable. Some of the substances which may be applied with a brush are whitewash, petroleum-tar creosote, coal-tar creosote, and various patented products of coal tar and petroleum tar. Paint and whitewash are inferior to antiseptic preservatives; products of coal tar (creosote, etc.) are the best. These are best applied hot, in two or more coats. A barrel (50 gallons) of creosote should be sufficient to paint at least 300 posts with three coats for the butts and two for the tops.

Dipping.

One defect of brush treatment is that the preservative does not enter readily the cracks and checks. This defect may be overcome by dipping the posts in the preservative. Another advantage of dipping, as compared with painting, is a saving in labor. On the other hand, dipping requires a larger quantity of preservative, and, in addition to the amount consumed, there must be enough surplus to keep the barrel or tank filled to the proper depth. This usually forbids the use of any expensive preservative for dipping. Petroleum tar, coal tar, and the creosotes, however, may often be advantageously employed.

Posts have been treated by dipping the butt in cement This is

hardly satisfactory, owing to the ease with which the protective covering may be broken; moisture is absorbed after treatment; and causes the wood to expand and crack the cement.

Cold-bath treatment.

This differs from dipping because penetration of the wood is secured by leaving the post in the bath for ten hours or more. As a rule, only the cheaper preservatives can profitably be used in the cold-bath treatment. Coal tar is so ropy and sticky that it will scarcely penetrate even the most easily treated woods. Crude petroleum enters the wood rather readily, but lacks strong antiseptic qualities. A long bath in crude petroleum may, however, prove a feasible method of treatment where petroleum is very cheap and the woods used are readily impregnated. Creosote is usually the best preservative to employ. Coal-tar creosote requires a slight heating to liquefy it. Water in the wood cells resists the penetration of the oil. Thorough seasoning before treatment, therefore, is necessary to allow the oil to penetrate readily and to prevent checking after treatment. The cold-bath method of treatment has not yet been thoroughly investigated. It is probable, however, that it will impregnate but few woods. The woods which are likely to prove most suitable are beech, cottonwood, the gums, pin and red oaks, the pines, sycamore, and tulip tree.

Impregnation with creosote.

The impregnation of fence posts with creosote is best accomplished by the so-called "open-tank" process, so designated to distinguish it from the "closed" or "pressure" cylinder process which is often employed in creosoting ties and piling. This consists of heating wood for a certain period and then cooling it in the preservative. The principle is simple: during the heating the high temperature causes the air and water contained in the wood cells to expand, so that a portion of this air and water is forced out. The rest contracts as the subsequent cooling progresses, and a partial vacuum is formed, into which atmospheric pressure forces the cool preservative.

The open-tank principle may be variously applied in the treatment of posts. The best way to heat the posts is to immerse their butts in creosote maintained at a temperature of 220° F. If a single tank is

used, the cooling bath may be given by permitting the temperature to fall, and in this case the preservative must, of course, be used for the hot bath. It is better, however, to employ an additional tank containing the cold preservative. If two tanks are used and a thorough impregnation of the top of the post is desired, the cold-bath tank should be large enough to permit the soaking of the entire post. The top of the post will not be too heavily impregnated, because it has not been immersed in the hot oil. With two tanks, crude petroleum or any heavy (high-boiling) oil may be used in the hot-bath tank. Creosote is usually the most satisfactory preservative.

Other wood.

Wood used on the farm in various forms other than post material may often be advantageously preserved from decay by chemical treatment, as all timbers used in foundations, sills, beams, and planking, as well as the lower parts of board fences, and the lumber used near the ground in sheds and barns. The treatment of these is very similar to that given posts.

Prolonging the life of shingles (Willis).

Water absorbed during a storm subsequently evaporates rapidly from the upper surface of shingles and rather slowly from the lower surface. Consequently, the upper part of the shingle shrinks more than does the under, and curling or warping results. The importance of excluding moisture is obvious. In addition to this, it is advisable to employ an antiseptic to retard decay. The best preservative, it follows, must possess such qualities as will operate in both these ways to prolong the life of the shingles. Apply preservatives only when the wood is thoroughly dry.

Non-antiseptic preservatives. — The application of paint is the preservative measure most commonly used with shingles. The method of applying it is of paramount importance. Dipping the shingles individually is the only satisfactory procedure. When a roof is painted ridges of paint are formed at the base of the shingles, owing to the irregularities of the surface over which the brush passes. These cause the water to permeate the crevices between the shingles and frequently hasten decay.

Antiseptic preservatives. — The best antiseptics for shingle treatment are creosote and other derivatives of coal tar. Painting the roof with these oils is a rather satisfactory method of treatment, since the coal-tar derivatives penetrate the shingles better than ordinary paint and do not leave ridges below the base of the shingles. At least two coats should be applied. Dipping the individual shingles gives good results. The best results, however, are obtained by heating and cooling the wood in the preservative, as described for the treatment of fence posts.

Suggestions for community action (Willis).

It is often difficult for a farmer efficiently to treat his own material with preservatives. This, however, does not indicate that the work should be neglected. Rather it points to some different means of securing the desired result.

There are two practical methods of doing this. One is for some individual to undertake the work for the neighborhood. A small wood-preserving plant could be profitably operated in connection with a threshing outfit, a feed mill, or sawmill. The other plan is for several farmers to coöperate in establishing and operating the plant. As an indication of the success which should attend such an undertaking, the coöperative creameries of various sections of the country may be cited.

Board Measure

Board measure is designed primarily for the measurement of sawed lumber. The unit is the board foot, which is a board one inch thick and one foot square, so that with inch boards the content in board measure is the same as the number of square feet of surface; with lumber of other thicknesses the content is expressed in terms of inch boards.

Lumber is always sold on a basis of 1000 feet board measure, the abbreviation for which is B.M., and for thousand is M. Thus, 500 feet B.M., costing \$18 per thousand, would be \$9; 100 feet B.M., \$1.80; 10 feet B.M., 18 cents.

At \$10 per M., B.M., lumber costs 1¢ per square foot; at \$12, 1.2¢ square foot; at \$14, 1.4¢; at \$15, 1½¢; at \$17, 1.7¢; at \$20, 2¢ square

foot. At \$9 M., 1 sq. ft. is $\frac{9}{10}\phi$; at \$8, $\frac{8}{10}\phi$. Multiply the number of square feet B.M. by the price per square foot.

To find the B.M., multiply the length in feet by the thickness and width in inches, and divide the product by 12. Thus, a plank 18 ft. long, 2 in. thick, and 8 in. wide contains $\frac{18 \times 2 \times 8}{12} = 24$ ft. B. M.

Or, the length of the plank in inches may be multiplied by the end area in square inches, and the result divided by 144. For example, the number of feet B. M. in a piece 18 ft. long, 2 in. thick, and 8 in. wide, will be 216 in. (18 ft. \times 12) multiplied by 16 sq. in. (2×8 , the end area), or 3456 sq. in., 1 in. thick; dividing by 144, the result is 24 ft. B.M.

Cord Measure (The Woodsman's Handbook, U. S. Forest Service)

Firewood, small pulp-wood, and material cut into short sticks for excelsior, etc., is usually measured by the cord. A cord is 128 cubic feet of stacked wood. The wood is usually cut into 4-foot lengths, in which case a cord is a stack 4 feet high and wide, and 8 feet long. Sometimes, however, pulp-wood is cut 5 feet long, and a stack of it 4 feet high, 5 feet wide, and 8 feet long is considered 1 cord. In this case the cord contains 160 cubic feet of stacked wood. Where firewood is cut in 5-foot lengths, a cord is a stack 4 feet high and $6\frac{1}{2}$ feet long, and contains 130 cubic feet of stacked wood. Where it is desirable to use shorter lengths for special purposes, the sticks are often cut $1\frac{1}{2}$, 2, or 3 feet long. A stack of such wood, 4 feet high and 8 feet long, is considered 1 cord, but the price is always made to conform to the shortness of the measure.

A cord foot is one-eighth of a cord, and is equivalent to a stack of 4-foot wood 4 feet high and 1 foot wide. Farmers frequently speak of a foot of cord wood, meaning a cord foot. By the expression "surface foot" is meant the number of square feet measured on the side of a stack.

In some localities, particularly in New England, cord-wood is measured by means of calipers. Instead of stacking the wood and computing the cords in the ordinary way, the average diameter of each log is determined with calipers and the number of cords obtained by consulting a table which gives the amount of wood in logs of different diameters and lengths.

Log Measure (The Woodsman's Handbook)

In the United States and Canada logs are most commonly measured in board feet. In small transactions standing timber is often sold by the lot or for a specified amount per acre. Standing trees which are to be used for lumber are occasionally sold by the piece. Hoop poles and other small wood are sold by the hundred or thousand. Ties and poles are sold by the piece; piles and mine props by the piece or by linear feet, the price varying in piece sales according to specifications as to diameter, length, and grade.

Firewood and wood cut into short bolts, as for small pulp-wood, excelsior-wood, spool-wood, novelty-wood, and heading, is ordinarily measured in cords.

In certain sections of the East it has been the custom to use a standard log as a unit of measure. In the Adirondacks a common unit of measure is the 19-inch standard, or, as it is often called, the "market." In this case the standard log is 19 inches in diameter at the small end inside the bark and 13 feet long. In New Hampshire the Blodgett standard is in common use. This unit is a cylinder 16 inches in diameter and 1 foot long. There were formerly other standards in use, such as the 24-inch standard once used in New England, and the 22-inch standard in use in certain parts of Canada and northern New York. The standard measure is decreasing in use.

The cubic foot is the best unit for measuring the volume of logs. It has gained a foothold in this country, and will unquestionably be the unit of the future. Even now, red-cedar pencil-wood, wagon stock, and other valuable hardwood material is occasionally sold by the cubic foot in certain sections of the East. The unit is used by a few companies in Maine for measuring pulp-wood. A special commission on the measurement of logs has recently recommended to the legislature of Maine that the cubic foot be adopted as a statute unit of measurement.

The cubic foot has for a long time been used for the measurement of square timber. Round logs are often measured in terms of cubic feet, but the plan is to determine the contents of the square which can be cut from the log, rather than the full contents, including slabs. The cubic foot is in common use in the measurement of precious woods which are imported from the tropics.

In continental Europe and the Philippine Islands, the cubic meter has been established as the standard unit for the measuring of logs and timber.

In recent years, board measure has also been used as a unit of volume for logs. When so applied, the measure does not show the entire content of the log, but the quantity of lumber which, it is estimated, may be manufactured from it. The number of board feet in any given log is determined from a table that shows the estimated number which can be taken out from logs of different diameters and lengths. Such a table is called a log scale or log rule, and is compiled by reducing the dimensions of perfect logs of different sizes, to allow for waste in manufacture, and then calculating the number of inch boards which remain in the log.

The amount of lumber that can be cut from logs of a given size is not uniform, because the factors which determine the amount of waste vary under different circumstances, such as the thickness of the saw, the thickness of the boards, the width of the smallest board which may be utilized, the skill of the sawyer, the efficiency of the machinery, the defects in the log, the amount of taper, and the shrinkage. This lack of uniformity has led to wide differences of opinion as to how log rules should be constructed. There have been many attempts to devise a log rule which can be used as a standard, but none of them will meet all conditions. The rules in existence have been so unsatisfactory that constant attempts have been made to improve upon them. As a result there are now actually in use in the United States 40 or 50 different log rules, whose results differ in some cases as much as 120 per cent for 20-inch to 30-inch logs and 600 per cent for 6-inch logs. Some of these are constructed from mathematical formulæ; some by preparing diagrams that represent the top of a log and then determining the amount of waste in sawdust and slabs; some are based on actual averages of logs cut at the mill; while still others are the result of making corrections in an existing rule to meet special local conditions.

The large number of log rules, the differences in their values, and the variation in the methods of their application have led to much confusion and inconvenience. Efforts to reach an agreement among lumbermen on a single standard log rule have failed so far. A number of states have given official sanction to specific rules; but this has only added to the confusion, because the states have not chosen the same rule, so

there are six different state log rules, and, in addition, three different official log rules in Canada. It is probable that a standard method of measuring logs will not be worked out satisfactorily until a single unit of volume, like the cubic foot, is adopted for the measurement of logs.

The Forest Service of the United States Department of Agriculture has adopted the Scribner Decimal Rule for timber sales on the National Forests. It has been in use for about four years, and, in the main, has proved satisfactory, since competitive bids enable the buyer to bid higher if the character of the logs indicates a mill overrun.

Scribner decimal log rule

The total scale is obtained by multiplying the figures in this table by 10. Thus the contents of a 6-inch 8-foot log are given as 0.5, so the total scale is 5 board feet. A 30-inch 16-foot log is given as 66, or a total scale of 660 board feet.

DIAMETER	LENGTH (FEET)						DIAMETER	LENGTH (FEET)					
	6	8	10	12	14	16		6	8	10	12	14	16
<i>In.</i>	<i>Bd. ft.</i>	<i>Bd. ft.</i>	<i>Bd. ft.</i>	<i>Bd. ft.</i>	<i>Bd. ft.</i>	<i>Bd. ft.</i>	<i>In.</i>	<i>Bd. ft.</i>	<i>Bd. ft.</i>	<i>Bd. ft.</i>	<i>Bd. ft.</i>	<i>Bd. ft.</i>	<i>Bd. ft.</i>
6	0.5	0.5	1	1	1	2	42	50	67	84	101	117	134
9	1	2	3	3	3	4	44	56	74	93	111	129	148
10	2	3	3	3	4	6	48	65	86	108	130	151	173
12	3	4	5	6	7	8	50	70	94	117	140	164	187
15	5	7	9	11	12	14	54	82	109	137	164	191	218
18	8	11	13	16	19	21	56	88	118	147	176	206	235
20	11	14	17	21	24	28	60	101	135	169	203	237	270
22	13	17	21	25	29	33	65	119	159	199	239	279	319
24	15	21	25	30	35	40	70	139	186	232	279	325	372
26	19	25	31	37	44	50	75	161	215	269	323	377	430
28	22	29	36	44	51	58	80	185	247	309	371	432	494
30	25	33	41	49	57	66	85	210	281	351	421	491	561
33	29	39	49	59	69	78	90	236	315	393	472	551	629
36	35	46	58	69	81	92	95	262	350	437	525	612	700
40	45	60	75	90	105	120	100	289	386	482	579	675	772

U. S. Forest Service Log-Scaling Directions

Unless timber is sold on the basis of an estimate, it must be scaled, counted, or measured before it is removed from the cutting area, or from the place agreed upon for the scaling, the counting, or the measuring.

All saw timber will be scaled by the Scribner Decimal log rule. This rule drops the units and gives the contents of a log to the nearest ten. When the total scale of a log is desired, all that is necessary is to add one cipher to the sum of the numbers read from the scale stick, excepting the contents of 6 and 8 foot logs, 6 and 7 inches in diameter. These are given as 0.5, which, multiplied by 10, gives 5 feet as the actual contents.

In the absence of a scale stick, or where the position of logs in the pile makes its use difficult, the diameters and lengths may be tallied and the contents figured from a scale table later.

Purchasers should be required to skid logs for scaling, if the cost of scaling will be materially decreased by these requirements and if the cost of logging will not be greatly increased.

The forest officer should always insist on having one end of piles or skidways even, so that ends of logs may be easily reached.

When necessary and possible, the purchaser will be required to mark top ends of logs to avoid question when they are scaled in the pile.

Each log scaled must be numbered with crayon. The number will be the same as that opposite which the scale of the log is recorded in the scale book.

The logs in all skidways must be counted, and the number in each checked with the entries in the scale book.

Each merchantable log after scaling will be stamped "U.S." on at least one end. Logs so defective as to be unmerchantable will not be stamped, but will be marked "cull."

On all national forests except those in Alaska and on the west slope of the Cascade Mountains in Washington and Oregon, logs over 16 feet long will be scaled as two or more logs, if possible in lengths not less than 12 feet.

The following table shows how the lengths will be divided when scaling logs 18 to 60 feet long. The number of inches to be added to the diameter at the small end of each log, to cover taper, is placed under each length.

For example, a 42-foot log 16 inches in diameter at the top would be scaled as —

One 12-foot log with a diameter of 16 inches.

One 14-foot log with a diameter of 17 inches.

One 16-foot log with a diameter of 19 inches.

Allowances for taper in logs

This table is intended to be used simply as a guide. The allowances for taper should be varied to conform to the actual taper

TOTAL LENGTH		LOG LENGTH				TOTAL LENGTH		LOG LENGTH			
Feet	Butt Log	Sec-ond Log	Third Log	Top Log	Feet	Butt Log	Sec-ond Log	Third Log	Top Log		
18	10'	—	—	8'	40	16'	12'	—	12'		
Increase	1"	—	—	0"	Increase	3"	1"	—	0"		
20	10'	—	—	10'	42	16'	14'	—	12'		
Increase	1"	—	—	0"	Increase	3"	1"	—	0"		
22	12'	—	—	10'	44	16'	16'	—	12'		
Increase	1"	—	—	0"	Increase	3"	1"	—	0"		
24	14'	—	—	10'	46	16'	16'	—	14'		
Increase	1"	—	—	0"	Increase	4"	2"	—	0"		
26	14'	—	—	12'	48	16'	16'	—	16'		
Increase	1"	—	—	0"	Increase	4"	2"	—	0"		
28	14'	—	—	14'	50	14'	12'	12'	12'		
Increase	2"	—	—	0"	Increase	4"	3"	1"	0"		
30	16'	—	—	14'	52	16'	12'	12'	12'		
Increase	2"	—	—	0"	Increase	4"	3"	1"	0"		
32	16'	—	—	16'	54	16'	14'	12'	12'		
Increase	2"	—	—	0"	Increase	5"	3"	1"	0"		
34	12'	12'	—	10'	56	16'	16'	12'	12'		
Increase	3"	1"	—	0"	Increase	5"	3"	1"	0"		
36	12'	12'	—	12'	58	16'	16'	14'	12'		
Increase	3"	1"	—	0"	Increase	5"	3"	2"	0"		
38	14'	12'	—	12'	60	16'	16'	14'	14'		
Increase	3"	1"	—	0"	Increase	5"	3"	2"	0"		

Cubic Log Measure (The Woodsman's Handbook)

A cubic unit, either the cubic foot or cubic meter, ultimately will be in common use for the commercial measurement of timber. This will come about with the increase of the value of timber. When the whole log, including slabs, can be used, the owner cannot afford to sell his logs purely on a basis of an estimated product in manufactured boards. If logs are bought according to their solid contents, though they may not cost more, yet the buyer will feel that he pays for the material he wastes, and therefore will be more eager to utilize it.

There are a number of methods of determining the solid contents of logs in cubic feet. The two methods in most common use for commercial work are given in this book. Other methods, designed for scientific work, are discussed at length in treatises on forest mensuration.

Method of cubing logs by the measurement of the length and of the middle diameters.

To cube logs, one method requires the measurement of the average diameter of the log at its middle point and the length. The volume of the log is obtained by multiplying the area of the circle corresponding to the middle diameter of the log by the length:—

$$V = B_{\frac{1}{2}} \times L,$$

in which V is the volume of the log in cubic feet, $B_{\frac{1}{2}}$ the area of the middle cross section in square feet, and L the length in feet.

Example: Suppose a log to have a middle diameter of 15 inches and a length of 30 feet. One finds in a table of areas of circles (giving the diameter in inches and the area in square feet) the area corresponding to 15 inches, namely, 1.227; then $V = 1.227 \times 30 = 36.8$ cubic feet.

This method is very simple, because it requires only two measurements of the log — the diameter at the middle and the length. Tables showing the areas of circles in these units are readily accessible, and also tables showing the cubic contents of logs of different middle diameters and lengths, so that there is no computation necessary.

Method of cubing logs by measurement of the length and end diameters.

By this method the diameters of the two ends of the log and its length are measured. The volume is obtained by multiplying the average of the areas of circles that correspond to end diameters by the length:—

$$V = \frac{B + b}{2} L,$$

in which V is the volume of the log in cubic feet, B and b are the areas in square feet that correspond to the diameters of the two ends, and L is the length in feet.

Example: A log is 12 feet long, and the diameters at the ends are 16 and 18 inches. The areas that correspond to the end diameters are found in a table of circular areas, and used in the formula, as follows:—

$$V = \frac{1.396 + 1.767}{2} \times 12 = 18.97 \text{ cu. ft.}$$

This method requires one more measurement than the previous, and is therefore not as rapid for ordinary work in commercial scaling. It is, however, a very convenient formula for determining the contents of logs where it is not possible to take the measurement at the middle, as on logs piled on a skidway.

Solid cubic contents of logs (in cubic feet)

LENGTH IN FEET	AVERAGE DIAMETER IN INCHES													
	6	8	10	12	15	18	20	24	30	33	36	40	44	48
10	1.96	3.49	5.45	7.85	12.27	17.67	21.82	31.42	49.09	59.40	70.69	87.3	105.6	125.7
11	2.16	3.84	6.00	8.64	13.50	19.44	24.00	34.56	54.00	65.34	77.75	96.0	116.2	138.2
12	2.36	4.19	6.55	9.42	14.73	21.21	26.18	37.70	58.90	71.27	84.82	104.7	126.7	150.8
13	2.55	4.54	7.09	10.21	15.95	22.97	28.36	40.84	63.81	77.21	91.89	113.4	137.3	163.4
14	2.75	4.89	7.61	11.00	17.18	24.74	30.54	43.98	68.72	83.15	98.96	122.2	147.8	175.9
15	2.95	5.24	8.18	11.78	18.41	26.51	32.72	47.12	73.63	89.09	106.03	130.9	158.4	188.5
16	3.14	5.59	8.73	12.57	19.63	28.27	34.91	50.27	78.54	95.03	113.10	139.6	168.9	201.1
17	3.34	5.93	9.27	13.35	20.86	30.04	37.09	53.41	83.45	100.97	120.17	148.4	179.5	213.6
18	3.53	6.28	9.82	14.14	22.09	31.81	39.27	56.55	88.36	106.91	127.32	157.1	190.1	226.2
19	3.73	6.63	10.36	14.92	23.32	33.58	41.45	59.69	93.27	112.85	134.30	165.8	200.6	238.8
20	3.93	6.98	10.91	15.71	24.54	35.34	43.63	62.83	98.17	118.79	141.37	174.5	211.2	251.3
21	4.12	7.33	11.45	16.49	25.77	37.11	45.82	65.97	103.08	124.73	148.44	188.3	221.7	263.9
22	4.32	7.68	12.00	17.28	27.00	38.88	48.00	69.11	107.99	130.67	155.51	192.0	232.3	276.5
23	4.52	8.03	12.54	18.06	28.23	40.64	50.18	72.26	112.90	136.61	162.58	200.7	242.9	289.0
24	4.71	8.38	13.09	18.85	29.45	42.41	52.36	75.40	117.81	142.55	169.65	209.4	253.4	301.6
25	4.91	8.73	13.64	19.64	30.68	44.18	54.54	78.54	122.72	148.49	176.71	218.2	264.0	314.2
26	5.11	9.08	14.18	20.42	31.91	45.95	56.72	81.68	127.63	154.43	183.78	226.9	274.5	326.7
27	5.30	9.42	14.73	21.21	33.13	47.71	58.90	84.82	132.54	160.37	190.85	235.6	285.1	339.3
28	5.50	9.77	15.27	21.99	34.36	49.48	61.09	87.96	137.44	166.31	197.92	244.3	295.7	351.9
29	5.69	10.12	15.82	22.78	35.59	51.25	63.27	91.11	142.35	172.25	204.99	253.1	306.2	364.4
30	5.89	10.47	16.36	23.56	36.82	53.01	65.45	94.25	147.26	178.19	212.06	261.8	316.8	377.0
31	6.09	10.82	16.91	24.35	38.04	54.78	67.63	97.39	152.17	184.13	219.13	270.5	327.3	389.6
32	6.28	11.17	17.45	25.13	39.27	56.55	69.81	100.53	157.08	190.07	226.19	279.3	337.9	402.1
33	6.48	11.52	18.00	25.92	40.50	58.32	71.99	103.67	161.99	196.01	233.26	288.0	348.5	414.7
34	6.68	11.87	18.54	26.70	41.72	60.08	74.18	106.81	166.90	201.95	240.33	296.7	359.0	427.3
35	6.87	12.22	19.09	27.49	42.95	61.85	76.36	109.96	171.81	207.88	247.40	305.4	369.6	439.8
36	7.07	12.57	19.64	28.27	44.18	63.62	78.54	113.10	176.71	213.82	254.47	314.2	380.1	452.4
37	7.26	12.92	20.18	29.06	45.41	65.38	80.72	116.24	181.62	219.76	261.54	322.9	390.7	465.0
38	7.46	13.26	20.73	29.85	46.63	67.15	82.90	119.38	186.53	225.70	268.61	331.6	401.2	477.5
39	7.66	13.61	21.27	30.63	47.86	68.92	85.08	122.52	191.44	231.64	275.67	340.3	411.8	490.1
40	7.85	13.96	21.82	31.42	49.09	70.63	87.27	125.66	196.35	237.58	282.74	349.1	422.4	502.7

Cubic Contents of Square Timber in Round Logs (Woodsmen's Handbook)

The most common methods of determining the cubic contents of square timber that may be cut from round logs is the so-called Two-thirds Rule, and the Inscribed Square Rule.

The two-thirds rule.

In the Two-thirds Rule the diameter of the log is taken at its middle point, or the diameters of the two ends of the log are averaged. The diameter of the log is reduced one-third to allow for slab, and the remaining two-thirds is taken as the width of the square piece which may be hewed or sawed out of the log. The cubic contents of the squared log are then obtained by squaring this width and multiplying by the length of the log.

Square timber cut from round logs (in cubic feet)

(Inscribed-Square Rule)

LENGTH IN FEET	AVERAGE DIAMETER IN INCHES									
	6	8	10	12	18	20	24	30	33	36
10	1.3	2.2	3.5	5	11.3	13.9	20	31.8	37.8	45
12	1.5	2.7	4.2	6	13.5	16.7	24	38.1	45.4	54
14	1.8	3.1	4.9	7	15.8	19.4	28	44.5	52.9	63
16	2.0	3.6	5.6	8	18.0	22.2	32	50.8	60.5	72
18	2.3	4.0	6.2	9	20.3	25.0	36	57.2	68.1	81
20	2.5	4.4	7.0	10	22.5	27.8	40	63.5	75.6	90
22	2.8	4.9	7.6	11	24.8	30.1	44	69.9	83.2	99
24	3.0	5.3	8.3	12	27.0	33.3	48	76.2	90.8	108
26	3.3	5.8	9.0	13	29.3	36.1	52	82.6	98.3	117
28	3.5	6.2	9.7	14	31.5	38.9	56	88.9	105.9	126
30	3.8	6.7	10.4	15	33.8	41.7	60	95.3	113.5	135
32	4.0	7.1	11.1	16	36.0	44.4	64	101.6	121.0	144
34	4.3	7.5	11.8	17	38.3	47.2	68	108.0	128.6	153
36	4.5	8.0	12.5	18	40.2	50.0	72	114.3	136.2	162
38	4.8	8.4	13.2	19	42.8	52.8	76	120.7	143.7	171
40	5.0	8.9	13.9	20	45.0	55.6	80	127.0	151.3	180
42	5.3	9.3	14.6	21	47.3	58.3	84	133.4	158.8	189
44	5.5	9.8	15.3	22	49.5	61.1	88	139.7	166.4	198
46	5.8	10.2	16.0	23	51.8	63.9	92	146.1	174.0	207
48	6.0	10.7	16.6	24	54.0	66.7	96	152.4	181.5	216
50	6.3	11.1	17.4	25	56.3	69.5	100	158.8	189.1	225
52	6.5	11.5	18.0	26	58.5	72.2	104	165.1	196.7	234
54	6.8	12.0	18.7	27	60.8	75.0	108	171.2	204.2	243
56	7.0	12.4	19.4	28	63.0	77.8	112	177.8	211.8	252
58	7.3	12.9	20.1	29	65.3	80.6	116	184.2	219.4	261
60	7.5	13.3	20.8	30	67.5	83.3	120	190.5	226.9	270
62	7.8	13.8	21.5	31	69.8	86.1	124	196.9	234.5	279
64	8.0	14.2	22.2	32	72.0	89.9	128	203.2	242.0	288
66	8.3	14.7	22.9	33	74.3	91.7	132	209.6	249.6	297
68	8.5	15.1	23.6	34	76.5	94.5	136	215.9	257.2	306
70	8.8	15.5	24.3	35	78.8	97.2	140	222.3	264.7	315
72	9.0	16.0	25.0	36	81.0	100.0	144	228.6	272.3	324
74	9.3	16.4	25.7	37	83.3	102.8	148	235.0	279.9	333
76	9.5	16.9	26.4	38	85.5	105.6	152	241.3	287.4	342

The inscribed-square rule.

The Inscribed-Square Rule gives the cubic contents of square pieces which can be exactly inscribed in cylinders of different sizes. The width of this square piece is usually obtained by multiplying the diameter of the cylinder by 17 and dividing the result by 24, or by multiplying the diameter by 0.7071. This rule of thumb for calculating the width of the inscribed square piece is based on the fact that one side of the square inscribed in a circle 24 inches in diameter is 17 inches long.

The exact mathematical rule for determining the side of a square inscribed in a circle is to square the diameter, divide by 2, and extract the square root. The table on the preceding page was computed by this method.

Practically the same results are obtained by the Seventeen-inch Rule, which is based on the fact that a 17-inch log will square 12 inches. According to the Seventeen-inch Rule, the cubic contents of a log are obtained as follows: Multiply the square of the diameter of the log by its length, and divide by the square of 17.

CHAPTER XIII

WEEDS

A WEED is a plant that is not wanted. The methods of weed-control depend largely on the character of soil, system of farming practiced in the neighborhood, and, particularly, on the type of weed concerned, whether annual, biennial, or perennial. The better the crop-scheme, the less will be the difficulty from bad weeds. The prime remedy, therefore, is to improve the general farm plan and practice, and to use only clean seed. Special means and methods may be discussed, however; and these discussions are drawn from Farmers' Bulletins of the United States Department of Agriculture, from bulletins of the Rhode Island, Ohio, and North Dakota Stations, Cyclopedia of American Agriculture, and other sources.

General Practices

For *annual weeds*, which reproduce from seed only, the root and branch dying each year, the essentials for eradication are the use of clean seed, the killing of plants before they ripen seeds, and the prevention of new infestation by such means as manure from stables where weed forage has been used. For permanent pastures, lawns, and roadsides the prevention of seed production is often the most practicable method, and it is sufficient if persistently followed. In cultivated fields the land thus seeded may first be burned over to destroy as many as possible of the seeds on the surface. It may then be plowed shallow, so as not to bury the remaining seeds too deeply. The succeeding cultivation, not deeper than the plowing, will induce the germination of seeds in this layer of soil and kill the seedlings as they appear. The land may then be plowed deeper, and the tillage repeated until the weed seeds are cleared out to as great a depth as the plow ever reaches. Below that depth, eight to ten inches, very few weed seeds can germinate and push a shoot to the surface. Barren summer-

fallowing is often practiced to clear out weedy land by the method just described; but usually a cultivated crop may better be grown.

For biennials, which also reproduce from seed, mowing them when coming into flower or cutting the roots below the crown is usually effective. Autumn is the best time for such grubbing. Biennial weeds are readily killed by such tillage as is given to hoed crops.

For perennials which reproduce both from seed and from surface runners or perennial underground roots or stems, seed production must be prevented and the underground part must be killed. Seed production may be prevented by mowing when the first flower-buds appear. The best methods for killing the roots or rootstocks vary considerably according to the soil, climate, character of the different weeds, and the size of the patch or the quantity to be killed. In general, however, the following principles apply:—

1. The roots, rootstocks, bulbs, and the like, may be dug up and removed, a remedy that can be practically applied only in small areas.

2. Salt, coal oil, or strong acid applied so as to come in contact with the freshly cut roots or rootstocks destroys them for some distance from the point of contact. Crude sulfuric acid is probably the most effective of comparatively inexpensive materials that can be used for this purpose, but its strong corrosive properties render it dangerous to handle. Carbolic acid is less corrosive, and nearly as effective. Arsenite of soda and arsenate of soda, dangerous poisons, are effective, particularly the former, applied as a spray on the growing weeds. Fuel-distillate, a petroleum product, is very promising.

3. Roots may be starved to death by preventing any development of green leaves or other parts above ground. This may be effected by building straw stacks over small patches, by persistent, thorough cultivation in fields, by the use of the hoe or spud in waste places, and by salting the plants and turning on sheep in permanent pastures.

4. The plants may usually be smothered by dense sod-forming grasses or by a crop like hemp, buckwheat, clover, cowpeas, or millet that will exclude the light.

5. Most roots are readily destroyed by exposing them to the direct action of the sun during the summer drought, or to the direct action of the frost in winter. In this way plowing, for example, becomes effective.

6. Proper crop rotation is one of the best means of eradication.

Chemical Weed-Killers or Herbicides

The usefulness of chemicals as weed-killers is largely limited to the following cases (Jones):—

1. When an especially obnoxious weed, as poison ivy, occurs in a limited locality and is to be destroyed regardless of consequences to soil or neighboring plants.

2. When the aim is to render the soil permanently sterile, as in roadways, tennis courts, and the like.

3. When the weed plant, as orange hawkweed and mustard, is much more sensitive than the associated useful plants to the action of some herbicide.

Kinds of herbicides (L. R. Jones).

The chemicals used as herbicides, the worth of which has been established, are the following:—

Salt (sodium chlorid), is more commonly used than any other compound, chiefly because of cheapness and handiness. It should be applied dry or in strong solution; and it is most effective in hot, dry weather. Salt can be used in any weed-killing operation, but it is most valuable on roadways and like surfaces and for certain lawn weeds. Hot brine (one pound salt to one gallon water) is useful on walks and roadways.

Blue vitriol (copper sulfate).—This is more powerful in herbicidal action than salt, but its cost prohibits its general use. For most purposes it is best used in solution, 2 to 10 per cent being effective. It is often used on gravel walks and similar surfaces, but salt will generally be found cheaper and arsenical poisons more effective. Its chief value is against charlock or mustard.

Copper sulfate solution, containing 8 to 10 pounds of blue vitriol to 50 gallons of water, and applied at the rate of 40 to 50 gallons per acre, is a good formula.

Iron sulfate (copperas) solution, containing $1\frac{1}{2}$ to 2 pounds of iron sulfate to the gallon of water (100 pounds iron sulfate to 52 gallons of water), is a good herbicide. Use at the rate of 50 to 75 gallons per acre.

Kerosene.—This and other coal-oil products will kill plants. It is weak in efficiency, and relatively more costly than any other chemical

here listed. A pint of crude carbolic acid will do better service than two gallons of kerosene, and costs much less.

Carbolic acid. — This is one of the quickest and most valuable herbicides. The crude acid is relatively cheap. It is not quite equal to the arsenical poisons for penetrating the soil, or in lasting effects, but it is often preferable because of cost or convenience. It does not corrode metals, and therefore may be applied with any spray-can or pump. An effective method is to squirt the strong acid from an ordinary oil can on the roots or crown of individual weeds. If it is to be sprayed or sprinkled broadcast on the foliage or ground, it should be diluted with 15 to 30 parts of water, and this mixture agitated frequently during use.

Sulfuric acid (oil of vitriol). — This is destructive to everything it touches. It can be applied in the crown or about the roots of coarse or especially hardy plants, provided the user is willing to kill the adjacent vegetation also. In general, carbolic acid will be preferred, partly because sulfuric acid can be handled only in glass vessels.

Caustic soda. — A strong solution of this material makes a cheap and effective herbicide, commended especially for pouring on soil where it is desired to destroy poison ivy or other deep-rooted or woody plants. Soil so treated will be rendered sterile for some time, but the soda will gradually leach away. Like salt, this is most effective if applied in hot, dry weather.

Arsenical compounds. — One or another of the soluble arsenical compounds form the most effective herbicides known, to use on roadways and other plain surfaces. These form the basis of all, or nearly all, of the various proprietary "herbicides" or "weed-killers." The simplest to employ is arsenite of soda. This needs only to be dissolved in water for use, the rate of 1 pound in 3 to 9 gallons of water. White arsenic is still cheaper, but according to Schutt's formula it must be combined with sal soda, which is somewhat bothersome. (White arsenic, 1 pound; washing soda, 2 pounds; water, 3 to 9 gallons.) An important characteristic of these arsenical poisons is that they endure for a long time and do not readily wash or leach away.

Application of Herbicides

Gravel roadways, gutters, tennis courts, walks, and like surfaces can be kept free from weedy growths by the application of any of the above.

If salt is used, it should be scattered freely in the dry form. Caution is necessary where it is liable to be washed on to lawns, lest it damage the grass borders. Carbolic acid or arsenical poisons are preferable, being both less liable to wash and more enduring in their action. One quart of crude carbolic acid in eight gallons of water, or one pound of either arsenical compound mentioned above in a like amount of water, will suffice to cover a square rod or more of surface; and one or at most two applications per year will be sufficient.

Walks should be so made that weeds cannot grow in them. This can be done by making a deep stone foundation and filling between the stones with cinders, coal ashes, or other similar material.

List of weeds that may be controlled by means of chemical sprays.

The following named weeds may be eradicated or largely subdued in cereal grain fields through the use of chemical sprays: False-flax, worm-seed mustard, tumbling mustard, common wild mustard, Shepherd's purse, pepper-grass, ball-mustard, corn cockle, chickweed, dandelion, Canada thistle, bindweed, plantain, rough pigweed, king-head, Red River weed, ragweed, cocklebur.

Weeds on which field spraying methods as now in use are not effective.

The following weeds are not effectively controlled by chemical sprays as now used: Hare's ear mustard, French weed, pink cockle, perennial sow-thistle, lamb's-quarters, pigeon-grass, wild oats, chess, quack-grass, sweet-grass, or holy-grass, and wild barley.

Results of spraying with iron sulfate for the control of weeds (Rhode Island Sta.)

PLANT		EFFECT
Common Name	Botanical Name	
Yellow dock	Rumex crispus	Plants checked for about three weeks.
Sheep sorrel	Rumex Acetosella	All blossoms killed and 90 per cent of all leaf growth. Killed. Can be controlled.
Common chickweed .	Stellaria media	Practically killed, but not so easily as the common chickweed.
Mouse-ear chickweed .	Cerastium vulgatum	
Purslane	Portulaca oleracea	Young leaves and tips of stems killed. Old growth not injured.

Results of spraying with iron sulfate—Continued

PLANT		EFFECT
Common Name	Botanical Name	
Buttercup	Ranunculus bulbosus	Killed.
Shepherd's purse . . .	Capsella Bursa-pastoris	Completely controlled.
Five-finger	Potentilla Canadensis	Young plants killed, old plants seriously injured.
Poison ivy	Rhus Toxicodendron	Not injured when sprayed with concentrated solution.
Wild carrot	Daucus Carota	Only slightly injured.
Common plantain . . .	Plantago major	Leaves badly spotted, plant not killed.
Rib grass, narrow-leaved plantain . . .	Plantago lanceolata	Young plants killed, old ones prevented from maturing seeds.
Robins plantain	Erigeron pulchellus	Blossom buds killed, no seed formed.
Yarrow	Achillea Millefolium	Practically no injury.

With the exception of the application to the poison ivy, the iron sulfate was applied as a 20 per cent solution, using it at the rate of 100 to 150 pounds per acre.

At the *South Dakota Station* the following weeds were entirely killed by the use of *iron sulfate*:—

Wild mustard (*Brassica arvensis*); ragweed (*Ambrosia artemisefolia*); king-head or greater ragweed (*Ambrosia trifida*); bindweed (*Convolvulus Sepium*); marsh elder (*Iva xanthifolia*); milkweed (*Asclepias* sp.); pepper-grass (*Lepidium Virginicum*); pigweed (*Amarantus* sp.); sweet clover (*Melilotus alba* and *M. officinalis*). Those that were more or less badly injured: Russian thistle (*Salsola Kali*); sunflower (*Helianthus* sp.); dandelion; dock (*Rumex crispus*); thistle (*Carduus* sp.); white clover (*Trifolium repens*); red clover (*Trifolium pratense*); alfalfa (*Medicago sativa*). The following were but slightly injured: plantain (*Plantago major*); sheep sorrel (*Oxalis violacea*); prairie rose; lamb's quarters (*Chenopodium album*). Grasses in general, including the grains (wheat, oats, corn, barley, and speltz were sprayed in our experiments) were none of them seriously injured.

According to the *Ohio Station*, salt has thus far proved the best spray tested for Canada thistle, poison ivy, yarrow, and horse-nettle. In the

Northwest, *sodium arsenite* (1½ pounds sodium arsenite in 50 gallons water) is given first rank. Salt is probably the most effective to destroy dandelion and some other weeds. *Iron sulfate* is very satisfactory to kill mustard weeds, ragweed, white-top, yarrow, and we believe a great many other broad-leaved weeds. Neither the salt nor the iron sulfate is regarded as offering any risk of application to pastures in which stock is running. Sodium arsenite is a very active poison, and rather dangerous for that reason. *Calcium chlorid* (of same strength as common salt solution) has done very well where tested, but appears to be slightly inferior to salt. *Copper sulfate* solutions may be used in grain fields for mustards, especially, but owing to the poisonous nature of the copper sulfate, it has a very narrow range of application.

Experiments by the *Cornell Station* gave the following general conclusions: Wild mustard growing with cereals or peas can be destroyed with a solution of *copper sulfate*, without injury to the crop. A 3 per cent solution (about 10 pounds to the barrel, or 40 gallons of water), at the rate of 40 to 50 gallons per acre, gives very satisfactory results.

The following notes on the effect of the *copper sulfate* solution on different plants are from observations and reports from *various sources*:

“Plants reported killed by copper sulfate solutions: wild mustard, wild radish, wild barley, penny-grass (if young), shepherd’s purse, wild buckwheat, lamb’s quarters, ragweed, sow-thistle, hemp-nettle, bindweed, dock, dodder.

“Plants reported severely injured; curly dock, black bindweed, dandelion, sow-thistle, and senecio.

“Plants reported as not injured: wild rose, poppies, pigweed, spurge, corn-flower, field-thistles, chamomile, couch-grass, bent-grass, and horsetails.

“Crops that may safely be sprayed: all cereals, as wheat, rye, barley, and corn; the grasses; peas; sugar beets.

“Crops that are killed or severely injured by the copper sulfate solution: beans, potatoes, turnips, rape.”

Charlock, known also as kale or wild mustard (*Brassica Sinapistrum*), is easily destroyed in oat-, wheat-, or other grain-fields by spraying with a solution of 1 pound of copper sulfate in 4 to 6 gallons of water (2 to 3 per cent solution). A force pump should be used, supplied with fine

nozzles. The treatment is most effectively made when the grain is 3 to 6 inches tall, since at this stage the large charlock leaves spreading above the grain are easily covered by the spray. About one barrel of the solution (30 to 50 gallons) suffices to cover an acre and destroy the charlock, and this amount causes little or no damage to the grain. This same treatment is reported to be more or less effective against a variety of other common grain-field weeds. The wild turnip (*Brassica campestris*) and some allied cruciferous weeds are less easily killed because the spray does not adhere to their smooth leaves.

When to apply weed sprays (Ohio Station).

In practice, the time of applying sprays needs to be adjusted to the condition of the growing crop, and the relative development of the weeds to be killed. It seems probable that very early spraying will be less effective than spraying after the weeds have developed a fair supply of leaves. The first spraying should be made not later than the beginning of bloom. Repeated applications need to be made as often as a new supply of leaves is developed, provided the condition of the host crop permits this. In grain-fields, the best results will be obtained on practically all weeds, when only a single spraying is to be made, to apply the spray just as the crop is ready to occupy the land. With mustards, this will find some already in bloom. With ragweed, it is best to spray before the stems of the plants become hardened. With other weeds, of which these two are the type, as well as with these, it is often profitable to make an extra earlier spraying than that designated. For perennial sow-thistle, wild lettuce, and orange hawkweed, the spraying in grain-fields should precede the blooming of the plants, and in cases of bad infestation with perennial sow-thistle or the golden hawkweed, two sprayings should be made before the grain occupies the land. It is not clear just what can be done in the handling of bindweeds in grain-fields, but similar principles will apply. For spraying in timothy or other grass meadows to kill white-top, yarrow, self-heal, ox-eye daisy, and a number of meadow weeds, the principle is similar to that stated for grain-fields, namely, to spray thoroughly just before the grass begins heading out. This will be during late May and early June for Ohio.

In spraying pastures to check weeds, the maximum returns will usually come from a beginning application in late June or early July before many weeds are coming to bloom. After the initial application,

the spraying should be repeated as often as there is development of new foliage to a marked degree.

In general, better results are secured from applications made in cloudy weather, although any weather, except that followed by rain, is satisfactory.

Treatment for Particular Weeds

Poison ivy and similar woody-rooted pests can be eradicated by cutting off the tops in hot, dry weather in midsummer and pouring a saturated solution of caustic soda about the roots. The arsenical solutions mentioned above can be used, but are generally objectionable because they render the soil sterile for so long a period thereafter.

Prickly lettuce (*Lactuca Scariola*), called also milk-thistle, English thistle, and compass plant. Biennial or annual. Mow the plants repeatedly as they first begin to blossom. Thorough cultivation with a hoed crop is most effective. Mow and burn mature plants. Most frequently introduced as an impurity in clover, millet, and the heavier grass seeds.

Bracted plantain (*Plantago aristata*). Annual. Employ hand pulling and burning. If well established, a series of hoed crops may be necessary to eradicate. In permanent pasture, mow the plants as the seed stalks first appear.

Horse nettle (*Solanum Carolinense*). Perennial. Keep the plants mown to prevent seed production. To destroy the roots, practice clean cultivation and grubbing or spudding to prevent any development above ground. A thick growth of grain will weaken the roots. After the grain is cut, the land should be immediately plowed and harrowed repeatedly, and then sown to a winter crop. Then follow with a hoed crop.

Buffalo bur (*Solanum rostratum*). Annual; subdued by preventing seed production by mowing as often as the yellow blossoms appear.

Spiny amaranth (*Amarantus spinosus*). An annual, subdued by preventing seed production by thorough cultivation, mowing, or grubbing out the plant before the flower spikes develop. An intertilled crop followed by a winter crop will keep down the weed.

Spiny cocklebur (*Xanthium spinosum*). Annual; may be choked down by any quick-growing crop that will crowd and shade it. In permanent pastures and waste places mow the plants twice a year, in

August and September, or cut them out with hoe or spud in May and June.

Chondrilla (*Chondrilla juncea*). Biennial. Destroyed by cultivation and fertilizers to encourage the growth of desirable grasses.

Wild carrot (*Daucus Carota*). Biennial. In permanent pastures, mow persistently as the flowers appear. Cutting the roots well below the surface and hand pulling are effective. Thorough cultivation subdues it.

Wild oats (*Avena fatua*). Annual. Stir the land when it is warm and moist to cause the seeds to germinate, then cultivate to kill. Keep the ground occupied or stirred. Omit oats from the rotation. Plow shallow in late fall. In the spring, plow deep and summer fallow, keeping the ground clean. Plant to grain the next season without reploting. Then plow deep early the next fall. Then repeat the fallow, followed by grain two years later, again without reploting.

False flax (*Camelina sativa*). Annual. Omit winter wheat and rye from the rotation, and raise crops that will permit full cultivation. Hoed crops are best, as they induce the seeds to germinate. If well established in permanent pastures, plow and cultivate the land.

Mustard, Charlock (*Brassica Sinapistrum*). An annual, destroyed by early cultivation. Destroyed by spraying, when the plants are just beginning to bloom, with iron sulfate, copper sulfate, common salt, and sodium arsenite. Use 75-100 pounds of iron sulfate in 52 gallons of solution per acre; of copper sulfate, 12-15 pounds to each 52 gallons of water; common salt, $\frac{1}{3}$ barrel to each 52 gallons of water; sodium arsenite, 1 $\frac{1}{2}$ pounds to each 52 gallons of water. Spray after a rain, or in a wet season on a bright, still day.

King-head, Greater ragweed (*Ambrosia trifida*). Annual. Cultivate to cause seed germination a sufficient time before cropping to allow the killing of the weeds by a subsequent cultivation. If the weeds are large on summer fallow, plow them completely under or collect and burn. Spray, when the plants are tender, with common salt, copper sulfate, iron sulfate, or sodium arsenite at the same rate and strengths as for mustard, except that at least 100 pounds of iron sulfate should be used for each 52 gallons. Throw the spray forcibly.

Canada thistle (*Carduus arvensis*). Perennial. The plant should never be allowed to produce seeds, and the underground stems, which are usually 3 to 12 inches under ground, must be removed or starved

by covering with straw. Cutting the plants just before the budding period is destructive. To eradicate by cutting or cultivation no plant should be allowed to show green leaves for a period exceeding a few days. The most effective spray is sodium arsenite, $1\frac{1}{2}$ to 2 pounds per 52 gallons water; or common salt, $\frac{1}{3}$ to $\frac{1}{2}$ barrels to 52 gallons water; or copper sulfate, 15 pounds to 52 gallons water; or iron sulfate, 75 pounds to 52 gallons of water, sprayed on twice, one week apart. Spray just before the budding period. Spray again after the crop is harvested. Repeat the second year. Sodium arsenite is a very active poison, and must be used with care.

Dandelion (*Taraxacum officinale*). Perennial. Dig up with spud or strong knife. Keep lawn heavily seeded to crowd out the dandelion. Spray with iron sulfate, $1\frac{1}{2}$ to 2 pounds for each gallon of water. Spray two or three days after mowing lawn, and do not again mow until two or three days after spraying. Spray on bright, sunshiny days. Heavy wetting within two days after spraying destroys the weed-killing power. Spray at intervals of four to six weeks.

New York State Station (Geneva) reports, 1911, that spraying dandelions with iron sulfate was not successful. The second season of treatment the grass was considerably injured.

Sow-thistle (*Sonchus arvensis*). Perennial. Spraying is not effective. Practice bare cultivation for two seasons, allowing no green leaves to appear. On small patches, smother by covering with straw or manure. There are annual species of *Sonchus*.

Quack-grass (*Agropyron repens*). Perennial. In small patches, uproot in dry, hot weather and remove all underground stems. Cut off closely in July, and smother with straw or manure. In large areas, mow when in blossom, and break the sod shallow in mid-July. Back-set in mid-August slightly deeper than before. Disc and harrow throughout the fall, allowing no green leaves to show. Then plow deeply in late fall. Plant cultivated crop next season, and dig out every blade of grass. Or sow a heavy seeding of millet or other dense-growing annual forage late in May on a well-prepared seed bed. The drier the ground and the hotter the weather, the better the killing effect of cultivation.

White daisy, White-weed (*Chrysanthemum Leucanthemum*). Perennial. Plow up old infested meadows. Spray with iron sulfate at rate of 150 to 200 pounds per acre. Spray when blossom stalks

are just forming. Two or more years are required for eradication. (R. I. Sta.).

Black mustard (*Brassica nigra*) and *wild mustard* (*B. arvensis*). Annual. Spray with iron sulfate, 50 gallons to acre, using 75 to 100 pounds of iron sulfate, depending on whether the plants are tender and succulent or more mature and hardy.

Orange hawkweed (*Hieracium aurantiacum*), *chickweed* (*Stellaria media*), and some other of the shallow-rooted succulent weeds of lawns and grass lands can be combated effectively by the use of salt, more so than by any other chemical. Fine, dry salt should be applied on a bright, hot summer day (late June or early July best), broadcasting it so as to cover all plants uniformly, since it kills chiefly by drawing water from the leaves. One to four quarts of salt can be used per square rod, with little or no permanent injury to the grass if on a strong soil in the north-eastern states. Since the effect varies with local conditions, advance trials should be made on small scale. Following the application, the dead weeds should be raked out and a liberal application of grass-seed made.

Weeds in lawns.

Lawns

Weeds usually come up thickly in newly sown lawns. They are to be prevented by the use of commercial fertilizers or very clean manure and clean grass-seed. Clean June-grass, or blue-grass, seed is usually best. Grass-seed should be sown very thick — 3 to 5 bushels to the acre — and annual weeds cannot persist long. Frequent mowings will keep these weeds down (except low growers like chickweed), and most species will not survive the winter. In old lawns most perennial weeds can be kept down by frequent mowings. Grass can stand more cutting than weeds. If mowing cannot be practiced often enough for this purpose, the weeds may be cut off below the surface with a long knife or spud, and the crowns are then readily pulled out. Or a little sulfuric acid or other herbicide may be poured on the crown of each plant.

It will usually be found that weedy lawns are those in which the sod is poor and thin. The fundamental remedy, therefore, is to secure a strong sod. This is done by raking or harrowing over the lawn in late spring, when it is somewhat soft, and sowing a liberal dressing of chemical

fertilizer and grass-seed. Roll the land down level. All poor spots in lawns should be repaired in this manner every year. The use of fresh and coarse stable manure on lawns should be discouraged, both because it is offensive and because it generally abounds in weeds.

Moss on lawns and walks.

In damp and shady places, and also in sterile places, moss may appear on walks and lawns. If the conditions cannot be improved, the following treatments may be tried:—

One pound oil of vitriol (sulfuric acid) to ten quarts of water. Wet the surface thoroughly, being careful not to sprinkle edgings or good sod.

In early spring when the ground is soft, work it backwards and forwards with a long-toothed rake, in order to bring the moss to the surface. Clear away the moss, and leave the ground untouched for a fortnight. Early in March repeat the operation, and about the middle of that month apply a dressing of rich compost, which may consist of any old rubbish well decomposed, adding one-sixth of fresh lime. Mix with compost a few days before using. Cover the ground with the compost at the rate of 200 barrow-loads per acre, passing it through a $\frac{3}{4}$ -inch sieve, to save the trouble of rolling. Rake it evenly over the surface, and when dry seed down. An English method.

Endeavor to improve the sod, as recommended on page 232, and thereby drive out the moss. In shady places, where grass will not grow, plant some shade-loving plant, as periwinkle (*Vinca minor*), lily-of-the-valley, violets, moneywort (*Lysimachia nummularia*), or species of carex. Note the ground-cover plants that grow in shady places in the region.

Moss or Lichen on Trees

Moss on fruit-trees is usually an indication of lack of vigor. Cultivate and prune. Wash the trees with soap or lye washes. Scrape off the bark, exercising care not to expose the "quick," or the tender inner bark. A good scraper is made of a small and much-worn hoe with the handle cut to about two feet long.

The moss is readily destroyed by bordeaux mixture and other good fungicides.

CHAPTER XIV

PESTS AND NUISANCES

VARIOUS kinds of mammals and birds become plagues and nuisances at times, sometimes destroying plants, sometimes annoying human beings; and with these may be included mosquitoes and flies.

Roaming cats are often nuisances that demand control. A trespassing cat should be considered as much a transgressor as a trespassing dog or chicken or goat, — and perhaps even more so if the neighborhood is choice of its music. Owners of cats are under just as much responsibility to keep their cats at home as to keep their horses or pigs at home; if they cannot keep them at home, they should not be allowed to have them.

A clean and tidy place harbors few pests. In general, if the plantation is free of litter, and the adjacent fields contain no harbors of brush, mice and rabbits are rarely annoying to orchards. In hard winters, with deep snow, these animals are more destructive than in open winters. Rabbits browse young growth of nursery stock and small trees. Sheep and hogs rarely girdle trees if they are given sufficient food and water, the latter being especially important.

Mice and Rats

To prevent mice from girdling trees in winter.

In heeling-in young trees in the fall, do not use straw or litter, in which mice can make their nests. In orchards, see that tall grass, corn-husks, or other dry materials do not gather about the trees in fall. If danger from mice is apprehended, tramp the first snow firmly about the trees, in order to compact the grass and litter so that mice cannot find shelter.

Where the paper-birch grows, it is a good plan to place sections of birch-bark from limbs or small trunks about the base of the tree,

These sections roll tightly about the tree, and yet expand so readily with the growth of the tree that they may be allowed to remain, although it is advisable to remove them each spring, so that they will not become a harboring-place for insects. Tie thin strips of wood, as laths or shingles, about the tree. Common window-screen placed about the tree is effective and safe. Remove in spring, as it is likely to attract borers. Tarred paper is sometimes advised to keep away mice and borers, but it is very likely to kill the bark, especially on young trees, if tied on, or if left on in warm weather.

Washes to protect trees from mice.

Wash the trees with some persistent substance in which is placed paris green. Maynard finds the following substances useful for holding the poison: portland cement of the consistency of common paint; portland cement 10 parts and gas-tar 1 part; portland cement 10 parts and asphaltum 1 part; portland cement 10 parts and Morrill's tree-ink 1 part.

Lime-wash, to which is added a little sulfur, tobacco-decoction, and soapsuds.

Carbonate of baryta for rats and mice.

Sugar and oatmeal or wheat flour, of each 6 ounces; carbonate of baryta, $\frac{1}{4}$ pound; oil of anise-seed, enough to give the mixture a pretty strong odor.

This remedy is frequently made simply of oatmeal and barium-carbonate, 1 part poison to 8 of oatmeal, the combined materials being made into a stiff dough by the use of water. This has the advantage of working so slowly that the victims generally leave the premises in search of water.

Tartar emetic for rats and mice.

Tartar emetic, 1 part; oatmeal or flour, 4 parts; beef or mutton suet enough to make all into a paste.

Strychnine solution for mice.

Mice have been successfully poisoned by the use of wheat soaked in strychnine solution. (See *ground squirrel remedies*, p. 241.)

Camphor for rats and mice.

Mix a few pieces of camphor with vegetable seeds, to repel vermin.

French paste for rats and mice.

Oatmeal or wheat flour, 3 pounds; powdered indigo, $\frac{1}{2}$ ounce; finely powdered white arsenic, 4 ounces; oil of anise-seed, $\frac{1}{2}$ dram. Mix, and add of melted beef suet or mutton tallow $2\frac{1}{2}$ pounds, and work the whole up into a paste.

Commercial forms of phosphorus are popular as exterminators of vermin.

To protect seed-corn from burrowing animals (chiefly field mice).

Drop poisoned bait into small holes made into runways, then cover the holes. Corn or wheat treated as for ground-squirrels is effective. Or the grain may be moistened with water containing a little gum arabic, and then dusted with ordinary white arsenic. The grain may be allowed to dry before using. To prepare a bait that will work in a planter, it is recommended to dissolve one-eighth of an ounce of strychnia sulfate in two quarts of hot water, preferably rain water. Soak the corn in this for forty-eight hours, and then spread it out and dry thoroughly. A teaspoonful of coal-tar to a peck of dampened grain seems to be effectual protection.

Rabbits*Wash for keeping rabbits, sheep, and mice away from trees.*

Some writers recommend fresh lime, slaked with soft water (old soap-suds are best); make the wash the thickness of fence or house wash. When 1 peck of lime is used, add, when hot, $\frac{1}{2}$ gallon crude carbolic acid, $\frac{1}{2}$ gallon gas-tar, and 4 pounds of sulfur. Stir well. For summer wash leave gas-tar out, and add in place of it 1 gallon of soft soap. To keep rabbits and sheep from girdling, wash late in fall, or about the time of frost, as high as one can reach.

Blood for rabbits.

Blood smeared upon trees, as high up as rabbits can reach, will generally keep them away.

To drive rabbits from orchards.

Dip rags in melted sulfur, and then secure them to sticks which are stuck promiscuously through the orchard.

Another wash to protect trees from rabbits.

Fresh cow dung, 1 peck; quick-lime, $\frac{1}{2}$ peck; flowers of sulfur, $\frac{1}{2}$ pound; lampblack, $\frac{1}{4}$ pound. Mix the whole into a thick paint with urine and soapsuds.

California rabbit-wash.

Commercial aloes, 1 pound to 4 gallons of water, both sprinkled on leaves and painted on the bark, gives a bitter taste, which repels rabbits.

California rabbit poisons.

1. Pieces of watermelon, canteloupe, or other vegetables of which they are fond, may be poisoned with strychnine and then scattered around the orchard.

2. To 100 pounds of wheat take 9 gallons of water and 1 pound of phosphorus, 1 pound of sugar, and 1 ounce oil of rhodium. Heat the water to boiling-point, and let it stand all night. Next morning stir in flour sufficient to make a sort of paste. Scatter it about the place.

3. Another preparation is $\frac{1}{2}$ teaspoonful of powdered strychnine, 2 teaspoonfuls of fine salt, and 4 of granulated sugar. Put all in a tin box and shake well. Pour in small heaps on a board. It hardens into a solid mass. Rabbits lick it for the salt, and the sugar disguises the poison.

Sulfur for rabbits.

Equal proportions of sulfur, soot, and lime, made into a thick paint with cow-manure. Smear upon the trees.

Cow-manure for rabbits.

A mixture of lime, water, and cow-manure, made strong, is said to be an excellent anti-rabbit composition.

Asafetida for rabbits.

A teaspoonful of tincture of asafetida in $\frac{1}{2}$ pailful of liquid clay, mud, or muck of any kind. Apply with a brush to the stem and branches of young trees. Two or three applications during winter.

Kansas methods of protecting trees from rabbits (Kansas Station).

1. *Trapping.*—Traps of various sorts may be constructed. A simple and successful method is to sink a barrel in the ground level with its surface. Fit the head slightly smaller than the top, and allow it to swing freely on a rod or old broomstick. Pieces of apple or grains of corn may be placed on the outer edge of the cover, and when the rabbit attempts to get these, the lid tips up, and he slides into the barrel, while the lid, which is slightly heavier on one side than the other, assumes its original position. The heavier side should strike against a heavy nail or bolt so that only the lighter side of the lid will drop. It should be covered over with brush or light, flat stones.

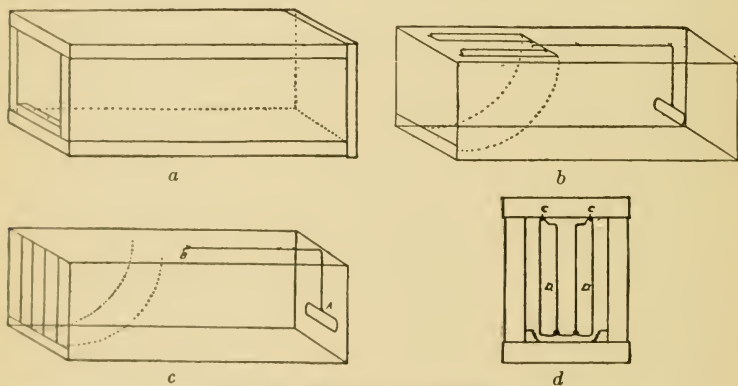

FIG. 5—Wellhouse rabbit-trap.

An ingenious trap for catching rabbits has been designed by Walter Wellhouse, and used with remarkable success by him in his orchards (Fig. 5). The trap consists of a box made of fence boards (old ones preferred), six inches wide and one inch thick. The boards are cut twenty-two inches long, and the top and bottom boards are nailed on to

the side boards, thus making the opening four inches wide and six inches high. The door, *D*, is made of wire, shaped as shown in fig. *d*, and hung with two staples, *cc*, to the under side of the top board. To prevent the rabbit from pushing the door open, a strip three-fourths of an inch square is inserted in the opening and nailed to the bottom board, as shown in fig. *a*, and in part in fig. *d*. The door must be made long enough to reach well below this catch, as shown in fig. *d*. The trigger is made of wire, bent as shown in figs. *b* and *c*, and hung loosely with two staples to the center of the top board. These staples must be carefully placed, to allow the trigger to be pulled forward far enough so that the door will rest upon it when the trap is set, and also to allow the loop in the trigger, *A*, fig. *c*, to be pushed against the back of the trap by the rabbit when it is sprung, thus preventing its being bent. To operate the trap, push the door, *D*, inward, and with the forefinger catch the hooked end of the trigger, *B*, fig. *c*, and pull it forward until the door rests upon the wire above the hook. The rabbit enters the trap, prompted by curiosity or otherwise, just as he enters a hollow log, and thinks no more of the wire trigger than he would of a small piece of brush which he must push out of his way. As soon as he touches the trigger, the door drops and the rabbit is caught. No bait is used, and the trap cannot easily be sprung by birds or wind. Care must be taken to see that all staples are loosely set, so that the trigger slides easily and the door will drop of its own weight. If new boards are used, it would be well to stain with some dark coloring material which is not offensive to the rabbit's delicate sense of smell.

2. *Wrapping*. — When one has only a few trees, such as fruit or shade trees, the most satisfactory method is to wrap them. An ordinary tree veneer which is made of very thin wood may be purchased from any seed store or nursery company. This fits closely about the body of the tree, and will enlarge as the tree grows. However, during the summer it may offer a harbor for injurious insects, and should remain on the tree only during the winter. Trees may be wrapped with burlap, corn-stalks, or ordinary lath. The only caution with any of these is to remove them when the tree resumes growth in the spring. Ordinary wire screen answers very well as a protection for the tree.

3. *Repellents*. — The tree may be covered as far as the rabbit can reach with blood. The entrails and blood of the rabbit itself rubbed over the tree is quite effective, but is very apt to be washed off by rain.

A concoction of tallow and tobacco smeared on to the trees acts as a repellent. However, where there are a great many trees, and especially small trees, such as honey locust, elm, and others, used as windbreaks, it is out of the question to treat each individual tree by hand. In this case, a spray applied by a hand pump will be found effective. The common lime and sulfur spray used to destroy the San José scale has been recommended, and can be applied with an ordinary spray pump. Mix together dry, fresh hydrated or ground lime, 4 pounds; powdered sulfur, 3 pounds. Add water to form a thin paste, and boil from one-half to one hour, or until the mixture becomes a reddish amber color. Dilute to 10 gallons, spray on to the trees while the liquid is still warm. This spray is excellent for the trees as well, but must not be applied to the trees while they are in leaf.

Commercial aloes at the rate of one pound to four gallons of water sprayed on to the trees gives the bark and leaves a bitter taste which repels rabbits.

A spray made of buttermilk and common stove soot has proven quite satisfactory here. Buttermilk, 1 gallon; common stove soot, $\frac{1}{4}$ pound. Boil for twenty minutes. Keep well stirred to prevent clogging the pump.

4. *Poisoning.* — Much may be done in eradicating this pest with poison. The "Wellhouse" poison is made as follows: Sulfate of strychnine, 1 part; borax, $\frac{1}{4}$ part; white syrup, 1 part; water, 10 parts. Put the mixture into a jug or large bottle, and shake well. Cut fresh twigs — apple water sprouts are best — and with a small brush paint them, especially over the terminal bud, with the above preparation. Scatter the twigs in the runways and about the trees where the rabbits feed. Stock or fowls will not molest this poison, and it is said that dogs may eat the dead rabbits and suffer no ill effects.

The Western Australia Department of Agriculture recommends a similar poison. Dissolve $1\frac{1}{2}$ ounces strychnine in 1 quart of vinegar; dilute with 5 gallons of water; add 2 pounds of flour and 1 pound of sugar; stir well and apply to twigs as recommended above.

A jam made of fruit and sugar is readily eaten by the rabbits. Chop apples or melons into small cubes. Add sugar equal to one-half the weight of the fruit. Boil until the mass forms a thick jam. Add strychnine, either powdered or dissolved, at the rate of 1 ounce to 25 pounds of the jam, and mix thoroughly.

To remedy the injury done by mice, rabbits, and squirrels.

1. Pare and clean the wound, and cover it thickly with fresh cowdung, or soft clay, and bind it up thoroughly with a cloth. Grafting-wax bound on is also good. Complete girdling, when done late in spring — when settled weather is approaching — can be remedied in this way.

2. Insert long scions over the wound, by paring them thin on both ends, and placing one end under the bark on the upper edge of the wound and the other under the bark on the lower edge. Wax thoroughly the points of union, and tie a cloth band tightly about the trees over both extremities of the scions.

Ground Squirrel or Spermophile Remedies

1. Secure 5 quarts of clean wheat; scald with water; drain. Take $\frac{2}{3}$ cup of white sugar, dissolve with sufficient water to make a syrup; add 1 ounce powdered strychnine, stir thoroughly until a thin paste is formed. Pour this on the damp wheat. Stir thoroughly for at least 15 minutes. Add 1 pint powdered sugar, stir; add 5 to 10 drops of rhodium and 5 to 10 drops of oil of anise-seed. Place a few grains in each squirrel-hole, putting it as far in as possible.

2. Dissolve $1\frac{1}{2}$ ounces of strychnia sulfate in a quart of hot water. Add a quart of molasses, — molasses, sorghum, or thick sugar and water, — and a teaspoonful of oil of anise. Thoroughly heat and mix the liquid. While hot pour it over a bushel of clean wheat and mix completely. Then stir in two or more pounds of fine corn-meal. The quantity of corn-meal will depend on the quantity of extra moisture present. There should be enough to wet every grain of the wheat, and no more. Let the poisoned grain stand over night, and distribute it in the early morning of a bright day. A tablespoonful is placed near the mouth of the burrow, scattered in two or three little piles. The best time to use this or other poisons is in early spring, when the ground-squirrels are hungry from their winter fast, and when the destruction of the old ones before the young are born will greatly lessen the numbers of the pests.

3. Bisulfid of carbon is also largely used. A small quantity is poured into the burrow, and the hole is immediately closed securely with dirt.

4. Tying newspapers about trees in such manner as to allow the upper part of the paper to project loosely a few inches frightens the squirrels away.

Moles

Moles are rather easily poisoned by inserting in the runways corn in the milk stage, freshly cut from the ear, and poisoned with strychnine solution.

Moles live in loose and sandy land. If the place is watched, they may be destroyed when they are heaving their burrows. Mole-traps are on the market. (See *gophers*, p. 243.)

Prairie-dogs

Prairie-dogs may be destroyed by much the same means as are ground squirrels. (See *ground squirrel remedies*, p. 241; and *wood-chuck or ground-hogs*, p. 243.)

Poisoning by grain soaked in strychnine solution has proved most successful. The following method has been devised and used by the Kansas Experiment Station: The mixture is in the form of a syrup, composed of the following ingredients (for 1 quart): 1 ounce strychnia sulfate (powdered), 1 ounce potassium cyanide, 1½ ounces alcohol, 1 pint syrup. One ounce of green coffee-berries is mixed with the white of one egg, and allowed to stand at least fourteen hours. The strychnia is dissolved in a half-pint of boiling water. The potassium cyanide is dissolved in a quarter-pint of hot water and allowed to cool. Add a little warm water to the mixture of coffee and eggs, and mix it with the potassium cyanide. Then strain this mixture through a coarse sieve into the mixing vessel, and add the syrup. Mix the alcohol with the hot solution of strychnine, and add it to the other mixture. Stir all thoroughly. One quart of the mixture is sufficient to poison a half-bushel of wheat or kafir. The mixture must be thoroughly stirred before it is poured over the grain. Two or three pounds of fine corn-meal are stirred in with the grain to take up the extra moisture. On a bright, warm morning in January, February, or March, place half a teaspoonful or less of the bait in two or three little piles at the outside of each burrow occupied by prairie-dogs. A half-bushel of grain should poison 500 to 600 holes.

Woodchucks or Ground-hogs

These animals are readily trapped at the mouths of their burrows. They are also easily killed by the vapor of bisulfid of carbon, the liquid being poured on a handful of moss, cotton, or other absorbent material, and pushed down the burrow, all openings being at once closed. The vapor is heavier than air, and will settle to the bottom, where it will kill any animal present.

Pocket-gophers

These pests are readily destroyed by poisoned grain, corn being especially recommended for the purpose, although various other materials may be employed. A dibble, made by adding a metal point to a spade handle, is used to make holes in the runways, into which the poisoned bait is dropped. "A skillful operator," writes D. E. Lantz, "can go over twenty to forty acres of badly infested land in a day, and, if the work is done carefully, at a time when the pocket-gophers are active, all the animals should be destroyed by the first application of poison." The pests may also be destroyed by trapping and by fumigation with carbon bisulfid.

Wolves and Coyotes

These animals are most easily destroyed by hunting out the breeding-places in early spring and killing the litters of pups. They may also be poisoned and trapped.

Muskrats

Powdered strychnia sulfate sweetened with powdered sugar or commercial saccharin and sprinkled over freshly cut pieces of apple, carrot, or ripe squash has proved effective. Crystals of the same poison may be inserted in the bait with a knife.

Pestiferous Birds

Bird poisons.

1. Place a shallow box on the end of a pole, and put it four or five feet from the ground to keep the poison out of the way of domestic fowls. In the box sprinkle corn-meal and a very little strychnine, which mixture the birds eat. It will not hurt dogs or cats to eat the

dead bird, for the reason that there is not enough poison absorbed by the bird. (California.)

2. Put the strychnine in pieces of apples, and stick them on the ends of limbs of the trees. (California.)

3. *Poison for English sparrows.*

Dissolve arsenate of soda in warm water at the rate of one ounce to one pint; pour this upon as much wheat as it will cover (in a vessel which can be closed so as to prevent evaporation), and allow it to soak for at least twenty-four hours. Dry the wheat so prepared, and it is ready for use. It should be distributed in winter in places where the sparrows congregate. Wheat may be similarly prepared with strychnine.

4. Put $\frac{1}{8}$ ounce of strychnia sulfate into $\frac{3}{4}$ of a gill of hot water, and boil until dissolved. Moisten $1\frac{1}{2}$ teaspoonfuls of starch with a few drops of cold water, add it to the poison solution, and heat till the starch thickens. Pour the hot poisoned starch over a quart of wheat, and stir until every kernel is coated.

To protect fruits from birds.

One of the best devices is mosquito-bar spread over the bushes or trees. For bush-fruits and small trees the expense is not great. There is a commercial netting made for the purpose.

Have a taxidermist mount several hawks, and place them in natural positions in the trees or vines.

In large plantations of cherries or other fruits subject to the deprivations of birds, the injury is generally proportionately less than in small areas. Some cherry-growers plant early sweet varieties to feed the birds, which, getting their fill, give less attention to the main crop. Birds prefer the Russian mulberry to cherries, and an occasional tree in the cherry orchard may protect the crop.

Plantings of mulberry, buckthorn, elder, and chokeberry may serve to protect raspberries and blackberries. For strawberries, sweet early varieties which are left to ripen on the vines have been recommended.

To protect newly planted seeds from birds.

Coat the seeds with red lead by moistening the seeds slightly and stirring in red lead until all the seeds are thoroughly coated. Let the seeds dry for two or three hours before sowing.

Several ways to protect corn from crows.

Dip the kernels in coal-tar, and then dust them with plaster; tar the seed; plant it deeply; scatter soaked corn over the field to attract attention from the young plants; hang streamers of cloth from twine strung about the field on poles; or use scare-crows.

To protect young chickens.

Young chickens may be protected from hawks by covering their runways with fine wire netting. Chickens are comparatively safe when king-birds or purple martins breed about the farm-yard, as these birds drive hawks away. They should be encouraged. Some hawks are frightened away by guinea-hens. A pair of ospreys or fish-hawks nesting near a farmhouse will keep other hawks away.

Mosquitoes

The discovery that certain mosquitoes carry the organisms of malaria and other diseases has started a crusade against these pests. We now feel that mosquitoes must be controlled, both as a sanitary measure and as a relief against the insects themselves.

The chief mode of attack is to *destroy their breeding-places*. They breed only in *standing water*. Draining the breeding-places, or filling them up and emptying all receptacles in which water stands, is the first thing to be considered. The big gray mosquitoes that breed in tide marshes are specially pestiferous. They propagate in the brackish pools. These pools should be filled or drained, or else the tide dyked out so that the pools may dry.

The second thing to consider, if the above cannot be carried out, is to cover the breeding-pools with oil so that mosquito larvæ may be deprived of air (they rise to the surface to breathe).

In fountain tanks, lily ponds, and other water areas that are to be retained, the mosquitoes may be kept down by stocking with fish that eat the larvæ or wrigglers.

Kerosene for mosquitoes (Needham).

An ounce of kerosene to every 15 square feet of surface is about the right proportion, according to Howard. The film of oil will be retained

for about two weeks. The grade of kerosene known as "light fuel oil" is best.

Any kerosene will kill aquatic plants, if sprayed on them. It should be poured on surface of water in cultivated ponds and spread with a broom or mop. It should be applied oftener than once in two weeks in such cases, and in much less quantity. One-fourth as much twice as often will probably be equally effective.

It is best not to use kerosene at all on ornamental ponds; it is unsightly; it smells badly; it kills *all larvæ* that require air derived from the surface, including those of many of the higher diptera which as adults are useful flower pollinators; it endangers the plants even when most carefully applied, to say nothing of smearing them.

Fishes available for destruction of mosquito larvæ (Needham).

1. Goldfish eat eggs by preference, also the larvæ. They thrive in any warm pool, or even in cisterns with scant light; eat prepared foods, so can be readily supplied with supplemental food if necessary. They are easily obtained in the market, and are ornamental. Must be taken indoors for winter.

2. Top minnows are natural enemies of mosquitoes in native water. They are hardy and long-lived; but they are not on the market, and have to be sought with a seine. Not especially ornamental.

3. Sunfish are fond of mosquito larvæ. They do well only in midst of aquatic growth; require much food, and insect food is preferred. Ornamental.

4. Sticklebacks are most voracious mosquito enemies, and are also worthy of cultivation for their remarkable nest-building habits. Rather particular as to conditions, but in proper pools they are hardy.

All these fishes require room in which pasturage may grow. A pair of the smallest of them would probably find scant natural food in a square rod of water area.

Hibernating mosquitoes.

Some mosquitoes hibernate in cellars, and from them the breeding starts in spring. Cellars may be fumigated with powdered *Datura Stramonium* (Jimson weed), or with *culicide* (*culex* is the generic name of the greater number of mosquitoes). In either case, according to J. B. Smith, the cellar to be fumigated should be as tightly closed as possible,

to hold the fumes and make them most effective. The powdered stramonium is used at the rate of eight ounces for each 1000 cubic feet of space, mixed with one-third its weight of saltpeter to facilitate combustion. Spread the mass out on a tin plate or stone flag and light at several points to hasten the burning. The vapor is not dangerous to human life, so even if some escapes into the rooms above, no harm will be done. If the cellar is leaky, use two or three times as much as advised, and in all cases keep it as tightly closed as possible for two hours at least.

Culicide is made of equal parts by weight of carbolic acid crystals and gum camphor. Melt the acid crystals over a gentle heat, and pour slowly over the gum. The acid dissolves the camphor, and makes a clear, somewhat volatile liquid, with rather an agreeable odor. This solution is permanent, and may be kept indefinitely in tight jars. Use three ounces of this culicide for every 1000 cubic feet of space, and volatilize over a lamp of some kind. A simple and inexpensive apparatus for this purpose (J. B. Smith) consists of an 8-inch section of galvanized-iron stove-pipe, cut so as to leave three legs, and with a series of $\frac{1}{4}$ -inch holes near the top to make an outlet for the draft. Upon this place a shallow, flat-bottomed basin to hold the culicide, and beneath this use an ordinary glass or other alcohol lamp. Two ounces of culicide may be evaporated with $\frac{1}{2}$ an ounce of alcohol in twenty-five minutes, and a larger quantity would probably require proportionately less time if given a larger evaporating surface in a dish of larger diameter than the pipe. This combination is inflammable, but not explosive, and should be used on a cement, earth, or stone floor, or on bricks in a tub of water, to avoid danger of fire. The fumes are not dangerous to human life until they become very dense, and such as might penetrate into upper rooms through leaky floors or doors would do no harm to anything. This also should be allowed to act at least two hours before the doors are opened again. Flies and other insects succumb as readily as mosquitoes.

Rules for extermination and prevention of mosquitoes. (Anti-Mosquito Convention, N. Y.)

Pools of rain water, duck ponds, ice ponds, and temporary accumulations due to building; marshes, both of salt and fresh water, and road-

side drains; pots, kettles, tubs, springs, barrels of water, and other back-yard collections should be drained, filled with earth, or emptied.

Running streams should have their margins carefully cleaned and covered with gravel to prevent weeds and grass at the water's edge.

Lily ponds and fountain pools should, if possible, be abolished; if not, the margins should be cemented or carefully graveled, a good stock of minnows put in the water, and green slime (algæ) regularly cleaned out, as it collects.

Where tanks, cisterns, wells, or springs must be had to supply water, the openings to them should be closely covered with wire gauze (galvanized to prevent rusting), not the smallest aperture being left.

When neither drainage nor covering is practicable, the surface of the standing water should be covered with a film of light fuel oil (or kerosene) which chokes and kills the larvæ. The oil may be poured on with a can or from a sprinkler. It will spread itself. One ounce of oil is sufficient to cover fifteen square feet of water. The oil should be renewed once a week during warm weather.

Particular attention should be paid to cesspools. These pools, when uncovered, breed mosquitoes in vast numbers; if not tightly closed by a cemented top, or by wire gauze, they should be treated once a week with an excess of kerosene or light fuel oil.

Certain simple precautions suffice to protect persons living in malarial districts from infection:—

First: Proper screening of the house to prevent the entrance of the mosquitoes (after careful search for and destruction of all those already present in the house), and screening of the bed at night. The chief danger of infection is at night (the anopheles bite mostly at this time).

Second: The screening of persons in malarial districts who are suffering from malarial fever, so that mosquitoes may not bite them and thus become infected.

Third: The administration of quinine in full doses to malarial patients to destroy the malarial organisms in the blood.

Fourth: The destruction of mosquitoes by one or more of the methods already described.

These measures, if properly carried out, will greatly restrict the

prevalence of the disease, and will prevent the occurrence of new malarial infections.

It must be remembered that when a person is once infected, the organisms may remain in the body for many years, producing from time to time relapses of the fever.

A case of malarial infection in a house (whether the person is actively ill or the infection is latent) in a locality where anopheles mosquitoes are present, is a constant source of danger, not only to the inmates of the house, but to the immediate neighborhood, if proper precautions are not taken. It should be noted in this connection that the mosquitoes may remain in a house through an entire winter, and probably infect the inmates in the spring upon the return of the warm weather.

The House-Fly (C. R. Crosby)

The typhoid fly, or house-fly (Musca domestica).

For ages this ubiquitous pest has been looked upon as a harmless though annoying and unpleasant nuisance, and its presence has been tolerated as a necessary evil. It has now been scientifically demonstrated that it plays an important rôle in the transmission of certain intestinal diseases, such as typhoid, cholera, infantile diarrhœa, etc., by carrying infected matter from the excreta of patients to the food of healthy persons. It is now thought that next after polluted water and contaminated milk, flies are the most important factor in the spread of typhoid. Both in city and in country the presence of these pests is a constant menace to the health of the community.

House-flies breed chiefly in horse manure, and to a less extent in garbage, human excrement, and other filth. Each female lays about 120 eggs, which hatch in a few hours. The maggots become full grown in about five days, and an equal period is spent in the pupal stage. The whole life cycle thus requires only ten to fourteen days in midsummer. In the climate of Washington, D.C., there are twelve or thirteen generations annually. Dr. L. O. Howard reports finding 1200 larvæ and pupæ in a single pound of horse manure. The winter is passed either as adults hidden away in houses or as pupæ beneath manure piles.

Control.

The house-fly nuisance can be abated most easily by the elimination of possible breeding-places. The great majority of the flies found in houses breed in piles of horse manure about near-by stables. Breeding in such places may be easily prevented by storing the manure, pending its removal, in a dark, fly-proof bin. This receptacle may be built as a lean-to attached to the stable with which it is connected by a small screen door. A larger door outside provides for the removal of the contents. The manure should be carted away at least once a week, and spread out on the land, where by drying it soon becomes unfit for breeding purposes. Whenever it is necessary to store such material in piles in the open, they should be located as far as possible from the nearest dwelling or milk-house. Flies do not usually travel more than one-fourth mile from the place in which they breed.

When only two or three horses are kept in a town, the manure can be handled in regular garbage-cans, in the same way as the kitchen refuse or ashes.

Breeding in manure piles can be prevented by borax. Sift borax on manure, particularly around edges of pile, immediately after removal from barn, then sprinkle with water. Use $\frac{3}{4}$ lb. borax to 8 bu. of manure.

Kitchen refuse and similar garbage should be kept in tight cans and removed at frequent intervals. Flies should be rigidly excluded from all places where food is exposed to contamination, including kitchens, dining-rooms, stores, etc. Especial care should be taken to protect milk and milk utensils, since milk furnishes an excellent medium for the growth of typhoid bacteria and is a common source of infection.

Flies may be driven from rooms by leaving one door open and darkening all the rest. Then evaporate a spoonful of carbolic acid over a lamp, or burn some pyrethrum insect-powder. They may be caught on sticky sheets, or poisoned with a sweetened 5 per cent solution of commercial formaldehyde.

On isolated farms each owner has it in his power by proper measures in the disposal of manure to reduce the fly nuisance to a minimum. In towns the case is different; there coöperation is necessary.

In attempting to reduce the numbers of house-flies in the District of Columbia, the health department has formulated a series of rules which L. O. Howard has summarized as follows:—

“ All stalls in which animals are kept shall have the surface of the ground covered with a water-tight floor. Every person occupying a building where domestic animals are kept shall maintain, in connection therewith, a bin or pit for the reception of manure, and, pending the removal from the premises of the manure from the animal or animals, shall place such manure in said bin or pit. This bin shall be so constructed as to exclude rain water, and shall in all other respects be water-tight, except as it may be connected with the public sewer. It shall be provided with a suitable cover, and constructed so as to prevent the ingress and egress of flies. No person owning a stable shall keep any manure or permit any manure to be kept in or upon any portion of the premises other than the bin or pit described, nor shall he allow any such bin or pit to be overfilled or needlessly uncovered. Horse manure may be kept tightly rammed into well-covered barrels for the purpose of removal in such barrels. Every person keeping manure in any of the more densely populated parts of the District shall cause all such manure to be removed from the premises at least twice every week between June 1 and October 31, and at least once every week between November 1 and May 31 of the following year. No person shall remove or transport any manure over any public highway in any of the more densely populated parts of the District, except in a tight vehicle which, if not inclosed, must be effectually covered with canvas, so as to prevent the manure from being dropped. No person shall deposit manure removed from the bins or pits within any of the more densely populated parts of the District without a permit from the health officer. Any person violating any of the provisions shall, upon conviction thereof, be punished by a fine not more than \$40 for each offense.”

Slime on Ponds

The slime, or algæ, on ponds may be destroyed by copper sulfate. The common spirogyra is dispatched by 1 part of the sulfate to 25,000,000 parts of water, and other forms by a stronger solution. These weak solutions are little injurious to the higher plants and not much so to any animals. A better way is to keep the toads and to let their tadpoles eat the algæ. Red-bellied minnows would also help.

CHAPTER XV

FUNGICIDES AND GERMICIDES FOR PLANT DISEASES

BY DONALD REDDICK

PLANT diseases are caused by parasitic fungi or by bacteria, or other vegetable parasites; or by forms of physiological disturbance. Each disease calls for special treatment. Most plant diseases must be prevented, not cured.

It should be understood that spraying is only one of the control measures effective against plant diseases. Many diseases are not affected by spraying, though perhaps more are susceptible to this treatment than to any other.

A satisfactory fungicide must be one that does not injure the plants and at the same time is effective against the parasite. For spraying, additional requirements are imposed; it should not dissolve readily in rain water; it should adhere to foliage and fruit; in some cases it should be colorless in order not to make ornamentals more unsightly than when diseased. The fungicide which has been used most for general purposes is bordeaux mixture. Lately some other preparations, particularly lime-sulfur combinations, have come into use, and in many cases are supplanting bordeaux. There are in addition a large number of other substances which have fungicidal value and are in more limited use for specific cases.

Practices

Destroying affected parts.— It is important that all affected parts should be removed and burned, if possible. In the fall all leaves and fruit that have been attacked by fungi should be raked up and burned. Diseased branches should be severed at some distance below the lowest visible point of attack. Fungus diseases often spread rapidly, and prompt action is usually necessary. Practice clean and tidy culture.

Rotation of crops. — One of the most effective and practical means of heading off fungous diseases. Especially applicable to diseases of roots or root-crops, but also to many other diseases of annual plants.

Sterilizing by steam. — An effective fungicidal practice for several soil-inhabiting organisms which attack roots and stems. This includes nematode worms. It is especially applicable in the greenhouse, where it may be applied (a) through sub-irrigation tile or through specially laid perforated steam pipes in the bottom of the bed. Cover the beds with blankets, introduce steam under pressure of 40 to 80 pounds for two hours. Insert thermometers at various places to see that the soil is being uniformly heated. (b) A large galvanized iron tight box may be constructed with finely perforated trays 4 to 6 inches in depth. Soil placed in these trays and steamed for two hours as above will be freed from parasitic organisms. In this case the frames should be sprayed with a solution of formalin, 1 pint in 10 gallons of water.

Steam sterilization of soil may be used on intensively cultivated areas or extensive seed-beds. A portable boiler is necessary. The beds are sterilized after they have been prepared for seed, and just before the seed is sown. A galvanized pan 10 by 6 feet and 6 inches deep is inverted, and the edges are pushed down into the soil one or two inches. The pan is connected with the steam boiler by means of a steam hose and live steam is run into the pan for about forty minutes under a pressure of 100 pounds and up. The higher the pressure the more thoroughly the soil will be sterilized.

The cost of sterilizing is approximately three-fourths of a cent the square foot. It should be noted that soil sterilization has an invigorating effect on the plants, and it will be necessary to run greenhouses at a lower temperature (5° – 10°) both night and day. Field sterilization also kills weed seeds, and with the reduction of the cost of weeding makes the process practicable.

Substances

Bordeaux mixture. — A bluish-green copper compound that settles out when freshly slaked lime and a solution of copper sulfate (blue-

stone) are mixed. Many formulas have been recommended and used. The 5-5-50 formula may be regarded as standard. In such a formula the first figure refers to the number of pounds of copper sulfate, the second to the stone or hydrated lime, and the third to the number of gallons of water. Bordeaux must often be used as weak as 2-2-50, on account of injury to some plants.

To make 50 gallons of bordeaux mixture, proceed as follows: (1) Pulverize 5 pounds of copper sulfate (blue vitriol), place in a glass, wooden, or brass vessel, and add two or three gallons of hot water. In another vessel slake 5 pounds of quicklime in a small amount of water. When the copper sulfate is all dissolved, pour into a barrel and add water to make 40 or 45 gallons. Now strain the lime into this, using a sieve 50 meshes to the inch or a piece of cheese-cloth supported by ordinary screening. Stir thoroughly, and add water to the 50-gallon mark. The flocculent substance which settles is the effective fungicide. Always stir vigorously before filling the sprayer. Never add the strong lime to strong vitriol. Always add a large amount of water to one or the other first. Blue vitriol used alone would not only wash off quickly in a rain, but cause a severe burning of fruit and foliage. Lime is added to neutralize this burning effect of the copper. If the lime were absolutely pure only slightly more than one pound would be required to neutralize this burning effect. For many purposes an excess of lime is not objectionable and may be desirable. For nearly ripe fruit and ornamentals an excess of lime augments spotting. In such cases the least amount of lime possible should be used. Determine this by applying the cyanide test (2).

(2) Secure from the druggist 10 cents' worth of potassium ferrocyanide (yellow prussiate of potash) and dissolve it in water in an 8-ounce bottle. Cut a V-shaped slit in one side of the cork, so that a few drops of the liquid can be obtained. Now proceed as before. Add lime with constant stirring until a drop of the ferrocyanide ceases to give a reddish-brown color.

(3) When bordeaux mixture is desired in large quantities, stock solutions should be made. Place 100 pounds of copper sulfate in a bag of coffee-sacking, and suspend in the top of a 50-gallon barrel, and add water to the 50-gallon mark. In twelve to fifteen hours the vitriol will be dissolved and each gallon of solution will

contain 2 pounds of copper sulfate. Slake a barrel of lime, and store in a tight barrel, keeping it covered with water. Lime so treated will keep all summer. It is really hydrated lime. This is often dried, pulverized, and offered on the market in paper bags of 40 pounds, each, under such names as ground lime, prepared lime, hydrated lime, etc. If the paper is not broken, the lime does not air-slake for a long time. One and one third pounds of hydrated lime equals in value one pound of quicklime. Air slaked lime cannot be used in preparing bordeaux mixture.

Arsenical poisons can be combined with bordeaux mixture. See Chapter XVII, page 290.

Ammoniacal copper carbonate.—For use on nearly mature fruit and on ornamentals. Does not discolor. Weigh out 3 ounces of copper carbonate, and make a thick paste with water in a wooden pail. Measure 5 pints of strong ammonia (26° Beaumé) and dilute with three or four parts of water. Add ammonia to the paste, and stir. This makes a deep blue solution. Add water to make 50 gallons.

Copper carbonate.—For use in the above formula, it may be obtained as a green powder, or may be prepared as follows: Dissolve 12 pounds of copper sulfate in 12 gallons of water in a barrel. Dissolve 15 pounds of sal soda in 15 gallons of water (preferably hot). Allow the solution to cool; then add the sal soda solution to the copper sulfate solution, pouring slowly in order to prevent the mixture from working up and running over. A fine precipitate is formed which will settle to the bottom if allowed to stand over night. Siphon off the clear liquid. Wash the precipitate by adding clear water, stirring, and allowing to settle. Siphon off the clear water, strain the precipitate through muslin, and allow it to dry. This is copper carbonate. The above amounts will make about 6 pounds.

Copper sulfate.—See SULFATE OF COPPER, p. 258.

Corrosive sublimate (mercuric bichloride).—Used for disinfecting pruned stubs and cleaned-out cankers, at the rate of one part in 1000 parts of water. Can be secured from the druggist in tablet form in vials of 25 each, and costing 25 cents. One tablet makes a pint of solution. Make and store solution in glass and label *poison*.

Formalin (forty per cent solution of formaldehyde gas in water).—

A pungent, clear liquid, very irritating to eyes and nose. Obtained at any drug store at about 40 cents per pint. Used for potato-scab, oat smut, bunt in wheat, soil disinfection, etc.

Lime.— Offered for sale in the following forms. (a) Ground rock or ground limestone; air-slaked lime is of the same composition, i.e. a carbonate of calcium. (b) Lump, barrel, stone, or quick lime; this is burned limestone, and should preferably test 90 per cent oxide of calcium. (c) Prepared, ground, or hydrated lime; this is water or steam-slaked quicklime, dried and pulverized. Used as an applicant to the soil to correct acidity (p. 77), for club-root of cabbage, etc., and for preparing spray mixtures.

Lime-sulfur (see page 294).— In the many possible combinations, lime-sulfur is coming to be equally as important as bordeaux mixture, in the control of many plant diseases.

(a) A mixture of equal parts of dry lime and powdered sulfur is often dusted on plants for surface mildews.

(b) A paste of equal parts of lime, sulfur, and water. This is painted on the heating pipes in the greenhouse, and is valuable for keeping off surface mildews.

(1) Home-boiled dilute lime-sulfur. This solution has been widely used in the past as a dormant spray, particularly for San José scale and peach leaf-curl. It is likely to be supplanted by (2) or (3). For preparation see page 295.

(2) Home-boiled concentrated lime-sulfur.— When a great deal of spraying is to be done, a concentrated lime-sulfur solution may be boiled at home and stored in barrels to be used as needed. For method of preparation see page 295.

Test with a Beaumé hydrometer, which has a scale reading from 25° to 35°. Dilutions are reckoned from a standard solution testing 32°. If the solution tests only 28°, it is not as strong as standard, and cannot be diluted as much as a solution testing 32°. The table on opposite page shows the proper dilution for solutions testing 25° to 35° Beaumé.

Decimals are given in all cases, but for practical purposes the nearest even gallon or half gallon can be used, unless appliances for more accurate measurement are at hand. It is understood in making all dilutions that water is added to one gallon of the con-

centrate to make the stated amount. Do not measure out the stated amount of water and add the concentrated solution to it.

	1-10	1-15	1-20	1-25	1-30	1-40	1-50	1-60	1-75	1-100
25°	7.4	11	14.7	18.4	22.1	29.5	36.8	44.2	55	73
26°	7.7	11.6	15.4	19.3	23.2	30.9	38.6	46.3	58	77.2
27°	8.1	12.1	16.1	20.2	24.3	32.4	40.5	48.5	60.6	80.7
28°	8.4	12.7	16.9	21.1	25.4	33.8	42.3	50.7	63.5	84.5
29°	8.8	13.2	17.6	22.1	26.5	35.3	44.2	53	66.3	88.2
30°	9.2	13.9	18.4	23	27.6	36.9	46.1	55.3	69	92
31°	9.6	14.4	19.3	24	28.8	38.4	48	58	72	96
32°	10	15	20	25	30	40	50	60	75	100
33°	10.4	15.6	20.8	26	31.2	41.5	52	62.4	78	104
34°	10.8	16.2	21.6	26.8	32.4	43.2	54	64.7	80.8	108
35°	11.2	16.8	22.4	28	33.4	44.9	56	67.4	84.2	112

(3) Commercial concentrated lime-sulfur. — As manufactured and placed on the market is a clear amber liquid, and should test 32° to 35° Beaumé. It costs about 20 cents per gallon retail, and comes ready to pour into the spray tank. For apple and pear diseases. Arsenate of lead can be used with this solution, and increases its fungicidal value.

(4) Self-boiled lime-sulfur. This is a mechanical mixture of the two substances, and is really not boiled, the heat being supplied by the slaking lime. In a small barrel or keg place 8 pounds of good quicklime. Add water from time to time in just sufficient amounts to prevent burning. As soon as the lime begins to slake well, add slowly (preferably through a sieve) 8 pounds of sulfur flour. Stir constantly, and add water as needed. As soon as all bubbling has ceased, check further action by adding a quantity of cold water, or pour into a barrel or tank and make up to 50 gallons. Keep well agitated. Very effective against peach scab and brown rot. Several other formulas have been used: 10-10-50 and 5-5-50. Arsenate of lead can be used with this mixture.

By using boiling water and allowing the hot mixture to stand for half an hour, a stronger spray mixture of the above can be secured. It cannot be used safely on peaches, but has been used successfully on grapes for surface mildew. The addition of sulfate of

iron or sulfate of copper, one or two pounds to 50 gallons, has been used for apple rust.

Potassium sulfid (liver of sulfur). — Simple solution 3 ounces in 10 gallons of water. For mildew in greenhouses, on rose-bushes and other ornamentals.

Resin-sal-soda sticker. — Resin, 2 pounds; sal soda (crystals), 1 pound, water, 1 gallon. Boil until of a clear brown color, *i.e.* from one to one and a half hours. Cook in an iron kettle in the open. Add this amount to 50 gallons of bordeaux. Useful for onions, cabbage, and other plants to which spray does not adhere well.

Sulfate of copper (blue vitriol). — Dissolve 1 pound of pure sulfate of copper in 25 gallons of water. A specific for peach leaf-curl. Apply once before buds swell in the spring. Cover every bud. For use in preparing bordeaux mixture. Costs from 5 to 7 cents per pound, in quantity.

Sulfate of iron (copperas). — A greenish granular crystalline substance. Dissolve 100 pounds in 50 gallons of water. For mustard in oats, wheat, etc., apply at the rate of 50 gallons per acre. Also for anthracnose of grapes as a dormant spray.

Sulfur (ground brimstone, sulfur flour, flowers of sulfur). — Should be 99 per cent pure. Valuable for surface mildews. Dust on dry or in the greenhouse used in fumes. Evaporate it over a steady heat, as an oil stove, until the house is filled with vapor. Do not heat to the burning point, as burning sulfur destroys most plants. To prevent burning, place the sulfur and pan in a larger pan of sand and set the whole upon the oil stove.

CHAPTER XVI

PLANT DISEASES

BY DONALD REDDICK

SOME knowledge of the habits of the organism causing a disease is usually necessary in order successfully to combat it and prevent its ravages. Those diseases caused by powdery mildew fungi (which are surface infestations) can be cured. Practically all others must be prevented.

Fungi attacking parts of plants above ground are usually disseminated by means of spores. Water is often necessary to liberate the spores from the fungus proper, and is nearly always necessary to permit spore germination and infection of other plants. Heavy dew sometimes furnishes sufficient moisture, but prolonged drizzling rains are more favorable. For this reason a fungicide, in order to be effective against such parasites, must be applied before the rain. If it is going to rain to-morrow, spray to-day. But how know whether it is going to rain? This can best be told from a study of the United States weather maps, which are printed and distributed from the many weather stations, or else appear in the daily papers. Storm periods, indicated by a "low" barometer, travel quite regularly from west to east, and are usually accompanied or followed by rain. This can be determined by noting the amount of precipitation, if any, in the wake of the storm. Local conditions are often a factor to be considered. A few minutes' study of the weather map each day will soon make one reasonably efficient in predicting the weather. See Chap. I.

It is unfortunate that a definite system of naming plant diseases has not been formulated. Diseases of plants of a similar nature should bear the same common name. The term "blight" is commonly used for many kinds or forms of diseases. It might well be restricted to bacterial diseases like fire-blight of pear or bean blight. When some definite system of naming diseases is adopted, it is likely that a tabula-

tion of methods of control will be somewhat simplified, for if the term "blight" is restricted to bacterial diseases of the nature of pear blight, it will be understood that certain control measures, such as spraying, will not be effective. At present, each case must be considered separately, and in the following pages the popular names are used. These names are followed by the technical botanical name of the organism causing the disease, in *italics*, and this by a brief description of the disease, the most prominent symptom being mentioned first.

Certain General or Unclassified Diseases

Damping-off. — A term applied to the decay of young seedlings or cuttings at or near the surface of the ground. The trouble is due to the action of various organisms, especially *Pythium deBaryanum*, *Phytophthora cactorum*, *Rhizoctonia* sp., etc. Wet soil, confined atmosphere, and crowded plants are conducive to damping-off.

Control. — Steam-sterilize seed or cutting beds. Sterilize nursery seed beds with formalin, using 1 gallon of 1 per cent solution to the square foot, *i.e.* 1 pint of formalin in 12-15 gallons of water.

Œdema or Dropsy. — A disorder of various plants under glass, as tomatoes, violets, geraniums, which have insufficient sunlight, stimulating temperature and soil, and too much moisture. It has also been observed on twigs of the apple. It is usually indicated by elevated corky or spongy points or masses, much resembling fungous injury. The leaves curl. The only remedy is to improve conditions under which the plants are grown.

Smuts of cereals. — Practically every cereal is attacked by a specific smut fungus, and most of them by two perfectly distinct species. These smuts are confined to a single species of cereal, and never cross from one to another. Some of the smuts produce a loose black spore-mass (loose smuts), while in others (covered smuts) the seed coat of the grain is not affected, so that the smut is not detected until the grain is broken open. The most important difference to be noted, however, is the method of wintering. In some the spores adhere to the surface of the seed and infect the young seedling plant at the time of germination, while in the other case the spores fall upon the blossoms and grow down into the seed directly, there lying dormant until the seed is planted.

Control. — The treatment is very different in the two cases. If the spore is on the surface of the seed, it may be killed with formalin; but if the seed is infected internally, a different treatment is necessary. The formalin treatment is very simple and inexpensive. Select a clean place on the barn floor, and heap the seed grain upon it. Make a solution of formalin at the rate of 1 pint of formalin to 50 gallons of water. Use as many gallons of this solution as there are bushels of grain to treat. Shovel the grain over, and at the same time spray the formalin over with a sprinkling pot. Shovel over twice, and then cover two hours or over night with blankets or canvas. Spread out the grain to dry. Make allowance for swelling of the seed at the rate of one peck per acre. When the infection is internal, the hot water process of treatment must be resorted to. Obtain a reliable thermometer, and make arrangements to keep a quantity of water at perfectly uniform temperature. Soak the seed in water at ordinary temperature for five to seven hours. Then place it in small loose sacks or wire baskets containing not more than a half peck each, and allow to drain. Provide two tubs or vats, of 30 or 40 gallons capacity, which can be heated, or provide in addition an iron kettle for heating a quantity of water. Heat the water in the two vats to the temperature indicated below. Immerse the drained sacks of seed in tub 1 to remove the chill, then suspend in tub 2 for the indicated length of time. Keep the temperature of tub 2 constant by applying heat or adding small amounts of boiling water. Treat for the indicated time, remove, and dry.

BARLEY. COVERED SMUT (*Ustilago hordei*). — The covering is thin and easily broken, and when old may resemble loose smut. Seedling infection.

Control. — Formalin, as indicated above.

LOOSE SMUT (*Ustilago nuda*). — The smutted heads are loose and black from the first. Flower infection.

Control. — Hot water, as indicated above. The temperature of tub 2 should be 127° F., and the seed should be left in fifteen minutes. If the temperature of tub 2 varies slightly from 127°, the length of treatment should be lengthened or shortened accordingly as the temperature is below or above that desired.

In no case should the temperature go above 129° or below 124° F. This treatment will also be effective for covered smut.

OATS. LOOSE SMUTS (*Ustilago avenæ* and *Ustilago levis*). — Both characteristic loose smuts, and both seedling infection.

Control. — Formalin treatment, as indicated above.

WHEAT. STINKING SMUT OR BUNT (*Tilletia foetens*). — Can be detected in the field by the flaring of the beards, in the bin by the peculiar fetid odor and by breaking open the kernels. The seed coat remains intact. Seedling infection.

Control. — Formalin treatment, as above.

LOOSE SMUT (*Ustilago tritici*). — Characteristic loose smut of the head appearing at blossoming time. Flower infection.

Control. — Hot water, as indicated above. The temperature of tub 2 should be 129° F., and the seed should be left in ten minutes. If the temperature of tub 2 should go above 129° or fall below 126° the length of treatment should be diminished or increased accordingly. In no case should the temperature go above 131° or below 124° F.

Storage rots (*Penicillium expansum* and *P. italicum*). — These two organisms are responsible for much of the rot appearing in storage or transportation. The former is the common one on apples, the latter on oranges and lemons. These organisms are not able to enter through an unbroken surface, but are dependent upon cracks, bruises, scab spots, etc.

Control. — Avoid puncturing the skins with shears or fingernails, handle and pack with care to prevent bruises, and spray to prevent scab spots. Store at a temperature of 32°. In making long distance shipments, pre-cool the car and ship under ice.

Diseases of different Plants or Crops

Alfalfa. LEAF SPOT (*Pseudopeziza medicaginis*). — Small black spots on the leaves. Causes the leaves to turn yellow and fall.

Control. — Frequent close mowing usually holds the disease in check.

DODDER (*Cuscuta epithymum*). — A tangled mat of yellow threads entwining the alfalfa stems. Usually appears in spots in the field and spreads from these points. Is easily spread by the rake,

and especially in seed. Dodder is not a fungus, but a specialized parasitic plant of the morning-glory family.

Control. — As soon as discovered, cover the infested spot with straw and oil and burn. Screen the alfalfa seed to remove seed of dodder. Make a screen 12 inches square by 3 inches deep with a 20 × 20 mesh wire-cloth made of No. 34 steel wire. Sift each half pound of seed vigorously for one half minute.

Almond. BLIGHT (*Coryneum beyerinkii*). — See PEACH BLIGHT, p. 275.
 YELLOWS. See under PEACH.

Apple. BLIGHT. — The same disease as PEAR BLIGHT, which see.

BITTER-ROT OR RIPE-ROT (*Glomerella rufomaculans*). — Produces a browning and drying of the fruit. Progressing in concentric rings from a central point. Attacks nearly mature fruit. Also occurs on limbs, where it produces a canker scarcely distinguishable from New York apple-tree canker (p. 264).

Control. — Trim out all cankers early in the spring, and remove all mummied apples from the trees. In addition to the sprayings for apple scab, make three, four, or five sprayings with Bordeaux mixture, 3-3-50, according to the severity of the disease and the character of the summer as regards rainfall.

BLACK-ROT of fruit. — Fruit stage of the New York apple-tree canker disease, which see.

BLOTCH (*Phyllosticta solitaria*). — Attacks fruit, twigs, and leaves. Blotches a quarter of an inch or more in diameter appear on the fruit. These often coalesce, and the fruit often cracks deeply. Scurfy cankers are formed on the twigs while very small; circular spots a quarter of an inch in diameter are formed on the leaves. Ben Davis is especially susceptible.

Control. — Careful pruning to remove cankered twigs. Spray as for apple scab and bitter rot.

BROWN-ROT. — See under CHERRY (p. 267).

CANKER. — Smooth cankers in bark of trunk and limbs usually indicate blight, rough ones New York apple-tree canker.

COLLAR-ROT. — A dead area in the bark near the ground; often girdles the tree. Cause not known. May be started in some cases by the fire-blight organism, in others by winter injury. Common on King, Baldwin, and Ben Davis.

Remedy. — As soon as noticed, cut away dead bark and wood

to the living healthy tissue. Swab the wound with a solution of corrosive sublimate, 1:1000, and paint over with a lead paint which is free from turpentine. Slit the callus on the edge from year to year to make it spread faster, and keep dead wood well protected with paint.

CROWN-GALL (*Bacterium tumefaciens*). — See under PEACH, p. 276.

NEW YORK APPLE-TREE CANKER (*Sphaeropsis malorum*). — The fungus causing the disease attacks limbs, causing roughened cankers and often girdling the limb; attacks leaves, causing a reddish brown leaf-spot, and on the fruit produces a black rot. Abundant on Twenty Ounce.

Control. — Remove and burn old cankers. Clean out and disinfect small cankers as for collar-rot. Soak old limbs well with spray mixture when spraying for scab. Spraying as for apple scab usually controls black rot of fruit, though in the Ozark region a late spraying may be advisable for leaf-spot. Cultivate thoroughly.

POWDERY MILDEW (*Sphaerotheca leucotricha*). — Attacks nursery stock, covering the leaves with a grayish white, powdery mildew. Also on leaves and twigs of new growth in the orchard, often causing the leaves to fall.

Remedy. — Lime-sulfur, 1-40, as applied for scab is a specific.

RUST (*Gymnosporangium macropus*). — A bright yellow rust appearing on the young leaves and fruit. Enfeebles the whole tree and produces one-sided fruits. It is known that one stage in the cycle of the fungus is the cedar apple, which occurs on the red cedar. Apples are always infected from the cedar, never from apple to apple.

Control. — Destroy red cedars in the neighborhood, also wild apples and hawthorns. Spray thoroughly in the spring as for scab.

SCAB (*Venturia inaequalis*). Olive green, brownish or blackish scab-like spots on leaves and fruit. Arrests growth, and often causes distortion. In severe cases may make the leaves and young fruit fall. Makes leaves susceptible to spray injury. The fungus is known to be dependent upon weather conditions, as outlined in the beginning of this chapter. The fungus winters regularly on the dead fallen leaves. In the milder climate of Virginia, the fungus may winter on the twigs.

Control. — Rake and burn leaves, or plow under very early (before blossom buds open). Spray with lime-sulfur 32° Beaumé, 1-40, or bordeaux, 3-3-50: (a) when blossom buds show pink, but before they open; (b) when the majority of petals have fallen; (c) three weeks after *b* depending upon the weather; (d) if a late attack is feared, spray thoroughly before the fall rains begin.

Apricot. LEAF-RUST. — See under PLUM, p. 279.

YELLOW. — See under PEACH, p. 276.

BLACK-SPOT or SCAB. — See under PEACH.

Asparagus. RUST. — (*Puccinia asparagi*). A rust of the tops, which is often so severe as to kill them, thus interfering with root development.

Control. — Three weeks after cutting stops dust the young tops with dry sulfur at the rate of 1½ sacks of sulfur per acre. This should be done very early in the morning while the dew is still on, and only on a dewy morning. In a month or less make another application, using 2 sacks of sulfur per acre. The sulfur must go on in a dusty, smoky cloud and form a covering over all the growth. Flowers of sulfur is more satisfactory for this work, and is less expensive in the long run. Dusting machines may be obtained on the market.

Barley. SMUT. — See under SMUT OF CEREALS, p. 260.

Bean. ANTHRACNOSE or POD-SPOT (*Colletotrichum lindemuthianum*). — Reddish-brown scab-like spots appearing on stems, pods, and veins of leaves, particularly on yellow-podded snap beans. The fungus grows through the pod and into the young bean seed. It lies dormant in the seed, and becomes active when the bean is planted.

Control. — Select pods which are free from the spots and save the seed for planting. Such seed will grow a clean crop. If disease appears in the garden, it can be controlled by thoroughly hand spraying the vines from beneath as well as above, repeating the operation every ten days as long as necessary.

BLIGHT (*Bacterium phaseoli*). — A bacterial disease. Causes large, papery spots on leaves and watery spots on pods.

Control. — As for ANTHRACNOSE.

Bean, Lima. — BLIGHT (*Phytophthora phaseoli*). — Attacks the pods in August and September, covering them with a white, felted coating. It also attacks shoots and leaves.

Control. — Spray with bordeaux, 4-4-50, beginning about August first, and making applications at intervals of ten days or two weeks.

Beet. HEART-ROT (*Phoma betæ*). — Leaves appear spotted late in July, then wilt, and finally a dry heart rot appears.

Control. — Destroy infected plants. Practice long rotation. Treat seed with formalin, 1 pint in 30 gallons of water.

LEAF-SPOT (*Cercospora beticola*). — Ashen gray spots with reddish borders occurring on leaves. In advanced stages, leaf becomes much cracked and torn.

Control. — Spray with bordeaux mixture, 4-4-50, at frequent intervals.

SCAB (*Oospora scabies*). — Fungus produces a scabby patch on the root. The same disease as potato scab.

Control. — Avoid planting beets after potatoes for several years.

Blackberry. *Anthracnose.* — See under RASPBERRY, p. 280.

CROWN-GALL OR ROOT-GALL (*Bacterium tumefaciens*). — A bacterial disease which soon ruins the bushes.

Treatment. — Plow up and burn all bushes in a diseased patch. Plant clean roots in a new place.

RED OR ORANGE RUST. — See under RASPBERRY.

Brussels sprouts. **CLUB-ROOT.** — See under CABBAGE.

Cabbage. **CLUB-ROOT OR CLUB-FOOT** (*Plasmidiophora brassicæ*). — A contorted swelling of the roots of cabbage in the seed bed or field, preventing the plant from heading and causing it to assume a sickly color. Occurs on many allied plants — turnips, cauliflower, Brussels sprouts, chard, radish, wild mustard, etc.

Control. — Destroy affected seedlings. Rotate crops, and do not follow with other susceptible crops. Keep down weeds on which disease occurs. Lime the soil at least eighteen months before planting to cabbage, using at the rate of two tons of quicklime to the acre.

BLACK-ROT (*Bacillus campestre*). — The bacteria causing this disease get into the sap tubes, turn them black, and cause the leaves to drop, thus preventing heading.

Control. — Practice crop rotation. Soak the seed for fifteen minutes in a solution of mercuric chloride, one tablet in a pint of water.

Carnation. RUST (*Uromyces caryophyllinus*). — Produces brown, powdery pustules on stems and leaves.

Control. — Take cuttings only from healthy plants. Pick off diseased leaves. Spray once in two weeks with a solution of copper sulfate, 1 pound to 20 gallons. Keep water from leaves, and grow the plants at as low temperature as is compatible with best development.

STEM-ROT (*Rhizoctonia* and *Fusarium*). — The former produces a sudden wilting of the plant, and the stems are soon dead and dry. The latter produces a slow rot of the heart, one branch dying at a time. The treatment is the same.

Control. — In the field change the location every year. In the greenhouse sterilize the soil with steam.

Cauliflower. See under CABBAGE.

Celery. EARLY LEAF-BLIGHT (*Cercospora apii*). — A spotting and eventual blighting of the leaves early in the summer. Begins in the seed-bed. It is favored by hot weather, either wet or dry.

Control. — Spray with ammoniacal copper carbonate, 5-3-50, beginning in the seed bed and keeping the new growth covered throughout the season.

LATE BLIGHT (*Septoria petroselini* var. *apii*). — A fungous disease, appearing late in the season, causing a blight of the foliage, and often destructive after the celery is stored.

Control. — As above, except that spraying should be continued up to harvesting time. In either case, the disease is practically controlled by growing the plants under half shade.

Cherry. BROWN-ROT (*Sclerotinia fructigena*). — Attacks flowers, leaves, and fruit. The flowers die and decay, the leaves become discolored with irregular brown spots, and the fruit rots on the tree. Attacks also peaches, plums, and apples.

Control. — Spray with bordeaux mixture, 4-4-50, or lime-sulfur, 1-40, (a) just before the blossom buds open; (b) just after the blossoms fall; (c) make one or two more applications at intervals of ten days.

LEAF-RUST. See under PLUM, p. 279.

POWDERY MILDEW (*Podosphaera oxycanthæ*). — Attacks leaves and twigs, often causing defoliation. Serious on nursery stock. Spray-

ing as for brown rot usually controls this trouble. If it appears, spray with lime sulfur, 1-40, or dust heavily with powdered sulfur.

LEAF-SPOT (*Cylindrosporium padi*). — A fungous disease in which the leaves become thickly spotted with reddish or brown spots and fall prematurely. The spots often drop out, leaving shot holes.

Control. — Spray with lime sulfur, 1-40, or with bordeaux mixture, 4-4-50, as for brown rot.

WINTER INJURY. — Trees so injured make a scant growth; many leaves turn yellow and fall about picking time; gum exudes at the crotches and about the trunk; sometimes the bark on the stock is entirely killed, in which case the tree languishes and finally dies.

Control. — It is thought that heavy applications of highly nitrogenous fertilizers in late summer favor winter injury. Do not stimulate the tree to too active wood development. Cut out the gum pockets and cankers, and paint them with a heavy lead paint.

Chestnut. BARK DISEASE (*Diaporthe parasitica*). — A fungous disease, attacking the bark of the American chestnut. Limbs and trunk are girdled, and the tree dies. The disease is present in many of the nurseries.

Control. — Inspect nursery stock very carefully, especially about pruned stubs. Discard diseased trees. Make a careful examination of old trees, especially about old wounds and pruned stubs. If the disease is present, clean out the diseased wood with a gouge, and coat heavily with gas-tar. If the disease has progressed far, cut off diseased limbs or the whole tree and burn at once. Keep all wounds and pruned stubs covered with gas-tar.

Chrysanthemum. LEAF-SPOT (*Septoria chrysanthemi*). — First appears as dark brown spots, which increase in size until the leaf dies.

Control. — Pick and burn diseased leaves. Spray the plants with bordeaux mixture, 4-4-50.

RUST (*Puccinia chrysanthemi*). — Reddish brown rust pustules on the leaves.

Control. — Avoid wetting the foliage when watering. Spray as for LEAF SPOT.

Corn. EAR-ROT (*Diplodia zeæ*). — Several other organisms may cause an ear rot, but this is the more common one. The ear is imperfectly developed, soft, and overrun with a whitish mold. In many cases the husks and silk are also involved.

Control. — Destroy old infected ears and stalks. Practice a rotation which will exclude corn for two years from or near the given plat of ground.

RUST (*Puccinia maydis*). — Reddish pustules on the blades. Common on some varieties of sweet corn.

Control. — No satisfactory method of control is known.

SMUT (*Ustilago zeæ*). — Attacks stalks, ears, and tassels, producing abnormal boils or outgrowths. Will infect at actively growing points at any time.

Control. — Rotate crops. Do not manure corn ground. Cut out smut and burn it. Soaking seed is of no avail.

Cotton. **ANTHRACNOSE** (*Colletotrichum gossypii*). — Forms black or purplish colored spots on bolls. Disease also occurs on seed leaves and on the leaves and stems. Select seed from fields free from the disease. Rotate crops. Use disease-resistant varieties.

ROOT-ROT (*Ozonium omnivorum*). — Easily recognized by the sudden wilting and dying of the plants in the field.

Control. — A combination of rotation of crops and deep fall plowing is effective.

WILT (*Fusarium vasinfecta*). — Causes a gradual wilt and eventual death of leaves and stems.

Control. — Rotate crops. Secure seed of wilt-resistant varieties of cotton.

Cranberry. **BLAST or SCALD** (*Guignardia vaccinii*). — The fungus causes a blast of the flowers and very young fruits, and attacks older fruits, causing them to appear scalded or watery.

Control. — Spray five or six times with bordeaux mixture, 5-5-50, to which has been added 4 pounds of resin fish oil soap, making the first application just before the blossoms open. Long lines of hose are most satisfactory for this work, and the spraying must be done thoroughly.

ROT. (*Acanthorhynchus vaccinii*). — A disease which cannot be distinguished from scald with the naked eye.

Control. — As for SCALD.

HYPERTROPHY (*Exobasidium oxycocci*). — Appears on the young leaves soon after the water has been let off in the spring. The axillary leaf buds are attacked and produce short shoots with rather close, enlarged, swollen, and distorted leaves which are

pink or light rose color. The production of fruit is prevented or reduced.

Control. — Early spraying with bordeaux mixture has been advised.

Cucumber. ANTHRACNOSE. — See under MUSKMELON, p. 274.

BLIGHT or MILDEW (*Pseudoperonospora cubensis*). — A blighting and premature yellowing of the foliage.

Control. — Spray with bordeaux mixture, 5-5-50. Commence to spray when the plants begin to run, and repeat every ten to fourteen days throughout the season.

WILT (*Bacillus tracheiphilus*). — This is a disease caused by bacteria that get into the sap tubes of the leaf and stem, clog and destroy them, causing the plant to wilt. The bacteria are distributed chiefly by the striped cucumber beetle.

Control. — Control the striped beetle. See p. 318. Gather and destroy all wilted leaves and plants.

WILT (*caused by malnutrition*). — Excessive fertilizing with highly nitrogenous fertilizers will sometimes produce a peculiar curling and wilting of the leaves.

Currant. ANTHRACNOSE (*Glaosporium ribis*). — Small dark brown spots, chiefly on the upper surface of the leaf. The leaves finally turn yellow, and fall in July or August.

Control. — Thorough applications of bordeaux mixture, 5-5-50.

LEAF-SPOT (*Septoria ribis*, *Cercospora angulata* etc.). — Whitish spots with black centers. Appears in midsummer, and causes defoliation.

Control. — As for ANTHRACNOSE.

WILT or CANE-BLIGHT. — A destructive fungous disease which causes the canes to die suddenly. Character of the wilting much like that produced by the cane-borer.

Control. — No satisfactory method known. The most that can be done is to go over the patch three or four times during the summer, cut out and burn the blighted canes.

Ginseng. **BLIGHT** (*Alternaria panacis*). — Papery brown spots on the leaves, which spread until the whole leaf is involved. Also attacks the seed heads, producing a blast.

Control. — In the spring before the plants come through the ground spray the soil thoroughly with copper sulfate, 1 pound to

10 gallons of water. As the plants are breaking through the soil, spray with bordeaux, 3-3-50. Spray repeatedly while the plants are coming through the ground, making a special effort to cover the stems. Keep all growth covered with spray throughout the summer. Spray the seed heads thoroughly just after the blossoms fall, and again when they are two-thirds grown. Destroy all diseased tops.

FIBER ROT (*Thielavia basicola*). — Commonly called rust or rusty root, from the characteristic appearance. The plants eventually wilt and die.

Control. — Treat the soil with acid phosphate at the rate of 1000 pounds to the acre. Dip the roots in bordeaux mixture, 3-3-50, before planting.

MILDEW (*Phytophthora cactorum*). — Attacks tops shortly after they come up.

Control. — Thorough spraying early, as for blight, will control this disease.

WILT (*Acrostalagmus* sp.). — A sudden wilting of the whole plant, caused by the action of the fungus in the sap tubes of the root.

Control. — Remove the wilted plants as soon as discovered in order to prevent further spread.

ROOT-ROT. — Caused by various soil organisms. Favored by wet, soggy soil.

Control. — Underdrain the soil thoroughly.

Golden-seal. — Consult treatments under GINSENG.

Gooseberry. — **MILDEW** (*Sphaerotheca mors-uvæ*). — A powdery mildew attacking the fruit and young growth of English varieties of gooseberry.

Control. — As soon as the leaves begin to unfold, spray with potassium sulfid, 1 ounce to 2 gallons of water.

RUST (*Æcidium grossulariæ*). — Orange-colored rust pustules on the fruit and under side of the leaves.

Control. — Early spraying as for MILDEW. Keep down sedges and grasses.

Grape. **ANTHRACNOSE** (*Sphaceloma ampelinum*). — Occurs on the fruit as a definite dark brown spot with a lighter aureole; on canes as deep pits with an elevated red margin, and on veins of

the leaves, causing the leaves to crimp. Occurs on all varieties, especially Roger's hybrids. Not so abundant as formerly.

Control. — It is said that an early spraying before the buds open with sulfate of iron, 100 pounds to 50 gallons of water, is very important. Later sprayings for black rot will also be effective in preventing spread.

BLACK-ROT (*Guignardia bidwellii*). — The most serious disease of grapes east of the Rocky Mountains, especially southward. Attacks all green parts. Produces a brown circular spot on leaves, a black, elongated, sunken pit on petioles, canes, etc., and on the berry a brown rot with shriveling and wrinkling; finally the berry becomes black and hard.

Control. — This disease may be controlled by timely applications of bordeaux mixture, 4-4-50. It is of great importance that spraying be done before rain storms, as the berry enlarges so rapidly. Spray (a) when the third or fourth leaf has unfolded; (b) as soon as the blossoms have fallen; (c) when the berries are the size of a pea; (d) in about two weeks. In a wet season make two more applications. After July 20 make the bordeaux 4-2-50, or use ammoniacal copper carbonate. In case of dense foliage all applications except the first two should be made by hand. Attach trailers to the sprayer, and have two men following to apply the spray directly to the clusters. About ten acres can be sprayed in a day, and the total cost of labor and material should not exceed 75 cents per acre for each application.

CALIFORNIA VINE-DISEASE. — An obscure disease, which destroyed thousands of acres of vines in California. Cause not known, and at present practically unknown and of no importance economically.

CROWN-GALL or **BLACK KNOT** (*Bacterium tumefaciens*). — A tumorous, gnarled outgrowth on roots and stems, especially on European varieties. Frost injury often forms an infection court for the bacteria. See p. 276.

Control. — Grub out and burn infected vines.

DOWNY MILDEW or **LEAF-BLIGHT** (*Plasmopara viticola*). — Appears in white frost like patches on under side of leaf, the upper side of the leaf showing a yellowish discoloration; gradually spreads to all parts of the leaf causing it to dry up. Attacks the berry, which

remains hard and white or gray. Worst on hybrids with *vinifera* blood ; especially common on Delaware and Roger's hybrids. Widespread in North America.

Control. — Spray as for BLACK-ROT.

NECROSIS or DEAD-ARM DISEASE (*Fusicoccum viticolum*). — Attacks shoots, and progresses from there to the old wood, causing a dry rot and eventual death of the vine.

Control. — Inspect canes at trimming time, and use care not to leave those on which the brownish black spots are present. Train up renewals from the root, and cut off the old stem below the diseased area.

RIPE-ROT (*Glomerella rufomaculans*). — See under APPLE, p. 263.

Treatment as for black-rot is efficacious.

SHELLING or RATTLES. — Cause unknown. The berry breaks squarely off at its juncture with the pedicle. The leaves on such vines usually turn reddish brown about the margin. Powdery mildew is sometimes responsible for shelling.

Control. — No method is known.

Hollyhock. ANTHRACNOSE (*Colletotrichum malvarum*). — Angular brown spots on leaves and stems which spread, killing the entire leaf.

Control. — As for RUST.

RUST (*Puccinia malvacearum*). — Attacks all parts of the plant, causing reddish brown pustules on affected parts ; later leaving deep pits ; may entirely destroy the leaves. It is abundant on the common mallow or "cheeses."

Control. — Eradicate the mallow ; pick off diseased leaves in the fall, and burn all litter. Repeat in the spring, and spray new growth thoroughly with bordeaux mixture, 4-3-50. Spray every week until the flower-stalks are well developed.

Lettuce. LEAF PERFORATION (*Marssonia perforans*). — Dead areas in the leaves which finally drop out. Also on veins of the leaves.

Control. — As for ROSETTE (p. 274).

DOWNY MILDEW (*Bremia lactuæ*). — Yellow spots on the upper surface of the leaf, accompanied by a frosty growth on the opposite side.

Control. — Destroy infected plants. Keep water from the leaves ; furnish water by means of subirrigation.

DROP or ROT (*Sclerotinia libertiana*). — Base of the leaves or stem rots off, allowing leaves to drop.

Control. — Sterilize the soil with steam before planting. See under *Steam* in Chapter XV, p. 253.

ROSETTE (*Rhizoctonia* sp.). — A rotting or damping-off of the stem. Late affected plants have a rosetted appearance.

Control. — Start seed in steam-sterilized soil, and transfer to beds that have been sterilized with steam, as for **DROP**.

Muskmelon. **ANTHRACNOSE** (*Colletotrichum lagenarium*). — Dead spots on the leaves and stems and sunken pits on the fruit. Thorough and frequent spraying with bordeaux mixture will hold this disease in check.

DOWNY MILDEW. — The same disease as on cucumbers (p. 270). Often very destructive.

Control. — A satisfactory method is not known. Spraying as for cucumber mildew has not proved effective.

WILT. — See **CUCUMBER**.

Nectarine. **Yellows, etc.** See under **PEACH**, p. 276.

Nursery Stock. — Foliage on young trees is apt to be attacked by various leaf-spot fungi. The damage comes in reducing growth, thus often making seconds. Several applications of bordeaux mixture to keep the new growth protected are beneficial.

Oats. **RUST** (*Puccinia coronata*). — A red rust of the blades.

Control. — There is no known method of control.

SMUT. — See under **SMUT OF CEREALS**, p. 260.

Onion. **MILDEW** (*Peronospora schleideniana*). — Causes a wilt or blight of the leaves.

Control. — Spray with bordeaux mixture, 5-5-50, to which has been added one gallon of resin-sal-soda sticker. The first application should be made when the third leaf has developed, and the application should be repeated every ten days until the crop is harvested.

SMUT (*Urocystis cepulæ*). — Forms black pustules on the leaves and bulbs. Seedlings may be killed outright.

Control. — Onions from sets or from seed started in soil free from the disease seldom have the smut. Practice crop rotation. Drill into the soil with the seed 100 pounds of sulfur and 50 pounds of air-slaked lime to the acre.

Pea. MILDEW (*Erysiphe polygoni*). — A powdery mildew on pods and leaves.

Control. — Dust dry sulfur over the plants, repeating the operation if necessary.

POD SPOT AND LEAF-SPOT (*Ascochyta pisi*). — Black circular spots on stems, leaves, and buds. The fungus grows through the pod into the seed, and is thus carried through the winter.

Control. — Select pods free from spots, and save the seed from these for the next year's planting. On a large scale have a clean seed garden in which to grow clean seed for the following year.

Peach. BLIGHT (*Coryneum beyerinkii*). — A spotting, gumming and death of the buds and twigs, particularly in the lower part of the tree. The fruit drops. Especially serious in California.

Control. — For California conditions two applications of spray are made: (a) in November or December, and (b) in February or March. This also controls leaf-curl. Bordeaux mixture, 5-5-50, or lime-sulfur, 1-10, may be used.

BROWN-ROT (*Scerotinia fructigena*). — Causes a rot of the fruit, and often runs down the spur, forming a canker in the limb. Also produces brownish irregular spots on the leaves.

Control. — Spray with self-boiled lime-sulfur, 8-8-50, adding 2 pounds of arsenate of lead. Spray first about time shucks are shedding from young fruit; second, two to three weeks later, and third, about one month before the fruit ripens. Omit the arsenate of lead from the third spraying. On early maturing varieties two applications may be sufficient. Spraying within a month of picking time is apt to leave the fruit spotted. It is especially important that sprayings be made before a continued storm period. Destroy rotten peaches. The rotten ones on the ground are as great a menace (especially if plowed under) as those on the tree, as the fungus winters readily on the fallen mummies. Brown-rot also occurs on cherries, plums, apricots, and sometimes on apples and pears.

LEAF-CURL (*Exoascus deformans*). — Causes the leaves to crimp and curl and often to turn bright red. Also causes shoots to swell and become distorted.

Control. — In an infected orchard more than 90 per cent of

the curl can be controlled the first year. The second year control should be complete. The secret of control of leaf-curl lies largely in the thoroughness with which the work is done. A number of spray substances may be used. A single thorough application before the buds swell in the spring is sufficient. Every bud must be covered and from all sides. Lime-sulfur as applied for San José scale will control curl. Commercial lime-sulfur, 1-20; bordeaux mixture, 4-4-50; or a simple solution of blue vitriol in water, 2-50, are all specifics.

LEAF-RUST. — See under PLUM (p. 279).

LITTLE-PEACH. — A disease that in its early stages resembles yellows. It differs from yellows in producing small fruit that matures later than normally. Fruit does not have the small red spots characteristic of yellows, nor are there slender sickly branches. The cause of this disease is unknown. Apparently spreads more rapidly than yellows and commonly destroys the affected tree sooner. Occurs in the northern states.

Preventive. — As for YELLOWS (see next page).

POWDERY MILDEW (*Sphærotheca pannosa*). — A whitish powdery growth on the young shoots and leaves, and whitish spots on the fruit.

Control. — Self-boiled lime-sulfur as for ROT.

ROOT-GALL, ROOT-KNOT, CROWN-GALL, HAIRY-ROOT (*Bacterium tumefaciens*). — Hairy roots or tumorous outgrowths on the roots and root crowns; sometimes occurs on trunks and limbs. Primarily a nursery disease. Does not seem to be a serious disease on peaches in the North, but is reported as very serious in the South. Attacks a wide range of orchard plants, including apple, pear, brambles, grape, etc.

Control. — Reject all stock showing symptoms.

ROSETTE. — An obscure southern disease of peach trees and some kinds of plums, characterized by bunchy growths containing very many rolled and yellowish leaves which fall prematurely. The tree dies the first or second year. There is no premature fruit as in yellows. It is often accompanied by gummosis of the roots. The disease is communicable by budding, and it may enter through the roots. All affected trees should be exterminated. Known in South Carolina, Georgia, Kansas, and Arkansas.

SCAB OR BLACK-SPOT (*Cladosporium carpophilum*). — Black scab-like spots on the fruit, often causing it to crack deeply.

Control. — Self-boiled lime-sulfur, as applied for BROWN-ROT.

YELLOW. — A fatal disease of peaches; also attacks nectarine, almond, apricot, and Japanese plum. Cause unknown. The first symptom in bearing trees is usually the premature ripening of the fruit. This fruit contains definite small red spots, which extend towards the pit. The second stage is usually the appearance of "tips," or short, late, second growths upon the ends of healthy twigs, and which are marked by small, horizontal, usually yellowish leaves. The next stage is indicated by very slender shoots, which branch the first year and which start in tufts from the old limbs, bearing narrow and small yellowish leaves. Later the entire foliage becomes smaller and yellow. In three to six years the tree dies. The disease spreads from tree to tree. It attacks trees of any age. Known at present only in regions east of the Mississippi. Peculiar to America, so far as known.

Preventive. — Pull up and burn all trees as soon as the disease appears. Trees may be reset in the places from which the "yellows" trees were taken. Laws aiming to suppress the disease have been enacted in most peach-growing states, and the enforcement of them will keep the disease well under control.

Pear. **BLIGHT** (*Bacillus amylovorus*). — A very serious bacterial disease. Bacteria winter just at the edge of the dead wood in trees blighted the previous year. With the advent of warm spring days they ooze through the bark in sticky drops and are carried by bees and flies to blossoms. The blossoms blight, and the spur may also blight. Plant-lice carry bacteria from blighted blossoms to spurs and shoots. If a spur becomes blighted, the bacteria may spread in the bark of the limb, causing a depression or canker. This may girdle the limb and cause its death. The leaves turn black and stick tenaciously, even through the winter. Succulent water sprouts are very apt to blight and cause large cankers. Generally distributed in North America, and known only in America. Attacks apple, quince, mountain ash, hawthorn; the Spitzenburgh is specially liable to attack.

Control. — Clean up hedgerows of hawthorn, old blighted pear trees and apple trees. In early spring cut out the blight

of the previous year and disinfect the stubs with corrosive sublimate, 1-1000. Clean out cankers with a sharp knife, and disinfect. Paint over with lead paint. At blossoming time make a systematic daily inspection for blossom blight, and break it out. Watch for blight in the shoots. When it appears get a long-handled pruning-hook, fasten a sponge near the knife, and saturate it with corrosive sublimate solution, 1-1000. Clip out the blighted twigs, cutting five or six inches below the blight, and sop the pruned stub with the sponge. During a blight epidemic, drop all other work. The work must be done systematically and persistently, or not at all. One week's work may save the pear crop and the pear trees.

LEAF-BLIGHT AND CRACKING OF FRUIT (*Fabrea maculata*). — Attacks nursery stock of pears and quinces, beginning as small circular brown spots on the leaves. These spread, and if numerous cause the leaf to fall. The same disease produces a black spot or pit on the fruit.

Control. — In nurseries spray with bordeaux mixture, 4-4-50. In the orchard spray as for pear scab, with perhaps one additional application.

LEAF-SPOT (*Mycosphærella sentina*). — Small lectionular spots with white centers on leaves. Spots become so numerous as to cause defoliation. The fungus is known only on leaves, and it winters on them.

Control. — Burn fallen leaves. Spray as for SCAB.

SCAB (*Venturia pyrina*). — Greenish brown or black spots on leaves and fruit, arresting growth and often causing fruit to crack. Severe on Flemish Beauty. Often attacks pedicles of fruits and causes them to drop, and may even cause defoliation. Is different from apple scab, but behaves much like it. Differs especially in the fact that the fungus winters on the twigs as well as on fallen leaves.

Control. — Owing to the nearness of the fungus (on the twigs) and the slowness with which the pear-leaf unfolds, two applications of spray before the blossoms open are sometimes necessary, and one immediately after they fall. Use lime-sulfur, 1-50, or bordeaux, 3-3-50.

Remarks in regard to apple scab (on page 264) are equally important here.

RUST (*Gymnosporangium globosum*). — Having the same habits and appearance as apple rust.

Control. — As for SCAB.

Plum. BLACK-KNOT (*Plowrightia morbosa*). — A black tumorous swelling from one to several inches in length, appearing on the limbs and twigs of American plums and sour cherries. Point of attack is usually under a bud or in crotches. Confined to America. A very serious disease. In some regions it has destroyed the plum industry. It was once supposed to be caused by an insect.

Control. — Burn all affected parts in the fall. Cut several inches below the swelling. A badly infected tree should be cut down at once, as there is no hope of saving it. Many states have a law requiring the destruction of affected trees.

BROWN-ROT. — See under PEACH (p. 275).

SHOT-HOLE FUNGUS. — See LEAF-SPOT OF CHERRY (p. 268).

LEAF-RUST (*Puccinia pruni-spinosæ*). — Small circular powdery spots of yellowish brown on the under surface of the leaves, and reddish spots on the upper surface directly above them.

Control. — Early spraying with bordeaux, 3-3-50, or self-boiled lime-sulfur, 8-8-50.

POWDERY MILDEW. — See under PEACH (p. 276).

Potato. EARLY BLIGHT (*Alternaria solani*). — A blight of foliage beginning as an even circular spot and coming early in the season, usually in July. Progresses slowly. This disease does not attack the tubers.

Control. — Bordeaux mixture at intervals of ten days, beginning when plants are 6-8 in. high.

LATE BLIGHT and POTATO-ROT (*Phytophthora infestans*). — The fungus winters in the tuber, which shows a faint pinkish tinge and a dry rot. Diseased tubers are planted, the fungus fruits on the cut surface and its swarm spores pass through the soil-water to the leaves which touch or are buried in the soil. An extensive irregular blighted area covers the leaf, the under surface of which may have a mildewy appearance. The disease spreads very rapidly. Later spores are washed down to the tubers and infect them. Appears late in the season, usually not much before August 1.

Control. — Can be controlled successfully by the use of bordeaux mixture, 5-5-50. It is always profitable to spray at least three times, and in a wet season six or more applications should be made. As the vines increase in size, greater quantities of spray and more nozzles must be used. Use from 40 to 100 gallons of spray mixture per acre.

DRY-ROT and WILT (*Fusarium oxysporum*). — A dry rot of the tuber in storage and wilt of plants in the field. Can be detected in the seed tuber before there is any external appearance by examining a section near the stem end. A black ring or chain of dots near the surface is indicative of the rot. Infection frequently takes place through wounds.

Control. — Reject all diseased tubers for seed. Practice a rotation in which potatoes are not grown on the soil for at least two years.

SCAB (*Oospora scabies*). — A scabby and pitted roughness of potato tubers. Lime, ashes or manure added to the soil increases the amount of scab by favoring the growth of the fungus. It has become one of the serious diseases of the potato.

Control. — Do not plant on land which has grown scabby potatoes. Plant clean seed. If only scabby seed is at hand, soak the uncut tubers in a solution of formalin, 1 pint in 30 gallons of water, for two hours. Drain, cut, and plant in clean soil. Use the formalin solution over and over. The same fungus also attacks beets.

Pumpkin. — See under MUSKMELON (p. 274).

Quince. **BLACK-ROT** (*Sphaeropsis malorum*). — A trouble which usually appears at the blossom end of young quince fruits, causing them to become black and hard, with a dry rot of the tissue. The same disease occurs on apples, which see.

BLIGHT. — See under PEAR BLIGHT (p. 277).

LEAF- AND FRUIT-SPOT. — See PEAR-LEAF BLIGHT, which is the same disease.

RUST. — The organism causing this disease is of the same habit and nature as that causing apple rust.

Control. — As for APPLE RUST (p. 264).

Radish. **WHITE RUST** or **MILDEW** (*Albugo candidus*). — A whitish powdery growth on the leaves and petioles, often causing distortion.

Control. — Steam-sterilize the soil before planting.

CLUB-ROOT. — See under CABBAGE (p. 266).

Raspberry. ANTHRACNOSE (*Glæosporium venetum*). — Circular or elliptical, gray scab-like spots on the canes.

Control. — Avoid taking young plants from diseased plantations. Remove all diseased canes as soon as the fruit is picked. Practice frequent rotation.

CROWN-GALL OR ROOT-GALL (*Bacterium tumefaciens*). — Tumerous outgrowths on the roots, especially on red varieties. It is contagious and destructive.

Control. — Never set plants which have galls on the roots. Avoid setting on infested land. See under PEACH (p. 276).

RED OR ORANGE RUST (*Gymnoconia interstitialis*). — A dense red powdery growth on the under side of the leaves of black varieties and of blackberries. The fungus hibernates in the roots.

Control. — Dig up and destroy infected plants.

Rice. BLAST, BLIGHT OR ROTTEN-NECK (*Piricularia oryzae*). — An extensive paling and drying of leaf and stem, and a partial failure of the heads to fill.

Control. — The selection of early maturing varieties is advisable. Burn stubble and trash left in the fields.

Rose. BLACK LEAF-SPOT (*Actinonema rosæ*). — Attacks the full-grown leaves, first appearing as small black spots, but later covering nearly or quite the whole surface with blotches. The spots have frayed edges.

Control. — Spray with ammoniacal copper carbonate, beginning with the first appearance of the spots and continuing at intervals of one week until under subjection.

MILDEW (*Sphærotheca pannosa*). — A white powdery mildew on the new growth.

Control. — For greenhouse roses keep the steam pipes painted with a paste made of equal parts lime and sulfur mixed with water. Out-of-door roses should be dusted with sulfur flour or sprayed with potassium sulfid, 1 ounce to 3 gallons of water.

Spinach. — There are numerous fungous diseases of this crop, but a practical method of control has not been developed. The best that can be done is to rotate crops.

Strawberry. LEAF-SPOT OR LEAF-BLIGHT (*Mycosphærella fragariæ*). —

Small purple or red spots appearing on the leaves. They increase in size and make the leaf appear blotched. The fungus passes the winter in the old diseased leaves that fall to the ground.

Control. — In setting new plantations remove all diseased leaves from the plants before they are taken to the field. Soon after growth begins, spray the plants with bordeaux mixture, 4-4-50. Make three or four additional sprayings during the season. The following spring spray just before blossoming, and again in ten to fourteen days. If the bed is to be fruited again, mow the plants and burn over the bed as soon as the crop is off.

MILDEW (*Spherotheca castagnei*). — A whitish cobweb-like mildew on fruit and leaves, causing the latter to curl.

Control. — Spraying as for leaf-spot ; dusting with sulfur flour.

Sweet-potato. BLACK-ROT (*Ceratocystis fimbriata*). — Causing black shank of the plant and a black rot of the tuber. The spots on the tuber are greenish black, from a quarter of an inch to four inches in diameter and extending for some distance into the tissue.

Control. — Never use affected potatoes from which to grow sprouts. Steam-sterilize the soil in the hotbed. Practice rotation.

ROTS. — The sweet-potato is susceptible to a large number of rots, soft, dry, hard, white, etc. In practically all cases the organism producing the disease is an inhabitant of the soil. The best method of preventing these diseases is to use perfectly sound potatoes for sprouts and plant on soil which has not grown sweet-potatoes for several years.

Tobacco. ROOT-ROT (*Thielavia basicola*). — A rot of the main root and dwarfs the plants. Occurs both in seed-bed and field.

Control. — Steam-sterilize the seed-bed by the inverted pan method. (See discussion on p. 253.) Rotate crops. Avoid liming, and add acid fertilizers.

WILT (*Bacterium solanacearum*). — A wilt of the plants caused by bacteria.

Control. — Very difficult to control, as the organism lives in the soil for years. Never plant on land known to be diseased. Do not cultivate related plants, as potato, tomato, egg plant, or pepper, on the same soil. Transplant early, and avoid breaking the

roots. Where tobacco is grown under shade (as is now a common practice) the soil should be steam-sterilized.

Tomato. BACTERIAL BLIGHT. — See TOBACCO WILT.

BLIGHT OR SCAB (*Cladosporium fulvum*). — Soft brown irregular spots on the under surface of the leaves. The upper surface becomes spotted with yellow. The leaves finally wither and die. Most serious in the greenhouse.

Control. — In mild cases the disease can be prevented by picking off the affected leaves. In severe cases spray with bordeaux mixture, 4-4-50, at intervals of ten days.

DOWNY MILDEW (*Phytophthora infestans*). — The same fungus that causes POTATO-BLIGHT, which see (p. 279).

END-ROT. — Not well understood, and no method of control is known.

LEAF-SPOT (*Septoria lycopersica*). — A serious disease attacking leaves and stems. At first small spots appear, which spread until the whole leaf is consumed. In severe cases the fruit may also be attacked.

Control. — Spray with bordeaux mixture, 4-4-50, making the first application two weeks after the plants are set out, and repeating every two weeks throughout the growing season.

ŒDEMA. — A diseased condition of forced tomatoes characterized by rolled or curled leaves, distended veins, and by swollen areas having a frosty appearance on leaf veins, petioles and stem. This condition may be brought about by insufficient light, too much water in soil, excessive fertilization, high soil temperature.

Prevention. — Avoid conditions favorable for the disease. Provide good ventilation in forcing-house; in field, cultivate deep and avoid topping plants. (See p. 260.)

Violet. LEAF-SPOTS and LEAF-BLIGHTS. — A number of different organisms are responsible. Usually not very destructive.

Control. — Destroy affected plants; use fresh soil for new plantings; spray the foliage in the summer and fall with bordeaux mixture, 4-4-50.

ROOT-ROT (*Thielavia basicola*). — The same as the root-rot of tobacco. The plants make poor growth, owing to the fungus on the roots.

Control. — Start in steam-sterilized soil, and transfer to sterilized beds.

Wheat-Smut. — See under SMUT OF CEREALS (p. 260).

Seed and Soil Treatments (Ohio Exp. Sta.)

SEED OR PLANT	FOR WHAT TREATED	TREATMENT	METHOD OF TREATMENT
Barley . . .	Smuts	Formaldehyde or modified hot water	Sprinkling with stronger formaldehyde, as for oats, is successful. Soak seed inclosed in sacks 4 hours in cold water, let stand wet 4 hours more, and dip 5 minutes in hot water at 130° F., or three degrees lower than for other hot water treatments.
Bean	Anthraxnose	(See spray calendar)	Submit to fumes for 24 hours in air-tight vessel or chamber.
Begonia . . .	Weevil	Bisulfid of carbon	Disinfect soil to be used by heating with steam, as described under cucumbers.
Cabbage and Cauliflower	Nematodes	Sterilize soil with steam	Apply stone lime (quicklime) preferably ground lime, before planting, at rate of 80 bu. per acre, and work into the soil with suitable tools.
	Clubroot	Quicklime on soil	Make hole in soil near roots, pour in about a teaspoonful of bisulfid of carbon, and fill holes with soil. Cover soil around stalks freely with tobacco dust once per week.
Cucumber . .	Maggot	Bisulfid of carbon or tobacco dust	See next.
	Nematodes in hothouse Nematodes in hothouse	Sterilize soil with steam Sterilize soil with steam	Sterilize soil with steam by perforated pipes, high pressure 1 to 2 hours, or low pressure in sub-drains 4 to 5 hours.
Lettuce . . .	Root-rot	Drench soil with formaldehyde	Drench soil with formaldehyde 3 to 4 lb. to 50 gal. of water preceding lettuce crop.
	Rosette	Sterilize soil with steam or drench with formaldehyde	{ Steam as above or drench with formaldehyde 1½ to 2 lb. where trouble follows with cucumbers 3 to 4 lb. to 50 gal. of water, 1 gal. solution to each square foot of surface. Two weeks must elapse before setting plants.
Oats	Rot	Steam soil	Treat seed as stated in next to kill adhering spores. This is only a partial remedy.
	Anthraxnose	Formaldehyde	{ Preferably sprinkle a pile of seed with shoveling to saturate with formaldehyde solution, one gallon to bushel, at three or four sprinklings; after three or four hours or over night in the pile, spread and dry.
Onion	Loose smut	Sprinkle seed with formaldehyde or immerse seed in hot water. Soak seed in potassium sulfid	Immerse seed contained in open vessel for 10 minutes in hot water at 132°-133° F., for 7 minutes at 136° F., or for 5 minutes at 140°-142° F., spread at once to dry. Soak seed in ¼ per cent solution potassium sulfid for 24 hours with stirring, then dry.
	Insects in stored grain Smudge	(See wheat) Use formaldehyde as for onion smut	Sow seed with formaldehyde as for onion smut; rotato onions with other crops.
Smudge . . .	Smut	Use formaldehyde or ground quicklime. Plant other crop. Use sets or transplanted seedlings	Use formaldehyde solution 1 lb. to 30 gal. of water sprinkled on seed in contact with soil, and cover at once, or better sow with drill and drip attachment, the solution falling with the seed. Or apply ground quicklime at the rate of 75 to 125 bu. per acre just previous to seeding on freshly plowed land, and stir into soil. (See Bulletin 131.)

Onion . . .	Storage-rots . . .	Disinfect with formaldehyde gas . . .	Fumigate to disinfect the dry onions, with formaldehyde gas in inclosed piles of flat crates for a period of 24 to 48 hours. (See description of method under No. 10 above.)
Pea . . .	Anthraxnose (Blight)	Spray the growing crop with Bordeaux . . .	Keep down infection of seed through spraying of plants. See Spray Calendar.
Potato . . .	Scab . . .	Soak uncut seed in formaldehyde or corrosive sublimate . . .	Soak seed for 2 hours in formaldehyde or 1 hour in corrosive sublimate; then dry and plant on scab-free soil; formaldehyde gas may be used.
Roses . . .	Rosette (Rhizoctonia)	Soak seed in formaldehyde as for scab . . .	Soak seed in formaldehyde as for scab; on infested soil use formaldehyde after manner in onion smut. (See Bulletin 145, or <i>Hand-book of Plant Diseases</i> .)
Roses . . .	Nematodes in hothouse	Sterilize soil with steam . . .	Heat soil with steam, as described above; thoroughly disintegrated soil from sod one year or more old is less dangerous. Lime water stimulates affected plants, but is not a remedy.
Rye . . .	Anthraxnose . . .	Formaldehyde . . .	Treat seed as for oats and wheat to kill spores. Remedy only partial.
Sweet Potato	Black-rot and Stem-rot	Formaldehyde . . .	Soak or fumigate seed roots as for potato-scab; discard old diseased hotbeds; drench slightly diseased beds with formaldehyde as for lettuce and tobacco. Then set plants on new soil.
Tobacco . . .	Root-rot and Bed-rot . . .	Drench beds with formaldehyde or sterilize with steam . . .	Drench beds in fall or early spring with formaldehyde 2 lb. or more to 50 gal. water, 1 gal. to each square foot. Do not seed until smell of formaldehyde has disappeared.
Tomato . . .	Nematodes in hothouse	Sterilize soil with steam . . .	As for roses and cucumbers above.
Turnip . . .	Club-root . . .	Quicklime in soil . . .	An insufficient water supply seems favorable to development of point-rot of green tomatoes.
Violet . . .	Nematodes in hothouse	Heat soil with steam . . .	As for cabbage and cauliflower. Avoid succession of these crops. The time for prevention is by soil treatment beforehand, as for cucumbers above.
Wheat . . .	Anthraxnose . . .	Formaldehyde . . .	Sprinkling as for stinking smut may prove partial remedy.
Wheat . . .	Loose smut . . .	Modified hot water . . .	Soak seed 4 hours in cold water, let stand 4 hours more in wet sacks, immerse 5 minutes in water at 133° and dry.
Wheat . . .	Stinking smut . . .	Formaldehyde, hot water or copper sulfate	Sprinkle grain in piles with formaldehyde as for oat smut, 1 gal. or less per bushel, and dry in same manner.
Wheat . . .	Insects in stored grain	Bisulfid of carbon . . .	Dip skimmed seed for 10 minutes in hot water at 133° F., and dry on disinfected surface or immerse for 10 minutes in solution of blue vitriol (copper sulfate); dry with air-slaked lime by shoveling. Use 2 lb. of blue vitriol to 10 gal. of water. Grain may be sprinkled in piles with copper sulfate or formaldehydes as for oats. (See Bulletin 97.)
Wheat . . .			Place 1 lb. of bisulfid of carbon for each 2000 lb. of grain in bins. Cover surface with blanket to hold the fumes which will spread through the mass, killing all insect life. Use in tight bins or buildings, and do not use near fire of any description.

CHAPTER XVII

INSECTICIDAL MATERIALS AND PRACTICES

BY C. R. CROSBY

THE results secured from the use of an insecticide or fungicide depend upon the operator. *Timeliness, thoroughness, and persistence* are the watchwords of success. It is easier to keep an enemy away than to drive him away. The worst foes are often the smallest ones ; and the injury is often done before they are detected. Be ready ; begin early.

General Practices

Cleanliness. — Much can be done to check the ravages of insects by destroying their breeding-places and hiding-places. Weeds, rubbish, and refuse should be eliminated.

Hand-picking is often still the best means of destroying insects, despite all the perfection of machinery and of materials. This is particularly true about the home grounds and in the garden. The cultivator should not scorn this method.

Promoting growth. — Any course that tends to promote vigor will be helpful in enabling plants to withstand the attacks of plant-lice and other insects.

Burning. — Larvæ which live or feed in webs, like the tent-caterpillar and fall web-worm, may be burned with a torch. The lamp or torch used in campaign parades finds its most efficient use here.

Banding. — To prevent the ascent of canker-worm moths and gypsy-moth caterpillars, various forms of sticky bands are in use. For this purpose there is no better substance than Tree Tanglefoot. It may be applied directly to the tree-trunk, but when so used leaves an unsightly mark and requires more material than when the following method is used : —

First place a strip of cotton batting three inches wide around

the trunk ; cover this with a strip of tarred paper five inches wide ; draw the paper tight and fasten at the lap only with three or four tacks. Spread the tanglefoot on the upper two-thirds of the paper, and comb it from time to time to keep the surface sticky.

Burlap bands are made by tying or tacking a strip of burlap around the trunk and letting the edges hang down. The larvæ will hide under the loose edge, where they may be killed.

Banding is now little used for the codlin-moth, since spraying with poison has been found so much more effective.

Fumigation.—Fumigating or “smoking” or “smudging” in greenhouses is performed by the slow burning of tobacco-stems. Best results are obtained when a sheet iron vessel made for the purpose is used, having holes in the bottom to supply draft. A quart of live coals is placed in the bottom of the vessel, and about a pailful of tobacco-stems is laid on them. The stems should not blaze, but burn with a slow smudge. If they are slightly damp, better results are obtained. Some plants are injured by a very heavy smoke, and in order to avoid this injury, and also to more effectually destroy the insects, it is better to smoke rather lightly and often. It is always well to smoke on two consecutive days, for the insects which persist through the first treatment, being weak, will be killed by the second. If the plants are wet, the smoke is more likely to scorch them. The smudge often injures flowers, as those of roses and chrysanthemums. In order to avoid this injury, the flowers should be covered with paper bags. Tobacco fumes can be conveniently generated by burning strips of prepared nicotine paper, or by vaporizing a concentrated aqueous solution of nicotine in pans over alcohol or special kerosene lamps.

Fumigation with hydrocyanic acid gas. — Hydrocyanic acid gas is a deadly poison, and the greatest care is required in its use. Always use 98 to 100 per cent pure potassium cyanide and a good grade of commercial sulfuric acid. The chemicals are always combined in the following proportion : Potassium cyanide, 1 ounce ; sulfuric acid, 1 fluid ounce ; water, 3 fluid ounces. Always use an earthen dish, *pour in the water first*, and add the sulfuric acid to it. Put the required amount of cyanide in a thin paper bag, and when all is ready, drop it into the liquid and leave the room immediately. For mills and dwellings, use one ounce of cyanide

for every 100 cubic feet of space. Make the doors and windows as tight as possible by placing strips of paper over the cracks. Remove the silverware and food, and if brass and nickel work cannot be removed, cover with vaseline. Place the proper amount of the acid and water for every room in two-gallon jars. Use two or more in large rooms or halls. Weigh out the potassium cyanide in paper bags, and place them near the jars. When all is ready, drop the cyanide into the jars, beginning on the top floors, since the fumes are lighter than air. In large buildings, it is frequently necessary to suspend the bags of cyanide over the jars by cords running through screw-eyes and all leading to a place near the door. By cutting all the cords at once, the cyanide will be lowered into the jars and the operator may escape without injury. Let the fumigation continue all night, locking all outside doors, and place danger signs on the house.

Fumigation of greenhouses. — No general formula can be given for fumigating the different kinds of plants grown in greenhouses, as the species and varieties differ greatly in their ability to withstand the effects of the gas. Ferns and roses are very susceptible to injury, and fumigation, if attempted at all, should be performed with great caution. Fumigation will not kill insect eggs, and thus must be repeated when the new brood appears. Fumigate only on dark nights when there is no wind. Have the house as dry as possible, and the temperature as near 60° as practicable.

Fumigation of dormant nursery stock. — Dormant nursery stock may be fumigated in a tight box or fumigating house made especially for the purpose. Fumigating houses are built of two thicknesses of matched boards with building paper between, and are provided with a tight-fitting door and ventilators. The stock should be reasonably dry to avoid injury, and should be piled loosely in the house to permit a free circulation of the gas. Use one ounce of potassium cyanide for each 100 cubic feet of space, and let the fumigation continue forty minutes to one hour.

Fumigation of citrus trees. — In this case the tree is covered with an octagonal sheet tent made of 6½ ounce special drill or 8 ounce special army duck, and the gas is generated in the ordinary way beneath it. The tent is so marked that when in position it is

an easy matter to determine the distance over the tent and the circumference at the ground. When these figures are known, the

16	18	20	22	24	26	28	30	32	34	36	38	40	42	44	46	48	50	52	54	56	58	60	62	64	66	68	70	72	74	76	78			
10	1	1	1	1 1/2	2	2 1/2																												
12	1 1/2	2	2 1/2	3	3 1/2	4	4 1/2	5																										
14	2	2 1/2	3	3 1/2	4	4 1/2	5																											
16	2 1/2	3	3 1/2	4	4 1/2	5	5 1/2	6	7																									
18	3	3 1/2	4	4 1/2	5	5 1/2	6	7	7 1/2	8																								
20	20	22	24	26	28	30	32	34	36	38	40	42	44	46	48	50	52	54	56	58	60	62	64	66	68	70	72	74	76	78				
22				3	4	4 1/2	5	5 1/2	6	6 1/2	7	8	8 1/2	9	9 1/2	10																		
24				4 1/2	5	5 1/2	6	6 1/2	7	7 1/2	8	8 1/2	9 1/2	10	10 1/2	11																		
26				5 1/2	6 1/2	7	7 1/2	8	8 1/2	9 1/2	10	10 1/2	11	11 1/2	12																			
28				7	8	8 1/2	9	9 1/2	10	10 1/2	11	11 1/2	12	13	14	14 1/2	15																	
30				8 1/2	9 1/2	10	10 1/2	11	11 1/2	12 1/2	13	13 1/2	14	14 1/2	15 1/2	16																		
32				10	11	11 1/2	12	12 1/2	13	14	15	15 1/2	16	16 1/2	17	17 1/2	18	18 1/2	19	19 1/2	20	20 1/2	21 1/2	22 1/2	23	23 1/2	24	24 1/2	25	25 1/2	26	26 1/2		
34				13	14	15	16	17	17 1/2	18	18 1/2	19	19 1/2	20	20 1/2	21 1/2	22 1/2	23	23 1/2	24	24 1/2	25 1/2	26 1/2	27 1/2	28 1/2	29	29 1/2	30	30 1/2	31	31 1/2	32	32 1/2	
36				14	15	16	17	17 1/2	18	19 1/2	20	20 1/2	21 1/2	22 1/2	23	23 1/2	24	24 1/2	25 1/2	26 1/2	27 1/2	28 1/2	29 1/2	30 1/2	31 1/2	32 1/2	33	34	35	36	37	38	39	
38				16	16 1/2	17 1/2	18 1/2	19	20 1/2	21 1/2	22 1/2	23 1/2	24	24 1/2	25 1/2	26 1/2	27 1/2	28 1/2	29 1/2	30 1/2	31 1/2	32 1/2	33 1/2	34 1/2	35 1/2	36 1/2	37 1/2	38 1/2	39 1/2	40 1/2	41 1/2	42 1/2	43 1/2	
40				40	42	44	46	48	50	52	54	56	58	60	62	64	66	68	70	72	74	76	78											
42				17	18	19	20	21	22	22 1/2	23	24	24 1/2	25 1/2	26 1/2	27 1/2	28 1/2	29 1/2	30 1/2	31 1/2	32 1/2	33 1/2	34 1/2	35 1/2	36 1/2	37 1/2	38 1/2	39 1/2	40 1/2	41 1/2	42 1/2	43 1/2	44 1/2	
44				18	19	20	21	22	22 1/2	23 1/2	24	24 1/2	25 1/2	26 1/2	27 1/2	28 1/2	29 1/2	30 1/2	31 1/2	32 1/2	33 1/2	34 1/2	35 1/2	36 1/2	37 1/2	38 1/2	39 1/2	40 1/2	41 1/2	42 1/2	43 1/2	44 1/2	45 1/2	
46				20	20 1/2	22	22 1/2	23	24 1/2	25 1/2	26 1/2	27 1/2	28 1/2	29 1/2	30 1/2	31 1/2	32 1/2	33 1/2	34 1/2	35 1/2	36 1/2	37 1/2	38 1/2	39 1/2	40 1/2	41 1/2	42 1/2	43 1/2	44 1/2	45 1/2	46 1/2	47 1/2	48 1/2	
48				21 1/2	22 1/2	23 1/2	24 1/2	25 1/2	26 1/2	27 1/2	28 1/2	29 1/2	30 1/2	31 1/2	32 1/2	33 1/2	34 1/2	35 1/2	36 1/2	37 1/2	38 1/2	39 1/2	40 1/2	41 1/2	42 1/2	43 1/2	44 1/2	45 1/2	46 1/2	47 1/2	48 1/2	49 1/2	50 1/2	
50				23	23 1/2	24 1/2	25 1/2	26 1/2	27 1/2	28 1/2	29 1/2	30 1/2	31 1/2	32 1/2	33 1/2	34 1/2	35 1/2	36 1/2	37 1/2	38 1/2	39 1/2	40 1/2	41 1/2	42 1/2	43 1/2	44 1/2	45 1/2	46 1/2	47 1/2	48 1/2	49 1/2	50 1/2	51 1/2	
52				25	25 1/2	26 1/2	27 1/2	28 1/2	29 1/2	30 1/2	31 1/2	32 1/2	33 1/2	34 1/2	35 1/2	36 1/2	37 1/2	38 1/2	39 1/2	40 1/2	41 1/2	42 1/2	43 1/2	44 1/2	45 1/2	46 1/2	47 1/2	48 1/2	49 1/2	50 1/2	51 1/2	52 1/2	53 1/2	
54				26 1/2	27 1/2	28 1/2	29 1/2	30 1/2	31 1/2	32 1/2	33 1/2	34 1/2	35 1/2	36 1/2	37 1/2	38 1/2	39 1/2	40 1/2	41 1/2	42 1/2	43 1/2	44 1/2	45 1/2	46 1/2	47 1/2	48 1/2	49 1/2	50 1/2	51 1/2	52 1/2	53 1/2	54 1/2	55 1/2	
56				28 1/2	29 1/2	30 1/2	31 1/2	32 1/2	33 1/2	34 1/2	35 1/2	36 1/2	37 1/2	38 1/2	39 1/2	40 1/2	41 1/2	42 1/2	43 1/2	44 1/2	45 1/2	46 1/2	47 1/2	48 1/2	49 1/2	50 1/2	51 1/2	52 1/2	53 1/2	54 1/2	55 1/2	56 1/2	57 1/2	
58				30 1/2	31 1/2	32 1/2	33 1/2	34 1/2	35 1/2	36 1/2	37 1/2	38 1/2	39 1/2	40 1/2	41 1/2	42 1/2	43 1/2	44 1/2	45 1/2	46 1/2	47 1/2	48 1/2	49 1/2	50 1/2	51 1/2	52 1/2	53 1/2	54 1/2	55 1/2	56 1/2	57 1/2	58 1/2	59 1/2	
59				31 1/2	32 1/2	33 1/2	34 1/2	35 1/2	36 1/2	37 1/2	38 1/2	39 1/2	40 1/2	41 1/2	42 1/2	43 1/2	44 1/2	45 1/2	46 1/2	47 1/2	48 1/2	49 1/2	50 1/2	51 1/2	52 1/2	53 1/2	54 1/2	55 1/2	56 1/2	57 1/2	58 1/2	59 1/2	60 1/2	

Dosage chart for fumigating citrus trees (Bureau of Entomology, U. S. Dept. Agric.)

proper dosage may be obtained from the above chart, which has been prepared for a strength of one ounce of cyanide for each 100 cubic feet of space.

The top line of numbers, beginning at 16 and continuing to 78, represents the distance in feet around the bottom of the tent. The outer vertical columns of larger numbers running from 10 to 59 represent the distance in feet over the top of the tent. The number of ounces of cyanide to use for a tree of known dimensions is found in that square where the vertical column headed by the distance around the tree intersects the horizontal line of figures corresponding to the distance over.

Using fungous diseases as insecticides. — Fungous diseases have been successfully employed against the citrus white-fly in Florida. There are seven species of fungus which attack the white-fly, and nearly all are more or less valuable. The object is to introduce some form of the fungus into orchards and on trees where it is absent. This may be accomplished by spraying the under side of the leaves with a mixture of fungus spores in water. The mixture may be made by placing two or three fungus-bearing leaves in a quart of water, and stirring occasionally for fifteen minutes. Strain through cheesecloth, and apply to those parts of the tree most badly infested with the white-fly larvæ.

The fungus may be introduced by pinning a dozen or so fungus-bearing leaves to the under side of the leaves of the tree infested with white-fly. The fungus-covered surface should face downward.

Insecticidal Substances

Arsenic. — Known to chemists as arsenious acid, or white oxide of arsenic. It is considered an unsafe insecticide, as its color allows it to be mistaken for other substances; but in its various compounds it forms our best insecticides. From one to two grains, or less, usually prove fatal to an adult; 30 grains will usually kill a horse, 10 grains a cow; and 1 grain, or less, is usually fatal to a dog. In case of poisoning, while awaiting the arrival of a physician, give emetics, and, after free vomiting, give milk and eggs. Sugar and magnesia in milk is useful.

A cheap and effective insecticide may be prepared from white arsenic by the following methods:—

For use with bordeaux mixture only. Sal soda, 2 pounds; water, 1 gallon; arsenic, 1 pound. Mix the white arsenic into a paste, and

then add the sal soda and water, and boil until dissolved. Add water to replace any that has boiled away, so that one gallon of stock solution is the result. Use one quart of this stock solution to 50 gallons of bordeaux mixture for fruit-trees. Make sure there is enough lime in the bordeaux mixture to prevent the caustic action of the arsenic.

For use without bordeaux mixture. Sal soda, 1 pound; water, 1 gallon; white arsenic, 1 pound; quicklime, 2 pounds. Dissolve the white arsenic with the water and sal soda as above, and use this solution while hot to slake the 2 pounds of lime. Add enough water to make 2 gallons. Use 2 quarts of this stock solution in 50 gallons of water.

Arsenicals. — A term popularly used for compounds of arsenic. The leading arsenicals used in destroying insects are arsenate of lead, paris green, and london purple.

ARSENATE OF LEAD. — This can be applied in a stronger mixture than other arsenical poisons, without injuring the foliage. It is, therefore, much used against beetles and other insects that are hard to poison. It comes in the form of a paste or powder, and should be mixed thoroughly with a small amount of water before placing in the sprayer, else the nozzles will clog. Arsenate of lead may be used with either bordeaux mixture or lime-sulfur without lessening the value of either. It is used in strengths varying from 4 to 10 pounds per 100 gallons, depending on the kind of insect to be killed.

LONDON PURPLE. — An arsenite of lime, obtained as a by-product in the manufacture of aniline dyes. The composition is variable. The amount of arsenic varies from 30 to 50 per cent. The two following analyses show its composition: (1) Arsenic, 43.65 per cent; rose aniline, 12.46; lime, 12.82; insoluble residue, 14.57; iron oxide, 1.16; and water, 2.27. (2) Arsenic, 55.35 per cent; lime, 26.23; sulfuric acid, 0.22; carbonic acid, 0.27; moisture, 5.29. It is a finer powder than paris green, and therefore remains longer in suspension in water. It is used in the same manner as paris green, but is sometimes found to be more caustic on foliage. This injury is due to the presence of much soluble arsenic; but it can be averted by the use of lime, as advised under paris green.

PARIS GREEN. — An aceto-arsenite of copper. When pure it contains about 58 per cent of arsenic. By the provisions of the federal

insecticide act of 1910, paris green must contain at least 50 per cent of arsenious oxide, and must not contain arsenic in water-soluble form equivalent to more than $3\frac{1}{2}$ per cent of arsenious oxide. It is applied in either a wet or dry condition; but in any case, it must be much diluted. For making a dry mixture, plaster, flour, air-slaked lime, road dust, or sifted wood ashes may be used. The strength of the mixture depends upon the plants and insects to which it is to be applied. The strongest dry mixture now recommended is one part of poison to fifty of the diluent; but if the mixing is very thoroughly done, 1 part to 100, or even 200, is sufficient.

Paris green is practically insoluble in water. When mixed with water, the mixture must be kept in a constant state of agitation, else the poison will settle, and the liquid from the bottom of the cask will be so strong as to do serious damage, while that from the top will be useless. For potatoes, apple-trees, and most species of shade trees, 1 pound of poison to 200 or 250 gallons of water is a good mixture. Paris green is very likely to burn the foliage of stone fruits, especially peaches and Japanese plums, and has been generally replaced by arsenate of lead for such purposes. In all cases, the liquid should be applied with force, in a very fine spray. At some seasons of the year foliage is more liable to injury than at others. The addition of a little lime (twice the bulk of lime as of paris green) to the mixture will tend to prevent any caustic injury upon the foliage.

Spraying with paris green or london purple does not endanger stock pastured in the orchard.

COMBINATIONS OF ARSENICALS AND FUNGICIDES. — Arsenicals may be used in connection with some fungicides, and both insects and plant diseases in this manner may be combated at the same time. The arsenicals may be added to bordeaux mixture in the same proportion as if the bordeaux were plain water. Arsenate of lead may be added to the lime-sulfur wash, but the addition of paris green or arsenite of lime is liable to cause burning.

The addition of lime to paris green and london purple mixtures greatly lessens injury to foliage, and, as a consequence, they can be applied several times stronger than ordinarily used, if they are combined with the bordeaux mixture. The free lime in the

mixture combines with the soluble arsenic, which is the material that injures the foliage, and the combination is thus made quite harmless.

Bait. Vegetable bait. — Spray a patch of clover or some other plant that the insects will eat with paris green or some other arsenical; mow it close to the ground, and while fresh place it in small piles around the infested plants. To avoid wilting of the bait, cover the heaps with a shingle or piece of board.

Bran-arsenic mash. White arsenic, $\frac{1}{2}$ pound, or paris green, 1 pound; bran, 50 pounds. Mix thoroughly and then add enough water to make a wet mash.

Sugar or molasses may be added, but is unnecessary. Poisoned baits are used against cutworms and grasshoppers. See CRIDDLE MIXTURE, below.

Bisulfid of carbon. — A thin liquid which volatilizes at a very low temperature, the vapor being very destructive to animal life. It is exceedingly inflammable, and should never be used near a lamp or fire. It is used for many root-insects. It is poured into a hole, which is immediately closed up, causing the fumes to permeate the soil in all directions. In loose soils it is very destructive to insects.

Against weevils infesting stored grain and corn, carbon bisulfid is effective at the rate of 5 pounds for each 1000 cubic feet, provided the application is made while the temperature is not below 65° F. Make the bins as tight as possible, and after sprinkling the liquid over the grain, cover tightly with gas-proof tarpaulin. Let the fumigation continue for at least twenty-four hours.

Carbolic acid and soap mixtures. — One ounce crude carbolic acid; 1 pound fish-oil soap; 1 gallon hot water. Mix thoroughly. This wash is used for borers. Apply with a cloth or soft broom. Use only on dormant wood.

Carbolic acid emulsion. — Soap, 1 pound; water, 1 gallon; crude carbolic acid (90 per cent strength), 1 pint. Dissolve the soap in hot water; add the carbolic acid, and agitate into an emulsion. For use against root-maggots, dilute with 30 parts of water.

Carbon bisulfid. — See BISULFID OF CARBON, above.

Criddle mixture. — Mix 1 pound of paris green with $\frac{1}{2}$ barrel of horse droppings, and add 1 pound of salt if the material is not fresh. For use against grasshoppers.

Distillate emulsion. — 5 gallons of 28° gravity untreated distillate ; 5 gallons boiling water, 1½ pounds whale-oil soap. Dissolve the soap in hot water, add the distillate, and thoroughly emulsify by means of a power pump until a yellowish, creamy emulsion is produced. For use on lemon dilute with 12 parts of water ; on orange, with 15 parts.

Formerly much used on citrus trees, but now generally replaced by fumigation.

Hellebore. — See WHITE HELLEBORE, p. 300.

Hot water. — Submerge affected plants or branches in water at a temperature of about 125°. For aphids. It will also kill rose-bugs at a temperature of 125°-135°.

Kerosene emulsion. — Hard, soft, or whale-oil soap, ½ pound ; water, 1 gallon ; kerosene, 2 gallons. Dissolve the soap in hot water ; remove from the fire and while still hot add the kerosene. Pump the liquid back into itself for five or ten minutes, or until it becomes a creamy mass. If properly made, the oil will not separate out on cooling.

For use on dormant trees, dilute with from 5 to 7 parts of water. For killing plant-lice on foliage dilute with from 10 to 15 parts of water. Crude oil emulsion is made in the same way by substituting crude oil in place of kerosene. The strength of oil emulsions is frequently indicated by the percentage of oil in the diluted liquid:—

For a 10 per cent emulsion add 17 gallons of water to 3 gallons stock emulsion.

For a 15 per cent emulsion add 10½ gallons of water to 3 gallons stock emulsion.

For a 20 per cent emulsion add 7 gallons of water to 3 gallons stock emulsion.

For a 25 per cent emulsion add 5 gallons of water to 3 gallons stock emulsion.

Lead, arsenate of. — See under ARSENICALS, p. 291.

Lime-sulfur. — A compound of lime and sulfur makes both a good insecticide and a good fungicide (for an account from the fungicide point of view, see page 256). There are several forms of it, as (1) the ordinary dilute home-made ; (2) the concentrated home-made ; (3) the commercial concentrated brands ; (4) the so-called self-boiled preparation. The three first are *solutions*, and are modi-

fications of one preparation ; the self-boiled is mostly a *mechanical mixture* of the lime and sulfur.

1. Home-made dilute solution of lime-sulfur.—Quick lime, 20 pounds; sulfur (flour or flowers), 15 pounds; water, 50 gallons. The lime and sulfur must be thoroughly boiled. An iron kettle is often convenient for the work. Proceed as follows: Place the lime in the kettle. Add hot water gradually in sufficient quantity to produce the most rapid slaking of the lime. When the lime begins to slake, add the sulfur and stir together. If convenient, keep the mixture covered with burlap to save the heat. After slaking has ceased, add more water, and boil the mixture one hour. As the sulfur goes into solution, a rich orange-red or dark green color will appear. After boiling sufficiently, add water to the required amount and strain into the spray tank. The wash is most effective when applied warm, but may be applied cold. If one has access to a steam boiler, boiling with steam is more convenient and satisfactory. Barrels may be used for holding the mixture, and the steam applied by running a pipe or rubber hose into the mixture. Proceed in the same manner as for boiling in the kettle until the lime is slaked, when the steam may be turned on. Continue boiling for forty-five minutes to an hour, or more if necessary to get the sulfur well dissolved.

This mixture can be applied safely only when the trees are dormant, — late in the autumn after the leaves have fallen, or early in the spring before the buds swell. It is mainly an insecticide for San José scale, although it has considerable value as a fungicide for certain diseases, like the peach leaf-curl. As the San José scale is not killed unless the solution comes in contact with it, great care should be exercised to completely cover the branches.

2. Home-made concentrated lime-sulfur wash.

For making the concentrated mixture, the steps are the same as in making the usual boiled wash, but the following formula should be used:—

	Pure calcium oxide	36 lb.
	or	
Lump lime	95 per ct. calcium oxide	38 lb.
	or	
	90 per ct. calcium oxide	40 lb.
Sulfur		80 lb.
Water		50 gal.

Slake the lime, make a thin paste, and add the sulfur. Flowers of sulfur or light or heavy sulfur flour may be used. The lime should be fresh lump lime, free from dirt and grit, containing 90 per cent or more of calcium oxide and less than 5 per cent of magnesium oxide. Stir thoroughly during the hour of cooking, to break up the lumps of sulfur. Enough water should be added at the start so that the evaporation will not leave the quantity less than 50 gallons when the cooking is ended. If kettles are used, 10 to 15 gallons additional will be needed, while with steam none may be required. The kettles should be considerably larger than the amount of wash to be made, to prevent loss of material by boiling over. The clear liquid should be drawn off into tight containers if to be kept any considerable time; and stored where there is no danger of temperatures much below freezing. For use, test the clear solution with the hydrometer, and dilute as indicated in the table:—

Dilutions of Concentrated Lime-Sulfur Solutions for Spraying
(N. Y. Exp. Sta.)

DEGREES BEAUMÉ	SPECIFIC GRAVITY	WITH EACH GALLON OF CONCENTRATE, USE —		DEGREES BEAUMÉ	SPECIFIC GRAVITY	WITH EACH GALLON OF CONCENTRATE, USE —	
		For San José scale	For Blister Mite			For San José scale	For Blister Mite
		<i>Gals. water</i>	<i>Gals. water</i>			<i>Gals. water</i>	<i>Gals. water</i>
35	1.3181	9	12	25	1.2083	5½	7½
34	1.3063	8½	11½	24	1.1983	5¼	7
33	1.2946	8	11	23	1.1885	4¾	6¾
32	1.2831	7¾	10½	22	1.1788	4½	6½
31	1.2719	7½	10	21	1.1693	4¼	5¾
30	1.2608	7	9½	20	1.1600	4	5½
29	1.2500	6¾	9	19	1.1507	3¾	5
28	1.2393	6½	8¾	18	1.1417	3½	4¾
27	1.2288	6	8¼	17	1.1328	3	4½
26	1.2184	5¾	7¾	16	1.1240	2¾	4
				15	1.1153	2½	3¾

3. Commercial concentrated mixtures.

The lime-sulfur may be purchased in the concentrated form and the trouble of making it avoided. The strength of the commercial product varies considerably, and in order to compute the proper dilution correctly the strength should be determined by means of a hydrometer. Having determined the strength of the concen-

trated mixture, the proper dilution for use against the San José scale and blister mite may be obtained from the table on opposite page.

4. *Self-boiled*. See page 257.

London purple. — See under ARSENICALS, p. 291.

Miscible oils.— There are now on the market a number of preparations of petroleum and other oils intended primarily for use against the San José scale. They mix readily with cold water, and are immediately ready for use. While quickly prepared, easily applied, and generally effective, they cost considerably more than lime-sulfur wash. They are, however, less corrosive to the pumps, and more agreeable to use. They are especially valuable to the man with only a few trees or shrubs who would not care to go to the trouble and expense to make up the lime-sulfur wash. For use they should be diluted with 15 parts of water. Use only on dormant trees, and when the temperature is above freezing and the trees are not wet.

Paraffine oil. — Essentially the same as KEROSENE, which see (p. 294).

Paris green. — See under ARSENICALS, p. 291.

Persian insect powder. — See PYRETHRUM.

Pyrethrum. — A very fine and light brown powder, made from the flower-heads of species of pyrethrum. It is scarcely injurious to man. Three brands are on the market :—

PERSIAN INSECT-POWDER, made from the heads of *Pyrethrum roseum*, a species also cultivated as an ornamental plant. The plant is native to the Caucasus region.

DELMATION INSECT-POWDER, made from *Pyrethrum cinerariaefolium*.

BUHACH, made in California from cultivated plants of *Pyrethrum cinerariaefolium*.

When fresh and pure, all these brands appear to be equally valuable, but the home-grown product is usually considered most reliable. Pyrethrum soon loses its value when exposed to the air. It is used in various ways :—

1. In solution in water, 1 ounce to 3 gallons. Should be mixed up twenty-four hours before using.

2. Dry, without dilution. In this form it is excellent for thrips and lice on roses and other bushes. Apply when the bush is wet. Useful for aphids on house plants.

3. Dry, diluted with flour or any light and fine powder. The poison may be used in the proportion of 1 part to from 6 to 30 of the diluent.

4. In fumigation. It may be scattered directly upon coals, or made into small balls by wetting and molding with the hands and then set upon coals. This is a desirable way of dealing with mosquitoes and flies.

5. In alcohol. (1) Put a part of pyrethrum (buhach) and 4 parts alcohol, by weight, in any tight vessel. Shake occasionally, and after eight days filter. Apply with an atomizer. Excellent for greenhouse pests. For some plants it needs to be diluted a little. (2) Dissolve about 4 ounces of powder in 1 gill of alcohol, and add 12 gallons of water.

6. Decoction. Whole flower-heads are treated to boiling water, and the liquid is covered to prevent evaporation. Boiling the liquid destroys its value.

Good insect-powder can be made from *Pyrethrum roseum*, and probably also from *P. cinerariæfolium*, grown in the home garden.

Resin and fish-oil compound.—Ten pounds of resin ; 1½ pounds of fish-oil, 3 pounds of caustic soda, and enough water to make 50 gallons.

Break the resin into small lumps, and place it together with the caustic soda in the boiler, with three or four inches of water. Stir till the resin is dissolved ; then add about one-fourth of the required water and boil one-half hour. Place in the spray tank and add the rest of the water.

Used in California against the cottony cushion scale and the brown apricot scale.

Soaps, whale-oil, or fish-oil soap.—Soaps are effective insecticides for plant-lice. Dissolve in hot water and dilute so as to obtain 1 pound of soap for every 5 or 7 gallons of water. Commercial whale-oil or fish-oil soaps frequently injure tender foliage because of the free alkali which they contain.

An excellent fish-oil soap free from uncombined alkali may be easily prepared at home, as follows :

Six pounds of caustic soda ; 1½ gallons of water ; 22 pounds of fish oil.

Completely dissolve the caustic soda in the water, and then add the fish-oil very gradually, under constant and vigorous stirring. The combination occurs readily at ordinary summer temperatures and boiling is unnecessary. Stir briskly for about twenty minutes after the last of the oil has been added. (New York Experiment Station.)

Soap and tobacco. — Dissolve 8 pounds of the best soft soap in 12 gallons of rain-water, and when cold add 1 gallon of strong tobacco liquor. For plant-lice.

Soda and aloes. — Dissolve 2 pounds of washing-soda and 1 ounce of bitter Barbadoes aloes, and when cold add one gallon of water. Dip the plants into the solution, and lay them on their sides for a short time, and the insects will drop off. Syringe the plants with clean, tepid water, and return to the house. For plant-lice.

Sulfur. — Fumes of sulfur are destructive to insects, but should be carefully used, or plants will be injured. The sulfur should be evaporated over an oil stove, until the room is filled with the vapor. The sulfur should never be burned, as burning sulfur kills plants. For greenhouse use. See p. 258.

Sulfur and water. — To 3 gallons of weak soap suds add 1 pound of flowers of sulfur and stir thoroughly. Apply as a spray. For red spider and mites.

Tanglefoot is a sticky commercial substance much used for banding trees. See under BANDING, p. 286.

Tar is sometimes used to prevent the female and wingless canker-worm from ascending trees. The tar should be placed on cotton, or some material which will prevent it from coming in contact with the bark, and a band of the preparation is then placed around the trunk. Care must be taken to see that the tar does not injure the tree.

Tarred paper may be rolled *loosely* about trees to keep away mice, but it should be removed before warm weather. It is sometimes recommended as a preventive of the attacks of borers, but it very often injures trees, and should be used, if at all, with great caution.

Tobacco. — 1. Stems, placed on the walks and under the benches of greenhouses, for plant-lice. Renew it every month.

2. Tobacco-water, used with whale-oil soap.

3. Dust and snuff. Snuff may be blown lightly on plants, as house-plants, for lice.

4. Fumes. Burn dampened tobacco-stems. See FUMIGATION, p. 287.

5. Nicotyl. Steep tobacco-stems in water, and evaporate the water.

6. Tea, or common decoction. Boil the stems or dust thoroughly, and strain. Then add cold water until the decoction contains 2 gallons of liquid to 1 pound of tobacco.

There are various concentrated commercial preparations of tobacco which have recently been giving good results against plant-lice.

White arsenic. — See ARSENICALS, p. 291.

White hellebore. — A light brown powder made from the roots of the white hellebore plant (*Veratrum album*), one of the lily family. It is applied both dry and in water. In the dry state, it is usually applied without dilution, although the addition of a little flour will render it more adhesive. In water, 4 ounces of the poison is mixed with 2 or 3 gallons; and an ounce of glue, or thin flour paste, is sometimes added to make it adhere. A decoction is made by using boiling water in the same proportions. Hellebore soon loses its strength, and a fresh article should always be demanded. It is much less poisonous than the arsenicals, and should be used in place of them upon ripening fruit. Used for various leaf-eating insects, particularly for the currant-worm and rose-slug.

CHAPTER XVIII

INJURIOUS INSECTS, WITH TREATMENT

BY C. R. CROSBY

INSECTS are of two kinds as respects their manner of taking food, — the mandibulate insects, or those that chew or bite their food, as larvæ (“ worms ”) and most beetles ; and those that suck their food, as the plant-lice and true bugs. The former class is dispatched by poisons, the latter by caustic applications, as kerosene or soap preparations.

General or Unclassified Pests

Angleworm or Earthworm. — The common angleworm often destroys greenhouse plants by its burrowing. It is sometimes annoying in gardens also.

Treatment. — Lime-water applied to the soil.

Ants. — See LAWNS, p. 322.

Aphides, Plant-lice or Green-fly, and Bark-lice. — Minute insects of various kinds, feeding upon the tender parts of many plants, both indoors and out.

Treatment. — Kerosene emulsion. Hot water (about 125°). Pyrethrum. Fish-oil soap. Tobacco-water or extracts. Alcoholic and water extracts of pyrethrum. Hughes' fir-tree oil. In the greenhouse, fumigation with tobacco or hydrocyanic acid gas. Knock them off with the hose. In window gardens, dry pyrethrum or snuff.

Bag-worm or Basket-worm (*Thyridopteryx ephemeraformis*). — Larva working in singular dependent bags, and feeding upon many kinds of trees, both evergreen and deciduous. In winter the bags, empty or containing eggs, are conspicuous, hanging from the branches.

Treatment. — Hand-picking. Arsenicals.

Blister-beetle (*Lytta*, two or three species). — Soft-shelled, long-necked and slim black or gray spry beetles, feeding on the leaves of many trees and garden plants.

Treatment. — Arsenicals. Jarring.

Brown-tail moth (*Euproctis chryorrhæa*). — This highly destructive European insect was introduced near Boston a number of years ago, and is now rapidly spreading over New England. The snow-white moths, with a large tuft of brown hairs at the tip of the abdomen, appear in July and deposit eggs on the leaves in elongate masses covered with brown hairs from the body of the female. The caterpillars become only partly grown the first season, and hibernate in conspicuous nests, three or four inches long, at the tips of the branches. The black-bodied caterpillars, clothed with rather long, brownish, stinging hairs, complete their growth the next spring, feeding ravenously on the tender foliage and causing great damage in orchards, parks, and forests.

Treatment. — Cut out and burn all winter nests before the buds start. In the spring spray with arsenate of lead, as recommended for the gipsy-moth. Prevent the ascent of caterpillars from other trees by banding the trunks with tanglefoot. Keep the bands fresh by combing the surface every few days.

Cutworm. — Various species of *Agrotis* and related genera. Soft brown or gray worms, of various kinds, feeding on the roots, crown, or even the tops of plants.

Treatment. — Encircle the stem of the plant with heavy paper or tin, coating the top with tanglefoot. Arsenicals sprinkled upon small bunches of fresh grass or clover, which are scattered at short intervals about the garden towards evening. They will often collect under boards or blocks. Arsenicals mixed with shorts and placed about the plants. Make two or three deep holes by the side of the plant with a pointed stick; the worms will fall in and cannot escape. Dig them out. Plow infested land in the fall to give birds a chance to find the worms.

Cutworm, Climbing. — Several species. The worms climb grape vines and small trees of various kinds at night and eat out the buds.

Preventive. — Band of cotton batting tied about the tree by lower edge, and the top rolled down like a boot-leg. Baits (see p. 293).

Treatment. — Arsenicals. Hellebore.

Flea-beetle (*Phyllotreta vittata*; *Haltica striolata*, etc.)—Minute, dark-colored beetles, feeding upon many plants, as turnip, cabbage, radish, mustard, potato, strawberry, and stocks. They jump upon being disturbed. Closely related species attack various plants. Very destructive to plants which are just appearing above the surface.

Treatment.—Bordeaux mixture applied liberally is the best remedy, — it drives them away.

Four-striped Plant-bug (*Pæcilocapsus lineatus*).—A bright yellow, black-striped bug about one-third of an inch long, puncturing the young leaves and shoots of many plants.

Treatment.—Jarring at any time of day into a dish of dilute kerosene. Kerosene emulsion (diluted five times) when the bugs are young, in their nymphal stage. Cut off and burn the tips of the growing shoots in early spring to destroy the eggs.

Galls.—See NEMATODE ROOT-GALL, below.

Gipsy-moth (*Porthetria dispar*).—Larva, between two and three inches long when mature, dark brown or sooty in color, with two rows of red spots and two rows of blue spots along the back, and with a dim yellowish stripe between them. Devours many kinds of foliage. Confined to New England. It has become a serious pest.

Treatment.—Spray with arsenate of lead as soon as the caterpillars hatch in the spring. Band trees with tanglefoot.

May-beetle or May-bug (*Lachnosterna fusca*).—A large and familiar brown beetle, feeding upon the leaves of many kinds of trees. The common white grub is the larval state. It often does great damage to sod and to strawberries. Sometimes called June-bug.

Remedies.—See under CORN, p 314.

Mealy-bug (*Pseudococcus citri* and *P. longifilis*).—A white, scale-like insect, attacking greenhouse plants.

Treatment.—Whale-oil soap. Carbolic acid and soap. Removing insects with brush on tender plants. House-plants may be washed in soapsuds. The best procedure in greenhouses is to knock them off with the hose. A small, hard stream of water upsets their domestic affairs.

Nematode Root-gall (*Heterodera radicola*).—A disease characterized by the knotting and contortion of the roots of the peach, orange, and many other plants. The knots are mostly rather soft swell-

ings, and on the smaller roots. It is usually most destructive on the peach. It is caused by a nematode, or true worm (not an insect). Gulf States. Attacks greenhouse plants in the North.

Preventive. — Plant non-infested plants in fresh soil; bud into healthy stocks. Fertilize highly, particularly with potassic fertilizers. Set the trees 8 or 10 inches deep in high and dry soils. Infested small trees may be remedied, in part at least, by transplanting them into highly manured holes which have been prepared contiguous to them. Does not live in regions where the ground freezes deeply. If it is feared in greenhouses, see that the soil has been thoroughly frozen before it is used. White-wash the benches.

Red-spider or mite (*Tetranychus bimaculatus*). — A small mite infesting many plants, both in the greenhouse and out of doors. It flourishes in dry atmospheres, and on the under sides of the leaves. In some forms it is reddish, but usually light-colored and two-spotted. Common.

Remedies. — Persistent syringing with water will generally destroy them, if the spray is applied to the under surface. Use much force and little water to avoid drenching the beds. Sulfur and water. Dry sulfur. On orchard trees flour paste may be used.

San José Scale (*Aspidiotus perniciosus*). — This scale is nearly circular in outline and about the size of a pin-head. When abundant it forms a crust on the branches, and causes small red spots on the fruit. It multiplies with marvelous rapidity, there being three or four broods annually, and each mother scale may give birth to several hundred young. The young are born alive, and breeding continues until late autumn, when all stages are killed by the cold weather, except the tiny, half-grown, black scales, many of which hibernate safely.

Spray thoroughly in the fall after the leaves drop, or early in the spring before growth begins, with lime-sulfur wash, or miscible oil, 1 gallon in 10 gallons of water. When badly infested, make two applications, one in the fall and another in the spring. In case of large, old trees, 25 per cent crude oil emulsion should be applied just as the buds are swelling.

Scale-insects. — Various species of small insects inhabiting the young growth of trees, and sometimes the fruit, in one stage character-

ized by a stationary scale-like appearance. Lime-sulfur and miscible oils are the best remedies. Species which migrate on to the young growth in spring can be readily dispatched at that time by kerosene emulsion.

Snails. — These animals are often very troublesome in greenhouses, eating many plants voraciously.

Preventives. — Trap them by placing pieces of turnip, cabbage, or potatoes about the house. Scatter bits of camphor-gun about the plants. Strew a line of salt along the edges of the bed. Lime dusted about the plants will keep them away.

White ants or termites. — These insects often infest orchard trees in the southern states, particularly in orchards which contain old stumps or rubbish.

Remedy. — The soap-and-arsenites wash brushed over the trunk and branches of the tree.

Wire-worm (various species). — Slim and brown larvæ, feeding upon the roots of various plants. They are the larvæ of the click-beetle, or snapping-beetle.

Remedy. — Arsenicals sprinkled upon baits of fresh clover or other material which is placed about the field under blocks or boards. Sweetened corn-meal dough also makes a good bait. The best treatment is to plow infested land early in the fall. A system of short rotations of crops will lessen injury from wire-worms.

Insects classified under the Plants they chiefly Affect

Apple. APPLE-BUCCULATRIX (*Bucculatrix pomifoliella*). — A minute yellow or green larva feeding upon the upper surface of the leaves, causing the lower surface to turn brown. The cocoons are white and slender, and are laid side by side upon the under side of twigs, where they are conspicuous in winter.

Treatment. — Lime-sulfur while tree is dormant. Arsenicals for the larvæ in summer.

APPLE-CURCULIO (*Anthonomus quadrigibbus*). — A soft, white grub, about half an inch long, living in the fruit.

Treatment. — Clean cultivation. Rake the small apples that drop early out into the sun where they will dry up. See PLUM-CURCULIO, p. 329.

APPLE FLEA-BEETLE (*Graptodera foliacea*). — Brassy, green beetle, one-fifth inch or less long, feeding upon leaves.

Treatment. — Arsenicals. Lime-sulfur or bordeaux mixture as a repellent.

APPLE-MAGGOT OR RAILROAD-WORM (*Rhagoletis pomonella*). — Maggot ; infests harvest and fall apples mostly, occasionally attacks winter fruit. It tunnels apples through and through, causing the fruit to fall to the earth.

Treatment. — Pick up all windfalls every two or three days, and either feed them out or bury them deeply, thus killing the maggots. Pasture to hogs.

BUD-MOTH (*Tmetocera ocellana*). — The small brown caterpillars with black heads devour the tender leaves and flowers of the opening buds in early spring.

Treatment. — Make two applications of either 1 pound paris green or 4 pounds arsenate of lead in 100 gallons of water ; the first when the leaf-tips appear, and the second just before the blossoms open. If necessary, spray again after the blossoms fall. In cases where lime-sulfur is used just before the buds open for scale or blister mite, arsenate of lead, 4 pounds to 100 gallons, may be added and will help to control the bud-moth.

CASE-BEARERS. The pistol-case-bearer (*Coleophora malivorella*) and the cigar-case-bearer (*C. fletcherella*). — The small caterpillars live in pistol or cigar-shaped cases, about a quarter of an inch long, that they carry around with them. They appear in spring on the opening buds at the same time as the bud-moth, and may be controlled by the same means.

CANKER-WORM. Spring and fall (*Paleacrita vernata* and *Alsophila pometaria*). — Larva ; a "measuring worm," an inch long, dark, and variously striped, feeding upon the leaves.

Preventive. — Band the trees with tanglefoot to prevent the wingless females from climbing.

Treatment. — Arsenicals, thoroughly applied in spray, are very effective. See BANDING, p. 286.

CODLIN-MOTH (*Carpocapsa pomonella*). — This is the pinkish caterpillar which causes a large proportion of wormy apples. The eggs are laid by a small moth on the leaves and the skin of the fruit. Most of the caterpillars enter the apple at the blossom end.

When the petals fall, the calyx is open, and this is the time to spray. The calyx soon closes, and keeps the poison inside ready for the young caterpillars' first meal. After the calyx has closed, it is too late to spray effectively. The caterpillars become full grown in July and August, leave the fruit, crawl down on the trunk, and there most of them spin cocoons under the loose bark. In most parts of the country there are two broods annually.

Treatment. — When the majority of the petals have fallen, spray with 4 pounds arsenate of lead in 100 gallons of water, using a stiff spray to force it into the blossom end of the apple. Repeat the application three weeks later. For use of the poison with bordeaux or lime-sulfur, see APPLE SCAB, p. 264. Paris green was formerly used.

FALL WEB-WORM (*Hyphantria cunea*). — Hairy larva, about an inch long, varying from gray to pale yellow or bluish black, feeding upon the leaves of many trees, in tents or webs.

Treatment. — Destroy by burning the webs, or removing them and crushing the larvæ. Spray with arsenicals.

LEAF BLISTER MITE (*Eriophyes pyri*). — The presence of this minute mite is indicated by small irregular brownish blisters on the leaves.

Treatment. — Spray in late fall or early spring with lime-sulfur, or miscible oil. For dilution of commercial lime-sulfur, see p. 296.

FLAT-HEADED BORER (*Chrysobothris femorata*). — Larva about an inch long, flesh-colored, the second segment ("head") greatly enlarged; boring under the bark and sometimes into the wood. They are readily located in late summer or fall by the dead and sunken patches of bark.

Preventive. — Soap and carbolic acid washes applied from May to July. Keep trees vigorous.

Treatment. — Dig out the borers in early summer and fall. Encourage woodpeckers.

PEAR TWIG-BEETLE. — See under PEAR, p. 326.

PLUM-CURCULIO (*Conotrachelus nenuphar*). — Beetle; deforms the fruit by its characteristic feeding and egg-laying punctures. The grubs develop in the fruit and cause it to fall.

Treatment. — Spraying with arsenate of lead, as for codlin-moth, whenever it can be applied with a fungicide so as not to increase expense, will help to control the trouble. Thorough su-

perforated tillage of the surface soil during July and August will kill many of the pupæ, and is recommended. For treatment on plum, see under PLUM, p. 329.

RAILROAD-WORM. — See APPLE-MAGGOT, p. 306.

ROOT-LOUSE, "AMERICAN BLIGHT." — See under WOOLLY APHIS, page 310.

ROSE-CHAFFER. — See under GRAPE, p. 322. At the first appearance of the beetles spray plants with arsenate of lead at the rate of 8 or 10 pounds to 100 gallons of water, to which should be added 1 gallon of molasses (New York Experiment Station).

ROUND-HEADED BORER (*Saperda candida*). — A yellowish white larva, about one inch long when mature. It is said to remain in the larval state three years.

Preventive. — Keep the beetles from laying eggs by spraying the trunks several times during the spring and summer with kerosene emulsion or by coating them with an alkaline wash made from soap, caustic potash, and carbolic acid. Tarred paper tree-protectors well tied at the top, or wire mosquito netting protectors closed at the top and encircling the trunk so loosely that the beetles cannot reach the bark, are effective in preventing egg-laying. Practice clean cultivation, and do not let water sprouts or other rank vegetation encircle the base of the tree.

Remedial. — Dig out the borers whenever they can be located by discolored bark or by the sawdust thrown out of the burrow.

SAN JOSÉ SCALE (*Aspidiotus perniciosus*). — See p. 304.

LEAF-CRUMPLER (*Mimola indigenella*). — Reddish brown caterpillars that live in slender, horn-shaped cases and feed on the tender leaves. They hibernate as partly grown larvæ and attack the opening buds the following spring. They usually live in a nest of several leaves fastened together with silk.

Treatment. — Gather the nests and burn them. Arsenicals when the buds open.

OYSTER-SHELL SCALE (*Lepidosaphes ulmi*). — This is an elongate scale (sometimes called bark-louse), one-eighth inch in length, resembling an oyster-shell in shape and often incrusting the bark. It hibernates as minute white eggs under the old scales. The eggs hatch during the latter part of May or in June, the date depending on the season. After they hatch, the young may be seen as tiny whitish

lice crawling about on the bark. When these young appear, spray with kerosene emulsion, diluted with 6 parts of water, or whale-oil, or any good soap, 1 pound in 4 or 5 gallons of water. Where trees are regularly sprayed with lime-sulfur as for the San José scale or blister mite, the oyster-shell scale is usually controlled.

SCURFY SCALE (*Chionaspis furfurus*). — This whitish, pear-shaped scale, about one-eighth inch in length, often incrusts the bark, giving it a scurfy appearance. It hibernates as purplish eggs under the old scales.

Treatment. — Spray as recommended for OYSTER-SHELL SCALE (p. 308).

TENT-CATERPILLARS (*Malacosoma americana* and *M. disstria*). — Larva, nearly two inches long, spotted and striped with yellow, white, and black; feeding upon the leaves. They congregate in tents or in clusters on the bark at night and in cool weather, and forage out upon the branches during the day.

Treatment. — Arsenicals, as for CODLIN-MOTH (p. 306). Burn out nests with torch, or cut them out and crush the larvæ. Pick off egg masses from twigs during winter and spring.

TUSOCK-MOTH (*Hemerocampa leucostigma*). — A handsome, red-headed, yellow and black tufted caterpillar, about an inch long, which devours the leaves and sometimes eats into the fruit.

Remedial. — Collect the frothy egg-masses in fall and winter and band the trees to prevent a reinfestation by migrating caterpillars. Spray with arsenicals as for codlin-moth, taking care to cover the under side of the leaves.

TWIG-BORER (*Schistoceros hamatus*). — Beetle, three-eighths inch long, cylindrical and dark brown, boring into twigs of apple, pear, and other trees. The beetle enters just above a bud.

Treatment. — Burn the twigs. The early stages are passed in dying wood such as prunings, diseased canes, and in upturned roots. Burn such rubbish, and thus destroy their breeding-places. This is also a grape pest.

TWIG-PRUNER (*Elaphidion villosum*). — Yellowish white larvæ, about a half inch long, boring into young twigs, causing them to die and break off.

Treatment. — Burn the twigs.

WOOLLY APHIS (*Schizoneura lanigera*). — Small reddish-brown plant-lice covered with a conspicuous mass of white, waxy fibers, found on the branches, sprouts, trunks, and roots.

Preventive. — Do not set infested trees.

Treatment. — For the form above ground drench the infested parts with 15 per cent kerosene emulsion ; for the underground form remove the earth beneath the tree to a depth of 3 inches, and apply 10 per cent kerosene emulsion liberally, and replace the earth. In the case of nursery stock the emulsion may be applied in a shallow furrow close to the row.

APRICOT. PEAR TWIG-BEETLE. — See under PEAR, p. 326.

PIN-HOLE BORER. — See BARK-BEETLE under PEACH, p. 325.

PLUM-CURCULIO. — See under PLUM, p. 329.

BROWN APRICOT-SCALE (*Eulecanium armeniaticum*). — A soft brown scale infesting the under side of the smaller branches.

Treatment. — Spray with resin and fish-oil compound, taking care to hit the underside of the twigs. In California the application should be made in January and February.

ASPARAGUS. COMMON ASPARAGUS-BEETLE (*Crioceris asparagi*). — Beetle, less than one-fourth inch in length, yellow, red, and shining black, with conspicuous ornamentation, feeding upon the tender shoots. Larva feeds upon the leaves and tender bark.

Treatment. — Freshly slaked lime dusted on before the dew has disappeared in the morning. Poultry. Cut down all plants in early spring to force the beetles to deposit their eggs upon the new shoots, which are then cut every few days before the eggs hatch ; or leave a row or so around the field as a lure for the beetles where they may be killed with arsenicals.

THE TWELVE-SPOTTED ASPARAGUS-BEETLE (*Crioceris 12-punctata*). — Similar to the last, but with twelve spots on the wing-covers.

Treatment. — Similar to that used above, except that the grubs cannot be destroyed by lime, since they live within the berry.

ASPARAGUS MINER (*Agromyza simplex*). — A maggot mining under the skin near the base of the plant.

Treatment. — Leave a few volunteer plants as a trap in which the fly will deposit her eggs. Pull and burn these plants in late June and early July.

Aster. ASTER-WORM (*Papaipema nitela*). — A small larva boring in the stem of garden asters about the time they begin to flower, causing the heads to droop.

All infested stocks should be burned. Destroy by burning all rank weeds, such as ragweed and cocklebur, before September.

Bean. BEAN-WEEVIL OR BEAN-BUG (*Bruchus obtectus*). — Closely resembles the pea-weevil, which see for description and remedies. Holding over the seed will be of no value with this insect.

SEED-CORN MAGGOT. (*Pegomya fusciceps*). — A maggot attacking germinating seeds and roots of young plants.

Treatment. — Avoid stable manure ; practice crop rotation. In the garden use sand moistened with kerosene around the plants to keep the flies from laying the eggs.

Birch. BRONZE BIRCH-BORER (*Agrius anxius*). — A slender, creamy white grub, three-fourths inch in length when full grown, that burrows under the bark of the white birch, ultimately killing the tree. The eggs are laid during May and June by a slender, olive-bronze beetle about one-half inch in length.

Treatment. — After a tree has become thoroughly infested, nothing can be done to save it. As the first indication of the presence of the borer is usually a dying of the topmost branches, such trees should be carefully examined, and if infested should be cut down and burned before May 1, to prevent a spread of the trouble to other trees.

Blackberry. CANE-BORER. — See under RASPBERRY, p. 330.

ROOT GALL-FLY. — See under RASPBERRY.

SNOWY CRICKET. — See under RASPBERRY.

Cabbage. CABBAGE-WORM OR CABBAGE-BUTTERFLY (*Pontia rapæ*). — The green caterpillars hatch from eggs laid by the common white butterfly. There are several broods every season.

Treatment. — If plants are not heading, spray with kerosene emulsion or with paris green to which the sticker has been added. If heading, apply hellebore.

FLEA-BEETLE. — See FLEA-BEETLE, p. 303.

COMMON CABBAGE-LOOPER (*Autographa brassicæ*). — A pale green caterpillar, striped with lighter lines. Feeds on the leaves.

Treatment. — Arsenicals applied to lower surface of leaves.

CABBAGE APHIS (*Aphis brassicæ*). — These small, mealy plant-lice

are especially troublesome during cool, dry seasons, when their natural enemies are less active.

Treatment. — Before the plants begin to head, spray with kerosene emulsion diluted with 6 parts of water or whale-oil soap, 1 pound in 6 gallons of water, or use one of the concentrated tobacco extracts. Destroy all cabbage stalks and other cruciferous plants in the fall. Dip infested plants in soap solution before planting.

HARLEQUIN CABBAGE-BUG (*Murgantia histrionica*). — Bug about a half-inch long, gaudily colored with orange dots and stripes over a blue-black ground, feeding upon cabbage; two to six broods.

Treatment. — Hand-picking. Place blocks about the patch, and the bugs will collect under them. In the fall make small piles of the rubbish in the patch, and burn them at the approach of winter. Practice clean culture. Destroy all cabbage stalks and other cruciferous plants in fall. Early in the spring plant a trap crop of mustard, radish, rape, or kale. When the overwintering bugs congregate on these plants, destroy them with pure kerosene or by hand.

MAGGOT (*Pegomya brassicæ*). — A minute white maggot, the larva of a small fly, eating into the crown and roots of young cabbage, cauliflower, radish, and turnip plants.

Treatment. — Carbolic acid emulsion diluted with 30 parts of water applied the day following the transplanting of the cabbage plants, and repeated once a week for several applications. Remove a little earth from about the plants, and spray on the emulsion forcibly. It has also been found practicable to protect the plants by the use of tightly fitting cards cut from tarred paper.

In seed beds protect the plants by surrounding the bed with boards one foot wide placed on edge, across which a tight cover of cheese-cloth is stretched.

Carrot. **PARSLEY-WORM.** — See under PARSLEY, p. 324.

CARROT-BEETLE (*Ligyris gibbosus*). — A reddish brown beetle one-half inch or more long, which attacks the young plants. The larva lives in the ground, where it feeds on humus.

Preventive. — Crop rotation and other remedies for white grub, which see under CORN, p. 314.

Cauliflower. CAULIFLOWER OR CABBAGE-WORM. — See under CABBAGE.

MAGGOT. — See under CABBAGE, p. 311.

Celery. CARROT RUST-FLY (*Psila rosæ*). Minute whitish yellow maggots infesting the roots and stunting the plants.

Preventive.—Late sowing and rotation of crops. Celery or carrots should not follow each other.

CELERY CATERPILLAR (*Papilio polyxenes*).—A large green caterpillar, ringed with black and spotted with yellow, which feeds on the leaves.

Treatment.—Hand-picking as soon as observed.

CELERY LEAF-TYER (*Phlycænia ferrugalis*).—A greenish caterpillar, feeding on the under side of the leaves.

Treatment.—Spray with arsenicals while the larvæ are still young.

LITTLE NEGRO-BUG (*Corimelæna pulicaria*).—Glossy black bugs one-eighth inch in length, which collect in clusters in the axils of the leaflets and cause the plants to wilt.

Treatment.—Kerosene emulsion or tobacco extract.

Cherry. CANKER-WORM. See under APPLE, p. 306.

PLUM-CURCULIO. See under PLUM, p. 329.

ROSE BEETLE. See under APPLE and GRAPE, pp. 308, 322.

SLUG (*Eriocampoides limacina*).—Larva, one-half inch long, blackish and slimy, feeding upon the leaves; two broods.

Treatment. Arsenicals, hellebore, tobacco extract.

APHIS (*Myzus cerasi*). Blackish plant lice infesting the leaves and tips of new growth.

Treatment. Spray as soon as the first lice appear with whale-oil soap or tobacco extract.

Chestnut. WEEVIL (*Balaninus proboscideus* and *B. rectus*).—A grub working in chestnuts, making them wormy.

The weevil is a curculio-like insect.

Preventives.—Destroy wild trees where the insects breed.

Plant the most immune varieties. Gather and destroy the infested nuts immediately after they fall.

Chrysanthemum. CABBAGE-LOOPER. — See under LETTUCE, p. 322.

CHRYSANTHEMUM LEAF-MINER (*Phytomyza chrysanthemi*).—

Remedy.—Spray leaves with "Nicofume Liquid," or "Black

Leaf 40," 1 part in 450 parts water, at intervals of week or 10 days.

Clover. FLOWER-MIDGE (*Dasyneura leguminicola*).—An orange-red

maggot infesting the flower-buds, where they consume the contents of the ovary.

Preventives. — Cut the first crop for hay as early as possible, thus destroying the undeveloped larvæ of the first brood. In the latitude of Illinois this should be done before June 25.

SEED-CHALCIS (*Bruchophagus funebris*). — A white grub found inside the seed.

Preventive. — Same as for FLOWER-MIDGE, above. Destroy all volunteer clover plants.

SEED-CATERPILLAR (*Enarmonia interstictana*). — A small whitish or orange caterpillar infesting the heads.

Preventive. — Early cutting of first crop, as for FLOWER-MIDGE.

ROOT-BORER (*Hylastinus obscurus*). — Small white grub burrowing in the roots.

Preventive. — Plow under badly infested fields as soon as possible after cutting.

HAY-WORM (*Hypsopygia costalis*). — A brownish caterpillar three-fourths inch long, infesting stacked or stored clover.

Preventive. — Remove old clover hay before putting in the new. Place stacks on log or rail foundation, and salt the lower layers. (Illinois Experiment Station.)

Corn. **CORN-ROOT APHIS** (*Aphis maidiradicis*). — A bluish green aphid infesting the roots.

Preventives. — A short rotation period in corn, especially in dry years. Deep and thorough and repeated stirring of old corn ground in fall and spring as a preparation for corn-planting. Maintenance and increase of the fertility of the soil.

WHITE GRUBS (*Lachnosterna* spp.). — The large white curved larvæ of the common June beetle.

Preventives. — Rotation of crops ; do not let corn follow sod, but let a crop of clover or clover and oats intervene. To help clear sod land of grubs, pasture to hogs any time between April and October. To prevent laying of eggs in corn-field, keep the ground free from weeds during May and June. Thorough cultivation and heavy fertilization.

NORTHERN CORN ROOT-WORM (*Diabrotica longicornis*). — A whitish grub two-fifths inch long, which burrows in the roots.

Preventive. — Crop rotation ; corn should not follow corn.

WIRE-WORMS (*Elateridæ*). — Hard, yellowish, or reddish, cylindrical larvæ feeding on the roots.

Preventives. — Crop rotation ; let clover intervene between sod and corn, planting the corn late the second or third year. Early fall plowing.

CUT-WORMS (*Agrotis*, *Hadena*, etc.). — Soft-bodied caterpillars eating and cutting off the young plants. See p. 302.

Preventives. — Early fall plowing of grass lands intended for corn ; pasturing by pigs of grass or clover land intended for corn ; distributing a line of poisoned bran by means of a seed-drill. To prevent the caterpillars entering from a neighboring grass field, destroy them with a line of poisoned vegetable bait.

SOD WEB-WORMS (*Crambus* spp.). — Gray or brownish caterpillars about one-half inch long, living in a silk-lined burrow in the soil at base of the plant. They thrive in grass land.

Preventive. — Early fall plowing of grass land intended for corn, or else plow as late as possible the next spring.

ARMY-WORM. (*Leucania unipuncta*). — A cut-worm-like caterpillar, which normally feed on grass. When this food supply is exhausted, they migrate in numbers to other fields and attack corn, wheat, etc.

Preventive. — To stop the advance of the "army," plow deep furrows so the dirt is thrown towards the colony ; in the bottom of the furrow dig post holes into which the caterpillars will fall and where they may be killed with kerosene.

CHINCH-BUG (*Blissus leucopterus*). — A red or white and black sucking bug, three-twentieths of an inch long. Attacks wheat and corn in great numbers.

Preventives. — Clean farming to destroy suitable hibernating shelter. Stop the migration of the bugs from the wheat-fields into corn by maintaining along the field a dust strip ten feet wide in which a furrow and post-hole barrier has been constructed. This may be supplemented by a coal-tar barrier.

GRASSHOPPERS (*Acrididæ*). — Kill them with poison bran mash flavored with lemons or oranges.

CORN EAR-WORM (*Heliothis armiger*). — A green or brownish striped caterpillar feeding on the corn beneath the husk. Three to six generations yearly.

Preventives. — Plant as early as possible, and still avoid a “set back” to the crop.

For insects infesting stored corn, see under FUMIGATION, p. 287.

Cotton. — **BOLLWORM** (*Heliothis obsoleta*). — This insect is also known as the corn earworm and tomato fruit-worm. The caterpillars are over an inch in length, and vary in color from greenish to dark brown.

Preventives. — Produce an early crop of cotton by planting early varieties, heavy fertilizing, early and frequent cultivation. Practice fall plowing, to destroy as many hibernating pupæ as possible. Use corn as a trap crop. Plant it in strips across the field and time it so that the crop will be in silk and tassel about August 1. In areas infested by the boll weevil follow the recommendations given below. (Bureau of Entomology, U. S. Dept. Agric.)

MEXICAN BOLL-WEEVIL (*Anthonomus grandis*). — A snout beetle about one-fourth inch in length, which lays its eggs in the squares and bolls, producing a grub which eats out the contents.

Treatment (U. S. Dept. Agric.): —

1. Destroy the vast majority of weevils in the fall by up-rooting and burning the plants. This is the all-important step. It results in the death of millions of weevils. It insures a crop for the following season.

2. Destroy also many weevils that have survived the preceding operation and are found in the cotton-fields and along the hedgerows, fences, and buildings. This is done by clearing the places referred to thoroughly.

3. As far as possible, locate the fields in situations where damage will be avoided. This cannot be done in all cases, but can frequently be done to good advantage.

4. Prepare the land early and thoroughly in order to obtain an early crop. This means fall plowing and winter working of the land.

5. Provide wide rows, and plenty of space between the rows and the plants in the drill, for the assistance of the natural enemies of the weevil, which do more against the pest than the farmer can do himself by any known means. Check-rowing, wherever practicable, is an excellent practice.

6. Insure an early crop by early planting of early-maturing varieties, and by fertilizing where necessary.

7. Continue the procuring of an early crop by early chopping to a stand and early and frequent cultivation. Do not lose the fruit the plants have set by cultivation too deep or too close to the rows.

8. Where the labor is sufficient, pick the first appearing weevils and the first infested squares. Do not destroy the squares, but place them in screened cages. By this means the escape of the weevils will be prevented, while the parasites will be able to escape to continue their assistance on the side of the farmer.

9. Use a crossbar of iron or wood, or some similar device, to cause the infested squares to fall early to the ground, so that they will be exposed to the important effects of heat and parasites.

10. Do not poison for the leaf-worm unless its work begins at an abnormally early date in the summer.

Cranberry. FRUIT-WORM (*Mineola vaccinii*). — Small caterpillar working in the fruits, eating out the insides.

Preventive. — For bogs with abundant water, reflow for ten days immediately after picking. Let the foliage ripen, and then turn on water for winter. Draw off water early in April, and every third or fourth year hold it on until the middle of May. For dry bogs spray three times with arsenate of lead during July. Bury all screenings.

FIRE-WORM, CRANBERRY-WORM, OR BLACK-HEADED CRANBERRY-WORM (*Eudemis vacciniana*). — Small larva, green, black-headed, feeding upon the shoots and young leaves, drawing them together by silken threads; two broods.

Treatment. — Flooding for two or three days when the worms come down to pupate. Arsenicals.

YELLOW-HEADED CRANBERRY-WORM (*Acleris minuta*). — Stout, yellowish-green, small caterpillar, with a yellow head, webbing up the leaves as it works.

Treatment. — Hold the water late on the bog in spring to prevent egg-laying. Arsenicals from the middle of May till July 1.

CRANBERRY-GIRDLER (*Crambus hortuellus*). — Small caterpillars feeding on the stems just beneath the surface of the sand.

Preventive. — Reflow just after picking, for a week or ten days, or reflow for a day or two about June 10.

FALSE ARMY-WORM (*Calocampa nupera*). — Green to blackish caterpillars devouring the leaves and buds.

Treatment. — Reflow for from twenty-four to thirty-six hours soon after the middle of May. It may be necessary to reflow a second time. Destroy all caterpillars washed ashore while the water is on.

In dry bogs, spray early in May with arsenate of lead.

Cucumber. **PICKLE-WORM** (*Diaphania nitidalis*). — Larva, about an inch long, yellowish white, tinged with green, boring into cucumbers; two broods.

Preventives. — Clean farming, fall plowing, and rotation of crops.

Remedies. — Kill the caterpillars before they enter the fruit by spraying with arsenate of lead about the time the buds begin to form, and repeat in two weeks.

STEM-BORER. — See under SQUASH (p. 331), where it is described as root-borer.

MELON-WORM. — See under MELON, p. 322.

SPOTTED CUCUMBER-BEETLE (*Diabrotica 12-punctata*). — Beetle, yellowish and black spotted, about one-fourth inch long, feeding upon the leaves and fruit. Sometimes attacks fruit-trees, and the larva may injure roots of corn.

Treatment. — Same as for STRIPED CUCUMBER-BEETLE, below.

STRIPED CUCUMBER-BEETLE (*Diabrotica vittata*). — Beetle, one-fourth inch long, yellow with black stripes, feeding on leaves. Larva one-eighth inch long and size of a pin, feeding on roots; two broods.

Preventive. — Cheap boxes covered with thin muslin or screens of mosquito-netting, placed over young plants.

Remedies. — Arsenicals in flour. Arsenate of lead. Ashes, lime, plaster, or fine road dust sprinkled on the plants every two or three days when they are wet. Air-slaked lime. Plaster and kerosene. Tobacco powder, applied liberally. Apply remedies when dew is on, and see that it strikes the under side of the leaves.

Currant. **BORER** (*Sesia tipuliformis*). — A whitish larva, boring in the canes of currants, and sometimes of gooseberries. The larva remains in the cane over winter.

Treatment. — In fall and early spring cut and burn all affected canes. These canes are distinguished before cutting by lack of vigor and by limberness.

CURRANT-WORM, or **CURRANT and GOOSEBERRY SAWFLY** (*Nematus ventricosus*). — Larva, about three-fourths inch long, yellow-green, feeding on leaves of red and white varieties; two to four broods.

Treatment. — White hellebore, applied early. Arsenicals for the early brood. Treatment should begin while the larvæ are on the lowermost leaves of the bushes. Before the leaves are fully grown, the holes made by the worms may be seen. The second brood is best destroyed by killing the first brood.

CURRANT MEASURING or SPAN-WORM (*Cymatophora ribearia*). — Larva somewhat over an inch long, with stripes and dotted with yellow or black, feeding upon the leaves.

Treatment. — Hellebore, applied stronger than for currant-worm. Arsenicals. Hand-picking.

FOUR-STRIPED PLANT-BUG. — See p. 303.

GREEN LEAF-HOPPER (*Empoa albopicta*). — Small insect working upon the under surface of currant and gooseberry leaves. Also upon the apple.

Remedies. — Pyrethrum. Kerosene emulsion. Tobacco-dust. Tobacco extracts.

Dahlia. **FOUR-STRIPED PLANT-BUG.** — See p. 303.

CABBAGE LOOPER. — See under **CABBAGE**, p. 311.

Egg-plant. **POTATO-BEETLE.** — See under **POTATO**, p. 329.

Elm. **CANKER-WORM.** — See under **APPLE**, p. 306.

ELM LEAF-BEETLE (*Galerucella luteola*). — A small beetle, imported from Europe, which causes great devastation in some of the eastern states by eating the green matter from elm leaves, causing the tree to appear as if scorched.

Remedy. — Arsenate of lead (1½ pounds to 25 gallons).

ELM SAWFLY LEAF-MINER (*Kaliosysphinga ulmi*). — A greenish white larva feeding between the two layers of the leaf, causing large blotches; when abundant, the leaf dies and falls. They sometimes kill the trees in two or three years.

Treatment. — When the blotches are about one-third to one-half inch in diameter, spray with "Black-leaf 40," tobacco extract, 1 gallon in 800 gallons of water, adding 4 pounds of whale-oil soap to each 100 gallons.

WILLOW-WORM. — See under **WILLOW**.

Endive. CABBAGE-LOOPER. See under CABBAGE, p. 311.

Gooseberry. CURRANT-BORER. — See under CURRANT, p. 318.

CURRANT MEASURING or SPAN-WORM. — See under CURRANT.

FOUR STRIPED PLANT-BUG. — See p. 303.

GOOSEBERRY or CURRANT-WORM. — See under CURRANT.

GOOSEBERRY FRUIT-WORM (*Dakruma convolutella*). — Larva, about three-fourths inch long, greenish or yellowish, feeding in the berry, causing it to ripen prematurely.

Treatment. — Destroy affected berries. Clean cultivation. Poultry.

GREEN LEAF-HOPPER. — See under CURRANT.

Grape. GRAPEBERRY-WORM (*Polychrosis viteana*). — Larva, about one-fourth inch long, feeding in the berry, often securing three or four together by a web; two broods.

Remedy. — Spray with arsenate of lead before blossoms open. Repeat after blooming and again in early July. Destroy wormy berries in August.

GRAPE-CURCULIO (*Craponius inæqualis*). — Larva, small, white, with a brownish head. Infests the grape in June and July, causing a little black hole in the skin and a discoloration of the berry immediately around it. The adult is a grayish brown snout-beetle, about one-tenth inch long.

Treatment. — Spray with arsenate of lead while the beetles are feeding on the leaves. The beetle may be jarred down on sheets, as with the plum-cureulio. Bagging the clusters.

GRAPE-SLUG or SAW-FLY (*Selandria vitis*). — Larva about one-half inch long, yellowish green with black points, feeding upon the leaves; two broods.

Remedies. — Arsenicals. Hellebore.

GRAPE ROOT-WORM (*Fidia viticida*). — The small white grubs feed upon the roots, often killing the vines in a few years. The adults are small grayish-brown beetles that eat peculiar chain-like holes in the leaves during July and August. Cultivate thoroughly in June, especially close around the vines to kill the pupæ in the soil. At the first appearance of the beetles spray the plants with arsenate of lead at the rate of 8 or 10 pounds to 100 gallons of water, to which should be added 1 gallon of molasses (Geneva Experiment Station).

GRAPE-VINE FLEA-BEETLE (*Graptodera chalybea*). — Beetle, of a blue metallic color, about one-fourth inch long, feeding upon the buds and tender shoots in early spring.

Treatment. — Arsenicals to kill the grubs on leaves during May and June. The beetle can be caught by jarring on bright days.

GRAPE-VINE ROOT-BORER (*Memphrus polistiformis*). — Larva, one and one-half inch or less long, working in the roots.

Preventive. — Thorough cultivation during June and July.

Treatment. — Dig out the borers.

GRAPE-VINE SPHINX (*Ampelophaga myron*). — A large larva, two inches long when mature, green with yellow spots and stripes, bearing a horn at the posterior extremity, feeding upon the leaves, and nipping off the young clusters of grapes; two broods.

Treatment. — Hand-picking. Arsenicals early in the season.

There are other large sphinx caterpillars which feed upon the foliage of the vine and which are readily kept in check by hand-picking and spraying.

PHYLLOXERA (*Phylloxera vastatrix*). — A minute insect preying upon the roots, and in one form causing galls upon the leaves.

Preventive. — As a rule this insect is not destructive to American species of vines. Grafting upon resistant stocks is the most reliable method of dealing with the insect yet known. This precaution is taken to a large extent in European countries, as the European vine is particularly subject to attack.

Remedies. — There is no reliable and widely practicable remedy known. Burn affected leaves. Bisulphide of carbon poured in holes in the ground, which are quickly filled, is very effective. Carbolic acid and water used in the same way is also recommended. Flood the vineyard.

SNOWY CRICKET. — See under **RASPBERRY**, p. 331.

LEAF-HOPPER (*Typhlocyba comes*). — These small yellowish leaf-hoppers, erroneously called "thrips," suck the sap from the underside of the leaves, causing them to turn brown and dry up.

Treatment. — Spray the under side of the leaves very thoroughly with whale-oil soap, 1 pound in 10 gallons of water, or with "Black-leaf" tobacco extract, 1 gallon to 100 gallons of water; or 1 gallon "Black-leaf 40" in 1000 gallons of water about July 1, to kill the young leaf-hoppers. When using tobacco extract add

about 2 pounds whale-oil soap to each 50 gallons to make it spread and stick better. Repeat the application in a week or ten days. In houses, tobacco-smoke, pyrethrum poured upon coals held under the vines, syringing with tobacco-water or soap suds.

GRASSHOPPERS. — See under CORN, p. 314.

ROSE-CHAFFER (*Macrodactylus subspinosus*). — The ungainly, long-legged, grayish beetles occur in sandy regions, and often swarm into vineyards and destroy the blossoms and foliage.

Treatment. — At the first appearance of the beetles spray with arsenate of lead at the rate of 8 or 10 pounds to 100 gallons of water, to which should be added 1 gallon of molasses.

HOLLYHOCK. BUG (*Orthotylus delicatus*). — A small green bug, attacking the hollyhock with great damage.

Treatment. — Kerosene emulsion. Tobacco extracts.

HOUSE-PLANTS. See APHIDES, MEALY-BUG, MITES, and RED-SPIDER, pp. 301-304.

LAWNS. ANTS (*Formica* sp.). — Insects burrowing in the ground, forming "ant hills."

Remedy. — A tablespoonful of bisulfid of carbon poured into holes six inches deep and a foot apart, the holes being immediately filled up.

LETTUCE. APHIS or GREEN-FLY. — A plant-louse on forced lettuce.

Preventive. — Tobacco-dust applied on the soil and plants as soon as the aphid makes its appearance, or even before. Renew every two or three weeks if necessary. Fumigating with tobacco is the surest remedy. See FUMIGATION, p. 288.

CABBAGE-LOOPER (*Autographa brassiae*). — Larva, somewhat over an inch long, pale green, with stripes of a lighter color, feeding on leaves of many plants, as cabbage, celery, and endive.

Remedies. — Pyrethrum diluted with not more than three times its bulk of flour. Kerosene emulsion. Hot water.

MELON. MELON-WORM (*Diaphania hyalinata*). — Larva, some over an inch long, yellowish green and slightly hairy, feeding on melon-leaves, and eating holes into melons, cucumbers, and squashes; two or more broods.

Remedies. — Hellebore. Arsenicals early in the season.

SPOTTED CUCUMBER-BEETLE. — See under CUCUMBER, p. 318.

SQUASH-VINE ROOT-BORER. — See under SQUASH, p. 331.

Mushroom. MUSHROOM-FLY. — The maggot bores through the stems of the mushrooms before they are full grown.

Preventive. — Keep the beds cool so that the fly cannot develop. When the fly is present, growing mushrooms in warm weather is usually abandoned.

Onion. MAGGOT (*Pegomya cepetorum*). — Much like the CABBAGE MAGGOT, which see (p. 312).

Remedies. — Carbolic acid emulsion. Bisulfid of carbon.

THRIPS (*Thrips tabaci*). — Minute elongate yellowish insects that cause a wilting and dying of the tops.

Treatment. — Clean culture, kerosene emulsion, tobacco extracts.

Orange and Lemon. PURPLE SCALE (*Lepidosaphes beckii*). — An elongate brownish purple scale resembling an oyster-shell in shape.

Treatment. — Fumigation, using heavy dosage.

RED-SCALE (*Aspidiotus aurantii*). — A nearly circular reddish or yellowish scale.

Treatment. — Fumigation. Distillate.

BLACK-SCALE (*Saissetia oleæ*). — A large soft-bodied dark brown or nearly black scale.

Treatment. — Fumigation. Distillate.

MEALY-BUG (*Pseudococcus citri*). — A mealy white soft-bodied insect nearly one-fourth inch long, occurring in masses in the angles of the branches, axils of the leaves, and around the stem of the fruit.

Treatment. — Fumigation. Destruction of all rubbish under the trees.

RED-SPIDER (*Tetranychus sexmaculatus*). — Minute greenish yellow mites found on the leaves. See p. 304.

Treatment. — Dry sulfur, or sulfur and water used as a spray.

WHITE-FLY (*Aleyrodes citri* and *A. nubifera*). — The immature stages are found on the underside of the leaves and are scale-like in form. The adults are minute white-winged flies.

Treatment. — Fumigation. Fungous diseases (p. 290).

RUST-MITE (*Phytoptus oleivorus*). — A minute mite, causing the rust on oranges and lemons.

Treatment. — Sulfur, dry or as a spray.

THRIPS (*Euthrips citri*). — A minute, active, yellow insect that scars the fruit and curls and distorts the leaves.

Treatment. — Make four applications of lime-sulfur (33° Beau-mé), 1 gallon in 75 gallons of water, adding "Black-leaf 40" tobacco extract at the rate of 1 part in 1800 parts of the dilute lime-sulfur, as follows: —

First. — Just after most of the petals have fallen from the blossoms.

Second. — Ten or fourteen days after the first.

Third. — From three to four weeks after the second.

Fourth. — In August or September, to protect later growths of foliage. (U. S. Bureau of Entomology.)

Parsley. PARSLEY-WORM (*Papilio asterias*). — Larva, inch and a half long, light yellow or greenish yellow with lines and spots; feeding upon leaves of parsley, celery, carrot, etc. When the worm is disturbed it ejects two yellow horns, with an offensive odor, from the anterior end.

Remedies. — Hand-picking. Poultry are said to eat them sometimes. Upon parsnip, arsenicals.

Parsnip. PARSLEY-WORM. — See under PARSLEY, above.

PARSNIP WEB-WORM (*Depressaria heracliana*). — Larva, about a half inch long, feeding in the flower cluster and causing it to become contorted.

Treatment. — Arsenicals, applied as soon as the young worms appear, and before the cluster becomes distorted. Burn the distorted umbels. Destroy all wild carrots.

Pea. PEA-WEEVIL or PEA-BUG (*Bruchus pisi*). — A small brown-black beetle, living in peas over winter. The beetle escapes in fall and spring, and lays its eggs in young pea-pods, and the grubs live in the growing peas.

Treatment. — Hold over infested seed for one year before planting. Late planting in some localities. Fumigation with carbon bisulfid.

PEA APHIS (*Macrosiphum pisi*). — A rather large green plant-louse, often attacking peas in great numbers and causing enormous losses.

Treatment. — Rotation of crops. Early planting. When peas are grown in rows, the brush-and-cultivator method may be used. The plant-lice are brushed from the plants with pine boughs, and a cultivator follows stirring the soil. This operation should be

performed while the sun is hot and the ground dry. Most of the lice will be killed before they can crawl back to the plants. Repeat every three to seven days.

PEACH. BLACK APHIS (*Aphis persicæ-niger*). — A small black or brown plant-louse which attacks the tops and roots of peach-trees. When upon the roots it is a very serious enemy, stunting the tree and perhaps killing it. Thrives in sandy lands.

Treatment. — Kerosene emulsion. Tobacco decoction and extracts.

ROUND-HEADED APPLE-TREE BORER. — See under APPLE, p. 308.

FLAT-HEADED BORER. — See under APPLE.

KATYDID. — This insect is often troublesome to the peach in the southern states in the early spring, eating the leaves and girdling young stems.

Remedy. — Poisoned baits placed about the tree.

GREEN PEACH-LOUSE OR APHIS (*Myzus persicæ*). — A small insect feeding upon the young leaves, causing them to curl and die.

Treatment. — Lime-sulfur, kerosene emulsion, or tobacco decoction. After the buds open, either of the last two.

PEACH-TREE BORER (*Sanninoidea exitiosa*). — A whitish larva, about three-fourths inch long when mature, boring into the crown and upper roots of the peach, causing gum to exude.

Remedies. — Dig out the borers in June and mound up the trees. At the same time apply gas-tar or coal-tar to the trunk from the roots up to a foot or more above the surface of the ground.

PEACH TWIG-MOTH (*Anarsia lineatella*). — The larva of a moth, a fourth inch long, boring in the ends of the shoots, and later in the season attacking the fruit. Several broods.

Remedy. — Spray with lime-sulfur just after the buds swell. Spray trunks and larger branches with kerosene or distillate emulsion in late spring to kill first brood pupæ in the curls of bark.

PEACH-TREE BARK-BEETLE (*Phlæotribus liminaris*). — A dark brown beetle one-tenth inch in length burrowing under the bark.

Treatment. — Burn all brush and worthless trees as soon as the infestation is observed. Keep the trees in healthy condition by thorough cultivation and the use of fertilizers.

Apply a thick whitewash to the trunk and branches three times

a season ; first, the last week of March ; second, second week in July ; third, first week in October.

FRUIT-TREE BLACK-BEETLE (*Scolytus rugulosus*). — A small beetle similar to the last.

Treatment. — Same as preceding.

PLUM-CURCULIO (*Conotrachelus nenuphar*). — In Missouri and Georgia this insect has been successfully controlled on peach by spraying with arsenate of lead, 4 pounds to 100 gallons of self-boiled lime-sulfur. Spray, first when the "husks" drop from the fruit; second, ten days or two weeks later. It is unsafe to spray peaches more than twice with arsenate of lead (p. 329).

ROSE-BEETLE. — See under GRAPE and APPLE, pp. 308, 322.

RED-LEGGED FLEA-BEETLE (*Haltica rufipes*). — A flea-beetle feeding on the leaves of peach trees, often in great numbers.

Remedies. — The insects fall at once upon being jarred, and sheets saturated with kerosene may be used upon which to catch them. Spray with arsenate of lead in self-boiled lime-sulfur.

Pear. APPLE-TREE BORER. — See under APPLE, p. 306.

BUD-MOTH. — See under APPLE.

CODLIN-MOTH. — See under APPLE.

FLAT-HEADED BORER. — See under Apple.

MIDGE (*Diplosis pyrivora*). — A minute mosquito-like fly ; lays eggs in flower-buds when they begin to show white. These hatch into minute grubs which distort and discolor the fruit. New York and eastward. Prefers the Lawrence. Introduced in 1877 from France.

Remedies. — Destroy the infested pears. Cultivate and plow in late summer and fall to destroy the pupæ then in the ground.

PEAR-LEAF BLISTER (*Eriophyes pyri*). — A minute mite which causes black blisters to appear upon the leaves. The mites collect under the bud-scales in winter.

Remedy. — Lime-sulfur or miscible oil as a dormant spray.

PEAR-TREE BORER (*Sesia pyri*). — A small whitish larva, feeding under the bark of the pear tree.

Remedy. — Same as for round-headed apple-tree borer.

PEAR-TWIG BEETLE (*Xyleborus pyri*). — Brownish or black beetle, one-tenth inch long, boring in twigs, producing effect much like pear-blight, and hence often known as "pear-blight beetle." It

escapes from a minute perforation at base of bud ; probably two broods.

Treatment. — Burn twigs before the beetle escapes.

PEAR PSYLLA (*Psylla pyricola*). — These minute, yellowish, flat-bodied, sucking insects are often found working in the axils of the leaves and fruit early in the season. They develop into minute, cicada-like jumping-lice. The young psyllas secrete a large quantity of honey-dew, in which a peculiar black fungus grows, giving the bark a characteristic sooty appearance. There may be four broods annually, and the trees are often seriously injured.

Treatment. — Clean culture ; remove rough bark from trunks and larger limbs to discourage adults from hibernating on the trees, and spray with miscible oils while trees are dormant. Spray with lime-sulfur wash at strengths used to combat scale, just before leaves appear, to destroy eggs. After blossoms have dropped, spray with whale-oil soap, 1 pound to 5 or 7 gallons of water ; kerosene emulsion diluted with 8 to 12 parts of water ; or standardized tobacco decoctions at strengths recommended on containers. If psyllas are abundant, trees should be frequently sprayed. (New York Experiment Station.)

PEAR THRIPS (*Euthrips pyri*). — Minute insects, $\frac{1}{16}$ inch in length, dark brown when adult, white with red eyes when young, that attack the opening bud and young fruits in early spring. They suck the sap from the tender growth, and the females lay eggs in the fruit stems, causing a loss of the crop. The nymphs hibernate in the ground a few inches from the surface. A serious pest in California and recently introduced into New York.

Treatment. — Thorough cultivation during October, November, and December (in California). Make two applications of "Black-leaf" tobacco extract, 1 gallon in 60 gallons of 2 per cent distillate oil emulsion, the first just as the fruit buds begin to open, the second just after the petals fall. In the East it may be controlled by timely applications of tobacco extract and whale-oil soap.

Pecan. BUD-MOTH (*Proteopteryx deludana*). — A brownish caterpillar about one-half inch in length, feeding on the opening buds in early spring and on the underside of the leaves in summer.

Treatment. — Arsenate of lead in summer to kill larvæ of second brood. Lime-sulfur and arsenate of lead in dormant season just before buds open, to destroy hibernating larvæ.

CASE-BEARER (*Acrobasis nebulella*). — A small caterpillar living inside a case which it carries with it. It attacks the opening buds.

Treatment. — Arsenate of lead as soon as the buds begin to open. Repeat if necessary.

BORER (*Sesia scitula*). — A wood-boring caterpillar working in the sapwood.

Treatment. — Digging out.

TWIG-GIRDLEERS. — See under PERSIMMON below.

ROSE-BEETLE. — See under GRAPE and APPLE, pp. 308, 322.

ROUND-HEADED BORER. — See under APPLE.

SLUG. — See under CHERRY, p. 313.

TWIG-GIRDLER (*Oncideres cingulatus*). — A brownish-gray beetle, about one-half inch long, which girdles twigs in August and September. The female lays eggs above the girdle. The twigs soon fall.

Remedy. — Burn the twigs, either cutting them off or gathering them when they fall.

TWIG-PRUNER. — See under APPLE, p. 309.

Persimmon. WHITE PEACH-SCALE (*Diaspis pentagona*).

Remedy. — Lime-sulfur when the trees are thoroughly dormant.

TWIG-GIRDLEERS (*Oncideres cingulatus* and *O. texana*). — Dark gray long-horned beetles that girdle the twigs, causing them to drop.

Remedy. — Pick up and burn fallen twigs in fall and winter.

Pineapple. KATYDID (*Acanthacara similis*). — A large katydid which attacks, among other plants, the leaves of the pineapple.

Remedy. — Arsenicals, before the plants are mature.

MEALY-BUGS (several species). — These mealy white insects attack the plant at the base of the leaves, usually underground.

Treatment. — Set only clean plants, or dip them in resin wash or kerosene emulsion. In the field apply tobacco dust freely in the bud before the bloom begins to appear, or spray with kerosene emulsion.

RED-SPIDER (*Stigmæus floridanus*). — Minute mites occurring in great number at the base of the leaf, where they induce rot.

Treatment. — Tobacco dust applied to bud.

Plum. CANKER-WORM. — See under APPLE, p. 306.

CURCULIO (*Conotrachelus nenuphar*). — Larva, a whitish grub, feeding in the fruit.

Remedies. — Arsenate of lead, 6 pounds to 100 gallons of water; apply as soon as the calyx falls, and repeat two or three times at intervals of about ten days. Jarring the beetles on sheets very early in the morning, beginning when trees are in flower, and continuing from four to six weeks, is probably the most sure procedure. There are various styles of sheets or receptacles for catching the insects as they fall from the tree. Clean culture.

FLAT-HEADED BORER. — See under APPLE.

PEAR-TWIG BEETLE. — See under PEAR, p. 326.

PLUM-GOUGER (*Coccotorus prunicida*). — A small larva, feeding upon the kernel of the plum. The beetle bores a round hole in the plum instead of making a crescent mark, like the curculio.

Remedy. — Catch the beetles over a curculio-catcher.

SCALE (*Lecanium corni*). — A large circular scale occurring on plum (and perhaps other) trees in New York.

Remedy. — Thorough spraying with kerosene emulsion, one part to five of water, in the winter. More dilute emulsion or tobacco extracts in midsummer, when the young insects are on the leaves and young shoots.

SLUG. — See under CHERRY, p. 313.

TWIG-PRUNER. — See under APPLE, p. 309.

Poplar. COTTONWOOD LEAF-BEETLE (*Lina scripta*). — A striped beetle feeding on the leaves and shoots of poplars and willows.

Remedy. — Arsenicals.

WILLOW-WORM. — See under WILLOW, p. 336.

POPLAR BORER (*Cryptorhynchus lapathi*). — A whitish grub burrowing in the wood.

Treatment. — In nurseries spray thoroughly about the middle of July with arsenate of lead to kill the parent beetles.

Potato. COLORADO POTATO-BEETLE (*Leptinotarsa decemlineata*). — Beetle and larva feed upon the leaves.

Remedies. — Arsenicals, either dry or in spray, about a third stronger than for fruits. Hand-picking the beetle.

STALK-WEEVIL (*Trichobaris trinotata*). — A grub boring in the stalk

of the potato near or just below the ground. Serious at the West and in some places eastward.

Remedy. — Pull all infested vines as soon as they wilt, and spread them in the sun where the insects will be killed. Burn the vines as soon as the crop is harvested. Destroy all solanaceous weeds.

FLEA-BEETLES (*Halticini*). — Small, dark-colored jumping beetles that riddle the leaves with holes. See p. 303.

Preventive. — Bordeaux mixture as applied for potato blight acts as a repellent.

POTATO TUBER-WORM (*Phthorimæa operculella*). — A small caterpillar burrowing in the stems and tubers both in the field and in storage.

Preventives. — Clean cultivation, sheep and hogs to destroy the small potatoes left in the field after digging. Crop rotation over a considerable area. On digging remove the potatoes at once to an uninfested storeroom. Do not leave them on the field over-night.

WIRE-WORMS. — See p. 305.

Privet or Prim. **PRIVET WEB-WORM** (*Diaphania quadrastigmalis*). —

Small larva feeding in webs on the young shoots of the privet, appearing early in the season; two to four broods.

Remedies. — Trim the hedge as soon as the worms appear, and burn the trimmings. Probably the arsenicals will prove useful.

Quince. **ROUND-HEADED BORERS.** — See under **APPLE**, p. 308.

SLUG. — See under **CHERRY**, p. 313.

QUINCE-CURCULIO (*Conotrachelus crataegi*). — This curculio is somewhat larger than that infesting the plum, and differs in its life-history. The grubs leave the fruits in the fall, and enter the ground, where they hibernate and transform to adults the next May, June, or July, depending on the season. When the adults appear, jar them from the tree on to sheets or curculio-catchers and destroy them. To determine when they appear, jar a few trees daily, beginning the latter part of May. Arsenicals.

Radish. **MAGGOT** (*Pegomya brassicæ*). — Treated the same as the **CABBAGE-MAGGOT**, which see (p. 312).

Raspberry. **CANE-BORER** (*Oberca bimaculata*). — Beetle, black, small, and slim; making two girdles about an inch apart near the tip of the cane, in June, and laying an egg just above the lower girdle; the larva, attaining the length of nearly an inch, bores down the cane. Also in blackberry.

Remedy. — As soon as the tip of the cane wilts, cut it off at the lower girdle and burn it.

RASPBERRY ROOT-BORER (*Bembecia marginata*). — Larva about one inch long, boring in the roots and the lower parts of the cane, remaining in the root over winter.

Remedy. — Dig out the borers.

RASPBERRY SAW-FLY (*Monophadnus rubi*). — Larva about three-fourths inch long, green, feeding upon the leaves.

Remedies. — Hellebore. Arsenicals, after fruiting.

ROOT GALL-FLY (*Rhodites radicum*). — A small larva which produces galls on the roots of the raspberry, blackberry, and rose, causing the bush to appear sickly, and eventually killing it. The swellings are probably often confounded with the nematode root-galls, for which see p. 303.

Remedy. — There is no remedy except to destroy the galls; if plants are badly affected, they must be dug up and burned.

SNOWY OR TREE-CRICKET (*Ecanthus niveus*). — Small and whitish cricket-like insect, puncturing canes for two or three inches, and depositing eggs in the punctures.

Remedy. — Burn infested canes in winter or very early spring.

Rhubarb. RHUBARB-CURCULIO (*Lixus concavus*). — A grub three-fourths inch long, boring into the crown and roots. It also attacks wild docks.

Remedy. — Burn all infested plants, and keep down the docks.

Hand-picking.

Rose. ROOT GALL-FLY. — See under RASPBERRY, above.

MEALY-BUG. — Tobacco extracts. Syringe the plants in the morning, and two hours later syringe again with clean water. See also p. 303.

ROSE-CHAFFER, ROSE-BEETLE, or "ROSE-BUG." See GRAPE, p. 322.

ROSE LEAF-HOPPER (*Typhlocyba rosæ*). — A very small hopper, white, often mistaken for thrips, living on the leaves of roses.

Remedies. — Whale-oil soap. Kerosene. Kerosene emulsion. Dry pyrethrum blown on bushes when leaves are wet. Tobacco extracts.

Squash. BORER or ROOT-BORER (*Melittia satyriniformis*). — Soft, white, grub-like larva which bores inside the stem and causes rot to develop, killing the vine.

Preventives. — Plant early squashes as traps. As soon as the early crop is gathered, burn the vines to destroy eggs and larvæ of the borer. Fall harrowing of infested fields will help to expose the pupæ to the elements. Cut out borers whenever found. After the vines have grown to some length, cover some of the joints with earth, so that a new root system will develop to sustain the plant in case the main root is injured.

Strawberry. CROWN-BORER (*Tyloderma fragariæ*). — White grub, one-fifth inch long, boring into the crown of the plant in mid-summer. The mature insect is a curculio or weevil.

Preventives. — Rotation of crops. Isolation of new beds from infested beds. Plant uninfested plants.

LEAF-ROLLER (*Ancylis comptana*). — Larva, less than one-half inch long, feeding on the leaves, and rolling them up in threads of silk; two broods.

Treatment. — Turn under in the fall all old beds that have become worthless. Spray with arsenate of lead, 4 pounds in 100 gallons of water, after the eggs are laid but before the leaves are folded — the first half of May in the latitude of New Jersey.

ROOT-BORER (*Anarsia* sp.). — Larva, about one-half inch long, whitish, boring into the crown of the plant late in the season, and remaining in it over winter.

Remedy. — Burn the plant.

ROOT-LOUSE (*Aphis forbesi*). — From July to the close of the season the lice appear in great numbers on the crowns and on the roots of the plants.

Remedies. — Rotation in planting. Disinfect plants coming from infested patches by dipping the crowns and roots in kerosene emulsion, or tobacco extract. Fumigation.

SAW-FLY (*Emphytus maculatus*). — Larva, nearly three-fourths inch long, greenish, feeding upon the leaves; two broods.

Remedies. — Hellebore. Arsenicals for second brood.

WEEVIL (*Anthonomus signatus*). — Beetle, one-eighth inch long, reddish black, feeding on flower-buds, particularly those of the polleniferous varieties.

Preventives. — Plant principally pistillate varieties. Every fifth row should be of some profusely flowering staminate variety

to insure pollinization. Clean culture. Destroy all wild blackberry and raspberry vines in the vicinity.

ROOT-BORER (*Typophorus canellus*). — A whitish grub one-eighth inch in length, feeding on the roots. The parent beetle is brownish, and appears in great numbers in May.

Treatment. — Arsenicals to kill the beetles. Plant new beds at a distance from old ones.

WHITE GRUBS. See under CORN, p. 314.

SUGAR-CANE (D. L. Van Dine). **STALK-BORER** (*Diatraea saccharalis*). —

This is the "cane-borer" of the South, and is a species of long standing in the southern United States. The insects attack corn and sugar-cane. The insect occurs as far south in the United States as the Rio Grande valley in Texas, and as far north as Maryland on the Atlantic coast. In corn-growing areas in the South, it is known as "the larger corn stalk-borer." The eggs of the insect are laid on the cane-leaves, and the caterpillar of the moth develops within the cane-stalk. Between the months of May and December, the complete development of the insect occupies a period of a little over thirty days, that is, a brood may be expected about every month.

Treatment. — The control measures consist of the burning of the trash after harvest, fall planting where possible, not to intercrop cane with corn, not to plant corn or cane on windrowed areas, that is, areas on which cane has been windrowed for the spring plant, and to cover all seed cane well to prevent the emergence of moths which may have developed from "borers" planted in the seed cane.

MEALY-BUG (*Pseudococcus calceolariae*). — Common on sugar-cane in the southern parishes of Louisiana, and recorded further in the United States from Florida and California. Known in Louisiana as "pou-á-pouche." The insects occur in a mass about the roots and beneath the lower leaf-sheaths of the cane plant, and the mass is covered by a white mealy secretion. The mealy-bug hibernates on the roots of the stubble beneath the surface of the ground or on the stalks put down in windrow as seed for the spring plant. Brood follows brood throughout the summer months.

Treatment. — Burning of trash after harvest, fall planting, and the selection of seed cane from non-infested areas are the main methods that may be employed in the control of this species.

ROOT-BEETLE (*Ligyris rugiceps*). — This insect occurs throughout the lower Mississippi valley and the southern states generally as far north as North Carolina. As the name implies, the beetle infests the roots of the cane plant. The insect hibernates in the advanced larval or the pupal stages, and the adult appears in the spring. The injury to the cane is accomplished by the adult eating into the young shoots just below the surface of the ground. From this point the insect works downwards to the roots, where the eggs are laid. The larva develops about the roots. In the case of young shoots the injury is sufficient to practically sever the shoot from the mother cane or stubble. This kills out the heart of the young plant, and unless the cane suckers well, the stand is seriously affected.

Treatment. — If the stubble cane is off-barred in the spring and the soil kept away from the young cane as late as the conditions will allow, much injury from the root beetle will be avoided. Frequent cultivation of the plant cane will disturb the beetles in the soil and lessen their chance of attacking the cane. No great amount of vegetable matter should be plowed under on those areas where the root beetle is abundant, since this favors the development of the larvæ or “white grubs.” The headlands and ditch banks should be kept clear of grass, since the beetle develops in these situations bordering the cane-fields. In districts where freezing temperatures occur, late fall plowing will turn out many of the grubs, and they will perish from exposure. During an attack, it is often profitable to have children follow and collect the beetles behind the hoe gangs.

Sumac. APPLE-TREE BORER. — See under APPLE, p. 308.

JUMPING SUMAC-BEETLE (*Blepharida rhois*). — Larva, half-inch long, dull greenish yellow, feeding on leaves; two broods.

Remedy. — Arsenicals.

Sweet-potato. SAW-FLY (*Schizocerus ebnus* and *S. privatus*). — Small larva about one-fourth inch long, working upon the leaves. The fly is about the size of a house-fly.

Remedies. — Hellebore and arsenicals.

ROOT-BORER (*Cylas formicarius*). — A whitish grub one-fourth inch in length, burrowing through the tubers.

Preventive. — Burn infested tubers and the vines.

TORTOISE BEETLES (*Cassidini*). — Beetles of brilliant colors and their slug-like larvæ which eat holes in the leaves of newly reset plants.

Treatment. — Same as for next.

FLEA-BEETLE. (*Chaetocnema confinis*). — Small, dark-colored beetles, which attack the plants soon after they are reset.

Treatment. — Dip the plants in a strong solution of arsenate of lead before resetting. Spray once or twice later with the same. Rotation of crops. Destroy all bindweed and wild morning-glory plants.

CUTWORMS. — Poisoned bait. Late planting. Keep the land free from weeds the previous fall. See p. 302.

Tobacco. **FLEA-BEETLE** (*Epitrix parvula*). — Small beetles eating holes in the leaves in the seed beds.

Treatment. — Cover the beds tightly with canvas, or spray thoroughly with arsenate of lead, one pound in 12 gallons of water.

CUTWORMS. — Use poisoned bait. Sod land should be plowed in fall.

HORN-WORMS. — See under TOMATO, below.

FLEA-BEETLES, GRASSHOPPERS, and TREE-CRICKETS. — Attacking the crop in the field, may be controlled by spraying with arsenate of lead, 1 pound in 16 gallons of water.

Tomato. **FRUIT-WORM** (*Heliothis obsoleta*). — Larva, one inch in length, pale green or dark brown, faintly striped, feeding upon the fruit. Also on corn and cotton.

Treatment. — Hand-picking. Avoid planting close to corn or cotton, or after either of these crops or after peas or beans. Practice fall or winter plowing.

TOMATO-WORM (*Phlegethontius sexta* and *P. quinquemaculata*). — A very large green worm feeding upon the stems and leaves of the tomato and husk tomato. Seldom abundant enough to be very serious; kept in check by parasites.

Remedies. — Hand-picking. Rotation of crops. Clean culture. Turkeys.

FLEA-BEETLES. — Dip the young plants in a strong solution of arsenate of lead. Bordeaux mixture acts as a repellent. See p. 303.

Violet. **APHIS.** — Fumigation when grown under glass.

GALL-FLY (*Contarinia violicola*). — The adult is a minute mosquito-like fly. The whitish or yellowish maggot feeds in folds of the opening leaves, which become deformed, turn brown, and die.

Treatment. — Fumigation is practically of no value. Thorough hand-picking as soon as any sign of injury is noticed. Do not let the pest become established in a house.

RED-SPIDER (*Tetranychus bimaculatus*). — Minute mites which cause the leaves to turn paler and become yellowish.

Treatment. — On greenhouse violets there is nothing better than a stiff spray of clear water so applied as not to drench the beds. Repeat the spraying once or twice a week. See p. 304.

Wheat. **HESSIAN-FLY** (*Mayetiola destructor*). — A small maggot infesting the plant between the leaf sheath and the stem. When full grown they transform to the puparium or "flaxseed" stage.

Preventives. — Crop rotation, destruction of all volunteer wheat. Burning stubble where practicable. Late sowing as follows: — After September 1 in northern Michigan; September 20 in southern Michigan and northern Ohio; October 1 in southern Ohio; October 10 to 20 in Kentucky and Tennessee; October 25 to November 15 in Georgia and South Carolina. (Bureau of Entomology.)

JOINT-WORMS (*Isosoma* spp.). — Small yellowish larvæ found in the straw, causing hard knots or galls.

Preventives. — Crop rotation. Heavy use of fertilizer to give a rapid growth. Burning of stubble wherever practicable.

CHINCH-BUG. — See under CORN, p. 314.

Willow. **WILLOW-WORM** (*Euvanessa antiopa*). — Larva, nearly two inches long, black, feeding upon leaves of willow, elm, and poplar; two broods.

Remedy. — Arsenicals.

CHAPTER XIX

LIVE-STOCK RULES AND RECORDS

FARM live-stock, as the term is usually understood, includes the mammals that produce edible products or perform agricultural labor, as the cow, the horse, the sheep, the goat, the swine. Strictly speaking, it should also comprise poultry (Chapter XX), but this large group usually is treated by itself. Many kinds of pets and of fancy stock — cats, dogs, covies, canaries — form another group.

Determining the Age of Farm Animals (Wing)

Cattle.

The teeth of the ox serve to help in the determination of its age, although not so accurately nor to so great an extent as in the horse. Under ordinary circumstances, the incisors are the only teeth that are used in the determination of age. Of these, the ox has eight, or four pairs, and on the lower jaw only. There are two sets, the temporary or milk teeth, and the permanent teeth, the latter differing from the former mainly in their greater size and width.

The calf is born with the two central pairs of milk teeth fully up, and the remaining pairs appear within the first month after birth. When the animal reaches the age of about eighteen months, the middle pair of milk teeth are replaced by permanent ones that are fully twice as broad as the milk teeth. The interval between the appearance of the succeeding pairs is rather variable, depending on the precocity or early maturity of the individual and also on the breed and the way in which the animal has been kept. Young cattle that have been ill-kept, and whose general development has been delayed, will have their dentition delayed, and will show a young mouth for their age. The interval between the appearance of each two pairs of teeth is seldom less than nine months, so that the age of the animal at the time each pair is up and in full wear may be reckoned as follows :

	MONTHS
First, or middle pair	18
Second, or first intermediate pair	27
Third, or second intermediate pair	36
Fourth, or outer pair	45

If there is any variation from the foregoing, the animal is likely to be older rather than younger than the teeth indicate. After the teeth are up and in full wear, there is comparatively little change in their appearance for several years. The teeth are broad, flat, and white in color, and their edges should almost or quite meet. They are never firmly fixed in the jaw, as in the case of the horse, but rather loosely imbedded in a thick, cartilaginous pad or gums. The looseness of the teeth should not therefore be taken by the novice as an indication of unsoundness or of advancing age.

After the animal has reached an age of eight or nine years, the teeth become narrower through wear. They shrink away from each other and often become more or less discolored and finally drop out one by one. A vigorous old cow will often do very well, especially if fed liberally on grain and succulent food, after the last incisor tooth has disappeared. And so long as the teeth are all present and reasonably close together, the animal is said to have a good mouth. This condition may remain up to ten or twelve years of age, and occasionally even longer.

The horns also afford a means for estimating the age of cattle, especially of cows. During the first two years, the horns grow rapidly and the greater part of the total growth is made in this time. Afterward, the growth is slow from year to year, and each year's growth is marked by a more or less distinct ring. The first ring appears when the animal is about three years old, and the age may be reckoned by adding two to the number of rings present.

Sheep.

Sheep have two sets of incisor teeth, on the lower jaw only. The first or middle pair of temporary teeth is replaced by permanent ones when the lamb is thirteen to fifteen months old, and thereafter the succeeding pairs of permanent teeth appear at intervals of a little less than a year. Most shepherds reckon a year for each pair, so that when the last pair is fully up and in wear, the sheep is four years old.

As age advances, the teeth grow narrower and slimmer until advanced age, eight or nine years, when they often shorten rapidly from wear, and finally disappear. So long as the teeth remain strong and fairly firm, the sheep may be said to be in good working condition.

Swine.

While swine have two sets of teeth, temporary and permanent, as in the other domestic animals, the dentition is so irregular as to be of little service in determining the age of the animal. Moreover, the difficulty of catching, holding, and examining the animal is so great that the teeth are seldom, if ever, used to determine the age of swine. In market stock, the age does not play an important part, as the value depends entirely on the weight and condition of the animal, except in the case of old sows and stags (castrated mature males). The former are easily distinguished by evidence of having suckled pigs, and the latter by the tusks and the development of the "shield" — a coarse heavy fold of muscle under the skin on the shoulder. In breeding animals, the age is always indicated on the certificate of registry of pure-bred stock.

Horse's teeth at different ages (Roberts).

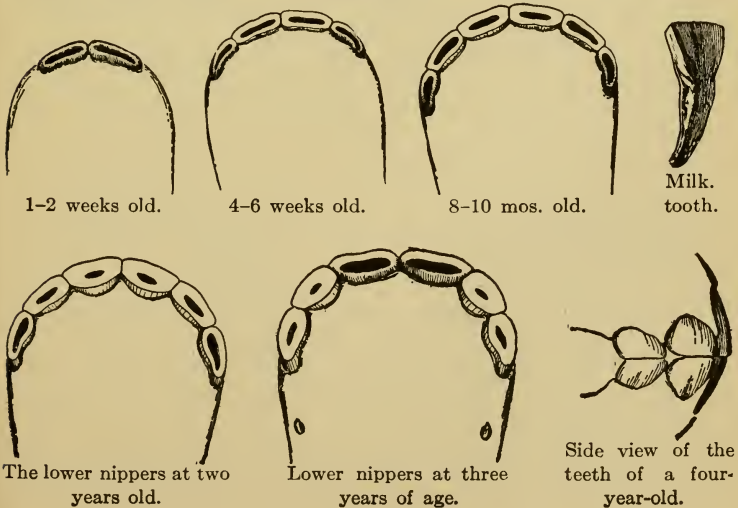

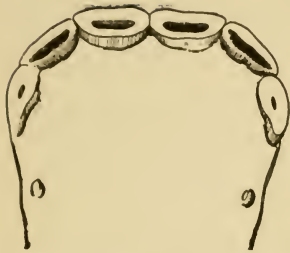

Lower nippers at four years of age.

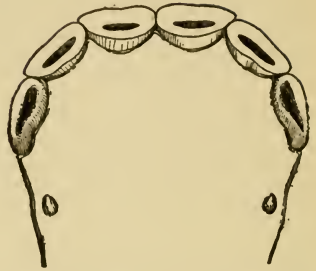

Lower nippers of a five-year-old.



Side view of the teeth of a five-year-old.



Side view of the teeth of a six-year-old horse.

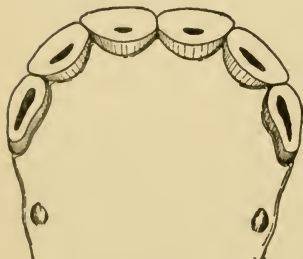

Lower nippers of a six-year-old.

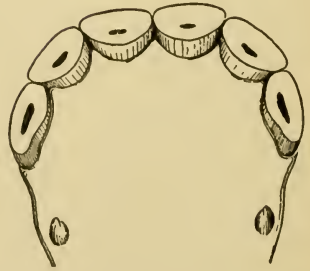

Lower nippers of a seven-year-old.

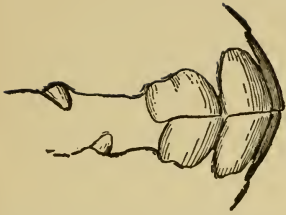

Side view of the nippers of a seven-year-old.



The lower incisor, or nipper, teeth of an eight-year-old.



Side view of the teeth of an eight-year-old.

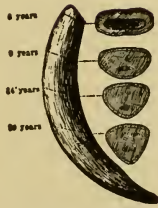

Cross section to show shape of incisor tooth at 4, 9, 14, and 20 years.



The lower incisor teeth of an old horse.



A side view of the nippers of an old horse.

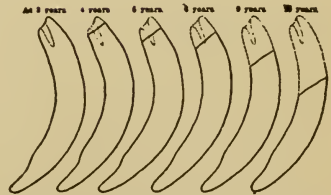

Showing, at the upper end, the wearing away of the cusps at 3, 4, 5, 6, 9, and 20 years.

Gestation and Incubation Figures

The period of gestation is the time between the impregnation of the ovum and the birth of the young. In egg-laying animals it is the period of incubation. The length of this period is subject to considerable variation, determined by various causes not well understood. In general its length is in relation to the size of the animal. The following list, and remarks, represents only a few animals and the period of gestation of each (F. B. Mumford):—

Elephant	20 to 30 months
Giraffe	14 months
Buffalo	10 to 12 months
Ass	12 months
Mare	11 to 12 months
Cow	9 to 9½ months (285 days)
Bear	6 months
Sheep and goat	5 months (21 weeks)
Sow	4 months
Beaver	4 months
Lion	3½ months
Dog, fox, or wolf	2 months
Cat	50 days
Rabbit	30 days
Squirrel and rat	28 days

The period of incubation extends as follows for domestic fowls:—

Turkey	26 to 30 days
Guinea	25 to 26 days
Pea hen	28 to 30 days
Ducks	25 to 32 days
Geese	27 to 33 days
Hens	19 to 24 days (average 21)
Pigeons	16 to 20 days
Canary birds	13 to 14 days

Small breeds hatch earlier. Hamburgs hatch at the end of the twentieth day; game bantams at the end of the nineteenth day. Duck eggs hatch earlier under hens than under ducks, probably because of the higher temperature of the hens' body.

Small breeds of animals require rather less time than larger breeds, although early maturity shortens the time. Cold weather retards the process of incubation especially. According to Youatt, all animals vary greatly without any known cause. The period of gestation in a horse has been known to vary from ten to over twelve months. Tessier reports 582 cases among mares, with a range of 287 to 419 days; 1131

cows ranged from 240 to 321 days. Earl of Spencer reported 764 cows with a range of 220 to 313 days. L. F. Allen reports results for one year among a herd of 50 Shorthorns, Herefords, and Devons, as ranging from 268 to 294 days, or an average of 284 days. Tessier observed 912 ewes with a range of 146 to 161 days. Darwin found that Merinos run about 150 days, while Shropshires and Southdowns require only about 144 days. Swine vary from 109 to 123 days, but usually run 116 days.

In practice there are some causes which hasten birth. A sudden cold spell will hasten the birth of a litter of pigs. Nervous excitement will hasten birth, especially in cows. Parturition of a neighboring cow often hastens birth. It is a popular opinion that male offspring require a longer period of gestation. There is not sufficient evidence to warrant this, but in one case of observation on cattle, the average period for five years was males 288 days, females 283 days. Heredity may influence the period somewhat.

Number of young at birth (Harper)

Elephant	1
Giraffe	1
Buffalo	1
Ass	1
Mare	1
Cow	1
Bear	2
Sheep	1-2-3
Sow	2-14
Beaver	4
Lion	2
Dog	3-8
Cat	3-6
Rabbit	4-8
Squirrel	3-6

Single-birthed animals occasionally bear twins. All multiple-birthed animals are exceedingly variable in the number at a birth.

[Number of eggs in brood (Harper)

Turkey	12-15
Guinea-hen	15-18
Pea-hen	10
Ducks	9-12
Geese	15-18
Hen	12-15
Pigeon	2
Canary	3-4

Other Characteristics

Average temperature of farm animals.

Horse, 100° F. ; ox, 101° to 102.5° ; sheep and swine, 103° ; dog, 102.5° and very changeable. It is lowest about 4 A.M., and highest at 6 P.M. The liver, of all the organs, has the highest temperature, 106.2° F. Poultry 105° to 106°.

The pulse of farm animals (Harger).

The pulse is a dilatation of the elastic wall of an artery at the moment of the heart-beat. Its character is some indication of the state of health. It is felt in the horse on the lower jaw-bone ; in the ox on the jaw, the inside of the elbow and cannon, and the base of the tail ; in the dog on the inside of the thigh.

Number of pulse-beats per minute : Horse, 36 to 40 ; ox, 45 to 50 ; sheep and pig, 70 to 80 ; dog, 90 to 100 ; camel, 28 to 32 ; elephant, 25 to 28. It is slower in the male than in the female. It is more rapid in the young than in the old, as for example, in the foal, 100 to 120 ; in the calf, 90 to 130. The daily work of the heart is estimated at 1,539,000 foot-pounds, or one-third of a horse-power.

Period of heat in farm animals (Mumford).

The beginning of puberty in the female is characterized by the ripening of a mature egg, and external symptoms which together are called the period of heat, or, in some wild animals, the rutting season. This period is accompanied by various manifestations. The external genitals become swollen and red, and this is accompanied by the discharge of a reddish mucus. There is frequent urination, and sometimes a swelling of the mammary glands. The female is often restless and utters loud cries.

The duration of heat varies, but normally continues in the mare two to three days, in the cow twelve to twenty-four hours, in the sow one to three days, and in the ewe two to three days. The frequency with which the heat recurs in different animals varies within rather narrow limits. The period of heat in the mare recurs rather irregularly, but most stallioners agree that the mare will come in heat nine

days after delivery and each two or three weeks thereafter. The cow comes in heat forty to sixty days after delivery, if suckling the calf, and twenty to thirty days if the calf is taken away at birth. After the first appearance of heat in the cow, the period recurs with considerable regularity each three weeks thereafter. The sow invariably shows signs of heat three days after weaning the pigs, and recurs every nine to twelve days. The mare and ewe come in heat regularly during the spring and autumn months. At other seasons, the period is irregular and often entirely absent.

(All dates and periods of this kind are exceedingly variable.)

Quantity of blood in the bodies of farm animals (Harger).

In the horse, $\frac{1}{15}$ (6.6 per cent) ; ox, $\frac{1}{13}$ (7.7 per cent); sheep, $\frac{1}{12}$ (8.01 per cent) ; pig, $\frac{1}{22}$ (4.6 per cent) ; dog, $\frac{1}{18}$ to $\frac{1}{12}$ (5.5-9.1 per cent) (Sussdorf). An average horse has about 66 pounds, or nearly 50 pints, of blood. In bleeding horses, about one pint of blood for every hundred pounds of body weight is removed.

Temperatures for Cold Storage of Animal Products (Hygia Refrigerating Co., Elmira, N. Y.)

Hams, pork loins, poultry, and all meats that are to be held for a long carry, should be put into the freezer at a temperature of 10° above zero or lower, and after they are thoroughly frozen they may be transferred to a temperature from 15° to 18°. Meats to be held for a short time only may be carried at 30° to 32°. Eggs 30°. Condensed milk is carried at 32°; fresh milk at a point just above freezing, where it can be carried, of course, only a short time. Condensed milk can be successfully carried several months; cheese at 31° to 32°; dried fruit, nuts, groceries, etc., at 35°; butter from zero to 10° below zero.

The success of storage depends not alone on the control and accuracy of temperature maintained, but on control of humidity, and in some cases on pronounced circulation of air. For temperatures for fruits, see page 149.

Advanced Registry

The herd-book conserves the purity of a breed, being based upon purity of blood, any animal being eligible to registry whose sire and dam have been recorded. An *Advanced Register* is a herd-book within

a herd-book based upon individual merit, and designed as an aid to improvement within the breed. Advanced registry is especially adapted to the improvement of the dairy breeds of cattle. The registry is made on the report of an official test as to milk yield and butter-fat, conducted by an Experiment Station.

The Advanced Registry system has had marked effect in discovering and publishing the good animals, eliminating the poor animals, and standardizing the performance. The four leading dairy breeds in America — Holstein, Jersey, Guernsey, and Ayrshire — now have well-authenticated records as a result of this system.

As illustrating the nature of the test to warrant Advanced Registry, the following set of general rules of the Holstein-Friesian Association of America is inserted:—

1. The Station representative shall be present at the last regular milking preceding the beginning of the test and shall satisfy himself that the cow is milked dry at that time. He shall note the hour at which this milking is made; and the final milking of the test, whatever its length, must be at exactly the same hour.

2. He must be present at each and every milking during the test, and satisfy himself that at the close of each milking the pail contains nothing but the milk drawn from the cow under test.

3. Under no circumstances can more cows than one undergoing test be milked at the same time. The Station representative must in every case be in position to observe the milker during the whole milking.

4. Immediately after the milk is drawn at each milking, he will take charge of the pail and contents, will weigh the same to pounds and tenths on scales provided by his State Experiment Station, and enter the exact weight of milk at once in his note-book. He will then take a correct sample of the milk, sufficient for his own tests and for the composite sample to be sent to the Station, in accordance with the following directions:

5. As soon as the milk has been weighed it is to be thoroughly mixed by pouring it from one pail to the other, or by means of a dipper; and a pint fruit jar is to be immediately filled about two-thirds full of milk for the test samples. The Station representative takes charge of and is personally responsible for this sample. It should be kept under lock and key until tested. The test is proceeded with as soon as convenient, after the milk has cooled to ordinary room temperature.

6. Fat determinations are always made in duplicate, and the average of the two determinations recorded on the record sheet. The sample taken of any one milking is not to be thrown away until a perfectly satisfactory test of the milking has been obtained. On completion of each test, the Station representative will at once indelibly enter in his note-book the results obtained. In making entries of fat, the supervisor shall use three decimal places. If the figure in the fourth place be a 5, or greater than 5, he shall count it as one of the next higher order; but if it be less than a 5, he shall drop it.

7. If any of the milk or the test sample from a milking be accidentally lost, the missing weight of the milk or fat credited to this milking is to be obtained by taking the average of all corresponding milkings during the whole test; that is, if *e.g.*, the evening milk is lost, or the test sample therefrom, the average of the weights of milk and of fat of all evening milkings during the test is taken as the yield of milk and fat for the milking lost. It must be stated on the report that data so obtained are estimated and not actual.

8. Composite-Test Sample. At the time the test of the milk is made, a sample, comprising as many cubic centimeters of milk as the number of pounds in the milking, is placed in a pint fruit jar, containing a small quantity of preservative, for the composite-test sample to be sent to the Station when the test is completed. A 25 c.c. glass pipette for taking this sample is furnished in each outfit.

Each and every milking must contribute to the composite-test sample in proportion to the amount of milk yielded each time, which will be accomplished by strictly following the directions. The Station representative will be responsible for the proper care of the composite sample, and will send it to the Station by express immediately on the completion of the test.

9. In selecting official test periods of not less than seven consecutive days for report, the test periods so selected may begin with any milking made at the regular hour for that milking; provided the previous milking, as well as the last milking of the test period selected, are also made at the regular hour. When any official test period forms a portion of any semi-official test, a detailed report of the whole official test period *must* be made; but the Superintendent of Advanced Registry will only report as A. R. O. record, or records, such consecutive portion, or portions, of the test as the owner may select.

The Station representative shall fill out all blanks furnished by his Station, or by the Holstein-Friesian Association, and shall make oath before a notary public to such reports as, in conjunction with the authorities of the Holstein-Friesian Association, are required by the Station.

10. The Station representative is not at liberty to decide as to which stipulations contained in the rules are essential and which are not, but is required to observe directions in all details. He shall report to the officer of his Station in charge of tests of dairy cows any irregularity or unusual occurrence in connection with the test which he may observe, and shall, in general, take all possible means to conduct a fair and equitable test of the cows placed under his supervision.

Schedule of charges for supervising records of cows

As an illustration of the costs involved in the testing of cows, a statement is here given of the charges made by one of the colleges of agriculture for such work. Something like one-half of all Holstein cows in the United States with advanced registry are tested according to this schedule. Of course the schedule applies to any breed.

A uniform flat rate is charged for supervising records of cows. This flat rate covers the entire cost of supervision to the breeders so far as the college of agriculture is concerned, and includes per diem of supervisor's traveling and hotel expenses, expressage, postage, etc. The owners and breeders supply the sulfuric acid, pay notary fees, arrange for conveyance to and from the nearest railway station, and provide for living expenses at the farm during the test. No supervisor will be allowed to remain more than 30 days at one place. The schedule is as follows:—

1 day record	\$6.00
2½ day record	\$9.00
7 or more days	\$2.25 per day
For each 7-day or 30-day record reported	\$1.00

A single supervisor will not be required to test more than 6 cows milked 4 times a day; 8 cows milked 3 times a day; or 15 cows milked twice a day.

Supervisors will be sent to suit the convenience of owners as far as possible, but we cannot promise a supervisor for any definite date. Between October and June, application for supervisors should be made at least three weeks in advance, in order to be reasonably sure of a supervisor at the time desired. An application for a supervisor may be canceled or a date deferred at any time up to three days before the man is due. Supervisors will be sent to waiting owners in order of date of application.

Holstein-Friesian records.

The Holstein-Friesian Association has four prize divisions, with seven classes in each division. Following are the leading records for each class in three of the divisions, — the 7-day, 30-day, and the semi-official or yearly division. Breeders are not usually satisfied to have their cows merely qualify, but strive to see how much they can exceed the minimum requirements, which are as follows: —

If the cow calves at two years of age or under, 7.2 lb. fat in seven consecutive days.

If the cow calves at three years of age, 8.8 lb. fat in seven consecutive days.

If the cow calves at four years of age, 10.4 lb. fat in seven consecutive days.

If the cow calves at five years of age or older, 12.0 lb. fat in seven consecutive days.

If the cow calves between two and three years, or between three and four years, or between four and five years old, every day of increased age adds to the requirement of the year .00439 of a pound of fat.

Leading Cows in the 7-day Division

NAME OF COW	H. B. NUMBER	AGE AT TIME OF CALVING	POUNDS OF MILK	AV. PER CENT	POUNDS OF BUTTER-FAT
K. P. Pontiac Lass	106812	5 5 20	585.9	6.03	35.343
Valdessa Scott 2d	72311	8 2 1	694.6	4.82	33.500
Johanna De Kol Van Beers	75131	8 7 7	663.4	4.83	32.059
Pontiac Lady Korndyke	92700	5 11 24	601.4	5.06	30.422
Pontiac Pet	69710	7 5 10	590.7	5.10	30.142
Tweede White Lady	83186	7 3 23	504.7	5.94	29.963
Pontiac Clothilde De Kol 2d	69991	6 10 24	646.1	4.60	29.766
Agatha Pontiac	99818	4 9 15	575.8	5.13	29.520
Lady Oak Fobes De Kol	104269	6 0 11	623.0	4.68	29.155

Leading Cows in the 7-day Division — *Continued*

NAME OF COW	H. B. NUMBER	AGE AT TIME OF CALVING	POUNDS OF MILK	AV. PER CENT	POUNDS OF BUTTER- FAT
Gerben Queen	68164	8 2 12	654.6	4.45	29.111
Aaggie Pauline Sarcastic	86737	5 11 24	619.9	4.69	29.079
Sadie Vale Korndyke	95127	5 7 16	655.7	4.42	28.961
Fairmont Zerma Segis Pietje	107672	4 1 11	608.4	4.68	28.484
Pietertje Maid Ormsby	78051	6 4 14	535.4	5.31	28.450
Semi-official Division (Yearly)					
Finderne Pride Johanna Rue	121083	5 4 4	28403.7	4.11	1176.47
Finderne Holingen Fayne	144551	3 4 14	24612.8	4.53	1116.05
Banostine Belle De Kol	90441	5 2 22	27404.4	3.86	1058.34
Pontiac Clothilde De Kol 2d	69991	6 10 24	25318.0	4.02	1017.28
High-lawn Hartog De Kol	84319	5 11 12	25592.5	3.90	998.34
Colantha 4th's Johanna	48577	8 1 19	27432.5	3.64	998.26
Lothian Maggie De Kol	90209	6 10 14	27967.6	3.54	990.80
Maple Crest Pontiac Flora Hartog	143950	5 2 1	25106.3	3.93	986.11
Crown Pontiac Josey	101812	6 0 20	28752.3	3.42	982.23
Maple Crest Pontiac Spotted Annie	141164	5 1 1	21393.0	4.59	981.02
Caroline Paul Parthenca	77784	9 4 23	25072.6	3.86	966.55
Daisy Grace De Kol	98228	4 3 13	21718.3	4.43	962.80
Tilly Alcartra	123459	5 1 6	30451.4	3.12	951.23
Lindenwood Hope	115655	4 8 0	20404.7	4.56	931.45
Buckeye De Kol Pauline 2d	94346	6 2 0	20784.3	4.46	927.61

Ayrshire records.

A cow is eligible for Advanced Registry in the Ayrshire Breeders' Association as follows:—

No cow shall be admitted to Advanced Registry unless she shall have been previously recorded in the Ayrshire Record.

Two-year-old form.— Year's record. If her record begins the day she is two years old, or before that time, she shall, to entitle her to record, give not less than 6000 pounds of milk in 365 consecutive days from the beginning of the test and 214.3 pounds of butter fat, and for each day she is over two years old at time of beginning the test there shall be added 1.37 pounds of milk to the 6000 pounds and .06 pound of butter fat to the 214.3 pounds.

Three-year-old form.— If her record begins the day she is three years old, she shall, to entitle her to record, give not less than 6500 pounds of milk in 365 consecutive days from the beginning of the test and 236 pounds of butter fat, and for each day she is over three years old at the time of beginning the test there shall be added 2.74 pounds of milk to the 6500 pounds and .12 pound of butter fat to

the 236 pounds, which addition shall be made in each succeeding form to maturity.

Four-year-old form. — Year's record — 7500 pounds of milk and 279 pounds of butter-fat.

Mature form. — Year's record — 8500 pounds of milk and 322 pounds of butter-fat.

Leading Records in each Class to June 1, 1915

CLASS	NAME OF COW	LB. MILK	% FAT	LB. FAT
Over 5 years	Auchenbrain Brown Kate 4th .	23,022	3.99	917.60
4½ to 5 years	Miss Nox 3d	15,015	3.84	576.94
4 to 4½ years	Agnes Wallace of Maple Grove	17,657	4.65	821.45
3½ to 4 years	Elizabeth of Juneau	15,122	3.55	536.15
3½ to 4 years	The Abbess of Torr	14,582	4.39	640.72
3 to 3½ years	Ethel of South Farm	15,056	3.91	589.20
2½ to 3 years	Henderson's Dairy Gem	17,974	4.11	738.32
2 to 2½ years	Jean Armour 3d	14,987	4.	599.91

Ten Leading Records in the Mature Class

	NAME OF COW	LB. MILK	LB. FAT	LB. BUTTER	% FAT
27943	Auchenbrain Brown Kate 4th, 547 . . Owned by Percival Roberts, Jr., Narberth, Pa.	23,022	917.60	1080	3.99
27950	Garclaugh Spottie, 772 Owned by John R. Valentine, Bryn Mawr, Pa.	22,589	816.25	960	3.61
22269	Lily of Willowmoor, 299 Owned by J. W. Clise, Redmond, Wash.	22,106	888.70	1046	4.02
36910	Auchenbrain Yellow Kate 3d, 1356 . . . Owned by Percival Roberts, Jr., Narberth, Pa.	21,123	888.33	1045	4.21
23853	Gerranton Dora 2d, 663 Owned by J. W. Clise, Redmond, Wash.	21,023	804.79	947	3.83
25487	Jean Armour, 635 Owned by W. P. Schanck, Avon, N.Y.	20,174	774.73	912	3.84
25295	Rena Ross 2d, 438 Owned by John R. Valentine, Bryn Mawr, Pa.	18,849	713.56	840	3.79
23985	Netherhall Brownie 9th, 371 Owned by J. W. Clise, Redmond, Wash.	18,110	820.91	966	4.53
26013	Keepsake 2d, 330 Owned by John R. Valentine, Bryn Mawr, Pa.	17,410	711.27	837	4.09
24673	Nether Craig Spicy Queen, 240 Owned by Geo. H. McFadden, Rosemont, Pa.	17,074	692.69	803	4.06

Guernsey records.

All animals admitted to the Advanced Register must previously be entered in the Herd Register of The American Guernsey Cattle Club. Any such will be admitted into the Advanced Register under any of the following conditions:—

Bulls having two daughters in the Advanced Register.

Cows having equalled or exceeded the following requirements:—

If record is commenced the day the animal is two years old, or previous to that day, she must produce within one year from the date 250.5 lb. butter-fat. For each day the animal is over two years old at the beginning of her year's period the amount of butter-fat she will be required to produce in the year will be established by adding .1 (one tenth) of a pound for each such day, to the 250.5 lb. required when two years old. This ratio is applicable until the animal is five years old, when the required amount will have reached 360 lb., which will be the amount of butter-fat required of all cows five years old or over. These yearly standards are based upon one complete year's record from time of beginning, regardless of the time lost by being dry or calving during that period, should such be the case.

Butter-fat.—The per cent of butter-fat shall be determined by the Babcock test for two full and consecutive days in each month in the yearly records.

Re-entry.—An animal having been admitted to the Advanced Register may be re-tested for purpose of giving a better record, and if successful so admitted and record published as "Entry of Additional Record," using the original number assigned the animal and giving reference to previous record.

Five Leading Cows in the Several Classes of the A. R. as they appeared
Sept. 15, 1915

Class A. — 5 years and over

	AGE		LB. MILK	LB. BUTTER-FAT	PER CENT BUTTER-FAT
	Yr.	Mo.			
Murine Cowan 19597, A. R. 1906, Re-entry	8	9	24008.00	1098.18	4.57
May Rilma 22761, A. R. 1726, Re-entry	6	4	19673.00	1073.41	5.46
Spotswood Daisy Pearl 17696, A. R. 790, Re-entry	7	5	18602.80	957.38	5.15
Julie of the Chêne 30460, A. R. 2752, Re-entry	6	1	17661.00	953.53	5.40
Imp. Daisy Moon III. 28471, A. R. 1909, Re-entry	6	4	18019.40	928.39	5.15

Class B. — 4½ to 5 years

NAME OF COW	AGE		LB. MILK	LB. BUTTER-FAT	PER CENT BUTTER-FAT
	Yr.	Mo.			
Dairymaid of Pinehurst 24656, A. R. 843, Re-entry	4	8	17285.30	910.67	5.27
Julie of the Chêne 30460, A. R. 2752	4	10	15174.20	827.26	5.45
Lady Lesbia 25142, A. R. 1348, Re-entry	4	10	13582.75	787.03	5.79
Pandora's Valentine of Rich Neck 27622, A. R. 1742, Re-entry	4	9	14341.60	784.22	5.47
Glenanaar of the Glen 23619, A. R. 1907	4	7	16813.10	780.66	4.64

Class C. — 4 to 4½ years

Azucena's Pride 2d 24957, A. R. 1469, Re-entry	4	1	16203.90	855.70	5.28
Governor's Pauline 30472, A. R. 2441, Re-entry	4	3	14930.00	844.47	5.66
Imp. Dora II. of Les Marais 37737, A. R. 1999, Re-entry	4	1	15434.90	770.38	4.99
Imp. Beauty II. of the Coutanchez 28465, A. R. 2081	4	5	13513.90	748.81	5.54
Stella's Favorite 2d 29167, A. R. 2283, Re-entry	4	0	14529.60	719.23	4.95

Class D. — 3½ to 4 years

Dolly Dimple 19144, A. R. 628, Re-entry	3	9	18458.80	906.89	4.91
Langwater Dorothy 27944, A. R. 1822, Re-entry	3	9	16099.70	781.65	4.86
Imp. Princess of the Blicqs 28485, A. R. 1908	3	8	12608.80	774.16	6.14
Rose of Langwater 24204, A. R. 1445, Re-entry	3	11	15008.20	751.62	5.01
Imp. Ma Charmante 6th 31925, A. R. 1995	3	8	15149.80	740.20	4.89

Class E. — 3 to 3½ years

Jehanna Chêne 30889, A. R. 2588	3	5	16186.70	863.36	5.33
Dairymaid of Pinehurst 24656, A. R. 843, Re-entry	3	1	14562.40	860.26	5.91
Masher's Elsie 24986, A. R. 1967	3	6	14458.70	745.75	5.16
Miranda of Edgewater 30970, A. R. 2363	3	0	14617.30	730.49	5.00
Sweet Maria 25151, A. R. 1803	3	0	12542.50	682.86	5.44

Class F. — 2½ to 3 years

NAME OF COW	AGE		LB. MILK	LB. BUTTER-FAT	PER CENT BUTTER-FAT
	Yr.	Mo.			
Langwater Hope 27946, A. R. 1978	2	7	15078.80	773.59	5.13
Azucena's Pride 2d 24957, A. R. 1469	2	9	12633.30	706.46	5.59
Rose of Langwater 24204, A. R. 1445	2	7	12966.50	669.89	5.17
Imp. Buttercup II. of Beauregard 35799, A. R. 2638	2	11	10623.30	659.71	6.21
May Belle of Linda Vista 29679, A. R. 2134	2	7	11981.76	653.02	5.43

Class G. — 2 to 2½ years

Cherry of Edgewater 38413, A. R. 3361	2	4	13454.20	732.97	5.45
Nella Jay 4th 38233, A. R. 3194	2	2	14772.70	726.32	4.92
Dolly Dimple 19144, A. R. 628	2	2	14009.13	703.36	5.02
Golden Elsie 2d 33422, A. R. 2274	2	0	13409.00	672.94	5.02
Princess Deasie 36703, A. R. 2275	2	3	11943.10	666.22	5.58

The average of these 35 leading Guernsey Cows is 15152.52 lb. milk; 795.46 lb. butter-fat. Average per cent of butter-fat, 5.25

Jersey records.

The regulations of the American Jersey Cattle Club governing "authenticated fat tests" are as follows:—

Seven, fourteen and thirty days' tests.—(1) In the case of tests for seven, fourteen or thirty days, the Babcock method must be applied to a sample of the milk of every milking during the test, and the milk of every milking must be weighed.

No record will be accepted of a test of less than twelve pounds of butter-fat in seven consecutive days.

No record will be accepted of a test for a period of ninety consecutive days or any shorter period down to seven days unless the butter-fat amounts, on the average, to one and seven-tenths pounds per day.

Year's tests.—(2) Year's tests must be authenticated by applying the Babcock test to a sample of the milk of every milking during two consecutive days in each month.

If a test for the period of one year is commenced the day the cow is two years old, or previous to that day, she must produce, within one year from the date the test begins, 250.5 pounds butter-

fat. For each day the cow is over two years old at the beginning of her year's test, the amount of butter-fat she must produce in the year is fixed by adding 0.1 (one-tenth) of a pound for each such day to the 250.5 pounds required when two years old. This ratio of increase applies until the cow is five years old at the beginning of her test, when the required amount will have reached 360 pounds, which will be the amount of butter-fat required of all cows five years old or over. These standards are based upon one complete year's record from the time of beginning, regardless of any time which may be lost by being dry or calving during that period.

The production of butter-fat for each month is to be estimated from the results obtained by the official application of the Babcock test. The milk of every milking during the continuance of a test must be weighed, and, in reporting the test to the Club, must be set forth in detail and certified to on a form provided for the purpose.

“Authenticated milk tests” of the American Jersey Cattle Club are as follows, (authentication consists of a check by the tester for two successive days per month, on which days he shall weigh the milk of every milking and report the same to the Club. Such milk yields as meet any of the following requirements may be received and published as authenticated milk yields):—

If a test for the period of one year is commenced the day the cow is two years old, or previous to that day, she must produce within one year from the date the test begins 6,000 pounds of milk. For each day the cow is over two years old at the beginning of her year's test, the amount of milk she must produce in the year is fixed by adding 3.65 pounds for each such day to the 6,000 pounds required when two years old. This ratio of increase applies until the cow is five years old at the beginning of her test, when the required amount will have reached 10,000 pounds, which will be the amount of milk required of all cows five years old or over. These standards are based upon one complete year's record from the time of beginning, regardless of any time which may be lost by being dry or calving during that period.

A cow meeting the requirements as to year's milk yield as stated above is eligible to the Register of Merit.

HIGHEST YIELDS OF JERSEYS

Best Five Records in Year's Tests at Various Ages. Sept. 1, 1915 (with H. R. No. of Cows)

CLASS 1. — COWS UNDER 2 YEARS

	MILK		BUTTER-FAT		BUTTER, 85% FAT	
	Lb.	oz.	Lb.	oz.	Lb.	oz.
Lucky Farce 298177	14260		635	11.8	747	14
Lass 64th of Hood Farm 266735	9830	5.	606	10.1	713	10
King's Golden Diploma 252638	9749	6.4	559	0.13	657	10
Northern Beauty 2d 296337	10214	11.2	543	8.9	639	7
Ruby's Bonnie Lass 264498	8823	1.	539	2.	634	4

CLASS 2. — COWS 2 YEARS AND UNDER 2½ YEARS

Pearly Exile of St. Lambert 205101	12345	8.	816	1.27	960	1
Lass 66th of Hood Farm 271896	14513	2.	720	8.	847	10
Corinne of Roycroft 247303	11115	11.	640	15.3	754	1
Lass 54th of Hood Farm 257375	14160	5.	628	1.5	738	15
Majesty's Eminent Lady 265699	11730	10.	626	14.	737	8

CLASS 3. — COWS 2½ YEARS AND UNDER 3 YEARS

Lass 73d of Hood Farm 277540	10953	6.4	659	6.5	775	12
Salem's Golden Lucy 271911	11891	1.6	609	9.0	717	2
Sayda's Tina of Meridale 274725	9178		591	2.3	695	6
Agatha's Elista 252719	10147		588	14.1	692	12
Mary Golden Letta 240917	9295	5.	557	7.8	655	14

CLASS 4. — COWS 3 YEARS AND UNDER 3½ YEARS

Lass 74th of Hood Farm 281203	13713	12.8	747	10.	879	8
Tonona Pogis' Azalia 261480	13339	11.2	702	3.1	826	1
Lass 63d of Hood Farm 266734	12694	15.	690	6.9	812	2
Successful Queen 278743	13088	6.4	682	7.5	802	14
Landseer's Pacific Pearl 205097	9045	15.	659	6.6	775	12

CLASS 5. — COWS 3½ YEARS AND UNDER 4 YEARS

Lass 66th of Hood Farm 271896	17793	11.2	910	9.6	1071	4
Figgis 97th of Hood Farm 273502	14796	14.4	750	9.1	883	
Lass 40th of Hood Farm 223642	15362	1.	747	5.2	879	3
Lass 47th of Hood Farm 240327	11410	9.	685	12.6	806	13
Lass 30th of Hood Farm 214511	11990	5.	684	13.9	805	12

CLASS 6. — COWS 4 YEARS AND UNDER 4½ YEARS

Lass 64th of Hood Farm 266735	13444	10	817	13	962	
Flying Fox's Maid 265318	14315	9.6	785	14.7	924	9
Golden Massey Polo 3d 234393	12426	11.2	747	15.6	879	15
St. Mawes Zoe 253435	11299	8	685	5.1	806	4
Mabel's Raleigh's Snowdrop 243890	12936	1.6	653	13.8	769	4
Edith Marigold 247304	11842		695	.8	819	10

CLASS 7. — COWS 4½ YEARS AND UNDER 5 YEARS

Olympia's Fern 252060	16147	13.6	937	13.3	1103	5
Sophie 19th of Hood Farm 189748	14373	3.	854	13.7	1005	11
Rosaire's Olga 4th's Pride 179509	14104	13.6	836	15.8	984	11
Lou 2d of Hood Farm 250505	12458	3.2	708	8.6	833	9
Lass 30th of Hood Farm 214511	11413	13.	664		781	2

CLASS 8. — COWS 5 YEARS AND OVER

	MILK		BUTTER-FAT		BUTTER 85 % FAT	
	Lb.	oz.	Lb.	oz.	Lb.	oz.
Sophie 19th of Hood Farm 189748	17557	12.	999	2.2	1175	7
Spermfield Owl's Eva 193934 . . .	16457	6.4	993	4.06	1168	8
Eminent's Bess 209719	18782	15.6	962	13.2	1132	12
Jacoba Irene 146443	17253	3.2	952	15.4	1121	2
Sophie 19th of Hood Farm 189748	15099	6.	931	15.5	1096	7

Best Records in Year's Tests at Various Ages. October 1, 1914

CLASS 1. — COWS UNDER 2 YEARS

	MILK		BUTTER-FAT		87 % BUTTER	
	Lb.	oz.	Lb.	oz.	Lb.	oz.
Lucky Farce 298177	14260		635	11.8	747	14

CLASS 2. — COWS 2 YEARS AND UNDER 2½ YEARS

Pearly Exile of St. Lambert 205101	12345	8.	816	1.27	960	1
---	-------	----	-----	------	-----	---

CLASS 3. — COWS 2½ YEARS AND UNDER 3 YEARS

Sayda's Tina of Meridale 274725	9178		591	2.3	695	6
--	------	--	-----	-----	-----	---

CLASS 4. — COWS 3 YEARS AND UNDER 3½ YEARS

Tonona Pogis' Azalia 261480	13339	11.2	702	3.1	826	1
---------------------------------------	-------	------	-----	-----	-----	---

CLASS 5. — COWS 3½ YEARS AND UNDER 4 YEARS

Lass 40th of Hood Farm 223642	15362	1.	747	5.2	879	3
---	-------	----	-----	-----	-----	---

CLASS 6. — COWS 4 YEARS AND UNDER 4½ YEARS

St. Mawes Zoe 253435	11299	8.	685	5.1	806	4
--------------------------------	-------	----	-----	-----	-----	---

CLASS 7. — COWS 4½ YEARS AND UNDER 5 YEARS

Olympia's Fern 252060	16147	13.6	937	13.3	1103	5
---------------------------------	-------	------	-----	------	------	---

CLASS 8. — COWS 5 YEARS AND OVER

Sophie 19th of Hood Farm 189748	17557	12.	999	2.2	1175	7
--	-------	-----	-----	-----	------	---

Fast Horse Records¹

Trotters

Arranged according to record to close of 1910

Uhlan, bl. g., by Bingen, 29567	1: 58	The Abbott, b. g., by Chimes, 5348	2: 03½
Lou Dillon, ch. m., by Sidney Dillon, 23157	1: 58½	Alix, b. m., by Patronage, 4143	2: 03½
Major Delmar, b. g., by Delmar, 13313	1: 59½	Highball, b. g., by Dr. Hooker, 24518	2: 03½
The Harvester, br. h., by Walnut Hall, 31641	2: 01	Nancy Hanks, br. m., by Happy Me- dium, 400	2: 04
Hamburg Belle, b. m., by Axworthy, 24845	2: 01½	Jack Leyburn, ch. g., by Alto Ley- burn, 38399	2: 04½
Sweet Marie, b. m., by McKinney, 8818	2: 02	Penisa Maid, b. m., by Pennant, 1968	2: 04½
Cresceus, ch. h., by Robert McGregor, 647	2: 02½	Sonoma Girl, b. m., by Lynwood W., 32835	2: 04½
		Bob Douglas, gr. h., by Todd, 33822	2: 04½

¹ Abbreviations are as follows:—

ch., chestnut in color	br., brown.	g., gelding.
bl., black.	gr., gray.	m., mare.
b., bay.	p., pacer.	h., horse.

Pacers

Arranged according to record to close of 1910

Dan Patch, br. h., by Joe Patchen, 30239	1: 55 $\frac{1}{4}$
Minor Heir, b. h., by Heir-at-Law, 14035	1: 58 $\frac{1}{2}$
Audubon Boy, ch. h., by J. J. Audubon, 16995	1: 59 $\frac{1}{4}$
Star Pointer, b. h., by Brown Hal, 16935	1: 59 $\frac{1}{4}$
Prince Alert, b. g., by Crown Prince	1: 59 $\frac{1}{2}$
Dariel, b. m., by Aleander, 6617	2: 00 $\frac{1}{4}$
John R. Gentry, b. h., by Ashland Wilkes, 2291	2: 00 $\frac{1}{2}$
Lady Maud C., ch. m., by Chitwood, 5212	2: 00 $\frac{1}{2}$
Bolivar, b. g., by Wayland W., 22516	2: 00 $\frac{3}{4}$
The Broncho, b. m., by Stormcliffe, 11674	2: 00 $\frac{3}{4}$
Copa de Oro, b. h., by Nutwood Wilkes, 22116	2: 01
Hedgewood Boy, ch. h., by Chitwood, 5215	2: 01
Joe Patchen, bl. h., by Patchen Wilkes, 3550	2: 01 $\frac{1}{4}$
Little Boy, b. g., by Kenton, 6779	2: 01 $\frac{1}{2}$
Robert J., b. g., by Hartford, 3574	2: 01 $\frac{1}{2}$

Fastest records for one mile

To Sulky — Race

Evelyn W., b. m., by The Spy	1912	2: 00 $\frac{1}{2}$
Minor Heir, p., br. h., by Heir-at-Law	1901	2: 00 $\frac{3}{4}$

To Sulky — Against Time

Dan Patch, p., br. h., by Joe Patchen	1905	1: 55 $\frac{1}{4}$
---	------	---------------------

To Wagon — Race

Angus Pointer, p., b. g., by Sidney Pointer	1904	2: 04 $\frac{1}{2}$
---	------	---------------------

To Wagon — Against Time

Dan Patch, p., br. h., by Joe Patchen	1903	1: 57 $\frac{1}{4}$
---	------	---------------------

Under Saddle

Country Jay, ch. g., by Jayhawker	1909	2: 08 $\frac{1}{4}$
---	------	---------------------

Team Record — In a Race

Charles B., p., bl. g., by Octoroon }	1900	2: 13
Bobby Hal, p., b. g., by Octoroon }		

Team Record — Against Time

Minor Heir, p., b. h., by Heir-at-Law }	1912	2: 02
George Gano, p., b. h., by Gambetta Wilkes }		

Team, Three Abreast — Against Time

Belle Hamlin, b. m., by Almont Jr. }	1891	2: 14
Globe, b. g., by Almont Jr. }		
Justina, b. m., by Almont Jr. }		

Team, Four-in-Hand — Against Time

Damania, ch. m., by Nutmeg }	1896	2: 30
Belnut, ch. g., by Nutmeg }		
Maud V, ch. m., by Nutmeg }		
Nutspra, ch. m., by Nutmeg }		

With Running Mate — Races

Frank, b. g., by Abraham	1883	2: 08 $\frac{1}{2}$
------------------------------------	------	---------------------

With Running Mate — Against Time

Uhlan, bl. g., by Bingen	1913	1: 54 $\frac{1}{2}$
Flying Jib, p., b. g., by Algona	1894	1: 58 $\frac{1}{4}$

Fastest records for two miles

In Harness — Race

Monette, bl. m., by Monon 1894 4 : 45

In Harness — Against Time

The Harvester, br. h., by Walnut Hall 1910 4 : 15½

To Wagon — Race

Dexter, br. g., by Hambletonian 10 1865 4 : 56½

To Wagon — Against Time

Ed Byran, b. g., by Little Corporal 1907 4 : 43

To Road Wagon — Against Time

Temple Hope, b. h., by Norval 1905 5 : 14½

Under Saddle

George M. Patchen, b. h., by C. M. Clay 1863 4 : 56

Fastest records for three miles

In Harness — Race

Fairywood, b. g., by Melbourne 1895 7 : 16½

In Harness — Against Time

Nightingale, ch. m., by Mambrino King 1893 6 : 55½

Fastest records for four miles

In Harness — Race

Longfellow, p., ch. g., by Red Bill 1869 10 : 34½

In Harness — Against Time

Joe Jefferson, p., br. h., by Thomas Jefferson 1891 10 : 10

Fastest records for five miles

In Harness — Race

Zambra, b. g., by McKinney 1902 12 : 24

In Harness — Against Time

Pascal, bl. g., by Pascarel 1893 12 : 45

Fastest records for six miles

In Harness — Against Time

Long Time, b. g., by Jack Rowett 1893 16 : 08

For ten miles

In Harness — Race

Controller, b. g., by May Boy 1878 27 : 23½

In Harness — Against Time

John Stewart, b. g., by Tom Wonder 1867 28 : 02½

For eighteen miles

In Harness — Race

Bill, ch. g., pedigree unknown 1885 58 : 10

For twenty miles

Capt. McGowan, roan h., pedigree unknown 1865 58 : 25

For thirty miles

Gen. Taylor, gr. h., by Morse Horse 1857 1 : 47 : 59

For thirty-two miles

Chancellor, gr. h., by Chancellor 1831 1 : 58 : 00

For fifty miles

Black Joke, bl. g., pedigree not traced 1835 3 : 57 : 00

For one hundred miles

Conqueror, b. g., by Bellfounder 1853 8 : 55 : 53

Fastest records at different decades since 1800

Yankee	1800-1810	2 : 59
Boston Horse, ch. g.	1810-1820	2 : 48 $\frac{1}{2}$
Bowery Boy, p., pedigree unknown	1820-1830 (2 miles)	5 : 04 $\frac{1}{2}$
Drover, p., b. g., pedigree unknown	1830-1840	2 : 28
Unknown, p., ch. g., breeding unknown	1840-1850	2 : 23
Pocahontas, p., ch. m., by Cadmus	1850-1860	2 : 17 $\frac{1}{4}$
Billy Bovee, p., b. g., by Corbeau	1860-1870	2 : 14 $\frac{1}{4}$
Sleepy Tom, p., ch. g., by Tom Rolfe	1870-1880	2 : 12 $\frac{1}{4}$
Johnston, p., b. g., by Joe Bassett	1880-1890	2 : 06 $\frac{1}{4}$
Star Pointer, p., b. h., by Brown Hal	1890-1900	1 : 59 $\frac{1}{4}$
Dan Patch, p., br. h., by Joe Patchen	1900-1910	1 : 55 $\frac{1}{4}$

Profit-and-loss Figures*Profit or loss in dairy cows (Conn. Agric. Coll.)*

The cow is charged with the cost of food eaten at regular market rates, in the locality where the herds were tested. The prices for the year averaged as follows : Hay \$16 per ton, silage \$3.50 per ton, and grain \$30 per ton. Besides the cost of food, each cow was subject to a fixed charge of \$45 for conducting the business, obtained as follows :—

Bedding for one year	\$2.00
Service of bull	1.00
Labor	27.00
Interest on investment	6.00
Taxes60
Insurance40
Depreciation	8.00
	\$45.00

It was estimated that one good man would do the work for 20 cows, including milking, feeding, handling of the milk, and delivering it to the depot, washing all utensils used about the barn, etc. Such

a man would be kept busy caring for twenty cows. If his wages were \$45 per month, it would therefore make a labor bill of \$27 per cow per year.

The next item is one of interest on investment. Allowing \$60 as the value of the cow, and \$60 as each cow's share of the investment in barn, tools, etc., the total investment per cow is \$120. Interest at 5 per cent equals \$6 per cow. Taxes at ten mills on one-half valuation calls for 60 cents, and insurance for at least 40 cents. These interest charges must not be overlooked in any careful reckoning.

The last item in the general bill of expense is one of \$8 per year for depreciation in the value of the cow. Unfortunately money put into cows is not a permanent investment. The period of usefulness of dairy cows will not average over four or five years. A large number turn out to be poor milkers not worth keeping, and must be sold at a loss. Others are ruined by accident and by sickness, so that probably five years covers the average milking period of dairy cows.

Summary for one herd of 16 cows for the year, February to February

AGE OF COW	LB. OF MILK GIVEN FOR THE YEAR	AVERAGE PER CENT FAT	VALUE OF MILK FOR THE YEAR AT 4 CENTS PER QUART	TOTAL INCOME FOR THE YEAR, COUNTING MANURE AND CALF WORTH \$12	COST OF FOOD FOR THE YEAR	TOTAL COST FOR THE YEAR, CHARGING \$45 PER COW FOR LABOR, DEPRECIATION, TAXES, INSURANCE, ETC.	NET PROFIT OR LOSS FOR THE YEAR PER COW
3	3289	5.0	\$61.18	\$68.18	\$34.68	\$57.18	\$11.00
10	4312	3.6	80.23	86.39	35.69	54.44	31.95
3	3209	4.2	59.69	65.85	32.93	51.68	14.17
3	2634	4.0	49.00	54.33	31.56	46.56	7.77
9	4507	3.1	83.84	95.84	62.94	107.94	- 12.10
8	7685	3.1	142.98	154.98	71.67	116.67	38.31
9	6735	3.0	125.40	137.40	69.70	114.70	22.70
9	7493	3.6	139.40	151.40	75.85	120.85	30.55
9	7853	2.9	146.10	158.10	71.00	116.00	42.10
—	6454	3.2	120.07	132.07	70.15	115.15	16.92
10	5678	4.3	105.64	117.64	63.40	108.40	9.24
8	5439	3.6	101.20	113.20	58.13	103.13	10.07
9	1804	4.3	33.57	39.73	25.66	44.41	- 4.68
6	6214	3.7	115.52	127.52	68.29	113.29	14.23
10	5738	5.1	106.76	118.76	61.98	106.98	11.78
8	7023	2.9	130.6	14.96	59.14	96.64	44.32

Profit or loss in fattening steers (Nebraska Bulletin 116)

84 days' feeding

Initial cost of 1043-pound steer	@ \$ 5.00	per cwt.	\$ 52.15
Cost of 1680-pounds corn	@ 52c	per bu.	15.60
Cost of 640-corn-stover	@ 4.00	per T.	1.28
Cost of 570-alfalfa hay	@ 7.00	per T.	2.00
Risk, labor, and shelter			5.00
Total cost			76.03
Selling price, 1274-pound steer	6.02	per cwt.	76.70
Value of manure			5.00
Income			81.70
Total cost of steer			76.03
Total profit			5.67
Profit per \$ 1.00 invested08

Profit or loss in fattening sheep (Ohio Bulletin 187)

96 days' feeding

Initial cost of 50-pound lamb	@ \$ 6.00	per cwt.	\$ 3.00
Cost of 134 pounds corn	@ 40c	per bu.	.96
Cost of 125 pounds clover hay	@ 12.00	per T.	.75
Risk, labor and shelter50
Total cost			5.21
Selling price, 74-pound lamb	@ 7.00	per cwt.	5.18
Value of manure60
Income			5.78
Total cost			5.21
Profit57
Profit per \$ 1.00 invested11

Profit or loss in fattening swine (Indiana Bulletin 137)

60 days' feeding

Initial cost of 115-pound hog	@ \$ 5.25	per cwt.	\$ 6.04
Cost of 214 pounds corn-meal	@ 18.00	per T.	1.93
Cost of 214 pounds middlings	@ 25.00	per T.	2.67
Risk, labor, and shelter75
Total cost			11.39
Selling price, 234-pound hog	@ 5.25		12.29
Value of manure50
Total income			12.79
Total cost			11.39
Profit			1.40
Profit per \$ 1.00 invested12

Cow-testing Associations (Cornell Station)

All evidence goes to show that the dairy business maintains a fairly profitable status only because good individual cows make up for the deficiencies of the poor ones. The elimination of poor producing

animals is undoubtedly the first step toward improvement, and this elimination cannot be successfully brought about unless records of individual production of each cow are systematically kept, and along with such records of production, it is also, if not absolutely essential, at least highly desirable, that a record of food consumed as well be kept.

There is no reason why any dairyman should not himself keep the records that are necessary for this selection, but the fact that most dairymen do not keep such records has led to the formation of cow-testing associations, so that the ordinary dairyman by coöperative effort may secure information at small cost that in most cases he would not take the trouble to secure for himself.

Cow-testing Associations may be organized in various ways and under various plans, and each association should be organized with due regard to its own local conditions. The essential feature in any organization is to secure a good, reliable, trustworthy, and painstaking man to do the work. Such organizations have now been in successful operation in other states for several years, and it would seem that the time is ripe for the dairymen of New York State to avail themselves of these organizations in order to make their business more satisfactory and more profitable.

The most feasible method of organizing such associations seems to be for twenty-five or twenty-six dairies to associate themselves into a cow-testing association, each owner agreeing to weigh the milk of each cow every day, and the tester to test the milk of each cow at least for one day each month. This may be done by the tester himself visiting the individual farms in turn and taking the samples and making the test; or it may be done by the owners themselves taking the samples and carrying them to a central point to be tested. In either case the tester makes the tests, calculates the production of fat for the cow for the month, and makes record of the same and of the food consumed, and reports regularly to the owner on blanks furnished for the purpose.

The details of carrying out this work may be varied to suit conditions. In any case it would require the services of a reliable man for his whole time, and this man will have to be paid a fair salary. Experience has shown that an assessment of one dollar for each cow represented in the association will cover the expense of the work for a year, and in some cases it has been done for somewhat less than this.

Apparatus required.

Babcock tester, not less than 10-bottle size, and if to be used in a creamery where steam is available, at least 24-bottle size. Babcock glassware (state brand). At least twice as many test bottles as the capacity of the machine, with acid measure, pipettes, thermometer, etc.

Sulfuric acid, -- about a pint or two pounds per cow per year.

Sixty-pound spring balance scales, graded to tenths.

As many wide-mouth sample bottles as there are cows in the largest herd to be tested. Each bottle should be supplied with a numbered metal band, or otherwise plainly and durably labeled.

A supply of record blanks, ruled so that the whole record for a cow for a year can be entered upon it.

The cost of the above should be approximately as follows:—

Wages of man one year at \$50 per month	\$600.00
10-bottle Babcock tester, \$10, $\frac{1}{4}$ original cost each year	2.50
Extra glassware and breakage	10.00
125 gal. sulfuric acid at 55 cents gal.	67.75
1 set spring balances	5.00
4 dozen sample bottles	10.00
Record blanks	20.00
	\$715.25

Value of cow-testing associations in Virginia (Virginia Bulletin 190)

Cow No.	TOTAL POUNDS MILK	AVERAGE PER CENT FAT	POUNDS FAT	VALUE OF FAT AT 30 CENTS AND 25 CENTS PER POUND	VALUE OF SKIM MILK AT 25 CENTS PER 100 POUNDS	TOTAL VALUE OF PRODUCTS	COST OF FOOD AND LABOR, LESS VALUE OF MANURE	PROFIT	Loss
1	8109	4.33	351.12	\$102.09	\$16.22	\$118.31	\$44.54	\$73.77	
2	5023	5.20	261.20	76.12	10.04	86.16	"	41.62	
3	4897	5.13	251.22	72.87	9.79	82.66	"	38.12	
4	4573	5.30	242.38	69.70	9.14	78.84	"	34.30	
5	4423	5.33	235.75	68.36	8.85	77.21	"	32.67	
6	4805	4.63	222.47	63.99	9.61	73.60	"	29.06	
7	4100	5.20	213.20	59.73	8.20	67.93	"	23.39	
8	3808	5.33	202.97	58.05	7.61	65.66	"	21.12	
9	3128	5.83	192.36	55.70	6.25	61.95	"	17.41	
10	3164	5.27	166.74	47.85	6.33	54.18	"	9.64	
11	2850	5.75	163.88	47.13	5.70	52.83	"	8.29	
12	3215	4.80	154.32	44.08	6.43	50.51	"	5.97	
13	2755	5.13	141.33	40.56	5.51	46.07	"	1.53	
14	2835	4.60	130.41	37.56	5.67	43.23	"		1.31
15	2345	5.13	120.30	34.15	4.69	38.84	"		5.70
	4002	5.13	203.31			\$66.66	\$44.54	\$21.99	

CHAPTER XX

POULTRY

THE term *poultry* is used to designate all birds that are in the nature of farm animals or farm live-stock, as chickens, geese, ducks, turkeys. Birds grown merely as pets or fancy animals, or to stock

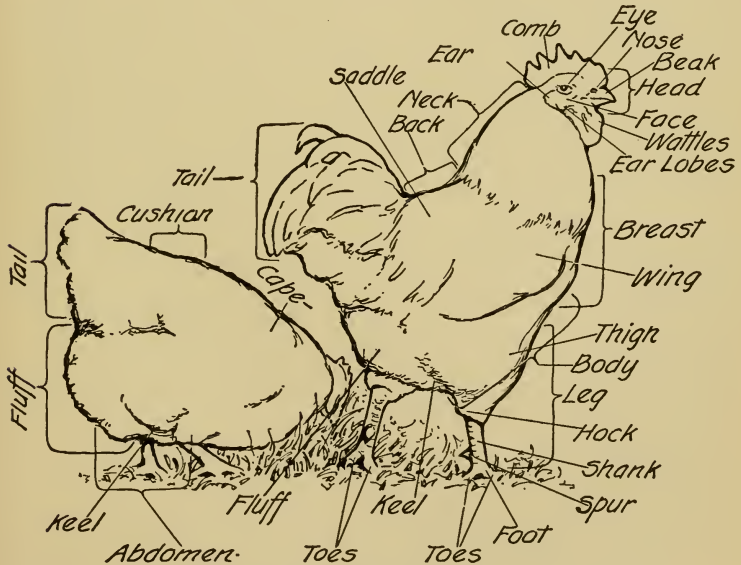

FIG. 6. — Parts of a fowl.

game preserves, are not classed as poultry ; but when any of these birds come to be grown as food animals (as pigeons), they are practically included with other domestic fowls under the general denomination of poultry.

Standard Weights of Poultry in Pounds (Am. Poultry Assoc., 1910)

	COCK	COCKEREL	HEN	PULLET
Plymouth Rocks, all varieties . . .	9.5	8.0	7.5	6.0
Wyandottes, all varieties	8.5	7.5	6.5	5.5
Javas, all varieties	9.5	8.0	7.5	6.5
Rhode Island Red	8.5	7.5	6.5	5.0
Buckeye	9.0	8.0	6.0	5.0
Brahma, Light	12.0	10.0	9.5	8.0
Dark	11.0	9.0	8.5	7.0
Cochins, all varieties	11.0	9.0	9.5	7.0
Langshans, all varieties	9.5	8.0	7.5	6.5
Minorca, Single-comb Black	9.0	7.5	7.5	6.5
Minorca, Single-comb White and Rose-comb Black	8.0	6.5	6.5	5.5
White-Faced Black Spanish	8.0	6.5	6.5	5.5
Blue Andalusians	6.0	5.0	5.0	4.0
Dorking, White	7.5	6.5	6.0	5.0
Silver-Gray	8.0	7.0	6.5	5.5
Colored	9.0	8.0	7.0	6.0
Redcap	7.5	6.0	6.0	5.0
Orpingtons, all varieties	10.0	8.5	8.0	7.0
Houdan	7.5	6.5	6.5	5.5
Crevecœur	8.0	7.0	7.0	6.0
La Fleche	8.5	7.5	7.5	6.5
Cornish	9.0	8.0	7.0	6.0
White-laced Red	8.0	7.0	6.0	5.0
Black-breasted Red Malay	9.0	7.0	7.0	5.0
Black-breasted Red Malay Bantam	26 oz.	24 oz.	24 oz.	22 oz.
Sebright Bantam	26 oz.	22 oz.	22 oz.	20 oz.
Rose-comb Bantam	26 oz.	22 oz.	22 oz.	20 oz.
Booted White Bantam	26 oz.	22 oz.	22 oz.	20 oz.
Brahma Bantam	30 oz.	26 oz.	26 oz.	24 oz.
Japanese Bantam	26 oz.	22 oz.	22 oz.	20 oz.
Polish Bantam	26 oz.	22 oz.	22 oz.	20 oz.
Game Bantam	22 oz.	20 oz.	20 oz.	18 oz.
Leghorns, Ancona, Polish, Hamburgs, Games, Sumatra, Sultan, Frizzle, no standard weights				
Turkey, Bronze	36	33	25	20
Narragansett	30	20	18	12
White Holland	28	20	18	14
Black	27	18	18	12
Buff	27	18	18	12
Slate	27	18	18	12
Bourbon Red	30	22	18	14
	Adult Drake	Young Drake	Adult Duck	Young Duck
Duck, Pekin	9	8	8	7
Aylesbury	9	8	8	7
Rouen	9	8	8	7
Cayuga	8	7	7	6
Crested White	7	6	6	5
Muscovy	10	8	7	6
Blue Swedish	8	6.5	7	5.5

Standard Weights of Poultry—Continued

	COCK	COCKEREL	HEN	PULLET
	Adult Gander	Young Gander	Adult Goose	Young Goose
Goose, Toulouse	25	20	20	16
Embden	20	18	18	16
African	20	16	18	14
Chinese	12	10	10	8
Candian or Wild	12	10	10	8
Egyptian	10	8	8	6

Descriptive Score-Card for Standard Poultry

American class (Cornell)

SECTION	PERFECT SCORE		DEFECTS IN SHAPE
	Shape	Color	
Symmetry	8	3	Rangy, blocky, unbalanced. Over, under, undeveloped. Not alert, low vitality, dirty, poor, fat. Flat, long, short, narrow, coarse. Sunken, dull, droopy.
Weight or size	6		
Condition	4		
Head and beak	3		
Eyes	3		
Comb	8		<i>Single and Pea</i> Extra points, few points, uneven, wrinkled, twisted, thumbmark, back slope, coarse texture.
Wattles and ear lobes	2	4	<i>Rose</i> Low front, hollow center, spike high, spike low, spike small. Long, irregular, unequal, torn, wrinkled, coarse.
Neck	3	6	Long, short, not arched, hackle undeveloped, scant at sides, scant at shoulders.
Wings	4	6	Outside: High, low, large, small. Inside: Feather out, broken, improperly folded.
Back	6	6	Roach back, narrow, drooping, deficient cushion.
Tail	4	5	High, low, pinched, sickles short, coverts scant, feathers out, broken.
Breast	5	5	Narrow, flat, shallow.
Body and fluff	3	3	Narrow, too low, tucked up, crooked keel.
			<i>Unfeathered Varieties</i>
Legs and toes	3	3	Long, short, feathered stubs or down, knock-kneed, thin, crooked, injured.
Perfect Score	100		

For Asiatic fowls, the Cornell score runs : Symmetry, 8 ; weight or size, 6 ; condition, 5 ; head, beak and eyes, 3 for shape and 3 for color ; comb, 8 ; wattles and ear-lobes, 5 ; neck, 4 for shape and 6 for color ; wings, 4 and 4, back, 4 and 5 ; tail, 4 and 5 ; breast, 5 and 5 ; body and fluff, 5 and 3 ; legs and toes, 8. (The reader may wish to compare these categories with scores for other live-stock in Chap. XXI.)

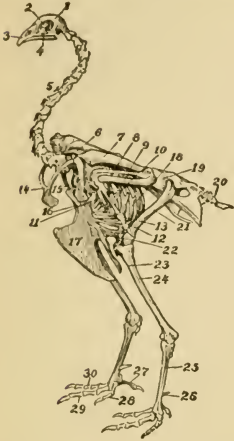

FIG. 7. — Skeleton of cock.

1, cranium; 2, septum inter-orbitale; 3, beak; 4, mandible; 5, cervical vertebræ; 6, scapula; 7, humerus; 8, radius; 9, ulna; 10, metacarpal bone; 11, thumb bone; 12, middle finger; 13, third finger; 14, furcula or wish-bone; 15, coracoid bone; 16, sternum; 17, crest or keel of sternum; 18, ribs; 19, pelvis; 20, caudal vertebræ; 21, femur; 22, patella; 23, tibia; 24, fibula; 25, metatarsus; 26, spur; 27, hind toe; 28, inner toe; 29, middle toe; 30, outer toe. — *Cyclo. Amer. Agric.*, after Ellenberger.

Eggs

Scoring and judging one dozen eggs (Cornell).

Disqualifications.—Extremes in size and shape ; very rough, freckled eggs in extras and firsts, dirty, or cracked shells ; badly spotted interior, or eggs having a noticeably loose content.

The entire dozen is discarded when more than two eggs are disqualified.

Eggs weighing one-half ounce more or less than the average for that dozen shall be disqualified for extras and firsts.

When two or less eggs are disqualified, deduct from the final score or the dozen, 8 points for each egg disqualified. A disqualified egg is not scored with the remainder of the dozen.

Grades. — “Extras” (XXXX). Large and uniform in size and color, weighing 26–30 ounces per dozen, and scoring 90 points.

“Firsts” (XXX). Good size and uniform in size and color, weighing 24–26 ounces per dozen, and scoring 90 points.

“Seconds” (XX). Weighing 20–24 ounces per dozen, and scoring 80 per cent.

“Thirds” (X). No weight clause required. Standard 24 ounces per dozen.

Each grade allows the possibility of a 100 per cent score.

“Seconds” include mixed eggs both of size and color, but they must be necessarily fresh. This grade would take ordinary farmers’ fresh eggs.

All preserved and cold storage eggs are debarred by the score of 80 per cent from every class except “thirds.”

The standard weight for each grade shall be the highest weight mentioned for that grade.

Students’ score-card for a dozen eggs

	VALUE SECTION	1st Doz.	2d Doz.	3d Doz.	4th Doz.	5th Doz.	6th Doz.
Grade							
Shape	12						
Color	12						
Condition of shell	12						
Appearance at candling	14						
Yolk, quality of	25						
White, quality of	25						
Cut for disqualified eggs							
Cut for under-standard weight							
Total cuts							
Final score							

Explanation of score-card :

Shape. — The shape should be uniformly oval throughout the dozen.

Color. — The color should be uniform over the entire shell and throughout the dozen. The standard should be a clear, pure white for white eggs and a rich, dark brown for brown eggs.

Condition of shell. — The shell should be spotlessly clean and unsmearred or glossy by washing. It should be of uniformly firm condition throughout, not twisted or folded.

Appearance at candling. — The contents should be clear and transparent, the yolk being scarcely perceptible. The air space should be very small. A large air space indicates greater age of the egg, except in water glass eggs.

An egg must necessarily be broken for scoring the yolk and white.

Yolk. — The yolk should be a rich golden in color, and should keep its shape when opened into a saucer. It should show no spots other than the germinal disc, and should be of a sweet, agreeable odor.

White. — The white or albumen of the egg should be fresh, sweet, clear, and viscous. The two layers of albumen should be of a distinctly different consistency, — the one very viscous, the other rather watery.

Scale of cuts:

Shape (one point for each egg). — Cut to the limit in proportion to the defect and then disqualify.

Color (one point for each egg). — Cut to the limit in proportion to the defect and then disqualify.

Condition of shell (one point for each egg). — One-half point when wrinkled severely; one-half to two points when three or four or more are glossy; one-half point for each weak shell; one-half to one point for each soiled egg.

Candling. — Cut one-half point for each egg showing distinctly cloudy appearance.

Cut one point for each egg having unmistakable blood spots.

Cut one-quarter to one-half point for each egg showing large air space.

Quality of yolk. — Five points for each spot on yolk other than the germ discs. Cut as high as ten points when odor is disagreeable. Cut as high as ten points when yolk flattens and breaks. Cut as high as five points on a pale color.

Quality of white. — Cut as high as fifteen points when the two albumens approach the same consistency. Cut as high as five points when albumen will not hold up the yolk.

Cut one-half point for each one-half ounce in weight under the standard weight of the grade for the dozen. Cut eight points for each disqualified egg.

Rules for Machine Incubation (Finch)

Never put the eggs in the machine until the temperature is properly regulated.

Temperature. — After the eggs have been put in the machine, the temperature will drop and remain low for some time, gradually increasing, often taking from twelve to fourteen hours to reach the desired degree. Do not try to run the heat up too quickly. It is better that the temperature should be increased gradually.

After the correct temperature is reached, the incubator should run with only slight variations. Although it is best to maintain an even temperature, it is not always possible to do so, and a variation of one-half degree, or more, from time to time, will not result seriously if the average temperature is correct. A high temperature should be avoided, especially at the beginning of incubation.

The temperature should be read through the glass door. The door should be opened as little as possible.

Temperature, first week. — The position of the thermometer should always be considered in determining the proper temperature to maintain. If the thermometer hangs above the trays, as it does in some machines, thereby registering the air temperature and not the temperature of the eggs, the actual temperature of the eggs would be from one to one and a half degrees lower the first week than the registered temperature. To give the eggs the proper amount of heat the first week, where hanging thermometers are used, it is necessary to keep the temperature at $102\frac{1}{2}^{\circ}$ or 103° ; whereas with contact thermometers, the temperature should be 102° . Contact thermometers should always be placed between two fertile eggs.

Temperature, second week. — The outside temperature has less influence over the machine temperature after the first week, owing to the increasing amount of animal heat given off by the growing embryos. Machines using a hanging thermometer should be held at 103° F., while in those using contact thermometers, the heat should be increased to 103° F.

Temperature, third week. — Hold the temperature as near 103° as possible up to about the eighteenth day, when it may be allowed to run up to 104° .

The eggs. — The eggs should not be put in the machine until it has been run for several days properly regulated and all directions have been followed out in regard to setting up, paying special attention to the manufacturer's directions about ventilators, felts, trays, etc.

Incubate eggs of uniform size, shape, and color as far as possible, and eliminate those with very porous or otherwise defective shells.

Eggs from the heavy type of fowls usually take a few hours longer to hatch than Leghorn eggs; therefore it is not advisable to set the two kinds of eggs together in an incubator.

Feeding

Cornell ration for egg-production

200 lb. wheat	}	Grain fed in deep litter sparingly in morning and freely at night
200 lb. cracked corn		
100 lb. oats		
60 lb. wheat middlings	}	Ground feed in hopper, afternoon.
60 lb. corn meal		
50 lb. beef scraps		
30 lb. wheat bran		
10 lb. alfalfa meal		
10 lb. linseed oil meal		
7 lb. salt		

Proportion about 2 lb. grain to 1 lb. ground feed.

Cabbage, beets, sprouted oats or grass; oyster shells; grit; water.

Results (1909-1910)

Best pullet laid 258 eggs.

Next pullet laid 253 eggs.

Fifteen selected pullets, averaged 236 } eggs each.

Best flock pullets averaged 182 }

Relation of food-consumption to egg-production (Cornell).

That the number of eggs produced bears a close relationship to the amount of food consumed is shown in the chart (Fig. 8) A and B where it will be seen that the hens which laid the largest number of eggs in a stated period consumed the most food. Periods of large egg-production always appear to be periods of increased food consumption, and *vice versa*.

It will be noticed that the increase in food consumed precedes, by a few weeks, the increase in production, showing that the fowl fortifies her body by storing up the nourishment from which to produce eggs (A, B, and C).

A glance at the plotted curves, comparing (B), the weight of the fowls during each period, and (C), the percentage egg-production for each period, will show how uniformly the curve expressing increase and decrease in production follows the curve of increase and decrease in weight. The weight of hen is greatest preceding heaviest egg-production.

A comparison of the amount of food consumed, the eggs laid, and the weight of flocks of different ages shows that the youngest fowls ate the most food and produced the largest number of eggs.

The percentage egg-production varies each month, according to the seasons, with remarkable regularity. This is strikingly

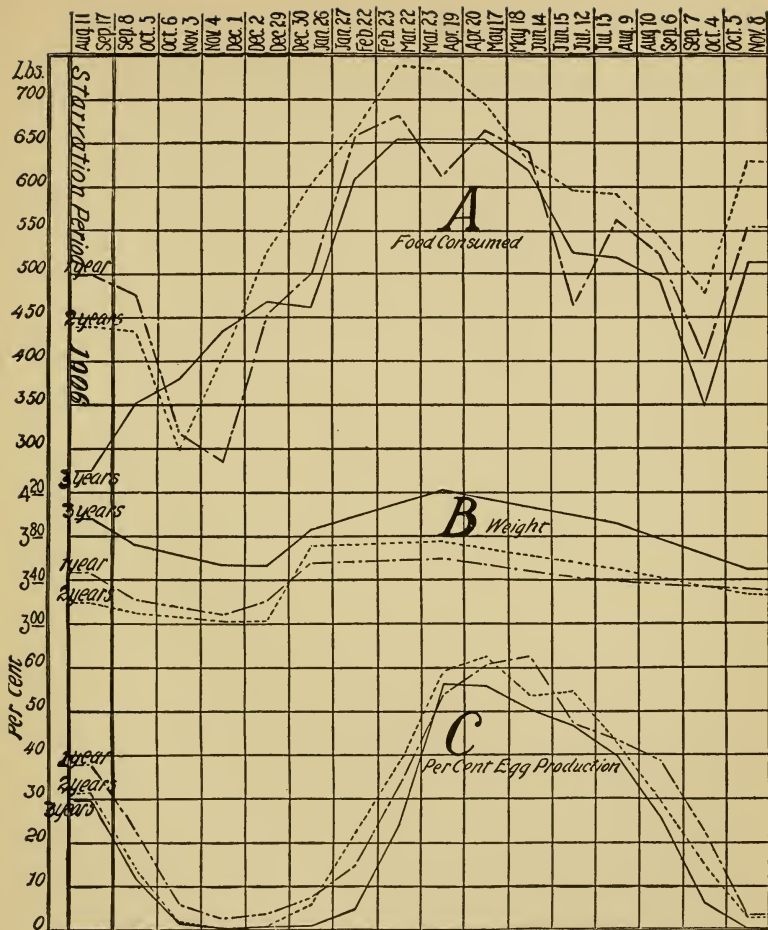

FIG. 8. — A comparison of one-, two-, and three-year-olds per period of 28 days, of both starved and fed fowls. *A* = Consumption of food. *B* = Weight of fowls. *C* = Percentage egg-production. Note that an increase or decrease in weight is usually preceded by corresponding increase or decrease in the amount of food consumed by each flock, and that an increase or decrease in per cent egg-production is preceded by a corresponding increase or decrease in weight of each flock. It will also be observed that there is great uniformity between the various flocks each period as to increase or decrease in food consumption, weight, and per cent egg-production. The transverse chart-lines show uppermost set starting at 1 year, 2 years, 3 years; middle set, 3 years, 1 year, 2 years; lowest set, 1 year, 2 years, 3 years.

illustrated in the plotted curves of production during the sixteen periods of twenty-eight days each, for the six flocks of fowls of different ages (C). From August 11, the beginning of the experiment, there was a gradual decline in production with all the flocks until the latter part of December. From this time production increased rapidly until the latter part of April, when it remained practically stationary until the middle of May ; then it declined gradually until the close of the experiment, November 8.

Preparing Fowls for Market by Bleeding (Graham)

Hold the head of the bird with the left hand, back of the head up, keeping the hand on the back of the neck to avoid cutting yourself should the knife slip and pass through the top of the head. Take the knife in the right hand, the back of the blade toward your body. Insert the blade in the mouth, keeping the point to the right side of the bird's neck and as near the outer skin as possible until it is well past the neck bone. Then press the edge toward the bone and slowly draw the knife from the mouth, the hand moving from your body, so that the knife appears to pass across the neck. Repeat the process on the left side of the neck. This should cause the bird to bleed freely, but by holding the beak up the blood will remain in the neck, giving you plenty of time to pierce the brain. The latter is located just above the eye and can be easily reached through the upper part of the mouth by using a stiff steel blade, inserted in the mouth with blade edge up and pointing slightly over the eye. With young birds little trouble is experienced in piercing the brain, but with older birds a very stiff blade is required, as the bones are much harder. When the point of the blade enters the brain, give the knife a quick twist to right or left to widen the aperture. If the brain has been reached, the bird will attempt to squawk or will give a nervous jerk as the blade touches the spot, and this touching the brain or nerves not only loosens the feathers of the bird for dry plucking, but will greatly improve the appearance of scalded stock.

A weight, which may consist of an old tomato can half filled with stones and cement, is immediately attached by means of a wire hook to the lower mandible of the bird. Then by grasping the wings close to the back, the bird will not be able to flutter, and can be easily and

rapidly plucked. This, of course, should always be done while the bird is bleeding. The can catches the blood, and by hanging the bird over a barrel the feathers may easily be saved.

Care of Feathers and Eggs (Lambert)

Feathers.

When dry picked and sorted so as to keep the stiff from the soft, and the white from the colored, feathers have a market value worth considering. Mixed colors of soft chicken feathers bring $4\frac{1}{2}$ to 10 cents per pound, and pure white bring 20 cents per pound. Duck feathers bring 33 to 42 cents per pound, goose feathers 42 to 60 cents per pound, goose quills 15 cents per pound. Long, bright-colored chicken feathers are sold for millinery purposes at about \$1 per pound. The stiff turkey feathers are in great demand for feather dusters and the like. Feathers are cured in sacks of thin material exposed to the sun and air for several days. They can be sold and shipped in these original sacks.

General care of eggs.

Eggs for market will keep better from spoiling if not fertilized. Those from mated pens should be kept from heat over 60° Fahr. The nests should be kept supplied liberally with dry sawdust or some clean absorbent. The eggs that become soiled should be wiped with a damp cloth and never submerged in water if they are to be kept more than one week. The natural color of the shell is not indicative of the quality of the contents, although the preferences of the market should be catered to, if one wishes to secure best prices. Brown-shelled eggs are usually larger than white shelled ones, because all the larger breeds except one lay brown eggs, or those from a delicate pink to a light chocolate. The color of the yolk is controlled by feeding green foods and certain grains. Eggs are porous and susceptible to taint from bad odors. Care must be taken to keep them in clean, cool places. Marking the shells in any way is not desirable. Cartons holding one dozen eggs can be purchased from paper dealers. These have specially printed covers, "One Dozen Fresh Eggs," etc., and can be used several times if desired. Cases holding fifteen or thirty dozen each, for shipping to the trade, are popular sizes.

Deliveries and shipments should be made each week ; if a private trade, on the same day of each week. There are wire fillers for the cartons that display the eggs very attractively, but require more time in placing the eggs and removing them from the trays. With the straw-board fillers, each egg is in a separate compartment, and there is little danger of breakage. If one becomes cracked, the leakage is usually confined to the one compartment.

Eggs intended for cold storage must be absolutely fresh, free from dirt, and packed in standard-size thirty-dozen cases ; and the fillers must be free from mold, dirt, or odors of any kind. Cold-storage plants begin operations as soon as the lower prices are reached, about April 1, and continue until the latter part of May. During warm weather the quality of eggs deteriorates, and they do not keep so well as when cooler. The market for these cold-storage goods opens in the fall and continues until Christmas.

Eggs should be gathered every day, and all broody hens removed from the house. If a nest is found in an unusual place, the eggs should be tested before a bright light, and the unclear ones discarded.

Preserving eggs.

There are several methods of preserving eggs during spring and summer and keeping them wholesome until they will bring higher prices, but none by which they can be kept any length of time and sold as fresh-laid ones. The shells may be covered with melted paraffin or vaseline to prevent evaporation, and they will not spoil so long as they are kept cool and turned every few days. Packing in common salt and turning occasionally is another method. The contents remain sweet and wholesome, but the albumen will not beat up as it will in fresh-laid ones. The shell will lose its freshness, and the eggs will not remain good long after being taken out of the preservatives, and they should be designated as preserved eggs when offered for sale.

The best method of preservation is as follows : One part of water-glass (sodium silicate) mixed with nine parts of boiled spring water. Put the eggs in a stoneware crock when gathered from the nests, if cool and clean, until the crock is nearly full ; then pour in the water-glass solution until there is at least two inches of liquid over the top layer of eggs. Keep in a cool place. If carefully done, this method is reliable.

Another successful method is to slake two pounds of good lump lime, and while hot add one pound of common salt. After cooling, add ten quarts of boiled spring water and stir thoroughly several times the first day. Then let it settle, using only the clear liquid, which may be poured over the eggs after they have been placed in a stoneware crock; or the liquid can first be put in the crock and the eggs put in that, day by day, when gathered. The eggs must always be two inches below surface. More of the solution can be put in when necessary. Stoneware vessels are the most desirable ones for keeping these mixtures in.

Eggs are sometimes removed from the shells, canned, and kept in cold storage or frozen, and sold to large consumers. The most wholesome method is evaporation. The egg is then reduced to powder that will keep any length of time, in any climate, and can be carried to places where poultry-keeping is out of the question and where all eatables carried must be reduced to a minimum weight.

Parasites of Fowls (Crosby)

HEN LOUSE (*Menopon pallidum*).—There are several species of lice infesting poultry, of which this is the commonest. When full grown, it is over one twenty-fifth inch in length, slender, and of a pale straw-yellow color. The eggs are laid on the feathers near the base. The lice do not suck blood, but run actively over the body and feed on the dried skin and feathers, but in so doing irritate the skin with their sharp claws.

Treatment.—Keep poultry in clean, airy, well-lighted houses, and use perches and nest boxes that can be removed easily. Spray perches, nest boxes, and the whole interior of the house either with a 2 per cent solution of cresol disinfecting soap (formula page 436) or with a mixture of one part of crude carbolic acid and three parts kerosene. The application should be repeated in about a week to kill any lice that may have escaped before. To free the fowls of lice, brush the powder (see formula, p. 436) in among the feathers about vent, fluff, and under wings. Repeat in two weeks in extreme cases.

CHICKEN MITE (*Dermanyssus gallinæ*).—Minute grayish or reddish mites which attack poultry, mostly at night, and suck their blood. During the day they hide in cracks and crevices about the perches and nests.

Treatment. — Keep the houses clean as directed above. Supply the fowls with a dust bath and separate sitting hens, which are especially liable to infestation, from the rest of the flock.

SCALY LEG (*Sarcoptes mutans*). — A disease caused by minute mites working beneath the scales on the feet and legs. The irritation causes the secretion of a fluid which on drying turns to a whitish powder beneath the scales and raises them from their natural position. Crusts or scabs are formed, and the fowls become lame.

Treatment. — Isolate infested birds to prevent the spread of the disease. Carefully remove the crusts by soaking in warm water and soap and apply carbolic ointment or a mixture of creosote and lard (1 to 20). Disinfect the house as directed on preceding page.

DEPLUMING SCABIES (*Sarcoptes laevis*). — Minute mites working at the base of the feathers, causing them to break at the surface of the body. The mites also set up an irritation which causes the birds to pull out their own feathers.

Treatment. — The disease is contagious, and infested birds should be isolated. Apply creosote and lard (1 to 20), or dust fresh Buhach into the feathers.

HEN FLEAS (*Argopsylla gallinacea*). — In the South these fleas are very annoying to fowls, especially to sitting hens. They attach themselves in great numbers to the face, comb, etc., where they remain until ready to lay eggs.

Treatment. — The same measures are advised as for lice and mites.

CHICKEN TICK (*Argas miniatus*). — A reddish brown tick, somewhat larger than the common bedbug, infesting poultry in the South.

Treatment. — Keep the houses thoroughly clean, and disinfect at frequent intervals.

Sample Rules and Regulations for the Exhibition of Poultry

Ontario (N. Y.) Poultry Association, 1911.

1. All entries must be made on blanks furnished by the Secretary, and all remittances should be made payable to the Secretary, and should be made by P.O. money order, express money order, or registered letter.

2. Labels will be sent to each exhibitor ; the reverse side must have the sender's name and address legibly written thereon, and the name of

the express company for their return delivery. If from accident the Association labels do not arrive in time, send exhibits without them, and the Secretary will make duplicates. Unhealthy specimens will not be exhibited, but will be returned to the owners at their expense. When more than one specimen is sent in the coop, each entry must be properly divided and separately labeled.

3. Entries will positively close Monday, January 9, 1911, but should be sent as long before that date as possible. This rule will be strictly adhered to. The building will be open for the reception of specimens at 8 A.M., Monday, January 16, and those not received by 8 A.M., Tuesday, January 17, will be debarred from competition.

4. All specimens shall be exhibited in their natural condition, with the exception of Games and Game Bantams. Any violation of this rule shall exclude the specimen from competing and cause the withholding of all premiums awarded the owner of such birds.

5. The reports of judges shall be made in writing to the Secretary, and will be final after having been approved by the Executive Committee. As soon as possible after the awards of the judges have been supervised and approved, a card or badge stating the premium will be placed on each winning coop, where it must remain until the close of the show, and each winning exhibitor will be notified by postal card at once.

6. The judges are strictly prohibited from making known their awards, except through the Secretary or Superintendent. Any person attempting to interfere with the judges in their decisions, by letter or otherwise, will be excluded from competition and exhibition.

7. No protests against awards will be received unless accompanied by a deposit of \$2, and if after the matter has been thoroughly investigated by the Show Committee, the protest should prove to be without foundation, the deposit will be forfeited to the Association. Protests must be made before 6 P.M., Wednesday, January 18, 1911, and must be made in writing.

8. All display premiums in the open classes, unless otherwise stated, will be decided thus: First Prize to count 6 points; Second Prize, 4 points; Third Prize, 3 points; Fourth Prize, 2 points; Fifth Prize, 1 point.

9. Season tickets will be issued free of charge to all exhibitors whose entry fee amounts to \$2; single admission tickets, 25 cents; tickets for

children above eight years and under fifteen years of age, 15 cents. Exhibitors' tickets are not transferable, and will be forfeited if presented by any one but the owner. Season tickets will be sold for \$1.

10. No specimens will be allowed in the hall except those which have been duly entered in the books of the Association and the entry fee and express charges paid.

11. The Association will be pleased to undertake the sale of birds for the exhibitor, free of charge, selling price to be stated on entry blank. All sales must be reported at the office at once.

12. During the exhibition no specimens can be removed except by order of the Secretary. Any fowl showing disease will be removed and cared for.

13. No one will be allowed in the aisle while judging is in progress, except by permit from the Superintendent.

14. The term "Cock" means hatched prior to 1910; the term "Hen" means hatched prior to 1910; the term "Cockerel" means hatched during 1910, and the term "Pullet" means hatched during 1910.

15. Prizes in cash, special prizes, ribbons, etc., for all exhibits will be awarded. Blue Ribbon for First Prize, Red for Second, Yellow for Third, and Green for Fourth. Lost prize ribbons will be duplicated at 15 cents each.

16. The entry fee for poultry, ducks, geese, turkeys, etc., in competition is 50 cents, exhibition pens, \$1.25, pigeons and pet stock, 25 cents each. This includes coop, feed, and attendance. All specimens entered for competition must be shown in coops provided by the Association.

17. The Association reserves the right to place more than one bird of the same variety and belonging to the same exhibitor in one coop.

18. There must in all cases, whether competing as pens or single birds, be four entries, or first prize will be awarded and second money paid, or if the birds are not worthy of first prize and gain second prize, they will be awarded third, etc. In no case will more than the entry fee be paid on any variety containing only one entry.

Four entries means four birds of the same kind and variety, as four cocks, four hens, etc., whether shown by one person or several.

Outline for Critical Examination of a Poultry Farm (Rice)

Visit the farm and make careful observations to secure answers to the following questions: —

PART I — *The location*

1. Where is the farm located?
 - (a) State.....(b) County.....(c) Town.....
2. What are the climatic conditions?

(a) Temperature:	Max.....	Min.....	Mean.....
(b) Season of frost:	Early.....	Late.....	
(c) Rainfall:	Max.....	Min.....	Mean.....
(d) Sunshine:	Max.....	Min.....	Mean.....

 - (e) Prevailing winds:
 - (f) Amount of snow (season of bare ground):
 - (g) As influencing egg production.
 - As influencing crop production.
 - As influencing number of labor days.
 - As influencing cost of buildings.
3. What are the market conditions?
 - (a) Name principal market or markets.
 - (b) Population.
 - (c) Distance from local station.
 - (d) Express rate on eggs (30 doz.); dressed poultry (100 lb.); live poultry (100 lb.).
 - (e) Freight rate (per ton feed).
 - (f) Passenger rate; frequency of train service.
 - (g) Commercial importance as regards kind and type of customers.
4. What is the condition of the roads?
 - (a) Dirt, stone, etc.
 - (b) Grades.
 - (c) Distance from farm
 - (a) R.R. Station.
 - (b) Express.
 - (c) Post office.
 - (d) Church.
 - (d) Free or toll.
 - (e) How kept in repair.
5. What is the size of the farm?
6. What is the shape of the farm? (Make sketch.)
7. What are the topographical conditions regarding:
 - (a) General direction of slope of the land?
 - (b) Air drainage?
 - (c) Contour as affecting location of buildings?
 - (d) Shelter from prevailing winds?
 - (e) Altitude.
8. What is the nature of the soil as regards:
 - (a) Fertility.
 - (b) Drainage — natural.....artificial.....
9. What is the condition of the farm as regards weeds, stone, stumps, old fences, etc.?
10. What is the condition of the farm as regards healthfulness?
11. What is the nature of the water supply?
 - (a) Quantity.
 - (b) Quality.
 - (c) How secured.
12. What are the existing crops?
 - (a) Timber — kind, size, and condition.
 - (b) Orchards — kind, size, and condition.
 - (c) Field crops — kind, size, and condition.

13. What are the educational advantages ?
 - (a) Distance from school ?
 - (b) Size and kind ?
14. What are the religious and social advantages ?
 - (a) Denomination ?
 - (b) Distance from church ?
 - (c) Character and progressiveness of people ?
 - (d) Organizations — Granges, farm clubs, poultry associations, coöperative associations, etc.
 - (e) Kind of neighbors and distance from residence.
15. What are the neighborhood conveniences — Telephone, R.F.D. of mail.

PART II — *Arrangement and nature of buildings*

16. Make a sketch of the farm showing the approximate location of all buildings, fences, fields, and crops.
17. Give dimensions of main building, and make sketch showing (a) front and (b) end elevation ; (c) floor plan, (d) state kind of materials used in construction, (e) square feet floor space, (f) cubic feet air space.
18. What kind or kinds of laying houses are used ? Take measurements, and make front and end elevation and floor plan sketches.
19. Estimate square feet floor space and cubic feet air space.
20. State kind of material used in construction of sides, roof, floor, and foundation.
21. Give dimensions of incubator cellar and nature of construction, and estimate square feet floor space and cubic feet air space.
22. Give number and dimensions of brooder houses, and make sketches showing end and front elevations and floor plan, and estimate square feet floor space and cubic feet air space.
23. Give number and dimensions of fattening houses, and make sketches showing end and front elevations and floor plan, and estimate square feet floor space and cubic feet air space.
24. Give number and dimensions of barn or other auxiliary buildings, and make sketches showing end and front elevations and floor plan, and estimate square feet floor space and cubic feet air space.
25. Make sketch and brief description of residence, giving principal dimensions, number of rooms, etc.

PART III — *Equipments*

26. Name all the more important machinery and equipment used on the farm.
27. State kind and capacity of incubators.
28. State kind and capacity of outdoor brooders.

PART IV — *Live-stock*

29. State kind and quantity of live stock :

(a) Fowls	{	Mature fowls Mature males Pullets Cockerels Young Chicks
-----------	---	--

- (b) Ducks.
- (c) Geese.
- (d) Turkeys.
- (e) Guineas.
- (f) Horses.
- (g) Cows.
- (h) Swine.
- (i) Sheep.

CHAPTER XXI

EXHIBITING AND JUDGING LIVE-STOCK. MARKET GRADES

It is intended in this chapter to give a sample plan for the administering of a live-stock exhibition, standards to aid in the making of judgments of the qualities of animals, and a view of a few regulations governing the grading of animals and animal products in the markets. This is comparable, in a way, with Chapter IX for plants and plant products.

General Rules and Regulations Governing Exhibits of Live-stock (Ohio State Board of Agriculture, slightly modified.)

Competition open to the world, except where otherwise specified.

Receiving exhibits.

1. All animals for competition and exhibition, except speed horses, having first been properly entered within the time specified in the rules, must be placed in proper position by the first day of fair at 9 o'clock A.M. Exhibits not in position by the time required will be positively excluded from competition.

2. Entries in the several departments must be received by the Secretary fifteen days before the opening of the Fair.

Entries of animals.

3. All entries of animals must specify the owners' names, and the name, age, sex, record number (if any), and description of every animal offered; ages of horses to date from the first of January of the year foaled; ages of other animals, except cattle, to be considered in months and days at date of fair, basing dates of dairy cattle to be February 1 and August 1, while in the beef breeds the basing date shall be September 1. A breeder is held to be the owner of the female at the time of service.

All entries of live-stock must positively be made on the regulation entry blanks, which will be furnished upon application to the Secretary.

4. Entries must be made in the names of bona fide owners. Should any be found to be otherwise entered, they will forfeit any premiums awarded by the judges.

5. An animal entered for exhibition in one class cannot compete for a premium in any other, except where specified.

6. A single animal may be exhibited as one of a pair or herd.

7. All animals shall be exhibited to the satisfaction of the awarding judges.

Recording entries.

8. On receipt of entries of live-stock, cards will be made out indicating the books, entry numbers, and classes, and will be ready for delivery by the superintendents of the appropriate departments when exhibitors arrive on the grounds, or will be sent by mail when specially requested.

Delivery of animals.

9. Exhibitors must see to the delivery of their animals to the superintendent of the appropriate department, and to placing them in position under his direction. The buildings and grounds will be in complete readiness for the reception of exhibits during the entire week previous to the opening of the Fair, and it will greatly facilitate arrangements if exhibitors will early take in hand the preparation for the display of their exhibits.

A place is provided for storing boxes, crates, and the like, all of which must be promptly removed from the buildings to this place of storing.

Removal of animals.

10. Live-stock, other than speed horses, may be removed the last day of the Fair, at 4 o'clock P.M. Speed horses may be removed any time after their racing engagements.

Protection of animals.

11. The Fair Board will take every precaution in its power for the safe preservation of stock on exhibition, after its arrival and arrangement on the grounds, but will not be responsible for any loss or damage that may occur.

Register number of animals.

12. Persons exhibiting pure-bred animals, one year of age and over, will be required to furnish register number of animals to be exhibited, or, in case of younger animals not registered, the names and register number of sires and dams.

Animals exhibited as breeders.

13. Evidence satisfactory to the members in charge, or the Awarding Judges, will be required that the animals exhibited as breeders are not barren, and no awards of premiums shall be made where there is unsoundness in breeding animals, which is transmissible.

Interference with judges.

14. No person other than the judges, except the officers of the Fair Board, the superintendent, and the grooms in charge, will be permitted to go into the rings where the stock is being passed upon by the Awarding Judges, and no exhibitor or other person will be allowed to interfere or communicate with the judges of live-stock during the adjudications. If judges desire information from exhibitors or others concerning animals on exhibit, they will make the fact known and call for such explanation or information as may be necessary in the case. A violation of this rule will disqualify exhibitors from competing, or subject them to a forfeiture of any premium that may have been awarded.

Disrespect to awards or judges.

15. If any disrespect is shown to an award or to the Awarding Judges, by the exhibitor or his agent, he shall forfeit all awards made to him, and the member in charge shall report the same promptly to the Secretary.

False evidence.

16. Should a premium be found to have been obtained by false evidence or misrepresentation, or a violation of any of the rules of the Board, it will be withheld.

Animals entering the ring.

17. Horses and cattle can enter the arenas only under halter unless otherwise specified, and in charge of grooms, and sheep and swine only in charge of attendants.

Premiums indicated.

18. Horses, cattle, swine, and sheep will be exhibited in the arenas of ample capacity, and the premium ribbons attached or delivered by the judges before the animals leave the arenas. First premium, blue ; second premium, red ; third premium, white ; fourth premium, yellow ; fifth premium, green ; Championship, purple ; Reserve Championship, pink ; Grand Championship, royal purple rosette.

Protests.

19. Protests against awards in any of the departments of the Fair must be made in writing, clearly setting forth the grounds for protest, and must be filed with the Secretary not later than one day after the awards are made. All protests will be considered by the Board at its first meeting succeeding the Fair, unless otherwise ordered. Parties interested will be duly notified, and opportunity given them to submit evidence. Premiums on protested animals will be withheld until the protests are decided.

Animals not entered.

20. A charge of double the regular fee will be made for each stall or pen occupied by animals not entered for premium competition.

Advertising.

21. Exhibitors will not be permitted to attract attention to their exhibits by means of perambulating advertisers, or any method tending to objectionable noise and confusion. The promiscuous distribution of hand-bills or other advertising matter is strictly prohibited, and no tacking or posting of advertising bills or cards will be permitted on or in any of the buildings. Exhibitors may advertise at and distribute from their places of exhibit only.

Judges.

22. Expert judges, appointed by the Board, will report to the Secretary, and he will direct them to the members in charge of the departments in which they are to serve.

23. No person who is an exhibitor can act as judge, or in any other capacity, in the department in which he exhibits, or upon stock in which he has an interest.

24. When animals are not deemed worthy, judges will refuse to award premiums, whether or not there be competition in the classes.

25. Animals for which no premiums are offered, but which in the opinion of the judges deserve special commendation, will be so reported, but premium cards or ribbons must not be attached.

26. If there be any question as to the regularity of an entry or the right of an animal to compete in a given class, the judge shall report the same to the member in charge for adjustment.

27. Judges in the several departments, when requested, may give the reasons for their decisions, embracing the valuable and desirable qualities of the animals to which the premiums are awarded. As the one great object of the Board is to collect valuable information upon subjects connected with agriculture and the industrial arts, the several judges and superintendents are requested to gather all the information possible from exhibitors in their respective departments, and make their report as complete as circumstances will permit. Reports of awards are to be made to the members in charge as clearly as possible after the adjudications.

Payment of premiums.

28. Premiums are payable in cash (check) except when cups, medals, or diplomas are specified or desired in lieu of cash. Medals and diplomas will be forwarded as directed, to the proper person, by the Secretary. Speed premiums will be paid on the last day of the Fair, and all other premiums will be paid within fifteen days after the close of the Fair, or at the time stated.

All premiums awarded, and not called for during the calendar year in which awards are made, will be forfeited.

Exhibition and examination.

29. Examination by the judges for premium awards will begin in each of the live-stock departments at 9 o'clock A.M. of the day named for showing, except special classes as noted, and the judges will proceed in the order directed by the members in charge of the departments.

Forfeiture of space.

30. When space has been assigned to any exhibitor, the member in charge shall have the right, in case the exhibitor shall fail to make

or maintain a creditable display, to declare the space assigned, or any portion thereof, forfeited. Exhibitors must arrange their exhibits in as neat and attractive a manner as possible, in default of which the member in charge will report the entries to the Secretary for cancellation, and require the removal of the stock at the expense of the exhibitor.

Signs and arrangements of exhibits.

31. The members in charge of the several departments shall have the right to prescribe the dimensions and to regulate the positions of all signs, and generally to direct the arrangement of exhibits, so far as the same may be necessary to secure harmony and to be attractive in appearance.

Straw and feed.

32. Arrangements will be made with a responsible party to furnish straw, hay, corn, oats, and chopped feed on the grounds at market prices, in quantities to suit the purchasers.

Regulation for helpers.

33. The members in charge of the several departments will issue free daily admission tickets to such helpers as are necessary and actually under pay in caring for or operating exhibits. A list of such helpers must be furnished to the superintendents of the departments, on arrival of exhibits at the buildings or grounds.

Special rules governing horses.

34. Entries must be made fifteen days before the fair opens, and be accompanied by proper fees to cover charges for exhibitor's ticket and stall rent. Exhibitors are requested to specify the number of stalls required, upon receipt of which information stalls will be assigned and their numbers sent to the person or firm making entries.

35. Charges for stalls.

Box stall	\$4.00
Open stall	2.00
Pony stall	1.00
Exhibitor's ticket	2.00

36. The published order of exhibition will be conformed to as nearly as possible ; provided, however, the right is reserved to make such

changes in the order of exhibition, as in the discretion of the member in charge will facilitate the work.

37. The superintendent of each department must check the entries shown in the entry books in each ring, with the exhibits present, and so mark the entry books that they will show what animals were passed on by the judges.

38. The member in charge may exclude from competition exhibitors who occasion unnecessary or embarrassing delay in bringing animals into the show ring.

39. The judges shall not make any award where there is unsoundness in breeding animals which is transmissible.

40. All breeding animals must be recorded in Standard Stud Books, and exhibitors must be prepared to submit certificates or registry.

Speed classes — trotting and racing Conditions.

41. Entries will close the tenth day before the Fair opens at 11 o'clock P.M. Records made within fifteen days no bar. Entrance fee five per cent of purse, with five per cent additional from winners. The same horse entered in more than one class will only be required to pay entrance for the starts made, except if no starts are made the fee in each class entered may be required.

42. Five entries and three starters required. Horses will be called at 1 o'clock P.M. daily.

43. Races will be mile heats, three in five, to harness, and will be conducted under the rules of the National Trotting Association (or American Trotting Association).

44. Heats in each day's races may be trotted or paced alternately. The published order of program will be followed as nearly as possible, but the State Board of Agriculture reserves the right to make modifications, in the discretion of the member in charge of the speed department, to meet conditions as they arise. Usual weather clause rights reserved.

45. A horse distancing the field, or any part thereof, will receive but one premium.

46. All premiums for speed classes will be paid on the last day of the Fair, by bank check payable to the order of the owner or the party in whose name the entry is made.

47. The race track will be placed in the best possible condition for each of the interesting events. The track is a most excellent one, the back stretches being wide and easy, with a great home stretch one hundred feet in width.

48. The speed barns, located conveniently near the track, are in good condition and well equipped for the care of race horses. The races are in circuits that will give horsemen the advantage of several weeks' continuous work.

Special rules governing cattle.

49. Entries must be made fifteen days before the Fair opens, and be accompanied by proper fees to cover charges for exhibitor's ticket and stall rents. Exhibitors are requested to specify the number of stalls required, on receipt of which information stalls will be assigned and their numbers sent to the person or firm making entries.

50. Charges.

Each animal over one year old, \$2; each animal under one year old, \$1; exhibitor's ticket, \$2.

51. Purity of blood as established by pedigree, symmetry, size, early maturity and general characteristics of the several breeds of animals to be considered; the judges will make proper allowance for age, feeding and other conditions.

52. Persons exhibiting pure bred animals will be required to furnish to the Secretary, at the time of making the entry, the name and register number of each animal entered.

53. Basing dates of dairy cattle to be February 1 and August 1, while in the beef breeds the basing date shall be September 1.

54. All cows over thirty-six months old must have given birth to calf at full maturity within past year, or show unmistakable evidence of being in calf at time of exhibition.

55. All cows in the dairy breeds, to be judged in the morning shall be milked at six o'clock P.M., the day previous to being judged, and all dairy cows, to be judged in the afternoon, to be milked at six o'clock A.M., of the same day. The judge may, at his option, require any cow to be milked while in the ring or before the awards are made.

56. Exhibitors will be required to have blankets removed from cattle between the hours of nine A.M., and four P.M., each day of the Fair.

57. Cattle will be assigned to the exposition building, the judging to take place in the arena of same.

58. The superintendent of each department must check the entries shown in the entry books in each ring, with the exhibits present, and so mark the entry books that they will show what animals were passed on by the judges.

Special rules governing swine.

59. Entries must be made fifteen days before the Fair opens and be accompanied by proper fees to cover exhibitor's ticket and pen rent. Price of pens, \$1 each ; exhibitor's ticket, \$2.

60. Swine must be owned by the individual or firm making the exhibit and must be registered in the accredited records of their respective breeds.

61. The superintendent of each department must check the entries shown in the entry books in each ring, with the exhibits present, and so mark the entry books that they will show what animals were passed on by the judges.

Special rules governing sheep.

62. Entries must be made fifteen days before the Fair opens, and be accompanied by proper fees to cover cost of exhibitor's ticket and pen rent. Price of pens, \$1 each ; exhibitor's ticket, \$2.

63. Sheep must be owned by the individual or firm making the exhibit and must be registered in the accredited records of their respective breeds.

64. Each exhibitor restricted to two entries in one class.

65. Sheep competing in the Merino classes must be recorded in the American and Delaine-Merino Record Association, or the Merino Record Association of Ohio, Vermont, or New York, and certificates of registration, properly signed by the secretary of one of the above-named associations, must accompany each animal in the ring.

66. The superintendent of each department must check the entries shown in the entry books in each ring, with the exhibits present, and so mark the entry books that they will show what animals were passed on by the judges.

Score-cards for Farm Animals

Herewith are given sample score-cards for different species and classes of animals. For score-cards of the breeds see Vol. III, *Cyclo. Amer. Agr.* (from which most of the following cards, by F. B. Mumford, are taken):—

Draft-horse score-card

Class, Gelding

General characters

Form. — Broad, massive, blocky, low-down, compact and symmetrical. Scale large for the age.

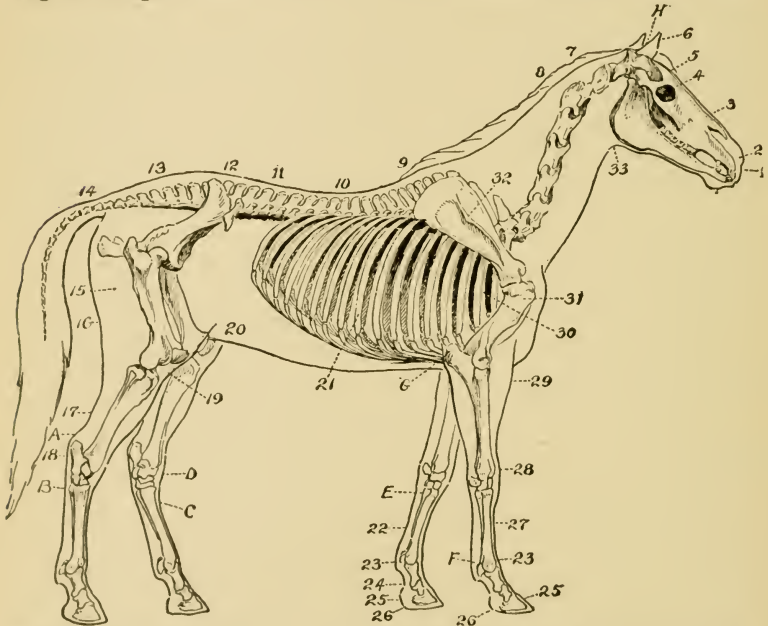

FIG. 9. — Parts of the horse. 1, muzzle; 2, nostrils; 3, face; 4, eye; 5, forehead; 6, ear; 7, neck; 8, crest; 9, withers; 10, back, 11, loin; 12, hip; 13, croup; 14, tail; 15, thigh; 16, quarter; 17, gaskin or lower thigh; 18, hock; 19, stifle; 20, flank; 21, ribs; 22, tendons; 23, fetlocks; 24, pastern; 25, foot; 26, heel of foot; 27, canon; 28, knee; 29, forearm; 30, chest; 31, arm; 32, shoulder; 33, throatlatch; A, thoroughpin; B, curb; C, bog and blood spavin; D, bone spavin; E, splint; F, windgall; G, cappel elbow; H, poll-evil. (*Cyclo. Amer. Agric.*)

Quality. — General refinement of clean-cut and symmetrical features; bone clean, large, and strong; skin and hair fine; tendons clean, sharply defined, and prominent.

Constitution. — Generous and symmetrical development; lively carriage; ample heart-girth, capacity of barrel and depth of flanks; eyes, full, bright and clear; nostrils large and flexible; absence of grossness or undue refinement.

Scale of points

	PERFECT SCORE
1. Height, estimated — hands; corrected — hands.	
2. Weight, estimated — lb.; corrected — lb.; score according to age and condition	10
3. Action, walk: rapid, springy, regular, straight; trot: free, balanced, straight	15
4. Temperament, energetic, tractable	3
5. Head, proper proportionate size; well carried; profile straight	1
6. Muzzle neat; nostrils large, flexible; lips thin, even, firm	1
7. Eyes, bright, clear, full, both same color	1
8. Forehead, broad, full	1
9. Ears, medium size, well carried	1
10. Lower jaw, angles wide, well muscled	1
11. Neck, well-muscled, arched; throat-latch fine; wind-pipe large	2
12. Shoulder, moderately sloping, smooth, snug, extending into back	3
13. Arm, short, strongly muscled, thrown back	1
14. Forearm, long, wide, clean, heavily muscled	2
15. Knees, straight, wide, deep, strong, clean	2
16. Fore cannons, short, wide, clean; tendons clean, well defined, prominent	2
17. Fetlocks, wide, straight, strong, clean	1
18. Pasterns, moderately sloping; strong, clean	3
19. Fore feet, large, even size; sound; horn dense, waxy; soles concave; bars strong, full; frogs large, elastic; heels wide, one-half length of toe, vertical to ground	8
20. Chest, deep, wide; breast bone low; girth large	2
21. Ribs, deep, well sprung; closely ribbed to hip	2
22. Back, broad, short, strong, muscular	2
23. Loins, short, wide, thickly muscled	2
24. Barrel, deep, flanks full	2
25. Hips, broad, smooth, level, well muscled	2
26. Croup, wide, heavily muscled, not too drooping	2
27. Thighs, deep, broad, muscular	3
28. Quarters, plump with muscle, deep	2
29. Stifes, large, strong, muscular, clean	2
30. Gaskins, long wide, clean, heavily muscled	2
31. Hocks, large, strong, wide, deep, clean, well set	8
32. Hind cannons, short, wide, clean; tendons clean, well defined	2
33. Fetlocks, wide, straight, strong, clean	1
34. Pasterns, moderately sloping, strong, clean	2
35. Hind feet, large, even size; sound; horn dense, waxy; soles concave; bars strong, full; frogs large, elastic; heels wide, one-half length of toe, vertical to ground	6
Total	100

Light-horse score-card

Class, Gelding

General characters

Form. — Light, lean, lithe and muscular; long-legged, short in back; having general appearance indicative of extreme activity.

Quality. — Extreme refinement of symmetrical and clean-cut features, showing every requirement of strength, endurance, style, and grace; skin thin and pliable, showing veins plainly; hair fine; mane and tail fine and long; bone possessing plenty of substance but great refinement; tendons clean, strong, and sharply defined.

Constitution. — Generous and symmetrical development; an expression of great nervous energy; action spirited; heart-girth large; floor of chest full; barrel well rounded and moderately deep; hind flanks properly developed; eyes full, bright, and clear; nostrils large; bone possessing abundant substance as well as refinement.

Scale of points

	PERFECT SCORE
1. Weight, — lb.; corrected — lb.	
2. Height, — hands; corrected — hands	2
3. Action, walk: long, fast, elastic, straight and regular; trot: rapid, regular, straight	15
4. Temperament, spirited, energetic, and tractable	5
5. Skin, thin, pliable, showing veins plainly; coat fine, soft, bright	3
6. Head, correct proportionate size, well carried; features clean cut; profile straight	2
7. Muzzle, neat, nostrils large, flexible; lips, thin, firm, and even	1
8. Eyes, full, bright, clear, same color	2
9. Forehead, broad and full	2
10. Ears, medium size, pointed, well carried, alert	1
11. Lower jaw, angles wide, space clean, well muscled	1
12. Neck, well muscled, arched, throatlatch fine; windpipe large	2
13. Shoulder, long, sloping, smooth, extending into back	3
14. Arm, short, strong, well muscled, thrown back	1
15. Forearm, long, wide, clean, well muscled	2
16. Knees, straight, wide, deep, strong, clean, strongly supported	4
17. Cannons, short, clean, wide; tendons large, clean, and prominent	2
18. Fetlocks, wide, straight, strong, clean	1
19. Pasterns, long, sloping, strong, clean	3
20. Fore feet, medium size, even and sound; horn dense and waxy; soles concave; bars strong and full; frogs large and elastic; heels wide, one-half length of toe; vertical to ground	6
21. Withers, high, extending well into back	1
22. Chest, deep, low, girth large	3
23. Ribs, deep, well sprung, closely coupled	2
24. Back, short, broad, strong, muscular	2
25. Loins, short, broad, thickly muscled	2
26. Barrel, long in under line; flanks well let down	1
27. Hips, smooth, wide and level	2
28. Croup, long, wide, muscular, not drooping	2
29. Tail, attached high, well haired, well carried	1
30. Thighs, deep, broad, strong, muscular	3
31. Quarters deep, plump with muscle	1
32. Stifles, strong, clean, muscular	2
33. Gaskins, long, wide, muscular	3
34. Hocks, large, strong, wide, deep, clean, well set	7
35. Cannons, short, clean, wide; tendons large, clean, and prominent	2
36. Fetlocks, wide, straight, strong, and clean	1
37. Pasterns, strong, sloping, springy, clean	3
38. Hind feet, medium size, even, sound; horn dense, waxy; soles concave; bars strong, full; frogs large, elastic; heels wide	4
Total	100

Student's card for the proportions of the horse (Cornell)

Name of Animal	Breed or service	
Sex	Age	
Color and Markings	Blemishes	
Defects		
Estimated Weight	Actual Weight	
Owner	P. O.	
		INCHES
Height at withers		
Height to highest point of croup		
Length from point of shoulder to quarter		
From lowest point of chest to the ground		
From the point of elbow to the ground		
From the point of elbow to trapezium		
From trapezium to ground		
Circumference of the arm		
Circumference of cannon in center		
Circumference of foot at coronet		
Length of head		
Width of forehead		
Circumference of muzzle at angle of mouth		
Width of chest from outside of shoulder points		
Width across hips		
From center of dock to anterior point of patella		
From point of hock to point of hip		
From point of hock to ground		
Circumference of thigh		
Circumference of shank in the center		
Circumference of body at the girth		
Length of croup		
Height of crest of occiput from ground		
Dorsal angle of scapula to hip		
From angle of lower jaw to forehead above eye		
From throat to superior border of neck		

Beef-cattle score-card

Class, Breeding Females

General characters

Form. — Compact, thick-set and short-legged in appearance; body deep, thick, and of medium length; top line straight, under line low in flanks; scale medium to large, not greatly above average for the breed.

Quality. — General refinement of symmetrical and clean-cut features; breed characters pronounced; bone fine and clean; hair fine and soft; skin of not more than medium thickness; head, neck, and legs short and fine, but strong.

Condition. — Great wealth of natural flesh, as from abundant supply of best grass or other roughage, but not excessively fat; flesh firm, mellow and springy, without ties, lumps, patches, or rolls, especially in the back and loin; skin loose and soft; depth and evenness of flesh consistent with degree of fatness.

Constitution. — Generous and symmetrical development; lively carriage; ample heart-girth, capacity of barrel and depth of flanks; eyes full, bright, and clear; nostrils wide apart, large and open; absence of refinement to point of delicacy; skin of at least medium thickness and free from scurf; coat soft and bright.

Early maturity. — General refinement and compactness; body large, extremities small; shortness of head, neck, and legs; amplitude of girth in chest, belly, and flanks.

Sexuality.—Strongly marked; a general appearance of sensibility and feminine refinement of features; moderate length and great capacity in coupling; width in loin, hip-bones, and pin-bones; well-developed udder and prominent milk veins; horn and coat fine; eyes expressive of mild and gentle sensitiveness.

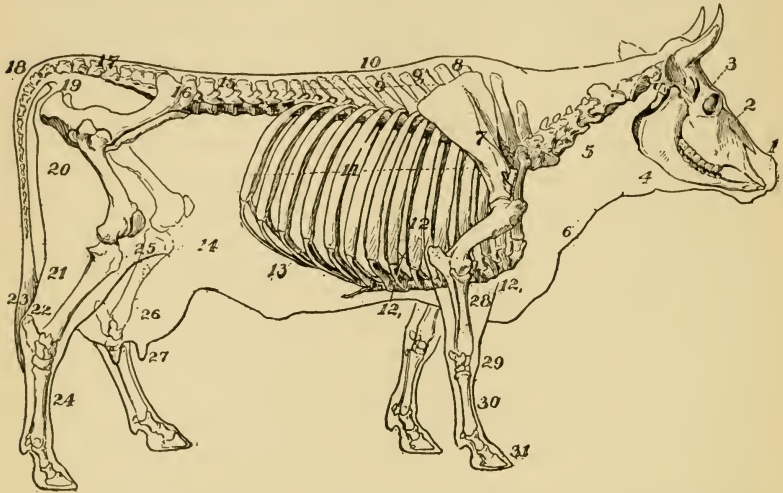

FIG. 10.—Parts of the cow. 1, muzzle; 2, face; 3, forehead; 4, throat; 5, neck; 6, dewlap; 7, shoulder; 8, withers; 9, back; 9₁, crops; 10, chine; 11, ribs; 12, fore ribs; 12₁, fore flank; 12, 12₁, chest; 13, belly; 14, flank; 15, loin; 16, hips; 17, rump; 18, setting of tail; 19, thurl or pin-bone; 20, quarter; 21, thigh; 22, hock; 23, switch; 24, leg; 25, stifle; 26, udder; 27, teat; 28, forearm; 29, knee; 30, shank; 31, hoof. (*Cyclo. Amer. Agric.*)

Scale of points

PERFECT SCORE

1. Age, estimated —; corrected —	
2. Weight, estimated — lb.; corrected — lb.; score according to age and condition	5
3. Skin, of medium thickness, loose, soft, elastic, free from scurf	3
4. Hair, fine, soft, thick; color and markings according to breed	3
5. Temperament, quiet, mild, and contented	3
6. Muzzle, mouth large, lips thin, nostrils large, open, and wide apart	2
7. Face, fine, moderately short and broad	2
8. Forehead, full, broad, and square	2
9. Eyes, full, bright, clear, and placid	1
10. Jaws, wide, deep, and strong	1
11. Horns, medium to small, fine texture, shape and color according to breed	1
12. Ears, medium size, fine texture	1
13. Neck, thick, short, curving smoothly into shoulders and brisket; throat clean; dewlap slight	3
14. Shoulders, compact, snug, smooth, well fleshed	5

	PERFECT SCORE
15. Fore legs, short, straight, strong; arm full; bone fine and clean; feet small, strong, even; hoofs dense	3
16. Brisket, moderately projecting, neat and broad	1
17. Chest, full, deep, wide; heart-girth large; fore flanks deep and full	10
18. Barrel, capacious, medium length	5
19. Crops, moderately full, flesh thick and even	5
20. Ribs, long, closely set, well sprung, extending fairly well back; back broad and straight; flesh thick and even	10
21. Loin, broad, straight; flesh thick and even	6
22. Hips, wide but not prominent, capable of being smoothly covered	3
23. Rump, long, level, wide; tail-head smooth; flesh thick and even	5
24. Pin-bones, far apart, not prominent	2
25. Tail, tapering, bone fine	1
26. Thighs and twist, full, muscled well down to hocks	6
27. Hind legs, short, straight, strong; bone fine and clean; feet small, strong, even; hoofs dense	3
28. Hind flank, low, full, thick	3
29. Udder, large, shapely, evenly quartered, not fleshy; teats uniform, medium-sized, squarely placed, milk veins prominent	5
Total	<u>100</u>

Beef-cattle score-card

Class, Breeding Bulls

General characters

Form. — Compact, thick-set, and short-legged in appearance; body deep, thick, and of medium length; top line straight, under line low in flanks; fore quarters heavier than in a cow; scale medium to large, not greatly above average for the breed.

Quality. — Features clean cut and symmetrical; showing great strength without grossness; breed characters pronounced; bone strong and clean; hair moderately fine and soft; skin of medium thickness; head, neck, and legs short, strong, and massive.

Condition. — Great wealth of natural flesh as from abundant supply of best grass or other roughage, but not excessively fat; flesh firm, mellow, and springy, without ties, lumps, patches, or rolls, especially in the back and loin; depth and evenness of flesh consistent with degree of fatness.

Constitution. — Generous and symmetrical development; lively carriage; ample heart-girth, capacity of barrel and depth of flanks; eye full, bright, and clear; nostrils wide apart, large, and open; absence of grossness or of undue refinement.

Early maturity. — Compactness and strength, with as much refinement as is consistent with masculinity; body large, extremities small; shortness of head, neck, and legs; amplitude of girth in chest, belly, and flanks.

Sexuality. — Strongly marked; a majestic carriage and general appearance of masculine power and aggressiveness; great strength without grossness in head, neck, and legs; chest well developed; shoulders very strong; well-developed sexual organs.

Scale of points

	PERFECT SCORE
1. Age, estimated —; corrected —	
2. Weight, estimated — lb.; corrected — lb.; according to age and condition	5
3. Skin, moderately thick, loose, soft, elastic, free from scurf	3

	PERFECT SCORE
4. Hair, thick ; moderately fine and soft, color and markings according to breed	3
5. Temperament, alert but quiet and good-natured	3
6. Muzzle, mouth large, lips round and firm ; nostrils large, open, and wide apart	2
7. Face, short, straight, strong, full	2
8. Forehead, full, very broad, heavy between eyes	2
9. Eyes, full, bright, clear, mild	1
10. Jaws, wide, deep, and strong	1
11. Horns, fine texture, strong ; shape and color according to breed	1
12. Ears, medium size, well haired, not coarse	1
13. Neck, short, massive, curving strongly into shoulders and brisket ; crest strong ; throat clean ; dewlap slight	3
14. Shoulders, strongly developed, compact, snug, well fleshed	5
15. Fore legs, short, straight, arm full, bone strong and clean ; hoofs large, strong, even, and dense	3
16. Brisket, deep, broad, rounded, neat, moderately projecting	1
17. Chest, full, deep, wide ; heart-girth large ; fore flanks deep	10
18. Barrel, deep, broad, medium length	4
19. Crops, full and thick, straight in top line	5
20. Ribs, long, closely set, well sprung, extending well back ; back broad and straight ; flesh thick and even	10
21. Loin, broad, straight ; flesh thick and even	6
22. Hips, wide, but not prominent, capable of being smoothly covered	3
23. Rump, long, level, wide ; tail-head smooth ; flesh thick and even	5
24. Pin-bones, far apart, not prominent	2
25. Tail, tapering, bone moderately fine	1
26. Thighs, full, wide and deep ; muscled well down to hocks	4
27. Twist, deep and full	4
28. Hind legs, short, straight, bone strong and clean ; hoofs large, strong, and even	3
29. Hind flank, full, low	4
30. Testicles, well developed, both present and normally placed	3
Total	100

Dairy-cattle score-card

Class, Breeding Females

General characters

Form. — Spare, angular, moderately short-legged ; barrel, capacious ; hind quarters, wide and deep ; scale, medium to large, not greatly above average for the breed.

Quality. — General refinement of symmetrical and clean-cut features ; bone fine and clean ; hair fine and soft ; skin of not more than medium thickness ; head, neck, and legs fine and of moderate length.

Condition. — Spare, no fat apparent ; skin loose and mellow.

Constitution. — Generous and symmetrical development ; lively carriage ; ample heart-girth ; capacity of barrel and depth of flanks ; eyes full, bright, and clear ; nostrils, wide apart, large, and open ; absence of refinement and spareness to point of delicacy or emaciation ; skin of medium thickness, free from scurf ; coat soft and bright.

Nervous energy. — Spinal column prominent, vertebræ wide apart ; forehead high and wide ; ears active ; temperament alert ; also the indications of constitution and quality.

Sexuality. — A general appearance of sensibility and feminine refinement of features ; moderate length and great capacity in barrel, width in loin, hip-

bones and pin-bones; well-developed udder; horn and coat fine; eyes expressive of mild and gentle sensitiveness.

Milk-giving capacity.—Udder large, shapely, evenly quartered, free from fleshiness, extending well up behind and far forward, strongly attached; milk-veins large and tortuous; milk-wells large; secretions of skin abundant and yellow; also the above indications of all the other general characters.

<i>Scale of points</i>	PERFECT SCORE
1. Age, estimated ———	
2. Weight, estimated — lb.; corrected — lb.; score according to age and condition	2
3. Skin, medium fine, loose, mellow, elastic, free from scurf; secretions yellow and abundant	5
4. Hair, fine, soft, thick; color and markings according to breed	2
5. Temperament, alert, but mild and tractable	5
6. Muzzle, clean-cut, mouth large, lips thin, nostrils large	1
7. Face, lean, fine, slightly dished	1
8. Forehead, broad, high, slightly dished	1
9. Eyes, full, bright, clear, mild	3
10. Horns, medium to small, fine texture, shape, and color according to breed	1
11. Ears, medium size, fine texture	1
12. Neck, fine, spare, medium length, throat clean; dewlap light; neatly attached to head and shoulders	2
13. Shoulders, lean, sloping; narrow at withers, moderately wide at points	2
14. Fore legs, straight, short, bone clean and fine; feet strong, hoofs dense and even	2
15. Brisket, light, thin	1
16. Chest, deep, capacious	8
17. Barrel, capacious, medium length	10
18. Back, lean, straight, medium length; vertebræ wide spaced and prominent; ribs long, broad, wide spaced, moderately well sprung	8
19. Loin, broad, lean, coupling, roomy	3
20. Hips, far apart, level with back	2
21. Rump, lean, long, broad; pelvic arch prominent; pin-bones high, far apart	4
22. Tail, tapering, bone fine, length according to breed	1
23. Thighs, thin, incurving, twist roomy	3
24. Hind legs, straight, short, bone clean and fine; feet strong; hoofs dense and even	2
25. Udder, large, shapely, evenly quartered, mellow, free from fleshiness, extending well up behind and far forward, strongly attached; teats uniform, well placed, of size and shape convenient for milking	20
26. Milk veins, large, tortuous; milk wells large	10
Total	100

Mutton-sheep score-card

Class, Fat Wethers

General characters

Form.— Compact, thick-set and short-legged; body deep, thick, and of medium length; top line straight; under line low in flanks; scale large for age.

Quality.— General refinement and symmetry of clean-cut features; mutton breed character pronounced; head, neck, and legs short; bone fine and smooth; fleece pure and fine.

Condition.— Prime; a deep, even covering of firm, mellow, and springy flesh, without lumps, patches, rolls, or undue accumulations of fat, especially in back

loin, rump, or fore flanks; neck thick; shoulder-vein full; top and points of shoulder, back-bone, and loin smoothly covered, and leg of mutton deep and full.

Constitution. — Should be thoroughly healthy.

Early maturity. — General refinement and compactness; body large; extremities small; shortness of head, neck, and legs; amplitude of girth in chest, belly, and flanks.

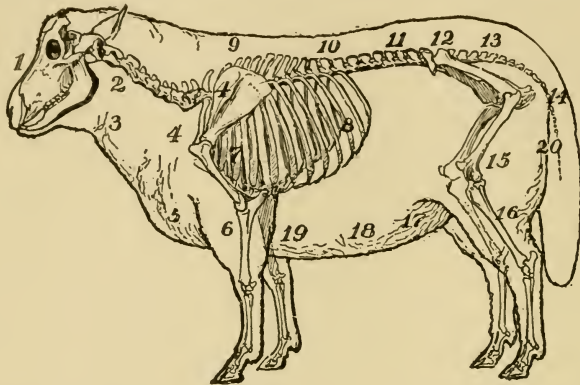

FIG. 11.—Parts of the sheep. 1, head; 2, neck; 3, shoulder vein; 4, shoulder; 5, brisket; 6, fore leg; 7, chest; 8, ribs; 9, top of shoulder; 10, back; 11, loin; 12, hip; 13, rump; 14, tail; 15, giggot or leg of mutton; 16, hind leg; 17, flank; 18, belly 19, fore flank; 20, twist. (*Cyclo. Amer. Agric.*)

Scale of points

	PERFECT SCORE
1. Age	
2. Scale, estimated weight — lb.; corrected — lb.; score according to age	12
3. Skin, bright, clean, and free from scurf; color according to breed	1
4. Fleece, pure, uniformly long and dense; crimp, even and fine; quality fine; condition bright, clean, and lustrous; yolk evenly distributed and moderately abundant; general character according to breed	12
5. Muzzle, fine, nostrils open	1
6. Face, short; color and covering according to breed	2
7. Eyes, bright and clear	2
8. Forehead, broad; woolled according to breed	2
9. Ears, fine; length, color, covering and carriage according to breed	2
10. Neck, short and thick, blending smoothly with shoulder	3
11. Shoulder, broad, compact and snug; thickly and evenly fleshed	5
12. Fore legs, straight, short, arm full; bone fine and smooth; feet strong; color and covering according to breed	3
13. Chest, deep, broad, and full; brisket wide, heart-girth large; fore flanks deep and full	5
14. Back, broad, straight, and of medium length; ribs well sprung; thickly and evenly fleshed	10
15. Loin, broad and straight; thickly and evenly fleshed	10
16. Rump, long, level and wide; hips smooth; thickly and evenly fleshed	10
17. Thighs, full, fleshed low down, twist deep and full	15
18. Belly, not unduly large	2
19. Hind legs, straight and short, bone fine and smooth; feet strong; color and covering according to breed	3
Total	100

*Breeding-sheep score-card**General characters*

Form. — Compact, thick-set, and short-legged; body deep, thick, and of medium length; top line straight; under line low in flanks; scale large for age.

Quality. — General refinement and symmetry of clean-cut features; breed character pronounced; head, neck, and legs short; bone smooth, moderately fine in ewe, somewhat stronger in ram; fleece pure, fine in ewe, somewhat coarser in ram.

Condition. — Great wealth of natural flesh, but not excessively fat; flesh firm, mellow and springy, without lumps, patches, rolls or undue accumulations of fat, especially in back, loin, rump, and foreflanks; depth and evenness of flesh consistent with degree of fatness.

Constitution. — Generous and symmetrical development; ample heart-girth, capacity of barrel and depth of flanks; eyes full, bright, and clear; nostrils large and open; throat free from lumps; absence of refinement to point of delicacy; skin bright; fleece bright, soft, and long, crimp even, yolk moderately abundant.

Early maturity. — General refinement and compactness; body large, extremities small; shortness of head, neck, and legs; amplitude of girth in chest, belly, and flanks.

Sexuality. — In males: A bold, active, and aggressive carriage; great strength without grossness in head, neck, legs, and shoulders; well-developed sexual organs.

In females: General refinement; good development of barrel; head, neck, and legs lighter and finer than in ram.

SCALE OF POINTS	MUTTON SHEEP	FINE-WOOLED SHEEP
	Perfect Score	Perfect Score
1. Age, —		
2. Scale, estimated weight — lb.; corrected — lb.; score according to age	10	8
3. Skin, bright, clean, and free from scurf; color according to breed	3	5
4. Fleece, pure, uniformly long and dense; crimp even and fine; quality fine; condition bright, clean, and lustrous; yolk evenly distributed and moderately abundant; general character according to breed	15	30
5. Muzzle, fine in ewe, broad in ram; nostrils open	1	1
6. Face, short; fine in ewe, strong in ram; color and covering according to breed	5	5
7. Eyes, large, bright, and clear	3	3
8. Forehead, broad in ewe, still broader in ram; woolled according to breed	3	3
9. Ears, fine; length, color, covering, and carriage according to breed	3	3
10. Neck, short, blending smoothly with shoulders; especially thick in ram	3	2
11. Shoulder, broad, compact, snug, and well fleshed	4	3
12. Fore legs, straight, short, arm full, feet strong; bone smooth, fine in ewe, stronger in ram; color and covering according to breed	4	3

SCALE OF POINTS	MUTTON SHEEP	FINE-WOOLED SHEEP
	Perfect Score	Perfect Score
13. Chest, deep, broad, and full; brisket wide; heart-girth large; fore flanks deep and full	10	10
14. Back, well fleshed, broad, straight, and of medium length; ribs well sprung	6	4
15. Loin, well fleshed, broad, and straight	6	4
16. Rump, long, level, wide, and well fleshed	6	4
17. Thighs, full; fleshed low down; twist deep and full	10	6
18. Body, deep and capacious in belly and hind flanks	4	3
19. Hind legs, straight and short; feet strong; bone smooth, moderately fine in ewe, strong in ram; color and covering according to breed	4	3
Total	100	100

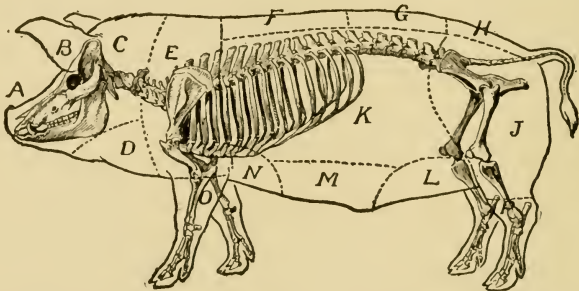

FIG. 12.—Parts of the hog. *a*, snout; *b*, ear; *c*, neck; *d*, jaw; *e*, shoulder; *f*, back; *g*, loin; *h*, rump; *j*, ham; *k*, side or ribs; *l*, flank; *m*, belly; *n*, fore flank; *o*, fore leg; *p*, hind leg (*Cyclo. Amer. Agric.*)

Fat-hog score-card

Class, Breeding Hogs

General characters

Form. — Low-set, broad and deep; standing squarely on short and strong legs and feet; back slightly arched; body compact in male, of good length in female; under line approximately straight; scale medium to large, not greatly above average for the breed.

Quality. — General refinement of symmetrical and clean-cut features; bone clean and strong, moderately coarse in male, moderately fine in female; skin smooth; hair fine; head, neck, and legs short; shields in male not unduly coarse; breed characters pronounced.

Condition. — Strongly muscled and thickly fleshed, but not excessively fat; flesh firm, mellow, even, and smooth.

Constitution.—Generous and symmetrical development; lively carriage; ample heart-girth, capacity of barrel and depth of flanks; eyes full, bright, and clear; coat thick, smooth, and bright; absence of refinement to point of delicacy.

Sexuality.—Strongly marked. In males: Active carriage, aggressive disposition; strength without grossness in head and legs; neck arched and heavy; snout broad; shoulders strong; shields present in mature animals; well-developed sexual organs. In female: General refinement of features; good length and depth in barrel; full number of well-placed and well-developed teats present; head lighter than in boar, neck narrower behind ears; good breadth in loin, hips, and rump.

Early maturity.—General refinement and compactness; body large, extremities small; shortness of head, neck, and legs; amplitude of girth in chest, belly, and flanks.

<i>Scale of points</i>		PERFECT SCORE
1. Age, estimated —; corrected —		
2. Scale, estimated weight — lb.; corrected — lb.; score according to age		6
3. Skin, smooth, mellow, and free from scurf		2
4. Hair, thick, bright, smooth, fine, and uniformly distributed; color and markings according to breed		2
5. Temperament, aggressive in male; gentle and quiet in female		2
6. Snout, short and smooth, tapering from face to tip of nose; broad in male, finer in female		1
7. Face, short, smooth, broad between eyes, dished according to breed; cheeks full; forehead high and wide		2
8. Eyes, full, bright, clear and not obscured by wrinkles		1
9. Ears, medium or small, fine in texture, neatly attached, carriage according to breed		1
10. Jowl, full, smooth, firm, and neat		2
11. Neck, wide, deep, short, and nicely arched, blending smoothly with shoulder; in male, heavy; in female, finer behind the ears		3
12. Shoulder, broad, deep, full, and compact; heavier in male than in female, but shields not unduly coarse		8
13. Fore legs, short, straight, strong, squarely set, wide apart; pasterns short; feet strong; bone moderately coarse in male, moderately fine in female		6
14. Chest, deep, wide, and full; breast-bone advanced		8
15. Back and loin, broad, strong, and slightly arched; moderately short in male, moderately long in female; thickly and evenly fleshed; ribs well sprung		12
16. Sides, deep, full, and smooth		8
17. Belly, wide; under line approximately straight		3
18. Udder (female), full number of well-developed and well-placed teats. Testicles (male), well-developed, both present and normally placed		8
19. Hind flank, low		2
20. Rump, long, broad, gradually rounding from loin to root of tail; thickly and evenly fleshed; hips wide and smooth		6
21. Hams, full, deep, and broad; fleshed well down to hocks		10
22. Hind legs, short, straight, strong, squarely set, wide apart; pasterns short; feet strong; bone moderately coarse in male, moderately fine in female		6
23. Tail, tapering, medium-sized, or small		1
Total		100

The fat-hog is peculiarly an American product. It is universal throughout the corn-belt. It is marked by extreme compactness and by very small development of bone and of waste parts. The hams and sides bring the highest prices, and these have been much developed. The tendency to lay on fat is very marked.

*Bacon-hog score-card**General characters*

Form. — Long, deep, smooth, and of medium width; sides straight; legs short for the breed; head light; back slightly arched, under line straight; scale large for age; standard weight 170-200 pounds.

Quality. — General refinement of symmetrical and clean-cut features; bone smooth, fine, and strong; skin and hair fine and smooth; head, neck, and legs short for the breed; bacon hog breed character pronounced.

Condition. — Heavily muscled, moderately fat; covering firm, smooth, and of uniform thickness, especially in sides and belly.

Constitution. — Should be thoroughly healthy.

Early maturity. — General refinement, especially of head, neck, and legs; body large; extremities small; amplitude of girth in chest, belly, and flanks.

Scale of points

	PERFECT SCORE
1. Scale, large for age	6
2. Skin, smooth and fine; color according to breed	2
3. Hair, abundant, fine, bright, smooth; color according to breed	1
4. Snout, shaped according to breed	1
5. Face, smooth and slightly dished	1
6. Eyes, full and bright; not obscured by wrinkles	1
7. Ears, fine in texture; shape and position according to breed	1
8. Jowl, light, smooth, and neat	3
9. Neck, light, medium length	3
10. Shoulders, smooth, compact, free from any coarseness; moderately fat	8
11. Fore legs, straight, short for the breed; bone fine, strong, and smooth; pasterns upright, feet strong.	3
12. Chest, deep; full in heart-girth	5
13. Back and loin, long, smooth, strong, medium and uniform in width; moderately fat	15
14. Rump, long, smooth, medium in width; rounding from loin to tail; moderately fat	5
15. Hams, firm, smoothly covered, fleshed deep and low toward hocks	10
16. Sides, long, smooth, deep, straight, moderately fat	20
17. Belly, long, smooth, straight, and firm	12
18. Hind legs, straight, short for the breed; bone fine, strong, and smooth, pasterns upright; feet strong	3
Total	100

Market Classes and Grades

Beef, veal, mutton, and pork recognized in Chicago wholesale markets. (Hall, Illinois Station.)

BEEF

The general divisions of the beef trade are (1) Carcass Beef, (2) Beef Cuts, and (3) Cured Beef Products.

CARCASS BEEF. — The classes are *Steers*, *Heifers*, *Cows*, and *Bulls* and *Stags*. They differ not only in sex, but also in the uses to which they are adapted.

The grades within these classes are *prime*, *choice*, *good*, *medium*, *common*, and *canners*. The grades are based on differences in form, thickness, finish, quality, soundness, and weight.

The terms "Native," "Western," and "Texas" beef each include various classes and grades of carcasses, and refer to general differences in form, finish, and quality.

The terms "Yearlings," "Distillers," "Butcher," and "Kosher" also include various classes and grades of beef, and merely indicate characteristic features of carcass beef used by certain branches of the trade.

"Shipping beef" refers to that sent to eastern cities and consists principally of steers, heifers and cows of medium to prime grades. Export beef consists largely of medium to prime steers.

BEEF CUTS. — The "straight cuts" of beef are *Loins*, *Ribs*, *Rounds*, *Chucks*, *Plates*, *Flanks*, and *Shanks*.

The grades of beef cuts are *No. 1*, *No. 2*, *No. 3*, and *Strippers*. The grade of a beef cut depends upon its thickness, covering, quality, and weight.

CURED BEEF PRODUCTS. — These are classified as (1) Barreled, (2) Smoked, and (3) Canned Beef.

Barreled Beef is graded as *Extra India Mess*, *Extra Plate*, *Regular Plate*, *Packet*, *Common Plate*, *Rolled Boneless*, *Prime Mess*, *Extra Mess*, *Rump Butt* and *Mess Chuck Beef*, *Beef Hams* and *Scotch Buttocks*.

Smoked Beef consists of *Dried Beef Hams*, *Dried Beef Clods*, and *Smoked Brisket Beef*.

Canned Beef consists principally of *Chipped Beef*, *Beef Loaf*, *Corned* and *Roast Beef*.

VEAL

The divisions of the veal trade are (1) Carcass Veal and (2) Veal Cuts.

CARCASS VEAL. — The grades are *choice*, *good*, *medium*, *light*, and *heavy*. The grade of a veal carcass depends upon its form, quality, finish, and weight.

The terms "Native" and "Western" veal each include several grades of calves, and refer to general differences in form, quality, and finish.

VEAL CUTS. — The regular veal cuts are *Saddles* and *Racks*. They are graded as *choice*, *good*, *medium*, and *common*, according to the same factors as carcass veal.

Subdivisions of the regular cuts are made in some markets and similarly graded.

MUTTON AND LAMB

The divisions of the trade are (1) Carcass Mutton and Lamb and (2) Mutton and Lamb Cuts.

CARCASS MUTTON AND LAMB. — The classes are *Wethers*, *Ewes*, *Bucks*, *Yearlings*, and *Lambs*.

The grades within these classes are *choice*, *good*, *medium*, *common* and *culls*. The grades are based on differences in form, quality, covering, and weight.

The shipping trade goes principally to cities in the eastern seaboard states, and consists largely of medium to choice lambs.

MUTTON AND LAMB CUTS. — The leading cuts are *Saddles* and *Racks*, together with *Legs*, *Loins*, *Short Racks*, *Stews*, and *Backs*. They are graded in the same manner as carcass mutton and lamb.

PORK

Hog products are described under three heads: (1) Dressed Hogs, (2) Pork Cuts, and (3) Lard.

DRESSED HOGS. — The classes are *Smooth*, *Heavy*, *Butcher*, *Packing* and *Bacon Hogs*, *Shippers*, and *Pigs*. The classification is based on the uses to which the hogs are adapted.

Distinct grades are recognized only in the *Packing* and *Bacon* classes, the former being based on weight and the latter chiefly on quality and finish.

PORK CUTS. — The classes are *Hams*, *Sides*, *Bellies*, *Backs*, *Loins*, *Shoulders*, *Butts and Plates*, and *Miscellaneous*.

Pork cuts are quoted as fresh pork, dry-salt and bacon meats, barreled or plain-pickled pork, sweet-pickled meats, smoked meats, "English" meats, and boiled meats, respectively.

The grading of pork cuts is much more complex than that of other meats. It involves not only their quality, shape, finish, and weight, but also the styles of cutting and methods of packing used.

LARD. — The grades are *Kettle-Rendered Leaf*, *Kettle-Rendered, Neutral*, *Prime Steam*, *Refined*, and *Compound Lard*. The grading is based on the kinds of fat, included, method of rendering, color, flavor and grain.

SWINE

GRADES

SUBCLASSES

GRADES

Prime heavy hogs, 350 to 500 lb.		Prime	
Butcher hogs, 180 to 350 lb.	Heavy butchers, 280 to 350 lb.	Prime Good	
	Medium butchers, 220 to 280 lb.	Prime	
	Light butchers, 180 to 220 lb.	Good Common	
Packing hogs, 200 to 500 lb.	Heavy packing, 300 to 500 lb.	Good	
	Medium packing, 250 to 300 lb.	Common	
	Mixed packing, 200 to 280 lb.	Inferior	
Light hogs, 125 to 220 lb.	Bacon {	English, 160 to 220 lb.	Choice Light Fat
		United States, 155 to 195 lb.	Choice Good Common
	Light mixed, 150 to 220 lb.	Good Common Inferior	
Pigs, 60 to 125 lb.	Light light, 125 to 150 lb.	Good Common Inferior	
		Choice Good Common	
Roughs.			
Stags.			
Boars.			
Miscellaneous: —			
Roasting pigs, 15 to 30 lb.			
Feeders.			
Governments.			
Pen-holders.			
Dead hogs.			

Roughs are hogs of all sizes that are coarse, rough, and lacking in condition — too inferior to be classed as packing hogs or as light mixed hogs. The pork from these hogs is used for the cheaper class of trade for both packing and fresh meat purposes.

Stags are hogs that at one time were boars beyond the pig stage and have been subsequently castrated. They sell with a dockage of eighty pounds. If they are of good quality and condition and do not show too much stagginess, they go in with the various grades of packing hogs. When they are coarse and staggy in appearance, they are sold in the same class with boars. The intermediary grades sell for prices ranging between these extremes, dependent on their freedom from stagginess and their quality and condition.

Boars are always sold in a class by themselves, and bring from \$2 to \$3 per hundredweight less than the best hogs on the market at the same time. They always sell straight, with no dockage. There is no distinction as to grades ; they simply sell as boars. The pork from these animals is used to supply the cheaper class of trade, and also for making sausage.

Roasting pigs are not generally quoted in market reports. They come to market in small numbers and only during holiday seasons, and their price varies greatly.

Feeders are hogs bought on the market and taken back to the country to be further fed, a practice which is followed only to a very limited extent.

Governments are hogs rejected by the government inspector as not sound in every respect. They are usually bought up by a local dealer and taken to one of the smaller packing houses, where they are slaughtered under the supervision of an inspector. If found to be affected so as to make their flesh unfit for human food, they are condemned, slaughtered, and tanked. The tank is a large, steam-tight receptacle, like a steam boiler, in which the lard is rendered under steam pressure. This high degree of heat destroys all disease germs with which the diseased carcass may have been affected. The product of the tank is converted into grease and fertilizer.

The commission men who sell the stock as it comes to the yards, and the speculators who handle part of it, pay nothing for their privilege of doing business in the yards. They hold their respective positions by common consent and their respective pens by keeping hogs in them. These hogs are called *pen-holders*, and have no influence on the market.

Dead hogs are those killed in the cars in transit. They are used for the manufacture of grease, soap, and fertilizer.

CHAPTER XXII

COMPUTING THE RATION FOR FARM ANIMALS

MODERN experiments (principally German) have resulted in formulating *standard rations* for different animals at different ages and under different conditions. These feeding standards are only approximate guides, but they are sufficient for practical purposes.

Computing by Energy Values

A method is proposed of calculating feeding requirements, reckoned on the protein and the *energy values* or therms of chemical energy. A therm is the heat required to raise the temperature of 1,000 kilograms of water 1° C. The chemical energy contained in anthracite is 3.583 therms per pound. (A pound of anthracite produces heat enough to raise the temperature of 3.583 kilograms of water 1° C.) In the same way the amount of chemical energy contained in many feeding stuffs has been measured. Following are determinations of chemical energy in 100 pounds (with 15 per cent moisture):—

	THERMS		THERMS
Timothy hay	175.1	Corn-meal	170.9
Clover hay	173.2	Oats	180.6
Oat straw	171.0	Wheat bran	175.5
Wheat straw	171.4	Linseed-meal	196.7

Maintenance requirements of cattle and horses, per day and head (Armsby)

(Production requirements are also determined, and must be used in calculating rations.)

LIVE WEIGHT	CATTLE		HORSES	
	Digestible protein	Energy value	Digestible protein	Energy value
	<i>Pounds</i>	<i>Therms</i>	<i>Pounds</i>	<i>Therms</i>
150	0.15	1.70	0.30	2.00
250	0.20	2.40	0.40	2.80
500	0.30	3.80	0.60	4.40
750	0.40	4.95	0.80	5.80
1000	0.50	6.00	1.00	7.00
1250	0.60	7.00	1.20	8.15
1500	0.65	7.90	1.30	9.20

Computing on Basis of Quality and Quantity of Milk

“The quality of milk is quite as important a factor in formulating a feeding standard or guide to feeding practice, as quantity of milk yielded,” according to Haecker (Minn. Bull. 79). “It would seem quite as consistent to feed an animal food regardless of its composition as to feed an assumed ration regardless of the composition of the product which is to be elaborated from the nutrients of the food.”

It is probably not possible to “feed fat into milk,” provided the animal is otherwise well nourished, but the Haecker standards are not founded on that idea, but on the assumption that the greater the yield of butter-fat the greater should be the feed of maintenance. This method is sometimes used instead of the German method (p. 413), in figuring rations for dairy cows.

Net nutrients used by mature cows for the production of one pound of milk testing a given per cent butter-fat (Haecker)

		PROTEIN	CARBOHYDRATES	ETHER EXTRACT
Milk testing	2.5	.0362	.164	.0124
“	2.6	.0369	.167	.0126
“	2.7	.0376	.171	.0128
“	2.8	.0383	.174	.0131
“	2.9	.0390	.177	.0133
“	3.0	.0397	.181	.0136
“	3.1	.0404	.184	.0138
“	3.2	.0411	.187	.0140
“	3.3	.0418	.190	.0142
“	3.4	.0425	.194	.0145
“	3.5	.0432	.197	.0147
“	3.6	.0439	.200	.0149
“	3.7	.0446	.204	.0152
“	3.8	.0453	.207	.0154
“	3.9	.0460	.210	.0156
“	4.0	.0467	.214	.0159
“	4.1	.0474	.217	.0161
“	4.2	.0481	.220	.0163
“	4.3	.0488	.223	.0165
“	4.4	.0495	.227	.0168
“	4.5	.0502	.230	.0170
“	4.6	.0509	.233	.0172
“	4.7	.0516	.237	.0175
“	4.8	.0523	.240	.0177
“	4.9	.0530	.243	.0179

Net nutrients used by mature cows — Continued

		PROTEIN	CARBOHY- DRATES	ETHER EXTRACT
Milk testing	5.0	.0537	.247	.0182
“	5.1	.0544	.250	.0185
“	5.2	.0551	.253	.0187
“	5.3	.0558	.256	.0189
“	5.4	.0565	.260	.0192
“	5.5	.0572	.263	.0194
“	5.6	.0579	.266	.0196
“	5.7	.0586	.270	.0199
“	5.8	.0593	.273	.0201
“	5.9	.0600	.276	.0203
“	6.0	.0607	.280	.0206
“	6.1	.0614	.283	.0208
“	6.2	.0621	.286	.0210
“	6.3	.0628	.289	.0212
“	6.4	.0635	.293	.0215
“	6.5	.0642	.296	.0217
“	6.6	.0649	.300	.0219
“	6.7	.0656	.303	.0222
“	6.8	.0663	.306	.0224
“	6.9	.0670	.309	.0226
“	7.0	.0677	.313	.0229
Coefficients for food of maintenance ¹ per cwt.		.07	7.7	.01

“ Given the daily yield of milk in pounds, its percentage of butter-fat, and the weight of the cow expressed decimally, it is an easy matter to determine the required ration. As an illustration, suppose a mature cow weighs 825 pounds, gives 20 pounds of milk daily testing 4 per cent butter-fat. One pound of 4 per cent milk requires of protein .0467, carbohydrates .214, and of ether extract .0159; multiplying these factors by 20 it is found that for the production of milk the cow needs .934 of protein, 4.28 of carbohydrates, and .318 of ether extract. For food of maintenance, multiply .07 protein, .7 carbohydrates and .01 of ether extract (maintenance formula) by 8.25, which gives protein .578, carbohydrates 5.78, and ether extract .082; adding to this the nutrients required for milk production, we have 1.51 of protein, 10.06 carbohydrates, and .40 ether extract, the nutrients required in the ration. They should be supplied in such manner with reference to bulk that the ration will satisfy the appetite. A ration like this should be largely made up of roughage.” (Haecker.)

For a cow weighing 850 pounds and yielding 40 pounds of 4 per

¹ Maintenance standards not detailed here.

cent milk daily, the required ration would be (P=protein; C. H. = carbohydrates):—

P.	C.H.	Fat	P.	C.H.	Fat
(.0467	.214	.0159) × 40 =	1.868	8.56	.636
(.07	.7	.01) × 8.50 =	.595	5.95	.085
Ration required,			2.463	14.51	.721

A ration like this should be largely composed of grain so that it will not contain so much bulk that the cow will go off her feed, and yet furnish the nutrients required. Cows do not require a uniform nutritive ratio, but the ratio varies according to the quantity of milk and weight of cow. To illustrate, let us suppose a cow weighing 1200 pounds and yielding 20 pounds of milk daily, and one weighing 850 pounds yielding 40 pounds of milk, both testing 4 per cent fat:

	P.	C. H.	Fat
Nutrients for 1 lb. of 4 per cent milk,	.0467	.214	.0159
Nutrients for 1 cwt., maintenance,	.07	.7	.01

For cow weighing 1200 lbs. and yielding 20 lbs. of 4 per cent milk :

	P.	C. H.	Fat	
Nutrients for 20 lbs. milk,	.93	4.28	.32	
Nutrients for 12 cwt. maintenance,	.84	8.40	.12	
Ration required,	1.77	12.68	.44	
Nutritive ratio,				1 : 7.7

For cow weighing 850 lbs. and yielding 40 lbs. of 4 per cent milk :

	P.	C. H.	Fat	
Nutrients for 40 lbs. of milk,	1.87	8.56	.64	
Nutrients for 8.5 cwt. maintenance,	.59	5.95	.08	
Ration required,	2.46	14.51	.72	
Nutritive ratio,				1 : 6.5

But if the cow weighing 12 cwt. yields 40 lb. of milk per day and the cow weighing 8.5 cwt. yields 20 pounds, the nutrient requirements for their respective rations according to table will be as follows:

	P.	C. H.	Fat	
Nutrients for 40 lbs. of 4 per cent milk,	1.87	8.56	.64	
Nutrients for 12 cwt. maintenance,	.84	8.40	.12	
Required ration,	2.71	16.96	.76	
Nutritive ratio,				1 : 6.8

	P.	C. H.	Fat	
Nutrients for 20 lbs. of 4 per cent milk,	.93	4.28	.32	
Nutrients for 8.5 cwt. maintenance,	.59	5.95	.08	
Required ration,	1.52	10.23	.40	
Nutritive ratio,				1 : 7.3

Computing the Balanced Ration by the Wolff-Lehmann Standards

The usual method of computing rations, however, is by the use of the German standards (Table I) as a basis, and then determining from the composition tables (Table II) how the various feeds may be compounded so that they will produce approximately the ratio of the feeding standards. Feeding standards have not been sufficiently worked out for poultry.

In the following dairy ration, the nutritive ratio is much too wide as compared with the standard:—

	DRY MATTER	PROTEIN	C. H. AND FAT	TOTAL	NUTRITIVE RATIO
20 lb. hay	17.40	0.560	9.300	9.860	—
4 lb. oats	3.56	0.368	2.772	2.640	—
4 lb. corn	3.56	0.316	3.056	3.372	—
Total	24.52	1.244	14.628	15.872	1 : 11.7
Feeding standard	24.00	2.5	13.4	15.9	1 : 5.4

The following table shows the ration more nearly balanced by the substitution of buckwheat middlings for the corn:—

	DRY MATTER	PROTEIN	C. H. AND FAT	TOTAL
20 lb. timothy hay	17.40	0.560	9.300	9.860
4 lb. oats	3.56	0.368	2.272	2.640
4 lb. buckwheat middlings	3.48	0.880	1.824	2.704
Total	24.44	1.808	13.396	15.204

Nutritive ratio 1 : 7.4

By adding cottonseed meal, and reducing the hay, the ration conforms practically to the standard:—

	DRY MATTER	PROTEIN	C. H. AND FAT	TOTAL
18 lb. timothy hay	15.66	0.504	8.370	8.874
4 lb. oats	3.56	0.368	2.272	2.640
4 lb. buckwheat middlings	3.48	0.880	1.824	2.704
2 lb. cottonseed meal	1.84	0.744	0.888	1.632
Total	24.54	2.496	13.354	15.850

Nutritive ratio 1 : 5.3

In computing the ration, proper consideration must be given to the digestibility (Table III), and also, as determined by experience, to bulk and palatableness. The fertilizing value of the manure differs with the different feeds, as is indicated in Table IV.¹

An exact mathematical method of equating rations is worked out by Willard in Bull. 115 of the Kansas Exp. Sta., and condensed in Cyclo. Amer. Agric. III, pp. 103-105. It rests on finding the protein-equating factor.

The Feeding-Standards

The relation between the protein, on the one hand, and the carbohydrates and fat on the other, is known as the *nutritive ratio*: thus 1:11.9 means protein 1 part to carbohydrates and fat nearly 12 (11.9) parts. A ratio less than 1:5 is usually said to be *narrow*; one more than 1:7 is said to be *wide*.

TABLE I. FEEDING-STANDARDS

A. — Per day and 1000 lb. live weight.²

	DRY MATTER	DIGESTIBLE			NUTRI- TIVE RATIO
		Protein	Carbo- hydrates and Fat	Total	
	<i>Pounds</i>	<i>Pounds</i>	<i>Pounds</i>	<i>Pounds</i>	
Oxen at rest in the stall	17.5	0.7	8.3	9.0	1:11.9
Wool sheep, coarser breeds	20.0	1.2	10.8	12.0	1:9.0
Wool sheep, finer breeds	22.5	1.5	12.0	13.5	1:8.0
Oxen moderately worked	24.0	1.6	12.0	13.0	1:7.5
Oxen heavily worked	26.0	2.4	14.3	16.7	1:6.0
Horses lightly worked	20.0	1.5	10.4	11.9	1:6.9
Horses moderately worked	21.0	1.7	11.8	13.5	1:6.9
Horses heavily worked	23.0	2.3	14.3	16.6	1:6.2
Milch cows, Wolff's standard	24.0	2.5	13.4	15.9	1:5.4
Milch cows, when yielding daily —					
11 lb. milk	25.0	1.6	10.7	12.3	1:6.7
16.6 lb. milk	27.0	2.0	11.9	13.9	1:6.0
22.0 lb. milk	29.0	2.5	14.1	16.6	1:5.7
27.5 lb. milk	32.0	3.3	14.8	18.1	1:4.5
Fattening oxen, preliminary period	27.0	2.5	16.1	18.6	1:6.4
Fattening oxen, main period	26.0	3.0	16.4	19.4	1:5.5

¹ The tables are abbreviated from *Cyclo. Amer. Agric.*; and nos. II, III, and V there adapted from Henry.

² The fattening rations are calculated for 1000 lb., live weight, at the beginning of the fattening.

TABLE I. FEEDING-STANDARDS — *Continued*

	DRY MATTER	DIGESTIBLE			NUTRI- TIVE RATIO	
		Protein	Carbo- hydrates and Fat	Total		
		Pounds	Pounds	Pounds		
Fattening oxen, finishing period . . .	25.0	2.7	16.2	18.9	1 : 6.0	
Fattening sheep, preliminary period . .	26.0	3.0	16.3	19.3	1 : 5.4	
Fattening sheep, main period	25.0	3.5	15.8	19.3	1 : 4.5	
Fattening swine, preliminary period . .	36.0	5.0	27.5	32.5	1 : 5.5	
Fattening swine, main period	31.0	4.0	24.0	28.0	1 : 6.0	
Fattening swine, finishing period . . .	23.5	2.7	17.5	20.2	1 : 6.5	
Growing cattle:						
<i>Average live weight</i>						
<i>per head</i>						
Age (months)						
2-3	150 lb.	22.0	4.0	18.3	22.3	1 : 4.6
3-6	300 lb.	23.4	3.2	15.8	19.0	1 : 4.9
6-12	500 lb.	24.0	2.5	14.9	17.4	1 : 6.0
12-18	700 lb.	24.0	2.0	13.9	15.9	1 : 7.0
18-24	850 lb.	24.0	1.6	12.7	14.3	1 : 8.0
Growing sheep:						
5-6	56 lb.	28.0	3.2	17.4	20.6	1 : 5.4
6-8	67 lb.	25.0	2.7	14.7	17.4	1 : 5.4
8-11	75 lb.	23.0	2.1	12.5	14.6	1 : 6.0
11-15	82 lb.	22.5	1.7	11.8	13.5	1 : 7.0
15-50	85 lb.	22.0	1.4	11.1	12.5	1 : 8.0
Growing fat pigs:						
2-3	50 lb.	42.0	7.5	30.0	37.5	1 : 4.0
3-5	100 lb.	34.0	5.0	25.0	30.0	1 : 5.0
5-6	125 lb.	31.5	4.3	23.7	28.0	1 : 5.5
6-8	170 lb.	27.0	3.4	20.4	23.8	1 : 6.0
8-12	250 lb.	21.0	2.5	16.2	18.7	1 : 6.5

B. — *Per day and per head*

Growing cattle:						
2-3	150 lb.	3.3	0.6	2.8	3.4	1 : 4.6
3-6	300 lb.	7.0	1.0	4.9	5.9	1 : 4.9
6-12	500 lb.	12.0	1.3	7.5	8.8	1 : 6.0
12-18	700 lb.	16.8	1.4	9.7	11.1	1 : 7.0
18-24	850 lb.	20.4	1.4	11.1	12.5	1 : 8.0
Growing sheep:						
5-6	56 lb.	1.6	0.18	0.974	1.154	1 : 5.4
6-8	67 lb.	1.7	0.18	0.981	1.161	1 : 5.4
8-11	75 lb.	1.7	0.16	0.953	1.113	1 : 6.0
11-15	82 lb.	1.8	0.14	0.975	1.115	1 : 7.0
15-20	85 lb.	1.9	0.12	0.955	1.075	1 : 8.0
Growing fat swine:						
2-3	50 lb.	2.1	0.38	1.50	1.88	1 : 4.0
3-5	100 lb.	3.4	0.50	2.50	3.00	1 : 5.0
5-6	125 lb.	3.9	0.54	2.96	3.50	1 : 5.5
6-8	170 lb.	4.6	0.58	3.47	4.05	1 : 6.0
8-12	250 lb.	5.2	0.62	4.05	4.67	1 : 6.5

Proteid requirements

From the results of a considerable number of fattening experiments with cattle, Armsby has formulated the approximate proteid requirements, comparing them with those for growth formulated by Kellner; and these are here followed by proteid requirements of sheep and swine:—

Approximate proteid requirements, in pounds, of cattle, per 1000 pounds live weight

AMERICAN RESULTS		GERMAN RESULTS (Kellner)	
	<i>Lb.</i>		<i>Lb.</i>
Age 1 month	4.80	Age 2-3 months	4.50
Age 2 months	4.00	Age 3-6 months	3.50
Age 3 months	3.50	Age 6-12 months	2.80
Age 1-1½ years	2.00	Age 1-1½ years	2.20
Age 2 years	1.75	Age 1-1½-2 years	1.50
Age 2½ years	1.50	Mature, fattening	1.60

Proteid requirements for sheep, per 1000 pounds live weight (Kellner)

	WOOL BREEDS	MUTTON BREEDS
	<i>Lb.</i>	<i>Lb.</i>
Age 5- 6 months	3.0	4.5
Age 6- 8 months	2.5	3.5
Age 8-11 months	1.8	2.5
Age 11-15 months	1.5	2.0
Age 15-20 months	1.2	1.5

Proteid requirements of swine, per 1000 pounds live weight (Kellner)

	BREEDING ANIMALS	FATTENING ANIMALS
	<i>Lb.</i>	<i>Lb.</i>
Age 2- 3 months	6.2	6.2
Age 3- 5 months	4.0	4.5
Age 5- 6 months	3.0	3.5
Age 6- 8 months	2.3	3.0
Age 9-12 months	1.7	2.4

Average weights of different feeding-stuffs (Mass. Sta.)

FEEDING STUFF	ONE QUART WEIGHS —	ONE POUND MEASURES —
	Lb.	Qt.
Barley meal	1.1	0.9
Barley, whole	1.5	0.7
Brewers' dried grains	0.6	1.7
Corn-and-cob meal	1.4	0.7
Corn-and-oat feed	0.7	1.4
Corn bran	0.5	2.0
Corn meal	1.5	0.7
Corn, whole	1.7	0.6
Cottonseed meal	1.5	0.7
Distillers' dried grains	0.5-0.7	1.0-1.4
Germ l oimeal	1.4	0.7
Gluten feed	1.3	0.8
Gluten meal	1.7	0.6
Hominy meal	1.1	0.9
Linseed meal, new process	0.9	1.1
Linseed meal, old process	1.1	0.9
Malt sprouts	0.6	1.7
Mixed feed (bran and middlings)	0.6	1.7
Oat feed (a variable mixture)	0.8	1.3
Oat middlings	1.5	0.7
Oats, ground	0.7	1.4
Oats, whole	1.0	1.0
Rye feed (a mixture of rye bran and rye middlings)	1.3	0.8
Rye meal	1.5	0.7
Rye bran (Conn. Sta.)	0.6	—
Rye, whole	1.7	0.6
Wheat bran	0.5	2.0
Wheat, ground	1.7	0.6
Wheat middlings (flour)	1.2	0.8
Wheat middlings (standard)	0.8	1.3
Wheat, whole	1.9	0.5
Mixed wheat feed (Conn. Sta.)	0.6	—

Sample rations.

The following twelve rations for milch cows are given as samples of the systems of feeding to be recommended in different parts of the country.

(1) Hay, 20 lb. ; oats, 3 lb. ; corn-and-cob meal, 3 lb ; oil-meal, 2 lb.

(2) Hay, 10 lb. ; corn-stalks, ad lib. ; wheat bran, 3 lb. ; corn meal, 2 lb. ; cottonseed meal, 2 lb.

(3) Roots, 60 lb. ; stover, ad lib. ; oats, 3 lb. ; bran, 3 lb. ; gluten feed, 3 lb.

(4) Corn fodder, ad lib. ; corn silage, 40 lb. ; shorts, 2 lb. ; dry brewers' grains, 2 lb. ; oil-meal, 2 lb.

(5) Silage, 40 lb. ; hay, ad lib. ; bran, 4 lb. ; oats, 2 lb. ; gluten meal, 2 lb.

(6) Corn silage, 45 lbs. ; hay, ad lib. ; oats, 4 lb. ; oil-meal, 2 lb. ; cottonseed meal, 1 lb.

(7) Corn silage, 35 lb. ; clover hay, ad lib. ; bran, oats, and corn meal, 2 lb. each.

(8) Clover silage, 25 lb. ; hay, 5 lb. ; corn-stalks, ad lib. ; oats, 3 lb. ; corn meal and oil-meal, 2 lb. each.

(9) Clover or alfalfa silage, 30 lb. ; hay, ad lib. ; bran, 4 lb. ; middlings, 3 lb. ; oil-meal, 1 lb.

(10) Alfalfa hay, 20 lb. ; oats, 4 lb. ; corn meal, 2 lb.

(11) Hay, 20 lb. ; cottonseed hulls, 10 lb. ; cottonseed meal, 4 lb. ; wheat bran, 2 lb.

(12) Corn silage, 30 lb. ; cottonseed hulls, 12 lb. ; bran, 6 lb. ; cottonseed meal, 3 lb.

Henry, in his "Feeds and Feeding," gives the following rations, from various sources, as a guide in determining the amount of feed that should be allowed the horse under various conditions :—

CHARACTER OF ANIMAL AND WORK REQUIRED	RATION	
	Concentrates	Roughage
<i>Trotting horse.</i> — (Wood-ruff.)		
Colt, weaning time . . .	2 lb. oats	Hay unlimited allowance
Colt, one year old . . .	4 lb. oats	Hay unlimited allowance
Colt, two years old . . .	6 lb. oats	Hay unlimited allowance
Colt, two years old, in training	8 lb. oats	Hay, allowance limited
Colt, three years old, in training	8-12 lb. oats	Hay, allowance limited
<i>Trotting horse.</i> — (Splan.)		
Horse on circuit	10 lb. oats	Hay, fair amount
Horse on circuit	{ 15 lb. oats, in excep- tional cases (as with Rarus)	Hay, fair amount
<i>Horse variously used.</i> — (Stonehenge.)		
Race horse	15 lb. oats	6-8 lb. hay
Hack	8 lb. oats	12 lb. hay

CHARACTER OF ANIMAL AND WORK REQUIRED	RATION	
	Concentrates	Roughage
<i>Horse variously used.</i> — (Fleming.)		
Pony	4 lb. oats	{ Hay, moderate allow- ance 12 lb. hay 10 lb. hay 12 lb. hay
Hunter, small	12 lb. oats	
Hunter, large	16 lb. oats	
Carriage, light work . .	10 lb. oats	
<i>The draft horse.</i> —(Sidney.)		
Heavy, hard work . . .	{ 13 lb. oats 6 lb. beans 3 lb. corn	} 15 lb. chaffed clover hay
<i>Farm horse.</i> —(Settegast.)		
Light work	6-10 lb. oats	{ 6-9 lb. hay 3 lb. straw 10 lb. hay 3 lb. straw 12 lb. hay 3 lb. straw
Medium work	10 lb. oats	
Heavy work	13 lb. oats	

Composition Tables

TABLE II. AVERAGE COMPOSITION OF AMERICAN FEEDING-STUFFS (Henry)

FEEDING-STUFFS	PERCENTAGE COMPOSITION						No. of analy- ses
	Water	Ash	Protein	Crude fiber	Nitro- gen-free extract	Ether extract	
CONCENTRATES							
Corn, dent	10.6	1.5	10.3	2.2	70.4	5.0	86
Corn, flint	11.3	1.4	10.5	1.7	70.1	5.0	68
Corn, sweet	8.8	1.9	11.6	2.8	66.8	8.1	26
Corn meal	15.0	1.4	9.2	1.9	68.7	3.8	77
Corn cob	10.7	1.4	2.4	30.1	54.9	0.5	18
Corn-and-cob meal	15.1	1.5	8.5	6.6	64.8	3.5	7
Corn bran	9.4	1.2	11.2	11.9	60.1	6.2	6
Corn germ	10.7	4.0	9.8	4.1	64.0	7.4	3
Hominy chops	9.6	2.7	10.5	4.9	64.3	8.0	106
Germ meal	8.6	2.4	21.7	3.8	47.3	4.2	23
Dried starch and sugar feed	10.9	0.9	19.7	4.7	54.8	9.0	4
Starch feed, wet	65.4	0.3	6.1	3.1	22.0	3.1	12
Gluten meal	9.5	1.5	33.8	2.0	46.6	6.6	12
Gluten feed	9.2	2.0	25.0	6.8	53.5	3.5	102
Wheat, all analyses	10.5	1.8	11.9	1.8	71.9	2.1	310
Flour, high grade	12.2	0.6	14.9	0.3	70.0	2.0	1
Flour, low grade	12.0	2.0	18.0	0.9	63.3	3.9	1

TABLE II—Continued

FEEDING-STUFFS	PERCENTAGE COMPOSITION						No. of analyses
	Water	Ash	Protein	Crude fiber	Nitrogen-free extract	Ether extract	
Flour, dark feeding . . .	9.7	4.3	19.9	3.8	56.2	6.2	1
Bran, all analyses . . .	11.9	5.8	15.4	9.0	53.9	4.0	88
Middlings	10.0	3.2	19.2	3.2	59.6	4.8	106
Shorts	11.2	4.4	16.9	6.2	56.2	5.1	94
Wheat screenings	11.6	2.9	12.5	4.9	65.1	3.0	10
Rye	8.7	2.1	11.3	1.5	74.5	1.9	57
Rye flour	13.1	0.7	6.7	0.4	78.3	0.8	4
Rye bran	11.6	3.4	14.6	3.5	63.9	2.8	29
Rye shorts and bran . . .	12.4	3.2	15.7	4.1	61.5	3.1	21
Barley	10.8	2.5	12.0	4.2	67.8	1.8	22
Barley meal	11.9	2.6	10.5	6.5	66.3	2.2	3
Barley screenings	12.2	3.6	12.3	7.3	61.8	2.8	2
Brewers' grains, wet . . .	75.7	1.0	5.4	3.8	12.5	1.6	15
Brewers' grains, dried . .	8.7	3.7	25.0	13.6	42.3	6.7	53
Malt-sprouts	9.5	6.1	26.3	11.6	44.9	1.6	47
Oats	11.4	3.2	11.4	10.8	59.4	4.8	126
Oatmeal	7.9	2.0	14.7	0.9	67.4	7.1	6
Oat feed	7.0	5.3	8.0	21.5	55.3	2.9	110
Oat dust	6.5	6.9	13.5	18.2	50.2	4.8	2
Oat hulls	7.4	6.7	3.4	30.7	50.5	1.3	11
Rice	12.4	0.4	7.4	0.2	79.2	0.4	10
Rice meal	10.2	8.1	12.0	5.4	51.2	13.1	2
Rice hulls	8.8	15.6	3.2	36.2	35.2	1.0	17
Rice bran	9.7	9.7	11.9	12.0	46.6	10.1	24
Rice polish	10.8	4.8	11.9	3.3	62.3	7.2	21
Buckwheat	13.4	2.0	10.8	11.7	59.7	2.4	33
Buckwheat flour	14.6	1.0	6.9	0.3	75.8	1.4	4
Buckwheat hulls	13.2	2.2	4.6	43.5	35.3	1.1	2
Buckwheat bran	8.2	4.9	12.6	32.9	37.9	3.5	4
Buckwheat shorts	11.1	5.1	27.1	8.3	40.8	7.6	2
Buckwheat middlings . . .	12.8	5.0	26.7	4.4	44.3	6.8	40
Sorghum seed	12.8	2.1	9.1	2.6	69.8	3.6	10
Broom-corn seed	12.8	2.8	9.9	7.0	64.3	3.2	4
Kafir seed	9.9	1.6	11.2	2.7	71.5	3.1	19
Millet seed	12.1	2.8	10.9	8.1	62.6	3.5	6
Hungarian-grass seed . . .	9.5	5.0	9.9	7.7	63.2	4.7	1
Flax seed	9.2	4.3	22.6	7.1	23.2	33.7	50
Linseed meal (old process)	9.8	5.5	33.9	7.3	35.7	7.8	191
Linseed meal (new process)	9.0	5.5	37.5	8.9	36.4	2.0	52
Cottonseed	10.3	3.5	18.4	23.2	24.7	19.9	5
Cottonseed roasted	6.1	5.5	16.8	20.4	23.5	27.7	2
Cottonseed meal	7.0	6.6	45.3	6.3	24.6	10.2	319
Cottonseed hulls	11.1	2.8	4.2	46.3	33.4	2.2	20
Cottonseed kernels (with- out hulls)	6.2	4.7	31.2	3.7	17.6	36.6	2
Cocoonut cake	10.3	5.9	19.7	14.4	38.7	11.0	—
Palm-nut meal	10.4	4.3	16.8	24.0	35.0	9.5	600
Sunflower seed	8.6	2.6	16.3	29.9	21.4	21.2	2

TABLE II—Continued

FEEDING-STUFFS	PERCENTAGE COMPOSITION						No. of analyses
	Water	Ash	Protein	Crude fiber	Nitrogen-free extract	Ether extract	
Sunflower-seed cake	10.8	6.7	32.8	13.5	27.1	9.1	—
Peanut kernel (without hulls)	7.5	2.4	27.9	7.0	15.6	39.6	7
Peanut cake	10.7	4.9	47.6	5.1	23.7	8.0	2480
Rape-seed cake	10.0	7.9	31.2	11.3	30.0	9.6	500
Pea meal	10.5	2.6	20.2	14.4	51.1	1.2	2
Soybean	11.7	4.8	33.5	4.5	28.3	17.2	16
Cowpea	14.6	3.2	20.5	3.9	56.3	1.5	2
Horse bean	11.3	3.8	26.6	7.2	50.1	1.0	1
ROUGHAGE							
<i>Corn forage, field-cured—</i>							
Fodder corn	42.2	2.7	4.5	14.3	34.7	1.6	35
Corn stover (ears removed)	40.5	3.4	3.8	19.7	31.5	1.1	60
<i>Corn forage, green—</i>							
Fodder corn, all varieties	79.3	1.2	1.8	5.0	12.2	0.5	126
Dent, kernels glazed	73.4	1.5	2.0	6.7	15.5	0.9	7
Flint, kernels glazed	77.1	1.1	2.7	4.3	14.6	0.8	10
Sweet varieties	79.1	1.3	1.9	4.4	12.8	0.5	21
Leaves and husks	66.2	2.9	2.1	8.7	19.0	1.1	4
Stripped stalks	76.1	0.7	0.5	7.3	14.9	0.5	4
<i>Hay from grasses—</i>							
Hay from mixed grasses	15.3	5.5	7.4	27.2	42.1	2.5	126
Timothy, all analyses	13.2	4.4	5.9	29.0	45.0	2.5	68
Timothy, cut in full bloom	15.0	4.5	6.0	29.6	41.9	3.0	12
Timothy, cut soon after bloom	14.2	4.4	5.7	28.1	44.6	3.0	11
Timothy, cut when nearly ripe	14.1	3.9	5.0	31.1	43.7	2.2	12
Orchard-grass	9.9	6.0	8.1	32.4	41.0	2.6	10
Red-top, cut at different stages	8.9	5.2	7.9	28.6	47.5	1.9	9
Red-top, cut in bloom	8.7	4.9	8.0	29.9	46.4	2.1	3
Kentucky blue-grass	21.2	6.3	7.8	23.0	37.8	3.9	10
Kentucky blue-grass, cut when seed is in milk	24.4	7.0	6.3	24.5	34.2	3.6	4
Kentucky blue-grass, cut when seed is ripe	27.8	6.4	5.8	23.8	33.2	3.0	4
Hungarian-grass	7.7	6.0	7.5	27.7	49.0	2.1	13
Meadow fescue	20.0	6.8	7.0	25.9	38.4	2.7	9
Italian rye-grass	8.5	6.9	7.5	30.5	45.0	1.7	4
Perennial rye-grass	14.0	7.9	10.1	25.4	40.5	2.1	4
Rowen (mixed)	16.6	6.8	11.6	22.5	39.4	3.1	23
Mixed grasses and clovers	12.9	5.5	10.1	27.6	41.3	2.6	17
Barley hay, cut in milk	15.0	4.2	8.8	24.7	44.9	2.4	1

TABLE II—Continued

FEEDING-STUFFS	PERCENTAGE COMPOSITION						No. of analyses
	Water	Ash	Protein	Crude fiber	Nitrogen-free extract	Ether extract	
Oat hay, cut in milk	14.0	5.7	8.9	27.4	41.2	2.8	4
Swamp hay	11.6	6.7	7.2	26.6	45.9	2.0	8
Salt-marsh hay	10.4	7.7	5.5	30.0	44.1	2.4	10
Wild-oat grass	14.3	3.8	5.0	25.0	48.8	3.3	1
Buttercups	9.3	5.6	9.9	30.6	41.1	3.5	2
White daisy	10.3	6.6	7.7	30.0	42.0	3.4	2
Johnson-grass	10.2	6.1	7.2	28.5	45.9	2.1	2
<i>Fresh grass —</i>							
Pasture grass	80.0	2.0	3.5	4.0	9.7	0.8	—
Kentucky blue-grass	65.1	2.8	4.1	9.1	17.6	1.3	18
Timothy, different stages	61.6	2.1	3.1	11.8	20.2	1.2	56
Orchard-grass, in bloom	73.0	2.0	2.6	8.2	13.3	0.9	4
Red-top, in bloom	65.3	2.3	2.8	11.0	17.7	0.9	5
Oat fodder	62.2	2.5	3.4	11.2	19.3	1.4	6
Rye fodder	76.6	1.8	2.6	11.6	6.8	0.6	7
Sorghum fodder	79.4	1.1	1.3	6.1	11.6	0.5	11
Barley fodder	79.0	1.8	2.7	7.9	8.0	0.6	1
Hungarian-grass	71.1	1.7	3.1	9.2	14.2	0.7	14
Meadow fescue, in bloom	69.9	1.8	2.4	10.8	14.3	0.8	4
Italian rye-grass, coming into bloom	73.2	2.5	3.1	6.8	13.3	1.3	24
Tall oat-grass, in bloom	69.5	2.0	2.4	9.4	15.8	0.9	3
Japanese millet	75.0	1.5	2.1	7.8	13.1	0.5	12
Barnyard millet	75.0	1.9	2.4	7.0	13.1	0.6	2
<i>Hay from legumes —</i>							
Red clover	15.3	6.2	12.3	24.8	38.1	3.3	38
Red clover in bloom	20.8	6.6	12.4	21.9	33.8	4.5	6
Red clover, mammoth	21.2	6.1	10.7	24.5	33.6	3.9	10
Alsike clover	9.7	8.3	12.8	25.6	40.7	2.9	9
White clover	9.7	8.3	15.7	24.1	39.3	2.9	7
Crimson clover	9.6	8.6	15.2	27.2	36.6	2.8	7
Japan clover	11.0	8.5	13.8	24.0	39.0	3.7	2
Alfalfa	8.4	7.4	14.3	25.0	42.7	2.2	21
Cowpea	10.5	14.2	8.9	21.2	42.6	2.6	17
Soybean	11.8	7.0	14.9	24.2	37.8	4.3	12
Pea vine	15.0	6.7	13.7	24.7	37.6	2.3	1
Vetch	11.3	7.9	17.0	25.4	36.1	2.3	5
Flat pea	8.4	7.9	22.9	26.2	31.4	3.2	5
Peanut vines (without nuts)	7.6	10.8	10.7	23.6	42.7	4.6	6
<i>Fresh legumes —</i>							
Red clover, different stages	70.8	2.1	4.4	8.1	13.5	1.1	43
Alsike clover	74.8	2.0	3.9	7.4	11.0	0.9	4
Crimson clover	80.9	1.7	3.1	5.2	8.4	0.7	3
Alfalfa	71.8	2.7	4.8	7.4	12.3	1.0	23
Cowpea	83.6	1.7	2.4	4.8	7.1	0.4	10

TABLE II—Continued

FEEDING-STUFFS	PERCENTAGE COMPOSITION						No. of analyses
	Water	Ash	Protein	Crude fiber	Nitrogen-free extract	Ether extract	
Soybean	75.1	2.6	4.0	6.7	10.6	1.0	27
Horse bean	84.2	1.2	2.8	4.9	6.5	0.4	2
<i>Straw —</i>							
Wheat	9.6	4.2	3.4	38.1	43.4	1.3	7
Rye	7.1	3.2	3.0	38.9	46.6	1.2	7
Oat	9.2	5.1	4.0	37.0	42.4	2.3	12
Barley	14.2	5.7	3.5	36.0	39.0	1.5	97
Wheat chaff	14.3	9.2	4.5	36.0	34.6	1.4	—
Oat chaff	14.3	10.0	4.0	34.0	36.2	1.5	—
Buckwheat-straw	9.9	5.5	5.2	43.0	35.1	1.3	3
Soybean	10.1	5.8	4.6	40.4	37.4	1.7	4
Horse bean	9.2	8.7	8.8	37.6	34.3	1.4	1
<i>Silage —</i>							
Corn (immature)	79.1	1.4	1.7	6.0	11.0	0.8	99
Sorghum	76.1	1.1	0.8	6.4	15.3	0.3	6
Red clover	72.0	2.6	4.2	8.4	11.6	1.2	5
Soybean	74.2	2.8	4.1	9.7	6.9	2.2	1
Cowpea vine	79.3	2.9	2.7	6.0	7.6	1.5	2
Barnyard millet and soybean	79.0	2.8	2.8	7.2	7.2	1.0	9
Corn and soybean	76.0	2.4	2.5	7.2	11.1	0.8	4
Rye	80.8	1.6	2.4	5.8	9.2	0.3	1
<i>Roots and tubers —</i>							
Potato	79.1	0.9	2.1	0.4	17.4	0.1	41
Beets, common	88.5	1.0	1.5	0.9	8.0	0.1	9
Beets, sugar	86.5	0.9	1.8	0.9	9.8	0.1	19
Beet, mangel	90.9	1.1	1.4	0.9	5.5	0.2	9
Turnip	90.1	0.9	1.3	1.2	6.3	0.2	8
Rutabaga	88.6	1.2	1.2	1.3	7.5	0.2	4
Carrot	88.6	1.0	1.1	1.3	7.6	0.4	8
Parsnip	88.3	0.7	1.6	1.0	10.2	0.2	—
Artichoke	79.5	1.0	2.6	0.8	15.9	0.2	2
Sweet-potato	68.3	1.1	1.9	1.1	26.8	0.7	48
MISCELLANEOUS							
Cabbage	90.0	0.8	2.6	0.9	5.5	0.2	1
Sugar-beet leaves	88.0	2.4	2.6	2.2	4.4	0.4	—
Pumpkin (field)	90.9	0.5	1.3	1.7	5.2	0.4	—
Prickly comfrey	88.4	2.2	2.4	1.6	5.1	0.3	41
Rape	84.5	2.0	2.3	2.6	8.4	0.5	2
Apples	80.8	0.4	0.7	1.2	16.6	0.4	3
Cow's milk	87.2	0.7	3.6	—	4.9	3.7	793
Cow's milk, colostrum	74.6	1.6	17.6	—	2.7	3.6	42
Skim-milk, gravity	90.4	0.7	3.3	—	4.7	0.9	96
Skim-milk, centrifugal	90.6	0.7	3.1	—	5.3	0.3	97

TABLE II — Continued

FEEDING-STUFFS	PERCENTAGE COMPOSITION						No. of analyses
	Water	Ash	Protein	Crude fiber	Nitrogen-free extract	Ether extract	
Buttermilk	90.1	0.7	4.0	—	4.0	1.1	85
Whey	93.8	0.4	0.6	—	5.1	0.1	46
Dried blood	8.5	4.7	84.4	—	—	2.5	3
Meat scrap	10.7	4.1	71.2	—	0.3	13.7	144
Dried fish	10.8	29.2	48.4	—	—	11.6	6
Beet pulp (wet)	89.8	0.6	0.9	2.4	6.3	—	116
Beet molasses	20.8	10.6	9.1	—	59.5	—	35
Apple pomace	83.0	0.6	1.0	2.9	11.6	0.9	6
Sorghum bagasse	83.9	0.6	0.6	3.2	11.7 ¹	—	2
Distillery slops	93.7	0.2	1.9	0.6	2.8	0.9	1
Dried sediment from distillery slops	5.0	11.3	27.4	8.0	36.1	12.3	1

¹ Includes fat (sorghum bagasse).

TABLE III. — DIGESTIBLE NUTRIENTS IN 1 LB. OF THE MORE COMMON FEEDING-STUFFS (Calculations by J. L. Stone)

KIND AND AMOUNT OF FEED	TOTAL DRY MATTER	POUNDS OF DIGESTIBLE NUTRIENTS			NUTRITIVE RATIO
		Protein	Carbohydrates + (fat × 2.25)	Total	
<i>Soiling fodder —</i>					
Fodder corn20	.010	.125	.135	1 : 12.5
Peas-and-oats16	.018	.076	.094	1 : 4.2
Peas-and-barley (Practically the same as peas-and-oats)	.16	.017	.077	.094	1 : 4.5
Red clover29	.029	.164	.193	1 : 5.6
Alfalfa28	.039	.138	.177	1 : 3.5
Hungarian-grass29	.020	.169	.189	1 : 8.4
Corn silage21	.009	.129	.138	1 : 14.3
<i>Roots and tubers —</i>					
Potatoes21	.009	.165	.174	1 : 18.3
Beet, mangel09	.011	.056	.067	1 : 5.1
Beet, sugar13	.011	.104	.115	1 : 9.4
Carrot11	.008	.082	.090	1 : 10.3
Flat turnip10	.010	.077	.087	1 : 7.7
<i>Hay and straw —</i>					
Timothy87	.028	.465	.493	1 : 16.6
Mixed grasses and clover87	.062	.460	.522	1 : 7.4
Hungarian hay92	.045	.546	.591	1 : 12.1
Red clover hay85	.068	.396	.464	1 : 5.8

TABLE III — *Continued*

KIND AND AMOUNT OF FEED	TOTAL DRY MAT- TER	POUNDS OF DIGESTIBLE NUTRIENTS			NUTRI- TIVE RATIO
		Protein	Carbo- hydrates + (fat × 2.25)	Total	
Alfalfa hay92	.110	.423	.533	1 : 3.8
Corn fodder58	.025	.373	.398	1 : 14.9
Corn stover60	.017	.340	.357	1 : 19.9
Pea-vine straw86	.043	.341	.384	1 : 7.9
Bean-straw95	.036	.397	.433	1 : 11.0
Wheat-straw90	.004	.372	.376	1 : 9.3
Oat-straw91	.012	.404	.416	1 : 33.6
<i>Grain —</i>					
Corn (average)89	.079	.764	.843	1 : 9.7
Wheat90	.102	.730	.832	1 : 7.2
Rye88	.099	.700	.799	1 : 7.1
Barley89	.087	.692	.779	1 : 7.9
Oats89	.092	.568	.660	1 : 6.2
Buckwheat87	.077	.533	.610	1 : 6.9
Peas90	.168	.534	.702	1 : 3.2
<i>Mill products —</i>					
Corn-and-cob meal85	.044	.665	.709	1 : 15.1
Wheat bran88	.122	.453	.575	1 : 3.7
Wheat middlings88	.128	.607	.735	1 : 4.7
Dark feeding flour90	.135	.658	.793	1 : 4.9
Low-grade flour88	.082	.647	.729	1 : 7.9
Rye bran88	.115	.548	.663	1 : 4.8
Buckwheat bran90	.074	.347	.421	1 : 4.7
Buckwheat middlings87	.220	.456	.676	1 : 2.1
<i>By-products —</i>					
Malt-sprouts90	.186	.409	.595	1 : 2.2
Brewers' grains, wet24	.039	.125	.164	1 : 3.2
Brewers' grains, dry92	.157	.478	.635	1 : 3
Buffalo gluten feed90	.232	.699	.931	1 : 3
Chicago gluten meal88	.322	.468	.790	1 : 1.5
Distillers' dried grains, Bile's xxxx92	.248	.552	.800	1 : 2.2
Hominy chops89	.075	.705	.780	1 : 9.4
Linseed meal (old process)91	.293	.485	.778	1 : 1.7
Linseed meal (new process)90	.282	.464	.746	1 : 1.6
Cottonseed meal92	.372	.444	.816	1 : 1.2
<i>Miscellaneous —</i>					
Cabbage15	.018	.091	.109	1 : 5.1
Sugar-beet leaves12	.017	.051	.068	1 : 3
Pea-vine silage27	.025	.141	.166	1 : 5.6
Sugar-beet pulp10	.006	.073	.079	1 : 12
Beet molasses79	.091	.595	.686	1 : 6.5
Apple pomace233	.011	.164	.175	1 : 14.9
Apples19	.007	.188	.195	1 : 26.8
Skim-milk, centrifugal094	.029	.059	.088	1 : 2
Buttermilk10	.039	.065	.104	1 : 1.7

TABLE IV. AVERAGE FERTILIZING CONSTITUENTS IN AMERICAN FEEDING-STUFFS

NAME OF FEED	FERTILIZING CONSTITUENTS IN 1000 LBS.		
	Nitrogen	Phosphoric Acid	Potash
CONCENTRATES			
	<i>Lbs.</i>	<i>Lbs.</i>	<i>Lbs.</i>
Corn, all analyses	18.2	7.0	4.0
Corn cob	3.9	0.6	6.0
Corn-and-cob meal	13.6	5.7	4.7
Corn bran	17.9	10.1	6.2
Gluten meal	54.8	3.3	0.5
Germ meal	34.7	3.9	2.1
Starch refuse	7.6	2.9	1.5
Grano-gluten	49.8	5.1	1.5
Hominy chops	16.8	9.8	4.9
Glucose meal	57.7		
Sugar meal	36.3	4.1	0.3
Gluten feed	40.0	3.7	0.4
Wheat	19.0	5.5	8.7
High-grade flour	19.2	5.7	5.4
Low-grade flour	28.9	5.6	3.5
Dark feeding flour	29.4	21.4	10.9
Wheat bran	24.6	26.9	15.2
Wheat shorts	28.2	13.5	5.9
Wheat middlings	26.3	9.5	6.3
Wheat screenings	20.0	11.7	8.4
Rye	18.1	8.6	5.8
Rye bran	23.3	22.8	14.0
Rye shorts	18.4	12.6	8.1
Barley	19.2	7.9	4.8
Malt-sprouts	42.1	17.4	19.9
Brewers' grains, wet	10.7	4.2	0.5
Brewers' grains, dried	40.0	16.1	2.0
Oats	18.2	7.8	4.8
Oat feed or shorts	12.8	6.1	7.2
Oat hulls	5.3	1.6	4.9
Rice	11.8	1.8	0.9
Rice hulls	5.1	1.7	1.4
Rice bran	19.0	2.9	2.4
Rice polish	19.0	26.7	7.1
Buckwheat	17.3	6.9	3.0
Buckwheat hulls	7.3	4.3	14.7
Buckwheat bran	20.2	4.2	12.7
Buckwheat middlings	42.7	12.3	11.4
Sorghum seed	14.6	8.4	3.4
Broom-corn seed	15.8	7.2	5.2
Millet	17.4	6.5	3.3
Flax seed	36.2	13.9	10.3
Linseed meal (old process)	54.2	16.6	13.7
Linseed meal (new process)	60.0	17.4	13.4
Cottonseed	29.4	10.5	10.9
Cottonseed meal	72.5	30.4	15.8

TABLE IV — *Continued*

NAME OF FOOD	FERTILIZING CONSTITUENTS IN 1000 LBS.		
	Nitrogen	Phosphoric Acid	Potash
CONCENTRATES			
Cottonseed hulls	Lbs. 6.7	Lbs. 4.3	Lbs. 10.4
Cocoanut cake	31.5	16.0	24.0
Palm-nut cake	26.9	11.0	5.0
Sunflower seed	26.1	12.2	5.6
Sunflower-seed cakes	52.5	21.5	11.7
Peanut cake	76.2	20.0	15.0
Rape-seed cake	49.9	20.0	13.0
Peas	37.9	8.4	10.1
Soybean	53.6	10.4	12.6
Horse bean	42.6	12.0	12.9
ROUGHAGE			
<i>Fodder corn —</i>			
Fodder corn, green	2.9	1.1	3.9
Fodder corn, field-cured	7.2	5.4	8.9
<i>Fresh grass —</i>			
Pasture grasses	5.6	2.6	7.4
Kentucky blue-grass	6.6		
Timothy, different stages	5.0	2.6	7.6
Orchard-grass, in bloom	4.2	1.6	7.6
Red-top, in bloom	4.5		
Oat forage in milk	5.4	1.3	3.8
Rye forage	4.2	2.5	7.1
Sorghum fodder	2.1	0.7	3.4
Meadow fescue, in bloom	3.8		
Hungarian-grass	5.0	1.2	4.2
<i>Hay —</i>			
Timothy (all analyses)	9.4	3.3	14.2
Orchard-grass	12.9	3.7	16.9
Red-top	12.6	3.6	10.2
Kentucky blue-grass	12.5	4.0	15.7
Hungarian-grass	12.1	4.3	15.4
Mixed grasses	11.9	2.7	15.5
Rowen (mixed)	18.6	4.3	14.9
Meadow fescue	11.2	4.0	21.0
Mixed grasses and clover	16.2		
Soybean hay	23.8	6.7	10.8
<i>Straw —</i>			
Wheat	5.0	2.2	6.3
Rye	5.0	2.5	8.6
Oat	5.8	3.0	17.7
Barley	7.0	2.0	10.6
Wheat chaff	7.2	3.8	8.2

TABLE IV — Continued

NAME OF FOOD	FERTILIZING CONSTITUENTS IN 1000 LBS.		
	Nitrogen	Phosphoric Acid	Potash
	Lbs.	Lbs.	Lbs.
<i>Fresh legumes — ROUGHAGE</i>			
Red clover, different stages	7.0	1.5	4.8
Alsike, bloom	6.2	1.1	2.0
Crimson clover	5.0	1.2	4.0
Alfalfa	7.7	1.3	5.6
Cowpea	3.8	1.3	4.6
Soybean	6.4	1.4	5.6
<i>Legume hay and straw —</i>			
Red clover, medium	19.7	5.5	18.7
Red clover, mammoth	17.1	5.2	11.6
Alsike clover	20.5	5.0	13.9
White clover	25.1	7.8	13.2
Crimson clover	24.3	4.0	13.1
Alfalfa	21.9	5.1	16.8
Cowpea	14.3	5.2	14.7
Soybean straw	17.5	4.0	13.2
Pea-vine straw	14.3	3.5	10.2
<i>Silage —</i>			
Corn	4.3	1.1	3.7
<i>Roots and tubers —</i>			
Potato	3.4	1.6	5.8
Beet, common	2.4	0.8	4.8
Beet, sugar	2.9	0.8	3.7
Beet, mangel	2.2	0.9	3.8
Flat turnip	2.1	0.9	3.4
Rutabaga	1.9	1.2	4.9
Carrot	1.8	0.9	2.6
Parsnip	2.6	2.0	4.4
Artichoke	4.2	1.4	4.7
MISCELLANEOUS			
Cabbage	4.2	1.1	4.3
Spurry	3.8	2.5	5.9
Sugar-beet leaves	4.2	1.5	6.2
Pumpkin, garden	2.9	1.6	0.9
Prickly comfrey	3.7	1.2	7.6
Rape	3.5	1.2	3.5
Dried blood	135.0	13.5	7.7
Meat scrap	114.0	81.1	
Dried fish	77.4	140.0	3.0
Beet pulp, wet	1.4	0.3	11.4
Beet molasses	14.5	0.5	56.3
Cow's milk	5.8	1.9	1.7
Cow's milk, colostrum	28.2	6.6	1.1
Skim-milk, gravity	5.6	2.0	1.9
Skim-milk, centrifugal	5.0	2.1	2.0
Buttermilk	6.4	1.7	1.6
Whey	1.0	1.1	2.0

CHAPTER XXIII

EXTERNAL PARASITES OF ANIMALS

THE many diseases of farm live-stock cannot be treated in a book of this kind, and very brief advice might be more dangerous than useful ; but the ticks, lice, fleas, and similar things that infest animals may be included. The spraying of live-stock is as important, in many cases, as the spraying of plants.

Handling the cattle-tick, or Texas-fever tick (*Margaropus annulatus*)

(H. W. Graybill, Bur. Animal Ind., U. S. Dept. Agric.)

On the pasture there are three stages of the tick — the engorged female, the egg, and the larva ; and on the host are four stages — the larva, the nymph, the sexually mature adult of both sexes, and the engorged condition of the female.

Animals may be freed of ticks in two ways. They may be treated with an agent that will destroy all the ticks present, or they may be rotated at proper intervals on tick-free fields until all the ticks have dropped.

Dips for cattle-ticks, their preparation and use

Crude petroleum. — Various kinds of crude petroleum have been used with more or less success in destroying ticks. The heavier varieties of oil are very injurious to cattle. On the other hand, the very light oils are so volatile that their effect lasts but a short time thus rendering them less efficient. The petroleum known as Beaumont oil, obtained from Texas wells, has given the best results. The best grade of this oil to use is one that has a specific gravity ranging from $22\frac{1}{2}^{\circ}$ to $24\frac{1}{2}^{\circ}$ Beaumé, containing $1\frac{1}{4}$ to $1\frac{1}{2}$ per cent of sulfur, and 40 per cent of the bulk of which boils between 200° and 300° C. The oil may be applied by employing a spray pump or a dipping vat.

Animals that have been dipped in crude oil, especially during warm

weather, should not be driven any great distance immediately afterwards, and should be provided with shade and an abundance of water. Unless these precautions are observed serious injury and losses may result.

Emulsions of crude petroleum.—In the majority of cases the best agent to use is an emulsion of crude petroleum, preferably Beaumont crude petroleum. The use of the emulsion makes the treatment less expensive than when the oil alone is used. The emulsion is not so injurious to the cattle and is almost if not quite as effective as the oil alone. The formula for preparing an emulsion of crude petroleum is as follows:—

Hard soap	1 lb.
Soft or freestone water : : :	1 gal.
Beaumont crude petroleum	4 gal.

Making five gallons of 80 per cent stock emulsion.

When a greater quantity of stock emulsion is desired, each of the quantities in the above formula should be multiplied by such a number as to furnish the required amount. For example, if it should be convenient to mix 10 gallons at one time, the quantities would have to be multiplied by 2 and if 15 gallons were desired, they would have to be multiplied by 3, and so on.

In preparing the emulsion the soap should be shaved up and placed in a kettle or caldron containing the required amount of water. The water should be brought to a boil and stirred until the soap is entirely dissolved. Enough water should be added to make up for the loss by evaporation during this process. The soap solution and the required amount of oil are then placed in a barrel or some other convenient receptacle, and mixed. The mixing may be effected by the use of a spray pump, pumping the mixture through and through the pump until the emulsion is formed. A convenient and time-saving method is to do the mixing in a barrel by first pouring in one part of hot soap solution and then four parts of crude petroleum, and repeating this until the barrel is filled. The oil should be poured in with as much force as possible, and the mixture stirred constantly with a long paddle until the oil is completely emulsified. The mixing is facilitated also by dipping up the mixture and pouring it back with a pail. If made properly, this stock emulsion is permanent, and will keep indefinitely.

To prepare the stock emulsion for use, it is diluted with water to a 20 or 25 per cent emulsion. In order to obtain a 20 per cent emulsion of oil, it is necessary to use one part of the stock emulsion to three parts of water, and for a 25 per cent emulsion, one part of stock emulsion to 2½ parts of water. The stock emulsion is permanent, but the diluted emulsion does not remain uniformly mixed, so that if allowed to stand it should be thoroughly mixed by stirring before using. Only rain or freestone water should be used for diluting, and if this is not available, the water should be "softened" by adding a sufficient amount of concentrated lye, sal soda, or washing powder. Care should be observed in this process not to use an excess of these preparations.

An 80 per cent stock emulsion is on the market, and much time and labor can be saved by obtaining this instead of making the emulsion. To prepare it for use, it should be diluted in the same manner as indicated above for the home-made stock emulsion.

The arsenical dip. — This dip is used considerably, on account of its cheapness and the ease with which it is prepared. In general, it has proved very effective in destroying ticks, and is less likely than crude petroleum or emulsions of the same to injure cattle when dipping has to be done in hot weather. Some injury to the skin is, however, likely to occur when the arsenical mixture is used, and this injury, which will be so slight as to be scarcely noticeable if the cattle are properly handled, is liable to be serious if the cattle are driven any distance, especially if allowed to run while being driven within a week after treatment. The formula given below for making an arsenical dip is the one most commonly used in this country : —

Sodium carbonate (sal soda)	24 lb.
Arsenic trioxid (white arsenic)	8 lb.
Pine tar	1 gal.
Sufficient water to make 500 gallons.		

If a stronger arsenical dip is desired, ten pounds of arsenic may be used in place of eight pounds, but in general the stronger solution should not be used. In warm weather particularly it is not advisable to use a solution stronger than that given in the above formula, if the animals are to be treated every two weeks.

In preparing the dip, a large caldron or galvanized tank is required for heating the water in which to dissolve the chemicals. Thirty or forty gallons of water should be placed in the caldron or tank and

brought to a boil. The sodium carbonate is then added and dissolved by stirring. When this is accomplished, the arsenic is added and dissolved in a similar manner. The fire is then drawn and the pine tar added slowly in a thin stream and thoroughly mixed with the dip by constant stirring. This strong stock solution is diluted to 500 gallons before using.

The diluted arsenical solution may be left in the vat and used repeatedly, replenishing with the proper quantities of water and stock solution when necessary. When not in use, the vat should be tightly covered with a waterproof cover to prevent evaporation on the one hand and further dilution by rain on the other hand. Securely covering the vat when not in use also lessens the risk of accidental poisoning of stock and human beings.

On account of the fact that arsenic is a dangerous poison, great care must be observed in making and using the arsenical dip. From the time the arsenic is procured from the druggist until the last particle of unused residue is properly disposed of, the most scrupulous care should be taken in handling this poison. Guessing at weights or measures or carelessness in any particular is liable to result in great damage, and not only may valuable live-stock be destroyed, but human beings may lose their lives as well.

In the use of arsenical dips care should be taken not only to avoid swallowing any of the dip, but persons using the dip should also bear in mind the possibility of absorbing arsenic through cuts, scratches, or abrasions of the skin, and the possibility of absorbing arsenic by inhalation of vapors from the boiler in which the dip is prepared or by the inhalation of the finely divided spray when the spray pump is used. It should be remembered that the absorption of even very small quantities of arsenic, if repeated from day to day, is liable ultimately to result in arsenical poisoning.

Cattle should always be watered a short time before they are dipped. After they emerge from the vat they should be kept on a draining-floor until the dip ceases to run from their bodies ; then they should be placed in a yard free of vegetation until they are entirely dry. If cattle are allowed to drain in places where pools of dip collect, from which they may drink, or are turned at once on the pasture, where the dip will run from their bodies on the grass and other vegetation, serious losses are liable to result. Crowding the animals before they are dry should

also be avoided, and they should not be driven any considerable distance within a week after dipping, especially in hot weather. If many repeated treatments are given, the cattle should not be treated oftener than every two weeks.

In addition to protecting vats properly containing arsenical dip when not in use, another precaution must be observed when vats are to be emptied for cleaning. The dip should not be poured or allowed to flow on land and vegetation to which cattle or other animals have access. The best plan is to run the dip in a pit properly protected by fences. The dip should not be deposited where it may be carried by seepage into wells or springs which supply water used on the farm. The same precautions should be observed when animals are sprayed as when they are dipped.

Method of spraying.

Spraying is probably the most practicable and convenient way of treating cattle on the majority of farms. A good type of pail spray pump, costing from \$5 to \$7, will be found to be satisfactory for treating small herds. About fifteen feet of three-eighths-inch high-pressure hose is required, and a type of nozzle furnishing a cone-shaped spray of not too wide an angle will be found satisfactory. A nozzle with a very small aperture should not be used, because the spray produced is too fine to saturate properly the hair and skin of the animals without consuming an unnecessary amount of time.

The animal to be sprayed should be securely tied to one of the posts of a board or rail fence, or better still, when convenient, to the corner post in an angle of the fence. This will facilitate the spraying by preventing the animal from circling about to avoid the treatment, and will reduce the amount of help necessary. Every position of the body should be thoroughly treated, special attention being given to the head, dewlap, brisket, inside of elbows, inside of thighs and flanks, the tail, and the depressions at the base of the tail. Crude oil alone may be used, but in general a 20 to 25 per cent emulsion will be found more satisfactory. All the cattle on the place should be sprayed every two weeks with this emulsion. The horses and mules should be kept free of ticks by picking or other means.

Disinfectant for ticks in infested stables.

Eradication will be much facilitated if at the beginning of the work all litter and manure are removed from stables, sheds, and yards that have been occupied by the cattle, and deposited on land where cattle are not permitted to run. After this is done, the buildings should be thoroughly disinfected to destroy any eggs or ticks that may be there. For this purpose the following substances may be used :

1. A mixture made with not more than $1\frac{1}{2}$ pounds of lime and $\frac{1}{4}$ pound of pure carbolic acid to each gallon of water.

2. Any coal-tar creosote dip permitted by the United States Department of Agriculture in the official dipping of sheep for scabies, diluted to one-fifth of the maximum dilution specified for dipping sheep.

A spray pump should be used to apply the disinfectant, and the walls, floors, and various fixtures of the buildings should be thoroughly sprayed.

Other External Parasites of Farm Animals (Crosby)*The insecticides.*

Following are the leading insecticidal substances used against fleas, lice, ticks, and other pests of farm live-stock :—

Lime-and-sulfur dip.

Unslaked lime	8 lb.
Flowers of sulfur	24 lb.
Water	100 gal.

Slake the lime in a little water and add the sulfur, stirring constantly. Transfer the mass to 25 gallons of hot water, and boil for two hours, adding water to replace that boiled away. Let the solution stand until all sediment has settled and then draw off the clear liquid and dilute to 100 gallons. (U. S. Bureau of Animal Industry.)

Nicotine solutions. — There are now on the market nicotine solutions with a guaranteed strength of from 5 to 40 per cent of nicotine. For use they should be so diluted as to give a solution containing $\frac{1}{100}$ of 1 per cent of nicotine, and $16\frac{1}{2}$ pounds of flowers of sulfur should be added to each 100 gallons of the liquid.

Eradication of ticks by rotation of fields (Graybill.)

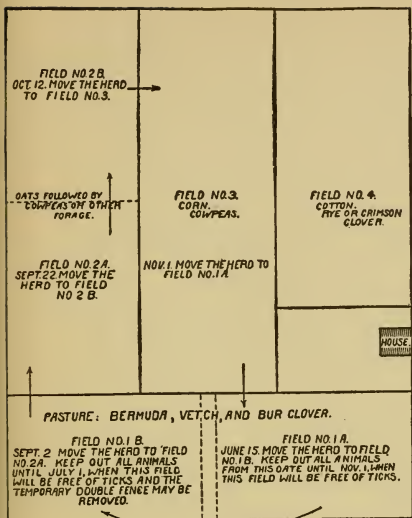

Fig. 13.—Rotation plan for freeing plantation in South from ticks in 4½ mos.

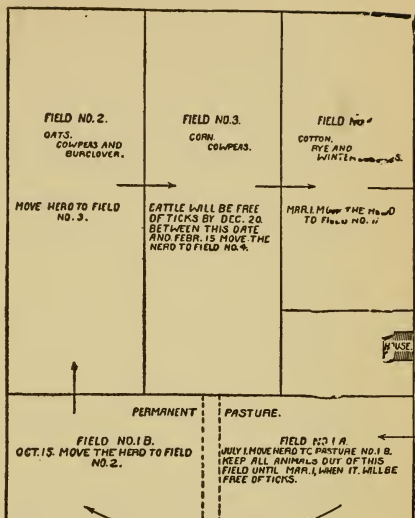

Fig. 15.—Plan requiring 8 mos.

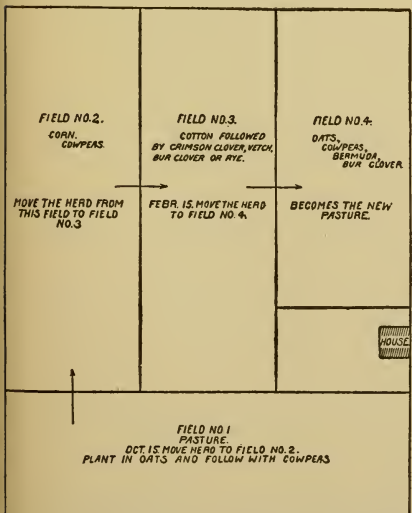

Fig. 14.—Plan requiring 4 mos., with new pasture.

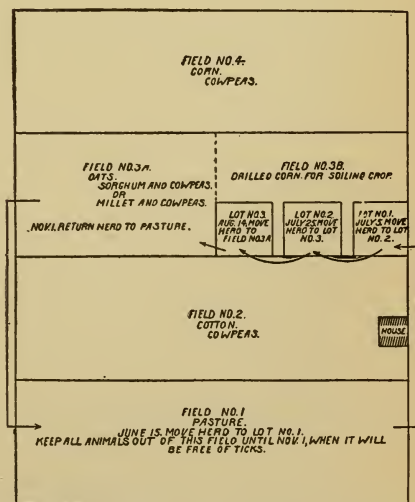

Fig. 16.—Feed-lot or soiling method of eliminating ticks.

Commercial dips. — There are a large number of these proprietary dips on the market, many of which contain as the active agent coal-tar derivatives. Use only those that have the approval of the United States Department of Agriculture, and follow closely the directions given on the container.

Crude oil emulsion (for spraying stock).

Soap	1 lb.
Crude oil	4 gal.
Water	1 gal.

Dissolve the soap in hot water, and while still hot add the oil slowly and agitate into an emulsion by pumping the mixture back into itself. For use, dilute with water so as to secure a 20 or 30 per cent emulsion (see p. 430).

Lice powder.

Gasoline	3 parts
Crude carbolic acid (90-95 per cent strength)	1 part

Mix these together, and then stir in enough plaster of Paris to take up all the moisture. If properly made, a dry pinkish powder will be the result. If good crude carbolic acid of the proper strength cannot be obtained, cresol may be substituted, but will not give quite as good results. Store in a closed can or jar.

Cresol disinfecting soap. — Measure out $3\frac{1}{2}$ quarts of raw linseed oil in a four or five-gallon stone crock; then weigh out in a dish 1 pound 6 ounces of commercial lye or "Babbit's potash." Dissolve this lye in as little water as will completely dissolve it. Start with $\frac{1}{2}$ pint of water, and if this will not dissolve all the lye, add more water slowly. Let this stand for at least three hours until the lye is completely dissolved and the solution is cold; then add the *cold* lye solution *very slowly* to the linseed oil, stirring constantly. Not less than five minutes should be taken for the adding of this solution of lye to the oil. After the lye is added, continue the stirring until the mixture is in the condition and has the texture of a smooth, homogeneous liquid soap. This ought not to take more than a half hour. Then, while the soap is in this liquid state, and before it has a chance to harden, add with constant stirring, $8\frac{1}{2}$ quarts of commercial cresol. The cresol will blend perfectly with the soap solution and

make a clear, dark brown fluid. The resulting solution of cresol soap is then ready to use. This cresol soap will mix in any proportion with water and yield a clear solution. Use a 20 per cent solution for disinfecting chicken houses, incubators, etc.

The kinds of parasites (Crosby).

Following are the leading external parasites of cattle, horses, sheep and swine (for parasites of poultry, see page 377).

CATTLE. OX BOT-FLY OR WARBLE-FLY (*Hypoderma bovis* and *H. lineata*). — Large lumps or warbles along the animal's back filled with pus, within which a large, thick-bodied maggot develops. When full grown these maggots, about an inch in length, work their way out through the skin, fall to the earth, and there after a time transform to a large blackish fly with yellow markings. The flies glue their eggs to the hair of the host, usually around the heels and flanks. The eggs are licked off by the animal, hatch in the mouth or œsophagus, and the larva bores its way through the tissues until it comes to lie under the skin along the back. The cattle have an instinctive dread of the flies, and are thrown into a panic by their presence. Badly infested animals lose flesh, and the flow of milk is greatly reduced; the holes made in the skin also decrease the value of the hide.

Treatment. — Squeeze out and crush the grubs and disinfect the sore. The practice of killing the grub under the skin by the application of grease or kerosene is more liable to cause an infection from the decaying maggot and produce a serious sore.

HORN-FLY (*Hematobia serrata*). — Flies considerably smaller than the house-fly, which they closely resemble in shape and color. They attack cattle in great numbers, clustering on any part of the body and sucking blood. They have the peculiar habit of resting in dense clusters on the horns. The eggs are laid and the maggots develop in fresh droppings, and the transformation to the fly takes place in the ground.

Treatment. — Spread out or mix with lime the manure as soon as deposited, to prevent the development of the maggots. Let hogs run with the cattle; scatter the manure. Spray the animals with crude oil emulsion often enough to prevent attack, or apply train oil or a mixture of two parts of crude cottonseed oil and one pint of pine tar. The last two may be applied with a large brush, and remain

effective for four or five days. Where the flies have produced sores, treat them with a weak solution of carbolic acid. On the range where large numbers of animals are to be treated, dip them in a dipping vat provided with a splash-board which will throw the spray down on the animal and kill most of the flies. Use any of the oily dips recommended for the Texas-fever tick.

CATTLE LICE (*Hæmatopinus* spp. and *Trichodectes scalaris*).—Cattle are especially liable to become infested with lice during the winter and early spring. They acquire a generally unthrifty look, and the flow of milk is greatly lessened. On young stock the injurious effects are more noticeable; lousy calves are thin and do not make the proper growth.

Treatment.—When the weather will permit, spray or wash infested animals with a 10 per cent kerosene emulsion or the nicotine-and-sulfur sheep dip as used for sheep scab.

SOUTHERN BUFFALO-GNAT (*Simulium pecuarum*).—A small black gnat or punkie occurring in the lower Mississippi Valley, where it causes immense loss to the live-stock interests. The larvæ are aquatic, and are able to develop only in swiftly running waters. The gnats appear in great swarms in early spring and attack cattle, mules, horses, sheep, and other animals in countless numbers. They feed by sucking the blood and at the same time inject a poison into the wound, causing great distress and producing an acute inflammation. Animals in poor condition from exposure or lack of food are frequently killed.

Treatment.—Protect the animals by smudges producing a dense smoke, or keep them in dark stables until the swarms of gnats have disappeared. Working teams can be protected by using train-oil or the cotton-seed oil and tar mixture advised, under **HORN-FLY**. To reduce the irritation caused by the bites, rub the animal thoroughly with water of ammonia and give internally a mixture of 40 to 50 grains of carbonate of ammonia in a pint of whiskey, and repeat the treatment every three or four hours until relieved.

SCREW-WORM FLY (*Chrysomya macellaria*).—Whitish maggots, three-fourths inch in length when full grown, infesting sores and wounds of animals in the Southern States. The eggs are laid on the wounds in masses of 100 or more by a bright, metallic green fly a little larger than the house-fly. The maggots enter the wound, feed on the putrid matter within, and as they increase in size burrow into the flesh, fre-

quently excavating a large cavity. The purulent discharge from such sores attracts other flies to lay their eggs, more maggots enter the wound, and unless aid is rendered the animal dies. A slight scratch or merely a mass of blood from a crushed tick may serve as a starting-point for the trouble. The flies also breed in decaying carcasses.

Treatment. — Prevent the deposition of eggs by washing all wounds as soon as noticed with a disinfectant, and then apply a dressing of pine tar or tar and grease. When wounds are found infested, dislodge the maggots by injections of carbolic acid diluted with 30 parts of water, or one of the coal-tar sheep dips may be used. After the maggots have been removed and the sore thoroughly disinfected, dress the wound with a coating of pine tar. Deep sores should be packed with sterilized absorbent cotton.

By careful attention to the destruction of garbage, carcasses, and other filth in which the maggots breed in enormous numbers, much loss may be avoided. Carcasses left to decay exposed to the air about pastures are constant sources of danger.

Horse. HORSE BOT-FLY (*Gastrophilus equi*). — The light yellow eggs are glued to the hairs on the shoulders, forelegs, and under side of the body by a brownish fly about three-fourths inch in length. By licking these parts the egg-cap is removed and young maggots taken into the mouth. On reaching the stomach they attach themselves to the walls and remain there until the following spring. When abundant they may nearly cover the whole inner surface of the stomach, interfere with the secretion of the digestive juices, and by collecting near the pyloric opening prevent the natural passage of the food from the stomach. When mature they loosen their hold and are voided with the excrement in late spring. These full-grown bots are about three-fourths inch in length; they burrow into the ground where the pupal stage is passed. The flies emerge thirty or forty days later.

Treatment. — Remove the eggs within a week after they have been deposited by clipping the hair, or destroy them by washing with a solution of carbolic acid in 30 parts of warm water. When only a few bots are present in the stomach, they do not seem to cause the animal inconvenience; when very abundant, they may cause fretting and colic, and the horse may loose flesh. In such cases consult a veterinarian.

Sheep. SHEEP BOT-FLY OR HEAD-MAGGOT (*Estris ovis*). — The dark brownish parent flies, somewhat larger than the house-fly, emerge during June and July, and deposit living maggots in the nostrils of sheep. The animals have an instinctive fear of the flies, and are thrown into a panic by their attack. The maggots work their way up the nostril, and find lodgment in the frontal sinuses, where they feed on the mucus. Their presence causes great irritation and the discharge of purulent matter. Sometimes the maggots penetrate into the brain cavity, and death may result.

Treatment. — It is almost impossible to dislodge the maggots by the injection of any substance, and such treatment is not advised. Never try to extract them with a wire. To prevent the flies from depositing their young, smear the sheep's nose with tar and grease. This is most easily done by placing in the pasture logs in which holes have been bored. Salt is placed in the holes, and the edges smeared with grease and tar. In trying to get the salt the sheep will keep their noses covered with the tar.

SHEEP SCAB (*Psoroptes communis*). — The cause of this disease is a minute mite which lives on the skin under a scab or crust and causes the wool to fall out in large irregular patches. The irritation causes intense itching, the sheep become restless, lose in weight and vitality, and in severe cases die. The disease is contagious and may be transmitted either directly from animal to animal or by means of infested quarters, cars or pasture fields.

Treatment. — Dip the infested or suspected animals in some reliable sheep dip at the temperature of about 100° Fahrenheit; hold the sheep in the liquid two or three minutes, and immerse the head once or twice just before the sheep is released. Soften thick scabs before dipping by wetting with some of the dip and by rubbing with a smooth stick, taking care not to draw blood. Repeat the dipping in ten days or two weeks to kill any mites which may have hatched from eggs since the last treatment. After dipping do not return the sheep to the same field in less than thirty days, to avoid reinfestation. When it is necessary to return the sheep to the same barn or pen, these quarters should be thoroughly cleaned and disinfected with cresol or some other coal-tar dip, used at the rate of one part to 50 parts of water. The addition of whitewash to the disinfectant will serve as a marker and show when the work has been thoroughly done. Avoid introducing the disease

by having all sheep brought from infested regions dipped before delivery.

SHEEP TICK (*Melophagus ovinus*). — Reddish or gray brown, flattened, wingless flies that infest sheep of all ages, but are most injurious to lambs. They remain on the sheep throughout their whole life cycle. The young are nourished within the mother until full grown, and are ready to pupate when born.

Treatment. — The nicotine-and-sulfur dip has given the best results in the control of this pest ; many of the commercial cresol and coal-tar creosote dips are also effective. The lime-and-sulfur dip will not kill the ticks. When only a few are to be treated, kerosene emulsion may be used as a spray and rubbed into the wool.

Swine. **HOG LOUSE** (*Hæmatopinus suis*). — Lousy hogs are likely to be in a stunted, unthrifty condition, and when badly infested the skin becomes covered with scales and sores.

Treatment. — Clean and whitewash the pens and sleeping quarters, adding 1 pint of crude carbolic acid to each 4 gallons of the white-wash. Spray or dip infested animals with 10 per cent kerosene emulsion, or use the tobacco-and-sulfur sheep dip. Repeat the application in two weeks to kill any lice that may have escaped. A wallowing trough containing five to eight inches of water on which is floated a thin layer of crude oil is frequently used with success.

CHAPTER XXIV

MILK AND MILK PRODUCTS; DAIRY FARMS

DAIRYING comprises two occupations, — dairy husbandry, or the producing of milk; and dairy industry, or the marketing and manufacturing of milk and milk products. This chapter is designed to compass chiefly some phases of the latter subject.

Composition of Milk

Composition of cow's milk

CONSTITUENTS	QUANTITY IN AVERAGE MILK	EXTENT OF VARI- ATION IN NORMAL MILK
	<i>Per Cent</i>	
Fat	4.0	2.5-8.0
Casein	2.6	2.0-3.5
Albumen	0.7	0.6-0.9
Sugar	5.0	4.0-6.0
Ash	0.7	0.6-0.8
Water	87.0	84.0-88.0

Fat in milk is in the form of minute globules having a diameter of $\frac{1}{15000}$ to $\frac{1}{25000}$ of an inch. These float in the milk, forming an emulsion. When highly magnified, these fat globules may be easily seen. In any milk, many different sizes of globules are found, but the average size of globules in Jersey and Guernsey milk is much larger than the average size of globules in the milk given by other breeds. As the specific gravity of the fat is .93 and the specific gravity of the remainder of the milk is about 1.04, the fat globules always tend to rise. They are more or less entangled by other constituents of the milk, and great numbers of the smallest sized globules fail to reach the top, or the cream layer (Pearson).

Milk-fat is a mixture of several different fats which are combinations

of glycerine and fatty acids. The principal fats and their proportion in milk-fat are as follows:—

	PER CENT
Palmitin	40
Olein	34
Myristin	10
Butyrin	6

A few others vary from 1 to 3 per cent each.

Butyrin is the characteristic butter-fat, and is absent from butter substitutes, such as oleomargarine. The melting-point of milk-fat is about 92° F. (Pearson).

Average composition of milk of various kinds (U. S. Dept. Agric.)

KIND OF MILK	WATER	TOTAL SOLIDS	PROTEIN			FAT	CARBOHYDRATES (MILK SUGAR)	MINERAL MATTERS	FUEL VALUE PER POUND
			Casein	Albumin	Total				
	<i>Per Cent</i>	<i>Per Cent</i>	<i>Per Cent</i>	<i>Per Cent</i>	<i>Per Cent</i>	<i>Per Cent</i>	<i>Per Cent</i>	<i>Per Cent</i>	<i>Calories</i>
Woman	87.58	12.6	0.80	1.21	2.01	3.74	6.37	0.30	310
Cow . .	87.27	12.8	2.88	0.51	3.39	3.68	4.94	0.72	310
Goat . .	86.88	13.1	2.87	0.89	3.76	4.07	4.64	0.85	315
Sheep . .	83.57	16.4	4.17	0.98	5.15	6.18	4.73	0.96	410
Buffalo (Indian)	82.16	—	4.26	0.46	—	7.51	4.77	0.84	—
Zebu . .	86.13	—	—	—	3.03	4.80	5.34	0.70	—
Camel . .	87.13	—	3.49	0.38	—	2.87	5.39	0.74	—
Llama . .	86.55	—	3.00	0.90	—	3.15	5.60	0.80	—
Reindeer	67.20	—	8.38	1.51	—	17.09	2.82	1.49	—
Mare . .	90.58	9.9	1.30	0.75	—	1.14	5.87	0.36	—
Ass . .	90.12	10.4	0.79	1.06	—	1.37	6.19	0.47	215

Average composition of typical cow's milk (Conn. Sta.)

AUTHORITY	TOTAL SOLIDS	FAT	SOLIDS NOT FAT	PER CENT OF FAT IN SOLIDS
English (Richmond, 1906)	12.70	3.73	8.97	29.37
(Richmond, 1907)	12.64	3.71	8.93	29.35
(Richmond, 1908)	12.69	3.75	8.94	29.56
(Vieth)	12.90	4.10	8.80	31.78
Canadian (McGill)	12.62	3.80	8.82	30.11
German (Koenig)	12.83	3.69	9.14	28.76
German (Fleischmann)	12.25	3.40	8.85	27.25
Dutch (Fleischmann)	12.00	3.25	8.75	27.08
American (Van Slyke)	12.90	3.90	9.00	30.23
(Van Slyke, cheese factory)	12.60	3.75	8.85	29.76
(Voorhees, Ayrshire)	12.70	3.68	9.02	29.05
(Voorhees, Guernsey)	14.48	5.02	9.46	34.66
(Voorhees, Holstein)	12.12	3.51	8.61	28.96
(Voorhees, Jersey)	14.34	4.78	9.56	33.33
(Voorhees, Shorthorn)	12.45	3.65	8.80	29.32

The milk of different breeds.

The analyses of large numbers of samples of milk given by different breeds have been made by the New York Agricultural Experiment Station, and the averages of fat for the different breeds are:—

	PER CENT
Holstein-Friesian	3.4
Ayrshire	3.6
Shorthorn	4.4
Devon	4.6
Guernsey	5.3
Jersey	5.6

Composition of milk solids from six breeds of cows (Van Slyke)

BREED OF COW	FAT	CASEIN	SUGAR	ASH
Holstein	28.0	27.4	39.1	5.93
American Holderness	28.1	26.8	39.7	5.53
Devon	30.1	27.3	36.8	5.52
Ayrshire	27.3	26.3	40.8	5.34
Guernsey	35.1	24.7	35.0	5.16
Jersey	36.4	25.4	33.4	4.82

Ash in cow's milk and its products (Simon)

Whole milk0074
Skim milk0074
Cream0061
Buttermilk0067
Whey0065

Mineral constituents in milk (Abderhalden)

SPECIES	POTAS- SIUM	SODIUM	CHLO- RINE	IRON	CAL- CIUM	MAG- NESIUM	PHOS- PHOR- US	ASH
	Parts per hundred							
Human066	.190	.047	.0006	.035	.004	.025	0.20
Dog115	.058	.166	.0014	.325	.012	.222	1.33
Swine078	.058	.076	.0028	.178	.010	.135	0.80
Sheep810	.064	.130	.0029	.175	.090	.128	0.84
Goat108	.046	.102	.0025	.141	.090	.124	0.78
Cow148	.072	.137	.0015	.119	.014	.083	0.70
Horse087	.010	.031	.0014	.089	.008	.057	0.40
Rabbit209	.147	.135	.0014	.637	.033	.435	2.50

Variation in average composition of 574 samples of market butter samples collected each month for a period of one year (Illinois Experiment Station).

MONTH COLLECTED	NUMBER SAMPLES EACH MONTH	PERCENT			
		Water	Fat	Salt	Casein and Ash
March	47	13.59	82.73	—	—
April	49	12.94	83.34	—	—
May	49	13.48	82.97	—	—
June	49	13.23	83.58	—	—
July	40	13.92	82.83	—	—
August	37	13.64	83.57	—	—
September	54	13.31	83.64	2.33	0.74
October	49	14.05	82.73	2.36	0.85
November	50	13.31	83.53	2.34	0.82
December	41	13.35	83.56	2.09	0.94
January	53	14.16	82.59	2.25	0.99
February	56	13.54	83.29	2.14	1.04
Average	—	13.54	83.20	2.25	0.90

Nutrients and energy in 1 pound of the water-free edible portion of several food materials in comparison with milk (United States Department of Agriculture).

FOOD MATERIALS	PROTEIN	FAT	CARBOHYDRATES	MINERAL MATTER	FUEL VALUE
	<i>Pound</i>	<i>Pound</i>	<i>Pound</i>	<i>Pound</i>	<i>Calories</i>
Whole milk	0.25	0.31	0.39	0.05	2,475
Skim milk (0.3 per cent fat)36	.03	.55	.06	1,835
Buttermilk33	.06	.53	.08	1,845
Cheese39	.52	.03	.06	2,990
Beef, round57	.40	—	.03	2,750
Smoked ham26	.66	—	.08	3,275
Wheat flour13	.01	.85	.01	1,865
Wheat bread15	.02	.82	.01	1,865
Potatoes10	.01	.85	.04	1,790
Apples03	.03	.92	.02	1,885

Average composition of milk products and other food (U. S. Dept. Agric.)

MATERIAL	REFUSE	WATER	PROTEIN	FAT	CARBOHYDRATES	ASH
	<i>Per cent</i>	<i>Per cent</i>	<i>Per cent</i>	<i>Per cent</i>	<i>Per cent</i>	<i>Per cent</i>
Whole milk	—	87.0	3.3	4.0	5.0	0.7
Skim milk	—	90.5	3.4	.3	5.1	0.7
Cream	—	74.0	2.5	18.5	4.5	0.5
Buttermilk	—	91.0	3.0	.5	4.8	0.7
Whey	—	93.0	1.0	.3	5.0	0.7
Condensed milk, unsweetened	—	71.3	7.4	8.5	11.1	1.7
Condensed milk, sweetened	—	26.0	8.2	9.6	54.3	1.9
Butter	—	13.0	1.0	83.0	—	3.0
Cheese, American Cheddar	—	33.5	26.0	35.5	1.5	3.5
Cheese, cottage	—	53.0	19.6	23.2	2.1	2.1
Cheese, Swiss	—	31.4	27.6	34.9	1.3	4.8
Milk powder (from skimmed milk)	—	3.0	34.0	3.1	51.9	8.0
Kephir	—	89.6	3.1	2.0	4.5 ¹	0.8
Koumiss	—	90.7	2.2	2.1	4.1 ²	0.9
Infant and invalid foods, farina- ceous	—	9.4	9.4	0.4	79.9 ³	3.9
Infant and invalid foods contain- ing milk and starches	—	4.3	9.6	3.8	80.2 ⁴	2.1
Infant and invalid foods, malted preparations	—	4.2	12.0	1.0	79.8 ⁵	3.0
Beef, sirloin steak	12.8	54.0	16.5	16.1	—	0.9
Eggs as purchased	11.2	65.5	11.9	9.3	—	0.9
Wheat flour, patent roller process	—	12.0	11.4	1.0	7.51	0.5
Wheat bread, white	—	35.3	9.2	1.3	53.1	1.1
Beans, baked	—	68.9	6.9	2.5	19.6	2.1
Potatoes, as purchased	20.0	62.6	1.8	0.1	14.7	0.8
Apples, as purchased	25.0	63.3	0.3	0.3	10.8	0.3

¹ Including 2.1 per cent alcohol and 0.8 per cent lactic acid.

² Including 1.7 per cent alcohol and 0.9 per cent lactic acid.

³ Including 6.62 per cent soluble carbohydrates (sugars).

⁴ Including 49.05 per cent soluble carbohydrates (sugars).

⁵ Including 48.39 per cent soluble carbohydrates (sugars).

Milk, Butter, and Cheese Tests

Babcock test for butter-fat (Pearson).

A measured sample of milk is mixed with strong sulfuric acid, which dissolves all of the milk constituents except the fat. The mixture of milk and acid is then subjected to centrifugal force in a specially constructed machine, by which the fat is separated from the heavy liquid, and, after the addition of water, the fat is brought into a part of the bottle where it can be quickly measured. The entire test can be made in fifteen to twenty minutes.

In detail the test is made as follows : The milk to be sampled is thoroughly mixed by pouring it several times from one vessel to another. By means of a milk pipette, or measure, graduated to hold 17.6 cc., this quantity of milk is transferred to a special form of bottle, which has a capacity of a little more than one ounce and a long neck with graduations or per cent marks from 0 to 10. The cubic capacity of the neck, from 0 to 10, is exactly 2 cc. This is the volume of 1.8 grams of melted fat, which is the substance to be measured on the scale. As the bottle is so graduated that 1.8 grams represents 10 per cent, it is necessary to use a sample weighing ten times as much, or 18 grams, and it is found that the 17.6 cc. pipette will deliver approximately this weight of milk. There is then added 17.5 cc. of concentrated commercial sulfuric acid, having a specific gravity of 1.82 to 1.83. The acid and milk are mixed by a rotary motion. The action of the acid on the water and solids of the milk generates considerable heat. The sample is promptly placed in a centrifugal machine and whirled for five minutes. Hot water is then added to bring the fat to the base of the neck. It is then whirled two minutes, and more hot water is carefully added until the fat rises in the neck so that it is opposite the graduations. The sample is then whirled one minute, to insure collecting as much fat as possible in the neck. While the fat is still warm, its percentage is ascertained by reading the marks at its upper and lower levels and taking the difference between them.

The cost of a small complete outfit for testing milk is \$6 to \$10.

Computing total solids of milk.

Babcock and Richmond have proposed formulæ for computing the total solids of milk. One of the best is : —

$$\frac{L}{4} + 1.2 F + .14 = \text{total solids.}$$

L represents the second and third decimal figures of the specific gravity, or the Quevenne reading, and F represents the percentage of fat. This formula is used largely, and for practical purposes agrees closely enough with results of gravimetric analysis.

Test for acid in milk (Pearson).

It is not practicable to isolate lactic acid from milk and measure it as milk-fat is measured. But its quantity can be easily determined by

slowly adding to a known weight of milk an alkali of known strength until all the acid is neutralized. The neutralization is indicated by phenolphthalein, which was previously added to the milk and which causes the milk to turn pink as soon as it begins to show an alkaline reaction. It is customary (Mann's test) to use deci-normal alkali solution, 1 cc. of which will neutralize .009 gram of lactic acid. The equipment includes, besides the neutralizer and phenolphthalein, a burette for measuring the neutralizer, cup and glass rod. If twenty grams of milk is used and it requires 6 cc. of alkali to neutralize the acid, it is known that the milk contains $6 \times .009$ or .054 gram of lactic acid, or .27 per cent. Alkali tablets (Farrington's), each capable of neutralizing .034 gram of acid, are on the market. They may be used in solution instead of the deci-normal solution.

Test for boiled milk.

It is sometimes desirable to determine whether milk has been subjected to 176° F. or higher heat. A successful test has been devised by Storch. To 5 cc. of the suspected milk add a few drops of potassium iodid and a similar quantity of starch solution, also a few drops of hydrogen peroxid. If the milk has not been cooked, an enzyme which is present will decompose the hydrogen peroxid, setting free oxygen. This combines with the potassium salt, and thus iodine is in turn set free and with the starch it forms a purple color. If the milk has been heated so that the enzyme is killed, no color will result.

Another test for cooked milk is given by Arnold, as follows: Tincture of guaiac is added, drop by drop, to a little milk in a test-tube. If the milk has not been heated to 176° F., a blue zone is formed between the two fluids. If it has been heated, there is no reaction. The guaiac-wood tincture is said to be more reliable than other tinctures, and it should not be used when fresh, but when at least a few days old and its potency has been determined.

The lactometer test for specific gravity in milk (Pearson).

As the specific gravity of milk is markedly changed when it is adulterated by the addition of water or the removal of cream, the lactometer is an important instrument to indicate such adulteration. It is of little use if both kinds of adulteration have been practiced on the same sample of milk, as the increase in weight due to removal of cream can be offset by the addition of water, which is lighter than

skimmed milk. In connection with the Babcock test, the lactometer is most valuable, and several formulæ are in use by which the solids not fat or the total solids of milk may be closely computed from the specific gravity and the fat test.

The lactometer is a form of hydrometer adapted especially for use in milk. Several styles are in use, the Quevenne being the most convenient because its readings indicate the specific gravity without the necessity of more than a simple mental calculation. The readings on the stem of the Quevenne lactometer are from 15 to 40, and they represent the second and third decimal figures of the specific gravity, the preceding figures always being 1.0 ; thus, a reading of 29 represents a specific gravity of 1.029. This instrument should be used in milk at a temperature of 60° F. If the temperature varies therefrom, a correction of the reading must be made, .1 of a lactometer degree being added to the reading for each degree of temperature of the milk above 60° F. or if the temperature is below 60° F, .1 of a lactometer degree is subtracted from the reading for each degree of temperature of the milk below 60° F. Thus, if the lactometer reads 31 at a temperature of 65° F., the corrected reading for 60° F. would be 31.5, and the specific gravity of this milk at 60° F. would be 1.0315. Special tables for making corrections for different temperatures are published in books treating on the subject. By the rule given, it is not advisable to attempt to correct for a variation of more than 10° from 60° F.

Another style of lactometer in common use is known as the New York Board of Health lactometer. Its graduations are from 10 to 120. The instrument stands at 100 in milk having a specific gravity of 1.029, and it would stand at 0, if graduated to that point, in a fluid having a specific gravity of 1. Thus, 100° in the B of H lactometer equals 29° on the Quevenne lactometer, and it is a simple matter to compute the equivalent reading of one lactometer for any given reading on the other by the formula :—

$$Q = .29 \text{ B of H, or B of H} = \frac{Q}{.29}.$$

Test for boric acid or borax used as preservatives (Van Slyke).

Add lime-water to 25 cc. of milk until the mixture is alkaline to phenolphthalein ; evaporate to dryness and burn to an ash in a small porcelain or platinum dish. Add a few drops of dilute hydrochloric acid

to the ash, care being taken not to use too much acid, then add a few drops of water, and place a strip of turmeric paper in this water solution. Dry the paper, and if either borax or boric acid is present, a cherry-red color will appear. This test is confirmed by moistening the reddened paper with a drop of an alkali solution, when the paper will turn to a dark olive color, if borax or boric acid is present.

Test for formaldehyde in milk.

This test can be performed in connection with the Babcock test. Measure into the Babcock test bottle 17.6 cc. of milk. Add five or six drops of ferric chloride solution and shake thoroughly. Add 17.5 cc. of sulfuric acid, but do not mix the acid and milk. If formaldehyde is present, a lavender-colored ring will appear at the point of contact of the acid and milk. If the contents of the bottle are mixed slowly, the entire mass of curd will turn a lavender color. This test will not work if the sample is too old.

Standardizing milk (Pearson).

Standardized milk is that which has been changed in its composition to cause it to contain a required amount of fat. This is usually accomplished by adding cream or skimmed milk. A convenient rule for determining the amount of ingredients to make a mixture testing a certain per cent of fat, is as follows, supposing cream and milk are to be used (in most States it is unlawful to add skimmed milk):—

Draw a rectangle, placing the per cent of fat in the cream at the upper left-hand corner, and the per cent of fat of the milk at the lower left-hand corner. Place the desired per cent of fat in the center. The difference between the numbers in the center and at the lower left-hand corner should be written at the upper right-hand corner, and the difference between the numbers in the center and at the upper left-hand corner should be written at the lower right-hand corner. These right-hand numbers represent the proportions of the substances represented at the corresponding left-hand corners, which must be mixed to produce a milk testing the desired amount of fat.

Thus : To raise the fat test of a 3.8 per cent milk to 4 per cent by the use of cream testing 25 per cent, by completing the figure as explained, it will be seen that for every 21 pounds of 3.8 per cent milk there should be used .2 of 1 pound of 25 per cent cream.

Butter moisture-test (Cornell test).

The apparatus used in the Cornell moisture-test is an alcohol lamp, stand, asbestos sheet, hot-pan lifter, aluminum cup for holding the sample, and a special moisture scale. The scale is especially adapted for moisture work, but may be used as a cream scale in operating the Babcock test.

The scale has a tare weight for balancing the cup and a large and small weight for weighing the sample and obtaining the percentage of moisture. The beam has two rows of figures, which give readings with the larger weight. The lower row gives readings in grams and the upper row in percentages. The smaller weight gives readings in grams when the weight is moved from 1 forward. Each notch represents .02 gram, the total value of the small scale being .2 gram. When the small weight is moved from 0 backward, each notch represents a loss of .1 per cent of moisture when 20.2 grams of butter are used. The small weight is intended to be used only in moisture work. In using the scale for Babcock work, the small weight is not used, but is left at rest on the figure 1. Then when the scales are balanced, the small weight is negligible. Care must be taken not to let any draft of air, as from an open window, strike the scales when in use, as they are so sensitive that a very slight current of air would throw them out of balance. The scales will give readings in percentages only when 20.2 grams of butter have been weighed, or, in other words, when the large weight is on 20 (of the gram scale) and the small weight is on zero.

The cup used is of cast aluminum, and is durable and perfectly smooth. The absence of creases or crevices allows it to be *cleaned* and *dried* thoroughly.

Taking the sample. — It is necessary that a representative sample be taken for a moisture-test. If the butter is sold in tubs, the sample should be taken from the tub with a butter-trier, after the butter has been packed. It is best to take three drawings — one from near the edge, one from the middle, and one half-way between the edge and the middle. Some butter-makers test the butter as soon as it is worked. This is a mistake, since considerable moisture is lost in the process of printing and packing.

Operation of the test.— After the cup is thoroughly cleaned and dried, it is placed on the scales and balanced by means of the tare weight on the round bar attached to the beam of the scales. The large weight should rest on the zero mark (of the gram scale) and the small weight on 1 while the cup is being balanced. The cup should not be balanced until it is about the same temperature as that of the room. After the cup is balanced, the larger weight is moved to the 20 mark (of the gram scale) and the small weight to the zero mark. Butter from the prepared sample is then added to the cup until the scales are *accurately* balanced. The alcohol lamp is then placed under the iron stand and the asbestos sheet placed on the stand. The lamp is lighted and the cup placed on the asbestos sheet. It is well to light the lamp at least two or three minutes before placing the cup on the asbestos in order to heat the asbestos and save time. The heat of the flame may be increased or diminished by raising or lowering the wick. The cup should always be handled with the hot pan lifter, as by so doing it will be kept clean and errors in weight due to dirt on the cup will be avoided.

While the sample is heating it should be shaken from time to time, as this breaks up the blanket of casein on the surface and hastens the escape of moisture. As soon as the casein has lost its snow-white color, the cup should be removed from the flame. When the moisture has all been driven from the sample, a slightly pungent odor may be noticed. This may also be used as a guide to tell when the sample has been heated enough. The foam begins to subside at this point. Often one or two small pieces of casein are slow to give up their moisture. This is indicated by the snow-white color of the pieces. Evaporation can be hastened by shaking the sample with a rotary motion and thoroughly mixing these pieces with the hot liquid. If this is not done, one might have to heat the sample so long that some of the fat which had already given up its moisture would volatilize.

After all the moisture is driven off, the sample is allowed to cool to room temperature. While cooling, the cup should be covered with something (a sheet of paper will do) to prevent the sample taking up moisture from the atmosphere. After cooling, the cup is placed on the scales. The sample is lighter than before heating, because it has lost its moisture. The bar of the scales will therefore remain down. The weights are then reversed until the scales just balance.

Each notch that the larger weight is reversed has a value of 1 per cent (reading on the upper scale), and each notch that the smaller weight is reversed has a value of .1 per cent. If, for example, after heating, the scales just balance when the larger weight rests on 15 (upper scale) and the smaller weight rests on .2, it would mean that the sample contained 15.2 per cent moisture.

Test for salt in butter (Ross).

Weigh out accurately, from a well-mixed sample, 10 grams of butter. Add to the 10 grams of butter 100 cc. of hot water, and thoroughly mix the butter with the water. Then cool to harden the fat, and pour off into a clean dish the 100 cc. of water. Repeat this operation until 300 cc. of water has been used. Thoroughly mix the 300 cc. of water, and measure out 17.5 cc. into a glass beaker or white cup, and add five or six drops of potassium chromate. This will turn the solution a lemon-yellow color. Run in from a burette an $\frac{n}{10}$ normal solution of silver

nitrate. Thoroughly mix the solution as the silver nitrate is added. When the solution turns to an orange-yellow color, enough silver nitrate has been added to neutralize all of the salt. The number of cc. of silver nitrate solution added equals the per cent of salt in the butter. For example, if it requires 2 cc. of silver nitrate, there is 2 per cent of salt in the butter. If more or less than 10 grams of butter are used and more or less than 17.5 cc. of the solution are used for the test, the burette will not give readings directly in terms of per cent. Care should be taken not to run in too much silver nitrate. If too much silver nitrate is used, the color will be a dull brick-red, and incorrect results will be obtained. An $\frac{n}{10}$ normal solution of silver nitrate,

which is accurate enough for the purpose, may be made by dissolving 17.5 grams of silver nitrate in 200 cc. of water and then making the solution to 1000 cc. or 1 liter.

Test for salt in cheese (Ross).

Burn to a gray ash in a porcelain dish 5 grams of the cheese. Care should be taken to keep the contents in the center of the dish. If this is done, it will make it easier to reduce the cheese to an ash.

Cool and dissolve the ash in 20 cc. of pure, clean water. Transfer the 20 cc. of the ash solution to a glass beaker or a white cup. Add five or six drops of a water solution of potassium chromate. This will turn the solution a lemon-yellow color. Run in from a burette an $\frac{n}{10}$ normal solution of silver nitrate. Thoroughly mix the solution as the silver nitrate is added. When the color of the solution turns to an orange-yellow, enough silver nitrate has been added to neutralize all the salt. Then multiply the number of cc. of silver nitrate used by .00585. Divide this result by 5, the number of grams of cheese taken, and multiply the quotient by 100. This is the per cent of salt in the cheese.

Care should be taken not to run in too much silver nitrate. If too much silver nitrate is used, the color will be a dull brick-red, and incorrect results will be obtained. An $\frac{n}{10}$ normal solution of silver nitrate, which is accurate enough for the purpose, may be made by dissolving $17\frac{1}{2}$ grams of silver nitrate in 200 cc. of water and then making the solution up to 1000 cc. or one liter.

Over-run in butter-making (Pa. Sta. and U. S. Dept. Agric.).

Over-run in butter is the amount of water, casein, and salt incorporated in the butter-fat in making butter. Creamery over-run, however, should always be computed from the number of pounds of butter-fat received and the pounds of butter sold.

The formula for calculating over-run in percentage is as follows :

$$\frac{\text{Pounds of butter made} - \text{pounds of butter-fat received}}{\text{pounds of butter-fat received}} \times 100 = \text{per cent over-run.}$$

In a whole-milk creamery it is possible to obtain from 18 to 20 per cent over-run and have only 14 to $14\frac{1}{2}$ per cent moisture in the butter, while in a creamery where hand separator cream is received, 20 to 22 per cent over-run can be obtained. This is shown by the following two examples :—

Example :

10,000 pounds 4 per cent milk contains 400 pounds butter-fat.

10,000 pounds 4 per cent milk gives 1600 pounds 24+ per cent cream and 8400 pounds skim milk.

1,600 pounds of cream testing 24+ per cent contains 391.6 pounds butter-fat.

8400 pounds skim milk, loss (maximum) .1 per cent, is 8.4 pounds butter-fat.

1600 pounds cream less 391.6 pounds butter-fat, leaves 1208.4 pounds buttermilk.

1208.4 pounds buttermilk at .2 per cent loss is 2.4 pounds butter-fat, the loss in churning.

8.4 pounds butter-fat, loss in skim milk, and 2.4 pounds butter-fat, loss in buttermilk, gives 10.8 pounds butter-fat loss in both.

10.8 pounds butter-fat from 400 pounds butter-fat leaves 389.2 pounds of butter-fat to be churned into butter.

If 389.2 pounds butter-fat is churned into butter containing 14 per cent water and 4 per cent salt and casein, it will make 474.6 pounds of butter.

474.6 pounds less 400 pounds gives 74.6 pounds of butter, which is the over-run.

74.6 pounds of butter times 100 makes 7460, divided by 400 gives 18.6 per cent over-run.

Spoon-test for oleomargarin and renovated butter.

Place in a tablespoon a piece of the sample, about the size of a hickory-nut. Hold the spoon over the flame until the sample is melted, and stir frequently while melting. Then lower the spoon into the flame. Oleo and renovated butter will boil with a loud crackling noise, and there will be almost no foam on the surface of the sample. Genuine butter will boil quietly and the surface will be covered with foam.

The test for moisture in cheese (Ross).

Obtain a representative sample of cheese as directed in the test for fat in cheese. Then in a flat-bottom dish at least three inches in diameter weigh out 3 grams of cheese. If no glass dish is at hand, a tea saucer

will answer the purpose. Heat the sample in a water oven at the temperature of boiling water for eight hours. Cool the dish, weigh and divide the loss in weight by the three grams of cheese taken. Multiply the quotient by 100. This quotient is the percentage of moisture in the cheese. Care should be taken to place the cheese in the dish in as thin a layer as possible. This will make it easier for the moisture of the cheese to escape.

The Babcock test for fat in cheese (Ross).

Secure a representative sample of the cheese. This is best done by means of a cheese trier, taking a plug from the center of the cheese one-half way between the center and the outside of the cheese and one very near the outside of the cheese. Using a knife, mince these three plugs as fine as possible and mix them thoroughly. After the sample is minced very fine and thoroughly mixed, weigh out on a set of cream balances in a cream bottle 4 grams of the cheese. Add 5 cc. of warm water and shake thoroughly for one or two minutes. Then make the sample up to approximately 18 grams by the addition of water, and add 17.5 cc. sulfuric acid. After the acid is added, shake the sample thoroughly for from two to three minutes. The purpose of this shaking is to dissolve all of the cheese curd. If this is not done, the fat column will be cloudy. Then place the bottles in the machine and proceed with the test in the ordinary way.

Test for determining casein in milk (Van Slyke and Bosworth).

A given amount of milk, diluted with water, is made neutral to phenolphthalein solution by addition of a solution of sodium hydroxid. The casein is then completely precipitated by addition of standardized acetic acid; the volume of the mixture is made up to 200 cc. by addition of water, thoroughly shaken, and then filtered. Into 100 cc. of the filtrate a standardized solution of sodium hydroxid is run until neutral to phenolphthalein. The solutions are so standardized that 1 cc. is equivalent to 1 per cent of casein when a definite amount of milk is used. The number of cubic centimeters of standard acid used, divided by 2, less the amount of standard alkali used in the last titration, gives the percentage of casein in the milk examined. When one uses 17.5 cc. (18 grams) of milk, the amount used in the Babcock milk-

fat test, the standard acid and alkali solutions are made by diluting 795 cc. of tenth-normal solutions to one liter. By using 22 cc. of milk, tenth-normal solutions can be used directly ; or by using 20 cc. of milk and tenth-normal solutions, adjustment is made by multiplying the final result by 1.0964.

Wisconsin curd-test.

This curd-test may be of use to creamerymen in detecting milk which is giving trouble on account of odors, taints, gas, and so forth. Sometimes the milk from a certain cow contaminates the milk of the entire herd. In such a case, the dairyman may find this test useful.

Sterilize as near as possible by immersing in boiling water for 30 minutes as many pint glass fruit-jars as there are samples to be tested. Cool the jars at the same time, keeping them covered to prevent contamination. Then fill the jars two-thirds full of the milk to be examined. Set the jars in a tank of water, the temperature of which is about 100° F., and allow the milk to come as near as possible to the temperature of the water in the tank. The temperature of the milk may be taken with a thermometer that has been held for at least one minute in boiling water ; the thermometer should be thus treated after taking the temperature of each sample to prevent carrying contamination from one sample to another.

When the temperature of the milk has reached about 95° F. to 98° F., add to each jar of milk about 10 drops of rennet and shake thoroughly. The rennet will coagulate the milk in about 20 minutes, and the whey should then be poured off. The whey will separate more readily from the curd if the latter is broken up with a knife or other instrument which has been dipped for at least one minute in boiling water. As much of the whey as possible should be drawn off. The jars should then be set in the tank and kept at a temperature of about 100° F. for 6 to 8 hours. Examination of odor and condition of the curd may be made every 30 minutes. The condition of the curd may best be told by cutting it with a sharp knife and examining the freshly cut surface for gas pockets.

Great care should be exercised in the entire process to have everything which comes in contact with the milk as near sterile as possible.

Propagation of Starter for Butter-making and Cheese-making (Guthrie)

1. Take three one-quart milk bottles or fruit jars.
2. Use fresh, clean milk (either whole milk or skimmed milk) which must have a nice flavor.
3. Fill the containers one-half to two-thirds full of milk.
4. Protect the containers with regular covers (caps or tops).
5. Pasteurize by heating to 180°-200° F. for thirty minutes or longer, and then cool to ripening temperature of 60°-75° F.
6. After pasteurization the milk is ready for inoculation. Inoculate in a quiet place where the wind cannot blow dirt and bacteria into this clean seed bed.
7. Incubate at about 60°-75° F. The first inoculation from the commercial culture should be incubated at about 70°-85° F.
8. The starter is ripe when a curd forms. This curd should be soft and like custard in appearance.
9. After the starter is ripe, hold it at 50° F. or a few degrees lower until time to use. For best results a starter should not be held longer than a few hours.
10. Upon examination the curd should be smooth and compact, without gas pockets. Gas shows the presence of undesirable bacteria.

Farm Butter-making (Trueman, Conn. Exp. Sta.)

The farmer will not ask, is it more scientific to make butter than to sell milk, or is it less trouble, or does it take less time and work, but, does it pay? That question can best be answered by a comparison of the amount received for 1000 pounds of milk by each method.

One thousand pounds of milk equals 465 quarts. At 3½ cents per quart, its value is \$16.27. The value of the same amount of milk made into butter will depend upon the richness of the milk. If it will test 4 per cent of fat, then the 1000 pounds will contain 40 pounds of fat. Under ordinary conditions this will make about 44.5 pounds of butter. This at 35 cents per pound is worth \$15.57. Add to this the value of 800 pounds of skim milk and 150 pounds of buttermilk, a total of 950 pounds at 25 cents per hundredweight, equal to \$2.37, a total of \$17.94 for the 1000 pounds of milk when made into butter. This gives a balance of \$1.67, in favor of making butter, to say nothing of the value

of the fertilizer material in the skim milk and the profit in having healthy, rapid-growing calves.

It will readily be seen that the side on which the profit will appear will depend wholly on the prices received for milk and butter. If the milk is sold at the farm at four cents per quart and the butter must be sold at 30 cents per pound, then the margin of profit would amount to \$2.88 per 1000 pounds of milk, in favor of selling by the quart, provided the milk tests 4 per cent as in the first case.

If, however, the herd in question consisted of well-bred Jerseys, giving milk testing 5 per cent on the average, the result would be somewhat different:

1000 lb. milk	465 quarts	
465 quarts @ 4¢		\$18.60
1000 lb. milk testing 5%	50 lb. fat	
50 lb. fat	57 lbs. butter	
57 lb. butter @ 30¢		\$17.10
950 lb. skim milk and buttermilk @ 25¢ per cwt.		2.37
Total		<u>\$19.47</u>

This leaves a balance of 87 cents per 1000 pounds of milk, in favor of making butter.

Bitter milk and cream.

Milk may have an acrid, bitter taste, caused by the cows eating ragweed, an herb which is common in pastures late in the summer. Flavors produced by what the cows eat are most noticeable when the milk is first drawn from the udder, while flavors produced by the growth of bacteria get worse as the milk gets older. The only remedy for ragweed flavor is to remove the cows from the pasture containing the weed.

Bitter milk is sometimes given by cows that are advanced in their period of lactation and giving a small quantity of milk. Such cows should be dried up at once.

Certain bacteria that develop at low temperatures may produce bitter flavors in the ripening cream. In this case the cream is all right when fresh but gradually develops the bitter flavor. This can be stopped by using plenty of steam or boiling water to sterilize thoroughly all utensils, and by using a good active starter to hasten the development of lactic acid. The cream should not be allowed to get old and the temperature should be kept up to 70° F. or 75° F. during ripening.

Why butter will not "come."

One of the most common complaints is that the butter will not come. This generally happens in the fall in herds where the cows freshen in the spring or early winter. When fall comes, these cows have been milking a long time and are not giving much milk. The character of the milk changes as the lactation period advances. The per cent of fat and of solids-not-fat, increases. This makes the cream more viscous, and more inclined to "whip," or to froth up and fill the churn. When this happens, and the churn is full of frothy cream, about the only thing to do is to add hot water to warm up the fat and to destroy the viscosity of the cream. Such treatment will not make the best of butter, but is better than churning all day and finally becoming so discouraged that the whole churning is thrown out.

This trouble may be avoided by using more starter, ripening at a higher temperature, say 75° F. to 80° F., and churning at a higher temperature, say 65° F. This again will not make the best of butter, but will enable one to handle successfully that kind of cream.

Sometimes the butter will not come because the cream is too thin. The fat globules are not crowded closely enough together in the milk serum to cause them to stick together when the cream is agitated. Cream should contain over 20 per cent of fat in order to make it churn easily, and 30 per cent is better.

Sweet cream does not churn as easily as sour cream. Souring tends to reduce viscosity and prevent whipping.

Frequently the butter will not come because the cream is too cold. The thermometer should be used, and if below 60° F. warm up by adding hot water, or by taking out some of the cream and warming it and then returning it to the main lot in the churn. Unless the cream is already too thin, hot water, added carefully, will generally be found satisfactory. Cream may become too cold from churning in a cold room, especially if a metal or crockery churn is used.

Too thick cream will sometimes stick to the sides of the churn and the butter will not come from lack of concussion. Water or skim milk of the proper temperature may be added to reduce the thickness of the cream.

If the churn is too full, the proper amount of concussion is not produced and the butter fails to come. Take out part of the cream and make two churnings.

Old cream makes poor-flavored butter.

Probably the most common cause of poor-flavored butter is cream that has grown stale before being churned. Fine, fresh-tasting butter, with delicate flavors and aroma, cannot be made from old cream. Three days should be the limit of age, if the best quality is to be produced.

White specks in the butter.

These are caused by dried cream, and by lumps of coagulated casein. The cream should be stirred frequently while ripening and always strained through a fine-mesh wire strainer, when put in the churn.

Mottled butter.

“Mottles” are caused by an uneven distribution of the salt. The action of the salt on the casein causes light streaks and spots to show all through the butter. The remedy is to wash well until the water is clear, and to work a little longer until the salt is evenly mixed with the butter. The proper point at which to stop working can be learned only by experience.

Effect of feed on butter-fat.

We have not much definite knowledge about the effect of feeds upon texture and flavor of butter. Strong-flavored feeds, such as turnips, garlic, cabbage, silage, etc., may be fed immediately after milking and they will then have little or no effect upon the flavor of the milk.

Gluten feed, oil meal and soy beans are known to produce softer butter than corn meal and cotton-seed-meal, the latter being especially noted for the production of a hard, tallowy fat.

Butter from Whey

The quantity of butter that can be made from the whey from 100 pounds of milk is somewhat variable, depending on the amount of fat that is lost in the whey during the process of cheese-making. This loss depends on a great many conditions, but on the average about 5 ounces of butter can be made from the whey from 100 pounds of milk.

Milk, Butter, and Dairy-farm Scores

Score-card for market milk (U. S. Dept. of Agric., Dairy Division)

NUMERICAL SCORE

Flavor, 40	Composition, 25	Bacteria, 20	Acidity, 5	Appearance of package and contents, 10	Perfect score, 100
					Judge's score.

DESCRIPTIVE SCORE

Flavor	Composition	Bacteria	Acidity	Package and contents
Excellent . . .	Perfect	Perfect	Perfect	Perfect
Good	_____	_____	_____	_____
Fair	Fat, — per cent	Total, _____	— per cent	Foreign matter
Bad	_____	_____	_____	_____
Flat	Solids not fat, —	Liquefiers —	_____	Metal parts
Bitter	per cent	_____	_____	_____
Weedy	_____	_____	_____	Unattractive
Garlic	_____	_____	_____	_____
Silage	_____	_____	_____	_____
Manure	_____	_____	_____	_____
Smothered . . .	_____	_____	_____	_____
Other Taints .	_____	_____	_____	_____

Remarks: _____.

Date: _____.

Directions for scoring

Flavor.

If rich, sweet, clean, and pleasant flavor and odor, score perfect (40). Deduct for objectionable flavors and odors according to conditions found.

Composition.

If 3.25 per cent fat or above and 8.5 per cent solids not fat or above, score perfect (25). Deduct one point for each one-fourth per cent fat below 3.25, and one point for each one-fourth per cent solids not fat below 8.5.

Bacteria.

Less than 10,000 per cubic centimeter	(perfect)	20
Over 10,000 and less than 25,000 per cubic centimeter		19
Over 25,000 and less than 50,000 per cubic centimeter		18
Over 50,000 and less than 75,000 per cubic centimeter		17
Over 75,000 and less than 100,000 per cubic centimeter		16
Deduct 1 point for each 25,000 above 100,000.		

When an unusually large number of liquefying bacteria are present, further deduction should be made according to conditions found.

Acid.

If 0.2 per cent or below, score perfect (5). Deduct one point for each 0.01 per cent above 0.2 per cent. (If Mann's test is used, discontinue adding indicator on first appearance of a pink color.)

Appearance of package and contents.

If package is clean, free from metal parts, and no foreign matter can be detected in the contents, score perfect (10). Make deductions according to conditions found.

Butter score-card (Cornell)

Flavor	45	—
Body	25	—
Color	15	—
Salt	10	—
Package	5	—
Total	100	—

NAME OF JUDGE -----

FLAVOR

Desirable

Due to farm conditions

Clean, creamery — pleasant bouquet, aroma.

Dirty (*name cause if possible*)
Pails, cans, barn, milkhouse, etc.

Undesirable

Weedy (*name weed if possible*)

Due to creamery conditions

Barny
Cowy
Feedy (*name feed if possible*)
Silage, hay, grain

Dirty (*name cause if possible*)
Churn vat, refrigerator, separator, etc.

Due to either creamery or farm conditions or both

Woody
Poor starter
Oily

Rancid
Too high ripening temperature

Flat
Smothered
Fishy
Turpentiney

Cheesy
Bitter
Metallic
Dirty strainer

BODY		SALT	
<i>Desirable</i>		<i>Desirable</i>	
Waxy, medium grain (in length)		Well dissolved, medium in amount	
<i>Undesirable</i>		<i>Undesirable</i>	
Weak	Too much water	Too high	Gritty
Tallowy	Not enough water	Too light	Not well distributed
Milky brine	Water not well incor-		
Greasy	porated		
Short grain	Leaky		
COLOR		PACKAGE	
<i>Desirable</i>		<i>Desirable</i>	
Uniform, medium shade (June or straw)		Neat, clean, attractive	
<i>Undesirable</i>		<i>Undesirable</i>	
Mottled	Too high	Not suited to market	Not finished
Streaked	Too light	Poorly packed	Moldy
Wavy	Not clear	Cheap	Not full
		Dirty	Damaged

Cheese score-card (Cornell)

Flavor . . . 50	—	{	Perfect, clean, too much acid, too little acid, sour, sweet, tainted. Weedy, cowy, old milk, bitter, fishy, yeasty, fruity, rancid, feedy.
Body and Texture . . . 25	—	{	Perfect, smooth, silky, waxy, pasty, stiff, curdy, mealy. Greasy, close, loose, gassy, yeasty, acidy, sweet, watery, too dry.
Color . . . 15	—	{	Perfect, white specks, streaked, seamy, mottled, wavy. Rust spots, acid cut, too high, too light, uncolored.
Finish . . . 10	—	{	Perfect, undesirable size, uneven, edges, cracked rinds, unclean surfaces, wrinkled bandage, greasy, no end caps.
Total . . . 100	—		

University of Wisconsin score-cards

CHEESE

Flavor	45
Texture	30
Color	15
General make-up and package	10
Total	100

BUTTER

Flavor	45
Body	25
Color	15
Salt	10
Package	5
Total	<u>100</u>

Butter Classifications and Grades (N.Y. Mercantile Exchange)

1. Butter shall be classified as Creamery, Process, Factory, Packing Stock, and Grease Butter.

Definitions.

2. CREAMERY. — Butter offered under this classification shall have been made in a creamery from cream separated at the creamery or gathered from farmers.

3. PROCESS. — Butter offered under this classification shall be such as is made by melting butter, clarifying the fat therefrom, and rechurning the same with fresh milk, cream, or skim milk, or other similar process.

4. FACTORY.— Butter offered under this classification shall be such as is collected in rolls, lumps, or in whole packages and reworked by the dealer or shipper.

5. PACKING STOCK. — Butter offered under this classification shall be original farm-made butter in rolls, lumps, or otherwise, without additional moisture or salt.

6. GREASE BUTTER shall comprise all classes of butter grading below thirds, or of packing stock grading below No. 3 as hereinafter specified, free from adulteration.

Grades.

7. Creamery, Process, and Factory shall be graded as Specials, Extras, Firsts, Seconds, and Thirds ; and Packing Stock shall be graded as No. 1, No. 2, and No. 3.

8. Grades of butter must conform to the following requirements :

Specials.

9. Shall comprise the highest grades of butter obtainable in the season when offered, under the various classifications. Ninety per

cent shall conform to the following standard ; the balance shall not grade below EXTRAS.

FLAVOR. — Must be fine, sweet, clean, and fresh, if of current make, and fine, sweet, and clean, if held.

BODY. — Must be firm and uniform.

COLOR. — A light straw shade, even and uniform.

SALT. — Medium salted.

PACKAGE. — Sound, good, uniform, and clean.

Extras.

10. Shall be a grade just below SPECIALS, and must be fine butter for the season when made and offered, under the various classifications. Ninety per cent shall conform to the following standard ; the balance shall not grade below FIRSTS.

FLAVOR. — Must be sweet, clean, and fresh if of current make, and sweet and clean if held.

BODY. — Must be good and uniform.

COLOR. — A light straw shade, even and uniform.

SALT. — Medium salted.

PACKAGE. — Sound, good, uniform, and clean.

Firsts.

11. Shall be a grade just below EXTRAS, and must be good butter for the season when made and offered, under the various classifications. Ninety per cent shall conform to the following standard ; the balance shall not grade below SECONDS.

FLAVOR. — Must be good, sweet and fresh if of current make, and good and sweet if held.

BODY. — Must be firm and fairly uniform.

COLOR. — Reasonably uniform, neither very high nor very light.

SALT. — May be reasonably high, light, or medium.

PACKAGE. — Sound, good, uniform, and clean.

Seconds.

12. Shall be a grade just below FIRSTS.

FLAVOR. — Must be reasonably good.

BODY. — If creamery, must be solid boring. If factory or process, must be 90 per cent solid boring.

COLOR. — Fairly uniform, but may be mottled.

SALT. — May be high, medium, or light.

PACKAGE. — Good and uniform.

Thirds.

13. Shall be a grade below SECONDS, and may consist of promiscuous lots.

FLAVOR. — May be off-flavored and strong on top and sides.

BODY. — Not required to draw a full trier.

COLOR. — May be irregular or mottled.

SALT. — High, light or irregular.

PACKAGE. — Any kind of package mentioned at time of sale.

No. 1 packing stock.

14. Shall be sweet and sound, packed in large, new, or good uniform second-hand barrels, having a wooden head in each end, or in new tubs, either to be parchment paper lined. Barrels and tubs to be packed full.

No. 2 packing stock.

15. Shall be reasonably sweet and sound, and may be packed in promiscuous or different kinds of barrels, tubs, or tierces, without being parchment-paper lined, and may be packed in either two-headed or cloth-covered barrels.

No. 3 packing stock.

16. Shall be a grade below No. 2, and may be off-flavored, or strong ; may be packed in any kind or kinds of packages.

17. Charges for inspection of packing stock shall be the same as the rules call for on other grades.

18. MOLD. — There shall be no grade for butter that shows mold.

Score-card for Production of Sanitary Milk (Cornell)

EQUIPMENT	SCORE		METHODS	SCORE	
	Perfect	Allowed		Perfect	Allowed
COWS			COWS		
Health	6	. . .	Cleanliness of cows	8	. . .
Apparently in good health			(Free from dust, 7; free from coarse dirt, 6)		
If tested with tuberculin within a year and no tuberculosis is found, or if tested within six months and all reacting animals removed			STABLE		
(If tested within a year and reacting animals are found and removed, 2.)			Cleanliness of stable	6	. . .
Food (clean and wholesome)	2	. . .	Floor	2	
Water	2	. . .	Walls	1	
Clean and fresh			Ceiling and ledges	1	
Convenient and abundant			Mangers and partitions	1	
STABLES			Windows	1	
Location of stable	2	. . .	Stable air at milking time	6	. . .
Well drained			Freedom from dust	3	
Free from contaminating surroundings			Freedom from odors	2	
Construction of stable	4	. . .	Cleanliness of bedding	1	
Tight, sound floor and proper gutter			Barnyard clean	2	. . .
Smooth, tight walls and ceiling			Well drained	1	
Proper stall, tie, and manger			Removal of manure daily to field or proper pit	2	. . .
Provision for light:			(To 50 feet from stable, 1.)		
Four sq. ft. of glass per cow	4	. . .	MILK ROOM		
(Three sq. ft., 3; 2 sq. ft., 2; 1 sq. ft., 1. Deduct for uneven distribution.)			Cleanliness of milk room	3	. . .
Bedding	1	. . .	UTENSILS AND MILKING		
Ventilation	7	. . .	Care and cleanliness of utensils	8	. . .
Provision for fresh air, controllable flue system			Thoroughly washed	2	
(Windows hinged at bottom, 1.50; sliding windows, 1; other openings, .50)			Sterilized in live steam for 30 minutes	3	
			(Placed over steam jet or scalded with boiling water, 2.)		
			Inverted in pure air	3	
			Cleanliness of milking	9	. . .
			Clean, dry hands	3	
			Udders washed and dried	6	
			(Udders cleaned with moist cloth, 4; cleaned with dry cloth or brush at least 15 minutes before milking, 1.)		

EQUIPMENT	SCORE		METHODS	SCORE	
	Perfect	Allowed		Perfect	Allowed
Cubic feet of space per cow, 500 feet 3 (Less than 500 ft., 2; less than 400 ft., 1; less than 300 ft., 0)			HANDLING THE MILK		
Provision for controlling temperature 1			Cleanliness of attendants in milk room	2
UTENSILS			Milk removed immediately from stable without pouring from pail	2
Construction and condition of utensils	1	Cooled immediately after milking each cow	2
Water for cleaning	1	Cooled below 50° F.	5
(Clean, convenient and abundant.)			(51° to 55°, 4; 50° to 60°, 2.)		
Small-top milking pail	3	Stored below 50° F.	3
Facilities for steam (hot water, .5)	1	(51° to 55°, 2; 56° to 60°, 1.)		
(Should be in milk house, not in kitchen.)			(If delivered twice a day allow perfect score)		
Milk cooler	1	Transportation below 50° F.	2
Clean milking suits	1	(51° to 55°, 1.50; 56° to 60°, 1.)		
MILK ROOM, OR MILK HOUSE					
Location free from contaminating surroundings	1			
Construction of milk room	3			
Floor, walls, and ceiling	1			
Light, ventilation, screens	1			
Separate rooms for washing utensils and handling milk 1					
Total	40	Total	60

Equipment + Methods = Final Score

NOTE 1.— If any exceptionally filthy condition is found, particularly dirty utensils, the total score may be further limited.

NOTE 2.— If the water is exposed to dangerous contamination, or if there is evidence of the presence of a dangerous disease in animals or attendants, the score shall be 0.

Milk inspection of farm dairies (Cornell)

Dairyman Date
 P. O. Location
 No. cows milking . . . In herd . . . Qts. Milk . . . Cans or Bottles . . .
 Name of family physician
 Milk sold to License No.
 Report by At milking time? Hour . . . M.

EQUIPMENT

I. *Cows.*

- Do all cows appear healthy?
- What signs are there of disease?
- Are udders sound?
- Are cows tuberculin tested?
- Date of last test By whom tested?
- Number of cows added to herd since last test
- Number and kind of other animals in cow stable
- Kinds of feeds used Roughage Concentrated
- Are they of good quality?
- Method of watering Cleanliness of trough and surroundings
- Is water supply abundant?
- Where are cows kept when sick or at calving time?

II. *Stables.*

- Is stable well located?
- Construction of ceiling Walls Are ceiling and walls
smooth and tight?
- Size of stable, length Width Height
- Size of stall, length Width
- Kind of stanchion Kind of mangers
- Kind of floor State of repair
- Kind of bedding used
- Cubic feet of air space per cow
- Number and size of windows
- Distribution of light Sq. ft. of light per cow
- How is stable ventilated?
- Any special provision for controlling temperature?
- Kinds and number of other animals, if any, in same room with cows

III. *Utensils.*

- Are all utensils well constructed and comparatively easy to clean?
- Are milk pails covered or small topped?
- Is any cooler used? Kind?
- Are there any facilities for sterilizing utensils?
- What are they?

IV. *Milk room or milk house.*

- Location
- Is milk house near any source of contamination, such as pig sty, privy?
Is milk house well drained?
- Construction, Floor Walls Ceiling
- State of repair?
- Is house well lighted? Ventilated?
- Are windows provided with screens?
- Are there separate rooms for handling milk and washing utensils?

METHOD

I. *Cows.*

- Are cows free from dirt? Dust?
- How often are cows cleaned?
- How are cows cleaned?
- Are udders and flank clipped? How often?

II. *Stable.*

- Is stable clean?
- Is there dust or cobwebs on ceiling? Ledges?
- Is there old dried manure on floor? Walls? Mangers or
partitions?
- Is stable whitewashed? How often?
- Is stable air free from dust and dirt?
- Is feeding done before or after milking?
- Has the stable any bad odors?

- Is bedding clean?
- Is barnyard clean? Well drained?
- How often is manure removed from stable?
- How far is manure removed from stable?
- Is pasture free from mud-holes or stagnant water?

III. *Milk room.*

- Is milk room clean? Has it any bad odors?

IV. *Utensils and milking.*

- Are utensils clean? Sterilized? How?
- How soon after milking are utensils cleaned?
- How are utensils cared for after milking?
- Are milkers healthy? Do they milk with clean, dry hands?
- Do they wear special over-all suits?
- How often are suits washed?
- Where are suits kept when not in use?
- How long before milking are cows cleaned?
- Are udders wiped with damp cloth before milking?
- Is stable floor dampened before milking? Where is milk strained?

V. *Handling the milk.*

- Are attendants in milk room clean?
- What kind of a strainer is used?
- How soon after milking is milk cooled?
- What kind of a cooler is used?
- To how low a temperature is milk cooled? Is ice used?
- How is milk protected during transportation to market?

Rules for the production of clean milk (Ross)

The presence of bacteria in milk is what causes the milk to become unfit for human food. If there were no germs in milk, it would keep sweet and wholesome indefinitely. The problem of producing clean milk is therefore one of keeping bacteria out of the milk.

The following rules are comparatively simple and inexpensive to follow, and at the same time they will do much to help the dairymen produce clean milk:—

1. Keep the cow clean.
2. Clip the hair about the flank and udder at least twice each year.
3. Wipe the udder with a damp cloth just before milking.
4. Do not brush or feed the cow just before milking.
5. Do not sweep the floor within three-quarters of an hour before milking.
6. Use a small-top or covered milk-pail.
7. Milk with clean hands and clean suits.
8. Rinse all of the milk utensils with cold water, and then wash them thoroughly with a brush and hot water in which washing powder has been dissolved. Then scald everything in *boiling* water.
9. Have the barns well lighted and ventilated. Bacteria do not thrive in sunlight. Have not less than four square feet of glass per cow.
10. Keep the milk utensils in a place free from dust.
11. In purchasing dairy apparatus, insist that all seams be filled with solder. Cracks and seams make an ideal place in which germs grow.
12. Keep the milk cold (at least 50° F.) after milking.

Rules for care of milk by consumer

1. Do not leave milk sitting on the door step or other place exposed to dust and rays of the sun.
2. Do not keep milk in the same compartment with other food.
3. Keep the milk on ice from time of delivery until it is used.

Sanitary inspection of city milk plants (U. S. Dept. of Agric., Bureau of Animal Industry, Dairy Division)

Owner or manager — Trade name —
 City — Street and No. — State —
 Number of wagons — Gallons sold daily { Milk —
 Cream —
 Buttermilk —
 Permit or license No. — Date of inspection —, 19 .

EQUIPMENT	SCORE. PERFECT	METHODS	SCORE. PERFECT
Plant:		Plant:	
Location	18	Cleanliness.	15
Convenience	6	Floor	6
Surroundings	12	Walls	4
Arrangement	7	Ceilings	1
Proper rooms	3	Doors	1
Convenience	4	Windows	1
Construction	9	Good order.	1
Floor	5	Free from odors	1
Walls	3	Machinery and utensils:	
Ceiling	1	Cleanliness	25
Light	1	Milk:	
Ventilation	1	Handling	25
Screens	1	(Clarifying, pasteurizing, cooling, bottling)	
Machinery and utensils	20	Storage	20
Kind and quality	7	45° F. or below	20
(Steam or hot water, bottle and can washer, bottling machine, drying racks, crates, sinks, pasteurizer, cold storage.)		45° to 50° F.	15
Condition	7	50° to 55° F.	10
Arrangement	6		
Water for cleaning	28	Wagons	6
Wagons:		Cleanliness	3
Construction, condition	4	Protection of product	3
Salesroom	11	Salesroom:	
Location	4	Cleanliness	9
Construction	4		
Equipment	3		
	100		100
ADDITIONAL DEDUCTIONS		ADDITIONAL DEDUCTIONS	
For exceptionally bad conditions:		For exceptionally bad conditions	
.	
.	
.	
.	
Total deductions		Total deductions	
Net total		Net total	

CHAPTER XXV

CONSTRUCTION, FARM ENGINEERING, MECHANICS

FARM engineering is concerned with layouts, and the projection of physical enterprises on the land, — as surveying, laying out drains, irrigation works, roads, bridges, and the like. Farm mechanics has to do with construction, and the principles of physics underlying it. Farm machinery as a department of knowledge has to do with the application of mechanics to those devices known as machines. Farm architecture is concerned with the building of barns, residences, and other housing structures.

Silos

Least number of dairy cows that should be fed from silos of given diameters
(Rawl and Conover)

DIAMETER OF SILO (IN FEET)	NUMBER OF COWS TO BE FED
10	12
12	17
14	23
16	30
18	38

Feeding capacity of silos (Wis. Sta.).

When the cows are getting 40 pounds of silage daily, each cow should be allowed 4 to 5 square feet of feeding surface in the silo. Ten cows would require a feeding surface of 50 feet. A silo 8 feet in diameter would have a cross section, or feeding surface, of 50 square feet. For 10 cows, therefore, a silo should be 8 feet in diameter. Fifteen cows should have a silo 10 feet in diameter ; 20 cows should have a silo 12 feet in diameter. The diameter of silos required for different numbers of cows is shown in the following table. It is assumed that each cow eats 40 pounds of silage daily.

Feed for 180 days

NUMBER OF COWS IN HERD	SILO 30 FT. DEEP, 24 FT. OF SILAGE		SILO 36 FT. DEEP, 30 FT. OF SILAGE	
	Fed down at rate $1\frac{1}{2}$ in. daily		Fed down at rate of 2 in. daily	
	Tons Silage	Inside Diameter	Tons Silage	Inside Diameter
14	36	10	36	9
15	54	13	54	11
20	72	15	72	12
25	90	16	90	14
30	108	18	108	15
35	126	19	126	16
40	144	21	144	18
45	162	22	162	19
52	180	23	180	20
60	216	25	216	21
70	252	27	252	23
80	288	29	288	25
90	324	31	324	26
100	360	33	360	28

Approximate quantity of silage required per day (Ill. Sta.)

KIND OF STOCK	DAILY RATION
	<i>Pounds</i>
Beef Cattle —	
Wintering calves, 8 months old	15 to 25
Wintering breeding cows	30 to 50
Fattening beef cattle 18-22 months old —	
First stage of fattening	20 to 30
Latter stage of fattening	12 to 20
Dairy cattle	30 to 50
Sheep —	
Wintering breeding sheep	3 to 5
Fattening lambs	2 to 3
Fattening sheep	3 to 4

This table, in connection with the following, may be used to determine the size of silo needed to fulfill various conditions. For example, if the silage is to be fed to a herd of 40 dairy cattle at the rate of 40 pounds per head per day, a silo 16 or 18 feet in diameter will be satisfactory.

Capacity of silo (King)

INSIDE DIAMETER	HEIGHT	CAPACITY TONS	ACREAGE TO FILL, 15 TONS TO THE ACRE	AMOUNT THAT SHOULD BE FED DAILY
				<i>Pounds</i>
10	28	42	2.8	525
10	30	47	3.0	525
10	32	51	3.4	515
10	34	56	3.7	525
10	38	65	4.3	525
10	40	70	4.6	525
12	28	61	4.1	755
12	30	67	4.5	755
12	32	74	5.0	755
12	34	80	5.3	755
12	36	87	5.8	755
12	38	94	6.4	755
12	40	101	7.3	755
14	28	83	5.5	1030
14	30	91	6.1	1030
14	32	100	6.7	1030
14	34	109	7.2	1030
14	36	118	7.9	1030
14	38	128	8.5	1030
14	40	138	9.2	1030
16	28	108	7.2	1340
16	32	131	8.7	1340
16	34	143	9.5	1340
16	36	155	10.3	1340
16	38	167	11.1	1340
16	40	180	12.0	1340
18	30	151	10.0	1700
18	32	166	11.0	1700
18	34	181	12.0	1700
18	36	196	13.2	1700
18	38	212	14.1	1700
18	40	229	15.26	1700
18	42	246	16.4	1700
18	44	264	17.6	1700
18	46	282	18.8	1700
20	30	187	12.5	2100
20	32	205	13.6	2100
20	34	224	15.0	2100
20	36	243	16.2	2100
20	40	281	18.8	2100
20	42	300	20.0	2100
20	44	320	21.3	2100
20	46	340	22.6	2100
20	48	361	24.0	2100
20	50	382	25.5	2100

Necessary diameter of silos for feeding different numbers of cows while removing from 2 to 3.2 inches of silage daily (King)

Each cow is allowed 40 pounds of silage daily ; silos to be of sufficient capacity to hold silage for 180 days.

No. of Cows	SILO 30 FT. DEEP, NO PARTITION MEAN DEPTH FED DAILY, 2 IN.				SILO 24 FT. DEEP WITH PARTITION MEAN DEPTH FED DAILY, 3.2 IN.			
	Contents		Round diameter in ft.	Square sides in ft.	Contents		Round diameter in ft.	Square sides in ft.
	Tons	Cu. Ft.			Tons	Ct. Ft.		
30	108	4,091	15.0	12 × 14	108	5,510	17.00	16 × 16
40	144	6,545	16.75	14 × 16	144	7,347	20.00	18 × 18
50	180	8,182	18.75	16 × 18	180	9,184	22.00	20 × 20
60	216	9,818	20.50	18 × 18	216	11,020	24.00	22 × 22
70	252	11,454	22.00	20 × 20	252	12,857	26.00	22 × 26
90	324	14,727	25.00	22 × 24	324	16,531	29.75	26 × 28
100	360	16,364	26.50	24 × 24	360	18,367	31.25	28 × 28

Other silo figures.

Silos are now preferably cylindrical, for the silage packs and settles more evenly than in square or cornered constructions. Most silos now are wooden tank-like structures built of upright wooden staves. In the northernmost dairy regions, the silo may be inside the barn ; but usually it is outside the main barn structure.

Weight of silage in silos of different depths two days after filling the silo (King)

DEPTH OF SILAGE	WEIGHT AT DIFFERENT DEPTHS	MEAN WEIGHT OF SILAGE FOR WHOLE DEPTH OF SILO
Feet	Lb. per cu. ft.	Lb. per cu. ft.
1	18.7	18.7
5	25.4	22.1
10	33.1	26.1
15	40.0	29.8
20	46.2	33.3
25	51.7	36.5
30	56.4	39.6
35	61.0	42.8

Approximate capacity of cylindrical silos for well-matured corn silage, in tons (King)

DEPTH FEET	INSIDE DIAMETER IN FEET												
	15	16	17	18	19	20	21	22	23	24	25	26	
	<i>Tons</i>	<i>Tons</i>	<i>Tons</i>	<i>Tons</i>	<i>Tons</i>	<i>Tons</i>	<i>Tons</i>	<i>Tons</i>	<i>Tons</i>	<i>Tons</i>	<i>Tons</i>	<i>Tons</i>	<i>Tons</i>
20 .	58.8	67.0	75.6	84.7	94.4	104.6	115.3	126.6	138.3	150.6	163.4	176.8	
21 .	62.9	71.6	80.8	90.6	100.9	111.8	123.3	135.3	147.9	161.0	174.7	189.0	
22 .	67.4	76.5	86.4	96.8	107.9	119.6	131.8	144.7	158.1	172.2	186.8	202.1	
23 .	71.7	81.6	92.1	103.3	115.1	127.5	140.6	154.3	168.7	183.6	199.3	215.5	
24 .	76.1	86.6	97.8	109.6	122.1	135.3	149.2	163.7	179.0	194.9	211.5	228.7	
25 .	80.6	89.6	103.6	116.1	129.3	143.3	158.0	173.4	189.5	206.4	223.9	242.2	
26 .	85.5	97.2	109.8	123.0	137.1	151.9	167.5	183.8	200.9	218.8	237.4	256.7	
27 .	90.2	102.6	115.8	129.8	144.7	160.3	176.7	194.0	212.0	230.8	250.5	270.9	
28 .	95.0	108.1	122.0	136.8	152.4	168.9	186.2	204.3	223.3	243.2	263.9	285.4	
29 .	99.9	113.7	128.3	143.9	160.3	177.6	195.8	214.9	234.9	255.8	277.6	300.2	
30 .	105.0	119.4	134.8	151.1	168.4	186.6	205.7	225.8	246.8	268.7	291.6	315.3	
31 .	109.8	124.9	141.1	158.2	176.2	195.2	215.3	236.3	258.2	281.8	305.1	330.0	
32 .	115.1	135.9	147.8	165.7	184.6	204.6	225.5	247.5	270.5	294.6	319.6	345.7	

Barn Figures

A comparison of the cost of material in round and rectangular barns, including foundation and silos (Ill. Sta.)

	ROUND BARN, 60 FEET IN DIAMETER	RECTANGULAR BARN, 36 x 78½ FEET	
		Plank frame	Mortise frame
Lumber in barn	\$799.76	\$1023.27	\$1233.41
Material in foundation	86.89	105.90	105.90
Material in silo	159.01	295.26	295.26
Total cost of material in barn	\$1045.66	\$1424.43	\$1634.57
Actual money saved		378.77	588.91
Proportional cost	100%	136%	156%

Wire Fence

On the model form of woven-wire fence, the tensile strain figures to a very small degree. What the manufacturer aims to accomplish is to produce a hard wire without having this of spring-steel grade, so that it will stand more or less abuse and still not be so hard but that it can be spliced. Some types of fence are of rather weak construction, and for top and bottom wire high carbon steel is used to hold up the fabric.

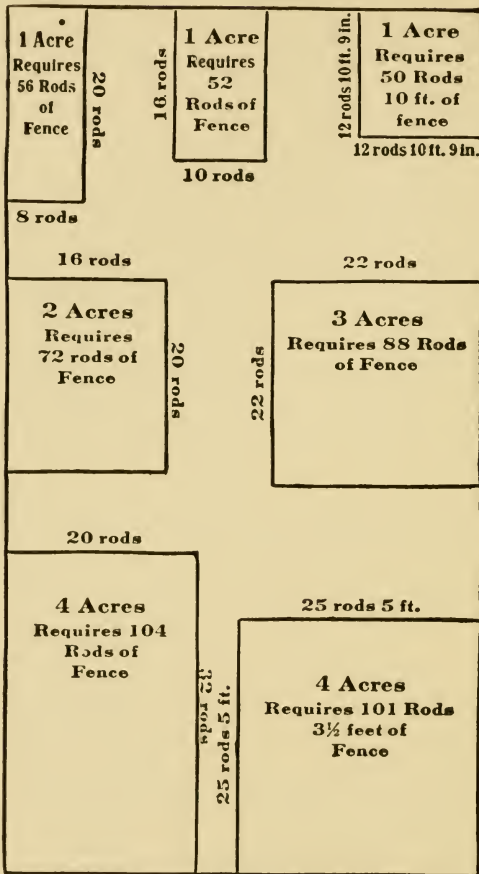

FIG. 17.—Dimensions of 1, 2, 3, and 4 acre lots, and fence required to enclose them. Dimensions given are exact, so that in buying fence, sufficient allowance should be made to cover fence taken up in wrapping around end and corner posts.

Gauges, sizes, and weights of plain wire

GAUGE	DIAMETER OF GAUGE, INCHES	WEIGHT ONE MILE, POUNDS	FEET TO POUND
12830	1128.0	4.681
22625	970.4	5.441
32437	836.4	6.313
42253	714.8	7.386
52070	603.4	8.750
61920	519.2	10.17
71770	441.2	11.97
81620	369.6	14.29
91483	309.7	17.05
101350	256.7	20.57
111205	204.5	25.82
121055	156.7	33.69
130915	117.9	44.78
140800	90.13	58.58
150720	73.01	72.32
160625	55.01	95.98
170540	41.07	128.6
180475	31.77	166.2
190410	23.67	223.0
200348	17.05	309.6

Barb-wire.

In barb-wire fencing, it is reasonably safe to estimate that four-point cattle barb-wire (which means barbs approximately five inches apart) weighs about one pound to the rod ; and that four-point hog barb-wire (barbs about three inches apart), measures about thirteen feet to the pound.

Galvanized coiled spring-steel wire.

Coiled or wavy wire is employed in making fences in various forms, although it is not used to any great extent. It is so coiled that it will retain its springiness against all expansion and contraction due to weather conditions.

GAUGE	FEET PER POUND	GAUGE	FEET PER POUND
No. 7	11.00	No. 10	20.00
No. 8	13.33	No. 11	24.61
No. 9	16.70	No. 12	32.00

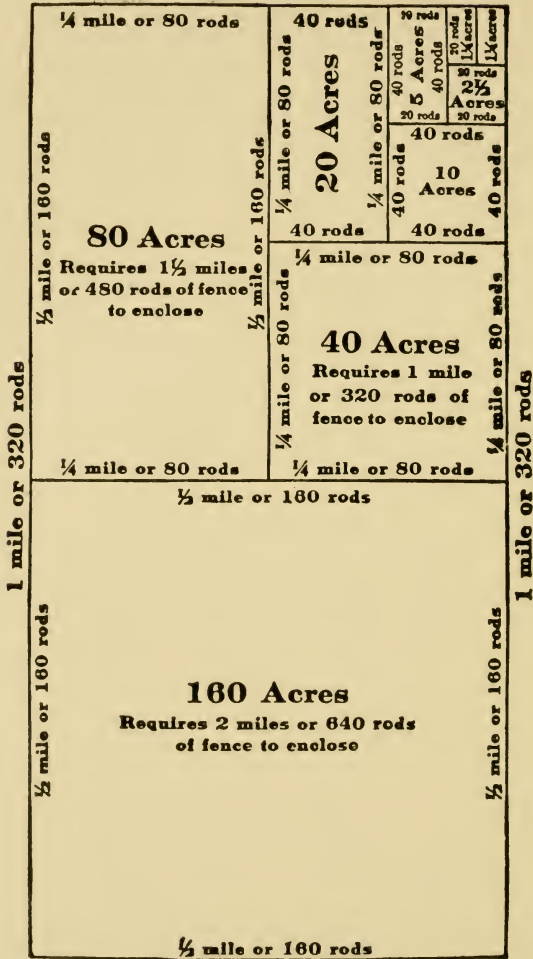

FIG. 18. — Number of rods of fence required to enclose fields of different sizes.

Tensile Strengths of Ropes

MANILA ROPE 3 STRANDS, 36 IN. LONG		MANILA ROPE 4 STRANDS, 36 IN. LONG		CAST-STEEL WIRE ROPE 6 STRANDS		
Circumference	Breaking load	Circumference	Breaking load	Circumference	No. of wires in strand	Breaking load
<i>in.</i>	<i>lb.</i>	<i>in.</i>	<i>lb.</i>	<i>in.</i>		<i>lb.</i>
1.625	1,750	2.825	4,250	1.062	6	6,285
2.25	3,680	3.375	6,050	1.375	19	11,850
2.375	4,750	3.75	7,700	1.563	19	12,590
2.812	5,400	4.25	11,140	1.595	19	19,500
3.188	6,800	4.825	14,020	1.780	19	19,150
3.625	7,635	5.375	16,550	1.938	19	21,510
4.375	8,980	3.188	7,700			
4.75	11,870	3.125	7,630			
5.125	15,100					
2.562	2,850					
3.033	4,930					
4.188	11,650					

Tile-draining

Number of feet of drain tile required per acre when placed the specified distances apart (Fippin)

20 feet apart	2180 feet
25 feet apart	1743 feet
30 feet apart	1452 feet
40 feet apart	1090 feet
50 feet apart	872 feet
100 feet apart	436 feet
150 feet apart	290 feet
200 feet apart	218 feet

Limit of size of drain tile to grade and length (Elliott)

SIZE OF TILE IN INCHES	MINIMUM GRADE PER 100 FT. IN FEET	LIMIT OF LENGTH IN FEET
210	600
309	800
405	1600
505	2000
605	2500
705	2800
805	3000
905	3500
1004	4000
1104	4500
1204	5300

These limits are based on perfectly laid tile, which is seldom achieved. The lay of the land, the nature of the earth, the occurrence of rocks and trees and other obstructions, the necessity of making detours, and other conditions, all influence the theoretical limits of efficiency.

Conditions that determine the size of the drains, particularly the mains (Elliott) :—

1. The depth of water to be removed in twenty-four hours over the area of the drainage system.
2. Rapidity with which the water is brought to the main, that is, the number, size, and fall of the laterals.
3. The existence of emergency surface drainage.
4. The texture and physical condition of the soil, that is, whether it is open and porous or dense and retentive.
5. The grade of the ditch.

Number of acres from which $\frac{1}{4}$ inch of water will be removed in 24 hours by outlet tile-drains of different diameters and different lengths with different grades (adapted from Elliott)

DIAMETER OF TILE IN INCHES	GRADE IN INCHES PER 100 FEET									
	1		2		3		6		9	
	LENGTH OF DRAIN IN FEET †									
	1000	2000	1000	2000	1000	2000	1000	2000	1000	2000
ACRES OF LAND DRAINED BY DIFFERENT SIZES OF TILE										
5 .	19.1	15.7	22.1	19.4	25.1	22.7	32.0	30.3	37.7	36.3
6 .	29.9	24.8	34.8	30.5	39.6	35.9	50.5	47.8	59.4	57.3
7 .	44.1	36.4	31.1	44.8	58.0	52.8	74.0	70.1	87.1	84.1
8 .	61.4	50.7	71.2	62.6	80.9	73.6	103.3	98.0	121.4	117.3
9 .	82.2	68.1	95.3	83.8	108.4	89.6	138.1	131.3	162.6	157.1
10 .	106.7	88.5	123.9	108.9	140.6	128.1	179.2	170.5	211.1	204.4
12 .	167.7	139.3	194.6	171.6	221.1	201.8	281.8	268.6	331.8	321.7
14 .	245.3	204.3	284.9	251.7	323.5	296.1	412.9	393.9	485.8	472.1
16 .	341.4	284.6	369.3	350.4	449.9	412.2	573.7	548.8	675.2	657.3
18 .	456.4	381.3	529.1	470.1	601.8	552.5	767.4	733.1	902.3	880.5
20 .	591.5	245.9	686.3	610.5	780.0	718.2	994.5	954.6	1170.0	1144.0

Average list price per one thousand (1000) feet of drain tile quoted by dealers in New York (Fippin). Subject to large discounts

DIAMETER OF TILE	PRICE PER 1000 FEET	DIAMETER OF TILE	PRICE PER 1000 FEET
2 inches	\$13.50	6 inches	\$62.00
2½ inches	16.50	8 inches	95.00
3 inches	21.00	10 inches	165.00
4 inches	34.00	12 inches	230.00
5 inches	44.00		

Prices, weights, and average carload of tile (Wis. Sta.)

DIAMETER	PRICE PER 1000 FEET, INCLUDING FREIGHT AT RATES PREVAILING IN THE SOUTHERN HALF OF WISCONSIN	POUNDS PER FOOT	AVERAGE CAR LOAD	
			Feet	Rods
<i>Inches</i>				
4	\$18.00	6	6500	390
5	26.00	8	5000	300
6	35.00	11	4000	240
7	45.00	14	3000	180
8	60.00	18	2400	144
10	80.00	25	1600	96
12	120.00	33	1000	60
14	185.00	43	800	48
15	200.00	50	600	36
16	225.00	53	500	30
18	310.00	70	400	24
20	400.00	83	330	20
22	500.00	100	320	19
24	550.00	112	300	18
27	800.00	150	240	15
30	1000.00	192	160	10

Cost per rod of digging the trench, laying the tile, and blinding with four inches of earth (Wis. Sta.)

SIZE OF TILE	FEET IN DEPTH			
	3	4	5	6
<i>Inches</i>				
4	\$ 0.30	\$ 0.50	\$ 0.80	\$ 1.25
535	.55	0.85	1.30
640	.60	0.90	1.35
845	.65	0.95	1.40
1050	.70	1.00	1.45
1255	.75	1.05	1.50

Drainage points (Fippin).

1. Surface or open ditches are :
 - Of low efficiency,
 - Wasteful of land,
 - Expensive to maintain,
 - Harbor weeds,
 - Interfere with cultural operations.
2. Stone drains are :
 - Not permanent,
 - They have a small capacity,
 - Therefore, are expensive.

Ten good rules

1. Use dense, hard-burned tile.
2. Water enters through the joints.
3. Round or hexagonal shapes are best.
4. An even grade is essential.
5. Avoid tile smaller than three inches on low grades.
6. Hill land may need drainage.
7. Ditching plows are very useful.
8. Carefully construct and protect the outlet.
9. Depth in heavy clay, two to three feet.
10. Depth in loam and sandy loam, three to four feet.

Don'ts in land drainage (Jones, Wis. Sta.).

1. Don't dodge the wet spots in cultivated fields. A few dollars spent in drainage will make these spots yield valuable crops and will make the cultivation of the whole field more convenient.

2. Don't be content with raising marsh grass on muck and peat marshes. Drainage is the step that begins their adaptation to tame grasses and other farm crops.

3. Don't condemn the muck and peat marshes on which timothy has died out once. Drain thoroughly and then apply barnyard manure or commercial fertilizers, as is done on uplands. In other words, give the marshes a square deal.

4. Don't wait for nature to drain the wet lands without assist-

ance. Nature alone did not remove the stumps and stones from the wooded, stony lands. Neither does she irrigate the arid lands of the West without the aid of man.

5. Don't let damaging water get on to land, if it can be prevented. An ounce of prevention is worth a pound of cure in drainage.

6. Don't think it takes a wizard to lay tile properly. Have a survey made sufficient in detail to show that there is sufficient fall. An intelligent use of this fall will then insure success.

7. Don't install a part of a drainage system to which the remainder of the system cannot later be joined with advantage.

8. Don't let the waste banks of ditches grow up to weeds. Get them sodded, and make them both valuable and attractive.

9. Don't let outlet ditches remain idle when they should be working. Have surface ditches and tile to keep them busy.

10. Don't spend a dollar for small ditches or tile on a marsh until an outlet is assured.

11. Don't fail to give land drainage the attention and thought it deserves.

“Our marshes and pot-holes are evils that tell:
Where corn shocks are thickest the land is drained well,
But justice to drainage demands first of all,
That we should drain wisely, or not drain at all.”

Road-drags

Use of the King road-drag (Chase).

The use of the drag is more satisfactory if the road has first been crowned with a blade grader, but whenever this is not convenient and the traffic is not too heavy, the road may be gradually brought to a crown by means of the drag (Fig. 19).

The surface of the average country road should be covered in one round with the drag. One horse should be driven on the inside of the wheel track and the other on the outside, the drag being set, by means of the chain, so that it is running at an angle of about forty-five degrees with the wheel track and working the earth toward the center of the road. In the spring, when the roads are more likely to be rutty and soft it is generally better to go over the road twice and in some places more times.

The drag should be floored with boards which are separated by open spaces of sufficient width so that the dirt which falls over will rattle through, and yet they should be close enough so that the driver can move about upon the drag quite freely.

To insure the successful operation of the drag, it is necessary for the driver to use careful judgment. Sometimes it is essential that the blade be held down so that the drag will cut roots and weeds, while at other times the front edge should not bear too heavily upon the surface, as it will dig out a soft place which would be better if left undisturbed. This regulation of the cutting edge can be accomplished by the driver moving back and forth or to the right and left on the drag.

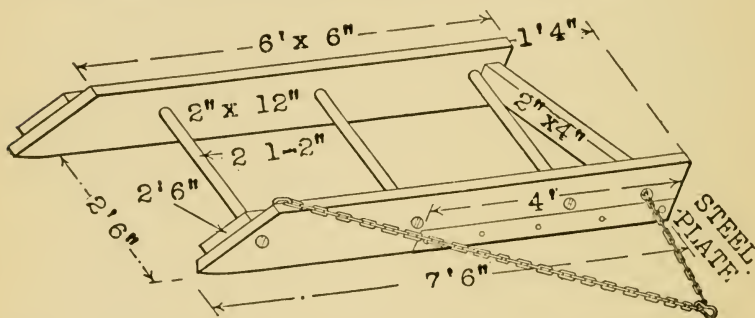

FIG. 19.—Road drag. It is faced part of the length on the front with a steel plate.

If the road is to be crowned with the drag, it is often well to plow a light furrow along the sides and work this loosened dirt to the center.

On roads with heavy traffic the drag should be used much oftener and with more care than on roads with light traffic.

The distance from the drag at which the team is hitched affects the cutting. A long hitch permits the blade to cut deeper than a short hitch, likewise a heavy doubletree will cause the cutting edge to settle deeper than a light one.

Strange as it may seem, the heavier the traffic over a properly dragged road the better the road becomes.

When to use the drag.—There are very few periods of the year when the use of the drag does not benefit the road, but it does the best work when the soil is moist and yet not too sticky. This is frequently within a half-day's time after a rain. When the earth is in this state

it works the best, and the effects of working it are fully as beneficial as at any other time. The Nebraska soils, when mixed with water and thoroughly worked become remarkably tough and impervious to rain, and if compacted in this condition they become extremely hard.

This action of the soil in becoming so hard and smooth not only helps to shed the water during a rain, but also greatly retards the formation of dust.

What may be expected from the use of the drag. — It often takes a whole season for the road to become properly puddled and baked to withstand the rains and traffic. After a road has been worked with a drag only a short time, it is not well to expect it to stand up to heavy traffic during a continued damp spell without being affected. However, it will take far heavier traffic than most earth roads receive to more than scuff up the surface.

It is not well to consider the benefits from a good road as solely confined to heavy traffic, for there is no doubt but that the time saved to light vehicles and the greater pleasure derived from their use over good roads far surpasses the economy in heavy hauling.

While driving over a well-crowned-smooth road, the team does not have to follow the usual rut, no slacking has to be made for irregularities in the surface, and it matters not whether one or two horses are being driven.

The split-log road-drag (D. W. King).

Two mistakes are commonly made in constructing a split-log drag. The first lies in making it too heavy. It should be so light that one man can easily lift it (Fig. 20).

The other mistake is in the use of squared timbers, instead of those with sharp edges, whereby the cutting effect of sharp edges is lost and the drag is permitted to glide over instead of to equalize the irregularities in the surface of the road. These mistakes are due partly to badly drawn illustrations and plans of drags which have occasionally appeared in newspapers, and partly to the erroneous idea that it is necessary that a large amount of earth shall be moved at one time.

A dry red cedar log is the best material for a drag. Red elm and walnut when thoroughly dried are excellent, and box elder, soft maple, or even willow are preferable to oak, hickory, or ash.

The log should be seven or eight feet long and from ten to twelve

inches in diameter, and carefully split down the middle. The heaviest and best slab should be selected for the front. At a point on this front slab 4 inches from the end that is to be at the middle of the road locate the center of the hole to receive a cross stake, and 22 inches from the other end of the front slab locate the center for another cross stake. The hole for the middle stake will lie on a line connecting and halfway between the other two. The back slab should now be placed in position behind the other. From the end which is to be

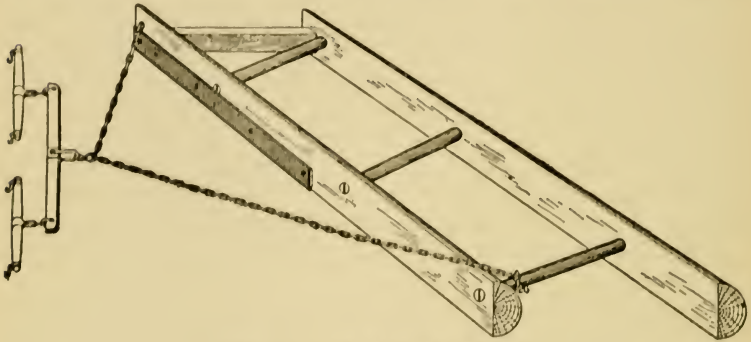

FIG. 20. — The split-log road-drag.

at the middle of the road measure 20 inches for the center of the cross stake, and 6 inches from the other end locate the center of the outside stake. Find the center of the middle hole as before. When these holes are brought opposite each other, one end of the back slab will lie 16 inches nearer the center of the roadway than the front one, giving what is known as "set back." The holes should be 2 inches in diameter. Care must be taken to hold the auger plumb in boring these holes in order that the stakes shall fit properly. The hole to receive the forward end of the chain should be bored at the same time.

The two slabs should be held 30 inches apart by the stakes. Straight-grained timber should be selected for the stakes, so that each stake shall fit snugly into the two-inch hole when the two slabs are in the proper position. The stakes should taper gradually toward the ends. There should be no shoulder at the point where the stakes enter the slab. The stakes should be fastened in place by wedges only.

When the stakes have been placed in position and tightly wedged,

a brace two inches thick and four inches wide should be placed diagonally to them at the ditch end. The brace should be dropped on the front slab, so that its lower edge shall lie within an inch of the ground, while the other end should rest in the angle between the slab and the end stake.

A strip of iron about $3\frac{1}{2}$ feet long, 3 or 4 inches wide, and $\frac{1}{4}$ of an inch thick may be used for the blade. This should be attached to the front slab, so that it will be $\frac{1}{2}$ inch below the lower edge of the slab at the ditch end, while the end of the iron toward the middle of the road should be flush with the edge of the slab. The bolts holding the blade in place should have flat heads, and the holes to receive them should be countersunk.

If the face of the log stands plumb, it is well to wedge out the lower edge of the blade with a three-cornered strip of wood to give it a set like the bit of a plane.

A platform of inch boards held together by three cleats should be placed on the stakes between the slabs. These boards should be spaced at least an inch apart to allow any earth that may heap up and fall over the front slab to sift through upon the road again.

Data on Water

1 U.S. gallon = 231 cu. in.

1 U.S. gallon = $8\frac{1}{8}$ lb.

1 cu. ft. water = 62.5 lb.

1 cu. ft. water = 7.48 gal.

Feet-head of water, and equivalent pressure

FEET-HEAD	POUNDS PER SQ. IN.	FEET-HEAD	POUNDS PER SQ. IN.	FEET-HEAD	POUNDS PER SQ. IN.
1	.43	60	25.99	200	86.62
2	.87	70	30.32	225	97.45
3	1.30	80	34.65	250	108.27
4	1.73	90	38.98	275	119.10
5	2.17	100	43.31	300	129.93
6	2.60	110	47.64	325	140.75
7	3.03	120	51.97	350	151.58
8	3.40	130	56.30	400	173.24
9	3.90	140	60.63	500	216.55
10	4.33	150	64.96	600	259.85
20	8.66	160	69.29	700	303.16
30	12.99	170	73.63	800	346.47
40	17.32	180	77.96	900	389.78
50	21.65	190	82.29	1000	433.09

Pressure and equivalent feet-head of water

POUNDS PER SQ. IN.	FEET-HEAD	POUNDS PER SQ. IN.	FEET-HEAD	POUNDS PER SQ. IN.	FEET-HEAD
1	2.31	40	92.36	170	392.52
2	4.62	50	115.45	180	415.61
3	6.93	60	138.54	190	438.90
4	9.24	70	161.63	200	461.78
5	11.54	80	184.72	225	519.51
6	13.85	90	207.81	250	577.24
7	16.16	100	230.90	275	643.03
8	18.47	110	253.98	300	692.69
9	20.78	120	277.07	325	750.41
10	23.09	125	288.62	350	808.13
15	34.63	130	300.16	375	865.89
20	46.18	140	323.25	400	922.58
25	57.72	150	346.34	500	1154.48
30	69.27	160	369.43	1000	2308.00

Table of equivalents for moving water

GALLONS PER MINUTE	MINER'S INCHES OF 9 GAL. PER MINUTE	CUBIC FEET PER MINUTE	GALLONS PER HOUR	42-GALLON BARREL		
				BBLs. PER MINUTE	BBLs. PER HOUR	BBLs. 24 HOURS
10	1.11	1.3368	600	.24	14.28	342.8
20	2.22	2.6733	1,200	.48	28.57	685.7
25	2.66	3.342	1,500	.59	35.71	857.0
27	3.0	3.609	1,620	.64	38.57	925.0
35	3.88	4.678	2,100	.83	50.0	1,200.0
36	4.0	4.812	2,160	.86	51.43	1,234.0
40	4.4	5.348	2,400	.95	57.14	1,371.0
45	5.0	6.015	2,700	1.07	64.28	1,543.0
75	8.33	10.026	4,500	1.78	107.14	2,581.0
80	8.88	10.694	4,800	1.90	114.28	2,742.0
90	10.0	12.031	5,400	2.14	128.5	3,085.0
100	11.1	13.368	6,000	2.39	142.8	3,428.0
125	13.8	16.710	7,500	2.98	178.6	4,286.0
150	16.6	20.052	9,000	3.57	214.3	5,143.0
175	19.4	23.394	10,500	4.16	250.0	6,000.0
180	20.0	24.062	10,800	4.28	257.0	6,171.0
225	25.0	30.079	13,500	5.35	321.4	7,714.0
250	26.7	33.421	15,000	5.95	357.1	8,570.0
270	30.0	36.093	16,200	6.33	385.7	9,257.0
360	40.0	48.125	21,600	8.57	514.3	12,342.0
400	44.4	53.472	24,000	9.52	571.8	13,723.0
450	50.0	60.158	27,000	10.7	642.8	15,428.0

Table of equivalents for moving water — Continued

GALLONS PER MINUTE	MINER'S INCHES OF 9 GAL. PER MINUTE	CUBIC FEET PER MINUTE	GALLONS PER HOUR	42-GALLON BARREL		
				BBLs. PER MINUTE	BBLs. PER HOUR	BBLs. 24 HOURS
500	55.5	66.842	30,000	11.9	714.3	17,143.0
540	60.0	72.186	32,400	12.8	771.3	18,512.0
600	66.0	80.208	36,000	14.3	857.1	20,570.0
630	70.0	84.218	37,800	15.0	900.0	21,600.0
675	75.0	90.234	40,500	16.0	964.0	23,143.0
720	80.0	96.25	43,200	17.0	1028.0	24,685.0
800	88.8	106.94	48,000	19.05	1142.0	27,387.0
900	100.0	120.31	54,000	21.43	1285.0	30,857.0
1000	111.1	133.68	60,000	23.95	1428.0	34,284.0
1350	150.0	180.46	81,000	32.14	1928.0	46,085.0
1500	166.0	200.52	90,000	35.71	2142.0	51,427.0
1800	200.0	240.62	108,000	42.85	2571.0	57,713.0
2000	222.0	267.36	120,000	47.64	2857.0	68,568.0
2500	266.0	334.21	150,000	59.52	3571.0	85,704.0
2700	300.0	360.93	162,000	63.33	3857.0	92,572.0
3000	333.0	401.04	180,000	71.43	4285.0	102,840.0

Foot-loss by friction of water through pipes, by gravity (Ogden)

The spring or other source used for a water-supply would have to be as much higher than the highest fixture is as shown in the table, in order to provide the pressure required to overcome the friction in the pipe. The table shows the force required to keep the water moving through a small pipe, expressed in number of feet of head, when the water flows by its own weight and is not forced by a pump :—

FLOW IN GALLONS PER MINUTE	HEAD IN FEET LOST BY FRICTION IN EACH 100 FEET OF LENGTH	
	½-inch pipe	1-inch pipe
0.5	4	
1.0	7	0.3
2.0	17	0.7
4.0	54	1.6
7.0	140	5.3
10.0	224	9.3

Friction-loss in pounds of water in pipes

Pounds pressure per square inch for each 100 feet of length in different size clean iron pipe, discharging given quantities water per minute.

GAL- LONS PER MIN- UTE	SIZES OF PIPE — INSIDE DIAMETER										
	$\frac{3}{4}$ in.	1 in.	1 $\frac{1}{4}$ in.	1 $\frac{1}{2}$ in.	2 in.	3 in.	4 in.	6 in.	8 in.	10 in.	12 in.
5	3.3	0.84	0.31	0.12	0.03	—	—	—	—	—	—
10	13.0	3.16	1.05	0.47	0.12	—	—	—	—	—	—
15	28.7	6.98	2.38	0.97	0.27	—	—	—	—	—	—
20	50.4	12.3	4.07	1.66	0.42	0.03	—	—	—	—	—
25	78.0	19.0	6.40	2.62	0.67	0.10	—	—	—	—	—
30	—	27.5	9.15	3.75	0.91	0.12	0.03	—	—	—	—
35	—	37.0	12.4	5.05	1.26	0.14	0.05	—	—	—	—
40	—	48.0	16.1	6.52	1.60	0.17	0.06	—	—	—	—
45	—	—	20.2	8.15	2.01	0.27	0.07	—	—	—	—
50	—	—	24.9	10.0	2.44	0.35	0.09	—	—	—	—
75	—	—	56.1	22.4	5.32	0.74	0.21	0.03	—	—	—
100	—	—	—	39.0	9.46	1.31	0.33	0.05	—	—	—
125	—	—	—	—	14.9	1.99	0.51	0.07	—	—	—
150	—	—	—	—	21.2	2.85	0.69	0.10	0.02	—	—
175	—	—	—	—	28.1	3.85	0.95	0.14	0.03	—	—
200	—	—	—	—	37.5	5.02	1.22	0.17	0.05	0.01	—
250	—	—	—	—	—	7.76	1.89	0.26	0.07	0.03	0.01
300	—	—	—	—	—	11.2	2.66	0.37	0.09	0.04	—

GAL- LONS	3 in.	4 in.	5 in.	6 in.	7 in.	10 in.	12 in.	16 in.	20 in.	24 in.	30 in.
350	15.2	3.65	1.28	0.50	0.25	0.05	0.02	—	—	—	—
400	19.5	4.73	1.68	0.65	0.32	0.06	—	—	—	—	—
450	25.0	6.01	2.10	0.81	0.42	0.07	0.03	—	—	—	—
500	30.8	7.43	2.70	0.96	0.49	0.09	0.04	0.009	—	—	—
600	—	10.6	3.45	1.72	0.86	0.13	0.05	—	—	—	—
750	—	—	5.40	2.21	1.11	0.18	0.08	—	—	—	—
1000	—	—	9.60	3.88	1.91	0.32	0.13	0.036	—	—	—
1250	—	—	—	—	—	0.49	0.20	—	—	—	—
1500	—	—	—	—	—	0.70	0.29	0.71	—	—	—
1750	—	—	—	—	—	0.95	0.38	—	—	—	—
2000	—	—	—	—	—	1.23	0.49	0.123	—	—	—
2500	—	—	—	—	—	—	0.77	0.188	—	—	—
3000	—	—	—	—	—	—	1.11	0.267	0.09	—	—
3500	—	—	—	—	—	—	—	0.365	0.124	—	—
4000	—	—	—	—	—	—	—	0.47	0.158	0.067	0.022
4500	—	—	—	—	—	—	—	0.593	0.20	0.08	0.027
5000	—	—	—	—	—	—	—	0.73	0.244	0.102	0.035

Friction-head in feet in clean wrought-iron pipe for each 100 feet of length when discharging various quantities of water from a windmill (Fuller)

If the water is to be carried some distance from the pump to a reservoir in the use of windmills in irrigation, then the pipe-line conveying the water to the reservoir will offer friction to the flow, and this friction expressed in feet should be added in determining the total head against which the pump must operate.

GAL- LONS PER MIN- UTE	FRICTION-HEAD IN PIPE, WITH DIAMETER OF —													SIZE OF PIPE TO USE FOR ECONOMI- CAL DIS- TRIBU- TION	
	¾ in.	1 in.	1¼ in.	1½ in.	2 in.	2½ in.	3 in.	4 in.	5 in.	6 in.	7 in.	8 in.	10 in.		12 in.
	Feet	Feet	Feet	Feet	Feet	Feet	Feet	Feet	Feet	Feet	Feet	Feet	Feet	Feet	Inches
5	7.60	1.93	0.71	0.27	0.07	—	—	—	—	—	—	—	—	—	1.5
10	29.95	7.28	2.42	1.08	0.28	0.07	—	—	—	—	—	—	—	—	2.0
15	66.12	16.08	5.48	2.23	0.62	0.14	—	—	—	—	—	—	—	—	2.0
20	116.12	28.33	9.37	3.82	0.97	0.30	0.07	—	—	—	—	—	—	—	2.0
25	179.71	43.77	14.74	6.03	1.53	0.48	0.23	—	—	—	—	—	—	—	2.5
30	—	63.36	21.08	8.64	2.09	0.69	0.28	0.07	—	—	—	—	—	—	2.5
35	—	85.24	28.56	11.63	2.90	0.96	0.32	0.11	—	—	—	—	—	—	2.5
40	—	110.59	37.09	15.02	3.68	1.17	0.39	0.13	—	—	—	—	—	—	3.0
45	—	—	46.54	18.77	4.63	1.42	0.62	0.16	—	—	—	—	—	—	3.0
50	—	—	57.37	23.04	5.62	1.86	0.80	0.20	0.07	—	—	—	—	—	3.0
75	—	—	129.25	51.61	12.25	4.14	1.70	0.48	0.13	0.07	—	—	—	—	4.0
100	—	—	—	89.85	21.79	7.37	3.01	0.76	0.27	0.11	—	—	—	—	5.0
125	—	—	—	—	34.33	11.26	4.58	1.17	0.39	0.16	—	—	—	—	5.0
150	—	—	—	—	48.84	19.12	6.56	1.58	0.57	0.23	—	—	0.05	—	6.0
175	—	—	—	—	64.74	21.76	8.87	2.18	0.78	0.32	0.07	0.07	—	—	6.0
200	—	—	—	—	86.40	28.73	11.56	2.80	0.97	0.39	0.18	0.11	0.02	—	6.0
250	—	—	—	—	—	15.29	17.87	4.34	1.49	0.60	0.30	0.16	0.07	0.02	7.0
300	—	—	—	—	—	64.65	25.80	6.12	2.13	0.85	0.41	0.20	0.09	—	8.0

Suppose, it is desired to deliver 60 gallons of water per minute through a pipe-line 100 feet long. The table shows that a 3-inch line delivers 50 gallons per minute at a loss of 0.8 foot head, and a 4-inch line 75 gallons per minute with 0.48-foot loss. The size desired is therefore between 3 and 4 inches, and as no intermediate size is made in wrought-iron pipe, the 4-inch pipe is best, and the total head to pump against would be 25 + 3 + 0.48, or a total of 28.48 feet.

Barometric pressure at different altitudes, as affecting pumps

With equivalent head of water and the vertical suction lift of pumps

ALTITUDE	BAROMETRIC PRESSURE	EQUIVALENT HEAD OF WATER	PRACTICAL SUCTION LIFT OF PUMPS
Sea level	14.70	33.95	25
$\frac{1}{4}$ mile, 1,320 ft.	14.02	32.38	24
$\frac{1}{2}$ mile, 2,640 ft.	13.33	30.79	22
$\frac{3}{4}$ mile, 3,960 ft.	12.66	29.24	21
1 mile, 5,280 ft.	12.02	27.76	20
$1\frac{1}{4}$ mile, 6,600 ft.	11.42	26.38	19
$1\frac{1}{2}$ mile, 7,920 ft.	10.88	25.13	18
2 miles, 10,560 ft.	9.88	22.82	16

Windmill Figures*Windmills for pumping (Rayner).*

Windmills vary in type and efficiency from a four-arm direct-connected paddle wheel, erected on a single post, to the modern curved blade, back-gearred, steel windmill, erected on a scientifically constructed steel tower.

To select a proper-sized windmill for the purpose required, the speed of the wind in the particular locality should be considered. In the United States, this information can be readily secured from the nearest weather bureau station. When the average speed is above eight miles per hour, throughout the year, the following table may be followed safely :—

	LIFT (ft.)
8-ft. diameter windmill	3 -inch diameter pump, 40
8-ft. diameter windmill	2½-inch diameter pump, 70
10-ft. diameter windmill	3 -inch diameter pump, 70
10-ft. diameter windmill	2½-inch diameter pump, 120
12-ft. diameter windmill	3 -inch diameter pump, 100
12-ft. diameter windmill	2½-inch diameter pump, 180
12-ft. diameter windmill	2¼-inch diameter pump, 200
12-ft. diameter windmill	2 -inch diameter pump, 300

When the average speed of the wind is less than given above, a proportionally larger diameter windmill should be chosen.

In the lift that is required of the pump, the elevation above the ground to the top of the elevated tank or cistern should be added to the depth of the well.

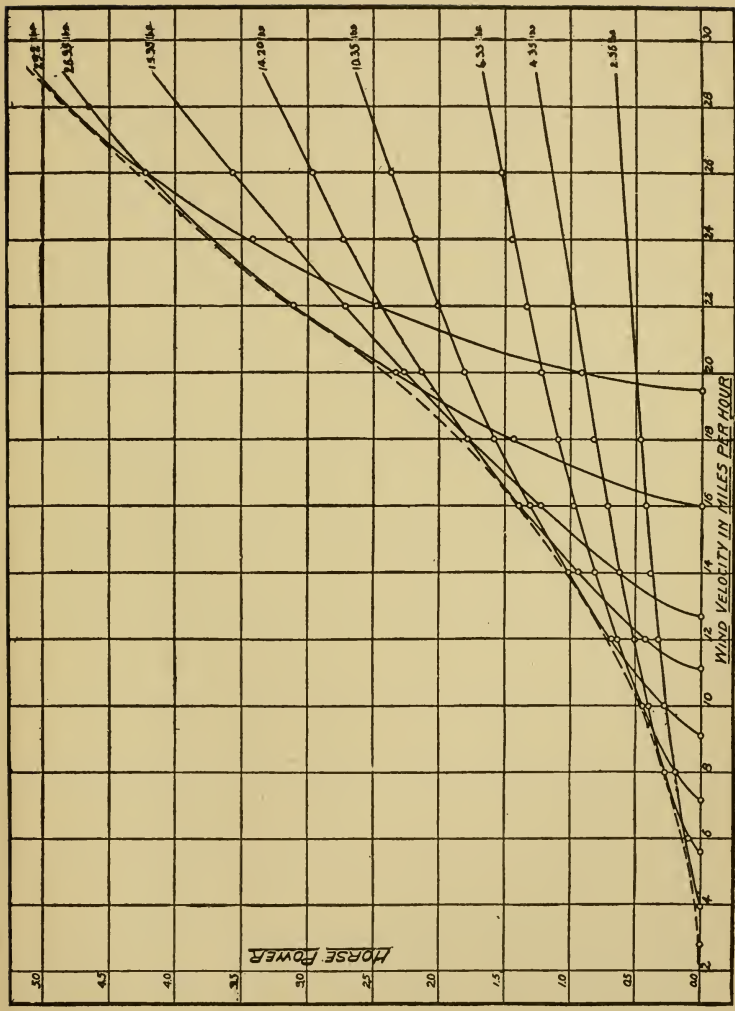

FIG. 21. — Diagram to show power developed by 14-foot windmill, with different loads in different velocities. Figures in the right-hand column are pounds (Fuller).

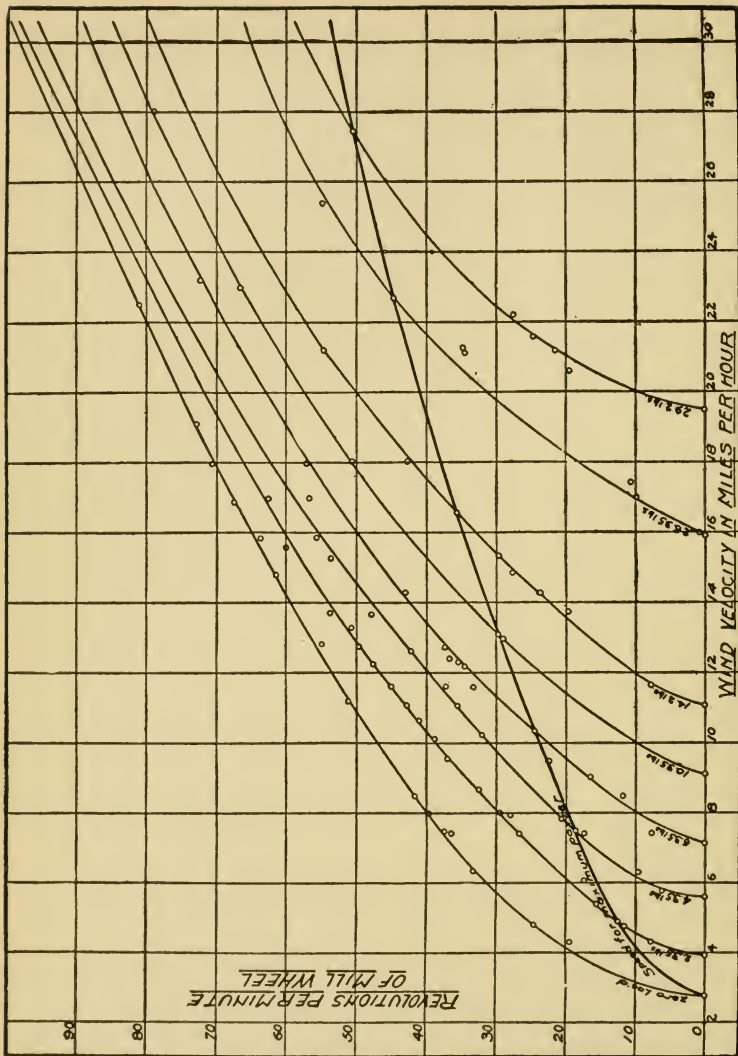

Fig. 22. — Diagram to show speed of wheel of 14-foot windmill in different wind velocities with different loads. Figures at ends of curves are pounds (Fuller).

Loading and speed of 14-foot power windmill when developing its maximum power (Fuller)

WIND VELOCITY— MILES PER HOUR	HORSE-POWER	SPEED OF WHEEL— REVOLUTIONS PER MINUTE	LOAD IN POUNDS PER STROKE
0-5	0.01	2.0	—
6-10	0.27	20.0	4.35
11-15	0.85	29.5	10.35
16-20	1.80	38.0	14.20
21-25	3.45	45.0	26.35
26-30	4.82	51.0	29.20
31-35	5.60	55.0	31.00

Sizes of circular reservoirs and estimated cost for various areas of land to be irrigated from windmills (Fuller)

The following table gives the dimensions of circular reservoirs of different capacities ; the quantities of earth in the embankments, if these have inside slopes of three to one and outside slopes of one to one ; the areas which can be irrigated, provided the reservoir full of water is used once in ten days throughout five months and the land receives water to a depth of one foot ; the sizes of mills recommended, and the costs of reservoirs and mills. The lift assumed in choosing the mills is 14 feet :—

Gross Capacity of Reservoir, Acre-ft.	Depth of Reservoir, Ft.	Diameter at Bottom Em- bankment, Ft.	Diameter at Top of Em- bankment, Ft.	Bottom Width of Em- bankment, Ft.	Top Width Em- bankment, Ft.	Amount of Fill Required, Cu. Yds.	Number and Size of Mills Recommended	Estimated Cost of Reservoir	Estimated Cost of Plant Erected and Completed ¹	Area Irrigated Acres
0.07	4	21.30	45.30	19	3	212.00	1 8-foot	\$21.20	\$81	1
0.16	4	34.96	58.96	19	3	281.52	1 8-foot	28.15	88	2
0.24	4	45.62	69.62	19	3	336.25	1 10-foot	33.62	113	3
0.32	4	54.61	78.61	19	3	381.88	1 10-foot	38.18	119	4
0.40	4	62.27	86.27	19	3	422.46	1 12-foot	42.24	202	5
0.49	5	58.58	88.58	24	4	684.71	2 10-foot	68.47	228	6
0.56	5	63.64	93.64	24	4	725.80	2 12-foot	72.58	392	7
0.63	5	69.00	99.00	24	4	747.75	3 12-foot	74.77	550	8
0.72	5	74.37	104.37	24	4	813.51	3 12-foot	81.35	561	9
0.80	5	79.36	109.36	24	4	854.16	3 12-foot	85.41	565	10

¹ Not including well.

Average cost of windmills of different sizes, and areas irrigated by them in Colorado (Fuller)

NUMBER OF MILLS	SIZE OF MILLS	AVERAGE COST	AVERAGE AREA
18	8	\$102	0.7
12	10	198	1.8
9	12	195	2.4
8	14	265	3.8
2	16	188	3.6

Machinery and Motors

Rules for widths of belting

d = diameter of either driving or driven pulley in inches.

n = number of revolutions per minute of pulley considered.

w_4 = width in inches of single leather belting or of 4-ply canvas or 4-ply rubber belting.

w_5 = width in inches of 5-ply canvas or of 5-ply rubber belting.

w_6 = width in inches of double leather belting or 6-ply canvas or 6-ply rubber belting.

H.P. = Horse-power to be transmitted by belt.

Rule: — $w_4 = 3000 \frac{H.P.}{dn}$

$w_5 = \frac{3}{4} w_4.$

$w_6 = \frac{1}{5} w_4.$

Rules for determining size and speed of pulleys or gears

The driving pulley is called the Driver, and the driven pulley the Driven.

To determine the diameter of Driver, the diameter of the Driven and its revolutions, and also revolutions of Driver, being given.

$$\frac{\text{Diam. of Driven} \times \text{revolutions of Driven}}{\text{Revolutions of Driver}} = \text{Diam. of Driver.}$$

To determine the diameter of Driven, the revolutions of the Driven and diameter and revolutions of the Driver being given.

$$\frac{\text{Diam. of Driver} \times \text{revolutions of Driver}}{\text{Revolutions of Driven}} = \text{Diam. of Driven.}$$

To determine the revolutions of the Driver, the diameter and revolutions of the Driven and diameter of the Driver being given.

$$\frac{\text{Diam. of Driven} \times \text{revolutions of Driven}}{\text{Diameter of Driver}} = \text{Rev. of Driver.}$$

To determine the revolutions of the Driven, the diameter and revolutions of the Driver, and diameter of the Driven being given.

$$\frac{\text{Diam. of Driver} \times \text{revolutions of Driver}}{\text{Diameter of Driven}} = \text{Rev. of Driven.}$$

If the number of teeth in gears is used instead of diameter, in these calculations, number of teeth must be substituted wherever diameter occurs.

DIAM. OF CYL. INS.	AREA, SQUARE INCHES	LENGTH OF STROKE IN INCHES																	
		2	4	5	6	8	9	10	12	14	16	18	20	24					
1/2	0.196	0.003	0.004	0.004	0.005	0.007	0.008	0.009	0.010	0.012	0.012	0.015	0.017	0.020	0.024	0.027	0.032		
5/16	0.307	0.005	0.007	0.008	0.011	0.015	0.017	0.019	0.023	0.027	0.031	0.034	0.037	0.042	0.047	0.052	0.062		
3/4	0.442	0.008	0.010	0.013	0.016	0.021	0.023	0.026	0.031	0.036	0.042	0.045	0.048	0.054	0.061	0.068	0.082		
7/8	0.601	0.005	0.010	0.013	0.017	0.020	0.027	0.033	0.034	0.041	0.048	0.054	0.061	0.068	0.076	0.086	0.107		
1	0.785	0.007	0.014	0.017	0.020	0.027	0.033	0.048	0.053	0.064	0.074	0.085	0.096	0.106	0.116	0.127	0.154		
1 1/4	1.227	0.011	0.021	0.027	0.032	0.043	0.048	0.069	0.077	0.092	0.107	0.122	0.138	0.153	0.168	0.184	0.229		
1 1/2	1.629	0.015	0.031	0.038	0.046	0.061	0.069	0.099	0.104	0.125	0.146	0.167	0.187	0.208	0.229	0.259	0.321		
1 3/4	2.405	0.021	0.042	0.052	0.063	0.083	0.094	0.124	0.125	0.146	0.170	0.187	0.208	0.229	0.259	0.299	0.386		
2	3.142	0.027	0.054	0.068	0.082	0.108	0.122	0.152	0.153	0.174	0.200	0.218	0.240	0.262	0.284	0.326	0.433		
2 1/4	3.976	0.034	0.069	0.086	0.103	0.133	0.155	0.172	0.206	0.241	0.275	0.309	0.344	0.383	0.425	0.510	0.661		
2 1/2	4.909	0.043	0.085	0.106	0.128	0.170	0.191	0.213	0.255	0.298	0.340	0.383	0.425	0.474	0.510	0.617	0.811		
2 3/4	5.940	0.051	0.103	0.129	0.154	0.206	0.231	0.257	0.309	0.360	0.411	0.463	0.514	0.565	0.617	0.744	1.000		
3	7.069	0.061	0.122	0.153	0.184	0.245	0.275	0.306	0.367	0.428	0.489	0.551	0.612	0.673	0.734	0.884	1.200		
3 1/4	8.296	0.072	0.144	0.179	0.215	0.287	0.323	0.359	0.431	0.503	0.575	0.647	0.718	0.789	0.862	1.040	1.400		
3 1/2	9.621	0.083	0.167	0.208	0.249	0.333	0.375	0.417	0.499	0.583	0.666	0.750	0.833	0.916	0.999	1.200	1.600		
3 3/4	11.045	0.095	0.191	0.239	0.287	0.382	0.430	0.478	0.574	0.669	0.765	0.861	0.956	1.051	1.147	1.380	1.840		
4	12.566	0.109	0.218	0.272	0.326	0.435	0.490	0.544	0.653	0.762	0.870	0.979	1.088	1.197	1.460	1.960	2.560		
4 1/4	14.186	0.123	0.246	0.307	0.368	0.491	0.553	0.614	0.737	0.860	0.982	1.105	1.228	1.351	1.640	2.200	2.960		
4 1/2	15.904	0.138	0.275	0.344	0.413	0.551	0.619	0.689	0.826	0.964	1.102	1.239	1.377	1.514	1.840	2.480	3.360		
4 3/4	17.721	0.153	0.307	0.384	0.460	0.614	0.690	0.767	0.920	1.073	1.227	1.380	1.534	1.841	2.480	3.360	4.480		
5	19.635	0.170	0.340	0.425	0.510	0.680	0.765	0.850	1.020	1.190	1.360	1.530	1.700	2.040	2.720	3.600	4.800		
5 1/4	21.648	0.187	0.375	0.469	0.562	0.750	0.843	0.937	1.124	1.311	1.499	1.686	1.874	2.248	2.960	3.960	5.200		
5 1/2	23.758	0.206	0.411	0.514	0.617	0.823	0.926	1.029	1.234	1.440	1.646	1.851	2.057	2.468	3.240	4.320	5.680		
5 3/4	25.967	0.225	0.449	0.562	0.674	0.899	1.011	1.124	1.348	1.573	1.798	2.022	2.248	2.696	3.520	4.640	6.160		
6	28.274	0.245	0.489	0.612	0.734	0.979	1.102	1.224	1.469	1.714	1.958	2.202	2.448	2.938	3.840	5.000	6.560		
6 1/4	30.680	0.266	0.531	0.664	0.797	1.062	1.195	1.328	1.593	1.859	2.124	2.390	2.656	3.186	4.160	5.440	7.200		
6 1/2	33.183	0.287	0.574	0.718	0.861	1.149	1.293	1.436	1.796	2.011	2.298	2.589	2.873	3.447	4.520	5.920	7.840		
6 3/4	35.785	0.309	0.619	0.775	0.929	1.239	1.394	1.549	1.858	2.168	2.479	2.788	3.098	3.716	4.800	6.240	8.240		
7	38.485	0.333	0.666	0.833	0.999	1.333	1.499	1.666	1.999	2.332	2.666	2.999	3.332	3.998	5.120	6.640	8.800		
7 1/4	44.179	0.383	0.765	0.956	1.148	1.530	1.721	1.913	2.295	2.678	3.060	3.443	3.825	4.590	5.920	7.640	10.000		
7 1/2	47.173	0.408	0.817	1.021	1.225	1.633	1.837	2.042	2.450	2.858	3.267	3.675	4.084	4.900	6.320	8.240	10.800		
8	50.266	0.435	0.870	1.088	1.306	1.741	1.958	2.176	2.611	3.046	3.482	3.917	4.352	5.222	6.720	8.800	11.600		
8 1/2	56.745	0.491	0.982	1.225	1.473	1.964	2.210	2.456	2.947	3.438	3.929	4.420	4.912	5.894	7.640	10.000	13.200		
9	60.132	0.520	1.041	1.301	1.561	2.082	2.342	2.603	3.123	3.644	4.164	4.685	5.206	6.240	8.160	10.640	14.000		
9 1/4	63.617	0.551	1.101	1.377	1.652	2.203	2.479	2.754	3.305	3.856	4.406	4.957	5.508	6.600	8.640	11.200	14.800		
9 1/2	70.882	0.613	1.227	1.534	1.840	2.454	2.761	3.068	3.681	4.295	4.908	5.523	6.136	7.344	9.600	12.400	16.400		
10	78.540	0.680	1.360	1.700	2.040	2.720	3.040	3.360	4.080	4.760	5.440	6.120	6.800	8.160	10.400	13.600	18.000		
15	176.715	1.530	3.060	3.825	4.590	6.120	6.885	7.650	9.178	10.710	12.240	13.770	15.300	18.360	23.600	30.800	40.000		
16	201.062	1.740	3.481	4.351	5.221	6.962	7.910	8.703	10.443	12.184	13.924	15.665	17.406	20.887	27.200	35.200	45.600		
18	254.470	2.202	4.404	5.506	6.607	8.809	9.910	11.012	13.214	15.416	17.619	19.821	22.024	26.428	34.400	44.800	58.400		
20	314.160	2.720	5.440	6.800	8.160	10.880	12.240	13.600	16.320	19.040	21.760	24.480	27.200	32.640	42.400	54.400	70.400		

Capacity per Stroke in Gallons or Decimal Parts Thereof

Table of power required to operate high-grade triplex pumps

The estimates given in the table are made with a liberal allowance of power. The power for other capacities and heights is, approximately, in proportion to that tabulated. By "head" is meant the vertical distance from surface of water supply to point of delivery. One foot head is equivalent to .43 pound pressure. The head is increased by the friction of the water in pipes and elbows.

General service pumps

DIAMETER AND STROKE OF PUMP		USUAL CAPACITY PER MINUTE	50 FEET HEAD OR 21 POUNDS PRESSURE	100 FEET HEAD OR 43 POUNDS PRESSURE	150 FEET HEAD OR 65 POUNDS PRESSURE	250 FEET HEAD OR 108 POUNDS PRESSURE	350 FEET OR HEAD 150 POUNDS PRESSURE
in.		gal.	h. p.	h. p.	h. p.	h. p.	h. p.
Single Acting	1¼ × 2	1.8	0.50	0.50	0.50	0.50	0.50
	1¾ × 2½	4.2	0.50	0.50	0.65	0.85	1.12
	2 × 3	6.0	0.50	0.50	0.70	1.05	1.33
	2½ × 4	12.0	0.60	1.0	1.36	1.85	2.33
	3 × 4	18.0	0.75	1.1	1.6	2.5	3.15
	3½ × 4	25.0	0.83	1.3	1.8	2.7	3.25
	4 × 4	32.0	1.2	1.5	2.0	3.0	4.0
	4 × 6	50.0	1.9	2.5	3.1	4.8	6.25
	5 × 6	75.0	2.0	3.5	4.0	6.25	8.75
	5 × 8	90.0	2.5	4.0	5.0	7.5	10.5
	5½ × 8	110.0	3.0	4.5	6.0	9.7	12.5
	6 × 8	132.0	3.6	4.5	7.0	11.0	15.5
	6 × 10	154.0	4.05	6.0	8.0	12.75	17.8
	6½ × 8	153.0	4.25	6.0	8.0	12.75	17.8
	7 × 8	180.0	5.0	7.0	9.5	15.0	21.0
	7 × 10	209.0	5.25	7.8	10.75	17.25	23.33
	8 × 8	234.0	5.85	9.0	12.0	19.5	25.5
	8 × 10	273.0	7.0	10.5	15.0	22.75	30.0
	8 × 12	312.0	8.25	12.0	17.0	26.0	34.0
	9 × 10	344.0	8.50	13.0	18.0	28.0	37.5
10 × 10	428.0	10.6	16.2	22.5	35.0	46.8	
11 × 10	516.0	12.7	19.5	27.0	42.0	56.2	
12 × 10	617.0	15.3	23.4	32.4	50.4	67.5	
Double Acting	8½ × 12	352.0	8.5	14.0	19.0	28.0	38.0
	9 × 12	396.0	9.5	15.6	21.3	31.3	42.5
	4 × 6	94.0	2.4	3.9	5.2	7.5	10.1
	4½ × 8	140.0	3.5	5.9	7.8	11.2	15.2
	5 × 8	175.0	4.4	7.3	9.75	14.0	19.0
	5½ × 8	211.0	5.3	8.8	11.7	17.0	22.8
	6 × 8	252.0	5.75	10.2	13.5	20.0	27.0
	6½ × 8	297.0	6.75	12.0	16.0	23.5	31.7
	7 × 8	346.0	8.5	13.0	18.0	28.0	37.0
	7 × 10	411.0	9.35	15.7	21.5	32.5	44.0
	8 × 10	533.0	12.0	20.0	28.5	42.0	58.0
	8 × 12	612.0	14.0	24.0	33.0	50.0	68.0
8½ × 12	684.0	15.7	26.5	36.7	55.0	75.0	
9 × 12	776.0	18.0	29.8	40.0	62.0	84.0	
10 × 12	952.0	21.6	36.6	50.0	76.0	103.0	

Table of theoretical horse-power required to raise water to different heights

Allowance should be made for friction; for ordinary pumps, allow twice the power given in table.

FEET	5	10	20	25	30	45	60	75	100	125	150	175	350	400
Gals per min.														
5	.006	0.012	0.025	0.031	0.037	0.06	0.07	0.09	0.12	0.16	0.19	0.22	0.44	0.50
10	.012	0.025	0.050	0.062	0.075	0.11	0.15	0.19	0.25	0.31	0.37	0.44	0.87	1.00
15	.019	0.037	0.075	0.094	0.112	0.17	0.22	0.28	0.37	0.47	0.56	0.66	1.31	1.50
20	.025	0.050	0.100	0.125	0.150	0.22	0.30	0.37	0.50	0.62	0.75	0.87	1.75	2.00
25	.031	0.062	0.125	0.156	0.187	0.28	0.37	0.47	0.62	0.78	0.94	1.09	2.19	2.50
30	.037	0.075	0.150	0.187	0.225	0.34	0.45	0.56	0.75	0.94	1.12	1.31	2.62	3.00
35	.043	0.087	0.175	0.219	0.262	0.39	0.52	0.66	0.87	1.08	1.31	1.53	3.06	3.50
40	.050	0.100	0.200	0.250	0.300	0.45	0.60	0.75	1.00	1.25	1.50	1.75	3.50	4.00
45	.056	0.112	0.225	0.281	0.337	0.51	0.67	0.84	1.12	1.41	1.69	1.97	3.94	4.50
50	.062	0.125	0.250	0.312	0.375	0.56	0.75	0.94	1.25	1.56	1.87	2.19	4.37	5.00
60	.075	0.150	0.300	0.375	0.450	0.67	0.90	1.12	1.50	1.87	2.25	2.62	5.25	6.00
75	.093	0.187	0.375	0.469	0.562	0.84	1.12	1.40	1.87	2.34	2.81	3.28	6.56	7.50
90	.112	0.225	0.450	0.562	0.675	1.01	1.35	1.68	2.25	2.81	3.37	3.94	7.87	9.00
100	.125	0.250	0.500	0.625	0.750	1.12	1.50	1.87	2.50	3.12	3.75	4.37	8.75	10.00
125	.156	0.312	0.625	0.781	0.937	1.41	1.87	2.34	3.12	3.91	4.69	5.47	10.94	12.50
150	.187	0.375	0.750	0.937	1.125	1.69	2.25	2.81	3.75	4.69	5.62	6.56	13.12	15.00
175	.219	0.437	0.875	1.093	1.312	1.97	2.62	3.28	4.37	5.47	6.56	7.66	15.31	17.50
200	.250	0.500	1.000	1.250	1.500	2.25	3.00	3.75	5.00	6.25	7.50	8.75	17.50	20.00
250	.312	0.625	1.250	1.562	1.875	2.81	3.75	4.69	6.25	7.81	9.37	10.94	21.87	25.00
300	.375	0.750	1.500	1.875	2.250	3.37	4.50	5.62	7.50	9.37	11.25	13.12	26.25	30.00
350	.437	0.875	1.750	2.187	2.625	3.94	5.25	6.56	8.75	10.94	13.12	15.31	30.62	35.00
400	.500	1.000	2.000	2.500	3.000	4.50	6.00	7.50	10.00	12.50	15.00	17.50	35.00	40.00
500	.625	1.250	2.500	3.125	3.750	5.62	7.50	9.37	12.50	15.62	18.75	21.87	43.75	50.00

Horse-power of steel shafting

For line-shaft service

Shaft Sizes In.	REVOLUTIONS PER MINUTE									
	100	125	150	175	200	225	250	300	350	400
1½	2.4	3.1	3.7	4.3	4.9	5.5	6.1	7.3	8.5	9.7
1¾	4.3	5.3	6.4	7.4	8.5	9.5	10.5	12.7	14.8	16.9
1½	6.7	8.4	10.1	11.7	13.4	15.1	16.7	20.1	23.4	26.8
1½	10.0	12.5	15.0	17.5	20.0	22.5	25.0	30.0	35.0	40.0
2½	14.3	17.8	21.4	24.9	28.5	32.1	35.6	42.7	49.8	57.0
2½	19.5	24.4	29.3	34.1	39.0	44.1	48.7	58.5	68.2	78.0
2½	26.0	32.5	39.0	43.5	52.0	58.5	65.0	78.0	87.0	104.0
2½	33.8	42.2	50.6	59.1	67.5	75.9	84.4	101.3	118.2	135.0
3½	43.0	53.6	64.4	75.1	85.8	96.6	107.3	128.7	150.3	171.6
3½	53.6	67.0	79.4	93.8	107.2	120.1	134.0	158.8	187.6	214.4
3½	65.9	82.4	97.9	115.4	121.8	148.3	164.8	195.7	230.7	243.6
3½	80.0	100.0	120.0	140.0	160.0	160.0	200.0	240.0	280.0	320.0
4½	113.9	142.4	170.8	199.3	227.8	256.2	284.7	341.7	398.6	455.6
4½	156.3	195.3	234.4	273.4	312.5	351.5	390.6	468.7	546.8	625.0
5½	207.9	260.0	311.9	363.9	415.9	459.9	520.0	623.9	727.9	830.0
6	270.0	337.5	405.0	472.5	540.0	607.5	675.0	810.0	945.0	1080.0
6½	343.3	429.0	514.9	600.7	686.5	772.4	858.0	1029.0	1201.0	1372.0
7	428.8	535.9	643.1	750.3	847.5	964.7	1071.9	1286.0	1500.0	1695.0
8	640.0	800.0	960.0	1126.0	1280.0	1440.0	1600.0	1920.0	2240.0	2560.0

Electric appliances on the farm.

Many electrically-operated machines and devices are now on the market. The list is being added to rapidly. The following tabulation will give some idea of the development along these lines, aside from electric lighting and house wiring :—

<i>Device</i>	<i>Horse-power Required</i>
Cream separator	½ to 4
Milking machine	3 to 5
Grindstone	½
Bottle-washer	½
Water-pump	1 to 10
Shredder	10 to 15
Silage-grinder	10 to 20
Feed-grinder	5 to 10
Threshing	10 to 20
Wood-saw	3 to 5
Corn-sheller	1 to 4
Hay-press	4 to 25
Refrigerating	½ to 25

The motor power of a stream (Rose).

The power of a stream may be calculated by the following formula : $P = Aw h$, in which A is the number of cubic feet of water falling in one second of time, w is the weight of a cubic foot of water, and h is the head or height through which the water falls. To reduce this to horse-

power the formula should read : $H.P. = \frac{A w h e}{550}$, in which e represents

the efficiency, in percentage, of the type of wheel to be used. The efficiencies of the various types of water-motors run about as follows :—

	<i>Per Cent</i>
Undershot water-wheels	35
Poucellet wheels	60
Breast wheels	55
High breast wheels	60
Overshot wheels	68
Pelton wheels	75
Turbines	60-80
Water-pressure engines	80
Rams	60

These values are only approximate, and may vary either way several per cent.

Hydraulic rams (Ogden).

The following table gives data as to size, capacity, and cost of hydraulic rams:—

SIZE	FLOW OF SPRING PER MIN.	DRIVE	DISCHARGE	WATER PUMPED PER MIN.	COST OF RAM
	gal.			gal.	
No. 2	1	$\frac{3}{4}$	$\frac{1}{2}$	$\frac{1}{7}$	\$6.00
No. 4	5	$1\frac{1}{4}$	$\frac{1}{2}$	1	8.00
No. 6	20	$2\frac{1}{2}$	1	3	15.00
No. 10	50	4	2	7	35.00

This table is based on the assumption that the length of discharge pipe is not over 100 feet, and that the head against which the ram works is not over five times as great as the fall of the stream. The drive pipe should always be made as short as the conditions will permit. In winter the ram may be kept from freezing by housing it and providing a small coal fire for the coldest weather.

Hot-air engines (Ogden).

The following table gives data of sizes, capacities, fuel cost, of the hot-air engines commonly used:—

DIAMETER OF CYLINDER	SIZE OF PIPE	FUEL CONSUMPTION PER HOUR			CAPACITY IN GAL.	COST
		Gas cu. ft.	Keros'e qt.	Coal lb.		
inch						
5	$\frac{3}{4}$	13	$\frac{1}{2}$	2	150	\$100
6	1	16	$\frac{3}{4}$	3	300	140
8	$1\frac{1}{4}$	20	1	4	500	175
10	$1\frac{1}{2}$	50	2	5	1000	250

CHAPTER XXVI

MASON WORK. CEMENTS, PAINTS, GLUES AND WAXES

ANY material that sets or hardens when dry is a cement ; and under this general name may therefore be included glues and materials used for mending or sticking together broken articles. As commonly used, however, the word *cement* now refers to building or construction material, used by masons.

The formulas here given are largely for home-made compounds, and many of them are old-fashioned.

Building or Mason's Cement; Gravel, and Pitch

Two kinds of building cement comprise the common construction grades in this country, — natural-rock cement (Rosendale), and portland cement. The former is made from limestone containing much clay; the material is burned at a low heat, and is then ground. It is a quick-setting cement. The portland cement (named from Portland Island on the south of England) is an artificial mixture of some form of carbonate of lime, with some clay, burnt at white heat and then ground. The natural-rock cements are light-colored, and weigh from fifty to sixty pounds to the cubic foot. The portland cement is dark-colored, and weighs from ninety to one hundred pounds to the cubic foot; it is one-half to twice stronger than natural-rock cements.

Approximate estimates of mason-work.

Three and one-half barrels of lime are required to cover 100 square yards plastering, two coats.

Two barrels of lime will cover 100 square yards plastering, one coat.

One and one-half bushels of hair are needed for 100 square yards plastering.

One and one-fourth yards good sand are required for 100 square yards plastering.

One-third barrel of plaster (stucco) will hard-finish 100 square yards plastering.

One barrel of best lime will lay 1000 bricks.

Two barrels of lime will lay one cord rubble-stone.

One-half barrel of lime will lay one perch rubble-stone ($\frac{1}{4}$ cord to perch).

To every barrel of lime estimate about $\frac{5}{8}$ cubic yard of good sand for plastering and brick work.

A barrel of portland cement contains approximately $3\frac{1}{2}$ cubic feet, and weighs 380 pounds; a bag contains about $\frac{7}{8}$ cubic feet, and weighs 95 pounds. A barrel of natural cement contains approximately $3\frac{1}{2}$ cubic feet, and weighs 300 pounds; a bag contains about $\frac{7}{8}$ cubic feet, and weighs about 75 pounds.

Use 1 part cement, 2 parts sand, 4 parts aggregate (gravel or crushed stone), for very strong and impervious work.

Use 1 cement, $2\frac{1}{2}$ sand, 5 aggregate, for ordinary work requiring moderate strength

Use 1 cement, 3 sand, 6 aggregate, for work where strength is of minor importance.

Floors, borders, walks, and foundations.

GROUT FLOOR.

1. To secure a good grout floor, make a good foundation of small stones or brickbats, and cover three or four inches thick with a thin mortar, made of two parts sharp sand and one part common cement.

2. Fresh powdered lime, 2 parts; portland cement, 1 part; gravel, broken stone, or brick, 6 parts. Mix with water to a liquid consistency, and let it be thrown forcibly, or dropped, into its position. It should be well beaten or rammed to render it solid. A "skim" of thin, rich mortar may be placed on top as a finish.

3. Equal parts of gravel, well screened, and clean river or pit sand. With 5 parts of sand and gravel mix 1 part of portland cement. Mix with water and apply 1 inch thick.

FOR GARDEN BORDERS.

4. Nine parts gravel and 1 part unslaked lime; slake the lime and cover it with gravel, then add water sufficient to make a very thin mortar. Apply three inches deep, allow it to stiffen a little, then roll. Finish an inch thick of 1 part lime and 3 parts gravel. Apply soft. See No. 11.

FOR WALKS.

5. Walks should always have a well-made foundation of stones or brickbats to give hardness and insure drainage. The top of the walk may be made of gravel, sifted coal ashes, cinders from foundries, furnaces, etc. If gravel is used, care should be exercised to avoid the round or washed gravel, particularly that lying in the beds of streams, for it will not pack. One part of clean clay to four or five of gravel makes a good walk. Or the following old English recipes may be used (6-10) :

6. One part mineral pitch, 1 part resin, 7 parts chalk, and 2 parts coarse sand. Boil together, and lay it while in a hot state, adding a little gravel.

7. Boil for a short time 18 parts of mineral pitch and 18 parts of resin in an iron kettle ; then add 60 parts of coarse sand, mix well and lay on the path to the thickness of one inch ; then sift a little fine gravel over it and beat it down before the cement sets.

8. Put down a coat of tar, and sift some road sand or coal ashes over it very thickly. When this is dry, repeat the operation until you have four coats of tar and as many of coal ashes or road sand.

9. Two parts of thoroughly dried sand, one part cinders, thoroughly dried. Mix together ; then spread the sand and cinders on the ground and make a hole in the center, into which pour boiling-hot tar and mix into a stiff paste ; then spread on the walk, beat and roll.

10. Two parts lime rubbish and one part coal ashes, both very dry and finely sifted ; in the middle of the heap make a hole ; into this pour boiling-hot coal-tar ; mix to a stiff mortar and spread on the ground two or three inches thick. The ground should be dry and beaten well. Cover with coarse sand ; when cold, roll well.

11. Cement walks. A good method of making concrete walks is to lay four to six inches on well-drained compact ground in proportion of 1 part cement to 6 of binder, as: 40 shovels fine cinders, 15 shovels sharp sand, 1 sack portland cement. Put on a finish, while the under part is not hard set, made of 30 shovels screened sharp sand and 1 sack portland. Also used for borders and gutters.

FOR FOUNDATIONS

12. Concrete foundations for buildings and heavy work may be made of portland cement, 2 parts ; sand, 7 parts ; gravel, 1 part.

COLORING CEMENT WORK.

For gray or black, lampblack may be employed.

For yellow or buff, yellow ocher.

For red, venetian red.

For blue, ultramarine.

For brown, umber.

Mending Cements

CEMENTS FOR IRON.

1. (Slow setting.) Sal ammoniac, 2 ounces ; sulfur, 1 ounce ; clean iron borings or filings reduced to powder, 12 pounds ; water enough to form a thin paste. Excellent for making a rust joint. If a quick-setting joint is desired, use half as much sal ammoniac as sulfur, and half as much iron borings as above ; not so good as above

2. Sal ammoniac, 2 ounces ; iron-filings, 8 pounds ; sufficient water.

3. One or two parts of sal ammoniac to 100 of iron-filings. When the work is required to set quickly, increase the sal ammoniac slightly and add a small amount of sulfur.

4. Iron-filings, 4 pounds ; pipe-clay, 2 pounds ; powdered potsherds, 11 pounds ; make into a paste with moderately strong brine.

5. Equal parts of red and white lead, mixed into a paste with boiled linseed oil. Used for making metallic joints of all kinds.

6. To four or five parts of clay, thoroughly dried and pulverized, add 2 parts of iron-filings, free from oxide, 1 part of peroxide of manganese, $\frac{1}{2}$ of sea salt, and $\frac{1}{2}$ of borax ; mix well, and reduce to a thick paste with water. Use immediately. Expose to warmth, gradually increasing almost to white heat.

7. Sifted coal ashes, 2 parts, and common salt, 1 part. Add water enough to make a paste, and apply at once. This is also good for stoves and boilers, as it stands heat.

BOILER CEMENTS.

8. Chalk, 60 parts ; lime and salt, of each, 20 parts ; sharp sand, 10 parts ; blue or red clay and clean iron-filings, of each, 5 parts. Grind together and calcine or heat.

9. Powdered clay, 6 pounds ; iron-filings, 1 pound. Make into a paste with linseed oil.

10. Powdered litharge, 2 parts ; silver sand and slaked lime, of each, 1 part ; boiled oil enough to form a paste.

These cements are used for stopping leaks and cracks in boilers, iron pipes, stoves, etc. They should be applied as soon as made.

TAR CEMENT.

11. Coal-tar, one part ; powdered slate (slate flour), three or four parts ; mix by stirring until thoroughly incorporated. Very useful for mending watering-pots, barrels, leaky sash, etc. It remains somewhat elastic. It does not adhere to greasy surfaces. It will keep for a long time before using.

COPPER CEMENT.

12. Beef blood thickened with sufficient finely powdered quicklime to make it into a paste is sometimes used to secure the edges and rivets of copper boilers, kettles, etc. Use immediately.

FIREPROOF OR STONE CEMENT.

13. Fine river sand, 20 parts ; litharge, 2 parts ; quicklime, 1 part ; linseed oil enough to form a thick paste. Used for walls and broken stonework.

EARTHENWARE CEMENT.

14. Grated cheese, 2 parts ; powdered quicklime, one part ; fresh white of egg enough to form a paste. Use as soon as possible.

For fine earthenware, liquid glue may be used.

CEMENT FOR GLASS.

15. Wood alcohol to render liquid a half dozen pieces of gum-mastic the size of a large pea ; in another bottle dissolve the same quantity of isinglass, which has been soaked in water and allowed to get surface dry, in 2 ounces of methylated spirit ; when the first is dissolved add two pieces of gum-galbanum or gum-ammoniac ; apply gentle heat and stir ; add the solution of isinglass, heat again and stir. Keep in a tightly stoppered bottle, and when used in boiling water.

SEALING CEMENTS.

16. Beeswax, 1 pound ; resin, 5 pounds. Stir in sufficient red ocher and Brunswick green, or lampblack, to give the desired color.

17. Black pitch, 6 pounds ; ivory-black and whiting, of each, 1 pound. Less attractive than the former.

These are used for sealing up bottles, barrels, etc.

Paints and Protective Compounds

HOME-MADE WASHES FOR FENCES AND OUT-BUILDINGS may be made by various combinations of lime and grease. The following are good formulas : —

1. Slake fresh quicklime in water, and thin it to a paste or paint with skim-milk. The addition of two or three handfuls of salt to a pail of the wash is beneficial.

2. Two quarts skim-milk, 8 ounces of fresh slaked lime, 6 ounces of boiled linseed oil, and 2 ounces of white pitch, dissolved in the oil by a gentle heat. The lime must be slaked in cold water and dried in the air until it falls into a fine powder ; then mix with $\frac{1}{4}$ part of the milk, adding the mixed oil and pitch by degrees ; add the remainder of the milk. Lastly, add 3 pounds of the best whiting and mix the whole thoroughly.

3. Slake $\frac{1}{2}$ bushel of lime in boiling water, keeping it covered ; strain and add brine made by dissolving 1 peck of salt in warm water, and 3 pounds rice flour, then boil to a paste ; add $\frac{1}{2}$ pound whiting and 1 pound of glue dissolved in warm water. Mix and let stand for a few days before using.

FIRE-PROOF PAINT.

4. In a covered vessel slake the best quicklime, then add a mixture of skim-milk and water, and mix to the consistency of cream ; then add 20 pounds of alum, 15 pounds of potash and 1 bushel of salt to every 100 gallons of the liquid. If white paint is desired, add to the above 6 pounds of plaster of paris.

FOR DAMP WALLS.

5. Three-fourths pound of hard soap to 1 gallon of water. Lay over the bricks steadily and carefully with a flat brush, so as not to form a froth or lather on the surface. After 24 hours mix $\frac{1}{2}$ pound of alum with 4 gallons of water ; let it stand twenty-four hours, and then apply it in the same manner over the coating of soap. Apply in dry weather.

6. One and one-half pounds resin, 1 pound tallow, 1 quart linseed oil. Melt together and apply hot, two coats.

WATER-PROOFING PAINT FOR LEATHER.

7. One-half pound of shellac, broken into small pieces in a quart bottle ; cover with methylated spirit (wood alcohol), cork it tight, put it in a warm place, and shake well several times a day ; then add a piece of camphor as large as a hen's egg ; shake again and add an ounce of lampblack. Apply with a small paint brush.

8. Put into an earthen jar $\frac{1}{4}$ pound of beeswax, $\frac{1}{2}$ pint of neat's foot oil, three or four tablespoonfuls of lampblack, and a piece of camphor as large as a hen's egg. Melt over a slow fire. Have both grease and leather warm, and apply with a brush.

9. One pint of linseed oil, $\frac{1}{2}$ pound mutton suet, 6 ounces of clean beeswax, and 4 ounces of resin ; melt and mix well. Use while warm with a brush on new boots or shoes.

FOR CLOTH FOR PITS AND FRAMES. (See page 200.)

10. Old pale linseed oil, 3 pints ; sugar of lead (acetate of lead) 1 ounce ; white resin, 4 ounces. Grind the acetate with a little of the oil, then add the rest and the resin. Use an iron kettle over a gentle fire. Apply with a brush, hot.

FOR PAPER.

11. Dissolve $1\frac{3}{4}$ pounds of white soap in 1 quart of water ; in another quart of water dissolve $1\frac{1}{2}$ ounces of gum arabic and 5 ounces of glue. Mix the two liquids, warm them, and soak the paper in it and pass through rollers, or simply hang it up to dry.

TO PREVENT METALS FROM RUSTING.

12. Melt together 3 parts of lard and 1 part of powdered resin. A very thin coating applied with a brush will keep stoves and grates from rusting during summer, even in damp situations. A little black lead can be mixed with the lard. Does well on nearly all metals.

TO PREVENT RUSTING OF NAILS, HINGES, ETC.

13. One pint of linseed oil, 2 ounces black lead ; mix together. Heat nails red-hot and dip them in.

TO REMOVE RUST.

14. Heavily rusted iron may be cleaned by immersing it in a bath (not too acid) of chlorid of tin, for twelve to twenty-four hours. After removing, rinse in water and then in ammonia.

15. Rusted steel may be brushed with a paste of $\frac{1}{2}$ ounce cyanide potassium (poisonous), $\frac{1}{2}$ ounce castile soap, 1 ounce of whiting, and water. Then wash in 2 ounces water containing $\frac{1}{2}$ ounce cyanide.

AMOUNT OF PAINT REQUIRED FOR A GIVEN SURFACE.

It is impossible to give a rule that will apply in all cases, as the amount varies with the kind and thickness of the paint, the kind of wood or other material to which it is applied, the age of the surface, etc. The following is an approximate rule : Divide the number of square feet of surface by 200. The result will be the number of gallons of liquid paint required to give two coats ; or divide by 18, and the result will be the number of pounds of pure ground white lead required to give three coats.

Glues**LIQUID GLUE.**

1. Dissolve 2 pounds of best pale glue in a quart of water in a covered vessel, placed in a hot-water bath; when cold, add to it 7 ounces of commercial nitric acid. When cold put in bottles.

2. Finest pale orange shellac, broken small, 4 ounces ; methylated spirit, 3 ounces ; put in a warm place in a closely corked bottle until dissolved. Should have the consistency of molasses. Or, borax, 1 ounce ; water, $\frac{3}{4}$ pint ; shellac as before ; boil in a closely covered kettle until dissolved ; then evaporate until nearly as thick as molasses.

FLOWER GUM.

3. Very fine white shellac mixed with methylated spirit in a stone jar ; shake well for half an hour and place by a fire, and shake it frequently the first day. Keep in a cool place. Leave the camel's-hair brush in the gum. Never fill the brush too full and gum the petals close to the tube.

GUM FOR LABELS AND SPECIMENS.

4. Two parts of gum-arabic, one part of brown sugar ; dissolve in water to the consistency of cream.

5. Five parts of best glue soaked in 18 to 20 parts of water for a day, and to the liquid add 9 parts of rock candy and 3 parts of gum-arabic.

6. Good flour and glue, to which add linseed oil, varnish, and turpentine, $\frac{1}{2}$ ounce each to the pound. Good when labels are liable to get damp.

Waxes for Grafting and for Covering Wounds

Common resin and beeswax waxes.

1. A standard and reliable wax is as follows :—

Resin, 4 parts by weight.

Beeswax, 2 parts by weight.

Tallow (rendered), 1 part by weight.

Melt all the ingredients together, exercising care to avoid boiling. Pour the hot liquid quickly into a pail of cold water. With greased hands flatten the spongy mass beneath the water so that it cools uniformly. Permit it to get cold and tough, but not brittle. Remove from the water and pull until ductile and fine in grain. Lumps in wax are common, and are due to improper handling. If too lumpy, remelt and pull again. Make into balls or small skeins and put away in a cool place. When wanted soften with heat of hand or in hot water. It can be kept for years. One of the best waxes, either for indoor or outdoor use.

For general purposes the above formula gives a wax of the proper consistency. The ingredients may be varied, however, for special purposes. If a softer wax is desired, more tallow in proportion should be added. The addition of more beeswax makes the wax tougher. By thus changing the amount of the different ingredients a wax for almost any purpose can be secured.

2. The following wax, which is slightly softer, may be applied more conveniently in cold weather :—

Resin, 4 parts by weight.

Beeswax, 2 parts by weight.

Linseed oil, 1 pint.

Melt all together gradually, turn into cold water and work as above. On account of the impurities contained in linseed oil, its use is not recommended for grafting wax. In general the tallow is to be preferred.

Alcoholic wax.

The alcoholic or liquid wax is a thick paste. It is useful for work in winter when the resin wax can not be applied ; and also for covering the wounds where bark has been injured or removed, and for bridge grafts.

Lefort's liquid wax :

White resin, 1 pound.

Beef tallow, 1 ounce.

Turpentine, 1 tablespoonful.

Alcohol, 5 ounces.

Melt the resin slowly. When hot, add the beef tallow. Remove from the fire and add slowly, stirring constantly, the turpentine and alcohol. Keep in closed bottles or cans. Use a brush or swab to apply.

Pitch wax.

Some of the French authors recommend the following :—

Two pounds 12 ounces of resin and 1 pound 11 ounces of Burgundy pitch. At the same time melt 9 ounces of tallow ; pour the latter into the former, while both are hot, and stir the mixture thoroughly. Then add 18 ounces of red ocher, dropping it in gradually and stirring the mixture at the same time.

Waxed string and bandages.

1. Waxed bandage. Waxed bandages are very useful for covering wounds where the bark has been broken or injured. They are prepared as follows.

Old cloth is torn into strips of the desired width and the strips wound into balls, or bandage cloth (not gauze) may be used. These balls are placed in the kettle of melted resin wax. In a few minutes they will be thoroughly saturated, when they should be removed and allowed to drain and dry.

2. Waxed string for root-grafting. Into a kettle of melted resin wax place balls of No. 18 knitting cotton. Turn the balls frequently, and in a few minutes they will be thoroughly saturated. Remove from

the kettle and allow to drain and dry, after which they may be put away for future use.

This material is strong enough and at the same time breaks so easily that it does not injure the hands. When the string is used, it sticks without tying.

Covers for wounds.

Before applying any dressing, the wounds should be thoroughly cleaned. Cut out or remove the broken bark and the decayed wood. It is also advisable to disinfect with Bordeaux mixture or a solution of corrosive sublimate, 1 ounce in 7 gallons.

It should be remembered that dressings do not hasten the healing of wounds, but they allow the healing process to progress unchecked, because they prevent the wounds from drying out and protect them from disease.

1. Any of the above grafting-waxes are excellent for dressing wounds, although most of them cleave off after the first year, in which case it is necessary to apply another dressing.

2. **HOSKINS' WAX.** — Boil pine-tar slowly for three or four hours; add $\frac{1}{2}$ pound of beeswax to a quart of the tar. Have ready some dry and finely sifted clay, and when the mixture of tar and wax is partly cold, stir into the above-named quantity about 12 ounces of the clay; continue the stirring until the mixture is so stiff and so nearly cool that the clay will not settle. This is soft enough in mild weather to be easily applied with a knife or spatula. — Used by the late Dr. Hoskins, of Vermont.

3. **SCHAEFELL'S HEALING-PAINT.** — Boil linseed oil (free from cottonseed oil) one hour, with an ounce of litharge to each pint of oil; then stir in sifted wood ashes until the paint is of the proper consistency. Pare the bark until smooth, as the fuzzy edge left by the saw will cause it to die back. Paint the wound over in dry weather, and if the wound is very large, cover with a gunny-sack.

4. **PAINT.** — One of the most convenient and useful dressings for wounds is paint. Use white lead, but mix thicker than usually applied. A little lampblack should be added to this until the paint is nearly the color of the bark. Apply with a brush or swab, working the paint into the grain of the wood. Be careful that it does not run down from the wound.

5. COAL-TAR. — Coal-tar is sometimes useful as a dressing, especially for shade or ornamental trees. Apply a thin coating to the wound.

6. Tar for bleeding in vines. Add to tar about three or four times its weight of powdered slate or some similar substance.

7. Collodion for bleeding in vines. In some extreme cases two or three coats will be needed, in which case allow the collodion to form a film before applying another coat. Pharmaceutical collodion is better than photographic.

8. Cement for cavities. Rotten spots and cavities in trees should be cleaned out to hard wood, the place filled solid with good cement. (See Manual of Gardening, 145-151.)

The grafting-waxes are applied to the cut surfaces of graft-unions for the purpose of preventing evaporation of the plant juices, and protecting from weather and the germs of decay. Buds covered by wax will push through as they grow. The softer the wax when it is applied, the closer will be its adhesion to the wood. Wax is often applied to ordinary wounds; but if the wounds are large they should first be treated with antiseptics (as bordeaux mixture or similar compounds).

CHAPTER XXVII

COMPUTATION TABLES

Most of the tables and estimates that the farmer needs in his "figuring" will be found in this chapter; but greenhouse computations will be found in Chapter XI, silos and other construction in Chapter XXV, and board measure and log measure in Chapter XII.

Tables of Regular American Weights and Measures

Avoirdupois or commercial weight

271½ grains	= 1 dram.
16 drams	= 1 ounce.
16 ounces	= 1 pound.
25 pounds	= 1 quarter.
4 quarters, or 100 pounds	= 1 hundredweight.
20 hundredweight, or 2000 lb.	= 1 ton.
480 pounds	= 1 imperial quarter.
100 pounds is also called	1 cental.
2240 pounds	= 1 long ton.

t.	cwt.	lb.	oz.	dr.	gr.
1	= 20	= 2000	= 32,000	= 512,000	
	1	= 100	= 1,600	= 25,600	
		1	= 16	= 256	= 7000
			1	= 16	= 4375

Troy or jewelers' weight

24 grains	= 1 pennyweight.
20 pennyweights	= 1 ounce.
12 ounces	= 1 pound.

lb.	oz.	pwt.	gr.
1	= 12	= 240	= 5760
	1	= 20	= 480
		1	= 24

Apothecaries' weight

20 grains	= 1 scruple.
3 scruples	= 1 dram.
8 drams	= 1 ounce.
12 ounces	= 1 pound.

lb.	oz.	dr.	scr.	gr.
1	= 12	= 96	= 288	= 5760
	1	= 8	= 24	= 480
		1	= 3	= 60
			1	= 20

Table of comparative weights

Avoirdupois	Troy	Apothecaries
7000 gr. = 1 lb.	5760 gr. = 1 lb.	5760 gr. = 1 lb.
1 lb.	= 1 $\frac{3}{4}$ lb.	= 1 $\frac{3}{4}$ lb.
or 144 lb.	= 175 lb.	= 175 lb.
1 oz.	= 1 $\frac{1}{2}$ oz.	= 1 $\frac{1}{2}$ oz.
or 192 oz.	= 175 oz.	= 175 oz.

Dry measure

2 pints	= 1 quart.
8 quarts	= 1 peck.
4 pecks	= 1 bushel.
8 bushels (480 pounds)	= 1 quarter.
36 bu.	= 1 chaldron.

bu.	pk.	qt.	pt.
1	= 4	= 32	= 64
	1	= 8	= 16
		1	= 2

Liquid measure

4 gills	= 1 pint.
2 pints	= 1 quart.
4 quarts	= 1 gallon.
31 $\frac{1}{2}$ gallons	= 1 barrel.
2 barrels, or 63 gallons	= 1 hogshead.

gal.	qt.	pt.	gi.
1	= 4	= 8	= 32
	1	= 2	= 8
		1	= 4

Apothecaries' fluid measure

60 minims	= 1 fluid dram.
8 fluid drams	= 1 fluid ounce.
16 fluid ounces	= 1 pint.
8 pints	= 1 gallon.

cong.	o.	f. 3.	f. 3.	m.
1	= 8	= 128	= 1024	= 61,440
	1	= 16	= 128	= 7,680
		1	= 8	= 480
			1	= 60

1 minim equals 1 drop of water.

Line or linear measure

12 inches	= 1 foot.
3 feet	= 1 yard.
5 $\frac{1}{2}$ yards, or 16 $\frac{1}{2}$ feet	= 1 rod or pole.
40 rods	= 1 furlong.
8 furlongs (320 rods)	= 1 mile (statute mile).
3 miles	= 1 league.

l.	m.	fur.	rd.	yd.	ft.	in.
1	= 3	= 24	= 960	= 5280	= 15,840	= 190,080
	1	= 8	= 320	= 1760	= 5,280	= 63,360
		1	= 40	= 220	= 660	= 7,920
			1	= 5 $\frac{1}{2}$	= 16 $\frac{1}{2}$	= 198
				1	= 3	= 36
					1	= 12

Surveyors' or chain measure

7.92 inches	= 1 link.
25 links	= 1 rod or pole.
4 rods, or 66 feet	= 1 chain.
80 chains	= 1 mile.

mi.	ch.	rd.	l.	in.
1	= 80	= 320	= 8000	= 63,360
	1	= 4	= 100	= 792
		1	= 25	= 198
			1	= 7.92

Square or surface measure

144 square inches	= 1 square foot.
9 square feet	= 1 square yard.
30¼ square yards	= 1 sq. rod or perch.
160 square rods	= 1 acre.
640 acres	= 1 sq. mile or section

sq. m.	a.	sq. rd.	sq. yd.	sq. ft.	sq. in.
1	= 640	= 102,400	= 3,097,600	= 27,878,400	= 4,014,489,600
	1	= 160	= 4,840	= 43,560	= 6,272,640
		1	= 30¼	= 272¼	= 39,204
			1	= 9	= 1,296
				1	= 144

Surveyors' square measure

625 square links	= 1 square rod or pole.
16 poles	= 1 square chain.
10 square chains	= 1 acre.
640 acres	= 1 sq. mile or section.
36 square miles (6 miles square)	= 1 township.

tp. sq. mi.	a.	sq. ch.	sq. rd.	sq. l.
1	= 36	= 23,040	= 230,400	= 3,686,400
	1	= 640	= 6,400	= 102,400
		1	= 10	= 160
			1	= 16
				1
				= 10,000
				= 625

Solid or cubic measure

1728 cubic inches	= 1 cubic foot.
27 cubic feet	= 1 cubic yard.
16 cubic feet	= 1 cord foot.
8 cord feet, or 128 cubic feet	= 1 cord of wood.
24¼ cubic feet	= 1 perch.

cu. yd.	cu. ft.	cu. in.	cd. cd. ft.	cu. ft.	cu. in.
1	= 27	= 46,656	= 1	= 8	= 128
				= 128	= 221,184

Paper and book denominations

24 sheets	= 1 quire.
20 quires	= 1 ream.
2 reams	= 1 bundle.
5 bundles	= 1 bale.

bale	bdl.	rm.	qr.	sheets
1	= 5	= 10	= 200	= 4800
	1	= 2	= 40	= 960
		1	= 20	= 480
			1	= 24

500 sheets is often called a ream in commerce.

Folio in a book or folded periodical	= 2 leaves, or 4 pages.
Quarto	= 4 leaves, or 8 pages.
Octavo	= 8 leaves, or 16 pages.
Duodecimo	= 12 leaves, or 24 pages.
16mo.	= 16 leaves, or 32 pages.
18mo.	= 18 leaves, or 36 pages.
24mo.	= 24 leaves, or 48 pages.
32mo.	= 32 leaves, or 64 pages.

Metric Weights and Measures

Metric weight

NAMES	NUMBER OF GRAMS	EQUIVALENTS IN DENOMINATIONS OF AVOIRDUPOIS WEIGHT
Millier or Tonneau	1,000,000	2204.6 lb.
Quintal	100,000	220.46 lb.
Myriagram	10,000	22.046 lb.
Kilogram or Kilo	1,000	2.2046 lb.
Hectogram	100	3.5274 oz.
Dekagram	10	0.3527 oz.
Gram	1	15.432 gr.
Decigram	$\frac{1}{10}$	1.5432 gr.
Centigram	$\frac{1}{100}$	0.1543 gr.
Milligram	$\frac{1}{1000}$	0.0154 gr.

One gram is the weight of one cubic centimeter of distilled water at its maximum density (39.1° F.) in a vacuum. As a matter of fact, however, the gram now in use is the one-thousandth part of the weight of a kilogram of platinum, which was deposited in the Palace of the Archives in Paris, in 1799, by the international commission which was appointed to fix the standards of what is now known as the metric system.

Metric capacity

NAMES	NUMBER OF LITERS	EQUIVALENTS IN DRY MEASURE	EQUIVALENTS IN LIQUID OR WINE MEASURE
Kiloliter or Stere	1000	28.372 bu.	264.17 gal.
Hectoliter	100	2 bu. and 3.35 pk.	26.417 gal.
Dekaliter	10	9.08 qt.	2.6417 gal.
Liter	1	0.908 qt.	1.0567 qt.
Deciliter	$\frac{1}{10}$	6.1022 cu. in.	0.845 gill.
Centiliter	$\frac{1}{100}$	0.6102 cu. in.	0.338 fluid oz.
Milliliter	$\frac{1}{1000}$	0.061 cu. in.	0.27 fluid dr.

1 liter is equivalent to 1 cubic decimeter.

Metric length

		EQUIVALENTS IN DENOMINATIONS IN USE
Myriameter	10,000 meters.	6.2137 miles.
Kilometer	1,000 meters.	0.62137 mile, or 3.280 ft. 10 in.
Hectometer	100 meters.	328 ft. 1 in.
Dekameter	10 meters.	393.7 inches.
Meter	1 meter.	39.37 inches.
Decimeter	$\frac{1}{10}$ of a meter.	3.937 inches.
Centimeter	$\frac{1}{100}$ of a meter.	0.3937 inch.
Millimeter	$\frac{1}{1000}$ of a meter.	0.0397 inch.

Metric surface

Hectare	10,000 square meters.	2.471 acres.
Are	100 square meters.	119.6 square yards.
Centare	1 square meter.	1550 square inches.

Metric cubic measure

Myriaster	10,000 cu. meters.
Kiloster	1,000 cu. meters.
Hectoster	100 cu. meters.
Decaster	10 cu. meters.
Ster	1 cu. meter.
Decister	$\frac{1}{10}$ cu. meter.
Centister	$\frac{1}{100}$ cu. meter.
Millister	$\frac{1}{1000}$ cu. meter.

The word *ster* is seldom used. The names of solid measures are commonly made by adding *cubic* to the denominations of linear measure; as cubic meter, cubic decimeter, and the like.

Equivalents of American measures in metric terms

LENGTH		
<i>Approximately</i>		<i>Exactly</i>
1 inch is 2½ centimeters		(2.54)
1 foot is 0.3 of meter		(.3048)
1 yard is 0.9 of meter		(.9144)
1 rod is 5 meters		(5.029)
1 chain is 20 meters		(20.117)
1 furlong is 200 meters		(201.17)
1 mile is 1600 meters		(1609.3)
1 nautical mile is 1850 meters		(1853.2)

AREA		
1 sq. inch is 6¼ sq. centimeters		(6.451)
1 sq. foot is 0.09 of sq. meter		(.0929)
1 sq. yard is 0.83 of sq. meter		(.8361)
1 sq. rod is 25 sq. meters		(25.29)
1 rood is 1000 sq. meters		(1011.7)
1 acre is 0.4 of hectare		(.4047)
1 sq. mile is 258 hectares		(258.99)

BULK		
1 cubic inch is 16¼ cubic centimeters		(16.387)
1 cubic foot is 0.028 of cubic meter		(.028316)
1 cubic yard is 0.76 of cubic meter		(.7645)
100 cubic feet is 2.8 cubic meters		(2.8316)
1 M board meas. is 2¼ cubic meters		(2.36)
1 cord is 3.6 cubic meters		(3.624)
1 U. S. liquid pint is 0.47 of liter		(.473)
1 U. S. liquid quart is 0.9 of liter		(.946)
1 U. S. liquid gallon is 3.7 liters		(3.785)
1 peck is 9 liters	(U. S. 8.81.	Eng. 9.08)
1 bushel is 36 liters	(U. S. 35.24.	Eng. 36.35)

WEIGHT		
1 grain is 0.06½ of gram		(.0648)
1 troy oz. is 31 grams		(31.103)
1 avoird. oz. is 28 grams		(28.35)
1 avoird. lb. is 0.45 of kilo		(.4536)
60 lb. (wheat bu.) is 27 kilos		(27.216)
80 lb. (coal bu.) is 36 kilos		(36.287)
1 cental is 45 kilos		(45.36)
112 lb. (cwt.) is 50 kilos		(50.8)
1 net ton is 0.9 metric ton		(.9072)
1 gross ton is 1 metric ton		(1.016)

Money Tables

English money

4 farthings (<i>qr.</i>)	= 1 penny (<i>d.</i>).
12 pence	= 1 shilling (<i>s.</i>).
20 shillings	= 1 pound or sovereign (<i>£</i>).
21 shillings	= 1 guinea (<i>g.</i>).

£.	s.	d.	qr.
1 =	20 =	240 =	960
	1 =	12 =	48
		1 =	4

1 pound is about \$4.86.

French money

10 millimes (<i>m.</i>)	= 1 centime (<i>c.</i>).
10 centimes	= 1 decime (<i>d.</i>).
10 decimes	= 1 franc (<i>fr.</i>).

fr.	d.	c.	m.
1	= 10	= 100	= 1000
	1	= 10	= 100

1 franc is nearly 20 (19.3) cents. 1 = 10

German money

100 pfennige (<i>pf.</i>)	= 1 mark.
A mark is about 24 cents.	

Dutch money

100 cents	= 1 florin or guilder.
A florin is 40 cents.	

Italian money

100 centesimi	= 1 lira.
A lira is nearly 20 (19.3) cents.	

Spanish money

100 centimos	= 1 peseta.
1 peseta is nearly 20 (19.3) cents.	

Russian money

100 copecks	= 1 ruble.
A ruble is about 51 cents.	

Austrian money

100 heller	= 1 crown.
A crown is about 20 cents.	

Monetary units of American countries, and value of coins in U. S. money (1911)

	MONETARY UNIT	VALUE IN TERMS OF U. S. GOLD DOLLAR
Argentina	Peso	\$0.965
Bolivia	Boliviano	0.389
Brazil	Milreis	0.546
British possessions, N. A. (except Newfoundland)	Dollar	1.000
Chile	Peso	0.365
Colombia	Dollar	1.000
Costa Rica	Colon	0.465
Cuba	Peso	0.439
Ecuador	Sucre	0.487
Guatemala	Peso	0.389
Haiti	Gourde	0.965
Honduras	Peso	0.389
Mexico	Dollar	0.498
Newfoundland	Dollar	1.014
Nicaragua	Peso	0.389
Panama	Balboa	1.000
Peru	Libra	4.866
Salvador	Peso	0.389
Santo Domingo	Dollar	1.000
Uruguay	Peso	1.030
Venezuela	Bolivar	0.187

In Argentine Republic, paper money is in circulation, convertible in U. S. gold at 44 per cent of face value. In Brazil, Chile, Colombia, Haiti, most Central American countries, the paper currency is inconvertible; the exchange rate is now (1911) approximately \$0.324 in Brazil, \$0.215 in Chile, \$100 paper to \$1 gold in Colombia, \$0.238 in Haiti, much depreciated and subject to wide fluctuations in Guatemala, Honduras, Nicaragua, Salvador. In British Honduras the monetary unit is the dollar, being worth par in U. S. gold.

Paraguay.—The Argentine paper peso, which has a value of 42.46 cents U. S. gold, circulates currently in Paraguay, as do the silver coins of Argentina. A large amount of paper money of the Republic of Paraguay is also in circulation. This money fluctuates in value, but usually a Paraguayan paper peso is worth about eight cents U. S. gold.

Other foreign coins in equivalents of U. S. money (1911)

			U. S. Money
Austria-Hungary	Crown	= \$0.203	" "
Belgium	Franc	= 0.193	" "
British India	Rupee	= 0.324	" "
China	Tael	= 0.420-0.649	" "
		(according to the province)	
Denmark	Crown	= 0.268	" "
Egypt	Pound	= 4.943	" "
	(100 piasters)		" "
Finland	Mark	= 0.193	" "
France	Franc	= 0.193	" "
Germany	Mark	= 0.238	" "
Great Britain	Pound	= 4.866	" "
Greece	Drachma	= 0.193	" "
Italy	Lira	= 0.193	" "
Japan	Yen	= 0.498	" "
Liberia	Dollar	= 1.000	" "
Netherlands	Florin	= 0.402	" "
Norway	Crown	= 0.268	" "
Persia	Kran	= 0.170	" "
Philippines	Peso	= 0.50	" "
Portugal	Milreis	= 1.08	" "
Roumania	Leu	= 0.193	" "
Russia	Ruble	= 0.515	" "
Servia	Dinar	= 0.193	" "
Siam	Tical	= 0.370	" "
Spain	Peseta	= 0.193	" "
Straits Settlements	Dollar	= 0.421	" "
Sweden	Crown	= 0.268	" "
Switzerland	Franc	= 0.193	" "
Turkey	Piaster	= 0.044	" "

The *shekel* of the Hebrews (silver) was probably between 70 and 75 cents in value.

The *talent* (silver) of the Hebrews was upwards of \$2100.

The *penny* (value in pennies is *pence*, as two-pence, six-pence) is an English denomination, equivalent to about 2 cts. in U. S. money; used also colloquially for the U. S. cent.

The *shilling* is typically an English denomination, practically equivalent to the "quarter" in the U. S. and Canada. In the U. S. it has different value in different regions (but now little used), due to the extent of depreciation of the pound when the decimal system was adopted. The usual values are 16½ cts. in New England, and 12½ cts. in New York and westward. In parts of the country farther south it was 13½ cts. and 21¾ cts. A shilling is sometimes called a *bit*.

Approximate money-table. (Baedeker)

ENGLISH			DUTCH		FRENCH AND BELGIAN		GERMAN		AMERICAN	
£	s.	d.	florin	cent	franc	cent	mark	pfgr.	dollar	cent
1			12		25		20		4	86
	19		11	40	23	75	19		4	53
	18		10	80	22	50	18		4	29
	17		10	20	21	25	17		4	5
	16		9	60	20		16		3	81
	15		9		18	75	15		3	57
	14		8	40	17	50	14		3	34
	13		7	80	16	25	13		3	10
	12		7	20	15		12		2	86
	11		6	60	13	75	11		2	62
	10		6		12	50	10		2	38
	9		5	40	11	25	9		2	14
	8		4	80	10		8		1	91
	7		4	20	8	75	7		1	67
	6		3	60	7	50	6		1	43
	5		3		6	25	5		1	19
	4		2	40	5		4			95
	3		1	80	3	75	3			71
	2		1	20	2	50	2			48
	1	8½	1		2	15	1	70		40
	1	7		96	2		1	60		38
	1			60	1	25	1			24
		9¾		48	1			80		19
		9		45		94		75		18
		8		40		83		66		16
		7		35		73		58		14
		6		30		62		50		12
		5		25		52		41		10
		4		20		42		33		8
		3		15		31		25		6
		2		10		21		16		4
		1		5		10		8		2

Legal rates of interest

	LEGAL RATE PER CENT	RATE ALLOWED BY CONTRACT. PER CENT
Alabama	8	8
Arizona	6	As agreed
Arkansas	6	10
California	7	As agreed
Colorado	8	As agreed
Connecticut	6	6
Delaware	6	6
District of Columbia	6	10
Florida	8	10

Legal rates of interest — Continued

	LEGAL RATE PER CENT	RATE ALLOWED BY CONTRACT. PER CENT
Georgia	7	8
Idaho	7	12
Illinois	5	7
Indiana	6	8
Iowa	6	8
Kansas	6	10
Kentucky	6	6
Louisiana	5	8
Maine	6	As agreed ¹
Maryland	6	6
Massachusetts	6	As agreed
Michigan	5	7
Minnesota	6	10
Mississippi	6	10
Missouri	6	8
Montana	8	As agreed
Nebraska	7	10
Nevada	7	As agreed
New Hampshire	6	6
New Jersey	6	6
New Mexico	6	12
New York	6	6 ²
North Carolina	6	6
North Dakota	7	12
Ohio	6	8
Oklahoma	7	10
Oregon	6	10
Pennsylvania	6	6
Rhode Island	6	As agreed
South Carolina	7	8
South Dakota	7	12
Tennessee	6	6
Texas	6	10
Utah	8	12
Vermont	6	6
Virginia	6	6
Washington	6	12
West Virginia	6	6
Wisconsin	6	10
Wyoming	8	12
Canada		
British Columbia	5	As agreed
Manitoba	6	As agreed
New Brunswick	5	As agreed
Nova Scotia	6	7 or 10
Ontario	5	As agreed
Quebec	6	As agreed
Scotland	5	As agreed
England	4	As agreed

¹ Maine, 15 per cent by contract unless stipulated.

² New York, on collateral loans of \$5000 and upward, any rate agreed.

Wage-Tables

Day wages (10-hr. day) — Continued on opposite page

FRACTIONS OF A DAY AT—

TIME	75¢ A DAY	\$1.00 A DAY	\$1.25 A DAY	\$1.50 A DAY	\$1.75 A DAY	\$2.00 A DAY	\$2.50 A DAY	\$3.00 A DAY
$\frac{1}{2}$ hour	.03 $\frac{3}{4}$.05	.06 $\frac{1}{2}$.07 $\frac{1}{2}$.08 $\frac{3}{4}$.10	.12 $\frac{1}{2}$.15
1 "	.07 $\frac{1}{2}$.10	.12 $\frac{1}{2}$.15	.17 $\frac{1}{2}$.20	.25	.30
2 hours	.15	.20	.25	.30	.35	.40	.50	.60
3 "	.22 $\frac{1}{2}$.30	.37 $\frac{1}{2}$.45	.52 $\frac{1}{2}$.60	.75	.90
4 "	.30	.40	.50	.60	.70	.80	1.00	1.20
5 "	.37 $\frac{1}{2}$.50	.62 $\frac{1}{2}$.75	.87 $\frac{1}{2}$	1.00	1.25	1.50
6 "	.45	.60	.75	.90	1.05	1.20	1.50	1.80
7 "	.52 $\frac{1}{2}$.70	.87 $\frac{1}{2}$	1.05	1.22 $\frac{1}{2}$	1.40	1.75	2.10
8 "	.60	.80	1.00	1.20	1.40	1.60	2.00	2.40
9 "	.67 $\frac{1}{2}$.90	1.12 $\frac{1}{2}$	1.35	1.57 $\frac{1}{2}$	1.80	2.25	2.70

Month wages (26 days)

When men are employed by the year at a monthly wage, it is customary to calculate by calendar months, whether they contain 25 or 27 working days.

TIME	\$15 MO.	\$18 MO.	\$20 MO.	\$22 MO.	\$24 MO.	\$25 MO.	\$27 MO.	\$30 MO.	\$35 MO.	\$40 MO.
1 day	.58	.69	.77	.85	.92	.96	1.04	1.15	1.35	1.54
2 days	1.15	1.38	1.54	1.69	1.85	1.92	2.08	2.31	2.69	3.08
3 "	1.73	2.08	2.31	2.54	2.70	2.88	3.12	3.46	4.04	4.62
4 "	2.31	2.77	3.08	3.38	3.69	3.85	4.15	4.62	5.38	6.16
5 "	2.89	3.46	3.85	4.23	4.62	4.81	5.19	5.78	6.73	7.70
6 "	3.46	4.15	4.62	5.08	5.54	5.77	6.23	6.92	8.08	9.24
7 "	4.04	4.85	5.38	5.92	6.46	6.73	7.27	8.08	9.42	10.76
8 "	4.62	5.54	6.15	6.77	7.38	7.69	8.31	9.24	10.77	12.30
9 "	5.19	6.23	6.92	7.61	8.31	8.65	9.35	10.38	12.11	13.84
10 "	5.77	6.92	7.69	8.46	9.23	9.62	10.38	11.54	13.46	15.38
11 "	6.35	7.62	8.46	9.31	10.15	10.58	11.42	12.70	14.81	16.92
12 "	6.92	8.31	9.23	10.15	11.08	11.54	12.46	13.84	16.15	18.46
13 "	7.50	9.00	10.00	11.00	13.00	12.50	13.50	15.00	17.50	20.00
14 "	8.08	9.69	10.77	11.85	13.92	13.46	14.54	16.16	18.85	21.54
15 "	8.65	10.38	11.54	12.69	14.85	14.42	15.58	17.30	20.19	23.08
16 "	9.23	11.08	12.31	13.54	14.77	15.38	16.62	18.46	21.54	24.62
17 "	9.81	11.77	13.08	14.38	15.69	16.35	17.65	19.62	22.88	26.16
18 "	10.38	12.46	13.85	15.23	16.62	17.31	18.69	20.76	24.23	27.70
19 "	10.96	13.15	14.62	16.08	17.54	18.27	19.73	21.92	25.58	29.24
20 "	11.54	13.85	15.38	16.92	18.46	19.23	20.77	23.08	26.92	30.76
21 "	12.11	14.54	16.15	17.77	19.38	20.19	21.81	24.22	28.27	32.30
22 "	12.69	15.23	16.92	18.61	20.31	21.15	22.85	25.38	29.61	33.84
23 "	13.27	15.92	17.69	19.46	21.23	22.12	23.88	26.54	30.96	35.38
24 "	13.85	16.62	18.46	20.31	22.15	23.08	24.92	27.70	32.31	36.92
25 "	14.42	17.31	19.23	21.15	23.08	24.04	25.96	28.85	33.65	38.46

WHOLE DAYS AT—

TIME	75¢ A DAY	\$1.25 A DAY	\$1.50 A DAY	\$1.75 A DAY	\$2.00 A DAY	\$2.50 A DAY	\$3.00 A DAY
2 days	1.50	2.50	3.00	3.50	4.00	5.00	6.00
3 "	2.25	3.75	4.50	5.25	6.00	7.50	9.00
4 "	3.00	5.00	6.00	7.00	8.00	10.00	12.00
5 "	3.75	6.25	7.50	8.75	10.00	12.50	15.00
6 "	4.50	7.50	9.00	10.50	12.00	15.00	18.00
7 "	5.25	8.75	10.50	12.25	14.00	17.50	21.00
8 "	6.00	10.00	12.00	14.00	16.00	20.00	24.00
9 "	6.75	11.25	13.50	15.75	18.00	22.50	27.00
11 "	8.25	13.75	16.50	19.25	22.00	27.50	33.00
12 "	9.00	15.00	18.00	21.00	24.00	30.00	36.00
13 "	9.75	16.25	19.50	22.75	26.00	32.50	39.00
14 "	10.50	17.50	21.00	24.50	28.00	35.00	42.00

Thermometer Scales

Fahrenheit. — The freezing-point is taken as the thirty-second degree of the scale, and 180 degrees are made between that and the boiling-point, which therefore becomes 212°. The zero of Fahrenheit was supposed to represent the absolute zero, or lowest possible temperature.

Centigrade or Celsius. — The freezing-point of water is taken as zero, and boiling-point as 100°.

Reaumur. — The freezing-point of water is taken as zero, the boiling-point as 80°. A degree Centigrade is therefore greater than a degree of Fahrenheit as 9 is greater than 5; and a degree of Reaumur is greater, as 9 is greater than 4.

To reduce Fahrenheit degrees to Centigrade, subtract 32 from the given degree of Fahrenheit, and multiply the remainder by 5 and divide it by 9; $(F. \text{ degrees} - 32) \frac{5}{9}$. To reduce Centigrade to Fahrenheit, multiply the given degree of Centigrade by 9 and divide the product by 5, then to the quotient add 32: $(\frac{9}{5} C.^\circ + 32)$.

To reduce Fahrenheit to Reaumur, subtract 32 from the given degree of Fahrenheit and multiply the remainder by 4 and divide by 9: $(F.^\circ - 32) \frac{4}{9}$.

To reduce Reaumur to Fahrenheit, multiply the given degree of Reaumur by 9 and divide by 4, then add 32: $(\frac{9}{4} R^\circ + 32)$.

To reduce Reaumur to Centigrade, multiply by $\frac{5}{4}$.

Miscellaneous Measures, Weights, and Estimates

Measures and dimensions of many kinds

$\frac{1}{16}$ of an inch	= a line (American).
$\frac{1}{8}$ of an inch	= a line (French).
3 inches	= a palm.
4 inches	= a hand.
9 inches	= a span.
18 inches	= a cubit.
2½ feet	= a military pace.
3 (or 3.3) feet	= a pace.
6 feet	= 1 fathom.
240 yards	= 1 cable's length.
12 of any article	= 1 dozen.
12 dozen	= 1 gross.
20 of any article	= 1 score.
A wine gallon (U. S. standard)	= 231 cubic inches.
A dry gallon	= 268.8 cubic inches.
An imperial gallon (British standard)	= 277.274 cubic inches.
An imperial or English bushel	= 2218.192 cubic inches.
A U. S. bushel	= 2150.42 cubic inches.
A U. S. bushel heaped (heaped to a cone 6 inches high)	= 2747.7 cubic inches.
1 pint of water weighs 1.0431 pounds.	
1 gallon of water weighs 8.3448 pounds.	
1 cubic foot of water weighs 62.425 pounds at 39.2° F.	
1 stone is	14 pounds.
An English (statute) mile is	1760 yards.
A Scotch mile is	1984 yards.
An Irish mile is	2249 yards.
A Dutch mile is	8101 yards.
A Roman mile is	1628 yards.
A German mile is	6859 yards.
A Russian mile is	1100 yards.
An Arabian mile is	2148 yards.
A sea (nautical) mile is	2026 yards (1½ mi.).
A knot is the traveling speed of a ship, reckoned by making 1 sea-mile in 1 hour.	
1 tael (Chinese) is	1½ oz. avoird.
1 Danish pound is	1.102 lb. avoird.
1 Russian pound is9 lb. avoird.
1 libra (Spanish) is	1.014 lb. avoird.
100 pounds nails	= 1 keg.
196 pounds flour	= 1 barrel.
150 pounds potatoes	= 1 barrel of freight.
280 pounds salt	= 1 barrel.
200 pounds beef, fish, or pork	= 1 barrel.
45 drops of water is a teaspoonful.	
1 teaspoonful equals 1 fluid dram.	
1 dessertspoonful equals 2 teaspoonfuls, or 2 drams.	
1 tablespoonful equals 2 dessertspoonfuls, or 4 teaspoonfuls.	
2 tablespoonfuls equal 8 teaspoonfuls, or 1 fluid ounce.	
1 common-size wineglassful equals 2 ounces, or ½ gill.	
1 common-size tumbler holds ½ pint.	
A small tea-cup is estimated to hold 4 fluid ounces, or 1 gill.	
1 pound of wheat is equal to about 1 pint.	
1 pound and 2 ounces of Indian meal is equal to 1 quart.	
1 pound of soft butter is equal to about 1 pint.	
1 pound of sugar is equal to about 1 pint.	
A pint of pure water is about a pound.	
A barleycorn is ⅓ inch.	
An ell is usually 45 inches.	
A point (in type) is ⅓ inch.	
A circle is 3.1415 times the length of its diameter (the ratio being known as pi).	

Weights of various varieties of apples per bushel

The following varieties, just from the trees in October, gave the following weights for a heaped bushel (Michigan):—

Baldwin	50	Fallawater	48
Belmont	50	Golden Russet	53
Ben Davis	47	Lawyer	47
Bunker Hill	49	Nickajack	51
Cabashae	57	Northern Spy	46
Esopus Spitzenburgh	44	Pennock	47
Rambo	50	Swaar	51
Rhode Island Greening	52	Sweet Bough	39
Roxbury Russet	50	Talman Sweet	48
Rubicon	46	Tompkins King	44
Stark	56	Yellow Bellefleur	46

Dried fruit and cider

A bushel of average apples gives from 6 to 7½ pounds of evaporated product. Seven pounds to the bushel is a good average.

PRODUCT OF DRIED RASPBERRIES (*W. J. Green*)

Ohio	9 lb. to the bu.	Ada	8½ lb. to the bu.
Gregg	8½ lb. to the bu.	Tyler	8½ lb. to the bu.
Hillborn	8½ lb. to the bu.	Shaffer	8 lb. to the bu.

In general, three and one-fourth quarts (about four pounds) of fresh black-cap raspberries are required for a pound of marketable dried berries.

A pound of dried peaches may be made from four or five pounds of fresh fruit, if the variety has a dry flesh; but six or seven pounds is often required.

In California, twenty pounds of grapes produce six or seven pounds of raisins.

From seven to twelve bushels of apples are required for a barrel of cider.

Various estimates.

Raspberries contain from one and one-half to three pounds of seeds to the bushel.

A pint of garden blackberries weighs about one pound.

Good clusters of American grapes weigh on an average from one-half to three-fourths pound, while extra-good clusters will reach a pound and a half. Clusters have been reported which weighed two pounds.

A bushel of sweet corn ears, "in the milk," with the husks which come from it, weighs from fifty to seventy pounds.

There are about 5000 honey-bees in a pound.

Watermelons are usually sorted into three grades. Of the largest size, about six melons are placed in a barrel. Of medium size, about eight (four melons in each of two layers), and of the smallest size, ten to twelve. A truck-load of melons comprises about 200 fair-sized fruits. A car-load numbers 1000 to 1500.

Coconuts are packed for shipment in bags which hold 100.

"Ekimis" branded upon boxes of Smyrna figs means A. No. 1, or Superior Selected. "Eleme" means Selected, the second grade.

A box $12\frac{1}{8}$ in. long, wide, and deep holds 1 bu.

A box $19\frac{3}{8}$ in. long, wide, and deep holds 1 bbl.

A box $8\frac{1}{2}$ in. long, wide, and deep holds 1 pk.

A box $6\frac{7}{8}$ in. long, wide, and deep holds $\frac{1}{2}$ pk.

A box $4\frac{1}{8}$ in. long, wide, and deep holds 1 qt.

To find the bushels of apples, potatoes, shelled corn, etc., in bins, divide the cubic contents in inches by 2747.7 (the cubic inches in a heaped bushel). If the corn is in the ear, deduct one-third from the result.

The cubic contents is found by multiplying together length, breadth, and height in feet, and reducing the product to inches by dividing by 1728 (the number of cubic inches in a cubic foot); or make the original multiplication in inches rather than in feet.

A struck bushel (not heaped) contains 2150.4 cubic inches. See p. 528.

If the sides of a corn-crib are flaring, it is customary to reckon the width as half the sum of the top and bottom widths. Of course, much will depend on how much it flares. A similar method may be applied to apples, potatoes, and roots in heaps.

To find the tons of hay in a mow or stack, divide the cubic contents by about 500, if the hay is not well settled; or by about 450 to 460, if the hay is well packed.

To figure the cost of hay by the ton, multiply the number of pounds by the price (in dollars) per ton, point off three figures at the right, and divide by 2 (point off more figures if there are fractions of a dollar in the price):—

96 lb. × \$ 11	ton = 1.056	÷ 2 =	.528 (52 $\frac{3}{10}$ cents).
96 " × \$ 11.30	" = 1.0848	÷ 2 =	.54.
1700 " × \$ 13	" = 22.100	÷ 2 =	\$ 11.05.
2100 " × \$ 18	" = 37.800	÷ 2 =	\$ 18.90.
3350 " × \$ 10.80	" = 36.180	÷ 2 =	\$ 18.09.

At \$ 5 per ton, divide the number of pounds by 4:—

$$96 \text{ lb. at } \$5 : 96 \div 4 = .24 \text{ cents.}$$

$$1350 \text{ " " } \$5 : 1350 \div 4 = \$3.37.$$

At \$ 10 per ton, divide the number of pounds by 2.

Capacities of Pipes and Tanks

Quantity of water held by pipes of various sizes

Diameter of Bore	Contents of 100 feet in Length gal.
½	1.02
1	4.08
1½	9.18
2	16.32
2½	25.50
3	36.72
4	65.28
5	102.00
6	146.90

Number of gallons in circular tanks and wells

To find the contents in gallons of circular tanks, square the diameter in feet, multiply by the depth, and then multiply by 5.875.

GALLONS WHEN THE DEPTH IS

Diameter	GALLONS WHEN THE DEPTH IS										
	3 ft.	4 ft.	5 ft.	6 ft.	7 ft.	8 ft.	9 ft.	10 ft.	11 ft.	12 ft.	
4	282.00	376.00	470.00	564.00	658.00	752.00	846.00	940.00	1034.00	1128.00	
5	440.63	587.50	734.38	881.25	1028.13	1175.00	1321.89	1468.76	1615.63	1762.50	
6	634.50	846.04	1057.50	1269.00	1480.50	1692.00	1903.50	2115.00	2326.50	2538.00	
7	863.63	1151.50	1439.38	1727.25	2015.13	2303.00	2590.89	2878.76	3166.63	3454.50	
8	1128.00	1504.00	1880.00	2256.00	2632.00	3008.00	3384.00	3760.00	4136.00	4512.00	
9	1427.63	1903.50	2379.38	2855.26	3331.13	3807.04	4282.89	4758.76	5234.63	5710.52	
10	1762.52	2350.00	2937.52	3525.00	4112.52	4700.00	5287.56	5875.04	6461.52	7050.00	
11	2132.63	2843.50	3554.38	4265.26	4976.12	5687.00	6397.89	7108.76	7819.63	8530.52	
12	2538.00	3384.00	4230.00	5076.00	5922.00	6768.00	7614.00	8460.00	9306.00	10152.00	

Approximate contents of cylinders

DIAM.	DEPTH	QUANTITY
1¾ in.	× 3 in.	contains 1 gill.
3½ in.	× 3 in.	contains 1 pint.
3½ in.	× 6 in.	contains 1 quart.
7 in.	× 6 in.	contains 1 gallon.
14 in.	× 12 in.	contains 8 gallons.
14 in.	× 15 in.	contains 10 gallons.

Number of gallons in square-built tanks

To find the number of gallons in any square or oblong vessel, multiply the number of cubic feet contained in it, by 7.4805; or, to find the contents of a depth not given in this table, multiply the contents of tank one foot deep by the required depth in feet.

For other comparable figures, see page 531; for capacities of silos, pages 473 to 477; for capacities of reservoirs, page 497. Various pipe figures may be found in Chapters XI and XXV.

SIZE OF TANK	1 FT. DEEP	3 FT. DEEP	4 FT. DEEP	5 FT. DEEP
4 by 4 feet	119.68	359.06	478.75	598.44
5 by 5 feet	187.01	561.03	748.05	935.06
6 by 3 feet	134.64	403.9	538.5	673.2
6 by 4 feet	179.53	538.5	718.1	897.6
6 by 5 feet	224.41	673.2	897.6	1122.0
6 by 6 feet	269.29	807.8	1077.1	1346.4
7 by 4 feet	209.45	628.3	837.8	1047.2
7 by 5 feet	261.81	785.4	1047.2	1309.0
7 by 6 feet	314.18	942.5	1256.6	1570.8
7 by 7 feet	366.54	1099.6	1466.2	1832.7
8 by 4 feet	239.37	718.1	957.4	1196.8
8 by 5 feet	299.22	897.6	1196.8	1496.1
8 by 6 feet	359.06	1077.1	1436.2	1795.3
8 by 7 feet	418.90	1256.7	1675.6	2094.5
8 by 8 feet	478.75	1436.2	1915.0	2393.7
9 by 5 feet	336.62	1009.8	1346.4	1683.1
9 by 6 feet	403.94	1211.8	1615.7	2019.7
9 by 7 feet	471.26	1413.8	1885.0	2356.3
9 by 8 feet	538.59	1615.7	2154.3	2692.9
9 by 9 feet	605.92	1817.7	2423.6	3029.6
10 by 5 feet	374.02	1122.0	1496.1	1870.1
10 by 6 feet	448.83	1346.4	1795.3	2244.1
10 by 7 feet	523.63	1570.9	2094.5	2618.1
10 by 8 feet	598.44	1795.3	2393.7	2992.2
10 by 9 feet	673.24	2019.7	2692.9	3366.2
10 by 10 feet	748.05	2244.1	2992.2	3740.2
11 by 6 feet	493.71	1481.1	1974.8	2468.5
11 by 7 feet	575.99	1727.9	2303.9	2879.9
11 by 8 feet	658.28	1974.8	2633.1	3291.4
11 by 9 feet	740.56	2221.7	2962.2	3702.8
11 by 10 feet	822.85	2468.5	3291.4	4114.2
11 by 11 feet	905.14	2715.4	3620.5	4525.7
12 by 6 feet	538.59	1615.7	2154.3	2692.9
12 by 7 feet	628.36	1885.0	2513.4	3141.8
12 by 8 feet	718.12	2154.3	2872.5	3590.6
12 by 9 feet	807.89	2423.6	3231.5	4039.4
12 by 10 feet	897.66	2692.9	3590.6	4488.3
12 by 11 feet	987.42	2962.2	3949.6	4937.1
12 by 12 feet	1077.19	3231.5	4308.7	5385.9

Legal Weights of the Bushel

List of products for which legal weights have been fixed in but one or two states

- Apple seeds, forty pounds (Rhode Island and Tennessee).
Beggarweed seed, sixty-two pounds (Florida).
Blackberries, thirty-two pounds (Iowa) ; forty-eight pounds (Tennessee) ; dried, twenty-eight pounds (Tennessee).
Blueberries, forty-two pounds (Minnesota).
Bromus inermis, fourteen pounds (North Dakota).
Cabbage, fifty pounds (Tennessee).
Canary seed, sixty pounds (Tennessee).
Cantaloupe melon, fifty pounds (Tennessee).
Cherries, forty pounds (Iowa) ; with stems, fifty-six pounds (Tennessee) ; without stems, sixty-four pounds (Tennessee).
Chestnuts, fifty pounds (Tennessee) ; fifty-seven pounds (Virginia).
Chufa, fifty-four pounds (Florida).
Cottonseed, staple, forty-two pounds (South Carolina).
Cucumbers, forty-eight pounds (Missouri and Tennessee) ; fifty pounds (Wisconsin).
Currants, forty pounds (Iowa and Minnesota).
Feed, fifty pounds (Massachusetts).
Grapes, forty pounds (Iowa) ; with stems, forty-eight pounds (Tennessee) ; without stems, sixty pounds (Tennessee).
Guavas, fifty-four pounds (Florida).
Hickory nuts, fifty pounds (Tennessee).
Hominy, sixty pounds (Ohio) ; sixty-two pounds (Tennessee).
Horseradish, fifty pounds (Tennessee).
Italian rye-grass seed, twenty pounds (Tennessee).
Johnson-grass, twenty-eight pounds (Arkansas).
Kafir, fifty-six pounds (Kansas).
Kale, thirty pounds (Tennessee).
Land-plaster, 100 pounds (Tennessee). See page 540.
Meal, forty-six pounds (Alabama) ; unbolted, forty-eight pounds (Alabama).
Middlings, fine, forty pounds (Indiana) ; coarse middlings, thirty pounds (Indiana).

[Continued on page 540]

[Continued from page 533]

- Millet, Japanese barnyard, thirty-five pounds (Massachusetts).
 Mustard, thirty pounds (Tennessee).
 Plums, forty pounds (Florida) ; sixty-four pounds (Tennessee).
 Plums, dried, twenty-eight pounds (Michigan).
 Popcorn, seventy pounds (Indiana and Tennessee) ; in the ear, forty-two pounds (Ohio).
 Prunes, dried, twenty-eight pounds (Idaho) ; green, forty-five pounds (Idaho).
 Quinces, forty-eight pounds (Florida, Iowa, and Tennessee).
 Rape seed, fifty pounds (Wisconsin).
 Raspberries, thirty-two pounds (Kansas) ; forty-eight pounds (Tennessee).
 Rhubarb, fifty pounds (Tennessee).
 Sage, four pounds (Tennessee).
 Salads, thirty pounds (Tennessee).
 Sand, 130 pounds (Iowa).
 Spelt or Spiltz, forty pounds (North Dakota) ; forty-five pounds (South Dakota).
 Spinach, thirty pounds (Tennessee).
 Strawberries, thirty-two pounds (Iowa) ; forty-eight pounds (Tennessee).
 Sugar-cane seed, fifty-seven pounds (New Jersey).
 Velvet-grass seed, seven pounds (Tennessee).
 Walnuts, fifty pounds (Tennessee).

Other articles.

One bushel of house ashes (wood) is calculated to weigh forty-eight pounds ; ground gypsum, seventy pounds (see p. 533, under land-plaster) ; sand, 122½ pounds.

For lime, see pp. 78, 536 ; cement, pp. 504, 505.

Legal weights of seeds and grains in Canada.

Section 90 of the Inspection and Sale Act of the Department of Agriculture for the Dominion of Canada, dealing with the legal weights of farm products, reads as follows :—

In contracts for the sale and delivery of any of the undermentioned articles a bushel shall be determined by weighing, unless a bushel by

measure is specially agreed upon, and the weight equivalent to a bushel shall, except as hereinafter provided, be as follows :—

	lb.
Barley	48
Buckwheat	48
Flaxseed	56
Indian corn	56
Oats	34
Pease	60
Rye	56
Wheat	60

Section 337 reads as follows :—

In contracts for the sale and delivery of any of the undermentioned articles, the bushel shall be determined by weighing, unless a bushel by measure is specially agreed upon and the weight equivalent to a bushel shall be as follows :—

	lb.
Beans	60
Beets	60
Blue-grass seed	14
Carrots	60
Castor-beans	40
Clover seed	60
Hemp seed	44
Malt	36
Onions	50
Parsnips	60
Potatoes	60
Timothy seed	48
Turnips	60

In the province of Quebec, when potatoes are sold or offered for sale by the bag, the bag shall contain at least eighty pounds.

Government Townships

The word "town" has a variety of meanings. It is commonly loosely used to designate merely a settlement or a community. In New England, however, it is the primary administrative division. It is there very irregular in shape and size, following the lines of contour and of early settlement. In New England, outside of Rhode Island, a township unit was essentially an ecclesiastical unit. In Rhode Island, the township government was separated from church control. In the South, the county came to be the primary

political unit in most cases, and there is no highly developed township system.

The New England type of town spread westward to New York, although the full town-meeting form of government did not follow; the townships remained irregular and followed no system of territorial division. When the new public domains began to be surveyed by the federal government, a regular system of townships, or territorial divisions, was laid out. These townships are right-angled, being six miles on a side and containing 36 square miles. They are determined and also divided by the intersection of meridians or range-lines running north and south, and by parallels or town-lines running east and west. The township is subdivided into 36 square miles, each of these square miles being known as a "section" and containing 640 acres. The sections

6	5	4	3	2	1
7	8	9	10	11	12
18	17	16	15	14	13
19	20	21	22	23	24
30	29	28	27	26	25
31	32	33	34	35	36

are numbered consecutively from 1 to 36, beginning at the northeast corner of the township and running directly across to the northwest corner, then back again to the east and back to the west, and so on back and forth until the 36th section stands at the southeast corner of the township, as shown in the diagram. In each township, section 16 is set aside for school purposes.

The sections are themselves divided into quarter-sections, each containing 160 acres. These quarter-sections are again divided into fours, of 40 acres each; and these 40 acres are the smallest divisions recognized in government surveys.

The location of any piece of land is determined by the section number and by the half-section or quarter-section in which it is located. The township itself is located by its town-line and its range. That is to say, a township in any state might be number 10 south of the base-line that was established by the government, and range 9 west of some one of the principal meridians fixed by the government. A particular quarter-section in this township might be the southwest quarter of section number 27 in township 10 south and range 9 west of the sixth principal meridian.

CHAPTER XXVIII

COLLECTING AND PRESERVING SPECIMENS FOR CABINETS OR EXHIBITION. PERFUMERY. LABELS

EVERY good farm establishment should have a room or a cabinet in which the museum materials of the particular farm are collected, — soils, minerals, plants, insects, curiosities, and the like.

Collecting and Storing Samples of Soil (Fippin)

The farmer should know his soil. The collecting of soils and their preservation and study has been a source of much interest to some persons, — quite as much as the collecting of seeds, plants, or souvenirs. To secure samples that fairly represent a particular soil-formation or soil-region requires much care in selection. Soils usually vary greatly from point to point. They also vary at different depths. Usually the top soil is more rich in organic matter than the subsoil. It is therefore best to take small samples from a number of points in an area of a few square rods and mix them together, and preserve the desired sample from this composite lot.

Some arbitrary depth must be chosen, and one foot is best on the average. Since the subsoil is also of great importance, it is desirable to have a sample taken from one to two feet in the same holes as the top soil. A common wood auger one and one-half inches in diameter with a handle sufficient to make a total length of thirty-six, with an eight-inch pipe cross bar at the top, is most convenient for collecting samples in soils that are not excessively stony. The stem may be made in sections, connecting by means of milled threads.

Before being finally stored, the soil samples should be thoroughly dried on a piece of paper in the air. Collection should not be made when the soil is so wet as to puddle, and the sample would preferably not be pulverized after drying.

The amount of the sample must depend on the object of the work. For general study and analysis, one quart is usually abundant, and one pint is often adequate for chemical and physical analysis. For private collections, even smaller samples put up in four- or six-ounce vials of five or six inches in length, straight sides, and metal screw-top, are very convenient. Regular specimen-jars holding about one-third of a pint or more and with cork in the bottom are excellent for small samples. For larger samples, screw-top glass fruit-jars are usually the most convenient form of storage vessel.

For shipping samples, a stout canvas bag closely woven and simply labeled on a tag is most convenient, and several such samples may be inclosed in a large bag of the same material.

Samples of Seeds and Grains

Every farmer should have samples in his study or elsewhere of the common commercial grades of wheat, oats, and other grains, and specimens of the seeds of the leading grasses and the most frequent weeds.

He can secure the weed seeds from the plants themselves ; or in some cases the Experiment Station will aid him to secure them. Whenever a pernicious weed appears on the plantation, seeds should be saved of it. The farmer should determine how it was introduced, whether with grain or with grass seed ; he will then be on the guard for future invasion. He should have a good hand lens with which to examine all grass seed and clover seed that he purchases.

He should have samples of pure grass seed, the different kinds of clover, alfalfa, and similar crops.

Samples of the different grades of wheat and other grains, of the leading varieties, and of shrunken or injured grains, would be very useful to persons who are engaged in the growing of grain or in the handling of it. They will serve as standards. In some of the states, the experiment stations supply such seeds ; if they do not supply them, they can put the farmer in touch with the ways of securing them.

All seeds should be placed in tight bottles and be thoroughly dried before being put away. In bottles they are easy of examination, and they are also free from weevils and other insects. If they should become affected with insects, the pests may be destroyed by pouring a little bisulfid of carbon into the bottle and quickly corking it up tight.

For samples of corn, buckwheat, rye, rice, and other commercial grains, it is well to use one of the small fruit-jars. The weed seeds may be put up in vials with wide necks.

Collecting and Preserving Plants for Herbaria

Collect samples of all parts of the plant, — lower and upper leaves, stem, flowers, fruit, and in most cases roots. In small species, those two feet high or less, the whole plant should be taken. Of larger plants, take parts about a foot long. Press the plants between papers or “driers.” These driers may be any thick porous paper, as blotting-paper or carpet-paper, or, for plants that are not succulent or very juicy, newspapers in several thicknesses may be used. It is best to place the specimens in sheets of thin paper — grocer’s tea paper is good — and place these sheets between the driers. Many specimens can be placed in a pile. On top of the pile place a short board and a weight of thirty or forty pounds, or a lighter weight if the pile is small and the plants are soft. Change the driers every day. The plants are dry when they become brittle, and when no moisture can be felt by the fingers. Some plants will dry in two or three days, while others require as many weeks. If the pressing is properly done, the specimens will come out smooth and flat and the leaves will usually be green, although some plants always turn black in drying.

Specimens are usually mounted on single sheets of white paper of the stiffness of very heavy writing paper or thin bristol-board. The standard size of sheet is $11\frac{1}{2}$ by $16\frac{1}{2}$ inches. The plants may be pasted down permanently and entirely to the sheet, or they may be held on by strips of gummed paper. In the former case, Denison’s fish-glue is a good gum to use. Only one species or variety should be placed on a sheet. Specimens that are taller than the length of a sheet should be doubled over when they are pressed. The species of a genus are collected into a genus cover. This cover is a folded sheet of heavy manila or other firm paper, and the standard size, when folded, is 12 by $16\frac{1}{2}$ inches. On the lower left-hand corner of this cover the name of the genus is written. A label should accompany each specimen upon the separate sheets, recording the name, date of collecting, name of the collector, and any notes that may be of interest.

The specimens are now ready to be filed away on shelves in a horizontal position. If insects attack the specimens, they may be destroyed by fumes of bisulphid of carbon (see page 293) or chloroform. The bisulphid treatment is probably the best yet devised, particularly for large herbaria. In this case it is necessary to place the specimens in a tight box and then insert the liquid. Lumps of naphthalin placed in the cabinet are useful in keeping away insects.

Various poisons have been used on herbarium plants. At one time, the Gray Herbarium used an arsenic solution, but this proved to be injurious to curators. Three corrosive sublimate (bichloride of mercury) recipes are as follows:—

1. Place as much corrosive sublimate in alcohol as the liquid will dissolve. Apply with a brush, or dip the plants before they are mounted and dry them between sheets. A common method.

2. Dissolve $1\frac{3}{4}$ ounces of corrosive sublimate in one pint of alcohol; add $2\frac{1}{2}$ fluid drams of carbolic acid, and apply with a paint brush.

3. One pound of corrosive sublimate, one pound of carbolic acid, to 4 gallons of wood alcohol.

Preserving, Printing, and Imitating Flowers and Other Parts of Plants

TO PRESERVE THE COLOR OF DRIED FLOWERS. — 1. Immerse the stem of the fresh specimen in a solution of 32 parts by weight of alum, 4 of niter, and 186 of water for two or three days until the liquid is thoroughly absorbed, and then press in the ordinary way, except that dry sand is sifted over the specimen and the packet submitted to the action of gentle heat for twenty-four hours.

2. Make a varnish composed of 20 parts of powdered copal and 500 parts of ether, powdered glass or sand being used to make the copal dissolve more readily. Into this solution the plants are carefully dipped; then they are allowed to dry for ten minutes, and the same process is repeated four or five times in succession.

3. Plants may also be plunged in a boiling solution of 1 part of salicylic acid and 600 of alcohol, and then dried in bibulous paper. But this should be done very rapidly, violet flowers especially being decolorized by more than an instantaneous immersion.

4. Red flowers which have changed to a purplish tint in drying may have their color restored by laying them on a piece of moistened paper

with dilute nitric acid (one part to ten or twelve parts of water), and then submitting them to moderate pressure for a few seconds ; but the solution must not touch the green leaves, as they are decolorized by it.

5. *With sulfur* (Quin). — Procure a chest about three or four feet square with a small opening in the under part of one side, to be closed by a bar, through which the basin containing brimstone must be put into the chest ; this opening must be covered inside with perforated tin, in order to prevent those flowers which hang immediately over the basin from being spoiled. Paper the inside to render it airtight. When the chest is ready for use, nail small laths on two opposite sides of the interior, at a distance of about six inches apart, and on these lay thin round sticks upon which to arrange the flowers ; these should not be close together, or the vapor will not circulate freely through the vacant spaces around the flowers. When the chest is sufficiently full of flowers, close it carefully, place a damp cloth on the sides of the lid, and some heavy stones upon the top of it ; then take small pieces of brimstone, put them in a small, flat basin, kindle, and put through the opening in the bottom of the chest and shut the bar. Leave the chest undisturbed for twenty-four hours, after which time it must be opened, and if the flowers be sufficiently smoked, they will appear white, if not, they must be smoked again. When sufficiently smoked, take the flowers out carefully and hang them up in a dry, airy place in the shade, and in a few days or even hours they will recover their natural color, except being only a shade paler.

To give them a very bright and shining color, plunge them into a mixture of ten parts of cold water and one of good nitric acid ; drain off the liquid, and hang them up again the same as before. The best flowers for this process are asters, roses, fuchsias (single ones), spiraeas (red-flowered kinds, such as Japonica, Douglasi, etc.), ranunculus, delphiniums, cytissus, etc. The roses should be quite open, but not too fully blown.

6. *In sand* (Quin). — Dry the plants in clean silver sand, free from organic matter (made so by repeated washing, until the sand ceases to discolor the water). Heat the sand rather hot, and mix with it by constant stirring a small piece of wax candle, which prevents the sand from adhering to the flowers. Have a box not higher than three inches, but as broad as possible ; this box should have instead of a bottom a narrow-meshed iron-wire net at a distance of three-fourths

inch from where the bottom should be. Place the box on a board and fill with sand till the net is just covered with a thin layer of sand ; upon this layer of sand, place a layer of flowers, on that a layer of sand, then flowers, and so on ; the layers of sand should vary in thickness according to the kind of flowers, from one-eighth to one-fourth inch.

When the box contains about three layers of flowers, it must be removed to a very sunny dry place, the best being close under the glass in an empty greenhouse, exposed to the full influence of the sun. After a week, if the weather is sunny and dry, the flowers will be perfectly dried ; then the box is lifted a little, the sand falls gently through the iron net, and the flowers remain in their position over the net without any disturbance whatever.

They should then be taken out carefully and kept in a dry and, if possible, dark place, where no sun can reach them, and afterwards they will keep very well for many years.

Care should be taken that the flowers are cut in dry weather, and that while lying in the sand no part of a flower shall touch another part, as this always spoils the color and causes decay. Sand should be filled in between all the parts of the flower ; therefore it is necessary to insert the double flowers in an erect position, in order to fill the sand between the petals, while most of the single flowers must be put in with the stalks upwards.

PRINTING PLANTS. — 1. First, lightly oil one side of paper, then fold in four, so that the oil may filter through the pores, and the plant may not come into direct contact with the liquid. The plant is placed between the leaves of the second folding, and in this position pressed (through other paper) all over with the hand, so as to make a small quantity of oil to adhere to its surface. Then it is taken out and placed between two sheets of white paper for two impressions, and the plant is pressed as before. Sprinkle over the invisible image remaining on the paper a quantity of black lead or charcoal, and distribute it in all directions ; the image then appears in all its parts. With an assortment of colors the natural colors of plants may be reproduced. To obtain fixity, rosin is previously added to the black lead in equal parts. Expose to heat sufficient to melt the rosin.

2. The best paper to use is ordinary wove paper, without water-marks ; if it can be afforded, use thin drawing-paper. First select the leaves, then carefully press and dry them. If they be placed in a plant

press, care must be taken not to put too great pressure on the specimens at first, or they will be spoiled for printing. An old book is the best for drying the samples to be used. Secure printers' or proof ink, and a small leather dabber; work a bit of ink about the size of a pea on a small piece of slate or glass, with the dabber, until it is perfectly smooth. A drop or two of linseed oil will assist the operation. Then give the leaf a thin coating, being careful to spread it equally; now lay the leaf ink downwards on a sheet of paper and place it between the leaves of an old book, which must then be subjected to a moderate pressure in a copying-press, or passed between the rollers of a wringing-machine. Impressions can be taken with greater rapidity by laying the book on the floor and standing upon it for a few seconds. Soft book-paper is the best. Previous to using it, place a few sheets between damp blotting-paper, which causes it to take the ink still more readily. At first you will find that you lay on too much ink. If the impression is too black, use the leaf again. If the midrib of the leaf is too thick, it must be shaved down with a sharp knife.

3. *Leaf-prints* (Engle). — 1. A small ink-roller, such as printers use for inking type. 2. A quantity of printers' green ink. 3. A pane of stout window-glass (the larger the better) fastened securely to an evenly planed board twice the size of the glass. A small quantity of the ink is put on the glass and spread with a knife, after which it is distributed evenly by going over in all directions with the ink-roller. When this has been carefully done, the leaf to be copied is laid on a piece of waste paper and inked by applying the roller once or twice with moderate pressure. This leaves a film of ink on the veins and network of the leaf, and by placing it on a piece of blank paper and applying considerable pressure for a few moments the work is done, and when the leaf is lifted from the paper, the impress remains with all its delicate tracery, faithful in color and outline to the original.

To make the ink of proper consistency, add several drops of balsam copaiba to a salt-spoonful of ink. If the leaf sticks, the ink is too thick.

SKELETONIZING PLANTS. — 1. *By maceration*. Place the leaves in water, and allow them to remain in the same water for from three to four months, until the soft matter decays, and the stem may be taken in the hand and the refuse shaken away. There remains behind a network or skeleton of the original object, which can be bleached with

a little lime. Leaves and pods may both be treated satisfactorily in this manner. The pod of the "Jimson weed" or *Datura Stramonium* is a favorite for this purpose.

2. *By chemicals.* — Chloride of lime, $\frac{1}{4}$ pound; washing soda, $\frac{1}{2}$ pound. Put the soda into $1\frac{1}{2}$ pints boiling water (rain-water is best) and let it thoroughly dissolve. Put the chloride of lime in a large pitcher, and add same quantity of cold water. Stir well and cover closely to prevent the escape of the chlorine. When the soda-water is cool, pour it on the chloride of lime, stir well together and cover tightly, leaving it for an hour or more. Then pour off very gently the clear liquid, which must be bottled tightly.

This solution will remove fruit-stains from white goods, and will bleach any vegetable substances. When used for cotton or linen, it must be considerably diluted, and the goods well rinsed afterwards.

WATERPROOF PAPER FOR ARTIFICIAL FLOWERS. — Waterproof paper, transparent and impervious to grease, is obtained by soaking good paper in an aqueous solution of shellac and borax. It resembles parchment paper in some respects. If the aqueous solution be colored with aniline colors, very handsome paper, of use for artificial flowers, is prepared. Prepared paraffin paper is now much used.

TO KEEP FLOWERS FRESH. — If cut flowers are not needed immediately, wet them and then wrap them in paper and place in a tight box in a cool place. Keep as cool as possible without freezing.

The disagreeable odor which comes from flowers in vases is due to the decay of the leaves and stems in the water. Therefore remove all the lower leaves before putting flowers in vases.

Flowers that have stood in a vase for a day or so can be greatly refreshed if taken from the vase at night, thoroughly sprinkled and wrapped, stems, blossoms, and all, as closely as possible in a soaked cloth and laid aside until the morning. They will be much fresher than if they had been left in their vases, yet will not have bloomed out so much. Before thus laying them aside, and again in the morning, a bit of each stem should be cut off, as the end soon hardens. This ought also to be done once or twice a day, even if the flowers are kept constantly in their vases. Roses that have drooped before their time — as, for example, when worn on the dress — may be revived if the stems, after being thus cut, are placed for ten minutes in almost boiling water and then removed to cold water.

Collecting and Preserving Insects

Flying insects are caught in a net made of mosquito-bar, or cheesecloth after the fashion of the minnow-net. The material is made into a bag about a yard deep, and about a foot in width at the top. The opening is fastened upon a wire hoop, which is secured to a pole — as a broomstick. Insects are killed by placing them in a “cyanide-bottle.” This is prepared by placing two or three lumps of cyanide of potassium the size of a quail’s egg in a wide-mouthed glass bottle, covering the lumps with a layer of fine sawdust held in place by snugly fitted pieces of pasteboard. The insects are quickly killed by the fumes of the poison. Keep the bottle corked. The cyanide is very poisonous, and the fumes should not be inhaled. Bugs and beetles, etc., may be pinned and mounted as soon as they are dead. It is customary to pin beetles through the right wing-cover, and bugs — as squash-bugs — through the triangular space between the wings. Butterflies and moths should have the wings carefully spread. This is done by placing on a “setting-board.” This apparatus is a little trough with a crack at the bottom. The sides of the trough are made of thin bits of board, three or four inches wide and a foot or more long. These sides have very little slant. The crack in the bottom of the trough is left about a half-inch wide, and it is covered beneath with a strip of cork. The body of the insect is now placed lengthwise the crack, a pin is thrust through the thorax or middle division of the insect, into the cork, and the wings are laid out on the sides of the trough. The wings are held in place by strips of cardboard or mica pinned over them. Take care not to stick the pins through the wings. In about two weeks the insects will be dry and stiff.

Insects must be kept in tight boxes to keep other insects from devouring them. Cigar-boxes are good. Tight boxes with glass covers are generally used by collectors. Place sheets of cork in the bottom of the box to receive the pins. If insects attack the specimens, expose them in a tight box to vapors of bisulfid of carbon or benzine.

Larvæ, and some other soft bodies, may be preserved in 95 per cent alcohol.

Making Perfumery at Home

PERMANENT ATTAR OR OTTO OF ROSES (Ellwanger). — The roses employed should be just blown, of the sweetest-smelling kinds,

gathered in as dry a state as possible. After each gathering, spread out the petals on a sheet of paper and leave until free from moisture; then place a layer of petals in a jar, sprinkling with coarse salt; then another layer of coarse salt, alternating until the jar is full. Leave for a few days, or until a broth is formed; then incorporate thoroughly and add more petals and salt, mixing thoroughly daily for a week, when fragrant gums and spices should be added, such as benzoin, storax, cassia-buds, cinnamon, cloves, cardamon, and vanilla-bean. Mix again and leave for a few days, when add essential oil of jasmine, violet tuberose, and attar of roses, together with a hint of ambergris or musk, in mixture with the flower ottos, to fix the odor. Spices, such as cloves, should be sparingly used.

PERFUME-JAR. — 1. One pound of dried rose-petals bought at a drug-store, 4 ounces of salt, and 2 ounces of saltpeter, on which put 8 drops of essence of ambergris, 6 drops of essence of lemon, 4 drops of oil of cloves, 4 drops of oil of lavender, and 2 drops of essence of bergamot.

2. One-half pound of common salt, $\frac{1}{4}$ pound saltpeter, $\frac{1}{4}$ ounce storax, one-half dozen cloves, a handful of dried bay-leaves, and another handful of dried lavender-flowers. This basis will last for years, and petals of roses and other fragrant flowers gathered on dry days may be added annually, or powered benzoin, chips of sandalwood, cinnamon, orris-root, or musk may be added.

LAVENDER-BAG. — One-half pound lavender-flowers, one-half ounce dried thyme and mint, one-fourth ounce ground cloves and caraway, one ounce common salt. Tie up in a linen bag, which is hung in a wardrobe.

Orris-root is a good medium in which to place delicate perfumes for perfumery bags.

The Preservation of Fruits for Exhibition Purposes

Six Canadian recipes (Frank T. Shutt, Experimental Farm, Ottawa, 1911). Specimens of course not edible.

In the preparation of these fluids, it is desirable to employ distilled water, usually obtainable from druggists at a small cost. The alcohol used in these formulæ may be the ordinary spirits of wine.

FLUID NO. 1. — FORMALDEHYDE

Formaldehyde (formalin)	1 part
Alcohol	5 parts
Water, to make	50 parts

To prepare one gallon of the fluid $3\frac{1}{2}$ ounces of formaldehyde and 16 ounces of alcohol will be required, the remainder of the gallon to be made up with water.

The addition of a volume of hydrogen peroxide equal to that of the formaldehyde has been found to somewhat enhance the value of this fluid for red fruits.

FLUID NO. 2. — BORIC ACID

Boric (boracic) acid	1 part
Alcohol	5 parts
Water, to make	50 parts

For one gallon, $3\frac{1}{2}$ ounces of boric acid and 16 ounces of alcohol will be required.

The powdered form of boric acid is the most convenient to use. There is no necessity to employ hot water, but stirring should be continued until complete solution is effected.

FLUID NO. 3. — ZINC CHLORIDE

Zinc chloride	3 parts
Alcohol	10 parts
Water, to make	100 parts

For one gallon of fluid, 5 ounces of zinc chloride and 16 ounces of alcohol will be required.

Zinc chloride, of good quality, passes readily into solution; any white, flocculent precipitate that may appear is allowed to settle out, and the clear fluid decanted.

FLUID NO. 4. — SULFUROUS ACID

Sulfurous acid	1 part
Alcohol	1 part
Water, to make	10 parts

For one gallon, 16 ounces each of sulfurous acid and of alcohol will be required.

FLUID NO. 5. — COPPER SULFATE

Copper sulfate	2 parts
Alcohol	10 parts
Water, to make	100 parts

For one gallon, $3\frac{1}{5}$ ounces of copper sulfate and 16 ounces of alcohol will be required.

To facilitate solution, powder the copper sulfate (bluestone) and dissolve it in a small quantity of hot water ; when cold, add the alcohol and the remainder of the water to the required volume.

FLUID NO. 6. — ALUM

Alum	5 parts
Alcohol	10 parts
Water, to make	100 parts

For one gallon, 8 ounces of alum and 16 ounces of alcohol will be required.

If powdered alum is not obtainable, crush the crystals and dissolve as directed in No. 5.

For the most successful treatment, it is desirable to have the fruit sound, unbruised, and not over-ripe when placed in the fluid. When practicable, the fruit should be left on the stalk or branch, the whole being so supported or suspended in the bottle that the fruit is not subjected to any undue pressure. Sufficient fluid should be used to completely cover the fruit. It is well to hermetically seal the stopper with melted paraffin and to keep the bottles of preserved fruit in a cool, darkened room.

Recommendation on the six Canadian recipes.

In the following paragraphs, the fluids are indicated that have proved to be the best preservatives with the various fruits under trial.

APPLES AND CRABS.

Red: No. 2 ; the best fluid in the larger number of tests.

No. 1 has also proved effective for many varieties.

No. 2. A fairly satisfactory fluid.

Green and russet: No. 3.

White and yellow: No. 4. This solution, while in most respects quite satisfactory, is apt to give the fruit an unnatural paleness.

BEANS IN POD.

Green: No. 5 ; this is undoubtedly the best fluid.

No. 1 may be used for short periods of preservation.

Yellow or wax: No. 3 has given the best results.

No. 4 can be used, but bleaches rather excessively.

CURRENTS.

Black: No. 1 and No. 2. Both are fairly satisfactory, the preference being with No. 1. Owing to the large amount of coloring matter extracted at the outset from this fruit, the fluid should be changed, say at the expiration of two or three weeks.

Red: No. 3, closely followed by No. 2, are successful preservatives for the fruit.

White: Nos. 2 and 3 are almost equally satisfactory.

GOOSEBERRIES.

No. 5; this fluid has given very good results — incomparably better than any of the other solutions under investigation.

GRAPES.

Black: No. 1 is satisfactory and excellent.

Red: No. 3 is probably the best.

No. 1 (with peroxide of hydrogen) and No. 2 have been used successfully.

White: (green) No. 2 and No. 3. Neither of these has proven satisfactory, but No. 2 seems to be the better.

PEAS IN POD.

No. 5; by far the best fluid.

No. 3 has been used with some success for short periods.

PLUMS.

Our experience in preserving this fruit has been very limited, but fluid No. 2 has been used with fair success.

RASPBERRIES.

Red and purple: A very difficult fruit to preserve in its natural form and color.

No. 6. This is the best of the many fluids tried; by an occasional change of solution, this preservative gives fairly good results.

White: No. 2.

STRAWBERRIES.

No. 1 ; this fluid, both with and without peroxide, will preserve the fruit with much of its natural color. No other fluid among those under experiment has proven at all satisfactory for this fruit.

TOMATOES.

No. 2 has given fairly satisfactory results.

Preserving fruits and vegetables for exhibition (A California method).

Glycerine	2 to 24 oz.
Sulfurous acid	1 to 3 oz.
Rock salt	1 oz.
Saltpeter	1 oz.

The above amounts are for one gallon of water. The amount of glycerine is governed by the specific gravity of the juice of the subject, it being requisite to have the density of the fluid the same as that of the juice. The amount of sulfurous acid is governed by the nature of the subject, fruits of delicate tint being given the minimum amount, while most vegetables will take the maximum.

It is absolutely essential for success to have pure sulfurous acid, and this is best obtained by treating charcoal with sulfuric acid and running the gas directly into the water in the preserving jar. The sulfurous acid must be generated in a strong vessel, as the chemical action is violent.

No particular pains are taken to have the fruit clean at the time it is placed in the jars. After the solution is on it, it must be set away in a dark, cool place, and carefully examined at intervals of a few days.

If any cloudiness or discoloration appears, the liquid must be promptly removed and replaced by fresh. This is best done by running in clear water from a hose until all the preserving fluid is displaced, and then recharging the water in accordance with the formula. This clearing will also remove all dirt and sediment. After the fruit has remained in a dark place for several months without change, the fluid should be removed and substituted by fresh, in which there is only one ounce of sulfurous acid to the gallon. This latter strength is known as the "show liquid."

Labels

TREE LABELS may be made of various kinds of material. The commonest and cheapest label is made of clean white pine, primed with thin white lead. These can be purchased of dealers in nursery-men's supplies. The ordinary nursery tree label is $3\frac{1}{2}$ inches long.

The Cornell tree label is made from the "package label" used by nurserymen. It is a pine notched tally 6 inches long and $1\frac{1}{4}$ inches wide. (Cost, painted, about \$1.30 to \$1.50 per thousand.) These are wired with heavy stiff wire, not less than eighteen inches long, so that the loop is five or six inches across. The labels are hung on one of the lower limbs of the tree, where they are very conspicuous. The ends of the wire are hooked together around the limb by means of pincers, and, being stiff, it is not readily removed by careless or mischievous persons. The name is written firmly with a very soft black lead-pencil, and when the label is hung upon the tree, it is dipped in thin white lead, which fixes the writings and preserves it almost indefinitely; or the name may be written firmly into a fresh white lead.

Labels made of small strips of common zinc are often used, the name being written on the metal with a lead-pencil. The label is wound about a limb, and it expands as the part grows. The label is so inconspicuous and so easily removed that it is unsatisfactory.

Thick tallies of lead, with the name stamped in with dies, are good.

Thin metal labels that hang on a wire are often broken or torn out at the eyelet by the wind.

STAKE LABELS, made of pine or other soft clear wood, are most satisfactory for garden use, unless, perhaps, in botanic gardens, or other permanent exhibition grounds where a more conspicuous and ornamental label is wanted. The label should be primed with white lead, after which it takes a permanent mark from a medium soft lead-pencil.

A good label for grounds which are cultivated by horses, and which are therefore likely to be broken by the whiffletrees, is a pine stake 2 feet long, $3\frac{1}{2}$ inches wide, and $1\frac{1}{2}$ inches thick, sawed to a taper at the lower end. Give them two coats of thin white lead, taking care not to pile them on their faces whilst drying. Make the record with a soft large lead-pencil. When the writing wears off, or the label is wanted for other uses, plane a shaving off the face, paint again, and it is as good as new.

TO PRESERVE WOODEN LABELS. — Thoroughly soak the pieces of wood in a strong solution of copperas (sulfate of iron); then lay them, after they are dry, in lime-water. This causes the formation of sulfate of lime, a very insoluble salt, in the wood.

BLACK INK FOR ZINC LABELS. — Verdigris, 1 ounce; sal ammoniac, 1 ounce; lampblack, $\frac{1}{2}$ ounce; rain-water, $1\frac{1}{2}$ pint. Mix in an earthenware mortar or jar and put up in small bottles. To be shaken before use and used with a clean quill pen on bright zinc.

Jars for Specimens

The jars, bottles, or boxes in which specimens are kept should be tight, to prevent evaporation, to keep out dust and mold, and to protect from insects. There are specially made museum jars of many attractive patterns. Four-sided fruit-jars with covers held by lever fastenings are also excellent. If one cannot secure such receptacles as these, he may prepare old bottles, and then fasten covers over them. Following are old methods of cutting bottles in two:—

1. Pass five or six strands of coarse packing-twine round the bottle on each side of the line where you want it divided, so as to form a groove $\frac{1}{8}$ inch wide; in this groove pass one turn of a piece of hard-laid white cord, extend the two ends, and fasten to some support. Saw the bottle backwards and forwards for a short time; after a minute's friction, by a side motion of the bottle throw it out of the cord into a tub of water, and then tap on the side of the tub and the bottom will fall off.

2. Fill the bottle the exact height you wish it to be cut, with oil of any kind; dip, very gradually, a red-hot iron into the oil. The glass suddenly chips and cracks all round, then the upper surface may be lifted off at the surface of the oil.

3. For cutting off bottoms of bottles, make a slight nick with a file, and then mark round with a streak of ink where you want it to come off. Make an iron red-hot and lay it on the nick. This will cause it to expand and crack; then, by moving the rod round, the crack will follow.

CHAPTER XXIX

DIRECTORIES

THE farmer now secures his technical information from the colleges and schools of agriculture and experiment stations in the different states, territories, and provinces (directories given on the succeeding pages) ; from the United States Department of Agriculture, at Washington ; from departments of agriculture at the capitals of the states, territories, and provinces ; and from other public institutions.

The number of agricultural and country-life societies is now very great. A general directory of them is printed in Vol. IV of the Cyclopedia of American Agriculture, and by the United States Department of Agriculture ; and local lists may sometimes be secured from the state departments of agriculture, and in the rural press.

Some of the Institutions and Agencies making for a Better Rural Life

1. Departments of Agriculture, national and state.
2. Colleges of agriculture, one for each state, territory, or province.
3. Agricultural experiment stations, in nearly all cases connected with the colleges of agriculture.
4. The public school system, into which agriculture is now being incorporated. Normal schools, into many of which agriculture is being introduced.
5. Special separate schools of agriculture and household subjects.
6. Special colleges, as veterinary and forestry institutions.
7. Departments or courses of agriculture in general or old-line colleges and universities.
8. Farmers' institutes, usually conducted by colleges of agriculture or by boards or departments of agriculture.
(The above institutions may engage in various forms of extension work.)
9. The agricultural press.

10. The general rural newspapers.
11. Agricultural and horticultural societies of all kinds.
12. The Patrons of Husbandry, Farmers' Educational and Coöperative Union, and other national organizations.
13. Business societies and agencies, many of them coöperative.
14. Business men's associations and chambers of commerce in cities and towns.
15. Local political organizations (much in need of re-direction).
16. Civic societies.
17. The church.
18. The Young Men's Christian Association, and other religious organizations.
19. Women's clubs and organizations, of many kinds.
20. Fairs and expositions.
21. Rural libraries.
22. Village improvement societies.
23. Historical societies.
24. Public health regulation.
25. Fraternal societies.
26. Musical organizations.
27. Organizations aiming to develop recreation, and games and play.
28. Rural free delivery of mail (a general parcels post is a necessity).
29. Postal savings banks.
30. Rural banks (often in need of redirection in their relations to the development of the open country).
31. Labor-distributing bureaus.
32. Good thoroughfares.
33. Railroads, and trolley extensions (the latter needed to pierce the remoter districts rather than merely to parallel railroads and to connect large towns).
34. Telephones.
35. Auto-vehicles.
36. Country stores and trading-places (in some cases).
37. Insurance organizations.
38. Many government agencies to safeguard the people, as public service commissions.
39. Books on agriculture and country life.
40. Good farmers, living on the land.

Agricultural and Forestry Colleges, Schools, and Stations in Canada

Ontario Agricultural College, Guelph, opened 1874.

Nova Scotia Agricultural College, Truro, present farm purchased and building begun 1885.

Prince Edward Island ; a professorship of agriculture in Prince of Wales College, Charlottetown.

Macdonald Institute, Guelph, Ontario, founded 1903, for home economics, nature study, and manual-training.

Macdonald College (incorporated with McGill University), Sainte Anne de Bellevue, Province Quebec, opened 1907.

Oka Agricultural School, Oka, Province of Quebec, recognized by province government in 1893.

Provincial Dairy School, St. Hyacinthe, Province of Quebec, present building erected 1906.

Eastern Dairy School, Kingston, Ontario, established 1894.

School of Forestry, Toronto University (1907).

Laval University Forestry School, Quebec (1910).

University of New Brunswick, chair of forestry.

Agricultural School of Sainte Anne de la Pocatière, Pr. Quebec, 1858.

Manitoba Agricultural College, Winnipeg, opened 1906.

Saskatchewan Agricultural College, Saskatoon (in course of erection).

Central Experimental Farms, Ottawa (for the Dominion, 1886) ; branches at Nappan, Nova Scotia, for the maritime provinces ; Brandon, Manitoba ; Indian Head, Saskatchewan ; Lacombe and Lethbridge, Alberta ; Agassiz, British Columbia.

Agricultural Colleges and Experiment Stations in the United States

The following table shows the number of acres of land received by each state from the Land-Grant Act of 1862, the date of establishment of the institution that cares for the agricultural work, and the date at which instruction in agriculture was begun : —

The experiment station is connected with the college, except in :
Ohio, at Wooster ; Georgia, at Experiment (dept. of the college at Athens) ; Conn. Experiment Station at New Haven, and Storrs Station at the college ; New York, the State Station at Geneva, but the federal station at the college.

STATE	NAME OF INSTITUTION, AND POST OFFICE	NUMBER OF ACRES	DATE OF ESTABLISHMENT	DATE OF ORGANIZING INSTRUCTION IN AGRICULTURE
Alabama	Alabama Polytechnic Institute, Auburn	240,000	1872	1872
Arizona	University of Arizona, Tucson	150,000	1891	1907
Arkansas	University of Arkansas, Fayetteville	150,000	1872	1868
California	University of California, Berkeley	90,000	1868	Sept. 28, 1881, in Storrs
Colorado	State Agricultural College of Colorado, Fort Collins	180,000	1877	Agricultural School
Connecticut	Connecticut Agricultural College, Storrs	180,000	1881	1870
Delaware	Delaware College, Newark	90,000	1870	1884 in the old Florida
Florida	University of the State of Florida, Gainesville	90,000	1884	Agricultural School
Georgia	Georgia State College of Agriculture and Mechanic Arts (at University of Georgia), Athens	270,000	1872	1854
Idaho	College of Agriculture of the University of Idaho, Moscow	90,000	1892	Oct. 12, 1892
Illinois	College of Agriculture of the University of Illinois, Urbana	480,000	1867	1868
Indiana	School of Agriculture of Purdue University, Lafayette	390,000	1874	September, 1879
Iowa	Iowa State College of Agriculture and Mechanic Arts, Ames	204,000	1869	Oct. 21, 1868
Kansas	Kansas State Agricultural College, Manhattan	82,313	1863	1863
Kentucky	Agricultural and Mechanical College of Kentucky, Lexington	330,000	1865	1866
Louisiana	Louisiana State University and Agricultural and Mechanical College, Baton Rouge	210,000	1874: 1877	1877
Maine	University of Maine, Orono	210,000	1865	1868
Maryland	Maryland Agricultural College, College Park	210,000	1859	1859
Massachusetts	Massachusetts Agricultural College, Amherst	360,000	1867	Oct. 2, 1867
Michigan	Michigan State Agricultural College, East Lansing	235,673	1855	May 13, 1857
Minnesota	College of Agriculture of the University of Minnesota, St. Anthony Park, St. Paul	94,000	1869	1869
Mississippi	Mississippi Agricultural and Mechanical College, Agricultural College	207,920	1880	1880
Missouri	College of Agriculture and Mechanic Arts of the University of Missouri, Columbia	277,016	1870	1870
Montana	Montana Agricultural College, Bozeman	90,000	1893	1893
Nebraska	Industrial College of the University of Nebraska, Lincoln	90,000	1869	1871

Nevada	College of Agriculture of the University of Nevada, Reno	1873	90,000	1888
New Hampshire	New Hampshire College of Agriculture and the Mechanic Arts, Durham	1866	150,000	1868
New Jersey	Rutgers Scientific School, the New Jersey College for the Benefit of Agriculture and the Mechanic Arts, New Brunswick	1864	210,000	1864
New Mexico	New Mexico College of Agriculture and Mechanic Arts, Agricultural College	1889		1890
New York	New York State College of Agriculture at Cornell University, Ithaca	1865	989,920	1868
North Carolina	North Carolina College of Agriculture and Mechanic Arts, West Raleigh	1889	270,000	1889
North Dakota	North Dakota Agricultural College, Agricultural College	1890	130,000	January, 1891
Ohio	The College of Agriculture and Domestic Science and of Veterinary Medicine, Ohio State University, Columbus	1870	630,000	
Oklahoma	Oklahoma Agricultural and Mechanical College, Stillwater	1891	250,000 ¹	
Oregon	Oregon State Agricultural College, Cornwallis	1868	90,000	
Pennsylvania	Pennsylvania State College, State College	1855	780,000	
Rhode Island	Rhode Island College of Agriculture and Mechanic Arts, Kingston	1888	120,000	1890
South Carolina	Clemson Agricultural College of South Carolina, Clemson College	1889	180,000	
South Dakota	South Dakota State College of Agriculture and Mechanic Arts, Brookings	1881	160,000	1884
Tennessee	State Agricultural and Mechanical College of the University of Tennessee, Knoxville	1794	300,000	1869-1870
Texas	Agricultural and Mechanical College of Texas, College Station	1871	180,000	1876
Utah	Agricultural College of Utah, Logan	1888	200,000	1888
Vermont	University of Vermont and State Agricultural College, Burlington	1865	150,000	1889
Virginia	Virginia Agricultural and Mechanical College and Polytechnic Institute, Blacksburg	1872	300,000	1872
Washington	The State College of Washington, Pullman	1892	90,000	January 14, 1892
West Virginia	West Virginia University, Morgantown	1867	150,000	1867
Wisconsin	College of Agriculture of the University of Wisconsin, Madison	1848	240,000	1868
Wyoming	College of Agriculture and Mechanic Arts of the University of Wyoming, Laramie	1887	90,000	

¹ Oklahoma, land from the state.

Forestry Schools in the United States, 1911-12

Many institutions give courses in forestry. Following are those that have separate schools, faculties, or comparable organizations, or that have four-year courses; there are many other American institutions giving more or less instruction in forestry.

Graduate schools

Yale University, New Haven, Conn., Yale Forest School (founded in 1900).

University of Michigan, Ann Arbor, Mich., Course of Forestry (founded in 1901).

Harvard University, Cambridge, Mass., Division of Forestry, School of Applied Science.

Undergraduate schools and departments

University of Minnesota, Minneapolis, College of Forestry.

University of Washington, Seattle, School of Forestry (estab. 1907).

Colorado College, Colorado Springs, School of Forestry (established 1905).

Colorado Agricultural College, Fort Collins.

University of Georgia, Athens, School of Forestry.

University of Idaho, Moscow.

Iowa State College, Ames.

University of Maine, Orono.

Michigan Agricultural College, East Lansing. Forestry course (established 1902).

University of Montana, Missoula.

University of Nebraska, College of Agriculture.

Oregon Agricultural College, Corvallis.

Pennsylvania State College, State College.

State College of Washington, Pullman.

University of Missouri, Columbia.

New York State College of Agriculture at Cornell University, Ithaca.

Biltmore Forest School. This school holds a winter session in

Germany, a spring session in the Adirondacks and Southern Appalachians, and during the autumn months in the Lake States.

Pennsylvania State Forest Academy, Mont Alto.

State College of Forestry, Syracuse University, N.Y. (legislation passed 1911).

North American Veterinary Colleges and Departments, 1910-11

Colleges, schools, and divisions, giving full courses or leading to veterinary degrees

Alabama Polytechnic Institute, College of Veterinary Medicine, Auburn.

Chicago Veterinary College (1883).

Cincinnati Veterinary College.

George Washington University, College of Veterinary Medicine, Washington, D.C.

United States College of Veterinary Surgeons, Washington, D.C.

Grand Rapids Veterinary College, Grand Rapids, Mich. (1897).

Indiana Veterinary College, Indianapolis (1892).

Iowa State College, Division of Veterinary Medicine, Ames (1884).

Kansas City Veterinary College (1891).

University Veterinary College, Kansas City.

Western Veterinary College, Kansas City (1897).

McKillip Veterinary College, Chicago (1894).

New York American Veterinary College, New York City (1899).

New York State Veterinary College, Cornell University, Ithaca (1896).

Ohio State University, College of Veterinary Medicine, Columbus (1883).

San Francisco Veterinary College.

Collins Veterinary Medical College, Nashville, Tenn.

University of Pennsylvania, School of Veterinary Medicine, Philadelphia (1884).

Washington State College, School of Veterinary Science, Pullman (1899).

University of Toronto, Ontario Veterinary College.

School of Comparative Medicine and Veterinary Science, Montreal (Laval University).

Departments and chairs

A regular professor or teacher in veterinary science is also provided in the institution carrying the college of agriculture in Arkansas, California, Colorado, Connecticut, Delaware, Georgia, Idaho, Illinois, Indiana, Kansas, Louisiana, Maine, Maryland, Massachusetts, Michigan, Minnesota, Mississippi, Missouri, Montana, Nebraska, Nevada, North Carolina, North Dakota, Oklahoma, Oregon, South Carolina, South Dakota, Tennessee, Texas, Utah, Vermont, Virginia, West Virginia, Wisconsin, Wyoming.

Teachers of animal husbandry give more or less instruction in the veterinary subjects.

Home Economics Institutions and Departments, 1910-11

Instruction of advanced or of college grade in the homemaking subjects is now provided in many of the colleges of agriculture, with particular bearing on rural conditions; and several other institutions also have departments for these subjects, and a few are devoted exclusively to such work. The work passes under different names, as domestic science, household science, domestic art, domestic economy, home economics.

In the colleges of agriculture, departments or teachers are provided for these subjects in Arizona, Colorado, Connecticut, Hawaii, Idaho, Illinois, Indiana, Iowa, Kansas, Kentucky, Maine, Massachusetts, Michigan, Minnesota, Missouri, Montana, Nebraska, Nevada, New Mexico, New York, North Dakota, Ohio, Oklahoma, Oregon, Pennsylvania, Rhode Island, South Dakota, Tennessee, Utah, Vermont, Washington, West Virginia, Wisconsin, Wyoming.

Among other institutions that provide instruction in the home and household subjects are Teachers College of Columbia University, New York City; University of Chicago; Northwestern University; Lewis Institute, Chicago; Simmons College, Boston; Pratt Institute, Brooklyn; Drexel Institute, Philadelphia; Worcester Domestic Science School, Worcester, Mass.; Mechanics Institute, Rochester, N.Y.; School of Domestic Science and Arts, Chicago; Domestic Science Training School, Chicago; University of Kansas (Lawrence); Boston Y. W. C. A. School of Domestic Science; Berea College (Ken.); Rockford College (Ill.); Bradley Polytechnic Institute, Peoria;

James Milliken University, Decatur, Ill.; Southern University, New Orleans; Northfield Seminary (Mass.); Louisiana Industrial Institute, Ruston; Stout Institute, Menomonie, Wis.; Milwaukee-Downer College; Lake Erie, College, Painesville, O.; American University, of Harriman, Tenn.; College of Domestic Arts, Denton, Tex.; Industrial Institute and College, Columbus, Miss.; Macdonald Institute, Guelph, Ont.; Macdonald College, Ste. Anne de Bellevue, P. Q.; Mt. Allison University, Sackville, New Brunswick; Manitoba Agricultural College, Winnipeg; and instruction is also supplied in normal schools, high-schools, seminaries, and in many other institutions, and in cooking schools.

**Institutions teaching Landscape Architecture (or Landscape Gardening)
of College Grade, 1910-11**

Full or extended college courses in landscape architecture are given at Harvard, Cornell, and Massachusetts Agricultural College. More or less instruction is given in the subject in departments of horticulture in some institutions; and it is separately represented in the colleges of agriculture of Illinois, Missouri, and Oregon. Colleges and departments of architecture give attention to these subjects.

**Library
N. C. State College**

INDEX

- Abderhalden, on milk, 444.
 Acanthacara similis, 328.
 Acanthorhynchus vaccinii, 269.
 Acetic acid, 29.
 Acleris minuta, 317.
 Acorus, 191.
 Acre, plants to the, 120.
 Acrobasis nebullella, 328.
 Acrostalagmus sp., 271.
 Actinomena rosæ, 281.
 Adiantum, 189.
 Advanced registry, 345.
 Æcidium grossulariæ, 271.
 Age of animals, 337.
 Agencies of better rural life, 559.
 Agricultural colleges, 561, 562.
 Agricultural virtues, 172.
 Agrilus anxius, 311.
 Agromyza simplex, 310.
 Agrotis, sp., 302, 315.
 Albugo candidus, 280.
 Alcoholic wax, 513.
 Aleyrodes spp., 323.
 Alfalfa, diseases, 262; fertilizer for, 62, 64; grading, 152.
 Algæ in ponds, 251.
 Alkali, 35.
 Allen, on gestation, 343.
 Almond, diseases, 263.
 Aloysia, 189.
 Alsophila pometaria, 306.
 Alternaria panacis, 270; solani, 279.
 Alum to preserve fruits, 554.
 Aluminum, 24, 25.
 Amendment, 40.
 Ammonia, 29.
 Ammoniacal carbonate of copper, 255.
 Ampelophaga myron, 321.
 Analyses of fertilizers, 57; of feces, 88; of fruits, etc., 90; of soils, 54.
 Anarsia sp., 325, 332.
 Ancyлис comptana, 332.
 Angeworm, 301.
 Aniline, 29.
 Animal bodies, composition of, 27.
 Animals, exhibiting, 383; feeding of, 409; judging, 383, 386, 392; parasites of, 429.
 Anthonomus grandis, 316; quadrigibus, 305; signatus, 332.
 Antidote for arsenic poisoning, 290.
 Antimony, 24.
 Ants in lawns, 322; white, 305.
 Aphides, 301.
 Aphis brassicæ, 311; forbesii, 332; maidiradicis, 314; on house plants, 189; persicæ-niger, 325.
 Aponogeton, 191.
 Apothecaries' measure, 517; weight, 516.
 Apple, boxes, 164, 165; diseases, 263; fertilizer for, 64; insects, 305; seed, weight, 533.
 Apples, for cider, 529; packing, 166; scoring, 177, 178; storing, 141; to preserve for exhibition, 554; weight, 529, 534.
 Appliances, electric, 502.
 Apricot, diseases, 265; insects, 310.
 Aquatic window plants, 191.
 Architecture, farm, 473.
 Argas miniatus, 378.
 Argentina, money, 522, 523.
 Argon, 24.
 Argopsylla gallinacea, 378.
 Armsby, on feeding, 409, 416.
 Army-worm, 315.
 Arsenate of lead, 291.
 Arsenic, 24; antidote for, 290; as insecticide, 290; for dips, 431; for weeds, 222, 224.
 Arsenious oxid, 29.
 Asafœtida for rabbits, 238.

- Ascochyta pisi, 275.
 Ash, 26.
 Ashes, analysis, 59; weight, 540.
 Asparagus, diseases, 265; fertilizer for, 65; insects, 310; packages, 170, 171; plumosus, 198; under glass, 190.
 Aspidiotus aurantii, 323; perniciosus, 304.
 Ass, gestation, 342, 343; milk of, 443.
 Aster, insect, 311.
 Atmosphere, composition, 25.
 Attar of roses, 551.
 Auger, soil, 543.
 Austrian money, 522, 523.
 Autographa brassicæ, 311, 322.
 Avoirdupois weight, 516.
 Ayrshire records, 350.
 Azalea, 198.
 Azolla, 191.
 Babcock, greenhouse heating, 194.
 Babcock test, 446, 456.
 Bacillus amylovorus, 277; campestre, 266; tracheiphilus, 270.
 Bacon, grades of, 406.
 Bacon-hog, scoring, 404.
 Bacterium phaseoli, 265; solanacearum, 282, 283; tumefaciens, 266, 272, 276, 281.
 Baedeker, money, 524.
 Bag-worm, 301.
 Bait for insects, 293.
 Balanced rations, 409, 410, 413.
 Balaninus sp., 313.
 Ball-weevil, 316.
 Bandages, waxed, 513.
 Banding for insects, 286.
 Barb-wire, 479.
 Barium, 24.
 Bark-lice, 301.
 Barleycorn, 528.
 Barley, diseases, 261; fertilizer for, 65; grading, 161; weight, 534, 541.
 Barn figures, 477.
 Barnyard manure, 88.
 Barometer indications, 1, 9.
 Barrels, apple, 165; various, 528.
 Baryta for mice, 235.
 Basket-worm, 301.
 Beal, W. J., on seeds, 104.
 Bean, diseases, 265; fertilizer for, 62, 65; insects, 311.
 Beans, packages, 170, 171; to preserve for exhibition, 555; under glass, 190; weight, 534, 541.
 Bear, gestation, 342, 343.
 Beaunis, quoted, 27.
 Beaver, gestation, 342, 343.
 Beef-cattle, scoring, 395.
 Beef, market classes, 404.
 Bees, in pound, 530.
 Beeswax, 512.
 Beet, diseases, 266; fertilizer for, 62, 66.
 Beets, packages, 170; under glass, 190; weight, 534, 541.
 Beggarweed, 139; weight, 533.
 Begonias, 189.
 Belgium money, 523.
 Belting, 498.
 Bembeia marginata, 331.
 Berkmans, on storing sweet-potatoes, 148.
 Beryllium, 24.
 Bichloride of mercury for fungicide, 255; for herbarium, 546.
 Bins, contents of, 530.
 Birch, insects, 311.
 Birds, pestiferous, 243.
 Bismuth, 24.
 Bisulfid of carbon, 293; also 241, 243, 544, 546.
 Bit or shilling, 523.
 Bitter milk, 459.
 Blackberries, weight, 529.
 Blackberry, diseases, 266; fertilizer for, 66; insects, 311; seed, 533.
 Black-knot, 279.
 Black-rot of grape, 272.
 Blepharida rhois, 334.
 Blight, pear, 277.
 Blissus leucopterus, 315.
 Blister-beetle, 302.
 Blood, analysis, 58; quantity in animals, 345.
 Blue-grass seed, weight, 534, 541.
 Blue-stone for bordeaux, 253.
 Blue vitriol as fungicide, 258; for bordeaux, 254; for weeds, 223.
 Board measure, 210.
 Boars, grades of, 408.
 Boiled milk, 448.
 Boiler cements, 507.

- Boilers, to prevent rust, 200.
 Bolivia, money, 522.
 Bollworm, 316.
 Bone, analysis, 57.
 Bone-black, analysis, 57.
 Bone charcoal, analysis, 57.
 Book measure, 519.
 Boracic acid to preserve fruits, 553.
 Borax in milk, 449.
 Bordeaux mixture, formula, 253.
 Borders, cement, 505.
 Borers, 307, 308, 325, 328.
 Boric acid test, 449.
 Boron, 24.
 Boston, dates in, 106.
 Bosworth, on casein test, 456.
 Bot-fly, 437, 439, 440.
 Bottles, to cut in two, 558.
 Bouguer, reflection of light, 198.
 Boxes for fruits, 163.
 Box packing of apples, 166.
 Bran, weight, 534.
 Brazil, money, 522, 523.
 Bremia lactuæ, 273.
 Brimstone as fungicide, 258.
 British India, money, 523.
 Bromin, 24.
 Bromus inermis, weight, 533.
 Brooks, on manures, 81, 82, 85.
 Broom-corn seed, weight, 534.
 Brown, Edgar, on seeds, 97.
 Brown-tail moth, 302.
 Bruchophagus funebris, 314.
 Bruchus obtectus, 311; pisi, 324.
 Brussels sprouts, diseases, 266; pack-ages, 169.
 Bucculatrix pomifoliella, 305.
 Buckwheat, fertilizer for, 66; weight, 534, 541.
 Bud-moth, 306.
 Buffalo bur, 229.
 Buffalo, gestation, 342, 343; milk of, 443.
 Buffalo-gnat, 438.
 Buhach, 297.
 Bulbs, 198.
 Burning insects, 286.
 Bushel, legal weight, 533, 534, 540.
 Bushels, capacities, 528, 530.
 Butter classifications, 465; making, 458; scores, 463; tests, 451-455.
 Butyric, 443.
 Cabbage, diseases, 266; fertilizer for, 67; insects, 311; storing, 142; weight, 533.
 Cabbages, packages, 169, 171.
 Cabinets or museums, 543.
 Cable, measure, 528.
 Cadmium, 24.
 Cæsium, 24.
 Calcium, 24, 25.
 California fruit packages, 161, 164.
 Calla, 189, 198.
 Calocampa nupera, 318.
 Calories in milk, 443.
 Caltha, 191.
 Camel, milk of, 443.
 Camphor for mice, 236.
 Canada, packages in, 167; weights in, 540.
 Canada thistle, 225, 230.
 Canadian weather signals, 8.
 Canary, incubation, 342, 343.
 Canary seed, weight, 533.
 Canker of apple, 263, 264.
 Canker-worm, 306.
 Canteloupe, weight, 533.
 Capacity measures, 517, 520.
 Carbolic acid as insecticide, 293; for weeds, 222, 223.
 Carbon, 24, 25.
 Carbonate of copper, 255.
 Carbon bisulfid, 293; also 241, 243, 544, 546.
 Carbon dioxide, 29.
 Carbonic oxid, 29.
 Carlyle, on soiling, 136.
 Carnation, 198; diseases, 267.
 Carnations, scoring, 179.
 Carpenter, greenhouse heating, 191, 195.
 Carpocapsa pomonella, 306.
 Carrot, as field crop, 140; fertilizer for, 67; insects, 312.
 Carrots, weight, 534, 541.
 Case-bearers, 306, 328.
 Casein in milk, 442.
 Casein-test, 456.
 Cast-iron pipe, 198.
 Castor-beans, weight, 534, 541.
 Cat, controlling, 234; gestation, 342, 343.
 Catch-crops, 139.
 Cattle, determining age, 337; manure, 81, 83, 87, 88; parasites, 437; scoring, 395; ticks, 429.

- Cauliflower, fertilizer for, 68; insects, 312; packages, 169; under glass, 190.
 Caustic soda for weeds, 224.
 Cavanaugh, quoted, 49, 54.
 Celery, diseases, 267; fertilizer for, 67; insects, 312; packages, 169; storing, 142.
 Celsius scale, 527.
 Cement, 504.
 Centigrade scale, 527.
 Centimes, etc., 522.
 Ceratocystis fimbriata, 282.
 Cercospora angulata, 270; apii, 267; beticola, 266.
 Cereals, smut, 260.
 Cerium, 24.
 Chætoenema confinis, 335.
 Chafer, rose, 308, 322.
 Chain measure, 518.
 Charcoal, 26.
 Charlock, 227, 230.
 Chase, on road-drags, 485.
 Chautauqua grape figures, 164.
 Cheese score-cards, 464; tests, 453, 455, 456-457.
 Cherries, scoring, 178.
 Cherry, diseases, 267; fertilizer for, 68; insects, 313.
 Chestnut, diseases, 268; insects, 313.
 Chestnuts, weight, 533.
 Chicken mite, 377; tick, 378.
 Chickens, to protect from hawks, 245.
 Chickweed, 232.
 Chile, money, 522, 523.
 Chimney sizes, 195.
 China, money, 523.
 Chinch-bug, 315.
 Chionaspis furfurus, 309.
 Chiswick pots, 199.
 Chlorin, 24.
 Chloroform, 29.
 Chromium, 24.
 Chrysanthemum, 198; diseases, 268; insects, 313; scoring, 180.
 Chrysobothris femorata, 307.
 Chrysomyia macellaria, 438.
 Chufa, weight, 533.
 Cider, 529.
 Cineraria, 198.
 Citrus measures, 164; trees, fumigating, 289.
 City milk plants, 472.
 Cladosporium carpophilum, 277; fulvum, 283.
 Clark, on the elements, 25.
 Classification of butter, 465.
 Clean milk, 471.
 Climate and crops, 19.
 Cloth for pits and frames, 200, 510.
 Clover, fertilizer for, 62, 68; insects, 313; seed, weight, 534, 541.
 Club-root, 266.
 Coal ashes, analysis, 59.
 Coal-tar cement, 508; for wounds, 515.
 Cobalt, 24.
 Coccotorus prunicida, 329.
 Cocklebur, 229.
 Coconuts, packing, 530.
 Cocos, 189.
 Codlin-moth, 306.
 Cold storage, 149; of animal products, 345.
 Coleophora sp., 306.
 Coleus, 189.
 Collecting specimens, 543.
 Colleges, lists of, 561, 562, 564, 565.
 Colletotrichum gossypii, 269; lagenarium, 274; lindemuthianum, 265; malvarum, 273.
 Colombia, money, 522, 523.
 Color of flowers, 546.
 Columbium, 24.
 Combinations in chemistry, 25.
 Commercial grades of crops, 150.
 Composition tables, 419.
 Compounds, 25, 28.
 Computations, 516.
 Computing fertilizer values, 49.
 Computing rations, 409, 410, 413.
 Conotrachelus crataegi, 330; nenuphar, 307, 326, 329.
 Conover, on silos, 473.
 Construction, chapter on, 473.
 Contarinia violicola, 336.
 Contents of pipes and tanks, 531, 532.
 Copeck, 522.
 Copper, 24.
 Copperas for weeds, 223, 227; as fungicide, 258.
 Copper carbonate, 255.
 Copper cement, 508.
 Copper sulfate as fungicide, 258; for bordeaux, 253; for ponds, 251; for

- weeds, 223, 227; to preserve fruits, 553.
- Corbett, on packages, 169.
- Cord measure, 211.
- Corimelæna pulicaria, 313.
- Corn, diseases, 268, 269; fertilizer for, 60, 68; grading, 159; insects, 314; meal, weight, 534; scoring, 177; weight, 529, 533, 534, 536, 538, 540, 541.
- Corrosive sublimate as fungicide, 255.
- Coryneum beyerinkii, 263, 275.
- Costa Rica, money, 522.
- Cotton, diseases, 269; grades, 150; insects, 316.
- Cottonseed, weight, 533, 534.
- Cover-crops, 138.
- Cow-dung for potting, 187.
- Cow, gestation, 342, 343; parts of, 396.
- Cows, profit-and-loss, 360.
- Cow-testing, 362, 364.
- Cox, on frost, 13.
- Coyotes, 243.
- Crab-apples, for exhibition, 554.
- Crambus spp., 315, 317.
- Cranberry, diseases, 269; weight, 536; insects, 317.
- Craponius inæqualis, 320.
- Crates, for fruits, 163.
- Cream, bitter, 459.
- Creamery, bitter, 465.
- Creosote for posts, 208.
- Cresol, 436.
- Cress under glass, 190.
- Cribs, contents of, 530.
- Criddle mixture, 293.
- Crioceris sp., 310.
- Crops for special purposes, 133.
- Crosby, on house-fly, 249; on insecticides, 286; on insects, 301; on poultry insects, 377; on animal parasites, 434.
- Crown-gall, 264, 272, 276, 281.
- Crown (of money), 522, 523.
- Crows, 245.
- Crude oil for stock, 436.
- Cryptorhynchus lapathi, 329.
- Crystallized fruit, 143.
- Cuba, money, 522.
- Cubic measure, 518, 520.
- Cubing logs, 217, 218.
- Cubit, measure, 528.
- Cucumber, diseases, 270; fertilizer for, 69; insects, 318; packages, 170, 171; under glass, 190; weight, 533.
- Curculio, 307, 326, 329, 330.
- Curd-test, 457.
- Currant, diseases, 270; fertilizer for, 69; insects, 318; to preserve for exhibition, 555; weight, 533.
- Cuscuta epithimum, 262.
- Cutworms, 302, 315, 355.
- Cyanide of potassium, 287.
- Cylamen, 198.
- Cylas formicarius, 334.
- Cylinders, capacities, 531.
- Cylindrosporium padi, 268.
- Cymatophora ribearia, 319.
- Cyperus, 189, 191.
- Dahlia, insects, 319.
- Dairy-cattle, scoring, 398.
- Dairy-cows, profit-and-loss, 360.
- Dairy farm scores, 467.
- Dairying, chapter on, 442.
- Dairy score-cards, 462-472.
- Daisy, white, 231.
- Dakrura covolutella, 320.
- Dalmatian insect powder, 297.
- Damping-off, 260.
- Damp walls, paint for, 509.
- Dandelion, eradicating, 231.
- Darwin, on gestation, 343.
- Dasyneura leguminicola, 313.
- Data on water, 489.
- Dates for planting, 106, 109, 110.
- Date-tables, 109, 110.
- Dean, radiation for glass, 196.
- Denmark, money, 523.
- Depluming scabies, 378.
- Depressaria heracliana, 324.
- Dermanyssus gallinæ, 377.
- Dew-point, 13, 15.
- Diabrotica longicornis, 314; sp., 318.
- Diaphania hyalinata, 322; nitidalis, 318; quadristigmalis, 330.
- Diaporthe parasitica, 268.
- Diaspis pentagona, 328.
- Diatræa saccharalis, 333.
- Digestable nutrients, 424.
- Dinar, 523.
- Diplodia zææ, 268.

- Diplosis pyrivora, 326.
 Dips for cattle, 431, 434.
 Directories, 559.
 Disinfectant for stables, 434, 436.
 Distances to plant, 109, 119, 120.
 Distillate emulsion, 294; fuel, 222.
 Dock, 225, 226.
 Dodder on alfalfa, 262.
 Dog, gestation, 342, 343; milk of, 444.
 Dollar, 522, 523.
 Domestic science schools, 566.
 Drachma, 523.
 Draft-horse, scoring, 392.
 Drags, road, 485, 487.
 Draining, tile, 481.
 Dried fruit, 529, 534.
 Dropsy of plants, 260.
 Dry measure, 517.
 Duck, incubation, 342, 343.
 Durum wheat, 155.
 Dutch money, 522.
 Duvel, seed table, 101.
 Dysprosium, 24.
 Earthenware cement, 508.
 Earth for potting, 187.
 Earthworm, 301.
 Ecuador, money, 522.
 Egg-plant, fertilizer for, 69; insect, 319; packages, 170, 171.
 Egg-production, 372.
 Eggs, care of, 375; scoring, 368.
 Egypt, money, 523.
 Eichhornia, 189, 191.
 Elaphidion villosum, 309.
 Electric appliances, 502.
 Electricity in producing potash salts, 44.
 Elements, the, 24.
 Elephant, gestation, 342, 343.
 Ell, 528.
 Elliott, draining, 481, 482.
 Ellwanger, on perfumery, 551.
 Elm, insects, 319.
 Emblematic flowers, 185.
 Emphytus maculatus, 332.
 Empoa albopieta, 319.
 Emulsions as insecticides, 294.
 Enarmonia interstictana, 314.
 Endive, insect, 320.
 Energy values, 409, 445.
 Engincering, chapter on, 473.
 Engines, hot-air, 503.
 Engle on leaf-prints, 549.
 English money, 521, 523.
 English sparrows, 244.
 Epiphyllum, 189.
 Epitrix parvula, 335.
 Erbium, 24.
 Eriocampoides limacina, 313.
 Eriophyses pyri, 307, 326.
 Erysiphe polygoni, 275.
 Eudemis vacciniaria, 317.
 Eulecanium armeniacum, 310.
 Euproctis chrysothorax, 302.
 Europium, 24.
 Euthrips citri, 323; pyri, 327.
 Euvassia antiopa, 336.
 Evaporated fruit, 529, 534.
 Excrement, animal, 88.
 Exhibiting live-stock, 383; poultry, 378.
 Exhibitions, rules for plants, 181.
 Exoascus deformans, 275.
 Exobasidium oxycocci, 269.
 Experiment stations, list of, 561.
 Fabrea maculata, 278.
 Fahrenheit scale, 527.
 Fairs, live-stock in, 383.
 False flax, 230.
 Farm architecture, 473; butter-making, 458; crops, composition of, 27; crops, propagation of, 132; engineering, 473; mechanics, 473; machinery, 473; points of, 174; practices, 172; scoring, 175.
 Fast horses, 357.
 Fat-hogs, scoring, 402.
 Fathom, measure, 528.
 Fat in milk, 442.
 Feathers, care of, 375.
 Feeding of animals, 409; poultry, 372; standards, 414; stuffs, composition, 419, 424; weights, 533.
 Fence-posts, 207.
 Fence, wire, 477.
 Ferns, temperature for, 198.
 Ferrocyanide of potassium, 254.
 Fertilizer analyses, 57; definition, 40; formulas, 45.
 Fertilizers, chapter on, 40; for various crops, 60, 63; trade values, 47, 50.

- Ficus, 189.
 Fidia viticida, 320.
 Field crops, dates to plant, 110; yields of, 127.
 Figs, grades, 530; storing, 144.
 Figuring fertilizer values, 49.
 Finch, on incubation, 370.
 Finland, money, 523.
 Fippin, on drains, 481, 483, 484; on soils, 33, 36, 78, 79, 543.
 Fireproof cement, 508, 509.
 Fish, analysis, 58; for mosquitoes, 246; for algae, 251.
 Fish-oil as insecticide, 298.
 Fitzroy, on weather, 12.
 Flax, fertilizer for, 70.
 Flaxseed, weight, 536, 541.
 Flea-beetle, 303, 306, 330, 335.
 Fleischmann, on milk, 443.
 Floors, material for, 505.
 Florida fruit packages, 164.
 Florin, 522, 523.
 Florists' plants, list, 191; scoring, 180.
 Flower gum, 511; flower-planting tables, 116; flower-pots, sizes, 199; to keep clean, 201.
 Flowers, preserving, 546; scoring, 179; state, 185; to keep fresh, 550.
 Fluorin, 24.
 Fodder, 133; composition, 28.
 Forage crops, 133.
 Forcing of vegetables, 190.
 Forecasts of weather, 6.
 Forestry, chapter on, 202.
 Forestry schools, 564.
 Forest-tree seeds, 96.
 Forest yields, 204.
 Formaldehyde for preserving fruits, 553; in milk, 450.
 Formalin, 256.
 Formulas for fertilizers, 45.
 Foundations, cement, 506.
 Four-striped plant-bug, 303.
 Fowl, parts of, 365; chapter on, 365; parasites of, 377; preparing for market, 374.
 Fox, gestation, 342.
 Fragaria for baskets, 189.
 Franc, 522, 523.
 Fraser, on grass seed, 94, 95, 96; on soiling, 136.
 Freesia, 189.
 French money, 522, 523.
 Friction of water in pipes, 491.
 Frost, 12; smudging, 16.
 Fruit crops, yields, 125; packages, 163; packages in Canada, 167; preserving for exhibition, 552, 556; protecting from birds, 244; scoring, 177.
 Fruit Marks Act, 167; fruit-tree seeds, 96; distances, 119.
 Fuchsia, 189.
 Fuel-distillate, 222.
 Fuller, windmills, 493, 495, 496, 497.
 Fumigation for insects, 287.
 Fungicides, 252.
 Fungous diseases as insecticides, 290.
 Fusarium oxysporum, 280; sp., 267; vasinfecta, 269.
 Fusicoccum viticolum, 273.
 Gadolinium, 24.
 Galerucella luteola, 319.
 Gall-fly, raspberry, 331.
 Gallium, 24.
 Gallons, capacities, 528.
 Galls, 303. (See Crown-gall.)
 Gardeners, rules for, 173.
 Gardens, dates to plant, 106.
 Garriott, on weather, 10, 11, 12.
 Gas-lime, analysis, 59.
 Gastrophilus equi, 439.
 Gears, 498.
 Geese, incubation, 342, 343.
 Geldings, judging, 393.
 Georgia, dates in, 108.
 German feeding standards, 413.
 Germanium, 24.
 German ivy, 189.
 German money, 522, 523.
 German potash salts, analysis, 42, 58.
 Germicides, 252.
 Germination, 100, 102.
 Gestation, period of, 342.
 Ginseng, diseases, 270.
 Gipsy-moth, 303.
 Giraffe, gestation, 342, 343.
 Girdling by rats and mice, 234.
 Glacé fruit, 143.
 Gladioli, scoring, 180.
 Glass, cement for, 508; radiation for, 191, 697.
 Glazing, putty for, 201.
 Glæosporium ribis, 270; venetum, 281.

- Glomerella rufomaculans*, 263, 272.
 Glucinum, 24.
 Glues, 511.
 Goat, gestation, 342, 343; milk of, 443, 444.
 Gœssmann, analyses, 90.
 Gold, 24.
 Golden-seal, diseases, 271.
 Gooseberries, storing, 144; to preserve for exhibition, 555; weight, 536.
 Gooseberry, diseases, 271; fertilizer for, 70; insects, 320.
 Gophers, 243.
 Grades of cotton, 150; of live-stock, 404.
 Grading butter, 465; of crops, 150.
 Grafting-wax, 512.
 Graham, on poultry, 374.
 Grain, grading, 153.
 Grape boxes, 163, 164; diseases, 271; fertilizer for, 70; insects, 320.
 Grapes and raisins, 529.
 Grapes, scoring, 178; storing, 144; to preserve for exhibition, 555; weight, 529.
 Graptodera chalybea, 321; foliacea, 306.
 Grass, fertilizer for, 61, 70, 71; seeds, 94, 95.
 Grasshoppers, 315.
 Graybill, on ticks, 429, 435.
 Great Britain, money, 523.
 Greece, money, 523.
 Green-fly, 301.
 Greenhouse heating, 191; work, 187; fumigating, 288.
 Green, on fence-posts, 207.
 Gross, 528.
 Ground bone, analysis, 57.
 Ground hogs, 243.
 Ground squirrels, 241.
 Grout floors, etc., 505.
 Grub, white, 303, 314.
 Guano, composition, 89.
 Guatemala, money, 522, 523.
 Guaves, weight, 533.
 Guernsey records, 351.
Guignardia bidwellii, 272; *vaccinii*, 269.
 Guilders, 522.
 Guinea-hen, incubation, 342, 343.
 Gums, 511.
 Guthrie, quoted, 458.
Gymnoconia interstitialis, 281.
Gymnosporangium globosum, 279; *macrosporus*, 264.
 Gypsum, 28, 37; analysis, 59; weight (land-plaster), 533, 540.
 Haberlandt, on seeds, 104.
Hadena sp., 315.
 Haecker, on feeding, 410.
Hæmatobia serrata, 437.
Hæmatopinus sp., 438, 441.
 Hair, plastering, weight, 536.
 Hairy-root, 276.
 Haiti, money, 522, 523.
 Hall, on grades of live-stock, 404.
Haltica rufipes, 326; *striolata*, 303.
 Hams, grades of, 406.
 Hand, measure, 528.
 Hand-picking insects, 286.
 Hardness of woods, 204.
 Hardy vegetables, 108.
 Harger, on pulse of animals, 344; on quantity of blood, 345.
 Harper, on young at birth, 343.
 Hawks, 245.
 Hawkweed, 232.
 Hay and pasture seeds, 94.
 Hay, grading, 151; to figure on, 530.
 Hazen, on frost, 15.
 Head-maggot, 440.
 Heat in animals, 344.
 Heating of greenhouses, 191.
Heliothis armiger, 315; *obsoleta*, 316, 335.
 Helium, 24.
 Hellebore insecticide, 300.
 Heller, 522.
Hemerocampa leucostigma, 309.
 Hemp seed, weight, 536, 541.
 Hen, fleas, 378; incubation, 342, 343; louse, 377.
 Henderson, quoted, 107.
 Henry, on feeding, 414, 418, 419.
 Herbarium, making, 545.
 Herbicides, 223, 228.
 Herd-book, 345.
 Herd's-grass, weight, 536.
 Hessian-fly, 336.
Heterodera radicolola, 303.
 Hickory nuts, weight, 533.

- Hinges, to prevent rusting, 510.
 Hog manure, 82, 83, 87, 89; parasites of, 441; parts of, 402.
 Hollyhock, diseases, 273; insect, 322.
 Holstein-Friesian registry, 346; records, 349.
 Home economics schools, 566.
 Home garden plan, 123.
 Home-mixing of fertilizers, 52.
 Hominy, weight, 533.
 Honduras, money, 522, 523.
 Hops, fertilizer for, 71.
 Horn-fly, 437.
 Horse, age of, 339; manure, 81, 83, 87, 88; milk of, 443, 444; parasites, 439; parts of, 392; rations, 418.
 Horse-nettle, 229.
 Horse-power to raise water, 501; of shafting, 501.
 Horse radish, fertilizer, 72; weight, 533.
 Horses, fast, 357; judging, 392.
 Hoskin's wax, 514.
 Hot-air engines, 503.
 Hot water as insecticide, 294.
 House-fly, 249.
 Household measures, 528.
 Household science schools, 566.
 House-plant insects, 322.
 Howard, on flies, 249, 250.
 Howard, on weather, 12.
 Human body, composition of, 26, 27.
 Human feces, 90; milk of, 443, 444.
 Hungarian-grass, weight, 536.
 Hunter, on soiling, 137.
 Hyacinths, 189, 198.
 Hydraulic rams, 503.
 Hydrochloric acid, 29.
 Hydrocyanic acid gas, 287.
 Hydrogen, 24, 25.
 Hygroscopic water, 32.
Hylastinus obscurus, 314.
Hyphantria cunea, 307.
Hypoderma sp., 437.
Hypsopygia costalis, 314.

 Incompatibles in fertilizers, 53.
 Incubation, machine, 370; periods, 342.
 India, money, 523.
 Indium, 24.
 Inorganic compounds, 25.
 Insecticides, chapter on, 286; for animal parasites, 434.
 Insects, collecting, 551; injurious, 301.
 Inspection of dairies, 469, 472.
 Institutions for agriculture, 599.
 Interest, rates of, 524.
 Iodine, 24.
 Iridium, 24.
 Iron, 24, 25; cements, 507; rust, 29.
 Iron sulfate as fungicide, 258; for weeds, 223, 227.
 Isobars, 5.
Isosoma sp., 336.
 Isotherms, 5.
 Italian money, 522, 523.
 Italian rye-grass, weight, 533.

 Japan, money, 523.
 Jars for specimens, 558.
 Jenyms, on weather, 12.
 Jersey records, 354.
 Jewelers' weight, 516.
 Johnson-grass, weight, 533.
 Jones, on drains, 484.
 Jones, L. R., on weeds, 223.
 Jordan, on fertility, 38.
 Judging animals, 383, 386, 392.

 Kafir, grading, 161; weight, 533.
 Kainit, analysis, 42, 59.
 Kale, weight, 533.
Kaliosysphinga ulmi, 319.
 Kali, works, quoted, 41, 42.
 Katydid, on peach trees, 325; on pineapple, 328.
 Keeping fruits and vegetables, 141, 149.
 Kellner, on feeding standards, 416.
 Kerosene for emulsion, 294; for mosquitoes, 245; for weeds, 223.
 King, on silos, 475, 476, 477; on tilage, 37.
 King, D. W., on road-drags, 487.
 King-head, 230.
 Knot, measure, 528.
 Koenig, on milk, 443.
 Kosher, 405.
 Kran, 523.
 Krypton, 24.

 Labels, 557; gum for, 512; to preserve, 558.
Lachnosterna fusca, 303, 314, 328.

- Lactometer test, 448.
 Lafean bill, 168.
 Lamb, grades of, 406.
 Lambert, on feathers and eggs, 375.
 Land-plaster, 28, 37; analysis, 59;
 weight, 533, 540.
 Lanthanum, 24.
 Lavender-bag, 552.
 Lawes and Gilbert, quoted, 27.
 Lawn, fertilizer for, 71; insects, 322;
 weeds in, 232.
 Lead, 24; arsenate of, 291.
 Leaf-curl, 275.
 Leaf-prints, 549.
 Lecanium corni, 329.
 Legal weights of bushel, 533, 534, 540.
 Leguminous cover-crops, 138.
 Lehmann feeding standards, 413.
 Lemon boxes, 164; insects, 323.
 Length, measures of, 517, 520.
 Lepidosaphes beekii, 323; ulmi, 308.
 Leptinotarsa decemlineata, 329.
 Lettuce, diseases, 273; fertilizer, 72;
 under glass, 190; insects, 322; for
 packages, 170, 171.
 Leu, 523.
 Leucania unipuncta, 315.
 Leuchars, on wind, 196.
 Lewis, C. I., quoted, 166.
 Liberia, money, 523.
 Lice, on cattle, 438; powder, 436.
 Lichen on trees, 233.
 Light-horse, scoring, 393.
 Light, reflection from glass, 198.
 Ligyrus gibbosus, 312; rugiceps, 334.
 Lily of the valley, 198.
 Lily, under glass, 198.
 Lima bean, diseases, 265.
 Lime as fungicide, 256; classification
 of, 79; for the land, 77; weight
 per bushel, 78, 536.
 Lime-sulfur dip, 434.
 Lime-sulfur, formula, 256, 294.
 Limnanthemum, 191.
 Limnocharis, 191.
 Lina scripta, 329.
 Lindsey, on soiling, 135.
 Line or linear measure, 517, 520, 528.
 Linseed, weight, 536.
 Lion, gestation, 342, 343.
 Liquid manure, 83; for greenhouses,
 188.
 Liquid measure, 517.
 Lira, 522, 523.
 Lists for window-gardens, 189.
 Litharge in cement, 508.
 Lithium, 24.
 Litmus test, 77.
 Litter (manure), 84.
 Little-peach, 276.
 Liver of sulfur, 258.
 Live-stock, exhibiting, 383; judging,
 383, 386, 392; rules, 337.
 Lixus concavus, 331.
 Llama, milk of, 443.
 Loess, 29.
 Log measure, 212, 216, 218; rules, 214,
 217, 219, 220; scaling, 214.
 London purple, 291.
 Longevity of fruit plants, 125; of
 seeds, 102, 104.
 Loudon's rules for gardeners, 173.
 Louse, hog, 441.
 Luke, on weather, 11.
 Lumber, defined, 202.
 Lutecium, 24.
 Lyon and Fippin, quoted, 33, 36.
 Lytta sp., 302.
 Macaroni wheat, 155.
 Maceration, skeletonizing plants, 549.
 Machine incubation, 370.
 Machinery, chapter on, 473.
 Macroductylus subspinosus, 322.
 Macrosiphum pisi, 324.
 Magnesium, 24, 25.
 Mahernia, 189.
 Mairs, on soiling, 136.
 Maize, weight, 534, 536, 541.
 Malacosoma, sp., 309.
 Malaria, 249.
 Malt, weight, 536, 541.
 Manganese, 24.
 Mangels as field crop, 140; fertilizer
 for, 62.
 Manure and house-flies, 249; chapter
 on, 81.
 Mare, gestation, 342, 343; milk of,
 443, 444.
 Margaropus annulatus, 429.
 Margolin, on forest yields, 205.
 Mark, 522, 523.
 Market classes of live-stock, 404.
 Marketing poultry, 374.

- Market milk, scores, 462.
 Marssonina perforans, 273.
 Mason work, 504.
 Massachusetts Hort. Soc. rules, 181.
 Matthew, on weather, 11.
 Maturities, 124.
 May-bug or beetle, 303, 314, 328.
 Mayetiola destructor, 336.
 McGill, on milk, 443.
 Meal, weight, 533, 534.
 Mealy-bug, 189, 303, 323, 333.
 Means, on alkali, 35.
 Measures and weights, 516.
 Mechanics, chapter on, 473.
 Melittia satyriniformis, 331.
 Melon, insects, 322.
 Melophagus ovinus, 441.
 Memythrus polistiformis, 321.
 Mending cements, 507.
 Menopon pallidum, 377.
 Mercuric bichloride as fungicide, 255.
 Mercuric oxid, 29.
 Mercury, 24.
 Merrill, on soil, 29.
 Methylated spirit, 508.
 Metric equivalents, 521; weights and measures, 519.
 Mexican boll-weevil, 316.
 Mexico, money, 522.
 Mice, 234.
 Michigan, dates in, 106.
 Middlings, weight, 533.
 Midge, pear, 326.
 Miles, different, 528.
 Milk, chapter on, 442; composition of, 442; inspection, 469; tests, 446.
 Millet, fertilizer for, 72; weight, 536, 540.
 Milo, grading, 160.
 Milreis, 522, 523.
 Mineola indigenella, 308; vaccinii, 317.
 Minnows for mosquitoes, 246; for slime, 251.
 Minns, on root-crops, 140.
 Miscible oils, 297.
 Mite, 304, 323.
 Moisture-test for milk, 451; for cheese, 455.
 Moles, 242.
 Molybdenum, 24.
 Monetary values, 522, 523.
 Money tables, 521, 524.
 Monophadnus rubi, 331.
 Moore, on soiling, 137.
 Mosquitoes, 245.
 Moss on trees, 233.
 Motors, 498.
 Mottled butter, 461.
 Mows, contents of, 530.
 Mulford, forestry, 203.
 Multiplication of plants, 130.
 Mumford, F. B., on gestation, 342; on heat, 344.
 Murgantia histrionica, 312.
 Muriate of potash, analysis, 58. (See Kainit.)
 Musca domestica, 249.
 Museums, 543.
 Mushroom, insects, 190, 323.
 Muskmelon, diseases, 274; fertilizer for, 72; packages, 170; under glass, 190.
 Muskrats, 243.
 Mustard, weight, 540; wild, 225, 226, 230, 232.
 Mutton, grades of, 406.
 Mycosphærella sentina, 278; fragariæ, 282.
 Myriophyllum, 191.
 Myristin, 443.
 Myrtus, 189.
 Myzus cerasi, 313; persicæ, 325.
 Narcissus, 189.
 National flowers, 186.
 Nectarine, diseases, 274.
 Needham, on mosquitoes, 245, 246.
 Nelumbium, 191.
 Nematode galls, 303.
 Nematus ventricosus, 319.
 Neodymium, 24.
 Neon, 24.
 Netherlands, money, 523.
 Newfoundland, money, 523.
 New York, dates in, 107.
 Nicaragua, money, 522, 523.
 Nickel, 24.
 Nicotine dips, 434.
 Niobium, 24.
 Nitrate of potash, 40; of soda, 29; of soda, analysis, 58.
 Nitric acid, 29; oxid, 29.
 Nitrogen, 24, 25; source of, 41.
 Nomenclature rules, 183.

- Norfolk, dates in, 107.
 Norway, money, 523.
 Nuphar, 191.
 Nurse-crops, 140.
 Nursery, for forest trees, 202.
 Nursery stock, diseases, 274; fertilizer for, 72; fumigating, 288.
 Nutrients, digestible, 424.
 Nutritive ratio, 413, 414.
 Nymphæa, 191.
- Oats, diseases, 262, 274; fertilizer for, 73; grading, 157; weight, 536, 541.
 Oberea bimaculata, 330.
Oecanthus niveus, 331.
 Edema, 260; of tomato, 283.
 Oemler, quoted, 108.
Oestrus ovis, 440.
 Ogden, on water-flow in pipes, 491; on hydraulic rams, 503; on hot-air engines, 503.
 Oils, miscible, 297.
 Okra, packages, 170.
 Olein, 443.
 Oleomargarin, test for, 455.
Oncideres sp., 328.
 Onion, diseases, 274; fertilizer for, 73; insects, 323; packages, 169, 171; weight, 536, 541.
 Oospora scabies, 266, 280.
 Orange boxes, 164; insects, 323; trees, distances, 119.
 Oranges, storing, 147.
 Orchard-grass, weight, 536.
 Organic compounds, 25.
 Organization of a farm, 174.
 Orris-root, 552.
Orthotylus delicatus, 322.
 Osage orange seed, weight, 536.
Oscinis sp., 313. (See *Phytopomyza*.)
Osmium, 24.
 Othonna, 189.
 Otis, on soiling, 137.
 Otto of roses, 551.
 Ouvirandra, 191.
 Over-run in butter-making, 454.
 Oxalis, 189.
 Oxygen, 24, 25.
 Oyster-shell scale, 308.
Ozonium omnivorum, 269.
- Pace, a measure, 528.
 Pacers, 358.
 Packages, for fruits, 163; for vegetables, 164, 171.
 Packing apples, 166.
 Paint, for greenhouse roofs, 201; for hot water pipes, 200; required for given surface, 511.
 Paints, 509.
Palearcita vernata, 306.
 Palladium, 24.
 Palmatin, 443.
 Palm, measure, 528.
 Palms, house, 189, 198.
 Panama, money, 522.
Papaipema nitela, 311.
 Paper for hotbeds, 200.
 Paper measure, 519.
 Paper, paints, 510.
Papilio asterias, 324; polyxenes, 313.
 Papyrus, 191.
 Paraffine oil, 297.
 Paraguay, money, 523.
 Parasites of animals, 429, 434; of fowls, 377.
 Paris green, 291.
 Parsley, insects, 324; under glass, 190.
 Parsnip, fertilizer for, 73; insects, 324; weight, 536, 541.
 Parturition, 343.
 Party flowers, 186.
 Pasture seeds, 94; soiling, 134.
 Pattison, on storing grapes, 145.
 Peach, diseases, 275; dried, 529; scoring, 177; weight, 536; fertilizer for, 74; insects, 325.
 Pea, diseases, 275; fertilizer for, 62, 74. (See Peas.)
 Pea-hen, incubation, 342, 343.
 Peanuts, weight, 536.
 Pear, diseases, 277; fertilizer for, 74; insects, 326.
 Pearson, quoted, 172, 442, 443, 446, 447, 448, 450, 467, 469.
 Pears, storing, 147; weight, 536.
 Peas, packages, 170, 171; to preserve for exhibition, 555; under glass, 190; weight, 538, 541.
 Pecan, insects, 327.
Pegomya brassicæ, 312, 330; *cepe-torum*, 323; *fusciceps*, 311.
 Pelargoniums, 189.
Penicillium sp., 262.

- Penny, 521, 523.
 Peppers, packages, 171.
 Perfume-jar, 552.
 Perfumery, 551.
 Peronospora schleideniana, 274.
 Persia, money, 523.
 Persian insect powder, 297.
 Persimmon, insects, 328.
 Peru, money, 522.
 Peseta, 522, 523.
 Peso, 522, 523.
 Petroleum for ticks, 429, 436.
 Pfennig, 522.
 Phalen, quoted, 43, 44.
 Phelps, on soiling, 135.
 Phenology, 17.
 Phenolphthalein, 448, 449.
 Philippines, money, 523.
 Phlæotribus liminaris, 325.
 Phlegethontius sp., 335.
 Phlycænia ferrugalis, 313.
 Phoma betæ, 266.
 Phosphate rock, production of, 41.
 Phosphoric acid, source of, 41.
 Phosphorus, 24, 25.
 Phosphorus for mice, 236.
 Phthorimæa operculella, 330.
 Phyllosticta solitaria, 263.
 Phyllostreta vittata, 303.
 Phylloxera, 321. Phytomyza, 313.
 Phytophthora cactorum, 260, 271;
 infestans, 279, 283; phaseoli, 265.
 Phytoptus oleivorus, 323.
 Pi, 528.
 Piaster, 523.
 Pickle-worm, 318.
 Pigeon, incubation, 342, 343.
 Pineapple, insects, 328.
 Pipes, contents, 531; paint for, 200.
 Piricularia oryzae, 281.
 Pistia, 191.
 Piston pumps, 499.
 Pitch wax, 513.
 Plan for home garden, 123.
 Plantain, 226, 229.
 Plant-bug, 303.
 Plant diseases, chapter on, 259.
 Plant-food, in soils, 34.
 Planting-tables, 106, 109, 110, 116,
 119; for forest trees, 202.
 Plant-lice, 301.
 Plants, collecting, 545.
 Plasmodiophora brassicæ, 266.
 Plasmopara viticola, 272.
 Plastering hair, weight, 536.
 Plaster of paris paint, 509.
 Platinum, 24.
 Plowrightia morbosa, 279.
 Plum, diseases, 279; fertilizer for, 74;
 insects, 329; scoring, 178; to pre-
 serve for exhibition, 555; weight, 540.
 Podosphæra oxycanthæ, 267.
 Pœcilocapsus lineatus, 303.
 Point (in type), 528.
 Points of a farm, 174.
 Poison ivy, 229.
 Poisons for herbaria, 546.
 Polychrosis viteana, 320.
 Pomological nomenclature, 183.
 Ponds, slime on, 251.
 Pontederia, 191.
 Pontia rapæ, 311.
 Popcorn, weight, 540.
 Poplar, insects, 329.
 Pork, grades of, 406.
 Porthetria dispar, 303.
 Portland cement, 504.
 Portugal, money, 523.
 Potash, 28; salts, analysis, 42, 58;
 source of, 42, 43, 44, 45.
 Potassium, 24, 25.
 Potassium cyanide, 287.
 Potassium ferrocyanide, 254.
 Potassium sulfid, 258.
 Potato, diseases, 279; packages, 169;
 weight, 538, 541; fertilizer for, 74;
 insects, 329; scoring, 177.
 Potting earth, 187.
 Poultry, chapter on, 365; farm, judg-
 ing, 381; manure, 84; rules, 378.
 Pound (of money), 521, 523.
 Prairie-dogs, 242.
 Præodinium, 24.
 Preservatives in milk, 449, 450.
 Preserving flowers, 546; fruits for
 exhibition, 552, 556; labels, 558.
 fence-posts, 207.
 Prickly lettuce, 229.
 Prim, insects, 330.
 Primrose, 189, 198.
 Primulas, 198.
 Prince, on weather, 11.
 Printing plants, 548.
 Privet, insects, 330.

- Profit-and-loss in dairying, 360.
 Propagation of crops, 130, 131, 132.
 Proteopteryx deludana, 327.
 Prunes, weight, 540.
 Prussiate of potash, 254.
 Pseudococcus calceolarie, 333; citri, 323; sp., 303.
 Pseudoperonospora cubensis, 270.
 Pseudopeziza medicaginis, 262.
 Psila rosæ, 302.
 Psoroptes communis, 440.
 Psylla, 327.
 Pteris, 189.
 Puccinia asparagi, 265; chrysanthemi, 268; coronata, 274; malvacearum, 273; maydis, 269; pruni-spinosæ, 279.
 Pulleys, 498.
 Pulse of animals, 344.
 Pumping by windmills, 494.
 Pumpkin, diseases, 280; fertilizer for, 74.
 Pumps, capacity of, 499, 500.
 Purity of seed, 100.
 Putty for glazing, 201.
 Pyrethrum powder, 297.
 Pythium deBaryanum, 260.
- Quack-grass, 225, 231.
 Quantity of seed per acre, 92.
 Quevenne readings, 447, 449.
 Quicklime, 28.
 Quin, on preserving flowers, 547.
 Quince, diseases, 280; fertilizer for, 74; insects, 330; storing, 147; weight, 540.
 Quincunx planting, 123.
 Quincy, on soiling, 134.
- Rabbit, milk of, 236, 238, 444.
 Racing horses, 357.
 Radiation for glass, 196.
 Radish, diseases, 280; fertilizer for, 75; insects, 330; packages, 171; under glass, 190.
 Radium, 24.
 Railroad worm, 306.
 Raisins, 529.
 Rams, hydraulic, 503.
 Rape seed, weight, 540.
 Raspberries, dried, 529; to preserve for exhibition, 555; weight, 540; diseases, 281; fertilizer for, 75, insects, 330.
 Rat, 234; gestation, 342, 343.
 Rations for animals, 409, 410, 413; for poultry, 372.
 Rawl and Conover, silos, 473.
 Raw materials of fertilizers, 46.
 Rawson, quoted, 106.
 Rayner, on windmills, 494.
 Reaumur scale, 527.
 Reddick on fungicides, 252; on plant diseases, 259.
 Red-spider, 304, 323, 328, 336.
 Red-top, weight, 538.
 Registry, advanced, 345.
 Regolith, 29.
 Reindeer, milk of, 443.
 Renovated butter, 455.
 Resin and fish-oil, 298.
 Resin-sol-soda-sticker, 258.
 Resin waxes, 512.
 Rhagoletis pomonella, 306.
 Rhizoctonia, sp., 260, 267, 274.
 Rhodites radicum, 331.
 Rhodium, 24.
 Rhubarb, insects, 331; under glass, 190; weight, 540.
 Rice, diseases, 281; weight, 538.
 Rice, on poultry farms, 381.
 Richmond, on milk, 443, 447.
 Rideal, on sewage, 90.
 Road-drags, 485, 487.
 Roberts, on horse's teeth, 339; on manures, 85, 86, 87; on soil, 34.
 Roofs for greenhouses, 199.
 Root-crops, 140.
 Root-gall, 303. See Crown-gall.
 Roots, composition, 28; storing, 147.
 Root-worm of grape, 320.
 Ropes, strength of, 481.
 Rose, 198; diseases, 281; insects, 331; scoring, 179.
 Rose blooms, to keep fresh, 550.
 Rose-chafer on bug, 308, 322.
 Rose, on motor power of stream, 502.
 Rosette of peach, 276.
 Ross, on dairying, 453, 455, 456, 471.
 Rotation for plant diseases, 253; for ticks, 435.
 Rothamsted, quoted, 30.
 Rot of potatoes, 279.

- Roughage, 133.
 Roughts, grades of, 407.
 Roumania, money, 523.
 Rubidium, 24.
 Ruble, 522, 523.
 Rules for gardeners, 173; for plant exhibitions, 181.
 Rupee, 523.
 Russian money, 522, 523.
 Rusting of boilers, 200; of nails and pipes, 510, 511.
 Rutabaga as field crop, 141, 538.
 Ruthenium, 24.
 Rye, fertilizer for, 75; grading, 157; weight, 538, 541.
 Rye-grass, weight, 533.
- Sage, weight, 540.
 Sagittaria, 191.
 Saissetia olæ, 323.
 Salads, weight, 540.
 Sal ammoniac, 507.
 Salt, 29; for weeds, 222, 223; test for butter, 453; for cheese, 453; weight, 538.
 Saltpeter, 29, 40.
 Salvador, money, 522, 523.
 Salvinia, 191.
 Samarium, 24.
 Sample rations, 417.
 Sanitary milk, scoring, 467, 471.
 San José scale, 304.
 Sanninoidea exitiosa, 325.
 Santo Domingo, money, 522.
 Saperda candida, 308.
 Sarcoptes sp., 378.
 Sawfly, currant, 319.
 Saxifraga, 189.
 Scab of apple, 264; of potatoes, 280; of sheep, 440.
 Scabies of fowls, 378.
 Scale in boilers, 200.
 Scale-insects, 304, 308, 323, 329.
 Scale, San José, 304.
 Scaly-leg of fowls, 378.
 Scandium, 24.
 Schæfell's wax, 514.
 Schistoceros hamatus, 309.
 Schizocerus sp., 334.
 Schizoneura lanigera, 310.
 Schöne, on soil, 31.
 Schools of agriculture, 561, 564.
- Schröeter, on seeds, 94.
 Scirpus, 191.
 Sclerotinia fructigena, 267, 275; libertiana, 274.
 Scolytus rugulosus, 326.
 Score, 528.
 Score-card for apples, 177; for carnations, 179; for cherries, 178; for chrysanthemum, 180; for corn, 177; for farms, 175; for gladioli, 180; for grapes, 178; for peaches, 177; for plums, 178; for potatoes, 177; for poultry, 367; for roses, 179; for sweet pea, 180; for animals, 392; for florists' plants, 180; cards in dairying, 462-472.
 Screw-worm fly, 438.
 Sealing cements, 508.
 Seaweed, analysis, 60.
 Sections of land, 542.
 Sediment in boilers, 200.
 Sedum, 189.
 Seed diseases, 284; per acre, 92; testing, 96, 100.
 Seeds, chapter on, 92; collecting, 544; composition, 28; vitality of, 102, 104.
 Seedsman's weights of seeds, 97.
 Selandria vitis, 320.
 Selenium, 24.
 Senecio, 189.
 Septoria chrysanthemi, 268; lycopersica, 283; petroselina, 267; ribis, 270.
 Serradella, 138.
 Servia, money, 523.
 Sesia pyri, 326; scitula, 328; tipuliformis, 318.
 Sewage, analysis, 90.
 Shafting, 501.
 Sheep, determining age, 338; gestation, 342, 343; judging, 399, 401; manure, 82, 83, 87, 89; milk of, 443, 444; parasites, 440; parts of, 400; profit or loss, 362.
 Shekel, 523.
 Shilling, 521, 523.
 Shutt, on preservatives, 552.
 Siam, money, 523.
 Silage, 134, 474.
 Silicon, 24, 25.
 Silos, 473.

- Silver, 24.
 Simon, on milk, 444.
 Simulium pecuarum, 438.
 Six's thermometers, 1.
 Size, measure, 528.
 Sizes of seeds, 98.
 Skeleton of cock, 368.
 Skeletonizing plants, 549.
 Slime on ponds, 251.
 Smilax, 198.
 Smith, J. B., on mosquitoes, 247.
 Smoking for insects, 287.
 Smudging for frosts, 16; for insects, 287.
 Smut of cereals, 260, 261, 262; of corn, 269; of onions, 274.
 Snails, 305.
 Snyder, quoted, 28.
 Soap insecticide, 293, 298, 299.
 Societies, rural, 560.
 Soda-and-aloes insecticide, 299.
 Sodium, 24, 25.
 Soil analysis, 54; chapter on, 24; diseases, 284; taking samples, 543.
 Soiling, 133, 134.
 Solid measure, 518.
 Sorghum, fertilizer for, 75; seed, weight, 538.
 Sow, gestation, 342, 343.
 Sow-thistle, 231.
 Spain, money, 523.
 Span, a measure, 528.
 Spanish money, 522, 523.
 Sparrows, 244.
 Spearmint under glass, 190.
 Specific gravity of soils, 31.
 Specimen jars, 558.
 Specks in butter, 461.
 Speltz, weight, 540.
 Spermophiles, 241.
 Sphaeceloma ampelinum, 271.
 Sphaeropsis malorum, 264, 280.
 Sphærotheca castagnei, 282; leucotricha, 264; mors-uvæ, 271; pan-nosa, 276, 281.
 Spinach, diseases, 281; fertilizer for, 75; packages, 170; under glass, 190; weight, 540.
 Spiny amaranth, 229.
 Spirogyra in ponds, 251.
 Split-log drag, 487.
 Spoonful, measure, 528.
 Spoon-test for oleomargarin, 455.
 Spraying cattle, 433; plants, 252, 286.
 Square measure, 518.
 Squashes, package, 171; storing, 147; fertilizer for, 76; insects, 331.
 Squirrel, gestation, 342, 343.
 Stable manure, 81.
 Stables, to disinfect, 434.
 Stacks, contents of, 530.
 Stags, grades of, 404, 407.
 Stake labels, 557.
 Standardizing milk, 450.
 Starch, 29.
 Stassfurt salts, 42.
 State flowers, 185.
 Steam, sterilizing by, 253.
 Stebler and Schroeter, 94.
 Steers, grades of, 404; profit or loss, 362.
 Sterilizing by steam, 253.
 Stevenson, on soil, 30, 32.
 Stewart, J. P., quoted, 49.
 Stigmæus floridanus, 328.
 Stocks, 198.
 Stocks for various plants, 131.
 Stone, J. L., on feeding, 424.
 Stone, a measure, 528.
 Storing fruits and vegetables, 141, 149; animal products, 345.
 Storms, 2.
 Straits Settlements, money, 523.
 Straw, grading, 151, 152; composition, 28.
 Strawberries, packages, 171; to preserve for exhibition, 556; weight, 540; diseases, 282; fertilizer for, 76; insects, 332.
 Stream, power of, 502.
 String beans, packages, 170.
 String, waxed, 513.
 Strontium, 24.
 Strychnine, composition, 29; for mice, 235; for sparrows, 244; for ground squirrels, 241, 242.
 Sugar, composition, 29.
 Sugar-cane, insects, 333; seed, weight, 540.
 Sulfate of ammonia, analysis, 58.
 Sulfate of copper as fungicide, 258; for bordeaux, 253; for ponds, 251.
 Sulfate of iron as fungicide, 258.
 Sulfate of magnesia, analysis, 58.

- Sulfate of potash, 29; analysis, 58.
 Sulfid of potassium, 258.
 Sulfur, 25; as fungicide, 258; as insecticide, 299; for rabbits, 237.
 Sulfuric acid, 29; for weeds, 222, 223.
 Sulfurous acid to preserve fruits, 553.
 Sumac, insects, 334.
 Surface measure, 518, 520.
 Surveyors' measure, 518.
 Surveys, government, 541.
 Sweden, money, 523.
 Sweet clover, 138.
 Sweet herbs under glass, 190.
 Sweet pea, 198; scoring, 180.
 Sweet-potato, diseases, 282; packages, 170; weight, 538; insects, 334; storing, 148.
 Swine, determining age, 339; grades of, 407; judging, 402, 404; milk of, 444; parasites, 441; profit or loss, 362.
 Switzerland, money, 523.

 Tablespoonful, 528.
 Tael, 523.
 Taft, on greenhouses, 199.
 Talent (of money), 523.
 Tanglefoot, 299.
 Tanks, circular, 531; square, 532.
 Tantalum, 25.
 Taper in logs, 216.
 Tar as insecticide, 299.
 Tar cement, 508.
 Tartar emetic for mice, 235.
 Taylor, on fruit packages, 164.
 Teaspoonful, 528.
 Teeth of animals, 337, 339.
 Tellurium, 25.
 Temperature for incubation, 370; of animals, 344; for animal products, 345; for plants under glass, 198.
 Tender vegetables, 108.
 Tent-caterpillar, 309.
 Terbium, 25.
 Termites, 305.
 Test-plots for soils, 56.
 Tetranychus bimaculatus, 304, 336; sexmaculatus, 323.
 Texas-fever ticks, 429.
 Texture of soil, 32.
 Thallium, 25.
 Therm, 409.
 Thermometer scales, 527.
 Thermometers, 1.
 Thielavia basicola, 271, 282, 283.
 Thorium, 25.
 Thrips. See rose, grape, pear, etc.
 Thrips tabaci, 323.
 Thulium, 25.
 Thyridopterix ephemeræformis, 301.
 Tical, 523.
 Tick of fowls, 378; of sheep, 441; cattle, 429.
 Tile-draining, 481.
 Tillage, 37.
 Tilletia foetens, 262.
 Timber, defined, 202.
 Time for germination, 102; for fruit-bearing, 124.
 Timothy seed, weight, 538, 541.
 Tin, 25.
 Titanium, 25.
 Tmetocera ocellana, 306.
 Tobacco, diseases, 282; fertilizer for, 76; insecticide, 299; insects, 335.
 Tomato, diseases, 283; packages, 169; weight, 538; fertilizer for, 76; insects, 335; storing, 149; under glass, 190.
 Ton, 516; to figure by, 530.
 Townships, measurement of, 541.
 Trade value of fertilizers, 47, 50.
 Tradescantia, 189.
 Trapa, 191.
 Tree seeds in pound, 96.
 Trichobaris trinotata, 29.
 Trichodectes scalaris, 438.
 Trotters, 357.
 Troy weight, 516.
 Truck packages, 169, 171.
 Trueman, on butter-making, 458.
 Tulip, 198.
 Tungsten, 25.
 Turbines, 502.
 Turkey, incubation, 342, 343.
 Turkey, money, 523.
 Turnip as field crop, 141; fertilizer for, 77; weight, 538, 541.
 Tussock-moth, 309.
 Twig-borer, 309.
 Twig-pruner, 309.
 Tylocladus fragariæ, 332.
 Typha, 191.

- Typhlocyba comes, 321 ; rosæ, 331.
 Typhoid fly, 249.
 Typophorus canellus, 333.
 Uranium, 25.
 Urine, 83, 88, 89, 90.
 Urocystis cepulæ, 274.
 Uromyces caryophyllinus, 267.
 Uruguay, money, 522.
 Ustilago sp., 261, 262, 269.
 Vallota, 189.
 Vanadium, 25.
 Van Dine, sugar-cane insects, 333.
 Van Horn, quoted, 41, 42.
 Van Slyke on fertilizers, 63 ; on milk, 443, 444, 449, 456.
 Veal, grades of, 405.
 Vegetable packages, 169, 171.
 Vegetables, dates for, 106 ; distances for, 109, 119 ; nomenclature, 183 ; propagation of, 131 ; under glass, 190.
 Velvet-grass seed, weight, 540.
 Venezuela, money, 522.
 Venturia inæqualis, 264 ; pyrina, 278.
 Veratrum album, 300.
 Vetch, as cover-crop, 138, 139 ; weight of, 139.
 Veterinary schools, 565.
 Victoria, 191.
 Vieth, on milk, 443.
 Vilmorin, on seeds, 98, 102.
 Vinca, 189.
 Violet, 198 ; diseases, 283 ; insects, 335.
 Voorhees, on milk, 443 ; quoted, 45, 50.
 Wage-tables, 526.
 Walks, material for, 505, 506 ; weeds on, 233.
 Walnuts, weight, 540.
 Wandering Jew, 189.
 Warble-fly, 437.
 Warren, scoring farms, 175.
 Warrington, quoted, 30.
 Washes for fences, 509.
 Water, data on, 489.
 Water in soil, 32.
 Water-cress, packages, 170.
 Watering plants, 188.
 Watermelon, fertilizer for, 77 ; grades, 530.
 Waterproofing, 510 ; paper, 550.
 Water-wheels, 502.
 Watson, on soiling, 136.
 Wax, grafting, 512.
 Weather, 1 ; map, 2, 4 ; records, 19 ; signs, 11 ; vane, 23.
 Web-worm, 307.
 Weed-killers, 223, 228.
 Weeds, chapter on, 221 ; lawns, 232.
 Weight of soils, 30 ; weights and measures, 516, 520 ; poultry, 366 ; seeds, 97, 98.
 Wellhouse, rabbit-trap, 238.
 Wells, capacities, 531.
 Wethers, scoring, 399.
 Whale-oil soap, 298.
 Wheat, fertilizer for, 77 ; grading, 153 ; insects, 336 ; weight, 538, 541.
 Wheeler, on lime, 77.
 Whey, butter from, 461.
 White ants, 305.
 White daisy, 231.
 White grub, 303, 314.
 White hellebore, 300.
 White-wash, 509.
 White-weed, 231.
 Whitney, on soil, 32.
 Widtsoe, on soils, 34.
 Wild carrot, 230.
 Wild oats, 230.
 Willis, on fence-posts, 207 ; on shingles, 209.
 Willow, insects, 336.
 Wilson, C. S., box packing, 166.
 Wilson, on weather, 11, 12, 16, 19.
 Wind, in cooling glass, 196 ; indications, 9.
 Windmills, 493, 494.
 Wing, age of animals, 337.
 Winter injury, 268.
 Wire, fence, 477.
 Wire-worm, 305, 315.
 Woburn, quoted, 31.
 Wolf, gestation, 342.
 Wolff, analyses, 90.
 Wolff-Lehmann Standards, 413.
 Woll, on soiling crops, 134, 135.
 Wolves, 243.
 Wood, hardness of, 204.
 Wood crops, 204.

- Woodchucks, 243.
Woolly aphis, 310.
Wounds, waxes for, 514.
Xenon, 25.
Xyleborus pyri, 326.
Yellows, 277.
Yen, 523.
Yields of forests, 204; of seeds, 105;
tables, 125, 127.
- Youatt, on gestation, 342.
Ytterbium, 25.
Yttrium, 25.
Zebrina, 189.
Zebu, milk of, 443.
Zinc, 25.
Zinc chloride to preserve fruits, 553.
Zirconium, 25.
Zizania, 191.

