

# Field Experiences With Floating Breakwaters in the Eastern United States

by

Andrew V. Baird and Neil W. Ross



MISCELLANEOUS REPORT NO. 82-4

JULY 1982

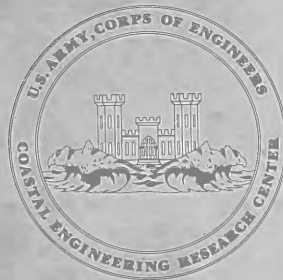

Approved for public release;  
distribution unlimited.

Prepared for  
U.S. ARMY, CORPS OF ENGINEERS  
COASTAL ENGINEERING  
RESEARCH CENTER

Kingman Building  
Fort Belvoir, Va. 22060

TC  
203  
U581  
MR 82-4

Reprint or republication of any of this material shall give appropriate credit to the U.S. Army Coastal Engineering Research Center.

Limited free distribution within the United States of single copies of this publication has been made by this Center. Additional copies are available from:

*National Technical Information Service  
ATTN: Operations Division  
5285 Port Royal Road  
Springfield, Virginia 22161*

Contents of this report are not to be used for advertising, publication, or promotional purposes. Citation of trade names does not constitute an official endorsement or approval of the use of such commercial products.

The findings in this report are not to be construed as an official Department of the Army position unless so designated by other authorized documents.

MBL/WHOI  
0 0301 0000 1000  
9 5896900 6835 9



REPORT DOCUMENTATION PAGE		READ INSTRUCTIONS BEFORE COMPLETING FORM
1. REPORT NUMBER MR 82-4	2. GOVT ACCESSION NO.	3. RECIPIENT'S CATALOG NUMBER <b>WHOI</b>
4. TITLE (and Subtitle) FIELD EXPERIENCES WITH FLOATING BREAKWATERS IN THE EASTERN UNITED STATES	5. TYPE OF REPORT & PERIOD COVERED Miscellaneous Report	<b>DOCUMENT COLLECTION</b>
7. AUTHOR(s) Andrew V. Baird and Neil W. Ross	8. CONTRACT OR GRANT NUMBER(s) DACW72-80-M-0626	
9. PERFORMING ORGANIZATION NAME AND ADDRESS Marine Resource Management, Inc. 12 Arrow Street Cambridge, Massachusetts 02138	10. PROGRAM ELEMENT, PROJECT, TASK AREA & WORK UNIT NUMBERS D31679	
11. CONTROLLING OFFICE NAME AND ADDRESS Department of the Army Coastal Engineering Research Center Kingman Building, Fort Belvoir, Virginia 22060	12. REPORT DATE July 1982	
	13. NUMBER OF PAGES 93	
14. MONITORING AGENCY NAME & ADDRESS (If different from Controlling Office)	15. SECURITY CLASS. (of this report) UNCLASSIFIED	
	15a. DECLASSIFICATION/DOWNGRADING SCHEDULE	
16. DISTRIBUTION STATEMENT (of this Report)  Approved for public release; distribution unlimited.		
17. DISTRIBUTION STATEMENT (of the abstract entered in Block 20, if different from Report)		
18. SUPPLEMENTARY NOTES		
19. KEY WORDS (Continue on reverse side if necessary and identify by block number)		
Boat traffic control	Log boom	
Coastal structure	Scrap-tire breakwater	
Fish reef	Shoreline protection	
Floating breakwater	Transmission coefficient	
Floating tire breakwater	Wave suppression	
20. ABSTRACT (Continue on reverse side if necessary and identify by block number)		
<p>In the past 10 years, the use of floating breakwaters as temporary coastal structures has become increasingly widespread in the United States as an inexpensive means for suppressing waves. However, as with any new technology, there have been many failures and a substantial number of imaginative, successful innovations. One of the chief problems contributing to the failure rate has been a lack of awareness by designers of reliable, up-to-date technical information. As part of a large research effort to remedy this problem,</p> <p style="text-align: right;">(continued)</p>		

a survey was conducted on field experiences with floating breakwaters in the Eastern United States.

Results of the survey confirmed that state-of-the-art technical literature is not being properly disseminated. Structures built according to early design manuals were shown to have failed before the completion of their design life. Conversely, floating breakwaters built to the standards set by recent research have fared well and show promise of meeting their design goals.

The weakest areas of the present technology are flotation and the anchoring systems. It is recommended that a concentrated research effort be directed toward these problem areas; it is also recommended that the monitoring of state-of-the-art projects continue.

## PREFACE

This report is published to assist coastal engineers and marine facility operators in the planning, design, and construction of floating breakwaters. The work was carried out under the U.S. Army Coastal Engineering Research Center's (CERC) Design of Floating Breakwaters work unit, Coastal Structures Evaluation and Design Program, Coastal Engineering Area of Civil Works Research and Development.

The report was prepared by Andrew V. Baird, Marine Resource Management, Inc., Cambridge, Massachusetts, and Neil W. Ross, who provided technical supervision, under CERC Contract No. DACW72-80-M-0626.

The authors express appreciation to the many marine facility operators who responded to the surveys, particularly to J. Poole, S.W. Richards, T.W. Kingman, and C.D. Biddick for helping develop the final questionnaire. The authors also wish to acknowledge the University of Rhode Island Sea Grant Program, the New York Sea Grant Program, and the Goodyear Tire and Rubber Company for assisting in the compilation of the floating breakwater inventory. The authors are especially indebted to Dr. E. Richey of the University of Washington and W.F. Baird, P.E., and J. Readshaw, P.E., of Hydrotechnology, Ltd., for their professional advice and support.

W.N. Seelig was the CERC contract monitor for the report, under the general supervision of Dr. R.M. Sorensen, Chief, Coastal Processes and Structures Branch, and Mr. R.P. Savage, Chief, Research Division.

Technical Director of CERC was Dr. Robert W. Whalin, P.E., upon publication of this report.

Comments on this publication are invited.

Approved for publication in accordance with Public Law 166, 79th Congress, approved 31 July 1945, as supplemented by Public Law 172, 88th Congress, approved 7 November 1963.

  
\_\_\_\_\_  
TED E. BISHOP  
Colonel, Corps of Engineers  
Commander and Director

## CONTENTS

	Page
CONVERSION FACTORS, U.S. CUSTOMARY TO METRIC (SI) . . . . .	5
I INTRODUCTION. . . . .	7
1. Methodology. . . . .	7
2. Reliability of Findings. . . . .	8
II GOODYEAR FLOATING TIRE BREAKWATER DESIGN. . . . .	10
1. Problem Areas. . . . .	10
2. Effectiveness in Suppressing Waves . . . . .	15
3. Cost and Additional Benefits . . . . .	15
III OTHER FLOATING BREAKWATER DESIGNS . . . . .	17
IV CONCLUSIONS AND RECOMMENDATIONS . . . . .	20
APPENDIX	
A FIELD EXPERIENCES: GOODYEAR FLOATING TIRE BREAKWATER . . . . .	23
B FIELD EXPERIENCES: OTHER FLOATING BREAKWATERS. . . . .	69
C FIELD EXPERIENCE QUESTIONNAIRE. . . . .	82
D OTHER KNOWN FLOATING BREAKWATER SITES . . . . .	89
E UNCONFIRMED FLOATING BREAKWATER SITES . . . . .	91

## FIGURES

1 Goodyear FTB . . . . .	11
2 Reported effectiveness of the Goodyear FTB as a function of the ratio of the structure's beam to the estimated length of an incident storm wave . . . . .	16
3 Pole-tire FB . . . . .	18
4 Timber caisson FB. . . . .	18
5 Steel pipe FB. . . . .	19
6 Steel caisson FB . . . . .	19
7 Log boom FB. . . . .	19

CONVERSION FACTORS, U.S. CUSTOMARY TO METRIC (SI) UNITS OF MEASUREMENT

U.S. customary units of measurement used in this report can be converted to metric (SI) units as follows:

Multiply	by	To obtain
inches	25.4	millimeters
	2.54	centimeters
square inches	6.452	square centimeters
cubic inches	16.39	cubic centimeters
feet	30.48	centimeters
	0.3048	meters
square feet	0.0929	square meters
cubic feet	0.0283	cubic meters
yards	0.9144	meters
square yards	0.836	square meters
cubic yards	0.7646	cubic meters
miles	1.6093	kilometers
square miles	259.0	hectares
knots	1.852	kilometers per hour
acres	0.4047	hectares
foot-pounds	1.3558	newton meters
millibars	$1.0197 \times 10^{-3}$	kilograms per square centimeter
ounces	28.35	grams
pounds	453.6	grams
	0.4536	kilograms
ton, long	1.0160	metric tons
ton, short	0.9072	metric tons
degrees (angle)	0.01745	radians
Fahrenheit degrees	5/9	Celsius degrees or Kelvins <sup>1</sup>

<sup>1</sup>To obtain Celsius (C) temperature readings from Fahrenheit (F) readings, use formula:  $C = (5/9) (F - 32)$ .

To obtain Kelvin (K) readings, use formula:  $K = (5/9) (F - 32) + 273.15$ .





FIELD EXPERIENCES WITH FLOATING BREAKWATERS  
IN THE EASTERN UNITED STATES

by  
*Andrew V. Baird and Neil W. Ross*

I. INTRODUCTION

In the past 10 years, the use of floating breakwaters (FBs) as temporary coastal structures has become increasingly widespread in the United States as a relatively inexpensive means for suppressing waves. However, as with any new technology, there have been many failures and a substantial number of imaginative, successful innovations. One of the chief problems contributing to the failure rate has been a lack of awareness by FB designers of reliable, up-to-date technical information. Similarly, much of the circulated technical literature has limited value because some of the authors of these reports were unaware of current FB technology and performance studies.

Recognizing the above problems, the U.S. Army Corps of Engineers initiated a research effort to gather all available data on existing FBs so that a central source of design information would be available to the next generation of builders. One component of this overall effort was a survey of field experiences with FBs in the Eastern United States (all states east of the Mississippi River). Marine Resource Management, Inc. (MRM) was chosen to conduct this work. MRM was aided by the technical supervision of the coauthor, Neil Ross, a pioneer in the development and testing of the Goodyear Floating Tire Breakwater (FTB) at the University of Rhode Island (URI).

1. Methodology.

Working closely with the Coastal Engineering Research Center (CERC), MRM developed a four-stage plan to retrieve and present the desired information. These stages included:

- (a) Developing an inventory of FBs installed, including those no longer in operation and those still in prototype;
- (b) sending out detailed questionnaires to FB operators;
- (c) cross-checking and expanding operator-provided information with other sources; and
- (d) analyzing the performance and problems experienced by each project to learn why the difficulties arose and how they might be prevented.

In developing the site inventory, MRM relied extensively on files maintained at URI by Mr. Ross and on Corps permits issued by the various eastern district offices. MRM also received a list of contacts from Hydrotechnology, Ltd., a Canadian firm which had done a similar, though broader study of North American FBs. The New York Sea Grant Program and the Goodyear Tire and Rubber Company were also contacted for possible leads.

From the above sources, a list of 81 potential sites was compiled. For each site, an attempt was made to contact the FB operator by an introductory letter. Three leads resulted in deadends with the contacts listed as unknown. Thirty-one did not respond to the letter, making their status unclear as to whether an FB was ever installed. Nine responded that while an FB was once planned, it was never built. Finally, 38 answered affirmatively that an FB was, at some point in time, in operation; these operators were then sent survey questionnaires. A total of 21 operators completed the survey. The survey results of the field experiences of the 16 FTB sites and the 5 FB sites are given in Appendixes A and B, respectively. Appendix C contains the questionnaire sent out to the FB operators. Appendix D lists the 17 known sites for which a survey was not completed. Appendix E lists the 31 unconfirmed sites which may or may not have had an FB in operation.

Once the surveys were in hand, the operator's information was cross-checked against any other data known for the site. Typically, this other information was available through the Corps permits, the Hydrotechnology, Ltd. files or site visits conducted by Mr. Ross or the staff of MRM. Where conflicting data existed, the respondents were contacted directly to resolve any inconsistencies. When satisfied with the degree of detail in the site data, the information was transferred to narrative summary sheets which are included in the body of this report.

The final step was to perform a simple qualitative engineering analysis of each FB project and suggest the causes for any problems arising and the actions needed for their successful resolution. To conduct this analysis, MRM relied heavily on Mr. Ross' extensive experiences since 1974 with FTBs and the staff's own coastal engineering expertise. Obviously, it is the intent of this report, based on the cumulative field experiences of many FB operators, to provide this capability to analyze and refine FB designs to future users.

## 2. Reliability of Findings.

For the most part, there is no reason to suspect that some of the values assigned by the operators to the physical parameters of the FB systems should be in question. Elements such as physical dimensions, construction materials, and mooring configuration are easily measured and reported. However, certain types of information, the most important of which are listed below, are much more difficult to accurately ascertain.

a. Site Conditions. Even with proper instrumentation, measuring wave height, length, and direction of propagation is a complicated undertaking. In many cases, the survey was probably the first time an operator had to face the quantitative question of what conditions exist off the site. It is believed that in most instances, the operators provided reasonably accurate answers for storm wave height and direction, for these parameters are the simplest to measure--requiring but two fixed reference points. However, most reported wavelengths appeared erroneous, since sea conditions often seem exaggerated to untrained observers. To compensate, MRM provided an estimated wavelength based on the reported fetch, windspeed, water depth, and outside wave height. However, even this empirical answer is questionable and should be viewed suspectly.

b. Structure Location. In response to the request for a site map, most operators drew a quick sketch of their facility and the FB's position. The redrawn maps provided in the report are helpful in understanding the orientation of the FB relative to the shoreline, but in no case should the positioning of the map elements be taken as precise or the representation of the protected facility be considered exact, for such accuracy is impossible from a simple, hand-drawn sketch.

c. Operational Problems Encountered. The survey asked the respondents to rate how severe various problem areas were in regards to their FB. The answers are clearly subjective (e.g., the problem of a breakwater trapping floating debris may be viewed as a major one by an operator sensitive to its waterfront appearance, while a second person may view it as a minor nuisance) and are occasionally conflicting due to the unintended overlap of certain problem areas. Nonetheless, based on information contained elsewhere in the survey, it usually has been possible to portray a representative picture of the problems encountered.

d. Transmission Coefficient. The transmission coefficient is the ratio of the wave height on the leeward side of the FB to the wave height on the exposed side of the structure. Thus, if 1.5-m (5.0 ft) waves are suppressed by an FB and reduced to a height of 0.9 m (3.0 ft), the transmission coefficient is 0.60. (Note that since the energy in a wave system is proportional to the wave amplitude squared, a 0.60 transmission coefficient means that 64 percent of the wave energy is being dissipated by the FB.) In most cases, the reported transmission coefficients are much lower (i.e., the FB is much more effective) than those reported in carefully monitored studies. This effect is probably due to an enchantment with the structure on the part of the operator, distorting the FB's physical effectiveness. Nonetheless, the reported findings are believed to be significant for they represent, albeit in an abstract sense, the satisfaction of the operator with the structure. Consequently, the reported transmission coefficients have not been altered. Furthermore, if it is assumed that this distorting effect is common to most of the responses, then the coefficients are also useful in a comparative sense.

e. Cost. Because many of the FB structures were essentially do-it-yourself projects or have changed ownership since their construction, it is suspected that several of the reported costs are just guesses made without the aid of accurate accounting. In other instances, it is believed that labor costs are underestimated or ignored because of the employment of an in-house work force. Thus, the cost breakdowns given by the respondents should be considered as general indicators of the actual price range. To simplify comparison of costs between projects, MRM calculated each project's 1980 dollar cost per square meter (and per square foot) of FB surface area through the use of construction-related inflation factors.

f. Additional Benefits. As with the evaluation of operational problems encountered, the determination of additional benefits provided by an FB is a highly subjective and occasionally arbitrary task. In particular, judging the effect of the structure on sediment movement, shoreline erosion, and water circulation is a difficult, if not impossible, evaluation to make without proper instrumentation and careful recordkeeping. Nevertheless, the benefits perceived by the respondents have been recorded as written, trusting that in a qualitative sense their integrated observations are true.

## II. GOODYEAR FLOATING TIRE BREAKWATER DESIGN

One of the earliest FB designs was the Goodyear Floating Tire Breakwater, conceived by Richard Candle of the Research Division, Goodyear Tire and Rubber Company, as an outgrowth of his automobile crash barrier research. The Goodyear FTB is, in its simplest form, a flexible mat of tires riding the surface of the water. The earmark of this design is the Goodyear module--a set of 18 tires coupled in a 3-2-3-2-3-2-3 vertical fashion (Fig. 1). These modules are bound parallel to one another to form a checkerboardlike mat of whatever dimensions the designer deems necessary for the site.

Because of its status as one of the first publicized designs, with the help of the Sea Grant Programs, and the decision by the Goodyear Tire and Rubber Company to allow the use of its design royalty-free, the Goodyear FTB is now the most common type of FB in the Eastern United States. In the data gathering efforts, more than 75 percent of all identified FB projects were Goodyear FTBs. For this reason, this section is devoted solely to an examination of the effectiveness of the Goodyear design. Field experiences at 16 FTB sites are given in Appendix A.

### 1. Problem Areas.

The survey identified 12 potential problem areas affecting the operation of an FB. The operators were asked to rate the severity of each problem according to the following scale:

Never-----Minor-----Moderate-----Major-----Extreme  
(0) (1) (2) (3) (4)

In the following discussion, each problem area is examined in turn. They are ranked according to the average severity voiced in the surveys. These severity ratings are listed in parentheses following the title of each problem area and are divided into separate saltwater-freshwater components (e.g., a rating of 2.0/1.0 would indicate that this area posed moderate problems to saltwater-based designs and minor problems to FTBs in freshwater).

a. Fouling Growth (2.5/0.8). In saltwater, there is no practical way of avoiding the weight problem posed by fouling growth if the FTB is in operation for over a year. The magnitude of the problem can be vast--one operator, a marine biologist at a research laboratory, noted that the dry weight of fouling growth found on each tire was 54.5 kg  $\pm$  28.1 kg (120 lb  $\pm$  62 lb) (unpublished research, D. O'Neil, Graduate School of Oceanography, URI). He suggests that the tires will sustain a maximum yield, beyond which excess fouling growth will slough off. The greatest weight was due to barnacles and mussels. While this may illustrate an extreme case, it does point up the fact that a highly positive flotation system is required for the FTB to survive the weight buildup and a maintenance program is needed to occasionally relieve the structure of this weight. Typically, this type of maintenance includes divers hand-scraping the growth off the FTB or, in the north, hauling the breakwater out of the water in the winter to let the cold kill the growth and the elements scrub it clean. In freshwater, fouling growth is little more than a nuisance problem with no indications that it adversely affects the structure's buoyancy.

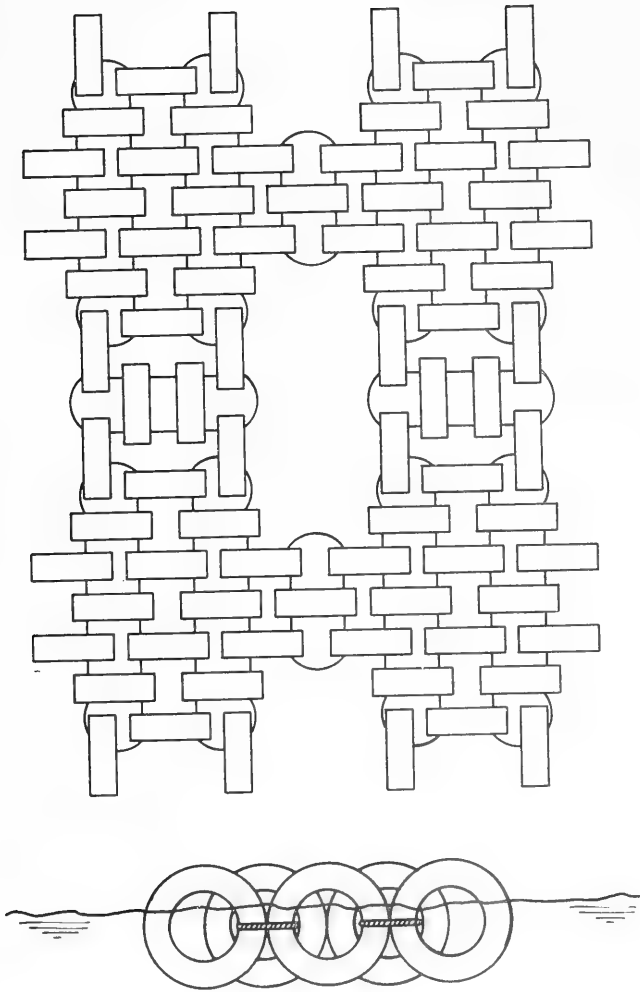

Figure 1. Goodyear FTB--top view of four connected modules (scale - 1:44, spacing between tires exaggerated) and side view of single module (scale - 1:32).

b. Inadequate Buoyancy (2.3/1.4). The original Goodyear design advocated a flotation system which relied on air trapped in the crowns of the tires and was replenished by normal wave action. By 1975, URI researchers had determined that this system was inadequate for long-term continuous use in saltwater; nonetheless, many of the structures surveyed, including some built in the late seventies, relied on this method for buoyancy. Without exception, this system failed for structures in saltwater and often failed for those in freshwater. In saltwater, an FTB usually will be overcome by fouling growth and however much air is trapped in the tire crowns will be inadequate to prevent some, if not all, of the structure from sinking. In freshwater, the system appears to work if compressed air is regularly blown into the structure to replace that which has escaped or been absorbed into the water. Oftentimes, such a measure was not included in routine maintenance, particularly for unattended sites.

To overcome flotation problems, many operators attempted to insert polyethylene blocks into the tire crowns. This procedure was usually a very difficult undertaking and a stopgap measure at best. Those blocks inserted in tires on the outer modules came loose and floated away under moderate wave action. Internal tires typically retained the foam under most sea conditions, which did allow for a modest improvement in buoyancy. A more successful approach was to pour liquid polyurethane foam into the tire crowns before assembling the modules. This expanded foam formed a much tighter fit and provided much greater buoyancy. While the foam is brittle and can break, then wash out under severe wave action, this method appears to be the most successful of all methods, for both saltwater- and freshwater-based designs. The greatest drawback with poured foam is its initial expense.

c. Litter Entrapment (2.0/2.0). Whether on saltwater or freshwater, an FTB will trap floating debris and can become an esthetic annoyance. This problem appears particularly acute in heavily traversed inner harbors and sites which have unusually fast currents. The only known solution is a regularly scheduled handpicking of the structure. Fortunately, litter entrapment appears to have no functionally bad side effects as does, for example, fouling growth. Two operators did not even regard litter entrapment as a problem. One was in the unique situation where a pier and set of docks were built atop a portion of his FTB. This accessibility permitted easy cleaning; however, the accessibility also meant that children would play on and around the structure which presented a safety hazard. The second operator expressly intended his very long FTB to act as a debris gate and keep his marina clean.

d. Anchoring System Failure (1.8/0.8). In this case, the mean severity rating is misleading. Anchoring system failure is usually catastrophic, with either a major or extreme failure occurring or no failure happening at all. The projects which did experience failure were, in hindsight, logical ones. Two sites found hurricanes passing overhead, one was directly exposed to an incredible fetch across the width of Lake Michigan and a fourth was positioned at a point experiencing some of the strongest tidal currents in the United States. In such cases, truly massive anchoring systems were required to hold the structure in position; otherwise, a reconsideration of whether an FTB is even appropriate for the site was in order.

There appears to be no simple solution to anchoring system failure. Maintaining any floating structure in place under severe sea conditions has always

been a monumental task and, at a certain point, all systems will fail. A builder must be aware of site conditions and determine the risk he or she is willing to take. Unfortunately, many operators indicated that the loads experienced by their FTBs were much greater than that postulated in the early technical literature. Consequently, there may be a serious gap in the theoretical knowledge of these systems, if not in the problem of access to more recent, definitive studies.

e. Coupling Failure (1.0/0.8). Many materials are used to couple the tires together. Rope was the first to be tried in the original 1974 trials, where it was found to quickly chafe, untie, and fail. (One early FTB was invaded by a colony of snapping turtles which quickly ate through almost every rope holding the structure together.) Wire and cable are used, though these materials can easily cut through the tires and corrode in saltwater or acidic freshwater. Nylon strapping has been tried, only to find that it will chafe and fray until failure occurs. Chain is frequently employed, but it is a very heavy coupler, will also corrode, and can abrade the tires. In contrast with the above couplers, rubber conveyor belting has been used with notable success. One FTB, under the influence of Hurricane Frederic in 1979, was ripped from its mooring site and dashed against a rock groin; yet, the tire mat coupled by conveyor belting remained intact. (The combined holding power of the anchoring system which dragged was estimated to be 235,700 N (53,000 lb).) Working with the belting can be as simple as with any other coupling material. The belting is easily cut by a sharp knife blade or handsaw and cold-punching bolt or rivet holes is straightforward. Drilling through the belting is not advised for the generated heat will cause the rubber to melt and subsequently bind the bit.

Fasteners for the coupling materials include clamps, bands, rivets, and bolts. To avoid the corrosive tendencies of saltwater, nylon bolts, dyed black to prevent ultraviolet deterioration, have met with good success. (If the nylon bolts are tightened too much, high internal stresses will result and the bolt may shear when strained.) While bolts can pull through the flexible hole in the conveyor belting or shear in tension, if properly fastened, nylon bolts have a very low failure rate. (One operator reported a 3- to 4-percent failure rate over 2 years of operation including the passing of two hurricanes.) At most freshwater sites, galvanized-steel bolts are sufficient with stainless-steel or nylon components being needlessly expensive. One enterprising builder on freshwater employed 6061-T6 aluminum rivets and, after 2.5 years of experience, now advocates their use. Davis (1977)<sup>1</sup> is the most definitive study on coupling materials.

f. Structural Failure (1.0/0.8). The purpose in examining this category was to learn of any structural faults in the primary construction material used in the FB. In the case of a Goodyear design, the primary construction material is the scrap automobile tire. With the exception of a few tires sawed through by wire, cable, or chain, the surveys indicate that the tires withstood all the punishment anticipated in an ocean environment. The relatively high rating given this category by the respondents probably indicates

---

<sup>1</sup>DAVIS, A.P., Jr., "Evaluation of Tying Materials for Floating Tire Breakwaters," Marine Technical Report No. 54, University of Rhode Island, Kingston, R.I., 1977.

some confusion with the term and links this area with inadequate buoyancy and coupling failure.

g. Instability (0.5/0.9). Because of the habit of an FTB to collect fouling growth, sand, silt, and litter on and in the tires, a once-stable structure can quickly become unstable. This is exhibited when it starts to sink at one of the far ends or at its exposed side. In extreme cases, this bending over will increasingly release trapped air or foam in the positively buoyant section until the entire structure suddenly sinks. Instability in an FTB is certainly a function of inadequate buoyancy and poor maintenance. Partial submergence is usually a solid indicator that total sinking may soon occur. Since stability is linked with the quality of the flotation system, those units which rely solely on trapped air for buoyancy have consistently experienced the most severe problems.

h... Mooring-Line Failure (0.5/0.6). In every case where mooring-line failure was cited, the anchoring system had also failed. Fortunately, mooring-line failure is rare with anchors dragging much more often than lines breaking. Typically, belting or chain is looped through several tires and joined at a shackle to which the mooring pennant is connected. Evidently, whether by the builders' intuitive knowledge or by a reversal in the design literature from its previous stance on anchoring systems, overdesign is typical and mooring lines manage to hold through the worst conditions. This last statement assumes, of course, that the entire system has not been drastically dragged out of its proper mooring configuration. In addition, if not properly maintained, any mooring system will eventually fail due to fatigue and wear, but it appears that no respondents have had their FTBs in location long enough for this problem to have arisen. Consequently, annual inspection is still advised, with the replacement of lines showing weakness.

i. Interference with Boating Traffic (0.5/0.3). Frequently, an operator noted that the FTB was a minor nuisance to boaters motoring through the area. In no case was this category cited as a moderate, major, or extreme problem. Several operators actually indicated that their FTBs served effectively in controlling traffic near their facilities and, by doing such double duty, had a clearly positive effect.

j. Ice Damage (0.2/0.6). Surprisingly, while several sites have flowing ice present in the winter, ice damage to the FTB was never reported as more than a minor problem. Flowing ice can build up tremendous forces on a moored coastal structure and carry it along in its flow. Nonetheless, no notable mooring or anchoring failures in this mode were cited. It is apparent, however, that several operators wisely sidestepped this problem by moving their FTB in the winter to a less exposed site (e.g., lashed against a fixed breakwater or permanent dock). Finally, one operator who has a rigid pier and dock built atop his FTB noted that ice did cause moderate damage to the docks, though had no effect on the FTB proper.

k. Corrosion (0.2/0.1). To a large extent, this category is subsumed under coupling failure. Corrosion is indeed a severe problem for structures in salt-water employing steel components and will usually lead to failure in 2 to 3 years unless excessively heavy steel couplers are used.



1. Collision Damage (0.0/0.2). A tire mat properly coupled is a highly resilient and strong structure. Due to its inherent flexibility, an FTB is unlikely to significantly damage a boat during a collision. Likewise, it is highly improbable that most boats could significantly hurt an FTB. There are two known instances of boats colliding with an FTB. In the first case, during a severe storm at night, a small occupied sailboat making for a harbor of refuge ran atop the FTB. The only damage which resulted was a bent propeller shaft. In the second case, a reckless and alleged drunken boater rammed his power cruiser against an FTB. The only damage which resulted was black tire marks on the boat's white hull. In both instances, witnesses claim that the FTBs probably saved boaters' lives--in the first case, the occupants of the sailboat; in the second case, people onboard their boats within the protected marina.

To circumvent collision problems, some FTBs are marked with fluorescent cones and others on freshwater have flashing lights installed. Several operators felt that this latter requirement, posed by the Coast Guard in certain inland waterways, was unnecessary and needlessly expensive.

### 2. Effectiveness in Suppressing Waves.

On a scale of zero (i.e., ineffective) to four (i.e., excellent), the operators gave the Goodyear design an average effectiveness rating of 2.8, a high level of performance. More than 80 percent of the users indicated that the FTB reduced storm wave heights by 50 percent or more. While the values assigned to this physical reduction of wave height may be suspect, the overall satisfaction of the operators with their FTBs' capabilities is not.

One of the indicators of an FTB's likely effectiveness in reducing wave height is the ratio of the structure's beam to the length of an incident wave. In theory and as borne out in model tests, as this ratio increases (i.e., as the FTB spans more and more of the wavelength), the effectiveness of the structure likewise improves. To determine if this trend was substantiated by field experiences, MRM plotted the reported transmission coefficients versus the beam to estimated wavelength ratios (see Fig. 2). While there is considerable scatter in the points, the trend is clear as illustrated by a line fitted by the least squares method. This trend agrees with theory. Generally speaking, those FTBs which were most successful were located at sites with reported conditions such that the FTB's beam equaled or exceeded 60 percent of the length of a typical storm wave (see Harms, 1979)<sup>2</sup>.

### 3. Cost and Additional Benefits.

The cost of a Goodyear FTB can vary substantially from site to site, depending on the coupling material used, the reserve flotation provided, the anchoring-mooring system deployed, and the labor available. However, based on the data, some indications of relative cost per square meter (and per square foot) of surface area are possible by separately examining saltwater and freshwater sites. For projects located in saltwater, total construction and installation costs varied from \$9.59/m<sup>2</sup> (\$0.89/ft<sup>2</sup>) to \$44.50/m<sup>2</sup> (\$4.13/ft<sup>2</sup>) with an

---

<sup>2</sup>HARMS, V.W., "Data and Procedures for the Design of Floating Tire Breakwaters," New York Sea Grant Program, Albany, N.Y., 1979.

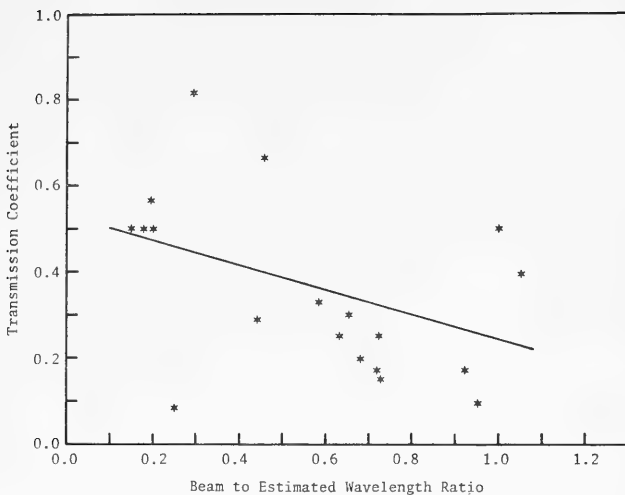

Figure 2. Reported effectiveness of the Goodyear FTB as a function of the ratio of the structure's beam to the estimated length of an incident storm wave.

average cost of \$26.87/m<sup>2</sup> (\$2.50/ft<sup>2</sup>). For freshwater sites, ignoring two extreme cases, total project costs varied from \$6.01/m<sup>2</sup> (\$0.56/ft<sup>2</sup>) to \$15.03/m<sup>2</sup> (\$1.40/ft<sup>2</sup>) with an average cost of \$10.28/m<sup>2</sup> (\$0.96/ft<sup>2</sup>). The two extreme cases included an FTB project with a rigid pier and dock built atop the structure for an overall cost of \$109.62/m<sup>2</sup> (\$10.18/ft<sup>2</sup>) and a city-funded FTB project with unusually high material and labor costs for a final cost of \$141.96/m<sup>2</sup> (\$13.19/ft<sup>2</sup>). This disparity in costs between saltwater and freshwater sites is logical, because the saltwater FTBs usually must withstand much more severe weather, corrosion, and fouling growth conditions.

Additional considerations in the cost of an FTB project are the leadtime required to obtain a permit for its installation and the design life of the structure. While these data are not included in the summary sheets, MEM did obtain information on these subjects from the operators. The length of time required for FTB builders to secure a Corps permit varied from 1 to 13 months. The average leadtime required was 5 months. In many cases, the cost incurred was considered negligible and is factored into the total cost estimates given above. The design life of the FTB was variously estimated from 3 to 30 years. The average design life was 13 years. For the four cases where final removal occurred, the disposal cost varied from \$2.16/m<sup>2</sup> (\$0.20/ft<sup>2</sup>) to \$6.31/m<sup>2</sup> (\$0.59/ft<sup>2</sup>) in 1980 dollars. The average disposal cost was \$4.88/m<sup>2</sup> (\$0.45/ft<sup>2</sup>). A final cost consideration is the maintenance required of an FTB. Little uniform data were available on this matter from the surveys and no general guidelines can be drawn at this time. Reported annual maintenance costs varied between 2.2 percent and 18.2 percent of total construction cost illustrating the wide discrepancy in routine maintenance practices.

Side benefits accruing from an effective FTB were many and included:

- (a) Substantial savings in maintenance to the protected facility;
- (b) increased boat-launching and haul-out periods in the spring and the fall;
- (c) additional dockage, thereby increasing revenues and stimulating boat sales and rental of slips;
- (d) fewer broken moorings and runaway boats during severe storms;
- (e) improved public relations for the protected facility;
- (f) improved boaters' comfort; and
- (g) improved boating safety.

In addition to serving as a breakwater, the Goodyear design occasionally did double duty, functioning in such diverse roles as a pier and dock, a boat traffic controller, a shoreline protection device, a movable breakwater temporarily used for a sailboat show across a bay, and a fish reef. Operators also noted that an FTB is effective in attracting sport fish to the site, preventing shoreline erosion, and drawing waterfowl away from their facilities. Overall, the FTB was seen as having no perceptible effect on sediment movement, unless positioned in very shallow water would it influence littoral transport or water circulation, and was typically viewed as being only slightly detrimental to waterfront appearance. Of the 17 sites surveyed, typical evaluations of the Goodyear design were in the range of moderate to high in terms of the structure's ability to meet design goals, capacity to satisfy the operator's needs, and overall performance.

### III. OTHER FLOATING BREAKWATER DESIGNS

Five FB designs radically different from the Goodyear concept were uncovered in the survey of FBs in the Eastern United States. These designs are the pole-tire FB (Fig. 3), the timber caisson FB (Fig. 4), the steel pipe FB (Fig. 5), the steel caisson FB (Fig. 6), and the log boom FB (Fig. 7). In all five cases, only one site was found for each design; consequently, there is no substantial statistical base from which to draw general conclusions.

The pole-tire FB and the timber caisson FB are both in the prototypal stage as of this writing, with less than 1 year of field experience each. These innovative designs certainly bear further scrutiny over the next several years to learn of their long-term problems and merits. The utility of the steel pipe FB appears totally constrained to freshwater sites; even then, its performance is questionable due to basic problems with its mooring system. Likewise, the steel caisson FB appears to be restricted in usefulness to freshwater sites. Also, it has an exceptionally high construction cost. The more historically used log boom FB is certainly a more frequent design than this study would suggest, but as testified by many case studies before this report, the log boom's usefulness appears limited to sites with but slight wave problems. In all these cases, readers are directed to the site-specific analyses in the appendixes to more fully understand the characteristics of these systems.

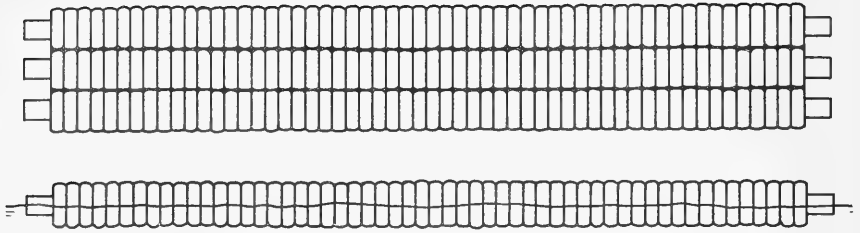

Figure 3. Pole-tire FB--top and side view of single module (scale - 1:84).

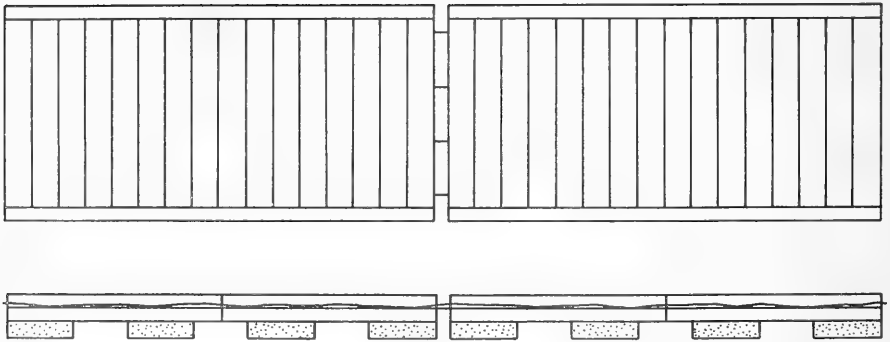

Figure 4. Timber caisson FB--top and side view of two connected modules (scale - 1:78).

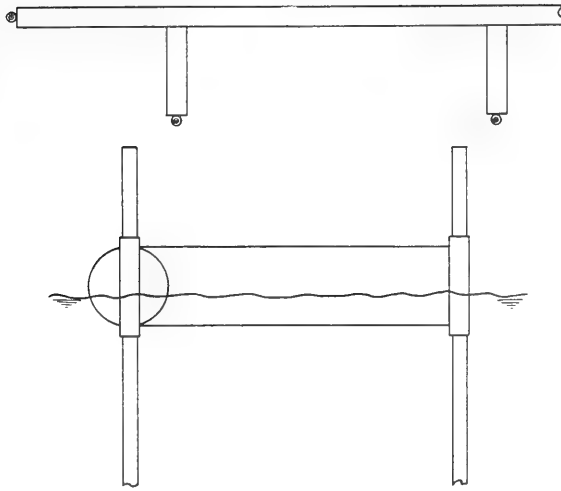

Figure 5. Steel pipe FB--top view of far section (scale - 1:156) and side view (scale - 1:40).

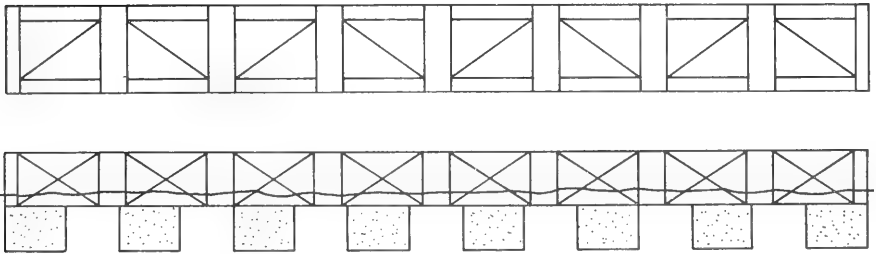

Figure 6. Steel caisson FB--top and side view of single module (scale - 1:78).



Figure 7. Log boom FB--side view of far section (scale - 1:62).

#### IV. CONCLUSIONS AND RECOMMENDATIONS

The first conclusion drawn from examining the field experiences is that design information in this field is not being properly disseminated. Too many of the Goodyear FTBs built in the late seventies employed construction techniques and materials determined to be ineffective several years earlier. Regardless of who shares the blame, whether designer, permit agency, or researcher, this fact is inescapable and has needlessly caused much money and effort to be wasted. A comprehensive, updated FTB bibliography is available free from the URI Marine Advisory Service, Narragansett Bay Campus, Narragansett, Rhode Island, 02882.

The successful field experiences thus far seem to indicate that an FTB should employ conveyor belting for coupling and nylon or galvanized bolts in saltwater or freshwater, respectively, for fastening. Reserve flotation should rely on poured polyurethane foam for both freshwater- and saltwater-based designs. Trapped air may provide sufficient buoyancy, however, for short-term or noncontinuous uses. Most conventional mooring systems are adequate if the site conditions are fully understood. Unfortunately, conventional anchoring systems have been shown to fail in several cases, indicating that a more conservative design approach is required.

Siting must be done judiciously. Few floating structures can be expected to survive in a terribly exposed position or where currents are incredibly strong. Once in place, an FB will cast a cone-shaped shadow of protection largely dictated by its length. Designers must take into account the ability of waves to diffract around the ends of an FB and designate a length which will ensure protection to the entire facility. Similarly, designers must realize that an FB's beam is functionally related to the length of the waves the structure is able to suppress. Based on the survey data, a better than a 50-percent reduction should not be expected in wave height of any incident wave two or more times the width of the FB. Again, a thorough understanding of offshore conditions and access to current state-of-the-art information are necessary for a designer to develop an effective breakwater.

A professional attitude should also be taken in the construction, installation, and operation of an FB. Volunteer labor was occasionally cited as poor quality and inconsistent work. A paid work force, while more expensive than volunteers, may save the operator money in the long run. Once installed, an FB should be regularly maintained. This maintenance must include monitoring the structure and immediate correction of faults. With the exception of severe storm conditions, there are usually reliable indicators of when an FB is about to fail. Good maintenance will discover such signals and provide the avenue for saving the structure.

When the above factors are adequately taken into consideration, field experiences indicate that an FB can act as a highly effective breakwater and can also pass along added benefits to the operator. These conditions appear most easily met in freshwater where the environment is not as harsh as that found in saltwater. Nonetheless, as technology has advanced, the FB has proven itself more capable in saltwater. However, the operator must fully realize that even under the best of conditions, an FB is only a temporary structure relative to a fixed rubble-mound breakwater. This aspect of transiency demands that an operator maintain the structure and account for its eventual disposal. Too often,

FBs were left unattended after installation, only to dismally fail. Survey after survey reinforces this point and it must not be overlooked.

On the basis of the case histories, it is apparent that several aspects of the FB designs are still not well understood and demand further research. These topics include:

(a) Foam flotation systems, inasmuch as no comprehensive tests have been carried out on flotation materials;

(b) mooring forces, since conventional anchoring systems seem to fail;

(c) fouling growth weight calculations;

(d) alternative FTB designs to improve upon the Goodyear FTB's wave suppression capability;

(e) long-term operational problems experienced by FBs, as opposed to the short-term problems uncovered in this work; and

(f) theoretical hydrodynamics governing the motion of flexible FBs and their modes of wave suppression.





APPENDIX A

FIELD EXPERIENCES: GOODYEAR FLOATING TIRE BREAKWATER

## LITTLE BAY FLOATING BREAKWATER - NEWINGTON, NEW HAMPSHIRE

Breakwater Type: Goodyear FTB

Operational Life: The breakwater was constructed in 1975 and is still in operation.

Contact: John Poole  
10 Cote Drive  
Dover, NH  
(603) 749-1631

Builder: J. Paul Griffin  
Great Bay Marina, Inc.  
Fox Point Road  
Newington, NH 03801  
(603) 436-5299

Operator: Same as contact

### Site Details

Water and Bottom Conditions: The structure is located in saltwater above a gently sloping bottom composed of mud and silt. Depth at mean low water is 2.4 m (8.0 ft). The tidal range is 2.9 m (9.5 ft).

Exposure: The site is exposed from the northwest with a fetch of 1.2 km (0.6 nmi).

Typical Storm Conditions: During a typical storm, prevailing winds are from the northwest with speeds between 55 km/hr (30 kn) and 90 km/hr (49 kn). Storm waves are between 0.6 m (2.0 ft) and 0.9 m (3.0 ft) in height. On the average, such storms occur 10 times per year.

Worst Storm Conditions: During a worst storm on an average year, winds will be from the northwest with speeds of 120 km/hr (65 kn). Seas will be from 0.9 m (3.0 ft) to 1.2 m (4.0 ft) high.

Currents and Ship Waves: The maximum current speed at the site is 9.7 km/hr (5.2 kn). Waves generated by passing boats represent an occasional problem to the site. Such waves are between 0.3 m (1.0 ft) and 0.6 m (2.0 ft) high.

Ice: Flowing ice causes damage to the facility in the winter.

### Breakwater Details

Purpose: This breakwater protects a marina and boatyard located in Newington, New Hampshire. Originally, the FTB was specifically intended to extend

the launching and haul-out periods for the marina by 2 to 3 weeks in the spring and the fall. The breakwater is in operation from April to December and is swung up against the shoreline when not in use. A fixed rubble-mound breakwater is also located at the site.

**Design Source:** The builder utilized design literature from the University of New Hampshire and the University of Rhode Island.

**Construction:** This FTB is 45.7 m (150.0 ft) in length and 6.4 m (21.0 ft) in width. Flotation relies on air trapped in the tire crowns and is aided by polyethylene blocks inserted in some of the tires. Rubber conveyor belting fastened with nylon bolts is used to couple the tires.

**Site:**

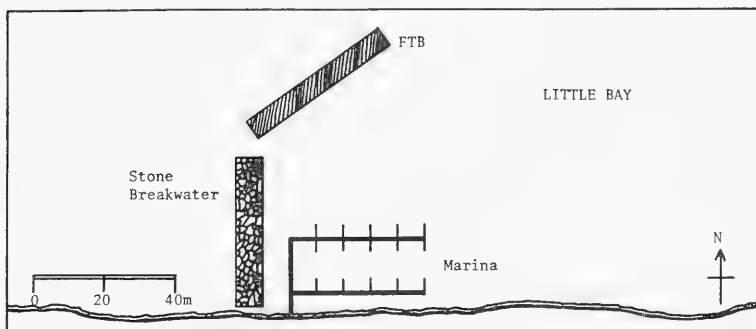

**Installation:** The breakwater is fastened at its southern tip to the fixed stone breakwater, elsewhere it is anchored in place. Seven anchoring points are located around the perimeter of the breakwater. The anchors are 1,589-kg (3,500 lb) stone blocks. Mooring lines are of nylon/chain.

**Special Equipment:** Orange traffic cones are situated atop the FTB to warn boaters of its presence.

### Field Experience

**Operation:** Numerous problems have been encountered in the operation of this breakwater. Litter entrapment is cited as an extreme problem. Fouling growth and inadequate buoyancy are regarded as major problems. To improve flotation which originally relied solely on trapped air, the operator later inserted polyethylene blocks into the tires. Because this repair was done while the FTB was in the water, it was a very difficult task with few blocks actually installed and little improvement made. The operator acknowledges the inadequacy of the present flotation system and notes that a much better one is needed. Anchoring system and mooring-line failures are considered moderate problems. On several instances, the anchors have dragged under strong wave and current action. Structural failure is cited as a moderate problem and instability as a minor one. Coupling failure is also considered a minor problem. Under typical storm conditions with

waves 0.8 m (2.5 ft) in height and 6.1 m (20.0 ft) in estimated length, the transmission coefficient is 0.40.

**Maintenance:** Scheduled maintenance includes winter storage of the FTB and occasionally cleaning the structure of fouling growth, an undertaking which the operator notes is very difficult.

**Benefits:** The operator rated the breakwater as having a positive effect on preventing shoreline erosion and on increasing boaters' comfort. He regarded the FTB as having a negative effect on waterfront appearance. The operator rated the breakwater as providing excellent performance in suppressing waves and moderate performance in meeting design goals and satisfying his needs. Overall performance was rated moderate.

**Fouling Characteristics:** A variety of marine life inhabits the structure including mussels, crabs, seagulls, and muskrats.

**Project Analysis:** The operator's analysis of this project appears exact. This FTB is a good wave suppressor; otherwise, it is providing but moderate performance. Inadequate buoyancy is the key problem. Although poured polyurethane foam is the best flotation system presently available, this was not the case in 1975. Anchoring system failure is also understandable considering the extreme tidal currents encountered at the site. Perhaps mushroom anchors should have been used instead of stone blocks, so that some additional resistance is met when the structure starts to shift. Finally, the specific purpose should be noted that was originally assigned this FTB--to extend the launching and haul-out periods of the marina during poor early spring and late fall weather. In this capacity, the breakwater met design goals perfectly.

## LITTLE HARBOR FLOATING BREAKWATER - GUILFORD, CONNECTICUT

Breakwater Type: Goodyear FTB

Operational Life: The breakwater was constructed in 1977 and, after incurring severe storm damage in 1978, was reconstructed in 1979. This second unit was destroyed by a hurricane in that same year.

Contact: Sarah W. Richards  
Little Harbor Laboratory  
69 Andrews Road  
Guilford, CT 06437

Builder: Same as contact

Operator: Same as contact

### Site Details

Water and Bottom Conditions: The structure is located in saltwater above a level bottom composed of sand, silt and mud. Depth at mean low water is 3.7 m (12.0 ft). The tidal range is 1.8 m (6.0 ft).

Exposure: The site is exposed from the southeast through the southwest with a fetch of 56 km (30 nmi).

Typical Storm Conditions: During a typical storm, prevailing winds are from the northeast or from the southeast through the southwest with speeds between 45 km/hr (24 kn) and 65 km/hr (35 kn). Storm waves are from 1.2 m (4.0 ft) to 1.5 m (5.0 ft) in height. Generally, such storms occur from four to five times per year.

Worst Storm Conditions: During a worst storm on an average year, winds will be from the northeast or from the southeast through the southwest and will reach 115 km/hr (62 kn). Seas will be 1.8 m (6.0 ft) high.

Currents: The maximum current speed at the site is 0.8 km/hr (0.4 kn).

Ice: Both stationary and flowing ice causes damage to the facility in the winter.

### Breakwater Details

Purpose: This breakwater protected an anchorage used by a marine research laboratory in Guilford, Connecticut. This facility is operated year round. The breakwater was in operation from March to December and was stored inside the protected harbor when not in use. Two stone breakwaters are also present at the site.

Design Source: The builder utilized design literature from the University of Rhode Island.

Construction: This FTB is 137.2 m (450.0 ft) in length and 9.1 m (30.0 ft) in width. The original structure relied on polyethylene blocks inserted in the tire crowns for proper flotation. After reconstruction, the breakwater relied on polyethylene scrap sealed in the tires by wire mesh and polyurethane foam for adequate buoyancy. Rubber conveyor belting fastened by nylon bolts was used to couple the tires. The operator noted that punching holes in the conveyor belting and tightening the belts was difficult.

Site:

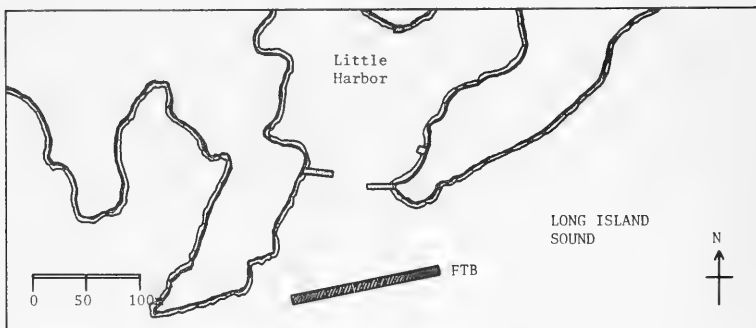

Installation: The first structure was moored to fourteen 23 kg (50 lb) danforth anchors with ten anchors positioned on the exposed side and four on the leeward side. Mooring lines were of nylon/chain and were 27.4 m (90.0 ft) in length. The reconstructed FTB was moored by a system including eight 91 kg (200 lb) danforth anchors, eight 227-kg (500 lb) cement blocks, one 726-kg (1,600 lb) Navy stockless anchor, and one 908-kg (2,000 lb) Navy stockless anchor. Each anchor was also fitted with 6.1 m (20.0 ft) of one inch steel link chain, weighing 91 kg (200 lb). Mooring lines were of 0.75-inch nylon and were 27.4 m (90.0 ft) long.

Special Equipment: Two fiberglass light buoys were situated near the FTB to warn boaters of its presence.

### Field Experience

Operation: Anchoring system failure posed extreme problems to the survival of the breakwater (see *Severe Storm Effects*). Fouling growth was also considered an extreme problem resulting in inadequate buoyancy as a major problem. The flotation systems were relatively unsuccessful. The first attempt, relying on inserted polyethylene logs, failed totally with the logs coming loose and washing away under moderate wave action. The second system fared better, though the brittle polyurethane foam would break under severe wave action and allow the polyethylene scrap to escape. This result was particularly noticeable on the outer tires. Litter entrapment was viewed as a moderate problem. Structural failure, interference with boating traffic, and coupling failure were all cited as minor problems. Under typical storm conditions with waves 1.7 m (5.5 ft) in height and 31.9 m (104.5 ft) in estimated length, the transmission coefficient was 0.82.

**Maintenance:** Scheduled maintenance included removing entrapped debris and inspecting the couplings.

**Severe Storm Effects:** The first anchoring system failed in September 1978 under 46-km/hr (25 kn) southwesterly winds producing waves 1.2 m (4.0 ft) high. All anchors dragged and the tire mat ended up on the easterly stone groin. For recovery, the FTB had to be cut out in small sections. One year later, the breakwater with its second anchoring system encountered Hurricane David and survived admirably. Under David, winds were from the south to southeast and reached 139 km/hr (75 kn). However, 10 days later, Hurricane Frederic arrived and the anchoring system failed. Sustained winds from the southwest in excess of 93 km/hr (50 knots) for a period of several hours were noted at the site. Waves were 1.8 m (6.0 ft) to 2.4 m (8.0 ft) high. The moorings gave way sequentially with the danforth anchors and cement blocks dragging first and finally the mooring pennants to the two massive Navy stockless anchors parting. The FTB again ended up on the stone groin.

**Cost:** The construction cost of this FTB was \$21,000 including the modifications later made. Planning and engineering costs were \$6,300 and installation costs were \$17,337. These figures translate to a cost of \$44.50/m<sup>2</sup> (\$4.13/ft<sup>2</sup>) for the latest design in 1980 dollars. Disposal cost of the breakwater in 1979 was \$2,375.

**Benefits:** The operator felt that the breakwater had a positive effect on drawing birds away from the facility. She felt the FTB had a negative effect on waterfront appearance and boaters' comfort. She also noted that there was a decline in the commercial catch of fish in the vicinity of the structure that was not seen elsewhere. The operator rated the FTB as providing poor performance in suppressing waves, meeting design goals, and satisfying her needs. Overall performance was rated poor to ineffective.

**Fouling Characteristics:** A variety of marine life inhabited the structure including seaweed, barnacles, sponges, sea-squirts, starfish, snails, mussels, crabs, other shellfish, seagulls, ducks, terns, and other birds. The operator further noted that the dry weight of fouling growth found on each tire was 54.5 kg ± 28.1 kg (120 lb ± 62 lb). She also reported sighting dogs on the FTB.

**Project Analysis:** The Little Harbor FTB highlights the troubles which may be encountered by improper siting. In this case, the site was too exposed for any inexpensive anchoring system to survive. A very massive and costly anchoring system would have been required to survive the seas experienced at the harbor entrance. Inadequate buoyancy was the second major problem with the structure relying on outdated or experimental flotation systems. Whether poured polyurethane foam could survive the severe wave conditions and extreme fouling growth is unknown, though it is expected to fare better than the composite system tried. One important feature of this case history is the total lack of coupling problems despite the stresses placed on the FTB. The rubber conveyor belting couplers fastened by nylon bolts took incredible punishment and seldom gave way. The final bolt failure rate was from 3 to 4 percent over the 2 years of operation.

## NARRAGANSETT BAY FLOATING BREAKWATER - JAMESTOWN, RHODE ISLAND

Breakwater Type: Goodyear FTB

Operational Life: The breakwater was constructed in 1975, sunk, then refloated in 1977, and is still in operation.

Contact: William Munger  
Conanicut Marina  
10 Ferry Wharf  
Jamestown, RI 02835  
(401) 423-1556

Builder: Same as contact

Operator: Same as contact

### Site Details

Water and Bottom Conditions: The structure is located in saltwater above a gently sloping bottom composed of sand. Depth at mean low water is 7.6 m (25.0 ft). The tidal range is 1.2 m (4.0 ft).

Exposure: The site is exposed from the northeast through the southeast with a fetch of 4.8 km (2.6 nmi).

Typical Storm Conditions: During a typical storm, prevailing winds are from the east with speeds around 55 km/hr (30 kn). Storm waves are 0.9 m (3.0 ft) high. On the average, such storms occur six times per year.

Worst Storm Conditions: During a worst storm on an average year, winds will be from the east through the southeast with speeds in excess of 95 km/hr (51 kn). Seas will be 1.5 m (5.0 ft) high.

Currents and Ship Waves: The maximum current speed at the site is 3.2 km/hr (1.7 kn). Waves generated by passing ships represent an occasional and potentially damaging problem to the facility. Such waves are typically 0.9 m (3.0 ft) high.

Ice: Flowing ice is present in the winter, though poses no problem to the facility.

### Breakwater Details

Purpose: This breakwater protects a marina located in Jamestown, Rhode Island. This facility is operated from the spring through the fall. The breakwater is in operation year round and is the singular means of wave protection for the facility. During its first 2 years of operation, this FTB also served as a breakwater for an annual boat show held across



the bay. In this capacity, it was twice towed over to the facility, where it remained for a month each time, before being returned to the Jamestown, site.

**Design Source:** The builder utilized design literature from the University of Rhode Island.

**Construction:** This FTB is 61.0 m (200.0 ft) long and 3.7 m (12.0 ft) wide. Primary flotation originally relied on air trapped in the tire crowns. After sinking in 1977, the FTB was retrofitted with polyethylene blocks inserted in the tires. Rubber conveyor belting fastened by nylon bolts is used to couple the tires. Rope is used to couple the modules.

**Site:**

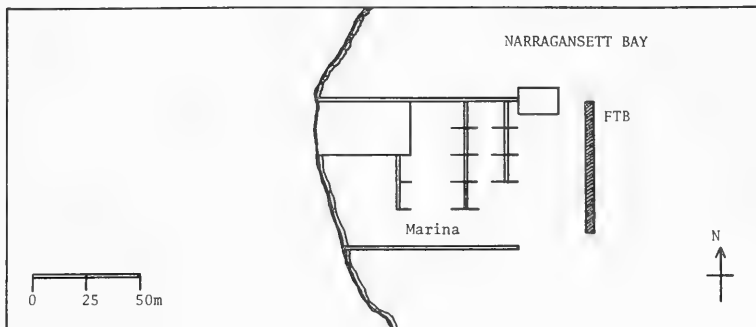

**Installation:** The breakwater is anchored to four 908-kg (2,000 lb) concrete blocks spaced evenly along the structure's exposed side. Mooring lines are of chain and are 22.9 m (75.0 ft) in length.

### Field Experience

**Operation:** Inadequate buoyancy is cited as a major problem and fouling growth as a moderate one. Together, these problems were most vividly apparent in 1977 when the structure sank. Since then, polyethylene blocks have been added, though this still has not fully resolved the problem. Structural failure with strands of modules breaking loose due to rope failure is considered a minor problem. Interference with boating traffic and litter entrapment are also regarded as minor problems. Under moderate wind conditions, around 25 km/hr (14 kn), with waves 0.3 m (1.0 ft) in height and 3.9 m (12.8 ft) in estimated length, the transmission coefficient is 0.10.

**Maintenance:** Scheduled maintenance consists of blowing compressed air into the structure three to four times per year.

**Severe Storm Effects:** During an exceptionally bad storm in October 1980, winds reached 113 km/hr (61 kn) and seas were very rough. Under these conditions, the FTB provided no effective protection to the facility, but suffered no damage itself.

Cost: The total construction cost for this breakwater was \$5,600 divided as follows: \$500 for materials, \$2,500 for labor, \$100 for legal fees and permits, \$500 for planning and engineering and \$2,000 for installation. This figure translates to a cost of \$35.80/m<sup>2</sup> (\$3.33/ft<sup>2</sup>) in 1980 dollars. Annual routine maintenance costs \$150 for material and \$800 for labor.

Benefits: The annual savings in maintenance to the facility was estimated at \$500. The operator felt the breakwater had a positive effect in attracting sportfish and drawing birds away from his facility. He also rated the structure as having a negative effect on waterfront appearance. He rated the FTB as providing moderate performance in suppressing waves and meeting design goals, and as completely ineffective in satisfying his needs. Overall performance was rated moderate.

Fouling Characteristics: A variety of marine life inhabits the structure including seaweed, barnacles, sea-squirts, starfish, snails, mussels, geese, seagulls, ducks, terns, and other birds.

Project Analysis: Given the opportunity to rebuild the structure, the operator noted that he would improve the flotation system and construct a wider mat. His suggestions are quite insightful. The present flotation system is inadequate and too expensive to maintain. Polyurethane foam poured into the tire crowns would perform much better than the few blocks of polyethylene now in place. A wider tire mat would make the breakwater more effective in suppressing long waves. Presently, the FTB removes the chop off short, steep waves and performs poorly in storm conditions. A larger FTB would also give more satisfaction to the operator for it would extend the shadow of protection across the entire facility and not permit waves to diffract into the marina. The use of rope as the intermodule coupling material has also been a problem. It should be noted though that when first built, this breakwater's design life was 3 years. It was intended as a very temporary and highly portable structure, though this latter condition should not have affected the quality of its construction. Through the operator's perseverance, the FTB has continued in operation and given reasonable service.

## POCASSET HARBOR FLOATING BREAKWATER - CATAUMET, MASSACHUSETTS

Breakwater Type: Goodyear FTB

Operational Life: The breakwater was first constructed in 1976 and then reconstructed in 1980. It is still in operation.

Contact: T.W. Kingman  
Cataumet Marina, Inc.  
Shipyard Lane  
Cataumet, MA 02534  
(617) 563-7136

Builder: Same as contact

Operator: Same as contact

### Site Details

Water and Bottom Conditions: The breakwater is located in saltwater above a level bottom composed of silt. Depth at mean low water is 2.4 m (8.0 ft). The tidal range is 1.2 m (4.0 ft).

Exposure: The site is exposed from the northwest through the southwest with a fetch of 1.8 km (1.0 nmi).

Typical Storm Conditions: During a typical storm, prevailing winds are from the northwest through the southwest with speeds from 30 km/hr (16 kn) to 80 km/hr (43 kn). Storm waves will be 0.3 m (1.0 ft) in height and above. Generally, such storms occur from one to twenty times per year.

Worst Storm Conditions: During a worst storm on an average year, winds will be from the southwest and will reach 140 km/hr (76 kn). Seas will be 1.8 m (6.0 ft) high.

Currents: The maximum current speed at the site is 1.6 km/hr (0.9 kn).

Ice: Stationary ice causes damage to the facility in the winter.

### Breakwater Details

Purpose: This breakwater protects a marina and boatyard located in Cataumet, Massachusetts. This facility is operated from the spring through the fall. The breakwater is in operation year round and is the singular means of wave protection for the facility. The breakwater also served as a test project for the University of Rhode Island.

Design Source: The builder utilized design literature from the University of Rhode Island.

Construction: This FTB is 17.1 m (56.0 ft) in length and 6.4 m (21.0 ft) in width. Originally, the breakwater relied on trapped air for flotation and on a variety of experimental materials, including rope, chain, and stainless-steel cable, for coupling. This structure lasted approximately 2 years before the couplings failed and flotation became a major problem. The reconstructed unit uses rubber conveyor belting fastened with nylon bolts as the coupling material. Polyurethane foam poured into the tire crowns now provides primary flotation. The only problem encountered in constructing the breakwater was difficulty in drilling through the belting.

Site:

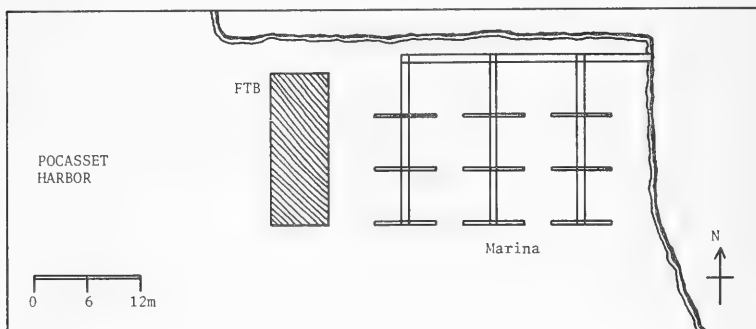

Installation: The breakwater is anchored by five 909-kg (2,000 lb) concrete blocks. Three of the anchors are positioned on the exposed side of the structure and two on the leeward side. Mooring lines are of nylon/chain and are 4.3 m (14.0 ft) in length.

### Field Experience

Operation: Inadequate buoyancy and coupling failure posed major problems to the original FTB. Since reconstruction, the breakwater has performed admirably with no problems experienced. Under typical storm conditions with waves 0.9 m (3.0 ft) in height and 8.9 m (29.2 ft) in estimated length, the transmission coefficient is 0.17.

Maintenance: Scheduled maintenance consists of inspecting the couplings and moorings.

Severe Storm Effects: During an unusually severe winter storm in 1976, winds from the southwest reached 154 km/hr (83 kn). Seas were 1.8 m (6.0 ft) high. The operator noted that the breakwater was highly effective in suppressing the swells and prevented any damage from being done to his docks. He estimated that from \$6,000 to \$7,000 in potential damage was averted by the FTB.

Cost: The original construction cost in 1976 was \$1,000. Reconstruction cost in 1980 was \$2,000; this cost does not include the reused moorings.

These figures translate to an overall cost of \$21.33/m<sup>2</sup> (\$1.98/ft<sup>2</sup>) for the present breakwater. Annual routine maintenance costs \$100, primarily for labor.

**Benefits:** The estimated annual savings in maintenance to the facility is from \$1,000 to \$6,000. The operator cited the breakwater as having a positive effect on boaters' comfort. The operator rated the FTB as providing excellent performance in suppressing waves, meeting design goals, and satisfying his needs. Overall performance was rated excellent.

**Fouling Characteristics:** A variety of marine life inhabits the structure including seaweed, barnacles, sea-squirts, mussels, crabs, and other shellfish. The operator further noted that clam and quahog seed grows profusely in the tires, and oyster seed thrives outside the tires.

**Project Analysis:** While this project has not had enough time to fully validate the conjecture that rubber conveyor belting fastened with nylon bolts and polyurethane foam are the best coupling and flotation materials, it does strongly point in that direction. The metal couplers corroded and failed and rope rotted and failed. Trapped air did not provide sufficient buoyancy after fouling growth became substantial. It is predicted that this new unit, built according to the state-of-the-art, should fare well and continue to provide excellent performance to the operator.

## SANTA ROSA SOUND FLOATING BREAKWATER - PENSACOLA BEACH, FLORIDA

Breakwater Type: Goodyear FTB

Operational Life: The breakwater was constructed in 1976 and removed in 1978.

Contact: Chris Jones  
336 Weil Hall  
University of Florida  
Gainesville, FL 32611  
(904) 392-2460

Builder: Charles A. Gifford  
Baseline, Inc.  
Pensacola, FL 32502

Operator: Same as builder

### Site Details

Water and Bottom Conditions: The structure was located in saltwater above a gently sloping bottom composed of sand. Depth at mean low water is 0.9 m (3.0 ft).

Exposure: The site is exposed from the northeast and from the northwest with a fetch of 4.8 km (2.6 nmi) in each direction.

Typical Storm Conditions: During a typical storm, waves are from 0.6 m (2.0 ft) to 0.9 m (3.0 ft) in height.

Worst Storm Conditions: During a worst storm on an average year, winds will reach speeds in excess of 95 km/hr (51 kn). Seas will be 1.5 m (5.0 ft) high.

### Breakwater Details

Purpose: This breakwater protected the shoreline of a residence located in Pensacola Beach, Florida. The FTB was specifically intended to interact with the littoral transport and accumulate sand in its shadow of protection. This project was supported by the Florida Sea Grant Program.

Design Source: The builder utilized design literature from the University of Rhode Island.

Construction: This FTB was 30.5 m (100.0 ft) in length and 6.7 m (22.0 ft) in width. This breakwater differed from the standard Goodyear design in that large truck tires were used as the connecting tires between the modules. At low tide when the FTB would strand, the truck tires would keep most of the tire mat off the sea floor and therefore prevent sand from accumulating

in the tire bases. Holes, 1.5-inch diameter, were drilled in the truck tire bases to prevent sand from accumulating in them. It was also hoped that the high sidewalls of the larger tires would aid in keeping out sand. Because the tires were substantially exposed at low tide, flotation relied solely on air trapped in the tire crowns. Rubber conveyor belting coupled the tires and was fastened by tying the end of the belting into square knots.

Site:

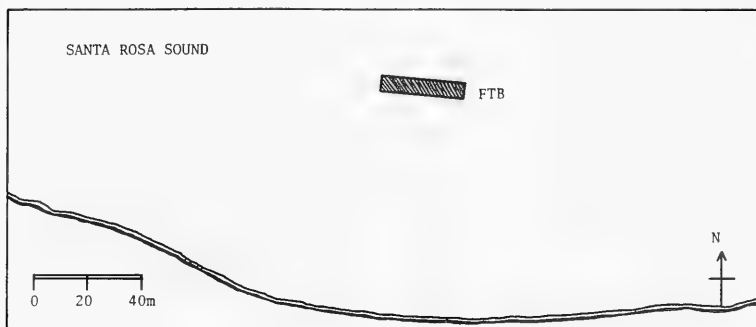

Installation: The breakwater was moored by six 11 kg (25 lb) danforth anchors placed at each corner and in the middle of each end. The mooring lines were of 0.5-inch nylon and were 9.1 m (30.0 ft) in length.

### Field Experience

Operation: Coupling failure was a moderate problem with approximately 10 percent of the square knots untying. To solve this problem, the operator fastened the loose ends of the square knots together by means of galvanized lag screws. Mooring-line failure was a minor problem due to the nylon lines chafing. To resolve this problem, the operator led the mooring lines through flexible plastic tubing at points where they were wrapped around the tires. The steps taken to prevent sand accumulation in the tire bases worked overall. The truck tires would occasionally ratchet around under heavy wave action with some rotating to the point where the hole was above the waterline thereby releasing trapped air. However, this problem was not severe and adequate buoyancy was always maintained. Finally, fouling growth was a moderate problem with a considerable weight buildup noted. Under typical storm conditions with waves 0.8 m (2.5 ft) in height and 10.2 m (33.5 ft) in estimated length, the transmission coefficient was 0.30. The operator believed that the extra rigidity of this FTB because of the use of truck tires was an important factor in achieving such a low transmission coefficient.

Benefits: The FTB performed admirably in its design role of accumulating sand in its shadow of protection. During the project's brief life, accretion built a 6.1-m (20.0 ft) sand point along the length of the breakwater. No effect was observed on the neighboring shorelines. The operator noted

that a significant parameter affecting the capacity of a breakwater to influence littoral transport is the ratio of the length of the structure to the distance offshore. For this project, this ratio was 1:2.75. This breakwater provided excellent performance in suppressing waves, meeting design goals, and satisfying the operator's needs. Overall performance may also be considered excellent.

**Fouling Characteristics:** A variety of marine life inhabited the structure including barnacles, tube-building worms, oysters, crustaceans and small fish. The operator noted that a few of the oyster seed reached three inches in 6 months and over half had done so by 9 months. He also observed the transitory appearance of rooted submerged grasses in the wave shadow, in spite of severe cold.

**Project Analysis:** This case history illustrates a second potential use of floating breakwaters, that of restricting sediment movement. In this capacity, the FTB appeared to work well. Tying the belting into square knots was a needless difficulty which the operator later discovered. The efforts to prevent sand accumulation in the tire bases were innovative, though the use of truck tires to keep the structure off the bottom was probably the sole reason for the project's success in this regard. The holes in the tire bases could have easily been plugged by fouling growth and, as noted by the operator, the tires would rotate and turn this feature of the design against itself. Whether trapped air was a sufficient flotation system is unclear since the project's life was too short to determine the side effects of the fouling growth in time. Nonetheless, it was a well thought-out design and highly successful for its duration.



## SPRING POINT FLOATING BREAKWATER - SOUTH PORTLAND, MAINE

Breakwater Type: Goodyear FTB

Operational Life: The breakwater was constructed in 1980 and is still in operation.

Contact: Bob Soucy  
Port Harbor Marine, Inc.  
231 Front Street  
South Portland, ME 04106  
(207) 767-3254

Builder: Same as contact

Operator: Same as contact

### Site Details

Water and Bottom Conditions: The structure is located in saltwater above a gently sloping bottom composed of silt. Depth at mean low water is 3.0 m (10.0 ft). The tidal range is 6.1 m (20.0 ft).

Exposure: The site is exposed from the northeast with a fetch of 12.9 km (7.0 nmi).

Typical Storm Conditions: During a typical storm, prevailing winds are from the northeast with speeds between 45 km/hr (24 kn) and 65 km/hr (35 kn). Storm waves are from 0.9 m (3.0 ft) to 1.2 m (4.0 ft) in height. On the average, such storms occur four times per year.

Worst Storm Conditions: During a worst storm on an average year, winds will be from the southeast and will reach 80 km/hr (43 kn). Seas will be from 1.2 m (4.0 ft) to 1.5 m (5.0 ft) high.

Currents and Ship Waves: The maximum current speed at the site is 0.8 km/hr (0.4 kn). Waves generated by passing boats represent a nuisance problem to the boaters using the facility. Such waves are typically 0.6 m (2.0 ft) high.

Ice: Stationary ice causes damage to the facility in the winter.

### Breakwater Details

Purpose: This breakwater protects a marina located in South Portland, Maine. This facility is operated from the spring through the fall. The breakwater is in operation year round and is the singular means of wave protection for the facility. The FTB also serves as a means for boat traffic control.

Design Source: The builder utilized design literature from the University of Rhode Island.

Construction: This FTB is 243.8 m (800.0 ft) in length with half the structure 10.7 m (35.0 ft) wide and the remainder 6.4 m (21.0 ft) wide. Primary flotation relies on air trapped in the tire crowns. Rubber conveyor belting fastened by bolts is used to couple the tires.

Site:

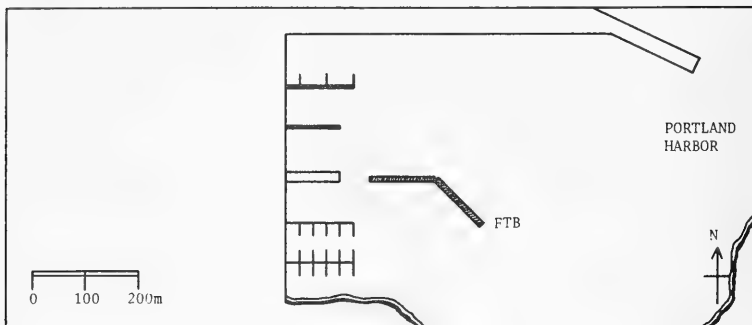

Installation: The breakwater is tied to pilings by rubber conveyor belting. On the structure's exposed side, the pilings are spaced 15.2 m (50.0 ft) apart and on its leeward side, 30.5 m (100.0 ft) apart.

### Field Experience

Operation: Piling failure posed the first moderate problem to the operation of this new breakwater. In response, the operator removed the old pilings, drove new ones and added greater slack in the mooring connections between the modules and the pilings. Ice damage to the pilings contributed to this failure and represents a minor problem. Fouling growth is also considered a moderate problem, resulting in minor trouble with buoyancy. Under typical storm conditions with waves 0.9 m (3.0 ft) in height and 18.5 m (60.7 ft) in estimated length, the transmission coefficient is 0.33.

Maintenance: Scheduled maintenance consists of checking for sunken tires each month.

Cost: The total construction cost for this breakwater was \$20,000. This figure translates to a cost of \$9.59/m<sup>2</sup> (\$0.89/ft<sup>2</sup>). Repairs due to storm damage over the past year required \$2,000.

Benefits: The operator felt that the breakwater had a positive effect on boaters' comfort and on drawing birds away from his facility. He also noted that the structure had improved public relations for the marina. He rated the FTB as providing moderate performance in suppressing waves, meeting design goals, and satisfying his needs. Overall performance was rated moderate.

**Fouling Characteristics:** A variety of marine life inhabits the structure including seaweed, barnacles, mussels, seagulls, ducks, and terns.

**Project Analysis:** The present problems with the pilings will probably be overcome by the operator's attention and efforts to remedy the trouble. With such a large tidal range, the site effectively required such an anchoring system. Unfortunately, a much more severe problem lies ahead due to the fouling growth. Already in 1 year of operation, fouling growth is a moderate problem and inadequate buoyancy a minor one. Without any reserve flotation, the FTB will be dragged under by the barnacles and the mussels in all likelihood. To circumvent this end, the operator will either have to regularly shoot compressed air into the structure or reconstruct the FTB with foam flotation.

## STUART CAUSEWAY FLOATING BREAKWATER - MARTIN COUNTY, FLORIDA

Breakwater Type: Goodyear FTB

Operational Life: The breakwater was constructed in 1979 and, after incurring severe storm damage, was reconstructed in 1980. This second unit sank in that same year.

Contact: James L. Garland  
Chief, Engineering Division  
Jacksonville District  
U.S. Army Corps of Engineers  
P.O. Box 4970  
Jacksonville, FL 32232  
(904) 791-2204

Builder: William R. Gehring  
Florida Institute of Technology  
1707 Northeast Indian River Drive  
Jensen Beach, FL  
(305) 334-4200 33457

Operator: Same as contact

### Site Details

Water and Bottom Conditions: The structure was located in saltwater above a gently sloping bottom composed of sand. Depth at mean low water is 1.2 m (4.0 ft). The tidal range is 0.4 m (1.2 ft).

Exposure: The site is exposed from the southeast with a fetch of 4.2 km (2.3 nmi).

Typical Storm Conditions: During a typical storm, prevailing winds are from the southeast with speeds around 50 km/hr (27 kn). Storm waves are 0.5 m (1.5 ft) high. On the average, such storms occur twice per month.

Worst Storm Conditions: During a worst storm on an average year, winds will be from the southeast and will reach 115 km/hr (62 kn). Seas will be 0.6 m (2.0 ft) high.

Ship Waves: Waves generated by passing boats represent a frequent problem to the site and erode the shoreline.

### Breakwater Details

Purpose: This breakwater was a shoreline erosion control demonstration project conducted by the U.S. Army Corps of Engineers in Martin County, Florida.

**Design Source:** The builder utilized design literature from the University of Rhode Island.

**Construction:** The first unit was 118.9 m (390.0 ft) in length and 6.1 m (20.0 ft) in width. Primary flotation relied on polyethylene blocks inserted in the tire crowns. The tires were coupled by polypropylene rope. The reconstructed structure was also 118.9 m (390.0 ft) in length, but only 4.0 m (13.0 ft) in width. Primary flotation was derived from polyurethane foam poured into the tire crowns. Steel cable, 3/8-inch diameter, was used to couple the tires.

**Site:**

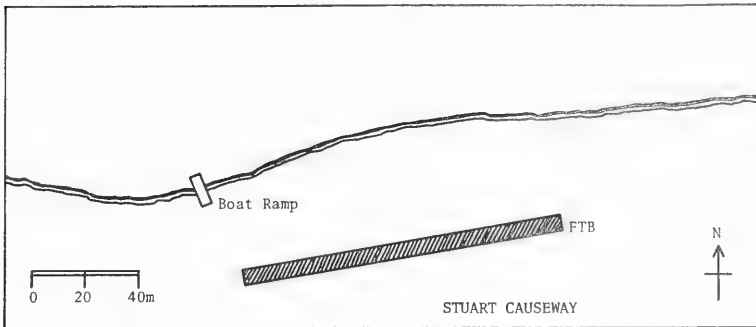

**Installation:** The original structure was moored to 10 danforth anchors. Seven anchors were spaced evenly along the exposed side of the FTB and three were spaced uniformly on the leeward side. Mooring lines were of 3/8-inch steel cable and were 9.1 m (30.0 ft) long. The second breakwater used the same mooring configuration and same type of mooring line, but employed tiedown-type helix anchors in place of the danforths.

**Special Equipment:** Four 1-inch-diameter PVC pipes, each 1.2 m (4.0 ft) high, were painted with fluorescent red stripes and positioned atop the FTB to act as navigational markers.

### Field Experience

**Operation:** Anchoring system failure was cited as a major problem for the original FTB (see *Severe Storm Effects*), as was structural failure. This latter trouble was the result of the polypropylene rope failing. Fouling growth and inadequate buoyancy were also cited as major problems for both structures. Litter entrapment was considered a moderate problem and corrosion and instability were regarded as relatively minor problems. Given the chance to rebuild the breakwater, the operator would place additional foam in the tire crowns and punch holes in the tire bases to prevent silt from accumulating. Under typical storm conditions with waves 0.6 m (2.0 ft) in height and 9.0 m (29.5 ft) in estimated length, the transmission coefficient was 0.20.

Maintenance: No routine maintenance was scheduled.

Severe Storm Effects: In September 1979, Hurricane David passed over the project area. Winds reaching 145 km/hr (78 knots) were sustained for nearly 2 hours. Seas were from 0.6 m (2.0 ft) to 0.8 m (2.5 ft) high. Under these conditions, the anchoring system eventually failed and the tire mat was dragged ashore.

Cost: The original construction cost was \$12,500 divided as follows: \$3,000 for materials, \$6,000 for labor, \$1,000 for legal fees and permits, \$1,500 for planning and engineering, and \$1,000 for installation. Rebuilding the FTB in 1980 was an additional \$10,000. These figures translate to an overall cost of \$23.13/m<sup>2</sup> (\$2.15/ft<sup>2</sup>) for the latest design. Disposing of the sunken structure was \$3,000.

Benefits: The operator rated the structure as having a strongly beneficial effect on sportfishing and bird habitation. In its primary role as a shoreline protection device, the FTB was considered as having a positive effect on both sediment movement and shoreline erosion. It is interesting to note that its length to distance offshore ratio was 1:0.36, indicating that its influence on littoral transport should have been very strong. Finally, the operator regarded the breakwater as having a negative effect on waterfront appearance. He rated the FTB as providing high performance in suppressing waves and meeting design goals, and providing moderate performance in satisfying his needs. Overall performance was rated moderate.

Fouling Characteristics: A variety of marine life inhabited the structure including seaweed, barnacles, oysters, crabs, seagulls, terns, and other birds.

Project Analysis: The primary fault with this project was the use of outdated design literature. Several years before this project began, it was known that polypropylene rope and steel cable were poor couplers. Likewise, it was known that inserted polyethylene blocks seldom held fast and usually provided insufficient buoyancy to balance heavy fouling growth. The eventual sinking of the structure testifies to this--that both accumulated sand and extreme fouling growth overcame the flotation system. More poured foam should have been used, in addition to the structure being placed farther out from shore. Based on the case history of the Santa Rosa Sound FTB, it would appear probable that the breakwater could still protect the shoreline in somewhat deeper water where sand accumulation would not have been so severe. Finally, it should be noted that the lack of regular maintenance precluded any chance of relieving the structure of its problems and signaled the unfortunate demise of the project.

## BARCELONA HARBOR FLOATING BREAKWATER - WESTFIELD, NEW YORK

Breakwater Type: Goodyear FTB

Operational Life: The breakwater was constructed in 1979 and sank that same year. It was removed in 1980.

Contact: Donald Q. Eno  
20 South Gale Street  
Westfield, NY 14787  
(716) 326-3404

Builder: Barcelona Harbor Commission  
Town of Westfield  
23 Elm Street  
Westfield, NY 14787  
(716) 326-3211

Operator: Same as builder

### Site Details

Water and Bottom Conditions: The structure was located in freshwater above a level bottom composed of silt. Depth at mean low water is 2.1 m (7.0 ft). The seasonal water depth range is 0.9 m (3.0 ft).

Exposure: The site is exposed from the northwest through the northeast with a fetch of 80.5 km (43.4 nmi).

Typical Storm Conditions: During a typical storm, prevailing winds are from the northwest through the northeast with speeds in excess of 25 km/hr (13 kn). Storm waves are from 0.6 m (2.0 ft) to 1.5 m (5.0 ft) in height. On the average, such storms occur eight times per year.

Worst Storm Conditions: During a worst storm on an average year, winds will be from the northwest and will reach 65 km/hr (35 kn). Seas will be 1.8 m high.

Ice: Stationary ice causes damage to the facility in the winter.

### Breakwater Details

Purpose: This breakwater protects a marina, anchorage and boat ramp located in Westfield, New York. This facility is operated from the spring through the fall. The breakwater is in operation year round. Two fixed steel breakwaters are also present at the site. The FTB was intended to dampen waves reflected by the fixed breakwaters.

Design Source: The builder utilized design literature from the New York Sea Grant Program and the Goodyear Tire and Rubber Company.

**Construction:** This FTB was 61.0 m (200.0 ft) in length and 17.1 m (56.0 ft) in width. Primary flotation relied on air trapped in the tire crowns. Rubber conveyor belting fastened by bolts was used to couple the tires. A volunteer work force was used to build the breakwater and this resulted in inconsistent and poor-quality construction.

**Site:**

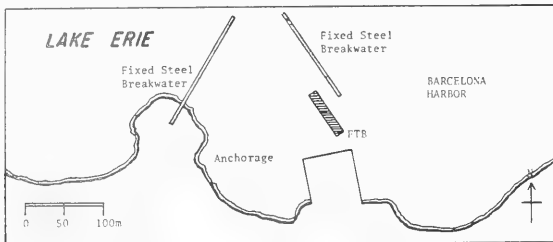

**Installation:** The breakwater was anchored to 1,634-kg (3,600 lb) concrete blocks. On the structure's exposed side, the blocks were spaced 4.3 m (14.0 ft) apart and on its leeward side, 8.5 m (28.0 ft) apart. Mooring lines were of chain and were 12.2 m in length.

### Field Experience

**Operation:** Inadequate buoyancy was an extreme problem, as was litter entrapment. Presumably, large amounts of silt were trapped in the tire bases and this factor, when combined with the nominal flotation available, caused the sinking of the structure. Fouling growth was cited as a moderate problem. Finally, a host of troubles were listed as being relatively minor and inconsequential problems. These included structural failure, collision damage, interference with boating traffic, ice damage, anchoring system failure, mooring-line failure, and coupling failure. Under typical storm conditions with waves 1.2 m (4.0 ft) in height and 17.0 m (55.8 ft) in estimated length, the transmission coefficient was 0.50.

**Cost:** Construction materials cost \$8,000; labor cost was \$2,000. Installation was an additional \$500. These figures translate to an overall cost of \$11.46/m<sup>2</sup> (\$1.06/ft<sup>2</sup>) in 1980 dollars. Disposing of the FTB was \$5,000.

**Benefits:** The operator regarded this project as a completely negative experience. He felt the FTB was totally ineffective in suppressing waves, meeting design goals, and satisfying his needs. Overall performance was rated ineffective.

**Project Analysis:** Obviously, this project had severe buoyancy problems. Reserve flotation, such as that provided by poured polyurethane foam, should have been included. Maintenance should also have been scheduled. In this case, the most effective maintenance would have been regularly blowing compressed air into the structure. One interesting observation by the operator was the poor craftsmanship seen resulting from the use of volunteers, indicating the advantages of a paid, professional work force.



## CHIPPEWA BAY FLOATING BREAKWATER - HAMMOND, NEW YORK

Breakwater Type: Goodyear FTB

Operational Life: The breakwater was constructed in 1978 and is still in operation.

Contact: William H. Schermerhorn  
Schermerhorn Boat Sales, Inc.  
RD #2  
Box 42  
Hammond, NY 13646  
(315) 324-5966

Builder: Same as contact

Operator: Same as contact

### Site Details

Water and Bottom Conditions: The structure is located in freshwater above a level bottom composed of mud. Depth at mean low water is 2.0 m (6.5 ft). The seasonal water depth range is 0.9 m (3.0 ft).

Exposure: The site is exposed from the west with a fetch of 1.6 km (0.9 nmi).

Typical Storm Conditions: During a typical storm, prevailing winds are from the west with speeds around 50 km/hr (27 kn). Storm waves are 0.6 m (2.0 ft) in height. Such storms occur frequently during the spring and the fall.

Worst Storm Conditions: During a worst storm on an average year, winds will be from the west and will reach 80 km/hr (43 kn). Seas will be from 1.2 m (4.0 ft) to 1.5 m (5.0 ft) high.

Currents and Ship Waves: The maximum current speed at the site is 6.4 km/hr (3.5 kn). Waves generated by boats traversing the St. Lawrence River represent a frequent and potentially damaging problem to the site. Such waves are typically 0.3 m (1.0 ft) high.

Ice: Both stationary and flowing ice are present at the site in the winter.

### Breakwater Details

Purpose: The breakwater protects a marina located in Hammond, New York. This facility is operated from the spring through the fall. The breakwater is in operation year round and is the singular means of wave protection for the facility.

Design Source: The builder utilized design literature from the New York Sea Grant Program.

Construction: This FTB is 91.4 m (300.0 ft) in length and 1.8 m (6.0 ft) in width. Flotation relies solely on air trapped in the tire crowns. Rubber conveyor belting fastened with stainless-steel bolts is used to couple the tires.

Site:

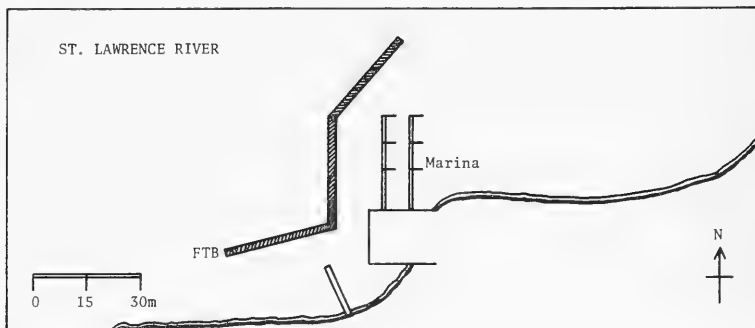

Installation: The breakwater is tied to pilings by conveyor belting on its leeward side and anchored on its exposed side. The pilings are spaced 3.0 m (10.0 ft) apart. The anchors are 227-kg (500 lb) concrete blocks and are spaced 7.6 m (25.0 ft) apart. Anchor lines are of chain and are 6.1 m (20.0 ft) long. The builder noted that transporting the breakwater from its inland construction site to the water was a very difficult undertaking.

Special Equipment: Red and green navigational lights and daymarkers are installed on the structure as per local Coast Guard requirements. On his own initiative, the builder placed flashing white lights between the colored navigational lights to further deter possible collisions.

### Field Experience

Operation: Litter entrapment is considered a major problem by the operator. Inadequate buoyancy is cited as a moderate problem. Given the opportunity to rebuild, the operator would fill the tires with polyurethane foam to improve flotation. Ice damage and fouling growth are both minor problems. Under typical storm conditions with waves 0.6 m (2.0 ft) in height and 7.4 m (24.3 ft) in estimated length, the transmission coefficient is 0.08.

Maintenance: Scheduled maintenance consists of occasionally lifting the tires to retrap air.

Severe Storm Effects: During an exceptionally bad storm in April 1979, some of the tires sank and it was necessary to lift them out of the water to capture air and refloat them. Nonetheless, the FTB successfully

suppressed the storm waves and prevented the destruction of a boathouse and two docks.

**Benefits:** It is estimated that several thousand dollars is saved in annual maintenance to the protected facility due to the structure. The operator rated the FTB as having a positive effect on sport fishing, shoreline erosion, drawing birds away from his facility, and boaters' comfort. He felt that the structure had a negative effect on water circulation. He rated the breakwater as providing excellent performance in suppressing waves and in satisfying his needs. Overall performance was rated excellent.

**Fouling Characteristics:** While not intended as such, the FTB acts as an effective fish reef for pan fish. Seagulls, ducks, and blue herons also inhabit the structure.

**Project Analysis:** This FTB appears to be a success though it does possess some flaws. As the respondent wisely notes, flotation could be improved by the addition of foam in the tires. The shallow site may also be contributing to this buoyancy problem due to silt accumulating in the tire bases. Shooting compressed air into the tires may pose a less intense and expensive solution to present maintenance which consists of physically hauling the tires above the water's surface. The use of stainless steel bolts as fasteners was unnecessary for a freshwater site, with galvanized steel bolts being a less expensive alternative. The reported transmission coefficient is incredibly low; however, the respondent's satisfaction with his FTB nor its general effectiveness as a breakwater cannot be questioned.

## DALE HOLLOW LAKE FLOATING BREAKWATER - CELINA, TENNESSEE

Breakwater Type: Goodyear FTB

Operational Life: The breakwater was constructed in 1980 and is still in operation.

Contact: Ronald Roberts  
Cedar Hill Resort  
Route #1  
Celina, TN 38551  
(615) 243-2254

Builder: Same as contact

Operator: Same as contact

### Site Details

Water and Bottom Conditions: The structure is located in freshwater above a steeply sloping bottom composed of mud and bedrock. Depth at mean low water is 10.7 m (35.0 ft). The seasonal water depth range is 6.1 m (20.0 ft).

Exposure: The site is exposed from the east through the southeast with a fetch of 3.2 km (1.7 nmi).

Typical Storm Conditions: During a typical storm, prevailing winds are from the southeast through the south with speeds around 25 km/hr (14 kn). Storm waves are from 0.3 m (1.0 ft) to 0.6 m (2.0 ft) in height. Such storms occur from five to six times per year.

Worst Storm Conditions: During a worst storm on an average year, winds will be from the southeast through the south and will reach 70 km/hr (38 kn). Seas will be 0.6 m (2.0 ft) high or greater.

Ship Waves: Waves generated by passing boats represent a frequent and damaging problem to the facility. Such waves are typically between 0.3 m (1.0 ft) and 0.6 m (2.0 ft) high.

### Breakwater Details

Purpose: This breakwater protects a marina and anchorage located in Celina, Tennessee. This facility is operated year round as is the breakwater. The structure represents the only means of wave protection available to the facility.

Design Source: The builder relied upon design information supplied by the U.S. Army Corps of Engineers.

Construction: This FTB is 30.5 m (100.0 ft) in length and 1.8 m (6.0 ft) in width. Flotation relies on air trapped in the tire crowns. Nylon strapping fastened by banding clamps is used to couple the tires.

Site:

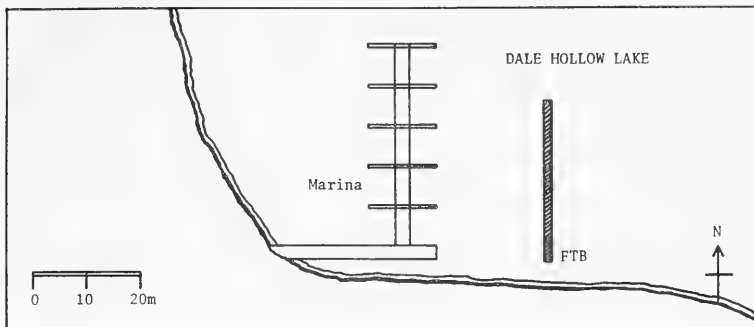

**Installation:** The breakwater is moored by two anchors located at the extreme ends of the structure. Each anchor is a 55-gallon drum filled with concrete. The mooring lines are of wire rope and are 24.4 m (80.0 ft) in length.

### Field Experience

**Operation:** A host of problems are listed as infrequently occurring, but all are considered minor problems of little consequence. These problems include instability, structural failure, collision damage, interference with boating traffic, inadequate buoyancy, anchoring system failure, mooring-line failure, coupling failure, and litter entrapment. Under typical storm conditions with waves 0.5 m (1.5 ft) in height and 9.0 m (29.5 ft) in estimated length, the transmission coefficient is 0.50.

**Maintenance:** Scheduled maintenance consists of periodically inspecting the FTB and replacing broken bands.

**Cost:** The total construction cost for this breakwater was \$330. This figure translates to a cost of  $\$6.01/\text{m}^2$  ( $\$0.56/\text{ft}^2$ ). Annual maintenance costs are estimated to be \$60, covering mostly labor.

**Benefits:** The operator felt that the breakwater had a positive effect on boaters' comfort, adding that he now has much fewer maintenance problems with his marina. He regarded the FTB as having a negative effect on waterfront appearance. The operator also rated the breakwater as providing high performance in suppressing waves, meeting design goals, and satisfying his needs. Overall performance was rated high.

**Project Analysis:** It is likely that the problem of coupling failure will increase in magnitude dramatically in the next 2 years. Under moderate wave action, FTBs coupled with nylon strapping have been known to fail due to the banding chafing, fraying, and finally failing. Because site conditions are modest and maintenance includes checking the strapping, it is possible that this problem can be sidestepped, but this is still unlikely. In other respects, the project should fare well since the site is relatively tame.

## DIVERSEY HARBOR FLOATING BREAKWATER - CHICAGO, ILLINOIS

Breakwater Type: Goodyear FTB

Operational Life: The breakwater was constructed in 1978 and removed that same year.

Contact: Chicago Park District  
425 East McFetridge Drive  
Chicago, IL 60605  
(312) 294-2260

Operator: Same as contact

### Site Details

Water and Bottom Conditions: The structure was located in freshwater above a level bottom composed of sand. Depth at mean low water is 6.1 m (20.0 ft). The seasonal water depth range is 1.2 m (4.0 ft).

Exposure: The site is exposed from the northeast with a fetch of 362.0 km (195.5 nmi).

Typical Storm Conditions: During a typical storm, prevailing winds are from the northeast through the east with speeds around 80 km/hr (43 kn). Storm waves are from 1.2 m (4.0 ft) to 2.4 m (8.0 ft) in height. Generally, such storms occur from two to three times per year.

Worst Storm Conditions: During a worst storm on an average year, winds will be from the northeast through the east and will reach 95 km/hr (51 kn). Seas will be 2.4 m (8.0 ft) high.

Ice: Flowing ice causes damage to the facility in the winter.

### Breakwater Details

Purpose: This breakwater protected a marina and yacht club located in Chicago, Illinois. This facility is operated in the summer. The breakwater was intended to be in operation year round. It was specifically intended to knock down tall storm waves to less than 0.6 m (2.0 ft) in height. Fixed groins and jetties were also present at the site.

Design Source: The builder utilized design literature from the Goodyear Tire and Rubber Company.

Construction: This FTB was 91.4 m (300.0 ft) in length and 8.5 m (28.0 ft) in width. Primary flotation was derived from both polystyrene blocks inserted in the tire crowns and polyurethane foam poured into some of the tires. Chain fastened by clamps was used to couple the tires.

Site:

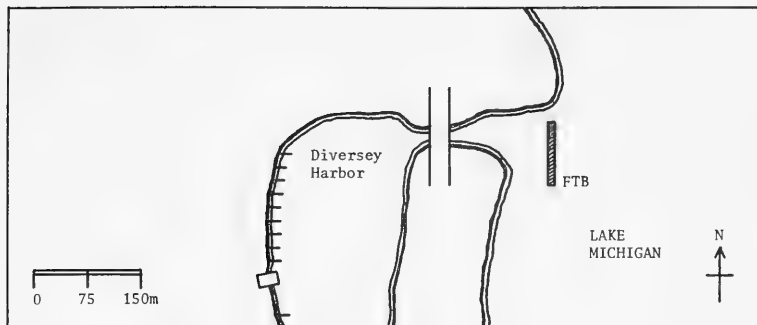

**Installation:** The breakwater was anchored by twenty 1,226-kg (2,700 lb) concrete blocks. On the structure's exposed side, the anchors were spaced 7.6 m (25.0 ft) apart and on its leeward side, 15.2 m (50.0 ft) apart. Mooring lines were of chain and were 10.4 m (34.0 ft) in length.

**Special Equipment:** Two navigational lights were installed at each end of the structure and a daymarker was placed in the center.

### Field Experience

**Operation:** Inadequate buoyancy and sand accumulation in the tire bases were extreme problems resulting in the partial submergence of the structure within a few months of its installation. The operator noted that the polystyrene was damaged by gasoline on the water and believed that the polyurethane foam absorbed water. Anchoring system failure (see *Severe Storm Effects*) and instability were both regarded as major problems. Structural failure was cited as a moderate problem and mooring-line failure was considered a minor problem. During moderate wind conditions with waves 0.9 m (3.0 ft) in height and 18.5 m (60.7 ft) in estimated length, the transmission coefficient was 0.67. Under worst lake conditions, the FTB was considerably less effective with the operator noting that a much wider tire mat was needed.

**Maintenance:** No scheduled maintenance was conducted during the brief deployment of the FTB.

**Severe Storm Effects:** During the first major storm encountered, the FTB was dragged from its position, indicating a totally inadequate mooring system. The breakwater was also ineffective in significantly reducing the height of the swells. Inasmuch as these conditions were the design conditions and the FTB exhibited no effectiveness, the structure was permanently removed.

**Cost:** The construction materials cost \$30,000; labor cost was \$60,000. Planning and engineering fees were an additional \$1,000. These figures translate to an overall cost of \$141.96/m<sup>2</sup> (\$13.19/ft<sup>2</sup>) in 1980 dollars.

On a per square meter basis, this FTB is the most expensive structure documented. Final disposal costs were \$4,000.

Benefits: The operator rated the breakwater as being totally ineffective in suppressing waves, meeting design goals, and satisfying his needs. Overall performance was rated ineffective.

Project Analysis: Of all the projects surveyed, this breakwater is probably the greatest failure. Its cost was immense and its operational life was a brief half year. The project's major fault lay in its siting. Being exposed to the diagonal width of Lake Michigan, the FTB experienced very harsh lake conditions. A truly massive anchoring system would have been required to survive the storms and a very wide tire mat needed to significantly affect the waves. The flotation system should also have been improved by using conveyor belting as the coupler instead of heavy chain and by exclusively using polyurethane foam. It is doubted that this foam can substantially become waterlogged, but this uncertainty does point up the need for research on foam flotation systems. Routine maintenance should also have been scheduled, including regularly blowing compressed air into the structure. Finally, because this is a freshwater site with but moderate fouling growth problems, punching holes in the tire bases may have alleviated some of the sand accumulation problem.



## DUNKIRK HARBOR FLOATING BREAKWATER - DUNKIRK, NEW YORK

Breakwater Type: Goodyear FTB

Operational Life: The breakwater was constructed in 1975, reconstructed in 1976 and removed in 1979.

Contact: Michael J. Bednar  
Director of Public Works  
City of Dunkirk  
City Hall  
Dunkirk, NY 14048

Builder: Same as contact

Operator: Same as contact

### Site Details

Water and Bottom Conditions: The structure was located in freshwater above a gently sloping bottom composed of sand and silt. Depth at mean low water is 1.2 m (4.0 ft).

Exposure: The site is exposed from the northwest through the northeast with a fetch of 1.6 km (0.9 nmi).

Typical Storm Conditions: During a typical storm, prevailing winds are from the northwest through the north with speeds between 65 km/hr (35 kn) and 80 km/hr (43 kn). Storm waves are 2.1 m (7.0 ft) high. Generally, such storms occur from two to three times per year.

Worst Storm Conditions: During a worst storm on an average year, winds will be from the northwest and will be in excess of 80 km/hr (43 kn). Seas will be 2.4 m (8.0 ft) high or greater.

Currents: The maximum current speed at the site is 24.1 km/hr (13.0 kn).

### Breakwater Details

Purpose: This breakwater protected marinas and yacht clubs located in Dunkirk, New York. The facilities were operated in the summer. The breakwater was in operation year round. A bottom-resting offshore breakwater is also present at the site, as well as a submerged inner wall. This FTB was specifically intended to act as a temporary structure for 3 years until fixed rubble mound breakwaters could be erected.

Design Source: The builder utilized design literature from the New York Sea Grant Program and the Goodyear Tire and Rubber Company.

**Construction:** The original FTB was 182.9 m (600.0 ft) in length and 8.5 m (28.0 ft) in width. This FTB's flotation relied solely on air trapped in the tire crowns. Stainless-steel wire was used as the coupling material. When reconstructed, the FTB was extended to 304.8 m (1,000.0 ft) in length. Polyethylene blocks were inserted in the tires to aid flotation and open link Campbell chain replaced the stainless-steel wire.

**Site:**

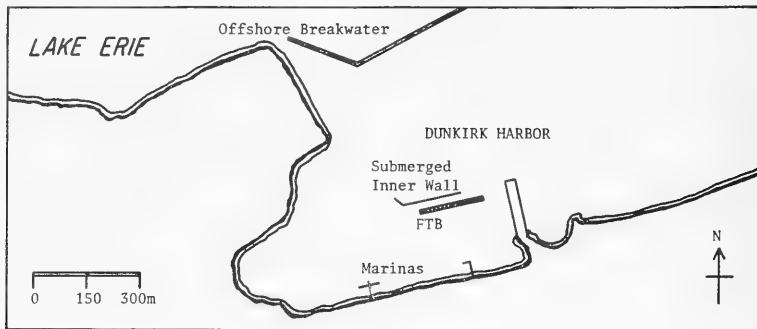

**Installation:** The breakwater was initially anchored by 24 cylindrical-shaped 272-kg (600 lb) cement blocks. These were found to roll on the bottom during strong wave action and so were replaced by a like number of rectangular-shaped cement blocks. Mooring lines were of chain and were 19.5 m (64.0 ft) in length.

### Field Experience

**Operation:** Litter entrapment was cited as a major problem. Anchoring system and mooring-line failures were regarded as moderate problems. Much of this trouble was solved by using rectangular-shaped blocks instead of cylindrical weights. Coupling failure, structural failure, and instability were all cited as moderate problems. Presumably, these all reflect the quick failure of cable as a coupler and the steady failure of chain as its replacement. Fouling growth and inadequate buoyancy were both considered minor problems. Under typical storm conditions with waves 2.4 m (8.0 ft) in height and 17.1 m (56.0 ft) in estimated length, the transmission coefficient was 0.50.

**Maintenance:** Scheduled maintenance consisted of regularly inspecting the structure and realining it when necessary.

**Cost:** For the reconstructed FTB, the coupling materials cost \$5,228 while the mooring system components cost \$2,880. Navigational lights and buoys cost \$5,860. Total labor costs were \$2,650. These figures translate to an overall cost of \$8.59/m<sup>2</sup> (\$0.80/ft<sup>2</sup>) in 1980 dollars.

**Benefits:** The breakwater was seen as having a positive effect on attracting

sport fish and drawing birds away from the protected facilities. The harbormaster cited the FTB as also having a positive effect on boaters' comfort. This effect was most vividly apparent by an immediate increase in slip rentals and transient boaters visiting the harbor. In meeting its design goals, the FTB had a high performance.

Project Analysis: This project met with considerable success despite some severe flaws in its coupling, flotation, and anchoring systems. The success which was achieved is testimony to the City's persistence in correcting the faults and constantly monitoring the structure. The coupling material should have been rubber conveyor belting fastened by galvanized steel bolts. Proper flotation would have been met if polyurethane foam had been poured in most of the tire crowns. The final anchoring system used appeared adequate, particularly since lake conditions were partially dampened by the submerged inner wall before interacting with the FTB. The harbormaster's observation of increased revenues as the end result of the project was an important one, for it does illustrate that an FTB can bring in money, in addition to reducing repair costs to wet-stored boats. Finally, this case history highlights a valuable use of this type of breakwater--as a temporary structure before a permanent breakwater can be planned and installed. In this capacity, the FTB was most successful.

## KEEWAYDIN POINT FLOATING BREAKWATER - ALEXANDRIA BAY, NEW YORK

Breakwater Type: Goodyear FTB

Operational Life: The breakwater was constructed in 1979 and is still in operation.

Contact: Laurence Geoghegan  
1000 Islands State Park Commission  
Keewaydin State Park  
Alexandria Bay, NY 13607

Builder: James Becker  
1000 Islands State Park Commission  
Keewaydin State Park  
Alexandria Bay, NY 13607

Operator: Same as builder

### Site Details

Water and Bottom Conditions: The structure is located in freshwater above a gently sloping bottom composed of bedrock. Depth at mean low water is 5.5 m (18.0 ft). The seasonal water depth range is 0.8 m (2.5 ft).

Exposure: The site is exposed from the north with a fetch of 0.4 km (0.2 nmi).

Typical Storm Conditions: During a typical storm, prevailing winds are from the northwest with speeds around 40 km/hr (22 kn). Storm waves are 0.9 m (3.0 ft) in height. Generally, such storms occur six or more times per year.

Worst Storm Conditions: During a worst storm on an average year, winds will be from the northeast and will reach 80 km/hr (43 kn). Seas will be 1.2 m (4.0 ft) high.

Currents and Ship Waves: The maximum current speed at the site is 16.1 km/hr (8.7 kn). Waves generated by ships and boats traversing the St. Lawrence River represent a frequent and potentially damaging problem to the site. Such waves are typically 0.6 m (2.0 ft) high.

Ice: Both stationary and flowing ice causes damage to the facility in the winter.

### Breakwater Details

Purpose: This breakwater protects a marina located in Alexandria Bay, New York. This facility is operated from the spring through the fall. The breakwater is in operation year round and is the singular means of wave

protection for the facility. The FTB also serves as a means for boat traffic control.

**Design Source:** The builder utilized design literature from the New York Sea Grant Program and the Goodyear Tire and Rubber Company.

**Construction:** This FTB is 121.9 m (400.0 ft) in length and 5.9 m (19.5 ft) in width. Primary flotation is derived from polyurethane foam poured into the crowns of the tires. Rubber conveyor belting fastened with nylon bolts is used to couple the tires. The only problem encountered in the design stage was the public's reluctance to accept the project due to their anticipation that the FTB would have an unsightly effect on the waterfront. The operator noted that this bias vanished once the structure was deployed.

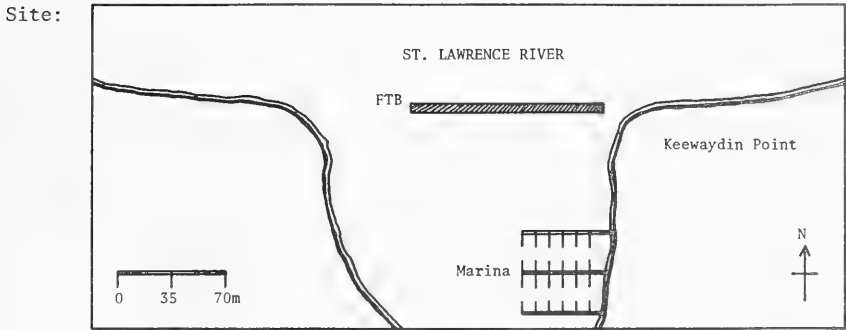

**Installation:** The breakwater is tied to pilings on both its exposed and sheltered sides and anchored also on its leeward side. The pilings are spaced 18.3 m (60.0 ft) apart. The anchors are 136-kg (300 lb) concrete blocks and are spaced 15.2 m (50.0 ft) apart. Mooring lines are of chain and are 30.5 m (100.0 ft) in length.

**Special Equipment:** A blinking green navigational light and a daymarker are installed as per local Coast Guard requirements. White blinking lights are placed on each outside piling, as well as fluorescent red traffic cones between pilings.

### Field Experience

**Operation:** Fouling growth and litter entrapment pose minor problems to the operation of this breakwater, otherwise the structure performs admirably. Under typical storm conditions with waves 0.9 m (3.0 ft) in height and 6.4 m (21.0 ft) in estimated length, the transmission coefficient is 0.17.

**Maintenance:** Scheduled maintenance includes checking the fastenings, removing entrapped debris, and replacing batteries in the blinking lights.

Cost: The total construction cost for this breakwater was \$9,500 in 1979.  
This figure translates to a cost of \$15.03/m<sup>2</sup> (\$1.40/ft<sup>2</sup>) in 1980 dollars.

Benefits: The estimated annual savings in maintenance to the marina is \$5,000. The operator rated the breakwater as having a positive effect on sport fishing and on drawing birds away from his facility and a strongly beneficial effect on boaters' comfort. He also noted that the structure improved upon waterfront appearance and water circulation over a previously installed floating concrete and steel breakwater which had disintegrated. The replacement cost of this rigid FB was estimated to be in excess of \$250,000. The operator also rated the breakwater as providing excellent performance in suppressing waves, meeting design goals, and satisfying his needs. Overall performance was rated excellent.

Fouling Characteristics: A variety of marine life inhabits the structure including seaweed, seagulls, herons, other fishing birds, and muskrats.

Project Analysis: While new with relatively little time for major problems to develop, this FTB appears to be a classic success. One should note that it is built according to the state-of-the-art, well maintained, and installed where site conditions are suited for an FTB. Its cost-effectiveness is especially dramatic in comparison with the previous floating concrete and steel breakwater.

## LAKE CHAMPLAIN FLOATING BREAKWATER - WESTPORT, NEW YORK

Breakwater Type: Goodyear FTB

Operational Life: The breakwater was constructed in 1978 and is still in operation.

Contact: Donald L. McIntyre  
Westport Marine Base Inc.  
Washington Street  
Westport, NY 12993  
(518) 962-4356

Builder: Same as contact

Operator: Same as contact

### Site Details

Water and Bottom Conditions: The structure is located in freshwater above a gently sloping bottom composed of mud. Depth at mean low water is 6.1 m (20.0 ft). The seasonal water depth range is 1.4 m (4.5 ft).

Exposure: The site is exposed from the northeast through the east with a fetch of 7.2 km (3.9 nmi).

Typical Storm Conditions: During a typical storm, prevailing winds are from the northeast through the east with speeds in excess of 16 km/hr (9 kn). Storm waves are up to 1.2 m (4.0 ft) high. Such storms occur frequently over the year.

Worst Storm Conditions: During a worst storm on an average year, winds will be from the northeast through the east with speeds from 45 km/hr (24 kn) to 65 km/hr (35 kn). Seas will be 1.4 m (4.5 ft) high.

Ice: Both stationary and flowing ice causes damage to the facility in the winter.

### Breakwater Details

Purpose: This breakwater protects a marina located in Westport, New York. This facility is operated from the spring through the fall. The breakwater is in operation from May to October and is the site's singular means of wave protection. When not in operation, the structure is lashed against permanent docks.

Design Source: The builder utilized design literature from Cornell University and the Goodyear Tire and Rubber Company.

**Construction:** This FTB is 198.1 m (650.0 ft) long and 9.1 m (30.0 ft) wide. Flotation relies on air trapped in the tire crowns and is aided by polyethylene blocks inserted in some of the tires. A 3/8-inch-high test chain bolted together is used to couple the tires.

**Site:**

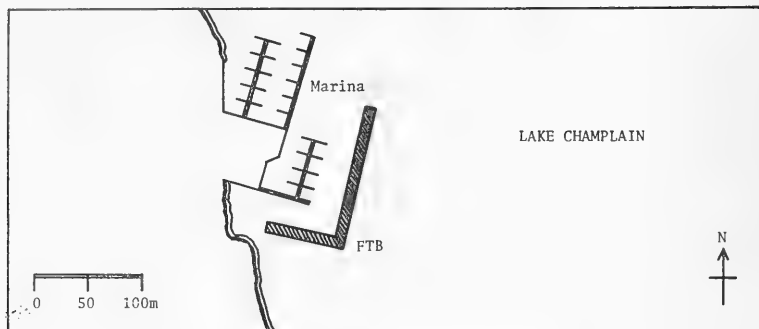

**Installation:** The breakwater is moored by 45 kg (100 lb) mushroom anchors on its leeward side and 363-kg (800 lb) to 454-kg (1,000 lb) railroad wheels on its exposed side. The anchors are spaced 30.5 m (100.0 ft) apart. Mooring lines are of chain-wire and are 18.3 m (60.0 ft) long.

**Special Equipment:** Flashing white lights and red pylons are situated atop the structure to warn boaters of its presence.

### Field Experience

**Operation:** A host of problems are listed as infrequently occurring, but all are considered minor problems of little consequence. These include instability, corrosion, interference with boating traffic, ice damage, fouling growth, inadequate buoyancy, coupling failure, and litter entrapment. Under typical storm conditions with waves 1.1 m (3.5 ft) in height and 20.9 m (68.5 ft) in estimated length, the transmission coefficient is 0.29. No deterioration in performance has been noted since installation.

**Maintenance:** Scheduled maintenance consists of shooting compressed air into the tires before the spring deployment for adequate buoyancy.

**Cost:** The total construction cost for this breakwater was \$10,000 in 1978. This figure translates to a cost of \$6.72/m<sup>2</sup> (\$0.62/ft<sup>2</sup>) in 1980 dollars.

**Benefits:** The operator felt that the structure had a positive effect on sport fishing and a strongly beneficial effect on boaters' comfort. He rated the breakwater as providing excellent performance in suppressing waves, meeting design goals and satisfying his needs. Overall performance was rated excellent with the added comment that without the structure, most of the docks could not be properly utilized or maintained.



Fouling Characteristics: The operator noted that the breakwater attracts seagulls by the dozens, but otherwise has no effect on marine life.

Project Analysis: With 2 years of operational life behind it and still no moderate or worse problems occurring, this FTB can be regarded as an engineering success. On initial inspection, inadequate buoyancy might be expected to be a problem, particularly since the builder used relatively heavy chain as the coupling material. However, fouling growth poses no major problem and the deepwater site probably eliminates substantial amounts of silt from accumulating in the tire bases. Also, the reserve flotation provided by the polyethylene blocks is helpful. Most importantly though, compressed air is annually shot into the structure and this maintenance will probably prevent any major problems with buoyancy from occurring. This project has the additional distinction of being the most cost-effective structure, in terms of its transmission coefficient relative to its cost per meter squared, of all Goodyear FTBs surveyed.

## LAKE CHARLEVOIX FLOATING BREAKWATER - CHARLEVOIX, MICHIGAN

Breakwater Type: Goodyear FTB

Operational Life: The breakwater was constructed in 1978 - 1979 and is still in operation.

Contact: Clifford D. Biddick  
Irish Boat Shop, Inc.  
Stover Road  
Charlevoix, MI 49720  
(616) 547-9967

Builder: Same as contact

Operator: Same as contact

### Site Details

Water and Bottom Conditions: The structure is located in freshwater above a gently sloping bottom composed of sand. Depth at mean low water is 4.0 m (13.0 ft). The seasonal water depth range is 2.1 m (7.0 ft).

Exposure: The site is exposed from the southeast with a fetch of 27.4 km (14.8 nmi).

Typical Storm Conditions: During a typical storm, prevailing winds are from the northeast through the southeast with speeds in excess of 30 km/hr (16 kn). Storm waves are 0.9 m (3.0 ft) in height. Such storms occur from four to six times per year.

Worst Storm Conditions: During a worst storm on an average year, winds will be from the southeast with speeds above 65 km/hr (35 kn). Seas will be from 1.2 m (4.0 ft) to 1.8 m (6.0 ft) high.

Ice: Stationary ice causes damage to the facility in the winter.

### Breakwater Details

Purpose: This breakwater protects a marina located in Charlevoix, Michigan. This facility is in operation from the spring through the fall. The breakwater is in operation year round and is the singular means of wave protection for the facility. Portions of the breakwater also serve as the pier and docks for the marina.

Design Source: The builder utilized design literature from the University of Rhode Island and the Goodyear Tire and Rubber Company.

Construction: The pier segment of the breakwater is 121.9 m (400.0 ft) long

with two dock-breakwater extensions each 91.4 m (300.0 ft) long. Enclosing the southern side of the marina is a second FTB, 161.6 m (530.0 ft) long. The width of these units is 3.7 m (12.0 ft). Primary flotation is derived from polyurethane foam poured into the tire crowns. Rubber conveyor belting fastened with bolts is used to couple the tires.

Site:

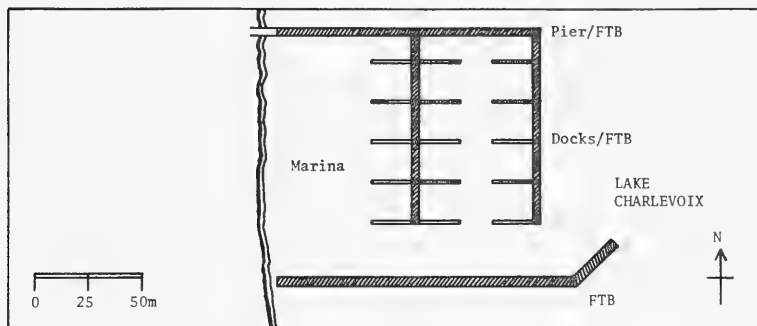

**Installation:** The breakwaters are both tied to pilings and anchored by 9 kg (20 lb) danforth anchors. Anchors and pilings are spaced from 3.0 m (10.0 ft) to 3.7 m (12.0 ft) apart. Mooring lines are of wire rope and vary from 3.0 m (10.0 ft) to 18.3 m (60.0 ft) in length.

**Special Equipment:** Red and green navigational lights are placed on the structure at the entrance to the marina. White lights are also placed at 15.2-m (50.0 ft) intervals along the breakwater. A wood dock running the full width of the structure is installed atop the first breakwater by means of a massive steel frame. The docks have full electrical and water service.

### Field Experience

**Operation:** The only moderate problems which have been encountered are ice damage and coupling failure to the rigid docks. Fouling growth is considered a minor problem. Litter entrapment is frequent, but due to the accessibility of the breakwater, this is considered a simple way by which the marina can be kept clean. The only problem encountered in the day-to-day operation of the structure has resulted from children who enjoy playing on and around the FTB. If he could rebuild the breakwater, the operator would suggest adding more flex joints at the corners of the docks and using different dock-to-piling connections for quieter operation. Under typical storm conditions with waves 1.1 m (3.5 ft) in height and 19.7 m (64.5 ft) in estimated length, the transmission coefficient is 0.57. No deterioration in performance has been noted since installation.

**Maintenance:** Scheduled maintenance includes checking the moorings and couplings, removing entrapped debris, and occasionally re-driving piles.

Severe Storm Effects: During several strong storms coming out of the southeast, ties connecting the docks to the pilings broke. However, at no point was the structural integrity of the breakwater in question.

Cost: Planning and engineering costs were \$12,000 and total construction costs were \$110,680. Legal fees and permits for electrical connections ran \$95 and installation costs were \$43,425. These costs were incurred between 1978 and 1979. These figures translate to an overall cost of \$109.62/m<sup>2</sup> (\$10.18/ft<sup>2</sup>) in 1980 dollars. Annual routine maintenance costs are estimated at \$1,000 for materials and \$3,000 for labor.

Benefits: The breakwater is seen as having a positive effect on boaters' comfort, shoreline erosion, sediment movement, and sport fishing. Other benefits include additional dockage which aids boat sales and allows more services to be provided. The operator rated the breakwater as providing high performance in suppressing waves and excellent performance in meeting design goals and satisfying his needs. Overall performance was rated excellent.

Fouling Characteristics: A variety of marine life inhabits the breakwater including algae, seagulls, ducks, other birds and muskrats.

Project Analysis: The installation of a rigid pier-dock structure atop a flexible FTB is a radical departure from the standard Goodyear design. As would be anticipated, the couplings between the docks and the breakwater are failing. If this problem can be overcome, a new and interesting use of the FTB will have been successfully developed. As such, this system bears watching over time. As just a breakwater, the project appears a success, ignoring the high cost which is distorted due to the pier and docks. It should be noted that this FTB is built according to the state-of-the-art and is well maintained.

## LAKE CUMBERLAND FLOATING BREAKWATER - ALBANY, KENTUCKY

Breakwater Type: Goodyear FTB

Operational Life: The breakwater was constructed in 1980 and is still in operation.

Contact: Tony Sloan  
Grider Hill Dock  
Albany, KY 42602  
(606) 387-7023

Builder: Same as contact

Operator: Same as contact

### Site Details

Water and Bottom Conditions: The structure is located in freshwater above a level bottom composed of mud and silt. Depth at mean low water is 38.1 m (125.0 ft). The seasonal water depth range is 7.6 m (25.0 ft).

Exposure: The site is exposed from the north through the northeast.

Typical Storm Conditions: During a typical storm, prevailing winds are from the northwest through the northeast and may reach speeds of 65 km/hr (35 kn). Storm waves are typically 0.6 m (2.0 ft) in height. Generally, such storms occur from three to four times per year.

### Breakwater Details

Purpose: This breakwater protects a marina, loading dock, and launching ramp located in Albany, Kentucky. The facility is operated year round as is the breakwater. The FTB is the facility's singular means of wave protection.

Design Source: The builder utilized design literature from the Goodyear Tire and Rubber Company.

Construction: This FTB is 152.4 m (500.0 ft) in length and 1.8 m (6.0 ft) in width. Primary flotation is derived from polyethylene blocks inserted in the tire crowns. The tires are coupled together with 0.25-inch cable fastened with clamps. The cable and clamps are of stainless steel due to the acidic nature of the water.

Installation: On its exposed side, the structure is moored by several 454-kg (1,000 lb) anchors. On its leeward side, the breakwater is moored to the shore via three concrete-filled barrels. Mooring lines are of stainless steel wire and are 91.4 m (300.0 ft) in length.

Site:

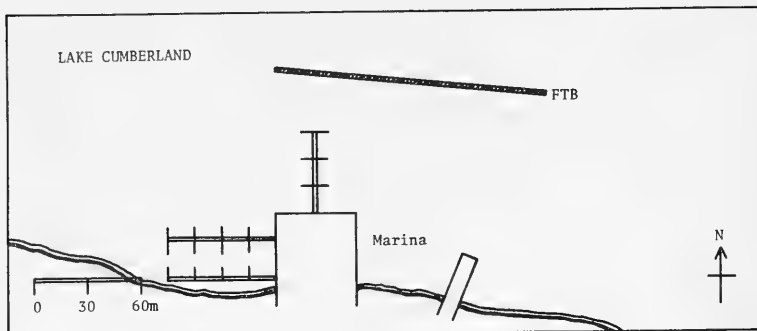

Special Equipment: Plastic jugs painted orange are situated atop the breakwater to warn boaters of its presence.

### Field Experience

Operation: Litter entrapment is considered a minor problem; otherwise, no other operational problems have been seen. Under typical storm conditions with waves 0.6 m (2.0 ft) in height and 11.9 m (39.0 ft) in estimated length, the transmission coefficient is 0.50.

Maintenance: Due to the structure's newness, no routine maintenance has as yet been scheduled.

Cost: The material components for the structure cost \$1,800, mostly due to the stainless steel parts. The builder felt that this was a high cost, but necessary to avoid coupling failure. Labor was \$800 and installation was \$300. These figures translate to an overall cost of \$10.57/m<sup>2</sup> (\$0.98/ft<sup>2</sup>).

Benefits: The estimated annual savings in maintenance to the facility is \$1,000. The operator rated the breakwater as having a positive effect on preventing shoreline erosion and a strongly beneficial effect on boaters' comfort. He felt the structure had a negative effect on waterfront appearance. The operator also rated the breakwater as providing excellent performance in suppressing waves, meeting design goals, and satisfying his needs. Overall performance was rated excellent.

Project Analysis: While new with relatively little time for major problems to develop, this FTB appears to be a success. While it is not built according to the state-of-the-art, because of the modest site conditions, the structure will probably fare well. The most extreme hazard the FTB will face is likely to be limited structural failure due to the wire cables cutting through the tires. This could have been prevented, possibly with some money saved, by using rubber conveyor belting. The simple use of orange plastic jugs as warning beacons is probably as effective a means for preventing collisions as is warranted. One should also note that this project has a deepwater site. An FB was really the only option open to the operator.

APPENDIX B

FIELD EXPERIENCES: OTHER FLOATING BREAKWATERS

## LAKE ERIE FLOATING BREAKWATER - ROCKY RIVER, OHIO

Breakwater Type: Pole-Tire FB

Operational Life: A prototype was constructed in 1980 and, based on the prototype's performance, a larger unit, several modules long, will be installed in 1981.

Contact: W. Whitney Slaght, Jr.  
250 Arundel Road  
Rocky River, OH 44116  
(216) 331-2876

Builder: Cleveland Yachting Club  
Rocky River, OH 44116  
(216) 333-1155

Operator: Same as builder

### Site Details

Water and Bottom Conditions: The structure is located in freshwater above a level bottom composed of silt. Depth at mean low water is 3.0 m (10.0 ft). The seasonal water depth range is 0.9 m (3.0 ft).

Exposure: The site is exposed from the north with a fetch of 0.4 km (0.2 nmi).

Typical Storm Conditions: During a typical storm, prevailing winds are from the northwest through the northeast with speeds in excess of 30 km/hr (16 kn). Storm waves are from 0.9 m (3.0 ft) to 1.2 m (4.0 ft) in height. Generally, such storms occur from six to eight times per year.

Worst Storm Conditions: During a worst storm on an average year, winds will be from the northeast with speeds in excess of 65 km/hr (35 kn). Seas will be 1.2 m (4.0 ft) high.

Currents: The maximum current speed at the site is 6.4 km/hr (3.5 kn).

### Breakwater Details

Purpose: This breakwater protects a yacht club located in Rocky River, Ohio. This facility is operated from the spring through the fall. The breakwater is in operation from June to November and is stored in a protected harbor when not in use. A fixed rubble-mound breakwater is also present at the site.

Construction: A pole-tire module consists of three telephone poles coupled parallel to one another by channel and threaded rod. Each pole is skewed with tires held in place by cable. Flotation relies on the



inherent buoyancy of the wooden poles. The prototype consisted of a single module and was 12.2 m (40.0 ft) in length and 2.4 m (8.0 ft) in width.

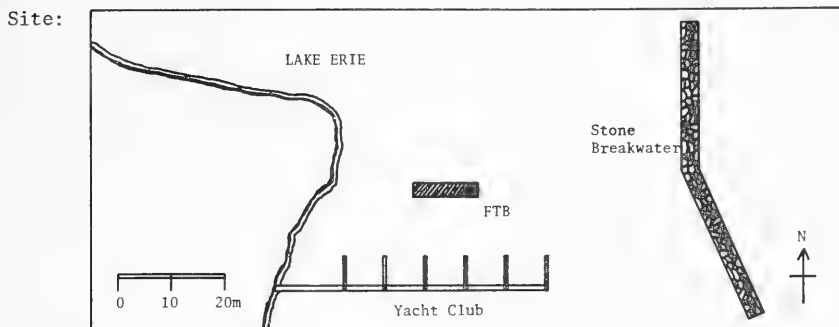

**Installation:** The breakwater is anchored by four 227-kg (500 lb) concrete blocks. The mooring points are located at the corners of the structure. The mooring lines are of chain.

**Special Equipment:** Flashing red and green lights, white lights, and daymarkers are installed as per local Coast Guard requirements.

#### Field Experience

**Operation:** During the brief trials of the prototype, only one problem was encountered. Inadequate buoyancy was cited as a major problem due to one end of the module being negatively buoyant. It was believed that by removing the existing pole ends and using new poles, proper flotation could be restored.

**Project Analysis:** Without any significant operational time, this breakwater has not had a chance to prove or disprove the merits of its design. On first inspection, it would appear that relying solely on the wooden poles for flotation might be unwise. Filling the tires with polyurethane foam or using some other form of reserve flotation would provide a greater margin of flotation safety than the structure presently has. Also, the utility of this design in saltwater is questionable, because of its use of steel coupling materials and exposed wood. This new design merits further observation over time. It may well pose a good solution for freshwater sites requiring substantial wave reduction. This breakwater appears considerably stiffer than the Goodyear design and this rigidity should improve its effectiveness.

## ANTIOCH BAY FLOATING BREAKWATER - SPRINGVILLE, TENNESSEE

Breakwater Type: Steel Pipe FB

Operational Life: The breakwater was constructed in 1974 and is still in operation.

Contact: V.L. Childs  
P.O. Box 849  
Tennessee National Wildlife Refuge  
Paris, TN 38242  
(901) 642-2091

Builder: Mansard Island Marina  
Springville, TN  
(901) 642-5590

Operator: Same as builder

### Site Details

Water and Bottom Conditions: The structure is located in freshwater above a gently sloping bottom composed of sand and mud.

Exposure: The site is exposed from the east through the southeast with a fetch of 4.8 km (2.6 nmi).

Typical Storm Conditions: During a typical storm, prevailing winds are from the east through the southeast with speeds between 40 km/hr (22 kn) and 50 km/hr (27 kn). Storm waves are 0.9 m (3.0 ft) high. Generally, such storms occur from three to six times per year.

Worst Storm Conditions: During a worst storm on an average year, winds will be from the east through the southeast and will reach 65 km/hr (35 kn). Seas will be from 1.2 m (4.0 ft) to 1.5 m (5.0 ft) high.

Ice: Stationary ice is present in the winter, but poses no problem to the facility.

### Breakwater Details

Purpose: This breakwater protects a marina, loading dock, and boat ramp located on Kentucky Lake near Springville, Tennessee. This facility is operated from the spring through the fall. The breakwater is in operation year round and is the singular means of wave protection for the facility.

Construction: This FB is a 121.9-m (400.0 ft) -long, 0.8-m (2.5 ft) -diameter sealed steel pipe held in position by numerous spudpoles. Flotation relies on air trapped in the welded pipe, made from 3/8-inch stock.

Ten 3.0-m (10.0 ft) steel fingers extend from the pipe and grasp the 4-inch diameter spudpoles by means of 0.9-m (3.0 ft) -long brackets made from 5-inch pipe.

Site:

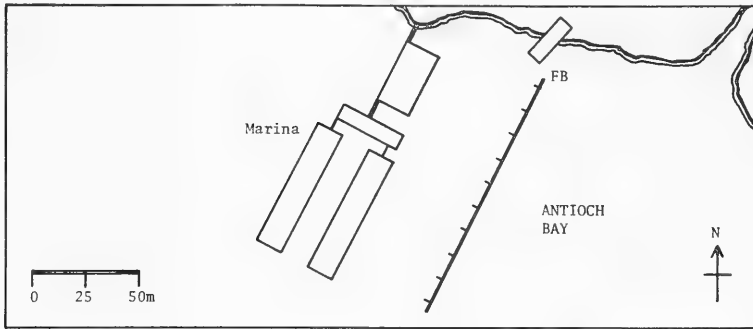

**Installation:** The breakwater is free to slide up and down the spudpoles. Ten spudpoles are positioned on the leeward side of the structure at 12.2-m (40.0 ft) intervals. There is also a spudpole at each end of the breakwater.

### Field Experience

**Operation:** The primary difficulty encountered by this design has been the habit of the structure to get caught upon and bend the spudpoles. This has led to moderate problems of instability, structural failure, and coupling (i.e., bracket) failure. If given the opportunity to rebuild the structure, the operator would add a matching set of fingers, brackets, and spudpoles on the exposed side to balance the mooring forces. Corrosion is also cited as a moderate problem. Collision damage, interference with boating traffic, ice damage, anchoring system (i.e., spudpole) failure, and litter entrapment all pose minor problems to the operation of this FB. Under typical storm conditions with waves 1.1 m (3.5 ft) in height and 20.0 m (65.5 ft) in estimated length, the transmission coefficient is 0.43. No significant deterioration in performance has been seen over the years.

**Maintenance:** Scheduled maintenance consists of checking the spudpoles and straightening those that have bent.

**Benefits:** The operator felt that the breakwater had a positive effect on preventing shoreline erosion, improving waterfront appearance and providing boaters' comfort. He believed that the structure had a negative effect on sediment movement. He rated the FB as providing high performance in suppressing waves and moderate performance in meeting design goals and satisfying his needs. Overall performance was rated high.

Fouling Characteristics: The marine life which inhabits this structure includes turtles, seagulls, and other birds.

Project Analysis: The utility of this design appears limited to freshwater sites with modest wave conditions. Effectively, this structure is a large steel log boom with a mooring system more complicated than that employed by more conventional log booms. In comparing this field experience with that of the New Tern Harbor log boom, it is hard to find any significant advantage in the elaborate mooring system or the use of steel pipe. The one possible exception may be that the steel pipe FB has a longer operational expense and maintenance required is quite questionable. Nonetheless, the adventurous, innovative spirit of the builder seems to be rewarded by an FB that does achieve moderate success.

## LAKE BARKLEY FLOATING BREAKWATER - EDDYVILLE, KENTUCKY

Breakwater Type: Steel Caisson FB

Operational Life: The breakwater was constructed in 1979 and is still in operation.

Contact: Richard Oberle  
Eddy Creek Resort & Marina  
Route 1  
Eddyville, KY 42038  
(502) 388-7743

Builder: Same as contact

Operator: Same as contact

### Site Details

Water and Bottom Conditions: The structure is located in freshwater above a level bottom composed of mud. Depth at mean low water is 3.4 m (11.0 ft). The seasonal water depth range is 2.9 m (9.5 ft).

Exposure: The site is exposed from the north with a fetch of 0.8 km (0.4 nmi).

Typical Storm Conditions: During a typical storm, prevailing winds are from the northwest through the northeast with speeds around 25 km/hr (14 kn). Storm waves are 0.3 m (1.0 ft) in height. Generally, such storms occur from five to six times per year.

Worst Storm Conditions: During a worst storm on an average year, winds will be from the north and will reach 65 km/hr (35 kn). Storm waves will be up to 0.9 m (3.0 ft) high.

### Breakwater Details

Purpose: The breakwater, consisting of two separate modules, protects a marina located in Eddyville, Kentucky. This facility is operated from the spring through the fall. The breakwater is in operation year round and is the singular means of wave protection for the facility.

Construction: Each steel caisson module is 12.2 m (40.0 ft) in length and 1.2 m (4.0 ft) in width. In design, this FB is essentially a deep draft floating dock. It is constructed of steel with primary flotation provided by large polyethylene blocks. The steel frame is bolted together.

Installation: Each module is moored to five 50-gallon metal drums filled with concrete. Mooring lines are of wire cable and are 18.3 m (60.0 ft) in length.

Site:

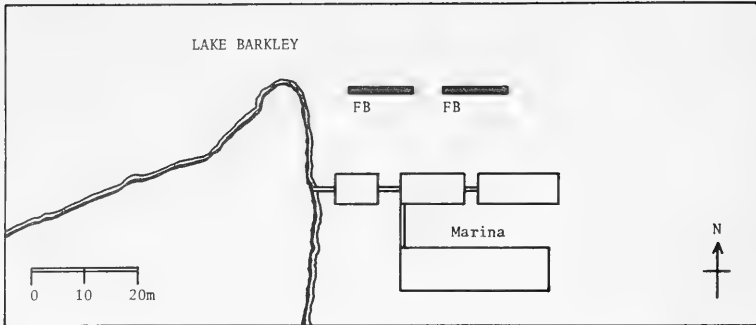

**Special Equipment:** A Corps of Engineers mooring sign is positioned atop each module to warn boaters of the mooring cables.

### Field Experience

**Operation:** Structural failure is cited as a moderate problem with corrosion and coupling failure posing minor difficulties. To counter these problems, the operator reinforced the steel frame, thereby improving the structural integrity of the FB. Anchoring system failure was also regarded as a moderate problem with mooring line failure being a minor one. In response to these troubles, the operator increased the scope of the mooring lines. Fouling growth also is considered a minor problem. Under worst storm conditions with waves 0.9 m (3.0 ft) in height and 6.4 m (21.0 ft) in estimated length, the transmission coefficient is 0.33.

**Maintenance:** Scheduled maintenance includes checking for loose bolts and inspecting the mooring lines.

**Cost:** The total construction cost of the two modules was \$10,000. This figure translates to a cost of \$388.66/m<sup>2</sup> (\$36.10/ft<sup>2</sup>) in 1980 dollars.

**Benefits:** The operator felt that the breakwater had a positive effect on boaters' comfort. He rated the FB as providing moderate performance in suppressing waves and meeting design goals and poor performance in satisfying his needs. Overall performance was rated moderate.

**Project Analysis:** The utility of this design appears limited to freshwater sites with modest wave conditions. Effectively, this structure is a small floating steel dock with a cost tremendously higher than that of scrap tire or wood FBs. By proper reinforcement, the frame can be made to withstand most wave forces. Also, a more conventional anchoring system can probably eliminate any further troubles with this aspect of the system. Therefore, the difficulties now being experienced can be resolved. One other problem will still remain, however, and that is the ease with which waves can diffract around and through the modules. The quick answer to this problem is to extend and connect the modules, but because of the high cost of the system, it would probably prove more cost-effective to examine alternative FB designs.

## NEWPORT HARBOR FLOATING BREAKWATER - NEWPORT, RHODE ISLAND

Breakwater Type: Timber Caisson FB

Operational Life: This breakwater is scheduled for construction in 1981.

Contact: Neill Gray  
Newport Yachting Center  
Commercial Wharf  
Newport, RI 02840  
(401) 846-4994

Builder: Wakefield Branch Company  
Wakefield, RI  
(401) 884-5277

Operator: Same as contact

### Site Details

Water and Bottom Conditions: The structure is located in saltwater above a gently sloping bottom composed of mud and silt. Depth at mean low water is 5.5 m (18.0 ft). The tidal range is 1.5 m (5.0 ft).

Exposure: The site is exposed from the southwest with a fetch of 2.0 km (1.1 nmi).

Typical Storm Conditions: During a typical storm, prevailing winds are from the southwest with speeds between 45 km/hr (24 kn) and 65 km/hr (35 kn). Storm waves are from 0.6 m (2.0 ft) to 0.9 m (3.0 ft) in height. Such storms occur frequently each year.

Worst Storm Conditions: During a worst storm on an average year, winds will be from the southwest through the west and will reach 80 km/hr (43 kn). Seas will be 1.2 m (4.0 ft) high.

Currents: The maximum current speed at the site is 1.6 km/hr (0.9 kn).

### Breakwater Details

Purpose: This breakwater will protect the Newport Yachting Center, the site for several internationally known in-water boat shows. This facility is operated from late spring to early fall. The FB will be in operation from May to October and will be stored inland when not in use. The breakwater will also serve as a set of docks for the boats on display. It is designed specifically for the purpose of knocking off the surface chop to a 0.6-m (2.0 ft) wave height--a design transmission coefficient of approximately 0.65.

Construction: Each timber caisson module is 6.1 m (20.0 ft) long and 3.0 m (10.0 ft) wide. In design, this FB is essentially a deep draft floating dock. It is constructed of timber with primary flotation provided by large polyethylene blocks. Modules are coupled together by steel rods held fast by bolts. The finished breakwater will be in two sections, each five modules long.

Site:

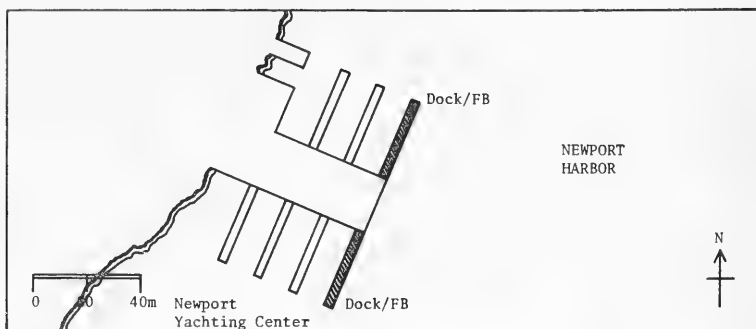

Installation: The breakwater will be tied to pilings. On the structure's exposed side, the pilings will be spaced 6.1 m (20.0 ft) apart and on its leeward side, 12.2 m (40.0 ft) apart.

### Field Experience

Operation: The breakwater is scheduled for installation in April 1981. No operational experience has, as yet, been accrued.

Maintenance: Scheduled maintenance will consist of removing the structure in the winter for storing inland.

Project Analysis: This project points up two important issues. The first is the utility of many FB designs to work in a double capacity--in this case, as a set of docks. The second point of interest is the well defined design goals set by the operator. Seldom has such explicit design purposes been set forth in the surveys. However, there can be no question that rigorously defining the future role of an FB will improve the design process and, therefore, increase the chances that the project will meet with success. This design merits further observation over time.



## NEW TERN HARBOR FLOATING BREAKWATER - NORTH WEYMOUTH, MASSACHUSETTS

Breakwater Type: Log Boom FB

Operational Life: The breakwater was constructed in 1973. Half of the structure has sunk and the other half is still in operation.

Contact: Michael Myers  
New Tern Harbor Marina  
275 River Street  
North Weymouth, MA 02191

Operator: Same as contact

### Site Details

Water and Bottom Conditions: The structure is located in saltwater above a gently sloping bottom composed of silt. Depth at mean low water is 0.9 m (3.0 ft). The tidal range is 3.4 m (11.0 ft).

Exposure: The site is exposed from the southwest.

Typical Storm Conditions: During a typical storm, prevailing winds are from the southwest with speeds in excess of 55 km/hr (30 kn). Storm waves are 0.9 m (3.0 ft) high or greater. Generally, such storms occur from three to five times per year.

Worst Storm Conditions: During a worst storm on an average year, winds will be from the southwest with speeds in excess of 95 km/hr (51 knots). Seas will be 1.5 m (5.0 ft) high or greater.

Currents and Ship Waves: The maximum current speed at the site is 11.1 km/hr (6.0 kn). Waves generated by passing boats represent an occasional and potentially damaging problem to the facility. Such waves are typically from 0.3 m (1.0 ft) to 0.6 m (2.0 ft) in height.

Ice: Both stationary and flowing ice causes damage to the facility in the winter.

### Breakwater Details

Purpose: This breakwater protects a marina and boatyard located in North Weymouth, Massachusetts. This facility is operated from the spring through the fall. The breakwater is in operation year round and is the singular means of wave protection for the facility.

Construction: The present operator inherited the log boom from the previous owner and is unaware of any problems arising during construction. The breakwater was once 121.9 m (400.0 ft) long, though it is now only 51.8 m

(170.0 ft) long. It is one log or 0.6 m (2.0 ft) wide. Flotation is aided by a few tires and some polyethylene blocks tied to the structure. Chain is employed to couple the logs.

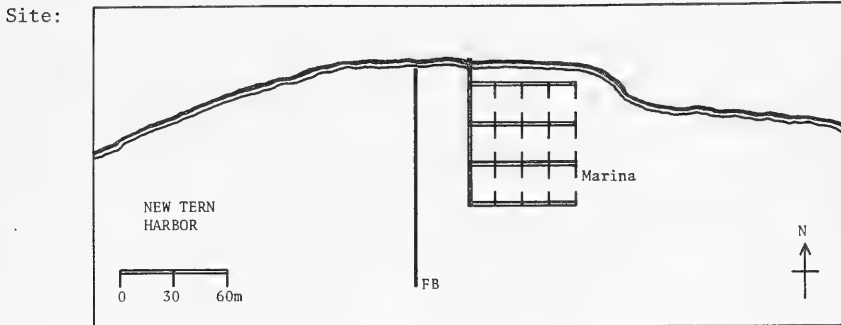

Installation: The breakwater is anchored to several large concrete blocks. Mooring lines are of chain and are 3.7 m (12.0 ft) to 4.6 m (15.0 ft) long.

### Field Experience

Operation: The operator sees many problems with this structure. Foremost among these is inadequate buoyancy which is considered a major problem. Over half of the original breakwater has sunk and the remainder is sinking. The operator has tied polyethylene blocks onto the logs to improve flotation, though this has not solved the problem. Given the opportunity to rebuild the FB, he would suggest filling the tires with polyurethane foam. The structure has also experienced moderate problems with corrosion, structural failure, fouling growth, anchoring system failure, mooring line failure, coupling failure and litter entrapment. Ice damage, instability and interference with boating traffic represent relatively minor problems. Under typical storm conditions with waves 0.9 m (3.0 ft) in height and 14.2 m (46.5 ft) in estimated length, the transmission coefficient is 0.33.

Maintenance: Scheduled maintenance consists of inspecting the couplings in the spring.

Cost: The original construction cost is unknown. Annual routine maintenance costs \$200, split evenly between labor and materials.

Benefits: The operator felt that the breakwater had a positive effect on boaters' comfort and a negative effect on waterfront appearance. He rated the structure as providing moderate performance in suppressing waves, meeting design goals, and satisfying his needs. Overall performance was rated moderate.

Fouling Characteristics: A variety of marine life inhabits the structure including seaweed, barnacles, sea-squirts, starfish, crabs, seagulls, ducks, and terns.

Project Analysis: The New Tern Harbor log boom is rapidly reaching the end of its operational life. The structure is waterlogged, eaten out, and literally, falling apart. With the operator's attention, the log boom may continue to survive for several more years, though its performance will increasingly deteriorate. If the structure actually has as high a transmission coefficient as the operator noted, the log boom has served well. However, observing that the operator rated this FB as providing but moderate performance in suppressing waves, it is assumed that its actual effect on waves is much less than that reported.

## APPENDIX C

### FIELD EXPERIENCE QUESTIONNAIRE

In most cases, the status of the project was confirmed before a detailed questionnaire was sent to an FB operator. This inquiry was done by sending a postcard-sized survey and cover letter to the unconfirmed lead. This miniquestionnaire asked for the type of structure built, its year of construction, and its current status. Those operators who returned the postcard were then sent the enclosed complete questionnaire.

# FLOATING BREAKWATER SURVEY

Marine Resource Management, Inc.

RESPONDENT: \_\_\_\_\_ TELEPHONE: \_\_\_\_\_

ADDRESS: \_\_\_\_\_

---

## General Information

OWNER            NAME: \_\_\_\_\_            COMPANY: \_\_\_\_\_

ADDRESS: \_\_\_\_\_            TELEPHONE: \_\_\_\_\_

DESIGNER        NAME: \_\_\_\_\_            COMPANY: \_\_\_\_\_

ADDRESS: \_\_\_\_\_            TELEPHONE: \_\_\_\_\_

BUILDER         NAME: \_\_\_\_\_            COMPANY: \_\_\_\_\_

ADDRESS: \_\_\_\_\_            TELEPHONE: \_\_\_\_\_

OPERATOR        NAME: \_\_\_\_\_            COMPANY: \_\_\_\_\_

ADDRESS: \_\_\_\_\_            TELEPHONE: \_\_\_\_\_

---

## Site Details

### WATER CONDITIONS AT FB SITE

PLEASE CHECK THE WATER AND BOTTOM CONDITIONS WHICH APPLY:

FRESHWATER \_\_\_\_\_ SALTWATER \_\_\_\_\_ BRACKISH \_\_\_\_\_ SAND \_\_\_\_\_ MUD \_\_\_\_\_ SILT \_\_\_\_\_

BEDROCK \_\_\_\_\_ LEVEL \_\_\_\_\_ GENTLY SLOPING \_\_\_\_\_ CRAGGY \_\_\_\_\_ STEEPLY SLOPING \_\_\_\_\_

WHAT IS THE DEPTH AT MEAN LOW WATER: \_\_\_\_\_ ft

WHAT IS THE TIDAL OR SEASONAL WATER DEPTH RANGE: \_\_\_\_\_ ft

### WIND & WAVES

FROM WHAT DIRECTION IS YOUR FACILITY MOST EXPOSED (THAT IS, HAS THE GREATEST FETCH):

W \_\_\_\_\_ NW \_\_\_\_\_ N \_\_\_\_\_ NE \_\_\_\_\_ E \_\_\_\_\_ SE \_\_\_\_\_ S \_\_\_\_\_ SW \_\_\_\_\_

WHAT IS THE FETCH IN THIS DIRECTION: \_\_\_\_\_ miles

WHAT ARE THE CHARACTERISTICS OF A TYPICAL STORM FROM WHICH YOU DESIRE PROTECTION FOR YOUR FACILITY?

WIND DIRECTION: W \_\_\_\_\_ NW \_\_\_\_\_ N \_\_\_\_\_ NE \_\_\_\_\_ E \_\_\_\_\_ SE \_\_\_\_\_ S \_\_\_\_\_ SW \_\_\_\_\_

WIND SPEED: \_\_\_\_\_ mph    WAVE HEIGHT: \_\_\_\_\_ ft    WAVE LENGTH: \_\_\_\_\_ ft

HOW OFTEN DO SUCH STORMS OCCUR OVER THE SEASON OF OPERATION: \_\_\_\_\_

WHAT ARE THE CHARACTERISTICS OF THE WORST STORM THAT OCCURS WHEN YOUR FACILITY NEEDS PROTECTION ON AN AVERAGE YEAR?

WIND DIRECTION: W \_\_\_\_\_ NW \_\_\_\_\_ N \_\_\_\_\_ NE \_\_\_\_\_ E \_\_\_\_\_ SE \_\_\_\_\_ S \_\_\_\_\_ SW \_\_\_\_\_

WIND SPEED: \_\_\_\_\_ mph WAVE HEIGHT: \_\_\_\_\_ ft WAVE LENGTH: \_\_\_\_\_ ft

#### CURRENTS & SHIP WAVES

WHAT IS THE GREATEST CURRENT SPEED AT THE FB SITE: \_\_\_\_\_ mph

DO WAVES GENERATED BY PASSING SHIPS OR BOATS DAMAGE YOUR FACILITIES?

NO: \_\_\_\_\_ YES, FROM SHIPS: \_\_\_\_\_, FERRYS: \_\_\_\_\_, TUGS: \_\_\_\_\_, OR BOATS: \_\_\_\_\_

DAMAGE OCCURS MONTHLY: \_\_\_\_\_, WEEKLY: \_\_\_\_\_, DAILY: \_\_\_\_\_, OR HOURLY: \_\_\_\_\_

WAVE HEIGHT: \_\_\_\_\_ ft WAVE LENGTH: \_\_\_\_\_ ft

#### ICE

DOES ICE DAMAGE YOUR FACILITY IN A TYPICAL WINTER: NO \_\_\_\_\_ YES \_\_\_\_\_

IF YES, IS THE PROBLEM DUE TO STATIONARY ICE: \_\_\_\_\_ ICE FLOWING WITH THE CURRENTS: \_\_\_\_\_, OR BOTH: \_\_\_\_\_.

---

### Breakwater Details

#### PURPOSE

TYPE OF FACILITY BEING PROTECTED:

MARINA \_\_\_\_\_ YACHT-CLUB \_\_\_\_\_ BOATYARD \_\_\_\_\_ SHIPYARD \_\_\_\_\_ ANCHORAGE \_\_\_\_\_

LOADING DOCK \_\_\_\_\_ LAUNCHING RAMP \_\_\_\_\_ OTHER (DESCRIBE) \_\_\_\_\_

FACILITY LOCATION: CITY \_\_\_\_\_, STATE \_\_\_\_\_

WHAT IS THE OPERATING SEASON OF YOUR FACILITY: WINTER \_\_\_\_\_ SPRING \_\_\_\_\_ SUMMER \_\_\_\_\_ FALL \_\_\_\_\_

WHAT IS THE SEASON OF FB OPERATION: YEAR-ROUND \_\_\_\_\_ SEASONAL\*, FROM \_\_\_\_\_ TO \_\_\_\_\_

(\*WHERE IS THE FB STORED WHEN IT IS NOT IN OPERATION: \_\_\_\_\_)

IS THE FB YOUR PRIMARY MEANS OF WAVE PROTECTION: YES \_\_\_\_\_ NO \_\_\_\_\_

IF NO, DESCRIBE OTHER PROTECTION: \_\_\_\_\_

#### DESIGN & CONSTRUCTION

PRIMARY SOURCE OF DESIGN INFORMATION: \_\_\_\_\_

WAS A CONSTRUCTION PERMIT REQUIRED: YES \_\_\_\_\_ NO \_\_\_\_\_

IF REQUIRED, HOW LONG DID IT TAKE YOU TO GET THE FOLLOWING PERMIT(S) (IN MONTHS):

LOCAL \_\_\_\_\_ STATE \_\_\_\_\_ FEDERAL (CORPS OF ENGINEERS) \_\_\_\_\_

TYPE OF FB CONSTRUCTED:

GOODYEAR FTB \_\_\_\_\_ WAVE MAZE \_\_\_\_\_ LOG RAFT \_\_\_\_\_ PIPE/TIRE FB \_\_\_\_\_ BARGE \_\_\_\_\_

TETHERED FLOAT FB \_\_\_\_\_ OTHER (DESCRIBE) \_\_\_\_\_

PRIMARY CONSTRUCTION MATERIAL FOR THE FB:

TIMBER \_\_\_\_\_ CONCRETE \_\_\_\_\_ STEEL \_\_\_\_\_ TIRES \_\_\_\_\_ FIBERGLASS \_\_\_\_\_

OTHER (DESCRIBE) \_\_\_\_\_

PRIMARY FLOTATION FROM:

LOGS \_\_\_\_\_ TRAPPED AIR \_\_\_\_\_ STYROFOAM BLOCKS \_\_\_\_\_ EXPANDED LIQUID FOAM \_\_\_\_\_

OTHER (DESCRIBE) \_\_\_\_\_

TYING MATERIAL USED TO COUPLE UNITS TOGETHER:

METAL BOLTS \_\_\_\_\_ STEEL RODS \_\_\_\_\_ CHAIN \_\_\_\_\_ ROPE \_\_\_\_\_ CABLE \_\_\_\_\_

RUBBER BELT \_\_\_\_\_ OTHER (DESCRIBE) \_\_\_\_\_

METHOD OF FASTENING TYING MATERIAL:

CLAMP \_\_\_\_\_ BOLT \_\_\_\_\_ SPLICE \_\_\_\_\_ OTHER (DESCRIBE) \_\_\_\_\_

SIZE OF THE FB: LENGTH \_\_\_\_\_ ft HEIGHT \_\_\_\_\_ ft WIDTH \_\_\_\_\_ ft DRAFT \_\_\_\_\_ ft

ESTIMATED FB DESIGN LIFE: \_\_\_\_\_ years

IS THE FB USED FOR ANYTHING IN ADDITION TO WAVE PROTECTION:

PIER \_\_\_\_\_ DOCK \_\_\_\_\_ ACCESS WAY \_\_\_\_\_ FISH REEF \_\_\_\_\_ ICE FLOW BUMPER \_\_\_\_\_

TRAFFIC CONTROL \_\_\_\_\_ NO OTHER USE \_\_\_\_\_ OTHER (DESCRIBE) \_\_\_\_\_

PROBLEMS ENCOUNTERED IN CONSTRUCTING THE FB (IF ANY, DESCRIBE): \_\_\_\_\_  
\_\_\_\_\_

LOCATION & MOORINGS

PLEASE SKETCH COASTLINE AND RELATIVE ORIENTATION OF YOUR FACILITY AND FB, WHEN FB WAS FIRST INSTALLED.

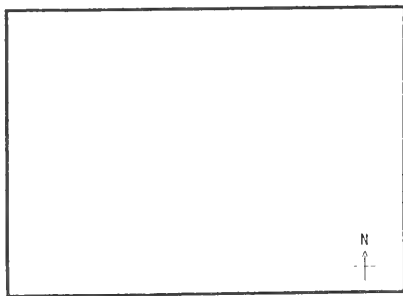

DATE OF CONSTRUCTION: \_\_\_\_\_

PRESENT STATUS OF THE FB:

IN ORIGINAL POSITION \_\_\_\_\_ SUNK (DATE) \_\_\_\_\_ REMOVED (DATE) \_\_\_\_\_ LOST (DATE) \_\_\_\_\_

SOLD (DATE & BUYER) \_\_\_\_\_ OTHER (DESCRIBE) \_\_\_\_\_

METHOD OF FB MOORING: TIED TO PILINGS \_\_\_\_\_ TIED TO FIXED STRUCTURE \_\_\_\_\_ ANCHORED\* \_\_\_\_\_  
 (\*IF ANCHORED, MUSHROOM \_\_\_\_\_ DANFORTH \_\_\_\_\_ SCREW \_\_\_\_\_ CONCRETE BLOCK \_\_\_\_\_  
 STONE BLOCK \_\_\_\_\_ DRILLED IN ROCK \_\_\_\_\_ OTHER (DESCRIBE) \_\_\_\_\_)  
 (\*WEIGHT OF ANCHORS \_\_\_\_\_ lbs)

DISTANCE BETWEEN ANCHORS/PILINGS ON OUTSIDE \_\_\_\_\_ ft AND ON INSIDE \_\_\_\_\_ ft

TYPE OF MOORING LINE:

NYLON \_\_\_\_\_ DACRON \_\_\_\_\_ POLYPROPYLENE \_\_\_\_\_ CHAIN \_\_\_\_\_ WIRE ROPE \_\_\_\_\_ OTHER \_\_\_\_\_

LENGTH OF MOORING LINE \_\_\_\_\_ ft

ARE THERE ANY SPECIAL NAVIGATIONAL MARKINGS ON THE FB: NO \_\_\_\_\_ YES (DESCRIBE) \_\_\_\_\_

DESCRIBE ANY SPECIAL EQUIPMENT INSTALLED ON THE FB, NOT COVERED ABOVE: \_\_\_\_\_

DATE OF INSTALLATION: \_\_\_\_\_

PROBLEMS ENCOUNTERED IN INSTALLING THE FB (IF ANY, DESCRIBE): \_\_\_\_\_

OPERATION & MAINTENANCE

HOW SERIOUS HAVE THE FOLLOWING PROBLEMS BEEN IN REGARDS TO YOUR FB:

NEVER                  MINOR                  MODERATE                  MAJOR                  EXTREME

INSTABILITY					
CORROSION					
STRUCTURAL FAILURE					
COLLISION DAMAGE					
INTERFERENCE WITH BOATING TRAFFIC					
ICE DAMAGE					
FOULING GROWTH					
INADEQUATE BUOYANCY					
ANCHORING SYSTEM FAILURE					
MOORING LINE FAILURE					
COUPLING FAILURE					
LITTER ENTRAPMENT					

MODIFICATION/IMPROVEMENTS MADE TO THE FB, TO SOLVE PROBLEMS ENCOUNTERED: \_\_\_\_\_

ESTIMATED WAVE HEIGHT INSIDE THE FB DURING TYPICAL STORM CONDITIONS: \_\_\_\_\_ ft

AND OUTSIDE THE FB: \_\_\_\_\_ ft

HAS THE PERFORMANCE OF THE FB DETERIORATED OVER THE YEARS (IF SO, DESCRIBE TO WHAT EXTENT): \_\_\_\_\_



DESCRIBE ROUTINE MAINTENANCE PROCEDURES: \_\_\_\_\_  
 \_\_\_\_\_

DESCRIBE PROBLEMS ENCOUNTERED IN OPERATING AND MAINTAINING THE FB OTHER THAN DURING SEVERE STORMS  
 (INCLUDE DATE(S) OF EVENT(S)): \_\_\_\_\_  
 \_\_\_\_\_

DESCRIBE ANY EXCEPTIONALLY BAD STORMS EXPERIENCED BY THE FB AND ANY DAMAGES WHICH MIGHT HAVE  
 RESULTED (INCLUDE YEAR OF OCCURRENCE): \_\_\_\_\_  
 \_\_\_\_\_

IF SOMEONE WISHED TO BUILD AN FB LIKE YOURS, WHAT IMPROVEMENTS WOULD YOU SUGGEST: \_\_\_\_\_  
 \_\_\_\_\_

COSTS & BENEFITS

PLEASE ESTIMATE THE FOLLOWING DOLLAR COSTS FOR YOUR FB:

CONSTRUCTION (MATERIAL) \_\_\_\_\_ CONSTRUCTION (LABOR) \_\_\_\_\_ LEGAL FEES & PERMITS \_\_\_\_\_  
 PLANNING & ENGINEERING \_\_\_\_\_ INSTALLATION \_\_\_\_\_ INSURANCE \_\_\_\_\_  
 ANNUAL ROUTINE MAINTENANCE (MATERIAL) \_\_\_\_\_ ANNUAL ROUTINE MAINTENANCE (LABOR) \_\_\_\_\_  
 REPAIR DUE TO STORM DAMAGE \_\_\_\_\_ DISPOSAL \_\_\_\_\_ OTHER (DESCRIBE) \_\_\_\_\_

WHAT IS THE ESTIMATED ANNUAL SAVINGS IN MAINTENANCE TO YOUR FACILITY DUE TO THE FB: \_\_\_\_\_

WHAT OTHER BENEFITS HAVE BEEN REALIZED AS A RESULT OF THIS FB (FOR EXAMPLE, ABLE TO MOOR MORE BOATS):  
 \_\_\_\_\_  
 \_\_\_\_\_

HOW HAS YOUR FB AFFECTED THE FOLLOWING  
 (AT OR NEAR YOUR FACILITY):

HIGHLY ADVERSE      NEGATIVE      NONE      POSITIVE      STRONGLY BENEFICIAL

	HIGHLY ADVERSE	NEGATIVE	NONE	POSITIVE	STRONGLY BENEFICIAL
SPORTFISHING					
SEDIMENT MOVEMENT					
SHORELINE EROSION					
BIRD HABITATION					
WATER CIRCULATION					
WATERFRONT APPEARANCE					
BOATERS' COMFORT					

PLEASE RATE THE PERFORMANCE OF YOUR  
 FB FOR THE FOLLOWING:

INEFFECTIVE POOR      MODERATE      HIGH      EXCELLENT

	INEFFECTIVE	POOR	MODERATE	HIGH	EXCELLENT
WAVE SUPPRESSION					
MEETING DESIGN GOALS					
SATISFYING YOUR NEEDS					
OVERALL PERFORMANCE					

MARINE LIFE OBSERVED INHABITING FB:

SEAWEED \_\_\_\_\_ BARNACLES \_\_\_\_\_ SPONGES \_\_\_\_\_ SEA-SQUIRTS \_\_\_\_\_ STARFISH \_\_\_\_\_  
SNAILS \_\_\_\_\_ MUSSELS \_\_\_\_\_ CRABS \_\_\_\_\_ OTHER SHELLFISH \_\_\_\_\_ TURTLES \_\_\_\_\_ GEESE \_\_\_\_\_  
SEAGULLS \_\_\_\_\_ DUCKS \_\_\_\_\_ TERNS \_\_\_\_\_ OTHER BIRDS \_\_\_\_\_ SEALS \_\_\_\_\_ BEAVERS \_\_\_\_\_  
MUSKRATS \_\_\_\_\_ OTHER MAMMALS \_\_\_\_\_

APPENDIX D  
OTHER KNOWN FLOATING BREAKWATER SITES

Goodyear Floating Tire Breakwaters

Bob Edgar  
Peninsula Marina  
Route #2  
Glasgow, KY 42141

Charles Denney  
Conley Bottom Resort  
Route #1  
P.O. Box 90  
Monticello, KY 42633

Roberto G. Tassinari  
10 White Street  
Salem, MA 01970

Chrysler Yacht Club  
P.O. Box 03651  
Highland Park, MI 48203

Murray E. Young, Jr.  
Huron Yacht Club  
6131 Duffield Road  
Flushing, MI 48433

Leonard Zabilansky  
U.S. Army CREEL  
Lyne Road  
Hanover, NH 03766

Dave Sweet  
Montys Bay Marina, Inc.  
Chazy Landing Road  
Chazy, NY 12921

Hudson River Boat Sales  
Broadway  
Verplanck, NY 10596

Dock & Coal Company, Inc.  
1 Dock Street  
Plattsburgh, NY 12901

Jeff Baker  
The Boathouse  
West Bay Road  
Fair Haven, NY 13064

John G. Suipizio  
Lorain Port Authority  
City Hall  
Room 511  
Lorain, OH 44052

John Bartholomew  
U.S. Army Engineer District, Philadelphia  
Planning Branch  
U.S. Customs House  
2nd and Chestnut Streets  
Philadelphia, PA 19106

Pickwick Cove Marina, Inc.  
Route #1  
Counce, TN 38326

Larry Franks  
U.S. Army Engineer District, Huntington  
P.O. Box 2127  
Huntington, WV 25721

Floating Pipe-Tire Breakwater

Ron Chim  
Mamoroneck Beach & Yacht Club  
Mamoroneck, NY 10543

Log Boom Breakwater

Donald R. Dube  
3797 Riverside Avenue  
Somerset, MA 02726

Tethered Float Breakwater

Richard V. Carroll  
201 Padonia Road West  
Timonium, MD 21093

APPENDIX E  
UNCONFIRMED FLOATING BREAKWATER SITES

Connecticut

John Bartach  
University of Connecticut  
Corporate Extension Service  
New London, CT 06320

Florida

Robert M. Snyder  
Snyder Oceanography Services  
169 Beacon Lane  
Jupiter, FL 33458

Georgia

Robert Banfield  
Allatoona Landing, Inc.  
RFD  
Cartersville, GA 30120

Kentucky

Burnside Marina  
Burnside, KY 42519

Sulphur Creek Marina  
Kettle, KY 42752

Louisiana

Tim Murray  
Tim Murray Sailboats, Inc.  
7590 Lakeshore Drive  
New Orleans, LA 70124

Walter Burk & Associates  
4176 Canal Street  
New Orleans, LA 70119

Howard Peckham  
Bell Aerospace Company  
P.O. Box 29307  
New Orleans, LA 70189

Maryland

Calvin Jenkins  
Bowleys Point Yacht Basin  
1700 Bowley's Quarters Road  
Baltimore, MD 21220

Massachusetts

Boston Harbor Marina, Inc.  
542 East Squantum Street  
Squantum, MA 02171

Mississippi

William H. Barrett  
401 1st Avenue  
Pass Christian, MS 39571

New Hampshire

U.S. Coast Guard Station  
Portsmouth, NH, 03801

New Jersey

Joe Tombro  
Clarks Landing Marina  
847 Arnold Avenue  
Point Pleasant, NJ 08742

New York

Essex Marine Base, Inc.  
Main Street  
Essex, NY 12936

Jack Frauenheim  
JAFCO Marina  
2192 Niagara Street  
Buffalo, NY 14207

Junior Sea Knights of America  
135 Edgewater Street  
Staten Island, NY 10305

Tom Dawes  
Anchor Marine Sales, Inc.  
Clover Street  
Sodus Point, NY 14555

North Carolina

Tom Jarrett  
U.S. Army Engineer District, Wilmington  
P.O. Box 1890  
Wilmington, NC 28402

Ohio

Frank Balint  
Wingfoot Lake Recreational Park  
993 Goodyear Park Boulevard  
Mogadore, OH 44260

Clinton Reef Marina  
P.O. Box 490  
Lakeshore Drive West  
Port Clinton, OH 43452

Mentor Harbor Yacht Club  
5330 Coronado Drive  
Mentor-on-the-Lake, OH 44060

Rhode Island

William Parent  
Parent's Marina  
35 Wilcox Avenue  
Pawtucket, RI 02863

Edgewood Yacht Club  
Shaw Avenue  
Cranston, RI 02905

Mike Cuddy  
Rhode Island Yacht Club  
Ocean Avenue  
Cranston, RI 02905

Coweset Marina  
100 Folly Landing  
Warwick, RI 02886

John Dickerson  
Apponaug Harbor Marina  
21 Arnold's Neck Road  
Warwick, RI 02886

South Carolina

Dick Youtz  
Western Carolina Sailing Club  
Anderson, SC 29621

Tennessee

Willow Grove Dock  
Route 1  
Allons, TN 38541

Hermitage Landing  
Route 2  
Bell Road  
Hermitage, TN 37076

Dearl Burns  
Brownfield Resort  
P.O. Box 315  
Dover, TN 37058

Lakewood Marina  
Old Hickory, TN 37138

200

201







<p>Baird, V. Andrew Field experiences with floating breakwaters in the Eastern United States / by Andrew V. Baird and Neil W. Ross.--Fort Belvoir, Va. : U.S. Army, Corps of Engineers, Coastal Engineering Research Center ; Springfield, Va. : available from NTIS, 1982. [93] p. : ill. : 28 cm.--(Miscellaneous report ; no. 82-4) Cover title.</p> <p>Marine Resource Management, Inc., conducted a survey on field experiences with floating breakwaters in the Eastern United States to provide design information to future builders. Recommendations are made that a concentrated research effort be directed toward the problem areas of flotation and anchoring systems, and that monitoring of state-of-the-art projects continue.</p> <p>1. Shoreline protection. 2. Breakwaters. 3. Ocean waves. I. Ross, Neil W. II. Title. III. Series: Coastal Engineering Research Center (U.S.). Miscellaneous report no. 82-4. IV. Series: Coastal Engineering Research Center (U.S.). Contract DACW72-80-M-0626. V. Series: Marine Resource Management, Inc. no. 82-4</p> <p>TC203 .U581mr 627</p>	<p>Baird, V. Andrew Field experiences with floating breakwaters in the Eastern United States / by Andrew V. Baird and Neil W. Ross.--Fort Belvoir, Va. : U.S. Army, Corps of Engineers, Coastal Engineering Research Center ; Springfield, Va. : available from NTIS, 1982. [93] p. : ill. : 28 cm.--(Miscellaneous report ; no. 82-4) Cover title.</p> <p>Marine Resource Management, Inc., conducted a survey on field experiences with floating breakwaters in the Eastern United States to provide design information to future builders. Recommendations are made that a concentrated research effort be directed toward the problem areas of flotation and anchoring systems, and that monitoring of state-of-the-art projects continue.</p> <p>1. Shoreline protection. 2. Breakwaters. 3. Ocean waves. I. Ross, Neil W. II. Title. III. Series: Coastal Engineering Research Center (U.S.). Miscellaneous report no. 82-4. IV. Series: Coastal Engineering Research Center (U.S.). Contract DACW72-80-M-0626. V. Series: Marine Resource Management, Inc. no. 82-4</p> <p>TC203 .U581mr 627</p>
<p>Baird, V. Andrew Field experiences with floating breakwaters in the Eastern United States / by Andrew V. Baird and Neil W. Ross.--Fort Belvoir, Va. : U.S. Army, Corps of Engineers, Coastal Engineering Research Center ; Springfield, Va. : available from NTIS, 1982. [93] p. : ill. : 28 cm.--(Miscellaneous report ; no. 82-4) Cover title.</p> <p>Marine Resource Management, Inc., conducted a survey on field experiences with floating breakwaters in the Eastern United States to provide design information to future builders. Recommendations are made that a concentrated research effort be directed toward the problem areas of flotation and anchoring systems, and that monitoring of state-of-the-art projects continue.</p> <p>1. Shoreline protection. 2. Breakwaters. 3. Ocean waves. I. Ross, Neil W. II. Title. III. Series: Coastal Engineering Research Center (U.S.). Miscellaneous report no. 82-4. IV. Series: Coastal Engineering Research Center (U.S.). Contract DACW72-80-M-0626. V. Series: Marine Resource Management, Inc. no. 82-4</p> <p>TC203 .U581mr 627</p>	<p>Baird, V. Andrew Field experiences with floating breakwaters in the Eastern United States / by Andrew V. Baird and Neil W. Ross.--Fort Belvoir, Va. : U.S. Army, Corps of Engineers, Coastal Engineering Research Center ; Springfield, Va. : available from NTIS, 1982. [93] p. : ill. : 28 cm.--(Miscellaneous report ; no. 82-4) Cover title.</p> <p>Marine Resource Management, Inc., conducted a survey on field experiences with floating breakwaters in the Eastern United States to provide design information to future builders. Recommendations are made that a concentrated research effort be directed toward the problem areas of flotation and anchoring systems, and that monitoring of state-of-the-art projects continue.</p> <p>1. Shoreline protection. 2. Breakwaters. 3. Ocean waves. I. Ross, Neil W. II. Title. III. Series: Coastal Engineering Research Center (U.S.). Miscellaneous report no. 82-4. IV. Series: Coastal Engineering Research Center (U.S.). Contract DACW72-80-M-0626. V. Series: Marine Resource Management, Inc. no. 82-4</p> <p>TC203 .U581mr 627</p>





