

# THE FIELD STUDY OF PLACE A PRACTICAL GUIDE

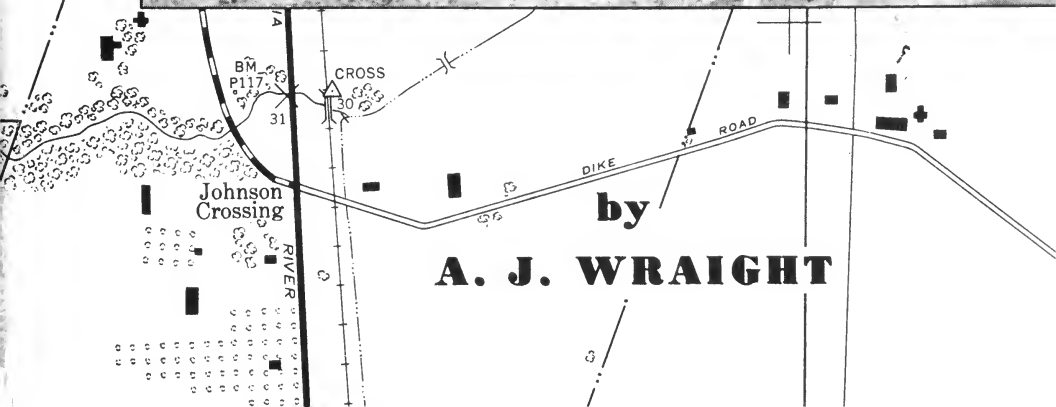

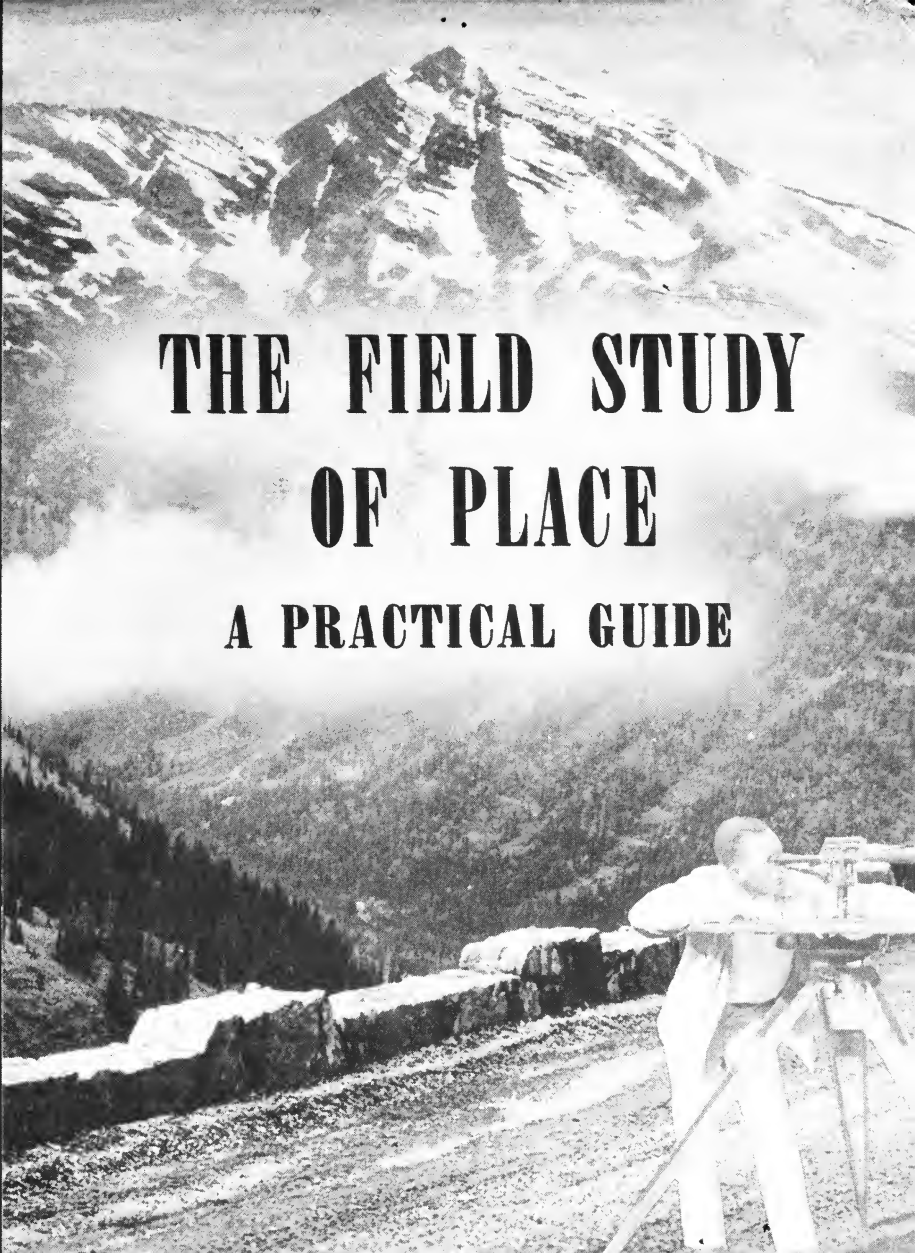

### DR. A. J. WRAIGHT

Author of what has been called "the first book on field study to bridge the gap between an Engineering Manual and the Boy Scout Handbook," was born in St. Louis, where he received his early training and later taught both in private schools and at Washington University and St. Louis University. He received his Ph.D. from Clark University. For fourteen years, Dr. Wraight has been a consultant in geography for government agencies and private industry.

#### What one expert says about THE FIELD STUDY OF PLACE:

"This handy book fills a long-felt need. It is a not-too-technical guide for those who from time to time must do field work and write field reports, and can do so without having acquired the more highly specialized training of the engineer or geologist. This guide should be of great help to planners, realtors, beginning geographers, biologists, agricultural economists, sociologists, and others."

—*William Van Royen*  
*Head, Department of Geography,*  
*University of Maryland*  
*College Park, Maryland*



From the collection of the

o <sup>z</sup> <sup>n</sup> <sup>m</sup> Preinger  
v <sup>a</sup> Library  
t p

San Francisco, California  
2006

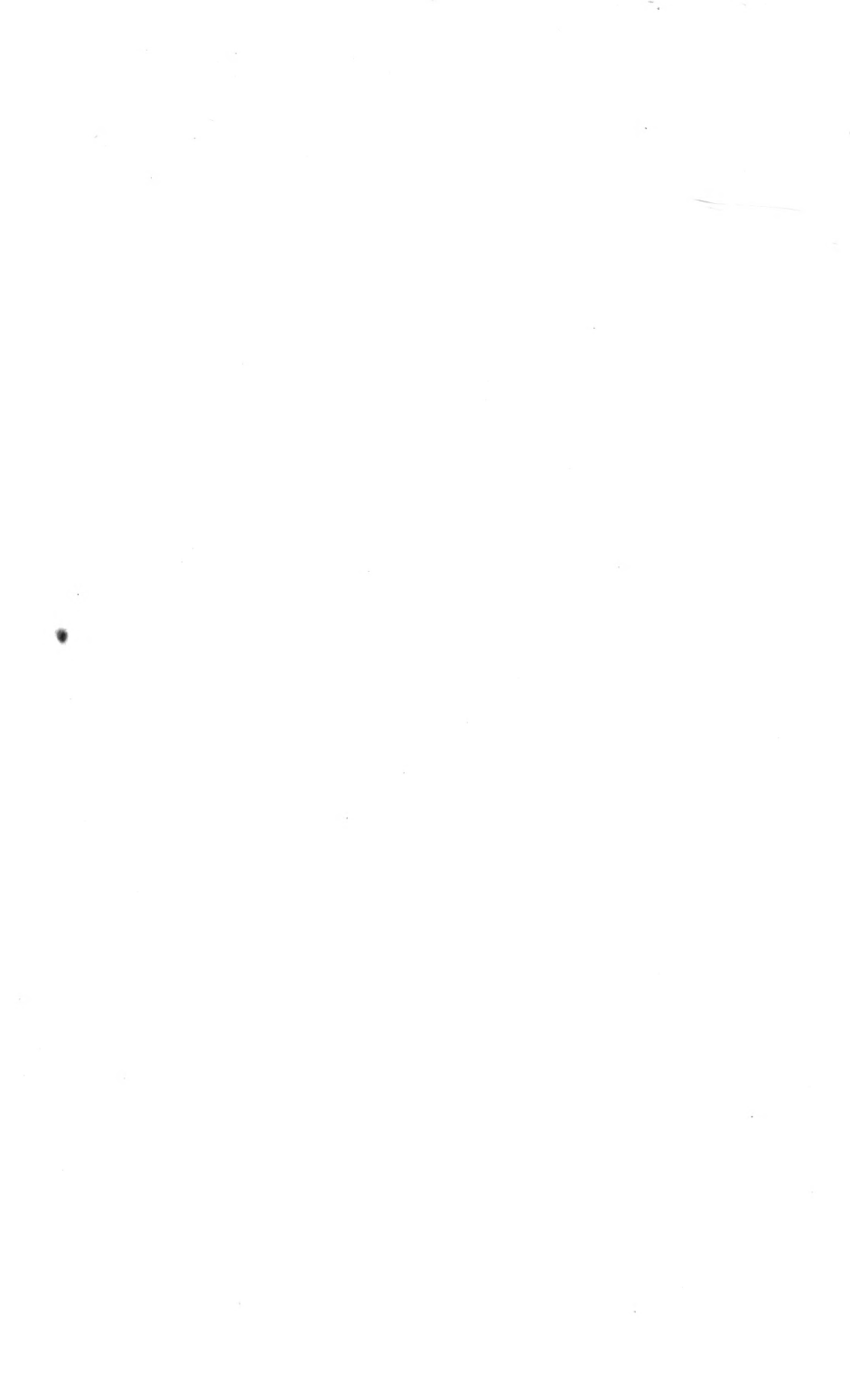



*THE FIELD STUDY  
OF PLACE*

*A PRACTICAL GUIDE*

A. J. WRAIGHT, Ph D  
Lecturer, The Graduate School  
U. S. Department of Agriculture

THE UNIVERSITY PRESS OF WASHINGTON, D.C.

WASHINGTON 4, D.C.

Copyright 1954 by  
A. J. Wraight

Library of Congress  
Card Number 54-12582

PRINTED IN THE UNITED STATES OF AMERICA



# CONTENTS

Introduction

Chapter I: The Place of Field Study 1

Chapter II: Sources to Check Before Field Study 4

Chapter III: Choice of Field Method 18

Chapter IV: Field Equipment 23

Chapter V: The Field Investigation 51

Chapter VI: Multiple Feature Mapping 69

Chapter VII: The Field Report 77

Selected References

Appendix:  
Stadia Tables

Index



# ILLUSTRATIONS

Fig. 1: Status of Topographic Mapping in the U. S.	9
Fig. 2: Description of Triangulation Station and Bench Mark	12
<u>Special Insert:</u>	
Portion of a Topographic Map	15
Air Photo Showing Approximately Same Area	16
Fig. 3: Compass Face at Two Attitudes	25
Fig. 4: Magnetic Declination Chart of U. S., 1945	27
Fig. 5: Locke and Abney Hand Levels	29
Fig. 6: Protractor and Dividers	31
Fig. 7: Brunton Hand Transit	33
Fig. 8: Plane Table and Alidade	35
Fig. 9: Fields of Vision in Alidade Telescope	38
Fig. 10: Three Arm Protractor - Steel Type	44
Fig. 11: Transit	45
Fig. 12: Vernier	46
Fig. 13: Dumpy Level	48
Fig. 14: Traverses, Showing Side Shots, Check Points, and Intersections	55

<b>Fig. 15: Adjustments for Error in Vertical and Horizontal Closure</b>	<b>62</b>
<b>Fig. 16: Field Map Using Fractional Code</b>	<b>76</b>
<b>Fig. 17: Smooth Map of Associations on Fig. 16</b>	<b>76</b>

## INTRODUCTION

This work was undertaken as the result of encouragement by many of my associates in the fields of geography, law, engineering, biology, and real estate brokerage. In my seven years of field study, and in my consulting activities, I have had the opportunity to initiate many people into field work, and, through constant revision, I have found the procedure described in this book to be most effective. Many of my proteges have exhorted me to publish this procedure, as have many others who were only observers. It is out of this encouragement, and in the hope that layman in general may benefit from it, that this work is presented.

As indicated, this book is for the layman. It is not intended for professional engineers, although some of those may find part of it useful. It is aimed at those who would not be lured by more technical works -- property owners, real estate dealers, geographers, lawyers, biologists, economists, and others who deal with the land but do not have technical backgrounds. In fact, the reader of The Field Study of Place needs no special training. He will find it a simple, practical guide in his attempts to find out something about a given area when field study is necessary.

The book is designed also to serve as a text for courses in Field Geography, Field Biology, and an infinite variety of summer or camp field courses. Even the instructors need not have a technical background. The basic text was used successfully for courses in Field Geography and Research at St. Louis University.

So many people have contributed so much toward the making of this work that a specific listing of credit would be cumbersome. I wish to express special gratitude, however, to Mr. Dwight Greene, Engineer, and Mr. Lewis Heck, Geographer, for reading the manuscript and for making numerous suggestions.

Also I wish to thank personnel of the Geographic Branch of the U. S. Coast and Geodetic Survey for aid in the preparation of illustrations. To all the others who helped make this work possible, I wish to express my deep appreciation.

While preparing this text, I received many encouraging letters from prospective users among members of various organizations such as outdoor clubs and speleological groups. The indicators in this book are calculated for employment in field projects within these frames of reference. Even surveying and mapping in caves can be effected by the methods here set forth.

A. J. Wraight

Washington, D. C.  
August 2, 1954

## CHAPTER I

# THE PLACE OF FIELD STUDY

Field study is fascinating. It is the most interesting part of any investigation which has to do with place. It involves getting out of doors, walking or driving through the countryside, seeing interesting landscapes and features, and finding out why things appear as they do. It is the one phase which lifts most investigations out of the realm of humdrum routine and gives them vitality and color.

Yet field study should be productive, particularly if it is a part of the business or professional activities of a geographer, lawyer, economist, biologist, realtor, or any other person who has to deal with place. Often it has to show results, to stand the critical scrutiny of those who may hold the purse strings of a project. It should reveal direction, efficiency and production. In the following pages the field investigation dealing with place is treated so that the investigator can not only achieve these ends but take wholesome enjoyment in his field study.

First of all, it must be understood clearly what is meant by place, field study, and investigation involving place. Place, of course, is a common term and can refer to anything from a building to an entire country. Here, as in most cases, it applies to a part of the earth's surface arbitrarily delimited by an investigation. It may be a whole state, it may be a mining region, or it may be a tract of land comprising a real estate subdivision. Whatever it is, it is down to earth. It is not some elusive fantasy. It is real. It can be seen, traversed and measured.

Field study, then, is the process of seeing, traversing and measuring that particular area or place chosen for investigation. It means obtaining firsthand data and information of details in the area involved. It often comprises making a map of the area showing the location of important features and their relation to each other. It may involve showing the way the land is used in a certain part of the country; it may concern the

location of some devastating nuisance industry near productive farm land; it may deal with occurrence of certain forest formations; or it may seek for the best way to lay out a subdivision on a given tract of land. In short, it is the process of collecting information firsthand from the land.

As should now be apparent, investigation involving place means the overall project which involves investigating the land use of a given area, or the investigation in a law suit involving a nuisance industry, a biological study of certain forest formations, or the project of subdividing a piece of land. These investigations obviously involve place. Many of them require field study. But field study is only a part of the entire investigation. There may be library research and checking of official records involved in the investigation. Often, all that is necessary to know can be ascertained without field study. But frequently information is desired which can be obtained by no other way than going out into the area itself and getting it. That is the part of investigations involving place with which this book deals primarily.

Since field study is just a part of an investigation of place, the question rises as to where in the overall investigation it should come. It must be remembered that field study, although pleasurable, is sometimes time consuming, and should be resorted to only after other sources have been exploited. Naturally, a familiarizing trip through the area in question should be taken at the outset of any investigation, but the actual getting out and doing field study should come after other sources have been consulted and should check and supplement information already possessed. Too often a field investigator, after completing an admirable piece of work, has been confronted with a document showing exactly the information he has worked hard to get in the field, done by another investigator at some previous time. Naturally, it follows that first of all careful search should be made of previous work done in the area. There are many organizations which conduct inspections into special phases of place, and some aspect of the area in question may have been covered by them. Their findings are usually published, and their reports should be found and used. This will make the field study more efficient and will avoid duplication. The sources the investigator should check before field study are given in the next chapter. After he has checked these he can go into the field with direction and work with efficiency.



This is the place of field study. This is where it belongs in an overall investigation involving place. This is where it contributes most to the project involved and to the investigator's personal pleasure and sense of accomplishment.

## CHAPTER II

# SOURCES TO CHECK BEFORE FIELD STUDY

As taxpayers and customers of an infinite variety of businesses, we help support a vast amount of research, and we help pay for the housing of many useful records. Many government bureaus, both federal and local, carry on extensive investigations about the land. Their findings are a valuable asset, and these are available for the asking. It is every citizen's right to use these records, as they are public property, made possible by public funds and housed in public buildings, such as libraries. Even records of private industries may sometimes be of use and should be consulted whenever necessary. These are usually made available very readily, as most managers of industries feel they owe something to the public. Such public and private records are the first sources a person investigating a place should check. A survey of these is given and explained here. Although not every possible source is listed, the number and variety offered are sufficient to help the investigator prepare for field study.

The Public Library. It may seem almost unnecessary to mention this source, since most people have had some contact with a public library sometime or other during their lives. It is surprising to find, however, the extent to which well-informed people actually do not know how to use this common facility. Many have merely visited the periodical room or have asked the desk librarian for specific books. Many do not know of the existence of a card catalogue, much less how to use it. It is with this in mind that a short description of the services the public library offers is given here.

Let us say, for example, that a person owning a large tract of land would like to learn as much as he can about the area. It is a natural thing, as the only way one can use or deal with anything well is to know as much as possible about it. Undoubtedly, he has already ridden through the area, but he gained only a superficial impression of it through that trip. Later,

he may want to go back for closer study or actual field work, but now he wants to find out as much as he can about the property before he goes into the field.

His obvious destination is the public library. The information he desires will not be lying around on periodical shelves, nor can the busy librarian give too much help, particularly since the investigator does not know at this point the specific books for which to ask.

The card catalogue is the first logical place to look. Practically every library has one. It is usually a large case containing a number of small drawers. These drawers usually contain 3x5 inch cards, and each book or article in the library is listed on at least one of these cards. Besides the title, there is usually listed the author, publisher, date and place of publication, number of pages, and a brief statement about the contents of the book. Also, a number is given on the upper left hand corner of the card — the reference number by which the librarian can locate the book.

The cards are filed alphabetically by subject and by author. Usually one case, so marked, will contain drawers full of cards filed alphabetically by author. In short, each book or article in the library will have at least two cards in the card catalogue.

Having no specific authors or titles to look for at this point, the investigator will naturally look first under subject. He knows, of course, in what state and county his area is located, so, logically, he will look under the names of the state and county. From descriptions of the contents of the various books given on the cards he can select those he would like to examine and call for them by number at the desk. If little satisfactory information is gleaned from these books, which are likely to be general or entirely historical, he can then look in the subject file under the names of the specific attributes of place.

By the attributes of place is meant the things which are part of place. This refers to the soil, the weather and climate, the natural vegetation and animal life, the topography, drainage, geologic structure, ground water, minerals, location with relation to other places (markets, etc.), and last, but not least, the people or the works of man on the place. These attributes are usually directly or indirectly interrelated, but

should be sought in the card catalogue under the subjects just listed. Frequently all of these will be interrelated under the title Geography, and that heading should certainly be searched in the card catalogue.

After looking over the various books and articles discovered so far, the investigator is probably able to select those which would be most useful to him. In more careful study of these selected books he will undoubtedly find further reference in their bibliographies. These references he can search in the card catalogue by author. If they are not available at his library, he can make arrangements with the local librarian to get them from a library that does have them by means of Inter-library Loans. This nation-wide system makes it possible for him to tap even remote sources, from virtually any library in the country, public or institutional, and even from the Library of Congress in Washington.

Having exploited the sources offered to him by the library, the investigator has probably gained much information about his place, which will be of aid to him when he goes to the field. Even if very little useful data was afforded, his time has not been wasted, as it has eliminated the possibility that there is a book in some library somewhere containing the information he wants. It has helped to indicate to him just how much he can expect to do when he does go to the field.

In his checking through the card catalogue under Geography, he has undoubtedly found reference to a publication of the American Geographical Society called "Current Geographical Publications." This annotated list is published quarterly, and back numbers are in bound volumes. If they are not available at his library, he should try to get them by Inter-library Loan or visit a library that does have them. This valuable index to sources, which should not be overlooked, lists all geographic publications by area and subject, and it is not difficult for the investigator to check for his area in these lists. There are other indexes in many libraries, such as the periodical guides, which might well be checked.

Government Bureaus. After the investigator is satisfied with his check through library sources, his next step is to take advantage of the vast amount of current and past research carried on by government bureaus. His best approach is to

make contact by letter with the various individual bureaus or the Government Printing Office in Washington. Most of the bureaus which may be of service to the investigator are given below, and the nature of their offerings is indicated. When he writes to the Director of each of these bureaus in Washington, stating his problem, he may feel relatively sure of good response.

THE U. S. GEOLOGICAL SURVEY should be one of the first of these bureaus to be approached. The location of the area should be given, and topographic maps and geologic information should be requested. There will be a nominal charge for these maps and data.

The topographic maps the investigator will receive will be in the form of quadrangles, each covering  $7\frac{1}{2}$  or 15 minutes of latitude and longitude. They are usually printed on scales of 1:62,500 (approximately 1 inch equals 1 mile) or 1:24,000,\* (1 inch equals 2000 feet), and they show the slopes of the land, the drainage, and the works of man, such as roads, railroads and buildings.

The portion of a topographic map shown on the Special Insert illustrates the way these features are depicted. The slopes of the land are shown in brown by contour lines (lines connecting points of equal elevation above sea level). The apparent maze of these lines can be deciphered easily when one realizes that their purpose is merely to show the slopes of the land; they are close together when the slope is steep and far apart when it is gentle. The drainage and other water features are appropriately shown in blue, with roads, buildings and other works of man, in black. Some of these maps even show what areas are wooded by use of a green tint.

These sheets are excellent as base maps for small scale work by the investigator. They show a great deal about the land in themselves, and they are accurate enough to aid in

---

\*There are often other scales used; e.g., 1:50,000; 1:30,000; 1:25,000. These scales merely mean that one inch on the map equals 50,000 on the ground, etc.

identifying various types of land forms;<sup>1</sup> and serve as a reliable base on which to record other data about the area in the field. There are varying degrees of accuracy in these maps, as indicated by figure 1, but even the lowest grade of these is not impossible for use as base maps. As indicated, there are a few parts of the country not covered by topographic maps at all. In such instance, at least one of the other types of maps which will be mentioned later will cover the area and can serve as a base map. A situation like that will require more field work by the investigator when he does go to the field, however.

Other publications of the U. S. Geological Survey for the area may include a geological map, bulletins, and geologic structure sections. These will show the kind of rock underlying the land and the way this rock dips. Descriptions of the various formations are often included to aid identification in the field. A ground water paper may be included, which will tell about the water underground, and a portfolio or a report of the area may be furnished, describing the underlying rock and specifying minerals or mineral potentialities. These may not be available for all areas, but if they are available, they will be furnished, and will be a great help to the investigator.

THE U. S. COAST AND GEODETIC SURVEY should also be among the first agencies tapped. This bureau can also furnish good maps, especially if the area involved is near tidewater. Again, the location of the area should be given, and maps should be requested. If the area is on tidewater, there are excellent nautical charts showing shoreline detail with precision and the depths of water areas. Topographic maps of these areas may also be furnished. If the area is inland, this agency can furnish aeronautical charts, since it makes this type of map for the United States and its possessions. (For aeronautical charts of foreign areas, the U. S. Air Forces should be consulted.) These maps are on a smaller scale and do not show the minute detail afforded by topographic maps, but they are well-made charts and can be very useful if the area involved is large.

---

<sup>1</sup> Various kinds of land forms may be identified, e.g., sand dunes, stream flood plains, etc. If such identification is desired by the investigator, he may find them admirably described in most books on the subject, Geomorphology. An outstanding book in this field is by A. K. Lobeck (McGraw-Hill, New York.)

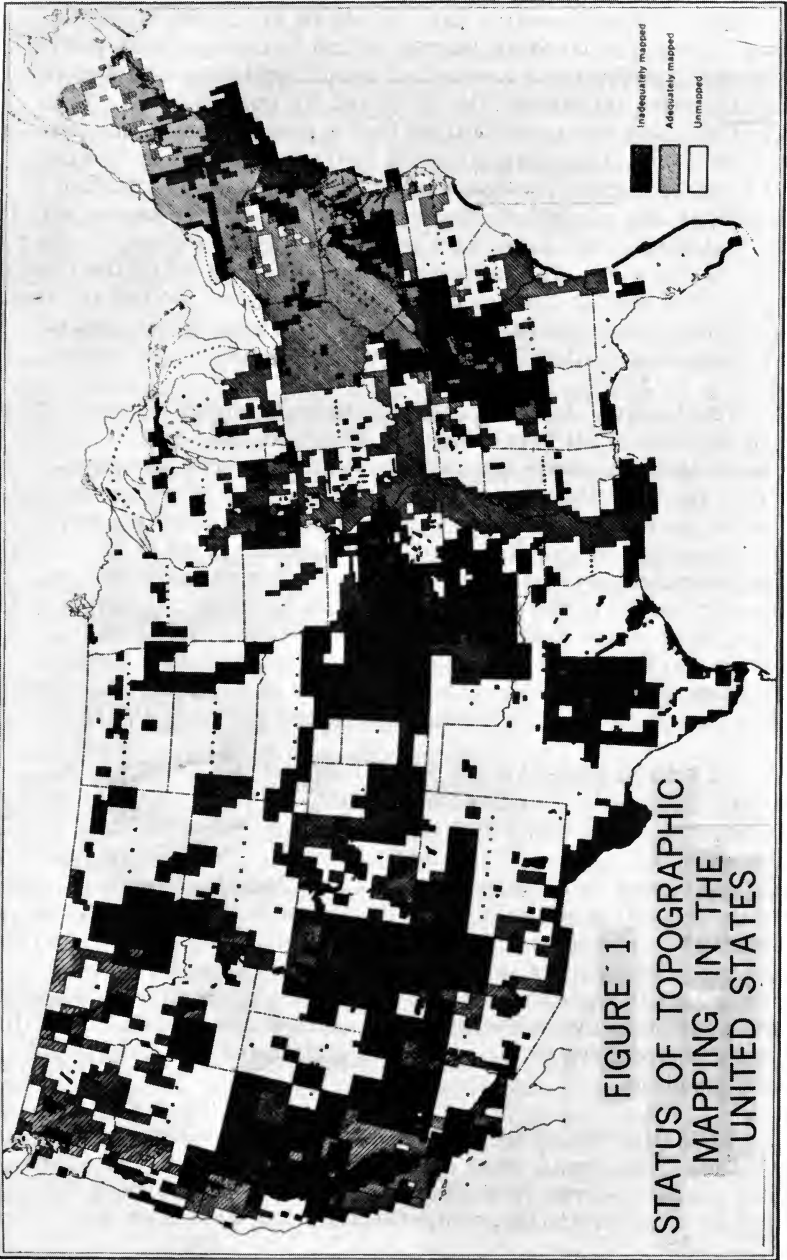

Geodetic and leveling data should be requested from the U. S. Coast and Geodetic Survey which is charged with providing and distributing a network of precision horizontal and vertical control throughout the U. S. and its possessions. The geodetic data furnished will include a position and a description of each triangulation station in the area. These stations are marked places, whose exact latitudinal and longitudinal positions are computed. Such information may be useful if the investigator wants to make a controlled detail survey of all or part of the area. These stations should be plotted on the base map. It is best to ask for a sheet with stations plotted and then scale them onto the base map. However, most maps suitable as base maps will have them shown, e.g. topographic maps.

The leveling data supplied will include elevation description and location of all bench marks. These marked places, whose exact elevation above sea level are known, serve as bases from which the investigator can ascertain the exact elevation of other places in the area. Of course, approximate elevations can be found on the topographic maps of the property, but if more than approximate elevations are desired, the bench mark data will be very useful to the investigator when he goes to the field. Most base maps, such as topographic sheets, will show the bench marks. If not, they should be put on by actual location or from the description. (A description of a typical triangulation station and a typical bench mark are shown in figure 2).

THE U. S. BUREAU OF PLANT INDUSTRY, SOILS, AND AGRICULTURAL ENGINEERING (SOIL SURVEY) and the SOIL CONSERVATION SERVICE should be approached for data on the soils of the area. Frequently a soil map will be available for the county or counties in which the place is located. These maps are extremely useful, as they show soil types in minute detail and are accompanied by a descriptive report, which even gives the usability of the different soil types, as well as description for their identification in the field. If no such map or information is available for the area, then the investigator will likely be referred to the nearest County Agent for help in the soil problem.

THE U. S. WEATHER BUREAU should be asked about weather and climatic data for the area. This agency can furnish actual records from the nearest weather recording station as to precipitation, temperature, wind, pressure, and



## SOURCES TO BE CONSULTED BEFORE FIELD STUDY 11

light. Monthly and yearly summaries can be obtained, as well.

THE U. S. BUREAU OF FORESTRY can furnish excellent forest maps and much detail about the vegetation of the region if the property is in or near a national forest. The maps are exceedingly good and are reliable as base maps.

THE U. S. ARMY MAP SERVICE can supply some quadrangle maps much like those published by the U. S. Geological Survey. (Also the Tennessee Valley Authority.)

THE U. S. ARMY ENGINEERS should be asked about the navigable streams involved. Since these streams are under their jurisdiction, the Engineers can furnish all data as to flow, silting, and flood potentialities.

THE U. S. FISH AND WILDLIFE SERVICE is an excellent source for information about the animal life in the area and the fish in the waters. This data is valuable to more than just sportsmen and resort owners. Information about microscopic animal life is available, and this can be critical to the health of humans as well as to crops.

THE U. S. BUREAU OF LAND MANAGEMENT can be of great assistance in many of these respects, especially concerning the biological aspects of the area. Information here about the vegetation of certain areas may be useful.<sup>2</sup> This agency may also be queried about maps and boundary marks in sectionized country.

THE U. S. BUREAU OF RECLAMATION is helpful with respect to information about its own operational areas, largely in the west. (Also true of the National Park Service.)

THE U. S. BUREAU OF THE CENSUS can furnish most statistical data about man and his activities in the area. A

---

<sup>2</sup> A guide for identification of plant formations may be useful to some investigators. Reference to these can be found in any library. One very useful book is: Plant Ecology, by J. E. Weaver and F. E. Clements (McGraw-Hill, New York, 1938). Also Shantz and Zon "Natural Vegetation", Atlas of American Agriculture, 1924 (see Bibliography).

## FIGURE 2

Ganahl (St. Louis County, Mo., H. W. Hemple, 1931).—In T. 45 N., R. 4 E., on large suburban estate of J. C. Ganahl, northwest of the intersection of Clayton Road and Kehr Mill Road, about 188 feet northwest of near face of east porch of Mr. Ganahl's house, and 54.5 feet west of center line of private road passing along east side of house. To reach from St. Louis follow Clayton Road west about 22 miles to above-mentioned intersection, thence northwest along private road to site. Surface and underground marks are standard disk station marks in concrete.  $38^{\circ}36'36.336''$  N.,  $90^{\circ}34'07.492''$  W.

## DESCRIPTION OF A TRIANGULATION STATION

## DESCRIPTION OF BENCH MARK

Elevation 133.5911 meters

Designation: X 204

State: Missouri

Nearest town: Valley Park

County: St. Louis

Distance and direction from nearest town: 3.5 miles southeast

Character of mark: Bronze disk set in top of a concrete post. Stamping: X 204 1946

Established by: U. S. Coast & Geodetic Survey

Detailed description: At the Weiss Airport, 100.0 feet northwest of the northwest corner of the Administration Building, 31.0 feet south of the center line of an asphalt road along the north side of the field, 16.0 feet west of and about level with the center line of the west entrance drive and 1.0 foot north of a 4" x 4" market post. A bronze disk set in the top of a concrete post which projects about 2 inches above ground.

## DESCRIPTION OF A BENCH MARK

population census made every ten years is published in volumes which may be consulted at the Public Library. In addition, a census of industry is made at irregular intervals, as well as one of business. These are bound and likewise may be consulted at the library. The published data, however, are often summaries, so it is advisable to write to the Bureau direct for more detailed information. It is best to delimit the area and to ask for all census data concerning it. Many useful facts will be supplied. Even if there is very little of this information to be recorded in the area involved, it is extremely useful to know these things about similar adjacent areas, so queries should be worded accordingly.

THE PRODUCTION AND MARKETING ADMINISTRATION, U. S. DEPARTMENT OF AGRICULTURE and the MAP INFORMATION OFFICE, DEPARTMENT OF THE AIR FORCE should be asked for air photo coverage of the area. If photos are available for the property, and are not restricted, they will be furnished at a nominal cost. These pictures can be extremely helpful in the field, since they enable the observer to ascertain the character of the area from certain vantage points, without having to undertake the almost impossible task of visiting every single corner of the property. They can in some instances be substituted for maps.

These photos can be used to advantage even before going to the field. Cultural features such as roads can be seen readily and drainage can be made out as well as such factors as differences in vegetation. These things can be sketched on to the base map, if they are not shown already. This must be done with a certain amount of care, however, since the scale of the photograph and that of the base map may be different. The approximate scale of the photos should be known, and that of the base map will be shown thereon. The ratio of the differences in scales between the photos and the base map should be applied when transferring detail. If an equal distance is two times as large on the base map as on the photos, then all distances scaled from the photos to the map should be expanded double.

The Special Insert shows an air photo and a prototype topographic map. These illustrations can be helpful to familiarize the reader with the use of air photos, but the best and surest way is to take the photos to the field. The investigator

sketches on the base map all that he is sure of beforehand, of course, but it is in the field that the photos can be of most service. Here, identification of a certain tone on the photo with a certain type of vegetation may enable the investigator to ascertain with confidence the extent of that vegetation type throughout the entire area.

Although this is not a complete list of government bureaus and their services, it will help to find the most critical material. If more material from this type of service is needed, the investigator can expand his search easily, especially from references given in the materials offered by the agencies mentioned above.

State Bureaus. These offices can furnish valuable data, and if the investigator needs them, he should certainly use them. The State Highway Department should certainly be asked for road maps, particularly County road maps for the areas involved. These are often very good products and can be substituted for base maps if up-to-date topographic maps are not available.

Private Business and Industry. This source of information is often overlooked. It is extremely valuable, and should certainly be investigated before field work is begun. Perhaps a mining or quarrying company is or has been working in the area, or a lumbering company may have exploited the property. An infinite variety of private concerns may have had something to do with the area. The names of these companies are available at the County Recorder's Office. The extent of their exploitation of the property may be learned, as well as the potentialities not yet tapped. The nature and value of the resources they dealt with may be ascertained in detail not available through other sources.

County Offices. As mentioned before, the County Recorder's Office should be visited. If there is any concern about property boundaries and the like, this office and the County Surveyor can be of help. Also, very often there is a County Farm Agent who can be of great help concerning agriculture in the area, and he may have useful air photos. The County Clerk's office may be of help, also, as well as a variety of other local offices. These sources should not be by-passed.

Lucia

Creek

MONTEREY

Rock

10

S

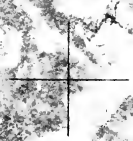

500

*Special Insert TOPOGRAPHIC MAP (Corresponding Air Photo)*  
**NOTES AND SKETCHES.** In field mapping, since projects are variable, the investigator himself must ascertain what notes he wants to make. He is sure to record seasonal changes and other circumstances not recordable cartographically. Field sketches, usually made in the notebook, are drawings designed to highlight significant features, frequently without much regard for scale. Such information is then transferred to the base map.

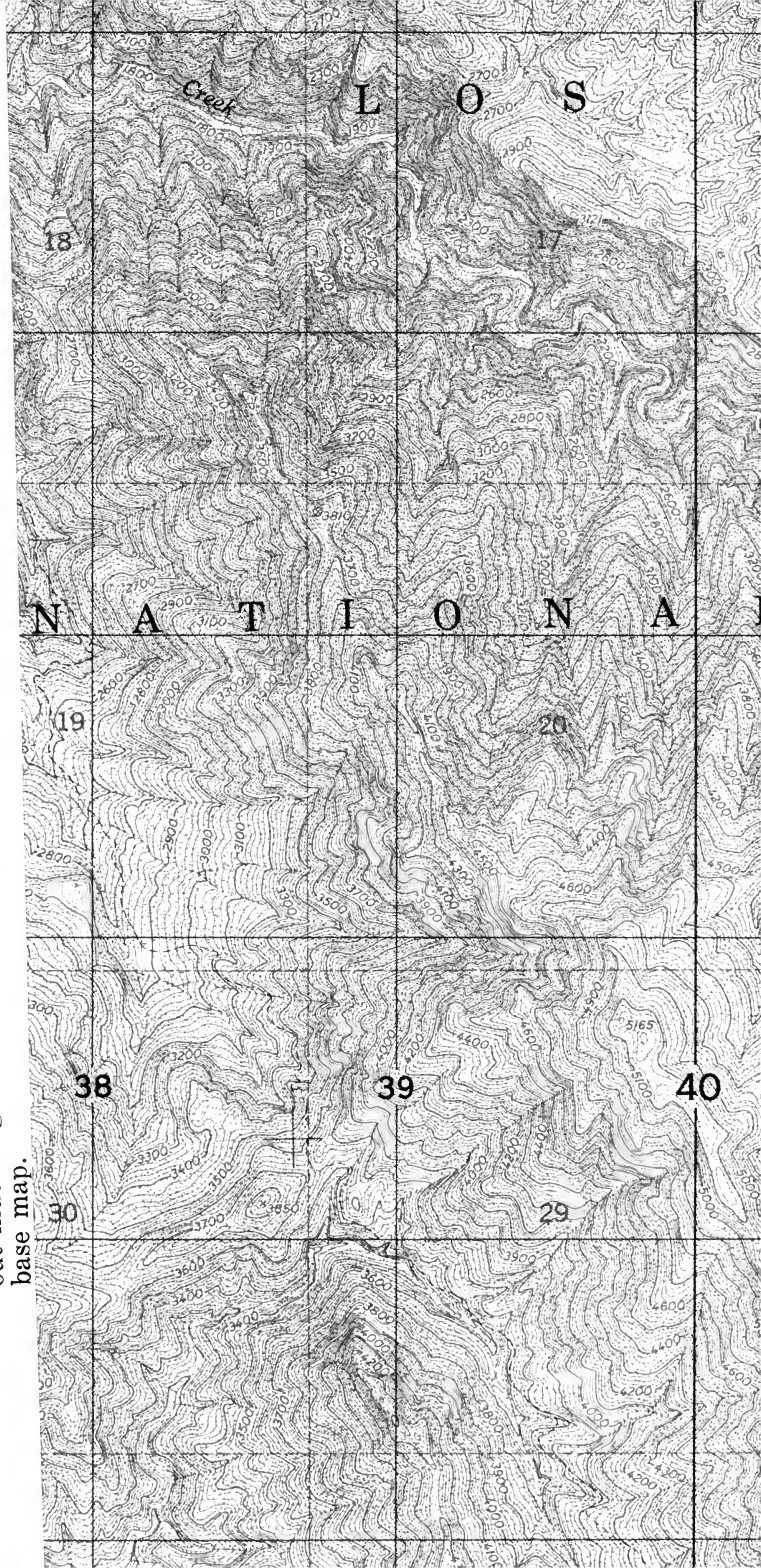



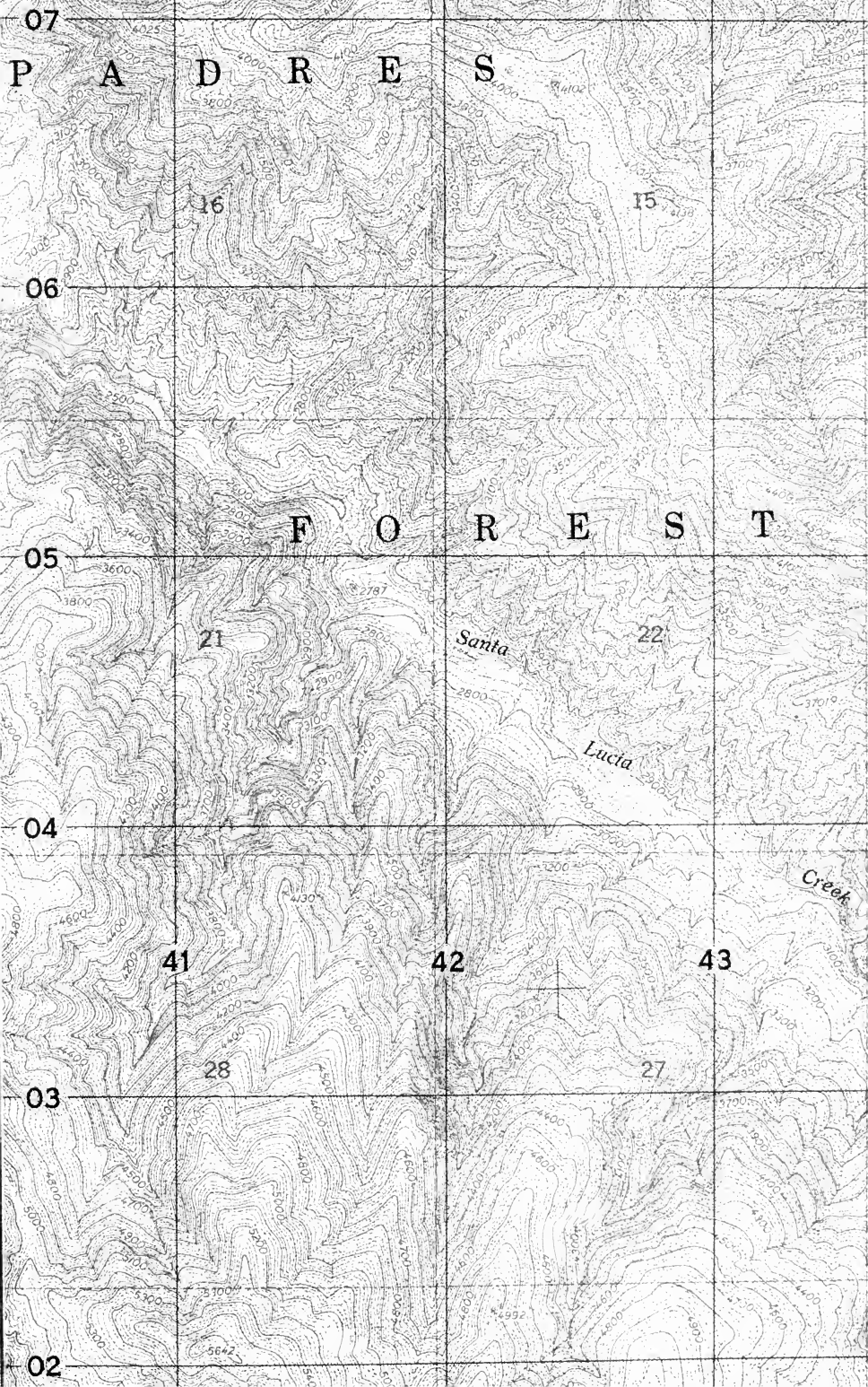

07

P A D R E S

16

15

06

05

F O R E S T

21

22

Santa

Lucia

04

Creek

41

42

43

03

28

27

02

3787

430

4992

5642

Lucia

Creek

MONTRENY

South

Park

PARIS





*Special Insert* AIR PHOTO (Corresponding Topographic Map)

PHOTO MAPPING. If mapping is done on air photos, data can be scaled to the base map after completion of field work. Features such as roads and triangulation markers, identifiable on both, aid this operation. Such transference is sufficient for most projects. If more precise compilation is desired, obtain from Superintendent of Documents, Washington 25, D. C.: *Topographic Manual, Part II, Photogrammetry*, U. S. Coast and Geodetic Survey Special Publication 249.

Local Informants. Although this source can sometimes be considered a part of actual field work, it is here viewed as preparatory. Nevertheless, it is an important source, and a wise investigator will not overlook it. County officers can usually guide inquirers to these local inhabitants, who, for some reason or other, have made some surprisingly good whole or partial studies of the area. Such work should be appraised and used according to its merit. It is surprising how many local studies are really good.

The foregoing is admittedly sketchy, but this guide does not purport to be a full treatise on research. The suggestions are made to aid the investigator in his preparation for field work. If he explores these suggestions, he will gain a great deal of information about his area which will help him in his field work. Before he is through, he will be led to many sources not mentioned here through references by the sources given. Thus, the present list may be considered as key sources.

It is possible that the investigator may find all the data he needs from these sources and will not have to go to the field. More than likely, however, he will see at this point that there are large gaps in his data.<sup>3</sup> These are the things which should be filled in by field work. This, and spot checking all the information gained, is the real province of field work.

At this point the investigator knows where he is going. He knows what has been done before, and he knows what has to be done in the field. He has probably recorded much of the data on a base map, which he can take to the field with him. He has made the biggest stride in preparing for the field, so he can work with direction and efficiency when he goes there.

---

<sup>3</sup> It may be that he is concerned with only one of the aspects of the area, e.g. soils. After checking the specific sources dealing with that phase, he will probable see the need for some supplementary field work.

## CHAPTER III

# CHOICE OF FIELD METHOD

With a clear knowledge of what he has to do in the field, the investigator is now ready to decide on how he is going to accomplish his task, to select his field method. This choice is contingent upon several things; first, as indicated before, the amount of work that has to be accomplished; second, the size and shape of the area involved; third, the amount of time at his disposal; fourth, the finances available for him; and fifth, the degree of accuracy desired in the results. These contingencies come in various combinations, a different one for almost every area undertaken, but generally one of four methods of accomplishing the task is acceptable. The four methods found most useful are: The Reconnaissance, The General Method, The Semi-Detail Method, and The Detailed Method.

(1) The Reconnaissance. This method is not designed for accuracy and should not be considered where highly accurate results are demanded. It is expedient, however, when only a quick rough survey of the area is needed. It is good, too, for extremely large areas, or for peculiarly shaped tracts traversal of which necessitates considerable travel. It is the least costly method and is often selected as an initial field survey. Very often the investigator gets all he needs with this method. Yet again, he may get most of what he wants in this manner, and, from that survey, be able to select those parts of the area that need more accurate attention. It is certainly the method to be selected if the investigator is still in doubt about the degree of accuracy needed. He can see from the findings in his reconnaissance if that satisfies his demands. If it does not, he has lost nothing, since he can use the knowledge of the area gained in the reconnaissance as an aid to his more accurate surveys later. In brief, this is a rough survey, a method of covering large areas in a short time, where accurate results are not required.

A more detailed description of how to accomplish this method in the field will be given in Chapter 5, but a general picture of the nature of the method is presented here to aid in selection. If, for example, a man has a tract of land comprising nearly a hundred square miles. The area is virtually a wilderness, with no paved roads and no human habitation. The investigator has been able to find little about the area from published sources and has very little time at his disposal. He has no good base map of the tract, except a road map which shows roads surrounding the area but leaves a blank space for the tract itself. The map, however, shows latitude and longitude and can serve as a base map. The investigator is faced with the difficult task of getting all the information about the area from the field, and at a minimum of time and cost.

Naturally, in accomplishing his task he cannot hope to attain very great accuracy. He will have to use the reconnaissance method and generalize on his findings. He cannot hope to locate features exactly, or show boundaries of tree, soil, geologic, or other formations with any great degree of definition. He will have to be satisfied with locating them reasonably near their actual true location.

Without going into the details of the actual process at this point, let it suffice to say that he will have to traverse the area by some way of conveyance like a horse or jeep. He will have to measure distances by some rough means, like the speedometer on his jeep, and he will have to obtain elevations from some relatively accurate instrument, like an altimeter. He will not be able to cover the tract completely. He can only traverse it at different places, and mark changes in soil, geologic, tree or other formations as he goes along; then he can sketch the boundaries between the points on his traverses. When he is finished he will have a good overall picture of the area, but naturally it will not be very accurate. However, it will serve the purpose if he is satisfied with that type of result in terms of the project requirements. The reconnaissance method is certainly the one to choose in cases like that, and, as indicated before, this kind of survey can serve as a base for planning more accurate surveys later.

(2) The General Method. If more detail and accuracy is desired than can be obtained in reconnaissance, and yet time and funds are meager, this method should be selected. It is

so called, not so much that the results obtained are general, but rather that it is in general use by the layman. It usually serves his needs well as to accuracy and cost, and the operation is simple enough for him to do the work himself without special training. The instruments for this type of survey are relatively inexpensive and easy to operate. Those for the more accurate surveys are often more than four times the cost of these. Areas nearly as large as those recommended for reconnaissance may be undertaken, and the survey can be accomplished in only a slightly longer time and at only slightly more cost. Yet the results are considerably more accurate, and a vastly greater amount of detail may be obtained. This is the kind of survey usually recommended to those for whom this book is written.

The accomplishing of this survey will be dealt with in Chapter 5. What is presented here is merely an aid in selection of method. Let us assume that the investigator has a tract of land slightly smaller than the one mentioned for reconnaissance, that it is similarly a wilderness, and that the only sheet for a base map is a road map showing roads around the edge of the area, like the one described for reconnaissance. He will traverse this area, as in reconnaissance, either on foot or by some means of conveyance like a jeep, measuring distance by pacing or odometer and direction by compass. He will carry his base map clipped to a board and will sketch in detail, with control, right in the field. He will obtain his elevations by hand level. He will use a hand level with a vertical arc attached, so that he can obtain elevations of places without actually visiting them. Likewise, he will secure location of these places without occupying them, by graphic means on his board oriented by compass. Thus he will obtain much more detail than in reconnaissance, without spending much more time.

When he is finished he will have a fairly accurate and fairly detailed picture of the area. The results will satisfy most general requirements, and there will be no strain on any budget. This is certainly the preferred method for the layman.

(3) The Semi-Detail Method. This is a more accurate survey. It can usually be performed within a reasonable length of time and at moderate cost. It is designed for medium sized areas, about half the size of tracts where the General Method is chosen, and where the funds available are more than treble.

This method is more desirable for areas which are more compact in nature and where not such great distances have to be traversed. It can serve well where no work has been done in the area previously, or to check and supplement previous work.

Again, the actual working of this method in the field will be given in Chapter 5, but a brief sketch of its nature is given here to help selection. The area involved here is, say, less than fifty square miles, and the investigator has reasonable funds with which to work. There are some paved roads in the tract, a fairly good road map is available for a base map, and there are horizontal and vertical control in the area. He has ample time to do the project, and the desired results are such that features should be located fairly accurately.

Naturally, the investigator will choose the Semi-Detail Method in a case like this. He will traverse the area largely on foot, and he will use instruments which will procure some degree of accuracy, such as an alidade to measure distances and differences in elevation, supplemented by a marked (stadia) rod. He will traverse the area rather completely, taking elevation and marking changes in soil or other formations at critical spots as he goes along. He will usually have a helper along to hold the rod and help carry instruments. When he is finished he will have a good and reasonably accurate picture of the area.

(4) The Detailed Method. This method is designed for a high degree of accuracy and should be selected when precision is demanded in the results of the work. It is a slower process than the others and, of course, more costly. Naturally, unless unlimited time and funds are available, it should be relegated to small, compact areas, or to special portions of a larger tract. It is most effective in places where there is already a good deal of information available, but where more precision is desired. It can, however, be used in areas where little has been done before.

The workings of this method will be treated, along with the others, in Chapter 5, but, as in the case of the others, a thumb-nail sketch is given here. The area in this case is, for example, only a few square miles, and there are considerable funds available. There are good roads in the area and good topographic sheets for use as base maps. In addition, there is an abundance of horizontal and vertical control. The investigator has plenty

of time to do his work, but his results have to be accurate. He is trying to work out a plan, let us say, for diverting drainage on his property. Naturally, slight differences in elevation and position are critical in a case like this, so he chooses the Detail Method. His base maps, although good, are not at a scale large enough for his purposes, so he uses this method to supplement them and gain his desired accurate data.

Again, he will traverse the area on foot, and he will use instruments which will secure him a high degree of accuracy. He will use a level for elevations, and he will measure distances accurately with a steel tape. He will have several helpers, as measuring with a tape (chaining) is a tedious task. He will cover the area completely, taking nothing for granted, and locating all objects and changes in elevation, boundaries, etc., very accurately and to their fullest extent on his base map. When he finishes he will have an accurate and concise picture of the tract, one on which he could lay out most detailed plans.

Thus the selection of method depends on what the investigator has to put into the project and what he wants from it. One of the four foregoing methods will satisfy his needs; they will all be treated at greater length in later chapters.

## CHAPTER IV

# FIELD EQUIPMENT

After choosing his method, the investigator is ready to equip himself and go into the field. His equipment will depend largely upon the method he has selected. Certain basic items are peculiar to each method, and these items are described briefly here, along with suggestions as to how to use them. The instruments are designed for three major purposes: to measure direction, distance and elevation.

There are several reliable companies from which this equipment can be obtained by mail. One is the Dietzgen Company of Chicago; another, the Keuffel and Esser Company of New York, and still others, the Gurley Company of Troy, New York, the Wild Company of New York City, and the Elliot Instrument Company of Pittsburgh. Their catalogues are available for the asking, and items may be ordered by numbers. In addition, in almost every large city stores representing these or all companies may be found in the classified telephone directory under the heading "Engineering Supplies". In many cases the instruments may be rented. With most instruments will come instructions as to care and use, for example, how to set a compass needle for magnetic declination. Such instructions, handbooks, or circulars should be requested at the time these instruments are purchased or rented.

1. The Reconnaissance. If this method is chosen, the investigator will need the following basic items:

- (1) Compass
- (2) Altimeter or hand level
- (3) Odometer
- (4) Watch
- (5) Base map (and air photos, if any)
- (6) Plotting scale and dividers
- (7) Protractor
- (8) Pencils and notebook
- (9) Means of transportation (optional)



When he learns how to use his equipment, he is ready to go out into the field and do his reconnaissance.

(1) The Compass. This instrument is basic in reconnaissance. It measures direction, and it is necessary to know what direction one is going at all times when traversing an area, particularly a wilderness tract. In brief, a compass is an instrument shaped like a watch lying on its back. Instead of the hours, the edge of the face is graduated into the 360 degrees of a circle, and instead of the hands there is just one free swinging arm all the way across the face and balanced in the middle. This arm always points toward magnetic north. At the top of the face is marked North (N), at the bottom South (S), at the right (where 3 o'clock would be) is marked West (W), and at the left (where 9 o'clock would be) is marked East (E). Across the glass atop the compass (or on the lid folding out adjacent to it) is a line between North and South, or continuous with it, which is the "direction line" (Figure 3). (The compass described here is the Forestry type).

The use of the compass is simple. The user merely holds it face up in his hand and keeps the direction line, or the letter N on the compass face, pointed the way he is going. The free-swinging arm will do the rest; it will point toward the direction in which he is going. It is best to read the directions relative to North or South. If the arm (better called the "magnetic needle") is pointing between N and W, the reading will be North- so many degrees West; if it points between S and E, it will be South- so many degrees East. Care should be taken that no large metal objects are near the compass while taking a reading, as they may influence the magnetic needle.

It is necessary to keep in mind magnetic declination when using the compass. This is advisable because the compass points to the magnetic north rather than the true north. If the differences are great, then the number of degrees of declination need to be added or subtracted from the compass reading, depending on the case. Figure 4 gives the declination zones in the United States, the number of degrees of declination in each zone, and indication as to what is East and what is West declination. If, for example, the area is in West declination, which means that the magnetic needle will point a little West of true North, then the number of degrees of the declination should be added to all readings between N and W and S and E; correspondingly, they should be subtracted from readings

FIGURE 3

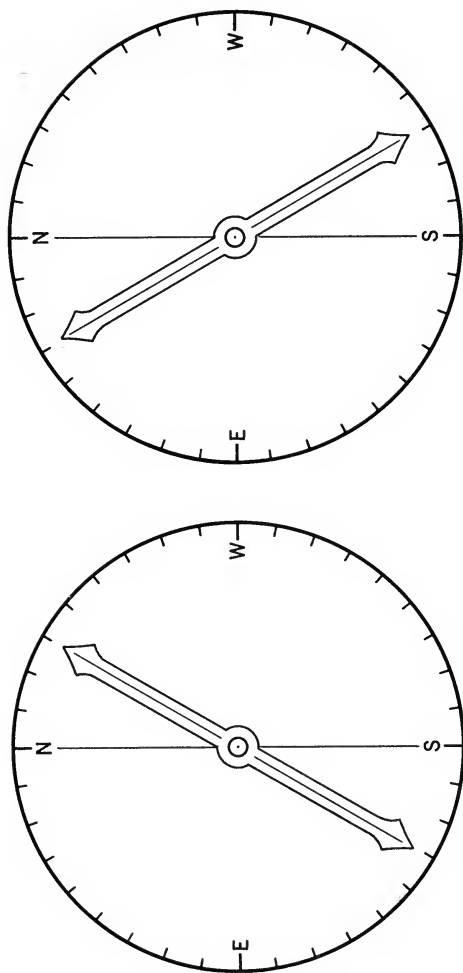

COMPASS FACE AT TWO ATTITUDES

between N and E and S and W. The compass can be set for magnetic declination at the beginning of the work, so that this adjustment will not have to be made with every observation.<sup>4</sup>

Thus the investigator can keep a record of his direction and change of direction throughout his traverse. This is important in reconnaissance as in the other methods.

(2) Altimeter and Hand Level. These instruments are designed to measure differences in elevation. They do not produce the most accurate data possible, but they are good enough for the results demanded in reconnaissance.

(a) The Altimeter is an instrument which is sensitive to changes in atmospheric pressure. Thus, when it is carried from lower to higher elevation (or vice versa) it shows the difference in pressure and, hence, the difference in elevation. Corrections are sometimes made for weather conditions, such as diurnal changes in temperature and atmospheric pressure. The results are gratifying, particularly as to the area that can be covered with it in a day. There are two outstanding types of this instrument, the Aneroid and the Paulin, the latter being the more accurate. These instruments are excellent to use when traversing the area in some sort of conveyance, like a jeep.

(b) The Hand Level is best used when going over the tract on foot. It is a small metal tube with a cross hair at one end and a level bubble which can be seen hovering near the cross hair when the tube is held near horizontal. When the tube is held to the eye and leveled to where the bubble and cross hair coincide, then the object seen on the ground, cut by the cross hair, is the same elevation as the eye of the user. Therefore, to use this instrument the investigator need only to ascertain the height of his eye (his H I) above his feet; then he can stand on a known elevation and measure up a slope by locating with his hand level an object the height of his eye, and then occupying that object and locating another the height of

---

<sup>4</sup> This may be accomplished by screwing the back off the compass and rotating the face (while the compass is held steadily with the direction line pointing North) the direction and number of degrees of the declination, then clamping and replacing the back.

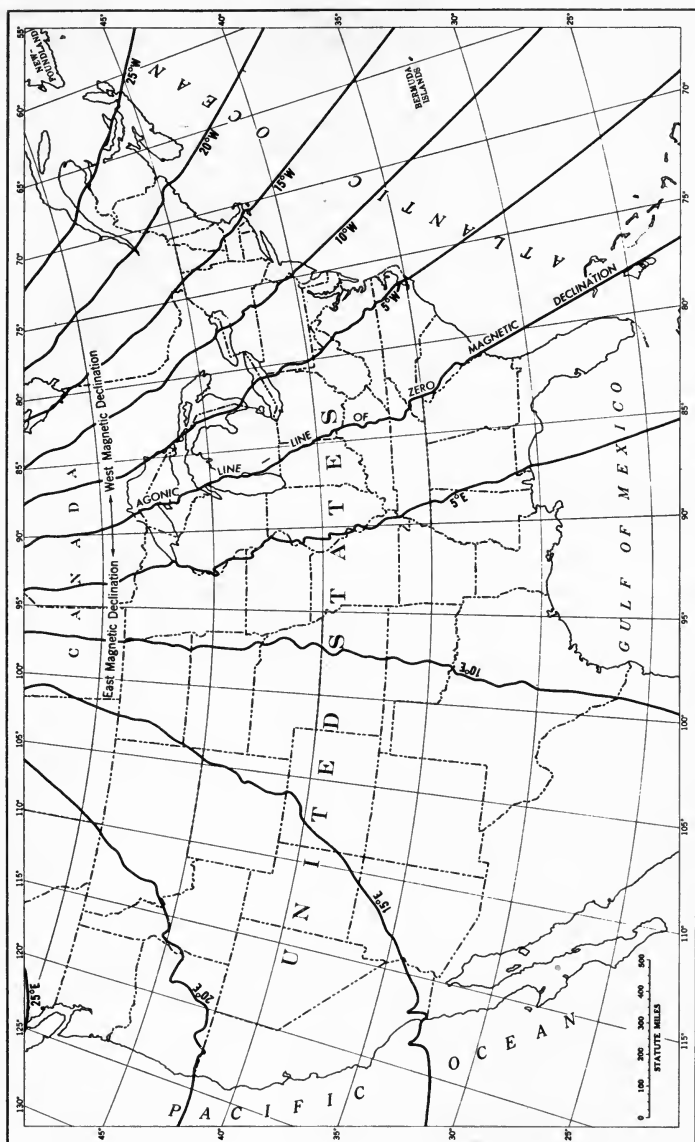

Distribution of magnetic declination in the United States for 1945.

FIGURE 4

his eye higher, and so on. The reverse of this can be done in measuring down a slope. When ordering an instrument like this it is best to refer to it as the Locke level (Figure 5).

If one is desired which has a graduated arc on it and can be tilted so that the angle between horizontal and the top of some elevated object can be read, then the Abney level should be procured (Figure 5). This level is very handy for ascertaining the height of features which are difficult to climb, like a cliff. The observer need only to hold the bubble level and then raise the tube through degrees of the arc until he can see the top of the cliff through it. He thus gets the angle between a line at the height of his eye above the base of the cliff and the top of the feature. He need then only to ascertain his distance out from the base of the cliff, and then he can calculate the height by solving a right triangle, where he knows two angles and a side. He, of course, has to add his H I to the results.

This problem can be handled more easily, however, by merely setting the angle at 45 degrees and pacing out from the base of the cliff to where the top of the cliff can be seen through the tube. The height of the feature will thus be the same as the distance he has paced, as he has a right triangle whose two legs are equal. In this way an Abney hand level can be doubly useful. In all other respects its operation and use is just like that of the Locke hand level.<sup>5</sup>

(3) The Odometer. This instrument measures distances traveled in a vehicle. Most of us are familiar with the automobile variety, the speedometer. It clocks off the distance traveled in miles and tenths of miles. Varieties of this instrument can be attached to bicycles, wagons, or any conveyance on wheels. It produces a rough but rapid measurement of distance.

(4) The Watch. This piece of equipment is valuable in many ways in the field. It has special use, however, when traveling on horseback or donkey. The amount of area covered by the

---

<sup>5</sup> Very often a Brunton compass is used. It combines the functions of both a hand level and a compass. In addition, vertical angles may be read with it, much like with an Abney hand level. It has open sights also, which aid in sighting objects.

FIGURE 5

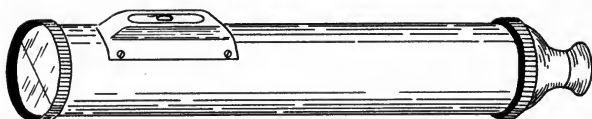

LOCKE HAND LEVEL

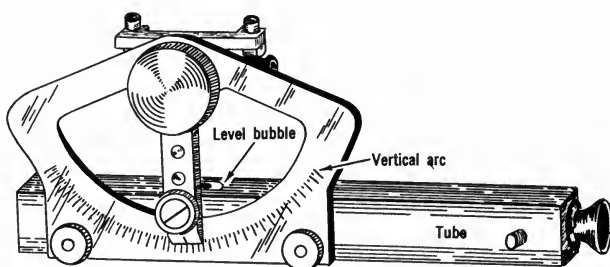

ABNEY HAND LEVEL

beast in a given time at a certain gait can be ascertained; then the watch can tell the rider approximately how far he has gone during any given time, provided he has maintained an even gait.

(5) Base Map and Air Photos. The importance of and details about a base map have already been discussed in Chapter 2. It is important that the investigator take this map to the field with him, as well as any air photos of the area. As mentioned in Chapter 2, these photos can serve best in the field. Their user can determine right on the ground how certain features look on the photos, and thereby locate others like them without actually having to visit them. When spotting these features on the base map, however, he will have to take into consideration the difference in scale between his base map and the photos.

(6) Plotting Scale and Dividers. As previously mentioned, the scale of the base map has to be considered in plotting anything on it, from photos or from actual field measurement. It is best to set up a little graduated scale beforehand for the base map, to carry around in the field. If the scale is three miles to the inch, then a six inch ruler can be used, with divisions much finer than the sixteen divisions to an inch. Thus small distances can be measured off on the map through the aid of this finely graduated plotting scale. The Dividers (two steel points whose distance apart can be adjusted) can be of great aid in this respect (Figure 6). The dividers can be set for the distance on the plotting scale, and the distances can then be transferred by them to the base map.

(7) The Protractor. This instrument is for plotting on the base map also; it is for plotting direction (Figure 6). It is a half circle marked off with the 180 degrees of a half circle. It can be used on the spot in the field to mark changes in direction. The straight part of the instrument, which would be the same as the diameter of the circle, should be laid in a north-south line across the point on the map occupied by the observer, with the center of the straight part on the point. Then the compass reading, which may be north- so many degrees west, or, south- so many degrees east, can be marked off on the map, and a line drawn showing the new direction at that turn in the traverse. Of course, the protractor can be used later to plot on the base map from field notes, but it is more advisable to use it on the spot if possible.

FIGURE 6

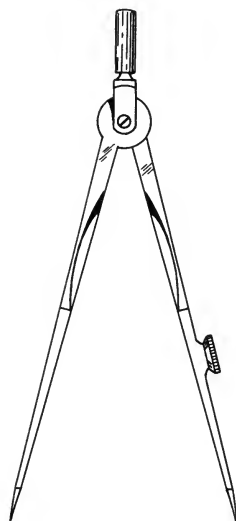
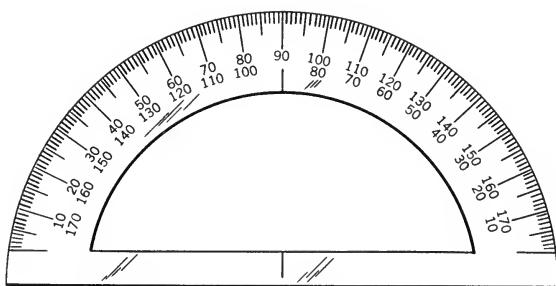

PROTRACTOR AND DIVIDERS

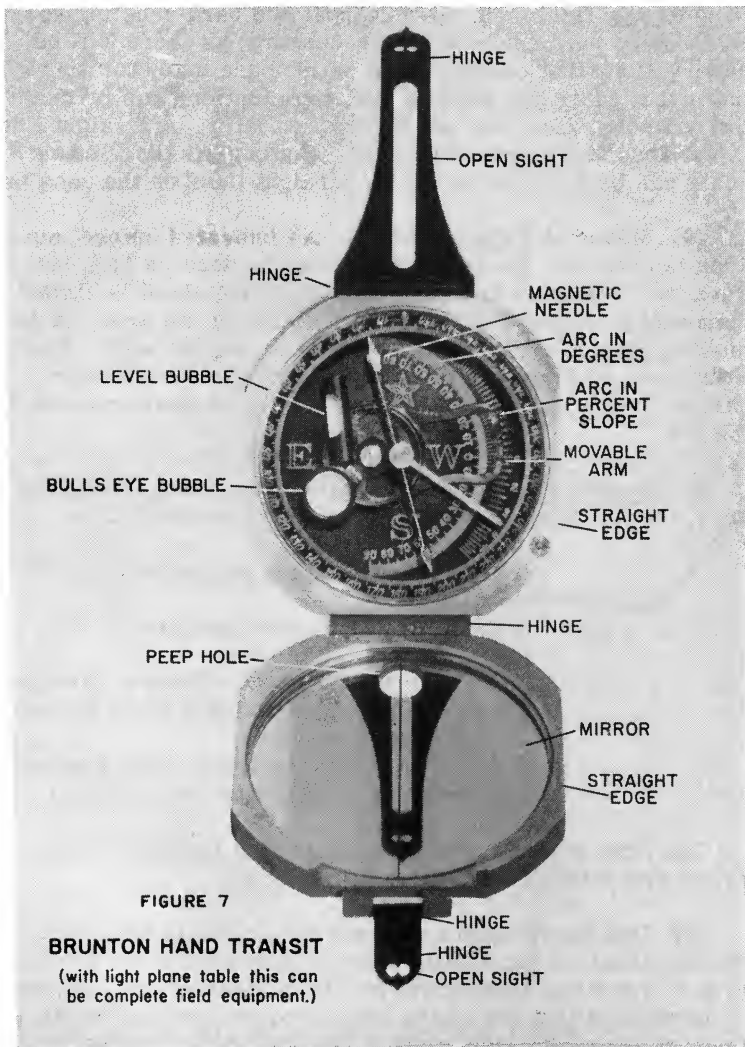



Figure 7

## BRUNTON HAND TRANSIT

This instrument can be used as complete field equipment, particularly with a light plane table. It has the properties of an open sight alidade with its sights and edges. It has value as a compass with the magnetic needle. Also, it serves as a level with its level bubble and arm moveable (in conjunction with the mirror and peep hole). It can also level the plane table with its bulls eye bubble. Vertical angles may be read on the arcs in both degrees and percent, as with the Abney Hand Level.



(8) Pencils and Notebook. These pieces of equipment hardly need be mentioned, but, surprisingly, they are often forgotten by field men. Several soft and hard pencils should be taken along. A notebook is necessary, as there will be observations that cannot be put on the base map, but for which the investigator has definite use. Calculations can be made in the notebook, also, and can be checked later. A Straight Edge is not absolutely necessary to carry along, as the Plotting Scale can be used for laying off straight lines on the base map.

(9) Means of Transportation. As indicated before, conveyance is optional. Reconnaissance can be done on foot, but, if the area is large, a faster means of getting about is almost mandatory. Depending on the passability of the area, an automobile, jeep, bicycle, horse, or donkey may be used. Some tracts are so impassable, however, that the work can be carried on only on foot. Usually the jeep or the horse can do the job.

2. The General Method. Should this method be decided upon, the following equipment should be secured:

- (1) Base map and air photos
- (2) Compass
- (3) Plotting Scale and Dividers
- (4) Pencils and Notebook
- (5) Abney Hand Level or Brunton Compass
- (6) Drawing Board (at least 24 by 24 inches)  
or light plane table
- (7) Stadia Tables (optional) (See Appendix.)
- (8) Means of Transportation (optional)

The first four categories of equipment have just been taken up, so they will not be treated here again.

(5) The Abney Hand Level was described briefly under Reconnaissance, but a little more will be said about it here, as it is a critical instrument in this type of survey. In most respects it is like the Locke hand level, except that it has a vertical arc on its side, so that vertical angles can be read (Figure 5). There is an indicator on the vertical arc and a level bubble attached, which moves the indicator through degrees of the arc when the tube is raised or depressed. If a vertical angle shot is to be taken, the indicator should first

FIGURE 8

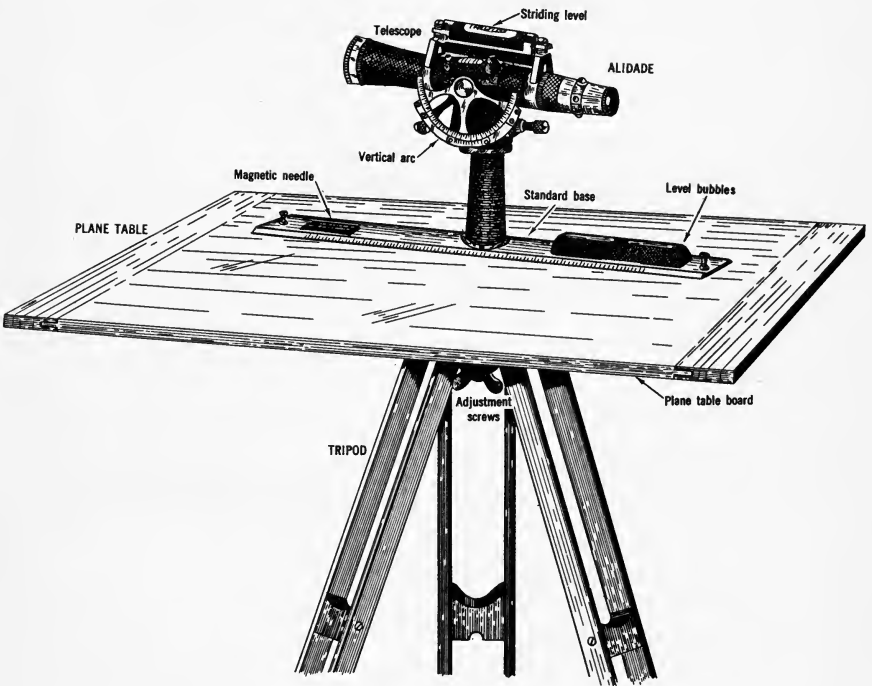

PLANE TABLE AND ALIDADE

be set at zero. In this position the bubble in the field of vision is coincident with the cross hair. Then the level tube should be raised or lowered, carrying the indicator through degrees of the arc while the bubble is held level, until the object sought can be sighted. The bubble, still held in a level position, will coincide with the cross hair, cutting the object sighted when the full angle has been intercepted. The degrees and minutes read on the arc will be the angle of raise and depression. The elevation of an object so sighted can then be ascertained, provided the distance to the object is known and the elevation at the feet of the observer. The angle can be looked up in Stadia Tables (see Appendix) and the Difference in Elevation given there should be multiplied by 1/100 of the distance to the object. The result will be the difference in elevation. The height of the observer's eye above his shoes would have to be added to or subtracted from the result, according to whether the object is higher or lower.

The vertical arc is graduated into percentages, also. (Figure 5). That is, there is a set of graduations going to 100 on either side of the O mark. Hence, percentage of slope can be read. Differences in elevation can be obtained by reading these graduations without reference to stadia tables. The distance to the object should be multiplied by the percentage of slope read on the arc. For example, a 12% upslope is read to an object 600 feet away, and the observer's eye is 5 feet above his shoes. The difference in elevation would be:  $600 \times .12 + 5 = 77$  feet. If the reading is downslope, the elevation would be:  $600 \times .12 - 5 = 67$  feet.<sup>6</sup>

(6) Drawing Board. Such a board, at least two feet square, should be taken along to the field. On this can be clamped the base map. Then in the field the base map can be oriented by compass and held on this sturdy board. If this board is mounted on a light portable tripod it is much better for holding

---

<sup>6</sup> The Brunton Hand Transit (compass) also has an attachment for reading such angles (See Figure 7). Its best feature is that it has open sights for sighting objects. It takes the place of both compass and Abney Level. It is recommended for use with the light plane table. An Open Sight Alidade, which is essentially a straight edge with sights on it, is sometimes used for sighting and drawing lines toward objects when a light plane table is used.

position steady. Such a mounted board is called a plane table.

(7) **Stadia Tables.** It is optional as to whether or not the investigator wants to use these tables in this method. As indicated before, he can use them in conjunction with the Abney hand level, but he may prefer to use the percentage-of-slope arc, as that eliminates the use of tables. A description of how to use these tables accompanies them in the Appendix. They will be taken up again under equipment for the Semi-Detail Method.

(8) **Means of transportation (optional).** A means of transportation may be used with this method, as with all others, so long as a device for measuring distances, like an odometer, is used. This method usually involves work afoot, but a means of transportation can be helpful if the area is particularly large.

3. The Semi-Detail Method. If this method is selected, the basic equipment should be the following:

- (1) Base Map and Air Photos
- (2) Plotting Scale and Dividers
- (3) Pencils and Notebook
- (4) Plane Table and Alidade (with or without Declinator)
- (5) Stadia Rod
- (6) Stadia Tables (or Stadia Slide Rule)

The first three categories of equipment have been discussed under Reconnaissance as items (5), (6) and (8), so they will not be repeated here.

#### (4) Plane Table and Alidade

(a) The Plane Table is a smooth board of varying sizes set atop a tripod, the most popular size being 24 by 31 inches. The connection between the board and the tripod has adjustment screws so that the board may be leveled or turned about so that any given edge can point in any chosen direction. The base map can be attached to this board, and the board can be leveled and oriented so that north on the map points north. Then, with the aid of the Alidade, rather accurate measurements can be made and plotted directly and concisely on the base map right on the spot in the field.

FIGURE 9

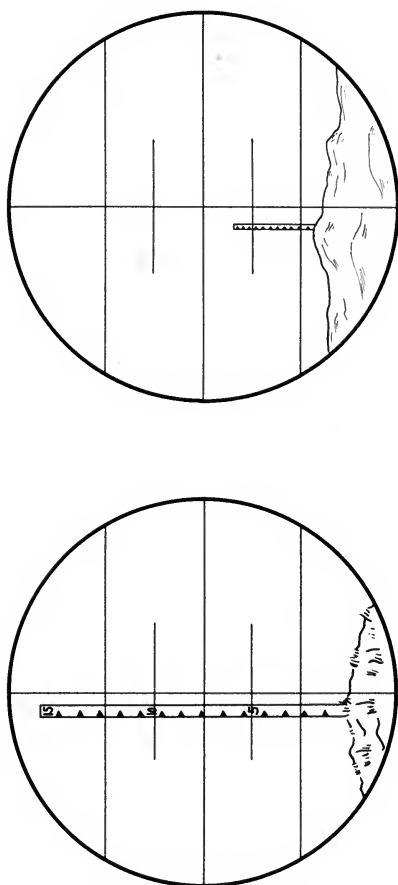

FIELDS OF VISION IN ALIDADE TELESCOPE

(b) The Alidade is an instrument for measuring distances, direction, and elevation all in one, and must be used with a plane table (Figure 8). It is a telescope mounted by vertical standards at its middle to a flat metal base which serves also as a straight edge. The telescope can be swung on its standards to point slightly upward or downward, and there is an arc on its side to indicate the degrees and minutes the scope has been raised or depressed from level. There is, of course, a striding level on the telescope to show when it is level. Correspondingly, there is a small "bull's eye" level on the flat base of most alidades for leveling the plane table. The alidade can be moved about freely over the top of the table, which is handy for leveling the table, as well as for all aspects of work with plane table and alidade. The telescope itself has a vertical hair and a cross hair intersecting one another in the center of the field of view. In addition, it has at least two other hairs, parallel with and above and below the center cross hair. These are called Stadia Hairs and are so set that they read a distance of one foot between the top and bottom hairs on a rod graduated into feet and tenths of feet at a distance of one hundred feet (Figure 9). Thus, distances can be read by this means. If the difference between the hairs is 7.5 feet on the rod, then the distance between the instrument and the rod is 750 feet. In short, all that need be done is to multiply by one hundred readings on the rod. Naturally, if the rod is so far away that it does not cover the distance between the two stadia hairs, then the reading should be made between one stadia hair and the cross hair and multiplied by two hundred. Most alidades have another set of hairs, called Quarter Hairs, which are parallel with and half way between the top stadia hair and the center cross hair. If the rod is so far away that only a quarter hair can be read, then the reading should be multiplied by four hundred (Figure 9).

At the same time that distance is read, elevation and direction may be ascertained by the alidade. If the plane table is level and the telescope level, the reading of the cross hair on the rod can give the elevation of the land where the rod is. The height of the instrument above sea level (H I) can be gotten by having the rod held on a known elevation, and then adding the cross-hair reading to that elevation. Then the rod can be moved around to other spots, and the elevation of these spots can be ascertained by subtracting the cross-hair reading on the rod from the height of the instrument. The direction of the various



shots can be determined and marked off on the base map by placing the edge of the alidade's base on the point occupied while the telescope is pointed at the rod. A line drawn on the map along the base of the alidade will give the direction graphically. This, of course, is contingent upon the fact that the table is oriented so that north on the base map points north.

(c) The Declinator is best for orienting the table. This is a needle which points to magnetic north, balanced in a slender box about six inches long. The edge of this box should be placed on the line on the base map indicating magnetic north, and the table board should be rotated until the needle swings freely to the center, indicating magnetic north. Care should be taken that the declinator is put on the magnetic north line, and not on true north. On most maps suitable to be used as base maps both lines are shown. If magnetic north is not shown, then it should be laid off on it with a protractor, from figures obtained from the magnetic declination map. On most alidades there is a built-in needle, and it should be used in the same way for orienting the table, lining up the edge of the alidade base with the magnetic north line (Figure 9).

All the foregoing is, of course, applied only to the condition where the telescope is kept level, and where a substantial part of the rod is seen in the field of view of the level telescope. If the position of the rod is above or below this field of vision, then the telescope has to be raised or lowered accordingly. This means that the distance read is a slope distance, and the horizontal distance is desired for plotting on the map. Hence, the angle of raise or depression should be read on the telescope's arc, and with that and the slope distance, the horizontal distance can be determined. This can be done mathematically by solving a right triangle, but it is more easily accomplished by using Stadia Tables (see Appendix). These may be obtained also with the alidade, or from an Engineer Supply Store, or from the Government Printing Office, Washington, D. C.

The elevation of the spot where the rod is can be ascertained, too. Knowing the slope distance, the angle of elevation or depression, and the reading of the cross hair on the rod, the investigator can calculate how much lower or higher his reading is above or below his H I by again solving a right triangle. But this is unnecessary, since Stadia Tables or a Stadia Slide Rule can give the answer. Of course, the reading on the rod will have

to be subtracted from the result to get the elevation at the base of the rod.

The foregoing is only a brief treatment of the plane table and alidade. More complete explanation is encompassed in some of the field and technical manuals issued by the Superintendent of Documents, Washington, D. C. If this method is selected, then the investigator should obtain one of these books. They are reasonably priced (about \$1.50) and they may be ordered in individual or quantity lots. Plane table surveying is the subject of numerous books, a recent one being Plane Table Surveying, by Julian W. Low, (Harpers, N. Y., 1952). This book, however, is more costly than the government manuals. Manuals may even be obtained from private concerns, such as the Gurley Company of Troy, New York, which issues an excellent manual on surveying instruments. Some of the government manuals are:

- Technical Manual 5-235, Surveying, Dept. of the Army, \$1.50
- Technical Manual 5-245, (Topography and Surveying), Map Reproduction in the Field, Dept. of the Army, \$ .60
- Technical Manual 5-246, Interpretation of Aerial Photographs, Dept. of the Army, \$1.00
- Field Manual 21-105, Engineer Soldier's Handbook, Dept. of the Army, \$ .25
- Special Publication 85, U. S. Coast & Geodetic Survey, A Plane Table Manual, \$1.50

(5) The Stadia Rod. This piece of equipment has been roughly described previously. It is a wooden or metal strip, about three inches wide and usually 12 to 16 feet long (Figure 9). It has a handle on the back side for steadying, and the front side is marked off in feet and tenths of feet. It is usually painted white with red and black markings, generally triangular in shape, to aid seeing at a distance. The numbers are usually three or four inches high. While they can be purchased at Engineers Supply firms, the user can also make his own. Sometimes this is preferable, as the rod can then be suited to the particular alidade employed.

(6) Stadia Tables and the Stadia Slide Rule have been mentioned in connection with the alidade. Either of these may be

used to ascertain difference in elevation and horizontal distance for an angle shot taken with the alidade. The Appendix to this book supplies Stadia Tables, with directions on how to use them. A stadia slide rule may be obtained from any of the engineer supply firms previously mentioned or from an engineer supply store. Directions on how to use the rule should accompany the package.

At least one helper is needed when using a plane table and alidade. The helper's function is to carry the rod and hold it up for shots at critical points. He is generally referred to as a rodman. One experienced in this work can pick critical points such as tops of hills, bottoms of draws and road intersections without specific instructions, but it is not too difficult to train a novice for this task.

With the above items of equipment the survey of the Semi-Detail Method may be effected most successfully. The results gained with these instruments are usually good, and they generally satisfy the demands for most projects.

4. **The Detailed Method.** If this method is chosen, it is advisable to hire an experienced surveyor to do the instrument work, as it is sometimes rather technical. Also, it is sometimes advisable to rent the instruments, since they are rather expensive. If a surveyor is hired, the investigator can accompany him and point out what shots he wants, while the surveyor and his helpers make the precision measurements.

For this method, the following pieces of equipment would likely be used:

- (1) Base map and air photos
- (2) Plotting scale and dividers
- (3) Protractor
- (4) Pencils and notebook
- (5) Transit or theodolite
- (6) Wye level or Dumpy level (optional)
- (7) Stadia rod or level rod
- (8) Steel tape

Again, the first four categories of the equipment have been treated before, so they will not be taken up here. With respect to the base map, if the triangulation markers and bench marks

(horizontal and vertical control) are not adequately shown, then they should be plotted on the map by means of a three-arm protractor (Figure 10). This device is simply a graduated circle with three movable arms fastened to the center. Each arm is to be lined up with a feature referred to in the description, and the distance given laid off accordingly to the base map scale. When this is done, the center of the circle will be the location of the marker on the map.

(5) Transit or Theodolite. (a) The Transit is the most popular instrument among surveyors. It can perform all the functions of an alidade, and more accurately. It is a telescope mounted on a tripod above a graduated circle (Figure 11). A device called a vernier is attached which enables the circle to be read to minutes, and even half minutes (30 seconds) in some cases. (The vernier is a set of graduations in minutes, and when the reading is made the number of minutes beyond the degree indicated is the number shown where there is coincidence between a graduation mark on the vernier and on the circle. Reading from right to left in Figure 12, the reading would be  $39^{\circ} 33'$ .) Thus, direction can be read with a considerable degree of accuracy on a transit. There is no drawing board on the transit, however, so the directions have to be plotted on the map by protractor, either in the field, or back in the "room" at the end of the day. The direction, or angle of change of direction, is secured by sighting back along a direction one knows (azimuth line), a road, or a line one just traversed, and then turning the telescope on a new point along the new direction. The angle blocked out by this movement is the angle of direction change and is the one to be plotted by protractor on the map.

The telescope has the vertical and cross (stadia) hairs, like the alidade. The telescope can be raised and depressed, too, in the same way, and vertical angles can be read with even greater degree of accuracy. Instead of the vertical arc, as on an alidade, there is a full graduated circle on the transit. If distances are measured by stadia the process is the same as with an alidade. There is a level bubble on the telescope and circular base of the transit too, so level shots may likewise be made as with an alidade. The big difference is that this instrument is vastly more accurate.

FIGURE 10

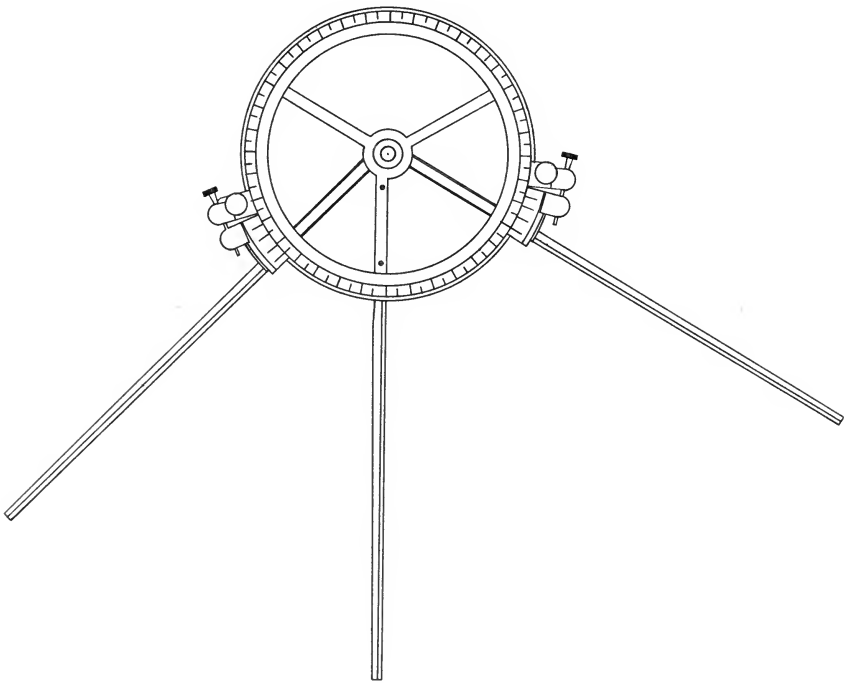

THREE ARM PROTRACTOR - STEEL TYPE

FIGURE 11

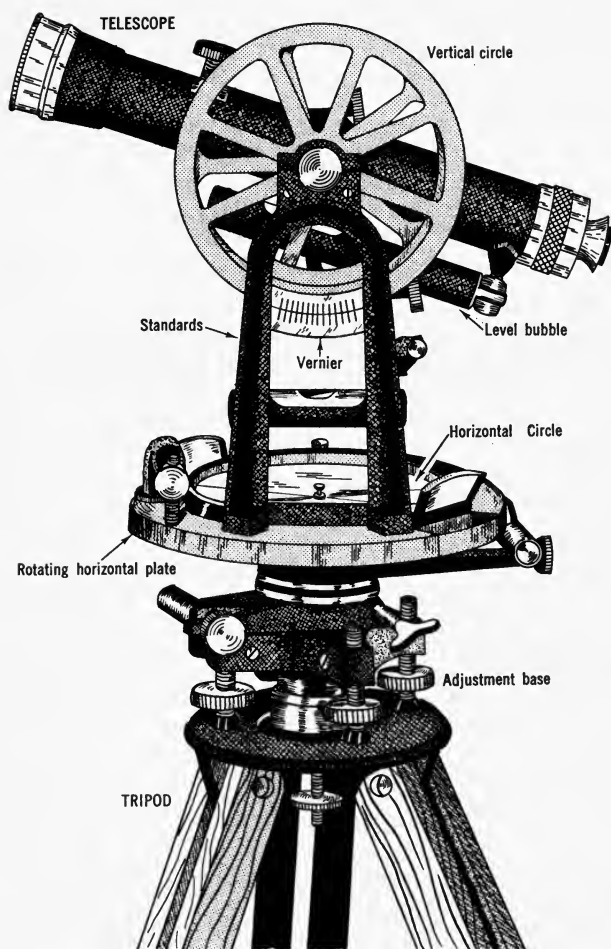

TRANSIT

FIGURE 12

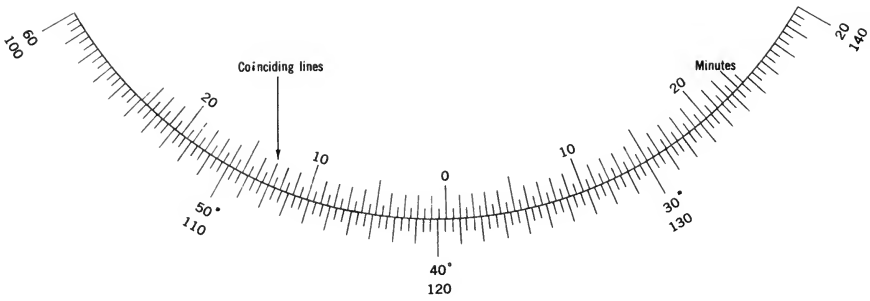

VERNIER

(b) The Theodolite is a transit refined to even a greater degree of accuracy. The basic mechanism and operation is the same, except that the theodolite can be read to seconds and some sometimes to fractions of seconds. It is a delicate and precise instrument, and can give extremely accurate results, if such are desired.

#### (6) Wye Level or Dumpy Level

(a) The Wye Level is a telescope mounted on a tripod in a Wye, and thus can be raised or depressed so that the bubble on the telescope can show level rather precisely. There is a vertical and a cross hair in the telescope, and level readings can be made by reading the cross hair on the rod. Again, level reading on the Wye Level is the same as with the alidade, except it is more accurate.

(b) The Dumpy level is the same, except that the telescope is mounted on an adjustable base, rather than a Wye (Figure 13).

(7) Stadia Rod and Level Rod. The stadia rod has been alluded to before, in connection with work with the plane table and alidade. The level rod is on the same principle, except that it is graduated more finely. A stadia rod can be used with the level, but better results are obtained with a level rod. The Philadelphia Level Rod makes for excellent precision, as there is an adjustable target on the rod, which can be set by the rodman on the point of the exact level reading from directions given by the instrument man. Thus, some of the so-called "human-error element" can be eliminated.

Using the level and level rod may seem useless when level shots may be taken with a transit. If precise results are desired, however, then the instrument best suited for precision in each phase of the work should be used. The transit or theodolite should be used for direction, and the level rod for elevations. This leaves the consideration as to what is best for distance. The steel tape, described below, is generally recommended.

(8) The Steel Tape. This is by far the most precise instrument for measuring distance. It is a flexible steel tape about a quarter of an inch wide and about one hundredth of an inch



FIGURE 13

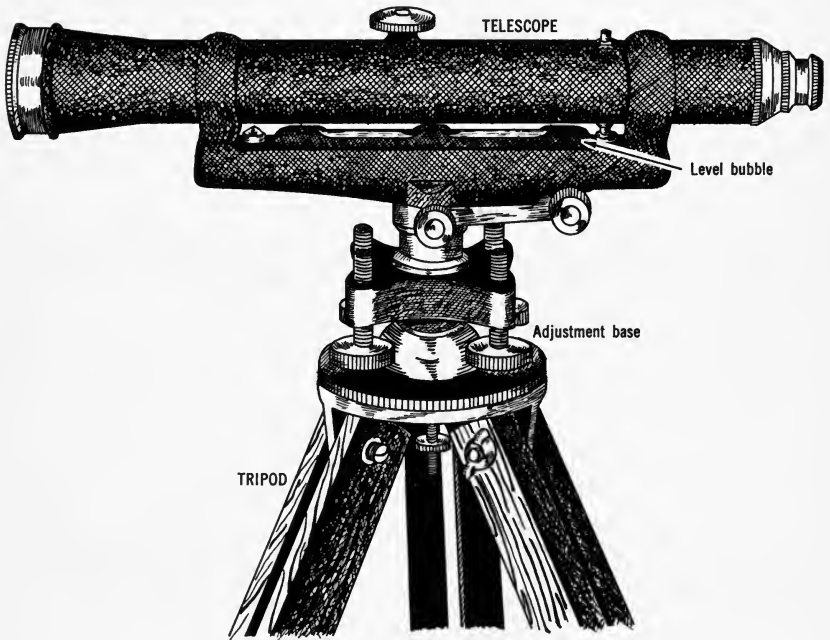

DUMPY LEVEL

thick. It is at least one hundred feet long, and is graduated into feet, and hundredths of feet. It is wound on a reel, which is reversible for rewinding. Distances can be read accurately by this device. The process is the same as measuring distances around one's own home with a cloth tape. Steel is used for precision work, because it is not subject to the distortive stretching characteristic of the cloth tape. There is some little expansion of the steel tape in midday heat, and, in really precise surveys, even this is adjusted. One care which should be taken in using this device is that of making all measurements on the horizontal. That is, when taping up or down a slope the tape should not incline parallel with the ground, but rather it should be held level, so that true horizontal, rather than slope, distances will be obtained. If measurements are made along the slope, then the horizontal distance will have to be obtained by solving a right triangle or from tables.

(9) Plumb bobs, Axe and Stakes are taken along on this type of survey, as they are necessary accessories for obtaining high accuracy. They aid in accurately setting up instruments, accurately marking turns, and in clearing the way for good clear shots.

Using these precision instruments, each for what it can do best, may seem like a tedious task. However, precision is bound to be tedious. The results obtained with these pieces of equipment, in spite of the painstaking care in their use, are as good as can be obtained, and more than offset the effort.

The descriptions and illustrations of the Detailed Method instruments given here are only sketchy, and are not meant to enable the investigator to use them. They are aimed only at familiarizing him with them, so that he may have some idea as to what the surveyor he hires is doing. The instruments and instrument work should be left to the surveyor. Full treatment of such instruments can be found in the manuals referred to in connection with the Semi-Detail Method, should more familiarity be desired.

Although not specifically listed under any one method, the camera is a piece of equipment which might well be taken along, regardless of the method. Pictures of various phenomena may prove invaluable when the investigator later comes to compiling his report.

Now, having chosen his method, and having obtained and learned how to use his equipment, the investigator is at last ready to go into the field. He has made a sound preparation, and, as in most other endeavors, a good preparation almost always assures successful execution of the task.

A Note on Urbanized Areas. Where a portion of the project area is urbanized, the field study is confined to delimiting the different urban functions. Areas predominantly industrial, commercial, residential, recreational, or institutional are delimited. These differentiations are usually recognized easily by the investigator, and the areas are marked on a map without use of survey instruments. Large-scale street maps of such urbanized areas, usually available from the City Engineer, serve well as base maps. If air photos are available, they serve excellently as a base for such mapping. In the case of residential areas, the field man may break the differentiation down and delimit separately areas of tenements, apartments, single unit housing of the row type, and single unit housing of the large yard type. The degree of breakdown is contingent on how much detail is desirable. The big job of the investigator in any case is to cover the area thoroughly so that all functional parts are properly delimited.

## CHAPTER V

## THE FIELD INVESTIGATION

Properly equipped with instruments and knowledge of what has been done in the area before, the investigator goes to the field. He has chosen his method and his equipment. He has fortified himself with knowledge about the attributes of the place. He knows what type of geologic formations to look for, he knows the different kinds of soil to seek, what plant associations to discern, what topographic features to record, and what kinds of land use to anticipate. His problem in the field investigation is to delimit these attributes, to get quantitative measurement of their distribution, to make notes about them, and from this to show their interrelationships.<sup>7</sup> In this chapter, the process and techniques of getting this data by means of each of the four field methods will be discussed.

1. The Reconnaissance. The way the investigator attacks his reconnaissance depends largely on whether or not he has a means of transportation. In either event he would need his compass. However, if he has some means of transportation, he would likely use a barometer for elevations. He would use the odometer for distance if he uses a vehicle, or a watch if he is on horseback. If he is on foot, he has the choice of a barometer or hand level for elevations. In such cases the hand level is preferred. His distances on foot, of course, would be obtained by pacing.

His first step in the field would be to find a starting point and to locate himself with reference to his base map. In or near his area there is usually some definite feature which is shown on the base map, like a road intersection, a confluence of streams, a building, or any other definite feature, which he

---

<sup>7</sup> Perhaps his interest is in only one of the attributes, e.g. plant associations or land use. The methods of gathering the data are nevertheless just as applicable as though he were treating them all.

can use for a starting point. He should also note other such definite features in or near the area and plan a tentative route throughout the tract, so that he will touch these other features occasionally, and still traverse the area enough so that sufficient changes in formations, land use, etc., would be shown to predicate the drawing of lines between these differences.

It is difficult to say how closely to traverse the area, because so much depends upon the size of the tract, but certainly the traverses should not be more than a half mile apart. The touching of recognizable features on the base map now and then is for periodic check of direction and distance. If record of direction and distance has been kept correctly, then the last change in direction as shown on the map would point toward the recognizable feature for which the investigator is heading. Likewise, the distance from the last turn to the recognizable feature should scale the same on the map as it measures on the ground. In reconnaissance, considerable error in this closure is allowed. But an adjustment for this can be made on the map (which will be explained later under the General Method) so that the features located along the line can be brought more nearly into true location. Very often no adjustment is made in reconnaissance, since the demands for accuracy are not so great with this method.

It is desirable that the recognizable features on the map be of known elevation. This is particularly true for the starting point. If the base map is a topographic sheet there will be ample elevations, but, if the map is not, then it is necessary to establish an elevation at the starting point and at some of the check points. This can be accomplished by carrying elevation from some known elevation outside the area, like a bench mark. An altimeter can be used in the case of reconnaissance. In the other methods a level would be used.

Having established elevations at his starting feature and check points, the investigator can check his accuracy in elevation at the same places he checks his direction and distance. If his elevation reading is off at one of his check points, then he has erred somewhere between that and the last point. Again, reconnaissance allows considerable error in elevations. If the investigator wishes to adjust his line of elevations, so that all elevations he has taken along the line can be brought closer to true elevation, he can employ a means described under the

General Method. In reconnaissance, however, such lines are not adjusted unless they are radically wrong.

His criss-crossings of the area are known as traverses, which are simply the courses he takes connecting his stopping points between check points. These stopping points are usually places where he makes observations, and should be indicated on the map by number, along with the lines making the traverse. In his notebook he records his observations by number. As indicated before, the places of observation should be at critical points, like the change in tree, soil, or geologic formations, the tops of hills or confluences of streams, or the change in land use (agricultural land, pasture land, residential land, etc.). If his traverses are nearly one-half mile apart, he will not usually be able to see all the area in between; therefore, he will have to generalize his lines when showing difference such as those in land use regions, when he draws his map. If he has air photos with him, however, the tones on the photos will indicate the continuation of the differences to him, and he may draw the lines more accurately. Upon reaching one of his check points he will see how his traverse closes, as described before, and then start another traverse to a new check point, until he is finished. With his traverses shown on the map and his notes, he will be able to present a fairly good picture of the area from his reconnaissance.<sup>8</sup>

2. The General Method. A reasonably accurate type of survey can be made with a compass, Abney hand level and/or Brunton compass, and base map clipped to a board (on light plane table). The amount of detail obtained and the accuracy achieved are better than through reconnaissance, and yet the cost is low. For these reasons this is the most popular type of survey for the layman.

The process of effecting this survey is somewhat like reconnaissance, except that more care is taken in obtaining detail and accuracy. It is often accomplished on foot, although a means of transportation may be used. A starting point, which is definitely recognizable on the base map, should be selected.

---

<sup>8</sup> If enough places on the ground were recognizable on the map, he would not have to run traverses. He would merely occupy these places, such as road intersections, and locate data on the map with reference to these points.

Likewise, recognizable check points should be selected throughout the area. These can be triangulation stations, road intersections, bridges, boundary corner markers, fire towers, confluences of streams, or even buildings, so long as they are clearly shown on the base map. It is preferable to select these points around the edge of the area, at intervals not more than one-half mile apart, if possible. Figure 14 shows a hypothetical area with check points so located. It is recognized that sometimes not many such check points can be found, in which case the traverses between such points as do exist would have to be longer.

Elevations should be obtained for the starting, finish, and check points. If the base map is a topographic sheet, elevations will be shown for many of these places. If not, their elevations must be secured. If there is even one road intersection where an elevation is shown, then the elevation of the others can be ascertained by running a hand level line around the edge of the area, touching all of these points. This line should close at the origin point or at another place of known elevation, so that a check can be made to see that not too much error was made in carrying the elevations. If no elevation is shown on the base map, then the nearest bench mark should be found and elevations carried in the same manner from there. A typical description of a bench mark and one of a triangulation station are shown in Figure 2.

After selecting his start, finish, and check points (often referred to as control points), and establishing their elevation, the investigator should follow courses between these points which will afford him the best observation of the area. As mentioned before, these courses are known as traverses. Each traverse starts with a control point and ends with one. Along each traverse there will be stops where observations are taken. These stops are sometimes alluded to as observation points, but more often as set ups. Thus, by a series of traverses, each starting and ending with a control point, the survey, or field inventory, can be made. Figure 14 shows several of these traverses through an area.

The investigator naturally begins his first traverse at his chosen starting point. He sets out toward a check point along a course which he thinks will afford him the most observation. At the starting point he orients his board with the base map

FIGURE 14

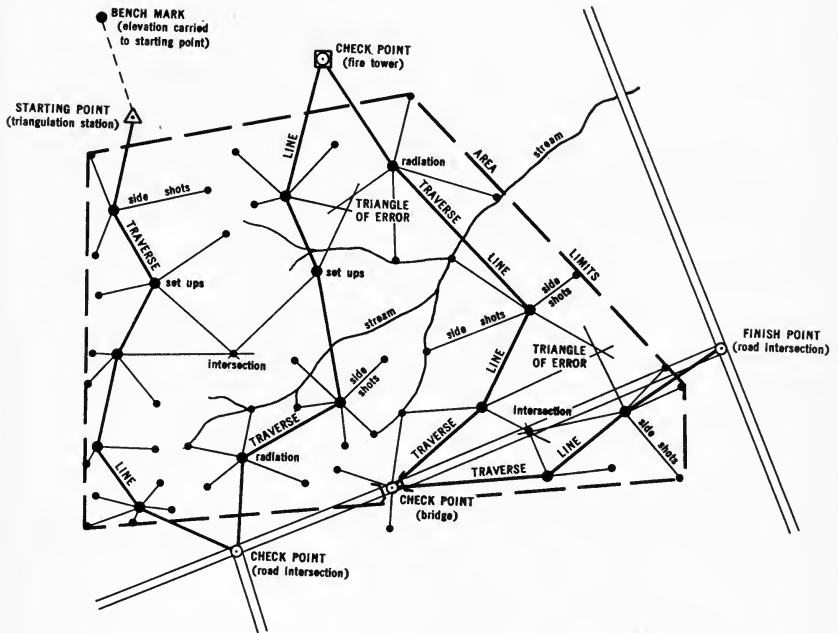

TRAVERSES, SHOWING SIDESHOTS, CHECK POINTS, AND INTERSECTIONS



clipped thereon, so that north on the map points north. This he accomplishes by placing his compass along the magnetic north line and rotating the board in his arms or on the plane table tripod until the needle points north. Holding or clamping the board so oriented he then places the edge of his plotting scale or open sight alidade along the starting point on the map and points it toward some critical object on the ground along the course he intends to traverse. He draws a line on the base map along the edge of the plotting scale, which represents the direction this object is from the starting point. He then proceeds to that object, counting his paces as he goes. Upon reaching the object he plots on the base map the distance he has paced, along the direction line he drew, with the aid of his plotting scale. Thus he locates the position of that object on the base map.

The elevation of the object may be determined at the same time. Knowing the elevation of the starting point, the investigator carries the elevation with his Abney hand level or Brunton compass as he paces to the object. This he accomplishes, as has been mentioned previously, by first ascertaining the height of his eye (H I) by adding the distance his eye is above his feet to the already known elevation. If the object is higher than the starting point, he stands on the starting point and sights toward the object with the hand level, raising or lowering it until the bubble is coincident with the cross hair. Whatever feature on the ground is cut by the cross hair has thus the elevation of his H I. He then occupies this feature (for example, a rock or a clump of grass), and repeats the process until he has reached the object whose position he has determined. He has then ascertained both the position and elevation of this object.

• If the object is lower than the starting point, he proceeds in the direction of the object to a point where he thinks he is about the height of his eye below the starting point. He then sights back to the starting point, walking backward or forward until the cross hair, with the level bubble coincident, in his hand level cuts the starting point. The elevation of the land at his feet is thus the distance between his eye and feet below the elevation of the starting point. Having established the elevation of this new position, he marks it with something like a stick, which he can see at a distance, and proceeds farther toward the object of his destination. He repeats this process until he reaches the object, thus establishing an elevation thereon. He then has both

the position and the elevation of this object. It is the first observation point, or set up, in his traverse between the starting point and the first check point (Figure 14).

Undoubtedly this object is a critical one, such as the summit of a hill, which he naturally wants well located on the base map. But it may be just a good observation place, from which he can see much. This is his first set up, and from here he can locate the position and elevation of many features not on the path of his traverse. This process is often referred to as radiation, from a single set up, and the measurements taken to various features are alluded to as side shots (Figure 14). In this manner a wide area on either side of the traverse lines can be surveyed with reasonable accuracy, and at a minimum of time and cost.

At this set up the investigator orients his board. This he accomplishes by rotating it so that he can sight back to his starting point along a plotting scale or with the sights of a Brunton compass or open sight alidade lined up along the traverse line he has just drawn. This is known as orientation by backsight. He may also orient by compass, as he did at the starting point. However he orients, he should leave the board so oriented on the plane table tripod or on some elevated object, like a rock. There he is able to sight toward features on all sides and draw direction lines toward them on the base map.

This process of taking side shots (radiation) is illustrated on Figure 14. Distances to these features can be ascertained by pacing, and elevations by hand level. The board should be left at the set up and the information plotted there upon return from side shots. As indicated before, these side shots should be critical features which the investigator wants to record, such as tops of rises, bottoms of draws, contacts between soil, geologic, or plant formations, places of change of land use, corners of fields, and edifices not already shown on the base map. These features should be sketched on the base map right in the field at the set up. This eliminates voluminous note taking and the possibility of error inherent in reliance upon memory. It should be remembered that map making is simply drawing a picture of part of the earth's surface, with control. It is not difficult to see that the best sketching is accomplished on the spot where the features being sketched can be seen. In this respect air photos can be of great help. Certain changes in tone

on the photos may indicate, for example, contact between two types of plant formations. After ascertaining this in the field, large extents of this contact may be scaled onto the base map from the photos.

After taking all the side shots he wants at his first set up, the investigator sights forward toward a place where he wants to make his second set up, still keeping in mind that this course should lead him to his first check point. The process of locating the point, establishing the elevation, and orienting the board at the second set up is the same as the first. The taking of side shots is also the same. Successive further set ups are then occupied, comprising the route of a traverse toward the first check point (Figure 14).

It is possible that there might be features visible from several set ups which are not accessible easily from any. These features may be located and their elevation determined also, without actually visiting them, through a process usually referred to as intersection. Frequently an entire survey is made by intersection, without any radiation side shots. This is a faster process, since the investigator does not have to budge from his traverse line. Of course, he loses the advantage of actually visiting the sites of his shots, but often this is unnecessary, since he may be able to ascertain their value from his traverse set up.

The process of intersection is in some ways similar to that of radiation. At his first set up the investigator orients his board as usual. Likewise he sights features he would like to locate on his map, and he draws lines on the map toward them. The big difference is that he does not pace or hand level out to them. Instead, he moves to his second set up, a point at which he can see the same features. After orienting his board he sights and draws lines on his map toward these same features. Where the two lines drawn to each feature intersect is the location of that feature. Usually a third such line drawn to each feature from a third set up is desirable. The intersection of these three lines locates the feature rather definitely on the map (Figure 14). There may be a slight imperfection at times in the intersection of the third line with the other two. This is called a triangle of error (Figure 14). There are mathematical ways of locating the point with relation to this triangle, but the most expedient means is to locate the feature as near to the center of the triangle as possible by eye.

Elevations of these points of intersection may be ascertained also, without leaving the traverse line. At any one of the set ups where lines are drawn toward the features, the vertical angles to the features may be read with the Abney hand level or Brunton compass. This may be accomplished by holding the bubble on the instrument level, then raising or depressing the tube through degrees and minutes of the arc until the feature sought is sighted. The arc should be read, and that reading is the angle of elevation or depression from horizontal. The distance to each feature from this set up is ascertained by intercepting with the dividers the length of the lines to each feature on the scale on the map. Thus, the elevation of the feature above or below the height of the eye is ascertained by solving a right triangle, knowing one angle other than the right angle and the length of one leg. This can be effected easier, however, by use of Stadia Tables, by looking under the degrees and minutes of the angle, and then reading the difference in elevation in that column. That difference, however, is only a unit figure. The number of feet the feature is away should be divided by 100 and the result multiplied by this difference to obtain the full difference in elevation. For example, if the figure read in the Difference Elevation column is 11.25 feet, and the feature is 750 feet away, then 11.25 is multiplied by 7.5, and the full difference in elevation is 84.38 feet. If the percentage of slope graduations are read on the arc, then stadia tables need not be used. The percentage read is simply multiplied by the distance. For example, if a 10% slope is read for an object 200 feet away, the difference in elevation is  $200 \times .10 = 20$  feet. Then that difference should be added or subtracted to or from that of the set up, (depending on whether the feature is higher or lower than the set up), adding or subtracting also, of course, the height of observer's eye above the ground. Thus elevations may be secured for all the features located by intersection without actually visiting them.

This system of intersection effects a fast and rather good survey. It is not a complicated process and can be mastered easily without previous experience. Once one traverse is made using this process, the investigator finds that he has gained considerable skill and efficiency at the work. Even set ups can be far apart with this process. It is really not necessary that set ups be so close together that they are in view of one another. A distant set up can be made, as long as three previously located features are in view. Then the board

is oriented by compass, the three features sighted along ruler or plotting scale, and lines drawn on the base map from these features toward the investigator. Where these lines intersect is the position of the new set up. Of course, a line should then be drawn on the base map between this and the last set up to keep the traverse line intact. This system of locating a new set up is known as resection. Obviously, it is the opposite of intersection.

The elevation of the new set up can be ascertained, likewise, by the reverse of the process used in intersection. The vertical angle to one of the features of known elevation can be read with the Abney hand level, and the distance can be ascertained from the length of the line from that feature on the map. The process is the same. In the Stadia Tables the Difference Elevation column should be sought for the degrees and minutes of the angle. The figure obtained should be multiplied by one hundredth of the distance to the feature; the result is the difference in elevation. This, according to the case, should be added or subtracted from the elevation of that feature to ascertain the elevation of the set up. The height of the observer's eye above the ground should be subtracted also, to get this elevation.

Whether the side shots are obtained by intersection or radiation, or whether or not the set ups are located by backsight or resection, the investigator continues his traverse, keeping the traverse line intact, until he reaches his first check point. That, in effect, ends one traverse. The next one starts from this point toward a second check point. At this first check point he "closes" his first traverse, seeing how it checked out as far as elevation and location are concerned. If the elevation he obtains when his traverse reaches the check point is radically different from the known elevation of that point, then he has to adjust the entire line to bring all points more closely in line with their true elevation. Likewise, if the line sighted toward the check point at the end of the traverse, and the distance measured, misses the location of the check point radically when plotted on the base map, then he has to adjust the whole traverse (including the side shots) so that all points may be brought more closely in line with their true location. These adjustments will be explained in the succeeding paragraphs.

There is no real substitute for re-running a line which checks badly. Unfortunately, time does not usually permit this,

so the next best thing is to adjust it. It must not be assumed that adjustment eradicates the error. All it does is distribute it through all the points, so that none will be off too radically. Usually the error is in one place, and a re-run of the line locates it; adjustment simply spreads out that error, so that all points, rather than one, share it.

In adjusting the line for error in vertical closure, it is most expedient to divide the amount of the error by the number of points on the line, less one, and then distribute the result proportionally, as in the following example: Assuming that a line, on which there were six set ups (including the start and finish points) at which elevations were taken, checked out five feet too high. That is to say, when the sixth point was reached, which was a check point, it was found that an elevation of 30 feet was shown by the investigator, rather than the 25 feet, which is the known elevation. Obviously, all elevations along the line would have to come down a little, so that the last reading would be 25 feet, the correct figure. The first point, the starting elevation, naturally does not count, so the number of points to deal with here would be six, less one, or five. By dividing five into the five feet of error, it becomes obvious that each point has to be lowered one foot. But this can not be accomplished by simply subtracting a foot from each elevation along the line, but rather it has to be progressive (Figure 15). One foot should be subtracted from the elevation of the first point out from the starting point; then two feet from the second, three from the third, four from the fourth, and five from the last, so that the last elevation then corresponds to what it is supposed to be. This progressive subtracting becomes obvious when one considers that the lowering of the first point a foot has already put a foot of debt on the second point, which would have to be lowered two feet to accomplish its adjustment, and so on.

In adjusting a line for error in horizontal closure the problem becomes a little more complex. Here two errors must be corrected, that in distance and that in direction, as they usually occur together. Assume that the previously mentioned traverse ended out to the north of the known location of the check point. Here it would be advisable to draw a straight line lightly on the map between the starting point and the check point, and another between the starting point and the place where the erring traverse ended (Figure 15). The point of ending of the

FIGURE 15

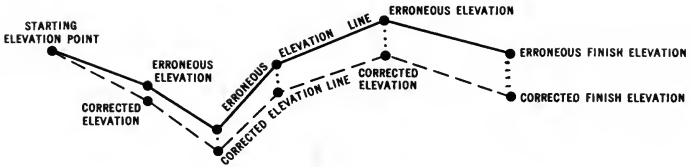

ADJUSTMENTS FOR ERROR IN VERTICAL CLOSURE

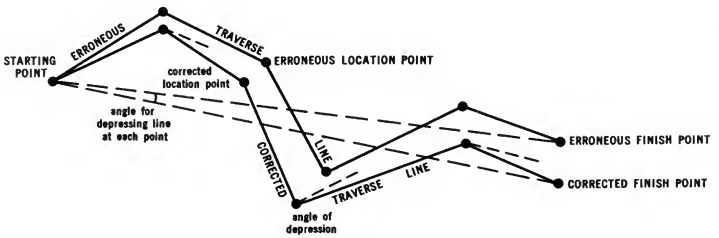

ADJUSTMENTS FOR ERROR IN HORIZONTAL CLOSURE

erring traverse would be considered directly north or south of the check point, along the last line of the traverse. In this case it is directly north. To adjust the error in direction all that need be done is to measure the angle between the two straight lines just drawn, and then depress to the south that many degrees each line on the traverse. This brings the last line (or leg) of the traverse into correct direction, so that it comes to the check point, as it should. There would be, however, an attendant error in distance, to be remedied by measuring the two long straight lines just drawn and dividing the former by the latter. This shows what percentage the line between the starting and check point is of the line between the starting and erroneous finish point. If the result is 90%, then the length of each leg on the traverse is 10% too long. The adjustment is made easily by shortening each leg 10%. The traverse will therefore check directly on the finish point, as it should, and the error will be distributed equitably.<sup>9</sup>

3. The Semi-Detail Method. The investigator may have to traverse the area in this process as well; in fact, his traverse lines should be closer together (preferably not more than a quarter of a mile apart), so that he will be able to see the entire area between his lines. He would undoubtedly go on foot, although a means of transportation is sometimes used to cover the distance between points where the plane table is set up. He would obtain his directions, distances and elevations by plane table and alidade, and he would plot and sketch his findings right on the spot, on his map mounted on the plane table.

He would have to select a starting point and check points throughout the area, as in the other methods. The principle of the traverse is the same, but the demand for accuracy is greater here, and the equipment used is capable of effecting that accuracy. Likewise, the starting point, the check points, and the final check point (finish point) should be more definite. If

---

<sup>9</sup> As indicated before, traverses are not necessary if there are many points on the land identifiable on the base map (e.g. a topo map). In that case the field man would orient his board at, say, a road intersection by lining up one of the roads on the map with one on the ground. He would draw lines to features, and then he would set up again at a nearby identifiable point and draw lines again to the same features, etc. He would thus be doing intersection without making a traverse.



possible, the start and finish points (and as many check points in between as possible) should be a triangulation marker or a state, county or local survey marker. The elevation of these points should be fairly definite also. It would be advisable to carry elevations to these points from a bench mark with the plane table and alidade or a wye level before starting the traverse.

At the start of the traverse the investigator is likely not to set his plane table up over the starting point. He probably sets it up some distance away, and at a place where he can see a number of things he would like to locate on his map. After setting up and leveling his table he orients it with the declinator or alidade, making sure he lines these instruments up on the magnetic north line and not the true north or grid north (GN) line. He has his helper hold the stadia rod up at the starting point, and, by placing the fiducial edge of the alidade base on this point on the map and rotating it about until the vertical hair lines up on the rod, he ascertains his direction graphically from the starting point. The length of the line depends on the distance he reads on the stadia rod. If  $7\frac{1}{2}$  feet are read between the stadia hairs on the rod, then he scales off 750 feet on his plotting scale and transfers that distance along his line on the map; that is the length of the line, and the terminus of the line is his location. At the same time he reads the number of feet intersected by the cross hair on the rod. If the reading can be made with the alidade telescope level, then he merely adds that number of feet to the known elevation of the starting point, and he has the elevation or height of his instrument (H I). If the telescope has to be inclined for the shot, then he refers to stadia tables for difference in elevation (see Chapter IV), but he still has to add the reading of the cross hair to his results to establish his H I.

With the position and H I established and situated in view of a number of features to be located on the map, the investigator is now in a position to start mapping and taking notes. For convenience he numbers his set up on the map and uses that number in his notebook for his notes. From his position he can take side shots, locate and number them on the map, and record his observations in the notebook under the corresponding numbers. This system of taking side shots from a single position of the table has been referred to before as radiation. (Figure 14). Many investigators train their helpers to operate

the alidade, and they themselves go out with the stadia rod to give these shots, as they know best what they want to show. His shots, as indicated before, are at tops of hills, confluences of streams, contacts between soil formations, contacts between plant associations, man-made features such as houses, and particularly the land use. Some of these features may already be shown on his base map, so, aside from an occasional check on the accuracy of their location, he need concern himself only with what is not shown. If the topography is not adequately depicted, then he has to sketch in contours on his map. He can do this with a few selected shots, at the tops of hills, bottoms of draws, and confluences of streams. Having location and elevations of these points, he can sketch his contours on the map right in the field.

It is possible that the investigator has been able to sketch geologic and soil formations on his base map from materials gained in his research before coming to the field. But frequently he has not been able to get such data, or he has incomplete information. In these cases, he has to get shots and sketch them in the field, or he has to check and supplement incomplete data. It is more than likely that he has to discern and delimit the plant associations, and, even if his base map does show cultural features, it is likely that there have been changes and additions since the publication of that map which he has to locate and add.

One thing he is almost sure to have to map from "scratch" is the land use, as very little has been accomplished in this direction on a large scale in the United States. A rather thorough job has been done in the British Isles under the direction of L. Dudley Stamp, in Puerto Rico under Clarence Jones (then at Northwestern University), and in Massachusetts under Dr. Samuel Van Valkenburg of Clark University. Even if the base map is made up of recent topo sheets with green coloring showing forested areas, the cleared areas are simply shown in white, without indication of land use. The investigator has to locate and map in the different phases of land use. This involves locating the edges of fields where there is a marked difference in type of agriculture or crops grown, or where there are changes such as from crop agriculture to pasture land or residential land. Air photos can be of help in this phase, since different types of crops, as well as the difference between crop and pasture land, show up readily on the photos,

once the tones have been identified by the investigator in the field. This phase of mapping will be discussed in detail in the next chapter.

Having taken all the radiation shots he wants at his first set up, the investigator is ready to move on to his next set up. He makes sure he knows the elevation of the ground beneath his table at his first set up before he moves on. This can be done by holding the rod up next to the table and measuring the height of the instrument above the ground and subtracting that measurement from his H I. He leaves his rodman at this point and moves on to select a new set up, again located at a place where he can see back to his rodman and see a wide area about where he can take side shots. Again he orients his table and lines himself in as to location, and he ascertains his H I in the same manner as before.

At his new point the investigator proceeds much as he did before. He takes radiation shots and moves on to the successive observation points. If he is pressed for time he may not send the rodman out or go out himself to all the side shots, particularly if he can be sure from the plane table of the features he wants to locate. He locates these features graphically on his map by a process of intersection (Figure 14). As described previously, in essence, he draws lines out toward these features on his map on the oriented plane table at one of his set ups, and again at the next and again at a third. Where these lines intersect for each of the features is their location. He ascertains the distance these places are from the scale of his map, and, if the shots are vertical angle shots, he determines their elevation by referring to his stadia tables.

And so the investigator continues his traversing of the area until he reaches his finish point. At each of the check points he "closes" his traverse. With this method he is not allowed to be off very much in closure, vertically or horizontally. If he is off a great deal it is advisable for him to adjust the traverse to bring all his observations more nearly in line with true elevation and location. Methods of adjusting such lines are the same as those treated under the General Method.<sup>10</sup>

---

<sup>10</sup> Again, if there are enough identifiable objects in the area the traverse could be eliminated. The field man could set up at each of these points and take side shots without any traverse at all.

At each check point the investigator should close the traverse and see how it checks. He should traverse the area, as described before, until he has reached the last check point. His field work is then finished, and he should have, by then, enough data to satisfy the demands of most projects and to present a reasonably thorough and accurate picture of the area. Asking questions of local residents about the area should not be overlooked. It is surprising how much valuable data can be obtained this way. Notes should be taken on all of this, and, of course, the information should be checked before final acceptance.

4. The Detailed Method. As stated before, an experienced surveyor should be hired as an instrument man if this method is used. He is not only able to handle the highly precise instruments well, but he can secure reasonable rental of them. If the entirety of a small area is to be covered by this method, or small parts of a larger area, the system of making traverses is the same here as in the Semi-Detail Method. The difference here is a matter of accuracy and attention to detail. The closure of traverses vertically and horizontally should be very close. Adjustments are seldom made. If the traverse checks too far off, it should be re-run. More radial shots should be taken, and they should be measured accurately. The lines of traverse, of course, should be much closer together, sometimes less than 200 yards apart. Also, copious and accurate notes should be taken, as the traverses cannot be drawn on the spot, since there is no plane table. The investigator should take his base map along and direct the operations, and then he and the instrument man can plot the traverses on the map after each traverse is completed, or after a day's work is finished.

The establishment of the starting, check, and finish points first is the same also, except that they should be of a high order of accuracy, tied into a C & G S triangulation station and a bench mark by transit and level for horizontal and vertical control respectively. The actual running of the traverses is the same; only the accuracy and amount of detail is different. The investigator should go around with the helpers to see that the proper shots are given to the instrument man. A variety of instruments are used, whichever give the satisfactory results for each particular operation. This choice should be left to the instrument man. The transit, steel tape, and a Philadelphia rod are likely to be most used.

The process is the same as described under the Semi-Detail Method from starting point, through check points, to the finish point. Directions are taken by transit, distances by steel tape, and elevations either by transit or level. Notes are kept and the detail is plotted on the map with the aid of protractor and plotting scale from the notes at the end of the day. The kind of detail to be shot in is the same kind as in the Semi-Detail Method. The investigator picks out much greater detail to show when using this method.

After the traverses are all run, and the finish point has been reached, the field work is done. After completing work by this method, the investigator has one of the best pictures of the area possible. He has a great amount of accurately recorded detail. Although costly and time consuming, this method is the most satisfactory in every respect.

Whatever method is used, when the investigator has checked with local residents and reached his finish point with a satisfactory closure, the field phase of the work is completed. It remains now to prepare the results in presentable form, usually by map or maps and a report. Chapter VII discusses at length the accomplishment of the Field Report.

---

Of vital importance in checking with local residents is the matter of geographic names. If a map of the area is to be made later the geographic names should be as correct as possible, since this often casts reflection on the entire study. All names should be checked as to correctness in application and form. At least three local residents should agree on each name, and, in the case of conflict, local informants should be consulted until one name stands out as preferred. Previously unpublished names should be sought, checked and used. These additions often add considerable value to the study.

## CHAPTER VI

# MULTIPLE FEATURE MAPPING

The preceding chapters have dealt largely with the investigation or mapping of only one phenomenon at a time. A biologist may be mapping only plant associations, whereas a soil scientist may deal only with soil types. The problem of plotting the different plant associations on a map in the field may be entirely simple, as there would be only a limited number of associations to show. But if the investigator wanted to plot the soil and the areal geology, as well, each of which may contain many different types within itself, the job would be exceedingly difficult. There would be too many categories and too many conflicting lines for one map.

This problem has been met by many field men by use of what is often called the "overlay". That is, several transparent sheets are fastened over the base map so they can be folded back, and a different phenomenon is plotted on each. When plotting the plant formations the investigator merely pulls that particular transparent sheet over the base map, and, seeing the map underneath, plots on that overlay the lines and categories he would ordinarily plot on the base map. He does the same with each of the other sheets. Thus he has a separate overlay to scale for each phenomenon, and tied directly to the base map.

Many field men find it easier to have several copies of the base map at hand, rather than overlays. Maps generally prove easier to handle and less fragile. They are usually fastened with the original base map at the top, and are folded down as needed. Each one is designated for a different phenomenon - one for plant formations, one for soil, etc. An appreciable degree of accuracy is assured in the plotting of the various phenomena with these duplicate maps, but, as with overlays, there is a good deal of folding back and forth of sheets to contend with. This is often considered too cumbersome by some field men.

The problem is sometimes met by a system of mapping several phenomena together in association. It has never been done completely, however, as the degree of association between underlying geology and plant groups, for example, is usually not close enough. It still seems advisable to map these phenomena on separate sheets or overlays if any degree of accuracy in the investigation is to be maintained. The mapping of land use, however, in association with slope, drainage, stoniness, and soil character has been effected with some degree of success.

In the era between World Wars I and II groups of geographers devised systems of measuring such associations of phenomena and recording them on field maps. In effect, areas were outlined on maps where the same percentage of slope, character of soil, amount of drainage, degree of surface stoniness, major land use, field size, and percent of idle land persisted. Boundaries were drawn whenever any of these factors varied, thus making new associations. With so many variable factors involved, it is obvious that many different types of associations were identified in any given area of study. In order to effect these fine distinctions and to record them clearly on one map, various fractional code systems were devised whereby each element in an association was identified by a part of a complex fraction. Thus each area delimited on the map as a separate association had a different complex fraction from the next. The keys to the maps, identifying what the numbers in the fractions meant, were usually detailed. A great deal was mapped and shown at one stroke, and the efforts were commendable. Moreover, separate maps for each of the phenomena involved may later be made from the data on the one field sheet with a reasonably fair degree of accuracy. This type of mapping is the most significant contribution made to field techniques by geographers. It is an extremely interesting and challenging type and deserves greater recognition than it has been given heretofore. It recognizes that there is an appreciable degree of association of elements in the field and seeks to measure that degree, as well as to delimit areas of relative homogeneity of such association. It is an excellent type of mapping for the layman who wants to obtain the facts about an area without undue use of time and expense. It gets all the pertinent data in one mapping session, with a single set of measurements. It has the potentiality of being the fastest type of mapping, considering all it encompasses.

This kind of mapping may be done by the first three methods explained in Chapter V. It would not fit well with the fourth, the Detailed Method, because a fine degree of accuracy is not called for when the objects mapped are associations. Obviously, the boundaries of associations of elements are never clearly definitive, so the fine accuracy of the Detailed Method would be wasted. The other methods - the Reconnaissance, the General Method, and the Semi-Detail Method - have all been tried and proven successful with this kind of mapping. Most useful was the General Method, which has been recommended as the best for the layman. In fact, a combination of this type of mapping and the General Method is often recommended as the best for the layman; and the layman is the field man to whom this discussion is primarily directed.

As with all types of mapping, air photos are a definite asset. Much of this mapping can be done directly on photos, and compilation of the photos into maps can be effected later in the office. Locating boundaries between associations on photos can be done easily by means of intersection or resection, explained in Chapter V. With photos it is usually not necessary to run traverses. The board or plane table with the photo attached may be set up at a point recognizable on the photo like a road intersection and may be oriented without use of a compass, by lining one of the roads on the photo with the corresponding one on the ground. Sights can then be made and lines drawn on the photo toward several points along the general line of contact between two associations. This may be repeated at several other set ups recognizable on the photo, and the points of intersection will represent points on the line of contact between associations. Through these the line of contact can be drawn directly on the photo. Thus the necessity of running traverses can be eliminated if enough places on the ground are recognizable on the photo. If a good base map, such as a topo sheet, is used, the traverse can likewise be eliminated. Set ups and orientation can be effected at recognizable points on the maps as on the photos, and the mapping can be done in the same manner.

It is important to remember when using photos that sufficient triangulation markers have to be located on the ground and spotted on the photos in order to aid the subsequent compilation of maps from the photos. A sample of a description of one of these markers was given in Chapter II, along with



information as to where to obtain the descriptions. The search for markers from these descriptions sometimes makes an interesting game. They are usually bronze discs set in some stationary object, often a concrete form set in the ground. When found, they have to be located with care on the photos, since they represent the exact latitude and longitude of those spots. As with locating other objects on photos, they have to be located by intersection or resection from other objects on the ground which are also identifiable on the photos. When they are properly located they should be clearly marked on the photo by a pricked point surrounded by a small triangle ( $\Delta$ ) and the name of the marker.

Ability of the investigator to recognize complex associations in the field can be developed. Many have been trained in a surprisingly short time and have proven themselves good field investigators. Many have trained themselves successfully. The layman often experiments and readily recognizes plant associations such as the Hickory-Walnut or the White Oak-Sugar Maple associations. Accordingly, he learns rapidly to recognize these broader and more complicated associations of related natural and cultural elements which appear to occur together in the field. Many have become experts and have done this kind of mapping on large projects such as the TVA.<sup>11</sup> Notable projects where investigators were or became experts include those in Puerto Rico<sup>12</sup> and Wisconsin.<sup>13</sup> Examples of the kind of associations to look for will be given here. With a little practice the investigator will quickly grasp the "knack".

Systems have been devised for mapping the associations of most of the significant elements in the landscape. Most of these use complex fractions, whereby each fraction represents a particular type of association and is delimited from the others. In these fractions each specific digit is designated to represent constantly one specific element. For example, let the first digit above the line always represent major land use, the second above the line the crop emphasis, the third field size, etc.; let the first digit below the line always represent percentage of slope, the second character of soil, etc. The

---

<sup>11</sup> See under G. D. Hudson, Bibliography.

<sup>12</sup> See under C. F. Jones, Bibliography.

<sup>13</sup> See under V. C. Finch, Bibliography.

various conditions of these different elements would vary, but each would always be shown in its respective place. Thus the percent of slope may be represented on a scale of 1 to 3 in its place as first below the line. If 1 is 0% to 7% slope, 2 is 8 to 20%, and 3 is above 20%, the number put in that particular digit place may vary from place to place. Accordingly, the other elements may be represented by such scales. Scales have been built up by various investigators through long experience and represent more than just arbitrary categories. A fraction with the same combination of numbers in the respective digit places is considered as representing a homogeneous association and is delimited as such. When the number in any of the digit places changes, then a new association is recognized and separation lines are drawn.

Thus areas of homogeneous combinations of character of the significant elements in the landscape are recognized and mapped. With experience an investigator can learn to recognize these associations at a glance in the field and can see one as the fraction  $\frac{4-7-2}{3-2-9-1}$ , which may be one he has had dealings with many times before. He may even become so proficient that he gives it a nickname, such as "II", which takes less space on the map. He sees the limits of this association in the field, and he takes measurements and draws in the boundaries on his map or photo by one of the methods treated in Chapter V. When the investigator can recognize the associations quickly and map them rapidly, he is a good field man.

Several effective types of fractions, with various scales for each of the digits have been worked out. The one given here has proved itself valuable in the field on several occasions. In this particular system the digits above the line in the fraction indicate the man-made or cultural aspects, whereas those below the line are the physical or natural. This follows largely the system which was used in the TVA mapping project in the '30s, with some revisions which were found advisable. The first digit above the line represents major land use, the second - agricultural emphasis, third - field size, fourth - amount of idle land, and fifth - quality of farmstead and equipment. Below the line the first digit represents the kind of slope, the second is the kind of drainage, the third - the nature of erosion, fourth - the amount of stoniness of the surface, fifth - amount of rock exposure, sixth - soil depth, and seventh - soil fertility. These values were arrived at through practice and constant revision:

## THE FIELD STUDY OF PLACE

ABOVE THE LINE (Values such as field size may vary from region to region)

1st digit Major Land Use	2nd digit Agri. Emphasis	3rd digit Field Size	4th digit Amt. Idle Land	5th digit Qual. House & Equip.
1 Gen. farming	1 Corn	1 Large	1 Little	1 Excellent—House and barn well painted, fence good, equip. well oiled.
2 Animal Indus.	2 Grain (small)	—over 20 acres	—under 10%	2 Good—Same, except paint isn't recent, etc.
3 Cash crop fam	3 Beef cattle	2 Medium	2 Limited	3 Moderate—Same, except paint and equipment are old.
4 Part time farm	4 Dairying	—10 to 20 acres	3 Considerable	4 Poor—Old paint, fence bad, bldgs and equip in disrepair.
5 Subsistant fam	5 Sheep	3 Small	—20 to 40%	5 Very poor—Complete state of disrepair, without conveniences, etc.
6 Forest land	6 Hogs	—5 to 10 acres	4 Excessive	
7 Recreational	7 Poultry	4 Very small	—Over 40%	
8 Rural village	8 Tobacco	—under 5 acres		
9 Urban-resident	9 Cotton			
10 Mfg. & Commerce	10 Truck			
11 Mining	11 Orchard			
12 Inst., etc.	12 Forage			

BELOW THE LINE

1st digit SLOPE	2nd digit DRAINAGE	3rd digit EROSION	4th digit STONINESS
1 Rel. level —0 to 3% slope	1 Thorough—no evid. of stag. water	1 Prac. none—Little evid. of runoff by sheet or gully.	1 Free of stones
2 Undulating —3 to 12%	2 Adequate—very little such evid.	2 Little—Some evid. of the above	2 Mod. stony—Scattered.
3 Und. to hilly —12 to 30%	3 Poor—dried beds of stag. water.	3 Sheet erosion—Evid. of uniform expose of new soil surf.	3 Stony—scat. over ¼ surface
4 Hilly —30 to 40%	4 Very poor—about a third area shows stag. water evid.	4 Excess sheet eros and gullyng—new soil expose, and some gullys.	4 Very stony—scat. over ½ or more of surf.
5 Steep —over 40%	5 Excessive—Evid. that not enough stands to sink in.	5 Excessive gully—About ¼ area cut by gullys.	

5th digit ROCK EXPOSURE	6th digit SOIL DEPTH	7th digit SOIL FERTILITY
1 Little or none	1 Deep—6 ft. or more	1 Exceptionally fertile black, friable, etc.
2 Limited—Scattered	2 Mod. deep—3' to 6'	2 Fertile—dark and friable, etc.
3 Considerable—About ¼ of surface.	3 Shallow—1' to 3'	3 Moderately fertile—brown and friable, etc.
4 Excessive—Scat. over ½ or more.	4 Very shallow—Less 1 ft.	4 Low fertility—gray and less friable, etc.
5 Barren—Over ½.		5 Poor fertility—gray and clayey, etc.

It would thus follow that the fraction  $\frac{1-2-1-1-2}{1-2-1-1-1-2-2}$  indicates that a particular section of the area is characterized by general farming, the crop is grain, the fields are large (over 20 acres), there is no idle land, and the farmstead and equipment are good. Also it indicates that the land is level (less than 3% slope), drainage is adequate, there is practically no erosion, there is no stoniness or rock outcrop, and there is moderately deep (3 to 6 feet) and fertile (dark and friable) soil.

Since these associations usually come in definite combinations, speed can often be attained after the investigator has gained adequate proficiency by designating some of the complicated fractions by shorter substitutes like the "II" previously mentioned. In addition, when final maps are made of the area, these associations may be given popular names, such as the "Cash grain-Large field Association", and shown in a specific pattern of zipitone or color. A section of a field map with the fractions shown thereon may look like the drawing on Figure 16, and the final map may look like that on Figure 17.

Thus multiple feature mapping by associations is effected with a reasonable degree of definiteness. An innovation in modern mapping, it deserves more recognition than it has enjoyed heretofore. Its best feature is that it shows things about the land and use of the land which no other mapping has shown so far. Many feel that more of it should be done, even as part of a hobby or vacation, since every bit helps in producing a thorough picture of our land, which is one of the bases of our national security.

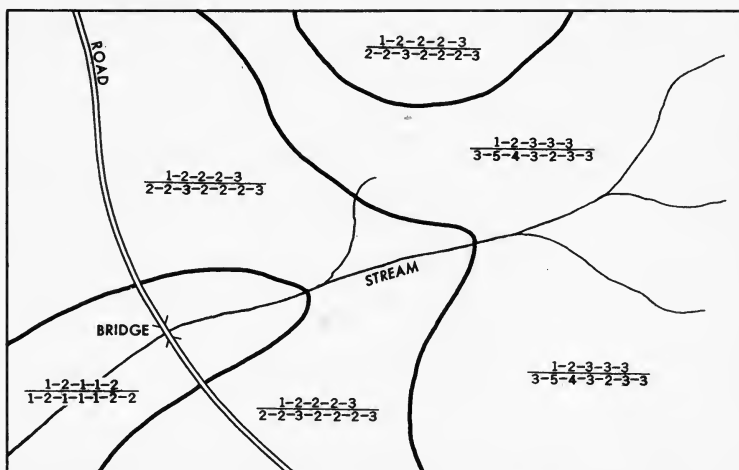

FIGURE 16 FIELD MAP USING FRACTIONAL CODE

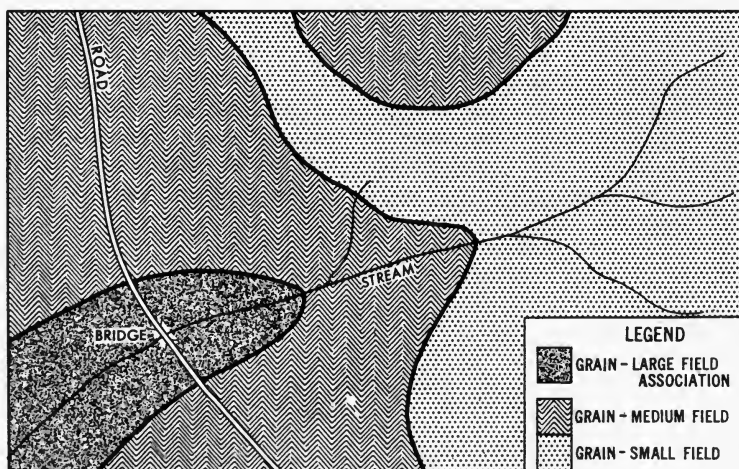

FIGURE 17 SMOOTH MAP OF ASSOCIATIONS ON FIGURE 16

## CHAPTER VII

# THE FIELD REPORT

It is important that due attention be given to the making of a good report. A poor report can considerably dim a brilliant piece of work. Not that a good report can hide a bad field job, but it can highlight the outstanding qualities of a good performance. Too often field men have little patience with report making, and they turn in sloppy reports reflecting unfavorably upon their entire work.

Actually, report making is not a very difficult task. It becomes so only when the investigator makes it that way, when he considers it a bogymen, and consequently makes something difficult out of a simple operation. A man who can describe his findings eloquently in conversation with friends may find himself almost inarticulate when he tries to write them down. When he is talking with his friends he unconsciously presents things simply and clearly, but when he tries to write, he becomes stilted. His best course is to strive for the same simplicity and clarity, since these are the essence of a good report.

His first step toward a clear and simple report is naturally the preparation of a map or maps showing as much as possible of his findings. Most of the data he wishes to show comes directly from his base map and/or overlays. Obviously, after being used in the field, his base map is messy and shoddy looking. He can not turn that sheet in as part of a report in that condition, so his first task is to make some clear and simple maps from the data on his base map.

Unscrambling an array of lines and markings on his base map and/or overlays might look formidable at first, but, with the aid of his notes, he finds it both easy and interesting. The best way is to take one thing at a time.<sup>14</sup> Taking first

---

<sup>14</sup> If his investigation involves only one of the attributes of the area, e.g. geology, then only one map and the accompanying report on that aspect would be necessary.

topography, he should strive to make a simple topographic map. If his base map was a good topographic sheet to start with, he needs only get a new copy of that sheet and mark any changes he observed in the field. If his base map had no topography on it at the beginning, or if it was a poor topo sheet, then he should make a separate map showing nothing but topography and drainage. He might even make a separate map called a "slope map", showing areas of comparable angles of slope, and he may even construct a "geomorphic map" delimiting various land forms (drumlins, etc.)

Unless he is an excellent cartographer, he should not attempt to lay out his own projection. He should select what scale he would like all his maps to be and then trace a projection (latitude and longitude lines) from some published map on that same scale. It is best to make a number of copies of that same projection, as it is desirable that he keep all maps in his report on the same scale, for expediency in making comparisons. If possible, it is desirable also to use the same scale as the base map. Then data may be transferred easily, without reference to change of scale.

In making his topographic map he transfers the elevations, contour lines and drainage, which he got in the field, from his base map and notes to his new map. He does not have to be a good draftsman, but he should attempt to be as neat as possible. He should label the sheet as a topographic map and indicate scale and contour interval. He then has a clear and simple sheet showing the topography of the area. The various kinds of land forms he has identified, e.g. stream flood plains, can be identified and labeled on this map. Homogeneous slope areas can be indicated also, if no separate map is made for these.

His next step is to do the same with the soils shown on his base map or overlays. He depicts the various soil formations on another sheet of the same scale and same projection from his notes and the lines he drew in the field from his shots and observations at soil contacts. He shades in, with different kinds of hatching, the areal extent of the various soil formations. Then he labels the map accordingly, showing scale and a legend to indicate what different soil formations are depicted

by the various hatchings. He now has another simple and clear sheet, on the same scale, showing the soils of the area.<sup>15</sup>

He then makes another map, of the same nature and by the same means, of the geologic formations in the tract. And still another of the plant associations. This gives four simple and clear maps on the same scale, each depicting a specific attribute of the place. He then constructs a land-use map of the area by the same means, using the data on his base map and in his notes. This map should be on the same scale as the others, with title and legend. He finally has a set of simple and clear maps, which serve as the nuclei around which he can build his report and make comparisons and recommendations.

With his maps, notes and information gleaned from research before going to the field, the investigator is now ready to start on his report. It would expedite matters if he separated his notes into the following categories:

Climate	Vegetation
Topography	Animal life
Geology	Works of man (land use):
Soil	Agriculture, grazing, mining, etc.

He should place his maps with the appropriate categories. Naturally, he would have no specific climatic or animal life map of the area, but he would have data resultant of his earlier research. He might even have photographs which he took in the area. These, too, should be placed with their respective categories.

The most direct approach is to build the report around the maps, with the aid of the notes. The following outline has proved itself successful for presentation of material.<sup>16</sup>

---

<sup>15</sup> If his base map were a series of overlays or separate maps the problem would be simple. If it were a multiple feature map, then he would separate the various numbers representing the various types of soil and interpolate lines between them. Some loss of accuracy is expected in this process, of course.

<sup>16</sup> If only one attribute of place is involved in the investigation, then much of the suggested outline would not be applicable. However, some of it may be involved, e.g. plant formations may be directly or indirectly related to the distribution of rainfall, soil formation, and the kinds and distribution of land use.



Part I. Introduction: Location, size, shape, and general description of the area.

Part II. The Physical Setting.

1. Climate
2. Topography (drainage, slope, geomorphic forms)
3. Geology
4. Soils
5. Vegetation
6. Animal life

Part III. The works of man (land use)

1. Agriculture (including orcharding)
2. Grazing and dairying
3. Forestry (lumbering, tree cropping, etc.)
4. Mining (including quarrying)
5. Gathering, hunting, fishing
6. Manufacturing and commercial
7. Residential and recreational

Part IV. Interrelationships and Recommendations: The tie evidenced between the works of man and the physical setting as well as the tie between the various facets of the works of man should be summarized here, along with suggestions as to where the tie could be improved to increase the productivity of the area.

With this outline as a guide, and with his notes and maps arranged accordingly, the investigator may then proceed to prepare his report in an orderly manner and to present the material simply and clearly.

Part I. Introduction. This covers a brief, clear account of the location, size and shape of the area, comprising simple statements, illustrated, if possible, with a location map, large enough to show what town (or towns) the area is near and the general shape of the tract. The size will be evident on the map from the scale.

The description of the area should be general, almost literary. The writer should recall the impressions gotten in the field while traveling between shots during the traverses. He

must not attempt to be technical or quantitative. He should write as if he were describing a friend's living room to his wife.

**Part II. The Physical Setting.** In this part all the aspects of the area without the work of man should be taken up individually and systematically.

1. **Climate.** From data gleaned in pre-field research, particularly from the U. S. Weather Bureau, the facts about the climate should be recorded. Seasonal distribution of temperature, precipitation and wind should be given quantitatively, as well as information about atmospheric pressure, cloud, fog, and climatic phenomena like tornadoes, hail storms, and hurricanes. Daily differences in temperature, precipitation and wind should be given also, if they are available.

2. **Topography and Drainage.** With his notes and his prepared topographic, slope and geomorphic maps before him, the investigator can write clearly and simply about topography and drainage. Most of the facts would be evident on the map, but they should be highlighted by statements in the text. Statements as to whether the area is part of a dissected plateau or a coastal plain are pertinent. How steep the slopes are, where the high and low elevations are located, and what way the drainage runs are critical observations to make. Reference should be made in the text to the topographic map, so the reader can be led to see these things on the map.

3. **Geology.** Again, with notes and geological map at hand, the investigator can build this part of the report around the map. He should describe the various geological formations, and then he should tell where they are located in the area, making reference to the map.

4. and 5. **Soil and Vegetation.** The same procedure as used with geologic formations can be used with soil and plant formations. Reference should be made to the respective maps continuously, and they should be located in the text as near as possible to the section they represent.

6. **Animal Life.** This part can be written from notes gathered in pre-field research. Sometimes there is little to say about animal life, except possibly the fish in the streams

and insect life. But whatever there is to say should be said simply and clearly, with as little use as possible of technical terms.

**Part III. The Works of Man (Land Use).** In this part the works of man, as evidenced in the landscape, are taken up. They should be dealt with by individual types of activities to facilitate clarity.

1. **Agriculture (including orcharding).** A separate map showing the distribution of the various types of agriculture need not be made; the land-use map would suffice to show this. Referring to the land-use map, the various agricultural activities in the area should be described and then areal distribution pointed out. The relation of this distribution to the distribution of various physical aspects of the tract should be indicated. For example, climate, topography and drainage, soil, and sometimes animal life have definite relationships with these activities.

2. **Grazing and dairying.** If these activities exist, their distribution should be indicated. Again, the areal relation between these industries and the physical setting should be pointed out. Reference should be made not only to the land-use map, but also back to the various physical maps and data, to make clear the relationships.

3. **Forestry (lumbering, tree cropping, etc.)** Areal distribution and relations to the physical setting should be pointed up here, as well. Any notes as to how these industries are carried on should be included.

4. **Mining (including quarrying).** The locations of mines and quarries should be singled out and their relation to geologic formations and other physical factors expounded. How the mining and quarrying is carried on is an important matter for discussion, since it is often related to the character of the geologic formations and the topography.

5. **Gathering, hunting, and fishing.** Frequently all the information about these activities is in the notes taken in conversation with local residents. These should be related to the physical setting, particularly the animal life.

6. **Manufacturing and Commercial.** If the area in question includes such activities, their location should be pointed out and their relation to the physical setting specified. If, as frequently occurs, factors outside the area partially influence these industries, this should be indicated.

7. **Residential and Recreational.** If the area has manufacturing and commercial activities, it is likely to have residential and recreational elements. Their locations should be highlighted, and their relation to not only the physical setting but also other phases of the works of man should be discussed.

Having presented these various physical and cultural aspects of the area, the investigator will have presented a clear and simple picture of the tract, in a direct and effective manner. All that remains now is a brief summarization of ideas and some practical recommendations. An alphabetized list of references, by author, of the sources used should comprise a bibliography at the end of the report.

**Part IV. Interrelationships and Recommendations.** Here the investigator can summarize the interrelationships he has previously expounded between the physical aspects and the works of man in the area, as well as between the various aspects of the works of man. From this he is able to point out various inconsistencies in these relationships and can make recommendations as to how parts of the land may be better used to effect the maximum productivity of the area.

Having followed these procedures, the investigator will have produced a clear, simple, and effective report on the area. A good field report should be the logical and inevitable end-product of a field study project. It is likely to become a reality when the project has been attacked in such a manner that it is accomplished with direction and efficiency and to the satisfaction of all concerned, including the investigator himself.



# SELECTED REFERENCES

- Baker, O. E., "Agricultural Regions of North America", Economic Geography, 2-9, 1925-1933.
- Davis, R. E., F. S. Foote, & W. H. Rayner, Surveying, Theory and Practice, New York, 1934.
- English, W. A., "Some Plane Table Methods", American Association of Petroleum Geologists, Bul. 14, 1930, pp 1049-58.
- Farrell, J. H., Practical Field Geology, New York, 1912.
- Finch, V. C., and O. E. Baker, Geography of the Worlds Agriculture, U. S. Dept. of Agriculture, Washington, 1927.
- Finch, V. C., "Geographic Surveying", Geographic Society of Chicago, Bul. 9, 1933, pp 3-11.
- "Montfort, A Study in Landscape Types in South-western Wisconsin", Ibid, pp 15-44.
- Fuller, M. L., "Quick Method of Reconnaissance Mapping", Economic Geology, Vol. 14, 1919, pp 411-433.
- Hayes, C. W., Handbook for Field Geologists, New York, 1909.
- Hinks, A. R., Maps and Survey, Cambridge University Press, London, 1942.
- Hill, R. A., "Preliminary Survey Procedure", American Paulin System, Los Angeles, 1929.
- Hudson, G. D., "Methods Employed by Geographers in Regional Surveys", Economic Geography, 12, 1936, pp 98-104.
- "The Unit Area Method of Land Classification", Annals of the Association of American Geographers, 26, 1936, pp 99-112.
- Kellogg, C. E., The Soils that Support Us, New York, 1941.
- Soil Survey Manual, U. S. Dept. of Agriculture Miscellaneous Publication 274, Washington, 1951.
- Lobeck, A. K., Geomorphology, New York, 1941
- Low, J. W., Plane Table Surveying, New York, 1952.
- Marbut, C. F., "Soils of the U. S.", Part III, Atlas of American Agriculture, U. S. Dept. of Agriculture, Washington, 1935.
- Moon, F. W., "Field and Office Methods in Preparing Geological Reports", Economic Geology, Vol. 8, 1913, pp 795-97.
- Northwestern University, Dept. of Geography, The Rural Land Classification Program of Puerto Rico, Northwestern University Studies in Geography, No. 1, Evanston, Illinois, 1952. (Study was made under direction of C. F. Jones).
- Schoenmann, L. R., "Description of Field Methods Followed by the Michigan Land Economic Survey", American Soil Surveys Association, Bul. 4, 1923, pp 44-52.

- Shantz, H. L., and Zon, R., "Natural Vegetation", Atlas of American Agriculture, U. S. Dept. of Agriculture, Washington, 1924.
- Swanson, L. W., Topographic Manual, U. S. Coast and Geodetic Survey, Special Publication 249, Washington, 1949.
- U. S. Coast and Geodetic Survey, A Plane Table Manual, Special Publication 85, Washington, 1939.
- U. S. Geological Survey, Topographic Instructions, Bul. 788, Washington, 1928.
- War (Defense) Dept. of U. S., Surveying, TM5 235, Washington, 1940.
- , Topography and Surveying, Map  
Reproduction in Field, Washington, 1940. (TM5-245).
- , Interpretation of Air Photos, TM5,  
246, Washington, 1941.
- , Engineer Soldiers Handbook,  
FM21-105, Washington, 1940.
- Weaver, J. E., and F. E. Clements, Plant Ecology, New York, 1938.
- Wright, J. K., and E. T. Platt, Aids to Geographical Research, American Geographical Society Research Series, no. 22, New York, 1947.

# APPENDIX STADIA TABLES

These tables give differences in elevation and horizontal distances for angle shots up to 30 degrees. The degrees are listed along the top line and the minutes down the left side. The operation is simple. For distance the figure should be located under "Hor. Dist." for the number of degrees and minutes of the angle. This should then be multiplied by the number of feet blocked off by the cross hairs on the rod. The procedure is the same for difference in elevation, except that the figures should be located in the "Diff. Elev." column. For example, an angle of 6 degrees 30 minutes is read, and the stadia hairs block off 7.5 feet on the rod:

$$\text{Horizontal distance} = 98.72 \times 7.5 = 740.40 \text{ feet}$$

$$\text{Difference in elevation} = 11.25 \times 7.5 = 84.375$$

Minutes	0°		1°		2°		3°	
	Hor. Dist.	Diff. Elev.	Hor. Dist.	Diff. Elev.	Hor. Dist.	Diff. Elev.	Hor. Dist.	Diff. Elev.
0.....	100.00	0.00	99.97	1.74	99.88	3.49	99.73	5.23
2.....	100.00	0.06	99.97	1.80	99.87	3.55	99.72	5.28
4.....	100.00	0.12	99.97	1.86	99.87	3.60	99.71	5.34
6.....	100.00	0.17	99.96	1.92	99.87	3.66	99.71	5.40
8.....	100.00	0.23	99.96	1.98	99.86	3.72	99.70	5.46
10.....	100.00	0.29	99.96	2.04	99.86	3.78	99.69	5.52
12.....	100.00	0.35	99.96	2.09	99.85	3.84	99.69	5.57
14.....	100.00	0.41	99.95	2.15	99.85	3.90	99.68	5.63
16.....	100.00	0.47	99.95	2.21	99.84	3.95	99.68	5.69
18.....	100.00	0.52	99.95	2.27	99.84	4.01	99.67	5.75
20.....	100.00	0.58	99.95	2.33	99.83	4.07	99.66	5.80
22.....	100.00	0.64	99.94	2.38	99.83	4.13	99.66	5.86
24.....	100.00	0.70	99.94	2.44	99.82	4.18	99.65	5.92
26.....	99.99	0.76	99.94	2.50	99.82	4.24	99.64	5.98
28.....	99.99	0.81	99.93	2.56	99.81	4.30	99.63	6.04
30.....	99.99	0.87	99.93	2.62	99.81	4.36	99.63	6.09
32.....	99.99	0.93	99.93	2.67	99.80	4.42	99.62	6.15
34.....	99.99	0.99	99.93	2.73	99.80	4.48	99.62	6.21
36.....	99.99	1.05	99.92	2.79	99.79	4.53	99.61	6.27
38.....	99.99	1.11	99.92	2.85	99.79	4.59	99.60	6.33
40.....	99.99	1.16	99.92	2.91	99.78	4.65	99.59	6.38
42.....	99.99	1.22	99.91	2.97	99.78	4.71	99.59	6.44
44.....	99.98	1.28	99.91	3.02	99.77	4.76	99.58	6.50
46.....	99.98	1.34	99.90	3.08	99.77	4.82	99.57	6.56
48.....	99.98	1.40	99.90	3.14	99.76	4.88	99.56	6.61
50.....	99.98	1.45	99.90	3.20	99.76	4.94	99.56	6.67
52.....	99.98	1.51	99.89	3.26	99.75	4.99	99.55	6.73
54.....	99.98	1.57	99.89	3.31	99.74	5.05	99.54	6.78
56.....	99.97	1.63	99.89	3.37	99.74	5.11	99.53	6.84
58.....	99.97	1.69	99.88	3.43	99.73	5.17	99.52	6.90
60.....	99.97	1.74	99.88	3.49	99.73	5.23	99.51	6.96



## STADIA TABLES

Minutes	4°		5°		6°		7°	
	Hor. Dist.	Diff. Elev.	Hor. Dist.	Diff. Elev.	Hor. Dist.	Diff. Elev.	Hor. Dist.	Diff. Elev.
0	99.51	6.96	99.24	8.68	98.91	10.40	98.51	12.10
2	99.51	7.02	99.23	8.74	98.90	10.45	98.50	12.15
4	99.50	7.07	99.22	8.80	98.88	10.51	98.48	12.21
6	99.49	7.13	99.21	8.85	98.87	10.57	98.47	12.26
8	99.48	7.19	99.20	8.91	98.86	10.62	98.46	12.32
10	99.47	7.25	99.19	8.97	98.85	10.68	98.44	12.38
12	99.46	7.30	99.18	9.03	98.83	10.74	98.43	12.43
14	99.46	7.36	99.17	9.08	98.82	10.79	98.41	12.49
16	99.45	7.42	99.16	9.14	98.81	10.85	98.40	12.55
18	99.44	7.48	99.15	9.20	98.80	10.91	98.39	12.60
20	99.43	7.53	99.14	9.25	98.78	10.96	98.37	12.66
22	99.42	7.59	99.13	9.31	98.77	11.02	98.36	12.72
24	99.41	7.65	99.11	9.37	98.76	11.08	98.34	12.77
26	99.40	7.71	99.10	9.43	98.74	11.13	98.33	12.83
28	99.39	7.76	99.09	9.48	98.73	11.19	98.31	12.88
30	99.38	7.82	99.08	9.54	98.72	11.25	98.29	12.94
32	99.38	7.88	99.07	9.60	98.71	11.30	98.28	13.00
34	99.37	7.94	99.06	9.65	98.69	11.36	98.27	13.05
36	99.36	7.99	99.05	9.71	98.68	11.42	98.25	13.11
38	99.35	8.05	99.04	9.77	98.67	11.47	98.24	13.17
40	99.34	8.11	99.03	9.83	98.65	11.53	98.22	13.22
42	99.33	8.17	99.01	9.88	98.64	11.59	98.20	13.28
44	99.32	8.22	99.00	9.94	98.63	11.64	98.19	13.33
46	99.31	8.28	98.99	10.00	98.61	11.70	98.17	13.39
48	99.30	8.34	98.98	10.05	98.60	11.76	98.16	13.45
50	99.29	8.40	98.97	10.11	98.58	11.81	98.14	13.50
52	99.28	8.45	98.96	10.17	98.57	11.87	98.13	13.56
54	99.27	8.51	98.94	10.22	98.56	11.93	98.11	13.61
56	99.26	8.57	98.93	10.28	98.54	11.98	98.10	13.67
58	99.25	8.63	98.92	10.34	98.53	12.04	98.08	13.73
60	99.24	8.68	98.91	10.40	98.51	12.10	98.06	13.78

# STADIA TABLES

Minutes	8°		9°		10°		11°	
	Hor. dist.	Diff. elev.	Hor. dist.	Diff. elev.	Hor. dist.	Diff. elev.	Hor. dist.	Diff. elev.
0.....	98.06	13.78	97.55	15.45	96.98	17.10	96.36	18.73
2.....	98.05	13.84	97.63	15.51	96.96	17.16	96.34	18.78
4.....	98.04	13.89	97.62	15.56	96.94	17.21	96.32	18.84
6.....	98.01	13.95	97.60	15.62	96.92	17.26	96.29	18.89
8.....	98.00	14.01	97.48	15.67	96.90	17.32	96.27	18.95
10.....	97.98	14.06	97.46	15.73	96.88	17.37	96.25	19.00
12.....	97.97	14.12	97.44	15.78	96.86	17.43	96.23	19.05
14.....	97.95	14.17	97.43	15.84	96.84	17.48	96.21	19.11
16.....	97.93	14.23	97.41	15.89	96.82	17.54	96.18	19.16
18.....	97.92	14.28	97.39	15.95	96.89	17.59	96.16	19.21
20.....	97.90	14.34	97.37	16.00	96.78	17.65	96.14	19.17
22.....	97.88	14.40	97.35	16.06	96.76	17.70	96.12	19.32
24.....	97.87	14.45	97.33	16.11	96.74	17.76	96.09	19.38
26.....	97.85	14.51	97.31	16.17	96.72	17.81	96.07	19.43
28.....	97.83	14.56	97.29	16.22	96.70	17.86	96.05	19.48
30.....	97.82	14.62	97.28	16.28	96.68	17.92	96.03	19.54
32.....	97.80	14.67	97.26	16.33	96.66	17.97	96.00	19.50
34.....	97.78	14.73	97.24	16.39	96.64	18.03	95.98	19.64
36.....	97.76	14.79	97.22	16.44	96.62	18.08	95.96	19.70
38.....	97.75	14.84	97.20	16.50	96.60	18.14	95.93	19.75
40.....	97.73	14.90	97.18	16.55	96.57	18.19	95.91	19.80
42.....	97.71	14.95	97.16	16.61	96.55	18.24	95.89	19.86
44.....	97.69	15.01	97.14	16.66	96.53	18.30	95.86	19.91
46.....	97.68	15.06	97.12	16.72	96.51	18.35	95.84	19.96
48.....	97.66	15.12	97.10	16.77	96.49	18.41	95.82	20.02
50.....	97.64	15.17	97.08	16.83	96.47	18.46	95.79	20.07
52.....	97.62	15.23	97.06	16.88	96.45	18.51	95.77	20.12
54.....	97.61	15.28	97.04	16.94	96.42	18.57	95.75	20.18
56.....	97.59	15.34	97.02	16.99	96.40	18.62	95.72	20.23
58.....	97.57	15.40	97.00	17.05	96.38	18.68	95.70	20.28
60.....	97.35	15.45	96.98	17.10	96.36	18.73	95.68	20.34

## STADIA TABLES

Minutes	12°		13°		14°		15°	
	Hor. dist.	Diff. elev.	Hor. dist.	Diff. elev.	Hor. dist.	Diff. elev.	Hor. dist.	Diff. elev.
0	95.68	20.34	94.94	21.92	94.15	23.47	93.30	25.00
2	95.65	20.39	94.91	21.97	94.12	23.52	93.27	25.05
4	95.63	20.44	94.89	22.02	94.09	23.58	93.24	25.10
6	95.61	20.50	94.86	22.08	94.07	23.63	93.21	25.15
8	95.58	20.55	94.84	22.13	94.04	23.68	93.18	25.20
10	95.56	20.60	94.81	22.18	94.01	23.73	93.16	25.25
12	95.53	20.66	94.79	22.23	93.98	23.78	93.13	25.30
14	95.51	20.71	94.76	22.28	93.95	23.83	93.10	25.35
16	95.49	20.76	94.73	22.34	93.93	23.88	93.07	25.40
18	95.46	20.81	94.71	22.39	93.90	23.93	93.04	25.45
20	95.44	20.87	94.68	22.44	93.87	23.99	93.01	25.50
22	95.41	20.92	94.66	22.49	93.84	24.04	92.98	25.55
24	95.39	20.97	94.63	22.54	93.81	24.09	92.95	25.60
26	95.36	21.03	94.60	22.60	93.79	24.14	92.92	25.65
28	95.34	21.08	94.58	22.65	93.76	24.19	92.89	25.70
30	95.32	21.13	94.55	22.70	93.73	24.24	92.86	25.75
32	95.29	21.18	94.52	22.75	93.70	24.29	92.83	25.80
34	95.27	21.24	94.50	22.80	93.67	24.34	92.80	25.85
36	95.24	21.29	94.47	22.85	93.65	24.39	92.77	25.90
38	95.22	21.34	94.44	22.91	93.62	24.44	92.74	25.95
40	95.19	21.39	94.42	22.96	93.59	24.49	92.71	26.00
42	95.17	21.45	94.39	23.01	93.56	24.55	92.68	26.05
44	95.14	21.50	94.36	23.06	93.53	24.60	92.65	26.10
46	95.12	21.55	94.34	23.11	93.50	24.65	92.62	26.15
48	95.09	21.60	94.31	23.16	93.47	24.70	92.59	26.20
50	95.07	21.66	94.28	23.22	93.45	24.75	92.56	26.25
52	95.04	21.71	94.26	23.27	93.42	24.80	92.53	26.30
54	95.02	21.77	94.23	23.32	93.39	24.85	92.49	26.35
56	94.99	21.81	94.20	23.37	93.36	24.90	92.46	26.40
58	94.97	21.87	94.17	23.42	93.33	24.95	92.43	26.45
60	94.94	21.92	94.15	23.47	93.30	25.00	92.40	26.50

# STADIA TABLES

91

Minutes	16°		17°		18°		19°	
	Hor. dist.	Diff. elev.	Hor. dist.	Diff. elev.	Hor. dist.	Diff. elev.	Hor. dist.	Diff. elev.
0	92.40	26.50	91.45	27.96	90.45	29.39	89.40	30.78
2	92.37	26.55	91.42	28.01	90.42	29.44	89.36	30.83
4	92.34	26.59	91.39	28.06	90.38	29.48	89.33	30.87
6	92.31	26.64	91.35	28.10	90.35	29.53	89.29	30.92
8	92.28	26.69	91.32	28.15	90.31	29.58	89.26	30.97
10	92.25	26.74	91.29	28.20	90.28	29.62	89.22	31.01
12	92.22	26.79	91.26	28.25	90.24	29.67	89.18	31.06
14	92.19	26.84	91.22	28.30	90.21	29.72	89.15	31.10
16	92.15	26.89	91.19	28.34	90.18	29.76	89.11	31.15
18	92.12	26.94	91.16	28.39	90.14	29.81	89.08	31.19
20	92.09	26.99	91.12	28.44	90.11	29.86	89.04	31.24
22	92.06	27.04	91.09	28.49	90.07	29.90	89.00	31.28
24	92.03	27.09	91.06	28.54	90.04	29.95	88.96	31.33
26	92.00	27.13	91.02	28.58	90.00	30.00	88.93	31.38
28	91.97	27.18	90.99	28.63	89.97	30.04	88.89	31.42
30	91.93	27.23	90.96	28.68	89.93	30.09	88.86	31.47
32	91.90	27.28	90.92	28.73	89.90	30.14	88.82	31.51
34	91.87	27.33	90.89	28.77	89.86	30.19	88.78	31.56
36	91.84	27.38	90.86	28.82	89.83	30.23	88.75	31.60
38	91.81	27.43	90.82	28.87	89.79	30.28	88.71	31.65
40	91.77	27.48	90.79	28.92	89.76	30.32	88.67	31.69
42	91.74	27.52	90.76	28.96	89.72	30.37	88.64	31.74
44	91.71	27.57	90.72	29.01	89.69	30.41	88.60	31.78
46	91.68	27.62	90.69	29.06	89.65	30.46	88.56	31.83
48	91.65	27.67	90.66	29.11	89.61	30.51	88.53	31.87
50	91.61	27.72	90.62	29.15	89.58	30.55	88.49	31.92
52	91.58	27.77	90.59	29.20	89.54	30.60	88.45	31.96
54	91.55	27.81	90.55	29.25	89.51	30.65	88.41	32.01
56	91.52	27.86	90.52	29.30	89.47	30.69	88.38	32.05
58	91.48	27.91	90.48	29.34	89.44	30.74	88.34	32.09
60	91.45	27.96	90.45	29.39	89.40	30.78	88.30	32.14

## STADIA TABLES

Minutes	20°		21°		22°		23°	
	Hor. dist.	Diff. elev.	Hor. dist.	Diff. elev.	Hor. dist.	Diff. elev.	Hor. dist.	Diff. elev.
0.....	88.30	32.14	87.16	33.46	85.97	34.73	84.73	35.97
2.....	88.26	32.18	87.12	33.50	85.93	34.77	84.69	36.01
4.....	88.23	32.23	87.08	33.54	85.89	34.82	84.65	36.05
6.....	88.19	32.27	87.04	33.59	85.85	34.86	84.61	36.09
8.....	88.15	32.32	87.00	33.63	85.80	34.90	84.57	36.13
10.....	88.11	32.36	86.96	33.67	85.76	34.94	84.52	36.17
12.....	88.08	32.41	86.92	33.72	85.72	34.98	84.48	36.21
14.....	88.04	32.45	86.88	33.76	85.68	35.02	84.44	36.25
16.....	88.00	32.49	86.84	33.80	85.64	35.07	84.40	36.29
18.....	87.96	32.54	86.80	33.84	85.60	35.11	84.35	36.33
20.....	87.93	32.58	86.77	33.89	85.56	35.15	84.31	36.37
22.....	87.89	32.63	86.73	33.93	85.52	35.19	84.27	36.41
24.....	87.85	32.67	86.69	33.97	85.48	35.23	84.23	36.45
26.....	87.81	32.72	86.65	34.01	85.44	35.27	84.18	36.49
28.....	87.77	32.76	86.61	34.06	85.40	35.31	84.14	36.53
30.....	87.74	32.80	86.57	34.10	85.36	35.36	84.10	36.57
32.....	87.70	32.85	86.53	34.14	85.31	35.40	84.06	36.61
34.....	87.66	32.89	86.49	34.18	85.27	35.44	84.01	36.65
36.....	87.62	32.93	86.45	34.23	85.23	35.48	83.97	36.69
38.....	87.58	32.98	86.41	34.27	85.19	35.52	83.93	36.73
40.....	87.54	33.02	86.37	34.31	85.15	35.56	83.89	36.77
42.....	87.51	33.07	86.33	34.35	85.11	35.60	83.84	36.80
44.....	87.47	33.11	86.29	34.40	85.07	35.64	83.80	36.84
46.....	87.43	33.15	86.25	34.44	85.02	35.68	83.76	36.88
48.....	87.39	33.20	86.21	34.48	84.98	35.72	83.72	36.92
50.....	87.35	33.24	86.17	34.52	84.94	35.76	83.67	36.96
52.....	87.31	33.28	86.13	34.57	84.90	35.80	83.63	37.00
54.....	87.27	33.33	86.09	34.61	84.86	35.85	83.59	37.04
56.....	87.24	33.37	86.05	34.65	84.82	35.89	83.54	37.08
58.....	87.20	33.41	86.01	34.69	84.77	35.93	83.50	37.12
60.....	87.16	33.46	85.97	34.73	84.73	35.97	83.46	37.16

# STADIA TABLES

Minutes	24°		25°		26°		27°	
	Hor. dist.	Diff. elev.	Hor. dist.	Diff. elev.	Hor. dist.	Diff. elev.	Hor. dist.	Diff. elev.
0	83.46	37.16	82.14	38.30	80.78	39.40	79.39	40.45
2	83.41	37.20	82.09	38.34	80.74	39.44	79.34	40.49
4	83.37	37.23	82.05	38.38	80.69	39.47	79.30	40.52
6	83.33	37.27	82.01	38.41	80.65	39.51	79.25	40.55
8	83.28	37.31	81.96	38.45	80.60	39.54	79.20	40.59
10	83.24	37.35	81.92	38.49	80.55	39.58	79.15	40.62
12	83.20	37.39	81.87	38.53	80.51	39.61	79.11	40.66
14	83.15	37.43	81.83	38.56	80.46	39.65	79.06	40.69
16	83.11	37.47	81.78	38.60	80.41	39.69	79.01	40.72
18	83.07	37.51	81.74	38.64	80.37	39.72	78.96	40.76
20	83.02	37.54	81.69	38.67	80.32	39.76	78.92	40.79
22	82.98	37.58	81.65	38.71	80.28	39.79	78.87	40.82
24	82.93	37.62	81.60	38.75	80.23	39.83	78.82	40.86
26	82.89	37.66	81.56	38.78	80.18	39.86	78.77	40.89
28	82.85	37.70	81.51	38.82	80.14	39.90	78.73	40.92
30	82.80	37.74	81.47	38.86	80.09	39.93	78.68	40.96
32	82.76	37.77	81.42	38.89	80.04	39.97	78.63	40.99
34	82.72	37.81	81.38	38.93	80.00	40.00	78.58	41.02
36	82.67	37.85	81.33	38.97	79.95	40.04	78.54	41.06
38	82.63	37.89	81.28	39.00	79.90	40.07	78.49	41.09
40	82.58	37.93	81.24	39.04	79.86	40.11	78.44	41.12
42	82.54	37.96	81.19	39.08	79.81	40.14	78.39	41.16
44	82.49	38.00	81.15	39.11	79.76	40.18	78.34	41.19
46	82.45	38.04	81.10	39.15	79.72	40.21	78.30	41.22
48	82.41	38.08	81.06	39.18	79.67	40.24	78.25	41.26
50	82.36	38.11	81.01	39.22	79.62	40.28	78.20	41.29
52	82.32	38.15	80.97	39.26	79.58	40.31	78.15	41.32
54	82.27	38.19	80.92	39.29	79.53	40.35	78.10	41.35
56	82.23	38.23	80.87	39.33	79.48	40.38	78.06	41.39
58	82.18	38.26	80.83	39.36	79.44	40.42	78.01	41.42
60	82.14	38.30	80.78	39.40	79.39	40.45	77.96	41.45

## STADIA TABLES

Minutes	28°		29°		30°	
	Hor. dist.	Diff. elev.	Hor. dist.	Diff. elev.	Hor. dist.	Diff. elev.
0	77.96	41.45	76.50	42.40	75.00	43.30
2	77.91	41.48	76.45	42.43	74.95	43.33
4	77.86	41.52	76.40	42.46	74.90	43.36
6	77.81	41.55	76.35	42.49	74.85	43.39
8	77.77	41.58	76.30	42.53	74.80	43.42
10	77.72	41.61	76.25	42.56	74.75	43.45
12	77.67	41.65	76.20	42.59	74.70	43.47
14	77.62	41.68	76.15	42.62	74.65	43.50
16	77.57	41.71	76.10	42.65	74.60	43.53
18	77.52	41.74	76.05	42.68	74.55	43.56
20	77.48	41.77	76.00	42.71	74.49	43.59
22	77.42	41.81	75.95	42.74	74.44	43.62
24	77.38	41.84	75.90	42.77	74.39	43.65
26	77.33	41.87	75.85	42.80	74.34	43.67
28	77.28	41.90	75.80	42.83	74.29	43.70
30	77.23	41.93	75.75	42.86	74.24	43.73
32	77.18	41.97	75.70	42.89	74.19	43.76
34	77.13	42.00	75.65	42.92	74.14	43.79
36	77.09	42.03	75.60	42.95	74.09	43.82
38	77.04	42.06	75.55	42.98	74.04	43.84
40	76.99	42.09	75.50	43.01	73.99	43.87
42	76.94	42.12	75.45	43.04	73.93	43.90
44	76.89	42.15	75.40	43.07	73.88	43.93
46	76.84	42.19	75.35	43.10	73.83	43.96
48	76.79	42.22	75.30	43.13	73.78	43.98
50	76.74	42.25	75.25	43.16	73.73	44.01
52	76.69	42.28	75.20	43.18	73.68	44.04
54	76.64	42.31	75.15	43.21	73.63	44.07
56	76.59	42.34	75.10	43.24	73.58	44.09
58	76.55	42.37	75.05	43.27	73.52	44.12
60	76.50	42.40	75.00	43.30	73.47	44.15

## A

Abney hand level, 28, 29  
 (illus.), 34  
 Adjustment for error, hori-  
 zontal, 61, vertical, 61  
 Aeronautical charts, 8  
 Agriculture, 79, 80  
 Agricultural emphasis, 73  
 Air Force, 10  
 Air photos, 13, 30, 71  
 Air photo, example of, 16  
 Alidade, 21, 37, 39, 35 (illus.)  
 Altimeter, 19  
 American Geographical Soci-  
 ety, 6  
 Aneroid barometer, 26  
 Animal life, 5, 77, 80  
 Animal Industry, 74  
 Army Engineers, 11  
 Army Map Service, 11  
 Association, 69, 70, 76 (map)  
 Atlas of American Agricul-  
 ture, 11  
 Atmospheric pressure, 26  
 Attributes of place, 5

## B

Barometer, 26  
 Base map, 8, 23, 30  
 Bench mark, 10, 12, 54  
 Bench mark, (illus.) 12  
 Backsight, 57  
 Brunton compass (hand trans-  
 it), 28, 34, 33 (illus.), 36, 59  
 Buildings, 7  
 Bulls eye bubble (illus.), 39

## C

Camera, 49  
 Card catalogue, 4  
 Cartographer, 78

Cash crop farming, 74  
 Census, Bureau of, 11  
 Census of Business, 13  
 Census of Industry, 13  
 Chaining, 22  
 Check points, 54, 55 (illus.)  
 Clark University, 65  
 Climate, 5, 79  
 Clements, F. E., 11  
 Coast and Geodetic Survey, 8  
 Compass, 20, 23, 24  
 Compass face, 25  
 Commercial areas, 74  
 Complex fraction, 73  
 Control points, 54  
 Contour interval, 78, special  
 insert  
 Contour lines, 7, special in-  
 sert  
 County Agent, 10, 14  
 County Clerk, 14  
 County offices, 14  
 County Recorder, 14  
 County road maps, 14  
 County surveyor, 14  
 Crop emphasis, 72  
 Cross hair, 36, 39  
 Cultural elements, features,  
 13, 72  
 Current Geographical publi-  
 cations, 6

## D

Declination zones, 24  
 Declinator, 40  
 Degrees of circle, 24  
 Dept. of Agriculture, 13  
 Detailed method, 18-21, 67, 68  
 Deitzgen Company, 23  
 Direction line, 24  
 Direction, measurement of, 23  
 Distance, measurement of, 23  
 Dividers, 23, 30, 31 (illus.)  
 Drainage, 5, 73



Drumlins, 78  
 Dumpy level, 42, 47, 48 (illus.)

## E

East declination, 24  
 Elevation, measurement of, 23  
 Elliot Instrument Co., 23  
 Engineering supplies, 23  
 Erosion, 73

## F

Farmstead, 73  
 Fertility of soil, 74  
 Field equipment, 23-50  
 Field investigation, 51-68  
 Field inventory, 59  
 Field of vision (alidade). 38  
 Field method, choice of, 18-22  
 Field report, 77, 83  
 Field size, 73  
 Field study, 1  
 Finch, V. C., 72  
 Finish point, 54  
 Fish and Wildlife Service, 11  
 Forestry, Bureau of, 11  
 Forest land, 74  
 Forestry, 80  
 Fractional code, 76  
 Friability of soil, 74

## G

General farming, 74  
 General method, 18, 19, 65-68  
 Geodetic data, 9  
 Geographers, 70  
 Geography, 6  
 Geological Survey, 7  
 Geologic bulletins, 8  
 Geologic maps, 8  
 Geologic structure sections, 8  
 Geomorphic map, 78

Government bureaus, 6  
 Graduated arc, 36  
 Grazing, 80  
 Ground water, 8  
 Gullying, 74  
 Gurley Company, 23

## H

Hand level, 20  
 Hickory-walnut association, 72  
 H I (height of instrument or eye), 26, 64  
 Horizontal closure, 62  
 Horizontal control, 21  
 Horizontal distance, 40  
 Hudson, G. D., 72

## I

Idle land, 73  
 Industrial areas, 74  
 Indexes to periodicals, 6  
 Instrument companies, 23  
 Inter-library loans, 6  
 Interrelationships, 80  
 Intersection, 55, 58  
 Investigator, 2  
 Investigation involving place, 2

## J

Jeep, 34  
 Jones, C. F., 34, 72

## K

Keuffel and Esser Co., 23

## L

Land use, 65  
 Land use map, 79  
 Land Management, Bureau of, 11

Latitude, 7  
 Level Bubble, 26  
 Leveling data, 9  
 Level rod, 42, 47  
 Library of Congress, 6  
 Light plane table, 33  
 Local informants, 17, 68  
 Locke hand level, 28, 29  
 (illus.), 34  
 Low, Julian W., 41

## M

Magnetic declination, 24, 27  
 Magnetic needle, 24  
 Magnetic north, 40  
 Manufacturing areas, 74  
 Map information office, 13  
 Markets, 5  
 Minerals, 5, 8  
 Mining areas, 74  
 Moveable arm, 33  
 Multiple feature mapping,  
 69-76

## N

National Park Service, 11  
 Natural elements, 72  
 Natural vegetation, 11  
 Naugical charts, 8  
 Notebook, 23

## O

Observation point, 54  
 Odometer, 23, 28  
 Open sight alidade, 36  
 Orchardring, 82  
 Orientation, 57  
 Overlay, 69

## P

Paulin barometer, 26  
 Pencils, 23  
 Percentage of slope, 74  
 Periodical room, 4  
 Philadelphia level rod, 47  
 Physical setting, 81  
 Place, 1  
 Place of field study, 1-3  
 Plant table, 35, 37, 35 (illus.)  
 Plane table board, 39  
 Plant associations, 69, 79  
 Plant Ecology, 11  
 Plotting scales, 23, 30  
 Plumb bob, 49  
 Points of compass, 24  
 Population Census, 13  
 Protractor, 23, 30, 31 (illus.)  
 Precipitation, 10  
 Pressure, 10  
 Private business and industry, 14  
 Production and Marketing  
 Adm., 13  
 Projections, 78  
 Public Library, 4

## Q

Quadrangles, 7  
 Quarter hair, 34, 39  
 Quarrying, 82

## R

Radiation, 57  
 Railroads, 7  
 Recommendations, 83  
 Reconnaissance, 18, 51, 53  
 Resection, 60  
 Reclamation, Bureau of, 11  
 Road maps, 14  
 Rock exposure, 73  
 Rural village, 74

## S

Scale, 7, 78  
 Semi-detailed method, 18, 20,  
 63, 67  
 Set Up, 54  
 Side shots, 55, 57, 55 (illus.)  
 Slope, 7, 73  
   Angle or percent of, 74  
 Slope distance, 40  
 Slope map, 78  
 Soil, 5  
 Soil character, 73  
 Soil Conservation Service, 10  
 Soil depth, 73  
 Soil fertility, 73  
 Soil formations, 78  
 Soil map, 10  
 Sources before field study,  
 4-17  
 Stadia hairs, 36, 39  
 Stadia Tables, 37, 59, Appen-  
 dix  
 Stadia rod, 21, 42, 47  
 Stadia slide rule, 40  
 Stamp, L. Dudley, 65  
 Standard, 39  
 Starting point, 54  
 State Bureaus, 14  
 State Highway Depts., 14  
 Steel tape, 22, 47, 49  
 Stoniness, 73  
 Straight edge, 39  
 Striding level, 39  
 Subsistant farm, 74

## T

Technical manuals, 41  
 Telescope, 39  
 Temperature, 10  
 Tennessee Valley Authority, 11  
 Theodolite, 43, 47  
 Three arm protractor, steel  
 type, 44

Topographic maps, 7  
   section of, 15  
 Topographic mapping in U.S.,  
   status of, 9  
 Topography, 5, 15  
 Transit, 43, 45 (illus.)  
 Traverse, 53, 54, 55 (illus.)  
 Tree cropping, 82  
 Triangle of Error, 58  
 Triangulation stations, 10, 12,  
 54  
 Tripod, 39

## U

Urbanized areas, 50  
 Urban residential areas, 74  
 Urban settlements, 74  
 Underground surveying, Intro-  
 duction

## V

VanValkenburg, Dr. Samuel, 65  
 Vegetation, 5, 59  
 Vernier, 43, 46 (illus.)  
 Vertical arc, 39  
 Vertical closure, 62  
   adjustment for error, 62  
 Vertical control, 21  
 Vertical hair, 36, 39

## W

Watch, 23, 28  
 Weather, 5  
 Weather Bureau, 10, 80  
 Weaver, J. E., 11  
 West declination, 24  
 White oak-sugar maple associ-  
 ation, 72  
 Wilde Company, 23  
 Wind, 10  
 Work of man, 79, 80  
 Wye level, 42, 47





**This University Extension Text Book was prepared  
under the auspices of the University Press Fund.**













**THE FIELD STUDY OF PLACE: A Practical Guide** is a University Extension Textbook prepared and published under a grant from the University Press Fund. \$2.25

OTHER BOOKS published by The University Press of Washington, D. C. include:

**INTRODUCTION TO AFRICA: A Selective Guide to Background Reading**, prepared by The Library of Congress. \$1.75

**A BIBLIOGRAPHY ON RESEARCH ADMINISTRATION—ANNOTATED** by George P. Bush, The American University. (\$4.00) Also available the key previous works in this field issued by The American University: **Scientific Research: Its Administration and Organization** (\$3.25) and **Teamwork in Research** (\$4.00), both by George P. Bush and Lowell H. Hattery.

The University Chapbooks . . . **DREAM AND RESPONSIBILITY: Four Test Cases of the Tension Between Poetry and Society** by Peter Viereck. \$1.50

The Pocket Poets . . . **THREE POEMS FOR NOW**, a book on the implications of the Atomic Age by Gorden Link. \$1.50

Contributions to Learning . . . **EGYPT AND THE ANGLO-EGYPTIAN SUDAN** by The Library of Congress. \$0.50

## THE UNIVERSITY PRESS OF WASHINGTON, D. C.

Munsey Building . . . Washington 4, D. C.

Sponsored by the University Press Fund as a publishing outlet for colleges and universities which have no campus press facilities and for selected government agencies which produce materials of wide public interest. Editorial control is by member institutions of the University Press Fund Council.

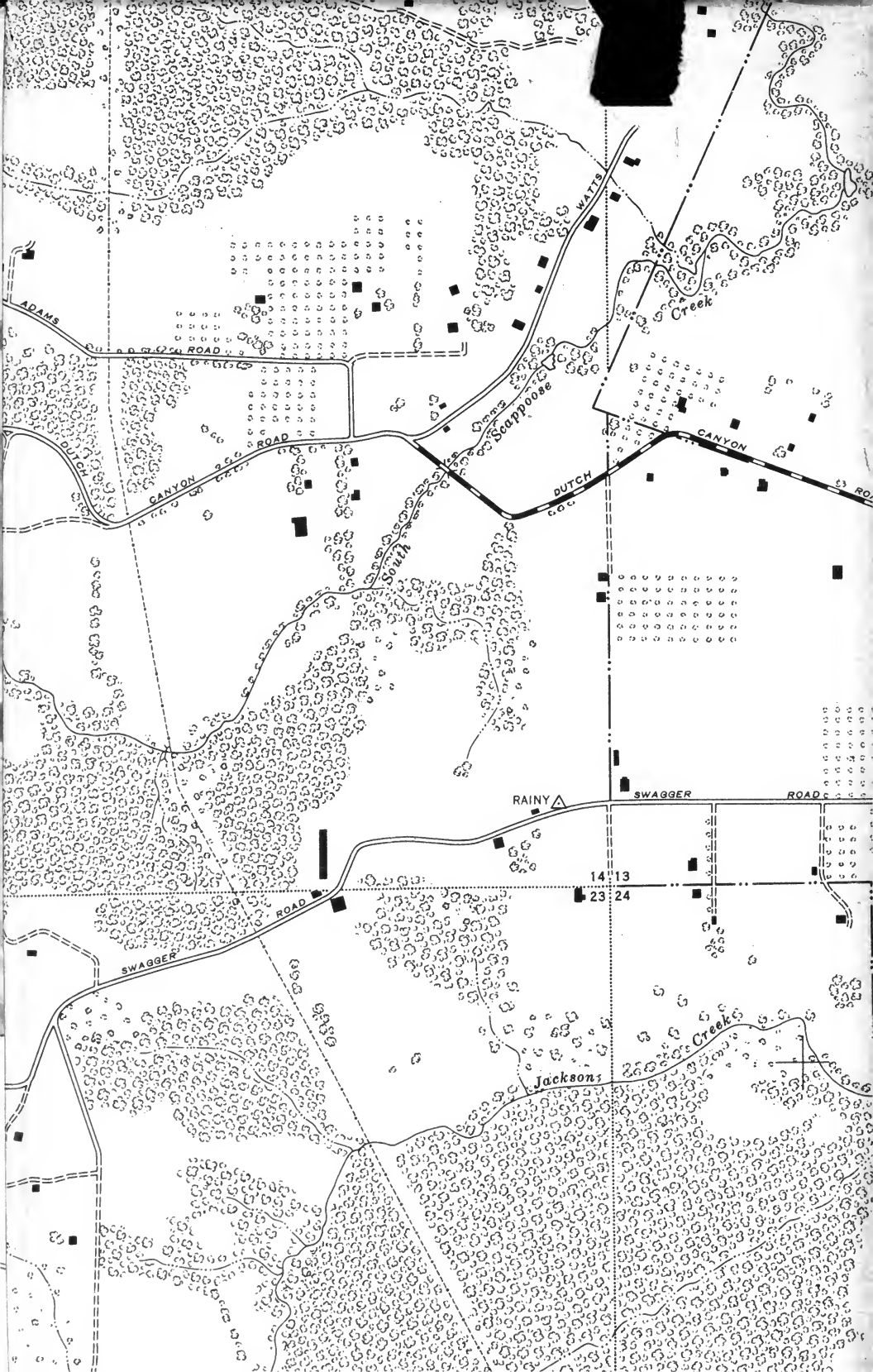

ADAMS

CANYON ROAD

CANYON ROAD

SWAGGER ROAD

DUTCH CANYON ROAD

RAINY

SWAGGER ROAD

Jacksons Creek

14 13

23 24

WATTS

Out

Creek

CANYON

Scappoose

South