

LIBRARY
OF THE
UNIVERSITY OF CALIFORNIA.

Class

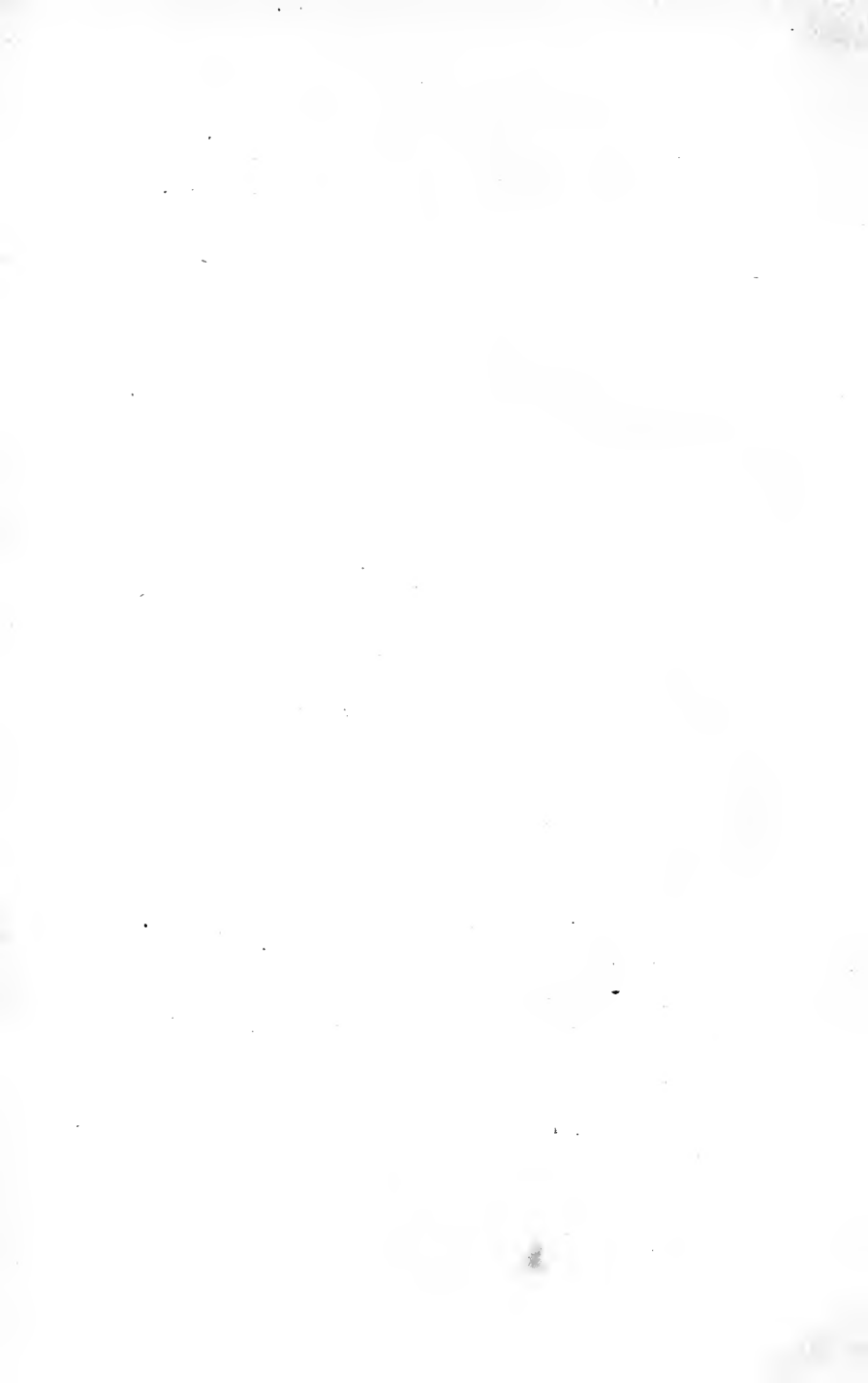

GEAR-CUTTING MACHINERY

COMPRISING

A COMPLETE REVIEW OF CONTEMPORARY
AMERICAN AND EUROPEAN
PRACTICE

TOGETHER WITH

A LOGICAL CLASSIFICATION AND EXPLANATION
OF THE PRINCIPLES INVOLVED

BY

RALPH E. FLANDERS

ASSOCIATE EDITOR OF *MACHINERY*

AUTHOR OF "BEVEL GEARING"

FIRST EDITION

FIRST THOUSAND



NEW YORK

JOHN WILEY & SONS

LONDON : CHAPMAN & HALL, LIMITED

1909

TJ187
F5

GENERAL

COPYRIGHT, 1909,
BY
RALPH E. FLANDERS

Stanbope Press
F. H. GILSON COMPANY
BOSTON, U.S.A.

PREFACE.

THE author undertakes, in this book, to present a complete review of the present state of the art in the field of gear-cutting machinery. He aims to illustrate and describe every important contemporary design, whether of American or European origin. The book deals with the underlying principles involved, and the general features of the mechanisms described; it does not concern itself particularly with those details of construction which are common to all machine tools, of whatever type. The discussion is closely confined, also, to present day machines and methods, references to earlier practice being made only in cases where that practice conceals the germ of possible future development.

The arrangement of the subject matter follows the classification set forth in the opening chapter. That is to say, the machines are described in the order determined — first, by the form of gear each is designed to cut; next, by the principle of action involved; next, by the method of operation employed; then by the kind of mechanism used; and, finally, by the structural design of the machine. In every case particular stress is laid on the underlying principles on which the mechanism operates.

The book is believed to be unique in the thoroughness with which it treats of a given form of machine tool. This thoroughness will be invaluable to the shop manager, foreman or operator whose work requires him to keep fully informed as to developments in gear-cutting machinery. Great pains have been taken to explain in a simple but adequate way the underlying principles of the different mechanisms, and the intelligent machinist will have no difficulty in comprehending them. The designer or manufacturer will find

that the logical classification which has been followed is just what is needed to stimulate the mind to a systematic solution of the problems that arise in the inventing of new machines. He will be led to consider all possible modifications of the fundamental idea he is studying, and will thus be enabled to arrive at the proper solution of his problem by a sure and orderly method of procedure. The student of mechanism will find described in the following pages the finest examples of the application of kinematic laws to be found in any branch of machinery. The range of principles illustrated is wide, and the use made of them is ingenious.

The author's thanks are due to the many manufacturers, both in this country and in Europe, who have so freely furnished him with the necessary photographs, blue-prints and information. It is certainly worthy of note that but two of the scores of firms approached refused to furnish the required material, and in neither case was the machine in question of particular importance. The main subject matter of this book first appeared serially in the columns of *Machinery*. The author desires in this place to make acknowledgment of the kindness of the publishers of that journal in permitting the material to be collected in the present form.

R. E F.

NEW YORK CITY, May, 1909.

CONTENTS.

CHAPTER I.

| | PAGE |
|--|------|
| METHODS OF FORMING THE TEETH OF GEARS..... | 1 |
| The Classification of Gear-Cutting Machinery | 2 |
| Five Principles of Action..... | 3 |
| Four Methods of Operation | 10 |

CHAPTER II.

| | |
|---|----|
| MACHINES FOR FORMING THE TEETH OF SPUR GEARS..... | 14 |
| Machines using Formed Shaper or Planer Tools..... | 15 |
| Standard Machine Tools and Attachments using Formed Milling Cutters..... | 19 |
| Semi-automatic Machines using Formed Milling Cutters..... | 22 |
| Automatic Machines using Formed Milling Cutters. — Gen- eral Principles of Design..... | 25 |
| Milling Machine Type of Automatic Spur Gear Cutter | 29 |
| The Orthodox Automatic Spur Gear Cutter..... | 33 |
| Standard Type of Automatic Formed Cutter Machine for Heavy Work..... | 47 |
| Machines for Heavy Work with Column Adjustable for Diameter | 55 |
| Spur Gear Cutting Machines with L-Shaped Bed..... | 58 |
| Precision Formed Cutter Machines..... | 59 |
| The Formed Tool Principle applied to the Grinding or Abrasion Process | 65 |
| The Templet Principle applied to cutting the Teeth of Spur Gears..... | 66 |

CHAPTER III.

| | |
|---|----|
| MACHINES FOR FORMING THE TEETH OF SPUR GEARS (<i>Continued</i>) . | 69 |
| Molding-generating Machines working by Shaper Action | 69 |
| The Molding-generating Milling or Hobbing Machine and its Action | 77 |
| A Milling Machine Attachment for Hobbing Spur Gears..... | 80 |
| A Column-and-Knee Type Spur Gear Hobbing Machine..... | 81 |
| Gear Hobbing Machines with Cutter Slide on Bed..... | 83 |

| MACHINES FOR FORMING THE TEETH OF SPUR GEARS (<i>Continued</i>). | PAGE |
|--|------|
| The Standard Form of Hobbing Machine | 86 |
| Hobbing Machines with Adjustable Spindle Column | 93 |
| Gear Hobbing Machines of Special Design | 96 |
| The Grinding or Abrasion Operation applied to the Molding-generating Process | 99 |

CHAPTER IV.

| MACHINES FOR CUTTING THE TEETH OF INTERNAL GEARS AND RACKS | 104 |
|--|-----|
| Machines and Attachments for cutting Internal Gears by the Formed Cutter Principle | 104 |
| Cutting Internal Gears by the Molding-generating Principle | 108 |
| Formed Tool Rack-cutting Attachments to Standard Machines | 110 |
| Special Formed Tool Rack-cutting Machines | 114 |
| The Molding-generating Method applied to Rack Cutting | 126 |

CHAPTER V.

| MACHINES FOR CUTTING THE TEETH OF WORMS AND HELICAL GEARS | 129 |
|--|-----|
| Machines using Formed Tools in a Shaping or Planing Operation | 130 |
| Standard Machine Tools using Formed Milling Cutters | 135 |
| Specialized Forms of Milling Machines for cutting Spirals by the Formed Cutter Method | 142 |
| Specialized Formed Cutter Machine for Herringbone Gears | 151 |
| Automatic Machines for Milling Helical Gears with Formed Cutters | 151 |
| Molding-generating Principle for cutting Helical Gears.— Planing Operations | 154 |
| The Hobbing Modification of the Molding-generating Principle for cutting Helical Gears | 159 |
| Hobbing Machines with Cutter Slide on Bed | 163 |
| Hobbing Machines of Special Types | 171 |
| The Field of the Hobbing Process for cutting Helical and Herringbone Gears | 180 |

CHAPTER VI.

| WORM-WHEEL CUTTING MACHINES | 182 |
|---|-----|
| Gashing Worm-wheels by the Formed Cutter Process | 184 |
| The Molding-generating or Hobbing Process | 186 |
| Hobbing Worm-wheels in the Milling Machine | 188 |
| Hobbing Worm-wheels in Machines designed for cutting other Forms of Gearing | 191 |

CONTENTS.

vii

| WORM-WHEEL CUTTING MACHINES (<i>Continued</i>). | PAGE |
|---|------|
| The Fly-tool and Taper Hob Methods of cutting Worm-wheel Teeth..... | 196 |
| Machines and Attachments for cutting Worm-wheels by the Fly-tool or Taper Hob Method..... | 201 |
| Cutting Wheels for Multiple Threaded Worms by the Fly-tool Process..... | 214 |
| The Various Methods Compared..... | 215 |
| The Manufacture of Hindley Worm Gearing..... | 216 |

CHAPTER VII.

| | |
|---|-----|
| MACHINES FOR FORMING THE TEETH OF BEVEL GEARS..... | 221 |
| Five Principles of Action..... | 224 |
| Four Methods of Operation..... | 228 |
| Machines using Formed Milling Cutters for Shaping the Teeth of Bevel Gears..... | 232 |
| Attachments for forming the Teeth of Bevel Gears by the Templet Principle..... | 242 |
| Machines for shaping or planing the Teeth of Bevel Gears by the Templet Principle..... | 248 |
| A Machine for milling the Teeth of Bevel Gears by the Templet Principle..... | 261 |
| Machines employing the Templet Principle for grinding the Teeth of Bevel Gears..... | 266 |
| Machines Working on the Odontographic Principle for cutting the Teeth of Bevel Gears..... | 267 |

CHAPTER VIII.

| | |
|---|-----|
| MACHINES FOR FORMING THE TEETH OF BEVEL GEARS (<i>Continued</i>) | 275 |
| Finishing Bevel Gears by the Operation of Impression..... | 275 |
| Machines operating on the Molding-generating Principle, and employing the Planing or Shaping Operation..... | 278 |
| Milling the Teeth of Bevel Gears on the Molding-generating Principle..... | 296 |
| Bevel Gear Cutting Machines using a Hob and operating on the Molding-generating Principle..... | 301 |
| Comparison of Molding-generating Machines for Bevel Gears.. | 313 |
| Conclusion..... | 314 |



GEAR-CUTTING MACHINERY.

CHAPTER I.

METHODS OF FORMING THE TEETH OF GEARS.

THERE is no form of machine tool which has called for more ingenuity in design than the gear-cutting machine. The methods by which gears may be cut are so numerous, the requirements are so varied, the possible application of ingenious geometrical principles through the mechanism used are so nearly limitless, that a wonderful variety in design and construction has been evolved, affording a field of study which is unparalleled in its interest to the mechanic and engineer.

The earliest form of gear-cutting machinery to attain anything like its present state of development was the automatic spur gear machine using a milled cutter to shape the tooth. Later came a period in which various forms of bevel gear cutting machinery were evolved, the demand being stimulated by the necessities of the chainless bicycle business. More recently the requirements of the automobile have resulted in another period of inventive activity, which has resulted in the development of new machines and processes for gears of all kinds, though the bulk of the attention has been given to the spur and bevel forms.

In the following pages the author has attempted to cover the whole field of gear cutting, illustrating, so far as possible, every machine and process which has come into commercial use, including at the same time some which

have been built and used successfully, but which have not, for one reason or another, been placed on the market. Some of these machines are old, some of them new, some of them simple, some of them complicated. Some of them are used for the finest kind of work, such as is required in watch and instrument gearing, while one of them will cut gears up to 40 feet in diameter. The reader will see as we proceed that all these widely varying tools may be brought into a definite classification which links them all into one large family — the old and new, simple and complicated, large and small — by characteristics which are common to the different groups.

THE CLASSIFICATION OF GEAR-CUTTING MACHINERY.

Gear-cutting machinery may be classified, first, according to its *product*. There are four main divisions in this classification, separating from each other the machines designed for cutting spur, spiral, bevel, and worm gearing, respectively. The cutting of internal gears and racks is analogous to the cutting of spur gears, and is included with it. Twisted or herringbone gears having parallel axes are in general cut in the same way as spiral gears, though, as gears, they belong to a different class. Some machines are so designed as to be capable of cutting more than one form of gear, but it is only done by making certain adjustments or using certain attachments which, for the time being, convert them into machines of other types. The best example of a machine which covers all the divisions of this classification is the universal miller, which may be arranged to cut the teeth in any one of the four forms mentioned.

The second classification of gear-cutting machinery depends on the *principle of action* involved. The five methods we will consider are: the formed tool, templet,

odontographic, describing-generating, and molding-generating methods. This classification relates particularly to the way in which the tool is held and guided with reference to the work, to produce the desired form for the tooth surfaces.

The third method of classification relates to the *nature of the operation*. The four operations we will consider are: forming the tooth by impression, by planing or shaping, by milling, and by grinding or abrasion.

In studying the various combinations possible in these three different classifications it will be simplest to first consider the matter of cutting the teeth of spur gearing, investigating the principle of action involved, and the nature of the operation performed, in the different methods. From that we will be able to proceed to the application of these principles and operations to the spur, bevel, and worm forms of gearing.

FIVE PRINCIPLES OF ACTION.

The Formed Tool Principle: This, the simplest and most obvious way of forming a gear tooth, is illustrated in Fig. 1. The gear to be cut is held firmly on a work arbor which, in turn, is firmly supported in the machine, in such a way that it can be *indexed* (or rotated through an angular distance corresponding to one tooth) from time to time as occasion requires. In the upper part of the cut is shown a planer or shaper tool-post, carrying a formed tool having outlines accurately corresponding to the shape of a space between two of the teeth it is desired to form. It is evident that this formed tool, when properly set and fastened in the tool-post of the planer or shaper, may be fed down into the work to the proper depth, in which case it will reproduce its outline in the work. The work may then be indexed, and the operation repeated to form

another tooth space. With the work indexed in the direction shown in the cut, four tooth spaces, or three complete teeth, have been formed. A formed milling cutter may be used instead of the planer or shaper tool. This is shown at work on the under side of the blank. It reproduces its outline in the work in the same way that the

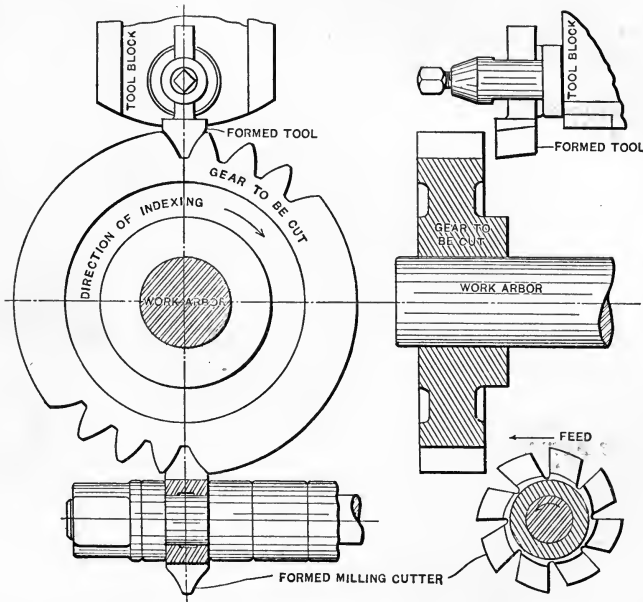

FIG. 1. The Formed Tool Principle of Action as exemplified by the Shaper Tool and the Milling Cutter.

planer tool does, being rotated in the direction indicated and fed through the work at the same time.

The Templet Principle: This method of cutting gears is shown in Fig. 2. As in the previous case, the work is held on the table of the shaper. A templet holder is also mounted on the shaper table, carrying a templet, having a surface formed to the exact outline desired for the

finished tooth. The tool slide is disconnected from the feed screw, and weighted so that it falls of its own accord. To its side is clamped the guide plate shown, whose horizontal lower edge bears on the templet. As the table of the shaper is fed to the right, it will be seen that the curved surface of the templet will raise the guide, the tool block, and the tool, in such a fashion that the desired outline will be reproduced on the gear tooth. The upper

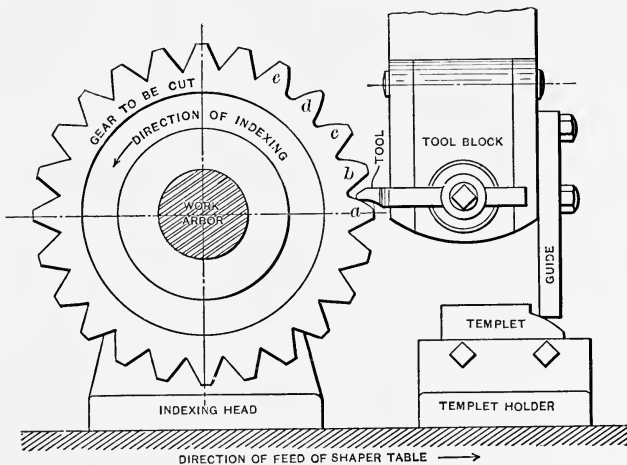

FIG. 2. The Templet Principle, as arranged to be applied to the Shaper.

surfaces of teeth *a*, *b*, *c*, and *d* have been formed in turn in this way, the work being indexed for this purpose as in the previous case. With the primitive arrangement shown, it will be necessary to reverse the work in the arbor to form the other side of the teeth. Teeth *d* and *e* had their faces finished in this way, tooth *d* being thus completely formed. It will be seen that obtaining accurate teeth by this method requires, first, an accurate templet; second, accurate setting of the templet and tool in proper relation to each other; and third, a bearing surface on the guide of

exactly the same shape as the cutting edge of the tool. The guide plate is, of course, wide enough to bear on the templet for the full stroke of the ram. As shown, the gear to be cut has had the tooth spaces roughed out to shape, so that the finishing operation removes a comparatively small amount of metal.

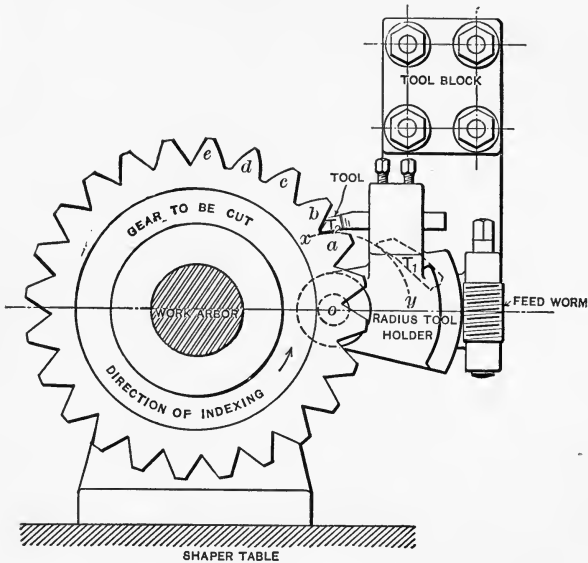

FIG. 3. The Odontographic Principle, which approximately outlines the Tooth Form by Mechanical Means.

The Odontographic Principle: In shaping teeth by the odontographic principle, the tool is guided in some way by suitable mechanism to closely approximate the desired tooth outline by means of circular arcs, or other easily obtained curves. A simple example is shown in Fig. 3. The gear to be cut is held and indexed as in the two previous cases. The blank has had the teeth roughed out as in the previous case. The gear to be cut has involute teeth. With teeth of this form, in most cases a circular arc

may be found which will more or less closely approximate the true outline. Such a circular arc is shown at $x y$, with its center at o . The radius tool holder shown has its center at o to agree with that of arc $x y$. The cutting point of the tool used is located on that arc. It will be seen from this that when the radius tool is fed from position T_1 to T_2 by the feed worm, its point will follow the desired arc and cut the desired outline for the tooth. By this means the upper surface of tooth a is formed. The same surfaces of teeth b , c , and d have previously been cut, as well as the opposite faces of d and e , tooth d being completed. To cut the opposite faces, the work must be reversed on the arbor.

The Describing-Generating Principle: This principle is shown in Fig. 4, applied to the shaping of involute teeth. The cutting of involute teeth only has been hitherto shown in these examples, owing to the fact that in other cases, as in this, it lends itself most readily to the purposes of illustration. The involute, as is well known, is the curve formed by a point in a cord which is being unwrapped from the periphery of a circle. In the illustration, the dotted line $x y$ shows an involute generated in this fashion from the *base circle* shown. This base circle is formed by the periphery of the rolling disk, which is rigidly connected with the gear to be cut through the work arbor on which both are firmly mounted. Unlike the previous cases considered, this work arbor is free to revolve on centers without being restrained by an indexing mechanism; as in previous cases, the blank has had the teeth roughed out. The machine used is a shaper, as before. To some fixed part of the machine is clamped the tape holder shown. This has fastened to it two thin flexible metallic tapes, M_1 and M_2 , the former stretched between screw S_1 on the tape holder and the corresponding screw

on the rolling disk, while the latter is similarly stretched between screws S_2 and S_2 . By this means, it will be seen that when the shaper table is fed in the direction indicated, the unwinding of M_1 and the winding of M_2 will roll the disk and the work with a positive motion. If now a tool be placed in the tool block of the shaper, having a cutting point set at the same height as the middle

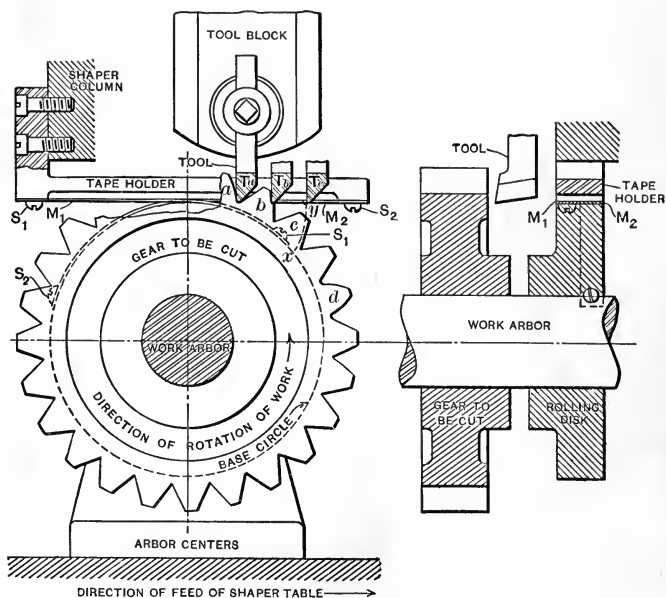

FIG. 4. The Describing-Generating Principle, by which the Point of the Tool is constrained to follow the Desired Outline.

thickness of the steel tapes, and if the table be fed as shown, the mechanism will constrain the tool point to cut an involute on the side of the tooth of the gear blank. When the tooth is at c , the tool will be at T_c ; when the tooth is at b , the tool, at T_b , will have cut down about half the length of the face, as shown; when the tooth is

at a , its outline will have been completed on that side by the tool, at T_a . The way in which the involute is generated will be easily understood when it is seen that the cutting point of the tool always coincides with a given point y in tape M_2 , so that the same involute as is generated by this point in the unwinding tape is reproduced by the tool point. The device is incomplete, as shown, in that no provision is made for indexing. In this case the gear to be cut and the rolling disk have to be indexed with relation to each other, so as to present the different teeth properly for the tool to act upon them. At d is shown a completed tooth.

The Molding-Generating Principle: This method of making gears depends on the fact that in a set of interchangeable gearing a gear formed correctly to run with one of the series will run with any of the series. The molding process consists in using a completed gear tooth or gear, of proper shape, to form other gears. Two examples of this are shown in Figs. 5 and 6. The first case supposes a forming gear, as shown, of correct shape. The blank to be formed is made of some plastic material like wax or clay. The blank and the forming gear are mounted on arbors at the proper distance apart, and rotated together at the proper speed ratio. The teeth of the forming gear, pressing into the plastic blank, will form spaces and press out teeth of the correct shape to mesh with itself, or with any other gear of the same interchangeable series.

In Fig. 6 the blank is of metal or other non-plastic material, and the forming gear is replaced with a forming cutter having sharp edges of exactly the same outline. The blank, which in this case is of the full outside diameter of the gear into which it is to be made, is rotated with the cutter as in Fig. 5. The cutter is reciprocated in the direction of its axis so as to take a series of cuts to form

the tooth spaces as the rotation takes place. The principle is identical with that shown in Fig. 5. Of course,

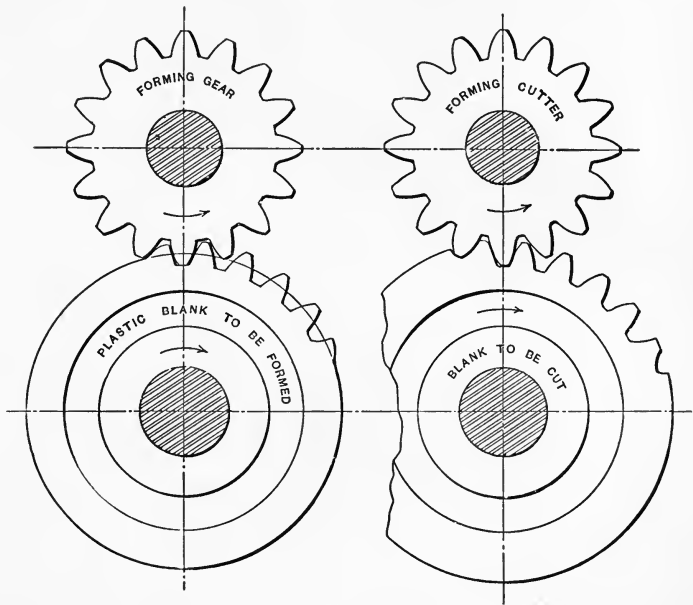

FIG. 5. The Molding-Generating Principle applied to Rolling the Proper Form in a Plastic Blank.

FIG. 6. The Same Principle employing a Cutter having a Shaping Action, cutting Teeth in a Solid Blank.

the cutter has to be fed directly in to the proper depth to start with, before the rotation commences.

FOUR METHODS OF OPERATION.

In classifying gear-cutting methods by the operations involved, we will take for the purpose of illustration the molding-generating method as applied to the spur gear. Later on we will see how the same operations are applied to the cutting of other forms of gears by other methods. In the four cases shown in Figs. 7 to 10 the molding-



generating is done by a rack working in a gear, not by one gear working in another, as in Figs. 5 and 6.

By Impression: Fig. 5 is an example of this kind, the teeth in the plastic blank being formed by the impression made by them on the forming gear. In Fig. 7 the same thing is shown, except that the forming member is a rack which has shaped the periphery of the gear with which it meshes into correct teeth, as shown.

By Shaping or Planing: In Fig. 8 but one tooth space of the gear is formed at a time, and instead of using a rack to do the forming, a tool T_1 may be used having an outline the shape of a rack tooth. This is fed along horizontally, and the gear to be cut is rotated in unison with it, the same way as in Fig. 7. If tool T_1 is given a cutting movement in a shaper, the spaces formed will be of exactly the right shape and identical with those formed in the previous case. Each of the spaces will have to be formed in the same way, one after another, the work being indexed with reference to the imaginary rack, to bring the tool into proper position for each of them. Instead of forming both sides of a space at one operation, as with tool T_1 , a single side tool T_2 may be used, corresponding with one side only of the rack. In this case one side only of each tooth is finished, so the tool or the work has to be reversed, after which the other sides are completed.

By Milling: Instead of using a planer or shaper tool to match the side of the imaginary rack tooth, a milling cutter may be used, as shown in Fig. 9. In this case the gear is rotated, and the milling cutter advanced to agree with the advance of the imaginary rack. The cutting face of the mill must of course be formed on a plane surface, as shown. This arrangement presents some difficulties when the gear to be cut has a wide face, since the circular mill will cut deeper into the tooth space at the center than it

will toward the edges. This deepening of the tooth space at the center does not affect the acting tooth surface, and so is harmless (except possibly in the case of the generation of pinions having a small number of teeth, and invo-

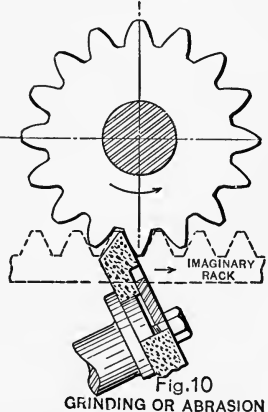
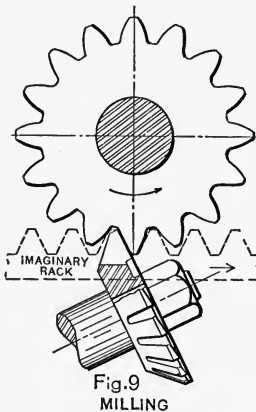
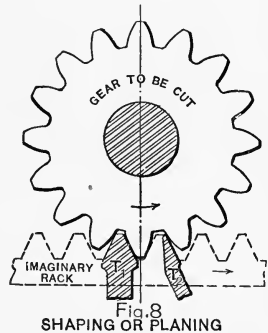
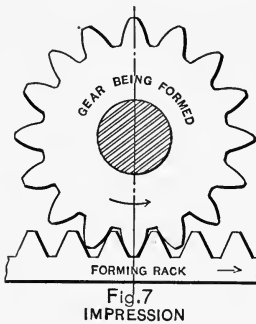

FIGS. 7, 8, 9 and 10. The Four Methods of Operation, as applied to the Molding-Generating Principle of Action.

lute outlines of low pressure angle, in which case the trouble due to interference is aggravated). The larger the diameter of the cutter as compared with the face of the gear, the less is the trouble on this score.

By Grinding or Abrasion: In Fig. 10 the milling cutter of Fig. 9 has been replaced by an emery wheel of similar shape, having a plane face perpendicular to the axis of the wheel spindle. The action on the work is identical with that in the previous case, subject only to the limitations of the grinding process, such as the rapid wearing away of the material of the wheel, involving the necessity for constantly truing it up. Besides this, only a small amount of stock can be removed in a given time, as compared with the execution possible with a milling cutter. The process has the advantage that it can be used in hardened work.

While the involute form of tooth has been used for illustration in Figs. 1 to 10 inclusive, all the various principles and operations can be used for forming cycloidal and other forms of teeth also, though the mechanism and cutting tools are simplest and most effective as applied to cutting the involute shape. It should be understood, furthermore, that each of these various principles and operations can be applied to helical, worm, and bevel gearing as well as to spur gearing; many of the possible combinations are impracticable, of course. The purpose of this limited preliminary discussion of methods is to assist in systematizing the study of the various machines illustrated and described in the following pages, and thus make their construction more easily understood.

CHAPTER II.

MACHINERY FOR FORMING THE TEETH OF SPUR GEARS.

As explained in the last chapter, spur gear teeth may be formed in any one of five ways — by the formed tool method, the templet method, the odontographic method, the describing-generating method, or the molding-generating method. The extent to which these various schemes have been applied in practical use varies greatly. The formed tool method is at once the most obvious and the most used of them all. The templet principle has been applied to a limited extent, principally for gears of very large size. So far as the writer is aware, no practical application of the odontographic principle has been made in the cutting of spur gears. The only machine that has come to his notice involving the describing-generating process was one invented by Mr. Ambrose Swasey and in use twenty years ago or more in the shops of the Pratt & Whitney Company. This was not used, however, for making gear teeth, but for making gear tooth cutters, before the days of the formed cutter, which it was not adapted to making. The molding-generating process in various forms has received a wide application, second only to the formed tool method.

The operations available for the formed tool method are: impression, shaping or planing, milling, and grinding or abrasion. Of these the impression process is obviously unsuited for practical work. The shaping or planing and the milling operations (particularly the latter) have a wide range of application. In the case of the process of grinding

or abrasion, but a single machine has ever been built embodying the formed tool principle, so far as the writer is aware.

MACHINES USING FORMED SHAPER OR PLANER TOOLS.

The primitive application of the formed tool method is that in which a gear blank is mounted on index centers on the planer or shaper table, and has its teeth cut by a tool having an outline corresponding to the desired tooth space. In this operation the tool is fed by hand to the proper depth and withdrawn. The work is then indexed for a second cut, the tool is fed down again, and the operation is repeated until the gear is finished. This was shown diagrammatically in the upper part of Fig. 1. It is the simplest method of cutting a gear which has to be made immediately and for which formed milling cutters are not available. It also has its application in the case of gears of unusual size. Under these circumstances, however, the machine used is generally a slotter instead of a planer or shaper. A formed tool is fastened in the tool-post of the machine, while the work is clamped to the revolving table. The indexing is done by such means as may be provided, usually a worm and worm gear or a master wheel. The Gleason and Newton templet machines (see Figs. 48 and 49) also may be, and doubtless often are, used in the same way.

Figs. 11 and 12 show a machine using the formed tool with the shaper method of action. The machine is an interesting one in its details, and it would require considerable space to go into full particulars, so only a general description of it will be given. The mechanism is mounted on a circular column. The work arbor is carried by a slide, vertically adjustable to suit the diameter of the work, the adjustment being obtained by the crank handle

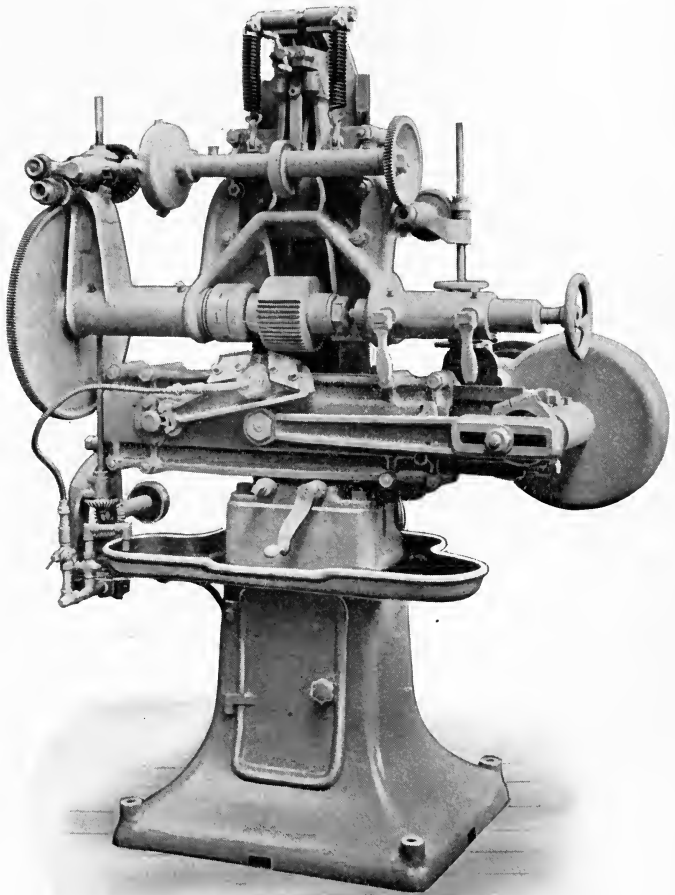

FIG. 11. The Pederson Formed Tool Gear Shaping Machine.

shown at the front of the column. The feed and indexing movements for the work are controlled by cams on the shaft shown at the upper side of the work slide. The cam shaft is operated by an adjustable friction mechanism

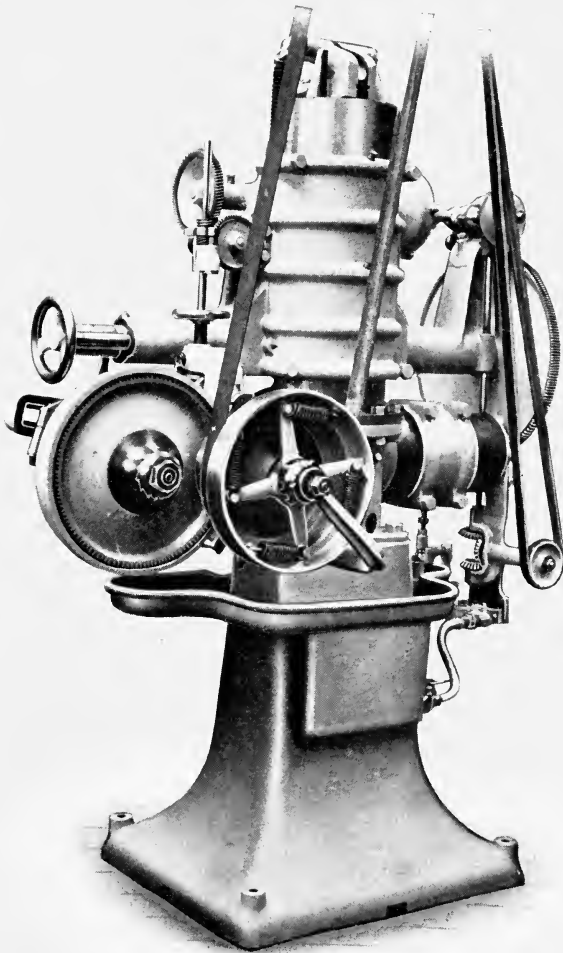

FIG. 12. Rear View of the Pederson Machine.

from the driving shaft. The feed cam, by suitable lever connections, forces the blank slowly down toward the cutters until the proper depth has been reached, when it allows the springs shown at the top of the column to

quickly return it, whereupon a cam at the left of the shaft trips the mechanism by which the work is indexed. The feeding cam then comes into action again — and so on until the work is completed. The depth of the feed given the work slide by the cam movement is varied by altering the position of the contact block by which the cam lever transmits the feeding movement to the slide. This is changed by the horizontal double-crank handle seen at the extreme top of the column. The indexing is effected through an index worm-wheel and worm, operated through the change gears shown in Fig. 11, from the vertical shaft driven by the bevel gears and small pulley at the left of the base. This pulley, and consequently the indexing mechanism, runs at constant speed, irrespective of the main drive. Provision is made for stopping the action of the machine automatically when the required number of teeth have been cut.

The cutter slide is driven by a back-gearred crank movement, adjustable for length of stroke and for various numbers of strokes per minute. Two tools are used, one cutting on the forward, the other on the return stroke. These tools, as may be seen from Fig. 11, are mounted in a rocking holder, which is tipped to bring first one and then the other into action as the end of each stroke is reached. This tipping is effected by the rocking and locking cam at the left end of the cutter slide in Fig 11. This rocking and locking cam is connected with a slot cam near the right-hand end of the slide, this latter being operated by a pin near the crank end of the connecting-rod. As the connecting-rod passes the center, going in either direction, it operates the slot cam, which, through its connection with the rocking and locking cam, brings the desired one of the two blades into action. The one of these blades which has the heaviest of the cutting to do

is of a simple U-shape, forming the bottoms and fillets of the tooth spaces. The other one, which has a lighter cut, forms the curved faces of the teeth.

Among the advantages claimed for this machine are rapidity of action and very low first cost. The cost of the cutters is also very moderate, being about one-fifth of that for formed milling cutters of the same pitch. These cutter blades are planed to shape, and may be ground on the face without change of contour. By means of special cutters straddling the teeth of the gear, provision is made for cutting pinions of few teeth and considerable under-cut. The British rights for this machine have been acquired by Vickers Sons and Maxim, who are manufacturing it at their works at Erith, Kent.

STANDARD MACHINE TOOLS AND ATTACHMENTS USING FORMED MILLING CUTTERS.

More gears are cut by formed milling cutters than in any other way. It is distinctly a commercially successful process. The cutting tools are comparatively inexpensive, and retain their shape until they are entirely ground away, which is only after the accomplishment of a surprising amount of work.

The simplest way to use a formed cutter is in the milling machine. In a milling machine provided with an indexing head no attachments are required for gears of moderate size and small pitch, and many thousands of them are cut with this simple equipment. For gears of larger diameter, though still of a pitch small enough so as to be within the range of the pulling power of the spindle, the worm-wheel of the dividing head becomes too small to accurately index the wheel. Many of the milling machine makers provide indexing attachments suitable for doing

work of greater diameter than is possible otherwise. In Fig. 13 is shown an equipment of this kind built by the Cincinnati Milling Machine Company, Cincinnati, Ohio. The head and foot stocks are mounted on elevating blocks to extend their swing. When working on large diameters, the table is raised and the cut taken on the under side of the work. This brings the thrust due to the cut down nearer to the bearing surfaces which have to resist it, and

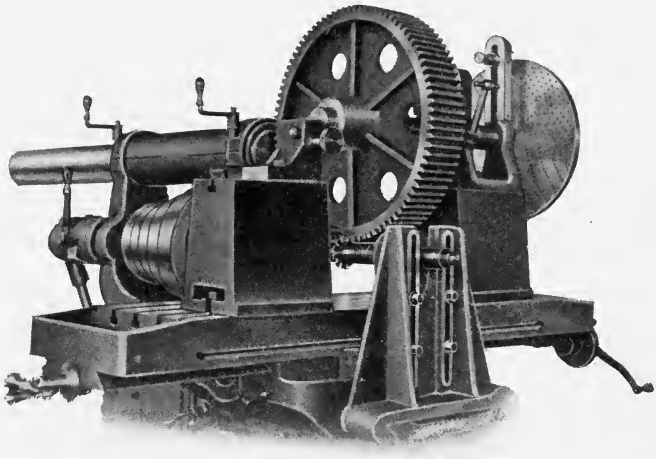

FIG. 13. Attachments for cutting Gears of Large Diameter on Cincinnati Milling Machines.

gives a steadier cutting action than would be the case if the work were lowered far enough to have the cutter act on the top of the blank. The indexing is done simply and directly by a plate with rows of holes, of numbers corresponding to the number of teeth it is desired to cut. This plate is of much greater diameter than the index worm of the regular spiral head, and so gives more accurate results.

Another method of mounting large gear blanks in the milling machine is shown in Fig. 14. Here the work is

held on a horizontal face-plate, indexed by a worm wheel of large diameter concealed within the base of the attachment. The indexing is effected by a crank on the worm-shaft having an index pin entering holes in a stationary index plate, as in the regular milling machine dividing head. When using the device the vertical movement of the knee on the column is employed to feed the work up past the cutter.

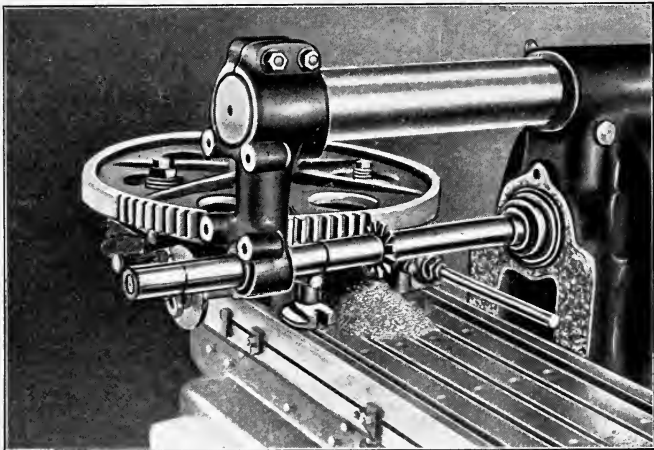

FIG. 14. Le Blond Circular Milling Attachment with Indexing Arrangement, used for cutting Large Spur Gears.

An attachment of a different kind for cutting gears in the milling machine is shown in Fig. 15. Here we have an arrangement which is bolted on the milling machine table and connected with the dividing head. This attachment is driven from the counter-shaft by a special belt connection which serves to operate the feed and indexing of the work, the usual feed connections being disconnected. The device renders the milling machine automatic in all its actions. The table with the work on it is fed forward

slowly until the cutter has passed through the work and formed the tooth space. The table and work are then rapidly returned, after which the work is indexed and again fed forward as before. These processes are repeated until the gear is finished. The milling machine is thus

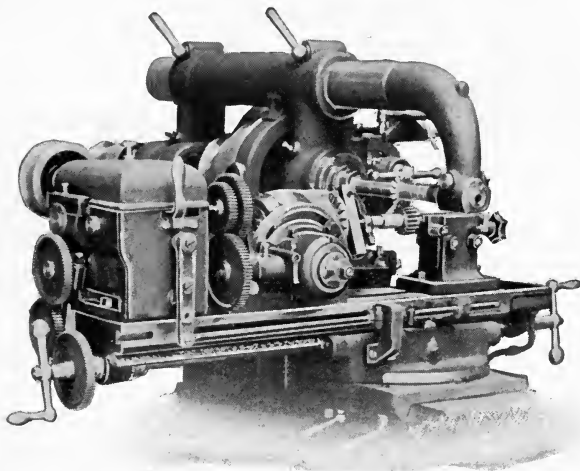

FIG. 15. Attachment made by Ludwig Loewe & Co. for converting the Milling Machine into an Automatic Gear Cutter.

made in effect an automatic gear cutter, capable of cutting bevel gears and clutches, as well as spur gears. This device is made by Ludwig Loewe & Co., Berlin, Germany.

SEMI-AUTOMATIC MACHINES USING FORMED MILLING CUTTERS.

Leaving the special use of the standard milling machine in this work, and coming to milling machines specially adapted to cutting gear teeth, we are met by a bewildering variety of designs of varying degrees of ingenuity and interest. We will first consider the simpler forms of these

specialized milling machines, or "gear-cutting machines," as we may better call them.

In the simpler forms the development from the milling

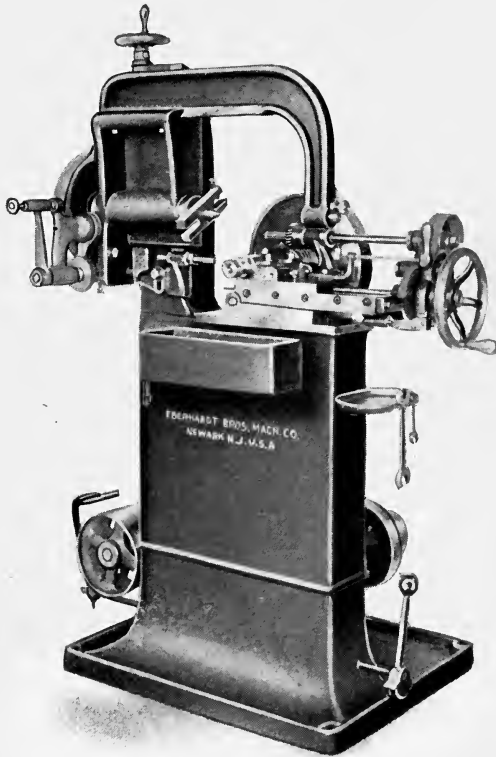

FIG. 16. Newark Gear-Cutting Machine Company's Semi-automatic Machine for Small Work.

machine consists principally in embodying the dividing mechanism as a part of the machine, instead of making it an attachment. The feed may be operated by hand, or it may be connected by belt or gearing with the spindle, so

as to be driven positively. In the latter case an automatic stop is provided for throwing the feed out when the cut is completed. In the automatic form of machine the indexing mechanism, as well, is operated by power, as is also the quick return of the feed; and the movements are made dependent on each other in such a way that the machine of itself feeds the cutter through the work, returns it when the cut has been completed, indexes the work, and repeats the cycle until the job is finished.

An example of the semi-automatic form of the machine, made by the Newark Gear Cutting Machine Company, Newark, N. J., is shown in Fig. 16. The mechanism is quite simple and may be readily understood from the cut. The cutter spindle is carried on a slide which has an automatic feed, driven by the spiral gears and change gears shown, which may be set to give the desired rate. An automatic stop is provided for throwing out the power feed when the required length of cut has been taken. The slide then has to be run back by hand and the work indexed by hand, when the automatic feed is again thrown out. The work spindle is carried on a slide gibbed to the face of the column of the machine. This slide carries the indexing mechanism also, and an overhanging arm for supporting the outer end of the work arbor. The indexing mechanism is of the same type as that illustrated in Fig. 17 and described later. Such tools are adapted to manufacturing in small quantities where unskilled labor is employed. The machines are inexpensive, and the operating skill required is of a comparatively low order.

Machines of similarly simple action, but for larger work, have been built from time to time by builders of special machinery as required by their customers. Of these the large Pratt and Whitney gear-cutting machine with L-shaped bed, is perhaps the best known.

AUTOMATIC MACHINES USING FORMED MILLING CUTTERS
— GENERAL PRINCIPLES OF DESIGN.

The fact that we illustrate twenty-eight automatic formed cutter machines, built by twenty-three makers, is good evidence of the commercial position of this type. Much thought and experience has gone into the development of the automatic gear cutter. In selecting such a machine, important requirements to be looked out for are: accuracy of indexing, power and durability of the feed and cutter-driving mechanisms, rigidity of construction, convenience of handling, and range of usefulness.

In the matter of accurate indexing (which is of prime importance, especially for gears which are to run at high speeds), the important considerations are the accuracy of the index worm-wheel and the mechanical construction of the indexing mechanism. With the exception of the machines shown in Figs. 19, 20, 43, 44, 45, and 46, which are for comparatively small work with small numbers of teeth, the principle of the indexing mechanism is the same for all of these machines.

The work spindle has mounted on it (see Fig. 17) a worm-wheel driven by an indexing worm. This worm is connected by change gears *A*, *B*, *C*, and *D* with a shaft which is arranged (usually) to make one complete revolution when the proper time for indexing arrives. The change gears are so set in connection with the invariable movement of the index shaft as to give the exact movement required to rotate the blank to the point where it is desired to cut the next tooth. In some machines provision is made for giving two or four complete revolutions to the driving shafts when the number of teeth to be indexed is small. It is important that the mechanism by which this shaft is set in motion and stopped shall be

very carefully designed, so that the stopping will always take place at exactly the same point in the rotation, thus permitting no over-running or under-running of the worm.

In the construction of the worm-wheel there are two plans followed. Some makers, notably the Brown & Sharpe Manufacturing Company, prefer to make each worm-wheel an accurate copy of a master wheel which they know to be of unimpeachable accuracy. Other builders prefer to make each index wheel by itself, and generate each one to a high

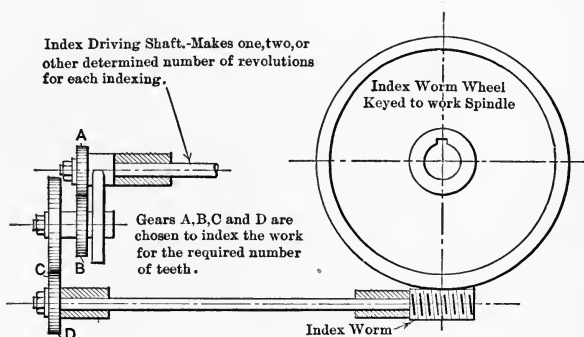

FIG. 17. Diagram showing the arrangement of the Standard Indexing Mechanism.

degree of perfection by methods well understood and commonly employed in such work, generally involving making the rim in halves.

In the matter of obtaining power and durability for the drive a variety of opinions will be found expressed in the various designs. Some of them have the spindles driven by spur gearing (or bevel gearing in some cases), while other makers prefer spiral or worm gear drives. There is much conflict of opinion as to the advantages of these various forms. In some cases the builder is restricted in

his choice by structural features which limit him to one form only. In any event the drive should be smooth and powerful.

The capacity of gear-cutting machines for taking heavy chips may be easily allowed to fall below the limit of the driving power available at the spindle, if the frame of the machine and the design of gibbing of the various slides are such as to make the machine lacking in rigidity. The various requirements for doing work rapidly and accurately may be understood from the rough sketch of a sec-

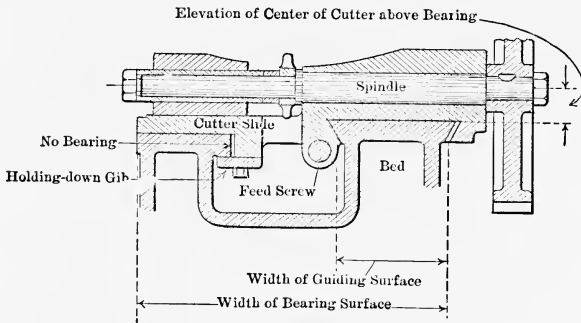

FIG. 18. Cross-section through Cutter Slide of Typical Gear Cutter, illustrating Certain Principles relating to Accuracy and Cutting Power.

tion through the spindle and cutter slide of a gear-cutting machine such as is shown in Fig. 18. This sketch does not represent any particular machine, but shows some features which are common to a number of makes; unnecessary details have been omitted. One of the requirements is that the strain of the cutting action shall be brought as close to the bearing surface as possible. This applies in the case of both the work spindle and the cutter spindle. It will be noted in Fig. 18 that the elevation of the center of the cutter above the bearing is very

small, so that the irregular thrust of the cutting action when working at full capacity has little effect in disturbing the rigidity of the machine. Bearing surfaces of great area are also advisable to give firmness to the structure. It will be noted that the bearing surface extends the full width of the bed of the machine in the sketch. With this wide bearing surface, however, provision should be made for guiding the slide for alignment, with much narrower surfaces, to prevent a cramping or "bureau-drawer" action, as it has been called. The guiding in this case is done entirely by the comparatively narrow dovetail slide at the right. There is no side bearing at the left, a clearance space being provided at the right-hand edge of that slide as indicated. A strap is provided here, however, for holding the slide down on to its bearing, thus checking any lifting tendency at this point. It will be noted that the feed screw is placed quite close to the cutting point. This provision also tends toward smoothness and ease of action, since the power is then applied directly instead of in a way to cramp the slide on its bearings. The rigidity and smoothness which these provisions insure are of great importance in permitting the use of very heavy cuts and in lengthening the life of the cutter.

In regard to these matters, and the matter of convenience of operation as well, much can be surmised from a careful inspection of the illustrations of the various machines here shown. Instead of making invidious comparisons in these particulars, it has been thought best to let the reader draw such conclusions as he can from the information given. The descriptions of the various automatic gear cutters will be found to contain explanations of their construction, and to refer to such particular points as may be peculiar to each case. To make comparisons easy, machines of similar type have been placed together

in regular order. Of course such of the good qualities in a machine tool as depend on accurate workmanship and the design of details not visible from the exterior will have to be judged by other means than a mere inspection of engravings. In the matter of accurate workmanship, particularly, the reputation of the builder will go a long way with the interested investigator.

MILLING MACHINE TYPE OF AUTOMATIC SPUR GEAR CUTTER.

As has been stated, the automatic gear cutter is a specialized form of the milling machine. There are no machines in our list that show this more plainly than the two illustrated in Figs. 19 and 20. The first of these is built by the Dwight Slate Machine Company, of Hartford, Conn. The machine at once shows itself to be a modified milling machine, with the usual screw feed replaced by a cam mechanism which gives a slow forward movement and a quick return. This is altered to give the proper length of feed, by means of the slotted link shown. The orthodox dividing head with worm and worm-wheel has been replaced by a dividing plate on the head-stock spindle, with notches to correspond with the number of teeth it is desired to cut. An automatic trip is provided which throws out the feed at the completion of the last tooth. The various adjustments for different diameters of gears and lengths of cut will be readily understood from an inspection of the figure. This machine is also made in a style adapted to the cutting of bevel gears as well as spur gears.

In the machine shown in Fig. 20, built by Sloan & Chace Manufacturing Company, Ltd., Newark, N. J., the feed is effected by a screw as in the ordinary milling machine, instead of by cams as in the previous case. The motion

for the indexing and quick return is taken from the counter-shaft by the pulley shown near the base of the machine at the left. This gives a constant speed at the highest practicable rate, whatever the spindle speed may be. The

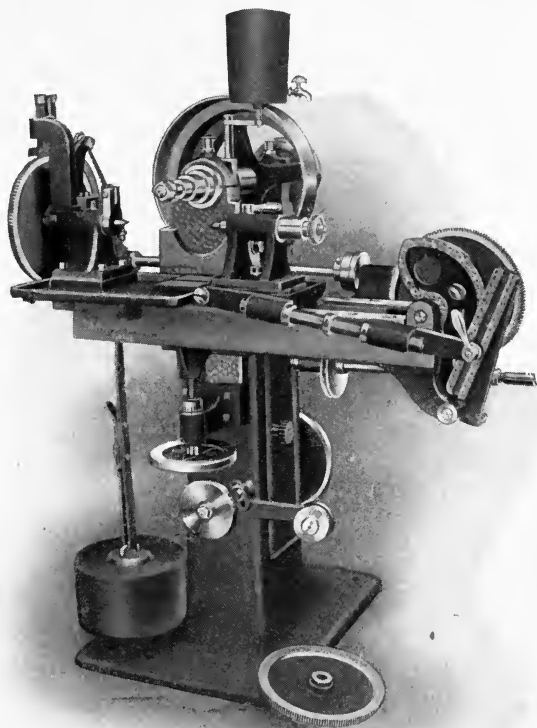

FIG. 19. The Dwight Slate Cam-actuated Automatic Gear Cutter.

cutting feed is obtained from a connection with the spindle through a feed box, giving three changes. The indexing is ingeniously effected by the first half-turn of the feed screw, and is done positively without requiring the use of springs. A dial plate is used as in the previous case.

The spindle head is adjustable in and out on the top of the column for centering the cutter. This machine shows the influence of the watch machinery maker's ideas applied to a machine of rather larger capacity than usual with such

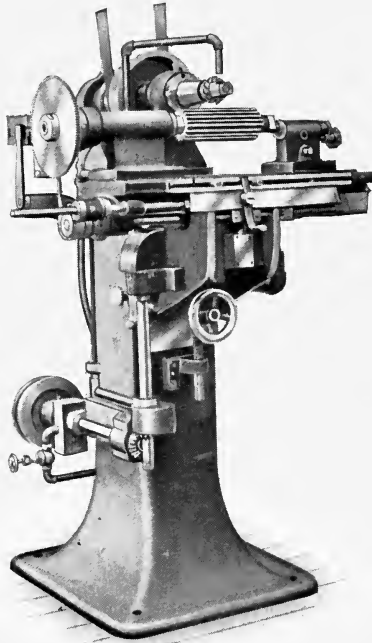

FIG. 20. The Sloan & Chace Automatic Gear Cutter for Small and Medium Size Work.

construction. It is intended to embody the watchmaker's ideas of accuracy as well.

Another machine that shows the hereditary influence of the miller is shown in Fig. 21. In this case, however, the relative positions of the work spindle and the cutter spindle have been reversed from that occupied in the milling machine or in the tools shown in the two pre-

ceding cuts. The work spindle passes through the uprights of the column, and carries a worm dividing gear at the rear end, while the cutter slide is located on the knee. In the position shown, with the intermediate quadrant

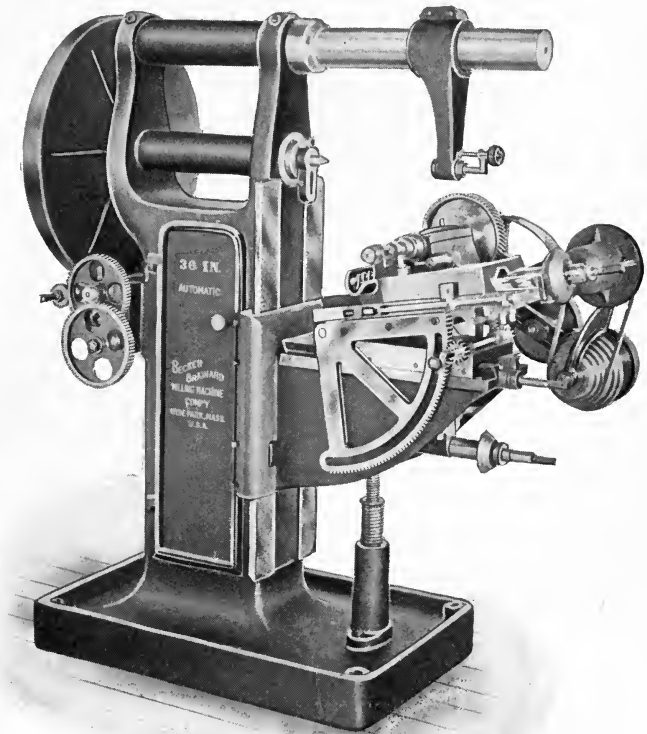

FIG. 21. The Becker-Brainard Automatic Gear-Cutting Machine.

elevated, the cut is being taken on an angle as would be required in cutting bevel gears, for which this machine is also adapted. For cutting spur gears the slide is horizontal. Change gears for dividing are seen at the rear of the column beneath the casing for the indexing wheel. The

indexing is done by a friction mechanism which is released at the proper time, coming up against a positive stop when one revolution has been made. The spindle driving and feed mechanisms are carried entirely by the knee. It will be noted that the gear driving the cutter spindle has helical teeth. Where a cutter spindle is to be driven by spur gears this is a construction often followed, particularly in Europe, to give a smoother and more even motion than would be obtained by teeth cut straight across in the ordinary fashion. An incidental convenience of this machine is a trough just beneath the cutter spindle, enclosing a slowly moving spiral conveyor. The chips fall from the cutter into the trough, and are pushed out by the conveyor over the edge of the knee into the pan base, away from the mechanism of the machine. This machine is built by the Becker Milling Machine Company, Hyde Park, Mass.

THE ORTHODOX AUTOMATIC SPUR GEAR CUTTER.

The automatic gear cutter of the conventional type, for small and medium-sized work, has the work and cutter spindles both horizontal, and arranged in the same relation to each other as in the Becker-Brainard machine. Instead, however, of adjusting the machine for the diameter of work by raising or lowering the knee carrying the cutter spindle, the work arbor is raised or lowered, being carried for that purpose in a head vertically adjustable on a column at the end of the bed of the machine. The cutter slide when arranged for cutting spur gears only is gibbed directly to the top surface of the bed.

One of the best known examples of this orthodox type of automatic gear-cutting machine is that built by the Brown & Sharpe Manufacturing Company, Providence, R. I. A front view of one of the smaller sizes is shown in Fig. 22.

The spindle of this machine is driven by worm gearing which has the parts reversed from the order they would naturally take, since the worm-wheel is the driver, and the worm, which is much larger in diameter than the wheel, is the driven member. This arrangement gives the

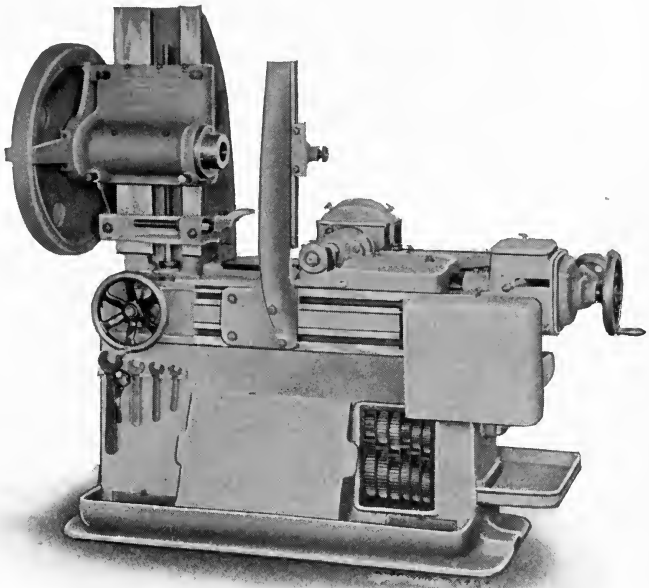

FIG. 22. An Example from the Brown & Sharpe Line of Automatic Gear Cutters.

smoothness of drive of worm gearing, an enlarged bearing area, and the advantage of being able to shift the whole spindle with its driving gear endwise in adjusting the cutter centrally with the work, instead of requiring that the driving gear remain fixed in position, driving the spindle by sliding keys, as in the ordinary construction. The plan generally followed by this company with all its

machinery, of building the various parts of the mechanism on the unit system and assembling them as units in the machines, gives an air of neatness in design to the tool which will be readily appreciated from the engraving. A feature common with most automatic gear cutters, the

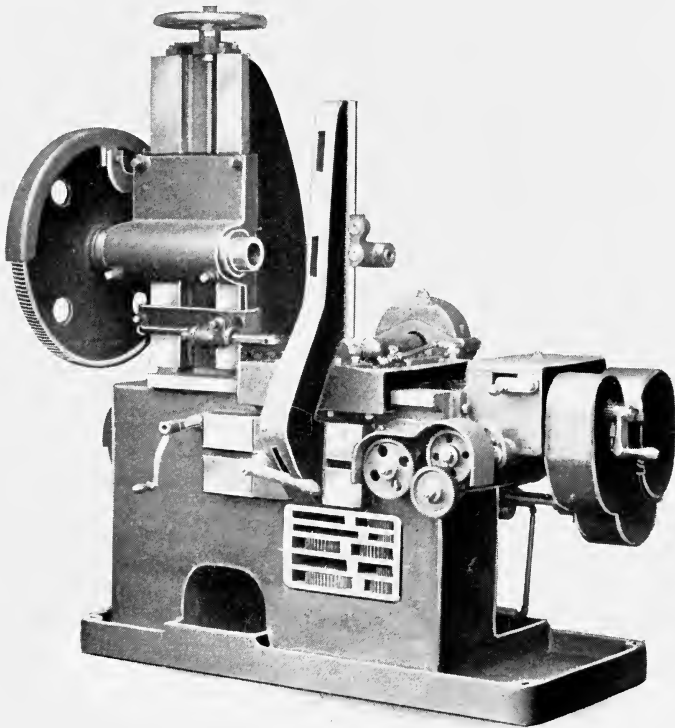

FIG. 23. Automatic Gear-Cutting Machine made by Cincinnati Gear Cutting Machine Company.

outboard support for the work arbor, will be noticed clamped to guiding surfaces on the front of the bed. The index wheel is solid, and is made an accurate copy of a precision master wheel, as previously explained.

The machine in Fig. 23 is built by the Cincinnati Gear Cutting Machine Company, of Cincinnati, Ohio. Its most noticeable characteristic is the simplicity and directness of its mechanism, which is worthy of study as an example of good design in this respect. The movements are interlocked to prevent any possible variation from the proper

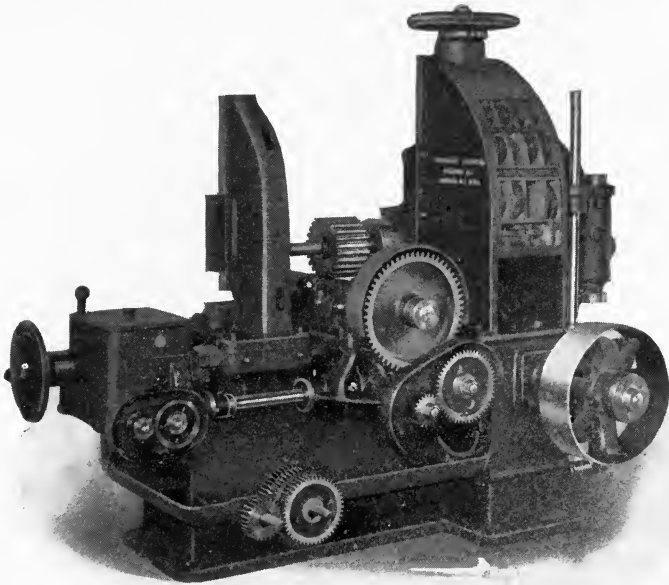

FIG. 24. A Machine made by the Newark Gear Cutting Machine Co., with Special Shortened Column, for cutting Coarse Pitch Pinions.

cycle of automatic operation, and a number of distinctive conveniences in setting and operation are provided. The illustration shows very plainly the weight and stiffness of the main castings.

The spur gear cutter shown in Fig. 24 is built by the Newark Gear Cutting Machine Company, of Newark, N. J. The machine shown was designed primarily for cutting

pinions of large pitch. For this reason the machine is ruggedly built and has a comparatively short column, limiting the diameter range for which it is adapted. The whole mechanism is driven from a pulley running at constant speed, the various changes of spindle speed and feed being obtained by change gears. It is like most other machines of its class, also, in the fact that the interior of the base of the machine serves as a collecting chamber for chips and a reservoir for the oil which is drawn from them. From here it is returned to the cutter by an oil pump. It will be seen that the cutter spindle driving gear in this case is a spur gear. The change gearing for altering the speed is placed next to it in the order of transmission, so that the splined shaft which leads the motion to the cutter shaft runs constantly at high velocity, whatever the speed of the cutter may be. Smaller machines of somewhat similar type are also built by this firm, some of them adjustable for cutting bevel gears as well as spur gears. This machine may also be supplied with a higher column than is here shown, providing for work of greater diameter.

An automatic gear cutter built by the E. J. Flather Manufacturing Company is shown in Fig. 25. One of the most noticeable features of this machine as compared with those previously considered is the construction of the column which supports the work-carrying head. This is made double, and the work-carrying head passes through it instead of being clamped to ways on its face. The handle shown projecting at an angle in front of the index wheel casing at the back of the column is used for clamping the work head solidly to its seat on both the front and back sides of the column, when the adjustment for depth of cut has been made. The spindle of this machine is worm-driven. The indexing mechanism is of the posi-

tively operated type, with a friction device to prevent rebound. As in previous cases, all changes of feed and speed are made by change gears, the machine being driven by a constant speed pulley.

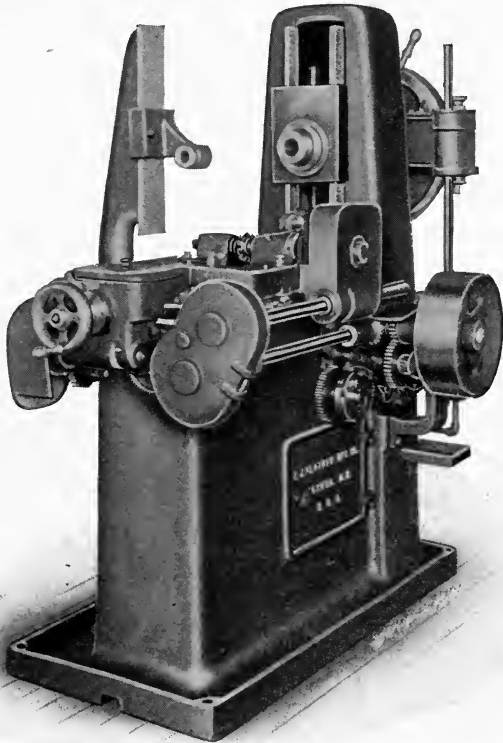

FIG. 25. The Flather Automatic Gear Cutter.

Another well-known tool in this field is that shown in Fig. 26. It is built by Gould & Eberhardt, Newark, N. J. In this machine, as in the previous one, the column is double and the work-carrying head passes through it. This machine is of larger capacity than any of the others shown so far and, in common with most large capacity

machines, is provided with a mechanism for raising and lowering the work spindle head by power. Another point of interest in this machine is the automatic clamping device with which it is provided, used for firmly holding

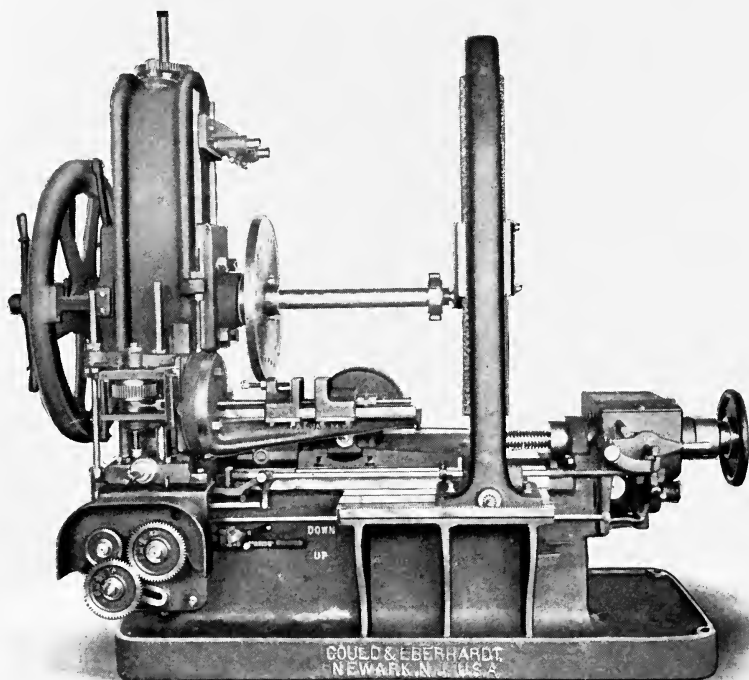

FIG. 26. Gould & Eberhardt Spur Gear Machine, with Special Automatic Rim-clamping Device.

the rim of the blank while the cut is in progress. This is in addition to the usual positive back stop against which the blank rests. This clamp consists of a pair of jaws, carried by slides on the adjustable arm shown at the front of the machine, and operated by a screw connected with the mechanism of the machine in such a way as to hold

the work firmly while the cut is in progress, releasing it while the indexing takes place, and again clamping it for a new cut. It is especially useful for comparatively slender work.

The general features of this line of machines can be best

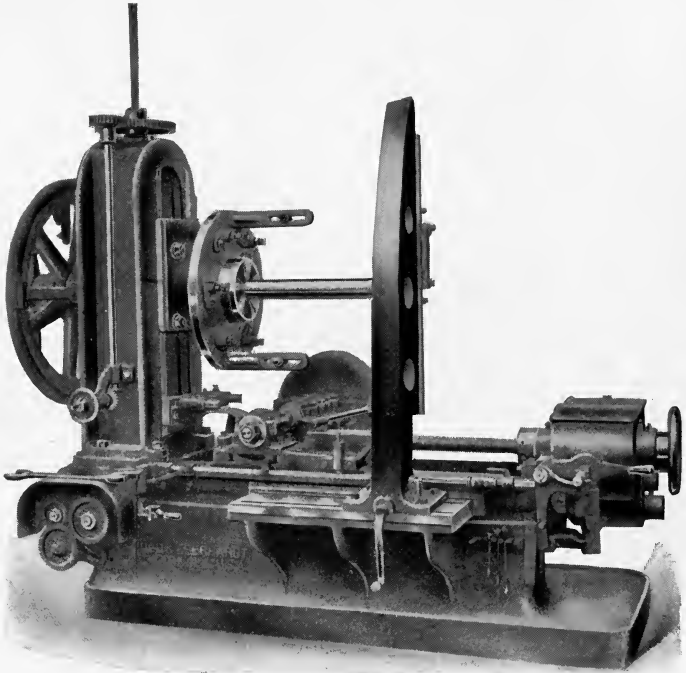

FIG. 27. Specialized Design of the Gould & Eberhardt Automatic Gear Cutter for Heavy Motor Gears.

seen by referring to Fig. 27, which shows another member of this line, specially constructed for the severe service of cutting steel motor gears. The cutter and feed screw are in line with each other, so that a direct central thrust is imparted to the slide. The machine is driven through a single pulley, from which the movement is transmitted

through gearing and keyed shafts to the different parts of the machine. The cutter spindle is driven by worm and worm-wheel through change gearing. The index wheel is of the split rim type with hobbled teeth, the final finishing

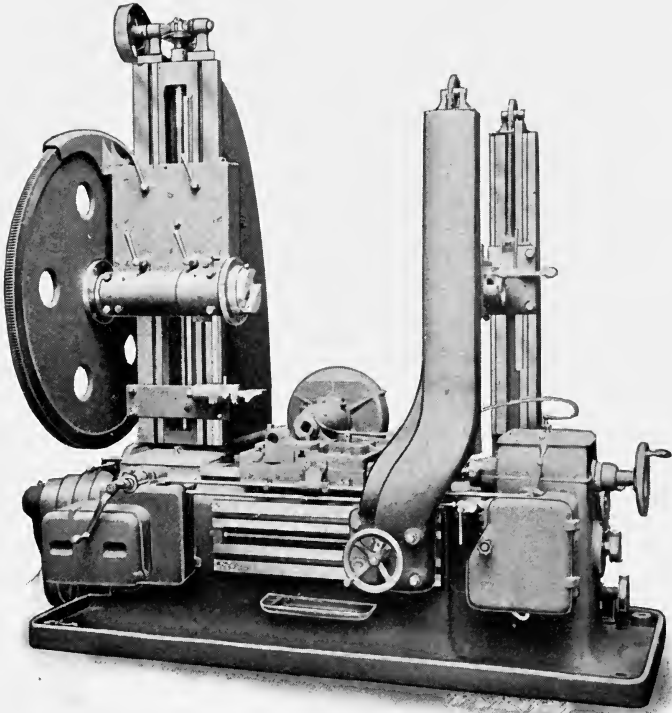

FIG. 28. The Largest Size of the Line built by Ludwig Loewe & Co.

of which is done with the dividing wheel in position on the machine. Means are provided for compensating for all wear and lost motion which may take place in this mechanism. A slight tension is constantly maintained between the stop cam and the worm in the direction of

rotation, which prevents all danger from back lash and rebound. The rigid construction of the outer support of the work arbor will be noticed. Its base is mounted on a bracket cast on the side of the main frame. In removing a finished gear from the machine, it slides back out of the way without disturbing the height adjustment of the out-board bearing.

An automatic gear cutter of continental design and manufacture is shown in Fig. 28. This tool is built by Ludwig Loewe & Co., of Berlin, Germany. Its most striking feature, so far as appearance is concerned, is the provision made for supporting the outer end of the work arbor. Two uprights are used, one at the front and the other at the rear of the bed, supporting a bearing for the work arbor. This bearing is counterweighted, so as to be easily adjustable for vertical position. The uprights can be moved back when it is desired to insert the work, by operating the hand-wheel shown at the base of the front one. The spindle of this machine is driven by a worm-gear. It has a large dividing wheel for the range of work it is intended for, having a diameter of 57 inches. It is made in two parts, by the method which generates each wheel anew, rather than making it a copy of a previously made master wheel. Eight changes of feed are provided, varying from .010 to 0.42 inch per revolution of the cutter. This machine is also built in two smaller sizes. The size shown will cut gears up to 78 inches in diameter.

The machine shown in Fig. 29 is built by J. Parkinson & Sons, Shipley, England. This machine cuts gears up to 48 inches in diameter by 10 inches face. The cutter spindle is driven by a worm and worm-gear, and has four changes of speed obtained by a sliding quick change gear arrangement, instead of by the usual removable gears. The dividing mechanism is driven by friction, and has a

device which starts and stops it gradually to avoid shock. The starting and stopping is done by the interposition of a pair of elliptical gears which gradually increase the rapidity of the indexing movement when it is started, and retard it in the same way as it is being completed. By means of suitably arranged connections, provision is made for multiple indexing, which is often resorted to, to

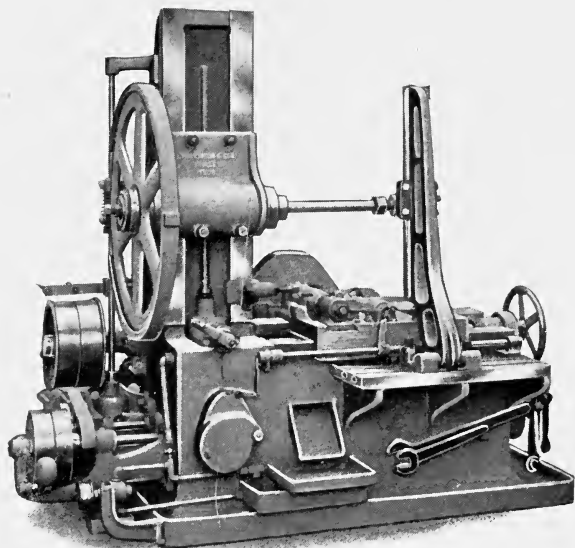

FIG. 29. An Example of English Design, built by J. Parkinson & Son.

avoid local heating. In cutting a gear having 45 teeth, for instance, every fourth tooth may be cut continuously, until the gear is completed. In this way the heat due to cutting is distributed more uniformly around the rim, avoiding the distortion due to local heating, which is liable to occur when teeth are cut in regular order. This multiple indexing is obtained without requiring the change gears to be specially calculated for it.

A gear cutter made by J. E. Reinecker, of Chemnitz-Gablenz, Germany, is shown in Fig. 30. The index wheel of this machine is of large diameter, about seven-tenths of that of the largest gear that can be cut. The mechanism controlling the movements of the machine is so arranged that the forward feed does not commence until the indexing

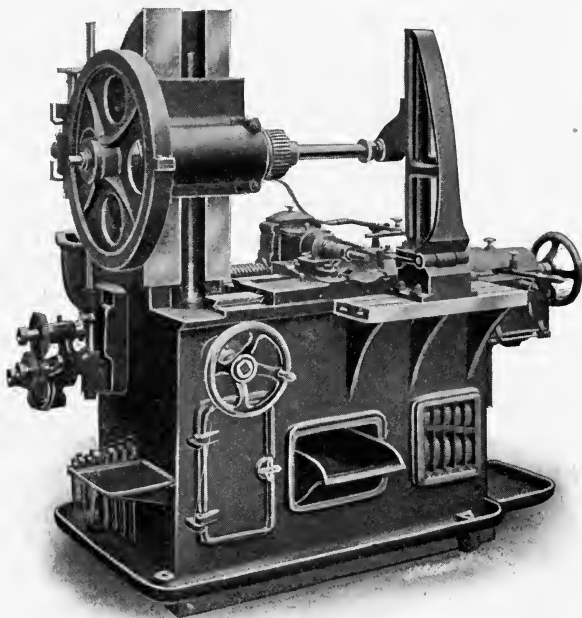

FIG. 30. The Reinecker Automatic Spur Gear Cutting Machine.

has been completed, the cutter slide being retained in its rearward position until that time, thus avoiding the possibility of damage to the machine or work from failure of the mechanism to operate properly. An unusual feature, seen at the rear of the machine in the illustration, is the spindle drive gearing. The spindle is driven by a worm. This is not of the ordinary type, with a hole through its

center, splined to be driven by the longitudinal shaft on which it slides as the table is fed forward or back; instead, a long worm is used, fixed longitudinally, and threaded for a sufficient length to accommodate the worm-wheel

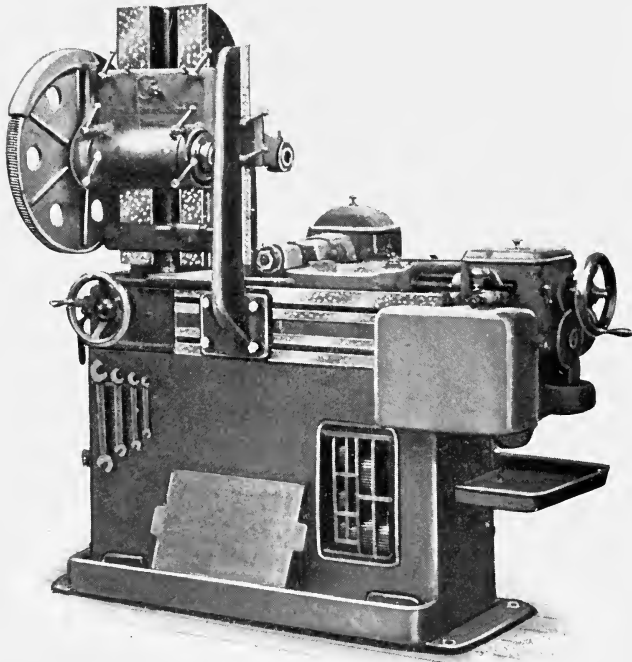

FIG. 31. A German Automatic Spur Gear Cutter which shows the Influence of American Design.

throughout the full travel of the slide. It will also be observed that the outboard support for the work arbor is hinged to facilitate the insertion and removal of the work.

A German machine, very similar to that shown in Fig. 22, is illustrated in Fig. 31. The mechanism is carefully enclosed, fixed handles are provided for all the adjustments,

and standard types of rim rests, outboard work supports, etc., are furnished. The speed and feed changes, as well as the indexing, are effected by change gears. The machine is built by Schubert & Sulzer, Chemnitz, Germany.

A gear cutter built by Messrs. G. Wilkinson & Son, of Keighley, England, is shown in Fig. 32. This is essentially the same in principle as the previous machines described,

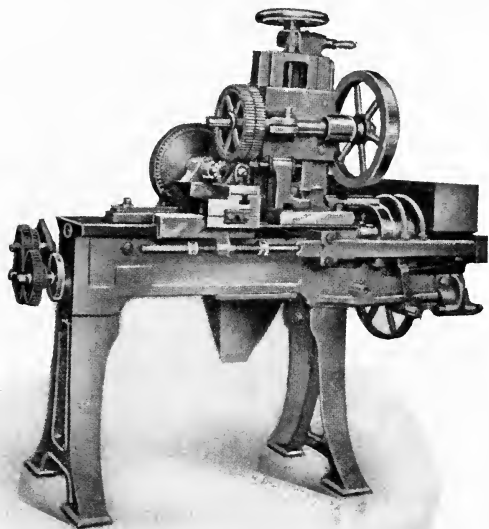

FIG. 32. The Wilkinson Automatic Machine for Small Gears.

but it has an entirely different appearance, due to the fact that the bed is set on legs, instead of extending down to a solid bearing on the floor. The controlling mechanism is also somewhat differently arranged, although the movements required are the same. It will be seen that it is intended for comparatively small work. It takes wheels up to 18 inches in diameter and 6 diametral pitch. The cutter spindle is driven by a spur gear of large diameter.

STANDARD TYPE OF AUTOMATIC FORMED CUTTER
MACHINE FOR HEAVY WORK.

The machines we have just been describing are representative of the standard form of automatic machine for small and medium work. Considerations of ease

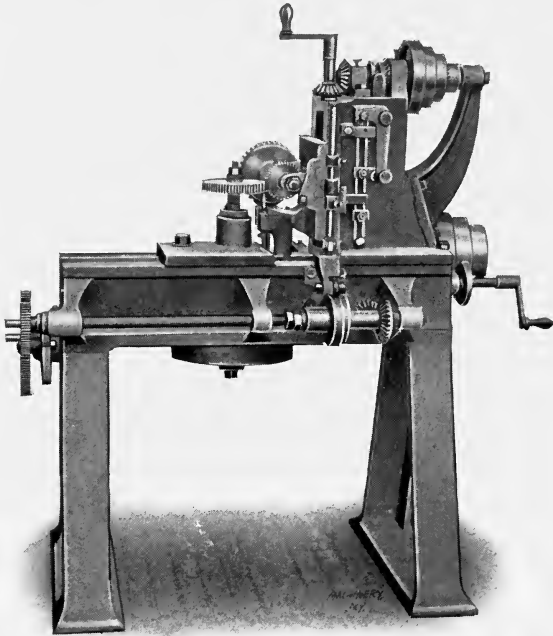

FIG. 33. A Small Armstrong-Whitworth Automatic Machine.

of handling the work and convenience in arranging the mechanism have evolved a somewhat different form of machine for the largest and heaviest work. The change made may best be described by saying that the previous type of machine is laid down on the back of its column, with the bed extending vertically upward into the air. In other

words, the change is simply a change of base. The bed becomes the column, and the column becomes the bed. This explanation will be easily understood by comparing the machines shown in Figs. 35 to 38 with those in Figs. 22 to 31. The principal advantage due to the change of base in this machine is the better support given to heavy work, the weight of which is carried directly by the bearing of the slide on the bed, instead of being taken by the elevating screw in the column, as in the design previously described.

Although it was stated that this construction was especially adapted for heavy work, the first three machines of this type here illustrated are comparatively small. That shown in Fig. 30 is built by Sir W. G. Armstrong, Whitworth & Co., Manchester, England. The machine is very simple in design and ruggedly built. The slow downward feed and quick return are obtained by epicyclic gearing in the feed cone at the top of the column. The clutches controlling this mechanism are operated by adjustable dogs on the side of the column. The indexing mechanism is of the frictional type, set by change gears for the required number of cuts.

The gear-cutting machine shown in Fig. 34 is built by John Hetherington & Sons, Ltd., of Manchester, England. A number of interesting points are evident from the cut. For instance, as may be seen, the vertical feed of the cutter slide on the face of the column is effected by a cam under the base, at the end of the horizontal bearing in the rear leg. This cam, and the roller and slide which it operates, are plainly visible beneath the machine. The slide is counterweighted to keep the roll always pressed up against the cam. Another ingenious detail of the mechanism is the belt tightener provided, which compensates for the change in position of the cutter slide. The belt is passed over an idler fastened to one end of a bell crank,

whose other arm has teeth engaging a rack on the cutter slide. As the slide descends, requiring more belt, the idler moves toward the right, furnishing the required amount. The same belt drives both the spindle mechanism and the feed mechanism. The index worm and

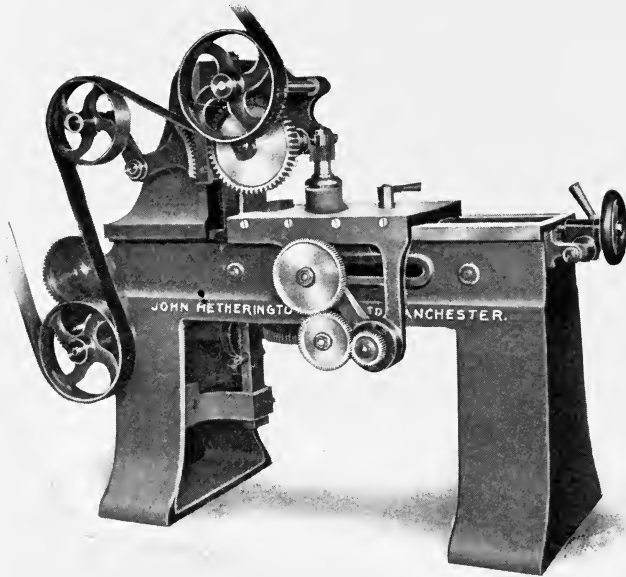

FIG. 34. A Simple Machine with Cam-operated Feed, built by John Hetherington & Sons.

wheel are beneath the table. A quick withdrawing motion operated by an eccentric lever is provided for bringing the spindle back from the cutter when it is desired to remove or replace work on the arbor; this can be operated without disturbing the setting for depth of cut. This machine will cut gears up to 30 inches in diameter, 4 inches face and 4 diametral pitch. The proper change gears for varying the feed and indexing are furnished with the machine.

The first of the heavier machines here shown, in Fig. 35, is another built by Sir W. G. Armstrong, Whitworth & Co. of Manchester, England. In this machine the index wheel is carried above the bed, while a second bearing for the work spindle is provided by the arm which springs from the work slide on either side and spans the index

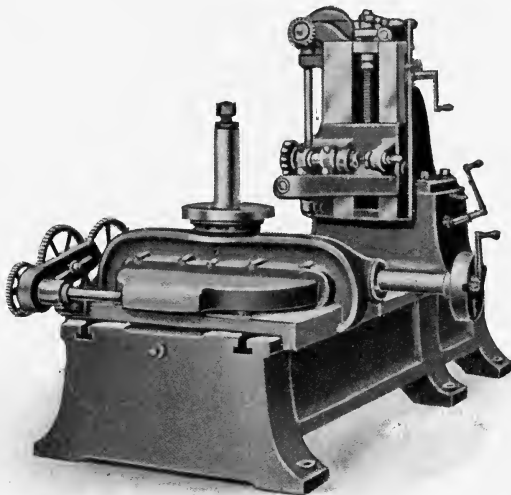

FIG. 35. Heavy Armstrong-Whitworth Gear-Cutting Machine.

wheel. This brings the top of the base rather low, so the column is carried on an upward extension of the bed, giving the whole structure a distinctive appearance. The change gears for indexing are mounted on the slide, and carried with it when adjustment is made for diameter. In this machine the indexing is either automatic or hand, as may be thought best. There is less gain in automatic indexing in very heavy work than in the medium size, since the time of feeding is proportionately longer, while the large machine should have at least as much attention as

is required for indexing. The cutter head of this machine can be set on an angle if desired, for gashing worm-wheels. The cutter spindle is supported at the outer end by a bearing and is driven by a coarse lead worm-gear. The machine is adapted to the cutting of wheels from 12 to 96 inches in diameter, up to 14 inches face.

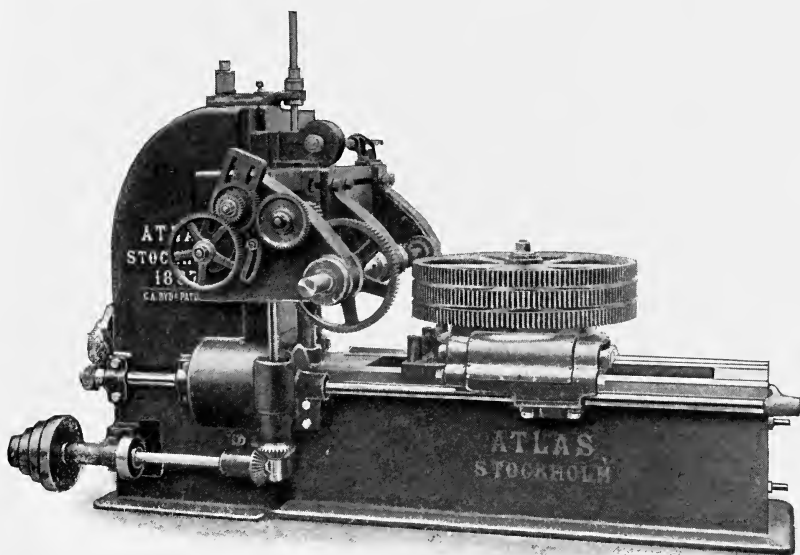

FIG. 36. An Example of Swedish Design — The Atlas Machine, as arranged for cutting Spur Gears.

The machine shown in Fig. 36, built by Nya Aktiebolaget Atlas, Stockholm, Sweden, is shown cutting a stack of large spur gears. It is in reality, however, a universal machine, being adapted to making spiral and worm gears as well as spur gears, so that it has mechanism in addition to that needed for cutting spur gears only, as may be seen from the illustration. The heavy cross rail

and the change gearing mounted on it are part of the mechanism required for cutting worm-wheels. Its action as a spur gear machine is automatic and similar to that of the machines previously described. Like the Arm-

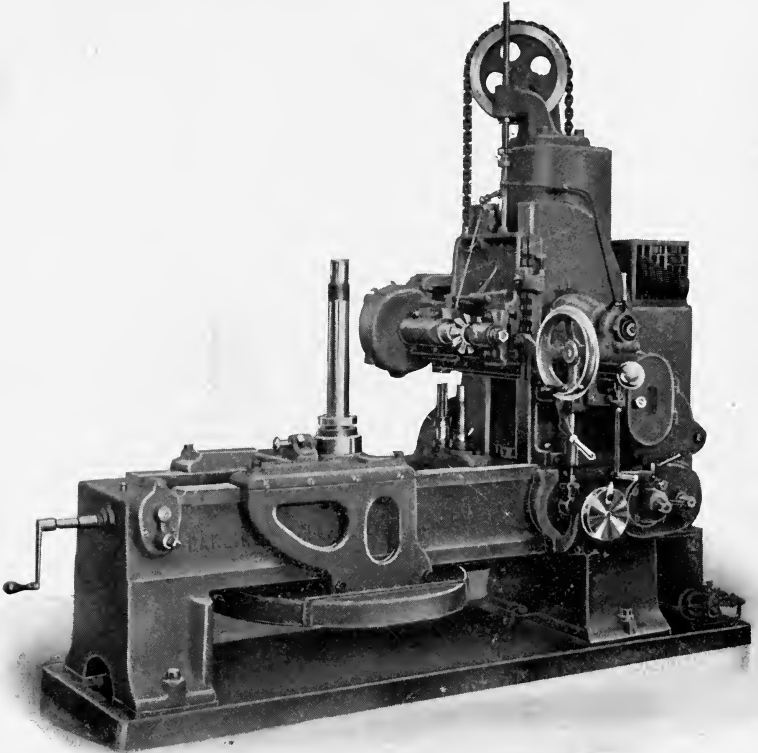

FIG. 37. The Darling & Sellers 4-foot Automatic Spur Gear Cutting Machine.

strong gear cutter in Fig. 35, it has the index wheel above the bed. The machine will cut gears up to about 8 feet in diameter. Other applications of this tool are illustrated later in Figs. 77, 104 and 146.

The machine shown in Fig. 37, built by Darling &

Sellers, Keighley, England, has the index wheel carried below the bed with the work spindle passing up through it. It will also be noted that the work carriage encircles the bed, having bearings on its sides, as well as being gibbed at top and bottom. The cutter spindle is driven by helical gearing. The spindle is hardened and carried in a long taper bearing, which is carefully ground to fit. The end-wise adjustment for centering the cutter is effected by moving the main spindle bearing bodily to the left or right. A permanent gauge is attached to the cutter slide which can be instantly lowered to test the centering of the cutter. A novel feature of this gear-cutting machine is the way in which the quick return of the cutter slide is effected by the excess weight of the counterbalance, which brings the slide immediately to its upper position when the feed is released, stopping against an air cushion. The feed change is accomplished by change gearing. The indexing device is of the friction type, but so interlocked with the feeding mechanism as to prevent the feeding of the cutter before the indexing has been completed. A larger size of this machine is provided with a clamping arrangement which firmly holds the rim of the work while the cut is being taken. This works automatically; a friction drive acting through a screw presses it down onto the work, while a positive clutch raises it again. The machine shown in the cut has a feed of 16 inches and will swing a 4-foot gear. The whole design of the machine is unusually interesting and attractive.

In Fig. 38 is shown an automatic gear-cutting machine built by the Newton Machine Tool Works, Philadelphia, Pa. This is intended especially for the cutting of heavy gears made of high carbon steel, such as are used in motor gears for electric cars, locomotives, etc., with the expectation of cutting two or three teeth at once. The massive propor-

tions of the machine give evidence of the duty for which it is intended. It is provided with a mechanism which renders it impossible to engage the downward feed until the dividing has been successfully completed for the next

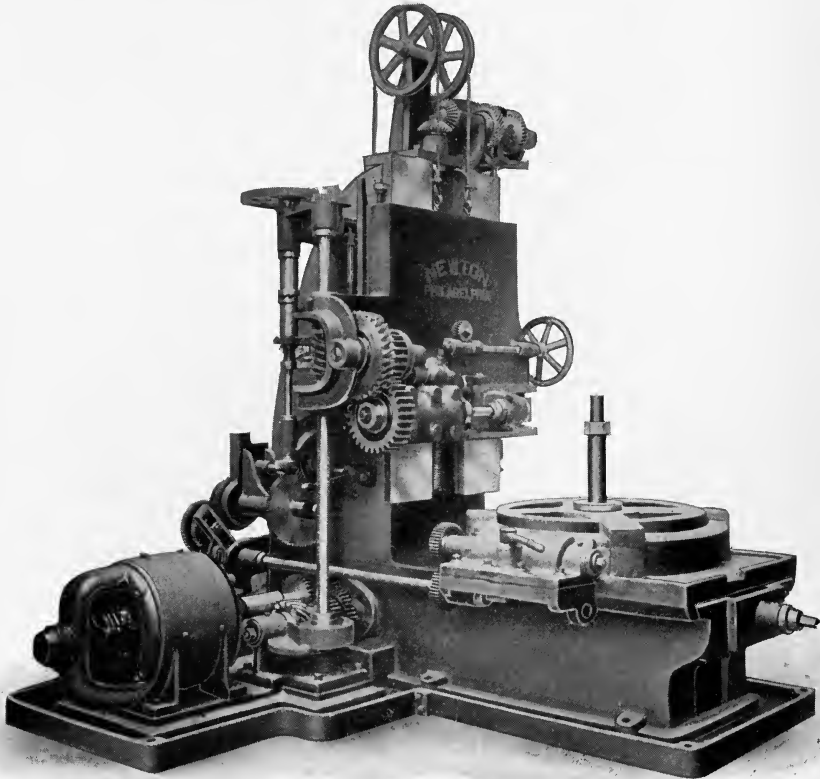

FIG. 38. A Newton Machine, especially designed for the cutting of Heavy Motor Gears and Pinions.

tooth. The machine shown is directly motor-driven, the spindle being connected to the motor through a train of spur, spiral, and worm gearing. The indexing worm-wheel is mounted above the slide, as may be seen.

MACHINES FOR HEAVY WORK WITH COLUMN
ADJUSTABLE FOR DIAMETER.

A modification of the heavy type of machine consists in making the column carrying the cutter slide adjustable on the bed to suit the diameter of the work, instead of adjusting the work spindle. An automatic machine of

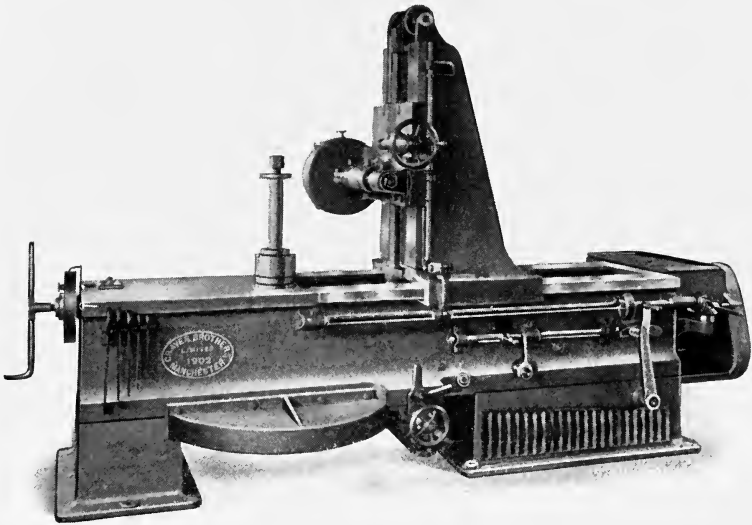

FIG. 39. The Craven Automatic Gear-Cutting Machine.

this type is shown in Fig. 39. This tool is built by Craven Brothers, Ltd., Manchester, England. The spindle head is counterbalanced, and is provided with four feeds which may be changed by a quick acting mechanism at the front of the machine. The cutter spindle is driven by a steep pitch worm and gun-metal worm-wheel. The outer end is supported in an adjustable bearing. The dividing mechanism can be operated either by hand or power.

The design is a neat one and shows evidence of careful planning.

The adjustable column machine shown in Fig. 40 is built by Gould & Eberhardt, of Newark, N. J. This is the 15-foot size of a line of three, of which the largest will cut, entirely automatically, gears up to 20 feet in diameter, 36 inches face and 6 inches circular pitch in cast iron, or

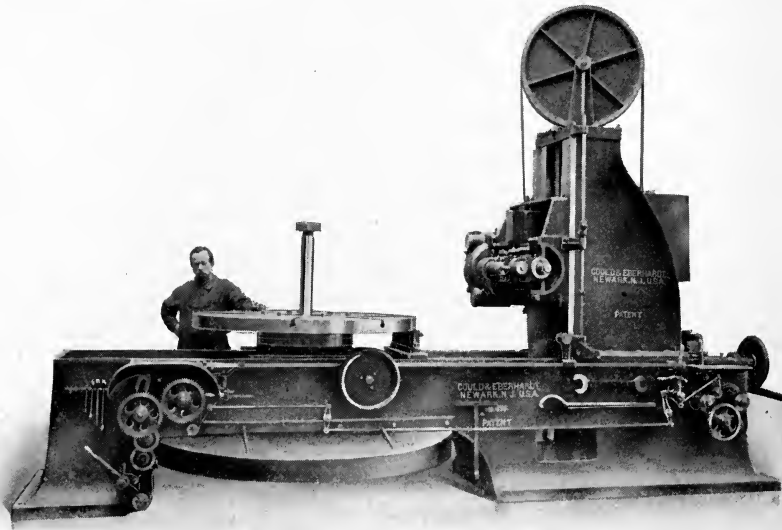

FIG. 40. The Horizontal Type of Gear Cutter, as built by Gould & Eberhardt.

$4\frac{1}{2}$ inches in steel. So far as the writer knows, this latter machine is the largest entirely automatic spur gear cutting machine that has ever been built. There are a number of interesting features in the design and construction of this machine. A safety device is incorporated in the indexing mechanism which makes it impossible for the cutter to feed downward before the indexing has been successfully completed. An auxiliary cutter spindle (shown

in place in the machine) is provided for finer pitch, small diameter cutters. When the heaviest work is being done, this small spindle and the boxes which support it are removed. The column has rapid power adjustment

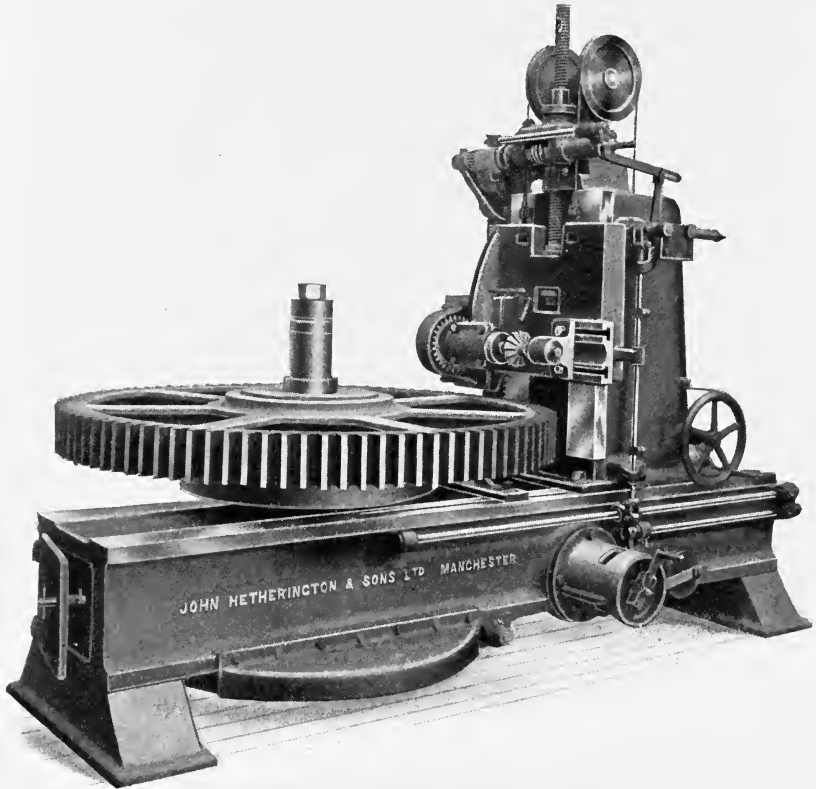

FIG. 41. The Hetherington Automatic Gear-Cutting Machine.

on the bed with fine hand adjustment for the final setting. This line of machines has been largely used in cutting cast-iron and steel gears which had formerly been made with cast teeth, giving very much better gears at an expense not much greater than was required for those with cast teeth.

In Fig. 41 is shown a machine of the adjustable column type built by John Hetherington & Sons, Ltd., of Manchester, England. This is a large capacity machine, being fitted for cutting gears up to 8 feet in diameter, 16 inches face and 1 diametral pitch. The dividing mechanism may be operated either automatically or by hand. In the former case the indexing is effected by means of a ratchet mechanism operated by a crank which starts the movement gradually and stops it in the same way, without shock and without danger of over-running. The spindle is driven by worm and spur gears from a 3-step cone pulley, driven by a wide belt running at high velocity. The worm-gear is of gun metal, and the worm of steel.

SPUR GEAR CUTTING MACHINES WITH L-SHAPED BED.

As the machines we have been describing for heavy work were evolved from the orthodox gear cutter by the expedient of laying that machine on its back and transforming the base into the column and *vice versa*, so a third type, occasionally met with, has resulted from laying the orthodox machine on its side, producing a bed having an L-shape. The old Pratt & Whitney gear-cutting machine was an example of this. This is familiar to most mechanics engaged in gear cutting, as there are many of them in use in various shops in this country for cutting spur gears and hobbing worm-wheels. The builders have discontinued making the machine, however, so we do not show it here.

Fig. 42 shows a contemporaneous example of this type, built by G. F. Smith, Ltd., of Halifax, England. As may be seen, one branch of the L furnishes ways on which the horizontal work spindle is adjusted to set the machine for the proper diameter of work. The other portion of the bed furnishes ways for the slide carrying the vertical cutter

spindle. This spindle is driven by spiral and worm gearing from a cone pulley. The indexing worm on the dividing wheel shaft is adjustable in the center to take up wear. All changes of feed and indexing are by positive gearing. An outboard support for the work spindle is

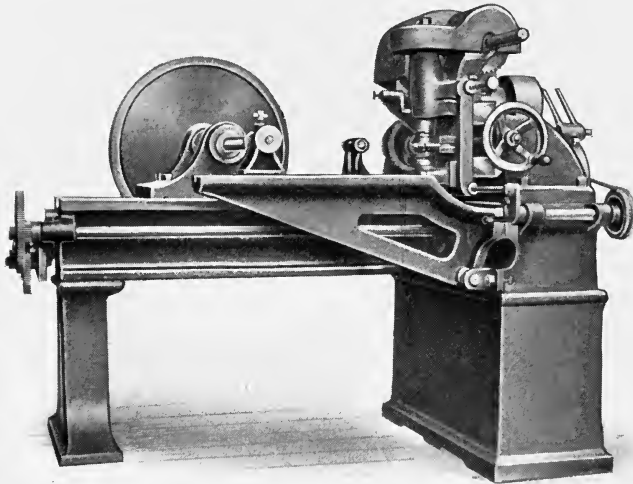

FIG. 42. An Example of Machine with L-shaped Bed, as made by G. F. Smith, Ltd.

plainly shown in the cut attached to the outer end of the cutter-slide branch of the bed.

Another example of this type of machine, though arranged with adjustments permitting the cutting of bevel gears, is that built by the Newark Gear Cutting Machine Company, shown in Fig. 172.

PRECISION FORMED CUTTER MACHINES.

The machines we have described are suited for the cutting of gears ranging from those used in machinery of ordinary size up to the largest and heaviest built. There

has been a development along somewhat different lines in machines for cutting teeth in minute pinions and gear blanks, such as are used in watches, fine instruments, etc. Some of these small machines cost as much as, or more than, larger ones for ordinary work. This is due in part perhaps to their complexity, but more to the accurate fitting necessary. An amount of play which would be just sufficient to provide oil space in the spindle of a large automatic gear-cutting machine, would give so loose a fit to the spindle of one of these minute mechanisms as to make it totally unfit for the work it has to do. Where the thickness of the teeth of the gear being cut is a matter of a few thousandths only, the required accuracy in the fitting of the spindle, slides, etc., must be expressed in tens of thousandths or even hundreds of thousandths of an inch. Even though a high degree of accuracy in fitting is obtained in these machines, it is often found necessary to take two or three and sometimes more cuts through each tooth space in order to make sure that the desired outline is obtained. In one of the machines here described provision is made for this automatically.

In Fig. 43 is shown a precision gear-cutting machine built by Hardinge Brothers, 1036 Lincoln Avenue, Chicago, Ill. It will be seen to follow somewhat in its mechanism the Slate and Sloan & Chace machines, shown in Figs. 19 and 20, being derived in form from the ordinary column and knee type of milling machine, though greatly reduced in size. In adjusting for diameter, however, the cutter spindle is moved up or down by swinging about the fulcrum of the arm on which it is carried; the table or slide carrying the work head-stock and foot-stock is not adjustable vertically for this purpose. The feeding and indexing movements are effected by a cam shaft driven by the large wheel shown at the back of the machine. The feeding

is governed by the slotted link mechanism at the front, connected by the adjustable reach rod shown with the bracket extending downward from the work table beneath the dividing head. Index plates are used instead of the index worm-wheel common in larger machines. Separate disks are used for locating the spindle and locking it in position after the indexing, the disk for the latter purpose

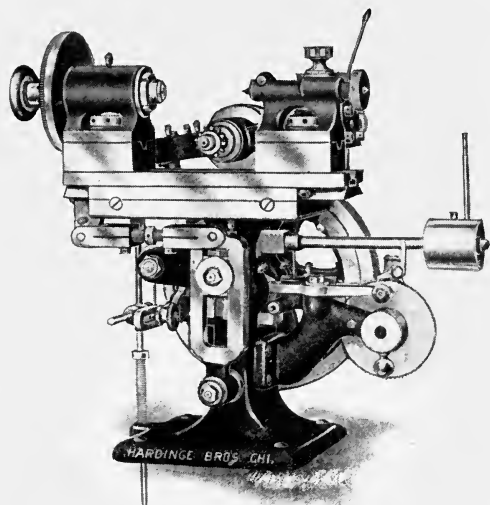

FIG. 43. The Hardinge Automatic Precision Gear Cutter.

being covered to prevent accidental injury. An arrangement is provided by which the cutter is lowered from the cut on the backward movement to prevent injuring the finished tooth space, and to allow the indexing to take place during the return movement. The ratchet wheel shown below the machine at the right is indexed a step for each tooth cut in the work, and may be set to lower the cutter out of the work and stop the feeding mechanism when all the teeth have been cut. The cutter spindle

still runs, however, and the indexing still proceeds, so that the working parts are constantly kept at the working temperature.

In Fig. 44 is shown a precision gear cutter made by the Standard Manufacturing Company, of Bridgeport, Conn. This machine has the indexing and feeding mechanisms operated by a cam shaft driven by the worm and worm-wheel shown at the left of the machine. It will cut gears up to 4 inches in diameter, in stacks 2 inches long. As in

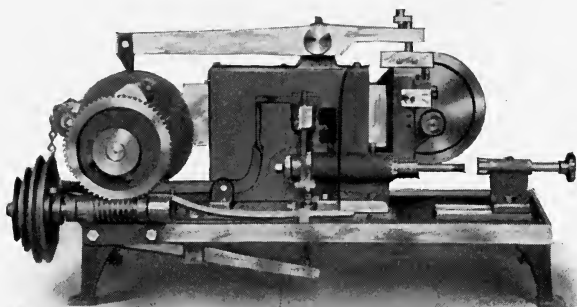

FIG. 44. The Standard Manufacturing Company's Automatic Precision Gear Cutter.

the previous machine, the cutter is raised out of the work while the blank is being indexed and the feed is being returned to commence the next stroke. Two speeds are provided for the cutter spindle, and nine feeds. The cutter works ninety per cent of the time, the indexing and returning movements being very rapid. Both the work and cutter spindles have tapered bearings adjustable for wear.

The machine shown in Fig. 45, made by the Sloan & Chace Manufacturing Company, Newark, N. J., is built on the same general plan as the previous machines so far

as concerns the use of dial plates for indexing and cams for performing the various movements. This machine, however, can be arranged to carry three cutters on the spindle if desired. The first cutter is used for roughing, the work being indexed clear around for that purpose. The cutter spindle is then shifted axially to bring the second cutter central with the work, when the operation is continued as before. The spindle is then shifted a second

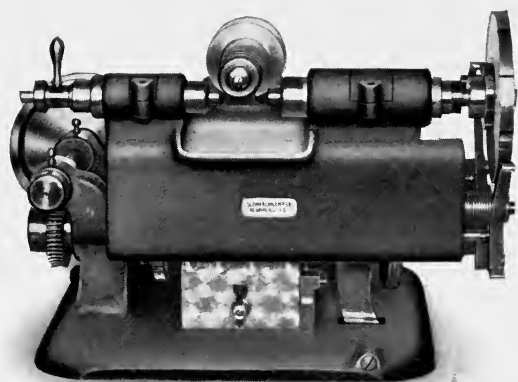

FIG. 45. The Sloan & Chace Automatic Precision Pinion Cutter, arranged for taking Three Cuts through Each Tooth.

time to bring the third or finishing cutter into position for operation, whereupon the work is completed. This little machine is ingeniously arranged to allow all three of the settings (the roughing, secondary, and finishing) to be separately adjusted for centering the cutter and depth of cut. All the movements are entirely automatic. The machine is essentially a pinion cutter rather than a gear cutter, as it is best adapted for gears having comparatively few teeth.

The automatic pinion-cutter shown in Fig. 46 is made by

the Waltham Machine Works, of Waltham, Mass. In this machine the automatic principle has been developed to a high degree, in that the machine feeds itself and takes out the work as well after it is completed. The long slide seen extending upward from in front of the cutter is a magazine in which pinion blanks are placed. This magazine is brought in line with spindles of the head and foot stock, which (by the action of the cams by which they are

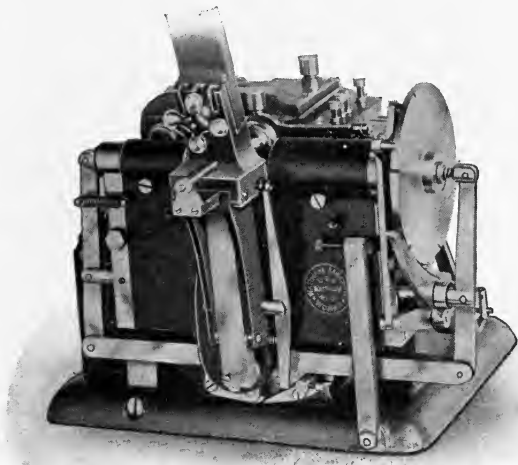

FIG. 46. The Waltham Automatic Pinion Cutter, with Magazine and Self-feeding Mechanism.

controlled) grasp the shanks of the blank and hold it firmly in position to be cut. The cutting and indexing then proceed as in previous machines. When the indexing has been completed, the hold of the chucks on the work is released and the work ejected. This operation is continuous as long as the cutter stays sharp and the magazine is kept full.

THE FORMED TOOL PRINCIPLE APPLIED TO THE GRINDING
OR ABRASION PROCESS.

The only representative of this process, so far as we know, is the machine shown in Fig. 47. This tool, built by Upton & Gilman, Lowell, Mass., is intended primarily for smoothing up teeth of cast gears, so perhaps it does not really belong in the category of gear-cutting machines;

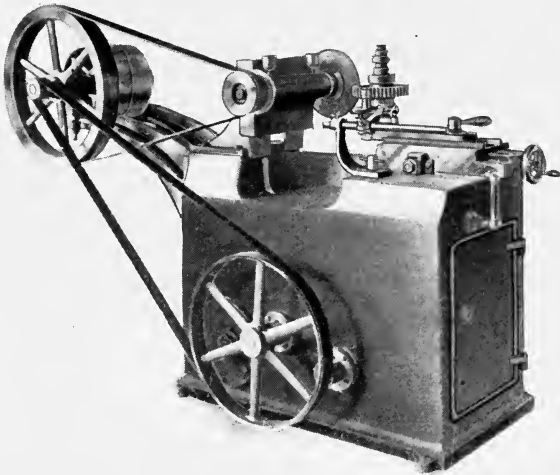

FIG. 47. The Upton & Gilman Machine for Finishing the Teeth of Cast Gears by Grinding with a Formed Wheel.

as the only representative of its class, however, it has been included. The grinding wheel is formed to the shape of the tooth space of the gear to be finished. The gear is mounted on the vertical spindle shown. When the machine is in operation the emery wheel is brought down through the tooth space, cleaning it out, and is then withdrawn. The work is indexed, and the operation is repeated. Owing to the fact that the shape of the space and the shape of the wheel are the same, the latter tends to preserve its

form, being used merely to remove irregularities in otherwise correctly shaped surfaces.

Besides the machines thus far described, a number of those primarily designed for cutting helical and bevel gears are adapted to the cutting of spur gears by the form tool method as well. Examples of such machines are shown in Figs. 110 and 167 to 172 inclusive.

THE TEMPLET PRINCIPLE APPLIED TO CUTTING THE TEETH OF SPUR GEARS.

The templet principle is practically limited, in the cutting of spur gears at least, to the shaping or planing process. Of these machines two examples are here shown.

Fig. 48 illustrates a templet spur gear planing machine built by the Gleason Works, Rochester, N. Y. In this tool the work spindle is horizontal, a pit being provided for gears of large diameter. The capacity of the machine is very great, it being adapted to cutting teeth in blanks up to 20 feet in diameter. The cutting tool is mounted in a traveling head at the right side of the machine. This traveling head is driven by a screw controlled by open and crossed belts and shifting mechanism similar to that used for a planer. The scale of the engraving is too small to show the templet mechanism clearly, but it is identical in principle with that illustrated in Fig. 2, in the first chapter of this book. For varying the diameter adjustment to suit the blank being operated on, the head-stock carrying the work spindle is moved toward or away from the tool slide. The machine shown is motor-driven.

Another remarkable example of templet machine for spur gears is shown in Fig. 49. In this case the tool is a modified slotter instead of being a modified Richards planer as in Fig. 48. The column part of this tool is, in fact, practically the portable slotter built by its makers,

the Newton Machine Tool Works, Philadelphia, Pa. It is mounted on a long base plate, and may be set at any desired position thereon to agree with the diameter of the gear being cut. The work is supported on a rotating table which is indexed by a worm and worm-wheel operated through change gears by a separate electric motor provided for that purpose. The head may be moved

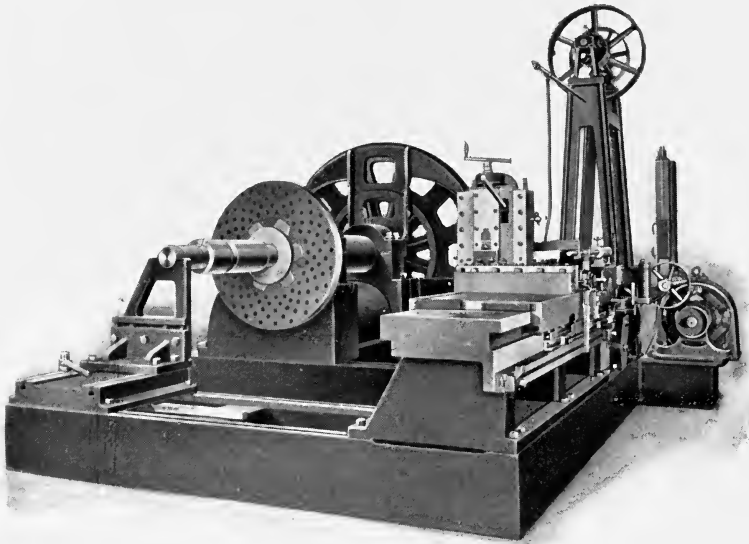

FIG. 48. The Gleason Templet Spur Gear Planer.

back far enough to swing work 40 feet in diameter. The templets for shaping the tooth outline are mounted in brackets on the tool head on either side of the tool-post of the portable shaper. The tool-post is pressed toward the right or left hand former by a spring, as may be required, and as it is fed outward by the feeding mechanism provided, it is thus shifted sidewise in such a fashion as to reproduce the outline of the templet on the teeth of the gear.

It has been used principally for large gears having teeth of very coarse pitch, too large to be formed by a formed tool or cutter covering the whole outline. It has the advantage over the formed cutter process of being com-

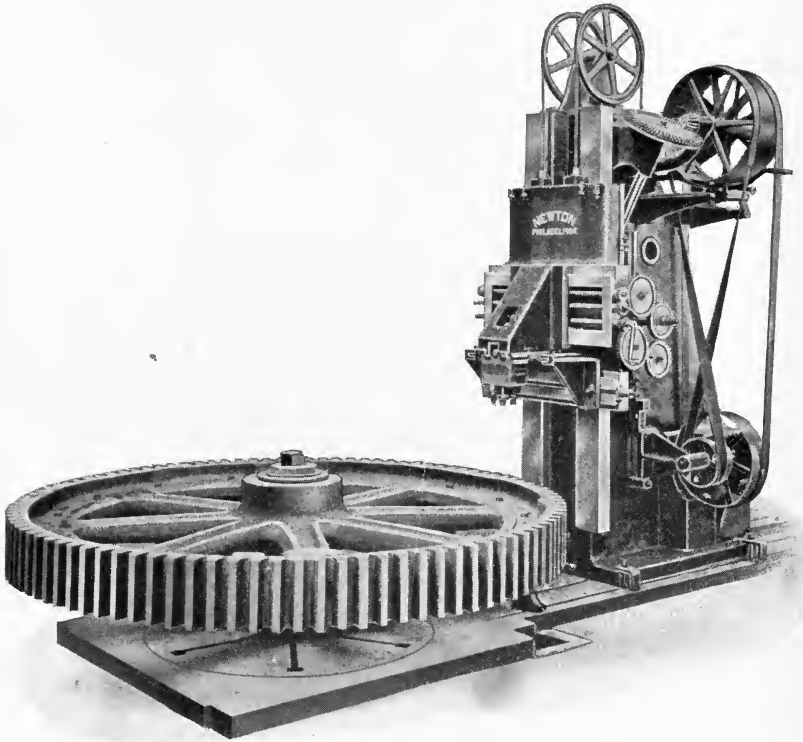

FIG. 49. The Newton Portable Slotter, arranged with Templet Mechanism and Indexing Base for cutting Spur Gears.

paratively simple in operation and adapted to special work at a minimum of expense, it being considerably cheaper to make a templet than to make a formed and relieved cutter of the same size.



CHAPTER III.

MACHINES FOR FORMING THE TEETH OF SPUR GEARS.

(Continued.)

WITH the molding-generating principle the operations which have been found most practical are planing or shaping, milling, and, to a very limited extent, grinding or abrasion. For spur gears, so far as the writer knows, no use has been made of the operation of impression; it would be as practicable as in the case of bevel gears, of which an example will be shown later (Figs. 194 and 195), but there is no need for trying it. In the shaping process the commercial use of the molding-generating idea is confined largely to one machine, which has found a very extended application. In the milling process there has been a wonderful development in the past few years, which is witnessed to by the large number of machines we are able to show involving this operation. But one example of the use of grinding can be illustrated.

MOLDING-GENERATING MACHINES WORKING BY SHAPER ACTION.

In Fig. 50 is shown an automatic spur gear cutting machine made by Hugo Bilgram, Philadelphia, Pa., and in use in his plant. The tool acts as a rack tooth, and generates the gear teeth in accordance with the principle of Fig. 8. Instead, however, of finishing one tooth space complete and then indexing to the next one, the operation is continuous. As has been explained, in the molding process the blank and tool must be rolled on each other as

if the former were a gear meshing with a rack, of which the latter represents a tooth. In the Bilgram machine,

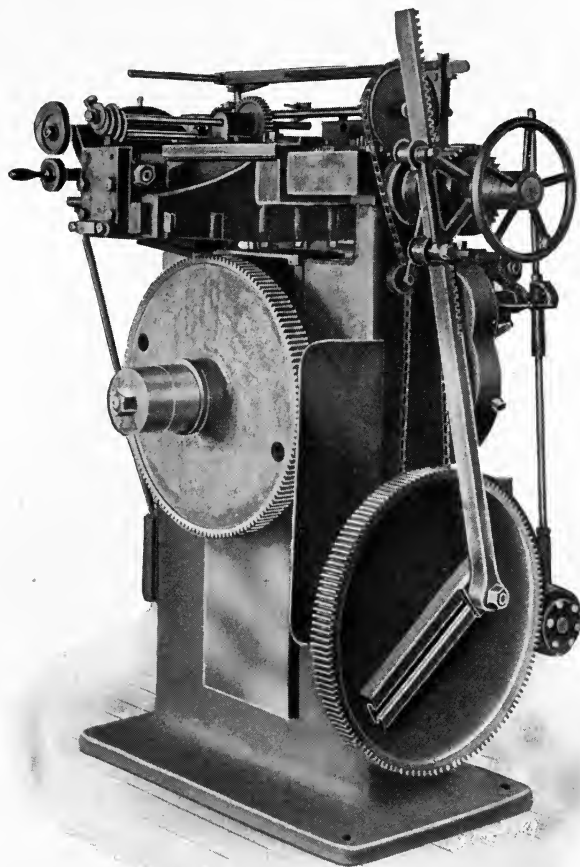

FIG. 50. The Bilgram Automatic Spur Gear Generating Machine, using a Shaper Tool shaped like a Rack Tooth.

instead of having this rolling action take place for each tooth, it takes place but once in the completion of the gear. The tool starts in at one side of the blank, being

given a motion similar to that given by a shaper. It cuts its first stroke in the work, which is thereupon indexed for the tool to take a second cut in the next tooth. This indexing proceeds with every stroke of the shaper ram, so that the teeth are all formed together. Besides the rotation of the blank due to the indexing, there is imposed on

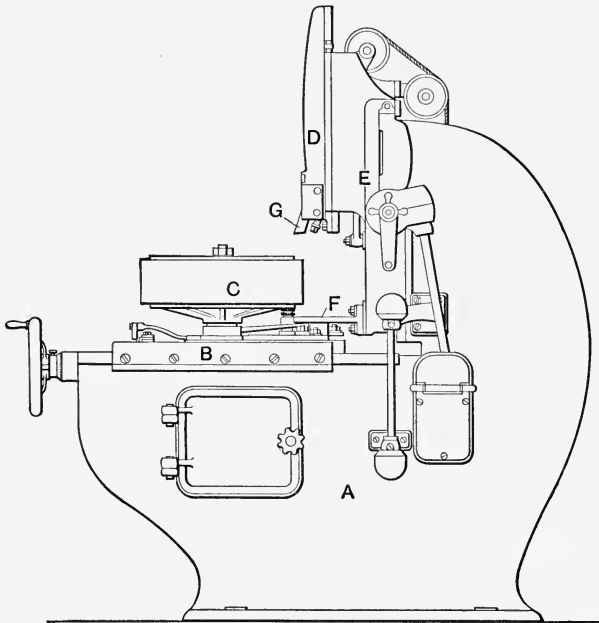

FIG. 51. Elevation of a French Spur Gear Generating Machine employing a Rack Tooth Form of Shaper Tool.

this that which we have described as being necessary for the rolling motion. For this, the blank is uniformly rotated, and the ram carrying the tool is fed along sideways to agree with the motion of the imaginary rack. These various movements are all attended to by change gearing. It will be seen that with this machine, as with others of the molding-generating type, but a single tool

is needed for a given pitch. This may be used to cut any gear, from the smallest to the largest.

The machine shown in Figs. 51 and 52, operating on the same principle, is built by the Société Française de Machines-Outils, St. Ouen, Paris. The resemblance of this machine to a slotter is at once evident. The work, which

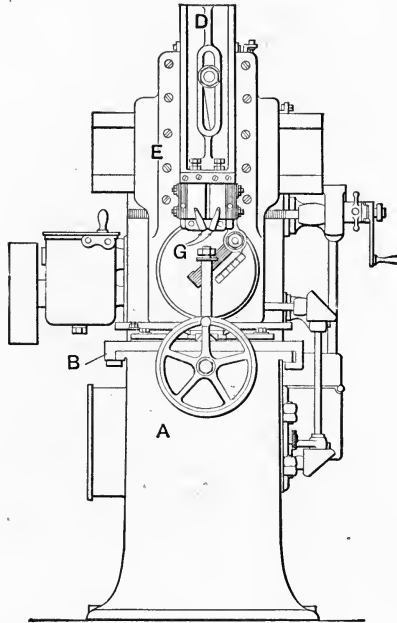

FIG. 52. Face View of French Spur Gear Generating Machine.

is shown mounted on the work arbor at *C*, is carried by table *B*, which is adjusted in and out on the bed *A* of the machine for diameter. The tools *G*, having the outline of the rack tooth, are mounted on a ram *D*, which is, in turn, guided in a cross slide *E*, which travels on a cross rail solid with the frame of the machine. In cutting a tooth the tool starts in at one side of the blank, and the ram *D*

on cross slide *E* is fed from right to left, in the face view of the machine. This lateral motion is transmitted by means of rack teeth on arm *F*, engaging suitable mechanism on the work table for rotating work *C* in unison with the lateral movement of the tool. When one tooth has thus been cut, and the slide *E* has been returned to the

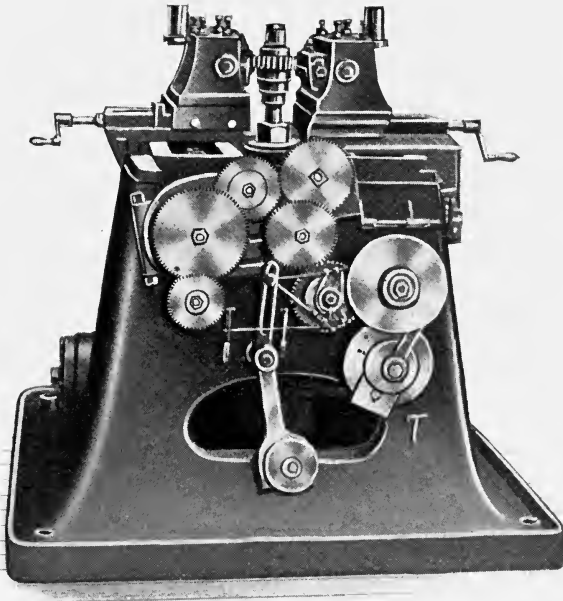

FIG. 53. An English Spur Gear Generating Machine employing Multiple Tools of Rack-shaped Outline.

starting point, the work is indexed, and a second cut is taken in the same manner — and so on until all the teeth are cut. The capacity of this machine is for work up to 20 inches in diameter.

A third machine is built by Spencer & Spiers of Huddersfield, England. The construction and movements are entirely different from the previous examples, though the

principle is the same. There are two sets of tools *AA*, as shown in the plan view Fig. 54, disposed on opposite sides

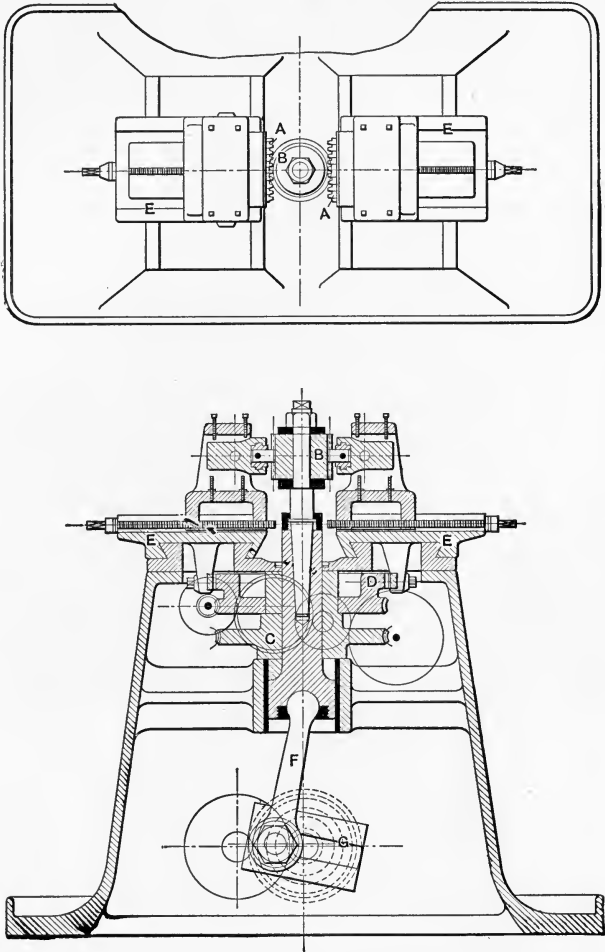

FIG. 54. Plan and Vertical Section through the Machine shown in Fig. 53, with Details of Controlling Mechanism.

of the work *B*. Each of these tools is formed of several rack teeth. As the work is reciprocated up and down

between them by crank G and connecting-rod F , these tools are fed oppositely in the direction of their pitch lines, and the work is revolved in unison at the proper ratio. To effect this the tools are mounted on parallel slides E , which carry racks engaging gear D , within the base of the machine. D also has worm-wheel teeth cut on it, driven by a worm which is connected by change gearing with worm-wheel C , which rotates the work. Owing to the fact that the two tools have several teeth each it is possible to finish pinions and small gears at one passage. For larger gears, provision is made for bringing the tools to the starting point again, and taking a second cut, with the work turned to present a new portion of the periphery to the action of the cutting edges.

The makers of this machine state that no outboard supporting bearing for the work arbor has been found necessary, owing to the fact that the cuts are perfectly balanced. This is effected by the use of the two tools, one on each side of the work. A larger machine has been built in which the tool slides reciprocate vertically instead of the work, the latter being mounted on a spindle which revolves as the cutters are fed past it. The design illustrated in Figs. 53 and 54 has been somewhat improved in later models.

The other machine we show of the molding-generating type involving the shaping process is one widely used, built by the Fellows Gear Shaper Company, of Springfield, Vt. One of these machines is shown later in Fig. 79, engaged in cutting an internal gear, while in Fig. 55 is a nearer view which shows the action of the cutter in forming the teeth of a long spur pinion. The principle by which it operates is exactly that shown in Fig. 6. The cutter is a gear having the outline of a member of the interchangeable series to which the gear to be cut belongs.

It and the blank are rotated together in the proper ratio. The cutter is first fed in to full depth and then the rotation is started and continued until the full periphery of the work has been formed. It is understood, of course, that the cutter is given a vertical shaping movement by the ram to which it is attached. The proper ratio between the cutter and the blank is obtained by change gears set

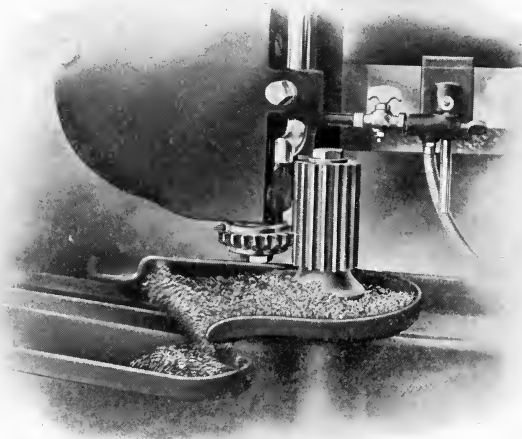

FIG. 55. Detailed View of the Fellows Gear Shaper in Action; see also Figs. 79 and 94.

for the number of teeth it is desired to have in the gear. The movements of the machine are automatic, in that when it has been set for the pitch of cutter and number of teeth, the machine will automatically feed itself to depth, stop this feeding and commence the slow rotary movement, continuing this until the work is completed, when the machine will stop. In the case of gears which have to be very accurately cut in refractory materials, provision is made for automatically taking a second cut

around at a slightly increased depth, so as to give assurance that the form of the tooth is as true as can be obtained. There are many interesting phenomena connected with this method of gear cutting which cannot be entered into here.

THE MOLDING-GENERATING MILLING OR HOBBIING MACHINE AND ITS ACTION.

The most widely used process involving the milling operation of molding-generating is the hobbing process. The principle of this method is shown diagrammatically in Fig. 56. Here we have an imaginary rack meshing with a gear, and molding its teeth in the same way as in Figs. 7 to 10. The teeth of this rack, shown in dotted outline, coincide with the outlines of a hob, shown in full lines, which has been set at such an angle as to make the teeth on its front side parallel with the axis of the gear. In other words, it has been set at the angle of its helix, measured at the pitch line. It will be seen that the teeth of the hob, when set in this position, correspond with the teeth of the rack. If, now, the hob and blank be rotated at the ratio required by the number of threads in the hob and the number of teeth in the gear, this movement will cause the teeth of the hob to travel lengthwise in exactly the same way as the teeth of the imaginary rack would travel if in mesh with the gear whose teeth are to be cut. It will thus be seen that the hob fulfills the requirements necessary for molding the teeth of the gear to the proper form. In practice the hob is rotated in the required ratio with the work, and fed gradually through it from one side of the face to the other. When it has passed through once, the work is completed.

Of the great number of machines built during the past few years involving this principle, many are arranged for

cutting spiral gears as well as spur gears. In describing these tools part of them have been classed as spur gear cutting machines, while the remainder will be found under machinery for cutting spiral gears. (See Figs. 117 to 128 inclusive.) Of course, all of the machines in the

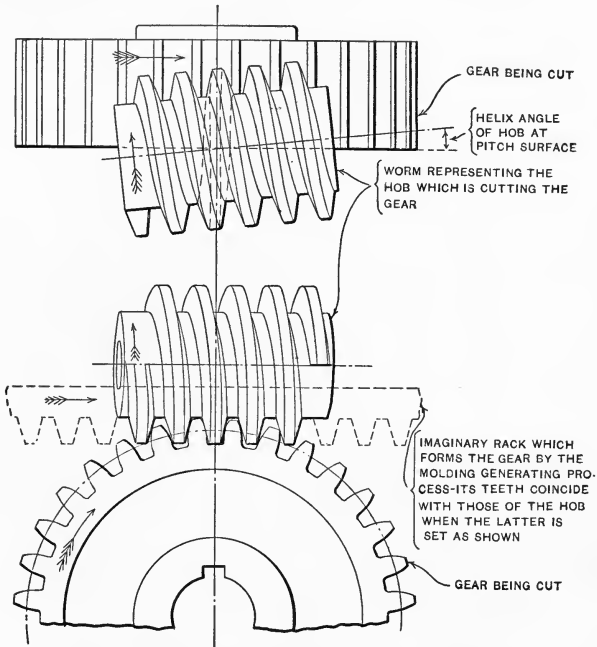

FIG. 56. Diagram illustrating the Principle of the Hobbing-Process of Forming Spur Gears.

latter division are capable of cutting spur gears also, and in referring to machines for cutting spur gears they should be classed with those described in the following paragraphs. Some of the machines illustrated in Figs. 58 to 72 can be used for cutting spiral gears as well, but have been described in this chapter because the engravings we have at our disposal show them arranged for cutting spur gears.

The spiral gear hobbing machine bears about the same relation to the plain spur gear hobbing machine that the universal miller does to the plain milling machine. The added adjustments and mechanism required in each case tend to somewhat limit the capacity of the machine in taking heavy cuts, though they add to its usefulness by extending the range of work it is capable of performing. The requirements of the successful gear hobbing machine are:

First. A frame and mechanism of great rigidity.

Second. Durable and powerful driving mechanism.

Third. Accurate indexing mechanism.

The first requirement is one of great importance, not only in its influence on the heaviness of the cut to be taken and the consequent output of work, but on the matter of accuracy as well. The connection between the hob and the work, through the shafts and gearing, is liable to be so complicated that the irregular cutting action of the hob produces torsional deflections in the connecting parts, leading to serious displacement from the desired relation between the hob and the teeth being cut. This displacement from the desired position results in teeth of inaccurate shape, weak and noisy at high speeds.

In its effect on the output, rigidity is even more important in the hobbing machine than in the orthodox automatic gear cutter. A heavier cut is taken, since a greater number of teeth are cutting on the work at once. The number of joints between the cutter and the work-supporting table and spindle must therefore be reduced to a minimum, and the matter of overhang both for the work and the cutter must be carefully looked out for. The reduction of overhang is hampered at the cutter head by the necessity for a strong drive and an angular adjustment. In the case of the work-supporting parts it is difficult to bring the cutting point close to the bearing on

account of the necessity for plenty of clearance below the work for the hob and its driving gear to run out into.

The matter of design of the driving mechanism for the hob and the work is a difficult one. Not only must it be rigid for the sake of accuracy, as previously explained, but careful attention must be given to durability as well. It requires great skill to design a durable mechanism for the purpose within the limitations imposed — in the cutter head by the necessity for reducing the overhang, and in the work table by the high speed required for cutting small gears.

Since the indexing wheel works constantly and under considerable load, it and the worm must be built of such materials as will preserve their accuracy after long continued use. Particular attention should be given to the homogeneity of the material of the index worm-wheel, to make sure that it does not wear faster on one side than on the other.

The field of the hobbing process for cutting spur gears has not yet been definitely determined. In some work it appears to have certain advantages over the usual type of automatic gear-cutting machine, while in other cases it falls behind. It will doubtless require continued use, with a variety of work, and for a considerable length of time, to determine just what cases are best suited for the hobbing machine, and what for the machine with the rotating disk cutter. It is not probable that in the future either of them will occupy the field to the exclusion of the other.

A MILLING MACHINE ATTACHMENT FOR HOBGING SPUR GEARS.

It is evident that the universal milling machine can be used for hobbing if suitable connections are made between the work and the cutter spindles. The miller shown in Fig. 57 is fitted with such connections, through an attach-

ment made by the R. K. LeBlond Machine Tool Company, Cincinnati, Ohio. The work is mounted between index centers whose index worm-wheel is connected with the cutter arbor by a series of gears and splined shafts which

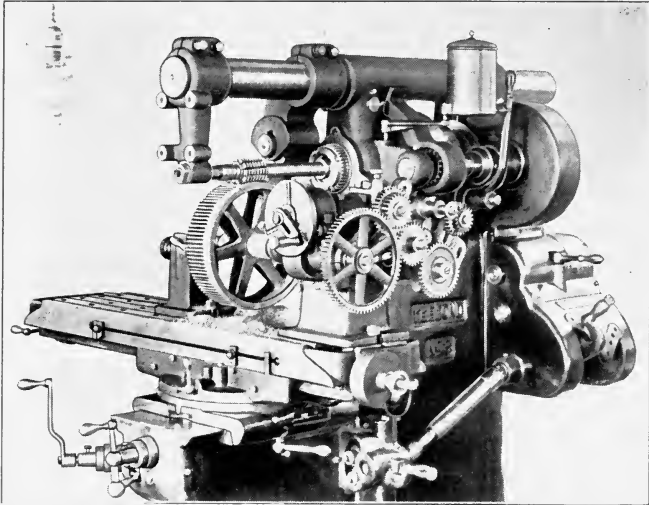

FIG. 57. Hobbing a Spur Gear with the Hobbing Attachment on a Universal Milling Machine.

permit free adjustment of the table in any direction. The table is set at the angle of the hob, and the action obtained is identical with that in Fig. 56.

A COLUMN AND KNEE TYPE SPUR GEAR HOBGING MACHINE.

The first gear hobbing machine we show (see Fig. 58) is built by J. E. Reinecker of Chemnitz-Gablenz, Germany. This builder was one of the first to make a commercial success of the hobbing process, having applied it several years ago in his "Universal" gear-cutting machine. The tool we show is a specialized form of that universal

machine, adapted particularly to the hobbing of spur gears. As may be seen, in form the machine is derived from the standard milling machine, bearing about the same relation to it that the Becker-Brainard gear cutter in Fig. 21 does. The cutter arbor is mounted on what

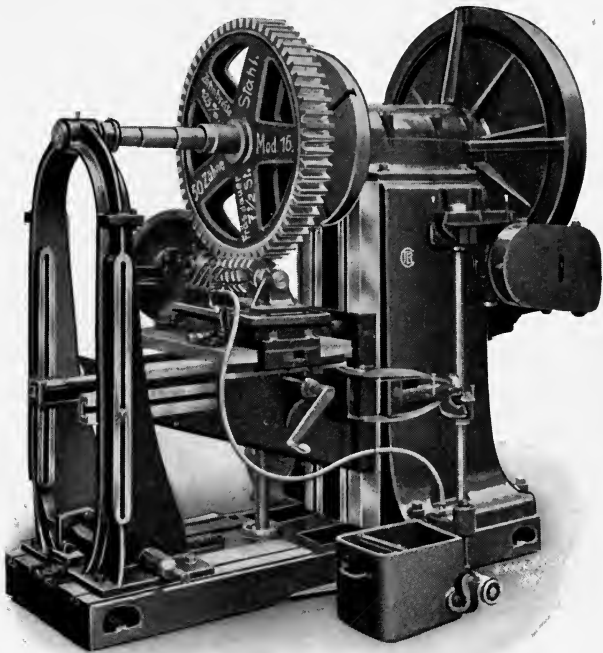

FIG. 58. The Reinecker Spur Gear Hobbing Machine.

corresponds to the work table of the miller, which is swiveled so as to bring the teeth of the hob on the upper surface parallel to the work spindle. The work spindle is driven from the rear of the column by the index worm-wheel, which is connected with the cutter spindle through change gears (shown at the left of the picture) and the splined shafts and bevel gear connections. The knee of

the machine having been raised so that the cutter is set at the proper height to cut teeth of the desired depth, and the machine being started, with hob and gear blank rotating in the proper ratio, the table with the hob is fed in along the knee toward the column of the machine, cutting the teeth in the wheel as it does so, the operation being com-

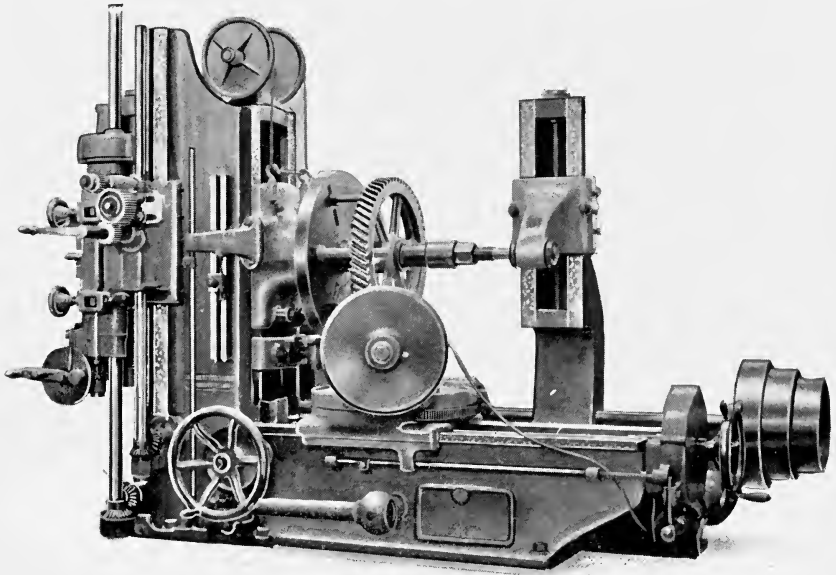

FIG. 59. Ducommun Gear Hobbing Machine.

pleted when the hob has made one pass through the work. It will be noted that the work arbor, the knee, and the base of the machine are all tied together by a rigid brace, which may be adjusted to suit different conditions.

GEAR HOBGING MACHINES WITH CUTTER SLIDE ON BED.

The machine in Fig. 59 is made by the Ateliers de Construction Mécaniques, ci-devant Ducommun, Mulhouse, Alsace, Germany. It is of the same type, so far as the

framework is concerned, as a regular orthodox gear cutter, it being almost identical in its lines with those shown in Figs. 22 to 31 inclusive. The differences in mechanism, of course, are those due to the necessity for connecting the work spindle and the cutter by change gearing to give the proper ratio, and for setting the spindle, as well, at the proper angle to agree with the helix angle of the hob. The feed, also, is continuously forward until the work is completed, instead of having a quick return for each tooth

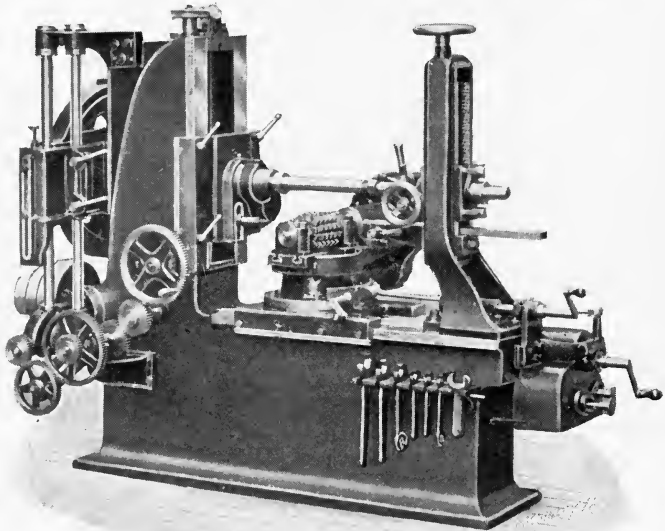

FIG. 60. Junghans Spur Gear Hobbing Machine.

cut. It is readily seen that this rearrangement means, on the whole, a somewhat simpler machine in the case of the hobbing machine than for the automatic gear cutter, particularly since intermittent indexing is avoided. An added complexity is, however, given to this particular design by the provision of mechanism for cutting helical gears by the formed cutter process. (As in Fig. 107.)

Another hobbing machine, built by Wilhelm Junghans

Werkzeugmaschinenfabrik, Chemnitz, Germany, has the base and column in one solid casting (see Fig. 60). It is also provided with elaborate rim and work supporting

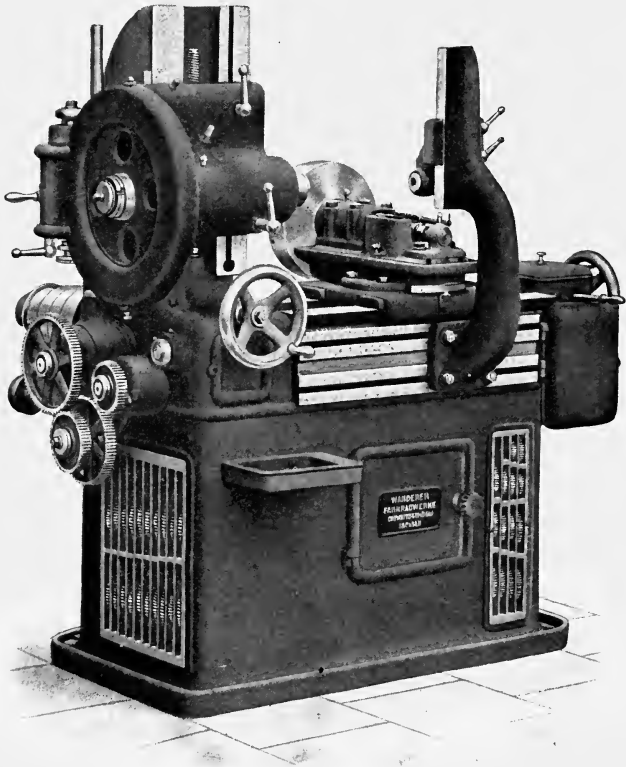

FIG. 61. The Wanderer Spur Gear Hobbing Machine.

arrangements, there being an outboard bearing for the spindle, and rim supports both front and back. This machine is designed for hobbing spur and worm gears. It is also provided, when so desired, with hand indexing mechanism for cutting spur gears with formed cutters.

A third example of this construction, more strongly resembling the orthodox gear cutter than either of the others, is illustrated in Fig. 61. A type of drive which has been used quite generally for this service is here employed. An internal gear of large diameter is mounted on the spindle; this is driven by a pinion on a parallel shaft, which is, in turn, geared to the short shaft about which the angular adjustment of the head is made. The

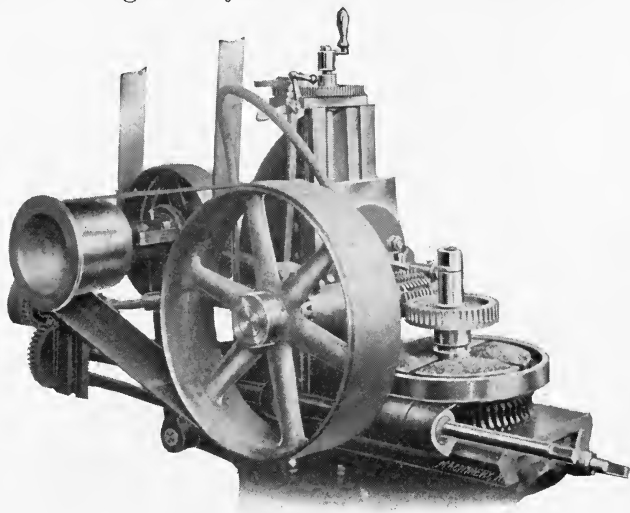

FIG. 62. The Farwell Spur Gear Hobbing Machine.

internal gear permits the use of larger and heavier driving gearing without raising the cutter spindle unduly above the bearings on the bed. This machine is built by the Wanderer Works, Schoenau, near Chemnitz, Germany.

THE STANDARD FORM OF HOBGING MACHINE.

The more usual type of spur gear hobbing machine differs from the examples we have just described in the position of the spindles. In this case the cutter spindle is mounted in a slide on the column, while the work is carried on the bed,

being adjusted in or out on it according to its diameter. In its general arrangement it bears a strong resemblance to the standard type of formed cutter machine for heavy work, as illustrated in Figs. 33 to 38. The small machine shown in Fig. 62 is of this construction. It is built by the Adams Company, Dubuque, Iowa. The simplicity of its design is

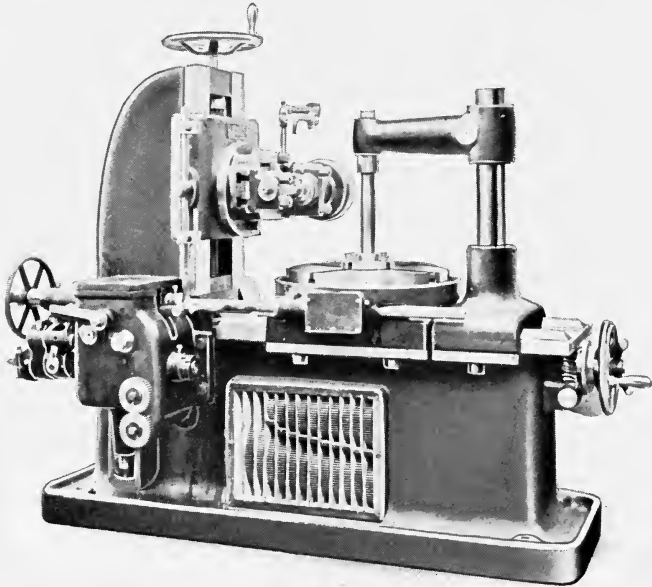

FIG. 63. The Gildemeister Gear Hobbing Machine.

at once evident. The belt drive permits the required angular drive of the spindle, and the connection with the work table through the change gears is reduced to the fewest possible parts. The feed of the cutter slide on the column is operated by an adjustable ratchet mechanism.

A larger machine of the same type, built by Gildemeister & Co., A. G., Bielefeld, Germany (see Fig. 63), is of the more usual form in which the base is carried clear down to the floor. Fig. 107 shows this machine cutting a spiral gear

with a formed cutter. This operation requires very little change in the mechanism needed for straight spur gear hobbing. The wide provision of this arrangement on European machines is doubtless due to the patent restrictions on the

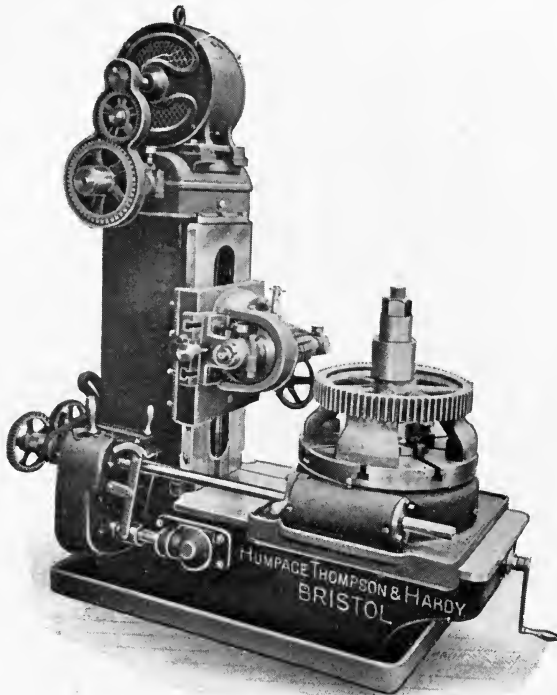

FIG. 64. An Electrically-driven Gear Hobbing Machine built by Humpage, Thompson & Hardy.

spiral gear hobbing process, which is described later. It is interesting to note the resemblance between this machine and the American-built one in Fig. 118.

In Fig. 64 is a machine built by Humpage, Thompson & Hardy, of Bristol, England. It appears to be of unusually heavy construction. The machine as shown is entirely

self-contained, a motor being mounted on top of the column. It can be made either motor or belt driven without other alteration than the removal of the motor and gears and the substitution of a pulley, or *vice versa*. The drive is of the

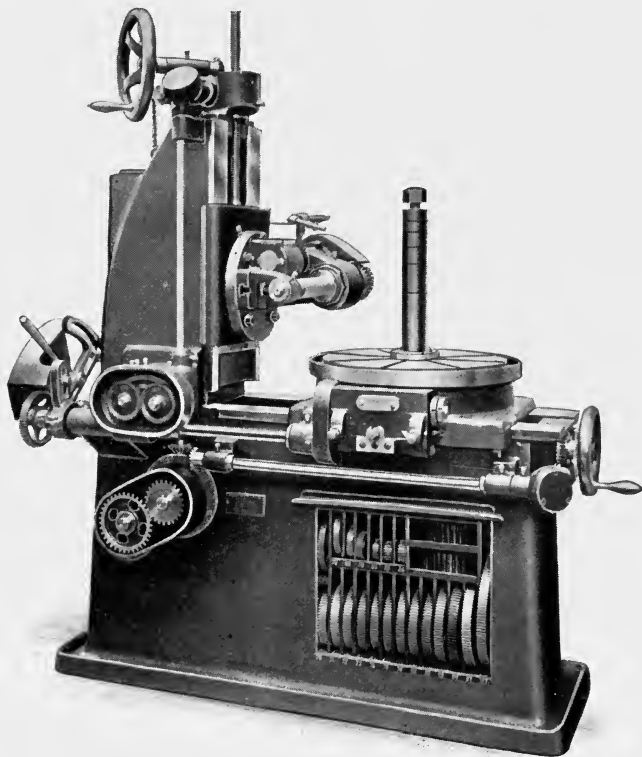

FIG. 65. The "Rhenania" or "Burton" Spur Gear Hobbing Machine.

constant speed type, the speed changes being obtained through gearing running constantly in a bath of oil. The machine is provided with an unusually ingenious feed mechanism. A pair of taper pulleys, carrying a light belt, is used as a primary means of changing the feed. This

operates, however, through the medium of an epicyclic gear arrangement through which most of the strain of transmission is taken. The cutter slide is overbalanced, so that it has to be fed against the pull of the counterweight, thus taking up all back lash.

The machine shown in Fig. 65 is sold on the continent by Alfred Schütte, and there known as the "Rhenania." In London, England, it is sold by Burton, Griffiths & Co. and called the "Burton." This is one of the machines which can be furnished for cutting spiral gears if desired, though in the form shown it is adapted for spur gears only. The spindle of this machine is driven somewhat differently from the previous ones shown. A worm connected at its inner end by bevel gears to the vertical power transmission shaft, and located on the axis of the angular adjustment, drives a worm-wheel on the short shaft mounted above and to the rear of the cutter. Spur gears connect this short shaft with the spindle. The work table may be revolved freely in setting the work by withdrawing the index worm, this being mounted on a dovetail slide, which is withdrawn or inserted again by operating the square-head collar screw shown. Adjustable stops limiting this motion determine its adjustment, which may be altered to compensate for wear. The worm is of hardened steel, ground all over after hardening. The work spindle may be supported, when necessary, by a stiff outboard bearing on an arm which is fastened to the back of the table and the back of the bed, tying the work, work table, and bed rigidly together.

Another machine of German origin, made by the Schubert & Salzer Maschinenfabrik, of Chemnitz, and sold by Selig, Sonnenthal & Co., of London, England, is shown in Fig. 66. This machine, like many of the others, has the spindle driven by an internal gear. To allow this to be made of unusually large diameter and still bring the hob as close to the face of

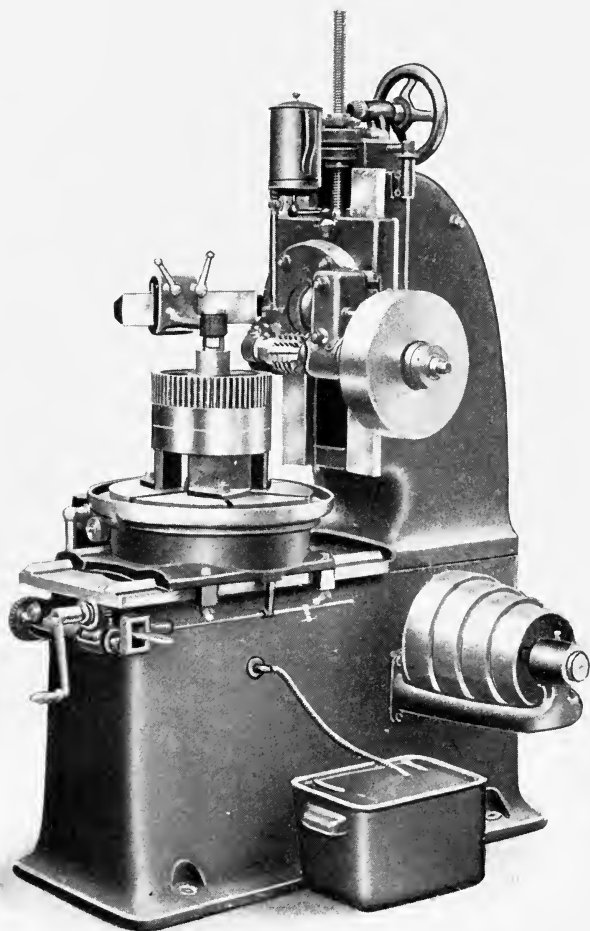

FIG. 66. A Continental Gear Hobbing Machine, sold by Selig, Sonnenthal & Co.

the column as possible, so as to give a rigid construction, the hob is carried below the axis around which the swiveled head is adjusted, instead of centrally with it, as is usually the

case. This limits the adjustment to the comparatively slight angle required for spur gears, but it would seem to greatly increase the stiffness of the construction and the power of the drive. As may be seen, the outboard support for the work arbor is of unusual design, consisting of an arm bolted to the side of the column, carrying a slide which may be adjusted in or out to suit the position of the work table.

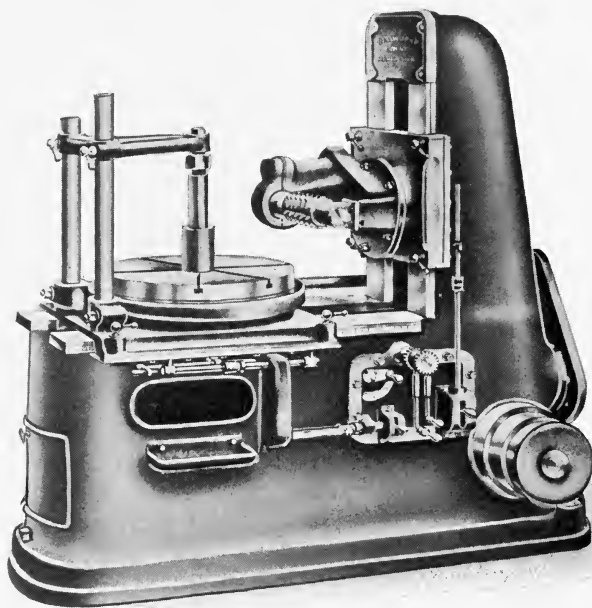

FIG. 67. The Wallwork Gear Hobbing Machine.

The machine shown in Fig. 67 is built by Henry Wallwork & Co., Ltd., Manchester, England, and sold by Alfred Herbert, Ltd., Coventry, England. A number of interesting features will be noted in this machine. The spindle drive, for instance, is unusual. A train of spur gears connects the shaft on the axis of the swiveling adjustment with a

short vertical shaft which drives the cutter arbor by worm or spiral gearing. The work support consists of a triangular arm supported by two vertical posts, the outer end of the arm having a bushing for the work arbor. One of the vertical posts is longer than the other, and the arm may be raised from the shorter one and swiveled about the longer one when removing or replacing the work. Since this support always travels with the table it does not have to be adjusted when adjustments are made in the position of the latter. The table has a large annular bearing, with an extended shank having a tail bearing fitted with lock nuts to prevent lifting. The chip pan is solid with the slide and does not rotate with the table as in some of the other machines.

HOBBIING MACHINES WITH ADJUSTABLE SPINDLE COLUMN.

The machine in Figs. 68 and 69 (Sir W. G. Armstrong, Whitworth & Co., Ltd., Manchester, England) belongs with the machines just described, but is differentiated from them by the fact that the column carrying the spindle is adjusted on the bed for the diameter of the work, instead of having the work table adjustable. In this respect it resembles the gear cutters shown in Figs. 39, 40, and 41. Since the work spindle is stationary, the index wheel is placed below the bed. The spindle drive is through spur and bevel gears from the vertical shaft alongside the column. This machine is so large that special provision is made for handling most of the movements, there being a power elevating device for the spindle head, and a power traverse of the head on the bed. As shown, also, the spindle head is swiveled by a worm meshing with worm-wheel teeth cut on a portion of the periphery of the sector.

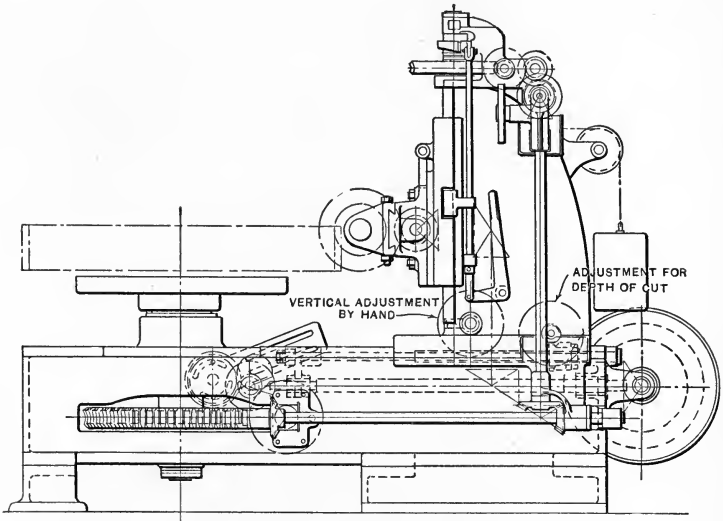

FIG. 68. Armstrong-Whitworth Hobbing Machine, with Column Adjustable for Diameter.

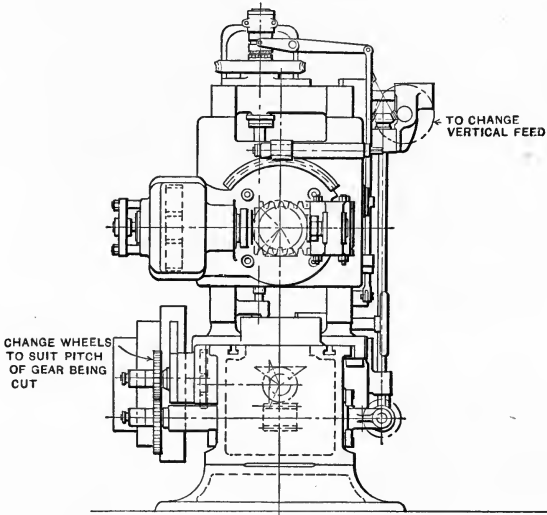

FIG. 69. End View of Armstrong-Whitworth Machine.

In Fig. 70 is shown a gear hobbing machine of this type made by Maschinenfabrik Lorenz, Ettlingen, Baden, Germany. The machine is made in several sizes. The exam-

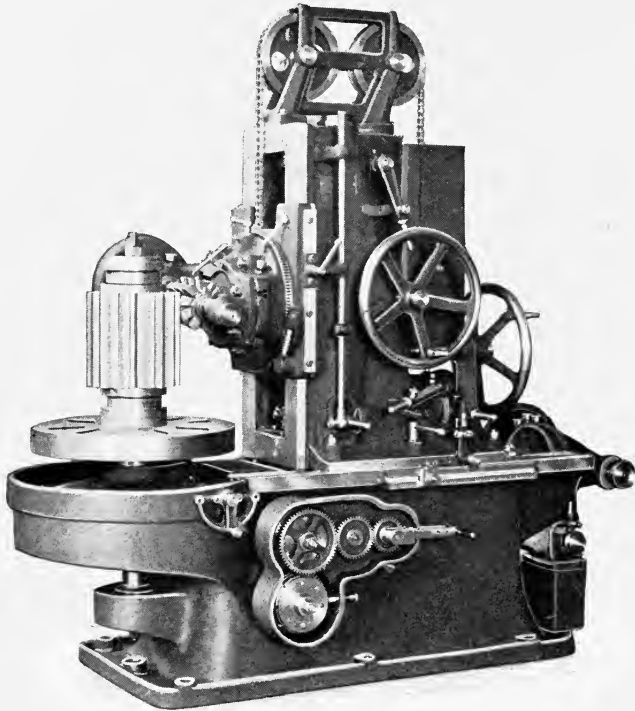

FIG. 70. Lorenz Gear Hobbing Machine.

ple shown, which is next to the largest size, will take work up to 110 inches in diameter. It is of very attractive design, and is provided with unique mechanism for spiral gear cutting, which will be described later. The stationary location of the work spindle with reference to the bed should permit of a stiff construction at this point.

GEAR HOBBIING MACHINE OF SPECIAL DESIGN.

A machine which cannot be classified with any of the previous examples is shown in Figs. 71 and 72. The main



FIG. 71. Reynolds Machinery Company's Automatic Spur Gear Hobbing Machine.

feature of novelty in its construction is plainly seen in the top view; the cutter slide has no swiveling adjustment, but is set permanently at a definite angle with the work

spindle. This is made possible by the fact that the angle of the thread on all the hobs used is the same, the diameter of each being so proportioned to the pitch as to effect this. The driving pulley is geared directly to the hob spindle.



FIG. 72. Top View of the Reynolds Hobbing Machine.

Change gears connect the outer end of the spindle with a worm-shaft, by means of which the work spindle gear is driven. This gear has straight, spur gear teeth, so that it may be fed forward as the work is fed over the hob, without requiring the usual splined connection. The worm shaft is at an angle, being parallel with the cutter spindle, and the worm is so proportioned that this is its proper angle for engagement with the teeth of work driving gear.

Of course the pitch diameter of a hob is larger when it is new than when it is old, so that the slide should, theoretically, be set at a slightly different angle as the diameter changes. It is a question if this slight change makes any practical difference. In any case the principle of the constant angle for a series of hobs of different pitches is an interesting and important one. This machine is built by the Reynolds Machine Company, Rock Island, Ill.

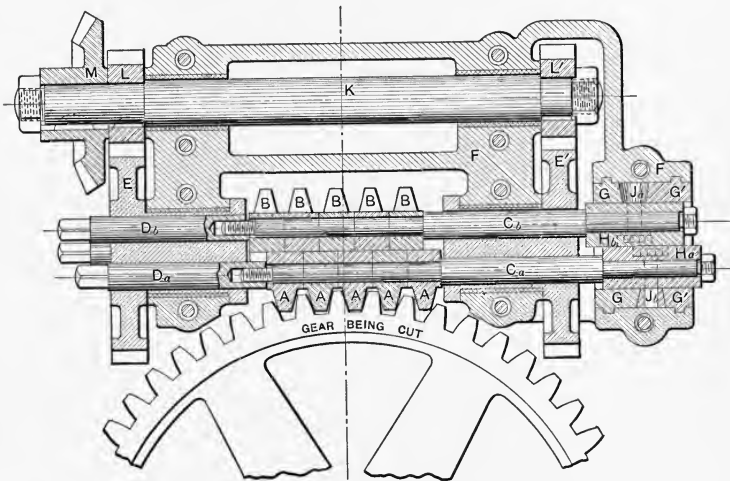

FIG. 73. The Cutter Controlling Mechanism of the Swasey Hobbing Machine.

An ingenious hobbing machine was built a number of years ago by the Warner & Swasey Company, Cleveland, Ohio. Instead of using a worm-shaped hob, the hob was formed of a series of formed rack cutters made in two halves, which were shifted endwise with relation to each other by a cam mechanism. In Fig. 73 one half of the "hob" is shown at *A*, and the other at *B*. The two halves of the cam controlling the two sections of the hob are at *G* and *G'*. This split hob and the blank are geared to rotate together

the same as in other hobbing machines. The half of the hob, *A*, which is cutting is fed forward by the cam to correspond with the rack movement required by the rotation of the blank. When this half of the hob has left the cut it is rapidly returned by the cam, ready to start in on its forward axial movement as soon as it again reaches the cutting position. Meanwhile *B* is cutting, and this too is drawn back as soon as it goes out of action, so as to be ready to start in again. Thus, by the alternate sliding on each other of these two halves, this split circular hob, set with its axis at right angles to that of the work, gives the same cutting action as the helical hob in Fig. 56, with its axis set at an angle.

It will be seen that the list of hobbing machine builders is quite an imposing one, including (see also Figs. 117 to 128) twenty four manufacturers of these machines. With the exception of the Reinecker machine, which dates from an earlier time, all of these were designed within the past few years, most of them to meet the demand for gear-cutting machinery created by the automobile trade.

THE GRINDING OR ABRASION OPERATION APPLIED TO THE MOLDING-GENERATING PROCESS.

One application of the molding-generating process involving the grinding operation uses the rack tooth principle in a manner exactly identical with that shown in Fig. 10, in forming the cutters used with the Fellows system of gear tooth shaping. A special machine is provided, carrying an emery wheel with a plane face which can be constantly kept straight by means of a diamond truing device incorporated in the machine itself. The hardened gear cutter, which has been cut to leave but a few thousandths of metal to finish on the sides of the teeth, is placed in the

machine and rolled past the face of the emery wheel under the restraint of metallic tapes in a way that is similar to that shown in Fig. 10.

An application of this principle to the finishing of the

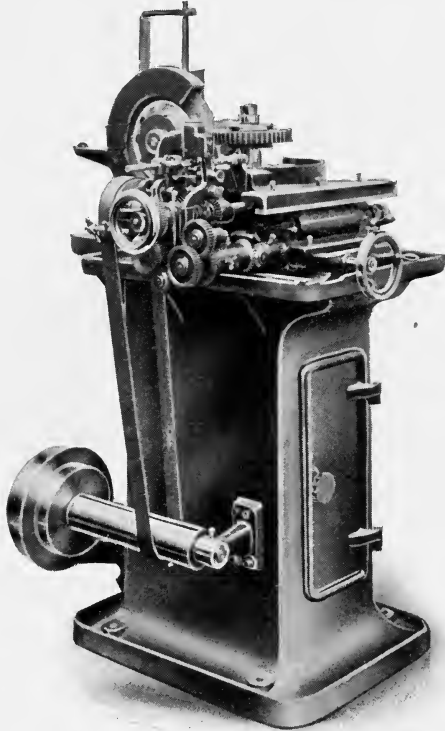

FIG. 74. A Machine for Grinding the Teeth of Gears to Accurate Shape after Hardening.

teeth of hardened gears is shown in Figs. 74 and 75. This machine trues the teeth of hardened gears used in automobile construction. The principle of its action is also the same as in Fig. 10, though carried out in a somewhat different way than in the case of the Fellows cutter grinding

machine just mentioned. In this case the emery wheel has its outline beveled to the shape of the rack tooth, using for this purpose both sides of the wheel, which has an outline more nearly resembling the shaper tool T_1 in Fig. 8 than the grinding wheel of Fig. 10. Attachments permanently set to the proper angle ($14\frac{1}{2}$, 15 degrees, or any other angle desired) are provided, by means of which the operator can almost instantly bring the wheel to the proper shape whenever it shows signs of losing it. The

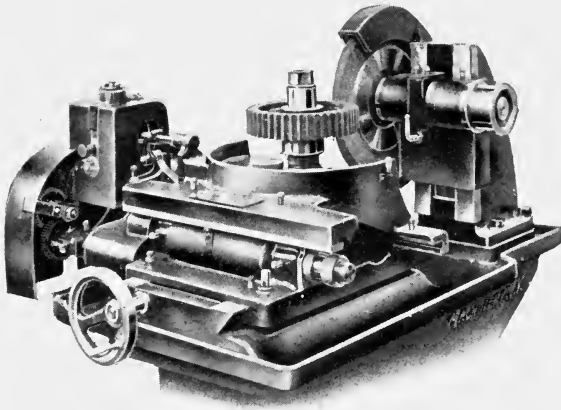

FIG. 75. Another View of the Machine shown in Fig. 74.

emery wheel has a continuous vertical reciprocating movement, great enough to cover the whole face of the wheel. It will be seen that it is thus made to cover the whole surface of the rack tooth which it represents in the molding-generating process.

The hardened gear to be operated on, previously cut to leave a few thousandths for finishing, is mounted on the vertical work arbor on the table as shown. By suitable change gears and controlling mechanism, this slide is made to travel across the face of the wheel while the work

is rotated at the same time, in such a ratio as to give the identical movement that would result from rolling the wheel on the imaginary rack, a tooth of which is represented by the outline of the emery wheel. The work starts in at one side of the wheel, out of contact with it, rolls into it until the grinding wheel is in action, passes by to the further side, and returns to its first position, thus finishing one tooth space to proper form. An automatic indexing mechanism (adjustable for any number of teeth between 12 and 60 inclusive) then indexes the wheel one space, and it again rolls along the front of the emery wheel and returns, thus finishing another tooth space. This operation is repeated automatically until the whole gear has been ground. The diameter of the wheel used is 12 inches. The maximum diameter of gear which can be finished is $11\frac{3}{4}$ inches with a 2-inch face. This machine, which is built by J. E. Reinecker of Chemnitz-Gablenz, Germany, is sold by E. Chouanard, 3 Rue Saint-Denis, Paris, and by C. W. Burton, Griffiths & Co., Ludgate Square, London.

Mention might be made here of a rather unusual extension of the hobbing process, and one which at first thought would seem to be impracticable. This is reported in a paper read before the British Institution of Mechanical Engineers in July, 1908, on "The Evolution and Methods of Manufacture of Spur Gearing," by Mr. Thomas Humpage, the maker of the hobbing machine illustrated in Fig. 64. Mr. Humpage relates that he has experimentally built and used a corundum "hob" for finishing gears on which a few thousandths had been left for grinding. In using these hobs or worms, the tool is adjusted axially so that one side of the thread touches one side of the teeth of the work. The wheel is then fed down automatically, grinding one side of all the teeth and generating them to the finished form. The machine is next stopped, the wheel raised by

hand, and a finishing cut taken. The other sides of the teeth are then ground and finished in the same way. Mr. Humpage proposes to make a machine using a hob of this kind in which a device like that on the fly-tool worm-wheel hobbing machines (see Fig. 141) will be used for traversing the hob to distribute the wear across its length. It is found that the wear on the hob is very slight, being about a thousandth of an inch in the worn part for cutting a 70-tooth, 7-pitch, $1\frac{1}{4}$ -inch face cast-iron wheel, which was finished in eight minutes. In the complete machine the author proposes to mount a corundum wheel for truing up the worm. He suggests also, that this finishing process should be applied to all gears, whether soft or hardened.

This completes the description of machines for forming the teeth of spur gears.

CHAPTER IV.

MACHINES FOR CUTTING THE TEETH OF INTERNAL GEARS AND OF RACKS.

As has been stated, the internal gear is akin to the spur gear, and the machinery for cutting it acts on practically the same principles, except as limitations are imposed by the concavity of the surface in which the teeth are cut, as compared with the convex shape of external gearing.

MACHINES AND ATTACHMENTS FOR CUTTING INTERNAL GEARS BY THE FORMED CUTTER PRINCIPLE.

For cutting internal gears, the formed tool method is the most obvious and the most commonly used. The teeth may, for instance, be cut by a shaper tool with a projecting head, formed somewhat after the fashion of the tools used for cutting keyways in the hubs of pulleys, etc., the work being mounted on the face-plate of an indexing fixture on the table of the shaper, slotter, or planer. One job came to the writer's notice in which the work was fastened to a face-plate on the spindle of an ordinary automatic gear-cutting machine, while the shaping tool was operated by a shaper bodily lifted to a position on the bed of the gear cutter and clamped in place there. In such cases the movements are, of course, largely controlled by hand, the tool holder being fed down into the work by the operator.

Most machines for internal gears use the formed milling cutter to shape the teeth. A common method of using this process employs an attachment to the regular auto-

matic spur gear cutting machine, carrying the cutter on a projecting arm adapted to enter the internal gear and work on its inner periphery. An example of this is seen in Fig. 76, which shows the attachment provided by Gould & Eberhardt, of Newark, N. J., for cutting internal gears on their regular spur gear cutting machine. The cutter is driven by a train of spur gears from a driving

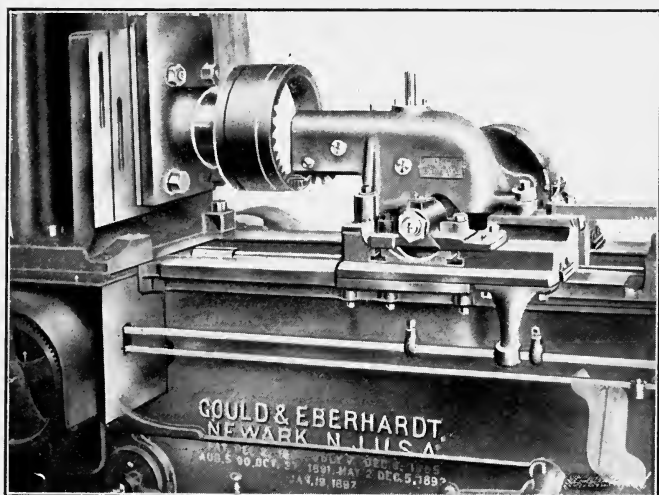

FIG. 76. Attachment to the Gould & Eberhardt Gear Cutter for Cutting Internal Gears.

gear on the regular cutter arbor. The pivots of these gears are shown by the projecting ends of the studs on which they run. While this arrangement furnishes a practical and much-used means for cutting internal gears, it is evident, of course, that it is not possible to take quite so heavy cuts as when cutting spur gears, on account of the indirectness of the means by which the cutter is driven, and the necessarily small diameter of the gear from which it receives its motion.

An attachment of a very similar kind, modified to suit the changed design of the machine, is shown in Fig. 77. This is the Atlas gear cutter shown in Fig. 36. As may be seen, the attachment is bolted to the face of the cross rail, and is fed down into the work in the same way that the attachment in Fig. 76 is fed forward into it. Other manufacturers make similar devices for use with their machinery.

In Fig. 78 is shown a machine of great capacity, arranged for the cutting of both internal and external spur gear

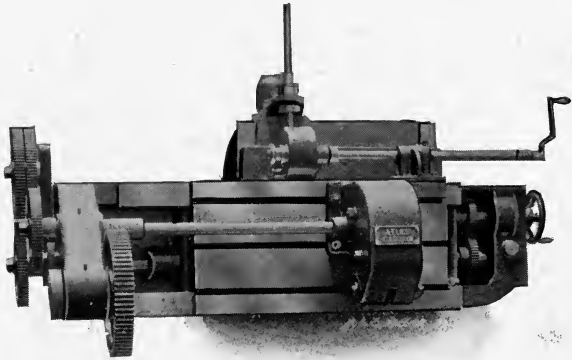

FIG. 77. The Atlas Machine as arranged for cutting Internal Gears; compare with Fig. 36.

segments. As posed, it is cutting internal teeth. The work is mounted on a sector pivoted at the left-hand end of the bed, and having gear teeth cut in its periphery, by which it is indexed. The work is clamped to this sector at the proper distance from the pivot to give the radius desired. The cutter slide operates on vertical ways on a carriage carried by the cross rail. Two cutter spindles are provided, one on the right and the other on the left hand side of the cutter head, one being used for internal and the other for external gears. The movement is

brought to the spindles through a train of spur and bevel gears as shown. This machine, which was designed primarily for dealing with gear segments for gun mountings,

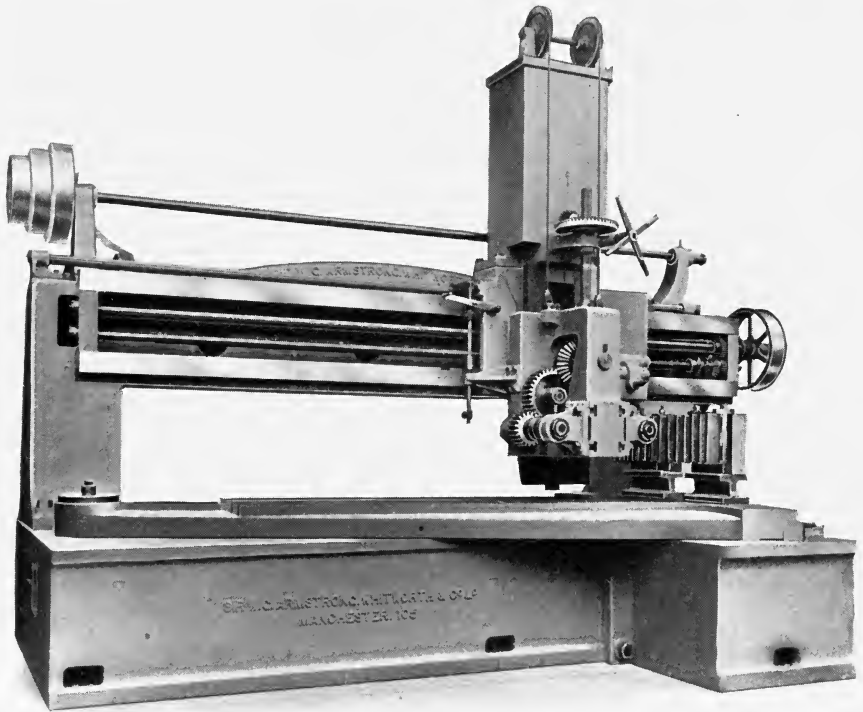

FIG. 78. Armstrong-Whitworth Machine for cutting Internal or External Teeth in Segments of Large Diameter.

will cut teeth in segments having an extreme radius of 13 feet and a face of 12 inches. It is automatic in all its movements, including the dividing mechanism. Sir W. G. Armstrong, Whitworth & Co., of Manchester, England, are the builders.

CUTTING INTERNAL GEARS BY THE MOLDING-GENERATING PRINCIPLE.

The Fellows system of gear cutting, previously illustrated in Fig. 55, is perhaps the most striking method of

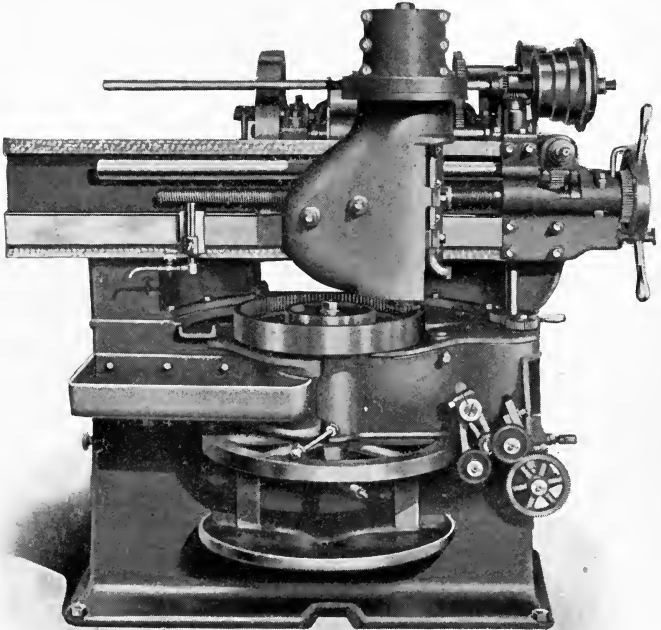

FIG. 79. The Fellows 36-Inch Gear Shaper at work on an Internal Gear.

cutting internal gear teeth. The machine shown in Fig. 79 is forming the teeth in an internal gear. The process, which belongs to the molding-generating order, is exactly identical to that employed for external spur gears, the cutter and work being geared to rotate together in the proper ratio.

It has a number of advantages over the formed cutter method. It does not require the exaggerated clearance at the bottom which the rotary cutter needs for running out into. The cutting tool works to as good advantage as when cutting external gears. No change in the machine is necessary, and special cutters are not required, the same tool being used as in cutting an internal gear of the same pitch. The ease with which internal gears may

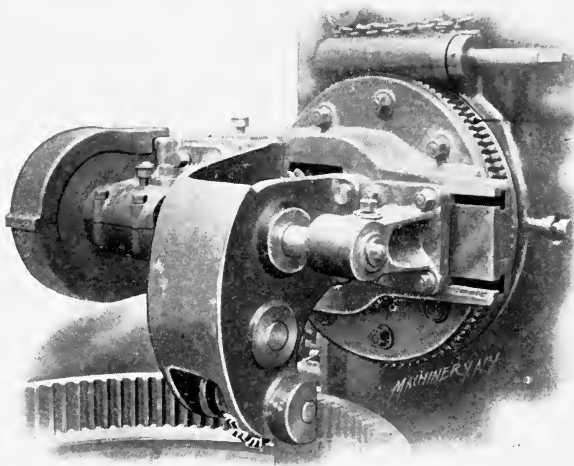

FIG. 80. An Attachment for hobbing Internal Gears.

be cut with this machine, and the fact that it is quite generally used for this work, have encouraged the use of internal gearing in the past few years for cases in which it is better fitted than external spur gearing, but where the difficulty of making it would formerly have barred its use.

Fig. 80 illustrates the surprising operation of hobbing an internal gear. This operation bears the same relation to the hobbing machine in which it is done that the use of the internal gear-cutting attachment shown in Fig. 76

bears to the orthodox spur gear cutting machine. The method of driving through a train of gearing connecting the cutter with the regular spindle is identical. With this attachment the hob has a pitch surface of a barrel-shaped form, with the radius of curvature corresponding with the pitch radius of the wheel to be cut. In producing these hobs a master internal toothed wheel is hardened, so that the teeth act as cutters. The soft hob blank is then placed in the machine the same as when at work, as shown in Fig. 80, and a theoretically correct profile is generated on it by the hardened internal wheel. The hob itself is then relieved, hardened, and ground ready for use. It is adapted only to cutting gears of the diameter and pitch for which it was made. David Brown & Sons, Huddersfield, England, are the originators of this device.

The odontographic and describing-generating methods are as limited in their application to internal gearing as to external gearing. The grinding or abrasion, and impression operations, also, have seldom, if ever, been applied to the cutting of internal gears.

FORMED TOOL RACK-CUTTING ATTACHMENTS TO STANDARD MACHINES.

As was the case with internal gearing, the formed tool method is the one most largely used for cutting racks. The primitive means consists in clamping the work on the table of the planer or shaper, and cutting the tooth spaces with a properly shaped tool in the regular tool-post of the machine. After each space has been cut, the tool-post is moved along the proper distance to bring it in position for a new space, or, in the case of the shaper, the work table is shifted the same amount for the same purpose. A new tooth space is then formed as before, and the operation is

repeated until the work is done. In making the measurements for the amount by which to shift the relative position of the work and the tool for each cut, various means may be used. A stop may be provided, set ahead of the previous position by an amount determined by a gauge of a thickness equal to the circular pitch of the tooth being cut.

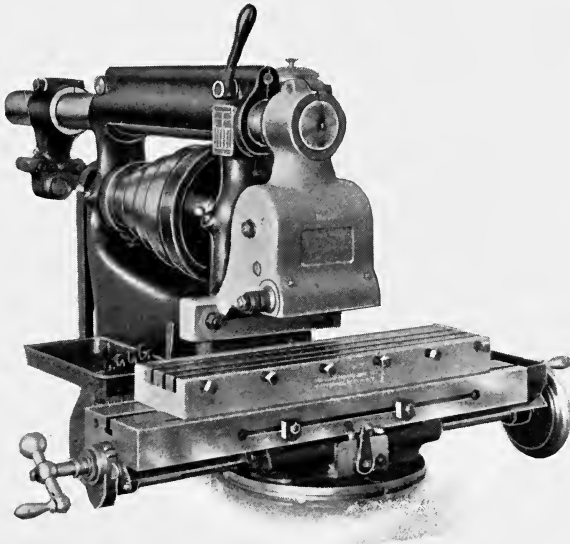

FIG. 81. The Rack-cutting Attachment used with the Brown & Sharpe Milling Machine.

After the adjustment has been made for a new tooth, it may again be located in position for the next cut by setting to the proper distance away, as determined by the thickness of the gauge. If the screw by which this adjustment is made is provided with a dial reading to thousandths, this may be used. One way is to set the dial carefully to zero before making each setting; then operate the screw to move the slide the proper amount in thousandths of an inch as

determined by the circular pitch of the tooth being cut. The dial may then be brought back to zero, repeating the operation when the next adjustment is to be made.

More elaborate means of indexing are provided for special rack-cutting machines. The arrangement generally used is identical with that shown in Fig. 16 as applied to the spur gear cutting machine, excepting that the index worm and index wheel are replaced by a lead-screw and

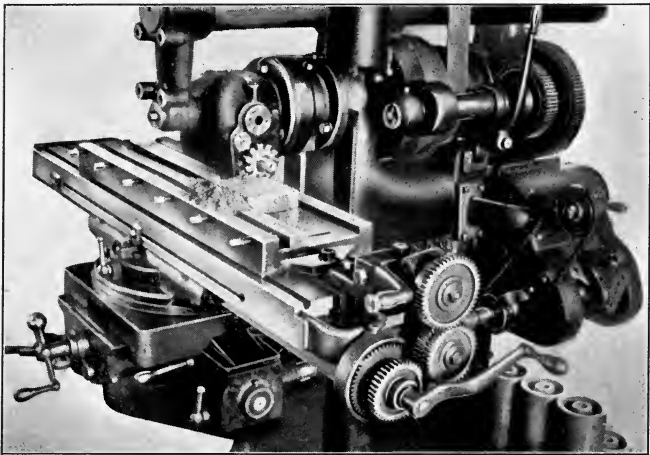

FIG. 82. Le Blond Change Gear Attachment for Spacing in Rack Cutting and Similar Operations.

nut, which serve to give a longitudinal movement to the work table in the same way that the rotary movement is given to the work spindle of the gear-cutting machine. This longitudinal movement equals the circular pitch, of course, and is obtained by using appropriate change gears between the one-revolution shaft and the lead-screw.

In Fig. 81 is shown an attachment for the milling machine used for cutting racks. This device, which is applied to the Brown & Sharpe milling machines, consists simply of a

holder clamped to the front of the column and the overhanging arm, and carrying a short cutter spindle at right angles and below the main spindle of the machine. This is connected to the main spindle by suitable gearing. On the projecting end of it a formed cutter of ordinary construction is fastened. The vise shown in the cut is pro-

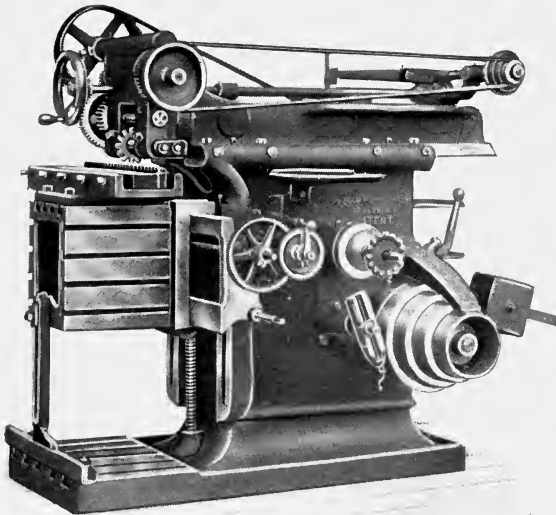

FIG. 83. The Gould & Eberhardt Shaper with Attachment for Cutting Racks.

vided for holding the work. The work may be indexed by using the graduated dial as explained, or by making use of a change gear attachment, furnished by the makers, operating on the principle described in the preceding paragraph.

In Fig. 82 is shown another milling machine having an indexing attachment for rack cutting. The feed screw of the table is turned by the crank shown. The screw is connected by change gearing with a disk carrying a

notch in which a stationary lock bolt may be seated. When this bolt is withdrawn, and the crank is turned until the bolt falls into place again, the table is advanced a definite amount, equal to the desired circular pitch, as determined by the change gears. The cutter driving attachment is similar to that in Fig. 81.

Rack-cutting attachments are made to apply to the shaper as well as to the milling machine. An example of one made by Gould & Eberhardt, Newark, N. J., is shown in Fig. 83. The regular swiveling tool head has been removed from the ram, and its place is taken by a casting carrying a cutter arbor and the necessary gearing and other mechanism for driving it. In addition to this, the ram is provided with attachments for giving a gradual forward screw feed for advancing the cutter through the work, in place of the usual reciprocating movement, which is disconnected when the machine is used in this way. A suitable vise for the work is clamped on the work table, and an indexing arrangement involving the use of change gears is provided for shifting the table from one cut to another.

SPECIAL FORMED TOOL RACK-CUTTING MACHINES.

Most commercial rack-cutting machines in their structural design are developments of the milling machine idea. The automatic rack-cutter for small size and accurate work, shown in Fig. 84, is an example of this type. This tool is built by Sloan & Chace Manufacturing Company, of Newark, N. J. Its resemblance to the milling machine and attachment shown in Fig. 81 is obvious. It is automatic in all its movements, which are mostly cam-operated, as is usual in gear-cutting machinery of the precision type built by manufacturers of watch- and clock-making machinery.

Another machine of this kind is built by Walcott & Wood Machine Tool Company, Jackson, Mich. (Fig. 85). This machine, as may be seen, involves the same structural features as the preceding one, but is built for much

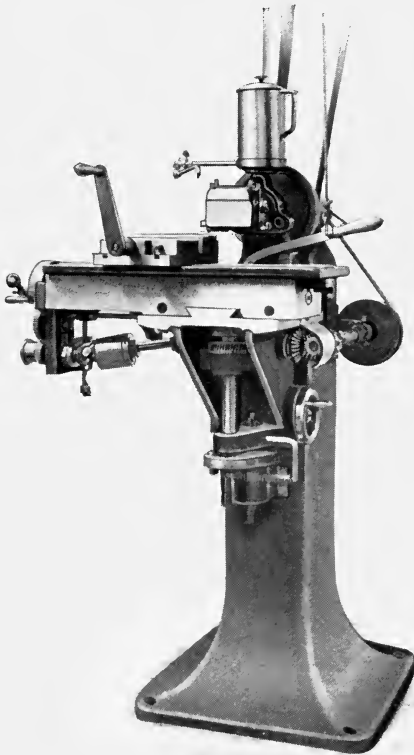

FIG. 84. The Sloan & Chace Rack Cutter for Small Work.

larger and heavier work. Its movements are obtained by screws and gear-driven mechanisms, instead of by cam movements. As shown, the cutter spindle is driven by gearing on each side, the main drive on the left being by herringbone gears. This tends to give a smoothness of

action which the necessarily small diameter of the driving pinion would otherwise make impossible. The cutter arbor is driven by a tongued connection from each end. It is held in position by two bolts passing through the

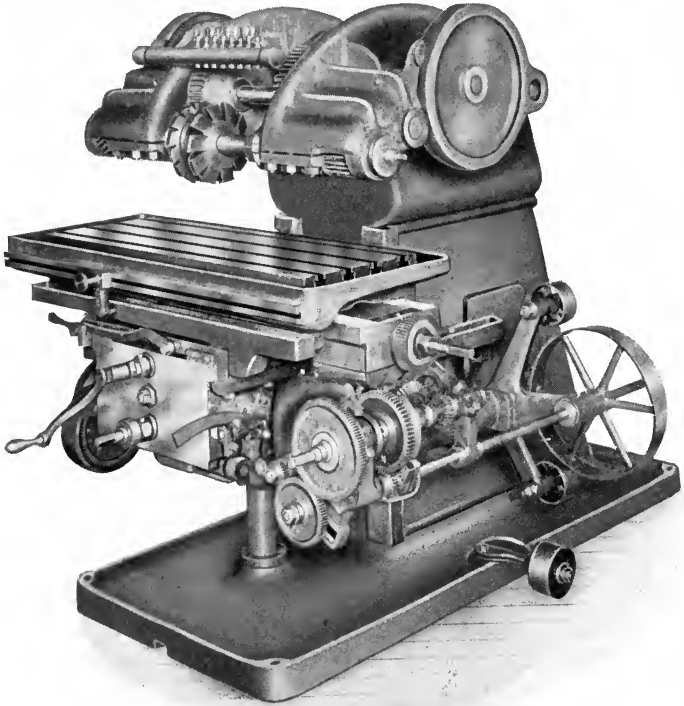

FIG. 85. The Walcott & Wood Automatic Rack Cutter.

driving spindles at each side, which, when tightened together, make driving spindles and cutter arbor practically a solid piece, giving a very powerful support. There being 10 inches of cutter space on the arbor, it is well adapted to the use of gang or multiple cutters. Provision is made for this in the gearing, there being two sets

of change gears, one of them set for the pitch in the ordinary way, while the other is set for the number of teeth it is desired to index at once. All of the gears shown are provided with guards, which have been removed in taking the photograph so that the drive may be more easily understood. A feature of this machine and the previous

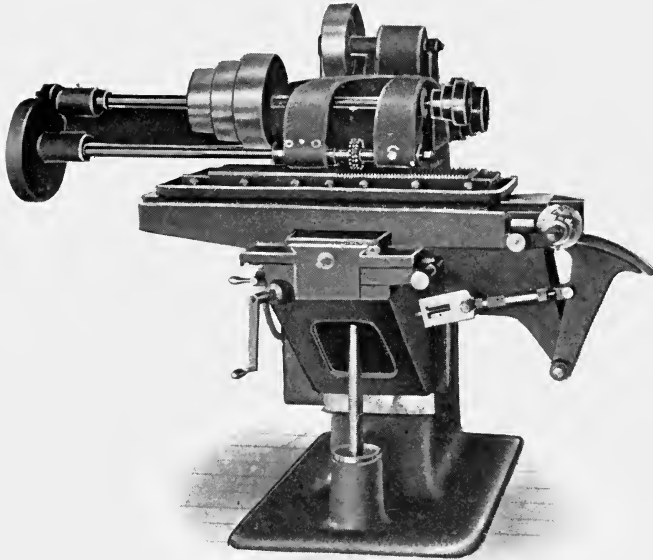

FIG. 86. The Machine built by Warner & Swasey Company to overcome the Driving Difficulty.

one is the automatic mechanism provided for throwing off the counter-shaft belt shifter when the required number of teeth has been cut.

In the machine shown in Fig. 86, formerly built by Warner & Swasey Company, of Cleveland, Ohio, the difficulty in the driving of the cutter spindle has been ingeniously overcome. The cutter spindle has been extended to great length at the left side of the machine, where it is

driven by a gear of as large diameter as is necessary to give it a powerful yet smooth and even movement. Of course the capacity of the machine for cutting racks is limited to the length from the cutter to the face of the driving gear. This is beyond the extreme indexing range of the table anyway, but the possible range may be doubled by cutting half the rack, and then reversing it so that the overhang of the work is at the right end of the table. The efficacy of this method of driving the spindle in avoiding some of the difficulties inherent in the rack cutter may be vouched for from the fact that the idea in a modified form has been applied to all the rack cutters of various types in the plant of one of the largest firms making a special business of cutting gear teeth.

As the rack-cutting machines just described are derived in form from the milling machine with rack-cutting attachment, so a machine may be made resembling in its movements the arrangement shown in Fig. 83, in which the cutter spindle is mounted on a shaper ram, which is fed forward bodily to pass the cutter through the work. One machine in very common use built on this plan is the Pratt & Whitney rack cutter. This firm is no longer building this machine, so we do not show a cut of it here, though it is of common occurrence and familiar to every one engaged in the business. Another machine of the same type, built by the R. K. Le Blond Machine Tool Company, is shown in Fig. 87. This was for use in the shops of the builders. It is a rugged, compact machine, fully automatic, with a single pulley drive. All the changes of speed, feed, and indexing are effected by change gears.

A third form in which the rack-cutting machine is built resembles in its construction the heavy type automatic gear cutter, such as that built by Craven Brothers and shown in Fig. 39. The only difference is in the substitu-

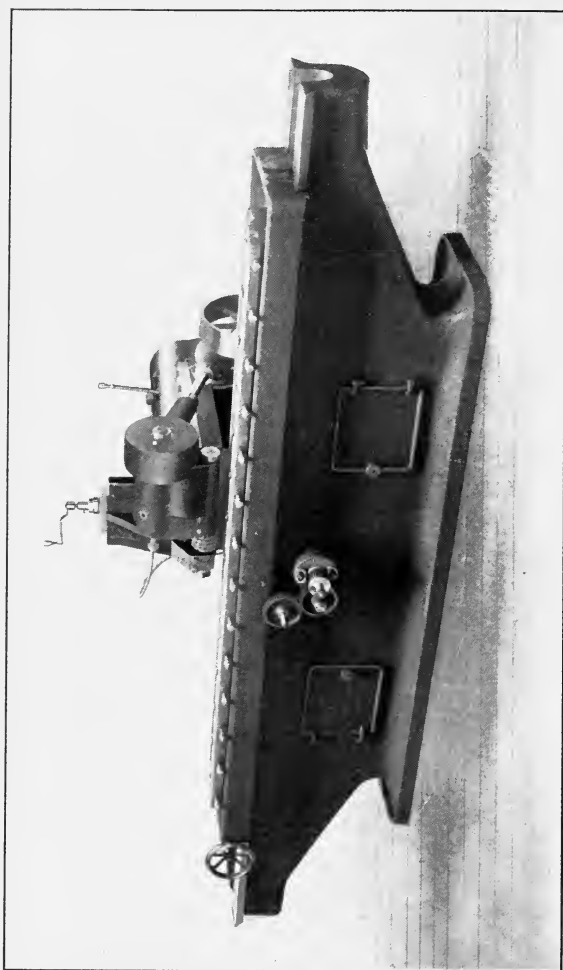

FIG. 87. Rack-cutting Machine built in the Shops of the R. K. Le Blond Machine Tool Company.

tion of a longitudinal work-carrying slide and indexing mechanism for the rotary work spindle and indexing wheel of the spur gear machine. This likeness may easily be traced in the case of the Gould & Eberhardt rack cutter, shown in Fig. 88. As in the spur gear machine, the spindle is mounted on a head sliding on vertical ways on the face of a column. This column may be adjusted in and out on the bed to suit the thickness of the

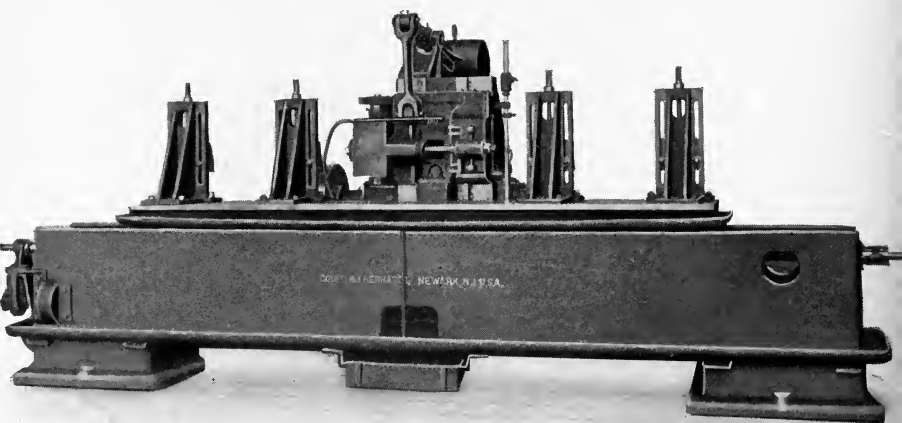

FIG. 88. A Large Size of the Line of Gould & Eberhardt Rack-cutting Machines.

work being operated on. The table, which takes the place of the spindle and face-plate of the spur gear machine, slides on ways on the main body of the bed. It will be noted that these ways are of unusual length, supporting the table well, even when it is moved out to the extreme of its travel in either direction. The change gears regularly furnished permit the cutting of either diametral or circular pitches. The table can be geared to index in either direction. The work may be fastened either directly

to the table by the T-slots provided or may be clamped in the angle vises shown. The cutter spindle is of chrome nickel steel, strongly gear-driven, by worm and worm-wheel and splined shafts. The holding of the blank in a vertical position, and the vertical travel of the cutter slide, permit a rigid support for the work against the thrust of the cut, besides causing the lubricant and chips

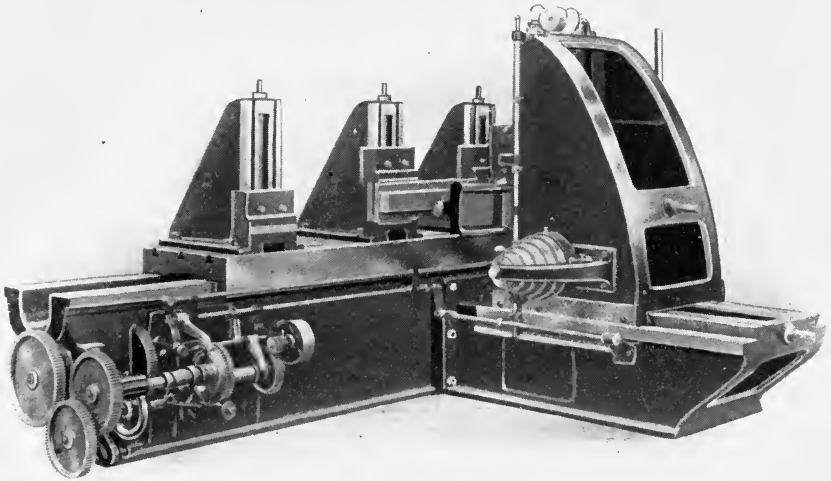

FIG. 89. The Reinecker Automatic Rack Cutter.

to drop freely out of the way. This type of machine is convenient for setting, inspecting, and testing the work.

The machine built by J. E. Reinecker, of Chemnitz-Gablenz, Germany, shown in Fig. 89, like the preceding one, is entirely automatic in all its movements, though it is furnished, if desired, in semi-automatic form. After the rack is cut through, a special arrangement returns the table to its starting position. This is of great advantage when stocking and finishing cuts are made, as the dividing

follows the same direction and from the same starting point.

The driving difficulty previously mentioned as being met with in the rack cutter is overcome in this machine in a novel manner — see the line drawing, Fig. 90. As there shown, the cutter spindle is set on an angle with the work, and the forms of the cutters used are made to suit; that is to say, the formed tools used in shaping them are set at the same angle as that given to the axis of the cutter spindle. This arrangement obviously allows the use of a

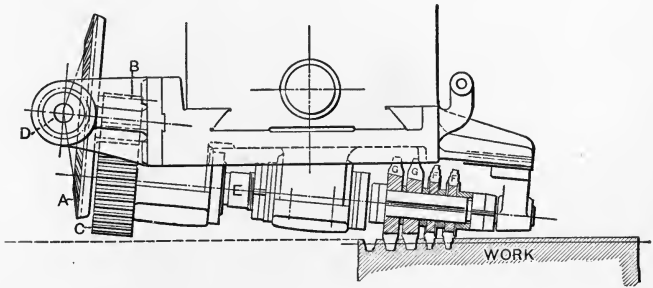

FIG. 90. Diagram showing Angular Position given the Spindle of the Reinecker Rack Cutter to obtain Large Driving Gear at C.

driving gear *C* considerably larger in diameter than the cutters. The drive is from a vertical shaft *D*, through a bevel pinion to bevel gear *A*, driving pinion *B* meshing with gear *C* on spindle *E*. As here shown, there are two roughing cutters *F*, and two finishing cutters *G*. Of course the angularity of the spindle necessitates an increase in diameter for each succeeding cutter on the arbor.

This scheme is especially interesting to the writer because a similar suggestion occurred to him at one time in conversation with the designer of the machine shown in Fig. 87. In talking the matter over, however, the arrangement seemed inadvisable, owing to the necessity

for special cutters and the added complexities of using them in gangs as here shown. Besides this, it would probably be impossible to cut cycloidal teeth of accurate form by this method, because it would be impossible to obtain clearance for the sides of the cutters at the pitch line, where, when theoretically correct, the sides of the teeth are parallel for an infinitesimally small distance. For involute cutters, also, it is obvious that the angle made by

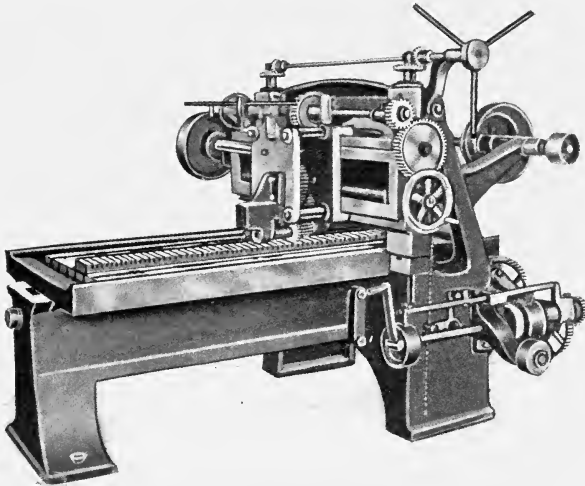

FIG. 91. Planer Type Automatic Rack Cutter, built by G. Wilkinson & Son.

the axis of the spindle with the face of the rack must not exceed the number of degrees in the pressure angle (or angle of the sides of the teeth) of the rack being cut. Mr. Reinecker appears to have found this method commercially successful, however, and an actual trial of it is the only true test in a case of this kind.

The rack cutter shown in Fig. 91, built by G. Wilkinson & Son, Keighley, England, is built after the planer pattern. The cutter head is mounted on a slide on the cross rail, on

which it travels as it is fed through the work. The work is clamped to the platen of the machine, which is indexed longitudinally for the spacing of the teeth. The indexing is done by hand, though the mechanism for moving the table is not released until the slide has been returned to

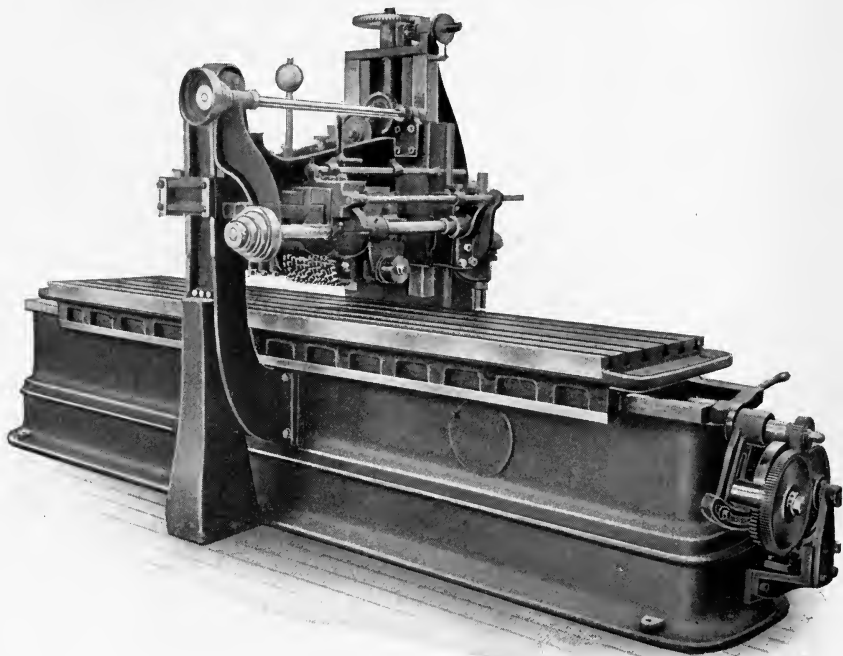

FIG. 92. Heavy Automatic Rack-cutting Machine of the Open-side Planer Type, built by Walcott & Wood.

cut a new tooth, this being done automatically, so that there is no possibility of the indexing being done by mistake at the wrong time. The slow forward feed and quick return of the cutter slide are automatic.

Another rack cutter with the structural features of the planer is shown in Fig. 92. In the case of this machine it

will be seen that its ancestors belonged to the "openside" instead of to the standard double-housing family of planers. The movements are about the same as in the previous case, though the machine has an entirely different appearance and is built for much larger work. It will cut racks up to 1 diametral pitch, 10 inches width of face,



FIG. 93. Armstrong-Whitworth Automatic Rack Cutter.

96 inches long, at one setting. For 1 diametral pitch racks the machine will take one roughing and one finishing cutter. For finer pitches, cutters are used in gangs, as shown in the engraving, up to the full width of space on the cutter arbor. The table is provided with a quick return, operated by power. The machine is regularly made full automatic, but may be furnished in the half-automatic

style if desired. It is built by the Walcott & Wood Machine Tool Company, Jackson, Mich.

The rack cutter shown in Fig. 93 is built by Armstrong, Whitworth & Co., of Manchester, England. The arrangement of the movements is somewhat different from any of the others we have considered. The cutter spindle, as may be seen, is driven by a worm and worm-wheel. The feed is effected by the forward movement of the cutter slide on the ways provided for it on the rearward extension of the bed. The spindle itself is mounted on a bracket, which may be adjusted vertically to give the proper depth of cut. One interesting feature of this machine is the provision made for cutting very long racks by shifting the position of the work in the vise when the full range of indexing movement has been exhausted. The central vise indexes step by step, being under the control of the indexing mechanism. The short end vises are screwed to the bed and do not move, the clamp screws with which they are provided being loosened while the work is being indexed. These end vises are used, in shifting the work, to hold it, while the central vise is loosened and returned to the starting point for a fresh grip. The particular machine shown is a somewhat specialized form, built for cutting racks used in wire fence knitting machinery.

THE MOLDING-GENERATING METHOD APPLIED TO RACK CUTTING.

Besides the formed tool method, the only other one commercially applied to rack cutting is the molding-generating method. The only example of this is in the Fellows system of gear shaping, which is applicable to the cutting of racks as well as to making spur and internal gears. The Fellows gear shaper as arranged for rack cutting is shown

in Fig. 94. This is a smaller size machine than the one shown in Fig. 79 cutting internal gearing, and the arrangement of its parts is somewhat different. In principle,

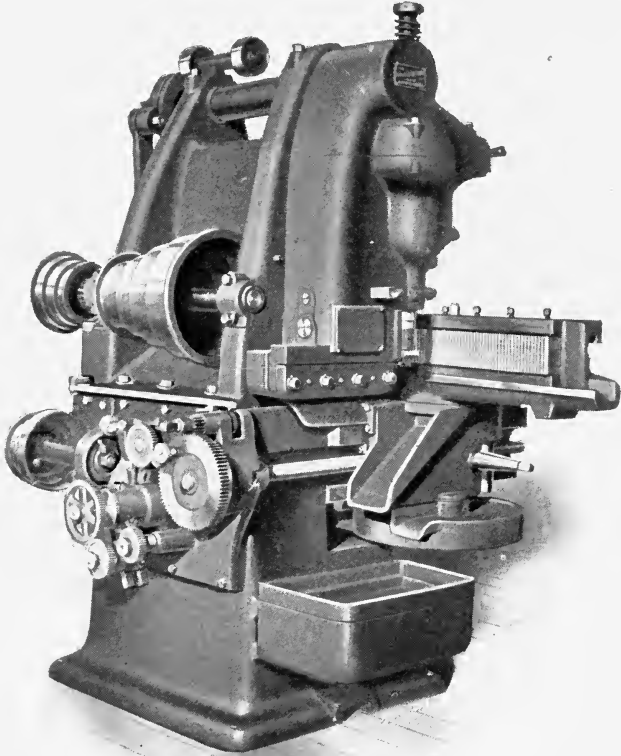

FIG. 94. The Fellows Gear Shaper, with Rack-cutting Attachment.

however, it is identical, the same cutter being used and the cutter and work being connected together in the same way. The face-plate or other work-holding device for spur gearing is removed, and in its stead is placed a pinion, firmly

fixed in the tapered hole of the spindle. A rack-cutting attachment is clamped to the machine, consisting of a guide provided with horizontal ways on which travels a work-holding carriage, having a rack in position to engage the teeth of the pinion clamped in the spindle. The vertical face of this slide forms a lengthened vise in which the work is held.

The method of operation is easily understood. If the spindle (and the pinion connected to it, which moves the work longitudinally) is geared in the proper ratio with the cutter, the machine may be started up with the cutter at the starting point, when the latter will roll on the work, exactly as if it were a pinion and the work were a rack with which it engaged. Under these circumstances the shaping action of the cutter will form rack teeth in the work, of suitable shape to mesh with all the gears in the series to which the cutter belongs. The operation is the same as shown in Fig. 8, except that it is reversed. Instead of having the rack the cutting tool and the gear the work, the gear is the cutting tool engaged in forming teeth in the rack. In addition to using an attachment to the regular machine, as in this case, the Fellows Gear Shaper Company, Springfield, Vt., have made special rack cutters involving this principle, in which the work table slides on a long bed, as in Figs. 87, 88, and 89.

This completes the description of machines for cutting the teeth of internal gears and racks.

CHAPTER V.

MACHINES FOR CUTTING THE TEETH OF WORMS AND HELICAL GEARS.

SPIRAL gearing, twisted and herringbone gearing, and worm gearing are all radically different in their action. The first two forms, however, and the worm member of the third, are identical so far as the principles governing the forming of their teeth are concerned; so we will consider them together in this chapter. It might be mentioned in connection with the name "spiral" gearing that gears of this kind are not spiral at all, but helical. A spiral is a figure contained in a plane. It resembles the shape of an ordinary watch or clock spring, starting from a central point about which it circles in widening curves. A helix has the shape of a string wound around a cylinder. The name "helical" has come into common use in describing springs of helical shape, and it ought to be used for gears as well. The writer would suggest that the reader practice using the term "helical gear." Criticism might also be directed toward the term "spiral staircase," but since carpentry is out of our field, we will not spend any time here in inaugurating that reform.

Almost as great a variety of methods of cutting teeth are possible for helical as for spur gears. Commercially, however, the formed tool and the molding-generating principles are the only ones of importance. The templet, odontographic and describing-generating methods of cutting gear teeth (in each of which the outline is worked out by the *point* of a tool, suitably constrained) are most useful for cutting gears of large size, in which tools acting on the

formed tool or molding-generating principle would be subject to too heavy cuts. Since helical gearing is generally confined to small and medium sized work, these processes are unnecessary, being by nature rather slow in action, and dependent for their accuracy on the preservation of the shape of easily injured points of comparatively small cutting tools. As in the case of spur gears, the molding-generating method is of comparatively recent introduction, and is confined almost wholly to the production of teeth of involute form.

MACHINES USING FORMED TOOLS IN A SHAPING OR PLANING OPERATION.

With the twisted teeth which we have in gears of the class we are discussing, it is evidently necessary, in employing shaping or planing operations, to give a rotary movement to the blank being operated on, at the same time as, and in the proper ratio with, the cutting stroke of the tool. This is necessary to compel the tool to follow the helix on which the teeth of the gear or the worm are to be formed. In Figs. 95 and 96 are shown two attachments for the shaper, working on different principles, giving the work the proper motion for cutting helical teeth. Both of these attachments were built by Gould & Eberhardt, of Newark, N. J.

In the first of these, Fig. 95, the work is mounted between centers on a supplementary bed, fastened to the work table of the shaper. The face-plate by which the work is driven from the head-stock spindle is connected to that spindle by an indexing mechanism, consisting of a notched plate, with a locking bolt for holding the work in the different positions for the different numbers of teeth required. The head-stock spindle is connected, by spiral gearing and a set of change gears, with a pinion operated by a rack, which rack

is fastened to the shaper ram. It will be seen that this connection with the shaper ram will give a rocking movement to the head-stock spindle and the work, in unison with the stroke of the tool. By selecting suitable change gears this rocking movement may be made of any desired amplitude for a given length of stroke, so that any lead of helix desired may be obtained. Provision is made, in the means

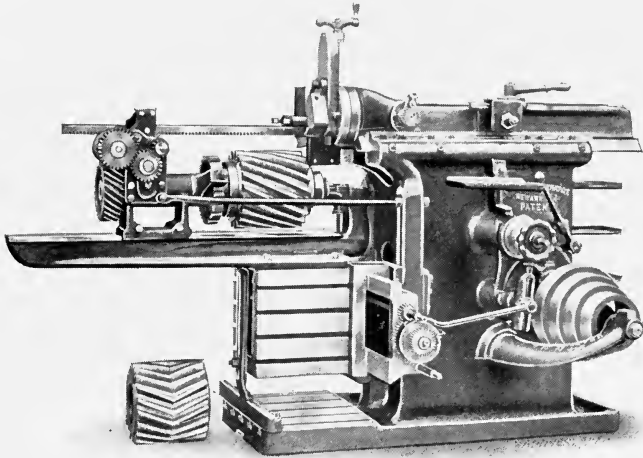

FIG. 95. Helical Planing Attachment for Gould & Eberhardt Shaper, in which the Lead of the Helix is obtained by Change Gears.

by which the rack is attached to the ram, for raising or lowering the work table to the position required for different diameters of work. The tool is, of course, fed downward by hand, and the indexing is done manually also. On the floor at the base of the machine will be seen a pair of right and left handed helical gears, similar to the one being operated on; the two together form a herringbone gear.

The second attachment, shown in Fig. 96, employs a radically different principle for varying the amplitude of the

rocking movement of the head-stock spindle for a given stroke of the ram, to obtain different leads of helix. The reader, of course, understands that the lead of the helix is the length of the cylinder required to allow a complete revolution of the helix. In this case a spur gear keyed to the head-stock spindle meshes with a vertical rack, sliding in a guide which is cast integrally with the head-stock. This vertical rack is pivoted to a block which slides in a

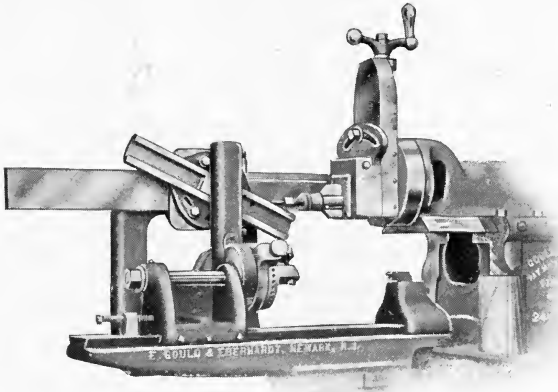

FIG. 96. Helical Attachment for Gould & Eberhardt Shaper, in which the Lead of the Helix is obtained by the adjustment of a Swiveling Guide Bar.

guide attached to a swiveling head, so that the guide may be adjusted to any angle. This swiveling head, in turn, is attached to a bar, which is fastened to the ram, and is guided on ways supported by a framework at the back of the head-stock. It will thus be seen that the forward and backward movement of the ram will impart an up and down movement to the rack, which will, in turn, give a rocking movement to the spindle of the head-stock and the work which it drives. The amplitude of this rocking can be increased or diminished by setting the swiveling guide at a

greater or less angle, so that the helices of various leads can be obtained. This makes the use of change gears unnecessary. The indexing device is similar in principle in the two arrangements.

It will seem strange at first thought, perhaps, to describe the cutting of worms in a lathe as an example of the use of formed tools in shaping or planing operations, but the operation is essentially the same as that shown in Fig. 95. Compare this with Fig. 97, imagining that the lead-screw shown in the latter is of such steep pitch that it can be rotated by pushing the carriage backward and forward. Under these circumstances, if provision is made for reciprocating the

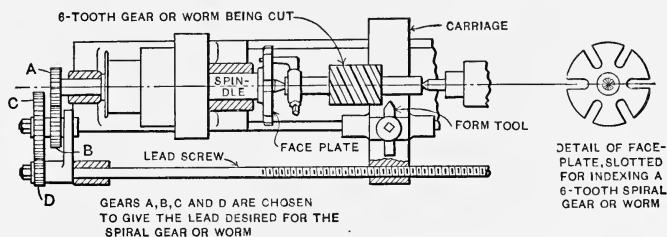

FIG. 97. The Lathe Method of Planing Helical Teeth in Gears or Worms.

carriage (corresponding to the ram for the shaper), the lead-screw will be rotated in unison with it, and this movement will be transmitted through change gears *A*, *B*, *C*, and *D* to the head-stock spindle, giving a rocking movement to the work. The only difference in the two cases is that in the lathe a screw of very steep pitch would have to be used to change the reciprocating motion of the tool to the rocking motion required by the work, while in the case of the shaper the more natural rack and pinion movement is employed. In the case of the lathe, of course, the power is not applied to the carriage but to the spindle. For that reason it is best adapted for cutting spiral gears of comparatively small lead, or "worms" as we ordinarily call them. If it

were attempted to cut 45-degree spirals, for instance, the lead-screw would have to be speeded up so fast, as compared with the movement of the spindle, that the driving belt would be unable to operate the machine. Special lathes have been built for cutting steep worm threads, in which the power has been applied to the lead-screw, the spindle being driven from it through the change gears. A lathe so arranged would have as much difficulty in cutting fine pitches as the ordinary lathe does in cutting coarse ones.

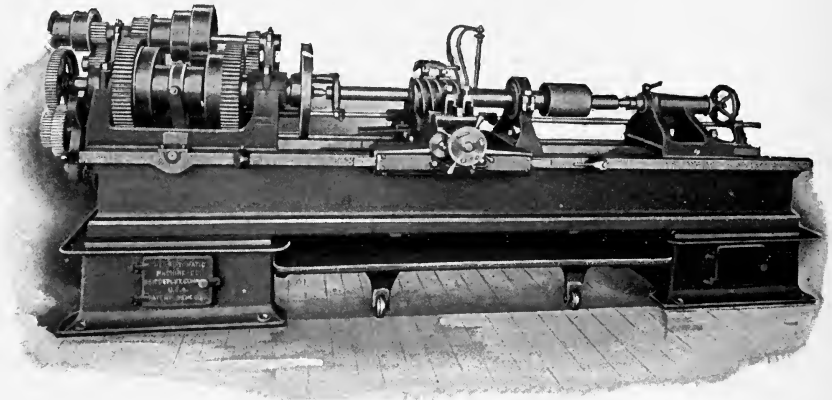

FIG. 98. Automatic Threading Lathe for Worms, made by the Automatic Machine Company.

Different methods of indexing may be used for the lathe. It will be noticed that in Fig. 97 the face-plate used has the same number of slots as the required number of teeth. After one tooth space has been cut, the work can be removed, and replaced again between the centers with the tail of the dog in another slot. After this space has been completed, the next one is cut, and so on until the whole six are finished. Other methods are in use, such as slipping of change gears *A* and *B* past each other a certain number of teeth, as determined by calculation.

Special lathes are built for threading, some of which are automatic in their action. One of these is shown in Fig. 98. It is built by the Automatic Machine Company, Bridgeport, Conn. The size shown is especially adapted to cutting worms. It is provided with mechanism for duplicating the action of a manually operated lathe engaged in threading. After a piece of work has been placed between the centers and the machine has been started, the work revolves, and the carriage feeds forward until the proper length thread has been cut; then the tool is withdrawn, and the carriage returns to begin again on a new cut — and so on without attention from the operator. The tool is fed in a certain suitable amount at the beginning of each cut, the amount of this feed being automatically diminished to give a fine finish for the final cuts. When the depth for which the tool has been set is reached the operation of the mechanism is automatically arrested. In cutting multiple threaded worms in this machine multiple tools may be used, thus avoiding the necessity for indexing the work. As many as eight cutting tools have been used at once on this machine, giving a total length of cutting edge of 8 inches.

STANDARD MACHINE TOOLS USING FORMED MILLING CUTTERS.

We have spoken hitherto of the formed tool or cutter method of shaping the teeth of gears as being one in which the tool accurately reproduces its shape in the tooth space it forms. This is true in cutting straight tooth spur gears and in planing the teeth of spiral gears by the process just described. It is not exactly true, however, of any possible process of milling spiral teeth. This is best seen in Fig. 99. In the three cases here shown we have, first, a planer tool; second, a disk milling cutter; and third, an end milling

cutter — all formed to the same identical outline and cutting helical grooves of the same lead and depth in blanks of the same diameter. The section in each case is on the plane normal to the helix at the pitch line. (Of course the true section to take would be that of the helicoid normal to the helicoid of the groove being cut. The plane in which we have taken the section, however, so nearly approximates this helicoid that the error is negligible.)

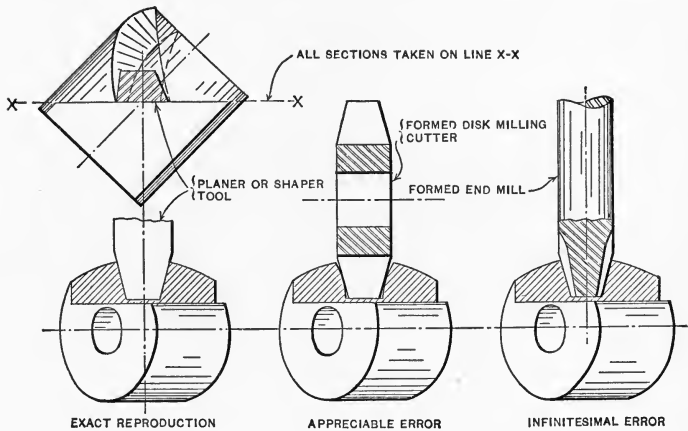

FIG. 99. Comparison of the Accuracy of Form Reproduction obtainable by Formed Planing Tool, Formed Disk Cutter, and Formed End Mill.

The planer tool necessarily cuts a groove of the same shape as its outline, the plane of its outline being the same as the plane of the section shown. The disk milling cutter, however, interferes with the sides of the groove it cuts. This interference takes place on one side as the teeth are entering, and on the other as the teeth are leaving. This results in a generating action which takes place in addition to the simple forming action, so that the tooth cut is not an exact duplicate of the outline of the cutter. In the case of

the formed end mill there is also an interference of the same kind as with the formed disk cutter, but it is so slight as to be absolutely undetectable in all ordinary cases. We only know of its presence from theoretical considerations.

In spite of its imperfect reproduction of the desired form, the disk cutter is the type generally used for milling, since it may be so relieved as to retain its shape even after repeated grinding. The end mill type of formed cutter cannot remove so much stock in a given time, and it is difficult to make it so that it can be ground without changing its form. The only way in which this grinding can be practically performed is by the use of some form of grinding machine, in which the wheel is guided by a templet to grind the desired form. The formed end mill is used to a limited extent, nevertheless.

The simplest way of using the milling process for cutting helical gears or worms makes use of the universal milling machine. With this machine the work, and the feed-screw of the table on which it is mounted, are so connected by means of gearing that the forward feeding gives a rotary movement to the work, producing a helix of the required lead. The mechanism is identical in principle with that shown in Fig. 97 for the lathe, and in Fig. 95 for the shaper, the only difference being that in the milling process the longitudinal movement is a steady feeding motion, made once for each tooth space, instead of being a continuously reciprocating motion, as in the previous cases. The simple indexing devices shown in Figs. 95 and 97 are replaced by the more elaborate index plate and worm-wheel device of the spiral head.

This mechanism, as exemplified in the Brown & Sharpe universal milling machine with its spiral head, etc., is illustrated in Fig. 100. The work has to be swung at an angle with the cutter to agree with the helix angle at the pitch

line, as indicated. This is done by swiveling the table of the universal milling machine to bring the work to the proper angle with the cutter. In most makes of machines it is inconvenient, if not impossible, to swivel the table to a greater angle than 45 degrees. For greater angles special

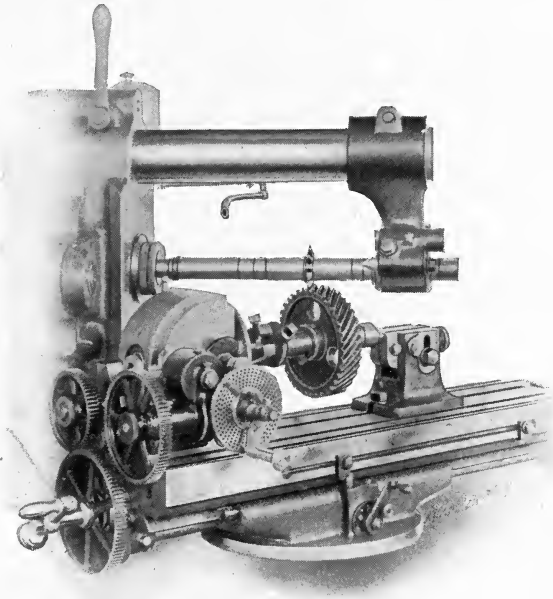

FIG. 100. Brown & Sharpe Milling Machine arranged in the Usual Manner for Cutting Spiral Gears.

attachments are provided for swiveling the cutter, leaving the table in its normal position at right angles to the spindle of the machine. Two examples of this are shown in Figs. 101 and 102. The first case shows a Brown & Sharpe milling machine engaged in cutting a spiral gear, using for the purpose a vertical milling attachment, which has been set to the required helix angle. The change gearing used for

connecting the spiral head with the feed-screw of the table can be plainly seen at the left. In Fig. 102 an attachment of another form is shown, built by the Cincinnati Milling Machine Company, Cincinnati, Ohio. In this case the

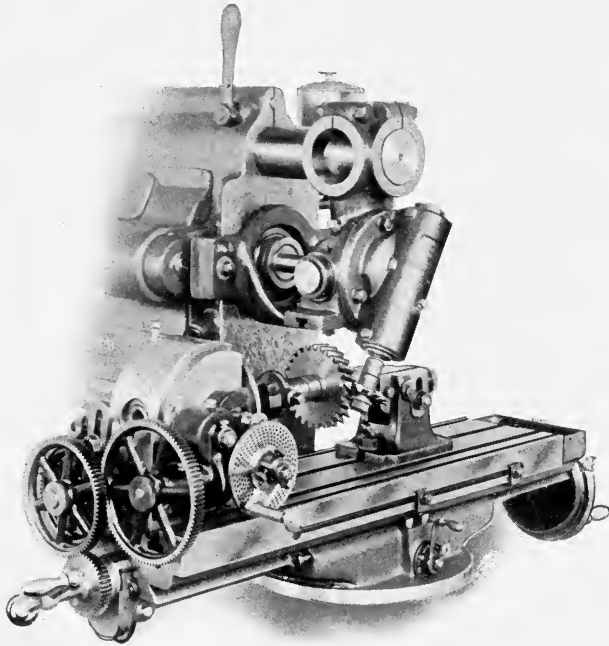

FIG. 101. Cutting Spiral Gears of Helix Angle too Great to allow the Method of Fig. 100; employing the Brown & Sharpe Vertical Milling Attachment.

cutter is adjustable about a vertical axis, being driven from the spindle by bevel and spiral gears. It may be set at any angle throughout the whole circle, and cuts on top of the blank, the table being set in the normal position, the same as in Fig. 101. The vertical attachment shifted to a horizontal position, or a rack-cutting attachment, may also be

used in milling helical gears to bring the cutter spindle at right angles to the main spindle of the machine. By this means it is possible to mill gears having a greater helix angle than 45 degrees without shifting the table more than 45 degrees.

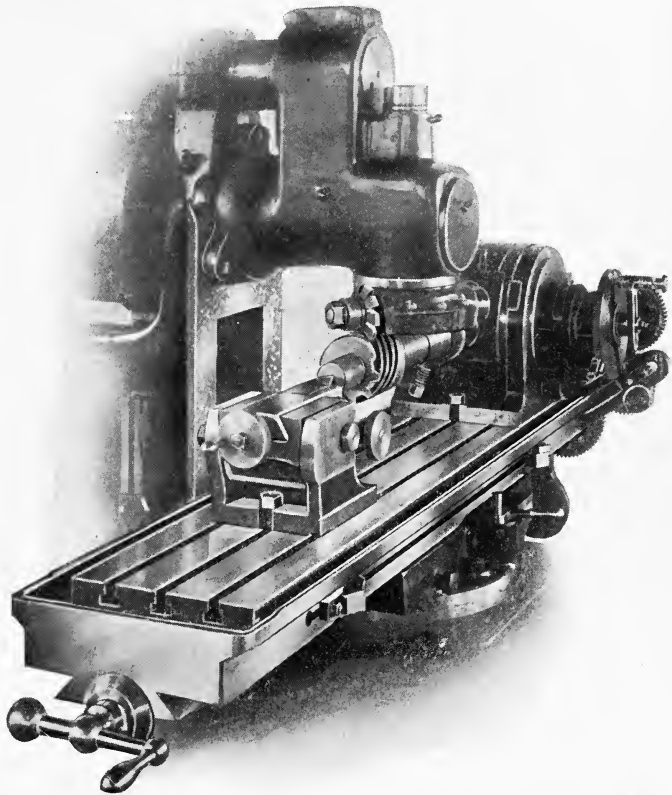

FIG. 102. Universal Milling Attachment of the Cincinnati Milling Machine Company in use cutting Gears of Large Helix Angle.

A third attachment, shown in Fig. 103, differs from the two previously shown, in the provision of an outboard bearing for the cutter spindle, and in the fact that the driving is so arranged that the vertical capacity of the machine

is not seriously affected by the attachment. In addition, it offers the advantage of allowing the cutter to be set central with the work before the angular adjustment is made. This apparatus is built by the R. K. Le Blond Machine Tool Company, Cincinnati, Ohio.

These various attachments allow the milling machine to work throughout a wide range of angles for helical gears

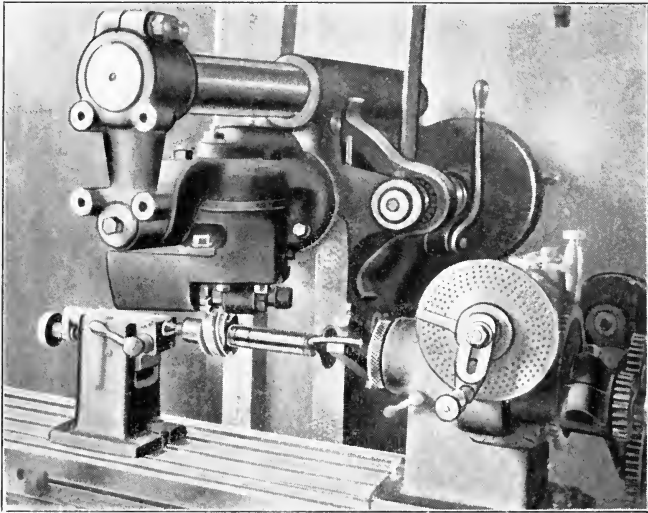

FIG. 103. Cutting a Spiral of Short Lead on the Plain Milling Machine, an Operation Impossible on the Universal Machine without Special Attachments.

and worms, the only limitation being one similar to that imposed on worm cutting in the lathe, though the limitation is reversed. For worms or gears of too small lead as compared with their diameter, the rotary movement of the blank is so great that the comparatively slow-moving feed-screw is unable to speed up the spiral head mechanism to get the required movement and still furnish power enough for feeding the work against the cutter. The operation

shown in Fig. 103 is about the limit in this direction. For greater angles it would be necessary to feed the work manually by the index crank, driving the feed-screw through the change gearing.

SPECIALIZED FORMS OF MILLING MACHINES FOR CUTTING SPIRALS BY THE FORMED CUTTER METHOD.

The principle of the universal milling machine for cutting spiral gears and worms has been applied to the design of various special machines for the same purpose. A num-

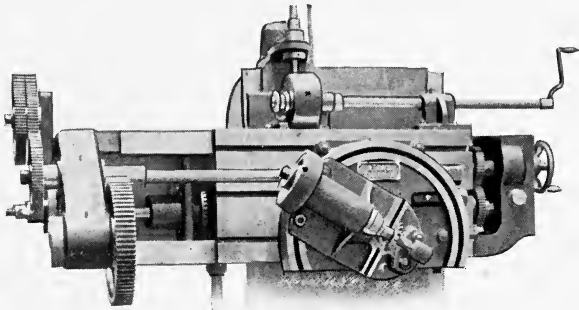

FIG. 104. Helical Gear-Cutting Attachment used with the Atlas Gear-Cutting Machine shown in Fig. 36.

ber of these are shown in Figs. 104 to 109. The specialization of the machine includes making the spiral and indexing mechanisms integral parts of the tool, so that they have a much greater capacity for taking heavy cuts than is the case where they are merely attachments, as in the cases previously shown.

In the first case shown the spiral cutting mechanism is still something in the nature of an attachment, the machine being designed for cutting other kinds of gears as well. This tool (see Fig. 104) is the universal gear-cutting machine made by Nya Aktiebolaget Atlas, Stock-

holm, Sweden, already illustrated in Figs. 36 and 77. The cutter spindle is mounted in a swiveling head, which may be set at the required angle for the helix to be cut, the angular adjustment thus being identical with that in Fig. 103. The cross rail with the cutter is fed down through the work, which is rotated by its gearing connections so as to produce the helix required. In this machine the indexing is done by power, being regulated by change gears as in the orthodox automatic spur gear cutter. There must, then, be some sort of a differential gear mechanism combining the indexing movement and the rotation of the work for the helix, both of which must be allowed to operate on the work without interfering with each other. We are not informed as to the exact nature of this mechanism, though it is doubtless similar in principle to that described for the following machine.

It was stated that the spur gear cutting machine shown in Fig. 58 is a modification of a universal gear-cutting machine made by J. E. Reinecker, of Chemnitz-Gablenz, Germany. In Fig. 105 is shown a side elevation, and in Fig. 106 a diagram, of the index worm connections of the universal machine referred to, as arranged for cutting helical gears by the formed milling process. The machine is arranged, like the Becker-Brainard machine (see Fig. 21), on the general lines of the milling machine, excepting that the work spindle is at the top of the column and the cutter spindle on the knee.

The cutter, at *B*, is driven by an internal gear *A* of large diameter (see also Fig. 58) and is mounted on a swivel table *C*, which can be set to the required helix angle. The form of cutter slide shown will give any angle up to 30 degrees. For greater angles this is replaced with a slide which can be rotated to any angle throughout the whole circle.

The screw which feeds cutter slide *C* along the knee is driven from cone pulley *D*, through vertical shaft *E* and its gear connections. Cone pulley *D* is also connected with change gearing *F*, which is, in turn, connected with the

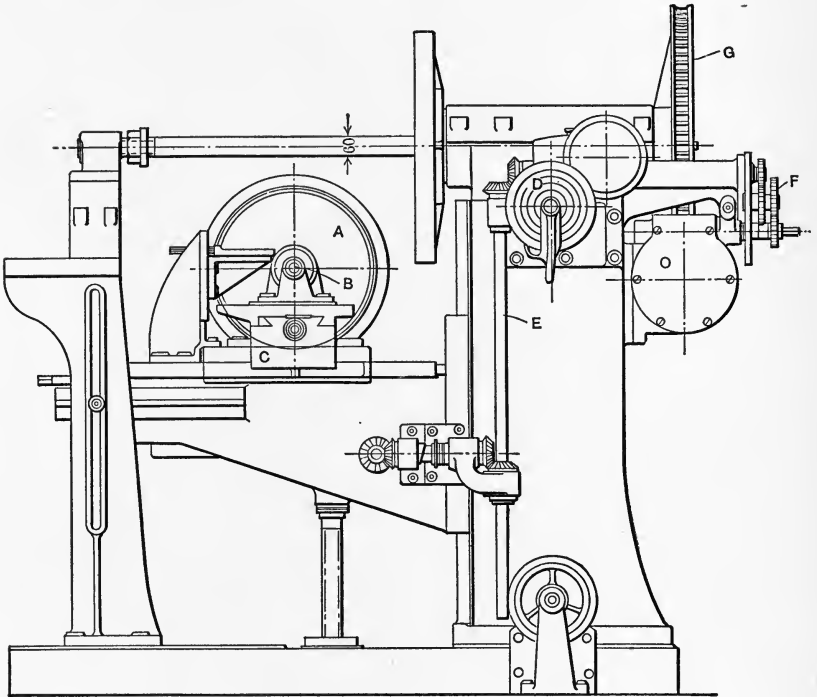

FIG. 105. Side View of the Reinecker Universal Gear-Cutting Machine, showing the Geared Connections between the Index Worm-Wheel and the Feed of the Cutter Slide.

index worm, so as to rotate index wheel *G* and the work properly, for any desired helix. The principle of this is the same as in the universal milling machine, change gears *F* acting the same as the change gears used to connect the spiral head with the table feed-screw in Fig. 100.

Now the worm-wheel *G* is used for indexing, as well as for rotating the work for the helix, in unison with the feeding of cutter slide *C*. The way in which these two motions are imparted to *G* without interfering with each other may be understood by reference to Fig. 106. Similar parts have similar reference letters in this engraving and the preceding one.

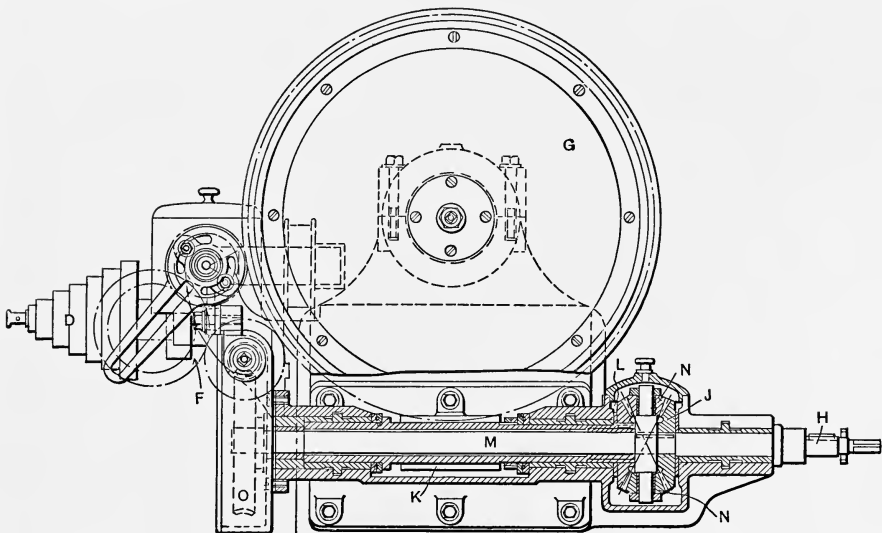

FIG. 106. Detail of the Machine in Fig. 105, showing the Differential Mechanism by which the Motions for Helical Cutting and for Indexing are combined to rotate the Work.

At *H*, on the opposite side of the machine from that shown in Fig. 105, are mounted the change gears by which the indexing is accomplished. These gears drive bevel gear *J*. Index worm *K*, meshing with index worm-wheel *G*, is mounted on a hollow sleeve, keyed fast to the bevel gear *L*. Shaft *M* carries a hub with projecting pivots on its right-hand end, on which are mounted bevel pinions *N*. Shaft *M* is driven by worm-wheel *O*, connected with the

feed of the slide cutter through change gears F . Gears J , L , and N form a differential mechanism of the well-known "jack-in-the-box" type. The action of this mechanism is such that if shaft M be at rest, change gears at H may be operated for the indexing, transmitting the motion from gear J to L through pinions N as idlers, thus revolving index worm K . On the other hand, with the indexing mechanism still and the cutter slide feeding, the movement thus imparted to shaft M may be transmitted (by the rolling of pinions N on stationary bevel gear J , and the consequent rotation of bevel gear L) to worm K , and thence to worm-wheel G and the work. It will thus be seen that the indexing, and the rotation for the helical cutting, can take place independently of each other. But more than this, the two motions can be operated together without interference. In fact, either of the motions imparted to shaft M or gears at H may be stopped or reversed independently, and each will have its proper influence on the index wheel and the work.

With this understanding of the differential mechanism, the operation of the machine is easily comprehended. Change gears H are connected through a one-revolution friction trip with the main driving shaft. The cutter, set at the proper angle, is fed forward through the work, which is rotated by change gears F , shaft M , and worm K , at the proper rate to cut the proper helix. The cutter is then dropped down to clear the work (provision for this being made in the machine), and returned, ready to begin on a new tooth. The indexing mechanism is then tripped by hand, and the work is rotated into position for the new tooth by change gears at H , gear J , and worm-wheel K . This is repeated until the gear is done.

There were three other spur gear hobbing machines of which it was said that they were equipped for cutting the

teeth of spiral gears by the formed tool method. These were the Ducommun machine in Fig. 59, the Gildemeister machine in Fig. 63, and the Lorenz machine in Fig. 70. Fig. 107 shows the Gildemeister machine at work on a spiral gear, performing the operation in the same way that it is done in the universal milling machine. There is no special provision for relieving the cutter on the return in these machines, so far as the writer knows.

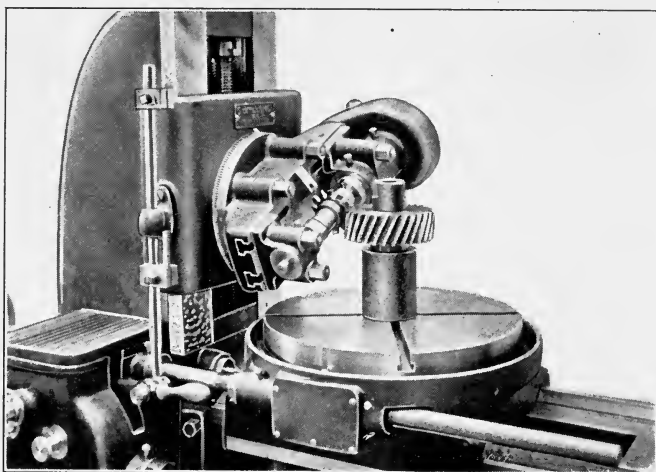

FIG. 107. The Gildemeister Machine (see Fig. 63) cutting a Spiral Gear by the Formed Tool Process.

In the Lorenz machine in Fig. 70, the arrangement for indexing is different from any that has been described in connection with the cutting of spiral gears. At the completion of a cut the cutter is returned to the starting point ready for the next feeding movement. The dividing worm is then disconnected from the feed mechanism by which it is controlled when forming the tooth space, and is connected with the index mechanism. This latter

consists of a one-revolution crank, shown at the side of the base in the engraving, connected with the dividing worm by change gears to give the number of teeth desired. After the indexing, the connection is again made with the feed mechanism, and the indexing mechanism is released. While this intermittent connection with the index mechanism would seem to be dangerous from the standpoint of accurate dividing, it is said to work out satisfactorily in practice. The index or work-driving worm-wheel is of bronze, driven by a worm of special construction, which the builders claim gives a much more durable contact than is usually obtained. There is at least one of these machines in use in the United States.

In the machines hitherto shown, power is applied to the feed-screw, from which the work is rotated through change gearing. This arrangement is best for helices of great lead. When it comes to milling helical gears with small leads, *i.e.* worms, it is necessary to use the lathe principle and apply the power to rotating the work, the longitudinal feed being driven from the work spindle through change gearing. We show two examples of machines of this kind in Figs. 108 and 109.

The well-known thread milling machine made by Pratt & Whitney, Hartford, Conn., is illustrated in Fig. 108. Probably few mechanics have ever thought of this as being a gear-cutting machine, but it is here shown engaged in the perfectly legitimate work of cutting a worm, so that it should be classified with gear-cutting machinery of the kind described in this chapter. The machine is so well known as to scarcely need description. The cutter spindle is mounted in a head which can be swiveled to any angle, and the slide which carries it is fed lengthwise along the bed, the proper lead being obtained by connecting the head-stock spindle and feed-screw by change gearing.

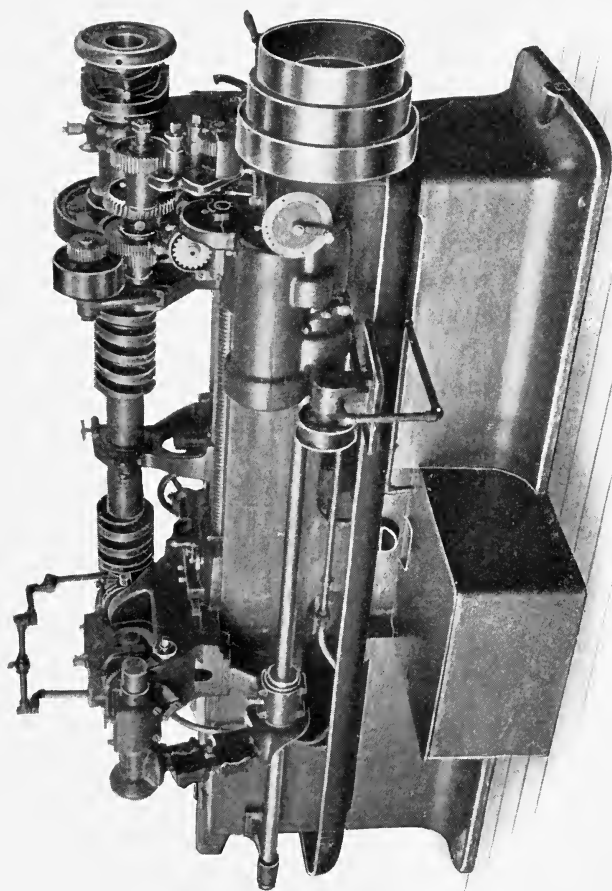

FIG. 108. The Pratt & Whitney Thread Milling Machine, engaged in Cutting a Worm.

A second machine of this kind is shown in Fig. 109. It is built by J. E. Reinecker, of Chemnitz-Gablenz, Germany, and is intended especially for milling worms, although it is well adapted for small spiral gears also. The cutter, driven by worm gearing, is mounted in a heavy swiveling head, which is fed along the bed on ways

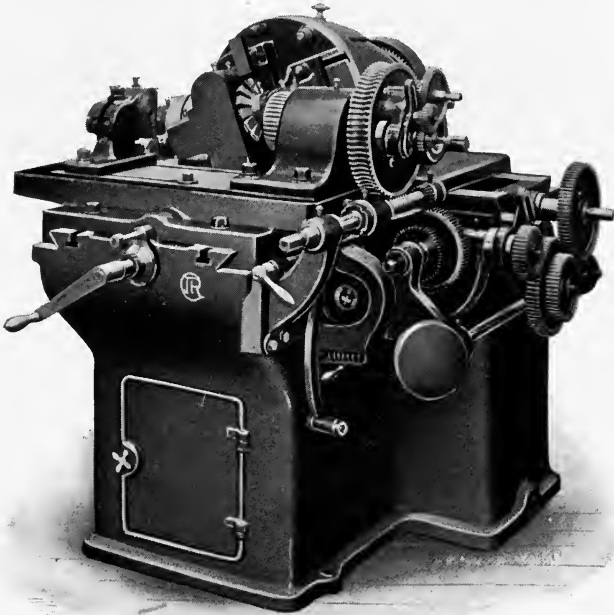

FIG. 109. The Reinecker Worm Milling Machine.

at the rear of the machine. The adjustment for diameter is made by moving the work table, with its head and foot stocks, away from or toward the cutter. Cone pulleys and gearing are provided for varying the rate of feed of the cutter head, while the connection between the feed movement of the cutter and the rotation of the work is governed by change gears. On the worm-wheel which drives the work

spindle will be seen mounted a change gear mechanism which is used for indexing. The indexing is by hand, and the whole mechanism is carried around by the spiral movement, so that a differential mechanism is unnecessary.

SPECIALIZED FORMED CUTTER MACHINE FOR HERRING-BONE GEARS.

There is a specialized form of herringbone gear made by André Citroën & Co., 202 Rue de Faubourg St. Denis, Paris. The teeth of these gears, we are informed, are shaped by an end cutter like that shown in Fig. 99, guided by suitable mechanism to produce the continuous "wavy" form of herringbone teeth characteristic of these gears. This process also has the advantage of not requiring the blank to be made in two pieces. The same principle has been applied by the builders to the cutting of herringbone bevel gears.

Other manufacturers make use of the formed end mill, to a limited extent, at least. The worms or spiral gears which drive the racks of the Sellers drive planers, made by at least one of our prominent planer builders, are cut by end mills in a specialized milling machine of simple design, made especially for this purpose.

AUTOMATIC MACHINES FOR MILLING HELICAL GEARS WITH FORMED CUTTERS.

A number of full automatic machines have been built in an experimental way for milling spiral gears with formed cutters. They have usually been modeled after the automatic spur gear cutter. Evidently the mechanism has to be considerably more complicated. The first complication involved is due to the fact that the index wheel must be under the influence of both the helical and

the indexing movements, as in the Reinecker machine in Figs. 105 and 106. The differential gearing there shown is the arrangement generally used to effect the combination of these movements in the automatic helical gear cutter.

Another complication is introduced by the necessity for relieving the cutter on its return stroke, after finishing the forward feed through the blank. Backlash in the rotating mechanism between the cutter slide and the work so alters the position of the cutter and the work on the return stroke that the latter will drag on one side of the groove it has just cut, unless it is separated slightly from it. This has been done in various ways in the various machines built; in some cases by mounting the cutter on a supplementary holder which rocks back out of the way on the return stroke, and in other cases by withdrawing the work by mechanism provided for the purpose.

These various complications seem to have militated against the commercial success of the automatic spiral gear cutting machine to such an extent that, so far as we know, but one of the various designs built has ever left the shop where it was made. The design we refer to is that shown in Fig. 110, built by Gould & Eberhardt, of Newark, N. J. As will be seen, it is a machine of large capacity, built in the form of the horizontal machines for cutting spur gears shown in Figs. 32 to 38. The cutter spindle is, of course, set in a swiveling head, and is driven by worm gearing. Three sets of change gears are used — one of them for the indexing mechanism, one for obtaining the proper lead of the helix, and one for changing the feed. The relieving mechanism operates as follows: As the cutter is being rapidly returned to allow the work to be indexed for a new cut, the work is withdrawn slightly from contact with the cutter by a cam-actuated device connected with the indexing mechanism. On the con-

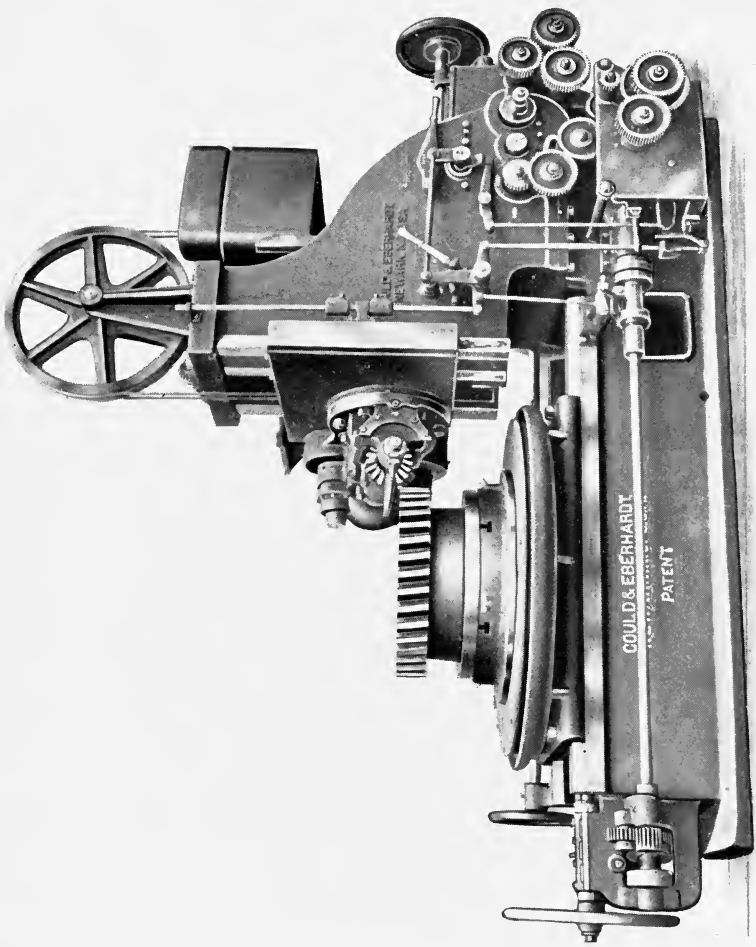

FIG. 110. Automatic Helical Gear-Cutting Machine, made by Gould & Eberhardt.

clusion of the indexing the work is again brought up to the cutting position, and the cutter is fed downward for a new tooth.

MOLDING-GENERATING PRINCIPLE FOR CUTTING HELICAL GEARS — PLANING OPERATIONS.

Passing by the templet, odontographic, and describing-generating principles, for the reasons mentioned in the introduction to this chapter, we come to the molding-

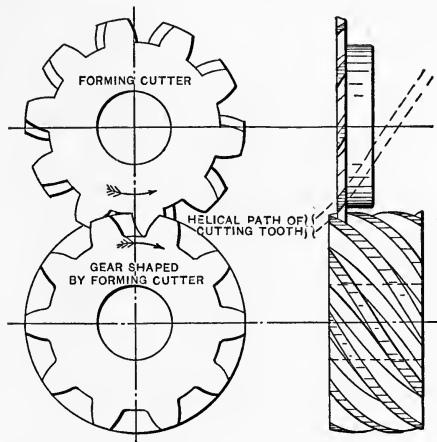

FIG. 111. The Molding-Generating Principle arranged to employ a Cutter having a Helical Shaping Action, cutting Teeth in a Solid Blank; compare with Fig. 6.

generating principle. This is applied to helical gears in the same way as to spur gears, with such modifications as are necessary to allow for the helical shape of the teeth. The counterpart of Fig. 6 is shown in Fig. 111. The forming cutter and the blank to be cut are rolled together as in Fig. 6, while the forming cutter is reciprocated axially. In combination with the axial movement, however, the cutter has to be given a rocking movement about its

center line, so that its teeth will follow the path of the dotted lines shown, which indicate the helix of the spiral gear which the cutter represents.

This process was contemplated by Mr. Fellows, of the Fellows Gear Shaper Company, in the original working out of his system of gear cutting. Given suitable cutters, the necessary changes in the machine shown in Fig. 79 would simply be those involved in giving the cutter a rotary rocking motion in unison with its reciprocating movement, to compel the tooth to follow the line of the helix of the gear which the cutter represents. It is not probable that this process will ever come into commercial use, as the great number of helix angles required would involve too large a stock of cutters.

The counterpart of Fig. 7, for helical gears, is shown in Fig. 112. Here the forming rack has teeth set on the same angle as the helix angle desired in the gear being formed. The rolling of a plastic blank over this forming rack will form in the blank helical teeth of the shape desired. A top view of the rack is shown, which will make this clearer. Instead of the forming rack shown by the full lines, we may use one like that shown in the dotted lines, whose teeth coincide with those of the first, but which moves in a direction at right angles to the direction of its teeth. If this dotted rack is moved at such a rate of speed that its teeth always coincide with those of the rack shown in full lines, they will evidently both form teeth of exactly the same shape in the blank.

In Fig. 113 we have the dotted rack of the top view of Fig. 112, shown engaged in the operation of generating the teeth of a gear identical with that in Fig. 112. This view has been taken at an angle so as to show the normal view of the rack. If the proper relative rates of rotation of the work and movement of the rack are maintained in Figs. 112

and 113, and the normal sections of the racks in each case are the same, the gears generated will be the same. It is evident in Fig. 113 that the teeth of the rack may be replaced by shaper or planer tools T_1 and T_2 , which may be used in forming teeth on the blank by rotating the gear and moving the tools endwise in the proper ratio

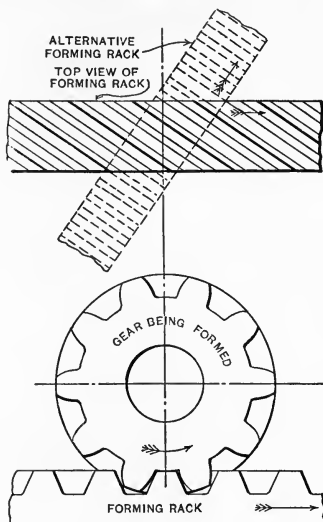

FIG. 112. A Rack with Teeth set on an Angle, operating by impression on the Molding-Generating Principle, to form Teeth in a Helical Gear; compare with Fig. 7.

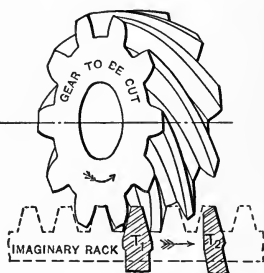

FIG. 113. Shaper Tools representing Teeth of Imaginary Rack, operating on the Molding-Generating Principle to generate Teeth in a Helical Gear; compare with Fig. 8.

prescribed by the conditions in Fig. 112. Fig. 113 is thus the counterpart of Fig. 8 for helical gearing. Similar counterparts may be drawn for Figs. 9 and 10, showing the milling and grinding processes, but since no practical application is made of these they are omitted.

Fig. 113 is interesting in that it hints at the principle

on which the action of the helical gearing is based. As drawn, it shows very plainly the action of the well-known Sellers drive for planers. It will be noted that for a short space the rack teeth exactly fill the outline of the gear tooth. Contact between the gear and the rack takes place on straight lines running diagonally across the plane faces of the rack teeth. Much might be written about the contact between spiral gears and racks, and the contact of spiral gears with each other, that has not been published, so far as the writer is aware; but since this subject is not germane to the subject of this book it will not be touched on here.

Practical application has been made of the principle shown in Fig. 113. The Bilgram spiral gear planing machine, involving this principle, is shown in Fig. 114. The work is mounted on a spindle carried in a head, which swivels about a vertical axis so that it may be set to the helix angle of the gear being cut. The cutting tool, having a shape to represent a tooth of the imaginary generating rack, is carried by a ram which works in and out, cutting on the return stroke. This ram is carried by a head which is fed along the bed of the machine. This longitudinal feeding of the ram-carrying head is connected with the rotary movement of the work spindle by change gearing, in the proper ratio for the case in hand, so that the gear will roll with the movement of the head just as it would if it were acting under the influence of the imaginary rack, one of whose teeth is represented by the cutting tool. The conditions are thus exactly the same as in Fig. 113.

Under these conditions, if the machine is set properly, the cutting tool will start to work at one side of the blank and pass through it, feeding at the end of each successive stroke, with the work rolling in such a way as to form a tooth space of the proper shape. This action is modified

somewhat by the method of indexing adopted, which is the same as for the somewhat similar spur gear planing machine by the same builder, shown in Fig. 50. The

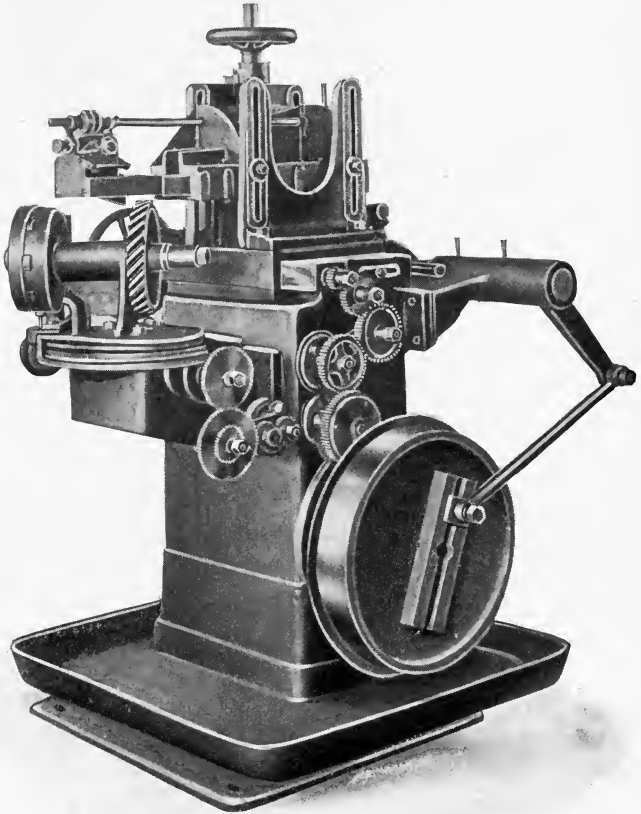

FIG. 114. The Bilgram Machine for cutting Helical Gears, operating on the Principle of Fig. 113.

arrangement used indexes the work at every stroke, so that when the tool has once passed through the work the gear is entirely completed, every tooth having been

worked on. This indexing movement and the rolling motion required for the generating are superimposed on each other by suitable differential mechanism, so that neither interferes with the other.

It may be mentioned incidentally that this machine is the only one known to the writer in which *all* the requirements for theoretical accuracy in cutting helical gears have been taken care of. There is a minute, though actual, error involved in even the otherwise perfect hobbing process for cutting these gears.

THE HOBGING MODIFICATION OF THE MOLDING-GENERATING PRINCIPLE OF CUTTING HELICAL GEARS.

Instead of using the shaper or planer tool to take the place of the teeth of the imaginary rack shown in Fig. 113, we may use a hob, in the same way that it was used in Fig. 56 for hobbing spur gears. This condition is shown in Fig. 115, which should be compared with Figs. 56 and 113. The upper or plan view best shows the respective angular settings of the work and the hob. The hob is set at an angle with the line of movement of the imaginary rack, equal to its own helix angle, as for spur gears. The gear being cut is set at an angle with this same line equal to its own helix angle, so that in this case (in which both gear and hob are right-hand) they are set at an angle to each other equal to the difference between the helix angles. If the hob represented by the worm in the diagram is revolved in the direction shown, its teeth will have the same outline and the same movement as the teeth of an imaginary rack moving in the direction shown. If the work be revolved in the proper ratio with the hob, the latter will form the teeth in the former in the same way that the imaginary rack would, provided it is fed progressively through the work in the direction of line *XX*.

This necessity for feeding the hob through the work introduces an added complexity to the machine in the case of spiral gears, beyond that needed for the spur gear hobbing machine. To understand this, suppose that in Fig. 115 the spindle mechanism is stopped, so that both the spindle and work ceased to revolve. To make it possible to feed the hob through the work in the direction of line *XX* without having the teeth of the one strike

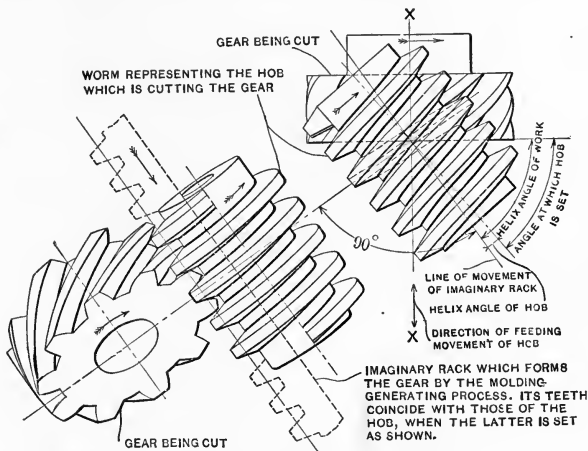

FIG. 115. Molding-Generating Method of cutting Spiral Gears, as Exemplified in the Hobbing Process; compare with Figs. 56 and 113.

against the other, it will be necessary to revolve either the work or the hob. Suppose that the work be connected by change gearing with the feed-screw of the cutter slide, so that it is revolved as the cutter is fed up or down, in the same way that the work in Fig. 100 is revolved as the table is fed backward and forward. Under these conditions the cutter may be moved through the work freely, the latter revolving to allow the cutter to pass. Not only must the work revolve in a definite relation with the feeding of the cutter slide, but the work must also

revolve in unison with the cutter or hob, as for spur gears. It must then be so connected with the cutter and with the cutter slide feed-screw that it will be under the influence of either or both of them, without any interference of the two movements with each other. This connection is usually made by a "jack-in-the-box" or differential mechanism, exactly identical in principle with that shown in Fig. 106 for combining the indexing and helical feeding

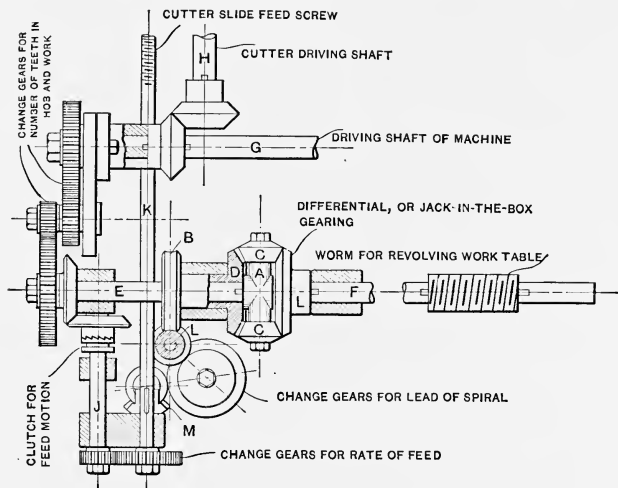

FIG. 116. Typical Arrangement of Gearing for Spiral Gear-hobbing Machine.

movements for revolving the work in the Reinecker universal machine. In the case of the spiral gear hobbing machine we have a helical feeding movement and a cutter spindle movement to combine for revolving the work.

A typical arrangement of the mechanism used for this purpose is shown in diagrammatic form in Fig. 116. Power is applied to the machine through driving shaft *G*. The bevel gears shown connect this driving shaft with vertical shaft *H*, by means of which the hob is driven.

Change gears shown connect shaft *G* with shaft *E*. Considering for the time being that worm-wheel *B* and the attached bevel gear *D* are stationary, the rotation of *E* and the cross arm *A* keyed to it will cause bevel gears *C* to roll around on stationary gear *D*, thereby revolving gear *L* and shaft *F* to which it is keyed, thus rotating the work table. The change gears connecting *G* and *E* are selected to give the proper ratio of movement between the hob or cutter spindle and the work table, to agree with the number of threads in the hob and the number of teeth in the gear being cut. The cutter slide feed-screw *K* is connected by change gears with shaft *J*, which is, in turn, connected through the clutch and the bevel gears shown with shaft *E*. The clutch furnishes the means of stopping and starting the feed, and the change gears serve to give the rate of feed desired. Change gears are also provided connecting bevel gear *M* on feed-screw *K* with worm *L*, which drives worm-wheel *B* running loosely on shaft *E*. By this means, supposing for the moment that shaft *E* and its attached cross arm *A* are stationary, the rotation of the feed-screw is communicated through the change gears to worm-wheel *B* and its attached bevel gear *D*, which, driving bevel pinions *C* on their stationary studs, revolve gear *L*, and with it shaft *F* and the worm driving the work table. In this way, by selecting suitable change gears, the work may be revolved to agree with the length of the lead of the spiral on which its teeth are formed, so that the cutter may be fed up and down through it without interfering with the teeth.

We thus see that the mechanism shown in Fig. 116 may be arranged to connect the hob and the work in the proper ratio, as for hobbing spur gears, and also for connecting the feed-screw and the work in the proper ratio, as for cutting spiral gears in the milling machine. But this mechanism

not only performs these two functions separately, but it will perform them together as well, so that either the feed or the cutter-revolving mechanism may be started, stopped, or reversed independently of the other movement, and the work will still be properly controlled under all conditions. The mechanism shown is not that invariably used, but it is typical of the arrangement employed in many hobbing machines designed for cutting helical gearing.

HOBGING MACHINES WITH CUTTER SLIDE ON BED.

The first hobbing machine for spiral gears we show is that in Fig. 117, made by Biernatzki & Co., 60 Zschopauerstrasse, Chemnitz, Germany. This machine is built on the general lines of the orthodox automatic spur gear cutter shown in Figs. 22 to 31. The machine is stiffly constructed, the column and head being apparently made in one piece. A noticeable feature is the rigid construction of the outer work support. In a smaller size machine this is mounted on the front of the bed, but in the case shown it is supported on ways at the rear, behind the cutter slide. A rack and pinion movement, operated by hand-wheel, is provided for moving it toward or away from the column. This rapid adjustment is very convenient in changing the work. Three sets of change gears are used, as shown. Those just behind the hand-wheel at the left are set for the lead of the spiral; those at the end of the bed are set for the feed of the cutter; while the ones at the rear are altered to give the proper ratio of movement for the number of teeth in the work and the hob, thus closely conforming to the mechanism in Fig. 116. One point of difference from its prototype, the automatic gear cutter, which may be noted, is made necessary by the fact that the work is constantly revolving instead of being intermittently indexed. The work support

clamped to the face of the column in the regular gear cutter is usually a simple abutment, adjusted by screw and nut to support the work against the thrust of the

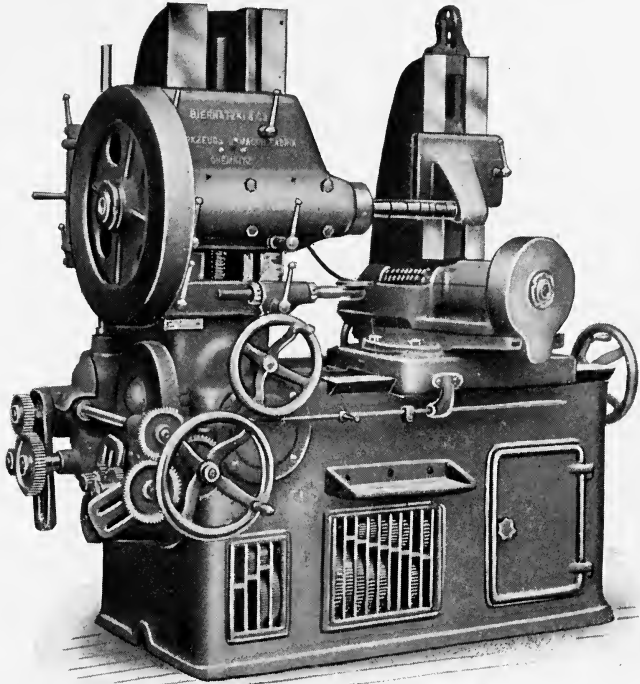

FIG. 117. Biernatzki Gear-hobbing Machine.

cutter. In this case, as may be seen, the support carries a disk or roller against which the work bears as it revolves.

STANDARD FORM OF HELICAL GEAR-HOBBING MACHINES.

In the Gould & Eberhardt hobbing machine, shown in Fig. 118, the "horizontal" form of construction has been adopted, in which the work is carried by a slide adjusted longitudinally on the top of the bed, while the cutter slide

is mounted on the face of a vertical column. It thus follows the general plan of the machines shown in Figs. 33 to 38 and 62 to 67. This machine is rigidly constructed,

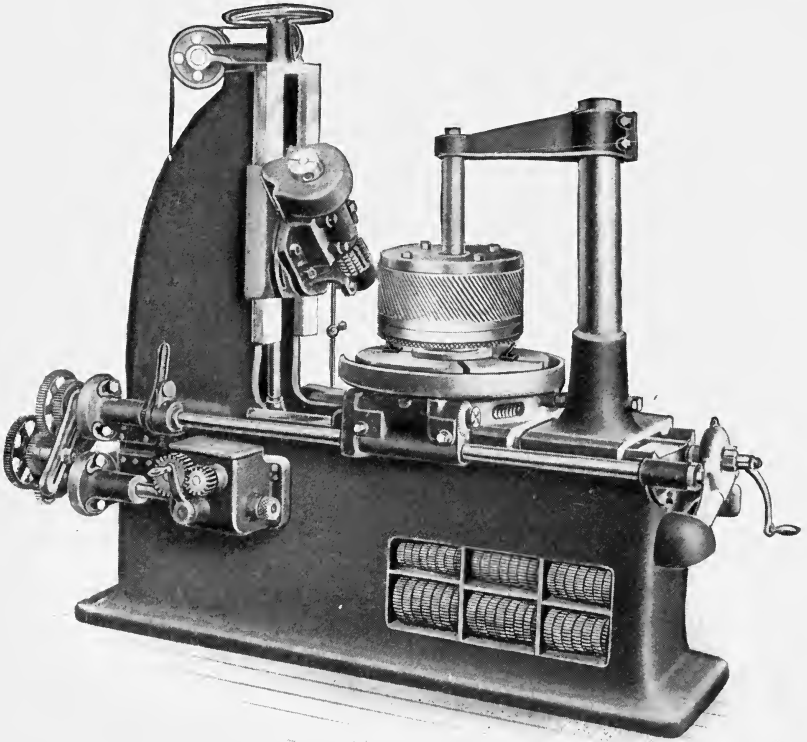

FIG. 118. Gear-hobbing Machine made by Gould & Eberhardt,
Newark, N. J.

the column and bed being in one piece and special attention being given to the construction of the cutter head and work table to give the stiffness so necessary for accuracy and output in a machine of this kind. The outboard support for the work is particularly noticeable. It consists

of a heavy post, carried by a slide working on the same ways as the work table, to which it may be connected to form one piece. A rapid traverse for the cutter head is provided, so that it is ordinarily unnecessary to operate the feed of the cutter slide manually. The cutter head may be swung around through an angle of 180 degrees above the horizontal. With this arrangement, the driving

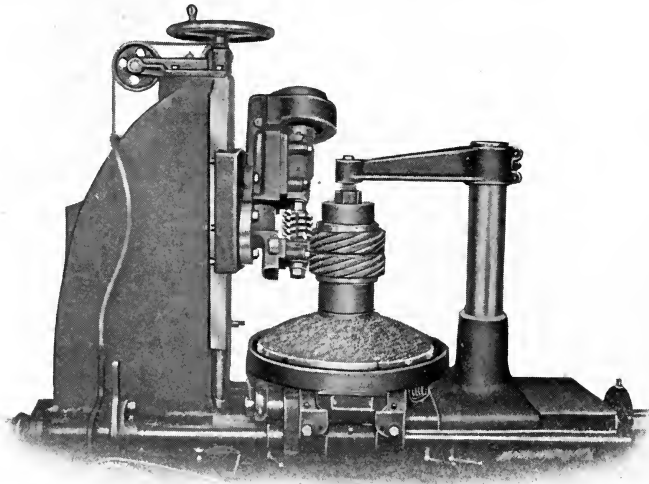

FIG. 119. Gould & Eberhardt Machine cutting Spiral Gears of Large Helix Angle.

gear is always above the center line of the head, so that less clearance is required below the work. This means that blanks can be held down closer to the table, giving less overhang and greater rigidity. In Fig. 119 this machine is shown hobbing spiral gears of great helix angle.

In Fig. 120 is shown a machine built by Holroyd & Co., Ltd., of Milnrow, near Rochdale, England. The engraving shows a spur gear in the machine having its teeth hobbed, but provision is made for hobbing spiral gears as well.

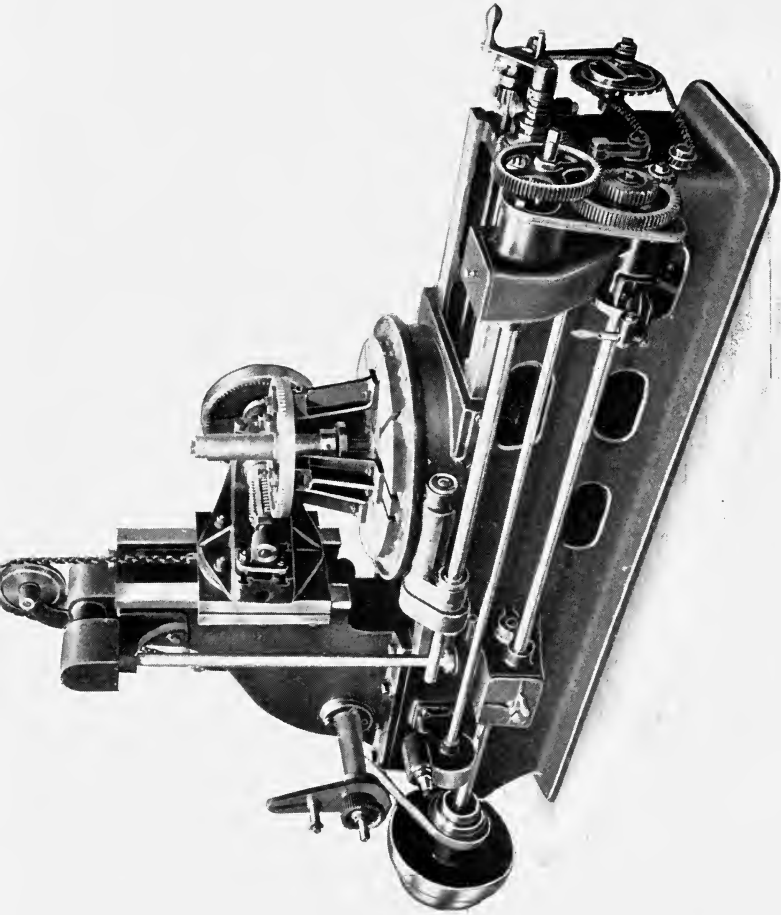

FIG. 120. Holroyd Gear-hobbing Machine. Though shown cutting Spur Gears, it will cut Helical Gears as well.

As may be seen, the cutter spindle is driven by an internal gear of large diameter. The engraving shows quite plainly the usual method followed of supporting work in machines of this type. The work is centralized with the table by the arbor which passes through it, but most of the support is taken by brackets mounted on the table or face-plate and provided with T-slots in their upper faces by which the work is clamped to them. This arrangement makes the work practically solid with the face-plate.

Of the three shafts extending along the front side of the bed, the lower one (*G* in Fig. 116) is connected with the cutter driving mechanism and drives through change and differential gearing the upper of the three shafts (*F* in Fig. 116) which is connected with the index worm of the work table. A place for change gearing will be seen at the base of the column carrying the cutter slide. This connects the feed movement of the cutter with the central shaft (*L* in Fig. 116), which in turn is connected with differential gearing in the enclosed casing seen at the right-hand end of the bed, in the foreground.

In this, as well as in previous machines shown, provision is made for hobbing worm gearing, the mechanism being introduced at the right-hand end of the bed for this purpose. Reference will be made to this later. Provision is also made for intermittent indexing, so that a formed gear cutter can be used. For this purpose the lower shaft in Fig. 120 may be driven through a friction slip if desired. The lever shown below the differential gear box at the right-hand end may be used to release or arrest a disk keyed to this shaft, so that it may be allowed to make one revolution when desired. The change gears at the end of the machine are then set for the number of teeth required. Under these conditions it will be seen that it may be used for gear cutting by the formed cutter method, being then prac-

tically the same sort of machine as those illustrated in Figs. 33 to 38, except that it is not fully automatic.

In Fig. 121 is shown a gear-hobbing machine built by

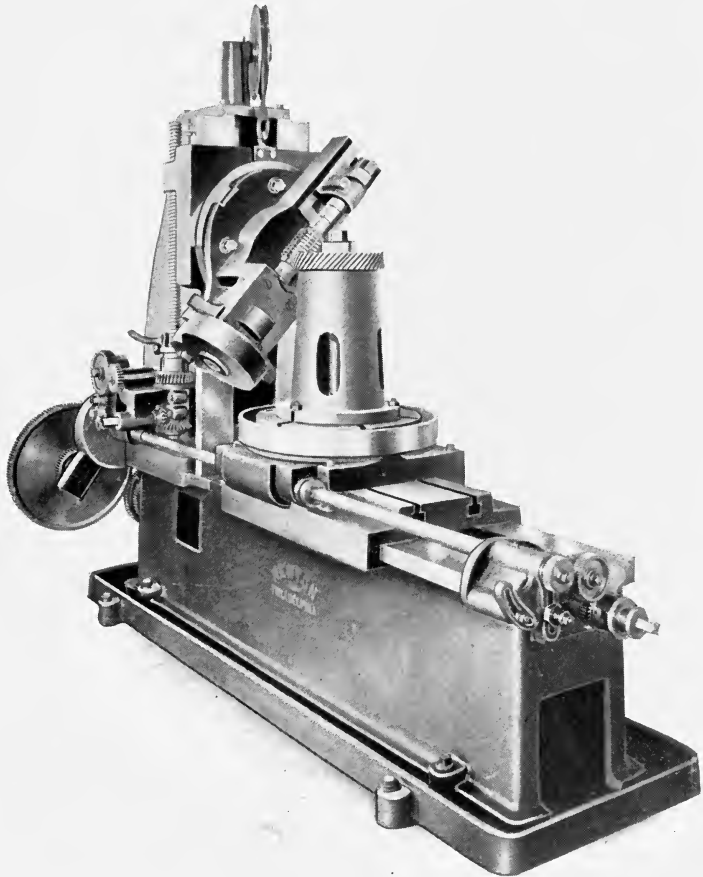

FIG. 121. Newton Machine at Work on a Helical Gear.

the Newton Machine Tool Works, Inc., Philadelphia, Pa. It is shown at work on a spiral gear, which is supported in a somewhat different manner from the cases previously

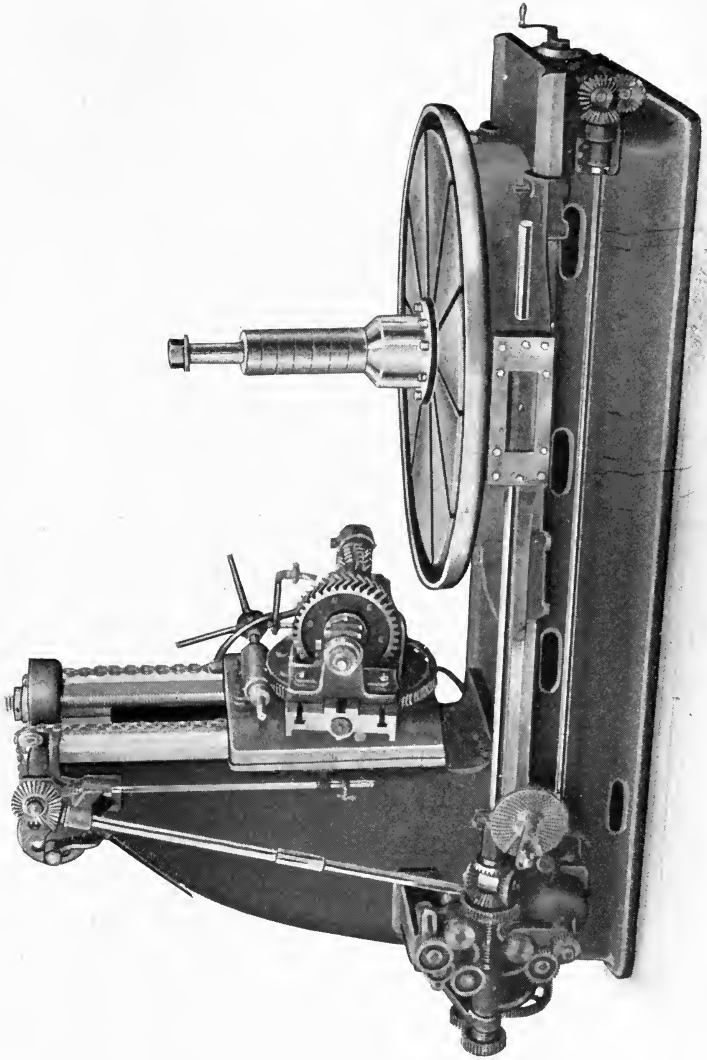

FIG. 122. Pfauter Gear-hobbing Machine, sold by Schuchardt & Schutte.

shown. A special support, in the form of a cast sleeve or column, is provided for raising the work high enough above the table so that the driving gear of the spindle clears the table when the cutter has been fed through the work. In cutting spur gears, of course, it is not necessary to set the work so far above the table, less clearance being required for the spindle driving gear.

The Pfauter machine, shown in Fig. 122, is sold by Schuchardt & Schütte of New York, Berlin, London, etc. The differential mechanism is shown quite plainly in this engraving, which represents the No. 4 size. The change gearing above the index worm-shaft is for the lead of the helix, that below for the feed, while the larger gearing at the left end of the machine is for connecting the hob and the work in the proper ratio. The cutter spindle of this machine is driven by herringbone gears to insure smoothness of action. This line of machines is made in a great range of sizes. The smallest of these has a maximum capacity for a blank 6 inches in diameter, while the largest will take a gear 104 inches in diameter. Provision is made in the larger sizes for intermittent indexing of the work-table by hand, so that the teeth may be cut by formed cutters if desired. The swiveling head is adjusted by a worm on the larger sizes.

HOBGING MACHINES OF SPECIAL TYPES.

The machine shown in Fig. 123, made by the Grant-Lees Machine Company, 6901 Quincy Avenue, Cleveland, Ohio, cannot be classified structurally with any of the previous examples. It is an outgrowth from a hobbing machine for worm gears formerly built by its designer, Mr. John Grant. The work is mounted on a vertical spindle carried by a slide which is adjusted horizontally for the diameter.

The feed of the work past the cutter is effected by raising the spindle vertically. The cutter is driven by a combination of bevel gears which is best shown in Fig. 124, and it may be adjusted throughout a full circle. The

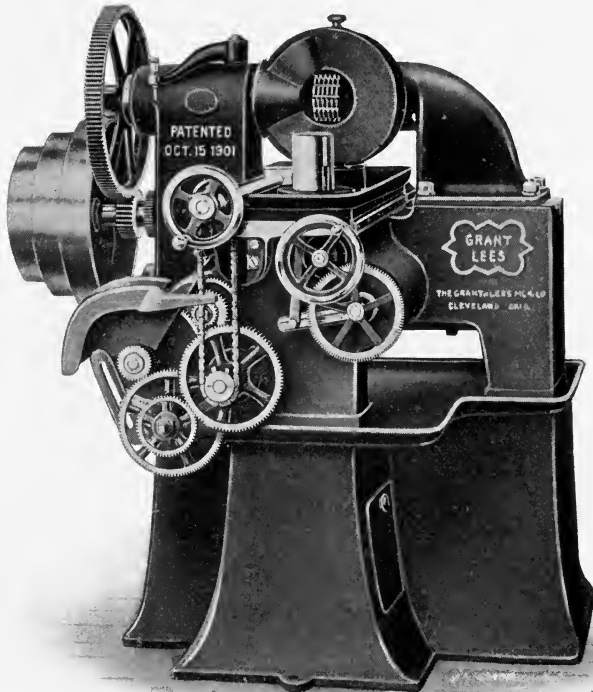

FIG. 123. Gear-hobbing Machine of Special Construction, made by Grant-Lees Machine Company, Cleveland, Ohio.

bevel gear on the hob spindle meshes with a large ring bevel gear, which in turn is driven by a bevel pinion on the driving shaft. The bevel pinion on the hob shaft occupies a different portion of the ring bevel gear from that occupied by the driving pinion, so it may be adjusted

around the full circle without interference. Provision has been made in the mechanism to revolve the work as it is fed upward, independently of the movement given by its connection with the hob, thus meeting the requirements for spiral or helical milling. The machine is shown in Fig. 124 completing a helical gear.

A gear-hobbing machine built by George Juengst & Sons, Croton Falls, N. Y., is decidedly worthy of study on

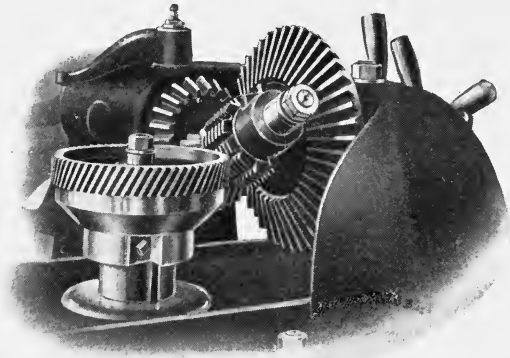

FIG. 124. Grant-Lees Machine hobbing a Helical Gear.

account of the unique principle involved, although the builders have never placed the machine on the market. The unique feature is the method adopted for avoiding differential gearing. The spur gear hobbing machine does not require any connection between the feed-screw and the work-revolving mechanism, because the hob can be fed back and forth through the work after it has been completed, without interference. In the Juengst machine the same effect is accomplished by setting the feeding movement at the angle of the teeth of the work. As is shown in Fig. 125, the work is mounted on the column, while the cutter, which may be swiveled to agree with its

helix angle, is fed along a slide which may be, in turn, swiveled to agree with the helix angle of the work. The line of travel of the hob, as shown in Fig. 126, being thus set in the same direction as the teeth of the gear, the hob can be fed diagonally through the work without interfering with the teeth, whether the machine is in motion or not, it

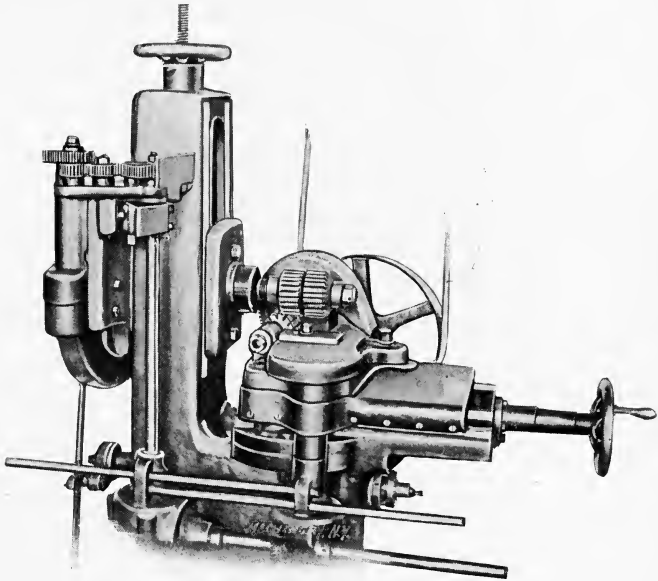

FIG. 125. Juengst Gear-hobbing Machine, employing a Novel Principle for Helical Milling.

being taken for granted, of course, that the hob and the work are properly geared together. Differential gearing is thus done away with, being replaced by the swiveling adjustment of the cutter slide, which permits the line of travel of the hob to be adjusted to the helix angle of the work.

This same result has been accomplished in another way by a patent granted to an English inventor. With his

arrangement the work is mounted on a face-plate on the bed, while the cutter slide feeds up and down the column, as usual. The column, however, instead of being solid with or bolted to the bed, is mounted on ways so that it may be fed horizontally at right angles to the line of adjustment of the work table. The feed-screw controlling this adjustment is connected by change gearing with the vertical feed-screw of the cutter slide on the column, so that these two movements take place simultaneously in any desired ratio

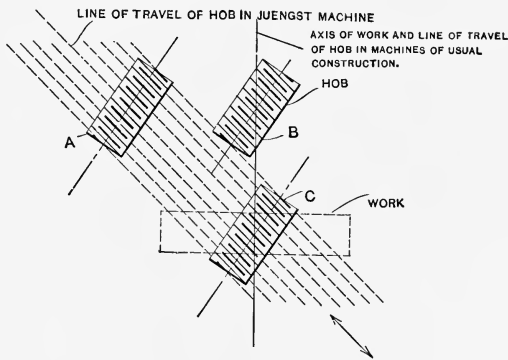

FIG. 126. Method of Feeding the Hob in the Juengst Machine.

with each other. By this means the combined vertical and horizontal movements of the cutter slide give a component in an angular direction, which may be made to give any desired angle of travel, such as that shown, for instance, in the line of travel of the hob in the Juengst machine, Fig. 126.

The difficulty with these otherwise attractive plans for hobbing helical gears by moving the hob at an angle instead of using differential gearing, appears to be that a longer hob is required for going in an angular direction across the face of the gear than would be necessary in feeding vertically

downward, as is the case with the usual differential mechanism. The hob would have to be unusually long if it were desired to cut a bank of spiral gears in one operation, as is being done in Fig. 118.

There are still other methods possible for taking care of the helical movements required besides those already discussed. For instance, instead of using differential gearing to combine the motion derived from the feed-screw with that of the cutter spindle driving shaft, it may be used to combine movements derived from the feed-screw with that of the index worm shaft and applying the combined motion to driving the hob. Furthermore, the differential mechanism may be discarded entirely, by providing an index worm of considerable length and shifting it longitudinally at the proper rate in connection with the feeding of the cutter slide. This would impose on the work rotation in connection with the cutter slide feed without interfering in any way with the rotation due to the connection with the cutter or hob. Differential gearing would thus be avoided as in the case of the Juengst machine. This device would have its limitations for gears of small lead, as it would require too great a length of worm to give the proper amount of rotation to the work.

An example of this latter plan is furnished by the machine made by the Pratt & Whitney Company, of Hartford, Conn., for cutting the wonderful herringbone gears run at such tremendous speed in the De Laval steam turbine. The mechanism is shown diagrammatically in Fig. 127. Attached to the cutter head is an angular slide, which may be set to any desired angle. A roll is confined in the slot in this guide, whose vertical movement thus imparts a cross movement to the sliding frame on which the roll is mounted. On the frame are mounted the bearings of the index worm, which is thus shifted endwise with the vertical

movement of the cutter slide; and this endwise shifting of the worm, in turn, rotates the index worm-wheel in unison with the feed of the cutter. By setting the slide at a greater or less angle, this rotation of the worm-wheel and the work may be adjusted to give very accurately the desired lead of the helix — more accurately, in fact, than it can be obtained by change gears, which cannot always be selected to give just the movement desired. The rotation of the work in unison with the hob, it will be seen, is

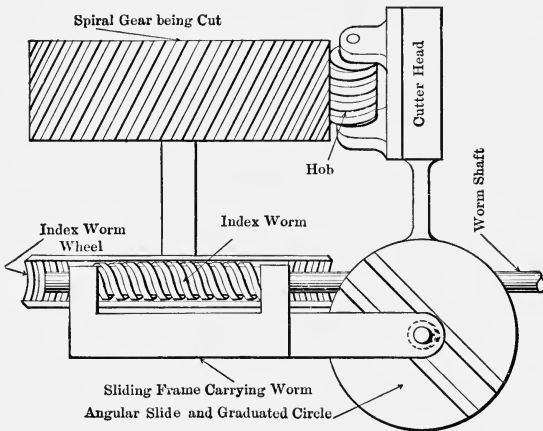

FIG. 127. Diagram showing Spiral Mechanism in De Laval Machine.

effected by the rotation of the worm, while its rotation in conjunction with the feed of the cutter slide is effected by the endwise movement of the worm. There is thus no conflict between the two movements, which are combined as effectively as in the differential mechanism shown in Fig. 116. This mechanism may be compared with that in Fig. 96.

Still another method of avoiding the differential gears has been employed, which permits cutting spiral gears on a spur gear hobbing machine. In Fig. 116, when the three

sets of change gears are set for the number of teeth in the gear, lead of spiral, and rate of feed, respectively, the rotation of the work bears a definite ratio to that of the hob. We can then set the change gears between *G* and *E* to this ratio, disconnect the change gears for the spiral, couple *E* and *F* together, and get along without the differential gears entirely. In other words, the differential is avoided by modifying the change gears connecting *G* and *E*, to agree with the feed and the lead. Whenever either

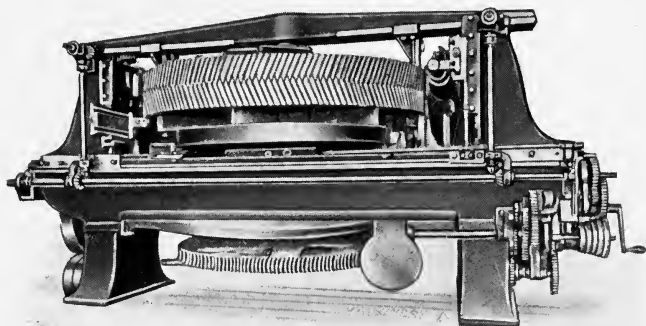

FIG. 128. Machine for cutting Solid Herringbone Gears by the Wüst Process.

is changed, this gearing must be changed also. A spur gear machine may thus be set to cut any spiral gear within the range of the angular setting of the hob spindle, if the proper change gears are furnished. This same principle is exemplified in the worm-wheel cutting machine in Figs. 152 and 153.

It would appear from the drawings furnished the writer that the Reinecker universal gear-cutting machine (see Figs. 105 and 106) could be arranged to hob spiral gears by the simple expedient of connecting the indexing change gear train positively with the cutter driving mechanism instead

of through the friction slip used for the semi-automatic indexing. This would give a combination identical in principle with that shown in Fig. 116. Probably the matter of German patent infringements accounts for not using the machine for hobbing spiral gears.

A machine for helical gear hobbing, provided with some special features, is shown in Fig. 128. This machine is used by C. E. Wüst & Co., Seebach, Zurich, Switzerland, for cutting herringbone gears of a special form, in which it is unnecessary to cut the two halves in separate sections, as is the usual case. As may be seen in Fig. 129, the cuts are staggered so that the teeth on one side run into the spaces

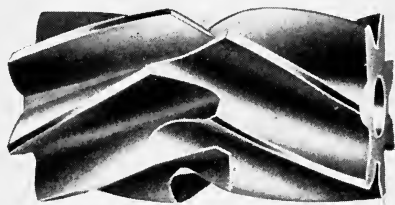

FIG. 129. A 7-tooth Pinion, formed by the Wüst Process.

on the other in such a way as to permit cutting them with hobs without having the cutting tool on one side interfere with the teeth cut on the other side. No detailed information as to the type of differential mechanism used on this machine is available, nor is any information given as to precautions necessary in the design and setting of the hobs to prevent the teeth from running into each other. The most interesting thing about the machine is its product; the large gear shown in the machine in Fig. 128, and the pinion shown in Fig. 129, are examples of two extremes in the range of work for which the process is applicable.

Besides the machines we have just described, two of the

hobbing machines illustrated and described under the heading of spur gear machinery are specially adapted to the cutting of helical gears. These machines are the Rhenania machine shown in Fig. 65 and the Wallwork machine shown in Fig. 67. The only change necessary to adapt these machines to cutting spiral gears is the addition of the differential gearing and the connection for change gearing between the feed-screw and the work table revolving worm. Provision is made for this mechanism in the design of the machines. Of course all of the hobbing machines we have described are adapted for cutting spur gears, and those shown in this chapter should be included in the list when studying spur gear cutting machinery.

THE FIELD OF THE HOBGING PROCESS FOR CUTTING HELICAL AND HERRINGBONE GEARS.

There are some limitations to the hobbing process of cutting helical gears. It is not particularly successful in the cutting of gears of such small lead and great helix angle that they would be classed as worms rather than spiral gears. For such cases the rate of rotation which has to be given the blank is so great in proportion to the downward feed of the cutter by which the rotation is effected (through the change and differential gearing) that it is almost impossible to drive it, the difficulty being the same in kind, though reversed in direction, as that met with in cutting very steep pitches in the lathe. By a slight complication of the machine, however, mechanism could be introduced to overcome this difficulty and make the hobbing machine universal for all kinds of gears within its range.

In the discussion of the hobbing processes for cutting spur gears it was stated that its field was not yet definitely determined. It may be said, on the whole, that there is no

such indefiniteness in regard to the field of the hobbing machine for cutting helical gears. With a well-constructed machine and with hobs of proper shape spiral gears can be cut more accurately and cheaply by this method than by any other known. There are none of the mechanical difficulties of indexing and relieving to be taken care of as is the case in automatic machines working on the formed cutter process; and there are none of the uncertainties as to tooth shape due to interference met with in cutting a helical groove with a formed cutter, as shown in Fig. 99. There has been some little difficulty in getting the correct shape of teeth by the hobbing process, due to the elasticity of the mechanism connecting the hob and the work and to errors in the construction of the hob itself. These difficulties, however, will surely disappear with further experience and investigation.

Apparently the recent rapid development of the hobbing process for cutting spiral gears is the solution of a problem which has long seemed somewhat perplexing. The flexibility of the spiral gear, and the numerous advantages of the herringbone or the twisted tooth spur gear for transmitting great power noiselessly and smoothly at high velocities, have long been appreciated, but their extended use has waited for the development of some accurate and inexpensive method of forming helical teeth.

This completes the description of machines for forming the teeth of worms and helical or herringbone gears.

CHAPTER VI.

WORM-WHEEL CUTTING MACHINES.

To correctly classify and comprehend the various methods and machines for cutting the teeth of worm-wheels, it is first necessary to clearly define the term "worm gearing." When we say "worm gearing" in this chapter we mean gearing of the type of which a cross-section is shown at the right of Fig. 130, in which the acting face of the wheel is curved to fit the form of the worm and in which the whole width of the wheel face is in active working contact with the worm.

The action is best understood by taking a vertical section on the center line *AA*, and on other lines such as that at *BB* parallel with the center line. Sections on lines *AA* and *BB* are shown at the right of the cut. With worm gearing of standard form the section on line *AA* shows the worm to have the profile of an involute rack, while the teeth of the wheel show outlines identical with those of the corresponding involute gear of the same pitch and number of teeth suited to engage with the rack. In other words, the teeth of the gear are such as would be formed by the teeth of the worm if the latter acted as a rack in a molding-generating operation identical with that shown in Fig. 7. A section on line *BB* shows that the teeth of the worm have a distorted outline on planes removed from the axial plane. If we consider these distorted teeth as the teeth of a rack molding their mating tooth spaces in a gear running on the same center as the worm gear and at the same speed, it will form, by the process of

Fig. 7, the distorted wheel teeth shown for the section on line *BB*. In a word, each section of the worm parallel to the axial section *AA* is a rack section which molds in the wheel below it the proper teeth to mesh with it in accurate conjugate action. The true worm-wheel, it is thus seen, must be formed by the molding-generating process.

The same worm as that shown in Fig. 130 may be made to engage with a spiral gear of the same number of teeth

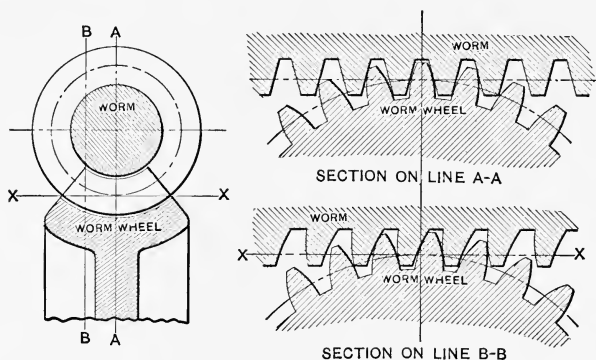

FIG. 130. Action of a True Worm-Wheel.

as the worm-wheel, provided the teeth are of the proper pitch and set at an angle to agree with the helix angle of the worm. The action of such gearing, however, does not, like that in Fig. 130, take place on all sections *AA*, *BB*, etc., but is confined to a point at or near the center line *AA*. The contact, in other words, is point contact, and not line contact extending clear across the face of the wheel. Such a combination, in fact, is not a case of worm gearing, but a case of spiral gearing — and a very poor case at that.

GASHING WORM-WHEELS BY THE FORMED CUTTER PROCESS.

While the method of forming a true worm-wheel is thus seen to be accurately performed only by the molding-generating process, the accurate teeth produced by that process may be closely approximated in many cases by the "gashing" method, which belongs in the formed cutter classification. In this operation, illustrated in Fig. 131, a milling cutter is used having approximately the

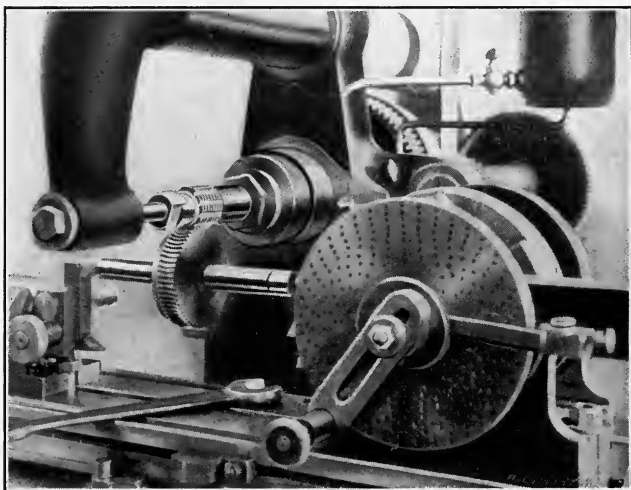

FIG. 131. Gashing a Worm-Wheel in the Milling Machine.

outline of a normal section of the teeth of the worm to be used. This cutter is of the same diameter as the worm, and is set with relation to the axis of the work at the helix angle of the worm, as measured on the pitch line. It is centered over the wheel, and fed into the latter to the proper depth to form a tooth space; it is then drawn out again, the work is indexed to the next tooth space,

and the cutter again sunk in to depth, the operation being repeated until the wheel is completed. In Fig. 131 a universal milling machine is being used for this operation.

With the table set at 90 degrees, the cutter is first brought centrally over the work arbor by adjusting the saddle on the knee of the milling machine, and then the work is brought centrally with the cutter arbor by adjusting the table by the feed-screw. The work table is next swung to the helix angle of the worm which is to be used with the wheel. Then the cutting is proceeded with.

This gashing process gives a tooth very closely approximating the true tooth form when the diameter of the worm is large as compared with the pitch and when the worm is single threaded. For multiple-threaded worms of smaller diameter in proportion to their pitch the process is impracticable. This method is used by at least one of the best-known builders of gear-cutting machines in forming the teeth in the index worm-wheel. It is used under the conditions which give a very close approximation to the true form of tooth, and is employed in this particular case for the sake of the high degree of accuracy obtainable. The index wheel is divided, in cutting, by a carefully made and carefully preserved master wheel. The step by step gashing process allows the spacings of this superior master wheel to be accurately reproduced in the index wheel being cut — more accurately than would be possible if it were to be reproduced by the hobbing operation described later.

The gashing process is also used for roughing out worm-wheels preparatory to hobbing. In a previously gashed wheel, as will be explained later, the hobbing operation is one of extreme simplicity, not requiring special machines or mechanism of any kind.

THE MOLDING-GENERATING OR HOBBIING PROCESS.

As explained, the molding-generating principle is the only one for accurately forming the teeth of worm-wheels. The principle involved is shown in Fig. 132. The forming worm (or hob) is connected by gearing with the plastic worm-wheel blank to be formed, in the same ratio as

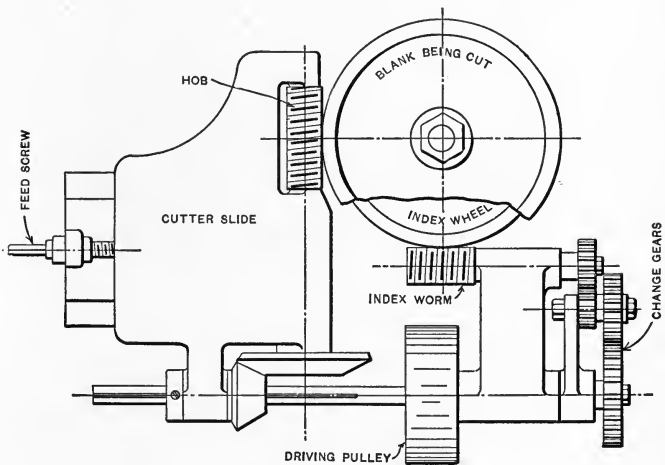

FIG. 132. Diagram showing the Arrangement of the Mechanism for the Hobbing Process for Cutting the Teeth of Worm-Wheels.

given by the finished worm gearing. While the blank and the forming worm (or hob) are rotated together in this ratio, the latter is fed into the blank slowly, its threads forming the proper shaped tooth in the wheel. As the worm revolves, an axial section would give the appearance of a rack like that shown in section *AA* of Fig. 130 moving continuously and forming suitable gear teeth in the wheel below it. Any other section, such as *BB* in Fig. 130, would also act as a distorted rack, forming cor-

respondingly distorted gear teeth in that portion of the worm-wheel in the same plane. The process is thus seen, as previously explained, to be identical with that in Fig. 7.

Of the various methods of operation, shaping or planing is of course impracticable. Milling is the method generally employed. Grinding or abrasion is used to a limited extent, it being sometimes employed in the case of "grinding in" a worm with a wheel already roughly cut to shape. In this operation the worm and wheel are run together in place under considerable pressure, the teeth of the gear being liberally supplied with sand, ground glass, or



FIG. 133. Side and End Views of a Worm Gear Hob.

rouge, which acts as an abrasive and forms the teeth of the gear and worm to fit each other.

In the commonly employed milling operation the process is that known as "hobbing," and the milling cutter or tool used is a "hob," of which an example is shown in Fig. 133. The hob (barring modifications required for relief or clearance, and allowance for regrinding) is practically a replica of the worm which is to be used, but with grooves cut in it so as to form teeth. This hob is rotated in the proper ratio with the work, exactly as shown in Fig. 132, and fed slowly down into it, cutting out the tooth spaces in the wheel as it does so. When it has reached the proper depth, the teeth are all formed to the proper shape.

HOBGING WORM-WHEELS IN THE MILLING MACHINE.

The simplest method of rotating the hob and the work in the proper ratio with each other is that in which the work is first gashed, as shown in Fig. 131, and then finished with the hob in such a way as to be driven by the latter, the work and the hob thus furnishing their own driving mechanism. The same wheel which is being

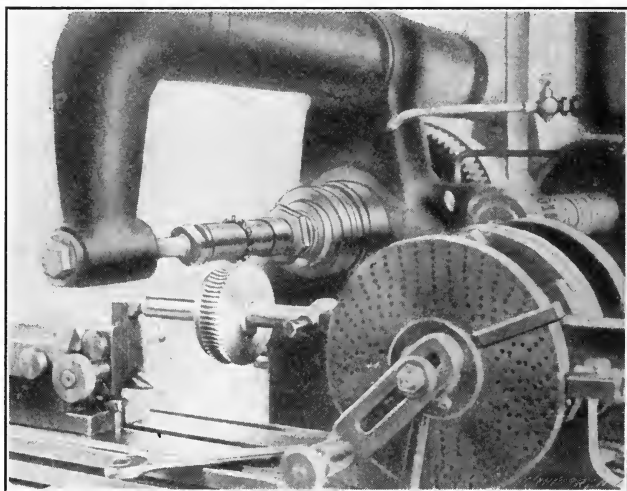

FIG. 134. Hobbing a previously Gashed Worm-Wheel on Dead Centers in the Milling Machine.

gashed in Fig. 131 is shown having its teeth finished to the proper shape with the hob in Fig. 134, the hob driving the work as described. The latter is mounted so as to revolve freely on dead centers. This is the simplest method of making correct worm-wheel teeth. It does not require special appliances of any kind, being done in an ordinary milling machine with a gashing cutter and a hob.

In cases where it is desired to hob worm-wheels directly

from the solid without preliminary gashing, it is necessary to provide some special device for rotating the hob and the work in unison as in Fig. 132. Such a case is shown in Fig. 135, which illustrates the Le Blond attachment of Fig. 57 arranged for hobbing worm-wheels. The connection between the cutter spindle and the work is the same as for spur gears, but the work is fed vertically up into the

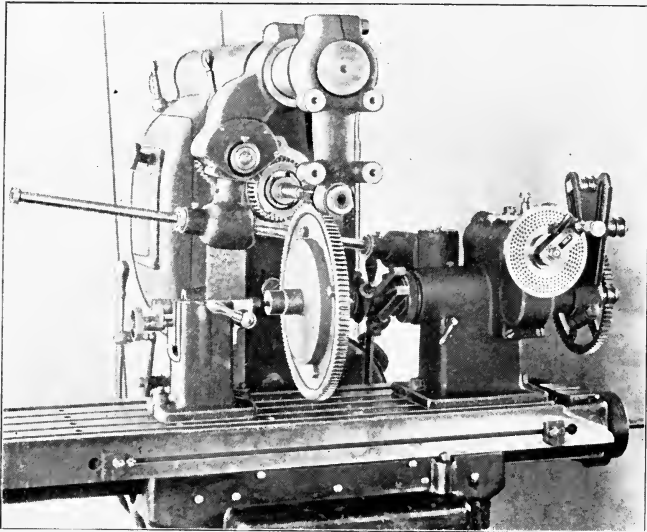

FIG. 135. Hobbing Attachment for the LeBlond Milling Machine, Cutting a Large Worm-Wheel.

hob instead of being fed past it by the regular table movement. The driving connections are more plainly shown here than in Fig. 57.

Another attachment for the same purpose, but differently arranged, is shown in Fig. 136. This is built by the Wanderer Fahrradwerke, Schonau, bei Chemnitz, Germany. This attachment is self-contained, and carries a vertical work spindle, driven by a worm and worm-wheel, which

are in turn connected by change gearing with a spiral gear driven from the shaft. The hob is fed to depth in the work by the operation of the regular feed-screw. The analogy between this mechanism and that shown in Fig. 132 will be readily traced.

In Fig. 137 is shown a hobbing attachment applied to another form of miller, in this case a horizontal spindle

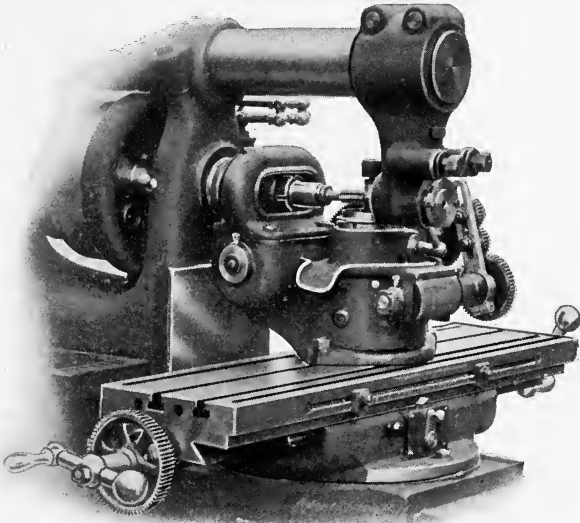

FIG. 136. The Wanderer Positively-driven Attachment for Hobbing Worm-Wheels in the Milling Machine.

machine of the planer type made by the Newton Machine Tool Works, Philadelphia, Pa. The attachment consists primarily, as in the previous case, of a base provided with bearings for a vertical spindle, which is revolved by a worm-wheel enclosed within the base. The worm is connected by change gearing with a splined shaft driven through a train of gearing from the spindle. The machine is set to the diameter of the work, and the hob is fed to

depth by the operation of the regular longitudinal feed-screw. A special feeding mechanism is provided, oper-

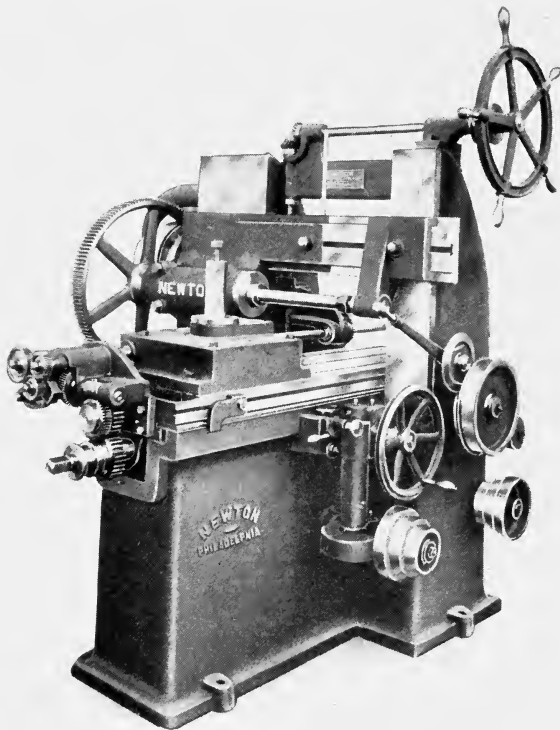

FIG. 137. Positive Hobbing Attachment used in the Newton Milling Machine.

ated from the attachment instead of from the regular feed cones.

HOBGING WORM-WHEELS IN MACHINES DESIGNED FOR CUTTING OTHER FORMS OF GEARING.

With slight changes, the orthodox spur gear cutting machine can be adapted to hobbing worm-wheels. An example of such an adaptation is shown in Fig. 138, the

machine adapted in this case being an automatic gear cutter made by the Newark Gear Cutting Machine Co., of Newark, N. J. The indexing mechanism is operated from the same splined shaft by which the spindle is driven, so that, to obtain the proper ratio of movement between the hob

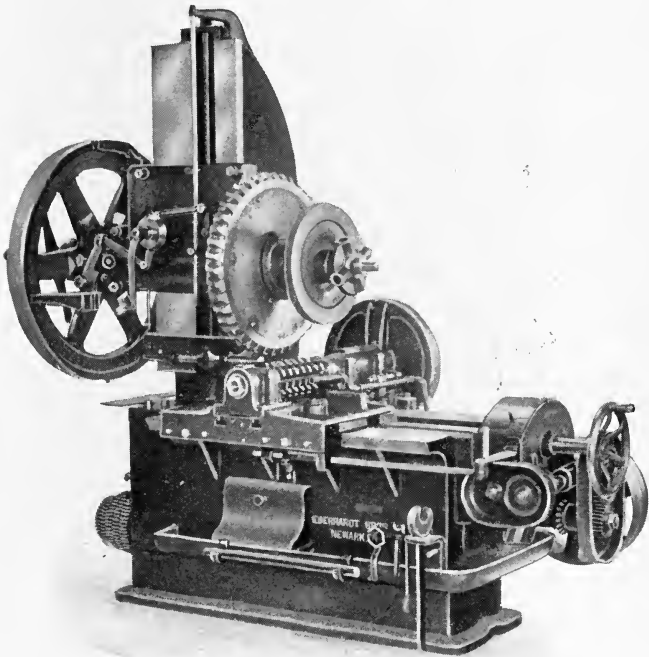

FIG. 138. Orthodox Gear-Cutting Machine arranged for Hobbing Worm-Wheels, with Ratchet Feed operated from Index Wheel.

and the work, it is only necessary to connect the index gearing positively with the driving shaft, instead of using the intermittent indexing motion ordinarily employed. With the index gearing thus permanently connected with the spindle driving mechanism, proper change gears may

be selected to give the required ratio of movement between the worm-wheel to be cut (which is, of course, mounted on the work arbor) and the hob, carried on the cutter spindle in place of the regular spur gear cutter. Another provision that has to be made is that for feeding the cutter into the wheel as the work progresses. This is effected in this particular case by lugs on the arms of the index wheel, which, rotating continuously, act on a link mechanism which operates an adjustable ratchet motion for the vertical feed shaft. This ratchet motion may be varied to give any rate of feed desired. By this means the work is fed down into the cutter as the operation progresses.

In Fig. 139 is shown a gear-cutting machine made by Gould & Eberhardt, Newark, N. J., arranged for hobbing worm-wheels. In this case, also, the hob and the work are connected by means of the splined driving shaft and the index gearing, so that they revolve in unison and in the proper ratio. It will be seen that the work in the machine is so heavy as to make it advisable to support the outer end of the work arbor by means of the outboard bearing regularly provided for that purpose. To permit the downward feeding of the wheel, necessary to sink the cutter in to depth, the adjusting screw of this outboard bearing and the elevating screw of the work spindle head are geared together, so that they work in unison. The feed movement is applied to these two screws in such a way as to gradually lower the work into the cutter as the two revolve together.

All of the various gear-hobbing machines we have shown in Figs. 58 to 72 and 117 to 126 are adapted to the hobbing of worm gears without requiring special attachments of any kind. The only requirement in addition to the mechanism needed for hobbing spur gears is the pro-

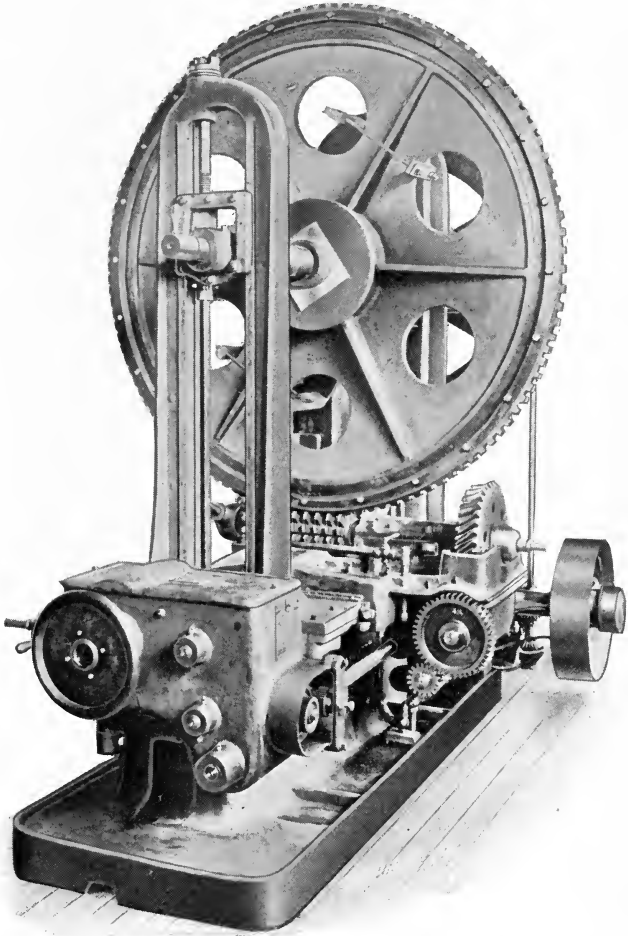

FIG. 139. Gould & Eberhardt Gear-Cutting Machine arranged for Hobbing Worm-Wheels.

vision of a feed mechanism for sinking the cutter in to depth. The work saddles or tables of most if not all these machines are provided with this feed movement. The gearing for revolving the work and the hob in proper

ratio with each other is of course embodied in the design of this type of machine. In Fig. 140 is shown one of these hobbing machines (the Grant-Lees machine of Fig. 123) engaged in hobbing a worm gear.

In addition to the machines we will describe later in which, though the hobbing process may be used, different movements are involved than in the cases we have been con-

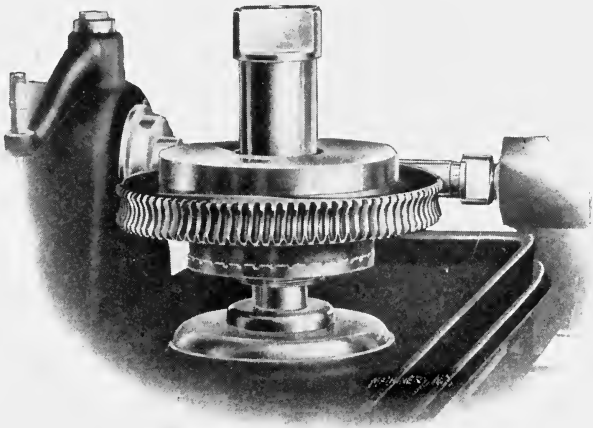

FIG. 140. Worm-Wheel being finished in Grant-Lees Gear-hobbing Machine (see Figs. 123 and 124).

sidering, special hobbing machines have been built from time to time, identical in their action with the various machines shown in Figs. 135 to 140. Most of these machines have been specially built to suit the requirements of the user, without conforming to any settled type or design; very few of them have been built as a commercial product to be placed on the market. The Grant-Lees machine, however, was originally a worm-gear machine pure and simple, being afterward adapted to hobbing spur and spiral gears.

THE FLY-TOOL AND TAPER HOB METHODS OF CUTTING
WORM-WHEEL TEETH.

By providing a suitable driving and feeding mechanism it is possible to use a simple fly-cutter for forming the teeth of worm-wheels in place of the expensive hob used in the operations previously described. The movements required for this method will be understood from a study of Fig. 141. Here is shown in dotted lines a worm meshing with a worm-wheel, a portion only of whose periphery is seen. As previously described in referring to Fig. 130, such a worm, properly located with reference to a plastic blank and rotating with it in the proper ratio, will form accurate teeth in the latter by the molding-generating process. As we have also previously described, gashing this worm makes of it a cutter by means of which the same form may be given to a blank of solid metal. The teeth of such a gashed hob coincide with the outlines of the thread of the worm.

In Fig. 141, in full lines, is shown a cutter bar with a blade T_1 of the same outline as the thread of the worm and the tooth of the corresponding hob. In order to permit this single cutting tool to perform the function of the worm as it molds a plastic substance, or of the hob as it cuts its shape in metal, it must be fed helically as the bar and work revolve, following the outlines of the imaginary worm from one end to the other as the cutting progresses. Beginning at the left, for instance, the blade may be fed helically in the line of the thread, passing through positions T_1 and T_3 , until the feed finally runs out at the extreme right.

The methods of giving this progressive helical change of position to the fly-cutter are various. It would be possible, for instance, to so connect the feed-screw by which the cutter bar is advanced with the rotating mechanism for the bar, through differential and change gearing, that a rotating

movement due to the axial feeding of the latter would be added to or imposed upon the rotation due to its connection with the work, just as, in Fig. 116, the rotation due to the downward feed of the cutter slide is combined with that due to the connection with the cutter spindle for rotating the work. If the proper change gears were selected so that, with the spindle- and work-driving mechanisms stationary, the feeding forward of the cutter bar would rotate the latter at the proper rate to give the lead of the work, the blade

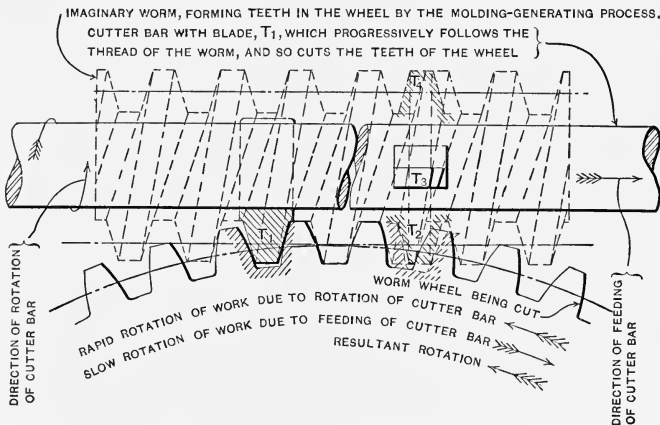

FIG. 141. Diagram showing the Principle of the Fly-Tool Method of cutting the Teeth of Worm-Wheels.

would evidently follow the path of the thread of the imaginary worm, as shown at T_1 and T_3 in Fig. 141. Owing to the action of the differential mechanism, it would still follow the thread of the imaginary worm, even if the latter, with the spindle- and work-driving mechanism, were in motion.

Another method consists in combining in the work, also by differential gearing, a rotation due to the revolving of the cutter with a rotation due to the axial feed of the cutter bar.

That this produces the same effect as the previous arrangement will also be understood from Fig. 141.

First, let the rotation of the cutter be arrested. If the cutter bar with a worm mounted on it, such as shown by the dotted lines, be now fed axially in the direction of the arrow, the positive connections between the feed and the work spindle through the change gearing and the differential gearing will cause the work to rotate uniformly with it. If the feed is arrested after a time, and the bar is started revolving, the imaginary worm mounted on it will still be kept in proper mesh with the work, owing to the change gear connections between the cutter bar and the work spindle acting through the differential gearing. As we have previously explained, the office of the differential gearing is to combine in the work the rotation due to the feeding and that due to the rotation of the worm, in such a way that they can take place simultaneously as well as separately; so that it will be seen that if the connections are properly made the worm may be fed endwise and revolved at the same time, always keeping in perfect step with the work.

Now, the imaginary worm and the fly-tool are both firmly fixed to the cutter bar, so that the fly-tool must always follow the movements of the imaginary worm. Being set to coincide with the outlines of the worm thread at the start, it must always coincide with those outlines, and since the worm is never out of step with the work, the fly-tool also will never be. It will thus be seen that it will always follow the helical path of the dotted lines in Fig. 119, in moving, for instance, from T_1 to T_3 . Revolving in the position T_3 , T_4 , T_2 , etc., the work, as shown in the dotted lines of T_2 , will always be in proper relation with the fly-tool, as it is with the imaginary worm.

With this arrangement, if the change gearing connecting

the driving mechanism of the cutter bar and the work were disconnected while the bar was fed through from left to right, the rotary motion given by the connection of the feed of the bar with the work would shape one tooth. If, on the other hand, the gearing connecting the feed of the bar with the rotation of the work were disconnected while the connections between the drive of the bar and the work were in operation, the cutter would partially shape each tooth of the work. By combining the two movements in

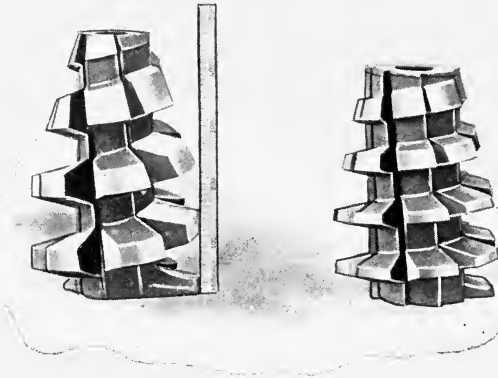

FIG. 142. The Taper Hob, adapted to the Fly Cutter Machine.

the differential gearing the cutter perfectly forms all the teeth.

Another form of cutting tool, the taper hob, shown in Fig. 142, may be used in machines adapted for cutting teeth by the fly-tool method. This tool is fed through the worm-wheel along the spiral path of the imaginary generating worm, as in the previous case. It is fed small end first, and sinks into the work deeper and deeper until the full diameter at the rear has been reached. When this has passed through the work the gear is finished. The taper

hob and the fly-tool may be used indiscriminately in the machines shown in Figs. 144 to 153 inclusive.

The original machine for using the taper hob, built by Mr. Reinecker, employed a different form of combining or differential movement from that just described. It is

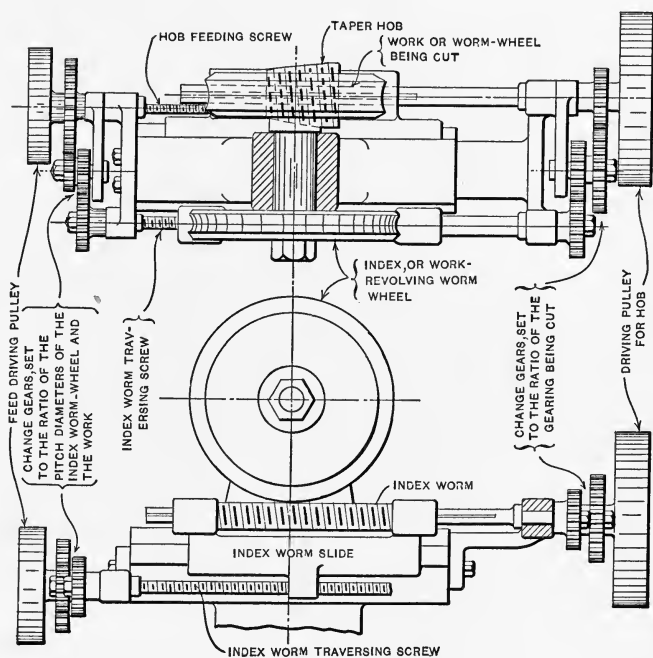

FIG. 143. Diagram of Original Form of Mechanism for Generating Worm-Wheels with Taper Hob.

shown diagrammatically in Fig. 143. In this case the tapered hob is connected by change gearing with the worm driving the indexing wheel, as before. The worm, however, is mounted on a slide, allowing it a considerable range of axial movement. This axial movement is controlled by a screw and nut, as shown. This screw is connected by change gearing with the screw by which the taper hob is

fed. It will thus be seen that the feeding of the hob rotates the work by shifting the index worm lengthwise, while the rotating of the hob rotates the work through the rotation of the index worm and worm gear. The two movements are independent of each other, but are combined with the same effect as produced by the "jack-in-the-box" differential gearing previously described. With this arrangement the ratio of table movement and lengthwise worm movement should be proportioned in the ratio of the pitch diameters of the worm-wheel being cut and the index worm-wheel. The reason for abandoning this construction was doubtless its limited range of movement, which, though enough for the hobbing of worm-wheels, was not enough (when applied to the universal gear-cutting machine, Figs. 105 and 106) for cutting spiral pinions of great helix angle.

MACHINES AND ATTACHMENTS FOR CUTTING WORM-WHEELS BY THE FLY-TOOL OR TAPER HOB METHOD.

The device shown in Fig. 144 is used in the shops of the Garvin Machine Company, New York City, for hobbing worm-wheel segments for automobile steering gears. The fact that the wheel to be cut is segmental makes it necessary to have some form of positively driven apparatus, and the taper hob principle has been adopted, probably for convenience in using the power cross feed with which the milling machine is provided. The mechanism is identical with that in Fig. 143, but is considerably simpler, since the attachment is made for hobbing one size of gear only. The index worm is of the same diameter and pitch as the worm with which the finished segment is to mesh, so it is geared to run at the same speed as the hob. The index wheel is also a duplicate, in its essentials, of the work. The taper hob is fed into the work by feeding the table and saddle outward on the knee by the automatic cross feed.

The first regular machine we show employing the progressive fly-tool principle is the product of the Nya Aktiebolaget Atlas, of Stockholm, Sweden. This is the same machine that we have previously described, and illustrated in Figs. 36, 77, and 104; in Figs. 145 and 146 it is shown set up for cutting worm-wheels. The machine is driven from cone pulley *A*. Shaft *B*, to which this pulley is keyed,

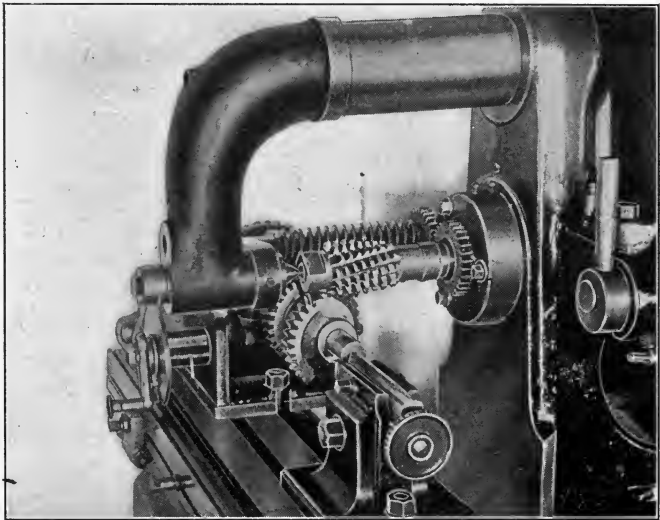

FIG. 144. A Positive Hobbing Attachment, employing a Taper Hob.

is connected by the bevel gearing shown with vertical splined shaft *C*, from which, through change gears *D* and driving gear *E*, the fly-cutter arbor *F* is driven. Gearing in case *G* connects shaft *C* with horizontal driving shaft *H*, which rotates the worm for revolving the work table and the work. Change gears *D* thus furnish the means for rotating the work and the hob in the proper ratio with each other.

Pulley *J* is connected inside the frame to the feed shaft

K , seen in the end view. K is connected through change gears L and M with shaft N , which also leads to casing G . Change gears M are not altered for cutting worm gearing, being employed for indexing in the case of spiral and spur gears. Change gears L , however, are set to the lead of the

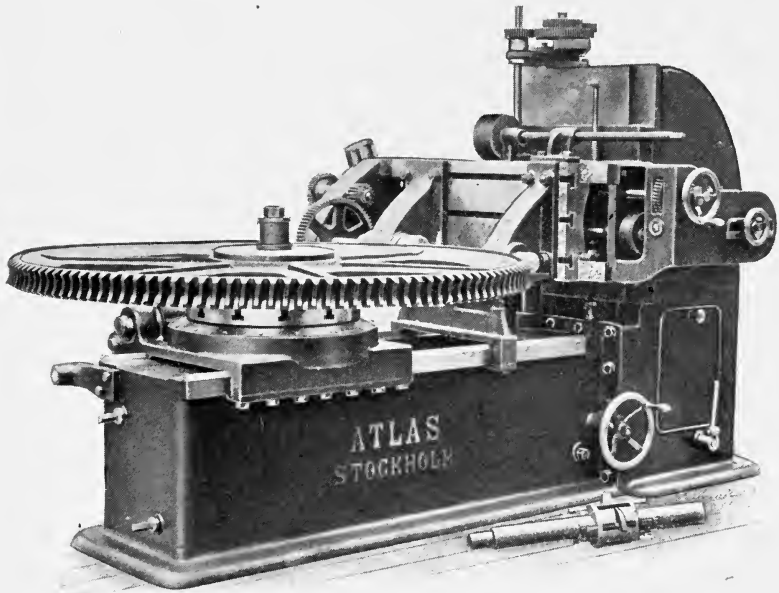

FIG. 145. The Atlas Gear-Cutting Machine, also shown in Fig. 36, arranged for cutting the Teeth of Worm-Wheels by the Fly-Tool Process. Note Quadruple Fly-Tool on the Floor at the Base of the Machine.

worm. Shaft K , besides being thus connected to shaft N , drives, through suitable shafts and gearing, feed screw O , by means of which is traversed on the cross rail the slide on which the fly-cutter arbor is carried, this arbor F being driven by a spline in the hub of gear-wheel E . Casing G contains differential gearing which combines the move-

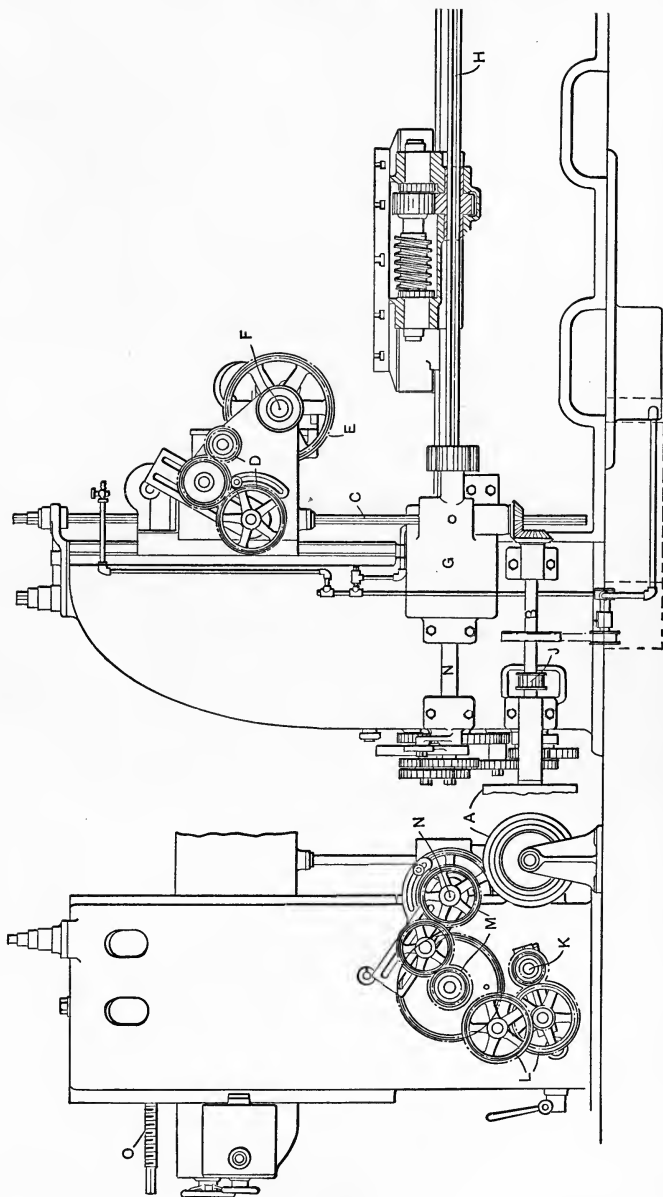

Fig. 146. Diagram of the Driving Connections of the Atlas Gear-Cutting Machine shown in Fig. 145.

ments of shafts *C* and *N* in shaft *H*. It will thus be seen that by setting change gears *D* the work will be given a rotation to correspond with the ratio of the number of threads in the worm and the number of teeth in the gear, while by setting change gears *L* properly the work will be rotated in unison with the axial feeding of the cutter bar

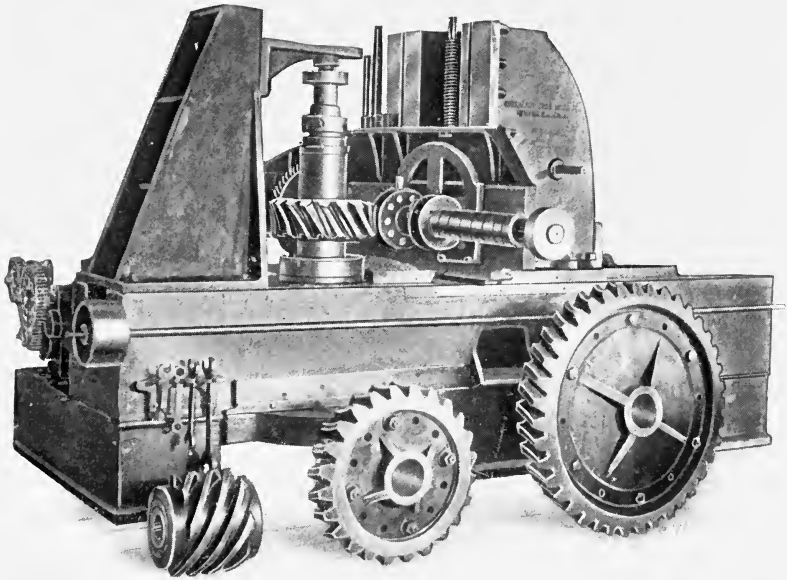

FIG. 147. Newark Gear-Cutting Machine Company's Fly-Tool Worm-Wheel-Cutting Machine, with Samples of Work.

as in moving T_1 to T_2 in Fig. 141, thus filling the necessary conditions.

Aside from the ingenuity of the mechanical movements thus described, this well-known machine is carefully planned throughout, being of pleasing design and simple construction, considering the variety of work it is intended

to perform. This work includes, as we have before mentioned, the cutting of helical, internal, spur, and worm gears.

Another machine of the same class, built by the Newark Gear Cutting Machine Company, 66 Union St., Newark, N. J., is shown in Figs. 147 to 149. In this tool the work table is stationary as to its position on the bed, while the column carrying the cutter slide is adjusted in and out to suit the diameter of the work, thus reversing the conditions that obtain with the Atlas machine in Fig. 145. Another change in the construction is in the provision for the axial feeding of the cutter bar. In the case of this machine, instead of supporting the cutter on a slide which is fed along the cross rail, as in Fig. 145, the supports for the bar are stationary, the latter being fed through them by a sliding head (*P* in Figs. 148 and 149) at the outer end of the cross slide. By this means the cutter bar is brought much closer to the face of the column, and one of the sliding joints between it and the column is eliminated. Both of these features tend toward rigidity and consequent increase in output.

The mechanism will be easily understood from a study of the diagrams in Figs. 148 and 149. Driving pulley *A* is connected by gears *B* (which are changed to give the desired spindle speeds) with shaft *D*, which, by means of bevel gears *C*, in turn drives vertical splined shaft *W*, by means of which connection is made with the worm and worm-wheel *E* which drives the cutter bar. Shaft *D* is continued along the bed to change gears *F*, which are changed to give the proper ratio between the rotation of the cutter and of the work. These gears drive one of the members of the differential gearing *X*.

Feed cone *J* is connected by gearing *K* with shaft *Q*. The latter, through two sets of worm gearing and vertical shaft *L*, drives horizontal shaft *M* on the cross rail. From

here, through gears *N*, the movement is led to feed-screw *O* by which head *P* is traversed to feed the cutter bar axially. *Q* is also connected by change gears *R* and the

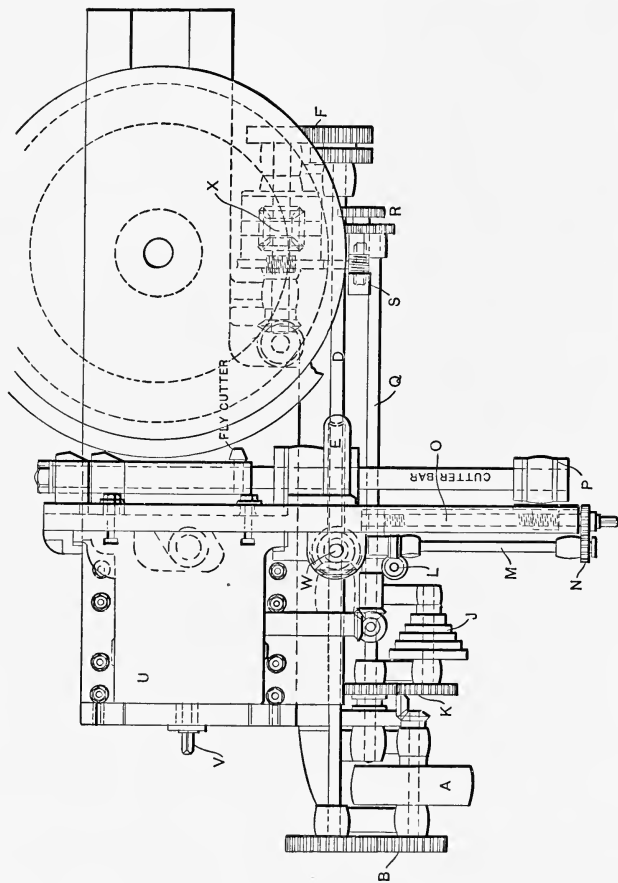

Fig: 148. Plan View of the Fly Cutter Hobbing Machine shown in Fig. 147.

worm gearing shown with differential gearing *X*; gears *R* are selected to agree with the pitch diameter of the work. In differential gearing *X*, motions from shafts *D* and *Q* are combined to rotate the work table and the work in the same

way as in the Atlas machine and as required in Fig. 141. For small blanks the spindle is rotated through spur gearing at *H*. For heavy work, however, a driving pinion is

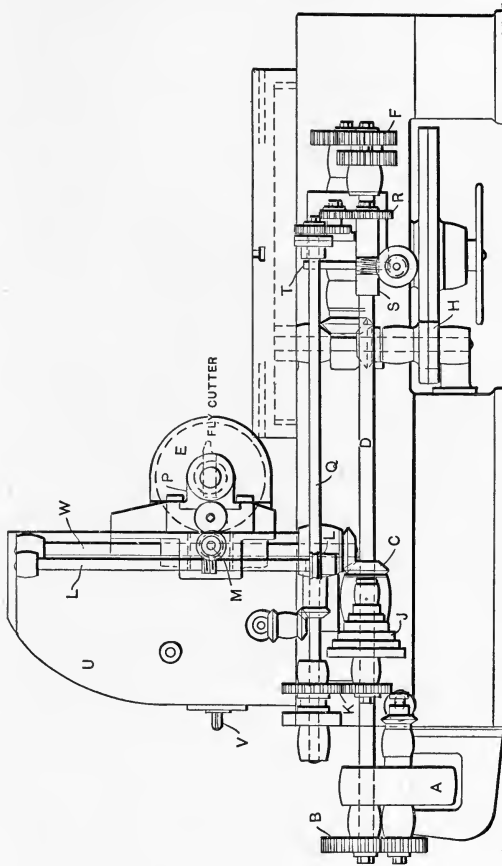

Fig. 149. Side Elevation, showing the Driving Connections of the Machine in Fig. 147.

directly connected with teeth on the inner rim of the work table, so that a very powerful drive is obtained.

This machine can also be arranged to use the ordinary cylindrical hob, in which case the feed of head *P* is thrown out, and the column *U* is fed inward on the bed by means

of screw V , so that the hob enters the blank in the same manner as for the machines in Figs. 134 to 140.

The machine shown in Fig. 150, built by John Holroyd

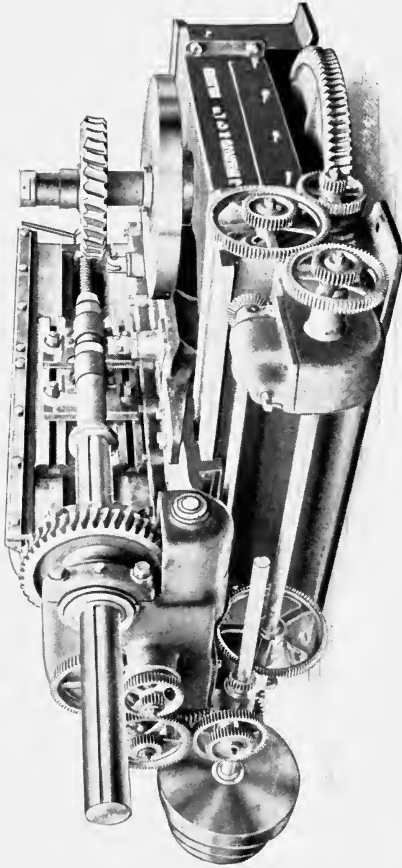

Fig. 150. The Holroyd Worm Gear Generating Machine using a Fly Tool or Taper Hob.

& Co., Ltd., Milnrow, near Rochdale, England, is similar in general design to that illustrated in Fig. 147, in that the work spindle is vertical and stationary as to location on the bed, while the cutter slide is carried by a

column horizontally adjustable for the diameter of the work. The machine is of unusual size and capacity. It will hob wheels from 12 inches to 72 inches in diameter. The main bearing of the work spindle is 8 inches in diam-

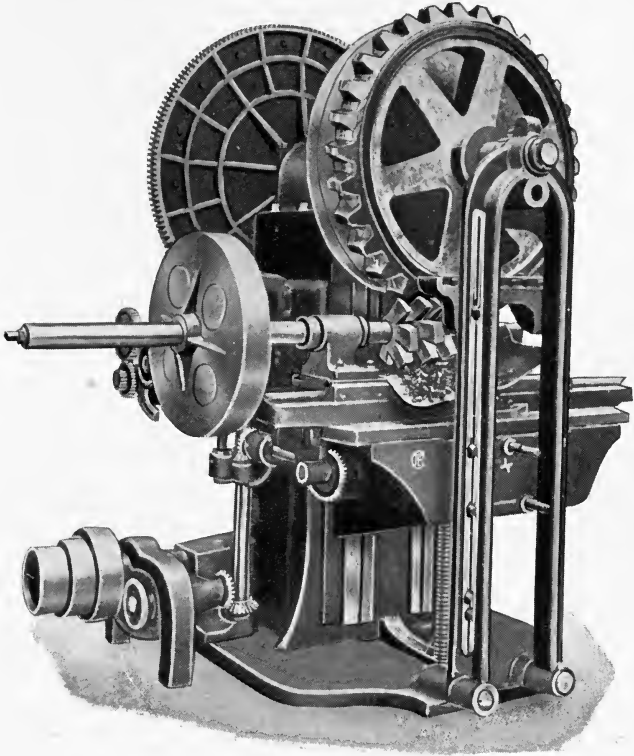

FIG. 151. Machine for Generating Worm-Wheels with a Taper Hob; built by J. E. Reinecker, Chemnitz, Germany.

eter by 16 inches long. The approximate weight of the whole apparatus is ten tons. This same firm builds a machine of similar design for smaller work, in which, however, the work spindle is horizontally adjustable instead of the cutter slide column.

In Fig. 151 is shown a gear-hobbing machine built by J. E. Reinecker, of Chemnitz-Gablenz, Germany. This machine has the movements required for performing the work of the Atlas and Eberhardt machines, since it combines in the rotation of the work a movement due to the longitudinal feed of the cutter spindle and a movement due to the rotation of the cutter spindle. It is ordinarily used, however, with a hob instead of a fly-cutter. This hob is tapered as shown. The machine is practically identical with the universal gear cutter by the same maker, previously shown in Figs. 105 and 106, it being adapted, as there shown, to cutting worms by the same process. The differential mechanism used is the same as in Fig. 106, the axial feed of the cutter spindle being applied to shaft *M*, while the rotative movement of the cutter spindle is connected with shaft *H*, the two being combined in gears *J*, *L*, and *N* to rotate the indexing wheel *G*.

In Figs. 152 and 153 are shown half-tone and line engravings of a fly-tool gear-hobbing machine built by Henry Wallwork, Ltd., Redbank, Manchester, England. The work is carried by the face-plate and vertical spindle *A*, while the fly-tool *B* is mounted in the cutter spindle *C*. This latter is supported in slide *D*, which is adjustable on the top of the bed for the diameter of the work, and is fed axially by screw *E*. The fly-tool starts in at one side of the work and feeds axially through it, the work and tool revolving together, as in previous cases. A peculiarity of this machine, however, is that no differential mechanism of any kind is employed. The way in which this is avoided may be explained thus:

Suppose that in the Eberhardt machine in Fig. 148 the fly-cutter be engaged in hobbing a worm-wheel of 100 teeth to mesh with a single-threaded worm. If, then, the fly-cutter makes 100 revolutions per minute, the worm-

wheel will make one revolution per minute. If now the cutter spindle be fed longitudinally with a certain definite feed, the differential mechanism will modify the rate of rotation of the worm, making it slightly more or slightly less than one revolution per minute, depending on the rate of the feed and its direction as compared with the direction of rotation of the work. We may say, then, that if

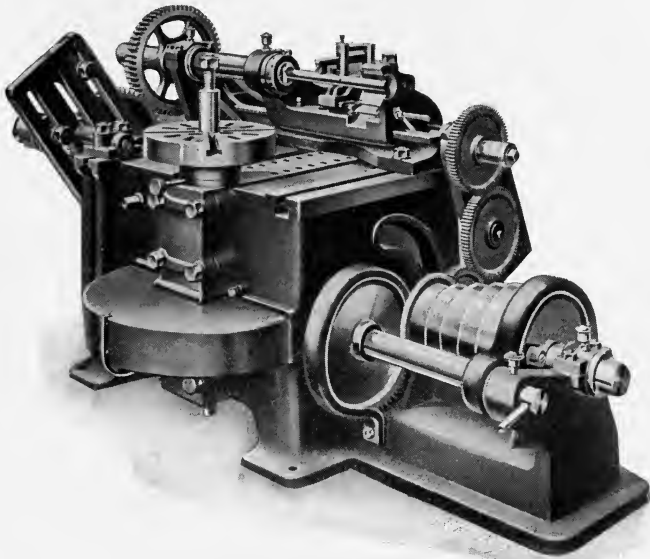

FIG. 152. The Wallwork Machine, which cuts the Teeth of Worm-Wheels with a Fly-Tool without using Differential Gearing.

the cutter revolves at a certain number of revolutions per minute and feeds at a certain fraction of an inch per minute, the work will rotate at a certain number or fraction of a number of revolutions per minute. Where the gearing required with the Eberhardt machine would give a ratio of 100 to 1 between the hob and the work, as modified by the feed this ratio might be 100.0073 to 1, for

instance. It will thus be seen that since these conditions remain constant until the work is completed, the differential mechanism may be dispensed with entirely if we select the change gears connecting the hob and the work to agree with the new rate of turning of the work as modified by the feeding of the hob.

This is what is done in the Wallwork machine. The driving shaft *F* is connected with the driving cone *G* either directly or through back gears, as may be required. This

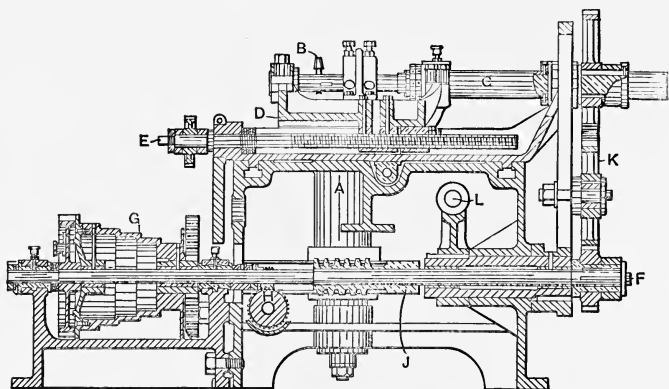

FIG. 153. Vertical Section through Wallwork Worm-Wheel Generating Machine.

shaft, through worm-wheel *H* and change gears shown in Fig. 152, drives feed-screw *E*. It also has keyed to it worm *J*, meshing with the indexing worm-wheel by which the work on the vertical spindle *A* is rotated. At the extreme right in Fig. 153 this driving shaft is connected with cutter spindle *C* by change gears *K*, mounted on a sector which is provided with a worm-wheel adjustment at *L* for setting it, owing to its great weight. It will thus be seen that the feed, the work, and the cutter bar are all connected by positive gearing. For setting up the

machine, suitable change gears for connecting screw E with the driving-shaft mechanism are used to give the desired rate of feed. Then change gears K are selected to give the proper ratio between the work spindle A and cutter spindle C , as determined by the ratio between the number of threads in the worm and the number of teeth in the worm-wheel, modified (as explained) by the rate of feed. The change gears are set from calculated tables.

This arrangement would seem to possess both advantages and disadvantages as compared with the differential scheme. It results in a much simpler mechanism, but it makes it impossible to change the feed without changing, as well, the gearing connecting the work spindle and the hob. The same principle is used for spiral gear hobbing, see pages 177 and 178.

CUTTING WHEELS FOR MULTIPLE-THREADED WORMS BY THE FLY-TOOL PROCESS.

The method of cutting multiple-threaded worms was not described in discussing the principle of the fly-tool process. At the base of the machine in Fig. 145 is shown a form of tool which may be used for cutting wheels to match with multiple-threaded worms. In this case, in which a quadruple thread has to be provided for, a cutter head is provided in which four blades are carried, spaced equidistant. The feeding through of these four blades simultaneously finishes the worm-wheel complete in one operation. An alternative method would be to index the cutter bar with relation to its driving gear, giving it three positions for a triple-threaded worm, four for quadruple threads, etc. This could be done by a notched index plate and locking bolt, or by unmeshing the gearing from engagement at some point in the driving train and shifting it the

required number of teeth before reëngaging it. No special provision has to be made, of course, for multiple-threaded taper hobs.

THE VARIOUS METHODS COMPARED.

Each of the various methods of cutting worm-wheel teeth which we have described has its field of usefulness. Gashing, as we have seen, is applicable either to cheap, rough-and-ready work on the one hand or, on the other hand, to the cutting of worm-wheels which are not required to transmit a great amount of power but in which the highest degree of accuracy is required. The process of hobbing previously gashed blanks requires the least degree of specialization in the machinery used, the ordinary milling machine having all the movements and adjustments required. This process is perhaps the one followed in most shops in making worm gearing of small size. The arrangement (such as shown in Figs. 132 to 140) in which the work and the hob are positively geared together so that previous gashing is not required, is quicker than the last mentioned method, but requires special machines or attachments. The fly-tool method requires a still more elaborate machine, but is the least expensive of all in the matter of cutting tools. A large hob is an exceedingly costly appliance, and raises the cost of production to an alarming degree, particularly when but one worm-wheel has to be cut. The use of a simple fly-cutter, which may be ground accurately to size after hardening so that all inaccuracies are avoided, is thus the cheapest as well as the most accurate means of cutting a large worm-wheel. Where many large wheels of the same size are to be cut, the taper hob method would seem to be a most satisfactory one. A high degree of accuracy could be maintained, as the full-size teeth at the back end of

the hob do not come into play until the finishing cut is reached, so that they tend to preserve their shape indefinitely. Another item that tends to accuracy in this method of hobbing is the fact that the distance between the work arbor and the cutter spindle is fixed at exactly the distance between the axis of the worm and the worm-wheel in the finished gearing. This is a refinement of greater importance than is usually realized, and one that is not always looked out for in hobbing operations in which the cutter spindle is fed in toward the work. Hobbing by this method is, of course, more rapid than by the fly-tool process employed on the same machines, though the latter is not a tedious operation by any means, as a solidly supported and powerfully driven tool can be given a heavy feed, taking off chips of respectable thickness.

The methods followed in cutting the other member of this form of gearing, the worm, have already been described in connection with machines for cutting helical and herringbone gears.

THE MANUFACTURE OF HINDLEY WORM GEARING.

An old form of gearing which has come into extensive use of late years in elevator service and other applications in which considerable power has to be transmitted, is shown in Fig. 154. This is commonly known as "Hindley worm gearing," though it is not worm gearing at all, being entirely different in its action. It should properly be classed as "globoid" gearing, a term which, so far as the writer knows, was first employed by Prof. Reuleaux. The characteristic feature of its action is the fact that contact takes place on or near the axial plane of the worm, as shown in the engraving. Unlike other forms of gearing, neither member of this pair has a pitch line or a pitch

diameter. The form of gearing is an old one, but it has only recently come into practical use.

It is often stated that this style of gearing gives surface contact, but this statement can scarcely be true. The impression doubtless arose from a consideration of sections on the two planes shown in Fig. 154, in which it

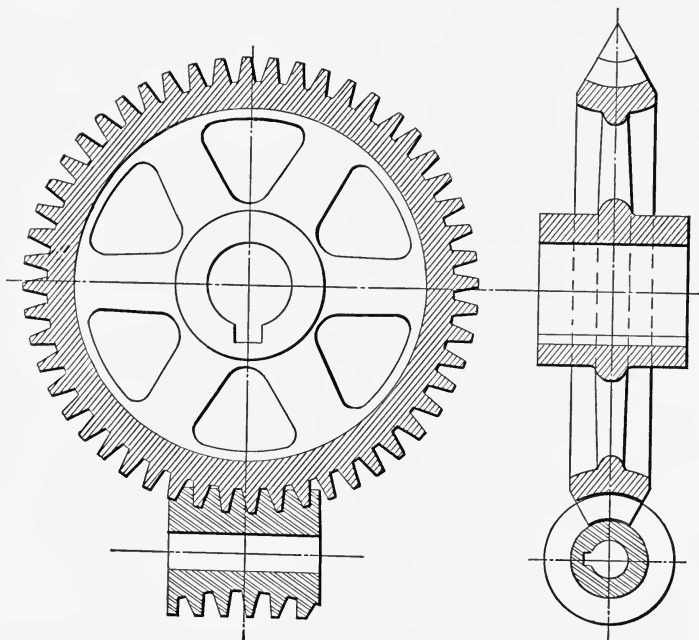

FIG. 154. The Form of Globoid Gearing generally known as "Hindley Worm Gearing."

may be seen that the wheel is curved to fit the worm, and the worm is curved to fit the wheel, thus giving the appearance of intimate contact over the whole face of the tooth. It is probable that the surfaces more nearly match than in ordinary worm gearing, giving an approximation to surface contact.

Any positively operated worm-wheel hobbing attachment or machine, such as shown in Figs. 135 to 140, may be used. The manufacture begins with the cutting of the worm, which is effected as shown in Fig. 155. The blank is mounted on the spindle of the machine ordinarily occupied by the hob, while a large-diameter disk provided with cutting tools clamped to its face is mounted in place to

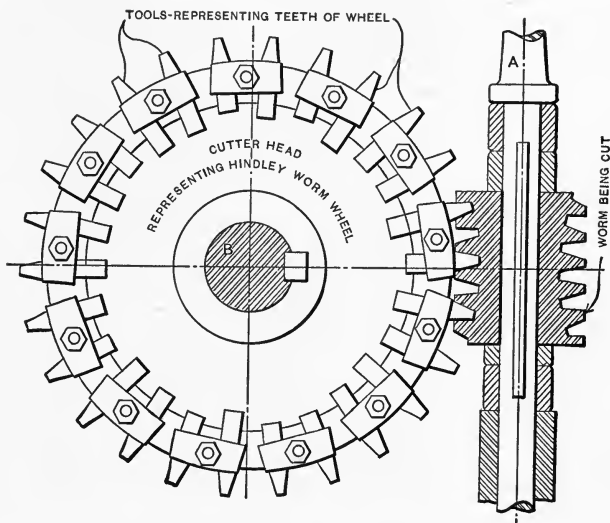

FIG. 155. Method of Cutting Hindley Worm with Rotary Cutter having Teeth corresponding with those of the Wheel.

represent the worm-wheel. The cutting tools mounted on this disk each represent a tooth of the wheel, being of the same shape and cutting on the same diameter. They are clamped to the face of the disk in such a way that the whole arrangement represents accurately a central section of the worm-wheel, of which (in this particular case) only every other tooth is used. This cutter and the worm to be cut are geared together, and slowly fed toward each

other as when hobbing worm-wheels. The teeth, cutting deeper and deeper into the blank, finally form it into the characteristic "hour-glass" shape of the Hindley worm.

In cutting the wheel, the process is reversed, as shown in Fig. 156. A hob cut in the same way as the worm in Fig. 155, but with its teeth relieved, is fed into the wheel blank and cuts the teeth in a way exactly identical with

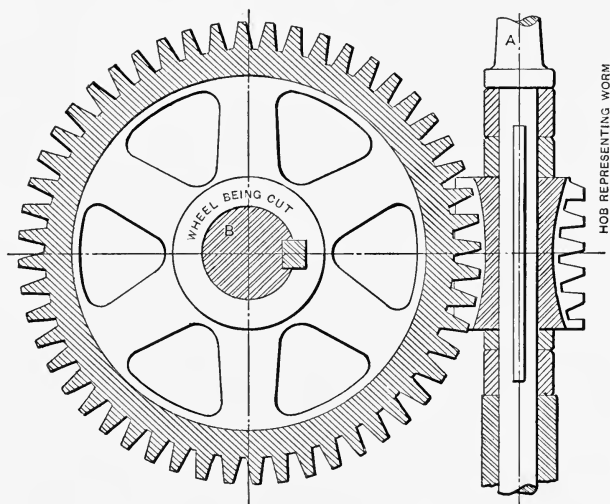

FIG. 156. Cutting the Teeth of the Hindley Wheel with a Hob corresponding with the Worm.

the method followed in hobbing worm-wheels, the only difference in the process being the difference in the shape of the hob and in the shape of the teeth produced.

The foregoing description applies to what may be called the "classical" form of Hindley gearing. As made for practical purposes, the operations just described are used for roughing only. A second cut is taken over the worm by the same tool as in Fig. 155, but with the

blades set to a larger diameter. This trims off the inner faces of the worm teeth. Then the worm and the wheel are run together with sand or ground glass. This is the true finishing operation, which gives a bearing considerably different from that of the theoretical gear, and one difficult of analysis. The process of cutting Hindley worms and wheels has never been rationalized, so far as the writer knows, and is dependent on previous experience and good judgment for its success.

This completes the consideration of machines and processes for cutting the teeth of worm gears.

CHAPTER VII.

MACHINES FOR FORMING THE TEETH OF BEVEL GEARS.

IN studying methods and machines for cutting the teeth of bevel gears we come to the most fascinating branch of the whole subject which we have been considering. So great is the number and variety of these machines that it will be impossible to do more than give the bare outlines of the ingenious mechanisms which have been devised for this work. Almost any of those here described, operating on the templet or the molder-generating principles, would require a dozen pages and as many illustrations to explain the details of its construction. We can, however, in the comparatively short descriptions here given, get an understanding of the principles of operation of each of them. This will best be done by analyzing the various principles of action and methods of operation applicable to the cutting of bevel gear teeth, as was done for spur gears in Chapter I, following the same classification there given, but making the necessary changes in the mechanisms shown in Figs. 1 to 10 to fit them for the work of cutting bevel gears instead of spur gears.

The changes required in the spur gear cutting devices to adapt them for cutting bevel gears, made necessary by the difference in the nature of the two forms of gearing, are explained in Figs. 157, 158, and 159. The action of a pair of mating spur gears may be seen and studied on the plane perpendicular to their axes. To be understood correctly, the action of bevel gearing, on the other hand,

must be observed on a spherical surface. In Fig. 157 are shown three bevel gears with axes OA , OB , and OC . The bevel gear on axis OA is of the form known as the "crown gear." It is practically a rack bent in a circle about center O . Pinion OB and gear OC are familiar types of bevel gears. In Fig. 158 are shown the pitch surfaces of the gears in the preceding figure. It will be seen in Fig. 157 that the pitch lines of the gear on the axis OC , for instance, converge at the center O . These pitch lines represent a conical pitch surface which is shown

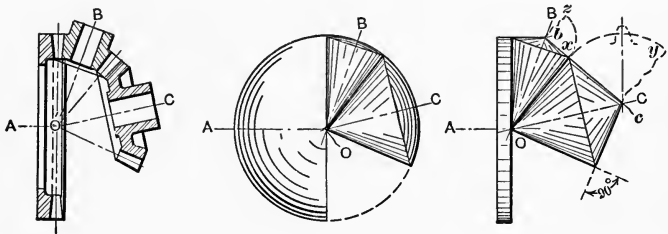

FIGS. 157, 158, 159. Illustrating the Spherical Basis of the Bevel Gear, and Tredgold's Approximation for Developing the Outlines of the Teeth on a Plane Surface.

cut out from a sphere on axis OC in Fig. 158. In a similar way the cone about axis OB represents the pitch surface of the pinion, while the plane face of the hemisphere at the left of Fig. 158 is the pitch surface of the crown gear of the preceding figure. If we wish to draw accurate representations of the teeth of the bevel gears in Fig. 157, in order to study their action in the same way that we can when drawing the teeth of spur gears on the plane surface of the drawing-board, we would have to draw them on surfaces of the sphere from which the pitch cones in Fig. 158 are cut. The pitch circles, etc., of the various gears would be struck from centers located at the points where the

various axes OA , OB , and OC break through the surface of the sphere. Except for the different surfaces on which the drawing would be done, the procedure would be identical with that for spur gears. It should be noted that straight lines on spherical surfaces are represented by great circles, that is to say, by the intersection with the surface of planes passing through the center of the sphere.

Owing to the impracticability of the sphere as a drawing-board, an approximate process, known as "Tredgold's," is usually followed for laying out the teeth of bevel gears approximately. This is shown in Fig. 159 applied to the same case as in the two preceding figures. The conical pitch surfaces vanishing at the center O are identical with those in Fig. 158, as is also the plain circular face of the crown gear. For the bevel gear and pinion, however, the teeth are supposed to be drawn and the action studied on surfaces of cones complementary to the pitch cones, that is, on the cones with apexes at c and b . The surface of these cones can be developed on a flat piece of paper, as partially shown for that on axis OC , in which case the pitch line becomes the arc xy . Teeth drawn on this pitch line, as for a spur gear, may be laid out on the conical surface and used as the outlines of bevel gear teeth. The difference in the shape of tooth obtained under the same system by the two methods shown in Figs. 158 and 159 is so slight as to be negligible, except, perhaps, in gears having very few teeth. Whatever the method pursued for laying out or studying the action, all the elements of which the teeth are formed consist of straight lines which meet at the center O of the pitch cones; consequently the teeth grow small toward the inner end, vanishing at the center if they are carried that far.

FIVE PRINCIPLES OF ACTION.

All of the five principles of action on which spur gear teeth may be formed (the formed tool, the templet, the odontographic, the describing-generating, and the molding-generating principles) may be also applied to the cutting of bevel gears, though the describing-generating principle has never been so used, as far as the author's knowledge goes, so we will not give any time to its consideration.

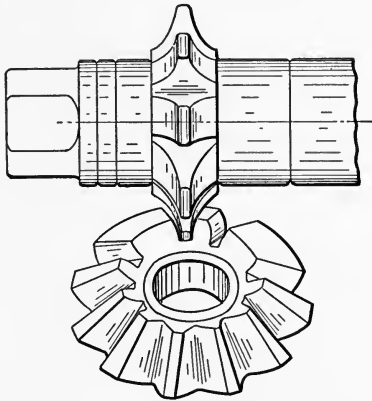

FIG. 160. Shaping the Teeth of a Bevel Gear by the Formed Cutter Process.

The Formed Tool Principle: The use of this principle is illustrated in Fig. 160, where we have a bevel gear blank set in position to have the tooth spaces cut by a formed milling cutter. This method, though perhaps the commonest employed of all, is in its nature an approximate one only, it being impossible by it to form the tooth correctly. The reason for this may be seen in Fig. 160, where it is evident that the right-hand side of the cutter is reproducing its own unchanging outline along the whole length of the base of the tooth at the right. This form should not be unchanging, for, as previously explained, the teeth and the

spaces between them grow smaller toward the apex of the pitch cone, where they finally vanish; so it is evident that the outline of a tooth at the small end should be the same as that at the large end, but on a smaller scale — not a portion of the exact outline at the large end, as produced by the formed tool process and as shown in the figure. To make this error as small as possible, it is customary to use a cutter which gives the proper shape at the large end, and set the blank so that the tooth is cut to the proper pitch line thickness at the small end. This leaves the top of the tooth at the small end too thick, an error which is often remedied by filing. Of course, the principle is the same with the formed planer or shaper tool as with the formed milling cutter, and the errors involved in the process are also identical. It is evident that but one side of the tooth space can be cut at a time, so that at least two cuts around will have to be taken.

The Templet Principle: This principle is illustrated in Fig. 161, in skeleton form only. A former is used which has the same outline as would the tooth of the gear being cut if the latter were extended as far from the apex of the pitch cone as the position in which the former is placed. The tool is carried by a slide which reciprocates it back and forth along the length of the tooth in a line of direction (OX , OY , etc.) which passes through the apex O of the pitch cone. This slide may be swiveled in any direction and in any plane about this apex, and its outer end is supported by the roller on the former. With this arrangement, in the case shown, as the slide is swiveled inward about the apex, the roll runs up on the former, raising the slide and the tool so as to reproduce on the proper scale the outline of the former on the tooth being cut. Since the movement of the tool is always toward the apex of the pitch cone, the elements of the tooth vanish at this point,

and the outlines are similar at all sections of the tooth, though with a gradually decreasing scale as the apex is approached — all as required for correct bevel gearing.

The arrangement thus shown diagrammatically is modified in various ways in different machines, but the movement imparted to the tool in relation to the work is the

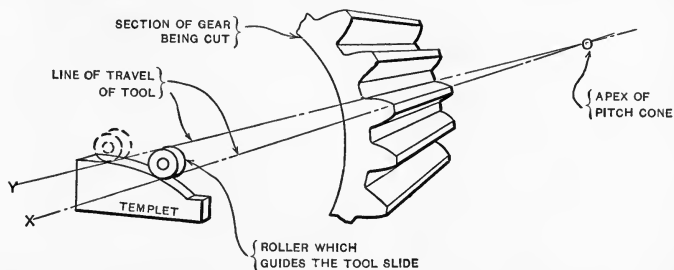

FIG. 161. Diagram illustrating the Templet Principle for Forming the Teeth of Bevel Gears.

same in all cases where the templet principle is employed, no matter what the connection between the former and the tool may be.

The Odontographic Principle: As explained for spur gears in Fig. 3, it is often possible to approximate the exact curves required for the teeth of gears by mechanisms which make use of circular arcs or other easily generated curves. In Fig. 162 is shown in diagrammatic form an arrangement for obtaining, by means of link work, a close approximation to the exact form of an involute outline, such as might be produced by the templet in Fig. 161, for instance. This true involute outline may be very closely approximated by a circle drawn on the surface of a sphere. To give this required circular movement to the point of the tool, the slide on which the tool reciprocates may be constrained by a link as shown, pivoted at the base to the frame of the machine, and at the upper end to the slide. The axes of these pivots should pass through

the apex of the pitch cone, as required by the spherical nature of the bevel gear. This link work (which is thus of the "conical" type), if properly proportioned and located,

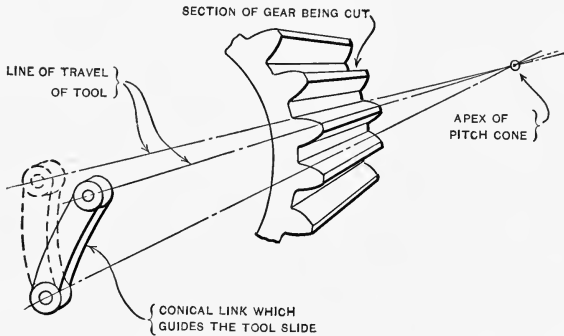

FIG. 162. Diagram illustrating the Odontographic Principle for forming the Teeth of Bevel Gears.

will guide the tool slide and the tool point in very nearly the same way as a properly constructed templet, used as shown in Fig. 161.

The Molding-Generating Principle: The counterpart of

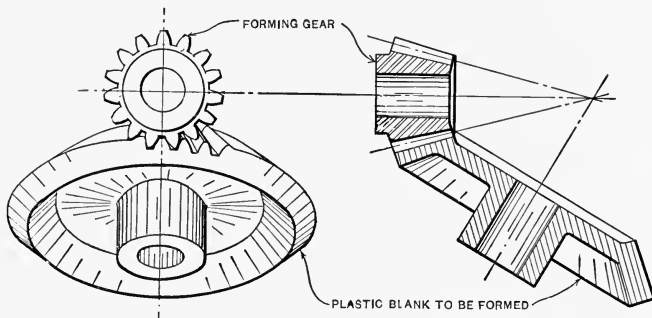

FIG. 163. The Impression Operation, applied to forming the Teeth of a Bevel Gear by the Molding-Generating Process.

the spur gear process shown in Fig. 5 is illustrated for the bevel gears in Fig. 163. Here a correctly formed gear is

being rotated in the proper position and in the proper ratio with a plastic blank. This operation, as in the case of the spur gear, forms teeth in the plastic blank which are properly shaped to mesh with the forming gear or with any other gear of the same series. Fig. 6 has, obviously, no possible counterpart in the cutting of bevel gears.

FOUR METHODS OF OPERATION.

By Impression: The same four methods of operation as for spur gears may be applied to the molding-generating principle, and quite generally to the other principles as well. Instead of using for illustration a rack as the generating member, we will have to use its bevel gear counterpart, the crown gear shown in Fig. 157. The impression method would simply consist of rolling the crown gear on axis OA and the pinion blank on axis OB together, when, if the latter were formed of a plastic material, the teeth of the crown gear would produce in its smaller mate corresponding tooth spaces and teeth of the proper shape.

By Shaping or Planing: There is but one form of tooth to which the planing operation of molding-generating is adapted. This is the form in which the crown gear has teeth with plane sides, which may be cut with a straight-sided tool. If the drawing of an involute rack (with straight-sided teeth) were wrapped around the periphery of the disk in Fig. 159, and the tooth outlines thus determined used for teeth vanishing at O , the resulting crown gear would be very nearly of this type. In Fig. 164 such a crown gear is shown combined with a simple mechanism for making use of the planing or shaping operation in the molding-generating process. The gear being cut is keyed on a loosely revolving spindle, to which is also keyed a master gear, formed on the same pitch cone and having, in this case, the same number of teeth. This spindle is

so set in relation to the axis about which the crown gear revolves, that the master gear and the crown gear mesh together properly, the crown gear being of the required pitch and having the proper number and shape of teeth for this action. If now the crown gear be rocked about its axis, the master gear will also rock with it, carrying the gear being cut.

The blade is set, as shown in the view at the right, so that its cutting edge coincides with the plane of one of the teeth of the crown gear, and it is held in a slide which

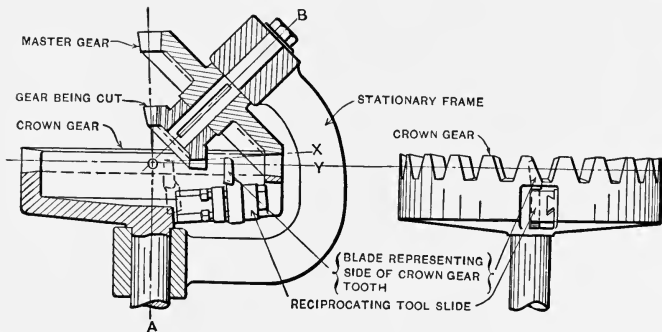

FIG. 164. Simple Mechanism illustrating the Shaping or Planing Operation, applied to the Molding-Generating Principle of forming the Teeth of Bevel Gears.

guides it in such a way that it moves in this plane, so that its point follows the line OX , radiating from the apex O of the pitch cones. The tool will evidently represent the side of the tooth of an imaginary crown gear, which is adapted to mesh properly with any bevel gear (such as that shown being cut) keyed to the master gear and having the same pitch cone shape and number of teeth.

If, with the mechanism so arranged, the crown gear be rotated so as to start the cut at one side of a tooth of the work (which should be first roughly cut to size) the continued rotation of the crown gear will roll the master gear

in such a way that the reciprocating blade (representing the side of an imaginary crown tooth meshing with the work) will shape the side of the tooth being cut to the proper form, by the molding-generating process, on the same principle as shown in Fig. 8.

This arrangement, of course, is not a practical working machine as shown, since there is no provision for making it universal for cutting bevel gears of other pitch cone angles and numbers of teeth, or for indexing the work with relation to the master gear to cut the remaining teeth of the work shown in place. Arranged as shown, however, the machine will cut any gear within its range, of the same pitch cone angle and number of teeth as the master gear. To cut a different number of teeth it would only be necessary to alter angle XOY , as required, setting the slide at a greater angle for fewer and larger teeth, or at a less angle for more and smaller teeth.

This principle will be found applied in this and in modified forms in machines we will describe later. One of the modifications which will be seen is equivalent to making the crown gear in Fig. 164 stationary, and swinging the frame around it about axis OA , thus rolling the master gear and the work in the same relation to the tool as when the frame is stationary and the crown gear is revolved, in the way we have just described. Still another possible modification would consist in holding the master gear and work still, while the frame is swung about axis OB . In this case the crown gear would roll on the master gear, rocking the tool slide in such a way as to give the required movement. It is not possible to form a tooth space complete with a single tool, as shown for spur gears, at T_1 in Fig. 8, without cutting the tooth space too deep at the outside end. A separate blade has to be used for each side of the space or of the tooth.

By Milling, and by Grinding or Abrasion: Milling cutters or grinding wheels may be used to represent the shape of the tooth, as they represent the rack tooth for spur gears in Figs. 9 and 10. In Fig. 165 is shown diagrammatically an arrangement by which two cutters or grinding wheels may be made to represent the two sides of a tooth in such a way that by them a tooth space may be finished complete in the gear to be cut in a mechanism similar to that in Fig. 164,

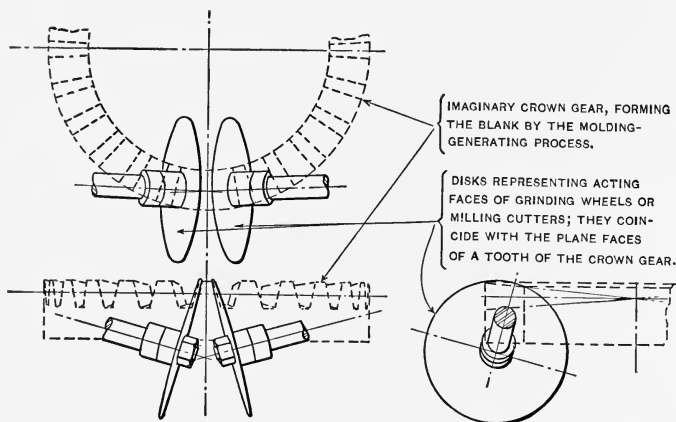

FIG. 165. Diagram suggesting the Arrangement of Milling Cutters or Grinding Wheels for forming the Teeth of Bevel Gears by the Molding-Generating Process.

but without requiring the reciprocating movement. The same difficulty arises as in spur gears, of the center of the tooth being cut in deeper than the ends, owing to the circular form of the cutter. This, however, makes no change in the action of the finished gear.

The variety of applications for these various principles and methods of operation is fully as great in bevel gears as in spur gears, and the machines in which they are incorporated apply these principles and methods in an even more ingenious fashion.

MACHINES USING FORMED MILLING CUTTERS FOR SHAPING
THE TEETH OF BEVEL GEARS.

One of the most commonly used machines employing the formed tool process is the ordinary milling machine. An example of the use of the Cincinnati miller for this purpose is shown in Fig. 166. The work is held on an arbor carried

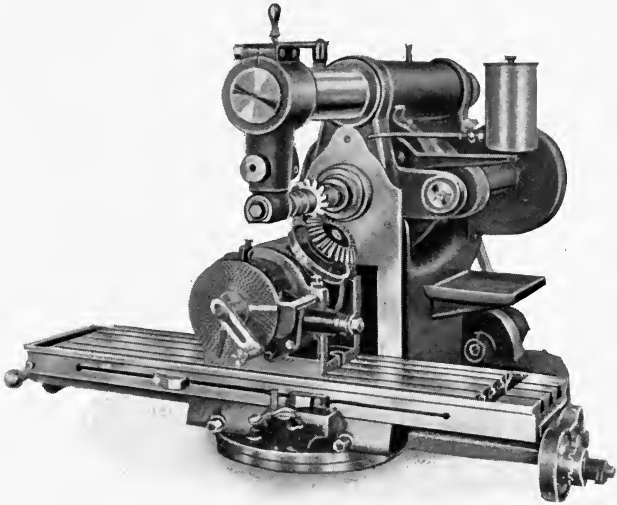

FIG. 166. Cutting Bevel Gear Teeth on a Milling Machine by the Formed Cutter Method.

by the spindle of the universal head, by which the blank is indexed for the required number of teeth. The head is set to the proper angle to make the bottom of the tooth space horizontal. As explained in the paragraph describing Fig. 160, it is possible to cut but one side of a tooth space at a time, if teeth of even approximate accuracy are desired. For this reason, and to obtain as nearly a correct form of tooth as possible, the side of the tooth to be cut is moved away from the cutter horizontally and then the

work spindle is revolved to bring it up to it again, the amount of "set-over" and "rolling" being adjusted by judgment and by "cut-and-try," to give the best results.

The automatic attachment built by Ludwig Loewe & Co., and shown in Fig. 15, is also adapted to the cutting of bevel gears in the milling machine, which it renders automatic, doing the work under the same conditions as in the regular machine shown in Figs. 168 to 171.

The dividing head of the milling machine may also be used on the shaper table, for indexing the work and setting it to the proper angle, when cutting the teeth with a shaper tool having a blade formed to the proper outline. The necessary set-over and rolling movements required to reproduce an approximation to the correct form are exactly identical with those necessary for the milling machine. The shaping process may be used for odd jobs where no formed cutter is available.

In Fig. 167 is shown a special machine which is identical in principle with the milling machine when used as shown in Fig. 166. Being built, however, especially for the work of cutting bevel gears, it is of simpler construction and less expensive. The bed of the machine carries sliding ways at the right, on which is mounted a knee on the face of which the cutter spindle is vertically adjustable. The latter is driven, through the twisted and bevel gearing shown, from a wide-faced pulley of large diameter. The knee is not mounted directly on the slide but is carried by an intermediate saddle along which it is adjustable in and out for the depth of cut. The feed is provided with an automatic stop, but is returned by hand. The work is mounted on a spindle set in a head, which may be clamped at the proper cutting angle on the base by which it is supported. This base may be adjusted toward or away from the cutter as well as parallel with the movement of the latter, to

approximately the position required. The work is indexed by a notched plate operated by hand. The index locking pin is itself carried by an arm which may be swung about

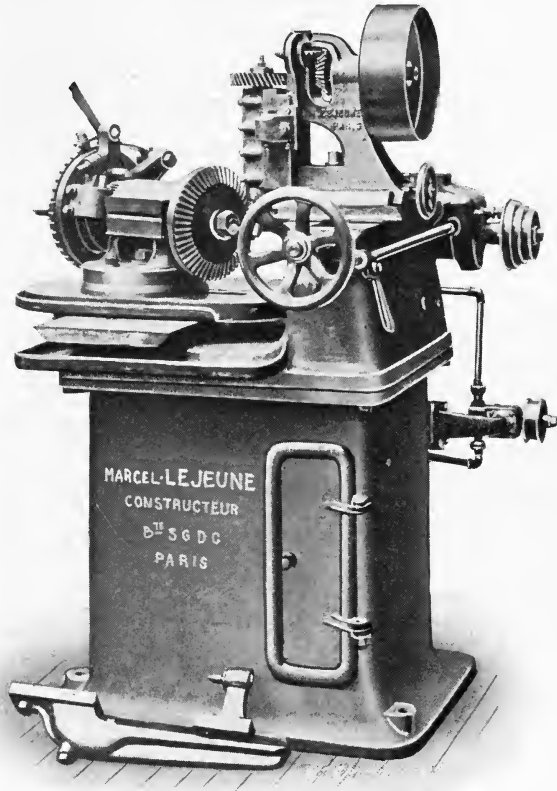

FIG. 167. A Special Milling Machine for Cutting Bevel Gear Teeth.

the axis of the work by a worm and worm-wheel adjustment to give the required rolling movement, independently of the indexing, for correcting the shape of the teeth. What corresponds to the cross movement given the blank in the milling machine is effected here by the vertical adjust-

ment of the cutter spindle on the face of the knee. Provision is made for making both of these adjustments positively and quickly. This machine is built by Etablissements Marcel Lejeune, 93 Rue D'Angoulême, Paris.

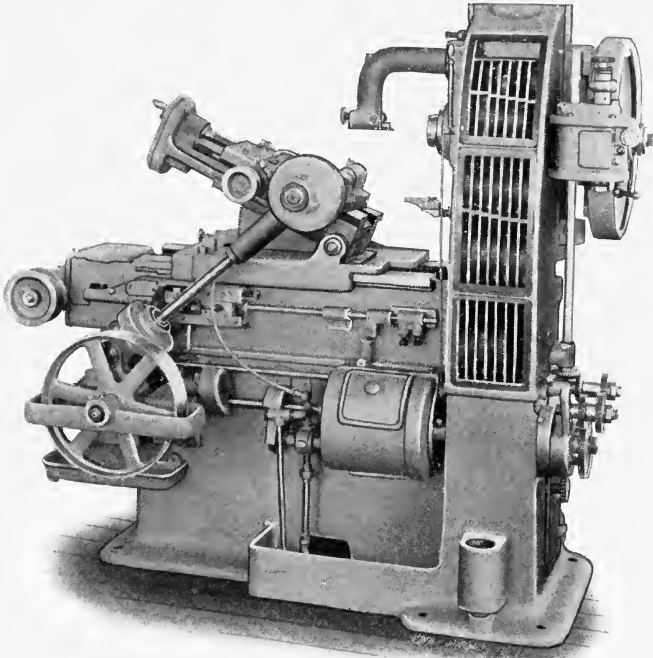

FIG. 168. Brown & Sharpe Automatic Spur and Bevel Gear Cutter, as set up for Cutting Bevel Gear Teeth.

Another favorite way of using the formed cutter principle for cutting the teeth of gears employs a modification of the orthodox automatic gear-cutting machine, such as previously shown in Figs. 22 to 31 inclusive. When this is done, one side of the tooth can be finished clear around without attention from the operator, the cutter slide feed-

ing up, returning, and the work indexing, as for spur gears. The cutter has to be set out of center with the blank and the latter rotated, to approximate the correct form, as with the machines previously described. After going around

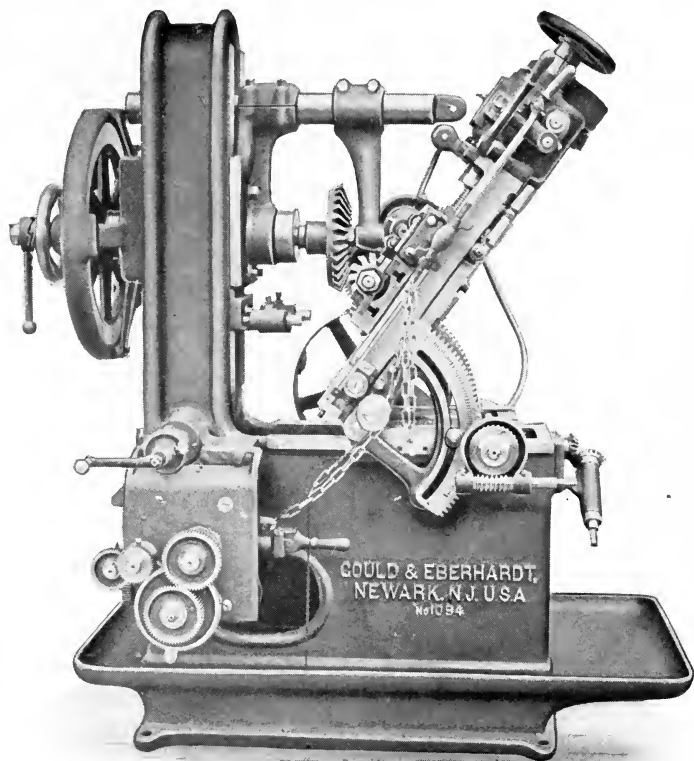

FIG. 169. Cutting a Bevel Gear on the Gould & Eberhardt Automatic Machine of the Orthodox Type.

one side of the tooth, this adjustment has to be reversed to complete the other side, so that two operations are necessary. Fig. 168 shows the Brown & Sharpe gear-cutting machine as provided with the angular cutter slide adjust-

ment for bevel gears, and Fig. 169 shows a Gould & Eberhardt machine arranged for the same work. Probably the greater proportion of the bevel gears made are cut on machines of this kind rather than in other ways. For slow

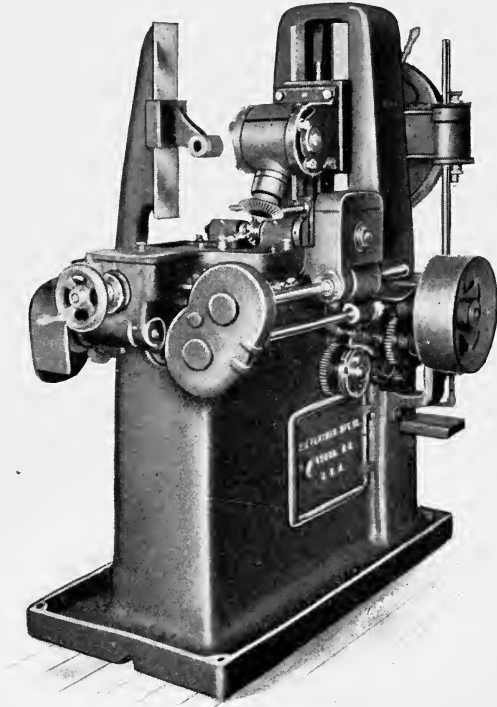

FIG. 170. An Attachment to the Fletcher Automatic Spur Gear Cutter for the cutting of Bevel Gears.

running gears, the approximation, especially if the teeth are afterward filed, may be made close enough to be correct for all practical purposes. For large, high-speed gears to transmit power, one of the planing processes to be described later should be used.

In Fig. 170 is shown still another method of adapting the orthodox gear-cutting machine to the work of cutting bevel gears. The machine shown in this case is that built by the E. J. Flather Manufacturing Company, of Nashua, N. H., and illustrated in Fig. 25. The attachment consists of a

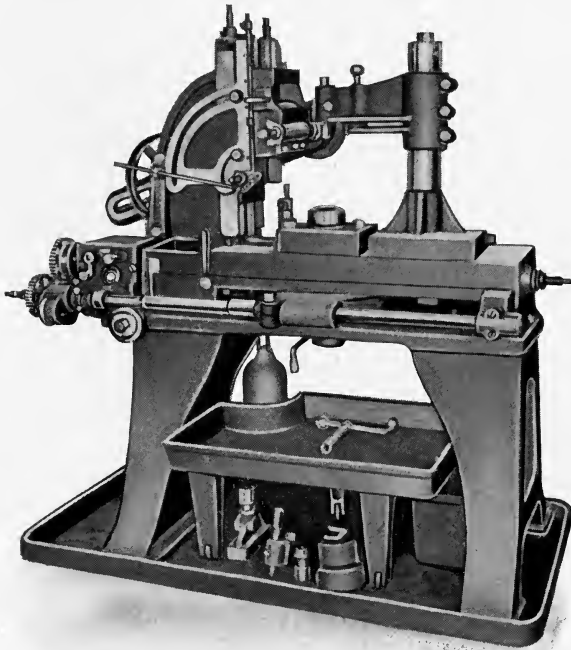

FIG. 171. The Whiton Automatic Gear-Cutter.

supplementary work spindle connected with the main work spindle by bevel gearing in such a way that it may be adjusted to any angle, thus making it unnecessary to complicate the cutter slide and feeding mechanism. The attachment is suitable for work of small diameter, and may be applied to machines not originally designed for cutting bevel gears.

An American machine of the same structural type as those shown in Figs. 33 and 34, built by D. E. Whiton Machine Company, New London, Conn., is shown in Fig. 171. Unlike the two English machines it is arranged for cutting bevel gears as well as spur gears, the cutter slide being mounted on an adjustable sector which may be set to the cutting

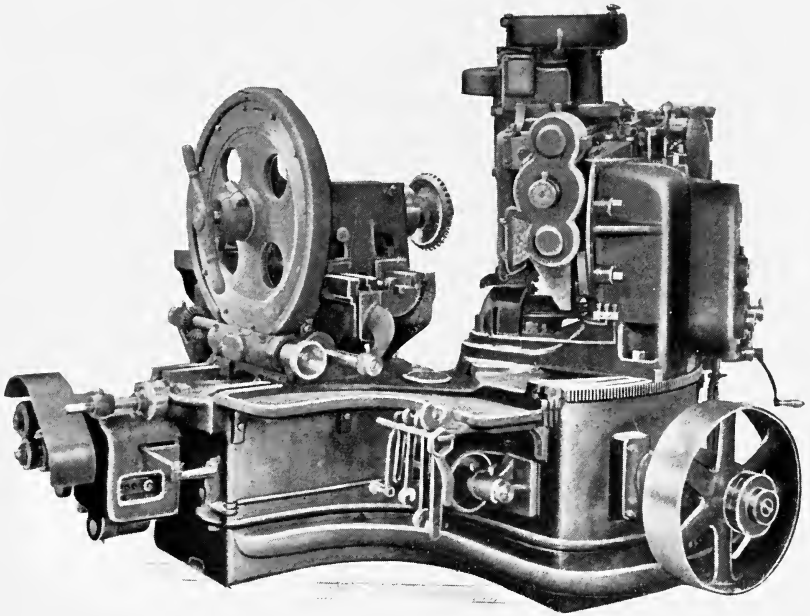

FIG. 172. Rear View of a "Universal" Automatic Gear-Cutting Machine.

angle of the bevel gear which is to be milled. It is fully automatic, and one of the features of its mechanism is a provision for making the starting of each movement dependent on the successful completion of the previous one. That is to say, the mechanism is so arranged that the reverse feed is locked until the forward feed is completed, and the indexing is locked until the reverse has been properly

made. There are no frictional devices, and but one stop adjustment — that for length of stroke, which also releases the indexing device.

An example of the machine with the L-shaped bed, such as shown in Fig. 42, but arranged for cutting bevel gears, is shown in Fig. 172. The ways which carry the cutter slide are mounted on a housing which is adjusted about a vertical axis to agree with the angle of the gear being cut. The machine is fully automatic, and is driven by a single pulley. It will cut spur gears and face gears, as well as bevel gears; and since the ways of the cutter slide have a second angular adjustment about a horizontal axis, teeth which are not in the same plane with the axis of the gear may be cut in spur gear blanks. Such gears may be satisfactorily used as worm-wheels for rough work, if the angle of the cut is made equal to the helix angle of the worm thread. The machine is built by the Newark Gear Cutting Machine Company, Newark, N. J.

The automatic idea has been carried further than in any of the cases previously illustrated, in a machine developed a few years ago by the Brown & Sharpe Manufacturing Company, of Providence, R. I., for cutting bevel gears for chainless bicycles. These gears were to be made in enormous quantities, so that the time lost in the side adjustment and the rolling of the work to bring the blank and cutter into position for cutting the other side of the teeth, after one side had been completed, consumed sufficient time to make the elimination of the operation profitable. The machine shown in Fig. 173 was therefore devised to first feed the cutter through, with the cutter and work set properly for finishing one side of the tooth; when the cutter had passed through the work, the slide on which it was mounted was shifted to a different angular location, so that when it was fed backward to its starting position, the return cut operated

on the opposite side of the tooth space, under conditions which finished it to the desired form. This change in angular position of the tool slide was so adjusted as to be equivalent to the rolling of the blank and the sidewise movement

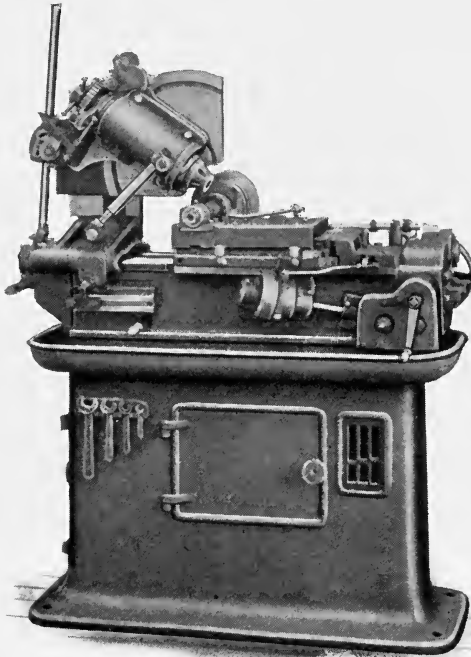

FIG. 173. A Special Bevel Gear-Cutting Machine in which provision is made for shifting the Line of Travel of the Cutter; Both Sides of the Teeth are finished automatically.

of the cutter or work, required in cutting bevel gears in the milling machine or automatic gear cutter.

This machine indexes the work by a notched plate, stops the feed when the last tooth has been cut, and is in other ways adapted to the rapid manufacturing of gears in large

quantities. The gears are afterwards finished by a molding-generating process to be described later (see Figs. 194 and 195), in which the inaccuracies inherent in the formed tool principle are smoothed out. Of course, its usefulness is not limited to the bicycle field for which it was first designed.

ATTACHMENTS FOR FORMING THE TEETH OF BEVEL GEARS BY THE TEMPLET PRINCIPLE.

The templet principle has found a much wider commercial application for cutting bevel gears than for cutting spur gears. This is due to the fact that the formed tool method, as we have seen, is not suited to producing theoretically accurate teeth in the bevel type of gear as it does in the case of the spur, since it does not give to the teeth an outline at the small end similar to that at the large end. Since the templet process is the least complicated way of forming a taper tooth similar in outline from one end to the other (in other words, one whose elements vanish at the apex of the pitch cone), a number of very successful commercial machines have been built involving this principle. The first cases we will consider, however, are not complete machines, but attachments to the shaper.

In Fig. 174 is shown an attachment built by the Act.-Ges. für Schmirgel- u. Maschinen-Fabrikation, Bockenheim-Frankfurt am Main. This is mounted on the shaper table so that the angularly adjustable head which carries the work spindle overhangs the side. The work spindle is indexed with worm and worm-wheel and index plate as in the case of the milling machine dividing head. This indexing mechanism is attached to a quill which is journaled in the work spindle head. It has adjustably mounted on its outer end a bar *B*, to which a holder is attached for supporting the templet *D*. An outer arm *C*, supported

from the frame of the attachment by a bar *G*, carries a roll which is adapted to engage with the edges of templet *D*. The blank, in feeding, is swung up into the tool about center *A*. This swinging movement is operated by a worm and worm-wheel sector controlled by a ratchet feed. As the work is thus gradually fed up into the tool, the action of

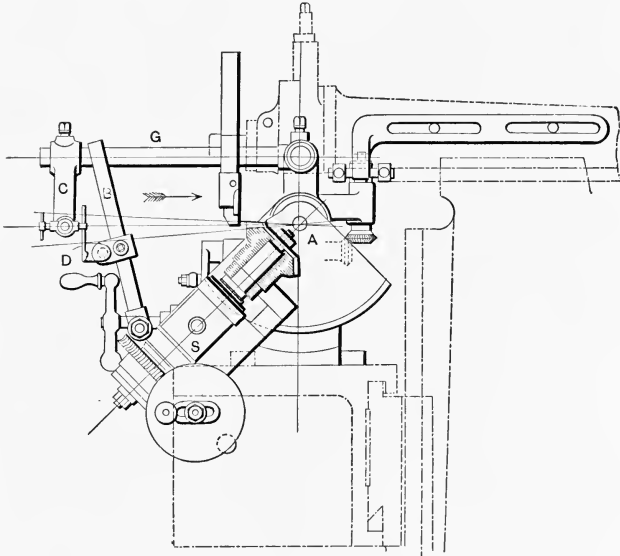

FIG. 174. A German Shaper Attachment for forming the Teeth of Bevel Gears on the Templet Principle.

the roll on the templet will rock bar *B* and the quill and index motion attached to it, thus swinging the work in such a way as to reproduce the outline of the templet on the outside of the tooth. The action is thus identical in its effects with that in Fig. 162, though the templet is used to control the work instead of controlling the tool.

The attachment shown clamped to the shaper table in Fig. 175 is the invention of Mr. Fred Mill, 704 Prytania Avenue,

Hamilton, Ohio. The design of the attachment will best be understood from the line elevations in Figs. 176 and 177. The work spindle is carried in a head *B*, which is swung on horizontal trunnions *A* in housing *C*. This housing is held by semicircular gibs to the circular base-plate *D*, so that it may be swung about a vertical axis. The feed rod *E*,

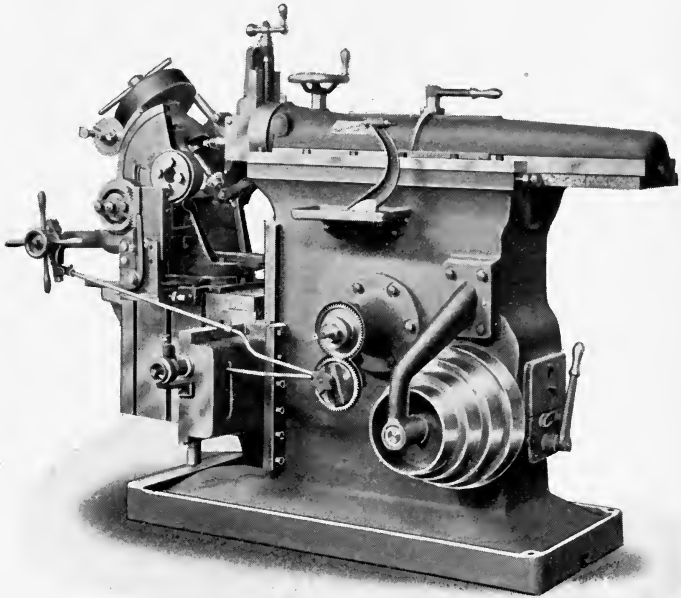
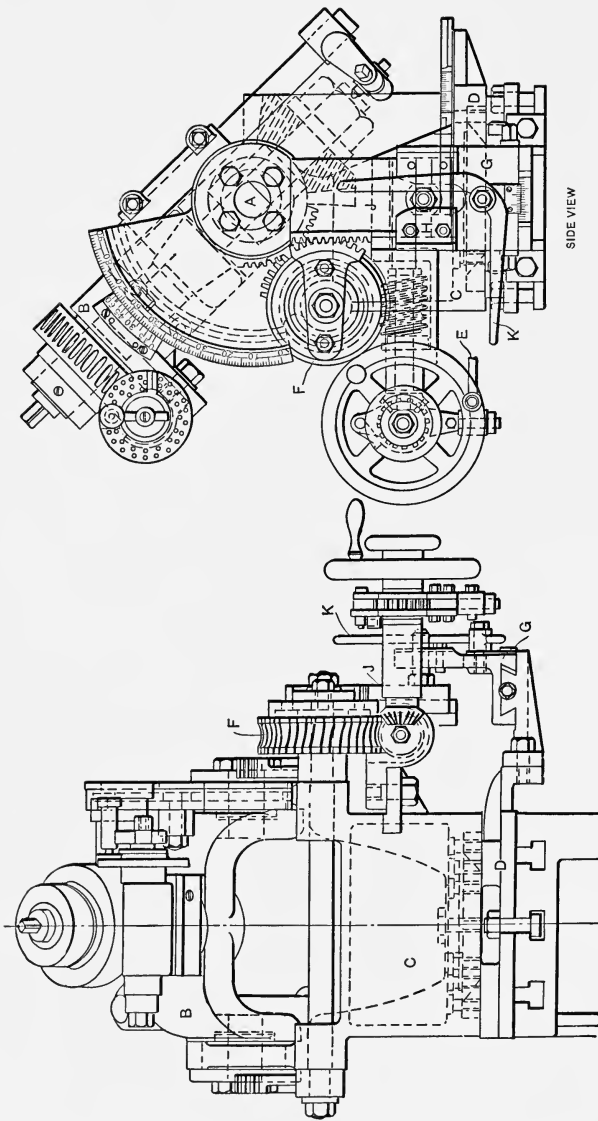

FIG. 175. An American Shaper Attachment employing a Templet for Controlling the Shape of the Bevel Gear Tooth produced.

operated by the regular feed movement of the shaper, is connected through a ratchet and hand-wheel with a worm and worm-gear *F*, connected by spur gear segments with the spindle head *B* in such a way as to swing it about its horizontal trunnions *A*, and thus feed the blank up into the tool.

On the base-plate *D* to which the housing is gibbed, is



Figs. 176 and 177. Rear and Side Elevations of the Bevel Gear Shaper Attachment shown in Fig. 175.

attached a holder G to which the former or templet is fastened. The roll which bears on this templet is held in a roller slide J , which is connected with the segment gears which swing the head in such a way that, as the blank is fed upward into the work, the roller slide is fed downward, carrying the roller along the face of the templet. Since the roll and roller slide are supported by the housing C , the templet moves the housing about its vertical axis, in conjunction with the swinging of the head about its horizontal axis, so as to produce the proper shape of tooth. The roll is held in contact with the templet by lever K , one end of which carries a weight, while the other bears on the roll stud. For shaping the other sides of the teeth, the templet is fastened on the other side of holder G , and the bent lever K is reversed so as to press the roll against the templet in its new position. A stop is provided which releases the automatic feed and quickly returns the head, so that the tool clears the work as soon as the cut has been made to the proper depth. We understand that Mr. Mill has designed an automatic machine operating on the same principle.

In Fig. 178 is shown a German bevel gear shaping attachment, the invention of Prof. Moritz Kroll of the Government Trade School of Pilsen. This device is also designed to be mounted on the shaper table. It has a base-plate to which are attached two standards, F and F_2 , having bearings for the trunnions on head B , which may be adjusted about these trunnions to the desired cutting angle by means of a worm, and worm sector E , fast to F_2 . The work is divided by the index plate and adjustable crank shown, operating a worm meshing with the index worm-wheel on the rear end of the work spindle A . This index mechanism is supported on an arm, whose lower forked end is seen at I . The contact points on either side of this

arm, as desired, may be made to bear under spring pressure on cam M , which is pinned to gear Q , in mesh with gear D , which is in turn keyed to the shaft C , carrying the worm engaging with sector E . All this mechanism is mounted on swinging head B , excepting E , which is pinned to standard F_2 . From this it will be seen that the work may be swung

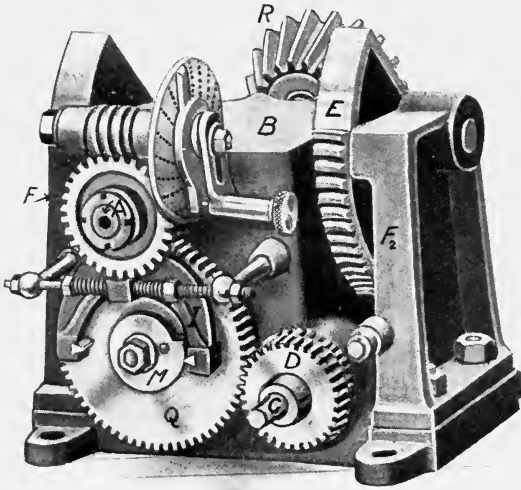

FIG. 178. Shaper Attachment devised by Professor Kroll, in which Circular Templet is used for forming the Teeth of Bevel Gears.

up into the shaper tool about the trunnions on head B by operating shaft C .

As the work is thus swung upward, gear Q is revolved, and with it cam or templet M , which rocks the lower end of lever I and with it the work. Templet M is so shaped that this rocking movement, in conjunction with the upward swinging of the blank, causes the point of the tool in the shaper to produce the required outline of tooth. In this, as in the previous cases, the point of the tool is set to

travel along a line which, if produced, would meet the intersection of the axis of the work spindle and the axis of the trunnions, about which the head rocks. It is possible, by providing suitable change gears between cam *M* and worm shaft *C* in place of the fixed gears shown, to use the same cam or templet *M* for cutting a large range of gears, it not being necessary in that case to have one for each tooth used.

MACHINES FOR SHAPING OR PLANING THE TEETH OF BEVEL GEARS BY THE TEMPLET PRINCIPLE.

In this country the templet principle is represented commercially by a single machine, that built in various sizes and designs by the Gleason Works, of Rochester, N. Y. This machine is illustrated in Fig. 179. The tool is carried by a holder reciprocated by an adjustable, quick-return crank motion. The slide which carries this tool-holder may be swung in a vertical plane about the horizontal axis on which it is pivoted to the head, which carries the whole mechanism of tool-holder, slide, crank, driving gearing, etc. This head, in turn, may be swung in a vertical axis about a pivot in the bed. The circular ways which guide this movement are easily seen in the illustration. The intersection of the vertical and horizontal axes of adjustment (which takes place in mid air in front of the tool slide) is the point *O* in Fig. 162, where the templet principle is shown in diagrammatic form. The apex of the pitch cone of the bevel gear must be brought to this point *O*. The blank is mounted on a spindle carried by a head which is adjustable in and out on the top of the bed of the machine so that the apex of the cone of the gear may be brought to this point by means of the gauges which are a part of the equipment of the machine. The work spindle is provided

with an indexing mechanism, which operates automatically as do all the other functions of the machine.

Three templets are used, mounted in a holder attached to the front of the bed, on the opposite side from that shown. The first of these templets is for "stocking" or roughing out

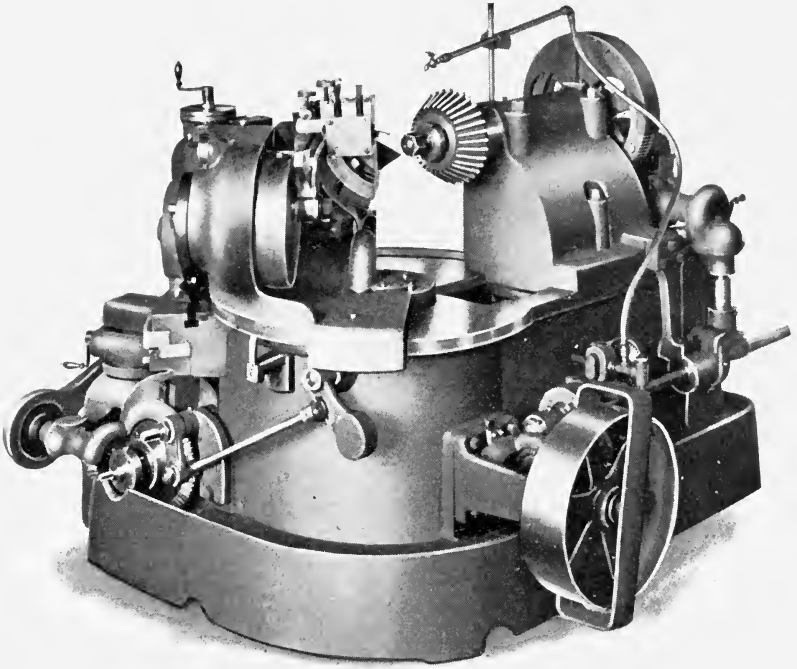

FIG. 179. Gleason Templet-controlled Bevel Gear Planing Machine.

the tooth spaces. It is simply a horizontal straight-edge on which rests a roller, attached to the outer end of the slide on which the tool-holder reciprocates. With the work and tool set properly, the whole tool-carrying head is swiveled about the vertical axis, feeding in at each stroke of the blade deeper and deeper, until the space has been properly roughed out. After each tooth space has been gashed in

this fashion, the templet holder is revolved to bring one of the formed templets into position, and a tool is set in the holder so that its point bears the same relation to the shape of the tooth desired as the cam roll does to the templet. The head is again fed in by swinging it around its vertical axis, during which movement the roll runs up on the stationary templet, swinging the tool about its horizontal axis in such a way as to duplicate the desired form on the tooth of the gear. One side of each tooth being thus shaped entirely around, the holder is again revolved to bring the third templet into position. This has a reverse form from the preceding one, adapted to cutting the other side of the tooth. A tool with a cutting point facing the other way being inserted in the holder, each tooth of the gear has its second side formed automatically as before, completing the gear.

The swinging movement for feeding the tool and the indexing of the work are taken care of by the mechanism of the machine without attention on the part of the operator. The swinging feeding movement about the vertical axis is effected by a cam and slotted link motion which may be adjusted to any degree of angular movement required. The head may be adjusted angularly with respect to its feed to agree with the pitch angle of the gear being cut.

The formers or templets for the Gleason machine are made by a molding-generating process, described by Mr. Fred Miller in a paper in Vol. 22 of the Transactions of the American Society of Mechanical Engineers.

A French machine, built by Usines Bouhey, 43 Avenue Daumesnil, Paris, is shown in Fig. 180. While it operates on the templet principle, the movement for producing the desired outline is somewhat different from that employed in the Gleason machine previously described. Instead

of applying to the tool the movement derived from the templet, it is applied to the work, in a manner which will be evident from the illustration and the following description:

The cutting tool is carried by an overhanging arm, at the top of the frame, operated by the slotted crank shown. The work spindle carrying the wheel to be cut, the index-

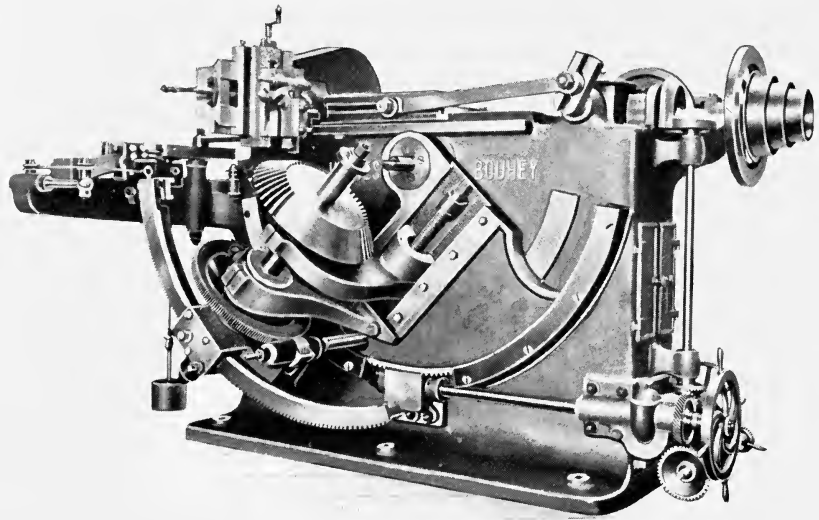

FIG. 180. The Bouhey Templet Planing Machine, in which Provision is made for the Cutting of Twisted Teeth.

ing worm-wheel, automatic dividing apparatus, etc., are carried on brackets attached to a swinging sector. The work spindle is so arranged that it may be adjusted longitudinally, to bring it into coincidence with the axis about which the sector is adjusted. The indexing mechanism is attached to a frame which is free to swing under the influence of the templet, which is attached to the upper end of an adjustable arm carried by this frame, and is

located in a position to bear on a fixed guiding plate supported by the bed of the machine. It is held in contact with it by a weight and cord.

The action is as follows: The wheel, properly mounted on its arbor, is swung upward toward the reciprocating tool by a worm feed movement, applied to worm-wheel teeth cut in the periphery of the sector. While this angular feeding movement is in progress, a variable rocking is imparted to the entire indexing mechanism, work spindle and work, through the action of the templet on the stationary guide plate. It is this variable motion, controlled by the templet, which produces the desired outline on the tooth. When the correct depth of tooth has been reached, the feed is automatically tripped and the sector returned to its original position. The work is then indexed, the forward feed automatically reengaged, and the cycle of operations continued until all the teeth are finished on that side, and the machine is stopped by the operator, and reversed for completing the teeth. The movements thus appear to be identical with those of the attachment in Fig. 174, but are performed automatically.

A unique provision of this machine is that made for cutting bevel gears with twisted teeth, as shown in Fig. 180. It consists simply in providing for a positive connection between the indexing mechanism and the crank-shaft driving the tool slide, through the medium of change gears, so that the work and crank rotate in unison at the proper ratio to give the number of teeth desired in the work. Since the stroke then takes place while the work is rotating, a twisted form of tooth is produced. This tooth has the same outline (when seen at the ends) as when a straight tooth is being cut by the usual method. For cutting another gear of any angle to mesh with a gear cut this way — such, for instance, as the one shown in the engraving

ing—it is only necessary to reverse the connection between the crank and the work so that rotation takes place in the opposite direction, and to set the slide and the templet for the new angle and the new tooth. This being done and the length of the stroke being the same,

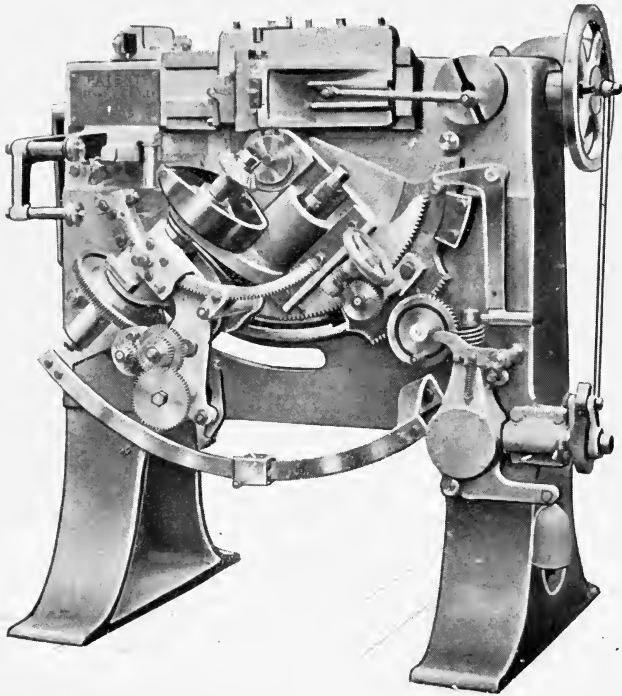

FIG. 181. The Greenwood & Batley Templet Bevel Gear Shaping Machine.

the teeth cut will exactly correspond in curvature with those previously cut in the mating gear.

Twisted tooth bevel gears are almost unknown in America, but have found considerable use in Europe, where twisted tooth gearing of various kinds is in much

greater favor than here. The teeth of gears thus made are not made to a true conical helix, since the motion is modified by the crank movement. All that is required, however, is that the curves of the gear and pinion should match. This requirement is met in this machine.

An English machine, built by Greenwood & Batley, Ltd., Albion Works, Leeds, is shown in Fig. 181. The action and general arrangement of the machine are almost identical with that of the previous case, excepting that no provision is here made for cutting twisted teeth. A comparison of the two tools serves well to show the wide variation in details resulting when two designers independently work out the same idea. Aside from the difference in details, there are two salient changes in the mechanism. One of these relates to the feed, which is of the ratchet type, driven from a slotted disk. The other change relates to the mounting of the head, which is carried on two superimposed swiveling sectors, which pivot on a common center whose axis meets the line of travel of the cutting tool. The outer sector is adjustable on the face of the inner one to suit the angle of the wheel being cut while the feed movement is applied to the latter. Except for the particulars enumerated, the action is identical with that of the Bouhey machine.

In Fig. 182 is shown still another machine with the same relations between the tool, the work and the temp-let. As may be seen, however, the design is so different that there is no resemblance between it and those shown in Figs. 180 and 181. The tool is carried by a ram reciprocated by a mechanism similar to that used in a crank-driven shaper; the whole arrangement of the machine, in fact, resembles that of a shaper and is structurally derived from it. The work is carried on a spindle mounted in a frame hung about a horizontal axis from pivots seated

in the arms shown projecting from either side of the head of the machine. The work is adjusted on the arbor to bring the apex of the pitch cone into the horizontal axis through the trunnions. A rigid outboard support for the work arbor is furnished, as shown.

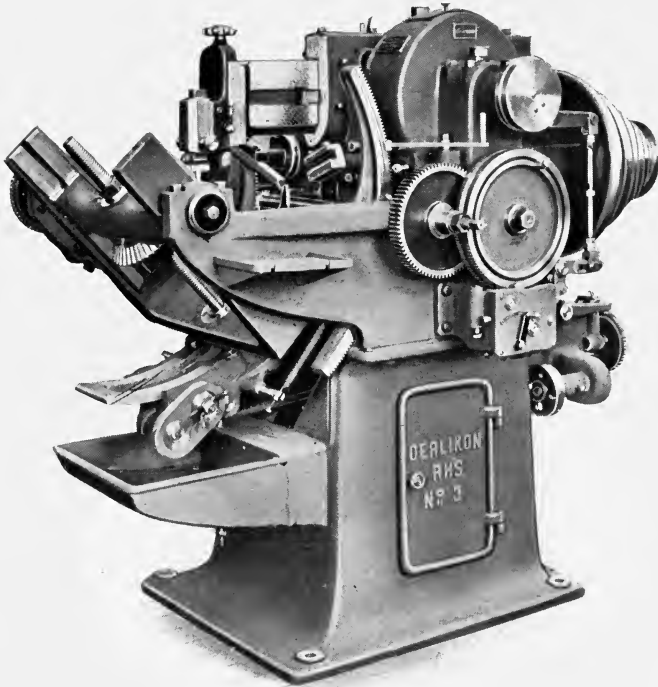

FIG. 182. The Oerlikon Single-Tool Templet Bevel Gear Shaper.

The frame carrying the work is swung upward about the horizontal trunnions by a movement operated by the tooth sectors shown on each side, which are engaged by pinions on a horizontal shaft, connected, in turn, by gearing with a ratchet disk seen at the side of the head. From this the feed movement is obtained. Stops are provided

on the face of the ratchet disk which limit the swinging feed movement, and actuate mechanism for returning the work rapidly when the cut has been completed, so that the tool is clear for indexing the blank. When the indexing has taken place, the upward feed is again automatically thrown in. As in the Greenwood & Batley machine, the entire dividing mechanism is attached to a bracket carrying an adjustable arm to the upper end of which the templet is attached. By means of springs this templet may be caused to bear on adjustable contact surfaces at either side, depending on which side of the tooth is being cut. The templet, bearing on the guide attached to the head of the machine on the side farthest from the observer, is somewhat imperfectly shown in the engraving.

We think it will be agreed that this tool gives evidences of careful design and construction. It has a decidedly rugged and business-like look. It is built by the Société Suisse pour la Construction de Machines-Outils Oerlikon, Oerlikon près Zurich, Switzerland.

Fig. 183 shows another templet machine, built by the same firm. The head carrying the slides is fed inward about a vertical axis, as in the Gleason machine. The swiveling movement of the tool slide about the horizontal axis is also similar to the Gleason machine, but the two are differentiated in their action by the provision of a second slide and tool-holder, both pivoting about the same horizontal axis. The movement which the templet imparts to the upper slide is duplicated on the lower one, though in the reverse direction, so that the same outline is formed on each side of the tooth simultaneously. Besides the use of the two tool slides, this machine differs from the Gleason in having the head carrying the work spindle and the automatic indexing mechanism, swivel for adjusting to the angle of the work, about the same vertical axis around

which the feeding movement of the cutter slide head takes place. This tool was designed by its builders to provide a maximum of accuracy and rapidity for work within its range.

A firm in Budapest, Hungary, whose name translated into English reads "Small Arms and Machine Factory

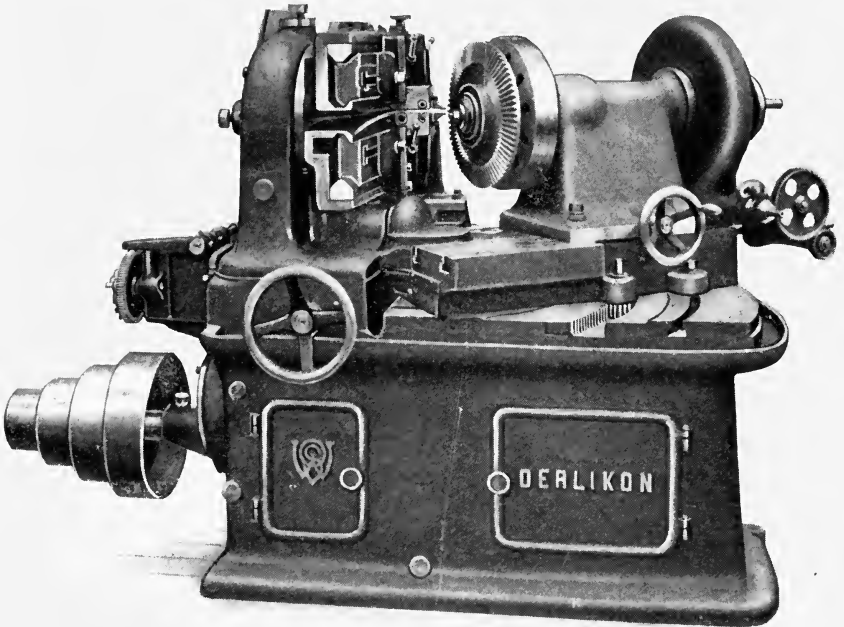

FIG. 183. Oerlikon Bevel Gear Cutter operating on the Templet Principle, and using Two Tools Simultaneously.

Company, Ltd.," has built for a number of years the templet bevel gear planer shown in Fig. 184. In this machine the work spindle is adjustable for the pitch cone angle, by moving it in a concave circular seat in the bed. This seat keeps the axis of the work spindle always in line with the horizontal axis of the swiveling adjustment.

The outer end of the work arbor is supported in a yoke which swivels about this axis. The mechanism on the upper part of the machine is the tool head, which carries two crank-driven slides, each of which carries a tool.



FIG. 184. A Hungarian Templet Bevel Gear Planer.

These slides are confined by guides which are pivoted about an axis passing through the apex of the pitch cone. The whole mechanism swivels about the horizontal axis passing through the same point. As the tools are swung down into the teeth about this horizontal axis, they are

spread apart about the vertical axis by the action of fingers on each tool slide guide, which bear on opposite sides of a suitably formed templet, held in the templet holder at the upper right of the machine. The swinging downward of the tool slide mechanism is accomplished by a revolving nut on the swiveling screw which connects this mechanism with the bracket to which the templet is

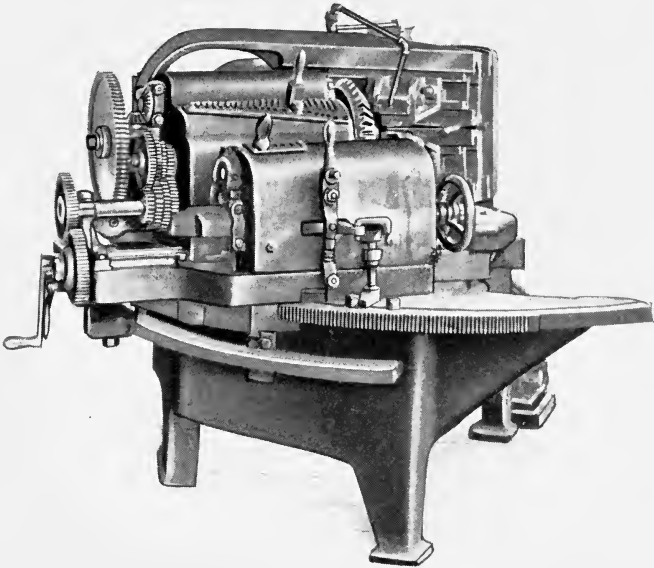

FIG. 185. The Browning Templet Bevel Gear Planer.

clamped. This latter is held in slides which are adjustable for both vertical and horizontal movement. In having the tools swivel about both axes while the work remains stationary, this machine resembles the Gleason machine shown in Fig. 179. It is not, however, fully automatic.

The templet machine shown in Fig. 185 is the design of Earl H. Browning, of the Browning Engineering Works,

Cleveland, O. As in Fig. 183, two tools are used, each mounted in separate slides which are swiveled about a common horizontal axis passing through the apex of the pitch cone of the gear to give the desired outline to the tooth. This swiveling of the cutter slides under the action of the templet takes place simultaneously with the swinging of the work-carrying head about a vertical axis. That is to say, as the tooth of the gear is swung in between the

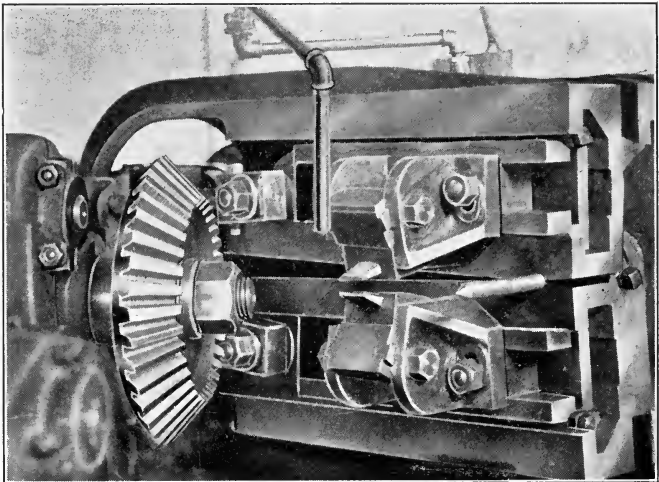

FIG. 186. Detail of the Browning Machine, showing the Two Tool-Holders.

points of the tools the latter are opened up with the proper movement to give the desired tooth outline. As the points of both tools travel toward the apex of the pitch cone of the gear, the outline of the templet is reproduced on a decreasing scale from the large to the small end of the tooth. In the details of the design this machine is original. One of the points of novelty is the use for the indexing mechanism of the quick change gear box seen on the work spindle head in Fig. 185. This gear box,

in combination with a further change of four ratios, gives the entire range for cutting any ordinary number of teeth without the use of loose change gears. The changes of speed and feed are also effected by quick change gear boxes. Fig. 186 shows a face view of the cutter slides, with the tools in place in the tool-holders. In this machine, the templet, which is not here shown, is in the form of a cylindrical cam with two grooves, each of which controls a roller attached to the outer ends of the tool slide guides, which are thus controlled.

A MACHINE FOR MILLING THE TEETH OF BEVEL GEARS BY THE TEMPLET PRINCIPLE.

In Fig. 187 is shown the principle of a templet bevel gear planing machine differing in many respects from any of those previously shown. This principle originated with Mr. Charles DeLos Rice, of Hartford, Conn., and the machine he designed, incorporating it, is much used for cutting chainless bicycle gears, though it is not now on the market. The differences consist principally in the form of templet used, and in the form of the follower and the cutting edge of the tool. In other templet machines the follower which makes contact with the templet is presumably a point, as should also be (to insure theoretical exactness) the cutting point of the tool. In reality, of course, the outlines of both these members are rounded, a roll being generally employed for making the contact with the templet, and a round-nose tool being used for doing the cutting. Theoretical accuracy could be obtained under these conditions if the shape of the templet were made to allow for the diameter of the roller which follows it (as is the case in making templets for the Gleason machine, at least) and if the shape of the point of the tool is also considered. The latter, however, should

grow continuously smaller in radius as it approaches the small end of the tooth, in the same scale with the decreased size of the tooth itself; and similarly it should grow larger as it approaches the large end. As it remains the same size all the time, of course, a slight error is introduced — so slight, however, as not to introduce anything except a negligible inaccuracy.

In the Rice machine the copying of the templet is done with theoretical precision. Both the guiding and the cut-

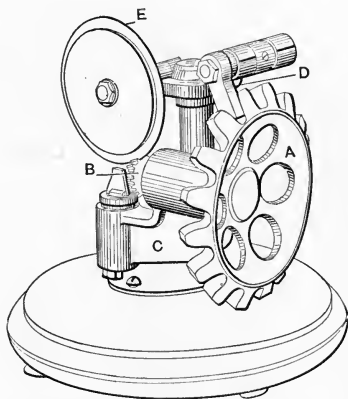

FIG. 187. Model illustrating the Principle of the Rice Machine shown in Fig. 188.

ting edges are plane surfaces, and being such, obviate the necessity for a change of scale in cutting outlines at different points of the stroke. Fig. 187 shows a model of the movement employed, especially made for the purpose of illustration. The templet, *A*, used, is a complete gear of the same proportions as the work to be cut, but on a larger scale. It is mounted on a spindle fast to the blank *B*. This spindle is carried by a swinging bracket *C*, pivoted about an axis at right angles to that of the work, and passing through the apex of the pitch cone of the work and

master gear. The sketch of the model shows a disk *E* mounted on a fixed horizontal spindle, entering one of the spaces which have been cut in the blank. The acting surface of the disk is in the plane of the vertical axis about which bracket *C* swings. In the same plane is the acting

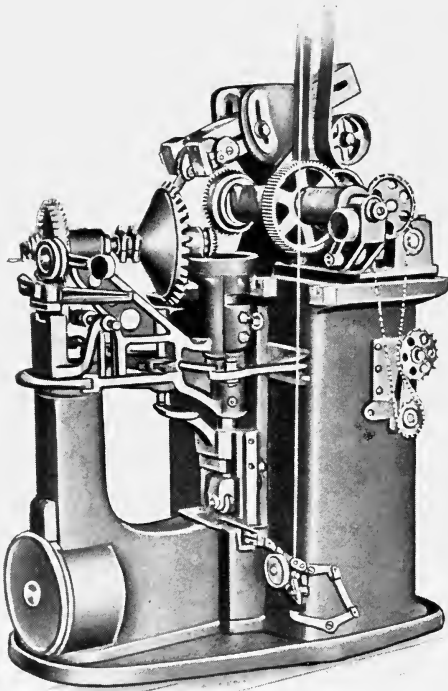

FIG. 188. The Rice Bevel Gear Milling Machine, which forms the Teeth from a Master Gear on the Templet Principle.

surface of a fixed stop or guide plate *D*, which, as shown, is mounted on the same pedestal as the spindle of the disk and enters the space cut in the master gear in the same way that the disk enters the space between the teeth of the work.

If the teeth of the master gear be pressed against the act-

ing side of the fixed stop, while the bracket supporting the master gear and the work is rocked about its vertical axis, it is evident that the stop will roll about the face of the tooth of the master gear or templet, making line contact with it, while the face of the disk will act in an identical manner, though on a smaller scale, with relation to the tooth of the work. If the disk be replaced with a cutter of the same diameter, and with a cutting face in the same plane as that occupied by the acting face of the disk, the rocking of the bracket about its vertical axis will evidently cause the cutter to mill out a tooth face identical with that of the templet or master gear, but on a smaller scale. While this operation appears to have the ear marks of the generating process, it operates on the templet principle in reality, as is shown by the description we have just given. The cutter is made of large diameter, as compared with the work, in order to give as straight a bottom to the tooth space as possible. The deepening of the tooth space in the center does not, of course, affect the accuracy of the working portion of the outline.

An automatic machine in which these principles are embodied is shown in Fig. 188. The mechanism is too intricate to be described without the use of a considerable number of line drawings and an extended description, so we will content ourselves with enumerating the movements which the mechanism effects. The master gear governs the tooth spacing, the tooth thickness, and the tooth form. The master gear and a previously-gashed blank being mounted in position in the machine with the guide plate and cutter positions and other adjustments properly made, the mechanism is started. The cam movements provided first feed the master gear and work spindle upward until the cutter is in to depth and the stop bears against the face of the master gear. The bracket carrying them is then rotated

about its vertical axis until one face of one tooth of the blank is completed. The work is now dropped down out of the way, and the spindle, with the blank and master wheel, are indexed one revolution, after which they are again raised, repeating the same operations as before. This is done repeatedly until the whole gear has been cut around on one side of all the teeth. When this has been done, the machine stops and the attendant rotates the segment of a hand-wheel rim seen encircling the front pillar of the machine. Through the link connections on this rim, the fixed gage and the cutter are each shifted axially a distance equal to their thickness, so as to bring them to positions to work on the other side of the tooth. The automatic mechanism for swinging the work spindle is also changed by the same movement, so that it swings in the other direction. The mechanism is then started up and the other sides of all the teeth are finished.

An interesting point in the product of this machine is that the gears produced are accurate copies of the master gear on a smaller scale. It is thus possible where bevel gears are to be made in large quantities, to make the master gear and pinion, and run them together under conditions severe enough to test their suitability for the work the smaller gears are to perform. Such corrections as may be required being made in these large gears, assurance is given that the smaller gears will behave in a satisfactory way. The principle of this machine could, of course, be adapted to a machine for general use, by using as a templet but a single tooth of the master gear, instead of employing an entire wheel, as here shown. It was at one time, we are informed, the intention of the inventor to develop such a machine, but so far this has not been done commercially. Obviously, this method of applying the templet principle cannot be applied to cycloidal teeth having concave surfaces.

MACHINES EMPLOYING THE TEMPLET PRINCIPLE FOR
GRINDING THE TEETH OF BEVEL GEARS.

The grinding operation has been used in a templet machine built by the Société Suisse pour la Construction de

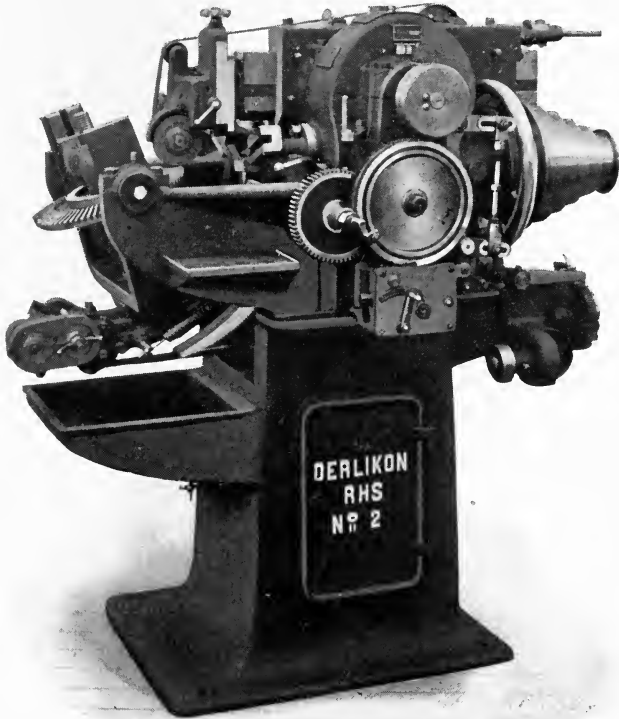

FIG. 189. The Oerlikon Templet Gear Shaper of Fig. 182, arranged with Grinding Wheel for finishing Hardened Bevel Gears.

Machines-Outils Oerlikon, Oerlikon près Zurich, Switzerland, and shown in Fig. 189. As may be seen, it is a modification of their regular templet planing machine, previously shown in Fig. 182. The change consists merely in replac-

ing the cutting point of the tool with the edge of a grinding wheel, carried on the head of the ram, and provided with suitable means for driving it at the proper speed. Under these conditions, the edge of the wheel shapes the teeth of the gear to the form of the templet provided. The builders state that by the employment of special wheels which they have developed for the purpose, it is possible to cut clear around a large gear without a perceptible change in the condition of the cutting edge, or a corresponding change in the profile of the tooth produced. If this is so, the greatest objection to the grinding process for gear cutting of any kind is largely obviated. The purpose of the machine is, of course, the finishing of the teeth of hardened gears to remove the inevitable inaccuracies due to distortion arising from the heat treatment. It has been found especially useful in automobile work.

This Swiss firm has done especially noteworthy work in the building of machines for cutting bevel gears. The three we have illustrated, Figs. 182, 183 and 189, and one later in Fig. 217, for rough-milling bevel gears, do not by any means exhaust their list of machines built for forming the teeth of gears of this type. Among other Oerlikon designs may be mentioned two of great interest, described in the paper by Mr. Fred. J. Miller, to be found in Volume 22 of the Transactions of the American Society of Mechanical Engineers.

MACHINES WORKING ON THE ODONTOGRAPHIC PRINCIPLE FOR CUTTING THE TEETH OF BEVEL GEARS.

A machine operating on the odontographic principle, in which the point of the tool is guided by mechanism which very nearly reproduces the theoretical shape, is shown in Fig. 190. It is built by Officina Meccanica Ing. E. Dubose, Via Principi d'Acaia, 62, Turin, Italy. In this machine, as

may be seen, the work spindle is horizontal and is indexed by a dividing wheel of large diameter. The work arbor is supported at the outer end in a stirrup held in the swing-

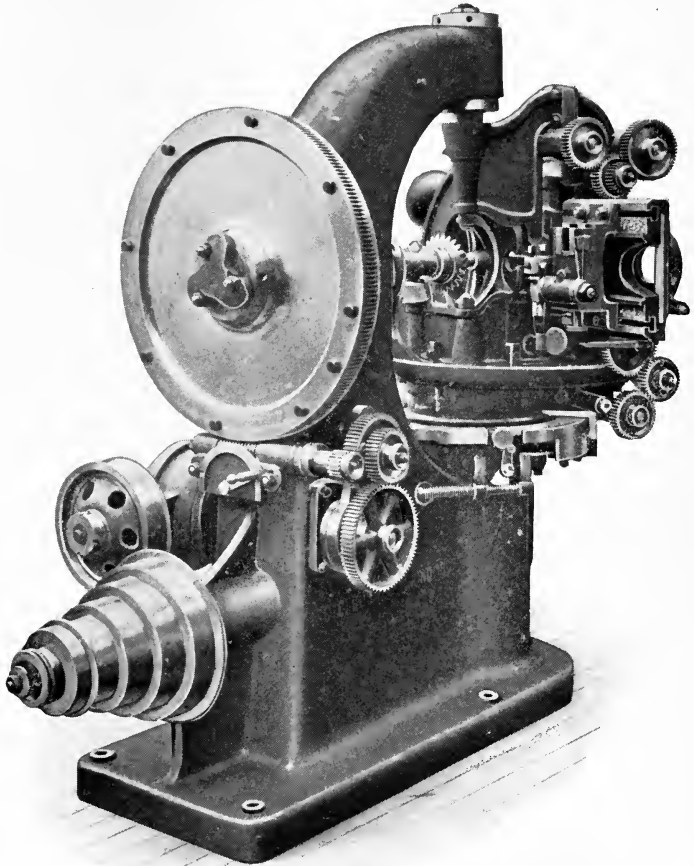

FIG. 190. The Dubosc Bevel Gear Planing Machine, cutting Involute Teeth by the Odontographic Principle.

ing tool frame, this support making it possible to do heavy and rapid cutting. The work is adjusted by means of suitable gages until the apex of its pitch cone lies in the center

line of the journals provided (at the top and bottom of the main casting of the machine) for the trunnions of the frame which swings about the work on a vertical axis. This frame carries most of the mechanism of the machine, and is provided with pivots in a horizontal axis, in the same plane with the vertical axis, about which swings a counter-balanced arm having guides for the tool slide. A tool may thus be set to have a reciprocating movement in any plane containing the apex of the pitch cone of the work. This being the case, if suitable mechanism for effecting it is provided, the tool may be made to plane a conical surface, vanishing at the center of the horizontal and vertical axes, and determined by any line drawn on the surface of a sphere having the same center. In this respect it resembles all templet and odontographic machines, which are distinguished from each other only in the means provided for guiding the tool, as shown in Figs. 161 and 162.

In the machine in question, the odontographic mechanism provided produces teeth of involute form. This mechanism (which is obscured in Fig. 190) is shown in diagrammatic form in Fig. 191, in two positions. We cannot take the space here to describe why the mechanism produces a curve of almost absolutely true involute form, nor can we enter into the details of the connections by which the movements effected by this mechanism are transferred to the point of the tool, as this would require a chapter in itself. It can only be said the pinion *A* is connected with a worm meshing with a segment of a worm-wheel fast to the base of the machine, by means of which the frame carrying the mechanism and the tool is rotated about its vertical axis. This pinion meshes with the segmental gear *B*, which carries a crank-pin *C*, angularly adjustable for a certain amount about the center of the gear. A connecting-rod *D*, adjustable for length, connects crank-pin *C* with a

second pin E attached eccentrically to a disk F , eccentrically seated in turn in a crank whose center is G . Disk F , with crank-pin E , may be adjusted for various angular positions about the center of the disk by worm H . Crank G is connected with mechanism for swinging the tool slide in a vertical plane about its vertical axis, the whole mechanism thus serving to connect the swinging movements of the tool about the horizontal and vertical axes. By

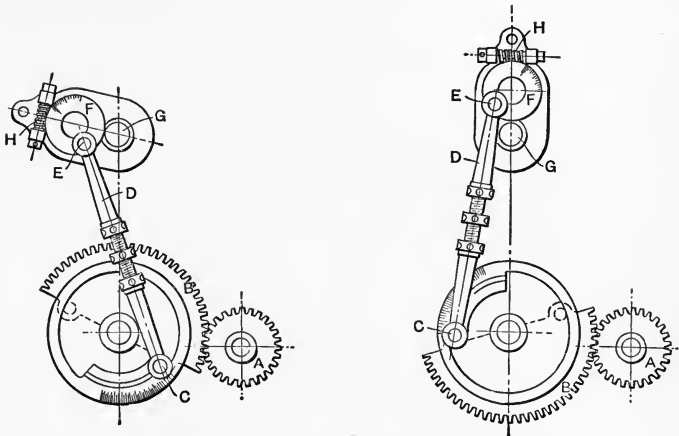

FIG. 191. The Odontographic Mechanism of the Dubosc Machine at the Beginning and End of the Cutting Action.

setting C according to graduations at various angular positions with relation to B , and by setting E at various positions by the rotating of disk F , and by adjusting the length of connecting rod D , the movements about the horizontal and vertical axes may be so connected as to produce tooth outlines of nearly theoretical accuracy.

This apparatus, as described, determines the form of the tooth. Change gears provided between G and the vertical movement which it accomplishes, and A and the horizontal movement with which it is connected, alter the scale of the

outline — that is, adapt it to a large tooth or a small tooth as may be required. Still other change gears are provided for the indexing, which is automatic, as are all the functions of the machine for completely forming one side of all the teeth of the gear. The shape that can be given varies from the straight side of the rack tooth (which is used for all gears having more than 150 teeth), to small bevel pinions with undercut flanks in which a reverse motion has to be given to the movement about the horizontal axis. The tool is provided with mechanism for cutting on both the forward and back stroke on work that is large enough to admit this.

We are informed by the English licensees of the Dubosc patents, Messrs. Selig, Sonnenthal & Co., 85 Queen Victoria Street, E. C., London, England, that the builders of the tool are preparing a new design, embodying a number of improvements in the mechanism.

The only other odontographic machine the writer is acquainted with is built by Smith & Coventry, of Manchester, England (see Figs. 192 and 193). It is somewhat easier to understand than the Dubosc machine, as the curves it employs are simple arcs of circles. Two tools T_1 and T_2 are used, each set in separate slides S_1 and S_2 pivoted about an axis at the apex X of the pitch cone of the blank being cut. These slides have rearward extensions in the form of arms $A_1 A_2$, ending in slotted arcs concentric with axis X . Each of these arms is clamped by bolts passing through the slotted arcs to blocks C_1 and C_2 sliding in horizontal guides on parallel bars D_1 and D_2 . Bar D_1 is supported on links E and E_1 , while bar D_2 , pivoted also to double-ended link E , is supported by it and short link E_2 . As link E is rocked, the two bars swing, one to the left and upward and the other to the right and downward, but with their guiding surfaces always parallel. As they are swung in this way, the two

slides A_1 and A_2 are brought together or opened out, as the case may be.

The rocking of this parallel linkage system is effected by a connection with the angularly adjustable head M , which

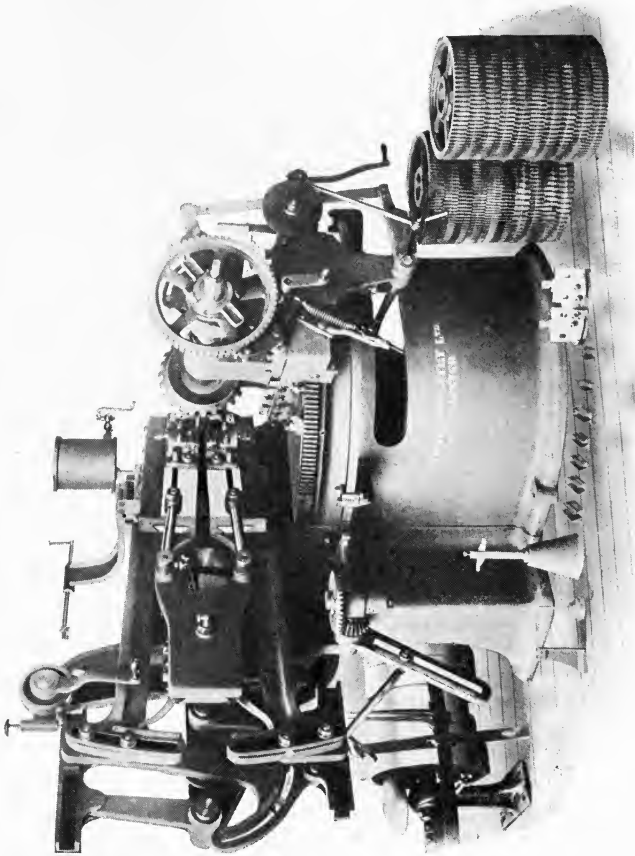

FIG. 192. The Smith & Coventry Odontographic Bevel Gear Planing Machine.

carries the work spindle. This is swung inward for the feeding movement to shift the tools down the sides of the tooth until the full depth has been reached. To slide M is clamped a circular bar N , whose rear end has teeth cut in it

engaging with those of a sector *G*, which, by the bevel gearing, is connected with slotted arm *H*. This arm is adjustably connected with link *E* by a connecting-rod *J*, which, as shown, may be altered slightly as to length and to

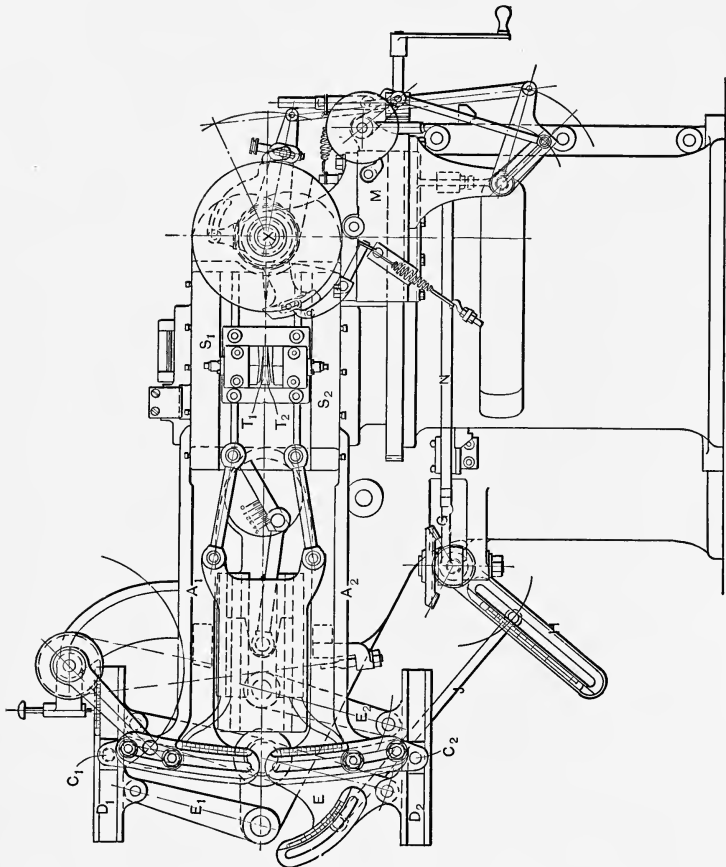

FIG. 193. The Mechanism of the Smith & Coventry Bevel Gear Planer.

the amount of movement given it, depending on the way in which it is clamped to *H*. From this it will be seen that as the work slide *M* swings around, moving the teeth of the blank inward toward the tools, its connection with circular

bar N through sector G , and the geared connections of the latter with arm H , operate the linkage system E, E_1, E_2 , and bars D_1 and D_2 , with the tool-slides S_1 and S_2 connected with them. By this means the tools are gradually opened out as the base of the tooth is approached, in such a way as to make their outlines correspond to circular arcs approximate to the desired involutes, the circular form being determined by the swinging of the links E_1 and E_2 about their centers. Tables are furnished for setting J with relation to H , and arms A_1 and A_2 with relation to D_1 and D_2 , so as to reproduce on the teeth the proper outlines.

It should have been mentioned that this machine does not work on the principle of completing one tooth, and then indexing to complete the next. The work indexes at every stroke of the double tools. After the first cut has been taken on the first tooth, the work is indexed and the same cut taken on the next tooth. When the work has been once around in this way, the tool starts in with a deeper cut on the first tooth again, this continuous rotation and gradual feeding in of the tool continuing until all have been simultaneously formed to the required depth and proper shape, being similar in this respect to the Bouhey machine in Fig. 180, and the Bilgram machines shown later in Figs. 196 and 197.

CHAPTER VIII.

MACHINES FOR FORMING THE TEETH OF BEVEL GEARS (*Continued*).

THIS chapter continues the discussion of machinery for cutting the teeth of bevel gears, being devoted to such of them as operate on the molding-generating principle.

FINISHING BEVEL GEARS BY THE OPERATION OF IMPRESSION.

In Fig. 194 is shown the only example known to the writer of a commercial machine using the operation of impression. This machine was built by the Brown & Sharpe Manufacturing Company, Providence, R. I., for performing the finishing and correcting operations on bevel gears, roughed out in the special full automatic formed-cutter machine, previously described, and shown in Fig. 173; it is not a machine which finishes the gear directly from the blank. The impression process is, of course, absolutely impracticable for operations that would require the pressing into shape of as much metal as would be required in that case.

The machine has two spindles, of which the one carrying the forming gear is driven by suitable belts and pulleys from the counter-shaft, while the other spindle is mounted in a head which, as shown, can be set at any angle with the first, to agree with the angle between the axes of the forming gear and the work being pressed into shape. The forming gear, instead of being a small pinion, as in Fig. 163, is a crown gear; this gear is chosen on account of the

facility with which it can be accurately made, the sides of the teeth in the system employed being plane surfaces, as described in connection with Figs. 164 and 165. In the final operation, a forming gear thus correctly made and hardened so as to resist the wear brought to bear on it, is mounted on the belt-driven spindle and brought into proper engagement with the roughly formed gear mounted

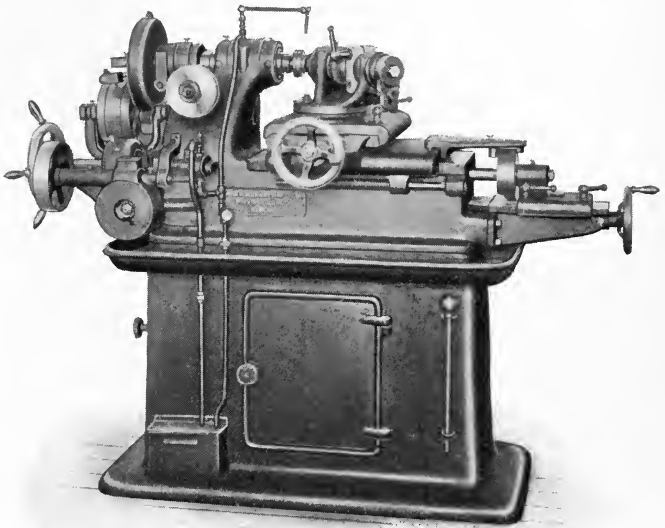

FIG. 194. Brown & Sharpe Machine for Correcting Bevel Gears by the Molding-Generating Principle, employing the Impression Process.

on the other spindle. The machine is started up and the two are revolved together. The mechanism provided is such that the pair run in one direction for a certain number of revolutions and then reverse and run in the other direction, repeating the process as long as the machine is in operation. Meanwhile a cam mechanism operates to jam the blank and forming gear together, relieve the pressure for a short

space and jam them together again, repeating the process continuously. By this means the hardened surface of the forming crown gear presses out the inaccuracies in the work and smooths the surfaces of its teeth, which were cut in the machine shown in Fig. 173.

The operation just described is the final one, however, and does little more than burnish the teeth. The same

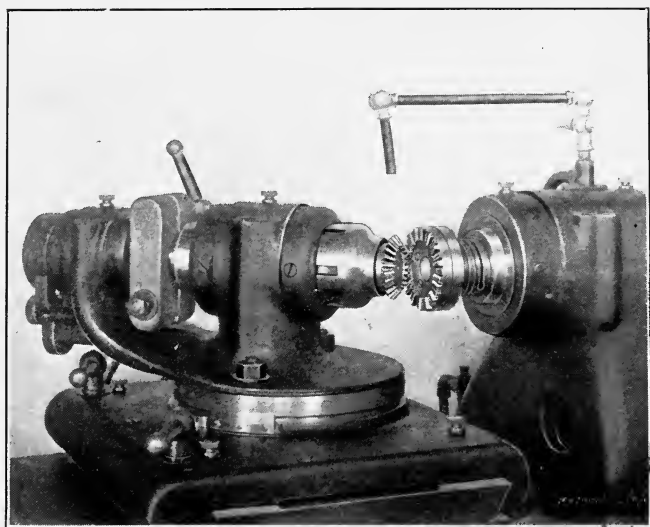

FIG. 195. Near View of the Tool and the Work in the Machine shown in Fig. 194.

machine is used for a preliminary operation which does most of the work of smoothing out the inaccuracies of the formed cutter process. This employs the same movements in the machine, but uses a different form of crown gear, shown in action in Fig. 195. As may be seen, the successive teeth are cut off at different heights. The edges thus formed where the teeth are cut off, dig into the roughed-out teeth of the work and remove the metal from the high

spots, while they pass freely and without action over the parts of the teeth which are of the correct contour. Being of so many different heights the whole face of each tooth of the work is acted on, though, of course, this is the case only when the number of teeth in the work and in the crown gear do not have a large common factor. In the bicycle trade for which these machines were developed, the gears were so designed that this contingency did not arise.

MACHINES OPERATING ON THE MOLDING-GENERATING PRINCIPLE, AND EMPLOYING THE PLANING OR SHAPING OPERATION.

The mechanism illustrated in outline in Fig. 164 is one that has been employed in a number of exceedingly interesting and ingenious machines. The first application of this principle was made by Mr. Hugo Bilgram, 1231 Spring Garden Avenue, Philadelphia, Pa. His form of machine has been used for a great many years, and produces work whose accuracy has almost become proverbial. An automatic machine of this make is shown in Fig. 196. The movements operate on the same principle as that in Fig. 164, but in one of the modified forms explained in the text accompanying that figure. This is to say, instead of rotating the crown gear and master gear together, the imaginary crown gear and, consequently, the tool, remain stationary so far as angular position is concerned, while the frame is rotated about the axis of the crown gear, thus rolling the master gear on the latter and rolling the work in proper relation to the tool. Instead of using crown and master gears, however, a section of the pitch cone of the master gear is used, which rolls on a plane surface, representing the pitch surface of the crown gear. The two surfaces are prevented from slipping on each

other by a pair of steel tapes, stretched so as to make the movement positive, in something the same way as shown in Fig. 4. A still further change consists in extending the work arbor down beyond center *O* of Fig. 164, mounting

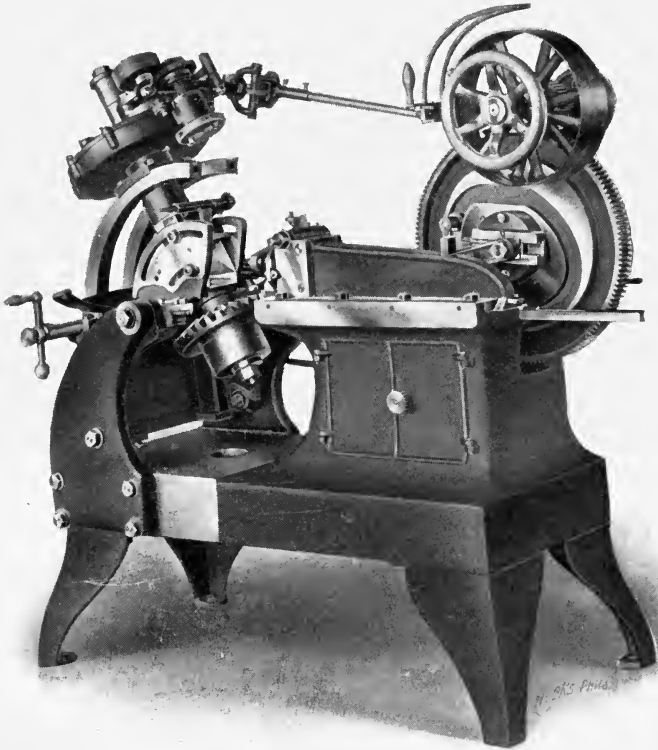

FIG. 196. Full Automatic Bilgram Bevel Gear Shaper, working on the Molding-Generating Principle.

the blank on the other side of the center so that the tool, being also on the other side of the center, is turned the other side up from that shown in the diagram. All these movements can be followed in Fig. 196. As explained, a

tool with a straight edge is used, representing the side of a rack tooth, and this tool is reciprocated by a slotted crank, adjustable to vary the length of the stroke, and driven by a Whitworth quick return movement. The feed of the machine is effected by swinging the frame in which the work spindle and its supports are hung, about the vertical axis of the imaginary crown gear. Suitable

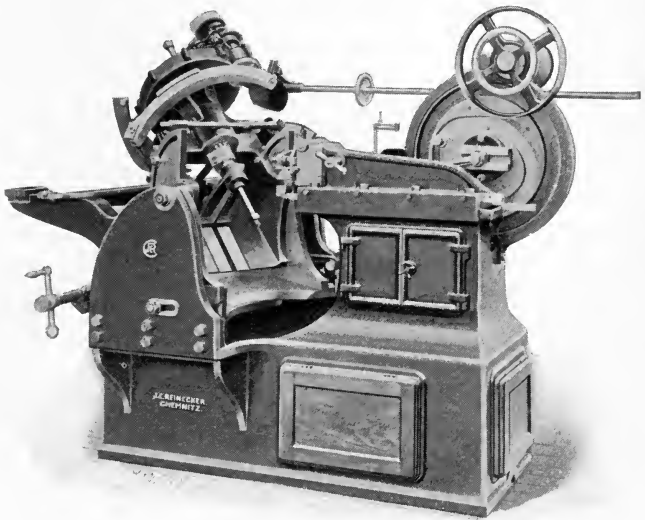

FIG. 197. Bilgram Bevel Gear Shaper as built by J. E. Reinecker.

feed connections, index mechanisms, etc., are provided for convenient operation.

This machine does not operate on the principle of completing one side of one tooth before going to the next. It follows the plan adopted by the same builder in his spur and spiral planing machines shown in Figs. 50 and 114, in which the work is indexed for each stroke of the tool, the rolling action being progressive with the indexing so as to finish all the teeth at once. A little thought will

show that these three Bilgram machines are identical in principle, with only the modifications required to fit that principle to the making of spur, spiral, and bevel gears, respectively. The bevel gear machine is the only one that has come into extensive use, since the bevel gear is the only one of the three kinds in which there is any great difficulty in cutting the teeth accurately enough for all practical purposes with formed tools.

In Fig. 197 is shown another example of this machine, built under the Bilgram patents by J. E. Reinecker, of Chemnitz-Gablenz, Germany.

A machine operating on the same principle is that built by the Ateliers de Constructions Mécaniques ci-devant Ducommun, Mulhouse (Alsace). (See Fig. 198.) The principal differences between it and the Bilgram machine (aside from the obvious differences of the shape of the framework and the arrangement of the mechanism) are the link motion used in place of the steel tape for giving rolling movement to the blank, and the provision made for using two tools simultaneously so that both sides of a tooth are finished at once. This machine is not fully automatic, but is arranged to cut both sides of one tooth, after which it is indexed by hand and the sides of another tooth cut.

The two tools are each carried in slides of their own, in the center of the circular top of the table. These slides are independently adjusted to bring the movement of the straight cutting edges in line with the plane surfaces of the teeth of the imaginary crown gear of Fig. 139. As in the Bilgram machine, the tool slides are stationary, while the frame carrying the work spindle is revolved about the vertical axis of the crown gear, a tooth of which is represented by the cutting edges of the tool. The swiveling movement of this frame is effected by a sector of a worm-wheel fastened to the circular table on which the frame

is mounted. Suitable feeding movements and automatic stops are provided.

The provision for constraining the blank to roll in the

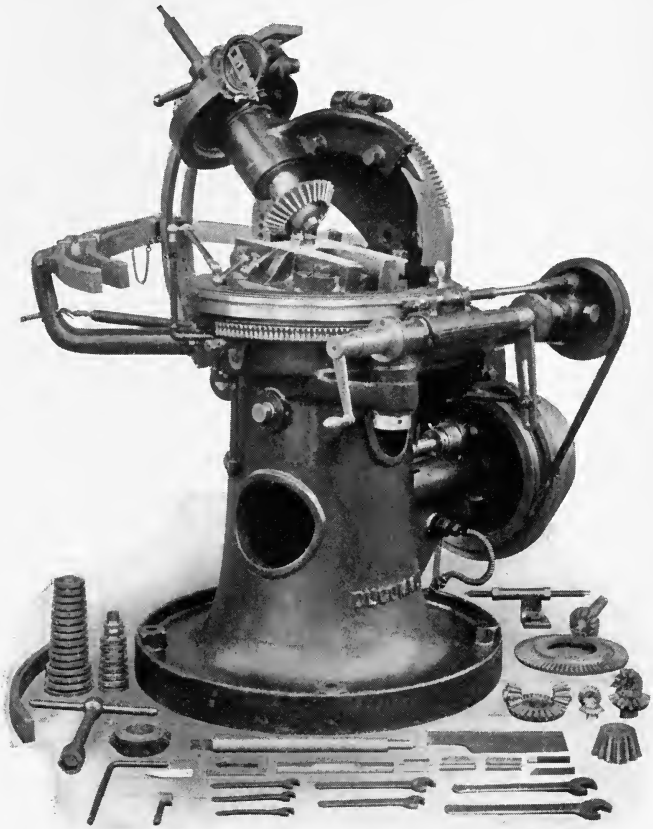

FIG. 198. Ducommun Bevel Gear Generator operating Two Tools.

proper ratio with the rotation of the housing about the top of the column, is the most original feature of the machine. The principle of its operation will be understood by reference to Figs. 199 to 204 inclusive. It will be

simplest to consider the problem first from the stand-point of the spur gear. In Fig. 200 is shown a gear being cut by two tools representing a tooth space of an imaginary rack, in a way similar to that shown in Fig. 8. It is here considered, however, that the gear to be cut is rolling on the imaginary rack, which is stationary. The rolling movement of the gear is obtained by a master gear of the

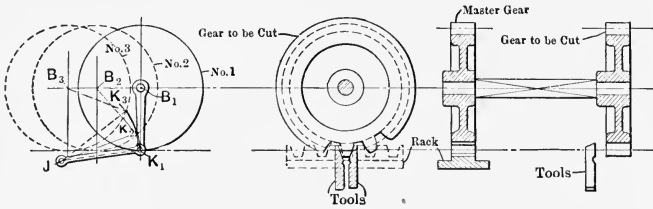

FIG. 199.

FIG. 200.

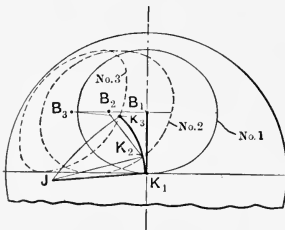

FIG. 201.

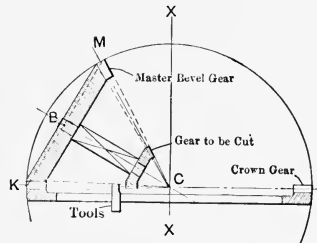

FIG. 202.

Diagrams illustrating the Action of the Ducommun Machine.

same pitch diameter, engaging a master rack, which, in the end view, coincides with the imaginary rack.

It is not necessary that a rack and master gear be used to give the desired rolling movement to the gear to be cut; the metallic tape arrangement shown for the describing-generating process (see Fig. 4) could be used, for instance. Still another method is indicated in Fig. 199. When the pitch circle of the master gear rolls on the pitch line of the

rack, as the center occupies the positions B_1, B_2 , etc., a point such as K_1 in the pitch circle of the master gear will trace a cycloid K_1, K_2, K_3 . A point J can be found so located that it will be the center of an arc very closely approximating the cycloid. If, therefore, instead of the master gear and rack, we substitute, as shown, a crank B_1K_1 in place of the gear, and a link JK_1 to connect the crank-pin with the point J determined as above described, then, when the axis of the blank is given a lateral movement, the link will so restrain the motion of the crank-pin K_1 that it will nearly follow the cycloid, and in so doing will give the blank a close approximation to the rotary motion obtained by the gear and rack in Fig. 200.

The same process as applied to the forming of bevel gears is shown in Fig. 202. The rack is replaced by a crown gear and the master gear is replaced by a master bevel gear whose axis passes through the central point of the crown gear. The gear to be cut is mounted on the axis of the master bevel gear and moves with it, and is so located that its pitch cone apex is at C , the center of the crown gear. If, then, the sides of the teeth of the crown gear be plane surfaces, a pair of tools with their cutting edges in the plane of the tooth faces of a rack space may be used to generate the teeth of the gear to be cut, when these tools are given a reciprocating motion which allows their cutting edges always to remain in the plane of the sides of the rack tooth. All this is substantially the same as shown in Fig. 164. The axis of the master gear and blank, instead of being given a rectilinear horizontal motion at right angles to the axis as in Fig. 200, is given a circular motion about vertical axis XX , so that line BC would describe a cone if it were completely revolved. The master bevel gear is thus given the proper rolling motion about the crown gear.

By a similar approximation to that illustrated in Fig. 199, we may do away with the crown gear and the master bevel gear. The pitch circle of the master bevel gear rolls about

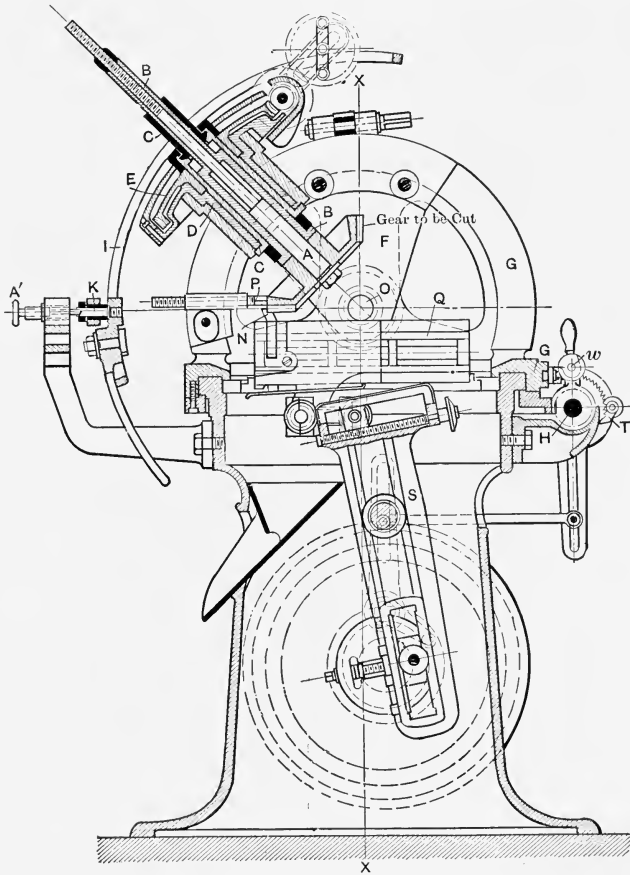

FIG. 203. Vertical Section through Plane of Work Spindle.

the pitch circle of the crown gear. In so doing, a point K_1 in the pitch circle of the master bevel gear will, as shown in Fig. 201, describe a spherical cycloidal curve determined by points K_1, K_2, K_3 , which are the positions that point

K_1 takes in the three positions of the pitch circle marked No. 1, No. 2, and No. 3 in the sketch. It must be remembered, in following this action, that all the lines shown are supposed to be drawn on the surface of a sphere with C as center. Now, as in Fig. 199, we find a point J such that with one point of the dividers located here, the other point will follow the spherical cycloid K_1, K_2, K_3 very closely. We may, then, as in Fig. 199, dispense with the master and crown gears, replacing them with a crank or link B_1K_1 , pivoted at one end to axis BC , and joined at the other end at point K_1 to the swing link pivoted at J . With this arrangement within reasonable limits, a rotation of axis BC about vertical axis XX will impart to the gear to be cut, through the restraining action of link JK_1 , a motion similar to that given by a master bevel gear and crown gear; and this will be suitable, as before explained, for shaping the correct form of tooth on the blank under the action of the two cutting tools.

Now let us trace in the machine the action explained by the two diagrams. Axis BC in Fig. 202 is that passing through the gear to be cut in Fig. 203. The rotation of this axis about the vertical axis XX of the machine is effected by rotating the whole structure on which it is supported around the circular bearing provided at the top of the column of the machine. The table, carrying the structure for holding the gear blank, has a section of a worm-wheel formed on a portion of its periphery, which is operated by a worm, and suitable slow-feed, quick-return and automatic stop mechanisms. So much for the movement about the axis XX . For the rolling motion, which must be given the blank to agree with that of the master bevel gear rolling on a crown gear, the approximation outlined in Fig. 201 is used. Link I in Figs. 203 and 204 is link B_1K_1 of Fig. 201. Point K in Figs. 203 and 204

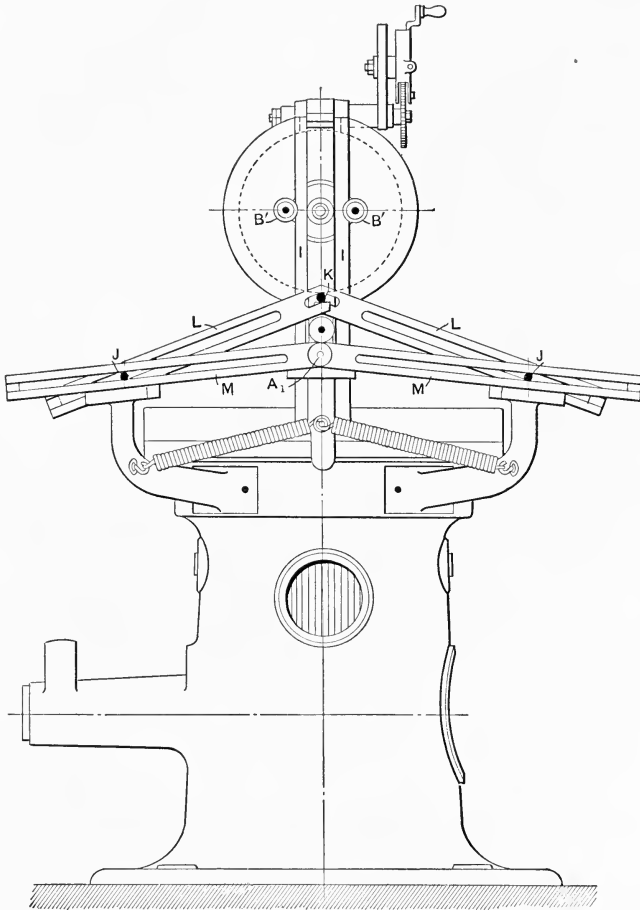

FIG. 204. Diagram showing Arrangement of Approximating Linkage.

is point K_1 in Fig. 201. In Fig. 204 pivot K has been raised from the position it should occupy directly back of point A_1 , to show the construction of links L . Considering, however, that the mechanism is in its proper condition, when the blank is given its rotation about vertical axis XX ,

point K_1 , if the proper rolling motion is given the blank, will trace a spherical cycloid identical with K_1 , K_2 , K_3 in Fig. 201. To insure that point K shall follow with great exactness this cycloid, as the blank rolls to the left, one of the pair of springs shown at the lower end of link I presses pivot K to the bottom of the open-ended slot in link L , which is pivoted at point J , this point being selected in the same manner as point J in Fig. 201. It will thus be readily understood that the rotary and rolling motions required for the blank are very closely approximated. Of course the cut is not started from the middle as we have been considering. The blank is first swung to the extreme right, for instance, so that it clears the tools. Under those circumstances the pivot K will bear on the bottom of the open-ended slot in the right-hand link L , being held there by the pressure of the right-hand spring. When it reaches the central position shown in Fig. 202 it will be under the restraining influence of both links L . As it continues to swing toward the left it will come under the control of left-hand link L and the left-hand spring.

An English machine of the molding-generating type operating on the shaper principle is shown in Fig. 205. Here the axes of both the work and the imaginary crown gear are stationary, the blank and the tool swinging about these axes. The proper ratio of rolling movement of these two parts is obtained by change gears. The machine has two distinctive features not found in other generating machines, so far as the writer is aware. One of them is the provision made in the mechanism for automatically gashing the wheel preparatory to the finishing generating cut. In this operation the blank is swung around into the reciprocating tool until the proper depth has been cut. It is then returned rapidly and the work is indexed for the next cut, which is taken in the same way. This swinging

of the work into the cutter and back again is effected by the adjustable crank shown at the front of the machine, which has a slow ratchet feed for cutting to depth and a quick movement for returning. This same crank mechanism is used without the slow ratchet feeding for bringing the cutter into depth for starting the generating cut, and

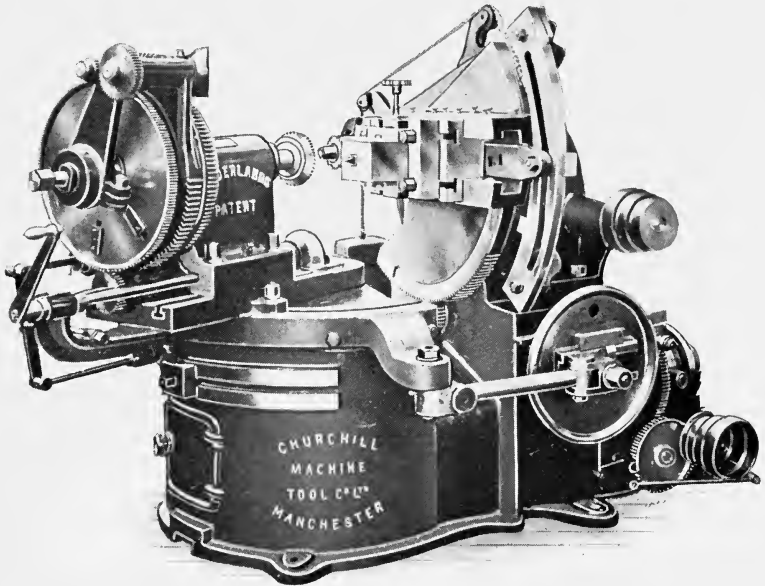

FIG. 205. The Churchill Bevel Gear Generating Machine, in which Provision is made for Modifying the Teeth to avoid Interference.

swinging it back at its completion to clear for the automatic indexing in the finishing operation. The other distinguishing feature of this machine is the provision made for correcting the teeth for interference. In other generating machines this correction is made by altering the addendum and dedendum of the gear and pinions in cases where it is necessary. In this case it is done by

modifying the tops of the teeth the same as in the standard shapes for spur gears. To accomplish this the swiveling movement of the tool slide is retarded as the tool is leaving the point of the tooth. A slotted cam groove will be seen, cut in a sector which is fastened behind the outer end of the swinging tool slide. This cam groove controls the movement of a short slide, which, in turn, by means of the diagonal groove and block shown, gives a relative movement between the slide itself and the sector on which it is mounted. This movement is sufficient to trim the tops of the teeth as required. The builder of this machine is the Churchill Machine Tool Company, Ltd., Manchester, England.

A French machine of the type we have been considering, built by H. Ernault, 169 Rue d'Alésia, Paris, is shown in Fig. 206. It was designed by M. Monneret, and shown at the Paris exhibition in 1900. The writer is not sure that it is being manufactured for the trade at the present time. It is of such interest, however, as to warrant illustration and description.

This machine is identical in its operation with the typical mechanism shown in Fig. 164, in that the axes of the work and of the imaginary crown gear are fixed in position, and are rotated in the proper ratio with each other to give the desired rolling movement of the tool and the blank on each other. The cutter slide is mounted on what resembles the head-stock of a lathe, at the right-hand side of the machine in the illustration. It is driven by a crank seen through the opening at the front of the slide. The tool is carried on the holder at the back upper end of the slide, and is provided with automatic means for positively relieving it on the back stroke.

To understand how this tool slide is rolled about its axis in unison with the rolling of the blank it is first

necessary to state that this machine will cut helical gears only, this being due to the fact that the crank-shaft and the blank are connected positively by change gearing, so that the blank rotates continuously, resembling in this particular the arrangement provided on the Bouhey

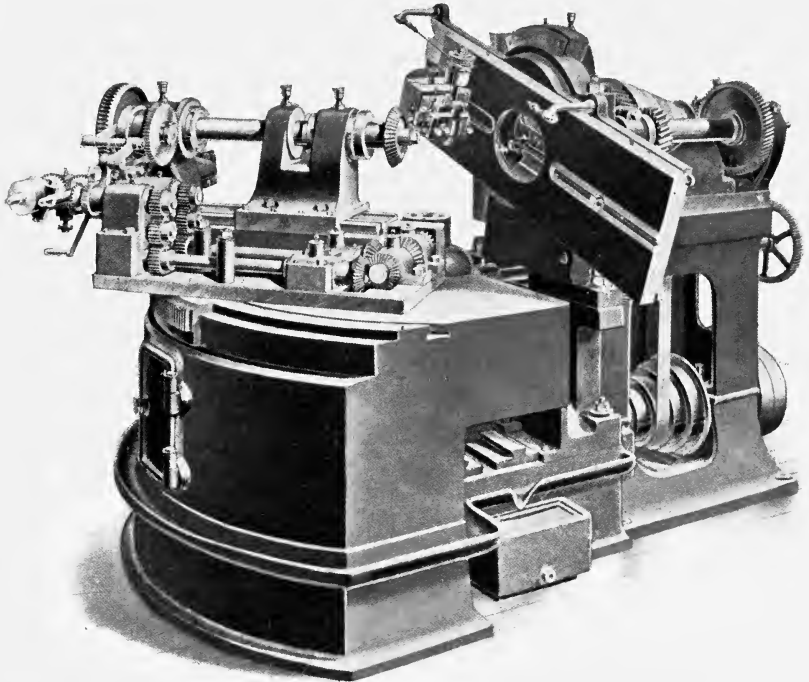

FIG. 206. The Ernault Bevel Gear Generating Machine, which cuts Gears with Twisted Teeth.

machine for making, when required, gears of this kind by the templet process. Unlike the Bouhey machine, however, the one we are describing cannot be used for making straight-tooth bevel gears; and, since the blank has to have imposed upon it a rotary motion in unison

with the rolling of the tool slide, and in addition to the rotating motion due to its connection through the change gears with the tool-slide crank-shaft, a differential movement has to be introduced for combining the two.

Change gears are set for the number of teeth to connect the crank-shaft and the indexing worm at the rear of the work spindle, through a train of positive gearing and shafts. The rolling movement of the blank (and of the tool slide about its axis) is driven by a cam and ratchet movement operated by the spur gearing leading from the work spindle at the left of the machine in the engraving. This ratchet-driven motion is connected by bevel gears with a screw which shifts, in the direction of its axis, a cradle or yoke in which is confined the index worm for giving the rotary movement to the blank. This worm is splined upon its shaft, so that it transmits to the work through its longitudinal motion a rolling movement derived from the ratchet feed, and a continuous rotary movement derived from the change gearing and the crank-shaft. These movements are combined without interfering with each other, and either may be started or reversed independently. It will be seen that the mechanism is exactly identical in principle with that described for the Reinecker worm gear hobbing machine in Fig. 143.

The same ratchet mechanism that shifts the indexing worm axially is connected by the train of gearing shown with a vertical shaft passing down through the center of the angular adjustment of the work slide, where it is connected with a screw, shown diagrammatically at *A* in Fig. 207. This screw is supported in bearings connected with the work slide in such a way that, as the latter is adjusted to the angle of the gear being cut, the screw is swiveled with it, being always at right angles to the axis of the work spindle. The nut *B*, which encircles this

screw, is pivoted to a sliding block *C*, which is dovetailed to slide *D*. *D* in turn slides in guiding ways *E* in the direction *xy*. Slide *D* is fastened to a rack meshing with a pinion, connected by shaft and gearing with mechanism for rocking the tool slide, the whole arrangement furnishing the means by which the rolling of the blank effects the corresponding rolling of the imaginary crown gear and the work in unison.

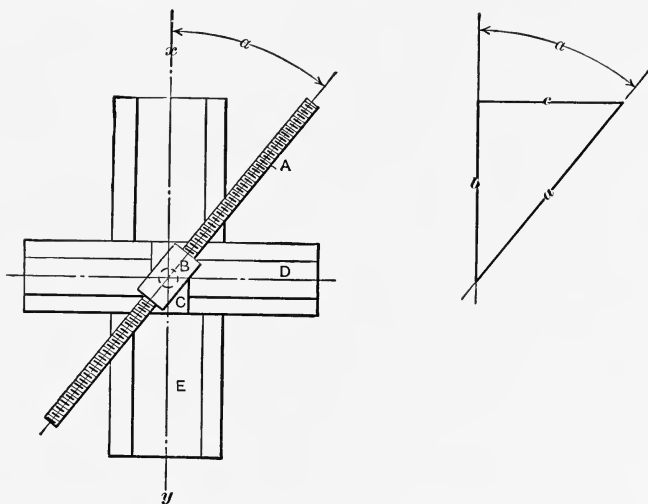

FIG. 207. The Mechanism by which the Proper Ratio of Rolling Movement for the Blank and Tool is obtained for the Machine in Fig. 206.

The ingenious feature of the mechanism in Fig. 207 is the way in which the proper ratio of movement for the rolling of the work and the tool is assured. When the axes of the work and of the imaginary crown gear are set in the same straight line, as would be required when cutting a crown gear, the axis of screw *A* is by that setting shifted until it is parallel with *xy*, and thus the movement of *D* on *xy* is the same as that of the nut *B* along the screw, and the work, consequently, rolls in unison with the tool

slide. If, on the other hand, the work spindle is adjusted to angle α with the axis of the crown gear, the mechanism will take the position shown in the engraving, and the screw, when moving the nut a distance a , will move slide D on ways E a smaller distance b , resolving the motion a into two components, b and c . Of these two, b is in exactly the right proportion to a to give the rolling movement required for the tool, and it is transmitted to the tool slide by the motion described. This, it will be seen, does away with the necessity for adjusting the rolling movements separately as required for all other generating machines.

In Fig. 208 is shown an American machine of the molding-generating type employing the planing or shaping operations. It differs from the previous machines of this kind we have described in employing two tools, one on each side of the tooth, resembling in this respect the templet planers shown in Figs. 183 to 186 inclusive. This tool is identical with the previous one and with the mechanism in Fig. 164, in having the axes of the tool slides and of the blank fixed in relation to each other during the operation, the tool-holders and the blank rocking about their axes to give the rolling movement for cutting. The connections, however, between the blank and the slide are entirely different, and the tools finish each tooth of the work complete before they commence on another. The rocking is effected by means of segments of an actual crown gear and master gear. The segment of the crown gear, seen beyond the work in the illustration, is permanently attached to the face of the rear of the cutter slide frame, while the segment of the master gear (of which there are several furnished with the machine, the one used being chosen to agree with the angle of the gear to be cut) is clamped to the semicircular arm pivoted at

the outer end of the machine at one side and fastened to the work spindle sleeve on the other. This arm is rocked by a cam mechanism and slotted link at side opposite that shown in illustration.

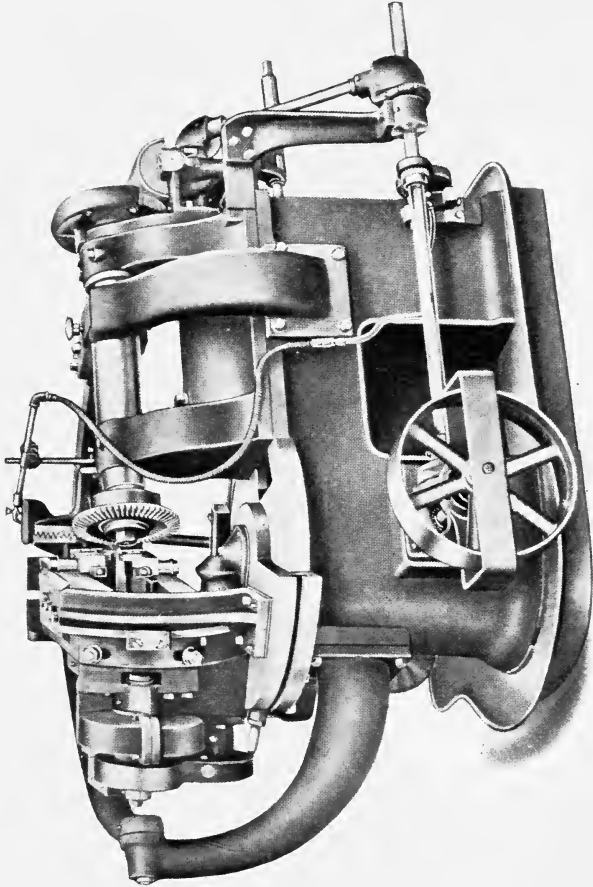

FIG. 208. The Gleason Bevel Gear Generating Machine.

The cycle of operation is as follows: The machine being adjusted properly in its preliminary position, the tool slide and the head on which it is mounted are swung back about the vertical axis so that the tools clear the

work. The blank being set in the proper position, a cam movement swings the cutter slide head inward until the tools reach the proper depth. The cam movement first mentioned now rocks upward the semicircular arm extending around the back of the machine, rolling the blank and (through the segmental crown and master gears) the slide, until the tools have been rolled out of contact in one direction, partially forming the teeth as they do so. The arm is then rolled back to the central position and along downward to the lower position, until the tools are rolled out of contact with the tooth in this direction, completing the forming of the proper shape as they do so. The cam then rocks the arm back to the central position, where the cutter-slide head is swung back to clear the tooth, and the work is indexed, after which this cycle of operations is continued for the next tooth. It will be seen that by starting from the central position, going to each extreme and returning, all parts of each tooth are passed over twice, giving a roughing and a finishing chip.

The machine is entirely automatic. The use of two tools presents a number of advantages. Not only does it increase the rate of working, but it balances the thrust of the cutting action of the two sides of the teeth and reduces chatter and vibration, thus giving greater accuracy. The slides of each of the two tools, of course, have to be relatively adjusted to each other, depending on the pitch and number of the teeth being cut.

MILLING THE TEETH OF BEVEL GEARS ON THE MOLDING-GENERATING PRINCIPLE.

One of the most interesting and ingenious of all the machines for cutting the teeth of bevel gears is that shown in Fig. 209. It operates on the principle shown in Fig. 165, in which the sides of the crown teeth are represented

by the plane faces of milling cutters. In this machine the milling cutters and the imaginary crown gear remain stationary so far as position is concerned, though, of course, the cutters revolve about their own axes. The work is

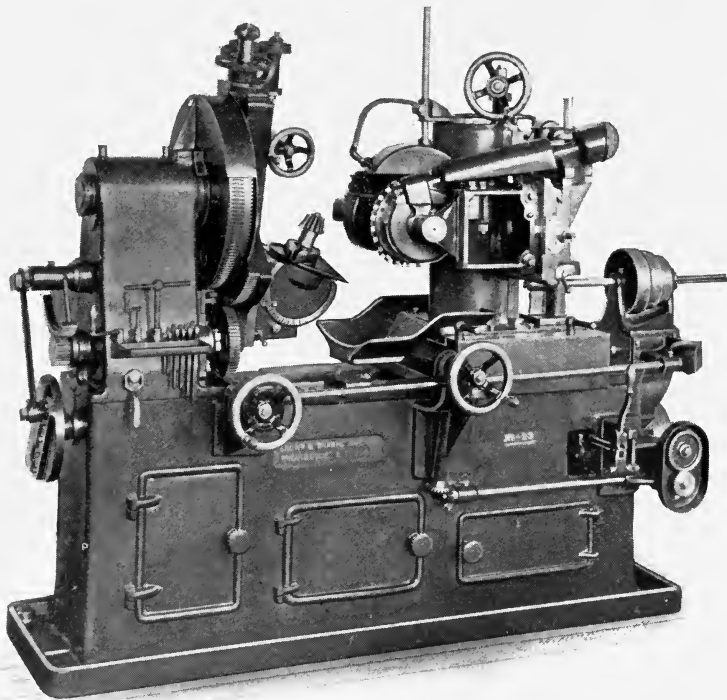

FIG. 209. Brown & Sharpe Bevel Gear Generating Machine, cutting the Teeth by the use of Interlocking Milling Cutters of Large Diameter.

held in the spindle of a head (resembling the universal head of the milling machine) which is mounted on the slide of a swinging sector at the left, which sector is rocked about a horizontal pivot in line with the axis of the imaginary crown gear. The work spindle and the

rocking movement of this sector are so connected by change gearing that, as the latter is oscillated through a sufficient angle to generate the teeth, the work is rolled in the proper ratio to mesh with the imaginary crown gear, a tooth of which is represented by the milling cutters. This movement is thus seen to be identical with that modification of the case in Fig. 164, in which the crown gear is stationary, while the frame is rocked, rolling the master gear on the crown gear and the work over the tool.

The cutters used are of large diameter in proportion to the work for which the machine is intended, in order to minimize the deepening of the tooth space at the center which is characteristic of a gear cut in this way, as was explained in connection with Fig. 165. It will be seen that the teeth of the two milling cutters are set so as to interlock. In this way comparatively stiff cutting blades may be made to represent a complete crown gear tooth of very fine pitch.

The machine is universally adjustable within its range. The cutter spindles may be set to give teeth of greater or smaller pitch, and to work with gears of large or small pitch cone radius. They may also be adjusted for teeth of greater or less angularity than the $14\frac{1}{2}$ -degree standard involute generally used. As in previous cases, it is not practicable to give here the details of the mechanism of this interesting machine.

In Figs. 210 and 211 are shown views of two sides of the Warren bevel gear generating machine, first developed and built, if the writer's memory serves him, by the Pratt & Whitney Company, of Hartford, for the manufacture of chainless bicycle gears. The machine we show, however, is a design built for general manufacturing use by Ludwig Loewe & Co., of Berlin, Germany. This machine is approximately similar in its action to the one built by Brown &

Sharpe and just described. Aside from the differences in the mechanism, however, there are two important differences in its action. One is the fact that the two cutters do

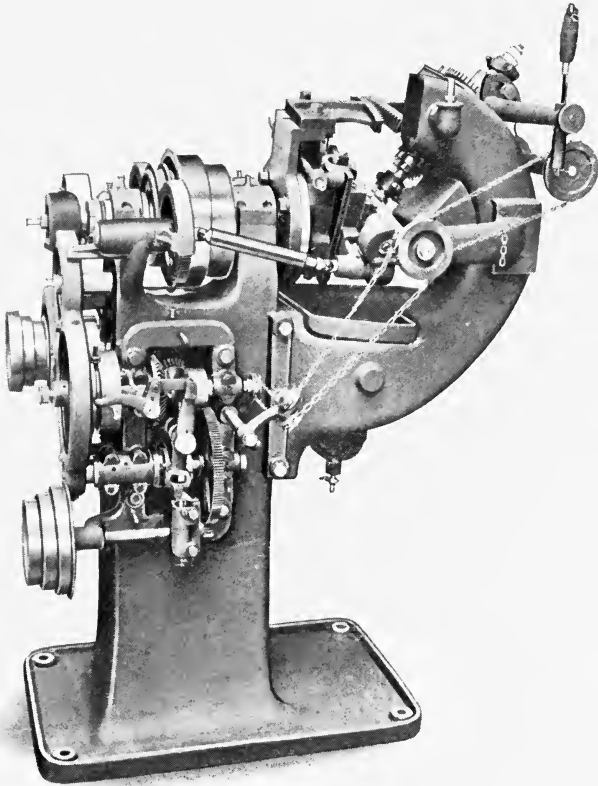

FIG. 210. The Warren Bevel Gear Generating Machine as built by Ludwig Loewe & Co., Berlin.

not cut on opposite sides of the same tooth space but on facing sides of alternate teeth, leaving a whole tooth untouched between them. The independent slides in which they are set are so arranged as to allow the plane

cutting face of the cutters to be set to agree with the corresponding faces of the imaginary crown gear. The other difference is the means taken to cut a tooth space having a straight bottom with cutters of small diameter. This is done by making the rolling of the cutter holder and the blank on each other a continuous rocking movement at a quite rapid rate. During this rapid rocking the cutter slides are fed inward on their respective guides to form the

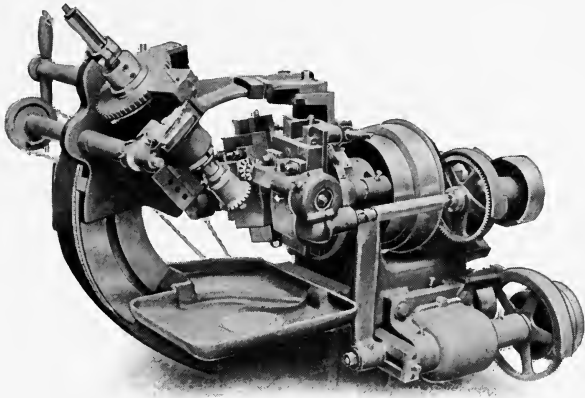

FIG. 211. The Working Side of the Warren Machine showing the Milling Cutters, whose Plane Surfaces represent Sides of Adjacent Crown Gear Teeth.

sides of the particular teeth at that time presented to the cutters.

The cutter slides and guides are mounted on a circular head, which is rocked about the axis of the imaginary crown gear by the slotted crank and link seen at the side of the machine in Fig. 211. The upper end of this circular slide carries a segment of a crown gear which meshes with the corresponding segment of a master gear on the work spindle, this arrangement being very similar to that of the Gleason machine shown in Fig. 208. The work and the cutters

being rapidly rocked about each other while the cutters are slowly fed down through the tooth spaces, the sides of the teeth exposed to the action of the cutters are properly formed to the theoretical tooth curves.

The construction of this machine is very ingenious, with provision for automatically effecting all the movements for rocking the cutter slides and the blank, feeding downward and returning, indexing, etc., with suitable adjustments for cutting gears of all kinds within the range of the machine.

BEVEL GEAR CUTTING MACHINES USING A HOB AND OPERATING ON THE MOLDING-GENERATING PRINCIPLE.

While the hobbing principle is easily and simply applied to the cutting of spur and spiral gears, as illustrated in Figs. 56 and 115, it requires but little thought to show that the application of the same principle to the cutting of bevel gears is a difficult if not hopeless task. Nevertheless, this problem has been attacked in two different directions. The principle of the mechanism and tools employed, however, requires to be studied with greater care than in the case of any of the machines we have previously described, if the reader is to have a clear understanding of their method of operation. The first of the two processes is that developed by M. Chambon, of Lyons, France. The operation of the machine is dependent on the principle of a peculiar hob, whose generation and finished form are illustrated in Figs. 212 to 216, inclusive.

In Fig. 212 is shown the basic principle of the molding-generating process applied to the cutting of bevel gears, identical in its essentials with the mechanism shown in Fig. 164, with the exception of the fact that a hob is used as a cutting tool instead of a reciprocating planer tool. At the left of the engraving a face view of the crown gear is shown.

The width of the top of the tooth at the outside diameter is W , at the inner end of the tooth w . A hob may be made, such as No. 1, having teeth whose shape on a normal section EF exactly matches the same section of a tooth of the crown wheel when the teeth of both are centered on line CD and the hob is set at the helix angle θ . Under these circumstances a tooth of the hob would have a width W at the top. If the hob is single-threaded, and the crown gear has,

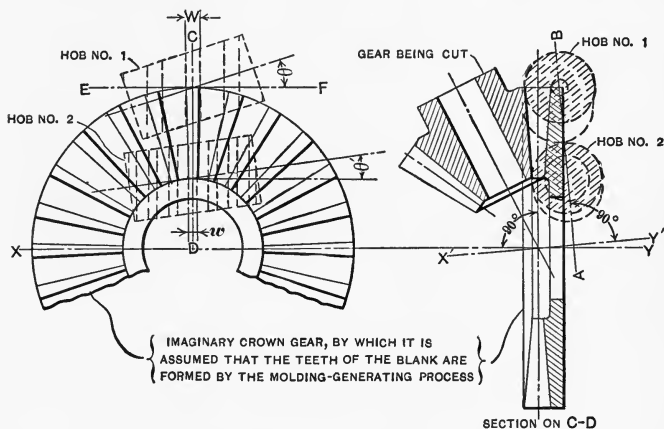

FIG. 212. Diagram showing the Possibility of Representing a Crown Gear Tooth by Teeth in a Series of Hobs of the Same Pitch Diameter but of Varying Lead and Helix Angle.

for instance, twenty-four teeth, the two may be revolved together, the hob making twenty-four revolutions to one of the crown gear. Then this tooth of the hob, which comes into action at the time it is central with line CD , will exactly match the outline at the larger end of each of the teeth of the crown gear in turn, as it revolves. To have a hob which would similarly match the teeth at the smaller or inner end, we could construct one of the same diameter and of smaller pitch, smaller helix angle θ' , and a smaller

width of flat, w , at the top of the tooth, all to correspond with the shape of the inner end of the crown gear tooth. It also should revolve in the ratio of 24 to 1 with the crown gear, and the tooth which comes central with the line CD at each revolution may be made to match accurately with the outline of the inner end of the tooth. In the same way hobs may be made to be used at any intermediate point in the length of the tooth of the crown gear, so that one of the cutting edges will match the outline of the tooth at this point, once for every revolution of the hob. The problem

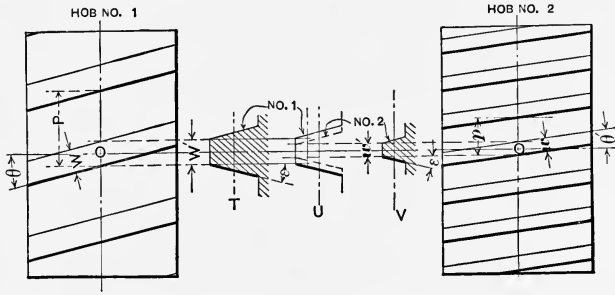

FIG. 213. Comparison of the Hobs representing the Large and Small Ends of the Crown Gear Tooth in Fig. 212.

is to construct a single hob which will do the work of hobs No. 1 and No. 2 and of all possible intermediate hobs between the two positions.

In Fig. 213 the two hobs of Fig. 212 are shown enlarged. As previously explained, they are of the same diameter, with the normal width at the top of the teeth W and w , the same as that of the large and the small ends of the tooth of the crown gear, and with the leads of each, P and p , of the size required by the pitch of the large and small ends of the teeth. This gives corresponding angles θ and θ' in the two cases. At T and V are shown axial sections of the thread for hobs Nos. 1 and 2. Since T and V correspond to the

large and small ends of the teeth of a crown gear, the widths W' and w' are proportional to the leads P and p , and the angle of inclination of the sides, ϵ , is the same in each case. What we have to do now is to combine Nos. 1 and 2 into a third which will do the work of both of the previous ones.

Suppose we take a blank of the same diameter as the two hobs in Fig. 213 and thread it first with the same shape and pitch of thread as for No. 1, and second with the same pitch and shape as for No. 2, except that while the width of the top and the inclination of the sides remain the same, the cut will be carried to the full depth required for the thread

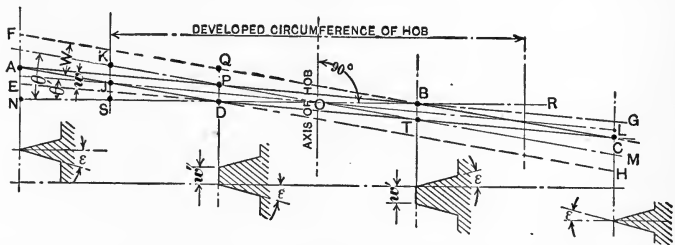

FIG. 214. Development of the Thread of a Hob of the Same Diameter as in Fig. 213, in which have been cut the Two Threads of the Two Hobs there shown.

of No. 1. As shown at U in Fig. 213, the dotted section of No. 2 is the same as for V , except for its increased depth. When the hob has been thus threaded the developed circumference at the point where the tops of the two threads cross each other will be shown in Fig. 214. Here lines FC and AH represent the top of thread No. 1, inclined at the threading angle θ as determined by the pitch, while the space included between lines AG and EC correspondingly represents the top surface of thread No. 2, inclined at angle θ' . These two threads have widths at the top of W and w , proportional to the pitch as before. The center lines of the

tops of the two threads cut in the blank cross each other at point O . The top of the thread is seen to be cut in a parallelogram $ABCD$, this being the metal left after the grooves for the two different threads have been cut. Axial sections of this remaining fragment of the thread are shown on lines FN , QD , BT , and CH ; as may be seen, the inclination of the sides of the thread, as measured on an axial section at each of these points (and at all other points as well), is made ε .

A short hob, threaded as in Fig. 214, is shown in Fig. 215. Similar points in each figure have similar letters. Since

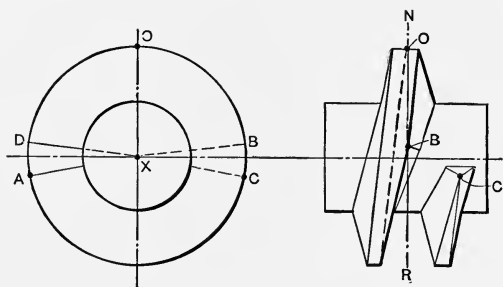

FIG. 215. Hob (ungashed) produced by combining the Two shown in Fig. 213; the Thread is the same as that shown Developed in Fig. 214.

the two sides of the teeth, which unite in point B , have the same inclination as measured on a plane passing through the axis of the hob, their intersection will also have the same inclination, and the line of intersection will pass through the axis of the hob. The same is true of point D on the other side of the thread. If the hob is gashed at B and D , the cutting edges thus formed are evidently common to both the large thread of width W and angle θ and the small thread of width w and angle θ' , and when properly set in the machine and rotated with the crown gear the relation to the imaginary crown gear will correspond exactly to that

gear in the position of either hob No. 1 or No. 2 in Fig. 212, the same hob thus taking the place of both.

It next remains to be shown that these two cutting edges at *B* and *D* in Fig. 215 can be made to correspond with all the sections of the crown gear intermediate between the large and the small ends in Fig. 212.

To prove this, we have to show that the sides of any thread cut in this hob with a center line passing through *O*, whose width of top and lead are in the same proportion as in Fig. 213, and whose sides have the same inclination as measured on an axial plane, will include the cutting edges *B* and *D*, which we have formed as described in the hob in Fig. 215. In Fig. 214 any thread of the given proportions, such as *FCAH*, will cut the horizontal line *NR* at *D*, in such a way that $OD:OS = DP:KS$. Now *DP* is half the width of the tooth on the axial section, and *KS* is half the circumferential pitch, so that $OD:OS = \frac{W'}{2} : \frac{P}{2} = W':P$. But all the threads we are concerned with have the same ratio between *W'* and *P*, so that the sides of all of them cross line *ES* at *D*. The same thing applies to the crossing at *B* on the upper side. The cutting edges, then, at *D* and *B* are common to all the hobs of the same diameter which will fill the required condition for the infinite number of sections between hobs Nos. 1 and 2 in Fig. 212.

In practice, the hob of Fig. 215, made as we have described, is gashed throughout the full length of the thread, as well as at the cutting edges *B* and *D*. Such a hob is shown in two positions in Fig. 216. The edges *B* and *D*, however, are the ones which are relied on to give the true shape to the teeth of the gear.

The next problem, and a somewhat complicated one, is that of providing a machine which will utilize this hob, in

accordance with the principles of its construction, to take the place of the imaginary crown gear of Fig. 212 in generating teeth in a bevel gear blank. In the first place, the hob must be moved from the position occupied by No. 1 to that occupied by No. 2, changing its angle continuously meanwhile from θ to θ' to agree with the change in helix angle due to the change of pitch as the tooth grows smaller. Next, the hob and the blank being cut must be rotated with each other, so that the hob revolves during one revolution of the gear as many times as there are teeth in the latter, the hob being supposed to be single-threaded.

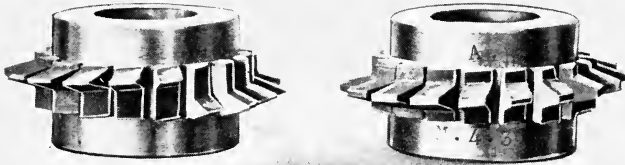

FIG. 216. The Completed Hobs used in the Chambon Machine, developed as shown in the Preceding Illustrations.

These two conditions are easily fulfilled, but there still remains a third. The two cutting edges we have made for the hob represent the sides of each tooth of the imaginary crown gear only when each tooth in turn is passing the center line CD . In order to have a generating action on the blank, the imaginary teeth of the crown gear must have a cutting action over a considerable angle about D , on both sides of the section CD . This may be effected by rocking the holder which carries the hob about center D in either direction, meanwhile rotating the hob to keep its thread in the proper relation with the teeth of the crown gear, as if the latter was stationary. In the machine this oscillation of the hob and its carrier about D ,

on each side of CD , takes place continuously, while the hob is being fed down from the position occupied by No. 1 to that of No. 2, and the rotation of the hob required by this oscillation (to keep the hob and the crown gear continuously in step) is superimposed on the other rotation in unison with the imaginary crown gear and the work, the two being combined by differential gearing of the same style as required for combining the movements in spiral gear cutting machines as illustrated in Fig. 116. When this is done, a cutting edge will be provided by the hob closely paralleling the molding action of the crown gear as shown at the right of Fig. 212.

The machine for accomplishing all this is shown in Fig. 217. The work is mounted on an arbor adjustable to any angle and to any axial position in relation to the hob. The spindle for the latter is mounted in a swinging carrier which slides on ways provided on the face of a head, which latter is oscillated about a horizontal axis. A suitable compensating movement is provided, so that this rocking movement is translated into the required rotary motion of the cutter, as was shown, to keep it from getting out of step with the imaginary crown gear, and for combining it properly with the constant rotation of the cutter, derived from its connection with the work-revolving mechanism. The spindle carrier feeds in along the ways of the oscillating head, being swung around by a templet as it proceeds, to change the helix angle θ as required. Suitable change gears are provided for all the movements, and one passing through of the continuously rotating hob finishes the gear complete. The mechanism is rather too intricate to describe here in detail. A number of compensating movements are required, which add somewhat to its complexity.

We should not leave the discussion of this machine and

its principle, ingenious though it is, without noting that the process involves a number of minor inaccuracies. For one thing, an error is introduced by the fact that in the machine the rocking of the spindle-head carrying the hob is about the axis $X'Y'$, instead of about axis XY , as it should be. (See Fig. 212.) This is doubtless done to

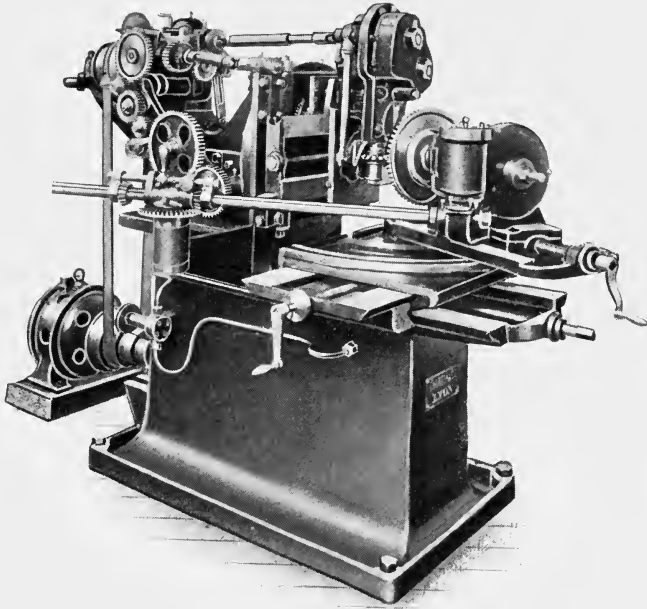

FIG. 217. The Chambon Continuous Bevel Gear Hobbing Machine, employing the Cutters shown in Fig. 216.

avoid the complication of having to set the machine for the angle of the top of the crown tooth. The error introduced would be entirely negligible except, perhaps, in the case of gears very closely approaching crown gears in their pitch cone angle. There are several other little discrepancies which, however, are scarcely worth taking into

account. This process and machine are the invention of M. Chambon, of Lyons, France.

In Fig. 218 is shown another machine operating on the Chambon plan, built by the Société Suisse pour la Construction des Machines-Outils Oerlikon, Oerlikon près Zurich, Switzerland. This machine employs the cutter

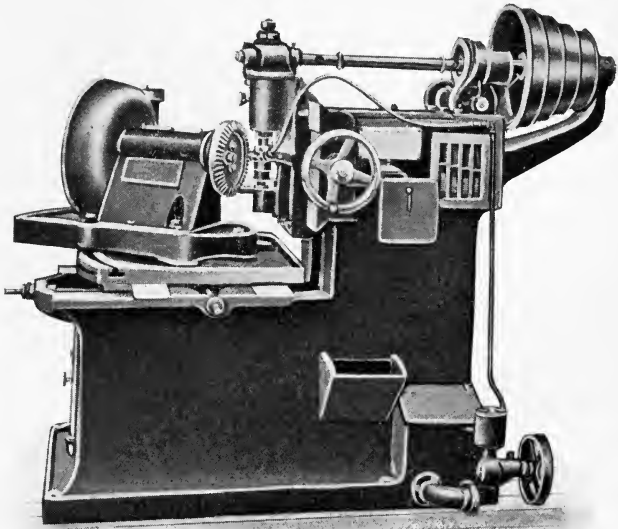

FIG. 218. The Chambron Bevel Gear Hobbing Machine as developed by the Oerlikon Company, particularly adapted for roughing Bevel Gears preliminary to planing.

in Fig. 216, but the mechanism is very much simpler, since the oscillating head and the connections required for operating it have been abandoned, the spindle slide being mounted directly on fixed ways on the front of the column. For this reason the generating action is not, it will be seen, fully carried out, the cutting action, however, resulting in the production of a groove tapering properly

from the large to the small end and of approximately the correct shape. The machine is thus especially adapted to roughing blanks previous to finishing them in a planing machine operating on the templet or molding-generating principles. It is claimed to do its work with great rapidity, and to be capable of leaving a very small and uniform amount of stock over the whole area of the sides of the tooth.

Besides this Chambon process, another and, it seems to

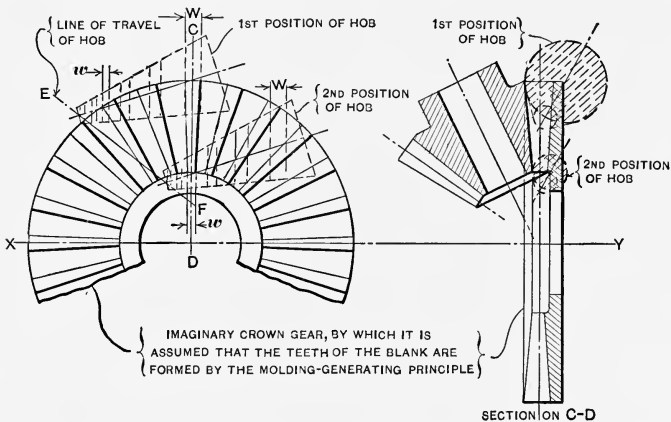

FIG. 219. Another Hobbing Process suggested for Bevel Gears.

the writer, a fruitless attempt has been made to cut the teeth of bevel gears by the molding-generating principle with a hob as the cutting tool. This method is shown in its principle in Fig. 219, the construction being referred to the imaginary crown gear and the bevel gear to be cut, as in the previous case. Also, as in the previous case, the action hinges about the design of the hob. Here we have a hob of such a taper, and with the pitch continuously decreasing in such a ratio, that the helix angle is constant. This decrease in pitch is, of course, accompanied by a cor-

respondingly uniform and proportional decrease in the section of the thread. In the machine the hob is so set (in the "first position," for instance) that the center line of the thread in the cutting position passes through center D of the imaginary crown gear. Here the width of the top of the hob tooth is W , corresponding to the desired width at the top of the imaginary crown gear tooth. In feeding, the hob is moved, without changing the angle of its axis, along line EF , so that when it arrives at the inner end of the face of the imaginary crown gear, that tooth that is on the center line CD will be so near the small end of the hob that it has the required width at the top, w , and the proper pitch, to agree with the small end of the tooth in the imaginary crown gear. In a similar way all the intervening positions match up with the teeth of the crown gear on line CD .

In the machine for utilizing this hob it is mounted on a slide which is adjustable to give the line of feed, EF , the angle for the conditions required, while, as shown at the right of Fig. 214, the spindle of the hob is set at such an angle that its pitch cone is tangent to the pitch plane of the imaginary crown gear. The feeding movement along line EF is so connected with the rotating mechanism of the hob that, as it progresses from the first to the second position, the hob is rotated to keep its diminishing thread always coincident with the central tooth of the crown gear shown. In addition to the rotation thus given the hob by the feeding movement, another rotating movement is given it in connection with the work, the same as for all hobbing processes. These two rotating movements are combined by differential gearing. It will thus be seen that with the machine properly set up the hob may be fed from the first to the second position, with the hob and work rotating together, the former being under a rotative

influence from the feeding movement as well, giving somewhat the effect of the rotation of the ordinary crown gear.

What the writer feels sure, however, is a vital error in the principle of this machine, is plainly evident in Fig. 219, where it is seen that the only point where the teeth of the hob coincide with those of the imaginary crown gear is on line CD . At the right of CD and at the left of it the coincidence ceases, and the hob teeth cross the crown gear teeth at different angles, so that they must cut entirely different shaped spaces in the work. Of course, everything in the diagram shown is exaggerated, but the exaggeration only shows the principle more clearly. While it is stated that the machine and the process are beyond the experimental stage, and while, from long experience, the writer knows that it is unsafe to predict the failure of any principle until it has actually been tried out, the analysis given above is surely enough to make one skeptical as to the success of this operation, particularly in the case of gears of such large pitch cone angle as to nearly approach the crown gear. With smaller angles, down to the spur gear, the action should be more nearly correct, as the blank curves away from the hob so rapidly as to avoid most of the interference, though even here the fact that the pitch is coarser at one side of the line CD than at the other would still prevent proper action. It would thus seem that interference would prevent the consideration of this device as a practical possibility.

COMPARISON OF MOLDING-GENERATING MACHINES FOR BEVEL GEARS.

It is interesting to note, in the various molding-generating machines for bevel gears, the different ways used for rolling the cutter head and the work in relation to each other. In the Bilgram machine the proper relation is maintained by the

rolling of the pitch surfaces of the work and the crown gear on each other, the rolling being controlled by steel tapes or wires in such a way as to make the movement positive. In the Ducommun machine the same movement is effected by spherical linkage, which, while not exact in its action, is so nearly so that the error introduced is entirely negligible. The Gleason and Ludwig Loewe machines employ segments of the actual crown and master gears shown in Fig. 164, although, of course, it is not necessary to have the teeth of the master gear of the same number for the full circle and of the same form as those of the work, the only requirement being that the pitch cone of the master gear be coincident with that of the work. In the Ernault machine the proper ratio of movement is obtained by a system of angular slides which automatically adjust themselves to the required ratio (which is dependent on the pitch cone angle of the gear) in the manner described in referring to Fig. 207. Finally, in the Brown & Sharpe, Chambon, and Churchill machines the proper ratio is obtained by the use of change gears.

Another interesting point relates to the considerable size and complication of each of these machines, as compared with the small size of the work they are adapted to operate on. While the principle of the molding-generating process is comparatively simple, as shown in Fig. 164, considerable mechanism is required for making a machine built according to this principle universal in its application, easily set up and operated, and automatic in its operation.

CONCLUSION.

This concludes our investigation of gear-cutting machinery. The number of commercial machines of this kind is much greater than was believed possible when the author began these chapters. It is safe to say that in no

other field of the machine tool business has there been such an opportunity for the display of mechanical ingenuity and skill in designing as in that of gear cutting, and in no field have these possibilities been so fully grasped. That we have not yet reached final development in any of the various forms of this machinery is shown by the fact that a number of new machines are in process of development in this country and Europe, and doubtless such as are worthy of mention will be brought to the attention of the readers of the technical press as soon as the information concerning them is available for publication.

INDEX.

| | |
|--|---|
| Act-Ges. für Schmirgel u. Maschinen-Fabrikation | 242 |
| Adams Company | 87 |
| Armstrong, Sir W. G., Whitworth & Co. | 48, 50, 93, 107, 126 |
| Ateliers de Construction Mécaniques, ci-devant Ducommun . | 83, 281, 314 |
| Atlas, Nya Aktiebolaget | 51, 106, 142, 202, 208 |
| Automatic Machine Company | 135 |
| | |
| Becker Milling Machine Company | 33, 82 |
| Biernatzki & Co. | 163 |
| Bilgram, Hugo | 69, 157, 274, 278, 281, 313 |
| Bouhey, Usines | 250, 254, 274, 291 |
| Brown, David, & Sons | 110 |
| Brown & Sharpe Manufacturing Company | 26, 33, 112, 137, 236, 240, 275, 297, 298, 314 |
| Browning | 259 |
| Burton, C. W., Griffiths & Co. | 90, 102 |
| | |
| Chambon, M. | 301, 310, 314 |
| Chouanard, E. | 102 |
| Churchill Machine Tool Company | 290, 314 |
| Cincinnati Gear Cutting Machine Company | 36 |
| Cincinnati Milling Machine Company | 20, 139, 232 |
| Citroën, André | 151 |
| Craven Brothers | 55, 118 |
| | |
| Darling & Sellers | 52 |
| Dubosc, Officina Meccanica Ing. E. | 267 |
| Ducommun (ci-devant) Ateliers de Construction Mécaniques . | 83, 147 281, 314 |
| Ernault, H | 290, 314 |
| | |
| Fellows Gear Shaper Company | 75, 99, 100, 108, 126, 128, 155 |
| Fletcher, E. J., Manufacturing Company | 37, 238 |
| | |
| Garvin Machine Company | 201 |
| Gildemeister & Co. | 87, 147 |

| | |
|--|--|
| Gleason Works | 15, 66, 248, 295, 300, 314 |
| Gould & Eberhardt | 38, 56, 105, 114, 120, 130, 152, 164, 193, 237 |
| Grant-Lees Machine Company | 171, 195 |
| Greenwood & Batley | 254 |
| Hardinge Brothers | 60 |
| Herbert, Alfred | 92 |
| Hetherington, John, & Sons | 48, 58 |
| Holroyd & Co. | 166, 209 |
| Humpage, Thomas | 102 |
| Humpage, Thompson & Hardy | 88 |
| Juengst, Geo. & Sons | 173 |
| Junghans, Wilhelm, Werkzeugmaschinenfabrik | 84 |
| Kroll, Moritz | 246 |
| Le Blond, R. K., Machine Tool Company | 21, 81, 112, 118, 141, 189 |
| Le Jeun, Etablissements Mareel | 235 |
| Loewe, Ludwig, & Co. | 22, 42, 233, 298, 314 |
| Lorenz, Maschinenfabrik | 95, 147 |
| Mill, Fred | 243 |
| Monneret, M. | 290 |
| Newark Gear Cutting Machine Company | 24, 36, 59, 192, 206, 240 |
| Newton Machine Tool Works | 15, 53, 67, 169, 190 |
| Oerlikon, Société Suisse pour la Construction de Machines-Outils, 256, 266, 310 | |
| Parkinson, J. & Son | 42 |
| Pederson | 16 |
| Pfauter | 171 |
| Pratt & Whitney Company | 14, 58, 118, 148, 176, 298 |
| Reinecker, J. E. | 44, 81, 99, 102, 121, 143, 150, 178, 200, 211, 281, 292 |
| Reynolds Machine Company | 98 |
| Rhenania | 90, 180 |
| Rice | 261 |
| Schubert & Salzer Maschinenfabrik | 46, 90 |
| Schuchardt & Schutte | 171 |
| Schutte, Alfred | 90 |

| | |
|---|-----------------|
| Slate, Dwight, Machine Company | 29, 60 |
| Sloan & Chace Manufacturing Company..... | 29, 60, 62, 114 |
| Small Arms & Machine Factory Company..... | 257 |
| Smith, G. F..... | 58 |
| Smith & Coventry..... | 271 |
| Société Française de Machines-Outils..... | 72 |
| Sonnenthal, Selig. & Co..... | 90, 271 |
| Spencer & Spiers..... | 73 |
| Standard Manufacturing Company..... | 62 |
| Swasey, Ambrose..... | 14 |
| Upton & Gilman..... | 65 |
| Vickers Sons and Maxim..... | 19 |
| Waleott & Wood Machine Tool Company..... | 115, 126 |
| Wallwork, Henry, & Co..... | 92, 180, 211 |
| Waltham Machine Works..... | 64 |
| Wanderer Fahrradwerke..... | 86, 189 |
| Warner & Swasey..... | 98, 117 |
| Warren..... | 298 |
| Whiton, D. E., Machine Company..... | 239 |
| Wilkinson, G., & Son..... | 46, 123 |
| Wüst, C. E., & Co..... | 179 |



SHORT-TITLE CATALOGUE

OF THE

PUBLICATIONS

OF

JOHN WILEY & SONS

NEW YORK

LONDON: CHAPMAN & HALL, LIMITED

ARRANGED UNDER SUBJECTS

Descriptive circulars sent on application. Books marked with an asterisk (*) are sold at *net* prices only. All books are bound in cloth unless otherwise stated.

AGRICULTURE—HORTICULTURE—FORESTRY.

| | | |
|---|-------|--------|
| Armsby's Principles of Animal Nutrition..... | 8vo, | \$4 00 |
| Budd and Hansen's American Horticultural Manual: | | |
| Part I. Propagation, Culture, and Improvement..... | 12mo, | 1 50 |
| Part II. Systematic Pomology..... | 12mo, | 1 50 |
| Elliott's Engineering for Land Drainage..... | 12mo, | 1 50 |
| Practical Farm Drainage. (Second Edition, Rewritten)..... | 12mo, | 1 50 |
| Graves's Forest Mensuration..... | 8vo, | 4 00 |
| Green's Principles of American Forestry..... | 12mo, | 1 50 |
| Grotenfelt's Principles of Modern Dairy Practice. (Woll.)..... | 12mo, | 2 00 |
| * Herrick's Denatured or Industrial Alcohol..... | 8vo, | 4 00 |
| Kemp and Waugh's Landscape Gardening. (New Edition, Rewritten. In Preparation). | | |
| * McKay and Larsen's Principles and Practice of Butter-making..... | 8vo, | 1 50 |
| Maynard's Landscape Gardening as Applied to Home Decoration..... | 12mo, | 1 50 |
| Sanderson's Insects Injurious to Staple Crops..... | 12mo, | 1 50 |
| Sanderson and Headlee's Insects Injurious to Garden Crops. (In Preparation). | | |
| * Schwarz's Longleaf Pine in Virgin Forests..... | 12mo, | 1 25 |
| Stockbridge's Rocks and Soils..... | 8vo, | 2 50 |
| Winton's Microscopy of Vegetable Foods..... | 8vo, | 7 50 |
| Woll's Handbook for Farmers and Dairymen..... | 16mo, | 1 50 |

ARCHITECTURE.

| | | |
|--|-------|------|
| Baldwin's Steam Heating for Buildings..... | 12mo, | 2 50 |
| Berg's Buildings and Structures of American Railroads..... | 4to, | 5 00 |
| Birkmire's Architectural Iron and Steel..... | 8vo, | 3 50 |
| Compound Riveted Girders as Applied in Buildings..... | 8vo, | 2 00 |
| Planning and Construction of American Theatres..... | 8vo, | 3 00 |
| Planning and Construction of High Office Buildings..... | 8vo, | 3 50 |
| Skeleton Construction in Buildings..... | 8vo, | 3 00 |

| | | |
|--|-------------|--------|
| Briggs's Modern American School Buildings..... | 8vo, | \$4 00 |
| Byrne's Inspection of Materials and Workmanship Employed in Construction..... | 16mo, | 3 00 |
| Carpenter's Heating and Ventilating of Buildings..... | 8vo, | 4 00 |
| * Corthell's Allowable Pressure on Deep Foundations..... | 12mo, | 1 25 |
| Freitag's Architectural Engineering..... | 8vo, | 3 50 |
| Fireproofing of Steel Buildings..... | 8vo, | 2 50 |
| Gerhard's Guide to Sanitary Inspections. (Fourth Edition, Entirely Revised and Enlarged)..... | 12mo, | 1 50 |
| * Modern Baths and Bath Houses..... | 8vo, | 3 00 |
| Sanitation of Public Buildings..... | 12mo, | 1 50 |
| Theatre Fires and Panics..... | 12mo, | 1 50 |
| Johnson's Statics by Algebraic and Graphic Methods..... | 8vo, | 2 00 |
| Kellaway's How to Lay Out Suburban Home Grounds..... | 8vo, | 2 00 |
| Kidder's Architects' and Builders' Pocket-book..... | 16mo, mor., | 5 00 |
| Merrill's Stones for Building and Decoration..... | 8vo, | 5 00 |
| Monckton's Stair-building..... | 4to, | 4 00 |
| Patton's Practical Treatise on Foundations..... | 8vo, | 5 00 |
| Peabody's Naval Architecture..... | 8vo, | 7 50 |
| Rice's Concrete-block Manufacture..... | 8vo, | 2 00 |
| Richey's Handbook for Superintendents of Construction..... | 16mo, mor., | 4 00 |
| Building Foreman's Pocket Book and Ready Reference.. | 16mo, mor. | 5 00 |
| * Building Mechanics' Ready Reference Series: | | |
| * Carpenters' and Woodworkers' Edition..... | 16mo, mor. | 1 50 |
| * Cement Workers' and Plasterers' Edition..... | 16mo, mor. | 1 50 |
| * Plumbers', Steam-Fitters', and Tinners' Edition.. | 16mo, mor. | 1 50 |
| * Stone- and Brick-masons' Edition..... | 16mo, mor. | 1 50 |
| Sabin's House Painting..... | 12mo, | 1 00 |
| Siebert and Biggin's Modern Stone-cutting and Masonry..... | 8vo, | 1 50 |
| Snow's Principal Species of Wood..... | 8vo, | 3 50 |
| Towne's Locks and Builders' Hardware..... | 16mo, mor. | 3 00 |
| Wait's Engineering and Architectural Jurisprudence..... | 8vo, | 6 00 |
| Sheep, | | 6 50 |
| Law of Contracts..... | 8vo, | 3 00 |
| Law of Operations Preliminary to Construction in Engineering and Architecture..... | 8vo, | 5 00 |
| Sheep, | | 5 50 |
| Wilson's Air Conditioning..... | 12mo, | 1 50 |
| Worcester and Atkinson's Small Hospitals, Establishment and Maintenance, Suggestions for Hospital Architecture, with Plans for a Small Hospital..... | 12mo, | 1 25 |

ARMY AND NAVY.

| | | |
|---|------------|------|
| Bernadou's Smokeless Powder, Nitro-cellulose, and the Theory of the Cellulose Molecule..... | 12mo, | 2 50 |
| Chase's Art of Pattern Making..... | 12mo, | 2 50 |
| Screw Propellers and Marine Propulsion..... | 8vo, | 3 00 |
| * Cloke's Enlisted Specialists' Examiner..... | 8vo, | 2 00 |
| * Gunner's Examiner..... | 8vo, | 1 50 |
| Craig's Azimuth..... | 4to, | 3 50 |
| Crehore and Squier's Polarizing Photo-chronograph..... | 8vo, | 3 00 |
| * Davis's Elements of Law..... | 8vo, | 2 50 |
| * Treatise on the Military Law of United States..... | 8vo, | 7 00 |
| DeBrack's Cavalry Outpost Duties. (Carr.)..... | 24mo, mor. | 2 00 |
| * Dudley's Military Law and the Procedure of Courts-martial... Large | 12mo, | 2 50 |
| Durand's Resistance and Propulsion of Ships..... | 8vo, | 5 00 |
| * Dyer's Handbook of Light Artillery..... | 12mo, | 3 00 |
| Eissler's Modern High Explosives..... | 8vo, | 4 00 |
| * Fieberger's Text-book on Field Fortification..... Large | 12mo, | 2 00 |
| Hamilton and Bond's The Gunner's Catechism..... | 12mo, | 1 00 |
| * Hoff's Elementary Naval Tactics..... | 8vo, | 1 50 |
| Ingalls's Handbook of Problems in Direct Fire..... | 8vo, | 4 00 |
| * Lissak's Ordnance and Gunnery..... | 8vo, | 6 00 |

| | | |
|---|----------------|--------|
| * Ludlow's Logarithmic and Trigonometric Tables..... | 8vo, | \$1 00 |
| * Lyons's Treatise on Electromagnetic Phenomena. Vols. I. and II.. | 8vo, each, | 6 00 |
| * Mahan's Permanent Fortifications. (Mercur.)..... | 8vo. half mor. | 7 50 |
| Manual for Courts-martial..... | 16mo, mor. | 1 50 |
| * Mercur's Attack of Fortified Places..... | 12mo, | 2 00 |
| * Elements of the Art of War..... | 8vo, | 4 00 |
| Nixon's Adjutants' Manual..... | 24mo, | 1 00 |
| Peabody's Naval Architecture | 8vo, | 7 50 |
| * Phelps's Practical Marine Surveying..... | 8vo, | 2 50 |
| Putnam's Nautical Charts..... | 8vo, | 2 00 |
| Rust's Ex-meridian Altitude, Azimuth and Star-Finding Tables..... | 8vo, | 5 00 |
| Sharpe's Art of Subsisting Armies in War..... | 18mo, mor. | 1 50 |
| * Tapes and Poole's Manual of Bayonet Exercises and Musketry Fencing, | 24mo, leather, | 50 |
| * Weaver's Military Explosives..... | 8vo, | 3 00 |
| Woodhull's Notes on Military Hygiene..... | 16mo, | 1 50 |

ASSAYING.

| | | |
|---|------------|------|
| Betts's Lead Refining by Electrolysis..... | 8vo, | 4 00 |
| Fletcher's Practical Instructions in Quantitative Assaying with the Blowpipe. | 16mo, mor. | 1 50 |
| Furman and Pardoe's Manual of Practical Assaying. (Sixth Edition, Re- | 8vo, | 3 00 |
| vised and Enlarged)..... | | |
| Lodge's Notes on Assaying and Metallurgical Laboratory Experiments..... | 8vo, | 3 00 |
| Low's Technical Methods of Ore Analysis..... | 8vo, | 3 00 |
| Miller's Cyanide Process..... | 12mo, | 1 00 |
| Manual of Assaying..... | 12mo, | 1 00 |
| Minet's Production of Aluminum and its Industrial Use. (Waldo.).... | 12mo, | 2 50 |
| O'Driscoll's Notes on the Treatment of Gold Ores..... | 8vo, | 2 00 |
| Ricketts and Miller's Notes on Assaying..... | 8vo, | 3 00 |
| Robine and Lenglen's Cyanide Industry. (Le Clerc.)..... | 8vo, | 4 00 |
| Ulke's Modern Electrolytic Copper Refining..... | 8vo, | 3 00 |
| Wilson's Chlorination Process..... | 12mo, | 1 50 |
| Cyanide Processes..... | 12mo, | 1 50 |

ASTRONOMY.

| | | |
|---|------------|------|
| Comstock's Field Astronomy for Engineers..... | 8vo, | 2 50 |
| Craig's Azimuth..... | 4to, | 3 50 |
| Crandall's Text-book on Geodesy and Least Squares..... | 8vo, | 3 00 |
| Doolittle's Treatise on Practical Astronomy..... | 8vo, | 4 00 |
| Hayford's Text-book of Geodetic Astronomy..... | 8vo, | 3 00 |
| Hosmer's Azimuth..... | 16mo, mor. | 1 00 |
| Merriman's Elements of Precise Surveying and Geodesy..... | 8vo, | 2 50 |
| * Michie and Harlow's Practical Astronomy..... | 8vo, | 3 00 |
| Rust's Ex-meridian Altitude, Azimuth and Star-Finding Tables..... | 8vo, | 5 00 |
| * White's Elements of Theoretical and Descriptive Astronomy..... | 12mo, | 2 00 |

CHEMISTRY.

| | | |
|--|-------------|------|
| * Abderhalden's Physiological Chemistry in Thirty Lectures. (Hall and | 8vo, | 5 00 |
| Defren)..... | | |
| * Abegg's Theory of Electrolytic Dissociation. (von Ende.)..... | 12mo, | 1 25 |
| Alexeyeff's General Principles of Organic Syntheses. (Matthews.)..... | 8vo, | 3 00 |
| Allen's Tables for Iron Analysis..... | 8vo, | 3 00 |
| Armsby's Principles of Animal Nutrition..... | 8vo, | 4 00 |
| Arnold's Compendium of Chemistry. (Mandel.)..... | Large 12mo, | 3 50 |
| Association of State and National Food and Dairy Departments, Hartford | | |
| Meeting, 1906..... | 8vo, | 3 00 |
| Jamestown Meeting, 1907..... | 8vo, | 3 00 |

| | | |
|---|-------------|--------|
| Austen's Notes for Chemical Students..... | 12mo, | \$1 50 |
| Baskerville's Chemical Elements. (In Preparation). | | |
| Bernadoux's Smokeless Powder.—Nitro-cellulose, and Theory of the Cellulose Molecule..... | 12mo, | 2 50 |
| Biltz's Introduction to Inorganic Chemistry. (Hall and Phelan). (In Press). Laboratory Methods of Inorganic Chemistry. (Hall and Blanchard). | 8vo, | 3 00 |
| * Blanchard's Synthetic Inorganic Chemistry..... | 12mo, | 1 00 |
| * Browning's Introduction to the Rarer Elements..... | 8vo, | 1 50 |
| * Claassen's Beet-sugar Manufacture. (Hall and Rolfe.)..... | 8vo, | 3 00 |
| Classen's Quantitative Chemical Analysis by Electrolysis. (Boltwood.)..... | 8vo, | 3 00 |
| Cohn's Indicators and Test-papers..... | 12mo, | 2 00 |
| Tests and Reagents..... | 8vo, | 3 00 |
| * Danneel's Electrochemistry. (Merriam.)..... | 12mo, | 1 25 |
| Dannerth's Methods of Textile Chemistry..... | 12mo, | 2 00 |
| Duhem's Thermodynamics and Chemistry. (Burgess.)..... | 8vo, | 4 00 |
| Effront's Enzymes and their Applications. (Prescott.)..... | 8vo, | 3 00 |
| Eissler's Modern High Explosives..... | 8vo, | 4 00 |
| Erdmann's Introduction to Chemical Preparations. (Dunlap.)..... | 12mo, | 1 25 |
| * Fischer's Physiology of Alimentation..... | Large 12mo, | 2 00 |
| Fletcher's Practical Instructions in Quantitative Assaying with the Blowpipe. | 12mo, mor. | 1 50 |
| Fowler's Sewage Works Analyses..... | 12mo, | 2 00 |
| Fresenius's Manual of Qualitative Chemical Analysis. (Wells.)..... | 8vo, | 5 00 |
| Manual of Qualitative Chemical Analysis. Part I. Descriptive. (Wells.)..... | 8vo, | 3 00 |
| Quantitative Chemical Analysis. (Cohn.) 2 vols. | 8vo, | 12 50 |
| When Sold Separately, Vol. I, \$6. Vol. II, \$8. | | |
| Fuertes's Water and Public Health..... | 12mo, | 1 50 |
| Furman and Pardoe's Manual of Practical Assaying. (Sixth Edition, Revised and Enlarged.)..... | 8vo, | 3 00 |
| * Getman's Exercises in Physical Chemistry..... | 12mo, | 2 00 |
| Gill's Gas and Fuel Analysis for Engineers..... | 12mo, | 1 25 |
| * Gooch and Browning's Outlines of Qualitative Chemical Analysis. | Large 12mo, | 1 25 |
| Grotenfelt's Principles of Modern Dairy Practice. (Woll.)..... | 12mo, | 2 00 |
| Groth's Introduction to Chemical Crystallography (Marshall)..... | 12mo, | 1 25 |
| Hammarsten's Text-book of Physiological Chemistry. (Mandel.)..... | 8vo, | 4 00 |
| Hanausek's Microscopy of Technical Products. (Winton.)..... | 8vo, | 5 00 |
| * Haskins and Macleod's Organic Chemistry..... | 12mo, | 2 00 |
| Hering's Ready Reference Tables (Conversion Factors)..... | 16mo, mor. | 2 50 |
| * Herrick's Denatured or Industrial Alcohol..... | 8vo, | 4 00 |
| Hinds's Inorganic Chemistry..... | 8vo, | 3 00 |
| * Laboratory Manual for Students..... | 12mo, | 1 00 |
| * Holleman's Laboratory Manual of Organic Chemistry for Beginners. (Walker.)..... | 12mo, | 1 00 |
| Text-book of Inorganic Chemistry. (Cooper.)..... | 8vo, | 2 50 |
| Text-book of Organic Chemistry. (Walker and Mott.)..... | 8vo, | 2 50 |
| * Holley's Lead and Zinc Pigments..... | Large 12mo, | 3 00 |
| Holley and Ladd's Analysis of Mixed Paints, Color Pigments, and Varnishes. | Large 12mo, | 2 50 |
| Hopkins's Oil-chemists' Handbook..... | 8vo, | 3 00 |
| Jackson's Directions for Laboratory Work in Physiological Chemistry..... | 8vo, | 1 25 |
| Johnson's Rapid Methods for the Chemical Analysis of Special Steels, Steel-making Alloys and Graphite..... | Large 12mo, | 3 00 |
| Landauer's Spectrum Analysis. (Tingle.)..... | 8vo, | 3 00 |
| * Langworthy and Austen's Occurrence of Aluminium in Vegetable Products, Animal Products, and Natural Waters..... | 8vo, | 2 00 |
| Lassar-Cohn's Application of Some General Reactions to Investigations in Organic Chemistry. (Tingle.)..... | 12mo, | 1 00 |
| Leach's Inspection and Analysis of Food with Special Reference to State Control..... | 8vo, | 7 50 |
| Löb's Electrochemistry of Organic Compounds. (Lorenz.)..... | 8vo, | 3 00 |
| Lodge's Notes on Assaying and Metallurgical Laboratory Experiments..... | 8vo, | 3 00 |
| Low's Technical Method of Ore Analysis..... | 8vo, | 3 00 |
| Lunge's Techno-chemical Analysis. (Cohn.)..... | 12mo, | 1 00 |
| * McKay and Larsen's Principles and Practice of Butter-making..... | 8vo, | 1 50 |
| Maire's Modern Pigments and their Vehicles..... | 12mo, | 2 00 |

| | | |
|---|-------------|--------|
| Washington's Manual of the Chemical Analysis of Rocks..... | 8vo, | \$2 00 |
| * Weaver's Military Explosives..... | 8vo, | 3 00 |
| Wells's Laboratory Guide in Qualitative Chemical Analysis..... | 8vo, | 1 50 |
| Short Course in Inorganic Qualitative Chemical Analysis for Engineering Students..... | 12mo, | 1 50 |
| Text-book of Chemical Arithmetic..... | 12mo, | 1 25 |
| Whipple's Microscopy of Drinking-water..... | 8vo, | 3 50 |
| Wilton's Chlorination Process..... | 12mo, | 1 50 |
| Cyanide Processes..... | 12mo, | 1 50 |
| Winton's Microscopy of Vegetables Food..... | 8vo, | 7 50 |
| Zsigmondy's Colloids and the Ultramicroscope. (Alexander)... | Large 12mo, | 3 00 |

CIVIL ENGINEERING.

BRIDGES AND ROOFS. HYDRAULICS. MATERIALS OF ENGINEERING. RAILWAY ENGINEERING.

| | | |
|--|-----------------------|------|
| Baker's Engineers' Surveying Instruments..... | 12mo, | 3 00 |
| Bixby's Graphical Computing Table..... | Paper 19½×24¼ inches, | 25 |
| Breed and Hosmer's Principles and Practice of Surveying. Vol. I. Elementary Surveying..... | 8vo, | 3 00 |
| Vol. II. Higher Surveying..... | 8vo, | 2 50 |
| * Burr's Ancient and Modern Engineering and the Isthmian Canal..... | 8vo, | 3 50 |
| Comstock's Field Astronomy for Engineers..... | 8vo, | 2 50 |
| * Corthell's Allowable Pressure on Deep Foundations..... | 12mo, | 1 25 |
| Crandall's Text-book on Geodesy and Least Squares..... | 8vo, | 3 00 |
| Davis's Elevation and Stadia Tables..... | 8vo, | 1 00 |
| Elliott's Engineering for Land Drainage..... | 12mo, | 1 50 |
| Practical Farm Drainage. (Second Edition Rewritten.)..... | 12mo, | 1 50 |
| * Fieberger's Treatise on Civil Engineering..... | 8vo, | 5 00 |
| Flemmer's Photographic Methods and Instruments..... | 8vo, | 5 00 |
| Folwell's Sewerage. (Designing and Maintenance.)..... | 8vo, | 3 00 |
| Freitag's Architectural Engineering..... | 8vo, | 3 50 |
| Goodhue's Municipal Improvements..... | 12mo, | 1 50 |
| * Hauch and Rice's Tables of Quantities for Preliminary Estimates..... | 12mo, | 1 25 |
| Hayford's Text-book of Geodetic Astronomy..... | 8vo, | 3 00 |
| Hering's Ready Reference Tables (Conversion Factors)..... | 16mo, mor. | 2 50 |
| Hosmer's Azimuth..... | 16mo, mor. | 1 00 |
| Howe' Retaining Walls for Earth..... | 12mo, | 1 25 |
| * Ives' Adjustments of the Engineer's Transit and Level..... | 16mo, bds. | 25 |
| Johnson's (J. B.) Theory and Practice of Surveying..... | Large 12mo, | 4 00 |
| Johnson's (L. J.) Statics by Algebraic and Graphic Methods..... | 8vo, | 2 00 |
| Kinnicutt, Winslow and Pratt's Purification of Sewage. (In Preparation). | | |
| * Mahan's Descriptive Geometry..... | 8vo, | 1 50 |
| Merriman's Elements of Precise Surveying and Geodesy..... | 8vo, | 2 50 |
| Merriman and Brooks's Handbook for Surveyors..... | 16mo, mor. | 2 00 |
| Nugent's Plane Surveying..... | 8vo, | 3 50 |
| Ogden's Sewer Construction..... | 8vo, | 3 00 |
| Sewer Design..... | 12mo, | 2 00 |
| Parsons's Disposal of Municipal Refuse..... | 8vo, | 2 00 |
| Patton's Treatise on Civil Engineering..... | 8vo, half leather, | 7 50 |
| Reed's Topographical Drawing and Sketching..... | 4to, | 5 00 |
| Rideal's Sewage and the Bacterial Purification of Sewage..... | 8vo, | 4 00 |
| Riemer's Shaft-sinking under Difficult Conditions. (Corning and Peele.)..... | 8vo, | 3 00 |
| Siebert and Biggin's Modern Stone-cutting and Masonry..... | 8vo, | 1 50 |
| Smith's Manual of Topographical Drawing. (McMillan.)..... | 8vo, | 2 50 |
| Soper's Air and Ventilation of Subways..... | 12mo, | 2 50 |
| * Tracy's Exercises in Surveying..... | 12mo, mor. | 1 00 |
| Tracy's Plane Surveying..... | 16mo, mor. | 3 00 |
| * Trautwine's Civil Engineer's Pocket-book..... | 16mo, mor. | 5 00 |
| Venable's Garbage Crematories in America..... | 8vo, | 2 00 |
| Methods and Devices for Bacterial Treatment of Sewage..... | 8vo, | 3 00 |

| | | |
|---|--------|--------|
| Wait's Engineering and Architectural Jurisprudence..... | 8vo, | \$6 00 |
| | Sheep, | 6 50 |
| Law of Contracts..... | 8vo, | 3 00 |
| Law of Operations Preliminary to Construction in Engineering and Architecture..... | 8vo, | 5 00 |
| | Sheep, | 5 50 |
| Warren's Stereotomy—Problems in Stone-cutting..... | 8vo, | 2 50 |
| * Waterbury's Vest-Pocket Hand-book of Mathematics for Engineers. 2¼ × 5¼ inches, mor. | | 1 00 |
| Webb's Problem's in the Use and Adjustment of Engineering Instruments. 16mo, mor. | | 1 25 |
| Wilson's Topographic Surveying..... | 8vo, | 3 50 |

BRIDGES AND ROOFS.

| | | |
|---|---------------|-------|
| Boller's Practical Treatise on the Construction of Iron Highway Bridges..... | 8vo, | 2 00 |
| * Thames River Bridge..... | Oblong paper, | 5 00 |
| Burr and Falk's Design and Construction of Metallic Bridges..... | 8vo, | 5 00 |
| Influence Lines for Bridge and Roof Computations..... | 8vo, | 3 00 |
| Du Bois's Mechanics of Engineering. Vol. II..... | Small 4to, | 10 00 |
| Poster's Treatise on Wooden Trestle Bridges..... | 4to, | 5 00 |
| Fowler's Ordinary Foundations..... | 8vo, | 3 50 |
| Greene's Arches in Wood, Iron, and Stone..... | 8vo, | 2 50 |
| Bridge Trusses..... | 8vo, | 2 50 |
| Roof Trusses..... | 8vo, | 1 25 |
| Grimm's Secondary Stresses in Bridge Trusses..... | 8vo, | 2 50 |
| Heller's Stresses in Structures and the Accompanying Deformations.... | 8vo, | 3 00 |
| Howe's Design of Simple Roof-trusses in Wood and Steel..... | 8vo, | 2 00 |
| Symmetrical Masonry Arches..... | 8vo, | 2 50 |
| Treatise on Arches..... | 8vo, | 4 00 |
| Johnson, Bryan and Turneaure's Theory and Practice in the Designing of Modern Framed Structures..... | Small 4to, | 10 00 |
| Merriman and Jacoby's Text-book on Roofs and Bridges: | | |
| Part I. Stresses in Simple Trusses..... | 8vo, | 2 50 |
| Part II. Graphic Statics..... | 8vo, | 2 50 |
| Part III. Bridge Design..... | 8vo, | 2 50 |
| Part IV. Higher Structures..... | 8vo, | 2 50 |
| Morison's Memphis Bridge..... | Oblong 4to, | 10 00 |
| Sondericker's Graphic Statics, with Applications to Trusses, Beams, and Arches..... | 8vo, | 2 00 |
| Waddell's De Pontibus, Pocket-book for Bridge Engineers..... | 16mo, mor. | 2 00 |
| * Specifications for Steel Bridges..... | 12mo, | 50 |
| Waddell and Harrington's Bridge Engineering. (In Preparation.) | | |
| Wright's Designing of Draw-spans. Two parts in one volume..... | 8vo, | 3 50 |

HYDRAULICS.

| | | |
|---|------------|------|
| Barnes's Ice Formation..... | 8vo, | 3 00 |
| Bazin's Experiments upon the Contraction of the Liquid Vein Issuing from an Orifice. (Trautwine.)..... | 8vo, | 2 00 |
| Bovey's Treatise on Hydraulics..... | 8vo, | 5 00 |
| Church's Diagrams of Mean Velocity of Water in Open Channels. Oblong 4to, paper, | | 1 50 |
| Hydraulic Motors..... | 8vo, | 2 00 |
| Coffin's Graphical Solution of Hydraulic Problems..... | 16mo, mor. | 2 50 |
| Flather's Dynamometers, and the Measurement of Power..... | 12mo, | 3 00 |
| Folwell's Water-supply Engineering..... | 8vo, | 4 00 |
| Frizell's Water-power..... | 8vo, | 5 00 |
| Fuertes's Water and Public Health..... | 12mo, | 1 50 |
| Water-filtration Works..... | 12mo, | 2 50 |
| Ganguillet and Kutter's General Formula for the Uniform Flow of Water in Rivers and Other Channels. (Hering and Trautwine.)..... | 8vo, | 4 00 |

| | | |
|---|-------------|--------|
| Hazen's Clean Water and How to Get It..... | Large 12mo, | \$1 50 |
| Filtration of Public Water-supplies..... | 8vo, | 3 00 |
| Hazelhurst's Towers and Tanks for Water-works..... | 8vo, | 2 50 |
| Herschel's 115 Experiments on the Carrying Capacity of Large, Riveted, Metal Conduits..... | 8vo, | 2 00 |
| Hoyt and Grover's River Discharge..... | 8vo, | 2 00 |
| Hubbard and Kiersted's Water-works Management and Maintenance..... | 8vo, | 4 00 |
| * Lyndon's Development and Electrical Distribution of Water Power..... | 8vo, | 3 00 |
| Mason's Water-supply. (Considered Principally from a Sanitary Stand- point.)..... | 8vo, | 4 00 |
| Merriman's Treatise on Hydraulics..... | 8vo, | 5 00 |
| * Molitor's Hydraulics of Rivers, Weirs and Sluices..... | 8vo, | 2 00 |
| * Richards's Laboratory Notes on Industrial Water Analysis..... | 8vo, | 50 |
| Schuyler's Reservoirs for Irrigation, Water-power, and Domestic Water- supply. Second Edition, Revised and Enlarged..... | Large 8vo, | 6 00 |
| * Thomas and Watt's Improvement of Rivers..... | 4to, | 6 00 |
| Turneare and Russell's Public Water-supplies..... | 8vo, | 5 00 |
| Wegmann's Design and Construction of Dams. 5th Ed., enlarged..... | 4to, | 6 00 |
| Water-Supply of the City of New York from 1658 to 1895..... | 4to, | 10 00 |
| Whipple's Value of Pure Water..... | Large 12mo, | 1 00 |
| Williams and Hazen's Hydraulic Tables..... | 8vo, | 1 50 |
| Wilson's Irrigation Engineering..... | 8vo, | 4 00 |
| Wood's Turbines..... | 8vo, | 2 50 |

MATERIALS OF ENGINEERING.

| | | |
|---|-------------|-------|
| Baker's Roads and Pavements..... | 8vo, | 5 00 |
| Treatise on Masonry Construction..... | 8vo, | 5 00 |
| Black's United States Public Works..... | Oblong 4to, | 5 00 |
| Blanchard's Bituminous Roads. (In Press.) | | |
| Bleining'er's Manufacture of Hydraulic Cement. (In Preparation.) | | |
| * Bovey's Strength of Materials and Theory of Structures..... | 8vo, | 7 50 |
| Burr's Elasticity and Resistance of the Materials of Engineering..... | 8vo, | 7 50 |
| Byrne's Highway Construction..... | 8vo, | 5 00 |
| Inspection of the Materials and Workmanship Employed in Construction..... | 16mo, | 3 00 |
| Church's Mechanics of Engineering..... | 8vo, | 6 00 |
| Du Bois's Mechanics of Engineering..... | | |
| Vol. I. Kinematics, Statics, Kinetics..... | Small 4to, | 7 50 |
| Vol. II. The Stresses in Framed Structures, Strength of Materials and Theory of Flexures..... | Small 4to, | 10 00 |
| * Eckel's Cements, Limes, and Plasters..... | 8vo, | 6 00 |
| Stone and Clay Products used in Engineering. (In Preparation.) | | |
| Fowler's Ordinary Foundations..... | 8vo, | 3 50 |
| * Greene's Structural Mechanics..... | 8vo, | 2 50 |
| * Holley's Lead and Zinc Pigments..... | Large 12mo, | 3 00 |
| Holley and Ladd's Analysis of Mixed Paints, Color Pigments and Varnishes..... | Large 12mo, | 2 50 |
| Johnson (C. M.) Rapid Methods for the Chemical Analysis of Special Steels, Steel-making Alloys and Graphite..... | Large 12mo, | 3 00 |
| Johnson's (J. B.) Materials of Construction..... | Large 8vo, | 6 00 |
| Keep's Cast Iron..... | 8vo, | 2 50 |
| Lanza's Applied Mechanics..... | 8vo, | 7 50 |
| Maire's Modern Pigments and their Vehicles..... | 12mo, | 2 00 |
| Martens's Handbook on Testing Materials. (Henning.) 2 vols..... | 8vo, | 7 50 |
| Maurer's Technical Mechanics..... | 8vo, | 4 00 |
| Merrill's Stones for Building and Decoration..... | 8vo, | 5 00 |
| Merriman's Mechanics of Materials..... | 8vo, | 5 00 |
| * Strength of Materials..... | 12mo, | 1 00 |
| Metcalf's Steel. A Manual for Steel-users..... | 12mo, | 2 00 |
| Morrison's Highway Engineering..... | 8vo, | 2 50 |
| Patton's Practical Treatise on Foundations..... | 8vo, | 5 00 |
| Rice's Concrete Block Manufacture..... | 8vo, | 2 00 |

| | | |
|---|------------|--------|
| Richardson's Modern Asphalt Pavements..... | 8vo, | \$3 00 |
| Richey's Building Foreman's Pocket Book and Ready Reference..... | 16mo, mor. | 5 00 |
| * Cement Workers' and Plasterers' Edition (Building Mechanics' Ready Reference Series)..... | 16mo, mor. | 1 50 |
| Handbook for Superintendents of Construction..... | 16mo, mor. | 4 00 |
| * Stone, and Brick Masons' Edition (Building Mechanics' Ready Reference Series)..... | 16mo, mor. | 1 50 |
| * Ries's Clays: Their Occurrence, Properties, and Uses..... | 8vo, | 5 00 |
| * Ries and Leighton's History of the Clay-working Industry of the United States..... | 8vo, | 2 50 |
| Sabin's Industrial and Artistic Technology of Paint and Varnish..... | 8vo, | 3 00 |
| Smith's Strength of Material..... | 12mo, | |
| Snow's Principal Species of Wood..... | 8vo, | 3 50 |
| Spalding's Hydraulic Cement..... | 12mo, | 2 00 |
| Text-book on Roads and Pavements..... | 12mo, | 2 00 |
| Taylor and Thompson's Treatise on Concrete, Plain and Reinforced..... | 8vo, | 5 00 |
| Thurston's Materials of Engineering. In Three Parts..... | 8vo, | 8 00 |
| Part I. Non-metallic Materials of Engineering and Metallurgy..... | 8vo, | 2 00 |
| Part II. Iron and Steel..... | 8vo, | 3 50 |
| Part III. A Treatise on Brasses, Bronzes, and Other Alloys and their Constituents..... | 8vo, | 2 50 |
| Tillson's Street Pavements and Paving Materials..... | 8vo, | 4 00 |
| Turneure and Maurer's Principles of Reinforced Concrete Construction. Second Edition, Revised and Enlarged..... | 8vo, | 3 50 |
| Waterbury's Cement Laboratory Manual..... | 12mo, | 1 00 |
| Wood's (De V.) Treatise on the Resistance of Materials, and an Appendix on the Preservation of Timber..... | 8vo, | 2 00 |
| Wood's (M. P.) Rustless Coatings: Corrosion and Electrolysis of Iron and Steel..... | 8vo, | 4 00 |

RAILWAY ENGINEERING.

| | | |
|---|------------------|------|
| Andrews's Handbook for Street Railway Engineers..... | 3×5 inches, mor. | 1 25 |
| Berg's Buildings and Structures of American Railroads..... | 4to, | 5 00 |
| Brooks's Handbook of Street Railroad Location..... | 16mo, mor. | 1 50 |
| Butts's Civil Engineer's Field-book..... | 16mo, mor. | 2 50 |
| Crandall's Railway and Other Earthwork Tables..... | 8vo, | 1 50 |
| Transition Curve..... | 16mo, mor. | 1 50 |
| * Crockett's Methods for Earthwork Computations..... | 8vo, | 7 50 |
| Dredge's History of the Pennsylvania Railroad. (1879)..... | Paper | 5 00 |
| Fisher's Table of Cubic Yards..... | Cardboard, | 25 |
| Godwin's Railroad Engineers' Field-book and Explorers' Guide..... | 16mo, mor. | 2 50 |
| Hudson's Tables for Calculating the Cubic Contents of Excavations and Embankments..... | 8vo, | 1 00 |
| Ives and Hilt's Problems in Surveying, Railroad Surveying and Geodesy..... | 16mo, mor. | 1 50 |
| Molitor and Beard's Manual for Resident Engineers..... | 16mo, | 1 00 |
| Nagle's Field Manual for Railroad Engineers..... | 16mo, mor. | 3 00 |
| * Orrock's Railroad Structures and Estimates..... | 8vo, | 3 00 |
| Philbrick's Field Manual for Engineers..... | 16mo, mor. | 3 00 |
| Raymond's Railroad Engineering. 3 volumes. | | |
| Vol. I. Railroad Field Geometry. (In Preparation.) | | |
| Vol. II. Elements of Railroad Engineering..... | 8vo, | 3 50 |
| Vol. III. Railroad Engineer's Field Book. (In Preparation.) | | |
| Searles's Field Engineering..... | 16mo, mor. | 3 00 |
| Railroad Spiral..... | 16mo, mor. | 1 50 |
| Taylor's Prismatical Formulæ and Earthwork..... | 8vo, | 1 50 |
| * Trautwine's Field Practice of Laying Out Circular Curves for Railroads..... | 12mo, mor. | 2 50 |
| * Method of Calculating the Cubic Contents of Excavations and Embankments by the Aid of Diagrams..... | 8vo, | 2 00 |
| Webb's Economics of Railroad Construction..... | Large 12mo, | 2 50 |
| Railroad Construction..... | 16mo, mor. | 5 00 |
| Wellington's Economic Theory of the Location of Railways..... | Large 12mo, | 5 00 |
| Wilson's Elements of Railroad-Track and Construction..... | 12mo, | 2 00 |

DRAWING.

| | | |
|---|-------------|--------|
| Barr's Kinematics of Machinery..... | 8vo, | \$2 50 |
| * Bartlett's Mechanical Drawing..... | 8vo, | 3 00 |
| * " " " Abridged Ed..... | 8vo, | 1 50 |
| Coolidge's Manual of Drawing..... | 8vo, paper, | 1 00 |
| Coolidge and Freeman's Elements of General Drafting for Mechanical Engineers..... | Oblong 4to, | 2 50 |
| Durley's Kinematics of Machines..... | 8vo, | 4 00 |
| Emch's Introduction to Projective Geometry and its Application..... | 8vo, | 2 50 |
| French and Ives' Stereotomy..... | 8vo, | 2 50 |
| Hill's Text-book on Shades and Shadows, and Perspective..... | 8vo, | 2 00 |
| Jamison's Advanced Mechanical Drawing..... | 8vo, | 2 00 |
| Elements of Mechanical Drawing..... | 8vo, | 2 50 |
| Jones's Machine Design: | | |
| Part I. Kinematics of Machinery..... | 8vo, | 1 50 |
| Part II. Form, Strength, and Proportions of Parts..... | 8vo, | 3 00 |
| Kimball and Barr's Machine Design. (In Press.) | | |
| MacCord's Elements of Descriptive Geometry..... | 8vo, | 3 00 |
| Kinematics; or, Practical Mechanism..... | 8vo, | 5 00 |
| Mechanical Drawing..... | 4to, | 4 00 |
| Velocity Diagrams..... | 8vo, | 1 50 |
| McLeod's Descriptive Geometry..... | Large 12mo, | 1 50 |
| * Mahan's Descriptive Geometry and Stone-cutting..... | 8vo, | 1 50 |
| Industrial Drawing. (Thompson.)..... | 8vo, | 3 50 |
| Moyer's Descriptive Geometry..... | 8vo, | 2 00 |
| Reed's Topographical Drawing and Sketching..... | 4to, | 5 00 |
| Reid's Course in Mechanical Drawing..... | 8vo, | 2 00 |
| Text-book of Mechanical Drawing and Elementary Machine Design..... | 8vo, | 3 00 |
| Robinson's Principles of Mechanism..... | 8vo, | 3 00 |
| Schwamb and Merrill's Elements of Mechanism..... | 8vo, | 3 00 |
| Smith (A. W.) and Marx's Machine Design..... | 8vo, | 3 00 |
| Smith's (R. S.) Manual of Topographical Drawing. (McMillan)..... | 8vo, | 2 50 |
| * Titsworth's Elements of Mechanical Drawing..... | Oblong 8vo, | 1 25 |
| Warren's Drafting Instruments and Operations..... | 12mo, | 1 25 |
| Elements of Descriptive Geometry, Shadows, and Perspective..... | 8vo, | 3 50 |
| Elements of Machine Construction and Drawing..... | 8vo, | 7 50 |
| Elements of Plane and Solid Free-hand Geometrical Drawing..... | 12mo, | 1 00 |
| General Problems of Shades and Shadows..... | 8vo, | 3 00 |
| Manual of Elementary Problems in the Linear Perspective of Forms and Shadow..... | 12mo, | 1 00 |
| Manual of Elementary Projection Drawing..... | 12mo, | 1 50 |
| Plane Problems in Elementary Geometry..... | 12mo, | 1 25 |
| Problems, Theorems, and Examples in Descriptive Geometry..... | 8vo, | 2 50 |
| Weisbach's Kinematics and Power of Transmission. (Hermann and Klein.)..... | 8vo, | 5 00 |
| Wilson's (H. M.) Topographic Surveying..... | 8vo, | 3 50 |
| * Wilson's (V. T.) Descriptive Geometry..... | 8vo, | 1 50 |
| Free-hand Lettering..... | 8vo, | 1 00 |
| Free-hand Perspective..... | 8vo, | 2 50 |
| Woolf's Elementary Course in Descriptive Geometry..... | Large 8vo, | 3 00 |

ELECTRICITY AND PHYSICS.

| | | |
|--|------------------|------|
| * Abegg's Theory of Electrolytic Dissociation. (von Ende.)..... | 12mo, | 1 25 |
| Andrews's Hand-book for Street Railway Engineering..... | 3×5 inches, mor, | 1 25 |
| Anthony and Brackett's Text-book of Physics. (Magie.)..... | Large 12mo, | 3 00 |
| Anthony and Ball's Lecture-notes on the Theory of Electrical Measurements..... | 12mo, | 1 00 |
| Benjamin's History of Electricity..... | 8vo, | 3 00 |
| Voltaic Cell..... | 8vo, | 3 00 |

| | | |
|---|----------------|--------|
| Betts's Lead Refining and Electrolysis..... | 8vo, | \$4 00 |
| Classen's Quantitative Chemical Analysis by Electrolysis. (Boltwood.) | 8vo, | 3 00 |
| * Collins's Manual of Wireless Telegraphy and Telephony..... | 12mo, | 1 50 |
| Crehore and Squier's Polarizing Photo-chronograph..... | 8vo, | 3 00 |
| * Danneel's Electrochemistry. (Merriam.)..... | 12mo, | 1 25 |
| Dawson's "Engineering" and Electric Traction Pocket-book.... | 16mo, mor. | 5 00 |
| Dolezalek's Theory of the Lead Accumulator (Storage Battery). (von Ende.) | 12mo, | 2 50 |
| Duhem's Thermodynamics and Chemistry. (Burgess.)..... | 8vo, | 4 00 |
| Flather's Dynamometers, and the Measurement of Power..... | 12mo, | 3 00 |
| Getman's Introduction to Physical Science. | 12mo, | |
| Gilbert's De Magnete. (Mottelay)..... | 8vo, | 2 50 |
| * Hanchett's Alternating Currents..... | 12mo | 1 00 |
| Hering's Ready Reference Tables (Conversion Factors)..... | 16mo, mor. | 2 50 |
| * Hobart and Ellis's High-speed Dynamo Electric Machinery..... | 8vo, | 6 00 |
| Holman's Precision of Measurements..... | 8vo, | 2 00 |
| Telescopic Mirror-scale Method, Adjustments, and Tests.... | Large 8vo, | 75 |
| * Karapetoff's Experimental Electrical Engineering..... | 8vo, | 6 00 |
| Kinzbrunner's Testing of Continuous-current Machines..... | 8vo, | 2 00 |
| Landauer's Spectrum Analysis. (Tingle.)..... | 8vo, | 3 00 |
| Le Chatelier's High-temperature Measurements. (Boudouard—Burgess.) | 12mo, | 3 00 |
| Löb's Electrochemistry of Organic Compounds. (Lorenz)..... | 8vo, | 3 00 |
| * Lyndon's Development and Electrical Distribution of Water Power. | 8vo, | 3 00 |
| * Lyons's Treatise on Electromagnetic Phenomena. Vols. I. and II. | 8vo, each, | 6 00 |
| * Michie's Elements of Wave Motion Relating to Sound and Light.... | 8vo, | 4 00 |
| Morgan's Outline of the Theory of Solution and its Results..... | 12mo, | 1 00 |
| * Physical Chemistry for Electrical Engineers..... | 12mo, | 1 50 |
| * Norris's Introduction to the Study of Electrical Engineering..... | 8vo, | 2 50 |
| Norris and Dennison's Course of Problems on the Electrical Characteristics of Circuits and Machines. (In Press.) | | |
| * Parshall and Hobart's Electric Machine Design..... | 4to, half mor, | 12 50 |
| Reagan's Locomotives: Simple, Compound, and Electric. New Edition. | | |
| | Large 12mo, | 3 50 |
| * Rosenberg's Electrical Engineering. (Haldane Gee—Kinzbrunner.) | 8vo, | 2 00 |
| Ryan, Norris, and Hoxie's Electrical Machinery. Vol. I..... | 8vo, | 2 50 |
| Schapper's Laboratory Guide for Students in Physical Chemistry.... | 12mo, | 1 00 |
| * Tillman's Elementary Lessons in Heat..... | 8vo, | 1 50 |
| Tory and Pitcher's Manual of Laboratory Physics..... | Large 12mo, | 2 00 |
| Ulke's Modern Electrolytic Copper Refining..... | 8vo, | 3 00 |

LAW.

| | | |
|---|-------------|------|
| * Brennan's Hand-book of Useful Legal Information for Business Men. | 16mo, mor. | 5 00 |
| * Davis's Elements of Law..... | 8vo, | 2 50 |
| * Treatise on the Military Law of United States..... | 8vo, | 7 00 |
| * Dudley's Military Law and the Procedure of Courts-martial.. | Large 12mo, | 2 50 |
| Manual for Courts-martial..... | 16mo, mor. | 1 50 |
| Wait's Engineering and Architectural Jurisprudence..... | 8vo, | 6 00 |
| | Sheep, | 6 50 |
| Law of Contracts..... | 8vo, | 3 00 |
| Law of Operations Preliminary to Construction in Engineering and Architecture..... | 8vo, | 5 00 |
| | Sheep, | 5 50 |

MATHEMATICS.

| | | |
|---|-------|------|
| Baker's Elliptic Functions..... | 8vo, | 1 50 |
| Briggs's Elements of Plane Analytic Geometry. (Böcher)..... | 12mo, | 1 00 |
| * Buchanan's Plane and Spherical Trigonometry..... | 8vo, | 1 00 |

| | | |
|--|--------------|--------|
| Byerley's Harmonic Functions. | 8vo, | \$1 00 |
| Chandler's Elements of the Infinitesimal Calculus. | 12mo, | 2 00 |
| * Coffin's Vector Analysis. | 12mo, | 2 50 |
| Compton's Manual of Logarithmic Computations. | 12mo, | 1 50 |
| * Dickson's College Algebra. | Large 12mo, | 1 50 |
| * Introduction to the Theory of Algebraic Equations. | Large 12mo, | 1 25 |
| Emch's Introduction to Projective Geometry and its Application. | 8vo, | 2 50 |
| Fiske's Functions of a Complex Variable. | 8vo, | 1 00 |
| Halsted's Elementary Synthetic Geometry. | 8vo, | 1 50 |
| Elements of Geometry. | 8vo, | 1 75 |
| * Rational Geometry. | 12mo, | 1 50 |
| Synthetic Projective Geometry. | 8vo, | 1 00 |
| Hyde's Grassmann's Space Analysis. | 8vo, | 1 00 |
| * Johnson's (J. B.) Three-place Logarithmic Tables: Vest-pocket size, paper, | | 15 |
| * 100 copies, | | 5 00 |
| * Mounted on heavy cardboard, 8×10 inches, | | 25 |
| * 10 copies, | | 2 00 |
| Johnson's (W. W.) Abridged Editions of Differential and Integral Calculus. | | |
| Large 12mo, 1 vol. | | 2 50 |
| Curve Tracing in Cartesian Co-ordinates. | 12mo, | 1 00 |
| Differential Equations. | 8vo, | 1 00 |
| Elementary Treatise on Differential Calculus. | Large 12mo, | 1 50 |
| Elementary Treatise on the Integral Calculus. | Large 12mo, | 1 50 |
| * Theoretical Mechanics. | 12mo, | 3 00 |
| Theory of Errors and the Method of Least Squares. | 12mo, | 1 50 |
| Treatise on Differential Calculus. | Large 12mo, | 3 00 |
| Treatise on the Integral Calculus. | Large 12mo, | 3 00 |
| Treatise on Ordinary and Partial Differential Equations. | Large 12mo, | 3 50 |
| Karapetoff's Engineering Applications of Higher Mathematics. | | |
| (In Preparation.) | | |
| Laplace's Philosophical Essay on Probabilities. (Truscott and Emory.) | 12mo, | 2 00 |
| * Ludlow and Bass's Elements of Trigonometry and Logarithmic and Other | | |
| Tables. | 8vo, | 3 00 |
| * Trigonometry and Tables published separately. | Each, | 2 00 |
| * Ludlow's Logarithmic and Trigonometric Tables. | 8vo, | 1 00 |
| Macfarlane's Vector Analysis and Quaternions. | 8vo, | 1 00 |
| McMahon's Hyperbolic Functions. | 8vo, | 1 00 |
| Manning's Irrational Numbers and their Representation by Sequences and | | |
| Series. | 12mo, | 1 25 |
| Mathematical Monographs. Edited by Mansfield Merriman and Robert | | |
| S. Woodward. | Octavo, each | 1 00 |
| No. 1. History of Modern Mathematics, by David Eugene Smith. | | |
| No. 2. Synthetic Projective Geometry, by George Bruce Halsted. | | |
| No. 3. Determinants, by Laenas Gifford Weld. No. 4. Hyper- | | |
| bolic Functions, by James McMahon. No. 5. Harmonic Func- | | |
| tions, by William E. Byerly. No. 6. Grassmann's Space Analysis, | | |
| by Edward W. Hyde. No. 7. Probability and Theory of Errors, | | |
| by Robert S. Woodward. No. 8. Vector Analysis and Quaternions, | | |
| by Alexander Macfarlane. No. 9. Differential Equations, by | | |
| William Woolsey Johnson. No. 10. The Solution of Equations, | | |
| by Mansfield Merriman. No. 11. Functions of a Complex Variable, | | |
| by Thomas S. Fiske. | | |
| Maurer's Technical Mechanics. | 8vo, | 4 00 |
| Merriman's Method of Least Squares. | 8vo, | 2 00 |
| Solution of Equations. | 8vo, | 1 00 |
| Rice and Johnson's Differential and Integral Calculus. 2 vols. in one. | | |
| Large 12mo, | | 1 50 |
| Elementary Treatise on the Differential Calculus. | Large 12mo, | 3 00 |
| Smith's History of Modern Mathematics. | 8vo, | 1 00 |
| * Veblen and Lennes's Introduction to the Real Infinitesimal Analysis of One | | |
| Variable. | 8vo, | 2 00 |
| * Waterbury's Vest Pocket Hand-book of Mathematics for Engineers. | | |
| 2½ × 5¾ inches, mor. | | 1 00 |
| Weld's Determinants. | 8vo, | 1 00 |
| Wood's Elements of Co-ordinate Geometry. | 8vo, | 2 00 |
| Woodward's Probability and Theory of Errors. | 8vo, | 1 00 |

MECHANICAL ENGINEERING.

MATERIALS OF ENGINEERING, STEAM-ENGINES AND BOILERS.

| | | |
|--|-------------|--------|
| Bacon's Forge Practice. | 12mo, | \$1 50 |
| Baldwin's Steam Heating for Buildings. | 12mo, | 2 50 |
| Barr's Kinematics of Machinery. | 8vo, | 2 50 |
| * Bartlett's Mechanical Drawing. | 8vo, | 3 00 |
| * " " " Abridged Ed. | 8vo, | 1 50 |
| * Burr's Ancient and Modern Engineering and the Isthmian Canal. | 8vo, | 3 50 |
| Carpenter's Experimental Engineering. | 8vo, | 6 00 |
| Heating and Ventilating Buildings. | 8vo, | 4 00 |
| Clerk's Gas and Oil Engine. (New edition in press.) | | |
| Compton's First Lessons in Metal Working. | 12mo, | 1 50 |
| Compton and De Groot's Speed Lathe. | 12mo, | 1 50 |
| Coolidge's Manual of Drawing. | 8vo, paper, | 1 00 |
| Coolidge and Freeman's Elements of Geenal Drafting for Mechanical En- gineers. | Oblong 4to, | 2 50 |
| Cromwell's Treatise on Belts and Pulleys. | 12mo, | 1 50 |
| Treatise on Toothed Gearing. | 12mo, | 1 50 |
| Dingey's Machinery Pattern Making. | 12mo, | 2 00 |
| Durley's Kinematics of Machines. | 8vo, | 4 00 |
| Flanders's Gear-cutting Machinery. | Large 12mo, | 3 00 |
| Flather's Dynamometers and the Measurement of Power. | 12mo, | 3 00 |
| Rope Driving. | 12mo, | 2 00 |
| Gill's Gas and Fuel Analysis for Engineers. | 12mo, | 1 25 |
| Goss's Locomotive Sparks. | 8vo, | 2 00 |
| Greene's Pumping Machinery. (In Preparation.) | | |
| Hering's Ready Reference Tables (Conversion Factors). | 16mo, mor. | 2 50 |
| * Hobart and Ellis's High Speed Dynamo Electric Machinery. | 8vo, | 6 00 |
| Hutton's Gas Engine. | 8vo, | 5 00 |
| Jamison's Advanced Mechanical Drawing. | 8vo, | 2 00 |
| Elements of Mechanical Drawing. | 8vo, | 2 50 |
| Jones's Gas Engine. | 8vo, | 4 00 |
| Machine Design: | | |
| Part I. Kinematics of Machinery. | 8vo, | 1 50 |
| Part II. Form, Strength, and Proportions of Parts. | 8vo, | 3 00 |
| Kent's Mechanical Engineer's Pocket-Book. | 16mo, mor. | 5 00 |
| Kerr's Power and Power Transmission. | 8vo, | 2 00 |
| Kimball and Barr's Machine Design. (In Press.) | | |
| Levin's Gas Engine. (In Press.). | 8vo, | |
| Leonard's Machine Shop Tools and Methods. | 8vo, | 4 00 |
| * Lorenz's Modern Refrigerating Machinery. (Pope, Haven, and Dean). | 8vo, | 4 00 |
| MacCord's Kinematics; or, Practical Mechanism. | 8vo, | 5 00 |
| Mechanical Drawing. | 4to, | 4 00 |
| Velocity Diagrams. | 8vo, | 1 50 |
| MacFarland's Standard Reduction Factors for Gases. | 8vo, | 1 50 |
| Mahan's Industrial Drawing. (Thompson.). | 8vo, | 3 50 |
| Mehrtens's Gas Engine Theory and Design. | Large 12mo, | 2 50 |
| Oberg's Handbook of Small Tools. | Large 12mo, | 3 00 |
| * Parshall and Hobart's Electric Machine Design. Small 4to, half leather, | | 12 50 |
| Peele's Compressed Air Plant for Mines. | 8vo, | 3 00 |
| Poole's Calorific Power of Fuels. | 8vo, | 3 00 |
| * Porter's Engineering Reminiscences, 1855 to 1882. | 8vo, | 3 00 |
| Reid's Course in Mechanical Drawing. | 8vo, | 2 00 |
| Text-book of Mechanical Drawing and Elementary Machine Design. | 8vo, | 3 00 |
| Richards's Compressed Air. | 12mo, | 1 50 |
| Robinson's Principles of Mechanism. | 8vo, | 3 00 |
| Schwamb and Merrill's Elements of Mechanism. | 8vo, | 3 00 |
| Smith (A. W.) and Marx's Machine Design. | 8vo, | 3 00 |
| Smith's (O.) Press-working of Metals. | 8vo, | 3 00 |
| Sorel's Carbureting and Combustion in Alcohol Engines. (Woodward and Preston.). | Large 12mo, | 3 00 |
| Stone's Practical Testing of Gas and Gas Meters. | 8vo, | 3 50 |

| | | |
|--|--|--------|
| Thurston's Animal as a Machine and Prime Motor, and the Laws of Energetics. | 12mo, | \$1 00 |
| Treatise on Friction and Lost Work in Machinery and Mill Work... | 8vo, | 3 00 |
| * Tillson's Complete Automobile Instructor. | 16mo, | 1 50 |
| * Titsworth's Elements of Mechanical Drawing. | Oblong 8vo, | 1 25 |
| Warren's Elements of Machine Construction and Drawing. | 8vo, | 7 50 |
| * Waterbury's Vest Pocket Hand-book of Mathematics for Engineers. | 2 $\frac{1}{4}$ × 5 $\frac{3}{8}$ inches, mor. | 1 00 |
| Weisbach's Kinematics and the Power of Transmission. (Herrmann—Klein.) | | 5 00 |
| Machinery of Transmission and Governors. (Herrmann—Klein.) | 8vo, | 5 00 |
| Wood's Turbines. | 8vo, | 2 50 |

MATERIALS OF ENGINEERING.

| | | |
|---|---------------|------|
| * Bovey's Strength of Materials and Theory of Structures. | 8vo, | 7 50 |
| Burr's Elasticity and Resistance of the Materials of Engineering. | 8vo, | 7 50 |
| Church's Mechanics of Engineering. | 8vo, | 6 00 |
| * Greene's Structural Mechanics. | 8vo, | 2 50 |
| * Holley's Lead and Zinc Pigments. | Large 12mo | 3 00 |
| Holley and Ladd's Analysis of Mixed Paints, Color Pigments, and Varnishes. | Large 12mo, | 2 50 |
| Johnson's (C. M.) Rapid Methods for the Chemical Analysis of Special Steels, Steel-Making Alloys and Graphite | Large 12mo, | 3 00 |
| Johnson's (J. B.) Materials of Construction. | 8vo, | 6 00 |
| Keep's Cast Iron. | 8vo, | 2 50 |
| Lanza's Applied Mechanics. | 8vo, | 7 50 |
| Maire's Modern Pigments and their Vehicles. | 12mo, | 2 00 |
| Martens's Handbook on Testing Materials. (Henning.) | 8vo, | 7 50 |
| Maurer's Technical Mechanics. | 8vo, | 4 00 |
| Merriman's Mechanics of Materials. | 8vo, | 5 00 |
| * Strength of Materials. | 12mo, | 1 00 |
| Metcalf's Steel. A Manual for Steel-users. | 12mo, | 2 00 |
| Sabin's Industrial and Artistic Technology of Paint and Varnish. | 8vo, | 3 00 |
| Smith's ((A. W.) Materials of Machines. | 12mo, | 1 00 |
| Smith's (H. E.) Strength of Material. | 12mo, | |
| Thurston's Materials of Engineering. | 3 vols., 8vo, | 8 00 |
| Part I. Non-metallic Materials of Engineering. | 8vo, | 2 00 |
| Part II. Iron and Steel. | 8vo, | 3 50 |
| Part III. A Treatise on Brasses, Bronzes, and Other Alloys and their Constituents. | 8vo, | 2 50 |
| Wood's (De V.) Elements of Analytical Mechanics. | 8vo, | 3 00 |
| Treatise on the Resistance of Materials and an Appendix on the Preservation of Timber. | 8vo, | 2 00 |
| Wood's (M. P.) Rustless Coatings: Corrosion and Electrolysis of Iron and Steel. | 8vo, | 4 00 |

STEAM-ENGINES AND BOILERS.

| | | |
|---|------------|------|
| Berry's Temperature-entropy Diagram. | 12mo, | 2 00 |
| Carnot's Reflections on the Motive Power of Heat. (Thurston.) | 12mo, | 1 50 |
| Chase's Art of Pattern Making. | 12mo, | 2 50 |
| Creighton's Steam-engine and other Heat Motors. | 8vo, | 5 00 |
| Dawson's "Engineering" and Electric Traction Pocket-book. | 16mo, mor. | 5 00 |
| Ford's Boiler Making for Boiler Makers. | 18mo, | 1 00 |
| * Gebhardt's Steam Power Plant Engineering. | 8vo, | 6 00 |
| Goss's Locomotive Performance. | 8vo, | 5 00 |
| Hemenway's Indicator Practice and Steam-engine Economy. | 12mo, | 2 00 |
| Hutton's Heat and Heat-engines. | 8vo, | 5 00 |
| Mechanical Engineering of Power Plants. | 8vo, | 5 00 |
| Kent's Steam boiler Economy. | 8vo, | 4 00 |

| | | |
|--|---------------|--------|
| Kneass's Practice and Theory of the Injector. | 8vo, | \$1 50 |
| MacCord's Slide-valves. | 8vo, | 2 00 |
| Meyer's Modern Locomotive Construction. | 4to, | 10 00 |
| Moyer's Steam Turbine. | 8vo, | 4 00 |
| Peabody's Manual of the Steam-engine Indicator. | 12mo, | 1 50 |
| Tables of the Properties of Steam and Other Vapors and Temperature-Entropy Table. | 8vo, | 1 00 |
| Thermodynamics of the Steam-engine and Other Heat-engines. | 8vo, | 5 00 |
| Valve-gears for Steam-engines. | 8vo, | 2 50 |
| Peabody and Miller's Steam-boilers. | 8vo, | 4 00 |
| Pupin's Thermodynamics of Reversible Cycles in Gases and Saturated Vapors (Osterberg.). | 12mo, | 1 25 |
| Reagan's Locomotives: Simple, Compound, and Electric. New Edition. | Large 12mo, | 3 50 |
| Sinclair's Locomotive Engine Running and Management. | 12mo, | 2 00 |
| Smart's Handbook of Engineering Laboratory Practice. | 12mo, | 2 50 |
| Snow's Steam-boiler Practice. | 8vo, | 3 00 |
| Spangler's Notes on Thermodynamics. | 12mo, | 1 00 |
| Valve-gears. | 8vo, | 2 50 |
| Spangler, Greene, and Marshall's Elements of Steam-engineering. | 8vo, | 3 00 |
| Thomas's Steam-turbines. | 8vo, | 4 00 |
| Thurston's Handbook of Engine and Boiler Trials, and the Use of the Indicator and the Prony Brake. | 8vo, | 5 00 |
| Handy Tables. | 8vo, | 1 50 |
| Manual of Steam-boilers, their Designs, Construction, and Operation. | 8vo, | 5 00 |
| Manual of the Steam-engine. | 2 vols., 8vo, | 10 00 |
| Part I. History, Structure, and Theory | 8vo, | 6 00 |
| Part II. Design, Construction, and Operation. | 8vo, | 6 00 |
| Steam-boiler Explosions in Theory and in Practice. | 12mo, | 1 50 |
| Wehrenfennig's Analysis and Softening of Boiler Feed-water. (Patterson). | 8vo, | 4 00 |
| Weisbach's Heat, Steam, and Steam-engines. (Du Bois.). | 8vo, | 5 00 |
| Whitham's Steam-engine Design. | 8vo, | 5 00 |
| Wood's Thermodynamics, Heat Motors, and Refrigerating Machines. | 8vo, | 4 00 |

MECHANICS PURE AND APPLIED.

| | | |
|---|-------------|-------|
| Church's Mechanics of Engineering. | 8vo, | 6 00 |
| Notes and Examples in Mechanics. | 8vo, | 2 00 |
| Dana's Text-book of Elementary Mechanics for Colleges and Schools. | 12mo, | 1 50 |
| Du Bois's Elementary Principles of Mechanics: | | |
| Vol. I. Kinematics. | 8vo, | 3 50 |
| Vol. II. Statics. | 8vo, | 4 00 |
| Mechanics of Engineering. Vol. I. | Small 4to, | 7 50 |
| Vol. II. | Small 4to, | 10 00 |
| * Greene's Structural Mechanics. | 8vo, | 2 50 |
| James's Kinematics of a Point and the Rational Mechanics of a Particle. | Large 12mo, | 2 00 |
| * Johnson's (W. W.) Theoretical Mechanics. | 12mo, | 3 00 |
| Lanza's Applied Mechanics. | 8vo, | 7 50 |
| * Martin's Text Book on Mechanics, Vol. I, Statics. | 12mo, | 1 25 |
| * Vol. II, Kinematics and Kinetics. | 12mo, | 1 50 |
| Maurer's Technical Mechanics. | 8vo, | 4 00 |
| * Merriman's Elements of Mechanics. | 12mo, | 1 00 |
| Mechanics of Materials. | 8vo, | 5 00 |
| * Michie's Elements of Analytical Mechanics. | 8vo, | 4 00 |
| Robinson's Principles of Mechanism. | 8vo, | 3 00 |
| Sanborn's Mechanics Problems. | Large 12mo, | 1 50 |
| Schwamb and Merrill's Elements of Mechanism. | 8vo, | 3 00 |
| Wood's Elements of Analytical Mechanics. | 8vo, | 3 00 |
| Principles of Elementary Mechanics. | 12mo, | 1 25 |

MEDICAL.

| | | |
|---|-------------|--------|
| * Abderhalden's Physiological Chemistry in Thirty Lectures. (Hall and Defren.) | 8vo, | \$5 00 |
| von Behring's Suppression of Tuberculosis. (Bolduan.) | 12mo, | 1 00 |
| Bolduan's Immune Sera. | 12mo, | 1 50 |
| Bordet's Studies in Immunity. (Gay). (In Press.) | 8vo, | |
| Davenport's Statistical Methods with Special Reference to Biological Variations. | 16mo, mor. | 1 50 |
| Ehrlich's Collected Studies on Immunity. (Bolduan.) | 8vo, | 6 00 |
| * Fischer's Physiology of Alimentation | Large 12mo, | 2 00 |
| de Fursac's Manual of Psychiatry. (Rosanoff and Collins.) | Large 12mo, | 2 50 |
| Hammarsten's Text-book on Physiological Chemistry. (Mandel.) | 8vo, | 4 00 |
| Jackson's Directions for Laboratory Work in Physiological Chemistry | 8vo, | 1 25 |
| Lassar-Cohn's Practical Urinary Analysis. (Lorenz.) | 12mo, | 1 00 |
| Mandel's Hand-book for the Bio-Chemical Laboratory | 12mo, | 1 50 |
| * Pauli's Physical Chemistry in the Service of Medicine. (Fischer.) | 12mo, | 1 25 |
| * Pozzi-Escot's Toxins and Venoms and their Antibodies. (Cohn.) | 12mo, | 1 00 |
| Rostoski's Serum Diagnosis. (Bolduan.) | 12mo, | 1 00 |
| Ruddiman's Incompatibilities in Prescriptions. | 8vo, | 2 00 |
| Whys in Pharmacy. | 12mo, | 1 00 |
| Salkowski's Physiological and Pathological Chemistry. (Orndorff.) | 8vo, | 2 50 |
| * Satterlee's Outlines of Human Embryology. | 12mo, | 1 25 |
| Smith's Lecture Notes on Chemistry for Dental Students. | 8vo, | 2 50 |
| * Whipple's Typhoid Fever. | Large 12mo, | 3 00 |
| Woodhull's Notes on Military Hygiene. | 16mo, | 1 50 |
| * Personal Hygiene. | 12mo, | 1 00 |
| Worcester and Atkinson's Small Hospitals Establishment and Maintenance, and Suggestions for Hospital Architecture, with Plans for a Small Hospital. | 12mo, | 1 25 |

METALLURGY.

| | | |
|--|-------------|------|
| Betts's Lead Refining by Electrolysis. | 8vo, | 4 00 |
| Bolland's Encyclopedia of Founding and Dictionary of Foundry Terms used in the Practice of Moulding. | 12mo, | 3 00 |
| Iron Founder. | 12mo, | 2 50 |
| " " Supplement. | 12mo, | 2 50 |
| Douglas's Untechnical Addresses on Technical Subjects. | 12mo, | 1 00 |
| Goesel's Minerals and Metals: A Reference Book. | 16mo, mor. | 3 00 |
| * Iles's Lead-smelting. | 12mo, | 2 50 |
| Johnson's Rapid Methods for the Chemical Analysis of Special Steels, Steel-making Alloys and Graphite. | Large 12mo, | 3 00 |
| Keep's Cast Iron. | 8vo, | 2 50 |
| Le Chatelier's High-temperature Measurements. (Boudouard—Burgess.) | 12mo, | 3 00 |
| Metcalf's Steel. A Manual for Steel-users. | 12mo, | 2 00 |
| Minet's Production of Aluminum and its Industrial Use. (Waldo.) | 12mo, | 2 50 |
| Ruer's Elements of Metallography. (Mathewson.) | 8vo, | |
| Smith's Materials of Machines. | 12mo, | 1 00 |
| Tate and Stone's Foundry Practice. | 12mo, | 2 00 |
| Thurston's Materials of Engineering. In Three Parts. | 8vo, | 8 00 |
| Part I. Non-metallic Materials of Engineering, see Civil Engineering, page 9. | | |
| Part II. Iron and Steel. | 8vo, | 3 50 |
| Part III. A Treatise on Brasses, Bronzes, and Other Alloys and their Constituents. | 8vo, | 2 50 |
| Ulke's Modern Electrolytic Copper Refining. | 8vo, | 3 00 |
| West's American Foundry Practice. | 12mo, | 2 50 |
| Moulders' Text Book. | 12mo, | 2 50 |

MINERALOGY.

| | |
|--|--------------------------------|
| Baskerville's Chemical Elements. (In Preparation.) | |
| Boyd's Map of Southwest Virginia. | Pocket-book form. \$2 00 |
| * Browning's Introduction to the Rarer Elements. | 8vo, 1 50 |
| Brush's Manual of Determinative Mineralogy. (Penfield.) | 8vo, 4 00 |
| Butler's Pocket Hand-book of Minerals. | 16mo, mor. 3 00 |
| Chester's Catalogue of Minerals. | 8vo, paper, 1 00 |
| | Cloth, 1 25 |
| * Crane's Gold and Silver. | 8vo, 5 00 |
| Dana's First Appendix to Dana's New "System of Mineralogy". | Large 8vo, 1 00 |
| Dana's Second Appendix to Dana's New "System of Mineralogy". | Large 8vo, 2 00 |
| Manual of Mineralogy and Petrography. | 12mo, 2 00 |
| Minerals and How to Study Them. | 12mo, 1 50 |
| System of Mineralogy. | Large 8vo, half leather, 12 50 |
| Text-book of Mineralogy. | 8vo, 4 00 |
| Douglas's Untechnical Addresses on Technical Subjects. | 12mo, 1 00 |
| Eakle's Mineral Tables. | 8vo, 1 25 |
| Eckel's Stone and Clay Products Used in Engineering. (In Preparation). | |
| Goesel's Minerals and Metals: A Reference Book. | 16mo, mor. 3 00 |
| Groth's Introduction to Chemical Crystallography (Marshall). | 12mo, 1 25 |
| * Hayes's Handbook for Field Geologists. | 16mo, mor. 1 50 |
| Iddings's Igneous Rocks. | 8vo, 5 00 |
| Rock Minerals. | 8vo, 5 00 |
| Johannsen's Determination of Rock-forming Minerals in Thin Sections. 8vo, | |
| With Thumb Index | 5 00 |
| * Martin's Laboratory Guide to Qualitative Analysis with the Blow-pipe. | 12mo, 60 |
| Merrill's Non-metallic Minerals. Their Occurrence and Uses. | 8vo, 4 00 |
| Stones for Building and Decoration. | 8vo, 5 00 |
| * Penfield's Notes on Determinative Mineralogy and Record of Mineral Tests. | 8vo, paper, 50 |
| Tables of Minerals, Including the Use of Minerals and Statistics of Domestic Production. | 8vo, 1 00 |
| * Pirsson's Rocks and Rock Minerals. | 12mo, 2 50 |
| * Richards's Synopsis of Mineral Characters. | 12mo, mor. 1 25 |
| * Ries's Clays: Their Occurrence, Properties and Uses. | 8vo, 5 00 |
| * Ries and Leighton's History of the Clay-working Industry of the United States. | 8vo, 2 50 |
| * Tillman's Text-book of Important Minerals and Rocks. | 8vo, 2 00 |
| Washington's Manual of the Chemical Analysis of Rocks. | 8vo, 2 00 |

MINING.

| | |
|--|------------------------|
| * Beard's Mine Gases and Explosions. | Large 12mo, 3 00 |
| Boyd's Map of Southwest Virginia. | Pocket-book form, 2 00 |
| * Crane's Gold and Silver. | 8vo 5 00 |
| * Index of Mining Engineering Literature. | 8vo, 4 00 |
| | * 8vo, mor. 5 00 |
| Douglas's Untechnical Addresses on Technical Subjects. | 12mo, 1 00 |
| Eissler's Modern High Explosives. | 8vo, 4 00 |
| Goesel's Minerals and Metals: A Reference Book. | 16mo, mor. 3 00 |
| Ihlseng's Manual of Mining. | 8vo, 5 00 |
| * Iles's Lead Smelting. | 12mo, 2 50 |
| Peele's Compressed Air Plant for Mines. | 8vo, 3 00 |
| Rtemer's Shaft Sinking Under Difficult Conditions. (Corning and Peele.) 8vo, | 3 00 |
| * Weaver's Military Explosives. | 8vo, 3 00 |
| Wilson's Hydraulic and Placer Mining. 2d edition rewritten. | 12mo, 2 50 |
| Treatise on Practical and Theoretical Mine Ventilation | 12mo, 1 25 |

SANITARY SCIENCE.

| | | |
|---|-------------|--------|
| Association of State and National Food and Dairy Departments, Hartford Meeting, 1906. | 8vo, | \$3 00 |
| Jamestown Meeting, 1907. | 8vo, | 3 00 |
| * Bashore's Outlines of Practical Sanitation. | 12mo, | 1 25 |
| Sanitation of a Country House. | 12mo, | 1 00 |
| Sanitation of Recreation Camps and Parks. | 12mo, | 1 00 |
| Folwell's Sewerage. (Designing, Construction, and Maintenance.) | 8vo, | 3 00 |
| Water-supply Engineering. | 8vo, | 4 00 |
| Fowler's Sewage Works Analyses. | 12mo, | 2 00 |
| Fuertes's Water-filtration Works. | 12mo, | 2 50 |
| Water and Public Health. | 12mo, | 1 50 |
| Gerhard's Guide to Sanitary Inspections. | 12mo, | 1 50 |
| * Modern Baths and Bath Houses. | 8vo, | 3 00 |
| Sanitation of Public Buildings. | 12mo, | 1 50 |
| Hazen's Clean Water and How to Get It. | Large 12mo, | 1 50 |
| Filtration of Public Water-supplies. | 8vo, | 3 00 |
| Kinnicut, Winslow and Pratt's Purification of Sewage. (In Preparation.) | | |
| Leach's Inspection and Analysis of Food with Special Reference to State Control. | 8vo, | 7 50 |
| Mason's Examination of Water. (Chemical and Bacteriological). | 12mo, | 1 25 |
| Water-supply. (Considered principally from a Sanitary Standpoint). | 8vo, | 4 00 |
| * Merriman's Elements of Sanitary Enigneering. | 8vo, | 2 00 |
| Ogden's Sewer Construction. | 8vo, | 3 00 |
| Sewer Design. | 12mo, | 2 00 |
| Parsons's Disposal of Municipal Refuse. | 8vo, | 2 00 |
| Prescott and Winslow's Elements of Water Bacteriology, with Special Reference to Sanitary Water Analysis. | 12mo, | 1 50 |
| * Price's Handbook on Sanitation. | 12mo, | 1 50 |
| Richards's Cost of Cleanness. | 12mo, | 1 00 |
| Cost of Food. A Study in Dieteries. | 12mo, | 1 00 |
| Cost of Living as Modified by Sanitary Science. | 12mo, | 1 00 |
| Cost of Shelter. | 12mo, | 1 00 |
| * Richards and Williams's Dietary Computer. | 8vo, | 1 50 |
| Richards and Woodman's Air, Water, and Food from a Sanitary Standpoint. | 8vo, | 2 00 |
| * Richey's Plumbers', Steam-fitters', and Tinners' Edition (Building Mechanics' Ready Reference Series). | 16mo, mor, | 1 50 |
| Rideal's Disinfection and the Preservation of Food. | 8vo, | 4 00 |
| Sewage and Bacterial Purification of Sewage. | 8vo, | 4 00 |
| Soper's Air and Ventilation of Subways. | 12mo, | 2 50 |
| Turneure and Russell's Public Water-supplies. | 8vo, | 5 00 |
| Venable's Garbage Crematories in America. | 8vo, | 2 00 |
| Method and Devices for Bacterial Treatment of Sewage. | 8vo, | 3 00 |
| Ward and Whipple's Freshwater Biology. (In Press.) | | |
| Whipple's Microscopy of Drinking-water. | 8vo, | 3 50 |
| * Typhoid Fever. | Large 12mo, | 3 00 |
| Value of Pure Water. | Large 12mo, | 1 00 |
| Winslow's Systematic Relationship of the Coccaceæ. | Large 12mo, | 2 50 |

MISCELLANEOUS.

| | | |
|---|------------|------|
| Emmons's Geological Guide-book of the Rocky Mountain Excursion of the International Congress of Geologists. | Large 8vo, | 1 50 |
| Ferrel's Popular Treatise on the Winds. | 8vo, | 4 00 |
| Fitzgerald's Boston Machinist. | 18mo, | 1 00 |
| Gannett's Statistical Abstract of the World. | 24mo, | 75 |
| Haines's American Railway Management. | 12mo, | 2 50 |
| Hanausek's The Microscopy of Technical Products. (Winton). | 8vo, | 5 00 |

| | | |
|--|-------------|--------|
| Jacobs's Betterment Briefs. A Collection of Published Papers on Organized Industrial Efficiency. | 8vo, | \$3 50 |
| Metcalf's Cost of Manufactures, and the Administration of Workshops. | 8vo, | 5 00 |
| Putnam's Nautical Charts. | 8vo, | 2 00 |
| Ricketts's History of Rensselaer Polytechnic Institute 1824-1894. | Large 12mo, | 3 00 |
| Rotherham's Emphasised New Testament. | Large 8vo, | 2 00 |
| Rust's Ex-Meridian Altitude, Azimuth and Star-finding Tables. | 8vo, | 5 00 |
| Standage's Decoration of Wood, Glass, Metal, etc. | 12mo, | 2 00 |
| Thome's Structural and Physiological Botany. (Bennett). | 16mo, | 2 25 |
| Westermaier's Compendium of General Botany. (Schneider). | 8vo, | 2 00 |
| Winslow's Elements of Applied Microscopy. | 12mo, | 1 50 |

HEBREW AND CHALDEE TEXT-BOOKS.

| | | |
|---|----------------------|------|
| Gesenius's Hebrew and Chaldee Lexicon to the Old Testament Scriptures. (Tregelles). | Small 4to, half mor, | 5 00 |
| Green's Elementary Hebrew Grammar. | 12mo, | 1 25 |





$\frac{f_{100}}{100} S'$

UNIVERSITY OF CALIFORNIA LIBRARY
BERKELEY

Return to desk from which borrowed.
This book is DUE on the last date stamped below.

11 Mar 49 MW

SEP 10 1998

JUN 28 1980

7/28/80

SEP 18 1998

REC. CIR. JUL 28 '80

OCT 10 1997

OCT 02 1997

YC 12795

U C BERKELEY LIBRARIES



C054912168

195040

Flanders

