

UMASS/AMHERST



312066005091410

The background of the book cover is a dark, textured surface, possibly cloth or paper, with a pattern of embossed or printed leaves. The leaves are scattered across the cover, with some showing detailed vein patterns. The overall color scheme is monochromatic, using shades of gray and black.

GREENHOUSE
MANAGEMENT
FOR AMATEURS

MASSACHUSETTS
STATE COLLEGE



Class I



LIBRARY

SB
415
M37

ure.

2

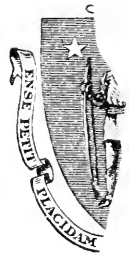

Class

GREENHOUSE MANAGEMENT FOR AMATEURS :

DESCRIPTIONS OF THE BEST GREENHOUSES AND FRAMES,
WITH INSTRUCTIONS FOR BUILDING THEM;
PARTICULARS OF THE VARIOUS METHODS OF HEATING;
ILLUSTRATED DESCRIPTIONS OF THE MOST SUITABLE PLANTS,
WITH GENERAL AND SPECIAL CULTURAL DIRECTIONS;
AND ALL NECESSARY INFORMATION FOR THE
GUIDANCE OF THE AMATEUR.

SECOND EDITION, REVISED AND ENLARGED,
And Illustrated throughout.

BY W. J. MAY,

Author of "Vine Culture for Amateurs," "Vegetable Culture for Amateurs," &c.

LONDON:
L. UPCOTT GILL, 170, STRAND, W.C.

622
17
1112

LONDON:

A BRADLEY, LONDON AND COUNTY PRINTING WORKS,
DRURY LANE, W.C.

PREFACE TO SECOND EDITION.

THE success which attended the first issue of this work has induced us to publish another edition. This volume has been arranged on a basis which will prove of great value to amateurs, for whose benefit it was specially prepared. Indeed, it has been entirely recast and remodelled, and a careful revision has taken place in matter and style. The principal feature of the work is the addition of illustrations, which, to amateurs, are of much practical value, as they convey at a glance the form and character of the plants which are under notice. We do not profess to lead our readers by any new or easy way to the art of greenhouse management; but we have set down in plain language the method to be followed by the amateur, and placed before him simple instructions which should be carefully observed. It is practice alone which leads to perfection; and that can only be attained by patience and experience, in combination with observation and common sense.

A book may do much by shortening the experimental stage, by giving the result of the oft-times dearly-bought experience of others, and that is all that we claim for "Greenhouse Management for Amateurs."

The plants which we recommend for cultivation are those which we know by practical experience an amateur is able to grow successfully if our directions are followed.

For the convenience of those of our readers who wish to keep their greenhouses or conservatories furnished with flowers the year through, we have appended tables showing at a glance all the plants mentioned in this book which bloom in each month.

We have only to add, that we shall be pleased at all times to give any further information, or to answer questions on gardening subjects, through the columns of *The Bazaar*, which is published at 170, Strand, London, W.C.

W. J. M.

DEC 20 1938 gift

CONTENTS.

	PAGE
CHAPTER I.	
INTRODUCTION AND GENERAL REMARKS	1
CHAPTER II.	
GREENHOUSES AND FRAMES	6
CHAPTER III.	
HEATING	18
CHAPTER IV.	
INSECTS	37
CHAPTER V.	
CULTURAL DIRECTIONS... .. .	50
CHAPTER VI.	
DICTIONARY OF PLANTS	62
CHAPTER VII.	
MONTHLY CALENDAR	348
CHAPTER VIII.	
MONTHLY LIST OF PLANTS IN BLOOM IN THE GREENHOUSE ...	370

Greenhouse Management for Amateurs.

I.—INTRODUCTION AND GENERAL REMARKS.

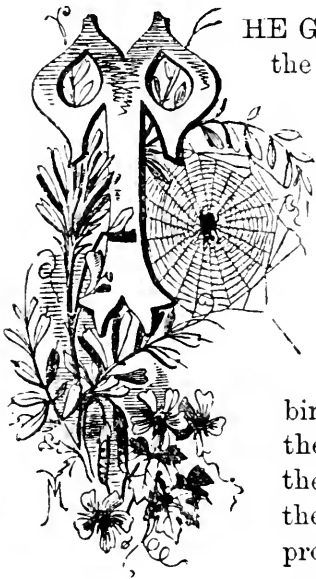

THE Greenhouse is a structure that is perhaps the most varied in shape, size, style, and appearance, of any that are used for horticultural purposes, and the contents are as a rule of the most heterogeneous character. Apart from the house or plants, the heating arrangements are generally far from useful, and on this alone much of course depends. As it is our wish to give only useful information combined with practicability, we shall treat the subject from the beginning, describing the way to stock various structures for the use of amateurs. As all our readers probably know, a greenhouse is a rather costly building when put up by a builder,

as generally a lot of superfluous ornamentation is added to the erection, which, while giving a rather showy appearance to the

house, tends to obstruct the light, and so reduce the value of the house for horticultural purposes. Ventilation is a subject of paramount importance, as on the method of obtaining this a very great deal depends; in fact, we may say that more plants are injured from bad ventilation than from any other cause. Ill-placed ventilators, and inaccessible swing sashes, are often sources of continued annoyance and loss, and in a well-found house or conservatory should not exist, but still it often happens that for some caprice of the builder the ventilation is "badly arranged"; and as a certain consequence the plants suffer. The heating arrangements are the most troublesome of any, as in hundreds of cases some loudly praised affair which is well recommended by the vendor is purchased by the amateur, and before the season is out breaks down, and consequently entails the whole or partial loss of the stock of plants that has cost so much labour to get together. It is therefore the best plan to have a well-constructed affair at first, the cost of which in most cases not being much more than the cheap (?) apparatus.

Stock.—The stock of plants should not be too great at first, as there are always plenty of opportunities to add to it. Indeed, if the house is only about 12ft. square, two or three dozen permanent plants will be ample, as there are plenty of season plants to keep the house gay at all times. A few pots of crocuses, musk, scarlet pelargoniums, &c., serve to give a very bright appearance to what would otherwise be a dull uninteresting mass of green, and if the amateur has a taste for tricolor and bronze pelargoniums, then at no season of the year will the house be devoid of interest. Camellias, azaleas, epacris, chorizemas, solanums, Cape pelargoniums, and genistas, are a host in themselves, while of roses it may truly be said that they are of inestimable value. We would advise our readers to have only a few plants, and do them all well, rather than have a large collection and do none of them well. There are many ways of making a house look gay at a far less expense than is generally allowed, thus making a greater pleasure in the place than there otherwise would be.

Pots and Sand.—Pots and sand should be selected with

care, as they are of some importance in horticultural work. Pots should be of a porous and hard nature, and when suspended and hit with the knuckles should give off a sharp resonant sound. Close smooth-grained pots should be avoided, especially if made of the London clay, as they soon go rotten and crumble away. Coarse sand should be used for all purposes, as it gives far better results than the fine, and has not that tendency to become covered with a green slimy coating that very frequently shows up on dirty and fine soft sands.

Soils.—Soils and manures should be of the best quality and suited to the work for which they are required, and cheapness should not be a consideration in laying in a stock of these necessary adjuncts to the greenhouse.

The necessary soils for general use are maiden loam, yellow loam, peat, leaf mould, and sand, and these we will describe in turn. Loams should be laid up for at least six months to become quite rotten and mellow, and to attain that state so necessary to the well-being of the plants.

Maiden loam is the top spit of a pasture, and should be free from clay and, if possible, wireworm. It should also be free from red, rusty looking streaks, as such loams are, as a rule, taken from water-logged pastures, and are generally sour and bad. If the common hard-rush is found in the herbage, it is also a sign that the soil is poor, and, therefore, of course, should be avoided. Our plan is to use turf cut off as for making lawns, and laid up for a year, as it is much richer in fibre, and plants of all kinds do better in it. The price of ordinary loam in London is about 6s. per cubic yard, and the turf about 9s. per 100, and it will be found that the latter is the cheaper in the end.

Yellow loam is, as its name implies, yellow in colour, and is the top 6in. from a common. Wimbledon and Epping loam used to be considered the best near London, but since this has become unobtainable we believe the article is obtained much farther off. The best is full of fibre and bracken roots, and is quite mellow. It also contains a certain, or rather uncertain, quantity of sand, and no clay. We have found the

loam, peat, and sand, supplied by Mr. Kennard, of Old Swan-place, Old Kent-road, to be the best to be obtained in or near London, as Mr. Kennard makes a speciality of such things.

Peat is the top spit of a "dry" bog, and is quite distinct from the peat that is used for fuel, which latter is useless for plant food. Fibrous sandy peat is the best, and can be obtained of Mr. Kennard, as above.

Leaf mould is simply thoroughly rotted hard-wood leaves, and the soil is thus full of humus, a very necessary condition for primula and similar plants.

Silver sand is a white sand formed principally of pure silica, and free from lime. It should be very coarse and sharp, and also very clean, or it soon becomes covered with a green slimy film, which, although very beautiful under the microscope, is almost certain death to cuttings or seedlings that may be surrounded by it. Reigate sand is generally esteemed the best. The fine white scouring sand sold at the oilshops is of very little use for plants.

Manures.—Manures are a matter of importance, and are generally the least thought of. With the majority of greenhouse plants a steady lasting effect is desired, and not a sudden spurt, and then a complete standstill, and to obtain the best effects thoroughly rotten good manure must be used. Horse and cow manures are the best, either mixed or separate as occasion may require, and they should be used for all purposes. Guano is a substance that has a great effect in driving the plants up, but they are useless for any purpose afterwards. For quick-acting liquid manure we prefer sulphate of ammonia, but for all hard-wooded plants, the best liquid manure is made by soaking a quantity of rotten horse manure in water, and using the clear liquid after the solid portions have settled.

With all soils and manures it is the better plan to have a shed, with compartments in which the soils can be placed and kept free from superfluous moisture.

Sundries.—A good supply of crocks for drainage should also be provided, or the plants will probably suffer for want

of the proper means for the exit of superfluous water. A hammer, trowel, water cans, both of the ordinary shape and what is known as a strawberry pot, and a few other tools will be required, but of these we will speak in the future. Amongst the sundry requisites of a greenhouse are a good syringe—one of Read's 15in., with three roses, is as good as can be bought—labels, flower pots of various sizes, square propagating pans, some squares of glass, one of Brown's or Dreschler's Patent Fumigators, some insecticides, flowers of sulphur, and a few camel-hair pencils, besides a few other articles that are more for show than use. Of course, a strong potting board, a pail, step ladder, and two or three brushes and brooms, and the necessary tools for the stokehole, are absolutely necessary. We may as well mention here that plain, serviceable and strong tools and utensils are far better than showily got up goods, although the former may cost a lot of money if judged by appearance only; in all cases it is far better to have good tools (although they are expensive) than cheap ones that will do no service, as it is certain that cheap tools are dearer in the end. Another thing to be borne in mind is, never to buy a lot of useless articles, however much they may be puffed up, as success does not lay in the tools, but in the cultural skill displayed.

We consider frames to be a necessary adjunct to an amateur's house, and therefore two or three two-light boxes should be at hand for use. The form of house is not of much consequence, so long as it is well built and ventilated.



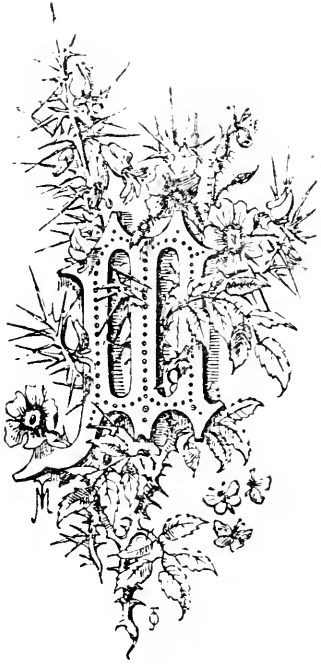

II.—GREENHOUSES AND FRAMES.

ANY and various are the houses or glass structures that are made expressly for amateur gardeners, and, as they range in price from £5 to £50, it is as well to point out the best forms of house, bearing in mind cost and general suitability to the purpose in hand. Of course, with existing structures, very little can be done, as it is, as a rule, expensive to meddle with old buildings, the wood very often being half decayed, and

the nails rusted in; consequently, in separating or removing portions of woodwork, they are very much damaged, and, in many cases, are rendered quite useless. It also frequently happens that another obstacle presents itself, viz., the house will not fit another place, and we know, from sad experience, that it costs as much to alter such a house as to build a new one. We may as well mention here that we always deal with Messrs. Lascelles & Co., Bunhill-row, London, and find their prices moderate, and the articles they supply are, as a rule, first-class. Wood, workmanship, and shape are as near as can be, perfect, and, considering the price the articles are made at, it is indeed a remarkable fact that so few persons possess really serviceable glass houses.

Lean-to House.—The most general form of house is the lean-to, shown at Fig. 1. The cost of erecting one of these

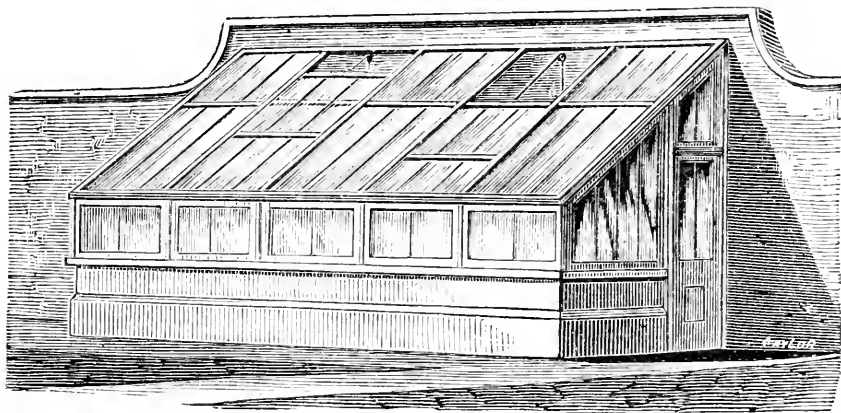

FIG. 1.—LEAN-TO HOUSE.

varies according to the manner in which it is built, as some persons have heavy sashes and timber, and, in some cases,

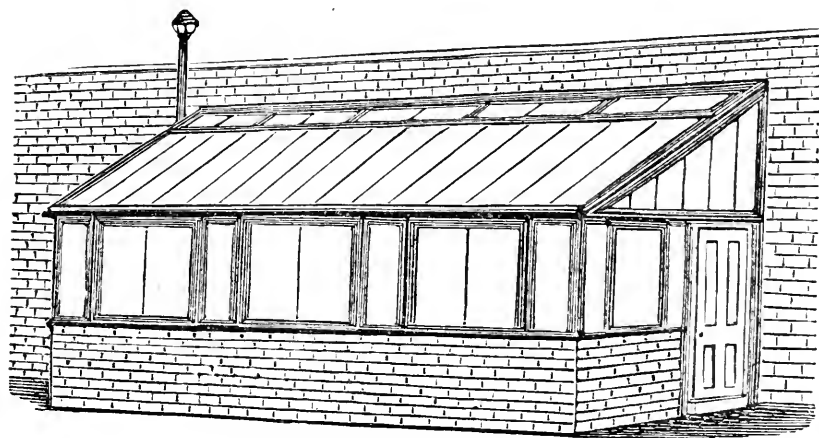

FIG. 2.—LEAN-TO HOUSE.

ornamental guttering, fancy designs in painting, &c., all of which cost money, and have the disadvantage of making the

house considerably darker, which causes the plants "to draw" and makes it more difficult to keep them in good order than it would be in a light place devoid of superfluous woodwork. A house, 12ft. square, built in this style, would cost at least £50, and in some cases it will be found that £75 will not cover all expenses. If, however, it is desirable to study economy, a house of the same size as that mentioned can be put up for about £35 in the style of Fig. 2. As will be seen in the figure, no top sashes are used, but simply ventilators, which answer

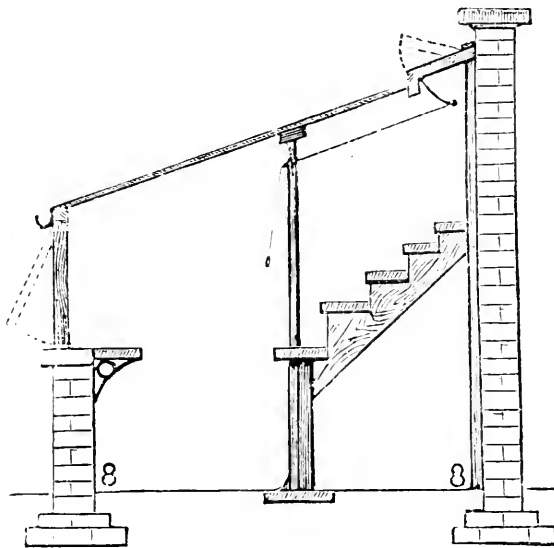

FIG. 3.—SECTIONAL VIEW OF LEAN-TO.

quite as well; front sashes are, of course, necessary, but need not be so heavy as those generally used. In the example before us there are three front sashes, and five glazed ventilators at the top, and a door at one end. The cost of erecting the house a few years ago was £28 17s. 6d., without heating apparatus, which subsequently cost £12 10s., thus making a total of £41 7s. 6d. for a good house 12ft. by 8ft., staging, heating, building, and all complete. Now, had heavy sashes and timber been used, about £20 more would have

been charged, and, besides the additional price, a great deal less light would have been admitted. In this instance 3in. timber was used, consequently great weight was avoided, the staging was made to accommodate plants of a large size as well as small pots, each shelf being a foot wide. The uprights and stays were made of sound yellow deals, and the glass used was 21oz. Belgian, which is, by the bye, a very useful and serviceable article. Fig. 3 is a sectional view of the house.

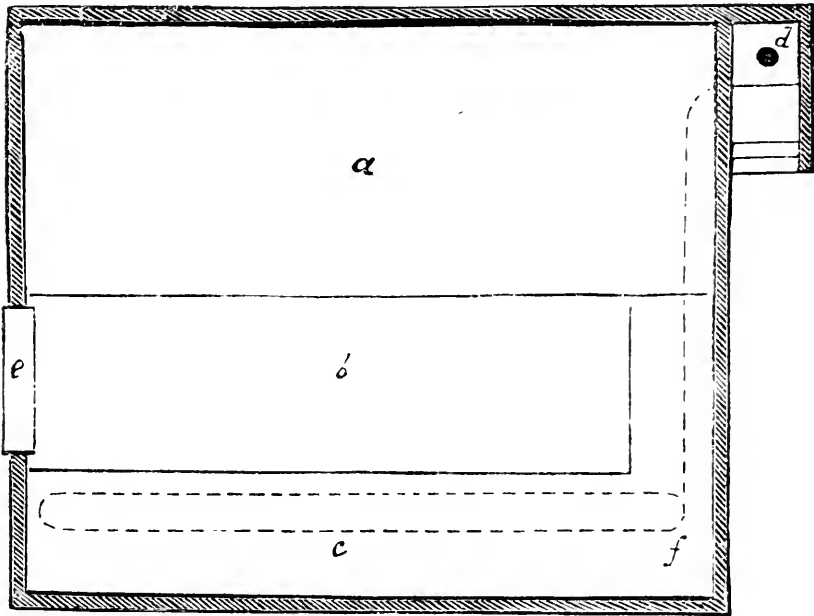

FIG. 4.—GROUND PLAN OF LEAN-TO.

We will here give the plans for a lean-to greenhouse, as no doubt some of our readers are amateur carpenters, and with a little care such persons can be their own greenhouse builders. We propose to take in hand a house 10ft. by 12ft., 5ft. 9in. high in front, and 9ft. high at back, a very handy size for general work. Indeed, we have seen very fine plants, and grapes too, grown in such a house, and it was entirely built by the gentleman himself. Fig. 4 is a ground plan of the house, showing the walls, back stage (*a*), path (*b*), front stage (*c*),

boiler and stokehole (*d*), and stone door sill (*e*); the pipes are shown by the dotted lines, a single flow to the corner (*f*),

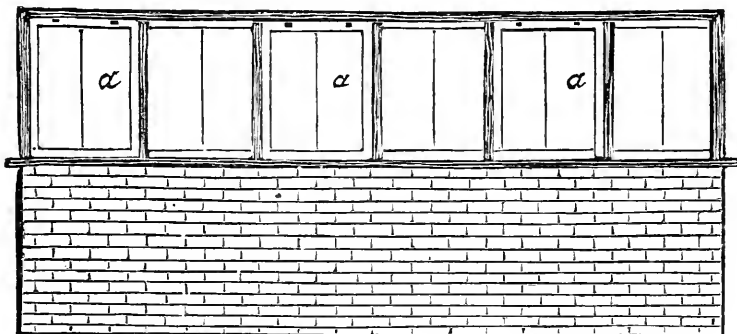

FIG. 5.—FRONT ELEVATION OF LEAN-TO.

and then a double flow along the front of the house, as shown, with a single return back to the boiler. All must be 4in.

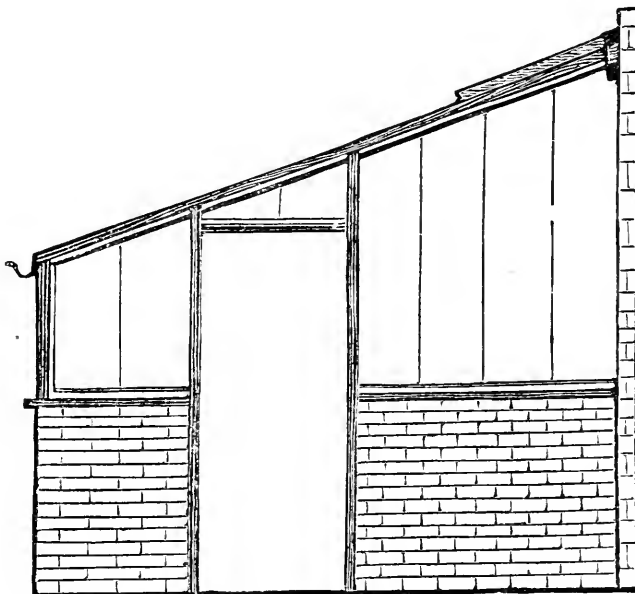

FIG. 6.—SIDE ELEVATION OF LEAN-TO.

pipes or sufficient heat will not be obtained. Fig. 5 is the front elevation of the house. In the first place, there is a 3ft.

brick wall around the house, and this must be of 9in. work if carried up in mortar, or $4\frac{1}{2}$ in. if put up with Portland cement; but in any case, if the district surveyor sees the place, he will insist on 9in. work. A two-course footing will be found necessary for the security of the building. On the top of the wall a 2in. wooden plate must be laid, and well bedded in either mortar or cement, as the case may be. This plate should overlap the wall on either side, and on the outside a groove

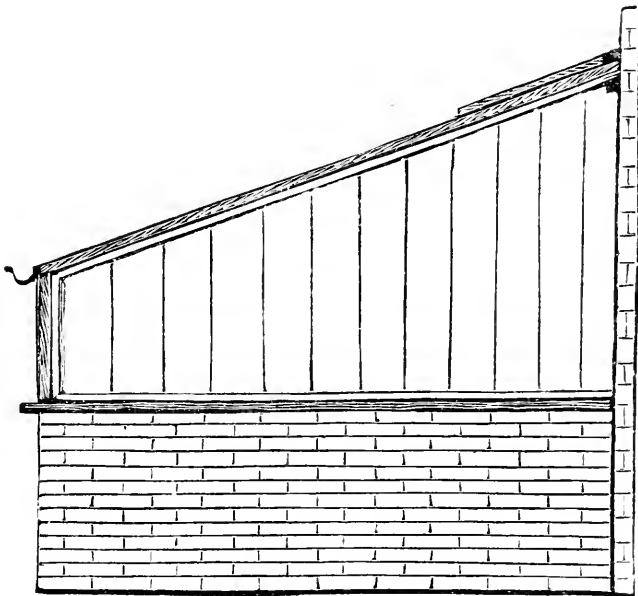

FIG. 7.- SIDE ELEVATION OF LEAN-TO.

should be cut out with the plough to allow the water to drip off instead of running down the wall; this is very necessary, or the wall soon becomes green and unsightly, besides causing the plate to rot where it is laid on the wall. Upright quartering 3in. by 3in. is used for the corners, and divisions between the sashes, and along the top of these, a plate 4in. by 3in. is laid to form the front of the roof. There are three fixed, and three swing lights (*a*) which are sufficient for all practical purposes. Fig. 6 shows the end view where the door is, and Fig. 7 the

other end. It will be seen that the sash bars reach from top to bottom of the house at the ends, and the glass is held in its place by iron brads, besides the putty. By this plan there is no fear of the glass falling out by the jar consequent on the slamming of the doors, &c. The roof is shown in Fig. 8, and it will be at once seen by what means the ventilation is obtained. Four sashes 3ft. square, rising on hinges, occupy the

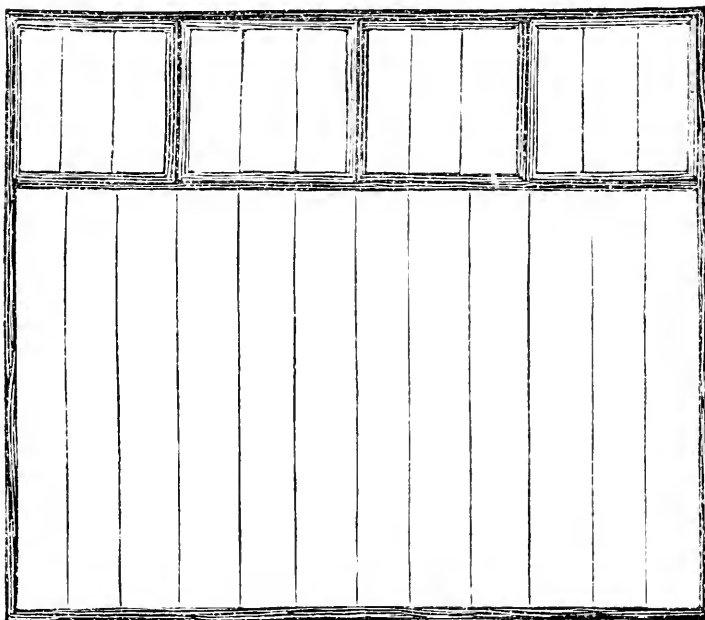

FIG. 8.—ROOF TO LEAN-TO.

upper portion of the roof, and the lower portion is formed of sash bars, a plan that greatly increases the light admitted, besides materially decreasing the cost of building; a 3in. by 4in. beam goes across the roof, where the top lights close down, and one upright support takes its bearing in the centre of this beam. It will be found quite an easy matter to build such a house as we have described, as all the parts can be purchased in a prepared state, and ready for use. A saving of at least

25 per cent. will also be effected by building houses in this manner, therefore there is a double advantage in building your own greenhouses. If the amateur desires to make every part himself, he will find very minute directions in "Carpentry and Joinery for Amateurs."*

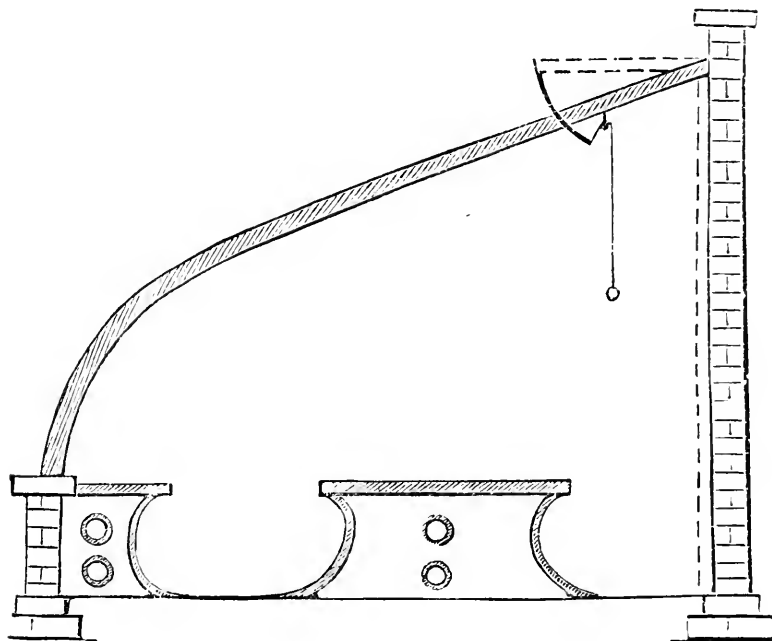

FIG. 9.—CURVED ROOF HOUSE.

Curved Roof House.—Where the object is to obtain the lightest house possible, the curvilinear form offers the best design for the fulfilment of the object in view; but, at the same time, the price is much more than a plain lean-to, or span, as in many cases bent glass has to be used, and this is rather expensive. It is not often that amateurs go in for this style of house, but still, where it is desired to grow plants for exhibition, it is sometimes of use to have such an one. Iron is the best material to use for the sash bars, and in some places the whole of the building may be of iron, doors and staging, of course,

* "Carpentry and Joinery for Amateurs:," Containing full descriptions of the various tools required in the above Arts, together with practical instructions for their use. By the author of "Turning for Amateurs," "Working in Sheet Metal," &c. In cloth gilt, price 2s. 6d., post free. London: L. Upcott Gill, 170, Strand, W.C.

excepted. In Fig. 9 we give a sectional view of a house that was built by a good firm, and which looked very well. It was built of wood and iron, and for stability it was unequalled. This style of house is good for conservatories or greenhouses, as the plants are not liable to "draw" so much as in ordinary lean-to houses, and, as before mentioned, light is a great point in the culture of some plants.

Half-span House.—Houses with short back roofs, or, as some persons call them, half-span roof (Fig. 10) are very useful,

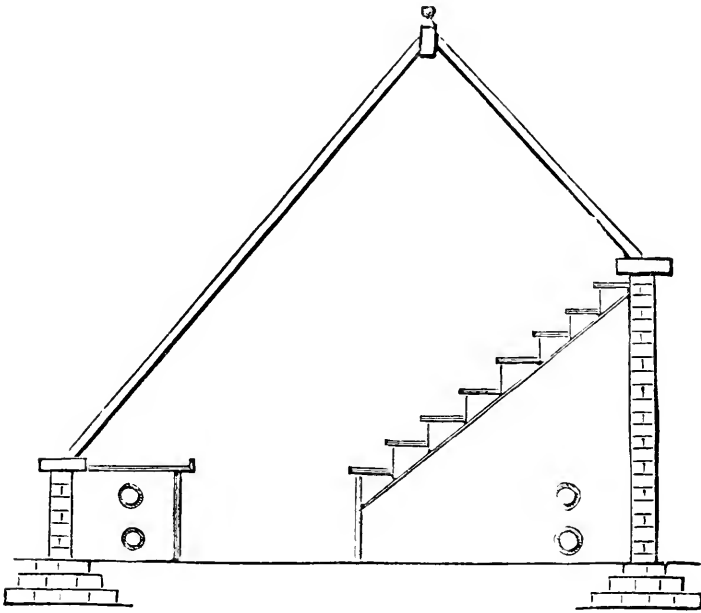

FIG. 10.—HALF-SPAN HOUSE.

and as they may occupy the same positions as the lean-to houses, they afford greater facilities for the culture of plants in general. They are easily built, and may be put up by anyone who has any skill at carpentering, although span-roofed structures are more troublesome to erect than lean-to's. The great advantage in using them is that a portion of the back light is utilised, especially where houses face north or north-west, the additional light and heat gained being of great service. This style of

house is particularly useful against low walls and in similar situations.

Span-roof House.—The span-roofed house is, however, the best for plant culture, where it can be erected, and, unless vines are grown, should take the place of all others. The cost is not excessive, and although more trouble to put up than a lean-to, anyone handy at carpentering could easily put one up. A handy size is 12ft. wide, and, of course, as long as desirable.

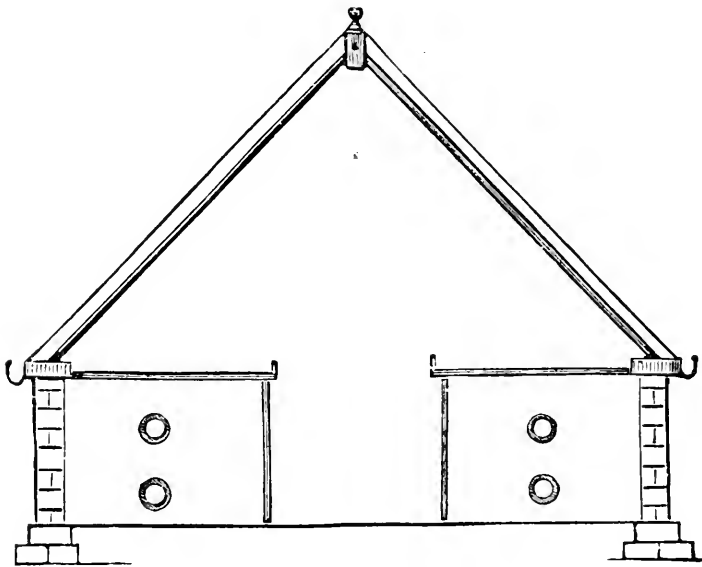

FIG. 11.—SPAN-ROOF HOUSE.

Less width will generally be found to cramp the paths, &c., although 10ft. wide gives a very good centre path and side stages; but if a centre stage is required, then the house must be of greater width. There are several styles of span-roofed houses, but the two examples given will be found useful for all general purposes. Fig. 11 shows a very cheap form of this style of house, and, at the same time, one that is in much favour with growers for the London markets, especially for soft-wooded stuff. As will be seen from the cut, there are no side lights;

the ventilation is provided for by means of sliding sashes or ventilators that open on hinges, as before described. As a rule, a central path is made about 2ft. 9in. or 3ft. in width, and there are two side stages, or rather benches, the farthest edge of which is about 9in. from the glass. In the second example (Fig. 12) there are side lights, and, of course, the place is much higher and more expensive. This kind of house is useful for all

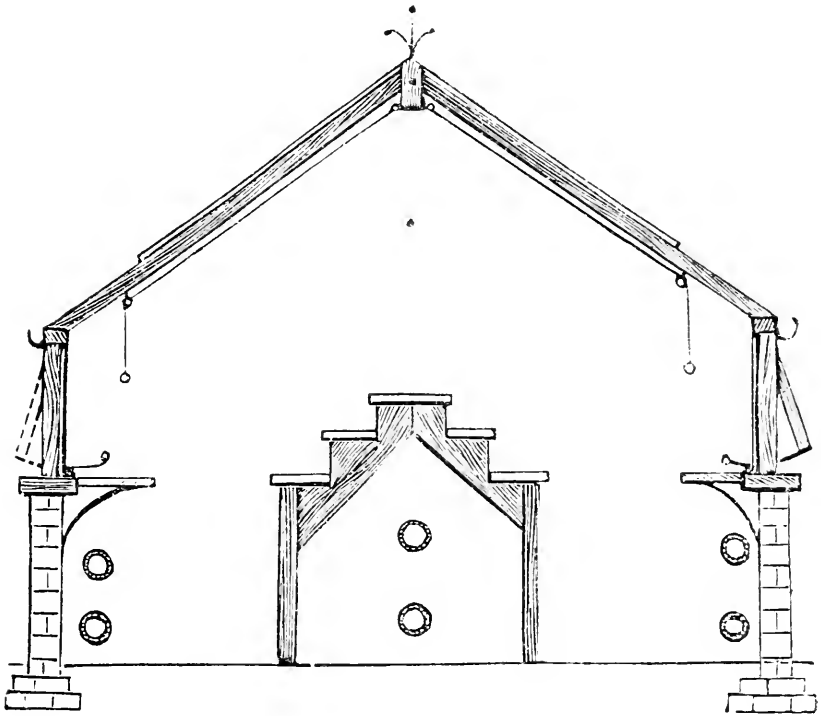

FIG. 12.—SPAN-ROOF HOUSE.

the ordinary kinds of plants, both hard and soft wooded. It is also one of the best forms of house for growing specimen plants. Where it is possible, the best plan is to have a centre stage and side stages, with paths around; this allows of the proper distribution of the plants, and more suitable positions to some of them than can be obtained in a lean-to. For this reason we prefer a span-roofed house for all ordinary collections of plants.

Frames.—As these are necessary adjuncts to a greenhouse, a word or two on them may not come amiss here. The uses to which they may be put are so many and various that to omit a notice of them would be to omit one of the most important parts of our book. In the first place, there is the common melon or cucumber frame, which answers all ordinary purposes. It should be stood on a concrete bottom with a channel in front to allow the water to run clear away, or damp will do much damage. These common frames answer all practical purposes, and on account of their portability and the ease with which a hotbed can be made under them, they will be found the best for amateurs. The best size is that technically termed “two-light frames,” with 6ft. by 4ft. lights, as more lights cause a difficulty when making up a hotbed. We do not give an illustration of these, as they are so generally known. The only point is to have them made of the best yellow deal, as free from knots and shakes as possible, and painted three coats with the best lead paint.

It is not our intention to treat of conservatories and window cases, as, although they are sometimes affected by wealthy amateurs, yet in the majority of cases the greenhouses before mentioned, or modifications of them, are the rule among persons who make a hobby of gardening themselves, and do not employ gardeners to do the work for them. Window cases or conservatories do not therefore come within the scope of the present work.





III.—HEATING.

EATING is rather a difficult matter to treat, as the wants and requirements of such a large community as amateur gardeners are so great that one might write a volume without exhausting the subject. In the first place, the sort of greenhouse to be treated is a great consideration, for, as the term is now generally applied, a glazed rabbit hutch and a winter garden may equally be termed greenhouses, provided there are a few plants in them. We have seen "greenhouses" about 4ft. by 6ft., and about 7ft. high, and

to these no apparatus could be affixed that would heat the small space thoroughly, without using an extravagant amount of fuel in proportion to the size of the place. Of course, it is an easy matter to heat any place when expense is no object, but with the majority of gardeners the cost is one of the most prominent points of consideration. For many small places the cost of the special fuel required by some of the contrivances offered is a great drawback. Patent fuel is often objectionable, as it cannot always be obtained in country places. Another objection to many stoves is that the fire does not last a sufficient time after being made up, and the

consequence is that the frost gets in and destroys the whole of the plants. In a garden where a large amount of glass has to be kept at a nearly uniform temperature, the gardeners have to visit the fires during the night. But there are few persons who would like to leave their beds on a cold, and, probably, frosty night, for the sake of attending the fire of a small house in which there is perhaps only a pound's worth of plants; and, therefore, the stove should be so constructed as to burn at least eight hours, if not longer. In the case of simple stoves that give out heat only and do not retain it like hot water, this slow combustion principle should be very nearly perfect, or failure will result. In hot water apparatus, of course, it is an advantage to have the fire kept in for as long a period as possible; but at the same time, if there is a sufficiency of water, heat will be given out long after the fire is out, and circulation has ceased.

Nothing less than 4in. pipes should be used in a house of any size; and if frost is not too severe, and the boiler and furnace have been fixed in a proper manner, a good heat should be given off for twelve hours at least. In fact, we have had boilers fixed under our own superintendence that would give a good circulation of water (*hot*, not warm) for fifteen hours right off, without any attendance during the time, but as boilers are very often set by country bricklayers, three or four hours' non-attendance is sufficient to let the frost into the house. Heating by means of flues is a very good plan where firing is no object, but when coals are up to 25s. per ton, it will be found to be a case of penny wise and pound foolish to have flues. The lamps or stoves to burn mineral oils serve for small places only, and gas is not always to be obtained.

Heating with Mineral Oils.—The stoves for this purpose are of various constructions, and also degrees of utility, and most of them are advertised to do more work than they are really capable of doing in a regular way. It must be borne in mind that a glass house is more exigent of warmth than a room, and requires at least three times as much heat to keep out the frost in proportion to the size

of the structure. What would keep a room 12ft. square at a nice heat would not keep the frost out of a greenhouse 6ft. square, unless such house was very much sheltered. Now, for all practical purposes, a sufficient heat must be given to keep out frost, and at the same time no great amount of smoke must be engendered by the (imperfect) combustion of the oil. To this end the wick after it is lighted must be turned down under the dome, so that a sufficient amount of oxygen shall be con-

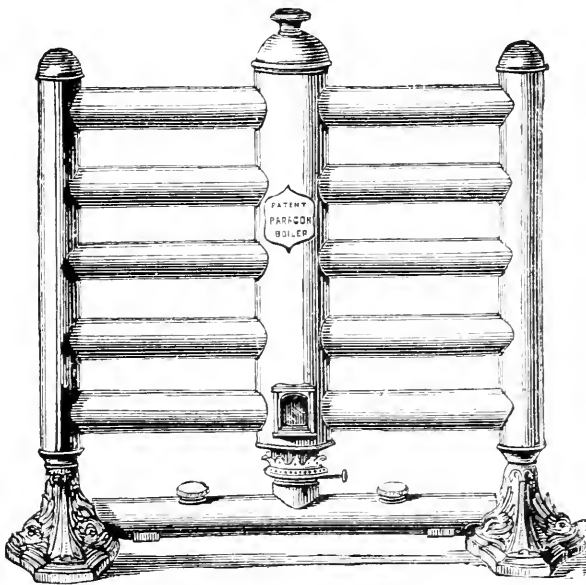

FIG. 13.—MESSRS. DIETZ AND Co.'s PARAGON BOILER FOR MINERAL OIL.

sumed to ensure the perfect combustion of the oil. It should also be remembered that smoke is simply unconsumed fuel, and the more smoke made the greater the amount of fuel that will be required. This should be remembered by all persons who have the charge of any kind of heating. A good stoker is a truly valuable person in either a dwelling or an

engine house, and should be kept when obtained.

But to return to our oil stoves, anyone with care may use one of Hinck's or Dietz's kerosine stoves in a house that has not more than 500 cubic feet of interior capacity; over that, large sized stoves must be used, or more than one of the smaller size, but of this it is only possible to give a decisive opinion on a personal inspection. We would have it understood that we only advise the use of oil stoves for small places, as for larger houses other plans are more effective, and not more expensive. In all plans of heating, of course price is a con-

sideration, and therefore we advise readers to use oil stoves for small houses.

Both the Albion Lamp Co. and Dietz and Co. (Fig. 13) make a good form of stove for using mineral oils. They are somewhat similar in construction to Wright's gas stove, and consist of a boiler, mineral oil lamp, and three or more hot water pipes, and they do their work well, and from the increased heating surface obtained by using hot water, a greater heat is given off than from a lamp alone. We have seen both in operation, and think them well worth the money charged, and all things considered, they will be of far more use in small conservatories than any simple lamp. A friend of ours who has one of each maker's apparatus in use says there is no difference in the oil consumed, and the heat given off is about the same, while compared with the simple lamps, or stoves, as they are called, two of this new apparatus give off as much heat as, or rather raise the temperature in the small conservatory he has higher than will three lamps which he has been using, thus showing a clear saving of nearly a gallon of oil per week. Three lamps cost him £4 10s., and the two apparatus in question cost him altogether about £6.

Both George's Calorigen and Ritchie's Lux Calor, described further on, can be used with mineral oil lamps.

Heating with Hot-air Stoves.—Under this we class all the various stoves that are heated with coal, coke, or cinders, and which give off dry heat. In the majority of cases these are, for more than one reason, objectionable. In the first place, they give off dry, overheated, and deleterious fumes, especially if they are made of wrought iron, and, as a natural consequence, the plants do not succeed well. In the next place, they are generally dirty and untidy, and, lastly, their fires have a nasty habit of going out when most wanted. The last objection is the trouble of attendance, which, if not very great, is not a cleanly job. Of course, very much of the pleasure of a greenhouse depends on the nature of the work that has to be done by the owner; for if there is much work of a dirty kind, the place soon loses favour, and then comes discontent, and eventu-

ally failure. In choosing a stove, have one with a cast-iron fire bucket, or one that is lined with fire bricks, by which means direct heat is kept from the wrought iron, and the fumes given off are reduced to a minimum, so increasing the probabilities of growing plants successfully. In addition to this cast-iron or brick-fire-pail, it is also necessary to have some contrivance to hold water to be evaporated, and so tend to regulate the dryness caused by the stove. Of course, the amount of moisture that is necessary will be regulated by the number of plants in the house, and the quantity of water given.

Nearly all the stoves that have chimneys answer well, with care in stoking and by using cinders and coke broken small for fuel; they must be small, or they will cake together. We can, however, only speak of Green's Patent Suspension Stoves from experience, as we have generally had hot-water apparatus under our charge. There are, however, many other stoves with flues that answer well if they are constructed as described above. It is all very well to purchase a stove without a flue for the reason that there is no smoke, but though no visible smoke exists, there are fumes of a most deadly nature both to plant and animal life, which get dispersed over the house in which the stove is inclosed, and eventually ruin and destroy the whole of the plants. There is, indeed, the one probability that the glazing of the house is so bad that sufficient draughts obtain admission to blow off the vapours that would otherwise accumulate; but in many cases the house is comparatively air-tight, and so the plants die.

The size of the stove of course regulates the size of the house it will heat, but one of Green's Suspension Stoves, that burns about a bushel and a half of fuel daily, will heat from 500ft. to 1500ft. of cubical capacity, according to the situation and exposure of the house. To a certain extent the space that can be heated by stoves is unlimited, but of course, the larger the space to be heated the greater must be the heat given off by the stove. A drier atmosphere will thus be obtained, and the growth of the plants will be more or less seriously affected. It also equally applies in heating schools, &c., with stoves, that if there is not sufficient heating surface to give

off enough heat without overheating the stoves, very undesirable results will follow: severe colds, itching of the eyes, and sometimes sore throats, are caused by this means alone, all of which, we venture to say, would never appear were the stoves sufficiently powerful to heat the place while at a comparatively low heat themselves. With plants the effect is very bad, and it is far better to have two stoves at a moderate, than one at a fierce heat.

In fixing these stoves two things are requisite. a draught sufficient to keep the fire alight fairly, and sufficient piping to exhaust the whole of the heat before it reaches the chimney.

The first is easy to attain if the pipes can be led into a chimney belonging to the dwelling house, but some difficulty will often be found in obtaining sufficient length of pipe. We have found it the best plan to take the pipe upright for three or four feet, and then turn it off at right angles, and take it across the house into the chimney; this, of course, allows of the whole of the heat being utilised, that would otherwise be blown out of the roof. The joints should be made good with red lead and oil, so that no fumes escape, and the whole is then complete—complete at least so far as the fixing goes; but the more important item of stoking still remains. This is a point that requires much attention, as on it the durability of the fire depends. In the first place, light the fire with shavings or paper and short pieces of wood; when these are well alight put in a little coke broken small, or perhaps a few cinders, but no coal. If coal is used the greatest probability will be that the fire will cake and go out, and consequently the frost will get in and the plants will be lost. As soon as the fuel first put on is well alight, fill up the stove with dry fuel, and partially close the air inlet at the bottom. With a little care the fire may be kept well alight from eight to twelve hours, or as long as can reasonably be expected with the amount of fuel consumed.

Heating with Gas.—This is one of the vexed questions of the day, and will never be definitely settled until we can have gas at a good pressure throughout the night, and at a moderate price; and even then the risk attendant on this system of

heating will debar very many persons from using it. It must in all cases be remembered that the low first cost of an apparatus of any kind does not imply that it will be cheap in the end; in fact, it is very often quite the reverse, as cheaply made articles as a rule are not so well made as those for which a fair price is charged. Joints and rivets are insufficiently fastened, plates are cracked because the holes are not drilled large enough, and, worse than all, the arrangements are such that in the case of an apparatus that depends on hot water for the heating medium, the water in many cases will not circulate. We have had a good experience of gas apparatus, and in no case have we found that the work done, in proportion to the cost, equals that done by good sound fuel in a plain conical boiler. The plates used in the manufacture of gas apparatus are generally very thin, and the action of the gas where it burns against them soon causes them to break into holes, and so allow the fumes of the gas to escape, to the great injury of both plant and animal life. Common burners are also used in many of the contrivances, and the result is that the gas is not thoroughly burnt, and therefore an exorbitant quantity of gas has to be used in proportion to the heat obtained.

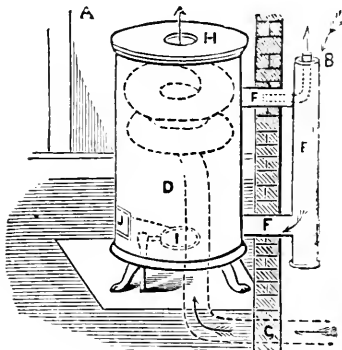

FIG. 14.—GEORGE'S CALORIGEN.

A, room; B, exterior of building; C, wall; D, Calorigen; E, cylinder; F F, pipes communicating with stove and cylinder to supply air for combustion and to carry off products of combustion; G, pipe for supply of air to be warmed; H, outlet of warmed air.

A good burner that allows the gas to be well oxygenated makes very little smoke, and consequently there is not so great a waste of heat as where large deposits of soot are formed. All parts of the apparatus that come in contact with the flame should be of copper, and where a boiler is used it should be entirely of copper, so that the greatest amount of durability shall be insured.

There are two plans of heating with gas, with or without hot water. In the latter case, heating by means of the gas alone, George's Patent Gas Calorigen (Fig. 14) is about the best

apparatus there is, as by its use a current of fresh heated air is supplied to the interior of the place to be heated, whilst the products of combustion are carried out into the outer air, thus obviating all inconvenience that generally arises from the fumes of the gas. The whole apparatus is of neat appearance, and is constructed to burn well, independently of draughts.

Next to the Calorigen, a plain conical tube, with straight chimney, gives the best results, provided down draughts can be guarded against. A plain ring of lights impinge on the sides of the cone near the bottom, and of course heat it to the top. No bottom is required to such an apparatus, but the joints and seams must be perfectly sound and tight, and to ensure this, all joints, &c., should be luted with red lead and oil, which will make the whole tight. Open gas fires should on no account be used, as the fumes given off will destroy all the plants.

The Lux Calor (Fig. 15) is also a very good simple gas stove for small houses.

A is a door which opens on a Bunsen atmospheric burner, and B B are tubes in which the products of combustion are condensed (with the exception of the carbonic acid) into fluid form. These tubes become hot, and the heat is then radiated from them.

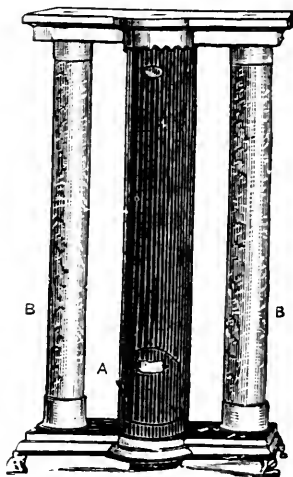

FIG. 15.—RITCHIE'S LUX CALOR.

In the more important class of apparatus, *i.e.*, that in which water is used as a heating medium, there are various makes of more or less excellence, but all of them require the services of a gasfitter or hot-water engineer to fix them to the best advantage. In all hot-water arrangements it must be remembered that hot water ascends, and the cold portion contained in the pipes descends; therefore it is of the greatest importance that the point most distant from the boiler should be the highest, and that this part should contain an air pipe to relieve the pipes from any air or vapour which may from time to time accumulate. It is almost useless to attempt to specify any

particular one amongst the many kinds of apparatus that are offered to the public; nor do we wish to imply that those we mention are the only good ones; on the contrary, we know that there are many that are good if properly fitted up.

The gas boiler made by Wright and Co., of Birmingham, of which an illustration is given (Fig. 16), is a good one, and does its work economically and well. The Shrewsbury gas boiler is also very good. Mr. Mussett, of Winstanley-road,

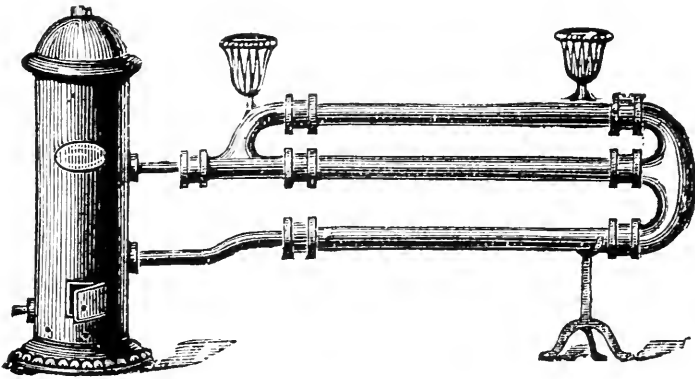

FIG. 16.—MESSRS. WRIGHT AND CO.'S GAS BOILER.

Clapham Junction, S.W., and Mr. W. G. Pendleton, of Walton-on-Thames, also make some very efficient apparatus at reasonable prices; and there are many other makers who supply good articles at fair prices.

We would give a word or two of advice to all about to use gas for heating conservatories. In the first place, employ none but really competent workmen to fix the apparatus when bought; make all joints and crevices secure with red lead putty, have hot water pipes fixed so that they rise to the point farthest from the boiler, and, lastly, buy a good article. It is a good plan to have a written warranty with each apparatus, a warranty that specifies exactly what the boiler will do, and that it is in a proper order to do it. If this rule were always observed fewer mishaps would happen.

Heating by Hot Water.—This is comparatively a modern invention, but it is about the cheapest and best method of applying heat to horticultural purposes. Who first made a really practical use of hot water is rather a disputed point, and may possibly never be satisfactorily determined, but for our present purpose it is sufficient that it is about the only really good method that is in practice. Of course, it is necessary that a proper amount of care be paid to having a due proportion of heating surface to the space to be warmed, and also that the boiler be large enough to heat the length of pipe, but if these points be conceded, no method at present in use will give such uniform diffusion of heat as hot water will. Neither will the amount of fuel burned be so small in proportion to the results attained. Hot water is also better for plant life, as it does not produce that dryness of the atmosphere that is caused by flues or other modes of applying heated air, and the hot water pipes, extending the whole length of the house, cause the warmth to be equally distributed.

Sealed pipes we object to, but if these are left out, so long as the return pipe, or any part of the return pipe, is *not* below the bottom of the boiler, a circulation can be kept up. The cheapest plan is to have both the flow and return pipe above the boiler, but still, by the use of a syphon, as we shall presently describe, this is not absolutely necessary.

The golden rule in hot water work is to have this fact constantly in mind: hot water always *ascends*, while cold water *descends*, and on this success depends. An egress for air must be provided at the highest point of each system of pipes, and wherever there is a dip under a doorway or other place, otherwise a partial vacuum will be formed, and the circulation will be seriously impeded, if not stopped. It must be remembered that all water becomes foul while confined in the pipes, and foul water generates gas, besides which, the fluctuation in the heat of the water considerably assists to draw in air from outside; therefore, in all cases, air cocks or pipes should be provided wherever necessary.

It is likewise very desirable that draw-off cocks should be placed in the boiler, and also in some of the angles of the pipes,

as the accumulation of dirt and scale makes it necessary to clean out the whole apparatus at times. Although no one would be so foolish as to fill a boiler and hot water pipes with dirty water, yet dirt will get in, and if not removed, causes a choked state of some of the smaller pipes, and a poor and sluggish circulation is the result.

The connection between the boiler and pipes should be of $1\frac{1}{2}$ in. or 2in. pipe, external, or $1\frac{1}{2}$ in. gas barrel, as smaller pipes soon get furred up. All connections between house and house, or between coils, should be of 2in. cast pipe; but between boiler and coil it should be as we mentioned before. Too much small pipe, or variation from large to small, chokes the circulation somewhat, and renders the heating power of a given amount of fuel much less. Besides, for many other reasons, avoid small pipes, and notably because a small pipe chokes or furs up sooner than larger ones, and sometimes where the matter is not thoroughly understood, a blow-up is the result, especially where water is much impregnated with lime or organic matter. We have ere now had hot-water apparatus taken to pieces, and have found the 1in. gas barrel so encrusted, or furred, that we could scarcely pass an ordinary lead pencil through. Where there is any danger of this incrustation taking place largely, if the water is slightly acidulated with muriatic acid, say a half pint of acid to 100 gallons of water, incrustation will be very greatly reduced. More acid than in the proportion given must not be employed. Salt water should not be used for any hot-water apparatus, as the boiler and pipes soon get incrustated with saline particles, and require burning or some other method of cleaning to free them.

Where pipes have to be taken underground, they should be carried through a brick or board trough, so constructed as to be water-tight, as the earth absorbs an immense quantity of heat. In fact, a 4in. pipe, 50ft. in length, would lose more heat in the soil than would one of thrice the length in a trough that was closed alike from air and moisture. For this reason it is a matter of economy that all pipes used for bottom heat be in a hollow chamber.

For many reasons, it is necessary to have valves, and the

more simple these are the better it is for the person using them. For all ordinary purposes we prefer the plain throttle valves, but, where pressure has to be applied, there is a specially strong valve for the purpose. Special valves are made for special purposes, but these are not ordinarily required. It is a good plan to have a number of valves, although they are rather expensive, but it is absolutely necessary to have them where more than one house is heated from the same boiler. It is also advantageous to have one or more valves to regulate the top and bottom heat in the same house, but of this we will speak hereafter.

The pipes may be packed with red lead and oil putty well mixed with yarn or tow; with tarred yarn and Portland cement; or, with indiarubber rings and Portland cement, or, where the pipes are on a firm base, with the rings alone, as in Fig. 17. The socket and spigot ends of two pipes (A A) are shown *in situ*, with the ring (B B) and Portland cement packing (C C). If not packed with cement, only the ring (B B), will be in its place, the cavity shown filled with cement, being then left open. We do not advise the use of iron cement, as where it is employed there is great liability of the

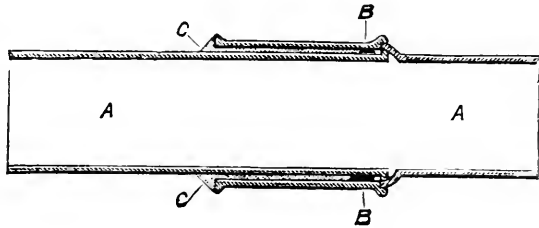

FIG. 17.—JOINT IN HOT-WATER PIPE.

A A, socket and spigot ends; B B, indiarubber ring;
C C, Portland cement packing.

sockets splitting from unequal expansion, and where this happens a continual expense is incurred, for split pipes are unsafe under pressure. And another thing militates against the use of iron cement for joining pipes; if from any cause the pipes have to be taken apart, they have to be cut at the back of the socket, or, in fact, the socket has to be cut out, and a loose socket or "thimble" substituted. Gas barrel pipes are, of course, connected with union sockets.

Two 2in. pipes should be used for bottom heat, in preference to one 4in. one, and in some cases 3in. pipes will be found better

than larger ones. One foot of 2in. pipe contains about 72 square inches of heating surface; 1ft. of 3in. pipe about 108in., and 1ft. of 4in. pipe 144in.; and 1ft. of the latter should heat about 90 cubic feet of interior capacity in an ordinary greenhouse. For other houses, however, more or less may be needed in proportion to size, or the plants grown. The greater the superficial area of the glass roof, combined with a comparatively small interior space, the more pipes are required to heat a given length.

Amongst the many inventions in pipes, we do not find any to beat the old-fashioned plan, and therefore pass them over without comment. Flange pipes, joined with bolts and nuts, are used sometimes, but they have no advantage over the common form of pipe.

The fuel used depends on the class of boiler employed, but there is nothing to equal clean hard coke, broken to about the size of hens' eggs, if the boiler is constructed so that the draught can be well regulated. Such boilers as the Independent conical, plain conical, and others on the slow combustion principle, are really the best for amateur use, and for these coke is most suitable, but for saddle and some other boilers, if properly set, coal, cinders, and refuse of almost any kind may be used. It is, however, very doubtful whether there is much saving effected or economy gained in heating a given space by using rubbish as fuel, and particularly if the boiler is not properly set or a good stoker is not at hand. There is considerable art in proper stoking, and the difference between good and bad stoking is very great, so great, indeed, that a saving of 25 per cent. in fuel may be effected by a really competent man.

The choice of a boiler for amateur work is rather a difficult matter, as, unlike a gardener, who *must* do certain work compulsorily, the man who has money does not care too often to soil his hands, and therefore the boiler, or form of boiler, which does its work well and requires the least amount of attention is the one most suitable. For this reason boilers which can be used on the slow combustion principle are the best for amateur use and for those who are liable to be called away at uncertain intervals. Where, however, there is a staff of men kept and a large amount

of glass to be heated, it is necessary that a good boiler, or, perhaps, two boilers, be used, as in using such, a great economy is effected in the fuel and labour, and, besides, one fire is not so

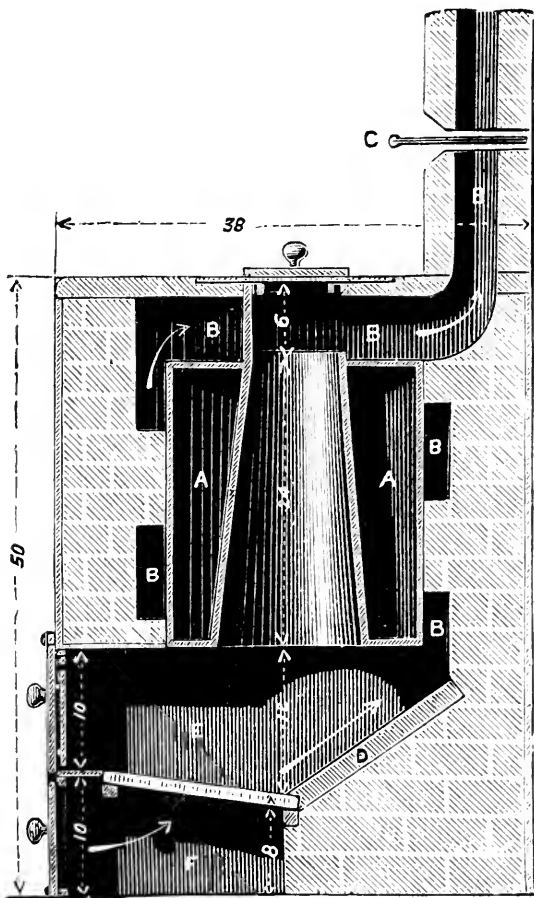

FIG. 18.—PLAIN CONICAL BOILER.

A A, boiler; B B B B B, flue, both spiral and top; C, damper; D, fire lump; E, furnace; F, ash pit. The arrows show the direction of the draught.

liable to be forgotten as one in a dozen. Where labour is plentiful and cheap it is of very little consequence whether a saddle, conical, Cornish, or other boiler is used, but we prefer the plain conical boiler, as it is easy to work, moderate in con-

tubular conical boiler (Fig. 19), and here certain drawbacks have to be contended with in setting, for, if not closely watched, many bricklayers will use their own ideas about the matter. The most common faults are either to brick close to the tubes, and so make the fire burn inside where it should be dead, or otherwise to leave too large a chimney, which causes the fire to burn in one place only. Set as shown, the boiler will keep going for twelve or fourteen hours, and heat the pipes in an efficient manner. In both Fig. 18 and Fig. 19 the measurements are marked in inches.

The saddle boiler, if well set and of sufficient size, will be found as good as any in an economical sense, and, indeed, it possesses many advantages. In the first place, cinders, hard or soft coals, coke, slack coal and clay, culm and clay, or even coal and wet ashes, will burn and keep up the heat, but the boiler must be long, and not choked too much at the back. A saddle boiler should not be less than 3ft. long, and where a great length of pipe has to be heated, a 5ft. saddle is not a bit too large. The L ended saddle boiler is a great improvement on the old one, to which, from careful trial, we prefer it. More surface is exposed to the fire, and greater heat is thus extracted from it.

The Independent saddle boiler is very useful where

drainage is bad, and this and the next one (Fig. 20), the Independent conical boiler, are perhaps the two best independent boilers. They are, however, much more expensive than those which require fixing in brickwork, but as they are absolutely

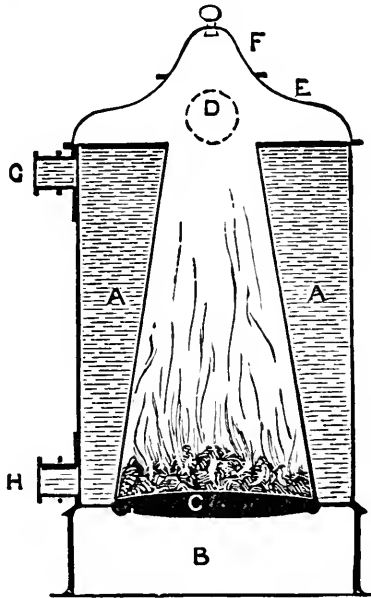

FIG. 20.—THE INDEPENDENT CONICAL BOILER.

A A, wrought iron boiler; B, cast base; C, fire-bars; D, flue; E, dome top; F, feeding lid; G, flow pipe; H, return pipe.

owned by the tenant they are cheapest in the end, particularly where the property is only held on a short lease.

There are dozens of forms of boiler for fixing in brickwork, and, properly fixed, they are, no doubt, good, but the more simple the boiler the better the results, as a rule, unless a brick-layer used to firework has the setting of them. Coil boilers we have but little faith in, if we except those made by Deards, and these are best in the larger sizes.

As fuel has a great deal to do with the performance of heating apparatus, we will say one or two words on the matter. In the first place, such boilers as Figs. 18, 19, and 20 should be fed with coke or anthracite coal only, but open boilers, like the plain saddle, will burn almost anything. This much must, however, be said: fuel to be most effective should be broken up small enough to pass through a $1\frac{1}{2}$ in. or 2in. ring, according to the size of the boiler, and should be free from dust. Slack coal and other stuff burnt in the common saddle boiler should be on top of the fire, and should be well wetted before use, so that it shall cake. Coke should also be used wet, as it burns better and throws off more heat. Where cinders are used it is always best to sift them through not less than a half-inch meshed sieve, as a finer sieve would hold back too much dirt, and ashes are of no use to burn.

In the selection of a boiler, always have one too large for the work required, *i.e.*, if you have about 100ft. of 4in. pipe to heat, choose a boiler that will heat nearly as much again, and then you will be safe in the hardest weather, and not have to "drive" the boiler. Always have a wrought iron boiler, as cast boilers are liable to split, and, should a stoppage occur in any of the pipes, will sometimes explode with some force, whereas a wrought boiler is only likely to rip or tear, so doing less damage. The best material for any kind of boiler is copper, but the great cost—say, £60 to £70 per ton—is against it.

We do not give plans of heating, as there is scarcely a case where two houses can be heated alike in all details.

In wet places, where several houses at different levels have to be heated from one boiler, the following arrangement (Fig. 21) can be used, provided the *return* pipe is *not below* the boiler. A

siphon from 5ft. to 15ft. high rises above the boiler, and the water *descends* through the whole of the pipes. A is top of boiler, B B siphon, C air pipe. The water rises in the direction of the arrows, the top of the siphon being the highest point in the whole system. In working this plan very strong boilers are necessary, and it is also desirable that the strongest cast pipes be used for the siphon. We have shown flanged pipes, but these are not absolutely necessary, as the ordinary form of socket pipe will answer all purposes. Good workmanship is absolutely necessary, or failure is sure to result, the pressure in the boiler and siphon being so much greater than with the ordinary system of heating.

The points to be observed are: First, a boiler large enough for the work, as it is false economy to have a boiler too small. Secondly, that the boiler shall be properly fixed. Thirdly, that the pipes are large enough and of a sufficient length to heat the house properly; and, lastly, that an experienced hot-water fitter be employed for the fixing, &c. If these points are attended to, success will follow.

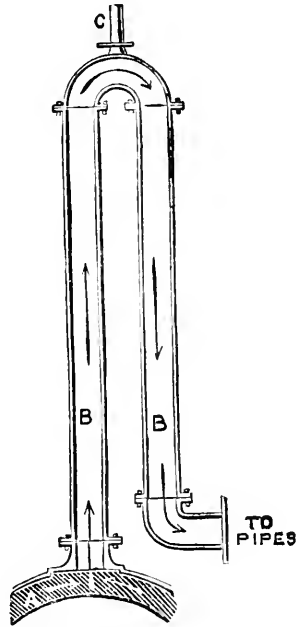

FIG. 21.—SIPHON FOR HEATING ON THE DESCENDING SYSTEM.

A, top of boiler; B B, siphon pipe; C, air pipe. The arrows show direction of flow.

Heating with Flues.—This old-fashioned method is hardly worth describing at the present time, as it is so little used, but for the benefit of those who may like the plan, we give a few hints. In the first place, a furnace is required, and this must be constructed so that the flames and heat *rise* into the flue. The construction is very simple, as it consists of a long chamber, about a foot high, and a little wider, if convenient, with an ashpit under; it is also desirable to provide it with good fire bars, as the common ones soon burn through.

The flue should rise from the top of the furnace in a slanting direction, and should have no dips or sudden falls in it, or in many cases failure will result, as hot air, like hot water, always rises. In building the flue it will be necessary to raise it the thickness of a brick on edge above the floor of the house, and this is done by placing the brick so that the edges of two tiles (10in. square) lie on each brick; these must be well bedded in mortar, and when the whole of this foundation is laid, three bricks on edge should be built up on each side, on the tiles, and this should be covered in with other tiles, well mortared together, or the smoke will escape. The flue, when finished, will have an interior size of about a foot high and from five to six inches wide, and as it will get very hot it will be necessary to use good materials. It will be found the best plan to employ a good bricklayer to do the work—if possible a man who is used to it—as it is necessary to have it done well, but, at the same time, it is far cheaper in the end to have a properly fitted hot-water apparatus. It will be found that, unless fuel is cheap, a great loss will result in a very few years—in fact, more than would pay for the first cost and maintenance of a hot-water apparatus, which would, moreover, be of far greater practical use. The smoke, too, from most flues is simply a nuisance, oft times to an intolerable degree, whereas there is but little smoke from properly set boilers, for, generally, these latter consume their own smoke. The stoking is also a subject that few persons will undertake, as the fire wants attention every few hours, and, from experience, we can confidently say that it is no pleasant job to have to get out of bed at three or four o'clock in the morning to look after the fires, and perhaps find it raining or snowing hard.

In concluding our notice of heating we may add that a few mats thrown over the roof or front of a house to exclude the wind from the laps in the glass, will often save a great deal of firing, while a stout canvas cover, such as a rick cloth, if fastened so as to leave a space between it and the glass, will make a difference of several degrees. The hardier the plants the less heat will be required, and it is as well to keep the plants as hardy as possible.



IV.—INSECTS.

ET destruction, and, still more, prevention, be applied to insect pests, which are of more importance, and engross more time and cause more trouble than is generally allowed by amateurs. There is not the least excuse for having plants covered with insects of any kind, as they are all amenable to proper treatment; and it must always be borne in mind that a crop of insects most decidedly means a vast quantity of unprofitable work, and work that could be easily avoided if the proper method of doing things were only taken. It is not of the least use relying on clearing off the insects in one lot, should they become too numerous, "because a few cannot do much harm," as that is just where the mischief lies; for two or three scale, or aphides, or red spider, multiply and grow very numerous, and what could have been done in half an hour a fortnight ago takes five or six hours now, and much damage has been done besides.

Where it is really desired to grow plants worth looking at *it is absolutely necessary that all insect pests should be destroyed when they first appear*, and close attention should be given to this matter, for on the absence of insects the future of the plants depends. If an aphid or other insect is seen, crush it at once; or should a slug or snail leave its slimy track across a leaf or on the floor of the house, hunt till his death can be safely

registered; and if ferns or orchids appear to be eaten, do not rest until every wood-lice, beetle, and cockroach is exterminated, as it is a certain fact that where there is one now, in a short time there will be hundreds. No sentimental feeling should be allowed to get the better of us in this work, for sentiment and good plants will not go together. The live-and-let-live policy is no good in plant growing, as it does not work well, neither is it satisfactory so far as the results go.

Amongst the insects that are injurious to pot plants may be enumerated aphides, thrips, red spider, scale, caterpillars, wood-lice, and the ordinary slugs and snails; while weevils, wire worms, juli, and maggots also attack some plants. The first three are perhaps the most troublesome, as they are so prolific, though in a collection of hard-wooded plants scale is very troublesome, but still if they are taken in time a little care will soon eradicate them. Wire worms and juli are not so easy to be rid of, as they are in the soil, and are not always suspected until the mischief is done, and then the matter is past recall. Maggots in cutting pots at times do much damage, but they are easily managed. Wood-lice are perhaps the most troublesome of all the larger insects, as there is great difficulty in persuading them to come and be killed. In fact, once get a stock of them and they remain for ever. We will take the insects we have named in rotation, and give some remedies that have been found useful for their destruction, premising that all insecticides are used with due care and discrimination.

Ants.—In the greenhouse the presence of ants is a source of unmitigated trouble, and unless stopped in time, the insects will work great mischief. The damage done is principally mechanical, and the plants are not in any way injured in the manner that aphides or red spider cause injury, but the soil in the pots is disturbed, and the plants are seriously injured by that means. As a rule, the plants die, or at least, become much injured by the water passing through the pots by means of the ant runs, instead of going through the whole of the soil and moistening it, and, therefore, some means must be taken to destroy the producers of this evil. Where there is

plenty of dry rotten wood, virgin cork, or other light dry material in which they can work, the large black ants are liable to put in an appearance, but the small black ant is the one that is most to be feared. The red ant, too, will sometimes be found, but not so often as the black ones, and, as the same methods can be used for the destruction of the whole family, it matters but little which attacks have to be guarded against.

Where the ants have taken up their head-quarters in pots, the best, and, indeed, the only plan, is to plunge the pots in water for ten or twelve hours, and so drown the insects. In this it is necessary to use some discrimination, as balsams and plants of a similar nature would not do well if this treatment was often repeated, and hard-wooded plants at rest would in many cases start into growth prematurely, and thus perhaps the cure would be worse than the disease. As, however, in the greenhouse proper, the plants and the ants commence active life together as the weather becomes warm, this flooding is not likely to do much harm, but still some amount of judgment is necessary, as at times failures do occur.

Our favourite plan, although a dangerous one, can easily be applied to all plants not in pots, and, as we never have a failure, we give it here. To half-a-pound of fine sugar add an ounce of white arsenic, and mix intimately with about a pound of medium oatmeal, keeping the whole dry. To use, spread small portions about the places the ants frequent, and in a very short time they will all disappear. Again: Two ounces of white arsenic boiled in about a half-pint of water, to which is added, after the mixture is boiled, a quarter-pound of treacle, and allowed to cool. To use, dip a sponge or piece of bone in the mixture, and place near the haunts of the ants, or sprinkle the mixture around the hill or infested place, and the ants consuming it, die in great numbers. It is needless to state that these preparations of arsenic are deadly poison, and should be used only when other remedies fail. Great care should also be taken that the packages or bottles containing these mixtures are labelled "poison," and kept in a secure place.

Other plans are to lay shallow saucers of oil near the runs of the insects, in which large numbers will get killed—of course

changing the saucers sometimes. A sponge soaked in weak sugar-water and placed in their runs will collect a great many, and if the sponge is taken up two or three times a day and thrown into very hot water a large quantity can be killed. A marrow bone is also a very good trap, the insects being scalded to death when a large number have congregated together; and there are also some other traps of a similar nature.

Boiling water poured down the runs and nests of the ants is of much use in destroying these pests; but perhaps the best and simplest plan is to see that no accumulations of soil exist in out-of-the-way places, and that all the brickwork, flooring, and woodwork is in sound condition, and free from crevices in which these ants can make their nests. In no case can carbolic acid, chloride of lime, or other offensive agents be used in the greenhouse, as such do more harm than the ants themselves.

Aphides.—Of these there are two that claim especial attention—the green fly (*Aphis rosæ*) and the black or cherry fly (*Aphis cerasi*)—both of which have to be combated at one time or another. Everyone knows the green fly, which seems to have an indiscriminate taste for feeding on all succulent foliage, and which, if taken in time, is easily kept under. There is this to remember, however, and that is, the harder the foliage on which the aphides feed the harder it is to destroy them.

Fowler's Insecticide, if applied as directed on the bottles, is a good remedy, and one that does not injure the plants. It is also not objectionable so far as appearance goes.

Gishurst Compound is another very good insecticide for hard foliaged subjects, but it has to be washed off after twenty-four hours or the foliage will be much stained. It is also not advisable to apply this article to plants having hairy or woolly leaves, or to plants having tender foliage, as the results will frequently not be very desirable.

Tobacco water made from the liquid expressed from "pigtail," "ladies' twist," and similar tobaccos, and sold by most large seedsmen, is very useful for many subjects, but must not be applied to tender foliage or blooms, as it leaves a stain. The

strength is about a quarter ounce to the gallon of water, applied in the evening and washed off in the morning following.

Pooley's Tobacco Powder is a very useful dry application, and should be always at hand. It is the waste tobacco from the large factories, and is mixed with lime and a small quantity of assafœtida, but not enough to make the use of the powder offensive. In this state it is sold duty free, and is consequently much cheaper than snuff and quite as effective. The powder should be dredged or sprinkled on the plants through a small dredger—a penny tin pepper-box answers admirably—and washed off with the syringe the next morning. If allowed to remain on too long it is apt to disfigure the plants, but with ordinary care it is one of the safest and most easily applied insecticides there is. Hardman's Insect Powder, applied with one of the little tin French bellows to be had for a few pence of most chemists, is a first-rate insecticide.

Fumigation with tobacco, tobacco paper, tobacco cloth, or any of the numerous preparations of tobacco that are in the market, is also a sure method of dealing with these pests, but it smells badly, which renders fumigation particularly obnoxious where ladies have the handling of plants. Where plants are in full bloom it is also very dangerous to use tobacco smoke, as it takes all the blooms off; therefore, before fumigating any plant house, it is necessary to remove all the plants that may be in bloom—a task that cannot always be performed. The whole of the plants in the house should be fairly dry at the roots, and the foliage should be quite dry when fumigation has to be done, care also should be taken that there is no water on the leaves, or there is a great probability of the foliage being badly spotted, so spoiling the beauty of the plants and injuring them as well. When all is ready, two or three pots should be prepared by placing some well-lighted charcoal in the bottom of each, and on this the fumigating material in a damp state should be placed. The material should have been previously prepared by tearing into small pieces, and it should be just damp enough not to flame, or the consequences will be disastrous to the plants around. Care must be taken that the pots do not burst into a flame after they are lighted, but otherwise

no further attention is requisite. The necessary amount of smoke is difficult to determine accurately, but it is better to give two or three fumigations on alternate nights than to overdo the matter in the first fumigation. Of course, it is desirable, or rather necessary, that all the glass in the house is in good condition, and that extra large crevices are stopped up with moss or other material, so that the smoke shall be kept in the house as long as possible, or it will only be waste of time and material to attempt to fumigate the place. The morning after fumigating, the plants should be thoroughly syringed, and plenty of fresh air should be admitted to clear off the bad smell, and reduce the bad effects on the plants, if there is any chance of such effects occurring; and in fact the place should be thoroughly cleaned out. Where the plants are badly infested with fly, at least three fumigations on alternate evenings will be necessary to destroy the young broods, but if taken in time one fumigation will be sufficient. Where the expense is not objected to, one of Dreschler's or Tebb's fumigators will be found to far supersede the use of pots; or if the matter of a guinea is not too much, one of Brown's patent fumigators will render the process of filling the house with smoke a not very unpleasant matter, as the operator can stand outside with the machine and fill it both rapidly and well with no further trouble than turning a handle. In fact, for the amateur there is no machine to beat Brown's, as no inconvenience need be experienced with it.

Other methods of destroying aphides besides those we have mentioned are in use, but they are not so useful to the amateur. If a few plants only are infested, they can be fumigated under a box; but the use of some insecticide will be found preferable as a rule.

Caterpillars. — Caterpillars and grubs of various kinds sometimes attack the foliage of plants, but the attacks are more particularly confined to those which have large succulent leaves, such as pelargoniums, and on these they show to serious disadvantage. The common butterflies do very great damage amongst collections of tricolour geraniums

and other plants of a like nature, and therefore it is a matter of good policy to keep them from entering the house if possible. This is best done by using tiffany netting, or Haythorn's netting, over all the openings; but where this cannot be done it is advisable to destroy all the butterflies that can be caught. Next to this, constant attention, so far as examining the plants and destroying the caterpillars go, is all that can be done, and hand-picking is the only real remedy. There is no application of any real service, and therefore it is really useless to go further into the matter. Hand-picking and constant attention are the only remedies, and without these the foliage is sure to be punctured and eaten.

Maggots.—It frequently happens that in cutting pots a large white maggot puts in an appearance, and, in some cases, it does a great deal of damage. There is only one remedy for these maggots, and that is to bake the sand before using it. As, however, it is only in dirty sand that the maggots appear, cleanliness is one of the first requisites, and it is by having clean-washed sand that the best results can be had. If the maggots appear at any time, there is nothing left but to take the cuttings out and bake the sand. There is no application that can be safely applied to the pots for the destruction of these insects.

Red Spider.—The red spider (*Acarus telarius*) is one of the worst insects that can get into a house, and, at the same time, is one of the most difficult to eradicate. When the conditions under which they thrive best are known, it should be an easy matter to prevent the appearance of the spider from obtaining any great headway; but at times the plants require an atmospheric condition that is favourable to the spider, and then it is that various remedies have to be employed to destroy it. A dry arid atmosphere, combined with dryness at the roots of the plants, will be almost certain to cause the red spider to put in an appearance, and outdoors, in very hot dry weather, the insects also appear, and thence gain an entry into the house. Some plants are more liable to the attacks of spider than others, and special treatment has to be given in such cases, but with the

ordinary stock plenty of clean water applied with the syringe to both surfaces of the foliage, and applied pretty often, will be found as good a cure as any. We have no faith in insecticides for this purpose, but there is no harm in trying them if it is desired to spend money over the matter.

Where it is not convenient to use the syringe, sulphur can be dusted over, or rather under, the foliage and blown off with a pair of bellows in a few hours, and in many cases this will be an effectual cure, but care must be taken that the foliage is not injured by the sulphur. To this end it is desirable that the full sun should not be allowed to reach the foliage while the sulphur is on, as the fumes given off would perhaps do injury.

Another good plan where there is much spider is to paint the hot-water pipes with a mixture of sulphur and clay, and then to warm the pipes to a nice heat, about as warm as the hand can bear comfortably, as if the heat is too great the plants will suffer from the fumes. In fact, this process should only be attempted by persons who are conversant with fumigating with sulphur, or serious effects may be caused.

A modification of the above is to heat some bricks in boiling water, and when nearly at the boiling heat they should be taken into the house and sprinkled with flowers of sulphur. On no account must the bricks be placed under tender or delicate plants, nor should they be placed so that the streams of ascending fumes impinge on any climbers on the roof, or the foliage will be seriously damaged. In no case must the bricks be heated in a fire.

Where practicable, the cold-water cure is, however, the best, and gives the least trouble, and therefore it is the safest in the hands of the amateur. The sulphur remedies require care to use safely, and in unpractised hands often do more harm than the red spider.

Snails and Slugs.—These are often introduced in the pots in which are close-growing plants, and it is therefore obvious that too great care cannot be taken to insure the cleanliness of both pots and plants. In all cases before introducing pots into the greenhouse or conservatory they

should be examined carefully, especially in the drainage holes, to see that neither the black nor white slugs are concealed about them; and the plants should also be looked over to see that they are clear from insects, as one or two slugs or snails will do damage to the extent of several pounds amongst valuable plants. Faulty brickwork, badly-arranged ventilators, and dirty houses, all tend to render it more difficult to exclude slugs and snails, and therefore these points should be carefully attended to, on the reasoning that prevention is better than cure. Hand-picking is the only way by which the number of these pests can be reduced, and we always make it a rule that if a trace of either slug or snail is seen, it should be traced to the end and the insect destroyed. There is no application that will destroy or deter these insects in the greenhouse, but outdoors soot and lime are useful.

Little heaps of wet bran laid about will attract the slugs, as will also cabbage leaves, and, in fact, any rubbish will attract them. Hence the necessity of great cleanliness in and about the houses.

Scale.—This is a very troublesome insect when once well established, and great care is necessary where it exists, as it soon spreads to other plants, and renders them comparatively valueless. There are two kinds of scale—the brown and the white—that are common, although there is, according to some authorities, a large variety, various trees having their own especial scale insect; but this we will not discuss. Suffice it to say that the brown scale is all that the amateur can wish for without having a dozen or more to contend with. Scale renders the plants unsightly, and does an immensity of damage, so that it is a matter of urgent necessity that it should be destroyed ere it gets established, or the house will never be clear. Of course, if taken in time, before there are many insects on the plants, but little harm, comparatively, will be done; but woe to the neglectful gardener who just lets the plants alone because “there are only two or three” scale on them. We can assure our readers that nothing is more prejudicial to the appearance of the plants than this mode of doing work, and it should be,

therefore, most carefully avoided; and anyone who takes the destruction of insects in hand before they have had time to become established—especially in the case of scale—will find that the battle is won, whereas if the scale have once the upper hand, only a losing war can be waged against them.

The methods of destroying scale are not numerous, and they are very simple, albeit rather tedious. In the first place, all the insects must be cleaned off, and then the stems of the plants should be washed with tobacco water, to which soft soap has been added in the proportion of two ounces to the gallon. After cleaning the plants, the surface soil of the pots should be carefully cleared off to the depth of from a half-inch to an inch, and fresh soil added to fill up the vacancy thus caused. If the scale again appears, the process must be again repeated, nor the insects allowed to attain too large a size before commencing operations against them.

Another plan is to apply weak size water with a syringe to plants such as oranges, camellias, and similar smooth-leaved subjects, and washing off with lukewarm water forcibly applied with a syringe after twenty-four hours. On no account must this be applied to hairy-leaved plants, or where there would be great difficulty in its speedy removal, for in such cases the remedy is as bad as the disease. The first is the better plan for the amateur to adopt.

Thrips.—These are perhaps one of the worst pests with which plants can become infested, as they are both very small and tenacious of life, while they multiply to a prodigious extent in a very short time. No plant that they are at least partial to long escapes their attacks, and therefore it is very desirable that, as soon as they appear, some steps should be taken to destroy them. The general cause of their overrunning a house is, plants are purchased containing more or less of their number, and thence they spread to other plants before they are noticed. It is necessary to use some thorough methods of destruction with them, and, whether fumigation is applied, or some liquid insecticide is used, it is necessary that it shall be repeated more than once, or in a few days the plants will be as

badly infested as before. Fumigating for three alternate nights is a good remedy; but it is necessary that no plants be in bloom in the house, or the bloom will all fall off. For full directions for fumigating, see under "Aphides."

Fowler's Insecticide is a good application, if applied on three alternate evenings; and where it is possible from the hardy nature of the plant to apply it, tobacco water made from the liquid previously mentioned is good.

Simpson's Antidote, Gishurst Compound, and various other insecticides are of use for destroying thrips, and, therefore, we need only add that constant attention is the chief point to be looked to.

Wireworm.—These are one of the greatest nuisances that it is possible for a gardener to be plagued with, especially in the case of the grower of carnations, pinks, stocks, and similar plants. There is no application that can be made to the soil for the destruction or eradication of these pests, and all that remains is to pull the soil in pieces by hand, or to bake it, but the latter process we object to, as it drives off some of the more useful chemical constituents.

In the preparation of all soil likely to contain these insects, it is desirable that it shall be carefully pulled into such small pieces as will not conceal them, unless, indeed, they be almost invisible; and when caught each worm should either be divided or else consigned to the fire. If it is considered more desirable to bake the earth, this operation should be done in such a manner as not to destroy the fibres in the soil, but it must be continued for such a time as to render the compost dust dry, and dry up any wireworm that is concealed therein. The same treatment applies to july, but these are not very often present. In no case must soil be boiled, as is often recommended, as boiling destroys its texture, thus entirely unfitting it for the growth of plants.

Weevils. — These sometimes give trouble where vines are grown, and they are not easily caught. The only effectual plan is to spread a sheet of paper or a white cloth under

the infested plants, and at night to come out with a light and shake the insects off and crush them. If, however, ordinary care in the destruction of the common insects of the house is persisted in, weevils of no kind will trouble the amateur, that is if the place is kept clean; but, as we said before, unless cleanliness is maintained, a clean bill, as regards insects, cannot be returned.

Woodlice.—These do much harm to ferns, tubers, and various of the ordinary greenhouse plants, paring or rasping off the outside cuticle, and then eating their way into the interior of the stems, &c. Woodlice are a sure accompaniment of dirt and decay of all kinds, and the cause removed, their number soon dwindles. Various methods are employed to destroy these pests, but only with partial success, as they seem to resist all allurements whatever. The best plan that we have found to succeed in practice was to fill a pot full of dirty moss, to which a few crumbs of potato were added, and leave the pot in one of their favourite haunts for a few days, then taking it up and dropping the contents into a pail of hot water, ridding the place of large numbers each time of operating.

Another plan is to place raw potatoes, scooped out in the centre, about their haunts, and to shake the woodlice into a pail of hot water each morning; and, indeed, almost any root will answer for this purpose, and a moderately large turnip is a good trap when several fair-sized holes are bored in it.

A very effectual trap is to obtain some dry horse droppings, and to mix a few potato parings amongst them; place in shallow boxes in dark places, and once a week empty the whole into a fire or a pail of boiling water, by which means vast quantities will be destroyed. Pouring boiling water around the crevices where they mostly congregate is also effectual, but the best plan is to stop all cracks and crevices in brickwork and wood, to have sound, clean floors, thoroughly lime-whited walls, and to keep a few toads about the place. Thorough cleanliness is the greatest enemy of woodlice.

Mildew.—Although this is not an insect, or the effect of insects, yet we give it a place here, as it has to be largely combated in badly-ventilated or badly-managed houses. It is simply the result of a warm, moist, and *stagnant* atmosphere, and if this is not maintained mildew will rarely appear. In a well-ventilated house mildew is not often troublesome.

Ewing's composition is a good cure for this disease, as is also flowers of sulphur applied one day and blown off the next. With care, however, the plants will easily be kept free from mildew, and where our directions are carried out not one of the pests mentioned above will give much trouble.

In "Garden Pests and their Eradication,"* we have described many other insects, which occasionally give trouble in the greenhouse, with the best method of destroying them, and we must refer our readers to that work should they unfortunately require further information on the subject than is contained in this chapter.

* "Garden Pests and their Eradication": Containing Practical Instructions for the Amateur to Overcome the Enemies of the Garden. With numerous Illustrations. In paper, price 1s., post free. London: L. Upcott Gill, 170, Strand, W.C.



VI.—DICTIONARY OF PLANTS.



BELIA.—Hardy hard-wooded shrub; grown for its flowers. Minimum temperature, 30deg. These are very ornamental and are well suited for the cold greenhouse, either trained on trellises or grown as pot plants. They form very neat bushes, from 18in. to 3ft. high, and when the blooms expand at the ends of the shoots, either in twos or threes, or perhaps singly, they have a very fine effect. The blooms are about 2in. long, and divide at the top into five segments. In appearance, the plants are like large daphnes, save as to the flowers. They are very floriferous when well grown, and are of very easy culture, growing well in a compost of peat and loam in equal parts, to which a sufficient quantity of sharp sand has been added. The care required is not much—simply watering, &c.—treatment as hardy plants being, in fact, sufficient. Of course they will bloom earlier in the house than out of doors, but forcing is not a desirable point with them. Such treatment as recommended to camellias suits these evergreens well.

Propagation is performed by inserting cuttings in pots of well drained compost of sand and loam, taking the cuttings when the plants are at rest. As, however, propagation is best done in houses devoted to this class of work, the amateur will generally find it better to purchase small plants at a nursery.

The better of the two varieties is *A. floribunda*, which bears

observed to prevent the plants being starved, as such starving tends to an early maturity, when the blooms are either to a large extent abortive, or they are small and stunted, while the plant itself is so diminished in size, injured in constitution, and the foliage so small and distorted, as to leave much doubt as to the identity of the variety itself. Insects are also very objectionable for the same reason, as well as from the mechanical harm they do in devouring the foliage, and, as it were, destroying the lungs of the plants.

The chief points in growing annuals are slow and steady growth, giving sturdy and firm habit, and with those plants which are from any reason too slender or weak to support themselves, a careful training and supporting by artificial means. Great care is also necessary to ensure a sturdy growth under glass, and the best means of preventing the plants drawing to an undue extent is to afford them as much air as possible, and to keep them as near the glass as their individual habits will allow.

Hardy Annuals are only of real practical utility for early work, *i.e.*, until about June, and therefore it is necessary that they be sown in the September previous. The way we grow hardy annuals for this and some other purposes is as follows: In the second week in September seed is sown of the various plants we require to stand the winter and the seed beds are well attended to until the plants are large enough to handle. Some beds of poor and rather sandy soil are then prepared, so that the glass of the lights does not stand above 6in. or 7in. from the soil. Into these beds the plants are transplanted, being set about three inches apart each way, or, with very slender things, two inches apart. After planting, the beds have a good soaking of water, and the lights are kept closed for a few days, but after a week the lights are removed on every favourable opportunity, and open at all times, except in frost or fog. The plants are prevented from becoming frozen, and the supply of moisture is so regulated that there is no rotting off during the winter months, and insects are kept in check. If fumigation has to be resorted to, great care is taken that the foliage is

perfectly dry, or the results would be most disastrous, the smoke having a great tendency to destroy it when it is damp. About February or March, according to the situation of the garden and earliness of the season, the plants are carefully taken up and potted in four or six-inch pots, in a good rich sandy compost, and a fair amount of drainage afforded. The soil is in a moist but not wet state, and, after potting, the plants stand for a day or two before watering. If, after potting, they are taken into a greenhouse at a temperature of about 45deg., and there placed in a light position near the glass, kept watered, and otherwise attended to, they soon come into bloom, and when fully out are removed where they are required. Successional batches are taken in as needed, and after the middle of April they either remain in the frames or are removed to the cold house as desired.

The following sorts are useful for the above purposes, and, grown as described, will not fail to give satisfaction: *Agrostemma cœli-rosa*, rose; *Asperula azurea setosa*, blue; *Bartonia aurea*, yellow; *Cacalia aurea*, orange; *C. coccinea*, scarlet; *Calandrinia grandiflora*, rose; *C. speciosa*, purple; Candytuft, the purple and crimson varieties; *Chrysanthemum Dunnettii*, double white and double golden; *C. Burridgeanum*, crimson and white; *Clarkia pulchella*, var. Tom Thumb, rose; *C. p.*, var. Tom Thumb, *alba*, white; *Collinsia bicolor*, lilac and white; *C. multicolor*, crimson, black and white; *Convolvulus minor*, various; *Coreopsis nigra nana*, dark red; *Erysimum Perofskianum*, orange; *Eucharidium grandiflorum*, red; *E. g. roseum*, rose; *Gilia minima cœrulea*, blue; *Godetia*, The Bride, white and crimson; *Godetia Whitneyi*, blush and crimson; *Godetia*, Lady Albemarle, carmine; *Gypsophila elegans*, lilac; *Hibiscus Africanus major*, primrose; *H. calisureus*, crimson, with black eye; *Jacobœa*, in double crimson, purple, rose, and white; *Kaulfussia amelloides*, blue; Larkspurs in variety; *Leptosiphons* in various colours; *Malope grandiflora*, crimson; Mignonette; *Mimulus* in variety, which can be treated as annuals, although they are strictly perennials; Nasturtiums of the Tom Thumb section; *Nemophila insignis*, blue; *N. i. grandiflora*, blue; *N. i. marginata*, blue and white; *N. atomaria cœlestis oculata*, blue with black centre; *N. dis-*

coidalis, black; *Nigella*, both blue and purple; *Sanvitalia procumbens*, both single and double, yellow; *Saponaria Calabrica*, pink; *Silene pendula compacta*, rose pink; Virginian Stock, red and white; *Viscaria oculata nana*, pink; *V. elegans picta*, crimson and white; *Whitlavia gloxinoides*, white and blue; and *Zea japonica variegata*, variegated maize.

Half-hardy Annuals, unlike hardy annuals, will not stand the winter in frames, but such sorts as are sown in autumn must be kept in pots or in store pots through the winter. Take lobelias, for instance—it is rare that anyone can obtain the plants of a sufficient size if sown in spring, but if sown in August, and pricked off into store pots or boxes, they can be wintered well, and in spring when potted off they make fine plants. Some things, such as marigolds, ageratum, one or two of the amaranthuses, *Eucnide bartonioides*, tobacco, perilla, ricinus, &c., if sown in the end of August, and kept in a light house during the winter, do much better than if sown in spring; at the same time it is too difficult an operation for the majority of amateurs. There is, of course, a little difficulty in keeping annuals in a house, as they require plenty of light and air, and not too much moisture, while the compost should be light and fairly rich. A temperature of about 40deg. is also necessary, but many degrees higher or lower will cause the plants to run up dwindly or else fog off, either of which renders the trouble taken of no avail. Where plants are kept in the manner described above, they should be potted off in March and gradually hardened to plant out in May.

The best plan for amateurs to adopt is to sow the seeds of the various half-hardy annuals in heat in January, and gradually grow the plants on in warm frames, or in a greenhouse, until April, when they should be transferred to the frames to harden off preparatory to planting out in May. By doing this, good results are obtained without the trouble of keeping through the winter. Well-drained seed pans or pots should be prepared in January, and a compost used of rich light soil; these pans should be well watered and set aside for some hours to drain. The seeds should be sown evenly and thinly

over the surface of the soil, and then covered with their own thickness of fine sandy compost. When placed in the position they are to occupy, each pot should be covered with a sheet of glass, and in a short time the young plants will appear. It is not advisable to water the pots overhead; the better plan is to stand each pot in a tub of water reaching to the rim of the pot only, and when the water soaks through, the pots should be set aside to drain, and then returned to their places, unless there is plenty of drainage at their own spot, when they can be put there as soon as they are removed from the tub. When the seeds have fairly commenced growth the glasses should be gradually removed, and the heat gradually diminished, air at the same time being admitted to the plants in proportion to the rate at which heat is taken off. When in rough leaf they should be potted off into single pots, or two or three in a pot, according to the size of the plants and the purpose for which they are intended. If for indoor use they should be put into small 60-sized pots, and thence transferred to 4in. pots when the roots kiss the sides of the pots; but if for outside work they should—with the exception of such things as ricinus—be stood where they are to remain until planted out. Plenty of drainage and a fairly rich and light soil are necessary for the well-being of the plants, whether grown in or outdoors. The general treatment is the same as for half-hardy soft-wooded plants if grown indoors; therefore we shall not refer to it further here.

For sorts of half-hardy annuals select from the following, those marked with an asterisk being most suitable for house decoration; *Abronia umbellata*, rose; **Acroclinium roseum*, rose; **A. roseum album*, white; *Alonsoa Warscewiczii compacta*, scarlet; *Amaranthus tricolor*, *bicolor*, and *melancholicus ruber*, fine foliage plants; *Arctotis breviscapa*, orange; *Asters of sorts (to be sown in March); **Begonia sedeni Victoria*, various colours; **Clintonia pulchella*, purple and yellow; **C. pulchella alba*, white; *Convolvulus* of sorts, various colours; *Datura ceratocaulon*, pink and white; *D. chlorantha fl.-pl.*, white; the daturas are very fine for borders; **Eucnide bartonioides*, yellow; *Fenzlia dianthiflora*, rosy lilac; *Gaillardia amblyodon*, deep red; *Helichrysum brachyrinchum*, yellow; *Helipterum*

Sandfordii, yellow; Ice Plant, white; *Ipomœa Learii*, violet and blue; *I. rubro cœrulea*, sky blue; *I. r. c. alba*, white; these three are fine for greenhouse work, other *Ipomœas* are useful for outside decoration; marigolds, in variety: *Martynia fragrans*, crimson; **Mesembryanthemum tricolor*, crimson and white; *M. t. album*, white, both useful for hot situations; *Nemesia versicolor compacta*, various colours; *Nicotiana virginica*, pink; *N. grandiflora purpurea*, purple; *N. macrophylla gigantea*, pink; *Nycteria Capensis*, white; *Perilla Nankinensis* and *P. atro purpurea laciniatus*, bedding foliage plants; *Phlox Drummondii*, various; **Portulacca*, of sorts, stands heat well; **Rhodanthe*, of sorts, various; *Ricinus*, various coloured foliage; *Salpiglossis atro-purpurea*, purple; *S. coccinea*, scarlet; **Schizanthus*, of sorts; Stocks, of sorts; *Tagetes signata pumila*, yellow, excellent for bedding purposes; *Waitzia aurea*, yellow; *W. corymbosa*, various; and *Zinnia*, of sorts, various colours, most useful for bedding purposes. The above do not comprise some for which we shall give special treatment.

Tender Annuals differ from the preceding, inasmuch as they require to be grown under glass for the greater part, if not for all the time of their existence. Balsams, cockscombs, and such like are tender annuals, and as they well repay any trouble in their culture, we have given separate instructions for their growth under their own headings in the "Dictionary of Plants." The chief points to be seen to are a light house in which to grow the plants, and a careful system of attention by which the plants will be kept as stocky as possible, as long, lanky plants are not good to look upon.

Raising Seeds.—Besides annuals, there are a large number of plants that can be raised from seeds, and, as they are often difficult to manage, it will not be amiss to give a few hints on the subject. The pot or pan in which the seeds are to be sown should be about one-third filled with crocks, and the soil should then be filled in to within about half an inch of the top, and gently compressed by tapping the bottom of the pot on the bench.

The pots should then be stood in a tub of water, up to the rims, until the water soaks through to the surface, and then be set aside to drain. When drained clear of all superfluous water, the seeds can be sown on the surface, and a covering of fine soil placed over them; this covering of soil not to exceed the thickness of the seeds themselves. With very small fine seeds it is not desirable to cover at all with soil, but rather cover the pot with a sheet of glass, and keep shaded until the seeds germinate. In fact, with all but the larger seeds, it is desirable that a sheet of glass be laid over the pot or pan in which they are sown, as by this means undue evaporation is prevented, and a more equable moisture both in the soil and atmosphere is maintained. These points are particularly important in the case of old seeds, or those where from any cause the germinating powers are feeble, such as is the case in seeds ripened under adverse conditions, or which have not ripened on the plant, although they have attained their full size; indeed, too much care cannot be taken to insure the proper conditions under which the seeds will germinate. While on this subject we may as well mention that there are but few seeds that will germinate properly in a lower temperature than 45deg., and for the majority of comparatively hardy plants that are raised under glass a temperature of from 50deg. to 60deg. is most advantageous to the raiser. With greenhouse plants generally the seeds should be subjected to a heat of from 50deg. to 75deg., according to the class of plants; and in palms, acacias, and some other hard seeds, a temperature of from 75deg. to 105deg. will not be too much, provided that a moist atmosphere is at the same time equally maintained.

Watering is a very important subject where seeds are concerned, for, unless this is done properly and in a consistent manner, the seeds will either rot in the soil or else the young plants will fog off ere they attain to sufficient size for potting off. It is useless to slop water around indiscriminately: far better leave the soil dry, as then the compost would not be destroyed if the seeds or plants were. What is required is sufficient judgment to tell when water is required, and to know how to apply it. Where large quantities of pots are used for

raising seeds, it is a good plan to keep a large square washing-tray, but where only a few are used an ordinary tub is sufficient for the watering process. The way to apply water is to stand the pots in water to the rims, and to allow them to remain so until the water has soaked up to the surface of the soil; by this method the whole of the soil becomes thoroughly moistened and the tender plants are not wetted, a matter of some importance. It is important to add that the water should be of the same temperature as the house, or the roots will be chilled, and the plants will, consequently, receive a more or less severe check.

The soil in which seeds are raised should be of a sandy, friable nature, so that when the plants are raised from the soil for the purpose of repotting, there will be a quantity of the soil adhering to the fibrous roots; but, at the same time, it is absolutely necessary that the soil shall be of such a nature that it breaks up freely without injuring the roots. On these points, however, the best medium is only attained by a little practice, and if a whole page were written on this subject but little practical service would be done.

In potting off the seedling plants, care should be taken to shift them ere they become too large, and, for a few days, they should receive as nearly as possible the same treatment as before, and then they can be gradually brought round to that which they are to receive for the future. In no case should violent changes, either of soil or temperature, be indulged in, and the treatment should always be as consistent as possible with the recognised methods of culture.

Propagation.—This is one of the most difficult parts of plant culture, and, unless proper conveniences exist, there are only a comparatively few plants that can be readily propagated by the general amateur. In nature, plants are most generally increased by means of seeds, offsets, and stolons, or runners; but in an artificial state cuttings, layers, and root division are resorted to, and to meet the exigencies of trade these modes of propagation are carried on to such an extent that the plants become partially exhausted by the rapidity with which they

are multiplied, and their inability to become sufficiently matured before being propagated from. If we take the ordinary scarlet pelargonium as an instance, the plant as raised from the seed is very robust, and with the general run of plants will attain a height of 5ft. or 6ft. if a little care is taken; but let the plants be of sufficiently high merit to create a demand, and it will be troublesome to make one of the young plants attain a height of 2ft. or 3ft. This we have practically tried when raising large standard plants, it being far easier to graft good varieties on the top of seedling stems than to attempt to raise standards on their own bottoms; while seedlings do best on their own roots, simply because they are not exhausted by undue multiplication.

Such plants as can be propagated by layers do not generally deteriorate in so great a degree as those raised from cuttings, and the deterioration is very much slower, but still, in time the habit of the plant is in more or less degree changed.

Where the plants propagate themselves by offsets or stolons, but little deterioration ensues, but still there is a tendency to deteriorate in a florist's point of view. In fact, the propagation of any kind of plant, if it has been improved, or in any way altered from its natural form, notwithstanding the care with which it is done, tends to cause the plant to revert in a greater or less degree to what it was naturally. Excessive propagation tends to weaken the plant to a vast extent, and, therefore, where possible it should be avoided. It is far better to have double the number of stock plants than to risk the loss of quality caused by over propagation.

In striking cuttings it is necessary that a free sandy soil be used, and that the pots be well drained, also that the pots are clean. The cuttings should be made of a moderate length only, and should be cut close below a leaf, with a sharp, smooth-edged knife. The cut should not be slanting, but should be directly across the stem, so that the smallest possible wound is made—with the exception of cuttings made from deciduous shrubs in winter. With soft-wooded plants of a sappy nature, it is advisable that a few hours should elapse between the making and inserting of the cuttings; but with

such things as fuchsias, verbenas, and other plants of a like habit that have to be struck in bottom heat, the fresher the cutting is the quicker will it root—at least, such is our experience. The soil in which cuttings (with the exception of succulents) are inserted should be fairly moist, or in a good state for ordinary potting, and on the top of the soil a half-inch of sharp, dry, silver sand should be placed, which, as the dibble is removed and the cutting inserted, fills the space between the cutting and the soil, and so tends to cause a more certain result. After the cuttings are inserted it is a good plan to water the pots to settle the soil around them, and after that the watering must depend on the requirements of the plants, as no fixed rules can be made on these points, the amount of water required wholly depending on circumstances over which the grower alone has control.

As to the varieties and species of plants to be raised in heat, these can only be ascertained by practice, as some persons can raise plants best in heat, while others do this better in the ordinary house, and hints on the subject are given with the ordinary cultural directions in the “*Dictionary of Plants.*” In all cases with hard-wooded subjects, it is better to purchase young plants from a nursery.

Layering consists of pegging a shoot or shoots of the subject to be increased into a pot of soil, or into the borders out doors, as the case may require, first making a slit in the under side of the shoot.

Runners of plants should be pegged down on the surface of a pot of soil, and when well rooted the connection with the parent plant can be separated. For this purpose the ordinary soil and treatment afforded to the parent plant are all that is necessary, except that the supply of moisture must be carefully looked to, so that the young plants are not rotted by an undue supply.

Offsets and divisions of the plants, as a rule, are very simple, the plants thus obtained being treated in the same manner as the old plants, with the exception of not being allowed to bloom, and more attention being paid to watering, &c.

Striking cuttings in water and similar devices we do not

hold with; still they are at times practised with more or less success; but, as a rule, the young plants thus obtained do very poorly, as the roots are very fragile, and get much damaged in potting off. We would rather lose half the cuttings in the ordinary methods of propagation than strike the cuttings in water and have such enfeebled plants as to be of no service when grown. In no case is it at all advisable to use methods that tend to weaken the plants, as from experience we find that amateurs generally have enough trouble with the most robust and healthy subjects, leaving out those which are rendered difficult of culture by unfair propagation.

The temperature in which cuttings emit roots varies, but for general purposes a temperature of about 60deg. will be found the most useful, unless, indeed, bottom heat is required, and then from 65deg. to 85deg., according to the subjects, will be found desirable. Care must always be taken that too great a heat, or too moist an atmosphere, is not maintained, or the results will not be of the most satisfactory kind. Of course, with stove subjects that luxuriate in a moist heat, the conditions under which the cuttings are struck must be somewhat similar to that in which the plants grow, but with the ordinary stock of the greenhouse great heat and moisture are quite unnecessary, so far as good work is concerned.

It is useless to attempt to strike plants of the ordinary character in an arid atmosphere, as they rarely succeed; and if—as should be the case—the foliage is left on the cuttings, the undue evaporation set up by such a method will cause both foliage and stem to shrivel, and so prevent the attainment of the end desired.

So soon as any kind of cuttings are well rooted, it is generally desirable that they should be potted off, and this operation should be carefully done, or the roots will be damaged, and, in some cases, wholly destroyed, which, of course, means the partial or complete destruction of the plants; in fact, the loss of part of the roots at this period of the plant's existence is felt for a long period afterwards, and with slow-rooting plants it frequently causes failure. Too great care cannot possibly be taken to keep the roots intact if real success is desired.

Where plants are rooted in heat, the soil used for re-potting should be of the same temperature as that from which the plants are taken, and the plants should be replaced in heat for a few days until the roots have taken hold of the new soil, or the chill given consequent on the change to a cooler temperature will almost inevitably cause a severe check, from which it is possible they may not recover until too late. All plants raised in heat should be gradually hardened off, so that all checks are avoided.

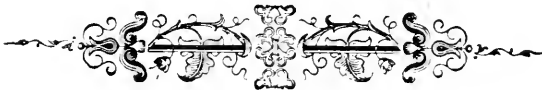

V.—CULTURAL DIRECTIONS.

ANNUALS—RAISING SEEDS— PROPAGATION.



IN the decoration of either greenhouse or conservatory, whether heated or not, annuals form most important decorative subjects, and as some of these are of a particularly floriferous nature, they make a vast display amongst plants that are quite devoid of bloom, leaving out of the question the advantage they have when mixed with other blooming plants. A few hardy annuals in pots come in very handily early in the season, particularly *Nemophila insignis* and *Collinsia bicolor*,

both of which are very easy to grow, and are also very effective. We have found that in a cold house hardy annuals form a very important feature, and plants grown as we shall hereafter describe answer every expectation, and more than repay any trouble taken with them. The chief point with annuals is to obtain plants that are fully developed, and to gain this, as long a season of growth as possible must be accorded them. Whether we take greenhouse annuals proper, or hardy annuals, great care must be

reddish pink blooms, and is the more floriferous. *A. triflora* does not produce its red flowers so freely as the other, and is not so well suited to house culture, but still at times it is very useful as a change.

Abutilon. — Greenhouse hard-wooded plant; grown for foliage and flowers. Minimum temperature, 36deg. This is a class of plants which, if well grown, are very beautiful, and deserve a place in every collection, and more particularly where heat can be given in the winter, as they will bloom well at that time. The Abutilons are erect-growing plants, with foliage somewhat resembling maple leaves, and bear rather bell-shaped axillary flowers. They attain a height of from 3ft. to 5ft., but should be kept down by pruning. Some varieties have variegated foliage. As a rule, the plants will bear much hardship; but while such may be the case with many of the varieties, there are some which will not stand harsh treatment. In all classes of work with these plants, the object should be to get hardy and sturdy growth, but unnecessary time should not be wasted in the process. For general treatment, the following will be found to work in well where there is a mixed collection of plants, but of course for special purposes some slight alterations will be needed. For soil use rather sandy loam, enriched with about a sixth part of well decayed manure, and pot fairly hard, but not sufficiently so as to cause the soil to become sour and so unsuited to proper plant growth. When planted out as wall or pillar plants, the same soil should be used, and good drainage provided, because sturdy, well-ripened wood produces the best and largest amount of flowers. Plant out in a comparatively small state, and by judicious training and pruning, the plants will soon furnish a large space well and effectively. In pot work the plants should be had in a small state—that is, in 4in. pots, and should be pruned into such a shape as will cause them to form a handsomely shaped bush, the pruning being done when growth is dormant. When growth has made a fair start pot on into 6in. pots, and keep in a light position, so that the plants are not crowded by other subjects. In July and August they can be stood out of doors, if necessary,

and in September again brought into the house, where they can, if the house is warm enough, be kept in good form till Christmas or later, and in a stove-house temperature through the winter, but this part of the work is outside our present purpose. When the plants are again dormant they can be again repotted, and treated as before, and fresh stock can always be kept growing on to take the place of that which becomes too large for the place. With *A. Thompsoni* a different plan can be pursued and the following will be useful where room can be spared, and will give a good stock of useful stuff for decorative purposes, where a winter temperature of about 50deg. can be kept up. Strike a batch of cuttings in heat early in the season, and pot off early into small pots. In June make up a rich bed out of doors, and plant out the young plants about eighteen inches apart. About once a fortnight cut round the roots with a garden trowel about three inches from the stem, to prevent them running away. Water when needed, and stop back the shoots two or three times to get good bushy plants. Early in September pot up into pots just large enough to hold the roots, and for the greater part of the winter they will make a really good display.

Abutilons are best propagated by means of cuttings struck in heat, using good sandy loam for a rooting medium. When rooted, pot off the cuttings into small pots, and when the roots kiss the sides of the pots stop the plants back to cause bushy growth. When young growth starts replot into 4in. pots, and afterwards treat as before described.

Good varieties are *A. striatum*, *A. Pattersoni*, *A. Verschaffelti*, *A. vexillarium*, *A. Boule de Neige*, *A. Thompsoni*, and *A. vexillarium variegatum*.

Acacia.—Greenhouse hard-wooded plant; grown for its flowers. Minimum temperature, 36deg. Acacias afford some of the most beautiful shades of yellow, and as they are early they combine with the first azaleas, and help to produce an effect that is unattainable without them. The bright tassels of yellow bloom inserted at the base of the leaf stalks and the dark foliage form a beautiful contrast, and is, in our

opinion, more effective in securing admiration than the more gaudy cytissus. Of course, the cytissus is an invaluable aid in arranging a large show, and one or two plants are useful, but the preference should rather be given to the different Acacias than to the last-named plant. The *Armata* section form dense bushes of dark foliage and stems from 1ft. to 5ft. high, and are much branched, while the taller growing kinds, such as *A. dealbata*, make a less branched growth, and bear more or less finely-divided leaves, like the Rose Acacia of the outdoor gardens, but have tassels like axillary flowers, instead of papilionaceous ones, as with the Rose Acacia (*Robinia*). The Acacias we are now referring to are not the common Acacias of the garden (*Robinia pseudo-acacia*), but Acacias proper, none of which are really hardy. There are several varieties of this family in use in our English gardens at the present time, the commonest of all being, perhaps, *A. armata*, a variety that has small globular tassels of bloom at the axils of the leaves. This variety is frequently seen in markets and on the costermongers' barrows, and ranges in price from 1s. 6d. to 5s. for plants fit for an amateur, while for large plants the price varies from 10s. to £5. The majority of growers have the plants very ugly, but it is really very little trouble to train Acacias into shape, if the training is commenced when the plants are young, but if they are allowed to get old and hard stemmed, then little hope can be held out on the subject of shapely plants, the wood being so very brittle. Some of these are also useful for pillars and trellises, the best for the purposes being *A. dealbata*, *A. longifolia magnifica*, *A. lophantha*, *A. pubescens*, and *A. verticillata*.

In training, the first thing is to determine what form the plants have to assume, and when this is settled satisfactorily, the necessary work of forming the base or frame of the plants must be proceeded with. The framework of these subjects must be formed or built up as the plant grows, for it is not often that sufficient bottom growth can be obtained after the plant has made a head. The size and height must, of course, depend on the size of the house, but for general use we find pyramids about 30in. high to be most suitable. Standards are also very

useful, and may be somewhat higher than other shapes, but with them it is advisable to have conical heads, as it sets off the bloom to greater advantage. The great point to be aimed at in training Acacias is to have a central stem, and to build up the framework of the plant while it is still pliable and young.

Our plan of cultivation with all free growing plants is to obtain good, sturdy, and at the same time free growth, to obtain it as early in the season as is consistent with safety, and to harden off and ripen the wood perfectly before the wet cold weather sets in. To get these results as much of the growth as possible should be made in the frames (in the case of nearly hardy plants like Acacias), and, if possible, the plants should have a structure to themselves, but, of course, this is not generally obtainable, and, therefore, the lightest and driest part of the house should be set apart for them.

For soil for Acacias use equal parts of maiden loam and sandy peat, with enough sharp sand to keep the compost open. Manure in no form enters into our compost, as we consider that it tends to make the young wood too soft and sappy, but it is often recommended by some gardeners as a part of the compost.

For amateur use, the best method of propagation is by means of seeds. Sow in pots or pans of well-drained sandy loam, and place on a gentle bottom heat, or if such is not at hand, in the greenhouse. If the seed is sown in spring, and the plants are potted on during the summer, they will make good plants the second year. *A. armata* and similar kinds are best purchased, however, as they are cheap, and a lot of trouble is saved.

There are about twenty sorts or varieties of Acacia, all of which are useful and of easy culture. We have found the following to be amongst the best: *A. affinis*, *A. armata*, *A. coccinea*, *A. dealbata*, *A. eriocarpa*, *A. lophantha*, *A. pubescens*, and *A. verticillata*, all of which are not yellow.

Acers. — Hardy hard-wooded plant; grown for foliage. Minimum temperature, 28deg. Acers are a class of a highly decorative order, and may with advantage be represented in nearly all collections of fine foliage plants. They are free-growing and moderately-branched trees, bearing leaves with

from three to five lobes, and the foliage in the kinds named is very ornamental. The size of the specimens for greenhouse work is regulated by pruning, but they are best when from 2ft. to 5ft. in height. The flowers, when borne, are valueless from a decorative point of view.

This class of plant is very effective on stems, as standards or half standards, and in these forms give a more finished appearance to a high structure than it would otherwise have. Of course, the larger the tree the larger the house required, and this must be borne in mind when purchasing.

We have grown these plants in rather rich loam and sand, with just a little manure, and they did thoroughly well, the variegated foliage coming very finely in this soil. Pruning must be done in spring, before the growth commences, and the last year's shoots should be reduced to three or four eyes. This causes an abundance of young shoots that are well furnished. We do not advise too early pruning, as wet will sometimes cause the shoots to die back, as they are not of solid construction.

All kinds of Maples (*Acer*) of the choicer kinds are grafted on stocks of the commoner kinds, a process which is beyond the reach of any but skilled operatives. Small plants should be obtained at a good nursery, because not one amateur in a hundred could do more than spoil the stocks on account of the peculiar nature of the scions.

Amongst those sorts that may be termed the best are *A. albophylla viride reticulata*, *A. atropurpurea*, *A. palmatum*, and *A. polymorphum variegatum*.

Agapanthus.—Semi-hardy bulbous plant; grown for flower and general effect. Minimum temperature, 30deg. This is a very old-fashioned plant, but at the same time its magnificent heads of bloom render it a fit associate for the choicest plants. The plant forms a large mass of flag-like leaves, about 2ft. high, and the umbels of bloom are borne on strong footstalks well above the foliage, the flowers being large and in great number in each umbel. The flowers are blue (or white in *albiflora*), and are borne on stout footstalks, and vary from fifteen to twenty-five

in number, forming a magnificent head of bloom. There is also a variety with striped leaves, but this we do not consider an advantage, except when the plant is out of bloom. All offsets must be kept removed during the growth, or the plants soon become weak, and give but few blooms. These offsets should be potted into small pots, and placed in a little bottom heat, when they will root freely, and if treated in the same manner as the old plants will make good blooming specimens. The soil we use is one-half sandy loam and one-half thoroughly rotted manure, with sufficient sand to keep the whole of a proper porosity; the pots being filled one-third full of crocks to insure proper drainage. Pot the plants about March, and place in a greenhouse or on a gentle bottom heat, and each time the pots are filled with roots, repot into a size larger until sixteen or twelve sized pots are reached, in which they should bloom. During the whole of the growing season give abundance of water, but this should be nearly discontinued during the season of rest. As soon as the bloom is over place the plants out of doors until autumn, when they should be removed into dry cold frames or pits for the winter. In spring remove all dead fibres and exhausted soil, and treat as before. With established plants it is an advantage to raise some in a pit as well as in a greenhouse, as the season is prolonged by this means.

Propagation by division of the bulbs, or, more properly, offsets when the plants are at rest. Treat as described for the old plants.

Four sorts, *A. umbellatus*, blue, *A. u. maxima*, blue, *A. u. variegata*, blue, variegated striped foliage, and *A. u. albiflora*, white, are the sorts mostly catalogued, and are all good.

Agave.—Succulent greenhouse plant; grown for its foliage. Minimum temperature, 40deg. These plants, Aloes as they are generally termed, are of easy culture, and need only an annual potting to keep them in good health. We prefer repotting in April or May, using well-drained pots, and for soil, a compost of about equal parts good yellow loam and pulverised mortar rubbish, potting very firmly. During the season of growth a good supply of water is needed, but beyond preventing the

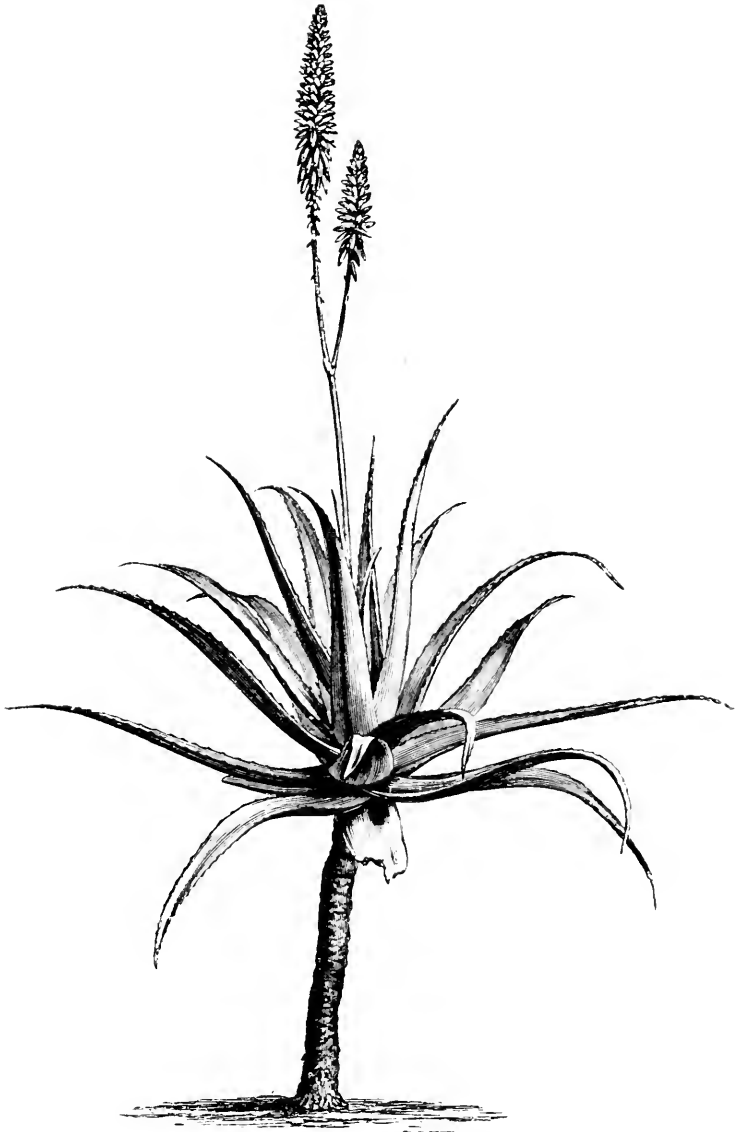

FIG. 22.—AGAVE AMERICANA.

foliage from shrivelling, no water is required during the season of rest. Great care should be taken to prevent the foliage being scratched or damaged, and unless this is done they become unsightly.

Propagation is effected by taking off the offsets, which are produced pretty freely round the collar of the main plants, and striking in sandy soil, preferably with a little bottom heat.

Good kinds for our present purpose are *Agave Americana* (see Fig. 22) *variegata*, *A. applanata*, *A. Verschaffelti* and *A. univittata*.

Ageratum.—Greenhouse soft-wooded plant; grown for its flowers, and for bedding purposes. Minimum temperature, 40deg. Ageratums, which are somewhat extensively used for bedding purposes, are also very useful for the conservatory if well grown. They are rather hairy-foliaged plants, ranging from 9in. to 2ft. in height, and bearing terminal clusters of cushion-shaped flowers, which are of varying shades of blue, and, in some varieties, white; in habit, they are somewhat like the calceolaria. Whether the dwarf or tall sorts are chosen, they come in useful, although, in our opinion, the larger sorts are best for the cool conservatory, and the more dwarf kinds for outdoor work. The culture is very easy, and within the reach of everyone who has a hot bed on which to raise the seed, for although Ageratums can be raised from cuttings, the same as other bedding plants, they are done easiest from seeds. We sow the seeds in January, in heat, on sandy soil, barely covering the seeds, and as soon as the young plants are large enough, we prick them off into thumb pots, and place in heat till they grow freely, and then they are brought into the warmest part of the greenhouse. Those for bedding we rarely repot, but those for indoors we shift as the present pots are full of roots, and keep on shifting until the end of June, when the pots used are 10in. or 12in. When these pots are full of roots, the plants are watered with liquid manure twice a week, and they soon bloom well, and make fine specimens. During the whole of the hot weather the plants are well syringed with cold water daily, to keep down red spider, and after July they are kept

in a cold frame until wanted indoors, but those for bedding purposes are put out in the end of June.

Propagated from seeds as described above, and from cuttings struck in bottom heat in spring. We, however, prefer seeds, as they come fairly true to name and are far less trouble than cuttings.

For sorts we use the old tall form of *A. Mexicanum*, which varies from azure to greyish blue, and the white *A. Imperial Dwarf*, and for bedding the latter named variety, *A. Imperial Dwarf* (blue), and *A. Tom Thumb* (blue), both indoors and out, but particularly in warm situations in the country. It is also very useful in a warm light house for cut blooms, from Christmas till April, but it must be kept clear of insects.

Alonsoa.—Half hardy annuals; grown for flowers and general appearance. Minimum temperature, 45deg., or for winter work, 55deg. These are showy plants, useful alike for indoor use, or summer decoration outdoors. The culture is very simple, being in fact the same as that for the ordinary stock of the greenhouse. Some of the varieties will bloom nearly the whole year round. They require a good rich light soil, similar to that which is used for several other plants, and as the plants go out of bloom they should be cut down, and they will bloom again in six weeks or two months.

A. incisifolia, scarlet, and *A. Warscewiczii*, deep orange, with black centre, are two of the best for the purpose in hand.

Propagated from seeds sown in March or April in gentle heat. Although really annuals, they will, like many other subjects, last several years as perennials, and be treated as such at pleasure.

The following are good kinds: *A. Warscewiczii compacta*, scarlet; *A. Warscewiczii*, deep orange; *A. linifolia*, scarlet; *A. incisifolia*, scarlet; and *A. myrtifolia*, scarlet.

Aloysia.—Greenhouse semi-hard-wooded plant; grown for its finely scented foliage. Minimum temperature when at rest, 30deg. *Aloysia citriodora* is a shrub that should never be omitted from a collection of plants, as its perfume is so fine, and

the appearance is so graceful, if the plant is well grown. Large plants are not as a rule desirable, but if room exists, they may be had on pillars, or trellises against walls. It bears long ovate lanceolate leaves of about 2in. in length in well-grown specimens, and the habit of growth is erect, and sparsely bushy in the current year's wood. It makes a bushy shrub, from 18in. to 3ft. high, according to age, and will bear pruning well. The flowers are of small value for decorative purposes. The first point in growing the *Aloysia*, or, as it is more generally termed, Lemon Verbena, is to afford generous treatment, instead of adopting the starvation system that is so much the practice. The best plan is to obtain well-grown thrifty young plants in spring, and grow them on for the season. As the wood ripens give less water until they are at rest, when the water must be nearly, if not quite, withheld. About the end of January bring into the light and warmth, and water thoroughly; as soon as the plants break, cut back to three or four eyes, and when the young shoots are about an inch long, re-pot into rich sandy soil, using pots a size or two smaller than they were in before, and as soon as the pots are full of roots re-pot into the pots that are to hold the plants for the season. By this mode of culture good specimens can be maintained for any length of time. It is almost useless to think of keeping this plant in an evergreen state, as it soon deteriorates if this is attempted.

Mr. J. Groom, of Henham Hall, writing to the *Garden* of Sept. 11th, 1875, says: "This little shrub, favourite though it be, is seldom seen in good condition. When confined in a pot it has generally a sickly aspect, but when planted out it becomes a large bush, or forms a handsome pillar plant. In the kitchen garden here, against a south wall, I have two plants of it that are 10ft. in height, and at least 3yds. in width, and the quantity of spray they yield for mixing with cut flowers is surprising. The only care which they require is protection from frost in winter, and to effect this they are generally unnailed in November; the branches are then tied into bundles and enveloped thickly in hay bands. Upon these is also put an outer covering of straw, which keeps all dry, their

base being covered with coal ashes. When all danger from frost is over in spring the cover is removed, the branches are spread out, and as soon as growth commences all dead wood is removed, the main branches being re-fastened to the wall. They require no summer training, their young growth being continually cut off for the many purposes of decoration to which they are applied, and to which they are so well adapted."

We can fully indorse Mr. Groom's statement, and besides outdoor work as he describes, the "Lemon Plant" is very useful in cold houses, where frost is only just excluded, provided they are planted out in the borders. We can with pleasure recall to memory a house where camellias were grown, and where a few plants of *Aloysia* were in the borders, and they thrived wonderfully, and were the admiration of all visitors. We may add that they are very easy to grow, and on no account should be omitted from any collection.

Propagation is effected by cuttings inserted in bottom heat, or by means of the small plants which are formed on the exposed roots at the base of the main stems. As, however, only a very few plants are desirable, it is the better plan to purchase them in a small state, as they are not very expensive.

Amaryllis.—Greenhouse bulbous plants; grown for their flowers. Minimum temperature, 45deg. This is a class of bulbous plants that is well worthy of cultivation in every collection, and although there may be some little trouble in growing them to perfection, they yet repay for all care bestowed on them. Like many other things, they have had their rise and fall, and although rather more in fashion than they were a short time back, they are not so much cultivated as they should be. Some of the varieties are evergreen, and others deciduous, and although the former require to be kept in a drier state during the season of rest, they must not be kept so dry as the deciduous kinds. The plants have flag-like leaves, and these are from 1ft. to 18in. in length, the flowers being borne on a stout footstalk, which rises well above the foliage. The flowers are large and handsome, and in some

kinds they are from 2½in. to 3½in. in diameter, and several are borne on each footstalk; the petals are recurved. The soil should be good sound fibrous loam, to which enough sand has been added to preserve the natural porosity, and to prevent the pots becoming waterlogged from the liberal application so necessary during their season of growth. Give plenty of drainage, and not too much root space—although it is not advisable to contract the roots too much—and good spikes of bloom will be produced. A temperature of not less than 45deg. is necessary in winter, and about 70deg. in the growing season. The deciduous kinds should be dried off in winter, while the evergreen kinds should have a diminished supply of water only.

Propagation is effected by division of the offsets or small bulbs while the plants are at rest. When in the new small pots and started into growth, treat the same as the old plants.

For sorts select from the following, which are all good: *A. Ackermanii*, *A. aulica*, *A. a. superba*, *A. Amazon*, *A. Brilliant*, *A. calyptrata*, *A. Cleopatra*, *A. conspicua*, *A. crocea grandiflora*, *A. delicata*, *A. Diadem*, *A. Eclipse*, *A. Edith*, *A. Excellent*, *A. falcata*, *A. Johnsonii*, *A. J. psittacina*, *A. longifolia*, *A. pardina*, *A. Prince of Orange*, *A. regina*, *A. vittata*, *A. Vivid*, and *A. William Pitt*. It must, however, be borne in mind that amaryllis require a warm greenhouse to do them at all well, and it is quite useless to attempt their culture in a cold greenhouse where the frost is only just kept out, as in such a house the bulbs rot away.

Amygdalus.—Hardy tree; grown for its flowers. Lowest temperature for pot specimens, 28deg. Almonds are very pleasing subjects if obtained in a small pyramidal shape, and, from their great beauty when in bloom, they form most appropriate subjects for the decoration of a medium-sized house. They are, however, not suited to a small place, as the plants, to bloom well and be effective, should be at least two or three feet high, and, of course, wide in proportion. A pot should be chosen that will hold the roots comfortably, and the tree should be carefully potted, using soil that will work freely and run into the interstices amongst the roots. After potting, water

thoroughly, and place the trees in a cold vinery or frame for a few weeks, when they can be removed to the place they are to occupy. We have premised that the tree has been prepared in the open ground in a nursery, and if such is the case if there are plenty of good fibrous roots, there is no reason why the trees should not bloom well the first year. A temperature of about 50deg. or 55deg. is amply sufficient to bring the plants into bloom, and indeed a higher temperature is apt to frustrate the object in view. Successional plants can be brought in from time to time, as the bloom does not last very long. After blooming the plants should be gradually hardened off until about the end of May, when they should be plunged out of doors for the season. Repotting should be done as soon as the leaves fall.

Propagation is effected by grafting on the common plum stock, and generally is beyond the reach of the amateur.

The best varieties of *Amygdalus* for our present purpose are *A. Persica flore-pleno*, double pink; *A. P. fl. pl. alba*, double white; *A. P. caryophylloides*, double carnation striped, and *A. P. rubra*, double crimson.

Anagallis.—Soft-wooded plant, grown for its flowers and general appearance. Minimum temperature, 35deg. This is a somewhat old-fashioned dwarf trailing or semi-trailing plant, very useful for baskets, vases, and pot work, bearing a showy and large amount of flowers, and being well adapted for general cultivation. The blossoms are produced in great profusion, and the plants are useful for both in and out-door work. The treatment is easy in the extreme, as the plants will do in any well-drained ordinary soil, all that is necessary being to pot on till 4in. pots are reached, or to divide and re-pot in spring as the case may be. Practically the treatment is similar to that of the ordinary stock of soft-wooded plants, and therefore needs no farther description.

In the hands of the amateur, propagation is best effected by means of seeds sown in spring in a warm greenhouse or frame and then potted on, as the different varieties come true to name from seeds.

Some good varieties are: *Anagallis grandiflora Brewerii*, blue; *A. g. Garibaldi*, vermilion; *A. g. Memoria del' Etna*, bright red; *A. g. Parksii*, rose; *A. g. Philipsii*, blue; and *A. g. Trionfo di Firenze*, pale blue.

Aniseed Tree.—See "Illicium."



FIG. 23.—ANTHERICUM LILIASTRUM.

Anthericum.—Hardy bulbous plant; grown for its flowers. Minimum temperature, 30deg. Anthericums are useful for cold houses, and as their culture is simple and the price moderate, they come within the reach of all. For soil use a compost of fibrous loam and coarse sand, enriched with a little thoroughly decomposed leaf soil, allowing plenty of drainage to the pots. The pots should be comparatively large, but if

they can be had of a deep pattern, it is far better than a wide one. The number of roots to be grown must depend on the size of the pots and on the size of the specimens required; but about three make a very good potful. Re-pot as soon as growth commences, and keep watered as advised for lilies. After blooming remove the pots to a bed of coal ashes and supply with water until the plants are ripe. Keep from frost and introduce to the house as required. A gentle warmth will hasten the blooms a little, but if forcing is attempted but poor results will be obtained.

Propagation is effected by division of the bulbs when at rest, as like lilies they break up into several new bulbs from time to time. After re-potting treat as above directed, or the smaller bulbs can be planted out doors to gain size.

A. Liliago (St. Bernard's Lily), white; *A. Liliastrum* (St. Bruno's Lily), white (see Fig. 23); and *A. graminifolium*, white, are all good and repay the trouble bestowed on them.

Aralia. — Greenhouse hard-wooded plant; grown for its foliage. Minimum temperature, 45deg. This is a family of ornamental foliage plants, and as such is worthy of a place where good-sized specimens can be used. Small plants of *Aralia* are not desirable, as they do not show the full beauty of the plant, and it is also not desirable to have big specimens of these large foliage subjects, and therefore means must be taken to restrict their growth to the proper proportions, not by ill treatment, but by using a moderately poor soil, and very firm potting. This we have found to answer very well, and by having young plants every three or four years, nice specimens can be kept. For soil good maiden loam, and enough sand to keep it open, will be found to answer well, provided the plants are potted firmly enough.

Propagation is effected by striking cuttings of young wood taken off with a heel of old wood attached, or half ripened wood in the same way as fuchsias. A good plan is to use gentle bottom heat, and get into small pots as soon as rooted. Too extended a root run is not needed for young plants, as they are liable to rot off at the collar when over-potted.



FIG. 24.—*ARALIA SIEBOLDI*.

For sorts we prefer *A. leptophylla*, *A. Sieboldi* (see Fig. 24), *A. Sieboldi argentea variegata*, and *A. Sieboldi aurea variegata*. The last three are perhaps the best for an amateur's use.

Araucaria.—Greenhouse hard-wooded tree; grown for foliage and general effect. Minimum temperature, 45deg. Like the Aralias, these are valuable for their habit of growth and graceful appearance, and not for any flowering properties. They are useful where large houses have to be filled, and in such situations are unequalled for effect by any other plants of the same habit; but they cannot be shown off to good advantage in a small house. Nearly everyone knows the *A. imbricata*, or Chilian monkey puzzle of gardens, and no doubt has admired it greatly on account of its fine foliage and unique form. When we say foliage, it must be remembered that these plants belong to the pine tribes, and do not bear leaves in the same way as apples or other trees, but, on the contrary, their leaves are more like those of firs, pines, &c. The greenhouse kinds are somewhat of the form of a silver fir, but with a much more elegant appearance, and have a good effect, whether used as small specimens, or as fair-sized plants about 3ft. or 4ft. high. They are, however, best suited to large conservatories.

We have found a mixture of equal parts of maiden and yellow loam, with a little sandy peat, do well for these plants, and keep them healthy; but they must not be overpotted.

Propagation is by seeds raised in a strong bottom heat, and as a rule is beyond the means of amateurs. Well grown plants should therefore be purchased.

A. excelsa and *A. Bidwilli* are very good for our purpose, as are also *A. Cooki* and *A. Cunninghami*.

Arum.—Hardy bulbous plants; grown for both flowers and foliage. Minimum temperature, 30deg. Some of these pay well in the cold house, and the treatment bestowed is so nearly similar to that required for *Calla Æthiopica*, that a detailed description is not necessary. They all bear a likeness to the calla, and vary in height from 1ft. to 2½ft., but while the form of the spathe is the same as that of the plant just mentioned,



FIG. 25.—ARUM CRINITUM.

the form of the foliage is in some cases quite distinct. The roots must not become frozen, nor yet soddened with water during the season of rest, although it is not advisable that the soil in the pots should become dust dry. During the season of growth liberal supplies of water must be given, and due care must be taken that the plants are not drawn up spindly. The curious spathes are of various colours, brown, yellow, and white being the chief, and the plants are certainly a change on the ordinary subjects one so often sees. A house is not really necessary for the plants, as a cold frame answers as well.

Propagation is the same as with *Calla Æthiopica*.

We have used the following for the present purpose: *A. albi-spathum*, brown; *A. cornutum*, yellow; *A. crinitum* (see Fig. 25), brown; *A. Italicum*, pale yellow; and *A. maculatum*, white.

Asparagus. — Greenhouse soft-wooded herbaceous plant; grown for its foliage. Minimum temperature, 40deg. This is a plant that is very useful, on account of its fine feathery spray, which works in well for bouquets and other floral decorations. In the house it can be trained against arches, &c., and has a very light appearance. The culture is very simple; a large pot filled one-third with crocks, and then to within an inch of the top with rich, moderately light soil, being all that is required if liberal waterings and plenty of air be given. The bright pea-shaped berries, or the insignificant blooms, are of far less use than the spray, which is very fine and chaste, and the plant has a fine, feathery, and light appearance, quite distinct from all other greenhouse plants. As a useful plant for cut spray this stands pre-eminent.

Propagated from seeds sown on a gentle bottom heat in spring. Seeds can only be had of a good nurseryman, as they are not usually quoted in trade catalogues. It is, however, well to start with a plant or two purchased at a nursery, and then, with good luck and care, a good stock of plants can be had.

Good kinds are *Asparagus decumbens*, *A. racemosus* and *A. plumosus nanus*, which last is, however, expensive, costing from 15s. to 21s. each.

Aspidistra. — Greenhouse soft-wooded herbaceous plant; grown for foliage only. Minimum temperature, 40deg. From their handsome appearance and general indifference to hardships in the way of gas and dust, these plants are very desirable for both greenhouse and room decoration. They have handsome flag-like foliage which, in the variegated form, is striped with creamy white, and if kept clean this variety is very pleasing. The blooms are not, however, of any decorative value. The culture is very simple, as the plants do well in almost any soil, but we prefer to have them in well-drained pots of loam, or loam and peat. When at rest they should not be overwatered, but when growing freely plenty of water is necessary; in no case should they be overpotted.

Propagation is effected by division, and sometimes a little bottom heat is needed to make the young plants start freely.

The best kinds are *Aspidistra lurida*, and its variegated form, *A. lurida variegata*.

Asters.—Half hardy annuals; grown for their flowers. Minimum temperature, 45deg. These are much esteemed for conservatory decoration when in pots, but our advice is, "Don't grow pot Asters in the pots; grow them in the open garden." We have seen them grown, and grown them in pots ourselves, and never have we come across such good specimens as those from the open garden. A bed of fairly rich good soil should be prepared in the kitchen garden, taking care that it is free from wireworms, and also that it is deeply dug. The seeds of aster should be raised in a cold frame in March or April, and when large enough, transplanted into the beds about 18in. asunder each way. Attention in the way of weeding, watering, &c., must be afforded, and when the first bloom opens, the plant should be carefully taken up with a good ball of earth adhering, and transferred to a pot sufficiently large to hold the roots comfortably. The whole of the plants should be served in the same manner as they become ready, and as soon as they are potted they should be removed to a frame facing the north, and kept shaded from sun, and should also receive liberal supplies of moisture. In from three days to a week

after potting they can be taken to the place they are to occupy. We leave the choice of sorts to the intending grower, but perhaps the pyramidal varieties are best. A reference to any catalogue will give a wide selection of colours and varieties.

Propagated by seeds only.



FIG. 26.
TRUFFAUT'S PERFECTION ASTER.



FIG. 27.
PÆONY-FLOWERED ASTER.

Good sorts are Pæony-flowered (see Fig. 27), dwarf-chrysanthemum-flowered, dwarf bouquet, and Betteridge's named varieties.

Astilbe.—See "Spiræa."

Aucuba.—Hardy shrub; grown for its berries and foliage. Minimum temperature, 30deg. These plants, although not really greenhouse plants, make a great show when well covered with berries, and, as the foliage is pretty, they are worth any one's notice. In the first place, the plants are perfectly hardy, and at the same time, of easy culture; and, besides, they stand much knocking about, while the price is pretty moderate. Plants fit for our present purpose can be had from ninepence each, while similar plants, if well berried, would cost from half-a-crown. Of course, a male plant is very necessary to produce pollen, with which to impregnate the

blooms of the female plant, which alone produces seeds, or, more properly, berries. The female plants are variously variegated, some of them being more beautiful than others, but all being noticeable for their glossy laurel-like leaves and fresh and cheerful appearance, which, on ripeness, is further enhanced by the beautiful scarlet of the berries. The bloom is rather inconspicuous and, from a floricultural point of view, of no value, the beauty of the plant lying in the foliage and berries. The male plants have generally green leaves, which, if clean, have a bright glossy appearance; they are, of course, necessary for the production of the fruit on the female plants, but one male plant produces (if it blooms freely) sufficient pollen for the impregnation of hundreds of female blooms.

The process of fertilising is very interesting, and brings out the more delicate skill of the operator. We say "delicate," as it is useless to attempt this kind of work in an off-hand manner, and with no more care than is generally exercised in cutting a cabbage, or the result will most probably be that the greater part of the available pollen will be lost, and the crop of berries will be almost *nil*. The proper mode of operating is to collect the pollen from the anthers of the male plant with a camel's-hair pencil, and then transfer it to the pistils of the female. This requires great delicacy of touch, especially as only a very few grains of pollen are necessary to each pistil. The time for applying the pollen is when the pistil exudes gummy matter, and otherwise shows signs of maturity. It, however, often happens that from some unforeseen cause the male blooms are open, and the pollen matured before the female blooms are ready. In this case it is well to collect the pollen on a *dry* pencil and transfer to perfectly dry sheets of glass, and when all the pollen is obtained, another sheet of glass should be laid on that on which the pollen was laid, and the whole should be placed in a dry, cool place till wanted. Pollen thus saved and stored will retain its vitality for a long time; in fact, we have used it when seven weeks old, and it has given very good results, although not perhaps so good as would have been attained with pollen fresh from the plant.

The cultivation is very simple. Pot the plants firmly in rather sandy yellow loam, allowing plenty of drainage; and during the growing season allow plenty of water; but as soon as the growth is over less water will do. During the summer the plants can be plunged into the borders out of doors, and can be brought in again as soon as required to occupy their situations in the house. One point we have, however, found of great importance, and that is, always keep the plants in rather small pots, so that the roots may not be allowed to ramble too much, and so tend to produce vigorous and unfruitful growth, such growth being most undesirable for our present purpose, however desirable it may be for outdoor work. Short-jointed hard wood is of most value for pot work, as it produces the best bloom, while the free growing suckers that spring from the base of the plant, as a rule, produce leaves only.

Propagation is effected by layering, by cuttings inserted in cold frames early in November, or in pots of sandy soil in January, on a gentle bottom heat. As, however, the plants are very reasonable in price, it is doubtful if there is any gain in propagating them to the exclusion of more profitable subjects.

For sorts, we prefer the following, as they have given general satisfaction as far as we have had them under our notice. There is, however, a difference in the berries, and as half a dozen would not be over many in a house, one of each would not be too many: *A. japonica albo variegata*, *A. japonica arborea vera fœmina*, *A. japonica aureo maculata*, *A. japonica aureo marginata*, *A. japonica lati-maculata*, *A. japonica longifolia*, *A. japonica longifolia variegata elegans*, for female varieties; and *A. japonica angustifolia maculata*, *A. japonica arborea vera mascula*, and *A. japonica viridis mascula* for males. *A. japonica viridis fructu-albo* has round white or cream-coloured berries, and green foliage; while *A. japonica luteo-carpa* has oval yellow berries and leaves of a full green, splashed more or less with yellow. The ordinary aucuba of the garden (*A. japonica maculata*) is too well known to render any detailed description of the other rather numerous varieties necessary, as they all are very similar in the habit of growth and form of the foliage, the distinction consisting chiefly in the variation of the leaves.

Azalea Indica.—Greenhouse shrub; grown for flowers and general appearance (see Fig. 28). Minimum temperature, 40deg. These are one of the mainstays of an amateur's house, and should be well represented, so that a continuance of bloom may be kept up. We do not wish to imply that the stock of hard-wooded plants should be wholly made up of the numerous varieties of Azaleas, but still a good proportion should be kept. In colour a very great diversity exists, from white to the brightest scarlet, salmon, purple, red, rose, orange, yellow, and various shades and tints of the different colours; while at the same time variegated flowers are in abundance; blotched, striped, and, in many cases, spotted flowers being produced, rendering a collection of Azaleas well worth a visit at any time from Christmas till June, and in some places later. It is a good plan to have a few plants (say two or three) of a sort, and say, five or six sorts, according to the size of the house. Of course, we should not advise more than a proper proportion of plants, as there are numerous other subjects that afford a fine display of differently habited forms, both of growth and blossom, and it would be a pity to oust them for the sake of one class of plant—many of the plants in question affording blue and yellow flowers, an object of much importance in greenhouse furnishing.

The culture of the Azalea is very easy, and, in fact, anyone can grow them if a few simple rules are followed. In the first place, potting claims attention—in fact, the way in which the plants are potted has more effect on their blooming capabilities than the soil in which they are potted. We make it a rule to put at least an inch of drainage into 4in. pots, and 2in. into 6in. pots and upwards, as we consider this is the first point in successful culture. For soil we use three parts sound old peat, one part best maiden loam, and one part sand. Using the loam is, however, a matter of choice; some persons omit it altogether, while others, again, use more than we do. But it must be remembered that peat is generally employed for all the heath family of which the Azalea is a member, and, therefore, it is necessary to use it in the compost. In repotting, the whole of the crocks should be removed from the base of the ball

of soil and roots, and the top should also be removed till the fine roots are reached. The plant should then be put in the new pot and the soil that is put in should be rammed firm to prevent the water running through it, and not wetting the ball of roots inside. In all cases the roots next the stem should be above the other soil, so that the water may not sink in next the stem, or disaster will certainly ensue. After potting, the plants should be kept close for a few days, and then may have the full benefit of the air. The best time for potting is after the growth



FIG. 28.—AZALEA INDICA.

has been made, as the roots then elongate, and take hold of the new soil. From October till June the plants should be in the greenhouse, and the other months in a cold frame, or if that does not exist, they should be plunged in the borders out of doors. Water will have to be given abundantly through the blooming and growing season, and at other times the plants must not become dry, or no bloom will result. A proper amount of care must of course be exercised, so that the plants are not swamped one day and dried up the next; but this will easily be seen by the person who has the charge of the collection.

Named varieties are propagated by grafting on seedling stocks.

In regard to sorts, we find the following to be very good and suitable for the purposes intended, and such a selection as we give is almost sure to give everyone satisfaction: *Admiration*, *Amœna grandiflora*, *Bijou de Ledeburg*, *Brilliant*, *Cedo Nulli*, *Comte de Hainault*, *Concinna*, *Criterion*, *Dieudonné*, *Duc d'Artemberg*, *Duc de Nassau*, *Duke of Edinburgh*, *Exquisite*, *Flag of Truce*, *Gem*, *Glory of Sunninghill*, *Grand Monarch*, *Her Majesty*, *Indica Alba*, *Insignis*, *Lateritia alba suprema*, *Leeana*, *Lizzie*, *Madame Ambroise Verschaffelt*, *Madame van Houtte*, *Magnifica*, *Mars*, *Ne Plus Ultra*, *President*, *Prince of Orange*, *Princess Alexandra*, *Princess Helena*, *Purity*, and *Queen Victoria*. All the above can be obtained of Messrs. Veitch and Co., King's-road, Chelsea, to whom we should advise readers to apply if they have not a nurseryman who supplies them regularly.

Azalea Sinensis, &c.—Hardy shrubs; grown for their flowers. Minimum temperature, 30deg. The hardy Azaleas are very useful for the cool house, and also for those where a little heat can be had, as they readily accommodate themselves to various situations, and if gradually brought into a heated structure, will bear a good amount of forcing. Plants should be well established in pots for this purpose, and the general treatment is much the same as for *A. Indica*; that is, so far as the management of the plants go. They should be re-potted annually as soon as the foliage is ripe, and either loam and peat in equal parts, peat, or fibrous loam alone, can be used, provided that sufficient sand is mixed with the soil, and a proper drainage is afforded. The plants should be brought into a warm house in successional batches; and the plants for this purpose should be kept in well ventilated cold frames, so that the sudden change shall not bring the buds off. With these, as with all plants, the changes from cold to heat should be gradual, or the effects will be most disastrous. In no case will nature perform its functions if excited by fits and starts, or if too sudden changes are indulged in.

The colours are very bright, and range from white through orange to red, and from red to crimson, and while some have blossoms while the stems are quite bare, others have both flowers and foliage together.

Propagated by seeds in the common varieties, named sorts are grafted on seedling stocks. Both processes are, however, beyond the reach of the ordinary amateur, and as the plants are very cheap they had better be purchased.



FIG. 29.—AZALEA SINENSIS

The various hybrids, and varieties of *A. mollis*, *A. Sinensis* (see Fig. 29), *A. nudiflora*, and *A. Pontica*, are very useful, and are obtainable at all hard-wood nurseries. It is, however, the best plan to select the plants while in bloom, as the colours or shades of colours are so numerous that no real idea of their appearance can be written. Suffice to say all are good, and reasonable in price.

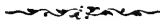



BALSAM.—Tender annual; grown for flowers and general appearance; minimum temperature, 50deg. A well-grown Balsam is a plant of which the grower may be well proud, but it is rarely that it is seen in good condition. The general fault

with plants grown by amateurs is the long stem and poor blooms—blooms that are not even semi-double being very common—and, except where Balsams form the one hobby of the grower, it is rare to see the camellia flowered and other varieties in good form. A good Balsam bloom should be quite as double as a camellia, and to show to the greatest advantage should appear like one in the arrangement of the petals. The great difficulty in starting the culture of these plants is obtaining good seeds, and unless the intending cultivator knows anyone who makes a fancy of Balsams, or unless he can obtain first-rate plants, some time will probably elapse ere a good fixed strain of flowers is obtained. Seeds should only be saved from the finest and most perfect flowers, and although the quantity must of necessity be small, the quality will be good, and this is what is of most importance. Only the best blooms on a plant should be reserved for seed, and if it is desired to have the seed extra good, only the blooms selected for seed should be allowed to remain on the plant.

The cultivation of Balsams is very easy, and provided the seeds are right, the results are sure to compensate for the trouble of culture. About the third week in March seeds should be sown on properly prepared pans of sandy rich soil, and placed in a gentle bottom heat, say of about 65deg., and as soon as the first rough leaf appears the plants should be potted off into 3in. pots, care being taken to keep them close down, *i.e.*, to let the seed leaves be close to the soil. As soon as the roots kiss the sides of the pots re-potting should be resorted to, and this should be repeated until the plants are in 8in. or 10in. pots. During the whole of the time the plants are under glass they

should be kept as near the light as possible, and be frequently turned around, so that they do not draw to one side and become unsightly. Careful training must be given to the plants, or at least to such as are required in fine form. Disbudding is also necessary to such plants as are wanted at their best, removing all bloom from the main stem and base of the branches until the

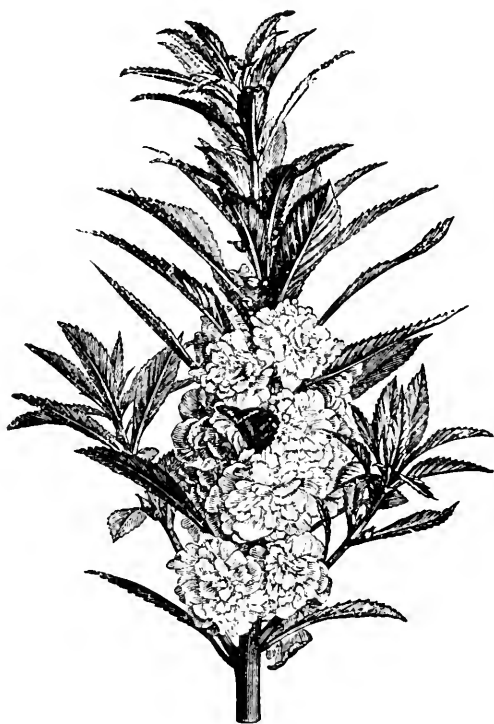

FIG. 30.—CAMELLIA-FLOWERED BALSAM.

plants are of sufficient size, and then the buds at the tops will bloom almost simultaneously, and cause the plants to be really splendid objects. The buds that will be formed afterwards will cause a continuance of blossom for a long time; in fact, for some months, if the plants are liberally supplied with liquid manure. Instead of being grown under glass the whole time, they may with advantage be treated in the following manner, the

same rules as to potting, training, &c., being applicable. By this method an advantage is gained, for although the plants will not be extra large they will be very hardy, and fit to stand about in places out of doors where required; and, being hardy in a comparative sense, they will be able to endure many little hardships, want of water alone excepted. About May the plants should be transferred to a frame where the heat is not above 50deg., and kept in a steady growing state, air being admitted as required, nor water omitted as necessary. They should be kept growing on steadily, disbudding and training as above mentioned. About June the plants should be fully exposed during the day, and when all danger of frost is over the lights may be kept off altogether. These should bloom in whatever size pots they are in at the end of June, and, if ordinary attention has been paid them, they will be very fine. In all cases plenty of drainage must be allowed, as the amount of water required is immense. Insects must also be looked after sharply, especially green fly, slugs, and snails, one of these latter often destroying several specimens in a night.

Propagated from seeds only.

For varieties the following will be found very good: Camellia flowered (see Fig. 30), Rose flowered, both containing various colours; Solferino, striped blooms, and Emperor, spotted, both kinds having various coloured grounds. The first is, however, generally most esteemed by lovers of fine flowers.

Bambusa.—Greenhouse hard-wooded plant; grown for its foliage and general appearance. Minimum temperature, 36deg. The Bamboos are a class of plants that are ornamental in the extreme, having erect simple stems clothed with willow-like leaves of various shades of green or, in some cases, green and creamy white, but from their nature they are not well adapted to small houses. There is one variety, however, that has a fine effect anywhere, as it is comparatively dwarf and compact, with finely variegated foliage, and is adapted to pot culture. We allude to *B. Fortunei variegata*, which comes from either China or Japan, and is really good. All the bamboos are semi-aquatic, growing naturally on the banks of rivers and in marshy

places. During the season of growth plenty of water must be applied, and if large growth is desired, weak liquid manure may be used with advantage. Like all free-growing plants, bamboos like a rather porous soil to grow in, and we use two-thirds of fibrous loam, one-third thoroughly rotted leaf soil, and plenty of coarse silver sand; we also hold that the plants should not be potted too firmly, or in some cases the young shoots will have some difficulty in pushing through. As a decorative plant, the one mentioned above will, if well grown, be found of great use, either for the greenhouse or for the table, as its foliage is both elegant and graceful, and shows well under gaslight. For the table, plants about a foot high, in 48-sized pots, surrounded with a plant or two of *Isolepis gracilis*, and the spaces filled in with *Selaginella denticulata* will be found to make very effective low centres for tables, and will last for two, or three months with ordinary care. We have frequently used a bamboo for the centre, five *isolepis* (in large 60 pots) around and close to the centre pot, and as many *selaginellas* in thumb pots as required, which generally amounted to from nine to twelve pots, if the plants were well grown.

Propagation is effected by division when the crowns of the plants are of a sufficient size, but this process must not be carried too far, or the whole stock will be lost. Propagation is best done just before growth commences.

Bambusa Fortunei variegata is the only dwarf kind fit for pot work, but where a large tub can be allowed and plenty of house room is at hand, a plant of *B. metake* or *B. gracilis* is very effective, but they are from eight to ten feet high.

Begonia.—Greenhouse soft-wooded plant; grown for both flowers and foliage. Minimum temperature, 40deg. Begonias, which are of comparatively easy culture, contain both blooming and fine foliage specimens, and the greater part of them can be grown well in a greenhouse that is kept about 40deg. There are also some nearly hardy kinds, but of these we do not intend to treat here. The fine foliage kinds are very useful for any kind of wall decorations, the larger foliaged kinds being particularly useful for the purpose, as they grow so that the leaves quite

hide the pots when the latter are suspended against a wall. The colours of the leaves are very rich, from silver to rich bronze, of a very metallic appearance. A single plant in a small vase also looks well on a table, and as the plants stand the gas pretty fairly, they do well for table decorations, or for sideboards, mantel shelves, &c. Of the ornamental foliated kinds, those of the *Rex* section (see Fig. 31) are very useful, as they will stand a fair amount of cold if it is not accompanied by a damp atmosphere. At one time they were classed as stove plants, but experience shows that they can be used for decorative purposes in almost any greenhouse where the temperature is kept at from 38deg. to 40deg. through the winter.

The culture is very easy, and the various hybrids of the different kinds, caused by crossing *B. rex* with other varieties, are really beautiful. The aim in winter in a cool house should be the preservation of the foliage that is already formed rather than the production of new, and this can only be done in a place where the atmosphere is not surcharged with moisture. Where the temperature exceeds 50deg. the plants can be kept growing, and so will maintain plenty of foliage. Re-pot once or twice a year, using equal parts of peat and loam and plenty of sharp sand, or perhaps, where the loam is heavy, one-third should be used to two-thirds peat; pot moderately firm, and while giving sufficient water do not overdo the matter, so that the plants become waterlogged. For this reason plenty of drainage must be given, or the same undesirable results will follow. With the tuberous-rooted kinds, which are now coming well to the fore as bedding plants, and have a wide variety of colours, a somewhat different style of treatment must be pursued, as the plants rest through the winter. Our plan is to pot in the end of March, in somewhat rich sandy loam, affording plenty of drainage, and placing the plants in the light. Here they soon break, and in due course produce their flowers. Most of the varieties require sticks to keep them in form, and as the plants can stand in the greenhouse throughout the season, they require some assistance, as they sometimes get a little drawn. Plenty of water is necessary during the growing season, and an occa-

sional watering with liquid manure will be found of great advantage. When the plants have bloomed out the supply of water should be lessened, and as the foliage dies off watering should be practically discontinued, but the soil must not become dust-dry. During the winter the roots should be kept in a place where the temperature is about 40deg., as in a much cooler place they would rot. Although Begonias are generally termed stove plants, they can, as a rule, be treated as green-



FIG. 31.—BEGONIA REX.

house plants, the only essential being that the temperature shall not fall below 40deg. Of course, for winter blooming, a stove is necessary, as the heat given to the Begonias would prove very injurious to the other plants in the greenhouse; but for summer and autumn decoration the plants are excellent. In fact, the fine-foliaged kinds are useful all through the year, while the latter kinds are not.

Propagation is effected by means of cuttings, division of the roots in the tuberous section, and by seeds. Cuttings root readily in sand, or sandy peat if on a good bottom heat, divided roots start well in a warm greenhouse if this mode of propagation is taken in hand just as the plants start into growth, and seeds will grow freely if started in a mild bottom heat or in a warm greenhouse. In fact, it is quite possible to have Begonias from seeds in all houses that are moderately warm in April or May, but preferably they should be sown in February if a proper heat of about 55deg. can be maintained. We have found it the better plan to sow thinly on well-drained pots of sandy peat, covering each pot with a sheet of glass to prevent undue evaporation, because as the seeds are small if much watering has to be resorted to a large quantity will be washed away.

For ornamental foliated plants select from the following, which are all good: *B. rex*, *B. Marshallii*, *B. Duchesse de Brabant*, *B. Queen Victoria*, *B. Comte de Lemminghe*, *B. Chas. Lievens*, *B. Diadem*, *B. nebulosa*, *B. Sambo*, and *B. Snowflake*. For blooming kinds select from *B. Breigeii*, white flowers and buds; *B. spathulata*, white; *B. nitida*, rose; *B. Saundersonii*, deep rose; *B. manicata*, flesh; *B. Fræbeli*, crimson-scarlet; and several of the intermediate hybrids. In fact, where there exists the means of raising the plants from seeds, a 5s. packet of seed will produce a good collection. M. Victor Lemoine, of Nancy, has also raised some double-blossomed varieties, which are excellent, but rather expensive. They are *B. Gloire de Nancy*, bright vermilion; *B. salmonea plena*, rosy salmon; *B. Mons. Lemoine*, orange vermilion; *B. President Burelle*, red, shaded scarlet; and *B. W. E. Gumbleton*, rosy salmon with orange centre. He has also raised some semi-double varieties of much excellence.

Bignonia.—Nearly hardy hard-wooded climbers; grown for foliage chiefly, but the flowers are interesting. Minimum temperature, 36deg. These are handsome climbers, of great use in comparatively large houses, and in such give great satisfaction when well grown; but if neglected, and the foliage rendered unsightly by the attacks of insects, are of but little beauty.

The great point in the culture of all climbers is to obtain free, and at the same time sturdy, growth, giving due attention to training, pruning, &c., or the plants soon exceed all limits. Like all free-growing plants, Bignonias do best planted out in the borders, and if in suitable soil they soon make a fine show, the fine pinnate leaves setting the large bell-shaped flowers off to the greatest advantage. *B. radicans* does well in a large cool conservatory, and in many places it answers fairly out of doors in a warm situation, and on a warm sheltered wall they grow and bloom well, and are therefore generally termed hardy in catalogues; but in many instances the term is delusive, as they do well only in the warmer parts of the British Isles. The best plan is to plant out in borders of comparatively light loam and leaf soil, affording plenty of drainage, and taking care the soil is in a sweet and fresh condition.

Propagation is effected by layers, and by short jointed cuttings inserted in pots of sandy loam, taking the cuttings when the plants are at rest. As, however, there is rarely any advantage in having more than one or two specimens, we advise the purchase of the plants at a nursery.

The sorts that are useful for our present purpose are *B. Australis*, *B. Capensis*, *B. capreolata*, *B. grandiflora*, *B. speciosa*, *B. Tweediana*, and *B. venusta*, all of which are good, that is, good for large houses.

Boronia. — Greenhouse hard-wooded shrub; grown for its flowers. Minimum temperature, 40deg. In a well-found greenhouse these should always be represented to a certain extent, more or less according to its size. It is, however, a rather tender plant if taken relatively with some of the other kinds, such as acacias, &c., but still, like the chorizema, it is of much individual beauty, as it has fair-sized flowers of taking colours, and the foliage is elegant, and well clothes the somewhat erect and slender stems.

It is not necessary, nor even desirable, to have too many plants of a sort in a small collection, and if such as those mentioned below are represented by one or two good (though not large) specimens, it will be far better than a large quantity

of small ones, as the numerous soft-wooded and hardy plants that can be introduced from time to time will generally supply plenty of variety and bloom without the trouble that generally has to be bestowed on the better class of hard-wooded plants. And another, and perhaps the more important point, is that the hardier subjects require less attention than the regular greenhouse subjects. Like many of the other plants that decorate our glass houses in winter, *Boronias* should be placed out of doors from July to September; in pits is the better plan, as then there are greater facilities for protecting from heavy rains and thunder storms. They should not be fully exposed when first put out, but in the course of a week they may have all the sun and air possible. Potting should be performed once a year, as soon as the top growth ceases, as the roots then extend themselves in preparation for their next year's work. For soil we use peat and maiden loam equal parts, and about one-sixth sharp silver sand, which we find best for general use, although many gardeners use a somewhat different compost. This plant also requires some attention in regard to water; it must not be allowed to get dry, or disastrous results will follow, especially in summer, as a little drought then will soon cause it to lose its foliage.

Propagated by cuttings taken off when the plants are at rest, and struck in sand or sandy peat, either in a warm greenhouse, or by the aid of a gentle bottom heat.

B. pinnata, purple, and *B. serrulata*, scarlet, are two of the best, while if more varieties are desired, *B. tetrandia*, red, *B. Drummondii*, and *B. anemonæfolia*, red, can be added.

Bougainvillea.—Greenhouse hard-wooded climber; grown for its flowers and general appearance. Minimum temperature, 40deg. This is one of the most useful climbers there is, either for comparatively cool or for warm conservatories. During the summer it does well in a cool greenhouse. It can be grown in pots, and in the borders, but it certainly does best in the latter, as the plant is essentially a very gross rooter, and therefore requires plenty of space in which to extend. Strict training and pinching are not very advantageous, as they do not

tend to induce the free production of bloom; indeed, the best plan is to allow the plants to ramble freely over the roof of a moderately high house, or along the upper portion of a back wall, and they will then bloom profusely for several months in the year, bearing terminal clusters of tube-shaped flowers, which set the large oval leaves off to great advantage. Always



FIG. 32.—BOUGAINVILLEA GLABRA.

provided that the proper attention is paid to feeding, and the plants are in a properly prepared medium. In preparing a border for the reception of Bougainvilleas, the first point to be considered is the drainage, which it is necessary to thoroughly secure. This is best done by laying in a quantity

of brick rubbish, about, 6in. in thickness, and communicating with the drain belonging to the greenhouse or conservatory, by which means all sourness and unfitness of the soil is obviated. The bed should be excavated to a depth of 2ft. or 3ft., according to the soil and position. For soil, use rough turf, loam, and fibrous peat, about two parts of the former to one of the latter, and about one-fourth to one-sixth part of sharp, gritty sand, according to the quality of the other soils, heavy loams requiring more sand than that which is more friable. Some cultivators use manure in the compost, but this we do not recommend, as it tends rather to cause the soil to become stiff and impervious to air, which, to say the least, is very undesirable, as such a condition is directly opposed to the well-being of any plant. We would rather advise the liberal application of liquid manure, as this supplies all the necessary food without destroying the porosity of the soil. As a rule, these plants do not answer for pot culture in the greenhouse, as for this kind of treatment they require stove heat, which cannot be generally given in such a house. When the plants cease blooming each year, say in November or December, they should be closely spurred in, the same as with vines, and all weak leaders should be removed, so that strong wood only is left. Scale and mealy bugs are the only insects to be feared, and these can only be kept down by hand picking.

Propagated by means of layers pegged down into the borders or into pots of sandy soil, and left for at least a year before they are severed from the parent plant.

For sorts choose from *B. glabra*, *B. speciosa*, and *B. splendens*, which are all good.

Bouvardia.—Greenhouse hard-wooded shrub; grown for the flowers. Minimum temperature, 40deg. Bouvardias are, *par excellence*, the flowers for cutting for bouquets, and are of comparatively easy culture. We think that the peculiar beauty of these plants well repays their cultivation, as no bouquet in winter is complete without them, their tubular jasmine-like fragrant flowers being very chaste and useful. The leaves are somewhat like those of the orange, and a well-grown plant,

about a foot high, having five or six trusses of bloom, is a very pleasing subject, the trusses being on the ends of the branches. The almost continual habit of blooming which Bouvardias possess when well grown renders them valuable to growers of cut bloom, leaving out their intrinsic value. We once had the curiosity to ask some of the salesmen in Covent Garden the value of what they had sold of these blooms in one morning, and we found that five of them had realized £50 between them. Of course, this was in the season when flowers are expensive, but still it shows the decorative value of the plant. The white varieties are, perhaps, the most valuable, as their colour is sure to match with almost any other, but, at the same time, the scarlet varieties are good.

The mode of cultivation differs somewhat, according to the season in which it is desired the plants shall bloom, and, therefore, it is necessary that they be prepared accordingly. It must, however, be distinctly remembered that Bouvardias are not fond of a cold house during winter, an intermediate house suiting them very much better. In fact, they are better adapted to those who have warm greenhouses than to persons who keep out the frost only, these latter not being able to achieve much success; for although these plants do well in frames during the summer months, they are very susceptible to the cold of our winters. For ordinary work the following practice will probably suit most amateurs, and we know it will suit the plants.

In the first place, soil is a consideration, as the plants are rather fastidious in this respect, and they require rich food to grow them at all well and keep them in health. We use two parts thoroughly rotted manure and leaf soil and three parts good loam, with enough sand to keep the compost open. Strike the cuttings in a brisk bottom heat in spring, and when rooted pot off into thumbs; still keep in a warm, genial, atmosphere, and as soon as the roots kiss the pot, pot off into large sixties. As soon as the pots are filled with roots, shift into forty-eights, and about the middle of June the plants may be put into airy frames out of doors; give each plant plenty of room to develop itself, and by a careful atten-

tion to stopping back during the earlier stages of their growth, let each plant have from six to eight leads. In the end of August pot into thirty-two sized pots, and keep close for a day or two until well established. About the end of September the plants should be housed in an intermediate house, if they are wanted for spring blooming, and just kept moving through the early part of the winter; at least 50deg. should be maintained as the temperature of the house where the Bouvardias are kept. It will be found that the plants kept thus will bloom in the end of February and March, as soon as the sun gets warm. Of course, the nearer they can be kept to the glass the better it will be for them, as they will remain sturdy and strong, and be in better condition for a long continuance of the blooming season. In such a house as is required for these plants, coleus, alternantheras, and other plants requiring warmth during winter, will do well. Those which are required for blooming in December and early the next year must have a brisk heat night and day through November and onwards, and they should be kept near the glass. About 65deg. at night is a very good temperature, but some little allowance must be made according to the weather. Water must be given to meet the requirements of the plants, but it must not be either over or under done, or bad results will be sure to follow. Bouvardias cannot be grown in the "handsome glass conservatory," such as is fixed to modern villas, unless they are heated, and built in such a manner as to retain the heat when it is applied. Neither can they be grown in a house from which sunlight is wholly or partially excluded, as they want all the light and sun they can get during winter. Young plants, liberal cultivation, and plenty of warmth in winter, is the only secret of success. Always water with water of the same temperature as the house, syringe well occasionally, and fumigate once or twice if green fly appears. We have, however, found that the less the plants are fumigated the better will they bloom, as the smoke appears to affect the foliage, and cause a partial arrest in the due performance of its natural functions.

Propagation is effected by means of cuttings struck on a

brisk bottom heat in spring, in the same way as fuchsias. Only young wood should be used for cuttings, and it should be quite free from aphides, or great trouble will be experienced, if, indeed, the trouble taken is not quite thrown away.

We have grown all the following, and found them good for their respective habits, but, perhaps, the easiest to do is *B. jasminæflora*. This very much resembles the white jasmine, and by some persons it is mistaken for that flower, although to those who are well up in flowers the difference is so great as to make the two flowers easily distinguishable. The list is as follows: *B. candidissima* (pure white), *B. Hogarth* (scarlet) *B. Humboldtii corymbiflora* (white), *B. jasminæflora* (white, very free), *B. Laura* (fine rose), *B. Leiantha* (bright scarlet), *B. Leiantha compacta* (scarlet), *B. longiflora flummea* (rosy-blush tubes, salmon lobes), *B. Rosalinda* (salmon), *B. triphylla* (orange-scarlet, very free), *B. Vrielandii* (white, tinged with blush). The preceding are all good, and anyone fond of flowers would find a collection of them invaluable for winter use, or, for that matter, summer use as well.

Brugmansia.—Greenhouse hard-wooded shrub or small tree; grown for its flowers. Minimum temperature, 36deg. These plants are well worth attention on account of their beauty, and also on account of their easy cultivation, and, as they are nearly hardy, they are very suitable for cool houses—in fact, more so than many of the more fashionable plants. They look best as standards from three to five feet in height, as the large ovate leaves and pendulous blooms, which are somewhat like immense lilies, can then be seen to the best advantage. The flowers are from five to seven inches in length, and about four or five inches in diameter, so that it does not take many to make a good display. A pretty large pot should be used, according to the size of the plant, and plenty of drainage must be afforded. For soil use either peat and loam, about one-third of the former to two-thirds of the latter, or use good sandy loam alone. A goodly amount of sharp sand should be allowed to keep the whole open, as a water-logged soil is not conducive to the welfare of the plants. Ordinary greenhouse treatment should be given, and

the plants will not fail to produce their fine blossoms in due season.

For sorts *B. lutea* (yellow), *B. Knightii* (cream), and *B. sanguinea* (red), are the best and most effective.

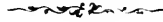

ALAMPHELIS. — Almost hardy climber. Grown for its ornamental foliage and flowers. Minimum temperature, 40deg. This is a useful evergreen climber, and is well worth growing in suitable positions, as it looks well, and is of comparatively easy culture. The orange-coloured flowers, which are shaped somewhat as those of the pentstemon, are borne in terminal racemes, and the light green foliage is small and somewhat like that of the ordinary garden pea, having a tendril at the end, which grasps any projection in the wall or trellis very firmly. It is of free growth and soon covers a large space, and therefore is very useful in many situations. The same cultural remarks apply to this as to *Cobœa scandens*, which is treated further on, and therefore it is unnecessary to enter on the subject here.

Propagated by seeds in the same manner as half-hardy annuals generally.

Calceolaria (herbaceous). — Nearly hardy soft-wooded herbaceous plants; grown for their flowers. Minimum temperature, 35deg. These, like the preceding, are very useful for both house and conservatory decoration. Unless a stock of named plants exists it is scarcely worth while to purchase named sorts, as a packet of seed from a first-class firm will produce a good percentage of flowers nearly, if not quite, equal to many of the named varieties. The chief reason for using plants from seed is, however, the cheapness of the process, for one or two good named sorts would cost half-a-crown,

while a hundred or so of good plants can be obtained from a packet of seed costing that amount. The seed should be sown about the middle of July on pans of light soil, which should have been previously soaked with water. Care must be taken to make the surface of the soil level, and also to sow the seed



FIG. 33.—HERBACEOUS CALCEOLARIA.

as evenly as possible, a matter of some little difficulty with fine seeds like *Calceolaria*, musk, lobelia, &c., as the seeds fall in bunches from inexperienced fingers. The seeds should be just covered (no more) with fine soil, a sheet of glass should be laid over the pan, which should be placed in a shady part of the greenhouse until the young plants show the first leaf. The glass

can then be gradually removed. As soon as they can be handled, the plants should be pricked out into pots or boxes, being kept about two inches asunder, and, as soon as they begin to crowd each other, each alternate one should be transplanted into other pots or boxes, so that the plants are about four inches apart. By the end of September to early in November they will be nice and strong, and fit for wintering, and the best place for them is in a dry pit, where frost is excluded, or on the shelf of a cold greenhouse. Give only enough water to prevent the plants flagging, and keep all dead leaves removed. At the first appearance of green fly, fumigate with tobacco, as this blight does a vast amount of harm. About the end of January remove the plants into their blooming pots, using those from 7in. to 9in. in diameter, giving plenty of drainage, and a compost consisting of one-half good fibrous loam, one-fourth thoroughly decayed manure (cow manure preferably), and one-fourth leaf soil. To this should be added sufficient coarse sand and powdered charcoal to keep the whole open. Take the plants up with good balls of earth and roots, and pot them moderately firm. A good watering should be given through a fine-rosed watering pot, and the plants should be put on an airy shelf in a cold pit or greenhouse, where frost can be just excluded. For a few weeks constant attention is necessary—watering, aëration, fumigating, &c., all being of paramount importance to the future well-being of the plants. Care must be taken to give plenty of room, and to support the flower stems as they rise with small neat sticks. About May the plants will commence blooming, and continue to do so for a couple of months. As soon as the bloom is over, if the plants are cut down and placed in a somewhat shady border of light rich soil, they will afford plenty of stock for the next year; but, at the same time, we advise the use of seedling sorts. Clear liquid manure, not too strong, is very useful for herbaceous *Calceolarias*, if employed in moderation; but it should not be used too often after the flowers show colour, as it tends to mar their clearness. The chief points in the culture of herbaceous *Calceolarias* are plenty of air and light, attention to watering, &c., and the destruction of fly as soon as it appears.

Propagated by seeds as described above, or by division of the plants in the case of named sorts. This division should be done in October when taking the plants up from the borders.

Calceolaria (shrubby). — Half hardy semi-hard-wooded plants; grown for their flowers. Minimum temperature, 35deg. Nearly every one is acquainted with this class of Calceolaria, which is so much used for bedding purposes, but only a comparatively small number know what fine decorative plants they are when well grown. This is much to be regretted, as a well grown shrubby Calceolaria in a 6in. or 8in. pot is really a very handsome and showy subject, useful alike in conservatory or dwelling house. It will be found more convenient to grow these in a pit or frame, as they are not so much attacked by fly in such a place, and also make sturdier plants. They are, however, a little later in blooming, but this is fully compensated by the better habit obtained and smaller trouble incurred. So long as frost is excluded, and the plants are kept moist, and receive plenty of air on favourable opportunities they will succeed very well in a frame, but should excessive moisture be applied or should the plants be frozen, then good pot plants will not be obtained. In the case of the amateur cultivator, it is a question as to which is the best time to strike cuttings of these plants, as unlike those set aside for bedding purposes, which are best struck at the end of September, the plants for pots are required of a pretty good size if large specimens are wanted, but if it is only desired to have medium sized plants they can be treated as the bedding plants are until spring. If large plants are required they should be struck in August, the cuttings put in a cold frame facing the north, and, as soon as rooted, potted off into sixty-sized pots; and when the roots kiss the sides of the pots, re-potted into large sixties, or 3in. pots, in which they will remain until the end of February. The points of the plants should then be pinched out, and as soon as they break they should be potted on into forty-eight size pots. If there are from four to six breaks to each plant it will be sufficient, but should such not be the case, the plants should be stopped again, when the requisite number of

breaks will probably be obtained. As soon as the roots kiss the pots the plants should be transferred to their blooming pots (either 6in. or 8in.), and the shoots should be tied out so as to develop fully, a point of much importance. Every effort should be exerted to maintain the foliage green to the base of the plants, and to attain this end the plants should be fumigated at the first appearance of green fly. From the end of February the plants should occupy a light airy pit, or frame facing the south, and as the warm weather arrives the pots should be plunged in coal ashes, as it is very essential that the roots should be kept cool, as in the native habitat of the plants. Very little manure should be used in the soil, but as the flower spikes are thrown up, weak liquid manure should be given two or three times a week. We follow the above plan successfully, and find that the plants are less liable to be attacked by insects than in an ordinary greenhouse, and from May till August the plants are all that can be desired. We place no reliance in old plants, but still, as is seldom the case, if a house is devoted to *Calceolarias*, they pay for attention.

Bedding varieties should not be potted, but should be inserted about 3in. apart over a bed in a cold frame, and after breaking (the tops should be taken off early in March or about the middle of April) should be planted out where they are to remain. By this means the "disease" will be obviated. Should frosty weather ensue, the plants should be protected with inverted flower pots, a piece of slate or crock being placed on the hole—we have thus often protected more tender plants than *Calceolarias*—the chief object being to shield from the drying winds that at times accompany frosts.

For soil use one-half good fibrous loam, one-eighth thoroughly rotted manure, and the remainder leaf soil, and enough sharp sand to keep the whole open.

Propagated from cuttings, as described above, or from seeds, as described for the herbaceous section.

We mention a few good shrubby *Calceolarias*; but, with the general grower, we would advise the use of seedlings in preference: *C. aurea floribunda*, yellow; *C. Excelsior*, orange-brown, gold cap; *C. Firefly*, orange-crimson; *C. Pluto*, dark

crimson; C. Aurora, crimson face, scarlet back; C. Clio, deep dark crimson; C. Sparkler, crimson, gold cap; C. Beauty of Montreal, bright crimson; C. Crimson Queen, scarlet tinted, bronzy crimson; C. Prince of Orange, red; C. Mrs. W. Paul, dark crimson; and C. Starlight, bright red.

Calla.—Tuberous greenhouse soft-wooded plant; grown for its flowers. Minimum temperature, 36deg. *Calla*, or *Richardia Æthiopica*, or the white arum lily, is one of the most useful plants of its class. It can be had in bloom at any season, and can be grown as a window plant anywhere where frost is excluded, while its fine white spathe and yellow spadix render it peculiarly interesting. It can also be treated as an aquatic, subaquatic, or terrestrial subject, and in all cases it repays cultivation. Like most of the aroids, it likes a moderately open compost, well enriched, and during the season of growth it is very greedy of water—in fact, if the plants have good drainage and a proper soil, it is scarcely possible to give them too much. Of course there is a medium in all things, and a careful cultivator is sure not to exceed this. There are two or three different modes of culture, two of which we have followed very successfully. The best plan in our hands is the following: As soon as the plants have ceased blooming, weak liquid manure is applied until the end of June, and meanwhile a trench has been prepared, like that for celery, well-rotted manure being used, and in this the plants are turned out, and kept well supplied with water during the growing season. A partially-shaded situation is best, and if a mulching with cocoa fibre refuse, or other fibrous material, is given, it tends to keep up a moist soil with fewer waterings. While planted out, all the flowers are removed, so that the strength of the plants is concentrated in the strong crowns. The plants are taken up about the end of September, and potted carefully in a rich and rather open compost, well watered, and placed in a close pit for a week or so, and thence they are removed to the greenhouse, where by forcing some and retarding others a continuation of bloom is maintained for a long time. The other plan, which is not so good as the preceding, is, however, more suited to small gardens

where a kitchen garden, in any form, does not exist. As soon as the plants cease blooming in spring they receive a liberal shift, the roots disturbed as little as possible, and a good



FIG. 34.—*CALLA ÆTHIOPICA.*

rich open soil used. They are then placed in a moist pit for a few weeks until they commence growth, when plenty of air and water is freely given. From the middle of June water is given

more sparingly, and the plants are gradually exposed to the air. The plants are plunged in coal ashes out of doors until the middle of August, only water enough being given to keep them from shrivelling. In August they are replaced in the pit, and well watered, and they soon commence growth, when by forcing some and retarding others a succession of blooms is maintained. In all cases plenty of drainage must be given, and close sticky soil must be avoided.

Propagated by the small offsets formed on the main root. These are taken off and planted in small pots when the parent plants are re-potted. In May or June these small plants should be put out into rich soil, kept well watered, and potted up in September for wintering. The second season they should be planted out again, and if carefully tended the majority of them will bloom the next year.

The two sorts we find best are *C. Æthiopica* and *C. albamaculata*.

Camellia.—Greenhouse hard-wooded shrub. Grown for its flowers. Minimum temperature, 40deg. The most important plant that is grown for fine blooms is the Camellia. Considering the price the cut blooms fetch in market, it is surprising that more attention is not paid to the cultivation of this plant by amateurs than is generally the case; but if anyone expresses astonishment at the fact, they are told that "the buds drop off," and the plants cannot be made to do anyhow. To this we would reply that Camellias are as easy to grow as any other plant if you only go the right way to work. Dryness of the atmosphere and want of water at the roots will generally be found the causes of failure, and the remedy for these evils will, of course, rest with the cultivator. During the summer, Camellias can be plunged in the borders, or other places out of doors, and thus afford a little decorative display, while at the same time they are making growth and bloom buds. For ourselves, we prefer to keep the plants always under cover if they are at all large, as we then contrive to get better results from them; in fact, we prefer to have the plants in the borders of a cool conservatory as permanent plants, as they then make

the finest growth. Indeed, permanent plants give far better results than any that are in pots or tubs, but as they require a large conservatory to give that room which is so necessary to them when grown in this manner, they are not generally



FIG. 35.—*CAMELLIA JAPONICA* FL. PL.

suitable to amateurs. The best mode of cultivation for amateurs is, therefore, in pots or tubs.

Before going into the matter of treatment it may, perhaps, not be amiss to point out a few of the uses to which the blooms

of the *Camellia* may be put, and foremost amongst these bouquet making certainly takes a place. White *Camellias* (with other flowers) are much used for bridal bouquets, for the hair, and for buttonholes, and also for table decorations, and the red are used for the same purposes, with the exception of bridal bouquets. A single bloom of *Lady Hume's Blush*, properly mounted and wired, is one of the nicest flowers imaginable for a lady's hair, as is also a bloom of *Imbricata*; they are also very good for buttonhole bouquets, although for our own part we should prefer a rosebud and a spray or two of *bouvardia*, backed with a frond of *Adiantum gracillimum*, as we consider a large flower is out of place in the coat. Some of the semi-double varieties come in very usefully in a half-expanded state, as they are pretty and not too large. In the decoration of a dinner table, both single and double sorts are very valuable, as they take the place of roses, and besides, they last for many days if they are properly gummed and mounted. Gumming is necessary with all flowers grown indoors, or they soon fall to pieces.

The cultivation of the *Camellia* is very simple, attention to a few easy rules only being necessary for their proper culture. The great faults in growing *Camellias* are too great heat, with very often a dry, arid atmosphere, and too much or too little water. We have very often seen plants kept dust dry, and as a natural consequence all the bloom buds fell off, as they would had they been kept over wet at the roots. Too much dry heat will fetch off the buds with a run, as will also forcing, or rather trying to force the plants into bloom early. The way to get *Camellias* to bloom well is to keep them just moist enough, and at a temperature of from 45deg. to 50deg., allowing 10deg. to 12deg. rise for sun heat; fresh air of the temperature of the house may be admitted, so that mildew is kept down, and little else has to be done. To obtain the blooms early, the plants should be gradually induced to ripen early, so that early blooming may follow, according to the natural order of things, as the plants will not bear to be forced in the general acceptance of the term. Plenty of light, also early varieties of the plants, are necessary for early work; and with care, *Camellias* can be had for some months, but they must, of course,

be rather strong in numbers. It should be remembered that Camellias are nearly hardy (in some places the single white blooms well out of doors), and in places where frost is excluded they do well if not neglected, but, as with all plants, attention is one of the secrets of success. The time to pot Camellias is when they cease blooming, using two parts good fibrous loam, one part peat, and enough sand to keep the whole open. Pot firmly and not deeper than before, or it is probable that the plants will be killed by the water settling round the collar. Liquid or other manure is not required, nor is it desirable to apply it, as it sooner or later causes the destruction of the plants.

As a rule, insects do not trouble this class of plants, but scale will sometimes appear, and can easily be removed by hand. Thrip also occasionally appears, when a little smoke will settle them. A mildew like that which attacks Cape pelargoniums sometimes shows up; but it is not very often the case, and a soft sponge and some lukewarm soapy water will soon clear it off, but if the place is ventilated, and kept fairly clean, there is very little fear of its appearance.

Propagation is effected by grafting on stocks of the common single varieties, and is beyond the reach of the ordinary amateur, such work being done well in quantities, and in houses devoted to Camellias only.

For a selection of double Camellias we would recommend **Imbricata* red; *Alba plena* white; **Lady Hume's Blush* white blushed carmine; *Angustina superba* transparent rose, occasionally spotted with white; **Bealii* crimson; *Circe* white; the flowers of this are small, and suited to bouquet making; *Comte de Gomer* soft rose; *Comte de Paris* salmon pink; **Duke of Lancaster* clear rose; **Eximia* dark crimson scarlet; *Exquisita* rose, flowers small and suitable for bouquets; *Fimbriata* white, the edge of each petal is nicely fringed; *Frederici* crimson, maroon; *Nigra* deep crimson lake, the darkest flower in the family; *Wilderii* soft rose. All the preceding are double, of fine form, those marked with an asterisk being old favourites with growers. The following are either single or semi-double, and are very useful for cutting

when half expanded: *Alba marginata* single red, variegated foliage; *Donckelaarii* semi-double, rich crimson, marbled and blotched white; *Reticulata* semi-double, bright rosy lake; *Sasanqua foliis variegatis*, single red, variegated foliage; *Sasanqua rosea* single, bright red; *Tricolor* semi-double, white, deeply flamed with carmine. We have excluded striped and flames flowers, because, as a rule they have a somewhat confused appearance, but if anyone wishes for them they are rather plentiful. All the above are suited to pot cultivation, and, if one of each is obtained, they make a nice selection.

Campanula. — Hardy herbaceous perennial. Grown for their blooms. Minimum temperature (when grown in pots), 30deg. Campanulas, or bell flowers, are amongst the most beautiful plants grown, both for form and colour of the bloom and the form and fresh green appearance of the foliage. The dwarf varieties are really very fine for pot culture, and form masses of light green foliage covered with a greater or less number of bright white or blue flowers, that render the plants very acceptable either for rooms or the cool greenhouse.

A comparatively rich sandy loam suits the plants, if plenty of drainage is afforded. We keep them in cold frames during the winter, and introduce them as required, unless, indeed, it has been found necessary to keep them in the greenhouse altogether. The chimney Campanula is quite out of place in a small house, and, besides, it is not of any great decorative merit, the dwarf kinds only being really admissible to the greenhouse. As a rule, Campanulas should be repotted in autumn; pot firmly, and keep the crown of the plant just a trifle raised above the soil, or at times they will fog off through the water lodging around the collars. The plants should be repotted each autumn, when they may be divided into as many plants as there are rooted crowns, if numbers are the chief object; but if moderate sized plants are desired, then the old plants should not be too much divided.

Propagated by means of division, or by seeds sown on sandy loam in April or May.

Of sorts there is a pretty wide selection, especially as the

greater part of the family can be cultivated in pots. *C. Garganica*, pale blue, 6in.; *C. G. alba*, white, 6in.; *C. Carpatica*, blue, 9in. (Fig. 36); *C. C. pallida*, pale blue; *C. C. alba*, white; *C. tur-*



FIG. 36.—*CAMPANULA CARPATICA*.



FIG. 37.—*CAMPANULA MEDIA*.

binata, purple blue, 9in.; *C. t. floribunda*, blue; *C. t. alba*, white; *C. Barrelieri*, 6in., blue; *C. nitida*, blue, 6in.; *C. n. flore pleno*, blue; *C. pulla*, 6in., blue; and *C. rubra*, red, 6in., we have found to answer the purpose well, and at times we have used the Canter-

bury bell—*C. media* (Fig. 37) and *C. media fl. pl.*—very successfully. The plants are grown out doors until just before the flowers open, and are then carefully potted up and watered; on being kept in the shade for a few days, the blooms open and become very handsome. The new variety, *C. media calycan-thema*, in which the calyx is of the same colour as the corolla, is also very effective when treated in this way.

Canna.—Half-hardy herbaceous perennial plant. Grown for its foliage. Minimum temperature when at rest, 30deg. These plants are used very much for subtropical gardening, and they are very fine, as will be seen by Fig. 39, and a few plants transferred into the house late in the year have a bright appearance for a month or so. It is, however, for the flower garden that the *Canna* is chiefly grown, and for this reason it is advisable to treat them for this purpose and for the cold greenhouse alone, and, if it is desired to introduce a few plants into the greenhouse late in the season, they can be grown in the borders or kitchen garden. Fig. 38 shows growth and inflorescence of *C. indica*.

As Cannas can be raised from seeds as well as division of the roots, we give the treatment from the first. Seeds should be sown in light soil in January or February, in a brisk bottom heat, and, when large enough, should be potted off singly into small pots, using rich moderately light soil. As soon as the roots kiss the sides of the pots, re-pot into 4in. pots, and get the plants hardened off by the end of May, so that they can be put out early in June. A deep, rich, loamy soil is the best for the plants while out of doors, and good drainage is a necessity. Plants to be put into the greenhouse should be taken up and potted into large pots about the end of August, well watered, and kept close for a week, when they may be stood out of doors until the time arrives for frost, and then they can be housed. As soon as the frost cuts down the foliage the old plants should be taken up, placed in boxes, and kept moderately dry until March, when they can be divided and started in the greenhouse preparatory to bedding-out in June. Besides the ordinary green foliage, some of the plants have leaves

finely marked, which thus form an additional attraction, while the flower (which somewhat resembles that of the gladiolus) is very handsome.

Propagated by seeds, as described above, and by division of



FIG. 38.—CANNA INDICA, SHOWING NEW GROWTH AND INFLORESCENCE.

the roots when growth has just started in spring. The latter plan is, perhaps, the best, as it takes a long time comparatively to get good plants from seeds.

The following is a selection of really good sorts, and well worth cultivation: *C. Annei*, large glaucous foliage; *C. A. dis-*

color, purple stems, orange flowers; *C. A. fulgida*, zebra-marked foliage; *C. A. rosea*, tall, orange flowers; *C. Auguste Ferrière*, very large oval green leaves, orange-red flowers, plants eight feet



FIG. 33.—CANNA, SHOWING ENTIRE PLANT.

high; *C. aurantiaca zebrina*, brown barred foliage; *C. coccinea vera*, scarlet flowers; *C. Daniel Hooibrench*, bright yellow flowers; *C. Député Heron*, leaves glaucous, flowers sulphur and

orange; *C. excelsa zebrina*, dark-veined long leaves; *C. expansa rubra*, dark leaves, blood-red flowers; *C. insignis*, large foliage rayed with chocolate; *C. limbata major*, undulated foliage, red flowers; *C. metallica*, magnificent reddish bronze leaves; *C. Rendatleri*, long narrow violet leaves, orange flower; *C. Schubertii*, ruby flowers; *C. tricolor*, very fine foliage, streaked and mottled with creamy white, and margined with red, and red stems; and *C. Warszewiczii major*, scarlet flowers, green musæ-like foliage, dark margins. Of course, all these will not be grown, but on no account should *C. tricolor* be omitted, as it is so very beautiful.

Carnation (Tree or Perpetual).—Hardy, or nearly hardy, soft-wooded plant. Grown for its flowers. Minimum temperature, 40deg.

These are, without doubt, some of the most useful plants grown for cut bloom, and, as the culture is of the easiest, it is a matter of much surprise to us that they are not more grown by amateurs than is at present the case.

We strike the plants from June till the end of September in the ordinary manner, and, when well rooted, pot them off into 3in. pots; when established in these, about the end of August, we give a shift into 4in. pots, in which they are wintered the first season. As the plants are nearly, if not quite hardy, all the light and air possible are given, and undue moisture avoided. The second season the plants are grown on and not allowed to bloom, two or three shifts being given until they are in 12in. pots, when they will be from 2ft. to 4ft. high, and capable of producing a large amount of bloom, as, unlike the old clove carnation, if well treated, they bear abundance of flowers, which are like those shown in the illustration (Fig. 40). Meanwhile the shoots are tramed out into their places, and the general contour arranged. When the pots are filled with roots, liquid manure is supplied, and about the middle of September the plants are taken indoors, and plenty of air admitted for some days. By maintaining a temperature of 5deg., and applying sulphate of ammonia as liquid manure, ample bloom is obtained in the proper season.

For soil we use good fibrous yellow loam, and sand enough to

keep the whole sufficiently porous to admit of the free passage of water. By this system late bloom is obtained.

Where heat can be afforded without detriment to other subjects in the house, the following is as good a plan of culture as any. From November to the end of February take cuttings and strike them in bottom heat; as soon as rooted pot them off and gradually harden them, so that they will bear removal to the greenhouse, where they should remain till April.

Then plant them out on heavily-manured ground, and water in, if necessary. In June go over the plants and take off the tops, and about once a fortnight take off the tops of any of the side shoots which may appear likely to bloom. About the end of September carefully pot up the plants, and shade for a week or ten days, being careful to keep them in a healthy state of moisture, and give an unlimited supply of air until frost sets in. Commence fire heat in the early part of November, gradually working up to and maintaining a night temperature of 60deg.,

admitting a free circulation of warmed air during the day. Fumigation must be resorted to if fly should put in an appearance, and, for mildew, flowers of sulphur should be thoroughly dusted over the plants, washing it off after three days, and being very careful to remove all dirt from the plants.

Propagated by layers or cuttings, as described above.

The following are very good sorts for general purposes: Garibaldi, rosy scarlet; Souvenir de Malmaison, blush white;



FIG. 40.—GROUP OF CARNATIONS.

Bride, pure white; Covent Garden Scarlet, scarlet, very fine; Dragon, scarlet; Boule de Feu, scarlet; Prince of Orange, yellow, edged crimson; La Belle, pure white; Jean Bart, bright scarlet; Oscar, yellow; Henshaw's Scarlet, good scarlet; Lee's Scarlet, a very good serrulated scarlet; Valiant, rosy scarlet; Rembrandt, large crimson; Maiden's Blush, blush white. Rather more trouble will be found with the yellows than with the other varieties, but the yellow sorts are often the most esteemed.

Cassia.—Greenhouse hard-wooded shrub. Grown for its flowers. Minimum temperature, 30deg. This is one of those good old-fashioned plants that the rage for novelties has nearly displaced, and consequently it is not seen so often as it should be. Its beautiful hawthorn-shaped golden blossoms, which are borne plentifully in terminal clusters from June till the end of the year, are always in demand for cutting, and make a back wall or pillar a mass of golden wealth. It is also a fine subject for outdoor decoration, as it blooms till frost cuts it down. Young stock struck in spring and grown on make very acceptable plants for autumn decoration, and, in fact, no house should be without them. Indeed, *Cassia corymbosa* (yellow) is one of those old neglected plants that well repay cultivation, but from prejudice, or some other reason, seem almost dying out. From the very simple nature of its culture it is essentially a plant for the amateur, and should never be omitted from a collection of hard-wooded plants. For indoor use we pot in maiden loam and sand and a little peat, and in this the Cassia does well. For outdoors, we plant out in June, and as soon as the frost touches the foliage we pot them up (after cutting back nearly to the old wood), and winter in the back part of the greenhouse, or where there is a vinery, in that, just keeping out frost. For beauty of bloom, easiness of culture, and general usefulness, in our opinion, there is no plant to beat this.

Propagated by cuttings inserted in pots of sandy soil, either in a greenhouse or by the aid of a little bottom heat. As a rule, spring is the best time to strike cuttings.

Celosia.—Tender annual. Grown for its inflorescence. Minimum temperature, 50deg. Unlike cockscombs, Celosias have large plumes of bloom, and form pyramidal masses of colour, not greatly unlike the old Love-lies-bleeding and Prince's feathers, which they resemble, in both leaf and inflorescence, to a great extent. The Celosias are, however, greenhouse subjects, while the amaranthuses are practically hardy. The plants attain a height of from 2ft. to 5ft., and in some strains they have a graceful pendant habit, which renders them particularly beautiful when they are well grown. Like cockscombs, they do not really answer unless a moist warmth is kept up, and, like them, they must be kept near the glass, and have plenty of room for their free development. With all the Celosias frequent syringings are also necessary to keep down thrips and red spider; but, if grown in a moist frame, less trouble will be experienced on this head. The seed should be sown in the same manner as cockscombs, and the treatment should be the same until the first potting. After this the plants should have frequent shifts until the blooming pots are reached, those for the largest plants being 12in.; but they can be bloomed from 6in. pots upwards. A moist genial atmosphere must be maintained, and the plants must not suffer from drought, or the foliage will be lost. As soon as they become too large for the frames, they should be transferred to a span-roof greenhouse, allowing plenty of room for the circulation of air and free admission of light, and plunging the pots in cocoa-fibre to maintain as equable a temperature of the soil as possible. As soon as the blooming pots are filled with roots, copious supplies of liquid manure should be given, and, where necessary, stakes should be placed to the plants to keep them upright under the weight of plumes. Such little matters of routine as we have frequently mentioned before will also require to be seen to and the plants will be well worth the trouble taken with them.

Propagated from seeds as described above.

The sorts of *Celosia pyramidalis* that are to be recommended are *C. p. aurea*, yellow; *C. p. coccinea*, scarlet; and *C. p. purpurea*, purple.

Centaurea.—Half-hardy perennial. Grown for its foliage. Minimum temperature, 40deg. These are white-foliaged plants of much use for bedding purposes, and also for the decoration of the greenhouse during the cooler months of the year; and as they have a somewhat snowy appearance, they blend well with richer forms of coloured foliage, but the thistle-like blooms, which are generally yellow, are of no value from a decorative point of view. The culture is simple.

Sow seeds in August on sandy soil, and prick off into small pots, and as soon as the roots fill them, re-pot into large sixties. Winter the plants in these, and in March re-pot into 4in. pots, in which the plants can stand until June, when, if large plants are required, they can be re-potted into 6in. pots. During the summer, the plants can be stood out in the frames, or where grown as bedding plants they can be put out, and the contrast afforded will be very good. A moderately rich and sandy soil is necessary, and freedom from excessive moisture is essential. The plants can also be raised from cuttings taken off with a heel attached, and struck during summer in a frame facing the north, or in a slight bottom heat in spring.

Propagated by seeds or cuttings, as described above.

For sorts choose from *C. argentea plumosa*; *C. gymnocarpa*; *C. ragusina*, and *C. r. compacta*.

Cerasus.—Hardy hard-wooded small tree or shrub. Grown for its flowers. Minimum temperature (for pot work), 30deg. The cherries are very useful for house decoration if treated the same as almonds. The double varieties are the best for the purpose, having flowers like large double daisies, either white or pinkish white, according to the nature of the soil. The single varieties are of little use indoors, but are fine outside; and as the bloom is not so persistent as in the double kinds, the plants are not so well suited for indoor work. The application of manure of a highly nitrogenous character frequently causes the blooms to be suffused with pink to a greater or less degree; but it is better to select plants having this characteristic while they are in bloom, so as to insure—to a certain degree—its

repetition. These are amongst the prettiest hardy deciduous hard-wooded subjects there are.

Propagation is effected by grafting on stocks of *C. Mahaleb*, or in modern practice generally by budding; grafting just as the growth starts, and budding when the bark will "run" well and the plants are in active growth.

C. Japonica multiplex, double dwarf pink; *C. J. alba fl. pl.* double dwarf white; *C. serrulata*, double Chinese; *C. sylvestris fl. pl.*, double French; and *C. vulgaris fl. pl.*, common double, are about the most useful of all the plants amongst the cherries, and, as we said before, they well repay any trouble bestowed on getting them forward in the house.

Chimonanthus.—Hardy hard-wooded shrub. Grown for its flowers. Minimum temperature, 30deg. This is a very useful class of plant, of very easy culture, best suited for planting out in the borders of a conservatory. In fact, we have never seen it done well in pots, either in a private garden or nursery, and, therefore, cannot recommend it for pot work. The plants should be grown in a compost of loam and sand, enriched with leaf soil, a sufficient root space should be afforded, and they should be trained against a wall, so arranged that a sufficient space for the full development of the large laurel-shaped foliage is afforded. The same general treatment as regards watering, ventilation, &c., should be given as to other hardy hard-wooded subjects, and the plants will grow and bloom freely. The flowers are highly fragrant, and although not very ornamental, are yet very useful for various purposes.

Propagated by cuttings, taken off while the plant is at rest, and struck in sandy soil in cold frames. It is, however, the better plan to purchase plants when needed, as but little good is to be gained by propagating plants of this class.

The sorts we would recommend are *C. fragrans*, brown, and *C. luteus*, yellow; *C. grandiflorus*, yellow, is also very good.

Chorizema.—Greenhouse hard-wooded shrub. Grown for flowers and general appearance. Minimum temperature, 40deg. This is a family of plants that is most decidedly ornamental,

and although not so easy of culture as some of the other hard-wooded plants, will repay any trouble bestowed on it. The pea-shaped flowers are very handy for bouquets, and the small holly-like foliage is also very elegant, being of a very fresh green. Trained on a balloon frame, about fifteen inches high, the plants when well bloomed form quite "a picture," and for decorating a window are first-rate. Allowed to grow naturally, small specimens are very effective, and amongst other flowering plants give a rich, bright appearance that few other subjects possess, and many amateurs we have known say they cannot wish for a better return for their care and attention than these plants give. The flowers, which are somewhat pea-shaped, are borne well above the foliage, and are not so awkward to arrange in a bouquet as some others, and for this reason alone would be worth cultivation, were the bright colours left out of consideration. The plants can be kept outdoors from the beginning of July till well into September, and require no trouble with the exception of watering. Potting should be performed as soon as the plants cease blooming.

The soil we use is two parts peat to one part maiden loam, and plenty of sharp sand. We are aware that some gardeners use a somewhat different compost, but we have always had good success with the above, and can recommend it.

Propagated by means of cuttings struck in a gentle bottom heat, or what is more useful to amateurs, by seeds sown in April, and as soon as large enough, potted off into small sixty-sized pots, where they will, after once stopping, remain till the following spring. Re-pot in March or April, and afterwards treat as for the older stock.

For sorts the following will suit the most fastidious, and we know that where we have had them they have given every satisfaction: *C. cordata*, red; *C. cordata splendens*, red; *C. flava*; *C. ilicifolia*, yellow; *C. Lavrenciana*, orange; *C. macrophylla*, red; *C. ovata*, scarlet; *C. varia*, orange, red; *C. varia nana*, dwarf yellow, red; *C. varia Chandlerii*, orange, red; and *C. varia rotundifolia*, red.

Chrysanthemum.—Hardy herbaceous perennial soft-wooded

plant. Grown for its flowers. Minimum temperature (for pot work), 36deg. These, though hardy, if grown for indoor decoration require such special treatment as to render them worthy of a place amongst greenhouse plants. Whether the pompones, ordinary sorts, or Japanese varieties are grown, the show of colour and varied form will be very great, and supposing



FIG. 41.—NEW JAPANESE CHRYSANTHEMUM, "CHINAMAN."

that a fair collection exists, a very good display of colour will result. Indeed, the varied colours render the greenhouse very gay for some of the duller months in the year. In all cases it is, however, very necessary that proper attention and liberal culture be given, or the plants will not be so brilliant either in foliage or bloom; and as good foliage is as much an essential as fine blooms, plants that are deficient in that respect are certainly

not good specimens of culture. With all flowering plants bare stems, as a rule, indicate some error in their cultivation, and to exhibit such plants on the stage of a greenhouse generally shows up their defects. The methods of cultivation are legion, and nearly everyone who grows for market or home use has some



FIG. 42.—JAPANESE CHRYSANTHEMUM, "RED DRAGON."

particular part or parts of his treatment different to his neighbour's. But whatever plan is pursued, the object is the same, *i.e.*, the production of well-furnished, free-flowering plants, of not too great a size. For the use of an amateur, large plants are frequently in the way, as are also those which attain a great height, unless, indeed, the bloom is required for cutting for exhibitions, when the best plan is to allow the plants to attain

their maximum growth, as finer flowers are then produced, but as only one or two blooms are allowed to each, plants grown for cut blooms are certainly not very ornamental.

In the end of March or the two first weeks in April, strong

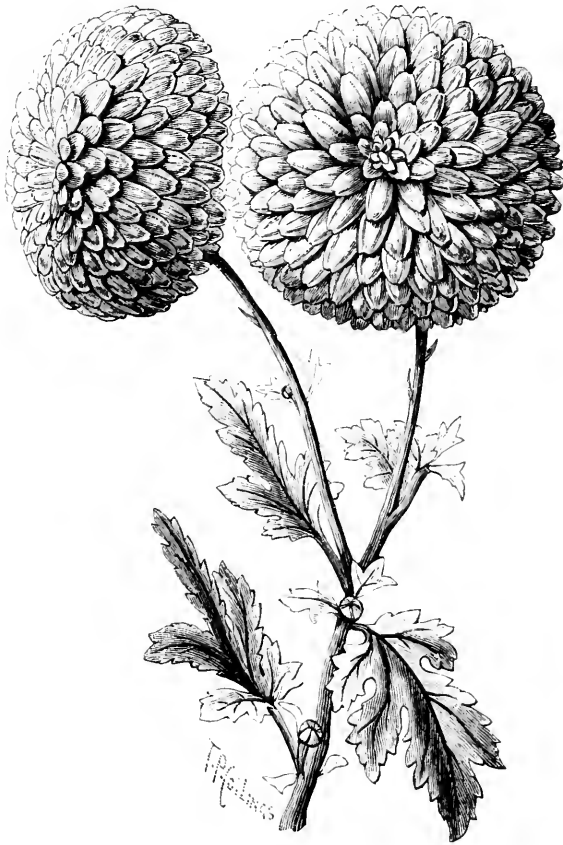

FIG. 43.—RECURVED CHRYSANTHEMUM, "DR. SHARPE."

cuttings, 3in. or 4in. long, should be inserted, three in a 3in. pot, and the pots should be plunged into a gentle hotbed. When well rooted, the plants should be hardened off somewhat and potted singly into 3in. pots, keeping them close for a few days and then giving air more or less freely, according to the weather. As

soon as the young plants have grown about 2in., the points should be pinched out, so that they may be induced to break freely, a point of much moment. As soon as the pots are full of roots (not pot bound) a shift into 4in. or 6in. pots should be given, particular attention being paid to watering and stopping back where necessary. About the end of May the plants can be removed to their blooming pots, 8in. or 10in., and at once plunged in a bed of coal ashes. The soil used

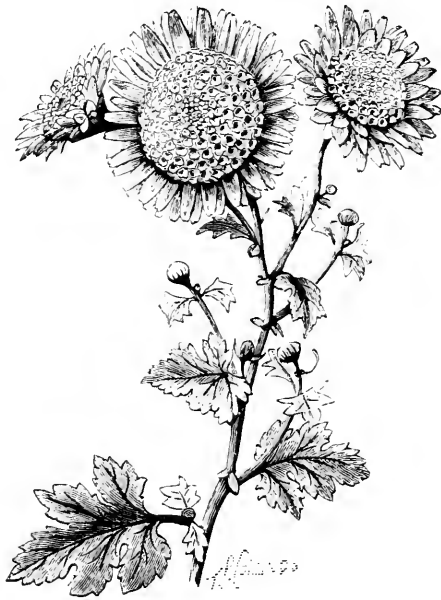

FIG. 44.—ANEMONE-FLOWERED POMPONÉ.

for potting should be composed of three parts good loam, one part rotten manure, and one part good rotten leaf soil, with, perhaps, a small quantity of hoof raspings from a farrier's shop. To these a sufficient quantity of sharp sand should be added to render the whole sufficiently porous to admit of the free passage of water. Drainage should be particularly cared for, on account of the large quantity of water the plants require during their season of growth. They should not be stopped after the middle

of June, but the branches should be kept well tied out, both to admit a free circulation of air and to maintain a comely, well-balanced shape. As the pots become filled with roots liquid manure should be supplied, and continued until the blooms begin to open, when it should be discontinued. Another plan is to turn the plants out into good soil in April and carefully grow them on outdoors, potting them up in the end of



FIG. 45.—NEW POMPONE, "MODEL OF PERFECTION."

September. Small plants are easily obtained by layering branches, and, when rooted, gradually severing the branch, and then potting the young plants without injuring the roots more than can be avoided. Chrysanthemums bloom well in a temperature of 38deg. to 45deg., provided plenty of air is admitted to keep down mildew. Fly must be got rid of by fumigation and mildew by dusting the parts affected with flowers of sulphur. The chrysanthemum fly is sometimes troublesome.

The egg is laid under the skin of the leaf, and if the grubs are not removed the plant is very much weakened. Their presence is easily detected by the brown channels they form in the leaves.

Propagation is effected by cuttings as described above.

The following are some good plants for pot culture, though most of them are old:—*Anemone-flowered*: Antonius, yellow; Empress, lilac; Prince of Anemones, lilac bluish; Lady Margaret, white; King of Anemones, crimson purple; Firefly, bright scarlet. *Pompones*: Aigle d'Or, yellow; Hélène, rosy violet; Madge Wildfire, bright red, gold tips; Mrs. Dix, bluish; Rose Trevenna, rosy bluish; The Little Gem, delicate peach; Model of Perfection (Fig. 45), beautifully quilled, and of a delicate mauve colour, with petals edged with a lighter tint. In Fig. 44 we illustrate an Anemone-flowered Pomponé. *Japanese*: Chinaman (Fig. 41) is one of the newest and most remarkable of this picturesque tribe, with curiously twisted florets, the effect of which is increased by the telling contrast of upper and lower sides. The other type we give of this class is our old favourite, Red Dragon (Fig. 42); this is a large, loose flower, of a rich red chestnut, tipped and centred with gold. Prince Satsuma, golden yellow; Tasselled Yellow, good yellow. *Chinese or ordinary*: *C. aurea multiflora*, pure yellow; Beverley, ivory white; General Slade, Indian red, orange tips; Gloria Mundi, golden yellow; Golden Beverley, rich gold; Golden Queen, canary yellow; Josiah Wedgwood, rosy carmine; Lady Slade, lilac, pink centre; Mount Etna, rich red; Miss Mary Morgan, delicate pink; Mrs. G. Rundle, white; Prince Alfred, rosy crimson; Queen of England, ivory white; Queen of Whites, large white; Rifleman, dark ruby; *Rosa mutabilis*, delicate peach; Sam Slick, ruby, bronze tips; Yellow Perfection, golden yellow. The reflexed flowered class form a very distinct group, one of the best of which is Dr. Sharpe (Fig. 43), a conspicuous, perfectly-shaped flower, of a rich amaranth colour, and of recent introduction. The above sorts, if obtained true, will be found to answer all requirements, and all the plants are good both in foliage and flower.

Cineraria.—Half-hardy perennial soft-wooded plant. Grown

for its flowers (see Fig. 46). Minimum temperature, 38deg. These are amongst the most ornamental, and, at the same time, most easily grown plants there are, and as a half-crown packet of



FIG. 46.—FLOWERING HEAD OF CINERARIA.

good seed will produce a vast assortment of colours, they should be grown by everyone possessing a house where frost is excluded during winter. The colours range from pure white to purple and crimson in selfs, and all the

various colours, banded with others, as white banded with crimson, white banded with blue, blue banded with white, &c., all of which contrasts are very effective and look excellently well as individual blooms. Some of the named varieties are fine, but, at the same time, many of the "strains" of seedlings of the last few years are (except in the view of professional florists) as near perfection as possible. In all cases it is advisable to grow *Cinerarias* in pits or frames, so that they do not exceed 1Sin. in height, with just enough heat to keep out frost; but, as the generality of amateurs cannot afford heated pits, the plants should be grown in frames until frost sets in, and then removed to a light airy position in the greenhouse to produce their daisy-like blooms. Seed should be sown under glass in July and August, and, when large enough, the young plants should be potted off into small pots, and kept close for a few days. As soon as the roots kiss the sides of the pots, give a shift into others an inch larger, and continue to do so until 8in. pots are reached, when liquid manure should be applied, and as the plants get pot bound they will commence to bloom. In the case of edged varieties, as soon as they commence to show colour the liquid manure should be discontinued and clear water substituted, or the flowers will become muddy, and not look well. With old plants the culture is much the same; the plants are divided early in August, repotted into small pots, and grown on as before directed.

For soil use the following compost: Two parts of fibrous loam, one part leaf soil, and one part cow manure, with enough sand to keep the whole open, for if once the plants get waterlogged they are spoiled. It is, therefore, necessary to provide plenty of drainage to each pot, and to stand the plants where the water will run away easily, instead of placing them in saucers where, as is too often the case, the stagnant water is not removed. Pegging out the foliage and tying out the blooms will, of course, be necessary to make the plant appear at its best. After blooming, such plants as it may be desirable to keep should be cut down to within 6in. of the pots, so that they shall afford plenty of suckers to provide the plants of the next season. Green fly must be kept down by frequent fumiga-

tion, and should mildew appear, flowers of sulphur should be dusted over the plants.

Propagated from seeds or divisions, as described above.

We give a selection of some really good named varieties:—*Selfs*: Adam Bede, bright rose; Blue Beard, deep blue; Brilliant, bright crimson; Captain Schriber, light blue; Duke of Cambridge, crimson; Eclipse, rosy carmine; Eclat, shaded purple; Reynolds Hole, scarlet crimson; Snowflake, pure white; Uncle Toby, deep purple. *Edged and banded*: Agrippa, white, rosy crimson edge; Amazon, light ground, crimson edge; Auricula, white, heavily tipped blue; Bridesmaid, white, purple margin; Chancellor, deep purplish crimson, white circle and disc; Chas. Dickens, white, rosy crimson edge; Evelyn, light ground, tipped crimson; Flora, pure white, crimson edge; Ino, white ground, heavily tipped crimson; Juno, crimson, white ring; Meteor, crimson, white ring; Miranda, white, blue edge; Orb of Day, rich glossy crimson, white ring; Zoë, rich crimson, light ring. As it is impossible to suit anyone's taste by a mere description, we would advise those who require a collection of really nice sorts, all distinct, to visit a good collection in the blooming season, and select the varieties that they prefer, as tastes vary greatly.

Citrus. — Hard-wooded greenhouse shrub or small tree. Grown for its flowers and general appearance. Minimum temperature, 40deg. (45deg. for fruiting plants). To this family belong the orange, lemon, citron, and two or three other fruits, and it is generally the wish of the proprietor of a greenhouse to grow and fruit one or other of these. Now, however unsuccessful anyone may have been, there is not the least reason why oranges should not be bloomed (if not fruited) in every light conservatory or greenhouse in the land, if only our directions are followed, and, in any case, it will be found that the bloom, which is five cleft, sweetly scented, and borne either separately or in small axillary clusters on the terminal branches, alone pays for any trouble bestowed on the plants. The first consideration is, what sort of orange to grow. In this, please yourself, as all the Citrus family are pretty, but for our own

part, *C. aurantium* (the sweet orange, Fig. 48) would be the choice, as it is no more trouble to grow than the comparatively useless bitter orange, and, should fruit be perfected, it is usable, whereas that of the bitter orange is of too acrid a flavour to be at all pleasant. The bloom is, moreover, as useful as is that of all the oranges (see Fig. 47). To grow any of the Citrus family well, attention must be paid particularly to the soil.



FIG. 47.—FLOWERING BRANCH OF ORANGE (*C. aurantium*).

This should be sound, heavy loam, to which a liberal portion of sand has been added. No manure should be used, as it tends to promote the growth of fungi. During the growing season some liquid manure should be regularly supplied, but as soon as growth begins to slacken, this should be gradually stopped and clear water substituted. A moist atmosphere should also be kept up while growth is vigorously going on, and for this reason

a vinery is a very good place for the plants at this season; where a dry atmosphere is maintained the plants are sure to have a starved and stunted appearance, very foreign to what it should be, and, as a rule, the bloom will be poor and scarce. In potting, the soil should be moderately hard in the pot, or the wood will be too soft and sappy and not ripen properly. It should not, however, be too much compressed, or the plants will not thrive. In a greenhouse the heat must not go below 40deg. in winter,



FIG. 48.—FRUITING BRANCH OF ORANGE.

and in summer, of course, it will depend on circumstances, but, in all cases, plenty of air is necessary unless frost is present. We have fruited the Tangerine orange in an ordinary greenhouse, heated by a flue, and always found (with some dozens of plants) the preceding treatment answer very well, as we had plenty of fruit and cut bloom. Of course, the plants have to be kept clear of insects and dirt, or they soon begin to suffer, as will any evergreen.

Properly worked plants must be obtained if flowers are desired, although those raised from seed are interesting from

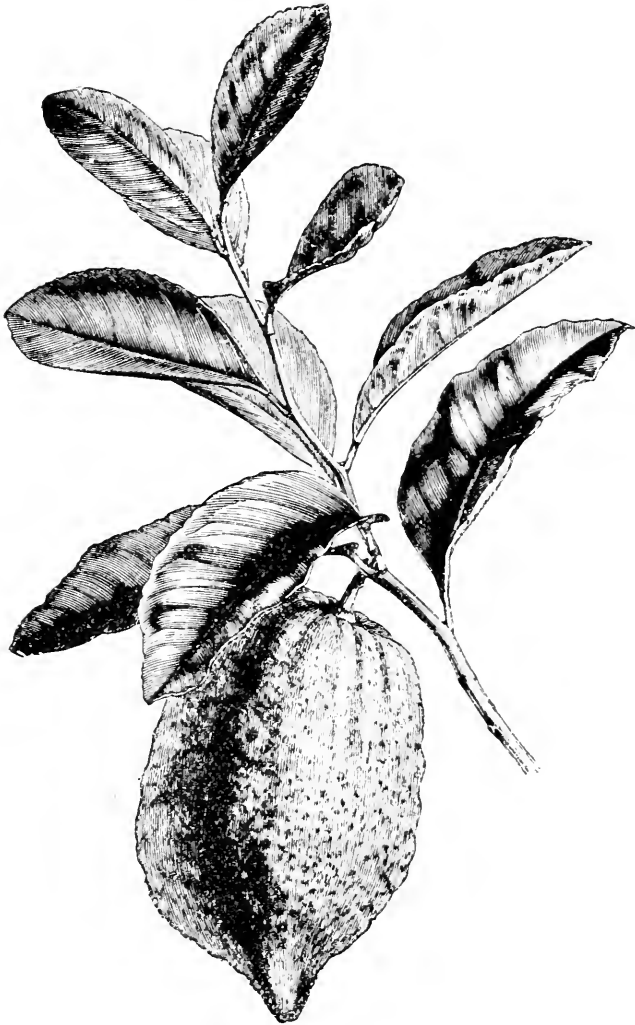

FIG. 49.—FRUITING BRANCH OF LEMON (*C. acida*).

the remembrances they bear. It is, however, many years before they bear fruit.

Propagated by grafting in the same way as the camellia, or from seeds, but seedlings take a very long time to get into a blooming state. It is by far the better plan to purchase the plants in a fruiting state at first, as then there is a good chance of achieving success.

The sorts we have grown comprise *C. acida*, lemon (Fig. 49); *C. aurantium*, sweet orange; *C. aurantium bigardia*, bitter orange; *C. aurantium sanguinea*, blood orange; *C. limonum*, lime; *C. Medica*, citron; and *C. myrtifolia*, myrtle-leaved orange.

Clematis.—Hardy hard-wooded climber. Grown for its flowers. Minimum temperature, 36deg. In this family we have a class of plants which is useful and good in all green-houses or conservatories alike. The flowers of some of the varieties are really magnificent, both as to size and colour; and when trained on a wall or on a balloon trellis the effect they produce is more easily imagined than described. The flowers of most of the Clematis are borne in axillary clusters, or singly, at the end of the current year's wood, and, in some kinds, are somewhat like the Japanese anemones in form, while in others they are more deeply cleft, and like single dahlias, save in colour and the number of petals, which are fewer. In size the flowers vary from an inch to four inches in diameter, but the medium flowering sorts of the Jackmanii type are the most floriferous. Of course, large effects cannot be expected from small specimens, and to produce large ones it is necessary to give liberal culture. The majority of Clematis are quite hardy, and should, therefore, receive plenty of air, and but little excitement from too great a heat, or the shoots exhaust the roots to a great extent, and, after a time, the plants become less floriferous and useful. For general purposes, therefore, it is preferable to have a well-lighted house for the cultivation of the Clematis, and care should also be taken to avoid a too close atmosphere, a well-ventilated house being a *sine quâ non*. As the blooms are produced on the ends of the current year's shoots the mode of cultivation should be such as will allow the plants to be well pruned back each winter, and also the situation chosen

should be suitable for this purpose, or a vast amount of bare stems will soon be obtained. The secret of success lies in liberal culture and close pruning; when we say close pruning, we mean spurring the shoots in to two or three eyes. For soil, use three parts good sandy loam and one-fourth well-rotted manure, thoroughly incorporated. To these may be added about an eighth part of broken sandstone, or broken bricks passed through a $\frac{1}{2}$ in. meshed sieve, so that the requisite porosity may be maintained, as Clematis dislike a wet, heavy soil, and, in fact, soon die out in it. If the plants are put into the borders, they should have 6in. of drainage, and 18in. to 24in. of the above compost in which to grow. During the period of growth liberal supplies of liquid manure should be given, and by cutting back the shoots when they cease blooming two or three successive lots of bloom can be easily obtained. A house that has a temperature of 40deg. to 50deg. is the best, and whether the plants are trained on the roof or on a back wall, the above rules should be observed.

Propagated by root grafting, which needs especial skill, and special structures.

The following are good for house cultivation: *C. aristata*, *C. indivisa lobata*, *C. Jackmanii*, *C. magnifica*, Thomas Moore, *C. Standishi*, Lady Bovill, Mr. F. C. Baker, Albert Victor, Lucy Lemoine, John Gould Veitch, *C. rubella*, Star of India, and Lady Caroline Nevill. All but the first two are hardy and have very fine flowers, and all or any of them are well worthy of cultivation.

Clanthus.—Greenhouse hard-wooded climber. Grown for its flowers and general appearance. Minimum temperature, 40deg. This is a greenhouse climber of much beauty, the papilionaceous flowers being both large and of a brilliant colour, in appearance like some of the Everlasting peas. The whole plant—the Glory Pea of New Zealand—is very ornamental when well in bloom, the large flowers and handsome foliage contrasting well with other plants; but from its great liability to the attacks of red spider, it has got into disrepute amongst amateurs and gardeners who do not take a real

interest in their work. Now, it is not difficult to keep down spider if it is not allowed to get a firm footing on the plants, but let it once get fairly at home on the foliage, it is almost an impossibility to be rid of it. The only way to keep down red spider is to syringe daily throughout the growing season with clean water. Scale sometimes attacks them, but careful hand picking and sponging with Fowler's Insecticide will keep this unwelcome visitant at bay. The best plan for an amateur to pursue is to obtain plants from a nursery in the fall of the year, and keep them in a greenhouse until April, when they should be examined, and if the roots are moving they should have a 2in. shift, good fibrous sandy loam and sand being used for compost, or, if this is not attainable, peat and sand. The compost should not be sifted, but should be broken up by hand and compressed firmly in the pots. After potting, the plants should be placed in a pit with other young hard-wooded subjects, kept close for a few weeks, and turned and syringed daily. Training must be attended to regularly if it is desirable to keep the base of the plants well furnished, as the wood when old is very liable to break off. If it is preferred to keep the plants in pots, they can be either trained out on sticks or on a trellis, either flat or balloon-shaped, or they may be planted out as pillar or wall plants, but from their liability to the attacks of spider the amateur will probably do them best in pots. Remove the points of the leading shoots and attend to watering at the roots, and the treatment is complete for the season. Winter as before, and give a 3in. shift in April, attending to watering and syringing, and as they will probably bloom during July or August, the leading shoots should not be stopped. After blooming the shoots should be cut back and the plants be treated as before. The next season give another 3in. shift and treat as previously, and a good head of bloom will result. If only moderate sized plants are required, instead of re-potting, remove the top 3in. of soil from the pots and fill with the compost above recommended, to which a fifth part of rotten manure has been added; apply liquid manure once or twice a week, and with this treatment the plants will last for years.

Propagated from seeds sown in spring in sandy soil on a gentle bottom heat, and re-potted and grown on carefully.



FIG. 50.—*COBÆA SCANDENS.*

They, however, are very awkward subjects to deal with in a mixed house for the first year, owing to the attacks of red spider, which cause much loss.

For sorts, *C. puniceus* (the Glory Pea of New Zealand) and *C. magnificus* and *C. Dampieri* are all that can be desired.

Clivia.—See “Imantophyllum.”

Cobæa.—Greenhouse hard-wooded climber. Grown for its foliage. Minimum temperature, 40deg. This is a family of free-growing climbers that is suitable for either greenhouse or conservatory, and also for summer use out of doors. It is very free-growing, and, during the season, its free growth renders it peculiarly useful for covering the roofs of ferneries or other places where shade is a desideratum, as it only requires a circulation of air to maintain it in good health, and, as it is not particularly liable to the attacks of insects, it is, to say the least, a desirable plant for the purposes mentioned. The variegated form is well suited for giving brightness to bare walls, or for arches, porches, &c., while, like all the family, the general gracefulness of outline renders it an object of admiration. The Cobæas are readily raised from seeds in spring, a little bottom heat alone being necessary if the seed is new; but old seeds are, as a rule, very unreliable. A free, moderately rich soil is necessary, and the plants do best if placed out in the border, but, at the same time, they do very well in large pots. In autumn the long shoots can be pruned back, and fresh growth will be made in spring. In fact, these are about the handiest plants there are for covering large spaces. The flowers, which are large, bell-shaped, and purple in colour, are noticeable for their size, but are not very decorative, and are useless for cutting.

Propagated from seeds as described above.

The sorts are, *C. scandens* (Fig. 50), *C. s. penduliflora*, and *C. s. variegata*, which has handsome variegated foliage.

Cockscomb.—Tender annual, grown for its inflorescence. Minimum temperature, 60deg. Before giving cultural directions for this plant (*Celosia cristata*), we may as well remark that it is of no use trying to cultivate it without heat, and many amateurs are without this requirement. Cockscombs, to be of real use, must be dwarf in stature, and the heads must be as

large as can be obtained, so as to present as great a mass of colour as possible to the beholder. To the general reader we say, buy the plants in full bloom, but, where it is really desired to grow them, great pains must be taken to obtain the proper conditions for their growth. A good Cockscomb should be not



FIG. 51.—COCKSCOMB.

more than 9in. high, and it should be quite that width over the top of the bloom, if not more. The bloom, which is well shown in Fig. 51, should also be as wide or thick as possible, and, whatever the colour, it should be at the same time clear and dense. The foliage must be kept quite green, and a sufficiency of leaves should occur on the stems, or the

plants will have a very poor and bare appearance, far from pleasing to look at. The first point in growing these plants is to have the seeds sown at the proper time, and in this respect different growers vary in opinion. It is, however, necessary to sow the seeds some time in March or April, using pans of well-drained, rich, sandy soil. Seed of a good strain should be obtained, and, if it is possible to obtain it from a gardener who has it about three years old, so much the better, as the plants raised therefrom are not so much inclined to run to leaf as those from new seeds. Where dependence can be placed in the seed, even if it is four or five years old, there is no harm done, but, in such cases, it is better to sow rather early, so that, if one sowing fails, there may be time to get in another without endangering the crop. After sowing, the pans should be placed in a hot-bed, with a night temperature of about 65deg., rising to about 70deg. with sun heat. A moist, but not stagnant, atmosphere should be maintained, and, as soon as the seeds germinate, they should have plenty of light and just a trifle of air, care being taken that the soil in the pans does not become dry, or the plants will be ruined. The pans must be kept near the glass, and, as soon as the plants are large enough to handle, they should be potted off into small 60-pots, the seed leaves being carefully kept close to the soil, as the object desired is dwarfness. The pots must be placed in a position close to the glass, in a frame where the same conditions are maintained as above mentioned, allowing a rise of 5deg. or 6deg. in the day-time. The plants should be grown on as quickly as possible, the soil being kept rather dry, but, of course, not dust-dry, and, as soon as the heads show so that the best-formed ones can be selected, these latter should be re-potted into 4in. or 5in. pots, with a good soaking of water ere re-potting, and a few hours allowed for the pots to drain. After potting, the plants should have a position close to the glass. The pots should subsequently be plunged to the rims in a bed of ashes or cocoa fibre on a hotbed, just sufficient water, but not too much, must be given, and more air must be admitted. It is necessary, however, that the surface temperature do not fall below 65deg., or a check

will be given that will probably retard the growth of the heads. If the heads are required large, another shift must be given before they are too large or much developed, and from 5in. to 8in. pots should be used for this final potting. The same rules as to keeping close to the glass, &c., must be observed, and, when the pots become filled with roots, liquid manure should be given about twice a week.

We have found the following to be a good compost for these plants, if due care is taken in potting: Three parts rather light loam, pulled to pieces, but not sifted, except for the seed pans, and one part of thoroughly decayed cow manure, to which has been added a good dash of sharp sand. In potting, the soil must be pressed pretty firm around the roots, but not too hard, or the water will not run through. Too loose potting, however, will cause the plants to run too much to leaf, consequently it is necessary to choose the medium course.

Propagated from seeds as described above.

Of varieties, crimson Tom Thumb and Sutton's prize Dwarf are good crimsons. There is also a yellow variety, and a variety having heads striped with crimson and yellow alternately; but the crimsons are best.

Coleus.—Soft-wooded stove plant. Grown for its handsomely coloured foliage. Minimum temperature, 55deg. These are foliage plants, unsurpassed for beauty of colour or richness of foliage, and whether grown as large or small plants, they are extremely useful for decorative purposes. The leaves, which are the chief points of beauty with coleus, vary in size from one to four inches long to from half an inch to two inches in breadth, and are shaped like those of a fuchsia, but instead of being glossy are of a velvety texture, and thus show off their varied colours to the greatest advantage. Their culture is very simple; no expensive manures or medicaments are required, but unless a minimum temperature of at least 55deg. is maintained, the plants cannot be wintered successfully. In such a case it is far better to purchase plants in April, grow them on carefully for the season, and then throw them away, than to encumber the house with what will prove to be so much

useless rubbish before the winter is out. The following is the plan we follow most successfully, as it saves us the trouble of wintering old plants.

In April we purchase a quantity of plants in thumb pots, at a cost of about 2s. 6d. per dozen. We then transfer them into 3in. pots, and place in a warm part of the house, keeping moderately moist. As soon as the plants are about two inches high the points are pinched out, and this causes the plant to break freely, and as each break gets to be about two inches long we repeat the process, until a good framework is obtained on which the future plant can be constructed. As soon as the roots touch the sides of the pots a 2in. shift is given, and this is repeated until 10in. pots are reached, when, with care in training, watering, &c., magnificent plants will have been made, as the structure prepared at first would carry a very fine head of foliage. For compost we use one-half rotten turf from an old pasture, one-fourth thoroughly rotted cow manure, and the other fourth composed of sharp sand and leaf soil in equal proportions. Pot moderately firm, and water freely when growth has commenced, giving occasional doses of liquid manure (not sulphate of ammonia), especially during the hot weather, as the plants grow very rapidly then. Plenty of air and light must at all times be afforded, so that the plants are short-jointed and the wood firm, long spindling shoots not holding the leaves firmly, consequently soon becoming bare. Great care must be taken that the plants do not suffer from the want of water, or the lower leaves will fall and render them unsightly. A well-grown plant should be of a globular or pyramidal form, and the lower leaves should cover the edge of the pot, so that neither bare stems nor soil are visible. The chief points to be observed in the culture of *Coleus* are, free rich soil, plenty of water, and a warm temperature, and careful attendance. The bloom is insignificant and of no decorative value; when, therefore, there is the least appearance of a flower spike, the point of the shoot should be at once pinched out.

Propagated by cuttings struck in bottom heat in spring, or, in fact, at any time. For greenhouse work, cuttings should be

struck in spring only. The plants, as a rule, cannot be kept through the winter.

The following are all good and effective sorts, and are well worth cultivation: Golden Gem, scarlet, edged gold, fringed edge; Brilliant, bronzy red, yellow edge; Hermit, dark purple, fringed brown; Sunrise, deep bronze red, edge beaded gold; Her Majesty, the same as preceding; Cloth of Gold, fine yellow self; Beauty of Widmore, dark marone, belted with rose and green, and edged with silver, very fine; Refulgens, deep velvety purple, beaded bright green; Warrior, intense black velvet, belted pale yellow; Princess of Wales, reddish carmine; Verschaffelti, rich crimson; Diadem, rosy crimson, gold edge; Mr. J. H. Claringbull, dark scarlet, wide golden edge; Mrs. Galbraith, bright scarlet, tinged purple, edged white; and at least five hundred other varieties are really as good. If a couple of each of the above are obtained in spring and carefully grown on, they will form a splendid collection.

Convallaria.—See “Lily of the Valley.”

Coprosma.—Hard-wooded greenhouse or bedding plant. Grown for its general appearance, but particularly for its ornamental foliage. Minimum temperature, 40deg. *Coprosma Baueriana variegata* is a shrub or plant of a highly decorative character, being of compact growth and having obovate leaves with edges of a creamy white, for which it is grown, both for the greenhouse and bedding out, although it is somewhat difficult of cultivation, or rather propagation. It requires a brisk bottom heat to strike the cuttings, but where convenience exists it well repays the necessary trouble. In the greenhouse one or two plants look very well, and they may be put out of doors throughout the summer. The green and white foliage is very conspicuous, and shows up well. Cuttings should be made in March, of young wood, taken off with a heel of the old wood adhering, and put into cutting pots filled two-thirds full of crocks, then a thin layer of rich light material, and on top a layer of sand. Place the pots in a brisk bottom

heat in a propagating frame, or into a sweet hotbed, covering the pots in the latter case with bell glasses, and during the time the cuttings are making root only just sprinkle the pots with water, or the cuttings will damp off. When rooted, pot into rich sandy soil, and gradually harden off as in the case of other bedding plants propagated in a similar manner. Another plan of propagation is to place the plants in a propagating bed, and layer the shoots that overhang the pot. Old plants should be potted in a similar compost to that recommended above, and should be pruned into shape each year if necessary.

Propagated by cuttings, as already described.

Cordyline.—For particulars of *Cordyline indivisa* see under “*Dracæna*.”

Coronilla.—Greenhouse hard-wooded shrub. Grown for its flowers. Minimum temperature, 38deg. This is both a pretty and an easy subject to grow, and, like the cytissus, should be in every collection. The flowers are borne in clusters, well above the foliage, and are pea-shaped. The foliage is of a pleasing and somewhat glaucous green, and when the plants are trained over a trellis have a very good appearance. The variety *C. glauca variegata* has the foliage striped or margined with creamy white, and while being much prettier than the species when out of bloom, is not so showy when the blooms are on it. We have found the treatment advised for the sorts of cytissus answer admirably in the hands of amateurs, and therefore it is not necessary to enter into a prolonged description.

Propagated by cuttings struck in sandy soil, in a close frame or greenhouse, during spring or autumn.

For sorts both *Coronilla glauca*, yellow, and *C. g. variegata*, yellow, variegated foliage, are good.

Correa.—Greenhouse hard-wooded plant. Grown for its flowers. Minimum temperature, 45deg. This is a class of plant that commences to bloom in April, and the different varieties keep in bloom till the end of the year. They are really fine

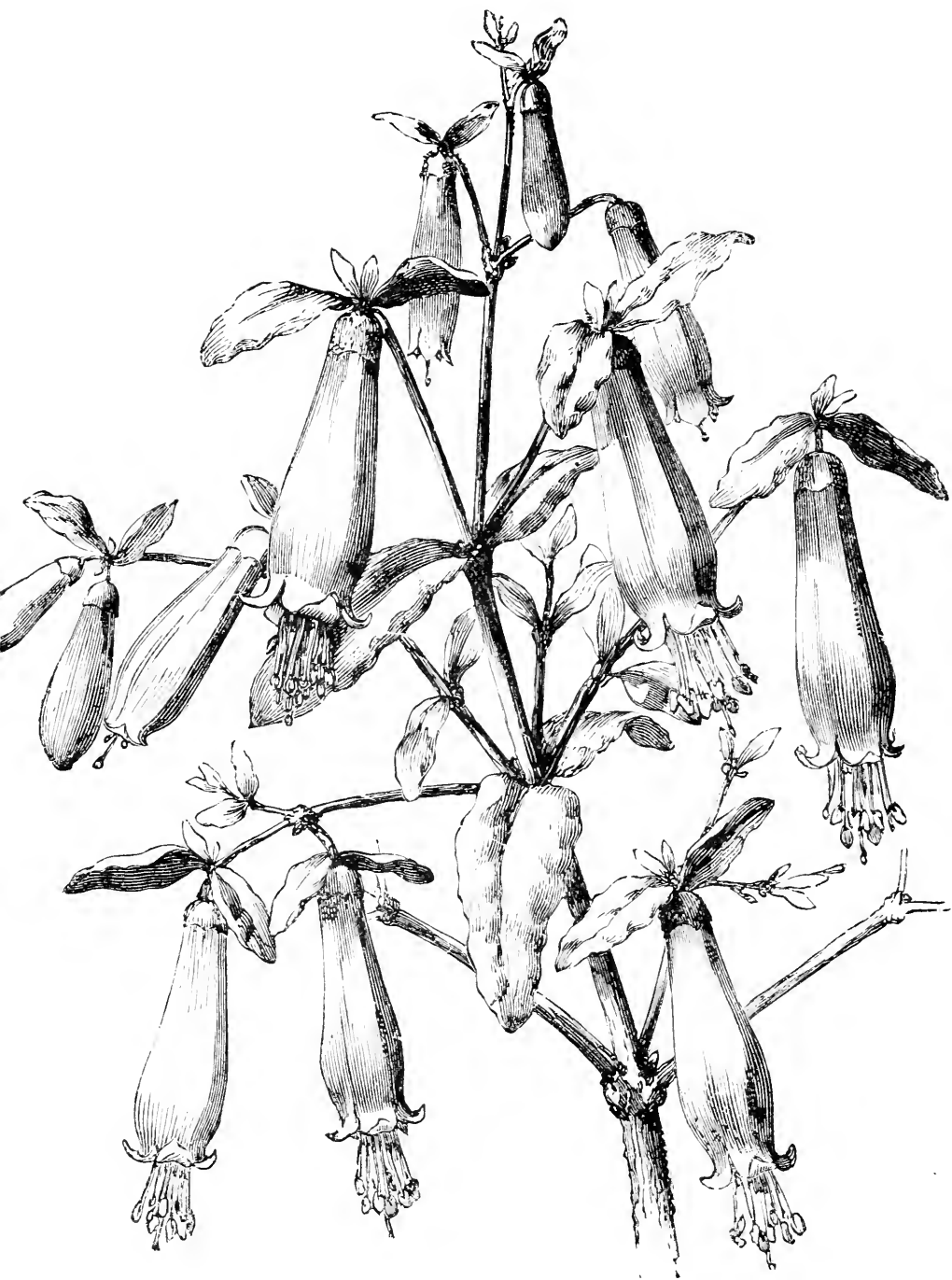

FIG. 52.—CORREA BICOLOR.

plants, and should be in every collection. The blooms, which vary in colour from scarlet to deep crimson in the tube, with a green or light coloured band near the apex, are tube-shaped, and are freely produced from the matured wood of the past season. As a decorative plant it is not easy to surpass it. It is of erect growth, and therefore does not require to be tied out like many others. In our opinion, it is far better to pinch back the points, so as to induce bushy growth, than to tie the branches out with a multiplicity of sticks, judicious pruning being in all cases preferable to sticks, if the plants are naturally shrubby. Of course, with young specimens it is necessary to keep the bottoms well furnished, both by pruning and tying out; but training is not a necessary operation after the plants are furnished and the growth is set. We find that these do very well with much the same treatment as oranges, so far as temperature and moisture go, and we have grown both *Correas* and oranges successfully side by side. The plants should be potted in April in good sound peat, to which is added a fair allowance of sharp sand to insure porosity for a length of years, as it is not advisable to reduce the ball of roots. When the plants reach 12in. pots, potting should cease, and they should be kept in blooming order by being watered with weak liquid manure once a week, by which means they will keep in blooming condition for two or three years; meanwhile young plants can be got on to take their place.

Propagated by cuttings of young wood taken off with a heel and struck in sand or sandy peat in a close frame, with or without a slight bottom heat.

For sorts we should choose *C. bicolor* (Fig. 52), *C. Brilliant*, *C. cardinalis*, *C. Cavendishii*, *C. delicata*, *C. Jardin d'Hiver*, *C. magnifica*, *C. Ne plus ultra*, and *C. victa superba*. All of these are good and well worth growing.

Crassula.—See “*Kalosanthes*.”

Crocus.—Hardy deciduous bulb. Grown for its flowers. Minimum temperature, 25deg., or when in active growth, 35deg. This is a class of early blooming bulbous plants that

comes in very usefully in either cold or warm greenhouses, and the culture is very simple. Place from three to seven bulbs in a pot, according to the show required, and arrange the colours according to taste. Use a compost of rather rich loam and sand, and allow plenty of drainage, as the plants will require liberal watering while growing. For further treatment see "Hyacinths."

Propagation is effected naturally by the increase of the bulbs, which occurs every year.

The following are good sorts for pot culture: *C. vernus*, various (Fig. 53); *C. vernus versicolor*, white striped with purple (Fig. 54); *C. Albion*, white, striped blue; *C. Alfred Tennyson*,



FIG. 53.—CROCUS VERNUS.



FIG. 54.—CROCUS VERNUS
VERSICOLOR.

dark violet, striped white; *C. Brunel*, dark shaded blue; *C. Mammoth*, white; *C. Marquis of Lorne*, dark purple; *C. Ne plus ultra*, blue, white margin; *C. Prince of Wales*, dark blue, edge white; *C. Purity*, pure white; *C. Golden Yellow*; *C. Cloth of Gold*, golden yellow, bronze crimson stripes; and *C. Sir John Franklin*, very dark indigo.

Cuphea.—Half-hardy perennial soft-wooded plant. Grown for its flowers and general appearance. Minimum temperature, 36deg. *C. platycentra* is very old-fashioned, very pretty,

and withal very easy to cultivate. It is useful either as a pot or a bedding plant, and, besides being simply pretty, the whole plant is both strong and interesting. The flowers are tube-shaped, about an inch long, of a reddish orange colour tipped with black, and are shaped somewhat as the blooms of *Fuchsia fulgens*. In fact, excepting that the flowers are axillary instead of terminal, the cuphea might be taken as a miniature *F. fulgens*, as the leaves and flowers are both like the fuchsia named, and the plant does not get above a foot and a half high. The old-fashioned plan was to raise the plants from cuttings, which strike freely in March or April if placed on a brisk bottom heat; but by far the better method is to sow seeds in January or February, and then grow the plants on in rich sandy loam. Grow on to nearly the size required, repotting from time to time, and, when large enough, let the plants fill the pots with roots, and then give ample doses of liquid manure occasionally. For vases, pots, window boxes, and various uses outdoors, Cupheas come in very useful, and for the conservatory they are fine subjects. In fact, we often wonder why they are so little grown now.

Propagated from seeds or by cuttings, as described above.

Cyclamen.—Half-hardy deciduous bulb. Grown for its flowers. Minimum temperature, 36deg. These are plants that should be represented in every greenhouse and conservatory, as their decorative power is great for a bulbous plant. *C. Persicum* is, perhaps, the best of the family for pot culture, but *C. Coum* (Fig. 55), *C. Europæum* (Fig. 56), *C. Atkinsii*, *C. repandum*, and *C. Ibericum* are all useful according to their different forms. The culture is comparatively simple, and with ordinary care success is certain, but while the plants are in active growth they must neither be neglected nor coddled up.

We have found the following method answer well in practice, although quite opposed to the old-fashioned plan of drying off the bulbs in summer, a plan that only tends to destroy the bulbs and render them the reverse of floriferous. The culture (to begin at the beginning) that we now adopt is as follows: In October we sow the seed in broad pans, using a compost of

leaf soil, sand, and fibrous loam, and then stand the pans in a warm hotbed until the plants are pricked off, in about six weeks from sowing. The pans will be all the more suited for the purpose if they are covered with flat sheets of glass, as it greatly hastens the vegetation of the seeds, and, at the same time, a hotbed is not then necessary, as a warm greenhouse or stove will do as well. When large enough we prick off into small pots and place on a shelf in a warm greenhouse until February, when we

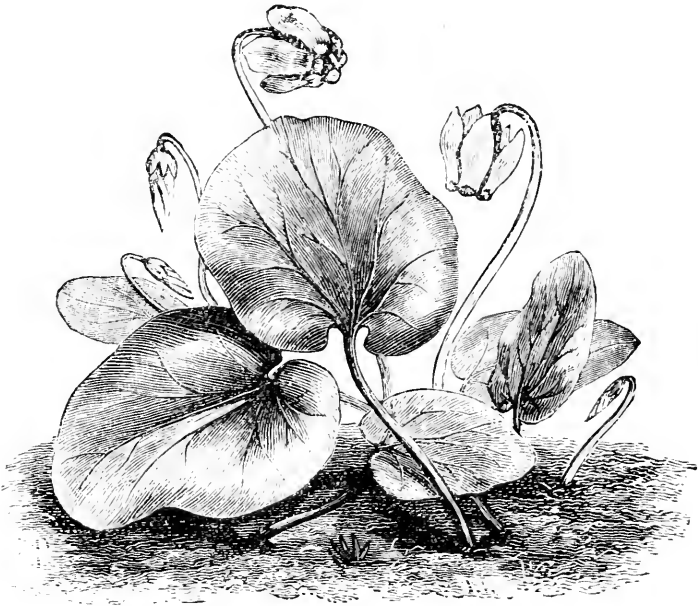

FIG. 55.—CYCLAMEN COUM.

pot off into 4in. pots, using good friable loam five parts and thoroughly rotted cow manure three parts, with a good quantity of sharp sand. We then grow them on briskly until the first week in May, and then transfer them to a pit or frame, and gradually harden off ready for planting out the last week in the month. Meanwhile, we prepare a bed for their reception, either on a north or a shady border. This bed is deeply dug and pulverised, and a liberal dressing of thoroughly rotten manure

and coarse sand is added to make it both rich and friable. We plant the bulbs out about a foot asunder, being careful to retain a good ball of earth to each, and not cover more than one-third of the bulb with soil. A good watering once a week and a sprinkling with a syringe every day are all that are required during the summer. About the second or third week in August we take the plants up, with good balls of earth adhering, and pot into 6in. or 8in. pots, placing them in a close frame for about ten days after they are potted, and then admitting air as necessary, at the same time paying due attention to watering, &c. About the end of September the pots are found full of roots, and the plants are then removed to a shelf near the glass in a warm light greenhouse. Here, with attention, they bloom for a long period, and about May they undergo the same treatment as before. Care must be taken to afford plenty of drainage at all times, and insects must be scrupulously destroyed. So much for *C.*



FIG. 56.—FLOWER, BUD, AND LEAF
OF CYCLAMEN EUROPEUM.

Persicum. For the hardy kinds a somewhat different treatment is necessary, but as they are quite hardy they do not require to be placed in a greenhouse at all. They should be potted into 4in. or 6in. pots, the soil being as before recommended; and, after potting, should be plunged in a pit or frame facing the north. About October the position should be changed, and the plants made to face the south during the winter. Air ought to be given at all times, except in actual frost, and during fine weather the lights should be thrown right off. In the place of partly burying the bulbs, as in the *Persicum* section, the

crowns of the bulbs of *C. Coum*, *C. Europæum*, &c., should be about half-an-inch below the surface of the soil, as in many cases the roots start just below the crown of the bulb, instead of the base.

During the summer we treat the hardy *Cyclamen* much the same as the tender section—that is, those for pot culture—but, of course, permanent plants do best in sheltered borders or in a rockery. In all cases it is absolutely necessary to give hardy *Cyclamen* a deep, rich, and well-drained border, where they are permanently planted; and it is also requisite that the plants should be protected from violent hail storms and very heavy rains, as the leaves, being persistent during winter, are very liable to be damaged if not protected.

Propagated by means of seeds as described above. The hardy kinds should be sown on pans of sandy soil in a cold frame, and potted as soon as they can be handled. The following season they can be grown on in pots or planted outdoors, as may be desired.

For sorts of *C. Persicum*, the following are distinct, but a packet of good seed will produce a great variety of colours and markings: *C. Persicum album*, *C. P. delicatum*, *C. P. punctatum*, *C. P. purpureum*, *C. P. roseum*, *C. P. rubrum*, and some others to be obtained at nurseries. For hardy sorts, *C. Atkinsii*, *C. A. carneum*, *C. A. roseum*, *C. Coum*, *C. C. carneum*, *C. C. vernum (marmoratum)*, *C. Europæum*, *C. Ibericum*, *C. I. album*, and *C. repandum*. For making a selection for pot culture alone, we should use the *Persicum* section only, unless, indeed, quiet instead of showy plants are required.

Cyperus.—Greenhouse soft-wooded plant. Grown for its foliage. Minimum temperature, 45deg. This plant, which is so much used on account of its graceful palm-like appearance, is not very hard to cultivate. Being a semi-aquatic, it likes plenty of moisture while in active growth, and also likes good drainage, so that the surplus water does not stagnate round the roots. A good loam, or peat and loam mixed, is the best soil, and the mode of culture is somewhat as follows: As soon as the stools start growth in spring they should be divided if necessary and

reotted into suitable soil, care being taken to provide good drainage, and to pot fairly firm. The soil should be moist, but not saturated with water, and the pots placed in the warmest part of the house. As growth increases so must the amount of water given be increased, because, when in full growth, great evaporation takes place. After the plants have attained their full size, they are in form very like miniature date palms, a foot or eighteen inches in height. If kept regularly moist, they will last for some months, but they must not be cut down till the young growth commences to appear, and the pots must not be allowed to get dry till then, or the stools (or roots) will be destroyed.

Propagation is effected by division of the stools or crowns when the plants start growth, as mentioned above.

Good sorts for greenhouse work are: *Cyperus alternifolius*, green foliage; *C. a. fol. var.*, variegated foliage, and where a minimum temperature of 50deg. can be maintained; *C. laxus fol. var.*, variegated foliage, is very useful.

Cytisus.—Half hardy hard-wooded shrub. Grown for its flowers. Minimum temperature, 36deg. This is a plant that is much grown for the London markets, and is well worth growing. Its racemes of bright yellow flowers and its elegant foliage make it a favourite with everyone, and a plant or two in a greenhouse gives a bright appearance to what would, perhaps, be only a mass of green foliage. The culture is very easy, and the adaptability of the plants to an amateur's treatment is very great, more so than scores of other hard-wooded plants; besides which the cost is very moderate; indeed, nice plants in full bloom are to be had from a shilling each in the season. It is one of the most popular spring plants that is grown near London for sale, one large firm of our acquaintance growing from 9000 to 12,000 plants annually. It is well adapted for house decoration, as it lasts in bloom for a long period, and, unless large plants only are grown, forms one of the most useful house plants with which we are acquainted. Plants about a foot high look very well for table decoration, only, as the flowers are golden yellow, they look white by gaslight.

Cytisus and Genista are the names the plant is known by in different places, and it is immaterial which is asked for, although Cytisus is now the generally accepted name.

The plants should be potted as soon as the bloom is over, in rich sandy loam, with sand enough to keep the soil well open. In the end of June they should be put out of doors, and should remain out until September, when they should be brought indoors, and placed in a light position, so that they may start soon after Christmas. They bear forcing very well, and, where convenience exists, may form part of the early batches of plants.

Propagated by seeds or by cuttings. Seeds should be sown on sandy soil early in the season, pricked off into small pots as soon as large enough to handle, and grown on till of a good size ere being allowed to bloom. Cuttings can be struck in cold frames or in the greenhouse in spring or autumn, friable soil being used for the purpose.

For sorts we prefer *C. racemosus*, yellow; *C. racemosus superba*, yellow; *C. Atleana*, yellow; and *C. filipes*, white; and they are really good. Where one or two plants only are grown, the first two will be found to give satisfaction.



~~~~~

**ACTYLIS.**—Half hardy soft-wooded plant.

Grown for its foliage. Minimum temperature, 38deg. These useful dwarf graminaceous pot plants are perfectly hardy, and must be brought into the house in relays as required. The inflorescence is not very noteworthy, and should be kept removed, as the foliage only is of value, and as this reaches only to about four inches high, and is very elegantly striped with a silver variegation, it is very effective. Either a warm or cold house suits them very well for a time, but, as the plants will not last long under glass, frequent changes must be made. A compost of sandy loam suits them

well, but, as plenty of water is required, good drainage must be afforded. Some care will be necessary to keep down green fly if the plants are in a warm house, and with this exception, but little fear of trouble from insects need be entertained. They are much used out of doors as edging plants in fixed designs, as their neatness renders them particularly useful in this respect. The plants can be wintered in a cold frame or in the greenhouse, where they are of value on account of their foliage and general appearance.

They are easily propagated by division, a sharp, sandy loam being used for compost, and the plants kept close for a day or two afterwards.

For sorts, *D. glomerata variegata*, and *D. g. elegantissima* are the best.

**Daphne.**—Greenhouse shrub. Grown for its flowers and general appearance. Minimum temperature 38deg. This is a class of plants well worthy of general pot culture, both for its foliage and its finely-scented bloom, which is borne in terminal bunches, and is tube shaped, and something like that of the lilac in form, but is not above half the size. The leaves are laurel shaped, but not much more than two inches in length, and being of a dark green set the flowers off to great advantage. Plants about eighteen inches high and well bloomed are very effective. As it is nearly hardy, a cool house suits it very well, and, as the cultivation is easy, it is a very desirable plant for the use of amateurs. It does very well trained on the walls in a partly shaded cool house, and in several large gardens it is trained on the back walls of the camellia house, where it affords the perfume that the camellia lacks, and the foliage works in very well with that of the camellias. As an ornamental perfumed plant, the *Daphne Indica* (red) is second to none, and, as it requires no forcing house to bring it into bloom during the short days when fragrant flowers are scarce, of course it is within the means of most persons who have a greenhouse. The two *Daphnes* we prefer for house work are *D. Indica rubra* and *D. cneorum* (pink); *D. cneorum* (Fig. 57), though it is perfectly hardy, yet pays

for potting-up and housing. The treatment of *D. Indica* is very simple. In the first place, instead of coddling the plants up in a high temperature, 55deg. is quite high enough for them during the growing season, and, if the bloom is wanted moderately early, the same temperature will gradually bring them on. They are of slow growth, although robust-looking.

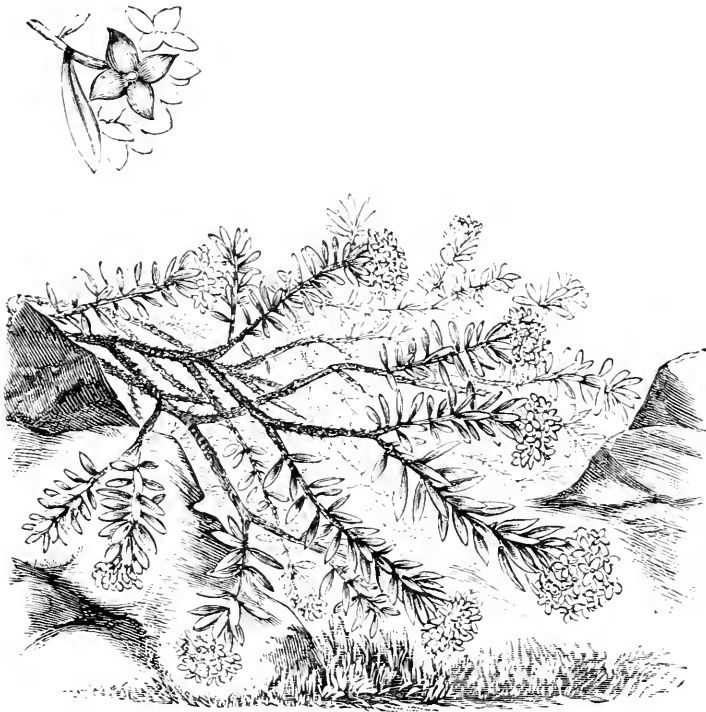

FIG. 57.—*DAPHNE CNEORUM*.

and care must be taken to get the wood well ripened. During summer the plants may be placed in a sheltered position out of doors, and brought in at the same time as camellias and other similar plants. A moist atmosphere suits them admirably during the time they are making growth, but, when ripening the wood, a drier situation is necessary. After blooming,

pruning may be resorted to; keep the plants in shape, or they become straggling in a few years, whereas they should be kept as bushy as possible, if good appearance is desired. As a rule, the plants are worked on one of the hardy kinds; but we advise amateurs to get them on their own roots, as we have found them grow best when propagated in that manner. It will not stand over-potting, blooming best if rather pot-bound. Pot in the middle or end of February; pot firmly, but, at the same time, insure sufficient drainage. For soil use two-thirds rich turfy loam, and one-third turfy peat, with plenty of very coarse sand, and it is no disadvantage if some charcoal or crocks are mixed with the soil.

Propagated generally by grafting, but, for an amateur's use, cuttings struck in a cold frame or greenhouse, in sandy soil, are best. Cuttings should be taken off as soon as the growth ceases.

For pot culture it will be found that *D. Indica rubra* is the best, as *D. Indica alba* (white) is somewhat liable to canker; but still cuttings struck in a cold frame under a bell glass will do very well for a year or two. The first blooms from October to April if the plants are brought on in succession, while the white blooms during summer; this latter is best planted out in the conservatory borders where there is room. *D. collina*, *D. dauphina*, *D. Fioniana*, and *D. Indica* are the best for cold house culture, and are very sweet scented, thus rendering them very useful for bouquets.

**Darlingtonia.**—Greenhouse soft-wooded plant. Grown for its flowers and general appearance. Minimum temperature 45deg. *D. Californica* is one of the so-called carnivorous plants, and is of American origin. As a manifestation of plant life it is curious and interesting, and the structure of the plant is alike wonderful and beautiful, albeit it is destitute of the gaudy characteristics of many of our more ephemeral beauties that "bloom and soon decay." It requires a warm house to grow it well, a house where the minimum temperature is at least 50deg., and a north-west aspect suits it well. A moist but not saturated atmosphere is required, and plenty of root moisture

is necessary. The best medium in which to grow this plant is chiefly chopped sphagnum mixed with about a fourth part of heath soil and charcoal, the whole surfaced with chopped sphagnum. Plenty of drainage must be afforded, and large pans are far preferable to pots, the plant being on a mound raised a little above the surface of the pan. Dr. Moore, of Glasnevin, has one of the finest specimens in Europe, and we believe his treatment is much the same as that just described. To an enthusiast in horticulture this will be found one of the gems of the greenhouse, but it requires skill and attention to grow it well.



FIG. 53.—*DEUTZIA GRACILIS*.

**Deutzia.**—Hardy shrub. Grown for its flowers, which are much esteemed. Minimum temperature (under glass), 30deg. These are about the hardiest of the dwarf white flowering shrubs, forming bushes about a foot or fifteen inches high, with oblong ovate, or willow-shaped leaves, and in their season covered with a dense multitude of small white star-like flowers, borne in axillary racemes for the whole length of the preceding year's growth, and, as they can be bloomed in either a cool or forcing house, they are doubly useful. To have them at their best it is, however, advisable to bloom them in a temperature of from 45deg. to 50deg., as then both foliage and flowers are well developed; but, at the same time, if only a cold house exists, they will do well in such an one. A compost of good sound loam,

enriched with about a sixth part of thoroughly decayed cow manure, and rendered sufficiently permeable to water by the addition of coarse sand, suits them well, while the pots, which should not be too large, should be well drained. The plants should be repotted each year after blooming, and plunged

in a bed of coal ashes, attention being paid to training and arranging the shoots in such a manner that an equal growth is maintained throughout the plant, so that it shall have a somewhat globular form. Remove to a frame before frosts come, and thence remove the plants to their blooming quarters. Water will be required in proportion to the growth, and an occasional dose of liquid manure will be of great advantage.

Propagated from cuttings, layers, or suckers, but, as well-grown plants are very cheap (about 5s. per dozen), it is not worth while to raise young plants; moreover, three years must elapse ere they are of useful size.

The two best sorts are *D. gracilis*, single white, and *D. crenata flore pleno*, double white, this latter being finer in the individual blooms, but less effective as a whole than *D. gracilis* (Fig. 58). *D. scabra* is too gross a grower for the purposes to which the others are put.



FIG. 59.—DIELYTRA EXIMIA.

**Dicentra.**—See “Dielytra.”

**Dielytra.** — Hardy herbaceous plant. Grown for both flowers and foliage. Minimum temperature (in pots), 36deg. This is the

familiarly named “Dutchman’s breeches,” of the herbaceous border, and is a deciduous perennial. The bright heart-shaped pink flowers which are borne on long spikes of a graceful drooping habit are very effective when combined with other plants, and the bright and somewhat glaucous foliage contrasts well with the darker greens of the hard-

wooded kinds. As a rule, it is not judicious to grow *Dielytras* in pots for more than one season. It is preferable to have fresh plants each year, returning those which were bloomed indoors into the borders, for one or two seasons, to recuperate their exhausted strength, and in their places to take others that have been in the borders for a similar term. The roots should be potted into a compost of sandy loam in well drained pots as soon as the foliage dies off,



FIG. 60.—*DIELYTRA SPECTABILIS*.

and the pots should be placed in a cold frame until introduced into the house. If grown in a warm house they should have a warm light position as near the glass as possible, and a moist growing temperature should be maintained. They should be neatly staked, and turned round frequently to equalise the growth. When the blooming is over, the pots should be



removed to a cold frame, and as soon as severe frosts are

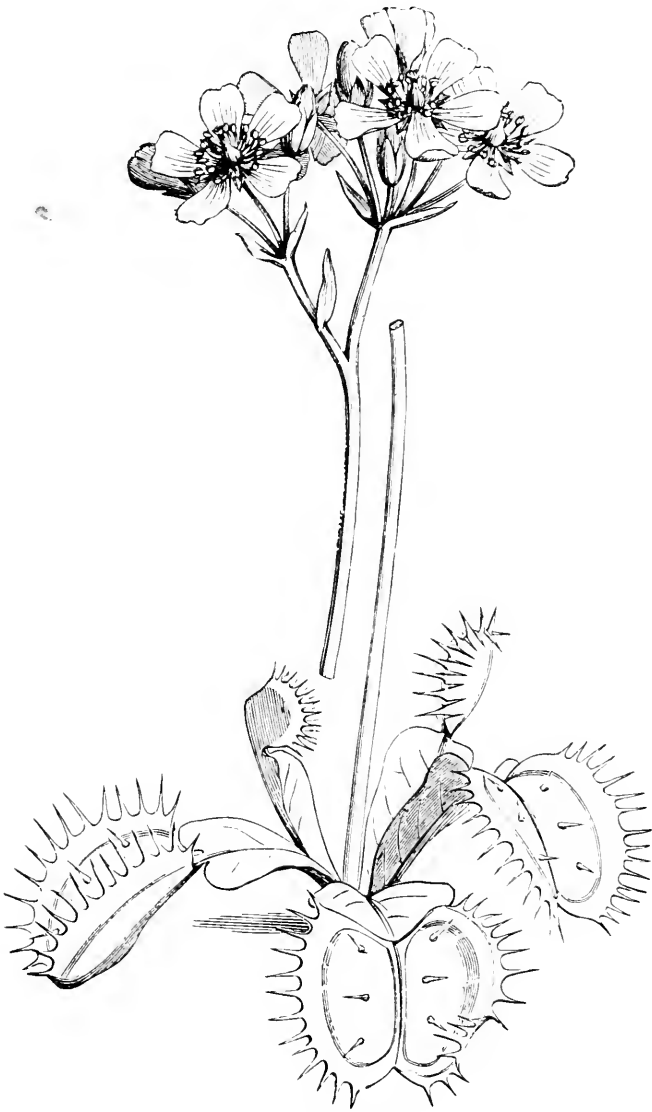

FIG. 61.—DIONEÆ MUSCIPULÆ.

past the plants can be placed out in the borders. Successional

batches must be brought in as occasion requires, and with little trouble bloom can be kept up from February to June. In the cold house the plants will flower—according to the severity of the season—from the end of March till June, and the general treatment is the same as in the warm house. Plenty of water is necessary when they are in full growth, and an occasional dose of weak liquid manure is an advantage. It is also necessary to keep down green fly, or ruin will be the consequence.

Propagated by division of the roots when they begin to make growth.

The best sorts for pot work are *D. spectabilis* (Fig. 60), pink; *D. spectabilis alba*, white; and *D. eximia* (Fig. 59), red; but this last is not so easily grown as the other two. *D. cucullaria*, yellow and white, thrives well in a cold house, but is not so good as the rest. In fact, one rarely sees it grown in pots.

**Dionæa.**—*D. muscipula* (Fig. 61) is a carnivorous plant. It does well with the treatment given to the *Sarracenia*, and is far easier to cultivate. It should be grown in pots one-third filled with crocks, the compost one-third fibrous peat, and two-thirds sphagnum, and some very sharp sand, with perhaps a small quantity of charcoal. It requires a moist atmosphere, and where this cannot be obtained in the house the plants should be grown under bell glasses. The *Dionæas* are very interesting subjects, the one named being about the best for the use of an amateur. Some of the *Droseras*, also, thrive well with the above treatment.

**Dodecatheon.**—Hardy herbaceous plants. Grown for their flowers. Minimum temperature (in pots), 36deg. These are the American cowslips or “shooting stars,” and although they prefer a cool situation in which to grow, still they can be used to decorate the cold house, provided a somewhat shady cool spot is found for them. We have grown them well with a very little trouble in frames, and in an old cold house just wind and water tight. The way our plants were treated was as follows: In November they were taken up and potted

in 6in. pots, in a compost of loam, enriched with leaf soil, and rendered porous with a sufficient quantity of sharp sand.

Ample drainage was afforded, as it is necessary to apply plenty of water while the plants are growing. They were kept in a cold frame until the first week in March, and then transferred to the house, water being applied as required. After blooming they were plunged in a bed of coal ashes, under a wall facing the north, but protected from inclement weather, and during the summer were well attended to. The following year they were treated in the same way, but larger pots given, and in the third season they were divided, so that they should not become too large. One thing



FIG. 62.—DODECATHEON MEADIA.

must always be remembered, namely, that these plants will neither stand hot sun nor forcing heat, and are only fit for blooming in the cold house, or frames, or to stand in rockwork, &c., as hardy plants.

Propagated by division when the plants are at rest.

*Dodecatheon Meadia* (Fig. 62) and its varieties are best for pot culture, as they are the least trouble; but the other kinds, if well grown, really repay the pains. *D. integrifolium*, crimson; *D. Jeffreyanum*, red; *D. Meadia*, red; *D. M. albiflorum*, white; *D. M. a. violaceum*, violet; *D. M. elegans-giganteum* of some—rose and lilac; *D. M. lilacinum*, lilac; and *D. M. purpureum longiflorum*, purple, are all good for the purposes we have mentioned, and the first two make good exhibition hardy plants.

**Dracæna.**—Greenhouse hard-wooded plant. Grown for foliage. Minimum temperature, 45deg. This is a class of ornamental variegated foliaged plants that commands attention for general culture by amateurs, as it is so useful for decorative purposes

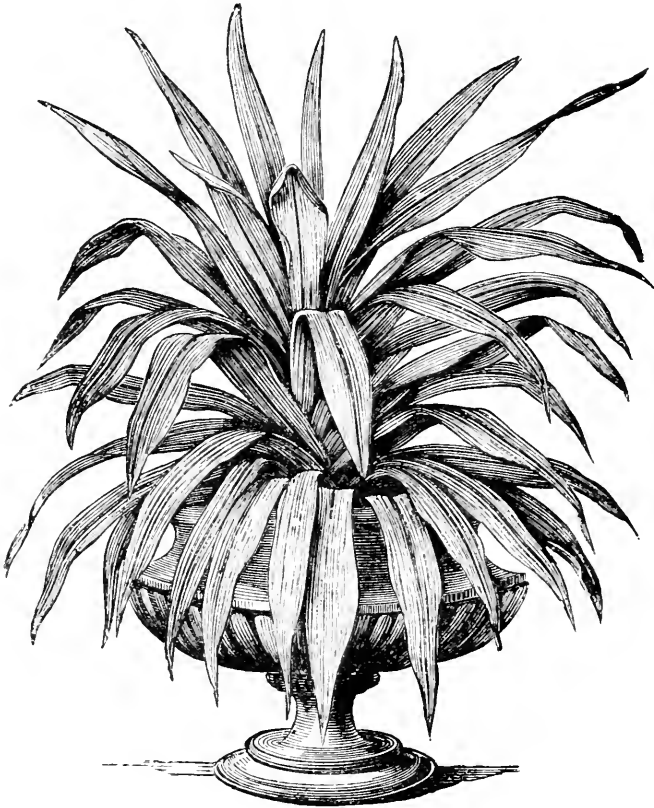

FIG. 63.—CORDYLINE (DRACÆNA) INDIVISA.

indoors. Small plants from 1ft. to 18in. high make very useful centres for tables; for windows, and to stand in halls. The foliage is leathery and stands gas well, and when dirty is easily cleaned with a sponge and lukewarm water. *Cordyline indivisa* is, in appearance, much like the *Dracæna*, and as the cultivation is much the same, we so treat it here. With these,

as with all other fine foliage plants, care must be taken to damage the leaves as little as possible, or the plants soon become very unsightly. Leaving out the varieties that require stove and intermediate house treatment, there yet remains a good variety for the greenhouse, which are all comparatively easy of cultivation. Scale is about the only insect pest to be feared, but with ordinary care can be kept down easily, hand picking being the means employed. We have, however, found that thrips will occasionally appear, but in a clean, well kept house, their visits will be few and far between.

Dracænas are not very particular as to soil, any ordinary potting soil answering pretty fairly; but, of course, to obtain the best results it is necessary to use the best only. This we find to consist of equal parts of peat and loam, with enough sharp sand added to keep the whole open enough for the water to pass through freely. The soil should be rather coarse, and not compressed too firmly, as the plants require plenty of water throughout the season of growth, and hard compressed soil makes it stagnate round the roots, thereby causing disease and finally death. For the same reason plenty of drainage must be afforded, and when large pots are used, they should be chosen with holes round the sides as well as at the bottoms. A rather humid atmosphere, plenty of water and warmth, and a light position are requisite during the growing season; and if the plants are to be removed indoors, they will require to be hardened off, or the leaves will suffer. For a start choose thrifty well-grown plants at a nursery, and grow them on carefully. The modes of propagation will be described at the conclusion of our remarks on plants.

Propagated by cuttings struck in a moist bottom heat, such as is afforded to stove plants.

The following will all be found very good: *Cordyline indivisa*, *Dracæna atrosanguinea*, *D. Australis*, *D. Banksii*, *D. Draco*, and *D. Veitchii*. We do not give the colour of the bloom as it is but rarely borne in the ordinary greenhouse.

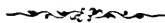



**CHEVERIA.**—Half hardy, succulent, soft-wooded plants. Grown for both foliage and flowers. These are what are termed succulents, and some of them are very fine when in bloom, while others are more conspicuous for their foliage. The plants are shaped like a rosette, and the common house-leek affords an example of the form of the plant, but the flowers are not the same. The flowers of the echeverias, which vary somewhat in colour, are borne on spikes, which issue from amongst the leaves, and these spikes bear flowers for their whole length, of a bag-like form, but which are very effective. The culture is very simple, that of the *secunda glauca* varieties particularly so, the chief point being to keep them through the winter, or until bedding time, as they will remain in the house throughout the summer and autumn. They are good plants for decoration, receive no injury from drought, bloom profusely in the season, and bear hardships that would utterly destroy less succulent plants. For all the *secunda* type, a good, fairly rich, sandy loam is necessary, as well as comparatively small pots, and plenty of drainage, but if they are required for house decoration it is advisable to use 4in. pots, and a somewhat richer soil. *E. metallica* forms a fine specimen in a 10in. or 12in. pot, especially when it is in bloom, and everyone knows its value as a bedding plant. Echeverias are easily propagated, either from seed sown in August, or from cuttings of the flower stems taken at the same time, which stems produce offsets; or, again, from offsets which are produced more or less freely from the base of the stems. These last should be placed singly on small pots of sandy soil, kept just moist, when they soon strike root. A frame is best for the purpose, kept nearly close. The young plants should have a shift in March, and if not used for bedding purposes should be placed in the frames in June. They should be shifted into 4in. pots, in which they may bloom; or else into 6in. pots, when the foliage will be finer. Plants taken up from

the ground should be potted firmly into small pots and kept nearly dry through the winter, as damp is the greatest enemy to be feared. All the *Echeverias* are useful for their foliage, and the bloom of all of them is interesting, especially in a mixed collection. The plants can be kept either indoors or out during the summer, and if by accident occasionally not watered, will not

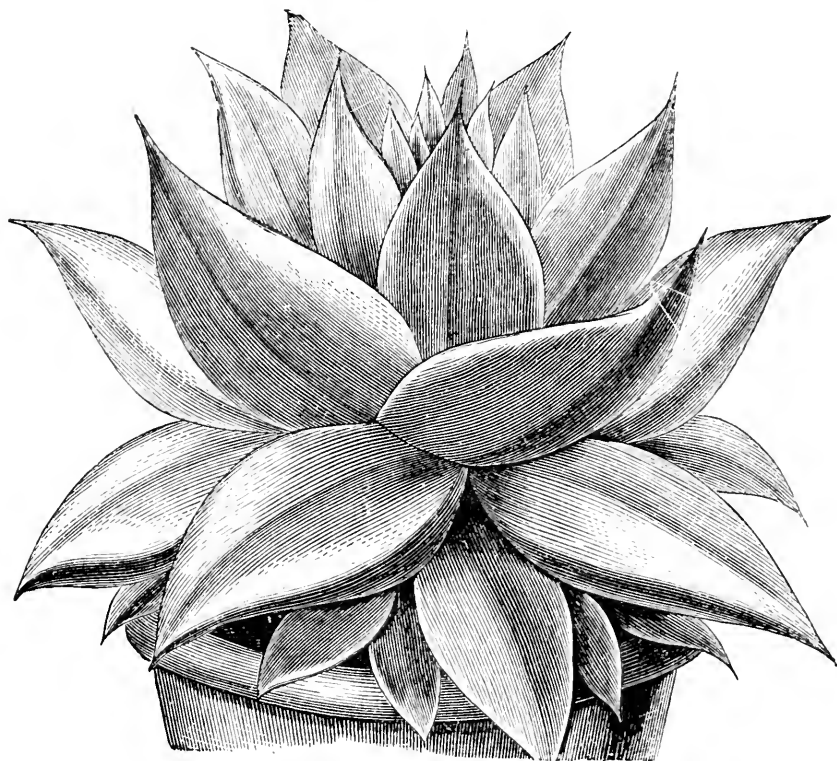

FIG. 64.—ECHEVERIA AGAVOIDES.

flag, unless drawn up weakly from want of light and air. They are also very easy to propagate, and anyone who has only a sitting room window can grow a very nice collection. They are, however, not quite hardy.

Propagated by division of the offsets, or by cuttings, according to species.

*E. pulverulenta* and *E. formosa* have both mealy, silvery leaves; *E. rotundifolia* is a cross between *E. metallica* and *E. secunda glauca*, and the leaves are nicely tinted on the edges; *E. fulgens* is good both for foliage and flower, but for the latter particularly, as it bears orange red flowers, with sometimes a yellow tinge; it blooms with ordinary greenhouse treatment in March, earlier if forced into bloom by a higher temperature. *E. secunda glauca* is good for its form and glaucous leaves; *E. secunda globosa* is one of the best of the series; *E. metallica* has large fleshy, massive foliage, of a rich metallic hue, and is very handsome; *E. agavoides* (Fig. 64) is very fine, with scarlet flowers, the plant being very much like an agave; and *E. atropurpurea*, also, is good for its bloom, the colour being purplish red.

**Epacris.**—Greenhouse hard-wooded shrub. Grown for its flowers. Minimum temperature, 40deg. These are worthy of more extensive cultivation, as they are little trouble, and very pretty when rightly managed. One of the chief causes of failure with the Epacris is neglect when it is out of bloom; and to this neglect very many of the failures are attributable, as the plant is perfecting itself for the production of new blooms while it is seemingly at rest; indeed, this is the case with the majority of plants, as they undergo many changes while not in actual growth. With blossoms, as most persons know, produced on the young wood, tube shaped and axillary, the Epacris are very like heaths, and, therefore, it is necessary that they should be properly grown and ripened to insure the setting of the bloom buds. As a whole, they have a somewhat erect habit of growth, and are frequently taken for heaths by the uninitiated, but are much easier to grow.

During the growing season it is a good plan to syringe overhead occasionally, but not often enough to produce mildew. After blooming, the plants should be cut down, and as soon as they start into growth should be re-potted into pots a size larger, good sound peat and sand being used for this purpose. Pot very firmly and afford plenty of drainage, so that the soil may not get sour, or the plants will suffer. Once in two



or three years is often enough to re-pot, unless it is desired to have large plants. The plants should be in frames through the summer, as, unlike heatbs, they do best under cover as a rule. In some varieties the growth is rather straggling; but this is of small consequence, each shoot becoming a mass of bloom in its season.

Propagated by ripe cuttings inserted in sandy soil, with or without gentle bottom heat.

For a selection, choose from the following, all of which are first-class: *Epacris alba odoratissima*, white; *E. carminata*, carmine; *E. Albertus*, pink; *E. delicata*, blush white; *E. densiflora*, blush; *E. elegans*, *E. grandiflora*, scarlet; *E. hyacinthiflora*; Fireball, scarlet; Lucifer, red; Model, blush; *E. multiflora*, *E. picturata*, blush white; *E. sanguinea*, red; *E. splendida*; Vesuvius, red, and *E. vesta*, blush.

**Epiphyllum.** — Greenhouse succulent soft-wooded plant. Grown for its flowers. Minimum temperature, 45deg. These are in reality cacti, or rather they belong to the cactus tribe; and they are often included in collections of plants, of which the majority are hard-wooded. As a decorative plant the Epiphyllum ranks in the first class, whether we use it exclusively in the greenhouse, or also for table decoration and cut bloom (which ranges in colour from pink to deep scarlet), as, in each case, it is very useful. The flowers are from lin. to 2½in. long, and are borne at the end of the leaves or branches, whichever they are termed, and are tubular, with a cleft lip. It is, however, impossible to properly describe them without an engraving, and it is better to see a well grown plant in bloom before adding them to the stock of plants. The treatment is very simple, as it is not supposed that an amateur will go to the expense of grafting, &c., which so often proves a source of trouble and annoyance, rather than pleasure. As a general rule, we consider that it is an ill-advised proceeding for an amateur to attempt the propagation of any plants which require special treatment and a special place to grow them in, as, however interesting the process may be, failure is almost sure to cause disgust with the plants

and all connected with them, and, therefore, should be avoided. In places where a proper heat and atmosphere are kept up, especially where a range of houses is under the charge of a competent gardener, *Epiphyllums* are very easy to graft, and in most houses under the charge of amateurs cuttings root freely, and form good plants for hanging baskets. *Epiphyllum truncatum* var. is the only variety we shall describe, as it affords plenty of variety for a beginner. We advise the purchase of young pyramid or umbrella-headed plants as a start, and then if basket plants are required they can be struck from cuttings.

As a rule, the plants bloom best if rather potbound; therefore, for general purposes, it is not well to give too much root room to blooming plants; but, at the same time, young growing specimens should have plenty of room to grow into large plants, as they are the most effective. The soil they do best in is good fibrous loam, lime rubbish, and cowdung rotted to mould. Drainage should be well provided for, or the soil will get sour, and the blooms will not last, a point that is of much importance. Pot in the end of February, and keep close for a few days, after which gradually expose to the full sun to harden the growth, and so promote a large crop of bloom. While in bloom, and during the growing season, plenty of water is necessary; but while the plants are at rest only a few waterings are required. The *Epiphyllum* should be in every greenhouse where a temperature of from 47deg. to 50deg. Fahrenheit is maintained during winter.

Propagated by cuttings inserted in sandy soil in a warm greenhouse, or by grafting on stocks of *Pereskia aculeata*.

For sorts make a selection from the following: *Epiphyllum truncatum albescens*, *E. t. amabile*, *E. t. bicolor*, *E. t. cruentum*, *E. t. magnificum*, *E. t. purpureum*, *E. t. majus*, *E. t. salmonium*, *E. t. splendens*, *E. t. tricolor*, *E. t. violaceum*, and *E. t. violaceum superbum*. It may as well be mentioned here that the best plan is to select from a large collection, and have as great a variety of colour as possible, or the plants will appear very similar to inexperienced eyes.

**Eriobotrya.**—Nearly hardy hard-wooded small tree, grown

for its foliage. Minimum temperature, 35deg. *Eriobotrya Japonica* (the Japan Medlar) (Fig. 65) is a very handsome large foliaged evergreen tree that almost rivals the *Ficus elastica* in stateliness. The plant, which is of doubtful hardiness, requires an ordinary greenhouse temperature to make it appear



FIG. 65.—ERIBOTRYA JAPONICA (FLOWERS AND FRUIT).

at its best, and then it has its leaves from 8in. to 14in. long. We have always raised the plants from seeds, and, as the only point was to obtain fine foliage, our treatment was as follows: As soon as seeds or fruit could be had in the shops, they were sown singly in 3in. pots, and placed in a cold frame. When •

frost set in the plants were taken into the greenhouse and kept moderately dry. In spring we re-potted into 5in. pots, and in June plunged in the borders out of doors, taking care the plants were not starved for water. They were wintered as before, and in spring re-potted into 8in. pots. The plants were then kept in the conservatory altogether, or stood out the same as oranges during the summer. A small shift was given each year until the pots got large, and then an annual top dressing and a regular supply of liquid manure while the plants were growing were found sufficient. Plants obtained from a nursery, properly prepared for the purpose, will bear yellow fruit about the size of a small apricot, and these are both useful and ornamental. They, however, require to be a good size for this purpose, and therefore it is only in large conservatories where they can be fruited.

Propagated by seeds sown in loamy soil in spring. Each seed should be sown separately in a small pot, and the plants should be grown on, re-potting as necessary.

**Erythrina.**—Half-hardy herbaceous plant. Grown for its ornamental berries or seed pods. Minimum temperature, 40deg. These are plants that are very ornamental when in fruit, and should be represented in every greenhouse. The plant is nearly hardy, and of an herbaceous nature, having particularly ugly root stocks, from which the roots spring. It is very easy to grow, and although it does best in a large pot, still moderate-sized specimens can be obtained with care. The height varies from 2ft. to 4ft., and the foliage is not bad-looking, but the chief things are the bloom and seeds, both of which are bright scarlet.

The soil that suits it best is a sandy loam, or peat, with water during the growing season, and treatment much the same as cannas. The seed pods, when they open, contain many orange red or scarlet seeds, which have the appearance of coral. The blooms are somewhat pea-shaped, and vary in length according to cultivation and sorts.

Propagated by seeds or division, but, as a rule, seeds are the best method. Sow when thoroughly ripe on pots of sandy soil in an ordinary greenhouse.

The only two we have grown are *E. crista-galli* (Fig. 66) and *E. profusa*; but from what we have seen of *E. conspicua*, *E. marginata*, *E. ornata*, *E. Belangerii*, and *E. Marie Belanger*, we think



FIG. 66.—ERYTHRINA CRISTA-GALLI.

them well worth cultivating. Cool treatment and proper rest are the chief points in the culture of Erythras.

**Erythronium.**—Hardy bulbs. Grown for both foliage and flowers. Minimum temperature (in pots), 35deg. The Dog's

Tooth Violet, as it is called, is a most useful pot plant if well grown in the cool house, and, with a little care, it can be done well also in a house that is heated moderately, but it is not advisable to subject it to too high a temperature. From its low growth of finely blotched and marbled leaves, which are

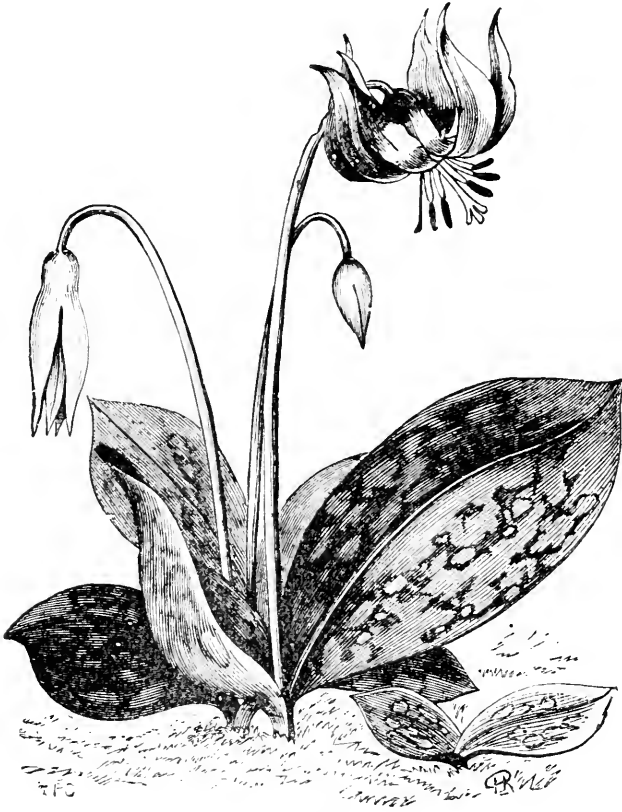

FIG. 67.—*ERYTHRONIUM DENS CANIS.*

about 3in. long, and its somewhat Cyclamen-like flowers, it is well worth growing in all places where there is accommodation for it. As with all the Liliaceæ, careful attention and steady growth are the only secrets in their culture, but should they be done on the fit-and-start principle, then success will be

very far from being attained. The destruction of insect pests, also, is a matter of importance, and, indeed, of necessity, as the plants, of which the accompanying cut (Fig. 67) gives a good representation, will not bloom unless kept clean. The bulbs should be taken up in August or September, and potted, so that the foliage when expanded will cover the pots, and the soil should consist of about one-third peat or leaf soil and two-thirds sandy loam, with plenty of drainage. Pot in soil that is in a moist (not wet) state, and stand in a cold frame facing the north, but from which frost is excluded. In December remove the pots to the greenhouse, either warm or cold, keep the soil just moist until the foliage appears, and then apply water more liberally. After the blooming remove the pots to a frame, and, when the foliage ripens, stand them in a bed of coal ashes; re-pot the plants again in August, or, what is better, transfer them to the borders, and pot up fresh ones.

Propagated naturally by the increase of the bulbs.

For sorts select from *E. dens canis album*, white; *E. d. c. majus*, red purple; *E. d. c. majus roseum*, rosy purple; *E. d. c. majus album*, white, brown base; *E. d. c. passiflorum*, light purple, shading to blue; *E. d. c. purpureum*, purple; and *E. Americanum*, yellow. The above will repay for any trouble that may be taken with them, the cyclamen-like flowers being very handsome indeed.

**Eurya.**—Greenhouse hard-wooded plant. Grown for its foliage. Minimum temperature, 40deg. *Eurya japonica variegata* is a plant that requires a rather warm house to do it well, but, as it is so handsomely variegated, it is worth a little extra trouble. During the summer, syringe once a day, and keep the roots well supplied with water, but after the middle of October this should not be persisted in, and the plants may be kept in a cool house during winter. Although it is nearly hardy, it makes finer growth in a warm greenhouse than in a cold one, and, consequently, the better plan is to give it the former. We make it a rule to pot twice a year, in February and June, until the plants have attained their full size, and then pot only once a year. The soil used is equal

parts of fibrous loam and peat, and a little sharp sand, and we find this do well. After it has attained its allotted size, ordinary greenhouse treatment should be given, and the plants will do very well. Insects of all kinds must be kept down, or they disfigure the leaves, and so spoil the beauty of the plants. Training out must be seen to if nice shapely plants are wanted, and any trouble will be amply rewarded.

Propagated by cuttings struck on a gentle bottom heat or in a warm greenhouse.



**FICUS.** — Greenhouse hard-wooded plant. Grown for its foliage. Minimum temperature, 36deg. *Ficus elastica*, which is more generally known as the Indiarubber Plant, is very much grown for indoor decoration, as its large glossy foliage stands gas and impure air far better than the majority of the plants generally used for the purpose, and so long as actual frost is kept from it, will do fairly well.

Producing, as it does, longish oval leaves from 10in. to a foot in length, for the whole length of the stem, it is very suitable for all places where a handsome foliaged plant is needed, and the height may be from two to five feet. The culture is very simple in a greenhouse, as, unlike many other plants which we have mentioned, there is no harm in allowing it to become pot-bound so long as a sufficient supply of root moisture is afforded. The general plan is to grow the plants as upright rods, well furnished with leaves, although they can also be made to assume a bushy form by stopping the points from time to time, but bushy plants do not, as a rule, look best. Plants should be obtained about a foot high to start with, and should be grown on to the size desired; but after a certain period the lower leaves will drop off, and they will become bare at the bottom. When this occurs they may either be placed



in a position where the stem is hidden, or they may be exchanged for young ones, or, what is perhaps better, they may be sent to a nurseryman to be cut down, and have young plants made of the tops of the shoots. Propagation is a point in the life of this plant which an amateur should not attempt unless he has a propagating pit, and very few amateurs have this accommodation. The soil used by us is sandy loam, three parts; rotten leaf soil, one part; and from one-eighth to one-sixth part of silver sand. Sometimes we substitute peat for the leaf soil, and we have grown the plants entirely in peat, but the foliage is more lasting in the first-mentioned compost. Scale and mealy bug sometimes attack the stems, but they are easily removed and kept down, and it is only in dirty houses where they occur. The foliage should be sponged occasionally to remove dust. *F. repens* and *F. collina*, also, are two good wall creepers, with foliage from 1in. to 2in. in length, and soon cover a rough wall or rockwork. As they have good hard glossy foliage, they look well, and form an agreeable background for bright flowering or foliated plants. For treatment see above.

**Fritillaria.**—Hardy bulbous soft-wooded plant. Grown for its flowers. Minimum temperature in pots, 38deg. These are useful plants, in habit somewhat like the tulip (as shown in Figs. 68 and 69), for early blooming, and are very little trouble. They can be had outdoors, in frames, or in the cold or warm house, but they must not be forced, or the foliage will be more remarkable than the flowers. They are chiefly useful for early work, but we have seen bulbs produce adventitious blooms in October, although such blooms are extremely rare. In August, or early in September, they should be potted, four or five in a pot, good sandy loam being used for compost, and plenty of drainage afforded. Treat the same as the tulip, and good results will be attained.

Propagated by the natural increase of the bulbs, which takes place annually.

*F. meleagris*, chequered purple; varieties of *meleagris*, of various colours; *F. Persica*, brown; *F. præcox*, white; *F. pudica*,

purple and yellow; *F. tristis*, brown; and *F. tulipifolia*, brown and purple, are all useful sorts. It is, however, best to select the forms of *F. meleagris* for chief dependence, as they are certain to bloom well if good bulbs are had in the first place.

**Fuchsia.**—Half-hardy soft-wooded plant. Grown for its flowers. Minimum temperature, 36deg. This is one of the most important of all the soft-wooded plants, and requires a very small amount of attention to produce ordinary small plants



FIG. 68.—FRITILLARIA MELEAGRIS.



FIG. 69.—FRITILLARIA PUDICA.

for summer use. Not that it is in the least necessary to grow them in the house through the summer, but only during the earlier stages of growth. In very few cases do amateurs go in for show plants—rather the reverse—small well-grown plants in 4in. or 6in. pots being all that is sought, and where such sorts as *Conspicua*, *Mrs. Ballantyne*, *Vainqueur de Puebla*, *Talma*, &c., are nicely grown, but little more is desired.

Cultivation depends on which part of the year these plants are wanted, whether early or late. If early, the cuttings should be got in before Christmas, but if not required until autumn they may be struck from January to early April. As soon as rooted

they should be potted off into thumb pots, and kept gently moving until March, when they should be placed in 4in. pots in a light position, growing on freely, and the first batch will be ready in May and June under glass. Those intended for autumn should be pinched back in May, and as soon as they break, placed in frames and closed for a few days. Then they should have plenty of air and light, and about June should have a shift into pots a size larger, and, with due attention to watering, nice plants for decorative purposes will be had in August. Cuttings struck in April and grown on into 6in. pots will bloom well from the end of August until near Christmas if taken indoors as soon as the wet season commences, and kept at a minimum temperature of 55deg. Liquid manure must, however, be given in this method of cultivation, sulphate of ammonia being preferable to other more gross manures.



FIG. 70.—FUCHSIA FULGENS.

For general use the preceding is good if due attention to stopping, watering, &c., is paid, the principles of which are described farther on.

We do not advise any amateur to attempt winter or early spring Fuchsias, as they do not pay for the trouble involved in growing them. As, however, some of our readers may possibly desire to grow exhibition plants, we will describe the process of culture. In September, cuttings should be taken of the desired sort, from robust tops free from bloom. If the cuttings have leaves produced in whorls of three, so much the better; but

this, though an advantage, is not absolutely necessary. These should be inserted in 4in. pots, one-third of which should be filled with crocks, and then the pots filled with a compost of leaf soil, loam, and sharp sand, in equal proportions. Put from six to eight cuttings in each pot, and water in, giving a good watering to settle the soil. The cuttings should then be placed



FIG. 71.—GARDEN FUCHSIA

on a light shelf in the greenhouse for the winter. Early in March the plants should be potted off into 3in. pots, with the same compost, but, perhaps, a little less sand. The strongest shoot, or "break," as it is technically termed, should alone be permitted to remain, the others being pinched off. As they attain 5in. or 10in. in height small sticks should be placed to

prevent them bending or knuckling over; also the points of the shoots should be taken out, so that side shoots may be induced to break. If the plants can have the benefit of a little warmth until the end of April, so much the better, always provided that proper care be taken to maintain as equable a temperature as possible. As soon as the roots kiss the sides of the pots, it is better to give a moderate shift than to wait until they become entangled and then give a large shift. This re-potting should be kept up until 6in. pots are reached, which should be about the second week in May, gradual hardening off going on meanwhile. Care must be given to stopping and training, so that a good framework may be obtained, it being remembered that the plants will be from 2½ft. to 5ft. high when finished. By the end of May, if they have progressed in a proper manner, they will be ready for transferring to the blooming pots, which may be 10in., 12in., or 14in., according to the size and habit.

For soil use one-half chopped fibrous loam, the other half leaf soil and thoroughly decayed manure, with enough coarse sand to keep the whole sufficiently porous. Pass through a ¼in. meshed sieve, not finer. Potting should be performed carefully, the soil being pressed firmly around the ball of earth and roots, but yet not made as hard as a gravel path. Place a neat stake, from 3ft. to 5ft. long, in the centre of the pot, tying the plant loosely to it. Now select a light, yet warm and sheltered, spot out of doors, and stand the pots on pieces of slate to prevent the ingress of worms. Carefully attend to watering and training, as before, and allow the plants to remain until the second week in June. Then plunge the pots into ashes, tan, or other material, turning them round once or twice a week to prevent them becoming lopsided or drawn. Liberal supplies of water must be given, and liquid manure should be given twice a week. Pinching should be discontinued about five weeks before the show, when the plants should be a perfect pyramid of foliage and bloom; and slight shade should also be given about a fortnight before. The composts given above should be used for all classes of Fuchsias, either for show or ordinary pot work.

Propagated by cuttings, as described above.

The Garden Fuchsia (Fig. 71) may be recommended. The

following, although not perhaps the newest, are good sorts for both form and colour. Dark single: Lord Eleho, Gipsy Girl, Senator, La Favorita, Prince Imperial, Souvenir de Cornelissen. Double: Rifleman, Percy, Universal, Amy Hoste. Single whites: Schiller, Rose of Denmark, Lady Heytesbury, Rose of Castille, Hugh Miller, Guiding Star, Maid of Kent, Fairest of the Fair. Red, with white corolla, single: Conspicua, Maria Cornelissen, Marchioness of Bath. Double: Vainqueur de Puebla, Mrs. Ballantyne, Emperor of the Fuchsias. To these may be added: Arabella Improved, Mrs. Marshall, Improvement, Nabob, Water Nymph, Avalanche, Blue Boy, Gen. Grant, Purple Prince, Sultan. and White Lady. In our opinion, the first twenty-four are the best for all purposes. Variegated foliage we object to, as it detracts from the bloom, which is the strong point in all Fuchsias. Among the showiest species is *F. fulgens* (Fig. 70).

**Funkia.**—Hardy herbaceous soft-wooded plants. Grown for both foliage and flowers. Minimum temperature (in pots), 35deg. As fine foliage plants for the cool or warm greenhouse there are very few that can equal the Funkias in particularly fine foliage, and, at the same time, the bloom is not to be despised. They are deciduous perennials, just as pæonies, and other plants of a like nature, having ovate leaves, and throwing up long spikes of flowers in their season, and when in their prime they appear as in the engraving (*F. Sieboldii*, Fig. 72). Consequently, they require to rest for a certain part of the year, and it is, therefore, best to keep them in a cold frame from which frost is excluded during the winter. In spring and early summer they can remain in the house, which they will help to decorate in a very effective manner; but from the end of July, until the foliage ripens, it is best to stand them out of doors, and their ornamental foliage will be useful in various places. The large ovate leaves of some of the varieties, and the gracefully curved spikes of drooping and somewhat lily-shaped flowers about an inch long, the spike being nearly two feet in length, render the Funkias very handsome specimens for flat vases, large pots, &c., and, as the beauty of the plants lies

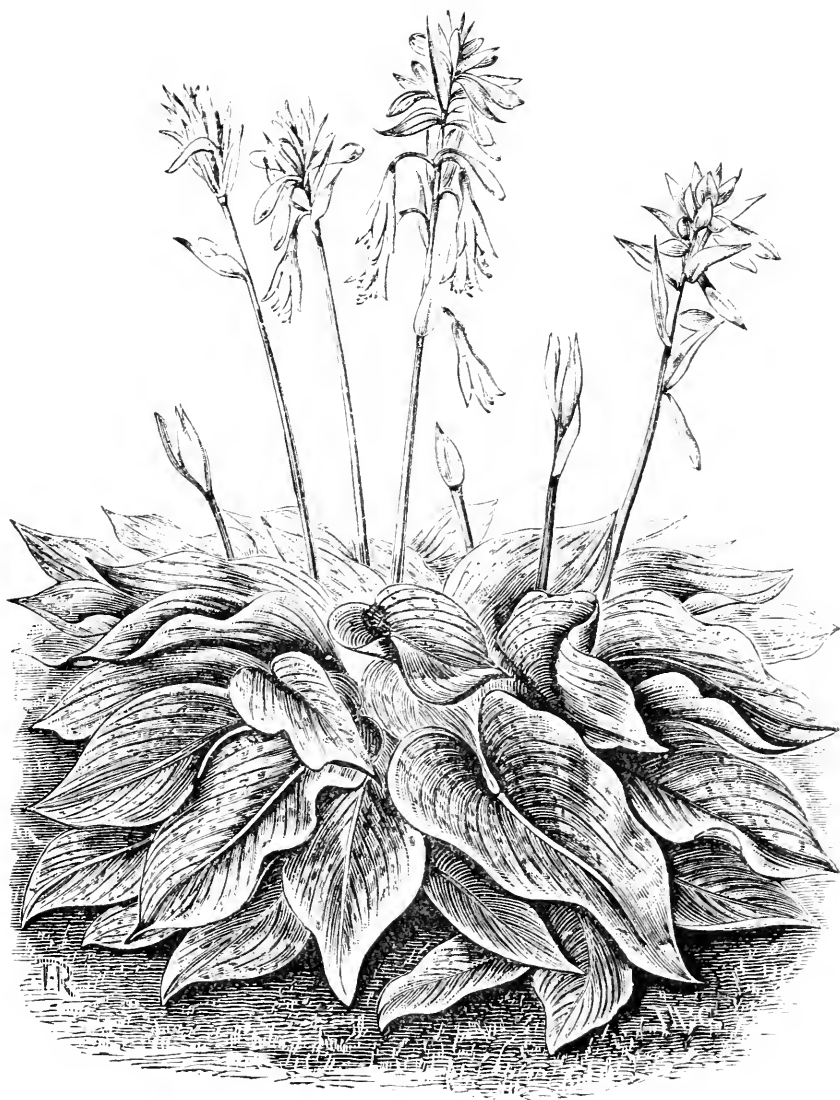

FIG. 72.—*FUNKIA SIEBOLDII*.

in the form and markings of the foliage, they do well stood rather low on the stages, or perhaps on the ground. It is, however, a matter of the greatest importance that plenty of light and air be given, and also that all insects, particularly green fly, slugs, and snails, be kept scrupulously destroyed, as, if these are allowed to prey on the plants, the foliage will be anything but handsome. We use a compost of loam, leaf soil, and rotten manure, to which some sharp sand has been added. Plenty of drainage is also necessary, as, during growth, the plants require free supplies of water.

Propagated by division of the crowns while at rest.

*Funkia Fortunei*, glaucous blue foliage; *F. glauca*, broad glaucous leaves; *F. grandiflora*, handsome foliage, highly fragrant white flowers, which, if the plants are taken into a temperate house ere frost comes, will continue in bloom until December; *F. ovata variegata*, leaves finely margined with white; *F. o. aurea*, soft yellow foliage; *F. ovata*, glaucous green foliage, puce flowers; *F. obovata*, fine foliage and puce flowers, and *F. undulata medio-variegata*, fine foliage and puce flowers, will all be found very useful for the purposes named, and, besides these, there are very many more which are useful for either in or out-door decoration. The best plan is to see the plants before purchasing, and a visit to a good nursery,—say, Mr. Ware's, at Tottenham.—from June to September, would amply repay the intending purchaser.



—•••••

**ALANTHUS.**—Hardy, bulbous, soft-wooded plant. Grown for its flowers. Minimum temperature (in pots), 30deg. The Snow-drops are so well known that a description is unnecessary; suffice it to say that a few pots in the cold house come in very handily early in the season. The culture is very simple—in fact, so simple that the only thing to be surprised at is the scarcity of these lovely blooms just after Christmas. All that is necessary is to pot the bulbs,



about five in a large sixty-sized pot, using a somewhat rich compost of sandy loam and leaf soil, to which some sharp sand has been added. The bulbs should be potted as soon as they can be had, and then stood in a cold frame until the end of November, when they should be taken indoors and kept just moist until growth commences, when more water should be given. It is also necessary that a light airy position should be chosen for them, and it is an advantage if the house is kept at



FIG. 73.—SNOWDROP (*G. NIVALIS*).

a temperature of from 35deg. to 40deg. After blooming, the bulbs can either be turned into the ground or thrown away.

Propagated by the natural increase of the bulbs.

The best sorts are *G. nivalis* (Fig. 73), *G. nivalis fl.-pl.*, and *G. plicatus*, all of which are white, tipped with green.

**Gazania.**—Half-hardy soft-wooded plant. Grown for its flowers. Minimum temperature, 36deg. These are showy.

nearly hardy bedding plants, and, from their habit and bloom, should be in every collection. The flowers are like very large single asters, and are two or three inches in diameter, according to kind and culture; the plants are somewhat trailing with lanceolate leaves, and being continuous bloomers, when well grown they are very effective. In many places they are quite hardy, while in others they require to be housed; but in all cases it is well to keep a few store pots in readiness to fill up blanks or to guard against loss, while in places where the bedding system is pursued it is a good plan to have the stock in small pots at planting time, as in this state they are most manageable, and work into the designs more readily. We take cuttings in August and insert them eight in a 6in. pot of sandy soil, half filling the pots with crocks. These pots we place in a frame or on a bed of ashes until about the middle or end of October, when they are placed in a cool house until March. We then pot them off into comparatively small pots (2½in. to 3in.), and in April place in a frame till required for bedding or for the furnishing of baskets, vases, &c. Too much heat or water should be avoided, and all insects should be kept down carefully. A good sandy loam suits the plants best.

Propagated as described above, or by seeds sown in a warm greenhouse in February.

For sorts, select from *G. pavonia*, yellow; *G. rigens*, orange; *G. splendens*, orange; and *G. splendens fol. var.*, orange flowers and variegated foliage.

**Genista.** — Hard-wooded plant. Grown for its flowers. Minimum temperature, 36deg. This is a very favourite plant for greenhouses and indoor decorations, as its bright yellow blossoms and light elegant foliage have a charming effect amongst other flowers. It is a plant that is very easily grown, and it is perhaps for this reason that it is so popular; however, its intrinsic merits fully entitle it to the high position it has attained. The Genista is more properly known as the Cytisus, and under that name full instructions for its cultivation and a list of the best varieties will be found.

**Geranium.**—Hardy soft-wooded plants. Grown for their flowers and foliage. Minimum temperature, 36deg. One or two of the Geraniums can be used sometimes in the cool house, or they can be grown in a cold frame, and transferred to the house when in bloom. The plants are perfectly hardy, and bloom very freely in their season, bearing cup-shaped or recurved circular flowers from one to two inches in diameter on erect stems, and generally in trusses, as with the pelargonium; but as they can be made to decorate the cold house so much the better, and the colours being of very pleasing shades tend to improve the appearance of the place greatly. The culture consists in simply re-potting when the growth commences, using a compost of leaf soil and sandy loam, and potting moderately firm. A fair amount of drainage must be afforded, or the plants will not thrive. In no case is it desirable to introduce them to a heated house, as they will not thrive well in such a place. Another good plan is to carefully lift them when showing bloom, and then pot them up, keeping in a shady place for a few days, and then introducing to the house.

Propagated by seeds or division of the plants when at rest. We do not here refer to pelargoniums, but Geraniums proper.

Some of the following can be used for cold house work: *G. albidum*, white; *G. angulatum*, purple; *G. Ibericum*, blue; *G. nodosum*, purple; *G. phæum*, black; *G. pratense*, blue; *G. roseum*, rose; *G. sanguineum*, blood red; and *G. Vlassovianum*, red.

**Grevillea.**—Greenhouse hard-wooded shrub or small tree. Grown for foliage chiefly. Minimum temperature, 36deg. This is a plant of an ornamental character, and is worthy of a place in all fair-sized collections. The foliage is ornamental, and of very elegant appearance, being finely divided, while the flowers are of rather a peculiar form, which it is impossible to describe without an engraving, particularly so in *rosmarinifolia*, and for this alone the plants would be interesting. As, however, they are grown almost solely for their fern-like foliage, a description of the flowers is a matter of small importance. As a comparatively cold house, or an ordinary

greenhouse only is required, they come within the reach of most amateurs. We would, however, advise our readers to see them before purchasing. For soil we generally use good fibrous loam, and enough sand to keep the compost sufficiently open for the passage of water, as most loams go into a bad state as soon as the fibre decays, unless sand is used. The plants should be re-potted when they cease blooming, and they require much the same treatment as *Cytisus*. As a rule, specimens about a foot to two feet in height are best, but they can be allowed to get much higher if desired.

Propagated by seeds sown in spring in a warm greenhouse, in sandy soil.

For sorts we should prefer *G. alpestris*, red, yellow; *G. Drummondii*, white, yellow; *G. Hilli*; *G. lavendulacea rosea*; *G. punicea splendens*, scarlet; *G. robusta*, orange; and last, but not least, *G. rosmarinifolia*, red.

**Guernsey Lily.**—See "Nerine."



**ABROTHAMNUS.** — Greenhouse hard-wooded shrub. Grown for its flowers and general appearance. Minimum temperature, 40deg. This is a plant that does well in a house that is heated to about 40deg. or 45deg. during winter, and although it is generally used as a climber it makes no despicable pot plant, as its foliage sets off the blooms to great advantage. It requires plenty

of pot room, and we always find it do best in a free and moderately rich soil, where it will produce its terminal clusters of bright coloured flowers for the whole season, and in a warm house for the whole of the year. For pot cultivation, cuttings should be struck in August, and when rooted should be potted as frequently as the roots reach the sides of the pots.

They should be pinched back early to cause them to become bushy, and if this is done early in January they often bloom well according to their size; but the next season they do better, as a rule, if potted, and grown on in the frames or outdoors. It is desirable to use large pots, as the plants require plenty of root room, and at all times they must be carefully looked after, in regard to watering, &c. Where it is desired that they shall form wall plants, they should have large boxes, or, what is better, should be planted out in the borders, and receive liberal treatment; bloom will then be plentiful.

Propagated by cuttings struck on a slight bottom heat, or in a close frame, as described above.

*H. elegans*, carmine; *H. fasciculatus*, crimson; and *H. elegans fol. argenteus* are three of the best.

**Hæmanthus.** — Greenhouse bulbous soft-wooded plant. Grown for its flowers. Minimum temperature, 40deg. This is a very showy class of bulbous plant, resembling the amaryllis, and is well worth cultivation. We have found it do well treated in the same manner as the Guernsey lily; in fact, we have had finer blooms by this treatment than by any other.

Propagated by offsets, which should be treated in the same manner as the old plants.

The best we have seen (not stove varieties) are *H. coccineus*, red; *H. albiflos*, white flushed pink, sometimes pure white; and *H. puniceus*.

**Hedychium.** — Greenhouse soft-wooded herbaceous plant, Grown for its flowers. Minimum temperature (when at rest) 35deg. *Hedychium Gardnerianum*, the Indian Garland Flower, as it is frequently called, is a subject that is well worthy of cultivation in all conservatories of a fair size, as it is best planted out, when it makes a fit associate to the various large-growing fine-foliaged plants used in such structures. Planted out in a wide border in a conservatory, with a compost of good loam enriched with a little thoroughly decayed manure, rendered porous by the addition of some sharp sand, the Hedychium will make heads of honeysuckle-like bloom and growths of Canna-

like foliage far surpassing anything grown in pots; yet in the latter they are not bad if properly grown. Occasional supplies of liquid manure are also very beneficial in producing increased strength and vigour.

For pot culture the following answers well: Purchase the plants in winter, and as soon as they show signs of growth re-pot into pots or tubs from 15in. to 18in. in diameter, giving about 3in. of drainage. Water thoroughly until growth pushes freely, and then apply pure water in an almost unlimited amount, occasionally giving a dose of liquid manure. By forwarding some and retarding others, a continuance of bloom can be maintained for some months. As soon as the bloom is over the flower spikes should be cut down, and the strongest of the others left through the winter, when some of them will produce early spikes of bloom. If the flowers are fertilised artificially they will produce seeds of a bright orange scarlet colour, very showy and interesting, but of course the production of seeds weakens the plants a little. In spring, when the plants are re-potted, the rhizomes can be divided, and many plants will be made; but, in our opinion, one or two good specimens are preferable to a number of smaller ones, the size of the plant rendering a large number out of place in any but very large conservatories. In the second season the spent earth can be partly removed, and the plants re-potted into pots or boxes only an inch or two larger, or, if this is not convenient, into the same sized pots or boxes, and they will carry (with the aid of liquid manure) from eight to fifteen flower spikes, which make a handsome specimen.

Propagated by division of the rhizomes, as described above.

There are red, orange, yellow, and white *Hedychiums*, which any good nurseryman can supply, although we believe they are mostly unnamed.

**Heliotropium.**—Half-hardy soft-wooded plant. Grown for its flowers. Minimum temperature, 40deg. Heliotrope is a constituent of most bouquets in the season when it is in bloom out of doors, and in winter it is very much esteemed, as it is one of the best scented flowers to be had; and as these are borne in close heads of small five-cleft florets, they are very

useful for cutting. It is not very difficult to grow if certain simple rules are followed, but if these are neglected, small success will follow. There is little labour required to produce bedding plants; simply strike the cuttings, in the autumn, and winter them in store pots, or keep old plants until early spring, and then strike cuttings and grow them on briskly, whichever is most convenient. In either case we find that it is the most convenient plan to strike the cuttings in a moderate bottom heat, and to strike in sand only. The advantage in keeping old plants is that sometimes plenty of bloom is had without any trouble, especially if a warm and moderately dry atmosphere is kept up; in fact, such a house as that in which tricolour pelargoniums are wintered will suit them nicely, provided bloom is not the chief point aimed at. Another plan, where bloom is required, is to take up the plants used for bedding, and, after potting them up, place in a moderately brisk bottom heat for a fortnight, and then cutting them back, place them in heat until they break freely, gradually hardening them off so that they may be brought into a house at a temperature of about 50deg. With care in training, &c., re-potting about the end of February, nice plants full of heads of fragrant bloom may be had during April and May. Planted out, and trained over a trellis in a conservatory, where a minimum temperature of 50deg. is maintained, heliotropes will bloom for the greater part of the year, and few plants answer better.

For soil, use good fibrous maiden loam two-thirds, and thoroughly decomposed manure one-third, adding sufficient sharp sand to maintain the whole in a porous condition. We strike in sand, and pot off into the above compost, in which the plants both bloom and grow freely.

For conservatory decoration, pursue the following plan. In July or August insert about six cuttings round the edge of a 6in. pot, giving plenty of drainage, choose strong terminal shoots for cuttings, which should be about 1½in. long. Stand the pots in a close frame, and shade from the sun, keeping the pots fairly moist. In about a month shift the young plants singly in 3in. pots, still keeping them in the frame, but admitting air freely. As soon as the pots get filled with roots, re-pot into 48-sized pots,

stand in the frame for a week or ten days, and then either remove the lights altogether or stand the plants out. Some of them will have a single stem only, and others will be bushy. The former should be nicely staked and reserved for standards, as plants of this form, about three or four feet high, are extremely useful. As soon as there is the least chance of frost, place the plants in an airy light position in the greenhouse, and give only just enough water to keep them alive during the winter. As soon as they start in spring, turn them out of the pots, reducing the balls of earth somewhat, and then re-pot into pots one size larger. At the same time shorten the branches of the bushy specimens a little, and give them all more heat and moisture, to induce them to break freely. About May give another shift, and also less fire heat, and increase the supply of fresh air. Then divide the plants into two batches—one to be placed in the frames in June after being re-potted into 8in. pots, the other to be kept in the conservatory, where they will bloom for a long time—many months, in fact. Those placed in the frames should be brought into the conservatory in September, and, by maintaining a temperature of 50deg. to 55deg., an abundance of bloom will be obtained until the late plants are ready. The first batch should be wintered and treated as before described.

Standards should be run up to the height desired and then stopped, and afterwards the shoots stopped and trained into a nicely-balanced head. The same general treatment applies as indicated above. The old *H. Peruvianum* makes a good plant to cover trellises in the conservatory, giving an abundance of bloom for many months in the year. The soil used must be the same as mentioned before.

Propagated by cuttings as already described.

The best sorts for pot culture or bedding are: Surpasse Guascoi, lilac to French white; M. Semeul, reddish purple; Mrs. Lewington, dark purple; Miss Nightingale, darkish purple; Hurst Metternich, French white; Madame Fillion, violet, white centre; Jersey Beauty, lavender; Mme. J. Amy, light blue; Mme. Bourcharlat, dark blue; Mons. Cassanave, dark purple; and Souvenir de Leopold I., light lavender lilac, very free and dwarf.



**Hibbertia.**—Greenhouse hard-wooded climber. Grown for its flowers and general appearance. Minimum temperature, 36deg. *Hibbertia volubilis* is a good pillar plant, as is also *H. Cunninghamii*, and the large yellow buttercup-like blooms which are freely produced over the leafy twigs of the whole specimen are very effective, rendering the whole of the space covered by the plants a mass of floricultural beauty. The Hibbertias are, however, only suited for covering pillars or walls, and should therefore only be used for such work. It is, however, not so much grown as it should be, although it deserves a place wherever there is space. It is a plant that requires plenty of root room, and may either be grown in large pots or planted out, care being taken to provide good drainage, a point that is too frequently neglected. We have grown it in peat and loam, both together and separate, always providing a sufficient quantity of sand to maintain the soil in a healthy porous condition, as in no case will any plant do well in a close sticky soil, hard-wooded plants particularly. If insects begin to attack, they must be got rid of at once, or they will soon cause the plants to become unhealthy and unsightly.

Propagation is best effected by seeds, in the hands of the amateur gardener, but as only one or two plants are likely to be needed, it is better to purchase them when they are required.

**Hovea.**—Greenhouse hard-wooded shrub. Grown for its flowers. Minimum temperature, 40deg. It is well worthy of cultivation, especially in point of its adaptability as a roof or bush plant. It has pea-shaped flowers, and very distinct foliage, the blooms being produced freely from the axils of the leaves of the previous year's growth. In propagation it is best to raise from seeds, as cuttings are rather difficult to strike. The plant is rather slow growing, and, therefore, particularly suited to small or medium-sized houses.

Sow on a gentle bottom heat in March, and pot off as soon as the rough leaf appears, using good turf, peat, or loam, with about one-sixth silver sand, to keep it open. Grow on till the plants are about three or four inches high, and then pinch out

the points, to cause the young plant to be bushy. As soon as a shift is required, a small one should be given. As the plants grow it is very likely that some of the shoots will take the lead over the others, and when such is the case they should be stopped back, and, in fact, it is not a bad plan to stop all the shoots again when they reach about six inches in height. This second stopping causes the plants to become pretty well furnished, and, as it were, lays the foundation of the future plants. Seedlings require the heat of an intermediate house rather than that of the greenhouse, for the first season, but after the first rest they can be transferred to the greenhouse. For this reason the amateur will find it by far the best plan to purchase plants that are of a moderate size from a nursery, as then all the preliminary trouble is avoided, and no other than a greenhouse is necessary. If, however, plants are required for roofs, they had better be raised from seeds, and not stopped until the required height is obtained, when, if they are pinched back, and carefully trained, they will make good plants, and be very ornamental.

The following treatment is more suitable for an amateur, and is that necessary for plants which have been purchased in 6in. pots in autumn. These should be wintered in a light house, as near the glass as possible, and at a temperature from 40deg. to 45deg. It is advisable to pick off the flowers the first season, if it is desired to have nice specimens; but at the same time it is not absolutely necessary to do so, if the bloom is particularly desired. As soon as they have started into growth an inch or so, give a shift into pots an inch or two larger, pot firmly, and allow sufficient drainage. Shut up the lights early in the afternoon to retain as much sun heat as possible, so as to ensure an early growth. About the end of April just sprinkle the plants in the afternoon with the syringe to ensure a good growth, and should any of the shoots be inclined to run away, tie them down, so that the flow of sap may be equalised. Shade is not required, but a proper amount of water is necessary to ensure success, although over watering is to be avoided. About the end of August admit air freely to harden the plants off. Winter as before, and in the following spring they will be very

fine from a decorative point of view. After blooming they should have a shift if the soil is full of roots, but if not it can be left for another year. The only insect that is likely to do much damage is scale, but this is easily destroyed by using a strong solution of "Gishurst Compound," or "Fowler's Insecticide," either of which will destroy it.

Propagated from seeds, as described above.

The varieties that we have found suitable are *H. Celsii*, blue; *H. purpurea*, purple; and *H. pungens major*, blue.

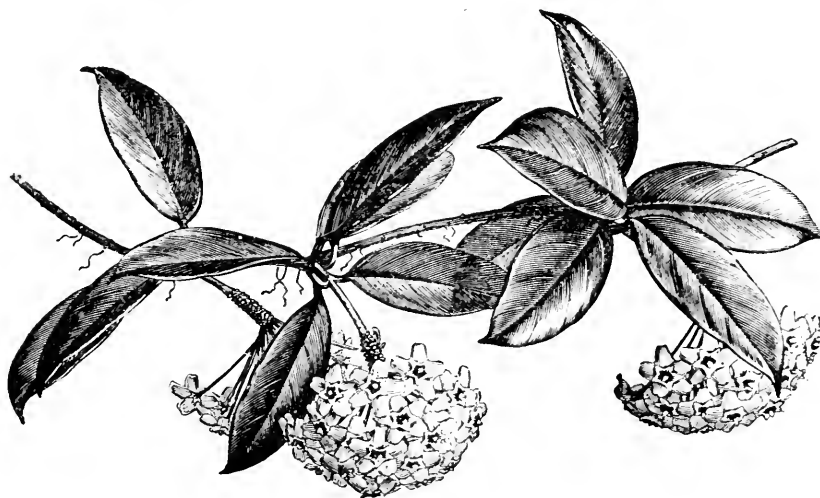

FIG. 74.—HOYA CARNOSA.

**Hoya.**—Greenhouse hard-wooded climber. Grown for its flowers and foliage. Minimum temperature, 40deg. This plant is remarkable for the wax-like appearance of the foliage and flowers which are shown in Fig. 74, and this is what causes it to be much sought after. It is one of those plants that give comparatively little trouble, but which always look well if kept clean. Even if no flowers are obtained the foliage is far prettier than that of many of the plants that are grown for their foliage alone, the peculiar brightness and waxy appearance being very beauti-

ful, and if we consider the appreciation it generally receives it stands pre-eminent as a wall climber. It can either be planted out, or grown in good-sized pots, according to the convenience of the grower, but in neither case must it get dry during the growing season, or the leaves will have a rusty appearance. For soil, use peat and loam in equal parts, with enough sand to keep the whole porous, and do not overpot, as there is no advantage derived from so doing. The temperature of the house must not sink below 40deg., and the plants should not be exposed to full sun during very hot weather. Training should be carefully attended to, and water should be applied when necessary.

Propagated by cuttings of ripe wood inserted in pots of sandy loam in the greenhouse.

For sorts, *H. carnosa* stands first, and, if one variety is not enough, add *H. c. variegata*—a variegated form of the preceding—or *H. bella*, which is not of such free growth as *H. carnosa*.

**Humea.**—Half-hardy herbaceous perennial. Grown for its flowers. Minimum temperature, 45deg. *H. elegans* and *H. purpurea* are two very useful half-hardy perennials; but they succeed best if treated as biennials, and, as the seed is very moderate in price, we recommend that course. Sow the seeds thinly in rather sandy soil in April, and transplant into small pots (thumbs) as soon as the first leaf appears. After the young plants root into the fresh soil, gradually harden them off, and place in cold frames about the end of May, being careful that the temperature does not fall below 45deg. As soon as the pots are full of roots (but not pot-bound), re-pot into one size larger, paying particular attention to watering, and keeping free from insects. Continue re-potting as necessary, but giving only one size larger each time; keep the plants as close to the glass as possible, when it is necessary to keep the lights on, and syringe every evening during hot weather. Early in September remove them to a light position, near the glass in a greenhouse, where a temperature of 45deg. to 50deg. is kept up, admitting as much air as can consistently be allowed, and re-potting from time to time as requisite, as

the chief secret in cultivating these plants is to keep them steadily growing. About the end of May they may be again transferred to the frames, the treatment being as before. From 12in. to 15in. pots will be found necessary to bloom them well, and, during the whole of their growth, no check must be given. They will bloom from about July till the end of October, or even later, and, as the plants are very imposing in appearance, about 4ft. in height, and the drooping feathery inflorescence is nicely perfumed, they are very welcome additions to the stock. In growing them a slightly moist atmosphere rather than a dry one should be kept up.

The best soil to use is a good rich light fibrous loam, with enough sand added to secure the necessary porosity, as, when growing vigorously, they require plenty of water, and consequently plenty of drainage.

Propagated from seeds as described above.

The two varieties we name are fairly distinct, and are certainly good, viz.: *H. elegans*, reddish brown; and *H. purpurea*, brownish crimson.

**Hyacinth.**—Hardy bulbous soft-wooded plant. Grown for its flowers. Minimum temperature (in pots), 40deg. Very few persons who have a greenhouse would care to have the Hyacinth absent, and as the plants are alike useful in both heated and cold houses, their value is so much the greater. The culture of the Hyacinth is comparatively simple, but at the same time it is necessary to observe certain rules. The first is to have perfectly sound heavy bulbs, which should be selected clear from offsets or protuberances, and, what is equally as important, with only one crown. In fact, a Hyacinth should be like a fine onion, clear in the skin, and smooth and well proportioned, and, at the same time, heavy for its size. Rich sandy soil should also be provided; and, lastly, a sufficient time for the production of roots should be allowed before they are brought to the light, or only very indifferent results will be obtained. A compost composed of one-half good loam, one-third good leaf soil, and the rest manure and sand, will suit Hyacinths well,

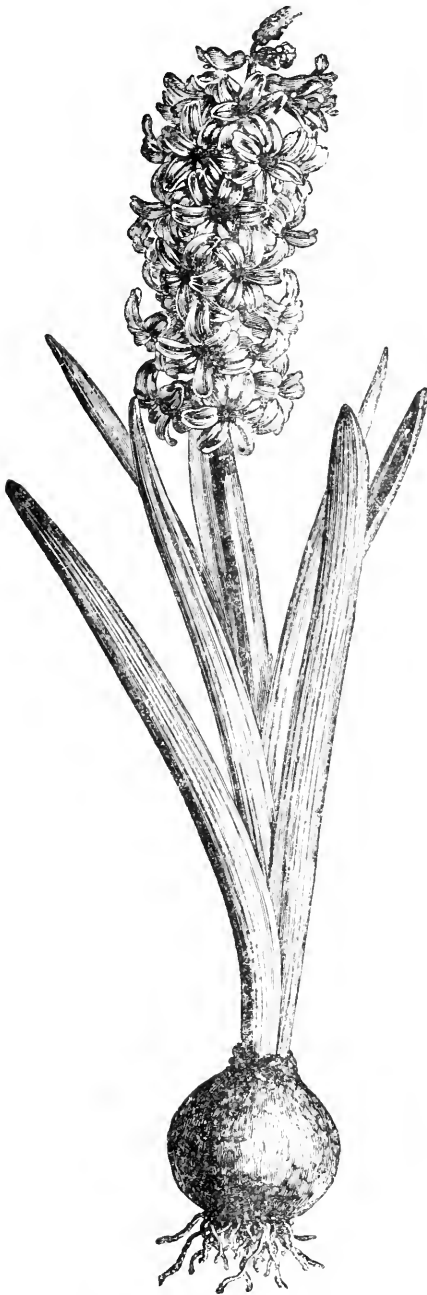

FIG. 75.—SINGLE HYACINTH.

and cause them to produce large spikes. The bulbs should be obtained as early in the season as possible, and a portion—including some of the white Roman—should be potted up at once, plenty of drainage being given with the compost mentioned above. The pots should then be plunged in a bed of coal ashes or cocoa fibre refuse, and the bulbs covered to a depth of six or seven inches. The other bulbs should be stored in a cool place, potted up from time to time, and treated as the first batch, and these later lots will make good successions to the first ones. After the bulbs have been under cover for about five or six weeks they can be taken out and placed in a frame or greenhouse, and kept moist. The flower spike will then soon throw up, and the plants should be kept near the glass, so that all the light that can be obtained may be afforded them. A temperature of 50deg. will bloom the bulbs well in the early house, and if plenty of water is afforded the plants when they are growing vigorously, fine spikes of bloom will result. The successional

batches must be brought forward from time to time, and treated the same as the first lot.

Propagated by division of the offsets, which are formed naturally round the base of each blooming bulb.



FIG. 76.—DOUBLE HYACINTH.

Some good single sorts (Fig. 75) for pot work are: Amy, bright red; Meyerbeer, bright red; Mrs. Beecher-Stowe, delicate rose; Ariadne, rose shaded with pink; Circe, carmine; Norma, delicate pink; Von Schiller, deep salmon pink; Tubiflora, blush

white; *Alba maxima*, pure white; Blanchard, pure white; Grand Vainqueur, white; La Candeur, white; Couronne de Celle, blue, light centre; Grande Vedette, pale porcelain blue; Baronne Van Tuyl, blue; Brunette, rich blue; Chas. Dickens, pale shaded blue; Nimrod, light blue; General Havelock, black purple; Mimosa, black; Anna Carolina, yellow; Heroine, pale yellow; Ida, good clear yellow; La Pluie d'Or, primrose. The yellows are not nearly so good for pot culture as other colours, but they make a change in the appearance of the plants. The doubles (of which Fig. 76 shows a good type) require special treatment, in order to make them worth notice; and we mention no varieties because, unless where exhibition purposes are contemplated, such treatment will not be repaid by results.

**Hydrangea.**—Hardy hard-wooded shrub. Grown for its flowers. Minimum temperature, 45deg. This, although a hardy shrub, is often grown in greenhouses, and when properly cultivated produces such a fine effect that it is worth a place amongst the more generally accepted greenhouse plants; it has a very handsome appearance, as shown in Fig. 77. *H. hortensis* (pink) and *H. paniculata* are the only members of the family to which we shall refer, as they are the best and most met with. The question to be determined is, whether plants with one large corymb of flowers, and about 18in. high (as grown for the London markets), or of larger size with several smaller ones, are desirable; for, although the treatment is similar, it is necessary to select the plants for the different plans. Strike cuttings in gentle bottom heat in the end of August, and when well rooted, pot off into 4in. pots in a free rich soil, containing a small allowance of peat, or, if this is not obtainable, leaf mould and silver sand; choose only the lateral or side shoots, and keep them growing in a warm greenhouse, near the glass, throughout the winter. Liberal supplies of water are necessary to ensure large flowers, and, consequently, there must also be good drainage. During the time the plants are in full growth, occasional supplies of weak liquid manure can be applied with advantage. If more



than one shoot is required, old cut-back plants can be used, but we think the single corymb makes the greater display, as, being larger, it is much more conspicuous. The same plants can, by attention to soil and culture, be made to bear blue flowers, and this opens to amateurs a wide field for interesting experiments. It is said that a ferruginous soil will produce the



FIG. 77.—HYDRANGEA HORTENSIS.

blue-colour, and we have certainly seen masses of Hydrangeas in Devonshire, where the soil is strongly impregnated with iron, covered with azure blossoms.

Propagated by cuttings of ripe wood of the current year's growth inserted in pots of sandy soil in a cold greenhouse or frame, or by layers.





**ICE PLANT.**—Half-hardy annual, grown for its foliage. Minimum temperature, 45deg. It is very often necessary to grow these for decorative purposes, as they will stand the sun so well. The perennial kinds can be raised from seeds, but we do not think that it is advisable to do so as a rule, as more certain results can be had from cuttings; but still they can be raised in the manner hereafter described if it is thought desirable. The Ice Plant, which is trailing, and has ovate leaves about an inch long, which appear to be covered with small globules of ice, and from which the name is derived, and one or two others which are best treated as annuals, do well if grown as under, and they are certainly fine plants in their particular section. In most cases where the Ice Plant (*Mesembryanthemum crystallinum*) is used for garnishing there is but poor foliage, *i.e.*, foliage deficient in crystalline beads, to use a common expression, and this is usually caused by their being grown in too shaded a place. For our own part, we should choose a place fully exposed to the sun, but where a somewhat moist atmosphere can be maintained, for the purpose of producing fine foliage, at the same time starving the roots somewhat. For the ordinary run of plants we sow in a warm house in February, using well-drained pans of sandy soil. The seeds are distributed thinly, and but slightly covered with soil, a sheet of glass being placed over the pans, as previously described for other seeds. The pans are then placed in a warm sunny position and not allowed to get dry, but at the same time they are not kept too wet, or the seedlings would rot off. As soon as large enough to handle, the plants are potted off in small pots, and as soon as these are filled with roots they are shifted into 3in. or 4in. pots in which they can remain for the season. A compost of two parts good loam, one part leaf soil or thoroughly decayed cow manure, and one part sharp sand, crushed mortar, and crushed charcoal in equal proportions, will be found to answer well, an inch of drainage being given to each pot.

Propagated from seeds as described above.

For sorts from seeds, and treated as annuals, we have found the following to be the best: *M. crystallinum* (Ice plant), white; *M. tricolor*, crimson and white; and *M. t. album*, white.

**Illicium.**—Half-hardy hard-wooded shrub. Grown for its flowers. Minimum temperature 36deg. *I. Floridanum* is by some persons much esteemed on account of its flowers being perfumed, the scent being very much like that from anisé. The *Illicium* is very nearly hardy, having bright evergreen leaves and bearing axillary flowers which hang in twos and threes, and may therefore be treated as described for other things of a similar nature, the plants being put out of doors during the summer, &c. For soil use good sound turfy loam, to which a little leaf soil has been added, with enough sharp sand to keep the whole open. Pot moderately firm, and do not over water, and the plant will bloom abundantly.

Propagated by cuttings as described for *Hydrangea*.

**Imantophyllum.**—Greenhouse bulbous soft-wooded plant. Grown for its flowers. Minimum temperature, 40deg. It is also called by the name of *Clivea*, at least so far as two or three of the varieties are concerned. The culture is very simple, and provided proper attention is paid them at some seasons, at others they can remain under the stage of the greenhouse. The chief point is to grow them well and freely during the summer, and to give them rest during the winter. We have grown them successfully in the same manner as *Amaryllis*, which they much resemble in bloom and foliage, and also in the following manner: In March the plants are re-potted in a compost of loam and leaf soil, with the addition of some sharp sand, in from 9in. to 11in. pots, and they are watered in accordance with the growth. The same heat as the other stock receives is given, and as the weather becomes warm, air is freely admitted, so that the plants shall be fairly hardy. The blooms should be supported by neat stakes, and as probably there will be several heads, they should be trained apart so that a fine head of bloom is shown on each plant. After the bloom is over it is well to keep the plants growing vigorously until

the leaves begin to ripen, and then gradually leave off watering until they are in a dormant state, when they can be placed under the stage.

Propagated by division in the same way as *Amaryllis*.

The sorts we have grown are *I. Aitoni*, *I. miniatum*, and *I. cyrtanthiflorum*. The colours are shades of orange red, and the flowers are produced in large numbers.

**Indian Garland Flower.**—See “*Hedychium*.”

**Indiarubber Plant.**—See “*Ficus Elastica*.”

**Ipomœa.**—Greenhouse and half-hardy annual climber. Grown for its flowers. Minimum temperature 45deg. to 50deg. Amongst the Ipomœas some of the prettiest climbers for the conservatory will be found; and they are very useful, as both bloom and foliage are very handsome. The blooms, in form like those of the convolvulus, which the plants generally resemble, are of various colours, and, as these are very diverse, a fine show may be made; if a little trouble is taken in hybridising the varieties, excellent results are almost sure to follow. It is, however, desirable not to save seeds from dirty-coloured flowers, such as brick reds or muddy-coloured blues, but in all the shades of colour clearness should be aimed at. The culture of the Ipomœas is very easy, and, in proportion to the beauty of the plants, may be said to be about as profitable as that of anything grown. Ipomœas require plenty of root room, and do best in a border in the house; but, where this cannot be afforded, large pots or boxes are necessary, that a sufficient run for the roots may be allowed. The plants are useful trained over trellises, or on pillars, or, in fact, anywhere, provided sufficient light is given, but, if the roof is overhung with grape vines, it will be useless to try to grow them. The time of sowing will depend much on the accommodation for growing, and, according as the seeds are sown early or late, so will be the period of blooming. Where convenience exists, it is well to sow early, placing two seeds in a small 60-sized pot. As soon as the roots kiss the sides of the pots, re-pot into 4in., and, when the

roots touch the sides of these, the plants should be transferred to where they are to bloom. Plenty of drainage must be afforded, and the soil in the larger pots should not be sifted, but broken up small with the hands. We have found a good compost to consist of equal parts of fibrous loam, rotten manure, and leaf soil, with enough sharp sand added to keep the whole well open. Plenty of water will be necessary during the growing season, and a rather moist atmosphere suits the plants best.

Propagated by seeds as described above.

For sorts, select from *I. coccinea*, crimson; *I. Learii*, violet and blue; *I. rubro cœrulea*, sky blue; and *I. r. c. alba*, white. There are several others, but we curtail the list so as not to include doubtful varieties.

**Iresine.**—Half-hardy, soft-wooded plant. Grown for its foliage. Minimum temperature, 40deg. This is much used for bedding, having oval leaves about an inch and a-half long, the plants being from 1ft. to 1½ft. in height, and, from the metallic bronze colour of the foliage, whether dark red or bronze-coloured reddish green, it contrasts favourably with other foliage plants of a brighter hue. The Iresines are, however, plants that require a brisk heat to grow them freely at certain times, that is, to obtain presentable plants for bedding out; but, at all other times, a minimum of 45deg. will keep them in fair health. The way we manage them is as follows: We take up the old plants in September, or strike young ones in the end of July, and grow them on in pots, housing them in September, giving a light place near the glass, at the same time not over-watering for the winter. In the beginning of March cuttings are taken off and struck in nearly all sand, the pots being placed in a brisk bottom heat. The old plants from which these were taken are also placed in heat, and supply an abundance of shoots. When the cuttings are rooted they are potted off into a compost of loam and leaf soil, to which a large amount of sharp sand has been added; they are returned to heat again, and, when about 3in. high, the tops are pinched out, and, as soon as the plants break freely, they are gradually

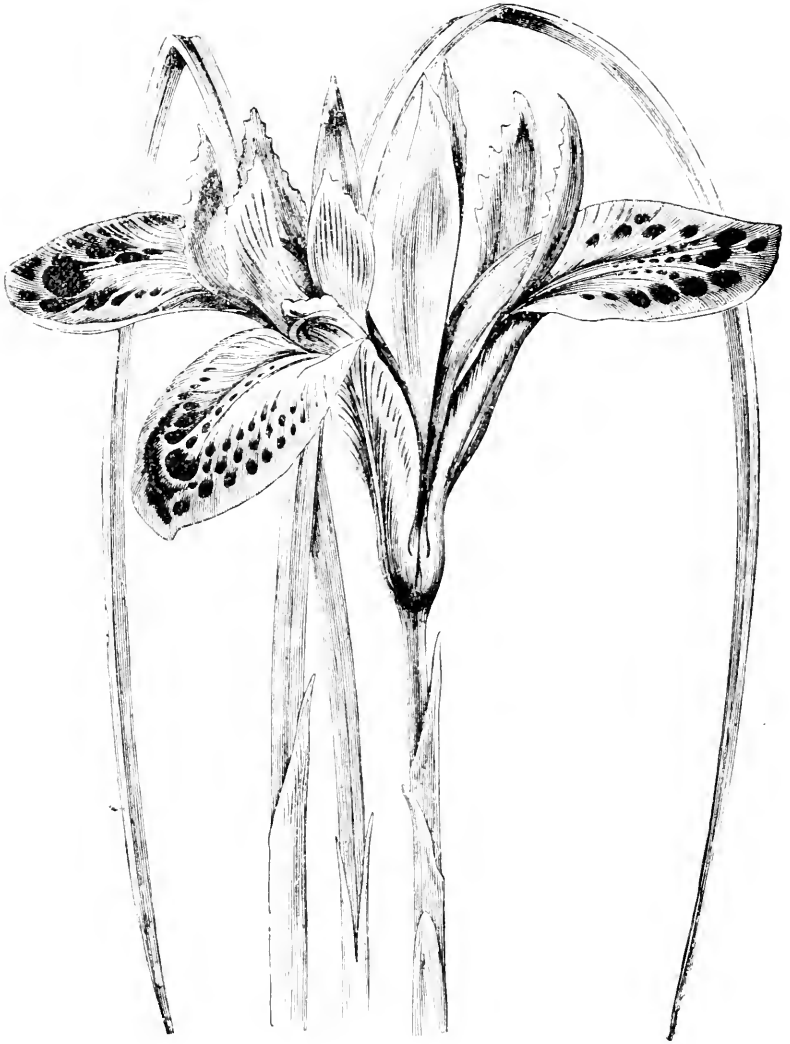

FIG 78.—IRIS HISTRIO.

hardened off, and finally bedded out in June. Some of them may, however, be grown on in pots, and, by shifting frequently until Sin. pots are reached, stopping from time to time, and paying due attention to watering, fine decorative plants will be made.

Propagated by cuttings, as described above.

The following three varieties are good, viz., *I. Lindeni*, dark blood-red leaves, tall; *I. acuminata*, taller than the next, but variegated like the latter, having brighter colours, fine for pot work; and *I. Herbstii*, dark crimson, ribs and stems of a carmine colour, but on some soils having a reddish bronze hue instead of coming true.

**Iris.**—Hardy, bulbous, soft-wooded plant. Grown for its flowers. Minimum temperature (in pots), 33deg. Some of the bulbous Irises are worth growing in pots for the decoration of the greenhouse, but more particularly for that of the cold house, as there the colours come very pure, and the markings are very distinct. Great care, however, must, be taken that insects are kept down, and that the plants are kept as near the glass as possible, so that they do not become drawn, for, if that should happen, or the plants become infested with green-fly, they will not bloom, and, unless they bloom, they are useless from a decorative point of view. They are from a foot to two feet in height, and in general appearance as shown in Fig. 79. The general treatment is the same as for fritillarias, and if the directions for the culture of those plants are followed, a good show of bloom may be reasonably expected. Some of the evergreen Irises may be bloomed in the cold house, or in a cold frame, if the roots are carefully taken up and potted in pots sufficiently large to hold the clumps without damaging the roots, with good sandy loam for soil, and plenty of drainage. As a rule, however, it is not safe to try to force the herbaceous sorts, as they will not stand being over-excited, but, in the cold house, they can be had in bloom very easily.

Propagated by offsets, which are produced naturally.

Amongst bulbous sorts, the varieties of *I. xiphoides* have the largest flowers; those of *I. xiphium* are the earliest. . The

following varieties of *I. xiphioides* are very good, and are really worthy of being well cultivated: Brutus, reddish purple; Damon, pure white; Gloriosa, pale blue and white; Grand Vainqueur, rosy lilac; La Beauté, lilac; Lord Palmerston, purple; Miss Barclay, white, splashed with violet; Mungo Park, dark violet; Penelope, white, mottled with lilac; Pourpre Blenâtre, rich

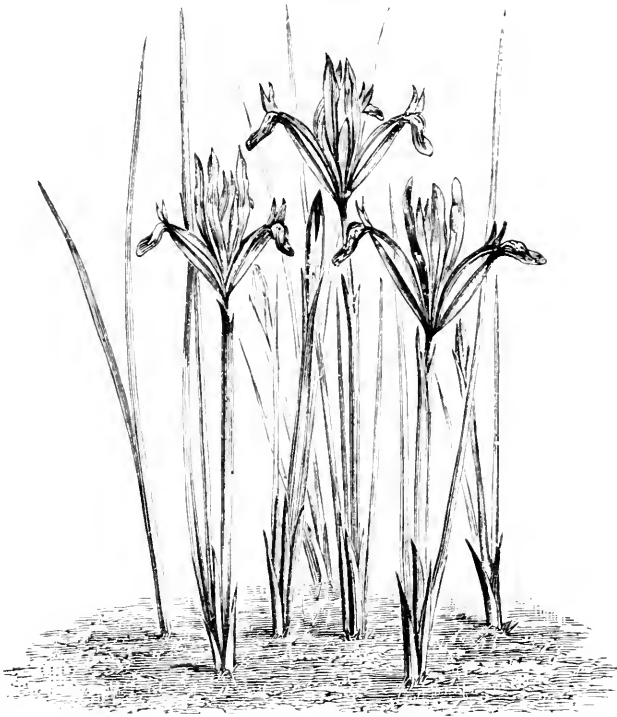

FIG. 79.—IRIS RETICULATA.

purple. Of *I. xiphium*, the following are really good: white, yellow, rich violet purple, and blue. If the bulbs are had to the colours named, no advantage will accrue by purchasing named sorts, the only difference being in the price. *I. Histrio*, which is of the *I. reticulata* type, is very handsome (Fig. 78)



and has also a very pleasant perfume, but, being of comparatively recent introduction, is not so common as others of the same type. It is well worth cultivation when bulbs can be had, and should be in every collection. *I. pavonia major* (peacock iris), beautiful white, with sky blue blotch on each petal; *I. Persica*, white, blue, and yellow; *I. reticulata*, deep blue and golden yellow (Fig. 79); *I. Susiana* (Chalcedonian iris), broad petalled blush tinted brown flowers, netted with dark lines (Fig. 80); *I. tuberosa* (snake's headed iris), rich violet, tinted glossy black flowers; *I. primula*, various; and *I. suavolens*, various, are all good for our purpose, if grown in a manner consistent with their various habits. The chief points are, to treat as nearly as possible as hardy plants, to give plenty of air, and to keep free from insects.



FIG. 80 — IRIS SUSIANA.

**Isolepis.** — Greenhouse soft-wooded plant. Grown for its foliage. Minimum temperature, 36deg. This plant, which is in reality a rush, is most useful for various decorative purposes, whether in rooms, in the greenhouse and conservatory, or for table decorations, its grass-like foliage surmounted with its tufts of flowers, in all about 9in. high, being very graceful and effective; consequently it should be grown in every greenhouse in the land; but, while it will do anywhere if frost is excluded, still it is far preferable to grow it in a house where at least a minimum of 45deg. is maintained. In fact, a higher temperature would produce better results, but, as in many cases this cannot be had without injuring the other stock, the former temperature must suffice. Where sufficient heat is at hand the plants can be kept growing briskly throughout the winter, while in cool houses they should be in an advanced stage before winter sets in, so that the chief point may be to preserve and prolong their beauty rather than cause a fresh

growth. Of course allowance must be made to meet any special features in the case, but the following treatment will be found to produce excellent results: Pot the plants (after dividing the old stools) in a compost of sandy loam, leaf soil, and thoroughly rotted cow manure in equal parts, adding enough sand to keep the whole open. Keep them close for a week or ten days, and then air can be admitted more or less according to the season. Re-potting can be done at almost any time when heat is readily obtainable, but in cold houses this operation is best performed in April and August, the plants being divided into two batches for the purpose. Few insects attack the *Isolepis*, but slugs and snails must be guarded against. In no case must the plants get dry at the roots, or the foliage will become brown and unsightly, and the beauty be thus lost.

Propagated by divisions of the tufts or crowns, and this division can be carried on to a very great extent if in a warm, moist greenhouse. Although seeds are to be obtained, they cannot be relied on, as they should be sown as soon as ripe.



**ASMINUM.** — Hardy hard-wooded climbing shrub. Grown for its flowers. Minimum temperature, 36deg. Jasminums, being of a not too robust growth, can be grown successfully in pots, and while young may be trained on trellises affixed thereto, either flat or balloon shaped. The

blossoms being tubular, and more or less odoriferous, they are very desirable for cut blooms, while the pinnate foliage is of a bright green, and very pleasing. The plants, which can be used on walls or pillars, or trained as bushes about two feet or more in height, are best purchased from a nursery in autumn, and kept in the greenhouse until about March, when they should be re-potted, or planted out

as the case may be, good sound peat being chosen, or two-thirds peat and one part loam, and a sufficient quantity of sharp sand to ensure the proper porosity of the soil. A minimum heat of at least 40deg. must be maintained to keep the plants in thorough order, and while plenty of ventilation is maintained when necessary, the ordinary temperature of the house will be sufficient. Water must of course be given as needed, and the syringe must be used occasionally both for the sake of cleanliness and to keep down red spider. Training must be afforded as required, and shoots that unduly take the lead over the general growth of the plants should be stopped.

Propagated by cuttings of ripe wood of the current year's growth, in sandy soil, with or without gentle bottom heat.

For sorts select from *J. Azoricum*, *J. gracile*, *J. grandiflorum*, and *J. odoratum*.

We have also seen the hardy *J. revolutum* grown well in a cool house, but it should be treated as a hardy plant during the summer, when, with careful treatment, it will bloom freely early in the season. The flowers are highly fragrant, of a bright yellow colour, and the foliage is of a very rich green. Treated as a shrub it does far better than as a climber or wall plant, and as it blooms better and earlier in the greenhouse than out of doors, it fully repays any trouble bestowed on it. For soil we use turfy loam one half, good peat, as used for azaleas, one part, and leaf soil, or rotten cow manure, and sharp sand in equal proportions, one part, potting rather firmly, and not allowing too much room at the roots. We rather prefer to have the plants slightly pot bound, and to assist them with liquid manure.

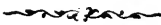



plants much resemble generally, and the treatment given to those will suit Kalmias. With care they will bloom well each year, but we prefer plants freshly lifted, for these generally answer best. The plants that have bloomed indoors can also then be planted out to prepare for indoor work again when required. A soil composed of peat and sand is necessary, and firm potting must be the rule. For treatment, see "Rhododendrons."

Propagated by cuttings or seeds, but as the plants are very cheap, and but few are needed, it is generally considered better to purchase than to be troubled with propagation.

The sorts most suitable are *K. glauca* and *K. latifolia* (Fig. 81), both of which are very pretty, and repay the trouble that may be taken with them.

**Kalosanthes.**—Greenhouse soft-wooded plant. Grown for its flowers. Minimum temperature, 40deg. These plants, which

**A L M I A.**—Hardy hard-wooded shrub. Grown for its flowers. Minimum temperature, 36deg. This useful class of American plant is well suited for the cool house. The flowers are very pretty, much like some of the rhododendrons, which the



FIG. 81.—*KALMIA LATIFOLIA* (Truss of Flowers.)

are so much esteemed for decorative purposes during the season, are of easy culture if ordinary care is used; but it is a sign of careless cultivation to see them 3ft. or 4ft. high, instead of



FIG. 82.—*KALOSANTHES COCCINEA*  
(Flowering Branch).

18in., and the clusters of blossoms consisting only of four or five, instead of several dozens.

The scarlet variety is most effective for decorative purposes; but if the blooms are cut and wired for table work, the flesh-coloured or pink variety also is very showy.

For the decoration of rooms they are at times useful, but as their habit is erect they are better suited for the conservatory, as they can be there worked in to greater advantage.

The flowers are also sweet-scented, which is an additional advantage, and the general appearance of the plant can be gathered from the flowering branch shown in Fig. 82.

The best way to grow them is as follows: In August or early in September, take cuttings about

3in. long, choosing shoots which have not bloomed; strip off a few of the bottom leaves and insert each cutting singly in a 3in. pot, using a compost of loam, leaf soil, and pounded brick or crocks in about equal proportions.

Place these pots on a shelf in the greenhouse or in a warm pit, keeping

them as near the glass as possible, and giving only enough water to prevent flagging. When well rooted, remove to a

cool dry greenhouse for the winter, giving but little water, so that the plants shall be kept at rest till the spring.

Early in March re-pot into Sin. or 10in. pots, using a somewhat heavier soil, and also plenty of drainage. After potting, carefully introduce the plants into a growing temperature, and induce them to grow freely, but, at the same time, take care that they are kept near the glass, or they will become long and spindly and of small value. As growth commences some of them will have several shoots, while others will have but one. In the former case remove all but seven or eight, and in the latter pinch off the top to induce the formation of young shoots, as it is these which will bear flowers. About the end of May plunge the plants in a bed of ashes outdoors, or stand them on a hard surface, as the plunging is not absolutely necessary; but it is necessary to give them a hot and open (though sheltered) spot from the time of re-potting until the fall, when they should be taken into a cool house before the weather becomes too cold. Here they can remain, until the flowers open, in a temperature of 45deg. to 50deg. Some may be got on earlier by giving more heat, while others may be retarded by keeping them a little cooler, so that a succession can be kept up. If due attention is paid to watering, staking, &c., during the summer, fine plants, covered with large trusses of flower buds will be produced by autumn, and then the only question is to get the buds open at the time desired, and this is done by the routine already described.

Propagated by cuttings as described above.

The sorts we prefer are as follow: *K. coccinea superba* and *K. coccinea* (Fig. 82), crimson; *K. versicolor*, flesh or pink. *K. splendens* is also very good; but the first two are decidedly the best.

**Kennedyia.**—Greenhouse climber. Grown for its flowers and foliage. Minimum temperature, 40deg. This is a family in which the old families of *Zychia* and *Hardenbergia* are incorporated, or at least the three plants are now classed under the first name by most botanists and nurserymen, and we therefore comply with the rule. These plants afford considerable variety and for this reason are suited for general cultivation on a larger scale than is usual. The cultivation is comparatively

easy, provided the soil is so prepared as to remain in a healthy condition, and plenty of drainage is afforded. Use either peat or peat and loam, with a sufficiency of sand, as previously advised for other plants, potting pretty firmly. Water must not be given more than is required, neither must the soil be permitted to become dust dry at any time, or serious damage will be done. A warm greenhouse or conservatory—where they will produce their pea-shaped flowers in great abundance, which being prominent above the trifoliate foliage are very conspicuous—suits them best, but still, if the minimum temperature in winter is from 40deg. to 45deg., they do very well. The attacks of insects must be kept down, as advised for other plants, or the foliage will become unsightly. Besides being useful as climbing plants, they can be trained on trellises or balloon-shaped wire frames, but not less than 15in. frames should be used.

Propagated by seeds sown on sandy soil in a warm greenhouse, or in a gentle bottom heat early in spring, and carefully grown on until the plants attain some size.

For sorts, select from the following : *K. Australis*, *K. coccinea*, *K. Comptoniana*, *K. digitata*, *K. inophylla*, *K. i. variegata*, *K. lilacina*, *K. monophylla*, *K. m. variegata*, *K. ovata*, *K. o. alba*, *K. o. purpurea*, *K. o. rosea*, *K. pannonosa*, *K. rubicunda*, and *K. r. superba*.



FIG. 83.—*KERRIA JAPONICA*  
(Flowering Spray).

**Kerria.**—Hardy shrub, the stems of which are biennial, as with the raspberry. Grown for its flowers. Minimum temperature

36deg. This old-fashioned plant is very good for bringing into bloom early in the season, and there is very little trouble in doing this. Suitable plants should be chosen as soon as the leaves fall, taken up carefully, so as to preserve all the roots, and potted up in pots of sufficient size to hold them comfortably. Good sandy soil should be used, and the pots should be well drained, but with the exception of these points no further special directions are necessary. The plants can either remain in a cold house, or they may be gradually introduced to a warm one, where the flowers will be freely produced. The blossoms, which are yellow—buttercup colour—are formed somewhat like a double daisy, and contrast admirably with the white cerasus, but they require wiring to be of use as cut bloom.

Propagated by division of the stools, in the same way as with the raspberries. As they are perfectly hardy, it is advisable to place out the forced pot plants each year, and take up fresh clumps which have been divided the year previously, and grown on in rich soil for the purpose of potting. By following this plan the best results will be obtained.

The only kind which is really worth cultivation in the greenhouse is *Kerria japonica flore-pleno*, the old double yellow, a flowering spray of which is shown in Fig. 83.



**ACHENALIA.**—Greenhouse bulbous soft-wooded plant. Grown for its flowers. Minimum temperature, 40deg. This is a class of greenhouse bulbous plants which, though of great individual beauty, is still much neglected. Indeed, at the time when they most require attention, as a rule, they have the least, probably owing to the fact that their blooming period is then over. The bulbs are comparatively cheap, and are to be had at most nurseries.

About October or November they should be put into 6in.



or Sin. pots, from seven to twelve bulbs in the 6in., and from twelve to eighteen in the 8in. pots. By this plan good masses of foliage with a fair number of spikes of bell-shaped pendulous flowers are obtained, and a better effect produced than by growing in smaller numbers, the lax flag-like foliage forming a handsome mass from which the flower spikes issue. It is well to mention that here a little discretion must be used, as in many cases the bulbs will be strong, and then a less number will be required; and, again, weak bulbs will require to be much closer together, so that in reality they must be planted according to size. By far the best plan is to place the larger bulbs in the centre and the smaller ones around, as the growth is then more evenly balanced. In potting, about an inch of drainage should be put, then an inch of thoroughly decayed cow manure, and the pot filled up with a compost of yellow fibrous loam and enough sharp sand to keep up the necessary amount of porosity. As the bulbs are very small, it is preferable to fill the pots and then insert the bulbs, first putting in a pinch of silver sand for the bulbs to rest on. No water should be given until the plants are growing well, and then it must be given freely. To grow them well they should be stood on a bed of ashes in a cool frame, and kept somewhat near the glass, but especial care taken to exclude frost. It is also a good plan to exclude light from the bulbs until they are well started. When well advanced they may be placed on the front shelf of a greenhouse until their beauty is over, then they should be taken back to the frame to complete their growth and ripen off the bulbs, as on this depends their value as decorative subjects.

Propagated by the division of the bulbs, which increase naturally.

The best three varieties are *L. pendula*, red, tipped with purple and green; *L. quadricolor*, and *L. tricolor*, scarlet, yellow, and green. For all cool houses these will be found gems amongst bulbs, but no forcing must be attempted.

**Lantana.**—Greenhouse soft-wooded plant. Grown for its flowers. Minimum temperature, 38deg. These plants are useful for greenhouse decoration and bedding-out; and whether grown

for one or other of these purposes, or for both, if grown well they are sure to give satisfaction. For ordinary greenhouse culture they are well adapted, as they produce flowers for six or seven months in the year, with no more trouble than is necessary to grow a geranium. They strike very freely, are easily raised from seed, and winter well, doing very well in a house where the temperature does not fall below 38deg. Combined with these good points, the heliotrope-like flowers are conspicuous, showy, and borne at the ends of the shoots, where they are in full view, and, what is more important to the amateur horticulturist, they are not subject to any insect pest to an appreciable degree. In many places they are used pegged down in place of verbenas, with this disadvantage, that crimson, scarlet, pure white, and self purple are absent, the shades generally having more or less orange in them. Nevertheless, the whole of the plants are well worth cultivating.

The way we manage them is to strike cuttings in August or early in September, pot off into small pots, and winter in an ordinary greenhouse, re-potting in March into 3in. pots, and when the side shoots are large enough stopping them back, and striking the points in a gentle bottom heat, by this means having plenty of plants from a small space. If it is desired to have large plants for decorative purposes, those that were stopped back should be re-potted into 6in. pots, and carefully grown on, a pyramidal form of growth being chosen, in which they will exhibit their flowers to perfection. Plenty of water will be necessary while the plants are growing freely, but no liquid manure should be used until the pots are full of roots; then a solution of sulphate of ammonia may be applied most advantageously, as this manure is best suited for the production of flowers. The ordinary stock may be bedded out in the proper season, and will be very useful both for the display of bloom obtained, and for cutting, but great care must be taken in the latter case that no *bruised* foliage is used, as it then emits a very unpleasant smell.

For soil, we find a compost of one part leaf mould and two parts good maiden loam, and a fair amount of sand answer well, and we pot moderately firm, but not too hard, or the plants

will not grow freely. We find Lantanas do best without manure.

Propagated by cuttings as described above.

The following sorts, which we have grown ourselves, are all good, and should be in all collections: Ne plus ultra, centre of truss straw yellow, and shades off at the edges to rose pink tinted with lavender; *Lutea grandiflora*, fine yellow; La Manula, rose pink centre, yellow outside; Julius Cæsar, bright bronze yellow; Marquis de St. Laporta, bronze self; Favorita, bronze yellow, changing to dark brownish scarlet, and tinted, bright purple; Dom Calmet, pink, changing to peach and yellow; Mons. Felix Aliburt, purple pink suffused with gold; Distinction, orange scarlet; Imperatrice Eugénie, pale pink, clear yellow centre; Victoire, white, lemon eye; Ninus, canary yellow; and Mons. Rougier Chauvière, yellow, bordered bright red, changing to scarlet. There are also other named sorts, of which we have not sufficient knowledge to justify recommendation, but the preceding we know to be good. A packet of seed from good varieties raised in heat in January or February will bloom some time between July and October, and will afford many different marked flowers, some of which are sure to prove useful.

**Lapageria.**—Greenhouse hard-wooded climber. Grown for its flowers and general appearance. Minimum temperature, 36deg. This is a very fine climber or roof plant, where there is plenty of room for it to grow; and as its long handsome bell-shaped and waxy-looking blooms are produced freely, it is of a very ornamental character. To be done well, however, it requires to be put out in a prepared border where plenty of room is afforded, although decent plants can be done in pots if care is taken. They are plants that dislike much sun, or a dry arid atmosphere, therefore the best plan is to grow them in a moist shady house, or on a wall that is somewhat shaded, and as a rule the north wall of a house suits them well, that is, if the long straggling shoots are allowed to ramble at pleasure, but if it is trained out in a stiff formal manner, it does not display its pendulous bell-shaped blooms to any great advantage. We think the best plant—or rather the best half-dozen plants—we ever saw were grown in

an old vinery, where the roof was glazed with glass six inches square only, and the laps were filled up with dirt. In fact, it was essentially a "dark" house, which few cultivators would care to possess. But for all that, the plants produced on an average about 2000 blossoms each year, and they were much admired by visitors, who prized a few cut blooms very highly, as they retain their beauty for nearly a month, if the water in which they are kept is changed from time to time. To obtain the full amount of flowers, *Lapagerias* should ramble at their own sweet will and pleasure, the only training given consisting of the leading of the shoots in the direction it is desired they shall go. It is nearly hardy in the southern and midland counties, and at Messrs. Pince's nursery, in Devonshire, it flourishes against a wall and blooms profusely. The method of cultivation in pots is much the same as in borders, except that the plant is more unmanageable, and therefore, where it is possible, we should advise the use of a border. The same treatment applies to pots as to borders. In all cases plenty of root room must be afforded, and if the plants are tried in pots, large ones must be used. In the event of cultivation in the border, the stations should be prepared as follows: In the first place, excavate the soil to the depth of three feet, and about four feet square, or a space of about the same capacity, the depth in all cases being the same. A good exit for superfluous water must be afforded, either by a drain or by a layer of rubbish, but preferably by a drain. At the bottom of the site put a layer, from six to twelve inches thick, of broken porous bricks; on this place turves of fibrous peat, not broken, and fill the interstices with very coarse sand or broken potsherds that will pass through a quarter-inch meshed sieve. Fill in the hole with lumps of peat and loam, adding small quantities of sharp sand as the work proceeds, so that a sufficient porosity of the soil be kept throughout. The soil must be lightly trodden, and then the place is ready for the reception of the plant. A good strong free-grown one is necessary to start with, and this should be carefully planted without disturbing the roots. This done, give a good watering to settle the soil around the roots, and as soon as the plant begins to grow freely, supply

water in greater abundance. The best time to plant is when the shoots commence growth, as they then take to their new quarters more readily. The chief insects which attack *Lapagerias* are thrips and a small white scale, both of which can be kept down by applying Fowler's Insecticide at a strength of about 6oz. to the gallon of clear water. Care must be taken not to break the leaves, which are very brittle at the axils, as faded or dead leaves do not enhance the beauty of any plant.

Propagated by layers of ripened wood of the present year's growth pegged down for about twelve months before removal from the parent plant.

The sorts are *L. alba*, *L. rosea*, and *L. rosea splendens*. The white one is, however, rather expensive, the cost being from £3 3s. to £5 5s. each for moderate-sized plants, whilst large specimens fetch higher sums.

**Lasiandra.**—Greenhouse hard-wooded shrub. Grown for its flowers. Minimum temperature, 45deg. These plants are well worth cultivating in places where it is desired to have a nice selection; and although—like all others of the better sort—they are rather more troublesome to grow than such as geraniums, they fully repay the care bestowed on them. They bloom in autumn and winter, and are, consequently, of much value, as at those seasons blooming plants are naturally scarce. The general appearance is like that of *Pleroma elegans*, but bearing large saucer-shaped flowers of a bluish purple; and although they do not last long, the flowers open successionally, and being from two to four inches in diameter, make a fine display. In autumn select plants in 4in. or 6in. pots, and, after wintering them, re-pot into 8in. pots in February. Choose such as have been stopped at the third or fourth eye above the collar, and have four or five shoots, otherwise there will be some difficulty in furnishing the bottoms. For soil, take either loam or peat—the former preferably; use a sufficiency of sharp sand to keep the soil open, as this plant requires much water whilst in a growing state, and also provide good drainage to prevent sourness. Keep in a light position with a temperature of 45deg. to 48deg. at night, and a little higher during the day.

As the sun gains power give air in the fore part of the day, and throughout the spring allow plenty of light. When the sun becomes very powerful apply a little shade, and about the end of June shift the plants into pots a couple of inches larger. Before they are re-potted—say six weeks previously—it is a good plan to stop the shoots, so as to maintain as bushy a habit as possible, or it is probable that some of them will have to be cut back, which means a loss of size in the plants. During the whole of the growing season syringe the foliage in the afternoon, and maintain a comparatively moist atmosphere, so that the growth may be good; and it is also necessary to tie out the shoots to maintain an equal balance to the plants. If everything goes on well, about the end of July nip out the points of the strongest shoots, and in September gradually remove the shading, at the same time keeping a drier atmosphere, to ripen off the wood. Cease syringing, and give plenty of air, and by the end of the year they will commence blooming, at which season they should have a temperature of from 48deg. to 50deg. About the end of the succeeding February cut back moderately, give a shift into 12in. pots, and apply a similar treatment to that recommended above, with the exception of the second potting. Red spider sometimes attack *Lasiandras*, but these can be kept in check by plentiful applications of clean water with the syringe during the summer. Brown and white scale also attack them; for the former of which use “Fowler’s Insecticide,” about 5oz. to the gallon, and for the latter “Abyssinian Mixture,” 7oz. to the gallon, well brushed into the bark two or three times while the plants are dormant.

Propagated from cuttings struck on a gentle bottom heat or in a warm greenhouse.

*L. macrantha* is, in our opinion, only suited for trellises or walls, and for this purpose should be planted out into the borders, or in large tubs or boxes, with much the same treatment as that just described. It should be grown the first year in pots, and then turned out into the borders. *L. macrantha* is not so suitable for pot culture as *L. macrantha floribunda*, which, with proper care, produces its blooms for some weeks.

**Laurustinus.**—See *Viburnum tinus*.

**Leucojum.**—Hardy bulbous soft-wooded plant. Grown for its flowers. Minimum temperature (in pots), 36deg. These are early blooming bulbous plants, of easy culture in the cold greenhouse, and are somewhat similar in appearance to the snowdrop, but they are much taller, and, as shown in Fig. 84, the form of the blooms is more globular. The culture is the same as for *Anthericum*, with a free sandy loam for soil and plenty of drainage.

The plants are not well suited to other than the cold house, and, therefore, forcing should not be attempted.

Propagated by the division of the bulbs, which increase naturally.

The sorts we have grown are *L. aestivum*, *L. pulchellum*, and *L. vernum* (see Fig. 84), all of which are white.

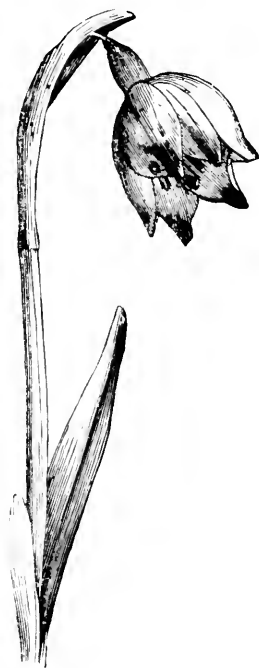

FIG. 84.—LEUCOJUM  
VERNUM.

**Leucophyta.**—Half-hardy soft-wooded plant. Grown for its silvery foliage. Minimum temperature, 40deg. This is useful alike for greenhouse decoration and for bedding-out purposes, and, from its colour, is a very desirable acquisition to the stock of plants grown. It is of a peculiar silvery white; the growth is quick and slender, presenting the appearance of some marine plant rather than one belonging to the land; and it is not at all easy to describe. The stems appear to branch and ramify at will, apparently bearing no foliage; but if closely examined they will be found to be thickly set with long narrow leaves. It is not very difficult to propagate, cuttings taken in August striking freely. We grow it in the same manner as the Lantana, using the same soil, and we find that it does well with such treatment. The only variety with which we are acquainted is *L. Brownii*.

Propagated by means of short-wooded cuttings struck in the greenhouse or close frame in August.

**Lilium.**—Hardy bulbous soft-wooded plant. Grown for its flowers. Minimum temperature (in pots), 38deg. The only one of the Lilies proper that we consider worth cultivating under glass is *L. auratum*, or the Golden-Rayed Lily of Japan (Fig. 85), as it is sometimes called. In a spacious house one or two large clumps look well and diffuse a fine perfume, but too many must not be used, or the scent will be too powerful and cause a feeling of nausea each time the house is entered. The way we cultivate these plants is as follows: As soon as we can procure the roots or bulbs we put them into pots of sufficient size for the purpose required, generally 12in. or 14in. In these we put about two inches of crocks, and on this, again, about the same quantity of compost. We then place the bulb or bulbs on this soil, allowing at the rate of one blooming crown to each two inches in diameter of the pot, whether the crowns are in one or several roots or bulbs. On the bulbs we lay about two inches of soil, pressed down moderately firm. The pots are then placed in a cold frame with a bottom of coal ashes, and no water is given until the plants begin to throw up the flower spikes, when a good soaking is administered. When the spikes are about six inches high, another two inches of rough soil is applied; and when the roots appear above this the pots are filled up, as, by this method, we find that much finer blooms are produced. As the stems increase in height, liquid manure is given occasionally with advantage, and they are neatly trained out with stakes just strong enough to bear the weight of the head of bloom. During the whole of the time the plants are growing they are kept as close to the glass as possible, and given the largest amount of air that can be consistently allowed. In fact, it is far better to grow the plants in the frame until the end of May, and then only cover in case of frost. As soon as the foliage dies off we re-pot the roots and treat them as before described. And here let us draw attention to the fact that there are no roots to beat those grown at home,



although they may be more expensive; for home-grown bulbs always retain the thick, fleshy roots at the base, which are absent in imported samples; and this makes a vast difference in the beauty of the flowers. For compost there is nothing better than pure fibrous maiden loam, to which is added enough



FIG. 85.—LILIUM AURATUM.

sand to maintain a porosity admitting the free passage of water. The soil should be roughly chopped up, so as to pass through a two-inch meshed sieve.

Propagated by the natural division of the roots.

There are two sorts we use, viz., *L. auratum*, the Golden-

rayed, and *L. rubrum vittatum*, the Red-rayed Lily. There are several different forms in both these, and therefore if one comes across a taking flower it is as well to secure the root, but if imported roots are purchased various forms of flowers will be obtained. Several of the other Lilies can, however, be tried in a cold house, *L. speciosum*, *L. Humboldtii*, and *L. Leitchlinii*, and some others being suitable for the trial; but, as a rule, unless the house is large, but little success will be obtained.

**Lily of the Valley.**—Hardy, herbaceous, soft-wooded plant. Grown for its flowers. Minimum temperature (in pots),

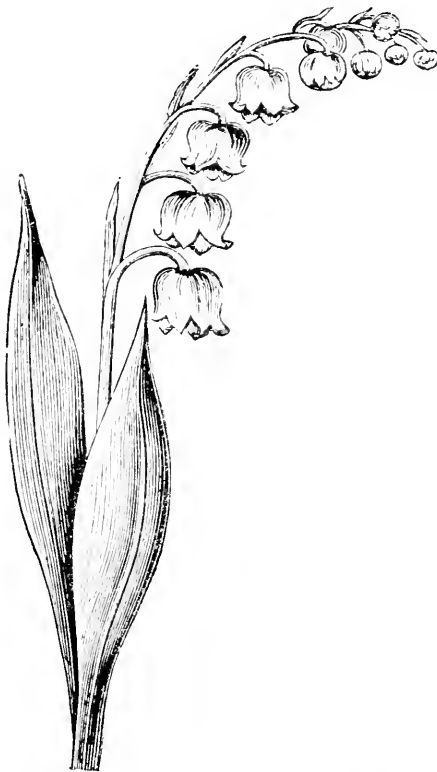

FIG. 86.—LILY OF THE VALLEY  
(Large Berlin variety).

36deg. The Lily of the Valley, or *Convallaria majalis* (Fig. 86), is in much demand during the early part of the season, but it is rarely to be found grown in a proper manner in the hands of the amateur. It must be remembered that the plants will not bear forcing, as the term is generally employed, but a little coaxing must be resorted to if they are required early. A compost of leaf soil and mellow loam in equal proportions, to which has been added a sufficient quantity of sharp sand to render the whole sufficiently permeable to the water that is applied, suits the plants very well for the time they are in the pots, for, after they have ceased blooming, they must be

turned into the open ground. Whether prepared clumps or

single crowns are used, it matters but little in the results obtained if the treatment is of a rational character, and, indeed, many persons are of opinion that the single crowns, if carefully selected, are the best. Suffice it to say that we have found but little difference in the two methods of preparing the roots. As soon as the roots can be obtained, they should be potted into four or six-inch pots, according to the display required and the size of the roots. The crowns should be just covered with soil to the depth that they are covered when growing naturally, and after potting the plants may be stood in a dark and moderately warm place till the shoots get about three inches long, when they should be gradually introduced to the light to get the colour into the foliage and to open the blooms of a good size and colour. The plants may also be potted up and placed under the stage in the greenhouse, and when started removed to the light, to grow and bloom. In the cold house but little trouble is necessary, as they will only bloom about a week or so before their natural season. A temperature of about 45deg. is quite high enough if a good head of flowers is desired, but an additional five degrees may be allowed as the foliage becomes fully expanded, as the flowers will open more freely in a temperature of about 50deg. Water must be given as required; but it must be remembered that while plenty of water is necessary at some stages of the growth of the plants, if too much is given the soil will become water-logged and totally unfit for the growth of these subjects, and as a natural consequence they will fail, and probably rot off. After blooming, the plants should be turned into a border of maiden loam and leaf soil in about equal parts, and plenty of water should be given through the hot dry weather. Fresh lots of crowns must be potted each year if a good show of bloom is required, as the plants rarely bloom the second season in pots.

Propagated by division of the crowns.

The varieties used are—*Convallaria majalis*, single white, the best for ordinary work; *C. m. flore pleno*, double white; *C. m. rosea*, rose; *C. m. foliis marginatis*, and *C. m. foliis striatis*, both having variegated foliage, and bearing white flowers.

In Fig. 87 we show a one-year-old crown, which produces

leaves only; in Fig. 88 a two-year-old crown, which is a doubtful



FIG. 87.—ONE-YEAR-OLD CROWN.

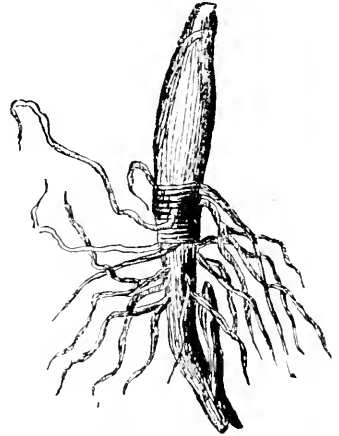

FIG. 88.—TWO-YEAR-OLD CROWN.

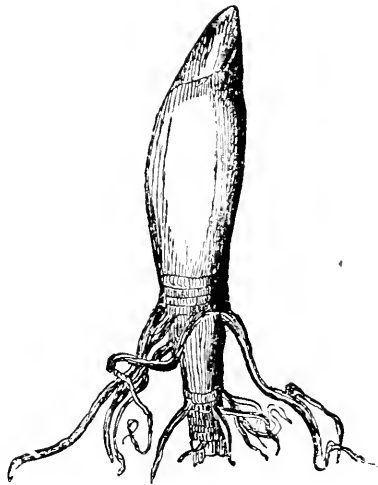

FIG. 89.—THREE-YEAR-OLD CROWN.

bloom-producer; and in Fig. 89 a three-year-old crown, which is sure to produce bloom under proper treatment.

**Lobelia.**—Half-hardy perennial soft-wooded plant. Grown for its flowers. Minimum temperature, 35deg. This class, which is rather large, is generally represented in most gardens by the ordinary blue *L. speciosa*, and its varieties, and it is chiefly used as an edging plant. Sometimes the hardy *L. cardinalis* (Fig. 90) is employed in the herbaceous borders, but



FIG. 90.—LOBELIA CARDINALIS.

this is not so often used now as it ought to be. Of these latter, however, we are not now treating; but rather of the sorts which have to be grown under glass for at least some part of the year.

Nearly everyone is acquainted with some of the varieties of *L. speciosa*, and to these dwarf bedding plants we will first direct attention. There are two ways of propagation which

are in general use, and the first of these is raising from seeds. Before attempting to raise a good stock of reliable plants from seeds, care should be taken to have *new* seed, and that, too, saved from a good strain of plants, otherwise disappointment is sure to ensue. Premising the seed is as it should be, the next point is to prepare some pots of rich soil on which to sow it; at least two inches of drainage should be allowed to a 4in. pot, and the soil should not come to within half-an-inch of the top. These should now be stood in a tub of water, but this must not be allowed to overflow into the top of the pots, and when the soil is well soaked they should be placed aside for an hour to drain. A small portion of clean seed should then be taken on the point of a penknife, and, by a dexterous puff with the breath, distributed over the surface of the soil. No soil should be put on the seeds, but each pot should be covered with a sheet of glass, the pots having been first placed in a brisk bottom heat, or in a greenhouse where a temperature of 60deg. to 65deg. is maintained. When the plants are sufficiently large to handle they should be transplanted at about an inch apart in other pots, and when large enough they should be re-potted into thumbs for use, and gradually hardened off as the season advances. The second plan is to cut down old plants in August, and, when they have broken freely, pot them up and place in a cold frame until the weather becomes too damp, and then take them into the greenhouse for the winter. In February the tops may be taken off and struck in heat, and if a warm temperature be given to the old plants they will produce a large number of cuttings, which may in their turn be struck, and a large stock of plants be made. The cuttings, when struck, should be treated the same as seedlings.

Double Lobelias should be struck in gentle heat in January, or in a shaded position in August, and wintered in a cool house. In February they should be re-potted into 3in. pots, and as the pots become full of roots (not pot-bound) shifted again into 4in. or 6in. pots, as the size of the plants require. By keeping them near the glass in a well-ventilated house until April, and then transferring to a cold frame, all the time paying attention to the wants of the plants as regards watering, &c., giving plenty

of air, but avoiding heavy rains, good pots of bloom will be had. It is, however, practically useless to plant these Lobelias out unless for the supply of cuttings, as they only make a good display for a short time, and then they are done for the season. A good soil for them is maiden loam three parts, rotten manure one part, and sufficient sharp sand to maintain the proper porosity of the soil.

There is a fine Lobelia very suitable for the decoration of the greenhouse—*L. subnuda*—a species with foliage much resembling some of the *Anæctochili*. It is one which, although not of very large size, is still extremely useful as a choice decorative plant, especially if small gems are desired for any special purpose. It is a native of Mexico, and, therefore, does best in the greenhouse. The plants form tufts about four inches, or a trifle more, in diameter, and the leaves are ovate, about an inch long. They are serrated at the margins, of a brownish-purple colour, the midrib and veins being bright green, thus forming a very elegant contrast. The under surface of the leaves is deep purple, while the flowers—which are produced freely on stems about six inches high—are of a very pale blue, but do not add much to the beauty of the plant. It is, therefore, a good plan to remove them as soon as they appear, unless seed is required, and then a spike or two may be left, as the plant seeds freely. The way we grow this plant is to sow seeds in April in a broad pan of sandy loam, distributing them thinly and evenly, and, when the plants are large enough, pricking each one into the centre of a 4in. pot. They are then carefully brought on in a warm position near the glass, but shaded from sun. With care in watering they soon get a good size and commence to bloom. If preferred, the seedlings may be placed in small pots at first, and then repotted, and perhaps they will do better thus than as we do them. For soil we use fibrous, sandy loam, enriched with a little thoroughly-decayed manure, to which some sand has been added to ensure the proper amount of porosity. *L. subnuda* is also sold as *L. picta*, but the former is the correct name.

Propagated by seeds or cuttings as described above.

For sorts of single varieties selection should be made from

the following: *L. speciosa* (true), *L. pumila grandiflora*, *L. pumila magnifica*, *L. speciosa compacta*, Brilliant, Henderson's Lustrous, Celestial Blue, Blue Boy, and Carter's Cobalt Blue, all various shades of blue. There are white varieties, but, with the exception of White Perfection and Duchess of Edinburgh for pot work, we do not recommend them. Of doubles, we think that *L. pumila fl. pl.* is the best, as culture more than variety causes size and doubleness in the blooms.

**Luculia.**—Greenhouse hard-wooded shrub. Grown for its flowers. Minimum temperature, 40deg. This is one of the old-fashioned sweet-scented plants that is now much out of cultivation, not because it is inferior to the new plants, or because it is not worth growing, but simply because it is somewhat out of fashion. As it is rather difficult of propagation, the best plan is to purchase fair-sized plants in autumn or early spring, and grow them on. We prefer to have the plants in 6in. or 8in. pots to start with, unless there is a regular gardener to attend to them, when, of course, the case is different. We have found that a somewhat similar treatment to that described for the *Hovea* answers well, with a compost of fibrous loam, peat, and silver sand. Good drainage must be afforded, as stagnant water is sure to stop growth. Shading from bright sun in summer and maintaining a moderately warm temperature during winter will cause the production of the magnificent cymes of pink hydrangea-like tubular flowers, which are often a foot across, in its season. The best place for *Luculias* is in the beds or borders of a conservatory where they have plenty of room to grow. With care they will make magnificent plants in the course of years. Insects are rather partial to the foliage, therefore it is necessary to keep a good look out for them, and destroy them as soon as seen, but, let the drawbacks of this sort be what they may, the plant is well worth cultivating.

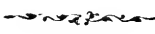





**MESEMBRYANTHEMUM.**—Half-hardy

succulent plant, grown for its foliage. Minimum temperature, 36deg. These succulent plants are very useful in many places, both for bedding out and other purposes, and some of them do not look bad in pots, but it is impossible to describe them in our limited space. We grow all of them in the same manner, and with great success, there being only one way of doing them well. The great secret of success we consider to consist in exposure to the full sun at all times, and not potting in too rich a soil, a compost of lime, rubbish, yellow loam, sand and cow manure, in equal proportions, suiting them well. The way we grow them is as follows: In March we either sow seeds in a little bottom heat, or strike cuttings in a position fully exposed to the sun, and when these are of a sufficient size we prick off into small pots, from which we shift them into 4in. pots when large enough, or transfer to the open ground if intended for bedding purposes. The whole of the time the plants remain in the most exposed part of the house, and are not over-watered, and in due season they make fine specimens. It is not, of course, intended that they shall perish for want of water, but what we would imply is that water is only given when really required, a saturated soil not being desirable for their well-being. Mesembryanthemums are best struck the same as cacti, *i.e.*, the cuttings inserted in dry sand and exposed to the sun till rooted, which operation takes place in a few days. When rooted some moisture may be applied, and, when potted off, the general routine may be followed.

Propagated by seeds or cuttings, as described above.

The following sorts are very interesting, either for pot culture or for planting out on rockwork during the summer months: *M. conspicuum*, mauve pink blooms; *M. lupinum*, yellow blooms; *M. tigrinum*, curious foliage; *M. echinatum*, curious foliage (Fig. 91); and *M. cordifolium variegatum*, creamy variegation,

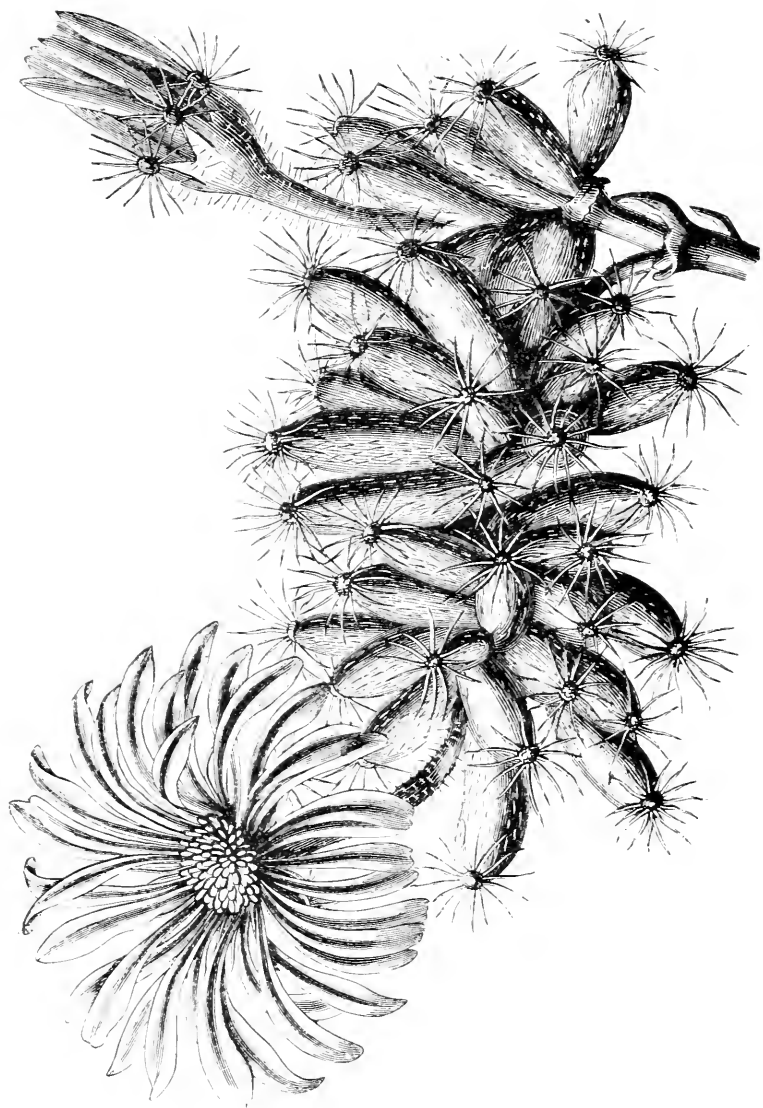

FIG. 91.—MESEMBRYANTHEMUM ECHINATUM.

rose-coloured blooms. As in these plants form varies so much, and as the chief beauty lies in the grotesque character of the foliage, it is impossible to describe the best, for what one person would admire others would be indifferent to; therefore we advise our readers to see a collection before purchasing largely. There are over fifty varieties grown by Mr. Ware, of Tottenham, and he does not, we believe, cultivate the whole of those grown.

**Mignonette.**—Half-hardy soft-wooded annual. Grown for its inflorescence. Minimum temperature, 45deg. This odorous plant, which is, as a rule, grown as an annual, blooms throughout the winter months if treated as a perennial. There are several modes of growing the plants for this purpose, but we shall give our own system.

In the first place, never attempt to transplant mignonette, or failure is almost sure to result, as it is an extremely difficult matter to successfully transplant things of this sort, which, as a rule, make but few fibrous roots. The best plan is to select the blackest seeds from a packet, and to sow two of these (a slight distance apart) in small 60-sized pots, and when up strongly to remove the weaker plant, and allow the other to remain. The time to sow is March, or early in April, and a little bottom heat should be used to start the plants. As soon as the pots become filled with roots, but not pot-bound, shift into 3in. pots, and continue shifting as necessary, until the second week in September, when the final shift should be given. During the hot weather the plants should stand on a bed of coal ashes, in a north-east aspect, and should be kept supplied with water, on no account being allowed to become dry, or the foliage will get rusty, and the wood hard, and all labour lost. After the last potting has been given in September, the plants should be removed to a light airy greenhouse, and should be placed near the glass, but care taken not to neglect watering, or the destruction of green fly. The flower buds must also be pinched out for the last time, and after this all blooms may be allowed to open. A temperature of about 45deg. to 50deg. will cause the plants to bloom well and freely.

To this end it is also advantageous to give occasional waterings with sulphate of ammonia, as this induces bloom.

For soil use two-thirds turfy loam, one part leaf soil, and one part road grit, with just enough sand to maintain the necessary porosity. Plenty of drainage must be afforded, and the plant must be neatly staked.

Another plan is to sow seeds in July or August, keeping the plants in a cool north aspect, and by having about three or four in a 6in. pot, and giving liberal treatment, they can be had in bloom from November till after Christmas, or even later, but, of course, much depends on the season.

Propagated by seeds as described above.

Amongst the many sorts, we have found the following good in practice: Crimson Giant, Parson's New White, Parson's Hybrid Giant, New Dwarf Compact, and Pyramidal Bouquet, all of which are distinct, good, and have some speciality in growth or colour, which, although scarcely worth describing at length, is still of enough note to render the plants sufficiently distinct while growing. As a rule we should advise the use of the whole of the sorts enumerated, and then a good show could be maintained.

**Mimulus.**—Hardy soft-wooded perennial plant. Grown for its flowers. Minimum temperature (in pots), 36deg. These are nearly hardy, very ornamental plants, from a foot to two feet in height, and bearing large, somewhat flaccid, flowers of an open tubular form, and of varied colour, and are also of very easy culture. The best amongst them are Clapham's and Henderson's strains, which, though unnamed, are of very great excellence, and we always grow them in preference to named varieties, on account of obtaining a finer show from them. We sow twice in the year, in October and April, using a little bottom heat to get the plants up. When large enough to handle, we transplant into 6in. pots, about twelve in a pot, and those sown in October remain thus until February, while those sown in March remain only until of sufficient strength to be transferred to single pots. If desired they can be transferred to thumb pots at once, and remain in these until

the roots kiss the sides of the pots, when they should be transferred to 6in. pots, and if large plants be required, from these they should be again transferred to 8in. pots, where, if proper care has been taken, they will make plants from 18in. to 2ft. high. As with musk, however, it is necessary to give them a position facing the north during the hot weather, and a large amount of water—in fact, they require very liberal treatment. For soil we use leaf mould one part, cow manure one part, good maiden loam two parts, and sand one part, and we put at least a couple of inches of crocks in the bottom of each pot. As the pots get filled with roots we stand them in saucers of water, and apply liquid manure once or twice a week.

Propagated from seeds, or by division of the stolon-like roots in spring.

The strains of *Mimulus* we mentioned above vary in hue from white, yellow, brown, maroon, &c., to almost black, and the flowers are beautifully spotted with tints very different from the ground colour, thus making very striking contrasts. The plants are

bushy, and are from a foot to two feet in height; the appearance may be gathered from the engraving (Fig. 92), which shows only one flowering branch.

As, however, some of our readers might fancy a few named sorts, we give the names of half-a-dozen which we have grown ourselves: *Attraction*, large scarlet, yellow throat, spotted with crimson; *Constellation*, canary yellow, deep crimson spots and



FIG. 92.—*MIMULUS VARIEGATUS*.

blotches; Goliah, clear yellow, richly spotted with crimson, very fine; Illustration, yellow ground, crimson lobes, very large and fine; Regulator, cream ground and margin, ruby crimson blotches, very fine; Regulus, deep crimson, canary spots and band; and *M. albus-elegantissimus*, creamy white ground, crimson blotched lobes, and plum-coloured margins. These are all most excellent in form and markings, and offer an inexhaustible store for the supply of seeds, but a packet of either Henderson's or Clapham's strain would be found to give quite as good results.

**Muscari.**—Hardy bulbous soft-wooded plants. Grown for their flowers. Minimum temperature (in pots), 36deg. The Grape Hyacinths are pretty bulbous plants, of dwarf growth, in habit somewhat like the scilla, blooming rather early in the season, and in the cold house making a nice show, but at times being a month earlier than their fellows out of doors. The colours range from white to purple, and are of very pleasing tints. The culture is rather simple, as they will do well if treated in the same manner as galanthus. The plants must not, however, be kept too wet, as they are liable to decay, and it is also necessary that plenty of drainage be afforded for the same reason. A rich sandy soil, or a compost of sandy loam and a little thoroughly decayed leaf soil to which some sharp sand has been added, suits the plants well, and as they are not so good in pots the second year, the chief point is to obtain the best possible effect the first season. After blooming it is a good plan to plant the roots in a prepared border of rich sandy soil, and let them

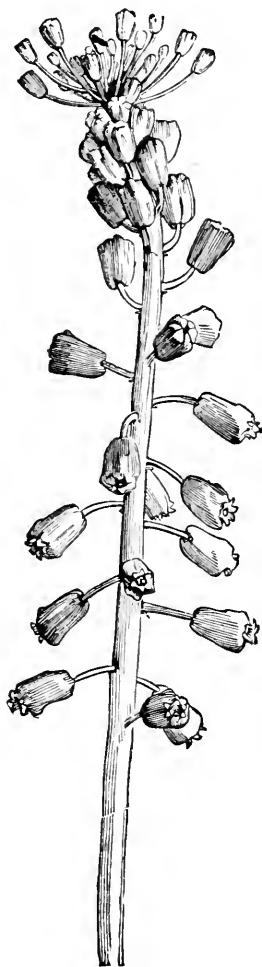

FIG. 93.—MUSCARI  
COMOSUM.

have a season's rest, and then they can be taken up and potted again, when a large increase will also be obtained. The bulbs are, however, cheap, and unless there is plenty of room outdoors, it is not worth while to save the bulbs for potting again.

Propagated by division of the bulbs, which increase naturally.

The varieties are—*M. botryoides*, blue; *M. b. album*, white; *M. b. carneum*, flesh; *M. b. pallidum*, white; *M. comosum*, purple (Fig. 93); *M. c. atro-cæruleum*, dark blue; *M. c. monstrosum*, blue; *M. moschatum*, blue and yellow; *M. pulchellum*, blue; *M. racemosum* and *M. r. major*, blue.

**Musk.**—Hardy soft-wooded perennial plant. Grown for its flowers and scented foliage. Minimum temperature (in pots), 35deg. Musk, or, more properly speaking, *Mimulus moschatus*, is a good old-fashioned plant, welcome alike in both mansion and cottage. Of course, all our readers are acquainted with the plant, therefore it needs no description; but the method of cultivation is quite another matter. To have a fine pot of Musk is generally everyone's ambition, and if the simple rules we give are followed, fair success, if not perfection itself, will be attained. In the cultivation of Musk, that is, if fine growth is desired, a somewhat shaded position should be chosen, and it is also desirable that no fierce sun rays should drop across the plants at any time, or the foliage will have a rusty, faded appearance. It is therefore better to grow them in a place having a north aspect during the summer, and as the sun loses power to bring them to the warmer side of the house. The way we manage the plants is as follows: In January some roots are introduced into a warm position in the greenhouse, and as soon as they break freely the young plants are potted off, about five in a 6in. pot, with rich, fairly open compost; plenty of drainage is also afforded, as they require an almost unlimited supply of water during the growing season. The young plants are then stood in a warm, somewhat moist position, and at once commence growth. As soon as they are about 2in. high they are stopped back, and this causes them to branch freely. Sticks are inserted round the sides of the pot at

an early stage of the plants' growth, and they are thus kept in a good form for a long time. About the first week in March, June, and August we also put in cuttings, and treat as before described, and thus have Musk in good order all the year round, which is not possible unless this practice is adhered to.

Propagated by seeds, cuttings, and division of the roots, as described above.

We are acquainted with only one species of Musk, *M. moschatus*. There are also varieties called the Giant Musk (*M. m. gigantea*) and Harrison's Giant Musk (*M. m. Harrisonii*), but these, we suspect, are only improved forms of the common species, and do not differ from the type, except in size.

**Myosotis.**—Hardy perennial soft-wooded plant. Grown for its flowers. Minimum temperature (in pots), 36deg. The Myosotis, or Forget-me-not, is a plant of which many persons are very fond, and certainly the flowers, and, in fact, the whole plant, are very pretty. It has only one fault, and that is the inducement it offers to the aphides, which prefer the sub-aquatic to any other plant, with the exception of the herbaceous calceolaria. *M. dissitiflora* is the best kind for general cultivation, as it does not need such vast supplies of water as does the sub-aquatic section, and, moreover, the colour is more pleasing. The habit of the plant is also more compact and suited to the use of pots for its culture. Frames should be prepared with a moderately rich sandy soil in September, into which plants raised from seeds sown in August should be pricked out about six inches apart. Treated in the same manner as other hardy plants in frames, they will remain until March, when they can be carefully taken up with a good ball of earth adhering to the roots, and potted into 4in. pots. They should be carefully but thoroughly watered, and returned to the frames for about a month, or until such time as the flower stems are thrown up, and then they should be transferred to the cold house, where, with ordinary attention, they will bloom for a considerable time.

Propagated by cuttings or by seeds, as described above.



**Myrsiphyllum.**—Greenhouse climber. Grown for its elegant foliage. Minimum temperature, 40deg. This elegant small-leaved climber is one of the plants which no amateur should be without, especially if he has any taste in vase or other table decorations. In the greenhouse it is also of great value, its extreme neatness rendering it useful for various purposes where larger and more striking plants are quite out of place. The *Myrsiphyllum* is very extensively used in America, where its beauties are far more appreciated than they are here; and a friend, writing from Boston, U.S.A., says that large houses are there devoted to this plant alone, and that immense quantities of the cut plants (we know no other term) are sent to Philadelphia and New York. The way they grow it in America is as follows: From July to September the roots are planted (indoors) in prepared beds of light rich soil from 1ft. to 18in. deep, and with a good amount of drainage below. One or two good waterings are given, and the plants are soon started, and grow rapidly away, so that in three months they are ready for cutting, that is, if they have been properly hardened off during the latter part of their growth. Each vine is trained up a single string, and when the time arrives it is cut, and the string being severed at top and bottom is slipped out, leaving the vine perfect. After this first cutting, more heat is applied, and treatment being given as before, in about three or four months the crop is again ready. During June and July rest is induced by nearly withholding water and by maintaining a cooler atmosphere; and then it can be started early in August, to finish off by Christmas. During the whole period of growth plenty of water must be given, and clear liquid manure must also be applied about twice a week; the plants being gross root feeders, this is absolutely necessary.

We have grown *Myrsiphyllum asparagoides* in pots, and by the method recommended by a friend who has travelled in the States. Our plan is the same as that given above, so far as soil and time of planting are concerned; but, as the plants are in pots, variations have to be made. In the first place, we plant from four to six roots in a large pot, and treat as

before described, but apply liquid manure when the plants are in full growth at least three times a week. The growth is gradually hardened off when it has attained the height of from four to six feet, and consequently it is then ready for use for decorative purposes. The chief rules for the culture of this plant are warmth, liberal treatment, plenty of water, early and continuous training, and hardening off before cutting the vines for decorative purposes.

Propagated by seeds, cuttings, and division of the roots.

The sorts we grow are as follow: *M. asparagoides*, *M. longifolium*, *M. variegatum*, and *M. gracillimum*, all of them being very useful for baskets, &c., but, with the exception of *M. asparagoides*, of little use for cutting.

**Myrtle.**—Half-hardy hard-wooded shrub. Grown for its flowers and scented foliage. Minimum temperature, 35deg. In nearly all cases these are to be found in the greenhouses of



FIG. 94.—FLOWERING SPRAY OF MYRTLE.

amateurs, whether large or small, and it is too often the case that while the plants produce foliage they are quite devoid of bloom. This is much to be regretted, as a well-bloomed myrtle is a very pretty object, not to mention the usefulness of the cut blooms. The scent of both foliage and blooms is very grateful to most persons, and hence the plant is much sought after. In the south and south-west of England myrtles are practically hardy, and bloom pretty well out of doors, but in less favoured positions they have to be protected during winter, or they are very liable to be destroyed by frost. Myrtles form bushy specimens from a foot

to three feet high, and the small, shiny, laurel-like leaves, about an inch long, set off the white flowers, which are shown in Fig. 94,

to great advantage. The plants do well in a compost of loam, sand, and leaf soil, with potting moderately firm, but not so hard as with azaleas, or fibrous rooted plants of that description; and by keeping them in a cool house, and attending to their wants as regards watering, aëration, &c., they will bloom well. The plants may stand out of doors throughout the summer, but must be prevented from becoming dry at the roots, or they will not bloom. During the growing season plenty of water will be found needful, and just a trifling shade during the hottest part of the day will be an advantage, although if the pots are plunged in the border it is not really necessary.

Propagated by cuttings of the current year's ripe wood inserted in pots of sandy soil in a greenhouse, or in a frame where frost is kept out.

For sorts, we prefer *Myrtus bullata*, *M. communis*, *M. c. angustifolia*, *M. c. flore pleno*, and *M. c. latifolia*, all of which are good.

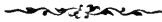

**ARCISSUS.**—Hardy, bulbous, soft-wooded plant. Grown for its flowers. Minimum temperature (in pots), 36deg. The Polyanthus Narcissus (*N. Tazetta*—Fig. 95) and the jonquil (*N. Jonquilla*) are both extremely useful for decorative purposes, and stand forcing well. They are also most useful in the cool house, as the extremely bright coloured flowers and fine scent render them objects of general

admiration. The culture varies but little from that of hyacinths, but, perhaps, it had better be described. In the first place, it is desirable that the bulbs—foreign by preference—should be had as early in the season as possible, and it is then a good rule to divide them into two lots, the first to be potted off at once, and the others to be kept in a cool place until the middle of October, when they should be potted up. When potted, they should

be put in a dark place, or *under* a bed of cocoa fibre for a few weeks—say from four to six—and thence they should be removed to the warm or cold house as occasion or season should require, and, if placed in a light position near the glass, the



FIG. 95.—NARCISSUS TAZETTA  
(POLYANTHUS NARCISSUS).

plants will bloom well, and throw up spikes of flowers without drawing to too great an extent. The amount of water required will, of course, depend on the degree of development, as we have frequently mentioned before, and aëration will depend on the weather; but where it is possible to admit air with comparative freedom the plants will thrive much better. A good rich sandy soil is requisite, and plenty of drainage must be given, as vitality will fail should the soil become waterlogged or sour, and, therefore, all necessary precautions should be

taken to prevent this. As the bulbs are only good for one year's pot work, as soon as they have done blooming they should be planted out in a sheltered border, or in the fronts of rhododendron and other beds, where, after a season's rest, and, if left undisturbed, they will from time to time produce very acceptable blooms for bouquets, &c.

Propagated by division of the bulbs, which increase naturally.

The sorts or varieties we have found to answer best are Grand Soleil d'Or, yellow, orange cup; Queen of the Netherlands, white, yellow cup; Grand Primo Citronnier, white Grand Monarque, white, pale yellow cup; and Lord Canning, yellow. Paper white, pure white, and the early Roman double white and yellow are all so easy to grow that anyone can grow them. We have not grown, but we have seen, Bazelman major, a fine white, and Bouquet Triomphant, in fine form; and perhaps the above will be as good a selection of the *N. Tazetta* section as can be had for amateur use. Of Jonquils, the ordinary double

yellow, single, and Campermelli are the three best, and grown as above directed they are sure to give satisfaction.

**Nerine.**—Greenhouse, bulbous soft-wooded plant. Grown for its flowers. Minimum temperature, 40deg. It is a section of *Amaryllis*, and is quite hardy on some soils; but as a rule, the bulbs are grown in pots for conservatory decoration. The botanical name is *Nerine*, and the name of the Guernsey Lily is *N. Sarniensis*. There are, however, other *Nerines* that are worth the same care as the Guernsey Lily, a list of which we give, and bearing, as they do, large trusses of open *Amaryllis*-like flowers, they should be in every collection. The culture is extremely simple; the plants growing in a good light rich sandy loam, a fair amount of drainage being afforded, as a matter of course.

Procure the bulbs early in September, and pot at once, say, three in a 6in. pot; place the pots on a front shelf in the greenhouse, or in a frame, near the glass, where they can receive plenty of light and air. Keep the soil fairly moist, and growth will at once commence. The flower spikes should be neatly staked, and, as soon as the blooms are well advanced, give plenty of water, and place the plants in a dry, cool, and airy position. As the bulbs are comparatively expensive, it is desirable to keep them for successive years; but as this cannot be done if they are starved, it is necessary that they should be re-planted. The best plan is to have some boxes a foot or thirteen inches deep, and of a size that is convenient to move about—claret cases, for instance—and, after providing for sufficient drainage, have ready some sandy loam chopped fine, but not sifted. Then, after blooming, turn the plants carefully out of the pots, and place each individual bulb about six inches from its neighbour; water gently, to settle the soil around the roots, and place in a situation where a temperature of 40deg. can be maintained, and plenty of air can be given on mild days. The same treatment should then be given as that which is generally afforded to greenhouse plants. When the foliage begins to fade, the water should be gradually discontinued, and, when ripe, the bulbs should be stored away until the next planting season.

Propagated by division of the bulbs, which increase naturally, but the young bulbs will have to be grown on for a year or two ere they bloom.

For sorts, select from the following: *N. corusca*, bright scarlet; *N. flexuosa*, pale rose; *N. Fothergillii*, vermilion scarlet; *N. pudica*, white; *N. rosea*, rosy red; *N. Sarniensis*, rose crimson; *N. undulata*, lilac rose; and *N. venusta*, crimson.

**Nerium.**—Greenhouse hard-wooded shrub. Grown for its flowers and general appearance. Minimum temperature, 40deg. This is a class of old-fashioned plants that is of much beauty. They afford very useful semi-double rose-like blooms for cutting for bouquets or table decoration, and these are very serviceable on the plant itself, as they are produced in terminal clusters on the ends of the branches of the previous year's growth. There is no reason why they should not be grown more extensively than they are, either as large or small plants, but they should not exceed 4ft. in height. In the latter case, however, a pretty brisk heat is required to do them well, and that method is, of course, out of place here, but, at the same time, good serviceable plants can be grown by ordinary treatment. We will begin with cuttings. These, as a rule, cannot be struck in the same way as geraniums and similar plants, but require a rather peculiar procedure. The method is as follows: As soon as the young growth is matured, take cuttings about 6in. or 7in. in length, and insert them singly in bottles of water, to each of which a teaspoonful of powdered wood charcoal has been added; place the bottles in a house where the temperature is about 60deg. to 70deg., and let them remain until pretty well rooted; then carefully pot them off into small pots in a compost of loam and river sand in equal parts, first putting in plenty of drainage. Keep in a warm place, and they will soon get established. The following April the plants should have a size larger pot, and should be grown on in a warm house, and they will bloom towards the end of the year. But it is not this style of work that, as a rule, the amateur can do, and, therefore, the better way is to grow the plants in large tubs, or planted out in the house, but this latter plan can

seldom be carried out. In growing the Oleander (Fig. 96) in pots, these should be increased in size as the plants grow, and the soil should be good sound loam and sand. During the growing season plenty of water should be given, both at the roots and the tops, but, at the same time, care must be taken to avoid the water at the roots becoming stagnant, or disease and death will be the result. No shade is at any time required, and, in fact, the warmest and sunniest spot in the house should be chosen for it. It is a very good plan to stand the plants out of doors from the middle or end of May until the end of September, but it is not absolutely necessary to do so.

Propagated by cuttings struck as above, or in a brisk bottom heat, in which case ripe wood of the current year's growth is taken and inserted in peaty soil, the pots being plunged in the fibre bed in a proper propagating pit.

The best sorts are *Nerium splendens*, *N. s. album plenum*, *N. s. luteum plenum*, and *N. s. variegatum*. The last is, however, more conspicuous for its leaves than its flowers. There are also some with single flowers, but these we do not give, as they are not so good as those named.

**Nicotiana.**—Half-hardy annual. Grown for its foliage and general appearance. Minimum temperature, 45deg. Tobacco, although most suited for outdoor decoration, is still worthy of a place indoors, if it can be had in bloom in the winter or spring months, and, as the plants are of stately appearance, having ovate leaves from 6in. to 15in. in length in the different varieties, they contrast well with the more dwarf stock of the soft-wooded plants that usually occupy the house of the amateur horticulturist. The seeds can be sown in April in a green-

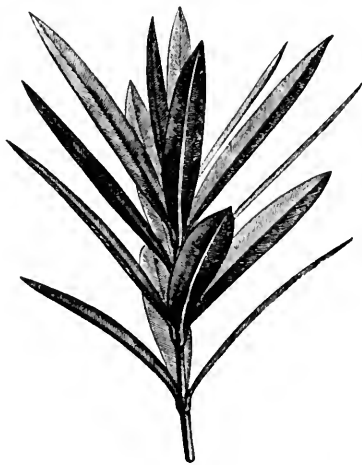

FIG. 96.—OLEANDER (NERIUM).

house in the ordinary manner, and as soon as the plants are large enough to handle they should be potted off into small pots, and from these they should be transferred into forty-eights. As soon as these become full of roots it is necessary to pot off into 6in. or 8in. pots, and in these they will remain. The plants should be kept in a partly shaded position, so that



FIG. 97.—FLOWER OF NICOTIANA.

they do not show bloom until September or later, and about the end of September they should be removed into a light house, where the temperature is not lower than 45deg. in winter. Great care must be taken that the foliage is kept clear from insects, for if the green caterpillar that is so common in the latter part of summer once obtains a good hold of the plants, the foliage will be spoiled, and the whole beauty lost. For soil use equal parts of loam, leaf soil, and cow manure and sharp sand, mixed; give plenty of drainage and supply such water as is necessary.

Propagated by seeds, as described above.

The best sort for the purpose is *N. macrophylla gigantea*, a good rosy pink; but at the same time *N. Virginica*, pink, *N. grandiflora purpurea*, purple, and *N. affinis*,

white and sweet-scented, are very good. As most persons know, the fine foliage of the above Tobaccos renders them very useful for various bedding purposes. The flower of *Nicotiana* is shown in Fig. 97.

**Nierembergia.** — Half-hardy soft-wooded plant. Grown for its flowers and general appearance. Minimum temperature,



36deg. The Nierembergias, which are very good for cool houses, as they bear a great number of campanulate flowers on their trailing stems, are of comparatively easy culture, and as they only require the exclusion of frost, say a temperature of 36deg. to 40deg., they are handy in many situations, especially where plants which do not require much heat are grown. We have grown them very successfully as follows, but we do not think the practice is in general use: We strike cuttings in August, and when well rooted pot off singly into small 60-sized pots, using sandy loam for the purpose. In the latter end of September we place these pots on a light airy shelf in the greenhouse, and through the winter give only enough water to prevent flagging. Of course, if a mean temperature of about 45deg. is kept up, we apply enough water to keep the plants growing, but not otherwise. In the second or third month we re-pot into 48-sized pots, if the plants are to bloom in pots, but if for outdoor decoration, then 3in. pots are used, and the plants do well. For soil we use good sandy loam three parts, thoroughly decomposed manure and sharp sand, mixed, one part, and the plants are potted pretty firm. A good light airy spot in the house is set aside for the purpose, and water is given according to requirements. When the heat becomes too great, the plants are removed to a sunny frame, and the pots are plunged in coal ashes, which keeps them in a healthy condition. When the pots are well filled with roots, a solution of sulphate of ammonia is applied, and plants thus treated never fail to bloom well.

Propagated by cuttings as described above, or by seeds sown in a warm greenhouse in spring, and the plants grown on as soon as they can be handled.

For sorts we use: *N. frutescens*, lilac and white; *N. gracilis*, blue; *N. gracilis picta*, blue, edged white, a cross between the two preceding; *N. rivularis*, cream; and *N. Veitchii*, pale lilac, *N. frutescens* is the tallest growing plant, and, in our opinion. *N. Veitchii* is the most dwarf, but probably difference in cultivation may have something to do with the matter.

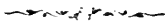



**LEANDER.**—See “*Nerium*.”

**Orange.**—Hard-wooded plant. Oranges are very useful, both for flowers and fruit, and if only for the sake of the former, are worth cultivation. Few persons who have not tasted a ripe Orange from the tree have the least conception of the delicate and refreshing flavour of this popular fruit, of which, if imported from abroad, it is almost devoid. A ripe sweet Orange, gathered in the cool of the morning, is simply delicious; while it surpasses everything for quenching thirst, and also for cooling the system. Full directions for culture are given under the head of “*Citrus*.”

**Oxalis.**—Hardy, herbaceous soft-wooded plant. Grown for both flowers and foliage. Minimum temperature (in pots), 36deg. These are greatly neglected now, and although they are very pretty, we think they should not occupy too much space in the house. They are dwarf-growing plants of very easy culture, and can be propagated freely if desired, and as their trifoliolate foliage is of a lively green, above which are borne the star-like flowers, singly or in trusses, they are very interesting. Plenty of drainage is necessary, but the plants never do so well in pots as in large clumps, in a rockery or herbaceous border, at least during the growing part of the year.

Many of the Oxalids are useful in the cold house, and the culture here is very simple. In fact, we may say that the whole of the Oxalids are useful in the cool houses to be found in most places, but as there are such a vast number—from fifty to nearly a hundred kinds, according to various botanists—we shall not give a full list of sorts here. Suffice it to say that in all nurseries where herbaceous plants are grown, and in many places where pot plants are to be had, more or fewer varieties are cultivated, and persons living near the metropolis can see good collections at the various large nurseries; where

nerbaceous plants are made a speciality, from thirty to seventy kinds can generally be seen growing. We give a short list below, and all the plants there mentioned can be grown in the cold house. A compost of two-thirds good mellow loam and one-third leaf soil and sharp sand in equal proportions will do the plants very well, provided plenty of water is given during the growing season and they are allowed all the light and air possible. A season of rest must also be allowed, and as this will nearly approach the time of the natural one when the plants are in the open ground, allowance must be made accordingly.

Propagation is effected by seeds and by division of the roots as growth recommences in spring. Seeds, however, are best for the general amateur.

For sorts select from *O. rosea*, rose; *O. tropæoloides*, yellow, rich brown foliage; *O. corniculata rubra*, rich velvety dark brown foliage; *O. Smithii*, pink; *O. rosea alba*, white; *O. arenaria*, dark rosy purple; *O. lobata*, yellow; *O. elegans*, rich purple lake, dark centre; *O. floribunda alba*, white; *O. f. rosea*, rose; *O. pentaphylla*, pink; and *O. purpurea*, purple.



**PACHYPHYTUM.**—Half-hardy succulent plant. Grown for its foliage. Minimum temperature, 38deg. It has very thick abruptly-pointed glaucous green leaves; and being of low growth, it is admirably suited for carpet bedding, and is also well worth a place in the greenhouse. The Pachyphytum is well adapted to stand on the edges of the stages, where it is brought conspicuously

before the eye, but if grown for bedding purposes it will be found necessary to have a large quantity, for although the plant is of much beauty, with its rich creamy colour and compact habit, still it is not effective in single specimens. A good sandy loam, or, rather, a very sandy loam, suits it as well

as anything, if plenty of drainage is provided, and the plants can stand the hottest weather without losing their beauty. Like most of the succulents, they will also bear much drought, but, except in winter, it is best to allow a fair amount of moisture when they are kept solely as greenhouse plants. During winter, however, they do not require water often, as too much moisture causes the foliage to rot off. The propagation is very simple; by taking off the leaves, with just a small shred of the bark attached, and after laying them in the sun for a day or two to dry, placing them round the edges of propagating pans or, in fact, all over the surface, and nearly withholding water, young plants will be formed at the base of each leaf, and when these are large enough to handle they can be potted off, and with a little care will do well. The tops may also be taken off in autumn and inserted singly in small pots. These, if placed on a dry shelf near the glass in a warm greenhouse, will root freely if not watered to cause them to rot off, and in spring they will be fine plants. The old stumps will make small though useful stuff by May.

Propagated from cuttings, as described.

*P. bracteosum* is the sort we have referred to above. If seeds can be obtained fine stocks of plants can be raised from them, but seed is very scarce, and as, in the majority of cases, the plants do not bloom, there is a great difficulty in obtaining it at all.

**Pancratium.** — Greenhouse soft-wooded bulbous plant. Grown for its flowers. Minimum temperature, 40deg. The *Panocratiums* are handsome bulbous plants that are well worth cultivation, but the majority are really stove plants, and unsuited to the general greenhouse. There are, however, four species that are suitable for cultivation in the ordinary greenhouse, and they all produce handsome umbels of superb white blooms. Our favourite is *P. crassifolium*, which until lately has been somewhat scarce. It is, however, now within the reach of all who have a greenhouse, as the price is only from half-a-crown to 3s. 6d. each. The *Panocratiums* belong to the *Amaryllidaceæ*, and require much the same treatment as most

of that order, but we give the treatment we have found successful. *P. speciosum* requires more heat, and produces its blooms towards the end of the year, while the others do so later in the season.

We have found the handsome white blossoms of very great use for the decoration of vases and baskets, and, in some cases, hair decoration; but they are more useful for the former purpose. Like many of the amaryllids, they are extremely useful, as they stand well for some days after cutting, and if a good selection of other flowers is mixed with them, the effect is both elegant and grand, that is, if grandeur can be associated with cut flowers. The description given of some of the amaryllids applies for the most part to the *Pancratiums*.

The way we treat them is as follows: About six or eight weeks after blooming, the plants are re-potted into pots of a size suitable to the bulbs, in a compost of two parts good sandy loam and one part thoroughly decayed leaf soil, to which sand has been added in sufficient quantities to keep the compost open. Good drainage is afforded, so that, when necessary, plenty of water can be given without waterlogging the soil. This is an important point with all bulbous rooted plants, for if the soil is waterlogged they sooner or later decay, and consequently are lost. After potting, the plants are kept watered according to their requirements, and are placed in a light position; from the end of June until well into September they are kept in a frame or pit with other greenhouse plants, and when brought indoors, placed well in the light, where they bloom in their season. After blooming, the supply of water is diminished to ripen the bulbs off somewhat before re-potting. In potting, only such roots as are dead should be removed, and all young bulbs should be taken off, and carefully potted either singly or three or four in a pot, according to their strength. These young bulbs, if carefully grown on, will, in the course of two or three years, make good blooming plants, and although at times they do not appear in large quantities, still, generally speaking, a couple of bulbs of each variety to start with will make a good stock in a few years, and superfluous bulbs are, as a rule, very saleable.

Pancretiums may also be treated in the same manner as evergreen amaryllis, and they do well so treated.

Propagated by division of the bulbs, which increase naturally.

The sorts for the purposes named above are *P. crassifolium*, *P. speciosum*, *P. maritimum* (Fig. 98), and *P. Illyricum* (Fig. 99),

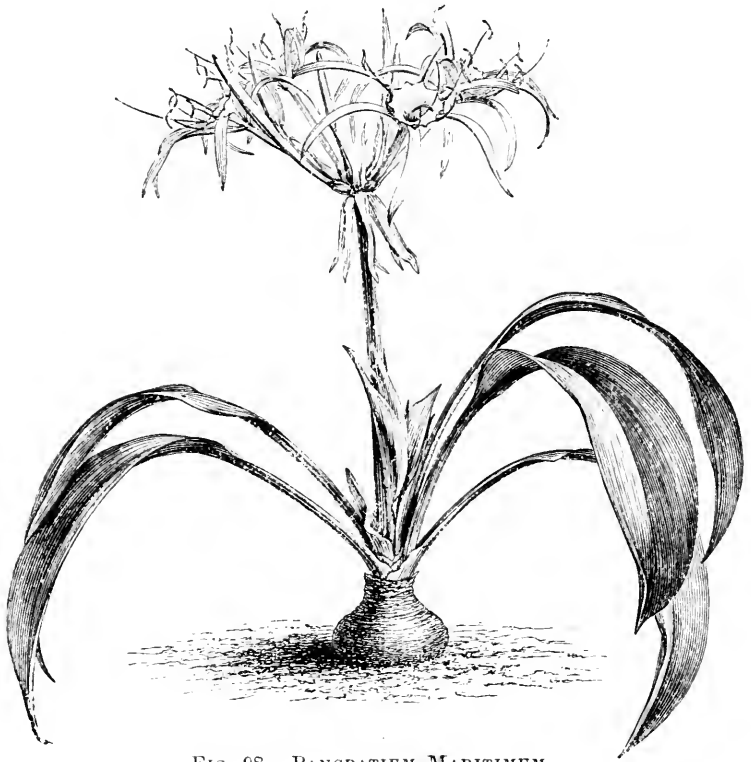

FIG. 98.—PANCRATIUM MARITIMUM.

the two latter not requiring so much heat as the former. In fact, in some places they are hardy, but in the majority of cases they do best as cool greenhouse bulbs. They are all white.

**Passiflora.**—Half-hardy hard-wooded climber. Grown for both flowers and foliage. Minimum temperature, 38deg. The

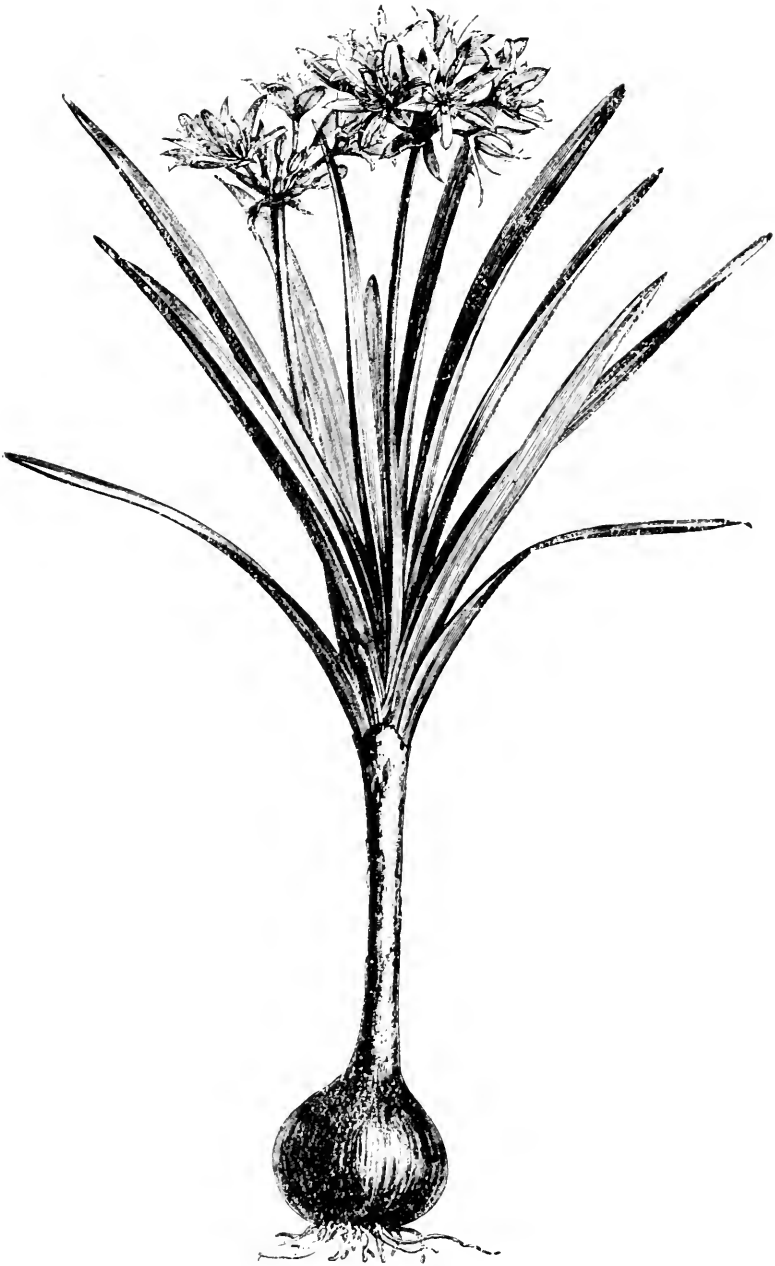

FIG. 99.—PANCRATIUM ILLYRICUM.

Passion Flowers belong to a class of plants that well repay liberal culture, but they require plenty of room in which to extend their growth. To obtain the best results they must grow pretty freely, and must not be starved or stunted, or an interminable crop of insects will take the place of bloom. Where care is taken of the plants, however, very little trouble will be experienced under this head, for a full flow of sap is adverse to the comfort of insect pests, slugs and snails perhaps excepted, but these rarely attack greenhouse roof climbers, although at times they make a meal of a promising young shoot at the base of a plant. These plants, like the *Lapageria*, require properly prepared stations, but they need neither be so large nor so deep, so long as drainage is well provided for. For the different varieties the soil requires some little variation as regards the quantity of sand used, but in other respects they will all do in the soil we mention. A good layer of broken bricks or potsherds must be placed in the bottom of the hole, which must be filled up with equal parts of rough fibrous peat and loam, to which some sand and broken charcoal have been added. This must be pressed moderately firm, but not trodden too hard, as the roots require a free run. The plants must be well watered in at first, and during the growing season abundance of water will be necessary. Training must be attended to as required, and the plants kept clear of insects if they chance to appear. The wood of the Passion Flower requires to be well ripened off by the admission of plenty of air, and then profuse blooming will result.

All the varieties have somewhat similar flowers to those of *P. cœrulea*, shown in Fig. 100.

Propagated by seeds, and by layers, but as generally seeds can be had pretty plentifully, they form the best method of propagation. Sow in spring on pans of sandy loam in a warm greenhouse, and prick off into single pots as soon as large enough.

For sorts use a selection from the following: *P. Bellotti*, *P. Campbellii*, *P. cœrulea*, *P. c. racemosa*, *P. c. racemosa rubra*, *P. fragrans*, *P. Comte Nesselrode*, *P. L'Imperatrice Eugenie*, *P. Newmanii*, and *P. palmata*, all of which are good.



FIG. 100.—SPRAY OF PASSIFLORA CERULEA, NEARLY FULL SIZE.

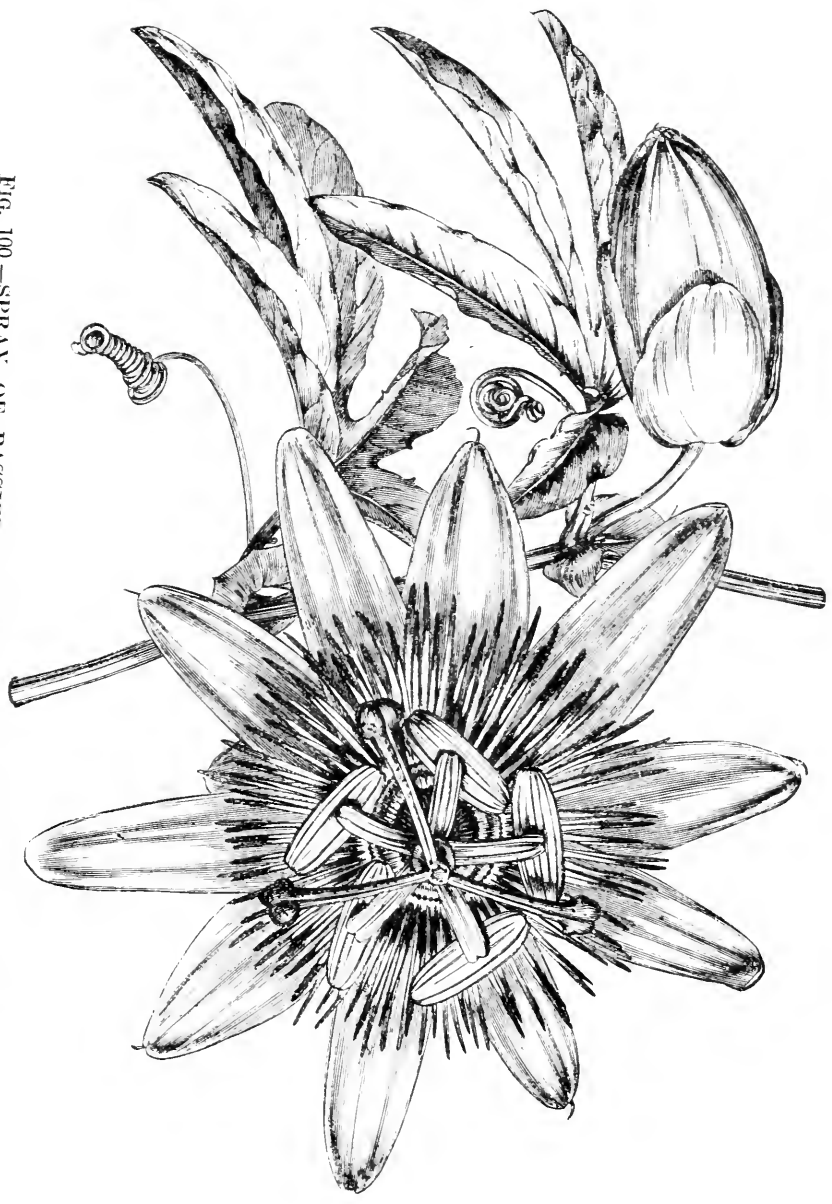

**Pelargonium.**—Half-hardy soft-wooded plant. Grown for its flowers. Minimum temperature, 36deg. This is a very large family of plants, and includes what are generally called Geraniums, that is, the scarlet and bedding varieties, and the Cape or fancy Pelargoniums.

The varieties amount to several hundreds, and it is much to be regretted that they are so multiplied, for in many cases they are so much alike that it is quite impossible to tell them apart. Scarlets, indeed, are so numerous that it is difficult to distinguish them by name at all, except in the case of a very few sorts, which are really distinct.

In the tricolor, bicolor, and bronze sections, also, the same difficulties arise, and, while we have grown some 150 sorts or varieties to name, we have not had above thirty that are really distinct. There are, of course, some which can be easily told apart, but, as we arranged a houseful once, no one out of the trade, and but few in it, could have told where one variety ended and the other began. Still, they were all true to name.

To commence, we will take the *scarlet* and *zonal* sections. These, as nearly every one is aware, are the sorts which are chiefly used for bedding-out purposes, and are, therefore, always in request. They are also useful for the decoration of the greenhouse during part of the year, and for ornament in rooms, &c. In fact, generally speaking, the scarlet and other zonal Pelargoniums are the most useful plants we have; certainly, they are most generally grown. The first consideration is to get good plants for bedding-out purposes, and these we manage to obtain as follows: In August or the first week in September, some 6in. or 8in. pots are got in readiness, by half filling them with crocks, and then filling up with a sandy compost, loam being the principal ingredient. A number of cuttings having been prepared, are inserted about twenty or thirty in each pot; the pots are well watered and stood in the full rays of the sun. In a short time they become rooted, when all dead foliage is removed, and about the end of the month they are removed into the greenhouse, there to remain until the next March. Only just enough water to keep them alive is neces-

sary, and so long as the house is kept fairly dry, and frost is well excluded, the young plants will do very well. About March they are potted off into large 60-sized pots, and, by affording more moisture and warmth, good plants are obtained in the proper season. A compost of maiden loam, enriched with a little thoroughly rotted manure and made sufficiently porous by the addition of some sharp sand, does the bedding varieties well.

For plants to bloom during winter we always strike the cuttings in June, and about August shift them into 6in. pots. They are carefully grown on until the second week in September, when some are removed into the greenhouse and others into frames. During the whole of this time they are not allowed to bloom, neither are they watered more than is necessary, as the aim is to obtain a potful of vigorous roots, and a comparatively dwarf sturdy head. When introduced into the house a temperature of about 50deg. to 55deg. is maintained, and a free circulation of air is allowed, the plants at the same time receiving more liberal treatment. Those left in the frames are not housed until October, and, of course, receive a similar treatment to the others. As the season advances, the maximum temperature may be reduced 4deg. or 5deg., so as to maintain a kind of equilibrium with the outer atmosphere. It may also be found useful to give a small quantity of liquid manure from time to time, but if it can be done without, so much the better. To grow plants for bloom during the winter months it is necessary to have a light house, and to give the plants liberal treatment, at the same time to use every endeavour to keep the growth as stocky as possible, as on this very much depends.

For summer use in pots, &c., the cuttings should be potted off singly into 3in. pots in August, and kept through the winter as before described, and then, about six weeks after Christmas, they should be shifted into 4in. pots, and by receiving due attention they will do well throughout the season.

We now come to the *bronze* and *golden bicolor* section, as being next to the ordinary scarlet and zonal varieties. These are most suitable for pot culture, and we shall therefore treat of them as pot plants, as the greatest amount of beauty can be got from them

as such. Of course, there are bronzes and bronzes, and in the majority of cases considerable management is needed to bring out the good points of the plants—particularly those which are of a very robust nature—as they all require a treatment suitable to their constitution. Moreover, a little judgment used in selecting the cuttings, and a little care in choosing soils, will save much time and anxiety in after work. Thus a very robust, free growing bronze, if propagated from soft free grown wood, will grow to an immense size, especially if the soil is rich, while at the same time the colour will not differ much from an ordinary zonal; but if the cuttings are made from poor starved specimens, and the soil is not over rich, the results will generally be all that can be desired. We therefore advise a poor, rather than too rich a soil, and, as a rule, rather firm potting.

The soil we use for bronzes and bicolors is sound yellow loam, passed through a lin. meshed sieve, and to this we add enough leaf soil and sharp sand to keep the whole open. For weak-growing plants a little thoroughly decomposed cow manure can also be advantageously joined; but it must not be overdone, or strength will be obtained at the expense of colour.

The way we grow this class of Pelargoniums is as follows: In February or in August, according to circumstances, we strike cuttings of the sorts we intend growing on in pots. This we do by inserting cuttings singly in thumb or small 60-sized pots, filled with sandy compost, until we have about 12 per cent. more cuttings than we require plants, to allow for losses. These plants are re-potted and placed in the frames about the second week in April, and as soon as the pots are full of roots they are shifted into such sized pots as they are to permanently occupy. Care must be paid to stopping, &c., and the plants must be kept near the glass. Water must be given as necessary, and during very bright hot sun it is well to apply a slight shade. In this they resemble tricolors. In fact, as a rule, the treatment may be the same as that for tricolors, with some slight difference to suit the habits of the plants.

In the *tricolor* or *variegated foliage* section, we find two divisions—silver and gold—both of which are very useful in

their places. The treatment is the same for both, and although we may be disbelieved by many unsuccessful growers, we assert that there is no more real difficulty in growing tricolors than there is in growing the ordinary zonal varieties, the only trouble being the propagation, and in this there is but little if it is commenced at the proper time. We strike our main crop or stock in August, and plants for pot culture, to come in late, we strike in March, as we find that at other times, although we can strike the cuttings freely, the plants are not of much service, as those struck during the winter are generally too poor in colour, and those struck during the summer are too large, and often too sappy to winter well. Besides, it rarely happens that tricolors retain their colour during the winter, and it is therefore necessary that the plants should not be incited to grow much during that time. We have ere now worked up a stock of about 500 plants from a seedling in less than twelve months; but if we had desired them for our own use, about one-fourth of that number only would have been raised, as excessive propagation reduces the constitution and vigour of these plants to such an extent that they are too weak for any purpose, and the colour is reduced to a minimum. In this as in other matters, it happens that the more the haste the less the speed. We would therefore desire our readers to remember that in no case should propagation be carried too far, and also that cuttings should only be taken from the strongest and best plants, as weak cuttings do not produce highly coloured plants.

For convenience, we generally adopt the following plan: In August cuttings are inserted singly in small 60-sized pots, previously prepared by filling about one-third full of crocks and the remainder with sandy loam, the sand used being very sharp. The cuttings are then potted firmly, and after twenty-four hours the pots are carefully watered, and then stood in a frame facing the south, the frame being filled up with ashes to a convenient height. Water is not again necessary for about a week or ten days, when the cuttings are just emitting roots, and after this time water is applied with care. The lights are only used to exclude heavy storms, and care is taken that a too vigorous growth is not induced, as the more dwarf

and hard the young plants are, the more easily are they managed during winter.

In wintering both old and young plants we take great care to place them in a light airy position near the glass, and to keep the house free from an excess of atmospheric moisture, at the same time maintaining a temperature of about 45deg. Very little water is given during the winter; in fact, only sufficient to keep the plants in a healthy condition, but at the same time excessive dryness is avoided, or they would be liable to damp off when watered. All dead and decaying foliage is kept scrupulously removed, and in fact everything that would tend to cause "damp" or decay is carefully avoided.

In spring, cuttings can be taken from the old plants, and struck in the greenhouse, always provided that they are exposed to the full sun. For convenience, we always strike these in single pots, as they are then so much more readily handled, and, what is more, the roots do not get broken, which is a most important point, as tricolors never have too many roots.

The plants struck in August should be re-potted in March, and the old plants from which cuttings have been taken should be re-potted as soon as they have broken well. Shift the young stuff into 48-sized pots, and the old ones into pots a size smaller than those which they occupy when cut back. Subsequent re-potting must depend on the wants and vigour of the plants, as no strict rule can be set in this respect.

About the second or third week in April the plants—with the exception of those for bedding-out purposes—can be placed on a bed of ashes in a cold frame, and with a little care as to closing the lights early, watering, and shading, &c., the foliage will soon obtain the true colours and habit. Bronzes also require to stand in a cold frame if the best colour is desired, and mixed with the tricolors they have a very pretty effect. It must be remembered that both bronzes and tricolors are variable as to the time when they show most colour, some being best in spring, and others in autumn; but very few are at their prime during the hottest part of summer, and even those which are in good form are only made so by shading

and other adventitious means. The soil we use for tricolors is composed of good maiden or fibrous yellow loam three parts, and one part thoroughly decomposed cow manure and leaf soil, or peat. To this compost is added enough sharp sand to maintain the whole in a proper state of porosity.

*Tricolors* should be put out in beds at least a week or ten days later than the ordinary zonal varieties, on account of their being much more tender, but it is well to remark that they are not so effective, as a rule, as other coloured foliage plants, and it is far better to use them as decorative pot plants only. In only a very few places are tricolors or bronzes really effective bedded out in the open ground.

*Ivy-leaved Pelargoniums* require much the same treatment as the ordinary zonal varieties.

The varieties with *scented foliage* also want similar treatment, the only difference being perhaps more sand in the compost, so that greater porosity may be maintained, as some of them have to be potted firmer than the ordinary zonals, on account of their running too gross if potted loose.

The *double* varieties thrive with the same treatment as ordinary scarlets, but they must not have too much room for the roots, or the foliage will be most conspicuous. Too rich a soil should also be avoided.

For the use of amateurs the varieties marked with an asterisk are best. Where convenience exists, doubles do best struck from eyes, as vines are, but there are few amateurs who can perform this part of a propagator's duties; and, to say the least, some skill and much attention must be paid, or failure is certain.

*Cape Pelargoniums* are really fine plants for the decoration of the greenhouse and conservatory, and grown in from 6in. to 8in. pots, form masses of bloom that cannot easily be equalled. The culture is most simple, and as the earliest bloom is that most desired, we give our plan of obtaining it, so that plenty of bloom is to be had from March to May, and, with a little management, even later than that. In the first place, we strike cuttings in March or April, and keep the young plants growing on until the middle of September, stopping back and training

into form as occasion may require. The plants at this time will be in 6in. or 8in. pots, according to their habits, and of good size, the pots not being over full of roots. Water is gradually diminished after September, until the plants are dormant, and some time in October they are placed on a light airy shelf in a greenhouse, where frost is excluded, but where a high temperature is not maintained. About the beginning of February some of them are started into growth, and a slightly increased temperature is afforded, and by the end of the month part are in bloom. The others are not started until the end of February, and these take the season of blooming into May.

Some plants struck in July, and wintered as described above, but re-potted in spring, will take the blooming season on until the end of August, that is if the plants are grown out of doors, or rather in cold frames. These may also be bedded out, but we find they do not answer well in all places. The various kinds have wide variations in the habit of growth, but although some will reach 4ft. in height, others, if care is not used, will not be more than 9in. or 1ft. in height.

For soil we use maiden loam, enriched with a little leaf soil, and thoroughly decomposed manure, and to this is added enough sharp sand to keep the compost well open. The quality of the soil must be varied somewhat, according to the habit of the plant, and a little care must be taken as to the amount of water given, so that a too vigorous, or, in fact, a too rapid and weak growth is not induced.

Although not generally treated as *annuals*, both Cape and zonal Pelargoniums are very easily grown as such; and, if the seeds are only saved in a careful manner from good plants, a fair show can be had late in the season. We do not advise the use of seedlings in preference to plants raised in the ordinary manner, as they are too late for bedding-out purposes, and, at the same time, there is no certainty of their producing flowers of the same floricultural value. There is, however, the chance of obtaining plants of sufficient merit to keep and propagate, and these will, of course, be in proportion to the quality of the seed. Some special features may also be obtained, which will render the plants worth cultivation inde-



pendent of their floricultural merit; thus, a very dwarf, or floriferous kind, may be very useful for some particular work, as was one we raised. This was a pink, the colour of Christine. The flowers were no better than the old phlox, but, as the plants did not exceed four inches in height, and the blooms were produced in great profusion, it made a fine edging plant; but no money value was attached to it—in fact, it was not worth a penny for sale. From some other seed we raised one—the only one of any use in over six hundred plants—that sold for £10 to a nurseryman, who exhibited it and took a certificate of merit, plainly showing the incertitude of raising these plants from seeds. We have also raised many tricolors of much use for ordinary work, but not sufficiently good to name, and a few have received certificates; but, from the trouble it requires, we doubt if it is a profitable speculation, unless it is the sole hobby of the grower. With the Cape Pelargoniums, if the seed is saved from good plants, there is generally enough variety in the seedlings to render the work profitable from an amateur's point of view, although there would probably have been a loss if the plants had been grown for sale. The best plan is to carefully hybridise the flowers from which the seeds are to be obtained, as then it is almost certain that some plants will be produced that are worth saving. Another point with seedlings of the Cape and zonal sections is that tall standard plants can be obtained very easily, and, even if the blooms are not models of perfection, still the plants render it possible to decorate large masses of shrubbery, &c., in a very pleasing manner.

For the zonal varieties it is desirable to sow in the greenhouse in January, and to grow on gradually until about June, giving the same treatment as described above, but, as soon as the plants reach 4in. pots, they should not be transferred again. During July and August they will come into bloom, and any worth saving can be either re-potted or propagated; but, unless a good place for their culture exists, they had better be kept in the 4in. pots until the succeeding spring. Such plants as are of no use may be destroyed ere winter comes, but they will make a little show for a time. Seed of tricolors and other variegated varieties should be sown in February, and receive

such treatment as we have previously advised. If the leaves are of good form, and when held between the eye and the sun the zone in the leaf appears of a dark rich chocolate or crimson, the plants should be saved, for, even if they do not show colour the first season, they will do so eventually; and it often happens that those which are longest in breaking colour are the best. The plants of all the zonal class that are considered worth saving should be cut down in the following March or April, according to the accommodation that is at hand for their culture. After they have started into growth they should be re-potted into good soil, and treated the same as ordinary plants.

Cape Pelargoniums should be sown about June, or the end of May, if the weather is fine, and the plants should be grown on and treated the same as ordinary stock for spring blooming, with a little more sand in the soil than for those struck from cuttings. Saved with ordinary care, the seeds will produce stock worth growing; and if saved from carefully hybridised flowers, the results will generally be very good, although it is not probable that many plants worth naming will be obtained; but still there is a chance of such plants being got. If one improved seedling is obtained in two or three hundred, it is very good work. We may add that a good stock of Pelargoniums may easily be raised from seed, and if once this plan is started, the amateur will rarely leave it off willingly.

For sorts select from the following: *Scarlet zonal*: Lord Derby, Vesuvius, Charley Casbon, Cybister, Stella, Lucius, Julius Cæsar, Dr. Livingstone, Albert Memorial, Caven Fox, Bonfire, John Thorpe. *Plain-leaved scarlet*: Punch, Tom Thumb, Aigburth Beauty, Amethyst, Boadicea, and Kentish Fire. *White-flowered*: Madame Vaucher, Mrs. Sachs, Madame F. Hoch, Purity, and White Swan. *Salmon-flowered*: President Thiers, Polly King, L'Aurore, Seraph, and Mr. Rendatler. *Oculed blooms*: Alice Spencer, Bride, Madame Werle, and Fairy Ring. *Pink and rose coloured flowers*: Rose Rendatler, Forget-me-not, Christine, Amaranth, Lady Louisa Egerton, Countess of Rosslyn, Amy Hogg, Violet Hill Nosegay, Madame Barr, Delight, and Caroline. *Various colours*: Monster, light

scarlet, immense truss; Purple Prince, bright magenta, shaded dark purple; Marginata, ground colour, bright pink, with pink edge on a pearly white ground, very fine if slightly shaded from bright sun; Wellington, dark maroon crimson; Reine Blanche, white nosegay; Phœbe, orange cerise. *Ivy-leaved section*:



FIG. 101.—DOUBLE-FLOWERED PELARGONIUM, "JEWEL."

*Green foliage*: Innocence, pure white, dark maroon stripe on upper petals; Wilsii rosea, rose, very fine; Elegans, mauve; Peltatum elegans, bright mauve; Alice Lee, violet crimson; Favonier, dark purple carmine. *Variiegated foliage*: Duke of Edinburgh and l'Elegante are the two best. *Scented foliage*:

Grandis odorata, sweet scented, like the oak-leaved variety; Crispum, citron scented; Filicifolia odorata, fern leaved; Lothario, and Capitatum. These are all useful, and are scented to a greater or less extent, but it is not possible to describe the scent of either so as to be generally understood. *Double-flowered: Scarlet:* \*Victor Lemoine, Goliath, \*Wilhelm Pfitzer, \*double Tom Thumb, and Jewel (Fig. 101). *Rose coloured:* \*Marie Lemoine, Crown Prince, Madame Lemoine, and \*Spark Hill Beauty. Of whites we will not mention any, for all we have seen have been white in name only, the greater part of the blooms appearing as if they had been in a plentiful shower of brick dust, as far as colour went. No doubt good whites will ultimately be brought out, but for these we must wait. *Tricolors:* Golden: Gem of Tricolors, Sunset, Mrs. Pollock, Sophia Dumaresque, Louisa Smith, Macbeth, Lucy Grieve, Lady Cullum, Sophia Cusack, Edwina Fitzpatrick, Achievement (Stevens's), Mrs. Dunnett, The Moonstone (Aldred's), Prince of Wales, Miss Goring, and Mr. Rutter. *Silver:* Lass o' Gowrie, Mrs. Col. Wilkinson, Mabel Morris, Charming Bride, Prince Silverwings, Velvet Cushion, Italie Unita, Silver Star, Enchantress, Mysterious Night, Lady Dorothy Neville, and Princess Beatrice. *Bicolors (not bronze): Yellow and green:* Doctor Primrose, Golden Chain, Golden Fleece, Pillar of Gold, and Crystal Palace Gem. *White and green:* Castlemilk, Miss Kingsbury, Snowdrop, Daybreak, Flower of Spring, Bijou, and Mangle's Variegated. *Plain yellow-leaved varieties:* Robert Fish, Creed's Seedling, Yellow Christine, Yellow Boy, and Golden Beauty. *Golden bronze:* Rev. C. P. Peach, Black Douglas, Earl of Rosslyn, Mrs. John Lee, Princess of Wales, Black Knight, Fairy Ring, Southern Belle, Harold, Crown Prince, Sybil, Rev. Mr. Radclyffe, Beauty, E. G. Henderson, Bronze Queen, Golden Banner, Crimson-crowned Canary, and Champion. *Cape Pelargoniums:* Admiration, Black Prince, Brilliant, Brigantine, Chas. Turner, Duke of Edinburgh, Envoy, Heroine, Joan of Arc, Maid of Honour, Mr. Rassam, Pollie, Ajax, Danaë, Hector, Midas, Rameau, Yvonne, East Lynn, Formosa, Leotard, Marmion, Princess Teck, Queen Victoria, and various others.

The full list of Pelargoniums, with descriptions, being very voluminous, we give only a selection of those we know to be good. Pelargoniums have been greatly overdone, and although they are *the* plants for amateurs, the varieties are so many and the forms of colouring, &c., so various, that we should most decidedly advise intending purchasers to trust to no list, but to see the plants when they are in the best form, and then to purchase only what suits their fancy.

**Persica.**—Hard-wooded tree. Grown for its flowers. Minimum temperature (in pots), 36deg. The double Peach in its red and crimson form is very handsome, and as it is suitable for either a large or small house, is generally useful. The trees resemble the almond in general appearance, but are not so large in stature, and the flowers are very double, like a double deutzia in fact, but much larger. It requires much the same treatment as the almond, and does well with the cultivation recommended for that tree.

Propagated by grafting on stocks of the common plum.

The varieties are—*P. vulgaris fl. pl.*, double red; *P. v. fl. pl. alba*, white; and *P. v. fl. pl. sanguinea*, crimson.

**Petunia.** — Half-hardy soft-wooded plant. Grown for its flowers. Minimum temperature, 36deg. These are old-fashioned plants of much beauty, and are very easily grown. They make a more or less shrubby growth, and produce axillary bell-shaped flowers, much like those of the convolvulus in form, but of various colours. The ovate leaves are closely set on the stems, and as the blooms are freely produced the plants are very useful. The double varieties have the centre of the blooms filled with a more or less confused mass of petals, and, while lacking the uniformity of such flowers as camellias, yet are very pleasing. Given the same treatment as the verbena, they form magnificent plants; and as they are not easily approached in colour by other subjects, they are really necessary in a well kept conservatory. The double kinds are very fine if well grown, and the single varieties are also useful for basket and vase decoration. Seeds raised and treated as half hardy

annuals also give great satisfaction out of doors, as the flowers, being from one to two inches in diameter and of various bright shades of colour, from pale rose to dark purple, produce an effect not always to be obtained with other plants, especially as they bloom very profusely from July until frost destroys them.

Propagated by seeds sown in spring as a half hardy annual, or by cuttings struck in heat in spring, or without heat in summer and early autumn.

Six good doubles are, P. Bonnie Dundee, purple, deeply margined with white; P. MacMahon, white-veined pink; P. Snowball, pure white; P. Lorraine, dark purple crimson; P. Marie Van Houtte, deep purple; P. King of Crimson, rich purplish crimson. Six good singles are, P. Spitfire, intense dark purple; P. Single Beauty, lavender, dark purple centre and rays; P. Othello, deep purple crimson, veined black; P. Perdita, bright crimson, shaded light, with white rays; P. Etoile du Nord, white, mottled with crimson and light purple; and P. Maggie Cochrane, purplish crimson, mottled with rosy white. Seeds saved from these singles produce very useful border plants, and, at times, a plant or two worth saving. For cultural directions see "Verbena."

**Phlox.**—Half-hardy annual. Grown for its flowers. Minimum temperature 40deg. *Phlox Drummondii* (Fig. 102), when nicely grown, forms as pretty a pot or low vase plant as can be desired, but unless some care is taken the growth is difficult. In the first place, it is of the greatest importance that the soil used shall be both rich and fairly porous, and also that good drainage shall be afforded; and although the plants, which are prostrate in habit, and have a general appearance much like a verbena, will last the whole season bedded out, still, in pots, they will not last more than a month or so. The seed should be sown on a gentle heat early in the season, and when sufficiently large to handle, the plants should be potted off into 4in. pots for single plants, or three plants in a 6in. pot. The soil we use is composed of two-thirds good fibrous loam and one part thoroughly decomposed cow manure, to which is added sufficient sharp sand to keep the whole open. Plenty of drainage

must be afforded, as the plants require a fair amount of moisture when growing freely. The same after treatment as afforded to petunias, &c., will answer very well for these plants, but they must be prepared and bloomed in frames before they are introduced to the house.



FIG. 102.—PHLOX DRUMMONDII.

Propagated from seeds as described above.

A packet of good mixed seed will produce a large variety of blooms, and unless it is desired to have expensive varieties, will answer all practical purposes. We, therefore, do not give a list here, but there are more than twenty names given in various

catalogues, and in some cases (but not always) the plants come true to colour.

**Phormium.**—Greenhouse hard-wooded plant. Grown for its foliage. Minimum temperature, 38deg. This is an ornamental plant of some beauty, and is suitable for houses where there is both plenty of room and plenty of height for the full development of the leaves. Its stately habit of growth renders it particularly useful for large conservatories and similar places, and, while in a comparatively small state, it is useful for room decoration to a certain extent, but, of course, other and more graceful plants should be associated with it if the full effect of its peculiar beauty is to be obtained. This plant, which is also known as New Zealand flax, has broad green or variegated flag-like leaves, from 3ft. to 5ft. in length, according to the variety, and will with little trouble attain a height of five feet or more. In Lord Meath's garden, at Kilruddery, co. Wicklow, Ireland, the leaves of a fine specimen (*out of doors*) attain a length of from 10ft. to 14ft., the whole forming a magnificent clump of foliage. But of these out-door plants we have nothing to say here, pot plants being at present our speciality.

For soil we use sound fibrous maiden loam and leaf soil, in equal portions, and about a sixth part of coarse, sharp sand. Plenty of drainage is necessary, and plenty of pot room is important. Repot each spring, giving a liberal shift, and potting rather firmly, keeping close for a few days, until the roots may be supposed to have recovered from the check consequent on re-potting. Plenty of water is necessary during the season of growth, and during the hot months the plants may stand out of doors.

Propagated by seeds raised in a gentle bottom heat in spring, or in a warm greenhouse in May and June.

For sorts, *P. Colensoi variegatum*, *P. Cookii*, *P. tenax*, and *P. tenax variegatum* will all be found of use, the variegated sorts, of course, being most effective for house decoration.

**Pimelea.**—Greenhouse hard wooded plant. Grown for its flowers. Minimum temperature 45deg. These plants are of



rather difficult culture, and unless the amateur means to go in for gardening in its entirety, are of no value to him; but where anyone intends to grow his plants well, they amply repay all trouble bestowed on them. They belong to a class of statice-like plants that is especially liable to the attacks of red spider unless properly grown, and then there is little fear of trouble from any kind of insect. Pimeleas are not suited for houses where the minimum temperature is less than 45deg. in winter, as they are never actually at rest, as are most other hard-wooded plants.

About the end of March or early in April young healthy plants in 6in. pots should be re-potted into some 2in. or 3in. larger, with a good fibrous loam chopped into lumps about the size of walnuts, and not sifted; to this should be added about one-sixth of sharp sand; pot the plants firmly, and stand in a position where they will receive no side air, for a fortnight or so. The stage on which the pots stand should be kept moist, and the plants should be gently syringed over every morning. Shade must be afforded from hot sun throughout the growing season, a point that is too frequently neglected. As the blooms of the first season will be of little worth, it is as well to remove them as soon as they begin to open, cutting the branches midway between the bloom and the place where they were cut in the previous year. This will prevent the branches becoming too long in proportion to the size of the plants. Get the plants to make as good growth during the summer as possible, both by careful shading and by judicious watering, syringing thoroughly every day, and in such a manner that the under, as well as the upper, side is wetted, so that the red spider shall be kept down, as no amount of care serves for recovery from their ravages. About the end of August more air and less shade may be given, and the syringing may be discontinued, so as to harden the plants off a little, and they must be wintered in a light position, where the minimum temperature is not less than 45deg. They will require water throughout the winter, but not so much as during the summer. In spring repot as before, giving from 2in. to 4in. larger pots, according to the state of the roots, and treat as before, with the exception of removing

the blooms, unless the plants are required for exhibition. After the bloom is over cut back and treat as already described, and take great care that the water from the syringe touches every part of the foliage, or the spider will get in and the plants will be spoiled. Very little training will be required, only a few sticks just to hold the branches down, so that the plants shall be well furnished, and perhaps a few more to hold the branches in their place when they get large, but these latter are not always wanted.

Propagated by cuttings struck in gentle bottom heat during summer or autumn.

For sorts select from *P. spectabilis*, *P. s. rosea*, *P. Hendersonii*, *P. elegans*, *P. decussata*, *P. hispida*, *P. mirabilis*, and *P. Neippergiana*, all of which are good. *P. hispida* and *P. Neippergiana* do best in good sandy, fibrous peat, but the general treatment is the same as for the others.

**Pittosporum.**—Half-hardy hard-wooded shrub. Grown for both flowers and general appearance. Minimum temperature, 36deg. This is a class of plants which is well worthy of cultivation, although not very largely grown now. It stands well and is seldom sickly, while it bears its pretty fragrant flowers freely. The flowers, which are produced in terminal clusters, show well above the foliage, as shown in Fig. 103, and in good-sized bushes the effect is excellent.

In the cultivation of these plants a fair amount of pot room must be afforded, and drainage must be well provided for. Any good soil answers, and we have found the following compost serve very well: Turfy loam three parts, thoroughly decomposed cow manure one part, and leaf soil and sand one part; pot rather firm, and grow on in a cool house. The same remarks apply to these as to other hard-wooded plants in regard to training, watering, &c. The plants can stand out of doors from July to September, and a light situation indoors should be given them for the rest of the year. Re-potting should be done in March, and the plants kept close for a few days after. Some have proved hardy in Ireland, but it is doubtful if they would live in many parts of England without protection.

It may not be amiss perhaps to mention that *P. Tobira* is grown in tubs in some parts of the Continent, and the plants in winter are stored away in cellars or sheds, and there is no reason why this plan should not be carried out in warm places in England. Pittosporums should form companions to the myrtle where the latter is grown in tubs or large pots.

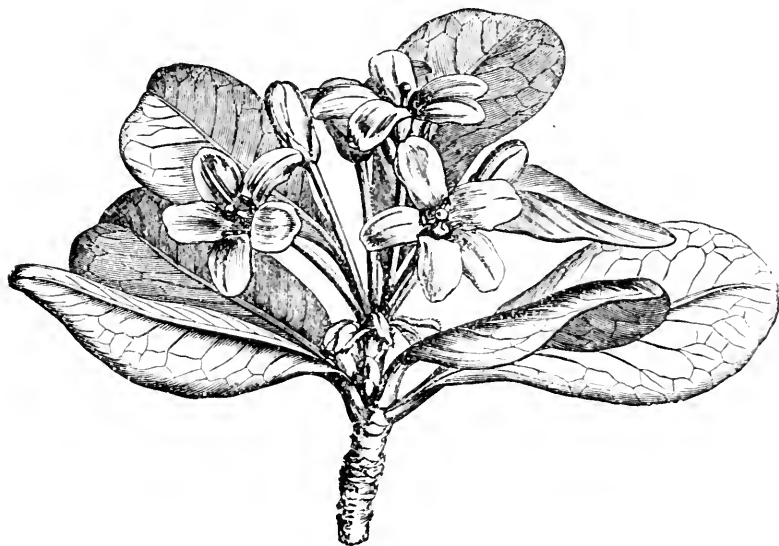

FIG. 103.—PITOSPORUM SINENSE.

Propagated from cuttings in the same manner as *Hovea*.

For sorts we prefer *P. Tobira*, *P. T. argenteo variegatum*, *P. undulatum*, *P. eugenoides*, *P. Sinense* (Fig. 103), *P. Mayii*, and *P. crassifolium*, which are all good.

**Pleroma.**—Greenhouse hard-wooded plant. Grown for its flowers. Minimum temperature, 40deg. This is a plant which to a degree resembles the *Hovea* in form, producing somewhat bell-shaped purple flowers, and making nice shrubs, about 18in. high, well furnished with foliage, but, as it has a better habit than that plant, and, as the bloom is brighter, it is of more value for pot culture. We have found the blossoms very

useful for bouquets that are used during daylight, but by artificial light the blooms lose their brilliancy and are not very effective. As a conservatory plant, while it is in bloom it stands pre-eminent when well done, and, although not suitable for a cold greenhouse, it well repays any trouble bestowed on it; it will not do in a house where the temperature is less than 40deg. in winter, and, therefore, it is useless for an unheated structure. The best mode of procedure is to purchase plants in 6in. pots, in autumn, and to place them in a greenhouse until about March, when the roots will probably be sufficiently active to warrant re-potting; use 9in. pots for the purpose, and, for compost, take good fibrous loam and about one-sixth of clean sharp sand; allow plenty of drainage; pot firmly, and stand in a close place for a few days. Care must be taken all through their growth to protect them from hot sun, by shading, and it is well to protect as early as March. Nor must it be forgotten to keep the strongest shoots trained to the outsides, and the weaker ones to the middle, so as to equalise the growth. As the weather gets warm the plants should be syringed in the afternoon, and plenty of water must be given to the roots. About August discontinue syringing, and give more air and light to harden them off for their season's rest. The next season again re-pot, giving another 3in. shift, and treat as before until August, when they should be removed to the open air under a tall hedge or trees, where the sun has no power on them. Bring them in about the middle of September, and place near the light; winter as before, and be careful the sun does not injure the foliage, and the plants will probably bloom in spring. By careful stopping and training, and by keeping relays in readiness, there is no difficulty in maintaining a sufficient stock for all ordinary work. Without Pleromas, a collection of plants would be incomplete.

Propagated from cuttings struck in sandy compost in a cool greenhouse.

**Plumbago.**—Greenhouse hard-wooded shrub. Grown for its flowers. Minimum temperature, 36deg. These plants are more

suited for use as climbers or wall plants than for culture as bushes, but as they are so very ornamental when well-flowered, and as by the following mode of treatment they can be made to do well, we treat them here rather as bushes. It is a plant that has a long straggling habit of growth, with aloysia-like foliage, and for this reason is more suited for walls or pillars; but, at the same time, where there is plenty of room, the *Plumbago* does well trained over a balloon trellis. The plants bloom best in a moderately warm house, bearing terminal clusters of tubular jasmine-like flowers, and it is not advisable to have them in any other house than one that can be kept comparatively warm. In the first place, plants should be obtained in autumn that have been stopped back to about 2in. from the collar, and which have five or six shoots or branches. A balloon trellis should be fixed in the pot and the branches trained over it, and by careful stopping about twice in the year, and training the shoots out carefully, the frame will be covered the first season. A moderate pruning must be given the next year, and the plants must be re-potted into larger pots, a free open soil being provided. We use good fibrous loam and sand, and a little peat, and, in some cases, a little thoroughly decomposed manure is admissible if the other soils are poor. Planted out in the borders of a warm conservatory, or in a warm greenhouse, these form some of the best plants for walls and pillars, and should be more extensively grown than at present.

Propagated from the rooted shoots from the base of the plants, or by cuttings which root freely in a gentle bottom heat when nearly ripe.

*P. Capensis*, *P. rosea*, and *P. Zeylanica* are all good, although, perhaps, the preference should be given to the two former.

**Polygonatum.** — Hardy herbaceous soft-wooded plant. Grown for its general appearance and scented flowers. Minimum temperature (in pots), 40deg. The Solomon's Seal is a fragrant early blooming plant, the habit and general appearance of which is shown in Fig. 104; it pays well either for forcing or in the warm or cool greenhouse, and the culture

is most simple. All that is necessary is to secure good clumps in the autumn, and to pot them in a compost similar to that advised for the dicentra, affording plenty of drainage, as at the time the plants are growing freely they require an abundance of moisture. The plants should be well watered after potting, and they can then be placed in heat or otherwise, as may be required, and as soon as they start growing they must have a light position near the glass, so that they shall be prevented



FIG. 104.—*Polygonatum multiflorum*.

from drawing up weak and spindly, their height being properly about 18in. The flowers, which are, as a rule, produced in axillary clusters, are of a greenish-white colour, and emit a pleasant perfume, particularly in the early part of the day. After blooming, the plants should be put out in a rich border to have a season's rest and recuperate themselves. Plenty of water is necessary during the growing season, and even in the season of rest the plants—if kept in pots—must not become dust dry, or the stems, when produced in spring, will be of but small value.

Propagated by division of the root stocks, which somewhat resemble those of the water flag.

The varieties that are useful for pot work are: *P. Japonicum*, *P. J. argenteum striatum* (variegated foliage), *P. multiflorum* (Fig. 104), *P. m. flore-pleno*, *P. m. aureum striatum* (variegated foliage), *P. roseum*, and *P. verticillatum*, all of which bear whitish-green or greenish-white flowers, with the exception of *P. roseum*, which has rose-coloured blossoms.

**Portulacca.**—Tender succulent annual. Grown for its flowers. Minimum temperature, 45deg. The Portulaccas are

very useful for either in-door or out-door cultivation where the situation is warm and dry, and where there is plenty of sun. The succulent nature of the plants renders them very useful for poor soils when used for bedding purposes, the colours being very bright and varied, while by keeping them pegged down the bed will be one mass of bloom and lively green foliage, and if the colours are kept separate, large masses of orange, purple, white, and crimson will easily be obtained. Planted from mixed seed, however, they will not look amiss; in fact, some persons prefer this plan. Nice plants in 4in. or 6in. pots are very useful for various decorative purposes.

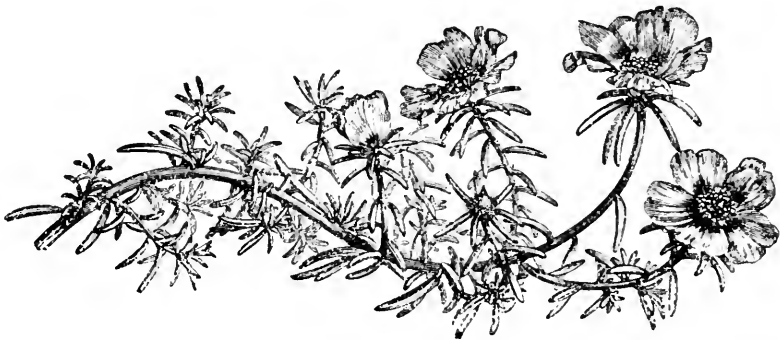

FIG. 105.—*PORTULACCA AURANTIACA*.

and if large flat stages in the conservatory have to be covered, these form one of the best plants to use largely. The seeds should be sown thinly on broad-mouthed pans or boxes, in sandy soil. Allow plenty of drainage, but be careful that the soil does not become dry, or the seeds will fail. A gentle bottom heat is a great advantage in raising the seeds, as the plants in that case come up quickly and well. When large enough they should be potted off into small pots, and be placed on a light shelf near the glass in a warm greenhouse. As soon as the pots become filled with roots, the plants should be shifted into the blooming pots, either 4in. or 6in., as desired. For soil we use a compost of good loam one part, decayed leaf

soil one part, and coarse sand and broken sandstone or corks together one part, potting the plants fairly firm, and applying water as may be requisite. A light, warm, but airy place will suit the plants well, and too much water must not be given if it is desired to have the finest show of bloom, but at the same time the supply must not be so stinted as to cause the foliage of the plants to turn yellow.

Propagated by seeds, as described above.

Various named sorts exist, but, for all ordinary purposes, a packet of double and single mixed will be amply sufficient. We, however, give some names: *P. alba*, white; *P. alba striata*, white and scarlet; *P. aurantiaca*, orange; *P. aurea striata*, orange and crimson; *P. caryophylloides*, striped; *P. Thellusonii*, crimson; *P. T. splendens*, rosy purple; and *P. Thorburnii*, yellow.

**Primula (Hardy).**—Hardy soft-wooded plant. Grown for its flowers. Minimum temperature (in pots), 36deg. The primroses are quite a host in themselves, and where there is only a cold house, or a house from which the frost only is excluded, they fill up a great gap in the supply of bloom, as many blossom as early as the end of February out of doors, and under shelter they may reasonably be expected to bloom at least a fortnight—if not three weeks—earlier. As the family is so large, we cannot afford space for a description of each kind (nor is that at all necessary), but must be content with general remarks.

*P. Sinensis* and its varieties will thrive in a light house where frost is excluded, as will any of the hardy varieties; but it must be remembered that in all cases where plants are in pots it is absolutely necessary that means shall be provided to protect the roots from frost. The best-sized pots in which to grow Primulas are 4in. and 6in., according to the natural habit of growth of each plant, and as the plants are very impatient of too much root moisture, care must be taken that the drainage holes are sufficiently large to admit of the free passage of superfluous water. The plants being in some cases rather deep rooting, the pots should be deep, rather than shallow, for their size. In all cases it is necessary to supply plenty of drainage, and also, in the case



of some of the alpine varieties, to place some broken sandstone among the soil, so that a certain amount of coolness and moisture shall be maintained during the hot weather. A good general compost consists of two parts good mellow fibrous loam, not sifted, one part thoroughly decayed leaf soil, and sufficient sharp clean sand to insure the requisite amount of porosity for the free passage of the superfluous moisture. If possible, the house should face the north-east, as, during the summer, if the plants were permanent occupants, the sun would otherwise be too powerful; but if there is plenty of frame room, any house would be suitable, as the plants could be removed to frames facing the north during the hot weather, or from the end of May until October, when they could be returned to the house. This latter would also be about the best plan to secure the blooms in perfection. As much air as possible should be admitted at all seasons, or the plants will become drawn and practically useless. Insects—but more particularly green fly, which will be sure to put in an appearance—are injurious, and it will therefore be found necessary to fumigate as soon as the first one appears, so that no damage may be done; for, as they attack the tenderest parts of the foliage, they soon destroy the heart, and consequently the bloom—if not the whole—of any plant which they may attack. Slugs and snails, although doing more damage individually, are not so much trouble to discover and exterminate as the fly, for while the former leave a slimy trail to show their whereabouts, the latter work so insidiously that only close examination will discover their presence.

Propagated by seeds and by division of the plants.

Amongst the kinds that may be grown in the cold house, the following are very good, but as the number of Primulas is so great, it is far the better plan for a purchaser to go to a large nursery and select such as suit his particular taste. The varieties of the common Primrose (*P. acaulis*)—but more particularly the double varieties—are very useful and pretty, and, as they can be taken up and bloomed in the house and then returned to the ground, they should be

largely used for this work: *P. acaulis fl.-pl.*, pale yellow; *P. a. alba fl.-pl.*, white; *P. a. lilacina fl.-pl.*, lilac; *P. a. lutea fl.-pl.*, deep yellow; *P. a. purpurea fl.-pl.*, purple; *P. a. rosea fl.-pl.*, rose; and *P. a. rubra fl.-pl.*, deep crimson, are the best doubles of the *acaulis* section. *P. auricula* (Fig. 106) contains many good things, especially the alpine varieties, and a dozen or two of good seedlings would not be a bad investment. *P. a. nigra fl.-pl.* is a good double black, and *P. a. lutea*, and its



FIG. 106.—PRIMULA AURICULA.

double variety, are good yellows, while the hybrids are legion. *P. Altaica*, purplish crimson; *P. Candolleana*, purple; *P. cortusoides* and its varieties, are good tall Primulas of rather robust habit. *P. erosa*, lilac; *P. minima*, rose (about the smallest of the family); and *P. verticillata*, yellow (Fig. 107), may all be grown, but they require much care to do them well, unless a house is devoted to them alone.

**Primula Sinensis.**—Half-hardy soft-wooded plant. Grown for its flowers. Minimum temperature, 38deg. The double (Fig.

109) and single (Fig. 108) varieties of *P. sinensis* are very useful for decorative purposes in the winter and spring months, and,

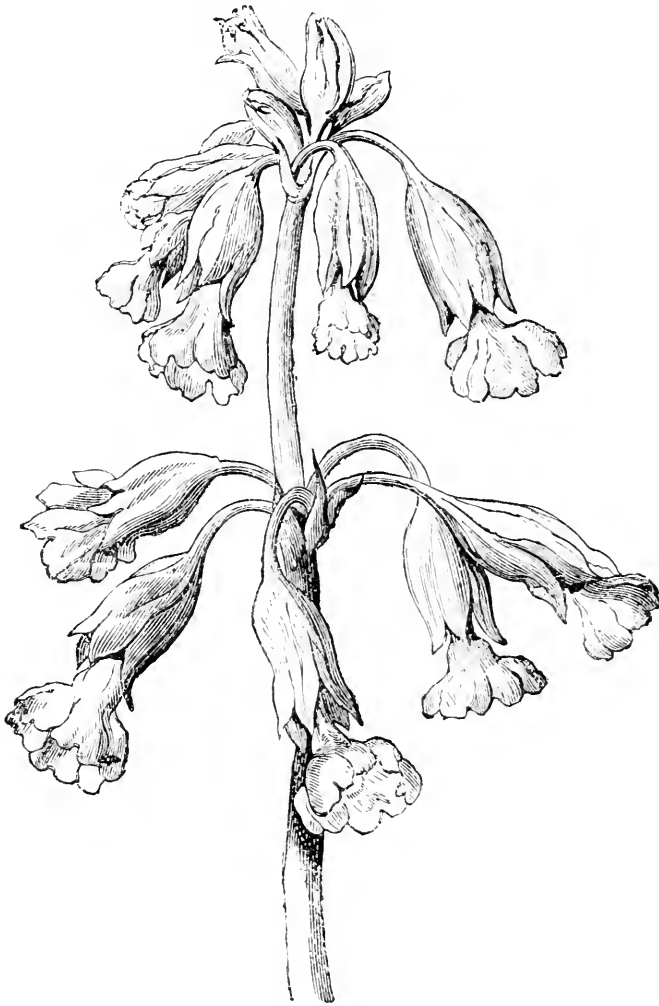

FIG. 107.—FLOWER OF PRIMULA VERTICILLATA.

as they are of comparatively easy culture, they form—or rather should—a very large part of the soft-wooded plants in bloom

from October to February. During the dull months of the year it often happens that ordinary geraniums and other miscellaneous plants are very chary of blooming, and then *P. sinensis* is very handy to have among plants that bloom at that season. Doubles are far more trouble to grow than single varieties, and the treatment is different; but the singles are as easy to grow as grass, if ordinary care is used. There are also semi-



FIG. 108.—PRIMULA SINENSIS.

double varieties that are easily raised from seeds, and they are as easy to do as the singles, requiring the same treatment; but, as we said before, doubles proper require quite a distinct treatment.

We will take the singles first. In the first place, it is absolutely necessary that the plants should be grown on steadily from the time of sowing until the time of blooming, nor during the whole period must they become pot-bound, for if they do

they will most assuredly commence blooming prematurely, and the consequence then is that much of their energy is wasted, and, unless care be taken, the subsequent blooms



FIG. 109.—PRIMULA SINENSIS FLORE-PLENO.

will be comparatively poor. For this reason it is advisable to make more than one sowing, as, by doing so, a better succession of bloom can be maintained. Besides, by having two or three sowings less risk is run, for if one batch is a

whole or partial failure others will not be so. And here let us say that it is useless to purchase cheap seed of Primulas, as the great cost and labour involved in saving good seeds, and the comparatively small quantity produced in the best strains, renders them expensive, and a really good article is worth a good price. Those usually retailed in sixpenny-worths and shilling-worths are very poor, even if they are such as will grow, and the flowers as much resemble a good fimbriated strain as a buttercup resembles a first-class ranunculus. Poor washy things, not so good in form as a common primrose, and of no decided colour, and very weedy withal, are produced from the seeds sold in ordinary retail trade. We therefore recommend the seeds in sealed packets, the lowest retail price of which is 2s. 6d.; and if a 5s. packet of a well-known English strain be obtained of a good house, little fear need be entertained as to quality.

We sow seeds in April, June, and August, on the surface of rather finely prepared soil, in well-drained pans, and cover with sheets of glass, which are thinly whitewashed on one side to prevent the admission of too much light. The pans are then placed in a pit or frame where a temperature of 60deg. to 65deg. is maintained. Here the seeds germinate freely, and, as the plants get on towards the third leaf, the whitewash is removed, and air is gradually admitted, but care is taken not to allow the sun to burn the plants, as they recover from such a check to their growth very slowly. Previous to sowing, the pots are well soaked with water, by standing them in a tub with the water reaching up to their rims only. By this means enough is absorbed by the soil to render more water unnecessary until the seeds have germinated. As soon as the young plants have their fourth leaf they are potted off into 3in. pots, well drained, and with more sand in the compost than that mentioned further on. Or, if it is considered desirable, the plants are pricked off into pans, about 1in. asunder, there to remain for a fortnight or three weeks. After this transplanting, they are removed to the pit or frame from which they were taken, and kept close for a few days to prevent them receiving a check, and then

air is gradually admitted. When the plants which were placed singly have filled the pot with roots, or when those pricked out have attained a fair size, the former are potted on into 4½ in. and the latter into 3 in. pots, and they are then put in a cold frame, but kept close for a week or ten days to prevent them from receiving a check. When they have again filled the pots with roots they are again transferred respectively, the one into their blooming, and the other into 4½ in. pots, these last having to be again shifted when the pots are full of roots. The plants are kept in a cold frame until well into October, when they are removed into the greenhouse, where a temperature of 45deg. or 50deg. causes them to bloom for a long time. At no time during their growth are they allowed to become dry at the roots, nor yet to become infested with insects, or failure is sure to result. It is also of much importance that the foliage be kept as short and healthy as possible, as long spindly leaves cause the blossoms to be hidden in a basin, as it were, instead of standing prominently above the foliage, as they should do to show to the greatest advantage. To ensure this, due attention must be paid to admitting air, &c., and, during the hottest part of the season, the plants may with advantage be stood in frames facing the north-west, as then the hottest rays of the sun will not reach them. Like most of the *Primulas*, *P. sinensis* (Fig. 109) and its varieties suffer much from a hot arid atmosphere, the majority of them requiring a somewhat moist condition while growing. When in the greenhouse during the winter season this must be nearly reversed, as then the fullest light must be afforded, and the house must be dry, or it is not at all improbable that the plants will damp off. Water must, of course, be given as required, but it will be found that less will be necessary than during the growing period.

It is necessary always to supply a good amount of drainage to the pots, and to vary the fineness of the soil according to the size of the pot. Thus, in a small one the soil should be much finer than in a larger, and, generally speaking, more sand will be requisite in the earlier stages of growth than

later on. On no account should liquid manure be given, or the result probably will be that the plants will rot off at the collars, or disease will set in and cause failure to a greater or less extent. For compost use about three parts good fibrous maiden loam, in a good mellow state, and one part cow manure and leaf soil in equal parts, both of which must be thoroughly rotten. To this add enough sharp silver sand to keep the whole open. But in this preparation of compost a little judgment has to be used, as some soils differ in texture to a great extent, and therefore it is necessary to vary the proportions.

We do not advise the keeping of *Primulas* of this section more than one season, as they do not repay the trouble the second year.

Double *Primulas* of the old variety are very troublesome subjects, and, unless proper accommodation for their culture exists, we do not advise their being taken in hand. Of course, for market purposes they pay a successful grower, but they do not pay the amateur for his trouble. The way they are successfully grown is as follows: The plants are broken up in April or May, and after each piece has been planted in a small 60-sized pot, they are placed in a brisk bottom heat, with a rather moist atmosphere. When well rooted, they are shifted into 4in. pots, and put back into the place whence they were taken until they are well established. When this is accomplished, they are removed into a more airy position, and placed as close to the glass as possible without actually touching it, and a certain amount of air is given to prevent them becoming too weak and spindly.

In potting, care must be taken that the plants are set sufficiently deep, or they will rot off at the collar. They should be buried to the base of the lower leaves, but not deeper, and if other points are properly carried out success is almost certain. Water must be carefully and not too abundantly supplied until the roots have taken good hold of the soil, but then the soil must not get dry, although at no time should it be soddened. The plants may be potted on until they reach 6in. or 8in. pots, according to their strength, in which sizes



they should bloom. It is also advisable to apply a slight shade through the very hottest weather, but this must not be overdone, or a great loss of strength will ensue. During the autumn and winter the plants should stand in a light airy house, somewhat near the glass, and a temperature of about 56deg. or 55deg. should be maintained, combined with a medium treatment, the plants being neither hurried nor allowed to stand still. Stagnant moisture should be carefully avoided, and air admitted according to the weather; but in any case a close, heavy, stagnant atmosphere should be guarded against, as it tends to render the plants more liable to rot off.

For compost, use three parts maiden loam, as recommended before, one part peat, and one or two parts leaf soil, with a liberal allowance of sharp sand. If, as sometimes happens, the loam is rather poor, a little decomposed cow manure may be added; but this is a matter that can only be decided on the spot. Plenty of drainage must be afforded, or the plants are sure to rot off.

Propagated from cuttings as described above.

**Pyrethrum aureum.**—Hardy annual. Grown for its foliage. Minimum temperature, 36deg. This plant, which is so largely grown for its golden foliage, and which is used so extensively in bedding, is best raised from seeds sown in a gentle bottom heat in February, and when large enough pricked off into boxes. Harden off in May, and plant out where it is to remain. If preferred, the young plants can be put singly into pots, and grown on in warm frames; but, except where large ones are needed, we fail to see any advantage in the plan, as those pricked out about two inches apart in boxes will be strong enough for all practical purposes.

Propagated by seeds as described above.

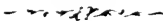



**REINECKIA.**—Greenhouse soft-wooded plant. Grown for its foliage. Minimum temperature, 38deg. *Reineckia carnea variegata* is a graceful little fine-foliaged greenhouse plant; the ovate leaves are variegated, one-half the leaf being white and the other half green. The plant is of comparatively easy culture, and does not attain to any large size.

We have generally grown it in the greenhouse for the whole year, and with the exception of keeping it well watered and attended as occasion required, have experienced no difficulty in its culture. A good compost of sandy loam and peat, and some sharp sand if necessary, is what we use, and of course a sufficiency of drainage is requisite. The plant is easily propagated by means of cuttings inserted in very sandy compost, and placed in a gentle bottom heat. When rooted the cuttings are potted off singly into small pots, and returned to the frame until the roots have taken possession of the soil, and then they can be hardened off somewhat, and placed in the greenhouse. During winter the plant can be kept growing, and presents a pretty appearance. If in a cool house it must be treated as a perennial of doubtful hardiness, as it is hardy only in some parts of the United Kingdom. For general work it can be done well in the manner described, and doubtful as it may appear to many, appears to thrive with the treatment given.

Propagated by cuttings as described above.

**Rhodanthe.**—Tender annual. Grown for its flowers. Minimum temperature, 40deg. As summer decorative plants the Rhodanthes hold a deservedly high place, as they are light and elegant in habit, and of pleasing colours. The flower is what is termed an everlasting, and, like other plants of this class, can be advantageously used for winter bouquets, provided they are cut and dried in a proper manner. For various bouquets the blooms

also come in useful, and in those for buttonholes nothing looks prettier if combined with other blossoms in a judicious manner. The blooms being rather tassel-like, and pendent or drooping, combine well with more erect subjects, and the colours also have the same advantage. The culture is very simple, so simple, indeed, that it is a matter of surprise to us that this plant is not more extensively grown by amateurs. With some of the metropolitan nurserymen, however, the case is different, as they find them very profitable, Mr. Maller, of Tottenham, alone selling from 10,000 to 15,000 each season, according to the space he can devote to them. The seeds are sown in February and March successionaly, in well-drained wide-mouthed pans with soil having a rich light compost, rendered porous by the addition of a fair quantity of sand. These pans should be placed in a moist gentle bottom heat, and when large enough the plants should be potted off five or six in a 4in. pot, in good, light, rich soil, and gradually inured to the greenhouse, which should be light and cool, or they will become drawn. If fair treatment is given, they will flower in May and June, well repaying the trouble bestowed on them. The ordinary treatment given to other soft wooded plants is all that is necessary.

Propagated by seeds as described above.

For sorts, use *R. Manglesii*, rose; *R. atro-sanguinea*, crimson; *A. maculata*, rose and yellow; and *R. maculata alba*, white, all of which are very pretty and useful.

**Rhododendron.**—Nearly hardy, hard wooded shrub. Grown for its flowers. Minimum temperature, 36deg. The greenhouse varieties of these plants are very beautiful, their large somewhat laurel-like leaves, and great terminal clusters of azalea-like flowers, being splendid, and, by using a little care in their selection, a fine and varied display can be had with no very great amount of labour. Of course, with all plants used in indoor work there is more or less trouble, but with rhododendrons this is small compared with the results obtained. In the first place, it is necessary that plenty of root room be afforded, for although not rooting so vigorously as many

other plants, these do not succeed well if much cramped for space. The best plan, where space exists, is to plant them out in the borders of a conservatory, and then their full beauty is obtained. Good sound fibrous peat will be found the best soil, to which should be added enough sharp silver sand to keep it well open, as the soil cannot be removed

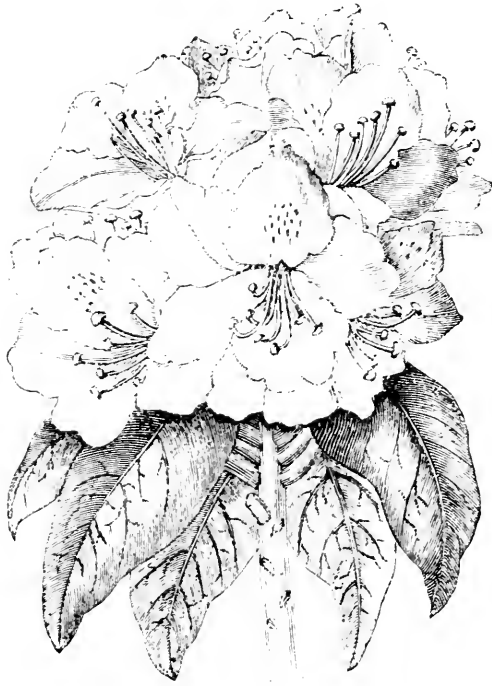

FIG. 110.—RHODODENDRON PONTICUM.

from amongst the roots, the close fibrous nature of which causes them to form solid balls, and of these the whole or partial destruction would cause the death of the plant, or loss of the greater part of the foliage—a great point with expensive varieties. As rhododendrons only require the exclusion of frost, a cold house is all that is necessary; but many of the sorts force well, and a large conservatory that it is desired to keep

well furnished with as little fire heat as possible is as good a place as any for the reception of these. As a rule, they should be re-potted every year, as soon as they have ceased blooming, not receiving more than a 2in. shift; press, or rather ram, the soil down hard by the side of the old soil, or the water will escape by the sides of the pots, and, as a consequence, the plants will become dry, and, if the evil is not rectified in time, they will soon die, or become injured irreparably. By using a little care in training, it is quite easy to maintain the plants in good form without much pruning or cutting back, which, unless the plants are very straggling, should not often be resorted to, other than to reduce their size should it become too large. At no time must the plants get dry, although the supply of water should be diminished in winter, but, during the growing season, almost unlimited supplies should be given. For this reason plenty of drainage should be allowed, or in many cases the soil will become sour and stagnant, and the plants necessarily suffer.

Propagation is by grafting on stocks of some inferior kind, but this is quite out of reach of the general amateur.

For sorts, the following will be found a good selection, and will, doubtless, please anyone choosing from it: *R. Princess Royal*, rich rose; *R. argenteum*, white, black spots; *R. Falconerii*, creamy white; *R. Countess of Haddington*, blush white; *R. campylocarpum*, primrose yellow; *R. ciliatum*, blush and white; *R. Dalhousie*, blush white; *R. Dennisonii*, white, lemon throat; *R. Edgworthii*, white; *R. fragrantissimum*, white, shaded blush; *R. fulgens*, crimson scarlet; *R. Gibsonii*, blush white; *R. jasminiflorum*, white; *R. Javanicum angustifolium*, orange yellow; *R. McNabii*, blush; *R. Nuttallii*, white; *R. Ponticum*, purple (Fig. 110); *R. Prince of Wales*, reddish orange; *R. Princess Alice*, blush white; *R. Princess Helena*, soft pink; *R. Princess Mary*, white; *R. tubiflorum*, dark reddish purple; *R. retusum*, reddish orange; *R. Veitchianum*, white, yellow base; *R. virgatum*, white. This last is most remarkable from its being the only one having axillary flowers; but all the others are desirable either for their blooms or scent, which latter in some kinds is very fine.

**Richardia.**—See “Calla.”

**Ricinus.**—Half-hardy annual. Grown for its foliage. Minimum temperature, 40deg. The Castor Oil Plant is very useful in the sub-tropical garden, and also in the conservatory as a fine foliaged plant, its large palmate leaves being very effective, especially when the plants are grown with one stem from two to four feet high, and, as it is of easy culture, there is no reason why it should not be grown for both purposes where space permits. The culture is of the simplest, as the plants will grow in any ordinarily good soil, and when grown in pots, a fairly rich free compost is all that is necessary, provided a good drainage is afforded. The seeds should be sown on a good bottom heat in March, and in the greenhouse in June, if plants are required late in the season for indoor use, as, for purposes of house decoration, they look better in a brisk growing state than when fully grown. We prefer to sow the seeds singly in small pots, and when large enough to transfer into 4in. pots, whence the plants can be permanently removed into 6in. or 8in. pots, as may be preferred, but at the same time they do best in the larger sizes. The earlier sown should be shifted into the greenhouse as soon as the first pair of leaves—not the seed leaves—are fully expanded, and can be grown on steadily, so as to be good plants to put out in June, while the second batch can be grown on in the frames, or outdoors until the end of September, when they can be taken indoors. It will be found necessary to give liberal supplies of water, and an occasional dose of manure in a liquid state. In other respects the treatment is the same as for the tobacco plant.

Propagated from seeds, as described above.

For sorts, use *R. communis major*, buff; *R. sanguineus*, red; *R. variabilis splendens*, various; and *R. viridus*, green. As companion plants to cannas and other stately subjects, the Ricinus are very fine.

**Rochea.**—Greenhouse succulent soft-wooded plant. Grown for its flowers. Minimum temperature, 38deg. *R. falcata*

is a nice, highly ornamental succulent, producing large heads of scarlet flowers, somewhat like the *Kalosanthes*, which the whole plant somewhat resembles, and it contrasts well with the fresh green colour of ferns, &c. As the plants can be had well in bloom in August, they are very useful, and if kept dwarf can be placed almost anywhere in decorating. It is this dwarfness that renders them so useful, and therefore it is necessary to use all possible means to obtain it. It is best done by keeping the plants near the glass during their growth, and this alone will cause them to be dwarf. We have generally given the plants the same treatment as *kalosanthes*, and we have found it to answer very fairly, so we must refer our readers to that head for the cultural directions. *Rochea falcata* is also very useful for window garden culture, and therefore young plants are generally much valued.

The mode of propagation is very easy, and in no essential point varies from that of *pachyphytum*. Of course, it is really necessary that only mature leaves be used for the purpose, and that they be perfect. The young plants should be placed as near the glass as possible after potting, and at all times care should be taken that they do not draw up too high, or all their beauty will be lost. With all succulents of this nature it is desirable to maintain the plants as dwarf as possible consistent with their habit, as bare stems are not beautiful.

**Roellia.**—Hard-wooded greenhouse plant. Grown for its flowers. Minimum temperature, 45deg. *Roellia ciliata*, from its peculiar appearance both of foliage and bloom, is worthy a place in all collections of hard-wooded plants, and, as it is quite distinct from the generality of greenhouse hard-wooded stock, it contrasts favourably with all of them. It is not a plant that is inclined to make over large specimens, or to outgrow the space allotted to it. For decorative purposes it is extremely effective, its distinct purple-tipped white blooms, about an inch across, and much resembling those of the *petunia* in form, almost covering the surface of the plant, and quite hiding the rusty appearance of the ovate foliage, which is the chief drawback to the general beauty of the

Roellia when out of bloom. In no case must this plant be subjected to *cold* treatment, as that simply means an earlier or later death from mildew. A minimum temperature of 45deg. or 50deg. must be maintained in winter without sun heat, and the plants must be kept near the glass, as they are essentially light-loving subjects, and must not be shaded at any time, either by shading the glass or by placing tall plants over them, or their great enemy, mildew, will soon put in an appearance and cause destruction. Plenty of drainage must be afforded, and for soil, use good fibrous peat, with about one-sixth part of sand added, potting moderately firm, as it is a rather free-rooting subject, much more so than would be generally supposed from its apparently weak habit. The best time to commence the culture of the Roellia is about the beginning of March. Obtain healthy plants in 6in. pots, make a shift into pots 2in. larger, and, as before mentioned, give plenty of drainage, and pot moderately firm. As this is a plant that requires training, a sufficiency of sticks should be put round the edge of the pot in the new soil to avoid damaging the roots, and to these sticks the shoots should be trained as much as possible. Care must be taken to remove the blooms as soon as they appear, and this is about all the pruning the plants will require, as they are very regular growers. Admit no side air for two or three weeks, and damp the stage on which the plants stand, but on no account must there be syringing overhead. Attention must also be paid to watering; give water only when they require it, and then give sufficient to pass through the pots, for, like most of the plants from the Cape, these do not like an indiscriminate supply of water, too much moisture at the roots causing bad health. Keep the plants in an airy, light house, near the glass, and during the spring and early summer months close early in the afternoon to retain the sun heat as much as possible. During the summer give plenty of air during the daytime, and wet the stages and pots, but not the foliage, as the latter would tend to make the plants more readily susceptible to the attacks of mildew. About the middle of August leave air on all night, and keep them quite cool until October, after which close the house at night or the plants will



be chilled. Remove all bloom buds as soon as formed, as it is not well to let the plants exhaust themselves in blooming the first season. Place through the winter near the glass, in a house where the temperature is not less than 45deg. at night, and keep the plants neatly trained out and tied. This is necessary, as the plant, being naturally of a procumbent habit, soon forms an unsightly straggling mass if left to grow as it pleases. About March re-pot and treat as before if exhibition plants are required, but if they are required for decoration only, let them bloom, which they will do freely if permitted; after blooming proceed as before described, and each year repeat the same treatment. The *Roellia* does not require to be placed out of doors during the summer, but rather the reverse, as cold or cutting winds cause a more rusty appearance, and do the plant no good. Mildew is the chief foe to be combated; for its better prevention all dead flowers and leaves must be kept removed; and for a cure, flowers of sulphur must be freely applied on its first appearance. The only insect that will live on the *Roellia* is brown scale, and that can be easily kept under by the aid of a small brush, as it does not increase very fast.

**Rose.**—Hardy hard-wooded shrub. Grown for its flowers. Minimum temperature, 36deg. Roses are among the most beautiful of the hardy subjects, and as they are of very easy culture indoors they should be well represented. Whether the house is heated or not, roses can be well grown in it if proper treatment and sufficient light be given; but it is not possible to bloom them well in a dark house. It is also almost, if not quite, impossible, to obtain any bloom if the plants become encrusted with insects; and to this point particular attention has to be paid, as on it the chance of ultimate success principally depends. Of course, other points have to be attended to, but the destruction of insects is one of the most important, as, however good the other treatment may be, if this is neglected, no good results can be obtained.

It is desirable that roses to be bloomed indoors should be well established in pots before they are brought in; and, indeed, it is

better if they have been so grown a couple of seasons before housing, as then they thrive the more. The method of potting and growing in pots will be found fully described in the Rev. J. H. D'Ombraïn's "Roses for Amateurs."\* It is necessary in growing roses indoors that plenty of drainage be afforded, and also that a rich and porous soil be used, as the amount of water

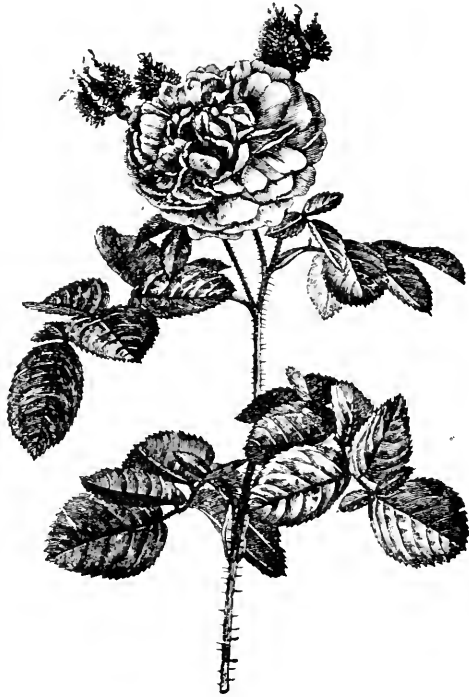

FIG. 111.—CRESTED MOSS ROSE.

that has necessarily to be given is apt to turn a close soil sour, and to render it unfit for the use of plants.

Roses can also be profitably employed to cover the interior of the roofs of conservatories or greenhouses; and for this

---

\* "Roses for Amateurs: A Practical Guide to the Selection and Cultivation of the best Roses, both for Exhibition or mere Pleasure." By the Rev. J. Honeywood D'Ombraïn, Hon. Sec. of the National Rose Society. Illustrated. Post free, 1s. (London: L. Upcott Gill, 170, Strand.)

purpose they can be planted out, either in inside or outside borders, in the same manner as vines, or they can be grown in large pots or tubs. The best plan, however, is to plant them out in a cool house, where light and ventilation are well provided, and then by judicious treatment a splendid harvest of bloom will be obtained with but little trouble.

Just as the plants may be required early or late so must



FIG. 112.—BOURBON ROSE.

the time vary for bringing them indoors, and due allowance must also be made for the temperature of the house. In no case should the plants be exposed to frost, but previous to bringing them in they should be kept in frames, and then they will be found to thrive far better.

Carefully prune the bushes and introduce them to a house

where the temperature is about 45deg. to 50deg.; keep the soil just moist until they break into growth, and then apply water according to development and to outside weather; when bright sunshine prevails, more moisture is requisite than when it is dull and cloudy. The breaks or shoots should be



FIG. 113.—NOISETTE ROSE.

reduced to from four to twelve of the strongest, according to the size of the bushes, and these should be carefully trained out so that both light and air are freely admitted to all parts of the foliage. Great care must be taken to prevent mildew, but should it appear, flowers of sulphur should be at once applied and syringed off at the end of twenty-four hours with water of the same temperature as the house; or Ewing's Mildew

Composition should be applied. Green fly must also be removed as soon as it appears, and this is best effected by the use of a small brush, say a stiff camel-hair pencil. Plenty of light is an absolute necessity, and air should be given more or less at every favourable opportunity.

When the plants cease blooming they should be removed to the frames until such time as they can be safely plunged



FIG. 114.—TEA ROSE.

outdoors, and great care must be taken throughout the growing season to cause them to make fine ripe wood, as on this the next year's bloom depends. In all cases it is absolutely necessary to remove insects, to keep the plants regularly and uniformly supplied with a sufficiency of moisture, and to treat as recommended above. Roses are essentially hardy plants, and must be so managed.

Propagated by budding or grafting on stocks of the wild briar, or on *Rosa manetti*. Full directions for this process are given in the book just referred to, also on raising young plants from cuttings.

The chief types of roses are: The Moss, Bourbon, Noisette, and Tea; and of these we give illustrations (Figs. 111, 112, 113, 114).

Amongst the sorts that are of most service in the house are—Marèchal Niel, bright yellow; Celine Forestier, deep canary yellow; Devoniensis, creamy white; Gloire de Dijon, buff, orange centre; Niphetos, white, pale straw yellow centre, buds very useful; Safrano, bright apricot, like the last, very fine in the bud; Souvenir de la Malmaison, blush, flesh centre; Victor Verdier, deep carmine; Senateur Vaisse, dazzling red; Prince Camille de Rohan, deep lurid crimson; Madame Victor Verdier, cherry rose; Madame Gustave Bonnet, pure white, shaded carmine; Jules Margottin, glossy pink; Géant des Batailles, crimson; Baronne de Maynard, pure white; and Madame Plantier, pure white, which are all useful for the above purpose, and, as we have grown them ourselves, we can recommend them with confidence. The fairy roses also are very useful, and require practically the same treatment.

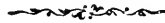

**SALVIA.**—Half-hardy, soft-wooded, plant. Grown for its flowers. Minimum temperature, 36deg. Salvias are plants which, from their beauty and easy culture, are well suited to the wants of the amateur, and, as most of them are grown as easily as a chrysanthemum, there is no excuse for not cultivating them. Some of the colours are very bright and attractive, and the scarlet *S. coccinea* and blue *S. patens* are very fine if grown well. Indeed, we believe that there is no blue flower to excel *S. patens* (which is shown in Fig. 115), for either purity or brightness. *S. Roe-*

*meriana* is a nice dwarf crimson variety, rarely exceeding 6in. in height, and, when well bloomed, the plants are very pretty. Salvias can be raised from seeds very easily, but, when a good variety is at hand, it is the more politic course to propagate by cuttings, as then the plants are certain to bloom as well as the parent, whereas with seedlings this cannot certainly be depended on, as in nearly all cases some variation from the parent plant ensues, and, although this may be of some advantage in perhaps a few plants, it is more generally a disadvantage, as some trifling defect, such as taller growth, duller colour, or perhaps not quite so floriferous a habit, will quite spoil the effectiveness of a lot of seedlings.

For decorative purposes Salvias come in very useful, as their spikes of sage-like blooms, when cut, can be worked in for many purposes, and the plants, when well grown in pots, are very effective for table and room decoration, but more particularly the latter. The objection to them for this purpose is that they exhale a disagreeable perfume if they are in the least crushed. As bedding plants, too, they are very useful if the soil is of the right sort, but in some soils the sage-like foliage will be more conspicuous than the flowers, and this is not very desirable in bedding plants.

The propagation by seeds is a very simple affair, so long as the seeds are good, but, if too old, very few will germinate, and the result will be a comparative failure. In fact, we have more than once suffered disappointment from this cause, and should therefore advise readers to save their own seed, or to purchase only of good firms. We have always found it the easiest plan, when raising plants from seeds, to sow them on sandy soil in well-drained pots, and to place these pots in a gentle bottom heat, keeping the soil uniformly moist, but not soddened with wet. As soon as the plants are in rough leaf they should be potted off into small pots and returned to the bed, and, as soon as the roots have taken possession of the soil, the plants should be gradually hardened off, and afterwards treated as rooted cuttings.

Cuttings should be made in March, and inserted in pots of sandy soil, having plenty of drainage; these pots should then

be placed in a gentle bottom heat, and if the ordinary rules for striking cuttings of this class be carefully attended to, they will



FIG. 115.—*SALVIA PATENS.*

nearly all do well. Of course, it is only reasonable to expect a certain amount of loss; this with us is only about five per cent., but where persons are not used to the work a larger percentage



may be fairly expected. When the cuttings are rooted they should be potted off into small pots, in a light sandy loam, and when the plants are established in their new quarters they should have treatment suited to their requirements. We do not recommend striking cuttings late in the season for winter work, for which purpose we prefer to treat the plants as described further on.

Plants for bedding purposes should be got into 48-sized pots as soon as the roots kiss the sides of the small ones, and the compost used should be a rich sandy loam, to which has been added some leaf soil or thoroughly decayed manure. They should be kept in a genial growing atmosphere, and such an amount of water applied as may be found necessary for their steady growth. Such plants as are inclined to run up too spindly should be stopped, to induce them to break freely and form bushy specimens, about 2ft. high, as these are most useful for bedding purposes. They should be gradually hardened off somewhat before planting outdoors, which should be done at the usual time.

Such plants as are to remain in pots for the season should be placed in a cold frame in May, and, as soon as necessary, re-potted into 6in. or 8in. pots, and kept close for a day or two. Heed must be given to stopping and training, so as to cause the plants to assume a nice pyramidal form, and also to prevent them from blooming; and the best preventive for this is not to allow the plants to become pot-bound or dry at the roots. About August they should be re-potted into 8in. or 10in. pots, as may be necessary, and pinching the points of the shoots must still be adhered to to prevent the formation of bloom, but about the third week in the month this should be discontinued, or the object of obtaining bloom during the winter will be frustrated. About the middle of September the bloom buds will commence appearing, that is, if the plants are sufficiently potbound, and then it is advisable that liquid manure—preferably sulphate of ammonia—should be given once a week. About the end of September the plants should be removed to their winter quarters in a light airy greenhouse, where a temperature of about 45deg. can be maintained, and by watering with liquid

manure from once to three or four times a week, according to the season, large quantities of bloom will be obtained. In growing plants in pots it is necessary to plunge them in a bed of ashes outdoors, from the end of June to the end of August, and it is needless to add that it is necessary to supply water in abundance during the hot weather. Frequent syringings will also be found necessary to keep down red spider, and the foliage must be wetted underneath as well as on the top. Although the foregoing is a good plan, we do not think that the plants do so well as when treated as described below.

Good thrifty plants should be chosen about the first week of June, and these should be planted out 3ft. or 4ft. asunder in rich soil in the kitchen garden, and care must be taken to get them in good form by pinching and training, as described above. A pyramidal form is the best, as it causes a greater display of bloom, and as a rule exposes the whole surface of the plant to light, a matter of much importance to plants of this description which are required to bloom in winter. During the season the soil should be often cut down at a distance of about 8in. from the stem of the plant to sever the roots, and so cause the production of a ball of fibrous roots, a point of the greatest importance. Plenty of water is necessary during the hot weather, and syringing must not be forgotten, or in sandy poor soil red spider will be very abundant. The last pinching should be given about the first week in August, and early in September the plants should be carefully taken up and placed in well-drained pots, boxes, or tubs, so that the roots are disturbed or reduced as little as possible. The interstices should be firmly filled in with good sandy soil, and the plants well watered to settle the roots. They should then be placed in a frame and kept close for a few days, and then removed to the house where they are to bloom. Old plants from the beds, if showing plenty of unexpanded buds, can also be treated in the same way. Old plants should be cut down, potted, and wintered in a shed, or any place where frost cannot reach, and if started in the greenhouse in February will afford plenty of cuttings. When they break again they can be divided, and then make good border plants.

Propagated by seeds or cuttings as described above.

For sorts, *S. patens*, blue; *S. coccinea*, scarlet; *S. c. pumila*, scarlet; *S. splendens*, scarlet; *S. Boliviensis verticulata*, scarlet; and *S. Heerii*, scarlet, are best suited for house decoration in winter; and *S. bicolor*, blue and white; *S. Rœmeriana*, scarlet; and *S. fulgens*, dull scarlet, for bedding purposes; but, at the same time, some of the hardy kinds are very useful.

**Sarracenia.**—Greenhouse soft-wooded plant. Grown for its foliage. Minimum temperature, 40deg. Amongst the so-called carnivorous plants, the Sarraceniæ hold a prominent position, and as some of them are of easy culture, we give them a place. The peculiar pitcher-like form of the leaves of these plants is the inducement to grow them, and this is well represented with the flower in Fig. 116, but the form of the pitchers varies with different kinds. The flowers are somewhat poppy-shaped, as shown, and are not unhandsome. One or two plants are very good in the greenhouse, as their presence tends to increase the interest in the place. As with a good many other things, it is, however, possible to have too many of them, and therefore it is as well to restrict the number to a few only, unless indeed they are grown to give away. Most growers give too much heat, and from our experience of plants grown in the following manner, we rather incline to a cool treatment. We have found a temperature of 40deg. to 45deg. through the winter, rising to about 70deg. in summer, to be quite enough to produce fine plants. *S. purpurea* is quite hardy; in fact, we might truthfully say that it is one of the hardiest exotic plants we have, standing in a cold exposed wet bog all the year through, and luxuriating in a position which would kill hundreds of our native plants. At Glasnevin it usually stands outdoors in frost and snow, and, according to some folks, seems to like the severe weather, but, as with all other hardy plants, if grown indoors, care must be taken that the pots do not become frozen, or the damage done to the roots, which are, as a rule, just inside the pot, and not protected by the soil around, will be very great. As one of the so-called carnivorous plants, this *Sarracenia* is well

worth growing. Of course, *S. purpurea* (Fig. 116) must be omitted from the following cultural remarks.

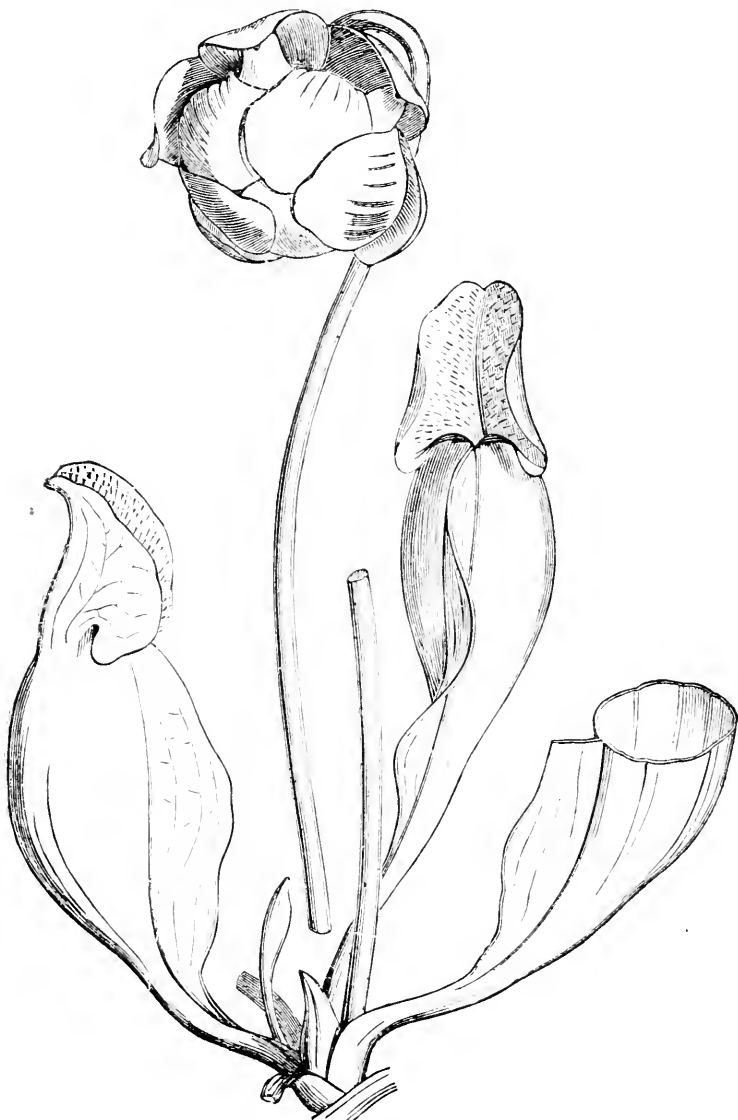

FIG. 116.—SARRACENIA PURPUREA.

The best compost is the following: Good fibrous peat, from which the soil has been taken, and chopped sphagnum in about

equal parts, to which should be added a fair amount of crocks and charcoal, broken rather small, and a liberal sprinkling of sand. In potting, use either Matthews' orchid pots or pots about half filled with crocks, so that plenty of drainage may be afforded, as these plants require large quantities of water to grow them well. With the exception of *S. Drummondii alba* and *S. D. rubra*, which should be re-potted in July, all the plants should be re-potted in February, the old soil being carefully removed. Pot moderately firm in such a manner that the creeping growths are just above the compost. Water must be applied daily as the plants come into full growth, sufficient to soak the soil being given at each watering. The plants should be stood on a shelf near the glass on the south side of the house, and the shelf should be covered with about an inch of charcoal or other absorbent substance. This layer should be soaked with water once or twice a day to maintain a somewhat humid atmosphere around the plants, as it is not advisable to syringe them. As the growth is ripening, less water should be given; and, during the time they are at rest water applied twice a week is ample. *S. purpurea* can be successfully grown in a cool house, or in a house not heated, but where frost is excluded; and the same general treatment, except temperature, may be given as for the others. The plants of this species can also be syringed with advantage; in fact, it is almost an aquatic.

Scale is the chief insect enemy that affects Sarracenias, and great care must be taken that they are destroyed as soon as they appear, or most disastrous results are almost sure to follow. A sharp watch must also be kept for other insects, thrips in particular, as they do much harm.

*S. Drummondii alba*, white; *S. Drummondii rubra*, red; *S. psittacina*, pinkish lilac; and *S. purpurea*, purple, are all good and interesting, and are, perhaps, as easy to grow as any. For the amateur, these plants are well suited, as they are both curious and beautiful.

**Saxifraga.**—Hardy, herbaceous, soft-wooded plant. Grown for both foliage and flowers. Minimum temperature (in pots),

35deg. One of the Saxifrages, *S. sarmentosa*, is very pretty as a hanging basket plant, and is, moreover, very easy to grow, its almost round, hairy, reddish veined leaves, and spikes of nearly white flowers, being very effective when the plant is suspended in a basket. The chief point is to keep it well supplied with water while it is in full growth, and to use a compost of about two-thirds sandy loam and one-third leaf soil and sharp sand mixed. A good sprinkling of broken sandstone or brick should be added to the compost, and plenty of drainage should be afforded. Provided the plants are kept well supplied with water, and have an occasional dose of liquid manure when in active growth, they will make fine specimens in a very short time. Re-potting once a year as soon as they have bloomed will keep them in good fettle for many years. They are easily propagated from the numerous offsets, pegging them down on a pot of soil being sufficient. The colour of the flower is rosy white, or its general appearance favours that impression.

Propagated by division of the rooted runners, as with strawberries.

**Schizanthus.**—Half-hardy annual. Grown for its flowers. Minimum temperature, 45deg. This is a handsome half-hardy annual of easy culture, suitable alike for both outdoor and greenhouse decoration, bearing an abundance of bloom (Fig. 117), and of bright colour and rather tall habit, rendering the plants very useful in their season. When well grown, either singly in 4in. pots, or, what is better, three in a 6in. pot, they are very effective, and the colours being very showy, they form very noticeable subjects. The seeds should be sown on a gentle bottom heat or in the greenhouse about March, or even the middle of February, but we have found March early enough for all practical purposes, although, to suit special places, the earlier time of sowing might be useful. The seeds should be sown on fairly rich light soil, rendered sufficiently porous by the addition of such a quantity of sharp sand as may be necessary for the purpose. As soon as the plants are large enough to handle they should be pricked

off singly into small pots, and gradually hardened off, so that they can be removed to the cold frame about the end of April. When these pots are filled with roots the plants should be shifted into their blooming pots, and care taken that they have sufficient drainage, and that the soil is rich enough to sustain them in good foliage. As soon as the weather admits, they should have full exposure, and should be treated as other pot plants; as the pots become filled with roots, weak liquid manure should be applied each alternate watering, and when the bloom buds show colour, the plants can be removed into a cool light conservatory to bloom. Seeds may be saved on the best plants, but it prolongs the bloom to keep the seed vessels picked off, as the effort used in producing seeds soon exhausts the vigour of the plants.

Propagated by seeds, as described above.

For sorts, select from *S. Grahami* (Fig. 117), scarlet and orange; *S. grandiflorus oculatis*, purple and rose; *S. oculatis pyramidalis*, violet; *S. pinnatus*, rosy purple; *S. retusus*, rose and orange; *S. albus*, white and orange; and *S. papilionaceus*, spotted.



FIG. 117.—SCHIZANTHUS  
GRAHAMI.

**Scilla.**—Hardy, soft-wooded, bulbous plant. Grown for its flowers. Minimum temperature (in pots), 36deg. Squills do very nicely for cold-house work where early bloom is required, and they can also be used in the warm greenhouse, but as they do not thrive so well in the latter as in the former, it is perhaps the better plan to devote them to the former class of house only. The culture is of the simplest: potting the

bulbs the same as crocuses, and using the same kind of soil, and, in fact, treating in the same manner as recommended for those plants. Their hyacinth-like habit and pleasing hues render them very useful as small decorative plants, and if the blooms are wired and mounted like those of the hyacinth, they work in well for table decorations and for bouquets, but more particularly for buttonhole bouquets.

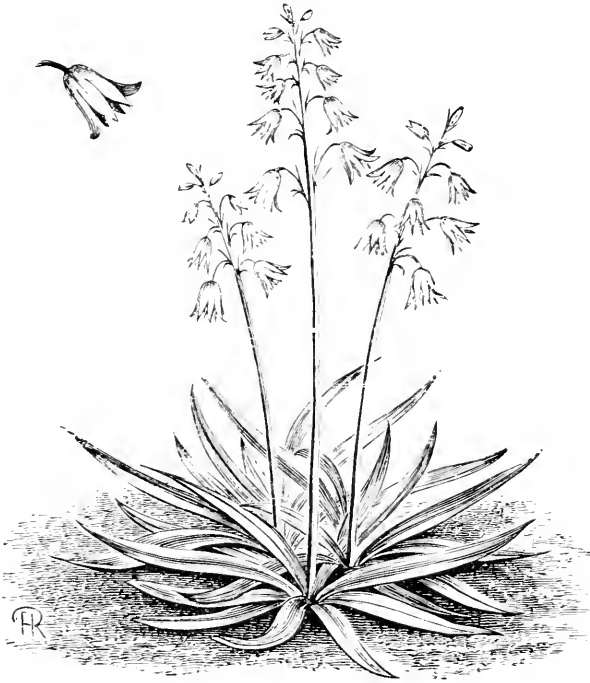

FIG. 118.—*SCILLA CAMPANULATA ALBA*.

Propagated by division of the bulbs, which increase naturally. *S. bifolia*, dark blue; *S. campanulata alba*, white (Fig. 118); *S. bifolia rosea*, rose; *S. nivalis*, pale blue; *S. Siberica*, blue; *S. Peruviana*, blue; *S. P. alba*, white; *S. verna*, blue; and *S. nutans rosea*, rose, are all gems for the cold house.

**Sericographis.**—Greenhouse hard-wooded shrub. Grown



for its foliage. Minimum temperature, 45deg. *Sericographis Ghiesbreghtii* is a plant that is suited to a warm conservatory or greenhouse only; but as it can be done very well with some of the plants we have already mentioned, and as it is very useful from a decorative point of view, we give the cultural directions for it. Its fine feathery scarlet flowers are set off to great advantage by the bright green shining leaves, and from its comparatively easy culture it will be found very useful where a little convenience exists to meet its requirements. In the first place, it is necessary to get the growth on early, that good useful plants shall be made during the summer, and that they may have time to mature ere winter sets in. As a general rule, late-struck plants do badly; for as they do not get thoroughly matured, they, as a matter of course, do not bloom at all, or, if they do, it is very poorly.

As soon as the plants have ceased blooming they should be placed in a brisk and moist bottom heat for a week or two to get them into free growth, when the tips of the shoots will strike freely if properly treated. Cutting pots should be prepared by half filling them with crocks on which a little coarse fibrous peat should be laid, and then the pots should be nearly filled with sharp propagating sand. The cuttings should be inserted about an inch or so apart, round the sides of the pots, which should have been thoroughly watered and drained previously to inserting the cuttings. These pots must be placed in a close moist heat, when the cuttings will strike freely, after which they should be potted off singly into small pots, and nursed gently on in a moderate moist heat. We have done this part of the process in an ordinary cucumber frame, where the bed had become sweet, and the plants throve very well; but, if a propagating frame exists in the greenhouse, it is best to strike all cuttings therein. When well rooted the points should be pinched out to induce a bushy growth, and, when this has been attained, or, rather, when the young plants have broken freely, they should be placed on a light, airy shelf until the middle or end of May, when they should be re-potted into 4in. pots, and gradually hardened off preparatory to placing outdoors in a cold frame. The time

for putting them out would depend on the state of the weather; well on into June will do if the season is hot, but if cold the plants may remain for another week or so in the house. When placed in the frames, the pots should be plunged in half-spent leaves, and the plants should be syringed once or twice daily, according to the weather. If treated thus, and the frame is closed early, the plants can be finally shifted into 6in. pots about the end of July. During September the syringing should be gradually discontinued, and the frames should be drawn off every fine day to harden off the plants and induce a good supply of bloom. About the last week in September they should be removed to a warm greenhouse, and they will soon commence to bloom well. During winter a temperature of 50deg. to 55deg. should be kept up. For soil, use peat and loam in equal parts, with enough sand to keep it open.

Propagated by cuttings struck in heat, as described above.

**Snowdrop.**—See “*Galanthus*.”

**Solanum.**—Half-hardy, soft-wooded plant. Grown for its berries and flowers. Minimum temperature, 38deg. The hybrids of this are very interesting, and, as they are best treated as soft-wooded plants, or, at least, like seedling stocks, we give our method of treatment. About June we sow seeds in sandy soil, placing the pans in a cold frame. The seeds are sown thinly and evenly over the surface of the soil, and the pans are well drained, as the seed is often a long time in germinating, and, consequently, it is necessary to prevent the soil becoming water-logged, and thus destroying the seeds. As soon as the plants are in rough leaf we pot them off into thumbs, and, as the roots kiss the sides, we shift into large sixties, where they stand the winter. For soil, we use two parts loam, one part leaf soil, and one part rotten cow manure and sharp sand, mixed.

The plants are taken in in the early part of the winter and placed on a shelf near the glass, no more water being given than really necessary, and being kept dormant. In spring, when they

break, they are cut back closely, so as to make good bushy plants, and in May they are put out into a rich open spot in the kitchen garden. Plenty of water is afforded if necessary, and the plants are pinched back in June and July, so as to cause them to make a good bushy growth. When the berries begin to colour, or about September, the plants are taken up, without injury to the roots, and placed in pots of sufficient size to hold them properly. They are then well watered, and kept close for a few days in a shaded—but not dark—frame, and thence are removed to the greenhouse, where they are very ornamental until growth recommences. Such is about the easiest mode of culture, and anyone having a house from which the frost is just excluded can grow them well.

Another plan is to put in cuttings in April or May on a slight bottom heat, and, as soon as rooted, to transfer them to 3in. pots. As soon as the roots kiss the sides the plants should be shifted into 6in. pots, where they are to fruit. They should remain in frames at a temperature of about 60deg., and should not want for water. In June the plants should be pinched back, so that they shall be of good shape, and, if required, a little training may be afforded, but it is advisable to dispense with sticks and ties as much as possible, as the plants look far better if grown in a natural manner. During the blooming period plenty of air should be admitted, and every means should be taken to prevent a check. As soon as the berries are of good size some of the plants should be taken indoors, and about September the whole of the stock should be housed, when, if properly cared for and in a light sunny place, they will ripen and retain their berries for a long time.

The soil we use is good sandy loam, to which some thoroughly rotted manure has been added, together with sufficient sharp sand to ensure porosity. Good drainage is, of course, necessary, but these plants do not require so much as some others. Fumigation will often be necessary to keep down fly, and outdoor plants must be syringed with some insecticide once or twice in the season.

Propagated by seeds and cuttings as described above.

The sorts we prefer are *S. capsicastrum* or *ccrasiformis*, *S. c.*

*variegatum*, Wetherill's hybrids, and Henderson's Conical-fruited *Solanum*, all of which are really good and useful. We may add that in some parts of the country these *Solanums* are hardy, or require only slight protection in winter, and they have a very cheerful appearance until the berries fall.

*S. jasminiflorum* and *S. j. variegatum* are two very good climbers for walls or trellises, and are interesting in appearance. The culture is not very difficult, and although these plants do best in the borders, still they can be done very well in pots. In any case, plenty of drainage must be afforded, and a pretty fair amount of root room. The soil should be loam and leaf soil in about equal parts, and a good dash of sharp sand to keep the whole open and sweet. Water should be given freely in the growing season, and during the time when the plants are at rest the soil should be allowed to become moderately (but not dust) dry. Insects of all kinds must be kept under as previously directed. These species are best propagated from cuttings as described above, and of course are not placed outdoors as are the berry-bearing section such as *S. cerasiforme* and others of a like nature.

**Solomon's Seal.**—See "Polygonatum."

**Sparmannia.**—Half-hardy hard-wooded shrub. Grown for its flowers. Minimum temperature, 36deg. This is a really good cool-house shrub, that is nearly always in bloom. It, however, attains a pretty good size, and therefore requires a fairly high house to grow in. The blooms are produced in rich masses, and are white in colour, the general appearance of both flower and foliage being well shown in Fig. 119, therefore it is a very valuable plant for use in large places; but comparatively small plants give very good results. The best plan is to strike cuttings under bell glasses in a moist bottom heat in February or March, and as soon as rooted to shift into small pots, keeping in a warm light position until rooted well, when they should be got into 4in. pots. When the plants are about 3in. high take out the points so as to induce a bushy growth. About June shift into 6in. or 8in. pots, and when rooted

into the new soil, place in frames out of doors, gradually hardening off. Bring in early in September and place in a light position, and with care they will bloom well. Re-pot again in March, using a mixture of peat and loam for the purpose, adding just enough sand to keep the soil well open. Pruning must be resorted to to obtain bushy plants. These shrubs also



FIG. 119.—SPARMANNIA AFRICANA.

look well as standards, and well repay any trouble that may be afforded them. The usual means must be taken to keep down insects, which, however, are not very troublesome if the plants are well managed. After the third or fourth potting the plants should be allowed to get slightly potbound, and liquid manure should be applied during the season of growth—a practice that

tends to encourage the formation of blooming wood. As a continuous blooming, cool house, or conservatory plant, this cannot easily be surpassed.

Propagated from cuttings as described above.

**Spiræa.**—Hardy, herbaceous, soft-wooded plant. Grown for its flowers. Minimum temperature (in pots), 38deg. *Spiræa japonica* is one of those plants which, although hardy, or nearly so, yet require special treatment if grown indoors. Its great beauty and decorative value render it almost a necessity where plants are required for table or window decoration, and therefore we give it a place as a greenhouse plant. The light feathery spray of which the truss, or rather spike of blooms, is composed, is also very useful for mixing in bouquets, for button-holes, and for the decoration of vases and epergnes. The entire plant, when well furnished with bloom, forms a magnificent object for the dinner table, or for a specimen for a solitary stand, as will be seen in Fig. 120, while amongst other plants the pearly whiteness of the feathery blooms and the fresh green foliage contrast well with darker and more gorgeous neighbours.

The culture is, comparatively speaking, easy, and, unless it is desired to have the plants in bloom very early, forcing need not be resorted to. The way we bloom the imported clumps is as follows: As soon as ripe clumps can be got, they are potted into 5in. and 6in. pots, while any that are extra large, and that have the largest number of blooming crowns, are potted off into 7in. or 8in. pots, according as they promise to cover them with foliage. A good depth of drainage is allowed, from one to three inches, according to the size of the pots. The clumps are potted fairly firm in a compost of fibrous loam two parts, leaf soil one part, and thoroughly decayed manure one part, with a sufficient quantity of sharp silver sand to keep the whole thoroughly permeable to water, as large supplies are necessary during growth. As soon as potted, the plants are put in a cold frame, and about the end of November they are placed in a house at a temperature of 45deg. They are well watered, and as soon as growth commences, stood

near the glass, and water given as required. Plenty of light is afforded, and care is taken to keep down insects. A temperature of about 50deg. may be maintained when the plants are in full foliage, and in this they will bloom. Other batches should be brought in at intervals of three weeks or a month until the end of March, and after that they can be bloomed in a frame.

When the plants have ceased blooming, they should still be



FIG. 120.—SPIRÆA JAPONICA.

attended to with water, &c., and in April they should be carefully planted out on a rich border facing the south, well watered to settle the soil around the roots, and in dry weather subjected to liberal supplies of liquid manure and water. About the end of August watering should be gradually discontinued, and when the plants have thoroughly ripened off in a natural manner, they should be taken up and potted as we have described.

Where only a cold house exists, the plants should be kept in a cold frame until February, and then they may be brought into the house. With care in watering, &c., such as the natural wants of the *Spiræa* require, very good results can be obtained, although the bloom will be late. We have, however, had the blooms finer in a cold house than where they have been forced; but, of course, the clumps used were really good. As a matter of fact, there is no more trouble in growing *Spiræas* than in blooming a hyacinth; and, indeed, we would rather grow *Spiræas* than geraniums, although the former are now far from profitable in a marketable point of view. Several of the hardy *Spiræas* bloom very well in a cold house or frame; but they are not desirable plants in a dwelling-house, as thrips and green fly are so very partial to them.

Propagated by division of the crowns or clumps.

**Static.**—Greenhouse hard-wooded plant. Grown for its flowers. Minimum temperature, 40deg. The Statices are pre-eminently suited for greenhouse culture or for exhibition, as they combine a good habit with comparative ease of cultivation, although, like several other plants, 45deg. is quite as low a temperature as they should be subjected to in winter, or no great success will be attained. On no account must the plants be rested, in the ordinary acceptation of the word, but must be kept growing all the winter, or the results will be far from desirable. Statices bear large heads of flowers of a papery texture, which may nearly be classed with the everlastings, but, strictly speaking, cannot be so considered. The calyx varies from lilac to blue in different plants, and the corolla (which soon drops off) is white; the leaves, which are leathery in some of the varieties, are 4in. or 5in. wide, and from 8in. to 12in. long. The season of blooming varies, but with the following sorts, if treated as we direct, the principal flowering stems will be thrown up in spring, and a succession of side blooms will be continued until autumn. At no time is it advisable to place the plants out of doors, or to give full exposure to the sun; they like a rather closer atmosphere than the generality of hard-wooded plants; but they must not be kept too close



or too far from the light, or success will not be attained. *S. profusa* is about the best of its class, and the treatment for this one applies to the whole family. Plants should be selected in autumn which have been stopped at 3in. or 4in. from the soil, and which have not been cramped up in small pots, as these rarely do well. The reason of this is that

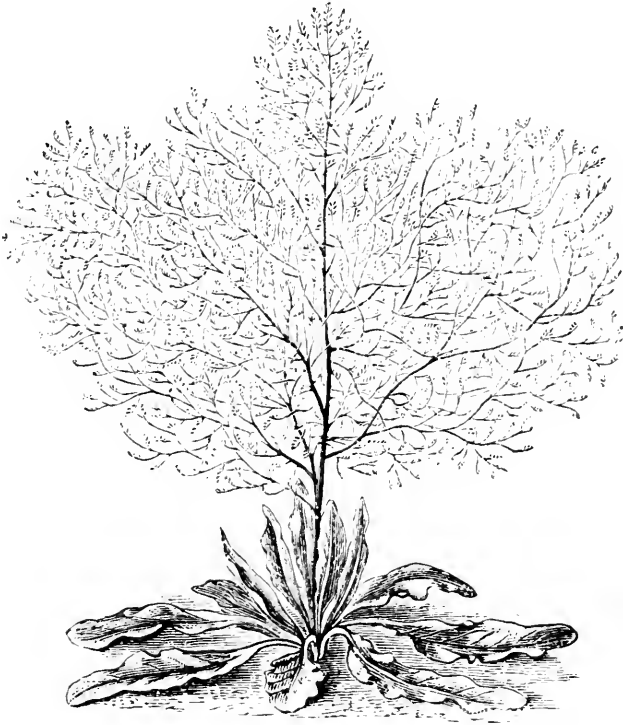

FIG. 121.—STATICE PROFUSA.

the *Statices* being very free rooting, get stunted if kept in small pots for too long a time, and when this occurs they never afterwards grow satisfactorily. During winter they should be on a shelf near the light, and kept at a night temperature of about 45deg., by which means the roots will be kept active throughout the time, a matter of much importance. They must not, of

course, be grown on at the same rate as they are in summer; but still growth must not stop entirely if good results are desired. Early in March the plants should be put into 9in. pots, in good turfy yellow loam, with enough sharp sand to keep it open. The soil must not be broken too fine, and the plants must be potted firmly. Plenty of water must be given, and, consequently, good drainage must be afforded, or the pots will get waterlogged, and the plants will suffer in consequence. For a week or two after potting, keep the plants rather close, and do not over-water; and afterwards place in the light, near the glass, but away from cold currents of air. Shade must be given to protect them from hot sun, but it should not be kept on longer than needful. Throughout the summer syringe in the afternoon, being careful to wet underneath the leaves, to keep down red spider, which soon does irreparable mischief. During the first season it is advisable to pick off the flower stems, which will be thrown up all through the summer; but the second season the first crop of bloom may remain. In the hot sunny weather a bed of coal ashes is preferable to a dry stage, for, in this latter case, the large leaves afford so great a surface for evaporation that the plants would frequently suffer from dryness. As autumn approaches, discontinue the use of the syringe, and give more air. Winter as before, and remove all bloom that may appear before spring. In March give another shift as before, and let them be similarly treated, but allow the blooms to open; while in bloom syringing should be discontinued, or the flowers will damp off. The plants should not be out of the growing house long, neither should the successional blooms be allowed to open that year, but should be removed as they appear. The side shoots should be carefully tied down, so as to form a nice base to the plant, and care must be used not to split the shoots out, as they are very brittle. Treat in the same manner each year until the plants get into 24in. pots, when they may be kept in good order for years by the use of liquid manure. After the second year, unless they are intended for exhibition, they may be allowed to bloom for their full season, but for show purposes they should not bloom fully until in 18in. pots. These plants are subject to red spider, thrip, and aphides. For

the first the cold water cure should be applied, while, for the two latter, fumigation is the only remedy.

Propagated from cuttings struck in sandy soil during the warm months of the year in the greenhouse.

For sorts, select from the following, always having the first two in a collection: *Statice profusa* (Fig. 121), *S. imbricata*, *S. brassicæfolia*, *S. Holfordii*, *S. macrophylla*, *S. macroptera*, *S. propinqua*, *S. Rattrayana*, and *S. sinuata*. All are good and useful, but the first two are the best for general work.

**Stocks.** — Half-hardy annuals. Grown for their flowers. Minimum temperature, 40deg. Stocks, both Intermediate and Ten-week, are almost necessities in the greenhouse during the early part of the year, on account of their perfume, and, as the blooms of the double varieties can be mounted with but little trouble, they scent a bouquet very nicely at any time without causing any unpleasant after-effects, as is the case with some other flowers. The culture is much the same, whether the Ten-week or Intermediate varieties are chosen, except that the former are sown in spring and the latter in autumn. Ten-week Stocks should be sown in gentle heat in January, and successively until the end of April, and as soon as the plants have their rough leaves they should be potted off; then, when the weather becomes sufficiently mild, they may be transferred to the cold frames. When the pots get fairly filled with roots, a shift into 4in. pots should be made, and any of the plants which show single flowers may be destroyed at once, unless the strain is very prolific of double flowers. Care must be taken to keep the plants as close to the lights as possible, to prevent their becoming drawn, or the beauty will be wholly destroyed. Where they are to be used for bedding out only, they should be turned out of the small pots and planted rather thickly about the end of April, or early in May, if the weather is sufficiently mild; a nice open spot should be chosen for the bed and rich soil provided.

The best Ten-week Stocks are those supplied in collections from Germany, but at times it is possible to obtain a good strain of home-grown plants. As, however, there is no actual certainty

of their turning out good when obtained from this source, it is by far the better plan to go in for German seed at once.

Intermediate Stocks have to stand the winter to obtain the best results from them, and the treatment is, of course, somewhat different to that given to the Ten-week varieties, in so far as the winter treatment is concerned. The seeds should be sown in the latter end of August, and, as soon as the plants are large enough, they should be potted off singly into 3in. pots. Here they will remain for the winter until about the end of February, when they should be transferred into 4in. or 6in. pots. The plants must be wintered in cold frames, from which frost is excluded, but to which air is admitted at all favourable opportunities. During this time they must be kept as dry as can be consistently allowed, and the frame in which they are kept must also be dry, or they will rot off, and the whole labour will be lost. As the plants commence growth in spring, water must be applied as required, and they should be turned round occasionally to keep the growth level. Plenty of room must also be given to allow them to develop fully, or they will have an appearance the reverse of elegant. For soil we find that in the earlier stages of growth a good maiden loam passed through a  $\frac{3}{4}$ in.-mesh sieve, and enough sand added to render the whole freely porous, answers well; and for the blooming pots nothing answers better than three parts maiden loam and one part thoroughly decayed manure, to which is added enough sand to render the soil permeable to the water that is given. The soil for the blooming pots should be passed through a lin.-mesh sieve only, as too close a soil is not good for the plants; but, of course, it is at the same time necessary to use a sufficient quantity of finer soil to fill the interstices, as the roots will not run in the larger portions alone.

Various strains of intermediate Stocks exist, some being good and some very inferior, and therefore it is desirable that only the best shall be used. The colours are scarlet, white and purple, which should be very clear and pure, but at times a dull-coloured strain finds its way into the market. The East Lothian varieties are a fine selection if obtained

true, but risk always attends the purchase of seed unless a good firm is dealt with.

Propagated by seeds, as described above.

The colours and shades of colour in the Ten-week varieties are very varied, but the best are scarlet, crimson and purple, the others, unless the strain is exceptionally good, being very dingy. It is judicious, therefore, to purchase only of a first-class seedsman.



**TACSONIA.**—Half-hardy hard-wooded climber. Grown for its flowers. Minimum temperature, 40deg. Tacsonias, which, in flower, foliage, and habit, are closely allied to the passion flowers, do well with same general treatment, both as to culture and training, &c. Of course, with these, as with their congeners, variations will have to be made in some minor details, but these will be readily seen. The flowers of some of the Tacsonias are very beautiful, and will commend themselves to the attention of most cultivators, where they have plenty of roof room, such as a large warm conservatory or a light greenhouse, and we should advise their use amongst passion flowers.

Propagated by seeds, &c., in the same manner as passifloras.

For sorts, select from the following: *T. Buchananii*, *T. ignea*, *T. manicata*, *T. mollissima*, *T. sanguinea*, and *T. Van Volxemii*.

**Tagetes.**—Half-hardy annual. Grown for its flowers. Minimum temperature, 40deg. *T. signata pumila* takes the place of the yellow calceolaria on soils where the latter will not grow well, and we therefore give it a place here. It should be sown on a gentle heat in March, and when large enough

potted off singly into small pots, and gradually hardened off to plant out at the ordinary bedding season. We cannot say much for the plants when grown in pots, but in beds or borders they answer their purpose very well. The colour is bright yellow.

Propagated by seeds, as described above.

**Tecoma.**—Half-hardy hard-wooded climber. Grown for its foliage principally. Minimum temperature, 38deg. This is a plant that requires plenty of head room, and a large amount of border in which to extend its roots. It is practically useless in a small place, but where it has plenty of room it is an acquisition. For soil use good fibrous peat, three parts, and sound fibrous loam, one part, with a good admixture of sand. Plenty of drainage must be afforded, as during the season liberal supplies of water must be applied. The young shoots should ramble at will, and not be trained to any formal pattern. For the domes of large conservatories, and similar positions, the Tecomas are very useful, bearing their trumpet-shaped flowers in drooping bunches, which are freely borne amongst the handsome foliage; but, as we said before, they are of little use for small places.

Propagated by seeds or layers, but as only a very few specimens of this plant are needed, it is, as a rule, the better plan to purchase from a nursery.

For sorts, the following are good: *T. Capensis*, *T. jasminoides*, *T. j. alba magna*, *T. j. rosea*, and *T. j. splendens*.

**Thalictrum.**—Hardy, herbaceous, soft-wooded perennial. Grown for its foliage. Minimum temperature (in pots), 36deg. Of the rather large variety of Thalictrums one is very useful in either the hot or cold house. *T. minus* is a plant having foliage resembling to a great extent the maidenhair fern. In the plant we more particularly desire to introduce to our readers—*T. adiantoides*—this resemblance is still greater, and where ferns cannot be done well it is extremely useful, as the foliage is well adapted for the same uses as those to which the fronds of the ferns are put. The flowers of *T. adiantoides*

are white, and those of *T. minus* are pale yellow; but the flowers are of no value compared with the foliage. The plants should be potted up as soon as the foliage is ripe, and may be kept in a cold frame during the winter if desired, or they can be taken into the cold house at once. In the warm greenhouse, if the plants are introduced during the season of rest, they should first occupy a cool shelf near the glass, and as growth commences they should be removed to a warmer part of the house, but they should be kept as near the glass as possible. The object to be attained being the production of fine, healthy, hard foliage, due attention must be paid to such little details as will be found necessary in practice; and, above all things, some amount of air must be allowed on all favourable occasions, both to harden the foliage and to obtain a good colour. Water must be given as may be found necessary from the state of the plants; for while they are in an almost dormant state very little moisture is required, whereas when in active growth they require more liberal supplies of water. A compost of sandy loam and leaf soil, rendered sufficiently porous by the addition of some sharp sand, is necessary. In all cases good drainage must be afforded, as the plants do not thrive in soil that is water-logged. In the cold house the treatment is practically the same as the preceding, except that the plants, coming into growth but a short time before their natural season, require only the ordinary treatment for hardy subjects.

Propagated by division of the roots when the plants are at rest.

The most suitable sorts for pot culture are: *T. adiantoides* or *adiantifolium*, white; and *T. minus*, pale yellow.

**Thea.**—Greenhouse hard-wooded shrub. Grown for its flowers and foliage. Minimum temperature, 40deg. Thea, or Tea, is a plant that from its economical value is of much interest, besides having a good appearance and pretty blooms. It is also of comparatively easy culture, and does not require excessive heat; a house where the temperature does not fall below 40deg. in winter suiting it very well. It is quite a different plant from the "tea tree" (so called) of the outdoor garden, which is in

reality *Lycium barbarum*, being much like the orange in appearance. Whether the *Thea* will produce leaves in England of any value economically, is a doubtful question, but still, in a collection of plants, it is very interesting. The plants should be re-potted every spring in a compost of three parts yellow loam, one part thoroughly decomposed manure or leaf soil, and enough sand to keep the compost open. Plenty of drainage must be afforded, or the soil will become sour. During the summer liquid manure should be occasionally supplied, and the plants must at no time get thoroughly dry. The *Thea* should be placed in frames during the summer, and treated much the same as camellias or oranges, the wood being well ripened before bringing into the house, where they should have a light airy position afforded them, and be further treated as oranges.

The sorts are: *Thea Assamensis*, *T. Bohea*, *T. viridis*, *T. v. variegata*. The first is the hardiest, though the second, in our opinion, is one of the best.

**Tobacco.**—See “*Nicotiana*.”

**Tradescantia.**—Greenhouse soft-wooded plant. Grown for its foliage. Minimum temperature, 40deg. *T. zebrina* is of very easy culture for the warm greenhouse, bearing trailing stems closely set with ovate leaves, coloured reddish-purple and green, and well worthy of a place in any collection. The green variety is useful to form a drooping mass of foliage, but is not so conspicuous as the preceding. Cuttings will strike freely in sandy soil in spring and during the summer, and by a little attention in watering and pinching back, they form good plants in a short time. We place six or seven cuttings in a 4in. or 6in. pot, affording plenty of drainage, and filling the pot with a compost of fairly rich light sandy soil. As soon as they are rooted and start growth, the points are pinched out, and this operation is repeated until the plants are of sufficient size. Plenty of water is necessary. A few plants are always useful, as they form one of the gems of the house.

Propagated by cuttings, as described above.



**Tropæolum.**—Half-hardy soft-wooded plant. Grown for its flowers. Minimum temperature, 40deg. Among these will be found very useful plants, useful either as climbers—or, more correctly, trailers—and dwarfs, very useful indeed both for in and out door use. For spring blooming they are unrivalled, and, if sufficient heat is obtainable, combined with a light position, the culture is of the simplest, for even if there is not



FIG. 122.—TROPÆOLUM TUBEROSUM.

sufficient means at hand for early work, still a good display can be made both in and out doors. Although the blooms are like the ordinary nasturtium, the plants are vastly different from them, both in habit and profuseness of bloom, and a few plants are very useful in every house. Vases and hanging baskets can be embellished with them most advantageously, and, in the season, they can be used most successfully outdoors for the same purpose. They stand heat well, provided it is not

of too arid a nature, and, with a little care, they always look handsome.

In the first place, they are propagated from cuttings, and this is the most difficult part of their culture. For winter blooming, the cuttings should be struck in the early part of July, healthy shoots being selected, about an inch to two inches long. These should be planted singly in small pots of well-drained, very sandy soil, and then placed in bottom heat to strike. As soon as the roots kiss the sides of the pots the plants should be hardened off somewhat, and then shifted into 6in. pots, and, when these pots are fairly filled with roots, the plants should be removed into 9in. or 10in. pots, in which they will stand through the winter. Until the end of September the ordinary cool house will be all that is necessary, but, after that date, a temperature of from 50deg. to 55deg. must be kept up, and, even if it rises as high as 60deg., no harm will be done. The plants should be stopped when about three feet high, and again when about double that height. After the final potting, they should be trained over the roof or from pillar to pillar in the house, and the shoots allowed to hang somewhat loosely, as more bloom is obtained thus than when the plants are trained too strictly. Thorough drainage is necessary, and about three inches of crocks should be placed in the 9in. pots, as it is necessary to give liberal, although not too abundant, supplies of water throughout the season. Plants for summer decoration should be struck in early spring, and then will come in most usefully for the various purposes for which they are generally employed.

The best soil is a compost of good turfy loam, free from grubs and wire worm, to which is added about one-third part of leaf soil and sharp sand. This, in fact, is the best compost for all the *Tropæolums*.

Among the sorts useful for cut blooms in the above section, and which are also very ornamental as plants, are: *T. Cooperi*, scarlet; *T. Lobbiani*, orange scarlet; and *Boule de Feu*, which is one of the best scarlets we have. In fact, with the above three, one might well be content.

Dwarf plants require much the same treatment if to bloom in

winter, but for outdoor work they should be struck in spring, and the following are good plants for the purpose: Yellow Dwarf, fine yellow; Lustrous, bright crimson; The Moor, dark maroon; Minnie Warren, richly variegated foliage, the variegation being pale cream; and *T. compactum coccineum*, rich orange scarlet. The following trailing kinds are also very useful for bedding purposes and for house decoration, if treated as recommended above: Attraction, citron yellow, blotched on each lobe with bright scarlet; Mrs. Tredwell, very fine brilliant red; Perfection (Dean), brilliant scarlet; and Coronet, yellow.

Propagated from cuttings, as described above.

*T. tricolorum* is one of the prettiest of the species, and is of very easy culture. It is a tuberous-rooted variety, having roots somewhat resembling potatoes, and bears a profusion of rich orange-scarlet flowers, which contrast extremely well with the fine green foliage. About November a compost of sandy turfy loam and peat should be prepared, and to this should be added a little sharp sand. The pots must also be well drained, and this drainage should be covered with a little moss or fibrous turf, to prevent the soil washing down amongst the drainage and so choking it. The tubers should be planted in 9in. pots, and if they are small several may occupy each pot; but if large, from one to three are sufficient. Place in a position in the greenhouse where they will not be disturbed, and the only care necessary will be to prevent them becoming dust dry. About April the young shoots will appear, and then more water may be given, and the supplies increased as the plants grow. A bundle of birch twigs inserted around the edge of the pot, or a young fir tree clear of its leaves, forms an excellent support for the foliage, and the only care necessary in training the plants is to see that they do not run into knots, but that each shoot travels fairly. About midsummer the foliage will begin to fade, and water must be gradually discontinued until the plants ripen, when the foliage should be removed, and the pots laid on their sides in a cool place until the next potting time.

There are several other varieties of *Tropæolum*, and among them the nearly hardy *T. tuberosum* (Fig. 122).

**Tulip.**—Hardy, bulbous, soft-wooded plant. Grown for its flowers. Minimum temperature (in pots), 36deg. The Tulip is one of those bulbs which, like the hyacinth, is of universal cultivation, and is also of universal use. To a certain extent the culture is very easy, provided the plants are not started too early in the season. As most persons are aware, the bloom of the Tulip starts from the interior of the bulb, which, at the same time, divides into a number of young bulbs. Unlike the hyacinth, the bloom of the Tulip derives the greater part



FIG. 123.—TULIP GESNERIANA  
(VAR. FLAMANDE).



FIG. 124.—TULIP GESNERIANA  
FL.-PL.

of its nourishment direct from the soil, consequently a rich compost must be provided. As the bulbs are very cheap, it is scarcely worth the trouble to save them over for the second season, and therefore it is only necessary to provide a soil for the present. We have successfully used a compost of two-thirds good mellow loam and one-third rotten cow manure, to which has been added enough sharp sand to render the soil freely porous. Plenty of drainage must be afforded, and a little crushed animal charcoal mixed with the

soil will intensify the colour of red and scarlet flowers. The bulbs should be put in in batches from the end of August until about the middle of November, about five in a 4in. pot, and treated in the same manner as hyacinths, so far as regards covering for a few weeks, to induce the production of roots. The plants should—when taken from the bed—be gradually brought forward to the light, a temperature of from 45deg.

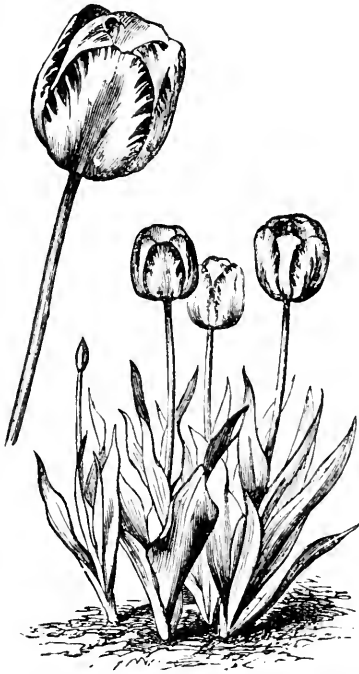

FIG. 125.—TULIP GESNERIANA  
(GRAND PIED).



FIG. 126.—TULIP TURCICA.

to 60deg. afforded, and the supply of root moisture regulated according to the growth. Plenty of light is absolutely necessary, and a somewhat moist atmosphere is an advantage, as dryness conduces to the more rapid production of the green fly, which is particularly partial to these plants. The several batches must be introduced at different times, so as to obtain a continuance of bloom. Great care must be

taken to destroy—or rather to prevent—fly, and we have found Fowler's Insecticide more advantageous to use than tobacco or fumigation. Another very good plan is to prepare some boxes in the same manner as the pots, and to place the bulbs in them about a couple of inches asunder, just covering with soil. These boxes, placed in a warm house close to the glass, and kept well supplied with water, give a large quantity of dwarf plants for various decorative purposes, especially for vase decoration and for the ornamentation of the dinner table.

In the cold house the cultivation of the Tulip is very simple: Pot the bulbs, and stand them back till they commence growth, when they should have the full benefit of both light and air, and the same rules as to watering, as given above, should be applied.

For very full instructions for Tulip growing we would refer our readers to Mr. Fish's book on "Bulbs and Bulb Culture." \*

Propagated by division of the bulbs, which increase naturally.

There are many species of the *Tulipa*, but *T. Gesneriana* is the fruitful parent of most of our garden varieties, of which Figs. 123, 124, and 125 show choice examples. The Parrot Tulip (*T. Turcica*, Fig. 126) is a remarkable species, with large and curious flowers composed of irregular wavy petals from 3in. to 5in. long.

For sorts for pot culture the following are most suitable; their earliness is given approximately, in the order in which they stand: *Singles*: Duc Van Thol, cinnabar red, orange border; Duc Van Thol, in varieties of rose blush, scarlet, white and yellow; Artis, bronze, crimson; Alida Maria, tipped and flaked cerise, white ground; Canary Bird, rich yellow; Bride of Haarlem, white, bordered with crimson; Feu d'Angers, scarlet;

---

\* "Bulbs and Bulb Culture: being Descriptions both Historical and Botanical of the Principal Bulbs and Bulbous Plants Grown in this Country and their Chief Varieties; with Full and Practical Instructions for their Successful Cultivation both In and Out of Doors." By D. T. Fish. Part I.—Snowdrop, Bulbocodium, Sternbergia, Crocus, Colchicum, Tulip, and Hyacinth. Part II.—Anemone, Narcissus, and the Lily. Part III.—Gladiolus, Lachenalia, Cyclamen, Ranunculus, and Scilla or Squill (Star Hyacinth). Part IV.—Ixias, Sparaxis, Tritonias, and Babianias; Iris, Tiger Iris; Schizostylis Coccinea; and the Dahlia. Part V.—Gloxinias, Paneratium, Tuberose, Fritillaria, Alstroemerias, Triteteia Uniflora, Agapanthus Umbellatus, Muscari (Musk or Grape Hyacinth), Pæonia, Oxalis, and Amaryllis. Price 1s. each. London: L. Upcott Gill, 170, Strand, W.C.

Golden Prince, golden yellow; La Belle Alliance, bronze scarlet; Queen Victoria, pure white; Silver Standard, white striped cerise-crimson; Vermilion Brilliant, scarlet. *Doubles*: Tournesol, scarlet and yellow, and the yellow variety; Duc Van Thol, red, edged pale yellow; Gloria Solis, bronze crimson, orange border; La Candeur, good clear white; Rex Rubrorum, bright scarlet; and Agnes, a bright scarlet dwarf.

**Tussilago.**—Hardy, herbaceous, soft-wooded plant. Grown for its foliage. Minimum temperature (in pots), 36deg. The variegated Coltsfoot (*T. Farfara foliis variegatis*) is handsome, producing fine roundish leaves, beautifully margined with a band of rich creamy white. The flowers are yellow, and of no particular beauty or interest, and, in fact, are not nearly so ornamental as the dandelion. The leaves, which are from four to six inches in diameter, lie flat on the surface of the pot or soil, and do not often rise more than from four to six inches above the level. As a low plant for the front of stages, or of a group of plants, this is one of the best, as it is both conspicuous and ornamental. The culture is very easy; pot each crown in a well-drained 4in. pot, using a rich sandy compost, and treat in the manner described for polygonatum. If the plants are not required to remain in the house throughout the whole season, they may be used outdoors, either as an edging plant, for which purpose they are well suited, or for placing in clumps of three or four in the borders. The other Tussilagos are practically useless for all but a botanical collection.

Propagated by division in spring, as the plant commences to make fresh growth.

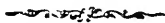



**VERBENA.**—Greenhouse soft-wooded plant.

Grown for its flowers. Minimum temperature, 40deg. Verbenas are very useful both for bedding out and as pot plants, and it is doubtful if there are any others which will serve the same purposes. For

ordinary border use, those raised from seed are as good as any, but, for pot culture, they are not of much value, unless, indeed, an unusually good strain is obtained. The raising of Verbenas from seeds is a very easy matter—in fact, as easy as raising any half-hardy annual; but, as we said before, those raised in this manner will not do for pot work.

To obtain plants from seeds, these should be sown in pots of fairly rich sandy soil, and but slightly covered. As soon as large enough, the plants should be shifted into small 60-sized pots, in which they may remain until planting time, if necessary, but, where time and space allow, they may be transferred to 3in. pots with advantage, and, with one pinching, will become very useful for bedding. It is, of course, quite possible that something good may be obtained by this method, although the probability is but small, but, if a good plant be produced, it should of course be saved and propagated.

In raising Verbenas from cuttings no trouble need be experienced, but, as it is necessary to have good plants from which to take the cuttings, we will give the culture from the commencement. In August a few cuttings should be struck and planted on a border facing the south, and, at the end of September, these should be carefully taken up and potted. About the second week in October the plants should be stored away in a dry pit or frame from which frost is excluded, and care should be taken that they be kept dormant, and as dry as can be allowed consistently with keeping them alive. If mildew should appear, then they should be liberally dusted over with flowers of sulphur; but, if care be taken, this will not be necessary. About February these old plants should be placed in heat to afford cuttings, and, as soon as good shoots are



formed, they should be taken off and inserted thickly in well-drained pans of very sandy soil, which should be kept rather moist and in a brisk bottom heat.

Another good plan to strike soft-wooded cuttings of this description is to half fill some pots with fine crocks, and on these place a thin layer of fibrous material to prevent the soil washing down amongst the drainage. Then fill the pots to within an inch of the top with rich sandy soil, and on this place half-an-inch of clean-washed sharp silver sand. The pots should then be well watered through a fine-rosed watering can, and, as soon as the superfluous water has drained off, the cuttings should be inserted, with just a sprinkle of water to fix them in position. The pots should then be stood in a brisk bottom heat, and, in a fortnight, they will be ready to pot off.

In potting *Verbenas*, a compost of three parts rich fibrous maiden loam, one part leaf soil, and one part rotten cow manure and sharp sand, should be used, and the soil should be in good working order. Pot moderately firm, and replace the plants in heat for a fortnight, when they may be gradually hardened off; and should there be time they may be transferred to 3in. pots as soon as the roots kiss the sides. If the plants are for pot work they should be put into 3in. pots when well rooted, but only the strongest plants chosen for the purpose. These should be treated as above until slightly hardened, and should then be transferred to a position near the glass in a light airy greenhouse. As soon as the pots are fairly filled with roots transfer the plants to 6in. pots, well drained and clean, and neatly stake them out. The shoots should be five or six in number, unless cut bloom for exhibition is required, and then three will be plenty. As the pots become filled with roots, apply weak liquid manure about twice a week, but in no case should sulphate of ammonia be used, or the foliage will suffer. When the trusses show colour remove the plants to a cooler position, as they will then last a long while, more especially if a little shade from bright hot sun be given. A dry (but not arid) atmosphere must also be maintained. These pot plants come in excellently well for table decoration, and, in fact, are as useful as any dwarf flowering plant grown.

Should fly or spider put in an appearance—and the latter will not come if the plants are properly grown—fumigation must at once be resorted to. Generally about three fumigations are required during the season. Mildew, if it does appear, should be kept under by dredgings of flowers of sulphur.

*V. venosa*, which is hardy on most fairly light soils, should be raised from either seeds or cuttings, but preferably from seed.

Propagated by cuttings, as described above.

The following are good bedding varieties: Crimson King, dense brilliant crimson; Snowflake, pure white; Purple King, purple; Lord Raglan, magenta, scarlet; Scarlet Defiance, scarlet; Géant des Batailles, lurid crimson, maroon eye; Firefly, pink, crimson eye; La Grande Boule de Neige, fine white; Ladybird, flesh, purple eye; Jupiter, rich plum; Rev. S. R. Hole, pale lilac, tinted crimson. For pots, the following are good, but to secure good plants for exhibition it is necessary to select from a good stock when in bloom, as fresh varieties are continually being added: Apollo, blush; King of Lilacs, lavender blue; Géant des Batailles, lurid crimson, maroon eye; Foxhunter, scarlet, white eye; Rev. S. R. Hole, pale lilac, tinted crimson; Princess of Wales, pink and white striped; Prince of Wales, scarlet; Richard Dean, purple, fine white eye; Thomas Harris, mulberry, white eye; Carnation, white and crimson striped; Bismarck, dark maroon, white eye; Blue Boy, blue; Anatole Leovy, dark purple, shaded maroon, white eye; and Basilisk, scarlet.

**Veronica.**—Half-hardy hard-wooded shrub. Grown for its flowers. Minimum temperature, 35deg. The shrubby Veronicas, though not actually greenhouse plants, are yet very ornamental, and in the North of England and on cold wet soils well repay house room. But some of the varieties are not hardy even so far south as London; and they consequently require indoor shelter, and only stand out during the summer. We have usually grown these in a compost of two-thirds loam and one part leaf soil, with enough sharp

sand to maintain the necessary porosity of the soil. The flowers, produced from small bushes, take the form of axillary spikes, from lin. to 4in. in length, and as the colours vary from white through pink to blue, they are very ornamental. The leaves are generally ovate, opposite, and closely cover the erect stems, and being from lin. to 2in. in length, allow the spikes of bloom to show well. Cuttings should be struck in January and planted out in the open in May. Pinch them back once or twice to make them bushy, and in October take them up with a good ball of earth attached, and pot them carefully. The old plants may be cut back and planted out of doors, and afterwards treated the same as young ones.

Propagated from cuttings struck in a warm greenhouse in spring, or in a cold frame in August and September.

For sorts select from *V. Andersonii*, blue; *V. A. fol. var.*, intense blue, attractive foliage; *V. atropurpurea*, rosy purple; *V. angustifolia alba*, pure white; *V. decussata*, dwarf blue; *V. d. alba*, dwarf white; Gloire de Lyon, bright red; *V. imperialis*, amaranth red; *V. lobeliodes*, fine blue; *V. multiflorum*, rosy carmine; *V. speciosa*, blue, cream coloured variegation; Mlle. Claudine Villermoz, indigo blue; Crème et violet, flesh pink, stamens violet; Blue Gem, light blue, very dwarf and free; Marie Antoinette, pink; and *V. rosea alba*, rose.

**Viburnum.**—Hardy hard-wooded shrub. Grown for its flowers. Minimum temperature (in pots), 36deg. *Viburnum tinus* (Fig. 127)—the Laurestinus—is good if treated in the proper manner. The best plan is to take up plants thickly set with bloom buds, about the end of September or early in October, pot carefully in sandy loam, and after watering thoroughly, place in a cold frame or vinery at rest where air can be freely admitted, and they will bloom freely at least a fortnight earlier than those outdoors. A temperature of about 46deg. will forward them somewhat, but a forcing heat should be avoided. Treat the same as rhododendrons after blooming.

Propagated by cuttings inserted in sandy soil in cold frames as soon as the wood is ripe, or by layers. It is, however, not

expedient to propagate this shrub, as it needs much ground to get good blooming plants, and they can be purchased very cheaply.

**Violet.**—Hardy soft-wooded plant. Grown for its flowers. Minimum temperature (in pots), 36deg. In contradistinction to the bedding Violas, the Sweet-scented Violet (*V. odorata*, vars.) is most useful on account of its scent. When properly grown the plants are but little trouble, but they are less trouble



FIG. 127.—VIBURNUM TINUS.

in the cold house than when kept in the ordinary greenhouse. In the first place, it is necessary to select stout firm runners in April or May, but preferably in April, and to place them under handlights on a moist shady border. Wiry runners, or those produced from pot plants, are practically useless, and therefore much care is necessary in the selection of the plants that supply the runners, as also in that of the runners themselves. When the plants are rooted they should be placed

out about six or eight inches asunder, according to the habit of growth. Take care that the soil of which the border is composed be of a rich light character, and that it face north or north-east, and be kept moist. In preparing the border, deep digging is of great importance, as a deeply-dug soil conduces greatly to the well-being of the plants. Careful attention as regards watering, &c., is also necessary, and by the end of September fine plants for potting will be obtained. These should be carefully taken up with a good ball of earth adhering to the roots, and potted into 4in. or 6in. pots, according to the size of the plants, and plenty of drainage should be afforded. The pots should receive a good soaking of water, and be placed in a shaded frame facing the north for a few days, until the plants have recovered from the check they received when shifted. Thence the plants may be removed to a light airy shelf in a greenhouse, kept at a temperature of about 45deg., where, if due attention be paid to watering, aëration, and the destruction of insects, they will bloom nearly the whole winter and spring.

In the cold house, all that will be found necessary is to prevent the pots becoming frozen, and to pay attention to the above points of culture, of course preparing the plants as previously described. As a rule, the single varieties are best for pot culture, but if massive blooms are desired the double kinds are preferable.

Propagated by rooted runners as described above.

Of sorts, the common White Violet, *Viola odorata alba*, is perhaps the sweetest; and The Czar, a fine long-stemmed blue, is the best scented blue, but the whole of the following are good: *V. odorata*, blue; *V. odorata alba*, white; *V. o. a. fl. pl.*, double white; *V. suavis* (Russian), blue; *V. s. alba*, white; *V. s. fl. pl.*, blue; and the varieties of *V. suavis*—Devoniensis, blue; The King, blue; The Queen, white; and Marie Louise, white. *V. o. Neapolitana*, pale blue, is good; and probably the new double white Belle de Chatenay will be useful for the same purpose as the above, and, from blooms we have seen, we consider it to be one of the best of Violets, provided it be of a sufficiently floriferous habit.

**Violet, Dog's Tooth.**—See "Erythronium."



**WEIGELIA.**—Hardy hard-wooded shrub.

Grown for its flowers. Minimum temperature, 36deg. W.

*rosea* (Fig. 128) is a very useful plant for the cold house, either

as a bush or climber, but it does better planted out than as a pot plant. It does well

in a compost of sandy loam slightly enriched with either leaf soil or thoroughly decayed manure. The plants should be grown out of doors during the summer, and as soon as frost comes should be housed, and with ordinary attention will bloom well in April and May. The blooms are very useful for both bouquets and table decoration, the purity of the colour being such as to render them very conspicuous. The plants do not force well or thrive in a high temperature, but they do excellently well in a cool or cold house. If rather cramped at the roots, so much the better do they bloom, and either in pots or borders this should not be lost sight of. The same general treatment applies as to other hardy deciduous plants, aëration, &c., having to be seen to in the ordinary manner.

Propagated by division of the rooted shoots or suckers from the base, by layers, and by cuttings inserted in cold frames in autumn.



FIG. 128.—WEIGELIA ROSEA.

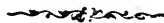



**ANTHOCERAS.** — Half-hardy hard-wooded shrub. Grown for its flowers. Minimum temperature, 36deg. *Xanthoceras Sorbifolia* is of recent introduction, and will probably prove what it is stated to be—hardy; but at the same time we doubt if it be hardy throughout the whole of England and Scotland. The flowers are white, with a flesh tint, and are produced at the same time that the leaves unfold; they are disposed in racemes, which attain a length of from 7in. to 8in. For soil, use fibrous loam and sand, and treat the same as nearly hardy subjects—veronicas, for instance.



## VII.—MONTHLY CALENDAR.



S perhaps many of our readers will find a calendar of operations useful, we give it for one year, so that this book may be complete in respect of managing a greenhouse such as we generally find in the hands of amateurs. We commence with August, as that month perhaps marks the commencement of general greenhouse work, and autumn is certainly the most convenient season for starting a greenhouse. Propagating soft-wooded plants of various kinds, the completion of the hardening-off process on hard-wooded plants, and various other circumstances, combine to make it the commencement of the season, as it were, so that by starting with August we shall keep the calendar in its proper order. We shall endeavour to make the hints we give here applicable to all houses that come under the head of greenhouses; but, of course, stove and forcing houses will be excluded, as they do not come within the scope of our present work.

As, however, it is not possible to give directions for every greenhouse, whatever its shape or position, our readers will have



to adapt the directions as to management in such a manner as may meet their particular requirements; and therefore we only give general descriptions of management here. The selection of subjects must also be left to the individual tastes of the owners, as the same plants do not suit everyone alike. One word of advice we will, however, give, and that is, do not have too large an assortment of plants, and do not try to grow such as require much heat in a house not suited to them. It is far preferable to grow a few suitable plants well, and have a good display from them, than to attempt too much and fail with the whole.

**August.**—The first point to be considered this month is the propagation of bedding plants of various descriptions, as the season has advanced quite far enough for the purpose. The modes of propagation having been before described, it is not necessary to enter into the matter further here, but we will give a few general hints that may be useful. For the majority of plants the best pots in which to strike cuttings are those that are rather flat for their height, and which are about six inches in diameter; when filled one-third or half full of crocks, these are the most useful so far as size is concerned. We prefer round pots in the ordinary greenhouse, although, as a matter of course, some space is lost by their use; but the advantages gained more than counterbalance the loss of space sustained, as the freer circulation of air and the more equable temperature obtained by this method well repay the loss of numbers in the plants, for they prevent loss through damping or fogging, as it is called. Of course, so far as the saving of room is concerned, square seed pans, or boxes made for the purpose of wintering cuttings, are best; but, in the hands of the amateur, these tend to embarrass rather than assist, as the quantity of plants lost by fogging is great. The method of heating is also a great consideration, as, in the majority of houses erected, the hot water or other heating apparatus is not fitted to be used with a large quantity of plants growing in boxes.

Cuttings of the majority of half-hardy bedding plants will root freely in the open air; but if a frame or two are empty, it

is a good plan to stand the pots in these, as then shelter from excessive rains can be provided. In no case is it wise to allow too great a quantity of water in striking cuttings intended to stand through the dull, damp days of winter, as plants that are full of sappy growth are very liable to fog off; it is, however, necessary that *sufficient* moisture be allowed, or the cuttings will shrivel up instead of rooting.

The soil in which cuttings are placed should also have some share of attention, lest some undesirable results should follow. Great care must be taken that worms, woodlice, and maggots, &c., are most conspicuously absent, and that there are no chips of wood, half-rotten leaves, or other rubbish present that may be likely to cause fungoid growth. For this reason, claret and other boxes made of poplar are most unsuitable for storing cuttings for the winter, because, as a rule, fungi of a most objectionable character, or rather the mycelium of the fungi, put in an appearance and destroy the cuttings. At least 25 per cent. more cuttings should be put in than the number of plants required, to allow for possible accidents.

This month is a good time to thoroughly clean all houses intended for the reception of plants, and also to mend the glass, and re-putty, and, in many instances, re-paint the roofs, as drip will do more harm than cold. When dry, the paint should have a glossy or shiny appearance, but it should not be put on too thickly; two thin coats are better than one thick one. The cleaning process should embrace all parts of the house, the stages should be washed down thoroughly, walls limewhited, flues cleaned out, water pipes freed from dirt and rust, valves and air pipes cleaned and put in thorough working order, and the furnace and boiler repaired. Another, and important point, is to see that ventilators and sash lines are in really good order, and if the least doubt exists as to their strength, they should be at once replaced with new ones. In fact, it is necessary that the place be put in thorough repair in all parts, as a sash line breaking, or a pipe or flue fouling on a frosty night, will often destroy the majority of the plants in the house; and, at the same time, a dirty house will produce such hosts of insects as to cause really serious damage.

Some of the earlier azaleas and camellias may now be got in, care being taken that the foliage is dry and that the pots are clear of slugs and other obnoxious insects; but all the later stock must be kept out, with such protection from heavy rains as may be necessary. All hard-wooded stock must have as much air and exposure as their habit requires, but heavy rains must be kept off. The pelargoniums cut down last month should now be shaken out, and re-potted into smaller pots. Chrysanthemums should be placed in their blooming pots, and should receive sufficient supplies of liquid manure. Cinerarias should be divided and potted in small pots, and the young plants should have a shift, if required; some seed may also be sown. Roman hyacinths and some other bulbs should be potted up, and all bulbs for early blooming should be kept in the dark for a few weeks, so that the roots may obtain firm hold of the soil ere the foliage starts. Annuals may in many cases be sown to stand the winter for early work, and a sandy friable soil should be chosen for the seed beds. They must also be transplanted before they become too large.

Where vines or other roof climbers exist great care must be taken to keep them in a sound, healthy state, and free from insects and mildew, or the results will be serious to the plants that will soon have to be introduced into the house. In short, every means must be taken to keep the place in the most perfect order and the plants in the best condition, all details of tying, removing dead flowers, and other little items being most particularly carried out.

**September.**—This month is generally a very busy one so far as the greenhouse is concerned, as all arrears of work have to be got up, and a vast amount of fresh work to be done. Among other things is the continued propagation of bedding plants, and this must be carried out as briskly as possible, for if left until too late much trouble and risk will be incurred. As it is, some things will root more readily by having a gentle bottom heat applied to them. In fact, it is a good plan where soft-wooded plants only are grown, to put the fire on for a few nights when the plants are first put in; but if there are vines or hard-wooded

plants in the house, this cannot be done with impunity. In all cases a plentiful circulation of air must be maintained, and water must be given as found necessary; but it is especially necessary that too much be not given, or the plants will become sappy and unfit to stand the winter. The same rule applies to hard-wooded plants; enough water should be given, and no more, and the circulation of air should be fully attended to. Great care must be taken that the drainage of the pots is perfect, and that both plants and pots are free from noxious insects.

The whole of the hard-wooded stock must be got into their winter quarters before the end of the month, the state of the weather being considered in determining when they shall be taken indoors. Great care must be taken that there are no worms in the pots, and that the drainage is perfect, or results the reverse of pleasant will ensue. Nor is it to be forgotten that the green slimy growth on the pots, which is not infrequently found in the case of pots not plunged in ashes, should be washed off carefully, and the pots allowed to dry ere being taken into the house. All plants liable to the attacks of scale should be carefully looked over to see that they are quite clear from this pest, and particular attention must be paid to searching for slugs, snails, and caterpillars, as they often do much damage.

This is about the best time to purchase a stock of hard-wooded plants, where such purchase is required, and here some little skill will be found necessary. In the first place, it is requisite that the plants shall be well-grown young stock, and that they have been grown on in a proper manner without check, or they will not be of very much service. They should also be quite free from insects, and therefore a close examination is needed. If, however, the plants are bought at a good nursery, and a fair price paid, but little trouble need be anticipated on this account.

In the general work much has to be done, and unless done at the proper time it will not be good for the plants. *Primulas*, *calceolarias*, and *cinerarias* require especial attention at this season, as also do other plants of a like nature. Particular attention is also necessary with those plants which are being

prepared for winter blooming, as a day's neglect often ruins the plants for the purpose for which they are intended. Any late Cape pelargoniums should be ripened off if the bloom is over, and then headed down. A good batch of cuttings should also be got in for use in summer, to succeed those potted off. Chrysanthemums may still be shifted into larger pots where it is considered necessary, or liquid manure may be applied regularly; and in places where the room is limited this latter plan is best. Mignonette may be sown to stand the winter, but for this purpose it does best in frames. A batch of Dutch bulbs should be got in, and plants in pots, such as weigelas, which ought to have ceased growth, should be induced to ripen by partially withholding water, but enough should be given to keep them in proper condition.

The aim of the gardener at this season should be to obtain a compact sturdy growth in all plants that are intended for winter blooming, and to avoid such treatment as will tend to have a reverse effect. Nothing is more injurious than to draw up the plants in a weak attenuated habit, as in such cases the bloom obtained is of the poorest, deficient both in quantity and substance, and should it be cut for bouquets or table decoration, it soon falls to pieces, and even if gummed, withers and becomes useless. Where good results are desired, a slow, steady, healthy growth should be maintained.

Grapes should be ripened off as soon as possible, and cut and stored in a dry fruit room, or the moisture from the plants will soon make them decay.

**October.**—It is advisable to continue introducing such soft-wooded plants as it may be desired to save during winter, and cuttings of geraniums and the like must be got in as soon as practicable, if more of them are to be struck at this season. As a rule it will be found requisite to use a little bottom heat in striking these late cuttings, yet in many cases it pays to do them even as late as next month, but the early-struck plants where they are possible are best, as they cost less in striking, stand better through the winter, and bloom longer and form more useful plants in spring. Where very

large quantities are required, and labour is limited, it frequently happens that time does not allow of a sufficient number being got in in due season, and therefore extraordinary methods will have to be adopted to obtain adequate stock. Old plants of zonal pelargoniums may be taken up, and cut in closely, as many as can be got in being put into 6in. pots, and these old stools will make a good lot of plants in the early part of the year, besides affording a good batch of cuttings, which will strike readily in March. The tops which are cut off now will also afford good cuttings, which, as we mentioned before, will strike readily with a little bottom heat. All the bedding plants which it is desired to save should be taken up before they are injured by frost, and care should be taken that they are not kept too wet after potting. Cuttings of shrubby calceolarias may also be put in now, as well as next month, care being taken that they are not frosted or infested with green fly. Before these are put in, the frames should be carefully examined to see that they are free from slugs or snails. Where, from the dampness of the climate, or the severity of the weather, it is found that annuals do not stand the winter well out doors, they should now be pricked out in frames, and while air is freely given, too much moisture must be excluded.

Hard-wooded plants should now be in a proper condition to stand the winter, and care must be taken not to get the pots water-logged, or the damage will be very great. Insects should be carefully looked for, and in no case should their presence on these subjects be passed by lightly.

Pelargoniums must be induced to become dormant by Christmas, and plants requiring much the same treatment must occupy a similar position. As regards the care bestowed on them, it simplifies matters to a great extent to have plants requiring similar treatment close together, and also allows of a better disposition of the plants in bloom in the house. Chrysanthemums will be the *pièce de résistance* for the next six weeks or two months, and therefore it is desirable to arrange them to the greatest advantage, and also to pay as much attention as possible to prolonging the time of blooming. Scarlet geraniums, and other

plants, will, of course, be making some show, but not to the extent of that afforded by the chrysanthemums. Some of the hardy plants will assist in the display, and mignonette should be well in bloom, if the three varieties are properly grown. In a short time some of the earlier primulas and cinerarias will follow, and, if time and care is bestowed in the right direction, a fair amount of interesting blooming plants will now put forth their beauty.

Successional batches of Dutch bulbs should be got in, and these should be kept in a dark place for a few weeks, as previously recommended. Where large plants are required primulas and cinerarias may have another shift; but, after 4in. or 6in. pots are reached, unless the house is large, it is not well to pot on, as the plants do not show well in a small house if the pots are too large, and large pots cannot well be hidden on too upright a stage. Some more seeds of cineraria and calceolaria may be sown if very late plants are desired and the house is suitable for the purpose.

Great care must be taken to keep down insects, and to remove all mildewed or rotten vegetable matter, as these evils cause much trouble during the damp winter months. A free circulation of air must be maintained, and a temperature of about 45deg. kept up; but rain or thick fog must not be admitted into the house.

Where vines are ripe enough, they should be pruned, and the rods tied along the front plate of the house, so that as much light as possible may be admitted. Cleanliness also should be the order of the day.

**November.**—This and the two succeeding months will be found the dullest part of the year for gardening matters, and therefore it is necessary that the greatest pains be taken with the glass structures in the garden. The good arrangement of the plants occupies a foremost place in the necessary work, for the plants should be re-arranged frequently, so that the interest in the house may be maintained. Fresh arrangement, and the introduction of all new subjects to prominent notice, tends to keep up the interest in the house or houses to a far

greater extent than is often supposed, and therefore particular attention should be paid to this point. Cleanliness also is an important part of the work in this department. The destruction of insects and mildew, and the removal of all dead foliage and other matters which tend to cause fungoid growth, or disease to the plants, should be rigidly attended to, and, in short, the house should be kept clear from all that is not of legitimate use. No empty pots, heaps of paper, tying material, flower sticks or *débris* of any kind should ever be found about the house.

Ventilation must be closely attended to, but in damp weather some caution is requisite in admitting air, as, unless there is enough fire heat to dry the atmosphere, many of the plants will damp off, and therefore much attention must be paid to this point. In thick fogs it is not advisable to open the house at all, particularly if there are plants in bloom inside, as fog exercises a most deleterious effect on the blooms, and with some subjects causes the petals to fall off. Too great a fire heat must not be kept up for the next two months, or the plants will draw, and become too weak and sappy; but enough heat must be maintained to keep the place sufficiently dry. This result is best attained by abundant ventilation and warmth enough for a temperature of 40deg. to 45deg.; but, of course, consideration will have to be given to the class of plants grown and their requirements.

The majority of plants will be at rest, but some will be blooming pretty freely, chrysanthemums being in strong force. Some re-potting will be found needful, but except where really necessary it is not desirable to shift plants at this season. The last batch of Dutch bulbs should be got in, as well as some of the hardy plants that we have mentioned previously, but discretion must be used in the choice of subjects. In fact, this is the slackest time of the year, and, as a rule, it is not advisable to do more than is absolutely necessary.

In some cases a root or two of rhubarb and a few pots of sea-kale can be brought in, and placed under the stage, and a very agreeable dish or two will be obtained with little trouble or



expense; but too large a quantity should not be grown, as it tends to increase the dampness of the house.

Hardy plants in the frames should have as much air as possible, and be treated as hardy; but frost and excessive rain must be excluded, as plants of all kinds can stand more cold when in a comparatively dry state than when saturated with moisture and making too sappy a growth. Vines in the house should be pruned as soon as ripe, and all the foliage, dead bark, and prunings should be burnt up out of the way.

**December.**—Except in such cases as are mentioned under the separate heads in the Dictionary of Plants, the work this month is practically the same as last; cleanliness and freedom from insects being most required. Care in ventilation and applying fire heat is also needed, but the rules have been given before. A further batch of hardy plants may be introduced. Practically, however, to the amateur work is at the minimum; all that is necessary should have been done last month.

**January.**—During the greater part of this month very little has to be done beyond the ordinary care of the plants; but towards the end of it propagation of soft-wooded subjects will demand attention, and the earlier the season the sooner will work in this direction commence. Before referring further to this matter we will take the earlier part of the month first. In the first place, it is necessary that due attention be paid to the individual plants composing the collection. All those which are showing bloom should be brought forward into the lightest and most prominent positions, while others may occupy positions not so conspicuous, each plant, at the same time, being allowed as nearly as possible the position most suitable to it. The previous directions as to cleanliness about the plants and house still hold good; and in the case of the destruction of insects, our remarks must be carefully attended to, as generally with the advent of the new year and brighter weather, the increase of these is very rapid, particularly of aphides, and perhaps they are the worst pests there are to contend with. How to destroy them has been previously described. Great

care is also necessary in watering, as too little or too much water is not calculated to keep the plants in the greatest health. A happy medium will have to be chosen, and this can only be learned by careful attention to the requirements and nature of the plants, and no amount of book knowledge will ever teach this part of the work of the greenhouse. The heat of the house should also be kept at some point between 40deg. and 50deg., according to the class of plants grown, but the temperature should not be such as to induce them to make premature and weakly growth. Ventilation must also be carefully attended to, as before explained, but, of course, in no case may a current of frosty air be carried over tender plants or plants in bloom. Hardy subjects require the same treatment as previously described, and, except in cases mentioned further back, they should not be induced to make any active growth yet.

In bad weather the preparation of the various soils and composts, getting ready a good store of crocks and labels, pot washing, and other necessary work, should be attended to, and everything got in readiness for active work so soon as it commences, it being sheer waste of time to have these things to attend to when they are actually required. Good heaps of compost, as well as the other necessary articles for potting, should be kept under cover, and then they are always to hand when wanted. Tools of all kinds should be looked over, and all other odd work about the place should be done.

Towards the end of the month, old plants of fuchsias, heliotropes, lobelias, lantanas, verbenas, &c., should be put into a gentle bottom heat to induce them to throw up cuttings, for which, again, a gentle bottom heat should be used to make them strike freely. Some seeds can be sown towards the end of the month, but of course due attention will have to be paid to the season, as the earlier this is the earlier will growth commence. Some cinerarias may be once again repotted, if extra large plants are required, and the young stuff must be brought forward as found necessary, but information on such points has been given in its proper place. More hardy plants and shrubs may be brought in to ensure

a further supply of bloom, and hyacinths, &c., showing bloom should have a warm light position.

**February.**—This month is generally a very busy one in the greenhouse, and, in fact, it will be found difficult to keep pace with the work where large quantities of bedding plants have to be grown. Foremost comes the preparation of the means for supplying bottom heat, and unless regular propagating frames are at hand, it is well to use a good steady hotbed. The heat required is not very high, but at the same time should be lasting. We give our method of making beds for this purpose.

Let there be a sufficient supply of leaves from hard-wooded trees or plants, and good horse manure that has been shaken out to a moderate shortness. These materials can either be shaken together or kept separate, but, if well made, the bed will be practically as lasting whichever process is followed. Turn and shake the materials about twice, so that a proper state of moisture shall be attained, and should the materials appear too dry apply some water, but it is important that they should not be too wet, or a sudden violent heat will result, and the bed will be cold in a few days. Let the bed be about 3ft. wider and longer than the frame to cover it, and put it together in small forkfuls, well shaking it about, and treading firmly as the work proceeds. When finished, the bed should be about 2½ft. high in front and 6in. or 9in. higher at the back, and should be 18in. wider than the frame on all sides; but if in a brick pit of course this will not be the case. Instead of having the materials mixed together, a layer of manure and a layer of leaves alternately may be used, in which case the leaves should be in layers about 3in. thick, and the manure treble the thickness, care being taken that the bottom layer is manure and the top one leaves. When the frame is put on, put inside about a couple of inches of soil, ashes, or sawdust to keep down any rank steam or gases that may be emitted by the heating materials, and cover the outsides of the frame, or rather the material that projects beyond the frame, with boards, long litter, or other medium

to keep off rain, as to get the outsides soaked with wet means a great diminution of the heat, besides the removal of a large quantity of the manurial value after the bed is cold. After about three days the bed will be in good fettle for the purposes desired, and the pots of cuttings may be placed in it; but it is necessary that just a chink, say of the thickness of a penny piece, at the back of the frame be left open, so that superfluous steam may escape, or it will condense on the foliage of the plants, and cause them to fog off. Great care must be taken that the covering of ashes or other material is not broken, as, should it be, the rank steam from the bed will escape, and cause very undesirable results. As well as for striking cuttings of the various bedding plants, this bed will be found useful for many purposes, starting seeds of lobelia, perilla, and other subjects, starting dahlia roots, and work of a like nature, together with many things that we have not space to enumerate. As to the varieties of plants to be struck now, we must refer our readers to the various articles on the subjects in view. Where cuttings are not sufficiently numerous the old plants should be placed in heat as advised last month, and as a rule this will have the desired effect.

Soft-wooded plants generally will require attention, but there is not so much to be done in the way of re-potting, &c., as there will be next month, especially if the season is late, as the dull weather rather retards the plants, and it is not advisable to act too much against Nature. It is, however, a good plan to select a few of the best fuchsias, petunias, zonal pelargoniums, &c., and give them a good shift, so as to obtain large plants for the various uses for which they are so often required. Cape pelargoniums should be trained, and in some instances re-potted, and care must be taken that the foliage is dry before the sun reaches it, or the leaves will be scalded or spotted. A good batch of cuttings should be got in for autumn blooming. Continue to re-pot calceolarias as they fill their pots with roots. If necessary, more seed may be sown; but of course this must be left to the judgment of the grower.

Most of the hard-wooded plants are now making growth rapidly—that is, if the season is early—necessitating careful looking over, and, in some cases, top-dressing; and young plants that are growing forward for specimens should be re-potted where necessary. These latter must also be very carefully attended to in point of training, &c., as the future appearance of the plants is dependent on receiving this while young. The foliage must also be kept clean, and a rigid destruction of all insects must be carried out. As the house will now be getting gay with the display of bloom from the various subjects, it will be found more difficult to keep insects under, and fumigation will have to be done outside in a place provided for the purpose, as inside the smoke would destroy the bloom.

More hardy subjects can be introduced from time to time, to keep up a good display, and nothing more will be necessary than to give the ordinary treatment afforded to the other occupants of the house. Hardy annuals, such as *nemophila*, *collinsia*, and similar subjects, should be potted off carefully in 4in. or 6in. pots, according to their various habits, and should be replaced in the frame, care being taken that insects are kept under.

Great care must also be taken to afford good ventilation to the house, and that the foliage of the plants is dry before the sun reaches it, or burnt or scalded leaves will result.

**March.**—If anything, the work this month is even more important than last, and the same amount of care must be given; but the results will be more marked, and the show of bloom will be largely increased. It is also very probable that the stock of green fly will be continually increased, and as the difficulties attending fumigation at this season are very great, recourse must be had to some insecticide, such as Fowler's, or Pooley's tobacco powder, either of which is very effective if properly applied. Slugs and snails must also be sharply looked after, as should also woodlice, as these do much harm, especially among ferns and other plants of a similar nature. Staking and tying out the various plants,

and removing dead leaves, must now be closely looked to, and it is also desirable that dead blooms should be removed ere they become too much decayed, as it is easier to introduce the germs of mildew into the house than it is to get rid of them. Ventilation, too, should be carefully attended to, especially where a fire is kept going, as a close, moist atmosphere at this season means plenty of mildew and insects. A free circulation of air is absolutely necessary, and must be varied according to the temperature outside, so that no blasts of cold air pass over the plants, especially in frosty weather. At the same time, air must be admitted sufficiently early to dry the foliage, for the reasons stated in last month's directions.

The propagation of bedding plants of all kinds should be vigorously proceeded with, and as soon as rooted the plants should be shifted into small pots, and carefully hardened off to a certain extent to fit them for the greenhouse. All the autumn stores should be at once potted off if not already done, and, in fact, the work of propagating and preparing soft-wooded stock should be pushed on as quickly as possible. And here let us point out a wrinkle in growing young soft-wooded stuff: always use plenty of sharp silver sand, and do not pot too firmly, as the roots, being very tender, do not push very freely in heavy soil, and hard potting tends to break them off. It is also a good plan to retain as much soil as possible round the roots, as it protects them during potting, and also affords a means of the plants obtaining the necessary moisture and nourishment without receiving a violent check. Cuttings of dahlias and similar plants should be struck forthwith, and when rooted, potted off and placed in heat until the roots have taken firm hold of their new quarters. Where room is scarce, towards the end of the month, such things as scarlet pelargoniums, &c., can be placed in pits outside, provided frost and damp can be kept at bay. Many things that are nearly hardy can also be transferred to the frames at this season, and the space they occupied in the house may be profitably used for other subjects.

Hard-wooded plants will require increased attention, and

all young stock will have to be frequently looked to in respect of training and the like. As, however, this matter has been fully treated, no further remark is necessary, except that the plants should be kept quite free, both from dirt and insects.

In the cold frames things will be requiring attention generally, and perhaps the most important is the proper treatment of the plants. Watering, ventilation, and the destruction of insects are all important matters, and after these comes the re-potting of those plants which require it. Many plants will have to be shifted into their blooming pots; and calceolarias, picotees, carnations, &c., all require this to be done now. Training the various plants as found necessary, and potting off cuttings, will also form part of the work. Nor must the sowing of the various half-hardy annuals, &c., be forgotten, as they make a grand display if treated properly. Indeed, at this time the greatest efforts have to be made to supply the plants that are required for the decoration of both flower garden and greenhouse at a later season.

**April.**—Arrears of work in the preparation of bedding plants must be made up forthwith, or, in many cases, they will not be large enough for any really decorative use. There is no reason for repeating our directions about this part of the work, as it is practically the same as that in previous months, except that a very great many of the plants can be propagated without fire heat, although those thus obtained will be late. The whole of the stock of zonal pelargoniums, and other nearly hardy plants of a like nature, should be in the frames, and, where necessary, should be re-potted; but unless extra large growths are required, or they are to stand in pots, 3in. pots are large enough for the ordinary run of bedding plants. Great care must be taken in destroying insects, as they do a greater amount of mischief as the weather becomes warmer, particularly in the case of slugs and snails, which, if left unmolested, will soon defoliate the whole of the plants in a large frame, especially those of a soft, succulent nature. Where red spider or thrips are prevalent

in the season, care should be taken that they are destroyed as soon as they appear, for "a stitch in time saves nine."

Hard-wooded and other plants will now be in full bloom, and great care must be taken that no drip falls on the flowers, neither must too damp an atmosphere be maintained, so that water condenses on the blossoms or foliage. This would do much harm to the appearance of the plants, but more particularly if the sun reached them ere the damp was dispelled, as in such case they become spotted and scalded, and very unsightly. To this end it is advisable to open the top lights of the house early in the morning, not later than seven o'clock, and to give a thorough current of air a little later according to the weather, and whether fire heat is or is not employed. Anyway, it is necessary that the foliage be dry before the sun reaches it.

The arrangement of the plants and training of roof climbers, &c., are in themselves very important portions of the work in this department, and must have especial attention paid them. On the manner in which these are done very much depends, the appearance of the house at this season being one of its chief attractions; and it is generally admitted that, however fine the specimens may be individually, unless they be well arranged, the effect they produce is but small.

In the frames there is still plenty to be done, many plants requiring to be re-potted, and many things to be trained out in the way they should go, rather than that which they desire. Various subjects will require liquid manure, and others top dressing, but for these items we must refer our readers to past directions. Cuttings of various plants must be got in, and in potting these a goodly quantity of sand must be used, both before and after they are rooted. Plenty of air must now be given; and insects must be kept at bay by the use of insecticides.

Vines must have great attention paid them where they are used instead of other roof plants; and it is scarcely needful to remark that they must not obstruct too much light, or the other plants will suffer.\*

---

\* For treatment of vines see "Vine Culture for Amateurs." London: L. Upcott Gill, 170, Strand; price 1s.



**May.**—All the bedding plants should now be out of doors, and the house should be occupied by such as are to be employed for its decoration only. The propagation of those for outside work should have been finished, and only that of subjects for indoor decoration should be in hand. The stock of bedding plants should be thoroughly hardened off, and, to afford room for the more tender subjects, calceolarias and other nearly hardy stock and hardy annuals should be got into the beds and borders early in the month, if not done in April; and at the end of it zonal pelargoniums, and other plants of a like degree of hardiness, should be got into their summer quarters. Some of the best of these, however, should be put by and potted on for various decorative purposes in pots; and these reserved plants should be carefully tended, as they come in very usefully for many places which would otherwise be bare. The more tender varieties may remain until next month, and the space that is obtained by placing the hardier kinds out can be occupied by them.

The remarks already made about the destruction of insects, and the general cleanliness of both plants and the places they occupy, need not be repeated this month; but, as a rule, these are just the points that the amateur neglects, and consequently he has more or less ill success with some of his plants, if not with all.

Where it is desired that a few cucumbers should occupy the house or frames after the bedding plants are got out of the way, they should be sown at once on a brisk heat. Choose such as Rollison's Telegraph or Masters' Prolific, both of which are good and free bearers; or, if preferred, plants may be purchased and put out at once.

As during the next two months the greater part of the present occupants of the house will be got into the frames, it is desirable that the plants that are to occupy their places should be pushed forward; and to this end fuchsias, balsams, celosias, begonias, lobelias, &c., should be got on so as to render the place as gay as possible during the time the other plants are out, although where there is a good garden the bareness of the house will not

much matter. At the same time, a well-furnished conservatory is a nice place to spend a short time in during rain, or after the heat of the day is over.

Besides such plants as we have mentioned, there are plenty of subjects which can be prepared in the frames, and brought into the conservatory to bloom, and these will, of necessity, occupy some time. Seeds of primula, cineraria, and a few other plants will have to be sown for early work; and various other items only noted by the owner attended to. Training and re-potting various plants, and the application of liquid manure where necessary, will also occupy time, and altogether this is a busy month, although not so much so as the previous one.

Ventilation must be carefully seen to, and while it is not altogether advisable to admit too much air on frosty mornings, still it is absolutely necessary that the foliage and bloom of the plants shall be quite dry ere the sun reaches them, or burnt and scalded foliage will greet the eyes, and in some cases the nose, of the amateur who allows this state of things to come about through neglect of the necessary precautions.

Vines being now in full bloom should be gently tapped or shaken a little before noon each day, so that the pollen shall be well diffused and a good crop of fruit set, as it is a comparatively easy matter to thin out superfluous berries, while it is an impossibility to place in fresh ones where they may be deficient. The proper training of all roof climbers should be well attended to, and a good look-out kept for scale and other insects which often infest them. Red spider and thrips must be particularly looked after, as they spread very rapidly in a dry atmosphere, but if care is taken they will not gain much head.

**June.**—Early in the month, if the weather is at all propitious, the whole of the bedding plants will be got out, and the space thus left vacant will be required for the hard-wooded stock, which should now be transferred to the frames. Some of the hard-wooded plants require to be kept in the house for the whole season, but such things as oranges, camellias, azaleas, &c., are

best out for part of the year. The best plan is to prepare beds of coal ashes in which to plunge the pots, as they are then not so liable to suffer from drought, or sudden changes, as when stood on the ground, and, besides, worms will not penetrate through the sharp ashes. Under the hole in each pot a piece of slate or tile should be laid, as an additional safe-guard against the ingress of worms, as they do a vast amount of harm to the plants which they honour by their presence. Where it is necessary, plants should be re-potted, and some will be benefited by the application of clear liquid manure, but it is for the grower to decide which plants do, or do not, require artificial aid. In fact, its good or ill effects is an open question; and although we use it in many cases, still we consider that with hard-wooded plants it is far better to re-pot than to apply stimulants, as the effects produced by the latter are not really lasting. With large specimens the case is somewhat different, as it may not be desirable to give larger pots, and therefore stimulating manures are necessary to keep the plants in full vigour for some time; but this artificial stimulus tells on the constitution of the plants, and sooner or later they are sure to die off. The plants must be protected from heavy rains, but should have all the exposure possible consistent with their well being. Due attention will have to be paid to watering and keeping clear of insects, and also to training the young stock, and each plant should have sufficient room in which to develop itself.

In the house some care is requisite to keep the plants that occupy the places of the hard-wooded stock in good order, and plenty of light is of primary importance to all things but ferns. Care must be taken that the foliage is not splashed when watering in mid-day, which will be necessary with some subjects which make a very gross growth. Ventilation must also be carefully attended to, the house being opened at six or half-past six every morning; in fact, air should be admitted all night, unless special reasons exist for the contrary. The necessity of staking the plants, keeping down insects, &c., is too evident to need more than a passing note. Permanent trees and climbers will, of course, require due attention in respect of watering, keeping clear

of insects, and other matters that will be readily seen, and, where requisite, the grosser shoots should be pinched back, so that the growth is equalised.

The various plants that are coming on for autumn decoration must be re-potted and trained as may be necessary, and some cuttings of zonale pelargoniums and a few other subjects should be put in, so that in winter some good blooming plants shall be at hand. Primulas should be potted off, and more seeds sown.

Vines and climbers must have a fair share of attention, not only in respect of training and the destruction of insects, but also as to a sufficiency of moisture, and in too many cases this latter point is neglected. Thinning grapes, where there are any, is also an important point at this time, and much skill and judgment are required in the operation, it being necessary that the berries should be left just thin enough to form a good bunch, but not over-thinned, as in the latter case the bunches will have by no means a pleasing appearance when placed on the table.

**July.**—Propagation in many cases will now be commenced, choice geraniums and other good plants of course taking precedence of others of less value; but as many that are difficult to strike later on now strike readily, choice should also be made of these. Seeds of various plants may yet be sown, and those seedlings which are of sufficient size should be potted off, and older plants shifted on. The various plants which are being grown on for autumn and winter use should also be shifted on as necessary, nor should any neglect be allowed to befall them. Watering is a matter that needs especial attention, and previous remarks on this subject should be attended to.

The plants for decorative purposes in the house must not be overlooked, and great care in watering, ventilation, &c., must be taken, especially with fine-foliaged kinds. Previous remarks as to drip and watering the foliage must be carefully attended to, and full ventilation must be given by seven o'clock in the morning at the latest, as after this hour any condensed

moisture on the foliage will not have time to get away ere the sun may come on the plants with too severe force, and so cause serious disfiguration. In fact, some ventilation should be given through the night. The destruction of insects must be attended to with unremitting care, and the house must be kept in a generally clean and tidy condition, both for the sake of the plants and the comfort of the visitors. Where necessary liquid manure should be applied, but, as before explained, its use should be chiefly on short-lived subjects, and not on those of more permanent nature.

Hard-wooded plants should receive all necessary care and attention; but the work is very similar to that of last month, and need not, therefore, be detailed. The less so, because the treatment for individual plants has been already described. It should be such as will tend to cause a good sturdy growth of a floriferous nature, and to this end as much exposure as possible should be given consistent with the habit. The earlier forced plants should be ripened off without loss of time, so as to be ready to come into the house early next month. Care must be taken to keep all insects cleared off as soon as they appear, especially those which attack the foliage, as they detract so very much from the appearance.

Vines and roof climbers will still require some attention in respect of training, &c. The final thinning should be given to grapes, and they should, after stoning, be well fed with liquid manure to cause them to grow apace, and become fine in the berry.

Repairs should be done at this season, and the outsides of the houses, frames, &c., should receive a good coat of paint, as this saves both the woodwork and putty, besides keeping the place watertight.



## VIII.—MONTHLY LIST OF PLANTS IN BLOOM IN THE GREENHOUSE.



GREENHOUSE MANAGEMENT would be incomplete without a list of plants arranged according to their blooming periods; for, although the times at which the various kinds come into flower vary with the treatment given, yet, as a rule, they are sufficiently approximate to afford a pretty accurate idea as to the subjects needed for maintaining a continued display. Forced plants are necessary during some part of the year to keep up a full and proper show of colour; but in November and December the variety of flowers

is smallest, and in these two months it is very difficult to get forced things well into bloom. Of course, some plants may be made to bloom out of season, and others will be noticeable for their foliage, and so the interest may be kept up; but, if there be only one kind, as, for instance, Chrysanthemums, in a house they grate on the sense of sightliness and beauty, for, excellent as they may be, they are too much alike to furnish a house well. In all conservatories variety, both of form and colour, is an absolute necessity if the greatest effect is to be

produced, and although a large quantity of flowers in bloom is not needed, yet some should be present, or the effect will be dull and heavy. Always, if possible, have some plants in bloom, even if only a scarlet pelargonium or two, as they show up the others to much greater advantage. We pass over arrangement here, as this must depend on individual taste, and our readers must make the best of their plants according to their fancy.

**January.**—*Abutilon*, *Amaryllis*, *Begonia*, *Bouvardia*, *Calla*, *Camellia*, *Carnation*, *Chrysanthemum*, *Crocus*, *Cyclamen*, *Epiphyllum*, *Fuchsia*, *Galanthus*, *Heliotrope*, *Hyacinth*, *Jasmine*, *Luculia*, *Laurestinus*, *Mignonette*, *Pelargonium zonale*, *Primula*, *Salvia*, *Solanum* (berries), *Rose* (in a few cases).

**February.**—*Abutilon*, *Amaryllis*, *Amygdalus*, *Azalea*, *Annuals* (if autumn sown), *Begonia*, *Bouvardia*, *Calla*, *Camellia*, *Carnation*, *Cerasus*, *Chrysanthemum*, *Cineraria*, *Crocus*, *Cyclamen*, *Cytisus*, *Daphne*, *Deutzia*, *Epiphyllum*, *Fuchsia*, *Galanthus*, *Heliotrope*, *Hyacinth*, *Jasmine*, *Lily of the Valley*, *Luculia*, *Lachenalia*, *Laurestinus*, *Mignonette*, *Pelargonium zonale*, *Persica*, *Polygonatum*, *Primula*, *Primrose*, *Rose*, *Scilla*, *Solanum* (berries), *Spiræa*, *Tulip*, *Violet*.

**March.**—*Abutilon*, *Acacia*, *Amaryllis*, *Amygdalus*, *Arum*, *Azalea*, *Annuals*, *Begonia*, *Bouvardia*, *Calla*, *Camellia*, *Campanula*, *Carnation*, *Cerasus*, *Chimonanthus*, *Chorizema*, *Cineraria*, *Citrus*, *Coronilla*, *Crocus*, *Cyclamen*, *Cytisus*, *Daphne*, *Deutzia*, *Dielytra*, *Dodecatheon*, *Epiphyllum*, *Erythronium*, *Epacris*, *Fuchsia*, *Fritillaria*, *Galanthus*, *Habrothamnus*, *Heliotrope*, *Hyacinth*, *Imantophyllum*, *Iris*, *Jasmine*, *Kerria*, *Lily of the Valley*, *Leucojum*, *Lachenalia*, *Laurestinus*, *Mignonette*, *Muscari*, *Myosotis*, *Narcissus*, *Pelargonium* (both *Cape* and *zonale*), *Persica*, *Petunia*, *Polygonatum*, *Primula*, *Primrose*, *Rose*, *Scilla*, *Solanum* (berries), *Spiræa*, *Stock*, *Tropæolum*, *Tulip*, *Violet*.

**April.**—*Abutilon*, *Abelia*, *Acacia*, *Amaryllis*, *Amygdalus*, *Arum*, *Azalea*, *Annuals*, *Begonia*, *Bouvardia*, *Calampelis*, *Cal-*

ceolaria, Calla, Camellia, Campanula, Carnation, Cassia, Cerasus, Chimonanthus, Chorizema, Cineraria, Citrus, Clematis, Coronilla, Cyclamen, Cytisus, Daphne, Deutzia, Dielytra, Dodecatheon, Epiphyllum, Erythronium, Epacris, Fuchsia, Fritillaria, Habrothamnus, Hyacinth, Hydrangea, Imantophyllum, Iris, Jasmine, Kalmia, Kerria, Lily of the Valley, Leucojum, Lobelia, Lachenalia, Laurestinus, Muscari, Myosotis, Narcissus, Oxalis, Pelargonium (Cape, zonale, and double), Persica, Petunia Polygonatum, Primula, Primrose, Rhodanthe, Rhododendron, Rose, Scilla, Spiræa, Stock, Tropæolum, Tulip, Violet, Weigelia.

**May.**—Abutilon, Abelia, Acacia, Ageratum, Amaryllis, Amygdalus, Anthericum, Arum, Azalea, Annuals, Begonia, Boronia, Calampelis, Calceolaria, Calla, Camellia, Campanula, Carnation, Cassia, Cerasus, Chimonanthus, Chorizema, Cineraria, Citrus, Clematis, Coronilla, Cuphea, Cyclamen, Cytisus, Daphne, Deutzia, Dielytra, Dodecatheon, Epiphyllum, Erythronium, Epacris, Fritillaria, Habrothamnus, Heliotrope, Hoya, Hyacinth, Hydrangea, Imantophyllum, Iris, Jasmine, Kalmia, Kerria, Lantana, Lily of the Valley, Leucojum, Lobelia, Lachenalia, Mignonette, Mimulus, Musk, Muscari, Myosotis, Narcissus, Oxalis, Pelargonium (Cape, zonale, and double), Persica, Petunia, Polygonatum, Primula, Primrose, Rhodanthe, Rhododendron, Rose, Spiræa, Stock, Tropæolum, Verbena, Violet, Weigelia, Xanthoceras.

**June.**—Abutilon, Abelia, Acacia, Ageratum, Amaryllis, Anagallis, Azalea, Annuals, Begonia, Boronia, Bougainvillea, Bouvardia, Brugmansia, Calampelis, Calceolaria, Campanula, Carnation, Cassia, Chimonanthus, Chorizema, Cineraria, Citrus, Clematis, Cobæa, Cuphea, Cyclamen, Cytisus, Crassula, Deutzia, Dielytra, Dodecatheon, Epiphyllum, Erythronium, Epacris, Fuchsia, Gazania, Habrothamnus, Heliotrope, Hibbertia, Hoya, Humea, Hydrangea, Iris, Jasmine, Kalmia, Kennedya, Lantana, Lily of the Valley, Lobelia, Mignonette, Mimulus, Musk, Myrtle, Nierembergia, Nerium, Oxalis, Passiflora, Pelargonium, Petunia, Phlox, Plumbago, Portulacca, Rhodanthe, Rhododendron, Rose,



Saxifraga, Spiræa, Stocks, Tropæolum, Veronica, Verbena, Weigelia.

**July.**—Abutilon, Agapanthus, Ageratum, Azalea, Annuals, Balsam, Begonia, Boronia, Bougainvillea, Bouvardia, Brugmansia, Calampelis, Calceolaria, Campanula, Carnation, Cassia, Celosia, Cockscomb, Chorizema, Citrus, Clematis, Cobæa, Cuphea, Crassula, Epiphyllum, Epacris, Fuchsia, Funkia, Gazania, Habrothamnus, Hedychium, Heliotrope, Hibbertia, Hoya, Humea, Hydrangea, Ipomœa, Iris, Jasmine, Kennedyya, Lantana, Lilium, Lobelia, Mignonette, Mimulus, Musk, Myrtle, Nierembergia, Nerium, Oxalis, Passiflora, Pelargonium, Petunia, Phlox, Plumbago, Portulacca, Rhodanthe, Rhododendron, Rose, Saxifraga, Schizanthus, Statice, Stock, Tacsonia, Tagetes, Tropæolum, Veronica, Verbena.

**August.**—Agapanthus, Ageratum, Anagallis, Annuals, Balsam, Begonia, Bougainvillea, Bouvardia, Brugmansia, Calampelis, Campanula, Carnation, Cassia, Celosia, Cockscomb, Chorizema, Clematis, Cobæa, Cuphea, Crassula, Epacris, Fuchsia, Funkia, Habrothamnus, Gazania, Hedychium, Hibbertia, Hoya, Humea, Hydrangea, Heliotrope, Ipomœa, Iris, Kennedyya, Lantana, Lapageria, Lilium, Lobelia, Mignonette, Mimulus, Musk, Nicotiana, Nierembergia, Nerium, Oxalis, Passiflora, Pelargonium, Petunia, Phlox, Pittosporum, Plumbago, Portulacca, Rhodanthe, Rose, Saxifraga, Schizanthus, Statice, Stocks, Tacsonia, Tagetes, Tropæolum, Veronica, Verbena.

**September.**—Agapanthus, Ageratum, Anagallis, Asters, Annuals, Balsam, Begonia, Bougainvillea, Bouvardia, Brugmansia, Calampelis, Calla, Campanula, Carnation, Celosia, Cockscomb, Chrysanthemum, Clematis, Cuphea, Cobæa, Crassula, Fuchsia, Funkia, Gazania, Habrothamnus, Hedychium, Heliotrope, Hoya, Humea, Hydrangea, Ipomœa, Lantana, Lapageria, Lilium, Lobelia, Mignonette, Musk, Nicotiana, Nierembergia, Nerium, Oxalis, Passiflora, Pelargonium, Petunia, Phlox, Pittosporum, Plumbago, Portulacca, Rhodanthe, Rose, Salvia,

Schizanthus, Solanum (berries), Statice, Stock, Tacsonia, Tagetes, Tropæolum, Veronica, Verbena.

**October.**—Ageratum, Asters, Annuals, Balsam, Begonia, Bougainvillea, Bouvardia, Brugmansia, Calla, Camellia, Campanula, Carnation, Celosia, Cockscomb, Chrysanthemum, Clematis, Cuphea, Cyclamen, Fuchsia, Gazania, Habrothamnus, Heliotrope, Hoya, Ipomœa, Lantana, Lapageria, Lobelia, Mignonette, Musk, Nicotiana, Passiflora, Pelargonium, Petunia, Phlox, Pittosporum, Plumbago, Portulacca, Rhodanthe, Rose, Salvia, Schizanthus, Solanum (berries), Statice, Stock, Tagetes, Veronica, Verbena.

**November.**—Ageratum, Asters, Annuals, Begonia, Bouvardia, Camellia, Carnation, Celosia, Chrysanthemum, Cyclamen, Epiphyllum, Fuchsia, Gazania, Habrothamnus, Heliotrope, Hoya, Ipomœa, Lantana, Laurustinus, Mignonette, Nicotiana, Pelargonium, Plumbago, Primula, Rhodanthe, Salvia, Schizanthus, Solanum (berries), Stock, Tagetes, Veronica.

**December.**—Amaryllis, Begonia, Bouvardia, Calla, Camellia, Carnation, Epiphyllum, Fuchsia, Heliotrope, Lantana, Laurustinus, Mignonette, Pelargonium, Salvia, Solanum (berries), Veronica, and perhaps Roman Hyacinths.

It must be remembered that differences in the weather, and in the treatment given to the various plants, will cause variations in the time at which particular plants come into bloom, and while one year they bloom early, at others they will be late, and *vice versâ*. We have omitted some things from the above list, and particularly such as are noticeable for their foliage only, as these come in at various seasons, according to the treatment given them, and not at fixed periods.



# INDEX.

---

## A.

Abelia, 62  
Abutilon, 63  
Acacia, 64  
Acers, 66  
Agapanthus, 67  
Agave, 68  
Ageratum, 70  
Alonsoa, 71  
Aloysia, 71  
Amaryllis, 73  
Amygdalus, 74  
Anagallis, 75  
Aniseed tree, 76  
Annuals, 50  
    Half-hardy, 53  
    Hardy, 51  
    Tender, 55  
Anthericum, 76  
Ants, 38  
Aphides, 40  
April, plants in bloom, 371  
    Work for, 363  
Aralia, 77  
Araucaria, 79  
Arum, 79  
Asparagus, 81  
Aspidistra, 82  
Asters, 82  
Astilbe, 83  
Aucuba, 83  
August, plants in bloom, 373  
    Work for, 349  
Azalea, 86

## B.

Balsam, 90  
Bambusa, 92  
Begonia, 93

Bignonia, 96  
Boiler, conical, 31  
    Gas, 26  
    Saddle, 33  
Boronia, 97  
Bougainvillea, 98  
Bourbon rose, 303  
Bouvardia, 100  
Brugmansia, 103

## C.

Calampelis, 104  
Calceolaria, herbaceous, 104  
    Shrubby, 167  
Calendar of work, 348  
    January, 357  
    February, 359  
    March, 361  
    April, 363  
    May, 365  
    June, 366  
    July, 368  
    August, 349  
    September, 351  
    October, 353  
    November, 355  
    December, 357  
Calla, 109  
Calorigen stove, 24  
Camellia, 111  
    Flowered balsam, 91  
    Japonica, 112  
Campanula, 115  
Canna, 117  
Carnation, 120  
Cassia, 122  
Caterpillars, 42  
Celosia, 123

Centaurea, 124  
 Cerasus, 124  
 Chilian monkey puzzle, 79  
 Chimonanthus, 125  
 Chorizema, 125  
 Chrysanthemum, 126  
     Anemone-flowered pompone,  
         130  
     Chinaman, 127  
     Japanese, 128  
     Pompone, Model of Perfection,  
         131  
 Cineraria, 132  
 Citron, 135  
 Citrus, 135  
 Clematis, 139  
 Clianthus, 140  
 Clivia, 143, 207  
 Cobæa, 143  
 Cockscomb, 143  
 Coleus, 146  
 Coltsfoot, 339  
 Conical boiler, 26  
 Convallaria, 148  
 Coprosma, 148  
 Cordyline, 149  
     Indivisa, 168  
 Coronilla, 149  
 Corræa, 149  
 Crassula, 151  
 Crocus, 151  
 Cucumbers, 365  
 Cultural directions, general, 50  
 Cuphea, 152  
 Curved roof house, 13  
 Cuttings, treatment of, 58  
 Cyclamen, 153  
 Cyperus, 156  
 Cytisus, 157

D.

Dactylis, 158  
 Daphne, 159  
 Darlingtonia, 161  
 December, plants in bloom, 374  
     Work for, 357  
 Deutzia, 162  
 Dicentra, 163  
 Dictionary of plants, 62

Dielytra, 163  
 Dionæa, 166  
 Dodecatheon, 166  
 Dog's-tooth violet, 177  
 Double camellia, 114  
 Dracæna, 168

## E.

Echeveria, 170  
 Epacris, 172  
 Epiphyllum, 173  
 Eriobotrya, 174  
 Erythrina, 176  
 Erythronium, 177  
 Eurya, 179

## F.

February, plants in bloom, 371  
     Work for, 359  
 Ficus, 180  
 Flax, 276  
 Flues for heating, 35  
 Frames, G, 17  
 Fritillaria, 181  
 Fuchsia, 182  
 Fuel, 30, 34  
 Funkia, 188

## G.

Galanthus, 188  
 Garden fuchsia, 185  
 Gas boiler, 26  
     For heating, 20  
 Gazania, 189  
 General remarks, 1  
 Genista, 157, 190  
 George's Calorigen stove, 24  
 Geranium, 191  
 Golden-rayed lily of Japan, 223  
 Grevillea, 191  
 Guernsey lily, 192

## H.

Habrothamnus, 192  
 Hæmanthus, 193  
 Half-hardy annuals, 53  
 Half-span house, 14  
 Hardenbergia, 218

Hardy annuals, 51  
 Heating, 18  
   By hot water, 27  
   With flues, 35  
   With gas, 23  
   With hot air stoves, 21  
   With mineral oils, 19  
 Hedychium, 193  
 Heliotropium, 194  
 Herbaceous calceolaria, 104  
 Hibbertia, 197  
 Hot air stoves for heating, 21  
   Water for heating, 27  
 Hovea, 197  
 Hoya, 199  
 Humea, 200  
 Hyacinth, 201  
 Hydrangea, 204

I.

Ice plant, 206  
 Illicium, 207  
 Imantophyllum, 207  
 Indian garland flower, 193, 208  
 Indiarubber plant, 208  
 Insecticide, Fowler's, 47  
 Insects, 37  
   Ants, 38  
   Aphides, 40  
   Caterpillars, 42  
   Maggots, 43  
   Red spider, 43  
   Scale, 45  
   Snails and slugs, 44  
   Spider, 43  
   Thrips, 46  
   Weevils, 47  
   Wireworm, 47  
   Woodlice, 48  
 Ipomœa, 208  
 Iresine, 209  
 Iris, 211  
 Isolepis, 213

J.

January, plants in bloom, 371  
   Work for, 357  
 Japanese chrysanthemum, 128  
   Medlar, 174

Jasminum, 214  
 July, plants in bloom, 373  
   Work for, 368  
 June, plants in bloom, 372  
   Work for, 366

## K.

Kalmia, 216  
 Kalosanthes, 216  
 Kennedya, 118  
 Kerria, 219

## L.

Lachenalia, 220  
 Lantana, 221  
 Lapageria, 223  
 Lasiandra, 225  
 Laurustinus, 227  
 Layering, 59  
 Leaf mould, 4  
 Lean-to house, 7  
 Lemon, 135  
   Verbena, 71  
 Leucojum, 227  
 Leucophyta, 227  
 Lilium, 228  
 Lily, golden-rayed, 228  
   Guernsey, 192  
   Of the valley, 230  
 List of plants in bloom, monthly,  
   370  
 Loam soils, 3  
 Lobelia, 233  
 Luculia, 236  
 Lux Calor stove, 25

## M.

Maggots, 43  
 Maiden loam soils, 3  
 Manures, 4  
 Maples, 67  
 March, plants in bloom, 371  
   Work for, 361  
 May, plants in bloom, 372  
   Work for, 365  
 Mesembryanthemum, 237  
 Mignonette, 239  
 Mildew, 49  
 Mimulus, 240

Mineral oils for heating, 19  
 Monkey puzzle, 79  
 Monthly calendar of work, 348  
     List of plants in bloom, 370  
 Moss rose, 302  
 Muscari, 242  
 Musk, 243  
 Myosotis, 244  
 Myrsiphyllum, 245  
 Myrtle, 246

## N.

Narcissus, 247  
 Nerine, 249  
 Nerium, 250  
 New Zealand flax, 276  
 Nicotiana, 251  
 Nierembergia, 252  
 Noisette rose, 304  
 November, plants in bloom, 374  
     Work for, 355

## O.

October, plants in bloom, 374  
     Work for, 353  
 Oleander, 250  
 Orange, 135, 254  
 Oxalis, 254

## P.

Pachyphytum, 255  
 Pancratium, 256  
 Paragon boiler, for mineral oil, 20  
 Passiflora, 253  
 Passion flower, 253  
 Peach, double, 273  
 Peat, 4  
 Pelargonium, 262  
 Persica, 273  
 Petunia, 273  
 Phlox Drummondii, 274  
 Phormium, 276  
 Pimelea, 276  
 Pittosporum, 278  
 Plants in flower in  
     January, 371  
     February, 371  
     March, 371

Plants in flower in  
     April, 371  
     May, 372  
     June, 372  
     July, 373  
     August, 373  
     September, 373  
     October, 374  
     November, 374  
     December, 374  
 Pleroma, 279  
 Plumbago, 280  
 Polygonatum, 281  
 Pomponne, chrysanthemum, 131  
 Portulacca, 282  
 Pots and sands, 2  
 Prices of greenhouses, 8  
 Primula, double, 292  
     Hardy, 284  
     Sinensis, 286  
 Propagation, 57  
 Pyrethrum aureum, 293

## R.

Raising seeds, 55  
 Red spider, 43  
 Reineckia, 294  
 Repairing greenhouse, 369  
 Rhodanthe, 294  
 Rhododendron, 295  
 Richardia, 298  
 Ricinus, 298  
 Ritchie's Lux Calor stove, 25  
 Rochea, 298  
 Roellia, 299  
 Rose, 301  
     Bourbon, 303  
     Moss, 302  
     Noisette, 304  
     Tea, 305

## S.

Saddle boiler, 33  
 Salvia, 306  
 Sand and pots, 2  
 Sarracenia, 311  
 Saxifraga, 313  
 Scale, 45

Schizanthus, 314  
 Scilla, 315  
 Seeds, 50  
     Watering, 56  
 September, plants in bloom, 373  
     Work for, 351  
 Sericographis, 316  
 Silver sand, 4  
 Siphon for heating, 35  
 Snails and slugs, 44  
 Snowdrop, 188, 318  
 Soils for seeds, 57  
     Leaf, 4  
     Maiden loam, 3  
     Peat, 4  
     Yellow loam, 3  
 Solanum, 318  
 Solomon's seal, 281  
 Span roof house, 15  
 Sparmannia, 320  
 Spider, 43  
 Spiræa, 322  
 Squills, 315  
 Statice, 324  
 Stock, 2  
 Stocks, 327  
 Stoves, Calorigen, 24  
     Lux Calor, 24  
 Sundries, 4

T.

Tacsonia, 329  
 Tagetes, 329  
 Tapping vines, 366  
 Tea plant, 331  
     Rose, 305  
 Tecoma, 330  
 Temperature for cuttings, 60  
 Tender annuals, 55  
 Thalictrum, 330  
 Thea, 331  
 Thrips, 46  
 Tobacco plant, 251  
     Powder for destroying insects,  
     41

Tradescantia, 332  
 Treatment of vines, 364  
 Tropæolum, 333  
 Tulip, 336  
 Tussilago, 339

## V.

Ventilation, 2  
 Verbena, 340  
     Lemon, 71  
 Veronica, 342  
 Viburnum, 342  
 Vines, tapping, 366  
     Treatment of, 364  
 Violet, 344

## W.

Watering seeds, 56  
 Weevils, 47  
 Weigelia, 346  
 Wireworm, 47  
 Wood lice, 48  
 Work in January, 357  
     February, 359  
     March, 361  
     April, 363  
     May, 365  
     June, 366  
     July, 368  
     August, 349  
     September, 351  
     October, 353  
     November, 355  
     December, 357

## X.

Xanthoceras, 347

## Y.

Yellow loam soils, 3

## Z.

Zychia, 218

**Garden**  
**Appliances**  
**Blossoms**  
**Bulbs**  
**Ferns**  
**Fruit**  
**Fruit Trees**  
**Plants**  
**Roses**  
**Seeds**  
**Vegetables**  
**Herbs**  
**Orchids**  
**Cacti**  
**Greenhouses**  
**Frames**  
**Syringes**  
**Tools**  
&c., &c.,

EASILY  
BOUGHT, SOLD,  
*or* EXCHANGED  
THROUGH  
**The Bazaar,**  
**Exchange and Mart.**

---

*Illustrated Articles on the Various  
Branches of Gardening, adapted to the  
requirements of Amateurs, are fre-  
quently given.*

---

**"That excellent but seductive journal."**  
*Saturday Review.*

---

PRICE 2d., OF ALL NEWSAGENTS.

Office: 170 STRAND, LONDON



*Catalogue of Practical Handbooks*  
*Published by L. Upcott Gill, 170,*  
*Strand, London, W.C.*

---

**ANGLER, BOOK OF THE ALL-ROUND.** A Comprehensive Treatise on Angling in both Fresh and Salt Water. In Four Divisions, as named below. By JOHN BICKERDYKE. With over 220 Engravings. *In cloth, price 5s. 6d., by post 6s.* (A few copies of a LARGE PAPER EDITION, bound in Roaburghe, price 25s.)

**Angling for Coarse Fish.** Bottom Fishing, according to the Methods in use on the Thames, Trent, Norfolk Broads, and elsewhere. Illustrated. *In paper, price 1s., by post 1s. 2d.*

**Angling for Pike.** The most Approved Methods of Fishing for Pike or Jack. Profusely Illustrated. *In paper, price 1s., by post 1s. 2d.; cloth, 2s. (uncut), by post 2s. 3d.*

**Angling for Game Fish.** The Various Methods of Fishing for Salmon; Moorland, Chalk-stream, and Thames Trout; Grayling and Char. Well Illustrated. *In paper, price 1s. 6d., by post 1s. 9d.*

**Angling in Salt Water.** Sea Fishing with Rod and Line, from the Shore, Piers, Jetties, Rocks, and from Boats; together with Some Account of Hand-Lining. Over 50 Engravings. *In paper, price 1s., by post 1s. 2d.; cloth, 2s. (uncut), by post 2s. 3d.*

**AQUARIA, BOOK OF.** A Practical Guide to the Construction, Arrangement, and Management of Fresh-water and Marine Aquaria; containing Full Information as to the Plants, Weeds, Fish, Molluscs, Insects, &c., How and Where to Obtain Them, and How to Keep Them in Health. Illustrated. By REV. GREGORY C. BATEMAN, A.K.C., and REGINALD A. R. BENNETT, B.A. *In cloth gilt, price 5s. 6d., by post 5s. 10d.*

**AQUARIA, FRESHWATER:** Their Construction, Arrangement, Stocking, and Management. Fully Illustrated. By REV. G. C. BATEMAN, A.K.C. *In cloth gilt, price 3s. 6d., by post 3s. 10d.*

**AQUARIA, MARINE:** Their Construction, Arrangement, and Management. Fully Illustrated. By R. A. R. BENNETT, B.A. *In cloth gilt, price 2s. 6d., by post 2s. 9d.*

**AUSTRALIA, SHALL I TRY?** A Guide to the Australian Colonies for the Emigrant Settler and Business Man. With two Illustrations. By GEORGE LACON JAMES. *In cloth gilt, price 3s. 6d., by post 3s. 10d.*

**AUTOGRAPH COLLECTING:** A Practical Manual for Amateurs and Historical Students, containing ample information on the Selection and Arrangement of Autographs, the Detection of Forged Specimens, &c., &c., to which are added numerous Facsimiles for Study and Reference, and an extensive Valuation Table of Autographs worth Collecting. By HENRY T. SCOTT, M.D., L.R.C.P., &c. *In leatherette gilt, price 7s. 6d., by post 7s. 10d.*

**BAZAARS AND FANCY FAIRS:** Their Organization and Management. A Secretary's Vade Mecum. By JOHN MUIR. *In paper, price 1s., by post 1s. 2d.*

- BEEES AND BEE-KEEPING:** Scientific and Practical. By F. R. CHESHIRE, F.L.S., F.R.M.S., Lecturer on Apiculture at South Kensington. *In two vols., cloth gilt, price 16s., by post 16s. 8d.*
- Vol. I., Scientific.** A complete Treatise on the Anatomy and Physiology of the Hive Bee. *In cloth gilt, price 7s. 6d., by post 7s. 10d.*
- Vol. II., Practical Management of Bees.** An Exhaustive Treatise on Advanced Bee Culture. *In cloth gilt, price 8s. 6d. by post 9s.*
- BEE-KEEPING, BOOK OF.** A very practical and Complete Manual on the Proper Management of Bees, especially written for Beginners and Amateurs who have but a few Hives. Fully Illustrated. By W. B. WEBSTER, First-class Expert, B.B.K.A. *In paper, price 1s., by post 1s. 2d.; cloth, 1s. 6d., by post 1s. 8d.*
- BEGONIA CULTURE,** for Amateurs and Professionals. Containing Full Directions for the Successful Cultivation of the Begonia, under Glass and in the Open Air. Illustrated. By B. C. RAVENSCROFT. *In paper, price 1s., by post 1s. 2d.*
- BENT IRON WORK:** A Practical Manual of Instruction for Amateurs in the Art and Craft of Making and Ornamenting Light Articles in imitation of the beautiful Mediæval and Italian Wrought Iron Work. By F. J. ERSKINE. Illustrated. *In paper, price 1s., by post 1s. 2d.*
- BIRDS, BRITISH, FOR THE CAGE AND AVIARY.** Illustrated. By DR. W. T. GREENE. [*In the Press.*]
- BOAT BUILDING AND SAILING, PRACTICAL.** Containing Full Instructions for Designing and Building Punts, Skiffs, Canoes, Sailing Boats, &c. Particulars of the most suitable Sailing Boats and Yachts for Amateurs, and Instructions for their Proper Handling. Fully Illustrated with Designs and Working Diagrams. By ADRIAN NEISON, C.E., DIXON KEMP, A.I.N.A., and G. CHRISTOPHER DAVIES. *In one vol., cloth gilt, price 7s. 6d., by post 7s. 10d.*
- BOAT BUILDING FOR AMATEURS, PRACTICAL.** Containing Full Instructions for Designing and Building Punts, Skiffs, Canoes, Sailing Boats, &c. Fully Illustrated with Working Diagrams. By ADRIAN NEISON, C.E. Second Edition, Revised and Enlarged by DIXON KEMP, Author of "Yacht Designing," "A Manual of Yacht and Boat Sailing," &c. *In cloth gilt, price 2s. 6d., by post 2s. 9d.*
- BOAT SAILING FOR AMATEURS.** Containing Particulars of the most Suitable Sailing Boats and Yachts for Amateurs, and Instructions for their Proper Handling, &c. Illustrated with numerous Diagrams. By G. CHRISTOPHER DAVIES. Second Edition, Revised and Enlarged, and with several New Plans of Yachts. *In cloth gilt, price 5s., by post 5s. 4d.*
- BOOKBINDING FOR AMATEURS:** Being Descriptions of the various Tools and Appliances Required, and Minute Instructions for their Effective Use. By W. J. E. CRANE. Illustrated with 156 Engravings. *In cloth gilt, price 2s. 6d., by post 2s. 9d.*
- BULB CULTURE, POPULAR.** A Practical Manual for the Amateur. By W. D. DRURY. Illustrated. *In paper, price 1s., by post 1s. 2d.*
- BUNKUM ENTERTAINMENTS:** A Collection of Original Laughable Skits on Conjuring, Physiognomy, Juggling, Performing Fleas, Waxworks, Panorama, Phrenology, Phonograph, Second Sight, Lightning Calculators, Ventriloquism, Spiritualism, &c., to which are added Humorous Sketches, Whimsical Recitals, and Drawing-room Comedies. *In cloth, price 2s. 6d., by post 2s. 9d.*
- BUTTERFLIES, THE BOOK OF BRITISH:** A Practical Manual for Collectors and Naturalists. Splendidly Illustrated throughout with very accurate Engravings of the Caterpillars, Chrysalids, and

- Butterflies, both upper and under sides, from drawings by the Author or direct from Nature. By W. J. LUCAS, B.A. *Price 3s. 6d., by post 3s. 9d.*
- BUTTERFLY AND MOTH COLLECTING:** Where to Search, and What to Do. By G. E. SIMMS. Illustrated. *In paper, price 1s., by post 1s. 2d.*
- CACTUS CULTURE FOR AMATEURS:** Being Descriptions of the various Cactuses grown in this country; with Full and Practical Instructions for their Successful Cultivation. By W. WATSON, Assistant Curator of the Royal Botanic Gardens, Kew. Profusely Illustrated. *In cloth gilt, price 5s., by post 5s. 4d.*
- CAGE BIRDS, DISEASES OF:** Their Causes, Symptoms, and Treatment. A Handbook for everyone who keeps a Bird. By DR. W. T. GREENE, F.Z.S. *In paper, price 1s., by post 1s. 2d.*
- CANARY BOOK.** The Breeding, Rearing, and Management of all Varieties of Canaries and Canary Mules, and all other matters connected with this Fancy. By ROBERT L. WALLACE. Third Edition. *In cloth gilt, price 5s., by post 5s. 4d.; with COLOURED PLATES, 6s. 6d., by post 6s. 10d.*
- General Management of Canaries.** Cages and Cage-making Breeding, Managing, Mule Breeding, Diseases and their Treatment, Moulting, Pests, &c. Illustrated. *In cloth, price 2s. 6d., by post 2s. 9d.*
- Exhibition Canaries.** Full Particulars of all the different Varieties, their Points of Excellence, Preparing Birds for Exhibition, Formation and Management of Canary Societies and Exhibitions. Illustrated. *In cloth, price 2s. 6d., by post 2s. 9d.*
- CANARY, THE PET.** With some Instructions as to its Purchase, Diet, Toilette, Cage, and Sanitary Keeping. Illustrated. By W. H. BETTS, Hon. Treas. Cage Bird Club. *Price 5s., by post 5s. 3d.*
- CARD TRICKS, BOOK OF,** for Drawing-room and Stage Entertainments by Amateurs; with an exposure of Tricks as practised by Card Sharppers and Swindlers. Numerous Illustrations. By PROF. R. KUNARD. *In illustrated wrapper, price 2s. 6d., by post 2s. 9d.*
- CARNATION CULTURE,** for Amateurs. The Culture of Carnations and Picotees of all Classes in the Open Ground and in Pots. Illustrated. By B. C. RAVENSCROFT. *In paper, price 1s., by post 1s. 2d.*
- CATS, DOMESTIC OR FANCY:** A Practical Treatise on their Antiquity, Domestication, Varieties, Breeding, Management, Diseases and Remedies, Exhibition and Judging. By JOHN JENNINGS. Illustrated. *In cloth, price 2s. 6d., by post 2s. 9d.*
- CHRYSANTHEMUM CULTURE,** for Amateurs and Professionals. Containing Full Directions for the Successful Cultivation of the Chrysanthemum for Exhibition and the Market. By B. C. RAVENSCROFT. New Edition. Illustrated. *In paper, price 1s., by post 1s. 2d.*
- COINS, A GUIDE TO ENGLISH PATTERN,** in Gold, Silver, Copper, and Pewter, from Edward I. to Victoria, with their Value. By the REV. G. F. CROWTHER, M.A. Illustrated. *In silver cloth, with gilt facsimiles of Coins, price 5s., by post 5s. 3d.*
- COINS OF GREAT BRITAIN AND IRELAND, A GUIDE TO THE,** in Gold, Silver and Copper, from the Earliest Period to the Present Time, with their Value. By the late Colonel W. STEWART THORBURN. With 32 Plates in Gold, Silver, Copper, &c. *In cloth gilt, price 7s. 6d., by post 7s. 10d.*
- COLLIE, THE.** Its History, Points, and Breeding. By HUGH DALZIEL. Illustrated with Coloured Frontispiece and Plates. *In paper, price 1s., by post 1s. 2d.; cloth, 2s., by post 2s. 3d.*

**COLLIE STUD BOOK.** Edited by HUGH DALZIEL. *Price 3s. 6d. each, by post 3s. 9d. each.*

**Vol. I.**, containing Pedigrees of 1308 of the best-known Dogs, traced to their most remote known ancestors; Show Record to Feb., 1890, &c.

**Vol. II.** Pedigrees of 795 Dogs, Show Record, &c.

**Vol. III.** Pedigrees of 786 Dogs, Show Record, &c.

**COLUMBARIUM, MOORE'S.** Reprinted Verbatim from the original Edition of 1735, with a Brief Notice of the Author. By W. B. TEGETMEIER, F.Z.S., Member of the British Ornithologists' Union. *Price 1s., by post 1s. 2d.*

**CONJURING, BOOK OF MODERN.** A Practical Guide to Drawing-room and Stage Magic for Amateurs. By PROFESSOR R. KUNARD. Illustrated. *In illustrated wrapper, price 2s. 6d., by post 2s. 9d.*

**CONJURING FOR AMATEURS.** A Practical Handbook on How to Perform a Number of Amusing Tricks. By ELLIS STANYON. *In paper, price 1s., by post 1s. 2d.*

**COOKERY FOR AMATEURS**; or, French Dishes for English Homes of all Classes. Includes Simple Cookery, Middle-class Cookery, Superior Cookery, Cookery for Invalids, and Breakfast and Luncheon Cookery. By MADAME VALÉRIE. Second Edition. *In paper, price 1s., by post 1s. 2d.*

**CRICKET.** The History of a Hundred Centuries, as Written by Dr. W. G. GRACE, and Edited by W. YARDLEY. *In paper, 6d., by post 7d.*

**CUCUMBER CULTURE FOR AMATEURS.** Including also Melons, Vegetable Marrows, and Gourds. Illustrated. By W. J. MAY. *In paper, price 1s., by post 1s. 2d.*

**CYCLIST'S ROUTE MAP** of England and Wales. Shows clearly all the Main, and most of the Cross, Roads, Railroads, and the Distances between the Chief Towns, as well as the Mileage from London. In addition to this, Routes of *Thirty of the most Interesting Tours* are printed in red. Fourth Edition, thoroughly revised. The map is printed on specially prepared vellum paper, and is the fullest, handiest, and best up-to-date tourist's map in the market. *In cloth, price 1s., by post 1s. 2d.*

**DESIGNING, HARMONIC.** Explaining a System whereby an Endless Variety of Most Beautiful Designs suited to numberless Manufactures may be obtained by Unskilled Persons from any Printed Music. Illustrated by Numerous Explanatory Diagrams and Illustrative Examples. By C. H. WILKINSON. *Demy 4to, price £2 2s. [In the Press.]*

**DOGS, BREAKING AND TRAINING:** Being Concise Directions for the proper education of Dogs, both for the Field and for Companions. Second Edition. By "PATHFINDER." With Chapters by HUGH DALZIEL. Illustrated. *In cloth gilt, price 6s. 6d., by post 6s. 10d.*

**DOGS, BRITISH, ANCIENT AND MODERN:** Their Varieties, History, and Characteristics. By HUGH DALZIEL, assisted by Eminent Fanciers. SECOND EDITION, Revised and Enlarged. Illustrated with First-class COLOURED PLATES and full-page Engravings of Dogs of the Day. This is the fullest work on the various breeds of dogs kept in England. In three volumes, *demy 8vo, cloth gilt, price 10s. 6d. each, by post 11s. 1d. each.*

**Dogs Used in Field Sports.** Containing Particulars of the following among other Breeds: Greyhound, Irish Wolfhound, Bloodhound, Foxhound, Harrier, Basset, Dachshund, Pointer, Setters, Spaniels, and Retrievers. SEVEN COLOURED PLATES and 21 full-page Engravings.

**Dogs Useful to Man in other Work than Field Sports; House and Toy Dogs.** Containing Particulars of the following,

among other Breeds: Collie, Bulldog, Mastiff, St. Bernards, Newfoundland, Great Dane, Fox and all other Terriers, King Charles and Blenheim Spaniels, Pug, Pomeranian, Poodle, Italian Greyhound, Toy Dogs, &c., &c. COLOURED PLATES and full-page Engravings.

**Practical Kennel Management:** A Complete Treatise on all Matters relating to the Proper Management of Dogs, whether kept for the Show Bench, for the Field, or for Companions. Illustrated with Coloured and numerous other Plates.

**DOGS, DISEASES OF:** Their Causes, Symptoms, and Treatment; Modes of Administering Medicines; Treatment in cases of Poisoning, &c. For the use of Amateurs. By HUGH DALZIEL. Third Edition. *In paper, price 1s., by post 1s. 2d.; in cloth gilt, 2s., by post 2s. 3d.*

**ENTERTAINMENTS, AMATEUR, FOR CHARITABLE AND OTHER OBJECTS:** How to Organize and Work them with Profit and Success. By ROBERT GANTHONY. *In coloured cover, price 1s., by post 1s. 2d.*

**FANCY WORK SERIES, ARTISTIC.** A Series of Illustrated Manuals on Artistic and Popular Fancy Work of various kinds. Each number is complete in itself, and issued at the uniform *price of 6d., by post 7d.* Now ready—(1) MACRAMÉ LACE (Second Edition); (2) PATCHWORK; (3) TATTING; (4) CREWEL WORK; (5) APPLIQUÉ; (6) FANCY NETTING.

**FEATHERED FRIENDS, OLD AND NEW.** Being the Experience of many years' Observation of the Habits of British and Foreign Cage Birds. By DR. W. T. GREENE. Illustrated. *In cloth gilt, price 5s., by post 5s. 4d.*

**FERNS, THE BOOK OF CHOICE:** for the Garden, Conservatory, and Stove. Describing the best and most striking Ferns and Selaginellas, and giving explicit directions for their Cultivation, the formation of Rockeries, the arrangement of Ferneries, &c. By GEORGE SCHNEIDER. With numerous Coloured Plates and other Illustrations. *In 3 vols., large post 4to. Cloth gilt, price £3 3s., by post £3 6s.*

**FERNS, CHOICE BRITISH.** Descriptive of the most beautiful Variations from the common forms, and their Culture. By C. T. DRUERY, F.L.S. Very accurate PLATES, and other Illustrations. *In cloth gilt, price 2s. 6d., by post 2s. 9d.*

**FERRETS AND FERRETING.** Containing Instructions for the Breeding, Management, and Working of Ferrets. Second Edition, Rewritten and greatly Enlarged. Illustrated. *In paper, price 6d., by post 7d.*

**FERTILITY OF EGGS CERTIFICATE.** These are Forms of Guarantee given by the Sellers to the Buyers of Eggs for Hatching, undertaking to refund value of any unfertile eggs, or to replace them with good ones. Very valuable to sellers of eggs, as they induce purchases. *In books, with counterfoils, price 6d., by post 7d.*

**FIREWORK-MAKING FOR AMATEURS.** A complete, accurate, and easily-understood work on Making Simple and High-class Fireworks. By DR. W. H. BROWNE, M.A. *In paper, price 2s. 6d., by post 2s. 9d.*

**FISHERMAN, THE PRACTICAL.** Dealing with the Natural History, the Legendary Lore, the Capture of British Fresh-Water Fish, and Tackle and Tackle-making. By J. H. KEENE. *In cloth, price 7s. 6d., by post, 8s.*

**FISH, FLESH, AND FOWL:** When in Season, How to Select, Cook and Serve. By MARY BARRETT BROWN. *In coloured wrapper, price 1s., by post 1s. 2d.*

- FOREIGN BIRDS, FAVOURITE**, for Cages and Aviaries. How to Keep them in Health. Fully Illustrated. By W. T. GREENE, M.A., M.D., F.Z.S., &c. *In cloth, price 2s. 6d., by post 2s. 9d.*
- FOX TERRIER, THE**. Its History, Points, Breeding, Rearing, Preparing, for Exhibition, and Coursing. By HUGH DALZIEL. Illustrated with Coloured Frontispiece and Plates. *In paper, price 1s., by post 1s. 2d.; cloth, 2s., by post 2s. 3d.*
- FOX TERRIER STUD BOOK**. Edited by HUGH DALZIEL. *Price 3s. 6d. each., by post 3s. 9d. each.*
- Vol. I.**, containing Pedigrees of over 1400 of the best-known Dogs, traced to their most remote known ancestors.
- Vol. II.** Pedigrees of 1544 Dogs, Show Record, &c.
- Vol. III.** Pedigrees of 1214 Dogs, Show Record, &c.
- Vol. IV.** Pedigrees of 1168 Dogs, Show Record, &c.
- Vol. V.** Pedigrees of 1662 Dogs, Show Record, &c.
- FRETWORK AND MARQUETRY**. A Practical Manual of Instructions in the Art of Fret-cutting and Marquetry Work. Profusely Illustrated. By D. DENNING. *In cloth, price 2s. 6d., by post 2s. 10d.*
- FRIESLAND MERES, A CRUISE ON THE**. By ERNEST R. SUFFLING. Illustrated. *In paper, price 1s., by post 1s. 2d.*
- FRUIT CULTURE FOR AMATEURS**. By J. T. WRIGHT. With Chapters on Insect and other Fruit Pests by C. T. DRUERY. Illustrated. *In cloth gilt, price 3s. 6d., by post 3s. 9d.*
- GAME AND GAME SHOOTING, NOTES ON**. Grouse, Partridges, Pheasants, Hares, Rabbits, Quails, Woodcocks, Snipe, and Rooks. By J. J. MANLEY. Illustrated. *In cloth gilt, price 7s. 6d., by post 7s. 10d.*
- GAMES, THE BOOK OF A HUNDRED**. By MARY WHITE. These Games are for Adults, and will be found extremely serviceable for Parlour Entertainment. They are Clearly Explained. and are Ingenious, Clever, Amusing. and exceedingly Novel. *In cloth, price 2s. 6d., by post 2s. 9d.*
- GARDENING, DICTIONARY OF**. A Practical Encyclopædia of Horticulture, for Amateurs and Professionals. Illustrated with 2440 Engravings. Edited by G. NICHOLSON, Curator of the Royal Botanic Gardens, Kew; assisted by Prof. Trail, M.D., Rev. P. W. Myles, B.A., F.L.S., W. Watson, J. Garrett, and other Specialists. *In 4 vols., large post 4to. In cloth gilt, price £3, by post £3 3s.*
- GARDENING IN EGYPT**. A Handbook of Gardening for Lower Egypt. With a Calendar of Work for the different Months of the Year. By WALTER DRAPER. *In cloth, price 3s. 6d., by post 3s. 9d.*
- GOAT, BOOK OF THE**. Containing Full Particulars of the various Breeds of Goats, and their Profitable Management. With many Plates. By H. STEPHEN HOLMES PEGLER. Third Edition, with Engravings and Coloured Frontispiece. *In cloth gilt, price 4s. 6d., by post 4s. 10d.*
- GOAT-KEEPING FOR AMATEURS**: Being the Practical Management of Goats for Milking Purposes. Abridged from "The Book of the Goat." Illustrated. *In paper, price 1s., by post 1s. 2d.*
- GRAPE GROWING FOR AMATEURS**. A Thoroughly Practical Book on Successful Vine Culture. By E. MOLYNEUX. Illustrated. *In paper, price 1s., by post 1s. 2d.*
- GREENHOUSE MANAGEMENT FOR AMATEURS**. The Best Greenhouses and Frames, and How to Build and Heat them, Illustrated Descriptions of the most suitable Plants, with general and Special Cultural Directions, and all necessary information for the

Guidance of the Amateur. Second Edition, Revised and Enlarged. Magnificently Illustrated. By W. J. MAY. *In cloth gilt, price 5s. by post 5s. 4d.*

**GREYHOUND, THE:** Its History, Points, Breeding, Rearing, Training, and Running. By HUGH DALZIEL. With Coloured Frontispiece. *In cloth gilt, demy 8vo, price 2s. 6d., by post 2s. 9d.*

**GUINEA PIG, THE,** for Food, Fur, and Fancy. Illustrated with Coloured Frontispiece and Engravings. An exhaustive book on the Varieties of the Guinea Pig, and its Management. By C. CUMBERLAND, F.Z.S. *In cloth gilt, price 2s. 6d., by post 2s. 9d.*

**HAND CAMERA MANUAL, THE.** A Practical Handbook on all Matters connected with the Use of the Hand Camera in Photography. Illustrated. By W. D. WELFORD. Third Edition. *Price 1s., by post 1s. 2d.*

**HANDWRITING, CHARACTER INDICATED BY.** With Illustrations in Support of the Theories advanced taken from Autograph Letters of Statesmen, Lawyers, Soldiers, Ecclesiastics, Authors, Poets, Musicians, Actors, and other persons. Second Edition. By R. BAUGHAN. *In cloth gilt, price 2s. 6d., by post 2s. 9d.*

**HAWK MOTHS, BOOK OF BRITISH.** A Popular and Practical Manual for all Lepidopterists. Copiously illustrated in black and white from the Author's own exquisite Drawings from Nature. By W. J. LUCAS, B.A. *In cloth, price 3s. 6d., by post 3s. 9d.*

**HOME MEDICINE AND SURGERY:** A Dictionary of Diseases and Accidents, and their proper Home Treatment. For Family Use. By W. J. MACKENZIE, M.D. Illustrated. *In cloth, price 2s. 6d., by post 2s. 9d.*

**HORSE-KEEPER, THE PRACTICAL.** By GEORGE FLEMING, C.B., LL.D., F.R.C.V.S., late Principal Veterinary Surgeon to the British Army, and Ex-President of the Royal College of Veterinary Surgeons. *In cloth, price 3s. 6d., by post 3s. 10d.*

**HORSE-KEEPING FOR AMATEURS.** A Practical Manual on the Management of Horses, for the guidance of those who keep one or two for their personal use. By FOX RUSSELL. *In paper, price 1s., by post 1s. 2d.; cloth, 2s., by post 2s. 3d.*

**HORSES, DISEASES OF:** Their Causes, Symptoms, and Treatment. For the use of Amateurs. By HUGH DALZIEL. *In paper, price 1s., by post 1s. 2d.; cloth 2s., by post 2s. 3d.*

**INCUBATORS AND THEIR MANAGEMENT.** By J. H. SUTCLIFFE. Illustrated. *In paper, price 1s., by post 1s. 2d.*

**INLAND WATERING PLACES.** A Description of the Spas of Great Britain and Ireland, their Mineral Waters, and their Medicinal Value, and the attractions which they offer to Invalids and other Visitors. Profusely illustrated. A Companion Volume to "Seaside Watering Places." *In cloth, price 2s. 6d., by post 2s. 10d.*

**JOURNALISM, PRACTICAL:** How to Enter Thereon and Succeed. A book for all who think of "writing for the Press." By JOHN DAWSON. *In cloth gilt, price 2s. 6d., by post 2s. 9d.*

**LAYING HENS, HOW TO KEEP** and to Rear Chickens in Large or Small Numbers, in Absolute Confinement, with Perfect Success. By MAJOR G. F. MORANT. *In paper, price 6d., by post 7d.*

**LIBRARY MANUAL, THE.** A Guide to the Formation of a Library, and the Values of Rare and Standard Books. By J. H. SLATER, Barrister-at-Law. Third Edition. Revised and Greatly Enlarged. *In cloth gilt, price 7s. 6d., by post 7s. 10d.*

**MAGIC LANTERNS, MODERN,** A Guide to the Management of the Optical Lantern, for the Use of Entertainers, Lecturers,

- Photographers, Teachers, and others. By R. CHILD BAYLEY. *In paper, price 1s., by post 1s. 2d.*
- MICE, FANCY:** Their Varieties, Management, and Breeding. Third Edition, with additional matter and Illustrations. *In coloured wrapper representing different varieties, price 1s., by post 1s. 2d.*
- MILLINERY, HANDBOOK OF.** A Practical Manual of Instruction for Ladies. Illustrated. By MME. ROSÉE, Court Milliner, Principal of the School of Millinery. *In paper, price 1s., by post 1s. 2d.*
- MODEL YACHTS AND BOATS:** Their Designing, Making, and Sailing. Illustrated with 118 Designs and Working Diagrams. By J. DU V. GROSVENOR. *In leatherette, price 5s., by post 5s. 3d.*
- MONKEYS, PET,** and How to Manage Them. Illustrated. By ARTHUR PATTERSON. *In cloth gilt, price 2s. 6d., by post 2s. 9d.*
- MOUNTAINEERING, WELSH.** A Complete and Handy Guide to all the Best Roads and Bye-Paths by which the Tourist should Ascend the Welsh Mountains. By A. W. PERRY. With numerous Maps. *In cloth gilt, price 2s. 6d., by post 2s. 9d.*
- MUSHROOM CULTURE FOR AMATEURS.** With Full Directions for Successful Growth in Houses, Sheds, Cellars, and Pots, on Shelves, and Out of Doors. Illustrated. By W. J. MAY. *In paper, price 1s, by post 1s. 2d.*
- NATURAL HISTORY SKETCHES** among the Carnivora—Wild and Domesticated; with Observations on their Habits and Mental Faculties. By ARTHUR NICOLS, F.G.S., F.R.G.S. Illustrated. *In cloth gilt, price 2s. 6d., by post 2s. 9d.*
- NEEDLEWORK, DICTIONARY OF.** An Encyclopædia of Artistic, Plain, and Fancy Needlework; Plain, practical, complete, and magnificently Illustrated. By S. F. A. CAULFIELD and B. C. SAWARD. *In demy 4to, 528pp., 829 Illustrations, extra cloth gilt, plain edges, cushioned bevelled boards, price 21s., by post 22s.; with COLOURED PLATES, elegant satin brocade cloth binding, and coloured edges, 31s. 6d., by post 32s. 6d.*
- ORCHIDS:** Their Culture and Management, with Descriptions of all the Kinds in General Cultivation. Illustrated by Coloured Plates and Engravings. By W. WATSON, Assistant-Curator, Royal Botanic Gardens, Kew; Assisted by W. BEAN, Foreman, Royal Gardens, Kew. Second Edition, Revised and with Extra Plates. *In cloth gilt and gilt edges, price £1 1s., by post £1 1s. 10d.*
- PAINTERS AND THEIR WORKS.** A Work of the Greatest Value to Collectors and such as are interested in Art, as it gives, besides Biographical Sketches of all the Artists of Repute (not now living) from the 13th Century to the present date, the Market Value of the Principal Works Painted by Them, with Full Descriptions of Same. *In 3 vols., cloth, price 15s. per vol., or 37s. 6d. the set of 3.*
- PAINTING, DECORATIVE.** A practical Handbook on Painting and Etching upon Textiles, Pottery, Porcelain, Paper, Vellum, Leather, Glass, Wood, Stone, Metals, and Plaster, for the Decoration of our Homes. By B. C. SAWARD. *In cloth, price 3s. 6d., by post 3s. 9d.*
- PARCEL POST DISPATCH BOOK** (registered). An invaluable book for all who send parcels by post. Provides Address Labels, Certificate of Posting, and Record of Parcels Dispatched. By the use of this book parcels are insured against loss or damage to the extent of £2. Authorized by the Post Office. *Price 1s., by post 1s. 2d., for 100 parcels; larger sizes if required.*



- PARROT, THE GREY**, and How to Treat it. By W. T. GREENE, M.D., M.A., F.Z.S., &c. *Price 1s., by post 1s. 2d.*
- PARROTS, THE SPEAKING.** The Art of Keeping and Breeding the principal Talking Parrots in Confinement. By DR. KARL RUSS. Illustrated with COLOURED PLATES and Engravings. *In cloth gilt, price 5s., by post 5s. 4d.*
- PATIENCE, GAMES OF**, for one or more Players. How to Play 106 different Games of Patience. By MISS WHITMORE JONES. Illustrated. Series I., 39 games; Series II., 34 games; Series III., 33 games. Each 1s., *by post 1s. 2d.* *The three bound together in cloth, price 3s. 6d., by post 3s. 10d.*
- PEN PICTURES**, and How to Draw Them. A Practical Handbook on the various Methods of Illustrating in Black and White for "Process" Engraving, with numerous Designs, Diagrams, and Sketches. By ERIC MEADE. *In cloth gilt, price 2s. 6d., by post 2s. 9d.*
- PERSPECTIVE, THE ESSENTIALS OF.** With numerous Illustrations drawn by the Author. By L. W. MILLER, Principal of the School of Industrial Art of the Pennsylvania Museum, Philadelphia. *Price 6s. 6d., by post 6s. 10d.*
- PHEASANT-KEEPING FOR AMATEURS.** A Practical Handbook on the Breeding, Rearing, and General Management of Fancy Pheasants in Confinement. By GEO. HORNE. Fully Illustrated. *In cloth gilt, price 3s. 6d., by post 3s. 9d.*
- PHOTOGRAPHY (MODERN) FOR AMATEURS.** New and Revised Edition. By J. EATON FEARN. *In paper, price 1s., by post 1s. 2d.*
- PIANOFORTES, TUNING AND REPAIRING.** The Amateur's Guide to the Practical Management of a Piano without the intervention of a Professional. By CHARLES BABBINGTON. *In paper, price 6d., by post 6½d.*
- PICTURE-FRAME MAKING FOR AMATEURS.** Being Practical Instructions in the Making of various kinds of Frames for Paintings, Drawings, Photographs, and Engravings. Illustrated. By the REV. J. LUKIN. *In paper, price 1s., by post 1s. 2d.*
- PIG, BOOK OF THE.** The Selection, Breeding, Feeding, and Management of the Pig; the Treatment of its Diseases; the Curing and Preserving of Hams, Bacon, and other Pork Foods; and other information appertaining to Pork Farming. By PROFESSOR JAMES LONG. Fully Illustrated with Portraits of Prize Pigs, Plans of Model Piggeries, &c. *In cloth gilt, price 10s. 6d., by post 11s. 1d.*
- PIG-KEEPING, PRACTICAL:** A Manual for Amateurs, based on Personal Experience in Breeding, Feeding, and Fattening; also in Buying and Selling Pigs at Market Prices. By R. D. GARRATT. *In paper, price 1s., by post 1s. 2d.*
- PIGEONS, FANCY.** Containing Full Directions for the Breeding and Management of Fancy Pigeons, and Descriptions of every known Variety, together with all other information of interest or use to Pigeon fanciers. Third Edition, bringing the subject down to the present time. 18 COLOURED PLATES, and 22 other full-page Illustrations. By J. C. LYELL. *In cloth gilt, price 10s. 6d., by post 10s. 10d.*
- PIGEON-KEEPING FOR AMATEURS.** A complete Guide to the Amateur Breeder of Domestic and Fancy Pigeons. By J. C. LYELL. Illustrated. *In cloth, price 2s. 6d., by post 2s. 9d.*
- POLISHES AND STAINS FOR WOODS:** A Complete Guide to Polishing Woodwork, with Directions for Staining, and Full Information

for making the Stains, Polishes, &c., in the simplest and most satisfactory manner. By DAVID DENNING. *In paper, 1s., by post 1s. 2d.*

**POOL, GAMES OF.** Describing Various English and American Pool Games, and giving the Rules in full. Illustrated. *In paper, price 1s., by post 1s. 2d.*

**POTTERY AND PORCELAIN, ENGLISH.** A Guide for Collectors. Handsomely Illustrated with Engravings of Specimen Pieces and the Marks used by the different Makers. New Edition, Revised and Enlarged. By the REV. E. A. DOWNMAN. *In cloth gilt, price 5s., by post 5s. 4d.*

**POULTRY-KEEPING, POPULAR.** A Practical and Complete Guide to Breeding and Keeping Poultry for Eggs or for the Table. By F. A. MACKENZIE. Illustrated. *In paper, price 1s., by post 1s. 2d.*

**POULTRY AND PIGEON DISEASES:** Their Causes, Symptoms, and Treatment. A Practical Manual for all Fanciers. By QUINTIN CRAIG and JAMES LYELL. *In paper, price 1s., by post 1s. 2d.*

**POULTRY FOR PRIZES AND PROFIT.** Contains: Breeding Poultry for Prizes, Exhibition Poultry and Management of the Poultry Yard. Handsomely Illustrated. Second Edition. By PROF. JAMES LONG. *In cloth gilt, price 2s. 6d., by post 2s. 10d.*

**RABBIT, BOOK OF THE.** A Complete Work on Breeding and Rearing all Varieties of Fancy Rabbits, giving their History, Variations, Uses, Points, Selection, Mating, Management, &c., &c. SECOND EDITION. Edited by KEMPSTER W. KNIGHT. Illustrated with Coloured and other Plates. *In cloth gilt, price 10s. 6d., by post 11s.*

**RABBITS, DISEASES OF:** Their Causes, Symptoms, and Cure. With a Chapter on THE DISEASES OF CAVIES. Reprinted from "The Book of the Rabbit" and "The Guinea Pig for Food, Fur, and Fancy." *In paper, price 1s., by post 1s. 2d.*

**RABBIT-FARMING, PROFITABLE.** A Practical Manual, showing how Hutch Rabbit-farming in the Open can be made to Pay Well. By MAJOR G. F. MORANT. *In paper, price 1s., by post 1s. 2d.*

**RABBITS FOR PRIZES AND PROFIT.** The Proper Management of Fancy Rabbits in Health and Disease, for Pets or the Market, and Descriptions of every known Variety, with Instructions for Breeding Good Specimens. Illustrated. By CHARLES RAYSON. *In cloth gilt, price 2s. 6d., by post 2s. 9d.* Also in Sections, as follows:—

**General Management of Rabbits.** Including Hutches, Breeding, Feeding, Diseases and their Treatment, Rabbit Courts, &c. Fully Illustrated. *In paper, price 1s., by post 1s. 2d.*

**Exhibition Rabbits.** Being descriptions of all Varieties of Fancy Rabbits, their Points of Excellence, and how to obtain them. Illustrated. *In paper, price 1s., by post 1s. 2d.*

**REPOUSSÉ WORK FOR AMATEURS:** Being the Art of Ornamenting Thin Metal with Raised Figures. By L. L. HASLOPE. Illustrated. *In cloth gilt, price 2s. 6d., by post 2s. 9d.*

**ROAD CHARTS (Registered).** For Army Men, Volunteers, Cyclists, and other Road Users. By S. W. HEPWORTH DIXON and A. B. H. CLERKE, Royal Artillery. No. 1.—London to Brighton. *Price 2d., by post 2½d.*

**ROSES FOR AMATEURS.** A Practical Guide to the Selection and Cultivation of the best Roses. Illustrated. By the REV. J. HONYWOOD D'OMBRAIN, Hon. Sec. Nat. Rose Soc. *In paper, 1s., by post 1s. 2d.*

**SAILING GUIDE TO THE SOLENT AND POOLE HARBOUR,** with Practical Hints as to Living and Cooking on, and Working a Small Yacht. By LIEUT.-COLONEL T. G. CUTHELL. Illustrated with Coloured Charts. *In cloth, price 2s. 6d., by post 2s. 9d.*

**SAILING TOURS.** The Yachtman's Guide to the Cruising Waters of the English and Adjacent Coasts. With Descriptions of every Creek, Harbour, and Roadstead on the Course. With numerous Charts printed in Colours, showing Deep water, Shoals, and Sands exposed at low water, with sounding. *In Crown 8vo., cloth gilt.* By FRANK COWPER, B.A.

**Vol. I.**, the Coasts of Essex and Suffolk, from the Thames to Aldborough. Six Coloured Charts. *Price 5s., by post 5s. 3d.*

**Vol. II.** The South Coast, from the Thames to the Scilly Islands, with twenty-five Charts printed in Colours. *Price 7s. 6d., by post 7s. 10d.*

**Vol. III.** The Coast of Brittany: Descriptions of every Creek, Harbour, and Roadstead from L'Abervrach to St. Nazaire, and an Account of the Loire. With twelve Charts, printed in Colours. *Price 7s. 6d., by post 7s. 10d.*

**Vol. IV.** The West Coast, from Land's End to Mull of Galloway, including the East Coast of Ireland. With thirty Charts, printed in Colours. *Price 10s. 6d., by post 10s. 10d.*

**Vol. V.** The Coasts of Scotland and the N.E. of England down to Aldborough. With forty Charts. *Price 10s. 6d., by post 10s. 10d.*

**ST. BERNARD, THE.** Its History, Points, Breeding, and Rearing. By HUGH DALZIEL. Illustrated with Coloured Frontispiece and Plates. *In cloth, price 2s. 6d., by post 2s. 9d.*

**ST. BERNARD STUD BOOK.** Edited by HUGH DALZIEL. *Price 3s. 6d. each., by post 3s. 9d. each.*

**Vol. I.** Pedigrees of 1278 of the best known Dogs, traced to their most remote known ancestors, Show Record, &c.

**Vol. II.** Pedigrees of 564 Dogs, Show Record, &c.

**SEA-FISHING FOR AMATEURS.** Practical Instructions to Visitors at Seaside Places for Catching Sea-Fish from Pier-heads, Shore, or Boats, principally by means of Hand Lines, with a very useful List of Fishing Stations, the Fish to be caught there, and the Best Seasons. By FRANK HUDSON. Illustrated. *In paper, price 1s., by post 1s. 2d.*

**SEA-FISHING ON THE ENGLISH COAST.** The Art of Making and Using Sea-Tackle, with a full account of the methods in vogue during each month of the year, and a Detailed Guide for Sea-Fishermen to all the most Popular Watering Places on the English Coast. By F. G. AFLALO. Illustrated. *In cloth, price 2s. 6d., by post 2s. 9d.*

**SEASIDE WATERING PLACES.** A Description of the Holiday Resorts on the Coasts of England and Wales, the Channel Islands, and the Isle of Man, giving full particulars of them and their attractions, and all information likely to assist persons in selecting places in which to spend their Holidays according to their individual tastes. Illustrated. Eighth Edition. *In cloth, price 2s. 6d., by post 2s. 10d.*

**SHADOW ENTERTAINMENTS,** and How to Work Them: being Something about Shadows, and the way to make them Profitable and Funny. By A. PATTERSON. *In paper, price 1s., by post 1s. 2d.*

**SHAVE, AN EASY:** The Mysteries, Secrets, and Whole Art of, laid bare for 1s., *by post 1s. 2d.* Edited by JOSEPH MORTON.

**SHEET METAL, WORKING IN:** Being Practical Instructions for Making and Mending Small Articles in Tin, Copper, Iron, Zinc, and Brass. Illustrated. Third Edition. By the Rev. J. LUKIN, B.A. *In paper, price 1s., by post 1s. 1d.*

**SHORTHAND, ON GURNEY'S SYSTEM (IMPROVED),** LESSONS IN: Being Instructions in the Art of Shorthand Writing as used in the Service of the two Houses of Parliament. By R. E. MILLER. *In paper, price 1s., by post 1s. 2d.*

- SHORTHAND, EXERCISES IN**, for Daily Half Hours, on a Newly-devised and Simple Method, free from the Labour of Learning. Illustrated. Being Part II. of "Lessons in Shorthand on Gurney's System (Improved)." By R. E. MILLER. *In paper, price 9d., by post 10d.*
- SHORTHAND SYSTEMS; WHICH IS THE BEST?** Being a Discussion, by various Experts, on the Merits and Demerits of all the principal Systems, with Illustrative Examples. Edited by THOMAS ANDERSON. *In paper, price 1s., by post 1s. 2d.*
- SKATING CARDS:** An Easy Method of Learning Figure Skating, as the Cards can be used on the Ice. *In cloth case, 2s. 6d., by post 2s. 9d.; leather, 3s. 6d., by post 3s. 9d.* A cheap form is issued printed on paper and made up as a small book, 1s., by post 1s. 1d.
- SLEIGHT OF HAND.** A Practical Manual of Legerdemain for Amateurs and Others. New Edition, Revised and Enlarged. Profusely Illustrated. By E. SACHS. *In cloth gilt, price 6s. 6d., by post 6s. 10d.*
- SNAKES, MARSUPIALS, AND BIRDS.** A Charming Book of Anecdotes, Adventures, and Zoological Notes. A capital Book for Boys. By ARTHUR NICOLS, F.G.S., F.R.G.S., &c. Illustrated. *In cloth gilt, price 3s. 6d., by post 3s. 10d.*
- STAMPS, POSTAGE,** and their Collection. A Practical Handbook for Collectors of Postal Stamps, Envelopes, Wrappers, and Cards. By D. FIRTH, Member of the Philatelic Societies of London, Leeds, and Bradford. Profusely Illustrated. *In cloth gilt, price 3s. 6d., by post 3s. 9d.* [In the Press.]
- TAXIDERMY, PRACTICAL.** A Manual of Instruction to the Amateur in Collecting, Preserving, and Setting-up Natural History Specimens of all kinds. With Examples and Working Diagrams. By MONTAGU BROWNE, F.Z.S., Curator of Leicester Museum. Second Edition. *In cloth gilt, price 7s. 6d., by post 7s. 10d.*
- THAMES GUIDE BOOK.** From Lechlade to Richmond. For Boating Men, Anglers, Picnic Parties, and all Pleasure-seekers on the River. Arranged on an entirely new plan. Second Edition, profusely illustrated. *In paper, price 1s. by post 1s. 3d.; cloth, 1s. 6d., by post 1s. 9d.*
- TOMATO AND FRUIT GROWING** as an Industry for Women. Lectures given at the Forestry Exhibition, Earl's Court, during July and August, 1893. By GRACE HARRIMAN, Practical Fruit Grower and County Council Lecturer. *In paper, price 1s., by post 1s. 1d.*
- TOMATO CULTURE FOR AMATEURS.** A Practical and very Complete Manual on the Subject. By B. C. RAVENSCROFT. Illustrated. *In paper, price 1s., by post 1s. 3d.*
- TOYMAKING FOR AMATEURS:** Being Instructions for the Home Construction of Simple Wooden Toys, and of others that are Moved or Driven by Weights, Clockwork, Steam, Electricity, &c. Illustrated. By JAMES LUKIN, B.A. *In cloth, price 2s. 6d., by post 2s. 10d.*
- TRAPPING, PRACTICAL:** Being some Papers on Traps and Trapping for Vermin. with a Chapter on General Bird Trapping and Snaring. By W. CARNEGIE. *In paper, price 1s., by post 1s. 2d.*
- TURKEY, THE.** A Handy Manual for both the Amateur and Professional Breeder of the Turkey, describing its Characteristics, Varieties, and Management. By W. WILLIS-HARRIS, Vice-President of the Turkey Club. *In paper, price 1s., by post 1s. 2d.*
- TURNING FOR AMATEURS:** Being Descriptions of the Lathe and its Attachments and Tools, with Minute Instructions for their Effective Use on Wood, Metal, Ivory, and other Materials. Second Edition,

Revised and Enlarged. By JAMES LUKIN, B.A. Illustrated with 144 Engravings. *In cloth gilt, price 2s. 6d., by post 2s. 9d.*

**TURNING LATHES.** A Manual for Technical Schools and Apprentices. A guide to Turning, Screw-cutting, Metal-spinning, &c. Edited by JAMES LUKIN, B.A. Third Edition. With 194 Illustrations. *In cloth gilt, price 3s., by post 3s. 3d.*

**VAMP, HOW TO.** A Practical Guide to the Accompaniment of Songs by the Unskilled Musician. With Examples. *In paper, price 9d., by post 10d.*

**VEGETABLE CULTURE FOR AMATEURS.** Containing Concise Directions for the Cultivation of Vegetables in Small Gardens so as to insure Good Crops. With Lists of the Best Varieties of each Sort. By W. J. MAY. Illustrated. *In paper, price 1s., by post 1s. 2d.*

**VENTRILOQUISM, PRACTICAL.** A thoroughly reliable Guide to the Art of Voice Throwing and Vocal Mimicry, Vocal Instrumentation, Ventriloquial Figures, Entertaining, &c. By ROBERT GANTHONY. Numerous Illustrations. *In cloth, price 2s. 6d., by post 2s. 9d.*

**VIOLINS (OLD) AND THEIR MAKERS:** Including some References to those of Modern Times. By JAMES M. FLEMING. Illustrated with Facsimiles of Tickets, Sound-Holes, &c. Reprinted by Subscription. *In cloth, price 6s. 6d., by post 6s. 10d.*

**VIOLIN SCHOOL, PRACTICAL,** for Home Students. Instructions and Exercises in Violin Playing, for the use of Amateurs, Self-learners, Teachers, and others. With a supplement on "Easy Legato Studies for the Violin." By J. M. FLEMING. *Demy 4to, price 9s. 6d., by post 10s. 4d.* Without Supplement, *price 7s. 6d., by post 8s. 1d.*

**WAR MEDALS AND DECORATIONS.** A Manual for Collectors, with some account of Civil Rewards for Valour. Beautifully Illustrated. By D. HASTINGS IRWIN. *In cloth, price 7s. 6d., by post 7s. 10d.*

**WHIPPET AND RACE-DOG, THE:** How to Breed, Rear, Train, Race, and Exhibit the Whippet, the Management of Race Meetings, and Original Plans of Courses. By FREEMAN LLOYD. *In cloth gilt, price 3s. 6d., by post 3s. 10d.*

**WHIST : MODERN SCIENTIFIC.** A Practical Manual on New Lines, and with Illustrative Hands. Printed in Colour. By C. J. MELROSE. *In cloth, price 6s., by post 6s. 3d.*

**WILDFOWLING, PRACTICAL :** A Book on Wildfowl and Wildfowl Shooting. By HY. SHARP. The result of 25 years' experience in Wildfowl Shooting under all sorts of conditions of locality as well as circumstances. Profusely Illustrated. *Demy 8vo, price 12s. 6d., by post 13s.*

**WINDOW TICKET WRITING.** Containing full Instructions on the Method of Mixing and Using the Various Inks, &c., required, Hints on Stencilling as applied to Ticket Writing, together with Lessons on Glass Writing, Japanning on Tin, &c. Especially written for the use of Learners and Shop Assistants. By WM. C. SCOTT. *In paper, price 1s., by post 1s. 2d.*

**WIRE AND SHEET GAUGES OF THE WORLD.** Compared and Compiled by C. A. B. PFEILSCHMIDT, of Sheffield. *In paper, price 1s., by post 1s. 1d.*

**WOOD CARVING FOR AMATEURS.** Full Instructions for producing all the different varieties of Carvings. 2nd Edition. Edited by D. DENNING. *Price 1s., by post 1s. 2d.*

**PUBLISHED BY E. and F. N. SPON.**

**RECENTLY PUBLISHED.**

Crown 4to, full gilt, fancy cloth, 478 pages Letterpress and 735 Engravings, price 7/6.

**POPULAR ENGINEERING:**

BEING INTERESTING AND INSTRUCTIVE EXAMPLES IN  
**CIVIL, MECHANICAL, ELECTRICAL, CHEMICAL, MINING,  
MILITARY, and NAVAL ENGINEERING,**

GRAPHICALLY AND PLAINLY DESCRIBED AND

Specially Written for those about to enter the Engineering Profession and the  
Scientific Amateur. With Chapters upon

**PERPETUAL MOTION and ENGINEERING COLLEGES and SCHOOLS.**

**By F. DYE.**

**MECHANICS' OWN BOOK.**

**SPONS' MECHANICS' OWN BOOK:**

*A MANUAL FOR HANDICRAFTSMEN AND AMATEURS.*

Complete in One large Vol., demy 8vo, cloth, containing 700 pp. and 1420 Illustrations.  
Fourth Edition, 6/- or half-bound, French morocco, 7/6.

***Contents:***

Mechanical Drawing; Casting and Founding in Iron, Brass, Bronze, and other Alloys; Forging and Finishing Iron; Sheet Metal Working; Soldering, Brazing, and Burning; Carpentry and Joinery, embracing descriptions of some 400 woods; over 200 Illustrations of Tools and their Uses; Explanations (with Diagrams) of 116 Joints and Hinges, and Details of Construction of Workshop Appliances; Rough Furniture, Garden and Yard Erections, and House-Building; Cabinet-making and Veneering; Carving and Fret-cutting; Upholstery; Painting, Graining and Marbling; Staining Furniture, Woods, Floors and Fittings; Gilding, Dead and Bright, on various Grounds; Polishing Marble, Metals and Wood; Varnishing; Mechanical Movements, illustrating contrivances for transmitting Motion; Turning in Wood and Metals; Masonry, embracing Stonework, Brickwork, Terra-cotta, and Concrete; Roofing with Thatch, Tiles, Slates, Felt, Zinc, &c.; Glazing with and without Putty, and Lead Glazing; Plastering and Whitewashing; Paper-hanging; Gas-fitting; Bell-hanging, Ordinary and Electric Systems; Lighting; Warming; Ventilating; Roads, Pavements and Bridges; Hedges, Ditches and Drains; Water Supply and Sanitation; Hints on House Construction suited to New Countries.

**HOUSEHOLD MANUAL.**

**SPONS' HOUSEHOLD MANUAL:**

*A TREASURY OF DOMESTIC RECEIPTS AND GUIDE FOR HOME  
MANAGEMENT.*

Demy 8vo, cloth, containing 975 pp. and 250 Illustrations. price 7/6; or half-bound,  
French morocco, 9/-

***Principal Contents:***

Hints for selecting a good House; Sanitation; Water Supply; Ventilation and Warming; Lighting; Furniture and Decoration; Thieves and Fire; The Larder; Curing Foods for lengthened Preservation; The Dairy; The Cellar; The Pantry; The Kitchen; Receipts for Dishes; The Housewife's Room; Housekeeping, Marketing; The Dining-room; The Drawing-room; The Bed-room; The Nursery; The Sick-room; The Bath-room; The Laundry; The School-room; The Playground; The Work-room; The Library; The Garden; The Farmyard; Small Motors; Household Law.

**London: E. & F. N. SPON, 125, Strand.**

**New York: SPON & CHAMBERLAIN, 12, Cortlandt Street.**

# ROWLANDS' ARTICLES

For the HAIR, COMPLEXION, & TEETH, are the  
PUREST AND BEST.



## ROWLANDS' ODONTO,

An antiseptic, preservative, and aromatic dentifrice, which whitens the teeth, prevents and arrests decay, and sweetens the breath. It contains no mineral acids, no gritty matter or injurious astringents, keeps the mouth, gums, and teeth free from the unhealthy action of germs in organic matter between the teeth, and is the most wholesome tooth-powder for smokers. It is most beautifully perfumed, and is a perfect luxury for the toilet-table of everybody. **2s. 9d.** per box.

## ROWLANDS' MACASSAR OIL

Is the best preserver and beautifier of the hair of children and adults; prevents it falling off or turning grey, eradicates scurf and dandruff, and is also the best brilliantine for ladies' and everybody's use, and as a little goes a very long way it really is most economical for general use; is also sold in a golden colour for fair-haired ladies and children; it contains no lead or mineral ingredients, has a most delightfully fragrant bouquet of roses, and is considered the most perfect toilet luxury ever produced. Bottles, **3s. 6d., 7s., 10s. 6d.**

## ROWLANDS' KALYDOR,

A most cooling, soothing, healing, and refreshing preparation for the Skin and Complexion of Ladies, and all exposed to the summer sun and dust, or the cold and damp of winter; it is warranted free from all mineral or metallic ingredients, or oxide of zinc, of which most Cosmetics are composed, and which ruin the skin. It effectually disperses Chaps, Chilblains, Freckles, Tan, Sunburn, Stings of Insects, Redness, Roughness of the Skin; relieves Irritation of the Skin, Prickly Heat, &c., renders the

### SKIN SOFT AND SMOOTH,

and produces a beautiful, pure, and delicate complexion. Size **4s. 6d.** and **8s. 6d.**; half-sized bottles, **2s. 3d.**

## ROWLANDS' ESSENCE OF TYRE

effectually dyes red or grey hair a permanent brown or black. **4s.**

## ROWLANDS' EUKONIA.

A pure Toilet Powder in three tints, White Rose, and Cream, for ladies of a Brunette complexion and those who do not like white powder. Boxes, **1s.**; large boxes, **2s. 6d.**

Ask Chemists for **ROWLANDS' ARTICLES**, of **20, HATTON GARDEN, LONDON**, and avoid spurious imitations.

# The Diet of all Lucky Dogs

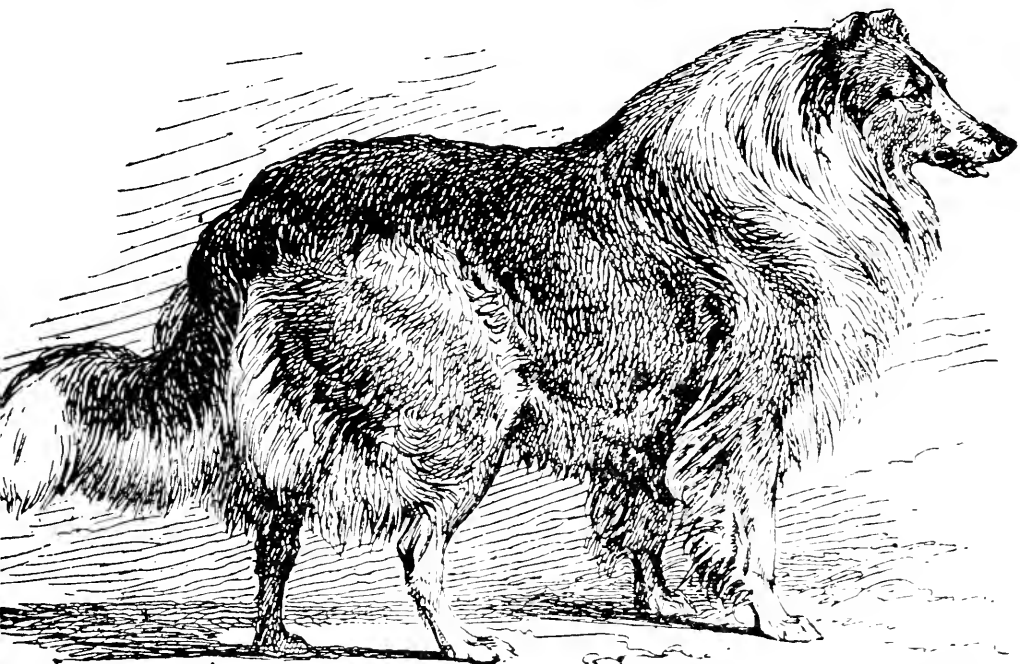

Copyright  
Spratts Patent Ltd.

## SPRATTS PATENT DOG CAKES.

-----  
*Pamphlet on CANINE DISEASES GRATIS.*  
-----

SPRATTS PATENT LIMITED, BERMONDSEY S.E.





