





**Marine Biological Laboratory Library**

Woods Hole, Mass.



Presented by

Dr. Philip Person  
Feb. 26, 1962

MBL/WHOI



0 0301 0020505 0



# HAEMATIN ENZYMES

I.U.B. SYMPOSIUM SERIES

VOLUME 19

INTERNATIONAL UNION OF BIOCHEMISTRY  
SYMPOSIUM SERIES

- Vol. 1. *The Origin of Life on the Earth*—A. I. OPARIN *et al.* (Editors)  
Vol. 2. *Enzyme Chemistry: Proceedings of the International Symposium in Tokyo-Kyoto*

PROCEEDINGS OF THE FOURTH INTERNATIONAL CONGRESS ON BIOCHEMISTRY  
VIENNA, 1958

- Vol. 3. (I) *Carbohydrate Chemistry of Substances of Biological Interest*  
Vol. 4. (II) *Biochemistry of Wood*  
Vol. 5. (III) *Biochemistry of the Central Nervous System*  
Vol. 6. (IV) *Biochemistry of Steroids*  
Vol. 7. (V) *Biochemistry of Antibiotics*  
Vol. 8. (VI) *Biochemistry of Morphogenesis*  
Vol. 9. (VII) *Biochemistry of Viruses*  
Vol. 10. (VIII) *Proteins*  
Vol. 11. (IX) *Physical Chemistry of High Polymers of Biological Interest*  
Vol. 12. (X) *Blood Clotting Factors*  
Vol. 13. (XI) *Vitamin Metabolism*  
Vol. 14. (XII) *Biochemistry of Insects*  
Vol. 15. (XIII) *Colloquia*  
Vol. 16. (XIV) *Transactions of the Plenary Sessions*  
Vol. 17. (XV) *Biochemistry*

- Vol. 18. *Biochemistry of Lipids*—G. POPJÁK (Editor)  
Vol. 19. *Haematin Enzymes (Parts 1 and 2)*—J. E. FALK, R. LEMBERG and R. K. MORTON  
Vol. 20. *Report of the Commission on Enzymes, 1961 (I.U.B.)*

PROCEEDINGS OF THE FIFTH INTERNATIONAL CONGRESS ON BIOCHEMISTRY  
MOSCOW, 1961  
(Provisional titles)

- Vol. 21. (I) *Biological Structure and Function at the Molecular Level*  
Vol. 22. (II) *Functional Biochemistry of Cell Structures*  
Vol. 23. (III) *Evolutionary Biochemistry*  
Vol. 24. (IV) *Molecular Basis of Enzyme Action and Prohibition*  
Vol. 25. (V) *Intracellular Respiration: Phosphorylating and Non-Phosphorylating Systems*  
Vol. 26. (VI) *Mechanism of Photosynthesis*  
Vol. 27. (VII) *Biosynthesis of Lipids*  
Vol. 28. (VIII) *Biochemical Principles of the Food Industry*  
Vol. 29. (IX) *Transactions of the Plenary Sessions*  
Vol. 30. (X) *Abstracts of Papers and Indexes to the Volumes of the Proceedings*





The building of the Australian Academy of Science, Canberra,  
where the Symposium was held.



# HAEMATIN ENZYMES

A SYMPOSIUM OF THE  
INTERNATIONAL UNION OF BIOCHEMISTRY  
ORGANIZED BY THE  
AUSTRALIAN ACADEMY OF SCIENCE  
—  
CANBERRA  
1959

*Edited by*  
J. E. FALK, R. LEMBERG  
*and*  
R. K. MORTON

PART 1  
(Pages 1 to 362)

SYMPOSIUM PUBLICATIONS DIVISION  
PERGAMON PRESS  
OXFORD · LONDON · NEW YORK · PARIS  
1961

PERGAMON PRESS LTD.

*Headington Hill Hall, Oxford  
4 & 5 Fitzroy Square, London W.1*

PERGAMON PRESS INC.

*122 East 55th Street, New York 22, N.Y.  
1404 New York Avenue N.W., Washington 5 D.C.  
Statler Center 640, 900 Wilshire Boulevard,  
Los Angeles 17, California*

PERGAMON PRESS S.A.R.L.

*24 Rue des Écoles, Paris V<sup>e</sup>*

PERGAMON PRESS G.m.b.H.

*Kaiserstrasse 75, Frankfurt am Main*

Copyright © 1961

PERGAMON PRESS LTD.

LIBRARY OF CONGRESS CARD NUMBER 60-53463

*Set in Monotype Times 10/12pt and  
Printed in Great Britain by the Pitman Press, Bath*

## PREFACE

THIS volume contains the papers and discussion material presented at the *Symposium on Haematin Enzymes*. It was held at Canberra between 31st August and 4th September, 1959, and was organized by the Australian Academy of Science for the International Union of Biochemistry.

The Symposium was arranged for the Academy by a Committee comprising A. H. Ennor, J. E. Falk, R. Lemberg and R. K. Morton (Convener). The Committee is grateful to several organizations, cited in the address by Dr. R. Lemberg, President of the Symposium, for financial and other assistance.

The titles and addresses of participants are given on pp. xvii-xx. For convenience, titles have been omitted from the scientific communications.

It is with profound regret that we record the untimely death in October, 1960, of Professor Enzo Boeri, one of the distinguished participants in the Symposium. He made many notable contributions to our knowledge of haematin enzymes and he will be remembered with admiration, respect and affection by all who were privileged to know him.

R. K. MORTON



# CONTENTS

	PAGE
Participants . . . . .	xvii
Presidential Address . . . . .	xxi
The Electronic Structure and Electron Transport Properties of Metal Ions Particularly in Porphyrin Complexes	
by L. E. ORGEL . . . . .	1
<i>Discussion</i>	
<i>Terminology in Ligand-Field Theory</i> . . . . .	13
<i>Spin States of Haem Compounds</i> . . . . .	15
<i>Electron Transport</i> . . . . .	16
<i>Mechanism of Oxidative Phosphorylation</i> . . . . .	18
The Role of the Metal in Porphyrin Complexes	
by F. P. DWYER . . . . .	19
<i>Discussion</i>	
<i>Higher Oxidation States</i> . . . . .	27
<i>Effects of Metal on Reactivity at Periphery</i> . . . . .	28
The Physico-Chemical Behaviour of Porphyrins Solubilized in Aqueous Detergent Solutions	
by B. DEMPSEY, M. B. LOWE and J. N. PHILLIPS . . . . .	29
<i>Discussion</i>	
<i>Cations of Porphyrins and Their Spectra</i> . . . . .	37
The Reactions Between Metal Ions and Porphyrins	
by J. H. Wang and E. B. Fleischer . . . . .	38
Some Physical Properties and Chemical Reactions of Iron Complexes	
by R. J. P. WILLIAMS . . . . .	41
<i>Discussion</i>	
<i>Oxidation-Reduction Potentials of Haem Compounds</i> . . . . .	53

Spectra and Redox Potentials of Metalloporphyrins and Haemoproteins	
by J. E. FALK and D. D. PERRIN . . . . .	56
<i>Discussion</i>	
<i>Correlations between Structure and Physical Properties.</i> . . . .	71
<i>Models for Haemoproteins</i> . . . . .	74
Some New Compounds of Haems with Bases	
by J. E. Falk . . . . .	74
Carbon Monoxide-Pyridine Complexes with Haems	
by J. H. Wang . . . . .	76
Equilibrium Constants for Reactions of Haems with Ligands	
by J. N. Phillips . . . . .	79
Modification of the Secondary Structure of Haemoprotein Molecules	
by K. KAZIRO and K. TSUSHIMA . . . . .	80
<i>Discussion</i>	
<i>The Haem-Binding Groups in Haemoproteins</i> . . . . .	94
The Nature of Haem-Binding, and the Bohr Effect	
by J. H. Wang and Y. N. Chiu . . . . .	94
Models for Linked Ionizations in Haemoproteins	
by P. George, G. I. H. Hanania, D. H. Irvine and N. Wade . . . . .	96
On the Stability of Oxyhaemoglobin	
by J. H. WANG . . . . .	98
<i>Discussion</i>	
<i>Oxygenation of Haemoglobin</i> . . . . .	102
Ferrihaemoprotein Hydroxides: A Correlation between Magnetic and Spectroscopic Properties	
by P. GEORGE, J. BEETLESTONE and J. S. GRIFFITH . . . . .	105
<i>Discussion</i>	
<i>Spin States and Spectra of Haemoproteins</i> . . . . .	139
The Electronic Origins of the Spectra	
by J. S. Griffith and P. George . . . . .	139
Analysis and Interpretation of Absorption Spectra of Haemin Chromoproteins	
by D. L. DRABKIN . . . . .	142
<i>Discussion</i>	
<i>Interpretation of Absorption Spectra of Haemoproteins</i> . . . . .	170
<i>The Bands in the Region of 830 and 280 m<math>\mu</math></i> . . . . .	171

The Haem-Globin Linkage. 3. The Relationship between Molecular Structure and Physiological Activity of Haemoglobins	
by J. E. O'HAGAN . . . . .	173
<i>Discussion</i>	
<i>Native globin</i> . . . . .	190
<i>The Linkage of Iron and Protein in Haemoglobin</i> . . . . .	190
 Early Stages in the Metabolism of Iron	
by J. B. NEILANDS . . . . .	194
 The Enzymic Incorporation of Iron into Protoporphyrin	
by R. A. NEVÉ . . . . .	207
<i>Discussion</i>	
<i>The Formation of Metal-Porphyrin Complexes</i> . . . . .	211
Co-ordination of Divalent Metal Ions with Porphyrin Derivatives Related to Cytochrome <i>c</i>	
by J. B. Neilands . . . . .	211
<i>Metal Incorporation in Model Systems</i> . . . . .	214
<i>On the Enzymic Incorporation of Iron</i> . . . . .	215
Biosynthesis and Metabolism of Cytochrome <i>c</i>	
by D. L. Drabkin . . . . .	216
 The Location of Cytochromes in <i>Escherichia coli</i>	
by A. TISSIÈRES . . . . .	218
<i>Discussion</i>	
<i>The Origin of the Respiratory Granules of Bacteria</i> . . . . .	223
 On the Cytochromes of Anaerobically Cultured Yeast	
by PAULETTE CHAIX . . . . .	225
<i>Discussion</i>	
<i>The Lactate Dehydrogenase of Yeast</i> . . . . .	233
<i>Components of the Respiratory Chain in Yeast Mitochondria</i> . . . . .	233
<i>On the 'Haemoglobin' Absorption Bands of Yeast</i> . . . . .	233

Irreversible Inhibition of Catalase by the 3-Amino-1:2:4-Triazole Group of Inhibitors in the Presence of Catalase Donors by E. MARGOLIASH and A. SCHEJTER . . . . .	236
Catalase Oxidation Mechanisms by M. E. WINFIELD . . . . .	245
<i>Discussion</i>	
<i>Oxidation States of Haemoproteins</i> . . . . .	252
<i>Peroxide Compounds of Catalase and Peroxidase</i> . . . . .	254
The Nature of Catalase-Peroxide Complex I by B. Chance . . . . .	254
Studies on Problems of Cytochrome <i>c</i> Oxidase Assay by LUCILE SMITH and HELEN CONRAD . . . . .	260
<i>Discussion</i>	
<i>Assay of Cytochrome c Oxidase</i> . . . . .	275
<i>Inhibition of Cytochrome c Oxidase by Cytochrome c</i> . . . . .	275
<i>Interaction of Cytochrome c with Other Compounds</i> . . . . .	276
The Effect of Cations on the Reactivity of Cytochrome <i>c</i> in Heart Muscle Preparations by R. W. Estabrook . . . . .	276
Composition of Cytochrome <i>c</i> Oxidase by W. W. WAINIO . . . . .	281
<i>Discussion</i>	
<i>Function of Copper in Cytochrome Oxidase Preparations</i> . . . . .	301
Cytochrome Oxidases of <i>Pseudomonas aeruginosa</i> and Ox-Heart Muscle and Their Related Respiratory Components by T. HORIO, I. SEKUZU, T. HIGASHI and K. OKUNUKI . . . . .	302
<i>Discussion</i>	
<i>Properties and Nomenclature of Cytochromes a and a<sub>3</sub></i> . . . . .	311
The Prosthetic Groups of <i>Pseudomonas</i> Cytochrome Oxidase by T. Horio and M. D. Kamen . . . . .	314
<i>The Reaction of Cytochrome c Oxidase with Oxygen</i> . . . . .	316
The Oxygen-Reducing Equivalents of Cytochromes <i>a</i> and <i>a<sub>3</sub></i> by B. Chance . . . . .	316



The Isolation, Purification and Properties of Haemin <i>a</i>	
by D. B. MORELL, J. BARRETT, P. CLEZY and R. LEMBERG	320
<i>Discussion</i>	
<i>Model Systems for Cytochrome Oxidase</i>	330
Absorption Spectra of Ferro- and Ferri-Compounds of Haem <i>a</i>	
by R. Lemberg	330
<i>Cryptohaem a</i>	333
<i>Mitochrome in Relation to Cryptohaem a</i>	334
 Cytochrome Oxidase Components	
by M. MORRISON and E. STOTZ	335
 The Structure of Porphyrin <i>a</i> , Cryptoporphyrin <i>a</i> and Chlorin <i>a</i> <sub>2</sub>	
by R. LEMBERG, P. CLEZY and J. BARRETT	344
<i>Discussion</i>	
<i>The Structure of Haem a and Haem a</i> <sub>2</sub>	358
The Structure of Porphyrin <i>a</i>	
by M. Morrison	358
The Properties of Haem <i>a</i> <sub>2</sub> and Cytochrome <i>a</i> <sub>2</sub>	
by J. Barrett and R. J. P. Williams	360
<i>Extractability of Ferro- and Ferricytochrome c</i>	361
 A Haemopeptide from a Tryptic Hydrolysate of <i>Rhodospirillum rubrum</i>	
Cytochrome <i>c</i>	
by S. PALÉUS and H. TUPPY	363
 Electrometric and other Studies on Cytochromes of the C-Group	
by R. W. HENDERSON and W. A. RAWLINSON	370
<i>Discussion</i>	
<i>Protein Configuration and Linkage to the Prosthetic Group in Cytochrome c</i>	382
Studies of the Haemochrome-forming Groups in Cytochrome <i>c</i>	
by E. Margoliash	382
The Amino Acid Sequence in Horse Heart Cytochrome <i>c</i>	
by E. Margoliash and R. Hill	383
<i>Comments on the Structure of Cytochrome c</i>	384
<i>Structure and General Properties of Cytochrome c</i>	385

	PAGE
Comparative Properties of Cytochrome <i>c</i> from Yeast and Heart Muscle by J. McD. Armstrong, J. H. Coates and R. K. Morton . . . . .	385
<i>Properties of Native Cytochrome c</i> . . . . .	388
<i>Reactivity of Native Cytochrome c in Oxidative Phosphorylation</i> . . . . .	389
<i>Structure of Bacterial Cytochromes of c-Type</i> . . . . .	389
<i>Structure and Redox Potentials of Cytochrome c</i> . . . . .	390
The Electron Transfer from Cytochromes to Terminal Electron Acceptors in Nitrate Respiration and Sulphate Respiration by F. EGAMI, M. ISHIMOTO and S. TANIGUCHI . . . . .	392
Cytochrome <i>c</i> <sub>3</sub> by J. POSTGATE . . . . .	407
<i>Discussion</i>	
<i>Nature and Properties of Cytochrome c<sub>3</sub></i> . . . . .	414
<i>Functional Aspects of Cytochrome c<sub>3</sub></i> . . . . .	415
<i>Evolutionary Aspects of the Sulphate-reducing Bacteria and of Cytochrome c<sub>3</sub></i>	416
The Atypical Haemoprotein of Purple Photosynthetic Bacteria by M. D. KAMEN and R. G. BARTSCH . . . . .	419
<i>Discussion</i>	
<i>The Functions of Cytochrome b<sub>4</sub> and of Cytochrome c<sup>544</sup></i> (Halotolerant Coccus) . . . . .	432
<i>Nomenclature of CO-binding Pigments</i> . . . . .	432
Cytochrome <i>o</i> by B. Chance . . . . .	433
<i>On the Oxidase Function of RHP</i> . . . . .	435
Spectrophotometric Studies of Cytochromes Cooled in Liquid Nitrogen by R. W. ESTABROOK . . . . .	436
<i>Discussion</i>	
'Trapped' Steady-states by B. Chance . . . . .	457
<i>Low-temperature Absorption Spectra of Cytochromes in Relation to</i> <i>Structure</i> . . . . .	458

## Studies on Microsomal Cytochromes and Related Substances

by C. F. STRITTMATTER . . . . . 461

*Discussion*

On the Nature of Cytoplasmic Pigments of Liver Cells

by B. Chance . . . . . 473

*Possible Functions of the Cytochromes of the Endoplasmic Reticulum of Animal Cells* . . . . . 476

*The Significance of  $E_0$  Values of Cytochromes in Relation to Cellular Function* . . . . . 477

## The Cytochromes of Plant Tissues

by W. D. BONNER, Jr. . . . . 479

*Discussion*

Cytochromes  $c_1$  and  $b_3$  of Particulate Components of Plants

by R. K. Morton . . . . . 498

*The Cytochromes of Roots* . . . . . 499

The Chemical and Enzymic Properties of Cytochrome  $b_2$  of Bakers' Yeast

by R. K. MORTON, J. McD. ARMSTRONG and C. A. APPLEBY . 501

Conditions for the Autoxidation of Flavocytochrome  $b_2$ 

by E. BOERI and M. RIPPA . . . . . 524

## Kinetic Studies on the Action of Yeast Lactate Dehydrogenase

by H. HASEGAWA and Y. OGURA . . . . . 534

## Various Forms of Yeast Lactate Dehydrogenase

by A. P. NYGAARD. . . . . 544

## Studies on Bakers' Yeast Lactate Dehydrogenase

by T. HORIO, J. YAMASHITA, T. YAMANAKA, M. NOZAKI and  
K. OKUNUKI . . . . . 552

*Discussion*

*The Problem of Cytochrome  $b_2$*  . . . . . 558

*Properties of Intact and Modified Cytochrome  $b_2$*  . . . . . 560

	PAGE
Nature of Bakers' Yeast Lactate Dehydrogenase by T. Horio . . . . .	560
<i>Nomenclature of Cytochrome <math>b_2</math> and Derived Proteins</i> . . . . .	562
<i>The Substrate Specificity of Cytochrome <math>b_2</math></i> . . . . .	563
<i>On the Cytochrome <math>b</math> Components in the Respiratory Chain in Yeast</i> . . . . .	564
<i>The Kinetics of Reactions Catalysed by Cytochrome <math>b_2</math></i> . . . . .	565
The Kinetics of Reduction of Cytochrome $b_2$ by B. Chance . . . . .	565
<i>The Absorption Spectrum in Relation to the Structure of Cytochrome <math>b_2</math></i> . . . . .	565
The Contribution of the Prosthetic Groups to the Absorption Spectrum of Cytochrome $b_2$ by R. K. Morton . . . . .	567
The Oxidation-reduction Changes in the Reaction of Lactate with Cytochrome $b_2$ by E. Boeri and E. Cutolo . . . . .	568
<i>The Function and Bonding of the Flavin Group of Cytochrome <math>b_2</math></i> . . . . .	569
The Bonding between the Flavin Group and Apoprotein of Cytochrome $b_2$ by J. McD. Armstrong, J. H. Coates and R. K. Morton . . . . .	569
Possible Free Radical Formation in Flavoproteins by G. D. Ludwig . . . . .	572
<i>Autoxidation of Cytochrome <math>b_2</math></i> . . . . .	573
 The Role of Cytochrome $b$ in the Respiratory Chain by E. C. SLATER and J. P. COLPA-BOONSTRA . . . . .	 575
<i>Discussion</i>	
<i>The Cross-over Theorem and Sites of Oxidative Phosphorylation</i> . . . . .	592
<i>The Oxidation-reduction Potential of Cytochrome <math>b</math></i> . . . . .	593
<i>On the Redox Potential of Cytochrome <math>b</math>, the Kinetics of Reduction of             Cytochrome <math>b</math> and the Existence of Slater's Factor</i> . . . . .	593
<i>The Influence of Cyanide on the Reactivity of Cytochrome <math>b</math></i> . . . . .	596
 Energy Transfer and Conservation in the Respiratory Chain by B. CHANCE . . . . .	 597
<i>Discussion</i>	
<i>Mechanism of Oxidative Phosphorylation</i> . . . . .	622

The Significance of Respiratory Chain Oxidations in Relation to Metabolic Pathways in the Cell	
by F. DICKENS . . . . .	625
<i>Discussion</i>	
<i>On 'Additional DPN' of Incubated Mitochondria</i> . . . . .	636
<i>Possible Structure of Complexes of DPN or of DPNH involved in Oxidative     Phosphorylation</i> . . . . .	637
Author Index . . . . .	641
Subject Index . . . . .	653



## PARTICIPANTS

- DR. C. A. APPLEBY Biochemistry Section, Division of Plant Industry, C.S.I.R.O., Canberra, Australia.
- MR. J. McD. ARMSTRONG Department of Agricultural Chemistry, Waite Agricultural Research Institute, University of Adelaide, Adelaide, Australia.
- MR. J. BARRETT Institute of Medical Research, Royal North Shore Hospital, Sydney, Australia.
- DR. N. K. BOARDMAN Biochemistry Section, Division of Plant Industry, C.S.I.R.O., Canberra, Australia.
- PROFESSOR E. BOERI\* Institute of Human Physiology, University of Ferrara, Ferrara, Italy.
- DR. W. D. BONNER Johnson Research Foundation, University of Pennsylvania, Philadelphia, U.S.A.
- MME. PROFESSOR P. CHAIX Laboratory of Biological Chemistry, University of Paris, Paris, France.
- PROFESSOR B. CHANCE Johnson Foundation for Medical Physics, University of Pennsylvania, Philadelphia, U.S.A.
- DR. P. S. CLEZY Institute of Medical Research, Royal North Shore Hospital, Sydney, Australia.
- DR. E. CUTOLO Italian Serum Research Institute, Naples, Italy.
- PROFESSOR F. DICKENS Courtauld Institute of Biochemistry, Middlesex Hospital Medical School, University of London, London, England.
- PROFESSOR D. L. DRABKIN Department of Biochemistry, Graduate School of Medicine, University of Pennsylvania, Philadelphia, U.S.A.
- PROFESSOR F. P. DWYER The John Curtin School of Medical Research, Australian National University, Canberra, Australia.

\* Died, 1960.

- PROFESSOR F. EGAMI Department of Biophysics and Biochemistry, Faculty of Science, University of Tokyo, Tokyo, Japan.
- DR. R. W. ESTABROOK Johnson Foundation for Medical Physics, University of Pennsylvania, Philadelphia, U.S.A.
- DR. J. E. FALK Biochemistry Section, Division of Plant Industry, C.S.I.R.O., Canberra, Australia.
- PROFESSOR P. GEORGE John Harrison Laboratory of Chemistry, University of Pennsylvania, Philadelphia, U.S.A.
- DR. R. W. HENDERSON Department of Biochemistry, University of Melbourne, Melbourne, Australia.
- DR. T. HORIO Graduate Department of Biochemistry, Brandeis University, Waltham, U.S.A.
- PROFESSOR M. D. KAMEN Graduate Department of Biochemistry, Brandeis University, Waltham, U.S.A.
- PROFESSOR K. KAZIRO Biochemical Laboratory, Nippon Medical School, Tokyo, Japan.
- MR. J. W. LEGGE Department of Biochemistry, University of Melbourne, Melbourne, Australia.
- DR. R. LEMBERG,  
Prof. a. D. (Heidelberg) Institute of Medical Research, Royal North Shore Hospital, Sydney, Australia.
- MR. W. H. LOCKWOOD Institute of Medical Research, Royal North Shore Hospital, Sydney, Australia.
- DR. G. D. LUDWIG Hospital of the University of Pennsylvania, Philadelphia, U.S.A.
- DR. E. MARGOLIASH Laboratory for the Study of Hereditary and Metabolic Disorders, College of Medicine, University of Utah, Salt Lake City, U.S.A.
- DR. D. B. MORELL Institute of Medical Research, Royal North Shore Hospital, Sydney, Australia.
- DR. M. MORRISON Department of Biochemistry, School of Medicine and Dentistry, University of Rochester, Rochester, U.S.A.



- PROFESSOR R. K. MORTON Department of Agricultural Chemistry, Waite Agricultural Research Institute, University of Adelaide, Adelaide, Australia.
- DR. F. J. MOSS School of Biological Sciences, University of New South Wales, Sydney, Australia.
- PROFESSOR J. B. NEILANDS Department of Biochemistry, University of California, Berkeley, U.S.A.
- DR. R. A. NEVÉ Department of Biochemistry, University of California, Berkeley, U.S.A.
- DR. A. P. NYGAARD Nutrition Institute, Blindern, Oslo, Norway.
- DR. Y. OGURA Department of Biophysics and Biochemistry, Faculty of Science, University of Tokyo, Tokyo, Japan.
- DR. J. E. O'HAGAN Red Cross Blood Transfusion Service, Brisbane, Australia.
- DR. L. E. ORGEL University Chemical Laboratory, University of Cambridge, Cambridge, England.
- DR. S. PALÉUS Biochemistry Department, Nobel Institute of Medicine, Stockholm, Sweden.
- DR. D. D. PERRIN Department of Medical Chemistry, John Curtin School of Medical Research, Australian National University, Canberra, Australia.
- DR. J. N. PHILLIPS Biochemistry Section, Division of Plant Industry, C.S.I.R.O., Canberra, Australia.
- DR. J. POSTGATE Microbiological Research Establishment, Porton, Wiltshire, England.
- ASSOC. PROFESSOR  
W. A. RAWLINSON Department of Biochemistry, University of Melbourne, Melbourne, Australia.
- PROFESSOR E. C. SLATER Laboratory of Physiological Chemistry, University of Amsterdam, Amsterdam, The Netherlands.
- DR. L. SMITH Department of Biochemistry, Dartmouth Medical School, Hanover, New Hampshire, U.S.A.
- DR. C. F. STRITTMATTER Department of Biological Chemistry, Harvard Medical School, Boston, U.S.A.

- DR. A. TISSIÈRES The Biological Laboratories, Harvard University, Cambridge, U.S.A.
- DR. P. TRUDINGER Biochemistry Section, Division of Plant Industry, C.S.I.R.O., Canberra, Australia.
- PROFESSOR S. F. VELICK School of Medicine, Washington University, St. Louis, Missouri, U.S.A.
- PROFESSOR W. W. WAINIO Bureau of Biological Research and Department of Physiology and Biochemistry, Rutgers, The State University, New Brunswick, New Jersey, U.S.A.
- PROFESSOR J. H. WANG Department of Chemistry, Yale University, New Haven, U.S.A.
- DR. R. J. P. WILLIAMS Inorganic Chemistry Laboratory, and Wadham College, Oxford, England.
- DR. M. E. WINFIELD Division of Physical Chemistry, Industrial Chemical Laboratories, C.S.I.R.O., Melbourne, Australia.

## PRESIDENTIAL ADDRESS

I DECLARE open the *Symposium on Haematin Enzymes* of the International Union of Biochemistry and welcome all who attend it.

It is a great pleasure for me to welcome the many distinguished scientists from overseas who have come to Australia to discuss with us the problems which interest us all. I hope that the stimulation which you may receive will repay you for your long and strenuous journeys to our distant shores, that you may carry back happy memories of this week spent in Australia—and that you will return! Your visit will certainly be a stimulus to Australian science.

I am particularly happy to receive you in this home of the Australian Academy of Science.\* When we discussed plans for its erection in the Council of the Academy only a few years ago, I little dreamt that I should have the honour of opening the first International Conference in it.

Our thanks are due to the International Union of Biochemistry, not only for accepting our invitation to hold the Symposium, but also for financial support; to the Australian Commonwealth Government; to the Wellcome Trust; and to the various Academies and national bodies, particularly to the National Science Foundation of the United States and to the Royal Society. The support of these various organizations made this meeting possible.

We decided that we wanted an intimate symposium in which all participants could be relied upon to make valuable contributions. We wanted to discuss our problems critically, but with some degree of leisure. This is a *Symposium* and even if we cannot do as the Greeks did, having a meal, wine and dancers in this hall, the comfortable lounge chairs are the nearest approach to it possible in these hurried times. There you may recline for a little snooze if the richness of the intellectual feast endangers your mental digestion.

Our Symposium has a peculiar note in that it calls together scientists of different branches, from quantum mechanics to microbiology, and asks them to direct the spotlights of their knowledge on to a comparatively narrow field, but a field of great biological importance and chemical interest. After reading the prepublished papers I am convinced that we were right in assuming that the difficulties of finding sufficient common ground for our various denominations are no longer insuperable. Still, we shall have to exert some patience and forbearance.

I ask the theorist not to be impatient with the experimenter, if he asks questions which reveal his lack of knowledge of theory, but to answer them in

\* See frontispiece (*Editors*).

brotherly love; I ask the experimenter not to be shy to ask such questions, for they may turn out to be quite searching and may indeed enforce modifications of theory. Again, I ask the theorist not to be shy to apply his theories to facts with which he may become familiar only at this meeting; and the experimenter to try to enlighten the theorist about these facts, again in brotherly love.

Finally, I am convinced that quite apart from the direct scientific results of the Symposium, our living together here for one week will cement bonds of friendship and comradeship which will remain a force long after the Symposium.

R. LEMBERG

# THE ELECTRONIC STRUCTURE AND ELECTRON TRANSPORT PROPERTIES OF METAL IONS PARTICULARLY IN PORPHYRIN COMPLEXES

By L. E. ORGEL

*Department of Theoretical Chemistry, University Chemical Laboratory,  
Cambridge*

## INTRODUCTION

THE ELECTRONIC structure of metal-porphyrins has often been discussed in terms of the valence-bond theory as developed by Pauling (1940). In recent years a related but more quantitative theory of metal complexes has been developed and is known as ligand-field theory (Griffith and Orgel, 1957; Moffitt and Ballhausen, 1956). The first part of this paper attempts to give an elementary account of this theory insofar as it is of interest to biochemists working with haem compounds. In particular I shall discuss the relevance of magnetic susceptibility and magnetic resonance data. In the later part of my paper I shall discuss some recent work on electron-transfer processes involving metal ions, and also show how the electronic structures of the haem enzymes may be relevant to the types of electron-transfer which can take place.

## LIGAND-FIELD THEORY OF REGULAR OCTAHEDRAL COMPLEXES

The five  $3d$  orbitals are fundamental to any discussion of the properties of iron porphyrins and related compounds. They are illustrated in Fig. 1. The fundamental idea of the ligand-field approach is that the effect of the environment of a metal ion is not the same for all the  $d$  orbitals and that many of the characteristic properties of transition-metal compounds depend on just this differential effect of the environment.

We consider first the case of regular octahedral co-ordination. Figure 1 shows that the  $d_{x^2-y^2}$  orbital is directed along the  $x$  and  $y$  axes while the  $d_{xy}$  orbital is directed along the bisectors of these axes. If we suppose that the ligands lie along the axes then clearly the  $d_{x^2-y^2}$  orbital comes closer to them than does the  $d_{xy}$  orbital. If the ligands are negatively charged or are dipolar with the negative ends of their molecular dipoles pointing towards the metal ion then clearly the  $d_{xy}$  orbital is more stable than the  $d_{x^2-y^2}$  orbital, since an electron in the former is repelled less by the ligands.

It is readily seen that the  $d_{xz}$  and  $d_{yz}$  orbitals have the same spatial relationship to the ligands in their planes as does the  $d_{xy}$  orbital to the ligands along the  $x$  and  $y$  axes. It follows from the identity of their environments that the  $d_{xy}$ ,  $d_{xz}$  and  $d_{yz}$  orbitals have the same energy. Figure 1 also shows that the  $d_{z^2}$  orbital is directed straight at the ligands along the  $z$  axis, and hence it is

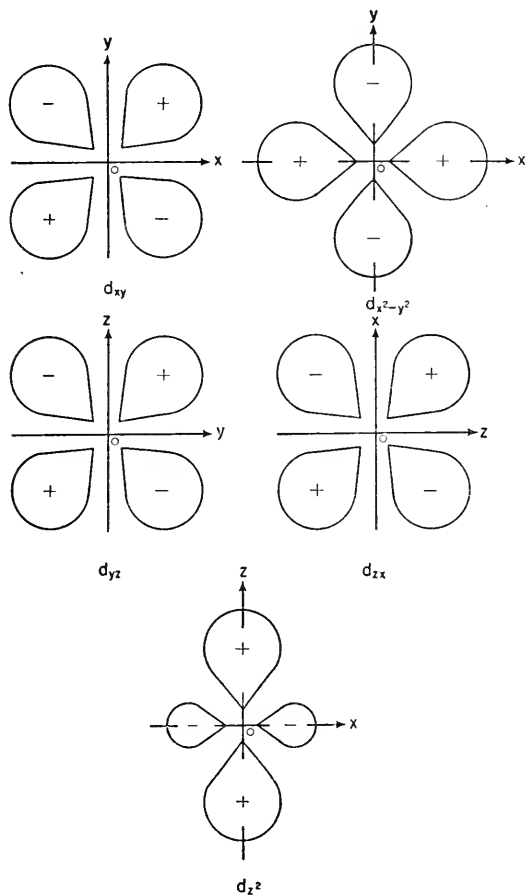

FIG. 1. The 5  $d$  orbitals.

plausible that it too is unstable. In fact calculation shows the  $d_{x^2-y^2}$  and  $d_{z^2}$  orbitals to have the same energy. Thus we may draw the energy level diagram of Fig. 2, which is the key to a great part of the ligand-field theory.

Our approach so far has been electrostatic, but fortunately our conclusions are not altered greatly when we come to take covalent bonding into account. Just as Pauling showed for valence-bond theory, ligand field (molecular-orbital) theory establishes that the  $3d_{x^2-y^2}$ ,  $3d_{z^2}$ ,  $4s$  and three  $4p$  orbitals can

be used to form six bonds between the metal and ligands. In the language of molecular-orbital theory six stable bonding orbitals may be formed by combining these metal orbitals with  $\sigma$  orbitals on the ligands, for example, with the unshared pair orbitals on amines. There are, however, also six unstable antibonding orbitals which are not considered in Pauling's theory, but to

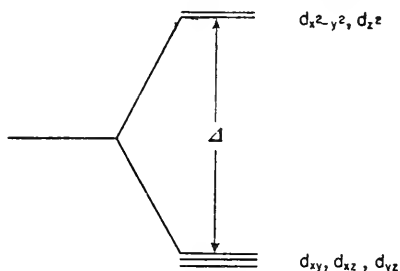

FIG. 2. The energies of the  $d$  orbitals in an octahedral environment.

which we attach considerable importance. In addition to these we must consider also the  $d_{xy}$ ,  $d_{xz}$ ,  $d_{yz}$  orbitals which take no part in  $\sigma$  bonding. The energies of these orbitals are illustrated in Fig. 3.

In almost all metal complexes each ligand supplies two  $\sigma$  electrons. There are then twelve ligand electrons which just fill up the bonding orbitals (forming

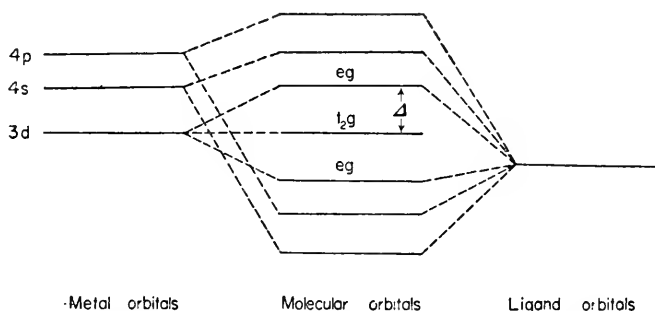

FIG. 3. Molecular orbital energies for an octahedral complex.

six bonds), leaving the  $d_{xy}$ ,  $d_{xz}$ ,  $d_{yz}$  orbitals and the antibonding  $d_{x^2-y^2}$  and  $d_{z^2}$  combinations to accommodate any extra electrons which come from the metal ion, e.g. 5 and 6 from  $\text{Fe}^{+++}$  and  $\text{Fe}^{++}$  ions, respectively. Thus the molecular-orbital theory supplements the electrostatic theory by showing that the  $d_{x^2-y^2}$  and  $d_{z^2}$  orbitals become mixed with ligand orbitals by covalent bonding, but it does not change the fundamental energy level scheme of Fig. 2.

Double bonding involving the  $d_{xy}$ ,  $d_{xz}$  and  $d_{yz}$  orbitals (Fig. 4) further changes the gap between the  $d_{xy}$ ,  $d_{xz}$  and  $d_{yz}$  orbitals on the one hand and the

$d_{x^2-y^2}$  and  $d_{z^2}$  on the other, but in a subtle and not easily predictable way if the compound is as complicated as a metal-porphyrin. Thus this gap, which is designated  $\Delta$  in Figs. 2 and 3, cannot be calculated, but must be considered as an empirically determined quantity.

If we have several  $d$  electrons available it might perhaps be thought that up to six would first fill the  $d_{xy}$ ,  $d_{xz}$  and  $d_{yz}$  orbitals and only electrons which cannot be accommodated in this way would go into the  $d_{x^2-y^2}$  and  $d_{z^2}$  orbitals.

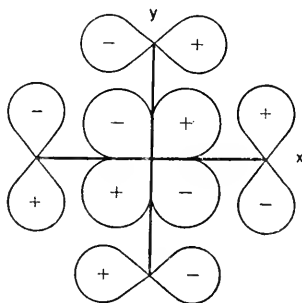

FIG. 4. Double bonding using the  $d_{xy}$  orbital.

This, however, is not necessarily the case, for electrons tend to keep apart as far as possible in order to lower their electrostatic energy and to maintain their spins parallel so as to maximize their exchange stabilization.\* If there are less than three  $d$  electrons they can all go into the lower orbitals with their spins parallel thus achieving a maximum stability both in terms of orbital (ligand-field) and exchange energy. If, however, there are 4–7  $d$  electrons present two different distributions of  $d$  electrons in the ground state are possible.

Let us consider the case of the ferrous ion which has six  $d$  electrons. If  $\Delta$  is very large then the exchange energy cannot compensate for the loss of orbital energy associated with promoting electrons to the  $d_{x^2-y^2}$  and  $d_{z^2}$  orbitals. Then all six electrons go into and fill up the  $d_{xy}$ ,  $d_{xz}$  and  $d_{yz}$  orbitals. Thus we must have three pairs of electrons each with their spins antiparallel. The compound therefore is diamagnetic. We say that diamagnetic ferrous complexes are high-field complexes since they occur only if  $\Delta$  is large.

In the free ion we know that five of the  $d$  electrons align their spins parallel and the other, of necessity, has its spin antiparallel to the rest. The free ion corresponds to  $\Delta = 0$  in Fig. 2, and so it follows that for sufficiently small values of  $\Delta$  we get four unpaired electrons and a correspondingly large magnetic moment.

We see therefore that there is a critical value of  $\Delta$  such that if it is exceeded

\* Exchange stabilization is a purely quantum mechanical phenomenon which tends to line up electrons with their spins parallel. It provides the explanation of Hund's rules concerning atomic states.



we get a diamagnetic complex, but otherwise a paramagnetic one. This then is the explanation we give of the existence of two types of complex known as covalent and ionic in Pauling's theory. We may remark that the theory as presented here is much oversimplified, and that a close correspondence exists between the qualitative features of the present and of Pauling's theory.

In Table I I give the corresponding electron arrangements for other configurations of  $d$  electrons. In the chemistry of the cytochromes,  $d^5$  and  $d^6$

TABLE 1.  $d$ -ELECTRON ARRANGEMENTS IN OCTAHEDRAL COMPLEXES

Number of $d$ electrons	Arrangement in weak ligand field	Arrangement in strong ligand field
1	$t_{2g}$ $\uparrow$ $e_g$ $\text{---}$	$t_{2g}$ $\uparrow$ $e_g$ $\text{---}$
2	$t_{2g}$ $\uparrow \uparrow$ $e_g$ $\text{---}$	$t_{2g}$ $\uparrow \uparrow$ $e_g$ $\text{---}$
3	$t_{2g}$ $\uparrow \uparrow \uparrow$ $e_g$ $\text{---}$	$t_{2g}$ $\uparrow \uparrow \uparrow$ $e_g$ $\text{---}$
4	$t_{2g}$ $\uparrow \uparrow \uparrow$ $e_g$ $\uparrow$	$t_{2g}$ $\uparrow \downarrow \uparrow$ $e_g$ $\text{---}$
5	$t_{2g}$ $\uparrow \uparrow \uparrow$ $e_g$ $\uparrow \uparrow$	$t_{2g}$ $\uparrow \downarrow \uparrow$ $e_g$ $\text{---}$
6	$t_{2g}$ $\uparrow \downarrow \uparrow$ $e_g$ $\uparrow \uparrow$	$t_{2g}$ $\uparrow \downarrow \uparrow$ $e_g$ $\text{---}$
7	$t_{2g}$ $\uparrow \downarrow \uparrow$ $e_g$ $\uparrow \uparrow$	$t_{2g}$ $\uparrow \downarrow \uparrow$ $e_g$ $\uparrow$
8	$t_{2g}$ $\uparrow \downarrow \uparrow$ $e_g$ $\uparrow \uparrow$	$t_{2g}$ $\uparrow \downarrow \uparrow$ $e_g$ $\uparrow \uparrow$
9	$t_{2g}$ $\uparrow \downarrow \uparrow$ $e_g$ $\uparrow \uparrow$	$t_{2g}$ $\uparrow \downarrow \uparrow$ $e_g$ $\uparrow \uparrow$

configurations are of particular importance but  $d^4$  and  $d^3$  may perhaps be relevant.

One result of considerable interest which emerges from the new treatment is that in a *regular* octahedral complex  $d^6$  ions may have 0 or 4 unpaired spins, but not 2 unpaired spins. Similarly,  $d^5$  ions can have 1 or 5 unpaired spins but not 3 (Griffith, 1956). Magnetic susceptibilities corresponding to the intermediate spin states, e.g. for  $\text{Fe}^{+++}$ , must be due to equilibrium mixtures of molecules with 1 and 5 spins. These may arise through chemical equilibrium of the normal sort, or because  $\Delta$  is so close to the critical value for crossing from 1 to 5 spins that the same *chemical* complex can exist in two different *electronic* states. We shall see that this is the case in ferri-haemoglobin hydroxide.

Extensive studies of the spectra of metal ions in solution have established that for a considerable range of metal ions, including  $\text{Fe}^{++}$  and  $\text{Fe}^{+++}$  ions, the value of  $\Delta$  increases whenever a ligand is replaced by a ligand to the right of it in the following series:



This explains for example why  $[\text{Fe}(\text{H}_2\text{O})_6]^{++}$  is paramagnetic but  $[\text{Fe}(\text{CN})_6]^{4-}$  diamagnetic. Similar considerations apply in porphyrin complexes and explain, for example, why compounds such as haemoglobin and

ferrihaemoglobin are low-field but carboxy-haemoglobin and cytochrome *c* high-field complexes. However, to understand the finer details of haem-protein interactions we must develop the theory further.

#### LIGAND-FIELD THEORY OF METAL PORPHYRIN COMPLEXES

The immediate environment of a metal ion in a porphyrin or phthalocyanine derivative consists of the four coplanar nitrogen atoms of the macrocyclic ring and up to two further groups. In nickel phthalocyanine, for example, the fifth and sixth co-ordination positions are empty, in ferric phthalocyanine chloride the metal atom is probably five co-ordinated, while in the biologically important haem derivatives the  $\text{Fe}^{++}$  or  $\text{Fe}^{+++}$  ions are believed to be six co-ordinated.

We consider therefore the way in which the energies of the different orbitals are changed when, in a regular octahedral complex, the two ligands on the

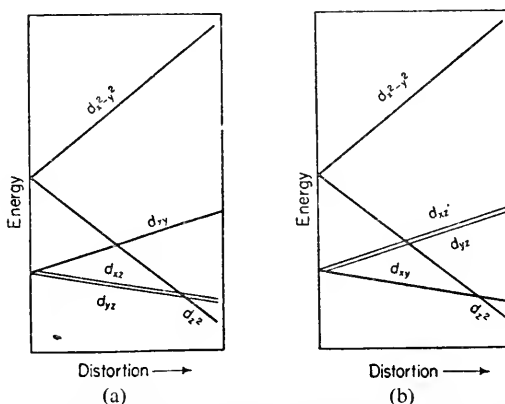

FIG. 5. Energy level diagram showing the effect of tetragonal distortions; (a) electrostatic theory; (b) a possible consequence of double bonding.

*z* axis are gradually removed. (This is formally equivalent to replacing two ligands by groups which produce smaller crystal fields.) In Fig. 5a we illustrate the results of calculations based on the electrostatic theory, and in Fig. 5b the way in which these calculations might be modified by covalent bonding effects. The principal features, namely the splitting far apart of the  $d_{x^2-y^2}$  and  $d_{z^2}$  orbitals and the maintaining of the degeneracy of the  $d_{xz}$  and  $d_{yz}$  orbitals are unaffected by covalent bonding, but the order of the  $d_{xy}$  orbital and the  $d_{xz}$  and  $d_{yz}$  orbitals might be altered.

If the  $d_{z^2}$  orbital becomes much more stable than the  $d_{x^2-y^2}$  orbital all the electrons may crowd together in the bottom *four* orbitals. Then we would get 0, 1, 2 and 3 unpaired electrons in  $d^8$ ,  $d^7$ ,  $d^6$  and  $d^5$  ions, respectively. These extreme conditions seem to apply in nickel phthalocyanine (diamagnetic), cobalt phthalocyanine (one unpaired electron) and ferric phthalocyanine chloride (three unpaired electrons).

In the biologically important haem compounds the environment seems more nearly octahedral and no "intermediate-spin" derivatives are known. (Magnetic resonance shows conclusively that ferrihaemoglobin hydroxide exists in a mixture of high- and low-spin configurations.)

Paramagnetic resonance absorption has not been detected in ferrous compounds and it is probable that even in the paramagnetic compounds it is outside the range of normal experiments. Paramagnetic resonance experiments, however, are perhaps the most sensitive tool at present available for the study of the detailed energy-level scheme both in high- and low-spin  $\text{Fe}^{+++}$  complexes. Once this is known inferences can be made about the detailed geometrical structure, and correlations established with other properties.

#### PARAMAGNETIC RESONANCE EXPERIMENTS

Here I can deal only with the energy-level diagrams deduced (mainly by Griffith, 1956, 1957, 1958) by an analysis of the experimental data of Ingram and co-workers (Gibson and Ingram, 1957; Gibson *et al.*, 1958). The

TABLE 2. RESONANCE CHARACTERISTICS OF SOME HAEMOGLOBIN DERIVATIVES

Compound	Spin-type	$g$ -values
Ferrihaemoglobin	High	$g_{\parallel} = 2$ $g_{\perp} = 6$
Ferrihaemoglobin fluoride	High	$g_{\parallel} = 2$ $g_{\perp} = 6$
Ferrihaemoglobin azide	Low	$g_x = 1.70$ $g_y = 2.2$ $g_z = 2.82$
Ferrihaemoglobin hydroxide I	Low	$g_x = 1.7$ $g_y = 2.3$ $g_z = 2.6$
Ferrihaemoglobin hydroxide II	Low	$g_x = 1.5$ $g_y = 2.4$ $g_z = 3.4$

theory employed is quite difficult and is given in the original papers. The compounds studied are listed in Table 2. The experiments show unambiguously that ferrihaemoglobin at low pH's and ferrihaemoglobin fluoride are high-spin complexes, as is well-known. Ferrihaemoglobin azide and hydroxide are predominantly low spin complexes, although the latter is in thermal equilibrium with the high-spin form.

So far there has been little detailed discussion of the electronic structure of the high-spin ferric complexes, although valuable information about the orientation of the haem planes in myoglobin and haemoglobin has been obtained. Unpublished calculations (Griffith and Orgel, 1957) suggest that

resonance studies in the mm region would give valuable and detailed information about metal-protein interactions.

The low-spin ferric complexes are perhaps the ones which offer the greatest hope of yielding useful information by means of conventional resonance experiments. So far no data have been reported for the cytochromes but three ferrihaemoglobin derivatives have been studied, namely the azide and the two forms of the hydroxide. The rest of the discussion of resonance experiments will be concerned with these compounds.

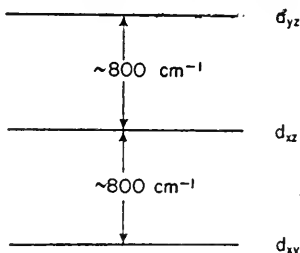

FIG. 6. The energy level diagram of the  $t_{2g}$  orbitals in ferrihaemoglobin azide.

The magnetic behaviour of crystals of ferrihaemoglobin azide naturally differs for directions parallel and perpendicular to the haem plane, for we have seen that the  $d_{xy}$  orbital is no longer equivalent to the  $d_{xz}$  and  $d_{yz}$  orbitals (the haem plane is the  $xy$  plane here). More surprisingly the spectrum is anisotropic within the haem plane.

By analysing the spectrum Griffith has estimated that the  $d_{xy}$  orbital lies lowest with the  $d_{xz}$  and  $d_{yz}$  orbitals about equally spaced  $600\text{--}1000\text{ cm}^{-1}$  above it as shown in Fig. 6. We must ask what it is that distinguishes the  $x$  from the  $y$  direction in the haem plane. There are two obvious explanations, namely that the asymmetry of the porphyrin molecule is responsible or that the other groups attached to the iron have less than cylindrical symmetry. On the whole I feel that the former explanation is unlikely on account of the following evidence, which, however, is not conclusive:

1. The degree of asymmetry differs markedly between the two hydroxide complexes.
2. The spectrum of the high-spin ferric complexes shows no sign of asymmetry.

If we reject this explanation we are led to the attractive hypothesis due to Ingram that the asymmetry is associated with the direction of the plane of the histidine group which is supposed to be attached to the metal ion. Double-bonding, which is a well-recognized feature in the electronic structure of these compounds, can affect the  $d$  orbital whose plane is perpendicular to that of the histidine molecule (Fig. 7) but not the one that lies in the histidine plane. This causes a marked change in the energy of only one of the pair of  $d_{xz}$  and  $d_{yz}$  orbitals, and so accounts for the calculated energy-level pattern.

If this is so then we have a very sensitive tool for measuring the closeness of association of the histidine group with the  $\text{Fe}^{+++}$  ion; any increase in the closeness of this approach will cause an increase in the anisotropy of the resonance in the haem plane. Such information should be most important in understanding how the protein configuration changes the chemical properties of porphyrin derivatives. An illustration of this may be found by comparing the forms of ferrihaemoglobin hydroxide obtained at pH 7 with those obtained at pH 8.5, the former being substantially less anisotropic. We must

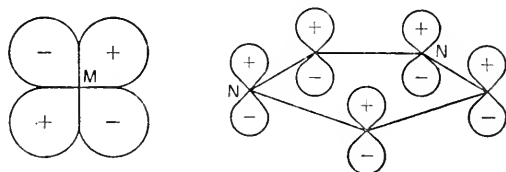

FIG. 7. Double bonding between a metal atom and the  $\pi$  orbitals of a conjugated iminazole ring.

conclude that there is a proton in the structure which, if removed, causes a weakening of the haem-protein interaction. Such a proton cannot be the histidine proton, for if removed it would strengthen the interaction. We presume then that the dissociation which occurs at about pH 8 is associated with a change in protein configuration which must make it more difficult for the histidine to co-ordinate closely to the metal.

This incidentally raises a general point in haemoprotein chemistry which seems to have received little attention. It is often supposed that the ability of similar haem groups to react with reagents such as  $\text{CO}$  or  $\text{CN}^-$  is a function of their accessibility; haem groups near the surface of proteins for example reacting more readily than those in the interior. While this is quite correct there is a second variable which makes uncertain stereochemical arguments based on the reactivity of haem groups, for this depends also on the closeness and rigidity of fit of the ligand group with the metal ion. The latter depends in turn on the details of protein configuration near the haem-protein linkage. I should like to emphasize that this is a much more sensitive dependence than is implied by the distinction between accessible and inaccessible positions in the protein; it is a matter of replaceability when the reactant has access to the metal ion, and is related to the extra thermodynamic stability conferred by chelation in simpler systems.

#### ELECTRON-TRANSPORT BETWEEN METAL IONS AND THE UTILIZATION OF THE REDOX ENERGY

While a great deal of work has been done on the electronic properties of haem compounds it has yet to be established that this has any direct relevance to the elucidation of their biological functions. The suggestions in this

section, like others in the field, are hypothetical and are only meant to draw attention to some of the recent work on electron transport which may be relevant. The detailed schemes proposed are meant to be illustrative, and not as detailed mechanisms for oxidative phosphorylation, etc.

We distinguish two types of mechanism by means of which redox energy may be transformed for example to pyrophosphate energy. In the first place some "low-energy" phosphate is oxidized to a product with a high phosphate transfer potential. The oxidized phosphate is then used to generate pyrophosphate (e.g. ATP), and finally the oxidized, dephosphorylated fragment reacts with the next member of the electron transport chain in its reduced form. Recent interest has been turning to various benzoquinones and naphthaquinones as possible carriers in the above scheme. Systems of this kind may achieve considerable chemical subtlety but they require little in the way of theoretical analysis.

In the remainder of this paper I shall discuss an alternative mechanism, not because I believe it to be intrinsically more (or less) plausible but because it requires some theoretical interpretation and if operative might depend in detail on those features of haemoprotein structure which I have already discussed.

Taube and co-workers (1959) in a series of brilliantly conceived experiments have shown that if  $\text{Co}^{+++}$  and  $\text{Cr}^{++}$  ions are placed in solution with fumaric or terephthalic acid, electron transport takes place as illustrated:

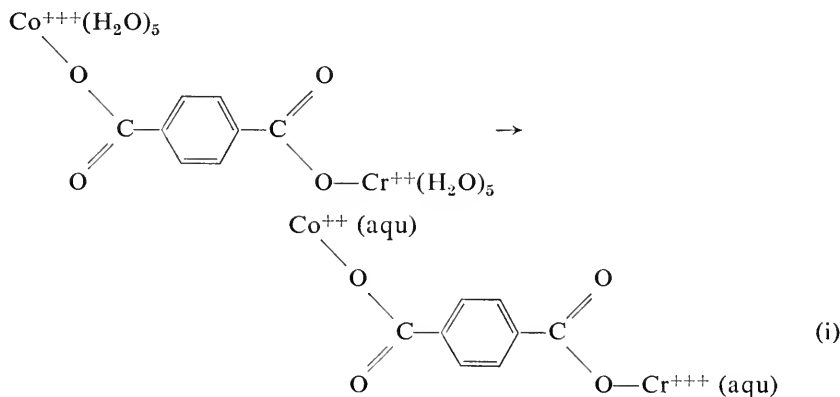

This shows in a particularly clear way that the bridging group involved in many redox reactions may be a conjugated molecule. The qualitative theory of electron transport through bridging groups has been discussed elsewhere (Orgel, 1956) and particularly for conjugated molecules by Griffith (1959).

Taube further observed that if fumaric or terephthalic acid is replaced by its monomethyl ester this is hydrolyzed during the course of the reaction, and the chemical behaviour of the solution suggests that the methyl group

appears as methyl alcohol attached to the  $\text{Cr}^{+++}$  ion (Taube, 1959). This implies the following mechanism:

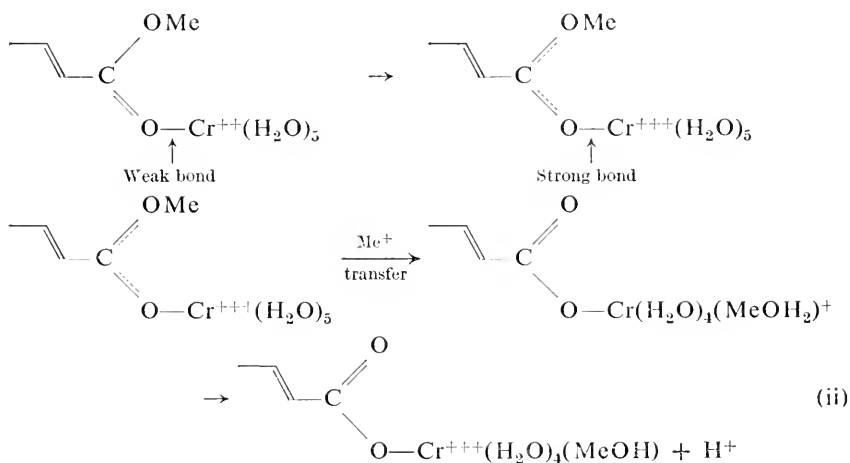

In this system the reaction achieved is hydrolytic, that is, the redox reaction catalyses stoichiometrically the hydrolysis of the ester, but I shall now show that this is not an essential feature of the process. In order to bring the discussion closer to the subject of the cytochromes, I shall replace the reactants by ones which may be biologically important, but only for illustrative purposes:

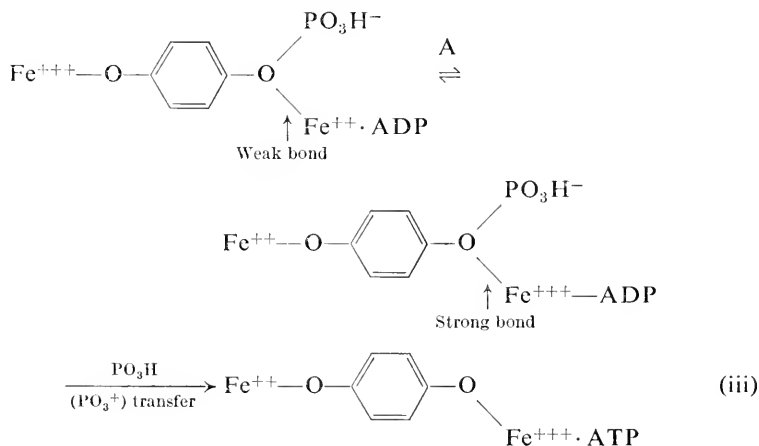

The essential feature of the reaction is that the redox energy is preserved because a ligand which normally appears only loosely associated with metal ions, owing to redox-equilibrium A, finds itself in a position normally occupied only by strongly co-ordinating ligands. Under such circumstances the weakly co-ordinating ligand undergoes fission to give a much more stable

metal complex and a reactive positively charged species which preserves and can utilize the free energy of the redox reaction. I hasten to add that the minor details which I have given are not essential, for example, the metaphosphate need never be liberated as such, but might be transferred directly to an appropriate acceptor in a concerted reaction, the mediator need not be a quinol, the transferred group need not be a phosphate, etc.

This type of system for utilizing redox free energy has much in common with ones previous proposed except that

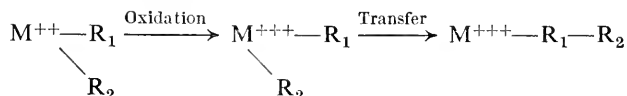

the "electron mediator" and the transferred group are part of the same molecule. The advantage of this in ensuring the efficient coupling between the redox and transfer processes is obvious.

If mediated electron transfer is important in oxidative phosphorylation, then the details of the electronic configurations of the metal enzymes concerned will be critical to the understanding of the process. Here I can summarize only a few of the most important considerations:

1. The effect of a metal ion in inducing the hydrolysis of a bond as in the reactions (ii) and (iii) will be large if the metal has a maximum number of spins paired after reaction, e.g. if the  $\text{Fe}^{+++}$  ion produced is low-spin rather than high-spin (of course it will also be greater for a trivalent than for a divalent ion, other things being equal).
2. The rate of transfer will be greatest if there is no need for a change of spin configuration during the process, i.e. if it occurs between two high-spin or two low-spin complexes.
3. The rate of transfer also depends on the degree of overlap between metal orbitals and mediator orbitals. This is greatest for low-spin complexes.
4. The most effective mediator molecules are likely to be ones which can act either as good electron donors or as good electron acceptors.

In conclusion I should like to note that even if oxidative phosphorylation does not involve steps which have an obvious appeal to the theoretician, but rather a sequence of conventional coupled redox reactions, both the redox potentials and the rates of reaction will certainly depend critically on the spin-states of the metal ions and hence on the details of their interaction with their environments.

#### REFERENCES

- GEORGE, P. & GRIFFITH, J. S. (1959). *The Enzymes*, 2nd edition, Ed. Boyer, Lardy and Myrbäck, Chap. 8.
- GIBSON, J. F. & INGRAM, D. E. (1957). *Nature, Lond.* **180**, 29.



- GIBSON, J. F., INGRAM, D. J. E. & SCHONLAND, D. (1958). *Disc. Faraday Soc.*, No. 26, 72.  
 GRIFFITH, J. S. & ORGEL, L. E. (1957). *Quart. Rev.* **XI**, 381.  
 GRIFFITH, J. S. (1956). *Proc. Roy. Soc. A.* **235**, 23.  
 GRIFFITH, J. S. (1956). *J. Inorg. Nucl. Chem.* **2**, 229.  
 GRIFFITH, J. S. & ORGEL, L. E., Unpublished calculations.  
 GRIFFITH, J. S. (1957). *Nature, Lond.* **180**, 31.  
 GRIFFITH, J. S. (1958). *Disc. Faraday Soc.* **216**, 91.  
 MOFFITT, W. & BALLHAUSEN, C. J. (1956). *Ann. Rev. phys. Chem.* **7**, 107.  
 ORGEL, L. E. (1956). *Proc. 10th Solvay Conference in Chemistry*, Brussels.  
 PAULING, L. (1940). *The Nature of the Chemical Bond*, Cornell University Press.  
 TAUBE, H. (1959). *Advances in Inorganic and Radio Chemistry* **1**, 1, Academic Press, London, New York.  
 FRASER, R. T. M., SEBERA, D. K. & TAUBE, H. (1959). *J. Amer. chem. Soc.* **81**, 2906.

## DISCUSSION

### *Terminology in Ligand-Field Theory*

WILLIAMS: Dr Orgel's paper contains a discussion of the quantity,  $\Delta$ , which is used by him both in thermodynamic and spectroscopic calculations. In one place it is suggested that there is a critical value of  $\Delta$  such that if it is exceeded a change of paramagnetic moment would be observed.  $\Delta$  is here used in a thermodynamic argument and is an indication of the field strength in the ground state of a complex. At another place it is stated that extensive studies of spectra have led to the relative values of  $\Delta$ ;  $\Delta$  is related to an excitation energy difference between two states, the ground and the excited states. What is  $\Delta$ ? Is it a parameter of the field or is it only to be correlated with differences in character between excited and ground states, or does it represent a confusion of these two factors? We shall now indicate why we consider the last statement to be true.

The order of  $\Delta$  given by Orgel for a series of ligands is part of the spectro-chemical series

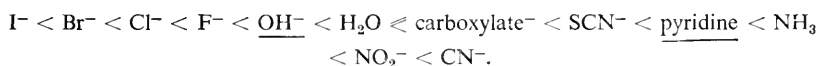

This series is often confused with a series of increasing field strength (Williams, *J. chem. Soc.* **8** (1956)). The effect of ligands in reducing the paramagnetic moment of ferric complexes (Scheler, Schoffa & Jung, *Biochem. Z.* (1957) **329**, 232) follows the different order

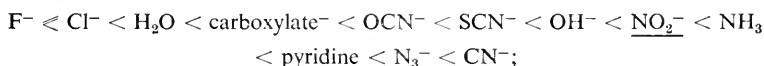

note particularly the underlined ligands. Again there is no doubt that the stability of metal complexes with different ligands does not follow a given order of ligands. With some cations an order somewhat like the spectrochemical series is observed, with others the order is almost completely reversed. Thus experiment shows that  $\Delta$ , obtained from spectra, is not to be used as a guide in discussions of thermodynamic quantities (see Jorgenson, Orgel, Williams, *Disc. Faraday Soc.*, **26**, 1958, p. 123-130, 110-115, 180-187).

However, theory (same references as above) also shows why this is so dangerous. The correlation of  $\Delta$  with field strength is only apparent in a first order perturbation treatment of a simple electrostatic crystal field model. A second order perturbation treatment introduces polarization of the ligand dependent upon the cation or, if one wishes to put it this way, covalency, and changes in the radial as well as the angular dependences of the  $d$  wave-functions affect the energies of states. This was pointed out by Owen (*Disc. Faraday Soc.*, **19** (1955)).

This covalency is in part independent of field symmetry and is often called central field covalency. It is best explained by saying that not only is there a tendency for the  $d$  electrons of the cation to go into particular directions in space when a field is applied but that they spread out radially in space over the ligands also. The stability of a complex depends not only on the ability of a ligand to polarize the  $d$  electrons into given directions, where they get out of the way of the ligand electrons, but also on the ability of the ligands to allow the  $d$  electrons to spread out over them and the ability of the cation to allow the ligand's electrons to spread over it. Jorgensen has shown that the series of ligands which allow increasingly the  $d$  electrons to spread out, is

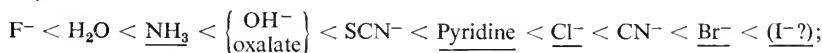

Note the underlined ligands.

This series is different again from the spectrochemical series. Thermodynamic properties such as the stabilities of complex ions and the relative stability of two spin states are just as likely to follow either one of the two series, spectrochemical and nephelauxetic, which are both derived from spectra. The order of ligands which will bring about a change of spin state is even dependent upon the valency state of the cation.

ORGEL: 1. The procedures used to derive  $\Delta$ , the spectroscopic ligand-field strength, and to determine the "nephelauxetic" series are well defined. To suppose that a single  $\Delta$  suffices for ground and excited states of a complex is an approximation, but one which is justified by the success of the simple theory in interpreting spectra. If, as Williams suggests,  $\Delta$  varies greatly from state to state, the ligand-field theory would never have been adopted, since it would have failed to accommodate even the simplest observations on the spectra of high-field complexes.

2. The approximations implicit in the treatment of spin-pairing are more serious since (a) The internuclear distances decrease on spin-pairing and so the ligand-field increases (this is in contrast to the situation encountered in spectroscopy, where all energies are determined for the same internuclear distance). (See, for example, Orgel, 10th Solvay Conference Proceedings, Brussels, 1955.)

(b) Increased delocalization in the low-spin state facilitates spin-pairing. (See, for example, the many papers on  $Co^{+++}$  in the spin-paired state.)

It may well be that in special cases these effects can change slightly the ligand-field order; I would only question whether any experimental evidence for this is available in the regular octahedral complexes to which the theory applies.

3. The series of ligands of Scheler, Schoffa and Jung may reveal a reversal of the ligand-field parameter. Before concluding that this is so Williams should establish:

(a) That detailed calculations show that the conclusions of the theory of regular octahedral complexes can be taken over for non-regular complexes. (This is plausible but by no means obvious or easy to demonstrate.)

(b) That the  $NO_2^-$  group is present as a nitro group (not a nitrito group) in both high- and low-spin forms of ferric haem complexes.

(c) That the addition of ligands to haems (and changes of pH, etc.) do not affect the protein-metal interactions.

4. Williams' identification of electrostatic (as contrasted with covalent) theories with first order perturbation theories, and the latter with ligand-field theory, is incorrect.

In conclusion, I should like to say that I usually find myself less in disagreement with Williams' view than with those which he attributes to others. In presenting material in reviews or introductory articles it is normal to omit the many qualifications which appear in the detailed literature, and to indicate that this has been done. That, for example, is why I say that the theory of spin-pairing as presented is "much-oversimplified" and why I placed pyridine and ammonia, for the purposes of an elementary treatment, together in the ligand series as amines. (The ligand-fields of the compounds are very similar and the order probably does change from one compound to another, both for electronic and stereo-chemical reasons.) A useful purpose

may be served by drawing attention from time to time to the well-recognized approximations of a theory; an even more useful purpose is served by doing something about them (see, for example, Hush and Pryce, *J. chem. Phys.* (1958), whose work could well be extended to cover the transition from high-spin to low-spin states).

WILLIAMS: It is not suggested that  $\Delta$ , the field strength in any one state, varies greatly from every state to every other state. The variation of  $\Delta$  will depend upon the character of the different excited and ground states. The spectrochemical series was observed to be a series roughly independent of whether one is dealing with low or high spin complexes or with metals from different transition metal series. Will Orgel state whether he believes this series to be also the series of the heats of interaction of ligands with a given cation, independent of cation? The case of the octahedral complexes could be taken as an example.

Orgel has made this assumption himself in his discussion here (3a) and elsewhere.

Under 3 (b); if the  $\text{NO}_2^-$  group changes from  $\leftarrow \text{N} \begin{array}{l} \text{O}^- \\ \diagdown \\ \text{O} \end{array}$  to  $\leftarrow \text{O}-\text{N} \begin{array}{l} \text{O}^- \\ \diagup \\ \text{O} \end{array}$  then this is

but an indication of a change in ligand character with cation or spin state and/or valence state which I wish to demonstrate. This will be described shortly, not only for this case, but for the  $\text{SCN}^-$  complexes also. Under 3 (c), the hydroxide ion produces spectroscopically the same effect in complexes of iron porphyrins where there are no proteins.

(4) needs amplification before I can discuss it. I agree with Orgel's conclusion. My criticisms stand if the over-simplifications of theory lead to inconsistency with experiment. I say that they do.

### *Spin-states of Haem Compounds*

FALK: I agree with Orgel that the relatively easy transition of many haemoproteins between the low- and high-spin states is very interesting. This phenomenon has fascinated me for some years, and Falk & Nyholm (*Current Trends in Heterocyclic Chemistry* (1958), p. 130) have discussed it briefly. But I think it is pertinent to remark that this phenomenon is established only for compounds of the haemoglobin, catalase and peroxidase types, and not for haemoproteins which are electron-transport agents in the classical cytochrome *c* fashion. I am not aware of any evidence, from magnetic susceptibility measurements, of high-spin low-spin changes in cytochromes of *c*, *b* or *a* types. If I may be allowed to guess, I would suggest that of these cytochromes, the properties of cytochromes *a* point to them as the most likely of the three types to show this phenomenon.

Orgel mentioned at one point the old observation of three unpaired electrons in ferric phthalocyanine chloride. In this context I think it is interesting to draw attention to the unpublished investigations of Nyholm and myself, mentioned in Falk and Perrin (this volume, p. 56) on ferriprotoporphyrin chloride ("haemin chloride"). We found no conductivity in nitrobenzene solutions, indicating that the compound is not an electrolyte, and in view of the 5 unpaired spins, reported in the literature and confirmed by us, have suggested that it must be a square pyramidal complex with  $4s4p^24d^2$  hybridization.

ORGEL: The observations of Falk and Nyholm are very relevant here. I wonder whether the ferric protoporphyrin chloride has the same structure both in the solid and in nitrobenzene solution. Perhaps it would have the 3-spin ground state in nitrobenzene corresponding to a pyramidal structure, but have five unpaired electrons and an octahedral structure (with shared chloride ions) in the solid.

GEORGE: I think there is some doubt whether the paramagnetic resonance absorption measurements at pH 7 and 8.5 carried out by Gibson, Ingram and Schonland (*Disc. Faraday Soc.*, 26, 72 (1958)) prove that ferrihaemoglobin hydroxide is a mixture of high- and low-spin forms. First, the  $pK$  of the ionization is about 8 at room temperature so that at pH 7 only about 10% of the ferrihaemoglobin would be present as the hydroxide. Secondly, Keilin and Hartree (*Nature Lond.*, 164, 254 (1949)) have shown that on cooling the conjugate acid is favoured in the dissociation equilibrium, as

would be expected for an endothermic ionization process. Hence, if the measurements were carried out at low temperatures (liquid air or liquid hydrogen) as is normally the case, without suitable control experiments it is not certain how much hydroxide was present. Thirdly, unless ferrihaemoglobin is carefully freed from ammonium salts there is a marked tendency for the ammonia complex to be formed in alkaline solution: so, if the experiments were made with either single crystals or a microcrystalline paste from an ammonium sulphate mother liquor, in the absence of suitable controls a contribution to the observed signal from the ammonia complex cannot be disregarded. In the case of measurements at low temperatures this would be more serious since there is good reason to believe that the formation of the complex would be exothermic.

The experiments reported in our present paper are not subject to these uncertainties, and they provide equally direct evidence for the existence of a thermal mixture.

### *Electron Transport*

LEMBERG: The interesting theory of oxidative phosphorylation involving a quinone-hydroquinone system (Todd and others) appears less likely in the phosphorylation step connected with the oxidation of cytochrome *c*, although Glahn and Nielsen (*Nature, Lond.*, **183**, 1578 (1959)) have recently suggested that this step involves binding of the phosphate to the formyl group of haem *a*. Orgel's explanation still leaves us with the difficulty that we do not know conjugated systems which might take up phosphate groups, except perhaps the histidine imidazoles bound to haem iron. The electron transport through a respiratory chain of several cytochromes makes it appear sterically unlikely that electron transport through the imidazoles as postulated by Theorell can be a sufficient explanation; similar difficulties exist with regard to haem-haem interactions in haemoglobin. I therefore ask whether the physicochemists consider it impossible that electron transfer may occur through "aliphatic" portions of a protein, or possibly through a chain of water molecules bound in the protein.

WINFIELD: The example of electron transfer given by Orgel (terephthalic acid complex) is one which can readily be demonstrated experimentally. But may there not be some kinds of conduction which are important in biology and yet not readily demonstrable? If one were able to remove an electron from one end of a paraffin chain simultaneously with addition of an electron at the other end, would not the resulting electron movement along the chain take place with negligible activation energy? It seems possible that conducting chains of this kind could be interposed between conjugated conducting groups of the type described by Orgel. In other words, conduction of electrons between the prosthetic groups of adjacent enzymes (*in vivo*) may not require a path which is conjugated throughout its length.

In the passage of electrons through a series of cytochromes in the living cell, I think that the individual enzymes are joined by metal bridges or hydrogen bonds. If the metal atom were calcium, one might expect that the electrons would pass across the bridge either not at all or with no pause. But with a metal atom such as iron or copper acting as bridge, I think that the electron would reside for a finite time in the metal ion and that there would be an activation energy required to move an electron across such a bridge. The pause might well be of biological significance. A small activation energy for the transfer of electrons between an interconnected series of cytochromes would restrict "hunting" in a system which would otherwise be uncontrollably sensitive to transient fluctuations in the environment. In addition the metal bridge could provide for by-passing part of the electron flow along paths which branch from the main respiratory chain.

LOCKWOOD: In proposing models for electron transport two essentially different ones have been given. There is one in which electrons can be put in at one end of the chain and taken out at the other and that can be repeated an indefinite number of times. The comparison to a piece of copper wire is convenient. I take it that the model given in reaction (1) of Orgel's paper is an example of this type of conductor. In other models that have been proposed an electron can be put in at one end of the chain and taken out at the other but this produces an alteration of the configuration and the process cannot be repeated till the electron transport has been reversed. An

example of this is electron transport transverse to the polypeptide chains of protein where the transport occurs through the CO and NH group via a hydrogen bond.

ORGEL: This could be compared to a condenser.

LOCKWOOD: Yes. The picture of the cytochrome change in particular preparations where the cytochromes are situated spatially side by side is a legitimate one and the distinction between the two types of models becomes important. The transport of the electrons through the members of the cytochrome chain is a process which is repeated an indefinite number of times and the model, to be satisfactory, should belong to the copper wire type. It appears to me that the condenser type of model would be useless to explain the transport of electrons through the cytochrome chain.

ORGEL: We cannot be sure that electron transport will never take place through aliphatic side chains. However, I myself would be very surprised to find transport through more than at most three or four carbon atoms. We are currently investigating this problem by magnetic resonance methods. Transport through the  $\alpha$  helix or similar protein structure *via* a long series of hydrogen-bonded C=O and NH groups is more problematical; again I suspect that this process is not favoured except in systems which have been excited optically.

CHANCE: Although we have been discussing in some detail the mechanisms by which electrons might be transferred through the peptide chain of the protein, an experimental test of this possibility suggests that an insufficient conduction rate would occur at least in the case of cytochrome *c*. Experiments carried out by my collaborator Patrick Taylor on dried cytochrome *c* in an atmosphere of nitrogen, show that less than 1,000th of the conductivity would be obtained when compared with the rate at which electrons are transferred in the cytochrome chain. While this experiment may not be conclusive it is certainly indicative of the difficulty of applying this approach. Our early experiments on the reaction of cytochrome *c* and the peroxidase intermediate have been reviewed and considerably extended by John Beetlestone. He finds that an active centre of the size of 5 Å would be adequate to explain the observed kinetic data. This size is larger than that of the iron atom but would fit nicely with the idea that a histidine group is involved. Thus to within the accuracy that is possible with this determination, some group on the outside of cytochrome *c* may be responsible for the interaction.

GEORGE: I would like to add a few comments to those of Chance on the subject of kinetic data for haemoprotein reactions. Even though some of the velocity constants are quite low, i.e.  $10^4$  to  $10^3$  M<sup>-1</sup> sec<sup>-1</sup> in comparison with high values of  $10^6$  to  $10^8$  M<sup>-1</sup> sec<sup>-1</sup>, these low values are often found to originate in large (unfavourable) activation energies  $E$ , so that when the temperature independent factor  $A$  in the Arrhenius equation,  $k = A e^{-E/RT}$ , is evaluated it is found to have remarkably high values of the order  $10^{13}$  to  $10^{17}$ .

Now in terms of the simple collision theory for bimolecular reactions  $A$  is equated to  $PZ$ , where  $Z$  is the collision frequency,  $10^{11}$ , and  $P$  is the steric factor. Considering "target areas" for haemoprotein reactions one would expect  $P$  to be a fraction, yet it is apparent that  $P$  can in fact be several powers of ten.

It would seem that other features are extremely important in these reactions of which we know very little at present. For example, the haem plate is hydrophobic in nature and undoubtedly alters the structure of the liquid water in its vicinity. In addition, around the haem plate, there is a constellation of ionic charges on the protein, which may be very important when a reaction between two haemoproteins occurs.

CHANCE: I agree with George that temperature-independent factors in haemoprotein interactions are high and variable and thus the accuracy with which one can determine the size of the active centre is definitely limited. However, the results are useful indicators nevertheless.

In this connexion, increasing knowledge of cytochrome *c* structure is of importance and the apparent inaccessibility of the haematin, due to the surrounding structures, provides independent support for the idea that the active centre of cytochrome *c* in the peroxidase reaction may have to exceed the size of the iron atom.

MARGOLIASH: Orgel's idea of the importance of the native configuration of the protein of haemoproteins in determining the closeness of attachment of the haem-iron ligands and hence the nature of the complex formed, fits well with the results of our study of the denaturation of cytochrome *c*. With this haemoprotein it appears that denaturation probably does not change the haem iron bound groups but rather has a quantitative effect on the haem iron-ligand bonds resulting, as denaturation proceeds, in the gradual disappearance of the specific properties of cytochrome *c* and its transformation into a normal chemical haemochrome (Margoliash, Frohwirt & Wiener, *Biochem. J.*, **71**, 559, 1959).

### *Mechanism of Oxidative Phosphorylation*

GEORGE: Lemberg has raised the question of the kind of mechanism by which the oxidation-reduction of cytochrome *c* can be coupled with phosphorylation, since, for structural reasons, it is difficult to see how an electron mediator can be involved like terephthalic acid or its ester in the oxidation of  $\text{Cr}^{\text{II}}$  by  $\text{Co}^{\text{III}}$ .

Arising from our studies of the opening of the crevice in ferricytochrome *c*, which happens when the azide and cyanide complexes are formed, Glauser and I have suggested that a conformational change in the protein may be involved as a consequence of a switchover to a different bonding group during the oxidation-reduction cycle.

For example, if the most stable crevice structures for the ferric and ferrous forms, at the pH at which oxidation-reduction occurs, differ in having a primary amino group and a histidine group respectively coordinated to the iron as in A and C,

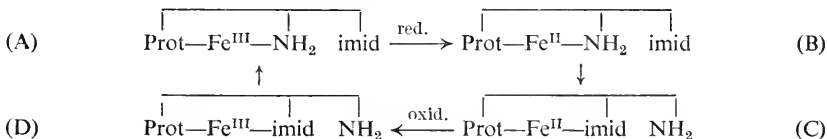

then upon reduction of ferricytochrome *c* (A) a metastable, "energy-rich" form of ferrocycytochrome *c* (B) would be produced, reverting to the stable form (C) with a release of energy. Likewise on oxidation of ferrocycytochrome *c* (C) an "energy-rich" form of ferricytochrome *c* (D) would be produced, reverting to the stable form (A) with a release of energy. The switchover of the crevice group in the reactions (B)  $\rightarrow$  (C) and (D)  $\rightarrow$  (A) would entail a conformational change in protein structure which could conceivably be linked in some way to a phosphorylation step (George, P., & Glauser, S. C. Abstracts Third Meeting Biophysical Soc., Pittsburgh, April 1959, D4).

CHANCE: I should like to ask Orgel for more information on equation (iii) of his paper.

At first I thought that you wished to distinguish between electron transfer reactions and the coupling to phosphorylation. However toward the end of your paper you show them to be intimately associated, unless I have misunderstood you. Further, is the iron atom to which ADP is linked a haematin or a non-haematin iron? Would you be willing to indicate to me arguments in favour of one or the other alternative?

ORGEL: I should like to make clear that in this paper I have tried to describe a very general scheme for preserving the energy of oxidation-reduction reactions. I had no particular chemical system in mind. If the  $\text{Fe}^{\text{+++}}$  is part of a haem compound then the ADP or other acceptor could not be attached to the metal atom but would have to be held in position by attachment to the protein; if the  $\text{Fe}^{\text{+++}}$  atom is not in a porphyrin ring, then the ADP could be attached to the metal directly. I have no view on the relative likelihood, if any, of the possible alternatives.

The main idea is that if an electron is extracted from a metal ion which is weakly associated with a ligand then the metal in its new valency may decompose the ligand in such a way as to preserve the redox energy. One illustration is given.

# THE ROLE OF THE METAL IN PORPHYRIN COMPLEXES

By F. P. DWYER

*John Curtin School of Medical Research, Australian National University*

## INTRODUCTION

THE MORE obvious implications of the co-ordination of organic molecules to metal ions: the effective charge reduction of the metal ion, and the polarization of the organic moiety, have tended to become obscured by the wide interest in ligand-metal bond theories. In as much as these of their nature incline to emphasize the separate entities of metal and ligand, attention has been directed away from the properties of the complex as a whole. Suggestions that many reactions can occur at the periphery of the metal-porphyrin molecule rather than exclusively at vacant or labile sites on the metal (Williams, 1956a; Chance, 1951; King and Winfield, 1959), deserve more serious consideration. The purpose of this paper is to direct attention to properties which are those of the whole complex unit rather than the ligand and metal components.

The metal-porphyrins are derived from a planar di-acid molecule which differs from the usual planar quadridentates such as 1:2-bis( $\alpha$ -pyridylmethyl)aminoethane (Fig. 1), by implication of the metal in a closed-ring system which probably contributes considerably to the stability of the complex structure, since the organic molecule cannot be detached point by point and hence unwrapped from the metal. Recent exchange work with the sexadentate molecule 1:2-propanediaminetetraacetic acid has shown that the six points of attachment to a metal can be broken progressively in this way (Dwyer and Sargeson, 1960).

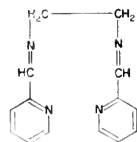

FIG. 1

Co-ordination proceeds with the extrusion of two protons and the metal complexes have zero or a small overall positive charge. As a result, since it is obviously easier to detach electrons from complexes with zero or a small positive charge, oxidation is facilitated. This is shown by the redox potential shift on passing from the simple hydrated ions to the iron and manganese complexes. Silver(I) acetate and protoporphyrin react, with the extrusion of a single proton, to yield a silver(I) complex, which spontaneously oxidizes with the extrusion of a second proton. The rather rare formal Ag(II) complex is favoured by the low charge and the planar arrangement of the bonds (Falk and Nyholm, 1958).

The two co-ordination positions at right angles to the plane of the quadridentate ring can be occupied by a variety of ligands: water, halide or cyanide ion, organic bases, the histidine anion, carbon monoxide. There is a good deal of still somewhat empirical evidence, e.g. lability, that these out of plane bonds are rather long, and the geometry is therefore tetragonal. The bonds may be so long that the complex is essentially planar. Long bonds in the polar, (1:6), positions of many copper, nickel and palladium complexes are well known (Nyholm, 1953; Nyholm *et al.*, 1956). In cytochrome *c* the interaction of the imidazole groups is sufficient to promote the maximum electron pairing in both oxidation states and the geometry must be octahedral.

The higher oxidation states favour co-ordination of anions because of the greater polarizing power of the metal and also the greater electronegativity. In the oxidized forms of the metal-porphyrins there is thus a stronger tendency to co-ordinate OH' and Cl' to available sites or by displacement of another ligand. The ionic structure ascribed usually to haemin chloride is unlikely.

The "*trans*-effect" may be of considerable significance in the 6-co-ordinate metal-porphyrins. The effect, which has been extensively studied in planar complexes (Chatt *et al.*, 1955), refers to the labilizing effect of groups, e.g. Cl, CN, CO, on other groups or ligands attached in the opposite (*trans*) position. In octahedral complexes, though the chemistry is more complicated, the "*trans*-effect" has been fruitful in elucidating substitution reaction mechanisms (Quagliano and Schubert, 1952; Basolo and Pearson, 1958). Strongly *trans* influencing groups: CO, CN, or the thiol anion, should modify the strength of attachment or even the properties of other ligands in the polar position.

The imposition of a fixed spatial arrangement on groups attached in the 1:6 co-ordination positions is an important function of the metal atom, especially when it is realized that donor atoms of the protein itself are often linked in this way. Part of the functional role of the cobalt atom in vitamin B<sub>12</sub> is the rigid and unique conformation imposed on the large organic moiety. Another part is probably the lability of the sixth co-ordination position normally occupied by cyanide ion, water or hydroxyl, but which can be used to attach a donor atom from protein.

#### CHARGE DISTRIBUTION IN COMPLEXES

The fundamental principles involved in the formation of metal complexes, first enunciated by Pauling (1938) have been elaborated by numerous authors (Martell and Calvin, 1952; Basolo and Pearson, 1958). Co-ordination of a ligand to a metal ion decreases the charge on the ion and makes the donor atom more positive. Since donor atoms are amongst the most electronegative of the elements, part or most of the positive charge spreads over the ligand molecule. In effect, this means that the ligand molecule is polarized, with the withdrawal of peripheral electrons, or electrons from electron donating



groups. It is well known that the stability of metal complexes is usually related directly to the strength of the ligand as a base, and this is merely another way of expressing this concept. Electron withdrawing substituents in the ligand molecule promote polarization in the wrong sense: compete with the metal atom for electrons. These ideas have been expressed succinctly in the "principle of essential neutrality" (Pauling, 1948). The pronounced curariform activity of complex cations containing phenanthroline, and bipyridine  $[M \text{ phen}_3]^{++}$ ,  $[M \text{ bipy}_3]^{++}$  in which the characteristic biological response must be due to distributed charge, supports the principle (Dwyer *et al.*, 1957).

The extrusion of protons during the formation of porphyrin metal complexes reduces the charge by two units but, even in the reduced form, the zero charge does not necessarily imply electrical neutrality of either the

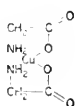

FIG. 2

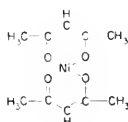

FIG. 3

metal or the ligand. Apart from the electrical capacities of the substituent groups, the transition metals are moderately electronegative. This property may well be enhanced by the spin-paired electronic situation existing in strongly interacting complexes.

Recently, it has been shown that the methylene groups in the neutral complexes *bis*(glycine)copper (Fig. 2) and *tris*(glycine)cobalt are sufficiently activated in this environment to enable Knoevenagel type condensations to be performed with acetaldehyde (Sato, Okawa and Akabori, 1957; Ikutani, Okuda, Sato and Akabori, 1959). A mixture of threonine and allothreonine was obtained from the cobalt complex in the presence of sodium carbonate. Djordjevic, Lewis and Nyholm (1959), found that nitrite ion and nitrogen dioxide attacked the neutral complexes *bis*(acetylacetonate)nickel (Fig. 3) and *bis*(acetylacetonate)copper, with the formation of complex organic nitrogen compounds, as yet unidentified. It is probable that the sites of attack are the activated resonating  $-\text{CH}-$  groups, which may carry a small positive charge.

In common with phthalocyanine, phenanthroline and bipyridine, metals are bound more firmly in the porphyrins than might be anticipated from the base strength of these ligands. The donor power of the ligand, concerned primarily with the primary co-ordination or  $\sigma$  bond, is responsible for the dissipation of charge from the metal atom. It is believed that much of the bonding strength of these molecules derives from at least two  $\pi$  bonds in which the  $d$  electronic orbitals of the metal overlap the vacant  $p$  orbitals of the donor atoms. These bonds tend to make the metal more positive. In the ferrocyanide ion

$[\text{Fe}(\text{CN})_6]^{4-}$  the excess negative charge conferred by six negatively charged donors is supposed to be nearly off-set by three  $\pi$  bonds from iron to carbon (Pauling, 1938). The charge interaction picture of donor *atom* and metal is thus quite complex.

The molecules 4:7-dihydroxy-1:10-phenanthroline (Fig. 4a) and 4:4-dicarboxy-2:2'-bipyridine (Fig. 4b) exist normally in the zwitterion forms. In neutral solution very little reaction occurs with iron(II) salts, but in alkaline solution very strong co-ordination occurs not only because the nitrogen atoms are now free, but because at least two protons have been

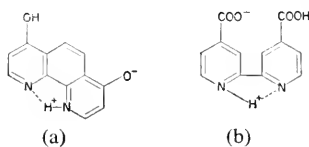

FIG. 4

detached and neutralized. The *tris*-chelate iron complexes have therefore zero charge or are anions depending on the pH. At the biological pH the carboxylic acid side-chains in many porphyrins, e.g. protoporphyrin, haemato-porphyrin, etc., make some contribution to the stability of the complex. Quite independently of other factors, such groups when sufficiently acidic promote oxidation by reducing the overall positive charge.

#### OXIDATION STATE OF THE METAL IN COMPLEXES

In the absence of obvious oxidizing or reducing conditions, the co-ordination of a ligand to a metal ion is taken to involve no change in the oxidation state. The number of unpaired electrons, but not necessarily their location, can be obtained from magnetic moment measurements. The validity of Hund's Rule, which usually needs to be invoked to translate magnetic data into the oxidation state, has been frequently questioned when the magnetic evidence is at variance with the chemical properties. *Bis*(dimethylglyoxime)-copper has the moment characteristic of one unpaired electron, but from the absence of metal-metal interaction in the crystalline state, it has been deduced that the unpaired electron is mostly located on the ligands (Rundle, 1954). It would not be unreasonable to think of the Cu atom as in the +3 diamagnetic state and the ligands as reduced. The observation that the 1-electron oxidation of copper phthalocyanine removes an electron from the ligand and not the metal suggests a similar disposition of the unpaired electron (Cahill and Taube, 1951).

The elaborate system of conjugated double-bonds in iron protoporphyrin makes it feasible that oxidation could yield stable semi-quinone structures without affecting the oxidation state of the iron. Recently, Gibson and Ingram (1956), using the electron spin resonance method, showed that the

oxidation of methaemoglobin removed an electron from peripheral carbon atoms and not from the metal, which was taken as formally remaining in the +3 state.

Some simple metal complexes containing nitric oxide provide examples of where chemical, magnetic and electronic structure considerations fail to establish the oxidation state of the metal. The ions  $[\text{Fe}(\text{CN})_5\text{NO}]^{2-}$  and  $[\text{RuCl}_5\text{NO}]^{2-}$  are both obtained by boiling salts of the trivalent metal ions  $[\text{Fe}(\text{CN})_6]^{3-}$  and  $[\text{RuCl}_5\text{H}_2\text{O}]^{2-}$  with concentrated nitric acid. They are diamagnetic and hence the oxidation state is assumed to be +2. It is proposed that nitric oxide co-ordinates as  $\text{NO}^+$  following the loss of its odd electron to the metal which is thereby reduced. A  $\pi$  bond also is formed between a  $d$  orbital of the metal and the vacant  $p$  orbital of the nitrogen. Exactly the same ultimate electronic structure would result had the nitric oxide formed the usual  $\sigma$  bond, and the  $\pi$  bond had come about by pairing the odd  $d$  electron of the metal with the odd  $p$  electron of the nitrogen, or had the metal lost an electron to nitrogen, which then utilized four electrons to form a double bond. It is questionable whether the donation of four electrons by  $\text{NO}^-$  is more objectionable electronically than of two electrons by  $\text{NO}^+$ . The metals should then be considered in the +4 state, which is certainly more consistent with the method of preparation and the resistance of the iron complex to oxidation.

Metal complexes are generally regarded simply as Lewis acid-base entities but it is possibly more fruitful, especially in their oxidation-reduction reactions, to regard some of them as integral internal redox systems in which the metal alone is not the sole electron source or sink. Certain band spectra of the strongly interacting transitional metal complexes with the porphyrins, phenanthroline and bipyridine have been assigned to the transfer of negative charge from the metal to the ligands, or in highly oxidized states of the complex, in the opposite sense. In the similar activated states in which reaction occurs we are, in effect, dealing with an oxidized or reduced ligand.

Rapid racemization of both species has been found to occur when aqueous solutions of  $d[\text{Os bipy}_3]^{++}$  and  $l[\text{Os bipy}_3]^{+++}$  are mixed. This must proceed through a peripheral electron, located most likely on a carbon atom in the 4-position to the nitrogen atom, leaking across to the oxidized form. Because of the large organic molecules and the octahedral geometry, the metal atoms themselves are inaccessible for direct electron transfer, even through a water bridge (Dwyer and Gyarfas, 1952):

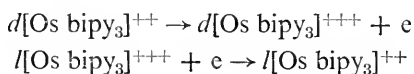

If we think of the oxidized complex as having an electron deficiency, i.e. a positive charge, localized on a similar carbon atom, which is then solvated, a water bridge is provided for electron transport (Fig. 5).

This mechanism, which is similar to that proposed by Williams (1956b) for the haemin catalysed oxidation of cysteine by molecular oxygen, is applicable also to the remarkable reaction first discovered by Blau (1889). The oxidized forms of the tris complexes of Fe, Ru and Os with phenanthroline, bipyridine and terpyridine undergo spontaneous reduction when the pH of the aqueous solutions is raised. Hydroxyl radical has been detected (Uri, 1952). This may reoxidize the complexes if the pH is lowered soon enough, or decompose to ozone (Blau, 1898) or hydrogen peroxide (Brandt, Dwyer

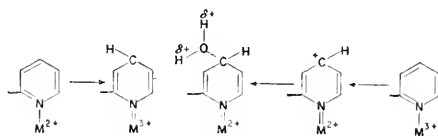

FIG. 5

and Gyarfas, 1954). The polarization of the carbon atom (Fig. 6) may be sufficient to lead to dissociation of a proton, as happens with simple hydrated cations, and the electron then is captured from the attached OH group. Reaction mechanisms of this kind could well be applied to oxidation-reduction reactions in the cytochrome systems, but may have applications to many synthetic processes involving activated  $-\text{CH}-$  and  $-\text{CH}_2$  groups, as discussed previously.

Undue attention seems to have been paid in metal porphyrins to the formal oxidation state of the metal in relation to possible oxidation states as deduced from simple compounds or salts. As a result, there has been much hesitation in invoking otherwise feasible reaction mechanisms involving, for instance, formal Fe(IV), Fe(V) or Mg(I). In such strongly interacting systems both the metal and the ligand are in unique electronic states because of their combination. The relevant fact is the number of electrons that can be added to or detached from the complex unit. The source or fate of the electrons is immaterial. Often this information can be obtained by electrolytic methods or simple chemical reagents.

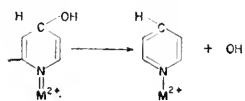

FIG. 6

### REDOX POTENTIALS OF RUTHENIUM COMPLEXES

Simple model metal-complex systems offer much promise in elucidating problems in metal-porphyrin chemistry (Williams, 1956a, b). This is especially so when considering redox potentials. Much useful information on the effect of substituents has been obtained from the iron *tris*(phenanthroline) and bipyridine complexes. In general, the results parallel those obtained with various porphyrins (Martell and Calvin, 1952). Electron attracting substituents ( $\text{NO}_2$ , Br, Cl) render oxidation of the complexes more difficult (potentials are more positive than in the unsubstituted complexes), whilst

electron donating groups cause the opposite effect (Brandt, Dwyer and Gyarfas, 1954).

Because of the non-equivalence of the electronic states in the oxidized and reduced forms of many metal-porphyrins true equilibrium is not attained on an electrode. This raises the question of the applicability of redox potential results obtained from truly reversible model systems to the metal-porphyrins.

The effect of substitution in the ligand molecule itself is but one aspect of the problem. There is little precise information available from models on the effect of the overall charge upon the redox potential, or of the effects that might be anticipated from various ligands when added to a basic planar complex. Recently, we (Dwyer and Goodwin, 1959) have prepared a large number of *mono*- and *bis*(bipyridine) and phenanthroline ruthenium(II) and (III) complexes which serve as better models for the metal-porphyrin systems than the *tris*(chelate) iron complexes. The *bis*(chelate) complexes which evidently are the more appropriate, however, always have the labile two groups in the *cis*(1:2) position instead of the desirable *trans*(1:6) position. Ruthenium is the heavier analogue of iron in Periodic Group 8, and unlike iron, the *mono*- and *bis*(chelate) complexes do not disproportionate. The complexes are spin-paired in both oxidation states and reversible redox potentials can be obtained. By suitable replacement of the labile positions, anions, cations and neutral complexes can be prepared. The effects of overall charge and of the nature of the ligand are shown in Table 1.

Oxidation is greatly facilitated by lowering the positive charge. The replacement of bipyridine, ( $pK_a = 4.33$ ) by two molecules of the stronger base pyridine ( $pK_a = 5.20$ ), also facilitates oxidation, but slightly. Large potential changes are associated with the co-ordination of ammonia, ethylenediamine and water. These seem much too large with the basic ligands to be ascribed wholly to their greater strength as bases. Water, of course, is a much weaker base than pyridine. The implied enhanced stability of the oxidized state can be related in considerable part to the capacity of the ligands to dissipate positive charge to their hydrogen atoms. The latter are then more strongly solvated or can form hydrogen bonds to the solvent water. At the acid concentrations used, dissociation of a proton from the aquo groups is unlikely, though this would stabilize the oxidized form most effectively by reducing the overall charge.

There are still insufficient data to make much of a comparison between the ruthenium systems and the metal-porphyrins containing various co-ordinated addenda. The potentials of the latter systems certainly cover a much narrower range, possibly because of the smaller overall charge. The replacement of the water molecules (or water and hydroxyl) in protoporphyrin, for instance, by pyridine only changes the potential from  $-0.14$  V to  $+0.107$  V. A much more positive potential might have been anticipated. Similarly, the potential of the dicyano-protoporphyrin couple ( $-0.183$  V) would be expected to be

more negative. In some of these couples, however, the electronic states are different. It is questionable whether comparisons between the spin-free protoporphyrin and the spin-paired *bis*(pyridine) and dicyano complexes can be made on the same basis as the electronically equivalent ruthenium complexes.

TABLE I. REDOX POTENTIALS OF RUTHENIUM COMPLEXES IN SULPHURIC ACID (1 N)

<i>Couple</i>		$E^0$
[Ru bipy <sub>3</sub> ] <sup>++</sup>	—[Ru bipy <sub>3</sub> ] <sup>+++</sup>	1.257V
[Ru bipy <sub>2</sub> py <sub>2</sub> ] <sup>++</sup>	—[Ru bipy <sub>2</sub> py <sub>2</sub> ] <sup>+++</sup>	1.25
[Ru bipy py <sub>4</sub> ] <sup>++</sup>	—[Ru bipy py <sub>4</sub> ] <sup>+++</sup>	1.246
[Ru bipy py <sub>3</sub> Cl] <sup>+</sup>	—[Ru bipy py <sub>3</sub> Cl] <sup>++</sup>	0.894
[Ru bipy Cl <sub>4</sub> ] <sup>—</sup>	—[Ru bipy Cl <sub>4</sub> ] <sup>—</sup>	0.35
[Ru bipy py <sub>3</sub> ·H <sub>2</sub> O] <sup>++</sup>	—[Ru bipy py <sub>3</sub> ·H <sub>2</sub> O] <sup>+++</sup>	1.041
[Ru bipy py <sub>2</sub> ·(H <sub>2</sub> O) <sub>2</sub> ] <sup>++</sup>	—[Ru bipy py <sub>2</sub> ·(H <sub>2</sub> O)] <sup>+++</sup>	0.782
[Ru bipy <sub>2</sub> (NH <sub>3</sub> ) <sub>2</sub> ] <sup>++</sup>	—[Ru bipy <sub>2</sub> (NH <sub>3</sub> ) <sub>2</sub> ] <sup>+++</sup>	0.875
[Ru bipy <sub>2</sub> ·en] <sup>++</sup>	—[Ru bipy <sub>2</sub> ·en] <sup>+++</sup>	0.74

(py = pyridine, en = ethylenediamine).

#### SUMMARY

The metal-porphyrins have been discussed as typical strongly interacting metal complexes in respect to such properties as the vacant co-ordination positions about the metal, the peripheral charge distribution and the oxidation state. A series of *mono*- and *bis*(bipyridine) ruthenium complexes has been proposed as model systems. The importance of the whole complex unit is emphasized in opposition to the concept of metal with attached ligand.

#### REFERENCES

- BASOLO, F. & PEARSON, R. G. (1958). *Mechanisms of Inorganic Reactions*, 34-90; 177-210 John Wiley, New York.
- BLAU, F. (1889). *Mh. Chem.* **10**, 367.
- BRANDT, W. W., DWYER, F. P. & GYARFAS, E. C. (1954). *Chem. Rev.* **54**, 959.
- CAHILL, A. E. & TAUBE, H. (1951). *J. Amer. chem. Soc.* **73**, 2847.
- CHANCE, B. (1951). *The Enzymes*, **2**, 428, Sumner and Myrbäck, Academic Press, New York.
- CHATT, J., DUNCANSON, L. H. & VENANZI, L. M. (1955). *J. chem. Soc.*, 4456.
- DWYER, F. P. & GOODWIN, H. (1959). Unpublished work.
- DWYER, F. P., GYARFAS, E. C., SHULMAN, A. & WRIGHT, R. D. (1957). *Nature, Lond.* **179**, 452.
- DWYER, F. P. & GYARFAS, E. C. (1950). *Nature, Lond.* **166**, 1181.
- DWYER, F. P. & SARGESON, A. M. (1960). *Nature, Lond.* **186**, 966.
- DJORDJEVIC, C., LEWIS, J. & NYHOLM, R. S. (1959). *Chem. and Ind.* **4**, 122.
- FALK, J. E. & NYHOLM, R. S. (1958). *Current Trends in Heterocyclic Chemistry*, 130-139, Butterworths, London.
- GIBSON, J. F. & INGRAM, D. J. (1956). *Nature, Lond.* **178**, 871.
- ITUKANI, Y., OKUDA, T., SATO, M. & AKABORI, S. (1959). *Bull. chem. Soc. Japan* **32**, 203.

- KING, N. K. & WINFIELD, M. E. (1959). *Aust. J. Chem.* **12**, 47.
- MARTELL, A. E. & CALVIN, M. (1952). *Chemistry of the Metal Chelate Compounds*, 207-237; 373-375, Prentice-Hall, New York.
- NYHOLM, R. S. (1953). *Chem. Rev.* **53**, 263.
- NYHOLM, R. S., HARRIS, C. M. & STEPHENSON, N. C. (1956). *Rec. trav. chim.* **75**, 687.
- PAULING, L. (1938). *The Nature of the Chemical Bond*, Cornell University Press, Ithaca, N.Y.
- PAULING, L. (1948). *J. chem. Soc.* 1461.
- QUAGLIANO, J. V. & SCHUBERT, L. (1952). *Chem. Rev.* **50**, 201.
- RUNDLE, R. E. (1954). *Conference on Coordination Compounds*, Indiana University, Bloomington, 25. *J. Amer. chem. Soc.* **76**, 3101.
- SATO, M., OKAWA, K. & AKABORI, S. (1957). *Bull. chem. Soc. Japan* **30**, 937.
- URI, N. (1952). *Chem. Rev.* **50**, 375.
- WILLIAMS, R. J. P. (1956a). *Nature, Lond.* **177**, 304.
- WILLIAMS, R. J. P. (1956b). *Chem. Rev.* **56**, 299.

## DISCUSSION

### Higher Oxidation States

LEMBERG: While it is certainly correct that we have strongly interacting systems in which both the metal and the ligand are in unique electronic states because of their combination, I feel that Dwyer has somewhat overstated his case. In such instances as the  $\text{RO}_2\text{H}$  or  $\text{H}_2\text{O}_2$ -complexes of peroxidase, catalase and ferrimyoglobin, one may well be in doubt about the exact valency state of the iron, but in most other haemoprotein compounds there is little doubt about the valency of the iron.

GEORGE: Gibson and Ingram (*Nature, Lond.* **178**, 871, 1956) demonstrated the presence of a free radical in the oxidation of ferrimyoglobin by  $\text{H}_2\text{O}_2$  by paramagnetic resonance absorption measurements, and identified this with the higher oxidation state,  $\text{Mb}^{\text{IV}}$ . However, in more recent experiments, Gibson, Ingram and Nicholls (*Nature, Lond.* **181**, 1398, 1958) have shown the radical to be present in much lower concentration than the oxidation state IV of the prosthetic group, invalidating the previous conclusion.

It is not unexpected that radicals can be detected in such a system because there is already ample chemical evidence for the production of a radical in the formation reaction, i.e.

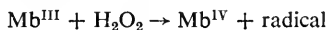

and furthermore, in the reduction of  $\text{Mb}^{\text{IV}}$ , which occurs spontaneously and more rapidly the higher the concentration, radical species must again be formed, since  $\text{Mb}^{\text{IV}}$  is a one-equivalent oxidation product of  $\text{Mb}^{\text{III}}$ . (George and Irvine, *Biochem. J.* **52**, 511, 1952.)

Some years ago it was shown that a simple radical structure of the type that was proposed by Gibson and Ingram would not account for the hydrogen ion participation in  $\text{Mb}^{\text{IV}}$  reactions, whereas the "ferryl ion" structure or an isomer of this structure is in accord with the experimental data (George and Irvine, *Sympos. on Coordination Compounds*, Danish chem. Soc., p. 135, 1954; *Biochem. J.* **60**, 596, 1955).

It should be emphasized that although paramagnetic resonance absorption provides an excellent technique for the detection of free radicals, other evidence must also be considered in discussing possible structures for intermediates in oxidation-reduction reactions. The same is true of the mechanism of oxidation-reduction reactions, since radical species could be formed in side reactions, and not necessarily be involved in the principal reaction path.

GEORGE: Another example where higher oxidation states are formed, somewhat similar to that of the  $\text{Cu}^{\text{II}}$ ,  $\text{Co}^{\text{II}}$ ,  $\text{Zn}^{\text{II}}$  and  $\text{Al}^{\text{III}}$  phthalocyanines, is that of  $\alpha$ - $\beta$ - $\gamma$ - $\delta$ -tetraphenylporphyrin (TPP). Whereas with the metal-free phthalocyanine the one-equivalent

higher oxidation state is very unstable, TPP yields both a one-equivalent and a two-equivalent higher oxidation state that are appreciably more stable, i.e.,

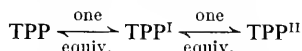

In phosphoric acid solution TPP is bright green, TPP<sup>I</sup> and TPP<sup>II</sup> are dull violet and orange-brown respectively. These oxidations are completely reversible like the one-equivalent oxidation of copper phthalocyanine, the addition of ascorbic acid, hydroquinone or ferrous salts regenerating the TPP. The structure of TPP<sup>II</sup> probably corresponds to the removal of the two pyrrole hydrogen atoms with the introduction of a new double bond into the ring system, as in the oxidation of reduced flavin. The copper salt of TPP yields a one-equivalent higher oxidation state like the phthalocyanine derivative, but on addition of more oxidant a whole series of highly coloured products are formed from which the original compound can no longer be recovered by the addition of reducing agents (George and Goldstein, *Abstracts 129th Meeting Amer. chem. Soc.*, Dallas, K 16, p. 13, 1956; George, Ingram and Bennett, *J. Amer. chem. Soc.* **79**, 1870, 1957).

### *Effects of Metal on Reactivity at Periphery*

- BARRETT: Concerning Dwyer's remarks on the effect of the introduction of metals into porphyrins, and the consequent events occurring at the periphery of the molecule, I would like to make this comment. Fischer and Boek (*Hoppe-Seyl. Z.* **255**, 1, 1931) exposed protoporphyrin in pyridine solution to light and obtained a substance with a chlorin-like spectrum. The substance is not a true chlorin, or dihydroporphyrin, but carries two or possibly three oxygen atoms. The addition of these oxygen atoms results in the formation of a hydroxy group and a carbonyl group (Barrett, *Nature, Lond.* **183**, 1185, 1959). A vinyl group is necessary for the formation of dioxyprotoporphyrin. Pertinent to Dwyer's remarks is the observation that photo-oxidation of the tetrapyrrole does not occur when complexed with a metal, e.g. Cu<sup>++</sup>, Fe<sup>+++</sup>, or if irradiated in 1-10% hydrochloric acid. Could Dwyer comment on these effects: the suppression of photo-oxidation by (1) the formation of a metal complex and (2) the formation of the di-hydrochloride?
- DWYER: One can anticipate a common effect as far as the peripheral charge is concerned by either protonation or the formation of a metal complex. However, I feel that the altered charge distribution is not *per se* the reason for the inhibition of photo-oxidation, but rather the effect of the proton or the metal is on the fluorescence of the protoporphyrin, and hence its ability to form active oxygen (or hydroxyl) which is presumably the attacking agent.



# THE PHYSICO-CHEMICAL BEHAVIOUR OF PORPHYRINS SOLUBILIZED IN AQUEOUS DETERGENT SOLUTIONS

By B. DEMPSEY,\* M. B. LOWE† AND J. N. PHILLIPS†

*Department of Chemistry, Royal Military College, Duntroon,  
and Division of Plant Industry, C.S.I.R.O., Canberra*

THE TETRAPYRROLES, and in particular the haem pigments, occur in a biological environment which is essentially aqueous. It is therefore desirable to determine their physico-chemical properties in an aqueous medium. Unfortunately, the information available, particularly as regards their ionization and co-ordination behaviour, is meagre (Phillips, 1960). The major experimental obstacle to obtaining such data has been the very low solubility of these compounds in water. Some measurements have been carried out in non-aqueous and mixed solvent media (Conant, Chow and Dietz, 1934; Aronoff and Weast, 1941; Aronoff, 1958; Barnes and Dorough, 1950; Caughey and Corwin, 1955; Corwin and Melville, 1955). However, such systems are unsuitable for electrochemical studies because of unknown ionic activity effects.

This situation led us to explore the use of aqueous detergent solutions as solvent media (Phillips, 1958). Studies have been carried out using fully esterified porphyrin derivatives to avoid electrostatic effects arising from the ionized carboxylic acid groups on the periphery of the nucleus. A wide variety of porphyrin esters has been shown to disperse molecularly in a number of detergent solutions, presumably by solubilization within the lipid micelle. This phenomenon is analogous to a phase distribution equilibrium in which one of the phases is of molecular dimensions. Macroscopically, such a system would behave as a single phase and equilibration between the phases would be expected to be extremely rapid. The distribution of the porphyrin molecules between the aqueous and micellar phases can be represented by a simple equilibrium of the type:

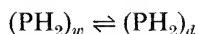

the solubilization constant  $K_s$  being defined by

$$K_s = \frac{[n_{(\text{PH}_2)_d}][N_w]}{[n_{(\text{PH}_2)_w}][N_d]}$$

\* *Royal Military College.*

† *C.S.I.R.O.*

where the subscripts  $d$  and  $w$  refer to the micellar and water phases respectively, and

$n_x$  is the number of molecules of species  $x$ ;

$N_d$  is the number of detergent molecules in the micellar phase; and

$N_w$  is the number of water molecules in the system.

When an ion, e.g. a hydrogen ion  $H^+$  or a metal ion  $M^{++}$ , is introduced into such a system it will presumably prefer the aqueous environment exclusively to that of the lipid micelle. Accordingly, any reaction involving such an ion and the porphyrin molecule must take place within the aqueous phase, the detergent micelles acting as a readily available reservoir for the porphyrin molecules.

Typical reactions which may be studied in this way are:



The products of such reactions may or may not be solubilized depending on their nature. For example, one might expect the nonionic metal complex

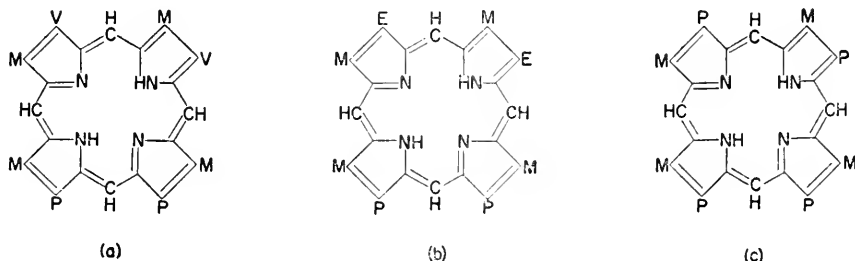

FIG. 1

(a) Dimethyl protoporphyrin ester (DMPP)

(b) Dimethyl mesoporphyrin ester (DMMP)

(c) Tetramethyl coproporphyrin III ester (TMCP)

$M = -CH_3$

$V = -CH=CH_2$

$E = -CH_2-CH_3$

$P = -CH_2-CH_2-COOCH_3$

(MP) but not the ionic porphyrin species ( $PH_3^+$  and  $PH_4^{++}$ ) to be readily solubilized.

The purpose of this paper is to indicate the type of data that may be obtained using the solubilization technique and to suggest how such data may be interpreted. The following discussion is primarily concerned with the ionization (as in equation (1)), co-ordination (as in equation (2)) and spectroscopic behaviour of porphyrins.

In particular, the discussion will refer to the behaviour of the fully esterified derivatives of mesoporphyrin IX (DMMP), protoporphyrin IX (DMPP) and coproporphyrin III (TMCP) (see Fig. 1). The detergent solutions used

were either 2.5% (w/v) sodium dodecyl sulphate (SDS) or 0.25% (w/v) cetyltrimethyl ammonium bromide (CTAB).

*Ionization Behaviour*

The ionization of porphyrins solubilized in aqueous detergent solutions can readily be studied spectroscopically. Two general types of behaviour occur, the one with cationic and non-ionic and the other with anionic detergent solutions.

In the former case two species only, the neutral porphyrin (PH<sub>2</sub>) and the dication (PH<sub>4</sub><sup>++</sup>) are observed upon spectroscopic titration within the pH range 0–12. The variation in optical density (*E*) with pH at a given wavelength is such as to indicate that the reaction involves two protons:



the overall dissociation constant (*K*<sub>obs</sub>) of the conjugate acid PH<sub>4</sub><sup>++</sup> being given by

$$K_{\text{obs}} = \frac{[\text{PH}_2][\text{H}^+]^2}{[\text{PH}_4^{++}]} \tag{4}$$

This does not necessarily imply the simultaneous addition of two protons in the kinetic sense. A more likely explanation is that under these conditions the monocation behaves as a stronger base than the free porphyrin.

The equilibria postulated to account for this behaviour are illustrated below.

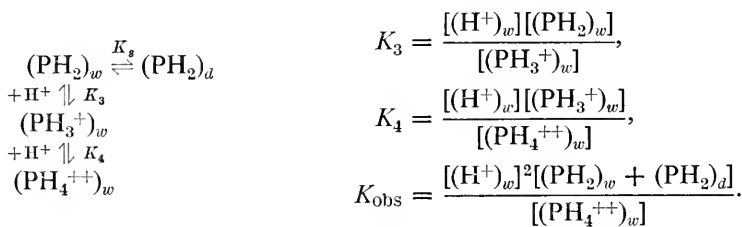

In terms of the scheme outlined the observed constant (*K*<sub>obs</sub>) would correspond to *K*<sub>3</sub>*K*<sub>4</sub>(1 + *K*<sub>s</sub>).

The p*K*<sub>obs</sub> (= -log<sub>10</sub>*K*<sub>obs</sub>) values for DMMP and TMCP in 0.25% CTAB were found to be 2.08 ± 0.05 and 2.24 ± 0.05 respectively. Unfortunately the corresponding value for DMPP was too low (< +0.5) to be determined with any certainty. It is clear, however, that the observed values will depend on the nature and concentration of the detergent, and that comparisons of p*K* values for different porphyrins in the same detergent solution will reflect differences both in their aqueous basicities and in their solubilization constants.

In anionic detergent solutions three species, corresponding to PH<sub>2</sub>, PH<sub>3</sub><sup>+</sup> and PH<sub>4</sub><sup>++</sup>, may be observed upon spectroscopic titration, each ionization

step corresponding to a one-proton addition. It has not been possible fully to interpret this behaviour theoretically, although it is certain that both the ionic porphyrin species  $\text{PH}_3^+$  and  $\text{PH}_4^{++}$  are being stabilized by some type of solubilization process. This leads to the observed  $\text{p}K$  values being a function of the intrinsic aqueous basicity constant and of the ratio of the solubilization constants of the species concerned in the equilibrium. Such a ratio would tend to eliminate specific porphyrin solubilization effects and hence one would expect the relative  $\text{p}K$  values for a series of porphyrins in anionic detergent solutions to parallel their values in water. In the case of DMMP, TMCP and DMPP, the  $\text{p}K_3$  values observed in 2.5% SDS were 5.94, 5.58 and 4.88, and the  $\text{p}K_4$  values 2.06, 1.80 and 1.84 respectively. The  $\text{p}K_3$  values appear to reflect the relative electrophilic character of the side chains, and this effect has been confirmed with a number of other porphyrin derivatives. The  $\text{p}K_4$  values appear less sensitive to the nature of the side chain. It is of interest to note that the  $\text{p}K_4$  of 1.84 for DMPP in 2.5% SDS is equal to the value for DMPP in water ( $\text{p}K_4 = 1.8$ ) as estimated independently from solubility measurements (Dempsey and Phillips, unpublished). This suggests that the solubilization constants for the species  $\text{PH}_3^+$  and  $\text{PH}_4^{++}$  not only parallel each other but are in fact very similar in magnitude.

#### *Co-ordination Behaviour*

The interaction between porphyrin molecules and divalent metal ions can be represented by an equilibrium of the type shown in equation (2). There are little quantitative kinetic or thermodynamic data available about such reactions, and it was therefore thought desirable to explore them using the solubilization technique.

It has been found that in cationic detergent solutions the reactions between porphyrins and metal ions are markedly dependent on temperature and also on the nature of the metal ion. At 20°C in 0.25% CTAB no reaction has been observed with  $\text{Co}^{++}$ ,  $\text{Ni}^{++}$ ,  $\text{Cu}^{++}$ ,  $\text{Zn}^{++}$ ,  $\text{Cd}^{++}$ ,  $\text{Mg}^{++}$ ,  $\text{Mn}^{++}$ ,  $\text{Pb}^{++}$ , or  $\text{Fe}^{++}$ , over a period of weeks. On the other hand, at 100°C very rapid reactions occurred with  $\text{Cu}^{++}$  and  $\text{Zn}^{++}$  under suitable pH conditions, though not with any of the other metal ions studied.

Accordingly the reactions involving  $\text{Zn}^{++}$  and  $\text{Cu}^{++}$  were investigated in greater detail. These reactions were shown to conform to equation (2), the apparent equilibrium constant ( $K'_e$ ) being given by:

$$K'_e = \frac{[\text{MP}][\text{H}^+]^2}{[\text{M}^{++}][\text{PH}_2]} \quad (5)$$

Such constants were evaluated by determining spectroscopically the ratio  $\text{MP}/\text{PH}_2$  at equilibrium, for a range of hydrogen and metal ion concentrations. Typical formation curves are shown in Fig. 2 for the zinc-mesoporphyrin

reaction at 60°C. The time required to attain equilibrium at this temperature in the presence of 10<sup>-1</sup> M zinc sulphate and 5 × 10<sup>-7</sup> M DMMP in 0.25% CTAB was approximately 48 hr. The reversibility of the equilibrium was demonstrated by studying both the forward and backward reactions as expressed by equation (2).

The  $K_e'$  value determined for the zinc mesoporphyrin equilibrium at 80°C, extrapolated to zero ionic strength is 6.0 × 10<sup>-3</sup>; the corresponding value at

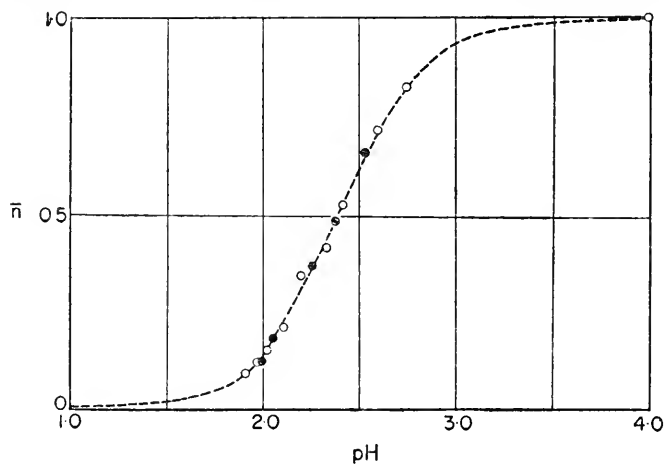

FIG. 2. Formation curves for the zinc mesoporphyrin complex at 60°C  
Forward reaction equilibrium points



Backward reaction equilibrium points



$$\bar{n} = \frac{ZnP}{T_{PH_2}}, \text{ where } T_{PH_2} \text{ is the total concentration of mesoporphyrin present.}$$

60°C is 2.5 × 10<sup>-3</sup>. The relationship between the observed equilibrium constants ( $K_e'$ ) and their value in water ( $K_e$ ) is given by:

$$K_e' = K_e \cdot \left\{ \frac{(1 + K_s^{MP})}{(1 + K_s^{PH_2})} \right\} \quad (6)$$

where  $K_s^x$  is the solubilization constant of species  $x$ .

If both species  $PH_2$  and  $MP$  were equally solubilized then the observed equilibrium constant would correspond to the water value. It seems likely that the solubilization constants will be of a similar order of magnitude, and in any event  $K_e'$  values are likely to parallel  $K_e$  values either when comparing the one porphyrin with different metals or different porphyrins with the same metal.

Preliminary results suggest:

- (i) that  $\text{Zn}^{++}$  reacts faster and forms a more stable complex with DMMP and TMCP than DMPP, as might be expected from the greater electrophilic character of the unsaturated vinyl side-chain compared with its saturated analogues;
- (ii) that  $\text{Cu}^{++}$  reacts faster and forms more stable complexes than  $\text{Zn}^{++}$  with DMMP, in accord with the normal relative chelating ability of the two ions (see Bjerrum, Schwarzenbach and Sillen, 1956-57); and
- (iii) that  $\text{Co}^{++}$  and  $\text{Ni}^{++}$  react infinitely more slowly than  $\text{Cu}^{++}$  or  $\text{Zn}^{++}$ , although there is evidence (Caughey and Corwin, 1955) to indicate that in general  $\text{Co}^{++}$  and  $\text{Ni}^{++}$  form the more stable porphyrin complexes. It is suggested that this reluctance on the part of  $\text{Co}^{++}$  and  $\text{Ni}^{++}$  may be associated with their tendency to form hexaco-ordinate compounds as compared with the tetra-co-ordinating tendency of  $\text{Cu}^{++}$  and  $\text{Zn}^{++}$ .

The overall kinetics conform to a simple bimolecular reaction involving metal ions and the neutral porphyrin species ( $\text{PH}_2$ ). This, and the fact that  $\text{Zn}^{++}$  reacts more readily with DMMP and TMCP than DMPP suggests that the reaction mechanism is of the displacement rather than the dissociation type (Basolo and Pearson, 1958).

For purposes of comparison it is convenient to express  $K_e'$  values in terms of the more conventional stability or formation constants ( $K_f$ ) defined by:

$$K_f = \frac{[\text{MP}]}{[\text{M}^{++}][\text{P}^-]} \quad (7)$$

In the absence of acidic  $\text{p}K$  data for mesoporphyrin the value for actio-porphyrin II at room temperature ( $\text{p}K_1 + \text{p}K_2 \sim 32$  (McEwen, 1936)) has been used. This leads to extrapolated  $\log_{10} K_f$  values for zinc mesoporphyrin at  $20^\circ\text{C}$  of  $\sim +29$ . The high stability of porphyrin metal complexes is illustrated by comparing this value with the corresponding figures in water for the zinc complexes of, for example, 8-hydroxyquinoline-5-sulphonic acid ( $\sim 16.0$ ), ethylene diamine ( $\sim 11.0$ ), and glycine ( $\sim 9.5$ ) (Bjerrum *et al.*, 1956-57).

### *Spectroscopic Behaviour*

Aqueous detergent solutions form useful solvent systems for studying the spectroscopic properties of porphyrin molecules, their salts and metal complexes. Anionic detergents are of particular interest in that they permit a study of the spectral behaviour of the monocationic species ( $\text{PH}_3^+$ ), a species which has proved virtually impossible to obtain in normal solvent media. Much theoretical argument (Platt, 1956; Kuhn, 1959) concerning electron distribution in the porphyrin nucleus has been based on the absorption spectra of the symmetrical free porphyrin ( $\text{PH}_2$ ) and its dication ( $\text{PH}_4^{++}$ ). It seems

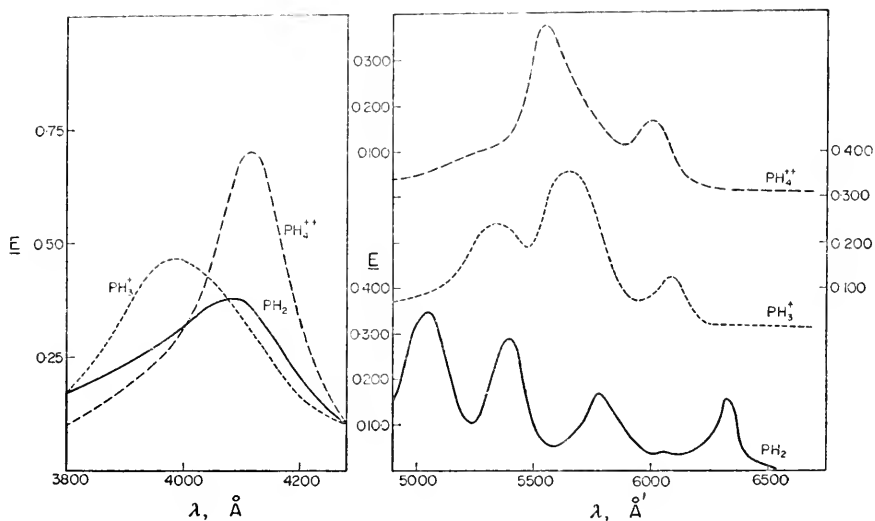

FIG. 3. Soret and visible absorption spectra for the various protoporphyrin species.

TABLE I. SPECTROSCOPIC PROPERTIES OF SOME PROTOPORPHYRIN DERIVATIVES IN 2.5% SDS

Species	Absorption maxima $\pm 5 \text{ \AA}$	Fluorescence excitation maxima $\pm 20 \text{ \AA}$	Fluorescence emission maxima $\pm 10 \text{ \AA}$
$\text{PH}_2$	4080 Soret 5050 } Visible 5405 } 5780 } 6330 }	4150 5080 5420 5820 6340	6340
$\text{PH}_3^+$	3985 Soret 5350 } Visible 5680 } 6095 }	4080 5370 5660 6100	6125
$\text{PH}_4^{++}$	4120 Soret 5570 } Visible 6020 }	4130 5580 6020	6060
ZnP	4120 Soret 5425 } Visible 5790 }	4150 5440 5780	5890

likely that similar information on the asymmetric intermediate species ( $\text{PH}_3^+$ ) would further facilitate the understanding of this problem.

Figure 3 compares the absorption spectra of the species,  $\text{PH}_2$ ,  $\text{PH}_3^+$  and  $\text{PH}_4^{++}$  for DMPP solubilized in 2.5% SDS. Such curves are typical for porphyrins having aetio type spectra. It will be observed that in the Soret region the absorption maximum for the monocation is displaced towards the violet relative to both the other species. In the visible region the four-banded spectrum associated with the neutral porphyrin ( $\text{IV} > \text{III} > \text{II} > \text{I}$ ) changes upon ionization to a three-banded type ( $\text{II} > \text{III} > \text{I}$ ) and finally to the typical two-banded dication spectrum ( $\text{II} > \text{I}$ ).

Measurements have been made also of the fluorescence excitation and emission spectra of the various protoporphyrin species and of the zinc protoporphyrin complex in 2.5% SDS. The fluorescence excitation and emission maxima are shown in Table 1 along with the absorption maxima. It will be observed that in each case the single fluorescent emission maximum lies at wavelengths 10 to 100 Å longer than the  $\alpha$  absorption band. In general the fluorescent excitation maxima correspond to the absorption bands.

#### SUMMARY

This paper is concerned with physico-chemical studies of porphyrin esters solubilized in aqueous detergent solutions. In particular, quantitative data have been reported for:

- (i) the relative basicity of proto-, meso- and copro-porphyrins at 20°C;
- (ii) the chelation of zinc ions by mesoporphyrin at 60° and 80°C; and
- (iii) the absorption and fluorescence spectra of the monocationic species of protoporphyrin at 20°C.

Preliminary results have also been reported for the zinc-protoporphyrin and copper-mesoporphyrin reactions at 80°C. The technique could readily be adapted to other physico-chemical studies, e.g. the further co-ordination of metalloporphyrins with other ligands and oxidation-reduction equilibria in metalloporphyrin systems.

Such studies, aimed at providing basic information on the physico-chemical behaviour of these pigment prosthetic groups, seem an essential prerequisite to a detailed understanding of the role of such molecules in biological processes.

#### Acknowledgement

The authors are indebted to Miss I. Verners for her skilled experimental assistance and to Dr. J. E. Falk for providing the purified porphyrin esters.

#### REFERENCES

- ARONOFF, S. (1958). *J. phys. Chem.* **62**, 428.  
ARONOFF, S. & WEAST, C. A. (1941). *J. org. Chem.* **6**, 550.  
BARNES, J. W. & DOROUGH, G. D. (1950). *J. Amer. chem. Soc.* **72**, 4045.



- BASOLO, F. & PEARSON, R. G. (1958). *Mechanisms of Inorganic Reactions*, p. 91, John Wiley, New York.
- BJERRUM, J., SCHWARZENBACH, G. & SILLEN, L. (1956-7). *Stability Constants*, Pts I & II, The Chemical Society, London.
- CAUGHEY, W. S. & CORWIN, A. H. (1955). *J. Amer. chem. Soc.* **77**, 1509.
- CONANT, J. B., CHOW, B. F. & DIETZ, E. M. (1934). *J. Amer. chem. Soc.* **56**, 2185.
- CORWIN, A. H. & MELVILLE, M. H. (1955). *J. Amer. chem. Soc.* **77**, 2755.
- KUHN, H. (1959). *Helv. chim. Acta* **42**, 363.
- MC EWEN, W. K. (1936). *J. Amer. chem. Soc.* **58**, 1124.
- PHILLIPS, J. N. (1958). *Current Trends in Heterocyclic Chemistry*, p. 30 (Ed. by A. Albert, G. M. Badger and C. W. Shoppe), Butterworths, London.
- PHILLIPS, J. N. (1960). *Rev. pure appl. Chem.* **10**, 35.
- PLATT, J. R. (1956). *Radiation Biology*, Vol. III, p. 71 (Ed. by A. Hollaender). McGraw-Hill, New York.

## DISCUSSION

### *Cations of Porphyrins and Their Spectra*

ORGEL: I should like to ask Phillips why it is that in the detergent system it is possible to measure the addition of a single proton to a metal-free porphyrin, while in the past those measurements which have been done have suggested that two protons are added simultaneously.

PHILLIPS: We believe the reason that the monocation is so readily obtained in anionic detergent solution to be due to its stabilization at the negatively charged micelle-water interface. It is of interest to note that no monocationic species can be detected in non-ionic or cationic detergent solutions.

LEMBERG: It is reassuring that on the whole there seems to be a satisfactory agreement between the conclusion as to basicity of porphyrins derived from the Willstätter

$\epsilon_{mM}$  and R I/IV and R III/IV of porphyrins

Porphyrin	I $\epsilon_{mM}$	R I/IV	III $\epsilon_{mM}$	R III/IV
Deutero	4.33	0.27	8.59	0.54
Aetio	5.18	0.38	9.50	0.70
Copro	5.15	0.35	9.97	0.68
Meso	5.41	0.38	9.82	0.69
Proto	5.58	0.38	11.58	0.79
Diacetyldeutero	3.52	0.29	6.7	0.55
Diformyldeutero	3.48	0.29	8.00	0.67
Monoacetyldeutero	1.56	0.17	10.5	1.14
Rhodo	2.0	0.17	15.0	1.29
Crypto <i>a</i>	2.35	0.21	14.7	1.32
Chlorocruoro	2.25	0.21	15.1	1.40
Acrylic acid	3.01	0.27	16.13	1.46
Phaeo $a_5$	1.88	0.20	16.06	1.71
Formylpyrro	1.86	0.19	16.74	1.77
Formyldeutero	1.82	0.20	15.7	1.73
Vinylrhodo	1.2	0.115	19.8	1.89
Diacetylpyrro	1.42	0.245	13.62	2.36
Acetylrhodo	2.21	0.27	21.0	2.40
<i>a</i>	1.30	0.15	21.0	2.40

number, and their basicity now more correctly established by Phillips' interesting method. It is also interesting to note that evidence for a monocation had previously been obtained by Neuberger and Scott for deuteroporphyrin disulphonic ester, somewhat resembling anionic detergents, although Walter had not been able to confirm this.

With regard to the spectra of porphyrin dications, it is of interest that on closer observation four, not two, absorption bands can be observed in the visible part of the spectrum. This leads me to doubt the correlations assumed by Platt for the neutral and acid spectra of porphyrins. In this connexion I should like to point out that the two bands I and III of neutral porphyrin spectra are not at all influenced in a similar manner by the substitution of an electron-attracting group on the porphyrin nucleus. Thus all formyl and ketonyl-substituted porphyrins have their band III greatly increased, but their band I greatly diminished as the table on p. 37 shows.

While it is true that band I is the most variable and band III the second in variability, there is, in fact, little difference between the variability of  $\epsilon_{\text{MM}}$  of bands II, III and IV in a variety of different porphyrins.

PHILLIPS: Walter's failure (*J. Amer. chem. Soc.* **75**, 3860, 1953) to detect the monocationic species observed by Neuberger and Scott (*Proc. Roy. Soc. A.* **213**, 307, 1952) was due to an unfortunate choice of experimental conditions. This aspect has been discussed by Scott (*J. Amer. chem. Soc.* **77**, 325, 1955).

## The Reactions between Metal Ions and Porphyrins

By J. H. Wang and E. B. Fleischer (Yale)

WANG: Phillips and his co-workers suggested that the combination of porphyrin esters with  $\text{Zn}^{++}$  to form  $\text{Zn}^{++}$ -porphyrin derivatives takes place through a displacement rather than a dissociation type of mechanism. I would like to report some work which not only confirms his suggestion but also gives a more detailed understanding of this displacement mechanism.

We found that the rates of the successive steps in the combination of a metal ion and a porphyrin derivative can be markedly affected by varying the solvent composition, presumably due to the change in solvation of the metal ion. In acetone solutions some metal ions,  $\text{Cu}^{++}$ ,  $\text{Bi}^{+++}$ ,  $\text{Hg}^{++}$ ,  $\text{Cd}^{++}$ , etc., react readily with the dimethyl ester of protoporphyrin even at room temperature to form the corresponding metallo-porphyrin, whereas other metal ions,  $\text{Fe}^{++}$ ,  $\text{Fe}^{+++}$ ,  $\text{Cr}^{+++}$ ,  $\text{Pt}^{++++}$ ,  $\text{Sn}^{++}$ ,  $\text{Zn}^{++}$ , etc., form a new type of complex with absorption spectra markedly different from that of the corresponding metallo-porphyrins; only upon heating do their spectra change to those of the metallo-protoporphyrins.

The spectra of some protoporphyrin derivatives in chloroform solution are shown in Fig. 1. The spectra are respectively (A) protoporphyrin dimethyl ester, (B) haemin dimethyl ester, (C) the new type of complex formed between ferric chloride and protoporphyrin dimethyl ester, and (D) the dihydrochloride of protoporphyrin dimethyl ester.

If alcohol or pyridine is added to the chloroform solution of this new complex formed between ferric chloride and protoporphyrin dimethyl ester, the spectrum changes immediately to that of protoporphyrin dimethyl ester, (A) in Fig. 1. This shows that the binding between  $\text{Fe}^{+++}$  and protoporphyrin in the new complex is quite weak, since the protoporphyrin can readily be displaced by other ligands. We suggest that this new complex has a sitting-atop type of structure as illustrated in Fig. 2. It is also of interest to note that the spectrum of the sitting-atop complex of  $\text{Fe}^{+++}$  bears striking resemblance to that of protoporphyrin dication,  $\text{PH}_4^{++}$ , as shown by diagram (D) in Fig. 1. This observation suggests that the observed absorption in (C) is probably due to electronic transitions in the protoporphyrin rather than the metal part of the complex.

Similarly, if acetone solutions of the sitting-atop complexes of  $\text{Fe}^{++}$ ,  $\text{Fe}^{+++}$ ,  $\text{Cr}^{+++}$ ,  $\text{Pt}^{++++}$ ,  $\text{Sn}^{++}$ ,  $\text{Zn}^{++}$  respectively are diluted with water the spectrum immediately changes

to that of the dimethyl ester of protoporphyrin itself, (A) in Fig. 1, as water molecules rapidly displace the organic ligand from the complex.

We have isolated the ferric sitting-atop complex in pure crystalline form. The structure suggested in Fig. 2 was confirmed by the infra-red spectrum of this complex dissolved in deuterated chloroform, 99%  $\text{CDCl}_3$ . In protoporphyrin dimethyl ester the N-H groups are responsible for three distinct infra-red absorption peaks at  $3.05 \mu$  (stretching),  $6.15 \mu$  (deformation), and  $9.06 \mu$  (rocking) respectively. In the infra-red spectrum of haemin dimethyl ester all of the above three peaks disappear as expected.

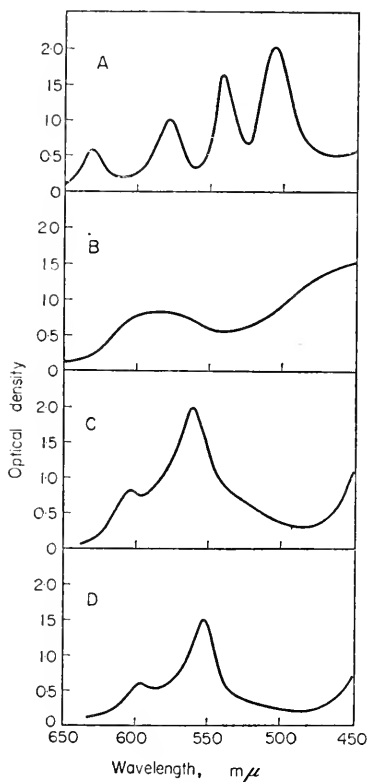

FIG. 1

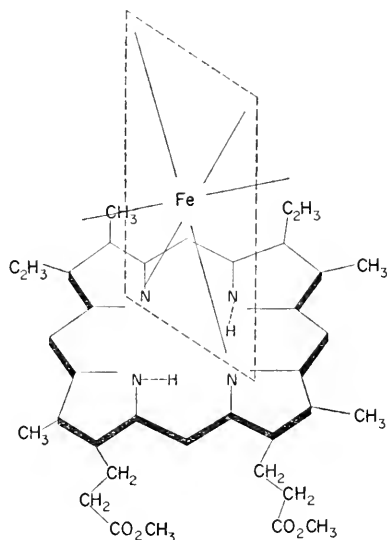

FIG. 2. Proposed sitting-atop type of structure for the reaction intermediate.

We found that in the infra-red spectrum of the ferric sitting-atop complex the  $3.05$  and  $6.15 \mu$  peaks shifted to  $3.11$  and  $6.64 \mu$  respectively, and that the  $9.06 \mu$  peak is no longer easily detectable. This observation confirms our proposed sitting-atop structure, since it shows that the corresponding N-H bonds still exist in the said complex. The observed frequency shift of the  $3.05$  and  $6.15 \mu$  peaks is presumably due to the polarizing influence of the ferric ion.

PHILLIPS: Wang's suggestion that the sitting-atop complex is involved in metal porphyrin formation is both novel and interesting. However, I find the suggestion that the dication structure involves two nitrogens each with two hydrogens and two nitrogens without hydrogens rather disturbing for a number of reasons, viz.

- (i) the spectra of the dication and dianion are identical, which would seem to support the symmetrical dication structure (i.e. 1 hydrogen per nitrogen atom);

- (ii) energetically one would expect the symmetrical structure to be favoured because of its greater conjugation; and
- (iii) Wang's postulated structure would imply that porphyrin basicity should be comparable to pyrrole itself whereas in fact it is many  $pK$  units stronger.

In our experience the reaction between anhydrous ferric chloride and dimethyl-protoporphyrin ester led either to the mono- or di-cationic species, probably due to the difficulty of removing the last trace of water from the system. It would be interesting to have the infra-red spectrum of the dihydrochloride for comparison with the other species.

# SOME PHYSICAL PROPERTIES AND CHEMICAL REACTIONS OF IRON COMPLEXES

By R. J. P. WILLIAMS

*Inorganic Chemistry Laboratory and Wadham College, Oxford*

THIS ARTICLE is intentionally speculative in that it will use a comparison between known properties and reactions of some simple iron complexes with chelating and conjugated ligands on the one hand, and of the wide range of haem-containing compounds of biology on the other, in order to make comments about the structure and mechanism of reactions of the latter molecules. First we restrict our attention to simple iron complexes. There are three classes of these. In class I all the properties and reactions are consistent with the iron ( $\text{Fe}^{++}$  or  $\text{Fe}^{+++}$ ) being in a high-spin state (ionic complexes). In class III the properties are consistent with the cation ( $\text{Fe}^{++}$  or  $\text{Fe}^{+++}$ ) being in a low-spin state (covalent complexes). In the intermediate group, class II, the properties and reactions are consistent with the cation being present in the complexes as an equilibrium mixture of high- and low-spin states. Table 1, which lists the properties and reactions of the groups, is a summary of evidence presented in detail elsewhere (Williams, 1955, 1956, 1958, 1959). The change in the character of the iron complexes (from one group to another) is to be associated with the change in the strength of the effective ligand field increasing from class I through class II to class III. The porphyrin unit supplies a ligand field which, together with groups above and below the porphyrin plane, places its iron complexes in either class II or class III, although the extreme weak-field members in class II can have properties very like complexes in class I. The evidence for this statement is collected and discussed elsewhere (Williams, 1955-59). Here we take this position as established. However we will illustrate it by reference to some physical properties of porphyrins.

## SPECTRA

The absorption bands in the spectra of iron porphyrins have been discussed (Williams, 1956) except for the *Soret band*. Here we will examine the shifts in the position of this band ignoring the others. Some band positions are given in Table 2. In Table 2 wavelengths are in  $m\mu$ . The description 'ionic' and 'covalent' is only applicable to the first three rows of data.

TABLE I. THE THREE CLASSES OF IRON COMPLEXES

	Class I	Class II	Class III
<i>Physical Properties</i>			
Magnetic moment	4.90	4.90-0.00	0.00
(++)	5.90	5.90-2.00	2.00
Visible spectra	weak $\epsilon_{\max} < 10^2$	$\epsilon_{\max} \sim 10^3$	strong $\epsilon_{\max} = 10^4$
(++)	strong $\epsilon_{\max} \sim 10^4$	intermediate	weak $\epsilon_{\max} < 10^2$
Stability	weak	intermediate	very high
(++)	quite high	high	high
(+++)			
<i>Chemical Properties</i>			
Metal and ligand exchange	rapid	rapid-slow	slow
(++)	rapid	rapid-slow	slow
(+++)	rapid	intermediate or rapid	slow
Autoxidation			
(++)			
Reaction with H <sub>2</sub> O <sub>2</sub>	rapid	usually rapid	slow
Electron transfer reactions	rapid	rapid	rapid
Examples of ligands in complexes	H <sub>2</sub> O, NH <sub>3</sub> , oxalate. Enta.	{(DMG) <sub>2</sub> (H <sub>2</sub> O) <sub>2</sub> , oxine.	{(DMG) <sub>2</sub> (NH <sub>3</sub> ) <sub>2</sub> , (DMG) <sub>2</sub> (pyridine) <sub>2</sub> , CN <sup>-</sup> .
(++)			
(+++)			

(DMG is dimethylglyoxime.)

In the table  $\epsilon_{\max}$  is the molar extinction coefficient.

TABLE 2

	Ferrous				Ferric		
	Ionic $\longrightarrow$ Covalent		Ionic $\longrightarrow$ Covalent				
	H <sub>2</sub> O	CO	CN <sup>-</sup>	Pyridine	H <sub>2</sub> O	OH <sup>-</sup>	CN <sup>-</sup>
Peroxidase	438	425		420	404	418	425
Myoglobin	435	424		420	405	414	425
Haemoglobin	430	418		420	404	409	419
Cyt. a <sub>3</sub>	448	432		430(?)	420(?)		
Cyt. a	444(?)	430	440	430	420		428
Cyt. b	425	no effect			416	no effect	
Cyt. c	415	no effect			410	no effect	
Cyt. d	423	415	420	415	390	407	404

Data taken from Lemberg and Legge (1949) and Morton (1958).

Theorell (1942), Williams (1955, 1956) and Scheler, Schoffa and Jung (1957) have drawn attention to the band-shifts as the magnetic moment of the ferric complexes changes. The Soret band moves to *longer* wavelengths in the lower moment complexes. Here we point out that in ferrous complexes the band moves in the opposite direction. The lower the moment of a  $\text{Fe}^{++}\text{PX}_2$  complex (P is porphyrin and  $\text{X}_2$  the further co-ordinating ligands) the shorter the wavelength of the absorption band. Now if we plot the difference in Soret band position  $\text{Fe}^{++}-\text{Fe}^{+++}$  ( $\Delta\lambda$ ) against the sum of the magnetic

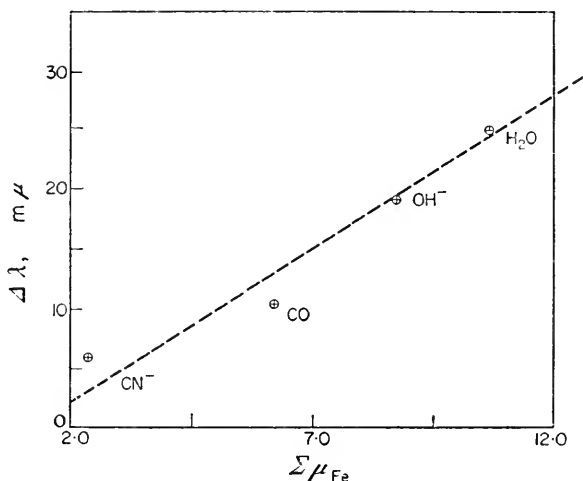

FIG. 1. The relationship between the sum of the magnetic moments of the ferrous and ferric haemoglobin complexes in the presence of the additional ligands shown and the difference in position of the Soret band in the two complexes.

moments ( $\mu\text{Fe}^{++} + \mu\text{Fe}^{+++}$ ) we can obtain a qualitative guide to the character of iron porphyrin complexes from their spectra (Fig. 1). A large value of  $\Delta\lambda$  implies ionic complexes. On this basis we have the series of complexes of decreasing ionic character: peroxidase = myoglobin = haemoglobin  $>$  cytochrome  $a_3$   $\gg$  cytochrome  $d$   $>$  cytochrome  $a$   $>$  cytochrome  $b$   $\gg$  cytochrome  $c$ . This series was devised by entirely different reasoning in earlier papers (Williams, 1958, 1959). The extreme members are ionic and covalent respectively (from magnetic observations), whereas the intermediate members are apparently mixtures of two spin forms in equilibrium (from spectroscopic evidence).

A possible explanation of the opposed band shifts in the ferrous and ferric series is that the two cations are differently affected in their character on going from the high-spin to the low-spin state. If we take the Soret transition to be either an  $n \rightarrow \pi$  or a  $\pi' \rightarrow \pi$  transition in which the electrons are more concentrated on the nitrogen in the ground state than in the excited state,

this transition is naturally more difficult in ionic ferric than in ionic ferrous complexes on account of the charge difference. The band is at shorter  $\lambda_{\max}$  in the ferric complex. In the low-spin states both ferrous and ferric ions become better  $\sigma$ -acceptors and on these grounds the Soret transitions should both be more difficult in the promoted state (low-spin) complexes and a shift of  $\lambda_{\max}$  to shorter wavelengths would be expected. Now the ferrous ion also becomes a stronger  $\pi$  donor in the low-spin state which again makes the transition of the electrons concentrated on the nitrogen more difficult (Note 1). Thus in the case of  $\text{Fe}^{++}$  both  $\sigma$  and  $\pi$  interactions of the cations in the ligand change so as to shift  $\lambda_{\max}$  (porphyrin) to shorter wavelengths when the complex becomes of low spin. On the other hand, the ferric ion in the promoted state is a  $\pi$  electron acceptor with one hole in the  $d\varepsilon$  shell. This property makes the Soret transition of the porphyrin easier. We conclude that the increased stabilization of  $\pi$  electrons in the excited state overrides the increased stabilization of the electrons in the ground state on change from the high- to the low-spin ferric state. Thus we can see that the difference in  $\pi$ -bonding characteristics of the cations can explain the opposed shifts. A similar explanation has been advanced in discussing the phenanthroline series of ferric and ferrous complexes where spectral changes in opposed directions are observed in a series of ferrous and ferric complexes which we have considered as models for the study of the physical properties of iron porphyrins (Williams, 1955, 1956).

A good illustration of the opposed shifts of the Soret band in the  $\text{Fe}^{++}$  and  $\text{Fe}^{+++}$  states is that observed in the study of the effect of pH upon the spectra of *Rhodospirillum* cytochrome (Morton, 1958). At pH 7 the band positions are:  $\text{Fe}^{++}$ , 424  $m\mu$ , and  $\text{Fe}^{+++}$ , 390  $m\mu$ , with a band at 640  $m\mu$  in the ferric spectrum indicating an ionic complex. At pH 11.8 the bands are:  $\text{Fe}^{++}$ , 413  $m\mu$ , and  $\text{Fe}^{+++}$ , 407  $m\mu$ , with no band at longer wavelengths than 565  $m\mu$  in the  $\text{Fe}^{+++}$  spectrum indicating a covalent complex. Thus at pH 7.0 this cytochrome is very largely ionic but at pH 11.8 it is largely covalent and the value of  $\Delta m\mu$  has changed from 34  $m\mu$  to 6  $m\mu$ . The suggested change of magnetic moment is in keeping with the observed fall in the ratio of the  $\gamma$  to  $\alpha$  peak intensities of the reduced cytochrome on increasing pH. The observations are also very suggestive with regard to the group of the protein which is responsible for the pH dependence. As both the ferric and ferrous complexes show changes it can not be the reaction  $\text{H}_2\text{O} \rightarrow \text{OH}^-$ . Imidazole groups are completely ionized at a pH just greater than 7.0 and we are left with the strong impression that the change involved is  $-\text{NH}_3^+ \rightarrow \text{NH}_2$  (see pp. 46, 49, 50).

It will be observed that from the above analysis we consider that cytochrome  $a_3$  is largely ionic. This tentative conclusion is supported by the following evidence. (1) The intensity ratio of the  $\alpha$  to the  $\gamma$  peak is 1:11. The usual ratio in covalent complexes is 1:6 as in the pyridine complex of haemoglobin



while in ionic complexes it is approximately 1:12, as in haemoglobin. (2) The reaction of cytochrome  $a_3$  with carbon monoxide is rapid and only ionic forms of ferrous complexes can undergo rapid substitution reactions of this kind (Table 1). All ferrous complexes which react rapidly with carbon monoxide also react rapidly with oxygen. (3) The ferric form of cytochrome  $a_3$  has a weak absorption maximum at  $\sim 650 m\mu$ , which only appears when at least some of the ferric couple is in the ionic state. A similar discussion of the same spectroscopic features would lead us to suppose that cytochrome  $a$  is largely covalent with but a small percentage of the ionic form.

The correlations between Soret band position and the magnetic moments of the ferrous complexes permit comment on the interaction between the ferrous ion and the protein. For example, Gibson (1959) observed that on intense illumination of carboxyhaemoglobin (HbCO) a short-lived species Hb\* was produced. This species has its Soret band at slightly *longer* wavelengths than Hb itself. The discussion presented here would lead us to conclude that the protein groups interacting with the ferrous ion must be *more weakly* bound in Hb\* than in Hb. In keeping, the reaction of Hb\* with CO is forty times as fast and of lower activation energy. Again, the Soret band of myoglobin (438  $m\mu$ ) is at a longer wavelength than that of haemoglobin (431  $m\mu$ ) which are to be compared with MbCO 424  $m\mu$ , MbO<sub>2</sub> 416  $m\mu$  and HbCO 418  $m\mu$ , HbO<sub>2</sub> 414  $m\mu$  (Lemberg and Legge, 1949). The values suggest that the protein groups are less strongly bound to myoglobin than to haemoglobin. This is in keeping with the more rapid reactions of myoglobin.

Before leaving this point it is clear that the spin state of a ferrous or ferric complex is very sensitive to environment. We must expect that extraction of a cytochrome will sometimes alter its properties either through a minor denaturation of the protein or even through a change of the medium dielectric constant.

#### OXIDATION-REDUCTION POTENTIALS

We have made several comments upon the redox potentials of ferrous/ferric couples (Williams, 1959; Tomkinson and Williams, 1958). The general impression of the variations in the FePX<sub>2</sub> potential with change of X is that either by (1) a continuous adjustment in the nature of X from water to increasingly improved donors such as ammonia or (2) a gradual reduction in the Fe-X distance for a group X which is a good donor, the redox potential can be made to go through a continuous series of values which show a maximum, see Fig. 2. The maximum is reached because the ferrous as opposed to the ferric ion undergoes electron rearrangement at lower effective electronegativities of the group X. At low electronegativities, increase in electronegativity favours ferrous over ferric, while at higher effective electronegativities increase in donor properties of the ligand favours ferric over ferrous. The maximum will be most accentuated for ligands which are

$\pi$ -electron acceptors (Note 2). In order to develop further the discussion of iron-porphyrin redox potentials we present some new data, Table 3, on the redox potentials of  $\text{Fe}(\text{NiOx})_2\text{X}_2$  couples in water where NiOx is cyclohexanedionedioxime. From the table we see that the potential of the complex with pyridine is higher than that with imidazole which is higher than that with ammonia. All these complexes except the hydrates in both ferrous and ferric forms are covalent (of low spin). The values fall with the increasing donor character of the groups as shown by the  $pK$  values, pyridine 5.2, imidazole 7.1

TABLE 3. REDOX POTENTIALS OF SOME IRON NIOXIME COMPLEXES

Ligand $X$ in $\text{Fe}(\text{NiOx})_2\text{X}_2$	$\text{H}_2\text{O}$ ( $\text{pH} \approx 3.0$ )	pyridine	imidazole	ammonia
Redox potential (mV)	+180	+130	+30	-370
Ease of autoxidation	slow very rapid at $\text{pH} > 4.0$	very slow	very slow	slow rapid at $\text{pH} < 8.0$

The redox potential in water alone is pH-sensitive, falling to about  $-250$  mV at pH approximately 10.0.

NiOx is cyclohexanedionedioxime.

and ammonia 9.1. Now the difference between the redox potential of  $\text{Fe}(\text{NiOx})_2$ ,  $(\text{NH}_3)_2$  and  $\text{Fe}(\text{NiOx})_2$  (imidazole) $_2$  is  $+400$  mV. This difference is close to that between cytochrome  $c$  and cytochrome  $b$ ,  $+200$  mV, but cytochrome  $b$  is a protoporphyrin complex whereas cytochrome  $c$  is a mesoporphyrin complex. The redox potential difference produced by the different porphyrins is  $\sim +80$  mV in their pyridine forms (Lemberg and Legge, 1949). This factor should be added to the observed difference between cytochromes  $b$  and  $c$  giving  $+250 - 300$  mV difference between the  $b$  and  $c$  type cytochromes had their porphyrins been identical. We conclude that if cytochrome  $c$  is an imidazole (histidine) complex, cytochrome  $b$  is likely to be an amine-imidazole complex. We will show later that the reactions of  $b$ -type cytochromes are in accord with this hypothesis as are their spectra (Williams, 1958).

We now turn to cytochromes  $d$  (using the nomenclature of Morton, 1958) which appear to us to be related to  $b$  cytochromes structurally in much the way haemoglobin is related to cytochrome  $c$ . For although the cytochromes  $b$  and  $d$  have similar redox potentials they have very different chemical properties. The cytochromes  $d$  are very readily autoxidized for example. As we have noted in Fig. 1 the value of  $\Delta\lambda$  (Soret) between the  $\text{Fe}^{++}$  and  $\text{Fe}^{+++}$  forms of cytochromes  $d$  suggests that they are largely ionic complexes. This is supported by the easy autoxidation, by the uptake of carbon monoxide in the reduced state, and by the position of the Soret band of the  $\text{Fe}^{+++}$  form

( $\lambda_{\max} \simeq 400 \text{ m}\mu$ ). Again there is evidence of bands at about  $640 \text{ m}\mu$  in the  $\text{Fe}^{+++}$  complexes, the band expected for ionic  $\text{Fe}^{+++}$  haems.

On the basis of this analysis of the properties of the cytochromes we need to modify the picture which we have given previously for the relationship between redox potential and the basicity of the co-ordinating groups amongst these compounds. Figure 2 gives our present impression. For all groups of haem-proteins there is a range of redox potentials and a range of other

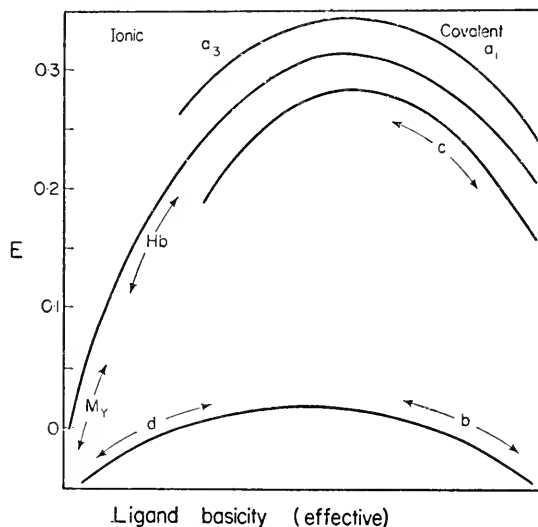

FIG. 2. The suggested relationship between redox potentials and ligand basicity for the cytochromes. The top three curves are for haem *a*, protohaem and mesohaem complexes in descending order of potential. All these complexes are assumed to be imidazole-coordinated. The lowest curve is for either protohaem or mesohaem complexes where the further binding of the haem from the protein is assumed to be through amino-nitrogen. By *effective* ligand basicity we imply that basicity which obtains under the conditions of steric hindrance realized in the protein and we suggest that steric hindrance increases from right to left in all the cases.

physical properties, such as magnetic moments and absorption spectra, as well as a range of chemical properties such as affinity for oxygen and carbon monoxide and rate of autoxidation. There is no reason to think that these groups of haem proteins can be rigidly differentiated, in fact.

The variation in combination between porphyrins and the type of group X so far suggested would then be (see Williams, 1958), as shown in table on page 48.

Inspection of these combinations leads to two immediate comments. Far from every possible intercombination between different porphyrins and different groups X or between different combinations of the two X groups for any one porphyrin has been postulated, let alone demonstrated. Second, where it is stated in the table that only one group is involved, say under

myoglobin, and the other group is water we imply that there is no other co-ordinating group very near to the iron. Between this extreme and the case where there are two groups equally and strongly co-ordinated, as in cytochrome *c*, every possible intermediate may arise through the inability of the protein to satisfy simultaneously the stereochemical requirements of the iron and those of hydrogen-bonding in its own structure.

Haem protein	Porphyrin substituent	Group X*
Cyt. <i>a</i> <sub>3</sub>	Aldehyde (hydroxyl (?))	Imidazole H <sub>2</sub> O
Cyt. <i>a</i>	Aldehyde (hydroxyl (?))	Two imidazoles (one weakly held)
Myoglobin	Vinyl	Imidazole H <sub>2</sub> O
Haemoglobin	Vinyl	Two imidazoles (one weakly held)
Cytochrome <i>b</i>	Vinyl	Two amino
Peroxidase	Vinyl	Carboxylate H <sub>2</sub> O or —NH <sub>2</sub>
Catalase	Vinyl	Two carboxylates
Cytochrome <i>d</i>	no unsaturation	One amino H <sub>2</sub> O
Cytochrome <i>c</i>	no unsaturation	Two imidazoles

\* See also Williams, p. 72 of this volume.

### The 'Imidazole' Hypothesis

Pauling and Coryell (1936) considered that the two dissociation constants of haemoglobin in the pH range 5–8 could be accounted for by assigning one  $pK$  to a dissociation of type (1), of an imidazole group which was at a considerable distance from the iron atom and a second to the reaction (2).

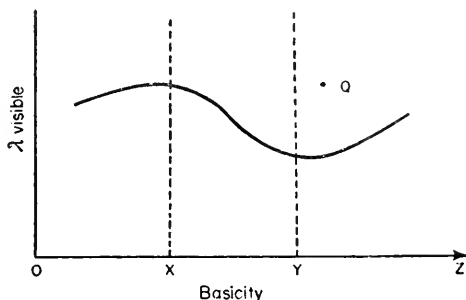

FIG. 3

This hypothesis is readily tested by examining the ionization of  $\text{Fe}(\text{DMG})_2$  (imidazole)<sub>2</sub>. We find that the imidazole ionizes as in reaction (1) but that reaction (2) does not occur up to a pH of 11.0 (Croft and Williams, unpublished). We add the following evidence against any such ionization.

(1) The absorption spectrum of  $\text{Fe}(\text{DMG})_2$  (imidazole)<sub>2</sub> does not change with pH from 6–11 except in intensity (Croft and Williams).

(2) The complex  $\text{Fe}^{++}(\text{DMG})_2$  (imidazole)<sub>2</sub> is extractable into *iso*-amyl alcohol (Croft and Williams).

(3) The complexes  $\text{Cu}^{++}(\text{histidine})$  and  $\text{Cu}^{++}(\text{histidine})_2$  show no ionization of the type (2) (Leberman and Rabin, 1959; James and Williams, unpublished).

(4) Amongst biological molecules,  $\text{Fe}^{++}$ -cytochrome *c* has no ionization in the expected range (Lemberg and Legge, 1949).

In the presence of oxygen it is observed that the lower *pK* is raised. We accept Pauling and Coryell's (1936) explanation, that this implies that the oxygen inserts itself between the imidazole and the  $\text{Fe}^{++}$  ion. It would appear that the second *pK* is not due to the imidazole groups at all. The *pK* shift could be due to the ionization of an  $-\text{NH}_3^+$  group in the protein, the basicity of which was altered by the change in protein stereochemistry on deoxygenation of haemoglobin.

Again, we have no evidence to show that  $\text{Fe}^{+++}(\text{NiOX})_2$  (imidazole)<sub>2</sub> undergoes any ionization up to pH 10.0. The titration of the complex with alkali, its insolubility in organic solvents, and its absorption spectrum all indicate that the ligand is imidazole and not the imidazole anion.

## CHEMICAL REACTIONS OF IRON COMPLEXES

It has always been our intention to proceed from a detailed study of the physical properties of ferrous and ferric complexes to a study of their chemical reactions. We have now made a start with the latter phase of this work.

### *Reactions of Molecular Oxygen*

Oxygen can either combine with ferrous complexes (oxygenation) or oxidize them (autoxidation). In biological systems both reactions occur. We have observed both reactions also in the chemistry of the complexes  $\text{Fe}^{++}(\text{DMG})_2\text{X}_2$  and  $\text{Fe}^{++}(\text{NiOX})_2\text{X}_2$ , where DMG is dimethylglyoxime. Our studies show that in the model systems the oxygenated complexes  $\text{Fe}(\text{DMG})_2\text{XO}_2$  are not stable if X is readily exchanged for water or if X is a group containing labile hydrogen. The reactions can be illustrated by examples. When X is imidazole or pyridine the oxygenated complex is stable with certain qualifications. The replacement of the ligands X in the imidazole and pyridine complexes is much slower than in other complexes. When X is water, hydrazine, ammonia, aniline or other substituted amines, or sterically hindered pyridines or imidazoles (e.g. histidine) the oxygenated complex *is not as stable* but undergoes autoxidation. The replacement of ligands in these complexes is more rapid. Autoxidation is different in different cases giving oxidation of the group X in some cases (e.g.  $\text{N}_2\text{H}_4$ ) and not in

others. In both cases the same ferric complex is always obtained,  $\text{Fe}^{+++}(\text{DMG})_2(\text{H}_2\text{O})\text{OH}$ . We suggest the mechanisms:

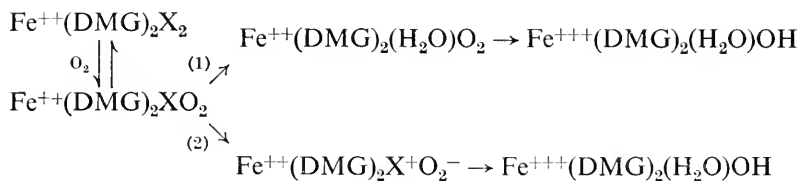

(Reaction (2) is a catalysed autoxidation of X.) No complex of a saturated base X is known which carries oxygen (cf. cytochromes *b* and *d*); however, all the complexes of unsaturated bases X can carry oxygen (cf. myoglobin, haemoglobin, cytochrome *a*). It is of great importance here to note that  $\text{Fe}(\text{DMG})_2$  (imidazole)<sub>2</sub> can even pick up molecular oxygen in the presence of borohydride, sodium formaldehyde sulphonylate, or sodium dithionite. This reaction is common to cytochrome *a* (Sekuzu, Takemori, Yonetani and Okunuki, 1959) but not to haemoglobin. It implies that the iron complex undergoes *slow* dissociation of its ligands as free oxygen reacts rapidly with borohydride or sulphonylate. Haemoglobin undergoes very rapid de-oxygenation under these circumstances. We can now make some comments about the binding in haemoglobin. We note first that covalent ferrous complexes (Class III, Table 1) undergo *slow* ligand exchange. Magnetic data show oxyhaemoglobin to be covalent, yet it takes part in fast reactions involving ligand replacement. The iron must be in an energy state which is only slightly more stable than its high-spin states. This is in agreement with spectroscopic evidence as well as with the value of its redox potential. Now if the oxygen is labile in  $\text{HbXO}_2$  the group X, the histidine, must be labile also. What is it then that prevents the autoxidation of haemoglobin in accord with equation (1) above? The answer which we suggest to this question is that it is the high activation energy of the rearrangement of the protein which prevents a water molecule replacing X and thus prevents autoxidation. On the other hand, the cytochrome *a* oxygen complex dissociates slowly to a covalent haemochromogen (judged by the spectra) whence there is little danger of dissociation of groups X leading to autoxidation. In cytochrome *a* we suggest iron is more strongly bound to imidazole than in haemoglobin. Elsewhere (Williams, 1958) we have reached this conclusion from a very different argument.

Amongst cytochromes some of the cytochromes *b* appear rapidly autoxidizable. We believe that this observation is irrelevant to biological function. If, as we suppose, cytochromes *b* (*d*) are amine ( $-\text{NH}_2 \rightarrow \text{Fe}$ ) complexes, then bringing them out of a cell environment to a pH of about 7.0 in free solution may well dissociate the  $\text{NH}_2 \rightarrow \text{Fe}$  link. We can show this easily with  $\text{Fe}(\text{DMG})_2(\text{NH}_3)_2$  which is fairly stable to autoxidation at pH 10.0 but

rapidly autoxidized at pH 7.0. The behaviour is also very similar to that of *Rhodospirillum* haemoprotein (cytochrome *d*) and could well arise in both cases through the high acid dissociation content of the  $-\text{NH}_3^+$  group. It seems to us that some lower organisms may not have suitable histidine-containing proteins to give rise to Fe-histidine cytochromes but must be content with Fe-amine cytochromes. If this is the case and our discussion is valid then these organisms are unlikely to be able to store or transport molecular oxygen. Their cytochrome oxidases and electron-transporting cytochromes are amine complexes whereas those of higher organisms are both amine and histidine complexes.

One such conjecture about these compounds leads immediately to another. The development of histidine cytochromes *a* and *c* in a cell gives the organism the advantage over cells containing only amine cytochromes *b* and *d* that the energy of the oxygen molecule can be more efficiently used. Some 300 mV more energy (the difference in redox potentials) can be stored chemically for each electron transported.

#### ELECTRON TRANSPORT

There are two reasons for thinking that electron transport occurs across the porphyrin of the cytochromes. If catalytic activity resided in the imidazole-Fe-imidazole bonds then it should be demonstrable in  $\text{Fe}(\text{DMG})_2$  (imidazole)<sub>2</sub>. The model complexes do not have the electron transporting properties of cytochromes as far as we can discover. Again using the models we have shown that although there is strong charge transfer interaction between  $\text{Fe}^{++}$  and (DMG) there is no evidence for it in  $\text{Fe}^{++}$ -imidazole. On the other hand, there is good evidence in  $\text{Fe}^{++}(\text{DMG})_2$  (pyridine)<sub>2</sub>. In this complex there is a band (absent in other  $\text{Fe}^{++}(\text{DMG})_2\text{X}_2$  complexes) at  $\sim 400 \text{ m}\mu$ . For differently substituted pyridines it moves in the following manner (Jillot and Williams, 1958):

Substituent	None	4-bromo	3-cyano	4-cyano
Maximum Absorption ( $\text{m}\mu$ )	385	385	460	475

If it is assumed that this band is due to a partial charge transfer of an electron from the ferrous atom to the pyridine, the band positions are explicable in terms of the electron-acceptor properties of the substituents. The band position is solvent-dependent, again suggesting a charge transfer band. The absence of such a band in the imidazole complexes would suggest that charge transfer and therefore electron-transport across the imidazole is not facile.

Finally, if we are correct in saying that cytochromes *b* and *d* are amine complexes then as amines are not unsaturated systems and presumably could not carry out electron transport we must assume in these cytochromes that the electron moves through the porphyrin. If this is so then it is very likely that electrons are mobile in the porphyrin of  $\text{FeP}$  (histidine)<sub>2</sub>, but of

course this by itself does not eliminate the possibility that electron transport occurs across both the porphyrin and the imidazole in cytochrome *c*.

#### NOTES

1. The position of the Soret band moves in the order of increasing wavelength with ligand ammonia, pyridine, carbon monoxide and oxygen, cyanide, water. This order, saturated bases < unsaturated bases < water is similar though not exactly the same as that found for the  $\alpha$  and  $\beta$  bands and the explanation which we offer is that given earlier (Williams, 1956).

2. We imply here that the ferrous ion is more stabilized than the ferric ion by  $\pi$ -electron acceptors. The evidence is given elsewhere (Tomkinson and Williams, 1958). Thus in Fig. 2 we expect that the maximum will be more sharply defined in a series of pyridine complexes of increasing pyridine basicity than in a series of amines. Imidazoles will occupy an intermediate position while for a series of oxygen anion-donors there need be no maximum as the ferric ion may well go over into the strong-field complex the more readily.

#### SUMMARY

An account is given of the properties of iron-porphyrin complexes of biological interest which is largely developed from a consideration of the properties of simpler iron complexes. Spectroscopic criteria for distinguishing between high- and low-spin complexes are suggested. New features of the inter-relationship of different cytochromes are proposed, based upon their redox potentials and their chemical reactions. Some comments are made upon the reactions of haemoglobin and their pH dependences. A discussion of the model iron complexes which are autoxidizable as opposed to those which can carry oxygen leads to a discussion of autoxidation and oxygenation of haem complexes.

#### Acknowledgement

I would like to acknowledge the help of the late B. A. Jillot, and of J. M. F. Drake and D. Croft, who have done all the experimental work connected with this paper.

#### REFERENCES

- CORYELL, C. D. & PAULING, L. (1936). *Proc. nat. Acad. Sci. Wash.* **22**, 159.  
 CROFT, D. & WILLIAMS, R. J. P. Unpublished observations.  
 GIBSON, J. F. (1959). *Disc. Faraday Soc.* **29**.  
 JAMES, B. R. & WILLIAMS, R. J. P. Unpublished observations.  
 JILLOT, B. A. & WILLIAMS, R. J. P. (1958). *J. chem. Soc.*, 462.  
 LEBERMAN, R. & RABIN, B. R. (1959). *Nature, Lond.* **183**, 746.  
 LEMBERG, R. & LEGGE, J. W. (1949). *Hematin Compounds and Bile Pigments*, Chap. 5 & 6, Interscience, New York.  
 MORTON, R. K. (1958). *Rev. pure appl. Chem.* **8**, 161.  
 SCHELER, W., SCHOFFA, G. & JUNG, F. (1957). *Biochem. Z.* **329**, 232.  
 SEKUZU, I., TAKEMORI, S., YONETANI, T. & OKUNUKI, K. (1959). *J. Biochem. Tokyo* **46**, 43.  
 THEORELL, H. (1942). *Ark. Kemi. Min. Geol.* **16A**, No. 3.  
 TOMKINSON, J. & WILLIAMS, R. J. P. (1958). *J. chem. Soc.*, 2010.



- WILLIAMS, R. J. P. (1955). *Special Lectures in Biochemistry*, University College, London. H. K. Lewis & Co., London.
- WILLIAMS, R. J. P. (1956). *Chem. Rev.* **56**, 299.
- WILLIAMS, R. J. P. (1958). *Disc. Faraday Soc.* **26**, 123.
- WILLIAMS, R. J. P. (1959). *The Enzymes* (Ed. by P. D. Boyer, H. Lardy & K. Myrback), vol. 1, p. 391, Academic Press, New York.

## DISCUSSION

### *Oxidation-reduction Potentials of Haem Compounds*

PERRIN: I should like to ask Williams what evidence he has for believing that with increasing ligand basicity the redox potentials of ferrous/ferric couples pass through a maximum. The only experimental evidence that I have so far found suggests, on the contrary, that in a related series of ligands there is a roughly linear dependence of redox potential on the  $pK$  of the ligand: the potential decreases continuously as the ligand  $pK$  increases. This is true, for example, of iron complexes with a number of 5-substituted-*o*-phenanthrolines (Brandt and Gullstrom, *J. Amer. chem. Soc.* **74**, 3532, 1952). Other systems where linearity is found include the 1:1 iron-amino-acid complexes (Perrin, *J. chem. Soc.* 290, 1959) and the iron complexes of 8-hydroxyquinolines and polyaza-1-naphthols (Albert and Hampton, *J. chem. Soc.* 505, 1954; Albert, *Biochem. J.* **54**, 646, 1953). The reported potential of 0.7 V for the iron complex of 4-hydroxy-3-carboxy-*o*-phenanthroline (Hale and Mellon, *J. Amer. chem. Soc.* **72**, 3217, 1950) appears at first sight to be anomalously low but I think it can be readily explained. In heterocyclic compounds a hydroxyl group in a *gamma* position relative to a nitrogen makes two tautomers possible—an enol form, where the H is on the oxygen, and an amide form where the H is on the nitrogen. Contrary to the way the formulae are generally written, the amide form is greatly favoured relative to the enol form (for example, in 4-hydroxyquinoline the ratio is 24,000 to 1 (Albert and Phillips, *J. chem. Soc.* 1294, 1956) and it would be expected to be even higher for a 1-hydroxy-*o*-phenanthroline). I suggest that this effect, together with the sparing solubility of the substance, leads to insufficient complex formation to prevent extensive hydrolysis of ferric ion and this is what causes the potential to be so low. It should be pointed out (1) that this system did not behave reversibly and (2) that the corresponding substance without the carboxy group was more soluble and gave a higher and reversible potential that was closer to the expected value (Hale and Mellon, *loc. cit.*).

In the metalloporphyrins and related substances also there seems to be, in all cases where both are known, a continuing decrease in redox potential with increasing  $pK$  of the ligand. Some examples are given in Tables 5 and 6 of the paper of Falk and Perrin (this volume, p. 69).

It seems reasonable to suppose that the change from high-spin to low-spin in a complex does not result in any great alteration in the nature of the metal-ligand bonds. The main differences would lie in the extent to which the metal's *3d* orbitals are made more or less available to take part in bond formation. As discussed more fully elsewhere (Perrin, *Rev. pure and appl. Chem.*, **9**, 257, 1959) I believe these and ligand field stabilization energy changes for any series of iron complexes would make only a slight contribution to change in their overall stabilities and hence their redox potentials.

Could Williams give any examples of iron complexes where the redox potentials in any series do, as he suggests, increase with the  $pK$  of the ligand?

WILLIAMS: The arguments I use in discussing redox potentials are set out in full in my papers. There is as yet no *direct* evidence for the maximum Perrin discusses. On the other hand for the series of ligands  $H_2O$ , pyridine, histidine, ammonia, there is good evidence that  $E_0$  has little relationship to  $pK$  of the base (see Dwyer, this volume, p. 25, and Falk and Perrin, this volume, p. 69). In both cases  $E_0$  goes through a maximum with  $pK$ . I do not accept either the discussion of iron phenanthroline or iron 8-hydroxyquinoline complexes given by Falk and Perrin (*loc. cit.*) and in the question, but prefer

our own interpretation of the data (Tomkinson and Williams, *J. chem. Soc.* 2010, 1958) for the reason given in that paper.

I do not agree with Perrin's interpretation of ligand field theory as presented in the question and in his paper (see discussion of Orgel's paper, p. 13). I think that bonds, both in energy and in length, undergo considerable changes on change of spin type and that in biological systems these changes are of greater importance than almost any other factor. I was well aware of the data on the redox potentials of iron porphyrin complexes and have tried to use them properly and with due reservation.

PERRIN: The experimental values of  $E'_0$  for metal porphyrin complexes with bases which Falk and I list represent probably the most complete series available in the literature. They show a general decrease with pK of the ligands and so cannot be quoted as support for Williams' suggestion that they should pass through a maximum. I think it is dangerous to attempt to argue too finely from redox potential differences. For example, the porphyrin in cytochrome *c* differs from mesoporphyrin (with which it was compared) by having two  $\text{CH}_2\text{CHSR}$  groups instead of ethyls. It would seem to be better to take haematoporphyrin, with two  $\text{CH}_2\text{CHOH}$  groups, rather than mesoporphyrin, as an approximation to porphyrin *c*. The difference in redox potentials is then much smaller for the reactions:

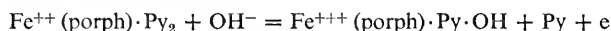

at pH 9.6,  $E'_0$  is + 15 mV for protoporphyrin, + 4 mV for haematoporphyrin, and - 63 mV for mesoporphyrin. (Lemberg and Legge, *Haematin Compounds & Bile Pigments*, 1949.) Potentials are even more different depending on whether the reaction is for the loss of a molecule of base from the ferric complex and its replacement by  $\text{OH}^-$ , as in the example just quoted, or simply for the loss of an electron from the  $\text{Fe}(\text{porph})\cdot\text{B}_2$  complex. The difference between the pyridine and the histidine complex of iron-protoporphyrin is < 80 mV in the first case and about 210 mV in the second case (calculated from Barron, *J. biol. Chem.* 121, 285, 1937, and Shack and Clark, *J. biol. Chem.* 171, 143, 1947). In the absence of other evidence as to the nature of the extra ligands in cytochromes and other metalloporphyrins, any suggestions from redox data must be almost entirely speculative. It should also be pointed out that there is not one, but many, members of each of the cytochrome families. There are, for example, many cytochromes *c* which, although similar in absorption spectra, do not have the same redox potential—compare cytochromes  $c_2$  and  $c_3$  where the  $E'_0$ -values differ by 0.545 V (Morton, *Rev. pure appl. Chem.* 8, 161, 1958).

Which of these should we assume from spectra or redox potentials to contain two imidazole groups bound to the metal, and how are mixed ligands to be ruled out?

WILLIAMS: In all my discussions of redox potential data I have been fully aware of Perrin's points. I therefore restate that

(i) All conclusions about structure are made taking into account spectra, redox, and magnetic properties (see *Chem. Rev.* 56, 299, 1959 for the way in which I do this).

(ii) A maximum in redox potential is only expected on change of spin type. None is expected for the compounds in the series of Falk and Perrin (p. 69) except in the sequence water, pyridine, imidazole,  $\text{NH}_3$ .

(iii) Mixed complexes are treated later in this discussion (p. 55). The cytochromes *c* of different kinds are discussed by myself and Chance in *Disc. Faraday Soc.* 27, 269, 1959. Mixed complexes are included in that discussion.

GEORGE: In answer to Williams' question about the  $E'_0$  for the  $\text{Fe}^{+++}/\text{Fe}^{++}$  tetrapyrrolyl couple, I would like to report on the results of an investigation recently carried out in collaboration with G. Haight and A. Bergh.

We thought originally, following Morgan and Burstall, that both ferrous and ferric derivatives were square planar complexes containing one tetrapyrrolyl molecule, somewhat analogous to haem and haemin. But while the ferric complex has the composition  $\text{Fe}(\text{tetrapyr})_1^{+++}$ , two ferrous complexes are formed with  $K_1 > K_2$ ,  $\text{Fe}(\text{tetrapyr})_1^{++}$  and  $\text{Fe}(\text{tetrapyr})_2^{++}$ .  $K$  for the ferric complex is greater than  $K_1$  for the first ferrous complex, so that upon the addition of tetrapyrrolyl,  $E'_0$  first falls below the value of 0.77 V for the  $\text{Fe}^{+++}/\text{Fe}^{++}$  aquo-ion couple. But, in principle at least, as

the tetrapyrrolyl concentration is increased  $E'_0$  will eventually increase again when the oxidation-reduction reaction becomes

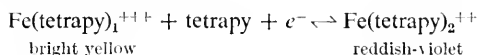

Using Courtauld atomic models we found that co-ordination of all four *N*-atoms to give square planar complexes is not possible. In all probability the structure of the  $\text{Fe}(\text{tetrapy})_2^{++}$  complex is that of a distorted octahedron with only three of the four nitrogens of each tetrapyrrolyl molecule co-ordinated to the iron. Its absorption spectrum resembles that of  $\text{Fe}(\text{tripy})_2^{++}$  very closely, which supports this hypothesis. The 1:1 complexes probably have only three bonded *N*-atoms, and we suppose that steric hindrance prevents the formation of the ferric complex corresponding to  $\text{Fe}(\text{tetrapy})_2^{++}$ .

MARGOLIASH: For cytochrome *c* the evidence we have obtained from a study of the chemical and physico-chemical properties of the denaturation products, as well as of those of the pepsin digested 'core', indicates that cytochrome *c* is probably not a di-imidazole haemochrome, but probably a mixed haemochrome with a primary amino-group and an imidazole group bound to the haem-iron. Moreover, by denaturation it is possible to obtain products having  $E'_0$  values ranging from that of native cytochrome *c* down to not far from 0 V. In cytochrome *c* the  $E'_0$  value seems to be an expression of the effect of the protein configuration on the haem iron-ligand bonds rather than an intrinsic property of the particular groups involved. I should therefore think it would be difficult to ascribe specific ranges of  $E'_0$  values to specific haemochrome-forming ligands in haemoproteins.

WILLIAMS: I consider that Margoliash has studied a series of complexes, often mixtures varying from di-imidazoles through mixed complexes, to di-amines. No simple explanation of his results is possible.

# SPECTRA AND REDOX POTENTIALS OF METALLOPORPHYRINS AND HAEMOPROTEINS

By J. E. FALK\* AND D. D. PERRIN†

*Division of Plant Industry, C.S.I.R.O., Canberra and Department of Medical  
Chemistry, Australian National University, Canberra*

WHY is it that there is no relationship between the oxidation-reduction potential of the cytochromes *a*, *b* and *c* and their absorption spectra (Table 1)? The porphyrin side-chains of these cytochromes increase in electron-attracting power in the order *c*, *b*, *a*. This sequence is reflected in the spectra of the

TABLE 1

Cytochromes	Side-chains in positions:	Fe <sup>++</sup> - cytochrome Absorption maxima (m $\mu$ )	<i>E</i> <sub>0</sub> '* pH 7 (V)	Pyridine haemochromes Absorption maxima (m $\mu$ )
<i>c</i>	<sup>2</sup> —CHSR·CH <sub>3</sub> <sup>4</sup> —CHSR·CH <sub>3</sub> <sup>8</sup>	550	+0.255	551
<i>b</i>	—CH=CH <sub>2</sub> —CH=CH <sub>2</sub>	564	+0.077†	557
<i>a</i>	—CHOH·CH <sub>2</sub> ·R <sup>2</sup> —CH=CH·R <sup>1</sup> —CHO	603	+0.29	587

Here and throughout this paper, the data, for the cytochromes of animal mitochondria, are taken from Morton (1958). Side-chains other than those shown are methyl and propionic acid groups, which have little effect upon the properties discussed. For side-chains in haem *a*, see Lemberg, Clezy and Barrett, this volume, p. 344.

\* The *E*<sub>0</sub>' for a reaction is the electrode potential for 50% oxidation at a stated pH.

† From Colpa-Boonstra and Holton (1959).

cytochromes and of the pyridine haemochromes of their prosthetic groups. But while the pyridine haemochrome of haem *c* has a spectrum very like that of the cytochrome itself, the spectra of cytochromes *b* and *a* are displaced far to the red of their respective haemochrome spectra. The redox potentials of the three cytochromes follow no sequence whatever in relation to their spectra, or the chemistry of their haem prosthetic groups. In the absence of protein, however, the electron-attracting power (Falk and Nyholm, 1958) of porphyrin side-chains is correlated with changes of both spectrum (Table 2) and redox potential (Table 3).

\* C.S.I.R.O.

† Australian National University.

TABLE 2

Substituents in deuteroporphyrin IX at positions:		Porphyrin absorption maxima, band I (dioxan) ( $m\mu$ )*	Pyridine haemochrome absorption maxima $\alpha$ -band ( $m\mu$ )
<b>2</b>	<b>4</b>		
—H	—H	618	545†
—C <sub>2</sub> H <sub>5</sub>	—C <sub>2</sub> H <sub>5</sub>	620	547†
—CH=CH <sub>2</sub>	—CH=CH <sub>2</sub>	630	558*
—H	—COCH <sub>3</sub>	634	571*
—COCH <sub>3</sub>	—COCH <sub>3</sub>	639	575*
—H	—CHO	640	578*
—CHO	—CH=CH <sub>2</sub>	644	583*
—CHO	—CHO	651	584*

\* From Lemberg and Falk, 1951.

† This study.

TABLE 3

	Haems Side chains in positions:		$E^0$ of the (CN <sup>-</sup> ) <sub>2</sub> derivatives*	$E^0$ of the Pyridine <sub>2</sub> derivatives†
	<b>2</b>	<b>4</b>		
1.	—CH <sub>2</sub> CH <sub>2</sub> COOH	—CH <sub>2</sub> CH <sub>2</sub> COOH	-0.247	-0.04
2.	—C <sub>2</sub> H <sub>5</sub>	—C <sub>2</sub> H <sub>5</sub>	-0.229	
3.	—CHOH—CH <sub>3</sub>	—CHOH—CH <sub>3</sub>	-0.200	
4.	—CH=CH <sub>2</sub>	—CH=CH <sub>2</sub>	-0.183	+0.107
5.	—CHO	—CH=CH <sub>2</sub>	-0.113	

\* From Martell and Calvin (1952).

† Vestling, 1940.

Among those cytochromes *b* for which it has been established that the prosthetic group is protohaem, there is again no correlation between spectrum and redox potential; the same is true for those cytochromes *c* for which it has been established that haem *c* is the prosthetic group (Morton, 1958).

These anomalies can be due only to some particular properties of the proteins. If we regard these biological compounds as further co-ordination complexes of haems, to what extent can these differences from model complexes be explained in terms of the nature of the protein-haem iron bonds? It is possible that, as ligands, the proteins may have properties difficult or impossible to reproduce in model systems. Thus, the stereochemical environment of the protein ligand atom may influence the way in which this atom co-ordinates. The protein, and in intact tissue perhaps other macromolecules,

may well create a specific micro-environment about the haem molecule. The evidence which Dr. Wang has found (Wang, Nakahara and Fleischer, 1958) that the dielectric properties of the medium affect some co-ordination properties of haem may be an example of such an effect. Nevertheless, we believe that it is important to see how much or how little can be learned from the study of model systems. The haemochromes which have been studied in any detail that bear any likely relationship to natural haemoproteins are, practically without exception, complexes between haems and ligands containing unsaturated nitrogen atoms ( $=N-$ ). But complexes of protohaem with such ligands do not have the range of absorption maxima of the cytochromes *b* (which are protohaem complexes), nor do they have comparable redox potentials.

We wish to outline here some theoretical aspects of porphyrins and metalloporphyrins and to draw some inferences from existing data. We discuss below (p.74) some studies we are making of complexes formed by several different haems with ligands of a variety of chemical types.

#### SOME THEORETICAL ASPECTS OF PORPHYRINS AND METALLOPORPHYRINS

It is convenient to picture the porphyrin molecule as a framework of atoms held together by ordinary, two-electron, single ( $\sigma$ ) bonds, while the remainder of the valence electrons occupy molecular orbitals which extend over the whole of this framework. The strong delocalization of these mobile ( $\pi$ ) electrons confers considerable stability and 'aromatic' character on the porphyrins. Electron-withdrawing substituents on the peripheral carbon atoms reduce the  $\pi$ -electron density on the pyrrole nitrogens, so that it becomes easier for the protons to dissociate from the two pyrrole N—H groups which make the porphyrin molecule a weak dibasic acid. Though little precise data exist, this clearly increases the acid strength of the porphyrin (lowers its  $pK_a$ ) and, as discussed later, raises the oxidation-reduction potential of metalloporphyrins.

#### *The Absorption Spectra of Porphyrins*

Another consequence of the extensive  $\pi$ -electron delocalization is that the highest of the occupied molecular orbitals and the lowest of the vacant orbitals differ in energy by an amount small enough for transitions between them to give rise to absorption bands in the visible and near ultra-violet. In the porphyrins themselves in neutral solvents there are four bands in the visible in addition to the Soret band at about 400  $m\mu$ . There appears to be good reason to believe (Platt, 1956) that the four visible bands are really two pairs of bands which would be superimposed if the porphyrin nucleus were strictly square and uniformly substituted. X-ray analysis of the closely similar phthalocyanine molecule has shown that its structure is slightly

distorted from square (Robertson, 1936), probably because the hydrogens bound on opposite nitrogen atoms each form hydrogen bonds with an adjacent nitrogen atom. This distortion probably occurs in the porphyrins also (Mason, 1958; Platt, 1956), leading to the fairly constant difference of 6–7 kcal between the energy levels of corresponding absorption bands (I and III, II and IV). This difference is removed in the di-anion, the di-cation and the metal complexes, and in all these cases only two of these bands are found.

By making some simplifying assumptions Longuet-Higgins, Rector and Platt (1950) and Seely (1957) have carried out molecular orbital calculations to find the nature of the transitions giving rise to the observed porphyrin spectra. Essentially the same conclusions are reached using an electron-gas model (Kuhn, 1959). The visible bands all arise in a similar manner, as transitions between filled orbitals of  $A_{2u}$ -type symmetry and vacant  $E_g$ -type orbitals (Fig. 1). In all cases these bands are associated with an electronic displacement towards the periphery and this may be either along (bands III and IV) or perpendicular to (bands I and II) the axis through the two H's which are on opposite nitrogens (Platt, 1956; Mason, 1958). Because bands I and III are for a 0–0 vibrational transition which is classed as forbidden, their intensities will depend very much more on any loss of symmetry in the porphyrin molecule than will bands II and IV which are interpreted as 0–1 vibrational bands (Platt, 1956). This symmetry, which is to be thought of in terms of possible pathways for the mobile electrons, will not be much affected by substituents such as alkyl groups, or carboxyl groups which are insulated by at least two  $\text{CH}_2$ 's as in propionic acid side-chains. Much greater distortion would be expected from substitution of a peripheral hydrogen by a group such as  $-\text{CHO}$ ,  $-\text{COCH}_3$ ,  $-\text{COOCH}_3$  and  $\text{COC}_6\text{H}_5$ , and it is among such porphyrins that 'oxorhodo' (III > II > IV > I) (Lemberg and Falk, 1951) and 'rhodo' (III > IV > II > I) type spectra are found rather than the 'aetio' (IV > III > II > I) type which is the usual one with alkyl and similar substituents (Stern and Wenderlein; for references see Lemberg and Falk, 1951). Extension of this generalization to porphyrins containing more of the symmetry-disturbing groups is difficult because of the necessity to allow for the vector directions of the moments of the substituents, but if this is done there is a reasonable correlation between observed and predicted spectra (Platt, 1956).

The  $\alpha$ - (long wavelengths) and  $\beta$ -bands of metal-porphyrin complexes seem to be related to bands I and III, II and IV, respectively. Thus bands II, IV and  $\beta$  are little affected by substituents, while bands I, III and  $\alpha$  vary considerably. It has also been shown that the intensity of the  $\alpha$ -band in some copper-porphyrin complexes varies with the intensity of band III of the corresponding porphyrins (Williams, 1956).

The Soret band is attributed to the transition to an  $E_g$ -type orbital of an electron in an  $A_{1u}$ -orbital (Fig. 1) in which it was confined to the carbon atoms

of the pyrrole rings. The  $E_g$ -orbital is one of a pair of equal energy strongly polarized along and perpendicular to the axis of the two NH's. Although the overall movement of electronic charge towards the periphery is negligible, the increase of electron density on the non-pyrrole carbons and a pair of

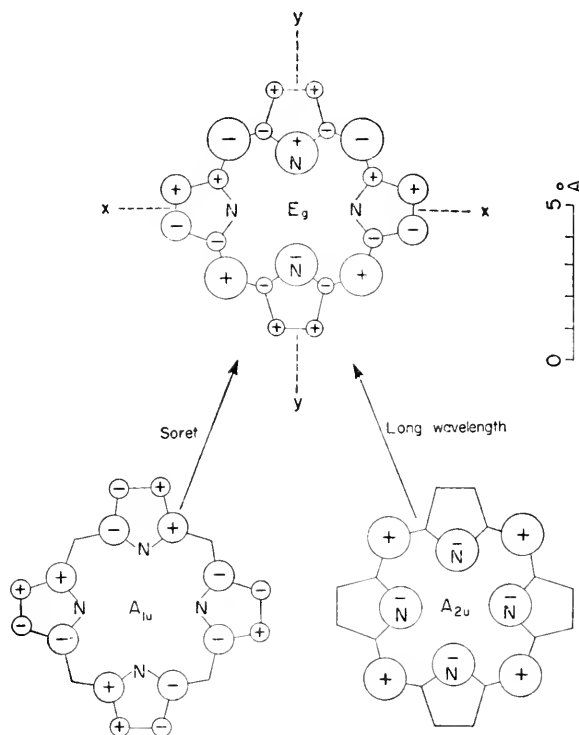

FIG. 1. Nature of transitions giving rise to porphyrin spectra. The signs + and - indicate wave functions. The areas of the circles give electron densities in the vicinities of atoms; the atomic distances are the same as in phthalocyanine (Robertson, 1936).

opposite nitrogens (Fig. 1) affects the absorption spectrum of porphyrins and metalloporphyrins.

#### *Co-ordination of Porphyrins with Divalent Metals*

The property that distinguishes transition metals from other elements in the Periodic Table is that their  $d$ -orbitals are incompletely filled with electrons. These orbitals have the directions in space shown in Orgel's paper (*loc. cit.*). Depending on whether electrons occupy these orbitals singly or in pairs, complexes will be para- or dia-magnetic.

This difference in magnetic properties is interpreted in the *Valence Bond Theory* as distinguishing two types of complexes. The main concept underlying



this theory, as applied to co-ordination complexes, is that suitable vacant orbitals of the metal are hybridized, and these hybrid orbitals are filled by electron pairs 'donated' by ligand atoms with the formation of  $\sigma$ -bonds. To be suitable for hybridization in this way an orbital must have an appreciable component in the directions finally occupied by some or all of the ligands. The diamagnetism of pyridine haemochromes is interpreted to mean that two of the  $3d$ -orbitals of  $\text{Fe}^{++}$  ( $d_{x^2-y^2}$  and  $d_{z^2}$ ) are used in this hybridization and are occupied by two pairs of ligand electrons; the electrons already in these orbitals are forced to pair up in the remaining  $3d$ -orbitals. Such complexes have long been called 'covalent' and, more recently, 'inner-orbital', 'spin-paired', or 'low-spin'. Their formation is favoured by ligands of low electronegativity and in octahedral complexes such as pyridine haemochrome they are described as being  $3d^24s4p^3$ , or  $d^2sp^3$ , types.

On the other hand, haemin chloride, like the  $\text{Fe}^{+++}$  ion itself, has 5 unpaired electrons. Such paramagnetic complexes ('semi-ionic', 'outer-orbital', 'spin-free', 'high-spin') are generally formed by ligands of high electronegativity which, in addition, have little or no  $d$  acceptor capacity for double bonding (e.g.  $\text{F}^-$  as against pyridine-N). It is now believed that high-spin complexes do have some degree of covalent bonding (cf. Craig *et al.*, 1954) and it is convenient to regard haemin chloride, for example, as a hybrid of the type  $4s4p^24d^2$ . There is little doubt that in 'haemin chloride' (ferriprotohaem chloride), traditionally regarded as a square-planar complex with the  $\text{Cl}^-$  ionically associated, the  $\text{Cl}^-$  is 'co-ordinately' bound. Falk and Nyholm (unpublished) have found a 0.001 M solution in nitrobenzene to be a non-conductor of electricity. Under these conditions, univalent electrolytes have conductivities of 20–30 r.o. It appears likely that ferriprotohaem hydroxide ('haematin') is a similar complex.

A more recent and more satisfying interpretation of the magnetic and other properties of complexes is provided by the *Ligand Field Theory* (Griffith and Orgel, 1957). In essence, this theory says that as co-ordinating groups, or ligands, approach a metal ion to form a complex,  $d$ -orbitals pointing towards the ligands are raised in energy and electrons in them become less stable, while  $d$ -orbitals pointing away from the ligands become more stable. Bonding molecular orbitals are formed by suitable electron-filled orbitals on the ligands with the metal's vacant  $s$ - and  $p$ -orbitals and the  $d$ -orbitals which point towards the ligands; in octahedral complexes, the  $d$ -orbitals involved are  $d_{x^2-y^2}$  and  $d_{z^2}$ . Any electrons already in these  $d$ -orbitals are removed by promoting them into antibonding orbitals, but their presence reduces the stability of the final complex. In any complex the magnitude of the differences in the energy levels of the various  $d$ -orbitals is a function both of the ligand and of the geometrical shape of the complex itself.

The electrostatic effect of ligands in splitting these levels is enhanced by 'back double bonding', which arises from the ability of suitably placed,

occupied  $d$ -orbitals on the metal to form molecular orbitals with vacant  $\pi$ -orbitals on the ligand, so that these electrons gain in stability. (If the  $\pi$ -orbitals are already filled the interaction is repulsive.) Similar interactions can take place between vacant orbitals on the metal and filled  $\pi$ -orbitals on the ligand. Effects such as back double bonding cannot be separated from

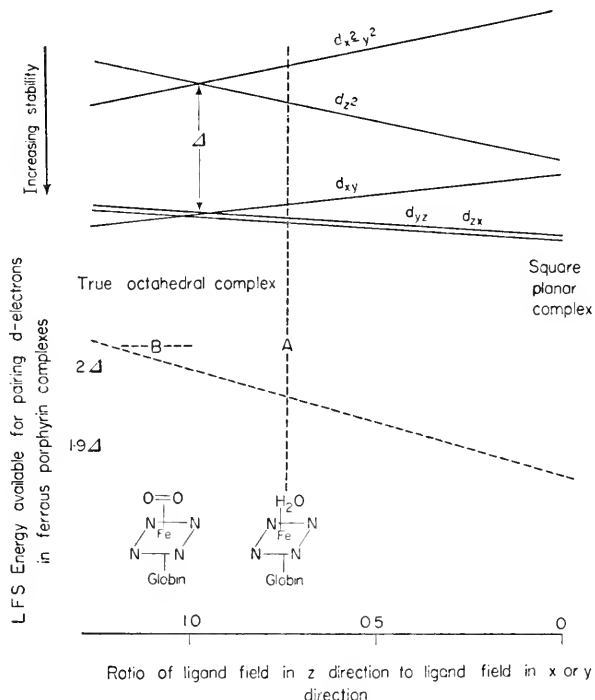

FIG. 2. Ligand field splitting of  $d$ -orbitals in Metalloporphyrins (qualitative only).

purely electrostatic contributions and they are probably important factors in unsaturated ligands, including porphyrins, oxygen, carbon monoxide, cyanide ion and unsaturated heterocyclic bases, all of which exert strong ligand fields.

The porphyrin nucleus confers a planar configuration on its metal complexes, and any additional co-ordination sites on the metal are perpendicularly above and below this plane (i.e. along the  $z$ -axis). This leads with most transition metals to a more or less vertically distorted octahedral structure and, in the metalloporphyrins, the effect of ligands occupying these positions is to split the  $d$ -orbital energy levels as shown qualitatively in Fig. 2. If the energy separations are greater than the energy needed to pair electrons in the lower energy levels, diamagnetic or low-spin complexes will be formed;

otherwise there will be as little spin pairing as possible. For example, in haemoglobin the situation is probably something like that shown at *A* in Fig. 2. The difference in ligand field stabilization energy (L.F.S.E.) between the low-spin and the high-spin alternatives is not great enough to prevent the *d*-electrons of the ferrous iron from spreading over all five of the *3d*-orbitals, four of which are occupied singly while the fifth, and lowest, holds a pair of electrons. Replacement of the water molecule in the sixth co-ordination position by oxygen, to give oxyhaemoglobin, displaces conditions towards *B* in Fig. 2, where the L.F.S.E. difference is sufficient to make the filling of the three lowest orbitals with pairs of electrons the more energetically-favoured process, giving a diamagnetic complex. For theoretical reasons complexes intermediate between high-spin and low-spin are unlikely. It is unnecessary to postulate any sudden changes in the nature of the ligand-metal bonds and, in fact, it is an important consequence of this theory that the magnetic behaviour of complexes does not provide a means of classifying complexes into 'outer-' and 'inner-orbital' or 'ionic' and 'covalent'.

#### THE SPECTRA OF SOME PORPHYRINS AND THEIR METAL COMPLEXES

Because the visible absorption spectra of porphyrins are associated with a displacement of electrons towards the periphery of the porphyrin nucleus, any effect which results in an extension of the distance the electrons can move in this direction reduces the energy required for these transitions, so that visible absorption maxima move to longer wavelengths. Any effect operating in the opposite direction moves these absorption maxima to shorter wavelengths. A number of examples illustrate this.

##### *The Effect of Porphyrin Side-chains*

As has already been seen (Table 2) the spectra of a series of free porphyrins, and of the pyridine haemochromes of their  $\text{Fe}^{++}$  complexes, move to longer wavelengths stepwise as the electron-attracting power of the porphyrin side-chains increases. This porphyrin side-chain effect operates similarly in the simple (square) porphyrin complexes with a variety of divalent metals (cf. Table 2 of Falk and Nyholm, 1958), and indeed throughout the metalloporphyrins of all types, including, in a broad sense, the haemoproteins (cf. Table 1). Among the latter, replacement of the protein with pyridine is a convenient way to obviate effects on spectrum peculiar to the protein; pyridine haemochrome spectra reflect accurately the effects of electron-attracting side-chains on the haem nucleus.

##### *The Effect of Co-ordinated Metal Ions*

Falk and Nyholm (1958) have compared the protoporphyrin complexes of a number of different divalent metal ions. It was found that the following

complexes fell into three classes, according to magnetic susceptibility, spectroscopic and other properties:

<i>A</i>	<i>B</i>	<i>C</i>
Co <sup>++</sup> , Ni <sup>++</sup>	Cu <sup>++</sup> , Ag <sup>++</sup>	Zn <sup>++</sup> , Cd <sup>++</sup>

From the point of view of valence-bond theory, the conclusion was reached that class *A* were spin-paired ( $3d4s4p^2$ ), class *B* spin-free ( $4s4p^24d$ ,  $5s5p^25d$  respectively); both *A* and *B* have great (qualitative) stability. Class *C* is also spin-free ( $4s4p^24d$ ,  $5s5p^25d$ ) but of great (qualitative) instability. Within the three classes the spectra were very similar, but from *A* to *B* to *C* the visible absorption moved to longer wavelengths.

From Fig. 2, the essential difference between classes *A*, *B* and *C* is that they have 0, 1 and 2 electrons, respectively, in the  $d_{x^2-y^2}$  antibonding orbital. These electrons are favourably placed for strong repulsive electrostatic interaction with electrons on the pyrrole-N's, so that the more electrons in  $d_{x^2-y^2}$  the easier it is to displace  $\pi$ -electrons towards the periphery. Hence, in agreement with experiment, the visible absorption maxima move to longer wavelengths in passing from *A* to *B* to *C*. In the transition which gives rise to the Soret band there is a displacement of some of the electron density to the non-pyrrole (methene bridge) carbons, i.e. in a direction away from  $d_{x^2-y^2}$  (Fig. 1). This transition should be facilitated in the same way and the Soret maximum should shift to longer wavelengths in a similar sequence, as observed by Falk and Nyholm (1958) for the protoporphyrin complexes in benzene, which at the time appeared to be an inert solvent. It has recently been found (J. N. Phillips, unpublished) that in fact this solvent modifies the spectra of certain of the metalloporphyrins. The measurements have been repeated in  $\text{CCl}_4$ , which shows no evidence of interaction, and the following maxima have been found:

	Co	Ni	Cu	Ag	Zn	Cd
$\alpha$ -band, m $\mu$	561.5	561	573	570	579	587.5
Soret, m $\mu$	403	403	409	417.5	411.5	414

The  $\alpha$ -bands have virtually identical maxima in benzene and in  $\text{CCl}_4$ , as do the Soret bands of the Co, Ni, Cu and Ag complexes. The Soret bands of the Zn and Cd complexes in benzene, however, were at 415 and 423 m $\mu$  respectively.

In the square planar, low-spin, cobalt ( $d^7$ ) and nickel ( $d^8$ ) complexes, since there are the same number of electrons in  $d_{xy}$  ( $= 2$ ) and none in  $d_{x^2-y^2}$ , similar Soret and visible maxima would be predicted and have been found. In the same way the ferrous *bis*-pyridine complexes which are diamagnetic

with an octahedral distribution of  $d$ -orbital splittings, have no electrons in  $d_{x^2-y^2}$  and two in  $d_{xy}$ . From a spectroscopic point of view they therefore approach conditions for square planar nickel and cobalt complexes. Back double bonding should shift the visible bands to slightly shorter wavelengths and the Soret band to slightly longer wavelengths. Thus, for the protoporphyrin metal complexes the predicted order of the visible wavelength maxima is:  $\text{Co} \simeq \text{Ni} > \text{FePy}_2$ , and the observed values are 561, 561 and 558  $m\mu$  respectively.

Although the stability of porphyrin metal complexes is due in large measure to the difficulty of providing enough energy to rupture four bonds, whether electrostatic or covalent, simultaneously, an additional effect in transition elements is the ligand field stabilization energy. Considerations of L.F.S.E. would suggest that the stability of these metalloporphyrins should lie in the series,  $A > B > C$ . This is because electrons occupying low lying  $d$ -orbitals increase the stability of a complex, while those in higher (antibonding) orbitals will remove some of this stability. The additional stabilization becomes zero when all five of the  $d$ -orbitals are equally occupied. We estimate the L.F.S.E. for the bivalent Co, Ni, Cu and Ag complexes of protoporphyrin dimethyl ester to be at least 40 kcal, and this may be one factor contributing to the qualitative differences in the difficulty of dissociation of the metal from these complexes, as against the Zn, Cd and Pb complexes (which have no L.F.S.E.) (Falk and Nyholm, 1958). For ferro- and ferrihaemoglobin the estimated L.F.S.E.s are 20 kcal and zero, respectively. The great stability of ferric iron in complexes is probably mainly due to the electrostatic forces of attraction between opposite charges.

#### *The Effect of Ligands in the 5th and 6th Co-ordination Positions*

We restrict our discussion here to further complexes of iron-porphyrins, i.e. the haemochromes. The 5th and 6th positions on these complexes, above and below the plane of the haem molecule, correspond to positions 1, 6 in octahedral complexes in general co-ordination chemistry. We discuss the spectra of the  $\text{Fe}^{++}$  complexes only, since, as is commonly recognized, their spectra are not complicated by the large component which has been attributed (Williams, 1956) to charge-transfer from the ligand to the metal in the  $\text{Fe}^{+++}$  complexes.

Ligands to haem iron such as pyridine and chemically similar bases, and  $\text{CN}^-$  ion, allow back-double-bonding of the electrons in the  $d_{yz}$  and  $d_{zx}$  orbitals of the metal. The time these electrons spend in the plane of the porphyrin molecule, and hence the average electron density in this plane are reduced, so that it is harder for electrons to move towards the periphery, and the visible absorption maxima move to shorter wavelengths. That is, there is less electrostatic repulsion in the ground state if double bonding can occur.

Ligands such as ROH (including HOH),  $RS^-$ ,  $RCOO^-$ ,  $HO^-$  and others, by their dipolar or electrostatic interactions with the metal ion, should facilitate the movement of the mobile porphyrin electrons away from the metal, and shift absorption to longer wavelengths.

Among the haemoproteins, one clear example of these two effects is seen when  $Fe^{++}$  cytochrome *c* and  $Fe^{++}$  peroxidase are compared. The former is low-spin (diamagnetic) and the latter is high-spin (4 unpaired electrons found). The visible absorption maxima lie at 520, 550  $m\mu$  and 558, 594  $m\mu$  respectively (Lemberg and Legge, 1949). In cytochrome *c* one, and possibly both, protein groups bound to the haem iron are histidine nitrogens, and in peroxidase the groups are a  $-COO$  on one side of the haem and probably a water molecule on the other (Chance, 1952; Theorell and Paul, 1944).

Among  $Fe^{++}$  haemoglobin derivatives a similar change from high- to low-spin (para to diamagnetism) is found on substitution of water (Hb itself) by the double-bonding ligands  $O_2$  or CO. Similarly, when the 6th position on the haem of  $Fe^{+++}$  haemoglobin is occupied by  $H_2O$ ,  $F^-$ ,  $OH^-$ , EtOH, high-spin complexes, and by the double-bonding ligands  $CN^-$ ,  $-SH$ ,  $N_3^-$  or imidazole, low-spin complexes are found (for references see Falk and Nyholm, 1958). Similar examples are to be found among peroxidase derivatives (Lemberg and Legge, 1949). Complexes of the haems with non-protein ligands have been studied extensively, but many of the data which may be very relevant to understanding of the haemoproteins are lacking. For comprehensive reviews of this subject, see Lemberg and Legge (1949) and Martell and Calvin (1953).

As might be expected, with ligand atoms of high field strength and also capable of double bonding, such as  $=N-$  (in pyridine, nicotine,  $\alpha$ -picoline, imidazole, etc.), low-spin complexes are formed. Thus all the complexes of protohaem listed in Table 5 are diamagnetic. Though there must be variations in complex-forming ability between these ligands, as indicated by their  $pK$  and  $E_0'$  values (Table 5), the spectra of the complexes are very similar; this is probably because of comparable back-double bonding ability. In these hexaco-ordinate complexes, the wavelengths would be expected to be modified by the ligands on the 5th and 6th co-ordination positions only if these ligands alter the spatial distribution of the electrons round the central metal ion in such a way as to affect electronic transitions in the plane of the porphyrin molecule. Such effects would be expected if spin-free and spin-paired complexes were compared, or even in complexes with very different amounts of back-double-bonding, spin-paired and least back-bonded having maxima displaced towards longer wavelengths.

However, especially with unrelated ligands, there is no reason why the factors that govern their complex-forming ability with two different valence states of a metal should bear any relation to the effective component of the metal's *d*-electrons at right angles to the direction of bond formation,

as would be required for any general correlation of spectra with redox potential.

#### OXIDATION-REDUCTION POTENTIALS

Factors affecting the oxidation-reduction potentials of metal complexes (Perrin, 1959b) include:

- (i) Purely electrostatic effects of attractions between ions or dipoles of opposite charge. Thus if the ligand is an anion this will always favour the higher valent state of the metal and the potential will be less than for the corresponding free metal ions in water. This is because the standard oxidation-reduction potential,  $E_L^\circ$ , of any pair of ligand-metal complexes is related directly to the stability constants of the complexes by the identity,

$$E_L^\circ = E_M^\circ - \frac{2.3036RT}{(n-m)F} (\log K_{M^{n+}} - \log K_{M^{m+}})$$

where  $E_M^\circ$  is the potential of the free metal ions.

- (ii) Back-double-bonding. Because this involves the removal of electrons from the vicinity of the positively charged metal ion, the effect is always greater for the lower valent state of the metal, so that it tends to raise the oxidation-reduction potential.
- (iii) Ligand field stabilization energies. The difference in L.F.S.E. varies with the particular pairs of cations and the ligands, as discussed in Dr. Orgel's paper (*loc. cit.*). For example, in weak ligand fields ferrous ion, but not ferric ion, is stabilized in this way: this raises the potential. On the other hand, in manganous, manganic systems manganic ion is stabilized but not manganous ion, so the potential is lowered.
- (iv) The acid dissociation constants ( $pK_a$ 's) of the ligands. In many series of closely related ligands the stability constants of metal complexes vary with  $pK_a$  in an approximately linear fashion:  $\log K \simeq \alpha pK_a + c$ . Such a relation would be expected if the factors governing the binding of protons and cations by ligands were similar. From a simple electrostatic model it has been predicted that  $\alpha$  should increase with increasing cationic charge (Jones *et al.*, 1958). As a direct consequence, the oxidation-reduction potentials of metal complexes in which the ligands are sufficiently similar should decrease linearly with increasing  $pK_a$ . For several series of iron complexes this has been found to be the case (Perrin, 1959b).

In the porphyrins, electron-withdrawing substituents at the peripheral carbons increase the acid strength of the porphyrin (lower the  $pK_a$ ) and hence raise the oxidation-reduction potential of the metal complex. Martell and

Calvin (1953) have discussed this correlation between electron-withdrawing effect and  $E_0$ ; potentials of iron complexes rise as the electron-attraction of side-chains increases (Table 3). The differences, although rather small, lie in the expected order.

In sufficiently alkaline solutions, complexes of nitrogenous bases with iron-porphyrins give oxidation-reduction potentials which vary linearly with pH. The reaction can be written:

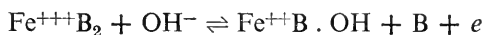

although the ferric complex may be present mainly as an easily split dimer (Shack and Clark, 1947). Such potentials should therefore be compared at approximately constant base concentration and pH. Around pH 9.6 reported potentials are as shown in Table 4.

TABLE 4

Haems Side-chains in positions:		$E_0$ at pH 9.6* (Pyr.) <sub>2</sub> complex	$E_0$ at pH 9.6* ( $\alpha$ -Picoline) <sub>2</sub> complex
2 —C <sub>2</sub> H <sub>5</sub> —CH <sub>2</sub> CH <sub>2</sub> CO <sub>2</sub> H	4 —C <sub>2</sub> H <sub>5</sub> —CH <sub>2</sub> CH <sub>2</sub> CO <sub>2</sub> H	—0.063 —0.036	
2 —C <sub>2</sub> H <sub>5</sub>	6 —C <sub>2</sub> H <sub>5</sub>	4 —C <sub>2</sub> H <sub>5</sub>	7 —C <sub>2</sub> H <sub>5</sub>
		—0.029	
2 —CHOHCH <sub>3</sub> —CH=CH <sub>2</sub> —CHO	4 —CHOHCH <sub>3</sub> —CH=CH <sub>2</sub> —CH=CH <sub>2</sub>	+0.004 +0.015	—0.099 —0.033 —0.010

Data from Martell and Calvin (1952).

\* For the reaction  $\text{Fe}^{+++}\text{B}_2 + \text{OH}^- \rightleftharpoons \text{Fe}^{++}\text{BOH} + \text{B} + e$ .

A different kind of comparison can be made by keeping the porphyrin nucleus constant and varying the base co-ordinating with the iron complexes. Taking the data of Barron (1937) for protoporphyrin-iron we find that at pH 9.2 nicotine, pyridine and  $\alpha$ -picoline give oxidation-reduction potentials showing the expected pH-dependence  $-\Delta E/\Delta \text{pH} = 0.06$ . On the other hand, the slope for histidine and pilocarpine is much less, indicating that the complexes  $\text{Fe}^{+++}\text{B}_2$  are also present in significant amounts. To minimize this interference the  $E_0$  values listed in Table 5 have been calculated from the data using as low a concentration of bases as possible. The series shows a roughly linear dependence on  $\text{p}K_a$ , with a slope of the order of  $-\Delta E/\Delta \text{p}K \sim 0.04$  V. This slope is similar in magnitude to that found for 1:1 iron



complexes with amino-acids, 8-hydroxyquinoline and *o*-phenanthroline (Perrin, 1959a).

TABLE 5. COMPLEXES OF PROTOHAEM WITH BASES

Base	p <i>K</i> <sub>a</sub>	[B] <i>M</i>	<i>E</i> ' <sub>0</sub> ,* pH 7	Haemochrome α-band, mμ
Nicotine	3.15	0.04	0.200	558†
Pyridine	5.2	0.7	0.158	558†
α-Picoline	6.2	0.5	0.115	558†
Histidine	6.0	0.03	> 0.079	
Pilocarpine	7.0	0.02	> 0.052	556.2‡

\*  $\text{Fe}^{+++}\text{B}_2 + \text{OH}^- \rightleftharpoons \text{Fe}^{++}\text{BOH} + \text{B} + e$ .

† This study.

‡ Barron (1940).

Much less information is available for reactions of the type

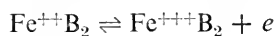

which become important in neutral solutions. For iron-protoporphyrin we find the values shown in Table 6. As would be expected the anion,  $\text{CN}^-$ ,

TABLE 6

Complexes of protohaem with:	p <i>K</i> <sub>a</sub>	<i>E</i> <sub>0</sub> *
Pyridine	5.2	+0.107†
Histidine	6.0	-0.105‡
Pilocarpine	7.0	-0.13‡
Water		-0.14†
Cyanide ion		-0.183†

\* For the reaction  $\text{Fe}^{++}\text{B}_2 \rightleftharpoons \text{Fe}^{+++}\text{B}_2 + e$ .

† Shack and Clark (1947).

‡ Barron (1937).

stabilizes the ferric state to a greater extent than any of the neutral ligands: among the latter the ferric state is favoured the higher the p*K*<sub>a</sub> of the ligand.

Compared with the cyanide complexes, potentials for these reactions appear to be much more sensitive to change in the porphyrin in the complex if the ligand is neutral (pyridine, Table 3).

#### SUMMARY AND CONCLUSIONS

We have outlined some theoretical aspects of the absorption spectra of porphyrins and metalloporphyrins, of the co-ordination chemistry of metalloporphyrins, and of the redox potentials of haems and haemochromes.

It has been shown that the following firm correlations exist among the non-protein complexes:

- (a) The more electron-attracting the side-chains on the porphyrin nucleus, the greater the shift to longer wavelength of the visible absorption maxima of porphyrins, their square metal complexes, and their haemochromes with double-bonding ligands.
- (b) The more electron-attracting the porphyrin side-chains, the more positive the redox potential of the haemochromes formed by double-bonding ligands.
- (c) The greater the electron-donation (higher  $pK_a$ ) of double-bonding ligands, the more *negative* the redox potential of the haemochromes formed by them.
- (d) For ligands, in the above group, of  $pK_a$  from about 3 to 7, although  $E_0$  varies by about 150 mV, the spectra of the haemochromes hardly differ. Reasons for this have been discussed.

Among the haemoproteins:

- (a) The effects of porphyrin side-chains upon both spectrum and redox are obscured and overweighed by the effects of the proteins.
- (b) The haemochromes which have been studied in any detail are mainly those formed by double-bonding ligands, and their spectroscopic and redox properties may have little value as models for haemoproteins, even in cases like cytochromes *c*, which resemble haemochromes in some ways.

#### REFERENCES

- BARRON, E. S. G. (1937). *J. biol. Chem.* **121**, 285.  
 BARRON, E. S. G. (1940). *J. biol. Chem.* **133**, 51.  
 CHANCE, B. C. (1952). *Arch. Biochem. Biophys.* **40**, 153.  
 COLPA-BOONSTRA, J. & HOLTON, F. A. (1959). *Biochem. J.* **72**, 4P.  
 CRAIG, D. P., MACCOLL, A., NYHOLM, R. S., ORGEL, L. E. & SUTTON, L. E. (1954). *J. chem. Soc.* 332.  
 FALK, J. E. & NYHOLM, R. S. (1958). *Current Trends in Heterocyclic Chemistry*, p. 130. Butterworths, London.  
 GRIFFITH, J. S. & ORGEL, L. E. (1957). *Chem. Revs.* **11**, 381.  
 JONES, J. G., POOLE, J. B., TOMKINSON, J. C. & WILLIAMS, R. J. P. (1958). *J. chem. Soc.* 2001.  
 KUHN, H. (1959). *Helv. chim. Acta* **42**, 363.  
 LEMBERG, R. & FALK, J. E. (1951). *Biochem. J.* **49**, 674.  
 LEMBERG, R. & LEGGE, J. (1949). *Haematin Compounds and Bile Pigments*, Interscience, New York.  
 LONGUET-HIGGINS, H. C., RECTOR, C. W. & PLATT, J. R. (1950). *J. chem. Phys.* **18**, 1174.  
 MARTELL, A. E. & CALVIN, M. (1952). *Chemistry of the Metal Chelate Compounds*, Prentice-Hall, New York.  
 MASON, S. F. (1958). *J. chem. Soc.* 976.  
 MORTON, R. K. (1958). *Rev. pure appl. Chem.* **8**, 161.  
 PERRIN, D. D. (1959a). *J. chem. Soc.* 290.  
 PERRIN, D. D. (1959b). *Rev. pure appl. Chem.* **9**, 257.  
 PLATT, J. R. (1956). *Radiation Biology*, **3**, 101. McGraw-Hill, New York.

- ROBERTSON, J. M. (1936). *J. chem. Soc.* 1195.  
 SEELY, G. R. (1957). *J. chem. Phys.* 27, 125.  
 SHACK, J. & CLARK, W. M. (1947). *J. biol. Chem.* 171, 143.  
 THEORELL, H. & PAUL, K.-G. (1944). *Ark. Kerni. Min. Geol.* 18A, No. 12.  
 VESTLING, C. S. (1940). *J. biol. Chem.* 135, 623.  
 WANG, J. H., NAKAHARA, A. & FLEISCHER, E. B. (1958). *J. Amer. chem. Soc.* 80, 1109.  
 WILLIAMS, R. J. P. (1956). *Chem. Rev.* 56, 299.

## DISCUSSION

### *Correlations between Structure and Physical Properties*

GEORGE: With regard to the correlations that are being sought between chemical reactivity, physical properties and structural factors in co-ordination chemistry, and their extension to haemoprotein compounds, I would call attention to the more detailed and revealing information that can often be obtained from  $\Delta H^0$  and  $\Delta S^0$  data, which it is not possible to get if only  $\Delta G^0$  data (e.g.  $E'_0$  and p*K* values) are considered. In many cases, notably when ligand field effects are being investigated,  $\Delta H^0$  is the significant thermodynamic quantity: and the successful correlations based on  $\Delta G^0$  probably result from the values of  $\Delta S^0$  remaining relatively constant throughout a series of compounds. But in some instances apparently valid conclusions based on  $\Delta G^0$  turn out to be rather misleading.

For example there is the well-known correlation between the affinity of structurally similar ligands for a metal ion and for the hydrogen ion; linear plots are obtained for log (stability constant) against p*K*. This suggests that the stronger the bond to hydrogen, the stronger is the bond to the metal. Yet an examination of the rather scanty thermodynamic data which are available indicates that the correlation is only determined by the  $\Delta H^0$  values, which contain the bond energy terms, for certain families of ligands, and that for others the  $\Delta S^0$  values dominate the relationship.

Similarly oxidation-reduction potentials are often regarded as a relative measure simply of the energy required to remove an electron from the reduced form of the couple. But this is not always so. For example, the  $E_0$  values for the  $\text{Fe}(\text{dipy})_3^{3+/2+}$ ,  $\text{Fe}_{\text{aq}}^{3+/2+}$  and  $\text{Fe}(\text{CN})_6^{3-/4-}$  couples are about 1.0, 0.77 and 0.36 V respectively. Yet this sequence is not determined by the electron-donating property of the ligands following the sequence  $\text{CN}^- < \text{H}_2\text{O} < \text{dipyridyl}$ . The values of  $\Delta H^0$  for the cell reaction in the presence of these ligands

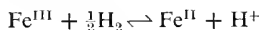

are about -30, -10 and -26 kcal/mole respectively, which show that the contribution from the ionization potential of the  $\text{Fe}^{2+}$  compounds is more nearly the same for the dipyriddy and the cyanide complexes, and that entropy changes play a very dominant role in determining the magnitude of  $E_0$ . This is not unexpected in view of the entirely different charge changes in the cell reactions, +3 to +2 in contrast to -3 to -4 respectively. Somewhat more surprising is the unfavourable entropy contribution for the corresponding couples of haemoglobin and myoglobin as compared to the favourable entropy contribution for the aquo-ion couple. The apparent charge changes are +1 to zero and +3 to +2 respectively, both of which should make a favourable contribution to  $\Delta S^0$ .  $\Delta H^0$  is nearly the same as that for the aquo-ion couple, and it is the entropy change which is responsible for the  $E_0$  values for the two haemoproteins being some 0.6 V lower, i.e. at about 0.2 V compared to 0.77 V. In setting up correlations, therefore, it can be extremely important to determine whether  $\Delta H^0$  or  $\Delta S^0$  is the dominant factor.

### *Spin Type and Spectra of Haem Compounds*

WILLIAMS: The spectra of metal porphyrins have recently been analysed by Gouterman (*J. chem. Phys.* 30, 1139, 1959). The suggestion that the band positions are solely due

to the  $\sigma$ -bonding power of the metal is, I believe, incorrect. The band positions are partly affected by metal acceptor power through  $\sigma$ -bonds and partly through the  $\pi$ -bond system (see Williams, *Chem. Rev.* 56, 299, 1956). However the total analysis of the spectra of porphyrins given by Gouterman is the best available to date.

The diagram in my paper, Fig. 1 (this volume, p. 43), is based on relatively little evidence for protoporphyrin and mesoporphyrin complexes. Lemberg has pointed out to me that it is inadequate for haem *a* complexes. While I deal with his complexes later I should like now to state the general case (see Fig. 1). In the region of high-spin complexes in both oxidation states  $\lambda_{\max}$  of both ferrous and ferric complexes moves to longer wavelengths with increasing  $\sigma$ -donor power of the ligands perpendicular to the porphyrin plane. This is also true for the band positions of completely covalent complexes. Both these statements have theoretical and practical support. In the region of mixtures of high- and low-spin complexes the Soret band of  $\text{Fe}^{++}$  complexes moves to shorter wavelengths while that of  $\text{Fe}^{+++}$  does not. The reasons I give for these shifts remain unaltered but here the discussion is empirical first and theoretical afterwards. In this region all the spectra are composite, part being due to low-spin and part due to high-spin forms.

Unlike Falk, I consider that some correlation between spectra and spin form must be established by us for otherwise there is little hope of knowing in what state the cytochrome is in the cell. It may be that the correlations I suggest are only partially true but I know of few exceptions to them.

In order to avoid terminological difficulties could I point out the equivalent definitions:

$$\begin{aligned} \text{ionic} &\equiv \text{high-spin} \equiv \text{weak field} \\ \text{covalent} &\equiv \text{low-spin} \equiv \text{strong field} \end{aligned}$$

The discussion of redox potentials given in my paper needs modification. In an exchange with Chance (Faraday Society Discussion on Energy Transfer, 1959) I was led to the conclusion that *b*-type cytochromes are mixed imidazole, amine porphyrin complexes. The diagram of redox potential against ligand basicity now should be as in Fig. 2 of my paper (this volume, p. 47).

I have attempted to show the relationships to simple haem complexes at the risk of over-simplification. My table of conclusions on the basis of spectra and redox potentials (this volume, p. 48) is incorrect now and should read: Cytochrome *b*, one amino, one imidazole. From some work we have done recently (Brill and Williams, unpublished) we have good reasons for supposing that peroxidase is an amine carboxylate complex rather than a simple carboxylate complex.

The chemical reactions of model compounds with oxygen have recently revealed a possible cause of the differences between cytochrome *a*<sub>3</sub>, uptake of oxygen and rapid autoxidation, and haemoglobin, uptake of oxygen only. The reactions we have observed are that whereas  $\text{Fe}(\text{dimethylglyoxime})_2(\text{imidazole})_2$  picks up oxygen reversibly,  $\text{Fe}(\text{cyclohexane dione-dioxime})_2(\text{imidazole})_2$  first picks up oxygen and is then slowly oxidized to a conjugated hydrocarbon. The oxidation is also possible with ferricyanide, and iridichloride. Schematically we have:

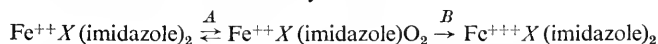

The reversible reaction, *A*, goes if *X* has no hydrogens which can react with  $\text{O}_2$  of the complex, while *B* follows if *X* contains suitable hydrogen. If analogies are helpful, the oxidation of cytochrome *a*<sub>3</sub> by  $\text{O}_2$  is due to the removal of a hydrogen from a sensitive group interacting with the porphyrin and the electron transport is initiated by hydrogen oxidation.

FALK: In the paper with Perrin (this volume, p. 56), the haemochromes in our Table 5 are low-spin by magnetic susceptibility measurements; the ligands forming these compounds are  $\text{=N-}$  atoms of *pK* values varying from 3 to 7. The visible spectra hardly differ from each other. I do not have Soret band measurements. In the compounds with primary and secondary aliphatic amines described a little later in this discussion, changes directly related to *pK* occur in both  $\lambda$  and  $\epsilon$  of the visible bands.

Soret band data are not available; magnetic susceptibility measurements have not yet been made on these. Because I suspect that there may be surprises in store in the magnetic properties of some of these new compounds, I suggest that we should be careful to refer to low-spin and high-spin *compounds* only when definitive magnetic susceptibility measurements have been made. If inferences are being made from spectra only, pending magnetic measurements, perhaps we could say 'low-spin spectral type', and so on. With this reservation, I do agree with Williams that we must continue to develop correlations between spectrum and spin-type.

PERRIN: I suggest that the electronegativity of the central metal is of less consequence in determining spectral shifts in porphyrin complexes than are the number of its *d*-electrons and the directions of the orbitals they occupy. Falk and I discussed this. In the case of ferrous ion the change from a high-spin to a low-spin configuration means that the unpaired electrons in the  $d_{x^2-y^2}$  and  $d_{z^2}$  antibonding orbitals vacate these positions and all six of the *d*-electrons fill, in pairs, the  $d_{xy}$ ,  $d_{yz}$  and  $d_{zx}$  orbitals. From the spatial distribution of these orbitals it is easy to see that this leads to an increase in electron density along the *xy* axes (i.e. through opposite methene carbon atoms) and a reduction in density along the *x* and *y* axes; the net increase in electron density in the plane of the porphyrin ring is probably small. If the transitions giving rise to porphyrin spectra are of the types shown in Fig. 1 of our paper (based on Longuet-Higgins, Rector and Platt, 1950; Seely, 1957; and Kuhn, 1959; see Falk and Perrin, p. 56, for references), what effects have the change from a high-spin to a low-spin ferrous complex on these transitions? The important thing to remember, and what distinguishes low-spin ferrous complexes from low-spin ferric complexes, is that in the former the  $d_{x^2-y^2}$  electron of the high-spin state has gone into the  $d_{xy}$  orbital, whereas in the latter it is in the  $d_{yz}$  or  $d_{zx}$  orbital. In ferrous complexes this makes the Soret transition more difficult because in the excited state there is increased electrostatic repulsion with electrons on the methene carbon atoms. This is diminished by back-double-bonding with ligands in the 5th and 6th co-ordination positions and this might be expected to displace  $\lambda_{\max}$  to longer wavelengths. On the other hand, for the visible bands in low-spin ferrous complexes there is decreased electrostatic repulsion in the excited state but this effect is reduced by back-double-bonding, so here  $\lambda_{\max}$  moves to shorter wavelengths the greater the back-double-bonding.

If the electronic transition which gives rise to the Soret band does not involve a net movement of electronic charge away from the metal in the high-spin ferric and ferrous complexes (which have symmetrical *d* electron distributions in the plane of the porphyrin)  $\lambda_{\max}$  would be expected to be at shorter wavelengths for ferric than for ferrous, irrespective of whether electron density on the pyrrole nitrogens is decreased as suggested by Williams or increased as suggested by Falk and myself.

In the ferric haemoproteins the Soret band shifts to longer wavelengths in the low-spin complexes. This is in line with expectation. The change from high-spin to low-spin includes taking an electron from  $d_{x^2-y^2}$  and putting it in  $d_{yz}$ ,  $d_{zx}$  (or possibly  $d_{xy}$ ): this makes it easier to put more  $\pi$ -electron density on the pyrrole-nitrogens in the excited state and hence lowers the energy needed for the transition if it is of the form Falk and I suggest in our Fig. 1. The opposing effect of increasing the electrons in  $d_{xy}$ ,  $d_{yz}$  or  $d_{zx}$  would be diminished where back-double-bonding is possible and, in fact, one might expect, other things being equal, that the longest wavelengths for Soret maxima will be given by the best back-double-bonding ligands.

WILLIAMS: As far as I can see Falk and Perrin used the same theory as I do, that of Platt, in the discussion of the spectra of porphyrins (see *Chem. Rev.* 56, 299, 1956). There is then the question of how metals affect the spectra. I appear to agree with the treatment given recently by Gouterman (*J. chem. Phys.* 30, 1139, 1959), and which is the best I know, while Falk and Perrin's discussion would say something different. I say that the Soret band shifts to longer wavelengths with decrease of effective electronegativity of the central metal. From what Perrin says I feel he must conclude that the opposite is true.

LEMBERG: I am not convinced that there is a general relationship between the Soret band positions and the spin type. The Soret band of high-spin ferrohaemoglobin lies at

longer wavelengths than that of the low-spin pyridine protoferrohaemochrome, but that of high-spin protohaem lies at still shorter wavelengths. Nor does there seem a clear relationship between bond-type and autoxidizability. We find autoxidizable haem compounds both with high-spin (haem) and low-spin (pyridine and imidazole haemochromes), and compounds slowly or not at all autoxidizable also both with high-spin (haemoglobin) and low-spin (cytochrome *c*).

**WILLIAMS:** I have discussed above the shift in Soret band with ligand (Fig. 1, p. 43). Only for haemoproteins will the Soret band shift to shorter wavelengths (with change of spin-type) as ligand basicity increases. For the change haem to haemoprotein (haemoglobin) there is no change of spin-type and the Soret band moves to longer wavelength with basicity. This is also likely to be true for all low-spin complexes.

I believe bond-type and autoxidizability to be clearly related. I wonder whether the compounds (pyridine and imidazole haemochromes), which Lemberg speaks of as low-spin, are in equilibrium with amounts of dissociated complexes (high-spin). It does seem that imidazole and pyridine reduce the rate of autoxidation of haems; thus imidazole and pyridine complexes of haems in strong solution pick up oxygen reversibly without being autoxidized (Corwin and Bruck, *J. Amer. chem. Soc.* **80**, 4736, 1958). I think oxidation occurs only on addition of water in this case.

### *Models for Haemoproteins*

#### Some New Compounds of Haems with Bases

By J. E. Falk (Canberra)

**FALK:** The properties of some new complexes of meso-, proto- and 2:4-diformyldeutero-haems are indicated in Figs. 1 and 2 and Table 1. These complexes were made in 0.01 N NaOH. The ligands hydrazine ( $pK_a$  8.1), ethanolamine (9.5), *n*-propylamine (10.5) and dimethylamine (10.6) form an interesting series of compounds with these haems. As shown in Fig. 1 both  $\lambda_{max}$  and  $\epsilon_{max}$  of the meso- and proto-haem complexes increase with  $pK_a$  of the ligand, and the effects are very similar for both haems.

With the diformyl haem, the  $\epsilon$  of the dimethylamine complex is similar to that found with meso- and proto-haems. It was not possible to measure  $\lambda$  values with the other amines because of spectral shifts associated with Schiff's base formation between the ligands and the formyl side-chains. This reaction was slow enough, however, to permit measurement with the reversion spectroscope of the position of the absorption bands of the initial complexes, and as shown in Table 1, the  $\alpha$ -bands of all these complexes, from hydrazine to dimethylamine, were at the same wavelength as the  $\alpha$ -band of the pyridine haemochrome. This lack of influence of the ligands upon the spectrum, as compared with meso- and proto-haems, is apparently related to the much greater electron-attraction in the side-chains of diformyldeuterohaem.

We were able to obtain interesting complexes of protohaem and the diformylhaem with 2-mercaptoethanol (Table 1 and Fig. 2); the  $\alpha$ -band of the protohaem complex is displaced 17  $m\mu$  to longer wavelength than that of pyridine protohaemochrome—the greatest shift we have yet encountered. Ethanol did not react in the same way under these conditions, so that as a first presumption, it appears that the thiol-group of mercaptoethanol is complexing with the haem iron. The electrophilic side-chains of proto- and diformyl haems appear to have some influence, since mercaptoethanol reacted poorly with mesohaem (Fig. 2).

The  $\epsilon_{mM}$  of the pyridine haemochrome of 2:4-diformyldeuterohaem at the  $\alpha$  maximum was assumed to be the same as that of protohaem.

As shown in Table 1, the  $\alpha$ -bands of these compounds of meso- and proto-haems more than cover the ranges of  $\alpha$ -band positions (cf. Morton, *Rev. pure appl. Chem.* **8**, 161, 1958) of the known cytochromes of types *c* and *b* respectively.

Absorption spectra were determined with a Beckman DU Spectrophotometer, except compounds marked \*, which were measured with a Beck-Hartridge reversion spectroscope (see text). The  $\epsilon_{mM}=31$  for the pyridine haemochrome of 2:4-diformyldeuterohaem is assumed, and the  $\epsilon_{mM}$  for the other ligands calculated on this basis.

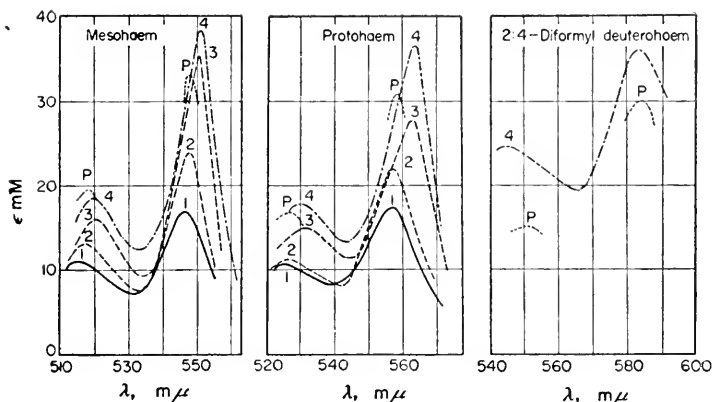

FIG. 1. Spectra of compounds of haems with bases. The haems ( $2 \times 10^{-6}$  M) were dissolved in 0.01 N NaOH; samples were reduced with dithionite immediately before adding the ligands and measuring the absorption spectra on the Beckman DU Spectrophotometer. Ligands were added in excess, higher concentrations causing no further change in absorption, in the following molarities:

	Mesohaem	Proto- and 2:4-diformyl haems
P. pyridine	3.41	3.41
1. hydrazine	0.488	0.195
2. ethanolamine	0.655	0.301
3. <i>n</i> -propylamine	0.282	0.159
4. dimethylamine	15.06	15.06

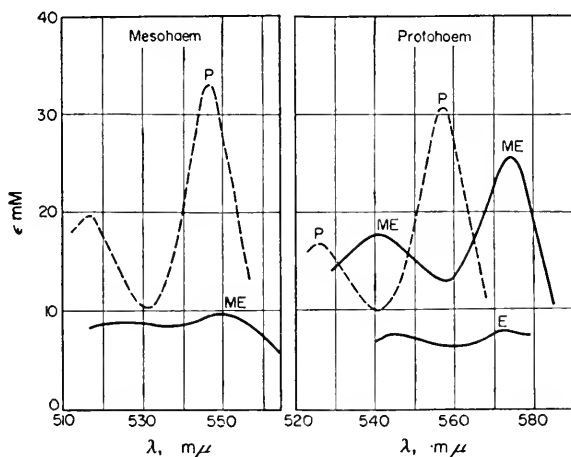

FIG. 2. Spectra of mercaptoethanol-haem compounds. The haem solutions and the procedure were as described in Fig. 1. The ligand concentrations were (M): pyridine (P), 3.41; ethanol (E), 8.5; mercaptoethanol (ME), 3.45.

TABLE I.  $\alpha$ -BANDS OF SOME HAEM COMPLEXES

Ligand	Meso		Proto		2:4-Di-formyldeutero	
	$\lambda$ (m $\mu$ )	$\epsilon_{mM}$	$\lambda$ (m $\mu$ )	$\epsilon_{mM}$	$\lambda$ (m $\mu$ )	$\epsilon_{mM}$
Pyridine	547	33.2	558	31	584	31
pKa						
8.1 Hydrazine	545	17.2	556	17.3	584*	
9.5 Ethanolamine	546	24.2	557	22.2	584*	
10.5 <i>n</i> -Propylamine	550	35.7	562	28.0	584*	
10.6 Dimethylamine	550	38.8	563	37	584	36.4
2-Mercaptoethanol	560	9.8	575	25.7	595	21.2

LEMBERG: There is considerable difficulty in finding suitable models for haemoproteins among simpler haem compounds. Thus amino acids at neutral pH are zwitterions and therefore unsuitable. Research with amino acids at a physiological pH should therefore be carried out with amino acid esters or poly-aminoacids, but such data are missing. Moreover, even then the affinity to haem may be far smaller than if the combining group is held in the protein in a restrained position close to the haem iron. In this regard Kaziro's approach offers perhaps more hope than model experiments. I was interested to note, in Falk's discussion (this volume, p. 74), the lack of variability of the diformyldeuterohaem spectrum with different ligands. This is quite different from the great variability of band position of nitrogenous compounds of monoformyl haems such as haem *a*.

FALK: Lemberg reinforces the point I have made—that relatively few model haem compounds have been studied; those which have been are largely of one class, in which the ligand atom is  $-\text{N}=\text{}$ . The reasons for this are partly the difficulties, as Lemberg points out—we are, in fact, studying amino acid esters and small peptides—and partly, perhaps, that we have all been over-impressed with the suspected role of histidine, and have modelled our models upon it. I agree that model studies can never entirely solve the problems of haemoprotein structure, but I believe that there still remains a great deal to discover about the chemistry of the combination of haem with new types of ligands, and that knowledge on this level will be a prerequisite for our eventual understanding of the haemoproteins.

Not only do we need data on compounds of haems with primary and secondary nitrogen atoms, with thiols, etc., but as Perrin and I have pointed out, there is a particular need for studies of mixed compounds, with one ligand of these types and the other of the  $-\text{N}=\text{}$  type. In this regard Wang's model (this volume, p. 98), in which the haem is held down on one side to a  $-\text{N}=\text{}$  bond, should be particularly valuable.

PHILLIPS: It is interesting to note that although free amino acids form haemochromes only with great difficulty, the corresponding amino acid esters react readily. The reluctance of the free amino acids to react is not simply due to electrostatic repulsion between the amino acid anion and the carboxylate anions on the porphyrin side chains, since a similar behaviour is observed in detergent solutions using porphyrin esters.

### Carbon Monoxide-Pyridine Complexes with Haems

By J. H. Wang (Yale)

WANG: In connexion with Falk's remarks on the special significance of mixed haemochromes, I should like to discuss some interesting results obtained in our equilibrium studies on the combination of carbon monoxide with haem in aqueous solutions containing small amounts of pyridine.



Our results show that as the concentration of pyridine in the solution increases, the affinity of haem for carbon monoxide also rapidly increases (Nakahara and Wang, *J. Amer. chem. Soc.* **80**, 6526, 1958). This observation shows that in dilute solutions the mixed complex pyridine-haem-CO has greater thermodynamic stability than both the complex  $H_2O$ -haem-CO and the complex pyridine-haem-pyridine. Indeed the affinity of haem for carbon monoxide is so high that when the latter is bubbled through a solution of dipyridine haemochrome in pure pyridine, some mixed complex pyridine-haem-CO is formed. On the other hand no detectable amount of dicarbonmonoxyhaem,  $OC$ -haem-CO, was found when aqueous haem solutions, whether with or without added pyridine, were equilibrated with carbon monoxide at even 1 atm. pressure (Wang, Nakahara and Fleischer, *J. Amer. chem. Soc.* **80**, 1109, 1958).

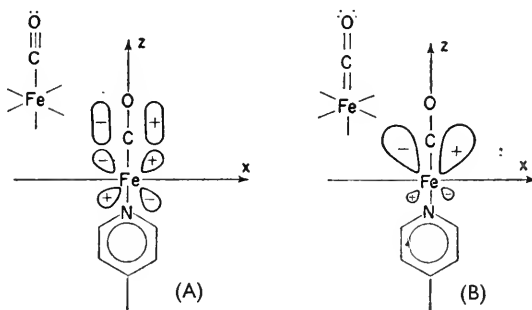

FIG. 1

This result leads to two puzzling questions: (1) Why does pyridine increase the affinity of haem for carbon monoxide? (2) Why does each haem combine with only one carbon monoxide molecule?

It is possible to find an answer for both of these questions if we assume that Pauling's structure (B) in Fig. 1 contributes substantially to the energy of binding of carbon monoxide by haem. To do this let us omit the more familiar  $\sigma$ -bonds in the mixed complex pyridine-haem-CO, and focus our attention on the  $\pi$ -bonds depicted in Fig. 1. In structure (B), the  $d_{zx}$  orbital of the  $Fe^{++}$  is combined with the  $p_x$  orbital of the C-atom to form a molecular-orbital for one of the possible  $\pi$ -bonds between  $Fe^{++}$  and the C-atom of carbon monoxide. Similarly, the  $d_{yz}$  orbital of the  $Fe^{++}$  can combine with the  $p_y$  orbital of the C-atom to form a molecular-orbital with maximum density in the YZ-plane for the other possible  $\pi$ -bond between  $Fe^{++}$  and the C-atom of carbon monoxide. The superposition of these two molecular-orbitals makes the Fe-C bond cylindrically symmetrical with respect to the Z-axis. The overall effect of this type of  $\pi$ -bond formation is to cause the  $d_{zx}$  and  $d_{yz}$  electrons of  $Fe^{++}$  to drift towards the positive direction of the Z-axis as illustrated in Fig. 1.

The effect of added pyridine on the affinity of haem for carbon monoxide can be qualitatively understood by examining the shape of these  $\pi$ -bonding orbitals. If the central metal ion is octahedrally bonded to six identical ligands, the  $d_{zx}$  orbital should be highly symmetrical as depicted by diagram (C) in Fig. 2. If, however, the co-ordinating electron-pairs of the two ligands in the positive and negative directions of the Z-axis are of different strengths, then the  $d_{zx}$  and the  $d_{yz}$  electrons of the central metal ion will be displaced toward the direction of the weaker ligand, as depicted by diagram (D) in Fig. 2. When the water molecule in carbonmonoxyhaem is replaced by a stronger ligand such as the pyridine molecule, the stronger field of the co-ordinating electron-pair of the pyridine will cause the  $d_{zx}$  and  $d_{yz}$  electrons of  $Fe^{++}$  to shift toward the direction of the CO-molecule on the other side of the haem plane. This will facilitate  $\pi$ -bond formation between  $Fe^{++}$  and the C-atom of the carbon monoxide and hence increase the affinity of haem for carbon monoxide. Conversely, since the

$\pi$ -bond formation between the C-atom and  $\text{Fe}^{++}$  decreases the probability-density of the  $d_{zx}$  and  $d_{yz}$  electrons on the other side of the haem plane, it enables the pyridine molecule to be bonded more effectively, i.e. the CO-molecule also enhances the affinity of  $\text{Fe}^{++}$  for the pyridine molecule attached to it. Thus because of this complementary electronic nature of carbon monoxide and pyridine, the mixed complex pyridine-haem-CO is not only thermodynamically more stable than the complex  $\text{H}_2\text{O}$ -haem-CO, but also more stable than bipyridine haemochrome.

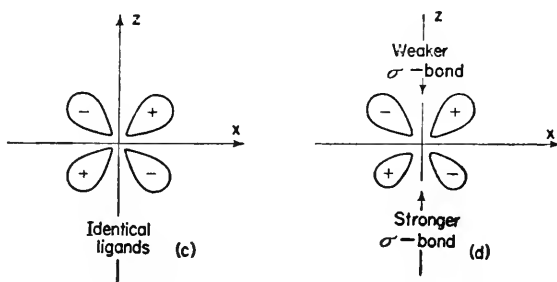

FIG. 2. Cross-section of  $d_{xz}$ -orbital in octahedral complexes.

If we assume that the ligand-field of the co-ordinating electron-pair of carbon monoxide is so weak that  $\pi$ -bonding between the  $\text{Fe}^{++}$  of haem and the C-atom of the CO-molecule is essential for the binding of the latter by haem, it would then be easy to see why each haem binds only one carbon monoxide molecule. The hypothetical complex OC-haem-CO should be unstable, since the two CO-molecules on opposite side of the haem plane would compete for the same  $d_{zx}$  and  $d_{yz}$  electrons in order to be bonded to the  $\text{Fe}^{++}$ .

Pauling suggested that this type of  $\pi$ -bond formation between the ligand and haem also plays a significant role in the binding of nitric oxide and oxygen by haemoglobin and related compounds. We would like to suggest further that this type of  $\pi$ -bonding could be the major cause for the haem-linked imidazole group to exhibit the famous Bohr effect. As illustrated by diagram (B) in Fig. 1, the  $\pi$ -bond formation causes the  $d_{zx}$  and  $d_{yz}$  electrons of the  $\text{Fe}^{++}$  to drift toward the  $+Z$  direction. This would cause the iron nucleus to be very incompletely shielded on the  $-Z$  side of the  $XY$ -plane and hence to exert an unusually large polarizing influence on the attached imidazole group.

### Equilibrium Constants for Reactions of Haems with Ligands

By J. N. Phillips (Canberra)

PHILLIPS: The question of mixed haemochromes is a rather interesting one. Mixed ligand complexes of the cyano-pyridine type are known for  $\text{Fe}^{++}$ ,  $\text{Fe}^{+++}$ ,  $\text{Co}^{+++}$  and  $\text{Mn}^{+++}$  porphyrins. Where quantitative equilibrium constants have been determined the stability of the mixed complex has been found to be greater than the stability of the corresponding pure complexes—as Wang also found with the mixed carbon monoxide-pyridine complex.

Figures 1 and 2 summarize the equilibrium constants at  $25^\circ\text{C}$  for the reaction between  $\text{Fe}^{++}$  and  $\text{Fe}^{+++}$  protoporphyrin and the ligands, water, hydroxide ion, cyanide ion, and pyridine. These results have been extracted from that very extensive series of papers by Clark and his co-workers and illustrate the danger of attempting to interpret in any simple fashion haemochrome formation in alkaline solution.

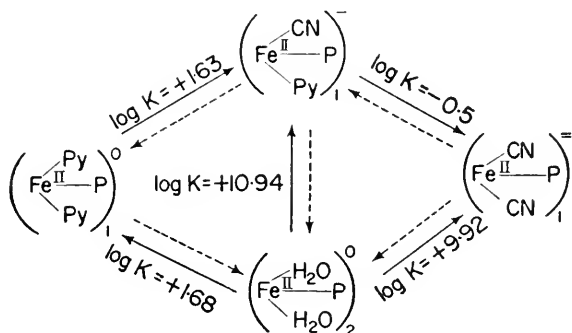

FIG. 1. Pyridine and cyanide haemochrome equilibrium constants in aqueous solution at room temperature.

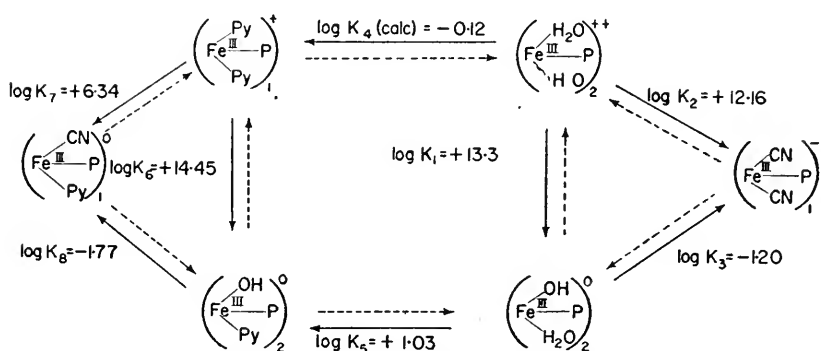

FIG. 2. Pyridine and cyanide ferrihaemochrome equilibrium constants in aqueous solution at room temperature.

#### FIGS. 1 AND 2

Log  $K$  refers to the logarithm to the base ten of the formation constant in the direction of the solid arrow calculated from the data of Clark *et al.* (see text). The subscripts 1 or 2 outside the brackets refer to the monomeric or dimeric nature of the complex.

CLARK, W. M. *et al.*, *J. biol. Chem.* (1940). **135**, 543; (1940). **135**, 623; (1940). **135**, 643; (1947). **171**, 143; (1952). **198**, 33; (1953). **205**, 617.

# MODIFICATION OF THE SECONDARY STRUCTURE OF HAEMOPROTEIN MOLECULES

By K. KAZIRO AND K. TSUSHIMA

*Biochemical Laboratory, Nippon Medical School, Tokyo*

ALTHOUGH the principal functions of haematin enzymes are based on the catalytic property of their central iron, the specific functions of the individual haematin enzymes are determined by their protein structures. This may be exemplified, for instance, in haemoglobin and cytochrome *c*. The former combines with molecular oxygen reversibly without activating the combined molecule, the latter functions as an electron carrier but does not react with oxygen. These specific functions are maintained strictly by the native state of the protein moiety. Any modification of the secondary structure of their protein molecules will cause diverse alterations of their essential properties. The present paper is concerned with the relationship between the functions of haemoproteins and their protein structures (Tsushima, 1954a, b; 1956a, b; Tsushima and Kawai, 1956; Tsushima and Miyajima, 1956; Okazaki and Tsushima, 1959; Kikuchi and Tomimura, 1954; Suzuki, Tomimura and Mizutani, 1956; Kajita, 1956a), which were studied mainly with haemoglobin as a model molecule of haematin enzymes.

Studies were made also on the haemochrome-forming chemical groups of some haemoproteins after the proteins had been artificially unfolded. This provides a new approach to the significance of the protein moiety of the native haematin enzymes in general.

## RESULTS AND DISCUSSION

### *Haem-haem Interaction and Bohr Effect of Haemoglobin in the Presence of Urea*

The well-defined characteristics of haemoglobin in the physiological adaptation to respiration are the Bohr effect and haem-haem interaction. In order to demonstrate the possible interrelationship between these physiological characteristics of haemoglobin and its protein structure, we studied the binding reaction of haemoglobin with ethyl isocyanide (EIC) (Warburg, Negelein and Christian, 1929; Russell and Pauling, 1939; St. George and Pauling, 1951) in the presence of urea at a concentration which is high enough to modify the protein structure (Okazaki and Tsushima, 1959). The absorption spectrum of reduced haemoglobin is converted to that of EIC-haemoglobin

on addition of EIC. Figure 1 shows the absorption spectra of haemoglobin in the presence of EIC at various concentrations. Clear isosbestic points at 542, 549 and 568  $m\mu$  were demonstrated indicating that the reaction system contained only two haemoglobin components. Figure 1, V represents the absorption spectrum of fully saturated EIC-haemoglobin. Taking the absorption spectrum of Fig. 1, V as that of the saturated EIC-haemoglobin,

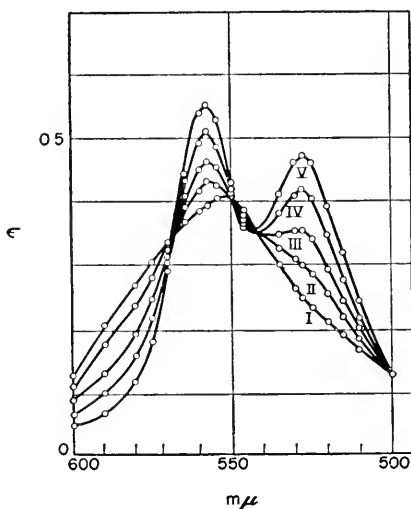

FIG. 1. Absorption changes of reduced haemoglobin at various ethyl isocyanide (EIC) concentrations. Haemoglobin concentration,  $3.0 \times 10^{-5}$  mole/l., and EIC concentrations: I, zero; II,  $4.85 \times 10^{-5}$  M; III,  $7.78 \times 10^{-5}$  M; IV,  $1.32 \times 10^{-4}$  M; V,  $1.32 \times 10^{-3}$  M and  $2.64 \times 10^{-3}$  M. Spectra were measured at pH 6.8 and at 25°C.

the percentual formation of EIC-haemoglobin at each EIC concentration can be calculated.

The plot of these values against the log concentrations of uncombined EIC gave rise to a sigmoid curve of a high order reaction shown in Fig. 2. The sigmoid coefficient  $n$  of the symmetrical sigmoid curve in Fig. 2 was calculated to be 2.4, by introducing the data obtained in the present experiment into Hill's equation (Hill, 1910)

$$Y = K_p^n / 1 + K_p^n$$

which has been proposed for the reaction of reduced haemoglobin with oxygen. It is thus proved that there exists a haem-haem interaction also in the reaction of reduced haemoglobin with EIC, the same as in the reaction of haemoglobin with oxygen. The sigmoid coefficient of the reaction of reduced haemoglobin with oxygen has been reported to be 2.8 (Wyman, 1948).

The sigmoid coefficient of the curves obtained with haemoglobin and EIC at any pH tested was found to be constant. In contrast, the affinity of haemoglobin to EIC was influenced by the change in pH.

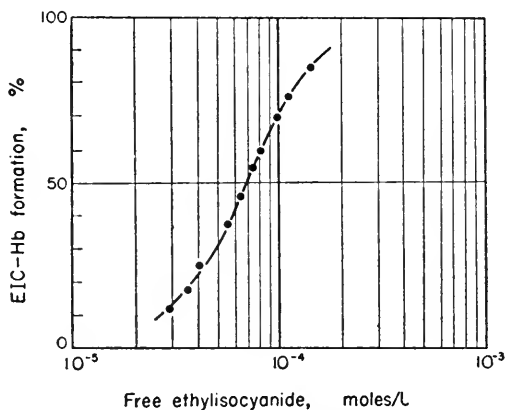

FIG. 2. EIC equilibrium curve of reduced haemoglobin. The measurements were made at pH 6.8 and at 25°C.

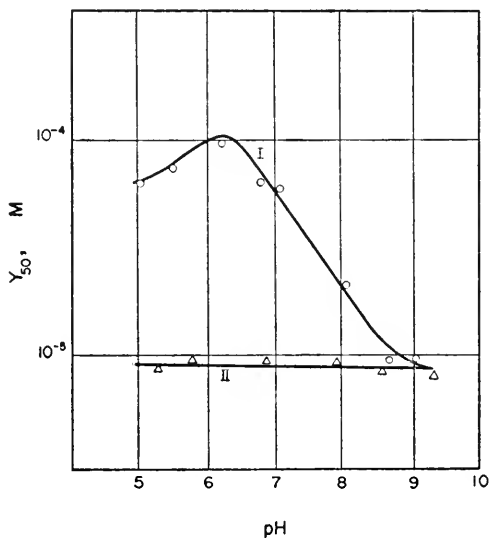

FIG. 3. pH dependence of  $Y_{50}$ . Concentration of urea: I, none; II, 6.0 M.

The curve in Fig. 3 (I) is a theoretical curve which was obtained by introducing the values of  $pK_1$  and  $pK_2$  of haem-linked acid groups of oxyhaemoglobin to Wyman's equation (Wyman, 1948).

As seen from Fig. 3 (I), the experimental values coincide closely with the theoretical curve. The results indicate that there exists a definite Bohr effect

in the reaction of haemoglobin and EIC and also that the values of  $pK_1$  and  $pK_2$  of EIC-haemoglobin are the same as those of oxyhaemoglobin.

Similar experiments with myoglobin have revealed that neither haem-haem interaction nor the Bohr effect exists in the reaction of myoglobin with EIC as would be expected from the reaction of myoglobin with oxygen.

The absorption spectrum of EIC-haemoglobin is not affected by the addition of 6.0 M-urea. However, it was found that the haem-haem interaction was decreased in the presence of 6.0 M-urea. The sigmoid coefficient dropped from 2.4 to 1.4 according to the concentration of urea added. It was also found that the binding affinity of haemoglobin with EIC increased with the increased addition of urea. These data are presented in Tables 1 and 2.

TABLE 1. EFFECT OF 6.0 M UREA ON THE REACTION OF REDUCED HAEMOGLOBIN AND ETHYL ISOCYANIDE

Concentrations of urea (M)	$Y_{50}$ ( $\times 10^{-5}$ M)	$n$
0	7.0	2.4
6.0	1.0	1.4

pH 6.0.

TABLE 2. EFFECT OF DIFFERENT CONCENTRATIONS OF UREA ON THE HAEM-HAEM INTERACTION ( $n$ ) AND THE ETHYL ISOCYANIDE BINDING AFFINITY ( $Y_{50}$ ) IN THE REACTION OF REDUCED HAEMOGLOBIN AND ETHYL ISOCYANIDE.

Concentrations of urea (M)	$Y_{50}$ ( $\times 10^{-5}$ M)	$n$
0	9.00	2.4
0.5	7.40	2.4
1.0	5.90	2.4
1.5	4.40	2.4
2.0	3.40	2.4
2.5	2.60	1.7
3.0	2.25	1.5
4.0	1.40	1.4
5.0	1.00	1.4

pH 6.85.

From the results in Table 2, it appears that there is no definite relationship between the haem-haem interaction and the EIC-combining affinity ( $Y_{50}$ ). At pH 6.0,  $Y_{50}$  decreased continuously with increase of urea concentration

(from 0.5 to 5.0 M), whereas the sigmoid coefficient remained constant at concentrations of urea up to 2.0 M.

It is apparent that the affinity of haemoglobin for EIC is very sensitive to even a slight modification by urea of the haemoglobin structure, whereas the haem-haem interaction is more resistant. The observed alteration of the EIC-combining affinity may be the result of the loosening of hydrogen bonds in the protein molecule. The secondary structure of a protein molecule thus modified may well be variable according to the extent of disruption of hydrogen bonds. The disruption seems to occur uniformly over the haemoglobin molecules as judged from the symmetry of the sigmoid curves obtained experimentally. It is interesting to note in the experiments with urea that the binding affinity of haemoglobin with EIC was not affected by pH changes within 5.3 to 9.3 (Fig. 3 (II)). Figure 3 shows the relationship between  $Y_{50}$  and pH in the presence and absence of urea. The results suggest that the Bohr effect is associated only with the intact haemoglobin molecule. The linkage of haem iron and acid groups of the haemoglobin molecule, which presumably is responsible for the Bohr effect, may be disrupted in the denaturation of the globin moiety by urea.

Summarizing the experimental results so far presented we may conclude that the binding affinity of haemoglobin with oxygen, the haem-haem interaction, and the Bohr effect of haemoglobin are all intimately connected with the secondary structure of the protein part, although these functions appear to be independent of each other. Particularly, the Bohr effect seems to be associated with a highly specific structure of the protein molecule.

#### *The Effect of Modification of the Protein Moieties of Haemoglobin and Cytochrome c on Their Catalytic Activities as Oxidases*

In order to obtain further information as to how far the specific functions of individual haematin enzymes are dependent upon their protein structure, we have investigated the alteration of the proper functionings of haemoproteins after the modification of their protein parts. This approach could provide a new clue to the problem. Haemoglobin, myoglobin and cytochrome *c* were the materials of our study along this line.

As reagents which cause the modification or disintegration of the secondary structure of the protein molecule, we have used various carboxylic acid salts such as benzoate, salicylate, laurate and palmitate. In some cases, we have tried sodium lauryl sulphate also.

As has been reported by Anson (1929, 1934) and Holden (1947), addition of these salts to methaemoglobin results in the spectral change of methaemoglobin to ferrihaemochrome indicating alteration of the secondary structure of the molecule. We have observed also that the addition of these salts enhanced the autoxidation of oxyhaemoglobin and subsequently increased its oxidase activity (Tsushima, 1954b; Kikuchi and Tomimura, 1954).



Figure 4 shows the effect of addition of sodium salicylate to haemoglobin. The oxidase activity of haemoglobin increased with addition of low concentrations of salicylate and reached its maximum at a salicylate concentration which was not sufficient to cause an appreciable change of the absorption spectrum of haemoglobin. A similar relation has been found with sodium laurate instead of salicylate. Four moles of laurate/mole of haemoglobin

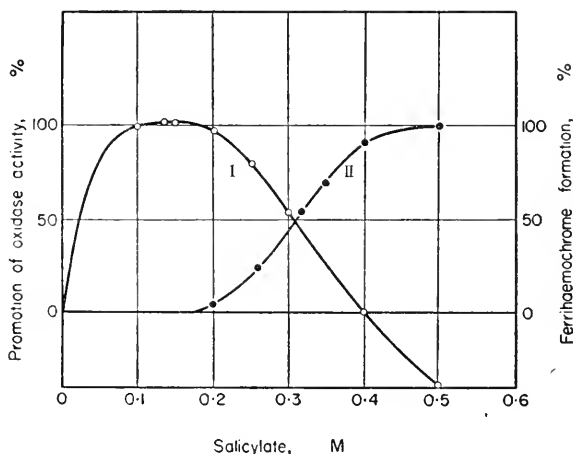

FIG. 4. Effect of salicylate on the oxidase activity of haemoglobin. The oxidase activity was measured with a conventional Warburg technique in the presence of ascorbic acid. The concentrations of haemoglobin and ascorbic acid were  $9.4 \times 10^{-5}$  M and  $1 \times 10^{-2}$  M, respectively. Ferrihaemochrome formation was measured spectrophotometrically at 535  $m\mu$ . One hundred per cent promotion of oxidase activity means that the oxidase activity with salicylate became twice as much as that without salicylate. Curve I: promotion of oxidase activity; Curve II: ferrihaemochrome formation.

were sufficient to raise the oxidative activity to its maximum. It is evident from this observation that the alteration of the secondary structure of the protein part, required for the increased activity as an oxidative catalyst, has already been completed at this concentration of laurate, although the modification of the structure was not detectable spectroscopically and hence the modification at this stage should be only slight.

When the modification proceeds so far as to be spectroscopically detectable, the appropriate condition for the activation of the latent oxidase activity of the haemoglobin molecule is lost. It seems to be essential for activation of the oxidase activity of haemoglobin that the extent of protein modification should be slight.

These experimental results are consistent with a stepwise nature of the modification of the protein moiety of haemoglobin. Similar stepwise modification was observed also with myoglobin and cytochrome *c* molecules

(Tsushima and Miyajima, 1956). Here we wish to mention one more experiment which was done with *p*-chloromercuribenzoate (PCMB) (Kajita, 1956b). As already reported by Riggs (1952), the haem-haem interaction of haemoglobin decreases on addition of PCMB. We have observed, however, that the

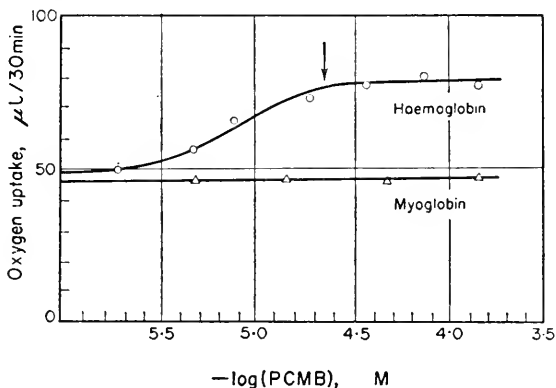

FIG. 5. Effect of *p*-chloromercuribenzoate on the oxidase activity of haemoglobin and myoglobin. Haemoglobin and myoglobin concentration,  $3 \times 10^{-5}$  M, ascorbate concentration,  $2.5 \times 10^{-3}$  M. The measurements were made at pH 7.5 and at  $37^\circ\text{C}$ .

addition of PCMB also gives rise to a marked increase in the oxidase activity of haemoglobin. As shown in Fig. 5, the oxidase activity of haemoglobin increases with the increase of PCMB concentration as compared to that of native haemoglobin. The maximum oxidase activity of haemoglobin (indicated by an arrow in Fig. 5) can be reached by the addition of two molecules of PCMB per atom of haemoglobin-iron.

In the study with cytochrome *c*, we took the appearance of the absorption spectrum of the CO-compound as one of the criteria of modification, taking advantage of the fact that native cytochrome *c* does not bind CO. As shown in Fig. 6, cytochrome *c* becomes able to bind CO at a concentration range of benzoate of 1.6–2.0 M. A similar relation obtains in experiments with salicylate. The addition of benzoate also makes cytochrome *c* active as oxidase. The oxidase activity of cytochrome *c* increases with increased addition of benzoate. The activity decreases, however, when the concentration of benzoate exceeds 1.0 M, suggesting that a progressive stage of modification of cytochrome *c* is brought about by the addition of higher concentrations of benzoate. Progressive modification of the cytochrome *c* molecule was found to be favourable to the formation of the CO-cytochrome *c* complex. The stepwise modification of the cytochrome *c* molecule appears to be similar to that which was observed with haemoglobin. It is noteworthy, however, that the oxygen activating ability of cytochrome *c* (using ascorbic acid as substrate) is brought about by lower concentrations of benzoate than the

appearance of CO-binding affinity by the modification of the cytochrome *c* molecule, because we know that the molecular size of CO is almost the same as that of O<sub>2</sub> and generally CO has strong affinity for many haem compounds. The experimental facts may, in turn, be evidence for the significance of the

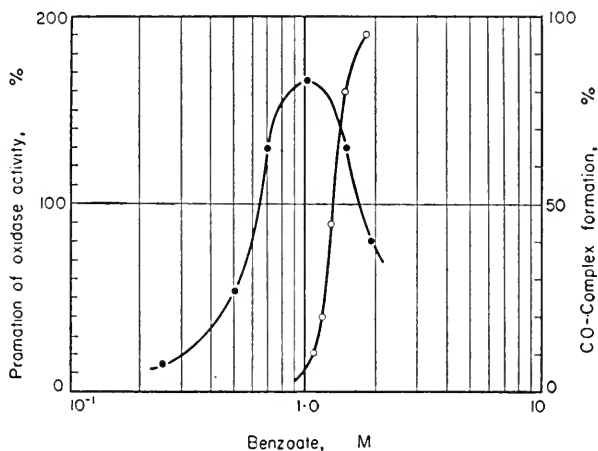

FIG. 6. Effect of benzoate on the oxidase activity of cytochrome *c*. The concentrations of cytochrome *c* and ascorbic acid were  $3.31 \times 10^{-5}$  M and  $1.5 \times 10^{-2}$  M, respectively. The concentration of benzoate was varied from 0 to 1.75 M. The measurements of CO-compound formation were made spectrophotometrically at 550 m $\mu$ . The measurement of oxidase activity and the expression of ordinate are the same as those of Fig. 4.

secondary structure of the molecule as the determining factor of the specificity of haemoproteins in general.

#### *Binding Affinity of Haem with Proteins*

Thus far, our experiments in section (1) and (2) have been concerned with the relationship between the function and the secondary structure of haemoproteins. Now, we wish to see how far the modification of the secondary structure of the protein moiety can proceed. As an approach to the study of this problem, we examined the affinity of the protein moiety for haem after controlled alteration of the protein part (Tsuchima, 1956a). As mentioned previously, when benzoate or lauryl sulphate was added to a methaemoglobin solution, a ferrihaemochrome spectrum was seen at a definite concentration range of the agent added. The nature and the extent of modification of the protein structure which led to the ferrihaemochrome spectrum is unclear as yet. However, it is certain that some nitrogen base of the unfolded protein is bound to the 6th co-ordination position of the haem-iron. As a matter of fact, the globin-N in the ferrihaemochrome structure can readily be replaced by cyanide as well as by azide.

Figure 7 shows the replacement of globin-N by cyanide. As seen from the figure, the reaction of replacement of globin-N by cyanide is competitive. In the case of the benzoate-induced ferrihaemochrome, the replacement by cyanide of the globin-N was found to follow a first order reaction (Fig. 7 (I)). However, globin-N of the completed ferrihaemochrome which was formed

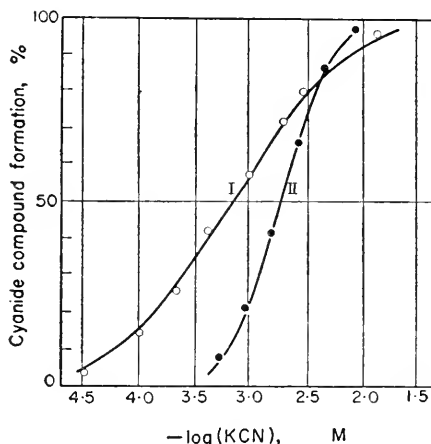
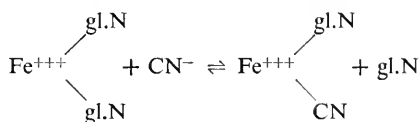
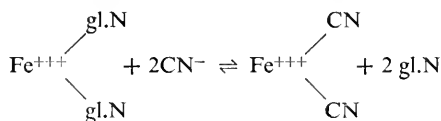

FIG. 7. The formation of cyanide-ferrihaemochrome at different concentrations of cyanide. Absorbancy changes of ferrihaemochrome induced by benzoate (Curve I) or lauryl sulfate (Curve II) in the presence of various concentrations of potassium cyanide were measured at 425  $m\mu$  in phosphate buffer, pH 8.0 and at 16°. The concentrations of methaemoglobin and sodium benzoate (or lauryl sulfate) were  $8.63 \times 10^{-6}$  M and 1.25 M (or  $10^{-3}$  M), respectively. The curves were calculated by use of the relation which is derived from the following equations:

I. cyanide-ferrihaemochrome formation in the presence of benzoate,



II. cyanide-ferrihaemochrome formation in the presence of lauryl sulphate,



$$\text{Cyanide compound formation (\%)} = 100 \times \alpha = \frac{(\text{CN})^n}{K^n + (\text{CN})^n}$$

where  $K$  is the apparent dissociation constant,  $(\text{CN})$  is the concentration of free cyanide and  $n$  is the number of cyanide ions combining with ferrihaemochrome.

At curve I  $n = 1$ , at curve II  $n = 2$ .

by the addition of lauryl sulphate was replaced by cyanide in a reaction following the second order type (Fig. 7 (II)).

In other words, the protein part of methaemoglobin seems to be modified more profoundly by lauryl sulphate so as to allow even the second globin-N to be replaced by cyanide.

In an electrophoretic study (Tsushima and Kawai, 1956) of the products of ferrihaemochrome formation from methaemoglobin with lauryl sulphate, two components were found which had electromobilities different from that of methaemoglobin. There was also a trace of another fraction which seemed to be lauryl sulphate. By the addition of lauryl sulphate to methaemoglobin, complex I appeared first. This complex disappeared after increased addition of lauryl sulphate and instead there appeared a new complex, II. After the addition of excess lauryl sulphate, only complex II remained observable. By the comparison of the electrophoretic data and the spectroscopic observations at various concentrations of lauryl sulphate, it was found that the process of ferrihaemochrome formation corresponded to the formation of complex I, and the ferrihaemochrome formation was completed at the stage of complex II formation. As mentioned previously, at the stage of complex II both of two globin-N's of the ferrihaemochrome can be replaced by cyanide. From the foregoing results, it is assumed that the combining affinity of haem to protein is affected to various degrees by the structural modification of the protein part.

#### *Haemochrome Formation of Alkali-denatured Proteins with Haem*

With respect to the problem of haemoprotein structure and function, it is desired to know to what group of the protein moiety the haem is attached. One well-known approach to this problem is to digest, for instance, cytochrome *c* and to isolate and analyse the haem-bound peptide. However, it is also well known that haem or haematin can co-ordinate with various nitrogen bases including amino acids. In this connexion, we have tried to find how many haems can actually be bound to the completely unfolded protein (Kajita, Uchimura, Mizutani, Kikuchi and Kaziro, 1959).

The protein was denatured by 1% NaOH and increasing amounts of haematin were added to the denatured protein. The binding of haem with the protein was measured by means of haemochrome formation after reduction by sodium dithionite. Figure 8 shows a typical experiment which was done with haemoglobin as the protein. With increase of haem added, the optical density at 558  $m\mu$  of alkali-denatured globin haemochrome increases and finally the slope of the increase in optical density becomes parallel to that of the blank without protein.

The number of haems which were bound to the protein and formed haemochrome can be calculated tentatively by the extrapolation of the two linear parts of the observed curve. The number of haem-binding groups of the

alkali-denatured protein should therefore be twice the number of bound haem molecules. The results of this type of experiment with various kinds of protein are summarized in Table 3. In the case of haemoglobin, apparently

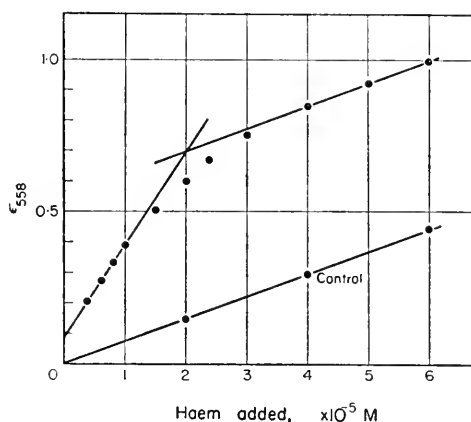

FIG. 8. Haemochrome formation of alkali-denatured haemoglobin with added haem. In this Fig., and in Figs. 10 and 12, the haem concentrations shown on the abscissa are amounts added, over and above the haem associated with the original denatured haemoglobin.

TABLE 3. BASIC AMINO ACID CONTENT AND THE HAEM BINDING GROUPS

Amino acids (moles/mole protein)	Horse myoglobin	Bovine cytochrome <i>c</i>	Horse haemoglobin	Bovine serum albumin	Human serum globulin
Histidine	9	3	36	18	25
Arginine	2	3	14	24	43
Lysine	18	18	38	57	86
Tryptophan	2	1	5	2	22
NH <sub>3</sub> -N	8	(8)	36	43	124
Total (A)	39	33	129	144	300
Haem-binding groups found (B)	16	10	68	27	32
B/A (%)	41 %	33 %	53 %	19 %	11 %

53% of the total nitrogen-base residues of the globin moiety can bind haem and the number is far beyond the total histidine content of haemoglobin. The results of these experiments are rather surprising when we recall that the affinity of haem to various amino acids is usually not so high, and especially that almost no haemochrome can be obtained by the reaction of free haem and free amino acids at such a high pH as used in the present experiments.

In other words, the affinity for haem of nitrogen of amino acids appears to increase when amino acids are integrated into larger polypeptides.

This was confirmed by our experiments with the digested protein molecule. Haemoglobin was digested with pepsin and samples of the digestion mixture were taken at different time intervals and tested for their haem binding affinity.

The results are shown in Fig. 9. The haem-binding affinity of the digested haemoglobin decreases sharply following the time course of the digestion. Also the time curve of the decrease of the haem-binding affinity is almost

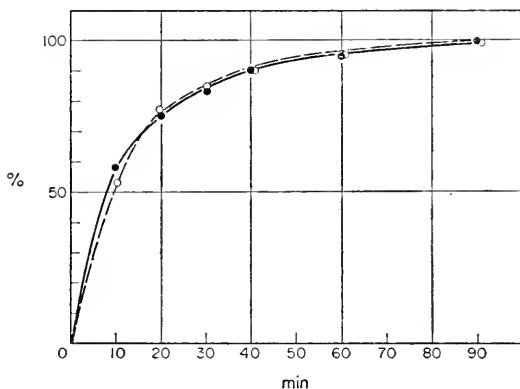

FIG. 9. Effect of pepsin digestion on the haem-binding affinity of haemoglobin. (---○---): per cent digestion of haemoglobin (measured by Folin test); (-●-): per cent decrease of the haem-binding affinity. Haemoglobin was digested by pepsin at pH 2.6, 30°C.

parallel with that of the digestion as judged by the intensity of the Folin reaction. Similar results were obtained also with trypsin-digested cytochrome *c*. These results suggest that the stability of a haemoprotein as a complex of haem and native apoprotein depends principally upon the haem being bound to a sufficiently large peptide molecule. The secondary structure of the protein moiety may also contribute to the stability as well as to the specificity of individual haemoproteins.

In this type of experiment, cytochrome *c* is of special interest because it is very resistant to higher pH. As shown in Fig. 10, slopes of the initial part of curves of the optical density change are different according to the difference in pH of the reaction mixture.

Taking the haem binding groups obtained at the highest pH to be 100%, the percentage of haem binding groups which is available at each pH was calculated and plotted against pH. The results are shown in Fig. 11. The curve coincides approximately with the theoretical curve of a first order reaction. We do not know, however, whether the curve of Fig. 11 is a reflection of the extent of unfolding of the cytochrome *c* molecule at different pH

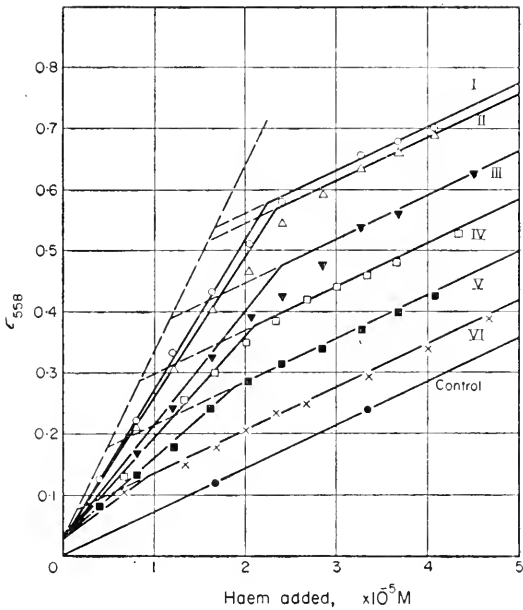

FIG. 10. Effect of pH on the affinity of cytochrome *c* for added haem. Cytochrome *c* concentration:  $3.3 \times 10^{-6}$  M. pH for I, 14.0; II, 13.3; III, 12.57; IV, 12.05; V, 11.8; VI, 11.3. The broken line indicates the concentration curve of alkali-denatured globin haemochrome.

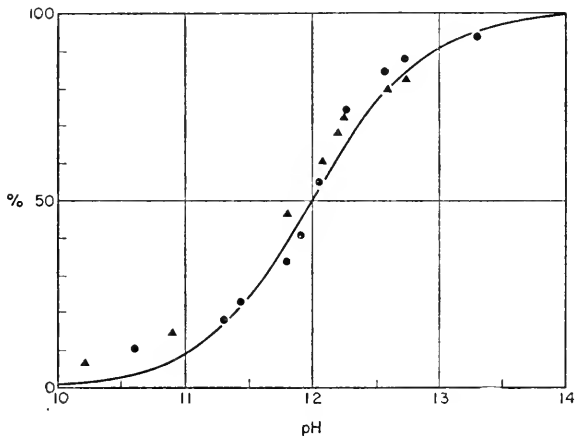

FIG. 11. pH dependence of the affinity of cytochrome *c* for added haem. Haem was added at each pH and the extinction was read (●). Haem was added to alkali-denatured cytochrome *c* at pH 13.3, and the extinction read at each pH (▲). The sigmoid curve is for a first order reaction having a pK value of 12.0.



values, or of the difference of affinity for haem of nitrogen bases of the unfolded cytochrome *c* molecule at different pH's. It was found also that the number of haem-binding groups of cytochrome *c* decreased when the molecule

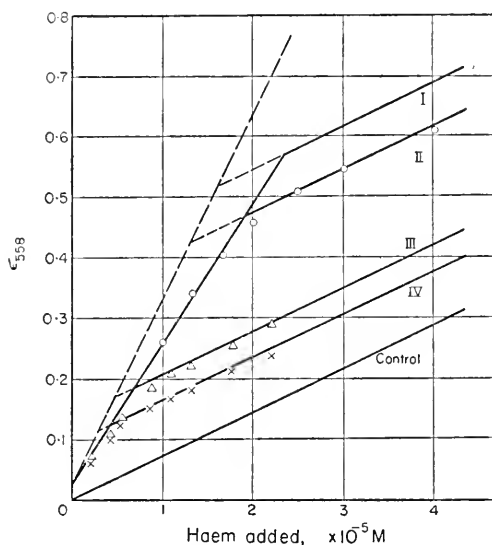

FIG. 12. Effect of acetylation of the cytochrome *c* molecule on its affinity for haem. Cytochrome *c* concentration,  $3.3 \times 10^{-6} M$ . I, non-acetylated; II, 25% acetylated; III, 80% acetylated; IV, 89% acetylated. The reaction was carried out at pH 13.2. Percentages of acetylated amino groups of cytochrome *c* were estimated by the DNP-method. The broken line indicates the concentration curve of alkali-denatured globin haemochrome.

was acetylated as shown in Fig. 12. The data suggest that chemical groups of cytochrome *c* which bind with added haem may be  $\epsilon$ -amino groups of lysine.

#### SUMMARY

It was shown that the haem-haem interaction, the Bohr effect and the affinity for ethyl isocyanide of haemoglobin were independent of each other and were affected in different ways by urea.

The addition of various carboxylic acid salts and detergents to haemoglobin and cytochrome *c* caused modification of the secondary protein structure and alteration of the proper functioning of the haemoproteins. These changes were shown to proceed stepwise.

The affinity of basic amino acids for haem appeared to increase when the acids were integrated into larger peptide molecules.

These studies provide evidence of the importance of the secondary structure of the protein moieties of haemoproteins for their specific functions.

## REFERENCES

- ANSON, M. L. & MIRSKY, A. E. (1929). *J. gen. Physiol.* **13**, 129.  
 ANSON, M. L. & MIRSKY, A. E. (1934). *J. gen. Physiol.* **17**, 399.  
 HILL, A. V. (1910). *J. Physiol.* **40**, 4.  
 HOLDEN, H. F. (1947). *Aust. J. exp. Biol. med. Sci.* **25**, 47.  
 KAJITA, A. (1956a). *J. Biochem. Tokyo* **43**, 243.  
 KAJITA, A. (1956b). *J. Jap. biochem. Soc.* **28**, 290.  
 KAJITA, A., UCHIMURA, F., MIZUTANI, H., KIKUCHI, G. & KAZIRO, K. (1959). *J. Biochem. Tokyo* **46**, 593.  
 KIKUCHI, G. & TOMIMURA, T. (1954). *J. Biochem. Tokyo* **41**, 503.  
 OKAZAKI, T. & TSUSHIMA, K. (1959). *J. Biochem. Tokyo* **46**, 433.  
 RUSSELL, C. D. & PAULING, L. (1939). *Proc. natl. Acad. Sci. Wash.* **25**, 517.  
 RIGGS, A. F. (1952). *J. gen. Physiol.* **36**, 1.  
 ST. GEORGE, R. C. C. & PAULING, L. (1951). *Science* **114**, 629.  
 SUZUKI, M., TOMIMURA, T. & MIZUTANI, H. (1956). *J. Biochem. Tokyo* **42**, 99.  
 TSUSHIMA, K. (1954a). *J. Biochem. Tokyo* **41**, 215.  
 TSUSHIMA, K. (1954b). *J. Biochem. Tokyo* **41**, 359.  
 TSUSHIMA, K. & KAWAI, M. (1956). *J. Biochem. Tokyo* **43**, 13.  
 TSUSHIMA, K. (1956a). *J. Biochem. Tokyo* **43**, 235.  
 TSUSHIMA, K. (1956b). *J. Biochem. Tokyo* **43**, 509.  
 TSUSHIMA, K. & MIYAJIMA, T. (1956). *J. Biochem. Tokyo* **43**, 761.  
 WARBURG, O., NEGELEIN, E. & CHRISTIAN, W. (1929). *Biochem. Z.* **214**, 26.  
 WYMAN, J. JR. (1948). *Advanc. Protein Chem.* **4**, 407.

## DISCUSSION

*The Haem-binding Groups in Haemoproteins***The Nature of Haem-binding, and the Bohr Effect**

By J. H. Wang and Y. N. Chiu (Yale)

WANG: I would like to suggest a possible interpretation of the extremely interesting results found by Kaziro and Tsushima that while native haemoglobin shows a Bohr effect in its reactions with both oxygen and alkyl isocyanide, myoglobin and urea-denatured haemoglobin show the Bohr effect only in their reactions with oxygen and not with alkyl isocyanide.

For convenience of the present discussion we may arbitrarily divide the low-spin complexes of haem into two classes: (1) Those in which "back- $\pi$ -bonding" contributes substantially to the thermodynamic stability of the complex, and (2) those in which "back- $\pi$ -bonding" is much less important for the ground state of the complex. Complexes formed by combining haem with CO, NO and presumably O<sub>2</sub> belong to the first class. If we use  $K_1$  and  $K_2$  to denote the formation constants for the complexes  $L$ -haem-OH<sub>2</sub> and  $L$ -haem- $L$ , i.e.,

$$K_1 = \frac{[L\text{-haem-OH}_2]}{[\text{H}_2\text{O-haem-OH}_2][L]} \quad K_2 = \frac{[L\text{-haem-}L]}{[L\text{-haem-OH}_2][L]}$$

where  $L$  represents the ligand, we have  $K_1 \gg 4K_2$  for complexes of the first class. Complexes formed by combining haem with ammonia, pyridine, imidazole, etc., belong to the second class, for which  $K_1 < 4K_2$ . The complex  $\text{^-NC-haem-CN^-}$  may be an intermediate case.

St. George and Pauling (*Science*, **114**, 629, 1951) found that each haem can combine with two alkyl isocyanides and that complexes of the type RNC-haem-CNR are probably even more stable than the corresponding monoisocyanide complex RNC-haem-OH<sub>2</sub>. This observation indicates that "back- $\pi$ -bonding" does not contribute substantially to the thermodynamic stability of these complexes, i.e., the binding of alkyl isocyanide by haem is essentially that represented by structure A.

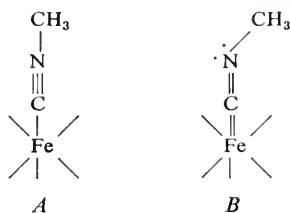

This conclusion is not entirely unexpected, because we cannot use a linear combination of  $\psi_A$  and  $\psi_B$  to represent the actual bonding since structures *A* and *B* involve different nuclear positions. Our conclusion that *A* is energetically favoured is supported by the electron diffraction finding that methyl isocyanide is essentially a linear molecule (Gordy and Pauling, *J. Amer. chem. Soc.* **64**, 2952, 1942). Presumably the binding of ethyl isocyanide by myoglobin and urea-denatured haemoglobin is also essentially represented by structure *A*. If we adopt the assumption that "back- $\pi$ -bonding" is also the main cause of the Bohr effect, we would expect the binding of isocyanide by haem, myoglobin and urea-denatured haemoglobin respectively to be practically independent of pH.

On the other hand, alkyl isocyanide may be just one of those borderline cases where the energy difference between structures *A* and *B* is so small that even additional secondary interaction in the system could reverse the relative stability of these two structures. This suggests an attractive possible explanation of Kaziro and Tsushima's data (this volume, p. 100). If we assume, as illustrated above, that the binding site in native haemoglobin is so crowded with the hydrophobic part of the protein that the isocyanide molecule will have to push the haem and the protein apart somewhat in order to be bonded, then the secondary interactions at the binding site may actually reverse the relative stability of *A* and *B*. Because of these secondary interactions, it is conceivable that the overall  $\Delta F^\circ$  for the ethyl isocyanide to be bonded like *B* above may be larger than that for *A*, and consequently it exhibits the Bohr effect. The structures near the binding site in myoglobin and urea-denatured haemoglobin respectively are probably much less rigid, and hence the advantage of structure *B* disappears, so does the Bohr effect.

**KAZIRO:** I am afraid Wang must have misunderstood my paper. In fact myoglobin shows no Bohr effect with either oxygen or alkylisocyanide. Further, one cannot test whether urea-denatured haemoglobin shows a Bohr effect in  $O_2$ , because of its great autoxidizability.

**WANG:** The existence of a weak Bohr effect in the oxygenation of myoglobin was shown by Theorell (*Biochem. Z.*, **268**, 55, 1934). His data are also supported by the results obtained by Chiu and Spencer in my laboratory on the combination of carbon monoxide with myoglobin which showed a definite Bohr effect though not as pronounced as in the case of haemoglobin. My remark on the contrasting behaviour of ethyl isocyanide and oxygen respectively toward myoglobin was based on the combined information obtained from the present work and Theorell's data.

**DRABKIN:** I would like to mention that some twenty years ago (in the *J. Biol. Chem.* and *Proc. Soc. Exp. Biol. Med.*), I made brief reports both upon the combination of haem with denatured proteins (haemoglobin, albumin, peptones) with findings similar to the present (and Zeile preceded me in this area), as well as upon the influence of 4 M urea on denaturation with alkali. Haemoglobin in 4 M-urea was found to be denatured 60 times faster than in the absence of urea. Myoglobin, exceedingly stable towards alkali, was denatured about 1000 times faster than in aqueous solution. Urea unfolds the molecule and exposes susceptible groups even in the case of myoglobin, which of course is of lower molecular weight than haemoglobin and contains one, not four, iron atoms per molecule.

**WANG:** Willians' work on  $Fe^{++}$ -dimethylglyoxime complexes has certainly widened our understanding of the structure of haem and related compounds. But in addition to

the similarities, there are also important differences between these two classes of compounds.

I wonder if his evidence against the imidazole hypothesis actually reflects an overlooked structural difference between oxy- or carboxyhaemoglobin and the other complexes. Recent studies by Y. N. Chiu and myself on the pH-dependence of the reaction between carbon monoxide and haem adsorbed on poly-1-vinylpyrrolidone showed a pronounced Bohr effect when histidine was used as the sixth ligand, but no apparent Bohr effect when pyridine or water was used as the sixth ligand as expected from the Pauling-Coryell hypothesis.

#### Models for Linked Ionizations in Haemoproteins

By P. George, G. I. H. Hanania, D. H. Irvine and N. Wade (Philadelphia)

GEORGE: With reference to linked ionizations in haemoproteins, it is remarkable how few data there are for simple co-ordination compounds possessing an ionizing group in the vicinity of the co-ordination centre, that can serve as a guide to the change in  $pK$  that might be expected when such a ligand is bonded to a metal.

Hanania and Irvine (*Nature, Lond.* 183, 40, 1959) have recently carried out an investigation of pyridine-2-aldoxime and its ferrous complex, rather similar to that reported by Williams on  $\text{Fe}(\text{DMG})_2(\text{imid})_2$ , and have obtained complete thermodynamic data for the ionization of the oxime OH-group in both the free ligand and the complex.

Consideration of the structure of the ferrous complexes shows how resonance stabilization would favour the formation of the anion, and an increase in acid strength would therefore be expected; but no quantitative predictions can be made. The free oxime has  $pK = 10.2$  at  $25^\circ\text{C}$  and  $I = 0$ :  $\Delta H^\circ = 6.0$  kcal/mole and  $\Delta S^\circ = -26$  e.u. In the  $\text{Fe}^{++}$ -tris-pyridine-2-aldoxime complex the ionization of the third oxime group occurs with a  $pK$  of about 7.0 so that in both cases the charge change is from zero to  $-1$ , and the ionizations are therefore strictly comparable. For the ionization of the group in the complex  $\Delta H^\circ = 1.4$  kcal/mole and  $\Delta S^\circ = -27$  e.u. Hence, on co-ordination, the acid strength of the oxime OH-group is increased by about 3 pH units, corresponding to a favourable change in the free energy of ionization of 4.3 kcal/mole. It is particularly interesting that this increase is borne almost entirely by the change in  $\Delta H^\circ$ : as can be seen the entropies of ionization are nearly identical.

Turning now to haem-linked ionizations in haemoproteins, Hanania, Wade and I have recently been studying the pH variation of the equilibrium constant for the formation of the imidazole complex of ferrimyoglobin. Russell and Pauling (*Proc. nat. Acad. Sci.* 25, 517, 1939) published a few results on the ferrihaemoglobin derivative, and reported a  $pK$  of about 9.5 for the NH ionization. From an analysis of our data we find the  $pK$  for the ferrimyoglobin complex to be about 10.0 at  $25^\circ\text{C}$ . The ionization can be represented as follows:

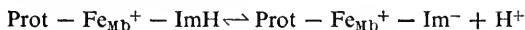

where ImH stands for the neutral imidazole molecule and  $\text{Im}^-$  for the anion. From spectrophotometric measurements in the region 225 to 250  $m\mu$ , we have found a  $pK$  value lying between 13 and 13.5 for the corresponding ionization in the free ligand; i.e.



Hence, on co-ordination of the glyoxalium N-atom to the Fe of ferrimyoglobin, the acid strength of the imino NH group increases by about 3 to 3.5 pH units. This change is very similar to that found by Hanania and Irvine (*loc. cit.*) for pyridine-2-aldoxime and its ferrous complex, and we are extending the measurements to obtain the  $\Delta H^\circ$  and  $\Delta S^\circ$  values.

The  $pK$  values for the haem-linked ionization in ferrimyoglobin derivatives lie between 6 and 7 (George and Hanania, *Disc. Faraday Soc.* 20, 216, 1956). Thus, if the group responsible is to be identified as the imino NH group of a histidine residue,

the present findings require that its acid strength should be increased by about 7 pH units as compared to the ionization in the free ligand, and by about 4 pH units compared to the ionization of the group in the imidazole complex. Although they do not render it inconceivable, these data cast doubt on the imidazole hypothesis as far as it is invoked to explain the linked ionization effects. It could well be that the haem is co-ordinated to a histidine residue, but the linked effects arise through the ionization of another group entirely.

CHANCE: In Kaziro's Figs. 4 and 6 (this volume, p. 80) it would appear the reaction with oxygen occurs with a considerably smaller extent of structural degradation than is needed for reaction with carbon monoxide. This agrees with the observation that autoxidation occurs at higher values of pH than does reaction with CO (Chance and Paul, unpublished observations). It seems to me that the differences are sufficiently great to raise the question of whether oxygen reacts to cause autoxidation at the same site as does CO. In view of spectroscopic evidence, we can accept that CO combines with the iron atom. Thus the oxygen reaction may occur elsewhere, perhaps at a histidine group.

LEMBERG: At my suggestion, Kaziro has used the term 'modification' for the type of change discussed in his paper. I feel that this is preferable to the term 'perturbation', suggested by Holden (*Aust. J. exp. Biol. med. Sci.* **25**, 47, 1947).

KAZIRO: I agree. I have frequently used 'perturbation' in publications, but the term has not yet found general acceptance.

# ON THE STABILITY OF OXYHAEMOGLOBIN

By J. H. WANG

*Sterling Chemistry Laboratory, Yale University, Connecticut*

It is well known that in the absence of oxygen, haem and haemochromes combine reversibly with carbon monoxide. But these carbon-monoxihaem compounds are rapidly oxidized when their aqueous solutions are exposed to air. By analogy it is generally inferred that free haem also combines with molecular oxygen, but the resulting 'oxyhaem' is so unstable in aqueous solutions that it immediately goes over to the  $\text{Fe}^{+++}$ -state.

Previous infra-red and magnetic studies (Wang, Nakahara and Fleischer, 1958) show that there is no detectable difference in the nature of the primary valence which binds the carbon monoxide molecule to haemoglobin and haem respectively. Quantitative equilibrium measurements show that the standard free energy of formation,  $\Delta F^\circ$ , of carbonmonoxihaem from carbon monoxide and haem is only about 2 kcal/mole higher than that of carboxihaemoglobin. This value is clearly too small to account for the much greater resistance of oxyhaemoglobin and carboxihaemoglobin toward oxidation by molecular oxygen as compared to 'oxyhaem' and carbonmonoxihaem respectively. In fact the standard free energy of formation of the complex pyridine-haem-carbon monoxide is even closer to that of carboxihaemoglobin (Nakahara and Wang, 1958).

On the other hand, one could attempt to attribute the stability of oxyhaemoglobin to the greater stability of the  $\text{Fe}^{++}$ -state (relative to the  $\text{Fe}^{+++}$ -state) in haemoglobin as compared to that in free haem. For example, at pH 8 and  $25^\circ\text{C}$  the standard potential of the couple

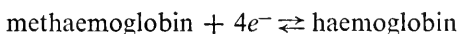

is 0.3 V higher than that for the couple

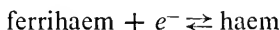

(Barron, 1937; Havemann, 1943). However, the standard potential of the couple

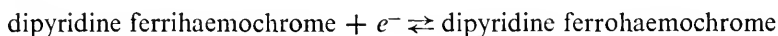

is about the same as that of haemoglobin, and yet it is a known fact that aqueous solutions of haemochromes, whether in monomeric form or

incorporated in poly-1-vinyl-4-pyrrolidone by copolymerization, are rapidly oxidized on exposure to air. Thus the greater reduction potential of methaemoglobin is, by itself, inadequate to explain the observed stability of oxyhaemoglobin.

The oxidation of haem by molecular oxygen may take place through one or more reaction paths. If the initial step of the oxidation involves the formation of 'oxyhaem' followed by the decomposition of the latter to ferrihaem and  $O_2^-$  or  $HO_2$ , one would expect the subsequent reduction of  $O_2^-$  or  $HO_2$  by other haem molecules to be comparatively fast. Consideration of coulombic interactions would predict the decomposition of 'oxyhaem' to ferrihaem and  $O_2^-$  or  $HO_2$  to be slow in non-acidic media of low dielectric constant. Thus if one assumes that the binding sites in haemoglobin are not completely exposed to water but are largely covered with hydrophobic groups of the protein, one would expect the decomposition of oxyhaemoglobin to methaemoglobin and  $O_2^-$  or  $HO_2$  to be much slower than the corresponding process for a freely exposed 'oxyhaem'. But one would expect the dissociation of such a protected 'oxyhaem' back to haem and molecular oxygen to be practically unhindered, although decomposition to products with net charge or high polarity would be retarded by the comparatively non-polar nature of the local environment. On the other hand, if the rate-determining step is a two-electron oxidation involving two haem molecules, then these protective hydrophobic structural elements could also effectively prevent the transfer of electron between the two haem groups and hence retard the oxidation.

## RESULTS AND DISCUSSION

In order to check the above hypothesis, synthetic models were made by embedding the derivatives of haem in a lyophobic matrix (Wang, 1958). The  $Fe^{++}$ -ion in each haem group was bound firmly on one side of the haem plane to a ligand molecule; on the other side, it was bound only loosely to another ligand molecule. These embedded haem groups combine reversibly with molecular oxygen, stable even in the presence of water.

These model materials were made by first preparing a solution of 1-(2-phenylethyl)-imidazole-carbonmonoxy-haem diethyl ester in benzene containing dissolved polystyrene and an excess of 1-(2-phenylethyl)-imidazole, drying in a warm stream of carbon monoxide, and then removing the bound carbon monoxide molecules by prolonged evacuation or flushing with an inert gas at room temperature. The resulting bright-red, transparent film showed a haemochrome-type of spectrum which varied somewhat with the composition of the matrix.

The spectra of a film made by imbedding such haem derivatives in a matrix of 25% polystyrene and 75% 1-(2-phenylethyl)-imidazole are shown in Fig. 1. The oxygenation is, within experimental uncertainties, quantitatively reversible.

The films with more than 90% polystyrene-content oxygenate and deoxygenate more slowly. The oxygenation property of these high polystyrene-content films can be destroyed by heating at 70–80°C for an hour in an inert atmosphere. This 'denatured' film can be reactivated by heating in carbon monoxide atmosphere at 70–80°C for several hours, cooling to room temperature, and then removing the bound carbon monoxide by prolonged flushing with nitrogen or by evacuation. The structures of the active centres in a high polystyrene-content film at various stages of this process are depicted in Fig. 2

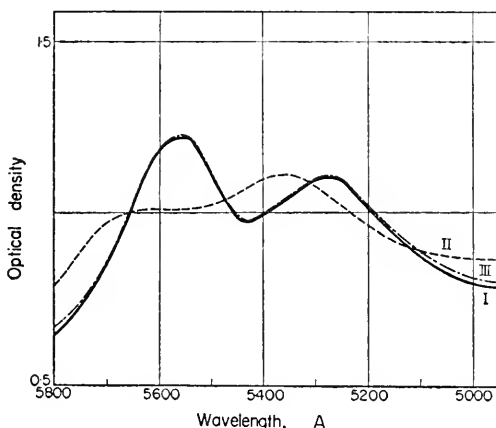

FIG. 1. Spectra of a low polystyrene-content film with embedded haem groups. Curve I, initial film, flushed with nitrogen gas for 3 hr 20 min after it was made to remove the bound carbon monoxide; Curve II, the film was then flushed with oxygen gas for 10 min; Curve III, the oxygenated film was then flushed 2 hr 10 min with nitrogen gas.

together with their absorption spectra. It is suggested in Fig. 2 that after the film is activated by removing the bound carbon monoxide, the second imidazole group at each active centre is only weakly bound to the  $\text{Fe}^{++}$ -ion because of the constraint due to the solid-like matrix. Consequently this second imidazole group can be readily replaced even by a weak ligand such as the oxygen molecule on exposure to air. By heating in an inert atmosphere, the solid-like matrix softens. This allows the second imidazole group to diffuse, within a short time, to the right position and orientation to form a stable co-ordination bond to the  $\text{Fe}^{++}$ -ion with maximum overlap of the atomic orbitals. Consequently this 'denatured' film shows a sharper haemochrome-type of spectrum, and is unable to combine with molecular oxygen.

These results strongly support the hypothesis that the binding sites in haemoglobin are largely covered with hydrophobic groups of the protein, that each  $\text{Fe}^{++}$ -ion is strongly bound to, presumably, an imidazole group on one side of the haem plane, but is only loosely attached to another ligand on the other side of the haem. This hypothesis is also consistent with the observed



behaviour of alkyl isocyanides (St. George and Pauling, 1951; Lein and Pauling, 1956), imidazole and pyridine toward haem and haemoglobin respectively. Perhaps even more striking is the reaction of cyanide ion with haem and haemoglobin. The cyanide ion is isoelectronic with the carbon monoxide molecule. It has been mentioned above that haemoglobin binds carbon monoxide slightly more strongly than free haem does. But the observed affinity of haemoglobin for cyanide ion is, on the contrary, very much smaller than that of free haem, corresponding to a ratio of about

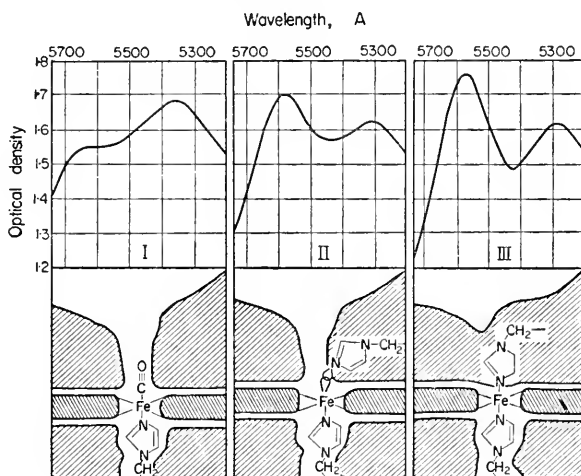

FIG. 2. Spectra and structural diagrams of a high polystyrene-content film at various stages of the experiment. Curve I, spectrum of the film saturated with carbon monoxide; Curve II, spectrum of the active form of the film; Curve III, spectrum of the same film after thermal denaturation. The schematic diagram under each curve represents the structure of the active centre at the corresponding stage of the experiment.

$1:10^5$  in the formation constants of the respective complexes (Callaghan, 1949; Stitt and Coryell, 1939). Since the cyanide ion and the carbon monoxide molecule have almost identical size and shape, the observed contrasting behaviour of haemoglobin and free haem toward carbon monoxide and cyanide ion respectively cannot be explained in terms of simple steric factors. But if it is assumed that the combining site in haemoglobin is covered with hydrophobic structural elements of the globin, then the free energy of formation of the cyanide complex should be greater than that for an exposed haem by an amount equal to the electrical work required to bring the charged cyanide ion from an environment of higher to one of lower dielectric constant. If the average dielectric constant of the surroundings of the combining site in haemoglobin is considerably lower than that for free haem, this work could be sufficient to account for the difference in the formation constants of the two cyanide complexes.

The present hypothesis only requires the immediate environment of the combining site in haemoglobin or myoglobin to have a low dielectric constant; it is generally non-committal regarding the other side of the haem plane except that there should be a strong ligand, presumably an imidazole group, snugly co-ordinated to the  $\text{Fe}^{++}$ -ion of the haem.

#### SUMMARY

(1) The existing physico-chemical data on haemoglobin and haem are examined, and a hypothetical structure for the combining sites in haemoglobin is proposed to account for the stability of oxyhaemoglobin.

(2) A synthetic model is made which oxygenates reversibly, is stable in the presence of water, and can be 'denatured' and reactivated by proper treatments.

(3) A molecular interpretation of the properties of this synthetic model is suggested, and its implication on the haemoglobin problem is discussed.

#### Acknowledgement

This work was supported in part by a grant (USPHS-RG-4483) from the Division of Research Grants, U.S. Public Health Service.

#### REFERENCES

- BARRON, E. S. G. (1937). *J. biol. Chem.* **121**, 285.  
 CALLAGHAN, J. P. (1949). *Hematin Compounds and Bile Pigments*, Lemberg, R. & Legge, J. W., p. 189. Interscience, New York.  
 LEIN, A. & PAULING, L. (1956). *Proc. nat. Acad. Sci. Wash.* **42**, 51.  
 HAVEMANN, R. (1943). *Biochem. Z.* **314**, 118.  
 NAKAHARA, A. & WANG, J. H. (1958). *J. Amer. chem. Soc.* **80**, 6526.  
 ST. GEORGE, R. C. C. & PAULING, L. (1951). *Science*, **114**, 629.  
 STITT, F. & CORYELL, C. D. (1939). *J. Amer. chem. Soc.* **61**, 1263.  
 WANG, J. H., NAKAHARA, A. & FLEISCHER, E. B. (1958). *J. Amer. chem. Soc.* **80**, 1109.  
 WANG, J. H. (1958). *J. Amer. chem. Soc.* **80**, 3186.

#### DISCUSSION

##### *Oxygenation of Haemoglobin*

DRABKIN: I should like to ask Wang two questions:

(1) Are your films 'dehydrated'? Haurowitz (at the Barcroft Memorial Symposium) postulated that a molecule of  $\text{H}_2\text{O}$  had to be co-ordinated with the Fe before haemoglobin could be oxygenated. Is his reported finding at all related to your spectroscopic findings?

(2) Do your studies shed light on what happens to the protein (globin) when haemoglobin is denatured?

LEMBERG: My remarks are also directed to Wang.

(1) The spectrum of your reduced film in nitrogen is rather a ferrohaemochrome spectrum than that of a ferrohaemoglobin.

(2) Would it not be advisable to use an imidazole not substituted on the nitrogen? A nitrogen-substituted imidazole appears to me a type of compound very different from an imidazole compound like histidine in the peptide chain.

WANG: Dehydration has little effect on the spectroscopic and oxygenating properties of our films. But this could be due to the fact that our films are so hydrophobic that they contain little water even before dehydration. Haurowitz's result is suggestive that the sixth ligand in haemoglobin is water. He may be right, but I do not consider his arguments as conclusive, since the conceivable structural changes in haemoglobin caused by dehydration may release an imidazole group which has hitherto been unavailable for close co-ordination because of constraints in the protein structure.

(2) I hope that our denaturation experiments show some interesting resemblance to the denaturation of haemoglobin. But there are also important inherent differences between our film and haemoglobin. I hope that you will not carry the rather interesting analogy too far.

LEGG: An old observation made by Robin Hill may be worth following up in relation to the molecular environment around the haem or haemoglobin. The addition of oxyhaemoglobin to chilled, concentrated KOH leads to the formation of a haemochrome which, however, reverts to the native ferrous pigment when cautiously neutralized with  $\text{NH}_4\text{Cl}$ . It may perhaps be easier to measure rates of autoxidation and equilibria with ligands in such a system than in the analogous system (Zeyneck, Haurowitz) where haemochrome formation is produced by removing water from dried haemoglobin. Hill's system is at any rate a 'model' which appears to revert to the original.

GEORGE: There is ample kinetic evidence showing that the oxidation of ferrohaemoglobin and ferromyoglobin to the ferric state by molecular oxygen are very complicated chemical reactions. Although a free radical mechanism with single-equivalent steps can be set up that leads to the observed rate equation it is more likely that two-equivalent steps are involved (George, *J. chem. Soc.* 5436, 1954).

An important feature, however, that undoubtedly contributes to the stability of oxyhaemoglobin and oxymyoglobin toward electron-transfer fission is the exothermicity of the formation of the oxygen complexes. Estimations of the ionization potential of ferrohaemoglobin and ferromyoglobin in aqueous solution (Hanania, Ph.D. Thesis, Cambridge, 1953) indicate that the reaction



is endothermic: as a consequence, activation energy equal to or greater than this endothermicity must be supplied for the reaction to occur. Now from a comparison of reaction (1) with the electron transfer fission of the complex as in reaction (2)

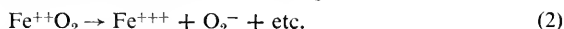

it can be seen that if  $\text{Fe}^{++}\text{O}_2$  is formed in an exothermic reaction from  $\text{Fe}^{++}$  and  $\text{O}_2$ , then the endothermicity of reaction (2) will be this much greater than that of reaction (1). Since the exothermicity is at least 10 kcal/mole, this would make a very significant contribution to the stability toward oxidation of ferrohaemoglobin and ferromyoglobin relative to other ferrohaemoproteins and haem derivatives that might otherwise have similar ionization potentials but not be capable of forming oxygen complexes in exothermic reactions (George and Stratmann, *Biochem. J.* 51, 418, 1952).

LEMBERG: Myoglobin is more autoxidizable, more accessible to cyanide in its ferrous form, and more ready to form mixed haemochromes with nitrogenous ligands than haemoglobin. Its lyophobic matrix would therefore appear to be less dense.

WANG: The nature of bonding between the oxygen molecule and haemoglobin in oxyhaemoglobin has been a subject of controversy for many years. The structures suggested by Pauling and by Griffith respectively are represented by *A* and *B* below.

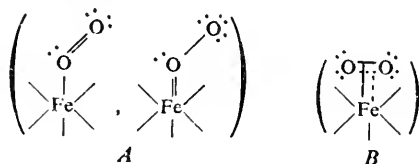

Griffith estimated the ionization potential for  $O_2$  in structure *A* to be 20.9 eV, but that in structure *B* to be 16.6 eV. Consequently he concluded that *B* is the energetically favoured structure (see *Proc. Roy. Soc. A235*, 23, 1956).

However, since part of the bonding electrons in both structures *A* and *B* are from the  $Fe^{++}$ , this problem may be treated by the usual molecular-orbital method. We may recall that in forming the molecular-orbital  $c_1\psi_1 + c_2\psi_2$  from the atomic orbitals  $\psi_1$  and  $\psi_2$ , with energies  $E_1$  and  $E_2$  respectively, the energy  $E$  of the bonding molecular-orbital is

$$E = E_1 - \frac{(\beta - ES)^2}{E_2 - E},$$

where

$$E < E_1 < E_2, \quad \beta = \int \psi_1^* H \psi_2 d\tau, \quad S = \int \psi_1^* \psi_2 d\tau.$$

In order to have effective bonding,  $E_2 - E_1$  must be small,  $\beta$  and  $S$  must be large, and the overlap of this bonding molecular-orbital with occupied non-bonding molecular-orbitals must also be small. Prediction of the relative stabilities of structures *A* and *B* by considering  $E_2 - E_1$  alone and neglecting all the other factors is hazardous. The fact that  $O_3$  has an obtuse rather than acute isosceles-triangular structure indicates that these other factors may indeed be more influential in determining the relative stabilities. (See structures *C* and *D*.)

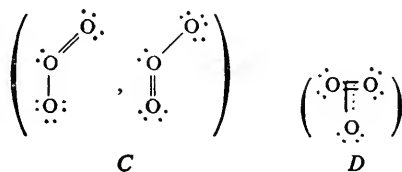

For this reason one should not overlook the possibility that *A* may actually be the energetically more favoured structure, and that consequently structure *B* can exist only when *A* is impossible without drastic rearrangements in the rest of the molecule, such as in the case of ethylene-metal complexes.

ORGEL: This may be a good moment to draw attention to the work of Elvidge and Lever (*Proc. chem. Soc.* 195, 1959) who have shown that manganous phthalocyanine is a reversible oxygen carrier in pyridine. The relevant reaction is probably

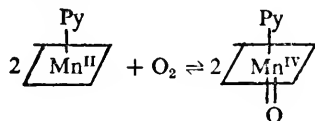

The  $Mn^{IV}$  compound is strictly analogous to the ferryl derivatives suggested by George to be important in various haem reactions. This system could be thought of as a model for oxidase action in which an oxygen molecule is dissociated and the atoms become attached to two different iron atoms—of course there is no evidence for this, but it may be worth considering along with other models.

# FERRIHAEMOPROTEIN HYDROXIDES: A CORRELATION BETWEEN MAGNETIC AND SPECTROSCOPIC PROPERTIES

By P. GEORGE, J. BEETLESTONE AND J. S. GRIFFITH

*Department of Chemistry, University of Pennsylvania, Philadelphia, U.S.A.*

## INTRODUCTION

FERRIHAEMOGLOBIN, ferrimyoglobin, ferriperoxidase and ferricytochrome *c* all undergo ionizations in alkaline solution that are accompanied by significant changes in absorption spectra and magnetic susceptibility. These reactions can be represented simply as



That of ferrihaemoglobin, where the colour changes from chocolate brown to wine red, is the most familiar, and has been known from the earliest days of spectroscopic observations on haemoglobin and haemin by Hoppe-Seyler, Stokes and Gamgee (Gamgee, 1868). The *pK* values which characterize these reactions are listed in Table 1. Ferricatalase, which in complex formation

TABLE 1. *pK* VALUES FOR FERRIHAEMOPROTEIN IONIZATION REACTIONS

Ferrihaemoprotein	Source	<i>pK</i>	Ionic strength	Temp. C.	Reference
Myoglobin	Horse heart	9.04 ± 0.03	1 → 0	20°	George & Hanania, 1952
Haemoglobin	Horse erythrocytes	8.86 ± 0.02	1 → 0	20°	George & Hanania, 1953
Haemoglobin	<i>Chironomus plumosus</i>	8.23	1 → 0	21°	Scheler & Fischbach, 1958
Leghaemoglobin	Soybean	8.25	0.10	22°	Sternberg & Virtanen, 1952
Peroxidase	Japanese radish	9.57	0.10	18°	Morita & Kameda, 1958
Peroxidase	Horseradish	10.9-11.3	—	20°	Theorell, 1942
Cytochrome <i>c</i>	Horse heart	12.8*	—	22°	Theorell & Åkesson, 1941

\* In this case the value of '*n*' for the titration was found to be greater than 1, i.e. 1.64, which may be an indication of additional reactions occurring in the very alkaline solution,

with many ligands resembles the other ferrihaemoproteins, is an exception for no such ionization has been observed. It may well be that the *pK* is so high that protein denaturation sets in before the ionization can take place.

It is generally accepted that these reactions involve the bonding of the hydroxyl ion to the ferriporphyrin iron atom, but the evidence is circumstantial. First, there are many ionizations of aquo-ions and simple co-ordination

compounds in which the bonding of  $\text{OH}^-$  is unequivocal (see Basolo and Pearson, 1958), e.g.

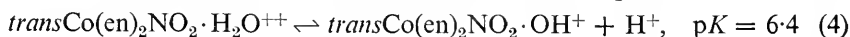
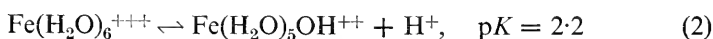

Secondly, the changes in spectrum and magnetic susceptibility when the ferrihaemoproteins ionize are similar to those which accompany the formation of complexes where other ligands such as  $\text{F}^-$ ,  $\text{CN}^-$ ,  $\text{N}_3^-$ ,  $\text{HS}^-$ , etc., are bonded to the iron. Yet the remote possibility that these changes originate in the ionization of a group distant from the iron, but, for instance, connected to it via a conjugated system of double and single bonds, cannot be excluded.

Following the general practice it will be assumed that hydroxides are produced, although the correlation developed in Section IV between spectroscopic and magnetic properties is equally valid provided that the same structural feature is present in the alkaline forms of all the ferrihaemoproteins upon which the calculations are based.

#### THE INTERPRETATION OF THE MAGNETIC MOMENTS OF THE HYDROXIDES ACCORDING TO VARIOUS THEORIES OF THE ELECTRONIC STRUCTURE OF CO-ORDINATION COMPLEXES

Coryell, Stitt and Pauling (1937) were the first to measure the magnetic moment of one of these hydroxides, and obtained 4.47 Bohr magnetons for the ferrihaemoglobin derivative. This value differed in a striking manner, not only from the values found for acidic ferrihaemoglobin and the  $\text{F}^-$  complex, 5.80 and 5.92 B.M., but also from those for the  $\text{CN}^-$  and  $\text{SH}^-$  complexes, 2.50 and 2.26 B.M. These other moments were in close agreement with the theoretical values calculated from the contribution of five and one unpaired electrons respectively. For five unpaired electrons the electronic configuration corresponds to  ${}^6S$  of the free ion, and therefore one expects a magneton number very close to the free spin value of 5.92 (see Table 2) as,

TABLE 2. SPIN MAGNETIC MOMENTS FOR METAL COMPLEXES CONTAINING FROM ONE TO FIVE UNPAIRED ELECTRONS,  $\mu = \sqrt{n(n+2)}$

Unpaired electrons, $n$	1	2	3	4	5
$\mu$ , Bohr magneton	1.73	2.83	3.87	4.90	5.92

for example, in  $(\text{NH}_4)_3\text{FeF}_6$ . For one unpaired electron there is a spatial degeneracy of three, and associated with this a considerable orbital magnetic moment. The observed magneton number for  $\text{K}_3\text{Fe}(\text{CN})_6$  is 2.33 compared with the spin-only value of 1.73, and the large difference is due to the orbital moment combined with effects of the spin-orbit coupling (Howard, 1935;

Kotani, 1949). According to the then current theory, Coryell *et al.* (1937) described the bonding of the iron as essentially ionic in the first group, and essentially covalent in the second group through  $3d^24s4p^3$  orbital hybridization.

It was noted that the intermediate value for the hydroxide corresponded more nearly to the theoretical value for the spin contribution of three unpaired electrons, which would be anticipated for a square planar ferric complex with essentially covalent bonding through  $3d4s4p^2$  orbital hybridization. But since the chemical structure of ferrihaemoprotein complexes requires octahedral co-ordination, it was suggested that while the moment of the hydroxide results from the electronic structure with three unpaired electrons, the four covalent bonds resonate among the six co-ordinated groups.

This interpretation was widely accepted, and was not seriously questioned for many years. In an extensive review of co-ordination compounds, Taube (1952) proposed that the utilization of *d*-orbitals with the next higher principal quantum number might occur in complexes having the high magnetic moments. For example, the bonding in the cyanide complex of ferrihaemoglobin would be attributed to  $3d^24s4p^3$  hybridization as before, but in the fluoride complex to  $4d^24s4p^3$  hybridization, leaving the five unpaired electrons in the *3d*-orbitals unaffected. Taube commented that with certain metal ions a close balance might occur between the energies of these inner and outer orbital complexes, so that with some ligands the complexes would have high magnetic moments, and with others low magnetic moments, e.g.  $K_3CoF_6$ , which is paramagnetic in contrast to the cobaltic amine complexes which are diamagnetic. Coryell, Stitt and Pauling's measurements on haemoglobin derivatives showed that  $Fe^{++}$  and  $Fe^{+++}$  porphyrin compounds come into the same category; and Taube went on to suggest that, since  $OH^-$  is intermediate in polarizability between  $H_2O$  and  $SH^-$ , an alternative explanation for the anomalous magnetic moment of the hydroxide is the presence of inner and outer orbital complexes in equilibrium.

During the last seven years a more detailed understanding of the electronic structure of transition metal compounds has been arrived at using that combination of the molecular orbital method and the simple rigid crystal field method which has come to be known as ligand field theory (see Griffith and Orgel, 1957). Ligand field theory is in many ways more general than Pauling and Taube's schemes which really only discussed directed bond orbitals on the central ion formed from atomic orbitals which were assumed to be unchanged from those in the free ion. On the other hand, because of its close relationship to the simple crystal field model, it preserves to a considerable extent the possibility of making detailed interpretations of the electronic structure and semi-quantitative calculations of experimental quantities.

We use here for convenience, but not necessity, the language of the crystal field theory. Briefly then, for the case of a regular octahedral complex, the five orbitals of the *d*-shell, which have the same energy in the free ion, are

split in the field imposed by six identical ligand groups into a lower set of three orbitals, denoted by  $t_{2g}$ , and an upper set of two orbitals, denoted by  $e_g$ , as shown in Figs. 1a and 1b. The five  $d$ -orbitals have different spatial orientations (regions of high electron density) characterized as far as their angular variation is concerned, by the subscripts  $xy$ ,  $xz$ ,  $yz$ ,  $z^2 - \frac{1}{3}r^2$  and  $x^2 - y^2$ .

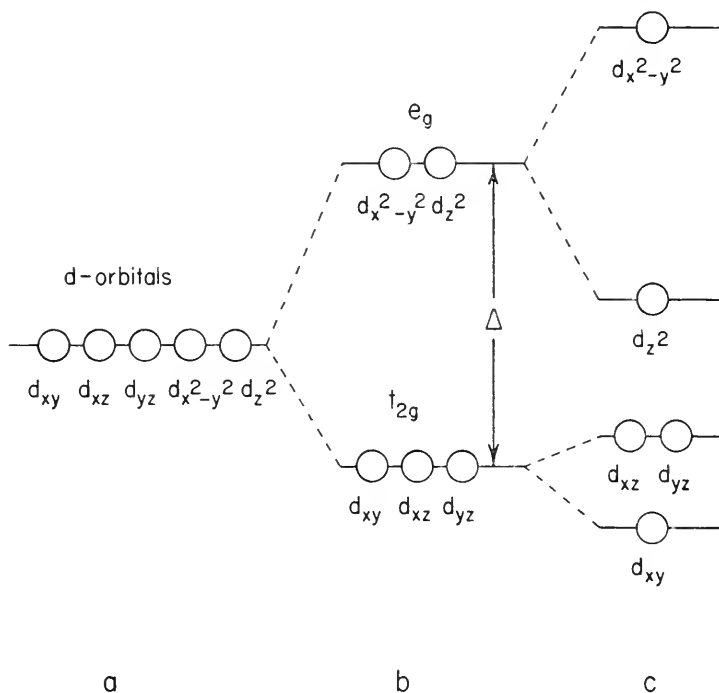

FIG. 1. Schematic illustration of the splitting of the energy level of the five  $d$ -orbitals of the free transition metal ion (a), by a regular octahedral field (b), i.e. six identical ligands, and by an irregular octahedral field (c), i.e. four ligands of one kind equidistant on the  $x$ - and  $y$ -axes, and two other ligands farther away on the  $z$ -axis.

For the first three, these regions lie midway between the axes  $x$  and  $y$ ,  $x$  and  $z$ , and  $y$  and  $z$  respectively, and thus point away from the ligand groups situated equidistantly on the  $x$ -,  $y$ - and  $z$ -axes (see Fig. 2). For the remaining two, i.e.  $z^2 - \frac{1}{3}r^2$  and  $x^2 - y^2$ , these regions lie in the directions of the axes. Hence the energy of an electron in the  $e_g$  orbitals will be substantially increased by the mutual electrostatic repulsion between electron and ligand, and also by molecular orbital effects associated with the overlap (Griffith, 1956b), whereas the energy of an electron in the  $t_{2g}$  orbitals will be much less affected.

When transition metal ions with 4, 5, 6 or 7  $d$ -electrons form regular octahedral complexes, a choice of at least two electronic configurations thus arises. If the electrons distribute themselves between the  $t_{2g}$  and  $e_g$  orbitals



the number of unpaired electrons remains the same, whereas if the lower  $t_{2g}$  orbitals are filled preferentially the number of unpaired electrons is necessarily reduced. For example, with ferrous and ferric complexes the former configuration gives 4 and 5 unpaired electrons, and the latter, zero and 1 unpaired electrons respectively, as shown in Figs. 3a and 3c. The former configuration

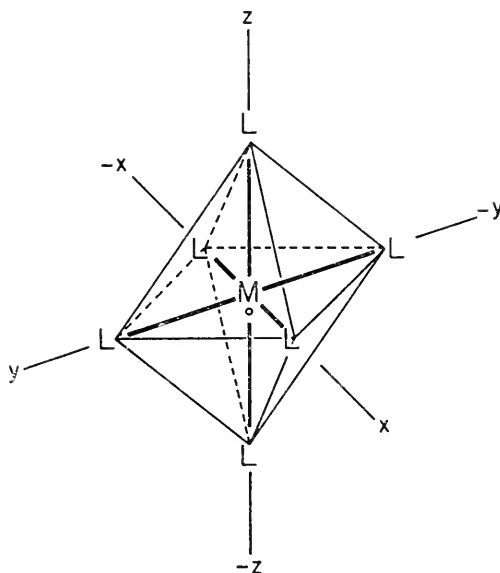

FIG. 2. An octahedral co-ordination complex,  $ML_6$ , showing the  $x$ -,  $y$ -, and  $z$ -axes with respect to which the orientation of the  $d$ -orbitals are defined.

will be favoured if the energy separation,  $\Delta$ , between the  $t_{2g}$  and  $e_g$  orbitals is small (i.e. a weak ligand field), and the latter by a large energy separation (i.e., a strong ligand field). In the latter case the gain in orbital energy, achieved by having the electrons together in the  $t_{2g}$  orbital, is to some extent offset by an increase in the Coulombic repulsion energy, and by a decrease in the quantum-mechanical exchange energy which affords extra stabilization for each pair of electrons with parallel spins. These two effects may be grouped together as 'electron-pairing energy'. Whether a particular complex of a given metal ion has the maximum or minimum number of unpaired electrons depends on the magnitude of this pairing energy and that of the energy separation,  $\Delta$ . The magnetic moments of several complexes, notably those of the cobaltic ion, have been discussed from this point of view (Orgel, 1955; Griffith, 1956a), and, following the suggestion of Griffith and Orgel (1957), the two types will be referred to as 'high-spin' and 'low-spin' complexes respectively.

The co-ordination in haemoprotein compounds is that of an irregular octahedron since the two groups bonded on the  $z$ -axis differ from the four

(identical) pyrrole nitrogen atoms bonded on the  $x$ - and  $y$ -axes. For such complexes the  $t_{2g}$  and  $e_g$  orbitals are split further, perhaps as shown in Fig. 1c. The asymmetry in the field splits the  $e_g$  much more than the  $t_{2g}$  orbitals because the former but not the latter point towards the nearest neighbour atoms. It appears probable from electron resonance measurements that  $d_{xy}$  lies lowest (Gibson and Ingram, 1957; Griffith, 1957),  $d_{x^2-y^2}$  is almost certainly at the top except possibly in some of the low-spin derivatives, but

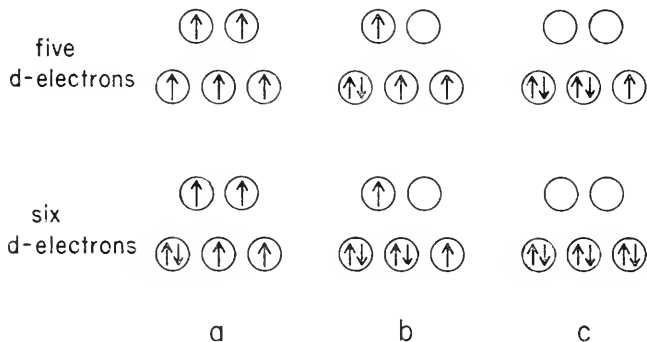

FIG. 3. Schematic illustration of the three ways in which the  $e_g$  and the  $t_{2g}$  orbitals can be occupied in regular octahedral complexes of metal ions containing five and six  $d$ -electrons (e.g. ferric and ferrous complexes).

- Maximum number of parallel spins: ferric 5, ferrous 4.
- Intermediate number of parallel spins: ferric 3, ferrous 2.
- Minimum number of parallel spins: ferric 1, ferrous 0.

the position of  $d_{z^2}$  is less certain. Similar considerations to those mentioned before determine whether electron pairing occurs.

For octahedral complexes of ions with five and six  $d$ -electrons, a third electronic configuration in addition to the two characterizing the high- and low-spin complexes has to be considered. The passage of just one electron from the  $e_g$  orbital to the  $t_{2g}$  orbital results in a configuration with an intermediate number of unpaired electrons, as shown in Fig. 3b. For a ferric complex this configuration with three unpaired electrons corresponds to that envisaged by Coryell, Stitt and Pauling (1937) for ferrihaemoglobin hydroxide. Theoretical treatment has shown however that a configuration of this kind is inherently unstable in the case of regular octahedral complexes. If spin pairing occurs to reduce the number of unpaired electrons from five to three, then further pairing is even more favoured energetically, reducing the number from three to one (Griffith, 1956a, b). Because of the lower symmetry this is not necessarily true for haemoprotein derivatives. However a similar type of argument suggested that it is improbable that there should exist a haemoprotein which possesses derivatives of all the three kinds, high-spin, low-spin and intermediate spin (Griffith, 1956c). Because of the definite existence of the first two this casts doubt on the suggestion that ferrihaemoglobin hydroxide

has three unpaired electrons, and again raised the possibility that it is a thermal mixture of high- and low-spin forms.

Against the background of these developments in electronic theory certain other experimental observations take on added significance.

(1) Taube's comment, that the existence of high- and low-spin derivatives of haemoglobin indicates a close balance between the energies of the two forms in the case of iron porphyrin compounds, is further borne out by the fact that with the same ligand, namely the azide ion, high- or low-spin complexes are formed depending on the particular haemoprotein. The magnetic moment of ferricatalase azide is 5.36 B.M., compared to 2.84 for the ferrihaemoglobin derivative (Deutsch and Ehrenberg, 1952; Coryell, Stitt and Pauling, 1937). A fairly close balance between the energies would be a prerequisite for the two forms to exist in thermal equilibrium.

(2) While the magnetic moment of ferrihaemoglobin hydroxide is 4.47 B.M., just a little in excess of the theoretical value for the spin contribution of three unpaired electrons, the moments of the other ferrihaemoprotein hydroxides are very substantially different, as shown in Table 3. Ferri-

TABLE 3. MAGNETIC MOMENTS OF FERRIHAEMOPROTEIN HYDROXIDES

Ferrihaemoprotein	Source	$\mu$ , B.M.	Reference
Myoglobin	Horse heart	5.11	Theorell and Ehrenberg, 1951
Haemoglobin	Horse erythrocytes	4.47	Coryell, Stitt and Pauling, 1937
Haemoglobin	<i>Chironomus plumosus</i>	4.45	Scheler, Schoffa and Jung, 1957
Peroxidase	Horseradish	2.66	Theorell, 1942
Cytochrome <i>c</i>	Horse heart	2.14	Theorell, 1941

peroxidase and ferricytochrome *c* hydroxides come into the category of low-spin complexes, with moments comparable to those of the CN<sup>-</sup> and SH<sup>-</sup> derivatives; whereas the magnetic moment of ferrimyoglobin hydroxide approaches that of a high-spin complex, the value of 5.11 B.M. being even greater than the theoretical value for the spin contribution of four unpaired electrons. Hence, although the three unpaired electron configuration could still be invoked for ferrimyoglobin, by assuming a large orbital contribution, it is clearly impossible in the case of ferriperoxidase and ferricytochrome *c*.

(3) For a given ligand, the spectra of ferrihaemoprotein complexes usually have absorption bands at approximately the same wavelengths with comparable extinction coefficients, independent of the particular haemoprotein. There are a few exceptions, and among them the hydroxides provide the most striking examples. These spectra show marked variations, exhibiting a regular trend from ferrimyoglobin at one extreme, through ferrihaemoglobin, to ferriperoxidase and ferricytochrome *c* at the other.

In the discussions of electronic structure little use has been made of these observations, and in the following sections it will be shown, first, that the trend in spectroscopic properties parallels the trend in magnetic moments, and secondly, that the data are quantitatively consistent with the view that the hydroxides are thermal mixtures of high- and low-spin forms.

#### QUALITATIVE CORRELATIONS BETWEEN THE MAGNETIC MOMENTS AND THE SPECTRA OF FERRIHAEMOPROTEIN DERIVATIVES

The close resemblance, which has long been recognized, between spectra of the same derivative of different haemoproteins, is illustrated in Figs. 4 to 6

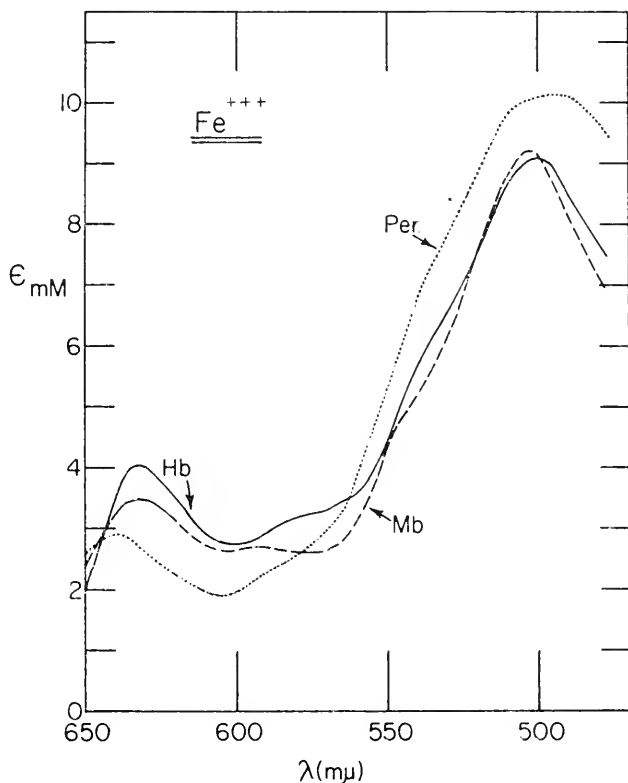

FIG. 4. Visible spectra of acidic ferrimyoglobin, ferrihaemoglobin and ferriperoxidase (Keilin and Hartree, 1951; Hanania, 1953).

in the case of the visible spectra of acidic ferrihaemoproteins and their fluoride and cyanide complexes. Furthermore, all the high-spin ferric complexes have visible spectra like the acidic ferrihaemoproteins and fluoride derivatives, with an absorption band between 600 and 640  $\mu$  and a second

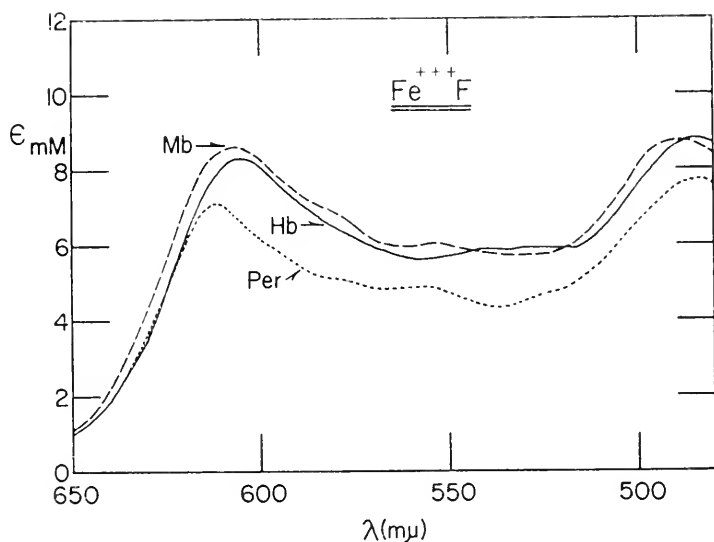

FIG. 5. Visible spectra of ferrimyoglobin, ferrihaemoglobin and ferriperoxidase fluoride (Keilin and Hartree, 1951; Hanania, 1953).

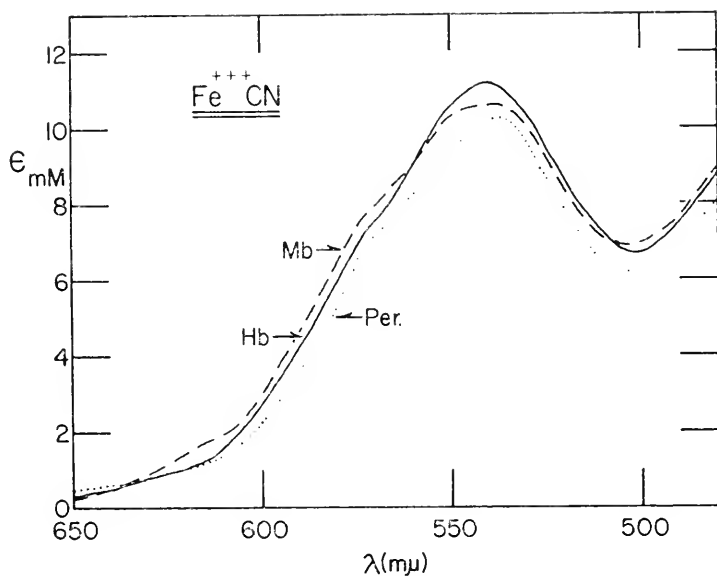

FIG. 6. Visible spectra of ferrimyoglobin, ferrihaemoglobin and ferriperoxidase cyanide (Keilin and Hartree, 1951; Hanania, 1953).

band at about  $500\text{ m}\mu$ ; and all the low-spin ferric complexes have spectra like the cyanide derivatives, with a very pronounced absorption band at about  $540\text{ m}\mu$  and a shoulder, or second band, at about  $580\text{ m}\mu$  (Theorell, 1942). The high-spin complexes have additional minor bands of lower intensity, at about  $580$  and  $540\text{ m}\mu$ , but for the present it is the positions of

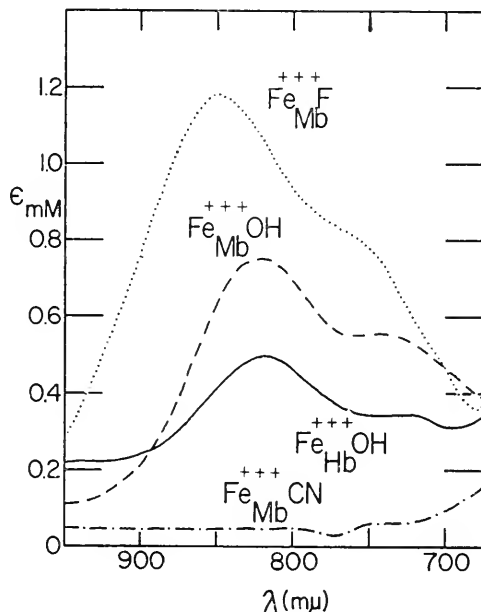

FIG. 7. Near infra-red spectra of ferrimyoglobin fluoride, hydroxide and cyanide, and ferrihaemoglobin hydroxide (Hanania, 1953).

the major bands which differentiate the two types of complex that are important.

Similar contrasting features appear in other regions of the absorption spectrum. In the near infra-red the fluoride complex has a well-defined absorption band at about  $850\text{ m}\mu$  with a shoulder at about  $750\text{ m}\mu$ , whereas the cyanide complex has remarkably low absorption throughout the whole range  $700$  to  $950\text{ m}\mu$  as shown in Fig. 7 (George and Hanania, 1955). In the ultra-violet, from  $280$  to  $450\text{ m}\mu$ , there are three regions to consider. The very intense Soret band lies between  $405$  and  $410\text{ m}\mu$  for the acidic ferrihaemoproteins and the fluoride complexes, the latter having lower absorption in the case of myoglobin and haemoglobin but higher in the case of peroxidase. On the other hand, the low-spin derivatives have the band shifted towards the red in the neighbourhood of  $418$  to  $425\text{ m}\mu$  (see Fig. 8). Minor bands occur at about  $350\text{ m}\mu$ . These are unresolved in the case of the acidic ferrihaemoproteins and the fluoride complexes, but two distinct bands at about

345 and 360  $m\mu$  can be distinguished in the case of the cyanide complex. At shorter wavelengths, from 260 to 300  $m\mu$ , absorption due to both the ferriporphyrin prosthetic group and tyrosine and tryptophane residues in the protein occurs, as evidenced by the greater absorption of the ferrihaemoproteins as compared to their apo-proteins. As shown in Fig. 9 the low-spin

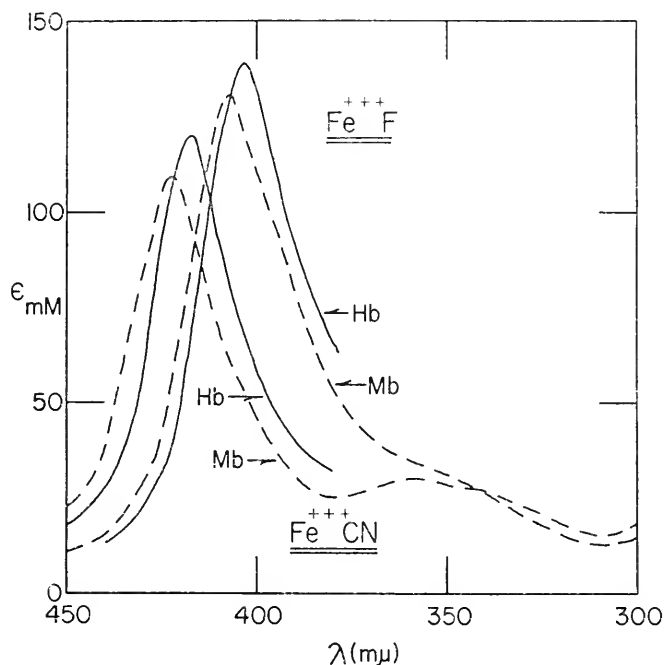
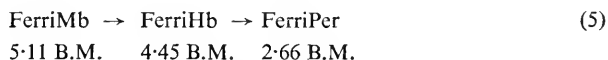

FIG. 8. Ultra-violet spectra of ferrimyoglobin and ferrihaemoglobin cyanide and fluoride (Keilin and Hartree, 1951; Hanania, 1953).

cyanide derivative has greater absorption than the high-spin fluoride derivative throughout this region, although the band at 290  $m\mu$  is less well resolved.

While the spectra of the high- and low-spin derivatives exhibit these characteristic distinguishing features, which as far as can be judged are common to myoglobin, haemoglobin and peroxidase, the spectra of the hydroxides vary a great deal as shown in Figs. 7, 10, 11 and 14. Moreover these variations are not haphazard, but appear to be related to the change in magnetic moment, i.e.



To take but one example, in the region of 600  $m\mu$ , the extinction coefficients follow the order

$$\epsilon_{\text{Mb}} > \epsilon_{\text{Hb}} > \epsilon_{\text{Per}} \quad (6)$$

as shown in Fig. 10.

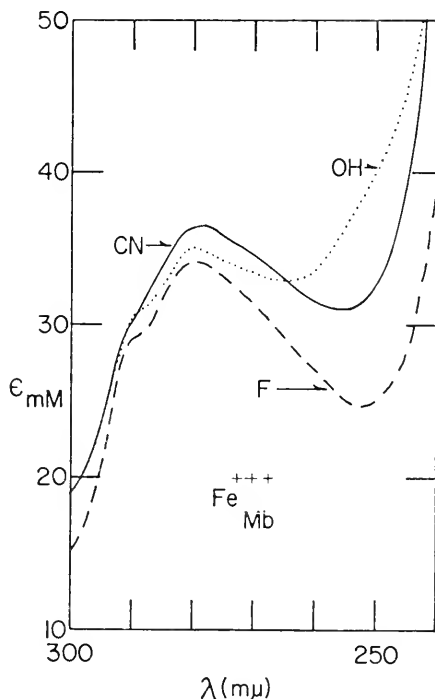

FIG. 9. Ultra-violet spectra of ferrimyoglobin fluoride, hydroxide and cyanide in the region of tyrosine and tryptophane absorption (Hanania, 1953).

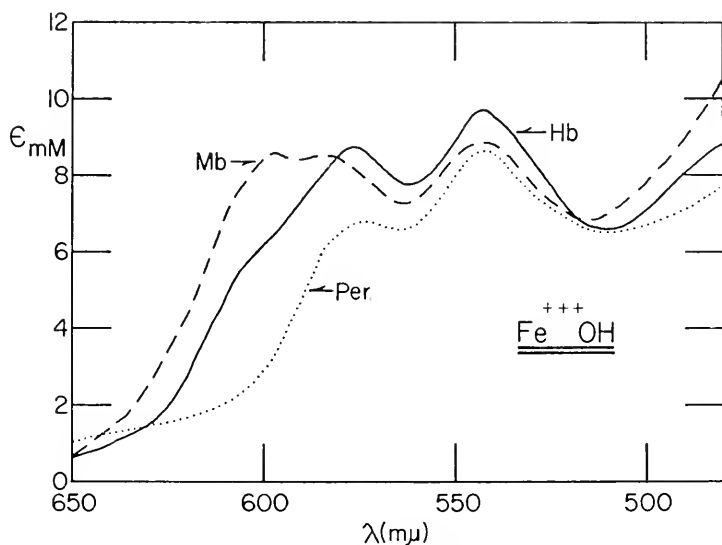

FIG. 10. Visible spectra of ferrimyoglobin, ferrihaemoglobin and ferriperoxidase hydroxide (Keilin and Hartree, 1951; Hanania, 1953).



Now the regular and systematic differences between the spectra of high- and low-spin complexes suggest very strongly that if the hydroxides are mixtures of high- and low-spin forms their spectra and magnetic moments should conform to a certain pattern.

(a) For the same haemoprotein, the extinction coefficients for the hydroxide should be intermediate in value between those for typical high- and low-spin complexes in the regions where the major absorption bands occur.

(b) For a series of hydroxides, there should be a regular trend in the extinction coefficients in the region of the major absorption bands, such that the

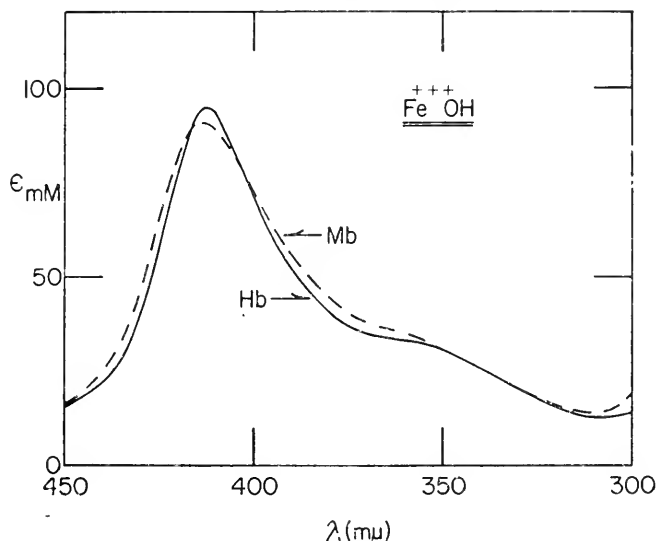

FIG. 11. Ultra-violet spectra of ferrimyoglobin and ferrihaemoglobin hydroxide (Hanania, 1953).

higher magnetic moment hydroxides resemble more closely the high-spin complexes, and the lower magnetic moment hydroxides resemble more closely the low-spin complexes.

In the case of ferrimyoglobin, the only haemoprotein for which complete data are available at present, the first criterion is found to hold throughout the entire range of wavelength, 250 to 950  $m\mu$ . For the visible region the myoglobin curve in Fig. 10 is to be compared with those in Figs. 5 and 6; Fig. 7 covers the region 700 to 950  $m\mu$ ; Figs. 8 and 11 give the Soret bands, and the smaller bands in the region 330 to 370  $m\mu$ ; and Fig. 9 covers the region of composite absorption, 250 to 300  $m\mu$ . The second criterion is borne out by a comparison of the spectra of ferrimyoglobin and ferrihaemoglobin hydroxides in Figs. 7 and 10, where the extinction coefficients follow the sequence

Fluoride Complex  $\rightarrow$  FerriMb Hydroxide  $\rightarrow$  FerriHb Hydroxide  $\rightarrow$  Cyanide Complex (7)

high spin

5.11 B.M.

4.47 B.M.

low spin

in order either of increasing or decreasing magnitudes, depending on the particular wavelength. In the ultra-violet region, 330 to 450  $m\mu$ , the trend is not so clear-cut, but, as will be shown in the next section, this can be attributed to the small but significant shift of all the ferrimyoglobin band maxima relative to those for ferrihaemoglobin, together with systematically

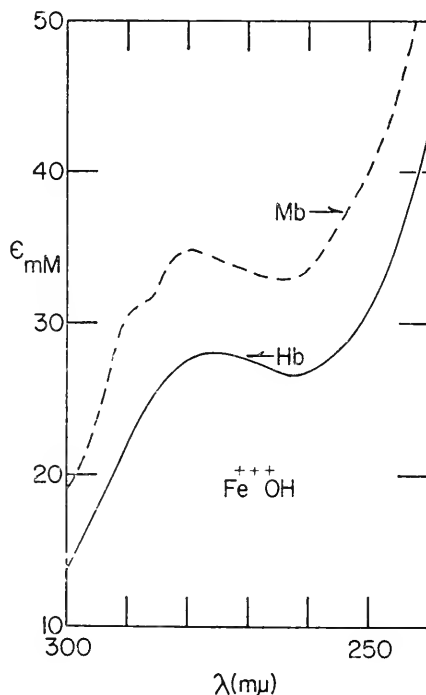

FIG. 12. Ultra-violet spectra of ferrimyoglobin and ferrihaemoglobin hydroxide in the region of tyrosine and tryptophane absorption (Hanania, 1953).

lower extinction coefficients (see Fig. 8). In the region 250 to 300  $m\mu$  no strict evaluation is possible because myoglobin and haemoglobin are not alike in tyrosine and tryptophane content. Nevertheless it is interesting that the curve for ferrimyoglobin hydroxide, which has higher moment, in contrast to that for ferrihaemoglobin with the lower moment, has a well-defined shoulder at 290  $m\mu$  like the high-spin fluoride complex (see Figs. 9 and 12).

The data for ferriperoxidase are not quite sufficient for it to be included in the sequence in equation (7), although there are ample indications that it would fit into the pattern and come between ferrihaemoglobin hydroxide and the low-spin cyanide complex. The magnetic moment has been determined for horseradish peroxidase, 2.66 B.M. (Theorell, 1942), but the absorption spectrum, recorded by Keilin and Hartree (1951) and reproduced in Fig. 10, refers to a pH of 11.4, which, judging from the  $pK$  of 10.9–11.3, would give

only about 60–75% hydroxide formation. It is already evident from Fig. 10, however, that the hydroxide has a pronounced peak at about 540  $m\mu$  with a second peak at about 575  $m\mu$ , and no peaks either in the region 600 to 640  $m\mu$  or at about 500  $m\mu$ . Spectroscopically, as well as magnetically, it can safely be classified as a low-spin complex. The spectroscopic type is fully substantiated by the corresponding spectrum for Japanese root peroxidase (Morita and Kameda, 1958), which has absorption bands at 548 and 578  $m\mu$ , with  $\epsilon_{mM} = 12.3$  and 10.1 respectively, together with relatively lower absorption in the region 620 to 650  $m\mu$ , compared to horseradish peroxidase in Fig. 10. But its magnetic moment has not yet been measured.

The data for two other haemoglobins may be considered at this point. The first, Chironomus haemoglobin (Scheler and Fischbach, 1958), presents some anomalous features. The visible spectrum of the hydroxide is most like that of ferrimyoglobin, and the shape of the curve in the region of 600  $m\mu$  suggests that it should come between ferrimyoglobin and ferrihaemoglobin in the sequence in equation (7), but on a quantitative scale nearer the former. However its magnetic moment is 4.45 B.M., a little less than that of ferrihaemoglobin hydroxide (Scheler, Schoffa and Jung, 1957). No explanation can be offered for this discrepancy, although it is to be noted that the magnetic moment of the acidic ferrihaemoglobin is appreciably lower than the values determined for ferrimyoglobin and erythrocyte ferrihaemoglobin, namely 5.68 and 5.80 B.M. respectively (Theorell and Ehrenberg, 1951; Coryell, Stitt and Pauling, 1937).

The second, root nodule haemoglobin (leghaemoglobin) is particularly interesting. The visible spectrum of the hydroxide, reproduced in Fig. 16 (Sternberg and Virtanen, 1952), is almost the same as that of Japanese root peroxidase, which indicates that it is a low-spin complex. Furthermore, preliminary spectroscopic observations by George, Hanania and Thorogood (1959) in the near infra-red have shown it to have significantly lower absorption in the region 700 to 900  $m\mu$  than the myoglobin and haemoglobin derivatives, which is in keeping with the trend in extinction coefficients from high- to low-spin complexes (see Fig. 7). The magnetic moment however still remains to be determined. Hence, provided it is appropriate to regard leghaemoglobin as a true haemoglobin\*, the haemoglobins themselves, without recourse to peroxidase, furnish a series of hydroxides covering almost the whole range of spectroscopic characteristics.

There is thus a substantial body of evidence to suggest that the hydroxides, especially of ferrimyoglobin and ferrihaemoglobin, are mixtures of high- and

\* This classification is based on the ability of ferroleghaemoglobin to form an oxygen complex, and it is further substantiated by the reaction of ferrileghaemoglobin with hydrogen peroxide. An intermediate compound is formed with absorption bands at 550 and 575  $m\mu$ , resembling the ferrimyoglobin and ferrihaemoglobin derivatives, in contrast to ferriperoxidase and ferricatalase, which give two such compounds neither having bands at these wavelengths.

low-spin forms, and in the next section this hypothesis will be put to a quantitative test.

QUANTITATIVE CORRELATION BETWEEN THE MAGNETIC MOMENTS AND THE SPECTRA OF FERRIHAEMOPROTEIN HYDROXIDES

Making the assumption that the hydroxides are mixtures of high- and low-spin forms, the magnetic moments and extinction coefficients at each wavelength should be interrelated in the following way. Denoting the moments of the high- and low-spin forms by  $\mu_h$  and  $\mu_l$ , the moments of, say, ferrimyoglobin and ferrihaemoglobin hydroxide,  $\mu_{Mb}$  and  $\mu_{Hb}$ , are determined by the equations

$$\mu_{Mb}^2 = \mu_l^2 \alpha_{Mb} + \mu_h^2 (1 - \alpha_{Mb}) \quad (8)$$

$$\mu_{Hb}^2 = \mu_l^2 \alpha_{Hb} + \mu_h^2 (1 - \alpha_{Hb}) \quad (9)$$

where  $\alpha_{Mb}$  and  $\alpha_{Hb}$  are the fractions of the low-spin form present in ferrimyoglobin and ferrihaemoglobin hydroxide respectively. The reason why the terms contain  $\mu^2$  rather than  $\mu$  is that the additive magnetic property is the molar susceptibility,  $\chi_M$ , which is related to  $\mu$  through the expression  $\mu = 2.84\sqrt{\chi_M T}$ . At a given wavelength the extinction coefficients of the two hydroxides,  $\epsilon_{Mb}$  and  $\epsilon_{Hb}$  are also determined by the fractions  $\alpha_{Mb}$  and  $\alpha_{Hb}$  according to the equations

$$\epsilon_{Mb} = \alpha_{Mb} \epsilon_l + (1 - \alpha_{Mb}) \epsilon_h \quad (10)$$

$$\epsilon_{Hb} = \alpha_{Hb} \epsilon_l + (1 - \alpha_{Hb}) \epsilon_h \quad (11)$$

where  $\epsilon_h$  and  $\epsilon_l$  are the extinction coefficients of the high- and low-spin forms at this particular wavelength. Since  $\mu_{Mb}$ ,  $\mu_{Hb}$ ,  $\epsilon_{Mb}$  and  $\epsilon_{Hb}$  are known experimental quantities, and since reasonable values can be adopted for  $\mu_h$  and  $\mu_l$ , these equations can best be used to evaluate  $\epsilon_h$  and  $\epsilon_l$ , and thus obtain the absorption spectra of the high- and low-spin components.

However, there are several reasons why calculations of this kind can only be approximate. First, although the high-spin hydroxide can be assigned a magnetic moment of 5.92 B.M., the theoretical spin contribution of five unpaired electrons, the value for the low-spin hydroxide is a matter of choice. Some contribution of orbital angular momentum must be taken into account in view of the values in excess of the spin contribution of one unpaired electron obtained for the cyanide complexes (see below), where the very strong ligand field makes it extremely unlikely that thermal mixtures exist. Secondly, although a value of 5.92 B.M. is equally valid for the high-spin form of both ferrimyoglobin and ferrihaemoglobin hydroxide, the moment of the low-spin form could very well differ by up to 0.5 B.M., since the values obtained for cyanide complexes are 2.35, 2.50, 2.66 and 2.29 B.M. in the case of ferrimyoglobin, ferrihaemoglobin, ferriperoxidase and ferricatalase respectively

(Theorell and Ehrenberg, 1951; Coryell, Stitt and Pauling, 1937; Theorell, 1942; Deutsch and Ehrenberg, 1952). In practice, slightly different values of  $\mu_l$  could be used in equations (8) and (9); but, in the absence of independent evidence, the same value will be used for the present calculations. Thirdly, the band maxima for corresponding derivatives of myoglobin and haemoglobin do not occur at exactly the same wavelengths, nor are the extinction coefficients identical, hence small variations would also be anticipated between the high-spin forms, and between the low-spin forms, of both haemoproteins. In those regions where the spectra of both fluoride and cyanide derivatives do differ in this way, correction factors can be introduced by adjusting the wavelength scale and/or all extinction coefficients by the appropriate amount. But even if this is done, the method of calculation leads unavoidably to extinction coefficients,  $\epsilon_h$  and  $\epsilon_l$ , that represent a kind of average of the true values for the two individual haemoproteins. Because of these limitations, reliance can only be placed on predominant features in the calculated absorption spectra, i.e., the positions and extinction coefficients of well-defined absorption bands. If the assumption of a thermal mixture is correct, then these would resemble those for the fluoride and cyanide derivatives; moreover, in no region of the spectrum should the extinction coefficients assume substantially negative values.

In all but one of the sets of calculations the value of 2.24 B.M. has been adopted for  $\mu_l$ . This is about the minimum obtained for ferric complexes of myoglobin, haemoglobin, peroxidase and catalase, and it has the advantage that  $\mu_l^2$  is a whole number, so that, on substituting for  $\mu_{Mb}$  and  $\mu_{Hb}$ , equations (8) and (9) are simply

$$26 = 5\alpha_{Mb} + 35(1 - \alpha_{Mb}) \quad (8a)$$

$$20 = 5\alpha_{Hb} + 35(1 - \alpha_{Hb}) \quad (9a)$$

The fractions of the low-spin forms ( $\alpha$ ) in ferrimyoglobin and ferrihaemoglobin hydroxide are thus 0.3 and 0.5 respectively. To check how sensitive the results are to the value chosen for  $\mu_l$ , 2.84 B.M. has been used in one set of calculations. This gives  $\mu_l^2 = 8$ ,  $\alpha_{Mb} = 0.33$  and  $\alpha_{Hb} = 0.55$ : but as will be seen, this change of about 10% in  $\alpha$  does not affect the type of absorption spectra obtained.

In view of the approximate nature of the present calculations, a small correction that should be made to the experimental values of  $\mu$  has been neglected. This amounts to about 0.13 for  $\mu = 2.70$ , and 0.06 for  $\mu = 5.92$ , when the values are obtained in the usual way by taking a haemoprotein derivative that has no unpaired electrons, e.g., carbonmonoxy-ferrohaemoglobin, as the reference compound to allow for the diamagnetism of the protein. This method entails the assumption that the paired *d*-electrons of the iron atom make no contribution to the magnetic moment, but recent calculations have shown that an orbital paramagnetism, induced by the

applied magnetic field, necessitates corrections of the magnitude quoted above (Griffith, 1958).

*The Visible Region, 480 to 650  $m\mu$*

Using the extinction coefficients for ferrimyoglobin and ferrihaemoglobin hydroxide given in Fig. 10, and without applying any corrections, the

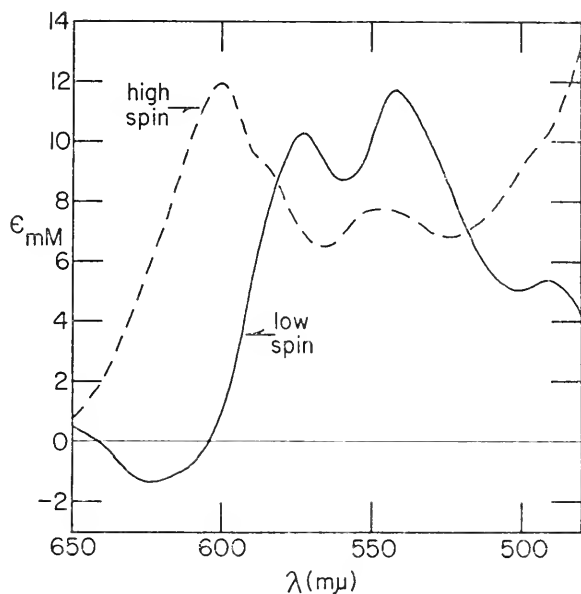

FIG. 13. Visible spectra for the high and low-spin hydroxides calculated from the data for ferrimyoglobin and ferrihaemoglobin hydroxides. No  $\lambda$  or  $\epsilon_{mM}$  corrections:  $\mu_l = 2.24$ ,  $\mu_h = 5.92$ .

absorption curves in Fig. 13 are obtained. The remarkable extent to which these spectra show the predominant features expected of high- and low-spin complexes is immediately apparent.

Reference to the spectra for the fluoride and cyanide derivatives in Figs. 5 and 6 shows that the extinction coefficients are so very similar for myoglobin and haemoglobin that no correction on this account need be considered. On the other hand, the absorption bands of the ferrimyoglobin derivatives are all displaced toward longer wavelengths by a few millimicrons relative to haemoglobin. Calculations allowing for a 2  $m\mu$ , 3  $m\mu$  and 5  $m\mu$  displacement have been carried out with the following results. The main absorption bands are little affected either in position or in intensity, as shown by comparing the data in lines *b*, *c* and *d* with those in line *a* of Table 4. However, minor improvements in the spectra are obtained. The extinction coefficients for the low-spin form take on small positive values,  $\epsilon_{mM} \approx 1$ , in the range

600 to 650  $m\mu$ , and the values are also increased a little in the region 480 to 510  $m\mu$ . Further calculations using  $\mu_l = 2.84$  B.M. gave almost identical spectra; the absorption bands occur at the same wavelengths, and the extinction coefficients change by only about 7% (see lines *d* and *e* of Table 4).

TABLE 4. CALCULATED BAND MAXIMA AND MILLIMOLAR EXTINCTION COEFFICIENTS (GIVEN IN BRACKETS) FOR THE HIGH- AND LOW-SPIN HYDROXIDES IN THE WAVELENGTH RANGE 480 TO 650  $m\mu$

$$\mu_{Mb} = 5.11: \mu_{Hb} = 4.47: \mu_{Per} = 2.66$$

Spectra used	Values adopted for $\mu_l$ and $\mu_h$	Details of calculations	High-spin hydroxide*	Low-spin hydroxide
(a) Hb and Mb	2.24, 5.92	No $\lambda$ or $\epsilon_{mM}$ corrections	600(12.0) 548(7.8)	573(10.2) 542(11.7)
(b) Hb and Mb	2.24, 5.92	$\lambda_{Mb}$ decreased by 2 $m\mu$	598(11.5) 538(7.8)	574 (9.9) 544(11.8)
(c) Hb and Mb	2.24, 5.92	$\lambda_{Mb}$ decreased by 3 $m\mu$	597(11.4) 535(8.1)	575 (9.7) 544(11.8)
(d) Hb and Mb	2.24, 5.92	$\lambda_{Mb}$ decreased by 5 $m\mu$	595(11.1) 532(8.4)	575 (9.4) 545(12.3)
(e) Hb and Mb	2.84, 5.92	$\lambda_{Mb}$ decreased by 5 $m\mu$	595(11.4) 532(8.5)	575 (9.1) 545(11.6)
(f) Per and Mb	2.24, 5.92	No $\lambda$ or $\epsilon_{mM}$ corrections	600(10.3) 538(7.8)	578(10.4) 548(12.6)
(g) Leg Hb and Mb	2.24, 5.92	No $\lambda$ or $\epsilon_{mM}$ corrections	606(10.5) 545(7.5)	572(10.6) 543(12.0)
(h) Leg Hb and Hb	2.24, 5.92	No $\lambda$ or $\epsilon_{mM}$ corrections	595 (9.0) 542(7.3)	572(10.6) 543(12.0)

\* Band at about 490  $m\mu$  not fully resolved.

Abbreviations: Hb, haemoglobin; Mb, myoglobin; Per, peroxidase; Leg Hb, leghaemoglobin.

The absorption curves for the hydroxides of Japanese root peroxidase and leghaemoglobin can be utilized in similar calculations, although at present assumptions have to be made as to the values of their magnetic moments. Adopting 2.66 B.M. for the Japanese root peroxidase derivative, like that for horseradish peroxidase,  $\alpha_{Per}$ , the fraction of the low-spin form,

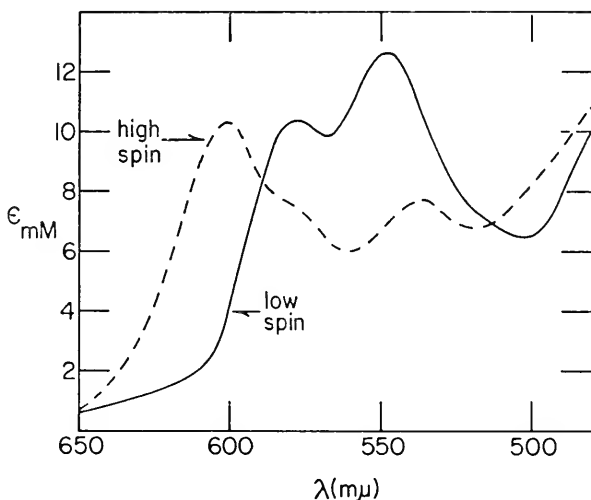

FIG. 14. Visible spectra for the high and low-spin hydroxides calculated from the data for ferrimyoglobin and Japanese root ferriperoxidase hydroxide (Morita and Kameda, 1958).

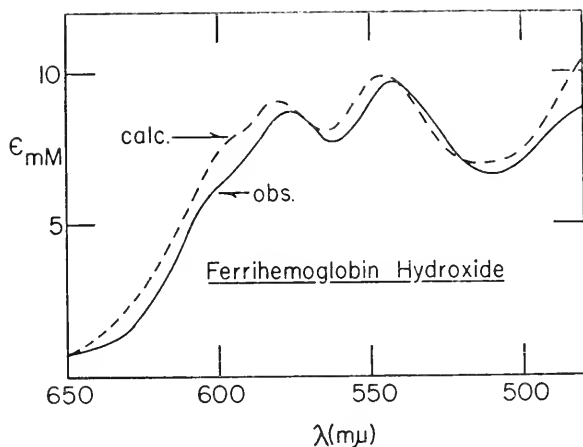

FIG. 15. The observed visible spectrum of ferrihemoglobin hydroxide, and that calculated from the spectra of the high- and low-spin forms illustrated in Fig. 14.

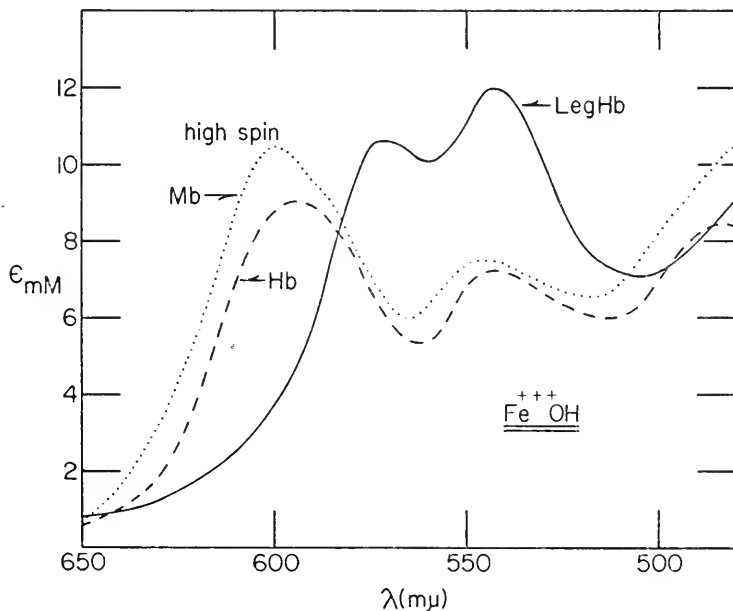

FIG. 16. Visible spectra of the high-spin hydroxide calculated from the data for ferrimyoglobin, ferrihaemoglobin and ferrileghaemoglobin hydroxide (Sternberg and Virtanen, 1952), assuming that the latter is 100% low-spin.

No  $\lambda$  or  $\epsilon_{mM}$  corrections:  $\mu_l = 2.24$ ,  $\mu_h = 5.92$ .



calculated from an equation corresponding to (8) or (9) is found to be 0.93. The fraction of the high-spin form is thus 0.07. Absorption spectra for the high- and low-spin forms based on the extinction coefficients of ferrimyoglobin hydroxide and this peroxidase hydroxide are plotted in Fig. 14 where it can be seen that they are very similar to those in Fig. 13. The spectrum of the low-spin form follows that of the root peroxidase derivative very closely, as would be expected with  $\alpha_{\text{Per}}$  having a value so near that of unity. In this case the extinction coefficients in the region 600 to 650  $m\mu$  have small positive values, with no corrections being applied. The band maxima occur at almost the same wavelengths, with extinction coefficients very similar to those obtained before, as shown in line *f* of Table 4.

With the previous value of  $\alpha_{\text{Hb}} = 0.5$ , these absorption curves can be used to calculate the spectrum of ferrihaemoglobin hydroxide, with the result shown in Fig. 15. The agreement is quite satisfactory, the shoulder at about 600  $m\mu$  being reproduced very well.

The absorption curve for ferrileghaemoglobin hydroxide can be used in a slightly different way. Making the assumption that this is entirely the low-spin form, the spectrum of the high-spin form can be obtained from either the ferrimyoglobin or the ferrihaemoglobin data as shown in Fig. 16. These spectra compare very favourably with those for the high-spin form in Figs. 13 and 14. The slight shift in the wavelengths for maximum absorption, and the small variations in extinction coefficients (see lines *g* and *h* in Table 4), are to be expected in view of the systematic displacement of the bands of ferrimyoglobin derivatives relative to those of ferrihaemoglobin noted previously. The spectra in Figs. 14 and 16 show very clearly that the main absorption bands are not very dependent on the low-spin values chosen for the magnetic moments of the root peroxidase and leghaemoglobin hydroxides.

#### *The Ultra-violet Region, 300 to 480 $m\mu$*

Inspection of the curves for the fluoride and cyanide derivatives in Fig. 8 shows that those for ferrimyoglobin are displaced by 4 to 5  $m\mu$  towards the red and have lower extinction coefficients throughout the Soret band region, 380 to 440  $m\mu$ . The ratios of Soret band maxima,  $\epsilon_{\text{Hb}}/\epsilon_{\text{Mb}}$ , are 1.06 and 1.10 for the fluoride and cyanide derivatives respectively. It is not surprising therefore that calculations using the extinction coefficients for the two hydroxides taken from Fig. 11, with no corrections to allow for these systematic differences, give absorption spectra for the high- and low-spin forms which show none of the expected features. A narrow band is obtained for the low-spin form having a maximum at 412  $m\mu$  with  $\epsilon_{\text{mM}} = 112$ , in contrast to a very wide band for the high-spin form, having a maximum at 418  $m\mu$  with  $\epsilon_{\text{mM}} = 88$  broadening out to a shoulder at 400  $m\mu$  with  $\epsilon_{\text{mM}} = 75$ .

Repeating the calculation, but correcting for the wavelength displacement by a factor of 5  $m\mu$ , and for the differences in intensity by multiplying the

extinction coefficients for ferrimyoglobin hydroxide by the average of the values given above, namely, 1.08, gives the curves shown in Fig. 17. These are now seen to exhibit the characteristic features of high- and low-spin complexes. The Soret bands are at  $405 \text{ m}\mu$  with  $\epsilon_{\text{mM}} = 116$ , and  $417 \text{ m}\mu$  with  $\epsilon_{\text{mM}} = 104$ , respectively: these positions and relative intensities compare very favourably with those for the fluoride and cyanide derivatives.

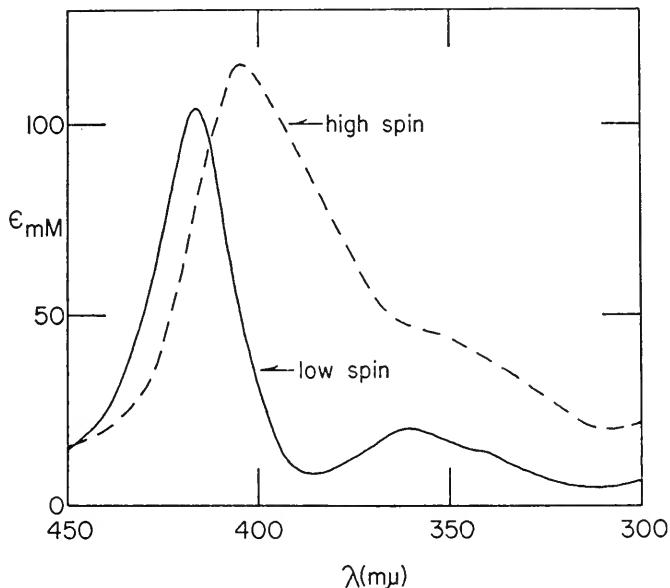

FIG. 17. Ultra-violet spectra of the high- and low-spin hydroxides calculated from the data for ferrimyoglobin and ferrihaemoglobin hydroxides. The absorption curve of ferrimyoglobin hydroxide has been corrected by a  $5 \text{ m}\mu$  displacement toward the red, and all extinction coefficients multiplied by 1.08:  $\mu_l = 2.24$ ,  $\mu_h = 5.92$ .

Furthermore, in the region  $330$  to  $370 \text{ m}\mu$ , the low-spin form has two distinct bands at about  $340$  and  $360 \text{ m}\mu$ , whereas the high-spin form has an unresolved shoulder at about  $350 \text{ m}\mu$ , like the cyanide and fluoride derivatives respectively (see Fig. 8). It is to be noted, however, that the band width of the high-spin form is larger than usual, and that of the low-spin form smaller, which results in the high-spin form having relatively higher extinction and the low-spin form relatively lower extinction between  $350$  and  $400 \text{ m}\mu$ .

#### *The Near Infra-red Region, 700 to 950 $\text{m}\mu$*

In the absence of spectroscopic data for ferrihaemoglobin fluoride and cyanide in this region, it is impossible to judge at present whether any correction factors should be applied. However, without correction, calculations based on the extinction coefficients of ferrimyoglobin and ferrihaemoglobin

hydroxide in Fig. 7 give the spectra for the high- and low-spin forms shown in Fig. 18, which can be seen to have the expected features. The high-spin form has well-defined bands at about  $740\text{ m}\mu$  with  $\epsilon_{\text{mM}} = 0.9$  and at  $830\text{ m}\mu$  with  $\epsilon_{\text{mM}} = 1.15$ , which correspond closely to the bands for the fluoride derivative: the low-spin form has scarcely any absorption

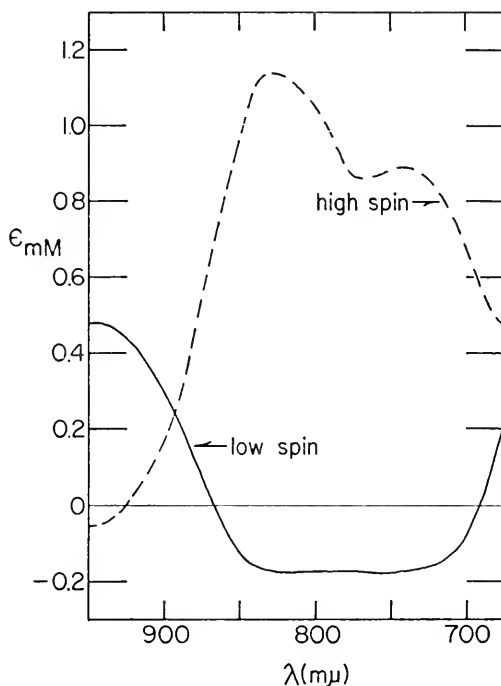

FIG. 18. Near infra-red spectra of the high- and low-spin hydroxides calculated from the data for ferrimyoglobin and ferrihaemoglobin hydroxide.  
No  $\lambda$  or  $\epsilon_{\text{mM}}$  corrections:  $\mu_l = 2.24$ ,  $\mu_h = 5.92$ .

throughout this region like the cyanide derivative (see Fig. 7). The small negative extinction coefficients actually obtained for the low-spin form can be attributed to the uncertainties in the calculation procedure when the correction factors are unknown, and also to experimental error. Precise extinction coefficients are very difficult to determine in this region because the magnitudes are so small, and errors introduced by extraneous background absorption, which is hard to remove completely, become significant.

### Summary

Assuming that the ferrihaemoprotein hydroxides are thermal mixtures, and adopting  $\mu_h = 5.92$  and  $\mu_l = 2.24$  as the magnetic moments of the

high- and low-spin forms, calculations give the following percentages for the various haemoproteins:

Myoglobin: High – 70%, Low – 30%

Haemoglobin: High – 50%, Low – 50%

Peroxidase: High – 7%, Low – 93%

From the extinction coefficients of the hydroxides the spectra of the high- and low-spin forms have been obtained over the range 250 to 950  $m\mu$ . Major absorption bands, or shoulders, occur at about the following wavelengths, with extinction coefficients having the approximate values given in brackets:

High-spin form: 830 (1.2), 740 (0.9), 600 (11), 540 (8), 490 unresolved band (10), 405 (116), 350 shoulder (44).

Low-spin form: 575 (10), 545 (12), 417 (104), 360 (20), 340 (14).

The calculation procedure has certain inherent limitations, nevertheless these absorption bands correspond so closely to those which distinguish high- from low-spin derivatives that the assumption of a thermal mixture can be regarded as entirely consistent with the spectroscopic and magnetic data.

#### THE EFFECT OF TEMPERATURE ON THE SPECTRUM AND ON THE MAGNETIC MOMENT OF FERRIMYOGLOBIN HYDROXIDE

As suggested previously, if the ferrihaemoprotein hydroxides are thermal mixtures of high- and low-spin forms, then changing the temperature would be expected to influence the equilibrium,

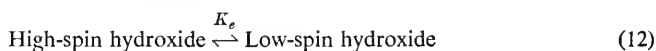

and a change should therefore be observable in the magnetic moment and in the absorption spectrum. The magnitude of the change would depend on the value of  $\Delta H$  for reaction (12), since this determines the variation of equilibrium constant with temperature according to the van't Hoff Isochore. But, since a close balance between the energies of the two forms is to be anticipated,  $\Delta H$  is likely to be small, and, as a consequence,  $K_e$  to have a small temperature dependence resulting in only slight changes in magnetic moment and absorption spectrum. This is borne out by the observation that there were no noticeable variations in the optical densities of ferrimyoglobin or ferrihaemoglobin hydroxide solutions at 582  $m\mu$  and 578  $m\mu$  respectively over the temperature range 7.5° to 37°C in experiments carried out to obtain thermodynamic data for the ionization reactions (George and Hanania, 1952, 1953).

However, further experiments have now been made using a sensitive recording spectrophotometer, and a temperature effect has been detected. The absorption spectrum of a concentrated solution of ferrimyoglobin

hydroxide at pH 11.0 and 5°C was recorded from 470 to 650 m $\mu$ , the optical density at 540 m $\mu$  being 0.7411. The reference cuvette, which previously contained buffer, was then filled with more of the hydroxide, and a baseline was recorded over the wavelength range with both solutions at 5°C. The solution in one cuvette was then rapidly warmed to 35°C, and maintained at

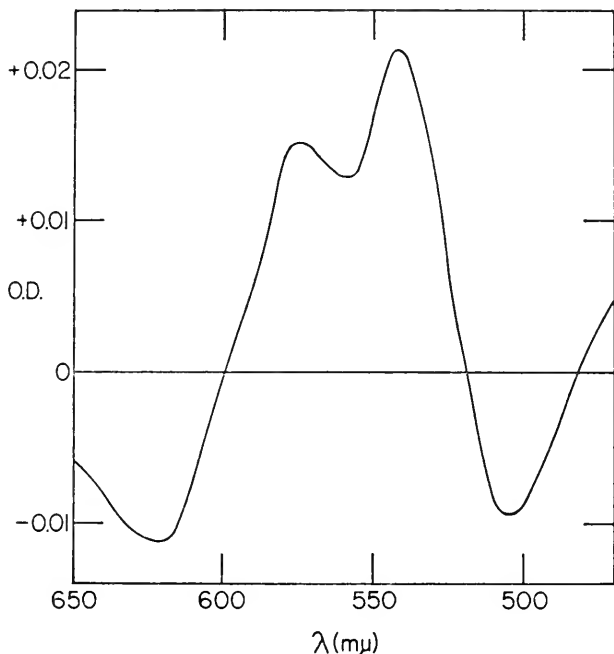

FIG. 19. The difference spectrum in the visible region for  $8.4 \times 10^{-5}$  M ferrimyoglobin hydroxide at 5° and 35°, plotted as  $(d_5^\circ - d_{35}^\circ)$ .

this temperature, by the insertion of a specially constructed hollow metal heating unit through which water from a thermostat was circulated. A difference spectrum was recorded, from which the curve illustrated in Fig. 19 was obtained after correction for the baseline. As can be seen, the effect of a 30° alteration in temperature is rather small. The change in optical density is at the most 2.9% at 542 m $\mu$ , while at 582 m $\mu$  it has dropped to 1.6%, which accounts for the effect escaping notice in the earlier investigations. Control experiments using the cyanide and fluoride derivatives showed no similar effect.

The negative regions from 480 to 520 m $\mu$  and above 600 m $\mu$ , together with the positive region in between which shows two well-defined bands, are qualitatively consistent with an increase in the fraction of the high-spin form as the temperature is increased. Some indication of its magnitude can be obtained from the difference between the extinction coefficients of the

high- and low-spin forms calculated in Section IV. At 540  $m\mu$  the difference in  $\epsilon_{mM}$  is about 4, which gives an increase of between 0.05 and 0.07, i.e., between 5 and 7%. However, in order to obtain the individual spectra of the high- and low-spin forms from the difference spectrum, an independent determination of the fractions present at the two temperatures is required. This can be seen from the equations,

$$\epsilon_5 = \alpha_5 \epsilon_l + (1 - \alpha_5) \epsilon_h \quad (13)$$

$$\epsilon_{35} = \alpha_{35} \epsilon_l + (1 - \alpha_{35}) \epsilon_h \quad (14)$$

where  $\epsilon_5$  and  $\epsilon_{35}$  are the extinction coefficients of the hydroxide at 5° and 35°,  $\alpha_5$  and  $\alpha_{35}$  are the fractions of the low-spin form at the two temperatures, and  $\epsilon_h$  and  $\epsilon_l$  are the extinction coefficients of the high- and low-spin forms. Since  $\epsilon_5$  is known and  $\epsilon_{35}$  can be obtained from the difference spectrum, provided  $\alpha_5$  and  $\alpha_{35}$  can be determined,  $\mu_h$  and  $\mu_l$  can be evaluated from the equations rearranged in the form,

$$\epsilon_h = \frac{\epsilon_{35} \alpha_5 - \epsilon_5 \alpha_{35}}{\alpha_5 - \alpha_{35}} \quad (15)$$

$$\epsilon_l = \frac{\epsilon_5(1 - \alpha_{35}) - \epsilon_{35}(1 - \alpha_5)}{\alpha_5 - \alpha_{35}} \quad (16)$$

The variation of  $\alpha$  with temperature has been obtained in the following way. Using a sensitive Gouy balance, constructed from a Varian electromagnet V4004 and a Sartorius Microbalance MPR 5 II, and equipped with a coaxial glass thermostat surrounding the sample tube and suspension fibre, the change in  $\Delta w$  was measured as a function of temperature over the range 1° to 30°C for the fluoride, cyanide and hydroxide derivatives of ferrimyoglobin. Calibration with nickel chloride solution enabled these changes in  $\Delta w$  to be converted into changes in molar susceptibility,  $\chi_M$ . The value of  $\chi_M$  obtained by Theorell and Ehrenberg (1951) for the three derivatives at 20°C were adopted, namely, 14,790, 2,340 and 11,040  $\times 10^{-6}$  c.g.s. units respectively, and hence values of  $\chi_M$  over the temperature range were obtained. The variation of  $\chi_M$  for the fluoride and cyanide derivatives was found to follow very closely the simple Curie law,  $\chi = \text{constant}/T$ . The magnitude of the change is illustrated by the following data: from 20° to 1°,  $\chi_M$  for the fluoride and cyanide derivatives increases by 1,046  $\times 10^{-6}$  and 82  $\times 10^{-6}$  c.g.s. units respectively. On the other hand,  $\chi_M$  for the hydroxide, although it has a high value approaching that of the fluoride, only increases by 145  $\times 10^{-6}$  c.g.s. units for the same decrease in temperature. As a consequence, the values of  $\chi_M$  do not follow the Curie Law, and the type of deviation is just what would be expected if, on lowering the temperature, the fraction of the high-spin form decreases.

The simplest method by which the fractions of the high- and low-spin forms can be calculated, throughout the temperature range, is to use the experimental values of  $\chi_M$  for the fluoride and cyanide derivatives at various temperatures as the values appropriate to the high- and low-spin forms, and substitute in the equation,

$$\chi_{M(\text{hydroxide})} = \alpha\chi_{M(\text{cyanide})} + (1 - \alpha)\chi_{M(\text{fluoride})} \quad (17)$$

In practice, this is equivalent to taking  $\mu_t = 2.34$  B.M., i.e., the value for the cyanide derivative, instead of 2.24 B.M., as in the majority of calculations in

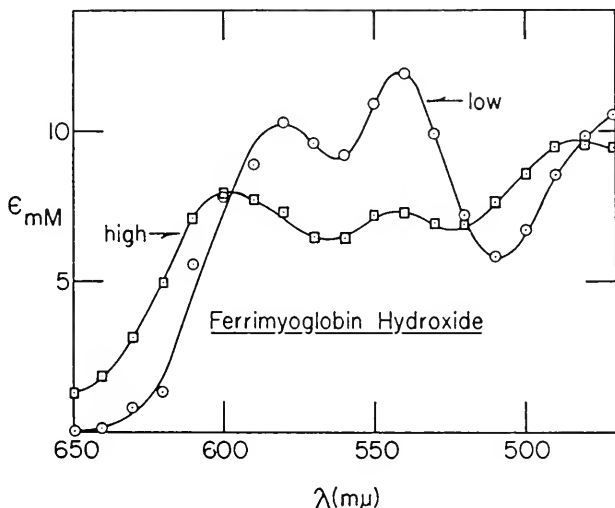

FIG. 20. The visible spectra of the high- and low-spin hydroxides calculated from the difference spectrum in Fig. 19, and the corresponding change in the fraction of the low-spin form, 0.055, as obtained from the variation of magnetic susceptibility with temperature.

Section IV. Such a slight change in  $\mu_t$  only affects the value of  $\alpha$  to a negligible extent, i.e., from 0.300 to 0.304. Values of  $\alpha$  and  $(1 - \alpha)$ , obtained in this way, are listed in Table 5 for temperatures from 0° to 30°, together with values for  $K_e$ , the equilibrium constant for the conversion reaction (12).

Interpolation and extrapolation for the temperature interval 5° to 35° gives 0.055 for the corresponding change in  $\alpha$ . The spectra of the high- and low-spin forms of ferrimyoglobin hydroxide were then obtained by calculating  $\epsilon_h$  and  $\epsilon_l$  throughout the wavelength range according to equations (15) and (16).

The similarity between these spectra, shown in Fig. 20, and those in Figs. 13, 14 and 16 is very gratifying. But it must be remembered that the previous spectra, calculated from data for pairs of haemoproteins, are

approximations, consisting of average values of the extinction coefficient appropriate to the two individual high-spin forms and the two individual low-spin forms. The new spectra in Fig. 20, based entirely on data for one haemoprotein, are therefore more valid.

#### THE SPECTRA OF FERRIMYOGLOBIN DERIVATIVES IN HEAVY WATER

The interplay of structural and electronic factors necessary for a ferrimyoglobin derivative to exist as a mixture of high- and low-spin forms is evidently so critical that the ligands most closely related to the hydroxyl group in chemical type give predominantly, or entirely, high-spin or low-spin complexes. On the basis of spectroscopic data, or magnetic data, or both, it is clear that the complexes with phenol, and presumably ethanol, i.e.,  $\text{Fe}_{\text{Mb}}^{+++}\text{—OC}_6\text{H}_5$  and  $\text{Fe}_{\text{Mb}}^{+++}\text{—OC}_2\text{H}_5$  come in the former category; whereas the complexes with the sulphur analogues, hydrogen sulphide, ethyl mercaptan and thiophenol, i.e.,  $\text{Fe}_{\text{Mb}}^{+++}\text{—SH}$ ,  $\text{Fe}_{\text{Mb}}^{+++}\text{—SC}_2\text{H}_5$  and  $\text{Fe}_{\text{Mb}}^{+++}\text{—SC}_6\text{H}_5$ , come in the latter (George, Lyster and Beetlestone, 1958; Coryell and Stitt, 1940; Keilin, 1933; Heussenstam and Coryell, 1954). The least drastic of all substitutions that can be achieved, with the exception of employing  $\text{H}_2\text{O}^{18}$ , is the replacement of hydrogen by deuterium, and the spectrum of the alkaline form in heavy water, which should accordingly have the structure  $\text{Fe}_{\text{Mb}}^{+++}\text{—OD}$ , has therefore been studied. In the preliminary experiments, reported below, the highest mole ratio of  $\text{D}_2\text{O}$  to  $\text{H}_2\text{O}$  that could be attained was 134:1. Hence, although the affinities of the iron atom for  $\text{OH}^-$  and  $\text{OD}^-$  also have to be taken into consideration because they determine the relative amounts of  $\text{Fe}_{\text{Mb}}^{+++}\text{—OH}$  and  $\text{Fe}_{\text{Mb}}^{+++}\text{—OD}$  formed, it is unlikely that in pure  $\text{D}_2\text{O}$  the effect observed would be very much enhanced.

A very concentrated solution of acidic ferrimyoglobin in ordinary water was used, so that only 0.02 ml in a total of 3 ml was required to give optical density values of about 0.7 at the band maxima in the visible region. Solutions of the alkaline form were prepared in the following way. Tiny quantities of caustic soda solution were added to acidic ferrimyoglobin (0.02 ml stock solution + 2.98 ml ordinary water) from a micro-syringe until the pH was 11.0. The same volume of caustic soda was added to a corresponding solution of acidic ferrimyoglobin made up in heavy water. Difference spectra were then recorded with the heavy water solution in the reference cuvette for the alkaline form, and, as controls, for the acidic form and the cyanide derivative, which was prepared by adding a little solid KCN.

With the cyanide derivative no difference could be detected and with the acidic form there was scarcely any change. But with the alkaline form a well-defined difference spectrum was obtained, very similar to that in Fig. 20, and the optical density differences were about the same in magnitude. The



simplest interpretation of this result is that for the  $\text{Fe}_{\text{Mb}}^{+++}\text{—OD}$  formed in heavy water the fraction of the low-spin form is about 6% higher than the fraction for  $\text{Fe}_{\text{Mb}}^{+++}\text{—OH}$  under similar conditions. Using the data given

TABLE 5. THE FRACTIONS OF THE LOW-SPIN AND HIGH-SPIN FORMS OF FERRIMYOGLOBIN HYDROXIDE,  $\alpha$  AND  $(1 - \alpha)$  RESPECTIVELY, AT DIFFERENT TEMPERATURES, CALCULATED FROM THE TEMPERATURE VARIATION OF  $\chi_{\text{M}}$  FOR FERRIMYOGLOBIN HYDROXIDE, FLUORIDE, AND CYANIDE

$K_e$  is the equilibrium constant for the conversion  
 high-spin form  $\leftrightarrow$  low-spin form  
 and is given by  $\alpha/(1 - \alpha)$ .

$T(^{\circ}\text{C})$	$\alpha$	$(1 - \alpha)$	$K_e$
0	0.34	0.66	0.52
10	0.32	0.68	0.47
20	0.30	0.70	0.43
30	0.28 <sub>5</sub>	0.71 <sub>5</sub>	0.40

in Table 5 for the hydroxide, an approximate value of the equilibrium constant for the reaction

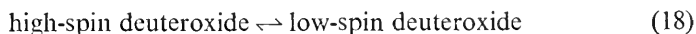

is found to be 0.55 at 25°C, compared to 0.41 for the hydroxide. Substitution of hydrogen by deuterium thus favours the conversion by about 0.2 kcal/mole in units of free energy. It is probable that the bulk of this difference arises *via* the water of solvation and not from any effect on the ligand field. The change of mass of the hydrogen nucleus affects the free energy of 'crystallization' around the iron ion directly but the ligand field only very indirectly through the effect of the change of vibrational amplitudes for the OH group on the mean ligand field.

#### GENERAL REMARKS

The experiments with heavy water offer particularly direct evidence for the existence of a thermal mixture in ferrimyoglobin hydroxide. Further, because the fundamental difference between the high- and low-spin form lies in the electronic structure of the iron ion, they show that water molecules (or those protons which are exchangeable with those of water) play an essential part in determining the free energy change. We would naturally guess that the water molecules which are 'crystallized' around the iron ion (and also the hydrogen of the OH<sup>-</sup> group) are the ones concerned here.

Although this is far from direct evidence for the existence of the hydroxide structure it is at least thoroughly consistent with it.

The hypothesis of a thermal mixture is also fully borne out in the case of ferrimyoglobin hydroxide by the temperature variation of its spectrum and magnetic moment as described in Section V; and, in view of the self-consistent results of the calculations using magnetic and spectroscopic data in Section IV, it can be concluded that ferrihaemoglobin hydroxide is also a mixture of high- and low-spin forms. This accounts equally well for its apparently anomalous magnetic moment as the explanation in terms of the electronic configuration with three unpaired electrons, which was shown to be unlikely on theoretical grounds (see Section II).

Thermodynamic data for the conversion of the high-spin to the low-spin form can be obtained from the values of  $K_e$  for ferrimyoglobin in Table 5. A plot of  $\log K_e$  against  $1/T$  gives  $\Delta H = -1.5 \pm 0.2$  kcal/mole, and from the equation  $\Delta G^\circ = \Delta H - T\Delta S^\circ$ , with  $\Delta G^\circ$  equal to 0.5 kcal/mole at  $25^\circ\text{C}$ ,  $\Delta S^\circ$  is found to be  $-6.7 \pm 0.7$  e.u. The conversion is thus favoured by the enthalpy change, but is appreciably hindered by the entropy change to such an extent that the resulting free energy change has a small positive value. In other words, with respect to their heats of formation the low-spin form is the more stable, whereas in terms of their entropies the high-spin form is the more stable.

The favourable value of  $\Delta H$  may be regarded as purely fortuitous, because, although the conversion to the low-spin form implies an increase in the value of  $\Delta$ , and hence extra stabilization, pairing energies have also to be taken into consideration and in addition solvent interaction effects may be important (see below). In order to discuss the entropy change accompanying the conversion, it is convenient to distinguish the contribution arising from the degeneracy of the electronic state of the iron in the two forms from the remainder. The following estimate shows that this contribution is unlikely to be more than about  $-2$  e.u.

In the high-spin form the ferric ion has a ground term which is spatially non-degenerate but has a sixfold degeneracy due to the spin  $S = 5/2$ . The ligand field combined with the spin-orbit coupling lifts the degeneracy into three Kramers doublets. If this splitting is large compared to  $kT$ , only one Kramers doublet is occupied and the effective degeneracy of the ferric ion is 2. If it is small then the degeneracy is 6. This means that the entropy associated with the degeneracy of the electronic state of the iron in the high-spin form lies between the two limits of  $R \log_e 2 = 1.38$  e.u. and  $R \log_e 6 = 3.56$  e.u. The actual magnitude of the splitting is unknown. If we assume that it may be represented in a spin-Hamiltonian for the ground term with  $S = 5/2$  by the quadratic expression

$$D \left( S_z^2 - \frac{35}{12} \right)$$

then electron resonance measurements show that  $D$  can hardly be less than 4°K (Bennett and Ingram, 1956; Griffith, 1956c). With  $D$  in these units, the partition function,  $Z$ , is given by the equation,

$$Z = 2e^{-\frac{10D}{3T}} + 2e^{\frac{2D}{3T}} + 2e^{\frac{8D}{3T}} \quad (19)$$

from which the entropy follows from the formula  $S = \partial(RT \log_e Z)/\partial T$ . For  $D/T$  small we deduce  $S = 3.56 - (28D^2R/9T^2)$ . The second term is inappreciable ( $< 0.01$ ) at room temperature for  $D < 12^\circ\text{K}$ , i.e., an overall splitting of 48  $\text{cm}^{-1}$ . Therefore it seems likely, although not certain, that at room temperature this contribution to  $S$  is close to 3.56 e.u.

In the low-spin form we have a spatial degeneracy of three and a spin degeneracy of two. Here, however, it is probable that the three Kramers doublets have a separation large compared with  $kT$  at room temperature (Griffith, 1957) so that the contribution to  $S$  from the degeneracy is close to 1.38 e.u. This means a contribution to  $\Delta S$  for the conversion of the high-spin to the low-spin form of  $1.38 - 3.56 = -2.18$  e.u. If our assumptions are incorrect the numerical value of this contribution will almost certainly be lower.

It is much more difficult to obtain any *a priori* numerical estimate for the remainder of the entropy change, which, using the value obtained in the last paragraph for the degeneracy contribution, is seen to amount to about  $-5$  e.u.\* We should expect it to be negative, however, for the following reason. In the high-spin form the overall distribution of the five  $d$ -electrons about the iron has nearly spherical symmetry, thus producing no orientating effect on the environment. On the other hand, in the low-spin form the five electrons are in the three orbitals away from the bond directions, thus imposing an extra rigidity on the environment of the iron. This would result partly in a more rigid ferrimyoglobin molecule, and partly in a more rigid arrangement of water molecules around the Fe—OH group.

Just as  $\Delta H$  for the conversion is determined by other energy terms besides the electronic stabilization energy arising from the splitting of the  $d$ -orbitals, so the values of  $\Delta H$  for the formation of complexes with different ligands cannot be taken as an accurate indication of the variation in  $\Delta$ . From one extreme to the other, however, a rough correlation would be expected, with the high-spin complexes having the less favourable values of  $\Delta H$ . This trend, which has also been discussed by Havemann and Haberditzl (1958), is illustrated by the data in Table 6. The values of  $\Delta S^\circ$  become progressively more negative from fluoride to cyanide, but they are not amenable to any straightforward correlation because the entropies of the ligands themselves vary so much, with  $\bar{S}^\circ$  for  $\text{F}^-$ ,  $\text{OH}^-$  and  $\text{CN}^-$  having the values  $-2.5$ ,  $-2.3$  and  $+28$  e.u. respectively. Some allowance for this can nevertheless be made

\* The assumed additivity of entropies is equivalent to a factorization of the partition function, which is probably a good approximation here at room temperature or below.

by comparing the differences in partial molal entropies of the complexes and the parent haemoprotein (George, 1956).

TABLE 6.  $\Delta H$  AND  $\Delta S^\circ$  VALUES FOR THE FORMATION OF FERRIMYOGLOBIN FLUORIDE, HYDROXIDE AND CYANIDE: AND THEIR MAGNETIC MOMENTS (GEORGE AND HANANIA, 1952, 1956: THEORELL AND EHRENBERG, 1951)

Ligand	$\Delta H$ kcal/mole	$\Delta S^\circ$ e.u.	$\mu$ B.M.	Type of complex
F <sup>-</sup>	-1.5	+1.8	5.75-5.92	high-spin
OH <sup>-</sup> *	-7.65	-2.6	5.11	70% high, 30% low-spin
CN <sup>-</sup>	-18.6	-24	2.35	low-spin

\* See footnote to Table 7.

A more rigorous correlation can be sought, if, for the same ligand, data are available for closely related haemoproteins. But if the whole range from high- to low-spin complexes is to be covered, this would clearly be restricted to those ligands capable of giving thermal mixtures in some cases. For example, the data in Table 7 for the various haemoglobin hydroxides show that the increase in the fraction of the low-spin form is accompanied by more negative (i.e., favourable) values of  $\Delta H$ , which was to be anticipated from the overall trend illustrated in Table 6. Furthermore, with a series of derivatives of this type, where the ligands are identical and the structure of the complex in the immediate neighbourhood of the iron is presumably very similar, the values of  $\Delta S$  can be taken as a true indication of a general trend paralleling the trend in  $\Delta H$ . As the fraction of the low-spin form increases,  $\Delta S$  assumes more negative (unfavourable) values, while  $\Delta H$  assumes more negative (favourable) values. This trend in  $\Delta S$  is entirely in accord with the entropy change obtained above for the conversion of the high-spin to the low-spin hydroxide in the case of ferrimyoglobin, and it can likewise be associated with a greater structural rigidity in the vicinity of the iron atom of the low-spin form.

The  $pK$  values for the ionization of ferriperoxidase and ferricytochrome *c* are so much higher than those for the haemoglobins (see Table 1) that inevitably either the  $\Delta H$  values, or the  $\Delta S$  values, and very probably both, would show marked deviations from the correlation set out in Table 7. This is not unexpected because the acidic forms of these haemoproteins have different structures, and as a consequence the formation of the hydroxide is a different type of chemical reaction.

In the case of the haemoglobins, the reactions of the acidic form can be very adequately expressed by the hydrate structure, e.g., Prot.—Fe<sub>Hb</sub><sup>+++</sup>(H<sub>2</sub>O), and the ionization is accordingly the simple dissociation of a proton,

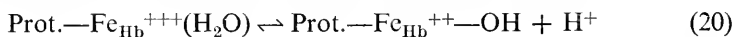
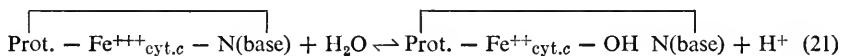

TABLE 7.  $\Delta H$  AND  $\Delta S^\circ$  VALUES FOR HYDROXIDE FORMATION\*

Haemoprotein	$\Delta H$ kcal/mole	$\Delta S^\circ$ (e.u.)	Type of hydroxide
Ferrimyoglobin	-7.65	-2.6	70% high, 30% low-spin
Ferrihaemoglobin	-9.5	-7.9	50% high, 50% low-spin
Ferrileghaemoglobin	-11.0	-13.0	approaches 100% low-spin

\* These values have been calculated from the corresponding data for the ionization reaction, and for the ionization of water ( $\Delta H = +13.4$  kcal/mole and  $\Delta S^\circ = -19.2$  e.u.). The references for ferrimyoglobin and ferrihaemoglobin are given in Table 1; for ferrileghaemoglobin, see George, Hanania and Thorogood (1959).

On the other hand, in the acidic form of ferricytochrome *c* the iron is bonded in an intricate crevice structure to nitrogenous base groups of the protein at both the fifth and sixth co-ordination positions. One of the crevice bonds must be broken if  $\text{OH}^-$  is to replace one of the groups, and the ionization reaction therefore takes the form,



With ferriperoxidase the nature of the reaction is rather more obscure, because in less alkaline solution the pH variations of the equilibrium constants for complex formation with cyanide, fluoride, azide, etc., differ systematically from the corresponding variations for ferrimyoglobin, ferrihaemoglobin and ferricytochrome *c*. The difference lies in the consumption of a proton accompanying the formation of the complex. George and Lyster (1958) have discussed various explanations that have been advanced, and suggested as a further possibility that acidic ferriperoxidase also has a crevice structure but with the labile bond, which is broken in complex formation and upon ionization, to some group other than a nitrogenous base, with a *pK* of about 10 in horseradish peroxidase. Whatever the true explanation may be, it is clear that no strict comparison can be made between thermodynamic data for the ionization of ferriperoxidase and ferricytochrome *c* and the corresponding data for the haemoglobins.

Finally, the question naturally arises as to whether any other haemoprotein derivatives are mixtures of high- and low-spin forms. Scheler, Schoffa and Jung (1957) and Havemann and Haberditzl (1958) have suggested that this may be the case for several other derivatives where the magnetic moments differ appreciably from the usual high or low values. However, no quantitative correlation of magnetic and spectroscopic properties, of the

kind used in Section IV to calculate the individual spectra of the high- and low-spin hydroxides, was considered. Since azide gives a high-spin complex with ferricatalase and a low-spin complex with ferrihaemoglobin, it is quite likely that the ferrimyoglobin derivative would contain a significant fraction of the high-spin form. Preliminary calculations tend to confirm this. Nevertheless, until temperature variations of the magnetic moment and absorption spectra have furnished direct experimental evidence for the existence of a thermal mixture, as in the case of ferrimyoglobin hydroxide, it is perhaps better to leave it as an open question with regard to the other derivatives.

### *Acknowledgements*

The work reported above forms part of a research programme on haemoproteins supported by grants from the National Science Foundation (G2309 and G7657). We wish to thank Dr. Britton Chance for making the facilities of the Department of Biophysics and Physical Biochemistry available to carry out the spectrophotometric study described in Section V.

### REFERENCES

- BASOLO, F. & PEARSON, R. G. (1958). *Mechanisms of Inorganic Reactions—A Study of Metal Complexes in Solution*, John Wiley, New York.
- BENNETT, J. E. & INGRAM, D. J. E. (1956). *Nature, Lond.* **177**, 275.
- CORYELL, C. D. & STITT, F. (1940). *J. Amer. chem. Soc.* **62**, 2942.
- CORYELL, C. D., STITT, F. & PAULING, L. (1937). *J. Amer. chem. Soc.* **59**, 633.
- DEUTSCH, H. F. & EHRENBERG, A. (1952). *Acta chem. Scand.* **6**, 1522.
- GAMGEE, A. (1868). *Phil. Trans. (London)* **158**, 589.
- GEORGE, P. (1956). *Currents in Biochemical Research*, p. 338 (Ed. by D. E. Green), Interscience, New York.
- GEORGE, P. & HANANIA, G. I. H. (1952). *Biochem. J.* **52**, 517.
- GEORGE, P. & HANANIA, G. I. H. (1953). *Biochem. J.* **55**, 236.
- GEORGE, P. & HANANIA, G. I. H. (1955). *Disc. Faraday Soc.* **20**, 293.
- GEORGE, P. & HANANIA, G. I. H. (1956). *Currents in Biochemical Research*, especially Table 5, p. 353.
- GEORGE, P., HANANIA, G. I. H. & THOROGOOD, E. (1959). Unpublished results.
- GEORGE, P. & LYSTER, R. L. J. (1958). *Proc. nat. Acad. Sci. Wash.* **44**, 1013.
- GEORGE, P., LYSTER, R. L. J. & BEETLESTONE, J. (1958). *Nature, Lond.* **181**, 1534.
- GIBSON, J. F. & INGRAM, D. J. E. (1957). *Nature, Lond.* **80**, 29.
- GRIFFITH, J. S. (1956a). *J. inorg. nuclear Chem.* **2**, 229.
- GRIFFITH, J. S. (1956b). *J. inorg. nuclear Chem.* **2**, 1.
- GRIFFITH, J. S. (1956c). *Proc. Roy. Soc. A* **235**, 23.
- GRIFFITH, J. S. (1957). *Nature, Lond.* **180**, 30.
- GRIFFITH, J. S. (1958). *Biochim. biophys. Acta*, **28**, 439.
- GRIFFITH, J. S. & ORGEL, L. E. (1957). *Quart. Rev.* **11**, 381.
- HANANIA, G. I. H. (1953). Ph.D. Thesis, The University of Cambridge, England.
- HAVEMANN, R. & HABERDITZL, W. (1958). *Z. phys. Chem.* **209**, 135.
- HEUSSENSTAM, P. & CORYELL, C. D. (1954). See Coryell, C. D., *Chemical Specificity in Biological Interactions* (Chap. 8, p. 108 and 113), Academic Press Inc., New York, 1954.
- HOWARD, J. B. (1935). *J. chem. Phys.* **3**, 813.
- KEILIN, D. (1933). *Proc. Roy. Soc. B.* **113**, 393.
- KEILIN, D. & HARTREE, E. F. (1951). *Biochem. J.* **49**, 88.
- KOTANI, M. (1949). *J. phys. Soc. Japan* **4**, 293.

- MORITA, Y. & KAMEDA, K. (1958). *Mem. res. Instit. Food Science, Kyoto, Japan*, No. 14, 61.
- ORGEL, L. E. (1955). *J. chem. Phys.* **23**, 1819.
- SCHELER, W. & FISCHBACH, I. (1958). *Acta Biol. Med. Germ.* **1**, 194.
- SCHELER, W., SCHOFFA, G. & JUNG, F. (1957). *Biochem. Z.* **329**, 232.
- STERNBERG, H. & VIRTANEN, A. I. (1952). *Acta. chem. Scand.* **6**, 1342.
- TAUBE, H. (1952). *Chem. Rev.* **50**, 69.
- THEORELL, H. (1941). *J. Amer. chem. Soc.* **63**, 1820.
- THEORELL, H. (1942). *Ark. Kemi, Min. Geol.* **16A**, No. 3, 1.
- THEORELL, H. & ÅKESSON, Å. (1941). *J. Amer. chem. Soc.* **63**, 1812.
- THEORELL, H. & EHRENBERG, A. (1951). *Acta chem. Scand.* **5**, 823.

## DISCUSSION

### *Spin States and Spectra of Haemoproteins*

#### The Electronic Origins of the Spectra

By P. George and J. S. Griffith (Philadelphia)

GEORGE: It is perhaps desirable to say something about the electronic origins of the spectra of the pure high-spin and low-spin compounds (ferrous and ferric), although we have not yet made a detailed analysis of them.

Considering first the iron-porphyrin group we may divide the possible electronic transitions into three categories: porphyrin transitions, metal transitions and charge-transfer transitions. Free porphyrin has strong absorption in the visible and also a Soret peak and the intensity associated with these cannot be lost in the metal compound. Therefore one naturally supposes the Soret band of the latter and some at least of its visible absorption to be porphyrin transitions. These porphyrin transitions have the characteristic that the electric vector of the light lies in the porphyrin plane so that when it is at right-angles to it the light does not get absorbed. This is not necessarily true of the other transitions discussed later. In thinking about the part of the spectrum which arises from the porphyrin ring one should also remember that the singlet-triplet transitions may enhance their intensity considerably through coupling with the metal ion when the latter has non-zero spin.

The metal transitions in the visible and infra-red are  $d-d$  transitions which would be of low intensity and probably completely masked by the porphyrin bands. At least they can hardly be responsible for the gross visible structure. The metal  $3d-4p$  transitions would probably be in the ultra-violet although it is possible that the  $4p_z$  orbital might have its energy lowered sufficiently by interaction with a porphyrin  $\pi$  orbital to invalidate this view. If this were so, however, the transition would also involve charge-transfer to the ring and so be partly included in our third category.

Charge-transfer transitions are of two kinds—to and from the metal ion. Naturally we expect the low energy ones to be to the metal ion for ferric compounds, and from the metal ion for ferrous compounds. In each case, then, they would involve the iron atom commuting between the ferrous and the ferric state. It is natural to suppose that the infra-red bands characteristic of high-spin ferric compounds, oxy-haemoglobin and myoglobin, and the single-equivalent higher oxidation states, are indeed charge-transfer bands. Some components of such transitions are of course fully allowed for electric dipole radiation, and can therefore account for the relatively high intensities.

The ligands in the fifth and sixth positions can also have transitions and give charge transfer to and from the iron, and so in a particular compound one or more bands may arise which have no counterpart in other compounds. It would be quite feasible, for example, that the infra-red band of oxyhaemoglobin might be of this type: it could be a transition from a weakly bonding to a weakly antibonding orbital embracing the ferrous ion and the oxygen molecule.

We have for simplicity deliberately treated the system as if it can be broken up in a unique and well-defined manner into a number of pieces. This is not strictly

allowable and it is important to remember that interaction may occur among the various types of excited state, resulting in shifts of their positions and donations of intensity from one transition to another.

WILLIAMS: In his introduction George has stated that the work he described on the equilibrium between two spin states was initiated in 1956. I do not wish to claim any priority in the discussion of the equilibrium between two spin states as it has been mentioned by a large number of authors since 1944 and extensive reference has been made to the factors controlling this equilibrium both by myself and others. In particular, however, I would refer to a three cornered discussion between myself, George and Griffith, in discussions of the Faraday Society, 1955, where I was the only one to maintain this point of view. I have held this point of view consistently since 1953 in discussing the very compounds now examined by George and co-workers.

The general idea that equilibrium exists between spin states has had excellent experimental foundation in the study of model complexes for some years past. I should add that I do not wish to detract from the importance of George's contribution which sets my discussion, and that of other earlier authors, on a firm basis.

Falk's contribution (see Orgel's paper and discussion, this volume, p. 15) should be read in the light of a summary of my views in Lardy and Myrback, *The Enzymes*, 1959. There, as previously, I elaborate on spin state equilibria in the cytochromes.

BOARDMAN: In their paper, George, Beetlestone and Griffith (this volume, p. 126) correct their calculations for differences in the millimolar extinction coefficients of the corresponding ferrihaemoglobin and ferrimyoglobin derivatives. I feel that these corrections are unnecessary as the extinction coefficients for the myoglobin derivatives appear to be too low by a factor of approximately 1.08.

The extinction coefficients for the myoglobin derivatives are taken from the work of Hanania, who assumed a molecular weight of 17,000 for myoglobin whereas now there is evidence to suggest that the molecular weight of myoglobin is above 18,000.

A few years ago, Adair and I at Cambridge succeeded in isolating two CO-myoglobins from horse-heart extracts by means of ammonium sulphate fractionation and chromatography on columns of Amberlite IRC-50. The main myoglobin fraction accounted for 90% of the total myoglobin. The molecular weight of the main component was determined from measurements of osmotic pressure and a figure of 18,400 was obtained. The extinction coefficient of the ferrimyoglobin cyanide derivative at  $542 m\mu$  was 0.613 for a 0.1% solution and this corresponds to a millimolar extinction coefficient of 11.3, if we assume a molecular weight of 18,400. Fig. 6 of the paper by George *et al.* (this volume, p. 113) shows a millimolar extinction maximum of 10.6 for ferrimyoglobin cyanide. A value of 11.3 agrees closely with the corresponding value for ferrihaemoglobin cyanide as determined by Drabkin. Theorell and Åkeson have concluded also that the molecular weight of horse myoglobin is above 18,000. Their preparation was purified electrophoretically. Three myoglobin components were obtained and the iron content of the main component was 0.297%. This figure gives a molecular weight of 18,800.

GEORGE: I would like to thank Williams for drawing attention to the early suggestion of Willis and Mellor (*J. Amer. chem. Soc.* **69**, 1237, 1947) that some co-ordination compounds may be thermal mixtures of high- and low-spin forms, and to his own remarks on the subject in the 1955 Faraday Discussion.

I agree with Boardman's comments on extinction coefficients. The spectrophotometric data employed in the calculations were obtained before the electrophoretic separation of myoglobin into a major and two minor components had been demonstrated. The sample used had been subjected to repeated recrystallizations from ammonium sulphate and treated with strong phosphate buffer, pH 5.7, to remove haemoglobin.

For a more exact analysis of the type described in Section IV of our paper it would not only be necessary to have extinction coefficients but also magnetic susceptibility measurements for single components. But an analysis of this kind only gives average spectra of the high-spin form and of the low-spin form for the pair of haemoproteins upon which the calculations are based. Undoubtedly there will be minor variations



from one haemoprotein to another as there are for other complexes, e.g. the cyanides and the fluorides. We regard these analyses rather as semiquantitative evidence for the existence of a thermal mixture, in that the calculated band maxima for the two forms occur at appropriate wavelengths with extinction coefficients of the right magnitude. The spectra of the two forms calculated from the temperature dependence of the spectrum and magnetic susceptibility of a single haemoprotein derivative, e.g. ferrimyoglobin hydroxide in Section V, are however free from this uncertainty.

LEMBERG: Applying similar spectrophotometric methods to those used by George, Beetlestone and Griffith, we find that in contrast to horseradish peroxidase itself, the compound of haematin *a* with the apoprotein of horseradish peroxidase has the most 'high-spin type' of spectrum of the haemoproteins *a* which we studied. There is thus an interesting difference between two compounds of the same protein with the two different haematins, haematin *a* and protohaematin.

O'HAGAN: Preliminary results suggest that actiohaematin does not attach to apomyoglobin at pH values higher than about pH 8. Holden and Hicks (*Aust. J. exp. Biol. med. Sci.* **10**, 219, 1932) considered alkaline ferrihaemoglobin to be a mixture of a compound in which linkage was not through the iron atom, and globin ferrihaemochrome. My results would appear to confirm this view and would seem to have some bearing on these results of George.

# ANALYSIS AND INTERPRETATION OF ABSORPTION SPECTRA OF HAEMIN CHROMOPROTEINS

By DAVID L. DRABKIN

*Department of Biochemistry, Graduate School of Medicine,  
University of Pennsylvania, Pennsylvania*

THE MOLECULAR spectra of various common haemin chromoproteins, their derivatives, and such related compounds as the haemochromes (nitrogenous ferro- and ferriporphyrins) exhibit selective absorption over the broad spectral range of 1000 to 200  $m\mu$ . The spectrum may be conveniently subdivided into four regions, in which individual maxima have a 500-fold difference in density (see Fig. 1). The most frequently examined region is the visible (2 in Fig. 1), the location of the  $\alpha$  and  $\beta$  bands, as they have been designated historically. The selective absorption in this region is very different for the different haemin chromoproteins and some of their derivatives, whereas the absorption in regions 3 and 4 (Fig. 1), respectively the location of the  $\gamma$  band (Soret, 1878, 1883a and b; Grabe, 1892) and the ultra-violet, is more generally similar for the different chromoproteins. Although the differences in absorption, as in the visible and near infra-red regions, form a very convenient and accurate basis for the quantitative determination of the various pigments (Drabkin, 1950; Gordy and Drabkin, 1957), they yield little obvious information concerning the relationship of the absorption to structures in the complex molecules.

Dhéré's finding that haemoglobin, like other proteins, had an absorption maximum in the vicinity of 275  $m\mu$  led him to conclude that the haemin nucleus was responsible for the absorption in the visible region, while the globin caused the absorption in the  $\gamma$  band and ultra-violet regions (Dhéré, 1906). In an early attempt to analyse the spectra of haemoglobin derivatives, Vlès (1914) presumably accepted Dhéré's earlier generalization, which has persisted to the present day. An examination of the spectrum curves of several haemoglobin derivatives led me to deduce about a quarter of a century ago that all the maxima (which represent bands) in the ultra-violet and some in the visible region were spaced at approximately equal frequency distances from each other (Drabkin, 1934). This was a potentially important discovery, since it materially simplified the interpretation of the complex spectrum from the viewpoint of its origin in the molecular structure. Before this work such a distribution of integrally related absorption bands, belonging to a spectral

series, had been demonstrated only in relatively simple molecules, such as  $\text{KMnO}_4$  (Hagenbach and Percy, 1922) and  $\text{CoCl}_2$  in concentrated  $\text{HCl}$  (Brode, 1928). It was deduced that the absorption spectra of haemoglobin derivatives were largely an expression of iron in a co-ordination complex, and attention was called to certain similarities in the spectra of  $\text{K}_3\text{Fe}(\text{CN})_6$

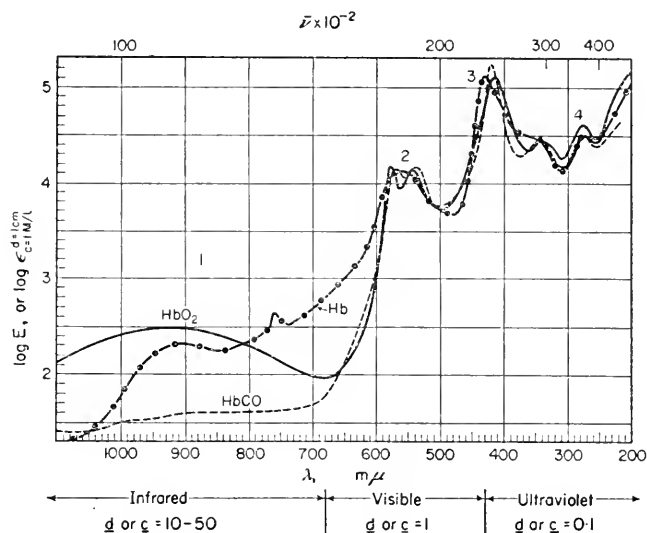

FIG. 1. Absorption spectrum curves of oxyhaemoglobin,  $\text{HbO}_2$ , deoxygenated haemoglobin,  $\text{Hb}$ , and carbonyl haemoglobin,  $\text{HbCO}$  (Drabkin, 1950; Gordy and Drabkin, 1957). The values of cuvette depth,  $d$ , or concentration,  $c$ , suggest the relative thicknesses of layer or concentrations required for optimal spectrophotometry in the different spectral regions, due to a 500-fold difference in the densities of the maxima over the spectral range of 1100 to 200  $m\mu$ . The use of  $\log E$  (the log of the molar or 1-Fe-atom equivalent extinction) permits the portrayal of the maxima in region 1 together with the rest of the spectrum. Many derivatives of the chromoproteins have weak bands in this region (the red and near infra-red). As examples, proto- and mesohaemin hydroxides have maxima in the region 810–820  $m\mu$ . Met- or ferrihaemoglobin hydroxide (alkaline methaemoglobin, pH 9), the spectrum of which in the near infra-red was originally studied by Horecker (1943), also has an absorption maximum at 820  $m\mu$  ( $\bar{\nu} \times 10^{-3} = 122$ ), with  $\epsilon$  (1  $\text{mm/l.}$ ) = 0.544 and  $\log E = 2.735$  (Gordy and Drabkin, 1957).

and cyanmethaemoglobin (Drabkin, 1936). The same deduction was later made from the similar paramagnetic susceptibilities of these iron complexes by Coryell, Stitt and Pauling (1937). The absorption spectrum curves were resolved into component bands by means of a novel graphic-mathematical analysis (Drabkin, 1937, 1938, 1940, 1950). Interestingly enough, the analysis indicated that the  $\alpha$  and  $\beta$  bands did not belong to the main spectral series and that the band at 275  $m\mu$  was not primarily owing to globin (Drabkin, 1937, 1938). Furthermore, the analysis predicted the potential occurrence of bands in the neighbourhood of wavelengths 833, 313 and 250  $m\mu$ . This was

verified by the finding of a definite maximum at 820  $m\mu$  in the spectrum of methaemoglobin hydroxide and at 314  $m\mu$  in the spectrum of ferrocytochrome *c* (Drabkin, 1941a). The maximum at 314  $m\mu$  was later designated as the  $\delta$  band (cf. Theorell and Nygaard, 1954; Tsou and Li, 1956; Morton, 1958).

The very brief past reports embracing this phase of our studies have presumably escaped notice by those more recently concerned with the analysis of the spectra of chromoproteins (Williams, 1956; Morton, 1958). In this communication a more complete description of our graphic analytical method will be supplied, together with an assembly of absorption data relevant to an interpretation of the spectra of haemin-protein complexes and possibly to the development of the theory of molecular spectra.

## MATERIALS AND METHODS

### Materials

The haemoglobins were crystallized preparations (Drabkin, 1946, 1949a), the solutions of which were rendered 'salt-free' either by dialysis or passage through 'Deeminac 16-4' resin (Drabkin, 1954). The cytochrome *c* was prepared from horse heart by Tint and Reiss (1950), and by our analyses (see below) was 96% pure, with reference to 0.43% iron content.

### Methods

*Spectrophotometry.* Most of the more recent measurements were carried out with the Beckman DU instrument, but in the earlier work the Hilger Spekker photometer and medium quartz spectrograph were used. When other types of instrumentation such as recording spectrophotometers were employed, this will be indicated in the legends to the figures.

TABLE I.  $\epsilon_{\max}$  OF CYANIDE DERIVATIVES IN THE DIRECT DETERMINATION OF HAEMIN IRON

Compound	Wavelength (in $m\mu$ )	$\epsilon_{\max}$ *	Fe-content† (%)	1-Fe-atom equivalent weight
Cyanmethaemoglobin	540	11.5	0.338	16,552‡
Cyanmetmyoglobin	545	11.5	0.339	16,503‡
Ferricytochrome <i>c</i> cyanide	537	11.0§	0.412	
Ferriprotohaemin dicyanide	545	11.3	8.57¶	652

\*  $\epsilon_{\max}$ , the millimolar extinction referred to 1 milliatom of iron.

† Iron determined independently as ferrous 1:10-phenanthroline (Drabkin, 1941b).

‡ May be rounded out to 16,500.

§ Provisional.

|| Sample was 96% pure on basis of 0.43% of iron, or 91.6% pure on basis of 0.45% of iron.

¶ Iron content of  $\alpha$ -chlorohaemin.

*Concentration of Reference.* The spectrum curves are plotted for a conventional depth of 1 cm. The concentration of reference, unless otherwise indicated, is 1 mM/l., where 1 mM represents 1 milliatom of iron. The iron content was determined independently (Drabkin, 1941b), but the spectrophotometric determination of the extinction at the maximum in the region of 545 to

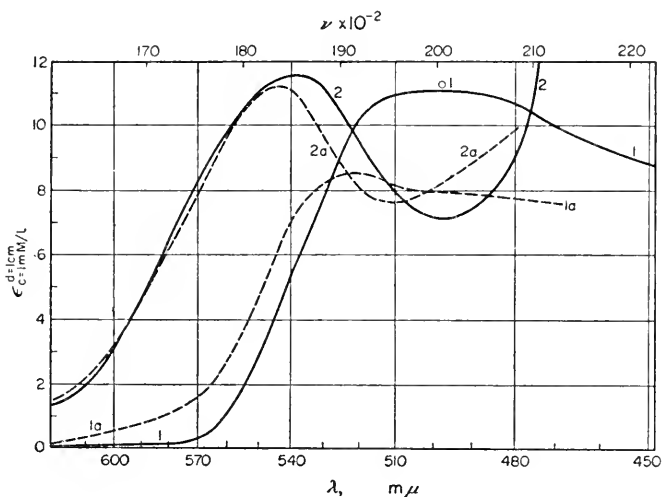

FIG. 2. Absorption spectrum curves of complexes of iron. Curve 1, ferrous 1:10-phenanthroline (ferrous *o*-phenanthroline). Curve 1a, ferrous dipyrindyl complex. Curve 2, cyanmethaemoglobin (ferrihaemoglobin monocyanide). Curve 2a, haemin dicyanide (ferriprotoporphyrin dicyanide). The  $\epsilon$  ( $c = 1$  mM/l.) for ferrous 1:10-phenanthroline is 11.05 at the maximum of 500  $m\mu$ , read against an appropriate blank. The open circle corresponds with a value of 11.25 for this complex read against water. For details see Drabkin (1941b). (Absorption spectra closely similar with those of cyanmethaemoglobin and haemin dicyanide are yielded by the cyanide derivatives of the ferrihaemochromes, such as monocyanide monopyridine ferriprotoporphyrin, with  $\epsilon = 11.7$  for the maximum at 545  $m\mu$  (Drabkin, 1942a) and by mesohaemin dicyanide and coprohaemin dicyanide with maxima respectively at 537 and 535  $m\mu$ , displaced about 10  $m\mu$  toward the shorter wavelengths in comparison with protohaemin derivatives (Drabkin, 1942b).)

535  $m\mu$  of corresponding cyanide derivatives of the ferri-complexes served in the direct, unequivocal evaluation of haemin iron (Drabkin, 1942a and b, 1949, 1954). Table 1 and Fig. 2 supply pertinent information. It may be noted that the writer's value of 0.338% for iron in haemoglobin (Drabkin, 1949b) has been tentatively accepted by the Protein Commission of the International Union of Pure and Applied Chemistry (cf. Drabkin, 1957). This iron content appears to be valid on a dry weight basis, and corresponds with a 1-Fe-atom equivalent weight of 16,500 for haemoglobin and 15,850 for globin, the total molecular weight of which may be taken as  $15,850 \times 4 = 63,400$ .

*Notation.* In the molecular interpretation of spectra, the frequency  $\nu$  (the number of waves passing a fixed point in a unit time, as 1 sec) is of more fundamental interest than the wavelength  $\lambda$ . A term closely related to the frequency is the wavenumber  $\bar{\nu}$  (the number of waves in a unit of length, as 1 cm). The relationship between  $\nu$  and  $\bar{\nu}$  is given by  $\nu = \bar{\nu} \times c$ , where  $c = 3 \times 10^{10}$  cm/sec, the speed of light, and the relationship between  $\bar{\nu}$  in  $\text{cm}^{-1}$  and  $\lambda$  in  $\text{m}\mu$  is given by  $\bar{\nu} = (1/\lambda) \times 10^7$ . Thus  $\lambda 500 \text{ m}\mu$  corresponds to  $\bar{\nu} = 20,000 \text{ cm}^{-1}$ . It is convenient to use  $\bar{\nu} \times 10^{-2}$ , and most of the graphs are so plotted. Another term, the fresnel,  $f$ , has been employed.  $f = \nu \times 10^{-12}$ . Hence,  $\bar{\nu} \times 10^{-2} = f/3$ . The absorption curves are plotted logically against  $\bar{\nu}$  in ascending order from left to right, which is in the descending order with reference to  $\lambda$  (cf. Drabkin, 1950).

*The Graphic Analysis of the Absorption Spectrum Curves.* In their analysis of the visible absorption spectrum of permanganate Hagenbach and Percy (1922) made the assumption that the component bands (represented by maxima in the spectrum) could be resolved into individual simple curves, all of the same shape, but of different height. The shape of the curves was determined by the curvature of the slope at the lowest frequency end of the absorption curve. The summation of the resolved curves yielded the absorption spectrum curve. Brode (1928) used effectively a similar method of analysis for the spectrum of  $\text{CoCl}_2$ . The spectra of these relatively simple molecules could be regarded as possessing essentially one broad band in which the multiple maxima represented a finer structure (Harrison, Lord and Loofbourow, 1948). The general character of the absorption spectra of the haemin chromoproteins is very different from that of  $\text{KMnO}_4$  or  $\text{CoCl}_2$  in  $\text{HCl}$  (see Figs. 1 and 4), and the spectrum curves could not be shown to be reproduced by a summation of component curves of the same shape, varying only in height.

A highly satisfactory resolution of the complex haemin-protein spectrum curves has, however, been attained (Drabkin, 1937, 1938, 1940 and 1941a) by assuming that the component elements (bands) did not have the shape of simple curves but could be described by the 'bell-shaped' normal frequency curves of the form

$$y = k e^{-\left(\frac{(x-a)^2}{2\sigma^2}\right)} \quad (1)$$

or

$$y = \frac{k}{e^{\left(\frac{(x-a)^2}{2\sigma^2}\right)}} \quad (2)$$

The summation of unit curves of this type, each with different values for  $k$  and  $\sigma$  (Fig. 3), reproduced very accurately the original (determined) spectrum curves. The families of curves in Fig. 3 are drawn for orientation to equation (1). In such symmetrical curves the values of  $y$  and  $x$  on each side of the

centre of distribution at 0 are the same.  $y$  is the height from the base of a point on the curve at a distance  $x$  from the centre.  $k$  is the height at the centre of distribution  $a$  (usually designated the 'mean') for a particular case (in the diagrams of this figure  $a = 0$ ).  $\sigma$ , the *standard deviation*, is a measure

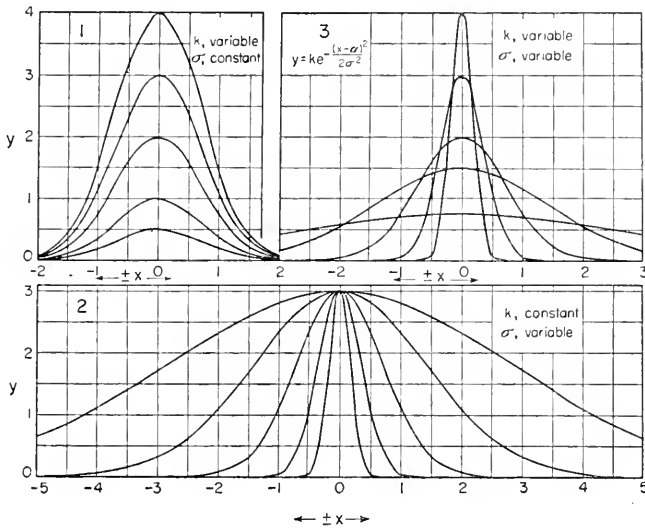

FIG. 3. Families of normal frequency curves of the form:

$$y = k e^{-\left(\frac{(x-a)^2}{2\sigma^2}\right)}$$

The effect of variability in either  $k$  or  $\sigma$  is shown in 1 and 2. In 3, most pertinent to the present analytical assumptions, both  $k$  and  $\sigma$  are variable.

of the spread or variation about the centre of the individual points, over two-thirds of which in such curves lie within the interval  $1\sigma$  and 95% within  $2\sigma$ .  $e$  is the base of natural logarithms, 2.7183.

In our application to spectra,  $y$  and  $k$  are in  $\epsilon$  units,  $x$  and  $a$  (the locations of the centres of the curves or bands, assumed or deduced from the locations of the maxima in the absorption data) in units of  $f$  or  $\bar{\nu}$ . In the construction of the curves,  $2\sigma^2$  is conveniently evaluated by a rearrangement of terms in equation (1).

$$2\sigma^2 = \frac{(x-a)^2}{\log_e k/y} \tag{3}$$

$k$  and  $y$  in equation (3) are derived either directly from the absorption data or by adjustment for overlapping of neighbouring component curves. In the case of prominent bands, as the so-called  $\gamma$  or Soret band in the spectra of the chromoproteins, or bands at the lower frequency end of spectrum as with

CoCl<sub>2</sub> (Fig. 4), a mean value of  $2\sigma^2$  is readily obtained from several points along the left contour of the determined absorption curve. In other cases simultaneous equations are useful in deriving appropriate values, aided by suitable processes of curve fitting, details of which cannot be supplied here. Having settled on values for  $2\sigma^2$  and  $k$ , values for  $y$  are calculated with

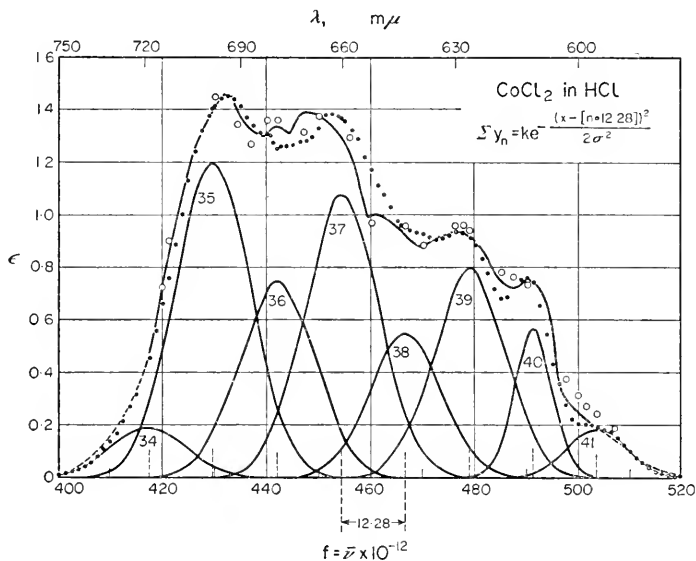

FIG. 4. The graphic-mathematical analysis of the absorption spectrum curve of CoCl<sub>2</sub> in concentrated HCl (Drabkin, 1940). The continuous solid line with multiple inflections is the absorption spectrum obtained by Brode (1928), and the open circles represent summational points obtained by his method of analysis (see text). The individual curves, numbers 34 to 41, were obtained by the writer's method of analysis with curves of the normal frequency form. The black dots show the summation of these curves, expressed by the equation inserted in the figure. For  $y_{34}$  to  $y_{41}$  the values of  $k$  are 0.19, 1.20, 0.75, 1.08, 0.55, 0.80, 0.57, and 0.19. The corresponding values for  $2\sigma^2$  are 102.0, 102.0, 102.0, 97.5, 93.8, 92.3, 27.2, and 66.2.

equation (2) to yield the curves. Experience will suggest labour- and time-saving devices in this type of graphical analysis. It should be clear that the choice of spectral interval in terms of  $\bar{\nu} \times 10^{-2}$  determines the locations (at equal frequency distances from each other) of the values of  $a$ .

It is of interest that the analysis of the absorption spectra of complex molecules into component bands of the shape of normal frequency curves makes it possible to express the spectra in relatively exact mathematical terms. This cannot be done with the earlier successful analytical procedure used for KMnO<sub>4</sub> and CoCl<sub>2</sub>. Hence it was desirable to test the applicability of the new method by the analysis of the spectra of the simpler molecules. Figure 4 and its legend give the analysis of the spectrum of CoCl<sub>2</sub>, and the



conclusion appears justified that practically as good a result is yielded by the new method as by the one used by Brode (1928). The latter's frequency spacing of  $f = 12.28$  was purposely retained in the analysis. It should be pointed out that the writer's method yielded one extra band (number 34) at the low-frequency end of the spectrum. This is explained by the fact that  $\sigma$  values, calculated from the left slope of the absorption curve were sufficiently discrepant from each other to denote skewness and suggest the presence of an additional component.

*Tentative Corollaries or Rules of the Analysis and Notation of Bands.*

(a) The presence of bands in the absorption curves may be indicated either by well-defined maxima, by inflections ('bumps') in the curve, or by regions of relatively flat absorption. On the other hand, several component bands may be merged together into an apparently single band or may be hidden in the final 'summational' spectrum curve. These propositions can be demonstrated by the summational results obtained with two or more neighbouring (overlapping) curves of the normal frequency type. (b) The positions of the maxima in the determined absorption spectrum may be displaced from their theoretically correct locations in the resolved components. Indeed, this is an expected consequence of the overlapping of the component elements in the proposed analytical method. (c) The analysis itself best discloses the multiple components, and, as has already been stated, 'predicts' the possible presence of hidden bands. Hence, certain component bands are represented by prominent maxima in the spectra of all haemin chromoproteins, others only in the spectra of some of the complexes or their derivatives (see Table 2).

The descriptive notation used for a particular band in the complex spectra may prove controversial. This matter need not be debated here. The historical designations  $\alpha$  and  $\beta$  have been retained for the bands in the visible green spectral region. Even this may be illogical, since bands are present in the red and near infra-red spectral regions (Fig. 1). The  $\alpha$  and  $\beta$  bands are deduced by our analysis to have a structural significance differing from the main frequency distributed series. For the latter, which includes the Soret and ultra-violet bands the designations  $\gamma$  and  $\delta$  appear inappropriate, and they will be assigned a number,  $n$ , which is an integer (3, 4, 5, 6, 7, etc.) based on the frequency spacing  $\bar{\nu} \times 10^{-2} = 40$ . Thus  $6 \times 40 = 240$ , the wavenumber location or  $a$  of the  $\gamma$  or Soret band;  $8 \times 40 = 320$ , the postulated location of the  $\delta$  band (Table 2, Figs. 5 to 10).

## EXPERIMENTAL

*Contribution of Haemin to Over-all Spectroscopic Character of the Haemin Chromoproteins.* In Tables 1 and 2 and in Figs. 1, 2 and 5 to 11, which with their legends are largely self-explanatory, the basis for the analysis of the spectra and deductions drawn therefrom is furnished. Attention may be directed to several points.

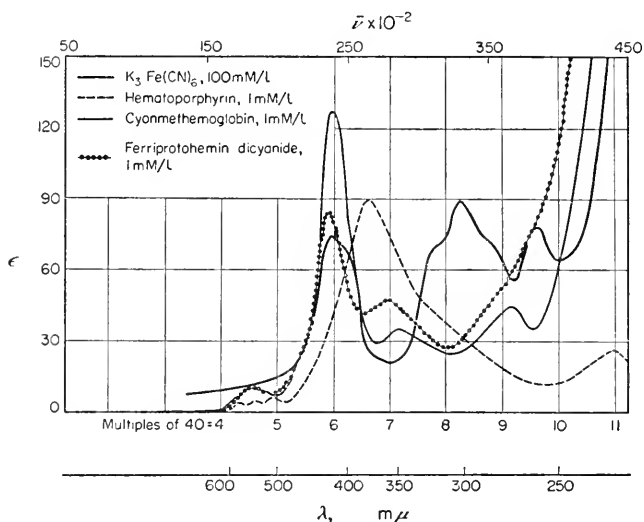

FIG. 5. Comparison of absorption spectra of  $K_3Fe(CN)_6$ , haematoporphyrin (in alkaline solution), cyanmethaemoglobin or ferrihaemoglobin monocyanide (from dog haemoglobin), and ferriprotohaemin dicyanide or haemin dicyanide at pH 13. Hogness and colleagues (1937) reported a maximum at  $230\text{ m}\mu$  (corresponding with  $\bar{\nu} \times 10^{-2} = 435$ ), with  $\epsilon = 32 \cdot 1$ , for haemin dicyanide. The abscissal scales indicate the postulated locations of bands in the equally spaced, frequency distributed series (Drabkin, 1936, 1938).

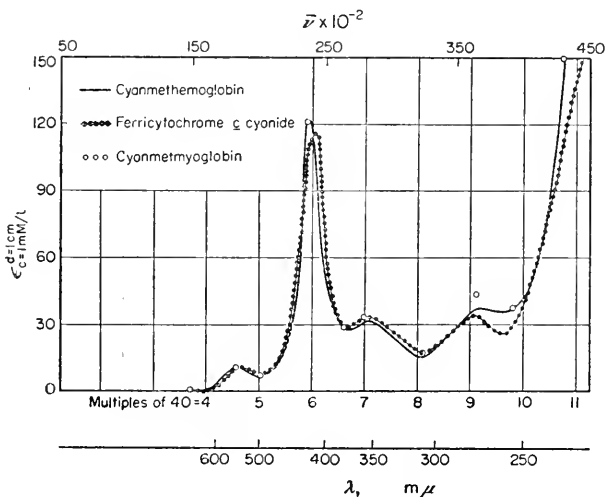

FIG. 6. Comparison of spectra of cyanmethaemoglobin (from the haemoglobin of man), ferricytochrome *c* cyanide at pH 10 to 11 (for preparation see legend to Fig. 7), and cyanmetmyoglobin (from horse heart myoglobin). The remarkable similarity of these spectra is evident. The abscissal scales indicate the postulated locations of bands in the equally spaced, frequency distributed series.

(1) The determination of haemin iron is most unequivocally and quantitatively accomplished through the characteristic absorption in the visible region of the cyanide derivatives of haemin and the haemin proteins (Drabkin, 1942a, 1949b), and the spectra are remarkably similar in both the visible and ultra-violet regions (Figs. 2 and 6). These findings indicate that a single major molecular characteristic is responsible for the general over-all spectrum. In the writer's analysis for iron by the 1:10-phenanthroline method the  $\epsilon$  value for the maximum of ferrous 1:10-phenanthroline was found to be close to identical with that of the cyanide derivatives of the haemin complexes (Table 1 and Fig. 2). Accordingly it was deduced that in the analytical procedure iron was liberated from one complex (hexaco-ordinated haemin iron; Drabkin, 1936, 1938) and bound up in another, diimine iron (Drabkin, 1941b). The similarity of the spectra favoured the idea of a spectroscopically operative structural similarity in these different classes of compounds. The spectroscopic similarity of the cyanide derivatives of the ferrichromoproteins has its counterpart in their low paramagnetic susceptibilities (Coryell, Stitt and Pauling, 1937; Theorell, 1941). It was deduced from their magnetic behaviour that they are essentially (though not fully) octahedral  $d^2sp^3$  covalent bonded stabilized structures, in essence of the Werner hexaco-ordination type (cf. Pauling, 1940, 1948, 1949).

(2) In Table 2 it may be seen that in some haemin complexes only a limited number of the bands, postulated by the analysis, are represented by definite maxima in the absorption spectra. However, considering the data on the different haemin complexes as an interrelated whole, maxima representative of at least eight, possibly nine bands (numbers  $n = 3$  to 11) of an equally spaced frequency distributed series are found. As has been stated, the spectrum of ferrocytochrome *c* (Drabkin, 1941a) proved to be particularly rich in maxima (Fig. 7) and disclosed the presence of bands missing from the earlier examined spectra of haemoglobin derivatives, but 'predicted' by the analysis. The basis for these differences in the spectra of reduced and oxidized cytochrome *c* and haemoglobin derivatives is not clear, unless it can be attributed to the difference in the bonding of the haemins with the protein (Theorell, 1938, 1941). With the exception of small 'shifts' in the location of some of the maxima, such spectral differences are erased in the spectra of the respective cyanide derivatives of these chromoproteins (Fig. 6).

(3) An examination of Table 2 will disclose that bands number 3, 6, 9 and 11 in the series  $\bar{\nu}_0 \times 10^{-2} = 40$  can also be distributed at regular frequency intervals on the basis of  $\bar{\nu}_0 \times 10^{-2} = 60$ . In the latter case the  $\beta$  band would be included as number 3 and the bands would be represented by  $n = 2, 3, 4, 5, 6$  and 7, with number 5 in an intermediate position between 7 and 8 of the spacing  $\bar{\nu}_0 \times 10^{-2} = 40$ . The 60 spacing was originally assumed (Drabkin, 1934), and led to the analysis, illustrated for the spectrum of cyanmethaemoglobin, in Fig. 8. In this figure it may be seen that, utilizing

the frequency interval of 60, the graphic-mathematical analysis into component bands fails to reproduce by their summation the observed absorption in the regions  $\bar{\nu} \times 10^{-2} = 160, 200, 280$  and  $320$ . These spectral regions do have representative maxima in the absorption spectra of some of the chromoproteins (Table 2), and either two or more separate series would have to be

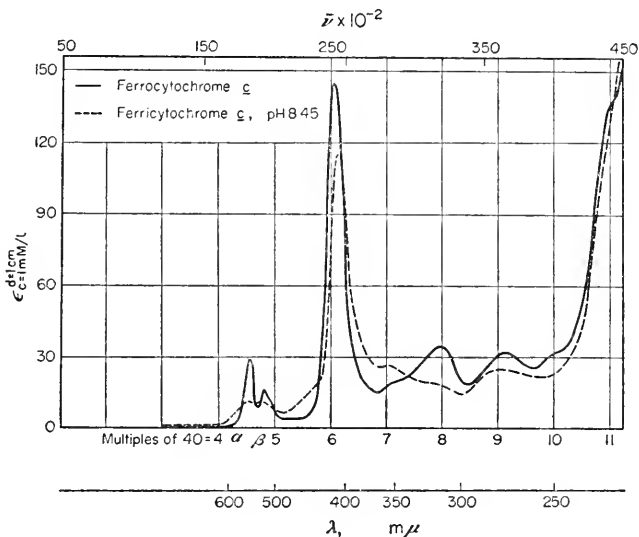

FIG. 7. The spectra of reduced and oxidized cytochrome *c* from horse heart, pH 8.45. The molecular weight of reference was taken as 13,000 (0.43% of iron). The preparation had 0.412% of iron by Drabkin's *o*-phenanthroline method (1941b). Reduction to ferrocyclochrome *c* was by means of  $\text{Na}_2\text{S}_2\text{O}_4$  for the data to 380  $m\mu$  and with palladium asbestos and hydrogen for the data in the ultra-violet region beyond 380  $m\mu$ . To insure complete oxidation to ferricytochrome *c* 0.4 of an equivalent of ferricyanide was added to the 60% oxidized preparation. In the measurements this was balanced out by an equivalent amount ferrocyanide. The abscissal scales indicate the postulated locations of bands in the equally spaced, frequency distributed series (Drabkin, 1941a).

assumed or a more appropriate single frequency spacing adopted. The latter alternative was taken, and accordingly the 40 spacing was tested. This spacing was preferred not only because of the locations of the observed maxima, but also intuitively since it excluded both the  $\alpha$  and  $\beta$  bands.

The supplemental Figs. 9 and 10 illustrate the analysis of the absorption spectrum of cyanmethaemoglobin, taking  $\bar{\nu}_0 \times 10^{-2} = 40$ . It may be seen that the summation of the analytically resolved ten absorbing units or bands agrees excellently with the observed spectrum, which can be expressed mathematically (Drabkin, 1937) by

$$\Sigma y_n = \left( k e^{-\frac{(x - [n \times 40])^2}{2\sigma^2}} \right) + \Sigma (y_\alpha, y_\beta) \quad (4)$$

The closeness of fit of the analytically derived spectrum with the experimentally determined one is reflected by values of 3.29 for the mean of deviations between them, 0.24 for the mean about which the deviations fall, 6.06 for S.D., and 0.47 for S.D. from  $151 \text{ to } 205 \bar{\nu} \times 10^{-2}$  (Fig. 10). All the absorption spectra of the haemin chromoproteins and their derivatives thus far studied by the writer (a partial list of which is given in Table 2) can be similarly analysed into their component bands, and equation (4) may be regarded as generally applicable.

(4) The dissection of the broad band of the spectrum of cyanmethaemoglobin at wavelength  $540 \text{ m}\mu$  or  $\bar{\nu} \times 10^{-2} = 185$  (Drabkin, 1937, 1938 and Fig. 10) merits particular attention. The accurate establishment of the left contour of this band reveals a very slight 'bump' in the vicinity of  $570 \text{ m}\mu$  (see curve 2 in Fig. 2 and the solid line in Fig. 10). There is also the appreciable absorption in the regions of 630–600 and  $500 \text{ m}\mu$ , the locations assigned in the analysis to bands 4 and 5, which are represented by definite maxima in some of the chromoprotein spectra (Table 2). These findings in themselves

TABLE 2. LOCATION OF MAXIMA (BANDS) IN CHROMOPROTEIN SPECTRA, POSTULATED TO BELONG TO SERIES  $n = (\bar{\nu} \times 10^{-2})/(\bar{\nu}_0 \times 10^{-2})$

$\bar{\nu}_0 \times 10^{-2}$  is assumed = 40 (where  $n = 1$ ). The values in brackets give the number  $n$  of the band in the series. The values in parentheses give locations of inflections (or bumps) in the absorption curve, as distinguished from obvious maxima.

Compound	$\alpha$	$\beta$	$\bar{\nu} \times 10^{-2}$ observed						
Oxyhaemoglobin	173	184	109 [3?]	241 [6]	290 [7]	362 [9]	417*	[11?]	
Carbonylhaemoglobin	176	186	111–125 [3?]	238 [6]	290 [7]	366 [9]	426 [11?]		
Cyanmethaemoglobin (from dog haemoglobin)		185		239 [6]	285 [7]	368 [9]	437 [11?]		
Cyanmethaemoglobin (from haemoglobin of man) <sup>†</sup>		185		237 [6]	282 [7]	366 [9]			
Methaemoglobin, pH 5.9	(173)	(184)	159 [4]	198 [5]	246 [6]	285 [7]	359 [9]	435 [11?]	
Methaemoglobin hydroxide, pH 9.2	173	184	122 [3]	167 [4]	(206) [5]	241 [6]	282 [7]	365 [9]	431 [11?]
Ferricytochrome <i>c</i> , pH 8.45	182	192	(135) [3?]	241 [6]	(284) [7]	319 [8]	(365) [9]	(403) [10]	(446) [11]
Ferricytochrome <i>c</i> , pH 8.45	182	191	(143) [3?]	244 [6]	280 [7]	(315) [8]	359 [9]	(430) [11?]	
Ferriprothaemin dicyanide, pH 13		183		235 [6]	278 [7]	(360) [9]		‡	

\* With the Beckman DU spectrophotometer, measurements in this spectral location are unreliable; with ferrocyclochrome *c* a definite inflection in the curve at  $\bar{\nu} \times 10^{-2} = 446$  was obtained with Hilger's Spekker photometer and medium quartz spectrograph.

† For the spectra of ferricytochrome *c* cyanide and cyanmetmyoglobin see Fig. 6.

‡ For a maximum reported to be present in this location see the legend to Fig. 5.

suggest the composite nature of this band. In the analysis, the order of solution was band 4 first, then 5, then  $\alpha$ , and finally  $\beta$ . The need for a  $\beta$  band and the locations of the centroids of  $\alpha$  and  $\beta$  were consequences of the analytical procedure. The centroids of the analytical  $\alpha$  and  $\beta$  bands are respectively at  $\bar{\nu} \times 10^{-2} = 179$  ( $559 \text{ m}\mu$ ) and  $187$  ( $535 \text{ m}\mu$ ) and  $k$  is larger

for  $\alpha$ . The locations and relative densities of the bands are very suggestive of those found in the spectra of ferrohaemochromes, like pyridine and globin ferroprotoporphyrins (see Fig. 17 and Drabkin, 1937, 1938). It is difficult to regard this analytical result as pure coincidence. It is at the least highly provocative, revealing as it does fundamental similarities in the spectrally

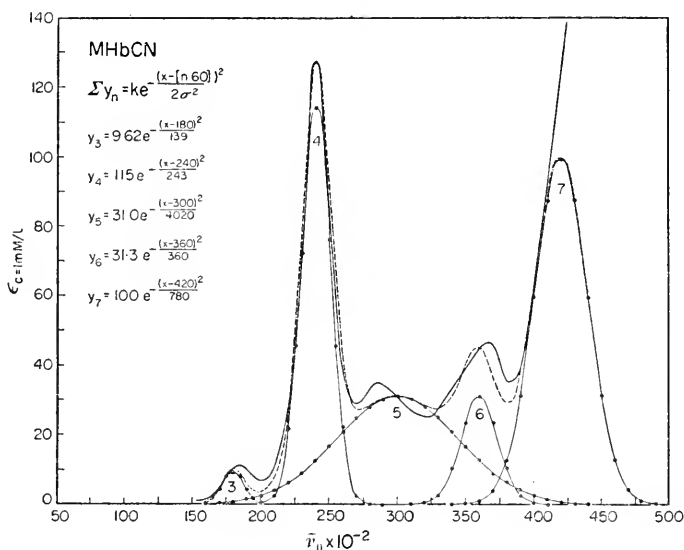

Fig. 8. The graphic-mathematical analysis of the absorption spectrum curve of cyanmethaemoglobin (from dog haemoglobin). The continuous solid line is the absorption spectrum obtained experimentally. The broken line represents the summation of the individual component elements or bands (solid dotted lines) of the normal frequency form, derived by the writer's method of analysis. The bands are numbers 3 to 7 in an equally spaced, frequency distributed series, with  $\bar{\nu}_0 \times 10^{-2} = 60$ . The summation of the resolved component bands is given by the equation inserted in the figure. The equations  $y_3$  to  $y_7$  (insert in figure) are for the respective components, with the applicable values for  $a$  and  $2\sigma^2$  substituted in equation 1 (see *Methods*).

divergent visible region of haemin-protein spectra. The single band of deoxygenated haemoglobin at  $555 m\mu$  can be similarly resolved into bands 4,  $\alpha$ ,  $\beta$  and 5.

To summarize, it may be concluded from the graphic-mathematical analysis that (1) the absorption spectra of all haemin chromoproteins and their derivatives (both oxidized and reduced) are fundamentally similar, (2) the  $\alpha$  and  $\beta$  bands have a different origin from bands 3 to 11 of the equally spaced frequency distributed series, and (3) the differences in the spectrum curves (largely evident in the visible spectral region) are an expression of the relative densities or intensities of the absorption bands in the different compounds (Drabkin, 1937, 1938, 1941a; Table 2 and Figs. 10 and 12).

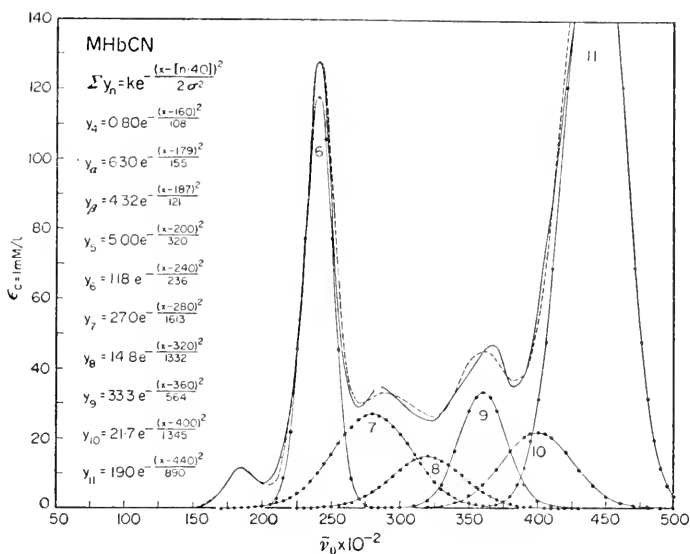

FIG. 9. The graphic-mathematical analysis of the absorption spectrum curve of cyanmethaemoglobin. (This figure and Fig. 10 are supplementary.) The continuous solid line is the absorption spectrum obtained experimentally. The broken line represents the summation of the individual components or bands (solid dotted lines) of the form of normal frequency curves, obtained by the writer's method of analysis. In contrast with Fig. 8, the bands in the equally spaced frequency distributed series are resolved on the basis of  $\bar{\nu}_0 \times 10^{-2} = 40$ . Bands with numbers  $n = 6$  to 11 are shown in this figure; numbers 4 and 5 and resolved bands  $\alpha$  and  $\beta$  in Fig. 10. The summation of the bands (4 to 11) in the single series and the mathematical formulation of each unit is given by the equations inserted in the figure. See Fig. 10 and the text.

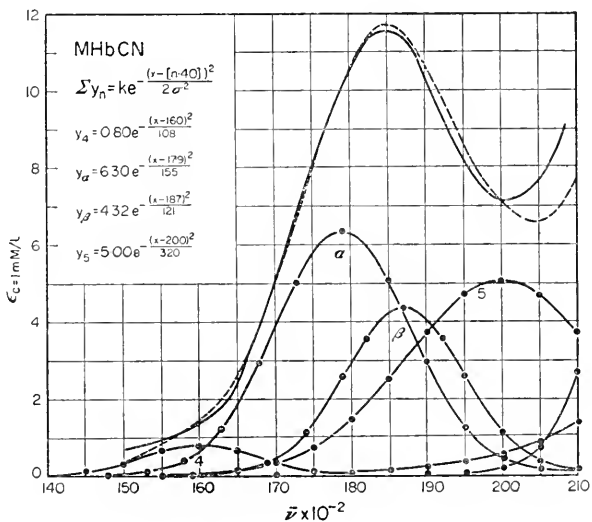

FIG. 10. The graphic-mathematical dissection of the band in the green spectral region of cyanmethaemoglobin. This figure is supplemental to Fig. 9. See legend to Fig. 9 and the text.

*Contribution of Protein to the Over-all Spectroscopic Character of the Haemin Chromoproteins.* From what has already been said, the affect of the metalloporphyrin complex is dominant throughout the spectral range, and the absorption of the haemoglobins and of cytochrome *c* in the ultra-violet region, even at the location of the so-called protein band (280–270  $m\mu$ ; band number 9 in the analysis), cannot be attributed exclusively to the protein moieties.

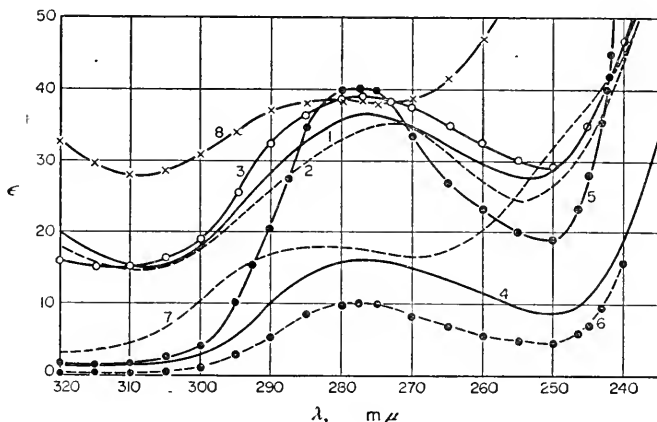

FIG. 11. The contribution of the protein moiety, globin, to absorption in the region 275 to 280  $m\mu$  ( $\bar{\nu} \times 10^{-2} = 360$ ; band number 9). Curve 1, heavy solid line, oxyhaemoglobin, 1 mM/l. (1 milliatom of Fe); curve 2, heavy broken line, carbonyl haemoglobin, 1 mM/l. (1 milliatom of Fe); curve 3, light solid line with open circles, met- or ferrimyoglobin, 1 mM/l. (1 milliatom of Fe); curve 4, light solid line, globin (from haemoglobin), 0.25 mM/l. (reference mol. wt. = 15,850); curve 5, light solid line with black dots, bovine plasma albumin, 1 mM/l. (reference mol. wt. = 68,000); curve 6, broken line with dots, bovine albumin, 0.25 mM/l. (reference mol. wt. = 17,000); curve 7, broken light line, denatured globin, 0.25 mM/l.; curve 8, light line with crosses, 1 mM/l. with reference to haemin (protohaemin added to amount of globin used for curve 7). Curves 4 and 6 afford a comparison of globin and albumin at approximately similar concentrations by weight. Curves 1 and 2 indicate that, if expressed on a molar basis (mol. wt. = 66,000), the absorption in this spectral region would be four times greater for the haemin proteins than for albumin. See the text.

The spectroscopic data plotted in Fig. 11 substantiates this conclusion. It may be seen that the bands of haemoglobin derivatives and metmyoglobin, though generally similar yet differ slightly from each other (curves 1 to 3). On the other hand, they are broader and smoother than the band of bovine albumin (curve 5). Misleading deductions as to the molecular origin of this band in chromoproteins may have been drawn because of the convention of expressing information on the chromoproteins on a 1-Fe-atom equivalent basis, whereas for proteins like albumin the molecular weight base has been used for reference. If the absorption for the haemoglobin derivatives were to be referred to 1 mM/l., instead of 1 milliatom of Fe/l., its maximum in this



spectral region would be four times higher than that of albumin (see curves 1 to 6 and the legend, Fig. 11). However, denaturation does have an influence on chromoprotein spectra in this region, as it does on the albumin spectrum (compare curves 4 and 7). The influence of haemin in this spectral region is suggested by curves 4, 7 and 8. Contrariwise, if the protein moieties do exert spectroscopic influence, they do so more evidently in the visible spectral region, the spectral changes in which may be deduced to be a function of the nature of co-ordinating groups or ligands bonded to the iron, which is also bonded to the four pyrrolic nitrogens. Thus, the alkaline denaturation of haemoglobin yields globin haemochrome, and the spectrum of globin ferroprotoporphyrin in the visible spectral region is practically indistinguishable from that of pyridine ferroprotoporphyrin (Drabkin, 1942a and Fig. 17). The situation with respect to spectroscopically operative protein structures is presumably different in the case of cytochrome  $b_2$ . The pronounced maximum at  $265 \text{ m}\mu$  ( $\bar{\nu} \times 10^{-2} = 377$ ) appears to be clearly ascribable to the riboflavin phosphate and a polydeoxyribonucleotide, which are structural components of this complex molecule (Appleby and Morton, 1954; Morton, 1958). Whether the influence of the nucleotide is confined to this spectral region or may be reflected in other spectral regions remains to be ascertained. Thus far no convincing evidence has appeared that the number 9 band in the chromoproteins may be a composite with finer structure attributable to the aromatic amino acids, as has been shown for non-haemin proteins (Holiday, 1936, 1937; Lavin, Northrop and Taylor, 1933; Lavin and Northrop, 1935). It may be concluded that from the qualitative viewpoint the protein moiety of the haemin proteins contributes only negligibly to their over-all spectra (see Discussion).

*The  $\alpha$  and  $\beta$  Bands and the Neighbouring Visible Spectral Regions.* Despite the fundamental similarities disclosed by the analysis of the spectra of the haemin proteins, in the past major attention has been devoted to characteristic and pronounced differences in these spectra in the visible spectral region. Such differences have been valuable in the accurate determination by means of spectrophotometry of biologically important derivatives as well as in the study of certain equilibria (Austin and Drabkin, 1935; Drabkin and Singer, 1939; Drabkin and Schmidt, 1945; Drabkin, 1950; Gordy and Drabkin, 1957), but may have directed attention away from the basic similarities. It may be said that the combination of haemoglobin with gases ( $\text{O}_2$ , CO, NO), the oxidation of haemoglobin to ferrihaemoglobin, the alkaline denaturation of haemoglobin to haemochrome, and the pH dependency of ferrihaemoglobin are all spectroscopically operative, and that many of these reactions have parallels in the spectroscopic behaviour of the cytochromes. Figures 12 to 17 and Table 3 are relevant in the interpretation of the differences in the visible spectra of chromoproteins, consonant with the analytical viewpoint that all the spectra have  $\alpha$  and  $\beta$  components straddled by bands 4 and 5 of the dominant

TABLE 3. CORRELATION OF SPECTROSCOPIC PATTERN WITH ELECTRONIC STRUCTURE  
*S* = strong band; *W* = weak band; *M* = moderately strong band; *N* = negligible band

Compound	Figure number	Spectrum bands			Number of unpaired electrons*	Type†
		4	$\alpha$	$\beta$		
Ferrihaemoglobin	12	<i>S</i>	<i>W</i>	<i>W</i>	5	Ionic (1)
Ferricytochrome <i>c</i> I and II	7	<i>S</i> ‡	<i>W</i>	<i>W</i>	5	Ionic (2)
Ferrohaemoglobin	1	<i>S</i> ‡	<i>M</i> ‡	<i>M</i> ‡	4	Ionic (3)
Ferrihaemoglobin hydroxide	12	<i>M</i> ‡	<i>S</i>	<i>S</i>	3	Ionic (1)
Ferrihaemoglobin cyanide	10	<i>W</i> ‡	<i>M</i> ‡	<i>M</i> ‡	1	Covalent (1)
Ferricytochrome <i>c</i> cyanide	6	<i>W</i> ‡	<i>M</i> ‡	<i>M</i> ‡	1	Covalent (2)
Oxyhaemoglobin	1	<i>N</i>	<i>S</i>	<i>S</i>	0	Covalent (3)
Carbonylhaemoglobin	1	<i>N</i>	<i>S</i>	<i>S</i>	0	Covalent (3)
Globin ferroprotoporphyrin	17	<i>N</i>	<i>S</i>	<i>S</i>	0	Covalent (4)
Pyridine ferroprotoporphyrin	17	<i>N</i>	<i>S</i>	<i>S</i>	0	Covalent (4)

\* The permanent magnetic dipole moment in these complexes is due almost entirely to  $\mu_s$ , the spin moment of the unpaired electrons.  $\mu_s$  is derived from the measured molal paramagnetic susceptibility. Theory for  $\mu_s$  for 1 to 5 unpaired electrons is 1.73, 2.83, 3.83, 4.90 and 5.92 Bohr magnetons.

† The terms *ionic* and *covalent* should be prefaced by 'essentially' to indicate partial ionic and covalent character. Thus, ferrihaemoglobin is more ionic than ferrihaemoglobin hydroxide (Pauling, 1940, 1948, 1949). References: 1, Coryell, Stitt and Pauling, 1937; 2, Theorell, 1941; 3, Pauling and Coryell, 1936b; 4, Pauling and Coryell, 1936a.

‡ Deduced from the graphic analysis of the spectrum.

series. The relative prominence of these four components results in the spectral differences. This is well illustrated in supplementary Figures 12 and 13, which show the transition with change in pH of the spectra of human met- or ferrihaemoglobin to ferrihaemoglobin hydroxide. The pH dependency of the spectrum of ferrihaemoglobin was originally studied by Hartridge, 1920 and Haurowitz, 1924. A detailed and very careful spectrophotometric study by Austin and Drabkin (1935) of dog ferrihaemoglobin, MHb, with reference to the equilibrium  $\text{MHb} \rightleftharpoons \text{MHbOH}$  revealed a reaction of the first order with OH ion, and  $\text{p}K_3$  (as it is now usually designated) was accurately established as  $8.12 \pm 0.01$  at  $\mu$  (ionic strength) = 0.1 and  $\alpha = 0.6$ . This value for  $\text{p}K_3$  has been confirmed by the independent techniques of magnetometric titration (Coryell, Stitt and Pauling, 1937) and differential acid-base titration (Wyman and Ingalls, 1941). Furthermore, the demonstration of the effect of ionic strength, regarded in that day as unusual for such complex compounds, was also apparent in their magnetic behaviour. Thus, the haemin-linked group, responsible for  $\text{p}K_3$  (i.e. the release of a proton from a molecule of water co-ordinated with the iron in acid ferrihaemoglobin,  $\text{MHb} \cdot \text{HOH}^+$ , to form  $\text{MHb} \cdot \text{OH} + \text{H}^+$ ) was spectroscopically, magnetometrically and titrimetrically operative. It appeared that at least in this case the electronic structural change involved in  $\text{MHb} \rightleftharpoons \text{MHbOH}$  (MHb, with a magnetic

susceptibility corresponding with 5 unpaired electrons, to MHbOH with 3 unpaired electrons; Coryell, Still and Pauling, 1937) could be correlated with the spectra of the transition of one spectroscopic species to the other. (In ferricytochrome *c*, appreciably more pH-stable than ferrihaemoglobin, four such spectroscopically operative acid groups have been uncovered (Theorell and Åkesson, 1941).)

The  $pK_3$  for human MHbOH is 8.15 at  $\mu = 0.1$ , nearly the same as that of dog MHbOH. This value is derived from the automatically recorded spectrum curves in Fig. 12 (Drabkin and E. Thorogood, unpublished). That only two species participate in the spectroscopic transition was evident both in the visible and near infra-red spectral regions and was reflected by the presence of 5 isosbestic points (see legend to Fig. 12). However, it may be seen in Fig. 13 that there is a departure from this behaviour in the near ultra-violet region, since band number 6 is appreciably higher and located at a shorter wavelength for MHb than the corresponding band for MHbOH (cf. also Hicks and Holden, 1929). In the present connection, the main point which may be stressed is that bands 4,  $\alpha$ ,  $\beta$  and 5 are evident in the spectra of both MHb and MHbOH, but in the latter  $\alpha$  and  $\beta$  dominate, whereas in the former  $\alpha$  and  $\beta$  are only weakly expressed, while 4, particularly, and 5 are relatively dominant (see Fig. 12).

Using the spectra of MHb and MHbOH as models, the relation between the quantum mechanical deductions drawn from measurements in Linus Pauling's laboratory of the molal paramagnetic susceptibilities of haemin and its derivatives and the spectra of these compounds may be placed upon a somewhat broader base by a suggestive correlation of the spectroscopic pattern with the corresponding electronic character. In general, all essentially covalent structures have prominent  $\alpha$  and  $\beta$  bands and weak number 4 bands, whereas essentially ionic structures may have relatively weak  $\alpha$  and  $\beta$  bands, but are mainly characterized by strong number 4 bands or marked absorption in the spectral region of the 4 band. This is brought out in Table 3. The spectral patterns in the visible region are not as diverse as may have been supposed (Drabkin, 1942a and b, and Figs. 15 to 17). However, oxy-, carbonyl, cyanide and pyridine derivatives of ferrohaem are spectroscopically distinguishable from each other, whereas their electronic configuration is the same (Table 3). It seems reasonable to infer that both the electronic structure of the haemin iron and the nature of the co-ordinating ligand contribute to the spectrum (cf. also Williams, 1956).

The co-ordination of haemin iron with OH ion is a general reaction, exhibited also by the ferrihaemochromes (cf. Haurowitz, 1927; Davies, 1940). In Fig. 14, the writer's spectrophotometric measurements of the equilibrium pyridine ferriprotoporphyrin  $\rightleftharpoons$  pyridine ferriprotoporphyrin hydroxide are supplied. From these data a  $pK$  value of 9.64 may be derived (see Insert to Fig. 14). However, there is a most interesting difference between these

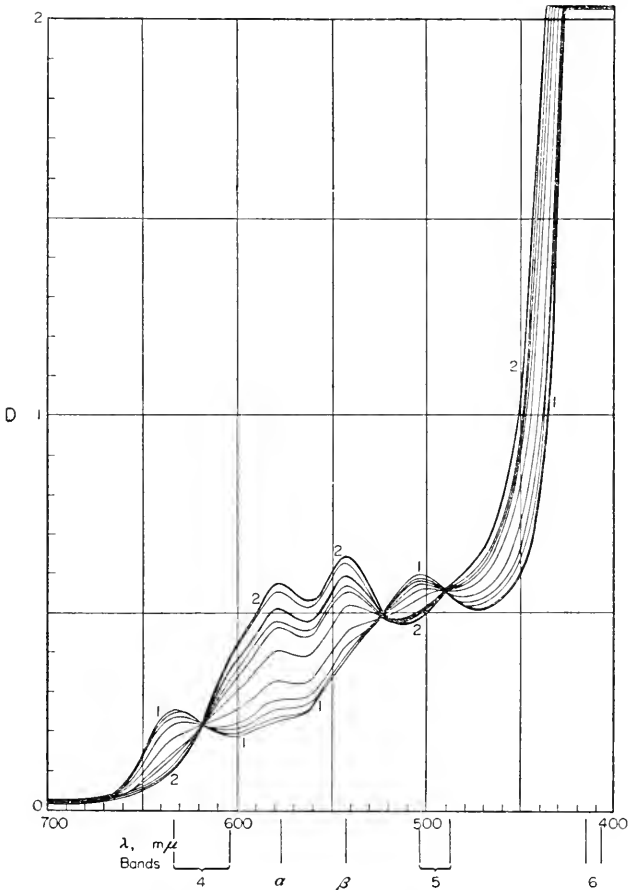

FIG. 12. Absorption spectrum curves of solutions of crystalline human met- or ferrihaemoglobin, buffered to various pH values. All the buffers had an ionic strength,  $\mu$ , of 0.1.  $D$  is the optical density. The spectra were obtained with the General Electric recording spectrophotometer on solutions with a haemoglobin iron concentration of 0.0584 mm/l. (Figs. 12 and 13 are supplementary.) Curve 1, methaemoglobin at pH 6.20 (taken as species 1). Curve 2, methaemoglobin hydroxide at pH 9.35 (taken as species 2). The nine intermediate curves represent mixtures of the two species at respective pH of 6.61, 7.05, 7.34, 7.7, 8.17, 8.50, 8.60, 8.80 and 9.20. Methaemoglobin hydroxide has an additional maximum at 820  $m\mu$  and there is an additional isosbestic point for the two species at 845  $m\mu$  (Gordy and Drabkin, 1957). For the earlier work on the equilibrium of methaemoglobin-methaemoglobin hydroxide and the treatment of spectrophotometric data in a two component system see Austin and Drabkin, 1935.

spectra and the corresponding ones for  $\text{MHb} \rightleftharpoons \text{MHbOH}$ . The colours of the spectroscopic species are reversed with reference to pH. MHb is brown, MHbOH red, whereas in the pyridine complexes the colour is olive brown at

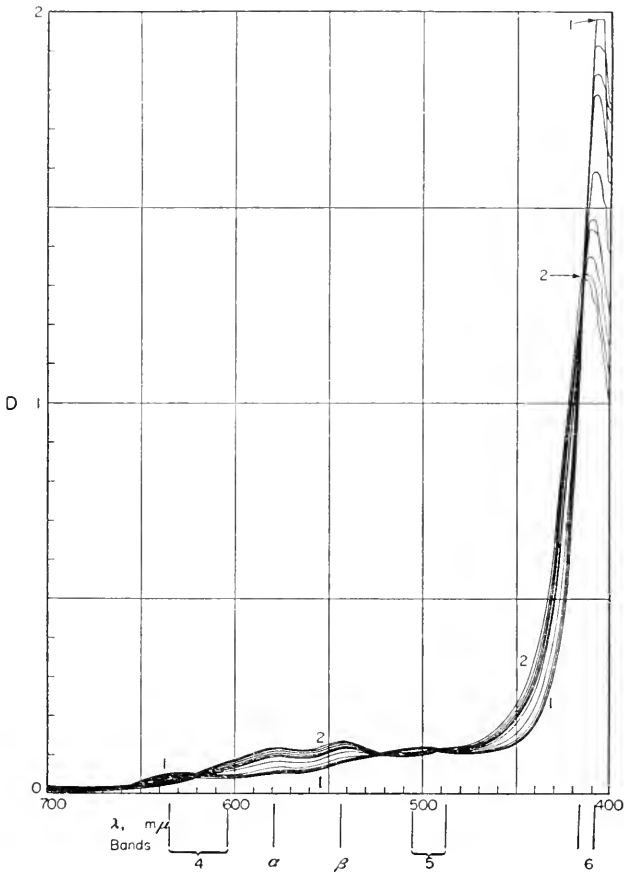

FIG. 13. Absorption spectrum curves of solutions of crystalline human met- or ferrihaemoglobin, buffered to various pH values. The solutions correspond to those shown in Fig. 12, but the concentration of haemoglobin is 0.0117 mm/l. (see legend to Fig. 12). The  $\epsilon$  (1mm/l) values for the maximum of methaemoglobin (pH 6.2) at 407  $m\mu$  and for the maximum of methaemoglobin hydroxide (pH 9.35) at 415  $m\mu$  are 169 and 113 respectively.

pH 11.38, red at pH 7.26. Uncertainties still exist as to the structure of pyridine ferriprotoporphyrin (Davies, 1940) and magnetometric measurements are available only for the hydroxy form (Rawlinson, 1940), which was deduced to be essentially covalent in contrast with MHbOH (see Table 3). Further information is required for the clarification of this situation, but at present the spectra cannot be easily reconciled with the proposed correlation.

*Contribution of Porphyrin to the Over-all Spectroscopic Character of Haemin Chromoproteins.* In the early days of the investigation of the structure of cytochrome *c*, Theorell (1939) questioned whether the thio-ether linkage he had proposed (Theorell, 1938) for the union of the protein with the haemin at positions 2 and 4 was present in the native compound or was

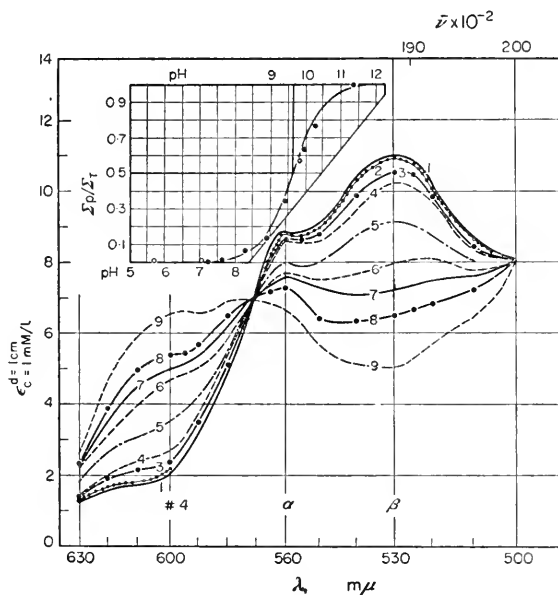

FIG. 14. Absorption spectra showing transition, with change in pH, from pyridine ferriprotoporphyrin to its hydroxide. In all solutions the final concentrations of haemin Fe and pyridine were 0.1 mM and 5700 mM/l. respectively. The pH was modified by the inclusion of HCl in all solutions except that represented by curve 9. Curve 1, absorption spectrum of species 1, probably dipyridine ferriprotoporphyrin, pH = 7.26. Curve 9, absorption spectrum of species 2, pH = 11.38. Curves 2 to 8, absorption spectra of mixtures of species 1 and 2. The pH values of the solutions represented by curves 2 to 8 were 7.62, 8.32, 8.95, 9.45, 9.86, 9.98, and 10.36. The insert in the figure shows the partition of species 1 and 2 against pH (see legend to Fig. 12). The solid circles are from data presented in the figure. The open circles are based upon absorption data not shown. See the text.

artificially obtained by the vigorous hydrolysis conditions employed in the isolation of porphyrin *c*. This led the writer (Drabkin, 1942b) to investigate the spectra of cyanide, pyridine and carbonyl derivatives of proto-, meso-, and coproferrohaem, and corresponding derivatives of haemoglobin and ferrocytochrome *c*. In protohaemin positions 2 and 4 are occupied by the unsaturated vinyl group, whereas in meso- and coprohaemin the substituents in this position are respectively ethyl and propionic groups. The spectra of the meso- and copro- derivatives were virtually indistinguishable from each other (Figs. 15 to 17 and see Drabkin, 1942b, for the individual spectra of

carbonyl derivatives), indicating that the  $C_2H_5$  and  $CH_3CH_2COOH$  side chains had individually no distinguishable spectroscopic effects, but the maxima in the spectra of all protohaemin complexes were shifted some  $10 m\mu$  toward the longer wavelengths. Three distinctive spectroscopic patterns were found for all the ferrohaems, characteristic for the combination with

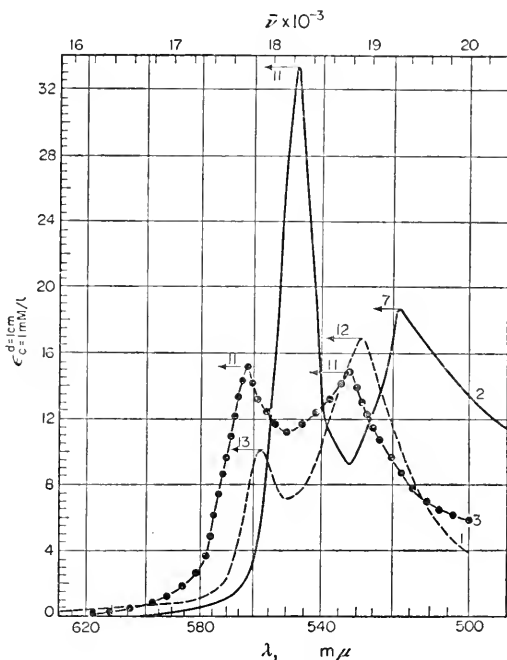

FIG. 15. The three distinctive spectral patterns exhibited by ferrohaems coordinated with three types of ligands, exemplified by derivatives of ferromesoporphyrin. Curve 1, cyanide ferromesoporphyrin, representative of Pattern Type 1. Curve 2, pyridine ferromesoporphyrin, representative of Pattern Type 2. Curve 3, carbonyl ferromesoporphyrin, representative of Pattern Type 3. In all cases the NaOH concentration was 0.2 M/l. and the  $Na_2S_2O_4$  concentration 5 mm/l. The pyridine concentration was 6.19 M/l. and that of cyanide 400 mm/l. The horizontal arrows and appended numbers represent the magnitude in  $m\mu$  of the shift of maxima towards longer wavelengths in corresponding derivatives of ferroporphyrin (Drabkin, 1942b).

cyanide, pyridine and carbon monoxide (Fig. 15). These conclusions were reached: (1) The shape and intensity of absorption in the visible region was a function of the nature of the co-ordinating ligand. (2) The wavelength location of the maxima (of the  $\alpha$  and  $\beta$  bands) was a function of the haemins (or porphyrins) themselves, and most probably of the groups substituted in positions 2 and 4. The maxima in the spectra of haemoglobin derivatives were in the locations expected for protohaemin derivatives. On the other hand, the

spectra of derivatives of cytochrome *c* (Figs. 16 and 17) were in the meso- or copro- locations. Hence, this was offered as evidence that the spectrum itself of cytochrome *c* revealed a structural difference of its haemin in positions 2 and 4, namely a vitiation of the unsaturated vinyl bond structure, such as would occur in Theorell's thio-ether linkage (Drabkin, 1942b)

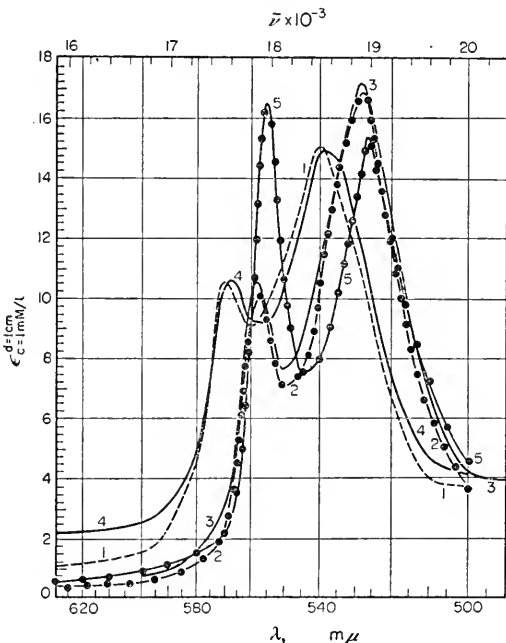

FIG. 16. Pattern Type 1; absorption spectra of cyanide derivatives of ferrohaems, haemoglobin, and ferrocytochrome *c*. Curve 1, cyanide ferroprotoporphyrin. Curve 2, cyanide ferromesoporphyrin. Curve 3, cyanide ferrocoproporphyrin. Curve 4, the reduced cyanide derivative prepared from dog haemoglobin in alkaline solution, probably cyanide ferroprotoporphyrin. Curve 5, the reduced cyanide derivative prepared from cytochrome *c* in alkaline solution, ferrocytochrome *c* cyanide. See legend to Fig. 15 (Drabkin, 1942b).

The spectral displacement of the protohaemin complexes toward the longer wavelengths was ascribed (Drabkin, 1942b) to the increase in the conjugated double bonds in the porphyrin system by the presence of the unsaturated vinyl radicals, analogously to the situation disclosed by the systematic studies of Hausser and Kuhn and their collaborators on polyene dyes of the type  $R-(CH=CH)_n-R'$  (Hausser, 1934; Hausser *et al.*, 1935a to e). Incidentally, on the basis of the above analysis, it could be prophesied that the haemin of cytochrome  $b_2$  must be ordinary protohaemin with the vinyl residues intact (Morton, 1958). I believe that in the haemin proteins the influence on spectral location of the maxima in the visible region, evident also in ferrihaemin complexes such as the cyanide derivatives



(Drabkin, 1942a), represents the major contribution of the structure of the porphyrin nucleus to the spectra, although it is tempting to draw analogies between the band distribution and location in the spectra of porphyrins and

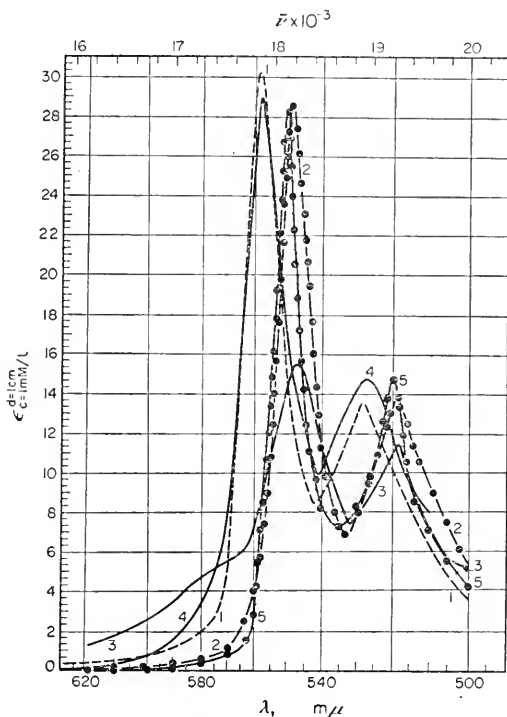

FIG. 17. Pattern Type 2. Absorption spectra of denatured globin (globan) derivatives of ferrohaemins (reduced haemochromogens) and the spectra of haemoglobin and ferrocytochrome *c* in alkaline solutions. Curve 1, globan ferroprotoporphyrin, prepared from human globin and protohaemin. Curve 2, globan ferromesoporphyrin, prepared from human globin and mesohaemin. Curve 3, globan ferrocoproporphyrin, prepared from human globin and coprohaemin. Curve 4, globan ferroprotoporphyrin, prepared from haemoglobin of man. Curve 5, ferrocytochrome *c* in alkaline solution. See legend to Fig. 15 and for details see Drabkin, 1942b.

their two-banded hydrochlorides and in haemin derivatives (Williams, 1956). Nevertheless, this is a matter of predilection, and Williams' interpretation that in porphyrins (see Fig. 5) the near ultra-violet band ('Soret band') is accounted for by a  $\pi \rightarrow \pi'$  electron transition, and the visible bands, I, II, III and IV by a second  $\pi$  electron transition may be valid for porphyrin spectra (Williams, 1956).

#### DISCUSSION

*Theory of Absorption Spectra.* In general the absorption of light energy by atoms and molecules may be considered to be the reverse of emission.

Enlargement of this assumption involves the inference that the internal energy of the atom or molecule is increased by the absorption of light, and transfers from lower to higher quantized energy states occur, which give rise to absorption bands. In the ultra-violet and visible spectral regions the bands may represent either transitions of optical or valence electrons (as distinguished from core electrons) through different quantized energy levels, or internal vibrational phenomena set up in the molecule by the absorption of light energy. Henri (1919, 1923a and b) and Lifschitz (1920) were among the first to recognize that orderliness exists in the distribution of bands in simple molecules, which is expressed by the spacing of the bands at constant frequency distances from each other. Such integrally related bands, forming a spectral series, were early demonstrated in the spectra of  $\text{KMnO}_4$  and  $\text{CoCl}_2$  (see Fig. 4), and have been interpreted as vibrational fine structure in a broad band of electronic origin (Harrison *et al.*, 1948). The important implication lies in the inference that all bands which are members of a single series probably originate from a common configuration in the molecule, or from the same fundamental molecular disturbance incident to the absorption of light energy.

*The Spectra of the Haemin Chromoproteins.* The finding—extended and supported by a graphic-mathematical analysis—that most of the bands (exclusive of  $\alpha$  and  $\beta$ ) in the spectra of haemin chromoproteins and their derivatives are spaced at equal frequency distances allows the interpretation that they originate (as in the simple molecules above) in a common molecular structure and from fundamentally the same dynamic source. This enormously simplifies the interpretation of the complex spectra of these complex molecules. In effect, spectrally they behave like much simpler molecules. The location of the bands in the ultra-violet and visible regions permits the deduction that they represent electron transitions. Furthermore, the total iron-porphyrin structure as a unit is held responsible for the bands in the spectral series. In the resonating conjugated double bond system of the porphyrins, each atom contributes an optical electron to the molecule's collection, but the electrons belong collectively to all the atoms in the complex, not to a particular atom. Such electrons, belonging to several atoms, are characterized by relatively low energy (hence the spectral bands in the near infra-red, visible and ultra-violet regions), and the energy levels associated with them are regarded as closely and regularly spaced (cf. Harrison *et al.*, 1948; Braude, 1945). The iron may be thought of as either facilitating or modifying the movement of the electrons over the atoms of the porphyrin ring. At any rate, the over-all spectrum is viewed as an expression of the spectrum of iron in a hexaco-ordinated Werner type structure. Supporting evidence for the common origin of the bands in the spectral series may be drawn from Warburg's classical deduction of the photochemical spectrum of cytochrome *c* oxidase (Warburg and Negelein, 1928; Warburg, 1929). The photochemical spectrum,

which measured the release of the enzyme from its carbonyl derivative (poisoned state) had several maxima in the ultra-violet, including the  $\gamma$  band. This would not have been the case unless the bands had a similar molecular origin.

The  $\alpha$  and  $\beta$  bands, as disclosed by the analysis, do not belong to the main spectral series, and have been shown to reflect more intimately the effect of different co-ordinating ligands. A broad correlation has been found between the paramagnetic susceptibilities and the corresponding spectral patterns in the area covered by bands 4,  $\alpha$ ,  $\beta$  and 5 (Table 3). This correlation would appear to justify the deduction that the visible spectra reflect electron transitions involved in the hybridization of the atomic  $s$ ,  $p$  and  $d$  orbitals of the iron cation (Pauling, 1949; Williams, 1956). Four major spectral patterns have been uncovered, namely those of ferrihaem and its derivatives with cyanide, and those of ferrohaem complexes with cyanide, pyridine or globin, and carbon monoxide. Identical patterns (see the text and Figs. 15 to 17) are obtained for corresponding derivatives of proto-, meso- and coprohaemin, except for the displacement of the maxima of the protohaemin complexes toward the longer wavelengths. This displacement is also apparent in the spectra of proto- and mesoporphyrin, and is regarded as the main evident contribution of porphyrin *per se* to the over-all haemin protein spectra.

Since the disclosure of the close similarity of the spectra of ferrous 1:10-phenanthroline and the cyanide complexes of ferrihaemin derivatives (Drabkin, 1941b, and Fig. 2), the structure of the ferrous diimine has been shown to be  $\text{Fe}_1\text{Phen}_3$  (Gould and Vosburgh, 1942; Harvey and Manning, 1952) and the anomalous colours of the metallic diimines have been explained as due to the resonance of  $\pi$ -electrons (and their increased mobility in the metal complex) over the non-metallic atoms composing the entire chelate ring, assuming that  $d$ -electrons of the metal are involved in the formation of the co-ordinate bond (Sone, 1952; Krumholz, 1953; see also Pauling, 1940; Calvin and Wilson, 1945; Chatt, 1949). Williams (1956) has used the metallic diimines and the postulated electronic basis for their spectra as models in his interpretation of the visible absorption spectra of the haemin chromoproteins.

The contribution of the protein moieties to the over-all spectra of the haemin chromoproteins is not identifiable in any alteration in spectral pattern, nor does it appear to be confined to a particular spectral region such as 280–275  $\text{m}\mu$ . The role of the protein is postulated to be that of a 'resonator' or 'enhancer'. The relative intensity of the bands, not their pattern, may be influenced, analogously with the effect of the alkaline earth metals on the emission spectrum of copper.

*The Graphic-mathematical Analysis.* It must be frankly stated that this is an empirical approach, and it is recognized that the solutions yielded by the adopted analytical procedure are influenced by underlying assumptions.

The novel use of curves of the normal frequency form—admittedly agreeable to the writer—need not imply that absorption bands actually possess this shape. Yet, made up as they are (in different spectral regions) of an electronic band, with blurred out vibrational or rotational elements, their shapes may really be similar to those employed in the graphical resolution. It is hoped that methods will be forthcoming which may permit an experimental resolution of the spectra of haemin derivatives at least, if not those of the haemin proteins. Among the possibilities are the spectra at very low temperatures in which interest has been renewed, and which were originally explored in porphyrins by Conant and his colleagues (Conant and Kamerling, 1931).

#### SUMMARY

A graphic-mathematical analysis, using curves of the normal frequency form, has been made of the absorption spectra of haemin chromoproteins.

The spectra in the near infra-red, visible and ultra-violet regions of all the derivatives examined are fundamentally similar, and represent the summational effect, which can be expressed mathematically, of the  $\alpha$  and  $\beta$  bands and bands numbers 3 to 11 of an equally spaced frequency distributed series.

The bands represent a series of electronic transitions and those in the demonstrated spectral series are inferred to originate from the same molecular structure, the resonating conjugated double bond system of the iron-porphyrin unit.

The special significance of the  $\alpha$  and  $\beta$  bands, the contributions of porphyrin and protein, and the influence of co-ordinating ligands have been discussed.

#### Acknowledgement

The writer's investigations of the chromoproteins have been supported by grants from the Office of Naval Research and the Bureau of Medicine and Surgery of the Navy, and, more recently, by a grant from the National Science Foundation, U.S.

#### REFERENCES

- APPLEBY, C. A. & MORTON, R. K. (1954). *Nature, Lond.* **173**, 749.  
 AUSTIN, J. H. & DRABKIN, D. L. (1935). *J. biol. Chem.* **112**, 67.  
 BRAUDE, E. A. (1945). *Ann. Rep. chem. Soc.* **42**, 105.  
 BRODE, W. R. (1928). *Proc. Roy. Soc. A*, **118**, 286.  
 CALVIN, M. & WILSON, K. W. (1945). *J. Amer. chem. Soc.* **67**, 2003.  
 CHATT, J. (1949). *J. chem. Soc.* 3340.  
 CONANT, J. B. & KAMERLING, S. E. (1931). *J. Amer. chem. Soc.* **53**, 3522.  
 CORYELL, C. D., STITT, F. & PAULING, L. (1937). *J. Amer. chem. Soc.* **59**, 633.  
 DAVIES, T. H. (1940). *J. biol. Chem.* **135**, 597.  
 DHÉRE, C. (1906). *Compt. rend. Soc. biol.* **61**, 718.  
 DRABKIN, D. L. (1934). *Proc. Soc. exp. Biol. Med.* **32**, 456.  
 DRABKIN, D. L. (1936). *J. biol. Chem.* **114**, xxvii.  
 DRABKIN, D. L. (1937). *J. biol. Chem.* **119**, xxvi.  
 DRABKIN, D. L. (1938). *Proceedings of the Fifth Summer Conference on Spectroscopy and Its Applications*, p. 94. John Wiley, New York/Chapman & Hall, London.

- DRABKIN, D. L. & SINGER, R. B. (1939). *J. biol. Chem.* **129**, 739.
- DRABKIN, D. L. (1940). *Proceedings of the Seventh Summer Conference on Spectroscopy and Its Applications*, p. 116. John Wiley, New York/Chapman & Hall, London.
- DRABKIN, D. L. (1941a). *J. opt. Soc. Amer.* **31**, 70.
- DRABKIN, D. L. (1941b). *J. biol. Chem.* **140**, 387.
- DRABKIN, D. L. (1942a). *J. biol. Chem.* **142**, 855.
- DRABKIN, D. L. (1942b). *J. biol. Chem.* **146**, 605.
- DRABKIN, D. L. & SCHMIDT, C. F. (1945). *J. biol. Chem.* **157**, 69.
- DRABKIN, D. L. (1946). *J. biol. Chem.* **164**, 703.
- DRABKIN, D. L. (1949a). *Arch. Biochem.* **21**, 224.
- DRABKIN, D. L. (1949b). *Haemoglobin*, p. 35 (Ed. by F. J. W. Roughton & J. C. Kendrew), Butterworths, London.
- DRABKIN, D. L. (1950). *Medical Physics*, **2**, p. 1039 (Ed. by O. Glasser), Year Book Publ., Inc., Chicago.
- DRABKIN, D. L. (1954). *Report to Ad Hoc Panel of the National Research Council (U.S.) on a Standard for Haemoglobin Measurement*. Unpublished.
- DRABKIN, D. L. (1957). *Fed. Proc.* **16**, 740.
- GORDY, E. & DRABKIN, D. L. (1957). *J. biol. Chem.* **227**, 285.
- GOULD, R. K. & VOSBURGH, W. C. (1942). *J. Amer. chem. Soc.* **64**, 1630.
- GRABE, H. (1892). *Untersuchungen des Blutfarbstoffes auf sein Absorptionsvermögen für violette und ultraviolette Strahlen*, Dorpat.
- HAGENBACH, A. & PERCY, R. (1922). *Helv. chim. Acta*, **5**, 454.
- HARRISON, G. R., LORD, R. C. & LOOFBOUROW, J. R. (1948). *Practical Spectroscopy*, Chaps. 10 and 11 (pp. 228-299), Prentice-Hall, New York.
- HARTRIDGE, H. (1920). *J. Physiol.* **54**, 253.
- HARVEY, A. E. JR. & MANNING, D. L. (1952). *J. Amer. chem. Soc.* **74**, 4744.
- HAUROWITZ, F. (1924). *Hoppe-Seyl. Z.* **138**, 68.
- HAUROWITZ, F. (1927). *Hoppe-Seyl. Z.* **169**, 235.
- HAUSSER, K. W. (1934). *Z. tech. Physik.* **15**, 10.
- HAUSSER, K. W., KUHN, R. & SEITZ, G. (1935a). *Z. phys. Chem. B.* **29**, 391.
- HAUSSER, K. W., KUHN, R. & SMAKULA, A. (1935b). *Z. phys. Chem. B.* **29**, 384.
- HAUSSER, K. W., KUHN, R., SMAKULA, A. & DEUTSCH, A. (1935c). *Z. phys. Chem. B.* **29**, 378.
- HAUSSER, K. W., KUHN, R., SMAKULA, A. & HOFFER, M. (1935d). *Z. phys. Chem. B.* **29**, 371.
- HAUSSER, K. W., KUHN, R., SMAKULA, A. & KREUCHEN, K. H. (1935e). *Z. phys. Chem. B.* **29**, 363.
- HENRI, V. (1919). *Etudes de Photochimie*, Paris.
- HENRI, V. (1923a). *C.R. Acad. Sci., Paris*, **176**, 1142.
- HENRI, V. (1923b). *C.R. Acad. Sci., Paris*, **177**, 1037.
- HICKS, C. S. & HOLDEN, H. F. (1929). *Aust. J. exptl. Biol. med. Sci.* **6**, 175.
- HOGNESS, T. R., ZSCHEILE, F. R. JR., SIDWELL, A. E. JR. & BARRON, E. S. G. (1937). *J. biol. Chem.* **118**, 1.
- HOLIDAY, E. R. (1936). *Biochem. J.* **30**, 1795.
- HOLIDAY, E. R. (1937). *J. sci. Instrum.* **14**, 166.
- HORECKER, B. L. (1943). *J. biol. Chem.* **148**, 173.
- KRUMHOLZ, P. (1953). *J. Amer. chem. Soc.* **75**, 2163.
- LAVIN, G. I. & NORTHROP, J. H. (1935). *J. Amer. chem. Soc.* **57**, 874.
- LAVIN, G. I., NORTHROP, J. H. & TAYLOR, H. S. (1933). *J. Amer. chem. Soc.* **55**, 3497.
- LIFSCHITZ, J. (1920). *Z. phys. Chem.* **95**, 1.
- MORTON, R. K. (1958). *Rev. pure appl. Chem.* **8**, 161.
- PAULING, L. (1940). *The Nature of the Chemical Bond, and the Structure of Molecules and Crystals*, 2nd ed., Cornell University Press, Ithaca/Oxford University Press, London.
- PAULING, L. (1948). *The Valences of the Transition Elements, Victor Henri Memorial Volume*. Liège: Desoer.
- PAULING, L. (1949). *Haemoglobin*, p. 57 (Ed. by F. J. W. Roughton and J. C. Kendrew), Butterworths, London.

- PAULING, L. & CORYELL, C. D. (1936a). *Proc. nat. Acad. Sci. Wash.* **22**, 159.  
 PAULING, L. & CORYELL, C. D. (1936b). *Proc. nat. Acad. Sci. Wash.* **22**, 210.  
 RAWLINSON, W. A. (1940). *Aust. J. exp. Biol. med. Sci.* **18**, 185.  
 SONE, K. (1952). *Bull. chem. Soc. Japan*, **25**, 1.  
 SORET, J. L. (1878). *Arch. sc. phys. et nat.* **61**, 322.  
 SORET, J. L. (1883a). *Arch. sc. phys. et nat.* ser. 3, **9**, 513.  
 SORET, J. L. (1883b). *Arch. sc. phys. et nat.* ser. 3, **10**, 429.  
 THEORELL, H. (1938). *Biochem. Z.* **298**, 242.  
 THEORELL, H. (1939). *Biochem. Z.* **301**, 201.  
 THEORELL, H. (1941). *J. Amer. chem. Soc.* **63**, 1820.  
 THEORELL, H. & ÅKESSON, Å. (1941). *J. Amer. chem. Soc.* **63**, 1812, 1818.  
 THEORELL, H. & NYGAARD, A. P. (1954). *Acta chem. Scand.* **8**, 1649.  
 TINT, H. & REISS, W. (1950). *J. biol. Chem.* **182**, 385, 397.  
 TSOU, C. L. & LI, W. C. (1956). *Scientia Sinica*, **5**, 253.  
 VLÈS, F. (1914). *Compt. rend. Soc. biol.* **158**, 1206.  
 WARBURG, O. (1929). *Naturwissenschaften* **16**, 245.  
 WARBURG, O. & NEGELEIN, E. (1928). *Biochem. Z.* **200**, 414.  
 WILLIAMS, R. J. P. (1956). *Chem. Rev.* **56**, 299.  
 WYMAN, J. JR. & INGALLS, E. N. (1941). *J. biol. Chem.* **139**, 877.

## DISCUSSION

### *Interpretations of Absorption Spectra of Haemoproteins*

PERRIN: Would Drabkin please indicate the theoretical significance he attaches to his serial band analysis? In, say, Fig. 9 of his paper (p. 155), how much latitude does his assigning of seven bands, with the resulting sixteen adjustable constants, allow in analysing the spectrum?

DRABKIN: I have frankly admitted in my paper that my analytical approach was an empirical one. My proposal was originally made a good many years before high- and low-spin complexes were recognized and before it was fashionable to speak of *d*- and  $\pi$ -electrons. It seemed to me very worthwhile, as a first step, to make the most simplifying assumptions. I used Gaussian curves because I liked their shape, and perhaps naively believed that the components (bands) in the complex absorption curves might indeed have such a form. I may say that I anticipated Perrin's searching questions, and posed them to myself, without a wholly satisfactory answer.

I recognize that from a rigid physical viewpoint the bands are spaced too far apart to be regarded as electronic in the usual sense, and probably represent a special case. As to the latitude of the analytical procedure, it is probably rather broad. For the pronounced maxima in the absorption spectra they would appear to be unequivocal. For regions of masked absorption the solution may not be unique. However, reference to my Table 2 (p. 153) will disclose that assembling the various derivatives, actual representatives with definite maxima in the postulated locations have been found. It should be stressed that this is the important experimental finding, independent of and, indeed, guiding the analysis. Yet, the proposal of the equally spaced, frequency-distributed series was made before all the data were available. The possible existence of certain maxima was prophesied, a prophecy fulfilled by later finding them in the spectra of oxidized and reduced cytochrome *c*.

WILLIAMS: My views and those of Drabkin as to the nature of iron porphyrin spectra are rather different. Drabkin has given us a detailed survey, empirically based, of a large number of absorption bands. This will be most valuable. I have attempted to use Platt's theory (*Radiation Biology*, **3**, 1956) of the porphyrin spectra to interpret the spectra of metal porphyrin complexes. The analysis led to the conclusion that some bonds in Fe<sup>+++</sup> porphyrins were due to the iron and had little to do with the porphyrin, notably at 650 *mμ* and about 500 *mμ*. In Fe<sup>++</sup> porphyrins there is a band at about 500 *mμ* due to the iron alone. There is no requirement for a frequency series in Platt's theory.

DRABKIN: Williams has suggested that the band at 500  $m\mu$ , which is No. 5 of my frequency distributed series and ascribed by me to originate in the dynamic haemin structure, is rather owing to iron itself. Having earlier discussed this question with him, I believe his deduction originates from finding a maximum at about 510  $m\mu$  in such complexes as ferrous orthophenanthroline (see my Fig. 2). This is a very broad maximum and doubtless includes several component bands. Of course my proposal also involves a co-ordination complex. I must respect his theoretical knowledge, but naturally I prefer my own proposal. At any rate, I believe we agree on many other aspects of our individual analytical approaches. Thus, we have brought out somewhat similar correlations between the absorption spectra and corresponding magnetometric data (see my Table 3 and text, p. 158).

It may be pointed out that, in Table 3, in the case of ferrihaemoglobin and ferrihaemoglobin hydroxide, one may now substitute the terms 'high-spin' and 'mixture of high-spin and low-spin' in place of the older 'essentially' or 'partially' ionic (see Orgel's, Williams', and George's papers, this symposium). I wonder whether it is possible that the unexpected behaviour in the vicinity of the Soret band (my band No. 6) in the transition spectra of MHb  $\rightarrow$  MHbOH (i.e. the absence of an isobestic point) may be related to a change from a high-spin complex to a mixture of high- and low-spin?

WAINIO: I wish to ask Drabkin, if the  $\alpha$ - and  $\beta$ -bands of the haem of any one of the haemoproteins is replaced by the bands of the corresponding porphyrin, will the latter fall into the frequency distribution series?

DRABKIN: In the ultra-violet region they do not fit well. Since I was making the most simplifying assumption, namely that the spectra are an expression of iron in a co-ordinated complex, I was content to start with, and confine myself to iron-porphyrin complexes. I am not at all convinced that there is real validity in drawing parallels between porphyrin bands and correspondingly located bands of haemin derivatives.

### *The bands in the region of 830 and 280 $m\mu$*

GEORGE: I should like to ask Drabkin whether the near infra-red bands of the ferri-myoglobin fluoride complex at 740 and 830  $m\mu$  can be fitted into the frequency series with successive values of ' $n$ '. If the wave-number separation is too small then one or the other would have to be regarded as belonging to another category like the  $\alpha$ - and  $\beta$ -bands.

DRABKIN: The band at 830  $m\mu$  is present in other haemin protein derivatives (as evident in Table 2 of my paper). This band corresponds to  $\bar{\nu} \times 10^{-2} = \sim 120$ , and is No. 3 of my proposed equally-spaced frequency series. The band at 740  $m\mu$  may correspond with the at present anomalous band at 760  $m\mu$  of deoxygenated haemoglobin (see my Fig. 1), and may in fact belong to a different series, or may be 'odd-man-out' as you have expressed it. Incidentally, in some derivatives (see Fig. 1, p. 143) there are maxima in the vicinity of wavelength 920  $m\mu$  which do not fit in the main series. This is brought out in my paper.

GEORGE: For myoglobin derivatives the millimolar extinction coefficients in the protein absorption region, 260–290  $m\mu$ , are about 30 compared to the value of about 13 for apohaemoglobin. Similar values have been reported for haemoglobin derivatives and apohaemoglobin, hence there can be no doubt that the haem absorbs significantly in this region. The same is true of vitamin B<sub>12</sub> and free benzimidazole, so the effect is not restricted to haemoproteins.

MARGOLIASH: In the case of cytochrome *c*, for which the amino acid composition is reasonably well known, it is easy to calculate the contribution of tryptophane, phenylalanine and tyrosine to the 280  $m\mu$  band. The results are roughly the same as those quoted by George for metmyoglobin. There is, moreover, a striking difference between the spectra of the ferro- and ferri- forms of cytochrome *c* in the 'protein' band region, indicating a distinct contribution of haem absorption to this band (Margoliash and Frohwirt, *Biochem. J.* **71**, 570, 1959).

POSTGATE: I think there exists some evidence against Drabkin's view that the 280  $m\mu$  peak in haematins is mainly due to some frequency in the iron-porphyrin system and not to residues of aromatic amino-acids. Cytochrome  $c_3$ , which has a molecular weight closely similar to that of cytochrome  $c$ , has two haemins/molecule. Yet in spite of this the absorption of this material at 280  $m\mu$  is negligibly small; the 280  $m\mu$  peak of cytochrome  $c$  is absent.

On the other hand, we find from qualitative observations that the aromatic residue content of  $c_3$  is very small, which would be consistent with the traditional view of the significance of the 280  $m\mu$  band.

MORTON: As will be seen from the tables in my review (Morton, *Rev. pure appl. Chem.* **8**, 161, 1958), there is a paucity of information concerning the influence of the state of oxidation on the absorption of cytochromes in the ultra-violet region. Our studies with cytochrome  $b_3$  suggest that the position and height of the band in the 260–280  $m\mu$  region does change between the oxidized and the reduced compound. Could Postgate comment on the difference between ferricytochrome  $c_3$  and ferrocycytochrome  $c_3$  in the 280  $m\mu$  region.

POSTGATE: We have never observed the 280  $m\mu$  range of ferrocycytochrome  $c_3$ ; because of its low  $E_0'$  we have found no reducing agent which will maintain the reduced form without absorbing strongly in this range.

DRABKIN: The situation Postgate describes in cytochrome  $c_3$  is certainly most unusual, perhaps unique for haemin chromoproteins. I would not be astonished by the absence of a well-defined maximum, but am puzzled by negligible absorption, particularly since co-ordination complexes such as haemin dicyanide (my Fig. 5) absorb rather strongly in this region. Perhaps the presence of a weak masked band could be brought out by the type of analysis I have employed. What is the nature of the ultra-violet absorption of reduced cytochrome  $c_3$ ? That approximately 30% only of the total absorption at 280  $m\mu$  can be ascribed to the specific absorption of the aromatic amino acids in most haemoproteins is in essential agreement with my own deduction, based upon the content of tyrosine, phenylalanine and tryptophane, as discussed in my paper. I believe that these aromatic amino acids contribute to the absorption, but the main contribution is owing to the haemin structure. It is misleading in the case of the haemin derivatives to speak of the protein band (at 280  $m\mu$ ).

WILLIAMS: I wonder should not one re-examine, in respect to the absorption at 280  $m\mu$ , the question of energy transfer from aromatic amino-acids to haemoproteins, e.g. in the photochemical decomposition of CO-complexed haemoproteins (Weber, *Disc. Faraday Soc.* **27**, 1959). As I understand Drabkin's remarks, there is a co-operative enhancement of the absorption of the aromatic amino-acids at 280  $m\mu$  by the haem unit.

DRABKIN: I am sorry that I am not acquainted with the actual experimental work of Weber to which you refer. In any event the energy would have to be quantized. In my paper I do refer to Warburg's classical study, and believe that his photochemical spectrum which includes a broad spectral coverage, with several maxima besides the 'protein' band at 280  $m\mu$ , must indicate that the same haemin structure is involved and photochemically effective in spectral regions which cannot be ascribed to protein. This appears to support my proposal of a similar origin for the various bands.

On the other hand, the total co-ordination complex includes residues from the protein. Hence, the effect of protein cannot be wholly separated from the haemin, and some protein contribution may be present over the whole spectral range (see discussion in paper).

LEMBERG: Most porphyrins have, indeed, a weak absorption in the region 260–280  $m\mu$ . For protoporphyrin in dioxane we have found an  $\epsilon_{mM}$  of 14 at 280  $m\mu$ . The absorption is thus far weaker than that of the Soret band, whereas many haemoproteins absorb at 280  $m\mu$  as strongly or more strongly than in the Soret region.



# THE HAEM-GLOBIN LINKAGE

## 3. THE RELATIONSHIP BETWEEN MOLECULAR STRUCTURE AND PHYSIOLOGICAL ACTIVITY OF HAEMOGLOBINS\*

By J. E. O'HAGAN

*Red Cross Blood Transfusion Service, Brisbane,  
Queensland, Australia*

THE REACTIONS of haemoglobins have been interpreted in terms of the imidazole, steric hindrance, haem-haem interaction and intermediate compound hypotheses, which have had wide acceptance. However, the opinion that the haem iron was linked by groups other than imidazoles has been expressed by Haurowitz (1954, 1959) and by O'Hagan (1959a). Theorell and Ehrenberg (1951) considered that a more acid group was responsible for this linkage in horse myoglobin, while Wyman (1948) in expounding the imidazole hypothesis, made a reservation that the evidence for the identification as imidazole of the more acid of the groups co-ordinating the iron in horse haemoglobin was not completely certain. Recent X-ray studies of ferrimyoglobin by Kendrew, Bodo, Dintzis, Parrish, Wyckoff and Phillips (1958), neither appear to support a hypothesis of co-ordination of the haem iron between two amino acid side-chains of the protein, nor confirm steric hindrance relationships. Roughton (1944), while paying tribute to the value of Wyman's work, pointed out that it did not account for the important carbamino reaction.

Strong arguments against the steric hindrance (or embedded haem) concept were presented by Keilin (1953), and these were supported to a certain extent by the preparation of artificial haemoglobins from haems of dimensions larger than protohaem (namely coprohaem III and tetramethyl-coprohaem III (O'Hagan, 1955, 1960)). George and Lyster (1958), after a careful analysis of the evidence, considered steric hindrance effects unlikely, at least for small ligands, which, after all, are the physiologically important ones.

The haem-haem interaction hypothesis as proposed by Pauling (1935) to interpret the sigmoid dissociation curve of oxyhaemoglobins has not been able to account for a number of apparent exceptions. The addition of oxygen to ferrohaemoglobin is linear when measured by either spectrophotometric (Nahas, 1951) or magnetometric methods (Coryell, Pauling and

\* Part 1, O'Hagan; Part 2, O'Hagan and George; *Biochem. J.*, **74**, 417, 424 (1960).

Dodson, 1939). Spectrophotometric titrations of the combination of imidazole (Russell and Pauling, 1939) or hydroxyl (George and Hanania, 1953) with ferrihaemoglobin also show linear relationships. None of the equations proposed, on the basis of haem-haem interaction, to explain the sigmoid oxygen dissociation curves, has been found to be satisfactory, except in a special case at pH 9.1, outside the range of the Bohr effect (Roughton, Otis and Lyster, 1955).

There appears to be reliable evidence that specimens of mammalian haemoglobins have at times exhibited hyperbolic dissociation curves (Barcroft, 1928; Hartridge and Roughton, 1925). Takashima (1955) found that at ionic strength 0.03-0.3 the  $n$ -value for the Hill equation was about 3, which would not be in accordance with Pauling's equation. At lower ionic strength, pronounced deviation from the Hill equation occurred, especially at the lower portion of the curves. Rossi-Fanelli, Antonini and Caputo (1959) found that human haemoglobin in 2 M sodium or potassium chloride (under which conditions it is dissociated into half molecules), gave an oxygen dissociation curve with slightly *increased* 'haem-haem interaction'. They did not show that the four haems were divided between the two fragments but if they were, as is most probably the case, their results could mean that the sigmoid curves of haemoglobins were not due to interaction between the haems.

*Gastrophilus* haemoglobin with two haems per molecule has a *hyperbolic* oxygen dissociation curve, i.e. no 'haem-haem interaction' (Keilin and Wang, 1946). The sigmoid dissociation curve of diluted chlorocruorin (Fox, 1932) of molecular weight of about 3,000,000, with the possibility of interaction between about 200 haems (Lemberg and Legge, 1949), and the 'atypical' curves of haemoglobins of species such as the duck and carp (Redfield, 1933), are difficult to reconcile with this hypothesis and have generally been conveniently ignored.

Some experimental support for the intermediate compound hypothesis would appear to have been found from the work of Itano and Robinson (1956) who detected intermediates when normal human adult carboxyhaemoglobin was partly oxidized with ferricyanide and the mixture submitted to electrophoretic separation. It does not necessarily follow, however, that their findings are applicable to the ferrohaemoglobin-oxyhaemoglobin system.

The finding by Hill and Holden (1926), Holden (1941) and Granick (1949) of attachment of porphyrins to apohaemoglobins, the instability of aetiohaemoglobin (O'Hagan, 1950, 1955, 1960) and the X-ray studies of ferri-myoglobin (Kendrew *et al.*, 1958) suggested the likelihood of linkages between the haematin propionate side-chains and basic side-chains of the apohaemoglobins and apomyoglobins. While studying the nature of these linkages it appeared that it might be possible to explain more satisfactorily the oxygen dissociation curves, the Bohr effect, the alkali-stability, and the differences

in crystal structure in terms of such linkages. They have therefore been examined with this in view and, as a result, a new interpretation of the structural and functional relationships of haemoglobins and myoglobins is presented.

## MATERIALS AND METHODS

### *Aetiohaemin III*

The preparation was as described by O'Hagan (1960).

### *Nickel Mesoporphyrin IX*

Mesoporphyrin IX was prepared by the method of Grinstein and Watson (1943) from dimethylprotoporphyrin IX (Grinstein, 1947). In 5% w/v HCl the absorption spectrum had bands at I, 590.7; Ia, 570.5; II, 547.5  $m\mu$  (order of intensity  $II > I > Ia$ , with the Hartridge Reversion Spectroscope). Bands I and Ia were 1  $m\mu$  lower than those reported by Fischer and Orth (1937). Two methods of conversion to the nickel complex were employed. The first followed the technique used by Fischer and Pützer (1926) to prepare nickel protoporphyrin, but the yield of crystals, even after standing several days in the refrigerator, was poor. The second, a very simple method of preparation, was as follows. About 0.1 g mesoporphyrin was dissolved in about 5 ml acetic acid, the solution was quickly heated to boiling and nickel acetate in acetic acid (prepared by leaving a piece of pure nickel, just covered with acetic acid, in a beaker for a few days) added drop by drop, with continued boiling, until the fluorescence of the porphyrin under ultra-violet light had disappeared. After cooling and adding  $\frac{1}{3}$  vol. distilled water, the precipitated nickel mesoporphyrin was centrifuged off, washed with alcohol and ether and dried in a vacuum desiccator over NaOH. It was then dissolved in 0.04 N NaOH, the solution centrifuged to remove a trace of undissolved material, the pigment in the supernatant precipitated with 0.2 N HCl, the precipitate centrifuged off, washed several times with distilled water and dried in a vacuum desiccator over NaOH. The nickel mesoporphyrin prepared by both methods had absorption peaks (Hartridge Reversion Spectroscope) as follows: in dioxane, I, 550.5; II, 513  $m\mu$  (order of intensity  $I > II$ , cf. Lemberg and Legge, 1949); in pyridine, I, 552.0; II, 514  $m\mu$  (order  $I > II$ ).

### *Proteins*

The horse apohaemoglobin was prepared by the method previously described for the human material (O'Hagan, 1960) and the apomyoglobin as reported by O'Hagan and George (1959), and both were estimated spectrophotometrically at 280  $m\mu$  using  $\epsilon_{mM} = 13$  as calculated by Hanania (1953). Before use, the solutions were left for several days at 1°C after adjustment to pH 7.8 to remove as much denatured material as possible. The 25% human serum albumin was a special batch of salt-poor albumin for transfusion

purposes which had not been subjected to the usual heat treatment to destroy hepatitis virus.

### *Imidazoles*

Caffeine B.P. and theophylline B.P. were supplied by Drug Houses of Australia Ltd. They were recrystallized from water and used as saturated aqueous solutions.

### *Buffer Solutions*

These were prepared with British Drug Houses A.R. grade chemicals from tables calculated by George and Hanania (unpublished), and kindly supplied by Professor P. George. The buffers were of constant ionic strength ( $I = 0.05$ ) and of the following composition: pH 2.0-3.8, HCl + KH phthalate; pH 4.0-6.2, NaOH + KH phthalate + NaCl; pH 5.6-8.0, NaOH +  $\text{NaH}_2\text{PO}_4$  + NaCl; pH 7.5-9.5 HCl +  $\text{Na}_4\text{P}_2\text{O}_7$  + NaCl; pH 9.9-11.1, NaOH + glycine + NaCl; pH 11.0-12.0,  $\text{Na}_2\text{HPO}_4$  + NaOH + NaCl; pH 13.0, NaOH.

### *Dithionite*

1% w/v solutions were prepared immediately before use from sodium hydrosulphite B.D.H., which was taken from a freshly opened ampoule (repacked from a 500 g bottle).

### *Standardization of Instruments*

The Hilger Uvispek Spectrophotometer, Beck Hartridge Reversion Spectroscope and Jones Electronic pH Meter were standardized as previously described (O'Hagan, 1960). All pH measurements were made with the standard glass electrode, and, although corrections were applied, all readings at high pH should not be regarded as exact.

## RESULTS

### *Decrease in the Acid Strength of Haematin Propionate Groups on Reduction to Haem*

It appeared possible that since substituents of R in  $\text{RCH}_2\text{CH}_2\text{COOH}$  could alter the pK value of the carboxyl by as much as 1.3 units (Edsall and Wyman, 1958), a change in the electronic structure of the haem iron atom producing alterations in the high resonance of the porphyrin ring system might have the same effect as a substitution of R in simple compounds, with subsequent change in the acid strength of the propionate groups. To test this hypothesis two reactions known to involve the propionate groups were investigated, those with human serum albumin, and with caffeine. A new reaction with theophylline was found, and preliminary results obtained supported those observed with caffeine.

*Attachment of Haematin and Haem to Human Serum Albumin*

Haematin combines with human serum albumin to form ferrihaemalbumin (see discussion by Lemberg and Legge, 1949). J. Keilin (1944) considered that the attachment of both haematin and haem to the albumin was through the porphyrin and Lemberg and Legge indicated the haematin carboxyls as being most likely involved. O'Hagan (1955, 1960) in showing by both spectrophotometric and paper electrophoretic studies that mesohaematin (but not aetiohaematin) combined, demonstrated that the carboxyls were responsible. Keilin (1944) believed it most likely that haem is attached in similar fashion, on account of the spectral differences of ferrohaemalbumin from free haem and from the haemochromes.

The extent of the combination of human serum albumin with haematin and haem was investigated by measuring the increment in absorbance in the Soret region on addition of the pigments to excess of the albumin in a series of buffer solutions of constant ionic strength. Tubes of 7 ml capacity were filled with 5 ml buffer (phthalate or phosphate), 1 ml 2.5% human serum albumin (the 25% solution diluted 1:10 with distilled water) and 0.1 ml  $2 \times 10^{-4}$  M freshly prepared protohaematin solutions (1.30 mg haemin dissolved in 1 ml 0.05 N NaOH, then 9 ml distilled water added). Other sets of tubes, one containing water in place of albumin and another with albumin but no haematin were set up at the same time. The solutions were stood at 21° for 3 hr, then portions transferred to a 10 mm cuvette and the absorbances read at 404  $m\mu$  in the spectrophotometer. Another series of three sets of tubes had 0.1 ml freshly prepared 1% w/v dithionite added to each tube and the tubes closed by long stoppers which excluded air almost completely, except for a small bubble which assisted mixing on inversion. After the 3 hr standing, portions of these solutions were carefully transferred with a Pasteur pipette and as little agitation as possible, to the cuvette and the absorbances read at 414  $m\mu$ , the Soret peak of ferrohaemalbumin.

The curves obtained in Fig. 1 show the increment in absorbance due to the addition of the albumin, i.e. they represent  $A_{ha} - A_h - A_a$ , where  $ha$  = ferri- or ferrohaemalbumin,  $h$  = haematin or haem and  $a$  = albumin.

The difference in the attachment of the haematin and haem, as indicated by the increment in absorbance, is at once apparent. Similar results were obtained for the ferrohaemalbumin when the dithionite was added to the ferrihaemalbumin after it had stood for 3 hr and the mixture stood a further 3 hr. No trace of verdohaem compounds was detected, but these were formed, as expected, when the reduced solutions were reoxidized, so that the reverse reaction (ferro- to ferrihaemalbumin) could not be investigated under these conditions. To check whether the dithionite itself interfered in any way, nickel mesoporphyrin (on which dithionite has no effect) was added to the albumin and the absorbance increment measured before and after addition

of the dithionite. The first curve was obtained after standing 3 hr, dithionite added at the same concentration as for the iron porphyrins, and the solutions stood another 3 hr to give the second curve. The slight difference is due to the

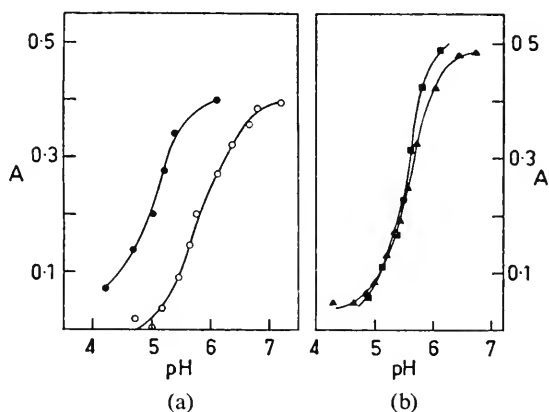

FIG. 1. Attachment of metalloporphyrins to human serum albumin.

- (a) Soret absorbance increment (A) curves prepared, as described in the text, for haematin + human serum albumin at 404  $m\mu$  ●-●-●, for haem + human serum albumin at 414  $m\mu$  ○-○-○.
- (b) Soret peak absorbance increment curves for nickel mesoporphyrin + human serum albumin at 394  $m\mu$  before ▲-▲-▲ and after ■-■-■ adding dithionite. (Buffers, pH 4.0-6.2 phthalate, pH 6.2-7.2 phosphate,  $I = 0.05$ ,  $T = 21^\circ\text{C}$ .)

decreased value for the metalloporphyrin (without albumin) which is not in true solution and whose absorbance is decreasing with time. It was concluded that reduction significantly decreased the acid strength of at least one of the haematin propionate groups.

#### *Attachment of Haematin and Haem to Caffeine*

Caffeine was found by J. Keilin (1943) to combine with copper uroporphyrin III and with manganese mesoporphyrin, but she detected no reaction between haematin and caffeine. This seemed unusual and O'Hagan and George (unpublished, quoted by O'Hagan and Barnett, 1958) found attachment at pH 11.3 (1.33 mol of caffeine/mol of haematin) and also at pH 7.0 (stoichiometric relationship not determined). This suggested stronger attachment of haematin than haem to caffeine since J. Keilin had found at least 20 mol of caffeine/mol of haem to be required for caffeine-haem formation at high pH.

A saturated solution of caffeine (about  $10^{-1}$  M) was substituted for the albumin in the experiments reported above and the absorption increments plotted as shown in Fig. 2. The peaks for the ferrihaemcaffeine and ferrohaemcaffeine were 402 and 420  $m\mu$  respectively. Nickel mesoporphyrin also

showed absorption increments on adding caffeine, with Soret peak at  $392.5\text{ m}\mu$  and attachment occurring from about pH 6.0, rising to a maximum at pH 7.0, and being unaffected by addition of dithionite.

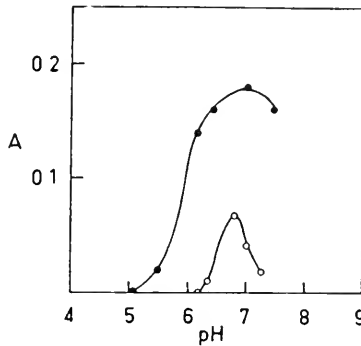

FIG. 2. Attachment of haematin and haem to caffeine. Soret absorbance increment curves prepared as described in the text, for haematin + caffeine at  $402\text{ m}\mu$  ●—●—●, and haem + caffeine at  $420\text{ m}\mu$  ○—○—○. (Buffers, pH 4.0–6.2 phthalate, pH 6.2–7.5 phosphate,  $I = 0.05$ ,  $T = 21^\circ\text{C}$ .)

#### *Preliminary Experiments with Theophylline*

Theophylline has an unsubstituted imino group and therefore resembles more closely the imidazole ring as it would be expected to occur as the side-chain of proteins. In a single series of experiments with theophylline, attachment of haematin occurred from about pH 5, with a pronounced maximum at pH 6.5 and a minimum at about pH 7.3, but no attachment of haem was detected in this range. At lower hydrogen ion concentration, J. Keilin (1943) also had not found combination of haem with theophylline, though she did with caffeine.

These experiments with the imidazoles are preliminary; more points should be obtained to plot the increment curves exactly, but if the curves are nearly correct, a mean increase of propionate  $pK$  value of about 0.9 unit could be indicated on reduction, of the same order as that suggested from the experiments with the albumin compounds. Further studies on the reactions of haematins with imidazoles will be reported later.

#### *Haem Propionate – Protein Linkages in Adult Horse Haemoglobin and Horse Myoglobin*

Nickel porphyrins would appear to be very useful compounds for the study of the attachment of haem propionate groups to the side-chains of proteins. They would be expected to be of almost identical size and shape to the iron porphyrins. Haurowitz and Klemm (1935) found nickel dimethylmesoporphyrin and Pauling and Coryell (1936) found nickel protoporphyrin to be diamagnetic and concluded that these porphyrins contained no unpaired

electrons. This means that neither the pyrrole nitrogens nor the metal atom are capable of further combination, only reactive side-chains can effect attachment to other compounds. The covalent linkage of the metal resembles, too, that of the iron in oxy- and carboxyhaemoglobins, and the resonance state of these metalloporphyrins might be expected to be akin to that of the haem in those proteins.

In the studies reported here, nickel mesoporphyrin was employed, both because it was found to be more readily prepared in pure form than the corresponding protoporphyrin complex and because its use eliminated confusion in interpretation of results, through possible (though unlikely) linkage to protein through vinyl groups. Hill and Holden (1926) had shown that it combined with ox apohaemoglobin, as also did nickel protoporphyrin (Holden, 1941).

To investigate attachment, 10 ml of buffer was placed into each of a series of tubes, then 0.1 ml  $5 \times 10^{-4}$  M apohaemoglobin solution (assumed M.W. = 16,500) and 0.1 ml  $1 \times 10^{-4}$  M nickel mesoporphyrin (1.34 mg pigment + 2 ml 0.05 N NaOH + 8 ml water) added. Other series replacing the apohaemoglobin solution or nickel mesoporphyrin solution with water were prepared at the same time and the tubes containing the three series stood at 1° for 16 hr and then at 21° for 2 hr before reading absorbances at 389  $m\mu$ , using a cuvette of 40 mm path length. For the apomyoglobin experiments the undiluted protein solution used was  $2 \times 10^{-4}$  M and the absorbances read at 410  $m\mu$ . Excess apoprotein was used because of the likelihood of a small variable quantity of denatured protein being present (O'Hagan, 1960), not removable by any treatment yet described, and likely to precipitate on bringing solutions to room temperature.

In order to rule out 'protective colloid' effects or non-specific attachment, carboxyhaemoglobin and ferrimyoglobin were substituted for the apoproteins in the experiments. A small peak centred about pH 9 was found with the haemoglobin, while no attachment was detected with the myoglobin. The results, shown in Fig. 3, indicate that attachment to the apohaemoglobin occurs over the pH range 5–12 with two maxima at about pH 7.4 and 10.0. At pH 9.8 nickel mesoporphyrin had an absorption peak at 380  $m\mu$ , intensifying and moving to 389  $m\mu$  (pH 5.7, 8.0, 9.95) on addition of apohaemoglobin (cf. with caffeine, 392.5  $m\mu$ ). With apomyoglobin the stability range was wider and the peak of the absorption curve shifted much further to 410  $m\mu$ . A difference in the position of the peaks with apohaemoglobin and apomyoglobin is in accord with the finding of differences by Hill (1939) when protoporphyrin was added to these proteins.

The section of the curve with maximum centred at about pH 7.4 for the apohaemoglobin complex is strongly suggestive of imidazolium combination with one or both of the propionates. The other section with maximum at about pH 10.0 varied in height and width with the preparation and is most



probably due to a combination with a group in some denatured protein present. Perhaps this group results from unmasking of the one giving the maximum attachment at pH 9 in the unsplit native protein. It might also be the group detected by Theorell (1942) in apo-haemoglobin, with  $pK$  of 10 at  $0^{\circ}\text{C}$ , not present in ferrihaemoglobin.

The increment curves presented here should not be considered to be exactly reproducible since comparison between solutions and colloidal suspensions is being made. The increments are, however, of such magnitude

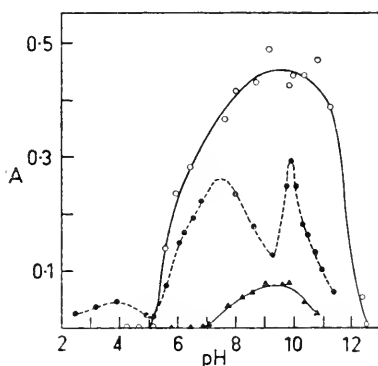

FIG. 3. Attachment of nickel mesoporphyrin to apo-haemoglobin, apomyoglobin and carboxyhaemoglobin. Soret absorbance increment curves prepared, as described in the text, for nickel mesoporphyrin + apo Hb at  $389\text{ m}\mu$   $\bullet\text{---}\bullet\text{---}\bullet$ , + apo Mb at  $410\text{ m}\mu$   $\circ\text{---}\circ\text{---}\circ$ , and + CO Hb at  $390\text{ m}\mu$   $\blacktriangle\text{---}\blacktriangle\text{---}\blacktriangle$ . (Buffers, pH 2-6.2 phthalate, 6.2-8.0, phosphate; 8.5-9.5, pyrophosphate; 9.9-11, glycine; 11.5, phosphate; 12.5, NaOH; I = 0.05, T =  $21^{\circ}\text{C}$ .)

(e.g. apomyoglobin increased the absorbance of nickel mesoporphyrin at  $410\text{ m}\mu$  from 0.22 to 0.67 at pH 10.0) that it seems legitimate to make quantitative comparison. The technique should prove useful in the detection and identification of linking groups in other haemoproteins.

#### *The Nature of the Acid Groups Linking the Haem Iron*

The likelihood of combination of haematin propionate side-chains with imidazolium side-chains of horse haemoglobin called for a re-examination of the evidence for the mode of attachment of the iron atom to the protein. Stability curves of ferrihaemoglobin and ferrimyoglobin reported by O'Hagan (1959a) suggested the possibility that groups of  $pK$  value lower than 5.3 were involved. Theorell and Ehrenberg (1951), after their exhaustive study of myoglobin, concluded that a group of more negative character than an imidazole was responsible for iron linkage, but gave the group a  $pK$  value of 5.3.

Since Coryell, Stitt and Pauling (1937) had shown that in acid ferrihaemoglobin the atom of iron was joined to other atoms surrounding it by

'essentially ionic' bonds, it could be assumed that as the haematin was being removed at increasing acidity the reaction could, for practical purposes, be regarded as ionic. Since the haematin would be likely to have a tendency to polymerize, with drop in absorbance, it might well act as an 'indicator' of the suppression of the ionization of the group ligating it.

To rule out the effects of linkages through the haematin propionate groups, aetio-myoglobin, the properties of which have been described by O'Hagan and

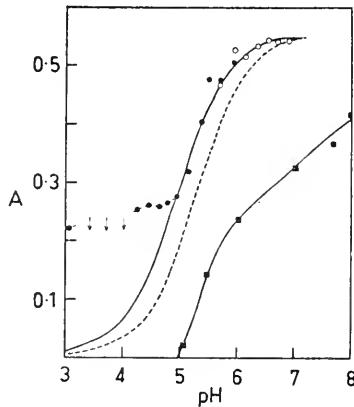

FIG. 4. Soret absorbance increment curve for ferriaetio-myoglobin at  $393.5\text{ m}\mu$  prepared as described in text,  $\circ\text{---}\circ\text{---}\circ$  phosphate buffer,  $\bullet\text{---}\bullet\text{---}\bullet$  phthalate buffer,  $\downarrow$  ppte.,  $\text{---}\text{---}\text{---}$  theoretical curve for acid with  $pK = 5.3$ ,  $\blacksquare\text{---}\blacksquare\text{---}\blacksquare$  curve for nickel mesoporphyrin + same conc. of apomyoglobin for comparison. (Buffers,  $I = 0.05$ ,  $T = 21^\circ\text{C}$ .)

George (1959) was utilized. It was prepared by adding  $0.5\text{ ml}$  of  $3 \times 10^{-3}\text{ M}$  aetiohaemin in methanol to  $5.5\text{ ml}$  of  $2.9 \times 10^{-4}\text{ M}$  apomyoglobin at pH 6.5 (no added buffer) and standing at  $1^\circ\text{C}$  overnight. A solution prepared by adding  $0.5\text{ ml}$  aetiohaemin solution to  $5.5\text{ ml}$  distilled water was treated throughout in the same manner as the aetiohaemin-apomyoglobin solution, to act as a control. Next day the solutions were spun at  $15,000\text{ g}$  for  $15\text{ min}$  (to remove free aetiohaematin) and the supernatant added in  $0.2\text{ ml}$  aliquots to  $5\text{ ml}$  portions of buffer solution. After standing  $6\text{ hr}$  at  $1^\circ\text{C}$  and  $3\text{ hr}$  at  $21^\circ\text{C}$  the absorbances were read ( $10\text{ mm}$  cuvette). The curve showing the absorbance increment due to the apomyoglobin is shown in Fig. 4. The nature of the buffer, phthalate or phosphate, made little difference to the shape of the curve in the range pH 5.5–6.8. At about pH 4.95 a discontinuity in the curve appeared, probably due to the taking up of the aetiohaematin by carboxyl groups liberated in the protein. The curve drawn through the points represents a theoretical curve for a group ionizing with  $pK = 4.95$ , and for comparison curves for a group with  $pK = 5.3$  and for the attachment of nickel mesoporphyrin to apomyoglobin are given. While by no means

conclusive, these studies could indicate the existence of a group of  $pK$  less than 5.3, if the aetiohaemin is behaving as a weak base (it does not attach to apomyoglobin above  $pH$  8.0) and is acting as an indicator of the ionization of the haem-linked group of the protein. These studies are being extended to apohaemoglobin combination.

### DISCUSSION

That a change occurs in the acid strength of the haematin propionate groups on reduction of the haematin iron is not unexpected, since it has been well established that variation of the side-chains influences the oxidation-reduction potentials of ferro-ferrihaemochrome systems (Lemberg and Legge, 1949). If alterations to the side-chains can affect the reactions of the iron atom, it is not unreasonable to expect that modifications to the electronic structure of the iron could alter the acid strength of ionizable side-chains. The parallelism between changes of the oxidation-reduction potential at 50% oxidation and  $\log p$ , where  $p$  is the oxygenation pressure at 50% saturation of haemoglobin, with alteration in hydrogen ion concentration, has been clearly demonstrated (Wyman and Ingalls, 1941; see Lemberg and Legge, 1949). We may therefore infer that oxygenation affects the acid strength of the propionate groups in much the same way as does oxidation of the iron.

It was first suggested by Altschul and Hogness (1939) that, on oxygenation, a change occurred in the acid strength of groups of the haem rather than of those of the apoprotein. They considered it very probable that the two carboxyl groups of each haem were influenced by oxygenation. They calculated the  $pK$  values of these carboxyl groups as shown in Table 1. The

TABLE 1. CALCULATED  $pK$  VALUES OF HAEM PROPIONATE GROUPS IN FERRO- AND OXYHAEMOGLOBIN (ALTSCHUL AND HOGNESS, 1939)

Assumed no. of acid groups affected	Calculated $pK$ values*		
	oxygenated	reduced	$\Delta pK$
1	5.5	6.9	1.4
2	5.8	6.5	0.7

\* Temperature unspecified, presumably 25°C.

actual values may lie somewhere between the extreme values of 5.5–6.9 since the two acid groups may not be altered in an exactly uniform manner, since the dissociation constants may differ as do those of dibasic acids. Examination of the haem structure shows that the vinyl groups at positions 2 and 4 give asymmetry, which may mean influence of the propionate at

position 6 to a greater or lesser extent than the one at position 7. Consideration of the grouping together of rings 1 and 4 and 2 and 3 seems justified, and there may be shared resonance between them as pairs, since on rupture the ring splits first at the  $\alpha$  position to form verdohaems and the tetrapyrrolic ring system of bilirubin splits at the central methylene group on diazotization (Lemberg and Legge, 1949). This could suggest that one propionate group would be more affected by oxygenation than the other, so that if they were joined by electrostatic linkages to the apoprotein, one might be a labile link under physiological conditions, while the other only split by such conditions as high ionic strength, high urea or high hydrogen ion concentration, with subsequent parting of the protein molecule into halves.

Whatever the actual  $pK$  values, those calculated by Altschul and Hogness show that carbonic acid of  $pK = 6.352$  at  $25^\circ\text{C}$  in water (Edsall and Wyman, 1958) could be displaced by a group or groups changing between minimum  $pK$  values of 6.5 and 5.8. The curves of Figs. 1 and 2 could suggest a change of 0.9 unit, compared with a calculated change of 0.7 for two groups and of 1.4 for one group.

The asymmetric haem could conceivably be attached to the apoproteins directly or inverted so that structural isomers would be possible unless some orientation by the side-chains occurred. Differences in the acid strength of the two propionates might decide the orientation and also which group could detach from the apoprotein on reduction.

The curves obtained for the increment in the absorbance of nickel mesoporphyrin on addition to apohaemoglobin show that a molecule of the size and shape of haem can link by its propionate groups in the pH range 5-9 to a residue in the apohaemoglobin not present in the carboxyhaemoglobin. A specific structure in the proteins binding one or both of the propionates is clearly indicated. That it is not the same as the one binding the iron atom can be deduced from the work with actiomyoglobin (Fig. 4). The measurements given by Wyman (1948) of the apparent heat of dissociation of horse oxyhaemoglobin and the work reported here, very strongly suggest that in this species the groups binding the propionates are imidazolium side-chains. The shape and range of the curves, and their similarity to the ones obtained for combination with caffeine (Fig. 2), support this.

Studies have not yet been extended to haemoglobins of other species; it may be that other amino acid residues are responsible for bonding in these, perhaps explaining the higher heat of dissociation given by Roughton (1944) for ox haemoglobin at pH 6.8, and accounting for his findings in respect to the carbamino reaction.

The relationship between the new data, representing the attachment of the propionate groups to the residue in horse apohaemoglobin, and the curve of German and Wyman (1937) is shown in Fig. 5. The top curve of Fig. 5 was obtained by subtracting the increments found for the attachment of nickel

mesoporphyrin to apohaemoglobin and to carboxyhaemoglobin. These curves are most probably also related to a differential carbamate equilibrium curve which can be prepared by subtracting the points of the curves of Figs. 5a and 5b of Stadie and O'Brien (1937) for ferro- and oxyhaemoglobin (species unspecified).

A new interpretation of the differential titration curve is suggested—(1) that the alkaline loop represents the attachment of propionate groups to imidazolium side-chains; (2) that the acid loop mirrors the difference between

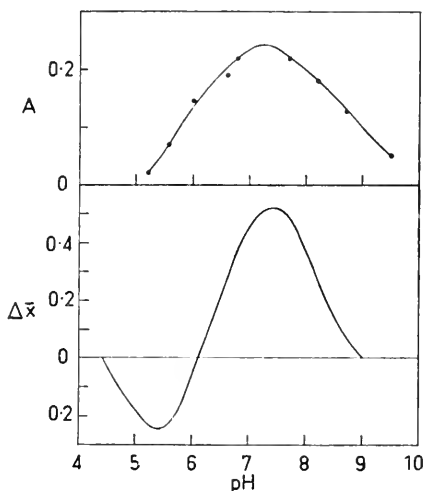

FIG. 5. Comparison of specific increment curve (upper) for attachment of nickel mesoporphyrin to apohaemoglobin with the differential titration curve (lower) of German and Wyman (1937) for ferroHb-oxyHb (upper curve) prepared by deducting increment with COHb from increment with apoHb).

the detachment of the haem iron, in the 'essentially covalent' (and stronger) linked oxyhaemoglobin and the 'essentially ionic' ferrohaemoglobin. As the hydrogen ion concentration increases, the group bonding the iron in ferrohaemoglobin will be liberated, that in oxyhaemoglobin will still be held by the stronger bond. The maximum difference occurs at about pH 5.4 after which the 'covalent' bond begins to break and the extent of ionization of the two groups becomes the same at pH 4.3. Preliminary studies (O'Hagan, unpublished) show very marked differences in the stability of carboxyhaemoglobin and ferrihaemoglobin in the pH range 4-6. If the above interpretation is correct, a more pronounced acid loop should be found for the differential titration of carboxyhaemoglobin-ferrohaemoglobin.

The experiment with apomyoglobin shows that a much stronger basic group or groups is bonding the propionate(s) as evidenced by the greater height of the curve in the pH range 5-9 and the major shift (30  $m\mu$ ) in the position

of the Soret peak. This finding of a stronger basic group could explain the considerably lower heat of oxygenation ( $\Delta H_0 = -17.5$  kcal) found for myoglobin by Theorell (1934), compared with the values of haemoglobins ( $\Delta H_0 \sim -12.5$  kcal, Wyman, 1948; see also George, 1956). The greater stability of myoglobin towards alkali (Haurowitz and Hardin, 1954) may also be explainable in terms of this basic group. Change in acid strength of the haem propionates would be expected to have less effect on bonds to such stronger basic groups, accounting for the small Bohr effect and minor effect on the shape of the oxygen dissociation curve with a change in the hydrogen ion concentration. Examination of the attachment in the pH range 11–13, using a hydrogen electrode, may give further information on the nature of the linking group.

German and Wyman (1937) and Wyman (1948) in discussion of the nature of the group binding the haem iron, pointed out the uncertainty that the group ionizing in the more acid range was imidazole, and that the second carboxyl group of dicarboxylic acids should also be considered. This seems to have been generally overlooked, and the matter calls for more attention in the light of the observations made here. Even a  $pK$  value of 5.3 appears low for an imidazole group by comparison with its value in compounds resembling those occurring naturally.

The strongest evidence against the hypothesis that the haem iron is linked to a group other than imidazole is the ingenious experiment of Wang (1958), who found that diethylprotohaem linked to 1-(2-phenyl-ethyl)-imidazole in a film of polystyrene, bound carbon monoxide which could be replaced by oxygen. However, substitution at position 1 on the imidazole ring would appear to change its character, making it unlike that presumed to occur in haemoglobins. It could be that such a substitution makes the free nitrogen acidic and that the acid strength of the linking groups rather than their structure is the important factor. This may apply also to the imidazole haem compound found by Corwin and Reyes (1956) to bind oxygen, though apparently very poorly. Whatever type of linkage exists between the iron and the apoprotein, whether it be imidazole,  $\beta$  or  $\gamma$  carboxyl or an unusual type not yet detected in proteins, should not materially affect the discussion which follows.

The oxygen dissociation curves of the haemoglobins can now be examined in the light of the new findings. It is interesting that Barcroft (1938) likened the curves to oxygen titration curves and we could perhaps visualize them as representing the 'titration' by haem propionates (of changing acid strength) of the weakly basic groups (haemoglobins) or more strongly basic groups (myoglobins). The oxygen dissociation curve of haemoglobin could be considered as representing the titration, from no combination to full combination, of the propionate group with the imidazolium group. The curve for myoglobin would be only the upper section of the curve for the titration of

a propionate group with a much more basic group, the strength of the combination being only slightly affected on reduction.

A weak acid-weak base linkage would be expected to be considerably affected by neutral salts and specific ions, as is the oxygenation of haemoglobin, while a linkage to a stronger base would be less affected. This concept could explain the effect known as 'haem-haem interaction', and at the same time account for the Bohr effect. That these effects are apparently interrelated is indicated by the loss of both under certain conditions of reconstitution of haemoglobins (Wyman, 1948). Rossi-Fanelli and Antonini (1959) from a study of human deuterohaemoglobin considered the vinyl groups to be involved in 'haem-haem interaction' and illustrated, but did not explain, the influence of removal of these groups in decreasing the Bohr effect at a given pH. The results seem comparable to the findings of Riggs and Wolbach (1956) on addition of mersalyl to horse haemoglobin. In both cases these effects would appear to be secondary, in the first from a decrease in acid strength of the haem propionates, brought about by removal of the vinyl groups; in the second on account of the propionate binding group of the protein becoming more basic, through combination of a neighbouring sulphhydryl group with the mersalyl.

A labile electrostatic linkage between at least one of the two haem propionates of each of the four haems and imidazolium side-chains of the apoprotein might explain, better than 'haem-haem interaction', the sigmoid oxygen dissociation curve and the Bohr effect in horse haemoglobin. Linkage to more or less basic groups than the imidazoliums of horse haemoglobin could conceivably explain the curves for other species, including those with 'atypical' curves. The detachment of the propionates in ferrohaemoglobins could explain the change in molecular shape on deoxygenation and also partly account for dry oxyhaemoglobin not releasing oxygen at low oxygen pressures (Haurowitz and Hardin, 1954), the electrostatic bond breaking only in solution.

While the exact state of the haemoglobin in the erythrocyte is unknown (see Wintrobe, 1956), the most likely condition—attachment to a framework of stromatin at an equivalent concentration of 34% haemoglobin—could be conceived as decreasing the velocity of diffusion of oxygen into the interior of the cell. A change in shape of the haemoglobin molecules on breaking the electrostatic link might counteract this to some extent by 'agitation' of the cell contents.

#### SUMMARY

1. Reduction of haematin to haem markedly decreases the acid strength of one or (more probably) both of the propionate side-chains.
2. Nickel mesoporphyrin which can only combine through its propionate side-chains, links with a group or groups in horse apohaemoglobin with imidazolium characteristics.

3. With horse apomyoglobin nickel mesoporphyrin combines with a more basic group or groups.

4. Fresh evidence is presented that the group in apomyoglobin binding the haem iron is more likely to be of the nature of a  $\beta$  or  $\gamma$  carboxyl than an imidazole group.

5. An interpretation of the sigmoid shape of the oxygen dissociation curve, the Bohr effect, the alkaline stability, and the change of molecular shape on oxygenation, in terms of labile electrostatic linkages between the haem propionate groups and imidazolium side-chains of horse apohaemoglobin is presented.

6. It is suggested that the change in shape of the haemoglobin molecule on oxygenation or reduction may 'agitate' the contents of the erythrocyte and thus assists the exchange of oxygen and carbon dioxide between the cell interior and the plasma surrounding its envelope.

#### *Acknowledgement*

Without the continued encouragement of Dr. A. E. Shaw and generous provision of facilities by the Queensland Division of the Australian Red Cross Society this work could not have been accomplished.

#### ADDENDUM

(Note added in proof)

The subsequent evidence of Kendrew, Dickerson, Strandberg, Hart, Davies, Phillips and Shore (1960) indicates that the haem iron in myoglobin is attached to imidazole nitrogen, not to a carboxyl group. Their work was carried out with crystalline ferrimyoglobin, mine with this compound in solution, but it is unlikely that the mode of attachment would be essentially different in the crystal and in solution.

#### REFERENCES

- ALTSCHUL, A. M. & HOGNESS, T. R. (1939). *J. biol. Chem.* **129**, 315.  
 BARCROFT, J. (1928). *The Respiratory Function of the Blood*, Pt. 2, p. 102, Cambridge Univ. Press.  
 BARCROFT, J. (1938). *Features in the Architecture of Physiological Function*, p. 71, Cambridge Univ. Press.  
 CORWIN, A. H. & REYES, Z. (1956). *J. Amer. chem. Soc.* **78**, 2347.  
 CORYELL, C. D., PAULING, L. & DODSON, R. W. (1939). *J. phys. Chem.* **43**, 825.  
 CORYELL, C. D., STITT, F. & PAULING, L. (1937). *J. Amer. chem. Soc.* **59**, 633.  
 EDSALL, J. T. & WYMAN, J. (1958). *Biophysical Chemistry*, **1**, 558. Academic Press, New York.  
 FISCHER, H. & ORTH, H. (1937). *Die Chemie des Pyrroles*, **2**, 442. Akademische Verlagsgesellschaft, Leipzig.  
 FISCHER, H. & PÜTZER, B. (1926). *Hoppe-Seyl. Z.* **154**, 39.  
 FOX, H. M. (1932). *Proc. Roy. Soc. B.* **111**, 356.  
 GERMAN, B. & WYMAN, J. (1937). *J. biol. Chem.* **117**, 533.  
 GEORGE, P. (1956). *Currents in Biochemical Research*, p. 338 (Ed. by D. E. Green), Interscience, New York.



- GEORGE, P. & HANANIA, G. I. H. (1953). *Biochem. J.* **55**, 236.
- GEORGE, P. & LYSTER, R. L. J. (1958). *Conference on Haemoglobin, May 2-3, 1957*, p. 33. Publication No. 557, National Academy of Sciences—National Research Council, Washington.
- GRANICK, S. (1949). *Harvey Lectures*, **44**, 228.
- GRINSTEIN, M. (1947). *J. biol. Chem.* **167**, 515.
- GRINSTEIN, M. & WATSON, C. J. (1943). *J. biol. Chem.* **147**, 671.
- HANANIA, G. I. H. (1953). Ph.D. Thesis, University of Cambridge.
- HARRIDGE, H. & ROUGHTON, F. J. W. (1925). *Proc. Roy. Soc. A.* **107**, 654.
- HAUROWITZ, F. (1959). Private communication.
- HAUROWITZ, F. & HARDIN, R. L. (1954). *The Proteins*, (Ed. by H. Neurath and K. Bailey), vol. 2, p. 332. Academic Press, New York.
- HAUROWITZ, F. & KLEMM, W. (1935). *Ber. dtsh. chem. Ges.* **68**, 2312.
- HILL, R. (1939). *Perspectives in Biochemistry*, p. 131 (Ed. by J. Needham and D. E. Green), Cambridge Univ. Press.
- HILL, R. & HOLDEN, H. F. (1926). *Biochem. J.* **20**, 1326.
- HOLDEN, H. F. (1941). *Aust. J. exp. Biol. med. Sci.* **19**, 1.
- ITANO, H. A. & ROBINSON, E. (1956). *J. Amer. chem. Soc.* **78**, 6415.
- KEILIN, D. (1953). *Nature, Lond.* **171**, 922.
- KEILIN, D. & WANG, Y. L. (1946). *Biochem. J.* **40**, 855.
- KEILIN, J. (1943). *Biochem. J.* **37**, 281.
- KEILIN, J. (1944). *Nature, Lond.* **154**, 120.
- KENDREW, J. C., BODO, G., DINTZIS, H. M., PARRISH, R. G., WYCKOFF, H. & PHILLIPS, D. C. (1958). *Nature, Lond.* **181**, 662.
- KENDREW, J. C., DICKERSON, R. E., STRANDBERG, B. E., HART, R. G., DAVIES, D. R., PHILLIPS, D. C. & SHORE, V. C. (1960). *Nature, Lond.* **185**, 422.
- LEMBERG, R. & LEGGE, J. W. (1949). *Hematin Compounds and Bile Pigments*, pp. 94, 121, 194, 214, 243, 295 and 458, Interscience, New York.
- NAHAS, G. G. (1951). *Science*, **113**, 723.
- O'HAGAN, J. E. (1950). M.Sc. Thesis, University of Queensland.
- O'HAGAN, J. E. (1955). *Abstr. 3rd int. Congr. Biochem., Brussels*, p. 10.
- O'HAGAN, J. E. (1959a). *Nature, Lond.* **183**, 393.
- O'HAGAN, J. E. (1959b). Ph.D. Thesis, University of Queensland.
- O'HAGAN, J. E. (1960). *Biochem. J.* **74**, 417.
- O'HAGAN, J. E. & BARNETT, C. (1958). *Abstr. 3rd Gen. Meeting, Aust. Biochem. Soc. Adelaide, 1958*.
- O'HAGAN, J. E. & GEORGE, P. (1960). *Biochem. J.* **74**, 424.
- PAULING, L. (1935). *Proc. nat. Acad. Sci. Wash.* **21**, 186.
- PAULING, L. & CORYELL, C. D. (1936). *Proc. nat. Acad. Sci. Wash.* **22**, 159.
- REDFIELD, A. C. (1933). *Quart. Rev. Biol.* **8**, 31.
- RIGGS, A. F. & WALBACH, R. A. (1956). *J. gen. Physiol.* **39**, 585.
- ROSSI-FANELLI, A., ANTONINI, E. (1959). *Arch. Biochem. Biophys.* **80**, 308.
- ROSSI-FANELLI, A., ANTONINI, E. & CAPUTO, A. (1959). *Nature, Lond.* **183**, 827.
- ROUGHTON, F. J. W. (1944). *Harvey Lectures*, **39**, 96.
- ROUGHTON, F. J. W., OTIS, A. B. & LYSTER, R. L. J. (1955). *Proc. Roy. Soc. B.* **144**, 29.
- RUSSELL, C. D. & PAULING, L. (1939). *Proc. nat. Acad. Sci. Wash.* **25**, 517.
- STADIE, W. C. & O'BRIEN, H. (1937). *J. biol. Chem.* **117**, 439.
- TAKASHIMA, S. (1955). *J. Amer. chem. Soc.* **77**, 6173.
- THEORELL, H. (1934). *Biochem. Z.* **268**, 73.
- THEORELL, H. (1942). *Ark. Kent Min. Geol.* **16A**, No. 14.
- THEORELL, H. & EHRENBERG, A. (1951). *Acta chem. Scand.* **5**, 823.
- WANG, J. H. (1958). *J. Amer. chem. Soc.* **80**, 3168.
- WINTROBE, M. M. (1956). *Clinical Haematology*, 4th ed., p. 89, Lea & Febiger, Philadelphia.
- WYMAN, J. (1948). *Advanc. Protein Chem.* **4**, 410.
- WYMAN, J. & INGALLS, E. N. (1941). *J. biol. Chem.* **139**, 877.

## DISCUSSION

*Native Globin*

DRABKIN: I would be glad if O'Hagan could tell us a little more about the state of his apo-haemoglobin as against that of his apomyoglobin. I am thinking in terms of the possibility that, since myoglobin is far, far more stable toward alkali than is haemoglobin, some question may be raised as to the strict validity of comparing the two apoproteins.

LEMBERG: Rossi-Fanelli has found that by his method any irreversible denaturation of globin from haemoglobin can be prevented, and O'Hagan followed his method rather closely. Denaturation will, however, occur if the recombined haemoglobin solutions contain an excess of free globin and are measured in the spectrophotometer at room temperature.

O'HAGAN: Initially trouble was experienced with these apoproteins due to precipitation of the denatured material at room temperature and neutral pH. The trick is to bring the pH to 7.8, leave at 21°C for 1 hr, leave at 0°C for three days to remove coagulated material, and centrifuge for 10 min at 20,000 × g. With one preparation, which I considered to be not as good as the others, on other evidence, the peak at pH 10 (see Fig. 3 of my paper) was higher and broader.

GEORGE: In our work on reconstituted ferrimyoglobin, O'Hagan and I obtained data similar to that of Rossi-Fanelli on reconstituted ferrohaemoglobin. In a comparison with native ferrimyoglobin we found that the affinity for fluoride is scarcely altered, and that the pK values of the haem-linked ionizing group associated with its Bohr effect are identical to within experimental error.

*The Linkage of Iron and Protein in Haemoglobin*

PERRIN: In systems such as haem, or haematin plus albumin, we have equilibria such as:

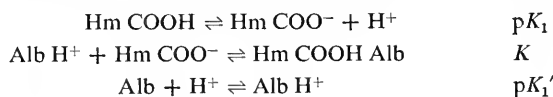

This is certainly a gross over-simplification but will serve to illustrate a difficulty in using O'Hagan's spectral absorption difference approach.

At constant albumin and total Hm concentration there are still three light-absorbing species in such a system and their concentrations are governed by three unknown constants,  $K$ ,  $K_1$  and  $K_1'$ . In addition, each of the absorbing species has its own molecular extinction coefficient, so that the absorbance increment at any given pH is not a simple function of the species. There is no reason to assume the  $K$ 's are the same for haem and haematin, and in fact they are most unlikely to be if any binding through the iron is involved.

I should like to ask O'Hagan how he arrives at the conclusion that 'reduction (of haematin to haem) significantly decreases the acid strength of at least one of the haematin propionate groups.'

Concerning Fig. 4, I should like to point out that stability curves of metal complexes such as ferrihaemoglobin cannot be used to obtain the pKs of the ligands. Falk, Phillips and I have discussed this elsewhere (*Nature, Lond.* **184**, 1651, 1959). The 'apparent pKs' in such cases are, in fact, functions not only of the pK of the ligand but also of the stability constant of the metal complex and the concentration of the ligand. It is quite erroneous to identify such 'apparent pKs' with the pK's of groups such as carboxyl or imidazole. The nature of the metal-to-ligand bond does not affect this conclusion: if a complex is present, there is, of course, a  $\Delta G = RT \ln K$  which leads to significant changes in the thermodynamics of the system relative to the proton-ligand system.

One cannot use the  $\Delta H$  for haem-protein dissociation where the iron-to-protein link is involved as evidence for COO<sup>-</sup> or imidazole linkage if one takes the data for

proton addition to the latter groups. There is no reason why  $\Delta H$  for metal-ligand bonding should be the same as for proton addition to the ligand.

PHILLIPS: The conclusion reached in part 4 of O'Hagan's summary seems not only unjustified but also contrary to the facts. One cannot deduce the  $pK$  of a ligand from the  $pH$  at which the co-ordination complex is half dissociated without knowing the stability constant of the complex and the concentration of the various species: One can be certain, however, that the  $pK$  will be greater than the  $pH$  of half-dissociation and all one can deduce from O'Hagan's results is that the  $pK$  of the co-ordinating group is  $> 5$  which could well be histidine ( $pK \sim 7$ ) or even lysine ( $pK \sim 9$ ) but is unlikely to be a carboxyl group ( $pK \sim 5$ ).

O'HAGAN: It is true that the  $pK$  values I have suggested are not exact; they were not intended to be. I was not attempting to obtain an absolute value under these conditions, but one which would at least indicate the most likely group ionizing. In regard to Phillips' point, curve (a) shows some preliminary results on the dissociation of horse oxyhaemoglobin in acid buffers. There is evidence that at  $pH$  5.0 groups are dissociating. These cannot be the haematin side-chain carboxyls, the evidence points to the groups linked to the iron. At  $pH$  4.9, Ferry and Green (*J. biol. Chem.* **81**, 175, 1929) found horse haemoglobin stable enough to obtain an oxygen dissociation curve. If we examine the curve for the apparent heat of dissociation of horse oxyhaemoglobin of German and Wyman (*J. biol. Chem.* **117**, 533, 1937), we can see that at  $pH$  5.0 the apparent heat of dissociation is about  $-1$  kcal. If there were imidazole groups ionizing we would expect a value of about 6 kcal. The value found would appear to indicate carboxyl groups are linked to the iron atoms.

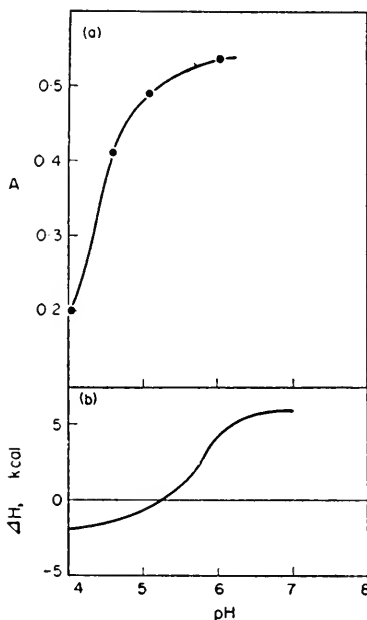

The Haem-Globin Linkage

(a) Change in the Soret peak absorbance at 410  $m\mu$  of horse oxyhaemoglobin in phthalate buffers ( $pH$  4.0-6.2,  $I = 0.05$ ).

(b) Curve for apparent heat of dissociation of horse oxyhaemoglobin from German and Wyman (*J. biol. Chem.* **117**, 533, 1937).

LEMBERG: Are we really sure that the combination between haematin and serum albumin is only through the haem carboxylic acid groups? This is certainly not so for the combination of haematin *a* with serum albumin, in which the spectrum clearly indicates combination with protein nitrogen. I was inclined to accept the suggestion of J. Keilin for the protohaematin compound, but I feel no longer sure about it now.

GEORGE: In considering various mechanisms that might account for haem-linked ionization effects, I recently calculated the pH range over which a salt bridge would remain intact, and I think this will clarify the points just raised by Orgel, Perrin, Phillips and Williams.

If the equilibrium constant for the formation of a salt bridge between, say, a carboxylate group and a substituted ammonium group is  $K_s$ ,

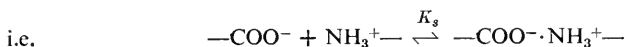

and the ionization constants for the two separate groups are  $K_{\text{COOH}}$  and  $K_{\text{NH}_3^+}$  respectively, then in acidic solution the pH at which 50% formation occurs is given by  $p(K_s K_{\text{COOH}})$ , and in alkaline solution the corresponding pH is given by  $p(K_{\text{NH}_3^+}/K_s)$ . As illustrated in the diagram the formation of the salt bridge results in the 'titration' of the carboxyl group in a lower pH range and the amino group in a higher pH range than usual—the apparent shift in the pK values being determined by the magnitude of  $K_s$ .

The shift in the pK values is in an opposite sense, because in acidic solution the bridge is broken by combination with  $\text{H}^+$ ,

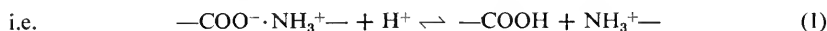

whereas in alkaline solution by the dissociation of  $\text{H}^+$ ,

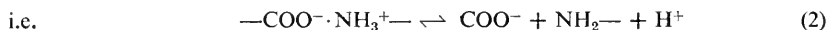

In reaction (1)  $\text{NH}_3^+$  can be thought of as competing with  $\text{H}^+$  for the  $\text{COO}^-$  group, thus lowering the 'pK'; in reaction (2) the combination of  $\text{H}^+$  with  $\text{NH}_2$  giving  $\text{NH}_3^+$  is favoured by the formation of the salt bridge; this has the effect of making  $\text{NH}_3^+$  a weaker acid, and hence raises its pK.

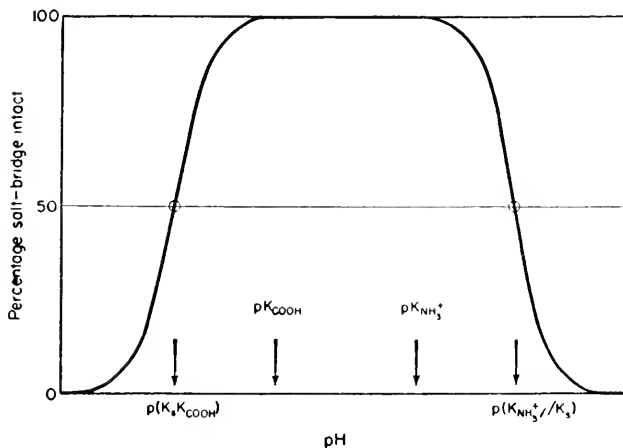

FALK: It is clear that the basis of the difference which Perrin, Phillips and I have had with O'Hagan is that he seems to consider the protein-haemoglobin bond as something like a simple electrostatic bond, with virtually zero stability constant, where we consider that co-ordination occurs to give a haem-globin complex with a finite stability constant.

Regarding  $\text{COO}^-$  as the protein-iron bond in haemoglobin, my objection to this is that of all the possible protein ligand groups,  $-\text{COO}^-$  would tend to stabilize the ferric state most. The stabilization of its ferrous state, compared to haem itself, is perhaps the most important and the most outstanding special property of haemoglobin.

# EARLY STAGES IN THE METABOLISM OF IRON

By J. B. NEILANDS

*Department of Biochemistry, University of California,  
Berkeley, California*

THERE are certain chemical and biochemical characteristics of iron which place it in a unique category in relation to the other common biocatalytic elements. Both ferric and ferrous ions are quite insoluble in aqueous solution at physiological pH; this property is of special significance in the case of ferric ion (solubility product  $10^{-36}$ ) since most of the iron available to living organisms will be encountered, at least initially, in the higher oxidation state. If one considers the very large proportion of iron that takes part in the transport and storage of oxygen as catalytic iron, then the latter element is seen to be quantitatively the single most important biocatalytic element in the entire realm of animal enzymology. Finally, since iron is bound relatively weakly to the usual type of naturally-occurring ligand, it might be expected that living cells, especially those with a high requirement for this metal, would have found it necessary to evolve special complexing agents which have the capacity to overcome such problems that are inherent in the transport and metabolism of this particular element.

The complete synthesis of an iron-enzyme involves the ultimate convergence of at least two, possibly three, biosynthetic pathways. If the broad definition of an iron-enzyme given above is adopted, it is clear that in many instances the major portion of enzyme iron will occur as the porphyrin chelate, i.e. haem. The early stages in the biosynthesis of the organic part of this prosthetic group have been thoroughly elucidated at least to the level of porphobilinogen (Shemin, 1955; Laver, Neuberger and Udenfriend, 1958) and partially clarified from thence to coproporphyrinogen (Granick and Mauzerall, 1958). Little exact information is available as yet concerning the immediate precursor of protoporphyrin although from the vitamin requirements for haem synthesis (Lascelles, 1957) it might be speculated that an acrylic acid side chain should occur as an intermediate between the carboxyethyl and vinyl side chains.

In recent years many investigators have examined the mechanism of uptake of iron by protoporphyrin. The concensus of opinion appears to be that the reaction is enzyme-catalyzed although the specific protein responsible for the observed effect has not been isolated. Until the latter has been achieved, the precise nature of the iron donor in the reaction will remain obscure.

Essentially nothing is known of the structure and origin of the active centres of the non-haem iron enzymes.

The special problems which arise in iron metabolism, as contrasted, for example with copper metabolism, can be illustrated by comparison of the characteristics and behaviour of the two elements in question. In the case of copper it is certain that smaller quantities are required by living tissues, the somewhat greater solubility of the hydroxide (saturated water solution of cupric hydroxide is  $>10^{-5}$  M at  $25^{\circ}$ , Seidell, 1940) and, finally, the ubiquitous  $\alpha$ -amino carboxylic acid structure provides an effective ligand capable of holding the cupric ion in solution at physiological pH.

In the present paper, results will be presented for certain experiments dealing with the early stages of iron metabolism in micro-organisms. The latter form of life has been chosen for investigation on account of the well-known metabolic flexibility characteristic of unicellular organisms; however, in spite of this advantage, it must be recognized that micro-organisms as experimental subjects suffer from the fact that each species may exhibit certain metabolic variations. This will effectively preclude the formulation of sweeping generalities about the detailed mechanism of iron metabolism in all forms of life.

The technique employed in the present instance has been that of cultivation of the aerobic micro-organisms *Bacillus subtilis* and *Ustilago sphaerogena* in the presence of diminished levels of iron. Such very aerobic species can be expected to have a reasonably high requirement for iron and a correspondingly well-developed system for the intermediary metabolism of this element. This statement is particularly true for *Ustilago sphaerogena* since this organism is known to form large quantities of cytochrome *c* (Grimm and Allen, 1954). The growth of such cells under conditions of iron deprivation provides valuable information about the early stages of iron metabolism. At very low levels of iron there is sparse growth, a feeble metabolism and essentially nothing can be learned about the intimate processes of iron utilization. Similarly, at abnormally high levels of iron, the substances usually involved as intermediates in iron metabolism may be produced in greatly diminished quantities in spite of the excellent cell yields. On the other hand, at *intermediate* levels of iron, three possible metabolic adjustments come into play which lead to the accumulation and excretion of iron-complexing agents:

- (i) The biosynthesis of specific ferric complexing agents, normally competitively inhibited and maintained at a low level by the presence of a variable amount of the ferric chelate, becomes a major metabolic activity of the cell.
- (ii) The deficiency of iron creates a metabolic block, the latter being manifested by the appearance of iron-complexing products which normally require iron for their further metabolism.

- (iii) The new substances produced in iron deficiency are intended to serve, either as such or as the ferric complex, as a by-pass for electron transport around the normal cytochrome system.

The isolation, characterization and chemical synthesis of *itoic acid* (iron-transferring-orthophenol; 2:3-dihydroxybenzoylglycine; 2:3-dihydroxyhippuric acid) has been described elsewhere (Neilands, 1958; Ito and Neilands, 1958). The following experiments relate to the iron-complexing activity, production and metabolism of the new compound.

The isolation and general properties of the ferrichrome compounds have been reviewed previously (Neilands, 1957). The present report will describe recent experiments leading to the identification of the iron-binding centre of the ferrichromes as a polyhydroxamic acid (Emery and Neilands, 1959; Emery, 1960).

## EXPERIMENTAL

### *Materials*

Itoic acid was synthesized from 2:3-dihydroxybenzoic acid and ethyl glycinate in the manner previously described (Ito and Neilands, 1958). The preparation, after recrystallization, was chromatographically homogeneous in the following solvent systems ( $R_f$  in brackets): *n*-butanol, 4, acetic acid, 1, water, 5 (0.80); benzene, 2, acetic acid, 2, water, 1 (0.29); methanol, 20, water, 5, pyridine, 1 (0.67); *tert.*-butyl alcohol, 10, methyl ethyl ketone, 10, water, 5, diethylamine, 1 (0.39). The chromatograms were analyzed by ultraviolet illumination or by spraying with either 1% aqueous ferric chloride alone or acidic sodium nitrite solution followed by dilute NaOH.

Ferrichrome and ferrichrome *A* were prepared by 'low-iron' fermentation with *U. sphaerogena* and recrystallized by published methods (Neilands, 1952; Garibaldi and Neilands, 1955). Both preparations gave single spots in *n*-butanol, 4, acetic acid, 1, water, 5 (0.40 and 0.51, respectively) and methanol, 4, water, 1 (0.68 and 0.52, respectively). The ferrichromes can generally be detected visually on paper as tea-coloured spots without the application of a developing spray; alternatively, when only very small amounts of material are present, the chromatograms may be sprayed first with dilute sodium sulphite solution and then with a very dilute solution of 1:10-phenanthroline. Under these conditions iron is instantly released from the ferrichromes and appears as the intensely red-coloured ferrous-phenanthroline complex.

### *Methods*

*Ferric Complex of Itoic Acid.* The colour reaction of itoic acid with ferric chloride was found to be markedly dependent on pH. A slight excess of itoic acid was added to a dilute solution of ferric chloride. The pH of the solution, initially about 2, was then raised in the automatic titration apparatus (Neilands and Cannon, 1955) by the addition of dilute alkali. The colour of



the solution was noted at various regions of the pH scale. The visible absorption spectrum of the ferric complex in the presence of excess itoic acid was determined in 0.05 M-phosphate, pH 7.0. The method of continuous variation was then applied, in conjunction with spectral analyses, in order to obtain information on the composition of the ferric complex formed in neutral solution.

In an attempt to study the reaction with ferric ion quantitatively, 13  $\mu$ -moles of ferric chloride and 39  $\mu$ -moles of itoic acid were mixed in 5 ml of water and subjected to automatic electrometric titration with 1 N-NaOH. Similar titrations were performed with 9.8  $\mu$ -moles of cupric chloride and 19.6  $\mu$ -moles of itoic acid. An estimation of the relative stability of the 3:1 complex was obtained by equilibration of  $\text{Fe}^{+++}$ —Itoic<sub>3</sub> with free ethylenediaminetetraacetic acid (EDTA). The surviving phenolic complex was determined spectrophotometrically at 560  $m\mu$ , a wavelength at which the ferric chelate of EDTA exhibits insignificant light absorption. The following equilibria were employed:



$$K_I = \frac{(\text{Fe}^{+++}\text{—Itoic}_3)}{(\text{Fe}^{+++})(\text{Itoic})^3}$$

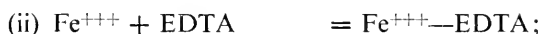

$$K_{II} = \frac{(\text{Fe}^{+++}\text{—EDTA})}{(\text{Fe}^{+++})(\text{EDTA})}$$

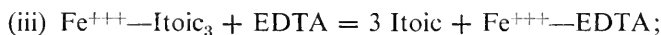

$$K_{III} = K_{II}/K_I = \frac{(\text{Itoic})^3(\text{Fe}^{+++}\text{—EDTA})}{(\text{Fe}^{+++}\text{—Itoic}_3)(\text{EDTA})}$$

The lability of both free itoic acid and the ferric complex was examined under different laboratory conditions such as in the light and dark and at different temperatures.

*Production of Itoic Acid as a Function of Iron Concentration.* The usual growth medium (Garibaldi and Neilands, 1956) was freed from iron by treatment with 8-hydroxyquinoline followed by extraction with chloroform. The itoic acid production by *B. subtilis* NRRL B-1471 as a function of added iron and time of incubation was determined by use of the known extinction coefficient of the 3:1 ferric complex in 0.1 M phosphate, pH 7.0.

*Utilization of Ferric-itoic<sub>3</sub> by Bacillus Subtilis.* In order to determine whether or not iron complexed with itoic acid is nutritionally available to *B. subtilis*, the following experiment was carried out. Eight 50 ml growth flasks fitted with side-arms were charged with 8 ml of the usual, i.e. not oxine-extracted,

medium. The flasks were sterilized by autoclaving and aliquots of sterile solutions of ferric chloride plus itoic acid, itoic acid alone and ferric chloride alone were added to duplicate flasks. The remaining two flasks served as controls. After adjusting the volume to 10 ml with sterile distilled water the flasks were inoculated and incubated at 25° under conditions of vigorous aeration. The turbidity was determined from time to time with a Klett colorimeter equipped with a green filter.

*Utilization of Itoic Acid by Bacillus Subtilis in the Presence of Iron.* Cultures of *B. subtilis* were grown in duplicate flasks with the usual medium. After 36 hr, when the itoic acid production had reached a maximum value, 1.0 ml of a sterile solution of ferric chloride was added to one flask. To the control flask was added 1.0 ml of sterile distilled water. At suitable time intervals, aliquots of each culture were aseptically withdrawn, the cells removed by centrifugation and the itoic acid determined by the ferric chloride reaction.

*Release of Hydroxylamine from the Ferrichrome Compounds.* Recrystallized samples of ferrichrome and ferrichrome A were heated at 100° in 3 N H<sub>2</sub>SO<sub>4</sub> and the liberated "hydroxylamine" determined by the method of Csaky (1948).

## RESULTS

### *Properties of the Ferric Complex of Itoic Acid*

The colour reaction with ferric chloride exhibited by itoic acid as a function of pH is illustrated in Table 1. It is apparent from these data that the reaction

TABLE 1. THE pH DEPENDENCE OF THE COLOUR REACTION OF ITOIC ACID WITH FERRIC CHLORIDE

pH	Colour
< 2	None
2.0	Light green
3.0-4.0	Green
4.7	Blue
5.0-5.5	Purple
5.9	Dark purple
7.3	Purple
9.0	Reddish purple
> 10.0	Wine colour

is strongly pH-dependent and that the structure of the complex undergoes several transformations in the region pH 2-10. At neutral pH the visible spectrum of the ferric complex in excess itoic acid showed general absorption in the region 500-700 m $\mu$  with a mm extinction coefficient of 3.7 per g atom of iron at 560 m $\mu$  (Table 2).

TABLE 2. THE mM EXTINCTION COEFFICIENT/g ATOM OF IRON FOR EXCESS ITOIC ACID IN THE PRESENCE OF FERRIC CHLORIDE IN 0.05 M-PHOSPHATE pH 7.0

Wavelength (m $\mu$ )	$\epsilon_{mM}$	Wavelength (m $\mu$ )	$\epsilon_{mM}$
500	2.7	600	3.4
520	3.2	620	3.1
540	3.5	640	2.7
560	3.7	660	2.3
580	3.6	680	1.7

From the results reported in Table 3 for the continuous variations experiment, it seems probable that a 3:1 structure is the most favoured combination in neutral solution.

TABLE 3. DETERMINATION OF THE COMPOSITION OF THE FERRIC COMPLEX OF ITOIC ACID BY THE METHOD OF CONTINUOUS VARIATION

All solutes in a final volume of 5 ml of 0.05 M Na-K-phosphate buffer pH 7.0. Optical density measurements were made after one hour at room temperature

$\mu$ moles itoic acid	0.524	0.734	0.784	0.840	0.890
$\mu$ moles FeCl <sub>3</sub>	0.524	0.315	0.274	0.209	0.157
Ratio itoic acid/FeCl <sub>3</sub>	1.0	2.3	2.9	4.0	5.7
Optical density at 560 m $\mu$	0.084	0.128	0.139	0.138	0.109

In the titration experiments referred to above the initial pH of both the ferric chloride and itoic acid solutions was 2.6. On mixing the solutions the pH was depressed still further, to a value of 2.1, thus indicating a strong complexing of ferric ion even in very acidic media. Two equivalents of base were consumed below pH 7 and between pH 7 and 8 one additional equivalent of base was taken up. The ferric ion remained in solution throughout the entire course of the titration. In the case of cupric ion, no additional production of acid was observed on mixing the reagents. There was no formation of precipitate in these solutions even at pH 10. The cupric complex was green at pH values of 3.8 or greater and the absorption maximum lay at a wavelength above 600 m $\mu$ . As with the ferric ion, two equivalents of acid were titrated below pH 5.5 and one additional equivalent was titrated with a pK of 6.6.

In the experiments in which the ferric chelate of itoic acid was equilibrated with EDTA, the colour of the solutions was found to reach a stable value several hours after mixing. If an apparent stability constant of  $10^{25}$  is selected for Fe<sup>+++</sup>—EDTA, the corresponding value measured for Fe<sup>+++</sup>—Itoic<sub>3</sub> is

$10^{33}$  to  $10^{35}$ . These data are not considered as highly accurate since considerable 'drift' was observed and since the equilibrium was not approached from the reverse direction. Nonetheless it is evident that itoic acid exhibits a very high avidity for ferric ion under approximately physiological conditions. Inasmuch as there was no pH effect on mixing solutions of itoic acid with cupric ion, the complexing of the latter metal is presumably weaker than for ferric ion.

Table 4 illustrates the lability of both free itoic acid and the ferric complex under various laboratory treatments. Under the conditions tested, the free substance was stable in both light and dark and was only slightly decomposed, concomitant with browning of the solution, on autoclaving. Solutions which were allowed to stand in dilute alkali, on the other hand, rapidly assumed a coffee-colour that could not be discharged by re-acidification. The ferric complex was stable for at least one day at room temperature but was largely decomposed on autoclaving or on standing over a period of several weeks at room temperature.

TABLE 4. LABILITY OF ITOIC ACID AND THE FERRIC COMPLEX UNDER VARIOUS CONDITIONS

The stability of the free substance was determined by use of the absorption maxima at 314  $m\mu$  ( $\epsilon_{\text{max}} = 3.0$ ) and the surviving ferric complex was measured at 560  $m\mu$ . The samples in light and dark were allowed to stand at room temperature; autoclaving was carried out at 15 lb for 15 min. The solvent was 0.1 M phosphate buffer, pH 7.0, and measurements were made 6 hr after mixing the solutions

Optical density at 560 $m\mu$ of 66 $\mu\text{M}$ solution of ferric-itoic <sub>3</sub>				Optical density at 314 $m\mu$ of 100 $\mu\text{M}$ solution of free itoic acid			
Light	Dark	Autoclaving		Light	Dark	Autoclaving	
0.240	0.240	Before	After	0.290	0.280	Before	After
		0.240	0.110			0.295	0.242

#### *Relationship Between Iron Supply and Itoic Acid Production*

The correlation between the initial iron level of the medium and the amount of itoic acid produced by *B. subtilis* is shown in Table 5. The cell yield was very low and very high at zero and 100  $\mu\text{g}$  of added iron/l., respectively. It is apparent that intermediate levels of added iron, i.e. 20  $\mu\text{g}$ , are the most conducive for the accumulation of itoic acid. It should be stressed that the application of the ferric chloride reaction to the crude, cell-free culture supernatant of *B. subtilis* will measure the total phenolic acid content. That the latter is essentially equivalent to itoic acid is indicated both from paper-chromatographic analyses and from the fact that 50 mg of crystalline itoic acid can be obtained per liter of medium. The yield of isolated itoic acid would thus be about 20%, an entirely logical figure in view of the several steps required in obtaining the pure compound from *B. subtilis* cultures.

TABLE 5. RELATIONSHIP BETWEEN ADDED IRON AND ITOIC ACID FORMATION BY *B. subtilis*

The initial iron contamination was eliminated by oxine treatment of the medium prior to the addition of the remaining mineral elements. Itoic acid was determined as the ferric complex

Iron added, $\mu\text{g/l.}$	Itoic acid produced, m-moles/l.			
	20 hr	40 hr	60 hr	80 hr
Zero	0.20	0.35	0.35	0.34
20	0.63	1.28	1.26	1.22
100	0.24	0.27	0.27	0.28

### Nutritional Availability of Iron Complexed by Itoic Acid

The growth response of *B. subtilis* to ferric chloride and to an equivalent amount of iron supplied as  $\text{Fe}^{+++}$ -Itoic<sub>3</sub> is given in Table 6. In the early phase of growth, free iron appeared to be somewhat more available to the organism; after 40 hr this discrepancy had disappeared and the complexed form of iron always provided slightly superior cell yields. It is also interesting to note that in the presence of externally added itoic acid, better growth was obtained after a certain stage in the culture after which contaminating iron in the medium would be expected to become limiting. This suggests that itoic acid increases the availability of the trace amounts of iron that are present.

TABLE 6. GROWTH RESPONSE OF *B. subtilis* TO FERRIC CHLORIDE AND TO IRON SUPPLIED AS THE ITOIC ACID COMPLEX

Duplicate growth flasks received the following additions (added as solutions previously sterilized by ultrafiltration): 179  $\text{m}\mu\text{-mole}$   $\text{FeCl}_3 \cdot 6\text{H}_2\text{O}$  and 539  $\text{m}\mu\text{-mole}$  itoic acid; 539  $\text{m}\mu\text{-mole}$  itoic acid; 179  $\text{m}\mu\text{-mole}$   $\text{FeCl}_3 \cdot 6\text{H}_2\text{O}$  and none (control). Sterile distilled water was added to give a final volume of 10 ml and each flask was then inoculated with a very dilute suspension *B. subtilis*

Addition	Average Klett reading (relative cell yield)		
	20 hr	40 hr	60 hr
$\text{Fe}^{+++}$ -Itoic <sub>3</sub>	85	420	450
Itoic	85	330	350
$\text{FeCl}_3 \cdot 6\text{H}_2\text{O}$	160	420	420
None	85	280	285

### Metabolism of Itoic Acid in the Presence of Iron

Table 7 records the result of adding excess iron to a culture of *B. subtilis* which contained a high level of pre-formed itoic acid. It is apparent that, in the presence of iron, the organism possesses a powerful mechanism for the elimination of itoic acid from the medium. From the previously determined

lability of the ferric chelate, it seems very doubtful if this disappearance of itoic acid could be the result of chemical instability of the compound.

TABLE 7. EFFECT OF ADDED IRON ON PREFORMED ITOIC ACID PRESENT IN A 36-HR CULTURE OF *B. subtilis*

Addition	Itoic acid, m-moles/l.		
	Hours after iron addition:		
	Zero	18	60
1 mg Fe (as $\text{FeCl}_3 \cdot 6\text{H}_2\text{O}$ )/l.	1.4	1.1	0.6
None (control)	1.4	1.6	1.5

### *The Iron-binding Centre of the Ferrichrome Compounds*

In the Csaky (1948) procedure for free and bound "hydroxylamine", the maximum amount of  $\text{NH}_2\text{OH}$  was liberated after a heating period of 12 hr. After correction for destruction of  $\text{NH}_2\text{OH}$  during hydrolysis, values very close to 3 moles/mole of iron were found for both ferrichrome and ferrichrome *A* (Table 8).

TABLE 8. "HYDROXYLAMINE" CONTENT OF THE FERRICHRROME COMPOUNDS AS DETERMINED BY ACID HYDROLYSIS

Duplicate samples were heated in 3 N  $\text{H}_2\text{SO}_4$  for 12 hr at 100° and the liberated  $\text{NH}_2\text{OH}$  determined by the method of Csaky (1948). A correction of 15% was applied for destruction of  $\text{NH}_2\text{OH}$  during hydrolysis

	Ferrichrome	Ferrichrome <i>A</i>
$\mu\text{mole NH}_2\text{OH}/\mu\text{mole iron}$	2.92, 2.86	2.94, 3.08

### DISCUSSION

The quantity of itoic acid produced by *B. subtilis*, in excess of 1  $\mu\text{mole/ml}$ , is more than sufficient to complex the total amount of iron available in the special growth medium employed in the present investigation. This fact, in conjunction with the observation that itoic acid prefers to form a 3:1 complex with ferric ion, renders it highly probable that this is the initial form of iron that enters into the metabolism of the organism. Further, itoic acid forms a very stable, probably highly specific, complex with ferric ion. In this respect the substance falls into the pattern of other all-oxygen ligands which are well-known to exhibit a marked preference for trivalent iron. The failure of the itoic acid chelate to lose iron as the hydroxide even at very high values of pH is a further indication of the tenacity with which it complexes this metallic ion.

In the titration experiments described above, the two acid groups titrated at low pH can be attributed to protons derived from the carboxyl and the orthophenolic groups. The third proton may arise from either the peptide hydrogen or the meta-hydroxyl. Experiments with space-filling models proved that considerable distortion would be required in order to co-ordinate the carboxyl oxygen with the ortho-hydroxyl group of the phenolic ring.

Paper-chromatographic analyses have revealed that, in addition to itoic acid, several other phenolic acids are produced by *B. subtilis* in minute quantities. These substances could all be converted to 2:3-dihydroxybenzoic acid by hydrolysis in 6 N HCl and it seems likely that they are conjugates of the single parent phenol with various amino acids and peptides.

Although neither free itoic acid nor the ferric chelate are particularly stable to decomposition, it can be concluded that their destruction would be negligible under the usual growth conditions required by *B. subtilis*.

Of the three possible metabolic mechanisms proposed to account for the appearance of itoic acid in the low-iron growth media, that of the substance acting as a by-pass around the cytochrome system seems to be the most unlikely. This follows from the fact that the relative complexing constant for ferrous ion is no doubt much lower than for ferric ion and also from the fact that there is no known mechanism whereby a cell can obtain energy by transmission of electrons through a quinone-hydroquinone system. The experimental evidence available does not allow a clear-cut choice between the two remaining hypotheses. However, various fragments of information can be pieced together to indicate that the production of itoic acid is the expression of a metabolic block created by the deficiency of iron. Thus iron is known to be required for the activation of ring-opening enzymes, such as catechol oxidase, and it is quite possible that the further metabolism of itoic acid is dependent on the presence of this metal ion. Pre-formed itoic acid is rapidly removed from *B. subtilis* fermentations following the addition of iron. Further evidence that itoic acid is an emergency agent thrown out to scavenge iron, when this essential element is deficient, comes from the observation that inorganic iron provides a slightly superior rate of initial growth. That a drastic alteration in the carbohydrate metabolism of the organism has occurred is apparent from the observation that the production of itoic acid is accompanied by the formation of large amounts of succinic acid. Thus a portion of the normal intermediates in the carbohydrate metabolism pathway may be forced to terminate at 2:3-dihydroxybenzoic acid which is then excreted as the glycine conjugate. The further metabolism of itoic acid under conditions of normal iron supply may, in fact, be a fairly general reaction in living tissues, including those of the animal organism. For example, administration of as much as 1 g of 2:3-dihydroxybenzoic acid to a single rat did not lead to the excretion in the urine of a free or conjugated phenol.

Since itoic acid does not appear to be formed in media containing over

0.5 mg of iron/l., it seems reasonable to conclude that it is an example of a metabolic product which requires iron for its metabolism and which, at the same time, happens to be a very effective ferric ion complexing agent. It has been repeatedly observed that itoic acid production cannot be obtained in fermentation vessels constructed even of high quality stainless steel. Assuming that itoic acid is made in undetectable amounts when there is a plentiful supply of iron, its augmented production in iron deficiency would result in the complexing and solubilization of iron from all available sources. The soluble metal ion could then be transferred to, or into, the cell where it could be released to the enzyme-forming systems by simple reduction.

The requirement of many species of green plants for chelated iron has, of course, been frequently encountered. In higher animals the stomach HCl may, to some extent, replace the function of the complexing agents which appear to be required by other forms of life.

The demonstration that both ferrichrome and ferrichrome *A* contain bound "hydroxylamine" is of special interest in connection with the structure and function of these compounds. The presence of such an oxidized form of nitrogen proves the occurrence in the ferrichrome molecules of the following general structure:

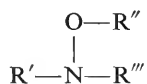

The ferric chloride reaction and the ease of liberation of "free  $\text{NH}_2\text{OH}$ " suggest that  $\text{R}'' = \text{H}$  and that either  $\text{R}'$  or  $\text{R}'''$  is an acyl substituent. The  $\text{pK}_a$  of approximately 9 found in the metal-free compounds (Neilands, 1957) also supports the conclusion that the  $\text{NH}_2\text{OH}$  is present as a hydroxamic acid. Acetylhydroxamic acid has been found in *Torulopsis utilis* by Virtanen and Saris (1956). That the remaining substituent ( $\text{R}'$  or  $\text{R}'''$ ) is a hydrogen atom is rendered probable from the ease of formation of "free  $\text{NH}_2\text{OH}$ " and also from the fact that the  $\text{pK}_a$  at pH 9 is spectrophotometrically operable (Neilands, 1957). The spectral changes observed with iron-free ferrichromes in dilute alkali, previously assigned to a keto-enol transformation, can in all probability be accounted for by the hydroxamic-hydroximic transformation. Since there are three such residues per atom of iron and since there is much evidence to indicate that ferrichrome is not made up of three separate fragments, the characterization of the iron-binding centre of the molecule as a polyhydroxamic acid seems proven beyond reasonable doubt. Experiments are now in progress in which an attempt is being made to remove the hydroxylamine under very gentle conditions so that the resultant carboxyl groups can be esterified and subsequently split with excess hydroxylamine. The synthetic ferrichrome obtained in this manner should resemble the natural product in all respects.

The occurrence of bound hydroxylamine in natural products is quite



rare and appears to be restricted to the microbial products aspergillic acid, mycobactin and cycloserine. Cycloserine contains O-substituted hydroxylamine whereas the two former are N-substituted derivatives. So far as the author is aware, there has been no previous report of the finding of a free hydroxamic acid as a biologically active natural product.

The hydroxamic acid reaction with ferric ion has found widespread application in analytical chemistry. Such reactions are usually employed in acidic media where the complex, although highly dissociated, exhibits a deep-red colour with an absorption maximum at about 500 m $\mu$ . At higher pH the maximum is shifted to lower wavelengths and the colour reaction is less specific. The spectrum of the ferrichrome compounds, on the other hand, is quite insensitive to pH. The maximum for ferrichrome and ferrichrome *A* remains at 425 and 440 m $\mu$ , respectively, even at pH 2. This behaviour may be explained in terms of the strong 'chelate effect' of three binding sites attached to the same molecule.

Ferrichrome is produced in small amounts by *Ustilago sphaerogena* even when the organism has been grown in the presence of excess iron. In view of the known ferric ion complexing characteristics of the ferrichromes (Neilands, 1957) and of hydroxamic acids in general, a fundamental role for these substances in microbial iron metabolism can be predicted.

#### SUMMARY

1. Itoic acid forms a stable, 3:1 complex with ferric ion.
2. The production of itoic acid by *B. subtilis* is dependent on the iron level of the medium and reaches a maximum at approximately 20  $\mu$ g of added iron/l.
3. The ferric complex of itoic acid is fully available as a source of iron to *B. subtilis*.
4. Pre-formed itoic acid is used by the micro-organism following the addition of iron to the medium.
5. The ferric ion-binding centre of the ferrichrome compounds has been characterized as a hydroxamic acid.

#### ADDENDUM

(Note added in proof)

The acyl moieties have been characterized as three residues each of acetic acid and *trans*- $\beta$ -methylglutaconic acid in ferrichrome and ferrichrome *A*, respectively (Emery and Neilands, 1960). The remaining substituent (R<sup>1</sup> or R<sup>11</sup>) is derived from the peptide portion of the molecule (Emery, 1960).

#### REFERENCES

- CSAKY, T. Z. (1948). *Acta chem. Scand.* **2**, 450.  
EMERY, T. (1960). *Doctoral dissertation*, University of California, Berkeley.  
EMERY, T. & Neilands, J. B. (1959). *Nature, Lond.* **184**, 1632.

- EMERY, T. & NEILANDS, J. B. (1960). *J. Amer. chem. Soc.* **82**, 4903.
- GARIBALDI, J. A. & NEILANDS, J. B. (1955). *J. Amer. chem. Soc.* **77**, 2429.
- GARIBALDI, J. A. & NEILANDS, J. B. (1956). *Nature, Lond.* **177**, 526.
- GRANICK, S. & MAUZERALL, D. (1958). *J. biol. Chem.* **232**, 1119.
- GRIMM, P. W. & ALLEN, P. (1954). *Plant. Physiol.* **29**, 369.
- ITO, T. & NEILANDS, J. B. (1958). *J. Amer. chem. Soc.* **80**, 4645.
- LASCELLES, J. (1957). *Biochem. J.* **66**, 65.
- LAVER, W. G., NEUBERGER, A. & UDENFRIEND, S. (1958). *Biochem. J.* **70**, 4.
- NEILANDS, J. B. (1952). *J. Amer. chem. Soc.* **74**, 4846.
- NEILANDS, J. B. (1957). *Bact. Rev.* **21**, 101.
- NEILANDS, J. B. (1958). *Abstr. 4th Int. Congr. Biochem.* Vienna, 125.
- NEILANDS, J. B. & CANNON, M. D. (1955). *Anal. Chem.* **27**, 29.
- SEIDELL, A. (1940). *Solubilities of Inorganic and Metal Organic Compounds*. III ed., p. 494. Van Nostrand, New York.
- SHEMIN, D. (1955). *Porphyrin Biosynthesis and Metabolism*, p. 1. Ciba Foundation Symposium, London.
- VIRTANEN & SARIS (1956). *Acta chem. Scand.* **10**, 483.

# THE ENZYMIC INCORPORATION OF IRON INTO PROTOPORPHYRIN

By R. A. NEVÉ\*

*Department of Biochemistry, University of California,  
Berkeley, California*

FOLLOWING the elegant studies on porphyrin biosynthesis, interest has centred on the incorporation of iron into protoporphyrin to form haem. There is evidence that iron may be complexed non-enzymically by coproporphyrinogen and protoporphyrinogen in aqueous solutions, and at physiological pH and temperature (Neilands and Orlando, 1957; Heikel, Lockwood and Rimington, 1958). However there is now a considerable amount of data demonstrating the enzymic incorporation of iron into protoporphyrin (Nishida and Labbe, 1959; Labbe, 1959; Minakami, 1958; Krueger, Melnick and Klein, 1956; Schwartz, Cartwright, Smith and Wintrobe, 1959). The information presented here substantiates the enzymic nature of this important biochemical union.

## MATERIALS AND METHODS

Approximately 200 ml of pooled blood from normal young chickens was collected in a heparinized container. The blood was strained through several layers of gauze and centrifuged at  $1000 \times g$  for 10 min at  $4^{\circ}\text{C}$ . The plasma was discarded and the red cells washed twice with isotonic saline. Leucocytes were removed by aspiration after the second washing. The cells were then lysed according to the method of Dresel and Falk (1954).

The haemolysate was centrifuged at  $20,000 \times g$  for 10 min at  $0^{\circ}\text{C}$ . The supernatant was saved to provide carrier haem. The haemolysate residue was washed twice with 0.25 M sucrose to remove haemoglobin from the particulate fraction. The residue was then suspended in 0.04 M  $\text{KHCO}_3$  containing 10 mg/ml of Tween 40 (pH 7.4) and homogenized for 10 min in a water-cooled ( $4^{\circ}\text{C}$ ) metal blender cup. The suspension was allowed to settle for 1 hr at  $4^{\circ}\text{C}$  and then centrifuged at  $20,000 \times g$  for 10 min. The residue was discarded and mercaptoethanol (final conc. 0.01 M) added to the supernatant. The bicarbonate-Tween extract was then stored at  $4^{\circ}\text{C}$  for future use.

Protoporphyrin IX was prepared by the method of Grinstein (1947).

\* Post-doctoral Fellow of the United States Public Health Service, National Heart Institute.

One microcurie of radioactive iron was added as  $^{59}\text{Fe}$  citrate to each sample. The iron concentration per sample was  $0.02 \mu\text{M}$  and protoporphyrin  $0.05 \mu\text{M}$ .

Incubation of the bicarbonate-Tween extract with porphyrin and  $^{59}\text{Fe}$  was carried out in 50 ml Erlenmeyer flasks at  $37^\circ\text{C}$  for 2 hr in air on a circular shaker. Labelled haemin was then isolated with carrier haemin (Labbe and Nishida, 1957) and recrystallized. Sufficient haemin was dissolved to give a concentration of 2 mg/ml in  $0.1 \text{ N KOH}$ . Two ml of this solution was measured for radioactivity in a Baird Atomic scintillation well counter (efficiency 28%). Results are expressed either as percentage activity or counts per minute.

### RESULTS

The optimal pH for iron incorporation into protoporphyrin was determined. Some workers have found a sharp peak of activity at pH 7.4 in a

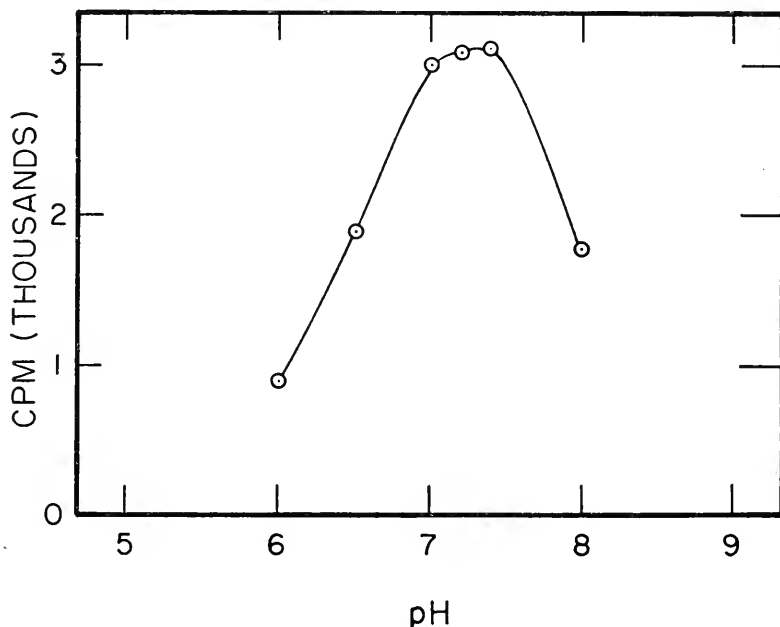

FIG. 1. Effect of pH on enzyme activity.

liver extract (Nishida and Labbe, 1959), while others report 7.9 as the optimal pH (Schwartz *et al.*, 1959). The results shown in Fig. 1 indicate this preparation to be most active at pH 7.4. The enzyme is also extracted from the nuclear fraction more easily, and is more stable during cold storage, at this pH.

The effect of the non-ionic detergent, Tween 40, is seen in Fig. 2. The incorporation of iron into protoporphyrin is not dependent on the solubilizing properties of the detergent during the 2 hr incubation period. In addition,

Phillips (this Symposium, p. 32) showed that there was no chelation of iron with protoporphyrin in the presence of a variety of Tweens.

The activity of the extract is also heat-sensitive (Fig. 2). Treating the extract at 60°C for 10 min destroys the activity almost completely.

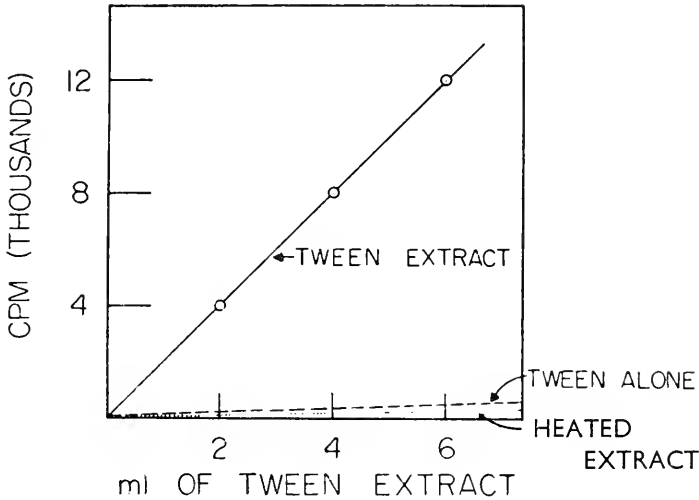

FIG. 2. Effect of detergent alone and heat on iron incorporation.

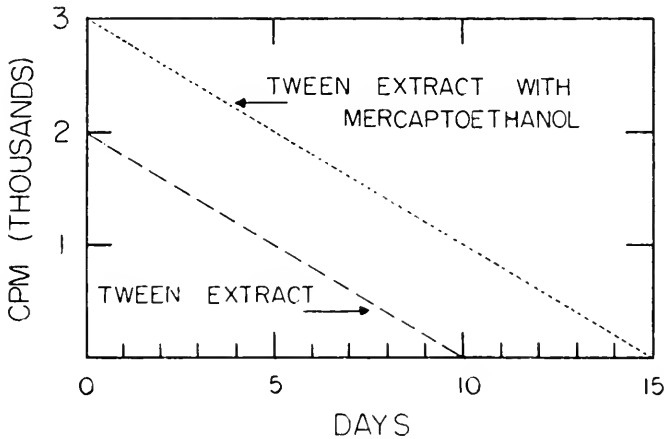

FIG. 3. Duration of enzyme activity with Tween 40 and with mercaptoethanol.

Increased stability of the enzyme solution is noted when Tween 40 is used for its extraction from the centrifuged residue of the red cells. The duration of enzyme activity in the original lysate is at most 24 hr, while in the Tween extracts it is of the order of 10 days. If mercaptoethanol is added (final concentration 0.01 M) the enzyme activity is increased and the duration of

activity extended an additional 4–5 days (Fig. 3). The stimulation by mercaptoethanol is similar to that given by other sulphhydryl compounds, e.g. glutathione and cysteine, which are effective on both liver and red blood cell extracts (Nishida and Labbe, 1959; Schwartz *et al.*, 1959).

In preliminary inhibition studies on the Tween extract, it was found that lead acetate ( $10^{-5}$  M) in phosphate buffer inhibited the iron incorporation by about 65%, while ethylenediaminetetraacetic acid (EDTA) ( $10^{-2}$  M) was completely inhibitory.

On fractionation of the Tween extract with ammonium sulphate the major part of the enzyme activity was found in the 50–60% saturated fraction (Table 1). This is similar to the fractionation carried out by Minakami (1958)

TABLE 1. ENZYME ACTIVITY IN THE AMMONIUM SULPHATE FRACTION OF THE TWEEN-KHCO<sub>3</sub> EXTRACT

Substrate plus	Haem-total cpm/sample	Protein mg/sample	Specific activity
Tween ext.	166	9.0	1.9
Tween ext.	592	18.0	33
Tween ext.	1184	27.0	44
Am. SO <sub>4</sub> fractions			
0–40% saturation	—	—	—
40–50% saturation	332	5.8	57
50–60% saturation	3510	16.2	217
Refractionation of 50–60% fraction from above			
45–50% saturation	—	—	—
50–55% saturation	355	1.5	236
55–60% saturation	11.8	102.5	1

who found the majority of the activity in the 50–75% ammonium sulphate fraction of a cholate extract of rat liver mitochondria. Refractionation of the 50–60% fraction resulted in some increased purification (Table 1). Further purification of this enzyme is in progress.

#### REFERENCES

- DRESEL, E. I. B. & FALK, J. E. (1954). *Biochem. J.* **56**, 156.  
 GRINSTEIN, M. (1947). *J. biol. Chem.* **167**, 515.  
 HEIKEL, T., LOCKWOOD, W. H. & RIMINGTON, C. (1958). *Nature, Lond.* **182**, 313.  
 KRUEGER, R. C., MELNICK, I. & KLEIN, J. R. (1956). *Arch. Biochem. Biophys.* **64**, 302.  
 LABBE, R. F. & NISHIDA, G. (1957). *Biochim. biophys. Acta* **26**, 437.  
 LABBE, R. F. (1959). *Biochim. biophys. Acta* **31**, 589.  
 MINAKAMI, S. (1958). *J. Biochem. (Tokyo)* **45**, 833.  
 NEILANDS, J. B. & ORLANDO, J. A. (1958). *Int. Symp. Enzyme Chem.* Maruzen, Tokyo, p. 324.

NISHIDA, G. & LABBE, R. F. (1959). *Biochim. biophys. Acta* **31**, 519.

SCHWARTZ, H. C., CARTWRIGHT, G., SMITH, E. L. & WINTROBE, M. M. (1959). *Blood* **14**, 486.

## DISCUSSION

### *The Formation of Metal-Porphyrin Complexes*

#### Co-ordination of Divalent Metal Ions with Porphyrin Derivatives Related to Cytochrome *c*

By J. B. Neilands (Berkeley)

NEILANDS: Although the iron bound to the primary, all-oxygen ligands is eventually passed on to the iron-containing enzymes, the mechanism of this transfer and the number of stages involved are still largely unknown. In those instances in which a porphyrin-protein serves as the ultimate repository for the iron, an enzymic incorporation of the metal ion into the prosthetic group has been indicated (Nevé, p. 207). For a more complete understanding of the total biosynthesis of metalloporphyrins it thus becomes very important to establish, if possible, the non-enzymic rate of reaction between porphyrin and metal ion. Such studies might, for instance, elucidate the mechanism of the enzymic insertion reaction and might also account for the metal specificity, i.e.  $\text{Fe}^{++}$  vs  $\text{Mg}^{++}$ , exhibited by the cyclic tetrapyrroles found in living tissues.

The work of H. Fischer (Fischer and Orth, 1937) and others has established that iron is more readily removed from (Morell and Stewart, 1956) and inserted into the porphyrin ring when the metal ion is in the ferrous state. In hot glacial acetic acid an equilibrium is apparently established between porphyrin and ferrous iron. Thus if a porphyrin is heated in acetic acid and a reducing agent added then the metal is removed; heating the free porphyrin with a great excess of ferrous acetate in acetic acid leads, on the other hand, to a very rapid insertion of iron. The use of acetic acid for the synthesis experiments is noteworthy since this organic acid is probably too weak to charge the nitrogen atoms of the pyrrole nuclei. By the same token, a relatively strong acid, even a mineral acid, is desirable for dissociation of the haem iron.

The slow reaction of iron with porphyrins under approximately physiological conditions may be attributed to a number of reasons, among which we may mention the following:

#### (a) *Structure of the ligand*

The rigid planarity of the porphyrin macrocycle restricts the iron to an attack which must be directed from either exactly above or exactly below the plane of the ring. This fact must at least contribute to the slow reaction rate, especially since it is known that ferrous ion is attached to the porphyrin by mainly 'ionic' bonds (Pauling and Coryell, 1936).

#### (b) *Insolubility and aggregation of the reactants*

Most porphyrins are either insoluble, or are at least rather severely aggregated, in aqueous solution at neutral pH. Furthermore, under these conditions the competition from hydroxyl ions for either  $\text{Fe}^{++}$  or  $\text{Fe}^{+++}$  is enormous and both oxidation states of iron will be present as their insoluble hydroxides.

The chemical incorporation of iron into porphyrins which have been treated with sodium amalgam has been described in some detail by Orlando (1958). Briefly, his results show that very good yields of iron complex can be obtained instantly in those cases where the reducing agent is allowed to act for only short periods on the porphyrin prior to the addition of the ferrous ion. This reaction has been interpreted in terms of a distortion of the planar configuration of the porphyrin with concomitant exposure of the pyrrole nuclei. The investigation did not reveal, however, why the yields for coproporphyrin were superior to those for some other common porphyrin compounds.

The combination of ferrous ion with porphyrins has been studied by Heikel,

Lockwood and Rimington (1958), and Mauzerall and Granick (1958) but rate data appear to be lacking.

#### EXPERIMENTAL

In order to test the influence of solubility and aggregation of the complexing agent, two water-soluble porphyrin derivatives were prepared. These substances, porphyrin *c* and 'porphyrin cytochrome *c*', are both closely related to cytochrome *c* and can thus be regarded as natural products.

Porphyrin *c* was obtained in crystalline form by a modification (Neilands and Tuppy, 1959) of the method of Zeile and Meyer (1939). This porphyrin is very soluble in water at all pH values except at the isoelectric point (about pH 4). The  $\alpha$ -amino-carboxyl groups in the side chains are probably without steric hindrance to the approach of the ferrous ion; on the contrary, they may assist in attracting the divalent metal ions to the complexing site.

'Porphyrin cytochrome *c*' is the name assigned to cytochrome *c* minus the iron atom. Besides providing a fully dispersed porphyrin, this derivative offered the additional possibilities of a fifth and sixth co-ordination position for the iron. Porphyrin cytochrome *c* was obtained by the following procedure: One micromole (16 mg) of cytochrome *c* (Sigma Chemical Company) was dissolved in 1.0 ml of pure formic acid containing 10 mg of dry oxalic acid. After the addition of 15 mg of platinum (Mohr) catalyst a stream of dry,  $O_2$ -free nitrogen was bubbled through the mixture for a period of two hours at room temperature. During this time the solvent evaporated to about one-half of the original volume. A 10 mg batch of ortho-phenanthroline was added, the solution decanted from the catalyst and dialyzed against one liter of distilled water for a period of four hours. The product was chromatographed on a small column of Amberlite XE-64 (Palés and Neilands, 1950), eluted with 1 M-ammonium acetate and lyophilized. Porphyrin cytochrome *c* is a water-soluble, intensely fluorescent, purple-coloured protein. The four-banded visible spectrum is sharply delineated thus indicating absence of aggregation in the region of the porphyrin moiety. There was no increase in optical density at 550  $m\mu$  in the presence of pyridine and dithionite. Use of the  $\epsilon$  for porphyrin *c* at 553  $m\mu$  in N HCl gave an apparent molecular weight of 20,000 for the compound. The preparation was not checked for the presence of bound water or for initial impurities which may have survived the de-ironing procedure.

#### *Incorporation of Divalent Ions into Porphyrin c*

The rate of formation of haemin *c* in the presence of pyridine and sodium dithionite could be followed by direct observation with the Unicam spectrophotometer set at 550  $m\mu$ . All solutes used in the reaction were dissolved in water which had been previously boiled and cooled. A buffer was not employed because of the likelihood of competition of the buffer ions for the iron. The final pH in all experiments was 7 to 8 and the temperature was 22° to 25°C. The various ingredients were added to a 1 cm cuvette in the following amounts:

Porphyrin <i>c</i>	$5 \times 10^{-5}$ M di-sodium salt	1.0 ml
Distilled water		1.7 ml
$Na_2S_2O_4$	1%	0.1 ml
Pyridine	1% v/v	0.1 ml
$FeSO_4 \cdot 7H_2O$	$3 \times 10^{-2}$ M	0.1 ml

The optical density increased at a linear rate from an initial value of approximately 0.05 to a terminal figure of about 0.150 after 2 hr. At the end of this period the spectrum of the reaction solution over the range 510 to 560  $m\mu$  was that of a typical mesohaemochrome. A control cuvette without iron showed gradual loss of porphyrin



light absorption at 550  $m\mu$ ; the  $\text{Na}_2\text{S}_2\text{O}_4$  appeared to be responsible for this effect. Thus although it is difficult to calculate the precise amount of haem synthesized in these experiments, the rate appears to be somewhat less than 2  $\mu\text{moles/l.hr.}$

The presence of  $\text{Na}_2\text{S}_2\text{O}_4$  was required in order to prevent the development of an incipient turbidity. Experiments carried out under  $\text{N}_2$  or in which the dithionite was added after a period of about one hour showed that approximately the same amount of haem had been formed in the absence of the reducing agent. It thus appears that  $\text{Na}_2\text{S}_2\text{O}_4$  is neither inhibitory (apart from bleaching of the porphyrin solution) nor is it essential for the reaction.

The use of higher concentrations of pyridine (supplied as the sulphate) or the substitution of imidazole for pyridine did not increase the rate.

Although porphyrin *c* in neutral aqueous solution exhibits a four-banded spectrum, the bands are not clearly separated and considerable aggregation is indicated. Consequently, sodium lauryl alcohol sulphonate was added as a dispersing agent. Although this reagent greatly strengthens and sharpens the visible absorption bands of porphyrin *c*, the iron-incorporation rate was diminished, possibly as a consequence of complexing of the iron by the added detergent. Some further experiments were carried out with cationic detergents but these likewise did not augment the reaction rate.

In summary, therefore, the reaction rate observed in the system given above is the maximum that it has been possible to obtain up to the present time.

Studies were conducted on the rate of uptake of several divalent ions (other than ferrous) by a  $1.7 \times 10^{-5}$  M porphyrin *c* solution in 0.1 M acetate buffer pH 5.7. The cupric ion gave a very insoluble precipitate which dissolved with difficulty in butanol and exhibited a turacin-like spectrum. The zinc ion, as judged by the rapid loss of the porphyrin band at 510  $m\mu$ , also reacted at a rapid rate. The two-banded spectrum of the zinc complex resembled that of the cupric complex except that in the former case the less intense band lay at the longer wavelength.

### *Incorporation of Divalent Ions into Porphyrin Cytochrome c*

$\text{Fe}^{++}$ ,  $\text{Mn}^{++}$  and  $\text{Co}^{++}$  were found to react very slowly with porphyrin cytochrome *c*. The cupric ion reacted rapidly and the zinc ion entered the porphyrin-protein at a moderate rate. The presence of the latter two metal ions inside the porphyrin ring was confirmed by spectral examination after dialysis of the new metallo-porphyrin proteins against glycine solution.

#### DISCUSSION AND CONCLUSIONS

Even under the most favourable conditions found, the rate of non-enzymic haem synthesis is only approximately equal to the average rate of synthesis of cytochrome *c* haem/l.hr. by a culture of *Ustilago sphaerogena*. In the case of the microbial reaction, the ligand concentration at the beginning of a 10 hr fermentation period is essentially zero. It thus appears highly improbable that any significant quantity of haem will be formed within living cells by a purely non-enzymic reaction.

The fact that both cupric and zinc ions react rapidly with porphyrin *c* suggests that aggregation in solution is not the most important factor limiting the rate for ferrous iron. The generally slower reaction of the divalent metal ions with porphyrin cytochrome *c* may be attributed to the known inaccessibility of the prosthetic group in this enzyme.

It is tempting to speculate on the mechanism of the relatively rapid reaction involved in those cases in which either partially-reduced porphyrins (so-called semi-porphyrinogens; Orlando, 1958) or higher temperatures have been employed for the synthesis. In particular, it would be interesting to know if these treatments (sodium amalgam; heat) lead to the temporary establishment of a more nearly octahedral orientation of the ligand atoms. If such a mechanism were indeed responsible in those few cases in which the chemical reaction will proceed at room temperature then it might be possible, with some adaptation, to apply the same mechanism to the enzymic synthesis.

### Acknowledgement

The author is indebted to Professor H. Tuppy for laboratory facilities and for helpful and friendly discussion. The John Simon Guggenheim Foundation provided financial support.

### REFERENCES

- FISCHER, H. & ORTH, H. (1937). *The Chemistry of the Pyrroles*. Leipzig.  
 HEIKEL, T., LOCKWOOD, W. H. & RIMINGTON, C. (1958). *Nature, Lond.* **182**, 313.  
 MAUZERALL, D. & GRANICK, S. (1958). *J. biol. Chem.* **232**, 1141.  
 MORELL, D. B. & STEWART, M. (1956). *Aust. J. exp. Biol. med. Sci.* **34**, 211.  
 NEILANDS, J. B. & TUPPY, H. (1960). *Biochim. biophys. Acta* **38**, 351.  
 ORLANDO, J. (1958). *Doctoral dissertation*, University of California. Berkeley.  
 PALÉUS, S. & NEILANDS, J. B. (1950). *Acta chem. Scand.* **4**, 1024.  
 PAULING, L. & CORYELL, C. D. (1936). *Proc. nat. Acad. Sci. Wash.* **22**, 159.  
 ZEILE, K. & MEYER, H. (1939). *Hoppe-Seyl. Z.* **262**, 178.

### Metal Incorporation in Model Systems

PHILLIPS: I should like to make three comments on Neilands' very interesting contribution.

1. The slowing down of metal ion incorporation into porphyrin *c* by the addition of detergents could well be due to solubilization removing the porphyrin from the aqueous (reactive) environment, rather than to an interaction between the detergent and the metal ion.

2. It is of interest to note the differential incorporation of  $\text{Cu}^{++}$  and  $\text{Zn}^{++}$  on the one hand as compared with the other metal ions ( $\text{Co}^{++}$ ,  $\text{Fe}^{++}$  and  $\text{Mn}^{++}$ ). This is similar to our results in detergent solution. We have recently attempted to check our hypothesis that incorporation proceeds more readily when the metal ion is tetra-co-ordinated by studying the incorporation of  $\text{Co}^{++}$  into dimethyl protoporphyrin ester under various conditions.  $\text{Co}^{++}$  has the useful experimental advantage of being pink in the octahedral configuration and blue in the tetrahedral configuration. Preliminary experiments suggest that the rate of incorporation of  $\text{Co}^{++}$  is a direct function of the tetrahedral character of the  $\text{Co}^{++}$  ion, a result which appears to apply to both aqueous and non-aqueous media.

3. With respect to the mechanism of the rapid incorporation of  $\text{Fe}^{++}$  into coporphyrin in the presence of Na-amalgam, there is a possible alternative explanation

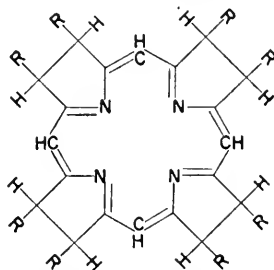

FIG. 1. The hexahydroprophyrin structure of maximum double bond conjugation.

to that suggested by Neilands. It is simply this: as the porphyrin is progressively reduced the degree of conjugation throughout the nucleus is markedly decreased; indeed a critical stage is reached when 6 H atoms have been added. The classical structure demands a break in the cyclic conjugation, but this can be avoided by a tautomeric shift of the two hydrogen atoms from the ring nitrogens to the beta pyrrole carbon atoms, to give the structure shown in Fig. 1. Such a structure would not

require two hydrogen atoms to be displaced for metal incorporation to occur and it is likely that the reaction would be rapid.

WANG: I would like to call attention to some work done by E. B. Fleischer at Yale which may be related to these problems. As I have mentioned (p. 38), the rate of 'swallowing-up' of the metal ions by porphyrin derivatives is strongly solvent-dependent. This is not too surprising, since in 'swallowing' the metal ion, the porphyrin also peels off most of the solvation of the ion. For example, we found that in acetone solution,  $\text{Cu}^{++}$ ,  $\text{Bi}^{+++}$ ,  $\text{Hg}^{++}$  and  $\text{Cd}^{++}$  react readily with the dimethyl ester of protoporphyrin to form the corresponding metallo-porphyrins, even at room temperature. But in aqueous solutions there was no detectable reaction at the same temperature. Since the biochemical incorporation of metal ions into porphyrins takes place in aqueous solution, special provisions have to be made by the catalytic system to furnish faster reaction paths. It appears possible that the main function of the enzyme systems is to replace the attached water molecules and modify the ligand environment of the metal ion in such a manner, though off-hand I do not know how, as to facilitate the 'swallowing-up' of the metal ion by the porphyrin.

DWYER: The mechanism of incorporation of iron brings to mind some recent experiments carried out at Canberra. The sexadentate molecules 1:2-propylenediaminetetraacetic and cyclohexanediamine-tetraacetic acids in the optically active forms are completely stereospecific in their metal complexes, i.e. the *D* configuration of the complex can contain only the *l* configuration of the organic molecule, and vice versa. The metal complex, e.g. *Dl* exchanges with inversion at a rate dependent on pH with the ligand of the opposite configuration:  $Dl + d \rightarrow Ld + l$ . The reaction can be followed easily in a polarimeter. The ferric complex exchanges its *l* ligand for the *d* ligand in less than one minute at pH 6, and 25°C. In the reaction the *l* ligand gradually detaches point by point and the *d* ligand enters by attachment to the vacated co-ordination sites.

### On the Enzymic Incorporation of Iron

FALK: Perhaps attention should be drawn to the evidence (Dresel and Falk, *Biochem. J.* 63, 388, 1956), that protoporphyrin itself does not behave as though it is a true intermediate in haem synthesis in chicken erythrocytes. We suggested in that paper that some reduced derivatives of proto-, copro- and uro-porphyrins might be the true intermediates. That this is true for uro- and copro-porphyrins has recently been demonstrated directly by Granick and Mauzerall (*J. biol. Chem.* 232, 1141, 1958), and there is as yet no evidence contrary to our suggestion that a reduced form of protoporphyrin is the true intermediate.

MARGOLIASH: How do the results obtained by Nevé compare with those of Schwartz, Hill, Cartwright and Wintrobe (*Fed. Proc.* 18, 545, 1959)? These authors have shown that both globin and protoporphyrin are required before any radioactive iron is incorporated into haemoglobin. In their system, it does not seem that the globin acts as an agent to keep either the porphyrin or the iron in solution, but rather that the enzyme responsible for iron incorporation will function only on the preformed globin-protoporphyrin complex.

NEVÉ: The ammonium sulphate purification shows an increase in specific activity, suggesting that the protein is acting more as an enzyme than as a solubilizing agent to the protoporphyrin and iron.

The Tween detergent is not responsible for iron incorporation as demonstrated in this paper. In addition, Phillips (this symposium, p. 32) while finding metallo-porphyrin complexing with a variety of Tweens and metals was unable to show any chelation of iron with protoporphyrin.

GEORGE: Haemoglobin derivatives are particularly insoluble in strong phosphate buffer at a pH of about 6: perhaps this property could be utilized in the enzyme purification to remove haemoglobin, as is done in the preparation of myoglobin.

FALK: As I see it, the essential problem with systems incorporating Fe into haem is to establish that one really has an enzymic system. There are certain incidental requirements: that the iron be maintained in solution, that sufficient of it be in the ferrous

state which seems to be required for haem formation, and that the porphyrin be kept in solution. I feel that Nevé is using the right approach, that is, to purify and fractionate until one does or does not finally isolate an enzyme system which appears to be specific.

LOCKWOOD: The entry of iron into a porphyrin structure with four  $\text{>NH}$  groups seems surprising and it was for this reason that Heikel in Rimington's laboratory compared the non-enzymic incorporation of iron into coproporphyrin, coproporphyrinogen and protoporphyrin using, however, concentrations far in excess of physiological conditions. With Teepol to keep the reactants in solution (or suspension) she was able to show some incorporation into all three compounds and we attributed the formation of coprohaem from the leuco-compound to its preliminary oxidation. However, in view of Neilands' findings of the very rapid incorporation of iron into the partially reduced porphyrin it seems worth while to consider the structure of these intermediate reduction products. Although these compounds are very badly defined and have not been obtained crystalline, it is generally accepted that there is a hexahydro-, a tetrahydro- and a dihydro-compound. Now the dihydro-compound probably has a structure with two  $\text{>NH}$  groups and two  $\text{>N}$  groups, that is, the same ligands as a porphyrin. It is suggested that the possible non-planar structure of this compound might allow a very rapid entry of iron.

LEMBERG: A dihydroporphyrin with reduction of two opposite methine bridges to  $\text{CH}_2$  would be tilted at these bridges and might be suitable for incorporation of iron into the bis-dipyrromethene system. Such a compound should have a spectrum similar to that of dipyrromethenes with an absorption band in the blue-green and be of yellow colour.

BARRETT: In connexion with Nevé's studies on the enzymic incorporation of iron into protoporphyrin, I should like to refer to the question of haem  $a_2$  biosynthesis. In non-enzymic systems the rate of incorporation of iron—and of metals generally—into a chlorin is very much slower than for a porphyrin with similar side-chains. The study of the enzymic incorporation of iron into chlorin  $a_2$  should be very interesting since one would expect a greater difference between the rates for the enzymic and non-enzymic systems.

A further point is relevant to Falk's evidence from studies with avian red cell haemolysates, suggesting that a reduced form of protoporphyrin not protoporphyrin itself, is the true precursor of haem. Reduction of chlorin  $a_2$  to a leuco-compound would be expected, through introduction of symmetry into the molecule, to facilitate greatly entry of iron into the tetrapyrrole ring.

LEMBERG: We must not forget that *in vitro* incorporation of iron into copro- and uroporphyrin is certainly no more difficult than into protoporphyrin. Yet a careful search by Lockwood for uro- or coprohaem has failed to reveal their presence in several tissues. This strongly supports the role of enzymes in iron incorporation *in vivo*.

### Biosynthesis and Metabolism of Cytochrome *c*

By D. L. Drabkin (Philadelphia)

DRABKIN: The systematic studies of the metabolism and biosynthesis of cytochrome *c* in the writer's laboratory have been previously reviewed (Drabkin, 1951a, 1955). The research findings have permitted the development of a number of major concepts:

(1) The independent biosynthesis of the different haemin proteins is a general property of living, aerobic cells (Drabkin, 1951b; Marsh and Drabkin, 1957). This was based on studies of the labelling of cytochrome *c* by means of  $[2\text{-}^{14}\text{C}]$  glycine and  $[2\text{-}^{14}\text{C}]$  lysine. A similar conclusion was reached independently by Theorell *et al.* (1951) in a study of liver and red cell catalases by means of  $^{59}\text{Fe}$ . In our *in vivo* studies (Drabkin, 1951b) the technique of liver regeneration after partial hepatectomy (Crandall and Drabkin, 1946) renders unequivocal the conclusion that new cytochrome

*c* has been synthesized. In our *in vitro* studies (Marsh and Drabkin, 1957) it appears safe to assume that biosynthesis (as distinguished from incorporation of isotope) had actually occurred, since [2-<sup>14</sup>C] glycine labels both the haemin and protein moieties, and, indeed, there was an early separation in time of the two processes. The labelling of the haemin cannot be ascribed to such reactions as transamidation, etc. This apparently 'minor' issue is worthy of consideration in studies of protein biosynthesis and deductions as to net synthesis. *In vitro* studies involve large losses due to leaching of materials into the medium in the usual methods. Special respiration techniques were developed (Drabkin and Marsh, 1956).

(2) Cytochrome *c* behaves like an adaptive enzyme; it responds to functional need. This is clear in the case of yeast grown anaerobically and then adapting to life in the presence of oxygen (Yčas and Drabkin, 1957). But, the adaptive behaviour can be deduced also from the increase in cellular cytochrome *c* in the experimentally induced hyperthyroid state (Drabkin, 1950a, 1951a, 1955).

(3) Cytochrome *c* is important in the growth of tissues and in protein synthesis. This role of cytochrome *c* is related to its adaptive behaviour. The concentration of cytochrome *c* increases in liver regenerating after partial hepatectomy (Crandall and Drabkin, 1946). Moreover, the full restoration of cytochrome *c* as well as RNA in regenerating rat liver precedes appreciable tissue regrowth (Drabkin, 1947a and b). It has been proposed accordingly that protein synthesis is 'triggered' by cytochrome *c* and ribonucleic acid. The mitochondrial particle fraction, which contains the cytochrome *c* is increased in volume during liver restoration (Drabkin, 1950b).

In our more recent work we have been concerned with the elaboration of details in the biosynthesis of cytochrome *c* and haemoglobin, as well as with the development of suitable techniques for the efficient recovery of cytochrome *c* from rat liver mitochondria.

These investigations were supported by grants from the Office of Naval Research and the Bureau of Medicine and Surgery of the Navy (U.S.).

#### REFERENCES

- CRANDALL, M. W. & DRABKIN, D. L. (1946). *J. biol. Chem.* **166**, 653.  
DRABKIN, D. L. (1947a). *J. biol. Chem.* **171**, 395.  
DRABKIN, D. L. (1947b). *J. biol. Chem.* **171**, 409.  
DRABKIN, D. L. (1950a). *J. biol. Chem.* **182**, 335.  
DRABKIN, D. L. (1950b). *J. nat. Cancer Inst.* **10**, 1357, 1360.  
DRABKIN, D. L. (1951a). *Physiol. Rev.* **31**, 345.  
DRABKIN, D. L. (1951b). *Proc. Soc. exp. Biol. Med.* **76**, 527.  
DRABKIN, D. L. (1955). *Porphyrin biosynthesis and metabolism*, Ciba Foundation Symposium (Ed. by G. E. W. Wolstenholme and E. C. P. Millar), p. 96, London.  
DRABKIN, D. L. & MARSH, J. B. (1956). *J. biol. Chem.* **221**, 71.  
MARSH, J. B. & DRABKIN, D. L. (1957). *J. biol. Chem.* **224**, 909.  
THEORELL, H., BÉZNAK, M., BONNICHSEN, R., PAUL, K. G. & ÅKESSON, Å. (1951). *Acta chem. Scand.* **5**, 445.  
YČAS, M. & DRABKIN, D. L. (1957). *J. biol. Chem.* **224**, 921.

MORTON: It may be of interest to recall that, since the *in vitro* biosynthesis of cytochrome *c* was so elegantly opened up by Drabkin, Simpson and co-workers have shown net biosynthesis of cytochrome *c* in calf-heart mitochondria (Bates, Kalf and Simpson: *Fed. Proc.* **18**, 187, 1959).



# THE LOCATION OF CYTOCHROMES IN *ESCHERICHIA COLI*

By A. TISSIÈRES

*Biological Laboratories, Harvard University,  
Cambridge, Mass.*

THE CYTOCHROMES are attached to granules of widely different sizes in bacterial extracts made by sonic vibration or by grinding the cells with abrasives (Tissières, 1952; Wilson and Wilson, and Smith and Kuby, cited by Smith, 1954; Alexander and Wilson, 1955; Marr and Cota-Robles, 1957; Tissières, Hovenkamp and Slater, 1957). A fraction containing cytochromes centrifuges in a field of about  $6000 \times g$ , while small granules, also bearing the respiratory catalysts, sediment at  $100,000 \times g$ , together with the ribonucleoprotein (RNP) particles. The small granules, although usually more active than the larger ones, are not qualitatively different: they all oxidize the same substrates and contain the same cytochrome pigments. There is no evidence for a class of respiratory granules homogeneous in size and shape.

It is shown here that (a) the small respiratory granules are distinct from RNP particles and can be separated from the latter, in agreement with the experiments of Cota-Robles, Marr and Nilson (1958) on *Azotobacter* preparations; (b) in *E. coli*, as in several bacterial species (Marr and Cota-Robles, 1957; Cota-Robles *et al.*, 1958; Mitchell, 1957; Storck and Wachsmann, 1957), the cytochrome components are attached to the cell membrane. The respiratory granules of varying sizes probably arise by disintegration of the cell membrane.

## MATERIAL AND METHODS

*E. coli*, strain B, was grown, harvested, and the cell free extracts were made by grinding with alumina powder, and extracting with 0.005 M 2-amino-2-hydroxymethylpropane-1:3-diol (tris) buffer pH 7.3 containing 0.01 M magnesium acetate, as described previously (Tissières, Watson, Schlessinger and Hollingworth, 1959). The mixture of alumina, broken cells and buffer was centrifuged at  $6000 \times g$  for 15 min, giving a sediment composed of two layers: a lower layer of alumina and an upper brown layer of large cell debris. The supernatant was centrifuged at  $100,000 \times g$ , yielding a pellet composed of RNP particles and respiratory granules. The RNP fraction, still containing respiratory granules, was freed of soluble proteins by differential

centrifugation (Tissières *et al.*, 1959). It consisted then of 90–95% of RNP particles and 5–10% of respiratory granules.

Reduced diphosphopyridine nucleotide (DPNH) oxidase activity was estimated according to Slater (1950) using the reaction mixture given by Tissières *et al.* (1957). Protein and ribonucleic acid (RNA) were determined by the biuret (Gornall, Bardawill and David, 1949) and orcinol (Dische, 1953) methods respectively.

A Zeiss microspectroscope fitted to a microscope, as described by Keilin and Hartree (1946) was used to examine the absorption bands of cytochromes. Fractions of small granules were isolated in a Model L Spinco ultra-centrifuge. The centrifugal forces given were calculated for the middle of the centrifuge tube. Analytical ultra-centrifugation was done with a Model E Spinco centrifuge, with schlieren optics.

Tris buffer was Sigma 7–9 biochemical buffer from Sigma Chemical Company, St. Louis, Missouri. The pH of tris solutions was adjusted to 7.3 by addition of 0.1 N HCl. Deoxyribonuclease was obtained from Worthington Biochemical Corp., Freehold, New Jersey, and lysozyme and DPNH from Sigma Chemical Company.

## EXPERIMENTAL

### 1. Cytochromes in the Various Particulate Fractions

The typical cytochrome components of *E. coli* were observed in cell debris and granules of all sizes, with the exception of purified RNP particles: the  $\alpha$ -absorption bands of reduced cytochromes  $a_2$ ,  $a_1$  and  $b_1$ , characteristic of *E. coli* (Keilin and Harpley, 1941), were seen under the microspectroscope.

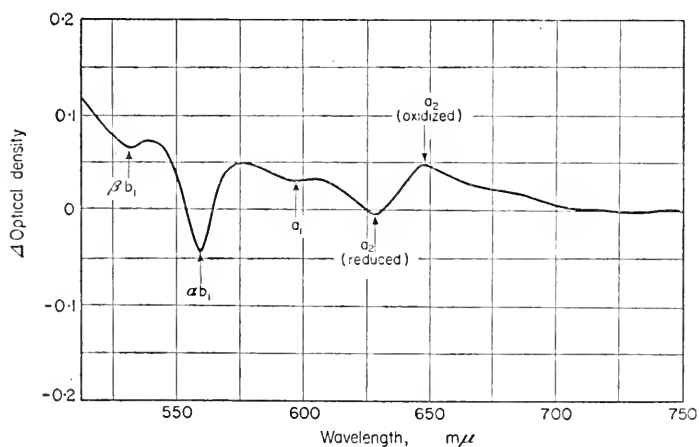

FIG. 1. Difference spectrum, oxidized minus reduced, of a small granule fraction. The base line, which corresponded to an optical density of 0 at 750  $m\mu$ , was somewhat shifted up at shorter wavelengths.

A difference spectrum (oxidized minus reduced), of a small granule fraction, taken in the visible region with the Cary Spectrophotometer, is shown in Fig. 1.

## 2. *Relative Amounts of Cytochrome $b_1$ in the Large Cell Debris and in the Small Granule Fraction*

A rough estimation of the amount of cytochrome  $b_1$  present in the large cell debris (sedimented in 15 min at  $6000 \times g$ ) and in small granules (sedimented in 120 min at  $100,000 \times g$ ) was obtained as follows: the pellets from the centrifuge tubes were resuspended in 3–4 vol. of 50% (w/v) sucrose solution containing 0.01 M phosphate buffer, pH 7.0, and 0.01 M sodium succinate. These preparations were examined under the microspectroscope with the light path adjusted so that the intensity of the  $\alpha$ -absorption band of reduced cytochrome  $b_1$  was the same for both large cell debris and small granule fractions. Thus, knowing the light path, and the volume for each preparation, it was found that the large cell debris contained 75–85% of cytochrome  $b_1$ , and the small granules 15–25%. The errors in these measurements were probably as great as 20–30%.

Grinding the cells with alumina for longer periods decreased the cytochrome content of the large cell debris and increased the number of small particles bearing cytochromes. This is consistent with the finding that large cell debris from *Azotobacter* can be broken down to yield small granules (Tissières *et al.*, 1957).

## 3. *Separation of the DPNH Oxidase Activity from Ribonucleoprotein Particles*

The DPNH oxidase system includes the cytochrome components; thus its activity, under some conditions, can be taken as a measure of the activity of the cytochrome system (Slater, 1950; Tissières *et al.*, 1957). The DPNH oxidase activity, the amounts of protein and RNA, and the area covered by the RNP particle peaks on the schlieren centrifugation diagrams, were measured on two RNP particle preparations isolated as described previously (Tissières *et al.*, 1959). Preparation 1 contained RNP particles with sedimentation coefficients of 30S and 50S; preparation 2, particles of 50S. Preparations 1 and 2 were centrifuged, at  $25,000 \times g$  for 45 min and at  $32,000 \times g$  for 30 min respectively, as shown in Table 1. The various measurements were then repeated on the supernatant in order to find out whether the RNP particles sedimented at the same rate as the DPNH oxidase system. With both preparations, the DPNH oxidase activity in the supernatant after centrifugation decreased 88–90% from its original value whereas the amounts of protein and RNA, and the area under the schlieren curve, decreased 25% (Table 1). These results indicate that the oxidases are attached not to RNP particles, but to granules which sediment faster. These granules are probably not homogeneous in size, since they did not form a visible peak on the



sedimentation diagram even though they represent 5–10% of the total fraction (see below).

TABLE 1. DPNH OXIDASE ACTIVITY, PROTEIN, RNA AND RELATIVE AMOUNTS OF RIBONUCLEOPROTEIN PARTICLES (AREA COVERED BY PEAKS ON SCHLIENEN DIAGRAMS) IN PREPARATIONS ISOLATED BY CENTRIFUGATION

	DPNH oxidase activity $\Delta E/hr/mg$ protein	Relative DPNH oxidase activity	Protein (%)	RNA (%)	Relative area covered by ribonucleoprotein particle peaks on schlienen diagrams
Preparation 1	14.4	100	100	100	100
Supernatant after centrifuging preparation 1 for 45 min at 25,000 g	2.0	10.7	76.5	77.5	85
Pellet		75 (14% loss)	24	—	
Preparation 2	39.0	100	100	100	100
Supernatant after centrifuging preparation 2 for 30 min at 32,000 g	4.8	12.3	84	76	90
Pellet		81 (7% loss)	16		

#### 4. Separation of Granules Containing Cytochromes from Ribonucleoprotein particles

(a) *Centrifugation in Caesium Chloride Solution with a Density of 1.46.* 4.3 ml of a 6% of 70 S RNP preparation made as described previously (Tissières *et al.*, 1959) was mixed with 5.7 ml of a 60% caesium chloride solution. The density of the resultant solution was approximately 1.46. The mixture was then centrifuged for 16 hr at  $80,000 \times g$  in a swinging bucket rotor. A gelatinous, transparent brown layer, about 2 mm thick, formed at the top of the centrifuge tube. This layer could be removed intact and spectroscopic examination showed strong absorption bands of cytochrome  $a_2$ ,  $a_1$  and  $b_1$ . The rest of the solution was colourless; at the bottom of the tube there was a colourless pellet of RNP particles. No cytochrome could be detected in either of these last two fractions.

(b) *Centrifugation in Sucrose Solution of Density 1.34.* Sucrose (11.2 g) was dissolved in 12 ml of a 2% of 70 S preparation. The mixture was centrifuged for 12 hr at  $100,000 \times g$  in the swinging bucket rotor. A brown layer formed at the top of the centrifuge tube, which showed strong cytochrome absorption bands, as in the preceding experiment. The RNP particles had sedimented to the bottom of the centrifuge tube: it was found that their sedimentation coefficient (70 S) had not been modified by this treatment. Before centrifugation in sucrose, the preparation contained 60% RNA and 40% protein, while after it, there was 65% RNA and 35% protein in the pellet of RNP particles. The amount of protein in the layer containing cytochromes, at the top of the tube, quantitatively accounted for this

difference: it amounted to about 8% (dry weight) of the preparation before centrifugation in sucrose.

#### 5. *E. coli* 'Ghosts' Containing the Bulk of the Cytochromes of the Cells

According to Repaske (1956), *E. coli* cells are lysed by lysozyme, at pH 8.0, in the presence of ethylenediaminetetraacetate (EDTA). 7 g of cells harvested in the exponential phase of growth and washed twice with 20 vol. of 0.1% NaCl, were suspended in 150 ml of 0.2 M sucrose, containing 0.01 M tris buffer, pH 8.0, and 0.01 M  $Mg^{++}$ . Lysozyme (3 mg) and 3 ml neutralized 0.1 M EDTA were then added. The mixture was left at room temperature for 30 min, then kept 12 hr at 4°. By that time 98–99% of the cells had undergone the characteristic transformation into spheroplasts. These spheroplasts were washed twice in sucrose-tris-magnesium mixture containing 1  $\mu$ g/ml deoxyribonuclease. Finally, they were lysed by re-suspending in 20 ml of 0.005 M tris, pH 7.3, containing 0.01 M  $Mg^{++}$  and 1  $\mu$ g/ml deoxyribonuclease. Weibull (1956) has shown that when protoplasts from *Bacillus megatherium* were lysed in the presence of 0.01 M  $Mg^{++}$ , the resulting 'ghosts' represented morphologically undamaged cytoplasmic membranes: they were slightly larger than the protoplasts and there was approximately one ghost per protoplast. In the experiment described here, the number of ghosts obtained was about the same as the number of spheroplasts from which they had derived. They appeared somewhat larger.

The lysate was centrifuged at 10,000 rev/min for 15 min. A large pellet of ghosts was formed, which was washed twice in the centrifuge with tris-magnesium mixture. Spectroscopic examination of the washed ghosts showed strong absorption bands of cytochromes  $a_2$ ,  $a_1$  and  $b_1$  on addition of succinate or dithionite. No absorption band of cytochrome was seen in the washings. The ratio of RNA to protein in the washed ghosts was found to be 5/100, while it was 50/100 in the supernatant after centrifugation at 10,000 rev/min. This supernatant was examined under the spectroscope in a 70 mm layer, in presence of DPNH, succinate or dithionite. The absorption bands of cytochrome were not visible.

The supernatant was next centrifuged for 120 min at  $100,000 \times g$ . A characteristic RNP particle pellet was thus formed, slightly yellow in colour. This pellet, from two 11 ml centrifuge tubes was resuspended in 5 ml of sucrose solution with a density of 1.30, and centrifuged for 15 hr at  $100,000 \times g$  in the swinging bucket rotor. A very thin yellow layer collected at the top of the tube. It was carefully removed and examined for cytochromes in the presence of dithionite, and also after addition of pyridine. No absorption band could be detected. The colourless solution below the top layer, and the RNP particle pellet were also examined under the spectroscope in the presence of reducing agents, as well as after addition of pyridine. The cytochrome components were not detected.

In conclusion, the ghosts formed under the conditions of this experiment bear all the cytochromes of the cell. This suggests that in *E. coli* the respiratory chain is located in the cell membrane.

### CONCLUSION

There is no evidence in bacterial cells for respiratory granules homogeneous in size and shape: the cytochromes are usually attached to granules of widely different sizes in the extracts and these granules probably derive from the breakdown of a larger structure, the cell membrane (Marr and Cota-Robles, 1957). Under some conditions, all the cytochrome system is bound to 'ghosts' or cell membrane preparations, however probably containing still some wall material. The ribonucleoprotein particles, which are uniform in size and seem to fill the bacterial cytoplasm (Tissières *et al.*, 1959) do not bear any cytochrome pigments.

### SUMMARY

1. In *E. coli* extracts granules bearing cytochromes can be separated from ribonucleoprotein particles.
2. 'Ghosts' lysed in the presence of 0.01 M magnesium ions contain all the cytochromes of the cell.

### Acknowledgement

I wish to thank Dr. N. Krinsky for measuring the difference spectrum shown in Fig. 1.

### REFERENCES

- ALEXANDER, M. & WILSON, P. W. (1955). *Proc. nat. Acad. Sci., Wash.* **41**, 843.  
COTA-ROBLES, E. H., MARR, A. G. & NILSON, E. H. (1958). *J. Bact.* **75**, 243.  
DISCHE, Z. (1953). *J. biol. Chem.* **204**, 983.  
GORNALL, A. G., BARDAWILL, C. T. & DAVID, M. M. (1949). *J. biol. Chem.* **177**, 751.  
KEILIN, D. & HARPLEY, C. H. (1941). *Biochem. J.* **35**, 688.  
KEILIN, D. & HARTREE, E. F. (1946). *Nature, Lond.* **157**, 210.  
MARR, A. G. & COTA-ROBLES, E. H. (1957). *J. Bact.* **74**, 79.  
MITCHELL, P. (1957). *Biochem. J.* **65**, 44P.  
REPASKE, R. (1956). *Biochim. biophys. Acta* **22**, 189.  
SLATER, E. C. (1950). *Biochem. J.* **46**, 484.  
SMITH, L. (1954). *Bact. Rev.* **18**, 106.  
STORCK, R. & WACHSMAN, J. T. (1957). *J. Bact.* **73**, 784.  
TISSIÈRES, A. (1952). *Nature, Lond.* **169**, 880.  
TISSIÈRES, A., HOVENKAMP, H. G. & SLATER, E. C. (1957). *Biochim. biophys. Acta* **25**, 336.  
TISSIÈRES, A., WATSON, J. D., SCHLESSINGER, D. & HOLLINGWORTH, B. R. (1959). *J. mol. Biol.* **1**, 221.  
WEIBULL, C. (1953). *J. Bact.* **66**, 688.  
WEIBULL, C. (1956). *Exp. Cell Res.* **10**, 214.

### DISCUSSION

#### *The Origin of the Respiratory Granules of Bacteria*

SLATER: The respiratory granules derived from the disintegration of the bacterial membrane which can be isolated by the methods described by Tissières are capable of carrying

out oxidative phosphorylation, as has been shown by several workers. In our laboratory, Miss Hovenkamp has been continuing the studies, begun by Tissières and myself in Cambridge, of the system bringing about oxidative phosphorylation in particles isolated from *Azotobacter*. The P:O ratios are low compared with those found with isolated mitochondria from animal cells, but the rate of respiration is so high that the rate of synthesis of ATP/mg protein by these bacterial-membrane fragments is the highest ever recorded.

Miss Hovenkamp has recently succeeded in dissociating reversibly the phosphorylation from the respiratory chain by suspending the particles in a medium of low ionic strength, following by centrifugation at high speed. Particles obtained in this way oxidize DPNH with little phosphorylation. Oxidative phosphorylation can be reconstituted by incubation of these particles with  $Mg^{++}$  and the supernatant obtained in this centrifugation (*Nature, Lond.* **184**, 471, 1959). It should be noted that, unlike other supernatant factors, Miss Hovenkamp's is derived not from the cell sap but apparently by disintegration of the washed small particles themselves. We do not yet know whether this supernatant factor is an enzyme related to oxidative phosphorylation, or is perhaps a structural factor required to restore the structure of the particles which has been disturbed by incubation in media of low ionic strength. This question is now being studied by Hovenkamp in Pinchot's laboratory.

# ON THE CYTOCHROMES OF ANAEROBICALLY CULTURED YEAST

By PAULETTE CHAIX

*Laboratoire de Chimie biologique de la Faculté des Sciences,  
Paris*

THE FIRST observations of cytochrome spectra, made at ordinary temperature by MacMunn between 1884 and 1886 and by Keilin in 1925, led to the conclusion that cells grown anaerobically are lacking in these pigments. This point of view appeared later to be confirmed and the term cytochrome, notably because of the intra-mitochondrial localization (Chance and Williams, 1955, 1956) of the components ( $a + a_3$ ),  $b$ ,  $c_1$  and  $c$  of aerobic cells, became synonymous with oxidation-reduction catalysts belonging to the respiratory chain.

At the present time, it is known that certain anaerobic cells (Postgate, 1954a, 1954b; Ephrussi and Slonimski, 1950) and certain cellular fractions lacking respiratory activity (Strittmatter and Ball, 1954; Chance and Williams, 1954) of anaerobic organisms may contain spectrographically detectable oxidation-reduction enzymes of haematin type, and the problem arises of trying to distinguish without ambiguity the cytochromes which belong to the respiratory chain from those which do not.

Bakers' yeast, which may be cultured aerobically or strictly anaerobically, appeared to us a particularly suitable material to elucidate such problems as these. This work has been done in collaboration with Thérèse Heyman-Blanchet and Francois Zajdela, with the aid of the spectrographic method for studying the cytochromes *in situ* at room temperature (Chaix and Fromageot, 1942) and subsequently adapted to low temperature measurements (Chaix and Petit, 1956, 1957).

## VARIATIONS OF THE HAEMATIN SPECTRUM OF YEAST CULTURED ANAEROBICALLY, AS A FUNCTION OF ITS GROWTH PHASES

*Saccharomyces cerevisiae* ('yeast foam' diploid) may be cultivated under strict anaerobiosis at 25°C either on a Difco yeast extract medium or on a synthetic medium. By adding to these two media Tween 80 and ergosterol, as recommended by Andreasen and Stier (1953, 1954) growth rates of  $\mu = 0.65$  and  $\mu = 0.45$  respectively (Heyman-Blanchet and Chaix, 1959) may be obtained.

If these yeasts are harvested during the exponential phase of growth their reduced haematin spectrum is characterized at low temperature by three  $\alpha$ -bands situated at 552.5 m $\mu$ , 558 m $\mu$  and 574.5 m $\mu$  (Fig. 1, curve 1) (Chaix and Heyman-Blanchet, 1957).

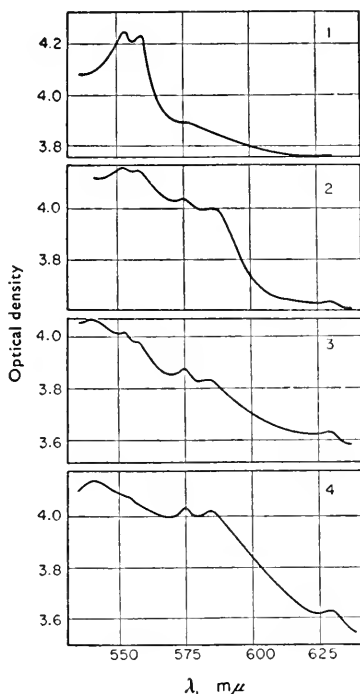

FIG. 1. Progressive change of the haematin spectrum of yeast cultured anaerobically on a yeast extract medium as a function of growth phase. Optical density of the culture was read at the time of harvesting. Reduction by endogenous substrate. For definition of the CU unit, see text below. (1), 64 CU; (2), 102 CU; (3) 120 CU; (4), 178 CU.

If the yeast is harvested after the exponential phase of growth the observed spectra change as the growth rate slows down.

When the culture reaches 102 CU (one CU unit means the optical density, measured with the Coleman photometer, which corresponds to 17.1  $\mu$ g dry weight of yeast/ml), the three  $\alpha$ -bands (spectrum 2) present during the exponential phase persist, but the band at 574.5–575 m $\mu$  has been accentuated; moreover two rather faint new bands have commenced to appear of which one, situated at 585 m $\mu$ , has already been observed by Lindenmayer and Smith (1957); the other is situated at 630 m $\mu$ . This last component does not seem to correspond to catalase since the catalatic activity of anaerobic yeast is very low.

When the culture reaches 120 CU (spectrum 3), the relative strength of the different bands has changed further; the bands located at 552.5 and 558  $m\mu$  have weakened while the three others have strengthened and a new band has appeared at 540  $m\mu$ .

When the culture has reached 178 CU (spectrum 4), the change has progressed further; the bands at 552.5 and 558  $m\mu$  have practically disappeared and the four other bands have become sharply accentuated.

#### INDUCTION BY OXYGEN OF RESPIRATORY CYTOCHROME COMPONENTS IN YEASTS CULTURED ANAEROBICALLY

In 1950 Ephrussi and Slonimski showed with resting cells from anaerobic cultures that the simple presence of molecular oxygen was able to induce rapidly the synthesis of the classical cytochrome system of aerobic yeast; it was then thought that yeast cultivated anaerobically showed a single type of spectrum only. We have been reinvestigating such induction phenomena,

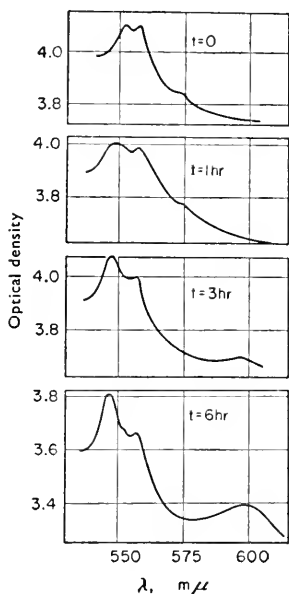

FIG. 2. Induction by oxygen of the air of the respiratory cytochrome system in resting cells of yeast from anaerobic culture on yeast extract medium, harvested in the exponential phase; 32 CU; reduction by endogenous substrates.

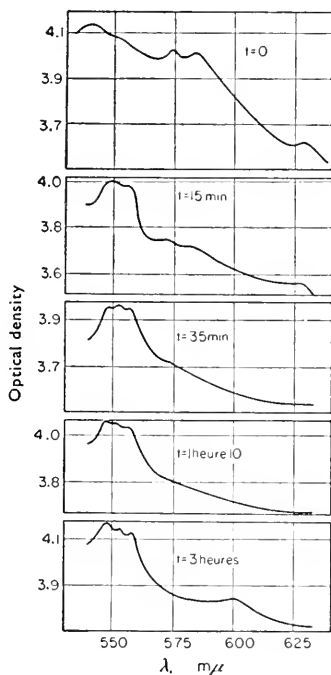

FIG. 3. Induction by oxygen of the air of the respiratory cytochrome system in resting cells of yeast from anaerobic culture on yeast extract medium, harvested in the stationary phase; 240 CU; reduction by endogenous substrates.

following with the aid of low temperature spectra the progressive transformation of the anaerobic spectrum into the classical aerobic spectrum in yeast harvested either in the exponential or in the stationary phase. The results of these experiments are shown in the series of curves of Figs. 2 and 3.

It may be seen that the induction by oxygen is slower when the yeast is harvested in exponential phase than when it is harvested in stationary phase. In each of these two cases the order of disappearance or appearance of bands is quite definitive. In the first case the  $c\alpha$  and  $(a + a_3)$   $\alpha$ -bands appear progressively without disappearance of the bands at 552.5 and 558  $m\mu$ . In the second case the induction begins with the appearance of the bands at 552.5 and 558  $m\mu$ , followed by appearance of the  $c\alpha$  and  $(a + a_3)$   $\alpha$ -bands while all the other bands weaken and disappear. It is striking to find that in the classical aerobic spectrum the  $c_1\alpha$  and  $b\alpha$  bands occupy the same positions as the components of the anaerobic spectrum situated at 552.5 and 558  $m\mu$ . The question arises as to whether the  $c_1$  and  $b$  components are identical with or superposed on the anaerobic components.

#### FRACTIONATION OF YEAST CELLS IN THE EXPONENTIAL PHASE OF AEROBIC AND ANAEROBIC GROWTH; LOCALIZATION OF HAEMATIN ENZYMES IN THE DIFFERENT FRACTIONS

##### (a) *Preparation of Yeast Protoplasts*

The yeast was harvested when the culture had reached 50 CU; in other words, before the last division of the exponential phase of growth. It was then washed by centrifugation in a solution of 0.25 M lactose, and resuspended, at a concentration of 34 mg dry weight/ml in the same lactose solution to which digestive juice of *Helix pomatia* had been added at a level of 0.025 ml/ml of suspension (Giaja, 1919, 1922; Eddy and Williamson, 1957). On incubation at 25°C for 1.5 hr with gentle shaking, the snail digestive juice brings about enzymic degradation of the yeast cell membranes. A mixture is thus obtained of protoplasts, intact cells with their membranes partly degraded, and cellular debris. The latter is removed by centrifugation for 15 min at 1000  $\times g$ ; the pellet is resuspended in 0.5 M lactose and recentrifuged.

##### (b) *Disruption and Fractionation*

The final pellet, consisting of protoplasts and intact cells, is suspended in a 7.5% solution of polyvinylpyrrolidone and disrupted in a Virtis Homogenizer. The homogenization is carried out in two steps; a first treatment for 10 min at medium speed (rheostat at division 75), and then, after standing for 10 min to allow penetration of the medium into the cells, a further treatment for 10 min at medium speed.

The homogenate so obtained is fractionated by centrifugation as follows:



Removal of intact cells and gross cellular debris,  
15 min at  $1000 \times g$ .

Centrifugation for 30 min at  $4000 \times g$ —Fraction I.

Centrifugation of supernatant I for 60 min at  $25,000 \times g$ —Fraction II.

Centrifugation of supernatant II for 60 min at  $105,000 \times g$ —Fraction III.

All these operations are carried out at about  $0^\circ\text{C}$ . At each stage the fractionation is followed by examination with a phase-contrast microscope.

For the fractionation of yeast cultured anaerobically all the operations are carried out under nitrogen to avoid induction by oxygen of respiratory enzymes.

(c) *Morphological and Spectrographic Properties of Fractions Isolated from Aerobic Yeast*

Study of the different fractions by electron microscopy shows that fraction I is a practically pure preparation of mitochondria; fraction II, rich in granules organized in clusters and various debris, contains hardly any mitochondria;

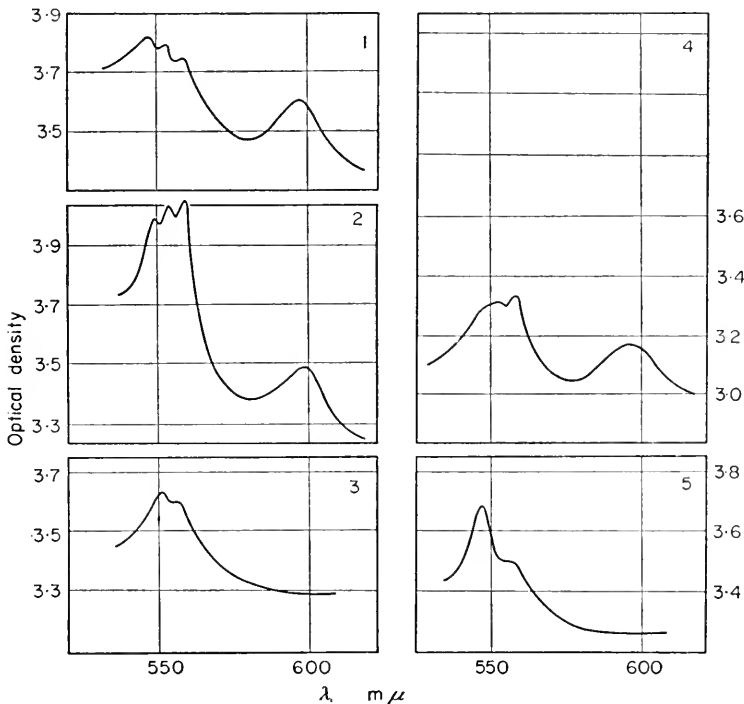

FIG. 4. Spectra of fractions I and III of aerobically grown yeast cells harvested during the exponential phase of growth.

A. Fractionation in polyvinylpyrrolidone

B. Fractionation in lactose

Curves 1, fraction I reduced with succinate; curves 2 and 4, fraction I reduced with  $\text{Na}_2\text{S}_2\text{O}_4$ ; curves 3 and 5, fraction III reduced with  $\text{Na}_2\text{S}_2\text{O}_4$ .

fraction III has no mitochondria and contains only free granules of homogeneous size (Vanderwinkel, De Denken and Wiame, 1958).

The low-temperature spectrum of fraction I (mitochondria), after reduction with succinate, is exactly the same as that of the whole cell in the exponential phase of aerobic growth (Chaix and Heyman-Blanchet, 1957) (Fig. 4, spectrum 1). If the reduction is carried out by sodium dithionite under the conditions previously described (Chaix, Petit, Monier and Zajdela, 1959) the  $b\alpha$  and  $c_1\alpha$  bands are strengthened (Fig. 4, spectrum 2). The presence of cytochrome  $c$  in the spectrum indicates that the polyvinylpyrrolidone medium used for the isolation of the mitochondria conserves their integrity better than the 0.5 M lactose (Fig. 4, spectrum 4 and 5), or the phosphate buffer media that we have used in previous experiments. It is probably because the mitochondria that he had isolated were altered that Chance (1957) found spectra partly lacking cytochrome  $c$ .

The spectrum of fraction II shows the  $c_1\alpha$  and  $b\alpha$  components, and in certain preparations a weak  $c\alpha$  band; fraction III contains only relatively weak  $c_1\alpha$  and  $b\alpha$  bands (Fig. 4, spectrum 3).

These experiments, by confirming the presence in aerobic mitochondria of the ( $a + a_3$ ),  $b$ ,  $c_1$  and  $c$  components and by excluding the existence of an extra-mitochondrial cytochrome  $c$  raise the question whether two other components, reducible by dithionite only and of which the alpha bands would occupy the same positions, are not superposed on  $b$  and  $c_1$ .

(d) *Morphological and Spectrographic Properties of Fractions Isolated from Anaerobic Yeast*

Examination by the electron microscope reveals that fraction I is composed of denser and smaller mitochondria than the aerobic mitochondria, mixed

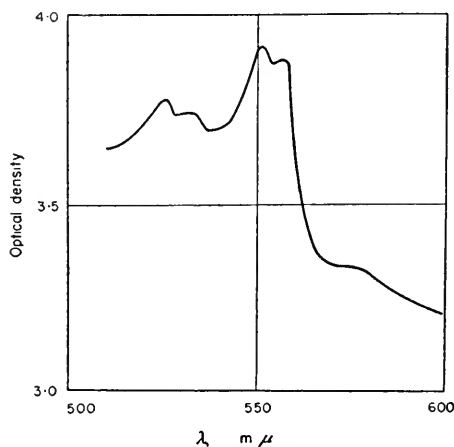

FIG. 5. Spectrum of fraction II of anaerobically grown yeast cells harvested during the exponential phase of growth.  $\text{Na}_2\text{S}_2\text{O}_4$ -reduced.

with a large quantity of small particles organized in clusters. Fraction II contains small particles organized in clusters and no mitochondria. Fraction III (very scanty), contains free granules of homogeneous size only and no mitochondria. These three fractions have the same haematin spectrum (Fig. 5) but that of fraction II is by far the stronger. The spectrum of these fractions contains bands situated at 552.5 ( $\alpha$ ), 525 ( $\beta$ ); and 558 ( $\alpha$ ), 532.5 ( $\beta$ )  $m\mu$ , reducible by dithionite only; the first two bands are sharper than the second two. We have established that these components cannot be reduced by reduced diphosphopyridine nucleotide (DPNH) or by lactate; cytochrome  $b_2$  (lactate dehydrogenase) thus does not correspond to these haematin compounds (Bach, Dixon and Keilin, 1942; Appleby and Morton, 1954, 1959; Boeri and Tosi, 1956).

#### DISCUSSION AND CONCLUSIONS

1. Our spectrographic studies at low temperature of yeast cells cultured anaerobically have shown that the haematin spectrum in the exponential phase of growth, when reduction is brought about by endogenous substrates, includes three  $\alpha$ -bands located at 552.5, 558 and 575  $m\mu$  (Chaix and Heyman-Blanchet, 1957). Lindenmayer and Estabrook (1958) have confirmed the presence of  $\alpha$ -bands at 552.5 and 558  $m\mu$  (to be precise these authors found the bands at 551 and 557.5  $m\mu$ ) but they did not find the  $\alpha$ -band at 575  $m\mu$ , no doubt because their preparations were reduced by dithionite and not simply by the endogenous substrates. In fact, this band at 575  $m\mu$ , which probably belongs to an oxyhaemoglobin (Keilin, 1953; Keilin and Tissières, 1954) disappears in the presence of dithionite.

During the stationary phase of anaerobic growth, the absorption bands of the exponential phase tend to weaken and three new bands appear, situated at 540  $m\mu$  and 585  $m\mu$  (Lindenmayer and Smith, 1957) and 630  $m\mu$  of which the physiological significance remains obscure.

2. During the induction by oxygen of the respiratory system of cells harvested in the exponential phase of anaerobic growth the two bands at 552.5 and 558  $m\mu$  never disappear. The  $c\alpha$  and ( $a + a_3$ )  $\alpha$ -bands simply appear little by little, just as though the  $b\alpha$  and  $c_1\alpha$  bands of the classical spectrum correspond to the bands at 552.5 and 558  $m\mu$  which exist before the intervention of oxygen, or are superposed on these. On this point our observations do not agree with those of Lindenmayer and Estabrook (1958), who considered that passage from anaerobiosis to aerobiosis entailed only displacement of the 557.5 band to 559  $m\mu$  and of the 551 band to 548  $m\mu$ , the  $c_1\alpha$  band at 554  $m\mu$  appearing secondarily only.

As regards the kinetics of the induction by oxygen with cells in the exponential phase on the one hand and in the stationary phase on the other, our findings are the same as those of Slonimski (1956) and Lindenmayer and Estabrook (1958). The speed of induction is much greater in the second case

than in the first. We do not have any experimental evidence to support any of the very numerous hypotheses which may be advanced to explain the different behaviour of the two types of cell.

3. Our attempts at fractionation of yeast in the exponential phase of aerobic and anaerobic growth have allowed us to establish several important points. We have been able to devise an isolation technique for mitochondria of aerobic and anaerobic yeast, using a polyvinylpyrrolidone medium, which allows us to obtain them in a good state of integrity as shown by electron-microscope examination. The aerobic mitochondria isolated in this medium have a spectrum in which the  $\alpha$  band has the same intensity as that observed in the spectrum of intact cells. These experiments speak strongly against the existence of an extra-mitochondrial cytochrome *c*.

The anaerobic mitochondria are much smaller than the aerobic ones but more dense, since they sediment largely at  $4000 \times g$ . The haematin components characterized by  $\alpha$ -bands at 552.5 and 558  $m\mu$  and  $\beta$ -bands at 525 and 532.5  $m\mu$ , not appearing until after reduction by dithionite, appear to belong not to these anaerobic mitochondria but rather to homogeneous granules which sediment mainly between 4000 and  $25,000 \times g$ . Our evidence does not appear to permit the assignment of lactate dehydrogenase activity to these haematin components.

#### REFERENCES

- ANDREASEN, A. A. & STIER, T. J. B. (1953). *J. cell. comp. Physiol.* **41**, 23.  
 ANDREASEN, A. A. & STIER, T. J. B. (1954). *J. cell. comp. Physiol.* **43**, 271.  
 APPLEBY, C. A. & MORTON, R. K. (1954). *Nature, Lond.* **173**, 749.  
 APPLEBY, C. A. & MORTON, R. K. (1959). *Biochem. J.* **71**, 492.  
 BACH, S. J., DIXON, M. & KEILIN, D. (1942). *Nature, Lond.* **149**, 21.  
 BOERI, E. & TOSI, L. (1956). *Arch. Biochem. Biophys.* **60**, 463.  
 CHAIX, P. & FROMAGEOT, C. (1942). *Bull. Soc. Chim. biol.* **24**, 1259.  
 CHAIX, P. & HEYMAN-BLANCHET, T. (1957). *Biochim. biophys. Acta* **26**, 214.  
 CHAIX, P. & PETIT, J. F. (1956). *Biochim. biophys. Acta* **22**, 66.  
 CHAIX, P. & PETIT, J. F. (1957). *Biochim. biophys. Acta* **25**, 481.  
 CHAIX, P., PETIT, J. F., MONIER, R. & ZAJDELA, F. (1959). *Bull. Soc. Chim. biol.* **40**, 1897.  
 CHANCE, B. (1957). *Methods in Enzymology* **4**, 273.  
 CHANCE, B. & WILLIAMS, G. R. (1954). *J. biol. Chem.* **209**, 945.  
 CHANCE, B. & WILLIAMS, G. R. (1955). *J. biol. Chem.* **217**, 395.  
 CHANCE, B. & WILLIAMS, G. R. (1956). *Advanc. Enzymol.* **17**, 65.  
 EDDY, A. A. & WILLIAMSON, D. H. (1957). *Nature, Lond.* **179**, 1252.  
 EPHRUSSI, B. & SLONIMSKI, P. (1950a). *Biochim. biophys. Acta* **6**, 256.  
 EPHRUSSI, B. & SLONIMSKI, P. (1950b). *C.R. Acad. Sci., Paris* **230**, 685.  
 GIAJA, G. (1919). *C.R. Soc. Biol.* **82**, 719.  
 GIAJA, G. (1922). *C.R. Soc. Biol.* **86**, 708.  
 HEYMAN-BLANCHET, T. & CHAIX, P. (1959). *Biochim. biophys. Acta* **35**, 85.  
 KEILIN, D. (1925). *Proc. Roy. Soc.* **B98**, 312.  
 KEILIN, D. (1953). *Nature, Lond.* **172**, 390.  
 KEILIN, D. & TISSIÈRES, A. (1954). *Biochem. J.* **57**, 29.  
 LINDENMAYER, A. & ESTABROOK, R. W. (1958). *Arch. Biochem. Biophys.* **78**, 66.  
 LINDENMAYER, A. & SMITH, L. (1957). *Fed. Proc.* **16**, 212.  
 POSTGATE, J. (1954a). *Biochem. J.* **56**, 11.  
 POSTGATE, J. (1954b). *Biochem. J.* **58**, 9.

- SLONIMSKI, P. (1956). *3rd int. Congr. Biochem. Brussels*, Academic Press, N.Y.  
 STRITTMATTER, C. F. & BALL, E. G. (1954). *J. cell. comp. Physiol.* **43**, 57.  
 VANDERWINKEL, E., DE DEKEN, R. H. & WIAME, J. M. (1958). *Exp. Cell. Res.* **15**, 418.

## DISCUSSION

### *The Lactate Dehydrogenase of Yeast*

- BOERI: I should like to ask Chaix for more information about the lactate dehydrogenase in yeast. In our experience, different results are obtained, by varying the electron-acceptor, in aerobic and anaerobic yeast. In aerobic yeast, there is an abundance of a dehydrogenase which reduces cytochrome *c* in the presence of lactate, while the strong lactate dehydrogenase activity of anaerobic yeast is not revealed by a test with cytochrome *c*, but instead by one with ferricyanide.
- CHAIX: We have found that lactate dehydrogenase activity in anaerobically grown yeasts is located almost completely in the supernatant. Anaerobic pigments are not reduced by DL-lactate.
- MORTON: A very recent paper of Slonimski and associates reported that anaerobic yeast contains a lactate dehydrogenase which is a flavoprotein (free from haem) specific for D(-) lactate, whereas the enzyme in aerobic yeast, the haemoflavoprotein, is specific for L(+) lactate. Could Chaix indicate as to where is the enzyme in the aerobic yeast?
- CHAIX: We have used DL-lactate with aerobically and anaerobically grown yeast. Concerning your second question, we have found lactate dehydrogenase activity only in the mitochondrial fraction in aerobically grown yeasts. In this case the cytochromes are reduced by DL-lactate.

### *Components of the Respiratory Chain in Yeast Mitochondria*

- CHANCE: It is important to emphasize the need for distinguishing between pigments of the respiratory chain and accessory pigments. An unusually effective way of doing this is to observe the cytochromes involved in the steady state of aerobic metabolism, since the existence of the steady-state reduction of a cytochrome in intact cells and in phosphorylating mitochondria is acceptable as preliminary evidence for its function in electron transfer. Accurate observation of steady states requires the difference spectrum technique: the oxidized minus the steady-state oxidized spectrum. It has recently been possible in studies with W. Bonner to obtain this steady-state difference spectrum at liquid nitrogen temperatures (see also Estabrook, this volume, p. 436). Thus the method simultaneously gives a clear identification of the kind of cytochrome and its function in electron transfer.

Two examples are given, one indicating respiratory enzymes of baker's yeast cells (Fig. 1 (p. 234)), the other of ox heart mitochondria (see Fig. 3, Chance, this volume, p. 607). Both these records show clearly what other methods fail to do: that cytochrome *c*<sub>1</sub> is reduced in the steady state and hence functional in electron transfer in the intact cell and isolated mitochondria.

- CHAIX: The experiments mentioned by Chance, which aim to distinguish between pigments which belong to the respiratory chain and the other pigments, are very interesting.

But in order to correlate his observations with ours we would first have to agree on the definition of the term 'respiratory chain'. It should be possible, for instance, to postulate that cytochrome *c* functions as an electron-carrier in both aerobic and anaerobic electron-transfer.

Chance considers this question from quite a different point of view from ours.

### *On the 'Haemoglobin' Absorption Bands of Yeast*

- LEMBERG: Are the bands at 575  $m\mu$  and 630  $m\mu$  observed by you in yeast abolished by dithionite? If they are resistant to dithionite, the former may be due to a cryptohaem *a*-cytochrome, the latter to a cytochrome of type *a*<sub>2</sub>.

CHAIX: The bands at 575  $m\mu$  and 630  $m\mu$  do not disappear after incubating the yeast cells for 90 sec at room temperature with dithionite ( $3 \times 10^{-3}$  M). Incubation in the same conditions, but with solid dithionite, causes the disappearance of these bands. In the latter case the disappearance may be due to a denaturing effect of dithionite.

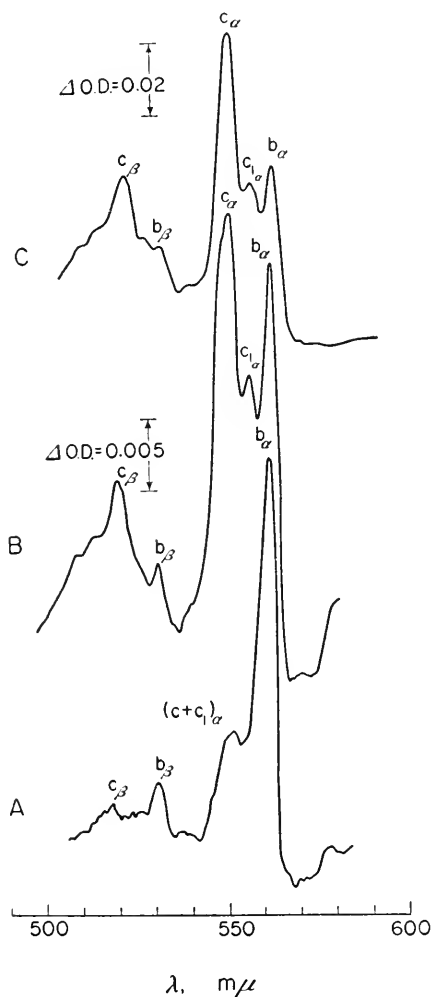

FIG. 1. 'Frozen steady-states' of cytochromes  $c$ ,  $c_1$  and  $b$  of baker's yeast cells. (A) glucose-treated; (B) ethanol treated; (C) oxidized-reduced (Expt. 938-2). Reprinted with permission of the Faraday Society (B. Chance and E. L. Spencer, Jr., *Disc. Faraday Soc.* 27, 200, 1959).

TISSIÈRES: Keilin and I have described an absorption band at 583  $m\mu$  in several moulds including some strains of yeast; this band appears on aeration, disappears on addition of dithionite and is replaced by a diffuse band at 575  $m\mu$  on treatment with CO. The band was therefore attributed to an oxyhaemoglobin. In the slow-growing 'petite colonie' strains which have a very low respiration rate, the oxyhaemoglobin absorption

band is much stronger than in other strains examined. While the properties of the pigment resemble those of haemoglobin, it is conceivable that it has some oxidase activity as well. The study of the isolated pigment would be of considerable interest.

MORTON: A pigment somewhat resembling that described by Keilin and Tissières was observed by Martin and myself (*Biochem. J.* **65**, 404, 1957) in plants.

STRITTMATTER: The properties of the 575  $m\mu$  band resemble those of the similar band, which may well be due to adsorbed oxyhaemoglobin, that is seen in liver microsomes if care is not taken to exclude or remove contaminating blood pigments during preparation of the microsome fraction (Strittmatter and Ball, *Proc. nat. Acad. Sci. Wash.* **38**, 19, 1952; *J. cell. comp. Physiol.* **43**, 57, 1954; Paigen, *Biochem. biophys. Acta* **19**, 297, 1956).

# IRREVERSIBLE INHIBITION OF CATALASE BY THE 3-AMINO-1:2:4-TRIAZOLE GROUP OF INHIBITORS IN THE PRESENCE OF CATALASE DONORS

By E. MARGOLIASH AND A. SCHEJTER

*The Laboratory for the Study of Hereditary and Metabolic Disorders, and the Departments of Biological Chemistry and Medicine, University of Utah College of Medicine, Salt Lake City, Utah, and the Department of Experimental Medicine and Cancer Research, The Hebrew University, Hadassah Medical School, Jerusalem*

3-AMINO-1:2:4-TRIAZOLE (AT) has come into widespread use as a plant growth regulator. When injected into laboratory animals this drug causes a rapid decrease of the catalatic activity of liver or kidney suspensions to low levels but produces no change in the catalatic activity of erythrocyte haemolysates (Heim, Appleman and Pyfrom, 1956). 3-Amino-1:2:4-triazole and a number of related substances were shown to cause the irreversible inhibition of purified recrystallized catalase preparations from liver and blood *in vitro* but only in the presence of a continuous supply of hydrogen peroxide (Margoliash and Novogrodsky, 1958). This reaction parallels the effect of 3-amino-1:2:4-triazole on the liver and kidney catalase activities in laboratory animals, but gives no explanation of the lack of effect of the drug on erythrocyte catalase *in vivo*.

A study of the kinetics of the irreversible inhibition demonstrated that this reaction was second order between the inhibitors and catalase-hydrogen peroxide complex I (Cat.  $H_2O_2$  I), during which the inhibitors become irreversibly bound to the enzyme (Margoliash, Novogrodsky and Schejter, 1960). If in addition to catalase, hydrogen peroxide and the inhibitor, the reaction mixture also contains a sufficiently high concentration of a catalase donor, i.e., a substance that can be oxidized by Cat.  $H_2O_2$  I, the concentration of Cat.  $H_2O_2$  I available for reaction with the inhibitor will be decreased (Chance, 1953) and the irreversible inhibition reaction will be slower.

The purpose of this paper is to develop the kinetic equations that will describe the irreversible inhibition of catalase by the 3-amino-1:2:4-triazole group of substances in the presence of catalase donors, and to show that the lack of effect of such inhibitors in blood haemolysates is due to the presence of a naturally occurring catalase donor in erythrocytes. The existence of



such a donor substantiates, at least for blood catalase, the ideas of the physiological role of catalase as a peroxidase in tissues rich in the enzyme (Keilin and Hartree, 1945).

### THEORY

Under conditions in which hydrogen peroxide is continuously supplied at a low concentration, to a mixture containing catalase, an irreversible inhibitor of the AT series and a catalase donor, the following reactions occur:

(1) The formation of Cat.  $\text{H}_2\text{O}_2$  I (Chance, Greenstein and Roughton, 1952):

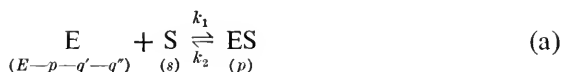

in which E represents the enzyme, S the substrate hydrogen peroxide, and ES represents Cat.  $\text{H}_2\text{O}_2$  I. The expressions in brackets are the concentrations of the reactants and the symbols represent the concentrations of the total original enzyme in terms of catalase haematin ( $E$ ), of Cat.  $\text{H}_2\text{O}_2$  I ( $p$ ), of the enzyme haematin bound reversibly by the inhibitor ( $q'$ ), and of the enzyme haematin irreversibly bound by the inhibitor ( $q''$ ).

(2) The reaction of the donor with Cat.  $\text{H}_2\text{O}_2$  I or peroxidatic reaction of catalase (Chance *et al.*, 1952):

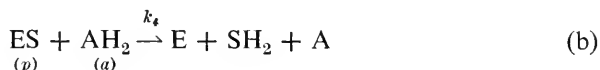

in which  $\text{AH}_2$  represents the donor and  $a$  its concentration.

(3) The reversible inhibition of catalase by the inhibitor, first reported for AT by Heim *et al.*, (1956) and shown to be due to a reaction of the inhibitor with the free enzyme (Margoliash and Schejter, unpublished results):

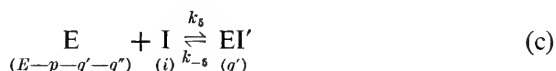

in which I represents the inhibitor,  $i$  its concentration and  $\text{EI}'$  the reversibly inhibited enzyme haematin. The symbol  $K_5$  will be used to represent the equilibrium constant for this reaction.

(4) The irreversible inhibition of catalase (Margoliash *et al.*, 1960):



in which  $\text{EI}''$  represents the irreversibly inhibited enzyme haematin.

The ratio of the catalase haematin bound by hydrogen peroxide in Cat.

$\text{H}_2\text{O}_2$  I to total active enzyme haematin, defined by Chance (1953), and represented by the symbol  $n$ , could be defined in the above system as:

$$\frac{p}{E - q' - q''} = \frac{k_1 s}{k_1 s + k_4 a} = n \quad (1)$$

considering  $k_2$  to be negligible with respect to  $k_1$ .

The reversible inhibition reaction (c) could be formulated:

$$(E - p - q' - q'')i = q'K_5 \quad (2)$$

The irreversible inhibition reaction (d) could be formulated:

$$\frac{dq''}{dt} = k_7 pi \quad (3)$$

Suitable transformations of equations (1) and (2), eliminating  $q'$  and solving for  $p$  gave:

$$p = \frac{\frac{(E - q'')K_5}{i}}{1 + \frac{K_5}{i} - \frac{1}{n}} \quad (4)$$

Introducing this value for  $p$  in equation (3) and integrating between the limits 0 and  $t$  for the time, and 0 and  $q''$  for the irreversibly inhibited enzyme concentration gave:

$$2.3 \log \frac{E - q''}{E} = \frac{k_7 K_5}{1 + \frac{K_5}{i} - \frac{1}{n}} t \quad (5)$$

Representing the coefficient of  $t$  in the above equation by  $\lambda$  one obtains:

$$2.3 \log \frac{E - q''}{E} = -\lambda t \quad (6)$$

in which  $\lambda$  is therefore the first order reaction constant for the irreversible inhibition of catalase, and has the following value:

$$\lambda = \frac{k_7 K_5}{1 + \frac{K_5}{i} - \frac{1}{n}} \quad (7)$$

Equation (7) may also be written in the following form:

$$\frac{1}{\lambda} = \frac{1-n}{k_7 K_5 n} + \frac{1}{k_7 n} \cdot \frac{1}{i} \quad (8)$$

This expression (equation (8)) is identical with the one previously obtained for the case in which the reaction mixture contained catalase, the irreversible inhibitor and hydrogen peroxide but no catalase donor (Margoliash and Schejter, 1959). In the absence of donor and under experimental conditions in which hydrogen peroxide is continuously supplied in excess, steady state conditions may be assumed for the catalytic reaction and  $n$  is a constant (Chance *et al.*, 1952). However, when a donor is present in the reaction mixture the concentration of Cat.  $\text{H}_2\text{O}_2$  I will vary with the concentration and the rate of reaction of the donor with Cat.  $\text{H}_2\text{O}_2$  I. Thus in the present system,  $n$  in equation (8) could not be considered a constant and was defined further. It should be noted, however, that for a particular concentration of a specified donor and a particular concentration of hydrogen peroxide  $n$  will remain constant, enabling  $\lambda$  to be measured under each set of experimental conditions while the concentration of Cat.  $\text{H}_2\text{O}_2$  I is constant.

A kinetic equation for estimating the equilibrium constant for the reversible reaction of an inhibitor with free catalase has been developed by Beers (1955); applying it to reaction (c) gave:

$$K_5 = \frac{ik_0^*}{(k_0^c - k_0^*)} \cdot \frac{R_K}{(R_K + 1)} \quad (9)$$

in which  $R_K$  is related to  $n$  by the expression (Beers, 1955):

$$n = \frac{1}{R_K + 1} \quad (10)$$

and  $k_0^c$  and  $k_0^*$  are respectively the first order reaction constants for the decomposition of hydrogen peroxide in the absence and in the presence of a concentration of reversible inhibitor equal to  $i$ . Defining the factor  $ik_0^*/(k_0^c - k_0^*)$  in equation (9) as  $K'$ , equation (9) can be written:

$$K_5 = K' \frac{R_K}{R_K + 1} \quad (11)$$

Substituting in equation (8) the value of  $n$  given by equation (10) one obtains after suitable transformations:

$$\frac{1}{\lambda} = \frac{R_K}{k_7 K_5} + \frac{R_K}{k_7 i} + \frac{1}{k_7 i} \quad (12)$$

Replacing  $K_5$  in equation (12) by its value shown in equation (11) gave:

$$\frac{1}{\lambda} = \frac{i + K'}{k_7 K' i} + \frac{i + K'}{k_7 K' i} \cdot R_K \quad (13)$$

Combining the values of  $n$  given in equation (1) and (10) one obtains the following relation:

$$R_K = \frac{k_4 a}{k_1 s} \quad (14)$$

Introducing this value for  $R_K$  into equation (13) gave:

$$\frac{1}{\lambda} = \frac{i + K'}{k_7 K' i} + \frac{i + K'}{k_7 K' i} \cdot \frac{k_4 a}{k_1 s} \quad (15)$$

It should be noted that  $R_K$ , as used in this derivation, is not a constant, since like  $n$ , in the system considered, it will vary with the ratio of  $a$  and  $s$  and the rate of reaction of the donor with Cat.  $H_2O_2$  I. However, as stated above for  $n$ ,  $R_K$  will remain constant for any particular set of experimental conditions. Equation (13) also shows that a plot of  $1/\lambda$  as a function of  $a$  or  $s$  will be a straight line.

#### EXPERIMENTAL

Rat blood was obtained by heart puncture under ether anaesthesia and defibrinated with glass beads. The erythrocytes were packed by centrifugation and washed three times with 0.9% NaCl in the centrifuge. The packed cells were lysed by adding three volumes of glass-distilled water. After complete haemolysis the red cell ghosts and debris were centrifuged off. The final concentration of all haemolysates was calculated in terms of the original volume of packed cells.

Catalase activity was estimated by the method of Feinstein (1949) with sodium perborate as substrate at 37°C. Ascorbate was used as a source of hydrogen peroxide in the presence of air (Margoliash and Novogrodsky, 1958). N-ethylmaleimide was a commercial preparation and the 3-amino-1:2:4-triazole used was a highly purified sample kindly given by Prof. D. Appleman.

#### RESULTS

##### *Effect of Dilution of Haemolysates on the Rate of Inhibition of Catalase by 3-amino-1:2:4-triazole*

The rate of the irreversible inhibition of catalase by AT in rat blood haemolysates was found to increase with the dilution of the haemolysate (Table 1).

It should be noted that these results were obtained with  $2 \times 10^{-5}$  M ascorbate as hydrogen peroxide source. When the concentration of ascorbate was increased to  $2 \times 10^{-3}$  M 98% inhibition of catalatic activity was obtained

TABLE 1

Effect of dilution of rat erythrocyte haemolysates on the irreversible inhibition of catalase by 3-amino-1:2:4-triazole. Final concentrations: 0.02 M AT;  $2 \times 10^{-5}$  M ascorbate; 0.02 M  $\text{NaHCO}_3$  buffer pH 8.5 and varying concentrations of rat erythrocyte haemolysate calculated as a dilution from the original volume of packed erythrocytes. Incubated at 37°C for 2 hr in air. At the end of the incubation, samples were suitably diluted and catalatic activity determined by the method of Feinstein (1949).

Dilution of haemolysate	% inhibition of catalase after 2 hr
1:10	30
1:20	48
1:50	71
1:100	96

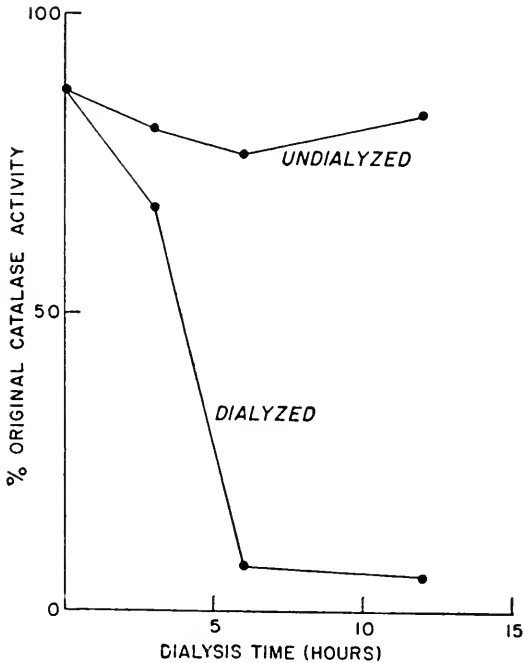

FIG. 1. Effect of dialysis on the irreversible inhibition of catalase by 3-amino-1:2:4-triazole in rat blood haemolysates. A 1:5 rat erythrocyte haemolysate was dialysed in cellophane tubing against running tap water at room temperature. A control haemolysate was kept at the same temperature. At intervals samples were removed and incubated with: 0.02 M AT;  $2 \times 10^{-5}$  M ascorbate; 0.02 M  $\text{NaHCO}_3$  buffer at pH 8.5 for 2 hr at 37°C in air. Final concentration of haemolysate in incubation mixture 1:7. At the end of incubation samples were removed, suitably diluted and catalase activity determined.

within 90 min, with a haemolysate representing a 1:10 dilution, as compared to a 30% inhibition in 120 min at an ascorbate concentration of  $2 \times 10^{-5}$  M.

Thus either a decrease of the haemolysate concentration or an increase of the hydrogen peroxide concentration resulted in an increased rate of inhibition.

*Effect of Dialysis on the Rate of Inhibition of Catalase by 3-amino-1:2:4-triazole in Rat Erythrocyte Haemolysates*

Figure 1 shows that when rat erythrocyte haemolysates were dialysed, the substance or substances responsible for preventing the AT inhibition of catalase in the presence of hydrogen peroxide rapidly disappeared. Within 6 hr of the beginning of dialysis the rate of catalase inhibition was essentially the same in the dialysed haemolysate as with purified catalase preparations (Margoliash *et al.*, 1960).

*Effect of N-ethylmaleimide on the Inhibition of Catalase by 3-amino-1:2:4-triazole in Rat Erythrocyte Haemolysates*

Table 2 shows that with a relatively concentrated rat erythrocyte haemolysate no inhibition of catalase by AT could be obtained under the usual

TABLE 2

Effect of N-ethylmaleimide on the inhibition of catalase activity in rat erythrocyte haemolysates by 3-amino-1:2:4-triazole. Final concentrations: 1:5 dilution of packed rat erythrocytes and  $5 \times 10^{-5}$  M ascorbate present in all incubation mixtures; 0.02 M NaHCO<sub>3</sub> buffer at pH 8.5 or 0.02 M 2-amino-2-hydroxymethylpropane-1:3-diol-HCl buffer at pH 7.2; 0.02 M AT; 0.002 M N-ethylmaleimide. The solutions were incubated for 90 min at 37°C in air. At the end of the incubation, samples were suitably diluted and catalatic activity was determined:

pH	Added substances	% original catalase activity after 90 min
8.5	None	90.5
	AT	90.9
	N-ethylmaleimide	90.3
	N-ethylmaleimide and AT	3.5
7.2	None	90.1
	AT	88.2
	N-ethylmaleimide	91.8
	N-ethylmaleimide and AT	0.6

conditions. However, the addition of N-ethylmaleimide, which itself had no effect on catalatic activity, completely reversed the protection of catalase in the haemolysate resulting in a normal rate of inhibition of the enzyme.

#### DISCUSSION

The physiological role of catalase particularly in tissues rich in the enzyme such as liver, red blood cells and kidney, has been the object of numerous

theories (see Lemberg and Legge, 1949). Keilin and Hartree (1945) on the basis of their finding that in the presence of a continuous supply of hydrogen peroxide catalase could oxidize various low molecular weight alcohols, proposed that the function of catalase was that of a peroxidase. The results presented above indicate that erythrocytes contain a substance or substances that can act as catalase donors, thus supporting the 'peroxidase theory' of catalase action in red blood cells. Indeed, it was shown that the relative lack of inhibition of catalase by AT in rat erythrocyte haemolysates (Margoliash and Novogrodsky, 1958) is due to the presence of a dialysable catalase donor in erythrocytes. This donor is probably a sulfhydryl substance since N-ethylmaleimide completely blocks its activity with respect to catalase. It should, however, be noted that the fact that AT does cause the irreversible inhibition of catalase in the liver and kidney of laboratory animals (Heim *et al.*, 1956) while the injection of a catalase donor such as ethanol prevents these inhibitions (Nelson, 1958) shows that both liver and kidney do not contain a significant concentration of catalase donors. Catalase therefore, cannot be acting to any large extent as a peroxidase in these tissues.

Heim *et al.*, (1956) first observed that AT injected into rats and mice causes a large and rapid decrease of the catalase activity of liver and kidney suspensions, but has no effect on blood catalase activity, even on continued administration. Feinstein (1958) and Feinstein and Dainko (1959) have found that the concentration of AT in erythrocytes following the injection of the drug is only about one-eighth that in the liver or kidney. This result might possibly be due to rapid equilibration of the drug present inside the red blood cells with the fluid outside the cells. In such a case washing the red cell suspension could decrease considerably the apparent AT content before it was determined, as compared to that of unwashed liver or kidney homogenates. Moreover, since the reaction of AT with catalase in the presence of hydrogen peroxide is irreversible (Margoliash and Novogrodsky, 1958), one would expect a decrease of the catalatic activity of the blood *in vivo* even though at lower concentrations of the drug it occurred more slowly than in the liver or kidney. The normal occurrence of a catalase donor in erythrocytes shown by the present experiments, affords another explanation of the lack of effect of AT on blood catalase activity *in vivo*.

The kinetic equation developed for the irreversible inhibition of catalase by the AT group of inhibitors (Margoliash *et al.*, 1960) in the presence of hydrogen peroxide and a catalase donor, indicates that the rate of inhibition depends on the ratio of the donor concentration to the hydrogen peroxide concentration. The results of the experiments in which the dilution of the haemolysates and the concentration of the hydrogen peroxide source were varied qualitatively verify this conclusion. A quantitative verification which would require an immediate accurate estimation of the hydrogen peroxide concentration has so far not been undertaken. It should be noted that

neither the kinetic expression for the irreversible inhibition of catalase by the AT group of inhibitors in the presence of hydrogen peroxide but in the absence of catalase donors (Margoliash and Schejter, 1960), nor that developed above for the case in which a catalase donor is present, predict any effect of increasing the enzyme concentration on the relative rate of inhibition, under the usual conditions where hydrogen peroxide, inhibitor and donor are at molar concentrations far above those of the enzyme. Thus the decrease in the rate of inhibition observed by Margoliash and Novogrodsky (1958) on increasing the catalase concentration was probably due to the presence of a catalase donor in the relatively crude enzyme preparation used.

#### SUMMARY

(1) A kinetic equation for the rate of the irreversible inhibition of catalase by the 3-amino-1:2:4-triazole group of substances in the presence of hydrogen peroxide and a catalase donor, has been developed.

(2) The lack of inhibition of catalatic activity by 3-amino-1:2:4-triazole in rat erythrocyte haemolysates has been shown to be due to a normally occurring, dialysable, sulfhydryl catalase donor. The lack of inhibition of blood catalase following the administration of 3-amino-1:2:4-triazole to laboratory animals is considered to be due to this donor.

#### Acknowledgement

This investigation was aided in part by research grants from the National Institutes of Health, United States Public Health Service, Bethesda, Maryland.

#### REFERENCES

- BEERS, R. F., JR. (1955). *J. phys. Chem.* **59**, 25.  
CHANCE, B. (1953). *Technique of Organic Chemistry*, Vol. VIII. *Investigation of rates and mechanisms of reaction*, p. 646 (Ed. by S. L. Friess and A. Weissberger). Interscience Publishers, Inc., New York.  
CHANCE, B., GREENSTEIN, D. S. & ROUGHTON, F. J. W. (1952). *Arch. Biochem. Biophys.* **37**, 301.  
FEINSTEIN, R. N. (1949). *J. biol. Chem.* **180**, 1197.  
FEINSTEIN, R. N. (1958). *Fed. Proc.* **17**, 218.  
FEINSTEIN, R. N. & DAINKO, J. L. (1959). *Cancer Res.* **19**, 612.  
HEIM, W. G., APPLEMAN, D. & PYFROM, H. T. (1956). *Amer. J. Physiol.* **186**, 19.  
KEILIN, D. & HARTREE, E. F. (1945). *Biochem. J.* **39**, 289.  
LEMBERG, R. & LEGGE, J. W. (1949). *Hematin Compounds and Bile Pigments*, pp. 415-419. Interscience Publishers, Inc., New York.  
MARGOLIASH, E. & NOVOGRODSKY, A. (1958). *Biochem. J.* **68**, 468.  
MARGOLIASH, E., NOVOGRODSKY, A. & SCHEJTER, A. (1960). *Biochem. J.* **74**, 339.  
MARGOLIASH, E. & SCHEJTER, A. (1960). *Biochem. J.* **74**, 348.  
NELSON, G. H. (1958). *Science* **127**, 520.



# CATALASE OXIDATION MECHANISMS

By M. E. WINFIELD

*Division of Physical Chemistry, C.S.I.R.O. Chemical Research  
Laboratories, Melbourne*

## INTRODUCTION

CHANCE and Fergusson (1954) have proposed that the catalytic cycle consists of:

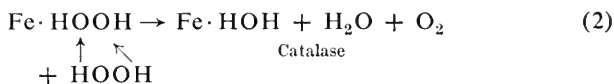
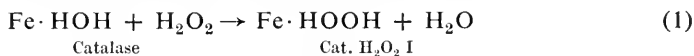

Contrary to the behaviour of the majority of catalysts for H<sub>2</sub>O<sub>2</sub> decomposition, catalase does not appear to function by 1-electron steps. In reaction (2) both reducing equivalents of the H<sub>2</sub>O<sub>2</sub> donor molecule are transferred to the catalase peroxide compound I (Cat. H<sub>2</sub>O<sub>2</sub> I) in a single step, in the sense that no intermediates can be detected by the most rapid means available. If intermediates do occur, their lifetime must be less than 10<sup>-7</sup> sec (Chance and Fergusson, 1954) and we can assume for practical purposes that the two equivalents are transferred simultaneously.

The scheme shown above is in accord with much of a large body of evidence obtained by kinetic, titrimetric, isotopic and other studies. To go further, and try to show in some detail the way in which reactions (1) and (2) take place, is to move into the realm of speculation, where it is necessary to draw upon analogies to the reactions of other co-ordination complexes, and on processes of elimination. King and Winfield (1959a) have discussed the merits of several possible structures for catalase complexes, and Dwyer *et al.* (1959) have attempted to show that 2-electron mechanisms for the oxidation and reduction of H<sub>2</sub>O<sub>2</sub> might be achieved with non-enzymic catalysts which have certain closely defined oxidation potentials, together with some means for limiting interaction between the oxidized and reduced forms of the catalyst. In the present paper we wish to indicate more clearly where our views on the catalytic mechanism are in harmony with those of Chance, and a few respects in which they differ.

## *Valency Changes*

## DISCUSSION

Catalase contains four iron-porphyrin groups. It is convenient however to refer to one iron atom when describing most of the reactions of the enzyme.

There are two ways in which to satisfy the widespread claim that during the catalytic cycle the valency of the iron atom does not change. One is to assume with Chance and Fergusson (1954) that peroxide co-ordinates to  $\text{Fe}^{\text{III}}$  of catalase without at any time extracting electrons from the metal atom. The co-ordinated peroxide essentially retains its identity until a second peroxide molecule approaches. The two then interact without participation of the iron atom, except in so far as it renders the first peroxide molecule more electro-negative and therefore able to withdraw two electrons from the second.

An alternative explanation assumes that the first molecule of  $\text{H}_2\text{O}_2$ , very rapidly after its co-ordination to  $\text{Fe}^{\text{III}}$ , does in fact remove two electrons from the iron porphyrin unit, but without appreciable change in the number of electrons in the orbitals of the iron atom. In other words, although there is an electron rearrangement about the metal atom, and although the conventions of co-ordination chemistry require us to write the iron atom as having a formal valency other than three, the removal of electrons from its vicinity is compensated by an approximately equal donation of electrons by one or more of the six ligands.

It is the second of the above alternatives that we favour, for the following reasons:

(i) In general peroxide, except when attached at both ends to a metal ion, is a weak ligand. We are drawing here on unpublished experiments on the reactions of  $\text{H}_2\text{O}_2$  and  $\text{O}_2$  with  $\text{K}_3\text{Co}(\text{CN})_5$ , as well as the work of Werner (1911) and others on peroxocomplexes in general. It is unlikely that peroxide can co-ordinate at one end to  $\text{Fe}^{\text{III}}$  strongly enough to account for the apparent dissociation constant of less than  $10^{-7}$  of the so-called catalase- $\text{H}_2\text{O}_2$  complex (Chance *et al.*, 1952).

(ii) Substitution of peroxide for the  $-\text{OH}$  or  $-\text{OH}_2$  group in position 6 on the iron atom cannot be expected to weaken drastically the Soret band, which we may expect to have an intensity within the range found with  $\text{H}_2\text{O}$ ,  $\text{OH}^-$ ,  $\text{Cl}^-$  or acetate ion as ligand. The large fall in extinction coefficient which accompanies the conversion of catalase to Cat.  $\text{H}_2\text{O}_2$  I indicates impaired resonance in the porphyrin ring, and can scarcely be attributed to co-ordination of peroxide. King and Winfield (1959a) have pointed out that simultaneous attachment of the peroxide to the porphyrin as well as to the metal is improbable.

(iii) The affinity of Cat.  $\text{H}_2\text{O}_2$  I for  $\text{NH}_2\text{OH}$ , fluoride, etc., is higher than that of catalase, and the interaction is relatively slow (see, for example, Beers, 1955)—observations which are inexplicable in terms of displacement of the peroxide ligand by fluoride.

### *Structure of Catalase Peroxide I*

When a co-ordination complex is oxidized in a succession of 1-electron steps, we may in general expect that electrons are lost from the metal atom

until its electronegativity exceeds that of the ligands, and that the latter provide the next electron to be removed. Especially when a ligand contains a large number of conjugated double bonds, only one or two electrons are likely to be extracted from the metal before the ligand suffers oxidation. Cahill and Taube (1951) were able to show with several metallo-phthalocyanines, apparently 4-co-ordinate, that an electron could be removed from the phthalocyanine ( $E^\circ = -1\text{ V}$  approx.) by a 1-electron acceptor. Two-electron oxidants of comparable strength were considerably slower in action. The closely related metallo-porphyrins are expected to behave similarly, and also the 6-co-ordinate forms which occur in catalase, peroxidase, metmyoglobin, etc., but in these latter compounds a higher oxidation state of the metal should be reached before an electron is lost from the porphyrin.

When metmyoglobin ( $\text{Mb}^{\text{III}}$ ) is oxidized by  $\text{H}_2\text{O}_2$  the solution contains a free radical which has been detected by electron spin resonance absorption (Gibson and Ingram, 1956). In later experiments Gibson, Ingram and Nicholls (1958) showed that the principal oxidation product ( $\text{Mb}^{\text{IV}}$ ) is not the free radical, and that the latter is present in about ten times lower concentration. We may infer that although when  $\text{Mb}^{\text{III}}$  is oxidized by  $\text{H}_2\text{O}_2$  an electron is given up rather more readily by the  $\text{Fe}^{+++}$  than by the porphyrin, the latter is the site of attack on some of the  $\text{Mb}^{\text{III}}$  molecules, either in a side reaction or by electron transfer between myoglobin molecules in different oxidation states.

It is thus necessary to consider the possibility that oxidation of catalase yields structures of the type  $\begin{array}{c} \diagup \quad \diagdown \\ \text{C} \quad \text{Fe}^{\text{III}} \\ \text{└─┘} \quad \text{└─┘} \end{array}$ ,  $\begin{array}{c} \diagup \quad \diagdown \\ \text{C} \quad \text{Fe}^{\text{IV}} \\ \text{└─┘} \quad \text{└─┘} \end{array}$ , etc. (notation of King and Winfield, 1959a); the carbon atom shown indirectly to Fe represents one of the carbon atoms of a ligand which, before loss of an electron, is shown as  $\begin{array}{c} \diagup \quad \diagdown \\ \text{C} \quad \text{Fe}^{\text{III}} \\ \text{└─┘} \end{array}$ .

Free radical character in the porphyrin is one of the possible explanations of the diminished Soret band in Cat.  $\text{H}_2\text{O}_2$  I (see, for example, George, 1952). A number of factors count against a free radical structure, however, and these will now be discussed.

Perhaps the most striking feature of the reactions of catalase and peroxidase is that no one has been able, in the course of numerous oxidations with a variety of agents, to remove one and only one electron from the enzyme molecule. Cat.  $\text{H}_2\text{O}_2$  II and the peroxidase-peroxide complex (Per.  $\text{H}_2\text{O}_2$  II) have an oxidation state corresponding to one less electron than catalase and peroxidase, but they cannot be formed directly from the latter (Fergusson, 1956). Apparently the ligands in catalase and peroxidase are protected by steric hindrance or other means from attack by a 1-electron oxidant, while the iron atom is co-ordinated in such a way that it strongly resists direct electron





in two distinct 1-electron steps, while little activation is required for the direct addition of two electrons to  $\text{Ru}^{\text{IV}}$

In the reactions of catalase and peroxidase the kinetic barriers, namely the activation energies required to transform the complexes from one bond type to another, are supplemented by steric barriers. Chance (1951) has suggested, for example, that in catalase the reaction sites are well below the protein surface. We may perhaps regard the iron-porphyrin as lying at the bottom of a pore whose radius is only a few Å units. Thus oxidizing or reducing agents may reach the metal atom without much restriction and yet be hindered from direct reaction with the porphyrin. By contrast the prosthetic group of peroxidase is thought to be relatively unprotected (Chance, 1951).

The following scheme is an example of how the barriers mentioned above can lead to apparently unidirectional pathways in electron transfer, and to preferences for 2-electron steps. Elsewhere we have indicated the way in which the 2-electron steps can be thermodynamically favoured (King and Winfield, 1959b).

In reaction (4) it is assumed that  $\text{Per. H}_2\text{O}_2$  I is in equilibrium with a small concentration of a more reactive, free radical form. In (5) the isomer reacts very rapidly with a hydrogen donor to give  $\text{Per. H}_2\text{O}_2$  II. More slowly the latter is reduced by a second donor to free peroxidase.

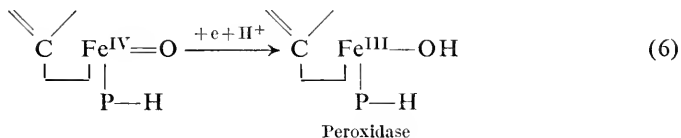
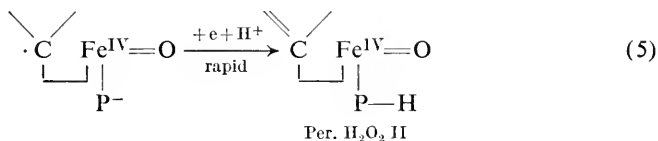
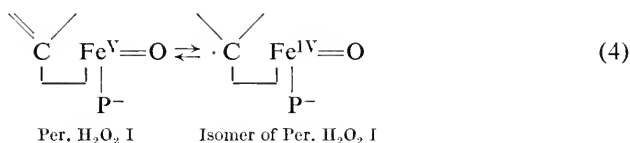

If in catalase the porphyrin molecule is sterically protected from direct attack by H-donors, we have for the  $\text{O}_2$  liberation reaction:

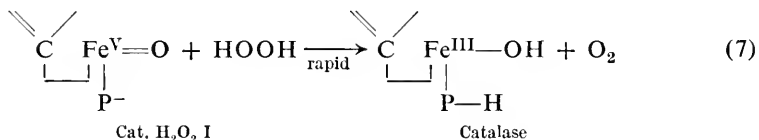

which is virtually a donation of  $H^-$  by the peroxide molecule to the  $FeO$  ion. A donation of  $H^-$  by an alcohol is also conceivable, as described by King and Winfield (1959a).

In the presence of excess  $H_2O_2$  there is a slow reaction:

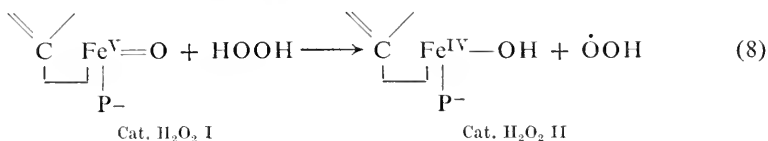

Little  $H_2O_2$  is normally decomposed by the pathway (8) because catalase and Cat.  $H_2O_2$  I are predominantly outer orbital while Cat.  $H_2O_2$  II is assumed to be appreciably inner orbital. The small activation energy introduced by the change in bond type involved in (8), compared with no change in (7), is sufficient to ensure that most of the peroxide molecules give up two electrons simultaneously, provided that the thermodynamics of the reaction are favourable.

In the type II complexes the  $\pi$  bond from oxygen to metal must be of fractional order, since the reduction of catalase or peroxidase to the ferrous state is known to be difficult. The  $Fe^{IV}-O$  bond is therefore much weaker

than that in  $\begin{array}{c} \diagup \\ \text{C} \\ \diagdown \\ \text{---} \\ \text{P}^- \end{array} \text{Fe}^V=O$  or  $\cdot\begin{array}{c} \diagup \\ \text{C} \\ \diagdown \\ \text{---} \\ \text{P}^- \end{array} \text{Fe}^{IV}=O$ , and the energy of the complex is comparable with that of  $Fe^{IV}-\bar{O}$  (inner orbital). Resonance hybrids are therefore possible (see, for example, Williams, 1956), and we may expect to find among those complexes of catalase and peroxidase which have one oxidizing equivalent, some with predominantly inner orbital characteristics, some largely outer orbital, and some which fit neither category. The latter are apt to have an absorption spectrum which is not obviously related to their magnetic moment. It is possible that they are sensitive to pH.

If we assume that Per.  $H_2O_2$  II is predominantly  $\begin{array}{c} \diagup \\ \text{C} \\ \diagdown \\ \text{---} \\ \text{P}^- \end{array} \text{Fe}^{IV}=O$  (outer orbital) with a fractional  $\pi$  bond from oxygen to metal, while Cat.  $H_2O_2$  II contains about an equal contribution from the two forms  $\begin{array}{c} \diagup \\ \text{C} \\ \diagdown \\ \text{---} \\ \text{P}^- \end{array} \text{Fe}^{IV}=O$  (outer orbital) and  $\begin{array}{c} \diagup \\ \text{C} \\ \diagdown \\ \text{---} \\ \text{P}^- \end{array} \text{Fe}^{IV}-\bar{O}$  (inner orbital), the comparative sluggishness of Cat.  $H_2O_2$  II as an oxidant, while having a spectrum little different from that of Per.  $H_2O_2$  II, is understandable (see Theorell and Ehrenberg, 1952).

Peroxidase is a feeble catalyst for  $H_2O_2$  decomposition for the very reason that it has high 'peroxidatic' activity, namely that Per.  $H_2O_2$  I can be reduced very rapidly by a 1-electron mechanism. In the presence of  $H_2O_2$  alone, or of  $H_2O_2$  and a 2-electron donor, reaction will mostly follow the pathway via

Per.  $\text{H}_2\text{O}_2$  II. It will be slow because Per.  $\text{H}_2\text{O}_2$  II is not reduced rapidly by  $\text{H}_2\text{O}_2$  or donors such as alcohols.

#### SUMMARY

1. The need for limiting interaction between the normal and the doubly oxidized state of the catalyst during decomposition of  $\text{H}_2\text{O}_2$  by a 2-electron mechanism leads to a consideration of the significance of bond-type in determining the reaction paths. In the reactions of catalase and peroxidase kinetic and steric barriers apparently co-operate with thermodynamic factors to establish the rather limited specificity of the enzymes.

2. Reasons are given for favouring a ferryl-type structure in the primary catalase complex, as suggested by George (1952), and the possible nature of the Fe—O bond is discussed, with preference for a form which may be written  $\text{Fe}^{\text{V}}\leftarrow\text{O}$ .

#### Acknowledgement

Dr. N. Ham and Dr. F. P. Dwyer are thanked for helpful advice.

#### REFERENCES

- BEERS, R. F., JR. (1955). *J. phys. Chem.* **59**, 25.  
 CAHILL, A. E. & TAUBE, H. (1951). *J. Amer. chem. Soc.* **73**, 2847.  
 CHANCE, B. (1951). *The Enzymes*, Vol. 2, Pt. 1, pp. 428–53. Ed. J. B. Sumner & K. Myrback. Academic Press Inc., New York.  
 CHANCE, B. & FERGUSSON, R. R. (1954). *The Mechanism of Enzyme Action*, pp. 389–98. Ed. W. D. McElroy & B. Glass. Johns Hopkins, Baltimore.  
 CHANCE, B., GREENSTEIN, D., HIGGINS, J. & YANG, C. C. (1952). *Arch. Biochem. Biophys.* **37**, 322.  
 DWYER, F. P., KING, N. K. & WINFIELD, M. E. (1959). *Aust. J. Chem.* **12**, 138.  
 FERGUSSON, R. R. (1956). *J. Amer. chem. Soc.* **78**, 741.  
 GEORGE, P. (1952). *Advances in Catalysis*, **4**, pp. 367–428. Ed. W. G. Frankenburg, V. I. Komarevsky & E. K. Rideal. Academic Press Inc., New York.  
 GIBSON, J. F. & INGRAM, D. J. E. (1956). *Nature, Lond.* **178**, 871.  
 GIBSON, J. F., INGRAM, D. J. E. & NICHOLLS, P. (1958). *Nature, Lond.* **181**, 1398.  
 KEILIN, D. & HARTREE, E. F. (1951). *Biochem. J.* **49**, 88.  
 KING, N. K. & WINFIELD, M. E. (1959a). *Aust. J. Chem.* **12**, 47.  
 KING, N. K. & WINFIELD, M. E. (1959b). *Aust. J. Chem.* **12**, 147.  
 THEORELL, H. & EHRENBERG, A. (1952). *Arch. Biochem.* **41**, 442.  
 WERNER, A. (1911). *New Ideas on Inorganic Chemistry*. London: Longmans, Green & Co.  
 WILLIAMS, R. J. P. (1956). *Chem. Rev.* **56**, 299.

#### DISCUSSION

##### *Oxidation States of Haemoproteins*

GEORGE: I think there is now a substantial body of evidence to show that the compounds which are formed when ferrimyoglobin, ferrihaemoglobin, ferriperoxidase and ferricatalase react with strong oxidizing agents are higher oxidation states of the prosthetic group, that can be formally represented as  $\text{Fe}^{\text{IV}}$  and  $\text{Fe}^{\text{V}}$  derivatives. Compounds of this type were suggested as the reactive intermediates in systems containing iron salts and hydrogen peroxide at least fifty years ago; but, although Polonovski, Jayle, Glotz and Fraudet proposed their participation in haemoprotein reactions in a series of papers from 1939 to 1941, systematic experimental studies to demonstrate the one and two equivalent oxidation steps, and to distinguish between some of the structures that are possible, have only been carried out over the last ten years.



In the physiological pH range these compounds have oxidation-reduction potentials in the neighbourhood of 1 V and are relatively inert, both with regard to mutual disproportionation reactions and to the spontaneous reduction that can occur with oxidizable groups on the protein. This stabilization of higher oxidation states can well be considered as remarkable a property as the reversible oxygenation of the haemoglobins.

Only in the case of myoglobin has the complete oxidation-reduction reaction for one of the couples been established. For the single equivalent oxidation it takes the form

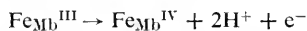

On the basis of a hydrate structure for  $\text{FeMb}^{\text{III}}$  (or an isomer) the appearance of two  $\text{H}^+$  ions as product is consistent with a ferryl ion type of structure (or an isomer) for  $\text{FeMb}^{\text{IV}}$ , i.e.

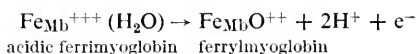

(George and Irvine, Symposium on Co-ordination Compounds, Copenhagen, 1953; Danish Chemical Society, p. 135, 1954; *Biochem. J.* **60**, 596, 1955). The aquo ferryl ion was suggested by Bray and Gorin in 1933 as an intermediate in the reactions of iron salts; while higher oxidation states, with structures very similar to that of 'ferrylmyoglobin', are exemplified by the vanadyl porphyrins and the manganyl phthalocyanine pyridine complex referred to by Orgel.

As the above reaction and countless other examples in inorganic and organic chemistry show, a knowledge of the way the  $\text{H}^+$  ion participates to balance the oxidation-reduction equation, as reactant or product or not at all, is an essential piece of evidence for eliminating some of the many structures that otherwise account for the increments in oxidation equivalents, i.e.  $\text{Fe}^{\text{II}} \rightarrow \text{Fe}^{\text{III}} \rightarrow \text{Fe}^{\text{IV}} \rightarrow \text{Fe}^{\text{V}}$ . This knowledge is clearly important too in deciding the type of reaction by which the reduction of a higher oxidation state is brought about, namely by the net transfer of electrons or hydrogen atoms. However, the structure for a higher oxidation state, or more precisely a family of isomeric structures, can only be specified with certainty if the structure of the lower oxidation state of the couple has already been established. This point is well illustrated by the relationship between the ferric hydrate and ferryl ion structures in the myoglobin reaction as written above. In this case a hydrate structure for the acidic ferrimyoglobin accounts very satisfactorily for all its other reactions, i.e. the reduction to ferromyoglobin, and the formation of cyanide and fluoride complexes, etc.

But in the case of ferriperoxidase and ferricatalase, neither the hydrate structure nor the structure with a carboxylate group bonded to the iron in the sixth co-ordination position will account for their combination with the familiar ligands, although such structures are often accepted as being well established. The variation with pH of the equilibrium constants for the formation of their complexes indicates that proton addition accompanies the bonding of anionic ligands—in contrast to ferrimyoglobin and ferrihaemoglobin, where the pH variation is consistent with the simple replacement of the co-ordinated water molecule in the hydrate structure, or the reaction of some equivalent structure. This difference in  $\text{H}^+$  ion dependence suggests that the parent ferric oxidation states of peroxidase and catalase have another kind of structure entirely, and, in view of the role of  $\text{H}^+$  ion in oxidation-reduction reactions, it may also be an important clue to different active types of higher oxidation state. This seems not unlikely, because, as is well known, ferriperoxidase and ferricatalase behave differently with strong oxidizing agents giving two relatively stable higher oxidation states ( $\text{Fe}^{\text{IV}}$  and  $\text{Fe}^{\text{V}}$ ) under conditions where ferrimyoglobin and ferrihaemoglobin give only one ( $\text{Fe}^{\text{IV}}$ ). Moreover the absorption spectra of the  $\text{Fe}^{\text{IV}}$  derivatives are not of the same form; the maxima, especially in the visible region, occur at different wavelengths, which is a further indication of important structural differences.

Labile crevice structures for ferriperoxidase and ferricatalase, in which the group that is liberated when complex formation occurs has a high proton affinity, e.g. a

phenolic or alcoholic OH group will account for the 'anomalous' pH variation of the equilibrium constants (George and Lyster, *Proc. Nat. Acad. Sci. Wash.* **44**, 1013, 1958). It cannot be a carboxylate group because the pK is too low. Furthermore, such structures offer the interesting possibility that they remain intact in higher oxidation states, thereby providing an explanation for the different reactivity of peroxidase and catalase toward oxidizing agents. Whatever the true explanation may be, it is clear that any structure suggested for a higher oxidation state that is equally applicable to myoglobin and haemoglobin on the one hand, and to peroxidase and catalase on the other, leaves many questions unanswered.

### *Peroxide Compounds of Catalase and Peroxidase*

LEMBERG: If there is any change in the porphyrin structure it is more likely to be in Cat. H<sub>2</sub>O<sub>2</sub> I than in Cat. H<sub>2</sub>O<sub>2</sub> II. As has been pointed out by Chance (*J. Biol. Chem.* **179**, 1331 (1949)), the band in the red part of the spectrum resembling that of verdohaemochrome and the low Soret band of the type I compound are indicative of interruption of conjugation in the porphyrin ring; no such evidence is available for the type II compounds of catalase and peroxidase, or for the ferrimyoglobin H<sub>2</sub>O<sub>2</sub> compound.

WILLIAMS: Recently Brill and I have been studying the absorption spectrum of compound I formed from ethyl hydrogen peroxide and bacterial catalase. The spectrum we have obtained is somewhat different from that given by Chance. In particular there is evidence for a new absorption band at about 340–360 m $\mu$  not present in the spectrum of free catalase, a weak band at 580–600 m $\mu$  very like that of the band found in peroxidase compound I, and a lower Soret band. Brill has shown that there is no evidence for free radicals of catalase. We interpret the spectrum, by using several different lines of other relevant evidence, as indicating that compound I is an equilibrium mixture of two components. One component does not have an intact porphyrin ring. We believe it to have a methene bridge which is oxidized to  $\text{>CHOH}$  and to have lost an electron from the ring. The second component is a simple ferric complex. In either event the ethyl hydrogen peroxide is a component of the compound I. The two components are also present in peroxidase compound I but the ratio of the two is very different. We will discuss the difference between peroxidase and catalase from the viewpoint of our new evidence.

### The Nature of Catalase–Peroxide Complex I

By B. CHANCE (Philadelphia)

CHANCE: The nature of catalase complex I is still an enigma in spite of much study. Two views on the structure of this intermediate are possible, viz. that the components of peroxide are:

- (a) a part of complex I;
- (b) are not a part of complex I.

Chemical configurations that illustrate these views are:

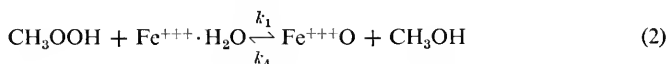
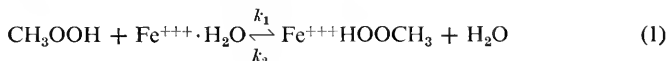

but these are only two of many possibilities, particularly with respect to Eq. (2) where the oxidizing equivalent could alternatively be located in the porphyrin or protein parts of the enzymes.

Ogura, working in this laboratory, attempted by kinetic methods to determine whether some intermediate form preceded the given complex I, first by optical studies

to times of about 1 millisecc and then by studies of the rate laws for peroxide decomposition up to about 10 M peroxide (Ogura, *Arch. Biochem. Biophys.* **57**, 288, 1955). No significant deviations occurred for half lives of such complexes of about  $5 \times 10^{-8}$  sec or less. This time is long enough, however, to allow intramolecular rearrangements to occur and no definitive conclusions were reached.

More recently Schonbaum and I have investigated the types of reactions that could be involved in Eq. (1) and (2) in order to determine whether some difference between the two reactions in their dependence on the concentration of methylhydroperoxide would be expected. If catalase forms a complex of peroxide and the enzyme, the usual form of the equilibrium equation should apply. If, however, instead of forming a complex, the components of peroxide are released as an alcohol, a modified equilibrium equation is required which involves a squared term in the intermediate concentration. We have considered several cases as discussed below.

The terminology used here is illustrated for a simple equilibrium:



$$p = \frac{x(e-p)}{k_2/k_1} \quad (4)$$

This represents Eq. (1) above.

It is perhaps trivial to indicate that a simple equilibrium followed by an irreversible transformation gives *no* equilibrium:



If the irreversible step is followed by a decomposition of the intermediate to the free enzyme, the system simulates an equilibrium but is actually in a steady state.



$$p = \frac{x(e-p)}{k_4 a / k_1} \quad (9)$$

Such a reaction appears to occur in peroxidase where endogenous donor ( $AH_2$ ) participates in the reaction of Eq. (9) and in catalase where endogenous alcohol participates. This equation is valid when such a donor is in excess, i.e.  $[AH_2] = \text{constant}$ . Both these reactions are negligible in pure enzyme preparations which contain no donor, i.e.  $[AH_2] = 0$ .

If the components of peroxide are expended in the initial reaction and a hydrogen donor such as an alcohol is formed, reaction (8) may give rise to a simulated equilibrium:



This represents Eq. (2) above. Here:

$$p'a = \frac{x(e-p')}{k_4/k_1} \quad (11)$$

However, in contrast to Eq. (9),  $a$  is not a constant, but is formed in amounts equal to  $p'$ . Substituting in Eq. (11)  $a = p'$ ,

$$(p')^2 = \frac{x(e - p')}{k_4/k_1} \quad (12)$$

Combinations of these reactions may occur and one of some interest is a reversible equilibrium followed by a first order transformation of the intermediate as in Eq. (10).



$$p'a = (p')^2 = x \frac{\left[ e - p' \left( 1 + \frac{k_4 a p'}{k_7} \right) \right]}{\frac{k_4}{k_1} \left( \frac{k_2 + k_7}{k_7} - 1 \right)} \quad (15)$$

Again a squared dependence is obtained, as in Eq. (12). The derivation is, however incomplete and a term  $k_4 a p' / k_7$  appears in the right hand member. The value of  $k_7$  must be sufficient to be consistent with the kinetic data obtained by Ogura,  $k_7 > 10^7 \text{ sec}^{-1}$ . This greatly exceeds  $k_4 a p'$  ( $10^3 \times 10^{-6} \times 10^{-6} = 10^{-9}$ ) and the equation has the form

$$(p')^2 = \frac{x(e - p')}{\frac{k_4}{k_1} \left( \frac{k_2 + k_7}{k_7} - 1 \right)} = \frac{x(e - p')}{\frac{k_4}{k_1} \cdot \frac{k_2}{k_7}} \quad (16)$$

Under these conditions the  $p'$  form would predominate because  $k_1 k_7 \gg k_4 k_2$ .

Lastly we may consider a combination of Eq. (10) and Eq. (13) in which the initial intermediate of Eq. (10) undergoes a transformation to form complex I.



$$p'a = (p')^2 = x \frac{\left[ e' - p' \left( 1 + \frac{k_4 a}{k_7} \right) \right]}{\frac{k_4 (k_4 a + 1)}{k_1 k_7}} \quad (20)$$

Again, for the condition  $k_7 \gg k_4 a$ ,

$$(p')^2 = x \frac{(e - p')}{k_4/k_1} \quad (21)$$

These equations suggest that, for all cases examined in which the components of peroxide are released as alcohol and an intermediate having an effective higher oxidation state is formed, a back reaction will be characterized by a squared dependency between the intermediate and the usual parameters of the equilibrium constant. On the other hand, a complex which retains the components of peroxide will follow the usual linear dependence of the equilibrium relationship.

The analysis just described would appear to have little relevance to catalase since no values for a dissociation constant of the primary complex have been reported; the values given are regarded to be 'apparent' dissociation constants (Eq. 7-9), due to endogenous donor. In bacterial catalase the latter is present in negligible amounts and the possibility of accurate titrations presents itself. Such titrations have been carried out with sufficient spectrophotometric sensitivity that millimicromolar amounts of intermediate compounds can be detected. The experimental details are given elsewhere, but a typical result is included in Fig. 1, which gives both  $p$  and  $p^2$  plots for the reaction of catalase and methyl hydrogen peroxide. It is clear that the data

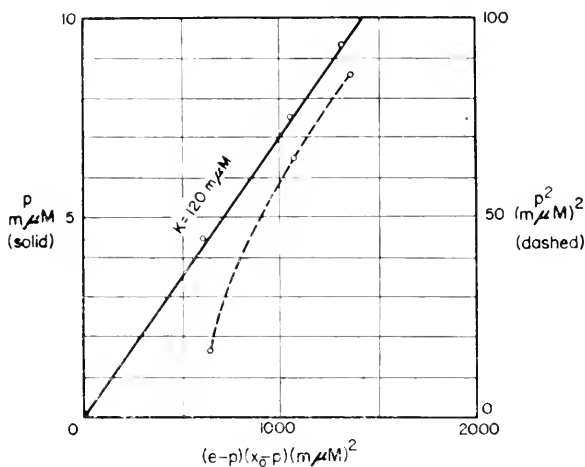

FIG. 1.

favour the hypothesis that catalase forms a peroxide complex in which the components of the peroxide are retained.

This result is consistent with our early hypothesis that the interaction of peroxide with catalase was not limited to the iron atom but could include interaction with the methene bridges of the porphyrin ring. At that time a hypothesis was put forward 'as to whether the porphyrin ring is actually oxidized on formation of the primary complex by electron transfer from the iron-peroxide complex. . . .' (Chance, *J. biol. Chem.* 179, 1331, 1949). This idea also is in accordance with the hypothesis here put forward by Williams and Brill, except that we regard the band in the red as adequately indicative of interaction with the porphyrin.

GEORGE: I would like to ask Chance whether he has any data on the reaction of horseradish peroxidase with methyl hydroperoxide, similar to that for catalase, since the behaviour of horseradish peroxidase with many strong oxidizing agents would suggest that the specific structural elements of hydrogen peroxide or ethyl hydroperoxides are not essential in the oxidant for the higher oxidation states to be formed; although of course there is a possibility that OH group attachment could occur through the intervention of a solvent water molecule at a special site on the prosthetic group.

The reactions in question may be summarized by the following scheme.

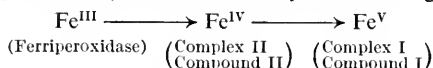

Hydrogen peroxide and alkyl hydroperoxides, both two-equivalent oxidizing agents, are particularly effective in oxidizing  $\text{Fe}^{\text{III}} \rightarrow \text{Fe}^{\text{V}}$ . With potassium chloridate, a one-equivalent oxidizing agent, an excess has to be used because of its additional reactions with oxidizable groups on the protein, and the product formed is  $\text{Fe}^{\text{V}}$ .

This presumably occurs through the two single equivalent steps,  $\text{Fe}^{\text{III}} \rightarrow \text{Fe}^{\text{IV}}$  followed by  $\text{Fe}^{\text{IV}} \rightarrow \text{Fe}^{\text{V}}$ . Evidence that supports this is as follows. First, if the  $\text{Fe}^{\text{IV}}$  derivative is allowed to form by the spontaneous reduction of  $\text{Fe}^{\text{V}}$ , produced either by peroxides or chloriridate, then the addition of chloriridate very rapidly effects the change  $\text{Fe}^{\text{IV}} \rightarrow \text{Fe}^{\text{V}}$ . Secondly, if potassium molybdcyanide is used instead of chloriridate as the one-equivalent oxidizing agent in the original reaction with ferriperoxidase, only the  $\text{Fe}^{\text{IV}}$  derivative is formed. Then again, if chloriridate is added to the  $\text{Fe}^{\text{IV}}$  derivative formed in this way,  $\text{Fe}^{\text{V}}$  results. Apparently chloriridate but not molybdcyanide, under the experimental conditions employed, has a sufficiently high  $E_0'$  to effect the oxidation of  $\text{Fe}^{\text{IV}}$  to  $\text{Fe}^{\text{V}}$ . Furthermore it is an interesting reflection on the ability of peroxides to engage in net two-equivalent oxidations that they are completely ineffective in bringing about this second step,  $\text{Fe}^{\text{IV}} \rightarrow \text{Fe}^{\text{V}}$  (George, *Science*, **117**, 220, 1953; *Currents in Biochemical Research*, Ed. D. E. Green, **2**, p. 338, 1956).

CHANCE: The success of the experiment illustrated by the figure above stems from our finding that the primary intermediate of bacterial catalase and methyl hydrogen peroxide is sufficiently stable to allow its titration with the substrate (Chance and Herbert, *Biochem. J.* **46**, 4, 1950, p. 402). Although chemical depletion of peroxidase of endogenous donor has given preparations in which the primary intermediate is more stable (Chance, *Arch. Biochem. Biophys.* **41**, 416, 1952), it is as yet inadequate for the precision demanded of these titrations.

The titrations with one-equivalent oxidants do suggest the mechanism outlined above by George; however, it may be that interaction of the one-equivalent oxidant with portions of the peroxidase protein could produce a two-equivalent oxidant—a possibility that could not be disproved on stoichiometric grounds (Chance and Fergusson, in *The Mechanism of Enzyme Action*, Johns Hopkins Press, Baltimore, 1954, p. 389; Fergusson, *J. Amer. chem. Soc.* **78**, 741, 1956). The experiments described here merely afford a new approach to the problem posed by Eq. (1) and (2) above. It is, however, a "kinetic" approach, and the interpretation of the result surely depends on the reactions postulated. A more elegant test would be afforded by chemical determination of alcohol formation in Eq. (2), a topic on which active experimentation is proceeding.

DWYER: A simple system recently investigated by Craig, Dwyer and Glaser (Craig, Dwyer and Glaser, *J. Amer. chem. Soc.*, in press) may be useful to this discussion. Trimethylamine N-oxide undergoes the rearrangement  $(\text{CH}_3)_3\text{N}\cdot\text{O} \rightarrow (\text{CH}_3)_2\text{NH} + \text{H}\cdot\text{CHO}$  in

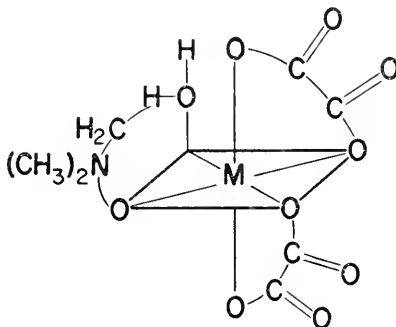

FIG. 2.

the presence of various metal complexes. The necessary conditions for the catalyst complex containing  $\text{Fe}^{\text{III}}$ ,  $\text{Ru}^{\text{III}}$ , or  $\text{V}^{\text{IV}}$  are (1) a site for the attachment of the N-oxide through the oxygen, (2) an adjacent site containing OH, and (3) the complex must be capable of oxidation. The intermediate complex shown in the figure is self-explanatory. The metal atom, e.g. Fe is either oxidized or polarized to simulate  $\text{Fe}^{\text{IV}}$  by the oxygen of the N-oxide. This oxygen then breaks the bond to the nitrogen carrying an electron

with it, leaving  $N^+$  and the one-electron oxidation is completed by migration of an electron from carbon. The oxygen finally is protonated to become OH. The metal atom then oxidizes the OH group bound through the hydrogen bond to the  $\alpha$  carbon atom. The oxidized OH finally attacks the  $\alpha$  carbon atom completing the two-electron oxidation. The resulting carbinolamine spontaneously rearranges to yield the products. It will be appreciated that the original metal complex with the vacant site and adjacent OH group is regenerated in the reaction.

MARGOLASH: Some of the observations made during the study of the irreversible inhibition of catalase bear on the points that have just been made. We studied the minimal structural requirements of compounds that showed the aminotriazole type of irreversible inhibition of catalase. Among other features was an absolute requirement for a free primary amino group. Any substitution on this amino group resulted in a complete disappearance of the inhibitory activity. The second point to consider is that when the haem was separated from the protein and the protein denatured, as occurs with the usual acid-acetone treatment, the irreversible inhibitor remained entirely bound to the protein. The inhibitor must, however, have interfered with the haem in some way since catalase irreversibly inhibited with aminotriazole did not react with the usual ferric ligands such as cyanide or azide. Finally, if one compares the spectrum of irreversibly inhibited catalase with that of catalase-hydrogen peroxide complexes, it seems to be more similar to that of complex I than to any of the others. These various observations led to the idea that the irreversible inhibitors may possibly be covalently bonded to the protein through an amide link to a particular carboxyl group at the active site of the enzyme. This hypothesis is being tested. No direct proof has been obtained as yet, partly because of the obvious experimental difficulties of working with a protein having a molecular weight of 240,000. The similarity of the spectrum of irreversibly inhibited catalase to that of complex I might be due to the binding of the inhibitor to the protein in a manner not entirely dissimilar to the effect of the 'peroxide' in complex I on the active site of the enzyme protein.

# STUDIES ON PROBLEMS OF CYTOCHROME *c* OXIDASE ASSAY

By LUCILE SMITH AND HELEN CONRAD

*Department of Biochemistry, Dartmouth Medical School and  
Johnson Research Foundation, University of Pennsylvania*

## INTRODUCTION

THE BEST evidence available indicates that the enzyme cytochrome *c* oxidase is a combination of cytochromes *a* and *a*<sub>3</sub>, and that the cytochrome *a*<sub>3</sub> reacts directly with oxygen (Keilin and Hartree, 1938, 1939; Chance, 1953; Smith, 1955). The combination can rapidly oxidize ferrocytochrome *c*, either when the cytochromes *a*, *a*<sub>3</sub> and *c* are all attached to insoluble particulate material or when the cytochrome *c* is in solution and the cytochromes *a* and *a*<sub>3</sub> are particle-bound. The reaction is usually represented as:

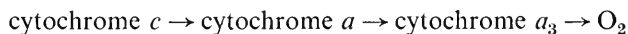

The affinity of cytochrome *a*<sub>3</sub> for oxygen is very high (Ludwig and Kuby, 1955; Chance and Williams, 1955).

There are several ways of assaying for cytochrome *c* oxidase: (1) The rate of oxidation of soluble ferrocytochrome *c* can be measured spectrophotometrically, the oxygen in solution being in ample excess. (2) The rate of oxygen uptake can be measured in the presence of a substance which will continuously reduce the cytochrome *c* nonenzymically; alternatively the rate of oxidation of the reducing agent, which may be a dye which changes colour on oxidation, is measured.

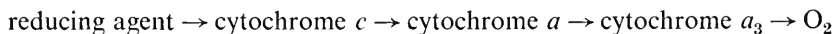

Here the assumption is made that the rate of reduction of the cytochrome *c* is rapid compared to the oxidation of the ferrocytochrome *c* by the oxidase. This assumption has been shown in one instance to be incorrect (Conrad, 1951). (3) A direct method of assay would be to measure spectrophotometrically the content of cytochromes *a* and *a*<sub>3</sub> in the preparation. The extinction coefficients for the difference between reduced and oxidized cytochrome *a*<sub>3</sub> and the extinction coefficient for the carbon monoxide compound of cytochrome *a*<sub>3</sub> have been measured (Chance, 1953). In turbid preparations such as tissue homogenates or mitochondria this type of measurement is difficult, except with specialized apparatus (Chance, 1954).



If all of the above assumptions are correct, a given concentration of cytochromes *a* plus *a*<sub>3</sub> (which seem to occur in a constant ratio in mammalian tissues) should represent a definite amount of cytochrome *c* oxidase activity. In a purified preparation of cytochromes *a* plus *a*<sub>3</sub> this has been shown to be so (Smith, 1955). With this type of preparation the dilution of the enzyme in the assay system must be great enough to eliminate the inhibitory effect of the cholate in the preparation on the enzyme activity. As discussed below, the activity of the oxidase in the purified preparation can be very high under special conditions. On the other hand, when the oxidase activity of tissue homogenates or particulate preparations from cells is assayed by variations of either method (1) or (2) above, the activity often appears to be quite low compared to the content of cytochromes *a* plus *a*<sub>3</sub>.

Our studies of the apparently low cytochrome *c* oxidase activity of many cellular extracts cover several aspects of the problem: (1) It has been shown that soluble cytochrome *c* actually inhibits cytochrome *c* oxidase activity (Smith and Conrad, 1956). This work has been published and will be only briefly summarized. (2) Other basic proteins besides cytochrome *c* have been found to be inhibitory to cytochrome *c* oxidase activity, and substances present in some tissue homogenates are also inhibitory. (3) Studies have been made of the activities of fractions separated from homogenates of different kinds in an attempt to determine which type of preparation gives maximal activity.

Although many methods have been devised for measuring cytochrome *c* oxidase activity by varying the type of substance oxidized by the enzyme system or the conditions of the assay, few observations have been made on the effect of the state of the cellular extract. It should be recalled that difficulties are met as a consequence of the attachment of the oxidase to insoluble particulate matter within the cell and that even in purified preparations one is not dealing with a water-soluble enzyme. Our studies have attempted to evaluate the different methods for measuring cytochrome *c* oxidase activity and particularly the relationship of the oxidase activity to the type of cellular homogenate or fraction.

## METHODS

### *Preparations*

The purified preparation of cytochromes *a* plus *a*<sub>3</sub> has been described (Smith, 1955).

The preparation of heart muscle particles was made by a modification of the method of Keilin and Hartree (Chance, 1952).

Mitochondria were isolated from liver (Lardy and Wellman, 1952), kidney (Hollunger, 1955) and heart (Cleland and Slater, 1953). Cytochrome *c* was removed from liver mitochondria by washing with saline (Estabrook, 1958). Homogenates of rat organs (10% or 20%) were prepared by grinding

the tissues in cold water in a Teflon homogenizer and discarding the material sedimented by centrifugation at 700 rev/min for 5 min in a Servall refrigerated centrifuge.

#### *Measurements of the Content of Cytochromes $a$ plus $a_3$ in Preparations*

In the optically clear purified preparations the difference in absorption spectrum between the oxidized preparation (nothing added) and the preparation reduced with sodium dithionite was measured to assay the content of cytochromes  $a$  plus  $a_3$ . These measurements were made either in a Beckman DU spectrophotometer or in the recording spectrophotometer described by Yang and Legallais (1954). The concentration of cytochrome  $a_3$  was measured by recording the absorption spectrum of the carbon monoxide compound formed by gassing the dithionite-reduced preparation with carbon monoxide. The concentration of cytochrome  $a_3$  was calculated using the extinction coefficient reported by Chance (1953).

In turbid preparations, such as heart muscle particles, the difference in optical density ( $\Delta E$ ) at 605 minus 630  $m\mu$  between the preparation with the cytochromes reduced (anaerobic preparation containing substrate) and that with the cytochromes oxidized (aerobic preparation) was used as a measure of the cytochromes  $a$  plus  $a_3$  present. Cytochromes  $a$  and  $a_3$  were considered to be reduced in anaerobic mitochondria and oxidized in aerobic mitochondria containing substrate and phosphate acceptor (Chance and Williams, 1955). With homogenates, which contained haemoglobin, a different procedure was followed. Here the difference in absorption spectrum was measured between two samples of aerobic homogenate, one of which contained  $10^{-3}$  M cyanide. The observed difference in optical density at 605 minus 630  $m\mu$  was multiplied by  $4/3$  to correct for the loss of absorption of the cytochrome  $a_3$  at 605  $m\mu$  in the presence of cyanide. All measurements were made in the recording spectrophotometer described by Yang and Legallais (1954) or the double-beam spectrophotometer designed by Chance (1951). Both instruments will record small differences in optical density of turbid preparations.

#### *Assay of Cytochrome $c$ Oxidase Activity*

The rate of oxidation of soluble ferrocytochrome  $c$  by the oxidase was followed by recording the decrease in optical density at the  $\alpha$ ,  $\beta$  or  $\gamma$  absorption peak of ferrocytochrome  $c$ , as previously described by Smith and Conrad (1956). The cytochrome  $c$  was prepared by the method of Keilin and Hartree (1947), purified according to Margoliash (1954) and reduced with hydrogen and palladium (Smith and Conrad, 1956).

#### *Chemicals*

Salmine sulphate, purchased from General Biochemicals, Inc., was dialyzed for several hours, first against  $10^{-3}$  M ethylenediamine-tetra-acetate (versene),

then against distilled water. Part of the salmine is lost through the Cellophane membrane during dialysis. The final concentration of protein remaining after dialysis was measured by the biuret method (Gornall, Bardawill and David, 1949) and the molarity of the salmine calculated assuming a molecular weight of 8000.

## RESULTS

### *Effect of the Concentration of Cytochrome c on Cytochrome c Oxidase Activity*

Figure 1 shows semilogarithmic plots of the optical density minus the optical density of totally oxidized cytochrome at the wavelengths indicated in

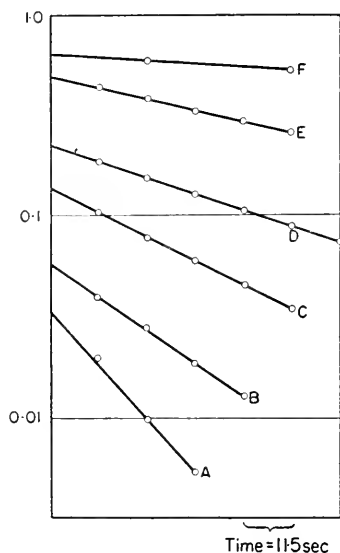

FIG. 1. Semilogarithmic plots of the observed changes in optical density as ferrocytochrome *c* is oxidized by the oxidase. Ordinate values are *E* values at given times minus *E* of the totally oxidized cytochrome *c*; abscissa represents time. The different experiments were run with different concentrations of cytochrome *c* in the tests, but with the same concentration of the oxidase. The data of curve *A* were measured at 415  $m\mu$ ; those of curves *B*, *C*, *D*, and *E* at 550  $m\mu$ , and those of curve *F* at 520  $m\mu$ .

*A* = 1.07  $\mu M$  cytochrome *c*

*D* = 16  $\mu M$  cytochrome *c*

*B* = 5.33  $\mu M$  cytochrome *c*

*E* = 32  $\mu M$  cytochrome *c*

*C* = 8.0  $\mu M$  cytochrome *c*

*F* = 128  $\mu M$  cytochrome *c*

the legend against time as ferrocytochrome *c* is oxidized by the oxidase. The different lines were obtained with different concentrations of cytochrome *c* in the test mixtures, the concentration of the oxidase being held constant. From the slopes of the plots, the first order velocity constants can be calculated in each case; these are plotted against cytochrome *c* concentration in

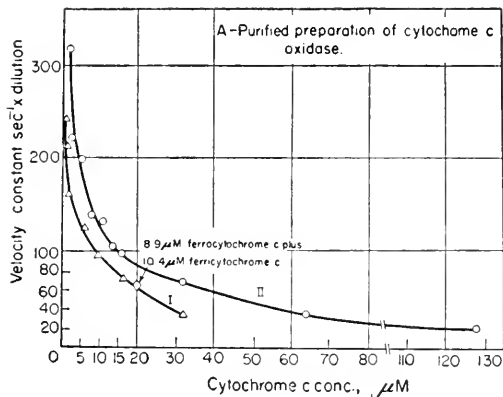

A

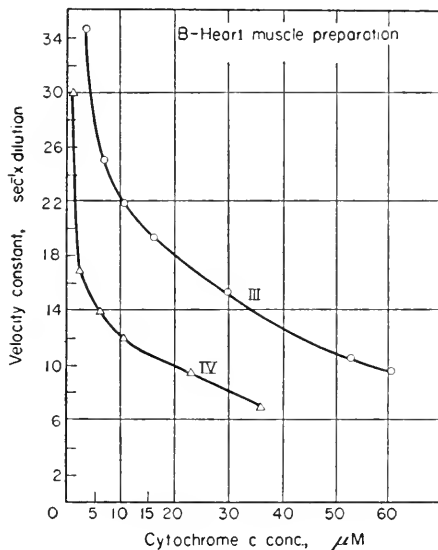

B

FIG. 2. The effect of the concentration of cytochrome *c* on the velocity constant for the oxidase reaction.

A. The two curves represent experiments with two different purified oxidase preparations.

I. The cytochrome *c* was the Keilin-Hartree preparation; temperature was 20°C. The final dilution of the oxidase in the test was 3000-fold.

II. The cytochrome *c* was purified according to Margoliash (1954); the temperature was 25°C. The final dilution of the oxidase in the test mixture was 6000-fold.

The point represented by  $\square$  was obtained with a mixture of ferri- and ferro-cytochrome *c*. The other points were obtained with cytochrome *c* which was more than 95% reduced.

B. Curves III and IV were obtained from experiments with two different heart muscle preparations.

III. Final dilution of oxidase preparation in test was 1200-fold; temperature was 25°C.

IV. Final dilution of oxidase in test was 600-fold; temperature was 20°C.

Figs. 2A and 2B. The different curves were obtained in experiments with two different purified preparations and two preparations of heart muscle particles. Measurements made with mixtures of ferro- and ferricytochrome *c* showed that the velocity constant is dependent upon the total concentration of cytochrome *c* (ferro- plus ferri-) in the reaction mixture. This is illustrated by

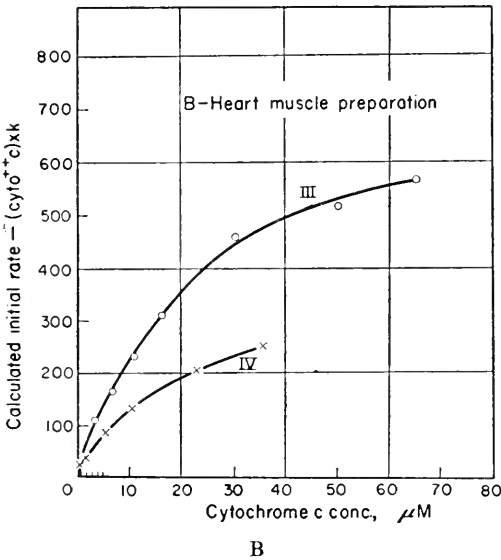
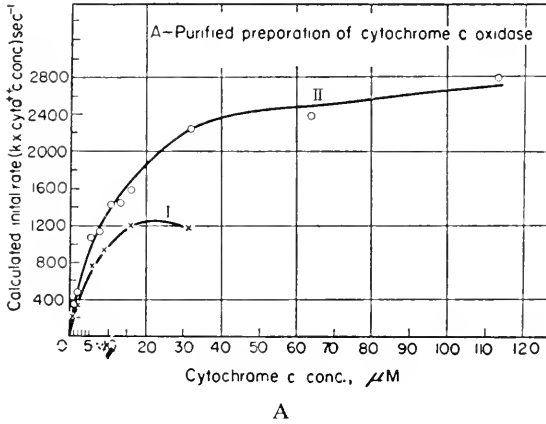

FIG. 3. Variation of the initial rate of oxidation of cytochrome *c* with the total concentration of cytochrome *c* in the test mixture. The initial rates were calculated from the data of Fig. 2 by multiplying the rate constants by the concentration of ferrocytochrome *c* in the test mixture.

the point marked  $\square$  on curve I of Fig. 2A. When the initial rates of ferrocytochrome *c* oxidation are calculated (velocity constant  $\times$  initial concentration of ferrocytochrome *c*) and plotted against the total cytochrome *c* concentration, as in Figs. 3A and 3B, hyperbolic plots are obtained, similar to those seen when measuring cytochrome *c* oxidase activity in the presence of a reducing substance. The data show that the apparent 'saturating' effect

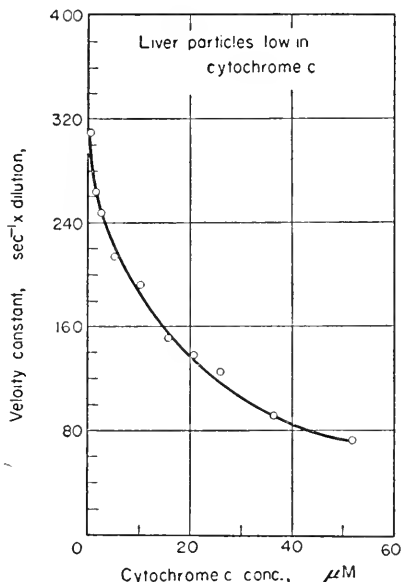

FIG. 4. The effect of the concentration of cytochrome *c* on the velocity constant for the oxidase reaction of liver particles treated to remove the endogenous cytochrome *c*. In each test 10  $\mu\text{l}$ . of a 20-fold dilution of the liver particles in 0.05 M phosphate buffer was used. The temperature was 25°C.

with increasing concentrations of cytochrome *c* is actually a reflection of an inhibitory effect of the cytochrome *c* on the oxidase activity.

The above-described experiments on oxidase preparations obtained from heart muscle have been repeated with a preparation derived from rat liver mitochondria treated to remove most of the endogenous cytochrome *c*. Entirely similar plots were obtained (Fig. 4). Thus in the presence or absence of endogenous cytochrome *c* the same kinetics are observed.

We have interpreted our data to mean that the soluble cytochrome *c* (either oxidized or reduced) reacts reversibly with the oxidase to form a combination in which the oxidase is inhibited or in which the oxidase is so masked that it cannot react with further cytochrome *c* in solution. Purification of cytochrome *c* in a number of ways did not change the observed kinetics, as illustrated in Fig. 2A. Thus the inhibitory effect of the cytochrome *c* does not appear to result from an impurity in the cytochrome *c* solution.

The inhibitory effect with increasing cytochrome *c* concentrations on the purified oxidase is greater than with the enzyme attached to the heart muscle particles. This could mean that the oxidase of the purified preparation is more exposed to form the unreactive binding with cytochrome *c* than is the enzyme which is still a part of the respiratory chain particles.

As far as the methodology of cytochrome *c* oxidase assay is concerned, the data indicate that:

(1) If comparative studies of the oxidase activity of a given kind of preparation are to be made, the concentration of cytochrome *c* must be held constant throughout the tests. Then only comparative values will be obtained, since the inhibitory effect of the cytochrome *c* will be present. If oxidase activities of different tissues or different kinds of preparations are to be studied, the inhibitory effect of cytochrome *c* on each kind of preparation must also be compared.

(2) The high concentrations of cytochrome *c* usually employed in the manometric method and in most colorimetric methods of cytochrome *c* oxidase assay will result in a greatly inhibited enzyme.

When the velocity constant of the reaction of the purified oxidase is measured at very low concentrations of cytochrome (around  $1 \mu\text{M}$ ), a very active enzyme is apparent. If a second order velocity constant is calculated by dividing the observed first order constant by the concentration of cytochrome  $a_3$ , values as high as  $10^7 \text{ M}^{-1} \text{ sec}^{-1}$  are obtained at  $25^\circ\text{C}$  (Smith and Conrad, 1956).

#### *Effect of Proteins Other than Cytochrome c on Cytochrome c Oxidase Activity*

Since cytochrome *c* is a protein with an isoelectric point above pH 10, the effect of other basic proteins on the cytochrome *c* oxidase activity was tested. Table 1 shows the effect of different concentrations of salmine on the oxidase activity of heart muscle particles, all other components being kept constant in the test. The concentration of cytochrome *c* in the mixture was  $7 \mu\text{M}$ . Figure 5 plots the oxidase activity with increasing concentrations of cytochrome *c* in the presence of a constant salmine concentration. The data show that at low concentrations salmine has a greater inhibitory effect than does cytochrome *c*. The inhibitory effect of cytochrome *c* is almost entirely eliminated in a preparation inhibited by salmine. Apparently salmine binds at or near the same site as does the cytochrome *c*.

With these effects of basic proteins on the oxidase in mind, we were led into a comparison of the cytochrome *c* oxidase activity of homogenates of some animal tissues with their content of cytochromes *a* and  $a_3$ . This examined the possibility that the low oxidase activity sometimes observed in homogenates results from inhibition of the oxidase activity by substances present in the homogenates. Table 2 shows some results obtained with rat liver homogenates. The oxidase activity of washed particles is about 4.5-fold

greater than that of the whole homogenate when expressed in terms of the content of cytochromes  $a$  plus  $a_3$ . Addition of some of the soluble fraction of the homogenate to the washed particles resulted in an inhibition of the

TABLE 1. INHIBITORY EFFECT OF SALMINE ON CYTOCHROME  $c$  OXIDASE ACTIVITY OF HEART MUSCLE PARTICLES

Heart muscle particles were prepared according to a modification of the Keilin-Hartree procedure. The concentration of cytochrome  $c$  in the test was  $7 \mu\text{M}$ .

Salmine conc. ( $\mu\text{M}$ )	Inhibition (%)
0	0
0.67	0
2.66	0
5.32	34
6.65	58
9.31	66
10.64	75
13.3	81

TABLE 2. RELATIONSHIP OF CYTOCHROME  $c$  OXIDASE ACTIVITY TO CONTENT OF CYTOCHROMES  $a + a_3$  IN FRACTIONS OF LIVER HOMOGENATE

The oxidase assay and the method for measuring  $\Delta E$  (difference in optical density between reduced and oxidized cytochromes  $a$  plus  $a_3$ ) are described in the section on Methods. The concentration of cytochrome  $c$  in the test was  $15 \mu\text{M}$ .

	Velocity constant $\times$ dilution	$\Delta E$ 605-630 $\text{m}\mu$	$k/\Delta E$
Whole liver homogenate	6.1	0.034	179
Supernatant from centrifuging homogenate at 900 rev/min for 5 min	6.8	0.024	281
Washed particles from supernatant	7.6	0.008	950

oxidase of the particles, but the inhibition was observed to be variable in extent and to depend upon the concentration of cytochrome  $c$ .

Again the data indicate the necessity for caution in interpreting data on



oxidase activity of homogenates. Although we have not carried out experiments with plant tissues, some published data show that in homogenates of some plant tissues the oxidase activity is low or absent, but appears on

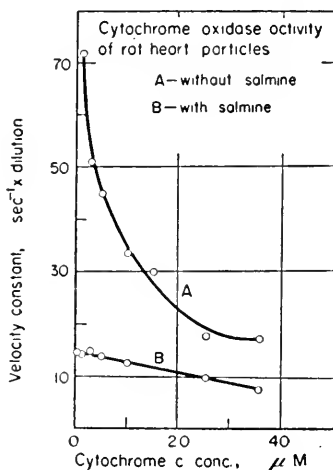

FIG. 5. The effect of cytochrome *c* concentration on the velocity constant of the oxidase reaction in the presence and absence of salmine. The oxidase preparation was a suspension of rat heart sarcosomes treated with 100 vol of distilled water. The concentration of salmine in the test was  $1 \mu\text{M}$ .

preparation of washed particles, indicating that something inhibitory has been washed away (James, 1956; Simon, 1957).

#### *Studies of Oxidase Activity of Fractions of Tissue Homogenates*

Some experiments were carried out which attempted to give some idea about the possible localization of the substances in homogenates which are inhibitory to cytochrome *c* oxidase. The oxidase is a part of the mitochondria, but the oxidase of intact mitochondria suspended in isotonic sucrose does not rapidly oxidize soluble ferrocytochrome *c* in the suspending medium. The oxidase does react rapidly after the mitochondria have been exposed to water or dilute buffer solutions. We have investigated the oxidase activity of mitochondria to determine under what conditions maximal oxidase activity can be obtained. When a small volume (5–10  $\mu\text{l}$ .) of a concentrated mitochondrial suspension in isotonic or hypertonic sucrose is added to ferrocytochrome *c* in 0.05 M phosphate buffer, the changes in optical density during the first 20 sec are not entirely due to the oxidation of cytochrome *c*, since the usual straight lines on a semilogarithmic plot are not obtained. These early changes in optical density, which presumably result from changes in light scattering as the mitochondria swell (Claude, 1946), are not significant after about 20 sec. However, it was found that if the mitochondria were allowed to stand diluted

TABLE 3. GUINEA PIG KIDNEY MITOCHONDRIA

A

4  $\mu$ l. of mitochondrial suspension in 0.25 M sucrose was added to 2.6 ml of buffer, then cytochrome *c* added at times indicated to a final concn. of 8  $\mu$ M.

Time (min)	Cytochrome <i>c</i> oxidase 1st order velocity <i>k</i> $\times$ dilution
0	28
15	45.2
65	89.2
87	82.7

B

3  $\mu$ l. of guinea pig kidney mitochondria was added to test mixture at 0 time, and the optical density readings for the first 20 sec were discarded (see text). 8  $\mu$ l. of heart muscle particles was used in the test. The sucrose-KCl medium contained 1.71 g sucroses, 0.30 g KCl and 0.121 g MgCl<sub>2</sub> in 100 ml 0.02 M phosphate buffer pH 7.4

	Cytochrome <i>c</i> oxidase 1st order velocity <i>k</i> $\times$ dilution	
	in sucrose-KCl medium	in 0.05 M phosphate buffer
Guinea pig kidney mitochondria	6.0	30.0
Heart muscle particles	7.0	8.3

TABLE 4. CYTOCHROME *c* OXIDASE OF RAT HEART MITOCHONDRIA

The concentration of cytochrome *c* in the test mixture was 5.1  $\mu$ M. The sucrose-versene mixture was 0.32 M sucrose, 0.001 M versene, 0.02 M phosphate, 0.01 M KCl, pH 7.4

	Cytochrome <i>c</i> oxidase activity 1st order velocity <i>k</i> $\times$ dilution
(a) 4 $\mu$ l. mitochondria added at 0 time to buffered cytochrome <i>c</i>	34.0
(b) 4 $\mu$ l. mitochondria incubated in 1.4 ml. water for 3 min, then buffer + cytochrome <i>c</i> added	56.4
(c) Mitochondria diluted 100-fold with water 10 min before assaying; 400 $\mu$ l. of diluted suspension used in test	64.0
(d) Mitochondria diluted in sucrose-versene and assay run in sucrose-versene	12.3
(e) Same as <i>d</i> + triton (0.13 mg/ml in test)	58.1

in buffer for varying lengths of time at room temperature, the cytochrome *c* oxidase activity increased somewhat. This effect is illustrated in the data of Table 3 obtained with guinea pig kidney mitochondria. As found by others, the oxidase activity is low when the assay is run in isotonic sucrose, as compared with the same preparation in 0.05 M phosphate buffer, although the activity of the enzyme in heart muscle particles is nearly the same in the two solutions. Similar observations were made with rat heart sarcosomes; these are summarized in Table 4.

About the same maximal cytochrome *c* oxidase activity (expressed in terms of cytochromes *a* and *a*<sub>3</sub>) can be obtained with hypotonically treated mitochondria after standing and with washed particles isolated from a water homogenate. Thus the inhibitory substances do not appear to be present in the mitochondria.

A more interesting observation is that the maximal oxidase activity that could be obtained was found to be different for different tissues. Table 5

TABLE 5. CYTOCHROME *c* OXIDASE ACTIVITY OF SEVERAL TISSUES EXPRESSED IN TERMS OF CONTENT OF CYTOCHROMES *a* PLUS *a*<sub>3</sub>

The oxidase assay and the method for measuring the difference in optical density between oxidized and reduced cytochromes *a* plus *a*<sub>3</sub> are described in the text. The concentration of cytochrome *c* in the test mixture in each case was 15 μM.

Tissue	Oxidase activity/ $\Delta E$ 605–630 mμ
Washed particles from rat liver homogenate	950
Rat heart mitochondria suspended in buffer before assaying	350
Guinea pig kidney mitochondria suspended in buffer before assaying	260
Rat brain mitochondria suspended in buffer before assaying	508

summarizes some representative values obtained with preparations from several rat organs, the assays being run at a constant cytochrome *c* concentration.

#### DISCUSSION

Taken all together, the various data show that conclusions based upon measurements of cytochrome *c* oxidase activity may be quite misleading. In such experimentation the following observations must be kept in mind:

(1) The oxidase activity of homogenates, washed particles or purified preparations will depend upon the (total) concentration of cytochrome *c* in the test system. Thus in a series of experiments comparing activities of a given kind of preparation, the concentration of cytochrome *c* must be kept constant. The lower the cytochrome *c* concentration, the higher will be the activity observed, when the activity is expressed as the first order velocity constant.

(2) The extent of the inhibitory effect of cytochrome *c* is different with different kinds of preparations. The extent of the inhibition must be measured with each kind of preparation.

(3) Other proteins besides cytochrome *c* are also inhibitory to cytochrome *c* oxidase activity, including some proteins found in tissue homogenates. Sedimentation of the insoluble fraction of the homogenates and washing of this fraction removes inhibitory substances.

(4) In several rat organs examined, the same maximal cytochrome *c* oxidase activity was observed with washed mitochondria treated in hypotonic solution and with washed particles from a water homogenate. However, with mitochondria there is a change in absorption spectrum due to changes in light scattering which lasts for about 20 sec after addition of the mitochondria to the buffer solution. Also the maximal cytochrome *c* oxidase activity is obtained only after the mitochondria have stood in the hypotonic solution for about 60 min.

(5) The maximal cytochrome *c* oxidase activity that can be obtained using a given cytochrome *c* concentration in the test mixture appears to be different for different tissues, when expressed in terms of the content of cytochromes *a* and *a<sub>3</sub>*.

What can be deduced about the nature of the oxidase from this type of observation? As might be suspected, since the oxidase is a particulate enzyme, the experiments appear to show structural differences related to the oxidase in different kinds of preparations, particularly regarding the extent of 'exposure' of the oxidase to reaction with cytochrome *c* in solution.

(1) In relatively intact mitochondria, the oxidase does not react rapidly with cytochrome *c* in solution.

(2) The oxidase of swollen or ruptured mitochondria or of the insoluble particles derived from the mitochondria is usually in a position to react with cytochrome *c* in solution. However, in some preparations (Mackler and Green, 1956) the structure of the particulate material is such that rapid reaction with soluble cytochrome *c* is not observed. Our data indicate that, in addition, cytochrome *c* or some other proteins can bind to the oxidase particles in such a way that the oxidase becomes inaccessible to reaction with cytochrome *c*. Some of these inhibitory proteins can be removed by washing.

(3) The oxidase of a purified preparation is most susceptible of all to the inhibitory binding of cytochrome *c*.

The simplest explanation of our data seems to be that the inhibitory effect of cytochrome *c* or salmine on the oxidase results from masking of the enzyme by the binding of these proteins. After addition of salmine, the cytochrome *c* has little further inhibitory effect. We have found that the addition of salmine has no effect on the steady-state levels of the cytochromes of heart muscle particles oxidizing succinate with oxygen. This seems to show that the salmine does not react specifically with one member of the oxidase system, but rather

acts to block interactions physically. The relatively small inhibitory effect of high concentrations of cytochrome *c* on the oxygen uptake of heart muscle particles indicates that the masking of the oxidase by cytochrome *c* inhibits the oxidative reaction of the oxidase with cytochrome *c* in solution, but may not block the reaction between the oxidase and the endogenous cytochrome *c* of the particles.

Preliminary observations on the effect of salmine on the succinate-cytochrome *c* reductase activity of particulate preparations indicate that in this case also the salmine has an inhibitory effect. The postulate might be made that the surface of the particles bearing the electron transport chain has structural parts that can bind basic proteins such as salmine strongly. This binding prevents the interaction of the particulate enzymes with cytochrome *c* in solution. The poor accessibility of soluble cytochrome *c* to a catalytic site on heart muscle particles has been suggested by Keilin and Hartree (1955).

Thus there appear to be at least two structural effects which can inhibit the reaction of the particulate oxidase with cytochrome *c* in solution. Some structural barrier inhibits the reaction with cytochrome *c* of the oxidase of intact mitochondria and of some kinds of particulate preparations derived from the breakdown of the mitochondria. With the latter, low concentrations of surface active agents such as cholate or deoxycholate can remove the inhibition (Smith and Stotz, 1954; Mackler and Green, 1956). The present data show that the oxidase can also be masked by binding of some proteins. To what extent the two effects which mask the ability of the oxidase to react with soluble cytochrome *c* are interrelated is not yet clear. But the effects are such that different maximal oxidase activities (expressed in terms of content of cytochromes  $a + a_3$ ) are observed with preparations from different rat organs, showing that the extent of the structural inhibitory effects varies in different tissues.

Although observations on the factors which may affect the oxidation of soluble cytochrome *c* by cytochrome *c* oxidase of tissue homogenates on particles indicate many difficulties in assessing variations in apparent oxidase activity, further experiments of this kind may lead to some insight into the nature of the reaction site of the enzyme.

Gamble (1957) has shown that liver mitochondria or mitochondrial fragments suspended in media of low ionic strength can definitely bind cytochrome *c* or salmine and that under these conditions aggregation of the mitochondria or fragments is observed. The binding of cytochrome he describes appears to be irrelevant to the present experiments, since it was not observed in solutions of phosphate buffer comparable to those used in the experiments reported here.

#### SUMMARY

Measurements of cytochrome *c* oxidase activity have been made by obtaining the first order velocity constant for the oxidation of ferrocytochrome *c*

by the oxidase under different conditions. These studies have shown that:

1. Cytochrome *c* oxidase is inhibited by soluble cytochrome *c* in either its reduced or oxidized form.
2. Other proteins besides cytochrome *c*, notably salmine, are also inhibitory to the oxidase. There is evidence that proteins that occur in water homogenates of rat tissues are also inhibitory, but some of these can be removed by washing the particles containing the oxidase.
3. With a given tissue the maximum cytochrome *c* oxidase activity is obtained with either the washed insoluble particles from a homogenate or with washed mitochondria which have been allowed to stand for about 60 min in water or dilute buffer.
4. The maximum oxidase activity obtained with washed particles or water-treated mitochondria is different with different tissues, when expressed in terms of the content of cytochromes *a* plus *a*<sub>3</sub>.
5. The observations on cytochrome *c* oxidase activity of tissue preparations are most simply explained by assuming that cytochrome *c* or other proteins can bind to the oxidase in such a manner that its oxidative reaction with cytochrome *c* in solution is blocked.

#### REFERENCES

- CHANCE, B. (1951). *Rev. Sci. Instrum.* **22**, 619.  
 CHANCE, B. (1952). *J. biol. Chem.* **197**, 557.  
 CHANCE, B. (1953). *J. biol. Chem.* **202**, 397.  
 CHANCE, B. (1953). *J. biol. Chem.* **202**, 407.  
 CHANCE, B. (1954). *Science* **120**, 767.  
 CHANCE, B. & WILLIAMS, G. R. (1955). *Fed. Proc.* **14**, 190.  
 CHANCE, B. & WILLIAMS, G. R. (1955). *J. biol. Chem.* **217**, 409.  
 CLAUDE, A. (1946). *J. exp. Med.* **84**, 51.  
 CLELAND, K. W. & SLATER, E. C. (1953). *Biochem. J.* **53**, 547.  
 CONRAD, H. (1951). Thesis, University of Rochester.  
 ESTABROOK, R. W. (1958). *J. biol. Chem.* **230**, 735.  
 GAMBLE, J. L. (1957). *Biochim. biophys. Acta* **23**, 306.  
 GORNALL, A., BARDAWILL, C. & DAVID, M. (1949). *J. biol. Chem.* **177**, 751.  
 HOLLUNGER, G. (1955). *Acta pharmacol. toxicol.* **11**, Suppl. 1.  
 JAMES, W. O. (1956). *New Phytol.* **55**, 269.  
 KEILIN, D. & HARTREE, E. F. (1938). *Proc. roy. Soc.* **B125**, 171.  
 KEILIN, D. & HARTREE, E. F. (1939). *Proc. roy. Soc.* **B127**, 167.  
 KEILIN, D. & HARTREE, E. F. (1947). *Biochem. J.* **41**, 500.  
 KEILIN, D. & HARTREE, E. F. (1955). *Nature, Lond.* **176**, 200.  
 LARDY, H. A. & WELLMAN, H. (1952). *J. biol. Chem.* **195**, 215.  
 LUDWIG, G. D. & KUBY, S. A. (1955). *Fed. Proc.* **14**, 247.  
 MACKLER, B. & GREEN, D. E. (1956). *Biochim. biophys. Acta*, **21**, 1.  
 MARGOLIASH, E. (1954). *Biochem. J.* **56**, 535.  
 SIMON, E. W. (1957). *J. exp. Bot.* **8**, 20.  
 SMITH, L. (1955). *J. biol. Chem.* **215**, 833.  
 SMITH, L. & CONRAD, H. (1956). *Arch. Biochem. Biophys.* **63**, 403.  
 SMITH, L. & STOTZ, E. (1954). *J. biol. Chem.* **209**, 819.  
 YANG, C. C. & LEGALLAIS, V. (1954). *Rev. Sci. Instrum.* **25**, 801.

## DISCUSSION

*Assay of Cytochrome c Oxidase*

SLATER: A practical use of cytochrome *c* oxidase assays is to measure the distribution of mitochondria in various fractions obtained by differential centrifugation. The assumption is made that all the cytochrome oxidase is in the mitochondria, so that the distribution of cytochrome oxidase in the various fractions is the same as the distribution of the mitochondria. We do this by using very high concentrations of cytochrome *c*, with *p*-phenylenediamine as reducing agent in 0.05 M phosphate buffer and measure the O<sub>2</sub> uptake manometrically. Do you think that the inhibitor which you find in the soluble fraction of tissue homogenates causes serious error in this procedure?

SMITH: Yes, I do. Like other workers, we have found that the sum of oxidase activity from different fractions of a tissue homogenate is usually considerably larger than the activity of the unfractionated homogenate.

LEMBERG: The paper of Smith shows how important it would be to have an analytical method for the estimation of the haem *a* content of tissues without reference to enzyme activity.

I mention only one example. Lahey, Gubler, Chase, Cartwright and Wintrobe (*Blood* 7, 1053, 1952) had believed that the lack of cytochrome *c* oxidase activity in organs of copper-deficient swine was due to the lack of copper in the oxidase molecule. However, Gallagher, Judah and Rees (*Proc. roy. Soc. B* 145, 134, 1956) have shown that haem *a* was almost completely absent from the liver in copper-deficient rats. Since Lahey *et al.* (*loc. cit.*) had found no lack of catalase in copper-deficient swine, it is evident that copper is specifically required for the biosynthesis of haem *a* from protohaem or its precursors.

Three such analytical methods have been worked out by us:

(1) The quantitative isolation of porphyrin *a* in a state of spectroscopic purity or near-purity. This can be satisfactorily applied only to tissues comparatively rich in haem *a* such as heart and requires at least 5 g of tissue. It is also technically not quite easy.

(2) The spectrophotometric determination based on measurements of the optical densities at 587 and 558 m $\mu$  of the mixed pyridine haemochromes. This requires less material but still a relatively high haem *a* content.

(3) The separation of haemin *a* from protohaemin by a modified Rawlinson-Hale procedure, followed by spectrophotometric analysis of the pyridine haemochrome. This method has given satisfactory results in the study of iron incorporation into haem *a* in rat tissues (Lemberg and Benson, *Nature, Lond.* 183, 678, 1959). The presence of lipid in the extracts still causes some difficulties which we hope to overcome.

WAINIO: Suppose a surface active agent was added to the particulates presented in Table 5 (Smith, p. 269), i.e. those that have different oxidase activity/ $\Delta E$  605–630 m $\mu$  values, would the results be more uniform?

SMITH: Addition of low concentrations of cholate to heart muscle particles will increase the oxidase activity/ $\Delta E$  605–630 m $\mu$  almost up to that obtained with liver particles. We have not made observations with preparations from kidney or brain.

*Inhibition of Cytochrome c Oxidase by Cytochrome c*

SLATER: Ever since Smith reported inhibition of the cytochrome *c* oxidase reaction by oxidized and reduced cytochrome *c*, we have attempted to incorporate this inhibition in reaction mechanisms, i.e. we thought that the inhibition in some way might be a part of the normal mechanism. Am I correct in concluding that you regard the inhibition as incidental to the enzymic reaction, i.e. that it is a side reaction caused by the fact that cytochrome *c* is a highly basic protein? If this is so, perhaps we have been wasting our time, and simpler mechanisms will be adequate.

SMITH: I feel that the observation that the inhibitory effect of cytochrome *c* can be duplicated by another basic protein, salmine, fits better with the assumption that the inhibition is a side reaction. Also in accord with this view is the lack of inhibition of electron

transport down the intact respiratory chain by rather high concentrations of cytochrome *c*; here there is apparently no problem of availability of the oxidase to the reaction site of cytochrome *c*.

HENDERSON: I wish to ask Lucile Smith whether the result was the same, independent of the iron concentration of the cytochromes? We have found that both the preparations with 0.34% and 0.43% iron, but particularly that with low iron, combine adequately with copper. This is interesting in view of Wainio's paper. In the low-iron preparation, the cytochrome *c* is already combined with non-basic proteins. Did you find any effect of long incubation time as observed by Tsou in 1951? He regained the complete endogenous activity on long incubation.

SMITH: We used cytochrome *c* of 0.34% iron, and the same preparation purified according to Margoliash, with identical results. In our hands the period of incubation makes no difference.

### *Interaction of Cytochrome c with Other Compounds*

#### **The Effect of Cations on the Reactivity of Cytochrome *c* in Heart Muscle Preparations**

By R. W. ESTABROOK (Philadelphia)

ESTABROOK: I would like to comment on a series of studies I have recently carried out using a cytochrome-*c*-deficient heart muscle preparation in order to investigate the role of cytochrome *c* in the succinoxidase system. These studies are complimentary

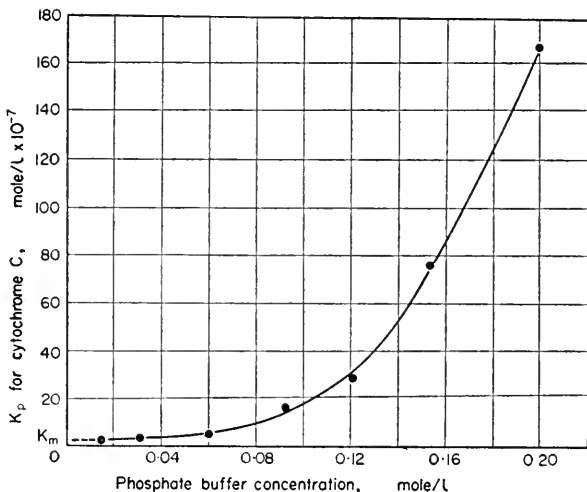

FIG. 1.

to those of Smith and bring up a necessary question concerning the interpretation of cytochrome *c* oxidase assays. During studies to assess the validity of a lipocytochrome *c* as required for enzymic activity and to determine the accuracy of previous claims that exogenous cytochrome *c* may be only 1/100 as active as endogenous cytochrome *c*, it was observed that the  $K_m$  for exogenous cytochrome *c*, in the manometric measurement of succinoxidase activity using the cytochrome-*c*-deficient heart muscle preparation, was markedly affected by the presence of cations in the medium. This is shown in Fig. 1 where the  $K_m$  is plotted as a function of the potassium phosphate concentration employed in the reaction vessel. One sees over a 100-fold difference



in the determined  $K_m$  as low salt concentrations are approached. This lower value for the  $K_m$  for cytochrome *c*, that is  $3 \times 10^{-7}$  M, when related to the concentration of endogenous cytochrome *c* which is normally present in such a heart muscle preparation, shows that exogenous cytochrome *c* is nearly as effective as endogenous cytochrome *c* thus negating the necessity of assessing the previously low activity values

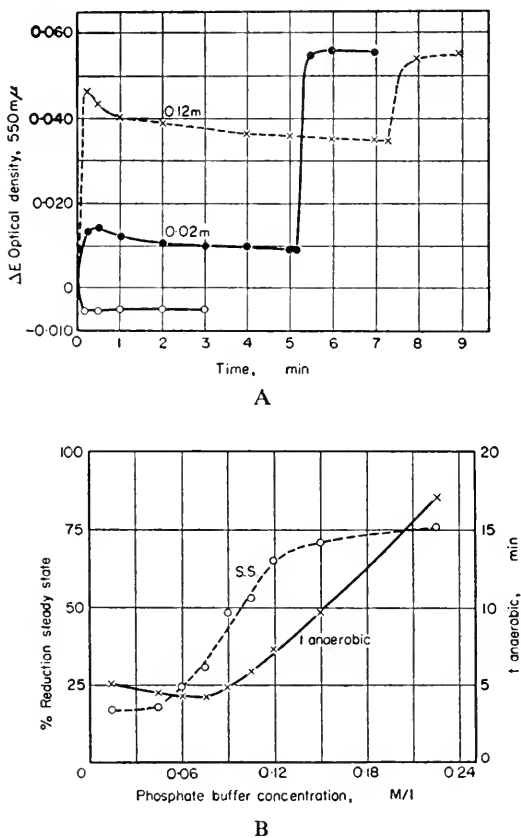

FIG. 2.

to the requirement for a lipocytochrome *c*. Other studies have shown that the inhibitory action of cations is dependent not only on their concentration but on their valency charge. That is, the divalent cations,  $\text{Ca}^{++}$ ,  $\text{Ba}^{++}$ ,  $\text{Mg}^{++}$ , are much more inhibitory than the monovalent cations,  $\text{Na}^+$ ,  $\text{K}^+$ , and  $\text{Li}^+$ . In turn, the trivalent cation  $\text{Al}^{+++}$  is much more inhibitory than the divalent cations.

By following spectroscopically the change in steady-state reduction of the exogenous cytochrome *c* present during succinate oxidation by such a system, it is possible to assess the locus of inhibition as between reduced cytochrome *c* and cytochrome oxidase. The decrease in oxygen uptake accompanied by the increase in steady-state reduction of the exogenous cytochrome *c* as the cation concentration increases is summarized in Figs. 2A and 2B.

The inhibitory effect of cations as determined from the change in  $K_m$  of the system for exogenous cytochrome *c* is also largely dependent on the enzyme concentration.

Thus the ratio of cation to a hypothetical active site for reduced cytochrome *c*-cytochrome oxidase interaction appears to be critical, that is, as the enzyme preparation is diluted at a fixed cation concentration more cytochrome *c* is required to obtain half maximal activity. With cytochrome *c* oxidase activities as currently determined spectrophotometrically the ratio of cation to hypothetical active site on the protein would be very large indeed introducing a serious source of inhibition of the type described above and would make the interpretation of the results of such assays most difficult. This would also explain in part the inability to saturate the cytochrome oxidase with cytochrome *c* as determined by such measurements.

A second point bearing on the problem of cytochrome *a* and cytochrome *a<sub>3</sub>* is the unexplained observation concerning the steady-state of these pigments during succinate

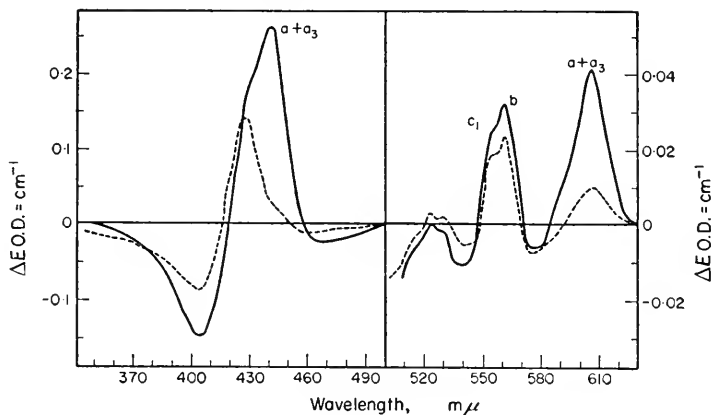

FIG. 3.

oxidation by a cytochrome *c* deficient heart muscle preparation. Figure 3 shows the difference spectra obtained when succinate is added to such a preparation. The dotted line represents the steady-state obtained in the presence of succinate while the solid line is that recorded when a sample is anaerobic. As one would expect, the pigments cytochrome *b* and *c<sub>1</sub>*, as determined from the magnitude of the absorption bands at 563 and 553 *mμ* respectively, are about 80 to 90% reduced in the steady-state. Unexplained is the large reduction at 605 *mμ*, a value almost 35% of that observed on anaerobiosis. If one considers a respiratory chain as represented by the scheme:



then the removal of cytochrome *c* should result in the reduction of cytochromes *b* and *c<sub>1</sub>* by succinate, but little or no reduction of cytochromes *a* or *a<sub>3</sub>*. This is especially true in the light of the observation that the rate of cytochrome *a<sub>3</sub>*-oxygen reaction and that of cytochromes *a* and *a<sub>3</sub>* interaction (Chance) is extremely rapid. The presence of a small amount of endogenous cytochrome *c* would be offset by the large velocity of these reactions and would not tend to invalidate the observations presented here. It should be noted, also, that the absorption at 444 *mμ* is only about 10% of that obtained on anaerobiosis. In agreement with previous measurements on the steady-state reduction of cytochromes *a* and *a<sub>3</sub>*, in a purified preparation (Smith), one must conclude that the 444 and 605 *mμ* absorption bands are not due to a single pigment, as based on their differences in steady-state values. One must also conclude that the linear chain representation as presented above is not truly representative in this instance and that one may have to place cytochrome *a* to a side path, much in the manner that Chance has put cytochrome *b* in a side path in such modified heart preparations.

WAINIO: In 1951 we demonstrated that the oxidation of ferrocyanochrome *c* by cytochrome *c* oxidase is maximal at pH 6.0 in 0.1 M phosphate buffer and that the activity decreases sharply on both sides of the optimum (*J. biol. Chem.* **192**, 349, 1951). More recently (unpublished) we have extended these studies, and although it appears as though the charge on the cation may be the controlling factor, there is still some question as to whether the total ionic strength is not also important. We are investigating the possibility that the increase in activity as the concentration of the buffer is raised from zero may be determined by the total ionic strength and that the decrease after the optimum may be largely an action of the cation charge on the  $K_m$ , as set forth by Estabrook.

The extinction coefficient (reduced-oxidized at 605  $m\mu$ ) which we used to calculate the haem content was obtained in our experiments where we used ferrocyanochrome *c* as a reductant (*J. biol. Chem.* **216**, 593, 1955). Under anaerobic equilibrium conditions the moles of ferrocyanochrome *c* oxidized were assumed to equal the gram atoms of iron (or haem) of cytochrome *c* oxidase that were reduced.

From the haem:protein ratio of 7.0 which is given in Table 1 it may be calculated that cytochrome *c* oxidase has a molecular weight of 140,000. However, this is based on the assumption that the total nitrogen of Fraction 6 (cytochrome *c* oxidase N + other protein N + lipid N) is cytochrome *c* oxidase nitrogen. These fractions have at no time been represented as being pure preparations of cytochrome *c* oxidase. The fractionation technique was applied only for the purpose of obtaining haem:Cu and Cu:activity ratios. The total protein was simply the common denominator before the ratios were taken.

HORIO: I should like to make a comment concerning the effects of native and modified cytochrome *c* on the oxidase activity, about which Henderson asked a question. Of the various modified cytochromes *c* preparations that we have found, at least one exists in a pure dimer form. Its molecular weight is calculated to be 24,400 based on its sedimentation and its diffusion coefficients. Compared with the native monomer form, this dimer form activates both the purified cytochrome *a* preparation and the particulate oxidase preparation very little.

MARGOLASH: In view of Smith's findings and those that Estabrook has just referred to in discussion, on the effect of cytochrome *c* and salmine as well as that of inorganic cations on the cytochrome oxidase reaction, would it not be possible to consider the binding of cytochrome *c* to the oxidase as due to a polycation-polyanion type of electrostatic interaction? I think Estabrook's description of the effect of polyvalent cations particularly suggestive in this respect. The extreme basicity of mammalian heart cytochrome *c* as well as Morrison's finding of an acid isoelectric point for cytochrome oxidase preparations would also fit such an interpretation.

BOARDMAN: The interaction between a protein such as cytochrome *c* and a polyanion appears to be very complex. Some of the factors governing such an interaction have been elucidated by studying the adsorption of cytochrome *c* on a polymethacrylic acid ion-exchange resin. The adsorption of cytochrome *c* on the resin is very dependent on the cation concentration and the pH of the medium. But it does not seem possible to explain the experimental data by visualizing the interaction as a purely electrostatic one between a polyvalent cation and a polyvalent anion. With substances of high molecular weight, short range forces such as Van der Waals or hydrogen bond forces may play an important role in the adsorption.

However, a study of the relationships between cytochrome *c* concentration, cation concentration and pH on the one hand and oxidase activity on the other does seem to provide an experimental approach to the problem of what is happening in the cytochrome *c* oxidase complex.

ARMSTRONG: There is a cytochrome *c* in *Micrococcus denitrificans* which has an isoelectric point of less than pH 7, which might be used to test this theory.

SLATER: Horio refers in his paper to the fact that his value for the  $K_m$  for cytochrome *c* in the system reducing agent—cytochrome *c*—oxidase—oxygen is the same as ours. It is perhaps desirable to point out that, if we accept Smith and Conrad's interpretation of the inhibitory action of cytochrome *c* on cytochrome oxidase, this  $K_m$  actually

represents the  $K_i$  of the cytochrome-*c*-cytochrome oxidase *inhibited* complex. This is rather amusing because this  $K_m$  has often been taken to be the dissociation constant of the Michaelis-Menten enzyme-substrate complex. The inhibition by cytochrome *c* of cytochrome *c* oxidase can account for the rectangular hyperbolic relationship between cytochrome *c* concentration and oxidase activity, and the first order kinetics found by Smith on the basis of the following simple mechanism written formally:

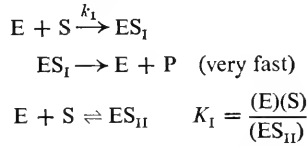

where  $ES_I$  is the active complex and  $ES_{II}$  is the inhibited complex.

$$\text{Velocity} = \frac{k_1 K_I e}{1 + (K_I/s)},$$

where  $s$  = concentration of cytochrome *c*, and  $e$  = concentration of cytochrome *c* oxidase, i.e.

$$\begin{aligned} V_{\max} &= k_1 K_I e \\ K_m &= K_I. \end{aligned}$$

# COMPOSITION OF CYTOCHROME *c* OXIDASE

By W. W. WAINIO

*Bureau of Biological Research and Department of Physiology and Biochemistry,  
Rutgers, The State University, New Brunswick, N.J.*

## INTRODUCTION

WHEN Keilin and Hartree (1938a, 1939) proposed that cytochrome *a* consisted of two components, namely, cytochrome *a* and cytochrome *a*<sub>3</sub>, they introduced a concept that has occupied many of the investigators in this field. In Keilin and Hartree's experiments both carbon monoxide and cyanide caused alterations in the 605 m $\mu$  band of reduced cytochrome *a*, viz. a spreading to 590 m $\mu$ . The 448 m $\mu$  band disappeared and was replaced by an intensified absorption at 430 m $\mu$  when carbon monoxide was used and by a new absorption at 452 m $\mu$  when cyanide was added. It was concluded by them that the component with a strong affinity for carbon monoxide in the reduced state and for cyanide in the oxidized state, and with a weak absorption at 600 m $\mu$  (relative to 605 m $\mu$ ) and a strong absorption at 448 m $\mu$  (relative to 452 m $\mu$ ) was cytochrome *a*<sub>3</sub>. The somewhat anomalous component with a strong absorption at 605 m $\mu$  and a weak absorption at 452 m $\mu$  was cytochrome *a*. Cytochrome *a*<sub>3</sub> was tentatively identified with cytochrome oxidase, and the possibility that cytochrome oxidase is a copper-protein was considered in some detail.

There was an immediate objection by Stern (1940), who stated that 'If the relationship is actually that described and sketched by the authors [i.e., that the  $\alpha$ - and  $\gamma$ -bands of cytochrome *a*<sub>3</sub> are weak and strong, respectively, compared with those of cytochrome *a*], it can hardly be reconciled with the further statement that the *a* and *a*<sub>3</sub> components are both haem-protein complexes with an identical haem nucleus and that both occur in comparable concentrations in various oxidase preparations'.

Stotz (1942) and Lundegårdh (1953) raised lesser objections, but since further work from their laboratories has emphasized the separateness of the two enzymes, it may be concluded that these objections are no longer considered valid.

We became interested in this problem in 1948 after having successfully prepared a soluble cytochrome oxidase with deoxycholate (Wainio, Cooperstein, Kollen and Eichel, 1947, 1948). Our view at that time was that cytochrome oxidase was a copper-porphyrin-protein and that the anomalous behaviour of the enzyme in the presence of carbon monoxide and cyanide

could be attributed to its copper content. Our evidence in support of this view was that the 605  $m\mu$  absorption in the reduced state was related to the copper content in several fractions made from the heart mitochondrial fragment (Eichel, Wainio, Person and Cooperstein, 1950). Because the activity could not be related to the copper content, and because later analysis of the pyridine haemochrome of the prosthetic group of the soluble enzyme revealed the presence of iron (Person, Wainio and Eichel, 1953), we were forced to abandon this view. Our position then became that the enzyme is a tetrapolymer of haemo-protein submolecules, as suggested by the statement of Warburg (1949), 'I almost regret that we cannot . . . assume that the enzyme is a four-fold polymerized haem compound', and by the experiments of Ball, Strittmatter and Cooper (1951) with carbon monoxide. It was thought that the apparent reactivity of two components could equally well be explained in terms of a differential sensitivity of the parts of a single polymeric molecule. When it became possible by the addition of a lipid activator to relate the activity to the copper content (Wainio, Vander Wende and Shimp, 1959), our hypothesis was altered so that the enzyme is now considered to be a single complex molecule containing both copper and haem. By virtue of its two dissimilar parts the enzyme could exhibit the properties demanded by Keilin and Hartree and others for the cytochromes  $a$  and  $a_3$  and by Warburg for the oxygen-transporting enzyme.

The advocates of two enzymes present the following evidence in support of their position.

(1) Morrison and Stotz (1955) and Morrison, Connelly and Stotz (1958) have claimed the existence of two cytochrome  $a$ -haems, an  $a_1$  and an  $a_2$ . They challenge the position of Lemberg (1953), who states that cryptoporphyrin  $a$ , which Morrison, Connelly and Stotz (1958) find is closely related to the porphyrin of haem  $a_1$ , is an artifact derived from the single haem  $a$ .

(2) Smith (1955) found that in the steady state after the addition of cytochrome  $c$  to the system ascorbate-cytochromes  $a + a_3$ -oxygen the 605  $m\mu$  peak was 59% of the totally reduced value, whereas the 445  $m\mu$  peak was only 24% reduced. It was concluded that the two peaks could not be those of one enzyme.

(3) Lundegårdh (1957) has made a careful study of the effects of carbon monoxide and cyanide on the spectrum of yeast and by optical subtraction has obtained the spectra of the two components. The ratios of the maxima of the absorption peaks were given for cytochrome  $a$ ,  $\gamma:\alpha = 1.0$ , and for cytochrome  $a_3$ ,  $\gamma:\alpha = 20.8$ .

The failure by us (Eichel, Wainio, Person and Cooperstein, 1950; Wainio, Eichel and Cooperstein, 1952) and by others to separate the two enzymes by techniques that have separated the other cytochromes may be taken as presumptive evidence in support of the one-enzyme concept. It must be

pointed out that from the very beginning the two enzymes have been viewed as being similar and as occurring in the same proportion wherever they were found (Keilin and Hartree, 1939). A 1:1.2 ratio has been reported by Chance and Williams (1955) for the cytochromes *a* and *a*<sub>3</sub> of rat liver mitochondria.

The two positions are defined by Slater (1958), who states that 'Those who demand physical separation will not accept the separate identity of the cytochromes *a* and *a*<sub>3</sub>, while those who prefer a functional differentiation will treat the two cytochromes as separate identities'.

## COMPONENTS OF CYTOCHROME *C* OXIDASE

### A. *The Haem*

The view that cellular respiration depends on a haem was proposed by Meyerhof (1924) and Harrison (1924), who believed that the experiments of Warburg and his associates were conclusive enough to show that the inhibitory action of cyanide was due to its combination with iron. Warburg (1924) himself was more conservative when proposing his theory for the role of iron as a biological catalyst. He simply characterized the catalyst as a complex iron compound. When Fischer and Hilger (1924) isolated a haem from yeast and higher plants the relationship between the iron and the complex iron compound was established.

The first separation of the prosthetic group of cytochrome *c* oxidase was performed by Anson and Mirsky (1925) in Cambridge from material largely supplied by Keilin. They used pyridine to extract the haems and identified two haemochromes: one which corresponded to the pyridine haemochrome of the haem of haemoglobin, and another with its  $\alpha$ -band at a higher wavelength. Fink (1932), subsequently, placed one of these bands at 584  $m\mu$ , while Negelein (1933) found two peaks in the absorption spectrum at 432  $m\mu$  and 587  $m\mu$ . More recently, Rawlinson and Hale (1949), Dannenberg and Kiese (1952), Person, Wainio and Eichel (1953), and Morrison and Stotz (1955) have verified that a two-banded pyridine haemochrome, whose peaks are centred at 430  $m\mu$  and 587  $m\mu$ , can be prepared from mammalian heart muscle or from soluble preparations of cytochrome *c* oxidase.

The past and present evidence points to the nonmetallic portion of the haem as being of the oxorhodo type. Rawlinson and Hale (1949) identified an aldehyde rhodofying group, while Lemberg and Falk (1951) and Dannenberg and Kiese (1952) agreed that the porphyrin contains a formyl group. Warburg and Gewitz (1951) found two carboxyl groups plus one presumably formyl, and one vinyl group. They also withdrew their earlier suggestion that the haemin might be a phytol ester. Having isolated the haemin from a soluble preparation of cytochrome *c* oxidase, Kiese (1952) came to the conclusion that in addition to the formyl group the porphyrin contains a labile

group, the nature of which was not then known. Lemberg (1953) chose to isolate the porphyrin and identified three characteristic side chains. These were a rhodofying group which is almost certainly a formyl group, a second rhodofying group containing an ethylenic double bond, and a large alkyl or fatty-acid nonesterified side chain.

The structure of haem *a* has also interested Warburg for many years. Warburg, Gewitz and Völker (1955) fused haemin *a*, obtained from beef heart, with resorcinol and obtained a cyto-deuteroporphyrin which differed from deuteroporphyrin in its melting point and in its reaction with bromine. Cyto-deuteroporphyrin took up three atoms of bromine which suggested that there were three free positions. The problem has been studied further by Marks, Dougall, Bullock and McDonald (1959), who concluded that cyto-deuteroporphyrin is deuteroporphyrin with hydrogen for methyl in the 8-position. Thus cyto-deuteroporphyrin, a derivative of porphyrin *a*, would have three methyl groups, 1, 3 and 5, two propionic acid side chains, 6 and 7, and three free positions, i.e. hydrogens, 2, 4 and 8.

In a very recent report, which is available only in abstract form, Morrison and Stotz (1959) state that haemin *a* has a molecular weight of 880. According to them it is a dicarboxylic acid having two propionic acid side chains, three methyl groups, a formyl group, a ketone aliphatic side chain containing 14 carbon atoms, and a vinyl group attached to the porphyrin nucleus.

The foremost question with regard to the haem is whether there are two haems *a* or one. Morrison and Stotz (1955) found that they could separate two haemins of the *a* type on a silicic acid column from the purified cytochrome *c* oxidase preparation of Smith and Stotz (1954). The two haemins were at first labelled  $a_1$  and  $a_2$ , a nomenclature now withdrawn. Their pyridine haemochromes had identical spectra. They subsequently found (Morrison, Connelly and Stotz, 1958) that there was cross-contamination of the two components on the column. With the aid of a new paper chromatographic technique they obtained the pure compounds. The reduced pyridine haemochrome of haemin  $a_1$  has its  $\alpha$ -maximum at  $582\text{ m}\mu$  and has a small  $\beta$ -peak at  $533\text{ m}\mu$ . The corresponding compound of haemin  $a_2$  has a maximum at  $587\text{ m}\mu$  and no  $\beta$ -peak. They identified haemin  $a_1$  with cryptohaemin *a* of Lemberg (1953), but did not agree with the suggestion that cryptohaemin *a* and presumably therefore haemin  $a_1$  may be an artifact of the preparative procedure.

In the isolations performed by Lemberg (1953), porphyrin *a* was always accompanied by another porphyrin whose haemin had maxima at  $533\text{ m}\mu$  and  $582\text{ m}\mu$  in pyridine-dithionite. This component was called cryptoporphyrin *a*. Its yield from wet heart muscle was about  $0.7\text{ mg/kg}$  which is to be compared with the  $16\text{--}18\text{ mg/kg}$  of porphyrin *a* that was obtained. On this basis Lemberg concluded that even if cryptoporphyrin *a* is derived from haemin *a* and is not an artifact, it is present in too small a concentration to



be the prosthetic group of either cytochrome *a* or *a*<sub>3</sub>. In their last publication Morrison, Connelly and Stotz (1958) do not record the relative amounts of the two haemins, *a*<sub>1</sub> and *a*<sub>2</sub>, which they separated. In the first experiments where there was cross contamination the amounts were about equal (Morrison and Stotz, 1955).

The uncertainty regarding the number of haems *a* has been further complicated by the discovery that porphyrin *a* may exist in two interconvertible forms (Lemberg and Stewart, 1955). The porphyrin which is isolated and purified is identified as *ax*. On treatment with aqueous hydrochloric acid *ax* is partly converted into porphyrin *aβ* which has the same absorption spectrum, but which differs in its solvent distribution and chromatographic behaviour.

### B. The Copper

The view that copper might be a part of cytochrome *c* oxidase seems to be contained in the accumulated studies of Warburg (1949) and his associates, who concluded, however, that because of the light-sensitivity of its carbon monoxide compound, the enzyme could only contain iron. The earliest, as well as the latest nutritional studies have supported an opposite view (Cohen and Elvehjem, 1934; Gubler, Cartwright and Wintrobe, 1957).

Keilin and Hartree (1938a, 1939) also briefly considered that cytochrome *c* oxidase might be a copper enzyme. However, when cytochrome *a*<sub>3</sub>, an apparent haem-enzyme, satisfied all of the criteria of cytochrome oxidase, they discarded the possibility.

Our interest in the copper content of cytochrome *c* oxidase arose as a consequence of the feeling that, since the response of the enzyme to carbon monoxide was unusual, there must be an unusual component. We prepared fractions from heart muscle mitochondrial fragments with deoxycholate and found a good correlation between the copper content and the height of the 601 *mμ* absorption of the reduced enzyme (Eichel, Wainio, Person and Cooperstein, 1950). Even though in these experiments the correlation between the copper content and the activity was not good (see also: Okunuki, Sekuzu, Yonetani and Takemori, 1958), we concluded that the enzyme was a copper-protein. An analysis of the metal content of the pyridine haemochrome of the prosthetic group prompted us to return to the classical view (Person, Wainio and Eichel, 1953). The view has persisted, however, that cytochrome *c* oxidase must also be a copper-enzyme.

Our position is supported by the recent results of Green, Basford and Mackler (1956) and Mackler and Penn (1957), who find that only those mitochondrial fragments with a pronounced spectrum for cytochrome *c* oxidase have considerable amounts of copper. It is also interesting to note that in Mason's (1957) classification of four-electron transfer oxidases, of which cytochrome *c* oxidase is one, the other three enzymes, laccase, the catechol

oxidase function of the phenol oxidase complex, and ascorbic acid oxidase, all have copper as the functional group.

We have now obtained evidence to show that not only is the copper content of fractions prepared from heart mitochondria related to the haem (as calculated from the 605  $m\mu$  absorption), but that it is also related to the activity of the enzyme. The latter relationship was established after it was found that surface active agents reduce the activity of cytochrome *c* oxidase and that certain phosphatides are reactivators of the enzyme (Wainio and Greenlees, 1958; Greenlees and Wainio, 1959).

TABLE 1. RELATIONSHIP OF THE COPPER CONTENT (DETERMINED SPECTROPHOTOMETRICALLY) AND THE HAEM CONTENT OF CYTOCHROME *c* OXIDASE

Fraction	Deoxycholate added	Protein	Copper-protein ratio	Haem-* protein ratio	Copper-haem ratio
	%	mg/ml	$m\mu$ moles/mg	$m\mu$ moles/mg	$m\mu$ moles/ $m\mu$ mole
Insoluble†		25.00	1.1		
1	1.0	12.30	0.2	0	
2	0.5	4.86	0.5	0	
3	0.5	1.05	2.3	1.2	1.9
4	0.5	0.84	5.3	4.1	1.3
5	0.5	1.21	8.2	5.8	1.4
6	1.0	0.77	8.1	7.0	1.2
7	1.0	0.78	6.8	4.9	1.4
Residue		4.90	3.3		

\* Calculated from the  $\Delta E$  at 605  $m\mu$  with the aid of the factor  $\Delta \epsilon 7.6 \times 10^3 \text{ cm}^2 \text{ mole}^{-1}$ .

† Insoluble heart muscle preparation.

TABLE 2. RELATIONSHIP OF THE COPPER CONTENT (DETERMINED COLORIMETRICALLY), THE HAEM CONTENT, AND THE ACTIVITY OF CYTOCHROME *c* OXIDASE

Fraction	Deoxycholate added	Protein	Copper-haem* ratio	Activity-protein ratio		Activity (with fraction 1)-haem ratio	Activity (with fraction 1)-copper ratio
				Without fraction 1	With fraction 1		
	%	mg/ml	$m\mu$ moles/ $m\mu$ mole	$k^1/\text{mg}$ protein	$k^1/\text{mg}$ protein	$k^1/m\mu$ mole	$k^1/m\mu$ mole
Insoluble†		25.00	1.0	0.660			0.33‡
1	1.0	11.60	1.0	0.027			
2	1.0	4.54	2.8	0.436	0.690	1.73	0.63
3	1.0	2.03	1.1	0.965	2.010	0.78	0.65
4	1.0	1.57	1.6	0.581	6.900	1.28	0.93
5	1.0	0.82	3.2	0	3.670	1.27	0.40
6	1.0	0.34	2.6	0	4.300	1.19	0.46
Residue		4.56		0	0.100		0.06

\* Calculated from the  $\Delta E$  at 605  $m\mu$  with the aid of the factor  $\Delta \epsilon 7.6 \times 10^3 \text{ cm}^2 \text{ mole}^{-1}$ .

† Insoluble heart muscle preparation.

‡ Activity without fraction 1.

The data showing the relationship of the copper to the haem (Wainio, Vander Wende and Shimp, 1959) for a typical experiment are presented in Table 1. The average ratio of copper : haem is 1.4. It is to be noted that the copper:protein ratio is high in those fractions (5 and 6) which have a marked absorption at 605  $m\mu$  in the reduced state (from which the haem content was calculated). In another experiment (Table 2) where the copper was determined colorimetrically, the copper:haem ratios were found to be higher and more variable (average = 2.1). However, since in these experiments the first fraction was employed as an activator, rather constant ratios were obtained for the activity:haem and activity:copper.

It is not possible to conclude from these experiments whether 1 or 2 copper atoms are present per haem, although the more likely figure is 2. The averages, 1.4 and 2.1, are to be compared with the value of 2.3 obtained by recalculating our earlier data (Eichel, Wainio, Person and Cooperstein, 1950). We find that one of our partially purified preparations '2.05-2' has a ratio of 1.6 and our presumed purest preparation '2-4-1.5' (Greenlees and Wainio, 1959) has a ratio of 1.0. According to unpublished data of Mackler (1956) the cytochrome *c* oxidase moiety of the electron transport particle has a copper:haem ratio of 2.5.

Vander Wende (1959) has analysed the state of the copper in cytochrome *c* oxidase. It has been reported by Okunuki *et al.* (1958) that the copper is firmly bound to the protein. In our experiments high concentrations (0.1 M) of cyanide, diethyldithiocarbamate, ethylxanthate, etc., and prolonged dialysis (up to 12 hr) were required to remove the copper and to decrease the activity. The copper exists in the cuprous state in the oxidized enzyme as shown by the specific reaction with biquinoline. Cupric ion was ineffective in restoring the activity of preparations from which the copper had been removed by dialysis against diethyldithiocarbamate. Cuprous ion was unexpectedly effective in one experiment, raising the activity to 320% of the control when 99% of the copper was restored. These experiments suggest that the metal does not participate in electron transport. It may function, as does the copper in haemocyanin, to complex the oxygen to the enzyme.

The spectral changes accompanying the removal of the copper were inconclusive. Some reagents caused no alteration in the spectrum of the reduced enzyme even though they removed much of the copper. However, those that did alter the spectrum, notably cyanide, diethyldithiocarbamate and ethylxanthate, caused a decrease in the absorption at 605  $m\mu$  with a shift in the maximum to about 595  $m\mu$  and a decrease in absorption at 442  $m\mu$  with a shift in the maximum to about 435  $m\mu$ .

### C. The Lipids

Cytochrome *c* oxidase is associated with the insoluble particulate matter of the cell. It is a mitochondrial enzyme which has been shown to be attached

to the membrane of the particle (Siekevitz and Watson, 1956). The insoluble nature of the particle permitted Battelli and Stern (1912) to separate it from the cell. Keilin and Hartree (1938b) modified the method of preparation so that the grossly impure enzyme could be obtained in a high yield from heart muscle where it occurs in a high concentration.

It has been suggested by many investigators that the insolubility of the enzyme may be due to its association with the lipids of the mitochondrion. In fact it has been further suggested that the oxidase may be a lipoprotein complex, because approximately 35% of the mitochondrion is lipid (Bensley, 1937) and because bile salts are needed to solubilize the enzyme (Yakushiji and Okunuki, 1941; Straub, 1941).

The soluble preparations that are being studied today are those that are made with either cholate or deoxycholate. It has been clearly shown that the solubility of this insoluble enzyme depends on the continued presence of a solubilizing agent. Smith and Stotz (1954) reported that the solubility of their preparation is dependent on the presence of both the cholate, and the ammonium sulphate used in the purification. Kremzner and Wainio (1955) found that a complete removal of the deoxycholate from the preparation '2-3' by ion exchange resins led to a precipitation of the enzyme, but not to its denaturation.

Among the soluble preparations of cytochrome *c* oxidase available for study is the preparation of Yakushiji and Okunuki (1941) as modified by Okunuki *et al.* (1958). However, these authors do not report a lipid analysis. The preparation '2-3' of Eichel, Wainio, Person and Cooperstein (1950) was analysed by Kremzner (1956), who found 45% of total lipid. A modified preparation '2-3', made by first washing the insoluble heart muscle particles with 20% methanol, was still active and contained only 19% of total lipid. The lipids in both preparations were predominantly phosphatidylcholine, and phosphatidylethanolamine. This finding has been verified and extended by Marinetti, Scaramuzzino and Stotz (1957), who reported that the soluble preparation of Smith and Stotz (1954) contains 14.7% of phospholipid (primarily phosphatidylcholine and phosphatidylethanolamine), 12.8% of neutral fat, 1.02% of free cholesterol and 3.12% of unidentified lipids. Green (1958) states that the soluble preparation of Mackler and Penn (1959) contains about 15% of lipid.

Marinetti, Erbland, Kochen and Stotz (1958) have more recently extended their chromatographic analysis of the phosphatides and have found again that phosphatidylcholine (33.4% of the total lipid *P*) and phosphatidylethanolamine (19.6% of the total) were the principal phosphatides. There was 8.2% of phosphatidylserine, 13.6% of a component tentatively identified as polyglycerophosphatide, 5.1% of unidentified phosphatides, and traces of lysolecithin and lysocephalin. Two compounds distinguished the lipids of the oxidase preparation from those of a purified cytochrome *b - c<sub>1</sub>* preparation

reported elsewhere. There were 13.9% (of the total lipid *P*) of inositol-phosphatide and 5.9% of sphingomyelin, both of which occur only in trace amounts in the cytochrome *b* - *c*<sub>1</sub> preparation. In addition to these differences, the oxidase alone contained an unidentified lipid which had the same mobility as a long chain cholesterol ester, but which gave different colour tests from those given by the ester. The oxidase contained a small amount of a fraction which, after reduction, and passage through florisil, had peaks in its absorption spectrum at 232 m $\mu$  and 272 m $\mu$ . The latter peak probably indicates the presence of the coenzyme *Q* of Crane, Hatefi, Lester and Widmer (1957).

TABLE 3. REACTIVATION OF CYTOCHROME *c* OXIDASE WITH A DEOXYCHOLATE EXTRACT

Preparation	Velocity constant
	$\times 10^{-3} \text{ sec}^{-1}$
2% deoxycholate extract	2.68
4% cholate extract	0.54
2-4-1.5*	0.31
2-4-1.5 + 2% deoxycholate extract	7.24
2-4-1.5 + 4% cholate extract	0.31

\* 2% deoxycholate to the insoluble heart muscle mitochondrial fragments, followed by 4% cholate, and then 1.5% deoxycholate.

TABLE 4. REACTIVATION OF CYTOCHROME *c* OXIDASE (Preparation 2-4-1.5\*) WITH PHOSPHATIDES

Addition†	Velocity constant
	$\text{sec}^{-1}/\text{mg protein per/ml}$
None	0.3
Purified phosphatidylcholine	0.9
Purified lysolecithin	3.1
Phosphatidylserine	6.7
Phosphatidylethanolamine	4.0
Cephalin plasmalogen	2.5
Crude phosphatidylcholine	4.6

\* 2% deoxycholate to the insoluble heart muscle mitochondrial fragments, followed by 4% cholate, and then 2% deoxycholate.

† 0.012 mg phosphatide *P* per cuvette, except crude phosphatidylcholine of which 0.25 mg was added.

Some of these lipids are known to participate in the cytochrome *c* oxidase system. Wainio and Greenlees (1958) (see also Greenlees and Wainio, 1959) have shown that when a soluble oxidase preparation was made by successively extracting heart muscle mitochondrial fragments with deoxycholate, cholate, and again deoxycholate, the activity was much reduced. Reactivation was accomplished by adding the first deoxycholate extract or one of a number of phosphatides (Tables 3 and 4). The following compounds were ineffective: oleic acid, vitamin K<sub>1</sub>, cholesterol, DL- $\alpha$ -tocopherol phosphate, choline, and phosphorylcholine. The activation has been verified by Hatefi (1958), who found that the mitochondrial lipoprotein of Basford and Green (1959) increased the oxidase activity of the green particle of Basford, Tisdale, Glenn and Green (1957). The lipid-soluble form of cytochrome *c* described by Widmer and Crane (1958) was also effective.

The role of all of these lipids remains obscure. There are, however, two possibilities to be borne in mind: (1) that they are structural components of the mitochondrion in the sense that they facilitate the optimal arrangement of the reacting enzymes; (2) that they are actually intermediates in electron transport.

#### D. *The Protein*

Very little is known about the protein of cytochrome *c* oxidase. Its properties have not been determined because it has not been obtained in a soluble form except with the aid of surface active agents, i.e. it has not been purified free of lipid.

Soluble cytochrome *c* oxidase has the absorption spectrum of a typical protein with a maximum at 279  $m\mu$  (Wainio, Person, Eichel and Cooperstein, 1951). Its molecular weight has been determined to be 75,000 by Warburg (1949) from the molar extinction coefficient of the protein at 283  $m\mu$ , as calculated from the photochemical dissociation of the carbon monoxide compound of the reduced enzyme in yeast after correction for the absorption by the carbon monoxide compound of the haem at this wavelength. Wainio, Eichel and Cooperstein (1952) calculated a value of approximately 58,000 by relating the uncorrected sedimentation coefficient of  $5.8 \times 10^{-13}$  sec to the uncorrected sedimentation coefficient for cytochrome *c* ( $1.2 \times 10^{-13}$  sec) and to its molecular weight (12,000).

### REACTIONS OF CYTOCHROME C OXIDASE

Since cytochrome *c* oxidase has been shown to contain copper and to require a lipid for its activity, it becomes necessary to reconsider the reactions of the enzyme in the light of these new data.

#### A. *Reaction with Ferrocyclochrome c*

Although it has been known since the early work of Keilin (1930) that ferrocyclochrome *c* is oxidized by oxidase preparations in the presence of oxygen,

the study of the interactions of the purified preparations has had to await the isolation of a soluble cytochrome *c* oxidase. Wainio (1955a) has demonstrated that cytochrome *c* oxidase (as measured at 605  $m\mu$ ) can be partially reduced under anaerobic conditions with the simultaneous partial oxidation of ferrocytochrome *c*. The calculated equilibrium constants varied somewhat suggesting that perhaps a third component was participating. This may have been residual oxygen. It is also possible to oxidize reduced cytochrome *c* oxidase partly with ferricytochrome *c* (Wainio, 1955b), although the equilibrium attained is not the same as when oxidized oxidase and ferrocytochrome *c* are mixed.

With two groups to be considered, the haem and the copper, it becomes necessary to assign tentatively to one of these the position of reacting with ferrocytochrome *c*. Since the group must accept the electrons from ferrocytochrome *c*, and if we assume that the copper is not oxidized and reduced, the role of electron acceptor falls to the haem.

The role of the lipid remains more uncertain. It might be asked whether the phosphatide activator serves to link cytochrome *c* and the oxidase together or even to transfer the electrons from one haem to the other. Furthermore, is its role the same or related to the role of the lipid in the lipid-soluble form of cytochrome *c*?

### B. Reaction with Oxygen

By definition cytochrome oxidase is the enzyme that reduces oxygen. Again it becomes necessary to ask the question whether it is the copper or the haem that acts as the electron donor. As has already been pointed out, the copper probably does not participate in electron transfer, by reason of its being in the reduced state when the haem is oxidized, but serves merely to attach the oxygen to the enzyme. The role of electron donor, as well as acceptor, would then be assigned to the haem.

Although the mechanism of the reduction is unknown, Michaelis (1951) has proposed that, according to the principle of single-electron transfer, oxygen can only be reduced in the following successive stages:  $O_2 \xrightarrow{e^-} O_2^{1-} \xrightarrow{e^-} O_2^{2-} \xrightarrow{e^-} O_2^{3-} \xrightarrow{e^-} O_2^{4-}$ , which in the presence of water would form the following compounds with four protons:  $O_2 \xrightarrow[H^+]{e^-} HO_2 \xrightarrow[H^+]{e^-} H_2O_2 \xrightarrow[H^+]{e^-} H_2O + HO \xrightarrow[H^+]{e^-} 2H_2O$ .

If the copper : haem ratio proves to be 2:1, as the preliminary data show, the conditions outlined above would be met. There would be two atoms of cuprous copper to attach the oxygen, and one molecule of haem to act as electron donor and to reduce the oxygen in successive one-electron transfers.

Sekuzu, Takemori, Yonetani and Okunuki (1959) have postulated the existence of an oxygenated form of cytochrome oxidase which is formed from

the reduced enzyme by bubbling oxygen through the solution reduced with dithionite. The 444  $m\mu$  and 605  $m\mu$  peaks are diminished in height and the maxima shift to 426–28  $m\mu$  and 603  $m\mu$ , respectively. The further addition of ferricyanide shifts the maxima to 424  $m\mu$  and 600  $m\mu$ . These last values are about 5  $m\mu$  higher than those reported by other investigators for the oxidized enzyme (see p. 347 of Wainio and Cooperstein, 1956) and seem to suggest that even with ferricyanide the preparation cannot become fully oxidized. As pointed out by Chance in the discussion of the paper of Okunuki, Hagihara, Sekuzu and Horio (1958), it is possible that the oxygenated intermediate compound is a mixture of the oxidized and reduced forms of an altered or damaged preparation. The maxima are very reminiscent of the partially reduced solution of our enzyme which we produced with ferrocyanide (Wainio, 1955c). This mixture had maxima at 425  $m\mu$  and 603  $m\mu$ .

### C. Reactions with Carbon Monoxide and Nitric Oxide

Warburg (1926) was the first to suggest that a reduced iron-containing enzyme should be the point of attachment of carbon monoxide. He and his associates went on to determine the photochemical action spectrum of the carbon monoxide compound of cytochrome *c* oxidase in yeast (Warburg and Negelein, 1928, 1929; Warburg, 1932; Kubowitz and Haas, 1932). Their method was based on the earlier observation that the inhibition by carbon monoxide is light-reversible and that the degree of reversibility is dependent on the wavelength of the incident light (Warburg, 1926). The maxima for the absorption by the components which absorbed the energy of the light to cause the reversal were found at 283  $m\mu$  and 430  $m\mu$ , at about 520  $m\mu$ , and at 540  $m\mu$  and 590  $m\mu$ . Chance (1953) has since shown that the photochemical dissociation spectrum of the carbon monoxide compound of the enzyme is the same in mammalian heart muscle.

The actual combination of the reduced cytochrome *c* oxidase with carbon monoxide was demonstrated by Keilin and Hartree (1939), who found a partial shift in the spectrum of a heart muscle preparation with new bands at 432  $m\mu$  and 590  $m\mu$ . These bands, which correspond to two of the principal peaks found by Warburg for the yeast enzyme, and the partial shift in the spectrum have been confirmed by Ball, Strittmatter and Cooper (1951), Dannenberg and Kiese (1952), Wainio (1955c) and Sekuzu *et al.* (1959) with soluble preparations of cytochrome *c* oxidase. The effects noted by Wainio (1955c) are presented in Fig. 1 where it can be seen that the  $\gamma$ -peak shifted from 443  $m\mu$  to 430  $m\mu$ , while the  $\alpha$ -peak shifted from 605  $m\mu$  to 603  $m\mu$  and became asymmetrical on its lower wavelength side. It is to be observed that a considerable absorption still persists at 443  $m\mu$  and 605  $m\mu$ . The difference spectrum has maxima for the carbon monoxide compound of the reduced enzyme (downward peaks in Fig. 1) at 428  $m\mu$ , 545  $m\mu$  and 590  $m\mu$ .

The effect of nitric oxide on the reduced enzyme (Wainio, 1955c) is shown



in Fig. 2 (see also Sekuzu *et al.*, 1959). The existence of two components, one which reacts with nitric oxide and one which does not, is shown even more distinctly here. The difference spectrum has maxima for the nitric oxide compound of the reduced enzyme at 426  $m\mu$ , 545  $m\mu$  and 597  $m\mu$ .

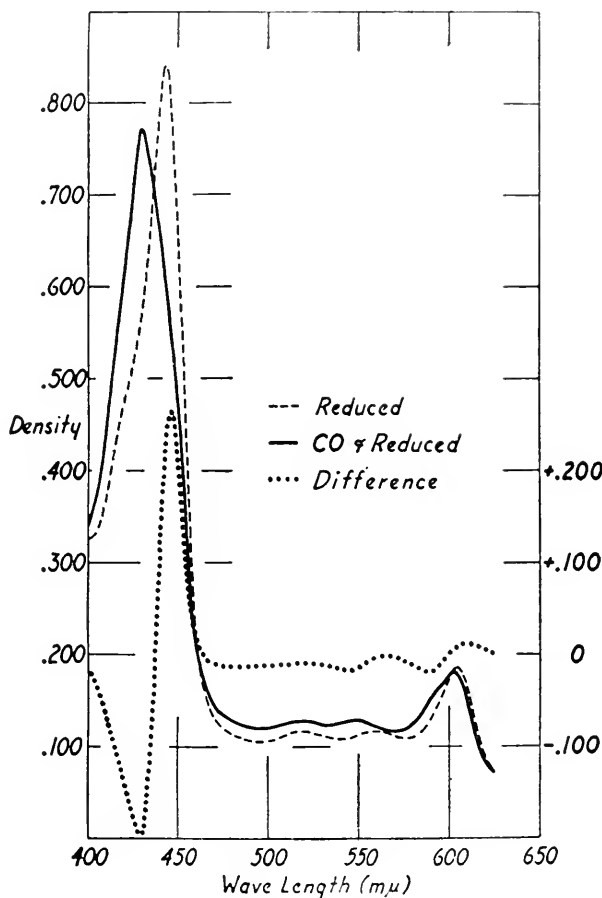

FIG. 1. Effect of carbon monoxide on the spectrum of reduced cytochrome *c* oxidase. The ordinate on the right is for the curve of the difference spectrum.

The effect of carbon monoxide, which prompted Keilin and Hartree (1939) to suggest the presence of two cytochromes *a*, and the more recently discovered effect of nitric oxide must be reinterpreted in the light of the newer knowledge that the enzyme contains copper. It is our suggestion that, if the site of oxygen-binding is the copper, then it must also be the site of carbon monoxide- and nitric oxide-binding. However, it must be carefully noted

that Warburg (1949) has not found a carbon monoxide compound of any metal other than iron which is decomposed by light. For example, the carbon monoxide compound of the copper of haemocyanin which has a Cu:CO ratio of 2:1 (Kubowitz, 1938) is not sensitive to light.

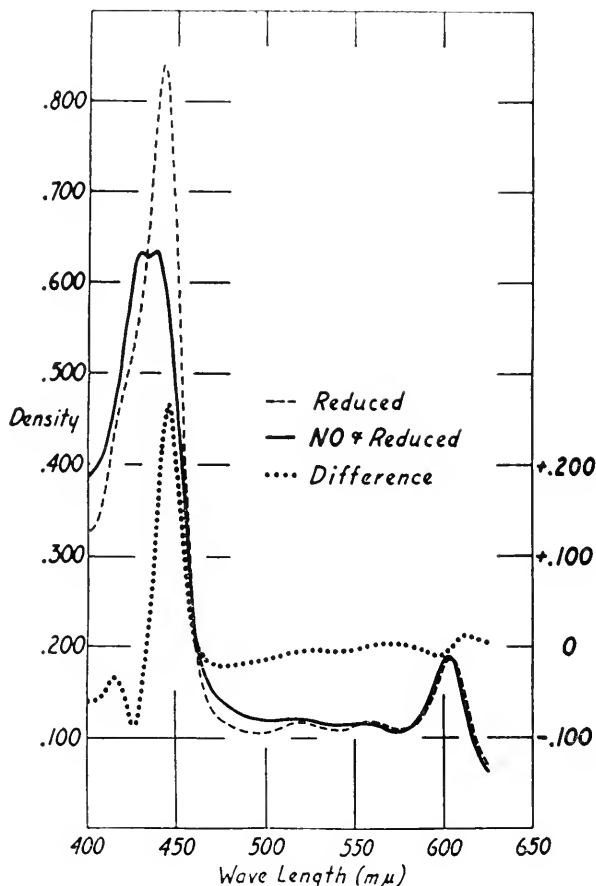

FIG. 2. Effect of nitric oxide on the spectrum of reduced cytochrome *c* oxidase.

Based on a study of the equilibrium between cytochrome *c* oxidase and carbon monoxide, Wald and Allen (1957) have concluded that the enzyme must contain more than one haem/molecule. They found the curve relating per cent saturation of the enzyme with carbon monoxide to the partial pressure of carbon monoxide to be slightly inflected and concluded that this was evidence for the interaction of haems. If it is assumed that carbon monoxide combines with the copper and that there are two copper atoms per molecule, the results of Wald and Allen would be explained.

## D. Reactions with Cyanide

Warburg's (1924) theory of the role of iron in biological oxidations was founded largely on the inhibitory effect of cyanide on respiration. Warburg (1927) later concluded that cyanide combines with the oxidized form of the enzyme. He found that the degree of inhibition by cyanide was independent

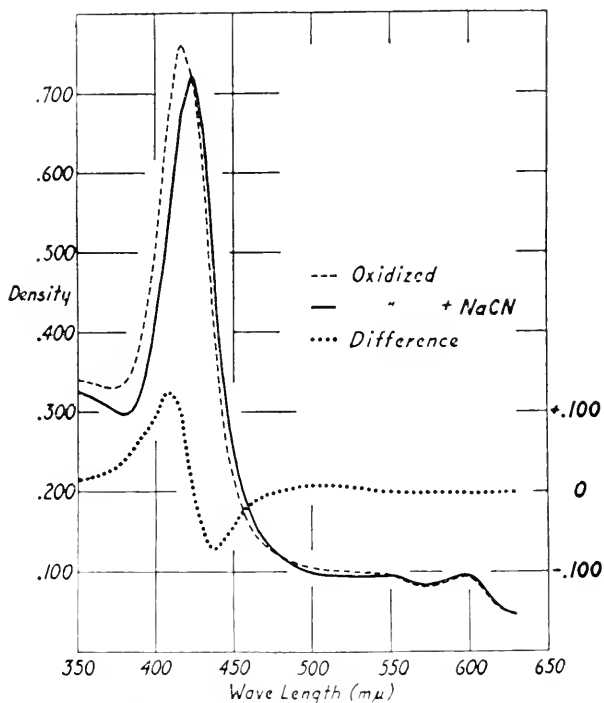

FIG. 3. Effect of cyanide on the spectrum of oxidized cytochrome *c* oxidase.

of the oxygen tension and therefore cyanide and oxygen were not competing for the reduced form of the enzyme. The inhibition was amply confirmed by Keilin and Hartree (1939), who used the partial effect of cyanide on the spectrum of the reduced enzyme as support for their concept that there are two cytochromes *a*.

The effects of cyanide on the spectra of both the oxidized and reduced forms of the soluble enzyme (Wainio, 1955c) may be seen in Figs. 3 and 4 (see also Smith, 1951; Ball and Cooper, 1952; Lundegårdh, 1953). It is first to be noted that the effects are much more pronounced with the reduced enzyme than with the oxidized enzyme. This would suggest that it is the reduced form of the enzyme that is cyanide-sensitive. Furthermore, a study of the oxidized curves suggests that cyanide, which is a reducing agent, has

caused the loss of oxidized enzyme and the appearance of reduced enzyme, viz., the 410  $m\mu$  and 438  $m\mu$  peaks on the curve of the difference.

We have also observed (Wainio, 1955d) that, whereas oxidized cytochrome *c* oxidase is readily reduced by ferrocyanide, the oxidation

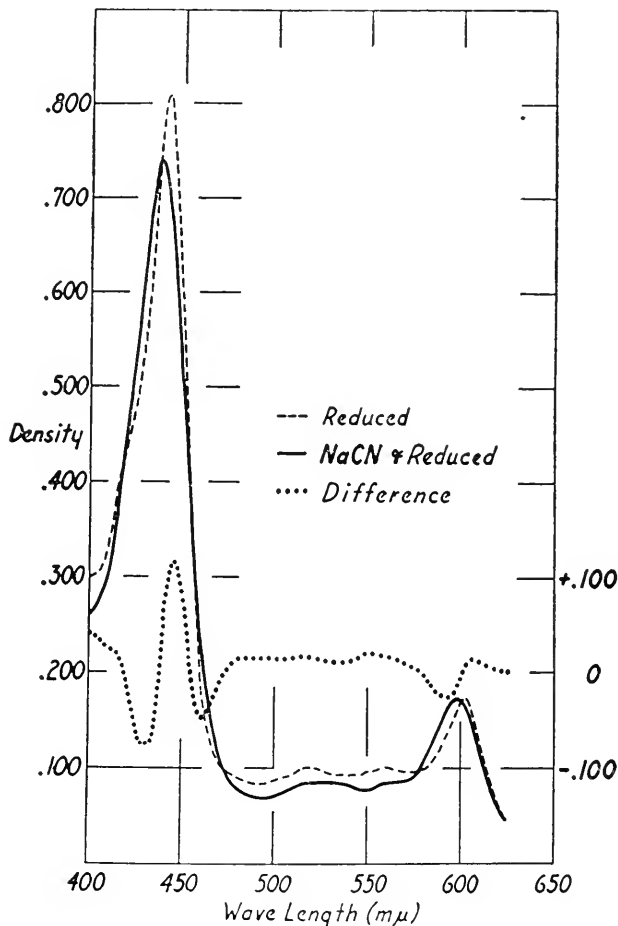

FIG. 4. Effect of cyanide on the spectrum of reduced cytochrome *c* oxidase.

of reduced cytochrome *c* oxidase proceeds only very slowly in air in the presence of cyanide. The slow rate is illustrated in Fig. 5 where the reciprocal of the fraction of cytochrome *c* oxidase in the reduced state is plotted against the time in minutes. The reaction is second order. These results would seem to support the view that it is not the oxidized, but the reduced form of the enzyme that is inhibited by cyanide. In order to reconcile this conclusion with Warburg's observation that cyanide and oxygen do not compete for the

reduced enzyme, it is suggested that cyanide combines principally with the haem and oxygen with the copper.

Not only has Vander Wende (1959) demonstrated that cyanide will remove the copper, but it is known that other copper-containing four-electron transfer oxidases are sensitive to cyanide. The fact that the cyanide will only

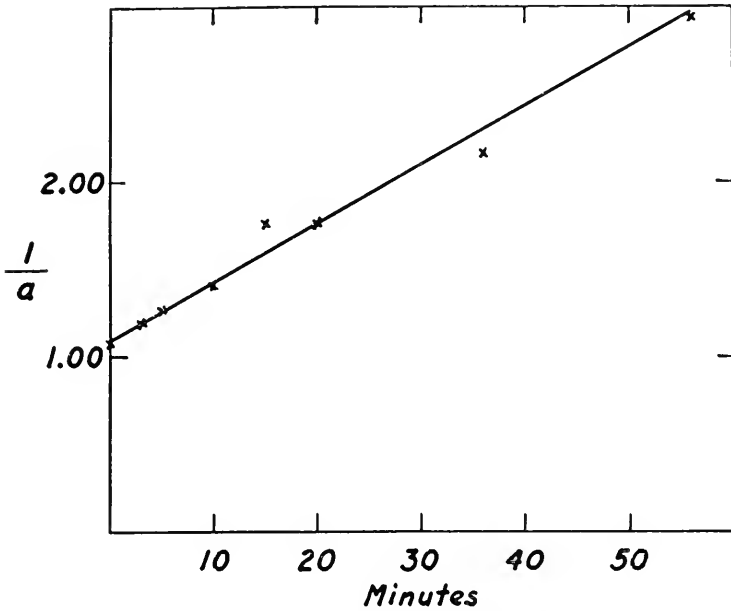

FIG. 5. Rate of oxidation of reduced cytochrome *c* oxidase by air in the presence of cyanide.

remove the copper with difficulty in our experiments, suggests that the copper is not too readily available to the cyanide.

Whether the copper is a component to be considered in relationship to the phenomenon presented in Fig. 6 (Wainio, 1956), can only be guessed at. If cytochrome *c* oxidase and a small amount of ferrocytochrome *c* (to reduce the oxidase) are incubated for 10 min with a range of concentrations of cyanide before the activity is determined spectrophotometrically by adding a substrate amount of ferrocytochrome *c*, the inhibitions observed in Fig. 6 are recorded. Preincubation of the oxidase alone with the cyanide, or of ferricytochrome *c* (which is the form of cytochrome *c* which combines with cyanide) alone with the cyanide, does not give these experimental points which lie on a doubly-inflected curve. The curve is indicative of two binding-sites for cyanide. One complex has a dissociation constant of approximately  $3 \times 10^{-8}$  moles/l. and the other a constant of approximately  $5 \times 10^{-6}$  moles/l. The curve (dashes) is a theoretical curve drawn on the assumption that each

cyanide is inhibiting the transfer of two electrons, whereas the other (dots) is drawn on the assumption that each cyanide is inhibiting the transfer of one electron. In this experiment the values fit the theoretical indicating that each cyanide is inhibiting the transfer of two electrons, but in other experiments the fit has not been as good, so that the points have fallen between the two curves.

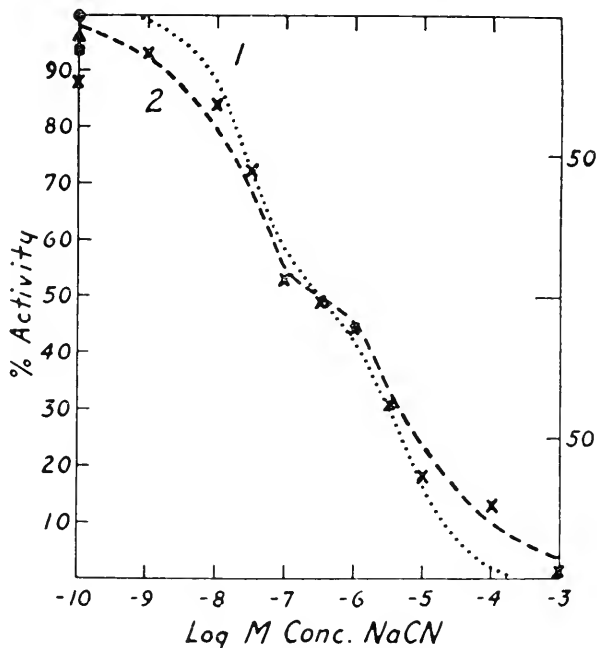

FIG. 6. Effect of cyanide on the activity of cytochrome *c* oxidase. ---- curve based on the assumption that each cyanide is forming a complex with a site transferring two electrons; . . . . curve based on the assumption that each cyanide is forming a complex with a site transferring one electron.

Therefore it can only be concluded that there are two binding sites for cyanide in a cytochrome *c*—cytochrome *c* oxidase mixture and that each site may control the transfer of two electrons each. Since this inflected curve is obtained on incubation with the cyanide only when the oxidase and the cytochrome *c* are together, it cannot yet be concluded that the two cyanide-sensitive sites are the two copper atoms. However, more than a single site must be involved and it must be borne in mind that copper will react with cyanide.

#### SUMMARY

The proposition has been explored that cytochrome *c* oxidase is one enzyme constituted of haem, copper, lipid and protein. It is suggested that the spectral and reaction anomalies which have supported the existence of two components, namely, cytochrome *a* and cytochrome *a*<sub>3</sub>, be reconsidered in

the light of the new evidence. It is particularly emphasized that cyanide may react with both the haem and the copper and that carbon monoxide may react more readily with the copper than with the haem.

## REFERENCES

- ANSON, M. L. & MIRSKY, A. E. (1925). *J. Physiol.* **60**, 161.  
 BALL, E. G. & COOPER, O. (1952). *J. biol. Chem.* **198**, 629.  
 BALL, E. G., STRITTMATTER, C. F. & COOPER, O. (1951). *J. biol. Chem.* **193**, 635.  
 BASFORD, R. E. & GREEN, D. E. (1958). Quoted by Hatefi, Y. (1958). *Biochim. biophys. Acta* **30**, 648.  
 BASFORD, R. E., TISDALE, H. D., GLENN, J. L. & GREEN, D. E. (1957). *Biochim. biophys. Acta* **24**, 107.  
 BATTELLI, F. & STERN, L. (1912). *Biochem. Z.* **46**, 343.  
 BENSLEY, R. R. (1937). *Anat. Record* **69**, 341.  
 CHANCE, B. (1953). *J. biol. Chem.* **202**, 397.  
 CHANCE, B. & WILLIAMS, G. R. (1955). *J. biol. Chem.* **217**, 395.  
 COHEN, E. & ELVEHJEM, C. A. (1934). *J. biol. Chem.* **107**, 97.  
 CRANE, F. L., HATEFI, Y., LESTER, R. L. & WIDMER, C. (1957). *Biochim. biophys. Acta* **25**, 220.  
 DANNENBERG, H. & KIESE, M. (1952). *Biochem. Z.* **322**, 395.  
 EICHEL, B., WAINIO, W. W., PERSON, P. & COOPERSTEIN, S. J. (1950). *J. biol. Chem.* **183**, 89.  
 FINK, H. (1932). *Hoppe-Seyl. Z.* **210**, 197.  
 FISCHER, H. & HILGER, J. (1924). *Hoppe-Seyl. Z.* **138**, 288.  
 GREEN, D. E. (1958). *The Harvey Lectures*, p. 177. Academic Press, New York.  
 GREEN, D. E., BASFORD, R. E. & MACKLER, B. (1956). *A Symposium on Inorganic Nitrogen Metabolism*, p. 125. Ed. by W. D. McElroy & B. Glass. Johns Hopkins Press, Baltimore.  
 GREENLEES, J. & WAINIO, W. W. (1959). *J. biol. Chem.* **234**, 658.  
 GUBLER, C. J., CARTWRIGHT, G. E. & WINTROBE, M. M. (1957). *J. biol. Chem.* **224**, 533.  
 HATEFI, Y. (1958). *Biochim. biophys. Acta* **30**, 648.  
 HARRISON, D. C. (1924). *Biochem. J.* **18**, 1008.  
 KEILIN, D. (1930). *Proc. roy. Soc.* **B106**, 418.  
 KEILIN, D. & HARTREE, E. F. (1938a). *Nature, Lond.* **141**, 870.  
 KEILIN, D. & HARTREE, E. F. (1938b). *Proc. roy. Soc.* **B125**, 171.  
 KEILIN, D. & HARTREE, E. F. (1939). *Proc. roy. Soc.* **B127**, 167.  
 KIESE, M. (1952). *Naturwiss.* **39**, 403.  
 KREMZNER (1956). *Dissertation Abstr.* **16**, 1206.  
 KREMZNER, L. T. & WAINIO, W. W. (1955). Abstracts of papers presented at the American Chemical Society Meeting, p. 52C, Minneapolis, Minn., U.S.A., Sept.  
 KUBOWITZ, F. (1938). *Biochem. Z.* **299**, 32.  
 KUBOWITZ, F. & HAAS, E. (1932). *Biochem. Z.* **255**, 247.  
 LEMBERG, R. (1953). *Nature, Lond.* **172**, 619.  
 LEMBERG, R. & FALK, J. E. (1951). *Biochem. J.* **49**, 674.  
 LEMBERG, R. & STEWART, M. (1955). *Aust. J. exp. Biol. med. Sci.* **33**, 451.  
 LUNDEGÅRDH, H. (1953). *Arkiv Kemi* **5**, 97.  
 LUNDEGÅRDH, H. (1957). *Biochim. biophys. Acta* **25**, 1.  
 MACKLER, B. (1956). Quoted by Green, D. E. in *Enzymes: Units of Biological Structure and Function*, p. 465. Ed. Gaebler, O. H. Academic Press, New York.  
 MACKLER, B. & PENN, N. (1957). *Biochim. biophys. Acta* **24**, 294.  
 MARINETTI, G. V., ERBLAND, J., KOCHEN, J. & STOTZ, E. (1958). *J. biol. Chem.* **233**, 740.  
 MARINETTI, G. V., SCARAMUZZINO, D. J. & STOTZ, E. (1957). *J. biol. Chem.* **224**, 819.  
 MARKS, G. S., DOUGALL, D. K., BULLOCK, E. & McDONALD, S. F. (1959). *J. Amer. chem. Soc.* **81**, 250.

- MASON, H. S. (1957). *Advanc. Enzymol.* **19**, 79.
- MEYERHOF, O. (1924). *Chemical Dynamics of Life Phenomena*. J. B. Lippincott Co. Philadelphia.
- MICHAELIS, L. (1951). *The Enzymes*, Vol. 2, p. 1. Ed. Sumner, J. B. & Myrbäck, K. Academic Press, New York.
- MORRISON, M., CONNELLY, J. & STOTZ, E. (1958). *Biochim. biophys. Acta* **27**, 214.
- MORRISON, M. & STOTZ, E. (1955). *J. biol. Chem.* **213**, 373.
- MORRISON, M. & STOTZ, E. (1959). Abstracts of papers presented at the American Chemical Society Meeting, Boston, Mass., U.S.A., April, p. 55C.
- NEGELEIN, E. (1933). *Biochem. Z.* **266**, 412.
- OKUNUKI, K., HAGIHARA, B., SEKUZU, I. & HORIO, T. (1958). *Proceedings of the International Symposium on Enzyme Chemistry*, 1957, p. 264, Maruzen, Tokyo/Pergamon Press, London.
- OKUNUKI, K., SEKUZU, I., YONETANI, T. & TAKEMORI, S. (1958). *J. Biochem. Tokyo* **45**, 847.
- PERSON, P., WAINIO, W. W. & EICHEL, B. (1953). *J. biol. Chem.* **202**, 369.
- RAWLINSON, W. A. & HALE, J. H. (1949). *Biochem. J.* **45**, 247.
- SEKUZU, I., TAKEMORI, S., YONETANI, T. & OKUNUKI, K. (1959). *J. Biochem. Tokyo* **46**, 43.
- SIEKEVITZ, P. & WATSON, M. L. (1956). *J. Biophys. Biochem. Cytol.* **2**, 653.
- SLATER, E. C. (1958). *Advanc. Enzymol.* **20**, 147.
- SMITH, L. (1951). *Fed. Proc.* **10**, 249.
- SMITH, L. (1955). *J. biol. Chem.* **215**, 833.
- SMITH, L. & STOTZ, E. (1954). *J. biol. Chem.* **209**, 819.
- STERN, K. (1940). *Ann. Rev. Biochem.* **9**, 1.
- STOTZ, E. (1942). *Symposium on Respiratory Enzymes*, p. 136, University of Wisconsin Press, Madison.
- STRAUB, F. B. (1941). *Hoppe-Seyl. Z.* **268**, 227.
- VANDER WENDE, C. (1959). Ph.D. thesis, Graduate Faculty of Rutgers, The State University, New Brunswick, N.J., U.S.A.
- WAINIO, W. W. (1955a). *J. biol. Chem.* **216**, 593.
- WAINIO, W. W. (1955b). (Unpublished results.)
- WAINIO, W. W. (1955c). *J. biol. Chem.* **212**, 723.
- WAINIO, W. W. (1955d). *Fed. Proc.* **14**, 299.
- WAINIO, W. W. (1956). *Fed. Proc.* **15**, 377.
- WAINIO, W. W. & COOPERSTEIN, S. J. (1956). *Advanc. Enzymol.* **17**, 329.
- WAINIO, W. W., COOPERSTEIN, S. J., KOLLEN, S. & EICHEL, B. (1947). *Science* **106**, 471.
- WAINIO, W. W., COOPERSTEIN, S. J., KOLLEN, S. & EICHEL, B. (1948). *J. biol. Chem.* **173**, 145.
- WAINIO, W. W., EICHEL, B. & COOPERSTEIN, S. J. (1952). *Science* **115**, 573.
- WAINIO, W. W. & GREENLEES, J. (1958). *Science* **128**, 87.
- WAINIO, W. W., PERSON, P., EICHEL, B. & COOPERSTEIN, S. J. (1951). *J. biol. Chem.* **192**, 349.
- WAINIO, W. W., VANDER WENDE, C. & SHIMP, N. F. (1959). *J. biol. Chem.* In the press.
- WALD, G. & ALLEN, D. W. (1957). *J. gen. Physiol.* **40**, 593.
- WARBURG, O. (1924). *Biochem. Z.* **152**, 479.
- WARBURG, O. (1926). *Biochem. Z.* **177**, 471.
- WARBURG, O. (1927). *Biochem. Z.* **189**, 354.
- WARBURG, O. (1932). *Angew. Chem.* **45**, 1.
- WARBURG, O. (1949). *Heavy Metal Prosthetic Groups and Enzyme Action*, p. 146, Oxford University Press, London.
- WARBURG, O. & GEWITZ, H.-S. (1951). *Hoppe-Seyl. Z.* **288**, 1.
- WARBURG, O., GEWITZ, H.-S. & VÖLKER, W. (1955). *Z. Naturforsch.* **10b**, 541.
- WARBURG, O. & NEGELEIN, E. (1928). *Biochem. Z.* **193**, 339.
- WARBURG, O. & NEGELEIN, E. (1929). *Biochem. Z.* **214**, 64.
- WIDMER, C. & CRANE, F. L. (1958). *Biochim. biophys. Acta* **27**, 203.
- YAKUSHUI, E. & OKUNUKI, K. (1941). *Proc. imp. Acad. Japan* **17**, 38.



## DISCUSSION

*Function of Copper in Cytochrome Oxidase Preparations*

SLATER: I was struck by the fact that in Wainio's Table 1 the copper-haem ratio decreased from 1.9 to 1.2, as the haem-protein ratio increased from 1.2 to 7.0. Does this not suggest that the copper concentration is decreasing as the cytochrome *c* oxidase is further purified?

WAINIO: There is only one high value for the copper-haem ratio and that is the first value of 1.9. The others range from 1.2 to 1.4 and are in no particular order.

SLATER: Is it possible that reactivation by copper after diethyldithiocarbamate treatment is due to removal of inhibitory diethyldithiocarbamate by added copper.

WAINIO: This kind of reactivation would be possible only if the reintroduced copper were bound in a loose fashion, because diethyldithiocarbamate will not inhibit the intact enzyme even after one hour of contact.

LEMBERG: We have attempted the addition of copper to various haemoproteins *a* in the presence or absence of CO, phospholipid, and/or deoxycholate. We have failed to notice any spectroscopic shift by the copper addition which would make the spectra of haemoproteins *a* more similar to those of cytochrome *a* and particularly cytochrome *a*<sub>3</sub>. We may not have found, of course, the right conditions to reconstitute such a specific copper-haemoprotein as Wainio postulates.

FALK: There is a certain amount of evidence that copper is required for cytochrome oxidase synthesis in animal tissues, and it is clear also that this enzyme acts in some kind of lipoprotein complex form. I think it is most important, since some people are trying to postulate chemical reaction mechanisms, to try to determine whether the copper is involved mechanistically in the oxidative activity, or is merely necessary for this activity in a secondary way, perhaps such as holding together the haem-protein-lipid complex. An experiment which might throw further light on this might be to try the effect of a bidentate chelator, which might be able to bind the copper but could not co-ordinate with a haem iron.

# CYTOCHROME OXIDASES OF *PSEUDOMONAS AERUGINOSA* AND OX-HEART MUSCLE, AND THEIR RELATED RESPIRATORY COMPONENTS

By T. HORIO, I. SEKUZU, T. HIGASHI\* AND K. OKUNUKI

*Department of Biology, Faculty of Science, University of Osaka,  
Osaka*

KEILIN and Hartree (1939) observed that their cytochrome oxidase preparation from ox-heart muscle contained a cytochrome component spectrophotometrically similar to cytochrome *a*, and they reported that the component differed from cytochrome *a* in the manner in which the component was sensitive to carbon monoxide. They thought that this component might be identical with cytochrome oxidase, calling it cytochrome *a*<sub>3</sub>. Thereafter in most reports, cytochrome oxidase preparations were described as containing both cytochromes *a* and *a*<sub>3</sub>. These two components have, however, not yet been separately purified. It is well known that the cytochrome oxidase preparation can oxidize cytochrome *c*, but not *p*-phenylenediamine, cysteine, or ascorbic acid, unless cytochrome *c* is present. Smith (1956) has found that the purified cytochrome *a* can be partially reduced by *p*-phenylenediamine. Okunuki *et al.* (1958) found that their preparation of purified cytochrome *a* showed the typical activity of cytochrome oxidase if cytochrome *c* was present, and that the preparation contained no spectrophotometrically detectable cytochrome component other than cytochrome *a*.

Negelein and Gerischer (1934), and Fujita and Kodama (1934) discovered that cytochrome *a*<sub>2</sub> was widely distributed among bacteria, and that it was autoxidizable and could combine with carbon monoxide and with cyanide. These properties led to the assumption that cytochrome *a*<sub>2</sub> had the function of a cytochrome oxidase. There are, however, some reports (Chance, 1953; Smith, 1955) that cytochrome *a*<sub>1</sub> may be the terminal respiratory enzyme in *Acetobacter pasteurianum*; these argue against the hypothesis that cytochrome *a*<sub>2</sub> acts as the respiratory enzyme of the bacteria. However, neither cytochrome *a*<sub>1</sub> nor cytochrome *a*<sub>2</sub> had been purified; moreover, it was not known in either case which substances could be oxidized by these cytochromes. Horio

\* Present address: *Department of Biochemistry, Medical School, University of Osaka, Osaka, Japan.*

(1958a and b), and Horio *et al.* (1958) succeeded in highly purifying four kinds of respiratory components of *Pseudomonas aeruginosa*. *Pseudomonas* (P-) cytochrome-551 and P-blue protein have been crystallized (Horio *et al.*, 1958; Horio, 1958b), and P-cytochrome oxidase has recently been obtained in a state of nearly homogeneous purity.

The present paper deals with reactions of the animal and bacterial cytochrome oxidases with their related respiratory components.

#### *Purification of Ox-heart and Pseudomonas Cytochrome Oxidases*

Ox-heart cytochrome *a* can be purified with the aid of cholate up to a state spectrophotometrically free of the other cytochromes. Yonetani *et al.* (1958) found that cholate inhibits the cytochrome oxidase activity of the cytochrome *a* preparation, and that the inhibitory action can be considerably diminished by the subsequent use of non-ionic detergents such as Emasol 4130 and Tween 80. By this method, the cytochrome oxidase activity of the preparation amounts to as much as one-third of the turnover number (oxygen consumed/cytochrome *a*) of the original extract.

The specific activity of P-cytochrome oxidase was increased approximately 250 times over the first cell-free extract of *Pseudomonas aeruginosa*, according to the method of Horio (1958a), and Horio *et al.* (1958), with some modifications in which zone-electrophoresis on a vertical starch column was adopted and acetone fractionation was not used. The enzyme could be further purified by dialysing a concentrated sample solution against distilled water, for the enzyme was remarkably less water-soluble in the absence of any salt than in the presence. The purified enzyme has been found to be ultracentrifugally homogeneous.

#### *Comparisons between Cytochrome Oxidase Activities of the Purified and Non-purified Oxidase Samples*

The purified cytochrome *a* is easily reduced by *p*-phenylenediamine, but only slightly by hydroquinone, and ascorbate. Despite this fact, the cytochrome *a* preparation does not consume oxygen with these reductants without the addition of cytochrome *c*. If a sufficient amount of cytochrome *c* is added however, the cytochrome *a* preparation shows a rapid oxygen uptake by the reductants, as shown in Table 1. The same fact can be observed with a particulate preparation of cytochrome oxidase which is free of cytochrome *c*. Moreover, the cytochrome oxidase activity of the cytochrome *a* preparation is inhibited by the typical inhibitors of cytochrome oxidase, carbon monoxide, cyanide, etc., in a manner similar to that of the cytochrome oxidase activity of the particulate preparation (Green and Brosteaux, 1936). Such similarities are observed with respect to optimal pH of the activity and effect of oxygen

tension on the activity between both preparations. These facts indicate that both preparations have the same kind of cytochrome oxidase.

TABLE I. INFLUENCE OF ADDITION OF CYTOCHROME *c* ON THE OXIDASE-ACTIVITY OF CYTOCHROME *a*

Oxygen uptake was measured with a Warburg manometer at pH 7.4 and at 30°C.

Experimental system	Substrate ( $10^{-2}$ M)		
	<i>p</i> -Phenylene-diamine	Hydroquinone	Ascorbic acid
	( $\mu$ l. oxygen consumed in 10 min)		
None	4	4	10
Cytochrome <i>a</i> ( $0.7 \times 10^{-7}$ M)	6	4	4
Cytochrome <i>a</i> + cytochrome <i>c</i> ( $1.4 \times 10^{-7}$ M)	104	126	80

When *Pseudomonas aeruginosa* grows anaerobically in the presence of nitrate, or under low oxygen tension (<20%) in the presence or absence of nitrate, the cytochrome content of the cells is greater than for normally grown cells and P-cytochrome oxidase can be purified from these cells as well as the other respiratory components. If grown under higher oxygen tension, the cells produce little or no cytochrome components, the respiration of the cells is not inhibited by the inhibitors, and the oxidase cannot be purified from these cells. Even with the cells grown anaerobically and under low oxygen tension, the oxygen respiration of the cells is not always completely inhibited by cyanide and carbon monoxide. The behaviour of hydroquinone oxidation by the cell-free extract of the cells grown anaerobically in the presence of nitrate towards various inhibitors is very similar to the oxygen respiration of the living cells. From this cell-free extract, two different kinds of enzymes capable of oxidizing hydroquinone can be purified: one is sensitive to cyanide and carbon monoxide (P-cytochrome oxidase), and the other is resistant (P-hydroquinone oxidase: Higashi, 1958). The former oxidase can rapidly oxidize P-cytochrome-551, and P-blue protein, while the latter cannot perform the oxidation. P-hydroquinone oxidase does not show any cytochrome-like absorption spectrum, and its physiological function is not yet known except that it can rapidly oxidize ascorbic acid as well as P-cytochrome oxidase.

#### *Properties of the Purified Preparations of Cytochrome a and P-cytochrome Oxidase*

The cytochrome *a* contained in the purified preparation is easily reduced by the addition of *p*-phenylenediamine, as is indicated by an increase in extinction of  $\alpha$ - (605  $m\mu$ ) and  $\gamma$ - (444  $m\mu$ ) absorption peaks. As shown in Fig. 1, the

reduction by *p*-phenylenediamine occurs even under aerobic condition, though the reduction rate is slow compared with the case under anaerobic conditions. The difference in rate between the two conditions indicates that cytochrome *a* itself is so slightly autoxidizable that this autoxidation cannot be considered to result from an enzymic activity. At present, it is not known whether the

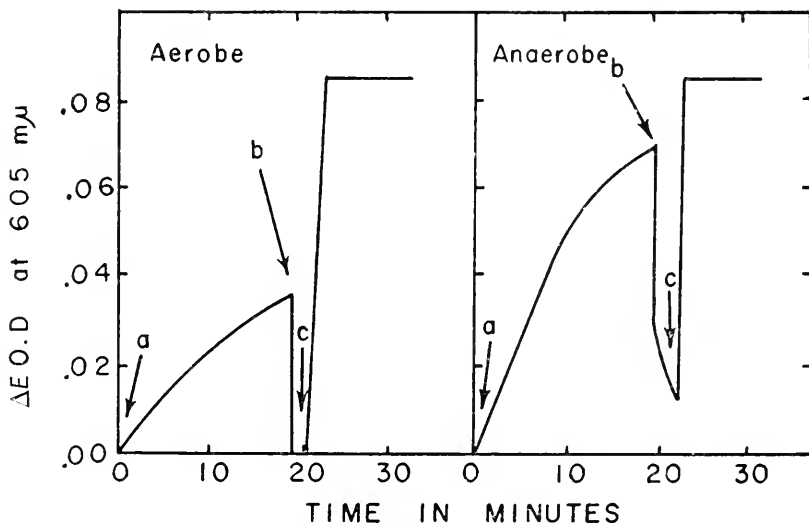

FIG. 1. Effect of cytochrome *c* on the oxidation of cytochrome *a*. Cytochrome *a* was incubated with *p*-phenylenediamine aerobically in 'Aerobe' and anaerobically in 'Anaerobe'. Other additions were made aerobically in both cases. The arrows indicate time of addition of each reagent: a,  $10^{-4}$  M *p*-phenylenediamine and a trace of sodium borohydride; b,  $5 \times 10^{-9}$  M oxidized cytochrome *c*; c, a trace of sodium dithionite. The addition of borohydride was made to prevent autoxidation of *p*-phenylenediamine.

autoxidizability results from the property of cytochrome *a* itself or from that of its modified form, just like the case of native and modified cytochrome *c*. If cytochrome *c* is present, the reduction of cytochrome *a* by *p*-phenylenediamine rapidly occurs under anaerobic condition. On the other hand, when cytochrome *c* is aerobically added to the cytochrome *a* previously reduced by an excess amount of *p*-phenylenediamine, cytochrome *a* cannot maintain its reduced form, and a rapid oxidation immediately occurs. This phenomenon of cytochrome *a* corresponds to that of the cytochrome oxidase activity of the purified cytochrome *a* preparation, as well as to that of the particulate preparation. It is, therefore, considered that cytochrome *a* itself displays an essential role in the cytochrome oxidase activity of its purified preparation. This consideration induces a concept in which the system, 'cytochrome *c* plus cytochrome *a*' works as cytochrome oxidase (so-called cytochrome  $a_3$ ).

The physicochemical constants of P-cytochrome oxidase are given in

Table 2. The oxidase contains no copper. The frictional ratio ( $f/f_0$ ) is calculated to be 1.2. Even after purification to a homogeneous state, P-cytochrome oxidase preparation shows a rather complex absorption spectrum, as if it contained so-called cytochrome  $a_2$  and  $c$ -type cytochrome. The  $a_2$ -type haem is easily extracted in acetone containing HCl according to the method of Barrett (1956) but the  $c$ -type haem remains in the acetone precipitate in a state bound to the protein moiety. Approximately half of the iron of the oxidase preparation is found in the acidic acetone extract. Therefore, it is sure that each molecule of P-cytochrome oxidase contains two different kinds of haems,  $a_2$ -type and  $c$ -type.

*Properties of the Respiratory Components Related to the Cytochrome Oxidases*

Cytochrome  $c_1$  can be purified separately from other cytochromes with the aid of cholate from ox-heart muscle. The purified cytochrome  $c_1$  does not show enzymic activities such as DPNH-cytochrome  $c$  reductase. However, the cytochrome  $c_1$  in its reduced form can rapidly transfer an electron to cytochrome  $c$ . The general properties of P-cytochrome-551 and P-blue

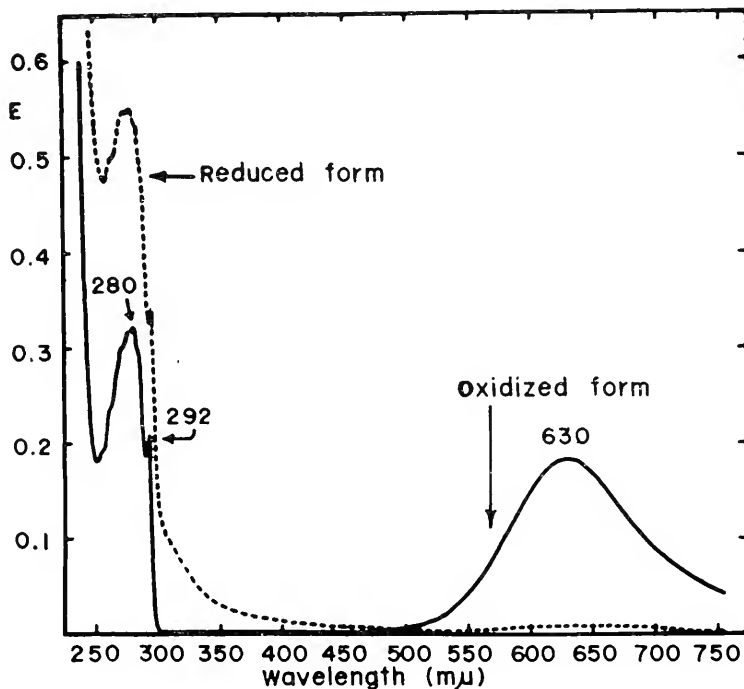

FIG. 2. Absorption spectra of crystalline *Pseudomonas* blue protein. The reduced form was made by adding sodium borohydride. Compared with the reduction of typical cytochrome  $c$ 's, a much larger amount of the reductant was required for complete reduction.



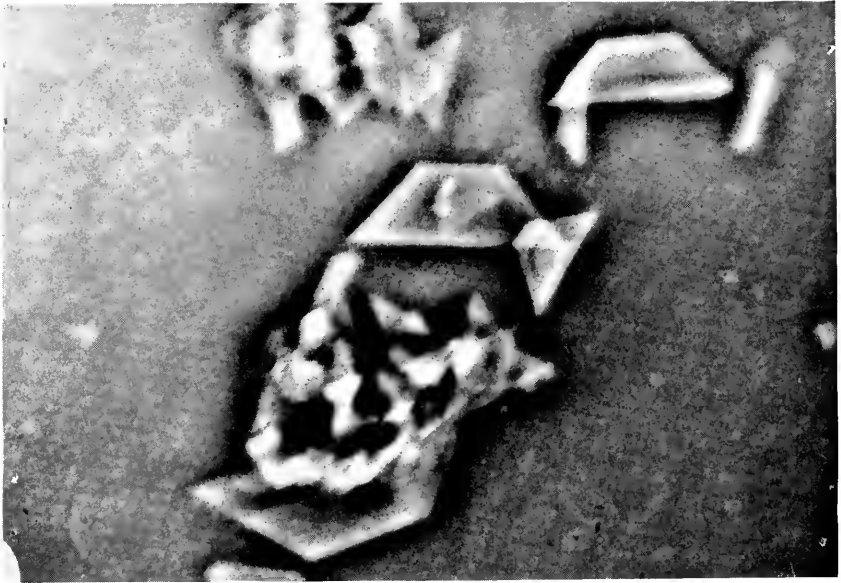

FIG. 3. Crystals of *Pseudomonas* blue protein. P-blue protein was crystallized in its oxidized form.  
Photograph  $\times 80$



protein crystallized are shown in Table 2. The absorption spectrum of the protein is as shown in Fig. 2. Finely crystallized P-blue protein has a shape as shown in Fig. 3. The copper bound on the protein can be split off from the

TABLE 2. GENERAL PROPERTIES OF P-CYTOCHROME OXIDASE, CRYSTALLINE P-CYTOCHROME-551 AND P-BLUE PROTEIN

	$S_{20, w}$	$D_{20, w}$	$\bar{V}_{20}^{\circ}$	$M_{S-D}$	$M_{Fe \text{ or } Cu}$	$E_0'$ (at pH 6.40)	Isoelectric point
	(Svedberg)	( $\times 10^{-7}$ $\text{cm}^2 \text{sec}^{-1}$ )	( $\text{ml g}^{-1}$ )			(V <sub>0</sub> )	(pH)
P-cytochrome oxidase	5.8	5.8	0.726	88,000	47,000	—	—
P-cytochrome- 551	1.34	14.8	0.710	7,600	8,100	+0.286	4.70
P-blue protein	1.91	10.6	0.749	17,400	16,600	+0.328	5.40

protein by dialysing it against cyanide solution at a neutral pH range. The copper-free P-blue protein does not show any absorption peak in the visible wavelengths even in the presence of oxidizing reagents, and the same absorption peak around  $630 \text{ m}\mu$  appears immediately after addition of a small amount of  $\text{CuSO}_4$  the colour of which can hardly be estimated spectrophotometrically.

#### *Reaction of Ox-heart Cytochrome a and Pseudomonas Cytochrome Oxidase with their Related Respiratory Components*

The hydroquinone oxidation by purified cytochrome *a* increases in rate up to its upper limit with an increasing concentration of cytochrome *c* externally added. Just at the concentration of cytochrome *c* at which the cytochrome oxidase activity reaches its maximal rate, the molar ratio of cytochrome *c* to cytochrome *a* is approximately one. This value is independent of the reactivation of the cytochrome oxidase activity of the cytochrome *a* preparation by the use of the non-ionic detergents as described above. The  $K_m$  for cytochrome *c* is  $3 \times 10^{-6} \text{ M}$ , which is similar to that obtained by Slater (1949). Purified cytochrome  $c_1$  is only slowly oxidized by cytochrome *a*, and the rapid oxidation of cytochrome *c* by the cytochrome *a* preparation is not influenced by the addition of cytochrome  $c_1$ . On the other hand, the slow oxidation of cytochrome  $c_1$  by the cytochrome *a* preparation is notably accelerated by the addition of a small amount of cytochrome *c*, as shown in Fig. 4.

P-cytochrome oxidase rapidly oxidizes the reduced P-cytochrome-551, and the reduced P-blue protein, but not the reduced P-cytochrome-554. The typical cytochrome *c*'s crystallized from baker's yeast and animal sources are very slowly oxidized by the oxidase, while the cytochrome *a* preparation does not oxidize P-cytochrome-551 and P-blue protein. P-cytochrome oxidase can oxidize several reductants such as hydroquinone, *p*-phenylenediamine, ascorbate, etc., as shown in Table 3 (Horio, 1958b). The oxidations by

P-cytochrome oxidase are similar to those of ox-heart cytochrome oxidase (Okunuki, 1941), except that P-cytochrome oxidase rapidly oxidizes these reagents regardless of the presence or absence of P-cytochrome-551 and P-blue protein, whereas the animal cytochrome oxidase is inactive unless

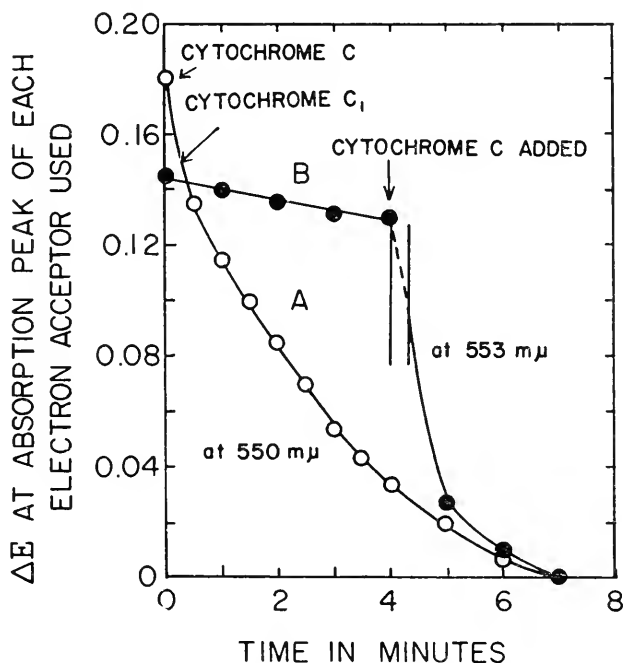

FIG. 4. Oxidations of reduced cytochrome *c*, and cytochrome *c*<sub>1</sub> by cytochrome *a*. The cuvette contained  $3.3 \times 10^{-2}$  M phosphate buffer of pH 7.4, 0.5% cholic acid,  $1.4 \times 10^{-6}$  M cytochrome *a*, and cytochromes *c* and *c*<sub>1</sub>, total volume made to 3.0 ml with water. Reactions were carried out at 15°C. The oxidations were initiated by the addition of cytochrome *a*, and the oxidations of cytochrome *c*, and cytochrome *c*<sub>1</sub> were measured by the decrease in optical densities at 550 mμ, and at 553 mμ (each  $\alpha$ -absorption maximum), respectively. Curve A, oxidation of  $0.9 \times 10^{-5}$  M cytochrome *c*; curve B, oxidation of  $1.4 \times 10^{-5}$  M cytochrome *c*<sub>1</sub>. The arrow shows the time when  $2 \times 10^{-6}$  M cytochrome *c* was added.

cytochrome *c* is present. The oxidation of the chemical reductants, P-cytochrome-551 and P-blue protein, by P-cytochrome oxidase is strongly inhibited by carbon monoxide and cyanide. The inhibition by carbon monoxide is reversed by light. The absorption peak at 625 mμ and the shoulder around 450 mμ of the reduced P-cytochrome oxidase are altered by carbon monoxide, but the other absorption peaks exhibit no such alteration. The absorption peaks of the oxidized P-cytochrome oxidase are not so significantly influenced by cyanide in spite of its strict inhibition. The hydroquinone oxidation by the oxidase reaches its half-maximal and full-maximal rates under the gas phase

TABLE 3. COMPARISON OF SPECIFICITY BETWEEN *PSEUDOMONAS* CYTOCHROME OXIDASE AND OX-HEART CYTOCHROME OXIDASE TO VARIOUS ELECTRON-DONATING SUBSTANCES

Oxygen consumption was measured by use of a Warburg manometer. Reactions with P-cytochrome oxidase were at 30°C in 0.04 M phosphate buffer of pH 6.0, and reactions using ox-heart cytochrome oxidase were carried out in the presence of cytochrome *c* at 25°C in 0.01 M phosphate buffer of pH 7.0

Substrate used $1 \times 10^{-2}$ M final concentration	Oxygen consumed			
	P-cytochrome oxidase		Ox-heart cytochrome oxidase	
	( $\mu$ l.)	(%)	( $\mu$ l.)	(%)
<i>p</i> -Phenylenediamine	60	100	80	100
<i>o</i> -Phenylenediamine	30	50	5	6
<i>m</i> -Phenylenediamine	0	0	0	0
Hydroquinone	65	108	96	120
Pyrocatechol	22	37	25	31
Resorcinol	0	0	0	0
<i>p</i> -Aminophenol	81	135	41	51
<i>o</i> -Aminophenol	121	202	57	71
<i>m</i> -Aminophenol	0	0	0	0
Pyrogallol	86	143	69	86
Phloroglucinol	5	8	0	0
L-Ascorbic acid	144	240	—	—

containing 2–3% and 20% oxygen, respectively. The  $K_m$  values for P-cytochrome-551, and P-blue protein are  $1.9 \times 10^{-5}$  M and  $3.9 \times 10^{-5}$  M, respectively, at 18°C and at pH 5.1, which is the optimal pH for both reactions. The turnover numbers for the oxidations of hydroquinone, P-cytochrome-551, and P-blue protein are 44 moles of oxygen consumed per mole of oxidase per min at pH 6.4 (optimum) and at 30°C, 87 moles at pH 5.1 and at 18°C, and 100 moles at pH 5.1 and at 18°C, respectively.

#### DISCUSSION

The cytochrome *a* preparation which is free of other cytochromes, shows the same cytochrome oxidase activity as does the Keilin–Hartree particulate preparation, which is free of cytochrome *c* but contains all other cytochromes and the succinate oxidase system. Moreover, the cytochrome oxidase activity of the cytochrome *a* preparation is identical in all its properties with the description of the animal cytochrome oxidase (so-called cytochrome  $a_3$ ), except for the turnover number. Based on the results of the oxidation and reduction of the cytochrome *a* present in the cytochrome *a* preparation, it is certain that cytochrome *a* displays a direct and essential function in the cytochrome oxidase activity of the purified *a* preparation. Because the cytochrome oxidase activity of the purified cytochrome *a* has a turnover-number one-third that of the original extract, it seems likely that the cytochrome oxidase activity of 'cytochrome *a* + cytochrome *c*' is still being partially inhibited



where the thick arrows indicate an electron-transferring pathway of greater physiological possibility than the slender ones. The box indicates that the enzymic protein of P-cytochrome oxidase has at least two different kinds of haems, and is capable of displaying cytochrome oxidase activity in the absence of any externally added respiratory components. In spite of the fact that some parts of the absorption spectrum of P-cytochrome oxidase are very similar to the  $\alpha$ -,  $\beta$ - and  $\gamma$ - absorption bands of P-cytochrome-551 and P-cytochrome-554, all attempts to split such a *c*-type cytochrome from native P-cytochrome oxidase have failed.

#### REFERENCES

- BARRETT, J. (1956). *Biochem. J.* **64**, 626.  
 CHANCE, B. (1953). *J. biol. Chem.* **202**, 383.  
 FUJITA, A. & KODAMA, T. (1934). *Biochem. Z.* **273**, 186.  
 GREEN, D. E. & BROSTEAX, B. (1936). *Biochem. J.* **30**, 1489.  
 HIGASHI, T. (1958). *J. Biochem. Tokyo* **45**, 785.  
 HORIO, T. (1958a). *J. Biochem. Tokyo* **45**, 197.  
 HORIO, T. (1958b). *J. Biochem. Tokyo* **45**, 267.  
 HORIO, T., HIGASHI, T., MATSUBARA, H., KUSAI, K., NAKAI, M. & OKUNUKI, K. (1958). *Biochim. biophys. Acta* **29**, 297.  
 HORIO, T., HIGASHI, T., NAKAI, M., KUSAI, K. & OKUNUKI, K. (1958). *Nature, Lond.* **182**, 1307.  
 KEILIN, D. & HARTREE, E. F. (1939). *Proc. roy. Soc.* **B127**, 167.  
 NEGELEIN, E. & GERISCHER, W. (1934). *Biochem. Z.* **268**, 1.  
 OKUNUKI, K. (1941). *Acta Phytochim.* **12**, 1.  
 OKUNUKI, K., SEKUZU, I., YONETANI, T. & TAKEMORI, S. (1958). *J. Biochem. Tokyo* **45**, 847.  
 SLATER, E. C. (1949). *Biochem. J.* **44**, 305.  
 SMITH, L. (1955). *Methods in Enzymology*, vol. 2, p. 732. Ed. by S. P. Colowick and N. O. Kaplan. Academic Press, New York.  
 SMITH, L. (1956). *J. biol. Chem.* **215**, 837.  
 YONETANI, T., TAKEMORI, S., SEKUZU, I. & OKUNUKI, K. (1958). *Nature, Lond.* **182**, 1306.

#### DISCUSSION

##### *Properties and Nomenclature of Cytochromes a and a<sub>3</sub>*

MORRISON: I think it pertinent to point out that we have been able to obtain two spectrally identical fractions on column electrophoresis of a cytochrome *c* oxidase preparation. One of these fractions was enzymically active, but the other fraction was enzymically inactive. Activity could not be restored to this inactive fraction.

Any difference in enzyme assays and chemical assays may certainly lie in the variable quantity of inactive cytochrome *c* oxidase present.

MORTON: I think that the evidence presented by Okunuki and co-workers (this volume, p. 310) is interpreted by them as establishing that there is only one cytochrome component, namely cytochrome *a*, which is required to carry out the functions usually attributed to 'cytochrome *c* oxidase'. However, the preparations obtained by Okunuki and co-workers differ from preparations obtained by other workers, and claimed to be preparations of 'cytochrome *a* + *a<sub>3</sub>*'. Chance, in particular, and Slater, have presented evidence in support of Keilin's original identification of cytochrome *a<sub>3</sub>* with cytochrome *c* oxidase (see for example, Morton, *Rev. pure appl. Chem.* **8**, 161, 1958).

Is it possible to reconcile these conflicting views by regarding 'cytochrome *a* + *a<sub>3</sub>*' as a single protein component with two different active sites, each involving haem *a*?

HORIO: The absorption spectra in the slides presented by Slater are almost the same as those of Wainio and ours (published in *Nature, Lond.* **182**, 1306 (1958)). The cytochrome oxidase activity of our cytochrome *a* preparation is, as I showed, essentially the same as that of the particulate preparation, if the cytochrome *a* is supplemented with cytochrome *c*. Therefore, if cytochrome  $a_3$  is the true cytochrome oxidase, our cytochrome *a* preparation should contain it to show the oxidase activity with no cytochrome *c*.

With respect to different kinds of cytochrome *a* present in the preparation which I suppose, and which is supported by Morrison's electrophoretic separation of active from inactive cytochrome oxidase, one may consider that the cytochrome *a* preparations contained varying amounts of admixed modified cytochrome *a*, or cytochrome *a* masked by non-ionic detergent. I believe that our preparation does not contain cytochromes other than cytochrome *a* and that cytochromes *a* and *c* show the oxidase activity but not cytochrome *a* alone.

I think that it would be of advantage to consider *Pseudomonas* cytochrome oxidase and the cytochrome oxidase activity of the cytochrome *a*, both being double-headed enzymes, at least in their functional state.

SLATER: Minnaert (*Biochim. biophys. Acta* **35**, 282, 1959) in our laboratory confirmed the observation of Okunuki and his colleagues that the absorption spectrum of cytochrome oxidase preparations in the presence of air and absence of hydrogen or electron donors is not the same as that obtained with  $K_3Fe(CN)_6$ . The difference is in fact somewhat greater than that found by Okunuki, and calculations show that it is not due to the presence of an inactive cytochrome *a* or  $a_3$  which is oxidizable by  $K_3Fe(CN)_6$ , but not by oxygen.

The same spectrum was obtained whether the  $K_3Fe(CN)_6$  was added in the presence of air or anaerobically to a preparation reduced spontaneously.

The positions of the absorption peaks are

	$\gamma$	$\alpha$
In air	420	598
$K_3Fe(CN)_6$	424	591-3
$Na_2S_2O_4$	444	605

It is thought likely that the spectra obtained with  $K_3Fe(CN)_6$  and  $Na_2S_2O_4$  are those of cytochromes  $a^{+++} + a_3^{+++}$ , and of  $a^{++} + a_3^{++}$ , respectively. In air, the spectrum is that of  $a^{+++}$  plus a second form of oxidized cytochrome  $a_3$ , possibly  $a_3$  ferryl.

It is not known whether both forms of oxidized cytochrome  $a_3$  are involved in the enzymic reaction. Both are, however, equally reactive in a system containing ascorbic acid and cytochrome *c*.

CHANCE: With reference to Morton's point, a number of cogent arguments have been advanced by Keilin, by Slater, and by myself on the separate identities of cytochromes *a* and  $a_3$  (for a summary, see Chance, B., Conference on Oxidative Metal Enzymes, Tokyo, 1957). Perhaps the most easily expressed is that, with intact cells and oxidase preparations, a sudden addition of oxygen to the reduced oxidase causes a greater disappearance of the absorption band at 445  $m\mu$  than of that at 605  $m\mu$  at times of about 10 msec (Chance, *Disc. Faraday Soc.* **20**, 205, 1955). This observation is inconsistent with the hypothesis that these bands represent the  $\alpha$  and  $\gamma$  bands of the same haematin group, and the two are thus concluded to belong to different chemical entities. Although we respect the idea that cytochrome oxidase may be one protein molecule (see for example, Ball, Strittmatter and Cooper, *J. biol. Chem.* **193**, 635, 1951, who suggest that cytochrome  $a + a_3$  be represented as a four-haem protein, and Wainio and Cooperstein, *Advanc. Enzymol.* **17**, 329, 1956), we feel that the experimental results cited above apply equally well under these circumstances.

To focus the discussion more sharply, we suggest here some speculative configurations, not because there are particular data in favour of them, but to evoke discussion and to indicate that basic objections apply to some of the structures. In the first

example (Fig. 1), two haem *a* groups may be bound to the protein in different ways, one to react with oxygen, the other to transfer electrons between the first and cytochrome *c*. The  $a_3$  group would be accessible to oxygen as a reactant, the *a* group would be 'buried' or in a 'crevasse,' as in cytochrome *c*, and would likewise be

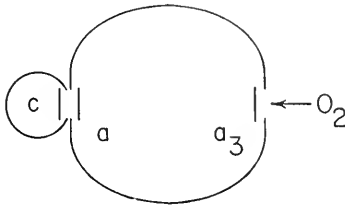

FIG. 1. A schematic diagram representing the relations of cytochrome *c* and a single oxidase protein containing one haem active in electron transfer (*a*) and one haem active in oxygen reduction ( $a_3$ ).

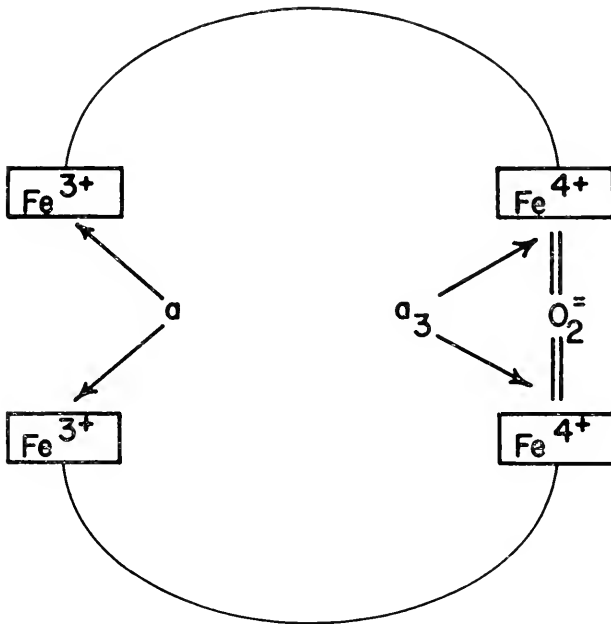

FIG. 2. A schematic diagram representing a possible oxygen-oxidase intermediate of a four-haem oxidase.

prevented from reacting with oxygen. The nature of the electron transfer mechanism between *a* and  $a_3$  would appear to require an electron conduction band—which may not exist (Taylor, *Disc. Faraday Soc.* 27, 237, 1959).

The mode of reaction with oxygen might well follow that suggested for manganese phthalocyanine by Orgel (see Elvidge and Lever, *Proc. chem. Soc.* April 1959, p. 123, and June-July 1959, p. 195) in which an effective oxidation state of four would be obtained in the two  $a_3$  groups (see Fig. 2). However, no spectroscopically identified intermediate has been observed in the rapid reaction of cytochrome  $a_3$  and oxygen

(see for example, Chance, in *Conference on Oxidative Metal Enzymes*, Tokyo, 1957). Also, this configuration would necessitate a conduction band, as in Fig. 1.

The configurations described above appear to offer no better agreement with available experimental data than a sequence in which the cytochromes interact by collision (Chance and Williams, *Advanc. Enzymol.* **17**, 65, 1956) and in which the chain is represented as a dimer in order to avoid the necessity of a two-to-one change in electron transfer from flavoprotein to cytochrome (Chance and Williams, *Advanc. Enzymol.* **17**, 65, 1956; Slater, Spallanzani Meeting, 1959). Two forms of the chain

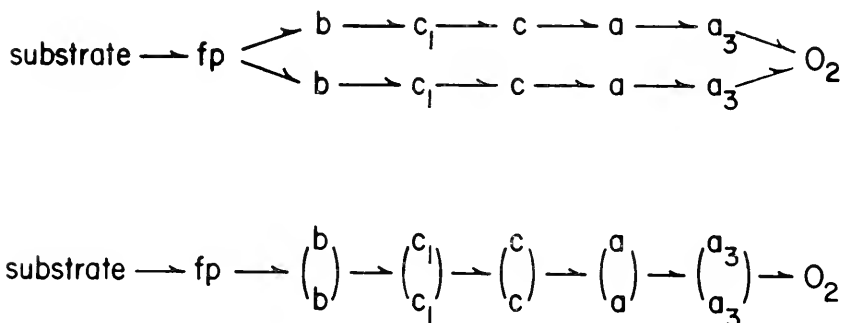

FIG. 3. Dimerized respiratory chains (a) with two proteins.

appear in Fig. 3, one in which the components are dimerized and one in which two parallel chains are operative.

SMITH: In the presence of cholate where the reactions of cytochromes  $a_3$ ,  $a$  and  $c$  are slower, there can be seen a difference in the kinetics of changes in the absorption spectrum at 445 and 605  $m\mu$ , indicating that these are not two absorption bands of one compound. This would agree with Chance's observations of a difference in rate of change of the two bands on addition of oxygen to anaerobic preparations.

### The Prosthetic Groups of *Pseudomonas* Cytochrome Oxidase

By T. HORIO AND M. D. KAMEN (Waltham)

HORIO: Very recently, Kamen and I tried a stepwise reduction of *Pseudomonas* cytochrome oxidase by titration of sodium ascorbate which was one of its substrates.

As shown in the accompanying figure, the  $a_2$ -type haem (630–625  $m\mu$ ) was much more slowly reduced than  $c$ -type haem (549  $m\mu$  and 554  $m\mu$ ). The shoulder around 450  $m\mu$  was influenced by both reductions of  $a_2$ -type haem and  $c$ -type haem, because the  $a_2$ -type haem split from the protein moiety by acid-acetone showed another peak in that region. In view of this result,  $a_2$ -type haem could be lower in oxidation-reduction potential than  $c$ -type haem. A rough calculation based upon their equilibrium shows that the difference between the normal redox-potentials of the two haems might be 20–30 mV. In a previous report (Horio, Higashi, Matsubara, Kusai, Nakai and Okunuki, *Biochim. biophys. Acta*, **29**, 297, 1958), the double  $\alpha$ -absorption peaks at 549  $m\mu$  and at 554  $m\mu$  of P-cytochrome oxidase had been supposed to be caused by two different kinds of  $c$ -type haems. But the lack of difference in the stepwise reduction of the oxidase at 549  $m\mu$  and 554  $m\mu$  indicated that these double peaks resulted from the same  $c$ -type haem. The iron analysis of the oxidase mentioned in the paper doubtlessly shows that P-cytochrome oxidase contains one  $a$ -type haem and one  $c$ -type haem in each molecule. This finding might be useful for an attack on the reaction mechanism of a cytochrome oxidase.



STEPWISE REDUCTION OF *PSEUDOMONAS* CYTOCHROME OXIDASE

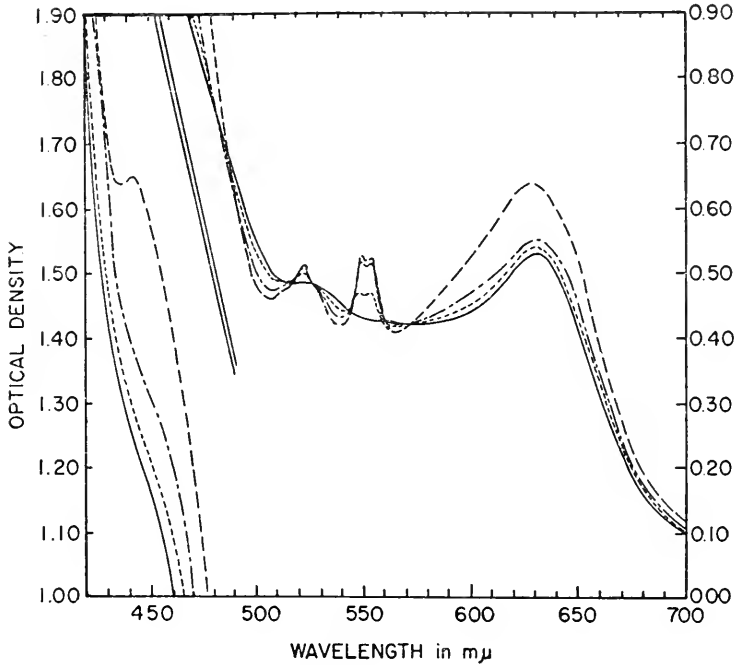

FIG. 1.

SLATER: Referring to the point raised by Morton, I believe that cytochromes *a* and *a*<sub>3</sub> refer to different haemoproteins, both containing haem *a* as prosthetic group. It is probable that the two proteins are physically closely linked in the mitochondria, and it may not be possible physically to separate them. All purified preparations of cytochrome *c* oxidase which have been described contain what Keilin and Hartree described in 1939 as cytochrome *a* and *a*<sub>3</sub>, i.e. a part of the  $\alpha$  and  $\gamma$ -bands do not react with KCN, CO, or O<sub>2</sub>, while another part does react with these compounds. That part which reacts is called cytochrome *a*<sub>3</sub>, that part which does not is called cytochrome *a*. The spectra observed in the presence of substrate, under various conditions, are

anaerobic	$a^{++} + a_3^{++}$
CO	$a^{++} + a_3^{++}CO$
anaerobic + HCN	$a^{++} + a_3^{++}CN$
aerobic + HCN	$a^{++} + a_3^{+++}CN$

If you wish to regard cytochrome oxidase as a single haemoprotein (called cytochrome *a*), you will find it difficult to interpret the spectral changes under the above-mentioned conditions, without postulating that part of cytochrome *a* reacts with CO, KCN and O<sub>2</sub>, and part does not. Why not, therefore, retain the name cytochrome *a*<sub>3</sub> for that part which reacts with these reagents, and cytochrome *a* for that which does not.

SMITH: I do not think that the question of the existence of two separate haemoproteins in the particulate cytochrome oxidase can be decided, since we do not have a water-soluble system. The important point is whether there are two separate reactive haem groups in the complex.

*The Reaction of Cytochrome c Oxidase with Oxygen*

**The Oxygen-reducing Equivalents of Cytochromes *a* and *a*<sub>3</sub>**

By B. CHANCE (Philadelphia)

CHANCE: It is of considerable interest to know how many oxygen-reducing equivalents are contained in cytochrome oxidase (*a* + *a*<sub>3</sub>), and L. Smith and I have contemplated this problem for some time. More recently Yonetani and I (Chance and Yonetani, *Fed. Proc.* **18**, 202, 1959) have obtained spectrophotometric titrations of reduced

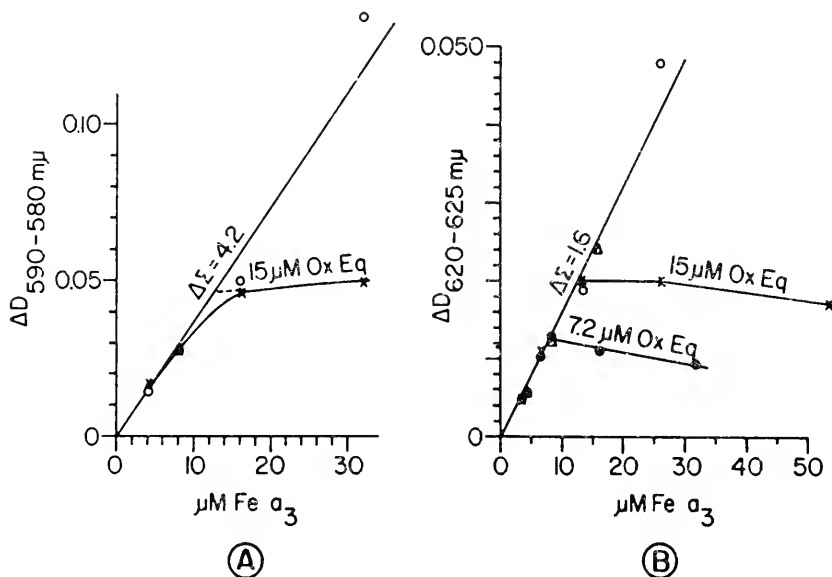

FIG. 1. An example of a spectrophotometric titration of cytochromes *a*, *a*<sub>3</sub> and *c* with 7.8  $\mu\text{M}$  oxidizing equivalents.

cytochrome oxidase by oxygen, and Yonetani and Nakamura have carried out independent magnetometric titrations.

The procedure we have used simulates enzymic activity of the oxidase. Substrate is added to a concentrated solution of the oxidase and after the dissolved oxygen has been exhausted and the oxidase is reduced, a small volume of air-saturated buffer is rapidly mixed by means of a modified Hartridge-Roughton flow apparatus (regenerative flow apparatus) and the maximal extent of oxidation of the oxidase is recorded in a few tenths of a second by spectrophotometric (double-beam spectrophotometer) or magnetometric (modified Rankine balance) methods.

In experiments with the rapid flow apparatus, it has been observed that upon addition of oxygen the absorption bands at 605  $m\mu$  and 444  $m\mu$  disappear even though cytochrome *c* is absent. Apparently cytochrome *c* is needed for the reduction of the oxidase, *not* for its oxidation as has been inferred above; the rapid oxidation of cytochromes *a* and *a*<sub>3</sub> is observable with our technique without the addition of cytochrome *c*.

The added oxygen is slowly expended in enzymic activity and the experiment is repeated with a more dilute solution of the oxidase. The experiment is begun with an excess of oxidase over oxygen and concentrations of the former are diminished until there is considerably more oxygen than oxidase. The utilization of oxygen due

to 'turnover' of the oxidase is negligible at the time of measurement. Furthermore the time of maximal oxidation of cytochromes *a* and *a*<sub>3</sub> overlaps sufficiently, so that the time of measurement of the maxima is not critical. When cytochrome *c* is present, its concentration is measured at the time of the maximum of cytochromes *a* and *a*<sub>3</sub> since cytochrome *c* is not simultaneously maximal. *p*-Phenylenediamine plus ascorbate, ascorbate alone, or cytochrome *c* plus ascorbate was used as the reductant.

The experimental results are of the kind indicated by Fig. 1 which shows the variation of the spectrophotometric effect with the oxidase concentration. It is apparent that the physical effect is maximal at a cytochrome *a*<sub>3</sub> concentration very nearly equal to that of the oxidizing equivalents added. In Fig. 2, the variation of the

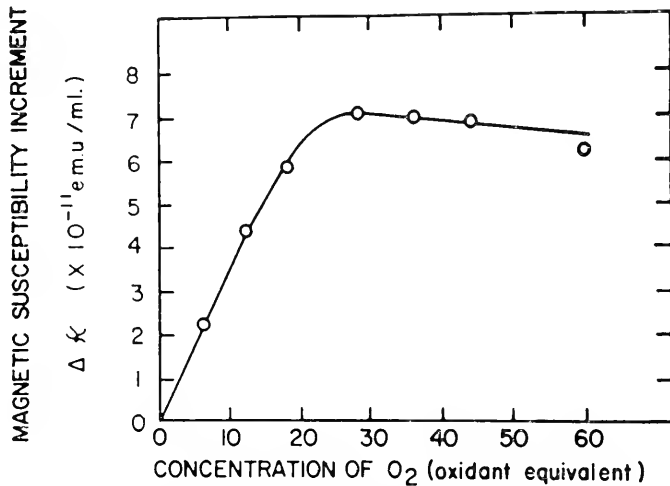

FIG. 2. An example of a magnetometric titration of cytochromes *a* and *a*<sub>3</sub> with oxygen. Reaction at 100 msec after mixing at 29°C. Concentrations as follows: cytochrome *a*<sub>3</sub>, 30 μM; cytochrome *c*, 6 μM; ascorbate, 100 mM.

magnetometric effect with oxygen concentration again shows an approximate equivalence of cytochrome *a*<sub>3</sub> and the oxidizing equivalents added. Table 1 summarizes the spectroscopic results.

In all experiments, the cytochrome concentration was calculated on the basis that the change of extinction coefficient between the reduced and the oxidized forms, as measured at 605 mμ and 630 mμ, is 16 cm<sup>-1</sup> × mm<sup>-1</sup> (Chance, *J. biol. Chem.* **202**, 407, 1953).

TABLE 1. SUMMARY OF RESULTS IN OXYGEN-CYTOCHROME OXIDASE STOICHIOMETRY

25°C, 10 mM *p*-phenylenediamine, pH 7.2, 40 mM ascorbate

Experiment	880a	880b	880c	880d
4(O <sub>2</sub> ) (oxidizing equivalents) (μM)	7.2	15	15	15
(Cytochrome <i>a</i> ) at end point (μM)	7.6	16	12	12.5
4(O <sub>2</sub> )/(Cytochrome <i>a</i> )	0.93	0.94	1.2	1.2
λ (mμ)	620	— 625	580	— 590
Optical path	←———— 10 mm —————→			

The usefulness of these data depends upon the accuracy with which the extinction coefficients for cytochromes  $a$  and  $a_3$  are known. The latter is known fairly accurately from photodissociation kinetics (Chance, *J. biol. Chem.* **202**, 407, 1953). The value for cytochrome  $a$  has been based on an analogy with other haemoproteins, and this value has more recently been found to check fairly well with chemical determinations in Okunuki's laboratory. The accuracy of these determinations is sufficient to indicate that electron donation from copper is rendered extremely unlikely. The data further raise the question of whether cytochrome  $a$  itself has an electron donating capacity: the optical constants are almost, but not quite, secure enough to justify a conclusion on this point.

WAINIO: With reference to Chance's observations, the calculations are based on the use of the  $\alpha$ -peak for one compound and the  $\gamma$ -peak for the other. If one were to average the two values, in this instance would not the oxidizing equivalents added and found be identical? This would indicate that only one, not two, enzymes are involved.

CHANCE: The idea that we are over-estimating the oxidizing equivalents by taking the  $\alpha$  and  $\gamma$  bands of the same haemoprotein as separate entities is another way of stating that cytochromes  $a$  and  $a_3$  are identical, and this has already been discussed by Slater and by me.

LEMBERG: As a first approximation Chance assumed that the absorption change of the  $\alpha$ -band at 605  $m\mu$  is entirely due to the oxidation of cytochrome  $a$ , that of the Soret band at 445  $m\mu$  to the oxidation of cytochrome  $a_3$ . Our studies of the model haemoproteins  $a$  make this appear unlikely, and Chance and Yonetani (*Fed. Proc.* **18**, 202, 1959) have also found that the ratios  $\gamma/\alpha$  for the two cytochromes are not so widely different as had previously been assumed.

If we make the more likely assumption that cytochromes  $a$  and  $a_3$  contribute almost equally to the  $\alpha$ -band, while the contribution of  $a_3$  to the  $\gamma$ -band is twice that of cytochrome  $a$ , and if we assume that the concentrations of both cytochromes are approximately equal, we obtain:

$$'a' = a + a_3, \quad 'a_3' = a_3 + \frac{1}{2}a \quad (1)$$

and

$$'a + a_3' = 1.75(a + a_3) \quad (2)$$

where ' $a$ ', ' $a_3$ ' and ' $a + a_3$ ' mean the values calculated by Chance, and  $a$ ,  $a_3$  and  $a + a_3$  the true values. The ratio ' $a + a_3$ '/ $a + a_3$  also depends on the choice of the extinction coefficients and on the  $a/a_3$  ratio, but the values assumed for them are probably not very far from the correct ones.

Our earlier estimation of the porphyrin  $a$  content of ox heart muscle agreed well with the values of Chance for ' $a + a_3$ ', but we may also have overestimated the porphyrin  $a$  content by assuming at that time a value of 20 for the specific extinction of band III of neutral porphyrin  $a$  instead of the correct value of 27.

CHANCE (note added in proof): It is clear that the interpretation of our results on the titration of cytochrome oxidase with oxygen depends upon the numerical values of the optical constants, and an interpretation of their meaning. In the experiment described above, the concentration of cytochrome oxidase was determined by dividing  $\Delta\epsilon_{605-630}(\text{red-ox})$  by  $16 \text{ cm}^{-1} \times \text{mm}^{-1}$ ; the concentration thus obtained was interpreted to be equal to that of cytochrome  $a$  alone. Thus a preparation containing equal amounts of cytochromes  $a$  and  $a_3$  would accept twice as many oxidizing equivalents. It follows from this that the value of  $\Delta\epsilon_{605-630}$  for calculating total haematin is  $8 \text{ cm}^{-1} \times \text{mm}^{-1}$ . This may be converted to  $\Delta\epsilon_{605}(\text{red-ox})$  of 7.3. This value may now be compared with those obtained from determinations of the total haematin content of cytochrome oxidase preparations of considerable degrees of purification. For example, the value currently used in this laboratory (T. Yonetani, personal communication) is  $11 \text{ cm}^{-1} \times \text{mm}^{-1}$ , and the value currently used at the Enzyme Institute (D. Griffith, personal communication) is  $9.0-9.5 \text{ cm}^{-1} \times \text{mm}^{-1}$ . It is important to note that none of these determinations of concentration depends upon the proportion of cytochromes  $a$  and  $a_3$  which may be evaluated at 605  $m\mu$ ; the total oxidase content is evaluated.

If in Table 1 (p. 317) the total oxidase concentration is calculated according to these more recent extinction coefficients, the stoichiometric ratio expected for  $4(0_2)/(a + a_3)$  is 2.0 and the observed values given in line 4 of Table 1 would be multiplied by 1.3 in the case of the value used at the Enzyme Institute and by 1.5 in the case of the value used in this laboratory. It is apparent that these values of extinction coefficient lead to closer agreement with the idea that both cytochromes  $a$  and  $a_3$  are titrated under our experimental conditions than does the older and less accurate value.

# THE ISOLATION, PURIFICATION AND PROPERTIES OF HAEMIN *a*

By D. B. MORELL, J. BARRETT, P. CLEZY AND R. LEMBERG

*Institute of Medical Research, Royal North Shore Hospital, Sydney*

THIS PAPER describes the isolation, purification and properties of the haemin derived from mammalian cytochrome *c* oxidase. As will be shown, existing evidence indicates that a single major haemin is obtained which is thus referred to as haemin *a*. Evidence is discussed indicating that haemin *a* is also obtained from cytochrome  $a_1$  of certain bacteria.

## PURIFICATION OF HAEMIN *a* AND PORPHYRIN *a*

Warburg and co-workers (Warburg and Gewitz, 1951; Warburg, Gewitz and Völker, 1955) purified haemin *a* from horse heart (without conversion to the porphyrin at any stage) and obtained crystalline material. At the stage before crystallization the yield was about 30%. Their method requires as starting material 64 horse hearts from which about 140 kg washed mince are obtained.

Other workers, notably Rawlinson and Hale (1949), Lemberg and co-workers (Lemberg, Falk, Rawlinson, Hale and Rimington, 1949; Lemberg and Falk, 1951; Lemberg, 1953; Lemberg, Bloomfield, Caiger and Lockwood, 1955; Lemberg and Stewart, 1955), Granick (1952), Dannenberg and Kiese (1952), have converted the haemin to the porphyrin during purification but have not obtained significant amounts of crystalline material. We have preferred the porphyrin approach for a number of reasons. The scale of the Warburg preparation is too large for our facilities, and attempts to repeat this preparation on a smaller scale were not satisfactory and gave no crystalline haemin *a*. We prefer conversion of the haemin to porphyrin at an early stage because alterations of the prosthetic group or the possible presence of different prosthetic groups can be more easily detected in the characteristic porphyrin spectra with their sharp and high absorption bands.

### *Method*

We have found that about 18 kg ox heart mince (from about 27 kg ox hearts) is a convenient amount of starting material.

The mince is washed in water and saline to remove most of the haemoglobin and myoglobin. It is then defatted by successive extractions with 80%

acetone: 20% water (v/v), 50% acetone: 50% ether and 80% acetone: 20% water. The haemins are extracted (once for 15 min, twice for 30 min) with fresh lots of acetone-HCl and the haemins driven into ether by washing out the acetone with dilute HCl. Undue contact of formyl-haemins with acetone-HCl must be avoided since we have found that, in the presence of HCl, acetone condenses with formyl groups. However, under the conditions employed during this extraction the amount of acetone condensate should be negligible since experiment has shown that at room temperature and under these conditions the reaction is complete only after 60 hr.

Evaporation of the ethereal solution of haemins to about 1500 ml precipitates much of the remaining protohaemin without appreciable loss of haemin *a*. Most of the cryptohaemin *a* is also precipitated at this step. The phospholipid content of the haemin solution is very greatly decreased by filtration from solutions of the haemin in small volumes first of acetone-ether and then acetone, both chilled at  $-15^{\circ}\text{C}$ .

The haemins are converted to the porphyrins by the ferrous sulphate method of Morell and Stewart (1956). Protoporphyrin and cryptoporphyrin *a* are separated from the porphyrin *a* by extraction into aqueous 7% (w/v) HCl solution. The ethereal solution now contains the porphyrin *a* together with some unsplit protohaemin. These are applied in solution in 50% ether-50% light petroleum to cellulose columns which are developed with ether. Much yellow lipid runs through the column near the solvent front, followed by traces of protoporphyrin if still present and by porphyrin *a*. Protohaemin remains on the column. The chromatography of this porphyrin *a* is repeated; fractions of ratio of band III/IV 2.30-2.35 are combined for the next step.

Ethereal solutions containing about 20 mg of porphyrin *a* are evaporated to dryness, spreading the porphyrin as thinly as possible on the walls of the flask. The flask is then heated to  $60^{\circ}\text{C}$  under vacuum for 30 min. This treatment permits the porphyrin *a* to be separated from much of the remaining lipid by extracting the porphyrin from ethereal solution into 17% HCl (w/v). This extraction is carried out in a cold room near  $0^{\circ}\text{C}$  to minimize the formation of porphyrin  $a\beta$  (see below). Porphyrin  $a\beta$  is formed from porphyrin *a* by standing at room temperature in strong aqueous HCl solution, it is extracted from ether by 7% (w/v) aqueous HCl whereas porphyrin *a* requires about 15% HCl. Both forms have similar spectra and the chemical change is as yet unexplained. Porphyrin  $a\beta$  is converted to porphyrin *a* (porphyrin  $\alpha x$ ) by increasing the temperature to about  $60^{\circ}\text{C}$  but some porphyrin is destroyed (Lemberg, 1955; Lemberg and Stewart, 1955).

The porphyrin *a* solution in 17% aqueous HCl is washed with ether and the porphyrin returned to ether by adjusting the aqueous HCl solution to 8% followed by vigorous shaking. This porphyrin *a* solution now has bands at  $647\text{ m}\mu$  (band I—barely discernible in the hand spectroscope),  $578\text{ m}\mu$

(band II, asymmetric), 559  $m\mu$  (band III) and 518  $m\mu$  (band IV). The ratio of bands III/IV in the best preparations is 2.40–2.45. The specific extinction (optical density in 1 cm cell/mg porphyrin per ml; solvent ether) is 20–24. From the molar concentration of the porphyrin, determined by using the copper titration method of Oliver and Rawlinson (1951) and the molecular weight derived from the values found by Warburg, Gewitz and Völker (1955) for the haemin, pure porphyrin *a* was calculated to have a specific extinction in ether at 559  $m\mu$  of 27. Our preparations thus contain about 12–20% impurities. The millimolar extinctions found for porphyrin *a* in ether at 559  $m\mu$  and 517  $m\mu$  are 21.1 and 8.75 respectively.

Attempts to crystallize the porphyrin using the above purification procedure failed. Conversion to the haemin, which was held in ethereal solution in concentrations up to 30 mg/ml at  $-15^\circ$  for about two months produced several rosettes, clearly crystalline, representing a very small proportion of the total haemin.

#### *Purification as the Haemin*

Apart from the Warburg type preparation we have investigated methods for preparing haem *a* from relatively small (2–4 kg) amounts of ox heart mince. Purification procedures giving some success were: (1) partial precipitation of phospholipids, (2) counter-current distribution between light petroleum–acetone and acetone–aqueous HCl (Kiese and Kurz, 1954) and (3) chromatography on cellulose columns. It was clear from this work that lipids are much more difficult to separate from haemin *a* than from porphyrin *a*; also that the presence of lipid prevented complete separation of protohaemin and haemin *a*. The spectrum of the haemin *a* prepared by this method was very similar to that prepared from our highly purified porphyrin *a* except for some absorption due to contaminating protohaemin.

#### *Removal of Iron from Haemins (De-ironing)*

Careful examination of this procedure was necessary because it was found that this step can be responsible for alteration of porphyrin *a*.

The iron atom is replaced by two protons when the iron is ferrous and when the proton concentration is high. The various factors affecting the rate of this reaction have been described by Morell and Stewart (1956). Since their publication it has been found that the formyl group of porphyrin *a* and other formyl porphyrins can be oxidized to carboxyl by an unidentified oxidant present in some batches of the acetic acid used as solvent for the haemin. A high proton concentration accelerates the oxidation reaction which is catalysed by ferrous, but not ferric, ions. The alteration of porphyrin *a* is prevented by refluxing the acetic acid for an hour in the presence of ferrous ions before distillation.



### *Conversion of Porphyrins to Haemins*

In the absence of HCl the equilibrium of the system, porphyrin +  $\text{Fe}^{++} \rightleftharpoons \text{haemin} + 2\text{H}^+$ , strongly favours haemin formation. The reactants are heated to  $80^\circ\text{C}$  to obtain a reasonable reaction rate.

The whole procedure of de-ironing and re-ironing was tested for its possible effect on the porphyrin or haemin. Porphyrin *a* of ratio bands III/IV 2.31 was converted to the haemin and again de-ironed. The ratio of the final porphyrin *a* produced was 2.24 and the band positions had not changed. This indicates that de-ironing and re-ironing by these methods had a negligible effect on the compound.

### *Paper Chromatography of Porphyrin a*

The porphyrin *a* purified by the method outlined here and after esterification gave only one spot in ascending paper chromatograms using the solvent systems, kerosene-propanol or light petroleum-acetone. However, previous to the heat treatment step in the purification two spots of about equal intensity were invariably obtained. When, after heating, the porphyrin was chromatographed on a cellulose column it could no longer be eluted with ether but required acetone. The porphyrin *a* in this eluate, esterified and run on paper, gave only one spot corresponding to the slower of the two spots mentioned above. After extraction into 17% HCl, however, the single spot obtained corresponds to the faster of these two spots and the specific extinction of the porphyrin is doubled.

These experiments show that heat treatment alters the chromatographic properties of the porphyrin-impurity complex and permits the separation of porphyrin from impurity by extraction into 17% HCl. They also demonstrate that chromatographic studies of impure porphyrins may be misleading.

## EVIDENCE FOR A SINGLE PROSTHETIC GROUP FOR MAMMALIAN CYTOCHROMES *a* AND *a*<sub>3</sub>

From the haemins extracted from ox heart we have obtained the following porphyrins: protoporphyrin, cryptoporphyrin *a* and porphyrin *ax*. The position of the absorption bands of cytochromes *a* and *a*<sub>3</sub> rule out protohaem as a possible prosthetic group for either cytochrome. We have been unable to find any evidence indicating that porphyrin *ax* is a mixture of porphyrins although differences in side chains not conjugated with the porphyrin ring and therefore not affecting the spectrum are possible.

The work of Parker (1959; see accompanying paper) and the demonstration by Morrison, Connelly and Stotz (1958) that cryptoporphyrin *a* exists in acetone-HCl extracts of heart muscle as the haemin, strongly suggest that cryptohaemin *a* is not an artifact produced during purification. However, a large number of analyses in this laboratory indicate that the amount of

cryptoporphyrin *a* derived from ox heart is of the order 5–10% of the porphyrin *a* content. The lower values are probably the more correct since the spectrophotometric analysis would tend to measure traces of non-cryptoporphyrin *a* material (e.g. haematoporphyrin derived from protoporphyrin) as cryptoporphyrin *a*. Since it is unlikely that the ratio of concentration of cytochrome *a*<sub>3</sub> to that of cytochrome *a* is less than 1:3, the concentration of cryptohaematin *a* in ox heart is too low for it to be the prosthetic group of cytochrome *a*<sub>3</sub>. We thus conclude that haem *a* is the prosthetic group of both cytochromes *a* and *a*<sub>3</sub>.

#### THE PROSTHETIC GROUP OF CYTOCHROME *a*<sub>1</sub>

Several workers have shown that the pyridine haemochrome derived from cytochrome *a*<sub>1</sub> of various bacteria has an  $\alpha$  band at 587  $m\mu$ , the same as haemochrome *a*. We have considerably purified the porphyrin derived from cytochrome *a*<sub>1</sub> of *Proteus vulgaris* and have obtained a product (after separation from chlorin *a*<sub>2</sub>) with absorption bands identical with the bands of porphyrin *a* from ox heart. The ratio of bands III/IV was 2.2 close to 2.4 for the ox heart porphyrin *a*.

#### QUANTITATIVE MEASUREMENT OF HAEMIN *a* AND PROTOHAEMIN IN TISSUES

We have used two methods. (1) Extraction of the haemins, conversion to the porphyrin and measurement of the protoporphyrin obtained by extraction from ether into 4% HCl and of porphyrin *a* obtained by extraction into 20% HCl. This method requires a minimum of about 0.1 mg porphyrin *a* in the tissue analysed, equivalent to 5 g wet weight of ox heart (Lemberg *et al.*, 1955; 1956). For tissues other than heart muscle porphyrin *a* of lesser spectroscopic purity is obtained and the error of determination correspondingly increased. (2) Extraction of the haemins followed by spectrophotometric analysis of the mixture of protohaemochrome and haemochrome *a* derived from these haemins. This method is more sensitive and has, for instance, been useful in the determination of the haem *a* and protohaem concentration in rat tissues where the rate of uptake of <sup>59</sup>Fe in these haems was being studied (Morell and Basser, unpublished; Lemberg and Benson, 1959). A disadvantage of this method is the difficulty of ensuring complete formation of the haemochromes. To avoid interference from cloudiness caused by lipids undissolved by the pyridine-alkali up to 15% by volume of ether is often necessary. The presence of this ether makes the complete reduction of the ferrihaemochrome by dithionite more difficult.

The haemins from most tissues studied are readily extracted by acid acetone. Yeasts (*Saccharomyces cerevisiae*, *Torulopsis utilis*) give some protohaemin by this treatment but very little haemin *a* in relation to their cytochrome *a* + *a*<sub>3</sub> content. It was found, however, that preliminary lysis with pyridine

(but not with toluene or chloroform) allowed an extensive extraction of haemin *a* into acid acetone. Much other cellular material also extracted by the pyridine-acid acetone mixture complicates further procedures. Using method (I) above we have obtained porphyrin *a* from *Torulopsis utilis* with the ratio of bands III/IV 2.24, but the probable losses associated with the necessary use of pyridine suggest that this determination is only a useful approximation.

### SPECTROSCOPIC PROPERTIES OF HAEM *a* COMPOUNDS AND HAEMOPROTEINS *a*

We have begun a study of the absorption spectra of various haem *a* compounds which may be useful as models for the cytochromes of group *a*. Spectral data are given in Table 1 (ferric compounds) and Table 2 (ferrous compounds) for compounds of haem *a* with pyridine, 4-methylimidazole, cyanide, carbon monoxide, native human globin, human and ox serum albumins, horse radish apoperoxidase, denatured human globin, denatured serum albumins, as well as for the carbon monoxide compounds of the haemoproteins and haemochromes.

TABLE 1. FERRIC HAEMATIN *a* COMPOUNDS  
 $\lambda$  in  $m\mu$ , in parentheses approximate  $\epsilon_{\text{max}}$ \*

Compound of haematin <i>a</i> † with	pH	Buffer	Alkaline haematin band	Ferri haemochrome band	Weak bands	Soret band
OH <sup>-</sup>	13	0.1 N NaOH	635(9.5)	—	none	405(59)
	9.0	0.05 M borate	630(8.9)	—	none	400(61)
	7.5	0.05 M barbital	635(7.9)	—	none	400(67)
CN <sup>-</sup> (0.1 M)	13	0.1 N NaOH	635(9.0)	—	none	405(60)
Pyridine (20%)	13	0.1 N NaOH	635(7.9)	587(7.5)‡	none	418(64)
	9.0	0.05 M borate water	635(7.2)	587(7.8)‡	to 530	410(81)
			—	587(12.0)	540(10.9)	414(111)
4-Methylimidazole (2%)	9.0	0.05 M borate	—	597(14.1)	548(12.0)	434(66)
Native human globin (1%)	9.0	0.05 M borate	635(6.9)‡	590(8.6)	none	418(77)
		0.2 M Na <sub>2</sub> HPO <sub>4</sub>	635(8.0)‡	590(11.7)	none	410(71)
HRP-apoperoxidase (0.5%)	9.0	0.05 M borate	640(8.5)	585(7.3)‡	none	405(50)
Human serum albumin (0.5%)	9.0	0.05 M borate	635(7.9)	590(8.8)	none	410(79)
	7.5	0.05 M barbital	630(8.8)	590(9.7)	none	405(45)
Ox serum albumin (cryst.) (0.5%)	7.5	0.05 M barbital	635 (8.8)‡	590(9.7)	none	405(40)
Alkali-denatured human globin (0.5%)	13	0.1 N NaOH	635(6.6)	585(5.8)	none	414(41)
Alkali-denatured ox serum albumin (0.5%)	13	0.1 N NaOH	630(8.4)‡	587(9.6)	none	407(78)

\* Concentration was calculated making use of  $\epsilon_{\text{max}}$  587  $m\mu$  of pyridine haemochrome *a* in 20% pyridine-0.1 N NaOH-Na<sub>2</sub>S<sub>2</sub>O<sub>4</sub> (30.0).

† Haematin *a* was extracted from its ethereal solution by 0.05 M borate buffer, or with 0.01 N NaOH followed by adjustment of pH to 7.5.

‡ No distinct maxima.

#### Ferric Compounds

Haematin *a* has a much greater affinity for hydroxyl ions than protohaematin. Thus, chlorohaematin *a* acquires the alkaline haematin *a* spectrum

TABLE 2. FERROUS HAEM *a* COMPOUNDS $\lambda$  in  $m\mu$ , in parentheses  $\epsilon_{\text{mM}}$ \*. Reductant: dithionite.†

Compound of haem <i>a</i> † with	pH	Buffer	$\alpha$ -band	Weak bands	Soret (?) band	Ratio : $\lambda$	Shift of band by CO to red in $m\mu$
Water	9	0.05 M borate	600-605(11.1)	none	415(56)	5.0	
	7.5	0.05 M barbital	598(9.7)	none	410(69)	6.9	
CO‡	9	0.05 M borate	602.5(24.7)	none	425(105)	5.0	?
	7.5	0.05 M barbital	607(18.9)	none	428(79)	4.2	9
Pyridine (20% v/v)	13	0.1 N NaOH	587(29.2-31.0)	none	430(117)	4.6	
	9	0.05 M borate water	587(29.9) 587(24.8)	none 530(10.5)	430(115) 429(91)	3.8 3.7	
Pyridine (20% v/v) + CO	13	0.1 N NaOH	592(17.1)	none	429(117)	6.9	5
4-Methylimidazole (2%)	9	0.05 M borate	594(22.2)	520(10.8)	441(70)	3.3	
4-Methylimidazole (2%) + CO	9	0.05 M borate	605(19.0)	none	435(57)	3.0	11
NH <sub>3</sub> (2%)	—	—	592.5(21.3)	none	435(77)	3.6	
Cyanide (0.1 M)	13	0.1 N NaOH	598(23.0)	534(10.9)	446(101)	4.4	
Native human globin (1%)	9	0.05 M borate	595(24.7)	none	442(103)	4.2	
Native human globin (1%) + CO	9	0.05 M borate	602.5(22.0)	none	432(126)	5.7	7.5
Apoperoxidase (0.5%)	9	0.05 M borate	596(15.6)	none	441(93)	5.9	
Apoperoxidase (0.5%) + CO	9	0.05 M borate	601(14.8)	550(10.8)	432(93)	6.3	5
Human serum albumin (0.5%)	9	0.05 M borate	590(20.3)	none	435(91)	4.5	
Human serum Albumin (0.5%) + CO	9	0.05 M borate	596(15.1)	542(13.2)	429(133)	8.8	6
	7.5	0.05 M barbital	599(14.2)	575(13.0) 540(12.6)	420(101)	7.1	9
Ox serum Albumin (0.5%)	9	0.05 M borate	590(25.2)	540(11.1) 510(11.0)	435(93)	3.7	
	7.5	0.05 M barbital	589(19.4)	540(11.2) 512(10.8)	428(69)	3.6	
Ox serum Albumin (0.5%) + CO	9	0.05 M borate	600(20.0)	none	431(102)	5.1	10
	7.5	0.05 M barbital	600(15.0)	545(11.8)	417(97)	6.5	11
Denatured globin (1%)	13	0.1 N NaOH	575(19.4)	530(11.7) 505(11.7)	429(101)	5.2	
Denatured globin (1%) + CO	13	0.1 N NaOH	584(15.1)	545(12.2)	424(147)	9.8	9
Denatured ox serum albumin (0.5%)	13	0.1 N NaOH	573.5(25.4)	530(14.1)	430(118)	4.6	
Denatured ox serum albumin (0.5%) + CO	13	0.1 N NaOH	583(18.0)	542.5(16.4)	423.5(155)	8.6	9.5
Denatured human serum albumin (0.5%)	13	0.1 N NaOH	574	530 505	430		

\* Concentration calculated as in Table 1.

† Haematin *a* cf. Table 1.

‡ A large excess of dithionite must be avoided. Reduction is somewhat slow.

§ The solution must be saturated with CO (prepared from formic acid-sulphuric acid) before reduction.

when its ethereal solution is washed with neutral sodium chloride solution. In contrast to protohaematin, haematin *a* does not react, or reacts very little, with cyanide in alkaline solution (0.1 *N* NaOH). The absorption spectrum is hardly altered by the addition of 0.1 *M* cyanide. The hydroxyl ion also competes with pyridine for the fifth and sixth co-ordination position of haematin *a*. Even at pH 9 a solution of haematin *a* in aqueous pyridine (20% v/v) gives mainly the spectrum of alkaline haematin *a*. In aqueous solution, however, without added buffer or alkali, pyridine of this concentration almost completely combines with haematin *a* to give the ferrihaemochrome. With 4-methylimidazole ferrihaemochrome formation is complete with 2% base in weak alkali. Haematin *a* has thus, like protohaematin, a much greater affinity for the imidazole than for pyridine.

### *Ferrous Compounds*

The  $\alpha$ -bands of the ferrous haem *a* compounds with bases or proteins can be grouped in three regions: (1) 587 *m $\mu$*  (pyridine haemochrome), (2) 590 *m $\mu$*  (serum albumins) and (3) 594–596 *m $\mu$*  (4-methylimidazole haemochrome and compounds with native globin and apoperoxidase). With the exception of haem *a* itself, no compound with  $\alpha$ -bands similar to those of cytochromes *a* + *a*<sub>3</sub> (603–605 *m $\mu$* ) has been found. Similarly ferrous chlorocruorin has an absorption band at 604 *m $\mu$* , while that of the pyridine haemochrome lies at 582 *m $\mu$*  (Fox, 1924). The serum albumin compounds have  $\alpha$ -bands similar to that of cytochrome *a*<sub>1</sub>. While the absorption spectra of the pyridine and methylimidazole protohaemochromes differ by no more than about 1 *m $\mu$* , those of the corresponding haemochromes *a* differ by 7 *m $\mu$* . According to the position of the  $\alpha$ -band the haem *a* iron may be bound to the imidazole of both globin and apoperoxidase, whereas it is assumed that in horseradish peroxidase the protohaem iron is bound to a carboxyl group of the protein. The considerable differences between the spectra of ferrous protohaemoglobin, protohaemperoxidase and protohaemalbumin are not observed in the series of haem *a* compounds, nor does the compound with human serum albumin differ in its spectrum from that of ox serum albumin.

The absorption maxima of the  $\alpha$ -bands of alkali-denatured protein haemochromes (but not of urea-denatured globin haemochrome in neutral solution) were found at 573–575 *m $\mu$* , 12–14 *m $\mu$*  to the blue compared to the band of pyridine haemochrome. This difference is surprising in view of the fact that with protohaem denatured proteins give haemochromes with  $\alpha$ -bands within 1–2 *m $\mu$*  of 558 *m $\mu$* . Possibly the denatured proteins react with the aldehyde group in alkaline solution; this reaction also appears to occur with chlorocruorin, whose absorption band of 604 *m $\mu$*  is shifted to 569 *m $\mu$*  on denaturation by alkali (Fox, 1924).

The millimolar extinctions of the  $\alpha$ -bands ( $\epsilon_{m\mu}$ ) vary between 29–30 for

the pyridine and 25 for the native globin compound to 15.5 for the apoperoxidase compound.

The ratio of extinctions  $\gamma$ -band/ $\alpha$ -band varies from 3.3 for the imidazole compound to 5.9 for the apoperoxidase compound, averaging 4.7 for the haemoproteins. The ratio  $\gamma$ -band/ $\alpha$ -band for the difference spectra ( $\Delta\text{Fe}^{++} - \text{Fe}^{+++}$ ) is similar to this (e.g. 4.4 for the ox serum albumin compound); this is in good agreement with the ratio 4.5 observed by Chance and Yonetani (1959) for cytochrome *a*. It has often been stated that this ratio is abnormally low for haemoproteins. A higher ratio is, however, by no means general for haemoproteins. For cytochrome *c*, e.g. it is 4.8. Cytochrome *a*<sub>3</sub> rather than cytochrome *a* appears to have an abnormal  $\gamma/\alpha$  ratio.

The Soret band of haem *a* lies at 410–415  $m\mu$ , but is shifted towards longer wavelengths by combination with nitrogenous compounds, e.g. to 446  $m\mu$  by cyanide, 442  $m\mu$  by globin, 441  $m\mu$  by methylimidazole and peroxidase apoprotein, 435  $m\mu$  by the serum albumins, and 430  $m\mu$  by pyridine or alkali-denatured proteins. The position of the  $\gamma$ -band of cytochrome *a*<sub>3</sub> (445  $m\mu$ ) thus resembles those of haem *a*-methylimidazole, haem *a*-globin and haem *a*-peroxidase. All the nitrogenous compounds, and also carbon monoxide alone, increase the Soret band of haem *a*.

#### *Carbon Monoxide Compounds*

Carbon monoxide shifts the  $\alpha$ -absorption band always towards the red by 5–11  $m\mu$  (with the exception of haem *a* at pH 9, but not at pH 7.5). This also holds for the compounds with denatured proteins, whose CO compounds have absorption maxima at 583–584  $m\mu$ . The  $\alpha$ -bands of the CO-haemoproteins and CO-haemochromes lie at 597–605  $m\mu$ . Thus so far no CO-haem *a* compound with an absorption maximum at 590  $m\mu$  has been observed, and no compound has as yet been found whose  $\alpha$ -absorption band is shifted by 15  $m\mu$  towards the blue by combination with CO, as is assumed for cytochrome *a*<sub>3</sub>. In this respect also, cytochrome *a*<sub>3</sub> appears to be an unusual haem *a* compound.

The position of the Soret band of the CO-compounds including CO-haem *a* has usually been found between 428 and 435  $m\mu$ , in agreement with the position of this band of cytochrome *a*<sub>3</sub>. For the denatured protein CO compounds the Soret band was found at 424  $m\mu$ .

In summarizing; we have obtained no haemoprotein *a* which resembles cytochromes *a* and *a*<sub>3</sub> in all properties. In contrast to cytochrome *a* our haemoproteins combine with carbon monoxide, and their  $\alpha$ -bands lie at 590–596  $m\mu$  instead of 605  $m\mu$ , but their  $\gamma/\alpha$  ratio and the position of the Soret band are those of cytochrome *a*. No haem *a* compound has been found which like cytochrome *a*<sub>3</sub> forms a carbon monoxide compound with shift of the absorption maximum towards the blue, or a haemoprotein with a  $\gamma/\alpha$  ratio of 15 reported for cytochrome *a*<sub>3</sub> by Chance and Yonetani (1959).

## SUMMARY

1. A method for the preparation of unaltered porphyrin *a* and haemin *a* from heart muscle is given.
2. Evidence is adduced to show that haem *a* is the prosthetic group of the cytochromes *a*, *a*<sub>1</sub> and *a*<sub>3</sub>.
3. Determinations of the haem *a* content of tissues as porphyrin *a* or pyridine haemochrome *a* are described and their limitations are discussed.
4. Spectroscopic properties of haem *a* compounds with nitrogenous bases, cyanide, and native and denatured proteins, as well as their carbon monoxide compounds are investigated. The properties of these proteins and their carbon monoxide compounds are compared with the properties of the cytochromes *a*, *a*<sub>1</sub> and *a*<sub>3</sub>.

## ADDENDUM

This paper was completed before we became aware of the recent work of Kiese and Kurz (1958). The German authors have also found the shift of the  $\alpha$ -absorption bands of the haemoproteins *a* to longer wavelengths by carbon monoxide, and the peculiar denatured protein haemochromes. There are small discrepancies, e.g. in the position of the  $\alpha$ -bands of ferrohaemoglobin *a* and ferrohaemalbumin *a*.

*Acknowledgement*

This research has been carried out with grants from the National Health and Medical Research Council of Australia.

## REFERENCES

- CHANCE, B. & YONETANI, T. (1959). *Fed. Proc.* **18**, 202.  
 DANNENBERG, H. & KIESE, M. (1952). *Biochem. Z.* **322**, 395.  
 FOX, H. M. (1924). *Proc. Camb. Phil. Soc. (Biol. Sci.)* **1**, 204.  
 GRANICK, S. (1952). *Fed. Proc.* **11**, 221.  
 KIESE, M. & KURZ, H. (1954). *Biochem. Z.* **325**, 299.  
 KIESE, M. & KURZ, H. (1958). *Biochem. Z.* **330**, 177.  
 LEMBERG, R., FALK, J. E., RAWLINSON, W. A., HALE, J. H. & RIMINGTON, C. (1949). *Abstr. Comm. 1st int. Congr. Biochem., Cambridge* p. 351.  
 LEMBERG, R. & FALK, J. E. (1951). *Biochem. J.* **49**, 674.  
 LEMBERG, R. (1953). *Nature, Lond.* **172**, 619.  
 LEMBERG, R. (1955). *Biochemistry of Nitrogen*, p. 165. Helsinki: Suomalainen Tiedekatemia.  
 LEMBERG, R., BLOOMFIELD, B., CAIGER, P. & LOCKWOOD, W. H. (1955). *Aust. J. exp. Biol. med. Sci.* **33**, 435.  
 LEMBERG, R. & STEWART, M. (1955). *Aust. J. exp. Biol. med. Sci.* **33**, 451.  
 LEMBERG, R., MORELL, D. B., LOCKWOOD, W. H., STEWART, M. & BLOOMFIELD, B. (1956). *Chem. Ber.* **89**, 309.  
 LEMBERG, R. & BENSON, A. (1959). *Nature, Lond.* **183**, 678.  
 MORELL, D. B. & STEWART, M. (1956). *Aust. J. exp. Biol. med. Sci.* **34**, 211.  
 MORRISON, M., CONNELLY, J. & STOTZ, E. (1958). *Biochim. biophys. Acta* **27**, 214.  
 OLIVER, I. T. & RAWLINSON, W. A. (1951). *Biochem. J.* **49**, 157.  
 PARKER, J. (1959). *Biochim. biophys. Acta* **35**, 496.

WARBURG, O. & GEWITZ, H. S. (1951). *Hoppe-Seyl. Z.* 288, 1.

WARBURG, O., GEWITZ, H. S. & VÖLKER, W. (1955). *Z. Naturforsch.* 10b, 541.

## DISCUSSION

### *Model Systems for Cytochrome Oxidase*

#### Absorption Spectra of Ferro- and Ferri- Compounds of Haem *a*

By R. LEMBERG (Sydney)

LEMBERG: With regard to the compounds of haem *a* and haematin *a* there appears to be, as in protohaematin compounds, a distinction between ferric compounds with absorption bands at 635  $m\mu$  and 500  $m\mu$  (probably 'ionic') and ferric compounds with a single band at about 590  $m\mu$  similar to but lower than that of the ferrous complex (probably 'co-valent'). As in protohaematin compounds, the (ferric) haematin *a*-proteins appear spectroscopically to be mixtures of the two types, with the 'co-valent' type prevailing in haematin *a*-globin and the serum albumin compounds, and 'ionic' compound prevailing in haematin *a*-apoperoxidase.

This seems quite distinct as there appears to be only one single characteristic band for each compound at 635 and 590  $m\mu$  respectively. There is, however, a rather poor correlation between  $\Delta m\mu$   $Fe^{++}$ - $Fe^{+++}$  for the Soret bands and the ratio  $\epsilon_{635}/\epsilon_{590} m\mu$  in the ferric compounds as shown in Table 1.

TABLE 1

	R635/590	$\Delta Fe^{++}$ - $Fe^{+++}$ $m\mu$
Methyl imidazole	0.33	7
Pyridine water	0.38	15
Globin-CN pH 7.5	0.60	—
Globin-fluoride pH 7.5	0.69-0.74	—
Globin pH 7.5	0.76	19
pH 9	0.80	24
Human serum albumin pH 7.5	0.91	10
pH 9	0.91	22-25
Ox serum albumin pH 7.5	0.91	20-23
Pyridine pH 9	0.92	14-20
Apoperoxidase	1.16	36
Pyridine pH 13	1.13	12-15
Haem pH 7.5	1.15	7 ?
pH 13	1.26	15-20
NH <sub>3</sub> 2%	1.26	—

The reason that CO always shifted the absorption band of all our models in the visible to longer wavelengths, not to shorter ones as with cytochrome *a<sub>3</sub>*, does not appear to be due to  $a_3$  being a more 'ionic' type of compound than any of our model haemoproteins *a*. Even the compound with apoperoxidase in which the absorption spectrum of the ferric compound as well as  $\Delta m\mu$   $Fe^{++}$ - $Fe^{+++}$  indicate a high degree of 'ionic' nature, still gives a shift to the red with CO. Moreover, CO always shifts the Soret band to shorter wavelengths, with our model haemoproteins as well as with cytochrome *a<sub>3</sub>*.

The haemochromes *a* formed with alkali-denatured proteins, with bands 13-14  $m\mu$  to the blue compared with pyridine haemochrome *a* are unusual. High pH is necessary for their formation. Urea-denatured globin at pH 9 gives a band quite close to that



of native haemoglobin *a*, and decreasing the pH to below 9 shifts the absorption band of the alkali-denatured globin-compound from 575 to 596  $m\mu$ . The reaction is also given by chlorocruorohaem and monoformyldeuterohaem. The absorption spectrum of porphyrin *a* is not altered by the addition of denatured globin to its alkaline solution. The reaction is not caused by alkali alone; pyridine haemochrome *a* is not altered by alkali; nor is the band at 573–5  $m\mu$  produced by imidazole,  $\text{NH}_3$ , glycylglycine, aminoacids (histidine, lysine, tyrosine) or SH-compounds (cysteine, GSH, thioglycolate) in 0.1 *N* NaOH. Possibly a Schiff's base is formed between the formyl groups of the haems and amino groups in the proteins, resembling alkaline 'indicator yellow', but having the instability to lower pH characteristic of retinylidenemethylamine (Morton and Pitt, *Biochem. J.* **59**, 128, 1955).

WILLIAMS: I wish to show why the model systems of Lemberg and co-workers do not reproduce the physical properties of cytochrome  $a_3$ . The predicted change in the

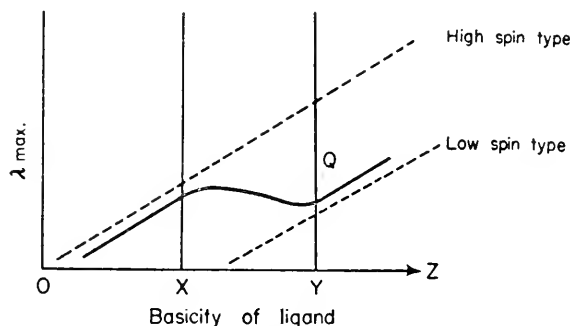

FIG. 1.

Soret band position of ferrous porphyrin complexes with change in the basicity of the ligand in the fifth and sixth positions is illustrated in Fig. 1.

For completely ionic high-spin complexes,  $O-X$ , the band position is predicted to move to longer wavelengths with increase in basicity. The same shift is expected for completely covalent complexes,  $Y-Z$ . In the region  $X-Y$  a change of magnetic moment occurs and there is a chemical equilibrium involving two spin states. In this region the  $\lambda_{\max}$  falls with the increase of basicity of the ligand. Complexes of small molecules such as  $\text{CO}$ ,  $\text{O}_2$ ,  $\text{CN}^-$  cannot be compared with other ligands by their basicity. They shift the absorption bands to longer wavelengths for reasons given in my paper. The point,  $Q$ , represents a typical band position for these low-spin complexes. Now if we have an ionic complex giving a band at long  $\lambda_{\max}$ , then the addition of  $\text{CO}$  will move the band to shorter wavelengths. A complex giving a band at position  $Y$  will show a band shift to the red on addition of  $\text{CO}$ . The models of Lemberg fall in the general region just before  $Y$ . Cytochrome  $a_3$  and to a slightly lesser degree cytochrome  $a$  fall near to  $X$ . Cytochromes  $b$  and  $c$  fall beyond  $Y$  with the other haemochromes of protoporphyrin and mesoporphyrin. I consider that nearly all the observations of Lemberg and co-workers are consistent with this interpretation.

The argument can also be extended to the visible region of the spectrum. Here the plot of  $\lambda_{\max}$  ( $\alpha$  and  $\beta$  bands) against ligand basicity is only slightly different (Fig. 3, p. 48 of this volume). In the ionic complexes there is little shift of  $\lambda_{\max}$  with basicity and the greatest change in band position is found in the region  $X-Y$ . The work of Fålk (this volume, p. 74) defines the region beyond  $Y$ .

We observe from the two diagrams that in complexes with ligands of very low basicity the Soret band will move in the opposite direction to the  $\alpha$  and  $\beta$  bands on the addition of carbon monoxide. This is observed with  $\text{FeP}(\text{H}_2\text{O}_2)$ . Turning to Lemberg's data on the visible spectra we find that whereas cytochrome  $a$  is very

largely ionic, the models are largely covalent. This is consistent with the interpretation of the Soret band shift and to a considerable degree with the changes in intensity of the  $\alpha$ -band (see Williams, *Chem. Rev.* **56**, 299, 1956).

The same analysis leads us to suggest that cytochrome  $a_1$  is more largely in the low-spin form.

The interpretation of the spectra of the ferric porphyrin  $a$  complexes, both band positions and intensities, needs no elaboration and is as in the text of my paper (this volume, p. 41).

CHANCE: It is highly desirable to emphasize the properties of the CO compound of cytochrome  $a_3$ , especially in consideration of the models studied by Lemberg and his collaborators. Our data are based upon very precise photochemical action spectra for the relief of CO-inhibited respiration; a compilation of two results from Castor's studies (Castor and Chance, *J. biol. Chem.* **217**, 453, 1955) is given in Fig. 2 and Table 1.

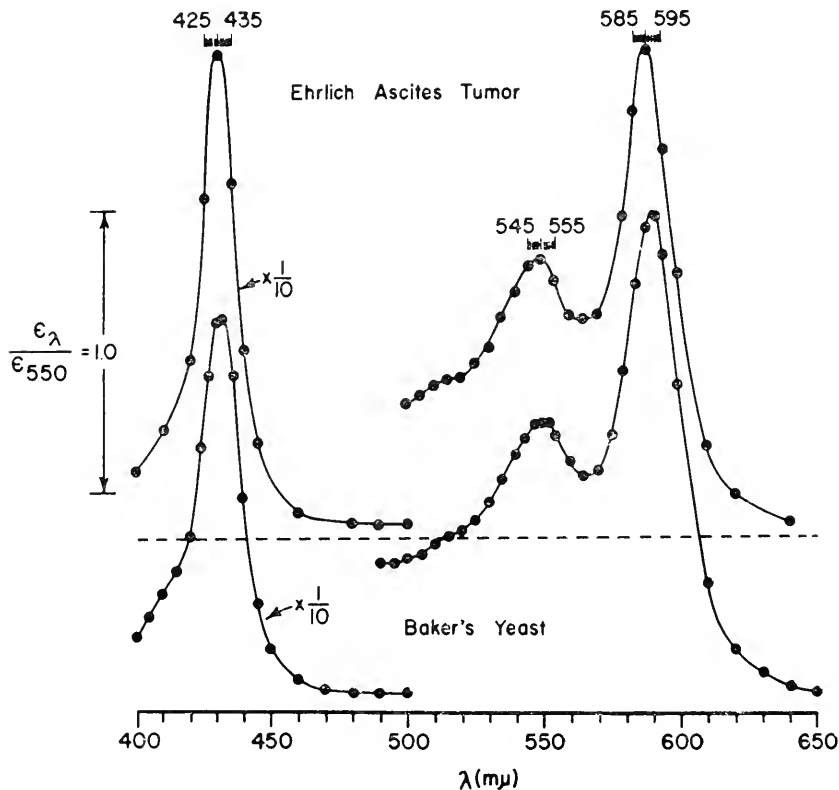

FIG. 2. The absorption bands of the carbon monoxide compounds of cytochrome  $a_3$ -CO in ascites tumour cell and baker's yeast obtained by photochemical action spectra.

The first point to be noted is the great similarity in the position of the peaks for yeast cells and ascites cells, even though the haem may well be bound to different proteins and is probably at a lower pH in yeast than the ascites cells. The second point, in addition to the well recognized properties of the  $\alpha$  and  $\gamma$  bands, is that there is a clear  $\beta$  band; the absence of the  $\beta$  band in the CO haemochrome and the multiplicity

TABLE I. COMPARISON OF EXTINCTION COEFFICIENTS OF CO COMPOUNDS

	Haem a-CO	Cytochrome $a_3$ -CO	
		muscle	yeast
$\alpha$ band	19-25	11.4	12
$\gamma$ band	79-105	110	115

of  $\beta$  bands in some action spectra have both been commented upon (Dixon and Webb, *Enzymes*, Academic Press Inc., 1958, p. 423). The third point is that the molecular extinction coefficients of the CO compound of cytochrome  $a_3$  are known from photo-dissociation kinetics to a reasonable accuracy to be  $12 \text{ cm}^{-1} \times \text{mM}^{-1}$  for the  $\alpha$  band and 115 for the Soret band. These data, when compared with haem a-CO data, show reasonable similarities.

### *Cryptohaem a*

MORRELL: The origin of cryptohaem is of some interest. In contrast to our earlier belief we do not now think that cryptohaem *a*, as defined by us, is an artifact. Morrison has suggested in his precirculated paper that cryptohaem *a* may arise from haem *a*, in aged cytochrome oxidase preparations. We think that a thorough characterization is necessary before this compound could be identified positively as cryptohaem *a*.

LEMBERG: The interesting observation of Morrison of the conversion of haem *a* into a haem similar to cryptohaem *a* by a kind of autodestruction of active cytochrome oxidase, requires further studies before it can be concluded that the haem in question is cryptohaem *a*. The chemistry of our cryptoporphyrin *a* (see the precirculated paper) and other observations of Parker (*Biochim. biophys. Acta* **35**, 496, 1959), make it appear unlikely that our cryptoporphyrin *a* is derived from haem *a*. Porphyrins similar to but distinct from cryptoporphyrin *a* have been obtained by Miss Parker from haemin *a*. Some of these porphyrins differed from cryptoporphyrin *a* in the  $R_F$  of their methyl esters; one which had a similar ester- $R_F$  had a distinctly different absorption spectrum. The cryptohaemin *a* of Morrison and Stotz may be the iron complex of one of these porphyrins. Unless the identity of the porphyrin from their cryptohaemin *a* with the cryptoporphyrin *a* now available as a well-crystallized methyl ester has been established, the latter cannot be considered to be a compound derived from one of the cytochromes *a*.

MORRISON: It would appear that we are all in agreement on that point, as we do not consider cryptohaemin *a* to be an artifact either (see Morrison, Connelly and Stotz, *Biochim. biophys. Acta* **27**, 214, 1958; Connelly, Morrison and Stotz, *J. biol. Chem.* **233**, 743, 1958). Cryptohaemin *a* is, in our opinion, a naturally-occurring material which may arise as the result of catalytic oxidation of the prosthetic group of the cytochromes *a*. This may well be a situation comparable to the iron biliverdin complex found in preparations of catalase. In identifying cryptohaemin *a*, we have used the spectral properties published by Lemberg and Falk (*Biochem. J.* **49**, 674, 1951) as our criteria. Our compound fits these criteria very closely, particularly as our spectra for the porphyrins were taken with pyridine as the solvent, and not with ether as Lemberg assumed.

The position of the alpha peak of the pyridine haemochrome is at 582  $m\mu$  both in the original work of Lemberg and Falk and in the case of the compound we call cryptohaemin *a*. In the more recently published work of the Sydney group, the alpha peak is variously located at 579  $m\mu$  and 581  $m\mu$ . It would appear that a clearer definition of what is being called cryptohaemin *a* is in order.

LEMBERG: I certainly agree with the last point made by Morrison. It is not justified, e.g., to

identify the non-purified "cryptoporphyrin" of Lemberg and Falk with the pure, crystalline cryptoporphyrin *a* as isolated by Parker.

### *Mitochrome in Relation to Cryptohaem a*

MORELL: The preparation of cytochrome oxidase which Morrison has aged to obtain the cryptohaem *a*-like compound is similar to those reported to give 'mitochrome'. According to Elliott, Hülsmann and Slater (*Biochim. biophys. Acta* 33, 509, 1959), 'mitochrome' from cytochrome oxidase preparations contains a modified haem *a* which gives a haemochrome band with pyridine at 575  $m\mu$ . Our pyridine cryptohaemochrome *a* has its  $\alpha$  band at 581  $m\mu$ . Thus aged cytochrome oxidase preparations give at least one modified haem *a* which is not cryptohaem *a*.

SLATER: The difference between the pyridine haemochrome isolated from mitochrome obtained by ageing of cytochrome *a + a<sub>3</sub>*, and that obtained by Morrison from his aged preparation is paralleled by a difference in the position of the  $\gamma$ -bands of the two preparations.

Preparation	$\gamma$ -band ( $m\mu$ )	$\alpha$ -band of pyridine haemochrome ( $m\mu$ )
Cytochrome <i>a + a<sub>3</sub></i>	444	587
Mitochrome	422	575
Morrison's aged preparation	432	582

It appears, then, either that the transformation of cytochrome (*a + a<sub>3</sub>*) has not proceeded all the way to mitochrome in Morrison's aged preparation, or that the latter is a mixture of cytochrome *a + a<sub>3</sub>* and mitochrome, yielding a mixture of the two pyridine haemochromes.

MORRISON: There are two things that are disturbing about the results that Slater cites. The first is the fact that one can obtain mitochrome whether one starts with a cytochrome *b* preparation or a cytochrome *c* oxidase preparation. These preparations are quite different in both enzymic properties and the nature of their haem groups.

The second is that the mitochromes derived from cytochrome *b* or cytochrome *c* oxidase appear to be identical spectrally. Yet the haemins derived from the respective mitochrome preparations are quite different, having pyridine haemochromes whose  $\alpha$  peaks are 17  $m\mu$  apart.

It is interesting that a haemochrome with an  $\alpha$  peak at 575  $m\mu$  has been described by Lemberg and termed cryptohaemochrome *p*. This compound was derived from oxidative procedures applied to protohaemin. Slater's compound, however, appears to have been derived from haemin *a* or cryptohaemin *a*.

Slater's suggestion that our results might be explained by virtue of a mixed haemochrome is not valid since we chromatographed our material.

# CYTOCHROME OXIDASE COMPONENTS

By M. MORRISON AND E. STOTZ

*Department of Biochemistry, School of Medicine and Dentistry,  
University of Rochester, Rochester, New York*

## THE PROSTHETIC GROUP OF CYTOCHROME OXIDASE

Two of the major unsolved problems in the area of electron transport are: (1) the mechanism by which the electrons are passed on to reduce oxygen and (2) the chemical mechanism by which energy is captured in biological oxidation and transformed into a utilizable chemical form.

An understanding of the structure of the prosthetic group of the enzyme which catalyzes the reduction of oxygen is of prime importance to the first of these problems. Extensive work by many investigators (see, for example, Dannenberg and Kiese, 1952; Kiese and Kurz, 1954; Lemberg, 1953; Lemberg, Bloomfield, Caiger and Lockwood, 1955; Morrison and Stotz, 1955; Person, Wainio and Eichel, 1953; Warburg, Gewitz and Völker, 1955) has clearly established that the prosthetic group of this enzyme is an iron porphyrin compound which has been labelled 'haemin *a*' or 'cytohaemin'.

One of the problems of establishing the structure of the prosthetic group of cytochromes *a* has been in obtaining adequate quantities of the haemin free of contaminating lipids and other haemins. In the course of developing procedures designed to obtain pure haemin *a*, several interesting observations were made.

A study of the haemins present in a cytochrome oxidase preparation showed that both haemin *a* and cryptohaemin *a* were extracted from the preparation (Morrison and Stotz, 1955). Investigation (Morrison, Connelly and Stotz, 1958) of the rate of extraction of haemins from a cytochrome oxidase preparation indicated that cryptohaemin *a* and protohaemin are extracted more rapidly than haemin *a*. More recently, the slower extraction rate of haemin *a* was again demonstrated, using liver mitochondria as a starting material. This differential rate of extraction suggested that cryptohaemin *a* was not an artifact derived from haemin *a* by the extraction and isolation procedures, as other workers have implied. This was further strengthened by studies which indicated that haemin *a* and cryptohaemin *a* were not interconvertible by any treatment employed in the extraction or subsequent manipulation of the haemins.

Thus, cryptohaemin *a* would appear to be present in the starting haemo-protein preparation, bound to protein. The spectral properties of haemin *a*

and cryptohaemin *a* are so closely related that either could have been the prosthetic group of either cytochrome *a* or *a*<sub>3</sub>.

The cytochromes *a* and *a*<sub>3</sub> have never been isolated and separated from each other. An attempt (Connelly, Morrison and Stotz, 1959) to achieve such a separation by electrophoresis was made in our laboratory using a purified cytochrome *c* oxidase preparation as a starting material. This effort was unsuccessful, although an active cytochrome *c* oxidase was separated from an inactive haemoprotein. This inactive haemoprotein retained the spectral properties of cytochromes *a* and *a*<sub>3</sub> and even the ability of cytochrome *a*<sub>3</sub> to combine with carbon monoxide. The inactive preparation could not be reactivated and the haemins present in the preparation were identical with those of the active enzyme.

In at least one micro-organism, however, nature has already performed the separation of cytochromes *a* and *a*<sub>3</sub>. Smith (1954, 1955) has shown that *Staphylococcus albus* contains only cytochrome *a*, at least insofar as it can be defined by spectrophotometric studies. The haemins from this organism were extracted by procedures that had been developed in our laboratory (Morrison and Stotz, 1955, 1957; Connelly, Morrison and Stotz, 1958). The haemins were separated and studied by chromatographic and spectral techniques with results showing that haemin *a* was the prosthetic group of the cytochrome *a* of *S. albus*. This added a second criterion to the already cited spectrophotometric work which more firmly establishes the cytochrome component in *S. albus* as cytochrome *a*, comparable to that of mammalian tissue. It is also an interesting demonstration of the use of a neglected tool for the characterization of cytochromes; that is, the characterization of the prosthetic groups of cytochromes by chromatographic methods. No cryptohaemin was identified in the haemins extracted from the *S. albus*.

Although there is no comparable source for observing cytochrome *a*<sub>3</sub> free of cytochrome *a*, we did turn to *Bacillus subtilis*, an organism in which the concentration of cytochrome *a*<sub>3</sub> is 2·3 times (Smith, 1954, 1955) the concentration of cytochrome *a*. We were able to isolate haemin *a* from this organism as well as some cryptohaemin *a*, but the ratio of cryptohaemin *a* to haemin *a* was less than that found for the haemins extracted from heart muscle (Morrison and Stotz, 1955; Morrison, Connelly and Stotz, 1958). Providing that the components in the bacteria are strictly comparable to those in heart muscle, these results do not support the suggestion that cryptohaemin is the prosthetic group of cytochrome *a*<sub>3</sub>.

When a cytochrome oxidase preparation is allowed to stand at 4°C for a prolonged period, it loses its enzymic activity. This loss is shown in Fig. 1, and is paralleled by a loss in haemin, as judged by the extinction at 605 m $\mu$ . After standing two weeks at 4°C, the spectrum of the solution is altered markedly. In the reduced form, the aged protein preparation has little absorption in the visible region and the Soret peak has shifted from 444 m $\mu$  to

432  $m\mu$ . Extraction of the haemin from this preparation, and a study of the chromatographic properties and spectra, showed that this preparation contains both haemin *a* and cryptohaemin. The total haemin recovered was lower, and the ratio of cryptohaemin to haemin *a* is greatly increased.

These results suggest that cryptohaemin *a* is a product of oxidative degradation of haemin *a*. This degradation appears to be the result of an autocatalytic destruction of the prosthetic group of cytochrome *a*. It is interesting

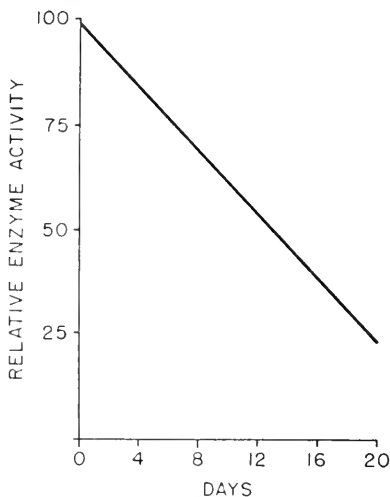

FIG. 1. Loss of cytochrome *c* oxidase activity. The enzyme preparation was allowed to stand at 4°C.

to note that at high concentrations of cholate, the cytochrome oxidase preparation is enzymically inactive and that degradation does not take place. On dilution, the preparation is enzymically active and degradation does occur. Since destruction of the enzyme is linked with enzymic activity and hence with activation of oxygen, it is conceivable that this activated oxygen is the cause of the destruction of the enzyme. Sekuzu, Takemori, Yonetani and Okunuki (1959) have already presented spectrophotometric evidence that such an activated form of the cytochrome does exist.

The structure of the prosthetic group of the cytochromes has not been neglected. The notable work of Marks, Dougall, Bullock and MacDonald (1959) on the structure of the deuteroporphyrin derived from haemin *a*, assigns the position and describes the nature of five of the groups substituted on the eight available positions on the porphyrin nucleus.

The problems which remain are: first to decide what are the three other groups substituted on the porphyrin nucleus, and second, the arrangement of these groups on the porphyrin nucleus.

There is ample evidence to suggest the presence of a formyl group and a

vinyl group as two groups in resonance with the porphyrin *a* nucleus (Dannenberg and Kiese, 1952; Lemberg, 1953; Kiese and Kurz, 1953; Warburg, Gewitz and Völker, 1955). Table I supplies such evidence. Haemin

TABLE I. VISIBLE ABSORPTION MAXIMA AND TYPE OF SPECTRUM OF PORPHYRIN *a* AND DERIVATIVES

Porphyrin	IV	III	II	I	Spectral type
Porphyrin <i>a</i>	516	558	582	647	O
Porphyrin <i>a</i> oxime	512	552	577	645	R
Porphyrin <i>a</i> (reduced with HI)	508	550	576	640	R
Porphyrin <i>a</i> (reduced with NaBH <sub>4</sub> )	502	540	573	624	A

A = aetio, R = rhodo, O = oxorhodo.

*a* reacts with dimedon to form a methone derivative; bromine adds to haemin *a* to form a product of which the haemochrome band is shifted 5 *m* $\mu$  towards the blue. These observations confirm the presence of a formyl and a vinyl substituent.

The third group removed in the resorcinol melt of haemin *a* may be an  $\alpha$ -ketoalkyl group on the following grounds: the infra-red spectrum indicates the presence of two carbonyl groups other than the carboxyl-carbonyls; one of these is the formyl group, while the other must be present in the third group. The long aliphatic side chain is probably present in the  $\alpha$ -ketoalkyl side chain rather than on the vinyl, since oxidation with permanganate yielded no long chain aliphatic acid or aldehyde. From our studies, the molecular weight of chlorohaemin *a* based on iron determination is 880. By difference, the alkyl group must account for 213 of the molecular weight.

The significance of the long aliphatic chain and the aldehyde and ketone groups in the functioning of the cytochromes *a* and *a*<sub>3</sub> is not apparent. It is clear that the long chain aliphatic group can help supply a non-polar environment. In view of the findings of Wang (1958) and Corwin and Bruck (1958), it could be suggested that the 'aliphatic' environment makes possible a haem-oxygen combination equivalent to that which takes place in the haemoglobin molecule and that the subsequent oxidation of the iron requires the transfer of an electron from a co-ordinating group on the protein.

#### CYTOCHROMES AND PHOSPHORYLATION

The clarification of the mechanism of oxidative phosphorylation in chemical terms is a second outstanding problem in understanding biological oxidation. This problem can be approached in a number of different ways. It has been investigated by spectrophotometric study (Chance and Williams, 1957) of the kinetics of interaction of the various cytochromes, flavoproteins and



pyridine nucleotides in intact mitochondria. Other approaches (see, for example, Boyer, 1957; Slater, 1958; Wadkins and Lehninger, 1958) have involved studying the relative rates of incorporation of  $^{32}\text{P}$  or  $^{18}\text{O}$  in an effort to evaluate the steps in the phosphorylation process. The phosphorylation steps have been studied by employing uncouplers and antibiotics (Lardy and McMurray, 1959). Slater (1958) has measured the pH optimum of the various steps involved in this process.

More directly, the classical approach of separation and isolation of the enzymes involved in the phosphorylative steps, has only recently shown signs of being fruitful. The process of oxidative phosphorylation has been considered to be catalysed by a complex of enzymes which are very unstable. Until comparatively recently, the intact mitochondria were the smallest units capable of this process. It is now possible, by various techniques (Green and Crane, 1957; Kielley and Bronk, 1958; Lehninger, Wadkins, Cooper, Devlin and Gamble, 1958) to prepare submitochondrial units which are capable of coupling oxidation and phosphorylation. More recently, it has been possible to subfractionate the complex of enzymes even further and isolate the enzymes involved in the terminal steps in the phosphorylation procedure (Remmert and Lehninger, 1959; Wadkins and Lehninger, 1958).

Still to be clarified are the enzymic steps in which the electron carriers themselves are involved in the chemical transformations resulting in phosphorylation. We decided to attack the problem by investigating this phenomenon in the steps involving cytochrome *c* and cytochromes *a* and *a*<sub>3</sub>.

It has been clearly demonstrated that in the oxidative sequence from cytochrome *c* to oxygen, at least one 'high-energy' phosphate can be derived per passage of two electrons (Judah, 1951; Maley and Lardy, 1954; Nielsen and Lehninger, 1954). Initial studies in our laboratories demonstrated that when purified isolated cytochrome *c* was added to the mitochondria, employing ascorbate as the substrate, the rate of both oxidation and phosphorylation increased. The increase in phosphorylation, however, did not parallel the increase in oxidation, and as a result there was a decrease in the P/O ratio with increasing concentrations of added cytochrome *c*.

Varying the concentration of mitochondria in the same type of experiment, showed that the rate of phosphorylation was proportional to the amount of mitochondria at any given concentration of added cytochrome *c*. This was not true of oxidation. At high levels of mitochondria, the oxygen consumption does not increase.

In the widely used scheme:

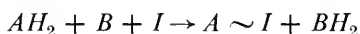

*A* and *B* are general symbols for electron carriers and *I* is a compound which forms a bond with one of the carriers in which the energy available from electron transfer is conserved; *I* is the coupler of oxidation and phosphorylation

and the *I*-electron carrier compound is the inhibited form of the electron transport system.

In 'tightly-coupled' mitochondria, oxidation cannot proceed without the presence of phosphate acceptors. This indicates that the component which inhibits oxidation and couples oxidation to phosphorylation, *I*, is present in amounts exceeding the electron transport components.

Cytochrome *c* is an electron transport system member which is directly involved in the coupling of oxidation and phosphorylation. The compound, *I*, which inhibits oxidation is present in amounts exceeding the concentration of cytochrome *c* initially in the mitochondria. The results of the experiments cited above can then be interpreted simply as a logical consequence of the mass law. On addition of cytochrome *c*, its concentration will equal and then exceed that of the inhibitor, *I*. Therefore, at high concentrations, more of the cytochrome *c* can be oxidized and reduced without reacting with the inhibitor. At low concentrations, where the ratio of *I* to cytochrome *c* is high, there is a great extent of reaction with the inhibitor. Increasing the concentration of mitochondria results in increased ratios of *I* to cytochrome *c*, with a resulting increase in the P/O ratio. Conversely, a lower ratio of *I* to cytochrome *c* results in a decreased P/O ratio. From these results, it would appear that cytochrome *c* does interact with the inhibitor, *I*.

With this information at hand, the following experiments were performed. 'Tightly-coupled' mitochondria were prepared and incubated with succinate in a nitrogen atmosphere. When the system became sufficiently anaerobic to deoxygenate the haemoglobin present, two volumes of boiling acetone were added. The contents were then placed in a water bath at 60°C for 5 min and the mitochondria were sedimented by centrifuging. The mitochondria were then extracted with salt solutions. The cytochrome *c* which was extracted was, almost exclusively, in the reduced form. More interesting was the fact that, quantitatively, the amount of cytochrome *c* extracted under these conditions was a function of the state of oxygenation of the mitochondria. More

TABLE 2. EXTRACTION OF CYTOCHROME *c*

Condition of extraction	Ratio of cytochrome <i>c</i> extracted from mitochondria $\frac{\text{anaerobic}}{\text{aerobic}}$
0.5 M NaCl pH 7.0	2.0 -1.5
0.5 M NaCl pH 7.0 (after pretreatment with dithionite)	1.75-1.4
0.5 M NaCl pH 7.0 (after pretreatment with ferricyanide)	1.8 -1.4

cytochrome *c* could be extracted from the mitochondria in the anaerobic state than that in the aerobic state.

This is not simply a function of the state of oxidation of the cytochrome *c*. After acetone powders were obtained from aerobic and anaerobic mitochondria, they were treated in order to oxidize the cytochrome *c*. The difference in the total amount of cytochrome *c* extractable from the two types of mitochondrial powders remains the same even when all the cytochrome is oxidized prior to extraction. This difference in extractability, then, can be interpreted as due to the difficult extraction of the cytochrome-coupler compound and not simply due to a difference in the extractability of free oxidized and reduced cytochrome *c*.

When aged mitochondria in which oxidation and phosphorylation are uncoupled were employed, the state of oxidation still affected the amount of cytochrome *c* which could be extracted. Thus, in agreement with other studies (Remmert and Lehninger, 1959), it would appear that the carrier inhibitor compound is still functioning even after ageing, though the steps involved in the transfer of the high energy bond are disrupted.

In addition to the previous evidence for the existence of cytochrome *c* inhibitor complex, our studies (Crawford and Morrison, 1959) on the succinate-cytochrome *c* reductase system have also yielded evidence that a cytochrome *b*-inhibitor complex may exist. A study of the rate of reduction of cytochrome *c* with our succinate-cytochrome *c* reductase preparation has indicated the presence of an inhibitor in the preparation. On extraction of this preparation with *iso*-octane, the kinetics can be interpreted as an increase in inhibitor. A study of the kinetics after the addition of tocopherol or vitamin  $K_1$  indicates that these lipids are able to reverse the effect of the inhibitor.

These results are compatible with a scheme in which the cytochrome first reacts with an inhibitor and the cytochrome-inhibitor compound can no longer be alternately reduced and oxidized.

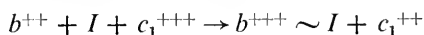

Following this, the effect of the lipid may be to react with the carrier  $\sim I$  compound to form a complex of the type  $I \sim X$  in which  $X$  is the lipid factor. This compound in turn might react with inorganic phosphate ( $P_i$ ) to form complexes of the  $X \sim P$  type, and preliminary evidence of such lipid-phosphate intermediates has already been obtained (Conover and Witter, 1958; Boyer, Dempsey, Schulz and Andesegy, 1959).

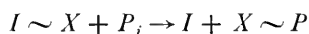
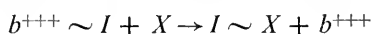

Spectrophotometric results are perfectly compatible with these results. On addition of succinate, both the cytochromes *b* and  $c_1$  are reduced. After

*iso*-octane extraction of the preparation, the addition of succinate results in a complete reduction of cytochrome  $c_1$  and only partial reduction of cytochrome  $b$ . According to the foregoing scheme, the cytochrome  $b$ -inhibitor compound cannot be reduced and consequently remains in the oxidized form after having reduced the cytochrome  $c_1$ .

Studies are now in progress which are designed to isolate and characterize cytochrome-inhibitor compounds. It is hoped by such studies to clarify the role of the electron carriers in oxidative phosphorylation.

### Acknowledgements

The research in this report was supported by Grant No. H-1322 from the National Heart Institute, National Institute of Health.

One of the authors (M.M.) was supported by a Senior Research Fellowship SF-47 from the U.S. Public Health Service.

### REFERENCES

- BOYER, P. D. (1957). *Proc. Inter. Symp. Enz. Chem. Japan* p. 301.
- BOYER, P. D., DEMPSEY, M. B., SCHULZ, A. R. & ANDESEGY, M. (1959). *Fed. Proc.* **18**, 195.
- CHANCE, B. & WILLIAMS, G. R. (1957). *Advanc. Enzymol.* **18**, 65.
- CONNELLY, J., MORRISON, M. & STOTZ, E. (1958). *J. biol. Chem.* **233**, 743.
- CONNELLY, J., MORRISON, M. & STOTZ, E. (1959). *Biochim. biophys. Acta* **32**, 543.
- CONOVER, T. E. & WITTER, R. F. (1958). *Fed. Proc.* **17**, 205.
- CORWIN, A. H. & BRUCK, S. D. (1958). *J. Amer. chem. Soc.* **80**, 4736.
- CRAWFORD, R. E. & MORRISON, M. (1959). *Fed. Proc.* **18**, 209.
- DANNENBERG, H. & KIESE, M. (1952). *Biochem. Z.* **322**, 395.
- FALK, J. E. & RIMINGTON, C. (1952). *Biochem. J.* **51**, 36.
- GREEN, D. & CRANE, F. L. (1957). *Proc. Inter. Symp. Enz. Chem. Japan* p. 275.
- HOLLOCHER, T., MORRISON, M. & STOTZ, E. (unpublished).
- HUNTER, E. (1951). *Phosphorus Metabolism*, vol. I, p. 297. Ed. by W. D. McElroy and B. Glass. The Johns Hopkins Press, Baltimore.
- JUDAH, J. D. (1951). *Biochem. J.* **49**, 271.
- KIELLEY, W. W. & BRONK, J. P. (1958). *J. biol. Chem.* **230**, 521.
- KIESE, M. & KURZ, H. (1954). *Biochem. Z.* **325**, 299.
- LARDY, H. & McMURRAY, W. C. (1959). *Fed. Proc.* **18**, 269.
- LEHNINGER, A. L., WADKINS, C. L., COOPER, C., DEVLIN, T. M. & GAMBLE, J. L. (1958). *Science* **128**, 450.
- LEMBERG, R. & FALK, J. E. (1951). *Biochem. J.* **44**, 674.
- LEMBERG, R. (1953). *Nature, Lond.* **172**, 619.
- LEMBERG, R., BLOOMFIELD, B., CAIGER, P. & LOCKWOOD, W. H. (1955). *Aust. J. exp. Biol. med. Sci.* **33**, 435.
- MALEY, G. F. & LARDY, H. A. (1954). *J. biol. Chem.* **210**, 903.
- MARKS, G. S., DOUGALL, D. K., BULLOCK, E. & MACDONALD, S. F. (1959). *J. Amer. chem. Soc.* **81**, 280.
- MORRISON, M. & STOTZ, E. (1955). *J. biol. Chem.* **213**, 373.
- MORRISON, M. & STOTZ, E. (1957). *J. biol. Chem.* **228**, 123.
- MORRISON, M., CONNELLY, J. & STOTZ, E. (1958). *Biochim. biophys. Acta* **27**, 214.
- NIELSEN, S. O. & LEHNINGER, A. L. (1954). *J. Amer. chem. Soc.* **76**, 3860.
- OKUNUKI, K., HAGIHARA, B., SEKUZU, I. & HORIO, T. (1957). *Proc. Inter. Symp. Enz. Chem. Japan* p. 265.
- PERSON, P., WAINIO, W. W. & EICHEL, B. (1953). *J. biol. Chem.* **202**, 369.

- REMMERT, L. F. & LEHNINGER, A. L. (1959). *Proc. nat. Acad. Sci. Wash.* **45**, 1.
- SEKUZU, I., TAKEMORI, S., YONETANI, T. & OKUNUKI, K. (1959). *J. Biochem. Tokyo* **46**, 43.
- SLATER, E. C. (1958). *Aust. J. exp. Biol. med. Sci.* **36**, 51.
- SMITH, L. (1954). *Bact. Rev.* **18**, 106.
- SMITH, L. (1955). *J. biol. Chem.* **215**, 847.
- STERN, A. & MOLVIG, H. (1936). *Hoppe-Seyl. Z.* **A177**, 365.
- STERN, A. & WENDERLEIN, H. (1936). *Hoppe-Seyl. Z.* **A176**, 81.
- WADKINS, C. L. & LEHNINGER, A. L. (1958). *J. biol. Chem.* **233**, 1589.
- WANG, J. H. (1958). *J. Amer. chem. Soc.* **80**, 3168.
- WARBURG, O., GEWITZ, H. S. & VÖLKER, W. Z. (1955). *Z. Naturforsch.* **10b**, 541.

# THE STRUCTURE OF PORPHYRIN $a$ , CRYPTOPORPHYRIN $a$ AND CHLORIN $a_2$

By R. LEMBERG, P. CLEZY AND J. BARRETT

*Institute of Medical Research, Royal North Shore Hospital, Sydney*

THIS PAPER deals mainly with the chemical structures of the prosthetic groups of the cytochromes of type  $a$ . Cytochromes  $a$ ,  $a_1$  and  $a_3$  have as their prosthetic group the iron complex of a formyl-porphyrin (porphyrin  $a$ , also called cytoporphyrin by Warburg). The presence in heart muscle of a second formyl-porphyrin, cryptoporphyrin  $a$ , suggests that another so far unknown haemoprotein of type  $a$  is present in heart muscle in small amounts. The prosthetic group of cytochrome  $a_2$  belongs to a different class, being the iron complex of a chlorin (dihydroporphyrin) without formyl side chains.

## PORPHYRIN $A$

### *Evidence for the Nature of the Side Chains: The Formyl Group*

The presence of a formyl side chain in the prosthetic group of the Atmungsferment was already postulated in the classical work of Warburg. This assumption, based on the similarity of the photochemical absorption spectrum with the spectra of chlorocruorohaem (also called spirographis haem) compounds has been amply confirmed by all later workers. The aldehyde group reacts reversibly with methanolic hydrochloric acid forming a methyl acetal, with hydroxylamine to form an oxime, with hydrazine to form a hydrazone, and with sodium bisulphite. The rapid rate of the reaction of the haemochrome with hydroxylamine at room temperature (Lemberg and Falk, 1951), the reaction with bisulphite (Lemberg, cf. Parker, 1959) and the dehydration of the oxime to the nitrile (Dannenberg and Kiese, 1952) prove that the carbonyl side chain is not ketonic. The presence of a ring-ketone group similar to that present in the isocyclic ring of chlorophyll, e.g. in phaeoporphyrin  $a_5$ , is excluded by the failure of phaeohaemochromes to react rapidly with hydroxylamine, by the reversibility of methyl acetal formation of porphyrin  $a$  (the conversion of phaeoporphyrins into chloroporphyrins being irreversible), and by the infra-red spectrum of porphyrin  $a$  (Lemberg and Willis, unpublished) which does not show the band at  $1695\text{ cm}^{-1}$  characteristic of the ring-ketone group. Recently, three more reactions of the formyl group in porphyrins have been studied in our laboratory, its oxidation by

chromic acid under mild conditions to carboxyl, its reduction by sodium borohydride to hydroxymethyl, and its condensation with acetone-HCl, probably to  $\cdot\text{CH}:\text{CH}\cdot\text{CO}\cdot\text{CH}_3$ . Porphyrin *a* undergoes all these reactions. Since acetone-hydrochloric acid is used in the isolation of haemin *a* from heart muscle, and for its crystallization in the Warburg procedure, the last-mentioned reaction is of interest; unless care is used, this reaction partially converts haemin *a* into its acetone condensate.

The magnitude of the shift of the absorption bands of porphyrin *a* in the oxime formation ( $\cdot\text{CHO} \rightarrow \cdot\text{CH}:\text{NOH}$ ) shows that only one carbonyl, i.e. the formyl group is present. The average shift for the four bands is 75 Å for porphyrin *a*, 82 for monoformyl deuteroporphyrin, 77 for chlorocruoroporphyrin and 79 for cryptoporphyrin *a*. This shift is about the same for acetyl and formyl groups, and two such groups cause a band shift of about 120 Å.

Porphyrin *a* does not contain a carboxyl group directly on the nucleus. After treatment of the porphyrin with hydriodic acid or after diazoacetic ester addition to the double bond, hydroxylamine gave aetio-type porphyrins (Rimington, Hale, Rawlinson, Lemberg and Falk, 1949); a carboxyl group would not be altered by these reagents and would retain its rhodofying effect on the spectrum. Two carboxylic acid groups can be demonstrated in porphyrin *a* by manometry (Morell, unpublished) and both are accounted for as propionic acid side chains, as the conversion of porphyrin *a* into cyto-deuteroporphyrin shows (Warburg and Gewitz, 1953). In the paper chromatography in lutidine-water (Nicholas and Rimington, 1949), porphyrin *a* had an  $R_F$  of 0.84, slightly higher than the 0.81 of other dicarboxylic acids.

#### *The Unsaturated Side Chain Conjugated to the Nucleus and Its Position Relative to the Formyl*

Rimington *et al.* (1949) believed to have evidence for the presence of two vinyl groups from absorption spectra of the oxime and its presumed diazoacetic ester adduct. The latter was, however, prepared by diazoacetic ester addition to porphyrin *a* before oximation. Since the formyl group also reacts with the ester, it is necessary to protect it by oximation first before the diazoacetic ester addition. This experiment was carried out in our laboratory (Parker, 1959) and gave evidence for only one vinyl group (band shift about 2  $m\mu$ , as for chlorocruoroporphyrin). Warburg and Gewitz (1951) also found that only two atoms of hydrogen (plus one needed for the reduction of the iron from ferric to ferrous) were added on catalytic hydrogenation of haemin *a* in borate buffer pH 11.

Porphyrin *a* differs, however, from chlorocruoroporphyrin, which has a formyl and one vinyl group in two aspects. Firstly, its absorption bands are slightly shifted towards the red (cf. Table 1). It may be noted that it is essential to compare absorption spectra in the same solvent. Chloroform, as

compared with ether, e.g. shifts all band positions from 2–6  $m\mu$  towards the red.

TABLE I. ABSORPTION SPECTRA OF PORPHYRIN *a*, CRYPTOPORPHYRIN *a* AND CHLOROCRUOROPORPHYRIN

		$\lambda$ in $m\mu$	in chloroform	
	I	II	III	IV
Porphyrin <i>a</i>	646	584.5	563.5	520
Cryptoporphyrin <i>a</i>	642.5	584	559	519
Chlorocruoroporphyrin	644.5	585	560	520

Secondly, while chlorocruoroporphyrin has a rhodotype spectrum, with the ratio of bands III/IV 1.3–1.4, porphyrin *a* has an oxorhodo type spectrum

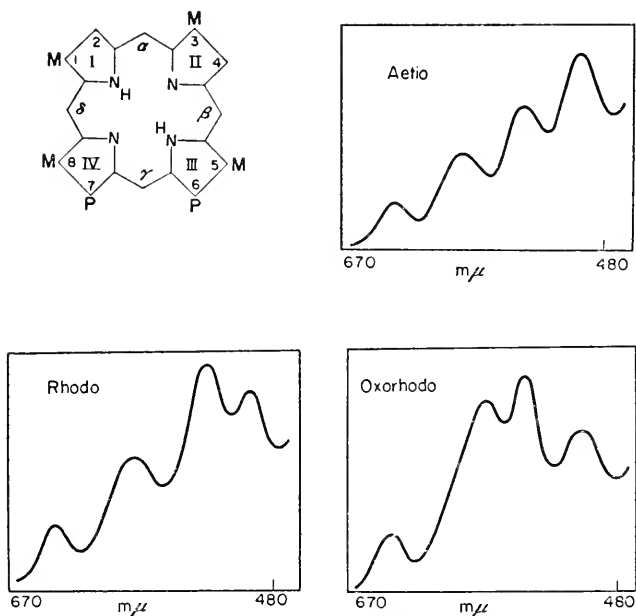
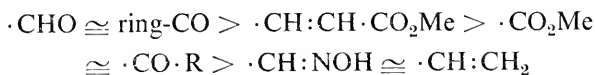

FIG. 1. Types of porphyrin spectra.

with both bands II and III higher than IV and the ratio III/IV as high as 2.40–2.45 (Fig. 1). The order of strength of the rhodifying influence of side chains is





Vinyl alone does not cause a rhodo-type spectrum. This made Lemberg and Falk (1951) postulate the presence of an acrylic acid side chain, which as vinylogue of the carboxyl side chain has a strong rhodofying effect. However, later evidence has not confirmed this assumption. Cytodeuteroporphyrin has two propionic acid side chains, and the infra-red spectrum of porphyrin *a* ester shows only the 1737 cm<sup>-1</sup> band due to the propionic acid side chains, while the acrylic ester should have a band at about 1725 cm<sup>-1</sup>.

It is, in fact possible to account for both the differences between porphyrin *a* and chlorocruoroporphyrin on the basis of two rhodofying groups, formyl and vinyl (or substituted vinyl) on opposite pyrrole rings, together with the presence of an  $\alpha$ -hydroxyalkyl group on the pyrrole ring in between (see below). The average displacement of bands towards the infra-red caused by replacement of an alkyl by an  $\alpha$ -hydroxyalkyl is 1 m $\mu$ , in agreement with the difference of band positions of porphyrin *a* and chlorocruoroporphyrin except for band III (3.5 m $\mu$ ). This band may be shifted further towards the red in porphyrin *a* owing to overlapping with the high band II, which in turn is shifted towards the blue in porphyrin *a*.

Whereas the position of absorption bands is little influenced by the relative position of the substituents, this is not so for band intensities. A second rhodofying group increases the ratio III/IV very strongly, if it substitutes the pyrrole ring opposite to the first; it decreases it if it substitutes a vicinal pyrrole ring, independent of whether the relative position is 1-4, 2-4 or 2-3 (cf. Table 2, No. 1-5).

TABLE 2. ANTIRHODOFYING EFFECTS OF RHODOFYING GROUPS ON VICINAL PYRROLES

No.	Porphyrin in chloroform	Relative position and nature of groups	Type of spectrum
1.	Diformyldeutero	2 F 4 F	} Actio
2.	3-Desmethyl-3-formylrhodo	3 F 6 CO <sub>2</sub> H	
3.	Rhodinporphyrin g <sub>5</sub>	3 F 6 CO <sub>2</sub> H ( $\gamma'$ -CH <sub>3</sub> )	
4.	Neorhodinporphyrin g <sub>3</sub> but	2 V 3 F ( $\gamma'$ -CH <sub>3</sub> )	
5.	Rhodoporphyrin g <sub>3</sub>	2 E 3 F ( $\gamma'$ -CH <sub>3</sub> )	Rhodo

F = formyl      V = vinyl       $\gamma'$  = methene bridge.

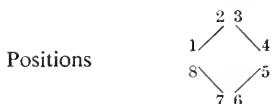

Table 3 shows that the vinyl group has also a rhodofying effect if it substitutes an opposite pyrrole (cf. 7 with 6, 10 with 9, Table 3) and an anti-rhodofying effect if it substitutes a vicinal pyrrole (cf. 3 with 1, Table 3, or 4 with 5, Table 2). Thus it raises R III/IV from 1.29 to 1.89 opposite to a carboxyl,

and from 1.72 to 2.15 opposite to a ring-ketonyl. Since the rhodofying effect of formyl is even stronger than that of ring-ketonyl (cf. 1 with 9, Table 3), a high R III/IV would be expected for porphyrin *a* with a vinyl opposite to formyl. The  $\alpha$ -hydroxyalkyl group has practically no influence on R III/IV (cf. 2 with 1, Table 3). Porphyrin *a* carboxylic acid has, indeed R III/IV quite similar to pseudoverdoporphyrin (vinylrhodoporphyrin).

TABLE 3. EFFECT OF SUBSTITUENTS ON R III/IV

No.	Porphyrin in chloroform	Rhodofying Group I	Rhodofying opposite	Group II vicinal	R III/IV
1.	Formyldeutero	CHO	—	—	1.77
1.	Monohydroxyethyl-formyl deutero	CHO	—	CH(OH)CH <sub>3</sub>	1.68
3.	Chlorocruoro	CHO	—	vinyl	1.40
4.	Porphyrin <i>a</i>	CHO	alkylvinyl	—	2.40
5.	Porphyrin <i>a</i> -carboxylic acid	CO <sub>2</sub> H	alkylvinyl	—	1.75
6.	Rhodo	CO <sub>2</sub> H	—	—	1.29
7.	Pseudoverdo	CO <sub>2</sub> H	vinyl	—	1.89
8.	Oxorhodo	CO <sub>2</sub> H	acetyl	—	2.39
9.	Phaeo <i>a</i> <sub>5</sub>	·CO·CH(CO <sub>2</sub> R)·	—	—	1.72
10.	Vinylphaeo <i>a</i> <sub>5</sub>	·CO·CH(CO <sub>2</sub> R)·	vinyl	—	2.15

Porphyrin *a* cannot therefore have the formyl and alkylvinyl groups in the positions at vicinal pyrroles as Warburg and Gewitz (1953) assumed. Lemberg (1953) postulated that the two rhodofying groups must be on opposite pyrroles and therefore one on a ring bearing the propionic acid side chains. There remained the possibility that the two groups substituted one and the same pyrrole ring, no porphyrins of this type being known. However, this possibility was excluded by later work, particularly of MacDonald (see below).

By the Schumm resorcinol method, followed by removal of iron, Warburg and Gewitz (1953) obtained from haemin *a* a crystalline porphyrin ester which they called cytodeuteroporphyrin ester. It differed from deuteroporphyrin ester obtained from protohaemin in its melting point. It has also absorption bands slightly more towards the blue than those of deuteroporphyrin ester (Barrett, unpublished). Chromic acid oxidation yielded methylmaleimide and haematinic acid. A formula having two free  $\beta$ -positions in 2 and 3 was suggested, but bromination revealed the presence of three, not two free  $\beta$ -positions. Recently Marks, Dougall, Bullock and MacDonald (1959) have succeeded in synthesizing cytodeuteroporphyrin. The three free  $\beta$ -positions are in 2, 4 and 8 (Fig. 2).

The two rhodofying groups must therefore occupy the positions 4 and 8 on rings II and IV. The structure of cytodeteroporphyrin with two propionic acid groups disproves the assumption (Lemberg, 1953; Dixon and Webb,

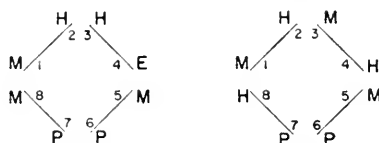

FIG. 2. Cytodeteroporphyrin.

1958) that the excess carbon and hydrogen in porphyrin *a* (see below) is present in the form of a long fatty acid side chain.

### The $\alpha$ -Hydroxyalkyl Side Chain

These studies raised the problem of the third substituent removed from position 2 in ring I in the resorcinol melt. As shown above, there was evidence against this being another carbonyl or vinyl side chain. In fact any of these groups in position 2 would have a strong anti-rhodofying effect, not in harmony with the oxorhodotype spectrum of porphyrin *a*. We have, e.g. recently obtained a porphyrin *a* derivative having a carbonyl group in this position. This had a rhodotype spectrum with R III/IV 1.21. Of groups known to be removed in the resorcinol melt only  $\alpha$ -hydroxyalkyl remained; haematohaemin is known to yield deuterohaemin. The low  $R_F$  of porphyrin *a* ester in chloroform-kerosene (0.10) or propanol-kerosene (0.26) was in agreement with such an assumption (Barrett, 1959) and also the analyses of haemin *a* (Table IV) which indicated the presence of at least 6 atoms of oxygen. Barrett (1959) has been able to acetylate the hydroxyl groups by acetic anhydride in pyridine with the increase of  $R_F$  from 0.10 to 0.56 and from 0.26 to 0.62 respectively. This hydroxyl group is present in the form of an  $\alpha$ -hydroxyalkyl group (Clezy and Barrett, 1959). In this work the use of the porphyrin *a* carboxylic acid (CO<sub>2</sub>H replacing CHO) was found useful, since it abolished by-reactions due to the sensitivity of the formyl group to oxidation. This compound had been obtained by mild chromic acid oxidation of the acetate of porphyrin *a*, followed by hydrolysis of the acetate of the oxidation product. As expected, oxidation of the  $\alpha$ -hydroxyalkyl to ketonyl by chromic acid-H<sub>2</sub>SO<sub>4</sub> in acetone decreased R III/IV (see above) from 1.75 to 0.78. If the reaction was carried out with porphyrin *a* itself (R III/IV 2.3), a compound of R III/IV 1.27 with intact formyl group was obtained in addition to the carboxylic acid compound with R III/IV 0.78. The resulting porphyrins resembled acetylporphyrins spectroscopically. Confirmatory evidence was obtained by dehydration. Using either porphyrin *a* carboxylic acid or porphyrin *a* alcohol (CH<sub>2</sub>OH replacing CHO), the  $\alpha$ -hydroxyalkyl side chain could be demonstrated by the band shift (2-3 m $\mu$  towards the red)

accompanying dehydration to vinyl or substituted vinyl, which was achieved by heating in acetic acid or in pyridine plus toluene-sulphonylchloride. The introduction of the vinyl at position 2 lowered, as expected, R III/IV of porphyrin *a* acid from 1.75 to 1.50. The  $\alpha$ -hydroxyalkyl group is therefore present on ring I (in position 2) between the two rhodifying groups at rings II and IV.

*Possible Formulae of Porphyrin a*

These findings can be summarized as establishing one of the two formulae of Fig. 3 for porphyrin *a*.

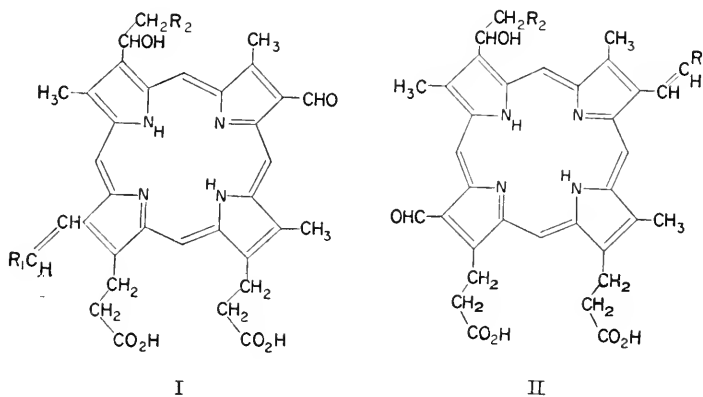
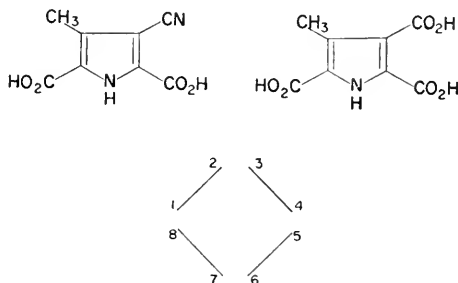

FIG. 3. Alternative formulae for porphyrin *a*

Nicolaus (private information) has been unable to obtain the pyrrole carboxylic acids



from the nitrile of porphyrin *a* oxidized by his alkaline permanganate method. This would seem to exclude formula I and support formula II of Fig. 3. However, the value of such negative evidence is uncertain. Dr. Clezy is attempting to solve this problem by Wolff-Kishner reduction of the formyl to methyl. A resorcinol melt of the product should then give deuteroporphyrin

IX if formula II is correct, but another porphyrin with two methyl groups on one pyrrole from a porphyrin of formula I. The results are as yet inconclusive. The dimethyl porphyrin ester obtained greatly resembled deuteroporphyrin IX ester, and gave no melting point depression with it, but had a lower melting point (203–206° compared with 220–222° of the deuteroporphyrin ester).

*Large Alkyl Group (or Groups) and Molecular Weight of Porphyrin*

The molecular weight of porphyrin *a* can be calculated from the analyses of haemin *a*, in particular its iron content (Table 4), and from the ratio of molar extinction to specific extinction of pyridine haemochrome *a* and porphyrin *a*. While these results are as yet not fully concordant (Table 5), they show that the molecular weight is considerably greater than that of protoporphyrin and that  $R_1 + R_2$  of the formulae in Fig. 3 is between

TABLE 4. ANALYSES OF HAEMIN *a*

Warburg and Gewitz (1951) C 64.47 H 6.79 N 6.50 Fe 6.42 Cl 4.20	Possible formulae $C_{16}H_{36}N_4O_6FeCl$
Lemberg (unpublished) (haemin reconstituted from porphyrin <i>a</i> ) C 65.41 H 6.56 N—Fe 5.90 Cl 3.75	$C_{51}H_{68}N_4O_7FeCl$

TABLE 5. MOLECULAR WEIGHT OF PORPHYRIN *a* AND SIZE OF *R* GROUPS ( $R_1 + R_2$ )

	M.W. of porphyrin	Additional C atoms
Warburg haemin analyses	760–790	12–14
Lemberg haemin analyses	835–860	16–18
Pyridine haemochrome <i>a</i> , $\epsilon_M/\epsilon_{sp}$	740–810	11–16
Porphyrin <i>a</i> , $\epsilon_M/\epsilon_{sp}$	< 875	< 20

$C_{12}H_{25}$  and  $C_{20}H_{41}$ . These alkyl groups or group can only be attached to the vinyl and the  $\alpha$ -hydroxylalkyl, since they are removed in the resorcinol melt. Some of it at least, must be attached to the vinyl since no crystalline porphyrin was obtained in the resorcinol melt after catalytic hydrogenation of the unsaturated group.

Since we have observed that an acetyl group is not removed by milder conditions in the resorcinol melt, we hope to solve the problem whether the group resulting from oxidation of the  $\alpha$ -hydroxyalkyl group is acetyl or a substituted acetyl group.

We have so far refrained from an attempt to obtain information by an oxidation of porphyrin *a* and the attempt at isolation of the fatty acid or acids,



suggested. In spite of its larger molecular weight, cryptohaemin remains together with protohaemin in the aqueous phase of the Rawlinson distribution between ether-pyridine and aqueous pyridine-HCl (Rawlinson and Hale, 1949), and also in the aqueous phase in the countercurrent distribution phase between light petroleum-acetone and aqueous HCl-acetone of Kiese and Kurz (1954), thus differing from porphyrin *a* of similar molecular weight.

Cryptoporphyrin *a* is not an artifact derived from protohaem. Removal of myoglobin from heart muscle before processing greatly decreases the protoporphyrin yield, but does not decrease the cryptoporphyrin yield. Porphyrins of similar spectroscopic properties can be obtained from red cells (cryptoporphyrins *p*) but these are chemically quite different compounds; they contain a ketonyl side chain and chlorine, not a formyl side chain (Lemberg, 1953; Clezy and Parker, unpublished).

At first it was assumed (Lemberg, 1953; Lemberg and Parker, 1955) that cryptoporphyrin *a* was an artifact derived from porphyrin *a* by alteration during the isolation process. Its yield, though always much smaller than that of porphyrin *a* varied considerably, and porphyrin *a* gave rise to a porphyrin resembling cryptoporphyrin *a* during treatment with acetone-HCl and reintroduction and removal of iron. It could be shown, however (Parker, 1959), that the altered porphyrin *a* thus formed was not identical with cryptoporphyrin *a*, while its formation in variable amounts can explain the apparent variation in yield. The variation was also less in later experiments. The yield of cryptoporphyrin *a* from heart muscle is between 5% and 10% that of porphyrin *a*.

These results make it likely that cryptoporphyrin *a* is derived from a so far unknown haemoprotein of heart muscle which has cryptohaem *a* as its prosthetic group. Connelly, Morrison and Stotz (1958) have independently come to the same conclusion by chromatographic separation of heart muscle haemins on silica gel. A reservation must be made, however. The spectrum of the porphyrin obtained from their "haemin *a*<sub>1</sub>" (Morrison, Connelly and Stotz, 1958) is not identical with that of cryptoporphyrin *a*, since its spectrum in ether is compared with that given by Lemberg (1953) for a solution of cryptoporphyrin *a* in chloroform. We have also found cryptoporphyrin *a* in chicken heart and liver.

Pyridine cryptohaemochrome *a* differs from pyridine haemochrome *a* in the position of its  $\alpha$ -band by 6  $m\mu$ , and in having a second absorption band in the green. Owing to these relatively small differences and the low concentration of cryptohaem *a*, it will be very difficult to discover the cryptohaemoprotein *a* in cytochrome oxidase preparations or in tissues. Its low concentration would not appear to suggest for it a role in the main respiratory chain, nor can it be the prosthetic group of cytochrome *a* or *a*<sub>3</sub>. However, its discovery shows that careful chemical isolation can still give results unobtainable by spectroscopic methods alone.

HAEM  $A_2$  AND CHLORIN  $A_2$ 

Haemin  $a_2$  (Barrett and Lemberg, 1954; Barrett, 1956) has been isolated from all micro-organisms in which the cytochrome  $a_2$  band at  $630\text{ m}\mu$  could be observed, and in small concentration in a few in which it had previously not been observed, e.g. *Bacillus subtilis*. Its amount paralleled the strength of the cytochrome  $a_2$  band. Further, anaerobically cultured bacteria containing no cytochrome  $a_2$  also failed to yield haemin  $a_2$ .

*Aerobacter aerogenes* was our main source. The bacterial haemins in acid ethereal solution showed an absorption band at  $630\text{ m}\mu$  not found in the spectrum of protohaemin. This was used as guide in the isolation procedure as  $E_{603\text{m}\mu}/E_{635\text{m}\mu}$ . This varied from 1.3 in cells with much cytochrome  $a_2$  to 1.0 in those with little, corresponding to a protohaem/haem  $a_2$  ratio of from 4–10.

The separation of the green haemin from protohaemin was achieved by silica gel chromatography and freezing out of protohaemin together with phospholipids at  $-70^\circ\text{C}$  from acetone solutions. Purified haemin  $a_2$  had an  $E_{603\text{m}\mu}/E_{635\text{m}\mu}$  ratio of 3.18.

Iron is removed more readily from haem  $a_2$  than from protohaem and even from haem  $a$ . This process could therefore be carried out with relatively low HCl concentration (0.4% w/v) at room temperature. This yielded a chlorin (dihydroporphyrin). It is known that metals are less strongly bound by dihydroporphyrins than by porphyrins. Re-introduction of the iron was correspondingly more difficult, but restored haemin  $a_2$ .

Further purification was achieved by silica gel chromatography, counter-current distribution in aqueous methanol–1% HCl and light petroleum, using as a guide the ratio  $E_{653\text{m}\mu}/E_{503\text{m}\mu}$  which is 3.3 in the purest chlorin, and by HCl-fractionation. The last traces of lipid are held very fast, as by porphyrin  $a$ , and haemin and chlorin  $a_2$  remained oily. It is therefore likely that haemin  $a_2$  contains a large alkyl side chain. Unlike haemin  $a$ , but like cryptohaemin  $a$ , it accompanies protohaemin in the Rawlinson separation. Paper chromatography by the lutidine-water method of Nicholas and Rimington (1949) shows that chlorin  $a_2$  is a dicarboxylic acid, but like porphyrin  $a$  its  $R_F$  (0.87) is somewhat higher than those of usual dicarboxylic porphyrins (0.80).

Haem  $a_2$  does not contain a carbonyl side chain; neither the haemochrome nor the chlorin reacted with hydroxylamine.

Like other chlorins, chlorin  $a_2$  was converted into porphyrins by catalytic hydrogenation and reoxidation, and by hydriodic acid. Neither of these reactions proceeds, however, without alteration of side chains. Preliminary experiments of dehydrogenation of vinylchlorins by photo-oxidation in the presence of quinones have been carried out and this method is being studied with chlorin  $a_2$ . The product of the catalytic hydrogenation closely resembled



mesoporphyrin, that of the hydriodic acid reaction monoethyl-monohydroxyethyl-deuteroporphyrin, porphyrins which are also obtained from protoporphyrin under these conditions. This evidence would not exclude that chlorin a<sub>2</sub> is protochlorin with two vinyl side chains, perhaps with an additional large alkyl group. The presence of one vinyl group, possibly two, can be demonstrated by diazoacetic ester addition; the shift of the main absorption band in the red to the blue was like that of phaeophorbide a (with one vinyl), but also like that of protoporphyrin with two. The position of the absorption bands of chlorin a<sub>2</sub> resemble those of pyrrochlorin (with one vinyl) rather than those of mesochlorin or mesopyrrochlorin (with none), except that the whole absorption spectrum is somewhat contracted.

However, the presence of an  $\alpha$ -hydroxyethyl (or  $\alpha$ -hydroxyalkyl) group is indicated by the low  $R_F$  values of chlorin a<sub>2</sub> in kerosene-chloroform (0.32) and kerosene-propanol (0.55) compared with those of mesochlorin (0.89 and 0.88) and by the fact that acetylation in pyridine-acetic anhydride increased the  $R_F$ . It is therefore most likely that chlorin a<sub>2</sub> is a monovinyl-monohydroxyethyl-deuterochlorin, differing from protochlorin by the hydration of one vinyl group as well as by addition of a large alkyl group to one or the other (or both) of these side chains.

TABLE 6. ABSORPTION BANDS OF HAEM a<sub>2</sub> COMPOUNDS AND OF CHLORIN a<sub>2</sub> (BARRETT, 1956)

	$\lambda$ in $m\mu$		$\lambda$ in $m\mu$
Fe <sup>++</sup> cytochrome a <sub>2</sub>	628-630	Chlorin a <sub>2</sub> in ether	<u>653</u> , 598, 573, 534, 503, <u>405</u>
Fe <sup>++</sup> CO-cytochrome a <sub>2</sub>	635		
Acid haematin	(750) 603		
Alkaline haematin	663	in 20% HCl	647
Haem	618	in 10% HCl	630
CO-haem	619	Cu complex	613, 562, 526, 401
Pyridine haemochrome	614	Zn complex	615, 564, 529, 408
CN-haematin	604		
CN-haem	618		

The absorption maxima of haem a<sub>2</sub>, chlorin a<sub>2</sub> and some of their compounds are given in Table 6. The ferrous cyanide compound of haem a<sub>2</sub> is more stable than its very unstable pyridine haemochrome. Since the position of the band of cytochrome a<sub>4</sub> from *Acetobacter suboxidans* (Chin, 1952) coincides with that of pyridine haemochrome a<sub>2</sub>, cytochrome a<sub>4</sub> may stand to cytochrome a<sub>2</sub> in the same relation as cytochrome a<sub>1</sub> to cytochrome a, but the haemochrome of the *Acetobacter peroxidans* cytochrome has not yet been studied.

Being an iron-dihydroporphyrin complex, haem a<sub>2</sub> is an interesting intermediate between chlorophylls and haem compounds, a new type of

intermediate, different from the magnesium porphyrins isolated by Granick and Bogorad (Granick, 1950; Bogorad and Granick, 1953) from *Chlorella* mutants.

Chlorophyll in the chloroplasts, haem *a* in the mitochondria, and haem  $a_2$  in much smaller bacterial particles perhaps derived from the protoplasmic membrane (Moss, 1954; Tissières, 1954) are all closely associated with phospholipids. While the lipid character of chlorophyll is due to its phytol ester group, neither haem *a* nor haem  $a_2$  are esters, but have lipophilic character owing to their large alkyl side chains.

Nothing is as yet known about the oxidation-reduction potential of cytochrome  $a_2$ . Nor is it as yet ascertained that cytochrome  $a_2$  acts as oxidase in the cytochrome system of *Aerobacter*, although the balance of the evidence appears to be in favour of this hypothesis (Tissières, 1952; Moss, 1952; Chance, 1953). The concentration of haemin  $a_2$  in *Aerobacter* is variable, but can be almost half as great as the concentration of haem *a* in ox heart muscle (14–43 mg/kg of dry weight). It is an induced enzyme, requiring oxygen for its formation, but in contrast to cytochrome oxidase is sensitive to iron-deficiency. While the recent studies of Layne and Nason (1958) and Horio (1958) do not yet exclude the possibility that their oxidase preparations from *Pseudomonas* contain mixtures of cytochrome  $a_2$  with cytochrome of type *c*, a double-headed enzyme containing haem  $a_2$  as well as cytochrome *c* type prosthetic groups is another possibility.

#### SUMMARY

1. Porphyrin *a*, the iron-free prosthetic group of cytochrome oxidase, is a dicarboxylic porphyrin substituted with formyl, with alkylvinyl (on the pyrrole ring opposite to that bearing the formyl) and with an  $\alpha$ -hydroxyalkyl on the pyrrole ring in between (pyrrole I). The alkylvinyl group and probably the  $\alpha$ -hydroxyalkyl group contain large alkyl groups. Two partial structural formulae are suggested which are in harmony with the available evidence.

2. Cryptoporphyrin *a* is another formyl-porphyrin which occurs in heart muscle in the form of a haematin compound, though only in small amounts. It greatly resembles chlorocruoroporphyrin from which it appears to differ only by the presence of a large alkyl group on the vinyl side chain.

3. Chlorin  $a_2$  is the iron-free prosthetic group of cytochrome  $a_2$ . It is a dihydroporphyrin without formyl groups and with one vinyl (or alkylvinyl) and one  $\alpha$ -hydroxyalkyl side chain instead of the two vinyl side chains of protoporphyrin.

#### Acknowledgement

This research has been carried out with grants from the Australian National Health and Medical Research Council.

## ADDENDUM

Piattelli in the laboratory of Nicolaus has recently obtained a 2:5-pyrrole dicarboxylic acid with propionic and nitrile side chains in the  $\beta$ -positions by permanaganate oxidation of porphyrin *a* nitrile (private information). This establishes the formyl group in position 8 on ring IV (formula II of Fig. 3). Porphyrin *a* is thus 1:3:5-trimethyl-2- $\alpha$ -hydroxyalkyl-4- $\beta$ -alkylvinyl-8-formyl-6:7-di( $\beta$ -carboxyethyl)-porphyrin. No ethyl-methyl-2:5-pyrrole-dicarboxylic acid could be discovered among the oxidation products of hydrogenated porphyrin *a*. This lends further support to the vinyl group of porphyrin *a* in position 4 carrying an alkyl substituent. Piattelli and Nicolaus (*R.C. Accad., Napoli*, Ser. 4a, **26**, p. 44, 1959) have now obtained the 2:5-pyrrole-dicarboxylic acid with methyl and carboxylic acid groups in the  $\beta$ -positions; the carboxyl is here derived by oxidation of the unsaturated side chain in 4 and probably also the  $\alpha$ -hydroxyalkyl side chain in 2 of porphyrin *a* (cf. also R. A. Nicolaus, *Rassegna di Medicina sperimentale*, **7**, suppl. 2 (1960)).

## REFERENCES

- BARRETT, J. & LEMBERG, R. (1954). *Nature, Lond.* **173**, 213.  
 BARRETT, J. (1956). *Biochem. J.* **64**, 626.  
 BARRETT, J. (1959). *Nature, Lond.* **183**, 1185.  
 BOGORAD, L. & GRANICK, S. (1953). *J. biol. Chem.* **202**, 793.  
 CHANCE, B. (1953). *J. biol. Chem.* **202**, 383.  
 CHIN, C. H. (1952). *Abstr. Comm. 2nd int. Congr. Biochem. Paris* p. 277.  
 CLEZY, P. & BARRETT, J. (1959). *Biochim. biophys. Acta* **33**, 584.  
 CONNELLY, J., MORRISON, M. & STOTZ, E. (1958). *J. biol. Chem.* **233**, 743.  
 DANNENBERG, H. & KIESE, M. (1952). *Biochem. Z.* **322**, 395.  
 DIXON, M. & WEBB, E. C. (1958). *Enzymes*, p. 414, London: Longmans, Green & Co.  
 GRANICK, S. (1950). *J. biol. Chem.* **183**, 713.  
 GRANICK, S., BOGORAD, L. & JAFFE, H. (1953). *J. biol. Chem.* **202**, 801.  
 HORIO, T. (1958). *J. Biochem. Tokyo* **45**, 195, 267.  
 KIESE, M. & KURZ, H. (1954). *Biochem. J.* **325**, 299.  
 LAYNE, E. C. & NASON, A. (1958). *J. biol. Chem.* **231**, 889.  
 LEMBERG, R. & FALK, J. E. (1951). *Biochem. J.* **49**, 674.  
 LEMBERG, R. (1953). *Nature, Lond.* **172**, 619.  
 LEMBERG, R. & STEWART, M. (1955). *Aust. J. exp. Biol. med. Sci.* **33**, 451.  
 LEMBERG, R. & PARKER, J. (1955). *Aust. J. exp. Biol. med. Sci.* **33**, 483.  
 MARKS, G. S., DOUGALL, D. K., BULLOCK, E. & MACDONALD, S. F. (1959). *J. Amer. chem. Soc.* **81**, 250.  
 MORRISON, M., CONNELLY, J. & STOTZ, E. (1958). *Biochim. biophys. Acta* **27**, 214.  
 MOSS, F. (1952). *Aust. J. exp. Biol. med. Sci.* **30**, 531.  
 MOSS, F. (1954). *Aust. J. exp. Biol. med. Sci.* **32**, 571.  
 NICHOLAS, R. E. & RIMINGTON, C. (1949). *Scand. J. clin. Lab. Invest.* **4**, 12.  
 PARKER, J. (1959). *Biochim. biophys. Acta* **35**, 496.  
 RAWLINSON, W. A. & HALE, J. H. (1949). *Biochem. J.* **45**, 247.  
 RIMINGTON, C., HALE, J. H., RAWLINSON, W. A., LEMBERG, R. & FALK, J. E. (1949). *Abstr. Comm. 1st int. Congr. Biochem. Cambridge* p. 379.  
 TISSIÈRES, A. (1952). *Biochem. J.* **50**, 279; *Nature, Lond.* **169**, 880.  
 TISSIÈRES, A. (1954). *Nature, Lond.* **174**, 183.  
 WARBURG, O. & GEWITZ, H. S. (1951). *Hoppe-Seyl. Z.* **288**, 1.  
 WARBURG, O. & GEWITZ, H. S. (1953). *Hoppe-Seyl. Z.* **292**, 174.

## DISCUSSION

*The Structure of Haem a and Haem a<sub>2</sub>***The Structure of Porphyrin a**

By M. MORRISON (Rochester)

MORRISON: Barrett (*Nature, Lond.* **183**, 1185, 1959) and Clezy and Barrett (*Biochim. biophys. Acta* **33**, 584, 1959) recently reported that porphyrin *a* contains a hydroxyl group that can be acetylated and that this group is present as —CHOH— group adjoining the porphyrin ring. Haemin *a* also can be acetylated by the procedure of Barrett. It is converted to two products, one with increased chromatographic mobility and the other with decreased chromatographic mobility in non-polar solvents. This acetylation causes a spectral shift of the  $\alpha$ -band of the pyridine haemochrome to shorter wavelengths (cf. Table 1). This indicates that an electron-withdrawing group has been removed from resonance with the porphyrin nucleus. The position of the  $\alpha$ -peak of the pyridine haemochrome is an excellent index of the number and type of electron-withdrawing groups in resonance with the porphyrin nucleus. Two of these groups are known to be formyl and vinyl. A comparison of haemochrome *a* ( $\alpha$ -peak 587  $m\mu$ ) with *Spirographis* haemochrome ( $\alpha$ -peak 583  $m\mu$ ) and of the haemochromes of their respective oximes (571  $m\mu$  and 561  $m\mu$ ) also indicates the presence of a third electron-withdrawing group in addition to formyl and vinyl. It should be noted that the effects of the electron-withdrawing groups except vinyl are lost on reduction with borohydride (cf. Table 1).

TABLE 1

Compound	Position of the $\alpha$ -peak of pyridine haemochrome
Haem <i>a</i>	587
Oxime	571
Br <sub>2</sub> addition	582
BH <sub>4</sub> <sup>-</sup> reduction	552
Dimedon	558
Acetylation	582
<i>Spirographis</i> Haem	583
Oxime	561

Since the infra-red spectrum of haemin *a* suggested the presence of another carbonyl group in addition to formyl, one can speculate that the third group is —CH(OH)—CO—R. The effect of this group is abolished by borohydride reduction and by acetylation. Since the formyl and vinyl groups must occupy opposite pyrroles, this group must occupy position 2, and if the formyl group occupies position 8 (according to the evidence of Piattelli quoted by Lemberg, p. 357), the formula of Lemberg *et al.*, p. 350, Fig. 3 (II), but replacing —CHOH—CH<sub>2</sub>—R<sub>2</sub> in position 2 by —CHOH—CO—R, can be assumed for porphyrin *a*. From the molecular weight of chlorohaemin *a* (880) it can be calculated that the *R* group has a molecular weight of 182 and might represent a 13 carbon saturated alkyl: —CH(OH)—CO—(CH<sub>2</sub>)<sub>12</sub>CH<sub>3</sub>.

CLEZY: Morrison's formula shows an  $\alpha$  ketol conjugated with the porphyrin ring system. It is difficult to reconcile this structure with the dehydration experiments reported in the paper by Lemberg, Clezy and Barrett (this volume, p. 349). Porphyrin *a* and its derivatives can be dehydrated with *p*-toluene sulphonyl chloride to a compound showing spectroscopic properties in accord with the introduction of a carbon-carbon double bond conjugated with the porphyrin ring system. This reaction requires at least one hydrogen atom on the carbon atom  $\beta$  to the porphyrin ring system.

LEMBERG: The conclusions of the Rochester school on the structure of porphyrin *a* as reported by Morrison are now in close agreement with ours, with the exception of

two points, namely, (a) the formulation of the side chain in position 2 as  $-\text{CH}(\text{OH})-\text{CO}-\text{R}$ , and (b) the distribution of the extra alkyl groups between the positions 2 and 4. The analyses of haemin *a* would appear to allow the presence of a seventh oxygen atom, assumed by Morrison in the  $-\text{CH}(\text{OH})-\text{CO}-\text{R}$  side chain. We have observed a shift of  $2\text{ m}\mu$  of bands III and IV of porphyrin *a* on acetylation; on hydrolysis the spectrum of porphyrin *a* is restored unaltered. Morrison observed a similar shift of  $5\text{ m}\mu$  in the position of the  $\alpha$ -band of the pyridine haemochrome. These observations may indicate that the group formulated by us as  $\alpha$ -hydroxyalkyl group is more complicated and bears another oxygen atom. However, the presence of a  $-\text{CH}(\text{OH})-\text{CO}-$  grouping appears unlikely since it is not in harmony with our dehydration of  $\alpha$ -hydroxyalkyl to  $\beta$ -alkylvinyl by *p*-toluenesulphonyl-chloride. We have evidence indicating that the  $\alpha$ -hydroxyalkyl group is not  $\alpha$ -hydroxyethyl. The ketonylporphyrins obtained by the resorcinol melt of haemins after cautious oxidation of  $\alpha$ -hydroxyalkyl to  $\alpha$ -ketonyl by chromic acid differed from acetylporphyrins by higher HCl-numbers and higher  $R_f$  in chloroform-kerosene. In particular the ketonylporphyrin thus obtained after conversion of formyl to methyl by the Wolff-Kishner reaction was not monoacetyl-deuteroporphyrin. Again, the porphyrin

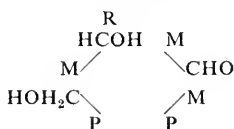

(obtained by a succession of reactions from porphyrin *a*) which differs from hydrated isochlorocruoroporphyrin only by the replacement of methyl by hydroxymethyl, should have a low HCl-number, if R is  $\text{CH}_3$ . In fact, it has a high HCl-number and still shows the  $\alpha \rightarrow \beta$  conversion typical for porphyrin *a*.

There is some evidence that the vinyl group in 4 is also substituted. More important than Warburg's inability to obtain cyto-deuteroporphyrin from hydrogenated haemin *a* in the resorcinol melt, is Piattelli's recent finding (see p. 357, this volume), that no  $\beta$ -ethyl- $\beta$ -methyl-pyrrole-2:5-dicarboxylic acid can be obtained by permanganate oxidation of hydrogenated porphyrin *a*. The fact that the alkyl group substitutes the vinyl group in  $\beta$ , not in  $\alpha$  is shown by the possibility of oxidizing it to formyl. Either the additional carbon atoms are distributed between  $\alpha$ -hydroxyalkyl in position 2 and  $\beta$ -alkylvinyl in position 4, or these two groups are interconnected by an alicyclic polymembered ring.

As we can now assume that these two groups replace vinyl, not methyl, of proto-porphyrin, a mode of biosynthesis of haem *a* different from those discussed in the pre-circulated paper must be postulated, i.e. oxidation of the two vinyls to formyl and coupling with a saturated fatty acid whose  $\alpha-\text{CH}_2$  is activated, perhaps by coenzyme A, followed by hydration of one of the two groups; or if an alicyclic ring is formed between 2 and 4, by condensation of the two formyls with a similar compound of a saturated dicarboxylic fatty acid.

WINFIELD: I should like to ask Lemberg by which method the molecular weight of his porphyrin was determined. If it was not by Brintzinger's diffusion method, I suggest that this might be used to advantage. For some compounds it is possible to determine the molecular weight with considerable accuracy, and with no necessity for pure preparations. It might well be possible to determine from the molecular weight the number of oxygen atoms present in the porphyrin.

LEMBERG: For the determination of the molecular weight of porphyrin *a* or haemin *a* we have relied either on the iron content of the haemin, or on the ratios of the specific extinctions of porphyrin *a* and its molar extinction as established by copper titration, or on the specific extinction of pyridine haemochrome *a* and its molar extinction as established on the basis of its iron content. These methods all depend on the purity of the preparation, but give concordant results for the purest preparations which agree with those of Warburg and of Morrison.

As Winfield has pointed out, the diffusion method has the advantage of being not

dependent on purity. However, it may not overcome the difficulty of the formation of rather firm linkages between the porphyrin and lipids which we have found.

ESTABROOK: I would like to ask Lemberg about the 2- $\alpha$  hydroxy in the structure of haemin *a*. The presence of such a hydroxy group confers asymmetry upon the associated carbon and should introduce optical activity to haemin *a*. Is haemin *a* optically active?

LEMBERG: We have no evidence on optical activity.

MORRISON: We have looked for optical activity in many ways, but have been unable to detect it.

WILLIAMS: Since the —CHOH group sits on a formylporphyrin ring, racemization might easily occur.

ESTABROOK: What is the evidence for the presence of the 2- $\alpha$  hydroxy group?

LEMBERG: The evidence is as follows:

- (a) Acetylation with alterations of  $R_F$ .
- (b) Dehydration with *p*-toluene-sulphonylchloride in benzene, shifting absorption to longer wavelengths.
- (c) Oxidation (by chromic acid) of CHO—R to CO—R with the formation of an  $\alpha$ -ketonylporphyrin.

### The Properties of Haem $a_2$ and Cytochrome $a_2$

By J. BARRETT (Sydney) AND J. P. WILLIAMS (Oxford)

WILLIAMS: We should like to make certain observations about cytochrome  $a_2$ . The prosthetic group is a dihydro-porphyrin and therefore has one p*K* value much lower than either of those of simple porphyrins (Conant and Dietz, *J. Amer. chem. Soc.* 56, 2185, 1934). Reduction in p*K* of the ligand reduces the stability of the iron complexes, ferric much more than ferrous (Williams, *Chem. Rev.* 1956; Falk and Perrin, this volume, p. 56). Thus where the further co-ordination of an iron-protoporphyrin and an iron-dihydroporphyrin to a protein are the same, equilibration between the ferrous and the ferric form of the chlorin should favour the ferrous. The addition of two hydrogen atoms to the beta position of one of the pyrrole rings results in an altered resonance pathway which is now markedly asymmetrical. As a consequence the stability of the low-spin forms relative to the high-spin states will be reduced. These changes from a simple porphyrin make the removal of iron from haem  $a_2$  relatively easy, as is observed. The model compounds of the iron-dihydroporphyrin are also of interest. Using Barrett's data (this volume, p. 355) we note the following:

(a) CO and CN<sup>-</sup> move the peaks to longer wavelengths relative to the pyridine haemochrome but less than expected from comparison with protoporphyrin and mesoporphyrin haemochromes.

(b) The pyridine haemochrome is rather unstable.

Both (a) and (b) are in keeping with the suggestion that the pyridine haemochromes are not 100% low-spin complexes.

(c) The acid haematin gives a band at 740  $m\mu$  which could be the charge-transfer band in these complexes. If this is so then the anomalous band-position of the hydroxide at 662  $m\mu$  would be a charge-transfer band too.

We now consider cytochrome  $a_2$  itself. The following points suggest that it is at least partly in the high-spin state in both the reduced and oxidized forms:

In the reduced form: (1) the band max. 628–630  $m\mu$  is at a considerably longer wavelength than the pyridine haemochrome; (2) a CO complex is readily formed; (3) an O<sub>2</sub> complex is obtained (Horio, this volume, p. 315).

In the oxidized form: there is a band at 750  $m\mu$  similar to that in the acid haematin compound. This is the charge-transfer band typical of ionic ferric species.

Following the remarks made about model complexes which pick up oxygen reversibly (Williams, this volume, p. 49) we conclude that the protein binds iron through an imidazole group. If this conjecture is correct the redox potential of cytochrome  $a_2$  will be about +0.30 V.

We predict that (1) the value of  $\Delta m\mu$  (Soret band) between the Fe<sup>++</sup> and Fe<sup>+++</sup>

forms will be large; (2) the ratio  $\frac{420 \text{ m}\mu}{630 \text{ m}\mu}$  will be larger for cytochrome *a*<sub>2</sub> than for pyridine haemochrome *a*<sub>2</sub>.

In some bacteria where cytochrome *a*<sub>2</sub> occurs, cytochromes *a*<sub>1</sub> and *b*<sub>1</sub> are also found. In others, cytochrome *a*<sub>2</sub> occurs with *c* type cytochromes (as well as cytochromes *a*<sub>1</sub> and *b*<sub>1</sub>). Castor and Chance (*J. biol. Chem.* **234**, 1587, 1959) have demonstrated that in some bacteria cytochrome *a*<sub>1</sub> can function as an oxidase and that it also combines with carbon monoxide. Nevertheless it appears to us that in other organisms it may function similarly to cytochrome *c* in other electron transporting sequences. Like cytochrome *c*, cytochrome *a*<sub>1</sub> appears to be a di-imidazole complex from consideration of its spectroscopic properties, which resemble those of pyridine haemochrome *a*. The redox potential of cytochrome *a*<sub>1</sub> we would expect to have a value around 0.20 V. We then speculate that in bacteria there exist the transport systems:

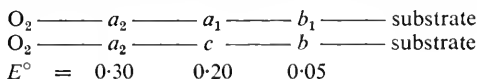

These systems are very like the graded redox systems of animal cells.

Terminal oxidase systems with a redox potential around 0.30 V can utilize oxygen with an almost optimal efficiency. There are now two ways of raising the redox potential and destabilizing the iron-protein complexes sufficiently for such efficient reactions to occur with oxygen

- (1) by introducing —CHO groups into the porphyrin ring, e.g. porphyrin *a*;
- (2) by addition of hydrogen to one of the pyrrole rings, e.g. chlorin *a*<sub>2</sub>.

In these proceedings it has been indicated why a chain of catalysts is required. In *Pseudomonas* oxidase, Horio (this volume, p. 302) has found that the oxygen-combining haem *a*<sub>2</sub> is accompanied by a type *c* haem. Okunuki and his school in their studies on "cytochrome *a*" have brought forward evidence that the initial oxidase combines with oxygen reversibly, and that it is only the presence of a second cytochrome which enables it to act as a cytochrome oxidase and not as an oxygen transporting haem-protein. Such may be the case with cytochrome *a*<sub>2</sub>. Evidently more model experiments are required to establish this argument.

### Extractability of Ferro- and Ferricytochrome *c*

SLATER: In Morrison's experiments, is the degree of extractability of cytochrome *c* from mitochondria a function of the degree of swelling of the mitochondria?

MORRISON: I do not believe that the degree of swelling of the mitochondria has much effect on the extractability of the cytochrome *c* since the structure of the mitochondria is destroyed by the acetone and salt treatment.

MARGOLIASH: Your treatment with boiling acetone would be expected to denature cytochrome *c*, and the degree of this denaturation might depend on its oxidation state.

LEGGE: Theorell's earliest preparation of cytochrome *c* made use of the differential adsorption of oxidized and reduced cytochrome *c* on cellophane.

If there is doubt as to whether cytochrome *c* is denatured by hot acetone, there would be no doubt that the other proteins would be, and therefore perhaps be able to adsorb the oxidized and reduced cytochrome differentially.

HENDERSON: In connexion with the extraction of cytochrome *c* from mitochondria treated with boiling acetone and then at 60°C, your experiments indicate that the well-known difference between the adsorbability of Fe<sup>+++</sup>- and Fe<sup>++</sup>-cytochrome *c* is not involved. Have you considered, however, the difference in the degree of modification brought about by this treatment on Fe<sup>+++</sup> as compared with Fe<sup>++</sup> cytochrome *c*? Okunuki's group (see, e.g. Hagihara *et al.*, *Nature, Lond.* **181**, 1588, 1958) have reported that Fe<sup>+++</sup>-cytochrome *c* is considerably more susceptible to modification than Fe<sup>++</sup>-cytochrome *c* and that this is reflected largely in the increased adsorbability of the former. It would seem that this could explain the observed results without implicating the extraction of a 'cytochrome coupler compound'.









