



LIBRARY
OF THE
UNIVERSITY OF CALIFORNIA.

GIFT OF

George L. Anderson

Accession 96698 *Class* 35





Digitized by the Internet Archive
in 2007 with funding from
Microsoft Corporation

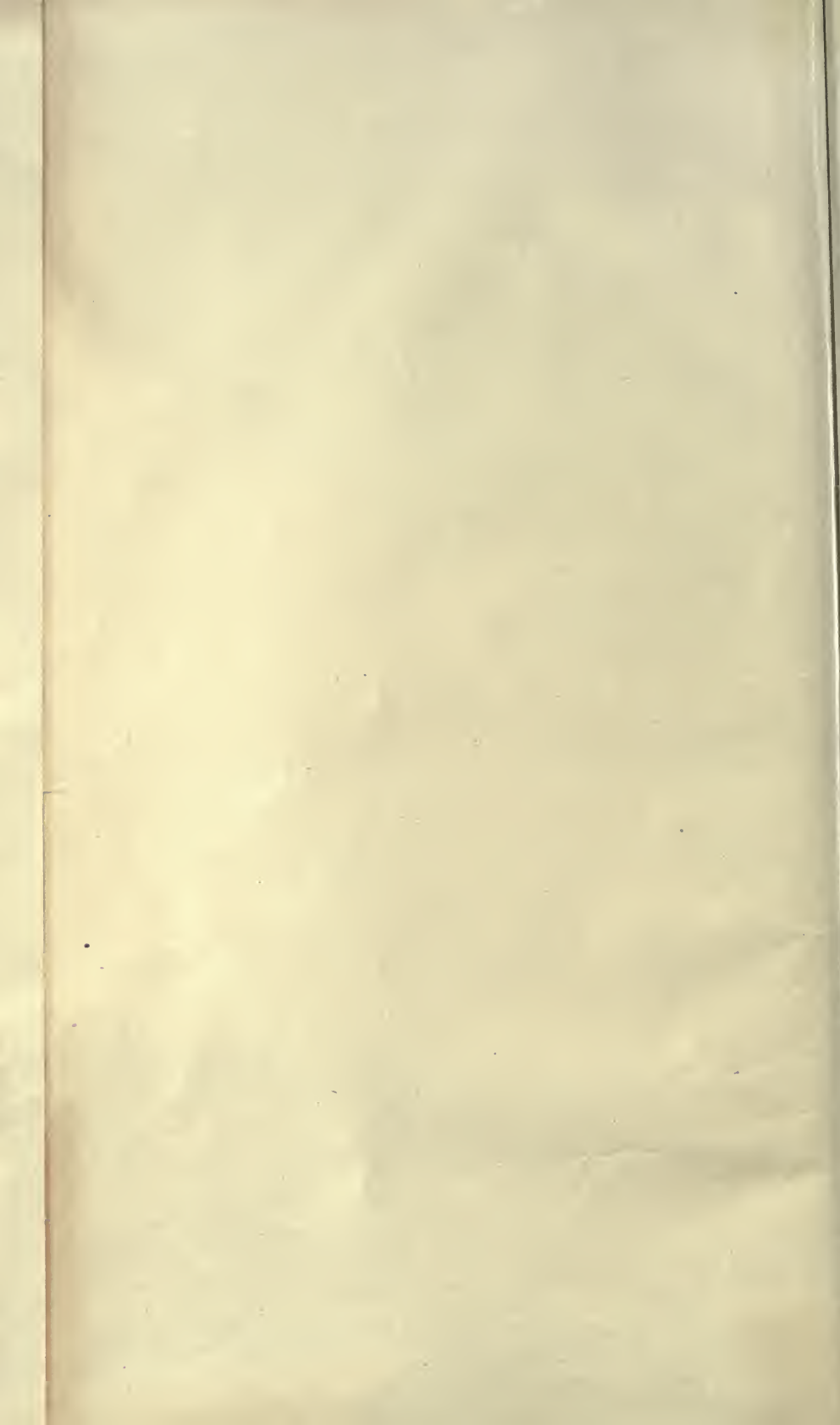

HANDBOOK

FOR THE

USE OF ELECTRICIANS IN THE OPERATION AND CARE

OF

Electrical Machinery and Apparatus

OF THE

U. S. SEACOAST DEFENSES,

BY

GEO. L. ANDERSON, A. M.
CAPTAIN, U. S. ARTILLERY.

U. S. War Dept

PREPARED UNDER THE DIRECTION OF THE LIEUTENANT GENERAL
COMMANDING THE ARMY.

D. VAN NOSTRAND CO.
23 MURRAY SLEET, NEW YORK.
U. S. GOV'T PRINTING OFFICE,
1902.



MEMORANDUM

TO :

FROM :

SUBJECT :

*Gift of
Author*

DATE :

BY :

APPROVED :

RECEIVED :

FILED :

PREFACE.

The installation and management of the electric machinery in United States battleships merit the attention of electricians in forts. Its character and object in the two situations are similar, and the conditions of dampness, limited space changing personnel and reliability are equally severe.

Every implement or portion of the fortification plant must be simple, certain in operation, effective, proved in the industries as standard in its class, and it should only be intrusted to the care and management of an efficient engineer. To be efficient he must have ambition, intelligence and the skill gained by careful handling. The good order and working of his machinery at all times furnish the only reliable testimonial regarding his fitness.

The preparation of the Handbook was suggested and aided by the electricians of the class of 1900, Fort Monroe. It contains in full the latest instructions issued by designers and constructors. The portion relating to land and sea mines is intended for separate publication. The diagrams were drawn by First Sergt. Karl P. Runa. Notice of errors in this first edition will be thankfully received.—G. L. A.

Boston, 1902.

(3)

46480
46



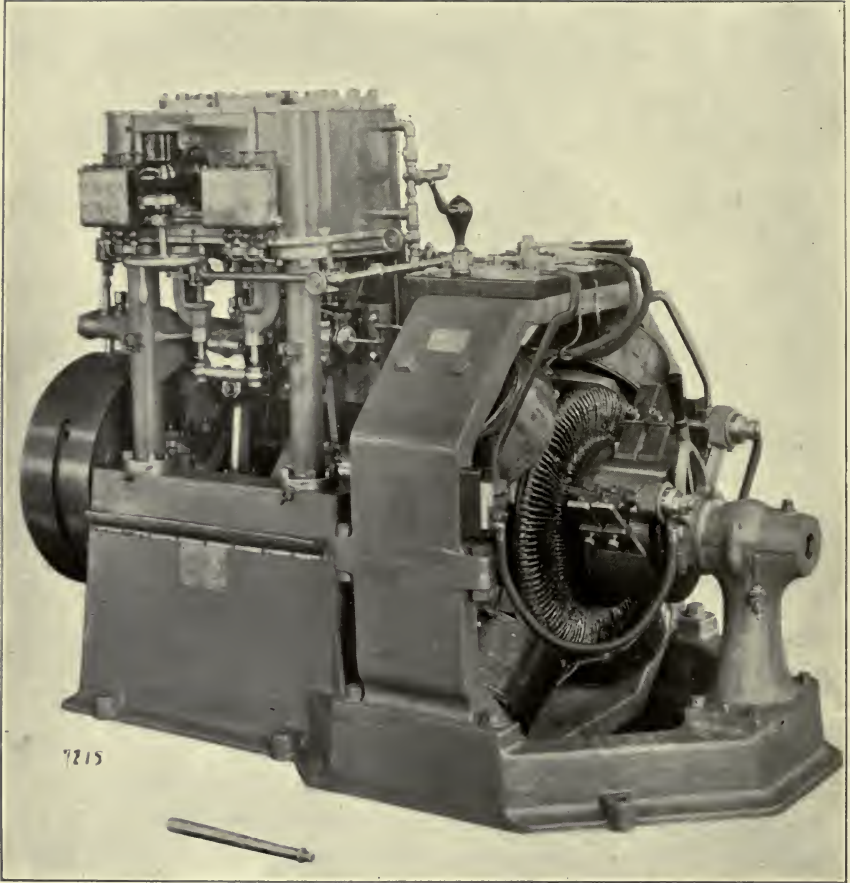

1. United States Navy D. C. Set Constructed by General Electric Company.



HANDBOOK FOR ELECTRICIANS.

SPECIAL INSTRUCTIONS TO ELECTRICIANS.

1. Your special duties are to secure the cleanliness and the best working order of every part of the fortification electrical equipment given to your care, whether it be a Schukert 60-inch projector or a glass insulator.

2. Upon taking charge of a plant, inspect it very carefully, and for your future protection, in a letter for file report everything found not in order, even to the tool marks on the machinery.

3. For ten days, if practicable, the retiring engineer should operate, in your presence, all apparatus to be turned over and you, in turn, in his presence.

4. Take written notes in your notebook of the information he gives you. Secure all diagrams, plans and instructions relating to the machinery.

5. Keep posted on boards, or in frames, in a lighted and frequented place as soon as convenient:

- (1) Oil Engine Directions obtainable from The De la Vergne Company, East 138th Street, N. Y.
- (2) The exact order of operating valves and switches in starting, running and stopping made out by yourself.
- (3) Instructions, Electric Storage Battery Company, Philadelphia, Pa.
- (4) Diagram of pipe connections, Engineer Office or yourself.
- (5) Wirings of dynamo and switch board, Engineer Office or contractor.
- (6) Blueprint of emplacements showing wires, lamps, etc., Engineer Office.
- (7) Diagram of search-light connections, General Electric Company or Engineer Office.
- (8) Diagram of each outside independent circuit under your charge.

6. Take care of the equipment in the following order of importance:

- | | |
|-----------------------------------|------------------------------|
| (1) Storage battery. | (9) Firing, night apparatus. |
| (2) Steam boiler. | (10) Telephones. |
| (3) Generating set, steam or oil. | (11) Telegraphs. |
| (4) Switch board. | (12) Night signals. |
| (5) Searchlight. | (13) Anemometers. |
| (6) External and internal wiring. | (14) Lines. |
| (7) Lamps and outlets. | (15) Electric bells. |
| (8) Motors and hoists. | |

7. Keep all machinery rooms clean, dry, ventilated and well lighted; all surfaces free from rust and dust, even if a banked fire or a kerosene burner is necessary.

8. Do not delay work or repairs because exactly what you need is not at hand. Proceed with that which is obtainable and do the best thing possible so as to avoid making excuses. Even a good excuse is unfortunate.

9. Make timely requisitions for only the necessary and the best stores. Use best mineral oil only.

10. If boiler, engine, dynamo or any iron piece or tool is to remain unused, its polished surfaces will be thoroughly cleaned in full light in a dry room on a dry day and covered with a thick, uniform coat of cosmic, with 25 per cent of resin added if interval will be long. Every three months clean off, repolish and re-new.

11. "Prevention" is the rule for machinery troubles, not "Cures."

12. In case of accident, "the other man" can not be pleaded by the electrician. The clearest evidence regarding his capacity is furnished by a single boiler fixture leaking, dirty water, incrustation or corrosion in boiler, an unsteady

steam gauge, water glass, or fire, an unusual noise in engine, a hot bearing or coil, a scratched or sparking commutator, an oil engine's chronic cough or thick exhaust, density, voltage or gassing of storage cells not uniform, battery standing at low voltage, burn-outs and tool marks on search light or other apparatus, dust, rust, or damp on any part, unsoldered joints or leaky circuits, and by other things.

13. A neat and well-fitting uniform will invariably be worn outside of the emplacements.

14. Always charge a storage battery at its given normal rate to full charge (density, 1.200; voltage, 2.5 per cell); do not discharge above the normal rate except in emergency, and never below density of 1.175 and voltage of 1.8 per cell.

15. Keep density, voltage and gassing of all cells uniform. To cover plates $\frac{3}{4}$ inch. water (or solution, 1.400, rarely) is added at the top directly after charging begins. If little used, the battery is partially discharged and regularly charged once each week.

16. Blow off boiler in starting at 10 pounds from water high, one or two gauges; oftener if necessary. Maintain uniform fire, water level, and pressure. Frequently inspect fire tubes for dirt, and boiler interior for deposit and corrosion.

17. Handle all machinery and apparatus with great care. Let their loads be increased and decreased uniformly and slowly. Guard against sudden rise of temperatures. Never hesitate to allow a machine to take its full load under these conditions, but not to exceed it.

18. An engine is always started as slowly as possible. A good engineer turns valves and switches deliberately while watching the effect; his order of starting and stopping is always the same.

19. Keep exposed conduit, cut-out, switch, junction and lamp boxes cleaned and painted, and all openings tightly sealed, so that the whole system is essentially air-tight.

20. For more complete information, electricians are referred to Crocker's (two volumes) *Electric Lighting*, Sheldon's *Dynamo Electric Machinery*, General Electric Company's *Bulletins and Instructions*, Westinghouse Company's *Bulletins*, Dawson's *Electric Traction*, Treadwell's *Storage Battery*, Goldingham's *Oil Engines*, Miller's *Telephony*, Maver's *Telegraphy*, Cushing's *Wiring*, Stromberg's *Steam Engine*, Hawkins' *Catechisms of Electricity and Steam Engine*.

21. The efficiency of all your machinery was long ago proved. The opinions, sometimes heard, that search lights, for instance, can not be controlled from a distance, that storage batteries are inefficient, that telephones near guns are inoperative, that oil engines and submarine mines are unreliable, result from the kind of knowledge which is dangerous.

22. In more than nineteen cases out of twenty in which a standard machine or apparatus, properly installed, fails, the fault rests with the attendant.

23. Remember that if there is any portion or piece of the fortification electrical equipment under your charge not in perfect working order, or not clean, and not reported as irreparable, and if you being for duty, are working less than ten hours daily on week days, you will be held blamable.

1.—HANDLING AND CARE OF STEAM FIRE-TUBE BOILERS.

(A) RAISING STEAM.

1. To start the fire in a small furnace, clean the grate of clinkers and the pit of ashes. See that grate works freely. Cover it evenly with shavings and wood and light the fire. When the upper stratum of hard wood is blazing well, throw on a uniform 2-inch layer of soft coal, closing furnace and opening the pit doors. When the coal is red, add a second similar layer. A third feeding should leave a greater depth of coal around the sides than in the center.

2. If the furnace is large, cover the grate all over with a 2-inch layer of hard coal, except a space in front for wood and shavings. Cover the coal at the back with a little heavy wood and light the fire. Add coal to the upper hard wood when aglow, as above, and so continue.

3. Regulate coal and draft for at least one hour's rise to full pressure in a small warm boiler, two hours for a small cold water boiler and five or six hours for a large cold boiler.

Horizontal Boiler for a Stationary Engine.

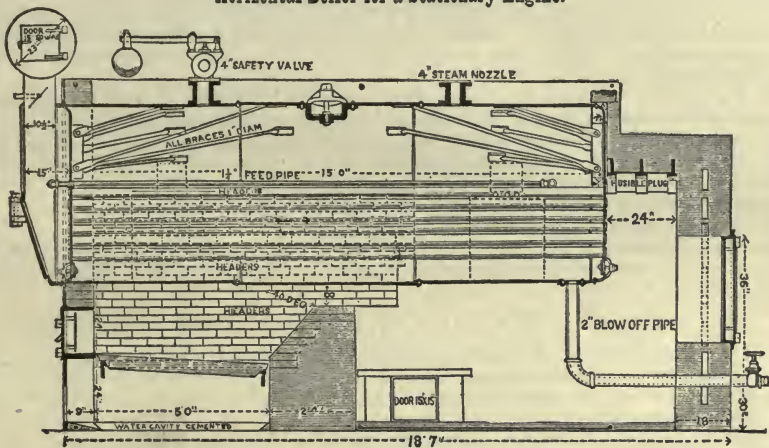

2. Horizontal Return Fire-Tube Steam Boiler.

4. After lighting the fire see that:

- (a) Gauge glass agrees with gauge cocks and is not choked.
- (b) Water stands to upper gauge at least.
- (c) Safety valve is in working order by raising it once or twice.
- (d) Steam feed, throttle, and blow-off cocks are closed.
- (e) Pump is oiled.
- (f) Upper gauge is temporarily open to equalize the pressure within.

5. At 10 to 15 pounds pressure blow off to second gauge to drive out mud and create circulation for even temperature.

(B) FIRING.

1. Before opening the furnace door have plenty of coal at hand—no piece larger than the fist. Spread the coal by throwing to the rear first and so on to the front in a thin uniform layer. Most firemen heap on too much fresh coal.

2. The thickness of coal fire is from 5 to 8 inches. If the necessary thickness makes too hot a fire, reduce the grate area by putting in fire brick, 8 inches high, around the sides of the furnace.

3. If the fire burns unequally, fill the vacant spots. Allow no air holes in the bed of fuel.

4. The cleaning tools are: The hoe for pulling or pushing the fire over the bars, slice bar for breaking up the fire, clinker hook and the T-bar for raking lengthwise of the bars beneath the fire to cause the ashes to fall through, and scoop shovel.

5. Clean or rake the fire as rarely and as quickly as possible, but always when clinker and ash are closing the grate, usually two or three times a day if coal is

hard. Dark spots, heavy smoke, and blue flame give warning. But leave the fire alone so long as it is at uniform glow and its light shows in the ash pit beneath.

6. To clean a fire, have plenty of water in the boiler, open damper and one furnace door, pack half of the fire to one side, raking out the dead clinkers and ash; then move the whole fire to the exposed grate and clean the other half; finally spread the fire evenly and throw on fresh dry coal. Cleaning reduces the depth of fire and lowers the boiler pressure. Shaking the grate is the best way to clean when it can be done.

7. The most effective and economical fire is moderately thick, steady, uniform and regulated, as far as possible, by the chimney damper. Enough air should be admitted above the fire through the door air holes to consume the rising gases and thereby increase the heat. With a steady fire the combustion is more perfect and there are less clinkers, less cleaning and less cold air.

8. The construction of a damper should not admit its closing the chimney entirely, as gases may otherwise collect in the flue and cause explosion.

9. To bank a fire, have three gauges of water. Allow fire to get low, clean and push it to the rear in a compact pile and cover it thickly with small coal or wet ashes. Leave clinker and ash on the front of grate. Leave fire doors open and close the pit doors tightly and the chimney damper partially. If the fire is found too cold the next morning less grate should be uncovered and the pile of fire be less compact. Banking the fire preserves the boiler by keeping its temperature more nearly even, saves time in starting, but is dangerous if not properly done.

10. To start a banked fire, clean out ashes and clinker or shake the grate, spread the fire evenly, feed a little wood for draft and add coal gradually.

11. Ashes left high in the ash pit may cause warping or burning out of grates.

12. When fuel and water are irregularly fed, or pressure is always changing, or the safety valve is now and then popping, or dampers and doors are being frequently opened and closed, or if there is a leaking of water, steam or oil, or room is dirty, the boiler's tender is outside of his sphere of usefulness.

13. Give the last two or three minutes in a boiler room to its inspection to make sure that everything will be left in order. Then close and lock all doors and windows.

(C) CARE AND MANAGEMENT OF STEAM BOILERS.

1. The steam boiler is the most important element of an electric plant.

2. An indifferent or intemperate fireman and a cheap boiler are alike dangerous.

3. The first thing on taking charge of a boiler is to inspect its safety-fitting and feeding apparatus.

4. Let the ear aid the eye in detecting troubles.

5. Never exceed the working pressure given by the builder or inspector.

6. Never open nor close a throttle, a blow-off or other steam outlet suddenly, nor leave it before it is closed.

7. Repair a leak or a damage in boiler or fitting as soon as possible. See that furnace, combustion chamber and smoke flue are tight.

8. Much smoke from the chimney shows that combustion is not perfect. All air must go through the grate bars or the little smoke burners.

9. The boiler room should be day lighted, well ventilated, spacious and dry. Never leave it while boiler is under steam.

10. Dry steam only is wanted. If a small jet from the upper gauge cock, close to the orifice, is transparent or even has a grayish-white color, the excess of moisture is less than 1 per cent. If the jet is strongly white, the excess is 2 per cent or more. Steam containing less than 3 per cent excess of moisture is fairly "dry."

11. Empty a boiler working daily once a fortnight. If water is muddy blow out 6 inches daily and use the surface blow-out more frequently. To avoid serious results examine blow-out and check valves whenever the boiler is filled.

12. Procure the manufacturers' directions of boiler and its fixtures.

13. Blisters and cracks may occur in the best boiler plate. Then put the boiler out of service and repair.

14. In case of low water, immediately open furnace doors and chimney damper, close pit doors tight and quickly cover the whole fire with ashes, soil or coal (wet if possible). Leave all steam outlets as they are. Do not draw fires until the pressure has dropped, nor turn on feed water, nor start nor stop engine, nor lift safety valve until the fires are out and the boiler is cooling. If water has only just disappeared there is no immediate positive danger. If the water gets too high, carefully open blow-off and let out gradually a gauge of water.

15. Foaming or priming is due to forcing the boiler or to small steam space or to other bad design or to dirty or high water or to opening the throttle

suddenly. There is rumbling in the boiler, the glass gauge jumps up and down and there is danger of water being carried over with the steam and of bursting the cylinder. Partially closing the throttle may stop it. If high or dirty water is the cause, blow off and pump. If the foaming is violent, check the draft and fires. The true water level can only be seen by closing throttle or supply-pipe valve long enough to observe.

16. If a boiler stands unused for a few days, fill it to the top; adding a little common washing soda is excellent. If it remains idle for some time, empty it and dry thoroughly with live coals inside the man or mud hole, allowing draft through the safety valve. Sometimes quicklime is used. Disconnect the feed steam and blow-off and finally seal the boiler air-tight by closing all openings and coating the joints with cosmic. Finally coat the boiler and fittings with linseed oil.

17. A boiler must be cool when filled. Never allow water from leaky joints or other source to come in contact with the exterior of the boiler. Feed water should enter in the direction of the boiler's circulation, and not near a heated surface.

18. A good engineer maintains a steady fire burning as slowly as the required pressure will permit, uniform height of water at the middle gauge and a uniform pressure. The safety valve, gauge glass, injector, valves, etc., are always in the best working order and constantly watched. All joints, connections and packing are tight. He knows the extent of scale, corrosion, and soot. All of his machinery and rooms are kept in order.

(D) THE STEAM BOILER AND ITS FITTINGS (FIG. 3).

1. Every steam boiler requires the best material, the highest grade of workmanship, correct setting, economy of maintenance, capacities for steam, water and

fire, heating surface to maintain the maximum pressure, free circulation of water, all parts accessible for cleaning, and repairs, complete combustion of fuel, joints and weak parts not exposed to fire, minimum repairs, constant vigilance, and care.

2. The piping is water-tight, smooth inside, direct, and so arranged as to take up expansion and not to collect water. All flanges and fittings are carefully put together. Rubber gaskets are essential between flanges to prevent leakage from pressures under 100 pounds; soft copper for higher pressures.

(a) Pipes conveying live steam are covered with asbestos or other nonconducting and noncombustible material, by which the loss of heat is often reduced three-fourths.

(b) All valves of brass or bronze are globe or gate, operating automatically or by means of an outside handle. Leakage is often caused by dirt or sticks in the water. Never close a valve or a cock so loosely as to leak nor so closely as to bind. The last half turn in closing is made very slowly, if, like the throttle, it checks a heavy pressure. Valves lift about one-fourth their diameter.

3. The safety valve is raised daily by hand to guard against sticking or tampering.

4. (Fig. 4.) The main valve *V* is held down on the two circular seats *M* and *N* against the steam pressure by the spring *S* acting on the rod *T*. The outer seat *N* is formed on the body *A* of the valve, while the inner and smaller seat *M* is formed on the upper edge of a cylindrical chamber *B* which is connected to the body *A* by arms containing the passages *C C*. The hollow chamber *B* forms a guide for the valve *V*. Ordinarily the steam exerts a pressure on the annular space between *M* and *N*; when the valve rises a little the steam rushes over the seat *N* into the air, and over the seat *M* into the chamber *B*, whence

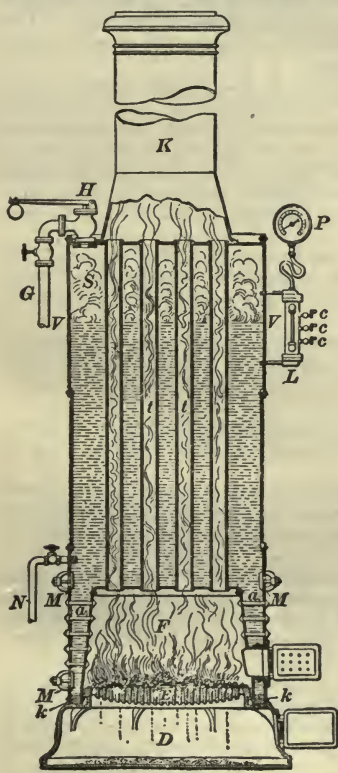

3. Upright Boiler.

1. *K*, smokestack; *H*, weight safety valve; *G*, feed pipe; *S*, steam space; *P*, pressure gauge; *c c c*, gauge cocks; *V*, water line; *t t*, fire tubes; *N*, feed pipe with stop valve; *M M M*, hand holes; *a a*, stay bolts; *F*, fire box; *E*, grate; *D*, ash pit; *k*, ring;

it escapes through the channels *C, C*. The channels are, however, not large enough to allow the steam to escape from the chamber as fast as it enters, and hence the pressure in the chamber rises and acts on the area inside the seat *M*. This additional pressure throws the valve wide open and quickly relieves the pressure in the boiler.

(a) Steam escaping from a safety valve is a signal of safety. It is set to open at 5 pounds above the working pressure. Changing, overloading or neglect is dangerous. About 1 square inch of valve opening is necessary for 3 square feet of grate surface.

(b) To set a weight safety valve: Steam pressure in lbs. \times valve area in sq. ins. \times dist. from fulcrum to center of valve = lbs. required to raise lever \times length of lever.

5. The pressure gauge is a brass circular tube of oval cross section having the open end connected with the boiler space by a pipe so bent as to retain water in the tube. The steam pressure on the water tends to make the oval section circular and therefore to straighten the hoop, whose free and closed end in moving turns a pointer by means of gearing. The pressure shown is that above atmosphere.

It must be accurate over the whole scale, should stand at 0 when there is no pressure and agree with the safety valve at blow-off. If not, compare it at once with another gauge and correct. The length of the invisible jet from the upper gauge cock is a rough check.

6. The gauge glass is the boiler fixture most closely watched. A majority of accidents are attributed to a choked water gauge which is never to be relied upon, especially when the boiler is foaming, unless verified by the three gauge cocks. Before firing and occasionally during the run, blow

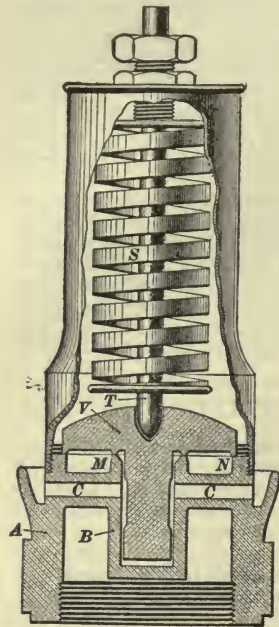

4. Pop Safety Valve.

out the glass twice to see that water returns to the same level and both passages are clear.

Cold drops of water or currents of air or scratches in cleaning are liable to fracture the glass. Then close lower and upper stopcocks, replace from stock always on hand by a new glass and soft rubber gaskets, taking care that the glass does not touch metal.

7. The three gauge cocks are tried many times every day as a check upon the indications of the glass and pressure gauge and are more reliable. The upper cock should show dry steam; the middle one, steam and water; the lower, water only.

8. The scum cock, for blowing out dirt from the surface of the water, is opened and closed alternately and quickly to prevent clogging. Continue so long as scum appears.

9. The blow-off cock of gun metal with metallic packing is opened at least once a day to guard against sticking. To insure against the blow-off being left open, the handle is a removable spanner or key which can only be put on or taken off when the cock is closed.

Blowing down at about 10 pounds pressure while raising steam drives out impurities on the bottom and equalizes the temperature throughout the boiler. If the pressure is high, open deliberately and keep the hand on the spanner while watching the glass. Make sure to close the cock. If water falls unaccountably in glass, look to the blow-off.

10. The feed pump (fig. 5) is an engine to be cared for and handled much like the main engine. It must be simple, double-acting, quiet, without leaks, positive under varying pressure, and have a suitable location, no dead center, a full supply of water, both a check and a stop valve in the delivery and a check valve and strainer at the suction extremity.

(a) The pump end is in good order if the pet cock, when opened, shows full stream at forcing and weak at suction. Streams on both suction and forcing strokes show that the pump valves are not closing. If there is no stream, look for air leakage in the suction or no water supply. If the receiving valve does not close, the pet cock shows hydrant pressure.

(b) If pump goes slow, the packing may be too tight or suction may be closed or steam has fallen. The packing is tight enough if on closing the delivery valve the plunger makes a stroke up and down and then stops.

(c) If the pump gets hot, water may be backing into it past the check valve from the boiler.

(d) If an accident happens to a pump and there is no injector, stop the engine, close boiler valves, draw the fire, raise the flue caps, and close the damper.

(e) If the suction pipe leaks, wrap sheet-rubber over the opening and bind it tight with string or copper wire as a temporary repair.

(f) A steam boiler requires both a pump and an injector, each capable of supplying 1 cubic foot of water per horsepower per hour.

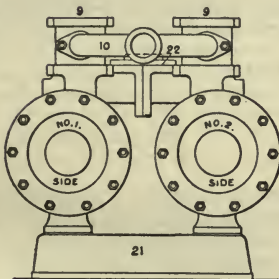
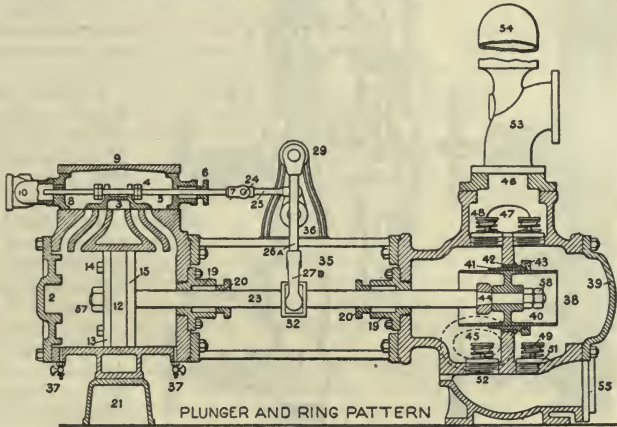

END VIEW OF STEAM CYLINDERS

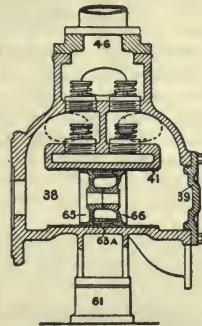

PISTON PATTERN WATER END

5. The Worthington Pump.

- | | | |
|--------------------------------------|--------------------------------------|-------------------------------------|
| 1. Steam cylinder (No. 1 and No. 2). | 23. Piston rod. | 42. Casing. |
| 2. Steam-cylinder head. | 24. Valve-rod head pin. | 43. Binder. |
| 3. Slide valve. | 25. Valve-rod link (long or short). | 44. Plunger hub. |
| 4. Valve-rod nut. | 26a. Long lever. | 45. Water-cylinder hand-hole plate. |
| 5. Valve rod. | 27a. Short lever. | 46. Force chamber. |
| 6. Valve-rod gland. | 27b. Fork end. | 47. Force-chamber hand-hole plate. |
| 7. Valve-rod head. | 28. Rock-shaft key. | 48. Valve guard. |
| 8. Steam chest. | 29. Upper rock shaft. | 49. Valve spring. |
| 9. Steam-chest cover. | 30. Lower rock shaft. | 51. Valve. |
| 10. Steam pipe. | 31. Crank pin. | 52. Valve seat. |
| 12. Piston ring. | 32. Spool. | 53. Delivery tee. |
| 13. Piston follower. | 33. Spool position pin. | 54. Air chamber. |
| 14. Piston-follower bolts. | 34. Spool key. | 55. Suction flange. |
| 15. Piston body. | 35. Cradle. | 57. Piston nut. |
| 16. Piston tongue. | 36. Cross stand. | 58. Plunger nut. |
| 17. Piston-tongue spring. | 37. Blow cock. | 61. Water-cylinder foot. |
| 18. Piston-tongue bracket. | 38. Water cylinder. | 63a. Solid water piston ring. |
| 19. Piston-rod stuffing box. | 39. Water-cylinder head. | 65. Packed water piston body. |
| 20. Piston-rod stuffing-box gland. | 40. Plunger. | 66. Packed water piston follower. |
| 21. Steam-cylinder foot. | 41. Plunger ring or cylinder lining. | |
| 22. Exhaust flange. | | |

11. The injector lifts, heats, and forces the water into the boiler but it is not so easily regulated to a small continuous flow as the pump.

(a) It has four nozzles: The steam nozzle 4, through which a jet of steam from the top of the boiler first passes; the combining nozzle *C* at whose extremity the steam and the water from the supply unite; the condensing nozzle *D* in which the steam's condensation is completed, and the delivery nozzle, seen just above 3, to the bottom of the boiler.

(b) There are four openings—steam, water, overflow and delivery.

(c) The Hancock injector (fig. 6) with 40 pounds dry steam will lift water below 100° F. up 25 feet and force it hot into the boiler. It has globe valves at 4, 5 and 3 and a check and globe valve to boiler not shown.

(1) To lift the water and to inject it, open valves 3, 1, 5 and 4 in order. Steam rushing through 4, *C* and *D* toward overflow 3 drives out the air. Water rises in 5 to *C*

Water rises in 5 to *C* and the steam jet is condensed by it at *D*. The resulting hot water jet has less cross section than the steam, but equal energy at the overflow. When the flow of water here appears steady, close 1 to turn the stream through *D*, open 2 one-half turn and close 3 to direct the flow into the boiler. The ear will recognize proper action. The jet into the boiler can be somewhat reduced by partly closing the water supply 5.

(II) To inject simply (the supply being above the injector) leave 1 always closed and open 3 and 5. When cold water appears at overflow, open 2 and 4 and close 3.

(III) Metropolitan, Rue and Korting are other good injectors similar in action.

(IV) Failure to act is due to improper handling, leakage of air, water insufficient or too hot, pressure too low or too high, or to obstructions in the tubes. If the stream breaks unexpectedly, look first to water and steam supply for the cause of the trouble.

(v) If hard scale forms on the nozzles, scrape it off or soak the injector in a one-tenth solution of muriatic acid or boil it in a mixture of vinegar and salt.

(vi) All pipes, valves and fittings of pump or injector must be air-tight and agree in size with pump or injector openings. The suction pipe is larger if long. Keep the fine wire strainer at its extremity clean. Injector and pump require each its own check valve and a stop valve in common in the delivery. Neither will lift hot water. There ought to be a water heater between the pump and boiler if the supply is cold. Use injector if the pump can only inject cold water.

12. A fusible plug (fig. 7) screwed into the crown sheet of a furnace, may not act unless examined and scraped clean on both furnace and fire sides whenever the boiler is cleaned. *R* is the fusible metal in the upper part of the plug *P*, so that when it melts from low water there is still water covering the crown sheet *Q*.

13. Several manholes are placed in large boilers, and hand-holes in small, for purposes of inspection and cleaning. Gaskets are liable to get hard or to become torn so that at least one extra set should be kept on hand.

14. The grate clogged with clinkers or ash stops the draft.

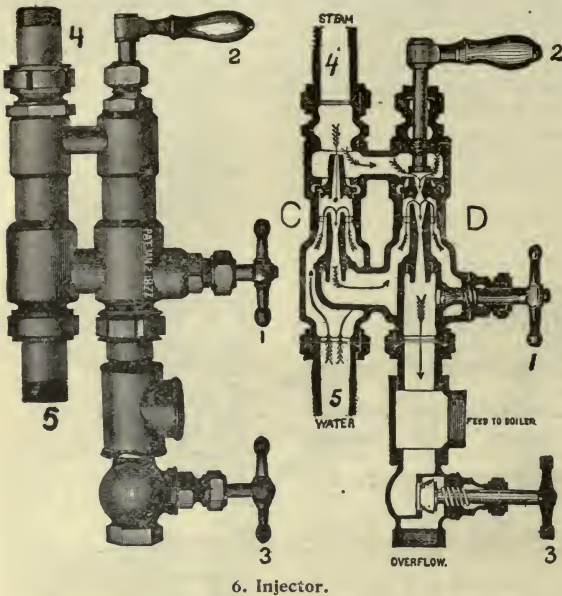

6. Injector.

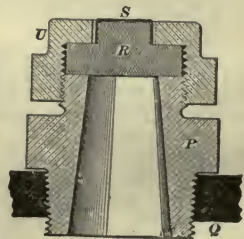

7. Fusible Plug.

(E) THE FEED WATER.

The feed water ought to be pure and hot. Rain water is usually satisfactory; well water is often good, sometimes very bad for the boiler. When the source is untried or the boiler is new, the man or hand holes are frequently opened to see if incrustation, corrosion or both have occurred. These maladies are the two greatest evils that operate against the life and safety of steam boilers and, unless prevented, will burn, granulate or distort the plates and tubes or cause pitting, grooving or wasting which results in explosions.

1. INCRUSTATION.

(a) Well water generally contains salts of lime, magnesia, silica and alumina. When the water is heated under pressure they are liable to separate from the water forming at first a soft deposit. Heat further bakes the sediment upon the boiler's interior into a nonconducting stone-like or glass scale which separates the water from the plates and leads to dangerous overheating; $\frac{1}{8}$ -inch scale makes 15 per cent more heat necessary.

(b) To maintain 90 pounds pressure, water must be heated to 320° F., and a clean boiler fire surface to 325° F. If $\frac{1}{4}$ -inch scale intervenes, the fire surface must be raised to 700° F. Above 600° F. iron becomes granular and is liable to bulge or crack under pressure.

(c) Incrustation can be prevented (I) by an expensive purifier which heats the water before entering the boiler until the salts are precipitated; (II) often by chemicals of pure quality such, for example, as caustic soda for lime carbonate deposit, or carbonate of soda for lime sulphate deposit, or good kerosene, etc., with more frequent blow-offs; (III) sometimes by frequent use of surface and bottom blow-offs alone.

The chemicals (II) simply make the hard deposit soft. They should be uniformly added in weak solutions to the boiler by way of the pump, gently at first, and the effect carefully watched by an experienced person. Excess may cause boiler leakage. Let the first trial be at the rate of $\frac{1}{2}$ pound salt per horsepower per month, or one quart daily of kerosene per 100-horsepower. Avoid all nostrums. Where the supply is poor, a good remedy lies in a large cistern and a wide roof, from which the first water of every rain is not collected.

(d) When the hard scale has been once deposited, the most certain remedy is to chip or pull it off by hand.

(e) Some waters having magnesia, etc., throw down a fine floury deposit which with little grease from the exhaust, and under pressure, often strains seams and rivets, causes leaks and bulges furnace plates. Oil filters and spare use of oil are remedies.

2. CORROSION.

(a) Corrosion is internal or external. Few boilers after some service are wholly exempt from pitting, grooving or wasting away in irregular and ill-defined patches. Internal corrosion (fig. 8) is the most destructive of all boiler diseases and serious enough to demand a remedy at once and subsequent careful watching. Stay bolts and rivet heads are sometimes attacked.

(b) It may be due to acid from vegetable matter in feed water, or decomposition of acid salts in the scale, or other impurity in hot water under high pressure, or to galvanic action. The ill effects can generally be reduced by pure soda ash, in solution, uniformly added by the pump. If galvanic action is suspected, fasten blocks of zinc into good metallic contact with boiler parts and near the patches. Change of water may cure. Or, let a chemist discover and apply a neutralizing agent.

(c) To prevent external corrosion, allow no water to come in contact with the boiler's outside, or dampness from leaking to remain in the seatings and coverings. Finally coat with linseed oil.

(d) A sensitive hydrometer, finely graduated above unity over a short range, will aid in detecting the waters which cause scale or internal corrosion.

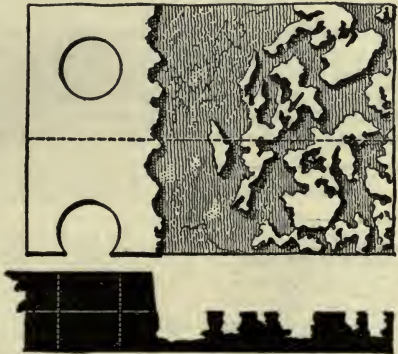

8. Corrosion Next a Lap.

(F) CLEANING THE BOILER.

1. While cleaning, watch for faults.
2. The heating surface, first of all, should be kept clean on both sides. Never allow scale or soot to exceed $\frac{1}{16}$ inch in thickness. A chisel may be used for scale; a scraper, chain or wire brush, and not steam, for flues.
3. The water in the boiler is changed every two or three weeks.
4. Empty and thoroughly clean once in five hundred working hours, oftener if the boiler is new or the water is bad, or the work has been intermittent. The interior, after it has cooled, is washed down with a hose and dried, all scale is removed and the boiler again washed. A small chain is sometimes dragged around the tubes to clean them. Before closing the manholes remove crust and tools that they may not choke the blow-off.

(G) THE INSPECTION OF A BOILER.

1. By a legalized inspector, once a year, extends to every part and fixture of the boiler, first empty and then under steam, after the defective parts have been replaced.
2. Boiler, flues and mud drum are first cleaned and dried in order to be seen.
3. The inspector ascertains the soundness and thickness of the plates by the sound and rebound of a very light hammer. The hammer test is usually sufficient. He notes the location and amount of incrustation and corrosion, and searches for blisters, cracks, loose rivets, broken or corroded stays, fractured joints, etc. All seams, head, and tube ends are examined carefully. A doubtful spot is examined with the aid of a magnifying glass. Sometimes a small hole is drilled through and, after inspection, plugged.
4. A loose rivet is replaced. A stay, brace, or fastening found defective, or a tube cracked is taken out and a new one is put in. A blister or a bulge is cut out and a patch is riveted inside if possible.
5. The hydraulic test is made when the boiler is new or extensively repaired or can not be thoroughly examined inside and out. Fill the boiler with water, close all outlets and use the force pump very slowly and evenly until the pressure is one and one-half times the working pressure. Or a gentle fire may be started under the filled boiler to get the desired pressure, but the temperature of the water should not exceed 212°. There is no danger of explosion if boiler is filled. Watch the gauge closely for any drop in pressure due to the boiler's yielding. By fixing points of sticks or wire close to the outer surface of furnace sheets, shell and ends, any deformation due to pressure may be detected. Any leakage in seams, rivets or joints is calked before continuing the test.
6. Under steam, the pressure gauge is compared with a standard along its entire scale; the safety valve is raised, operated, and, if necessary, reset. Look for leakage in cocks, valves, joints, and all fixtures, and for any faulty action in gauge glass, pump and injector.
7. The inspections of a boiler begin at its manufactory and continue so long as it is in use.

(H) EXPLOSIONS.

About 250 steam-boiler explosions occur annually in the United States, mainly due to preventable causes. Vigilance and execution of the foregoing rules will prevent them. When the first symptom of a disorder appears, apply the remedy.

In 1893, a single American insurance company examined 163,000 boilers, inspected 67,000, tested hydrostatically 8,000 and found 600 unsafe. In all, 123,000 defects were discovered, of which 12,000 were dangerous, as classified below:

Nature of defects.	Whole No.	Dan-gerous.	Nature of defects.	Whole No.	Dan-gerous.
Deposit of sediment	9,774	548	Leakage around tubes	21,211	2,909
Incrustation and scale	18,369	865	Leakage at seams	5,424	482
Internal grooving	1,249	148	Water gauges defective	3,670	660
Internal corrosion	6,252	397	Blow-outs defective	1,620	425
External corrosion	8,600	536	Deficiency of water	204	107
Defective braces and stays	1,966	485	Safety valves overloaded	723	203
Settings defective	3,094	352	Safety valves defective	942	300
Furnaces out of shape	4,575	254	Pressure gauges defective	5,953	552
Fractured plates	3,532	640	Boilers without pressure gauges	115	115
Burned plates	2,762	325	Unclassified defects	755	4
Blistered plates	3,331	164			
Defective rivets	17,415	1,569	Total	122,893	12,390
Defective heads	1,357	350			

The various causes are:

1. Excessive pressure, due to carelessness of the engineer who ought to have been intelligent, well paid and legalized; and to defective pressure gauge, safety valve and observation of water gauge—all three combined. The working pressure should not exceed two-thirds of the water test or one-fifth the safe theoretical pressure.

2. Overheating of plates due to low water or scale. While boiler is under steam the water line should always stand at the middle gauge, and the water glass should be cleaned and watched.

To stop scale, inspect and clean boiler regularly, blow off sufficiently often, use the scum cock, seek the proper solvent and change the water, if necessary.

3. Corrosion in patches and holes. After some explosions, plates are found wasted in places to the thickness of paper. Vertical boilers are more liable to explode from corrosion at the ends of tubes. Keep boiler full of water if it lies idle a few days.

4. Bad construction in material, design, or workmanship. There is no remedy. The prevention lies in purchasing boilers from a standard maker. There is only one grade of boiler to be selected, i. e., the best.

II.—THE STEAM ENGINE.

The type generally used in isolated plants is a simple, double-acting, single-slide or piston valve, automatic cut-off, high-speed, high-pressure, horizontal or vertical, direct-connected, steam engine. All types involve similar principles and require the same kind of care.

(A) ITS OPERATION.

STARTING.

1. Drain water out of steam feed pipe and close the drain.
2. Make sure that every part of the plant is in order.
3. See that both cylinder drains are open.
4. If the engine is not too large, turn it over by hand to see if it runs smoothly without play and leave the crank at 45 degrees, leaning toward and moving from the cylinder.
5. Open the throttle a small fraction of a turn to drive out water and to warm the cylinder while oiling.
6. In a regular order fill the oil cups and oil all bearings, and make sure that oil is not choked by gumming anywhere.
7. The cylinder must be warmed some time to allow free motion of the valve and piston.
8. Widen throttle slightly to start engine as slowly as possible during the first dozen turns.
9. Bring engine to full speed very gradually, standing ready to close instantly if a blow is heard.
10. Then turn throttle wide open.
11. Close the drain.
12. Adjust the oil cup and lubricator feeds, two to five drops per minute

RUNNING.

1. The engine should run without noise. Lost motion is taken up gradually as soon as it is detected.
2. The ear may aid the eye in detecting troubles.
3. Watch for heating especially in crank, crosshead, cylinder, stuffing boxes, main bearings and eccentric. When found, ease away on nut or key when possible and increase oil to which melted tallow may be added. Correct the fault at the first stop.
4. Uneven speed indicates sticking of the valve or governor parts or loose connections in the valve motion.
5. See that oil cups feed properly and that no bearing surface is dry. Guard against the use of too much oil.
6. A click in the cylinder from water should be quickly recognized. Open both drains until it stops.
7. An engine running requires constant vigilance and labor on the part of its attendant. There is no place for company or a chair in an engine room.

STOPPING.

1. Slow down engine gradually, especially if pressure is high, and be deliberate in last half turn of throttle. Leave the crank on outer dead center.
2. Close all oil cups.
3. Open drains and loosen belt.

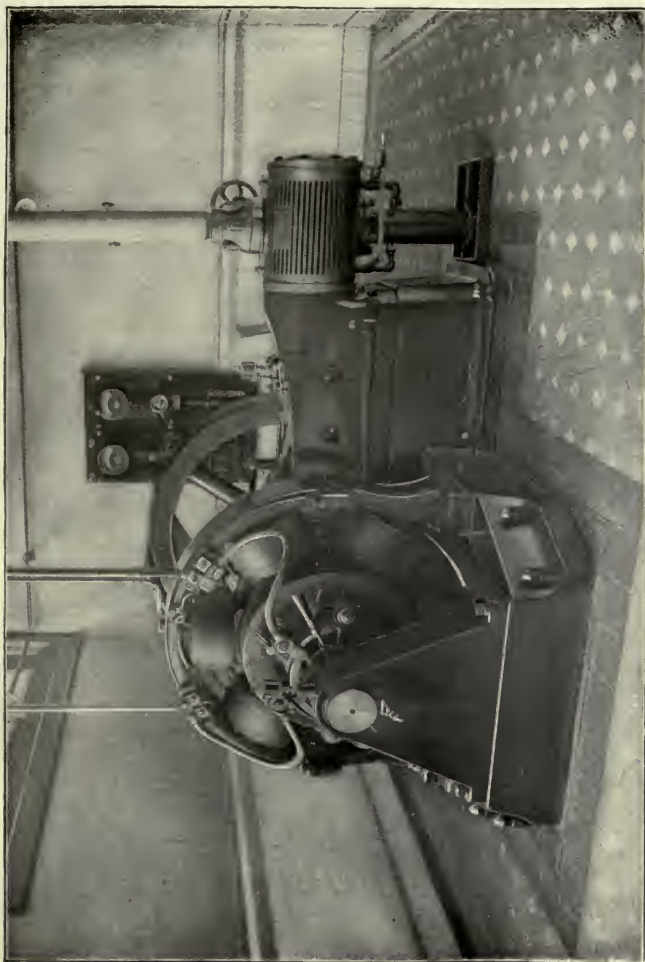

9. An Engine and Room in Order.



4. Feel crank, crosshead and other parts for heat.
5. Clean the engine thoroughly while warm.
6. Close the room tight, locking doors and windows, that engine may cool slowly.

(B) GENERAL CARE AND MANAGEMENT.

1. Never attempt to adjust a key or part without first marking its original position with a pencil or a metal point.

2. After making an adjustment run at first slowly on no load and on light loads. Experimental changes should never be allowed.

3. If the engine is unexpectedly stopped and the steam pressure is high, throw fresh coal on the fire, close damper to grate, open the furnace door, and start the pump.

4. Keep steam at uniform pressure while running.

5. If engine is new or just overhauled, run it slowly without load and with light loads for hours to let it wear to its bearings.

6. A cleanly kept engine in good order attests its engineer's capabilities. All bearing parts are kept free, smooth, oiled and without lost motion.

7. The new man gains all the information possible from the retiring engineer and should possess the manufacturer's directions.

8. No loose garment should be worn around an engine in motion.

9. Do not tinker with the engine. If it is necessary to repair some part, do it thoroughly and look over all other parts.

10. Inspect at least once a month for leakage in piston, valves and cocks. Watch gauge glass for leakage from boiler when engine is not running. See if piston and valve rods are in alignment, if cylinder is scored, if all bolts are secured, if shoulders are forming in the cylinder, if there is acid in the oil, etc.

11. If cylinder, valve, rod or guide is scored, graphite put on will fill the scratches and may restore the smoothness.

12. Always add oil to the graphite.

13. Packing allowed to become hard will flute the rods.

14. Packing, waste, iron parts, etc., temporarily laid on the floor, may carry dirt and grit to the bearing parts.

15. Every bearing surface requires a drop of the best mineral oil applied not often but regularly—a thick oil for cylinder and thin for other parts. Most engineers use too much oil. Never allow surfaces to get dry. Dirty oil from boxes may be filtered and reused.

16. Thin grease mixed with cylinder oil is the best lubricant for governors.

17. If there is not a belt tightener, put the belt partially on the pulley at rest, then run it on the engine pulley to be started with very slow motion.

18. The practiced ear can generally tell if the exhaust is regular. If the puffs are long and short alternately, the exhaust is freer at one end than the other. One exhaust may be heavier, yet the two may be equally timed. Equalizing the cut-off and exhaust is a partial remedy.

19. It is difficult often to locate knocking. Therefore, seek the place and cause, but proceed cautiously before making any changes intended to remedy the evil. It is usually due to the following causes:

(a) Lost motion in crank, crosshead, valve rods, main journals, etc. Try the hand on the suspected part at rest or in slow motion.

(b) Valve not set or the slipping of eccentric which admits steam suddenly; if due to valve, an indicator diagram is necessary.

(c) Engine out of line. See remedy elsewhere.

(d) Crank pin not parallel to main shaft. Disconnect connecting rod from crosshead and clamp to this end of the rod a spirit level parallel with the shaft. As the crank is turned the bulb will show if pin is not parallel with the shaft.

(e) Leaky piston rings, poor lubrication, water in cylinder.

20. Relief valve on cylinder is set at 5 pounds higher than the safety valve.

21. Heating is due to lack of good lubricant; dirt, grit, or filings in journals; bearings too tight; reciprocating or revolving parts out of line; improper fitting; too heavy load; too high velocity; too great pressure.

22. To feel for heating at crank pin in motion, stand in front of the engine and lower slowly the hand, palm down, until the crank barely touches it on the up stroke; or, starting from the crosshead end of the connecting rod, slide the hand along the rod to the crank.

23. Never permit the heating to reach a degree uncomfortable to the hand. If it remains moderate, oil and wear may stop it.

24. In case of smoke from overheating, slow down the engine as quickly and as far as possible, but do not stop it until the part has cooled. Then dismount quickly, clean off the brass from the steel, and correct the fault.

25. Piston rings should clear the cylinder at both ends a fraction of their width for smooth running.

26. Remember that the pump is a second engine.

27. If a valve leaks, clean it, reground the seat, but do not increase the pressure.

(C) THE CYLINDER LUBRICATOR (FIG. 10).

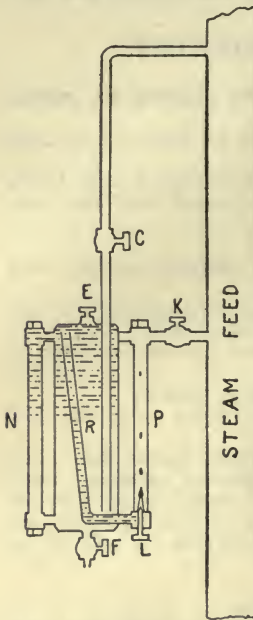

10. Sight Lubricator to Cylinder.

R, reservoir, oil shown in upper half; C, upper valve; E, filling plug; F, drain; K, discharge valve; L, regulating valve; N, gauge glass; P, sight-feed glass.

To refill with oil, close L, C and K in order. Unplug F to drain off reservoir, allowing air to enter at E. Close F and take out E to fill with oil. Replace E, open C and K, and regulate L from two to five drops a minute, depending upon the quality of oil and the amount of work.

If a glass breaks, close C and K and drain out. Loosen the packing nuts, replace with new glass and gaskets, taking care that the glass does not touch metal.

(D) THE FOUR CRITICAL POSITIONS OF VALVE AND OTHER MOVING PARTS.

1. When, as in fig. 11, the valve X is in the middle position, and the eccentric arm is nearly vertical, A a is the steam lap and B b is the exhaust lap of the valve. The lead of a valve is the distance the steam port is opened at the beginning of the crank's stroke (fig. 12). Full port opening (fig. 15) occurs at the end of the eccentric's stroke.

2. Lap, lead, or full port angle, or arc, is that made by either crank or eccentric while a point of the valve travels over lap, lead, or full port opening.

3. Travel = total distance valve moves = two times length of eccentric arm. Stroke = total distance piston

moves = two times length of crank. Angle of advance = amount of angle the eccentric is ahead of crank.

4. If we consider what takes place at one port, say the left, and on the left side of the piston during one full stroke and return, it will be seen that there are four critical positions of valve, piston, etc., during the one turn of the fly wheel, say clockwise, as in figs. 13, 16, 17, 18.

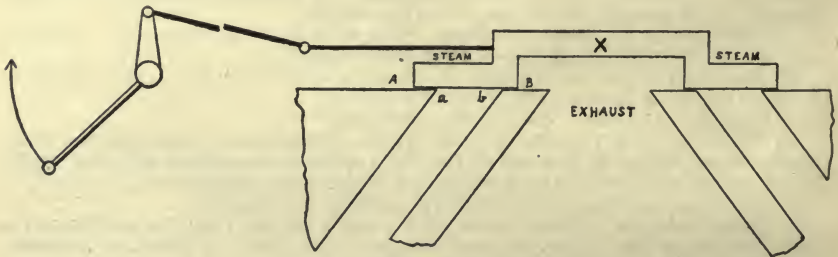

11. Laps.

- (1) Admission of steam begins when A is at a going to the right.
- (2) Cut off of steam begins when A is at a going to the left.
- (3) Release of steam begins when B is at b, going to the left.
- (4) Compression of steam begins when B is at b, going to the right.

These four events similarly occur on the right side during a stroke and return, and so on.

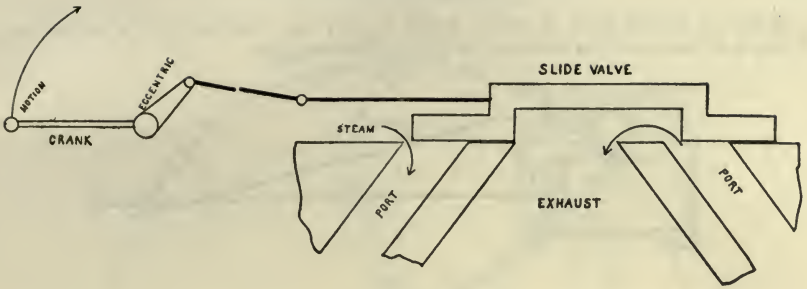

12. Lead.

Fig. 13 shows admission of steam to head end of cylinder before the end of a stroke, in order to form a cushion.

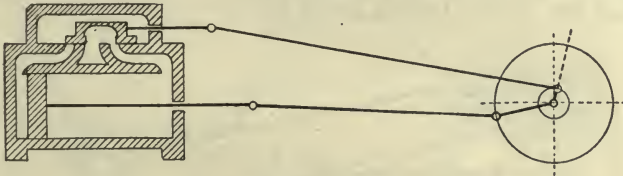

13.

In fig. 14 the piston (also crank) is at head dead center under full boiler pressure, and valve is at lead by definition.

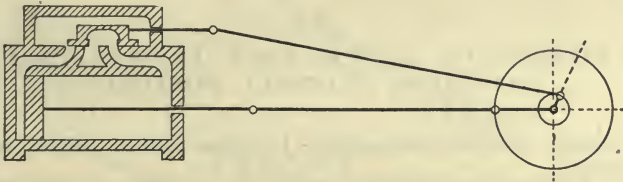

14.

In fig. 15 steam port is full open. Eccentric arm is at crank dead center.

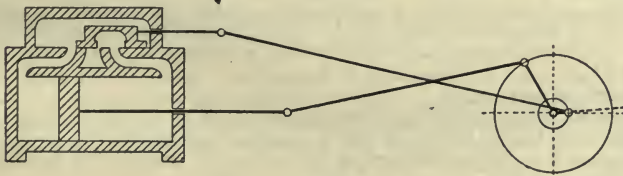

15.

In fig. 16 steam is cut off. Pressure on piston will now be due to expansion only of the steam in the cylinder. Eccentric makes nearly the same angle with vertical through O , as at admission.

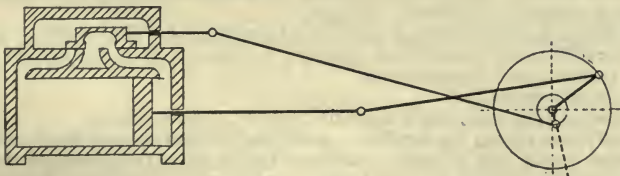

16.

In fig. 17 inside edge of valve going to left has reached port's inside edge. Release of steam or its exhaust to atmosphere begins.

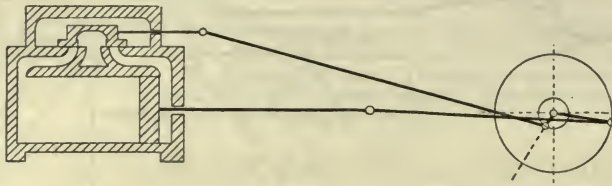

17.

In fig. 18 inside edge of valve going to right has reached the port's inside edge, and compression of steam in the cylinder follows. Eccentric makes about the same angle with vertical through *O* as at release.

Admission (fig. 13) next follows, and so on,

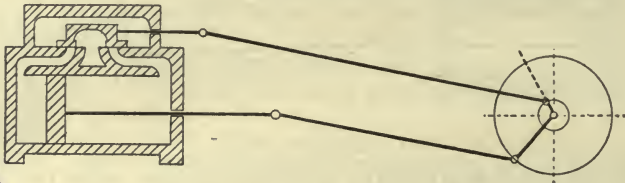

18.



(E) TO CONSTRUCT ACCURATELY IN ONE FIGURE (19) THE FOUR CRITICAL POSITIONS.

Given, travel = 3 inches; steam lap = $1\frac{1}{2}$ inches; lead = $\frac{1}{16}$ inch, and exhaust lap = $\frac{1}{4}$ inch.

On $H i = 3$ inches, draw eccentric's circle $m i n$; outside, crank's circle $M I N$. $O m$ is the eccentric arm's position at valve's mid travel.

Lay off $O E =$ exhaust lap, $\frac{1}{4}$ inch, $O L =$ steam lap, $L T =$ lead, erect verticals to get points $d, c, a, b,$ and t . The radii $O a, O b, O c,$ and $O d$ are by definitions the positions of the eccentric at admission, cut-off, release and compression.

$d m = c n =$ exhaust-lap arc; $m a = n b =$ steam-lap arc; $a t =$ lead arc.

$d O m =$ exhaust-lap angle; $m O a =$ steam-lap angle; $a O t =$ lead angle.

Lay off $H F = a t$, and through F draw $O A$. $A O a$ are the positions of crank and eccentric at admission.

The eccentric is always in advance of the crank by an arc = $m a + 90^\circ + a t$, or in angle = $m O a + 90^\circ + H O F =$ angle of advance.

Steam lap $O L +$ full-port opening $L i = \frac{1}{2}$ valve travel = $1\frac{1}{2}$ inches; full-port arc $a i = 90^\circ - m a$.

Lay off from b , arc $b x = m a + 90^\circ + a t$, or, since $b i = a i = 90^\circ - m a$, lay off from i the difference ($2 m a + a t$) to get x . $B o b$ are the positions of crank and eccentric at cut-off.

Lay off from c arc $c y = m a + 90^\circ + a t$, or, since arc $c i = 90^\circ + c n$, lay off from i the difference ($m a + a t - d m$) to get y . $C O c$ are the positions of crank and eccentric at release.

Lay off from d , arc $d z = m a + 90^\circ + a t$, or, since arc $d H = 90^\circ - d m$, lay off from H the difference ($m a + a t + d m$) to get z . $D o d$ are the crank and eccentric positions at compression.

Therefore the crank is—

At admission, the lead angle distant from first dead center.

At cut-off, two steam lap angles + lead angle from second dead center.

At release, steam lap + lead - exhaust lap (angles) from second dead center.

At compression, steam lap + lead + exhaust lap (angles) from first dead center.

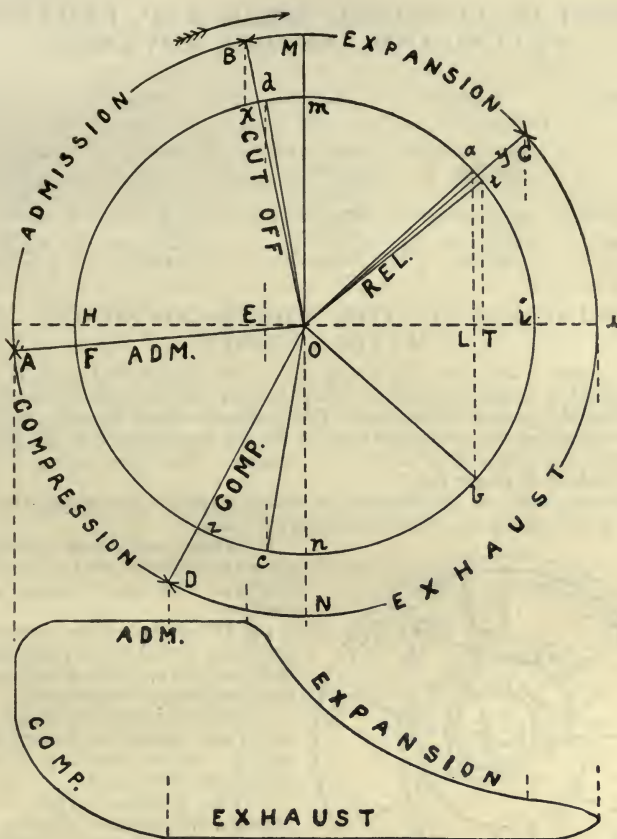

19. Four Critical Positions of Crank and Eccentric Arm.

(F) TO EQUALIZE THE FORWARD AND RETURN STROKES OF THE PISTON.

The foregoing would only be true for very long connecting rods. The angular position of an actual rod (about six times longer than the crank) delays the events on the stroke from the head end and produces them too early on the return. If, for instance (fig. 20), the piston is at A and C when crank is at the dead centers, it will be to the right of B, midway of A and C, when the crank is vertical; that is to say, the piston travels faster in the head end half.



20. Crank Moves Uniformly, Piston Does Not.

For a partial remedy equalize the leads of the valve and slightly alter one exhaust lap for equal release and compression. The valve position is less disturbed than that of crank because the eccentric arm is relatively short.

(G) EFFECT OF CHANGING STEAM LAP, EXHAUST LAP, TRAVEL AND ANGULAR ADVANCE.

By increasing.	Admission.	Expansion.	Exhaust.	Compression.
Steam lap -----	Begins later, ends sooner.	Begins sooner, lasts longer.	Unchanged -----	Begins at same point.
Exhaust lap -----	Unchanged -----	Begins same, lasts longer.	Begins later, ends sooner.	Begins sooner, lasts longer.
Travel or eccentric arm.	Begins sooner, lasts longer.	Begins later, ends sooner.	Begins later, ends later.	Begins later, ends sooner.
Angular advance -----	Begins sooner, period same.	Begins sooner, period same.	Begins sooner, period same.	Begins sooner, period same.

(H) PRINCIPLE OF THE WHEEL-GOVERNOR AUTOMATIC CUT-OFF.

1. If the angle of advance $A O a$ (fig. 19) is increased, full port $L i$ is made less, b approaches i , the cut-off $b O$ occurs earlier and the period of admission of steam against the piston is lessened. But the lead would thereby be increased. To keep it the same, the eccentric arm is, by the automatic cut-off, shortened at the same time the angle of advance is increased. The valve travel is thus lessened and the lead is preserved.

Or, admission may be prolonged by automatically decreasing the angle of advance and increasing in effect the eccentric's arm.

2. Wheel governors accomplish the above in different ways in order to keep uniform the speed under a varying load—

(a) If load decreases, speed increases, governor weight is thrown out by centrifugal force, valve travel and admission period are diminished.

(b) If load increases, speed decreases, governor weight is drawn in by the spring, valve travel and admission period are increased.

3. The governor (fig. 21) of the straight-line engine affords a typical, simple, and accurate automatic control of steam to load.

The eccentric is screwed to a plate, $A C$, pivoted at a on the fly-wheel, revolving clockwise. As the weight W flies out, the end d of the eccentric arm is shifted about a as a center toward c by the links ll moving with the arrow against the spring S . Governors usually have two opposite weights actuating the eccentric arm like the above.

Fig. 22 gives by the same letters the relative positions above of crank $h c$, eccentric arm $c d$, center of shaft c and center of governor motion a . Angle of advance = $h c d$. Describe arc through d to center a . When too high speed throws W outward, the free end of the eccentric arm is moved to some point e , the angle of advance becomes $h c e$, and the eccentric's length $c e$. The valve travel is shortened, the lead is preserved, cut-off occurs earlier, admission of steam and speed are less.

4. To adjust the governor for increase of speed, slide the weights, if movable, toward the center equally; or tighten the springs equally; note that the spirals do not touch each other. To run slow, loosen them, but seldom more than an inch.

5. To make sure that the tensions on both springs remain equal, count the turns made by the nuts in tightening, or listen to the sounds of the springs when struck after tightening.

6. For larger changes, procure other weights and springs. The governor can usually be changed to run reverse. If it ever works irregularly, look for a gummed or dry joint or a surface that binds.

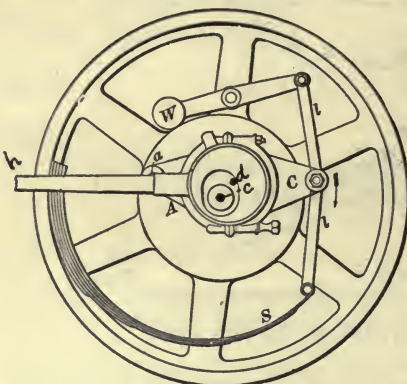

21.

$h c$ = general direction of crank and eccentric rod.
 $c d$ = eccentric arm.

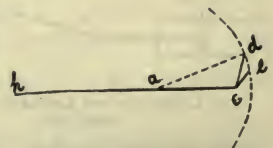

22. Wheel Governor's Automatic Control of Steam Valve.



LIBRARY
OF THE
UNIVERSITY
OF
CALIFORNIA

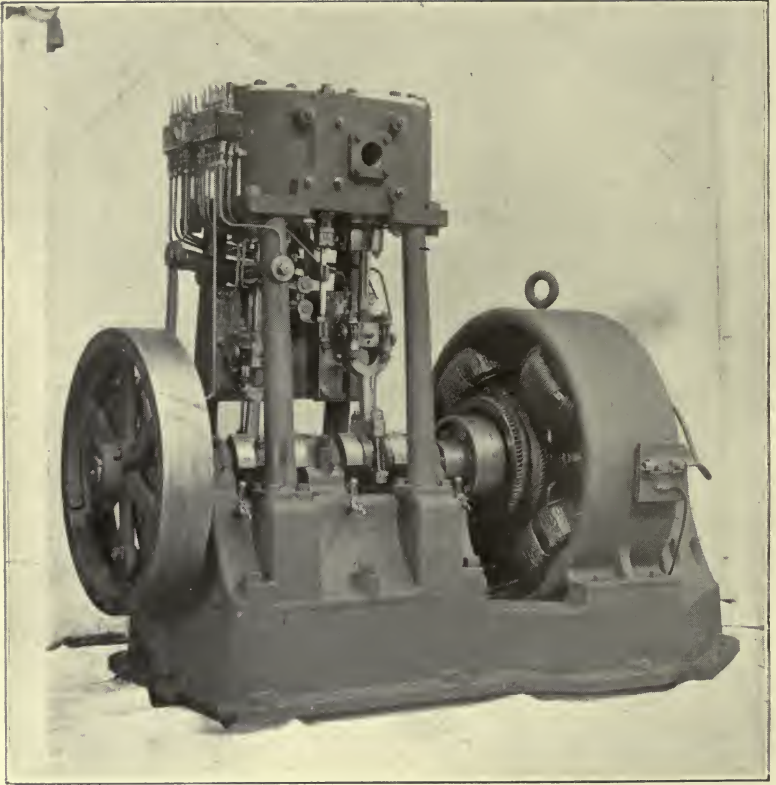

22a. Sturtevant Double Engine.

(I) A FULL INSPECTION OF AN ENGINE.

A full inspection extends to proving the level of its base; the alignment of cylinder, shaft, crank pin and guides; of valve rod and eccentric; trueness of cylinder bore, fly wheel, and bearing surfaces; equality of clearance; the fit of piston to cylinder; of crosshead to guides; of connecting-rod brasses to crank-pin and crosshead journals; of main shaft to its bearings; of packing to rods; the setting and critical positions of the valve; lengths of rods and the general order.

Tools required: Spirit level, inside calipers, plumb line, straightedge, ruled square, very fine stout string, stick slotted for a cylinder-head bolt. The rules given below for a horizontal engine suggest the course for a vertical.

1. To prove the base level, apply the spirit level in two positions at right angles on the base, always reversing the level.

2. To get the dead center, place a fine pointer from a fixed rest close to the fly wheel's outer rim in front. Turn fly wheel to bring the crosshead to about $\frac{1}{2}$ inch from the outer end of its travel. Mark accurately the guide at the end of crosshead and the rim opposite the pointer.

Continue the turn of the engine until the same end of crosshead returns exactly to the mark on the guide. Mark the pointer's place on the rim and turn the wheel so that the pointer stands midway of the two marks on the rim. The engine is now at its outer dead center. A fine straight line drawn on the guides along the crosshead end marks the position. Next find and mark the inner dead center.

3. To line up an engine (horizontal) is to find if cylinder's axis prolonged intersects the axis of the main shaft at right angles, and the axis of the crosshead pin in all positions, and if the main shaft is level.

Disconnect and remove all parts from crank pin to and including back cylinder head. To any bolt of this head, bolt the slotted stick across the head to hold one end of the fine string in the axis of the cylinder. Draw the string taut through the cylinder to an adjustable upright in front of the engine. With inside calipers carefully adjust the string to the centers of the two counterbores. This is the center line of the engine, to which other parts are adjusted.

(a) Put one leg of the square against an inner crank face so that the outer edge of the other leg is in the shaft's axis. See if the edge just touches the line as the crank is turned.

(b) To square the shaft, turn the crank pin forward so that it almost touches the center line of the cylinder. Caliper between line and crank or disc. Turn crank pin backward to line and likewise caliper. If the two distances are equal the shaft is square. If not square, move the out-end pillow block.

(c) To level the shaft, apply the spirit level on top and reverse it. Or, better, drop a plumb-line in front of the crank face and caliper at the up and down half stroke similarly as in squaring. If the shaft is out, shift it by liners, babbitt, thicken or thinner brasses, or by using a file, as required.

To verify both the level of shaft and trueness of fly wheel, drop a plumb line from the ceiling past the wheel's outer rim and center and turn the wheel.

(d) To line the guides, lay a straightedge across the two guides and caliper between it and the center line the whole length of the guides. Likewise caliper between line and the inside edges. Measurements will show if center line intersects the axis of the crosshead pin. If necessary, dress the guides with file or sandpaper, or insert shims.

(e) To verify (b and d), key up the connecting rod snug to the crank pin, and while turning the crank see if the free end of the rod moves parallel with the guides.

4. To align valve rod and eccentric, less liable to derangement, will require like expedients.

5. To find whether cylinder has worn out of true, caliper all around the center line in one circle, then another, and so on along the inside of the cylinder.

6. To test the fit of the piston: (a) Loosen the connecting-rod keys, and, by turning the fly wheel, bring the piston to the head end. Take off cover, also the follower on the piston, and see that the piston rings press against the cylinder bore all around without binding.

(b) For a check, put the engine to the other dead center and admit a little steam. Leaking, if any, can be seen at the open end.

(c) Or, without removing the head end, if the cylinder is piped for indicator, relief valve, or exhaust to air, turn crank to either dead center and open the cock at the end opposite from that at which steam is very slowly admitted. Steam will appear at the cock if the piston leaks.

(d) The split of a piston ring is down in a horizontal engine. If two rings, they break joints on the lower half.

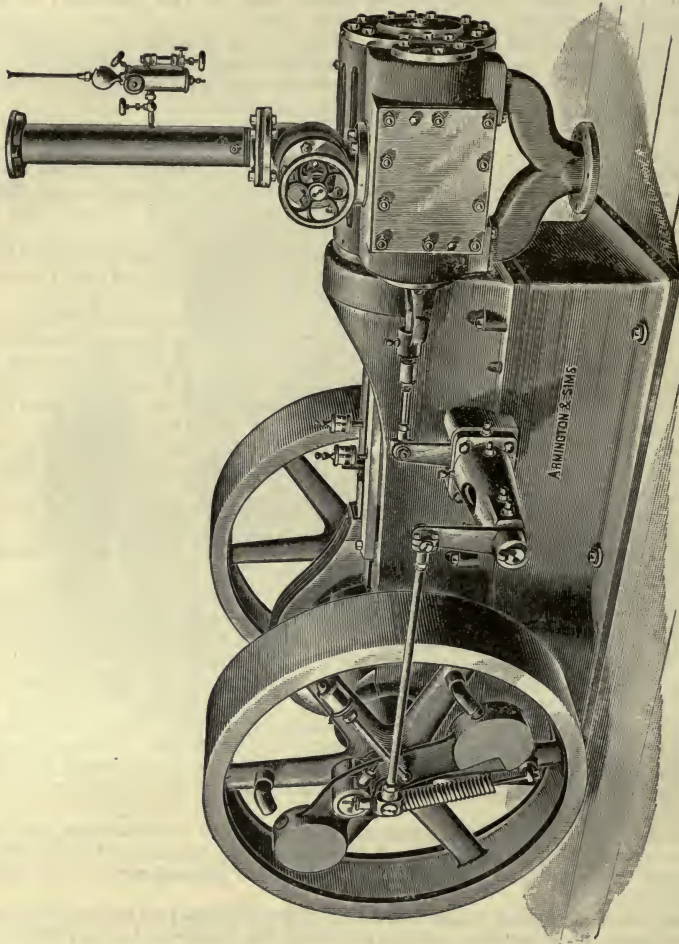

22b. Armington & Sims Engine.

7. *The crosshead.*—It is essential to keep the piston rod exactly in the center line. Give the gibs an easy sliding fit without lost motion. Ease away on the crosshead pin inside the connecting rod to prevent undue wear (fig. 24).

8. To get the true length of connecting rod: (a) Move piston, with crosshead disconnected, against one cylinder head, i. e., the striking point, and mark the guide opposite crosshead end. Do the same for the other head. Suppose the distance between both guide marks = 25 inches; between centers of crank pin and shaft = 12 inches. Then full stroke = 24 inches, and clearance at either end = $\frac{1}{2}$ inch. Now move crosshead $\frac{1}{2}$ inch back from the striking point mark, bring crank to dead center, and with a tram measure between the outside centers of crank pin and wrist pin for the required length.

(b) To lengthen the rod insert liners between its brasses and stud ends.

(c) To put on the rod move the piston slightly toward the crank and adjust the keys so that the bores of the brasses easily fit without play.

(d) To take up lost motion loosen the set screws, drive down the key, and tighten the set screws. It is a good plan to drive in the key until the brasses bind, mark the key and slide it back to a proper fit, marking it again for later adjustment, if necessary.

(e) To equalize clearance, usually $\frac{1}{4}$ to $\frac{3}{8}$ inch, in the cylinder, lengthen or shorten the connecting rod.

9. To adjust main shaft bearings, the shaft is shifted on either side, or both, by the use of thicker or thinner shims, babbitt or brasses. If the brasses meet, tighten the nuts to an easy bearing. If not, lay in a sufficiently thick wire of lead to take the compression and screw the nuts to a bearing. Then replace by a shim gauged to the same thickness and screw the nuts home.

If the lead wire is thicker at one end, the shim will be made the same.

10. To set a common slide valve, is to make the leads at both ports equal, and the full-port openings as nearly equal as possible. Leads are made equal or unequal by changing valve or eccentric rod's length; but if both leads are equal, change of amount is gotten by changing the angle of advance. Always compare the openings by inserting a long, thin wedge.

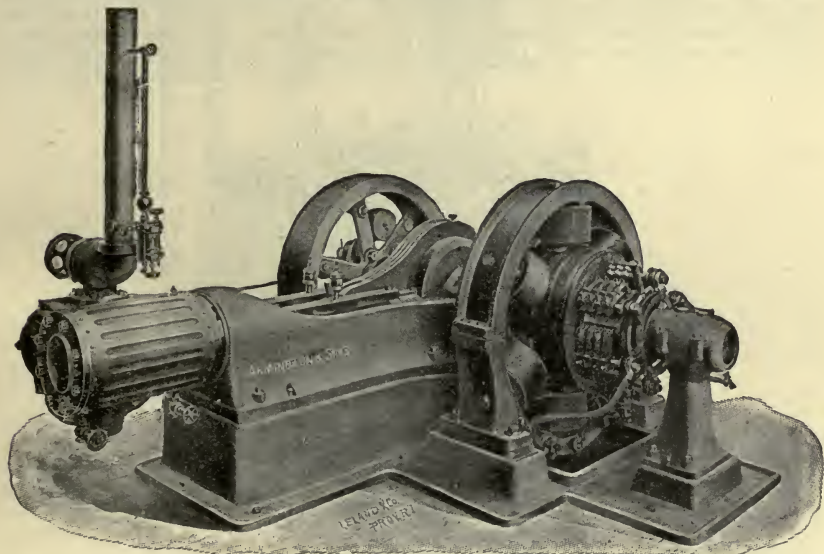

23. Armstrong & Sims D. C. Set.

(a) Take off the steam-chest cover (fig. 23), give all connections a close working fit, place crank at either dead center, and measure the lead for each port; if the leads are equal to each other and to the amount given by the builder, the valve is properly set. If not, change the valve rod's length by the half difference, and repeat the operation, which will probably first require a change of the eccentric's position to bring the lead right at the first dead center.

Suppose the valve has proper lead, $\frac{1}{16}$ inch with crank at first dead center, and shows a lap of $\frac{3}{8}$ inch at the other port with crank at second dead center, the

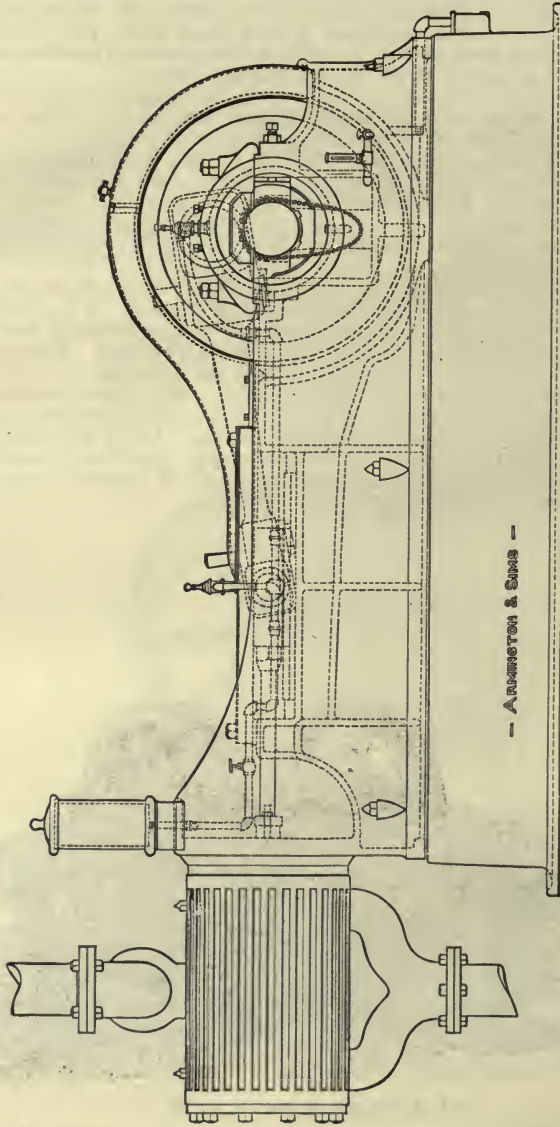

24. Armington & Sims Engine.

valve rod's length is then changed by $\frac{7}{8}$ inch. Now put crank at first dead center and change eccentric's position to give $\frac{1}{8}$ -inch lead and move crank (always in its working direction) to second dead center, and so on.

(b) If the valve is controlled by a wheel governor, block the weights out to their positions at normal speed and proceed as above. Both length of rod and angle of advance are successively changed in setting valves.

(c) In vertical engines with cylinder above, the lead at the crank-end port is given slightly increased lead over the upper to compensate for weight of moving parts and the wear downwards.

(J) TO PACK THE PISTON ROD.

(1) Cut the rubber or other material into four or more rings of square cross section with beveled split to fit rod and box so closely that the finger can push them into place. The first split is up; the others, break joints. Rub graphite or chalk on the outside to prevent its sticking to the iron.

Screw down the gland evenly, first one nut a partial turn and then the other a little more, and so on alternately.

(2) To stop a leak, tighten little at a time. If several trials fail, reverse the packing, or, better, renew with soft packing always kept in stock.

(3) The troubles with packing result from ill-fitting rings, engine out of line, rough rods, not correcting the first small leak, too long or too short or too few rings, or too small stuffing box. The valve rod is similarly packed.

(K) THE PISTON VALVE IN COMMON USE IS BALANCED.

This valve is cylindrical and usually hollow. Steam passes over its edges on all sides and does not force the valve against its seat with unnatural pressure as in the case of the D-slide valve. Its action is precisely the same and the foregoing principles apply, whether the piston valve admits steam at the ends of the chest and exhausts at the middle, or admits steam from the middle around the valve and exhausts at its ends.

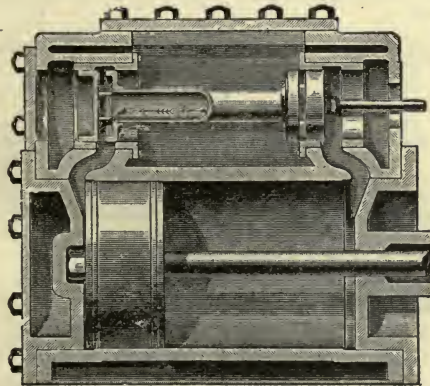

24a. The Cylinder and Valve.

To the latter class belongs the valve (fig. 24a) of the Armington & Sims engine, shown in the lead position. Live steam surrounds the valve and fills its interior through one or the other of its end openings. Steam has already started into the head-end port from the middle of the chest and from the interior of the valve by way of the right-hand opening. The exhaust occurs quickly at either end of the cylinder through direct passages. The valve carries check rings at both ends.

The Rites governor (fig. 24b) is extremely simple, sensitive and powerful. The eccentric arm at its greatest elongation is short, so that the valve's travel is small. The cut explains better than words its mode of operation.

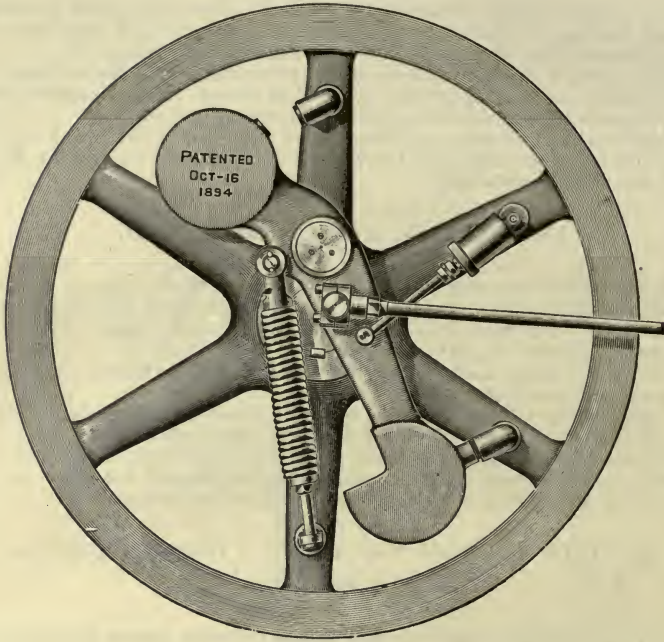

24b. A. and S. Governor.

The main journals have chain continuous oilers; the crank pin, a centrifugal oiling device; and the crosshead runs in oil, all supplied from a central reservoir. There is no throwing of oil.

Fig. 22a shows the new Armington & Sims wheel governor and its connection with the valve.

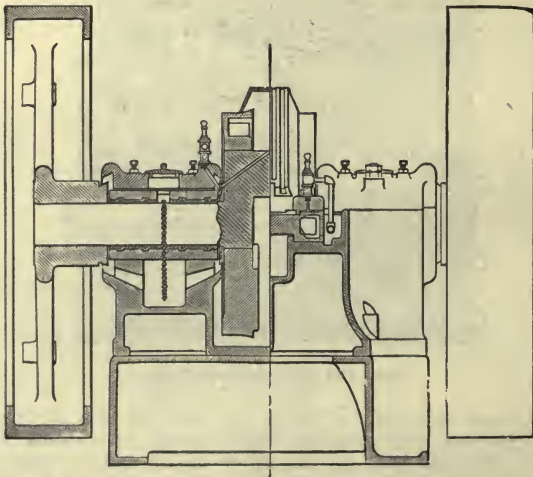

24c. End View Oiling Device.

III.—THE HORNSBY-AKROYD OIL ENGINE

Has no ignition apparatus and is, when properly attended, reliable. One pint kerosene maintains one horsepower for one hour.

(A) THE ENGINE.

1. The engine (fig. 26) is four cycle, i. e., in its propulsion four different operations occur behind the piston in the four strokes which cause two complete turns of the pulley. They are—

First stroke.—Admission (or suction). During the first outward stroke air is drawn into the cylinder and a thin, momentary jet of kerosene oil is sprayed into the adjoining hot combustion chamber or vaporizer (fig. 26a).

Second stroke.—Compression. In the following inward stroke the air is driven through the narrow neck into the vaporizer to form with the oil vapor a mixture which at the end of the stroke is ignited by the heat in the chamber.

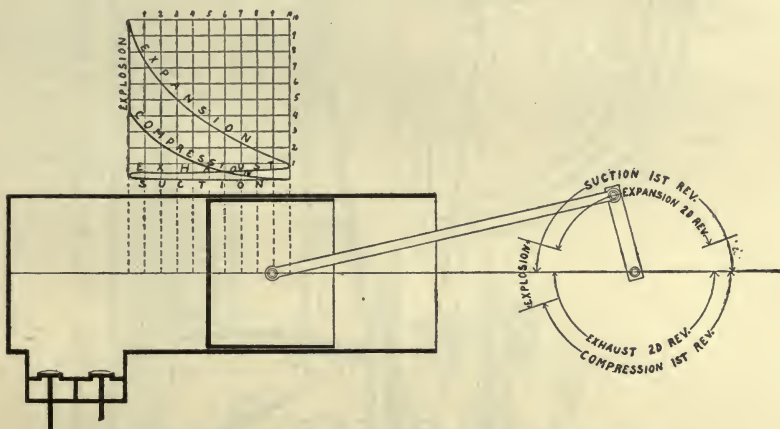

26. Beau de Rochas Cycle of H.-A. and most Explosive Engines.

Third stroke.—Explosion plus expansion of the gas through the neck into the chamber then drives the piston outward with a maximum pressure of 130 pounds per square inch and a mean of 40 to 75 pounds.

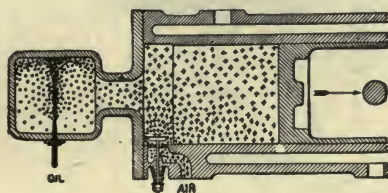

26a.

Fourth stroke.—Exhaust of the products of combustion from the cylinder into the exhaust chamber and pipe occurs during the next inward stroke, or final cycle.

During the first outstroke the thin stream of oil is instantly vaporized on striking the heated interior surface of the vaporizer, and the proper amount of

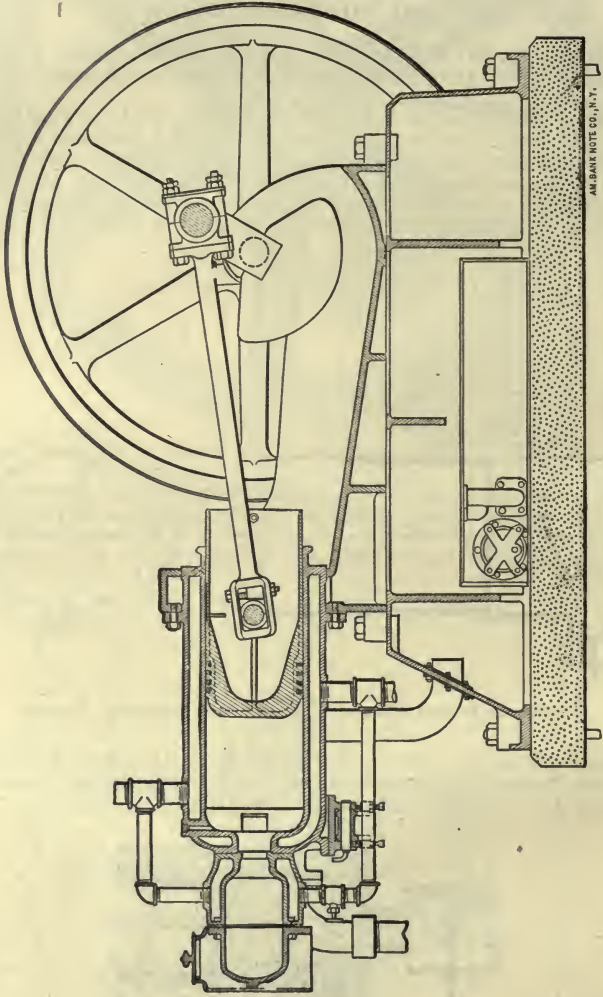

AM. BANK NOTE CO., N.Y.

25. Sectional View. (From Goldingham's "Oil Engines.")

air heated en route by the hot exhaust chamber, is drawn into the cylinder. Mixture and compression follow on the following instroke, at the end of which ignition is caused by the heating effects of compression, friction, and vaporizers combined. The impulse is given only during one stroke in four. The vaporizer is protected from cooling air currents by the hood, and its heating is controlled by the damper on top. Cylinder and valve box are cooled by a water jacket.

2. Number and names of parts:

- | | | |
|-----------------------------------|----------------------------------|------------------------------------|
| 1. Cylinder liner. | 30. Oil-pump gland. | 58. Governor balls. |
| 2. Cylinder casing. | 31. Bed plate. | 59. Governor counterweight. |
| 3. Vaporizer. | 32. Bearing cup. | 60. Governor-counterweight lever. |
| 4. Vaporizer cap. | 33. Splasher. | 61. Governor-regulating plate. |
| 5. Vaporizer-cap joint ring. | 34. Oil tank. | 62. Governor fork. |
| 6. Vaporizer cover. | 35. Oil filter. | 63. Governor-fork spindle. |
| 7. Vaporizer-cover lid. | 36. Filter cock. | 64. Governor connecting rod. |
| 8. Vaporizer-cover filling piece. | 37. Worm gear. | 65. Governor connecting-rod lever. |
| 9. Valve-box journal. | 38. Gear wheel. | 66. Valve lever. |
| 10. Valve-box sleeve. | 39. Gear guard. | 67. Air-valve cam. |
| 11. Spray nozzle. | 40. Crank shaft. | 68. Exhaust-valve cam. |
| 12. Horizontal valve. | 41. Crank-pin oiler. | 69. Cam rollers. |
| 13. Horizontal-valve spring. | 42. Oiler elbow. | 70. Lever fulcrum. |
| 14. Vertical valve. | 43. Piston. | 71. Lever-fulcrum pin. |
| 15. Vertical-valve spring. | 44. Piston rings. | 72. Air-valve lever. |
| 16. Valve box. | 45. Wrist pin. | 73. Exhaust-valve lever. |
| 17. Valve-box screw cap. | 46. Connecting rod. | 74. Cam shifter. |
| 18. Valve-box coupling. | 47. Connecting-rod head end. | 75. Locking handle. |
| 19. Overflow glass. | 48. Connecting-rod crank end. | 76. Air-exhaust valve box. |
| 20. Half union. | 49. Compression plates. | 77. Air-exhaust valve-box cover. |
| 21. Oil-pump can. | 50. Cam shaft. | 78. Air-exhaust valve spring. |
| 22. Oil-pump plug. | 51. Governor wheel. | 79. Air valve. |
| 23. Oil-pump plunger. | 52. Governor pinion. | 80. Exhaust valve. |
| 24. Oil-pump plunger spring. | 53. Governor-gear guard. | 81. Cylinder lubricator. |
| 25. Oil-pump plunger lock nut. | 54. Governor bracket. | 82. Cylinder-lubricator cover. |
| 26. Oil-pump plunger head. | 55. Governor spindle. | 83. Cylinder-lubricator pulley. |
| 27. Oil-pump plunger-head guide. | 56. Governor counterpoise. | 84. Fly wheel. |
| 28. Oil-pump gauge. | 57. Governor-counterpoise lever. | 85. Fly-wheel key guard. |
| 29. Oil-pump body. | | |

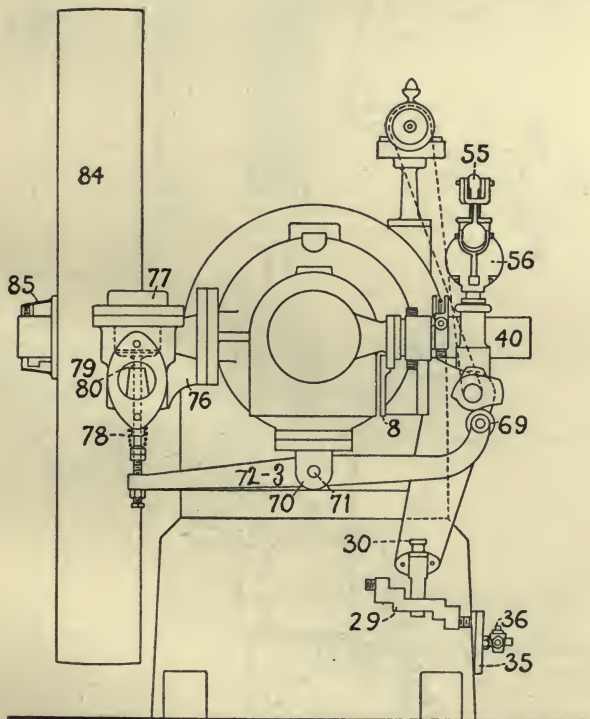

27a. Cylinder End Projection.

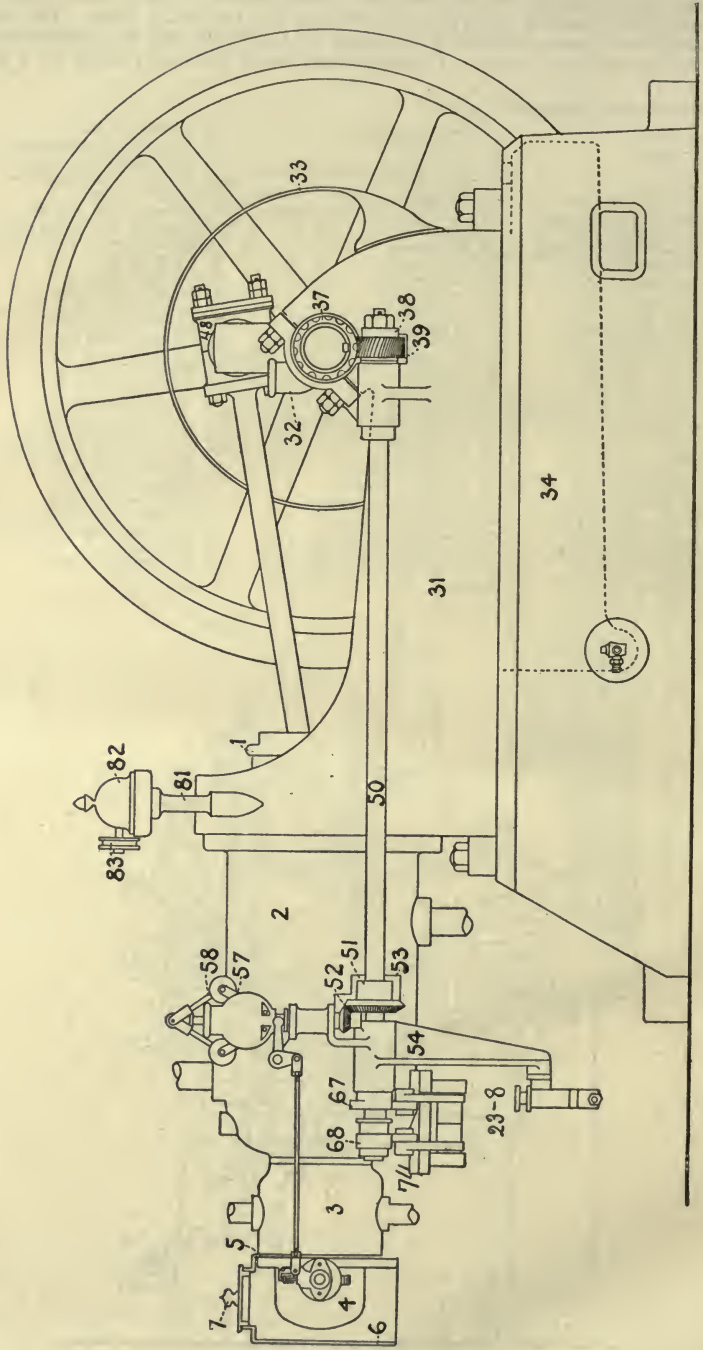

27. Governor Side Projection.

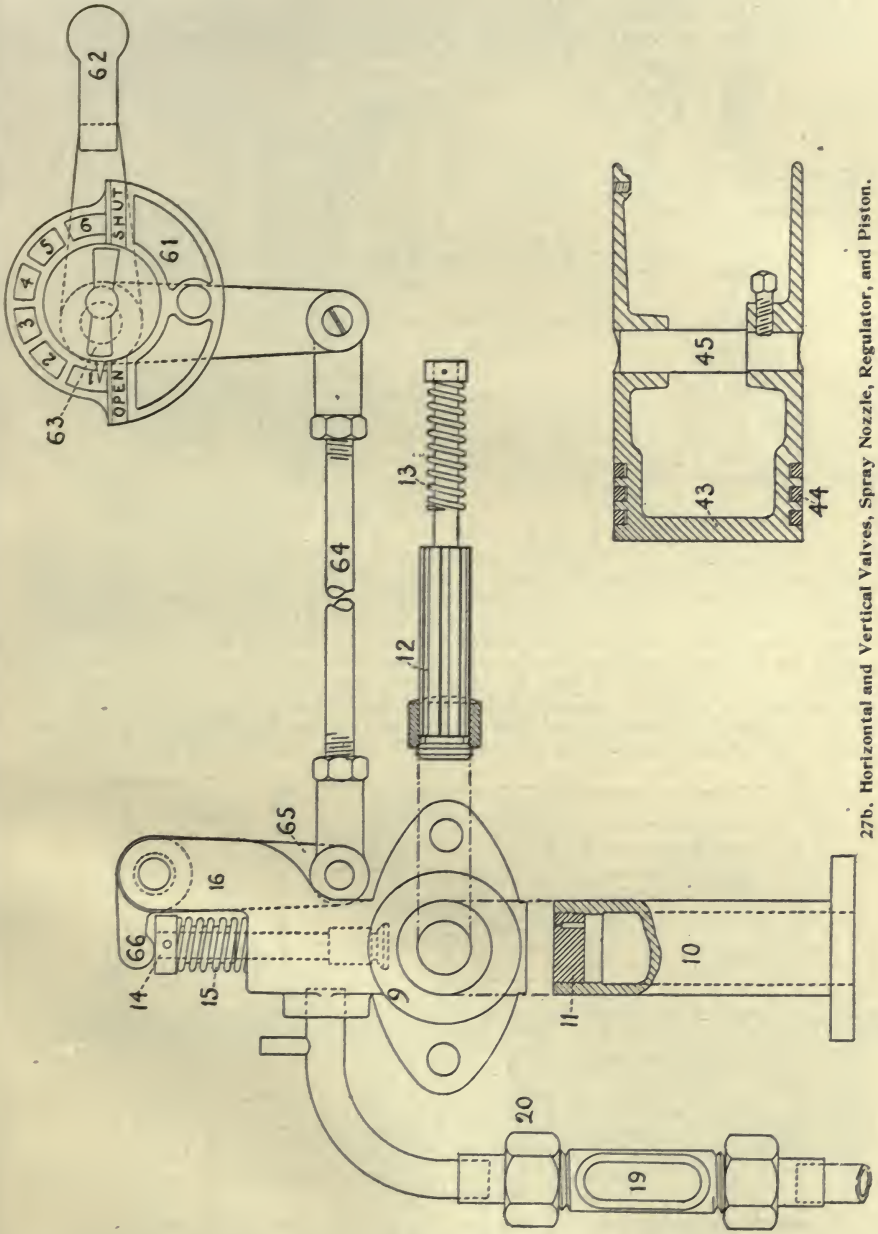

27b. Horizontal and Vertical Valves, Spray Nozzle, Regulator, and Piston.

3. The oil pump (fig. 28), actuated by the same lever as the air-inlet valve (fig. 30), performs the double office of suction on the upstroke and of forcing on the downstroke. The suction as well as the forcing side has two check valves in series for certainty of action. On the downstroke oil is forced direct to the valve box.

4. *Valve box* (fig. 29).—Here are two valves, the "horizontal" or check valve for keeping the oil from flowing back and preventing the possibility of premature explosion, and the "vertical" or by-pass valve for regulation.

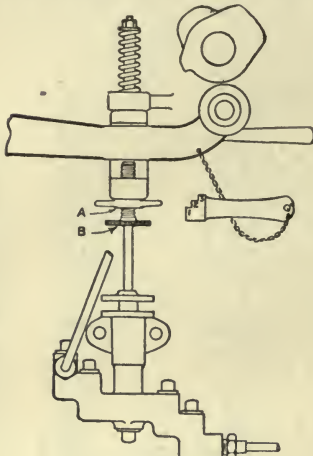

28. Oil Pump.

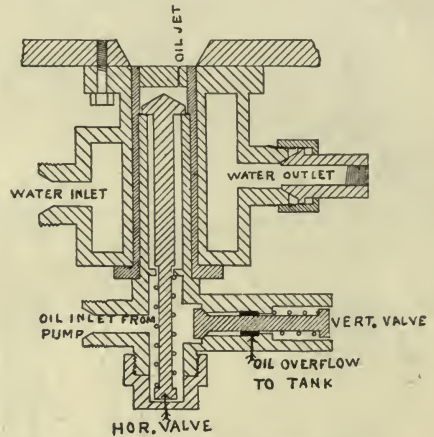

29. Check and By-Pass Valve Box.

5. The regulation of the engine is effected by altering the supply of oil in two ways: first, by changing the length of stroke of the pump, i. e., the oil supply, and, second, automatically by a sensitive ball governor which opens the by-pass valve in the valve box, and deflects a portion or all of the oil jet from the vaporizer through the overflow outlet back to the tank. During the piston's first or suction stroke the pump injects the oil (opening the "horizontal valve") through the spray nipples (see "oil jet," fig. 29) into the vaporizer; but if the by-pass valve is partially or wholly depressed at this time, part or all of the oil will overflow.

6. The air-inlet and the exhaust-poppet valves (fig. 30) close at the proper times the exhaust chamber to their respective pipes. Always under the tension

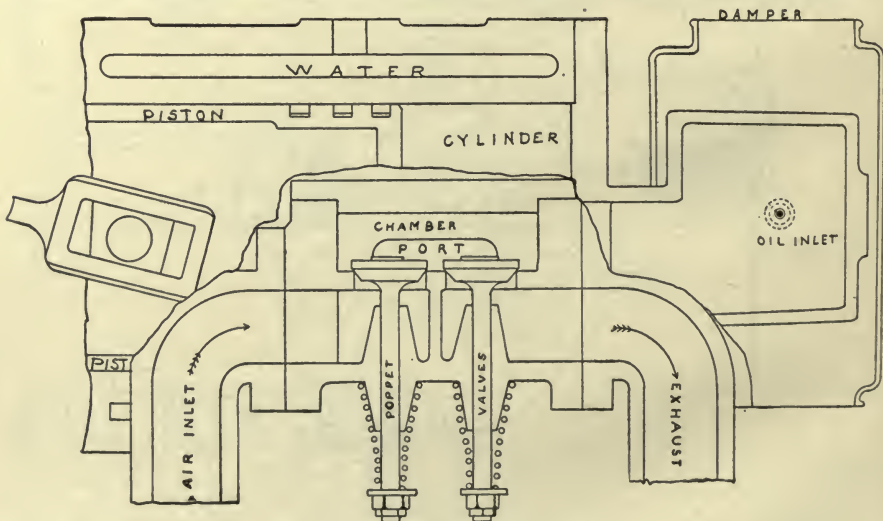

30. Exhaust-Chamber Side of Engine.

of springs they are actuated by levers moved by cams on the auxiliary shaft. Through the port (marked in the figure) leading from the exhaust chamber to the rear interior of the cylinder, the air passes on its way in and the exhaust products on their way out.

8. Fig. 30a gives the crank positions at the instants when the poppet valves open and close. The air valve closes just after the crank has passed out-center. The exhaust valve opens at about 85 per cent of full stroke and closes just after the air valve has opened.

9. The piston (fig. 27b) should make a good fit top and bottom, and not rub hard on the sides, as ascertained by inspection and turning the fly wheel. The three or five rings breaking joints on the underside must not leak. Their close fit and the good lubrication of the piston are absolutely essential. Mechanical or sight feed lubricator is always used.



30a.

(B) ENGINE-ROOM INSTRUCTIONS.

STARTING.

1. Before starting see that oil and water tanks (fig. 31) are full, and that the three cocks which supply water to the water jackets are fully open.

2. *Heating the vaporizer.*—Fill the lamp with oil outside of the engine room, to avoid smoke, and put a piece of wick into the cups which are formed round the pipes. These wicks which should consist of a piece of ordinary asbestos packing, will last for several weeks.

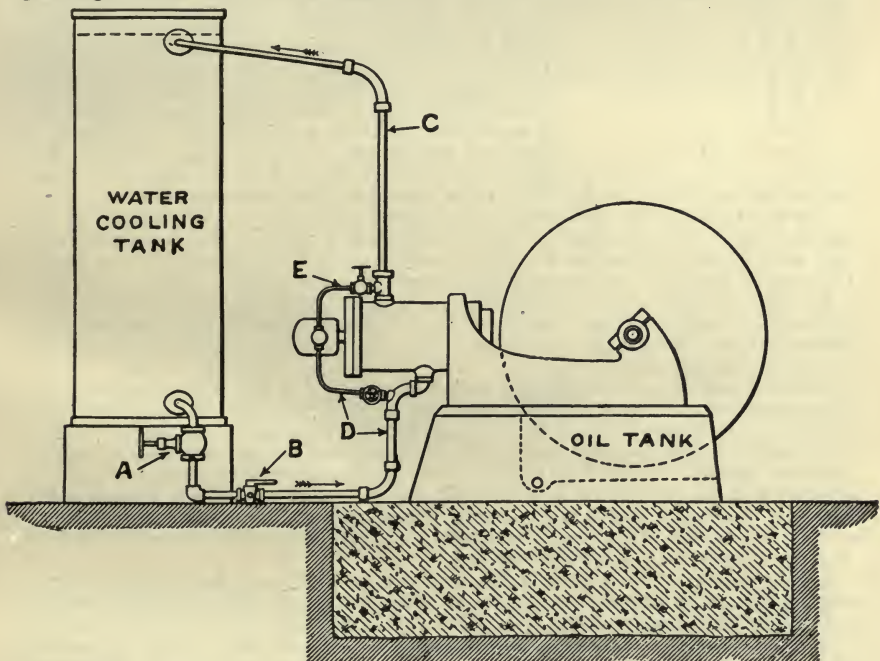

31. Water-Cooling Connections.

A little kerosene should then be poured into the cup under the coil and lighted. When this is nearly burnt out, pump up the reservoir with air by the air pump, when oil vapor will issue from the small nozzle and give a clear flame. Then place the lamp on the stand so that the coil is one-half inch from the vaporizer. Turn the damper for draft.

When it is required to stop the lamp, turn the little thumbscrew on the reservoir-filling nozzle, and let the air out. Should at any time the nozzle, where

the vapor comes out, get choked up, it can be cleaned with the small prickers which are sent for that purpose.

The heating up of the vaporizer is one of the most important things to be attended to, and care must be taken that it is made hot enough at starting. The attendant must see that the lamp is burning properly, and that a good clear flame is given off from five to ten minutes according to the size of the engine. If, however, the lamp is burning badly, it may take longer to get up the proper heat. It is most important that this should be carefully attended to, as, though the engine may start if the vaporizer is not as hot as it ought to be, the engine will run badly, and perhaps soon stop altogether. Failure to get engines to run properly can in most cases be traced to the above.

If the vaporizer is partly jacketed, close the valve on the inlet water pipe before heating up, and open or partially open while running.

3. *Oiling.*—See that the oil cups on the two main crank-shaft bearings are fitted with proper wicks and filled with oil. Adjust the lubricator of the large end of the connecting rod and oil the small one which is inside—also the bearings on horizontal shaft and the skew gearing—the rollers at the ends of the valve levers and their pins, and the pins on which the levers rock—the governor spindle and joints, the bevel wheels which drive same, and the joints that connect the governor to the small relief valve on the vaporizer—twenty places in all. For such bearings none but the best engine oil should be used. Oiling should always be done during heating up the vaporizer, and the lamp should be left burning for a few minutes after starting.

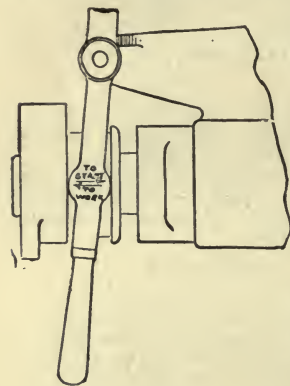

32.

4. *To start.*—Turn the small regulator on the governor bracket (fig. 27b) to position "Shut," and work the pump lever up and down until oil is seen to freely pass the overflow glass. Then turn the small regulator to position "Open," work the pump lever up and down again one or two strokes, then give the fly wheel one or two smart turns, when the engine will start readily. The engine will often start better by first turning the fly wheel the reverse way, when an explosion will sometimes be obtained which will start the engine, and in any case the rebound thus obtained from the compressed

air will help the fly wheel to be turned forward more easily.

The handle upon the cam shaft, before starting engine, must be placed in the position marked "To start," in order to relieve a part of the "compression," and immediately the engine has got up sufficient speed to affect the four cycles this handle should be placed in position marked "To work."

No time should be lost in starting the engine after the vaporizer has been sufficiently heated, as the engine will not run satisfactorily if the vaporizer is allowed to cool down after heating it. If too much oil is pumped into vaporizer it will be difficult to start up.

Starting gear is not necessarily required except for the larger engines, say 35-horsepower and upwards; 35-horsepower engines can, however, be started by two men. Release the air from the lamp directly the engine starts.

In turning over the fly wheel there is a certain knack by which a skillful engineer exerts his force only once or twice, and usually on a certain one of the spokes; it is the one which he reaches by stooping down to effect the compression. If the engine starts in the wrong direction it will generally reverse itself after a few turns, when give it assistance. To avoid accident, never put a foot or a leg on a spoke to assist in starting.

5. Failure to start is generally due to vaporizer not being hot enough (barely perceptible red in the dark). If the oil tank is full, if piston is clean, and if reheating the vaporizer again fails, examine the engine:

(a) *Oil pump.*—Turn the regulator to "Shut" and work the pump by hand as in starting to see if a full stream of oil free from air, passes the glass as it should do.

(b) If the stream is not a full one, open the three-way cock from oil reservoir; if oil flows out freely the filter is in order. If not, clean it.

(c) If the pump is still unsatisfactory, see if air is in the pump or pipes by disconnecting the oil-supply pipe from the vaporizer valve box, pumping until oil overflows, then pressing left thumb tightly over outlet, pump down once quickly. If the pump plunger yields, air is in the pipes. Or, pump several times

quickly and then remove the thumb suddenly; if air is in the pipes, its elastic force will cause a long jet (fig. 32a).

(d) If there is no air in the pipes, inspect the action of the valves by pressing the pump steadily down while closing the outlet with the thumb. If the plunger yields under a steady pressure but not under a sudden jerk, the suction valves are not tight. To stop leakage, wash out valve boxes with oil; if this fails, tap the steel ball valves on their seats with a copper punch.

(e) To examine the vaporizer valve box, take it off, reconnect it with its pipe, stroke the pump as in regular working and observe the jet. If the jet is full, positive and clear, and begins with the downstroke and does not dribble after the end of it, the jet is normal—a very important condition. Watch the effect of partially and wholly depressing the vertical valve while pumping.

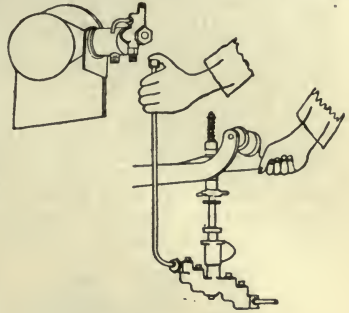

32a. Pump Detached.

RUNNING.

(a) Good action requires three things—

(1) Oil and air delivered to vaporizer in right amounts at the right time.

(2) Sufficient compression of the mixture before ignition.

(3) Ignition of gas complete at the proper time.

(b) *Regulation.*—(1) When the engine is working at its full power, the distance between the two round flanges on the pump plunger (fig. 28) should be such that the hand gauge will allow the part stamped "1" to just fit in between the flanges; and if at any time the positions of these flanges be altered, they can always be readjusted to this gauge. The other lengths on the hand gauge are useful for adjusting the pump to economize oil when running on a medium load "2" or a light load "3" of the gauge. Still, familiarity with an engine is better than the gauge for regulation. If overflows show oftener than once in 5 or 6 strokes, the pump stroke may be shortened.

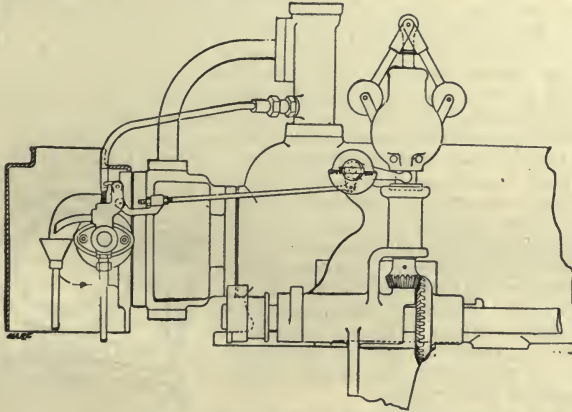

32b. Governor With Overflow Glass.

(2) The governor (fig. 32b) is adjusted to reduce the oil jet occasionally. At normal speed it revolves about $\frac{1}{4}$ inch clear of its seat. When it runs too fast its connecting mechanism depresses the vertical valve and diverts more or less oil to the overflow. Moving the weight out from the fulcrum slows the governor's action. "Governor hunting," causing the engine to run unsteadily, is due to joints or spindle becoming bent, dirty or sticky.

When engines are required to run empty or light, it is best to alter the stroke of the pump to just the amount of oil that will keep the engine running, and can even be reduced so that the speed of the engine is a few revolutions under the usual speed (so that the governor can not cut out any oil, which allows the vaporizer to get a small charge of oil each time), and thus keep it from getting cooled down. Also the cock on the return or lower water circulating pipe and

the cylinder jacket can be nearly closed, so as to keep the cylinder warmer. The above remarks do not apply when the work is intermittent, and the engine is not running light very long together.

(c) In the valve box (figs. 27b, 29), if the horizontal valve is not working properly, vapor from explosion will be found passing the overflow glass whenever the little lever or the finger presses down the vertical valve. Unscrew the cap and turn the valve by its tail around to dislodge any dirt in the seat of the valve, and see that the spring is closing the valve. If this does not stop leaking, take out the valve, ground it on its seat with a little emery flour and water, and take care in replacing valve and sleeve to preserve the same thickness of jointing material, and hence same valve opening.

(d) The spray hole or holes (figs. 27b and 29) are liable to get clogged. The valve box is taken off and each hole is cleared by the little wires supplied for the purpose, so as not to increase the size.

(e) If the pipe to the vaporizer valve box does not rise all the way from the pump, or if it gets bent down, an air pocket will be formed in which air will be compressed upon each stroke of the pump, and thus allow the oil to go in slowly and not, as it should do, suddenly. Also if the oil tank gets emptied of oil at any time, air will get into the suction and delivery pipes of pump, and it will take some time before the oil going through the pump and pipes will get rid of this air, so that for a while the engine would not work properly, as the air, by getting compressed as the pump works, will interfere with the oil being pumped in suddenly, as it should be. It is best, if ever the oil gets below the filter in the tank, to work the pump by hand for say ten minutes, holding open the relief valve on the vaporizer valve box so as to get air well out of the pipes. Derangement of the pump rarely

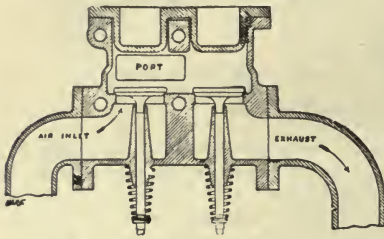

32c.

occurs. If the packing is renewed it should not be screwed so tight as to bind the plunger.

(f) The air inlet and exhaust poppet valves (fig. 32c) must always work freely and definitely and drop on to their seats. They can at any time, if required, be made tight by grinding in with a little flour of emery and water. The set screws (fig. 32d) at the ends of the levers that open these valves must not be screwed up so high that the valves can not close; this can always be ascertained by seeing that the rollers at the other end of the levers are just clear of the cams, that is, when the projecting part of the cams is not touching them.

(g) Cylinder's proper temperature lies between 110° and 130° F. The cooling tank is kept full of fresh water below 120° F. If the temperature tends to rise above this, cold water must be added, or a pump capable of delivering 10 gallons per hour per horsepower of engine is connected with the shaft to maintain from another source circulation around the cylinder. If a cheap supply under pressure is available, use it. If the supply is above 70° F., as at many southern posts, much more water will be necessary. Sea water, if unavoidable and if circulated rapidly, can be used, but the water jacket should be watched for deposits.

(h) If the piston gets black and gummy, or the exhaust gases are like smoke, or "coughing" is continuous, combustion is incomplete, due chiefly to excess of oil or too little air, or possibly to leakage over the piston rings.

(i) Ignition can be retarded by lessening the vaporizer's heat and slightly reducing compression by increasing the clearance in the cylinder. In starting or on light loads the water inlet to valve box may be partly or wholly closed to preserve the vaporizer's temperature.

(j) Heat in exhaust and vaporizer valve boxes sometimes causes the valves not to seat or their stems to stick, and necessitates regrounding.

(k) If a little oil is sent into the heated vaporizer and the fly wheel is turned forward, the engine should start freely. If not, test the spray by hand and turn the fly wheel backward to test the compression. If this pressure is so light

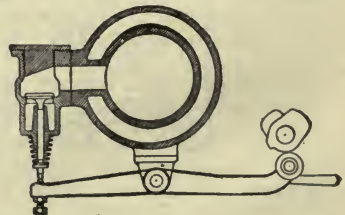

32d.

(the relief cam being out of action) that it can be overcome by hand, there is leakage in the piston rings, the air or exhaust valve or some joint or gasket.

(l) Watch the temperatures and oiling of bearings, especially of the cylinder; use just enough oil for the load and listen for regular action after fifteen minutes' run; keep every part clean.

(m) For subsequent reference in time of trouble, mark on the gearing or record when engine runs well, the exact positions of crank when the poppet valves open and close and for load and half load, or the usual load after an hour's satisfactory run, the motion of pump stroke, heat of outlet water, frequency of oil overflow, governor's rise, vaporizer's color in the dark, appearance of exhaust and piston.

(n) The engine is working efficiently if, after getting warmed up, it runs on its load smoothly to the eye and ear, if the piston shows no carbon deposit, if the exhaust gases are invisible or nearly so, and if the explosions sound regularly, except occasionally when the governor reduces the explosive charge.

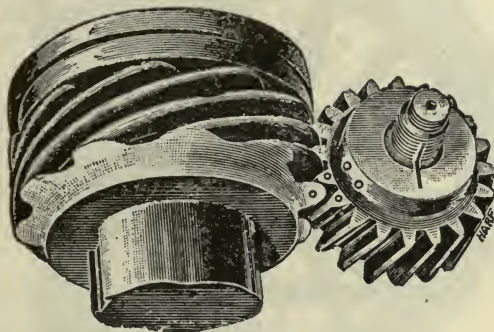

33.

STOPPING.

(a) Turn the small regulator on the governor bracket to position marked "Shut." To stop quickly, hold down the air-valve lever at the same time. If the engine does not then stop readily, the spring of the horizontal check valve is weak and oil is entering the vaporizer instead of all coming through the overflow valve, as it should at "Shut." If the stop is for a brief period, but more than five minutes, it will be necessary to start the lamp under the vaporizer.

(b) In frosty weather do not omit, before leaving the engine, to run all water out of the pipes and water jackets by first closing the main water-pipe cock and opening the floor cock. The small water cocks to the valve-box water jacket are usually left open.

Fundamental Alterations.—(a) If air or exhaust valves appear to be opening or closing at the wrong time, take off the nut on the end of the lay shaft which holds the skew when on, and see that the chisel cuts on the shaft and on the skew wheel are opposite to one another, as shown in fig. 33. The lay shaft is coned where the skew wheel is fixed, and is held on simply by friction, the nut being tightened against it.

Should it at any time be necessary to take out the crank shaft, always be sure that the skew wheel gearing is put together so that the tooth marked *O* on the crank-shaft skew wheel fits in between the two teeth marked *O* on the lay-shaft skew wheel, as shown on the sketch (fig. 33).

(b) To reverse the direction of rotation, exchange the relative positions of the cams actuating the air and exhaust valves and the fuel supply.

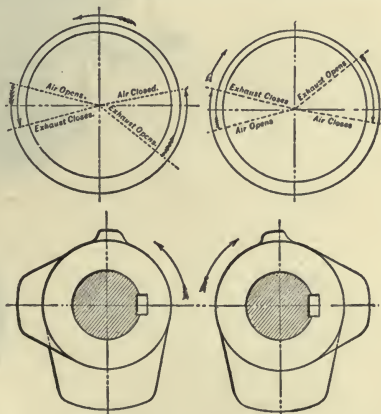

33a. Belt Pulls on Lower Run.

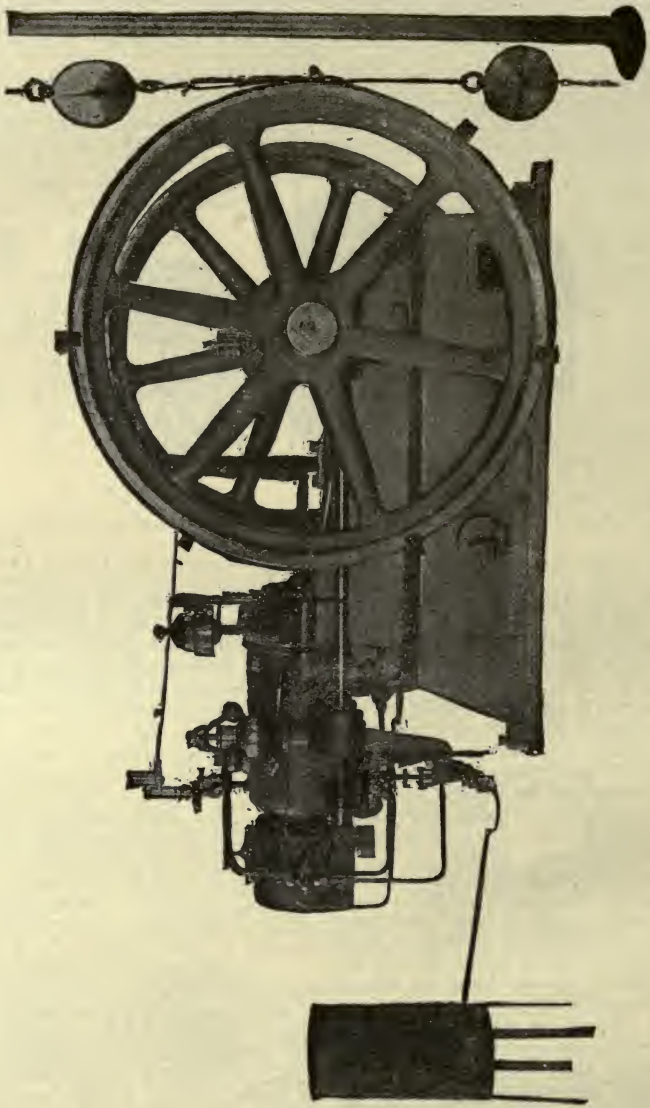

34. Under Test.

Fig. 33a gives also the positions of the crank at the moments when the air and exhaust valves open and close.

The pressure in the cylinder during four consecutive strokes and the important action of valves and other parts and the time of ignition during a run, can best be seen by means of cards taken with the Crosby or other indicator (fig. 34). If these show faults, adjustments may be made to correct them. Unless the indicator is properly set, its drawing will be misleading. The cut shows its attachment to the engine and the means for getting the brake horsepower and the amount of oil consumed.

All cylinders are tapped for indicator tests. The operation is similar to that for steam engines and the importance of getting a correct card is even more important.

In the *A* card ignition took place slightly before the piston reached the end of its stroke, and the pressure during the first third of the expansion stroke fell off too rapidly. The exhaust was not free and the compression was too great.

Diagram *B* shows good action on a load. The ignition line should be nearly perpendicular to the atmospheric. The exhaust opened at 90 per cent of the full stroke, and the pressure during exhaust and suction was 0. There is good area between the expansion and compression lines, and all lines show steadiness.

In the third card *C* the suction line below the atmosphere indicates that the inlet of air was hindered. The low compression line points to leakage past the poppet valves, oil inlet, or piston. From the waviness in the lines and shortness of figure, the indicator may not be in proper order.

In the *D* card the events are lettered in the order of occurrence. The exhaust was choked, and ignition took place too early. Compression began too soon and became too great.

Full directions for erecting, testing, installing, running, and repairing this remarkable engine will be found in Goldingham's "Oil Engines," from which the above cuts are taken.

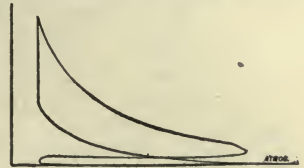

A.



B.

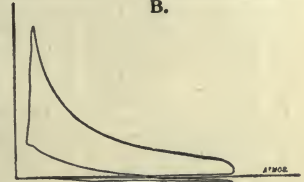

C.



D.

IV.—THE DYNAMO.

(A) GENERAL PRINCIPLES.

The short exploring magnetic needle will show that the space, or field, between the poles of a horseshoe magnet has the strongest magnetic force and that the imaginary lines therein which represent the direction and intensity of the force, are approximately straight, parallel and uniformly distributed (fig. 35).

I. Laws of the induction of an electromotive force in a loop are as follows:

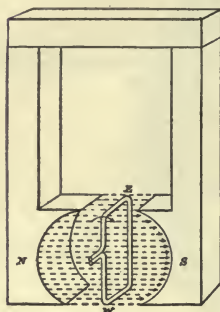

35. Magnetic Wind From N. to S. Pole.

1. *Induction.*—An E. M. F. is induced or generated in a coil whenever the number of lines of magnetic force through it is changing—either increasing or decreasing—by the motion of the coil or lines, or both.

2. *Direction.*—Its direction is clockwise when the number of lines through the coil is decreasing and counter-clockwise when increasing—this to a person looking at the coil from the side on which the lines enter it.

3. The *amount* of induced E. M. F. varies directly with the time rate (i. e., the rapidity) of change of the number of lines inclosed by the coil.

II. Or, the laws may be otherwise stated for any straight conductor as, for instance, any short length of a loop:

1. An E. M. F. is induced in any conductor while it is cutting across lines of magnetic force, by the motion of the conductor or of the lines or of both.

2. Hold thumb, forefinger and middle finger of the right hand, each at right angles to the other two. If the

middle finger represents the conductor, if the forefinger points in the direction of the lines of (fore) force, and if the thumb points in the direction the conductor moves, the middle finger will point in the direction of the induced E. M. F.

3. The amount of E. M. F. induced varies directly with the time rate (or rapidity) with which the number of lines of force is cut.

III. An alternating current is usually generated in a revolving loop. The negative part can be rectified in the outer circuit.

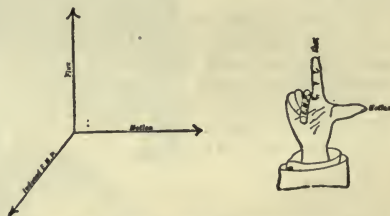

36. The Three Positive Directions at Right Angles.

1. It follows from either set of the above laws that if the coil in fig. 37 revolves uniformly as the brushes point, and if the external circuit is closed, (1) a current

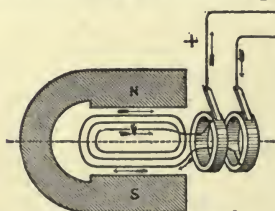

37. Simple A. C. Dynamo.

will be generated in the coil due to the induced E. (2) Its direction, during the entire half revolution of which the coil's position is shown in the figure midway, will be toward the brush marked +; in the next half revolution, to the other half. (3) The current strengths will be greatest at both vertical positions, and 0 at both horizontals, where their direction is reversed.

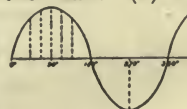

2. The current, or the E. M. F., induced during little more than one revolution, is expressed by

the curve in fig. 38. That part of the curve below the reference line represents the negative C generated.

3. The negative C may be rectified, i. e., so turned as to go to line as a positive C, by the device of a 2-part commutator (fig. 39) in place of the two rings of

fig. 37. The two parts of the commutator are the terminals of the coil, and so disposed that each brush shall pass from one part to the other at the instant the induced current changes or is zero. This is the simplest form of a direct current, self-exciting dynamo, such as the fuse-firing dynamo.

4. The current thus sent to the field and the external circuit consists of positive pulsations or waves, shown in fig. 40.

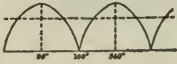

40.

5. In order to render the positive waves less abrupt, that is, to make the dynamo current more nearly like a battery current represented by the broken line in fig. 40, it is only necessary to increase the number of armature coils and of commutator strips.

6. *Principle of self-exciting dynamos.*—There is usually sufficient magnetism in the field of the soft-iron field magnet core to give rise to a small current in the armature coil when revolved. This current flowing, wholly or in part, through the winding of the field magnet, increases its magnetism and therefore the number of lines of force in the field between the poles. The current in the armature coil thereby is increased, and so the operation continues until the magnet is saturated and the dynamo gives its full current.

IV. The two principal armature windings are the ring and drum.

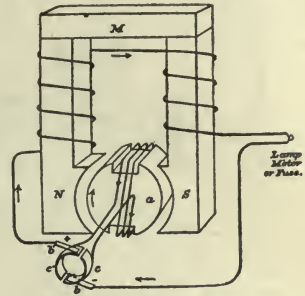

39. Simple D. C. Dynamo.



41.

1. Fig. 41 is a 2-pole, 4-coil, ring, winding around core of annealed soft iron wires or washers. Two circuits between brushes. Nearly all cores, ring or drum, are now made from soft-iron sheet in washer shape.

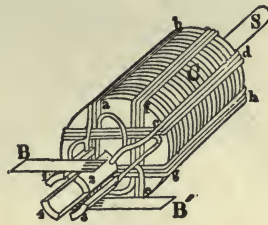

42.

Fig. 42 is a 2-pole, 4-coil, drum, lap winding over annealed soft-iron washers starting from 1. Coil *ab* is first wound, then *cd*, *ef*, *gh* in order. Back pitch, + 3; front pitch, - 2.

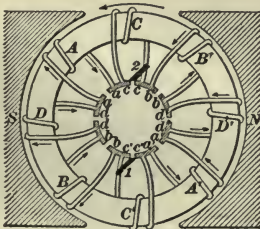

43.

Fig. 43 is a 2-pole, 8-coil, ring winding. Arrows show direction of currents.



44.

Fig. 44 is a 2-pole, 8-coil, lap, drum winding. Back pitch, + 7; front pitch, - 5.

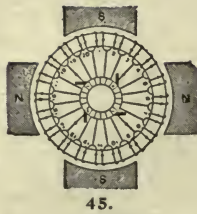

Fig. 45 is a 4-pole, 20-coil, ring, four windings through armature, making its resistance between poles = $\frac{1}{16}$ of that of the single winding. By connecting each bar of the commutator with the one opposite, two brushes 90° apart will be sufficient.

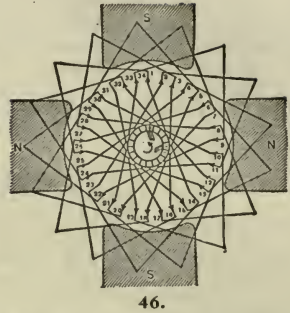
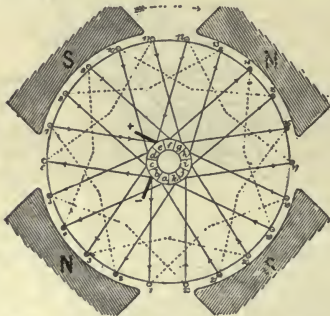
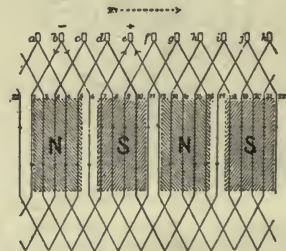

Fig. 46 is a 4-pole, 17-coil, wave, drum winding. Back pitch, 9; front pitch, 9. Two circuits between brushes. Short lines having arrowheads represent wires along the length of the cylinder; outside wires are back connections, inside wires, front connections.

2. An armature winding is more readily followed by considering the wires, bars and poles rolled out upon a plane surface as in fig. 47, for the armature shown in fig. 48. Or, upon paper, draw rectangles to represent all poles, in a parallel row show all of the bars, and then draw single lines from the bars to represent the coils as they are found on the cylinder in one position.



48. Drum Wave Winding—4-Pole.



47. Drum Wave Rolled Out.

3. The features of recent slow speed armatures are—

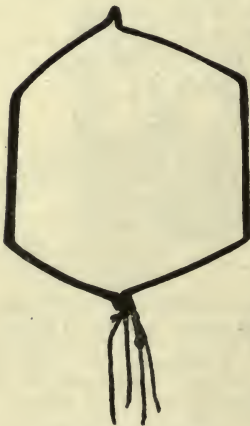

51. One Lap Coll.

(a) The core is composed of japanned washer-shaped discs stamped out of sheet iron and solidly assembled on a spider (fig. 52). Air ventilating ducts run radially and longitudinally through the core, and deep slots in which the coils are to be laid run longitudinally along the cylinder surface.

(b) The copper coils (figs. 51 and 53) are forged or formed on a collapsible block, then covered with tough and moisture-proof insulation and laid in lap form (fig. 50), or in wave form (fig. 52) in the slots between the teeth of the cylinder core where they are so firmly wedged by fiber and bound by band wires that no part can vibrate.

(c) Opposite active parts of the same coil occupy as nearly as possible corresponding positions (figs. 50 and 52) under the poles. Ends of coils are mechanically fastened and soldered to their proper bars so that open circuit may not occur. Back and front wires are equal. The air space is everywhere the same and the pull of all field magnets, alike. This method of wiring requires a minimum of length and allows any injured coil to be easily replaced.

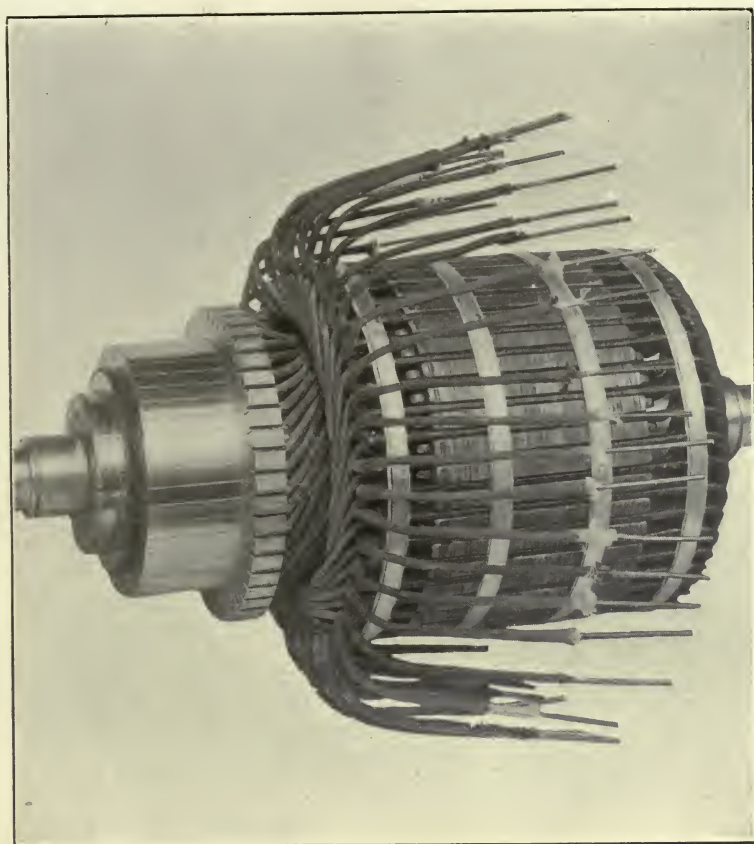

49. W-e M. P. Generator Armature, with Winding Unfinished.

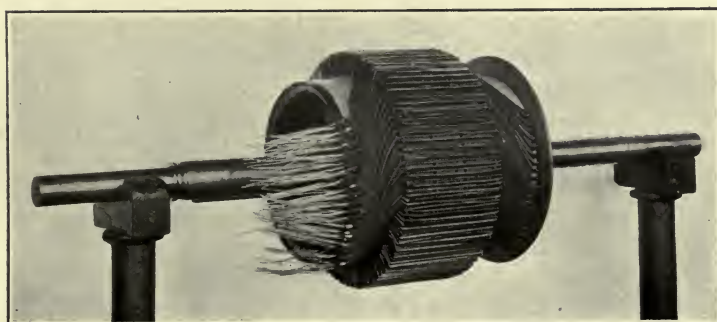

50. G. E. Core. Lap Winding Begun.



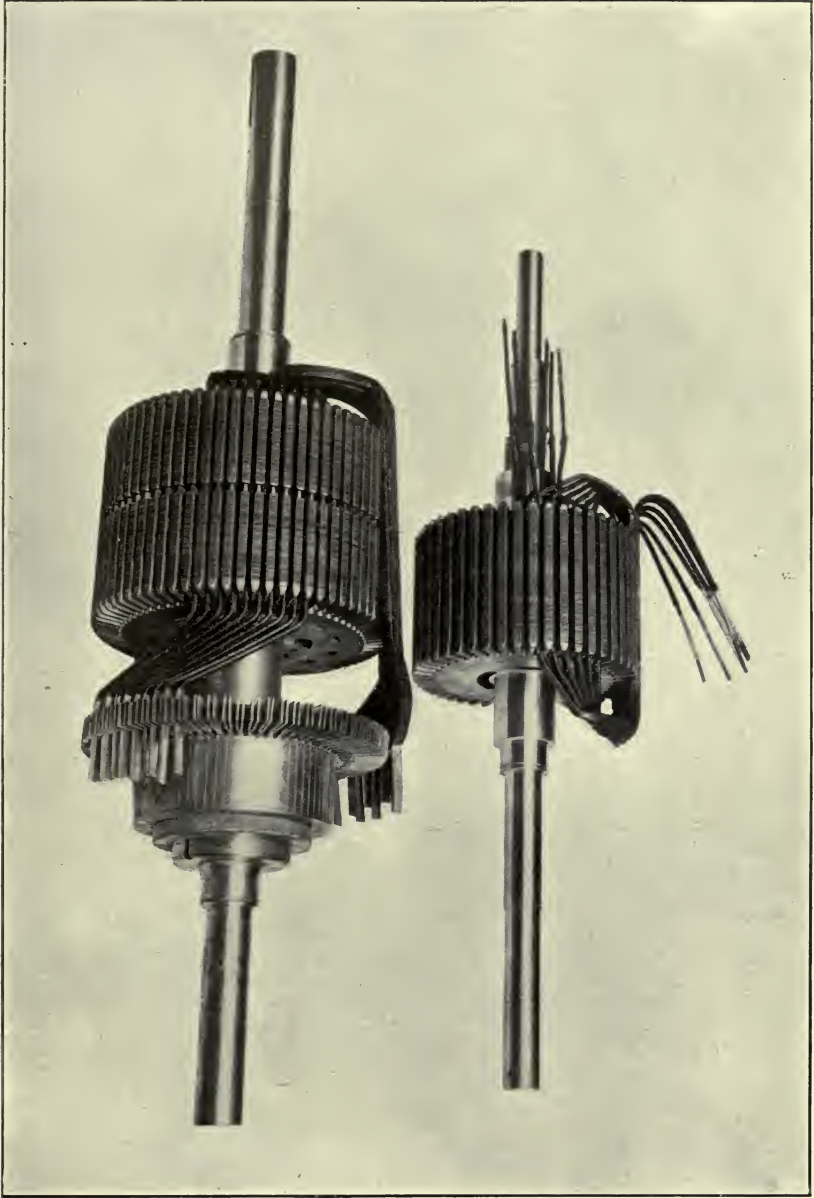

52. W-e Cores, Wave Winding Begun, 4-Pole.



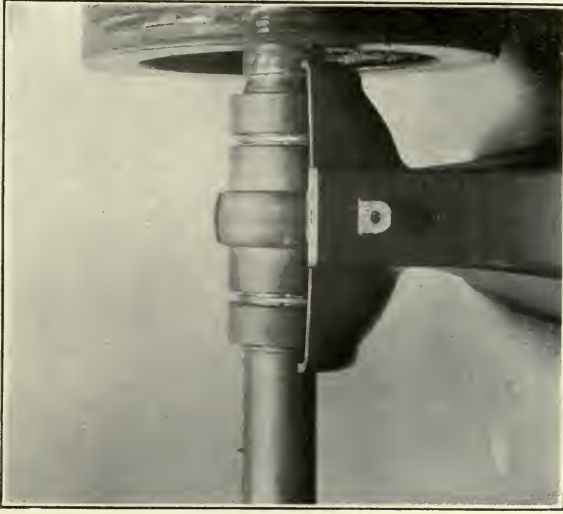

55. Bearing and Oil Rings. 44

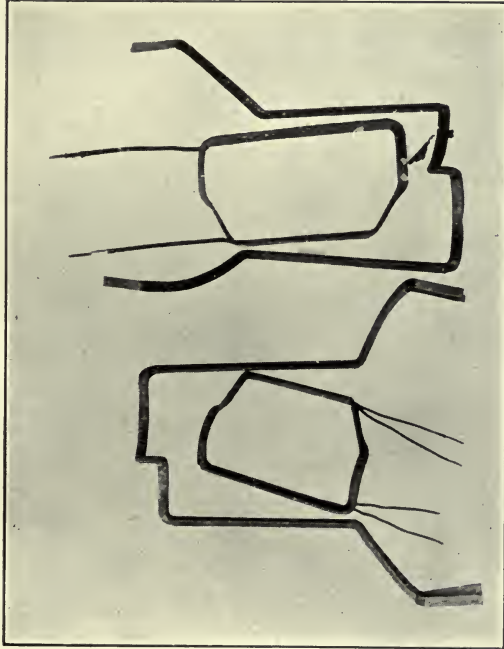

53. Wave and Lap Coils Formed or Forged.



(d) The bars of the commutator (fig. 54), of H. D. copper insulated by amber-colored mica, are sufficient in number to keep the P. D. between any two adjacent, below 10 volts.

(e) The bearings (fig. 55) are self-aligning, also self-oiling by means of revolving rings on the shaft.

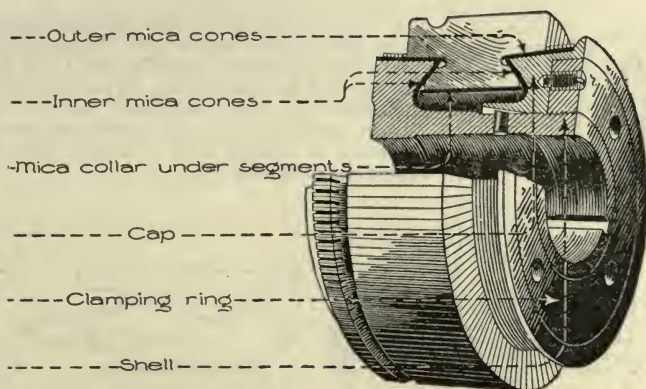

54. General Electric Commutator.

V. *Field windings*.—There are five methods of exciting the magnet which in turn render magnetic the space or field in which the armature coils revolve: Permanent Magnets (fig. 60), Separately Excited (fig. 56), Series (fig. 57), Shunt (fig. 58), and Compound Winding (fig. 59).

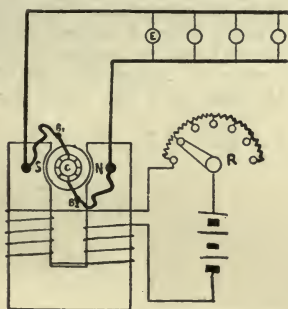

56.

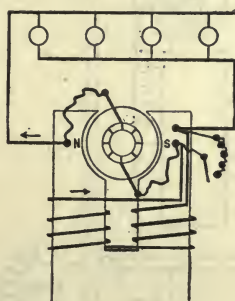

57.

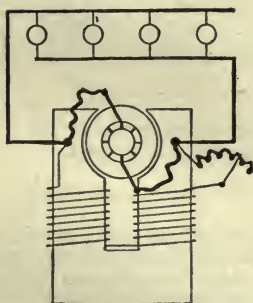

58.

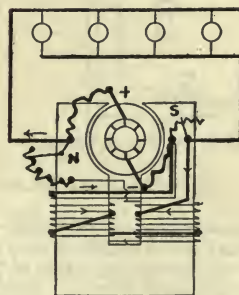

59.

The series winding is regulated by varying the resistance of a coil in shunt to it. The shunt winding is regulated by varying the resistance of a coil in series with it. The compound winding uses both methods of regulation.

(B) SPECIAL SERVICE GENERATORS.

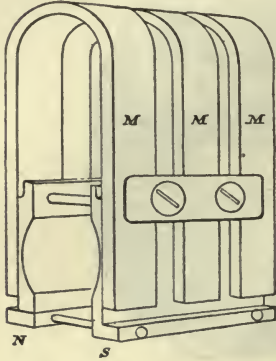

I. The telephone call box dynamo (fig. 60) has three permanent magnets *M* to create its field. The single Siemens armature coil *C*, of fine wire, has one end fastened to the soft-iron core at *a* and the other end fastened to the insulated pin *c*. The alternating current generated passes out through *c* to a spring in contact with it and returns through frame and bearing to *a*.

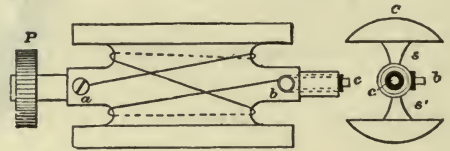

60.

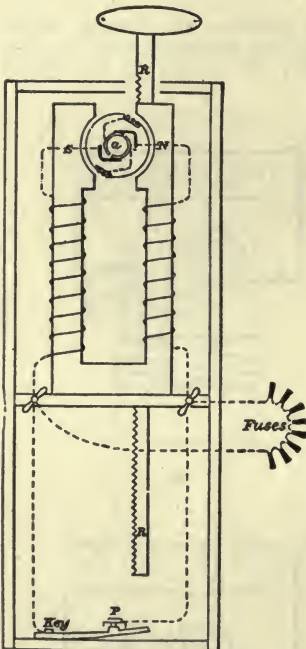

II. United States fuse-firing dynamo (fig. 61) is series wound, self-exciting. The Siemens armature coil is revolved eight times by means of its pinion gearing into the ratchet bar *R* when pushed down. At the end of the stroke the bar strikes and opens the short-circuiting key *P* and allows the full current to rush into the external circuit. No. 3 (16 by 8 by 5 inches) weighing 18 pounds, has 0.05-inch wire in magnet ($1\frac{1}{4}$ ohms), and 0.032-inch wire in armature (0.9 ohms), develops 15 volts and will fire eight fuses in series.

$$C = 15 \div (2.7 + R).$$

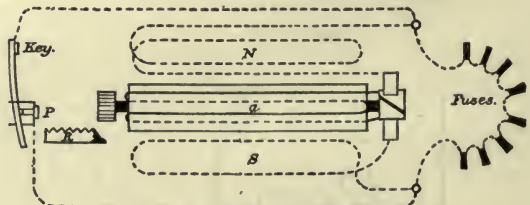

61. Dynamo for Firing Fuses.

Second View of Circuits.

III—GENERAL ELECTRIC DIRECT-COUPLED GENERATING SETS.

1. *Foundations—Installing.*—The generating set (fig. 62) should be provided with a foundation of ample proportions and mass to absorb the vibrations produced by the reciprocating parts of the engine. When placed upon a good foundation, the set will give the best results, require the least amount of attention, the bearings will run perfectly cool with a small amount of oil, and, in general, operating expenses will be reduced to a minimum.



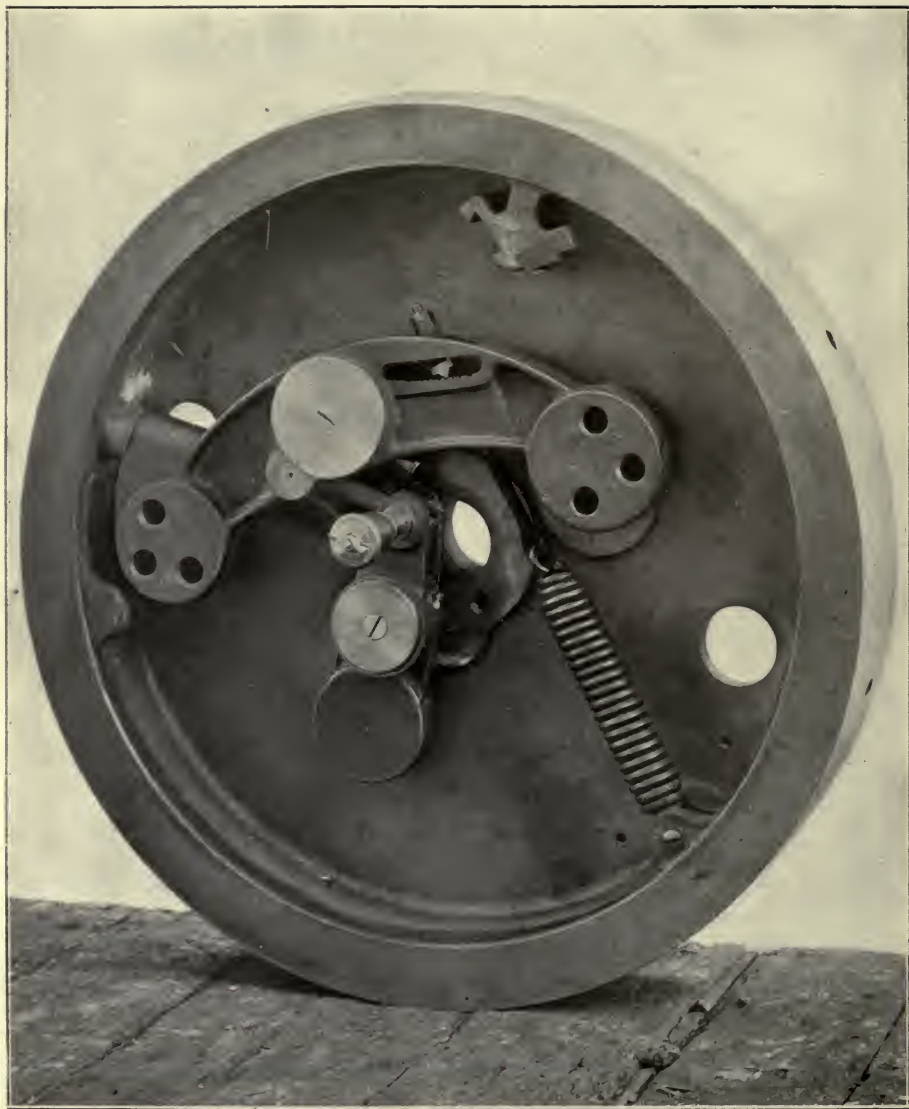

63. Governor.

The engines should run without perceptible vibration or noise if properly installed and given a reasonable amount of attention. When a generating set is installed in a building for isolated light or power, care should be taken to avoid having the engine foundation connected in any way to the foundation of the building or its adjacent walls. Pipes leading to the engine should also be as free as possible from connection to walls. A wooden base frame is sometimes found desirable under the generating set when installed in a building, as it will, to a large extent, prevent the transmission of noise and vibration.

2. *Steam pipes, pressure and speed.*—Sharp bends in the steam and exhaust pipes should be avoided as much as possible, and the steam pipe should be covered with good nonconducting material. A drain pipe with valve should be provided just above the throttle valve in order to drain the pipe line of condensed water. A separator should be installed on the steam pipe close to the engine, to protect it from water that is occasionally carried over with the steam. Often considerable trouble is experienced with foaming boilers, and

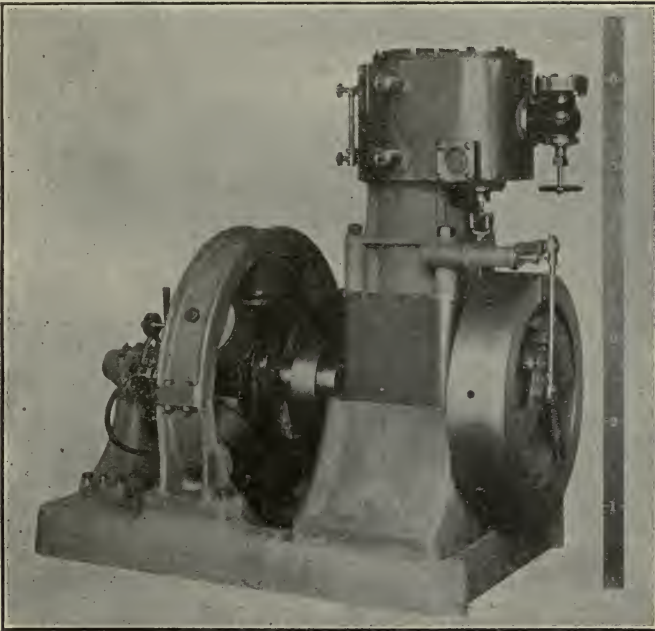

62. M. P. 6-20-305-125. Form of G. E. Generating Set, with Single 11 by 8 inch Cylinder.

accidents are liable to happen if no separator is used. When the engines are run noncondensing, a drain pipe $\frac{1}{4}$ inch to $\frac{3}{8}$ inch in diameter, depending upon the size of the engine, should be placed at the lowest point of the exhaust pipe.

3. *The engine.*—(a) The engine and generator are tested for several hours with the full rated output of the generator, and the engine is regulated to the proper speed, which is stamped on the name-plate. The valves of single engines are set to operate economically at a steam pressure of 80 pounds, and the ratings of single engines are based on 80 pounds steam pressure, noncondensing. Vertical tandem compound engines (fig. 73) are adjusted to operate at 125 pounds steam pressure, condensing, or 140 pounds noncondensing, and the sets are rated on this basis. Both single and compound engines give the best results when operated at their rated pressures, and if an engine is desired to run at a steam pressure lower than standard, it may be necessary to adjust the governor (fig. 63) by tightening the spring until the rated speed is obtained. Single engines may be run on a steam pressure up to 100 pounds without difficulty, but for higher pressures use reducing valves.

(b) If the speed of the engine is unsteady, the cause is probably sticking of the valve or parts of the governor, or loose connections in the valve motion. The governor should be taken apart, bearings thoroughly cleaned, and the lubricant removed. Only the best quality of thin grease—mixed with cylinder oil if desired—should be used in the governor.

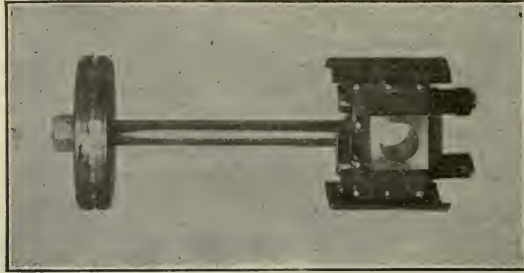

64. Piston Rod and Crosshead.



65. Governor Connecting Rod.



66. Piston Valve—20 KW. and Over.

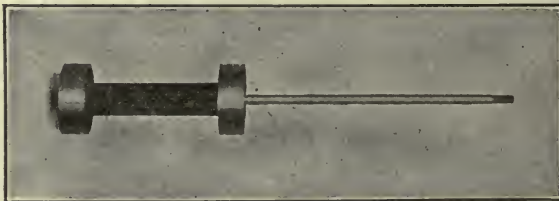

67. Piston Valve—Below 20 KW.

(c) The governor (fig. 63) has few moving parts and minimum friction. As the load is decreased, the fly weight, by increased centrifugal force, is moved out and the eccentric pin (seen near the center hole of the fly wheel) is moved toward the center of the shaft. This reduces the throw of the valve, changes the steam admission and compression to suit the load, and preserves the engine speed within small limits.

The governor can change the cut-off from $\frac{1}{4}$ to 0, and the speed can be changed within certain limits by tightening or loosening the spring. It will not allow, with 80 pounds steam, a variation exceeding $2\frac{1}{2}$ per cent in the number of its revolutions for a change from full load to one-fifth of the same; nor exceeding $3\frac{1}{4}$ per cent for a change from 80 to 100 pounds pressure; nor exceeding 5 per cent for both changes.

(d) The relief valves for taking care of the water that enters the cylinder should be adjusted for the working pressure at the engine, and should open freely at a pressure 5 pounds greater.

(e) If any valves leak, they should be taken out and cleaned, and the seats reground. The leak should not be stopped by increasing the pressure on the valves.

(f) The engine will run without noise, vibration or heating in any of its parts when given proper care and attention. All working surfaces are liberally proportioned, and wear is very slight, but as soon as any loss motion appears, it should be immediately taken up by the adjustment provided for that purpose. Use only Garlock square or other first-class packing, and the best quality of cylinder oil.

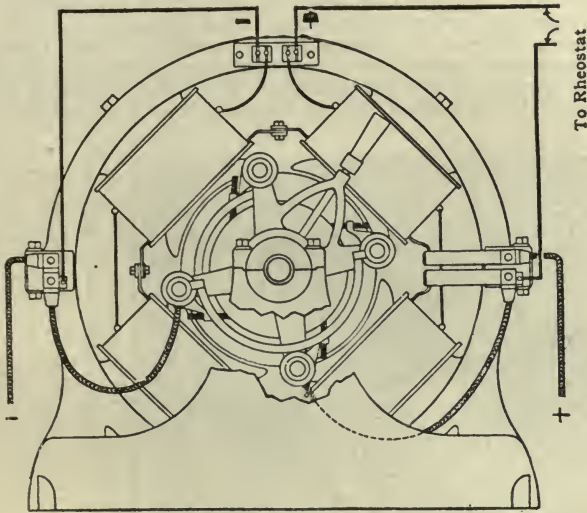

68. Counter-Clockwise Rotation.

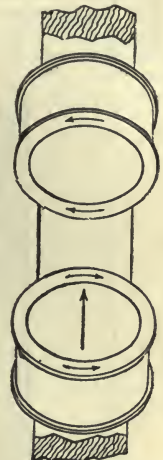

69. Engine Side.

4. The generator—(a) To place the spools.—Observer is supposed to be inside of frame and looking at faces of two lower pole pieces. Large arrow indicates direction of rotation of lower half of armature. Small arrows correspond to arrows on spool flanges, the spools being so placed that the arrows point in opposite directions on each succeeding spool. Arrows on bearings must point in direction of rotation.

(b) To adjust the compounding.—Every compound generator is provided with a shunt consisting of strips of German silver with suitable terminals attached, which should be connected to the series field terminals on the right-hand side facing the commutator (fig. 68). Any degree of compounding up to

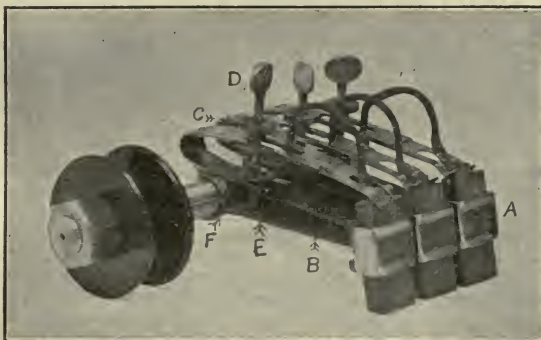

70. Freeing the Pigtail from the Brush Holder.

10 per cent may be obtained by changing the length of this shunt. The armature and field coils are, during winding, subjected to an insulation test with a voltage many times higher than the normal and their resistance is watched to locate short or open circuits.

(c) *To set the brushes*, place the brush holder on the studs so that the boxes *A* (see fig. 70) which hold the brushes, shall be about $\frac{1}{2}$ inch from the surface of the commutator, and clamp them firmly in this position. From time to time the brush holder should be turned slightly on the studs to compensate for the wear of the commutator.

Place the brushes in the holders, as shown in fig. 71, and screw down the pressure spring *B* by turning the nut *C*, so as to give about $1\frac{1}{2}$ pounds pressure for $1\frac{1}{4}$ -inch brushes and $\frac{3}{4}$ pound for $\frac{3}{8}$ -inch brushes. Nothing is gained by increasing the pressure per square inch on a carbon brush above 2 pounds, as the resistance per square inch beyond this point is practically not reduced, whereas, the friction is increased in direct proportion to the pressure.

Fit the carbon brushes carefully to the commutator by passing beneath them No. 0 sandpaper, the rough side against the brush and the smooth side held down closely against the surface of the commutator. Move the sandpaper in the direction of rotation of the armature, and on drawing it back for the next

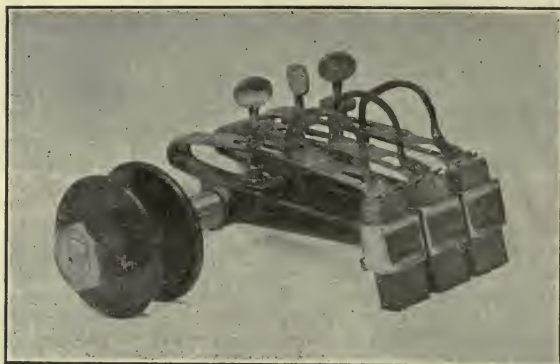

71. Correct Position of Brushes in Brush Holder.

cut, raise the brush so as to free it from the sandpaper, then lower the brush and repeat the operation until a perfect fit is obtained. If the brush requires considerable sandpapering, No. 2 sandpaper may be used at first, but the final fitting must be done with No. 0. If an attempt be made to fit the brushes without raising them when drawing the sandpaper back, it will in every case fail to give satisfactory results. When thick brushes are used—say $\frac{3}{8}$ -inch—in addition to following the above instructions, the machine should be run as long as convenient without load in order to improve their surface. As soon as the brushes of a set appear to make a good fit one of them should be removed from the brush holders in the following manner, to determine if they are worn to a surface:

Unscrew the stud *D*, thereby freeing the end of the pigtail *E*, and push the spring *B* forward so that there will be plenty of room to draw the tip *E* on the end of the pigtail through the slot *F* (see fig. 70). Then draw the pigtail through the slot *F*, bend it forward and turn the spring *B* to one side as shown in fig. 72. The brush may then be withdrawn from the box. In replacing the brush these directions should be followed in reverse order.

Care should be taken not to disturb the nut *C* after it has once been set, as it is not necessary to alter the pressure of the spring *B* in removing or replacing a brush. By this means a practically constant pressure may be kept on the brush.

(d) *To adjust the brush yoke*.—The design of these machines is such that no movement of the brushes is necessary when load is thrown off or on. The brushes should be set at no load, so that the reference mark on the pedestal is in line with the reference mark on the brush-holder yoke. With the brushes in this position generators will compound according to the name-plate stamping.

(e) *To take care of commutator*.—The commutator, brushes and brush holders should at all times be kept perfectly clean and free from carbon or other

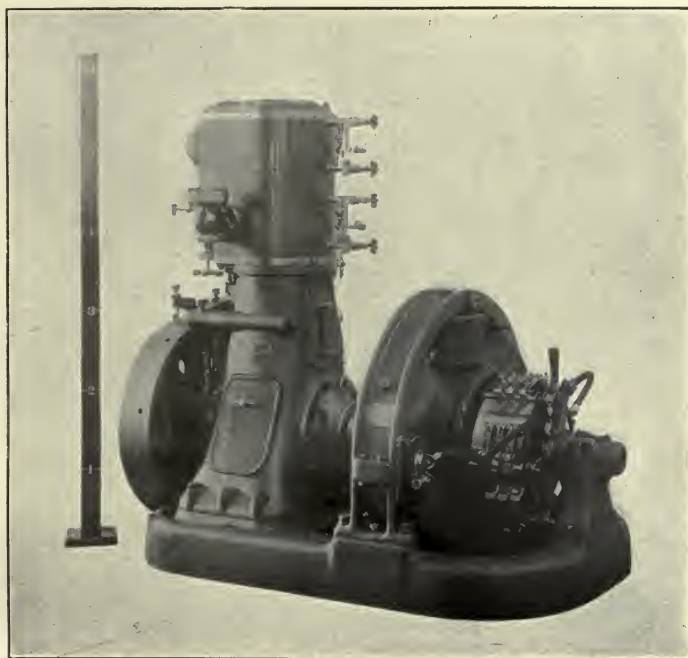

73. Small Direct-Coupled M. P. 6-25-450, with Vertical Tandem Compound Engine.



dust. Wipe the commutator from time to time with a piece of canvas, lightly coated with vaseline. If vaseline is not at hand, use oil, but lubricant of any kind should be applied very sparingly.

If a commutator when set up begins to give trouble by roughness with attendant sparking and excessive heating, it is necessary to immediately take measures to smooth the surface. Any delay will aggravate the trouble and eventually cause high temperatures, throwing of solder and possibly displacement of the segments. No. 0 sandpaper fitted to a segment of wood with a radius equal to that of the commutator, if applied in time to the surface when running at full speed (and if possible, with brushes raised), and kept moving laterally back and forth on the commutator, will usually remedy the fault. If this does not suffice, it will then be necessary to tighten up the segments and turn them off true. A machine tool will not leave the surface smooth enough to give perfectly satisfactory results. It is always necessary before putting on the load after the commutator has been turned, to carefully smooth the surface with the finest sandpaper, thus removing all traces of the tool point.

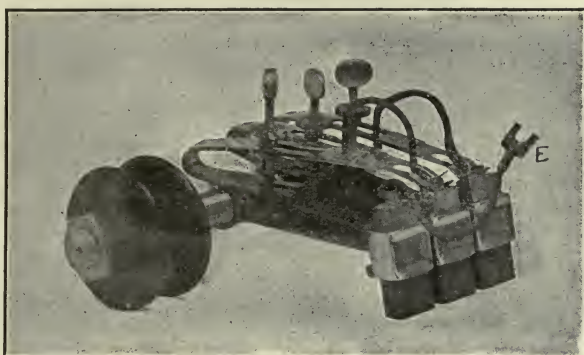

72. The Brush Ready for Removal.

5. *Starting and running the set.*—(a) Before starting, see that all screws and nuts are tight, that the oil cups are filled with oil free from dirt and grit, and that all working parts are well oiled. The feed should then be adjusted to give the required amount of oil to each bearing. The waste oil collects in the base and may be used again after running through a filter with some new oil added, but no advantage results from using too much oil. Turn the armature by hand to see that it is free and does not rub or bind at any point. The drain valves on the cylinder should all be opened to allow the condensed water to escape. Turn the steam on slowly at first, allowing the cylinder to get well warmed up and giving the condensed water a chance to get out before turning on full steam pressure. The piston valve will heat up as soon as the steam enters, but the cylinder requires some time before it expands sufficiently to allow the valve to move freely. When the engine has started, see that the oil rings in the bearings are in motion.

(b) As soon as the machine is set running see that it excites itself to full voltage. If it does not, trace out the field connections and test the polarity.

When the machine is to run in parallel with others and its polarity is wrong, raise the brushes and excite the fields by closing the main switch from the bus bars.

(c) A continuous run of four hours on full load should not raise the temperature of an armature or field coil 60° F., or of the commutator 72° F., above the air as determined by placing the bulb of a thermometer surrounded by waste upon it after the machine is stopped. Directly following the above, the machine will sustain a heat run continuously of two hours on 33 per cent above its full rated load without injury to the engine or dynamo. After this run which should only be done by an experienced person, it is a good time to make the insulation tests and to look for mechanical defects.

(d) To remove the armature, unbolt and lift off the upper field half, take off the brush holders, brush yoke, pulley and bearing caps, and put a sling on the armature.

(C) DISEASES OF DYNAMOS.

The DISEASES are stated in small capitals, their *causes* in italics; the remedy follows the cause when it is not evident and not structural. Dr. F. B. Crocker gives the following systematic statement:

I.—SPARKING AT THE COMMUTATOR is caused by:

1. *Armature carrying too much current*.—Due to overload, loose connections, reversed polarity, excessive voltage of current, short circuit or grounds in dynamo or external circuit.
2. *Brushes not at the neutral points*.—Shift the rocker to a point midway of those which give sparking.
3. *Commutator rough*.—Apply No. 0 sandpaper (not emery) laid inside a wooden form to fit the commutator, and before replacing brushes take care to remove all traces of sand or copper dust.
4. *Commutator very rough or eccentric or having a flat bar*.—Turn the commutator down, revolving slowly in its place *without play*, by means of a sharp-pointed tool, and finish in turn with a smooth flat file and emery; preferably put armature in a lathe. A flat is often caused by an open coil.
5. *A high bar*.—Tap it down and tighten up the clamping ring, or, if it can not be done, file the bar down.
6. *Brushes making bad contact*.—Due to roughened or burned ends, improper bedding, to oil, carbon, dust, or to insufficient pressure.
7. *A short or broken circuit in armature or field; a reversed coil*.
8. *A ground in the armature*.—Locate and replace the coil.
9. *A weak field or excessive shunt field resistance*.
10. *Unequal poles due to armature reaction being relatively too great*.
11. *Too high brush resistance*, as with certain carbons.
12. *Vibration*, from unbalanced armature or pulley or faulty belt.
13. *Chatter of carbon brushes*.—Clean commutator and apply vaseline or oil.
14. *Surging current*, from uncertain engine governor action.
15. *Break in armature*, only while running due to centrifugal force.

II.—HEATING OF COMMUTATOR AND BRUSHES is caused by:

1. *Heat from adjoining bearing or from armature*.
2. *Sparking*.
3. *Black carbon film from the brushes*, which offers resistance.
4. *Bad connections in brush holder*.
5. *Arcing between bars or other parts of the commutator*.
6. *Heating of carbon brushes from current*.—Coat the carbons with copper deposit.

III.—HEATING OF ARMATURE OR FIELD MAGNET is caused by:

1. *Excessive current*.—Same as cause 1 of sparking.
2. *Coils short-circuited permanently, or due to contact in armature only while running*.
3. *Moisture*.—Showing vapor driven off after a short run. Bake in an oven or send full current until vapor ceases.
4. *Foucault currents in iron core or Eddy currents in the coils*, structural.
5. *Reversed coils*.—Send a current through armature or field and note the deflections of a compass needle all the way around.
6. *Heat from adjacent parts*.

IV.—HEATING OF BEARINGS is caused by:

1. *Lack of good mineral oil*.
2. *Grit or dirt*.
3. *Shaft bearing rough or cut*.
4. *Bearings too tight*.
5. *Shaft sprung*, so that it turns harder at one point of a revolution.
6. *Bearings out of line or proportion*.
7. *Side thrust of shaft against bearings*.
8. *Too tight belt*.
9. *Armature closer to one pole than to another*.
10. *Heat from adjacent part*.

V.—ABNORMAL NOISE is caused by:

1. *Armature or pulley out of balance*. *Bad foundations*.
2. *Armature striking a pole piece*; rebabbiting, new liners, or reducing the projecting part.

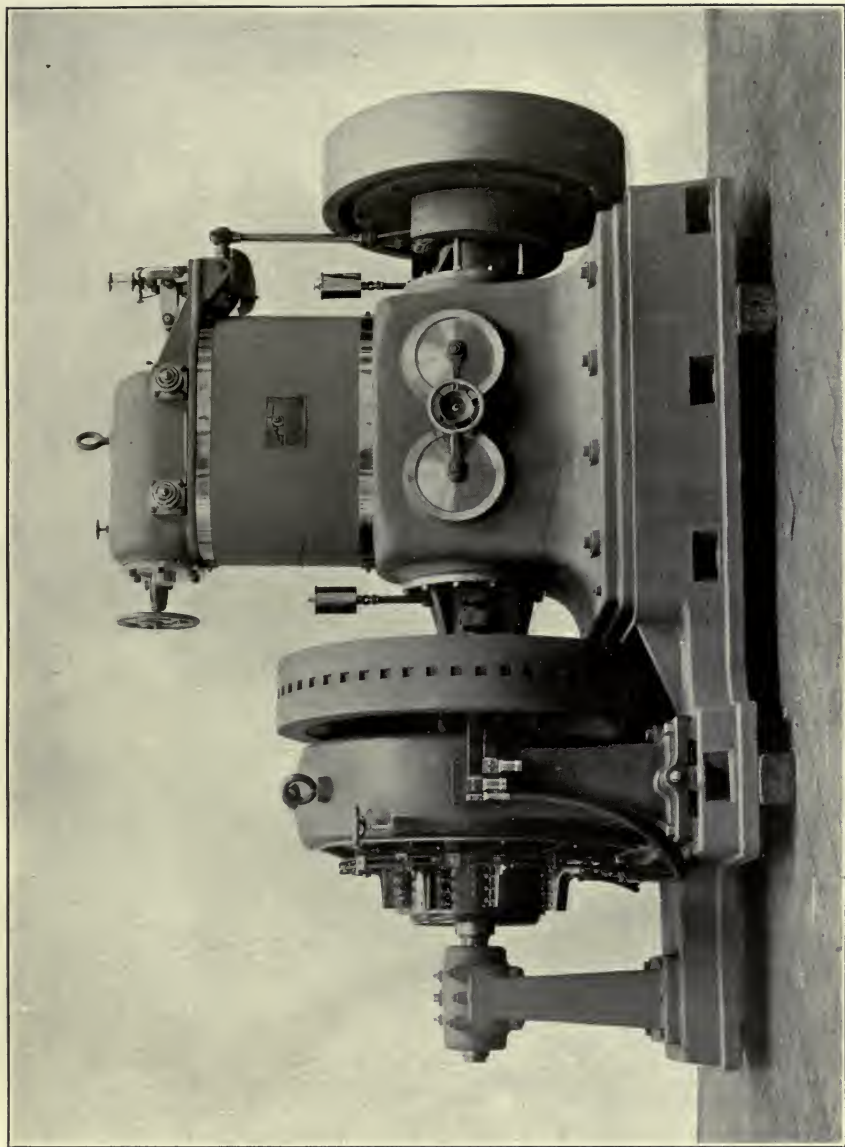

74. Westinghouse Engine-Type Generator Direct-Connected to Engine.



3. *Side thrust of shaft* due to bad alignment.
4. *Rattling of loose screws or other parts.*
5. *Humming or squeaking of brushes.*—Lift one of a set off at a time and, when found, apply a drop or two of oil.
6. *Flapping or slipping of belt, or striking of a belt joint on the pulleys.*—Tighten or loosen the belt; never apply resin.
7. *Humming of armature teeth passing the edge of pole pieces.*
8. *Straining of coupling* in direct connected sets. Reline and readjust.

VI.—SPEED TOO LOW is caused by:

1. *Overload.*
2. *Short circuit* in armature.
3. *Armature striking pole pieces.*
4. *Shaft not free to revolve.*
5. *Engine too slow or slipping belts.*

VII.—FAILURE TO GENERATE is caused by:

1. *Residual magnetism too weak*, due to (a) vibration, (b) proximity of another dynamo, (c) earth's magnetism, (d) accidental reversed current through field coils, but *not sufficient to reverse the magnetism*. Send a current from a few cells through the field coils in the proper direction.
2. *Reversed connections*, or direction of rotation.
3. *Short circuit to a shunt dynamo.*
4. *Field coils opposed.* A compass needle will show.
5. *Open circuit in dynamo*, at a brush contact, switch or fuse, or in the external circuit to a series machine.
6. *Brushes not in proper position.*

VIII.—VARIATION OF VOLTAGE is caused by:

1. *Irregular speed.*
2. *Lap or other bad belt joints.*
3. *Short or open circuits in armature or field.*
4. *Incorrect connections.*
5. *Engine governor out of order.*

(D) THE CARE AND MANAGEMENT OF D. C. DYNAMOS.

It is assumed that the machinery is properly constructed and installed. The engineer on taking charge and subsequently at intervals makes an—

1. *Inspection and adjustment.*—Every part of an electric plant is kept scrupulously clean if well managed.

The caps of bearings are taken off; all dirt, grit and old oil are removed; oil passages are cleared; the journals are examined; the caps are screwed back without binding; the boxes are filled with the best mineral oil.

The armature, rotated by hand, is examined for injured insulation, a bulge, loose coil or binding wire, contact with pole piece, unequal distance between armature and pole pieces due to wear or bent axle, contact between lug, tendency to stop in the same place.

A good commutator is cylindrical, smooth, and clean, and has a dark-brown polished appearance. A high bar must be filed down. For a low bar or flat, the whole commutator must be turned down. A rough surface from excessive sparking can be smoothed by fine sandpaper (not emery) laid inside a wooden form cut out to fit the cylinder which, after the brushes are raised, is given a slow speed; before letting down the brushes, make sure that no metal dust or filings lie in the insulation between the bars. If the commutator has worn eccentric or in ruts, it must be turned down by a tool on a sliding rest fastened to the bed.

The brushes, copper or carbon, with ends alike beveled and evenly bedded on the commutator, should set with tips exactly 180 degrees apart in 2-pole machines, 90 degrees in 4-pole, etc., in perfect alignment and at equal lengths from each rocker arm along which the brushes are, as a rule, unevenly spaced so that the wear on the whole commutator will be as nearly uniform as possible. In the absence of setting marks, adjust the tips of one set of brushes carefully to the edge of a bar and count the bars for the exact position of the other set.

The brush springs are next adjusted to a uniform, light, yet reliable, contact sufficient to take the full current without sparking. Too great pressure will soon wear and heat the commutator and cause sparking; too light pressure will

cause vibration, sparking and heating. Pressure of carbons seldom exceed 1 pound per square inch of contact surface and is usually less; of copper brushes, is much less.

See that the rocker can with steady force be moved over its range, can be locked in any position, and that no side play of it disturbs the bedding of the brushes.

Oil, water, grit or dust on any conductor insulation or part of the machine, a wrong or a bad connection, an unsoldered joint, a loose nut or bolt, or a tin oil can, tool, or loose iron near the machine will be quickly detected by a capable engineer and removed.

Dynamos usually run counter clockwise to a person at the commutator end. To reverse the rotation, shift the positive brush with its connections to the position of the negative, likewise shifted. To reverse the current, exchange the leads or reverse the polarity.

A belt should be heavy, single, or link, $\frac{1}{2}$ -inch narrower than pulley, without lace or lap, and just tight enough to prevent slipping. The pull is always on the lower run. It remains on the pulleys in intervals between daily runs of the dynamo slid back 6 inches.

N and S are labeled or marked by the engineer on magnets; + and -, on terminals; "on" and "off," on rheostats; initial letters of connections, on volt-meter switch points; currents on feeders, etc., for his aid in case of trouble.

The inspection extends also to a run of the plant.

STARTING.

2. See that all parts, screws, and nuts are tight; turn the armature by hand to see that it is free and does not rub or bind; put on the belt, tightening gradually after starting. Note that the main switch to line is open for shunt or compound machines and closed for a series; that the field rheostat is open and the V. switch is turned to dynamo + and -; fill oil reservoirs and start lubricators if sight feed; start the machine very slowly, noting that the oil rings turn and belt runs smoothly; bring it gradually to full speed; drop the brushes down if not there permanently; close field rheostat and cut out resistance for a gradual rise of potential, as shown by the voltmeter or pilot lamp, to the proper limit; stand ready to stop if anything goes wrong; shift the brushes at the first sign of sparking.

To light lamps raise the dynamo to its voltage and close in order and deliberately the overload, main, and feeder switches, watching the ammeters whose deflections should be anticipated. Of the feeders, close smaller first, if there is a choice, to increase the load as steadily as possible.

Before closing a feeder on a storage battery, find the battery's voltage and make sure that the voltage of the dynamo is 5 to 10 volts greater, while at the same time the lamps are kept at their normal voltage by the heavy current regulator.

A new or a repaired machine is first run empty, or on light load several hours with slack belt and plenty of oil.

If two compound machines are in parallel (fig. 75), start and close one on the main circuit as above; bring the other to normal speed; close its field rheostat

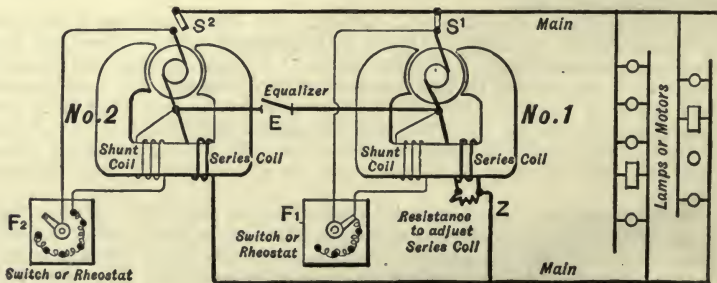

75.

to excite its shunt field; next close equalizing switch and regulate with shunt field rheostat to the potential of the first machine; then close main switch. Ammeters will show if either is doing its share of the work. To stop, reverse the above steps.



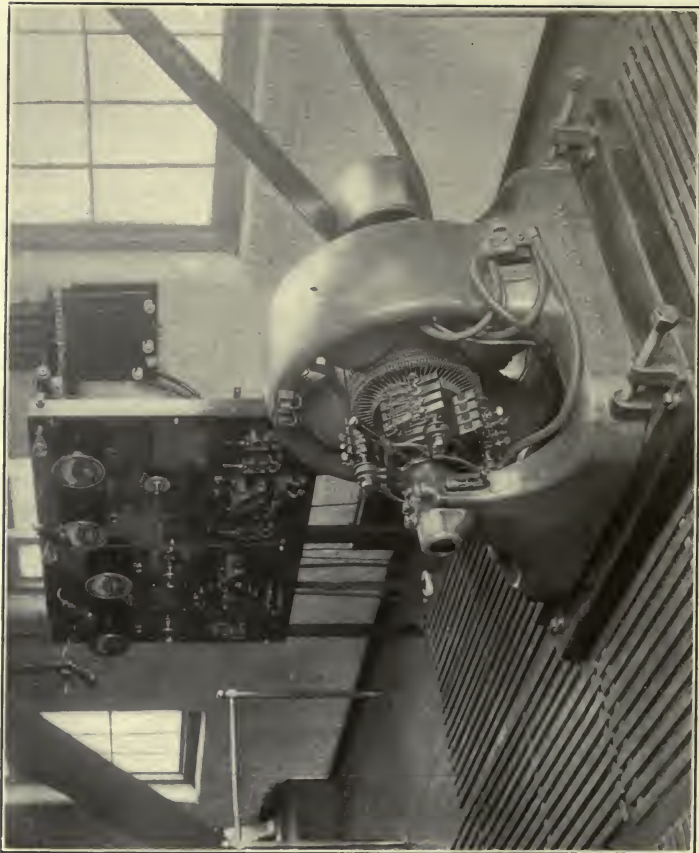

76. G. E. 30-H. P. Moderate-Speed Generator.

RUNNING.

3. A dynamo properly started and subsequently watched requires little care.

Any trouble should be detected at its beginning and corrected, if possible, without stopping. Sparking is the worst trouble. Allow no unusual or unnecessary noise to continue, nor change of voltage or speed, nor abnormal heating of bearings, field coil, armature or commutator. The heating of any part which the hand can bear indefinitely without discomfort is safe. The limit in modern dynamos and motors is 80° F. of any part above the room; if greater than this, something is wrong.

Feel the air near the armature revolving. The commutator should not be more than 10 degrees warmer than the armature.

Overloading is the cause of most troubles.

Handle a conductor with a stick or insulated tool. Use one hand only around a dynamo. Wear rubber gloves and shoes for 500 volts or more.

Stop the dynamo if violent armature sparking can not be suppressed or smoking appears.

In good dynamos the "lead" is small and the rocker has a wide range without sparking. Its proper position is midway of the two points which shows the first sparking or at that point which gives the highest voltage. Leave the rocker always clamped.

The lead of dynamo brushes advances slightly with rotation as the load increases.

One of two or more brushes in a set may be removed and cleaned while running. If carbon brushes "chatter," clean the commutator.

The oil on a new or repaired dynamo is drawn off after each run for three or four days to get rid of the grit. Afterwards draw off and add a little fresh oil every three or four weeks.

In case of a hot box, do not shut down unless the following alternatives have failed: Slacken the belt, loosen the cap, put more oil on, lubricate with vaseline or cylinder oil. If the heating is reduced, polish the shaft with crocus cloth and scrape the boxes after shutting down. But if the heating continues to increase take off the load, slow down, loosen caps, get the belt off as soon as possible, keep the armature moving to prevent sticking, take off the caps, then stop the revolving, take out the linings and allow them to cool in the air. Do not throw them into water. Scraping the linings can only be done by an experienced person. The shaft is also polished with crocus. Do not use ice or water to cool a hot box.

Occasionally hold a small piece of clean white cotton cloth—never waste—on the commutator to wipe it clean; then put on two or three drops of vaseline.

Keep printed directions and diagrams of all circuits posted.

STOPPING.

4. If the dynamo is alone and not charging a battery or supplying a motor, slow down the engine to a few revolutions; open main switch; raise brushes if copper; hold clean white cloth on commutator until no dirt shows; stop the engine; open the feeders and field rheostat; feel the armature winding for heat; loose the belt.

If a battery is being charged, reduce the charging current to a few amperes and open the battery switch, then slow down the engine and proceed as above. If a motor is being supplied, it must first be gradually cut out by its rheostat.

If the dynamo is working in parallel, reduce its current to nearly 0 and open its switch before reducing speed.

To prevent mechanical shock, never open a main switch carrying more than a few amperes except in case of emergency.

After stopping, dust the dynamo and clean it thoroughly while warm with cotton cloth—never waste. Remove any trace of oil or metallic dust, especially from brush, brush holder, or commutator. Every part is kept scrupulously clean. A bad joint or a loose nut is detected. Cover the machine. The room is then swept and dusted and, if not sunlit, a lamp is maintained to keep it dry.

V.—THE SWITCHBOARD.

(A) ARRANGEMENT AND CONNECTIONS.

1. The switchboard is the electrical center of an installation. Its distributing, measuring, regulating and protecting apparatus are systematically and conveniently arranged on the front of one or more slate panels held in a metal frame. On the back the bus bars and all copper wires connecting the apparatus are accessible, insulated, rigid and straight between supports except where they are bent out 1 inch in crossing.

Wires running from the switchboard are neatly aligned and run horizontally or vertically along ceiling and walls in conduit or taut between large porcelain insulators on asphalted strips. Connections are sweated and bolted; small wires may be jointed and soldered. As a rule, the drop from a dynamo post to any feeder on the same leg is less than one-fourth of 1 per cent. Fig. 78 suggests the entire system where cells are charged and discharged in series.

2. The switchboard connections should permit four conditions—first, the dynamo, or dynamos in parallel, to feed directly all lamps, motors, searchlights, etc., or any part of them, and in large installations to leave one spare unit idle; second, to charge the battery or batteries alone; third, to do both simultaneously; fourth, the battery to supply in case of a breakdown to the machinery, all current to the circuits of its emplacements except motors and searchlights.

3. There will then be one generator panel or board of panels in the power room centrally located, and a panel for each battery reserve near its emplacement, but not in the same room with the battery. If there is only one battery and the dynamo is near it, the two panels will be mounted together in the dynamo room.

The panel is of best slate, 1½ inches thick, held vertically 2 feet from the wall, 1 foot from floor by a metal frame from which it is insulated by ebonite bushings and washers. The dynamo panel, about 6½ by 2½ feet, will, when necessary, be mounted with others like it in a continuous board. The battery switchboard is about 6½ by 3½ feet wide and its bus bars will receive their supply either from a dynamo feeder or battery. A searchlight must have its own switchboard, supplied by a feeder from the dynamo board's bus bars.

4. The simplest and best form of switchboard arrangement affording, with the least apparatus, ample control and protection for one or any number of emplacements and batteries, is given for both generator and battery panel fronts on page 74. It will no doubt be adopted in the course of a few years. For a single, compact plant the arrangement may be as on page 75.

On account of the diversity of switchboards which will be met with, several diagrams are given below.

(B) GENERAL DESIGN.

The general design and apparatus ought to allow:

Separate feeders from dynamo board to battery panels, motors and searchlights; from each battery panel to its centers of distribution.

Such regulations that all centers of distribution may be kept at the same potential, all batteries may have their normal charging and discharging currents, and the charging of two battery halves may be equalized.

Magnetic protection to every dynamo, motor, and battery against overload and underload.

Measurements of *C* and *V* of any part desired and of leakage.

The details of apparatus are given in figs. 79 and 80. The same apparatus is indicated by symbols for other boards. The best switchboard arrangement to be found in forts appears on pages 58, 59.

1. Weston voltmeters, *V*, reading to 150; a recording volt gauge for the battery is advisable.

2. Weston shunt ammeters, *A*, reading to one-half excess of the maximum current.

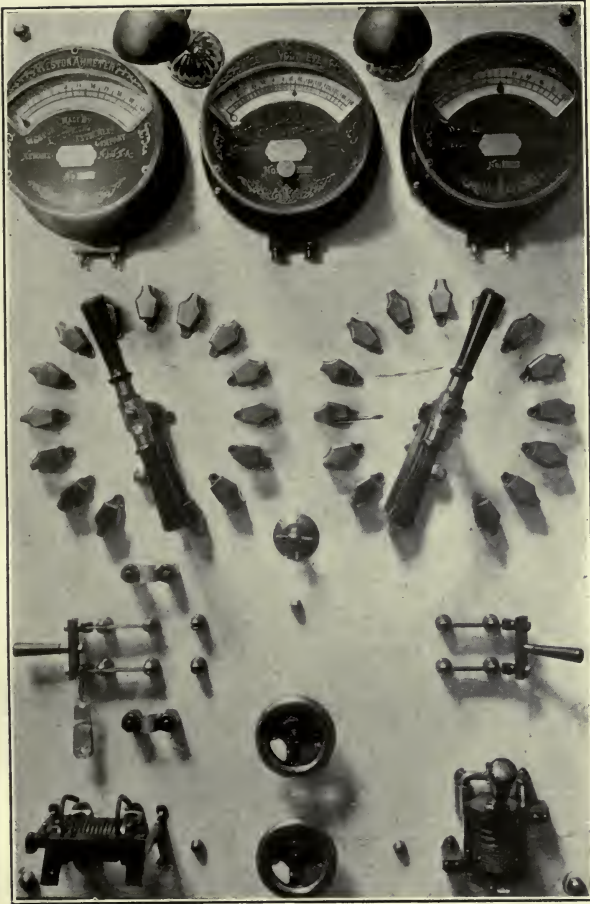

78. W-e Switch Board Front.



131
17

3. 6-point voltmeter switch on battery panel connected to give at will the voltage (a) between bus bars, (b) of first half battery, (c) of second half battery, (d) of whole battery, (e) between + bar and ground, (f) between - bar and ground; 4-point switch on dynamo panel to give the voltage (a) between supply mains, (b) bus bars, (c, d) either bus and ground.

4. Main regulating rheostat MR of noncombustible, nonabsorptive material is necessary to reduce the bus bar voltage while charging the battery. It has range and capacity to carry indefinitely with less than 200° F. rise, the charging current of both battery halves within 5 per cent of the normal while the bus bars remain at 112 volts; enough stops are provided to keep the bus bars within 1 volt of the potential necessary to supply the lamps.

5. Equalizing rheostats, ER , $E'R'$, have each ten steps for a total drop of 10 volts, and in construction are like the above.

6. The field rheostat, FR , supplied with the dynamo, can lower its maximum voltage on load to 110.

7. All rheostats are required to have:

Capacity to carry its maximum current indefinitely with less than 200° F. rise, and 30 per cent overload for one minute.

Contact arm on a spindle and touching one point before it leaves the other.

All material fire and moisture proof and conductor nonoxidizable.

Compactness, ventilation, and abundant radiating surface.

Insulation of 1 megohm between conductor and frame under A. C. test.

Words "high," "low," or "raise," "lower," to indicate the turn of contact arm to change the voltage.

8. Its overload circuit breakers, OL , operate with certainty and excess of force within 5 per cent of adjustment. This is usually made to open automatically the circuit at one-fourth increase of the normal current.

9. Its underload C. B.'s. operate within 5 per cent of adjustment, and is usually set to open the circuit with a fall of 5 or 10 amperes if the C. B. is "no current," and of voltage 30 per cent if the underload is "low voltage." It should not catch if the current or voltage is lower than that of the adjustment. Both OL and UL circuit breakers have carbon protection to the main contacts, and if combined on one base, have but one trip-catch.

10. Fuses have copper tips stamped with 80 per cent of the amperes which they can carry indefinitely, and will therefore blow at one-fourth excess of their normal current.

11. Knife switches are 50 amperes or larger, double pole, single or double throw, quick break, fused, carbon-tipped, hinged, and so constructed that contact will occur along the entire edge of the jaw at the same time, and no current can pass through a hinge or spring. Single-throw are closed by an upward motion to avoid accidental closing.

12. All conducting parts of the switch board are of drawn copper and have a cross section of about 1 square inch per 400 amperes; all joints are sweated and bolted with a contact area of 1 square inch per 180 amperes; all sliding contact surfaces have 1 square inch per 40 amperes. Bearing parts are phosphor-bronze or brass.

(C) THE U. S. ENGINEER SWITCHBOARD.

1. Figs. 79 and 80 give the details of apparatus and wiring of the dynamo and battery panels. The feeders, — + to the latter, come from FS off the dynamo panel's bus bars.

Fig. 81 shows the connections on the battery switchboard panel (fig. 80), while the storage battery is being charged, and fig. 82 while being discharged. The three figures are lettered to correspond.

2. By this arrangement, the battery of 58 cells is charged, 29 in series and 2 in parallel, by the throw of the triple-pole double-throw switch, $TPDT$, on the battery panel to the right and is discharged, 58 in series, by its throw to the left. The plan allows other and distant batteries, each with its own switch board, to be supplied by feeders from the same dynamo board's bus bars, permits the dynamo to feed all lamps, etc., at the same potential, offers little chance for mistakes or accident and fulfills the four conditions imposed in par. (A) 2, for isolated D. C. plants with battery reserves. But the apparatus is extensive and current is lost in dead resistance while charging and lighting at the same time.

3. Details of the apparatus:

(a) In the Weston voltmeter V , (fig. 79) a pivoted coil, of which only three turns are shown in cross section, is held in position between the poles N and S of a strong steel magnet by a light spiral watch spring F , seen in front, and one, R ,

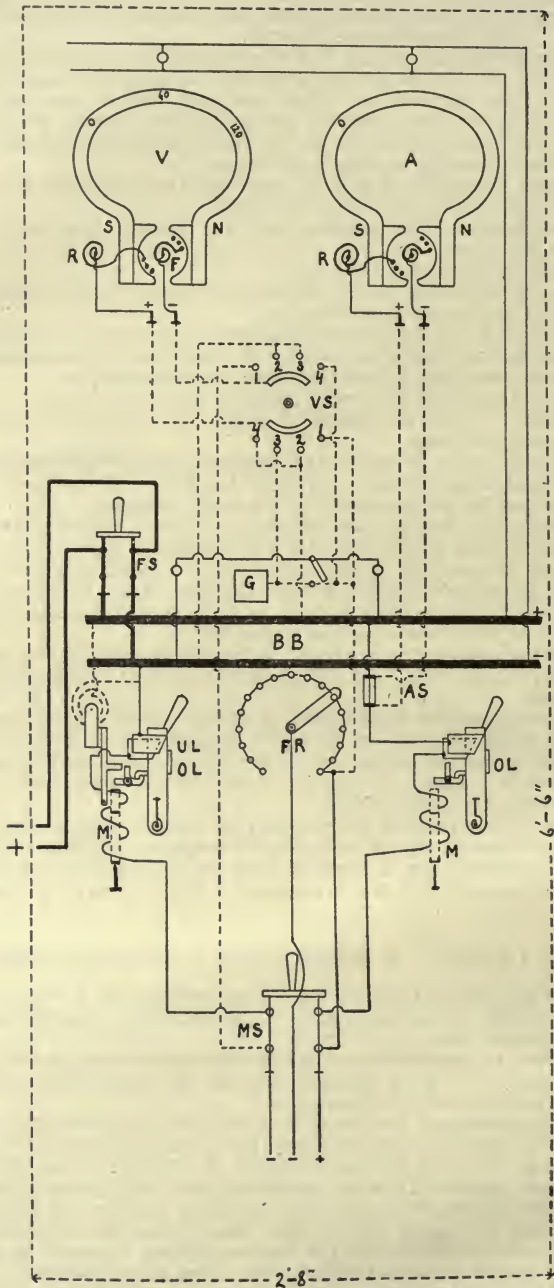

79. Present Generator Panel Apparatus in Detail.

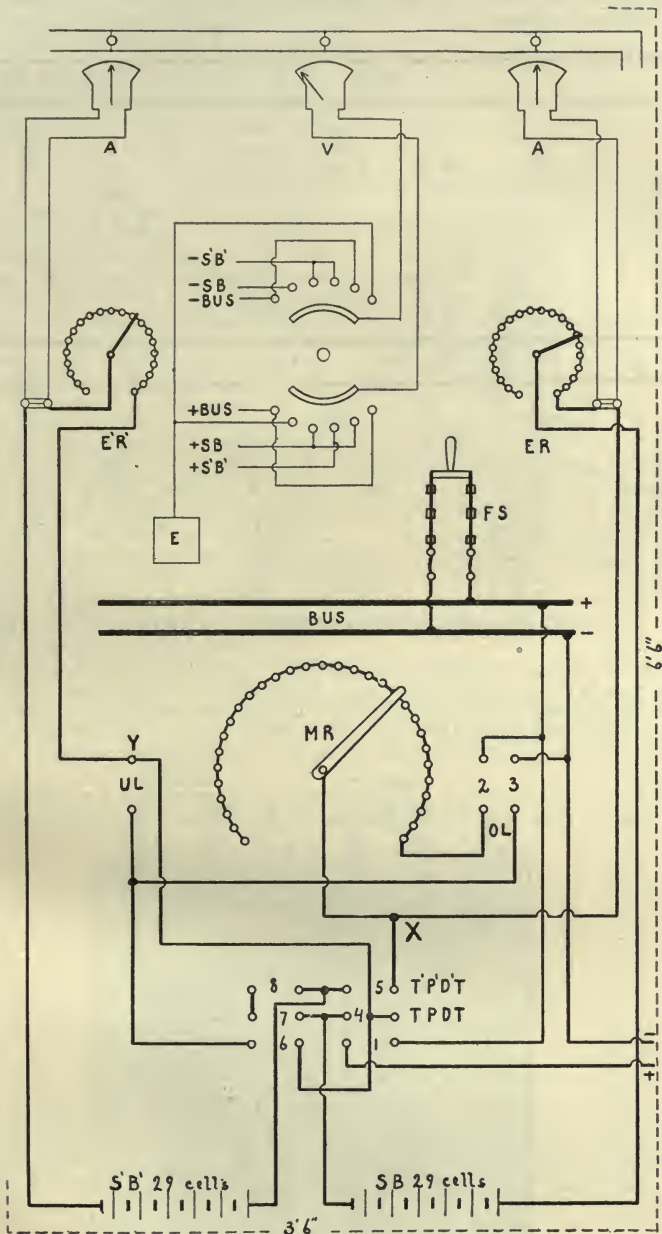

80. Engineer Battery Panel.

like it, in rear, but drawn on the left in order to be seen. When a current passes through the coil, it revolves on its pivots on the same principle as the armature of a motor and carrying with it the pointer along the scale. The V coil has many turns of very fine wire and a large fixed resistance in series, which is kept in the instrument case.

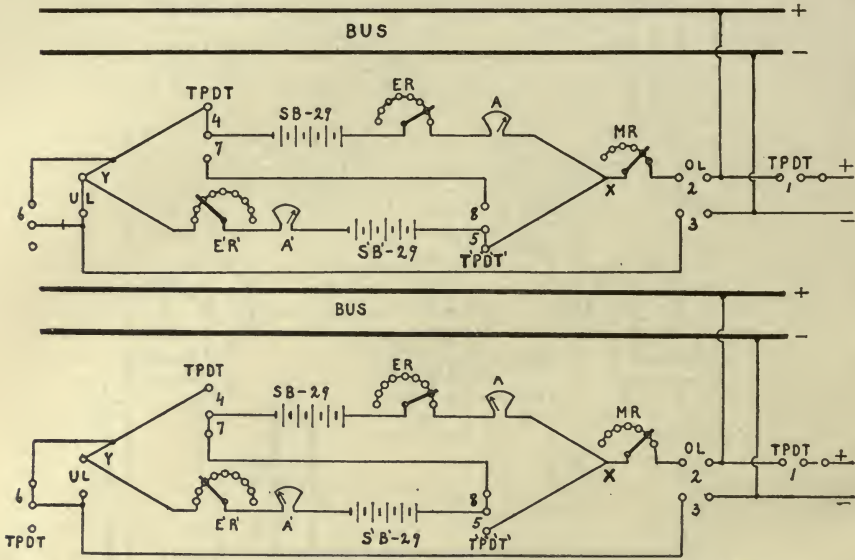

81 and 82. Diagrammatic Sketch of Engineer Switchboard Battery Panel.

(b) The Weston ammeter A is similarly constructed, but has fewer turns of coarser wire in the coil, which carries a very small but a fixed fraction of the main current through the shunt AS of German-silver strips in the main circuit. Ammeters and voltmeters are inclosed in iron cases to shield their fields, and they should be handled with care, so as not to disturb the pivots or weaken the magnets.

(c) The voltmeter switch VS has two brass arcs which are the terminals of the V circuit; also (fig. 79), four double brass points connected as shown. The

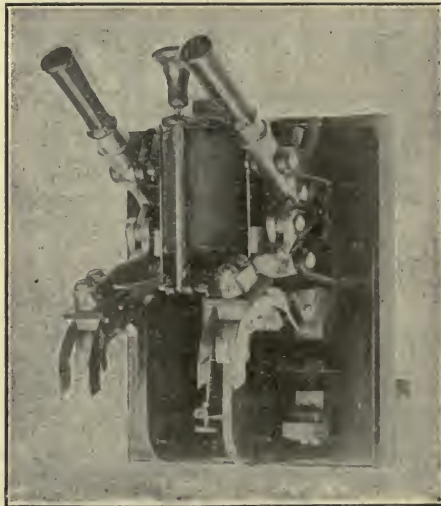

83. G. E., D. P. Overload Toggle-Joint C. B..

brass ends of the lever (not shown) are insulated from each other and bear upon the arcs and two opposite points at the same time. The voltmeter can thus be switched in between (1) dynamo posts, (2) bus bars, (3) — bus bar and ground, or (4) + bus bar and ground. The *V S* on dynamo panel has six points.

(d) In the overload switch *OL* the knife edge kept open by a spring is, when pushed into the jaws by its handle (thus closing the circuit), held in that position by a trigger catch. Beneath the catch and on the other side of its pivot is a plunger *R* over a vertical soft-iron movable core *I* (fig. 84), surrounded at its upper end by a coil carrying the main current. When the current becomes too great the core is drawn up, strikes the plunger and catch and releases the knife. The spring overcomes the friction of the jaw on the knife which then opens the circuit far more quickly and surely than is done by a fuse wire. The hand-screw shown below *I*, which moves the core up or down, affords regulation.

The figure (85) gives back connections of Ite C. B. and protected terminal fuse.

(e) *OL* and *UL* (fig. 79) is a combination overload and underload automatic circuit breaker. In addition to the overload cut-out, described above, there is a straight horizontal magnet with end pole pieces. It may be wound with fine wire connected for a fall in voltage as represented in the diagram, or with coarse wire in series with the *OL* coil to open for a fall in current. The armature is a horizontal soft-iron cross piece at the upper extremity of a vertical lever pivoted below and held by a spring normally away from the magnet. When

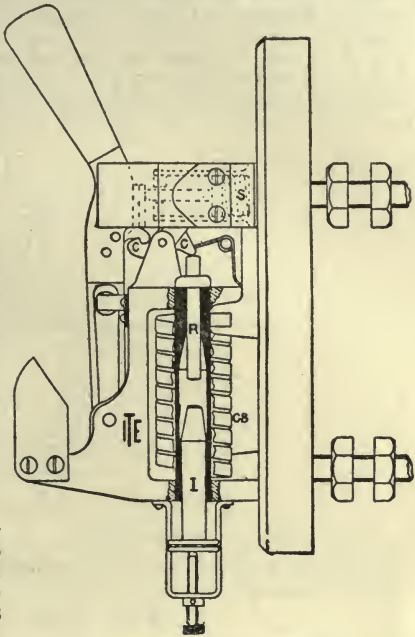

84. Ite Automatic Cut-out or Circuit Breaker.

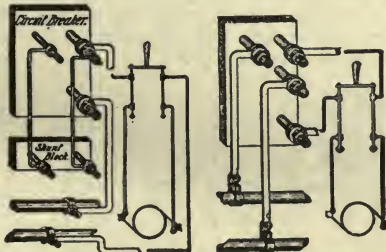

Diagram No. 1.

Diagram No. 2.

85.

the knife of the switch is closed by the handle, the armature is automatically moved into approximate contact with the pole pieces and held by their magnetism. If the voltage falls to the adjustment, the armature lever is released and strikes the trigger catch, releases the knife and opens the main circuit.

(D) THE PREBLE SWITCHBOARD.

(Fig. 86), for a single plant with a battery reserve, requires little apparatus, loses very little energy in regulation, gives little chance for accident, and it is simple. Lamps are 110 volt; dynamo, 110 to 150 volts; 58 cells charged and discharged in series vary from 110 to 145 volts. 1. Dynamo to light lamps—close *O L*, *M S*, and *F S* only; *M R* is cut out. 2. Dynamo to charge battery—close *T P D T* to right, *O L*, *O' L*, *U L*, and *M S* only. 3. Dynamo to do both—same as last and close *F S*. 4. Battery to light lamps—close *O' L*, *T P D T* to left and *F S*.

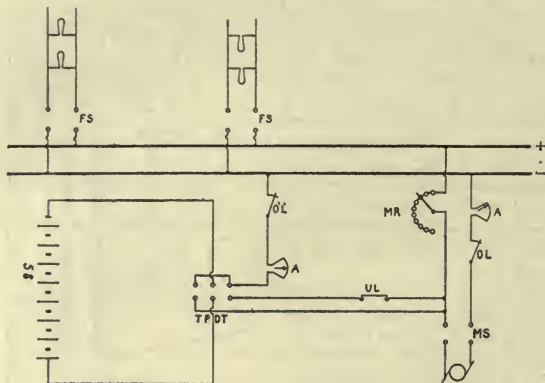

86. Preble Switchboard.

(E) KEY WEST SWITCHBOARD.

The relative sizes of wires, fuses, switches, etc., and the divided bus bars are shown in fig. 87. A shunt switch on the dynamo to the series field may be opened to raise the voltage.

The ten end cells, active or nonactive, may be gradually added or subtracted from the main battery, as required, by an end cell switch. Its arm consists of two parallel brass bars sliding on the stops and on two different brass rings connected by German-silver resistance. By this device the battery circuit is never opened and no cell can be short-circuited.

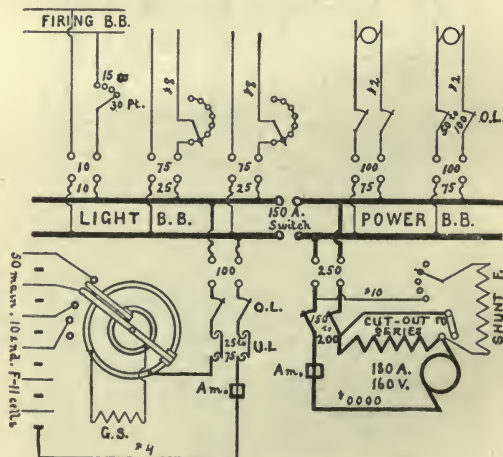

87. Key West Switchboard.

(F) THE GOLDEN GATE BOARD.

The Golden Gate board (fig. 88) distributes current to three points, 1,500 and 2,000 feet apart, each having its own battery for a reserve. The generator and No. 2 stations are together. Battery and lamps can be supplied simultaneously, but not battery and motors.

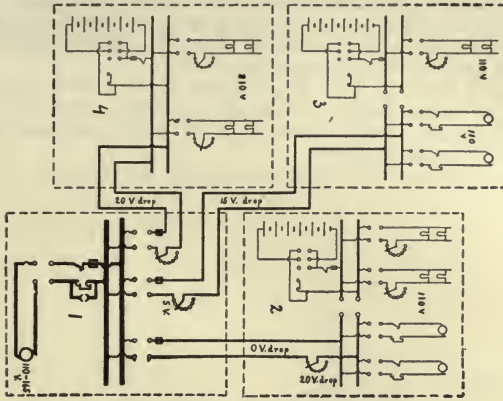

88. Golden Gate Switchboard.

(G) SWITCHBOARD ARRANGEMENT.

The switchboard arrangement in fig. 89 for dynamo, single battery, with 15 end active cells and 100 lamps, is economical. It fulfills the four conditions and the dynamo and battery can be placed in parallel to supply 400 lamps for three hours.

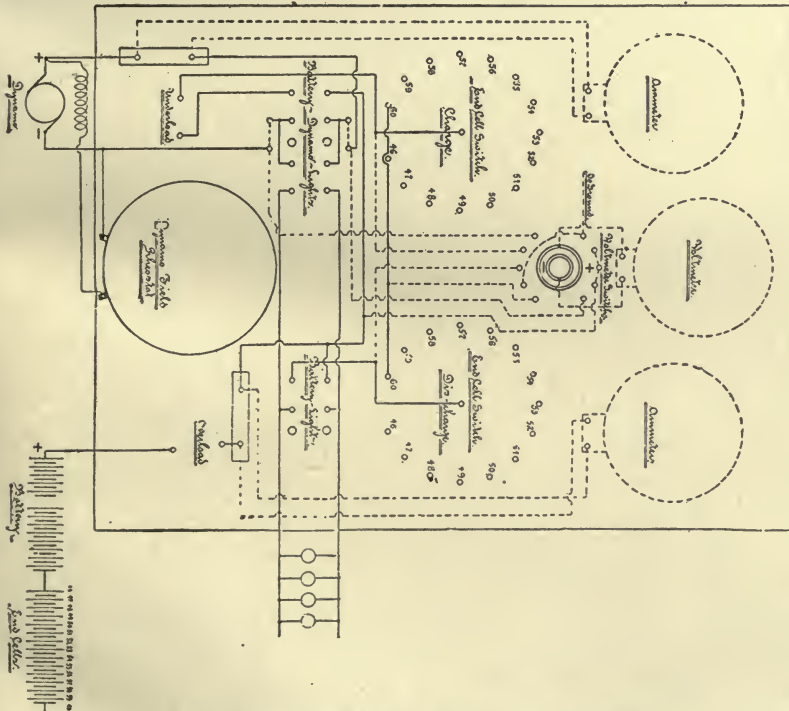

89. Shunt Dynamo, 45 Cells and 15 Active End Cells.

(H) TO OPERATE.

1. No one should be allowed to touch the switchboard unless he is familiar with all circuits connected with it, the strength of main and feeder circuits, the insulation of each part. Records of these are kept.

2. Always close a switch deliberately and firmly, while watching the ammeter and voltmeter, whose deflections were previously known, and while standing ready to open. Main switches loaded are opened only in an emergency.

3. The rule is to close feeder switches when practicable, so as to change the load as gradually as possible—the smaller first.

4. Guard against dust or wet, overheating in any part, unsoldered joints, loose nuts, wires or other parts, bad contact of rheostat arm on any stop, instrument not holding its zero, switch twisted or dirtied so as to not make good contacts; apparatus out of adjustment.

5. Leave all switches and circuit breakers open after a run.



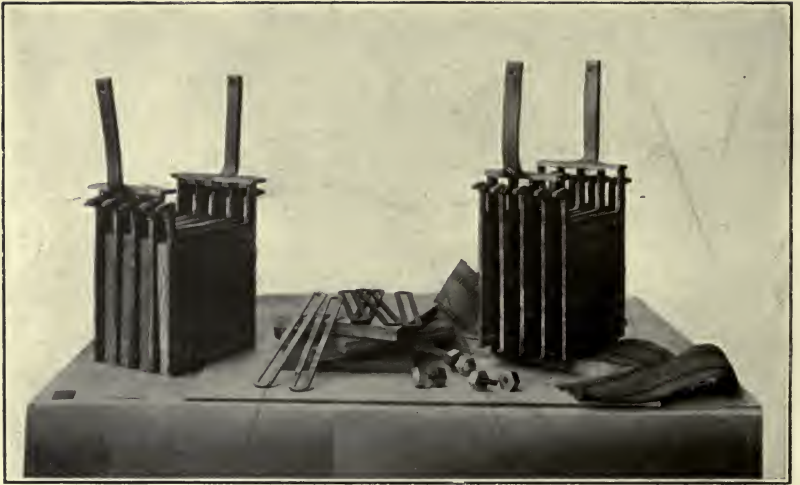

90. As Shipped and Prepared for Mounting.

VI.—STORAGE BATTERY (CHLORIDE).

(A) UNPACKING, SETTING UP, AND INITIAL CHARGING.

1. Great care should be taken in unpacking and all subsequent handling.
2. Open boxes and crates on the "up" side. Lift contents out, verify their number and condition, and never slide them by turning box on its side.
3. The construction of the stand is shown in fig. 91. Dimensions change with size of jar. When jars are 15 inches high by 13 inches wide by 11 inches deep, the cross section of the timbers are $5\frac{1}{4}$ inches deep by $3\frac{3}{4}$ inches wide. When each shelf carries two rows of cells, there will be four longitudinal stringers to each shelf instead of two stringers, as shown for the single row of cells.
4. The battery room should be so located or arranged that the temperature will be moderate and the air dry. If the room is damp there is danger of leakage from grounds and solution running over from absorption.
5. Usually, natural ventilation is sufficient if the proper inlets and outlets for the air have been provided, but in some cases forced draft is necessary. To obtain the best results and life from the battery, the temperature should be

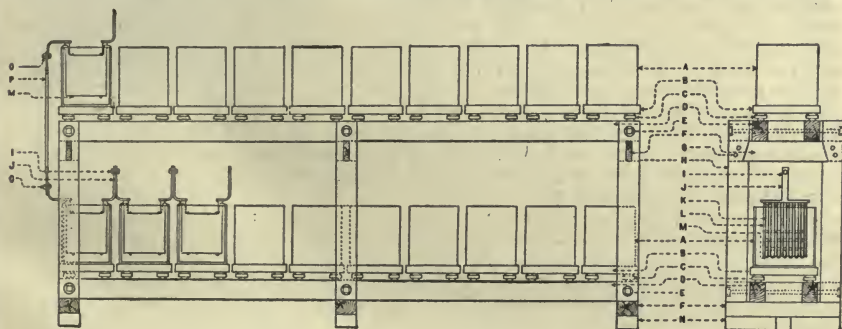

91. Method of Mounting. Working Plan of Frame.

A Glass jar.	G Wood dowel pin.	L Negative plate.
B Wood tray.	H Post.	M Rubber ring separator.
C Glass insulator.	I Lead-covered bolt connector.	N Vitrified brick.
D Stringer.	J Lead strap lug.	O Lead terminal lug.
E Iron bolt.	K Positive plate.	P Copper connecting conductor.
F Crosspiece.		

between 50° and 80° F. If the room is excessively hot (over 80°) for any great length of time, the life of the plates is very considerably shortened. If the temperature is low, no harm results, but the available capacity is reduced.

6. Place the jars, after they have been cleaned, in position on the stands which should be so situated in the room that each cell will be easily accessible. If the floor space is available, it is often preferable to install the cells on one tier, in which case a set of stringers properly fastened together and the insulating bricks will be all that is required.

7. Place the elements as they come from the packing cases (see fig. 90) on a convenient stand or table (the elements are packed positive and negative together, the positive having plates of a brownish color, the negative of a light

gray; the negative always has one more plate than the positive), cut the strings that bind them together and carefully pull the positive and negative groups apart, throwing the packing aside. After carefully looking over both elements, to see that they are free from dirt and other foreign matter, place two hard rubber separators on each positive plate, about an inch from and parallel with each vertical edge, and then slip these plates into position between the negatives, which have been placed crosswise on a board about two-thirds the width of the plates, so as to allow of easy readjustment of the separators, which may become disarranged (fig. 91).

8. To facilitate the lifting of the elements into the jars and to prevent the disarrangement of the separators when doing this, a short strip of webbing should be used; lay this on the board under the element (fig. 90). When putting into the jars, be careful that the direction of the lugs is relatively the same in each case, thus causing a positive lug of one cell to always connect with a negative of the adjoining one and vice versa. This insures the proper polarity throughout the battery, bringing a positive lug at one free end and a negative at the other.

9. Just before bolting or clamping the lugs together, they should be well scraped at the points of contact, to insure good conductivity and low resistance of the circuit; this should be done before the elements are taken apart and directly after unpacking, if the battery is to be set up at once. The jars rest on sand in wooden trays on glass insulators standing on framework as shown above.

10. Before putting the electrolyte into the cells, the circuits connecting the battery with the charging source must be complete, care being taken to have the positive pole of the charging source connected with the positive end of the battery, and so with the negative poles.

11. The electrolyte is dilute sulphuric acid of a specific gravity of 1.200 or 25° Baume as shown on the hydrometer at normal temperature (60° F). If it is not convenient to procure this from the Battery Company, already mixed and ready for use, it should be prepared by diluting suitable commercial sulphuric acid, or "oil of vitriol," as it is more commonly called, with pure water. The acid, as well as the water, must be free from impurities, such as iron, arsenic, nitric or hydrochloric acid; this is absolutely essential. When diluting, the acid must be poured into the water, not the water into the acid; the proportions of acid (of 1.840 specific gravity or 66° Baume) and water are one part of acid to five of water (by volume). The acid must be added to the water slowly and with great caution, on account of the heat generated; the final density of the solution (1.200 specific gravity) must be read when the solution has cooled. The vessel used for the mixing must be a lead-lined tank, glazed earthenware or one of wood which has not been used for other purposes; a new washtub or spirits barrel is recommended.

12. The electrolyte should cover the top of the plates by $\frac{1}{4}$ inch and must be cool when poured into the cells, which then should never be allowed to stand for more than two hours, before the charging is started.

13. The initial charge should be continued uninterruptedly, or as nearly so as possible, for about thirty hours at normal rate, or until the positive plates become a deep brown or chocolate color, the negative a light slate and the potential of each cell 2.5 volts (with current flowing), gas being freely given off from all the plates. The density of the electrolyte should again be 1.200 sp. gr., having fallen considerably after being put in the jars.

14. At the end of the first charge, it is well to discharge the battery about $\frac{1}{2}$; and then immediately recharge it. Repeat this treatment two or three times and the battery will be in proper working condition.

15. When the battery is in regular service, the discharge should not be carried below 1.8 volts per cell at full load; the charging should be started at once after a discharge and continued until the battery is full, as indicated by the four signs given above, i. e., potential, specific gravity, color, and gassing, the first two being most important. The cells must never be allowed to stand discharged. If, by chance, this should happen, then the charging must be proceeded with at half rate; the potential in this case at the end of charge should be 2.4 volts (0.1 volt less than normal) and the density of the electrolyte 1.200 sp. gr., the same as when the charge is at normal rate. Upon discontinuing a charge the potential of each cell will immediately fall to about 2.2 volts, and then to 2 volts when the discharge is started.

16. In order to determine whether the battery continues in good condition, it is essential that potential and density readings be taken at least once a week just before beginning the charge and also near the end.

(B) GENERAL INSTRUCTIONS FOR CARE AND OPERATION OF CHLORIDE STORAGE BATTERY.

To obtain the best results in the operation of the battery, it is absolutely essential that proper, careful, and methodical attention be given to all the details of its operation, the same as is necessary with the generating machinery, and for this reason the following information and rules should be most carefully noted and followed; if this is done the total work in connection with the operation of the battery will be reduced to a minimum:

1. *Charging.*—In the charging of the battery, which should preferably be at the normal rate, it is most important that it be continued until complete, but it is equally as important that it should not be repeatedly continued beyond that point, as not only will an unnecessarily rapid accumulation of sediment and excessive evaporation of the electrolyte result, but what is more important, the life of the plates will be very much shortened.

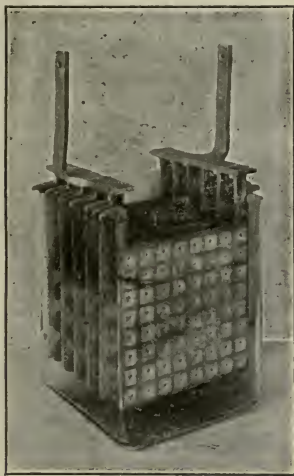

92. Type E-11 in Glass Jar.

At weekly intervals, however, it is advisable to slightly prolong the charge, in order that the electrolyte may be thoroughly stirred up by the prolonged gassing, and also to correct any unevenness in the working of the cells, which may have developed.

2. *A complete charge* which in general should exceed the previous discharge by from 12 to 15 per cent (in ampere hours) is determined by the voltage and specific gravity of the electrolyte or solution in the cells reaching a maximum (not necessarily a fixed value), also by the amount of gassing, and by the color of the plates, the first two being the chief guides.

3. *Determination of maximum voltage and specific gravity.*—With all of the cells in the battery in normal condition, with no impurities in the electrolyte and no material lodged between the plates or sediment touching them at the bottom, the maximum voltage and maximum specific gravity of the electrolyte is reached, when, with

the charging current constant at the normal rate, no further rise or increase in either (voltage or specific gravity) during a period of one-half hour is noted. For instance, if the charge has been continued for five hours with a gradual continued rise in the voltage and specific gravity during that time, but with an additional one-half hour of charging there is no further rise in either, then the charge is to be considered complete.

If the charging is at a rate lower than the normal, the interval during which no perceptible rise should occur must be proportionately increased.

4. *The voltage at end of charge* is not always the same throughout the life of a battery, being dependent chiefly upon two conditions, namely: the age of the battery and the temperature of the electrolyte, and for this reason it is most important in determining the completion of a charge, that these conditions be taken into consideration.

When first installed, the end of charge voltage will be 2.5 volts per cell, or higher, at normal rate and at normal temperature (70° F.), but as the age of the battery increases the point at which it will be fully charged is gradually lowered for corresponding rates and temperatures (see below) until, in many cases, with both normal, it will have fallen to 2.40 volts, or even less, per cell.

If the charging current is at the maximum rate, which should never be used except in cases of emergency, where a rapid charge is necessary, the final voltage will be approximately 0.05 volt per cell above that of the normal rate.

With rates lower than the normal, the voltage at end of charge will be approximately 0.05 volt less for each one-fourth decrease in the rate, viz:

If 2.50 volts at normal rate (100 amperes for illustration), then 2.45 volts at three-fourths normal rate (75 amperes for illustration), and 2.40 volts at one-half normal rate (50 amperes for illustration).

The effect of changes in temperature on the final charging voltage is that it is noticeably lowered with an increase in the temperature above the normal (70°) and correspondingly increased with lowered temperatures, irrespective of the age of the battery.

5. *Voltage after charge and before discharge.*—After the completion of a charge and the current is off, the voltage per cell will fall immediately to about 2.15 volts, and then to 2.00 volts when the discharge is started. If this is not begun at once, then the pressure will quite rapidly fall to 2.05 volts, and there remain while the battery continues on open circuit.

6. *Specific gravity of electrolyte at end of charge and conditions affecting it.*—As with the voltage, the specific gravity for complete charge is also affected more or less by the varying conditions during the progress of the life of the battery, in addition to the changes due to the evaporation and replacing of the water in the solution—the sulphuric acid not evaporating.

In the beginning it should be between 1.195 and 1.205 sp. gr., at normal temperature, and with the solution at the proper height ($\frac{1}{4}$ inch) above the top of the plates.

Gradually there is a slight loss of the acid from the electrolyte, through very small quantities being carried off in that portion of the minutely divided spray that is thrown up during gassing at end of charge, which is prevented from falling back into the cell by the air currents in the room. In addition, some of it is absorbed by and acts upon the sediment which slowly accumulates in the bottom of the tanks, and so can not go back into the solution again.

7. *Restoring lowered specific gravity.*—When this loss has become such that the highest reading that can be gotten at end of complete charge, all indications of such being present, is ten points below the standard or what it was when first put into regular service, i. e., if it has fallen from 1.200 sp. gr., the original reading, to 1.190 sp. gr., then this loss should be regained by the addition of dilute acid instead of water, when replacing evaporation. Under ordinary conditions it should not be necessary to add fresh acid oftener than once every two years, or possibly only at such times as the sediment is removed. A convenient density for this purpose is 1.400° sp. gr., because the proper density of the electrolyte will be more quickly and easily attained by the use of this heavier solution, it containing double the amount of pure acid, in comparison with that of 1.200, so that, for instance, if four carboys holding ten gallons each, of 1.200 sp. gr. solution, would be required in any particular case, the same result could be gotten by using two carboys holding ten gallons each, of 1.400 sp. gr.

As it is essential for the successful operation of the battery that the electrolyte be free from impurities (see under "Electrolyte" below) and as the ordinary commercial sulphuric acid is not of the proper degree of purity, it is very strongly recommended that all solution be purchased through the Storage Battery Company, which will undertake to supply the proper quality.

If, for any reason, the required supply is not procured, the solution may be prepared by diluting specially treated sulphuric acid, or oil of vitriol as it is more commonly called, with pure water.

In any case, a carefully collected sample (at least 8 ounces) should be submitted for test. For water analysis one quart is required.

8. *Gassing and color of plates—Additional indications of state of charging.*—At the end of complete charge, in addition to the voltage and specific gravity reaching a maximum, gas will be given off freely from all of the plates in the battery, and the color of the plates should be a deep chocolate or dark brown for the body of the positives and a uniformly light slate or gray for the negatives. Provided the body of the positive plates is of the proper color, no attention need be paid to the lodgment on the top of these plates or their projecting buttons, of a fine white powder that may be easily brushed off, the dark color then showing underneath. In fact, if these parts are of the deep chocolate color and no white powder is noticeable, it is an indication that the battery is being overcharged.

This white powder is composed of particles from the plates, thrown off by the gassing at end of charge, which become sulphated and of a light color while in suspension in the electrolyte.

9. *If there are end cells in the battery,* i. e., if some of the cells are so connected with the switchboard, that by either cutting them in or out, the pressure can be regulated, those that may have been successively cut into circuit on the discharge, should be cut out again on the following charge, as soon as they come up to a state of full charge and not be allowed to continually overcharge. If any of these cells are not used regularly or stand idle, they should be given a complete charge once a week.

10. *Counter electromotive-force cells.*—In some of the smaller plants it is at times more suitable to provide for the adjustment of the pressure by means of

what are known as counter electromotive-force cells, instead of connecting a number of the cells of the battery to the regulating switch on the board. These cells are made up of plain grids or plates without active material (storage capacity not being required), and do not receive any of the charging current, nor do they require the careful attention that end cells do. They should, however, be examined from time to time, to see that they are not short-circuited, and if found so, the cause should be removed, the same as in the case of the regular cells in the battery.

11. *Discharge.*—As from the voltage and specific gravity readings the degree of charge can be determined, so likewise can the amount of discharge.

12. *Drop in voltage and specific gravity indication of amount and safe limit.*—During the greater part of a complete discharge the drop in voltage is slight and very gradual, becoming greater with marked rapidity near the end.

The limit of discharge is reached when the voltage has fallen to 1.75 volts per cell with current flowing at ordinary rates; in usual service, however, it is advisable to stop the discharge considerably above this point, more especially to insure a reserve in case of emergency. The fall in density of the electrolyte also serves as an indication of the amount taken out, and is in direct proportion to the ampere hours discharged, thereby differing from the drop in voltage, which varies irregularly for different rates and degrees of discharge, and for this reason, under ordinary conditions, is to be preferred in determining the amount of discharge.

The actual amount of the variation in the strength of the electrolyte between a condition of full charge and of complete discharge is dependent upon the quantity of solution in the containing vessel, compared to the bulk of the plates.

If a cell contains the full number of plates, the range will be about 35 points, or from 1.200 sp. gr. down to 1.165 sp. gr. With fewer plates, in the same size containing vessel, the range will be about proportionately lessened.

13. *The color of the plates is also a guide,* as it is when charging.

As the discharge progresses, the positive plates become lighter, and the negatives darker.

14. *Interval between discharge and charge.*—When a battery is discharged it should be allowed to stand but a very short time (not more than an hour), if at all, before beginning charging again.

15. *Instruments for use with the battery.*—For the successful operation of the battery, there should be provided a portable low-reading voltmeter, reading to three volts and calibrated to 0.02 volt, for taking the individual cell readings; two or more hydrometers, with scale reading from 1.150 up to 1.250 sp. gr., and a portable lamp for inspecting the individual cells, in addition to the switchboard instruments, consisting of a voltmeter reading approximately three times the number of cells in series in the battery, a two-way ammeter and a recording voltmeter with a scale that will clearly show the total range in voltage for both charge and discharge, of the cells usually in circuit on the discharge.

The recording voltmeter is especially desirable, because it enables the attendant to easily and accurately note the progress of charge and discharge, and determine, in conjunction with the hydrometer readings, after the manner noted above, the proper time to stop either.

In addition to being a guide for the charge and discharge, it furnishes a permanent record of the working of the battery.

An ampere hour meter, for recording the amount of both the charge and discharge, is also valuable, and will act as a check on the readings taken with the other instruments.

16. *The electrolyte is dilute sulphuric acid,* and should be prepared by mixing suitable commercial sulphuric acid with pure water. It is absolutely essential that both acid and water should be free from impurities such as iron, arsenic, nitric acid or hydrochloric acid.



93. Long Flat Hydrometer.

If the user mixes his own solution, care must be taken to pour the acid into the water, not the water into the acid. The acid must be added to the water slowly and with great caution, because of the heat generated; the final density of the solution must be read when the solution has cooled.

The proportions of acid (of 1.840 sp. gr., or 66° Baume) and water are one part of the former to five of the latter (by volume). The vessel used for the mixing must be a lead-lined tank, one of glazed earthenware, or one of wood which has not been used for other purposes.

The water used in replacing evaporation should be of the best quality. If it is natural water, drawn from the city or town supply or other source, it should be submitted from time to time for test.

The water should be added to the top of the cells shortly after starting the charge; not after finishing a charge or during discharge. Do not insert a hose into the cell with the idea of stirring up the electrolyte; this may result in piling up the sediment, and so short-circuiting the plates.

The electrolyte must never be allowed to get below the tops of the plate.

Should it be known that any impurity has gotten into the cell, steps should be taken to remove it at once. In case removal is delayed and any considerable amount of metal becomes dissolved in the solution, this solution should be replaced with new immediately, thoroughly flushing the cell with water, before putting in the new solution. The change should be made when the battery is discharged, and just before charging. If in doubt as to whether the electrolyte contains impurities, a sample taken at end of discharge should be submitted for test.

17. *Maintaining the battery in proper condition.*—In order that the battery may continue in the best possible condition, it is essential, in addition to carefully following the points noted above, that each individual cell in the battery be regularly inspected with a view to reducing to a minimum the chance for any of them working irregularly or getting low; also that cell readings be taken and recorded at fixed intervals in such form that consecutive readings can be easily compared and any trouble that may have developed be detected and remedied at once.

For the individual cell inspections a portable lamp is required, so that any tendency for an accumulation or lodgment of material between the plates can be easily noticed and located. If the elements are in glass jars an ordinary lamp with extension cord attachment will be found most convenient and satisfactory, but if they are in lead-lined or other opaque tanks, then a lamp suitable for immersion in the electrolyte to the bottom of the tank will be necessary.

When examining a cell, great care should be taken to look between *all* the plates. Any accumulation of material found between them should be removed at once. If it is from the plates themselves, remove by pushing down to the bottom of the containing vessel with a piece of hard rubber or wood, but if foreign matter is present, it should be withdrawn from the cell. Metal of any kind must never be used for the purpose in either case.

These inspections should be so arranged that each cell is examined at least once every month; if it is not convenient to go over the entire battery all at once, a sufficient number of cells may be looked into, say on one day a week, to get over them all within the month.

In addition to the examination of the cells with the lamp, and to noting near the end of each charge whether all the cells are gassing equally well, readings of the voltage and specific gravity of each cell should be taken once a week at the end of the prolonged charge and so recorded, preferably in a book gotten up for the purpose, that consecutive readings can be compared.

Rule a large sheet in the following form:

Page 1.]					[Page 2.				
SPECIFIC GRAVITY.					VOLTAGE.				
Date, 1900.	11-26	12-2	12-9	12-16	Date, 1900.	11-26	12-2	12-9	12-16
Cell No.					Rate.	100 amperes.	95 amperes.	100 amperes.	
1	1201	1199	1200	-----	1	2.51	2.49	2.50	-----
2	1202	1201	1202	-----	2	2.52	2.51	2.52	-----
3	1199	1198	1200	-----	3	2.50	2.50	2.50	-----
4	1200	*1185	1201	-----	4	2.52	*2.27	2.50	-----
5	1200	1200	1199	-----	5	2.50	2.50	2.49	-----
6	-----	-----	-----	-----	6	-----	-----	-----	-----
59	-----	-----	-----	-----	59	-----	-----	-----	-----
60	1198	1200	1200	-----	60	2.50	2.52	2.51	-----
61	1202	1204	1201	-----	61	2.51	2.52	2.50	-----

From the above readings it will be noted that on 12-2, cell No. 4 is unusually low, being 15 points in specific gravity and 0.25 points in voltage lower than at the previous readings, thus indicating something wrong with the cell, and on examination it would probably be found that the cell was short-circuited. After a good charge the cell again came up, as is indicated by the reading taken on 12-9, no acid having been added.

These readings should be taken at the end of charge; the voltage readings always when the current is flowing; open-circuit readings are of no value.

If any of the cells show readings lower than the normal and do not gas freely at end of charge, then they should be examined at once with a cell lamp to determine the cause of the falling off.

18. *Getting low cells into normal condition.*—A cell which has been found to have gotten low will generally need more than the usual amount of charging to get it back into normal condition again, after the cause of the trouble has been removed. This may be accomplished in several ways.

The first and simplest being to overcharge the whole battery, but care should be taken not to carry this to excess.

The second, by cutting the low cells out of circuit over one or two discharges and in on the charges.

The third, by giving an individual charge while the other cells in the battery are on discharge; this may be done from a small dynamo, usually motor-driven.

Before putting a cell that has been in trouble into regular service again, care should be taken that all the signs of a complete charge are present, viz: the rise in potential and specific gravity to the proper value, the gassing from the plates and the normal color.

19. *Sediment.*—Another cause for cells working irregularly, especially after they have been in service a considerable time, is the accumulation of sediment in the bottom of the jar or tank, to such a depth that it touches the bottom of the plates which then become short-circuited.

For this reason the gradually increasing amount of sediment should be carefully watched and removed before it gets dangerously near the plates. It must never be allowed to get up to them.

As the accumulation is usually greatest under the middle of the plates of a cell, care should be taken not to be guided by an examination under the end plates only.

To remove the sediment, a convenient method, provided there is sufficient free space at one end of the tank, is to "rake" it out from under the plates and then "scoop" it up, always using a device containing no metal in its construction.

If, however, this method is impracticable, the electrolyte should be drawn off into clean containing vessels, the battery previously having been fully charged, and the cells then flushed with water (the city supply may be used for this purpose) in such a way as to thoroughly stir up the sediment, the whole then being drawn off, the process to be repeated as often as necessary to remove all the sediment. If there is not sufficient drop to allow of siphoning, a pump should be used. Pumps most suitable for this purpose are of the rotary type, with bronzed parts.

After the tanks or jars have been thoroughly cleaned, the electrolyte should be quickly replaced, to prevent undue heating and drying of the negative plates, and also the long charge required by dry plates to bring them to a state of full charge.

In addition to the electrolyte withdrawn from the cells, new must be provided to make good that displaced by the sediment. This should be of 1.300 or 1.400 specific gravity to counteract the effect of the water which was absorbed by the plates during the washing, and also to reduce the bulk of the new supply.

20. *Keeping electrolyte free from impurities.*—Still another cause for irregularity in cells would be the presence of foreign matter in the electrolyte. If it is known that any impurity, especially any of the metals (except lead) or other acids, has gotten into a cell in other than very minute quantities, the electrolyte should be replaced by new immediately, after the manner noted above under "Electrolyte."

21. *Battery used but occasionally.*—If, for any reason, the battery is discharged but occasionally, or the discharge is at a very low rate, a weekly freshening charge should be given.

22. *Putting the battery out of commission.*—If the use of the battery is to be discontinued for a time, say six months or more, it is very often best to take it entirely out of service by drawing off the electrolyte.

This should be done as follows:

After a complete charge, siphon off the electrolyte (which may be used again) into convenient receptacles, preferably carboys which have previously been cleaned and have never been used for other kinds of acid, and as each cell is emptied immediately refill with water. When water is in all the cells begin discharging and continue until the voltage falls to or below 1 volt per cell at normal load; when this point is reached draw off the water; the battery may then stand without further attention until it is again to be put into service.

23. *Putting the battery into commission again.*—To do this, proceed in the same manner as when the battery was first put into commission. After first determining that the polarity of the charging source has not been altered, so that its positive pole will still be connected to the positive end of the battery, put in the electrolyte and start charging at once at the normal rate, continuing until the charge is complete; from twenty-five to thirty hours at this rate will be required. The completion of this charge is determined in the same manner as are those when the battery is in regular service, as noted above.

24. The attached form is recommended for recording the readings, which should be taken in duplicate, carbon paper being used to obtain the second copy which should be forwarded to the Company's office.



94. Type G-19 in Lead-Lined Pine Tank.

(C) FORMS FOR KEEPING RECORDS AND MAKING TESTS.

1. STORAGE BATTERY WEEKLY INSPECTION REPORT.

Plant of _____ Date, _____, 190__ Time { _____ A. M.
 _____ P. M.
 at _____
 Consisting of _____ cells, type _____ "Chloride Accumulator."
 Battery { Charging _____ at _____ amperes.
 { Discharging _____
 Battery had been { Charging _____ } for _____ hours at average rate of _____ amperes.
 { Discharging _____ }
 Battery last inspected with lamp _____ (date).
 Cells (Nos.) especially worked on during week _____
 Height of electrolyte above top of plates _____ inch.
 Water was added to replace evaporation _____ (date).
 Temperature of electrolyte _____°F; of air of battery room _____°F.

Cell.	Volts.	Specific Gravity.	Cell.	Volts.	Specific Gravity.	Cell.	Volts.	Specific Gravity.	Remarks.
1			31			61			
2			32			62			
3			33			63			
4			34			64			
5			35			65			
6			36			66			
7			37			67			
Etc.			Etc.			Etc.			

2. TEST OF BATTERY OF "CHLORIDE ACCUMULATOR"

Consisting of ----- cells, type ----- Located at -----

CHARGE.	Date.	Time.	No. of Cells in Cir.	Total Volts.	Volts per Cell.	Amp.	Amp. Hrs.	PILOT CELL.			Remarks.
								Volts.	Sp.Gr.	Temp.	
DISCHARGE.											

NOTE.—Readings to be taken half hourly. All of the cells to be in as nearly uniform condition as possible before the test is started.
Pilot cell should be representative and in the main part of the battery.

3. TEST OF BATTERY OF "CHLORIDE ACCUMULATOR."

Consisting of ----- cells, type ----- Located at -----

CHARGE.			DISCHARGE.			CHARGE.			DISCHARGE.			Test taken by-----
TIME.	--- TO	--- TO	--- TO	--- TO	--- TO	TIME.	--- TO	--- TO	--- TO	--- TO	--- TO	REMARKS.
	--- P.M.	--- A.M.	--- A.M.	--- A.M.	--- A.M.		--- A.M.	--- P.M.	--- P.M.	--- P.M.	--- P.M.	
Cell.	Volts.	Sp. gr.	Volts.	Volts.	Sp. gr.	Cell.	Volts.	Sp. gr.	Volts.	Volts.	Sp. gr.	
1						36						The readings to be taken at the end of charge and discharge; the voltage with the current flowing, as recorded on the (2) sheet; the specific gravity immediately after the current is off. Two columns for "Volts" under "Discharge" are provided in case the first set of readings is taken before the battery is "down," or in case "check" readings are desired. The time when readings are started and finished to be recorded at head of columns.
2						37						
3						38						
4						39						
5						40						
6						41						
7						42						
8						43						
9						44						
10						45						
11						46						
12						47						
13						48						
14						49						
15						50						
16						51						
Etc.						Etc.						

(D) GENERATOR AND CIRCUIT PANEL AND BATTERY PANEL.

Generator and circuit panel (fig. 95) and battery panel (fig. 96) for use in connection with chloride accumulators as designed and manufactured for the U. S. Gov't by the Storage Battery Company, Phila. V. M. switch: 1, bus; 2, A + B discharge; 3, A charge; 4, B charge; 5, + ground; 6, - ground. The back connections will be evident.

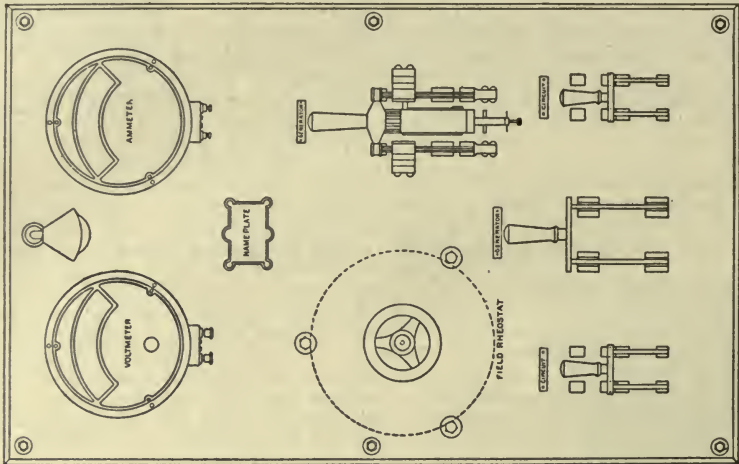

95.

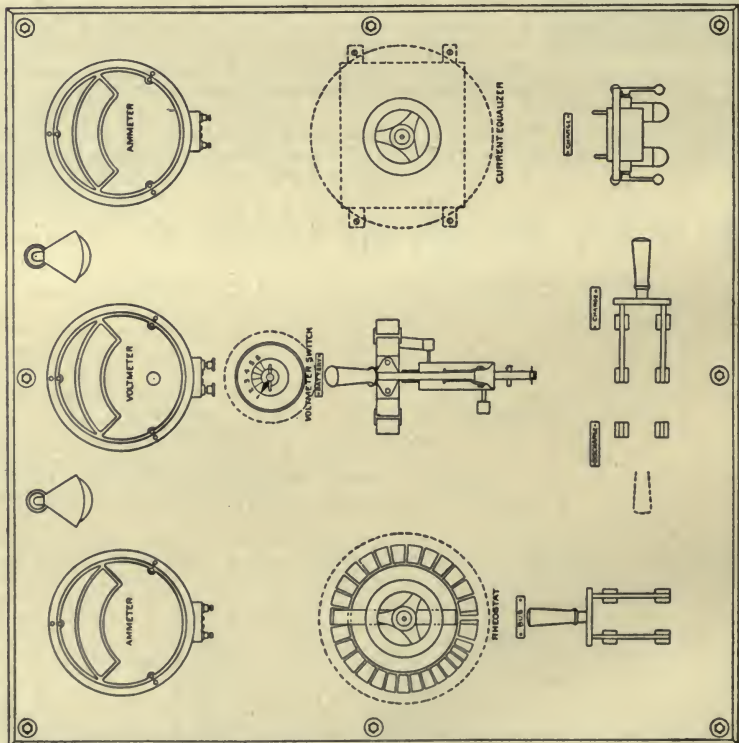

96.

(E) COMBINED GENERATOR AND BATTERY PANEL

For use in connection with chloride accumulators where battery is charged and discharged in series, as designed and manufactured for the U. S. Gov't by the E. S. Battery Company, of Philadelphia. Voltmeter switch: Point 1, dynamo point 2, battery; point 3, + ground; point 4, - ground.

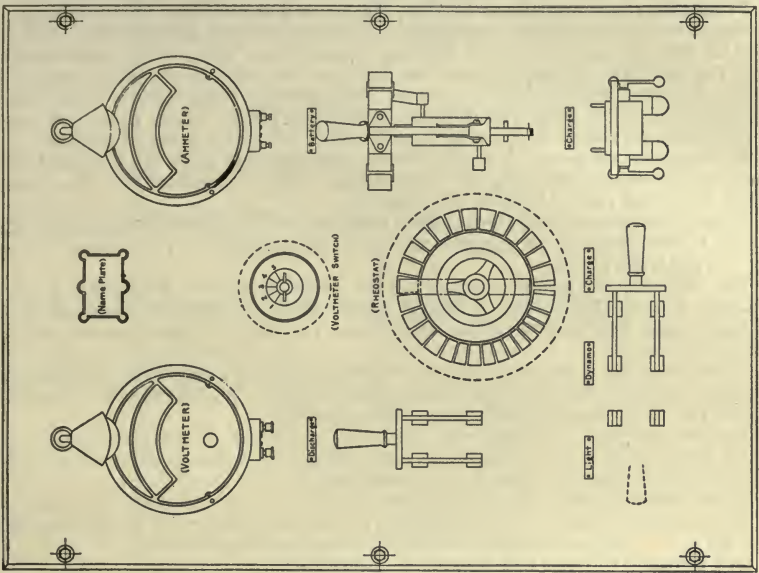

97.

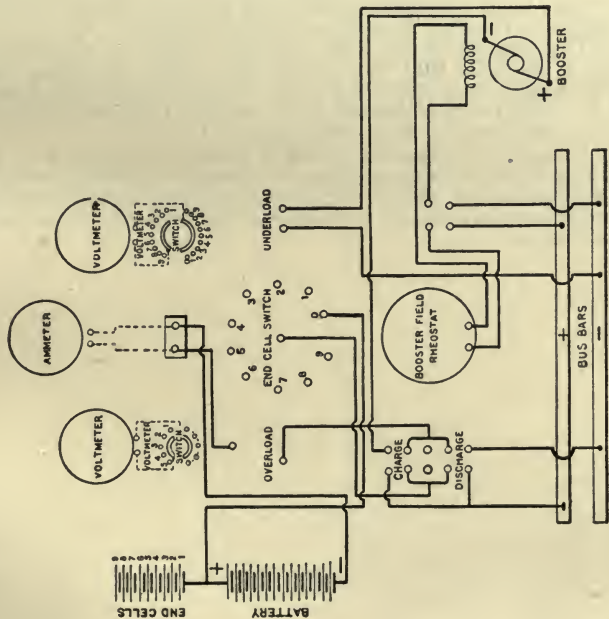

95a.

Fig. 95a gives the S. B. connections when a booster and end cells are employed in large installations. It is the most economical disposition shown.

(F) PRECAUTIONS.

1. Sulphating, buckling, and disintegrating of plates (positives are more susceptible than negatives) are the three most serious troubles with storage cells in general, but they may be avoided; if not too far gone they can be cured.

2. Sulphating is a whitish scale that forms in patches due to overcharge; to standing too long partially discharged, or to too strong electrolyte. It is also shown by loss of capacity and a higher voltage than the charge warrants. If slight, repeated slow charge below one-half the normal rate and discharge is the remedy; if considerable, carefully scrape off the white scale prior to slow charge. No attention need be paid to a whitish loose precipitate which does not extend into the plate, as found by cutting into the skin with the point of a knife.

3. Buckling or warping of a plate from unequal action on its two surfaces is caused by excessive charging or discharging rate or sulphating. To remedy, steadily press the plate between two boards.

4. Disintegrating of paste from plate results from sulphating, buckling, or old age and, if well started, new plates are the only remedy. It seldom or never occurs in chloride plates.

5. The office of the storage battery is to form a reserve for feeding lamps, operating night signal sets, igniting fuses, etc., in case of accident to the machinery, and to illuminate the magazines for short periods, so as to avoid starting the engine.

6. A well-managed chloride storage battery will last indefinitely on 6 per cent allowance of the cost for amortisation each year. Watt efficiency should be about 85 per cent; quantity efficiency, 90 per cent.

7. The normal rate of charge and discharge is about 12 amperes per square foot of positive plate counting one side only. The charge rate need not be exceeded; the discharge rate, only in emergency.

8. Guard against disturbing the plates in jars while connecting or disconnecting the lugs, and against solution falling from the hydrometer or stick, outside of the jar.

9. Dry plates will keep indefinitely in a dry place.

10. The deflection of a voltmeter across a connection should be no greater than for an equal length of lug.

11. To charge a portable battery of few cells from a 110-volt lighting, a 550-volt trolley or an arc-lighting circuit by placing in series with the battery a bank of lamps or a rheostat, is well explained in figure 98.

(a) The connection with an arc circuit, as in *D*, requires experience. The switch is so made that the contact arm *A* when thrown to the charging (two dotted lines) position shall not open the light circuit nor short-circuit the battery *A*. Heavy wire resistance *R* has terminal *C* so spaced between *B* and *D* that the arm must touch *C* before leaving *B* or *D*.

Or, *R* may be permanently placed in the arc circuit, its E. M. F. verified before switching in the battery and after the charge is finished and battery is opened, *R* is shunted out of circuit. The caution seems unnecessary that while being charged the switch should be opened at the first sign of fluctuation or stoppage of the current.

In the case of a battery of three cells or 6 volts requiring a charging C of 5 amperes from an arc circuit of 7 amperes, $R = 6 \div (7 - 5) = 3$ ohms.

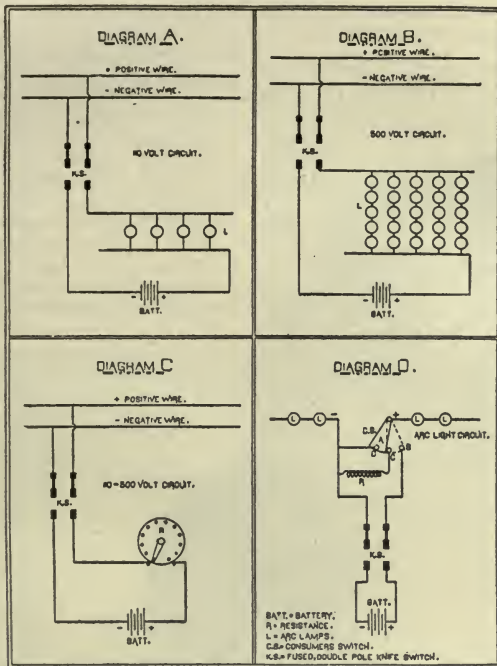

98. Charging Few Cells.

(b) In the case of the same battery charged from a 110-volt circuit the total resistance of lamps hot = $(110 - 6) \div 5 = 21$ ohms.

(c) In all cases the polarity and potential of the charging circuit must be known to be correct by means of the voltmeter before closing it on the battery. If no voltmeter is at hand, the polarity can be ascertained by dipping the terminals in salt water, when the greater flow of gas will appear at the negative terminal which is the one which should be connected with the negative of the battery.

VII.—D. C. ELECTRIC MOTORS.

(A) ESSENTIAL PRINCIPLES AND CLASSIFICATION.

1. Any D. C. dynamo supplied with current from an external source will operate as a motor. The lead of a motor, if any, is backward, not as in a dynamo, forward or with the rotation.

2. To get the direction of rotation of any conductor on the motor armature's surface, hold the left hand with its thumb and first two fingers extended

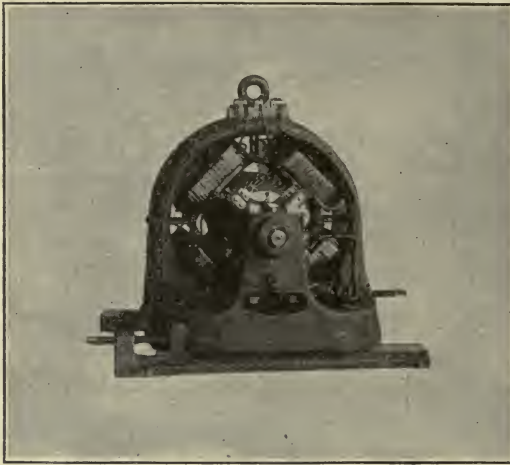

99. W-e Multipolar.

at right angles to each other, so that any one of the three lies parallel with the conductor pointing in the direction of the current through it, and so that another points in the direction of the lines of force of the field magnet; then the third will point in the direction the conductor is urged.

3. *Back electromotive force.*—The armature of a motor revolving in a field, owing to an external supply, has an E. M. F. set up in it precisely the same as if it were revolved as a dynamo. This E. M. F. or (e) has (from the rule with the right hand) a direction opposite to that (E) which actuates the motor, and is therefore called back or counter E. M. F. The motor's power varies directly with the resultant E. M. F., i. e., with ($E-e$). Ex. If 100 volts be applied to the brushes of a motor of 2 ohms internal resistance, and if the armature be clamped to prevent rotation, the current would be 50 amperes. But if the armature is allowed to revolve, a counter (e) will be set up

of say, 96 volts. The current then through the motor is $\frac{(100-96) \text{ volts}}{2 \text{ ohms}} = 2 \text{ amperes}$

and the power expended is $2 \times 100 = 200$ watts.

4. *Efficiency.*—The power input (C amperes $\times E$ volts) is always equal to the useful output or power at the pulley (torque in lbs-feet \times revs. per sec.) plus the energy wasted per second to overcome ohmic resistance, friction,

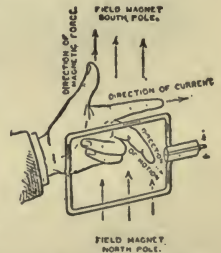

100. Motor Left Hand.

windage, hysteresis, Foucault and eddy currents. The total wastage amounts to 10 or 15 per cent. Efficiency of a motor = useful output \div input = 80 to 90 per cent usually.

5. Modern D. C. motors are usually wound for a constant potential supply of 500 volts for several miles transmission, 220 volts for a few thousand feet, and 110 volts for a few hundred feet as in forts. Like modern generators, they usually have 4 or more removable poles projecting inwardly from an outer field steel casting support toward an iron-clad armature, i. e., one in which the conductors are sunk and bound below the surface in slots parallel with the axis. Displacement of the winding is therefore impossible.

In the construction both field and armature coils are formed on moulds, insulated and laid without bending on their cores, which are laminated transversely to their main currents. The armature core has air ventilating ducts parallel and perpendicular to the axis to which it is rigidly held by a spider. The commutator has large diameter and many bars insulated by mica. The brushes are carbon, radially placed with little or no lead and are sparkless from full load to no load without adjustment.

6. *Each class has a special use.*—For constant current supply, motors are always series wound; for constant potential, they are series, shunt or compound wound.

(a) The series motor (fig. 101) has great starting torque (force \times lever arm), changes its speed greatly for small changes of load, does good work at the different speeds, races dangerously without load, and is regulated by a rheostat in series with it. If its supply is constant current, it may be safely overloaded to the point of stopping; if constant potential, it may run one-half hour on 25 per cent overload. It is suited to variable speed work as in railroads, automobiles, hoists and machines which require increased torque when slowed down from overload and have an attendant. Series motors run parallel across constant potential mains, work well on separate work; on joint work each must be geared (not belted) for a speed corresponding to its share of the voltage.

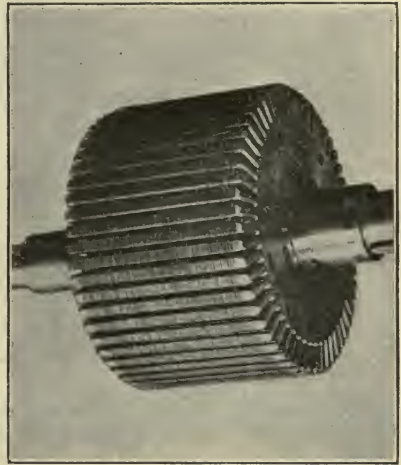

100a. W-c Core of M. P. Motor.

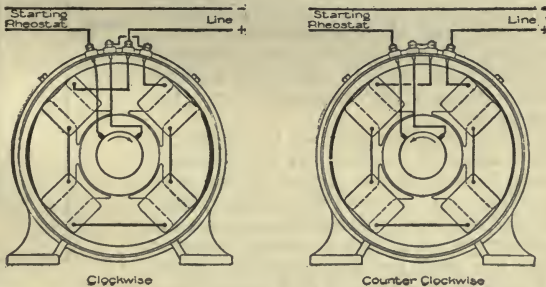

101. Series Wound.

(b) The shunt motor (fig. 102) has moderate torque at starting, gives nearly constant speed with varying load, falls in speed only a few per cent from 0 to full load, is largely self-regulating, and suited to blowers, lifts, and lathes. The armature and field circuits lie in parallel across the mains, and the speed can be regulated by a starting box in either one or in both; the rheostat in the armature circuit is essential at starting to prevent a destructive current. Several shunt motors of like voltage may be placed in parallel, even of unlike power,

either to work separately or each to do its part on one shaft; or in series, to work separately.

(c) A compound motor (fig. 103) is cumulatively or differentially wound—a compound dynamo as a motor has the latter winding. The former kind is coming into use. It has increased torque at slower speed, is partly self-regulating,

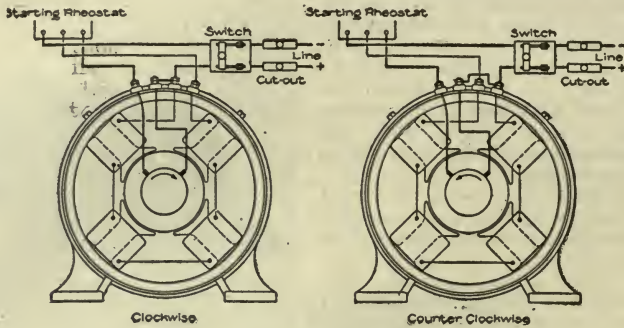

102. Shunt Wound.

and is adapted to work where heavy overloads occur and close regulation is not important, such as for printing presses and hoists. Their supply is constant voltage only.

(B) REGULATING AND PROTECTING APPARATUS.

1. When a motor armature is at rest there is no counter E. M. F., and if the potential of the supply were closed upon it, the current would be destructive. Hence, a starting and stopping rheostat (fig. 103) is always put in series with the motor and its resistance is gradually cut out as the motor gains speed and counter E. M. F.

When a starting box has not wire of sufficient cross-section to carry the motor current for any length of time without overheating, the switch must not remain on a point longer than two or three seconds. When the rheostat wire is large enough to carry the current indefinitely, the box is a speed regulator or controller.

2. The motor is slowed down and finally stopped by turning the same contact arm to throw resistance into the motor circuit and thus gradually to diminish the current from full strength to zero. To open the circuit as at the main switch while full current is flowing would endanger the insulation from the induced extra current.

3. In addition, a motor requires to be protected against sudden excess of current by an overload automatic circuit breaker in one or both of its feeders, which is quicker and more certain than a fuse; also by an underload automatic circuit breaker against the fall of the current or of the potential below a certain limit due to a cross or other accident which is liable to be followed by a rush of full current that would destroy the motor at rest.

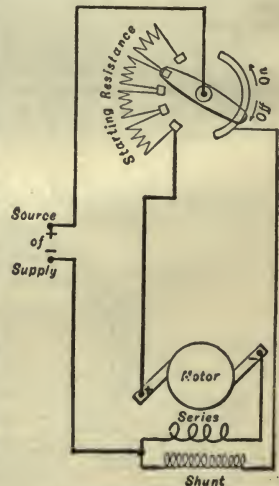

103. Compound Motor.



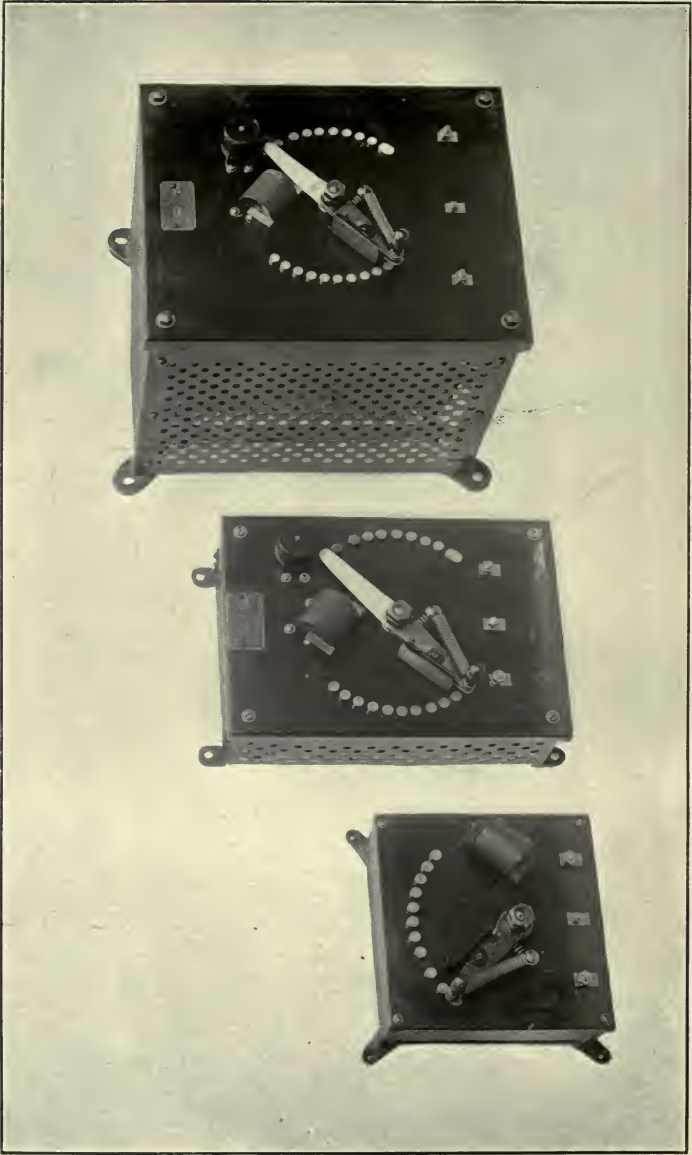

106. G. E. Boxes for S. and S. Rheostats etc.

(a) Diagram of General Electric S. and S. rheostat (fig. 104) with automatic release (underload C. B.) in armature circuit of small series motor. Box is shown for small shunt motor.

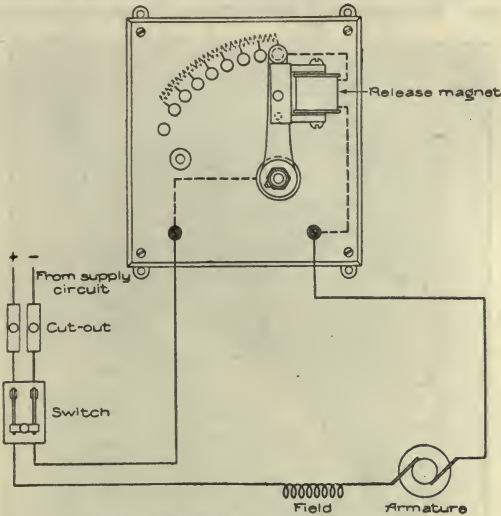

104. Diagram of S. and S. Rheostat.

(b) Diagram of General Electric S. and S. rheostat (fig. 105) for larger series motor with underload release magnet in the armature circuit and magnetic blow-out at the first step; stops on left-hand side are connected with middle pivots of coils on right-hand side.

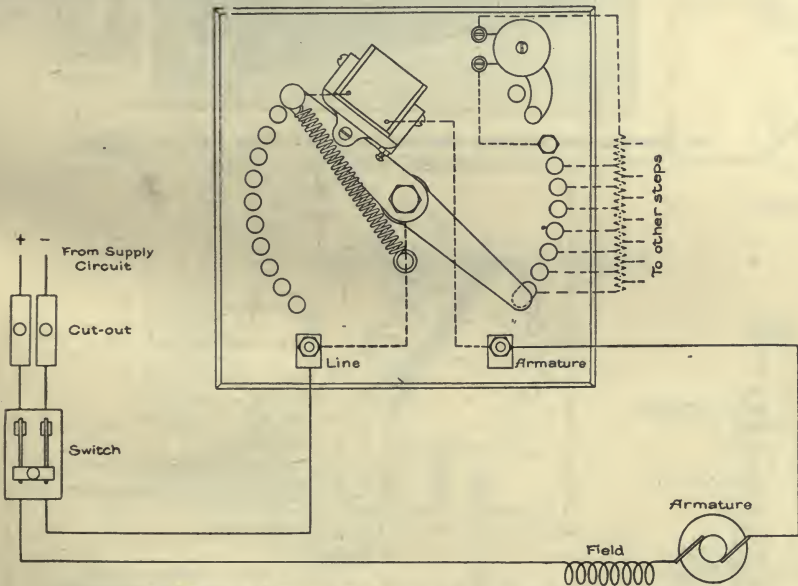

105. Diagram of S. and S. Rheostat for Larger Series Motor.

(c) The armature of the retaining magnet is adjusted by means of the screw and nut to hold at a current equal to about 55 per cent of the full-load amperes of the smallest size of motor with which the rheostat is used. Therefore these series motors must be loaded to about one-half their capacity, or the armature will not be held by the magnet.

Boxes for S. and S. rheostats (fig. 106) for shunt motors, two larger showing magnetic blow-out.

(d) Starting and stopping rheostat (figs. 107-8) for shunt motor with no voltage (underload), automatic circuit breaker in the field circuit, with overload release and magnetic blow-out in the main, and with switch shown in the "On" position in fig. 108. Mid-points of resistance coils are connected.

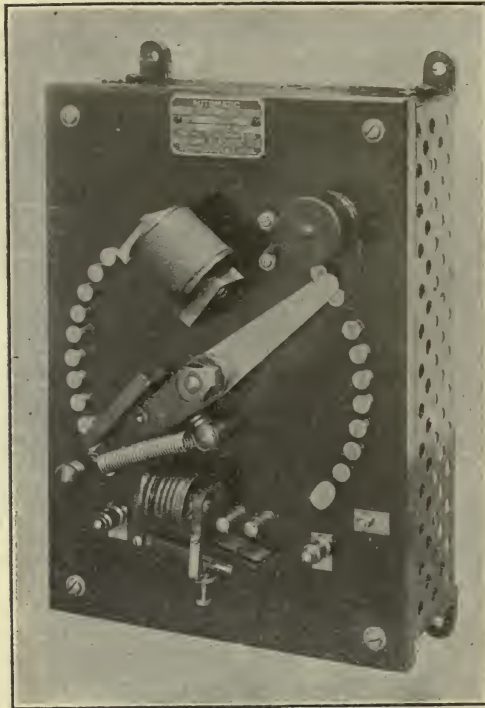

107. Starting and Stopping Rheostat for Shunt Motor with no Voltage.

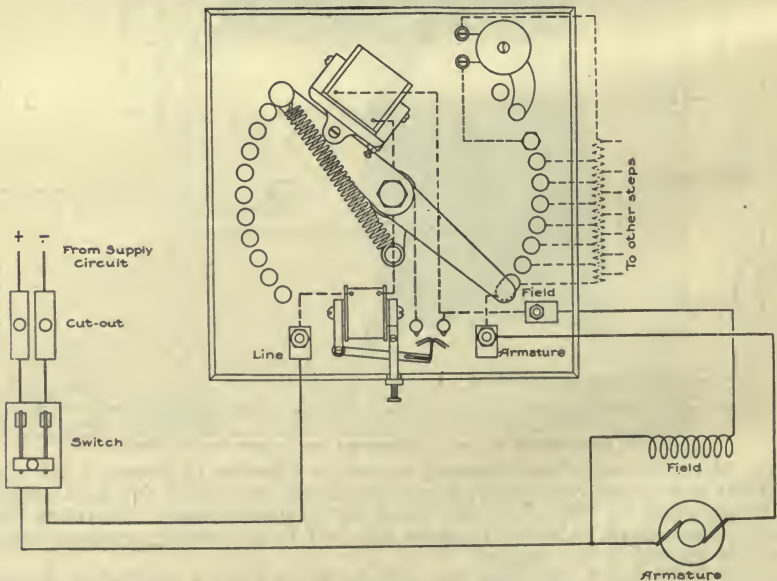

108. Wiring of Starting and Stopping Rheostat.

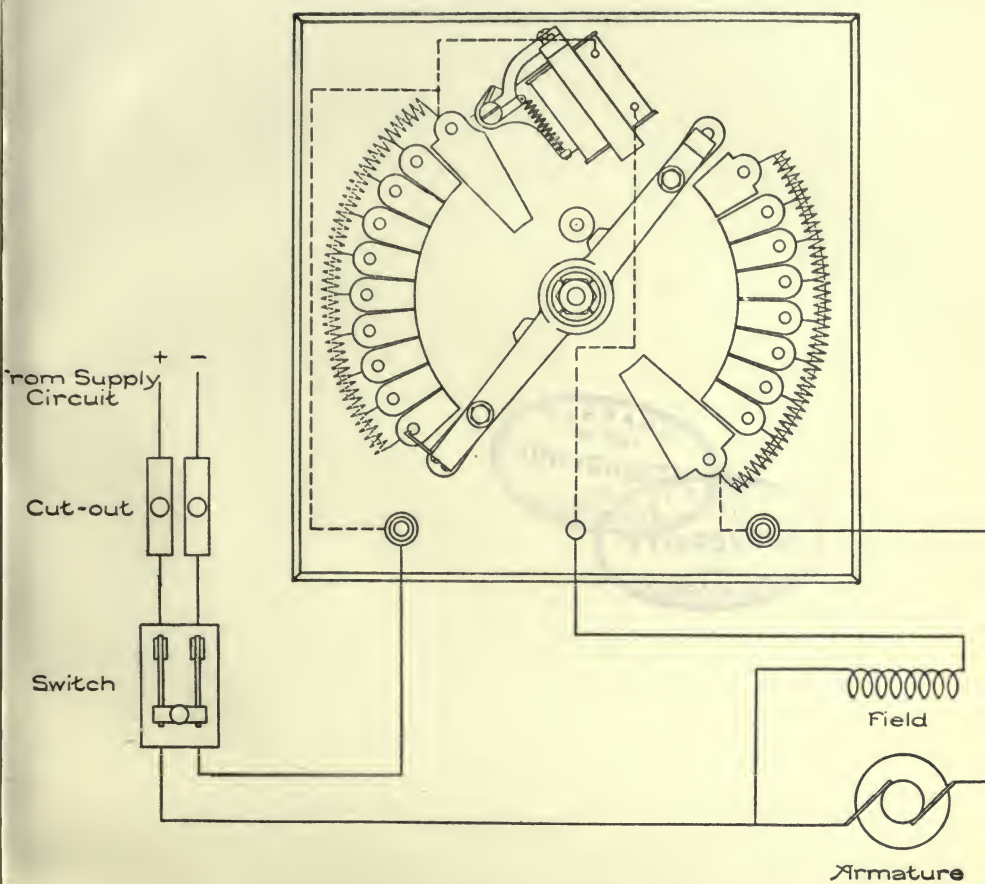

Details of Release Magnet

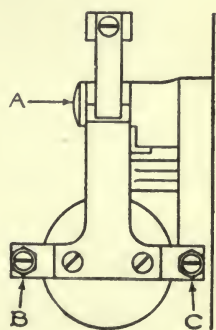
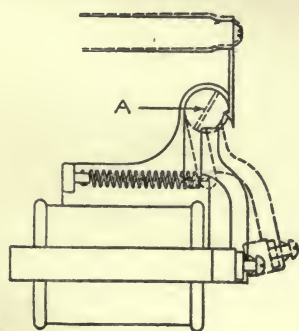

109. Rheostat and Connections.

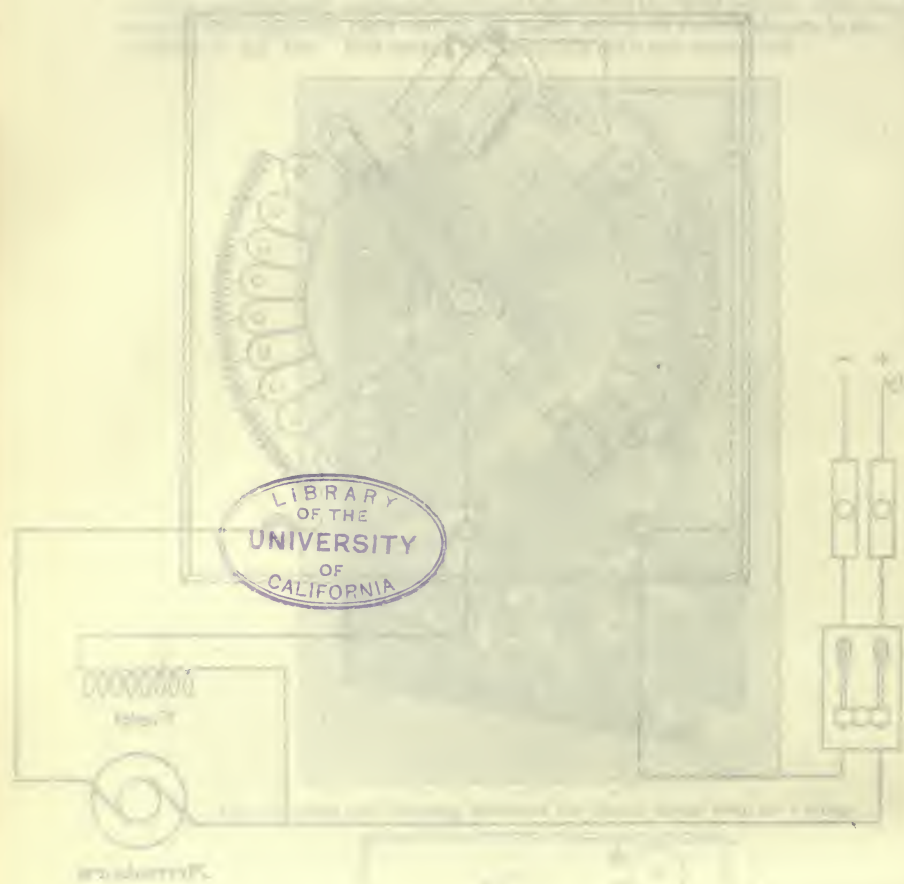

Department of Mechanical Engineering



Copyright 1910 by the University of California



LIBRARY
OF THE
UNIVERSITY
OF
CALIFORNIA

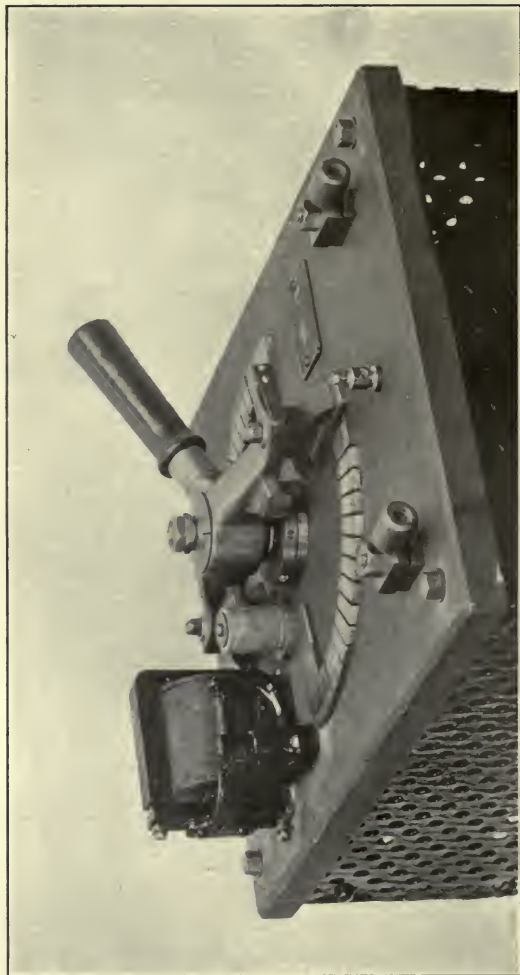

110. Rheostat and Connections.

The switch is moved gradually clockwise against the action of the spring and held by the U. L. upper magnet. If the potential of supply falls off say 25 per cent, the magnet releases the armature on the switch which flies to the "Off" position where the arc, if any, is blown-out.

If the current exceeds the allowable limit in the O. L. or lower magnet of heavier wire, the armature, lifted against the two pins, short-circuits the underload magnet which then operates as above. The spindle of the switch or contact-arm is connected by wires with one side of both magnets and the left pin.

(e) Figs. 109 and 110 show rheostat and connections for large shunt motor, with underload, circuit breaker of different form, whose details are plainly indicated in separate cuts.

(f) Automatic O. L. and U. L. circuit breaker (fig. 111) is held in the "On" position against the tension of a spiral spring in the hub.

6. Directions for installing rheostats are as follows:

(a) If the rheostat must be attached to ironwork of any kind, special care should be taken to thoroughly insulate it from the iron.

Attach the small rheostats which have no magnetic blow-out, to the wall with the retaining magnet on the right-hand side and the connection terminals at the bottom. The large rheostats, with magnetic blow-out, should be installed with the magnets at the top, otherwise the arc at the blow-out may cause trouble.

(b) *Adjusting.*—The rheostats are adjusted so that the arm will return to the "Off" position from any step. If it does not, the steps are generally found to be dirty. If on cleaning them, the arm still works too stiffly, slack up the adjusting nuts that are on top of the arm. These nuts must be left securely locked or the arm will again get out of adjustment.

The armature of the retaining magnet is adjusted by means of the screw and nut to hold at the average field current of the smallest size of motor with which the rheostat is used.

Sometimes, however, the field current may be less than the average, and it is therefore not enough to hold the armature to the magnet. In this case the point of the screw should be turned back into the armature until the latter holds securely. The adjustment also provides for the releasing of the armature when the field current falls to at least one-quarter of the average, and if any change is made in the adjustment to have the armature hold more securely, a trial should be made starting the motor, then cutting off the supply of current to see that the release takes place at about the time that the motor has slowed down to one-quarter speed. If the armature does not release by that time there is danger that it will not do so in time to protect the motor.

If the armature can not be made to hold securely with the range of adjustment, get a new magnet spool to suit the conditions. The overload release is adjusted by means of the screw below the armature, to operate when the amperes increase to the amount on the plate screw along the upper edge—usually 100, 125, or 150 per cent of the full load current of the largest motor for which the rheostat was built.

(c) The connections are such that the field of the motor is made as soon as the main supply switch is closed. Do not test the line for current by touching the first step with the arm and then allowing it to go back to the "Off" position; this draws an unnecessarily long arc at the first step, which uselessly burns the arm and contact.

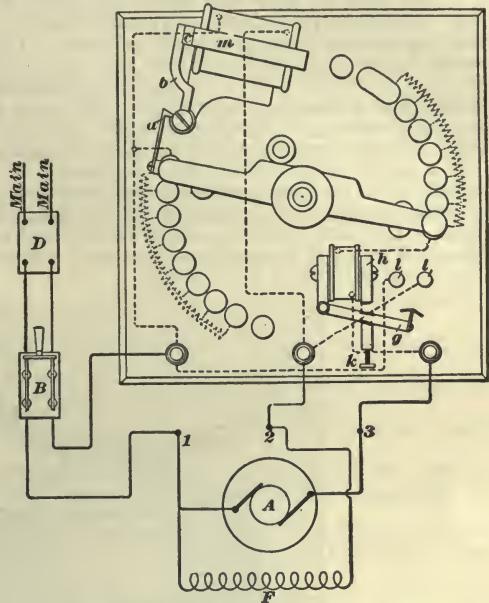

111. Automatic O. L. and U. L. Circuit Breaker.

(d) *Renewals.*—If the first step which is of copper and hexagonal in shape becomes burned, it may be removed by unscrewing it and substituting another. The arm may also be easily taken off and smoothed or renewed.

(C) OPERATION AND CARE OF MOTORS.

STARTING.

1. See that all nuts and parts are tight, that connections are correct, that the commutator is clean, that the brushes are properly set, and that the starting switch is in the "Off" position. Turn, if possible, the armature by hand, to see if it is free. Close the main switch. Turn the rheostat switch steadily clockwise until it strikes the automatic release, so that the motor starts slowly and increases uniformly to full speed, taking about one-half minute to turn the switch. If the motor is new, run it empty for a time and see that all parts operate properly when the motor is partially and fully loaded.

If a motor fails to start after beginning to cut out the resistance, turn the switch off to prevent accident before beginning to explore. With a voltmeter, or with the hands on low potentials, ascertain if the supply is present. If it is, take off the load, close the main switch, and see if the armature moves. If it does not, proceed from the mains with a voltmeter in search of a broken circuit. The break may be in the rheostat.

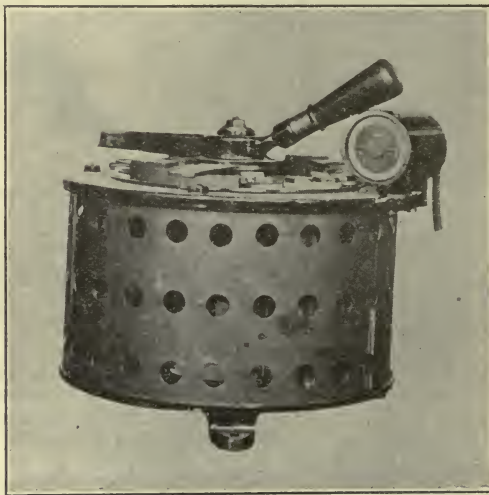

112. W-e S. and S. Box.

If motor terminals show potential and poles have no magnetism, there is a break in the field of a shunt or compound motor, or between the terminals of a series. But if the poles are magnetized, see if brushes are at the neutral point and pressed down, if commutator is clean, if adjacent poles are not alike, or if coils have not a short circuit.

RUNNING.

2. (a) See that the oil rings or feeds distribute oil properly, that the belt runs in the middle of the pulley without tendency to thrust the armature toward one end, and that no part gets overheated. The heating of any part is probably normal if its temperature is 110° F. or less above that of the surrounding air after several hours' continuous run on full load, as tested by a thermometer placed upon it and surrounded by waste. The danger point has not been reached if the hand can bear long contact without discomfort. Hot coils are usually due to overload, short or partly open circuit. Commutator and brushes often get hot from sparking or friction.

(b) From time to time, or whenever the bearings show signs of heating, draw off the oil and replace with new by bringing up the level until the rings flush the shaft freely, care being taken not to overflow the bearings.

A hot box is due to poor oil, grit, rough-bearing surface, tight box or belt, shaft bent or out of line, or overload.

(c) The usual load causes a certain rise of temperature in each part which is well known to the watchful attendant, and any increase of that amount requires immediate correction without, if possible, stopping the machine. If smoke appears, damage has been done.

(d) Irregularity of speed may be expected in a series motor whose load varies. But a shunt motor changes speed slightly for large variation of load; if overloaded it heats. Abnormally low speed indicates overload, short circuit or a defective contact.

(e) Keep all parts of the motor free from dirt, damp, waste oil and carbon dust.

STOPPING.

3. Turn steadily the rheostat switch contraclockwise to the open stop; then open the main switch. The order is the reverse of that in starting. Finally, take the same precautions as in leaving dynamos.

4. "Faults" in motors, together with their causes and remedies, are for the most part, the same as for dynamos (page 52). The motor on account of its duty is not, as a rule, so accessible as a generator; its care, equally important, is more likely to be neglected.

Prevention, not cure, is the rule for motor or dynamo troubles.

Dirt, sparking or overheating usually affords conclusive testimony regarding the attendant's fitness.

Oil cans, tools, or loose iron near the motor in operation are liable to be drawn into the armature.

To reverse a D. C. motor, reverse the current through the armature (usually) or the field—not both.

The voltage of supply should be within 5 per cent of that for which the motor was built.

Excess voltage to shunt motors will heat the fields and somewhat increase the speed; scant voltage will heat the armature and lessen the speed.

Remember main switch first, rheostat last in starting; rheostat first, main switch last in stopping.

Do not keep the rheostat switch long on one stop, except the end ones, unless the rheostat was built to carry the full current indefinitely as a regulator or controller.

Oil reservoirs may be half drawn every three or four weeks and refilled with new.

High-grade, dense, mineral oil, free from grit, is the proper lubricant; after filtration it may be reused.

Keep posted all motor circuits and manufacturer's directions.

A series motor always runs reverse to its direction as a generator; a shunt, in the same direction; a differential compound, according to the stronger field.

(D) SPECIAL FORMS OF MOTORS IN SERVICE.

1. (a) The Leonard motor control for guns, turrets, passenger elevators, etc., avoids violent stresses, bad sparking, and affords complete control with precision of stoppage.

(b) In fig. 113, *M* is the motor whose field is constantly excited direct from the mains. *G* is the generator, likewise excited, but through the reversing field rheostat *C*. The brushes of *M* and *G* are permanently connected.

(c) To start the motor the generator's field is weakly excited. As resistance is cut out of *C*, *G* delivers stronger current to *M* and increases the speed. The rheostat contact arm is divided by insulation at the pivot. Turning it to left reverses the *G* field and *M*'s motion.

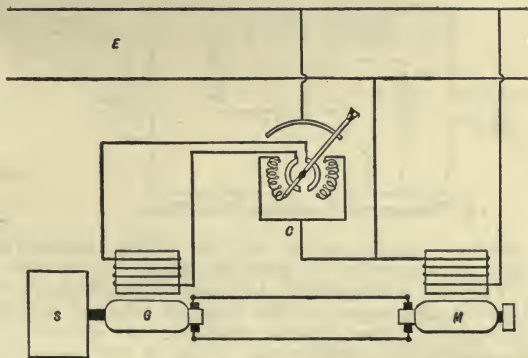

113. System for Training Guns.

2. The recording watt-hour meter (fig. 114) in general use is a compound wound ironless motor, whose main field coil carries the main service current, and whose armature of fine wire lies with dead resistance across the mains.

The revolutions varying as the C and E of supply and therefore as their product, are recorded as units, tens, etc., on the dials. The shunt field is added to compensate for friction. A copper disc on the armature shaft revolves between the poles of an adjustable magnet, which can slow down the motion 16 per cent or less as desired.

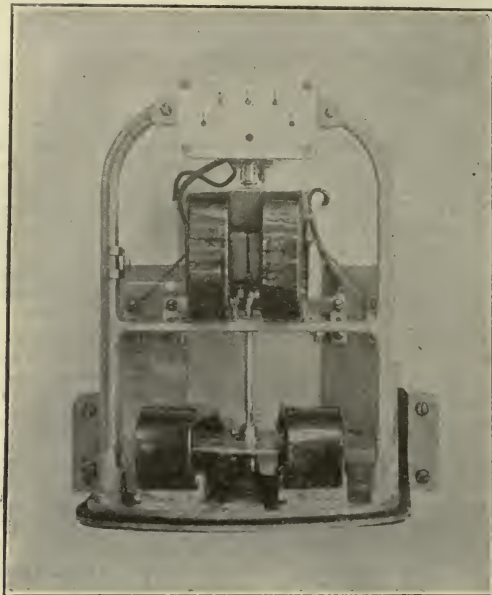

114. Measures Electrical Energy.

3. Dynamotors, motor generators, and boosters are rotating transformers of direct current having a dynamo and a motor armature winding and two commutators usually on the same shaft.

(a) The dynamotor has two armatures, or two separate windings on one armature revolving in one magnetic field. Its place in the Teazer system for

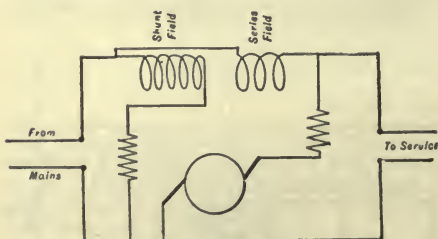

115. Thompson's Recording Watt Meter.

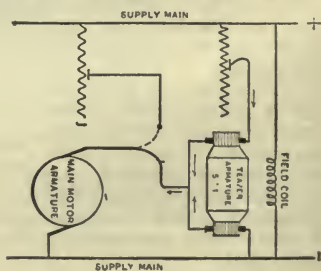

116. One of the Special Motors.

starting a main motor without taking excessive starting current from the mains is shown by "Teazer Armature" in fig. 116.

The left commutator belongs to the motor winding on the armature; the right commutator, to the dynamo winding which has about one-fifth of the potential of the motor's winding. At starting, the Teazer dynamo supplies about one-fifth of the main voltage to the main motor, giving proper torque at low speed without draining more than about one-fifth of the current from the supply mains which would be taken without the dynamotor. When the main motor has reached the highest speed attainable in this way, it can be switched to the supply mains and the Teazer circuit switched out without excessive drain from the mains.





118. Westinghouse 4-Pole Motor.

(b) The motor generator (fig. 117) has two armatures revolving on one shaft in separate fields. The motor commutation is at one end, the dynamo's at the other. It is not so efficient a transformer as the dynamotor, but its dynamo voltage may be given greater range and its modes of construction and operation are simpler in charging batteries, electroplating, supplying telegraph trunk lines or current to laboratories.

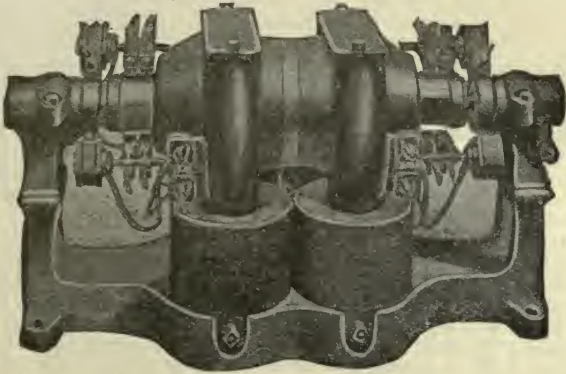

117. Motor Generator.

(c) A booster is an electrically or mechanically driven transformer whose dynamo commutator is in the main circuit at a distant point to raise the voltage there. Both the main and generated currents flow together in the dynamo armature winding, which has, therefore, very thick copper. Boosters are placed, for instance, at the ends of long feeders running from the same bus bars as short feeders, to keep the potential the same.

VIII.—ELECTRIC HOIST WITH AUTOMATIC SAFETY STOP.

It is applied to two platforms, *GG*, either of which is drawn upward, while the other descends, by a winch driven by a motor through worm or train gear. A 5-horsepower motor can raise 2,000 pounds counterweighted by 600 pounds of the other platform at the rate of 1 foot per second. The design is simple, inexpensive, and the motor and hoist are fairly well protected.

1. *M* is the motor with both series and shunt fields, the latter being excited when *MS* is closed. *RS* is a three-pole reversing switch shown in position for the right-hand platform to ascend.

2. The controller has a starting rheostat, *Rh*; a hand lever, *W*; a spring lever, *V*; an underload release, *UL*; and an overload release, *OL*. The magnet *UL* depends for its excitation upon the voltage of the motor terminals and also upon the integrity of its circuit at any one of the four points — *OL*, *RS*, *E*, or *F*. The main circuit from *MS* is through the electro-magnetic brake *EB*, series fields *OL*, to the contact piece *b*; when the lever *V* is held down by *UL* magnet, the circuit is closed from *b* through *d*, *V*, *W*, *Rh* (or direct after the motor has attained full speed), to *RS*, *M* to *MS*.

3. The main circuit is broken either when the lever *V* is released (*e* and *f* taking the spark), or when *W* is moved to the left (*k* and *l* taking the spark). The lever *V*, when released by *UL*, is carried to the right by the spring at its axis until it strikes *W*. The rheostat may be designed for running the motor continuously at different speeds, or as a starting box not to be in the circuit longer than thirty seconds.

4. *S* is a baby switch held open by a spring. Its object is to close, if desired, the *UL* magnet circuit when open at *E* or *F*.

5. *A* and *A* are the devices for automatically breaking the circuit through *UL*, and thus the main circuit when the platform ascending strikes the lug *g*, which is adjustable on the bar sliding in guides *h*. On the lower end of this bar an insulate copper wedge makes, when down, contact between two copper terminals at *E* or *F*, and breaks it when up, thus making or breaking the circuit through *UL*. *E* and *F* are alike and adjustable vertically 6 inches.

6. The right-hand platform is at its upper level, the left-hand is at its lower; the circuit through armature *M* has been broken and *V* is up against *W*. If now we try to start the motor without reversing *RS*, the circuit through *M* will still be open at *E*. But throw *RS* down and the circuit through *UL* will be closed at *F*, and the left-hand platform can be raised.

7. To start the motor at all, *W* must always be brought up to the left, pushing *V* before it until held by the underload magnet *UL*; then *W* may be moved to the right, closing the circuit first through *Rh* and at last without it.

8. When the left-hand platform, on nearly reaching its upper level, engages *g* and opens *F*, the main circuit will be opened at *b* and the motor will stop.

9. If it is necessary to move the platform farther up after the circuit has been broken at *E* or *F*, the switch *S* may be closed and the platform may then be moved by the motor. So long as *S* is closed *V* will not be released except for no voltage or overload.

10. The motor may be slowed down or even stopped by moving *W* to the left, provided *Rh* is large enough to carry the current.

11. The electro-magnetic brake on the gear wheel next the motor armature automatically clamps it whenever the main current ceases and the motor stops. It gives a quick stop for heavy or light loads.

12. If the electric machinery is disabled the motor is quickly thrown out and the platform can still be raised by a crank handle and gearing.

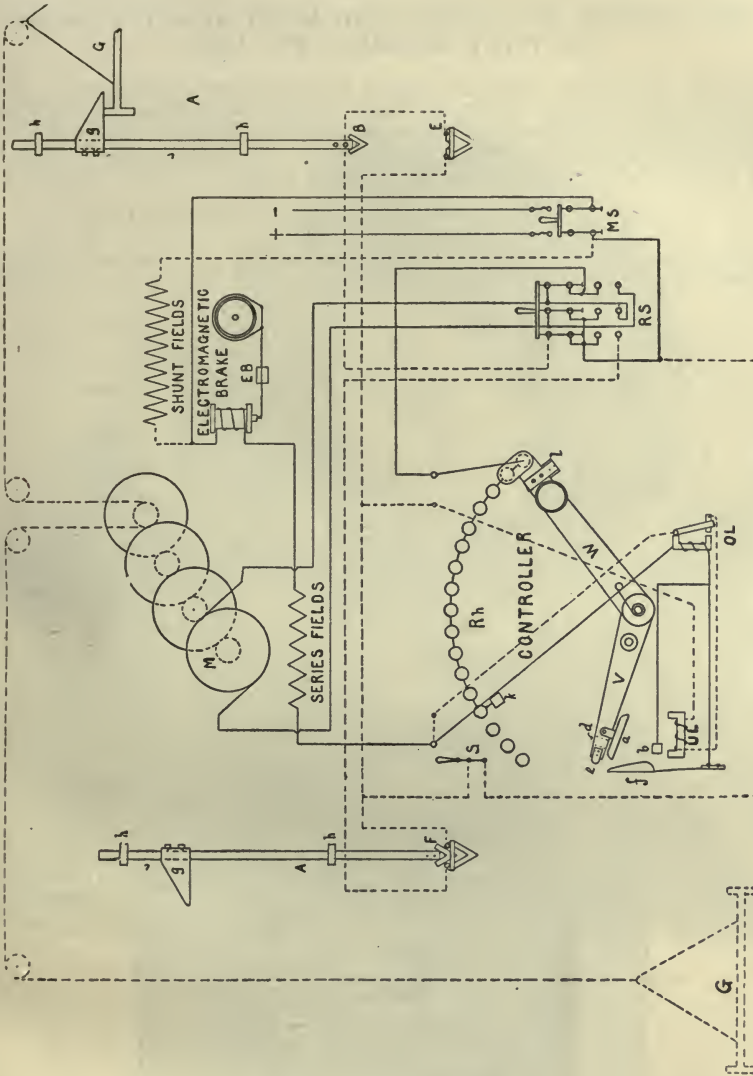

119. Ammunition Hoist.

IX.—SEARCH-LIGHT PROJECTORS.

THE 60-INCH DIAMETER SCHUKERT SEARCH LIGHT AT FORT MONROE (Fig. 120).

With 150 amperes, at about 60 volts, it has 194,000,000-candlepower. On a clear, dark night a person within its beam, 12 miles distant, can read ordinary print; it lights up an object $2\frac{1}{2}$ miles distant with the brightness of the full moon, and it will enable a person near the projector to distinguish, with the aid of a glass, a vessel at 6 miles distance.

(A) THE U. S. GOVERNMENT PROJECTORS

Are supplied by the General Electric Company in the following sizes or diameter of reflector:

CONTROL. (Hand, H; pilot house, P; elec- tric, E.)	SIZE.	CURRENT.		CARBONS.	
		Amperes.	Volts at Arc.	Positive— Cored.	Negative.
H. or P.	18"	35	47-50	$1\frac{3}{8}$ " x $8\frac{1}{2}$ "	$5\frac{1}{2}$ " x 5" solid.
H., P. or E.	24"	50	48-52	1" x 12"	$3\frac{1}{4}$ " x 7" cored.
H. or E.	30"	80	49-53	$1\frac{3}{8}$ " x 12"	$7\frac{1}{2}$ " x 7" cored.
H. or E.	36"	130	50-55	$1\frac{3}{4}$ " x 12"	1" x 7" cored.

All are fitted with true parabolic ground glass, silver-plated mirrors, as specified for standard use in the Navy Department. The light reflected from the parabolic mirror is whiter and more penetrating than from a spherical mirror.

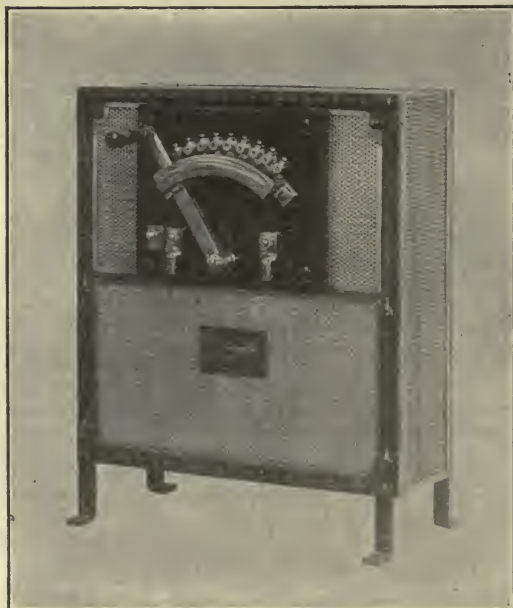

121. Rheostat for U. S. Government Projector.
(90)



120. 60-inch Diameter Schukert Search Light at Fort Monroe.



All projectors are fitted with horizontal automatic ratchet-feed focusing lamps. The lamps are designed to throw the greatest possible amount of light on the reflector, and screen shutters are provided to prevent the direct rays from leaving the projector, so that all the rays of light are reflected and sent out parallel.

Both positive and negative carbons are fed automatically at the same time, and are so proportioned that the arc remains in the focus of the mirror until they are entirely consumed.

The carbon holders or carriages are designed for vertical and horizontal adjustment of the carbons, and by means of a magnet fastened on the inside of the projector and surrounding the arc on all sides but the top, the arc is made to burn steadily near the center of the carbons and in focus with the mirror.

In order to obtain the best results the carbons must be hard, homogeneous, and of the best quality. Soft carbons fuse and make "mushrooms" which cut out a large portion of the light and prevent the arc from burning steadily.

All projectors are designed to operate on direct current incandescent circuits. A regulating resistance of G. S. ribbon (fig. 121) is placed in series with the lamp to reduce the voltage, 80 or 110, to the proper potential, which varies from 40 to 60 volts, according to the size of the lamp and current consumed.

(B) METHODS OF CONTROL.

1. The beam of light from the hand control projectors can be trained vertically or horizontally by the operator standing at the projector and moving the barrel in the desired direction with the handles. A star wheel, mounted on the arm, clamps the quadrant part of the trunnion and acts as a locking device by means of which the barrel of the projector may be held at any desired angle.

2. The pilot-house control projectors, entirely of brass (fig. 122), are mounted on top of the pilot or other house and operated from within. Both horizontal and vertical movements of the beam of light are accomplished by means of the same lever which is located conveniently within reach of the pilot. The projector may be locked at any desired angle by turning the handle of the lever so that it screws against the quadrant like a set screw. It has conductor rings and brushes in the base so that the projector can be rotated in a horizontal plane. If the projector is to be located at some distance, the above mechanism is adapted to rope belting.

3. Electrically controlled projectors (fig. 123) may be operated from a distance. They have two electric shunt motors mounted in the base of the projector, one motor operating a train of gears controlling the vertical movement, and the other motor operating another train of gears controlling the horizontal movement of the projectors. These motors are regulated by a controller conveniently located and connected to the projector by seven conductors. The movement of the beam of light corresponds to the movement of the handle of the controller, and both horizontal and vertical movement can be obtained at the same time. On releasing the handle of the controller, it is brought back by a strong spring to the neutral position, short-circuiting the armatures of the motors and holding the projector locked in position. An electrically controlled projector can also be operated as a hand control projector, by opening the circuit switch on top of the controller and releasing the clutches connected to the motors in the base of the projector.

The drum rotates on its trunnions and can be elevated 70° above and lowered 30° below the horizontal position. The turntable can be revolved freely in either direction in a horizontal plane.

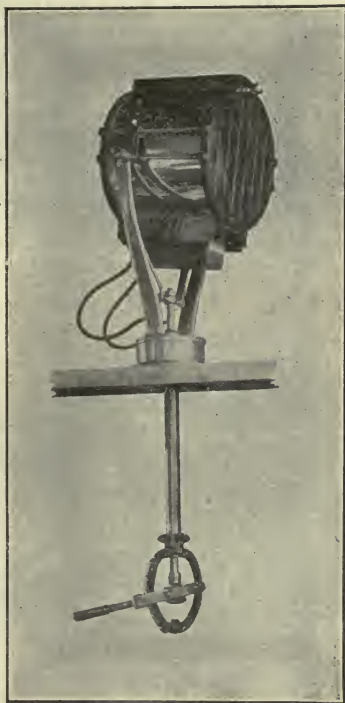

122. Pilot-House Control.

With electrical control, the highest speed obtainable in the horizontal plane is a movement of 360° in thirty seconds, and in a vertical plane 100° in sixty seconds. The motors may be operated at four slower speeds and also by steps, the angle of each step being less than a degree, that is to say, about one-third of the area covered by the beam.

4. In general the projector is designed to take either a spherical or a parabolic mirror. The trunnions being mounted on slides, allow the drum to be balanced with either mirror. The mirror is so mounted in a brass frame that it is securely protected against concussion and provision is made for expansion due to heat.

The plain front door, used when long range and small area of beam are required, is composed of strips of plate glass.

When projectors are required to furnish a beam of light covering a wide area, at shorter range, the front door is made up of strips of glass ground plano-convex, each strip being a lens, with the convex side outward. The beam of light passing through this door is diverged, making it wider but not increasing its height. These diverging doors are for either 10° , 20° , or 40° divergence for any projector.

(C) NUMBER AND NAMES OF PARTS.

1. The hand-control U. S. projector is complete with the following parts: The base with all the gears; turntable with arms and drum; 1 mirror; 1 front door with plain glass; 1 front door with diverging glass; 1 box for front doors; 1 lamp; 1 rheostat; 1 canvas cover; 125 positive carbons in tin boxes; 125 negative carbons in tin boxes; 1 extra set of plain glass front door strips in plain wooden box. One tool box containing the following articles: 1 crank-handled socket wrench for lamp feed; 1 wooden-handled socket wrench for adjusting carbons; 1 smoked glass with frame; 1 dust brush; 1 small dusting brush for lamp; 1 chamois skin for polishing mirror; 1 spare spring for starting magnet; 1 spare spring for feeding magnet; 1 contact spring; 1 contact screw; 2 round smoked glasses; 1 round ground glass; 2 pairs of carbon holder clamps, screws, and washers; 43 extra lava insulators; 1 small wrench for 8-32 and 10-32 nuts.

2. The pilot-house controlled projector has the same apparatus, except pedestal, but in addition rope and guide pulleys.

3. The electrically-controlled projector is furnished complete with the same parts as the hand-controlled projector, together with the following additional parts: 1 controller stand and canvas cover; 1 controller cable 25 feet long, with connecting plugs at each end; 1 controller receptacle; 2 pairs of carbon brushes for motors; 2 20-ampere fuses for controller; 6 8-32 nuts.

(D) INSTALLING PROJECTORS.

The arrowhead, which is cast or painted on the base or the pedestal of the projector, should point aft. Otherwise, the maximum allowable motion of the projector can not be obtained on account of the stop pin which is inserted to prevent twisting the cables.

The current should be led directly from the switch board in the dynamo room to a switch which should be mounted near the projector. A rheostat should be placed in series in the circuit, and also an ammeter to indicate the current.

1. Hand control projectors are shipped assembled, so that they may be immediately bolted to their place. When the lamp is inserted and the necessary connections are made to the supply wires the projector is ready to operate.

2. For pilot-house control projectors, select a desirable position on the house roof for the location of the projector, and cut a hole through the roof nearly the diameter of the inside of the low base; disconnect the handle and bow from the lower end of the rod and shell, and bolt the projector over the hole in the roof, using a gasket between the base and the roof to keep out water. The arrowhead on the base should point aft. When the projector is in place, the bow and handle can be replaced, and care should be taken to see that the handle points in the opposite direction from the beam of light; for example, when the beam is thrown forward the handle should point aft. The studs and terminals are marked + and -. The operating mechanism of the rope control consists of two small drums which are connected to the operating drums on the projector by ropes.

3. The E. C. projector, mounted upon a low truck, stands by itself under canvas cover in a dry, dust-proof, sun-lighted room, from which it may be run out to any desired point within 1,000 feet of the switch board and dynamo, and is supplied by means of twin-core cable. The controller cable should permit the controller to be operated at 150 feet distance from the projector. The connections and installation appear under head (F) page 97.

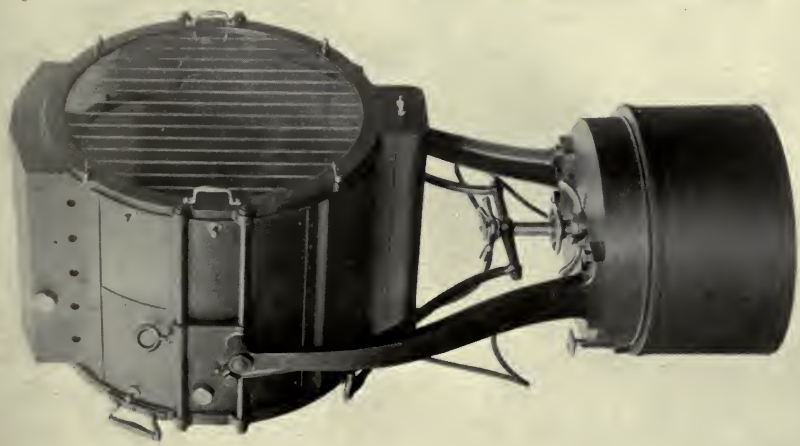
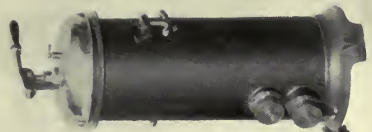
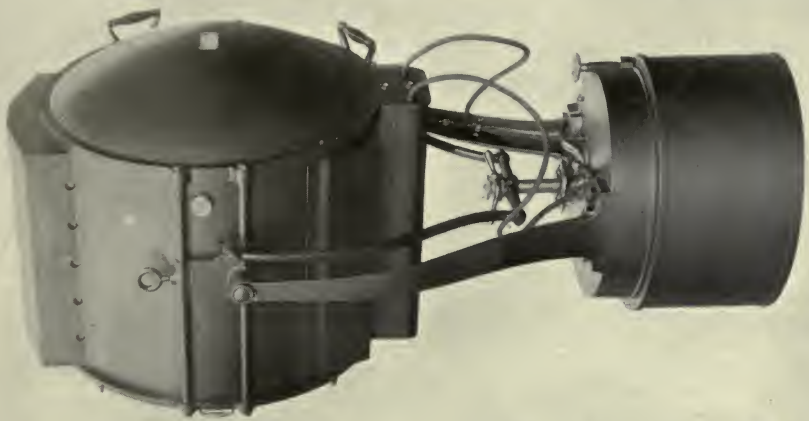

123. U. S. Government Search-Light Projectors, with Controller.





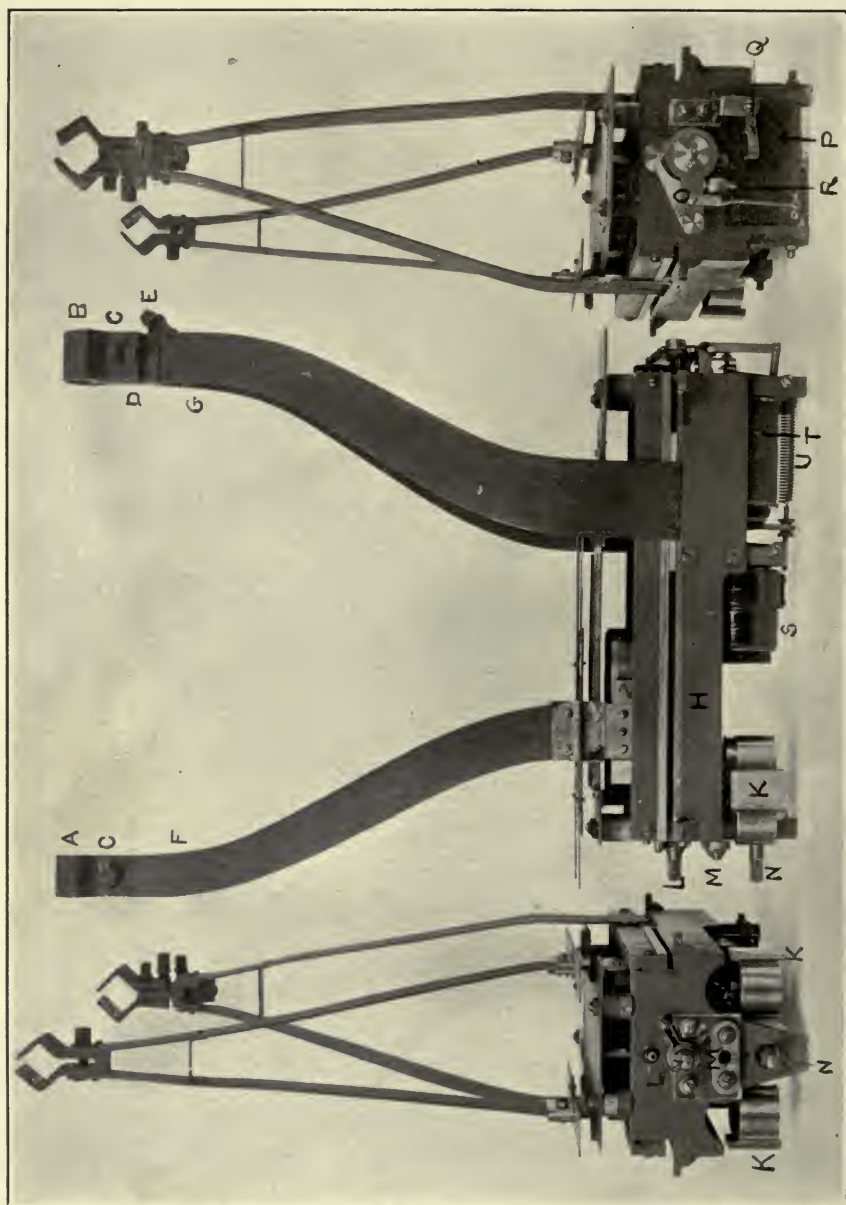

124. Parts of Lamo Mechanism.

(E) LAMP MECHANISM OF ALL PROJECTORS.

1. Parts of lamp mechanism are as follows (fig. 124):

- | | |
|--|---|
| A, negative carbon holder. | M, fixed nut for focusing screw. |
| B, positive carbon holder. | N, stud of lamp switch for cutting out |
| C, clamping screws for carbon clamps. | feeding magnet. |
| D, vertical screw positive carbon clamp. | O, ratchet and pawl. |
| E, horizontal screw positive carbon clamp. | P, feeding magnet armature. |
| F, negative carbon support. | Q, contact of circuit breaker. |
| G, positive carbon support. | R, adjusting screw for ratchet arm. |
| H, lamp frame. | S, starting magnet. |
| K, main lamp contact shoes. | T, feeding. |
| L, hand feed screw. | U, adjusting spring for feeding magnet. |

2. *Placing the lamp in the drum.*—The lamp may be lifted by the top plate, but it should never be lifted by the carbon supports, as the strain due to its weight is liable to spring them out of their correct position. The 18-inch and 24-inch projectors have obturators which prevent carboning the lamps before they are placed in the drums. The drums of these projectors are, however, sufficiently large to readily permit adjustments of the carbons after the lamps are in place. When inserting the 18-inch or 24-inch lamp in the drum, the

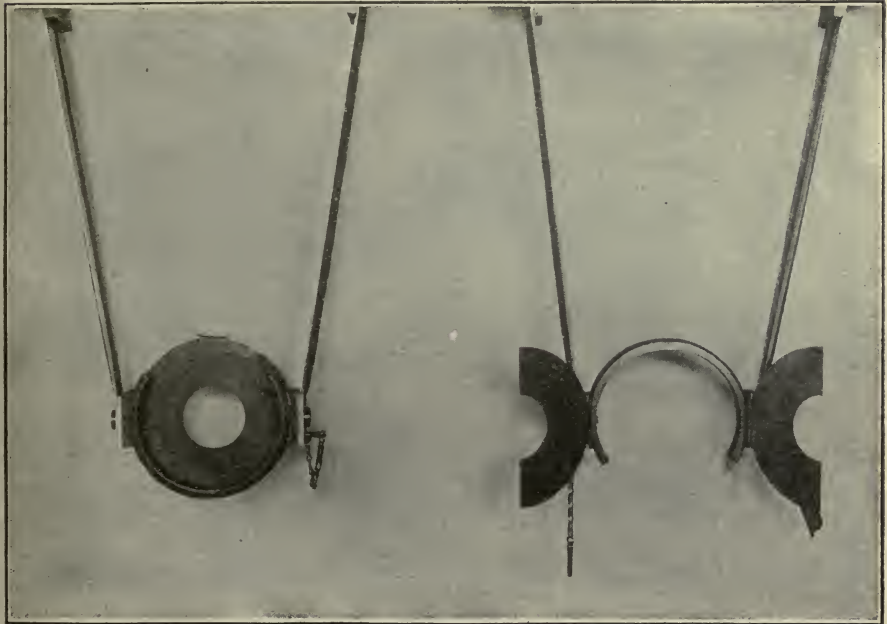

125. Obturator.

shutters of the obturator should be opened and the arc magnet turned so that the opening is downward. This adjustment may be made after removing the pin on the side. The lamp may now be placed in the projector, the arc magnet returned to its proper position, and the shutter of the obturator closed.

3 *Carboning the lamp.*—The carbons are placed horizontally in the focal axis of the mirror. The positive carbon should have its crater toward the mirror. The projectors are intended for use on circuits of 110 volts, and a regulating rheostat is furnished with each projector to provide the necessary voltage at the lamp terminals. The rheostat is shipped to conform with the voltage of the circuit, which should be stated when the projector is ordered. To obtain the best results, the rheostat should be adjusted once for all according to the volts and amperes given in the table at the head of this article.

The carbons must be of the best quality. Hardtmuth and Schmeltzer carbons are satisfactory.

In placing the carbons in the lamp, separate the carbon holders as far as possible by turning the feed screw. The larger, or positive carbon, should be placed in the clamp nearest the ratchet mechanism. Adjust the carbons so that they come in contact with each other exactly above the white line on top of the lamp. This line should coincide with the white line inside of the drum when the lamp is in place. The carbons should also be adjusted so that their axes coincide. Readjustment of the carbons is necessary from time to time so as to keep the crater in the center of the positive carbon and not allow it to burn off at the edge. If the crater becomes displaced on account of impurities in the carbons, the carbons should be readjusted so as to form a new crater in the correct position.

4. *Operating the lamp mechanism* (figs. 126-7-8).—(a) After closing the main switch, the carbons will begin to feed toward each other until they touch, and the circuit will be completed, so that the starting magnet will draw the carbons apart about $\frac{1}{8}$ inch, thus striking the arc. As the carbons burn away the arc becomes longer and the voltage across the arc increases. More current is thus compelled to pass through the feeding magnet in shunt with the arc. Its armature immediately breaks the circuit through the coil and then flies back, thus moving the pawl and turning the ratchet at the end of the feed screw.

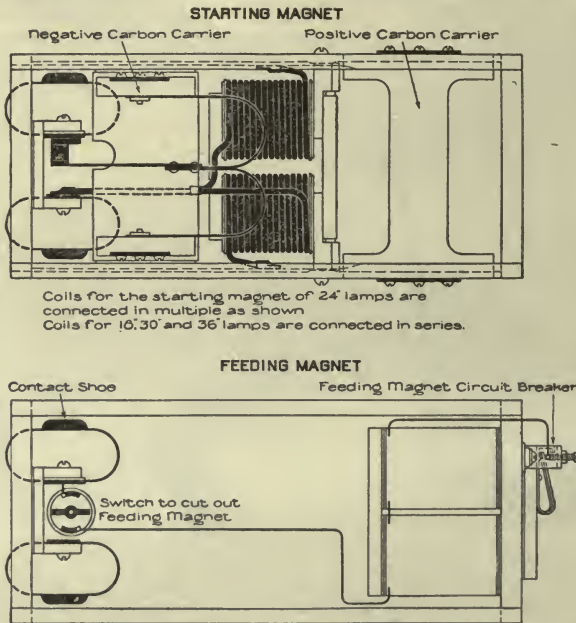

126. Connections of 18, 24, 30 and 36 inch Automatic Projector Lamps.

(b) *Focusing the lamp.*—After starting the lamp, focus it with relation to the mirror by watching the rays. When the rays diverge, the arc is too near the mirror, and when they cross at some distance from the projector, the arc is too far from the mirror. The proper distance between the arc and mirror is obtained by moving the lamp backward and forward by means of the focusing screw. The light will not be satisfactory unless the lamp is in focus, and the operator must, therefore, never neglect to focus the lamp before using the projector.

(c) When the arc is in the focus of the mirror the image of the carbons will fall on the ground glass of the vertical peep sight (see *S*, fig. 128a) so as to show the positive or larger carbon just touching the vertical line.

(d) In the 18-inch and 24-inch projectors the focusing screw is arranged to screw into the back of the lamp and is fastened permanently to the projector. The lamp should, therefore, be so placed that the thread of the focusing screw catches and draws the lamp into focus.

(e) If the carbons are placed as described and the lamp placed in the drum so that the two lines referred to under "Carboning the Lamp" coincide, the arc will be so nearly in focus that but little adjustment will be necessary.

(f) The lamp should be kept clean and free from carbon dust which occasionally drops from the carbons while burning.

(g) The feed screws may be oiled when necessary with a small amount of good clock oil, but care should be taken to carefully wipe them after oiling, as otherwise small particles of carbon dust may adhere and cut the thread. The carbon carriages and parts carrying current should never be oiled.

(h) As a few slight changes will be found in lamps constructed in different years, reference is made to figs. 127-8, alike lettered, from which the plan of operation of all will be readily understood.

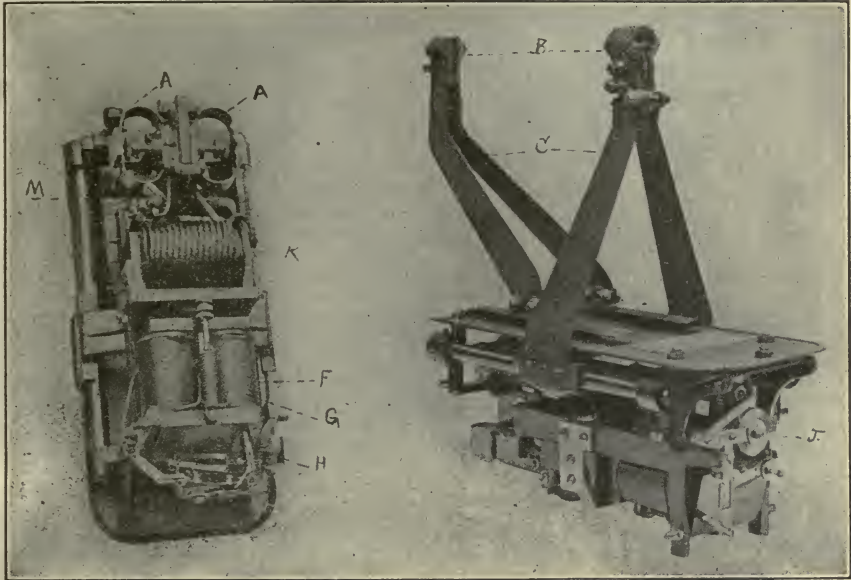

127. G. E. Search Light.

The springs *A* take current from leads to the contact rings of the pedestal, the path of the current being shown in fig. 128.

The carbons are secured in clamps *B* on supports *C*, the supports being movable in guides of the frame and controlled by screw-bars *D* and *E*. The larger clamp is for the positive carbon, in which the crater is formed and which will therefore be the farther clamp from the projector mirror. *F* is the automatic feed, shunted from the lamp leads, having an electro-magnet *G*, which controls the armature *H*, and which in turn operates the screw-bars *D* and *E* through a pawl-ratchet *F*, and gearing *J*, when the voltage in the magnet is above 50 to 52 volts. *K* is the series-striking arc magnet which operates only when the current is much in excess of that required for the lamp. A lug on its armature embraces the screw-bar *D* between two collars. The screw has a small play at *L* which is independent of the control of the automatic feed. Owing to the gear, the screw-bar *D* revolves but one-half as fast as *E*. *E* can also be turned by a removable crank socket wrench at *T*.

The method of operation is this: The carbons are first adjusted by the crank wrench to a separating distance of about half an inch. The automatic switch *M* should now be closed. The main switch is closed next, and, as no current can pass until the carbons touch, the voltage across the carbons up to that moment must be 110 volts. The shunt magnet (called the feed) commences to vibrate, the voltage being greater than 52 volts, and feeds the carbons together by means of the pawl and the gear wheels of the screw bars. When the carbons touch a heavy momentary current passes (since the resistance is small and voltage at 110), the armature of the striking arc magnet is attracted, pushes back

the negative screw bar and forms ("strikes") the arc. The resistance of the rheostat, in circuit when first set up, causes a drop of 50 to 60 volts as soon as the current passes, and should be adjusted by the lever to the voltage necessary for running the lamp without flaming and hissing. The voltage required in practice is usually from 45 to 49 volts; the feed will frequently operate at 50 volts. The working current for the lamp varies with the size of the lamp and, incidentally, with the size of the carbons; it is as great as 75 to 90 amperes for the 30-inch projectors, and from 25 to 35 amperes for the 18-inch type.

There is often some flaming of the carbons which can not be controlled by the rheostat; it is unimportant except from the fact that it decreases the intensity

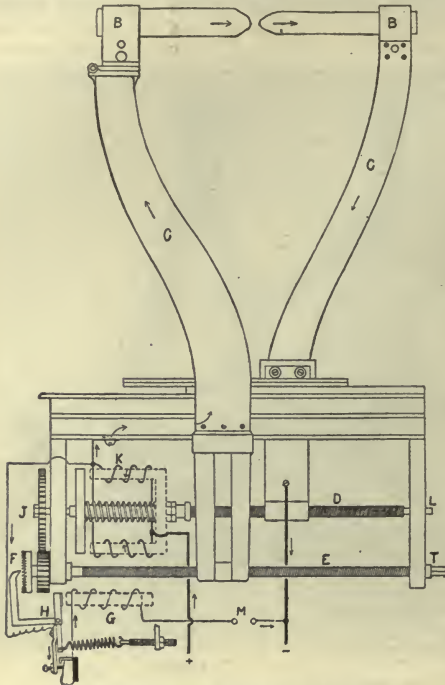

128. Lamp Details Showing Method of Operation.

of the light; it will usually disappear of itself. Horizontal lamps have a tendency to flame at the upper edge of the crater, thereby forming the crater on the upper edge of the positive carbon and distorting the reflection; this tendency is corrected in some projectors by a horseshoe magnet, attached to the diaphragm in the projector, which draws down the arc by magnetic attraction.

Some hissing will occur when starting up, especially with new carbons, and the lamp will not quiet down until a good crater has been formed in the positive carbon. This can be obviated by reaming out a crater in the positive carbon with a penknife before putting it in the clamp.

Flaming and hissing are promoted by inferior carbons and are much increased if the carbons have absorbed oil. Those now provided are of the Schmelzer manufacture and are very homogeneous; the positive carbon is usually bored axially and cored with a soft carbon, which materially assists in maintaining a good crater. Negative carbons are sometimes cored, but it is an open question whether this expedient does not conduce to the formation of mushrooms. Carbons are

packed in tins and should be kept covered in a dry place, as they readily absorb moisture.

The momentary current of short circuit, when the carbons touch, is ordinarily heavy and quite sufficient to throw the pointer of the ammeter clear across the scale and against the stops; it need occasion no apprehension if it does not continue; if it does, the switch at the switch board should be quickly opened. This current may be as much as 50 per cent above the working current.

Any abnormal current of the searchlight ammeter is usually traceable to either a mushroom on the negative carbon or careless handling of the socket wrench. In most cases of fusing of the contact plungers in the pedestal there is direct evidence of an attempt to regulate the feed by hand when the automatic gear is switched on. If the lamp does not feed, it is for the reason that there has been a burn out, or that the lamp itself is not clean, and in 90 per cent of the cases dirt is the cause; any attempt to remedy matters by use of a socket wrench, while the current is on, is quite sure to short-circuit the lamp and produce overload.

The mushroom appears as a small protuberance on the end of a carbon and is of a pasty consistency. It can readily be removed by the end of a screw-driver. Ordinary attention to the working of a lamp should guard against its formation. It will cause the carbons to adhere.

(F) CONNECTIONS AND INSTALLATION OF U. S. ELECTRIC CONTROLLED PROJECTOR.

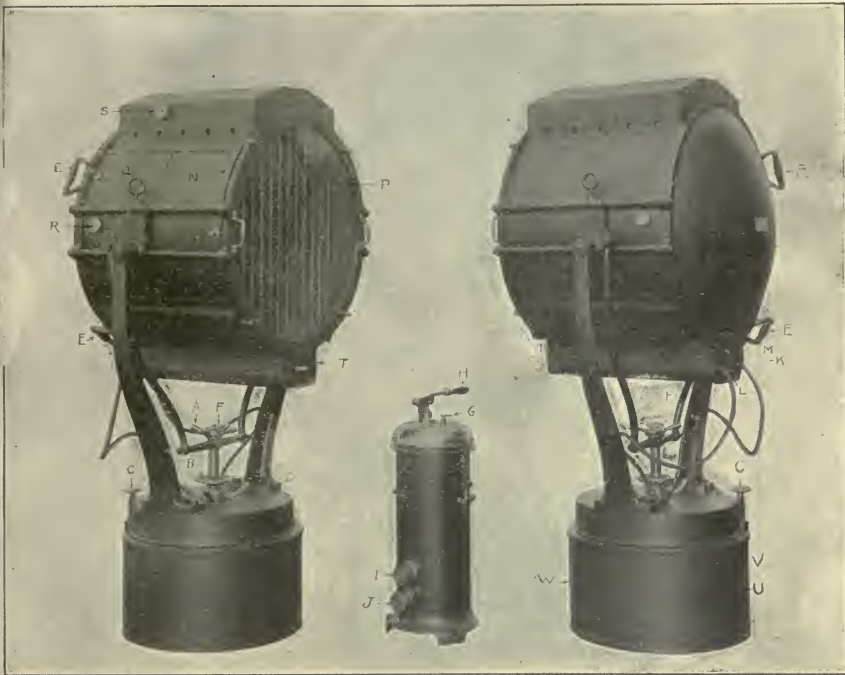

128a. Parts of Projector and Controller.

1. Parts of projector and controller are as follows:

A, hand star wheel for slow vertical movement.
 B, wheel for throwing out split nut used for connecting or disconnecting the drum from the base mechanism.
 C, wheel for slow horizontal movement.
 D, hand star wheel for clamping turntable to center pin for electrical control.
 E, wood handles on drum for moving drum by hand.
 F, hand wheel for clamping hand star wheel A when electric control is used.
 G, controller switch.
 H, controller handle.
 I, controller fuse box.
 J, controller coupling for connecting cable from the projector.
 K, focusing screw

L, socket for inserting wrench to operate lamp switch used for cutting out feeding magnet.
 M, socket for inserting wrench when feeding by hand.
 N, door used for adjusting the carbons and for cleaning the front door.
 O, door used when carbons are to be adjusted or changed.
 P, front door.
 Q, door used when adjusting negative carbons or cleaning the mirror.
 R, horizontal peepsights.
 S, vertical peepsights.
 T, sliding case to be opened when lamp mechanism is to be inspected.
 U, projector main switch.
 V, latches for fastening base sheeting.
 W, base sheeting.

2. Projector with base sheeting removed (fig. 129). The numbers indicate the places for oiling:

The worm 1 at the back of each motor; the two worm trays ought always to contain enough oil to allow the worm to bathe in it; the horizontal worm wheel at 2; the vertical countershaft at 3 and the tread wheel at 4, by unscrewing the plug and oiling through the hole while turning the turntable one complete revolution, so as to distribute oil along the groove in the tread wheel ring; the internal parts of the mechanism are oiled at 5, filling the grooves around the center rods; the crosshead at 6 and 7; the vertical training at 8, by loosening the clutch and putting the oil inside, and the trunnions at 9. The controller is oiled at 10. Any extra oil must be wiped off so as not to allow dust to stick to it.

3. Connections of E. C. projector and controller are shown in fig. 130.

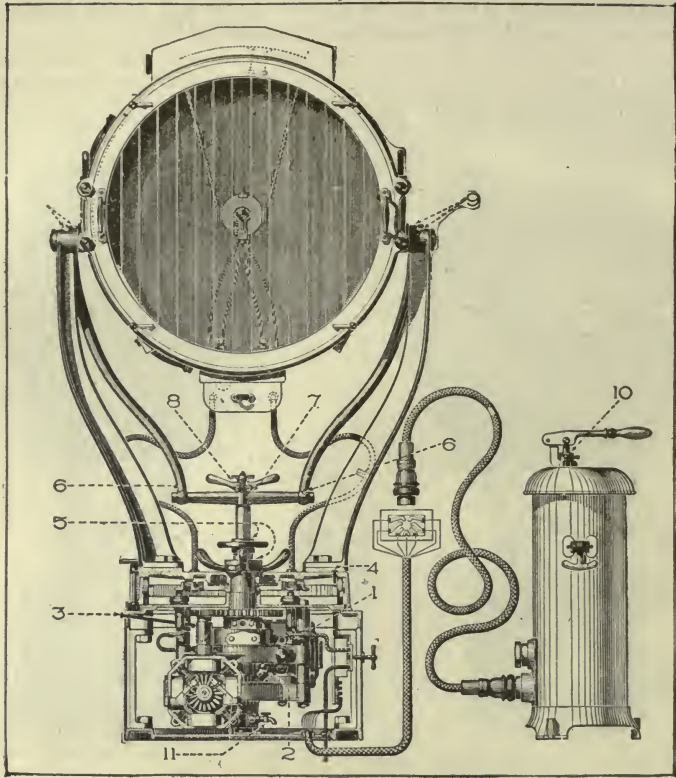

129. Training Mechanism Controller and Cable.

4. *Wiring diagrams.*—Fig. 130 shows searchlight connections except switch-board and lamp mechanism; fig. 132, switchboard and the vertical training mechanism shifted in position for clearness, and fig. 131 all important connections when both the horizontal $A B$ and vertical $A' B'$ training slides stand at their middle positions and neither motor runs.

In the horizontal training mechanism (all figs.) A and B are separate, insulated, metal plates on one block which slide together to the right or left for a total distance equal to one-half the width of the plate according as the controller's handle attached to the block is turned right or left. A loses contact with the left brush X as it first moves to the right, or with the right-hand brush Y as it first moves to the left, and with either motion it slides successively into contact with the five insulated brass fingers which press against it and which are the terminals of rheostat coils. Resistance is thus thrown out and into the armature circuit of the motor which trains the projector horizontally. Plate B , always in contact with its middle brush N , moves with A and, like it, loses contact with its left or right brush, M or O .

In a similar manner, insulated plates A' and B' , of the "vertical training" mechanism, lose and make contacts with their corresponding brushes by being moved up or down (fig. 130 alone shows right position) by means of the same controller handle as above.

A' , like A , slides in and out of contact, successively, with its five brass fingers, which thus throw rheostat coils out of and into the armature circuit of the motor which trains the projector in a vertical direction.

The "controller switch" being closed, the shunt fields of both motors are excited. Either motor is started by turning the controller handle right or left, up or down, sufficiently to slide $A B$ or $A' B'$ away from their respective brushes on one side. If to the right in the horizontal training mechanism, the current flows through the "horizontal training" motor's armature in one direction; if to the left, in the opposite direction—thus reversing the motor's motion.

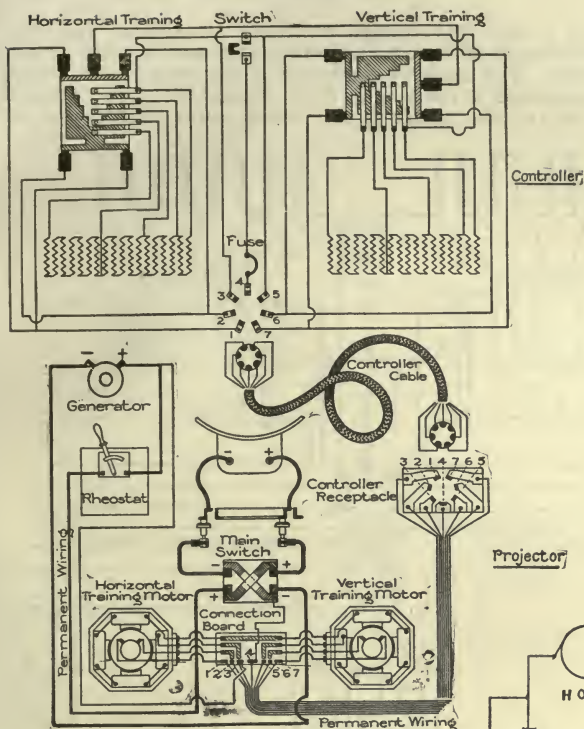

130. For Use in Assembling.

Likewise for the vertical training mechanism and motor. While the slides $A B$, $A' B'$ are at the mid positions shown, all rheostat coils are in the motor armatures' circuits which are short-circuited and can not therefore revolve. But when $A B$ or $A' B'$ is moved in either direction the short circuit is opened and the coils are gradually cut out and the speed is increased. There are four steps and either motor has accordingly four different speeds.

5. *Installing.*—For either hand or electric control the current should be led directly from the switch board in the dynamo room to the double-pole switch inside the base of the projector, both conductors going through insulated holes in the base-plate of the projector. Facing the switch the positive pole is to the left, and the negative to the right.

The dead resistance should be placed near the switchboard, and in circuit with the positive conductor. This method of connecting is essential on account of connections to the motor for electric control. The size of the conductors varies with the size of the projector used, and is determined by the amperes per circular mil allowed by specifications.

A third wire leading from the dynamo room to the projector base is connected at the positive projector switch on the switchboard, and at the other end to contact No. 3 on the connection board inside the base of the projector. The third wire

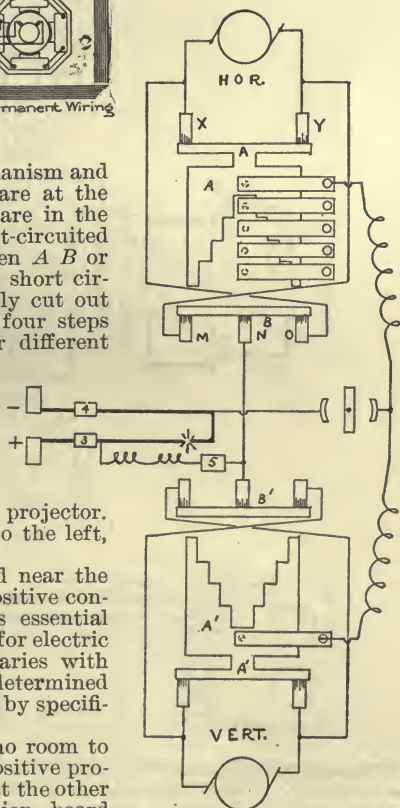

131. G. E. Controller and Connections with Training Mechanism.

is used in order to get full voltage at motor terminals. Its cross section will vary with the length of the circuit, but the total resistance must not measure more than .05 ohm. The negative conductor of the lamp circuit is used for the return, and is connected at the factory from contact No. 4 on connection board to the negative side of the main switch. Seven wires connect the contacts of

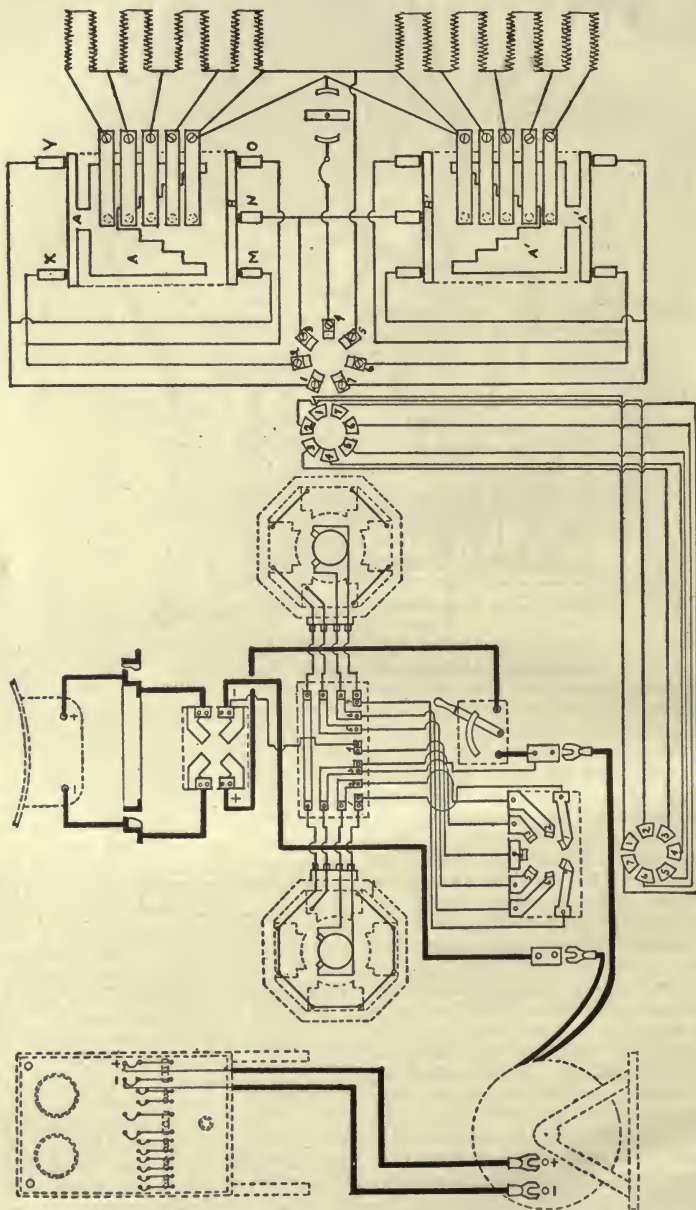

132. Complete Wiring of G. E. Switch Board, Training Motors, and Controller for U. S. Government Search Light.

the connection board inside the base of the projector and those of the controller receptacle. The contacts are numbered both on the connection board and on the receptacle, and should be connected accordingly. The controller receptacle should be placed within a radius of 20 feet of the controller. The required size of the seven conductors varies according to the length of the circuit. The





133. Hand Control.

following table gives the maximum allowable resistance for each wire, and the size of wire for circuits of various lengths:

Number of Conductor.	Size of Wire, B. & S. Gauge.			Maximum Resistance, Ohms.
	50 Feet.	100 Feet.	150 Feet.	
1	14	11	9	.14
2	14	11	9	.14
3	11	8	6	.07
4	10	7	5	.05
5	14	14	14	.62
6	14	11	9	.14
7	14	11	9	.14

The search-light barrel should move with the controller handle as if this were fixed to the rear part of the barrel. The farther the controller handle is moved, right or left, up or down, the more rapidly the projector should travel. Small motion can be gotten by momentarily striking, by means of the handle, a finger of the training mechanism.

(G) OPERATING THE E. C. SEARCH-LIGHT PROJECTOR.

1. The key to good search light operation and management is thorough cleanliness in all the parts and frequent opportunity for practice by those to be called upon.

2. The mirror will spot or frost in time if not kept in a dry place. The action is hastened by damp and by the practice of exposing it to the rays of the sun while drying out the barrel. The life of a projector is shortened one-half from lack of care.

3. Dust the mirror surface gently with a soft duster—do not clean by rubbing.

4. Set the carbons before operation and permit no use of the wrench except in focusing; there is rarely any occasion for its use on the screw bar after the lamp is in operation.

5. Every projector front should be fitted with an extra outside door

made of perforated fiber for the protection of the front glasses.

6. Diverging lenses are plano-convex in the horizontal plane only. The door is made in strips similar to that having the plain glass, each strip being a plano-convex lens.

7. The parabolic surface projector which is gradually replacing all other forms, lights up a distant object with greater brightness and distinctness.

8. The rheostat (fig. 134) must be able to carry the full current and have sufficient resistance to cause a drop ($C \times R$) of 30 volts from an 80-volt supply, or 60 volts from a 110-volt supply; this includes an adjustable resistance for a range of 10 to 20 volts.

9. While hot the reflector should not be moved nor its door opened.

10. The two carbons should lie in a straight line, the positive and larger is the farther from the mirror; if new or deformed a crater should be reamed out.

11. Waterproof covers are always provided for projector, controller and rheostat.

12. Cable couplings are liable to give trouble from moisture in spite of the water-tight gaskets. Use only two end couplings; splice and insulate all other joints; cover with painted canvas and keep them as dry as possible.

13. Fusing may occur in the contact plungers of the pedestal whose office is to connect the contact rings of the base with the main contacts for the lamp. When

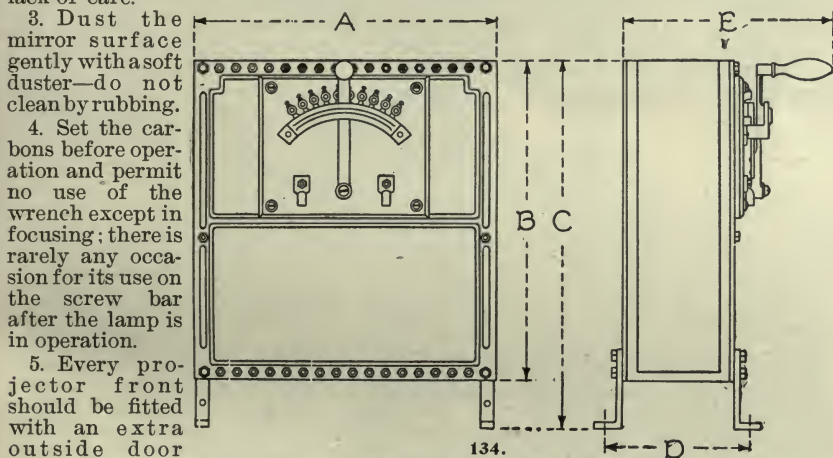

134.

this fusing takes place the pedestal becomes locked and can not revolve. It is commonly caused by the nonseparation of the carbons, either from failure of the mechanism or the adherence of the carbons due to the formation of a mushroom on the negative carbon. The remedy is to increase the contact area and to use greater care in operating.

14. For signaling, projectors may be operated by hand to throw the beam against the sky right, left, or down; or supplied with a Venetian shutter in front to make the one and two short flashes of the letters of the alphabet.

15. A good line of sight makes 3° or more with the beam at the object. The blinding effect of the beam is small at 7° angle.

16. On a clear, dark night, the 60-inch Schukert projector enables the naked eye near it to see a light object 30 feet high by 20 feet wide at 6 miles distance; but if dark it can be seen at this distance only by the aid of a strong glass, becoming visible to the naked eye at 4 miles. The 36-inch parabolic mirror permits the light object above to be seen at 4 miles, but if dark, only by the aid of the glass.

17. The generating set requires one electrician and assistant; the projector, one electrician and attendant; the cable, one attendant; observers, each with a signal man if at a distance. The last-named carries a lantern darkened on the side toward the enemy. The new observer sees little or nothing. To him objects appear unnatural at night. He has not even a mariner's experience, and he innocently reports the searchlight a failure, while the practiced observer will obtain good results. This one takes a position on either side of the beam and uses a field glass having the largest possible object lenses, low magnifying power, and no diaphragm. He forms some conception of the objective and notes all conspicuous details in the vicinity. It is important to find near the objective one or more points which are fixed, light colored and known, such as a house, beacon or shore, in order to direct the beam upon it quickly and then upon the objective. Well defined shadows caused by impurities in the atmosphere should not be taken for dark objects. Moonlight is a favorable circumstance. Mist or smoke, however thin, is unfavorable. Training and continued practice are indispensable.

18. Degrees of illumination of projectors:

MIRROR.	Distance in yards.	Diameter of beam in yards.	Diameter of spot in yards.	Coefficient of transparency.	Times illumination of full moon at zenith.
36" Spherical, C = 100 amperes.	3,300	120	90	0.8	40
	4,400	160	110	0.7	20
	5,500	190	140	0.66	12
60" Spherical, C = 180 amperes.	3,300	100	75	0.8	100
	4,400	130	100	0.7	55
	5,500	165	125	0.66	33
36" Parabolic, C = 130 amperes.	7,000	360	300	0.7	15
60" Parabolic, C = 150 amperes.	10,000	510	430	.7	20

19. The projector, readily movable to any desired point within 1,000 feet of the generator, is placed wholly apart from the works, more than 100 feet from the nearest heavy gun, as near as practicable to the area to be watched, not higher than is sufficient to overcome the earth's curvature, and in such position that objects may not obstruct the beam. Before it is lighted in the enemy's presence, it should be elevated to guard against illuminating objects in its own vicinity. After it is in working order, the screen, if any, is removed and the beam is gradually depressed to the horizon while moving to the right and left in exploration.

20. The probability of a 60-inch projector being hit while in operation at night by an expert marksman *on land* at a half mile distance is less than $\frac{1}{15}$. The danger to projectors from ship's fire from unstable mounts at the usual distance is therefore quite small. It will lessen the accuracy of the enemy's shots to extinguish the lamp occasionally or to move it quickly to some other point. The only special protection which can be given or will be required is the same as for all guns—a thick earth parapet reaching to the level of the lower side of the barrel. The largest search light constructed has a mirror $6\frac{1}{2}$ feet in diameter and an illuminating power of 3×10^9 candles.

(II) TRANSPORTABLE SEARCH-LIGHT EQUIPMENT.

Four sets (figs. 135-6) were ordered in the first preparations for the use of the army in Cuba but could not be delivered by the largest American electrical firm using all of its resources to complete them until four months after the necessity for them had passed.

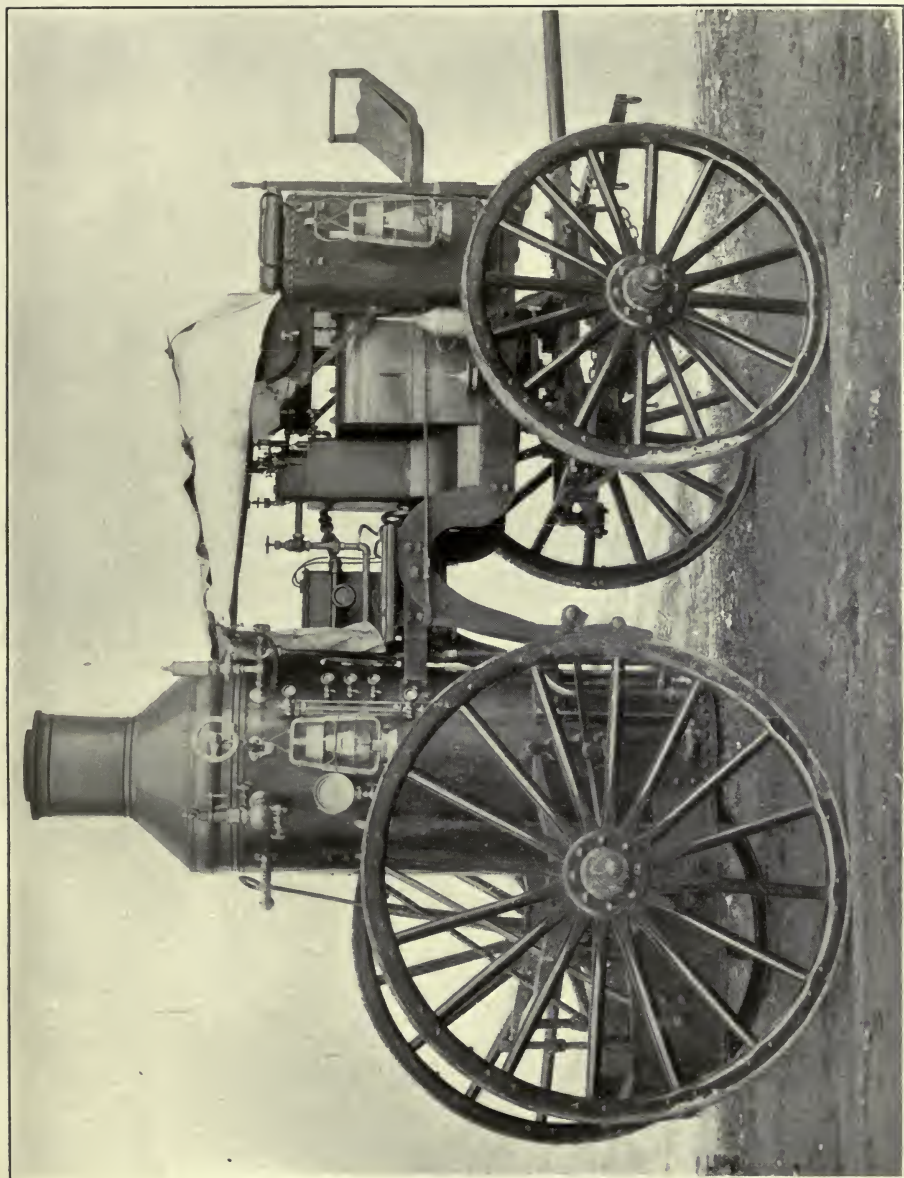

135. Transportable Search Light Equipment.





136. Transportable Search Light Equipment.







137. Keyboard for Night-Signal Set.

X.—GENERAL ELECTRIC COMPANY'S NIGHT-SIGNAL SETS AND TRUCK-LIGHT CONTROLLERS.

(A) NIGHT-SIGNAL SETS.

Night-signal sets include four parts, namely: keyboard, cable, lanterns, and ladder.

1. *Keyboard.*—The keyboard consists of a dial and operating handle mounted on a water-tight box containing the mechanism for connecting the lamps in various combinations. The keyboard is illuminated by an incandescent lamp supported on a goose neck, and the box has receptacles on the back for the line and the lantern cables. The mechanism consists of a central rotating stud with eight contacts which rest against eight semicircular plates. Each plate is made up of insulating sections of hard rubber and metal sections which connect with a lamp in one of the lanterns. Obviously, when one of the contacts of the rotating stud rests on an insulating section, the circuit through the lamp is broken; when on a metal section, the circuit is closed. When the pointer is turned to



138. Mechanism of Keyboard.

the position on the dial corresponding to the desired signal, some contacts rest on the hard rubber sections and others on the metal sections, thus connecting into circuit a certain combination of lamps. The lamps are not actually lighted, however, until the knife switch on the rotating stud is closed by swinging the knob of the handle down toward the operator.

2. *Connections.*—Current is supplied to the keyboard through two line plugs, one of which is connected to the central contact in the lantern cable receptacle, and the other, by means of a brush, to the knife switch on the central stud. Each semicircular plate is connected to a contact in the lantern cable receptacle, into which a plug is fitted to establish connection with the lamps through the lamp cable.

The cable is made up of sixteen conductors. One end of each conductor is connected to a lamp, and the other end to the plug which fits into the receptacle on the keyboard. Eight conductors run from the eight outside contacts of the plug to the eight lamps, and the other eight conductors form the return from the lamps and are connected to the central contact of the plug. When

lamps are lighted, the current flows as follows: From the generator to the line receptacle on the box, to the contact ring, to the switch, to the plunger contacts, to the semicircular plates, to the cable, to the lanterns, back to the cable, to the central contact of the receptacle on the box, to the line receptacle on the box, to the generator.

The circuits are shown in detail in the accompanying diagram (140). The plug and receptacle are made water-tight by means of a soft rubber gasket, and the sixteen cables from the plug pass through another gasket in the gland which makes a tight joint by compressing the soft rubber around them.



139. Keyboard, Showing Attaching Plug and Receptacle.

3. *Lanterns and ladder.*—Each of the four lanterns has two compartments, one with a red globe, and the other with a white globe. The wires pass through water-tight stuffing boxes in caps which screw on each end of the lantern with a gasket and support standard lamps and sockets.

The ladder is made up of galvanized-iron wires with metal cross pieces from which the lanterns are swung.

(B) OPERATION.

After the ladder, lanterns, and keyboard are in place they may be connected as follows:

Connections to the line should go to the two small outside receptacles on the back of the keyboard box, and the plug on the end of the lantern cable should be inserted in the receptacle between the line receptacles. This plug can be inserted only one way, as the receptacle has a pin which must fit into a slot on the plug. After the plug is inserted, the nut D (see fig. 141) should be screwed up tightly so as to compress the soft rubber packing. The plug should never be taken from the receptacle when the current is on, as the sparking is apt to injure the contacts, particularly the center one which carries the combined current for all the lamps. Therefore, before removing the plug see that the knob on the handle of the keyboard is in an upright position. To operate the keyboard, the arm with the pointer can be swung over the dial to the combination required, and the knob depressed. The cam actuated by the knob will then

engage with a slot so that the arm can not be moved, and will remain in this position until the knob has been raised again. This arrangement prevents the display of false signals. If pulsating lights are required they may be produced by means of the pulsator switch on the central shaft. It is a small lever which

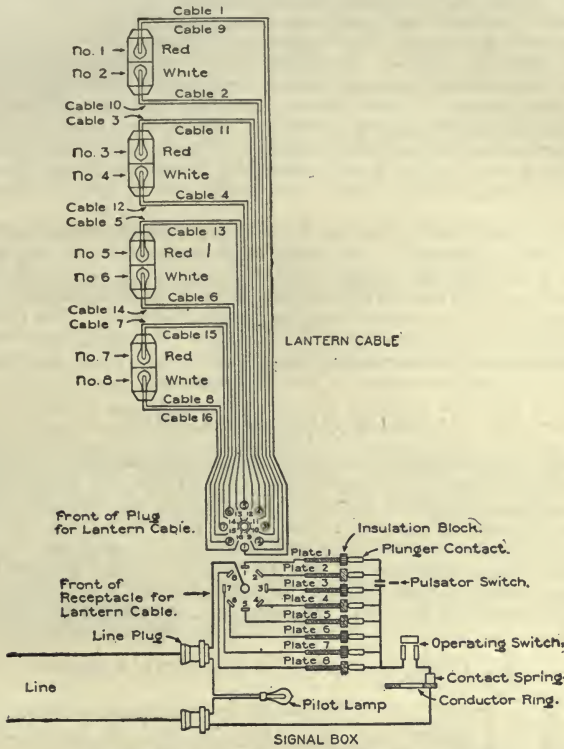

140. Diagram of Connections of Night-Signal Set.

extinguishes the lamps in the upper lantern when pushed to one side and lights them again when released. The lamp socket on the keyboard is provided with a switch, and when not in use the lamp should be extinguished to prevent excessive heating when the doors of the cover are closed.

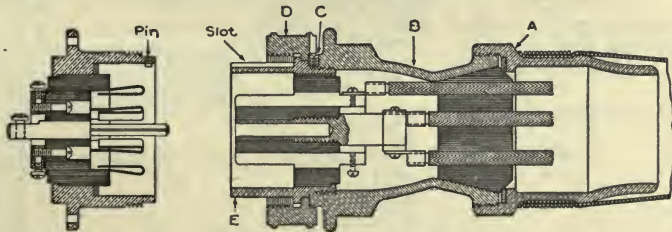

141. Receptacle-Plug.

(C) REPAIRS.

The soft-rubber packings used about the couplings and cables should be frequently examined and renewed from time to time, as the rubber becomes hard and partially vulcanized by the long continued compression and heat from the metal, which becomes quite hot when in the sun, especially in tropical climates. When worn out the cables can be replaced, one conductor at a time or all at once. To replace one conductor, unscrew the cap at the lantern and disconnect

the conductor from the lamp and pull the cable out after loosening the packing in the gland. Cut the seizing about the cable and separate the defective conductor as far as the cable plug on the box and cut away the canvas jacket. With the plug removed from the receptacle, unscrew part *A* and slip it up the cable some distance, then unscrew part *B* after taking out set screw *C*, and work the gasket back on the cables so that *B* and *E* can be separated. Pull *B* and *E* apart and disconnect the defective conductor from the contact and pull it out through the gasket. Unsolder the terminal on the conductor, and solder it to a new conductor; pass the new conductor through *A*, through the gasket, and then through *B*, and connect it to the contact. Screw *B* in place, and after replacing the set screw, push the soft rubber gasket down into the gland. As there are sixteen conductors, the rubber gasket is not easily inserted, but by pulling on one conductor at a time and changing about, the gasket can be worked into place, and then part *A* can be screwed up and a new canvas jacket put on.

To connect the other end of the conductor to the lamp in the lantern, pass it through the rubber gasket in the gland and connect it to the lamp socket. Screw up the gasket in the gland tightly, replace the cap on the lantern and screw it down hard. When repairing the cable in this manner a good opportunity is offered to put in entirely new gaskets all around. The method of procedure in removing the entire cable is, of course, the same as in removing one strand. The cable should be painted occasionally with some tar compound as a preservative, in the same manner as standing rigging.

(D) STANDARD OUTFIT.

The complete United States Government signal outfit includes: 1 keyboard, complete with cover and lamp; 1 ladder and cable with male half of coupling; 1 reel of extra single conductor cable; 5 lanterns (4 for ladder and a spare lantern); 10 32-candlepower, 110-volt lamps; 1 16-candlepower, 80-volt lamp for keyboard; 1 tool box containing the following—2 fork wrenches, 1 spanner, 1 grip for male plug and shell, 10 spare gaskets for lantern glands, 1 spare gasket for coupling of 16 conductor cables, 2 spare gaskets for main line plug contacts on keyboard, 2 spare washers for main line plug contacts on keyboard, 10 spare washers for lantern cap, 1 spare washer for coupling, 16 spare copper terminals.

(E) TRUCK-LIGHT CONTROLLERS.

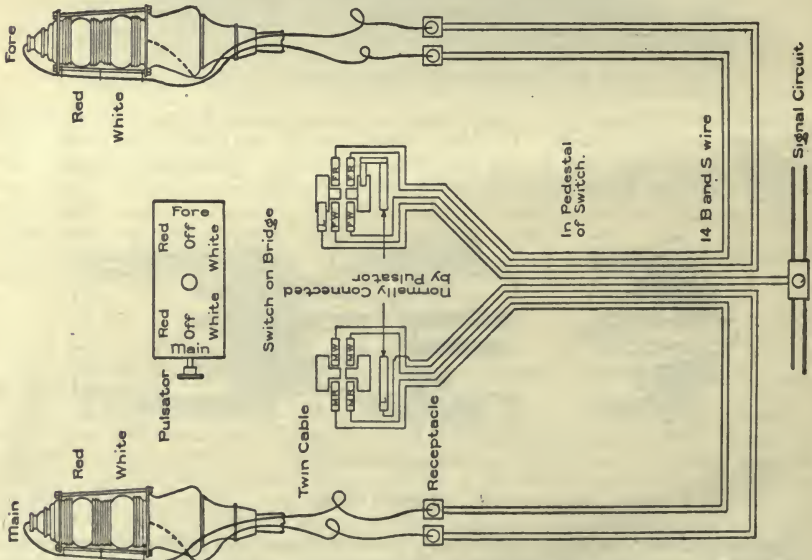

142. Diagram of Connections of Truck-Light Controller.

The controlling switch for truck lights is contained in a metal box and connected to the circuit by leads passing through the hollow pedestal on which the box is mounted. The handle on top of the box is used for operating the switch,

and the lamp lighted at any one position is indicated by the pointer. The light may be pulsed by moving the pulsator button on the side of the box in and out.

When connecting the truck-light controlling switches follow the diagram in fig. 142. The terminals on the inside of the box are marked *M R*, *M W*, *F R*, *F W*; those to which the line connections are made are marked *L*.

The line wires should be connected to the terminals marked *L*; those from the "main" red half of the lantern to *M R*; from "main" white to *M W*; from "fore" red to *F R*, and from "fore" white to *F W*.

Terminals are provided which should be soldered to the ends of the wires and fastened to the contacts with screws.

The covers on the sides of the box should be removed every three months. If the contacts are discolored they should be polished, and any irregularities or burnt places should be smoothed off with a file.

(F) DIRECTIONS FOR THE BOUGHTON NIGHT-SIGNAL SET.

It is transported in three boxes—keyboard, cable, lanterns.

TO ASSEMBLE.

1. Open box No. 1 and remove keyboard and secure its base at place where it is to stand by suitable screws or bolts.

2. Open box No. 2 and take out lantern support and lay same along the ground with its upper end (shown by absence of electric cable which depends from the lower end) near the foot of staff from which it is to hang.

3. Connect the electric cable which depends from the lower end of the wire cable lantern support to the keyboard, by its coupling, and screw the collar home. Connect keyboard with electric current of emplacement, through the two binding posts seen on under surface of keyboard. Wires should be equal to serve sixteen 10-candlepower lamps at once.

4. Unpack box No. 3 and take out glass lenses for lanterns, four red and four white, carefully dust and wipe same with clean cloth, and place same in frames thus making four double lanterns of white and red lenses, white above and red below.

The lantern frames are made ready for lenses by unscrewing the top and bottom nuts of the four side bolts which make the lantern frame, when the top or bottom sockets may be moved up or down ready for the lens.

The mid-division of the lantern carries the electric lamp sockets, and sustains the weight of the double lantern; it is clutched and bolted to the larger wire cable and is not to be moved.

Rubber gaskets are placed between each end of each lens and its support, making the lantern gas and water tight.

5. Wipe electric lamps with clean cloth, push lamps to mid-division of lantern, three on top and four on bottom. Lanterns are opened for setting lamps in place by unscrewing top and bottom caps. Replace lantern ends by screwing same home.

Test electric connections of each lamp of each lantern from keyboard. See that each lamp lights promptly, and gives its light in full candle power. Lamps failing to light fully are broken or not set right in socket, and must be replaced or properly placed in socket.

6. Hoist lantern frame to place on mast and make fast to outrigger, back stay and below.

7. Place pilot light in its socket at back of keyboard.

TO USE.

The keyboard swings on the base in an arc of 180° in order that the operator may face the point signaled.

To swing the keyboard, pull the stud at the side of upper part of base and swing the keyboard in the direction desired. The swinging device is self-locking at various intermediate points of its arc, by means of the stud above mentioned.

The telephotos shows the signals, letters or numerals shown on the top of the keys of the keyboard as a flash signal or as a standing signal at the will of the operator.

To signal by flash signal, press down the proper letters or numerals and hold same down, five, eight or ten seconds, according to the ability of the person

signaled to read signals; upon releasing the key, the signal disappears and you are ready to show the next. But one signal key may be used at once, to avoid confusing the receiver of the signal.

The pulsator may be used at any time with any signal.

To make a standing signal, press down the proper key as before and give the key a twist to the left and it will stay down. As long as the key is down its letter or signal is shown. To release the key, give the same a twist back and it will rise to the level of the others, and its signal will disappear.

Before sending important messages one should be familiar with the keys, learn what letter or numeral they represent, learn the pressure needed to bring down a key, the time required for a signal to appear, be read and to disappear, learn the use of the pulsator, and the interval.

To examine the contents of the keyboard, unscrew brass studs around outer margin of key plate, when key plate may be lifted out of place and all contents of keyboard will be in plain reach and sight and so simple as to require no explanation. In replacing key plate see that its rubber gasket is in place.

When not in use, the door in brass cover of keyboard should be pulled down, and the telephotos protected by a canvas cover.

The keyboard being hermetically sealed, might in some climates show signs of condensation on account of temperature in the box and that on outside not being equal. Should this ever occur, remove the keyboard plate and take small cork in bottom of box out. This will make temperature inside and outside alike.

XI.—MISCELLANEOUS APPARATUS.

(A) THE FIRING KEY.

The firing key is a small, single-throw knife switch with spring to keep the knife normally open, with an ebonite turn-buckle over the jaw for increased safety and with a brass pin to hold the knife locked in the jaws when desired.

(B) THE ELECTRIC FUSE.

The electric fuse offers the safest, simplest, cheapest and most effective means of firing high explosives or large charges of powder, and the only means of igniting separate charges simultaneously for greater destructiveness or a single charge from a distant point, or at a required moment, or under water.

1.—It consists of about $\frac{1}{4}$ -inch length of fine wire of platinum-iridium alloy, 0.001 to 0.003 inch diameter, $\frac{1}{2}$ ohm to 1 ohm resistance cold, called the bridge which is surrounded by a little gun cotton; next to this is placed fine gunpowder for igniting a powder charge or mercuric fulminate for detonating high explosives. The whole is fixed within a copper case. An electric current of specified strength reddens the bridge, ignites the gun cotton and fires the fuse.

1. The commercial fuse (fig. 143 is actual size) has a copper shell *A* with corrugation to hold more firmly the sulphur cement *F* which seals up the open end and holds firmly in place the fuse wires. *B* is the chamber containing 20 to 50 grains of fulminate. A little gun cotton surrounds the bridge which is soldered to the bared ends of the fuse wires *D*. The wires, 4 to 40 feet long, have cotton cover soaked in asphalt for ordinary outdoor work and gutta-percha covering for submarine work.



143.

2. The United States Navy electric fuse (fig. 144) has the copper case in two parts which screw together, $\frac{3}{16}$ -inch. The upper or inside part holds 35 grains of the fulminate. The lower, open at both ends, is filled with sulphur and glass, which holds fixed in place the wire ends and bridge. When the fulminate is dry, the spaces in both parts are filled with dry pulverulent gun cotton and the parts are screwed together.

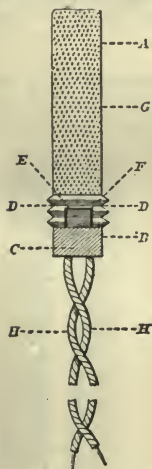

144.

A, lower tube; *B*, upper tube; *C*, plug of sulphur and glass; *D*, bridge legs; *E*, bridge; *F*, gun cotton; *G*, fulminate; *H*, fuse wires.

3. The mine fuse (fig. 145), without the copper case and fulminate may be used in ordinary work to fire gunpowder. To detonate explosives, attach the copper case containing mercuric fulminate which varies in quantity with the kind and size of the charge.

Plug *K* has two opposite longitudinal grooves in which the lead wires *C C*, covered with paraffined cotton braid, are buried. A cut round the middle allows the two leads to cross half over, so that each lead leaves the plug in the opposite groove from that which it entered, thus holding the wires fast. The cap *B* fits tightly over *K* and is glued to it in a solid piece. The copper case slips over the whole and is held by dents near the end.

4. The gun fuse (fig. 146) has a brass case *a* threaded on the exterior to screw into the axial vent of the breechblock to the shoulder. Its rear part is squared for a wrench. The interior is thinned at *b* for a gas check. A hard rubber plug, *f*, holding in a fixed position the leads to the bridge, is seated at *c*. Small-arms powder surrounds the bridge and gun

cotton. The escape of gas outside the fuse is prevented by the expansion of the thin part at *b*, and inside the fuse by the hard rubber being driven into the enlargement of the wire duct.



145. Mine Fuse.

A, copper case; B, hollow wood cap; CC, wires, 0.035 inch; D, bridge, 0.0025 inch; F, priming; H, fulminate of mercury, 10 to 24 grains; I, paper discs held by drop of collodion; K, plug of beech-wood.

II.—The electrical tests of a fuse are for—

1. Conductor resistance cold (bridge and short leads), 0.3 to 1 ohm.
2. Conductor resistance hot just before ignition, 0.45 to 2 ohms.
3. Insulation resistance between conductor and case, 1 megohm.

4. Strength of current required to fire, 0.3 to 0.8 ampere.

The testing current ought not to exceed one-tenth of that necessary to fire.

III.—Placing the fuse in a mine charge—

1. If of gunpowder, fill the bag one-third full, put the fuse, or two fuses in parallel, on top, fill up the bag, leaving 6 inches slack in the wires, and lash tightly the mouth of the bag and wires. If the bag is vulcanized india rubber for service under water, the mouth is well smeared with india rubber solution and closed between two hard-wood clamps bolted together. Tension on the fuse is prevented by a stout string from the clamp hitched to a point on the fuse wires.

2. If the charge is gun cotton, insert the detonator in the hole of the priming disc and lash the wire to the disc which is placed centrally in the charge. If the latter is very large, two or three priming discs, each with its detonator, are used. If the charge is wet gun cotton the primer must be dry and encased to be kept dry.

3. In a dynamite or gelatine cartridge (147), punch with a hard-wood pin a hole in the lower end or middle, 1 inch longer than the detonator and without removing the paper cover. Press

the cartridge to close the mouth of the hole after insertion, and lash with string the wires along the cartridge. Half hitches or other tying of the wires may cause short circuits.

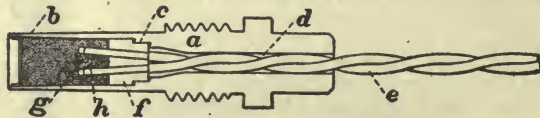

146.

IV.—To fire with a battery.—See that all persons are distant or protected; attach the leads; close the switch firmly; detach the leads.

Before using the battery ascertain from its constants and external resistance if it can supply the necessary current strength to each fuse. In no case can this be less than the current given for ignition, nor be more than 25 per cent in excess. If the fuses are two in parallel, instead of all being in series, double the current will be required.

V.—To fire with the service dynamo.—1. If no one is near the mine or gun, connect the leads to the posts; seize the handle with one hand; steady the box with the other; lift the ratchet-bar to its full length, then press it down quickly with constant force until the bar strikes the bottom with a thud, when the fuses will be fired; detach the wires. Churning the bar up and down to fire is useless and harmful.

When there are three binding posts on the box (fig. 148) and the number of fuses is small, join the leads to the middle and either outside post; when the number of fuses is large, join the main leads to the outside posts and run a third lead from the middle post to a point midway of the fuses in series.

2. In case of failure to fire when the number of fuses does not exceed the capacity of the battery or dynamo, there is probably a break, a poor joint or a contact between the two leads. The leads being detached, go over the whole circuit, lifting up the wire in search of a break inside the insulation, examining the joints and watching for contacts. If this fails to reveal the open circuit, locate it by use of a single high resistance cell and the fine wire coil of the detector or other Galv. of sufficient resistance to keep the testing current below $\frac{1}{10}$ ampere.

3. If trouble is suspected in the dynamo, try a fuse through a resistance; or, if after removing the endboards, a spark is seen at the short-circuiting key when the bar strikes it, the dynamo is in order. The resistance between the two binding posts should be zero when the bar is up and about 6 ohms when pressed



147.

down hard. When there are three posts and the bar is up, the *R* between the left-hand and middle ones, looking at them from their side of the box is 0, and between the middle and right ones, infinity.

VI.—Precautions in firing fuses are as follows:

The last thing done around a mine or a gun is the joining of the fuse wires to the leads.

At the battery or dynamo just before firing, attach the leads to the posts.

Place battery or dynamo in a safe place and as near the mine as safety permits.

A rough test of the generator just before firing can be made by its bringing for an instant to a barely perceptible red, a certain length of platinum fuse wire; or by firing a single fuse through a given resistance.

The service dynamo will fire a very few fuses joined two in parallel.

In jointing, scrape clean the ends, wind closely, solder if convenient, with resin for the flux, and in all cases wrap the joint with tape.

Fuses must be kept in a dry place remote from explosive or strong acid, and should be tested before using.

Fuses varying 10 per cent or more from their specified resistance are rejected.

Put detonators under test in a safety box; never turn a detonator toward a person.

A detonator must on no account be bent, struck, heated or roughly handled.

Avoid strain on a fuse by hitching a tension string from the charge case to the fuse wires.

For certainty of ignition of a single important charge, two fuses are connected in parallel.

Always use fuses of the same kind in a circuit. Lead wires have double the diameter of fuse wires.

Guard against injury to insulation in tamping, and bare wire at a joint or other point in the circuit.

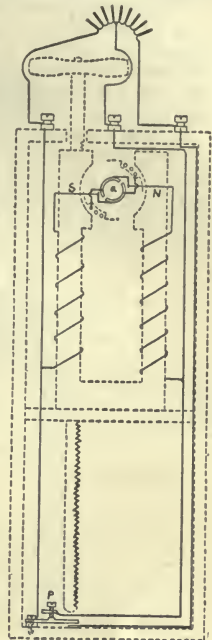

148. 30-Fuse Firing Dynamo.

(C) ELECTRIC BELLS.

1. Electric bells are of two kinds—single stroke (fig. 149) and vibrating.

In the vibrating bell (fig. 150), the armature is held by a spring, *C*, against *B*, adjustable at *D*. The key *K* being closed, a current flows through *L*, *P*, *B*, *F*, *C*, *E*, *P*, *K* and *L*, attracting the armature, striking the gong and breaking the circuit at *B*. As no current now flows, the spring at *C* throws the armature back against *B*, reestablishing the current which acts as before. Both contact points, *B* and *F*, are of platinum to prevent corrosion by the spark.

2. Trouble in bell circuits is usually due to dirty contacts at *B* and *F*, or to some part of the circuit touching the metal frame or to a break in the circuit, usually at a binding post, key or joint. Use insulated wire only; fasten wires

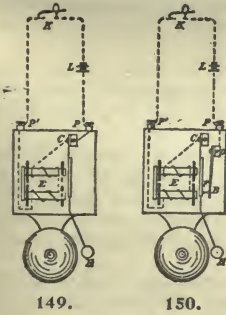

under composition staples without bending the wire; keep parallel wires one-half inch apart; never run two wires under the same staple or through the same hole; solder splices, and cover with insulation.

To ring two or more bells, each with its own button, by means of one battery, see fig. 151.

To ring one bell with one battery from two or more buttons, see fig. 152.

(D) THE ANEMOMETER (FIG. 153).

The anemometer measures the velocity of the wind in miles per hour.

1. It should be placed on top of a telegraph pole or other support without vibration, erected on the highest site in the vicinity. Any obstruction within 500 feet of the site and 10° or more above it is objectionable, as the velocity of the wind is diminished by friction from 20 to 50 per cent within 100 feet above the ground. Two wires run from it to the distant register.

2. Four brass cups, *C*, on the ends of arms, in a wind, turn a vertical shaft, *A*, whose screw thread, *B*, is geared into wheel, *D*. Two D-shaped lugs on the wheel are arranged as shown to close momentarily an electric circuit every 25 revolutions on a single-stroke bell, every 500 revolutions on a self-register, and permanently during 25 revolutions on the stop clock. The wheel must be specially constructed for each of the above registers; for the stop clock the two D-lugs are replaced by a semicircular ridge joining their positions, which then closes the circuit during one-half revolution of the wheel.

3. To get roughly the velocity of the wind in miles per hour with the single-stroke bell, connect up anemometer, bell, and battery, as in fig. 153. Note by means of the secondhand of an ordinary watch the number of seconds between two consecutive strokes. Divide 180 by that number.

EXAMPLE.—The seconds hand stood at 32 when the anemometer rung the bell and at 47 at the next stroke. Required, the velocity. Interval = 15 seconds; $180 \div 15 = 12$ miles an hour, approximate.

4. Anderson's stop clock performs the above automatically and more accurately, its electro-magnet taking the place of the bell's magnet in fig. 153. Its single second's hand moves over a dial having two scales—the inner one representing in the usual way seconds to a total of 60, the other scale of unequal parts, velocities in miles per hour. Experience shows that the velocities are a little greater than those given by the above rule.

By means of a lever and cam, the seconds hand can be brought to the vertical or 0 position from any other on the dial. A very light spring on the movable end of the armature bears normally

against the balance wheel and thus keeps the clock from running; when the magnet is energized from the anemometer, the armature both releases and starts the balance wheel, and the clock runs while the cups make 25 revolutions, or the air, $\frac{1}{10}$ mile; the armature then released stops the clock.

To operate: Close the circuit; bring the hand to 0; if it then starts, the anemometer has closed the circuit and it will be necessary to wait until the hand stops, when reset it at 0. In a few moments it will automatically start and later stop and register.

5. Gibbon's self-register (fig. 154) has an electro-magnet in the place of the bell's magnet of fig. 153, and a 4-inch diameter drum revolved uniformly and translated longitudinally by clockwork so that the point of a fixed pencil will describe a spiral upon a sheet of paper laid upon the drum's surface. The pencil is held at the movable end of the magnet's armature. The paper is ruled parallel with the drum's axis into five minute spaces.

Whenever the anemometer, after the connections are complete, makes about 500 revolutions, corresponding to points moving with the wind exactly 1 mile apart, it closes the circuit and the pencil makes a sharp dent in the spiral.

To put the sheet on the drum, place the cylinder *S* on a table with the screw *T* to the left-hand; place the paper on the cylinder with the top of it from the screw. Let the line marked 12 noon come on the line of the cylinder, and place a rubber band on each end. The lines at each end of the paper will then exactly coincide. Place the cylinder *S* in its position, so that the end opposite to the screw *T* will be near the post on which it rests. Slide the small sliding bar on the horizontal bars *O O* until it fits on the ends of the screw-axle *T*; then revolve the cylinder until the pencil rests on the end of the upper line marked 12 noon, or the line corresponding to the hour at which the instrument is set, and tighten the thumbscrew *N*.

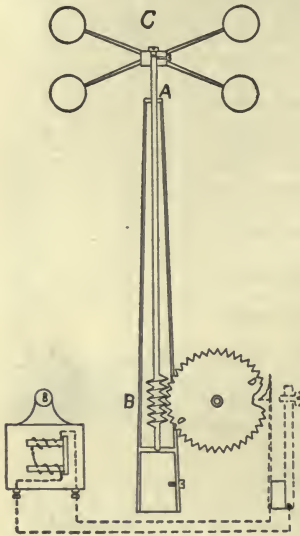

153. Anemometer.

To obtain the velocity from the self-register take the number of spaces and parts of spaces between the mile marks recorded in the five minutes preceding the time of observation and multiply the result by twelve.

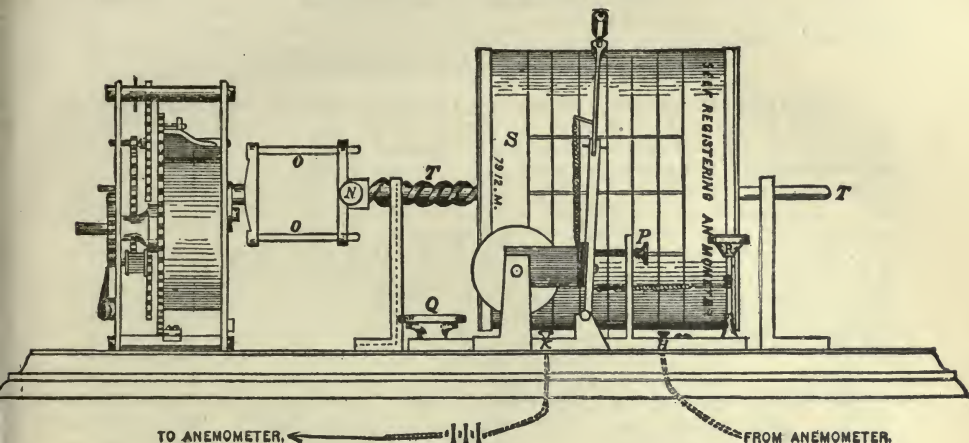

154.

Ex: Suppose the number of spaces indicating mile marks between 8.55 and 9 a. m. were $1\frac{1}{4}$; then the velocity of the wind is $1\frac{1}{4} \times 12 = 15$ miles per hour. When the velocity is less than twelve miles per hour the velocity will be determined as follows: If the interval between the last two mile marks is 7 minutes, then the current hourly velocity will be obtained by dividing 60 by 7 = $8\frac{4}{7}$ miles.

6. The velocity of the wind may be roughly estimated without anemometer:

Name.	Miles per Hour.	Apparent Effect.
Calm -----	0 -----	No visible horizontal motion to inanimate matter.
Light -----	1 to 2 -----	Causes smoke to move from the vertical.
Gentle -----	3 to 5 -----	Moves leaves of trees.
Fresh -----	6 to 14 -----	Moves small branches of trees and blows up dust.
Brisk -----	15 to 24 -----	Good sailing breeze, and makes white caps.
High -----	25 to 29 -----	Sways trees and breaks small branches.
Gale -----	40 to 59 -----	Dangerous for sailing vessels.
Storm -----	60 to 79 -----	Prostrates exposed trees and frail houses.
Hurricane -----	80 or more -----	Prostrates everything.

To find the pressure of the wind in pounds upon a surface exposed perpendicularly to the wind, multiply together, 0.005, the surface in square feet, and the square of the velocity of the wind in miles per hour. Or, $P = 0.005 SV^2$.

7. Care of Anemometer.—Keep mechanism clean and bearing parts oiled with clock oil. The anemometer should be compared every season and found to agree with at least two others supposed to be in good order.

XII.—PRIMARY BATTERIES.

(A) GENERAL DIRECTIONS.

1. When any two different metals are partially immersed without touching in a liquid which acts more upon one than the other, the combination forms an electric cell; if a wire joins the metals outside the liquid, a current of electricity will flow around the circuit thus formed. Zinc is usually one of the metals or plates; copper or carbon is the other and its upper part is the positive pole of the cell. Sometimes two liquids are used—each around its own plate—and kept separate by a porous diaphragm or by gravity.

2. The current from an electric cell diminishes after a time more or less rapidly, due chiefly to three causes: (1) impurities in commercial zinc, causing local action; (2) the production of new and hurtful compounds in the cell; and (3) polarization, or the formation on the copper or negative surface of hydrogen gas which not only increases the resistance of the cell but tends to make the poles alike.

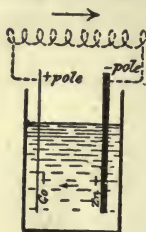

155. Typical.

(1) Local action is remedied by coating the zinc surface with mercury, a process called amalgamation; (2) hurtful compounds are removed from time to time; (3) polarization is partially or wholly checked by enlarging and roughening the surface of the negative plate, or, preferably, by surrounding it with an oxide or other substance, termed a depolarizer, which takes up the hydrogen as it forms.

3. *Management.*—(a) In mounting, see that all the parts are clean, the bearing surfaces of connections brightened and the connections made tight by using English binding posts, or doubling the wire through holes too large, so as to fit. Use only rain water and the best materials. Do not spill liquid or salt over parts to remain dry. The two plates of a cell should not touch, nor any two cells of a battery. Cells of different kinds are never joined in the same battery.

(b) For proper maintenance all cells should have covers to prevent evaporation, all zincs in acids should be amalgamated to prevent local action, and rims of jars should be dipped about an inch in melted paraffine to prevent salts from creeping over. Keep cells well insulated on porcelain holders or paraffined wood in a dry, cool and clean place, especially free from dust and change of temperature. The cells are preferably arranged in single rows on shelves accessible on both sides and having a hood to carry off the gases. Direct sunlight on glass jars may crack them.

The battery room, dry, light, ventilated, and with cement floor, should have a sink with entrance and exit water pipes, and such facilities as spare jars, pitcher, scales, brushes, syringe, hydrometer, funnels, graduated glass and mercury dish. All trace of grease or soap must be excluded.

(c) After dismounting, all battery parts are cleaned while wet. Scrape off old salt and crust, and rub with a brush until a bright surface appears. If plates are greasy, soak in strong soda solution. Carbon plates and porous cups are soaked in water several hours. Re-amalgamate the zincs. File or rub with emery the connections, and finally dry, re-paraffine and repaint with asphaltum. Varnish the tops of plates.

4. *Amalgamating zincs.*—First clean the zincs, then dip in sulphuric acid solution ($\frac{1}{10}$), or any old acid solution, about one minute. Then transfer it to an open shallow dish of iron or porcelain whose bottom is covered with mercury and a little of the solution. While turning the zinc over so that every part comes into the mercury, rub the surface with a swab made by winding cloth around the end of a stick.

Or, mix, by weight, 1 part nitric and 2 parts hydrochloric (muriatic) acid and add slowly $\frac{1}{4}$ part mercury. When dissolved add 3 parts more of hydrochloric acid and stir. Clean the zinc with potash and water; immerse in the above solution for a few seconds. Rinse in clear water and rub with battery brush.

5. Solutions are mixed in large jars to obtain uniformity by pouring in first rain or pure water, and adding the acid slowly while stirring. Let the mixture cool and settle and do not use the sediment.

6. The desirable qualities of a cell are (1) a large and constant E , (2) a small and constant R , (3) cheapness of materials, (4) no waste of materials when not giving a current, (5) easily inspected, (6) easily refreshed, (7) no offensive fumes, (8) first cost small. No one cell has all of them.

7. Several cells of the same kind and size may be united in series, parallel or both, to form a battery. The two forms of battery are the primary and secondary. There are five different kinds of primary in general use—Leclanché, dry, gravity, copper oxide, and bichromate.

(B) SPECIAL DIRECTIONS.

(a) LECLANCHÉ CELL (FIG. 156)

1. A zinc rod, or cylinder, and a carbon cup containing a mixture of nearly equal amounts of broken carbon and manganese dioxide stand in a saturated solution of sal ammoniac. E = about 1.48 volts; R of 5 by 7 inch cell with zinc rod is about 1 ohm.

2. The Leclanché furnishes a strong current for a short time, but it soon begins to polarize. Left on an open circuit, it regains its strength without the consumption of material. It is useful for intermittent work only.

3. *Mounting.*—Fill the jar about one-third full of water and stir in about 4 ounces of sal ammoniac, so that there may not remain an excess of the white salt. Put in the two plates with cover. Liquid is about 2 inches from the top. If porous cup, let the cell stand twelve hours before using; or better, fill the cup with solution through the gas hole in the seal. If prisms, they are held tight against the carbon by two strong rubber bands.

4. *Maintenance.*—Add water as it evaporates and a little salt as the current gets weak. Wipe off the first trace of white salt forming on the tops of parts due to carelessness in setting up the cell. Hard scale on plates shows that the solution is too strong.

Never leave the cell on closed circuit and for safety detach both poles when the cell is not required. If a Leclanché fails, examine the connections, or add a little salt, or replace the solution with new, or soak carbons in hot water for three hours, or scrape off the hard scale, or fill carbon cup with fresh mixture, or throw away all except the jar.

A green salt forming on a binding post is cleaned and the metal part is recoated with asphalt. One carbon outlasts three zincs; one zinc rod gives 30 to 40 ampere hours.

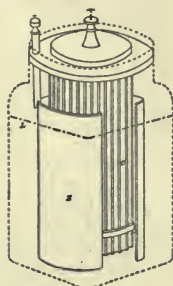

156. Sampson.

(b) THE DRY CELL (FIG. 157)

Belongs to the Leclanché class. A zinc can enveloped in pasteboard, and always having a sealed cover, serves both as jar and plate.

1. The central cylinder of carbon and manganese oxide is surrounded by an absorbent or gelatinous body well soaked in an exciting solution of 1 part (by weight) sal ammoniac, 1 part Zn. chloride, 3 parts plaster, 2 parts water. The ingredients are often kept secret.

2. E = 1.4 volts, and R = about 1 ohm for a 5-inch cell. Its ampere hours is less than for a liquid Leclanché. But it is cheap, portable, may be laid in any position, and kept for a long time if not overworked and if the inside moisture does not escape. A good dry cell may ring a door call bell eighteen months.

3. If it fails, bore a small hole in the seal and inject water. If its strength is regained, seal up the hole tightly; otherwise throw the cell away.

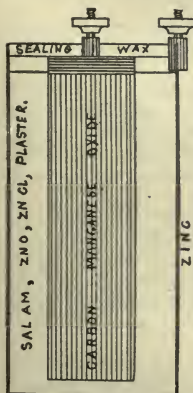

157. Dry Cell.

(c) GRAVITY CELL (FIG. 158).

1. A zinc plate, Z , stands in a solution of zinc sulphate, and a copper plate, C , in a solution of copper sulphate (bluestone), the copper being at the bottom. E = about 1.08 volts. R of a 6 by 8 inch cell in good condition is about 3 ohms. The gravity gives a steady current in a closed circuit and is employed for continuous work only. Good forms are Crowfoot and Eagle.

2. *Mounting.*—Unfold the leaves of the crowfoot copper so as to form a cross, place it in the bottom, bring its wire up straight and bend it sharply over the edge for a clamp. Drop in crystals of copper sulphate, about three pounds, to the top of the leaves.

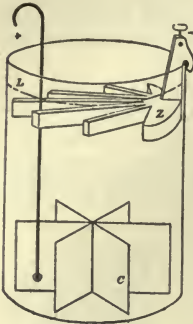

158. Gravity, Crowfoot.

Pour in rain or soft water until it covers the zinc, put on the cover and short-circuit for two or three days. If wanted sooner, let the water come to within an inch of the zinc and then pour carefully on top a solution of 3 ounces of zinc sulphate in sufficient water to cover the zinc, or zinc solution from an old jar, if clear, or a little sulphuric acid.

3. *Maintenance.*—The cell is in good condition when the lower copper solution has a deep blue color up to the point midway between the plates and the upper zinc solution, of 1.1 specific gravity, is clear like water, and when the dividing line between them is sharp. If the blue rises higher, reduce the external resistance or short-circuit; if it sinks much below the middle, leave it on open circuit a few hours. The cell normally should remain closed on a resistance and never jarred nor the plates within be disturbed. Copper sulphate crystals should always be seen in the bottom. When the zinc solution becomes too heavy, causing salt to form on the upper parts and copper on the zinc, or the specific gravity reaches 1.2, remove the top liquid by means of a syringe to an inch below the zinc, and replace with water slowly, so as not to disturb the solution below. When metallic copper forms on the zinc, take out the plate, scrape off the mud, chip off any cake formation, and after dropping in large crystals of bluestone (if needed), replace the zinc and cover.

4. *Dismounting.*—Take out the plates and save the top clear liquid to start the new cells. With a hammer and knife remove the hard crust from the zinc and the deposit from the copper. See that the attached wire is firmly riveted to the copper plate and that there is no break in the insulation.

5. *The Eagle cell is for portability.*—Fill the lead jar (fig. 159), whose inner surface has been brightened, one-third or one-fourth full of copper sulphate and cover with two-inch thickness of pressed excelsior, sponge or sawdust on which rests the zinc. Wooden sticks suspended from the rim prevent the zinc from touching the jar. Pour in water until it covers the zinc and short-circuit for three or four days. Let the jar stand on wood soaked in paraffine or on glass.

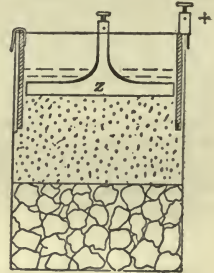

159. Eagle.

(d) COPPER OXIDE CELL (FIG. 160).

1. Plates of zinc and of copper oxide stand in a one-fourth solution by weight of caustic potash. E = about 0.8 volt. R of the 5 by 8 inch cell with oxide between two zinc plates is about 0.07 ohm. The cell is for either continuous or intermittent work.

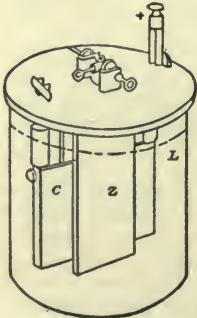

160. Copper Oxide.

2. *Mounting.*—Place the potash in the jar, and pour in water until its level shall be $\frac{1}{4}$ inch above the oxide plates when in position. Stir with a stick at intervals so as not to cause too great rise of temperature until the salt is dissolved. Pour carefully on top heavy paraffine oil so as to form a layer $\frac{1}{4}$ inch thick.

Pass the ends of zincs, well amalgamated, through the middle hole of porcelain cover and fasten them. Put the copper oxide plates in their frames, slip on the hard rubber separators, pass the ends of the frames through the holes in the cover and fasten them. Put plates and cover in position. If a strong current is wanted at once, short-circuit for ten or fifteen minutes.

3. *Maintenance.*—If necessary, move the cell without shaking. Glass jars are liable to crack. The top layer of oil is very essential and the level of the dividing line previously marked on the jar inside should be well above the oxide plates. There is no local action on open circuit. All materials are proportioned to be consumed in practically the same time.

(e) BICHROMATE CELL (FIG. 161).

1. Zinc and carbon plates stand in a solution of sulphuric acid and bichromate of potassium or sodium. $E = 2.1$ volts. R of 6 by 8 inch cell with zinc between two carbons = about 0.08 ohm.

The Grenet zincs are submerged only when a current is required. The current is very strong for a few hours.

2. *Mounting.*—To 1 gallon of water in an earthen vessel add from 1 to 2 pints of sulphuric acid, according to the strength required. While the mixture is still hot stir in one pound of bichromate of potash pulverized. When cool it is ready for use and is known as electropon fluid.

3. *Maintenance.*—Special care is taken to keep zincs well amalgamated; they should, when submerged, reach to the bottom of the jar so as to touch a little mercury. The zincs are raised out of the solution when not in use; the carbons may remain or not. Draw off some of the old liquid when it changes color and add fresh.

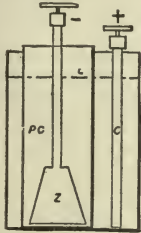

162. Fuller.

4. The Fuller bichromate (fig. 162) is used with long-distance telephones. Pour an ounce of mercury into the porous cup, 3 by 7 inches, put in the zinc, fill the cup with water and stand the cup with its contents in the jar containing, by weight, 6 parts sodium bichromate, 17 sulphuric acid, and 56 water. Alongside put in the carbon with its cover.

The zinc remains continuously in the cell, which needs no attention for four or five months if not overworked; otherwise once a month. There is very little local action on open circuit. When the rich orange color becomes bluish, add crystals. If the color is still orange and the cell weak, add acid. If the cell is still not active, renew the whole solution.



161. Grenet.

XIII.—TELEGRAPHY.

(A) DIAGRAM OF MORSE RELAY TELEGRAPH FOR LONG LINES (FIG. 163).

The main circuit is drawn full; the local circuits, broken. The former uses the ground; the local circuits are metallic. The main battery of gravity cells in series may be at any point of the main circuit, but a half is usually located at each end; if one of the halves has copper to line, the other must have zinc.

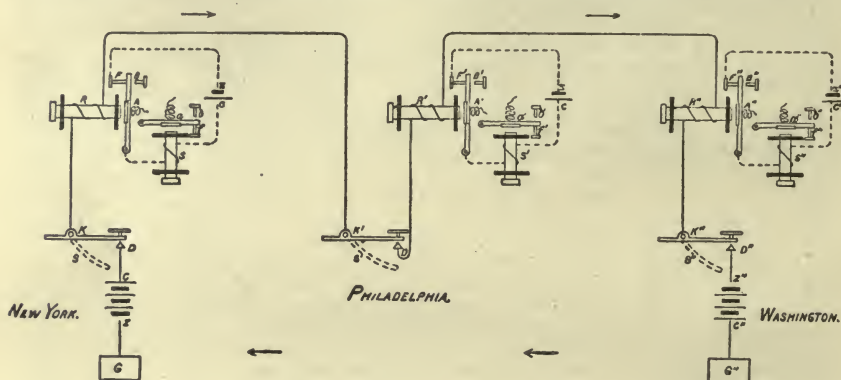

163. Diagram of Morse Relay Telegraph for Long Lines.

All relays of the same circuit should be alike. Many operators read the relay and dispense with the local circuit. For 5-mile circuits, 20-ohm sounders may take the place of relays and local circuits; both key and sounder have a common wooden base and the thin brass base of the sounder is raised $\frac{1}{8}$ inch for greater clearness.

A 150-ohm relay has about 4,320 turns in 30 layers, No. 30 on each core.

A 4-ohm sounder has about 470 turns in 10 layers, No. 24 on each core.

A 20-ohm sounder has about 938 turns in 14 layers, No. 25 on each core.

It is plain from the above diagram that all relays and sounders will respond to any key in the circuit and to one key only at a time if its switch is open. If a record is desired, a self-starting tape register takes the place of the sounder.

(B) TELEGRAPH CODE.

The dot, dash and space are the three Morse signals, and different combinations of them form the letters.

The dot (E) is made by a momentary downward stroke of the key lever. This is the unit of time. The dash (T) is made by holding the key down as long as it takes to make 3 dots. A space as in A occupies the time of 1 dot; a double space, as in R, equals 2 dots.

The space between letters is equal to 3 dots; between words, 6 dots; the sentence space is filled in by a period.

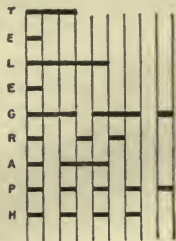

164.

THE MORSE CODE.

A — — — — —	Q — — — — —	5 — — — — —
B — — — — —	R — — — — —	6 — — — — —
C — — — — —	S — — — — —	7 — — — — —
D — — — — —	T — — — — —	8 — — — — —
E — — — — —	U — — — — —	9 — — — — —
F — — — — —	V — — — — —	, — — — — —
G — — — — —	W — — — — —	; S I
H — — — — —	X — — — — —	: K O
I — — — — —	Y — — — — —	. — — — — —
J — — — — —	Z — — — — —	() P N
K — — — — —	& — — — — —	? — — — — —
L — — — — —	0 — — — — —	! — — — — —
M — — — — —	1 — — — — —	" " Q N
N — — — — —	2 — — — — —	§ — — — — —
O — — — — —	3 — — — — —	§ S X
P — — — — —	4 — — — — —	

ABBREVIATIONS.

1 Wait a moment.	Ahr Another.	Msk Mistake.
4 Start me.	Ans Answer.	N M No more.
5 Have you anything?	Ck Check.	O B Official business.
7 Are you ready?	Col Collect.	O K All right.
8 Busy on other wire.	D Degrees.	Opr Operator.
9 Important, give way.	Fm From.	Pd Paid.
13 Do you understand?	D H Deadhead.	QK Quick.
18 What's the matter?	G A Go ahead.	R Repeat, are.
30 Close station.	G B Good bye.	S Station.
44 Answer quickly.	G M Good morning.	Sig Signature.
92 Delivered.	G N Good night.	U You.
134 Who is at the key?	G R Gov't rate.	! Ready.

(C) FORMS OF MESSAGE.

Between operators whose calls are S and J:

Smith.—“Come down on twelve o'clock train if you are off duty.”

Jones.—“Shall take six p. m. train.”

The call, message, and acknowledgment in which Jones fails at first to receive the word “twelve,” and misses the word “take,” occur thus:

Smith.—J J J J S J J J S J ———

Jones.—III J

Smith.—II Come down on twel——

Jones.—G A on.

Smith.—On twelve o'clock train if u r off duty

Jones.—O K Shall taken ——— take six p m train J

Smith.—O K S

Regular commercial or military message:

FORT MONROE, VA., July 30, 1901.

JOHN B. THOMAS, 80 State street, Richmond, Va.

When will you reach Old Point? Telegraph collect. W. J. BODELL.

It would be telegraphed as follows:

No 45 F S 7 Paid Fort Monroe Va 30 to John B Thomas 80 State street, Richmond Va. When will you reach Old Point. Telegraph collect Sig W J Bodell.

“No 45 F” indicates that this is the forty-fifth message sent from Fort Monroe whose office call is F. “S” is the sending operator's personal call. “7” indicates the number of words in the body of the message to follow. “Paid” indicates that the message has been paid for; otherwise the word is “collect” or “D H” (deadhead). The year and month are omitted. A period immediately precedes the body of a message and “Sig” always follows it. The receiving operator whose call is “A” sees that the message is apparently correct, verifies the number of words and telegraphs, “O K A.”

(D) ADJUSTMENTS OF INSTRUMENTS.

1. *Key*.—Loosen the binding nuts and turn the trunion screws close up so that the platinum contact points will touch squarely, then turn each slightly back so that the key lever moves freely up and down without lateral movement. If necessary rub the contact points with fine emery occasionally to prevent

"sticking." The vertical screws of the key should allow a small movement of the key lever with a moderate spring pressure. See that all the binding screws are tight and that the switch is firmly pivoted by its screw and scrapes well into its position when closed.

2. *Relay (or sounder).*—The trunnion screws, as in the key, should allow free motion to and fro (or up and down) without lateral movement. Next adjust the front (or lower) contact screw that the armature may not strike the magnet cores or approach nearer than the thickness of writing paper; withdraw it even further if the armature "sticks." The back (or upper) binding contact screw should allow small play, but sufficient to give a distinct sound. Adjust the screw of the spiral spring until the relay (or sounder) strikes with the key. Finally see that all of the binding screws are tight.

(E) INSTRUCTIONS FOR OPERATORS.

1. Keep key closed except when sending. If no current is on make sure that the trouble is not in your station; for this purpose touch a short piece of copper wire across the main wires entering the station to observe a spark or taste with the tongue. If a spark is seen or a current is tasted, the trouble is probably in your station.

2. Keep instruments screwed to the table and constantly in adjustment so that relay, sounder and key strike together; that all binding posts and screws are tight; that the ends of wires entering posts project through them and are bent around; that no dust, books, papers, etc., accumulate on or about the instruments. The table should be screwed down, and large enough to rest the elbow in sending. Never put instruments on a window sill or expose them to the weather.

3. To prevent instrument from working when not required, shunt it out. Never screw down the armature lever nor alter the spring nor detach the wires.

4. To call a station, first adjust to make sure the line is not in use; if not, open the key, make the call three or four times and sign your own call. Repeat until answered, when close the key.

5. To answer a call, wait until you hear the signature, then open the key and as soon as the distant key is closed repeat the letter "I" two or three times, or "O K" once, signing your own call. Close the key.

6. To send a message, call the station as above. When it is answered, open the key, send the message and close the key. If a mistake occurs make interrogation or six dots and begin with the last word sent correctly. Invariably observe the "forms" of message above. If no "O K" is received, the call, answer, and message are repeated.

7. To receive a message, answer the call and prepare to write down the message. The instant a word is missed, break and telegraph "G A" (go ahead) and the last word received. But if all that precedes is desired, telegraph "R R." In a regular message verify the number of words in the body before sending "O K." If the check does not verify, the sender must give the initial letter of each word until the mistake is found.

8. In the body of a message abbreviations do not occur, numbers are spelled out, periods occur between sentences but not at the end, and compound words and names of places count for one word.

9. Care should be taken to send uniformly. It is more difficult to send well than to receive well. Few operators send and receive 40 words per minute; 30 words is very rapid; the average speed does not exceed 20. Five letters count for the length of one word.

(F) DIRECTIONS FOR BEGINNERS.

1. (1) Memorize the alphabet. (2) Learn with the aid of an instructor to write Morse with the key. (3) Send and receive alternately with a companion at the same instrument. (4) Send and receive with a companion at a distant station. (5) Complete the practice in a regular telegraph office. A good operator should often be consulted to avoid acquiring a faulty sending.

2. To write, grasp the button with thumb under the edge and first two fingers above it; allow the wrist to be perfectly limber; rest the arm on the table at or near the elbow; let the grasp be firm but not rigid; never allow the fingers or thumb to leave the key nor the elbow to leave the table; avoid too much force. The motion to be imparted is directly up and down, principally at the wrist. Guard against rigidity of the muscles, graduate your writing to the capacity of the receiver and never crowd him.

3. To receive, always write with pen or pencil the words as they come from the sounder; do not attempt to anticipate. A tendency to anticipate causes errors and delays progress. It is good practice to have messages sent backwards from a book. Break in as soon as a word is missed and do not wait until several words are lost in the hope of catching a sufficient number to guess at the meaning of the message. Always break in at the first word missed and telegraph "G A" and the last word received; this will regulate the sending. In a short time words like "and," "the," etc., will always be recognized and later whole phrases without effort.

4. In the first practice take the following exercises in turn: (1) Make dots in succession until a uniform rate of about 120 per minute is acquired. (2) Make dashes in succession until a uniform rate of about 60 per minute is obtained. (3) Practice E, I, S, H, P, G, until each can be made at will correctly. (4) Make the spaces uniform in O, C, R, Y, Z, etc. (5) Be careful to proportion short and long dashes accurately in T, L, M, 5, 0. (6) Avoid leaving too long space between the dash and the dot next to it in A, U, V, 4 and in N, D, B, 8. (7) Practice the mixed combinations in F, G, J, K, Q, W, X, 1, 2, 3, 7, 9, period.

5. Follow "instruction to operators" given above.

(G) U. S. ARMY AND NAVY SIGNAL CODE.

(1) WIGWAG ALPHABET.

A-----22	J-----1122	S-----212	2-----2222
B-----2112	K-----2121	T-----2	3-----1112
C-----121	L-----221	U-----112	4-----2221
D-----222	M-----1221	V-----1222	5-----1122
E-----12	N-----11	W-----1121	6-----2211
F-----2221	O-----21	X-----2122	7-----1222
G-----2211	P-----1212	Y-----111	8-----2111
H-----122	Q-----1211	Z-----2222	9-----1221
I-----1	R-----211	1-----1111	0-----2112

(2) ABBREVIATIONS.

a-----after.	n-----not.	ur-----your.	x x 3----"numerals
b-----before.	r-----are.	w-----word.	follow" or "numerals
c-----can.	t-----the.	wi-----with.	als end."
h-----have.	u-----you.	y-----why.	sig. 3----signature.

End of a word-----3	Repeat last word-----121. 121. 3
End of a sentence-----33	Repeat last message--121. 121. 121. 3
End of a message-----333	Error-----12. 12. 3
Aye, "I understand"-----22. 22. 3	Move to the right-----211. 211. 3
Cease signaling-----22. 22. 22. 333	Move to the left-----221. 221. 3

(3) CODE CALLS.

A. S. U. Action Signals Use.	C. A. U. Cipher "A" Use.
I. C. U. International Code Use.	C. B. U. Cipher "B" Use, etc.
T. D. U. Teleg. Dictionary Use.	N. L. U. Navy List Use.
G. L. U. Geographical List Use.	V. N. U. Vessel's Numbers Use.
G. S. U. General Signals Use.	

(4) INSTRUCTIONS FOR SIGNALING WITH FLAG, TORCH, HAND LANTERN, OR BEAM OF SEARCH LIGHT.

There are but one position and three motions.

The first position is with the flag held vertically in front of the center of the body, butt of staff at height of waist, signalman facing squarely toward the station with which it is desired to communicate.

The first motion, or "1," is a motion of the flag to the right of the sender, and will embrace an arc of 90°, starting with the vertical and returning to it, and will be made in a plane exactly at right angles to the line connecting the two signal stations.

The second motion, or "2," is a similar motion to the left of the sender.

To make the third motion, "front," or "3," the flag is waved to the ground directly in front of the sender, and instantly returned to the first position.

Numbers which occur in the body of a message must be spelled out in full. Numerals may be used in signaling between stations having Naval Signal Books, using the Code Calls.

(5) TO SEND A MESSAGE.

"To call" a station, signal its initial or "call letter" until "acknowledged."
 "To acknowledge," signal "Aye," followed by its initial or "call letter."
 Make a slight pause after each "letter," also after each "front."

(6) FOG SIGNALS.

To apply this code to the "fog whistle" or "fog horn:"

One (1) toot (about one-half second) will be "one" or "1."

Two (2) toots (in quick succession) will be "two" or "2."

A blast (about two seconds long) will be "three" or "3."

The signal of execution for all tactical or drill signals will be one (1) long blast, followed by two (2) toots in quick succession.

The ear and not the watch is to be relied upon for the intervals.

(7) TO SIGNAL WITH FLASH LANTERN, HELIOGRAPH OR SEARCH-LIGHT SHUTTER.

Same as in fog signals; substitute "short flash" for "toot," and "long steady flash" for "blast." The elements of a letter should be slightly longer.

"To call" a station.—Make the initial or "call letter" until "answered." Then turn on a steady flash until answered by a steady flash. The station called will "acknowledge" and cut off its flash and the calling station will proceed with the message.

No abbreviations will be used in the body of the message.

All other conventional signals are the same as for flag or torch.

(H) ARTILLERY FIRING CODE.

T A = Target angle.

S A = Shot Angle.

T A D 23 M 45 = Target angle is 23 degrees and 45 minutes.

F F = Fire.

C S = Close station.

T T A = Take target angle.

T A 3 = Target angle No. 3.

2 R F = No. 2 gun is ready to fire.

R T A 2 = Repeat target angle No. 2.

R S A 4 = Repeat angle No. 4 shot.

R U R = Are you ready?

R U R F = Are you ready to fire?

(I) SETTING UP THE HELIOGRAPH.

1. Always spread the tripod legs wide enough for a good base and press them firmly into the ground so that the top is level.

2. The sun mirror has a peephole at the center; the station mirror, a paper disc. Both in position on the bar can be turned horizontally or vertically by tangent screws.

3. When the sun is in front of the operator while facing the distant station, the sun mirror only is required; with the sun in rear, both mirrors should be used, although a single mirror may often be worked to advantage with the sun well back of the operator. In the former case, the rays of the sun are reflected from the sun mirror direct to the distant station; in the latter, they are reflected from the sun mirror to the station mirror, thence to the distant observer.

4. *With one mirror.*—Attach the mirror bar to the tripod; insert and clamp in their appropriate sockets the sun mirror and the sighting rod, the latter with its disc turned down. Sight through the center of the mirror and turn the mirror bar, and raise or lower the sighting rod until the center of the mirror, point of sighting rod, and distant station are accurately in line; then clamp the mirror bar firmly to the tripod, taking care not to disarrange the alignment. Turn up the disc of sighting rod.

Move the mirror by means of slow-motion screws until the "shadow spot" from the unsilvered peephole falls upon the disc of the sighting rod. The flash will then be visible to the distant observer.

The shadow spot must be kept in the center of the disc while signaling.

Attach the screen to its tripod and place it, close to, and in front of the sighting disc, so as to intercept the flash.

5. *With two mirrors.*—Clamp the mirror bar diagonally across the line of vision to the distant station; clamp the sun mirror, facing the sun, to the end of mirror bar with tangent screw attachment; and the station mirror, facing the distant station, to the other socket. Stooping down, the head in rear of and near the station mirror, turn the sun mirror by means of its slow-motion screws until the whole of the station mirror is seen reflected in the sun mirror, and the unsilvered spot and reflection of the paper disc accurately cover each other.

Still looking into the sun mirror, turn the station mirror until the reflection of the distant station is brought accurately into line with, or is covered by, the unsilvered spot and the reflection of the disc; after this, the station mirror must not be touched.

Now stepping behind the sun mirror, throw upon the station mirror a full flash from the sun mirror so that the "shadow spot" falls upon the center of the paper disc. The flash will then be visible at the distant station.

The shadow spot must be kept in the center of the paper disc while signaling. The intercepting screen should allow room for adjusting the sun mirror.

(J) LOCATING FAULTS.

Most line faults are of three kinds—a break, an escape, or a cross.

1. The break may be: (1) complete, as when the line is severed or a key left open, etc.—all instruments in the circuit cease to work; or it may be (2) partial, as from a rusted joint or a loose contact, etc., which increases the conductor resistance—all instruments work equally feebly or not at all. A complete break, as in fig. 165, is found by inserting at either end a battery, one side of which is to earth, as shown. The lineman then proceeds along the line from the other side of the battery connecting, temporarily, at different points, the line to earth through the tongue or galvanometer. Near the battery he gets the full current. If at any point he fails to get it, he has passed the complete break. It is important to note the current strength from the taste or deflection near the battery; if, then, at any place it suddenly diminishes, but is still noticeable, a partial break has probably been passed.

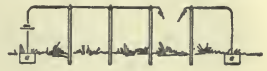

165.

2. An escape (fig. 165a) arises from defective insulation at some point, as when a bare wire falls to ground or touches a tree or building, or the covering of an insulated wire is injured, etc., and allows a portion of the current on the line to escape. Instruments work unequally. Those near the battery are stronger, those beyond the escape are weaker than usual.



165a.

The lineman may inspect the line to see if any pole, tree, building, etc., has come in contact with the wire. If it can not be found in this way he may open the line at some point. If an examination at the battery end still shows the escape the fault is on the side of him towards the battery; but if it has disappeared the fault is on the other side of him. He proceeds accordingly to open the line at another point, having closed the first.

3. A cross (fig. 166) is a fault caused by two parallel lines coming in contact; the instruments on one line respond to those in the other. Inspection of the line may reveal the fault. Or open both of the distant ends. Starting from the battery the lineman opens the line at some point; if he gets a current he has not reached the fault.



166.

Generally on a long line having several stations the fault is first located as between two stations, from one of which a lineman is sent out.

Periodic tests of the conductor and insulation resistances of every important line should be made regularly and the results kept in a record book.

(K) THE TELAUTOGRAPH.

(a) DESCRIPTION, PRINCIPLES AND OPERATION.

1. *Transmitter.*—By means of two light rods attached to the transmitting pencil near its point the arbitrary motions of writing or drawing are resolved into simple rotative or oscillatory motions of two pivoted arms, located on either side of the writing platen. These arms are included in the line circuits and

carry at their extremities small contact rollers which move to and fro upon two rheostats, or resistance coils, these being so connected through the arms to the line and to the source of energy as to act both as adjustable shunts and as rheostats in the line circuits. By this method the voltage supplied to the line is made to vary with the position of the pencil upon its writing platen and definitely variable writing currents are transmitted.

2. The receiver principle is equally simple. The variable line currents coming in over the line wires are led through two vertically movable coils, each suspended in a strong uniform magnetic field by a well-sweep arrangement, from which they derive the name of "buckets."

Each coil is supplied with an adjustable retractile spring which tends to oppose the movement of the coil downward through the field. It is evident that for given values of the line currents each coil will have a definite position in its respective magnetic field, depending upon the tension of its retractile springs. The vertical motions of these receiver "buckets," due to the varying line currents, are used to cause rotative motions in two pivoted arms, similar to those at the transmitter, which motions, through another system of light rods, compel the receiving pen to exactly reproduce the motions of the transmitting pencil.

3. To accomplish the pen-lifting at the receiver an automatic device is used, consisting of an induction coil at the transmitter, having two secondary windings and performing the double function of pen-lifting and reducing friction. The primary circuit of this coil is entirely local at the transmitter, and includes an interrupter and a shunt circuit controlled by the platen.

4. The vibratory secondary currents are superimposed upon the writing currents, and serve to keep the receiving pen in continual though imperceptible vibration, reducing friction in the moving parts to a minimum. The normal writing pressure of the pencil upon the transmitter platen opens the shunt circuit and causes an increase in the strength of the secondary vibrations. This operates a vibratory relay inserted in one of the line circuits at the receiver, opens a local circuit, and causes the armature of the pen-lifting magnet to be released and the pen is allowed to rest upon the paper.

5. Lifting the transmitting pencil from the platen decreases the strength of the vibrations, closes the local receiver circuit, the pen-lifting magnet attracts its armature and raises the pen clear of the paper.

6. The shifting of the paper at the transmitter is done mechanically by means of the master switch. The same motion of the switch operates an electro-magnetic device over one of the line wires, which automatically and positively shifts the paper at the receiver a corresponding amount.

The paper, 5 inches wide, is supplied in conveniently detachable rolls, which are mounted in brackets attached to the backboard of the instrument. For signaling, a push button at the transmitter operates a call bell at the receiver.

7. The transmitting pencil is a simple adjustable lead pencil. The receiving pen is made on the principle of the ordinary right-line drawing pen, so modified as to make perfect lines regardless of the direction of motion, and capable of holding an ample supply of ink.

8. The inking device consists of a bottle or supply well, with a hole and stopper for refilling, and also with a second small hole in the side of the well. This hole is below the surface of the ink, and the top of the well being corked and airtight, the ink is prevented from flowing out by the pressure of the external atmosphere.

The small hole is located at the unison point, and whenever the paper is shifted the pen returns to this position and automatically dips its point into the ink which stands at the mouth of the hole. Capillary attraction is sufficient to completely fill the pen, and, resting in the hole as it does, the point does not clog up with dry ink when not in use, but is always ready to start writing with a full fresh supply.

(b) EXPLANATION OF DIAGRAM.

1. *Transmitter.*—The motions of the transmitting pencil *A* are conveyed through the pencil arms *BB'*, and pencil arm levers *CC'* to contact arms *DD'*, which carry contact rollers *EE'*, these contact rollers bearing upon the periphery of rheostats *FF'*, the terminals of these rheostats being connected through master switch *G* to the positive and negative poles of a suitable source of electrical energy, indicated by battery *H*. The contact arm *D* is connected to the right line through one of the secondaries of the induction coil *I*, and through the right-line contacts *G'* of master switch, when the master switch is in the



167. Telautograph, with Cover Removed to Show the Working Parts.



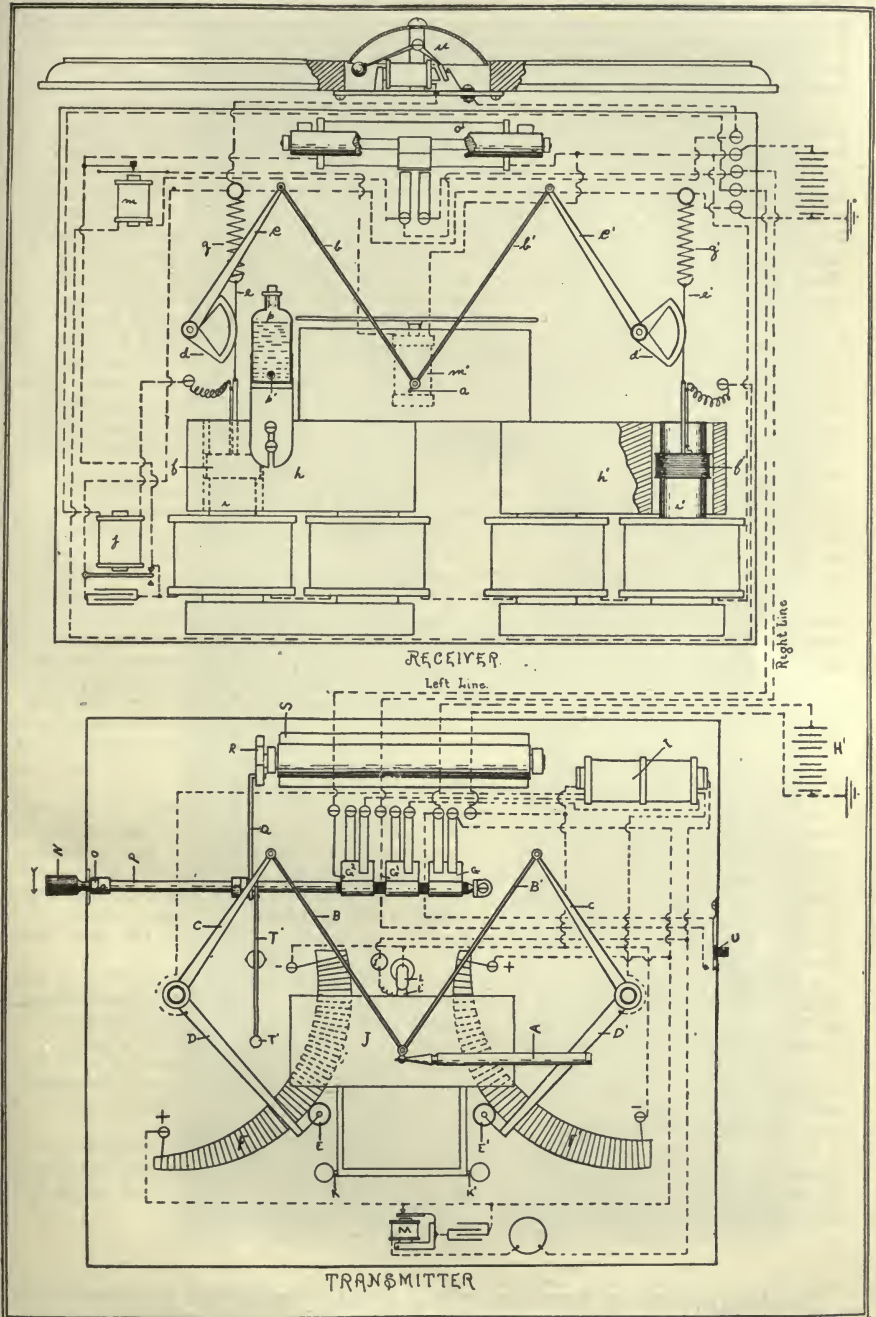

169. Transmitter and Receiver.

writing position as shown. The contact arm D is connected to the left line through the other secondary of the induction coil I through the left line contacts G^2 of master switch. The writing platen J is pivoted at $K K'$, and when pencil is off, the platen closes upper contacts $L L'$, shunting resistance l around the primary winding of induction coil I . The vibrator M is in circuit with the primary of induction coil I and battery H , and rapidly vibrates, the current passing through the primary of the induction coil, thus causing a vibratory current to traverse the right and left line wires, the strength of this vibratory current depending upon the position of the platen J ; when this platen is depressed by the pencil in the act of writing the shunt around the primary of induction coil I is open, consequently the strength of the vibratory currents on line is increased; this increased strength of vibration actuates the pen-lifting relay m (in receiver). The paper at the transmitter is shifted by moving the handle N of lever O , which is connected to shaft P , which carries the pawl Q , engaging the ratchet wheel R , mounted on shaft of paper-shifter roller S . Each movement of this handle N to and fro causes the roller S to rotate, which moves the paper forward. The shaft P also carries master-switch contact plates $G, G1, G^2$, which open and close the line and battery circuits, according to the position of handle N ; circuits being closed and instrument in sending position when handle N rests in position shown by arrow. The movement of the handle N in the opposite direction cuts the instrument out of circuit. The handle is locked in either position by lever P , and can not be released except by pressing point of pencil A on button T . A signal-switch push button is shown at U ; this switch when operated throws current of positive polarity through right line, which rings receiver bell u , as hereafter described.

2. *Receiver.*—The motions of receiver pen a are caused to duplicate the motions of transmitting pencil A through the pen arms $b b'$, pen-arm levers $c c'$, which are mounted on shafts carrying sectors $d d'$. Light metal bands $e e'$ are attached to the peripheries of sectors $d d'$ and carry at their lower ends coils (or "buckets") $f f'$, and their upper ends are attached to springs $g g'$. The coils $f f'$ are movable in the annular spaces between the poles of the magnets h and i , and h' and i' . Coil f is in circuit with Morse relay j and the left line, and coil f' is in circuit with pen-lifting relay m and the right line. As the transmitting pencil is moved its motions are transmitted to contact rollers $E E'$, the strength of current on line is varied, the currents becoming stronger as the rollers approach the positive ends of the rheostats $F F'$, these currents traversing line and passing through coils $f f'$, causing them to take different positions in the magnetic fields, opposing the pulls of the springs $g g'$, these springs being so adjusted that the position of the receiving pen in the writing field will always be the same as the position of the transmitting pencil on its writing platen.

3. The depression of platen J , causing a strong vibratory current to traverse line, causes the armature of pen-lifting relay m to vibrate and interrupt the circuit of pen-lifter m' , thus releasing the armature of pen-lifter and lowering the pen-arm rest so as to allow the pen to come into contact with the paper. Upon raising the transmitting pencil from its platen the vibratory current will be weakened, the armature of pen-lifting relay m ceases to vibrate, closes the circuit of pen-lifter m' , which attracts its armature and thus lifts the pen from the paper.

4. The paper-shifter o' is an electro-magnetic device and is controlled by the Morse relay j , the armature of this relay closing the circuit of the shifter through its forward contact when the relay j is energized by line current through the master switch by the movement of handle N in the position shown by arrow.

5. The signal bell u , which is of low resistance, is thrown in parallel with the right-line coil, or "bucket" f' , when no current is passing through the paper-shifter, consequently when signaling current passes over right line the bulk of the current passes through the bell, rather than through coil f' .

6. The ink well (an ordinary glass bottle) is shown at p , the receiver pen a entering the opening p' and receiving a fresh supply of ink every time the paper is shifted, the pen resting in this opening and in contact with the ink when the instrument is not in use.

(c) INSTALLING.

The instruments are furnished with a suitable backboard, the connections being made between the instruments and the circuits on the backboard by automatic contact pins, so that the instruments can be put on and taken off readily. The terminals on the backboard for connecting to line and battery are plainly marked so that the proper connections may be easily made.

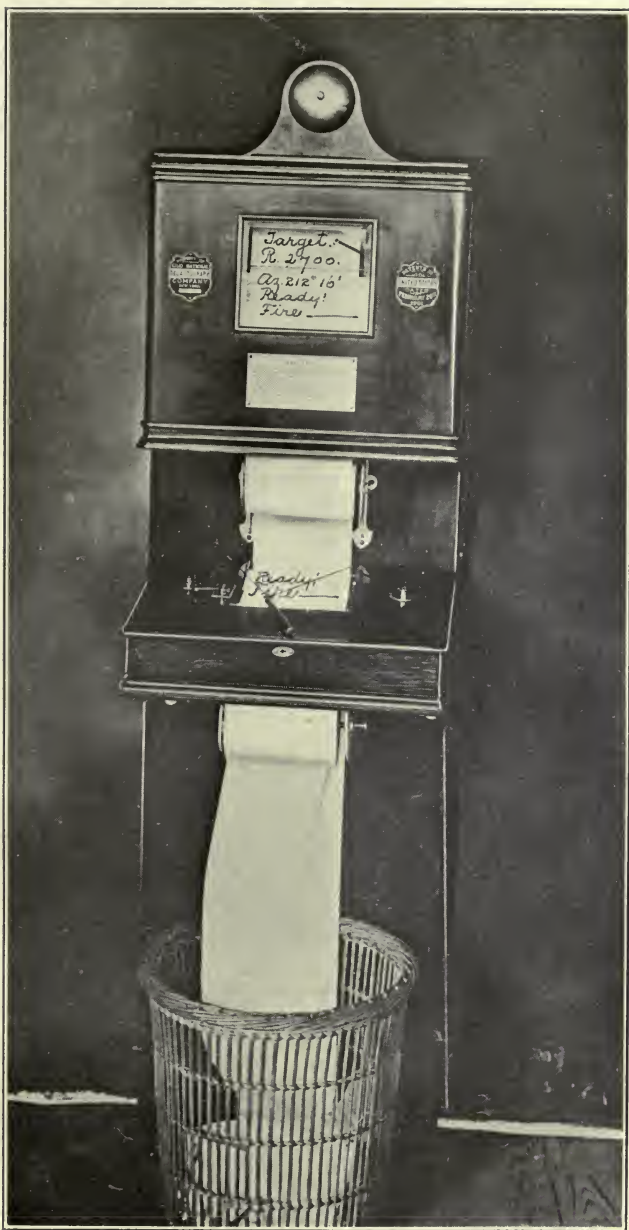

168. In Operation.



(d) OPERATION.

1. *To write.*—Depress button with pencil point and pull lever towards you a full stroke; release button with lever in this position, and write with firm pressure on paper.

2. *To shift paper.*—Depress button, holding it down until you have moved lever back and forth its full stroke as many times as you wish to shift paper, then release button with lever in position towards you.

3. *To hang up.*—Depress button, allowing lever to rest in position away from you. Always, after writing, leave the lever in position from you.

(e) CARE OF INSTRUMENTS.

The care of the instruments consists mainly in keeping the ink bottles properly filled with the ink which is supplied for that purpose, the occasional cleaning of the pen points, and the insertion of fresh rolls of paper which is supplied for that purpose.

XIV.—TELEPHONY.

(A) APPARATUS AND CONNECTIONS.

Fig. 170 gives details of the apparatus and connections of the bridge form of the American Bell telephone:

1. Western electric call box, 500 ohms in armature, 1,000 ohms in bell magnets.
2. Long-distance induction coil, 1,000 ohms in the secondary.
3. Solid back transmitter, 3 ohms.
4. Two double-pole watch receivers with head strap, 75 ohms each.
5. A porous cup, or a carbon cup Leclanché, the latter preferred.
6. Warnock hook.

Full lines represent electric circuits; those drawn heavy show the local or transmitter circuit.

7. When one turns the crank shaft in the call box to ring, a cam thereon causes the whole shaft to slide in opposition to a spiral spring, $\frac{1}{8}$ inch to the left, into contact at *A*. The generator's armature coil is thereby thrown into circuit; its terminals are the insulated pin *B* bearing against a spring and the armature shaft leading the current to metal frame and *A*.

8. When the receiver is off the hook, lever scrapes into good contact with both springs at *F*; when on, it opens these points. Both posts of the watch receiver *T T* are mounted on a triangular plate of ebonite inside the case.

9. *Polarized bell*.—The U-shaped, permanent magnet *NS* screwed at *N* to the backpiece of the electro-magnet, renders both poles of the electro-magnet north, and by induction, the middle of the armature where it is pivoted, north. Both armature ends are, therefore, south; i. e., either armature *S*-end stands opposite an *N*-pole. When a positive current enters the magnet coils, one *N*-pole is neutralized and the other is made stronger so that the latter attracts its armature end. A negative *C* makes the other *N*-pole attract its armature end, and so on. As there is no spring to be overcome, a polarized relay is very sensitive and deserves attention on account of its importance in the service. For the magneto which generates the alternating + and - currents, see page 46.

(B) MAGNETO, BELL, AND SECONDARY COILS.

The magneto, bell, and secondary coils of each station are joined to mains—

IN PARALLEL OR BRIDGE (FIG. 171.)

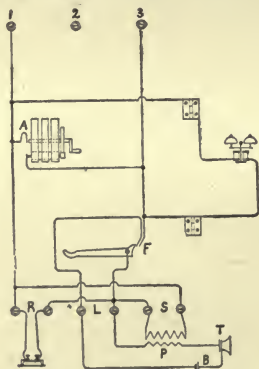

171. Parallel Telephone Station.

1. All bells are permanently bridged. They will respond to the magneto's slow alternations but their impedance acts like an infinite resistance to the rapidly alternating speaking current.

2. Magneto circuit, normally open at *A*, is closed automatically by the crank shaft when rotated, so that the generated current goes to line.

3. When the receiver is on the hook lever for calling, the circuit between terminals is—

1. Bells, 3.

4. When receiver is on and the crank is turned to call, the circuit is—

1. *A*, armature, 3.
1. Bells, 3.

5. When the receiver is taken off for talking, the circuit is—

1. Bells, 3.
 1. *S*, *F*, 3.
 1. *R*, *F*, 3.
- } Local circuit is—
} *B*, *T*, *P*, *F*, *L*.

IN SERIES (FIG. 172).

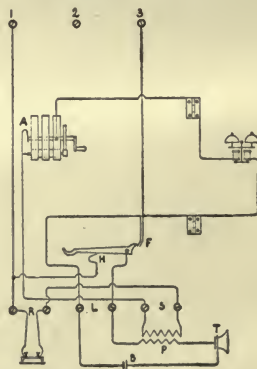

172. Series Telephone Station.

The three main coils have few turns of wire and low resistance, and operate in series.

Magneto circuit, normally short-circuited, has the shunt opened automatically at *A* by the crank shaft sliding to the right $\frac{1}{8}$ inch when rotated, so that the ringing current goes to line.

1. *H*, *L*, *A*, bells, 3.

1. *H*, *L*, *A*, armature, bells, 3.

1. *R*, *S*, *F*, 3. Local circuit is—*B*, *T*, *P*, *H*, *L*.

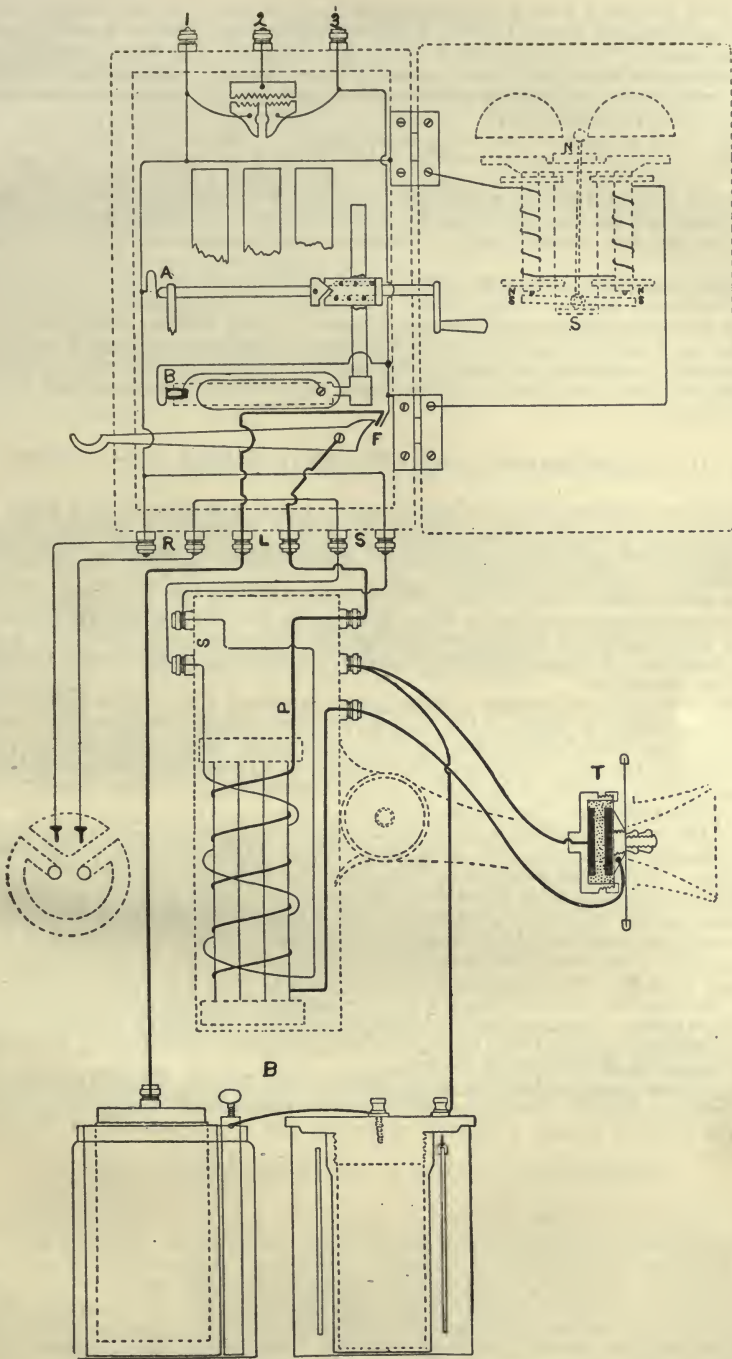

170. Complete Details of Bridge Telephone.
 (Porous cup and Hayden cells shown; use one kind only.)

6. Five bridge or four series telephones are the limit on one circuit. When more are required (as will rarely happen) a central exchange or a party line will be necessary. The main circuit is always metallic. On short, busy lines, as between range finder and four mortar pits, it will be advantageous to run four main wires—two for talking and two for signaling. All telephones on the same circuit must be alike.

(C) TO USE.

Give the bell crank one sharp turn, take the receiver from the hook, place it firmly against the ear and when the unhooking at the distant station is heard, give the number wanted if it is "Central" or the name desired if it is a party line.

Speak directly into the transmitter, with the lips close to it, in a low, distinct, and deliberate manner; never shout. Be guided by the listener as to your distance from transmitter and your articulation. When finished, hang the receiver on the hook and give a half turn to the crank. During storms and when closing for the day, shunt out the instrument by the lightning-arrester plug. Keep the instrument free from dust, the cells clean, and the solution at normal strength and height.

(D) TELEPHONE FAULTS AND THEIR LOCATION.

The three classes liable to occur are: (1) An open circuit at a joint, post, spring contact, or where rust is seen; (2) a short circuit in a magnet coil, cord, or where dust and filings collect; (3) derangement of magnets, bells, switch, transmitter, receiver, or battery.

An intermittent fault is more difficult than a lasting one to find, as, for example, when a line grounds only when swayed by the wind, or the resistance of a joint keeps changing, or the two wires of a cord touch only when it is in a certain position. To locate a fault promptly, a knowledge of the circuit and experience are essential.

The first steps in locating a fault are to question the user, to look carefully over the accessible parts, to try to ring, to listen for the characteristic noise in the receiver from scratching on the transmitter, and to determine at once whether the trouble is in the station or outside of it by cutting out the station from the rest of the circuit if necessary. The symptoms differ somewhat in bridge and series systems. Three cases arise:

1. *Station can not ring.*—See if the bell's armature is free, if wire joints around bell, hinges, hook, etc., are good, and if both shaft contacts at the magneto operate. If a bridge telephone, there may be a short circuit between its mains, in which case the crank turns with difficulty; or there may be a break in its magneto or its bell circuit, but not if the bell rings after detaching the line wires.

In a series telephone, there is probably an open circuit; it is outside if the bell rings after connecting the line posts by a short wire or by the lightning-arrester plug. If in this case there is no ring, the trouble is in the ringing circuit.

2. *Station can ring but can not hear.*—The speaking circuit is open or shunted at some point. If scratching or blowing into the transmitter is heard, the station's receiver circuit must be in order and the fault probably lies in the transmitter circuit of the distant station.

3. *Station can ring but can not be heard.*—The fault is probably in the local transmitter circuit. But if scratching on the transmitter is heard, the fault lies in the receiver circuit (receiver, secondary and lever contacts) of the distant station.

(E) IN GENERAL.

The usual induction noises heard in a receiver show that the main line and your station receiver circuit are in order; although the secondary may in this case be short-circuited. If so, blowing into the transmitter can not be heard. To verify, open the line and if the noises do not cease their cause lies within.

Cross talk, humming of motors, Morse clicks, etc., show that the telephone line runs parallel with a foreign wire for a greater distance on one side of it than on the other, or that there is leakage through the ground terminals. To prevent these noises, telephone lines are usually metallic, and if parallel with other wires they should run for equal distances on opposite sides of them. A twisted metallic or a balanced line has no induction noises.

Cracking or boiling sounds in the receiver are often due to bad contacts in the local or transmitter circuit.

The set entire is not in good adjustment unless the bell hammer responds promptly to slow turning, giving two strokes to each turn of the armature, and unless light scratching on the backboard is heard in the receiver. The receiver should be audible to a good ear at 10 feet distance from low, distinct talking at the distant station.

(F) DERANGEMENT OF APPARATUS.

1. *In magneto.*—(a) Short circuit from brass filings, dirt or burnt coils; (b) dynamo shaft in the bridge telephone not closing on the spring contact and in the series not opening when turned; (c) armature shaft not in contact with spring; (d) weak field magnets; (e) armature striking pole piece; (f) dust on lightning-arrester.

2. *In polarized bell.*—(a) Armature striking pole piece, or too distant, or not free to move, or not responding promptly; (b) bells not spaced to receive strokes alike, in which case loosen and turn them; (c) magnet too weak to hold by its own weight.

3. *In hook lever.*—Not scraping into good contacts; weak spring.

4. *In solid back transmitter.*—(a) Breaking of mica disc, which allows carbon granules to fall out; (b) "packing" of granules, which renders speech inaudible, and may often be remedied by moving transmitter quickly up and down; (c) diaphragm rusted, or its rubber hardened, or its spring too tight or too loose.

5. *In receiver.*—(a) Diaphragm too close, or too distant from pole piece. Its distance is correct when after removing ear piece and holding the receiver sideways in one hand and tapping with the other, the diaphragm falls partially off; if it does not start it is buckled or too close; if it falls entirely off it is too far away; (b) if diaphragm is buckled, replace it; (c) dirt between it and the poles; (d) a break in the circuit, discoverable by touching the ends of the receiver's cord to the poles of a cell; (e) a short circuit in the cord itself through which a series bell will ring and a bridge bell will not.

6. *In battery.*—See Fuller bichromate and Leclanché cells. One or two like cells in series usually afford sufficient battery power.

7. *In locating faults,* an assistant, a detector galvanometer with dry cell, and such tools as knife, small pliers, screw driver, file, and emery are useful.

8. Guard against dust, damp, unsoldered connections, loose wires under screw washers or binding posts from shrinkage of wood, breaks or contacts in the receiver cord.

(G) INTERCOMMUNICATING TELEPHONY

1 Is suitable for twenty or less stations near each other, as in a large building or in any fort. A cable having one, and in some cases two more wires than the number of stations, passes each station. There is no central (fig. 173). Any one station can be put into communication with any other on that system by the operator himself. The left hand figure at each switch designates the number of station or instrument to which the switch is connected, and the lever must always remain on left hand point except when another station is called. No. 1 wishes to communicate with No. 3. He moves the lever of his switch to the point marked 3, and after ringing him up can carry on conversation. When No. 1 has finished talking he replaces the lever of his switch to contact

point No. 1. A similar action takes place when any of the other stations wish to communicate. This system is specially adapted for communication in hotels, factories, office buildings, or any place where wires are all under one roof. When the distance between the terminal stations is over 500 feet the expense becomes high, owing to the number of wires required.

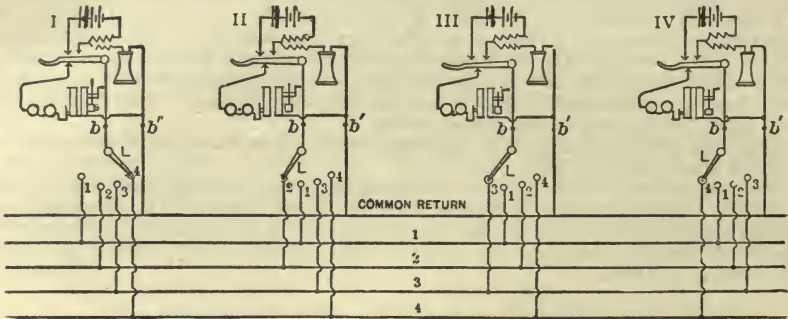

173. No Central.

2. A common battery is a feature of modern systems. In fig. 174 each of the ten lines is connected with 10-springs jacks on each of the ten telephones (three shown). *P* is plugged to the No. of the station called, *c* and *c* are impedance

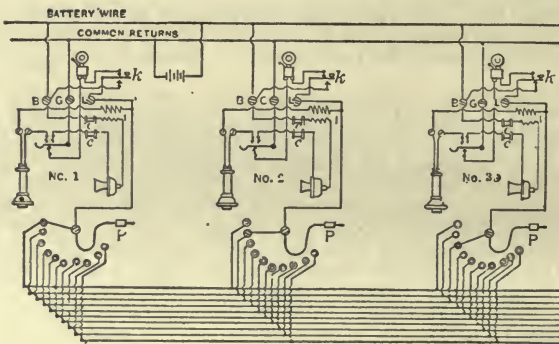

174. Common Battery, 10 Stations.

coils on either side of the transmitter circuit to prevent cross talk when more than two stations communicate.

3. The Holtzer-Cabot system is extensively used (fig. 175).

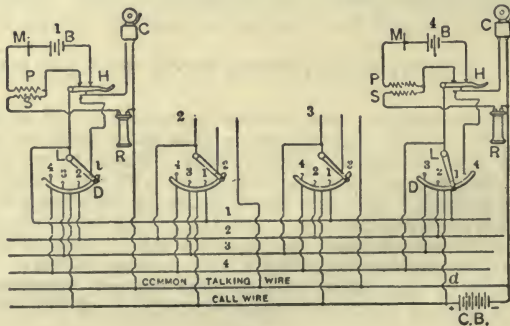

175.

(II) A CENTRAL STATION SYSTEM

1. Sometimes required, is shown for—

- 40 line drops, 1 per station, *A*.
- 10 clearing-out drops, *B*.
- 10 plugs with double cords, *C*.
- 10 listening keys, *E*, for 10 connections.
- 10 sets ringing keys, *F*, for 10 connections.

- Operator's transmitter.
- Operator's receiver.
- Operator's magneto.
- Night-bell switch.
- Operator's telephone battery.

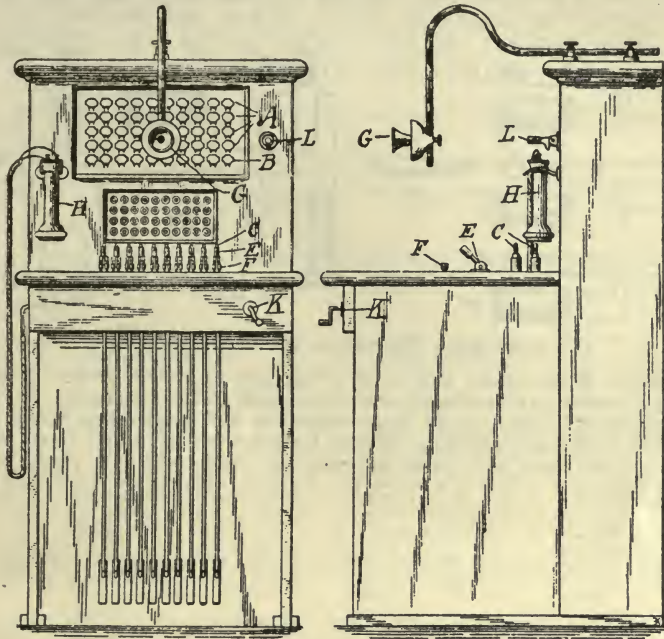

176. Central.

2. On this board (fig. 176) ten stations can be put in communication with ten others in pairs at one time, by way of the ten twin wire cords (fig. 178), kept from getting tangled by running weights. Plug *C* (fig. 176), or *P* (fig. 178), has two insulated metal parts, knob and cylinder, which are the terminals of the twin wires in the cord.

The line-drop magnet (figs. 177-8) on the board lets plate *S* fall and thus signals the number of the station which calls and desires a connection; its wires connect with mains to station; wire *u* is for a night local call bell circuit.

3. The "clearing-out drop" magnet, *C'*, in fig. 178, is like the line drop except in its winding of finer wire (500 ohms), soft-iron cover to prevent induction and is more closely adjusted armature; it is bridged across the two wires in the cord which connects the two stations placed in communication and will, therefore, signal when either station rings "off."

4. To illustrate the working of a board, it is only necessary to take three line drops, *f*, *f*¹, *f*², in fig. 178, two plugs, *P* and *P'*, and twin wire cord 1 and 2, one listening key, *K*, also one ringing key, *K'*, whose button being pressed, throws the magneto, always running on a large board, into the circuit of any pair of plugs.

5. When plug *P* is pushed into any spring-jack, as at *a*—

Its small end knob raises tip spring *e* from the drop's wire and joins one of the cord wires with one of the mains.

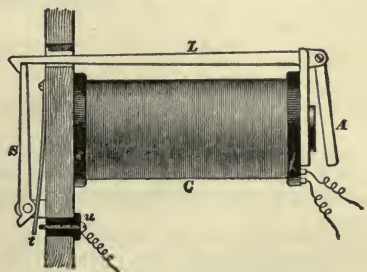

177. Gravity Drop.

The insulated cylinder next the knob connects at the same time the other conductor with the second main line to the station.

6. Suppose a call comes from station 1—

The drop falls, displaying number "1" to the operator.

She then inserts either plug, as *P*, of any pair, say the fourth, in the jack, closes the listening key, *K*, and learns that connection is desired with "40;" for example, the circuit being main line, jack "1," plug *P* and cord, key *K*, secondary and receiver.

She next inserts the other plug *P'* of pair 4, presses key *K'* and rings her magneto, the circuit being magneto *K'*, plug *P'*, jack to "40" and main line.

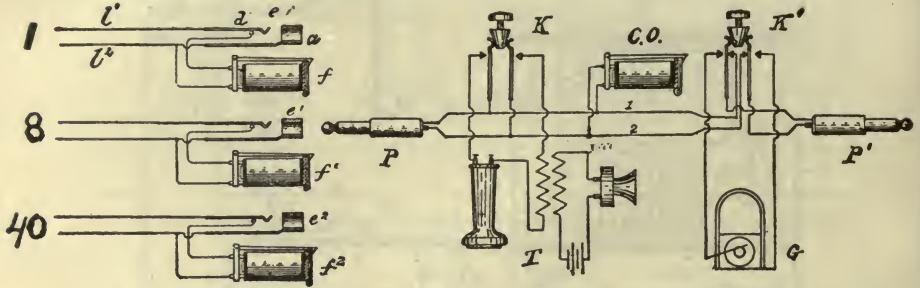

178. Three Jacks, Three Drops, One Clearing-out Drop.

On pressing *K* she hears station 40's response and then 40 and 1 talking. Releasing *K*, she may give attention to other calls and connections.

The clearing-out drop *C O.* of high resistance and impedance, being permanently bridged across the talking circuit, signals when 40 and 1 have finished. Their circuit was main line, jack, and plug 40, cord twin wire plug, jack and main line 1.

XV.—LAWS, WIRE TABLES, EXAMPLES.

(A) ELECTRICAL QUANTITIES, THEIR UNITS, AND THE LAWS OF THEIR RELATIONS.

Each quantity has one unit and every amount is expressed in terms of that unit by a decimal number.

QUANTITY, SYMBOL, LAW.	DEFINITION.	NAME OF UNIT.	VALUE OF PRACTICAL UNIT.	EXAMPLES, EQUIVALENTS.
Difference of potential, $P D$. $V = C \times R$.	With electricity precisely what difference of level is with water.	1 volt, $P D$.	$= \frac{1000}{1433}$ of the $P D$ between the plates of a Clark cell at $15.5^\circ C$.	2 volts $P D$ between storage plates; 40 volts $P D$ between arc lamp posts; 10,000 volts for 1-inch spark.
Electro-motive force, E . $E = C \times R$.	The force which moves electricity through a conductor.	1 volt, E .	$= \frac{1000}{1433}$ of the E of a Clark standard above $= \frac{2}{3}$ of a Leclanché cell.	A gravity cell has 1.1 volt E ; an inc. lighting dynamo has about 125 volts.
Current strength, C . $C = E \div R$.	The time rate at which electricity flows through a conductor.	1 ampere	$=$ the C which deposits in 1 second 1.118 mgms. of silver or other metal equivalent.	$\frac{1}{2}$ ampere flows in a 16-candle power, 110-volt lamp; 10 amperes in arc lamp.
Resistance, R . $R = E \div C$.	That property of a conductor which opposes the passage of electricity.	1 ohm (true.)	$=$ Res. of a mercury column 1 sq. mm. crosssection and 106.3 cms. long at $0^\circ C$.	1 mile trolley has 3 ohms; 1,000' cop. wire, 1 mil. diam. has 1 ohm; 16-candlepower lamp filament hot, 200 ohms.
Quantity, Q . $Q = C \times T$.	The total amount of electricity which flows in a given T (seconds).	1 coulomb	$=$ the quantity delivered by 1 ampere in 1 second.	To deposit 1 pound copper requires 1,500,000 coulombs.
Capacity, K . $K = Q \div E$.	Measured by the Q required to raise the container's potential 1 volt.	1 farad	$= K$ of container if 1 coulomb raises its potential 1 volt.	1 microfarad = one-millionth of a farad = capacity of $\frac{1}{8}$ mile ocean cable.
Work, W . $W = E \times Q$ $= C^2 R T$.	The product of a force into a path; also of quantity into potential.	1 joule	$=$ 1 volt-coulomb = work of 1 ampere through 1 ohm in 1 second $= 0.7373$ ft. lbs.	$\frac{1}{2}$ ampere in 110-volt lamp for 1 minute does 3,300 joules; power = 55 watts; heat = 1,375 calories.
Power, P . $P = W \div T$. (T in secs.)	The time rate of work. A horse pulling 75 lbs. at 5 miles per hour exerts 1 horsepower.	1 watt	$= P$ when 1 joule is done uniformly in 1 second. Watts = volts \times amperes = amperes ² \times ohms.	1 kilowatt = 1,000 watts; 1 horsepower = 746 watts; 1 kilowatt = $\frac{3}{4}$ horsepower, approx.
Heat, H . $H = .24 E Q$ $= .24 C R^2 T$.	772.55 ft. lbs. work will raise 1 lb. water $1^\circ F$. at $60^\circ F$, London sea level.	1 calorie	$= H$ required to raise 1 gm. water $1^\circ C$. at $0^\circ C$. = 1 gm. deg. C . = 0.004 lb. deg. F .	1 calorie = 4.16 joules = 3 ft. lbs.; 1 joule = 0.24 calorie.

1 inch = 2.54 centimeters.
1 meter = 3.28 feet.

1 megohm = 1 million ohms.
1 micro. = 1 millionth.

1 kilo = 1,000.
1 milli. = $\frac{1}{1000}$.

(B) RULES, LAWS, AND EXAMPLES.

I.—If a current should flow through the forefinger of the right hand, in the direction in which the finger points, the north end of a magnetic needle in the position of the thumb will point in the same direction as the thumb held perpendicularly to the finger. (Figs. 180-1.)

II.—OHMS LAW.—In every electrical circuit the strength of the current in amperes flowing uniformly is equal to the electro-motive force of the generator in volts divided by the total resistance of the circuit in ohms. Or, $C = E \div R$.

III.—The difference of potential between the ends of a conductor of a current (or the $E. M. F.$ in it) equals the product of the strength of the current by the resistance of the conductor. Or, $E = CR$.

IV.—The resistance of a conductor varies directly with its specific resistance and length and inversely with its cross section or with the square of its diameter.

V.—The resistance of two or more wires joined in series equals the sum of their separate resistances.

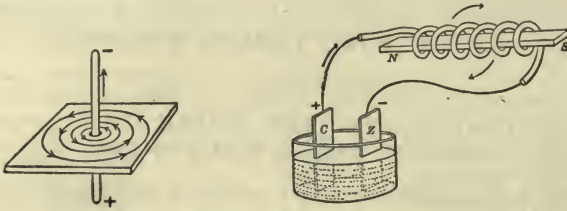

180, and 181. Magnetic Whirlwind around a Current.

VI.—The total resistance of two or more wires joined in parallel equals the reciprocal of the sum of their separate reciprocals.

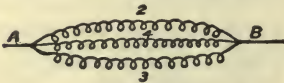

$$\frac{1}{2} + \frac{1}{3} + \frac{1}{3} = \frac{1}{\frac{3}{2}}$$

$$R = \frac{3}{2} \text{ ohm between A and B.}$$

Example.

VII.—The electro-motive force of a battery is equal to the *E* of one cell multiplied by the number of cells in series.

Ex. To find the *E* and *R* of four different batteries formed in turn from six gravity cells of 1 volt and 3 ohms each, connected up (1) all in parallel, (2) all in series, (3) three in series and two in parallel and (4) two in series and three in parallel, thus:

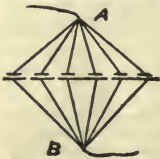

1 volt, $\frac{1}{3}$ ohm.

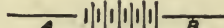

6 volts, 18 ohms.



3 volts, $4\frac{1}{2}$ ohms.



2 volts, 2 ohms.

VIII.—To obtain the strongest current with a given number of cells through a given external resistance, arrange the cells in such a way that the internal resistance shall be as nearly equal as possible to the external resistance.

Ex. For an external *R* of 18 or more ohms, the six gravity cells above should be in series; for 3 ohms external *R*, arrange cells two in series and three in parallel, and so on.

IX.—Each one of two or more parallel wires carries that part of the main current which the reciprocal of its resistance bears to the sum of the reciprocals of all the resistances.

Ex. A generator of 18 volts and 3 ohms, two leads of $1\frac{1}{2}$ and 3 ohms, and two branches of 4 and 2 ohms are connected, as shown. Find *R*'s, *C*'s, and *E*'s.

Resistance between *A* and *B* = $1 + (\frac{1}{2} + \frac{1}{2}) = \frac{3}{2}$ ohm. Total *R* in circuit = $\frac{3}{2} + 3 + 3 + \frac{3}{2} = 9$ ohms. Main *C* = $18 \div 9 = 2$ amperes. *C* in wire 4 = $2 \times (\frac{1}{4} + \frac{1}{2}) = \frac{3}{2}$ ampere; *C* in wire 2 = $2 \times (\frac{1}{2} + \frac{1}{2}) = \frac{3}{2}$; sum of *C*'s in both branches = 2 amperes.

P D of generator on open circuit = 18 volts; on closed circuit = 2×6 or $18 - 2 \times 3 = 12$ volts. Of *E* = 18 volts of the generator, 6 volts are used to overcome its own resistance, 6 volts to maintain the 2-ampere current in lead 3, $1\frac{1}{2}$ volts in lead, $1\frac{1}{2}$ and $\frac{3}{2}$ volts in the two branches.

Ex. *E R* of branches 2, 3, 6 = 1 ohm. Total *R* = 8 ohms. *C* = 2 amperes. *C* in branch 2 = 1 ampere, in 3 = $\frac{2}{3}$ ampere, in 6, $\frac{1}{3}$ ampere.

Eight volts used in battery; 4 volts in lead 2; 2 volts in branches and 2 volts in lead 1. Total, 16 volts.

P D between ends of wire 2 = $1 \times 2 = 2$ volts.

P D between ends of wire 3 = $\frac{2}{3} \times 3 = 2$ volts.

X.—The quantity of heat in calories produced in a conductor is equal to the continued product of $\frac{24}{100}$, the square of the current in amperes, the resistance of the conductor in ohms and the time in seconds. Or, $H = 0.24 C^2 R T$.

Thus, 10 amperes flowing through a fuse of $\frac{1}{2}$ ohm for 1 minute generates 360 calories = 1.44 lb. deg. Fahr. Power = 25 watts.

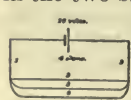

183.

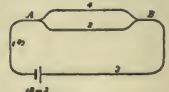

182.

XI.—The power in watts in any live wire or circuit equals the total volts multiplied by the amperes or the square of the amperes times the ohms. Or, $P = E C = C^2 R$.

Ex. A storage battery of 55 cells in lighting eighty 110-volt lamps falls from 112 volts on open circuit to 110, while the ammeter shows 40 amperes. How is the power expended?

Ans.: In each lamp, $110 \times \frac{1}{2} = 55$ watts; in external circuit, $40^2 \times 110 \div 40 = 4400$ watts; in battery $(112 - 110) 40 = 80$ watts; in entire circuit, $112 \times 40 = 4480$ watts.

XII.—The grams, W , of metal deposited, or gas freed, or electrolyte decomposed by C amperes in T secs. is $W = 0.000010384 C T Z$. Z is the chemical equivalent of the metal, etc.

(C) WIRING TABLE.

1. COPPER WIRING OF U. S. UNDERWRITERS.

Computed from—Weight 1 cubic foot copper = 555 lbs., and resistance 1 mil. foot commercial soft copper, 98% pure, at 68° F. = 10.367 international or true ohms.

Gauge No. B. & S.	Diam. in mils. = .001 inch.	Area circ. mils. = square of diam.	Capacity.		True ohms per 1,000 feet at 68° F.	Pounds per 1,000 feet bare.	Pounds per 1,000 feet insulated.	No. and size of strand cable.	d in mils. of B. W. gauge.
			No. amperes open work, W. P. wire.	No. amperes concealed work, B. C. wire.					
I.	II.	III.	IV.	V.	VI.	VII.	VIII.	IX.	X.
18	40	1,624	5	3	6.3880	4.92	18	-----	49
17	45	2,048	6	4	5.0660	6.20	21	-----	58
16	51	2,583	8	6	4.0176	7.82	25	-----	65
15	57	3,257	10	8	3.1860	9.86	31	-----	72
14	64	4,106	16	12	2.5266	12.44	38	-----	83
13	72	5,178	19	14	2.0037	15.68	43	-----	-----
12	81	6,530	23	17	1.5890	19.77	48	4-18	109
11	91	8,234	27	21	1.2602	24.93	64	4-17	129
10	102	10,380	32	25	.99948	31.44	80	4-16	134
9	114	13,090	39	29	.79242	39.65	97	8-18	148
8	128	16,510	46	33	.62849	49.99	116	8-17	165
7	144	20,820	56	39	.49845	63.03	118	8-16	180
6	162	26,250	65	45	.39528	79.49	166	16-18	203
5	182	33,100	77	53	.31346	100.23	196	16-17	220
4	204	41,740	92	63	.24858	126.40	228	16-16	238
3	229	52,630	110	75	.19714	159.38	265	32-18	259
2	258	66,370	131	88	.15633	200.98	296	32-17	-----
1	289	83,690	156	105	.12398	253.43	329	32-16	300
0	325	105,600	185	125	.09827	319.74	421	32-15	340
00	365	133,100	220	150	.07797	402.97	528	32-14	380
000	410	167,800	262	181	.06184	508.12	643	32-13	425
0000	460	211,600	312	218	.04904	640.73	815	32-12	454
Cables.	630	300,000	405	273	.03355	932	-----	37-000	-----
"	727.3	400,000	503	332	.02516	1242	-----	37-1039	-----
"	814.5	500,000	595	390	.02013	1553	-----	61-0905	-----
"	891.9	600,000	682	440	.01666	1863	-----	61-0991	-----
"	963.9	700,000	765	488	.01438	2174	-----	61-1071	-----
"	1030.5	800,000	846	540	.01258	2474	-----	61-1145	-----
"	1092.6	900,000	924	585	.01118	2795	-----	61-1214	-----
"	1152	1,000,000	1000	630	.01006	3106	-----	61-128	-----
"	1208.7	1,100,000	1075	675	.00915	3416	-----	61-1343	-----
"	1262.8	1,200,000	1147	715	.00838	3727	-----	91-1148	-----
"	1314.5	1,300,000	1217	755	.00769	4038	-----	91-1195	-----
"	1364	1,400,000	1287	795	.00715	4348	-----	91-124	-----
"	1413.5	1,500,000	1356	835	.00667	4658	-----	91-1285	-----
"	1458.6	1,600,000	1423	875	.00625	4968	-----	91-1326	-----
"	1503.7	1,700,000	1489	910	.00588	5278	-----	91-1367	-----
"	1547.7	1,800,000	1554	945	.00556	5588	-----	127-1195	-----
"	1571.9	1,900,000	1618	980	.00527	5898	-----	127-1223	-----
"	1630.2	2,000,000	1681	1015	.00500	6208	-----	127-1254	-----

Working formula for res. of l feet cop. of d mils. diam.

$$R = \frac{10.4 \times l}{d^2}$$

Res. increases 0.21 per cent for 1° F. rise of temperature.

Res. H. D. cop. = 1.0226 \times soft cop.

For actual cross-section multiply Nos. in III by 0.7854.

For ohms per mile multiply Nos. in VI by 5.28.

Nos. in VI give also volts fall of potential per ampere per 1,000 feet.

From III we can get equivalent strand cable for any wire. Four No. 3's may replace one 0000 wire because $4 \times 52630 =$ nearly 211600. For No. 0, take two No. 3's or four No. 6's.

Weight of insulation on cables varies for different kinds of work.

Rough rule.—One thousand feet of soft copper, one mil. in diameter (No. 10) has one ohm resistance at the ordinary temperature of a room.

2. TABLE FOR TAPS, BRIDGE WIRES, ETC., OF NEGLIGIBLE DROP (0.15 OF 1 PER CENT OR LESS.)

Wire Nos.-----	0	1	2	3	4	5	6	7	8	10	12	14	16	18
Lamp { 52 v.-----	300	260	200	160	130	100	80	65	50	38	24	15	9	6
Feet { 110 v.-----	1280	1085	860	680	560	435	345	280	220	160	100	60	40	25

3. TABLE OF SIZES OF SAFETY FUSES.

Fuse wires should be stamped with 80 per cent of the maximum amperes which they can carry indefinitely, thus allowing $\frac{1}{4}$ overload.

Amperes carried -----	$\frac{1}{2}$	1	2 $\frac{1}{2}$	4	5	60	7 $\frac{1}{2}$	8 $\frac{1}{2}$	11	14 $\frac{1}{2}$	19	22	24	30	35	45	53	70	80	100
Diam. in mills -----	$\frac{17}{17}$	$\frac{20}{20}$	$\frac{25}{25}$	$\frac{30}{30}$	$\frac{35}{35}$	$\frac{40}{40}$	$\frac{45}{45}$	$\frac{50}{50}$	$\frac{60}{60}$	$\frac{70}{70}$	$\frac{80}{80}$	$\frac{90}{90}$	$\frac{100}{100}$	$\frac{110}{110}$	$\frac{120}{120}$	$\frac{140}{140}$	$\frac{160}{160}$	$\frac{180}{180}$	$\frac{200}{200}$	$\frac{250}{250}$

In testing, allow naked open fuses five minutes to blow; inclosed fuses not in contact, a shorter period.

(D) GENERAL FORMULA.

- C =amperes. n =No. lamps in parallel. k =motor efficiency.
- R =ohms. c =amperes in 1 lamp. =ratio output to input.
- E =volts. e =volts in 1 lamp. =0.75 in 1 h. p. motors.
- P =watts. l =feet on one side of circuit. =0.80 in 5 h. p. motors.
- HP =horsepower. d =diameter of wire in mills. =0.90 in 10 h. p. motors.
- CP =candlepower. v =volts lost in wires. =0.95 in 50 h. p. motors.

- 1.—Ohm's law.— $C=E \div R$; $E=CR$; $R=E \div C$.
- 2.— $P=C^2 R=C E=E^2 \div R$. $1 HP=P \div 746=C^2 R \div 746$.
3. (a) Given the length, l , in feet and diameter, d , in mills. of copper wire, to find its resistance at the same temperature; $R=l \times 10.4 \div d^2$.
- (b) Given the resistance, R' , of copper or other pure metal at $t^\circ F.$, to find its R at any other temperature $t^\circ F$; $R=R' [1+0.0021 (t-t')]$.
- Ex. From the table the R of 1,000' No. 13, at 68 F =2 ohms; at 60 F.=2 (1-0.017)=1.97 ohms; at 100 F.=2.13 ohms.
4. Given the voltage and candlepower of an incandescent lamp, to find the current strength to light it: $c=C P \times 3.5 \div e$.
- Ex. A 32-candlepower, 52-volt lamp requires, therefore, 2.15 amperes. A 16-candlepower, 110-volt lamp requires $\frac{1}{2}$ ampere.
5. To find the size of copper wire for feeders, mains, branches, service wires, or inside work to feed n lamps in parallel taking each c amperes from a center of distribution distant l feet, so that the total drop in both wires will be v volts:

$$d^2 = \frac{n \times c \times 2 l \times 10.4}{v} \text{ (from Ohm's law).}$$

With the value of d^2 found, look in column III of the table for the next higher value. If this wire has the carrying capacity in open (IV) or concealed (V) work, as the case may be, it is taken; if not, the next larger wire.

Ex. What gauge of copper wire will supply fifty 110-volt, 16 candlepower lamps at 150 feet distance from the center of distribution with only 2 volts loss?
 Ans.: $c = 16 \times 3.5 \div 110 = 0.51$ ampere. $d^2 = 50 \times 0.51 \times 300 \times 10.4 \div 2 = 39730$ circular mills., No. 4 B and S.

6. Given the voltage e delivered to a lamp and the per cent drop (p as a whole number) in the wires of the voltage received to find the number of volts drop in the wires:

$$v = pe + (100 - p).$$

Ex. The leads to a cluster of 110-volt lamps are figured for a 4 per cent drop. What is the actual number of volts lost in the leads?

Ans.: $v = 4 \times 110 + 96 = 4.6$ volts. Voltage at supply end = 114.6.

Ex. What size of wire will carry with a 2 per cent drop, 30 amperes, 200 feet to a 220 volt motor?

Ans.: $v = 2 \times 220 + 98 = 4.5$ volts drop. $d^2 = 30 \times 400 \times 10.4 \div 4.5 = 27733$, No. 5 B and S.

Ex. Conversely, to find the per cent drop in the wires when the volts drop and volts delivered are given:

$$p = 100 v \div (e + v).$$

Suppose there are 6 volts drop or loss in the leads to a 104-volt cluster or motor; the per cent drop in the leads = $100 \times 6 \div (104 + 6) = 5.56$ per cent.

7. To find the volts drop in a given copper wire carrying a given current:

$$v = \frac{n \times c \times 2 l \times 10.4}{d^2}; \text{ or multiply the number in column VI of the table by the}$$

feet and amperes and divide by 1,000.

8. To find the sizes of feeder and mains in fig. 184, which give a drop or loss between feeder switch and the 32 16-candlepower lamps of 2 volts or less, lamp voltage to be as nearly uniform as possible.

On the plan mark all centers of clusters and measure along the wires the distances in feet between them. *C* is the heaviest main, having $10 \times 33 = 330$ lamp feet. Its 10 lamps are supplied over 33 feet of main and 100 feet of feeder. For a starter, consider at first the drops to be in proportion to the lengths, i. e., 0.5 volt in the main and 1.5 in the feeder.

A 1.5-volt drop gives for the feeder $d^2 = 32 \times \frac{1}{2} \times 200 \times 10.4 + 1.5 = 23187$, or No. 6 wire. But No. 6 causes a drop of 1.3 volts either from (5) or from the proportion $1.5 \times \frac{32}{36} = 1.3$, using in the fraction the first two figures only of d^2 as approximate. Therefore, the drop in all mains will be $\frac{7}{10}$ volt or less.

For main *C*, $d^2 = 10 \times \frac{1}{2} \times 66 \times 10.4 + 0.7 = 4903$, or No. 13.

Likewise No. 13 is found for the main to the 8 lamps in *A*, 40 feet from center.

No. 16 for *B* and No. 14 for *D*. Column *V* shows all five wires to have sufficient carrying capacity.

For a check, use column *VI*, which gives the volts drop per ampere per 1,000 feet. For example, in feeder, drop = 0.395 (No. 6) $\times \frac{200}{1000}$ (ft.) $\times 16$ (amperes) = 1.3 volts; in main *C*, drop = $2 \times 0.066 \times 5 = 0.66$ volt; in *A*, 0.64; in *B*, 0.64; in *D*, 0.63. Between *F.S.* and the ends of the four mains the losses are 1.96, 1.94, 1.94, and 1.93 volts.

If a problem gives the drop in per cent, find the volts from $v = pe \div (100 - p)$ and proceed as above. In extensive wiring, tables computed from above formulas are used.

Any tap off the main *D*, for instance, having a drop greater than 0.07 volt would cause the total to exceed 2 volts. For this limit, one lamp at 50 feet distance requires a No. 11 wire. But the sizes of tap wires may usually be taken from table page 138.

9. To find d^2 of copper required to transmit *HP* (horsepower), *l* feet, with *v* volts loss in the wires to a motor of *e* volts and *k* efficiency:

$$d^2 = \frac{HP \times 746 \times 2l \times 10.4}{v \times e \times k}$$

Then increase d^2 by 50 per cent for overloading and look in the table.

Ex. A 110-volt hoist motor of 12 horsepower is 100 feet from the closet switch. Select the tap wires to allow only 4 volts drop from switch to motor whose efficiency is 90 per cent.

Ans.: $d^2 = 47020$. Add 50 per cent and the wire is No. 1.

10. The volts required for a constant current motor of *HP* (horsepower) and *k* (efficiency) are, $E = 746 \times HP \div Ck$.

The amperes required for a constant potential motor of *HP* (horsepower) and *k* (efficiency) are, $C = 746 \times HP \div Ek$.

Ex. The current to be supplied to a 220-volt motor of 90 per cent efficiency to get 12 horsepower is $C = 746 \times 12 \div 220 \times 0.90$, or 45 amperes.

11. The insulation resistance of a wiring system, including dynamo, or of any part thereof, should be above 10,000,000 ohms, divided by the total amperes to

flow in the circuit or in the part considered. Or, $IR = \frac{10,000,000}{C}$ ohms.

Ex. The *IR* of an 80-ampere installation is, then, 125,000; of a branch supplying ten 16-candlepower, 110-volt lamps is 2,000,000 ohms.

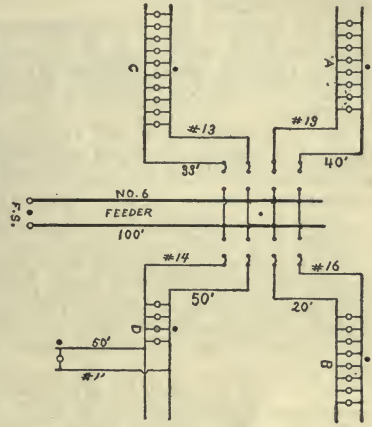

184. How to Find Sizes of Conductors.

12. To find the HP expended in a wire, $HP = C^2 R + 746$.

Ex. An arc light 10-ampere current flows in a 10-mile circuit of No. 6 B. and S. $R = 0.395 \times 5.28 \times 10 = 20.8$. The HP lost is $100 \times 20.8 \div 746 = 2.8$.

13. A storage battery, motor or arc lamp supplied by a generator E exerts a back electro-motive force e in the circuit. The effective E. M. F. is then $E - e$

and the current, $C = \frac{E - e}{R}$.

Ex. 1. Consider in simple circuit a dynamo of 3 volts and 0.02 ohm, a storage cell of 2 volts and 0.005 ohm, leads of 0.1 ohm and compute what ammeter and voltmeter should show.

Ans.: $C = 8$ amperes; drop-in leads = 0.8 volt; PD between dynamo posts $3 - 8 \times 0.02 = 2.84$ volts; PD between cell's posts = $2.84 - 0.8 = 2.04$ volts = (for a check) $2 + 0.005 \times 8$.

Ex. 2. What is the E of a dynamo of 0.02 ohm supplying 100 amperes to 54 cells in series of 2.3 volts B. E. M. F. and 0.0004 ohm each, the leads having 0.03 ohm? Also PD 's at dynamo and battery terminals?

Ans.: $E = (54 \times 2.3) + 100(0.02 + 0.03 + 54 \times 0.0004) = 131.4$ volts. $PD = 129.4$ and 126.4.

Ex. 3. A dynamo of 135 volts and 0.015 ohm was charging for seven hours through 0.025 ohm leads, 53 cells each of 0.0002 internal resistance and of 2.1 volts at starting and 2.35 at end of run. Find B. E. M. F., current and regulator resistance to keep C at 200 amperes at starting and stopping.

Ans.: At starting $e = 111.3$, $C = 460$, $R = 0.068$; at end of run, $e = 124.6$, $C = 206$ $R = 0.00165$.

Ex. 4. What must be the E of a dynamo of 0.02 ohm resistance in order to supply through 0.005 ohm leads, 7 brake HP to a motor of 90 volts back E. M. F., 0.025 ohm internal resistance and 300 watts internal friction, etc.?

Ans.: $C \times 90 + 300 \times 746 \therefore C = 61.4$ amperes, $E = 90 + 61.4(0.02 + 0.005 + 0.025) = 93.1$ volts. If E of dynamo be raised to 95 volts, the motor will develop 11.6 HP .

Ex. 6. The 0.11 ohm leads from a 50-volt PD source are carrying 10 amperes to an arc lamp of 39 volts, B. E. M. F., which has 0.09 ohm in the lamp coil, 0.08 and 0.12 ohm in the carbons and 0.1 ohm in the arc. What is the extra resistance which keeps the current in the lamp at 10 amperes?

Ans.: Total $R = \frac{50 - 39}{10} = 1.1$ ohm. $1.1 - [0.11 + 0.09 + 0.08 + 0.12 + 0.10] = 0.6$ ohm.

XVI.—ELECTRICAL MEASUREMENTS AND TESTS.

The apparatus required in the order of utility are: A portable Weston voltmeter (150—3 volts); an inexpensive upright Weston, in a square hard-wood box, having 0 at middle, movable coil of about 60 ohms, both a shunt and series coil to it such that two or three Leclanchés will deflect the needle to the scale end with either, and connections permitting the use of the movable coil alone or with the shunt or series coil; a London P. O. bridge; a few fresh dry cells; a Weston milli-ammeter with shunts for heavy currents; and, if at hand, a storage battery and the switch board instruments.

CARE IN HANDLING INSTRUMENTS.

Do not send a current through a galvanometer, ammeter, or voltmeter without first knowing its direction, and roughly its strength. Verify by striking with one of the galvanometer leads before closing for a reading.

Clean metallic connections which scrape into contact are always made.

Set down an instrument of any kind gently.

If the needle is pivoted, tap the case lightly before taking a reading—especially if the reading is small.

The pointer should stand at zero when there is no current.

A mirror beneath the pointer aids in getting a proper reading. To read, place the eye over the end of the pointer so that the pointer covers its reflection.

When the box rheostat is used, be sure that all plugs remaining in the box make such good connections as to cut out their coils.

Turn the plug clockwise both in plugging and unplugging to keep the contact surfaces scraped, and never carry the plugs in the hand or lay them in a dusty place.

If a galvanometer is not at hand, a telephone receiver or a telegraph relay may take its place in rough testing and the tongue for continuity.

A magneto series bell whose capacity is known, is convenient and useful in continuity and insulation tests.

Use a knife switch, not a contact key, to close a testing circuit.

The current from a storage battery ought not to exceed 12 amperes per square foot of positive plate surface, counting one side.

The dynamo or battery which furnishes the testing current, must be well insulated and care be taken not to short-circuit the generator or to heat a testing coil.

A Siemens detector galvanometer having a coarse and a fine wire coil, although not so good as the Weston described, is more useful than a magneto in testing. For a cheap W. B., string a G. S. wire of about 8 ohms up and down a hard-wood board 30 inches long, on which brass pieces are screwed as in fig. 187; for the third side procure a few coils of known R .

I.—*To measure the strength C of a current.*—Insert in the circuit an ammeter of sufficient capacity and of such low resistance as not to alter essentially the quantity to be measured. Good connections are specially required.

II.—*To find the difference V of potential between two given points of an electric circuit.*—Hold the positive voltmeter lead on the higher point and strike the other with the negative lead to verify the proper swing—both direction and amount—of the needle. Then hold the latter down and read. A high voltmeter resistance is required so as not to alter appreciably the quantity to be measured.

III.—*To test the continuity of a circuit by means of a detector galvanometer and a few cells.*—Connect this apparatus in series and strike terminals quickly to see that all is in order. Then join terminals to those of the circuit under test. A deflection shows continuity. If there is no deflection proceed along the circuit touching across at convenient points with an extra wire until the break is reached.

IV.—*To measure an ordinary resistance R of a conductor readily by the Substitution method.*—Connect the unknown R , a constant battery, a galvanometer (shunted if necessary) and a key in series, and note the deflection. Take out R and insert rheostat or G. S. wire from which throw into circuit a known resistance, r until the deflection is the same as before. Then, $R = r$. Small resistances in G and B and a large deflection of G are favorable conditions.

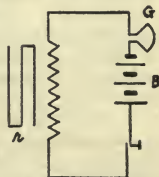

185. Substitution.

V.—To measure an ordinary resistance x of a conductor accurately with the Wheatstone bridge.—The Wheatstone bridge consists of three sets of known resistances, a , b and c , joined in series. They and the unknown resistance x form (for a picture) the four sides of a diamond-shaped figure. A galvanometer joins any two opposite points of the diamond, and a battery the other two. Figs. 186, 187, and 188 represent three forms, which are lettered to correspond. Two of the sides or sets, a and b , have usually three coils each, 10, 100 and 1,000 ohms, as in the London P. O. pattern (fig. 188), or consists simply of a German silver or a platinoid bare wire, as in the wire bridge form, fig. 187. The third set or side has usually 16 coils, so sized that any resistance expressed by a whole number between 1 and 11,111 ohms can be unplugged from it. Any resistance between $\frac{1}{100}$ and 1,111,000 ohms can be measured with the London W. B., and two infinity plugs permits its use as three separate rheostats.

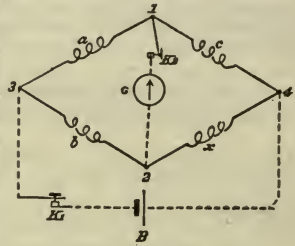

186. Student Form.

To measure with a W. B.—Connect, as in figs. 186-7-8, the unknown resistance x , with the three sets, a , b and c , of the bridge so as to form a simple closed circuit. There must be a certain amount of resistance in each set, the more nearly equal the better. Connect a sensitive galvanometer and key between any two junctions not adjacent and a battery and key between the other two junctions.

While holding the battery key K_1 down, depress (or better, strike) the galvanometer key K_2 . If there is no deflection the bridge is balanced. If there is a deflection, alter the resistance in one or more of the three sides, usually c , until there is no deflection; then the unknown resistance is equal to the resistance in c multiplied by that in b and divided by the resistance in a . Or $x = c \times b \div a$.

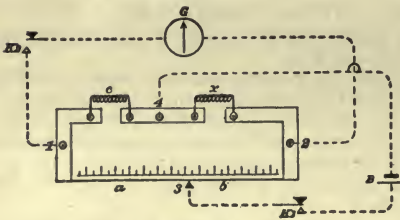

187. Workshop.

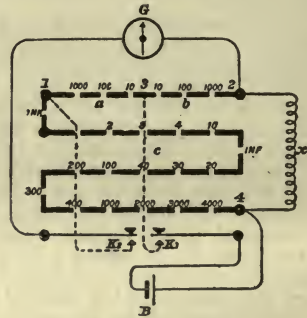

188. London P. O.

VI.—To measure a large resistance R like the insulation resistance of a conductor by means of a sensitive galvanometer whose constant or deflections are known and a battery of known V .—Detach the conductor from all others and guard against leakage at its two ends over the insulation. Join in series either end of the conductor, G , V and the frame or ground plate as the case may be. From the deflection the current C through the circuit is known. Then, $R = V \div C - G'$. G' is small enough, relatively as a rule, or can be made small by a shunt, to be called zero.

VII.—To measure a small resistance R like a piece of cable, joint, armature coil, etc., by means of a Weston ammeter and voltmeter.—Connect up as in the figure and read the deflections. Then $R = E \div C$.

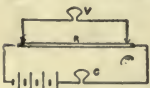

189. By Volt and Ammeter.

Ex. When a storage battery, a heavy rheostat to prevent short-circuiting, an ammeter and an armature whose resistance was sought were joined in series the current was 15 amperes. The voltmeter (small coil) bridged across the two commutator bars in contact with the brushes showed 0.09 volt. R of armature = 0.006 ohm.

VIII.—To measure the conductor resistance R of the main or any feeder circuit (lamps hot) by the switch-board voltmeter and ammeter.—Take the instrumental readings while current flows in the circuit to be measured and compute from $R = V \div C$.

A conductivity test of a main or feeder circuit with a *D G*, or an *R* measurement by the substitution method, will preclude all danger from short circuit when the feeder switch is closed.

IX.—To measure an ordinary resistance *R* by means of a voltmeter and a single known resistance *r*.—Connect as shown (fig. 190). If the deflection is *V* when the voltmeter leads are applied to the ends of *R* and *v* when applied to *r*, $R = r V \div v$. Large and nearly equal deflections for *V* and *v* are favorable conditions.

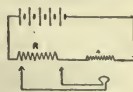

190. Comparison.

X.—To measure a small resistance *R* by means of a voltmeter and a bare German-silver wire *S* of known length and resistance.—Connect *R*, *S* and a few constant cells. Note the deflection *V* of the voltmeter when its leads are applied to the ends of *R*. Next attach one lead to the junction of *R* and *S* or the zero of the length of *S*, and slide the other lead along *S* until the deflection is the same.

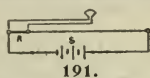

191.

R = the resistance readily computed of that part of the German-silver wire between the two contacts.

Resistances between 1 ohm and 1 megohm are usually measured by the *W. B.*; below 1 ohm by the potential method; above 1 megohm by the deflection method. But the substitution method being quick and approximate is often used for ordinary resistances.

XI.—To locate a short or a partially open circuit (poor contact) as in an armature by means of the voltmeter only.—Send a steady current through the armature by the brushes properly set. Apply the voltmeter terminals to 1 and 2 commutator bars, then to 2 and 3 and so forth on one side of the brushes, and in like manner on the other. If the deflections are all equal there is no open or short circuit. An increased deflection indicates a bad contact or unusual resistance; a diminished deflection, a short circuit.

Two or more magnet coils alike wound as on fields or a horseshoe, can be similarly examined by giving them the same current and comparing the potentials of the coils.

XII.—To test a joint, switch contact, battery connection, etc., by means of a voltmeter.—Let its maximum working current flow through it and apply the voltmeter leads to opposite sides of the joint, etc., and compare the deflection with that given by an equal length adjacent of wire or bar. If there is no deflection and the voltmeter is sensitive, there is no resistance. Joints in the same circuit may thus be compared and the loss of energy in them may be computed.

If the current *C* in amperes is known, the resistance in ohms of the joint, etc., can be found by $R = V \div C$.

Ex. A foot of search-light main having a connection showed a difference of potential of $\frac{1}{10}$ volt, and a foot of regular main showed $\frac{1}{80}$ volt while carrying 100 amperes. The joint was a poor one. Its *R* = 0.001 ohm. Power lost in joint alone = 7 watts.

XIII.—To measure a large *R*, as of insulation, by means of a well-insulated dynamo or battery, and a Weston two-coil voltmeter of *r* ohms (say 18,000) in the larger coil.—Connect *B*, *R* and large coil of voltmeter, *r* (fig. 192). If *V* is the deflection when the switch is closed and *v* when it is open, $R = \frac{V-v}{v} r$.

Ex. The deflection on a 20,000-ohm voltmeter closed on a dynamo was 100 volts, and in series with the dynamo and unknown *R*, was 40 volts. $R = 30000$.

Ex. The deflection by the 18,000-coil between the poles of a well-insulated storage battery was 120, and by the 3-volt coil between the extremities of the insulation *R* and battery joined in series was $\frac{1}{30}$ volt. $R = 65$ megohms. *R* in fig. 192 and in both examples may be the insulation resistance of a circuit whose conductor is joined at *A* and a ground plate to *X*.

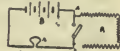

192.

XIV.—To measure the *R* of a ground on either leg of a parallel *D. C.* system by the above method.—The connections are made as shown for an unknown

ground on the upper main. Or, without the switch, the voltmeter leads may be applied first to both mains to get *V* and then to the lower main and ground to get *v*; whence, $R = (V - v) r \div v$ ohms insulation of upper side. The operation is similar for finding the amount of ground on the other or lower side.

Ex. The 19,000-ohm voltmeter gave 124 volts between dynamo brushes and 4 volts between one main and ground. The insulation *R* of the other main = $(124 - 4) 19000 \div 4 = 570000$.

If the insulation on one leg is *R* and on the other *R'*, the insulation of the system is $1 \div \left(\frac{1}{R} + \frac{1}{R'} \right)$.



193.

Ex. The insulation on the other main in the above example was 300,000 ohms. The system's insulation = 200000.

If no deflection shows between a main and one ground there is no ground on the other main. But if the deflection equals that between mains, $v = V R = O$, the fault on the other is a dead ground.

Every properly-arranged switch board permits the insulation on either side to be quickly taken of the whole system, or of any feeder circuit, or of the dynamo alone.

XV.—To measure the insulation R of the dynamo alone, the operation is similar after opening the main switch. If no deflection of a switchboard, Weston 18,000-ohm voltmeter between one side and ground is perceptible, say $\frac{1}{20}$ volt while the dynamo is running at 110 volts, the insulation of the other side must exceed from XIII, $18000 \times 110 \times 20 = 40$ megohms.

XVI.—To measure the internal resistance R of a dynamo or storage battery by means of a Weston voltmeter and ammeter as at the switch board.—Take the potential V of the generator on open circuit, and again the potential v when closed on as many lamps as convenient, and at the same time read the current C of the ammeter. $R = (V - v) \div C$.

Ex. The 116 volts of 58 storage cells on open circuit fell to 115 volts when closed on 40 lamps and the ammeter read 20. R of battery = $\frac{1}{20}$ ohm.

XVII.—To measure the internal R of a battery, with a voltmeter and a known r .—Connect as in fig. 194. Suppose V is the deflection when the switch is open, and v when it is closed, $R = \frac{V - v}{v} r$ ohms.

Ex. Three Leclanché cells in series when connected directly to the 5-volt coil showed 4.5 volts, and when shunted by 4 ohms showed 3 volts. R of battery = 2 ohms.

For a large storage battery a heavy current rheostat and the larger voltmeter coil would be necessary.

XVIII.—To measure the internal resistance R of a battery readily by means of a low, resistance galvanometer G , and a rheostat r .—Join R , G and r (well plugged) in series and note the deflection which should be made small by shunting G , if necessary. Next unplug r ohms from the rheostat until the deflection is halved. Then, $R = \frac{1}{2} r$. Close the battery for as brief a time as possible that its R may not change.

XIX.—To measure the resistance R of a galvanometer readily by means of a low-resistance battery and a known r .—Join R , B , and r well plugged in series; note the deflection which should be small by arranging the cells of B in parallel, if necessary; unplug r ohms until the deflection is halved. Then, $R = \frac{1}{2} r$ ohms. The R of a galvanometer is preferably measured as an ordinary resistance.

XX.—To test the insulation R of a conductor by means of a magneto.—Detach the conductor from the rest of the circuit. Join one terminal of the bell to the conductor and the other terminal to the ground, frame of instrument, dynamo, etc., from which the conductor should be insulated. If the bell rings feebly on turning the crank the insulation resistance is less than 25,000 ohms, or the capacity of magneto. If not, the insulation is greater,

XXI.—To select and label the conductors of a cable.—At one end connect any conductor (insulated from the others) to the sheathing; at the other end connect the sheathing, a few cells, and a detector terminal in series; tap rapidly with the other terminal each conductor's end in turn until a deflection is obtained. Tag this end and the other connected with the sheathing as wire "No. 1." In like manner find No. 2, and so on.

A telephone receiver and a cell, or a magneto and bell, may be used in place of the above and a separate wire in place of the sheathing. Conductors can likewise be selected at the middle without cutting by piercing the insulation with an ordinary fine needle, which is made the terminal of the detector.

XXII.—To test for crosses, grounds, and insulation of conductors in a cable.—Dry both ends of the cable; separate No. 1 for the test from the others at both ends; at the near end, bunch the others to the sheathing and connect the bunch in series with two or three cells and a telephone receiver post. When an insulated wire from the other receiver post is tapped quickly on No. 1, if well insulated, a click will be heard from a charge flowing to the wire, but not at the second or third succeeding tap. But if No. 1 is crossed or grounded the click will be alike for all taps. Having properly labeled No. 1, repeat the operation on No 2 withdrawn from the bunch, and so on.

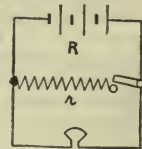

194.

XVII.—SPECIFICATIONS FOR REQUISITIONS, ALTERATIONS AND REPAIRS.

IN GENERAL.

Every electric machine or piece of apparatus for war uses shall be simple, certain in operation, proved in the industries to be standard in its class and supplied by one of the leading manufactories in the United States.

(A) POWER HOUSE.

1. Located centrally and 3 feet from protecting earth traverse or embankment; built of brick or old fortification granite; floored with concrete; roofed with slate and iron in shed form or with low middle ridge; supplied with at least five large, removable windows on three sides and with three large, window-paneled doors on the front. In the rare cases where the power house can not be protected, the machinery will occupy outer and sun-lighted rooms only, of the work.

2. Partitioned laterally into (a) boiler, (b) generator, (c) battery rooms.

(a) holds an inclosed coal bin for three days' supply, with outside chute at top and an inside shovel hole at the bottom accessible from furnace door. Large plants have separate coal rooms. Door permits horizontal tubes to be withdrawn. There is a ventilator at the highest point. For oil engines (a) holds water tank, oil and supplies.

(b) affords at least 4 feet clear space around engine and dynamo and in front of switch board facing dynamo. Door between (a) and (b).

(c) contains two battery stands of two tiers or shelves each, solidly built from one-size material (see "Storage battery"). They extend along the lateral walls and have 5 feet clear space between them, or preferably 30 inches or more clear space on both sides. Distance between shelves = $2 \times$ height of jars. Ventilators at top and bottom.

(B) BOILERS.

A boiler is rated at 1 horsepower, which, with easy firing, moderate draft, ordinary fuel, and good economy, can evaporate per hour 30 pounds (about $\frac{1}{4}$ cubic foot) of water at 100° F. into steam under 70 pounds pressure above the atmosphere.

1. For 35 horsepower or less, procure from the standard factories only, vertical fire tube; for larger power or as space permits, vertical or Hor. return fire tube without dome; working pressure = 100 pounds; water test = 150 pounds; safety factor = 5; requirements in practice in chapter I.

2. The shell is of mild, nontempering, open-hearth steel plate, $\frac{3}{8}$ to $\frac{5}{8}$ inch thick, having 60,000 pounds tensile strength, 56 per cent ductility, 20 per cent elongation of a piece 10 by 2 inches wide. This data and firm name are stamped on each plate. All holes are bored, not punched; all joints, lapped and double-riveted longitudinally and single-riveted laterally.

The tubes of cold-drawn, seamless steel, 2-inch diameter in vertical boilers, 3-inch in horizontal and at least $\frac{1}{4}$ inch thick, closely fit holes drilled $\frac{1}{4}$ diameter apart in the clear; the ends are expanded and flared.

3. Length, one and three-fourths to two and one-eighth times diameter; capacity = one-third greater than maximum required by engine; 12 square feet heating surface per horsepower if boiler is vertical; 15 square feet, if horizontal; 36 square feet heating surface per square foot grate; one-third to one-half of grate per horsepower; total tube opening, one-tenth to one-seventh of grate area; grate air passage = one-fourth to one-half grate area; chimney cross section = one-fifth of tube opening; water feed = 1 to $1\frac{1}{2}$ inch diameter; blow-off = 2 to $2\frac{1}{2}$ inch diameter; steam feed = engine opening.

4. Interior braces and stays of steel of 60,000 pounds, T. S., not welded nor worked in the fire, riveted and bolted, shall have such cross section that the

strain (= boiler pressure \times area braced \div cross section) shall be same as T. S. above with same safety factor and firm-name stamp. Openings, 2 inches or larger in the shell, shall be flanged. Manholes or hand-holes at bottom and top shall permit thorough inspection and cleaning. All seams are calked inside and out. Fire door has air inlet. Safety plug in tube is 2 inches below lower gauge and near a hand-hole.

5. Fittings, except pipes, are brass.

(a) All piping, wrought iron or steel, are direct and short, with few bends which must have large radii, and will be laid so as not to allow water to stand in them. Steam pipes rise slightly toward the shut-off valve next the boiler. Boiler and steam piping are covered with asbestos. No piping is embedded in concrete.

(b) Muffled pop safety valve, with lifting handle, has 1 square inch aperture to 3 square feet grate, and opens at 5 pounds above working pressure.

(c) Steam gauge, 6-inch face, has siphon and air cock.

(d) Three water-gauge cocks. Lowest is 2 inches above upper horizontal tubes, or one-third of the distance between lower and upper flue sheets.

(e) Glass gauge, with two cut-off valves, drain cocks, guards, and extra glasses.

(f) Blow-off valves, with screw motion. Scum blow-off cock.

(g) Injector, lifting, lies direct as possible between supply and the delivery above crown sheet. Delivery tube is so bent that water entering will flow with the circulation. Has both check valve and stopcock.

(h) Double-acting suction and force pump has air chamber, a branch in suction for boiler compound and an independent and straight connection.

(i) Feed water, heater and purifier.

(j) Steam separator.

(k) Exhaust directible into smokestack.

(C) GENERATING SET

1. Is either a (1) standard, direct-connected, simple, steam engine and dynamo on a common iron bed plate effectively grounded, or (2) a Hornsby-Akroyd oil engine, link-belt connected with a standard dynamo on wooden base and having an inertia wheel.

(a) Supplied by General Electric, Westinghouse, or like standard company.

(b) Stamped with name, volts, amperes, power, speed, + and - posts, N. and S. poles.

(c) Located with switchboard in a dry, ventilated, sun-lighted room used for no other purpose, and kept dry by an oil stove if subject to dampness.

(d) Bolted to concrete foundations of dimensions given by the makers.

(e) Tested for two hours on one-third excess of its full rated load without injury.

(f) Capable of long runs on full load without undue heat or wear.

(g) Perfectly balanced and runs true without vibration, noise or leaks.

(h) So efficient as to give by ammeter and voltmeter 0.80 of indicator's power.

2. It requires:

(a) A competent and devoted attendant.

(b) At least 4 feet surrounding clear floor space.

(c) Large windows on two sides.

(d) Full sets of tools, oilers, standard spare parts.

(e) Full working tracings and diagrams.

(f) If large, two or more like units with one spare.

(g) W. P. cover when not in use.

(h) Self-oiling of all bearing surfaces.

(i) Means to recover surplus oil.

(j) Guards to stop oil being thrown.

(k) Metal can for oily waste.

(l) That oil shall not run along shafts or spill.

3. (a) Engine, high-speed, double-acting, automatic cut-off, simple, vertical, if 30-horsepower or less, horizontal if larger, compound if very large; to work most economically on 80 pounds pressure if simple, on 100 pounds if compound; to allow, with economy, a variation of 20 pounds either way and fulfill conditions on page 47.

(b) The piston, rods, crosshead, guides, shaft, nuts, bolts, of the best forged-steel, are accessible for repair, capable of realignment when worn and strong enough to allow sudden throwing on and off of the whole load. The cylinder and valve chest, of cast iron encased with nonconductor, have relief valves removable for indicator connections.

(c) At full pressure the governor prevents a variation less than $2\frac{1}{2}$ per cent in the number of revolutions during a change from full load to one-fifth thereof, and less than 5 per cent for a change of both steam pressure within limits given above and of full load to no load.

(d) The engine will have cylinder, up-feed lubricator, automatic sight-lubrication elsewhere, oil collectors and guards. The exhaust, directible to smoke-stack and led outside and concealed, should be killed if flowing water is available.

(e) Ideal, Ball, Straight Line, McIntosh and Seymour, Armington and Sims, and Westinghouse are names of good engines.

4. The dynamo is direct current, multipolar, compound-wound, and has sufficient potential to maintain during full load and normal speed, 110 volts at the farthest lamp, and to charge 58 storage cells.

(a) It requires:

A ventilated, balanced armature; a laminated core of soft-iron disc rings; P. D. between adjacent bars less than 10 volts; two or more brush carbons in each set; rocker locked in any position; large self aligning and oiling bearings; field frame in upper and lower halves; fuses on both leads; equal magnetic pull by all poles; all circuits of 0.99 cond. of pure cop.; a field rheostat by same builder.

(b) It is capable of running eight hours on full load, or three hours on 15 per cent overload, without heating the commutator 50° F. or any other part 40° F above the surrounding air as given by a thermometer placed (in first case) on the heated part and covered with waste, and in the second case, 3 feet from dynamo in line with the shaft.

(c) A change from full load to no load, with brushes and rheostat fixed, causes less than 2 per cent variation of potential and no sparking. If the full load is suddenly thrown off, the swing of a Weston voltmeter from self-induction is less than 10 volts.

(d) No insulating part can be injured by moisture or 200° F. rise of temperature, and the insulation between circuits or between entire circuit and iron frame exceeds 1 megohm under 1,000 A. C. volt test both before and after a run.

(e) Armature windings must be symmetrical, systematic and replaceable; end connections, short and mechanically made to bars; wires having wide P. D. are kept apart; no wires cross in contact with each other.



195. Field Rheostat, W-c.

(D) SWITCHBOARDS.

Switchboards, preferably of slate, must not carry anything which is combustible or absorptive.

Be free from moisture, dust and accessible from all sides.

Have a main switch, main cut-out and ammeter for each generator; a D. P. switch and cut-out for each circuit leading from board and a voltmeter and ground detector.

Meet all requirements of pages 56-7-8.

Be wired as sufficiently indicated on page 74.

(E) STORAGE BATTERY (RESERVE EXCEPT FOR MOTORS AND SEARCH LIGHTS).

1. Fifty-eight chloride storage cells of about 1 square foot positive plate (one side) per 12 amperes of normal charging and discharging rate for eight hours should show 85 per cent efficiency and conform with requirements in VI.

2. The glass jars rest on sand in wooden trays on glass or porcelain insulators on shelves of paraffined solid framework.

3. Lead-lined strong wooden tanks are used when plates exceed $1\frac{1}{2}$ square feet.

4. Connections are lead-burned, if practicable, or so bolted that they allow no greater drop than an equal length of lead lug.
5. The jars, readily accessible on two sides if possible, should stand free from concussion and the direct rays of the sun.
6. Fully protected by an overload automatic cut-out and a D. P. switch near it.
7. Supplied with meters and facilities enumerated in VI and XII as necessary for the care of batteries.

(F) ELECTRIC MOTORS.

1. All electric motors should be—
Furnished by one of the leading manufactories in the United States.
Guaranteed to meet the general requirements given above for dynamos.
Located in a clean, dry, well-lighted place under oilcloth cover.
Insulated by moisture-proof wooden base frame if possible; else dead-grounded.
Slotted ring armature; brush holder capable of fine adjustment and fixable in the proper position.
Series wound (if hoist), multipolar and having 50 per cent excess of power.
If required, inclosed by frame against damp and dust. Hand-holes have covers.
Supplied with radial carbon brushes, two or more in each holder.
Constructed so as not to spark between no load and 15 per cent overload.
Fed direct through exclusive feeders having a cross-section to carry 50 per cent excess of current.
Protected by rheostat, overload and underload circuit-breakers, fuses and D. P. knife-switch within sight of motor.
2. Rheostats to motors constructed of fire and moisture proof material by the builders of the motors, have the overload and underload releases, usually attached, sufficient capacity without paralleling coils and 1 megohm insulation *R*. The contacts should be ample, the resistance such as to drop the full potential 80 per cent at the first point. Capacity and factory No. are plainly marked. There are three types:
 - (a) Starting, capable of carrying line voltage 15 seconds.
 - (b) Regulating, capable of carrying full line voltage indefinitely.
 - (c) Regulating and reversing. *C* through armature only is reversed. All springs are of bronze and carry no *C*. Points of control are clearly indicated. Rheostats in damp positions are inclosed by a water-tight, fire-proof case.

(G) SEARCH LIGHTS.

1. The brass projector, painted dead black inside and out, holds the parabolic glass mirror, 36 to 60 inches in diameter, $\frac{1}{4}$ to $\frac{1}{2}$ inch thick, and is mounted upon a low platform of a four-wheel truck. Its arc can be supplied at 1,000 feet distance from the dynamo through double cable.
2. The projector can be directed by hand or by means of a controller, multiple cable and two shunt motors, so that the beam can be turned to any desired point by a person 150 feet away from the projector, right or left, up or down, in agreement with like motions of the controller's single handle, and with a rapidity depending upon the amount of throw of the handle, or with as small motion as desired.
3. The drum must be evenly balanced, well ventilated, and fitted with peep-holes for watching and hand-holes for adjusting the arc.
4. In all the means of operation, in excellence of workmanship, and photometric power, all projectors must equal or excel the Schukert and General Electric search lights of like size manufactured for the United States Government in 1900, as given on pages 90-102 of the Handbook.

(H) INCANDESCENT LAMPS.

1. Sixteen-candlepower lamps, with Edison short base, screw into a brass outlet box closed by a glass, screw-rim globe (fig. 199) for ordinary use. For powder magazines, 32-candlepower lamps are clustered inside an air-tight, moisture and fire proof lantern which is placed in the end wall nearest the gallery and furnished with reflector and diffusing lens.
2. All lamps are 110-volt, and of standard size and make. Efficiency = 1 candle per 3.1 to 3.5 watts; useful life = 800 hours; apportion one 16-candlepower lamp to 1,000 cubic feet room space.
3. Filaments should stand centrally in a uniformly molded lead glass bulb without tip, have two or three curls without anchor, and show no dark or bright spot when heated to a dull red. The vacuum should allow no glow when tested on an induction coil delivering a $\frac{1}{4}$ -inch spark.

4. The mean horizontal candlepower obtained by revolving the lamp in a vertical position 180 times per minute should be within 1 candlepower of its rating, and should not fall below 80 per cent of the initial candlepower after 800 hours' use.

5. Sockets of brass, never less than 0.013 inch thick, have solid construction, standard screw threads, porcelain base, insulating lining fixed, tough and fire-proof, and points of opposite polarity at least $\frac{3}{16}$ inch apart, unless separated by reliable insulation. Except in special cases, they are keyless. If suspended, the flexible cord enters the socket through strong insulating bushing, $\frac{1}{4}$ inch inside diameter.

(1) WIRING.

1. The closet system of two-wire parallel distribution of direct current to lamps, motors, search lights, storage batteries, detonators, etc., afford the better control and protection, whether or not the wiring is partially overhead or underground, or wholly interior. It takes more wire than the tree system, but allows switches and cut-outs to be safely and conveniently grouped and lamps to be at more nearly equal voltage.

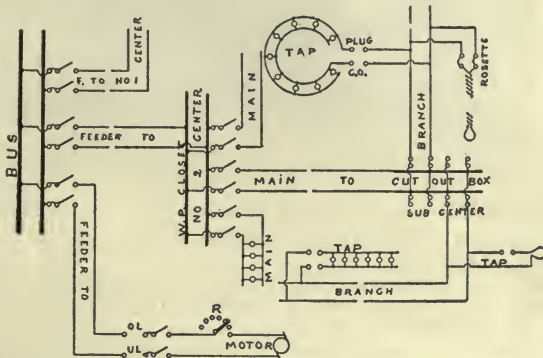

196. Distributing Current to Centers.

(a) Feeders run from bus bars to main centers in slate closets or to motors; mains, from main centers to cut-out boxes (sub-centers); branches, from cut-outs to places to be lighted, 12 or less lamps; taps, from branches to lamps.

(b) The route to a lamp is: (1) Bus bar, (2) D. P. knife switch, (3) fuses to protect feeder, (4) feeder, (5) bus bar main center distribution box, (6) baby D. P. knife switch, (7) fuse to protect the main, (8) main, (9) inclosed fuse of cut-off box to protect the branch, (10) branch, (11) tap to outlet, (12) snap switch, (13) lamps.

(c) Search light, motor, or storage battery has its exclusive feeder.

2. Safety fuse cut-outs are placed in full view at centers and subcenters of distribution, or where a smaller wire begins in a parallel system, or where a motor, battery, etc., requires protection from overload and inside a building where wires enter.

Safety fuse cut-outs are D. P. and mounted on insulating bases in a small dust, moisture and fire proof box, held out from walls on porcelains. Fuse-wires are in contact only with their connections and are $\frac{3}{4}$ inch long for 50 volts, 1 inch for 110, to prevent arcing.

Cut-outs require copper tips stamped with maker's initials and 80 per cent of the maximum *C* which the fuse will carry indefinitely, thus allowing one-fourth overload.

Any set of lamps requiring more than 660 watts should be dependent upon more than one cut-out between the lamps and dynamo.

Cut-outs and circuit-breakers are to protect and switches are to disconnect all circuits beyond them.

3. Magnetic circuit-breakers protect automatically dynamos, motors and batteries against overload with more certainty than fuses, also against underload. Both kinds must operate with excess of power and within 5 per cent of adjustment. Overloads are usually set to open the circuit at one-half excess of current or one-fourth excess of voltage; underloads, to open at 5 or 10 amperes of current, or at one-fourth fall, if voltage. They must meet the requirements on page 61 of Ite C. B's. (inverse time element). Magnet iron parts are copper-plated.

4. Switches and circuit-breakers are—

(a) Mounted on small slate, porcelain, or marble bases, or preferably on the switchboard when used there, make sliding and secure contacts, make and break rapidly without stop or spark.

Carbon-tipped and have threaded studs and flanged nuts to make back connections.

Stamped with words "on" and "off," maker's name, and maximum *C* or *V*.

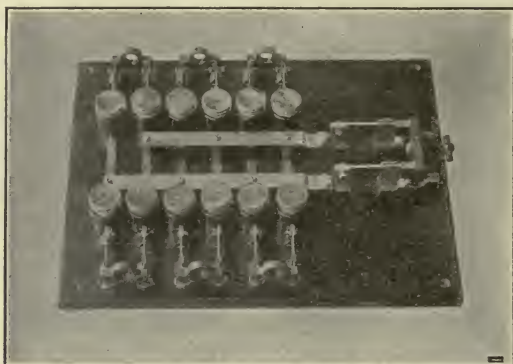

197. Cabinet Panel; Six Double Branches, Six F. S., One M. S.

(b) All conducting parts have such cross-section that heating from maximum *C* can not be felt by the hand.

(c) All switches are double pole; snap for 10 amperes or less; knife for larger but not smaller than 50 amperes; in conduit not at centers, snap switches, marine type, to 50 amperes may be used.

(d) Switches and cut-outs are located, and whenever possible grouped, inside a fire and water proof insulated box centrally located in a dry, accessible place which is free from inflammable material.



198. Cabinet Panel, Six Single Branches, at a Center.

5. *General rules for wires.*—(1) Coils purchased must show name of manufacturing company, date of manufacture, maximum voltage, and a guarantee to be "National Electrical Code standard."

(2) All conductors are No. 14 B. and S., single, and above that size in strand of 7, 19, 37, 61, 91, or 127 wires of one size—No. 19, 18, 17, 16, 15, or 14. One of a strand lies in the center, and others, in layers, are twisted uniformly around it, one turn in 20 or 30 inches, adjacent layers being wound in opposite directions.

(3) Copper is tinned. No variation of diameter greater than 0.002 inch allowed.

(4) On poles—H. D. copper with R. C. and W. P. insulation or bare aluminum. In conduit, ducts or on cleats—soft copper of 98 per cent conductivity of pure copper, coated with rubber and its compounds to a total thickness of $\frac{3}{8}$ inch on No. 14, increasing with larger sizes to $\frac{1}{4}$ -inch thickness on wire of 1,000,000 c. m. or larger.

(5) For all rubber-covered single conductors: (a) First layers are of 98 per cent pure para rubber, tough, elastic, at least $\frac{1}{8}$ inch thick for all sizes, and without flaws.

(b) Next layers are vulcanized rubber of 40 per cent pure Para, smooth, concentric, continuous, at least $\frac{3}{32}$ inch thick on No. 14 increasing to $\frac{1}{8}$ inch on wire of 1,000,000 c. m., and without holes or flaws.

(c) All layers of cotton tape thoroughly impregnated with rubber compound, lap tightly one-half of the width into an even circular section at least $\frac{1}{32}$ inch thick.

(d) All exterior braid is closely woven and thoroughly saturated with an insulating water-proof compound, uninjured by 200° F. dry heat, bending, or abrasion.

(6) Finished R. C. wires must show an insulation greater than 100 megohms per mile during thirty days' immersion at 70°F; also a dielectric strength such that 1 foot, after seventy-two hours' immersion, will resist for five minutes 3,000 volts A. C. per $\frac{1}{8}$ inch thickness of rubber.

(7) When a cable has two or more conductors, each is insulated with rubber and taped. Then all are twisted, usually in layers, around the central wire, the interstices often filled with jute, and the resulting cylinder is taped and sheathed.

6. *Interior conduit.*—(1) All interior wiring is drawn, for protection against moisture and injury, into low steel conduit, $\frac{3}{8}$ inch to 2½ inches inside diameter, enameled outside and inside and "dead-grounded."

(2) Its lengths are coupled together like gas pipe and screwed into bronze junction, closet, switch and outlet boxes having close-fitting doors or covers which are screwed home on rubber gaskets. All ends of pipe are sealed up. The lamp outlet box is closed by a glass globe over the lamp, screwing against a gasket (fig. 199).

(3) To the bottoms of all boxes is screwed a slate panel, or marble board, or porcelain block, which carries and insulates the switch, fuse, or socket.

(4) The conduit is either strapped to asphalt-painted wooden cleats, 3 feet apart, so as to run with all of its boxes 1½ inches out from ceilings or walls, or it is embedded in the concrete 2 inches from the surface of wall or ceiling. Its boxes lie on the surface in the latter case.

(5) The former or exposed conduit can be painted, repaired, altered, and kept air and water tight.

(6) A good conduit system is rigid, continuous, and practically air and moisture tight throughout.

(7) Rounded insulated capping to the ends of pipe inside of boxes prevents abrasion of the wire.

(8) Great force in drawing in wires is unnecessary and may cause leakage.

(9) Both positive and negative legs lie in one conduit where either has less than 30,000 c. m. conductor; if larger, each has a separate conduit. Clearance is $\frac{3}{16}$ inch at least.

(10) Conduit wires require $\frac{1}{32}$ inch thickness extra fibrous covering.

(11) Every length of good conduit is stamped with maker's name.

(12) Snap switches, being easily boxed, may be used with conduit to 12 amperes.

(13) D.P. knife switches are put in center of distribution closets.

(14) Wires are never "fished" in forts. Flexible iron armored conduit is permitted for repairs and "drop cords."

(15) Conduit is installed and all construction finished before wires are drawn in. Bends have 4 inches radius at least.

(16) After the wires are drawn in the ends of exposed conduit and outlets are sealed, all joints of pipe and boxes are painted with asphalt and precautions are taken to keep the interior air-tight.

7. *Underground lines.*—(1) Exterior electric wires will, as a rule, lie below frost, often 4 feet underground, by being drawn into wrought-iron pipe or glazed

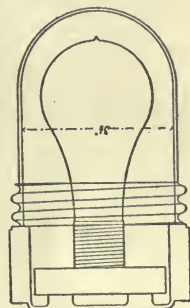

199. Water-tight Outlet Box and Glass Globe.

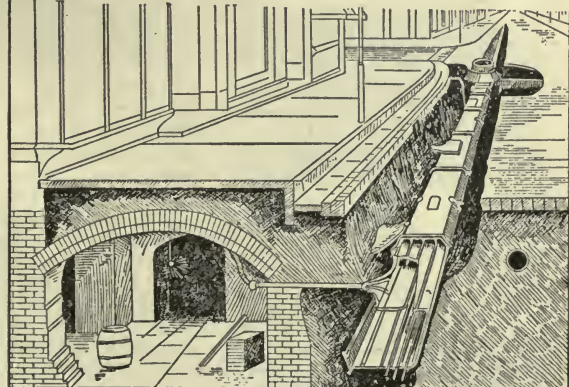

200. Exterior, Wire Conduit in Forts.

clay conduit set in concrete. Both of these ducts connect manholes about 250 feet apart and will last indefinitely.

(2) Wrought-iron pipe duct (figs. 201-3), in 20-foot lengths, of 3 to 4 inches diameter, $\frac{1}{4}$ inch thick, dipped in tar to prevent rust, are jointed by a screw coupling, so as to be water and gas tight.

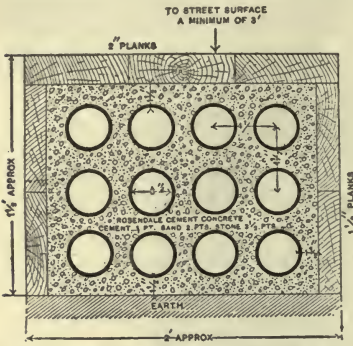

201. Cross-section of Iron-Pipe Conduit.

exactly fits the bore, preserves the alignment in laying the duct and prevents mortar getting inside. The bottom of each 18-inch length duct is slightly curved upward, so that the joints may not interfere with the drawing in of the cable.

(4) The manhole (fig. 203), about $3\frac{1}{2}$ by $3\frac{1}{2}$ by 7 feet deep inside, for allowing cable lengths to be drawn into the iron or earthen duct and for connecting supply branches, is built of brick and made water-tight. The masonry extends below the duct level to form a catch basin, and is provided at top with a cast-iron ring frame supporting two covers, the lower being screwed down upon a rubber gasket, and the other resting loosely on top. Both covers permit ventilation.

(5) For means to draw in the cable, push through a duct a steel wire, or 4-foot wooden rods, jointed, from one manhole to the next. This serves to pull through a small rope, then a large rope, then a cleaning steel scraper and brush, and finally the cable.

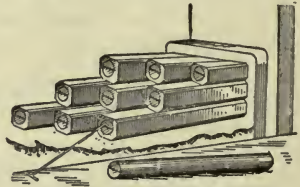

202. Clay Conduit in Cement Mandrel.

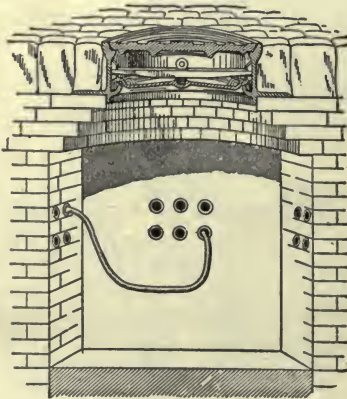

203. Manhole.

(2) Never attached to trees, buildings or outside concrete walls.

(3) Wires.—Hard drawn copper, No. 14 and larger, of 60,000 pounds tensile strength, 96 per cent conductivity of pure copper and tinned, is coated with $\frac{3}{4}$ -inch thickness of vulcanized rubber and covered with one or more cotton or hemp braids saturated with moisture and fire repellent; bare aluminum, 58 per

(6) Avoid twist and strain on the cable by the use of a swivel clevis attached to several iron wires wrapped spirally over the first 2 feet.

(7) Specimen underground cable (fig. 206) to be (a) No. 14 single or larger conductor in strand of wires, uniformly sized, tinned and twisted; (b) covered with one or more layers of pure Para rubber, tape spirally wound, half lapping; (c) then coated two or more times with rubber compound, each coat of two tapes laid on longitudinally and pressed into half-cylinder forms which unite in good longitudinal joints; (d) tightly bound with prepared rubber tape spirally wound. Then the rubber is vulcanized, the insulation is tested, and the outside tape and braid or lead is laid on.

8. Overhead lines.—(1) Erected in forts only where fully protected from fire or for temporary uses.

cent conductivity; bare galvanized iron in uninhabited country for signal purposes only.

(4) In contact only with double petticoat porcelain or glass insulators and run at least 1 foot apart and in such manner that water can not cross-connect.

(5) Protected when necessary from accidental contacts with other lines by insulated, dead guard, iron wires.

(6) Led into buildings through noncombustible insulating tubes slanting upward toward the inside. Drip loops outside, safety cut-outs inside.

(7) Strain on wire for tying not to exceed one-third its tensile strength.

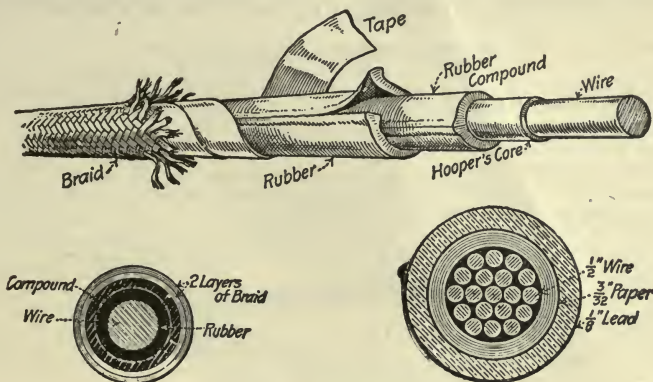

204, 205, 206.

(8) Sag = 1 to 2 per cent of distance between poles, depending on extremes of heat and cold.

(9) Signal wires unavoidably paralleling heavy current lines are stretched along lowest cross-arms. See Line Construction, page 155.

(10) A lightning-arrester in plain view is placed alongside of every overhead line near the point where it has entered the building, and is connected with a good ground (not gas pipe) by No. 6 copper wire direct as possible to ground. A choke coil is between arrester and dynamo.

(11) Poles.—(a) Wrought-iron tubing; or wood of cedar, chestnut, pine, or spruce, round or octagonal, tapering to 6 inches at top and painted. Galvanizing the iron or creosoting the wood may preserve the poles thirty-five years.

They are 30 to 60 feet long, have one-fifth to one-tenth of their length in the ground, according to soil, pole length, and number of wires, and stand vertically in as straight a line as possible, 125 feet apart. Lengths may vary with



207.

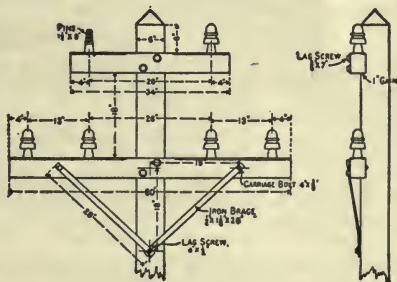

208.

the contour to keep the line more nearly straight. At unavoidable curves heavier poles are inclined outward, guyed or double-guyed laterally on the outside by strands of No. 6 or 8 galvanized iron from beneath the single cross-arm, or the middle of the lower half of several cross-arms to a guy stub or anchor, or they are braced on the inside by a half pole, solidly planted and bolted at 30° angle with the pole.

In raising, two spikes may replace the ladder; the "dead man" holds whatever is gained in raising.

(b) Cross-arms of iron are clamped; of clear yellow pine or oak wood are bolted (fig. 208) into gains cut in the poles, braced with iron and spaced as shown. The pins are of locust.

(c) Guys of iron strand are put laterally on every tenth pole of a straight line, on all poles from which service wires lead to either side, and longitudinally on the two poles of an unusually long span and the two or three end poles of every line.

(12) Insulators of porcelain or blown glass, subject to not less than a 6,000-volt, 5-ampere, break-down test, have the two or three petticoat form, and are screwed to iron or oak pins which are bolted or screwed to the cross-arm.



209.

(J) ITEMS NOT PREVIOUSLY SPECIFIED.

(Brackets refer to manufacturer.)

- Annunciator, index or gravity drop.
- Anti-hum, Clarke.
- Arc lamp, inclosed [G. E.].
- Babbitt metal, "Best."
- Bases, porcelain of all kinds [G. E.].
- Bell, single stroke, "Vigilant" or "Covered."
- Bell, vibrating, dust and water tight [W. E.].
- Binding post, English [W. E.] or Nos. 1, 2, and connectors [Mn.].
- Boards (panel), marine type [W. E.].
- Boxes (junction, outlet, switch), iron-armored or marine [W. E.].
- Buzzer, Eco or Lungen.
- Call box, Firman with Ans. back [B.].
- Clamp, Klein or "parallel."
- Conduit, iron-armored insulating [W. E.].
- Connectors, McIntire.
- Cut-outs, bases, receptacles [G. E.].
- Drill, hand, hollow handle [W. E.].
- Gong, clock to 60 strokes, marine [W. E.].
- Gauge, calculating U. S. Wireman's [Mn.].
- Gauge, caliper, Micr. 0.001 to 0.5 inch [Mn.].
- Instruments, portable, Weston.
- Insulators, glass, 2 or 3 petticoat.
- Insulators, porcelain, F. H. screw or G. E. knob.
- Junction box, iron-armored or marine.
- Lamps, incandescent, Navy [G. E.].
- Pliers, Stubs or "Universal" [Mn.].
- Push button, plain, bronze, water-tight.
- Receptacle, water-tight [G. E.].
- Rheostat, Carpenter.
- Socket, lamp, marine [G. E.].
- Soldering torch, gasoline, Imperial or Wellington.
- Soldering furnace, "Combination" or "Universal."
- Speed indicator, Starrett.
- Switch (in closet or on switch board), knife [G. E., W. E., or Mn.].
- Switch (in conduit) snap, D. P., marine.
- Switchboard (dynamo or battery) [G. E., W. E. or E. S. B.].
- Switchboard, telegraph or telephone [W. E.].
- Telegraph instruments [Bunnell]:
 - Key, steel lever, solid trunnion, with or without legs.
 - Key, cable, on rubber base.
 - Relay, Western Union.
 - Relay, box and key combined.
 - Relay, pocket, nickle-plated [W. E.].
 - Relay, polarized, armature lever vertical.
 - Register, ink, self starting and stopping, one or more pens.
 - Set, polar duplex, W. U.
 - Set, quadruplex, W. U.
 - Testing set, magneto to ring through 50,000 ohms.
 - Tool handle, "Cocobolo."
 - Tool handle, eleven tools [W. E.].
 - Voltmeter, recording, Bristol's.
 - Wheatstone bridge [W. E. or Biddle].

(K) RULES GOVERNING LINE CONSTRUCTION.

9. (1) Small conductor resistance, large insulation resistance, order, permanency and accessibility characterize good wiring. To wire neatly and effectively is an art.

(2) Wires which are separately insulated run at least 1 inch apart, parallel if in the same direction, straight between the fewest possible insulators, in contact with insulators only, and in such a way that no two wires can ever touch each other.

(3) Avoid temporary work; in construction regard all other wires as "live" and bare.

(4) If a kink or a nick occurs in the conductor, cut it out. If the insulation gets damaged, paint and tape the conductor as in jointing.

(5) In cutting a wire, grip it with the cutting jaws of the pliers so moved as to cut an arc of a circle. Twisting breaks the knife edge. Then grip the wire with the flat jaws close to the cut and one or two sharp twists will give a square break.

(6) Avoid "come alongs" or vises when they tear the insulation, but take a series of half hitches or noose wrap with a small rope.

(7) Jointing electrical conductors is of hourly occurrence and requires the care and skill acquired only by practice.

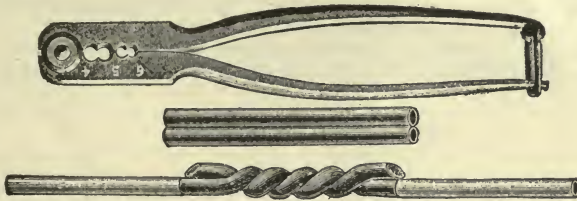

210, 211.

(a) Joints in copper or aluminum lines are often made with the McIntire (fig. 210) connector. The two ends brightened are slipped from the opposite directions into the close-fitting double sleeve which is then twisted by special pliers. Solder the ends only to avoid annealing the main line and smooth down projecting parts which might pierce the insulation.

(b) The lineman's splice (fig. 212) for galvanized iron, sometimes for soft copper, is made by holding the two cleaned ends at an angle in a hand vise, and twisting with pliers by half turns each end in succession five times closely around the line and soldering.

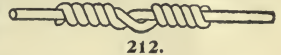

212.

(c) All joints of insulated wire, after being cleaned and thoroughly dried, are, as a rule, alternately painted with a thin, uniform coat of rubber or other solution, and wound with tape half lapping. Each winding is a little longer than the one before it and runs oppositely. In stripping insulation to make a joint, cut as in whittling toward the ends into a lead-pencil shape. For special wires follow the manufacturer's directions in jointing.

(d) The ends of a strand are separately joined by a twist or a connector, as above, in places not opposite, to avoid too large a bunch when finished. Then paint and tape alternately.

(e) The ends of a large solid core are beveled and notched for at least 1 inch, then soldered together into a round piece of the same diameter as the conductor, then wrapped closely with fine copper which is also solidly soldered, and the whole is finally taped. The finished insulated joint is considerably larger in diameter than the cable.

(f) *Insulating joints*.—Carefully cut the ends of the insulation, and clean with a little benzole. Rub a little rubber solution over, and then carefully wind spirally over the joint and tapered end of the insulation, pure rubber tape. Cover this with rubber solution and wind on more until the diameter of joint is about the same as the rest of insulation. Over this and for about two inches on each side of the cut ends of the insulation, wind especially prepared braiding. Finally varnish the whole.

(g) *Vulcanizing rubber joints*.—Cover joint with pure rubber strip. Rub in some special rubber solution, allow to dry, bind with vulcanizing rubber tape three or four layers. Then with prepared rubber tape cover the whole with a

piece of strong silicia cut to length of joint and then rolled round it, having a longitudinal seam. Bind this with strong cotton selvedge tape. Joint is now ready for the cure, which consists in subjecting it for half an hour or more to the action of molten sulphur, the joint being placed in a specially made box for the purpose. Molten sulphur is run out, and joint cooled, the outer wrapping of silicia and cotton removed and, if the vulcanizing is satisfactory, the joint is finished by braiding and varnishing.

(h) Most large cables and special makes have specially designed mechanical joint boxes.

(i) Make as few joints as possible. Solder all joints or other surfaces permanently in contact.

(j) Solder is to prevent rust between the wires of a joint; acid for cleaning, or a flux will later cause rust. Therefore use resin.

Use the soldering iron for small wires and dip the large wires in molten solder or pour on with a ladle. In all cases avoid burning the insulation.



213.



214.

(k) Work with clean hands in insulating a joint. If the tape gets burned or dampened or dirtied, cut the piece out and begin again.

(8) A standard tie is made by a short length of tie wire, bare or insulated like the main, but one or two numbers smaller. Fig. 213 is for galvanized iron; fig. 214 is for H. D. copper main, which should not be bent.

(9) A lightning rod of No. 6 bare galvanized wire extends from 1 foot above the top of every tenth pole to a few hand turns of the wire buried at its foot.



INDEX.

	Page.		Page.
BATTERIES, PRIMARY	114	DYNAMOS, D. C.—Continued.	
Amalgamating zincs	114	Brush setting	50-3
Bichromate	117	Care of	53-5
Care of	114	Coils, armature	44
Cells, how joined	115	Commutator	42-5, 50-3
Copper oxide	116	Compounding	49
Current weakens	114	Core, armature	44
Directions, general	114-5	Diseases	52
Dismounting	116-7	Drum	43-4
Dry	115	Failure to generate	53
Eagle	116	Field, magnetic	42
Gravity	115	Field, windings	45
Fuller	117	Foundations	47
Kinds of	115	Fuse firing	46
Le Clanché	115	G. E., D. C. sets	47
Local action	114-7	Generates alternating C.	42
Maintenance	115-6-7	Governor	48
Management	114	Heating	52-5
Mounting	115-6-7	Induction, laws of	42
Polarization	114	In parallel	51-4
Principles	114	Inspection	53
Qualities of good	115	Management of	53
Room	114	Lap winding	43-4-5
BOILERS, STEAM	7	Lead	55
Banking fires	8	Noise	52
Blow-off	10	Oil rings	45
Care of	8	Packing	49
Cleaning	13	Piping	47
Cleaning fires	8-9	Pressure	47
Corrosion	13	Ring winding	43-4
Explosions	14	Running	47, 54
Feed water	13	Self-exciting	43
Firing	7	Special service	46
Fittings	9	Speed	47-8, 53
Foaming	8	Spools	49
Gauge glass	10-17	Starting	51-4
Incrustation	13	Steam pipes	47
Injector	12	Stopping	55
Inspection	13	Telephone call	46
Low water	8	Tested	47, 51-2
Lying idle	9	Troubles	52
Management of	8	Valves, relief	48
Material	9	Wave winding	43-4
Piping	9, 47	Westinghouse (fig. 74)	72
Plug, fusible	10	Windings	45
Pressure gauge	10-13	ENGINE, OIL, H.-A.	29
Priming	8	Air inlet	34-8
Pump	10	Alterations, fundamental	39
Safety valve	9	Crank positions	35
Steam gauge	8	Critical positions	29
Tools	7	Cycles	29
DYNAMOS, D. C.	49	Cylinder	29, 38
Armature	43-4-6, 51-2	Exhaust	34-8
Bars	45	Failure of	36
Bearings	45, 52	Fly wheel	36
Brush holder	49, 50	Governor	27, 37

	Page.		Page.
ENGINE, OIL, H.-A.—Continued.		ENGINE, STEAM—Continued.	
Governor bracket	36	Testing	23, 47
Ignition retarded	38, 41	Travel, piston's	18
Indicator cards	29, 41	Valve's positions	18, 20
Instructions for	35	Valves, relief	48
Lamp, heating	35	Valve slide	25
Oiling	36-9	HOIST AMMUNITION	88
Oil tank	38	Automatic safety stop	88
Nomenclature	31	Connections	89
Piston	35-8	INSTRUCTIONS, SPECIAL	5
Piston's strokes	29	Directions, printed	5
Port	35	Text books	6
Principles of	29, 31	MEASUREMENTS AND TESTS	141
Pump	34-6	Apparatus required	141-2-4
Regulation	34-7-8	Armature resistance	142
Running	37	Battery resistance	144
Skew wheel	39	Cable's insulation	144
Spray hole	38	Care of instruments	141
Starting	35-6	Conduction resistance	141-2
Starting gear	36	Connections	143
Stopping	39	Continuity of circuit	141
Strokes	29	Current strength	141
Testing	40	Crosses	144
Valve box	34-7-8	Difference of potential	141
Valve, horizontal	34-8	Dynamos	144
Valve, vertical	34	Electromotive force	141
Vaporizer	29, 35-6-8	Galvanometer resistance	144
Water supply	38	Grounds	143-4
Works well	39	Insulation resistance	142-3-4
ENGINE, STEAM	16	Joints	142-3
Adjustments	17-23	Magneto	144
Angle of advance	18, 20-22	Open circuit	143
Bearings	25	Resistance, battery	144
Care of	17	Resistance, conduction	141-2
Clearance	25	Resistance, insulation	142-3-4
Connecting rod	25	Resistance, small	142-3
Crank	17	Resistance, ordinary	141-2-3
Cross-head	25	Storage battery, resistance	144
Cut-off	19, 22	Telephone, use of	144
Dead center	23	Wheatstone bridge	141-2
Eccentric arm	20-2	LAWS, EXAMPLES, TABLES	135
Exhaust	17	Bridge wire, table	137
Full port	18	Capacity	135
Governor	22-7-8, 48	Cells, combined	136
Heating	17-8	Copper wires, table	137
Inspection	23	Current, strength	135
Knocking	17	Difference of potential	135
Laps	18	Direction of current	135
Lead	18	Divided circuit	136
Level	23	Electromotive force	135-6
Lining up	23	Equivalents	135
Lubricator	18	Examples	138-140
Management of	17	Feeder, sizes	139
Oil	17	Formula, general	138
Operation	16	Fuses, sizes	138
Packing	17, 25, 49	Gauge, wire	137
Piston, fit of	23	Heat	135-6
Piston strokes	17, 21	Kilowatt	135
Piston valve	27	Metal deposited	137
Pressure	47	Ohm's law	135-8
Positions, critical	20	Power	135-7
Running	16, 51	Quantity	135
Slide valve	25	Resistance	135-6
Speed	47-8	Safety fuses	137
Starting	16, 51	Sizes of wires	138-9, 140
Stopping	16	Table, wiring	137
Strokes, piston	17, 21	Taps	138-9

	Page.		Page.
LAWS, EXAMPLES, TABLES—Continued.		MOTORS, ELECTRIC, D. C.—Continued.	
Underwriters' table	137	Westinghouse (fig. 118)	87
Units	135	Winding	79
Wires, copper	137	NIGHT-SIGNAL SETS	103
Wire, size of	137-8-9	Assembling	106
MISCELLANEOUS	109	Boughton set	106
Anemometer	112	Cable	103-5-6
Battery, firing	110	Connections	103-5-6
Bells, electric	111	Controller, trucklight	107
Care of anemometer	113	Keyboard (fig. 137)	103-6
Connections	110	Ladder	104
Detonator	111	Lanterns	104
Dynamo, firing	110	Mechanism	103
Failure to fire	110	Operation	104-8
Firing battery	110	Packings	105
Firing key	109	Plug	104-5
Fuses	109, 110	Receptacle	104-5
Mechanism	111-2-3	Switch, controlling	107
Mine charge	110	Truck light	106
Mine fuse	110	U. S. form	106
Placing the fuse	110	Wiring	103-5-6
Precautions in firing	111	SEARCH-LIGHT PROJECTORS	90
Pressure, wind	113	Arc	98
Self-register	112	Automatic feed	95
Stop-clock	112	Base sheeting	97
Velocities of wind	113	Beam	91-2
Wiring	111	Cable	98, 101
MOTORS, ELECTRIC, D. C.	78	Carbons	90, 91-4-6
Adjusting rheostat	81-3	Carbon holders	93
Back E. M. F.	78	Carboning lamp	93-5
Blow-out (figs. 107-8, 110)	82-3	Care of lamp	94-5-6, 101
Booster	87	Connections	97-8-9, 100
Care of	84	Controlled	91
Compound	80	Controller (fig. 123)	97-8
Connections	80-3-5	Couplings	102
Controller	88	Covers	102
Cores	79	Crater	95
Direction of rotation	78	Current	91
Dynamotor	86	Dead resistance	99
Electric hoist	88	Diagrams	130-1-2
Efficiency of	78	Drum	91
Heating	85	Feeding	91-6
Hoist, electric	88	Field (figs. 135-6)	102
Installing	83	Flaming	96
Leonard	85	Front door	92
Management of	84	Focusing lamp	94
Motor generator	86-7	General Electric Co.'s	90
Multipolar (fig. 118)	78-9	Hand control (fig. 133)	90
Overload, C. B.	83	Hissing	96
Principles	78	Illumination	102
Protection to	80	Image of arc	94
Regulation	80	Installing	92-7-9
Reversing	85	Lamp mechanism (figs. 124-7-8)	93
Rheostat, S. and S. (figs. 109, 110)	80-1	Largest size	102
Rheostats, installing	83	Location	102
Running	84	Mechanism (fig. 124)	95-7-8-9
Shunt	79, 82-3	Methods of observing	102
Series	79, 81-5	Mirror	101
Special forms	85	Motors	97-8
Special uses	79	Mushroom	96
Starting	84-5	Names of parts	92-3-7
Starting box	80	Navy	90
Stopping	85	Observers	102
Switch	83	Operating	101
Teazer system	86	Operating lamp	93-4-5-6
Underload, C. B.	83	Operators	102
Watt-hour meter	85	Parabolic mirror	90-2

SEARCH-LIGHT PROJECTORS—Continued.	Page.	SPECIFICATIONS—Continued.	Page.
Pilot-house	91	Rheostat, motor	148
Placing lamp	93	Safety valve	146, 9
Probability of injury	102	Search lights	148, 90
Rheostat	90	Shaft	146
Schukert (fig. 120)	90	Sockets, lamp	149
Screen shutters	91	Solder	156
Signaling with	102	Steam gauge	146, 8
Small motion	101	Storage battery	147, 65
Speed of control	92	Switchboard	147, 56
Sizes	90	Switches	150-1, 57, 61
Starting magnet	94	Ties	156
Striking the arc	96	Underground lines	151-2
Switch controller	98	Vulcanizing rubber	155
Training mechanism	98	Wires	150-1-2
Transportable	102	Wiring	149, 151-2-3
Truck	92	STORAGE BATTERY	65
U. S. form (fig. 123)	92	Back, E. M. F.	68
Voltage	95-6, 101	Battery room	65
Wiring	94-6-8-9, 100	Buckling	76
SPECIFICATIONS	145	Booster connection	75
Armatures	147, 43-4-6, 51	Care of	67
Battery room	145, 65	Charge of	67
Blow-off	146, 16	Charging, initial	67, 76
Boilers	145, 7	Connecting up	66, 74-5-7
Cabinets	150	Current	67
Cables	152	Density of solution	67-9
Circuit breakers	149, 150	Discharge	69
Closet system	149	Drop in voltage	69
Conduit	151-2	Electrolyte	66-8-9, 71-2
Construction of lines	154	End cells	62-4-8
Cross-arms	153	Endurance	76
Crosshead	145, 25	First charge	66
Cut-outs	149, 57-8	Gassing	68, 71
Deadman	153	Good condition	66
Duct	152	Inspections	70-1
Dynamo	146-7, 47	Instructions	67
Dynamo room	145, 48	Instruments	69, 74-5
Engine	146-7, 16	Jars	65
Feeders	149	Maintenance	70
Filament lamp	148	Management of	67, 70
Fuses	149, 109	Maximum rate	67
General rule in specifications	145	Mixing solution	70
Generators	146-7, 47	Object of	65, 76
Governor engine	147, 2-7-8	Out of commission	72
Guides	146, 23-4	Polarity	77
Guys	154	Portable	76
Injector, steam	146, 12	Records	71-2-3
Insulating joints	155	Restoration	68
Insulators	154	Room	65
Items, miscellaneous	154	Sediment	70-1
Joints	155	Separators	66
Lamps	148	Setting up	65
Lightning-arrester	153	Shipment	66
Lightning rods	156	Specific gravity	67-8-9
Lubricator	147, 18	Stand	65
Mandrel	152	Sulphating	76
Miscellaneous items	154	Switchboards	74-5
Motors	148, 78	Temperature effects	67
Outlets	151	Unpacking	65
Overhead lines	152	Voltage	67-8-9
Piping	146, 152, 9	SWITCHBOARDS	56
Piston rod	146	Ammeter	56, 60
Poles	153	Apparatus	56, 60
Power house	145	Arrangement	56
Projectors	148, 90	Back connections	61
Pump	146	Best for forts	56

	Page.		Page.
SWITCHBOARDS—Continued.		TELEGRAPHY—Continued.	
Care of.....	64	Receiving.....	120-1-2
Circuit breakers.....	57-8	Relay.....	118, 120
Conditions fulfilled.....	56	Searchlight.....	121-2
Connections.....	56	Sending.....	120-2
Design.....	56	Setting up heliograph.....	122
End cells.....	62-4-8	Signal flags.....	121
Engineer.....	57-8-9	Sounder.....	118
Fuses.....	61	Space, signal.....	118
Golden Gate board.....	63	Sticking.....	120
Key West board.....	62	Telautograph.....	123
Location.....	56	Torch.....	121
Management of.....	64	Transmitter (fig. 167).....	123-5
Overload, C. B.....	57-8	Wigwag.....	121
Operation of.....	64	TELEPHONY.....	128
Panel.....	56	Adjustments.....	131
Preble board.....	62	Apparatus.....	128
Switches.....	57, 61	Battery.....	131
Underload, C. B.....	57-8	Bell, polarized.....	128, 130-1
Voltmeter.....	56-7	Bridge.....	128
TELEGRAPHY.....	118	Care of.....	130-1
Abbreviations.....	119, 121	Central station.....	133
Adjustments.....	119, 120	Common battery.....	132
Beginners.....	120-1	Connections.....	128-8
Breaks.....	122	Cross-talk.....	131
Care of.....	120-4-6-7	Details.....	128
Code.....	118-9, 121	Drops.....	133-4
Code, artillery.....	122	Dynamo.....	46
Code, calls.....	121	Faults.....	130-1
Code, signal.....	121	Handling.....	130
Dash.....	118	Holtzer Cabot.....	132
Diagrams.....	118, 120-1	Induction.....	131
Directions.....	120	Intercommunicating.....	131
Dot.....	118	Jacks.....	134
Escapes.....	123	Keys.....	133
Faults, line.....	123	Magneto.....	46, 128, 131
Fog, signals.....	122	Management.....	130
Heliograph.....	122	Number on circuit.....	130
Installing.....	126	Noises, induction.....	131
Instructions.....	120-1	Parallel connections.....	131
Key.....	118, 120	Receivers.....	128, 131
Lantern.....	121	Secondary coil.....	128
Lineman.....	123	Series connections.....	128
Management.....	124-6	Transmitter.....	128, 131
Message forms.....	119	Troubles.....	130
Morse.....	118	Using.....	130
Operation.....	124	Without central.....	132
Principles telautograph.....	123		



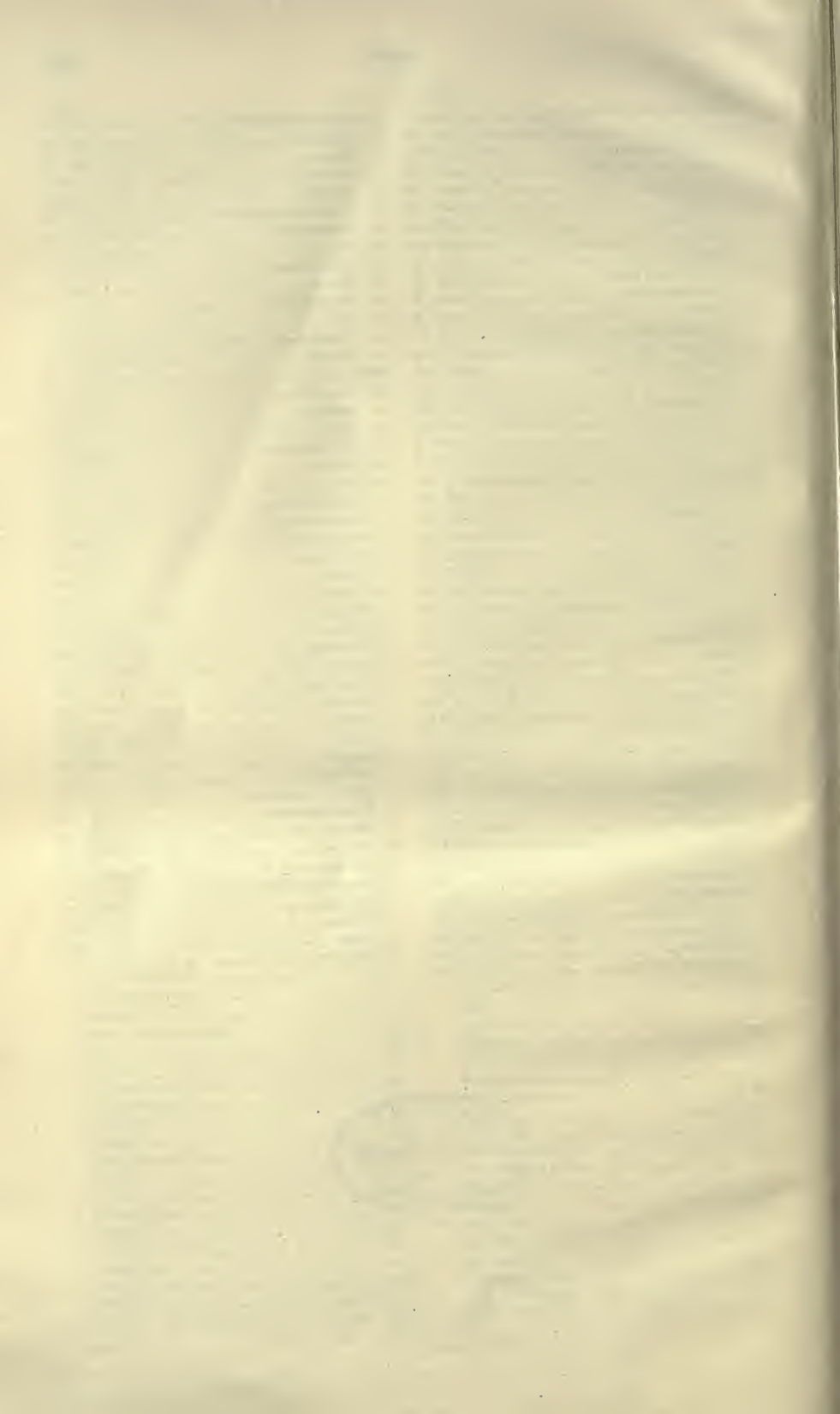

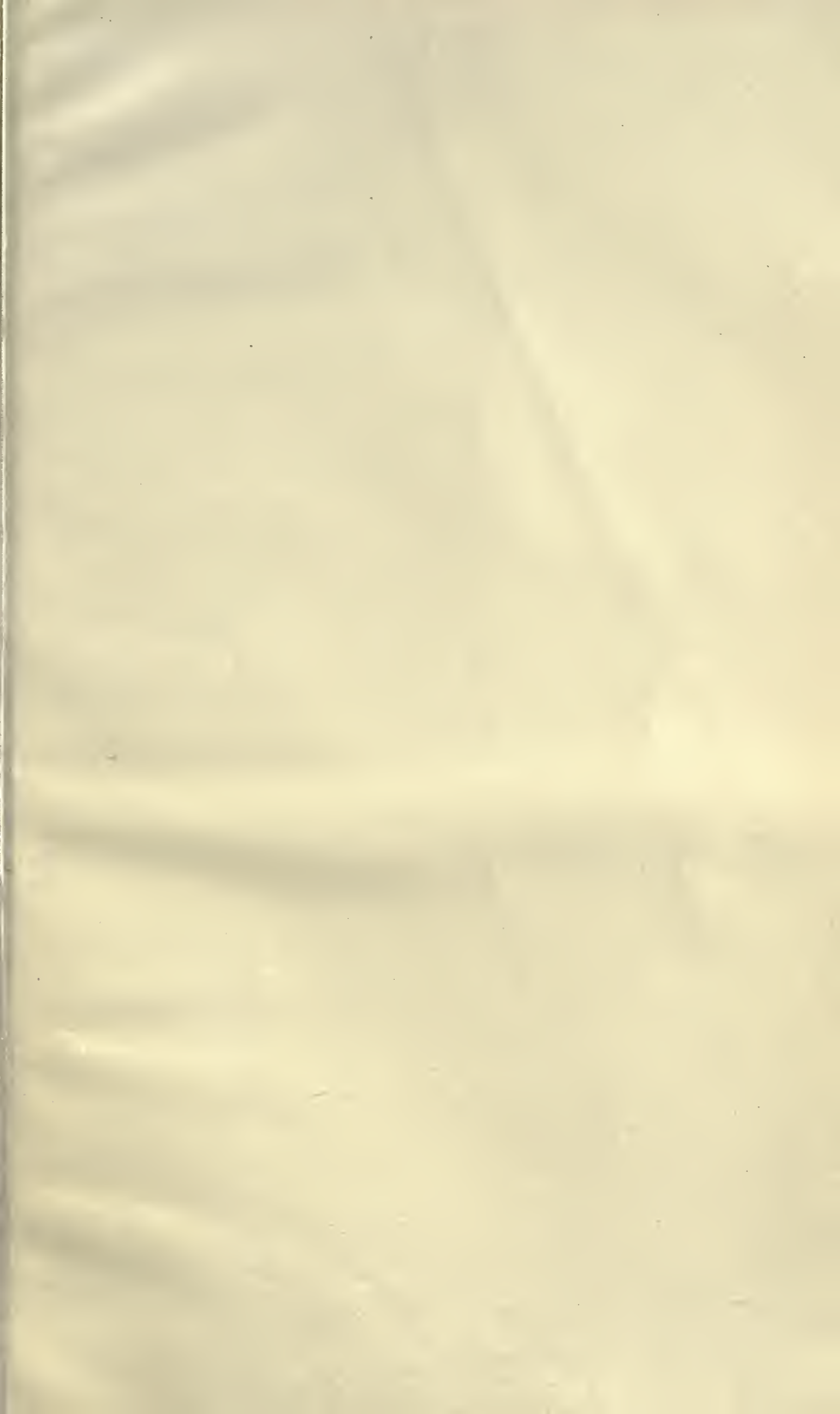

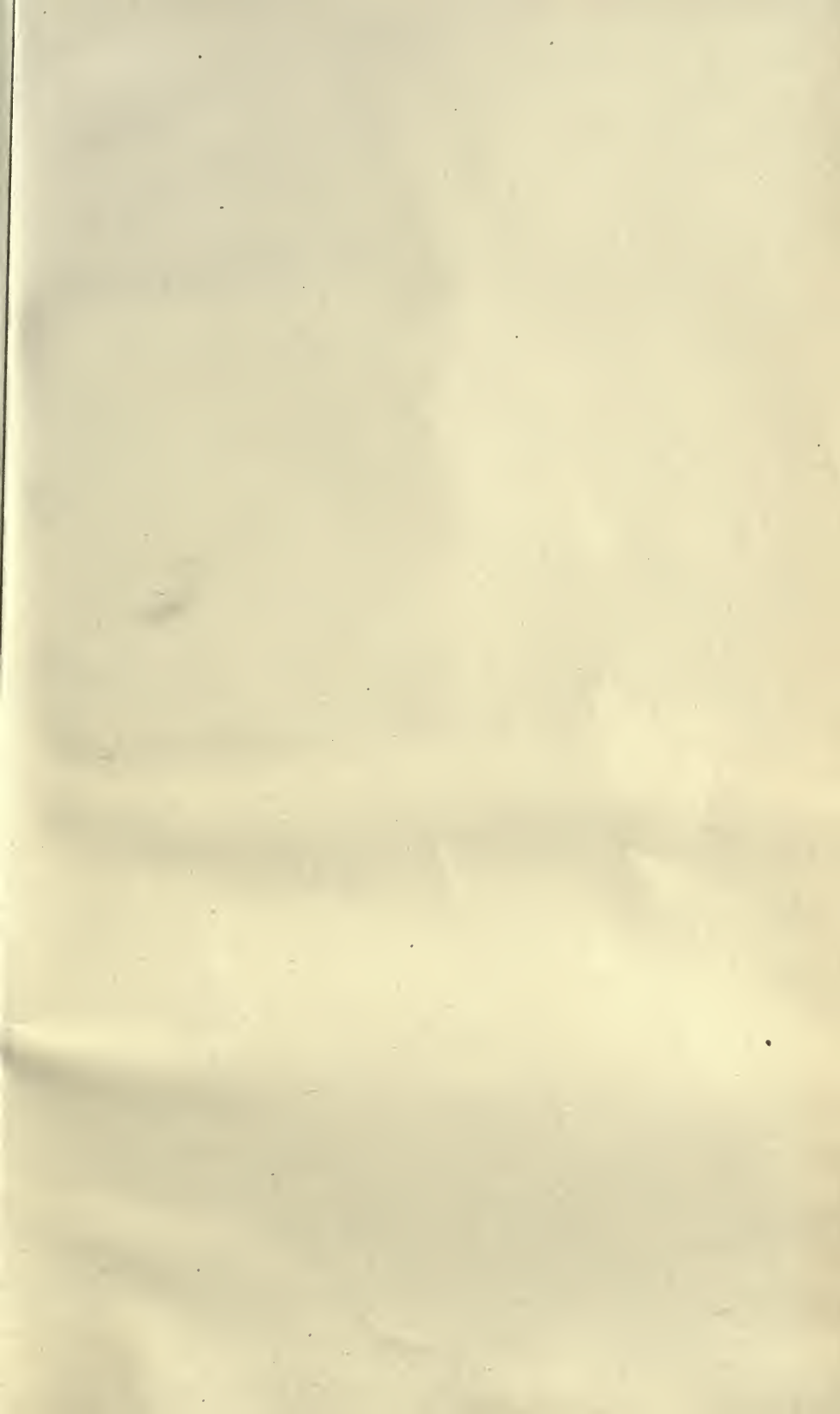

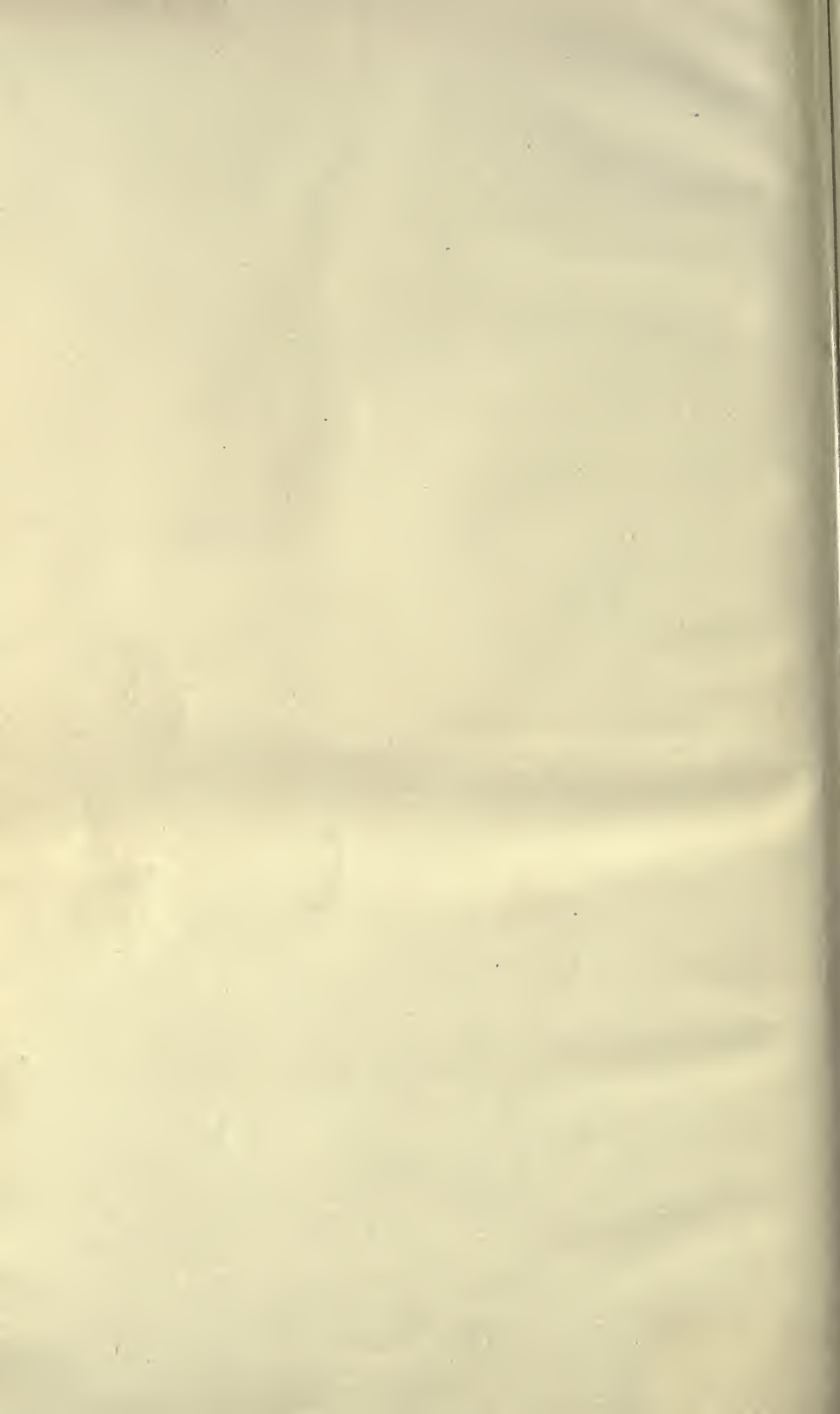

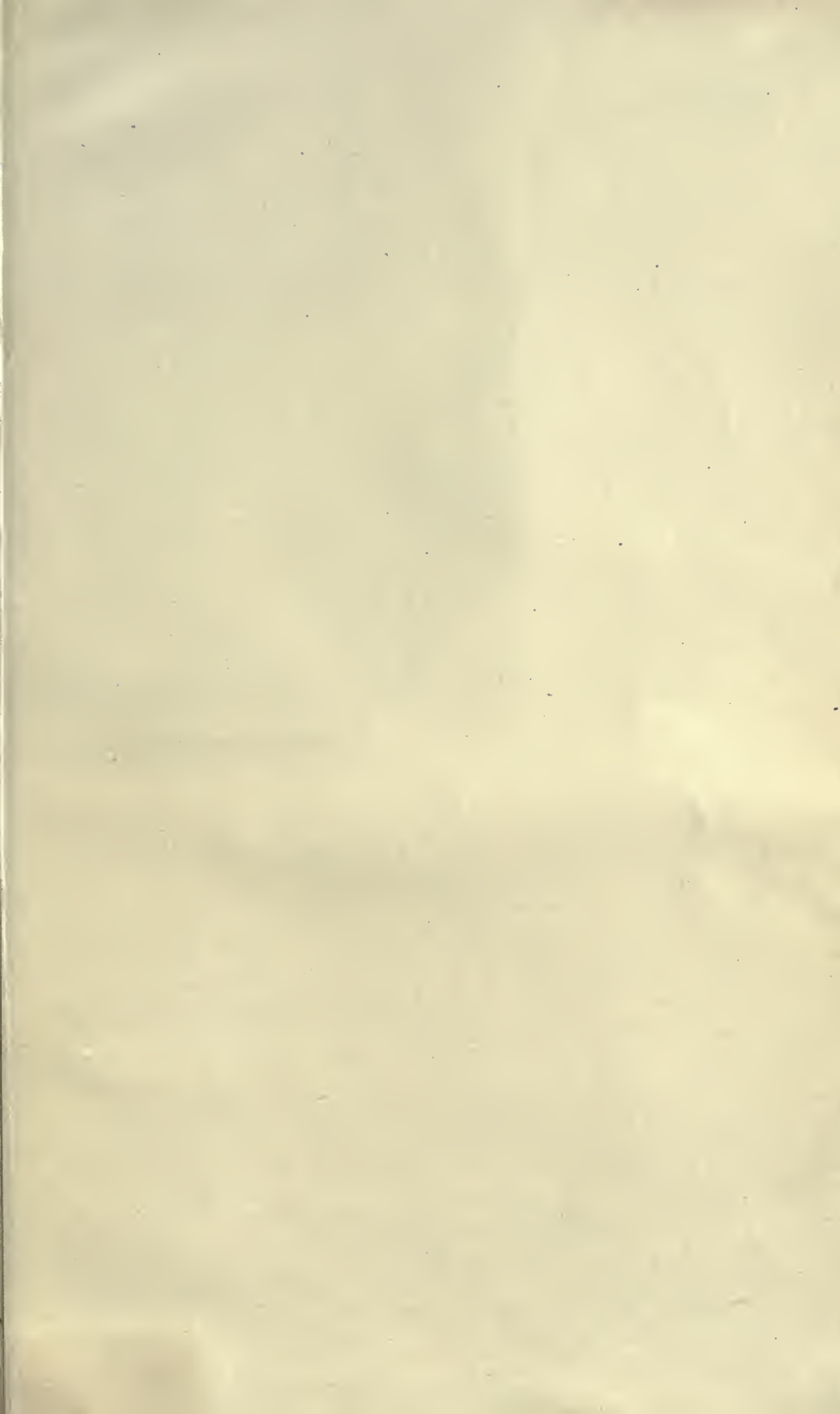

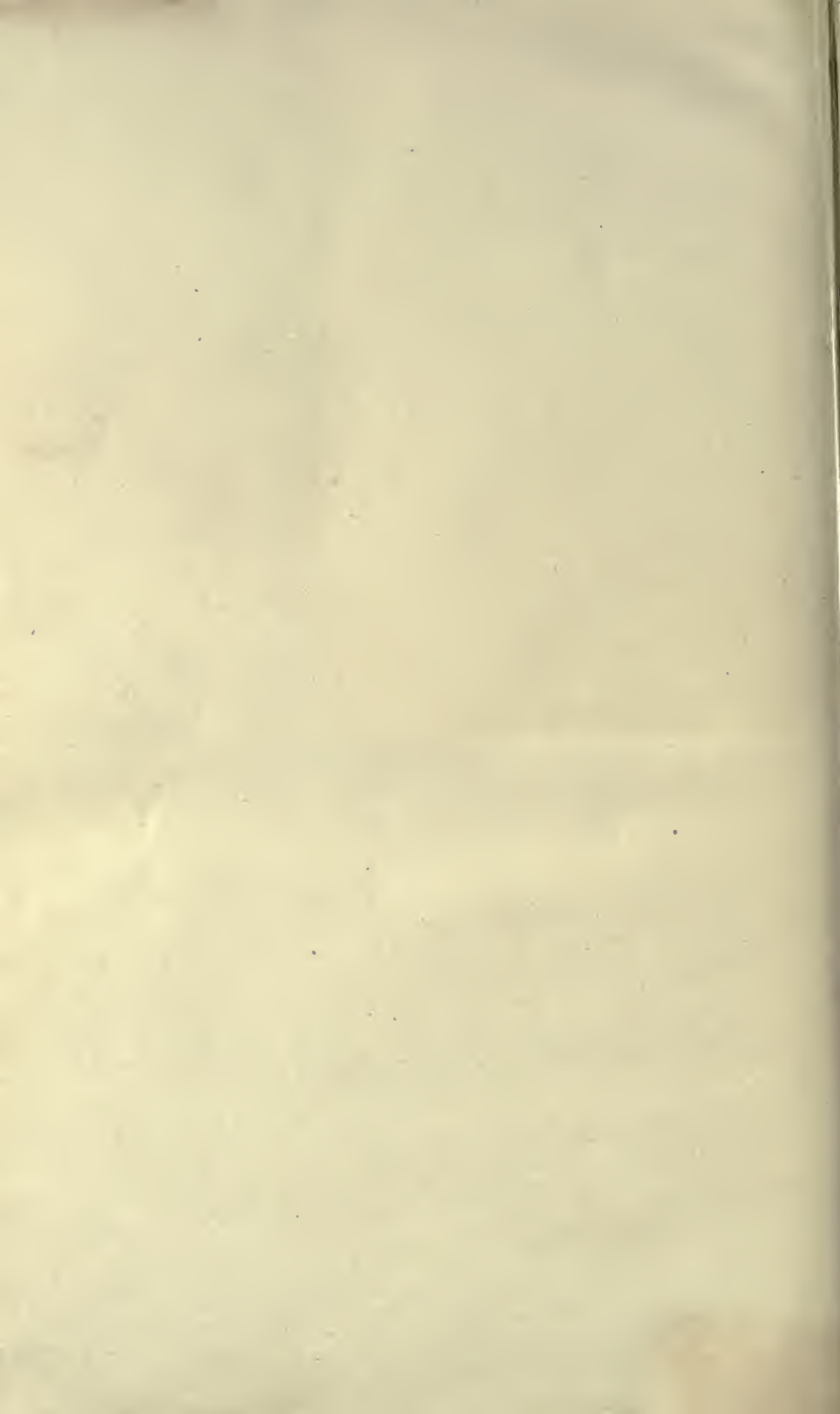

Handbook for the use of
electricians.

10 53895

UG430
U6

96698

UNIVER

LIBRARY

