

UNIVERSITY OF TORONTO



3 1761 01536823 6

DEPARTMENT OF SCIENTIFIC  
AND INDUSTRIAL RESEARCH

Fuel Research Board

# A Handbook on The Winning and the Utilization of Peat

By A. Hausding

*Translated from the Third German Edition  
by HUGH RYAN, D.Sc., Professor of  
Chemistry in University College, Dublin*



LONDON  
PRINTED AND PUBLISHED BY  
HIS MAJESTY'S STATIONERY OFFICE

1921

Digitized by the Internet Archive  
in 2007 with funding from  
Microsoft Corporation





~~For Use~~  
~~Q.R.~~  
~~Fue~~

(DEPARTMENT OF SCIENTIFIC  
AND INDUSTRIAL RESEARCH)

Gr. Brit. Fuel Research Board  
..

# A Handbook on The Winning and the Utilization of Peat

By A. Hausding

*Translated from the Third German Edition  
by HUGH RYAN, D.Sc., Professor of  
Chemistry in University College, Dublin*

LIBRARY  
FACULTY OF FORESTRY  
UNIVERSITY OF TORONTO



LONDON

PRINTED AND PUBLISHED BY HIS MAJESTY'S STATIONERY OFFICE,  
and to be purchased at the addresses given overleaf

1921

To be purchased through any Bookseller or directly from H.M. STATIONERY OFFICE, at the following addresses: IMPERIAL HOUSE, KINGSWAY, LONDON, W.C.2, and 28, ABINGDON STREET, LONDON, S.W.1; 37, PETER STREET, MANCHESTER; 1, ST. ANDREW'S CRESCENT, CARDIFF; 23, FORTH ST., EDINBURGH; or from EASON & SON, LTD., 40 & 41, LOWER SACKVILLE STREET, DUBLIN.

*Price* **£1 10s. 0d.** *Net.*

TN  
837  
H313  
1921

# CONTENTS

Introduction .. .. .	PAGE xv.-xxiii.
----------------------	--------------------

## PART I.—THE WINNING OF PEAT

### I.—General Remarks on Peat

1.—Origin, occurrence, and varieties of peat.. .. .	1
2.—Composition of peat, percentage of ash, and constituents of the ash	7
3.—Weight and density .. .. .	14
4.—Properties of peat affecting its use .. .. .	14

### II.—Preparation for Peat Winning by Drainage of the Bogs

1.—Natural drainage ; arrangement of the drains .. .. .	17
2.—Erection and working of pumping machinery for artificial drainage ..	20
(a) Centrifugal pumps .. .. .	20
(b) Steam-chamber pumps or steam-pulses (pulsometers) .. .. .	21
(c) Water-elevating wheels .. .. .	21
3.—Disadvantages of over-draining .. .. .	22

### III.—Winning and Properties of Hand Peat

1.—The winning of cut, stroked, trodden, dough, and dredged peat ..	23
2.—The winning of cut peat in the South German and Austrian bogs ..	31
3.—The winning of lump and crumb peat .. .. .	35
4.—The winning of cut peat (cut peat machines) .. .. .	37
5.—Peat-cutting machines and peat winning under water .. .. .	38
6.—Contrivances to ensure drying.	
(a) " Poling " in South Germany (especially Bavaria) and Finland	42
(b) Drying on spiked poles in Carinthia .. .. .	43
(c) Drying trestles of Carinthia, Tyrol, and other places .. .. .	45
(d) The " peat horses " of Sweden and the drying sheds of Sebastians- berg (Erzgebirge) .. .. .	46
(e) The drying huts of Styria .. .. .	47
(f) Drying on drying ramparts .. .. .	50
7.—Size of the drying ground .. .. .	50
8.—Cost of the various drying contrivances .. .. .	51
9.—Costs and results in the hand peat industry (Oldenburg peat-cutting industry, Feilenbach Peat Works, peat factory of the Rosenheim and Reichenhall Salt Works, Birmoos, Rottenmann Peat Works, near Wörschach, peat works of the Aussee Salt Company).. .. .	51
10.—Percentage of water in various bogs and kinds of peat ; quantities of water to be evaporated in drying, and yield of moist or dry substance	57
11.—Shrinkage and " condensation " of hand peat on drying .. .. .	59
12.—Defects of hand peat .. .. .	64

### IV.—Winning of Artificial, Press, and Machine Peat for Pro- duction on a Large Scale and for getting rid of the Defects of Hand Peat

1.—Summary of the methods proposed and on their value in general ..	67
2.—Description of the various methods .. .. .	74
A.—Manufacture of washed-out peat (Challeton's process) .. .. .	74
B.—Versmann's sieve process .. .. .	77
C.—Manufacture of press peat (peat briquettes) .. .. .	78
1.—The Exter-Gwynne dry press process .. .. .	78
2.—Resumption of dry pressing by Peters, Stauber, the Buckhau and Zeitz Machine Factory, &c. .. .. .	79
3.—The various wet press processes (Koch and Mannhart, Schöning-Heine, Ekenberg, Brosen, Wet Press Company, the Society for the Utilization of Moors and Peat, &c.)	85
4.—Press processes with simultaneous electrical dehydration (electrosmosis, osmone, pentane, &c.) .. .. .	89
5.—Hard peat (Baron von Verschuer) .. .. .	89

	PAGE
2.—Description of the various methods— <i>cont.</i>	
D.—Eichhorn's "ball peat" .. .. .	91
E.—Manufacture of condensed machine peat.. .. .	94
I.—Manufacture of machine-formed peat, Weber's (Staltach) process.	
1.—Essence of the process. Weber's machine at Staltach, Gysser's improvement, and the peat-forming machine of Hebert, of Rheims .. .. .	94
2.—Various kinds of peat-forming machines.	
(a) Vertical peat machines (with slowly running knife shafts) .. .. .	99
(1) The Schlickeysen machine and those related to it of R. Dolberg and Co., Gewert, Stütze Bros., Cegielski and Co., &c. .. .. .	99
(2) Peat machines for horse driving with intermediate gearing shafts .. .. .	105
(b) Horizontal peat machines with slowly running knife shafts .. .. .	106
(1) The simple horizontal peat machine.. .. .	106
(2) Schlickeysen's horizontal machine with feeding rollers .. .. .	107
(3) The "tube peat" machine of Ros, of Norköping .. .. .	108
(4) Clayton's peat machine .. .. .	110
(5) General characteristics of peat machines with slowly running knife shafts.. .. .	112
(c) Peat-forming machines with rapidly rotating or double knife shafts .. .. .	114
(1) Fundamental types of horizontal machines (L. Seydl) .. .. .	115
(2) The modern multiple-shaft peat machines of Dolberg, Heinen, Strengge, Wielandt, Schenck, Sugg and Co., Anrep, Åkermann, Koppel, &c. .. .. .	117
(3) Peat machine of L. Lucht, of Kolberg.. .. .	124
(4) Schlickeysen's horizontal peat machine with gripping and tearing contrivance .. .. .	127
(5) Schlickeysen's automatic digging and forming peat machine .. .. .	133
(6) Heinen's peat machine, with preliminary tearing and mixing contrivance .. .. .	134
II.—Manufacture of machine pulp or machine dough peat in Hanover, Oldenburg, Denmark, and Sweden.	
1.—The Hanoverian pulp peat machine .. .. .	138
2.—The Oldenburg pulp peat machine .. .. .	140
3.—Machine for making pulp peat, of A. Ingermann, of Koldmoos.. .. .	141
4.—Hodge's peat boat in Oldenburg, peat dredgers, &c. .. .. .	144
5.—Mecke and Sander's peat-dredging machine .. .. .	145
6.—The Strengge peat-dredging machine .. .. .	147
7.—Danish (Sparkjaer) machine-pulped peat winning .. .. .	149
8.—The Anrep-Jakobsson-Svedala machine-pulped peat winning, or the winning of machine field peat by means of Jakobsson's spreading, stroking, and cutting machine .. .. .	151
9.—Galecki's method of winning pulped peat .. .. .	152
III.—Fully automatic or large scale industry peat machines with dredgers and automatic sod spreaders.	
1.—Wielandt's peat-dredging and forming machine .. .. .	155
2.—The Strengge large scale industry machine with sod spreader .. .. .	158
3.—The Baumann-Schenck peat-dredging machine with sod spreader .. .. .	161
4.—The large scale industry machine of R. Dolberg and Co. .. .. .	164
5.—Other large scale industry machines (Ekelund, Munktell, Anrep, Jakobsson, Persson, &c.).. .. .	167
F.—Machine peat powder and machine peat dust for fuel purposes .. .. .	167



## V.—Details of Winning and Properties of Condensed Machine Peat

	PAGE
A.—On some important particulars with regard to peat machines and their use.	
1.—On knives and screws .. .. .	170
2.—On forming pieces and mouthpieces .. .. .	180
3.—On chopping and cutting contrivances .. .. .	187
(a) Chopping board and chopper .. .. .	187
(b) Rolling table with running boards .. .. .	187
(c) Roller bed with grid cutter .. .. .	188
4.—Automatic sod spreaders (of Wielandt, Streng, Baumann-Schenck, Dolberg, Persson, Eslöf, &c.) .. .. .	190
B.—On installing and driving machines in a peat bog.	
1.—Installation of driving and working machines .. .. .	192
2.—Driving peat machines by means of draught animals .. .. .	196
3.—Driving peat machines by means of wire ropes .. .. .	198
4.—Selection of driving power .. .. .	199
C.—Transport of raw peat to the machine and of machine peat to the drying ground or sheds.	
1.—Barrows and barrow tracks .. .. .	203
2.—Cars on railways (field railways and transport wagon railways) ..	205
(a) Tracks, crossings, switches, turntables, and turning plates .. .. .	206
(b) Transport cars for the raw peat and the machine-formed peat .. .. .	211
(c) Prices of the component parts of a field railway .. .. .	213
3.—Belt elevators, conveyers, automatic spreaders, and distributors	214
4.—Comparison of the powers required to move loads over various roads and railway tracks .. .. .	214
D.—Drying machine peat.	
1.—Drying in the open air .. .. .	216
2.—Drying on boards and trestles .. .. .	221
3.—Drying under cover .. .. .	223
E.—Cost of plant, and working expenses of machine peat factories ..	224
F.—Comparison of costs in the cases of fully automatic or large scale industry machines and ordinary peat machines .. .. .	230
G.—Description of some large machine peat factories.	
1.—The peat works of the North German Peat Moor Company of Triangel in the Gifhorn district .. .. .	232
2.—Feilenbach Peat Factory .. .. .	235
3.—Schussenried Peat Factory .. .. .	237
4.—Elizabethfehn Peat Works, Oldenburg .. .. .	239
5.—The Wiesmoor Peat Works at Aurich .. .. .	240
H.—Comparison of the properties of machine peat and cut peat from the same raw material, and influence of the various modes of winning on these properties .. .. .	241
1.—Condensation of machine peat and condensing effect of different machines .. .. .	241
2.—Comparison of dry-volume ratios, shrinkage and condensing effects, as well as percentages of water in, and absorption of water for, machine and cut peats .. .. .	246
3.—Absorption of water by the two peats in the anhydrous state ..	247
4.—Progress of the drying in the cases of cut peat and machine peat from the same bog .. .. .	250
5.—Action of frost .. .. .	251
6.—Density, shrinkage, weight of given volume, drying ground ..	252
J.—On the selection of new peat machines and on peat machine competitions.	
1.—General observations on the selection of new peat machines ..	254
2.—Peat machine competitions .. .. .	257

## VI.—Winning of Peat Litter and Peat Mull

1.—Preparatory work, preliminary conditions, and raw material ..	260
2.—The winning of peat litter on a manufacturing scale .. .. .	267
3.—Winning peat litter for use by farmers .. .. .	281
4.—Valuation of peat litter .. .. .	282

VII.—Patents relating to the Winning of Peat		PAGE
1.—Dehydration of peat by means of machines .. .. .	.. .. .	288
2.—Electrical dehydration of peat .. .. .	.. .. .	293
3.—Disintegration and sifting of peat .. .. .	.. .. .	294
4.—Peat machines and their components .. .. .	.. .. .	295
5.—Peat pressing ; piston and stamp presses (briquette presses) .. ..	.. ..	303
6.—The drying of peat .. .. .	.. .. .	306
7.—The winning and the treatment of peat fibres .. .. .	.. .. .	307

## VIII.—Notes

From the sections on the winning of peat .. .. .	.. .. .	312
--	---------	-----

## PART II.—THE UTILIZATION OF PEAT

## I.—The Utilization of Peat as Fuel

A.—General remarks on fuel and combustion.		
1.—On fuel .. .. .	.. .. .	319
2.—Calorific power per unit weight and per unit volume, and temperature of combustion .. .. .	.. .. .	321
3.—Composition, density, and calorific power of various fuels .. .. .	.. .. .	322
B.—Peat as fuel.		
1.—Calorific power of different varieties of peat and influence of the mode of winning on it .. .. .	.. .. .	323
2.—Influence of the percentages of moisture and ash on the calorific power of peat .. .. .	.. .. .	328
3.—Commercial values of peats containing different percentages of water and ash. Comparison of values with those of other fuels .. .. .	.. .. .	331
C.—Design and construction of fireplaces suitable for burning hand peat and machine peat.		
1.—On the air necessary for combustion and on the flue gases .. .. .	.. .. .	335
2.—Grate, height of layer of fuel, and shape of the fire chamber .. .. .	.. .. .	338
3.—Furnaces suitable for steam boilers, locomotives, evaporating pans, &c. .. .. .	.. .. .	341
Peat powder or peat dust firing .. .. .	.. .. .	349
Peat-firing for locomotives and locomobiles .. .. .	.. .. .	349
D.—Methods and plants for increasing the calorific effect of air-dry peat. Manufacture of kiln-dried peat.		
1.—Various modes of drying .. .. .	.. .. .	351
2.—Commercial value of kiln drying .. .. .	.. .. .	352

## II.—Manufacture of Peat Charcoal

1.—The various methods of carbonizing peat .. .. .		356
(a) Carbonization in piles .. .. .	.. .. .	358
(b) Carbonization in clamps .. .. .	.. .. .	360
(c) Carbonization in ovens .. .. .	.. .. .	360
(1) Hahnemann's oven .. .. .	.. .. .	361
(2) Wagenmann's oven .. .. .	.. .. .	363
(3) Weber's oven .. .. .	.. .. .	365
(d) Carbonization in muffles, &c. .. .. .	.. .. .	366
(1) Jüngst's peat-carbonizing oven .. .. .	.. .. .	367
(2) Lottmann's peat-carbonizing oven .. .. .	.. .. .	368
(3) Carbonizing ovens with horizontal iron muffles .. .. .	.. .. .	370
2.—Recent methods of carbonizing peat .. .. .		371
1.—Process of Gumbert and Loe .. .. .	.. .. .	371
2.—Ekelund's process .. .. .	.. .. .	371
3.—Jepsen's electrical process and other electrical processes .. .. .	.. .. .	374
4.—Ziegler's process .. .. .	.. .. .	374
5.—Bamme's peat-carbonizing process .. .. .	.. .. .	379
6.—Wielandt's peat-carbonizing process .. .. .	.. .. .	381
7.—Peat carbonizing by means of hot rollers, presses, plates, &c. (Fritz and Schöning's process) .. .. .	.. .. .	382
8.—Carbonization of peat by pressure or in mounds .. .. .	.. .. .	383
(a) A. Born's "mound-carbonizing" process .. .. .	.. .. .	383
(b) Heine's carbonization in mounds .. .. .	.. .. .	385
9.—The so-called wet carbonization .. .. .	.. .. .	385
3.—Best kind of raw peat for carbonization ; economic value of carbonization ; calorific power and properties of peat charcoal .. .. .		386

III.—Gasification of Peat for Fuel and Power Purposes		PAGE
1.—General remarks on the gasification of fuel and on gas furnaces..	..	392
2.—Production of fuel gas and power gas from peat .. .. .	..	397
(a) Fuel gas .. .. .	..	397
(b) Power gas and the gasifiers of the Deutz Gas Motor Factory, Körting Bros. and Co., Görlitz Machine Factory, &c. ..	..	400
3.—The Frank-Caro-Mond process for gasifying peat with recovery of nitrogen, and the gasifiers of Hoering-Wielandt, A. Born, &c. ..	..	408
4.—Economic value of the various peat-gasifying installations .. ..	..	412

#### IV.—Application of Peat-firing in various Branches of Industry. Results

1.—General heating installations and domestic fires .. .. .	..	414
2.—Iron and steel industry .. .. .	..	415
3.—Glass-works industry.. .. .	..	418
4.—Peat-firing for burning earthenware, bricks, lime, &c. .. .. .	..	421
5.—Peat gas furnaces for boiler installations, digesters, evaporators, &c. ..	..	424
6.—Peat in the railway industry .. .. .	..	431
7.—Erection of power stations in bog districts .. .. .	..	432
(a) The Wiesmoor electric power station .. .. .	..	434
(b) The Schweger Moor electric power station .. .. .	..	441
(c) The Bogorodsk electric power station .. .. .	..	442

#### V.—Utilization of Peat for Illuminating Purposes

1.—Substances formed by the distillation of peat .. .. .	..	444
2.—Illuminating gas from peat .. .. .	..	445
3.—Recovery of peat oil, paraffin, &c., from the distillation products ..	..	447

#### VI.—Utilization of Peat Litter and Peat Mull

1.—Peat litter and peat mull for the absorption and deodorization of manures and waste substances .. .. .	..	452
2.—Peat litter for use in stables.. .. .	..	455
3.—Peat mull for water-closets, town sewage disposal, &c. .. .. .	..	457
4.—Peat litter manures .. .. .	..	459
5.—Various industrial applications of peat litter .. .. .	..	461
(a) For packing and preserving perishable objects .. .. .	..	461
(b) As a bandaging and padding material .. .. .	..	461
(c) As an absorbent and filling material, as a sound damper, and as a heat insulator .. .. .	..	461
(d) For the manufacture of peat molassine meal .. .. .	..	462
(e) Other uses .. .. .	..	462

#### VII.—Other Methods of Utilizing Peat

1.—Textile fibres and cotton from peat .. .. .	..	463
2.—Manufacture of paper and mill-board .. .. .	..	466
3.—Peat as a substitute for wood and as a building material .. .. .	..	468
4.—Manufacture of alcohol from peat .. .. .	..	470
5.—Peat mud baths .. .. .	..	470

#### VIII.—Agricultural Utilization of Peat and of Bogs

(a) The use of raw peat as a manure .. .. .	..	471
(b) Moor burning and the moor-burning industry .. .. .	..	471
(c) The Dutch moor, fen, or fehn industry .. .. .	..	473
(d) The Rimpau ridge industry and other methods of cultivating bogs ..	..	474
(e) Reclamation of low bogs for meadows, &c. .. .. .	..	478
(f) Reclamation of high bogs .. .. .	..	478

#### IX.—Patents relating to the Utilization of Peat

1.—Peat furnaces .. .. .	..	481
2.—Peat carbonization, carbonizing ovens, and carbonizing presses ..	..	481
3.—Peat gasification and peat gasifiers.. .. .	..	487
4.—Peat as a fibrous material for paper, paste-board, textiles, &c. ..	..	490
5.—Utilization of peat in the form of mull, litter, and manure .. .. .	..	491
6.—Peat for building purposes, artificial wood, &c. .. .. .	..	492
7.—Peat for the manufacture of alcohol, feeding stuffs, &c. .. .. .	..	494

#### X.—Notes

From the sections on the utilization of peat .. .. .	..	495
--	----	-----

## Explanation of Contractions and Terms used

1 m.	= 1 metre.	1 a.	= 1 are = 100 sq. m.
1 cm.	= 1 centimetre.	1 ha.	= 1 hectare = 100 a.
1 mm.	= 1 millimetre.	1 g.	= 1 gramme.
1 sq. m.	= 1 square metre.	1 kilo.	= 1 kilogramme = 1,000 g.
1 sq. cm.	= 1 square centimetre.	1 km.	= 1 kilometre.
1 cb. m.	= 1 cubic metre.	1 m. ton	= 1 metric ton.
1 c.c.	= 1 cubic centimetre.		= 1,000 kilos.
1 l.	= 1 litre.		= 2,205 lbs.
1 hl.	= 1 hectolitre.	1 d. cwt.	= 100 kilos.
1 kw.	= 1 kilowatt.	1 c.	= 1 calorie.
	= 1,000 v.a.	1 h.p.	= 1 horse-power.
	= 1·36 h.p.		= 75 kilometre-seconds.
1 kw.-h.	= 1 kw.-hour.		= 736 w.
		1 v.a.	= 1 volt-ampere.
		1 w.	= 1 watt.

## Comparative Table of Weights and Measures

Relation of the metric system of weights and measures to those in feet and pounds of various countries.

	1 metre in feet.	1 square metre in square feet.	1 cubic metre in cubic feet.	1 kilo in lbs.	1 hectare equals
Bavaria .. ..	3·426	11·740	40·224	1·995	2·935 Days' work.
England .. ..	3·281	10·764	35·317	2·205	2·471 Acres.
Austria .. ..	3·164	10·009	31·667	1·786	1·738 Joch.
Prussia .. ..	3·186*	10·152	32·346	2·000†	3·917 Morgen.
Russia .. ..	3·281	10·764	35·317	2·442	0·915 Dessätine.
Sweden .. ..	3·368	11·344	38·209	2·352	0·203 M. ton.
Switzerland ..	3·333	11·411	37·037	2·000	2·778 Morgen.

\* 1 Saschen = 3 arschin = 7 feet. † 1 Pud = 40 lbs. (Russian) = 16·38 kilos.

Denmark, Norway, and Sweden are the same as Prussia, and Baden is the same as Switzerland.

## Other Contractions and Explanations

M. = 1 Mark. Pfg. = 1 Pfennig. 1M. = 100 Pfg.

1 Kr. = 1 Krone (Austrian) = 100 Heller = ca. 0·85M.

1 Kr. = 1 Krone (Swedish) = 100 Ore = 1·125M., therefore 1 Ore = 1½ Pfg.

1 Rouble = 100 Copcs = ca. 2·20M.

ca. = circa, about, approximately.

*Mitteilungen*, 1903 = *Mitteilungen des Vereins zur Förderung der Moorkultur im Deutschen Reiche*, Jahrgang 1903 = Proceedings of the Society for the Promotion of the Utilization of Bogs in the German Empire for the Year 1903.

20·5M. = £1.

## TRANSLATOR'S PREFACE

NOTWITHSTANDING the many excellent journals and handbooks devoted to peat which have been published on the Continent, the author felt that a new edition of his book was required to serve as a guide for those who are interested in the winning and the utilization of peat in Germany. If this want were felt abroad, how much more so should it be experienced here, where no such journals or handbooks exist! No apology is therefore required for the publication of this translation of a work which has earned for itself a high reputation amongst German readers.

The circumstance that the translation was carried out during the period of the late war, when collaboration between the translator and the author was impossible, may perhaps have led to an occasional misunderstanding, but these, if any, should be very few in number, since the translator has in all cases adhered as closely as possible to the letter and the spirit of the author's text.

It may reasonably be expected that this edition will prove very useful to those about to engage in the development of our peat resources. The translator would like to point out, however, that the estimates for the cost of winning peat by the various methods here described should be accepted with great reserve. Fluctuations in our labour market, uncertainty of our climate in comparison with that of Germany, and variations in the transport facilities for different localities, will greatly affect the cost of the product, which ought to be considered *de novo* in every particular case.

In places where coal or lignite can be obtained at cheap rates, the replacement of these by peat as a fuel for household or industrial purposes will not in general be remunerative. In peat districts remote from coal-mines, however, peat can be converted, in a commercially successful manner, into a fuel capable of replacing coal for all the purposes for which the latter is used.

The use of peat on a large scale for the production of power or the manufacture of substances such as glass, earthenware, or bricks, deserves careful attention. The cost of winning the peat will depend a good deal on the extent to which the bog has been drained. In a bog which has been badly drained the percentage of water in the peat may be as high as 93, while in a well-drained bog it may be as low as 86. The amount of raw peat which must be raised and worked in the machines is, for a given output of anhydrous peat, twice as much in the former as it is in the latter case. Again, owing to the difficulty of procuring labourers, the number of whom ordinarily required in a peat industry is large, it is very desirable to replace these whenever possible by machinery. It seems probable that the recent introduction of so-called large scale industry machines with automatic

spreaders will to some extent meet this difficulty, but even then the use of peat for a large industry will depend a good deal upon local circumstances. Wherever the raw materials required for an industry—calcium cyanamide, for instance—are to be found in the immediate neighbourhood of a good peat fuel bog, and the market for the product—in this case a fertilizer—is not far removed from the site of the factory, there is little doubt that the use of peat in a factory at the place will be preferable to that of coal.

It is probable, however, that peat can be most economically used on a large, or a semi-large, scale in smaller factories in the immediate neighbourhood of the bog where products such as glass, earthenware, bricks, potato starch, potato spirit, and beet sugar can be conveniently made, the peat being employed for power and fuel purposes.

HUGH RYAN.

University College, Dublin,  
*August, 1919.*

SINCE the above preface was written, two further German editions of Hausding's Handbook have appeared. These do not differ materially from the third edition, but—unlike the latter—they are provided with indexes. The last German edition gives some further particulars of the encouragement of the peat industry in various European countries. No advances, new in principle, have been made since 1917 with the exception of a hydraulic method of winning peat, practised on an experimental scale, near Bogorodsk in Russia. Large scale trials of the Peredatsch Electrical Company, near Bogorodsk, on the winning of peat by the action of high-pressure water jets on the face of a peat trench are said to have given satisfaction, the process requiring but few labourers. The large automatic machines of the Wielandt and Strenge types have almost completely displaced the smaller semi-automatic machines in the winning of peat for great industries. The Schweger Moor by-product recovery station is no longer worked with peat, but the Wiesmoor Turbo-alternator Station near Aurich has had its capacity extended to 20,000 kw. In a few instances, new tables of costs are given for peat factories, but, as the author states in his preface, these are of little permanent value since prices for materials and for labour vary from week to week in Germany. The costs of machines and of labour in Germany in 1920 were from ten to fifteen times what they were in 1916. Owing to coal shortage, however, this did not decrease the peat output. Fuel of any kind was readily saleable, no matter how high the price. The author deplors that owing to this, worthless peat containing high percentages of ash and water has in some cases been placed on the market.

HUGH RYAN.

*August, 1921.*

## AUTHOR'S PREFACE TO THE THIRD GERMAN EDITION

SINCE the publication, in 1904, of the second edition of this book the price of fuel has risen greatly owing to increase in trade, and an effort, due to an ever-growing deficiency in agricultural products in the country, has been made to bring new areas under tillage. It has, therefore, become of even greater importance for industry and agriculture than it formerly was that our bogs should be employed more extensively for the winning and the utilization of peat. Further attempts have been made to decrease the cost of winning peat for use as a fuel, to make it better adapted for this purpose, or to utilize it as a raw material in other industries. At the same time, attempts have also been made to reclaim, before or after cutting the peat, bogs which as waste land have hitherto been almost valueless.

The utilization of bogs, viewed from the industrial, the agricultural, and the national economic standpoints, is an important question of the moment not only in the peat districts of Germany, but also in those of Holland, Sweden, Norway, Denmark, Russia, Austria, and America (especially in Canada). A handbook covering the present state of the peat industry is necessary for the guidance of all interested in that industry, and this, the third edition of my book on peat, which has been rewritten and brought up to date in the more important parts, is intended to meet this want. It should prove as useful and reliable a guide in the domain of peat winning and peat utilization as the last edition, which has been out of print for a long time, was recognized to be in peat circles.

Adhering to the standpoint which I formerly took up, I have not hesitated to describe not only the present position of the peat industry and its well-tested schemes, but also the manner of their development, and therefore to describe and discuss older, out of date, or even unsuccessful methods and plants.

Experience has again demonstrated the importance of setting forth clearly in a treatise dealing with a special branch everything which has been attempted or proposed in the branch irrespective of its success or failure. Many of the "new" or "newest solutions of the peat problem" published even within recent years, and many of the supposed "newest discoveries" with regard to the utilization of bogs, are evidently due to want of knowledge of the processes and the problem at issue. Schemes have been resorted to and rediscovered as new which experts have long known to be unsuitable or uneconomical, and which could no longer be expected to give new life to the peat industry.

In this, as in the preceding editions, I have not confined myself to mere descriptions of methods and machinery, but have combined with these full discussions of the matters under consideration, and indicated the advantages and the disadvantages of each. In this way the reader who is in need of either guidance or instruction is enabled to estimate the value of any scheme under various conditions, and to avoid the selection of a faulty process on the one hand or the inauguration of useless experiments on the other.

The development of the peat industry, and the experience gained therein, made it necessary partly to rewrite and partly to complete the earlier work. The sections on machine-cut peat and peat-cutting machines, on new methods of dehydrating, carbonizing, and gasifying peat, on fully automatic or large scale industry machines, and on the erection of electrical power stations in bogs are new. Attention is again directed, at the conclusion of each part, by means of brief notes to whatever may be assumed as axiomatic or at least as worthy of attention in the present state of the industry.

As in the case of all similar industries, it was extraordinarily difficult to obtain reliable data (with regard to outputs, working costs, &c.) for the industry. Of the many statements I have received I have used only those which seemed to agree with my own observations or experience, and these particulars, even if prudence in their use be necessary, will help to serve as a basis for questions of costs, and for the economic side of various processes and machines.<sup>1</sup>

All the more or less complete accounts in the previous editions with regard to machines, and their products, which are no longer employed in the utilization of peat, as for instance the manufacture of "press peat," as well as with regard to the use of peat in locomotives, in the iron industry, in the manufacture of illuminating gas, and so on, have been struck out and replaced by quite brief notes. However valuable the detailed reports were in their time, as for instance those on the press peat factories which were revived towards the end of the last century, those on the use of peat in the iron industry and on railways, including the carefully determined results obtained by the Bavarian, Württemberg, and Oldenburg Railway Companies, they have now only historical interest. If necessary it should not be difficult to complete the brief accounts given in the present edition by referring to the earlier edition (in public libraries or similar places). By means of foot-notes at the corresponding places attention is drawn to the details which are given in the earlier edition.

---

<sup>1</sup> The changes in the rates of wages and in the prices of materials, machines, and apparatus in reference to the winning and utilization of peat due to the World War, which broke out just as the writing of this handbook ended, have not been considered. How far these will remain unaltered after the conclusion of Peace is still an open question. The prices given here, unless otherwise expressly stated in particular places, are those which were current up to the industrial year 1915.



So far as scientific demonstrations or calculations appeared necessary, either to support or to render comprehensible some statements, I have tried to give these in a simple form which anyone can understand, and have endeavoured to avoid all detailed statements which required technical knowledge on the part of the reader.

I have also avoided all elaborate accounts of the mode of formation of bogs, of the natural history of peat, and of the more or less recent experiments of scientific or theoretical interest only. I have, for example, avoided giving too much detail about the chemical and physical properties of peat, and its products in some processes which are economically unimportant for the industrial utilization of peat, as for instance, some carbonizing and gasifying processes and their by-products. In these cases also references are contained in the foot-notes to detailed accounts given elsewhere.

For the same reason, in spite of the desire expressed by some when discussing the earlier edition, I have refrained from going too fully into particulars relating to the agricultural utilization of bogs—the subject being so wide that it would require a handbook for itself. I have now, as formerly, confined myself to the brief accounts necessary in a general survey, and have given references from time to time to other more complete publications.

In works such as this we only too frequently meet with foreign words which interfere with facility of reading and of comprehending the subject. In this edition, so far as I could, I have avoided words of this character and replaced them by the expression used in the German industry. This course, which met with general approval when it was employed in the second edition, will, I hope, be even more acceptable now, since an ever-growing effort is being made in German technical publications to increase the clearness and facilitate the understanding of statements by using, where possible, only German expressions.

In conclusion, I tender my best thanks to all those who, when discussing my book, have spoken of it in appreciative terms and have given their support to me and my statements, and also to those who have assisted my work, and, therefore, the subject itself, by valuable contributions.

A. HAUSDING.

Berlin-Nikolassee,

*January, 1917.*



## INTRODUCTION

THE utilization of peat bogs, and the application on a large scale of peat as fuel in industry, have not been so extensive as we should have expected from the scarcity of fuel on the one hand and the wide distribution and area of bogs on the other; moreover, they have not kept pace with the development of the coal industry. The reasons for this are:—that not every variety of peat, and, indeed, only the smaller part of our peat supply, can be won in a simple manner by hand labour (cut, moulded, or dredged peat) as a firm fuel capable of being transported and suited for more or less large circles of consumers; and also the winning of hand peat in fairly large quantities requires many skilled workmen, who are difficult to procure in most districts. Moreover, in attempts to establish the winning of peat on an industrial scale by attracting foreign capital and by employing machinery, essential simplicity of equipment was not adhered to, and by means of unwieldy machines and expensive plants a fuel was obtained which could no doubt be used, but which was too costly when compared with coal or brown coal.

As the goal was not attained in this way, attempts were made about the middle of the last century to improve peat by means of “chemical actions” with cements, admixtures, &c., the object of which was to get rid of the loose, fibrous structure of the peat, which, in addition to the high percentage of water in the substance, was regarded as the chief obstacle to the introduction of peat into industry. Such attempts could only lead to unfavourable results. Capital, therefore, kept aloof from enterprises of this kind. Favourably situated and easily accessible bogs were developed to a limited extent for local requirements by ordinary hand labour, giving a fuel, good or bad, according to the nature of the bog, and only in the rarest cases capable of being utilized in large furnaces and on a large scale, especially in districts situated at some distance from the bog. Nevertheless, during this period the suitability of peat for heating purposes was repeatedly demonstrated, and inducements were continuously held out for attempts to free peat in an inexpensive manner from those defects which militated against its commercial success as a fuel.

The solution of this problem could not remain unaffected by the spirit of progress, and it was to a certain extent successfully attained when the greatest possible simplicity of method was recognized as the main requirement of a satisfactory mode of winning, and when advantage was taken of the experience gained in the earlier attempts with regard, for instance, to the influence

which the mixing and kneading of crude peat in a machine has on its natural condensation during drying. It was seen that a condensation of the loose, spongy, or fibrous raw material could be attained most cheaply, not by employing great mechanical force and unwieldy machines or powerful presses, but spontaneously and in a natural way, if, after removing the originally heterogeneous structure of the peat, and after kneading and intimately mixing the half-decomposed, more or less solid, fibrous particles with the humified, earthy, or bituminous constituents, the uniformly dense, pulpy mass thus obtained was allowed to dry, and to contract naturally as the water evaporated.

By supplementing hand labour by means of simple tearing and mixing machines the goal to be attained was approached in the second half of the preceding century and, as a matter of fact, for the first time in Bavaria. This goal was to prepare from peat by the aid of machines a firm and valuable fuel capable of being transported, to emancipate the industry, at least to some extent, from hand labour, which was becoming more expensive every year, and to enable it to be prosecuted on a large scale in a remunerative manner. The simplicity of the method and the tendency to make greater use of the large bogs, which existed everywhere and which were up to that time almost valueless, could not fail to give an impetus to the manufacture of machine peat, especially in Germany, Russia, Sweden, Norway, Denmark, and Canada. The most varied proposals were likewise made for the improvement of the ordinary, and for the introduction of new, and probably better methods of winning peat.

Insufficient knowledge of, or inattention to, the intrinsic properties of peat, the differences in the varieties of peat and of peat bogs, and local conditions of trade and labour, led to many blunders, which were naturally attended by complete failures of plants and great losses of money. The ultimate cause of these failures was a dearth of experts, due to the fact that skilled investigators and captains of industry, after the first failures in the peat industry, kept aloof from a problem the solution of which did not seem to offer much hope of success. It was mainly left to laymen to test, usually by very costly experiments, the possibility and the economy of working newly proposed schemes, which were generally merely the results of the idle thoughts of so-called discoverers, who had occasionally gained an insight into other branches of technics but who were, so far as peat itself was concerned, anything but competent and expert. As a rule, it was assumed that whatever had proved of use in other branches of industry for working, forming and drying raw materials which were supposed to be similar to peat, could be employed, without any radical change and with the same degree of success, for the improvement of peat. Wrong premises, as well as inattention to the natural properties of peat and to the means which are alone suited for its utilization, necessarily led to mistakes in plants and to economic failures.

A feeling of uncertainty was created by the designedly distorted

reports which appeared in technical and agricultural journals, as well as in the daily papers, from interested parties, and by the lack of unprejudiced expert opinion, based on science and experience, with regard to new proposals which were put forward from time to time. The consequence of this was, that owing to such recommendations of "new solutions of the peat problem" (which were often, indeed, only resuscitated older processes), owners of bogs or companies specially promoted for the purpose were induced to acquire these so-called discoveries and to erect costly experimental plant, only to arrive finally at a result which an expert could have predicted with certainty. This statement refers more particularly to the various old and new proposals for artificial dehydration, de-fibring, de-ashing, carbonizing, if not to complete de-naturing of the peat, as well as to artificial drying, pressing and re-pressing of the raw or "machine-formed" peat by dry or wet press methods, by chemical or physical processes, &c., which, in spite of the warning expressly given in the second edition of this book, have increased rather than diminished during the past ten years. It holds good also for the many, and, from the economic standpoint, generally valueless patents, which are mentioned under Patents in Section VII, as well as for the companies of all kinds which were formed to work these patents, and which very quickly, owing to loss of their capital, became bankrupt.

What we have just said about the winning of peat applies more or less to its utilization. In the latter case, however, the experiments were carried out in general with a clearer comprehension of the problem. Nevertheless, on account of ignorance of the experience already gained, often, indeed, many years previously, roads were again trodden by which the expected goal could not be attained.

The desire to utilize the bogs became for a time less pronounced in Germany, as increase in the output of coal and the opening of many new brown coal-mines, operated by the cheap open-cut system, lowered the price of coal a good deal. Moreover, as the preparation and transport of cheap, clean briquettes became more universal, a very convenient and saleable fuel, both for industry and the household, could be bought everywhere and at a price which did not exceed its value.

Owing to the extraordinary development of German industry towards the close of the past century fuel became notably scarce, the price of coal rose considerably, and the winning of peat for fuel purposes began again to attract more attention. The dry presses, which had throughout the country been introduced into, and found well suited for, the brown coal industry; the yearly increasing sale of press coal as fuel for households and industries; the better utilization of less valuable forms of fuel, by gasification, for the production of power gas with and without the recovery of the by-products; the knowledge that electrical power stations can be erected with advantage in bogs, and that the electric current can be transmitted without serious loss to points of utilization situated at great distances; all these factors could not

fail to react on the peat industry and give a stimulus to the erection of similar plants for raw peat, which was supposed to be a substance of similar character, and capable of being won more cheaply.

In the effort to employ the dry presses, which had proved successful in the case of brown coal, for the manufacture of a clean, handy, transportable press peat, similar to press coal, attention was not paid to the fact that peat, with its 90 per cent. of water, is, in comparison with freshly mined brown coal, with its 55 per cent. of water, a substance much less adapted for pressing, inasmuch as it requires inconvenient and expensive modes of drying, which in every case where press coal is ordinarily on sale must lead to economic failure.

For winning peat by machinery on a large scale the only machines that have proved successful are the mixing, kneading, and forming machines which are now generally employed, with or without dredgers and sod spreaders, for manufacturing machine-formed peat or machine-pulped peat or, briefly, machine peat. Real experts confine themselves, therefore, to the improvement of this method, if we exclude the winning by machinery on a large scale of machine-cut peat for use in producers at the locality in question. In the meantime, the knowledge that certain kinds of peat give an excellent litter for the absorption of effluents from farmyard manure, stables, or houses, and that peat mull is a very useful packing and preserving material, gave great importance to the manufacture of peat moss litter and peat mull.

In those countries which are poor in coal supplies, viz., Sweden, Norway, Denmark, and Russia, attempts have constantly been made to give special attention to plans for winning and utilizing peat, and also for national economic reasons to promote the utilization of the bogs by the State.

Committees of experts and owners of bogs were appointed, Peat Boards, Peat Experimental Stations, and, in connexion with these, Peat Societies were formed which in their own capacity or by means of nominated experts were to institute experiments on the best methods of cultivating and utilizing the bogs, to give advice to, to make proposals to, and to prepare working plans for, the owners of bogs, and also, in some States, to advance money to the bog owners.

In Germany, especially in Prussia, the importance of the bogs was regarded for a long time from the point of view of national economics only, or almost only, in respect to their agricultural utilization. The Prussian Central Moor Commission, appointed at the end of the seventies by the Prussian Minister of Agriculture, with its official Experimental Bog Station at Bremen and its many experimental fields, the Society for the Promotion of the Utilization of the Bogs in the German Empire (Chairman, Baron von Wangenheim, Klein Spiegel), which was founded in connexion with the Central Moor Commission and is supported by the State,<sup>1</sup> have only in recent times (since about 1900) included the

<sup>1</sup> It receives every year about 20,000M. from the Empire, 25,000M. from the Prussian States, and 10,000M. from Mecklenburg and Oldenburg.

technical utilization of bogs in the sphere of their labours. It is desirable that these Departments and Societies should make the technical side of the utilization of bogs even still more the object of their investigations, plans, advice, and publications. In pursuance of this object, the State has created a special section for Peat (at present under the direction of Professor Keppeler) in the Technical High School at Hanover, and has appointed a technical director (Arlandt) to the Bog Utilization Society. Until 1891 the Experimental Bog Station at Bremen was under the direction of Dr. M. Fleischer, now Privy Councillor and Professor at the Agricultural High School at Berlin, who has assisted very greatly by his exhaustive investigations in promoting the utilization of bogs. His successor, Professor Br. Tacke, has been engaged with a similar degree of success on the wider field of research which now engages the attention of the Experimental Station. The funds of the Station amount to 110,000M. to 120,000M., of which the Kingdom of Prussia contributes about 90,000M. Just as Prussia has at Bremen, so has Bavaria at Munich founded a Royal Bog Utilization Institute, to which the State contributes about 120,000M. per annum. Bavaria has also founded Bog Utilization Stations at Bernau, Karlshuld, Erding Bog, and Weihestephan. Several peat engineers, under the Agricultural Department, had been appointed to encourage the utilization of bogs. Important matters are discussed by the Bavarian Bog Utilization Commission, which acts as an advisory council to the Peat Utilization Institute. The amount expended by the Bavarian State for peat experiments, peat instruction and in contributions is about 500,000M. per annum. For particulars about the Württemberg Peat Society, see the so-called economic historical memoir of Dr. Fridolin Liebel (published by Cotta).

In Austria, since 1901, at the Imperial Agricultural Chemical Experimental Station at Vienna, a special section for the cultivation of bogs and the utilization of peat (Director, Chief Inspector Dr. Bersch) has been created, and in the Ministry of Agriculture a Bog Reclamation Inspector (Privy Councillor Koppens) has been appointed. There is also a German-Austrian Peat Society at Staab, near Pilsen (under the management of Hans Schreiber). Experimental fields have been laid out or free courses of instruction have been held in Sebastiansberg (Erzgebirge), Laibach, Klagenfurt, Admont, Sterzing, &c. In recent years the contributions made by the State for the promotion of the reclamation of bogs and the utilization of peat amounted to 50,000 kr. per annum.

In Sweden the State has founded an Experimental Bog Institute at Jönköping, and appointed a staff of four peat engineers and one assistant engineer to examine bogs for their owners as well as for the State, to work out plans for the peat fuel industry, to carry out heating experiments with peat, including its use in locomotives, and also to act in an advisory capacity.<sup>1</sup>

---

<sup>1</sup> In Sweden there are at present about 70 machine peat works, which are provided with about 100 peat-forming machines of the Anrep, Körner,

The chief peat engineer of the State (Ernst Wallgren) resides in Skara. Experts have been appointed to deliver free lectures in peat districts, and to test discoveries proposed for the utilization for peat. The Swedish Bog Reclamation Society, Svenska Mosskulturföreningen (Chairman, Dr. von Feilitzen), works on similar lines, and has established an experimental station at Flahult. The societies, Södra Sveriges Torfindustrie-Föreningen, at Eslöt, and Föreningen för torfindustriens befrämjande inom Vestergötland och Dalsland, devote their attention more to the advancement of the Swedish peat industry. A Peat School has been founded at Emmelunga, of which Anrep (now deceased) was for many years director, and who took an active part in the development of the machine peat industry. The Swedish State has voted a sum of 3½ million kronor as a loan fund for peat factories. In 1901 two engineers were sent, at the public expense, to report upon the peat industries in the large peat countries of Europe.<sup>1</sup>

The State grants an annual subsidy of 50,000 kr. to the Swedish Peat Society. There are, in addition:—

- (1) A general drainage fund of 450,000 kr., from which one-third to one-half of the cost of drainage is refunded.
- (2) A reclamation loan fund of 1,000,000 kr., from which loans up to 70 per cent. of the increase in the value of the soil can be given for the drainage of bogs capable of being utilized for agricultural purposes. These loans are free of interest for the first three years, and during the next three years they pay interest at the rate of 3 per cent., while from the seventh year onwards the rate is 6 per cent., of which 3·6 per cent. is interest and 2·4 per cent. is a contribution to a sinking fund.
- (3) A drainage fund for bogs, amounting to 2,000,000 kr., from which one-half of the costs of the drainage is refunded.
- (4) A general reclamation fund for bogs, amounting to 300,000 kr.
- (5) A similar fund for Middle and South Sweden, from which one-half of the costs of working and draining is lent, in amounts which do not exceed 500 kr., at 3 per cent. interest, and with redemption in the course of ten years.

In Norway there is a Peat Society, called *Det Norske Myrselskab*, at Christiania. In 1901 a report upon the peat

---

and Äkermann types, and 225 peat moss litter factories containing 340 balers. The winning of machine-pulped peat or kneaded peat is no longer practised. The machine peat works produce at present 90,000 m. tons of air-dried peat fuel every year, and the peat litter factories about 5,000,000 bales, each having a volume of 0·38 cb. m. Furthermore, peat winning for household requirements is carried on by hand to a greater extent. The average cost (including interest and amortization of plant) is 7·50 to 8·00 kr., and the selling price is 10 to 12 kr. per metric ton for quantities amounting to a wagon load; English coal costs 18 to 20 kr. per metric ton in Sweden. Owing to the unusually high price of coal, which has risen still higher owing to the war, the Swedish State Railways intend to erect a peat factory for themselves, and for this purpose they have acquired the Våkøe Bog in the Sälwesberg-Aelmhut district. From the State funds 500,000 kr. have been voted for this object.

<sup>1</sup> The complete report was published at Stockholm in 1902 under the title, "Om Bränttorfindustrien i Europa, berättelse, afgifven till Kongl. Maj.: T af Alf. Larson och Ernst Wallgren."



industries of Europe and Canada was made at the public expense.<sup>1</sup>

The development of the Norwegian peat industry (fuel and moss litter) was demonstrated at the Jubilee Exhibition in 1914.<sup>2</sup>

The State at present gives the Myrselskab an annual grant of 15,000 to 18,000 kr.

In Denmark there are the heather society, Danske Hedeselskab, and the Moseindustrielle Afdeling at Viborg, the latter being the successor of the Moseselskabet, which was formerly called the Moseindustriföreningen of Viborg, and which is now extinct. The State grants to the peat industry section of the Hedeselskabet (the Heather Society) amounted, in all, for the last five years to 19,200 kr.<sup>3</sup>

A peat fuel engineer has been appointed by the State in Finland, in which country there are approximately 100,000 sq. km. of bogs. The Peat Society at Helsingfors is subsidized by the State, from which it received 64,000M. (Finnish) in 1913.

Similar State subsidies for the utilization of peat are granted in the Netherlands and in Holland. In Holland, during the last fifty years of the past century, about 400 km. of main canals and about 800 km. of bog canals have been constructed at a cost of 12,000,000 gulden, i.e., 20,000,000M., with a view to promoting the advancement of the peat industry. During the same period a further sum of 11,200,000 gulden, i.e., 19,000,000M., was spent in improving and in increasing the depth and width of the older canals.<sup>4</sup>

Of these sums the State contributed 7,229,000 gulden and the Provinces 10,923,000 gulden. In the winning of peat in Holland about 10,000,000 cb. m. of bog are cut out every year, and in

<sup>1</sup> Published report of a visit abroad, "Indberetning fra ingeniør J. G. Thaulow om en foretaget reise for at studere torfdrift i Kanada m. fl. lande," Christiania, 1902.

<sup>2</sup> For a report on this, see "Meddelelser fra Det Norske Myrselskab," 1914, pp. 11-19. The larger machine peat works increased from 11 plants, with a yearly output of 3,300 m. tons in 1900, to 34 plants, with a yearly output of 12,500 m. tons, valued at 125,000 kr., in 1913. There are also at work, especially on the west coast, about 500 smaller (usually hand-worked) peat machines, intended to meet the household requirements of the less wealthy bog owners. At present there are about 60 more or less large peat moss litter factories with a yearly output of 280,000 bales, each weighing 65 kilos, the whole being valued at 420,000 kr., and about 300 smaller factories, the output of which is worth 600,000 kr. The machines required for these factories are usually made in the country itself. The amount of coal imported into Norway increased during the past thirty years (1884-1913) from 570,000 m. tons to 2,550,000 m. tons, and its import value from 7,500,000 kr. to 48,300,000 kr.

<sup>3</sup> The winning of peat fuel in Denmark is generally effected by the Rahbeck method, floating plants being seldom used. At the Holmgaard glass factory at Noestred (Zeeland) two Dolberg machines for the manufacture of machine-formed peat and one floating plant are employed. No electrical power stations have as yet been erected in the bogs. The amount of peat fuel won annually has increased from 46,760 m. tons in 1902 to 86,849 m. tons in 1914.

<sup>4</sup> Wortmann, "Festschrift des holländischen Ingenieurvereins, 1897."

this way an area of 400 ha. is gained annually for agricultural purposes. In the transport of the peat, over 30,000 boat-loads are carried.

In Russia there are considerably more than one thousand machine peat works in operation. The Government itself has a number of peat factories on the State bogs, and in 1901 it erected at Redkino, at a cost of about 1,500,000M., a large peat charcoal factory, which has, however, since then ceased work. In a Minute of the Ministry of Agriculture, issued in 1900, it was decided:—

- (1) To grant permission for the exploitation of the Crown bogs.
- (2) To subsidize the investigation of bogs.
- (3) To instruct the peasants in the simplest methods for the winning and the utilization of peat fuel.
- (4) To promote the construction of railways in peat districts.
- (5) To reduce the freightage (railway) on peat.
- (6) To guarantee advances and loans of money for the working of bogs.
- (7) To grant peasants plots of bogs for the winning of peat at 5 to 6 copecs a square fathom.

In recent years the Duma has assigned every year a sum of 120,000 roubles as a State subsidy for the winning of peat and for research on peat deposits. The peat fuel won in Russia amounts yearly to 150,000,000 pud, i.e., 2,500,000 m. tons. It is estimated that it is possible to win 5,000 milliard pud each year, and the Russian Government has therefore encouraged the institution of new investigations on the utilization of peat. At Bogorodsk, near Moscow, one of the largest known peat electrical stations has been erected, about which further particulars are given in Part II, Section IV, 7.

There are fifteen to twenty more or less large peat moss litter factories in Finland, which have an annual output of 60,000 bales, each weighing 60 kilos, and about 120 smaller co-operative factories, with several larger ones, in Russian Poland, as well as in the neighbourhood of Petrograd and Moscow.

Active participation in efforts to utilize peat bogs may be observed everywhere. The publications of official departments and experimental stations, as well as those of the societies named above, contain much that is worth our attention.<sup>1</sup>

---

<sup>1</sup> Amongst these publications are:—

- (1) *Die Verhandlungsberichte der Zentralmoorkommission in Preussen.* Berlin, Paul Parey.
- (2) *Mitteilungen des Vereins zur Förderung der Moorkultur im Deutschen Reiche,* Berlin. 24 parts yearly. This journal is referred to in the text of this book as *Mitteilungen.*
- (3) *Zeitschrift für Moorkultur und Torfverwertung* (Privy Councillor Koppens and Professor Bersch), Vienna.
- (4) "Jahrbuch der Moorkunde," Hanover, edited by Professor Tacke and Dr. Bersch.
- (5) *Oesterreichische Moorzeitschrift,* Staab, published by the Peat Society. 12 parts yearly.
- (6) "Handbuch der Moorkultur," by Dr. Bersch. 2nd edition, 1911.
- (7) "Handbuch der Moorkultur," by Professor von Seelhorst. 2nd edition, 1914.

Although it is quite certain that swampy beat bogs will never become gold-mines for their owners, it is just as certain that, if they are at all adapted for working for one or other purpose, they can be made just as remunerative as other industries, provided careful and business-like methods are adopted, and also that agriculture will be the richer by the handing over to it of the cut-away bogs.

Proof of this statement will be supplied in the matter set forth in the two parts of this book which follow, viz., "The Winning of Peat" and "The Utilization of Peat."

- (8) *Mitteilungen des Heidekulturvereins für Schleswig-Holstein.*
- (9) *Der Kulturtechniker*, Breslau. 4 volumes yearly.
- (10) "Meddelelse fra Mosindustri-Föreningen," Viborg.
- (11) "Meddelelser von Det Norske Myrselskab," Christiania.
- (12) *Svenska Mosskulturföreningens Tidskrift*, Jönköping. 6 parts yearly.
- (13) *Finska Mosskulturföreningens Arsbok*, Helsingfors.
- (14) *Föreningen för torfindustriens befrämjande inom Västergötland och Dalsland*, 1901, Tvenne Föredrag.
- (15) *Hedeseskabets Tidskrift*, Aarhus.
- (16) *Meddelande från Södra sveriges torfindustriförening.*
- (17) Ernst Wallgren: In addition to the Report previously mentioned, "Redogörelse för statens torfberedningsförsök vid Koskiwaara," "Profningar med torfindustriella Maskiner," and many others.
- (18) *Journal of the American Peat Society*, Washington.
- (19) Theodor Siegner: "Die Ausbeutung der bayerischen Moorschätze durch Staats und Privat-betriebe," Munich, Freysing, 1911.
- (20) Fr. Liebel: "Die Württembergische Torfwirtschaft," an historical-economic study, Stuttgart and Berlin, 1911.
- (21) Professor A. Baumann: *Bericht über die Arbeiten der königlichen Bayerischen Moorkulturanstalt*, Munich, 1910, and the following years.
- (22) "Das Moorwesen Sebastianbergs," by Hans Schreiber, Staab, 1913.
- (23) *Arbeiten des Laboratoriums für die technische, Moorverwertung an der Königlichen technischen Hochschule zu Hannover*, by Professor Keppeler (Vieweg and Son, Brunswick).
- (24) "Moornutzung und Torfverwertung," by Professor Paul Hoering, Berlin, 1915.
- (25) *Journal of the American Peat Society*, New York.



## PART I

# THE WINNING OF PEAT

### SECTION I

## GENERAL REMARKS ON PEAT

### 1.—Origin, Occurrence, and Varieties of Peat

PEAT is a combustible body formed by the humification of plants under certain conditions. It is, like brown coal and coal, a stratified mineral, and should be regarded as intermediate in nature between plant fibres and these coals.

The conversion of certain plants into peat is due to their growth from year to year, to the accumulation of their remains on the top of each other, and to decomposition of these plant remains while air is excluded from them as much as possible. The transformation of the plants into peat depends both on the locality and on the weather conditions. In similar circumstances it occurs even at the present day, and in the peat formed by the transformation, the nature of the plants from which the peat is derived may be recognized less or more according to the length of time during which the change has progressed.

Amongst these plants, which for the sake of brevity may be called "peat-formers," are almost all mosses, most of the cryptogams, and several of the phanerogams, especially the Sphagnums, Hypnums, Confervæ, and Algæ, and to these may be added, according to the locality, sometimes *marsh plants* (*Sphagnum*, *Nymphæa alba*, *Calla*, &c.), sometimes *heathers* (several varieties of *Erica*, *Vaccinium*, *Calluna*), sometimes *marine plants* (rushes, grasses, especially *Zostera marina*, and all varieties of seaweed), and sometimes *stems of trees* (*Pinus pumilio*), *roots, leaves, &c.*

According as the one or the other of these plants is the chief one engaged in the formation of the peat, the nature of the latter will vary, and we are therefore led to distinguish the varieties, *moss, marsh, grass, reed, heather, marine, and forest peats*. We may also classify peats according to the peat-forming plants which exist in them into:—

Light-coloured *moss* or *sphagnum peat*, *wool-grass* or *Eriophorum peat*, *rush* or *Scheuchzeria peat*, *sedge* or *Carex peat*, *reed* or *Phragmites peat*, *branching moss* or *Hypnum peat*, and *wood* or *forest peat*. When more fully humified, peats may be classed as *marsh, moss, and heather peats*.

The mere occurrence of the plants mentioned above, even when these are present in large quantities, is not in itself sufficient for the formation of peat. It is also necessary that the decomposition of these plants, which sets in after death, should not be that of "rotting" in the presence of air, i.e., of a sufficient amount of oxygen. It should take place in the absence of oxygen, or with the greatest possible exclusion of air, and should proceed as slowly as possible—the process being then one of carbonization (more correctly, peat formation).<sup>1</sup>

Under the term "coal" we cannot, however, include peat, even in the form of the black doughy or mull peat, which is often called *mud peat*.

Both these conditions are satisfied when the land is of such a nature that large quantities of water can accumulate and can be prevented from evaporating rapidly. This promotes, in the first place, the rapid multiplication and growth of the plants mentioned above which, as in the case of the mosses, algæ, marsh plants and the like, float on the water without connexion with the bottom, or in that of the water-grasses, reeds, rushes, &c., spread from the bank towards the centre, and it afterwards facilitates their rapid decomposition, when the former, owing to their ever-increasing weight, have become submerged, and the latter by dying have gradually covered the bottom of the pool. Fresh mosses, algæ, and grasses develop on the layers of mould, and these in the same way meet a similar fate. At the same time these layers, with the assistance of the overlying water, cut off the underlying layers from contact with the oxygen of the air, and by means of a slow carbonization, or humification, of the constituents of the plants help in the formation of peat. In this way, layer by layer, peat bogs, mosses, veens, venns, fens or felts, frequently of large area, are formed.

To facilitate the accumulation of water, the country must be shaped like a basin, and the subsoil must consist of an impermeable layer—clay, loam, or alluvium. These depressions may fill wholly or partially with water, due to rain, snow, dew, or heavy fog, or to overflowing of rivers or lakes into the basins.

In nature, the existence of this necessary condition can be observed in the case of every peat bog.

The plants which are generally concerned with peat formation—sphagnum, hypnum, algæ, &c.—contain, in addition to the woody fibres which resist decomposition for a long time, very easily decomposable vegetable substances, e.g., gum, plant glue, &c., which during the decay or decomposition pass rapidly into "humic

---

<sup>1</sup> More detailed investigations and information as to the mode of origin and the chemical nature of peat are contained in Wiegmann's prize essay: "Über die Entstehung, Bildung und das Wesen des Torfes," Brunswick, 1837; also in Senft's "Die Humus-, Moos-, und Limonit-bildungen als Erzeugungsmittel neuer Erdbildungen," Leipzig, 1862, in Weber's "Die wichtigsten Torfs und Humusarten," in the brochure, "Die Entwicklung der Moorkultur in den letzten 25 Jahren," Berlin, 1908, p. 80, and in Professor Hoering's "Moornutzung und Torfverwertung," Berlin, 1915.

acid" and "humic carbon,"<sup>1</sup> and thus impart a brown colour to the water and all the portions of the plants immersed in the latter.

The good preservation of human and animal bodies, which, for one reason or another, have become embedded in a peat bog, is to be ascribed to the humic acid and the tannins occurring in the peat.<sup>2</sup>

It is known that the decomposition<sup>3</sup> of the plants occurs by a portion of the hydrogen of the plant forming water and ammonia with the oxygen and nitrogen of the air, and by the oxygen of the woody fibre, thus set free, combining with a portion of the carbon forming carbon dioxide, the escape of which causes the loss of a considerable part of the carbon.

Since, however, this decomposition is much impeded by the water, and therefore less carbonic acid can form, relatively more carbon remains behind, and thus the formation of "humic acid" is favoured. Further changes in a deep layer of peat can occur only at the expense of the oxygen of the "humic acid," and the latter is therefore continuously transformed (more and more) into "humic carbon."

In this decomposition the carbon contained in the plants is almost completely retained and converted into "humic carbon" and "humic acid," and this occurs all the more, i.e., the peat formation proper has proceeded all the further, the older the bogs or their individual layers.<sup>4</sup>

For this reason the upper layers of a peat bog, i.e., those of

<sup>1</sup> The term "humic carbon" has here, as elsewhere, no definite chemical meaning.—TRANSLATOR.

<sup>2</sup> In 1747 a female body with antique sandals on its feet was found at a depth of 7 ft. in a bog on the Island of Ayholm, in Lincolnshire. The nails, hair, and skin were still quite fresh, the skin being soft, free from wrinkles, and merely coloured brown. In a peat bog at Hassleben, in Thuringia, two bodies, with flesh and hair intact, were found in 1830, and from the clothing and the gold clasps on their hands and feet they are believed to have come from the time of Julius Cæsar or Augustus. For further particulars of the most recent discovery (a male body 1.74 m. in height) from the lake bog at Demendorf (district of Eckernförde), which shows almost complete destruction of all the bones during the peat formation, see Dr. Grotrian and Professor Mestorf in the 42 *Bericht des Museums vaterl. Altertümer of Kiel University*.

<sup>3</sup> The view expressed here about the chemistry of the humification process is quite improbable.—TRANSLATOR.

<sup>4</sup> Many specimens of peat are very old. The Museum of Antiquities at Copenhagen contains a female mummy-like body from a peat bog at Heraldskioer, in Jutland, which was found fastened with hooks to a pole. Antiquarians concluded with a tolerable degree of certainty from the remains of its clothing that it came from the late Pagan period, and Petersen has attempted to prove that this mummy is the body of Queen Gunehilda, of Norway, whom we know to have been enticed into Denmark by a promise of marriage by King Harold Blaatand in 965, and to have been then sunk in a peat bog.

These and other discoveries, especially those of skeletons and bodies of primeval animals, the great mastodon, the giant elk, and many others, as well as the superposition of other minerals on peat, point to the great age of some bogs (Dr. Nöggerath, "Der Torf," Sammlung gemeinverständl. Wissenschaftl., Vorträge, No. 230).

more recent origin, are still rich in slightly humified plant fibres and are therefore light in colour and of low density. As examples, we have moss, heather, reed, and root peat, to which in general the name *moss* or *fibrous* peat is given, and which in the dry state rapidly burns away without giving much heat. The deeper layers and the older bogs contain a brown-black, heavy, well-humified peat, the so-called *marsh*, *mull*, or *dough* peat, which is also termed *mud peat*. The lowest layers contain a brownish-black, dense peat, possessing few recognizable plant remains, and giving, when cut in the dry state, a dark surface having a waxy lustre. This peat has the highest percentage of carbon and the greatest fuel value. As a rule it is called *pitch peat* or *bituminous peat*.

In many bogs is found under the pitch peat the so-called liver peat, formed by the decomposition of quite low forms of mosses (Cryptogams), which, however, on account of its age and the pressure due to the layers superimposed on it, is a completely transformed, black, earthy mass, which contains no plant remains, and which, as its drying progresses, falls completely into powder.

The humification, or peat formation, as well as the formation afresh of the above-named varieties of plants, proceeds even at the present day, and therefore peat bogs without any covering of earth or bogs which have been partially cut away during the winning and utilization of the upper layers are still to be seen slowly growing once more.

This after-growth varies a good deal in different places according to the nature of the ground and other circumstances more or less favourable towards it, so that, for instance, at Warmbrüchen, in Hanover, a peat layer 1 to 1½ m. in depth was able to form in a period of thirty years, while in other places, as in the Jura, the after-growth does not amount to much more than ½ m. in a century.

Although the process described above has taken place in this or a very similar manner in all bogs, the external appearance of the bogs is by no means always the same. Some bogs have long ago become covered with earth, sand, loam, or soil, and have perhaps become overgrown with trees and shrubs; others have only a slight sward, or consist of swamps with a more or less vigorous growth of the sedges and grasses characteristic of a peaty soil, or, finally, they may be entirely submerged under water, showing to the eye no trace of the presence of a bog.

According as the flooded areas have formed on mountain slopes, tablelands, or depressions in flat districts, the peat is found on plateaux and mountain ridges or in lowland wastes. The peat of mountain bogs is called mountain peat, while that of grass or lowland bogs is called grass peat. In general, the bogs may be divided into *high bogs* and *low, flat, or green bogs*.

High bogs, generally called *moss peat* or *moss bogs*, have been formed mainly from peat mosses (Sphagnum), heathers (Erica), and wool-grasses (Eriophorum). The peat mosses have the property of retaining water in large quantities, like a big sponge, or of sucking it up from the bottom. In this way the growth of these plants, unimportant in themselves, is greatly facilitated,



so that in the interiors they may grow to mounds showing the characteristic peat-forming plants of great depths (from 5 m. to 15 m.).<sup>1</sup> The large bogs of Oldenburg, Hanover, Bremen, Southern Bavaria, Bohemia, &c., belong to this class.

*Low* or *flat* bogs have been formed on a more fertile base from grasses, marsh grass, sedges, reeds, and rushes. They occur mostly in areas which are subject to inundation by rivers and lakes and form, as a rule, swamps and marshes, as in the Havel, Spree, Oder, and Danube basins.

The so-called *transition bogs* or *mixed bogs*, as regards their mode of origin, the classes of plants from which they have been formed and the peat contained in them, are intermediate between the *high* and the *low bogs*. More or less large areas or islands of the one kind of bog may occur in those of the other variety; high bogs may enclose grass bogs and vice versa. Sometimes the conditions of plant growth have so altered that in parts of a bog which was originally a grass or low bog, a high or moss bog several metres in thickness has formed, as, for example, in the Leba Bog, in Köslin.

In consequence of their situation, high bogs contain a smaller admixture of earthy substances, and have, therefore, as they are formed mainly from mosses, a very low ash and a high carbon percentage: they are poor in plant food. The low bogs, subject to frequent inundations and to deposits of dust carried by the wind, contain much earthy matter and have a more or less high percentage of ash. The peat-forming plants of the low bogs are poor in potash and phosphoric acid but are, on the other hand, rich in lime and easily soluble nitrogen.

The percentage of lime in the peat-forming plants is often utilized for the characterization and distinction of the various peat bogs. Thus, according to Professor Fleischer, *high bogs* are those in which the percentage of lime in the dry substance, supposedly free from casual constituents, does not exceed 0.5 and *low bogs* are those in which the percentage of lime does not fall below 2.5; transition, mixed, or intermediate bogs have percentages of lime lying between these limits.

As pointed out above, the land, in respect to its configuration and the impermeability of the soil, has a considerable effect on the formation of peat. No less important are the meteorological conditions of the country. Wherever frequent and strong winds continuously produce an undulatory motion of the water and give it atmospheric oxygen, or wherever southern heat and sun make the formation of flooded areas difficult, extensive peat bogs are rare. In the Torrid Zone peat bogs do not occur at all, while, conversely, the farther north one goes the more they increase in number and in extent.

In Europe, North America, and Northern Asia there is, indeed, no country which is not rich in large peat bogs. In Europe,

---

<sup>1</sup> Thus the Augstumal Bog, Heidekrug, is up to 10 m., the Great Moss Bog, Niedrup, up to 13 m., the Schehstedt Bog up to 20 m., and the Pentlack Bog, in East Prussia, up to 24 m. in depth.

Russia, Ireland, Sweden, Norway, Holland, Hanover, Oldenburg, Brandenburg, Pomerania, East and West Prussia, and the Russian Baltic provinces are noted for immense deposits. The farther south one goes, the greater the decrease in the area of the bogs; nevertheless, those of Bavaria, Württemberg, Baden, and Austria-Hungary are of considerable extent. Large bogs occur more rarely in France, Spain, and Italy.

The total area of all the bogs<sup>1</sup> in Europe alone cannot be given even approximately, since many of them, on account of their size and marshy nature, have not had even approximately trustworthy figures determined either for their areas or for their depths.<sup>2</sup>

The extent of the bogs in North-west Germany has been estimated as below<sup>3</sup> :—

The Württemberg and Baden peat bogs may be estimated at not less than 50,000 ha., the Bavarian at 100,000 to 150,000 ha., the Austrian at 400,000 ha.,<sup>4</sup> and the Swiss at 5,000 ha. The peat bogs of Sweden are extensive (approximately 5 million ha.), and also those of Norway (1 to 1½ million ha.) and Denmark (100,000 ha.), but considerably greater are those of Finland (about 10 million ha.) and Russia (up to 17 million ha.), where the *possible* winning of peat fuel per annum is estimated at 5,000 milliard pud = 82 milliard m. tons (cf. *Zeitschrift für Moorkultur*, Vienna, 1914, p. 170).

<sup>1</sup> The term "peat bog" has not yet been exactly defined. It is usual, in Germany, to include under this term only areas which have a peat layer of at least 20 cm. thickness; in the State peat statistics of Denmark, only the bogs which have a peat layer of at least one Danish foot (28 cm.) thickness are included. Hans Schreiber, Staab, proposes (*Osterr. Moorzetschrift*, 1914, p. 51) to define a *bog* as a district which has a peat layer of at least ½ m. in thickness and ½ ha. in area.

<sup>2</sup> The distribution of peat in Germany is treated in detail in von Dechen's "Die nutzbaren Mineralien und Gebirgsarten im Deutschen Reiche," Berlin, 1873, and Hoering's "Moornutzung," 1915.

<sup>3</sup> "Der gegenwärtige Stand der Moorkultur und der Moorbesiedlung in Preussen." Official publication, 1899; and Hoering, 1915.

	Hectares.
Hanover .. .. .	about 576,000
Oldenburg .. .. .	400,000
Brandenburg .. .. .	74,000
Pomerania .. .. .	312,000
Posen .. .. .	210,000
East Prussia .. .. .	200,000
Schleswig-Holstein .. .. .	180,000
Westphalia .. .. .	85,000
Silesia .. .. .	85,000
West Prussia .. .. .	85,000
Saxony .. .. .	85,000
Rhineland .. .. .	100,000
Total ..	2,392,000

<sup>4</sup> According to Dr. Bersch, Vienna; see also Zailer, *Jahrbuch der Moorkunde*, 1913.

## 2.—Composition of Peat, Percentage of Ash, and Constituents of the Ash

The investigation of the constituents of peat has given results which vary with the locality and the age of the bog from which the peat was derived, and with the plants from which it was formed.

The following researches give indications as to the compounds contained in peat :—

Wiegmann<sup>1</sup> found in 100 parts by weight of peat :—

	<i>High bog.</i>	<i>Dredged peat.</i>
"Humic acid" .. ..	27·6 ..	.. 10·4
Wax .. ..	6·2 ..	.. 0·25
Resin .. ..	4·8 ..	.. 0·425
Bitumen .. ..	9·0 ..	.. 2·25
"Humic carbon" .. ..	45·2 ..	.. 44·6
Water .. ..	5·3 ..	.. 2·2*
Calcium chloride .. ..	0·515 ..	.. —
Calcium sulphate .. ..	0·28 ..	.. 4·875
Silica and sand .. ..	0·72 ..	.. 16·4
Alumina .. ..	0·08 ..	.. 9·6
Calcium carbonate.. ..	0·44 ..	.. —
Iron oxide .. ..	} 0·265 ..	} 6·6
Calcium phosphate .. ..		

\* These samples must have been artificially dried.

Ferstl carried out a complete examination of a peat from St. Wolfgang in Upper Austria ; the peat contained 82 per cent. of organic matter, 3·5 per cent. of ash, and 14·5 per cent. of water. In 100 parts by weight of the peat there were :—

(1) *Soluble in water* :—

(a) Organic matter with traces of ammonia .. .. 1·50

(b) Inorganic matter :

Calcium sulphate .. ..	0·04
Sodium chloride .. ..	0·01
Potassium chloride .. ..	0·01
Magnesium chloride.. ..	0·05
Iron oxide .. ..	0·01
Alumina .. ..	0·01
Silicic acid .. ..	0·03
	——

0·16

1·66

(2) *Soluble in hydrochloric acid* :—

(a) Organic matter with traces of ammonia .. .. 0·13

(b) Inorganic matter :

Phosphoric acid .. ..	1·07
Magnesia .. ..	0·30
Lime .. ..	1·05
Iron oxide .. ..	0·12
Manganese oxide .. ..	0·04
Alumina .. ..	0·31
Silicic acid .. ..	0·05
	——

2·94

3·07

<sup>1</sup> Wiegmann, "Ueber die Entstehung, Bildung und das Wesen des Torfes," Brunswick, 1837.

(3) *Insoluble in water and acids*:—

## (a) Organic matter :

"Humic acid" .. ..	22·60
"Humic carbon" .. ..	34·70
Resin .. ..	4·10
Wax .. ..	1·40
Plant fibres .. ..	16·22

79·02

(b) Inorganic matter .. .. 0·29

79·31

(4) *Water* .. .. 14·50

Determinations of the ultimate composition of peat have been made more frequently. Professor Ritthausen,<sup>1</sup> of Königsberg, determined the percentages of (1) moisture, (2) ash, (3) nitrogen, (4) carbon, hydrogen, and oxygen in some peats from the Province of Prussia, after they had been powdered and air-dried, with the following results:—

No. of specimen .. ..	1	2	3	4	5	6
Moisture .. ..	13·36	16·94	18·19	14·89	16·42	14·75
Ash .. ..	1·37	1·72	1·73	1·74	11·92	5·18
Carbon .. ..	43·61	45·16	44·33	45·86	41·02	46·83
Hydrogen .. ..	5·17	4·65	4·48	4·65	4·27	4·52
Nitrogen .. ..	1·51	1·13	1·12	1·27	2·58	1·87
Oxygen .. ..	35·98	30·4	30·15	30·59	23·79	26·85

After allowing for the moisture, i.e., when in the anhydrous condition (dried at 110° C.), the samples contained:—

Ash .. ..	1·58	2·07	2·11	2·04	14·26	6·07
Carbon .. ..	50·33	54·38	54·13	53·9	49·0	54·93
Hydrogen .. ..	5·96	5·59	5·5	5·5	5·1	5·30
Nitrogen .. ..	1·81	1·36	1·37	1·49	3·08	2·19
Oxygen .. ..	40·32	36·6	36·89	37·07	28·56	31·51

And after allowing for the ash found in the various specimens, the organic portions of the peats had the following compositions:—

Carbon .. ..	1·13	55·52	55·29	55·02	57·15	58·48
Hydrogen .. ..	6·05	5·7	5·6	5·61	5·94	5·64
Nitrogen .. ..	1·83	1·49	1·4	1·52	3·59	2·34
Oxygen .. ..	40·99	37·29	37·19	37·85	33·32	33·54

The varieties of peat investigated were as follows:—

(1) Moss peat from Labiau, a very spongy, loose mass of plants, which had not been much transformed. The plants (*Sphagnum pallustre*) had a yellowish-green (slightly brown) colour, and were not much humified.

<sup>1</sup> "Bericht ueber die Verhandlungen und Exkursionen der Versammlung von Torfinteressenten zu Königsberg," 1873.

(2)–(4) Peat from Brandt Moor, Kurisch Haff, which is covered with fir trees. Sample No. 2 was taken from a depth up to 60 cm.; sample No. 3 from 60 to 120 cm., and No. 4 from 120 to 180 cm.

(5) Peat from Waldau, from the bog between Waldau and Stangau.

(6) Peat from Wolla, near Marienwerder.

Samples (5) and (6) were peats of ordinary quality but in the sod form; sample (6) was more solid than sample (5).

From the figures given it can be clearly seen that the peat becomes richer in carbon and poorer in oxygen the more it undergoes decomposition in the process of peat formation, and, further, that the oldest peats, (5) and (6), have the highest percentages of carbon and the lowest of oxygen.

Results, deserving of notice, with regard to the composition of the most important varieties of peat have been published by Professor Br. Tacke, of Bremen.<sup>1</sup>

They were obtained in a detailed examination of ten different specimens of peat at the Bremen Bog Experimental Station. The results, which are given in the table, p. 10, refer to anhydrous peat.

The weight of unit volume has been obtained from the fresh samples of the raw peat as taken from the bog, and with the aid of the above figures the quantities of combined nitrogen, lime, phosphoric acid and potash present in a cubic metre of the raw bog have been calculated. These are given in the table on p. 11.

It may be seen clearly from these figures how the various peats differ in their content of lime, and why the Bog Experimental Station has adopted the classification of the bogs for agricultural purposes according to their percentages of lime. According to Fleischer, the average percentages (referred to anhydrous peat) of the following substances in the upper peat layers are:—

		<i>Transition bog.</i>			<i>Low bog.</i>
		<i>High bog.</i>			
Nitrogen .. ..	0.81–1.20	..	2.0	..	2.50–4.00
Lime .. ..	0.25–0.35	..	1.0	..	4.00
Phosphoric acid ..	0.05–0.10	..	0.2	..	0.25–4.00
Potash .. ..	0.03–0.05	..	0.1	..	0.10–4.00

Of the varieties of peat in the table, p. 10, 1 to 4 are peats from high bogs, 5 is from a transition bog of low bog type, 6 and 8 are low bog peats, 8 (b) has the character of a high bog peat, and 9 that of a low bog peat.

Jacobsen<sup>2</sup> has examined in detail a peat from the neighbourhood of Hör, in Sweden. The appearance of the peat indicated the possibility of its having an unusual composition. The peat had a uniform brownish-black colour, and its cut surface had a strong resinous lustre. Perceptible remains of the peat mosses could be distinguished only in pieces taken from the higher layers; in the denser and darker lower layers only a few, more or less

<sup>1</sup> *Mitteilungen*, 1904, pp. 136–137.

<sup>2</sup> *Annalen der Chemie*, clvii.

Specimen No.	Variety of Peat	1		2		3		4		5		6		7		8		9		10					
		Recent sphagnum peat.	Nusse.	Intermediate peat.	(a)	(b)	Wörpeldorf.	Old sphagnum peat.	(a)	(b)	Wörpeldorf.	Transition moss and sedge peat.	Nusse.	Transition forest peat.	Nusse.	Marsh forest peat.	Pippinsburg.	Reed peat.	(a) containing earthy matter.	(b) with out admixtures.	Dieven Bog.	Liver peat.	Nusse.	Pippinsburg.	Heather peat.
	Source.	Nusse.	Nusse.	Wörpeldorf.	Nusse.	Wörpeldorf.	Nusse.	Nusse.	Nusse.	Wörpeldorf.	Nusse.	Nusse.	Ocholt.	Ocholt.	Pippinsburg.	Ocholt.	Ocholt.	Pippinsburg.	Ocholt.	Ocholt.	Dieven Bog.	Nusse.	Nusse.	Pippinsburg.	Pippinsburg.
	Combustible substances ..	97.18	93.86	98.45	97.79	97.97	98.36	95.43	92.44	83.44	49.91	96.53	49.91	2.23	0.44	2.23	0.60	38.70	49.91	2.23	0.60	58.24	58.24	38.70	38.70
	Nitrogen ..	0.67	1.16	0.92	1.33	0.95	1.79	1.48	1.88	1.93	1.82	1.30	1.82	0.14	1.93	1.82	—	0.82	1.82	0.14	—	1.97	1.97	0.82	0.82
	Mineral substances ..	2.82	6.14	1.55	2.21	2.03	1.64	4.57	7.56	16.56	53.09	3.47	53.09	0.29	16.56	53.09	3.47	61.30	53.09	0.29	—	41.76	41.76	61.30	61.30
	Insoluble in hydrochloric acid	1.22	4.26	0.71	0.85	0.63	0.34	1.07	1.22	13.46	37.27	1.69	37.27	0.08	13.46	37.27	1.69	60.05	37.27	0.08	—	32.20	32.20	60.05	60.05
	Lime ..	0.36	0.85	0.05	0.53	0.24	0.63	1.79	2.83	0.44	0.44	0.60	2.83	0.07	0.44	0.44	0.60	0.15	0.44	0.07	—	1.17	1.17	0.15	0.15
	Magnesia ..	0.12	0.07	0.20	0.07	0.27	0.05	0.13	0.15	0.14	0.35	—	0.15	0.08	0.14	0.35	—	0.09	0.14	0.08	—	0.53	0.53	0.09	0.09
	Iron oxide and alumina ..	0.42	0.45	0.17	0.26	0.35	0.17	0.82	2.02	1.29	11.76	—	2.02	0.09	1.29	11.76	—	0.74	11.76	0.09	—	5.48	5.48	0.74	0.74
	Manganese oxide ..	0.01	0.01	0.01	0.01	0.02	0.01	0.05	0.09	0.05	0.05	—	0.09	0.08	0.05	0.05	—	0.03	0.09	0.08	—	0.09	0.09	0.03	0.03
	Potash ..	0.10	0.03	0.05	0.03	0.07	0.03	0.05	0.04	0.08	0.18	—	0.04	0.06	0.08	0.18	—	0.09	0.18	0.06	—	0.50	0.50	0.09	0.09
	Soda ..	0.18	0.07	0.06	0.09	0.11	0.06	0.08	0.08	0.08	0.07	—	0.08	0.07	0.08	0.07	—	0.06	0.07	0.07	—	0.25	0.25	0.06	0.06
	Phosphoric acid ..	0.05	0.04	0.05	0.05	0.03	0.06	0.05	0.08	0.09	0.09	—	0.05	0.08	0.09	0.09	—	0.09	0.09	0.08	—	0.11	0.11	0.09	0.09
	Sulphuric acid ..	0.57	0.43	0.35	0.40	0.38	0.37	0.81	1.20	1.06	1.06	—	1.20	0.72	1.06	1.06	—	0.18	1.06	0.72	—	1.52	1.52	0.18	0.18
	Chlorine ..	0.04	0.04	0.06	0.07	0.03	0.07	0.03	0.04	0.04	0.04	—	0.03	0.04	0.04	0.04	—	0.04	0.04	0.03	—	0.03	0.03	0.04	0.04

From these figures the percentages of the various substances in the peat, free from matter insoluble (mainly sand) in hydrochloric acid, can be calculated with the following results:—

Combustible substances ..	98.38	98.04	99.15	98.63	98.59	98.70	96.46	93.58	96.99	74.78	98.19	85.19	96.87
Nitrogen ..	0.68	1.21	0.93	1.34	0.96	1.80	1.50	1.90	2.23	2.90	1.32	2.91	2.05
Lime ..	0.36	0.89	0.05	0.53	0.24	0.63	1.81	2.86	0.51	3.67	0.61	1.73	0.38
Phosphoric acid ..	0.05	0.04	0.05	0.05	0.03	0.06	0.05	0.08	0.10	0.59	0.08	0.16	0.23
Potash ..	0.10	0.03	0.05	0.03	0.07	0.03	0.05	0.04	0.09	0.29	—	0.74	0.23

Description.	Weight of a cubic metre in kilograms.		Amount (in kilos) in a cubic metre of raw peat of			
	Raw.	Anhydrous.	Nitrogen.	Lime.	Phosphoric acid.	Potash.
1. Recent sphagnum peat (Nusse)	952	83.2	0.56	0.30	0.04	0.08
2. Intermediate peat						
(a) Nusse .. ..	946	176.1	2.04	1.50	0.07	0.05
(b) Wörpedorf ..	1,042	133.8	1.23	0.07	0.07	0.07
3. Old sphagnum peat						
(a) Nusse .. ..	986	114.5	1.52	0.61	0.06	0.03
(b) Wörpedorf ..	1,041	107.5	1.02	0.26	0.03	0.08
4. Transition moss and sedge peat (Nusse)	992	138.7	2.28	0.87	0.08	0.04
5. Transition forest peat (Nusse)	889	134.6	1.99	2.41	0.07	0.07
6. Marsh forest peat (Ocholt)	1,060	140.5	2.64	3.98	0.11	0.06
7. Reed peat (Pippinsburg)	991	103.3	1.99	0.45	0.09	0.08
8. Mud peat						
(a) Containing earthy matter (Ocholt)	1,104	386.9	7.04	8.63	1.43	0.70
(b) Without admixtures (Dieven Bog)	1,072	154.4	2.01	0.93	0.12	—
9. Liver peat (Nusse) ..	1,060	180.9	3.56	2.12	0.20	0.90
10. Heather peat (Pippinsburg)	691	498.7	4.09	0.75	0.75	0.45

large, pieces of wood could be recognized. The density of the peat from the lower layers, when the peat was freed from the pieces of wood, was 1.07. When powdered, the peat lost on drying at 100° C. 11.5 per cent. of moisture, and contained 5.02 per cent. of ash.

The chemical examination showed that 100 parts of the peat contained:—

	Per cent.
Carbon .. ..	51.38
Hydrogen .. ..	6.49
Nitrogen .. ..	1.68
Oxygen .. ..	35.43
Ash .. ..	5.02

In 100 parts of the ash there were:—

	Per cent.
Potash .. ..	1.50
Soda .. ..	0.58
Lime .. ..	20.75
Magnesia .. ..	1.42
Alumina .. ..	6.60
Iron oxide .. ..	17.34
Sulphuric acid .. ..	1.55
Chlorine .. ..	0.67
Soluble silicic acid .. ..	6.50
Phosphoric acid .. ..	0.42
Carbonic acid .. ..	8.43
Sand .. ..	33.50

And traces of manganese.

Apart from the high percentages of lime and iron oxide in the ash, the results obtained did not support the conjecture mentioned above, but again bore out the general experience that the *chemical composition of pure peat is liable to only slight variations, and that deviations found in the composition of a peat and its behaviour on burning are mainly due to earthy admixtures, i.e., to the percentage of ash and the composition of the latter.*

The following table (see p. 13) contains the results of a number of peat investigations, which support what has just been stated.

From the figures contained in the table we may assume that the chemical composition of pure, ash-free, dry peat is:—

57 to 59 p.c. Carbon, 5 to 6 p.c. Hydrogen, and 34 to 38 p.c. Oxygen, or on an average, 58 p.c. Carbon, 5.5 p.c. Hydrogen, and 36.5 p.c. Oxygen; or, if we suppose that all the oxygen is combined with the hydrogen in the form of water, then have we approximately:—

58 p.c. Carbon, 1 p.c. Hydrogen, and

41 p.c. "chemically bound water."

In the same way we may assume that *air-dry* (25 per cent. moisture), *ash-free (cut) peat*, contains:—

44 p.c. Carbon, 0.75 p.c. Hydrogen, 30.25 p.c. "chemically bound water," and 25 p.c. moisture.<sup>1</sup>

It is immediately evident from the table that the percentage of ash in different kinds of peat is as varied as the composition of the ash. This is due partly to the mode of formation of the peat and partly to the position (i.e., to the locality) of the bog, as already indicated.

The *amount of ash* varies from  $\frac{1}{2}$  to 50 per cent. of the weight of the completely dried peat. When the amount of ash in the peat is less than 5 per cent. the peat is said to be *poor in ash*, when between 5 and 10 per cent. the peat is said to be of *medium ash content*, and when the percentage of ash is more than 10 the peat is said to be *rich in ash*.

A peat which contains more than 25 per cent. of ash is of no use as a fuel, since it is not commercially possible to wash out, or otherwise remove, the ash constituents. Moreover, there is naturally so great a quantity of peat with a more or less small percentage of ash that it has not hitherto been necessary to resort to the use of peat rich in ash.

The table on p. 15 contains the individual constituents of various peat ashes, and from it the varied nature of their composition may be seen. These figures are of value with regard to the fertilizing power of peat and peat ash (in the moor-burning industry), and also with regard to furnaces where it is a matter

<sup>1</sup> Under the term "moisture" is understood that amount of moisture or water in a body which is not chemically united with the other constituents but, in consequence of the loose or fibrous character of the body, is absorbed by the latter from the air, and which therefore varies with the moisture content of the air. The moisture is driven out of the body, and, measured by the decrease in weight of the latter, by more or less prolonged heating of the body at 100° to 110° C.



Peat from.	Percentage in dry peat of			Density.	Properties of the Peat.		Observer.
	Carbon. C.	Hydro- gen. H.	Nitro- gen. N.		Oxygen. O.	Ash.	
1. Cappoge, Ireland ..	51.05	6.85	39.55	2.55	..	..	Kane.
2. Killebegan, Ireland ..	61.04	6.67	30.46	1.83	..	..	Kane.
3. Philipstown, Ireland ..	58.69	6.97	1.45 32.88	1.99	..	Pale reddish-brown with roots	Kane.
4. Wood of Allen, Ireland ..	61.02	5.77	0.81 32.40	7.90	Up to 0.405	Deep blackish-brown, solid and dense	Kane
5. Vulcaire, near Abbeville..	57.03	5.63	2.09 29.67	5.58	0.639 to 0.672	Dark brown without plant mould	Regnault.
6. Lony .. .. .	58.09	5.93	30.77	4.61	..	Less completely decomposed than 5&6	Regnault.
7. Framont .. .. .	57.79	6.11	31.37	5.33	..	Solid and dense without plant mould	Walz.
8. Ramnstein, Rhine Prov.	62.15	6.29	1.66 27.20	2.70	16.7	Somewhat lighter .. .. .	Walz.
9. Steinwenda, Rhine Prov.	57.50	6.90	1.75 31.81	2.04	16.0	Light felted mass .. .. .	Walz.
10. Neidermoor, Rhine Prov.	47.90	5.80	42.80	3.50	17.0	.. .. .	..
	{ 50.13	{ 4.20	{ 31.44	{ 8.20	{ 15.17	.. .. .	..
	to	to	to	to	to	.. .. .	Baër.
11. Prussia .. .. .	55.01	5.36	35.24	21.17	21.70	Dense .. .. .	Mulder.
12. Frisia .. .. .	57.16	5.65	33.39	3.80	..	Light .. .. .	Mulder.
13. Frisia .. .. .	59.86	5.52	33.71	0.91	..	.. .. .	Mulder.
14. Holland .. .. .	50.85	4.64	30.25	14.25	..	.. .. .	..
15. Bremen .. .. .	57.84	5.85	0.95 32.76	2.6	..	Blackish-brown, dense and heavy	Brenninger.
16. Bremen .. .. .	57.03	5.56	1.67 34.15	1.57	..	Brownish-black and dense lower layer	Brenninger.
17. Schopfloch, Württemberg..	53.59	5.60	2.71 30.32	8.10	20	The same, middle layer .. .. .	Brenninger.
18. Sindelfingen .. .. .	45.44	5.28	1.46 26.21	21.60	18	.. .. .	..
	{ 46.75	{ 3.57	{ 25.87	{ 0.89	{ 11.77	.. .. .	..
	to	to	to	to	to	.. .. .	Nessler and Peterson.
19. Baden .. .. .	60.79	7.01	6.33 49.01	14.76	18.5	Dense, heavy, brown .. .. .	Jäkel.
20. Berlin, Havel basin ..	56.43	5.32	38.55	9.86	17.63	Light, loose, reddish-brown	Jäkel.
21. Berlin, Havel basin ..	53.51	5.90	40.59	6.60	19.32	Heavy .. .. .	Jäkel.
22. Hamburg Moor .. .. .	57.20	5.32	37.56	2.31	..	.. .. .	Webisky.
23. Grunewald .. .. .	49.88	6.50	1.16 42.44	3.72	..	.. .. .	Webisky.
24. Harz .. .. .	50.86	5.80	0.77 42.70	0.57	..	.. .. .	Webisky.
25. Harz .. .. .	62.54	6.81	1.41 29.24	1.09	..	.. .. .	Webisky.
26. Linum .. .. .	59.47	6.52	2.51 31.51	18.53	..	.. .. .	Webisky.
27. Handsmühl .. .. .	59.70	5.70	1.66 33.04	2.92	..	.. .. .	Webisky.
28. Haspelmoor .. .. .	58.93	5.72	35.35	8.43	15.50	Press peat .. .. .	Krant.
29. Neustadt Works .. .. .	59.61	5.43	31.64	3.32	10.31	The same .. .. .	Krant.
30. Montauger .. .. .	54.01	4.84	28.56	12.59	17.11	Peat by Challeton's process	Krant.
31. Neuchâtel .. .. .	46.78	4.38	28.56	20.28	18.72	The same .. .. .	Krant.
32. Kolbermoor .. .. .	58.51	6.17	35.32	4.21	15.50	Press peat .. .. .	Wagner.

of the purity or special composition of the flame, or where the substances to be heated, burnt, or melted come in direct contact with the fuel and its ash.

### 3.—Weight and Density

The weight of a cubic metre (without interstices) of peat freshly raised from the bog varies with the amount of water (which is generally from 80 to 95 per cent.) in the bog (i.e., the extent to which the bog is drained), and with the quality, age, and maturity of the peat. The following weights have been given for a cubic metre of freshly cut peat from various Swiss bogs. One cubic metre (raw peat) weighed :—

	Kilos.
From a bog at Orny-Orbe .. .. .	1,300
From a bog at Wanwyl .. .. .	1,300
From the Great Moss at Bern.. .. .	1,200
From the Great Moss at Freiburg .. .. .	950
From En Rosé Bog .. .. .	1,000
From Pont Bog .. .. .	850
From Einsiedeln Bog .. .. .	650

Unfortunately, in the determinations the percentages of ash and water in the samples examined are not stated.

We may assume that the average weight of a cubic metre (without interstices) of raw peat containing 85 to 90 per cent. of water is 1,000 kilos.

The density (or specific gravity) of crude dried peat depends largely on its percentage of ash and on the age of the bog, as well as on the depth of the layer and on the maturity of the raw material. According to Karmarsch, we may assume that the densities for the different kinds of peat vary within the following limits :—

Mossy, fibrous, or grassy peat .. .. .	0·213—0·263
Young, brown peat .. .. .	0·240—0·676
Mould peat, mud peat, dough peat .. .. .	0·410—0·902
Pitch peat, bituminous peat .. .. .	0·639—1·039

The latter limit is, however, not sufficiently high, since in Oldenburg a black, dense peat is frequently met with, the density of which amounts to 1·3.

Artificial treatment of peat, of course, also alters its density. Increasing the density of peat for use as fuel is the main object of the present methods of winning peat. How far this has been attained will be given further on under each of the methods of winning.

### 4.—Properties of Peat affecting its Use

The composition of the pure peaty matter contained in peat, which has been found from many experiments, is, on the average : carbon, 58 per cent. ; “ free hydrogen,” 1 per cent. ; and “ chemically bound water,” 41 per cent. We can see from the high percentages of carbon and hydrogen, the substances which are valuable for combustion, and from the extraordinarily wide

COMPOSITION OF VARIOUS SPECIMENS OF PEAT ASH.

Constituents.	Ashes from Bavarian peats, according to Zoller.				Ash from Upper Austria peat, accord- ing to Ferstl.	Ash from Dutch peat.	Ash from Scotch peat, according to Anderson.		Ash from American peat, according to Johnson.		Birmoos peat ash, according to G. Theinus.					
	1	2	3	4			5	6	7	8	9	10	11	12	13	14
	Potash	1.920	1.04	1.41			1.16	0.56	1.49	0.74	0.46	0.69	0.80	—	—	—
Soda	0.954	0.22	0.76	0.59	0.65	1.17	0.99	—	0.58	—	—	—	—	—		
Magnesia	2.660	0.90	0.86	0.44	1.37	4.57	0.40	—	6.06	4.92	1.54	1.63	1.55	1.45		
Lime	31.470	10.45	6.72	3.22	15.32	11.75	1.18	1.31	40.52	35.59	28.52	29.12	30.05	29.52		
Calcium sulphate	—	—	—	—	—	—	30.72	12.54	—	—	13.93	14.15	14.23	14.59		
Iron oxide	13.250	21.23	14.84	5.80	8.76	5.33	—	1.85	5.17	9.08	5.46	4.95	5.20	5.15		
Alumina	0.960	2.07	0.73	0.48	1.07	2.98	—	Traces	0.50	0.77	0.12	0.13	0.14	0.13		
“ Phosphoric acid ”	2.058	1.14	1.87	0.85	2.59	Traces	—	—	5.52	10.41	1.53	1.60	1.59	1.45		
“ Sulphuric acid ”	7.910	21.18	14.45	11.96	—	9.77	5.52	2.02	8.23	1.40	36.92	37.50	36.29	36.52		
“ Silicic acid ”	*0.568	*0.37	*0.48	*0.35	45.56	1.50	—	0.13	*0.15	*0.43	—	—	—	—		
Sodium chloride	38.242	39.30	57.00	74.56	†10.08	51.57	60.62	—	31.71	37.32	†11.25	†10.12	†10.10	†10.50		
Sand, alluvium (“ carbonic acid ”)	100.00	100.00	100.00	100.00	100.00	100.00	100.00	99.92	99.13	100.72	99.27	99.20	99.15	99.31		
Ash in 100 parts of dried peat	7.60	12.80	—	—	—	—	—	—	1.12	—	1.12	1.13	1.23	1.12		

\* Chlorine.

† Carbonic acid.

‡ With ferrous oxide.

occurrence of peat, that it must have been very early recognized as a fuel, and valued as such under certain conditions.

Even Pliny relates in his Natural History XVI, 1, of the Chauci, "that they weave nets of rushes and reeds to catch fish, and mould mud with their hands and dry the mud in the wind rather than in the sun. This earth they burn to cook their food and warm their bodies benumbed by the cold."

However early the use of peat as a fuel was recognized, its value for this purpose was not admitted until recent times. This was partly due to abundance of wood in the forests, which were regarded as inexhaustible, and, at a later date, partly to the introduction of coal and brown coal as fuel, and in part to faulty preparation of the peat and to lack of fireplaces suitable for burning it. In recent times, however, the great demand for fuel by large industries and the correspondingly high prices of wood and coal, as well as the advances in the art of working furnaces, gave rise to renewed and more intense interest in peat. On account of its composition it has attracted the attention of many technical men as a raw material for the *production of gas* and for the winning of *tar, ammonia, photogene, paraffin, peat charcoal, &c.*, formed as by-products during the gasification. Also, on account of the great absorptive power of light moss peat, the attention of land-owners has become directed to its utilization as peat litter and peat mull. From the conditions necessary for the formation of peat, it follows that peat occurs in nature either entirely under water, or in immediate contact with and saturated by it. Since peat in this wet condition is obviously not directly suitable for any of the above-mentioned purposes, the winning of peat as a dry, convenient, transportable substance must precede every utilization of the substance. Peat, on account of the smallness of the amount of useful bodies contained in it in respect to its total mass can only bear low costs of winning. This fact has affected to a varying extent the commercial success of the various methods hitherto employed for its utilization.

## SECTION II

# PREPARATION FOR PEAT WINNING BY DRAINAGE OF THE BOGS

### 1.—Natural Drainage ; Arrangement of the Drains

Drainage of the bog must precede the winning of the peat by any process. Owing to the manner in which bogs are formed and to the property possessed by peat-forming plants of retaining moisture, the water-level in bogs is so high that the loose structure of the upper layers of every bog partakes more or less of the properties of a swamp, accessible, for the purposes of winning on a large scale, by neither man nor beast.

When we speak in the following pages of the winning of peat, we shall mean only operations conducted on a large scale and in a systematic manner, and not that piratical winning sometimes practised in the smaller peat works. The latter mode should under all conditions be avoided, since it not only places obstacles in the way of the development, later on, of plans for the systematic cutting and drying of the peat, but also makes the drainage of the bog more difficult to accomplish owing to the irregular manner in which it has been cut up during the piratical winning. The latter method increases the amount wasted a good deal, and, moreover, a bog which has not been worked systematically is almost worthless for agricultural purposes.<sup>1</sup>

The Bog Preservation Law of April 1st, 1913, was passed in Germany to prevent such piratical winning and to ensure the possibility of utilizing the soil, later on, for agriculture and afforestation. This law became operative immediately on its passing for the Province of Hanover. Its operation in the other Provinces is dependent on the decisions of the Provincial Diets. By its provisions ground which, alone or in connexion with other plots, forms a bog of more than 25 ha. shall, so far as is required by the commonweal, be utilized for the winning of peat in a manner such as to assure the possibility of utilizing this ground later on for agriculture or afforestation.

Permission is not required for the winning of peat for one's own household or for sale, provided the transactions are limited to the workmen of a single house and to two other persons, at the most. Similar but even more comprehensive regulations have been in existence in Holland since 1810 and in Norway since 1913.

---

<sup>1</sup> Cf. Dr. Fleischer, "Die Verpflichtungsbedingungen zur Sicherung zweckmässiger Ausnützung zu verpachtender Moore und Torfländereien," in the Report of the Proceedings of the Central Moor Commission, First to Eleventh Meeting, p. 106.

In other countries which are rich in bogs regulations of this character are in course of preparation.

The drainage of bogs, the object of which is to remove all the water in the soil except that which the fibrous and spongy nature of the peat enables it to retain between its cells, if it can be effected in the natural way, or in an artificial way (by means of machines, pumps, &c.) at not too great an expense, should always be started a long time before the commencement of the actual operations of winning. It should be carried out very early in the spring, or, still better, a year or two beforehand, in order that the water may have sufficient time to ooze out and flow away from the bog.

When the bog is so far drained that the surface is able to bear men, beasts, and machines, the peat still contains 80 to 90 per cent. of water, which can, however, be removed from it, wholly or partially, simply by either drying it in the air or by means of artificial heat or by compressing it after it has been raised from the bog. Air-drying is the only method which has proved successful from the economical standpoint.

Natural drainage, that is, drainage by means of a number of drains cut in the bog in which the water collected is brought by natural falls through a main drain to a lower-lying place, brook, pond, or river (the so-called drainage of the catchment basin), is, as is hardly necessary to say, the cheapest method since the peat raised in cutting the trenches can generally be utilized by conversion into fuel by one of the methods described later on and since mechanical power and artificial aids, such as drainage by machinery, are not required to raise and remove the water. These aids to drainage are necessary when the district has not sufficient fall for the removal of the collected water by means of drains.

In cases where the possibility of the natural drainage of large bogs is not obvious or may seem even impossible to the mind of the layman, it is always advisable, before resorting to artificial drainage, to obtain the advice of an expert. The latter, either by measurements conducted with care or by removal of small obstructions, may show that natural drainage is possible and plan it correctly, or, on the other hand, by finding the most suitable point for the erection of draining machines, planning the collecting and connecting drains as well as indicating the size, character, and mode of driving of the machines which are best suited for the given case, will save the bog-owner from useless and expensive erections to which laymen might be led by not paying sufficient attention to the conditions in question.

The scarp of the drains may be from 1 :  $\frac{1}{4}$  for a firmly set and felted bog, and 1 :  $\frac{1}{2}$  for a soft, spongy bog, but should never be under 1 :  $1\frac{1}{2}$ .

The main drain should be directed, where possible, towards the deepest part of the bog and be led to a point from which the collected water can flow into a pond or watercourse or into which, after being raised by pumps to a higher level, it can be led by the fall thus artificially produced. A main drain is then opened into

the middle of the bog which is about to be worked and is connected in a regular manner with the rest of the bog by side-drains arranged in a radial or net-like formation.<sup>1</sup>

In Oldenburg, for instance, the water is removed by means of drains (Rajung-Grippen) having a width and depth of 0.6 m. which are cut every 50 m. from one another. These drain into the fen canal which passes through the bog, and smaller drains 10 m. apart, each having a depth of 0.5 m. and a width of 0.3 m., are cut crosswise to the others.

The drains are first cut as deep as the character of the bog will permit and later, when collapse of the trench slopes is no longer to be feared, they are cut to at least  $\frac{1}{2}$  m. below the water-level due to the drainage in the catchment basin, or  $\frac{1}{2}$  m. deeper than it is intended to cut the peat. In very wet bogs the main drains should be cut at first to depths of only 25 to 50 cm. After some time the

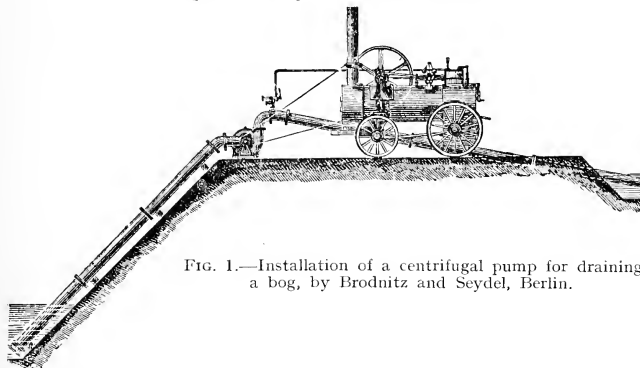

FIG. 1.—Installation of a centrifugal pump for draining a bog, by Brodnitz and Seydel, Berlin.

drains may have their depths increased to 1 m. or more, and in bogs with "back pressure" they may be connected with short cross-drains (so-called Kopfgrippen) 10 m. apart, which deliver into the middle drain at right angles to its two sides. These drains have a breadth of 60 cm., a somewhat smaller depth, and a length about three times the depth of the bog. The peat banks thus formed along the edges of the drains drying more quickly and, therefore, becoming better consolidated, offer some, and generally sufficient, resistance to the "back pressure" of the still undrained bog in the rear.

It is better to cut a much-branched net of smaller drains than a few large canals. As in draining land, the cross-section is calculated on the assumption that the flow is 0.65 l. per second for every hectare.

A good workman is able to dig (grippen) 60 to 80 linear metres of a drain, 0.6 m. in depth and width, in a day.

<sup>1</sup> Compare with this the mode of drainage practised in the Oldenburg bogs (Section III). For drainage systems, see also Vogler, "Grundlehren der Kulturtechnik," Berlin.

## 2.—Erection and Working of Pumping Machinery for Artificial Drainage

Centrifugal pumps, pulsometers, and water-wheels are generally recommended for raising water in peat bogs, owing to the ease with which they can be installed and worked.

(a) *Centrifugal pumps*, hitherto more generally known and used than water-spirals, although the construction and the utility of the latter were pointed out by Vitruvius 2,000 years ago, can be obtained from every important machine factory or shop. Nevertheless, it will be well to apply for them to special factories, for instance, B. Brodnitz and Seydel, in Berlin, Fr. Gebauer, in Berlin, R. Wolf, in Magdeburg-Buckau, amongst others, stating the object, the driving power intended to be used, the probable amount of water to be operated on and the height to which it is to be raised. By mistakes in designing them or by wrong selections of measurements or velocities, the efficiency of these pumps, approximately 75 per cent., may be considerably lowered.

These centrifugal pumps are easy to set up, require only a simple driving belt, and no special stonework foundations. They may be employed with advantage, especially when the heights to which the water must be raised are small (up to 10 m.).

The following table may serve as an approximate guide with regard to output, power required, and price.

OUTPUT, PRICE, AND DIMENSIONS OF CENTRIFUGAL PUMPS FOR PUMPING DISTANCES UP TO 15 M., AND SUCTION HEIGHTS UP TO 6 M.

Output in litres per minute	300	450	600	1,200	3,000	6,000	8,000	15,000
Diameter of tube in mm.	60	70	80	105	175	250	275	400
Diameter of belt-wheel in mm.	105	105	125	140	240	320	400	600
Width of belt-wheel in mm.	90	105	105	120	160	230	235	350
Horse-power required for pumping distance of								
3 m.	0·30	0·45	0·60	1·20	3·00	6·00	8·03	12·30
6 m.	0·60	0·90	1·20	2·40	6·00	12·00	16·00	24·6
9 m.	0·90	1·35	1·80	3·60	9·00	18·05	24·00	36·9
Price of pump with belt-wheel, in Marks	185	220	260	310	500	750	1,100	1,800
Price of foot-valve with pump-sieve, in Marks	29	30	32	42	85	301	150	225

If the position of the pump must be frequently changed it is advisable to employ a portable one; the steam boiler, the driving machine, and the pump itself being built on the same frame—"a portable centrifugal pump," such as is shown in Fig. 2. This facilitates to an extraordinary extent the installation and working of the pump, the belt, which would require tightening from time to time, being dispensed with, and the driving power, as well as the fuel consumption, being decreased.



A portable pump such as this costs :—for 12 h.p. and 6,000 l. a minute output, 6 m. suction height (approximately 4,400 kilos in weight), 7,200M., and for 20 h.p. and 10,000 l. a minute output, 6 m. suction height (approximately 6,000 kilos in weight), 9,000M.

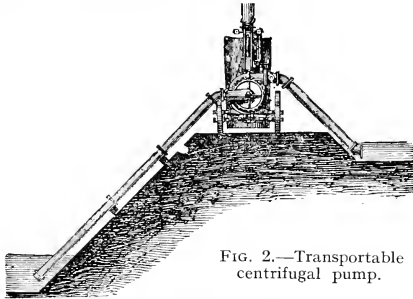

FIG. 2.—Transportable centrifugal pump.

(b) *Steam-chamber pumps* or *steam-pulses* (pulsometers) are characterized by simplicity of installation and convenience in working (they require only a simple steam connexion and, when suspended by a chain, can be lowered directly into any water trench). They require, however, when working, more steam for the same amount of water pumped and have, therefore, greater working expenses than good pumps. They are used whenever quantities of water must be quickly, but not continuously, removed.

For a pumping distance up to 8 m., a suction height up to 3 m., and an output per minute of . . . .	350	500	600	800	1,000	1,500	2,000 l.
Width of water tube, about	70	80	90	100	120	150	175 mm.
Weight of machine, about . .	150	200	300	350	400	450	700 kilos.
Price, including suction-sieve and foot-valve, about	310	360	400	500	600	800	1,000M.

These pumps are on sale by Körting Bros., Hanover; M. Neuhaus and Co., Luckenwalde; Henry Hall, successor to Karl Eichler, Berlin; C. W. Julius Blancke and Co., Merseburg, &c.

(c) *Water-elevating wheels*, which are driven by steam or electricity and have been constructed, with diameters up to 10 m. and widths up to 3 m., for the drainage of more or less large districts in Holland rather than in Germany, are used with advantage only for large quantities of water and small falls (up to a maximum of 1.5 m.). Plants of this character have been erected at Königsberg by the civil engineer Hagens. Thus, for instance, there are six of these water-wheels employed with good results on the drainage of the Memel basin at six different elevating points, the wheels being driven electrically by a 480 h.p. power station situated at some distance from them.<sup>1</sup>

<sup>1</sup> Cf. "Ueber die Technik der Wasserhebung bei künstl. Entwässerung von Mooren," Architect Danckwert, *Mitt. d. Ver. f. Moork.*, 1900, p. 101.

The consumption of coal, including loss of electricity in transmission, was, during some prolonged trials, 1.40 kilos for every 100 cb. m. of water raised to a height of 1 m.

### 3.—Disadvantages of Over-draining

However necessary a partial draining of the bog may be for the winning of peat, and however advantageously it may affect the character of the raw peat—inasmuch as the plant remains (roots, fibres, wood, &c.) still contained in the bog, which have obstinately withstood peat formation and decomposition under the water and which in this condition would greatly impede the winning and preparation of the peat, are once more subjected to a rapid humification—nevertheless, the removal of the water must not be continued until the individual layers become quite dry. In the latter case the brittle, friable character of the dry, loose peat would introduce difficulties of quite another kind and, indeed, it would again be necessary to add water to the peat if it were to be further worked by machines. The best percentage of water which peat that is intended for further treatment should contain depends on the consistency of the peat as well as on the method of winning and utilizing it. For the preparation of machine peat, which will be discussed in greater detail later on, this percentage of water lies between 70 and 80 and may be all the smaller the greater the tearing and mixing action of the machine employed. This is of great importance and should not be lost sight of in connexion with the labour and time required for drying. The percentage of moisture may be considerably lower in the case of crumb peat intended for gasification.

Frost exerts a very injurious effect on moist, that is, neither air-dry nor thoroughly wet, peat. If the "moist" peat freezes it will not retain, after thawing, the property of contracting and becoming denser on drying. By the action of the frost the union of the fibres with the peat particles and their mutual cohesion are destroyed, the peat forming, after drying, a very crumbly, light mass. When this frozen peat is dried after thawing it loses its fibrous character and in a short time becomes peat mould, the winning of which, owing to its crumbly nature, can no longer be effected by ordinary cutting, and even by utilizing other methods of winning great difficulty is experienced. By means of machines, however, it can be converted into machine peat after the addition to it of good, unfrozen raw peat. Frost exerts a less injurious influence on the winning of crumb peat intended for gasification.

To prevent loss due to the freezing of the upper layers in a peat bog which is provided with a drainage system and in which peat is *cut*, every main drain should be provided with a sluice by means of which the water may be dammed up at the end of the peat season, and the bog again saturated with water. Drainage can, as before, go on from early in spring to the beginning of the winning operations. This system of sluices is not required for machine peat winning.

### SECTION III

## WINNING AND PROPERTIES OF HAND PEAT

### 1.—The Winning of Cut, Stroked, Trodden, Dough, and Dredged Peat

When the drainage of a bog has proceeded so far that the peat while *in situ* contains 70 to 85 per cent. of water, the work of winning, properly speaking, can be started. Much peat, however, is won which contains a still higher percentage (over 90) of water even in cases where it is not entirely a matter of winning peat under or from water.

The winning of *cut peat* by cutting the peat with a spade is the best known and most generally employed of the hand methods. It is carried out in the most varied ways according to the custom of the locality or the character of the bog. We may divide these methods into *vertical* and *horizontal cutting*, of which the first is the more widely used. In this method the workman stands on the surface to be cut and with a slane (Fig. 7) cuts the sods,<sup>1</sup> as the pieces of peat won and prepared in regular form (mostly rectangular) and size are called, to the required length, lifts them with the slane and places them near him on the bog, from which they are removed by other workmen, who "spread" them for drying.

In *horizontal cutting* the bank is cut vertically, being thus divided into portions each having the width of a piece of peat (sod). A second workman standing in the trench cuts the pieces horizontally, employing for this purpose a small spade, sharpened on three sides, the width of which is that of the sods. With this implement, called a "*lifter*," he cuts every piece horizontally to the required thickness and lays it on the edge of the trench, where it is received and from which it is removed by a third workman.

It would take us too long to discuss fully the various modifications of these methods of winning,<sup>2</sup> and as the chief object of this

---

<sup>1</sup> The expression "*peat bricks*" or "*peat stones*" applied to sods in a few factories should never be used in the case of litter and fuel peat in technical articles by experts, so as not to cause obscurity. These terms should be reserved for regularly formed peat products which, like ordinary bricks (building bricks, tiles, cement bricks, &c.), serve for building purposes, for damping sound, for the thermal insulation of walls, for supports for insulating sheds, &c.

<sup>2</sup> For details, see the pamphlet "Ueber Gewinnung und Benutzung des Torfes in Bayern," Munich, 1839; also the memorandum "Die Landwirtschaft im Reg-Bez. Oberbayern," dedicated to the Twenty-sixth Excursion of the Bavarian Agriculturists (1885), in Tölz; see also an article by Dr. Zailer in the *Zeitschr. f. Moork. und Torfverw.*, 1911, p. 89.

book is to describe fully the winning of peat in so far as this is carried out on a large scale and by means of machinery, only the Oldenburg method of cutting, which is still widely employed, and the methods of winning hand peat most in vogue in South Germany and Austria will be considered, so that we may compare the results thus obtained, the costs of winning, and the requirements as regards labourers, &c., with the results obtained in the preparation of the so-called "*manufactured peat*" or "*machine peat*."

The Oldenburg Administration, with a view to the systematic utilization of their extensive peat moors, which are situated between Oldenburg and Leer, has divided a portion of these moors into so-called "Colonies,"<sup>1</sup> which various colonists are permitted to utilize on payment of a rent. The administration itself is concerned with the provision of navigable fen canals, which are cut at its expense:—

- (1) For the better drainage of the whole bog.
- (2) For means of communication between the various settlements as well as for easy and cheap transport of the peat when it has been won.
- (3) To provide for the watering (irrigation) of the cut-away bog for agricultural utilization.

The colonies set apart for working are intersected from west to east by the South Georgsveen Canal, which is in course of construction, and which they border to a depth of 70 m. to 100 m. They contain a total area of about 2,000 Calenberg acres.

There are dikes on both sides of the canal, and on each of these there is a road with a footpath 15 m. in width, which is separated from the adjoining colonies by the so-called surrounding channel ("*Ringschlot*"), i.e., a trench which has a width of from 3 m. to 1.5 m. and a depth corresponding to this width.

As a preparatory operation for the drainage of the whole surface a trench, "*Mittelrajung*" (midrib), 1 m. in width and 1 m. to 1½ m. in depth, is cut in the direction of the axis of the canal, and side trenches, 0.6 m. in depth and breadth, are cut in the direction of the "*Ringschlöte*" parallel to the midrib; the three trenches are kept in good condition by repairing them from time to time (about every two years). Where the boundaries of the next colonies are to be situated, that is, every 70 m., there are cross-drains, which are also 0.6 m. in depth and width. Land at a distance of 200 m. to 250 m. from the canal is allotted for four to five years to the colonists, who pay a small rent. In the case of the moor-burning industry (buckwheat cultivation) generally practised some years ago, the buckwheat cultivator began a regular system of draining by laying out plots of 2 rods (10 ft. each) = 20 ft. = 6 m., in width with trenches, called "*Grippen*," 0.6 m. wide and 0.3 m. deep, between them.

This process formed a good preparation for the succeeding peat-cutting industry, since it not only drained the upper portion

---

<sup>1</sup> Pope's map of East Frisia shows how the surface set aside for the colonies is divided.

of the bog but provided the level surface which is required for peat winning or peat digging.

The levelling of the ground, when the winning is not preceded by moor burning, costs the peat worker 0·15M. to 0·20M. per square metre.

After the main canal has been cut and the depths of the side trenches (Ringsch'öte) have been increased, the colony is auctioned by the State (formerly it was let at 150M. to 330M. earnest money for each colony.)

The new colonist now commences "digging" and begins, as a rule, at the side trench (Ringschlot) by stripping a piece (a bank)

#### HAND IMPLEMENTS FOR WINNING PEAT.

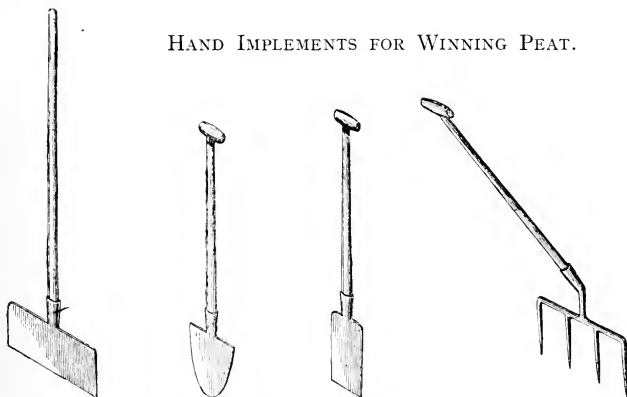

FIG. 3.—Cutter. FIG. 4.—Stripping spade. FIG. 5.—Lifter. FIG. 6.—Placing fork.

3 m. in breadth through the whole width of his plot, i.e., the loose soil, refuse, or "strippings," to a depth of 0·2 to 0·4 m. is thrown aside with the aid of a stripping spade (Fig. 4), or if the upper layer is capable of being directly worked, he removes the roots and other woody residues contained in it.

The peat cutters begin operations at the same time as the stripper (provided the spreading ground or drying field has been already levelled). The cutters include:—

- No. 1.—A "cutter" with 1 slane (Fig. 3).
- No. 2.—A "digger" with 1 lifter (Fig. 5).
- No. 3.—A "placer" with 1 placing fork (Fig. 6).
- No. 4.—A "wheeler" with 2 barrows (flat).

The cutter and the digger interchange operations every half to three-quarters of an hour.

In place of the straight slane, a three-sided slane (Fig. 7) is sometimes used, or, as in Bavaria, a double slane (Fig. 8) is employed.<sup>1</sup>

<sup>1</sup> For the other peat-cutting implements in use, see the article by Dr. Victor Zailer in the *Zeitschr. f. Moorh. u. Torfverw.*, 1914, p. 89.

No. 1 divides the surface of the bog with the slane, which is 45 cm. to 50 cm. long and 15 cm. wide, in pieces 12 cm. wide and 43 cm. long.

No. 2 cuts these pieces horizontally with the lifter (spade) to a depth of 12 cm. and throws them in the form of sods, 43 x 12 x 12 cm. on the edge of the bank, i.e., on the bounding edge, or trench edge, where No. 3 puts 12 to 14 sods in pairs over one another on the barrow, which is taken away by No. 4, the *wheeler*,



FIG. 7.—Three-sided slane.

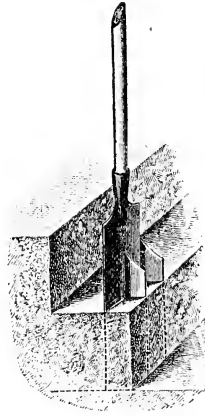

FIG. 8.—Double slane.

who spreads the sods on the drying ground by lifting them from the barrow and placing them in pairs side by side (or *spreading* them), as is indicated in Fig. 9.

When he has spread five or six pairs of sods he puts a third layer of single sods lengthwise on these. When one "stretch" has been "layered," he later on, by tipping the sods from the barrow, throws a batch against the layer so that the individual sods lean almost upright against the third layer of the "stretch,"



FIG. 9.—Drying cut peat in Oldenburg.

and continues this operation until the whole "stretch" has been "layered." In the case of black peat six, and in that of white peat seven, batches are thus "layered" together. The sods must be placed as regularly as possible with respect to one another.

The "layering ground" is situated near the bank, and has usually a width of 4 to 5 rods = 40 ft. to 50 ft. A "stretch" of this length with its seven batches is called a "turn." These "turns"

also lie at right angles to the bank, being 1 m. from it, and are separated from one another by spaces of 25 cm. to 30 cm. The width of a cutting bank is, as given above, 1 rod, or 10 ft. (fen measure) = 3·10 m.

The above four men with the stripper form a "team" and get through each day a "*day's work*," amounting in the case of black peat to 34 rods, and in that of white peat to 30 rods, each of 3·10 m in length = 12,200 to 12,225 sods of peat.

According as the "layering" of the sods can take place either on the cut-away bottom of the trench or on the uncut surface of the bog, five or six (sometimes even seven) workmen are required for cutting and spreading a "*day's work*." In 1914 the wages per hour of the men averaged 35 Pfg., the digger and cutter receiving generally 40 Pfg. and the stripper 20 Pfg. a day more than the wheeler and placer. Generally, thirteen hours a day are worked, but the men are seldom paid by the day. The labour is usually contracted for by the "*day's work*," and the cut peat is measured on the "layering ground" by the length of the "turns" in rods (1 rod = 10 ft., or 3·10 m.); one "*day's work*" is 30 or 34 rods = 93 or 100 m., and corresponds to an excavation in the bank having a volume of 75 cb. m.

The peat is left in the "layers" for eight to fourteen days, according to the state of the weather, before the "draining" is begun. For the latter operation, the sods in the first row of the seventh "batch" are removed and placed beside one another in groups, as in Fig. 10, *a*; after a day or two, the sods of the second row of the seventh "batch" are placed similarly, but in reverse formation, as in Fig. 10, *b*, on the first layer, and so on until all the "layered" peat has been "ringed." The first sods should not be placed too near one another, as otherwise the "rings" easily collapse.

As a rule, the "ringing" is carried out by women and girls, who, in the interval from 4 a.m. to 6 or 7 p.m., can "ring" a "*day's work*." When the peat in the "rings" is nearly air-dry it is collected into round heaps, each of which holds half a "*day's work*." The latter process is known as clamping. In this case, also, one woman can clamp one "*day's work*" in the above-mentioned interval of time.

In 1914, at Elisabethfehn, where two workers usually co-operate for cutting and "layering," the cost of winning by piecework, excluding the cost of the preliminary drainage, for the day's work—approximately 12,000 sods—is:—

For black peat	.. .. .	20M. to 24M.
For white peat	.. .. .	15M. to 18M.

for stripping, cutting and "layering." In addition, we have for the labour in drying:—

Ringling and clamping	.. .. .	4·00M.
Second ringling	.. .. .	1·50M.

So that the dry peat corresponding to the "*day's work*" costs:—

For black peat up to	.. .. .	25·5M. to 29·5M.
For white peat up to	.. .. .	20·5M. to 23·5M.



FIG. 10.

According to the class of peat the "day's work" weighs from 5,000 to 7,500 kilos, so that the cost of winning 100 kilos of cut peat at the above-mentioned rates of wages is, on an average, 0.35M. to 0.40M.

In the case of simple vertical cutting with a three-sided slane (Fig. 7) or a double slane (Fig. 8), a skilful workman is able to cut in twelve hours 6,000 to 8,000 sods, each 0.1 x 0.1 x 0.4 m., or to excavate 24 to 32 cb. m. of peat, which another workman can in the same time wheel and "layer" on the drying ground.

It is generally calculated that, with a daily wage of 3M. to 3½M., 100 kilos, clamped dry at the place of winning cost 0.35M. in a high bog and 0.30 M. in a low bog. To this must be added 0.20M. to 0.30M. for transport to the storage sheds or the point of utilization, interest and amortization of capital charges, drainage, supervision, and insurance, so that every 100 kilos of dry peat in the storage sheds cost 0.50M. to 0.65M.<sup>1</sup>

<sup>1</sup> In the *Mitteilungen*, 1912, p. 171, the following estimate is given for a more or less large cut peat industry, in which 15,000 m. tons of cut peat (sufficient for approximately 5,000,000 kw.) are won:—

A well-drained bog containing fairly dense peat yields at most 12 m. tons of peat fuel, containing 25 to 30 per cent. of moisture, from 100 cb. m. of the bog, and, as an average, 11 m. tons will be assumed. For 15,000 m. tons, then, 136,300, or approximately 140,000 cb. m. of bog must be cut. A bog 2 m. in depth and 400 ha. in area will in this case be sufficient for approximately fifty years. The capital charges are assumed to be 400,000M., which, at 5 per cent. (20,000M.), amount to 1.35M. per metric ton of peat fuel. Under ordinary circumstances we may reckon that the wages for each 100 cb. m., assuming a rate of 0.45M. per hour for a good workman, will be for—

	Marks.
Levelling the land .. .. .	2.50
Cutting .. .. .	25.00
Drying, ringing, clamping, and transport ..	16.00
Insurance of workmen, &c. .. ..	1.50
Superintendence and implements .. ..	2.50
Fire insurance .. .. .	0.50
Total .. .. .	48.00

Or 140,000 cb. m. = 67,200M., or 4.48M. per metric ton.

To this must be added the costs of loading and transporting the peat to the boiler-house or similar place, 0.8M. per metric ton, the expense due for interest on 100,000M. working capital (5,000M.), and that due to supervision (4,000M.), which amount to a further 0.60M. per metric ton. Altogether we have:—

	Marks.
Interest on capital and amortization .. ..	1.35
Wages .. .. .	4.48
Loading and transport .. .. .	0.80
Interest on working capital and supervision ..	0.60
Total cost of 1 m. ton of cut peat	7.23

Other estimates give 6M. to 6½M. as the cost of 1 m. ton of cut peat. The State Domesnes Department receives 3.80M. per metric ton for air-dry peat from the Vossberg Central Power Station in East Frisia, and makes a profit on the transaction (*Mitteilungen*, 1912, p. 100).



An indispensable requirement for good and rapid drying is that the surface of the bog should be as dry as possible.

In many districts of South Germany other methods of drying are preferred to that of "layering" and drying on the levelled bog bottom, especially when the latter is still very moist. These are the methods of building round poles ("poling") and the Austrian one of "spiking." In the first method ("poling"), staves 2 to 2½ m. in length are stuck vertically in the ground, and the peat is layered round these in single rows to a height of 2 m. In the second method, poles 3·8 m. in length and about 8 cm. in diameter are stuck in the bog; the poles are pierced crosswise over a length of about 3 m. with 9 to 12 staves, sharpened at both ends, which are approximately 25 mm. in thickness and 80 cm. in length. The peat, which is usually cut in pieces 25 cm. square and 8 cm. thick, is spread for some days on the ground and is then put in rows on the spikes, on which it is allowed to dry for about four weeks. These drying arrangements are more fully described in the article on "Contrivances to ensure Drying."

The occurrence, mentioned above, of different kinds of peat and the variations in the character of the peat in the different layers from one and the same bog not only increase the difficulty of winning cut peat in some instances, but, under certain circumstances and in the case of many kinds of peat, they make it quite impossible. The sods cut from the peat, owing to want of fibrous character and to the unequal distribution of the peaty matter, contract irregularly on drying, split and, during the operation of drying or loading, may completely break up into crumbs.

An attempt at improvement was, therefore, made by kneading and mixing the crude peat, after it had been observed that peat when dried after kneading and mixing was firmer and denser than cut peat which, having a density usually of 0·2 to 0·5, has only a small useful effect in comparison with its volume.

In winning this denser peat, it is cut from its layer in irregular pieces and thrown (the different layers being mixed) into a pit lined with timber or stone. It is worked in this pit by macerating it with shovels, beating and striking it with planks, or more usually by stamping on it with the naked feet (sometimes also by means of horses or oxen), until a uniform pulp is obtained (*stamped peat* or *kneaded peat*). If the crude peat be too dry for intimate kneading, as is generally the case, a suitable amount of water is added to the peat. The pulp thus obtained is stroked either, as in the case of hand bricks, in a single- or double-cell mould, which is emptied by turning it upside down on the drying ground, the sods being arranged in rows and the product being called moulded peat; or else a multi-cell, trellis-like frame (Fig. 11) is placed on the drying ground and filled with peat pulp, which is "stroked" tight into the various cells with the aid of a wooden scraper (*stroked peat*). Two men raise the frame by means of wooden handles and put it down close to its former position for the repetition of the filling, or the peat pulp is spread on the levelled peat field and left exposed for some time to the action of the air, when partly by

evaporation and partly by soaking into the ground a preliminary drying occurs. The mass is then further compressed by stroking and treading, for which operation the workmen fasten small boards under their feet. The mass is afterwards levelled. The levelling may occur during the treading or stroking with the boards, or it

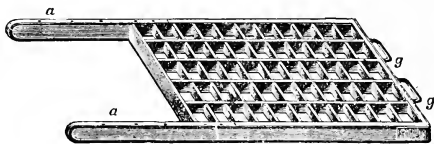

FIG. 11.—Stroking or moulding frame.

may be carried out by means of rollers. The peat is subsequently cut into rectangular pieces by means of a long knife. The pieces are turned after several days, then “ringed,” as in the case of cut peat, and in the further course of the drying they are clamped.

This method is practised generally in Holland and, to some extent, in Hanover. The fuel occurring in trade under the name *trodden peat*, *dough* or *pulped peat*, *mud peat* or *Hanover peat*, which is considerably firmer and denser than cut peat, is formed by this process.

Recourse is had to this method when the bog cannot be drained at all, or only at great expense, or when, as is usual in Holland, the peat must be raised from the bog as a rather fluid mud (*dredged peat*) by means of nets, shovels, or dredgers.

As this peat dries the less easily the greater its density, it is important in winning it to begin operations as early as possible in the spring, but not before the danger of night frosts has disappeared, and to stop at the end of July or the beginning of August, when the last portion spread should be dry. A disadvantage of the process is, therefore, that the winning season lasts only four months; moreover, bad weather causes much trouble and loss of peat inasmuch as heavy rain washes out the peat sods, which are very soft in themselves, so that sometimes only pieces without any regular shape remain, and even these in prolonged rainy weather may disintegrate still further.

The cost of winning moulded, trodden, or dough peat is generally 15 to 20 per cent. more than that of cut peat.

The fuel prepared by any of the above-described methods is generally called “*hand peat*” in order to distinguish it from manufactured or *machine peat*, and in the following pages the name *hand peat* will, for the sake of brevity, be employed when the substance discussed is any one of the varieties: cut peat, stroked or kneaded peat, trodden, and dough peat.

The following results were obtained with regard to the possible daily outputs on the occasion of the Gifhorn Peat Machine Trials, in which competition the men were all expert and the work was continued for a considerable time:—

(1) *Gifhorn or Hanoverian mode of cutting*.—A “Pasch”

("doublet") of peat-cutters—a man and a woman—produced every hour 1,000 sods, 25 x 8 x 9 cm., and placed them in heaps of 8 sods.

(2) *Landsberg mode of cutting*.—Two men produced every hour 800 sods, 25 x 10 x 10 cm., cut and heaped.

(3) *East Frisian mode of cutting*.—A team or group of four men, the wheeler of whom threw the sods in upright positions on the bog by tipping the barrow, produced every hour 1,000 to 1,200 sods, 40 x 10 x 10 cm.

(4) *Hand peat making, Hanoverian dough peat*—One man digs, divides and throws out the peat; one man mixes it in a box placed on rails and brings the mass to the forming table, where a woman strokes it in a four-cell mould. Size of sods: 25 x 10 x 10½ cm. Output: 400 sods an hour.

(5) *Hand peat making, Dutch dough peat*.—Three men are employed in raising the peat from the trench, throwing it into wooden boxes, adding water, disintegrating and mixing it, spreading the pulped mass between boards on the ground to a height of 34 cm., then trampling, levelling, and dividing it into sods. The output per hour covers an area of about 4 to 4½ sq. m., i.e., 400 sods, 34 x 10 x 10 cm.

## 2.—The Winning of Cut Peat in the South German and Austrian Bogs

While in North and West Germany either vertical cutting or horizontal cutting, or "trodden peat" winning preponderates for one and the same bog, in South German and Austrian bogs these methods are advantageously combined by employing, as a rule, vertical cutting as the more rapid method of working, but according to the way the peat occurs in the bog, horizontal cutting is employed by the same workman, if by cutting the peat "throughout the season" by the former method the product would be a loose peat easily breaking into crumbs.

The larger bogs show a carefully planned system of drains, which at the same time divide the bog to be worked into separate plots, the size of which is regulated so as to give sufficient room for the operations of cutting and drying for each group of workers during the whole season.

Usually two workers (a man and a woman, or a man and an assistant) co-operate. A man cuts, according to the size of the sods and the character of the bog, in an eleven-hour day about 2,000 to 4,000 sods, which the assistant brings to and spreads on the drying ground in the same period.

In the case of working groups such as these, the size of each working field required for the season's operations is about 24,000 sq. m., so that the working ground intended for two groups lying between two longitudinal drains must have an area of 48,000 sq. m., as each group works from the longitudinal drain towards the middle. If the distance apart of the drains be assumed to be between 60 and 80 m., the length of the working field for each group may be easily calculated.

The work of the peat-cutting groups is usually well organized and is generally as follows :—

The bog proprietor at the beginning of the season hands over to each group the winning of dry peat at a price agreed upon either per "thousand" or, still better, per cubic metre of dry peat, and allots a fixed working field to each group. The work must follow a programme exactly. It must be begun in the spring as early as the weather permits (usually on April 1st), and must be continued without break to August 1st of the same year. The quantity cut must be dried and delivered according to regulations agreed upon in detail (usually it must be placed in regular clamps or brought into the drying sheds). The conditions for taking possession of the allotment and for carrying out the work are printed and handed to the leader of each group, accepted by the latter's signing them and then form an agreement between him and the bog owner.

At the bank assigned to each group the peat must be cut in a direction and to a width and depth which are all prescribed. The bog must be cleared of its coat of moss or grass (stripped) beforehand to a prescribed depth (usually 20 cm.), and the strippings must be either used for the preparation and repair of socles, which are 40 cm. in height and serve as foundations for the peat-drying houses, or distributed on the cut-away ground so as to allow of the peat being spread directly on it for drying. The contract price for new, carefully made socles, 40 cm. in height, is generally 0·10M. per linear metre.

The sods must be cut in sizes which are also prescribed (usually 40 cm. long by 10 cm. square); the cutting of thicker sods, which are more difficult to dry on account of their thickness, is not allowed; cutters who cut larger sods, and after warning continue to do so, lose their employment. According to the nature of the drying ground the sods are either simply "spread" or laid crosswise on one another in groups of six or eight sods ("castled"), unless the whole amount cut is at once "poled," "spiked," or placed on trestles.

As much room must be left free on the drying ground as is required to accommodate all the sods cut in a fortnight. Each cutter must also bear in mind the drying houses still standing in his field, as he has to keep free the space required for temporary rails in case transport of the peat should be necessary. Every cutter has to prepare and maintain the water channel in his trench. Allowing walls to remain in or across the trench is emphatically forbidden. Roots which are laid bare in cutting must not be thrown back into the trench, but must be gathered into heaps. When the spread sods have become sufficiently firm they are castled, and when half dry they are put into higher heaps of 10 to 20 sods ("heaped") or placed round a pole, 1 to 1½ m. in length, which is stuck in the earth in such a way that 10 to 12 layers of two sods each can lie round it crosswise over one another. High piling ("poling," see Fig. 17) such as this exposes the individual sods more fully to the air draught and

therefore dries them better, while the pole stuck in the middle keeps the peat pile from being blown down by a strong wind.

The peat remains in these piles until it is completely dry and fit for the sheds (storing in magazines). All peat which is to be brought into the sheds is first examined by the superintendent, and it can only be brought to the sheds when he considers it sufficiently dry and has expressly given permission for it to be brought there.

The dry peat is stored either on the grass socles prepared for them (as in Bohemia and Lower Austria), or in clamps 2 m. in width, 3 to 4 m. in height and 15 m. in length (as in Salzburg, in Bavaria, and Baden), or in storing sheds (as in Styria, Carinthia, and, in isolated instances, in Bavaria).

The last is the driest but the most expensive way. One attains almost the same degree of success, but at a considerably lower cost, by clamping, when the clamps are covered in the excellent way followed in most peat works of the above-named localities. The method there employed may also be recommended

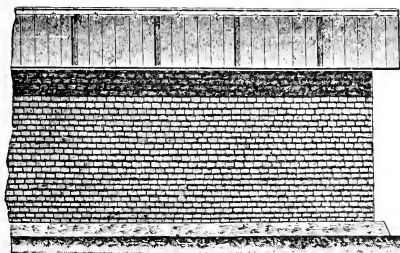

FIG. 12.—Storehouse for dry peat.

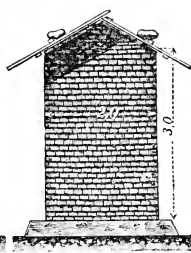

FIG. 13.—End view.

for machine peat works as a substitute for that of storing sheds, and for the protection of those kinds of machine peat which cannot withstand the alternating action of the sun and rain.

The peat clamps are firmly "set" with vertical walls (see Figs. 12 and 13) and are of the size given above; on the top, however, the sods form two slanting surfaces inclined to one another like a roof. These slanting surfaces are covered by flat boards which are made in separate lengths, fitted into one another, pushed against one another at the top and fastened together by hooks and eyes so that the clamps are protected from the action of falling rain completely on the top by the roof of boards, and nearly so on the sides by the eaves which project 30 to 50 cm. The boards which form the roof are weighted with stones to prevent them from being blown off by strong winds.

These roofs of boards, drying poles, planks, &c., are placed, according as they are required, at the disposal of the workmen by the officials in control of the operations; shovels and slanes for extending the drains and cutting the peat, as well as baskets for collecting peat during the drying operations, must be provided by the workmen themselves.

The peat-cutting work is all contracted for at prices per unit. For cutting, drying, and collecting a cubic metre (or thousand) of peat, the rate of wages for the whole season are agreed upon beforehand with the leaders of the various sections according to the quality of the cut peat, while the prices for digging and cleaning the drains, repairing the grass sods, levelling, &c., are also in each case agreed upon before the work is begun, and are paid for weekly according as it is carried out.

As the wages earned for winning the peat are paid only when the peat has been collected, payments on account are usually made every fortnight as the various operations progress. The prices per unit are approximately the following :—

For cutting 1,000 sods	..	..	1·00 to 1·50M.
For moulding 1,000 sods	..	..	2·50 to 3·00M.
For " heaping " 1,000 sods	..	..	0·25 to 0·30M.
For " poling " 1,000 sods	..	..	0·20 to 0·30M.
For storing 1 cb. m.	..	..	0·20 to 0·30M.

When removing clamps, full measure is given only for those which have been clamped at least six weeks beforehand ; in the case of more recently made clamps, 10 cm. are deducted from the height in order to allow for contraction.

Payment for the peat produced by the various groups takes place, after deduction of the payments on account already made, when the work is completed and the tools and utensils loaned to the workmen have been returned. If at the cessation of the work a part of the peat which has been cut cannot be clamped, the cutter has no claim for compensation for loss of remuneration. He is, however, at liberty to hand over the peat still " out " to other cutters or to collect it when the weather permits in the following spring.

In the peat-cutting industry a considerable loss would be experienced owing to the freezing every winter of the peat walls, which may occur up to a depth of 0·5 m. For a " bank " of about 30 m. and three cuttings this amounts to 2,000 sods, and, in addition, there is the cost of stripping in the following spring. The last cutting of the season is, therefore, made in steps along the whole wall, and the steps thus formed are covered obliquely with peat mould. The loss which would otherwise occur is totally avoided by means of this simple and inexpensive procedure.

At almost all the larger Austrian peat works the industry is carried out in this or a similar manner ; only in the drying operations are there considerable variations ; thus, for instance, the cut peat won by horizontal cutting at the Buchscheiden peat works is dried exclusively on " spikes," the dough peat won on the Freudenberg bog, as well as the cut peat produced in the Styrian peat works, is dried entirely in drying sheds and on drying scaffolds. These methods for ensuring the operation of drying are described more fully further on.

It may be seen from the mode of working (outlined above) employed at almost all the peat works, and from the circumstance that only dry peat is taken from the workers and that payment is

made only for dry peat, that the cost of production for the winning unit is almost the same in the various bogs and is sufficiently moderate to make the peat thus won a cheap fuel.

The outputs noted in the various workings are approximately the following :—

One workman cuts daily on an average 3,000 to 4,000 sods<sup>1</sup> of the above-mentioned size, which an assistant transports to and spreads on the drying field. Such a group of two workers produce in the season, according to the kind of the cut peat, 400 to 1,000—on an average, however, 500—cubic metres of dry peat. The cutters usually sublet the work of drying to others, who are engaged exclusively at this operation. In eleven working hours a labourer can “castle,” “heap,” or “pole” about 6,000 sods.

### 3.—The Winning of Lump and Crumb Peat

This method, the object of which is to work a bog on a large scale from above downwards with ordinary agricultural implements (spade, rake, plough, harrow, &c.) and to set free and dry the peat as irregular lumps or crumbs, is not as a rule applicable for the winning of a transportable fuel. It can be taken into consideration only for the gasification of peat for winning power gas on the bog itself, and even then only under favourable weather conditions, and for winning large amounts by means of special machines. Hand labour must be excluded, since it does not seem that the so-called lump peat obtained by hand labour could be made more cheaply than peat cut in regular sods. From the experience and the results of all peat-cutting industries, it can be shown that the average daily output of a peat-cutter is so great, that a larger output, in continuous work and without excessive exertion, cannot be attained by digging the peat in irregularly shaped pieces. It is a matter of indifference to the peat-cutter, who is accustomed to his work, whether he digs the peat in regular sods or in irregular lumps. He will, indeed, since the sods from the point of view of drying must not exceed a certain size, prefer to cut regular pieces, which can then be placed with the shovel or slane on a barrow near the edge of the trench. Ordinary labourers, however, who, perhaps on account of the lower rate of wages, may be introduced into the winning of lump peat, would not be able to produce as much peat in the same time as skilled peat-cutters. In winning the bulk, therefore, no advantage would be gained. It is equally obvious that, in the immediately ensuing work of drying, regular and uniformly large sods are much more easily and therefore more rapidly and more cheaply turned, heaped and collected than irregular and small lumps, which would, moreover, give rise to much greater loss in loading and transport. Also, when ordinary agricultural implements—ploughs, harrows, &c.—are utilized, scarcely any other result will be obtained than

---

<sup>1</sup> Compare this with the output of the Oldenburg peat-cutter (p. 31), which is considerably greater as regards number of sods.

the commercially unsuccessful one of the large scale experiments of the past. The crumb peat winning carried out at the Salt Works in Aussee resulted in complete failure.

It must in general also be characterized as wrong to work a bog, especially a high bog, in horizontal layers from above downwards, as the various layers, differing in character and in fuel value, would be won separately. Both in winning cut peat and in the machine peat industry attention is largely directed to the mixing of the layers from different depths with one another so as to obtain a fuel as uniform as possible during the whole working season. A necessary consequence of this is that the working takes place as simultaneously as possible through the whole depth along the cross or longitudinal section of the bog, and then progresses sideways.

Moreover, the drainage of a bog to the extent necessary for crumb peat winning can be carried out in only a relatively small number of bogs, since, especially in spongy high bogs, only the parts which are within 5 to 7 m. from the trenches are drained, the rest of the bog up to a few centimetres from the upper surface remaining very wet.

Supposing that the bog surface permitted ploughing or harrowing with oxen, the crumb peat thus won, which must be left there for further drying, would lie on the very wettest part of the whole bog, viz., the freshly ploughed under-surface; drying would therefore proceed very slowly in bogs provided with drainage canals of the usual character as the lower surfaces of the peat lumps would absorb moisture from the underlying ground, which is always wet. Oxen will, however, generally sink into the ground, so that these operations must be performed by hand or machine labour and would therefore entail too high initial or running expenses. Simple harrowing will not in general produce crumb peat from the upper fibrous layers of a high bog; it will simply tear out more or less large felted pieces. According to experience, only the lower layers of a high bog consist of humified or bituminous peat, so that the upper layers, if won separately by horizontal working, would give a very loose, spongy peat, which, especially when it has been loosened still more by harrowing and divided into smaller pieces, crumbs or re-absorbs water every time there is either a fall of rain or a thick fog, becoming again as moist as it was when freshly dug.<sup>1</sup>

This was the chief cause of the failure at Aussee, where, for instance, crumb peat winning was to have taken the place of that of cut peat. There the peat lumps, when half dry perhaps, became re-saturated with water during the frequent and protracted downpours of rain in the Tal valley, while at the same time the underlying ground, i.e., the drying ground, became so wet that

---

<sup>1</sup> On this account, the winning of lump peat or crumb peat is only justified in isolated cases, for the winning of crude peat for gasification purposes, especially for gasifiers, in which peat containing 35 to 40 per cent. of water can be used with advantage, or for peat litter, as is described in more detail in the section on peat litter.



the crumb peat, in spite of all efforts, could not be dried ; even the heavy night fogs generally gave as much moisture to the loose and felty peat lumps lying on the ground as had been evaporated during the previous day.

If the above-mentioned difficulties are so great that they make the application of the method impossible for ordinary peat fuel even in the case of the upper layers of the bog, they will become still greater as the depth of the working increases, on account of the greater power the lower layers have for retaining water, quite apart from the fact that, owing to drainage conditions, it would be possible only in the case of relatively few bogs to work them in more or less large layers from above downwards to any considerable depth. A surface situated in the deepest part of a bog worked in this way would only in the rarest cases be suitable for drying the peat which had been loosened.

The winning of peat in small lumps or crumbs can therefore at most be taken into consideration only for the large scale winning of half-dry raw materials for peat gas furnaces or for a press peat factory. This is the case especially when a bog, on account of its maturity and uniformity, is capable of being worked in horizontal layers, when it can be thoroughly drained, and also when, owing to the prevailing weather conditions and the use of technically perfect equipment—steam driven or electrically driven implements, ploughs, harrows, rakes, &c.—the winning of half-dry “small peat” is possible at a price which the commercial success of a gasifying plant or a press peat factory necessitates. For further particulars with regard to this, see the section on the preparation of press peat. In the favourable case the depth and area of the bog must ensure the industry a life so long that the annual amortization of the high capital costs of such an undertaking, calculated on the probable life of the industry, must not make the cost price of the manufactured press peat too high. For each separate case the practicability and the prospects of remuneration from such a plant demand serious technical and actuarial considerations. In several press peat factories, in Canada for instance, the crude material for grinding, drying, and pressing is won as crumb peat by ploughing, harrowing, and gathering the peat into heaps.

#### 4.—The Winning of Cut Peat (Cut Peat Machines)

More hopeful than the winning of crumb peat is the attempt to win ordinary cut peat, especially when this is required on a large scale, by special machines instead of by hand labour, which is ever becoming more and more costly. We may distinguish these machines from the ordinary peat-cutting machines by means of the name “*cut peat machines*” and the product obtained by their aid may be called *machine-cut peat*.

In recent years several machines of this class have been constructed (cf., for example, Nos. 156953, 166784, 177446, 225922, 239194, and 265684, under Patents, in Section VII, 4).

They have in common, adjustable longitudinal, cross and bottom knives fixed in the frame of a portable machine and as movable as possible so as to cut the peat in layers into ordinary sods during the motion of the machine over the surface of the bog. The raising, footing, clamping, and drying of this "*machine-cut peat*" are similar to those of ordinary "cut," kneaded, or machine-formed peat.

For the advantageous employment of this method of winning, as for the winning of "crumb peat," good drainage, the greatest possible freedom from wood or roots, and the existence of peat layers as uniform as possible from above downwards, are indispensable.

It is not known whether one or other of these machines has already proved successful on a large scale for any considerable length of time. They should, however, be considered mainly for winning dry peat in quantity and in a cheap manner either for peat moss litter factories or from a bog the deep layers of which are very uniform and free from wood.

One of these cut peat machines (Gress's Patent, No. 265684) was acquired in 1915 by the Rosenheim Salt Works for the Hochrunst factory, where its trial had proved satisfactory.

### 5.—Peat-cutting Machines and Peat Winning under Water

Where a bog cannot be easily drained or the peat, owing to the great depth of the bog, must be won from a more or less deep layer and from under water, a peat-cutting machine is very useful not only for winning ordinary cut peat, but also for winning raw material for the manufacture of dough, kneaded, or trodden peat, or the condensed machine-formed peat or machine-pulped peat described later. It is assumed, however, that for the advantageous use of such machines the bog must be as free as possible from wood and tree roots. That they are then capable of being used very advantageously is proved by the fact that thousands of these machines have been employed for this purpose.

Fig. 14 shows a peat-cutting machine in the original form in which it was constructed, in 1842, by Brosowsky, of Jasenitz, near Stettin.

The most important part of this machine is the cutting contrivance, which is illustrated on a somewhat larger scale in Fig. 15, *A* and *B*. The side-knives *a b*, *b c*, and *c d* of this cutter have different inclinations to the horizontal and form a box which is open at the top, the bottom, and the front.

The lower portion of this box is fastened to a wrought-iron bar *S*, the end of which is sharpened, and by means of which the preliminary cutting operation is performed by forcing the cutting mechanism into the peat, the bar at the same time acting as a guide for the cutter. The bar *S* is prolonged into a wrought-iron toothed rack which gears into a spur pinion *g* which is secured to the shaft of the capstan wheel *w* (Fig. 14). By turning the capstan wheel forwards or backwards the cutting mechanism is

raised or lowered by means of the spur pinion which moves the toothed rack through a guide in the trestle of the machine, and by utilizing the weight of the box and the toothed rack it can be driven into the peat to a depth of 6 m.

It should be observed that the machine can cut only at the side of a trench or else by beginning at a hole which has been previously cut, since the prolongation  $ll$  of the cutting box can

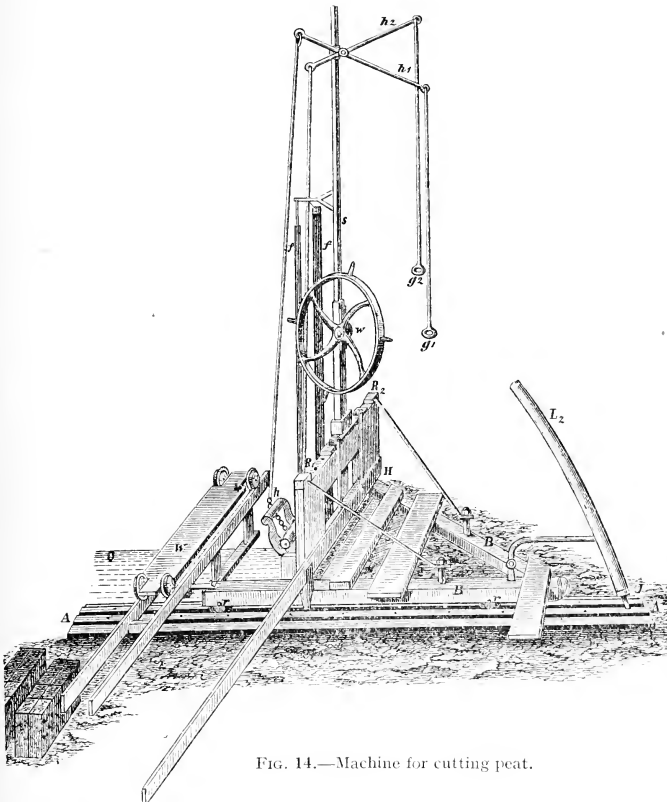

FIG. 14.—Machine for cutting peat.

move downwards only in a space free from peat. The knife  $a b c d$  has, therefore, to cut only on three sides; the broad, smooth bottom knife  $m n$ , which is sharpened at both edges, is fixed to the same side as the prolongation  $ll$ . The end of this knife moves in grooves and serves for cutting the under-surface of the piece of peat formed by the downward motion of the cutting box.

The knife  $m n$  can be set in motion by two chains,  $h$  and  $i$ , which are fastened to it at the point  $p$ . The chains are led over

two cylindrical rollers,  $v$  and  $w$ , and are drawn forwards and backwards by means of the two levers  $h_1 h_2$  (Fig. 14) with the aid of the ropes and grips  $g_1 g_2$ . While the cutting box is being drawn upwards by means of the toothed rack, spur pinion and the capstan wheel, the knife  $m n$  serves as a support for the piece of peat which has been cut. The guides  $f f$  are attached in order to prevent the piece of peat from falling off. According to the depth to which the cutting box is driven into the bog the piece of peat raised has a length of 3 to 6 m.; its cross-section is approximately 60 cm. x 70 cm., and the prism of peat is divided by hand into pieces 35 x 15 x 12½ cm. Every piece of peat thus cut gives 144 of these sods for every 3 m. of its length. The sods are then wheeled away in small cars,  $W$ , running on rails.

While this is occurring the cutting machinery with its guide is moved sideways a knife-breadth on the frame  $R_1 R_2$ . This frame is of such a width that that four cuts can be made beside one another,

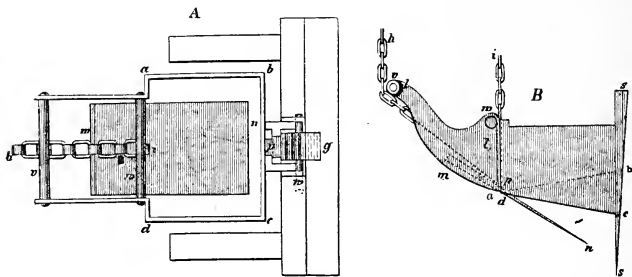

FIG. 15.—Cutting box of machine for cutting peat.

after which the machine must be moved forwards by the length of the knife  $a b$ . For the latter purpose the horizontal beams  $B$ , forming the triangular frame, rest on two rollers,  $r r$ , which run in grooves in the beam  $A$  while one beam of the frame rests on the smooth side of the fixed beam  $H$ . In the direction of the width of the machine there is a lever,  $L$ , the end of which can be moved up and down round a pin. By means of this lever the part of the frame resting on  $H$  can be raised so that its weight will rest on the rollers  $r r$ . If a second workman then moves the lever  $L_2$  from left to right the machine will move forward in the longitudinal direction since this lever has its fulcrum at  $J$ .

From two to four persons are employed in the operations. One workman puts the cutting mechanism in motion, the second helps in this and cuts the peat when raised, the third takes the peat away, and the fourth "layers" the peat.

The output of the machine for a cutting depth of about 4 m. may be assumed as follows:—

In winning cut peat with a gang of four men working for twelve hours, 10,000 to 12,000 peat sods (30 x 12 x 12 cm.) = 40 to 50 cb. m., are obtained.

If, however, the machine is employed only for cutting and lifting peat as raw material for further working into trodden or machine peat, two men will be sufficient to work it, and these will then produce in twelve hours about 60 cb. m. of crude peat. .

The weight of a machine is 500 to 800 kilos, and the price is for 2 m., 3 m., 4 m., and 6 m. cutting depth about 520M., 550M., 600M., and 650M., respectively.

Cutting machines of this type are constructed by R. Dolberg and Co., of Hamburg, Stützke Bros., of Lauenburg, Chr. Müller, successor to H. Witting, of Demmin, Bartsch and Mitschke, of Jasenitz, Karl Weitzmann, of Greifenhagen, and J. Sauer, Georgsburg, near Pinne (Posen). The latter has provided his machines with an improved cutting mechanism.

R. Dolberg and Co., Hamburg, have also arranged these machines for use with steam power. Fig. 16 shows the latter type together with a peat-forming machine.

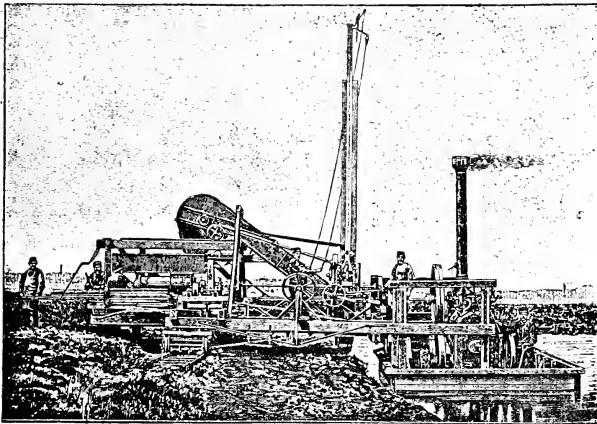

FIG. 16.—Steam-driven peat-cutting machine of R. Dolberg and Co.

The cutting machine is on a bridge which is supported on the right by a pontoon and on the left by two small cars on rails. The driving engine (a locomotive) is on the pontoon. It drives an intermediate shaft, placed on the bridge, from which the cutting machine and the peat machine are driven. The peat raised by the cutting machine is brought by the iron conveyer either to the hopper of the mixing and forming machine or to a transport car. The driving mechanism of the conveyer is connected with that of the cutting machine. The engaging of the cutter and conveyer is effected by turning a lever, and the throwing out of gear at the deepest and highest points is effected automatically by the machine. The depth to which cutting takes place can be regulated. After every cut the cutting machine is moved sideways through the

width of a cut by turning a hand wheel. After six cuts the whole arrangement must be moved forward by the length of a cut. For this purpose the shaft is extended under one of the rail cars and is provided with a spur pinion which gears into the toothed rack of the track. For working the steam-cutting machine, in addition to the stoker two men are required, who then produce with it four times as much as a hand-cutting machine. For the same output, therefore, twelve men less are necessary. The daily output is said to amount to 120 to 160 cb. m.

For winning peat *under water*, in addition to the Brosowsky cutting machine there have hitherto been employed: Hodge's (Canadian) peat boat, Fimmen's boat dredger, and ordinary hand and steam dredgers such as are used for dredging rivers and canals, and these in different peat works have given, according to local circumstances, quite different outputs.<sup>1</sup>

### 6.—Contrivances to ensure Drying

In so far as the simple air-drying already described has not proved sufficient for the winning of hand peat, the more fully elaborated methods of drying mentioned below have come into use. All of these aim at:—

(1) Withdrawing the substance to be dried from the influence of the moisture of the ground and bringing it into higher, drier, and windier layers of air.

(2) Exposing the peat sods more fully to draughts of air and protecting them on the other hand from rainfall by superposing them loosely in layers, by piling them, or by covering them.

(3) Diminishing the labour in the drying operations by dispensing with frequent "turning."

(4) Economizing in drying ground.

How far this is attained, wholly or partially, by the various contrivances may be judged from the following particulars:—

(a) "Poling" in *South Germany (especially Bavaria) and Finland*.—Poles (stakes),  $2\frac{1}{4}$  to  $2\frac{1}{2}$  m. in length and placed in rows at a distance of 0.8 to 1.0 m. from one another, are driven so far into the drying ground that the peat sods (also called "billets"), which are fairly long (up to 40 cm.), can be placed ("poled") round the pole, which projects from  $1\frac{1}{2}$  m. to 2 m. above the ground, in 15 to 20 layers of two sods each arranged crosswise over one another (Fig. 17). The pole prevents the column from falling even when the wind is fairly strong. Owing to the height of the column the preliminary drying must be continued until the sods of the lowest layer are sufficiently firm to support the weight of the column.

The method of "spearing" sods followed in Finland resembles that of "poling." The raw sods, immediately after being cut, are "speared" over one another on sharp-pointed stakes, which

<sup>1</sup> Compare the communications in Section IV on Hodge's peat boat in Oldenburg, and on the more recent peat-dredging machines, as well as the statements in Patents, Section VII.

are about  $1\frac{1}{2}$  m. in length and each of which takes eight to twelve sods.

(b) *Drying on Spiked Poles in Carinthia.*—This method, employed in the works of the Buchscheiden Peat Company which formerly belonged to the Buchscheiden Iron Works, consists not only of spreading the freshly cut peat on the drying field for the purpose of drying and letting it lie there, with frequent turning until partially dry, but also of sticking it on so-called spiked poles (thousands of which are fixed on the drying ground) and allowing it to dry while suspended in the air (cf. Fig. 18).

The "spiked poles" are pine or firwood stakes, 8 cm. thick in the centre and 3·80 m. in length. Each stake from the top to within 60 cm. from the bottom is pierced with ten holes, which are equidistant and arranged crosswise alternately. Through these holes the so-called spikes, i.e., staves of larchwood 70 to 80 cm. long, 3 to 4 cm. thick, and pointed at both ends, are placed.

The "spiked poles," each of which can take up to 100 sods, are sunk 40 cm. deep into the drying ground in regular parallel rows,  $1\frac{1}{2}$  m. apart. There were, for instance, at the time of the visit, 13,500 of these poles in the Buchscheiden Peat Works, near Feldkirchen, the spiking of which could be carried out twice in the months of March, April, and May, and three to four times in June, July, August, and September. In the other adjoining peat works there was a similar number of such "spiked poles."

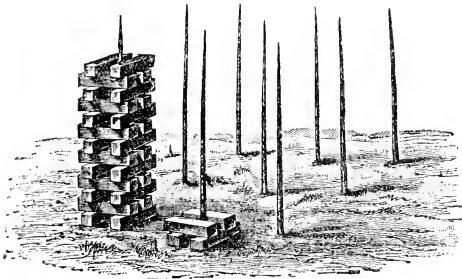

FIG. 17.—"Poling" peat in Bavaria.

The method employed is as follows: As already mentioned in the second section, the peat sods are cut horizontally in the form of flat pieces 20 to 25 cm. square and 6 cm. thick. In this operation generally three men work together, the first of whom cuts two rows vertically, while the second cuts one of these rows, and the third, following the second at some distance, cuts the other row horizontally, so that the depth (18 cm.) of the sods cut by the first man is divided, according to the quality of the peat, by three to five horizontal cuts. Hence, for every 18 cm. of depth, three to five sods are cut, and these are placed all together, by a single shovel-throw, on a barrow standing ready at the edge of the trench. These three men in a twelve-hour day cut 8,000 to 9,000 sods from

20 to 25 cb. m. of bog, and at the same time place the sods on the barrow. Eight to ten women wheel the sods between the "spiked poles" and place them on the right and left beside the barrow track in rows, three sods over one another, and with spaces between the rows so that a passage always remains free for the barrows. The sods lie in these rows for several days until they have formed crusts which are so strong that they will not tear asunder in consequence of their own weight and fall to the ground when they are stuck on the spikes through the centres of their flat sides. According to the thickness of the sods, four or five of them are stuck on each of the sides of a spike, so that one of these spiked poles carry 80 to 100 sods. The pieces of peat remain on the spikes until they can be taken away dry and brought to storage sheds of about 3,000 cb. m. capacity. Usually, three to four weeks are sufficient for this (even in unfavourable weather), so that the

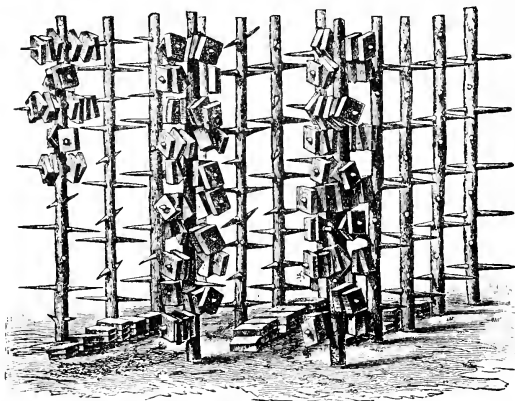

FIG. 18.—"Spiked poles" of Carinthia.

"spiked poles" can be stuck with sods on an average four times every summer. At each peat works there are as many sheds as are required for the storage of all the peat won.

The winning is let at a piece-rate to peat-masters, the latter receiving for a cubic metre (=160 to 170 kilos of dry peat) of the peat placed in the storage sheds (including all the labour of winning and drying) 1·30 kr.

A single "spiked pole," which should be 8 cm. thick in the centre, costs, when pointed and bored, 30 heller (0·28M.); for the larchwood spikes 2·00 kr. are paid per hundred, and for insertion of the "spiked poles" in the bog 2 heller (Pfennige) are paid for every three poles. From this we can estimate the cost of the "spiked poles" of the Buchscheiden Peat Works as follows:—

4,050 kr. for the stakes.  
2,700 kr. for the spikes.  
900 kr. for the insertion in bog.

Total 7,650 kr., or approximately 7,500M. capital expenses.



This, however, ensures the possibility of winning the minimum amount of dry peat required for the working of the industrial undertakings even in unfavourable weather conditions, whilst otherwise, without this expenditure (therefore without "spiked poles"), one could scarcely hope to be able to dry even in good weather more or less large quantities of peat on bogs which are surrounded by mountains, and which, situated as they are in the low-lying districts of the Ossiach Lake, are very wet, and have sometimes on their moist surfaces a growth of grass so prolific that it overgrows sods lying on the surface of the bog.

(c) *Drying Trestles of Carinthia, Tyrol, and other places.*—The Nothburga Works at the Freudenberg Bog in Carinthia, as well as other factories in the Tyrol, erected covered drying trestles (cf. Fig. 19) with the object of ensuring drying. These trestles had a depth of 90 cm. and a height, to the apex line, of 2·5 m. They were divided into six or seven compartments, on the longitudinal laths of which the sods of peat were placed edgewise, with spaces

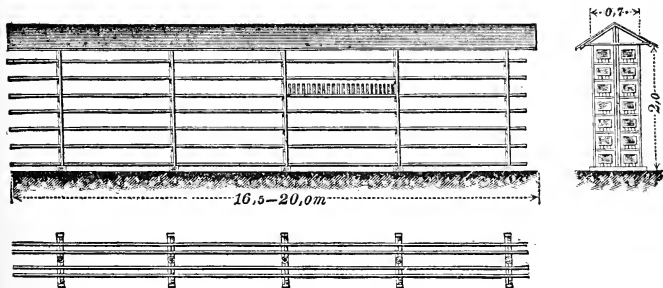

FIG. 19.—Covered drying trestles.

between them and two sods behind one another in depth, immediately after they had been cut or formed (if dredged). In the Freudenberg Bog, for instance, there were 43 such trestles, each 19·3 m., and 969 others, each 16·5 m., in length, altogether 1,012, with a gross length of 16,817·5 m., of which each of the former held 2,400 and each of the latter 2,000 sods of peat, so that the total amount spread was 2,041,200 sods of peat. The price of one of these trestles was approximately 100M., so that the capital required for the whole 1,012 was about 101,200M. As the distance from the railway was too great and the car freight due to this was high, the Nothburga Works shut down several years ago.<sup>1</sup> The Alpine Company has also given up its Carinthian Works (including

<sup>1</sup> The amount of dry peat required every year by the Nothburga Works was, on the average, 17,500 cb. m., 1 cb. m. of which contained 532 sods, and weighed 275 kilos. In number of sods, therefore, the amount required was about 9 millions. In estimating the cost, if we assume 12 per cent. for interest and amortization, calculate this for the capital required for the trestles (101,200M.), and distribute the resulting amount over the annual output of 17,500 cb. m., each of 275 kilos in weight, it would increase the cost price of 100 kilos of the dry peat by 0·25M.

the Buchscheiden Iron Works, which depended on the peat industry), and with the closing of this the larger peat works there were also closed. The numerous drying sheds on the Freudenberg

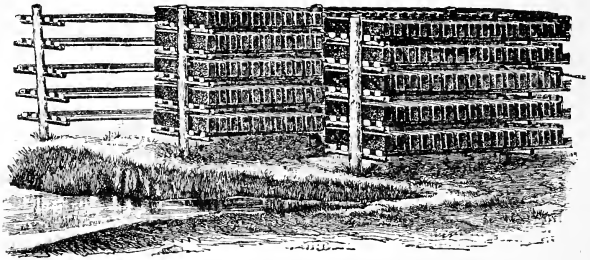

FIG. 20.—“Peat horses.”

Bog were removed by the new owner, and were afterwards re-erected, although in much smaller numbers, by the present owners. This re-erection has been carried out, for instance, on the Raunach Bog, which has an area of about 100 joch, at Pischeldorf, in the district of Klagenfurt, for the Wieser Peat Works, amongst others.

The peat is left on these drying trestles for four to five weeks, according to the state of the weather, until it is fully dry. During a season, therefore, the shed may be filled four times. The last filling remains, according to the state of the weather, on the trestles until the beginning of December, and sometimes, indeed, until it can be transported over the ice on sleighs.

(d) *The “Peat-horses” of Sweden and the Drying Sheds of Sebastiansberg (Erzgebirge).*—These are hurdles, quite similar to the Carinthian peat-drying trestles. They have been employed for several years past with good results in winning and drying crude peat for peat litter, and also in localities where only a relatively small drying surface is available.

According to a communication from a bog-owner,<sup>1</sup> on 1 sq. m. of bog 194 sods can be dried on “horses,” whereas only 22 sods can be dried by the ordinary method of drying on the ground.

The peat sods are placed on the “horses” immediately after being cut, and are not again disturbed until they are ready to be put into the drying houses or sheds. The ill-effects due to the great water-absorbing power of moss peat, especially when the sods lie in contact with the bog, are in this way avoided.

Firwood or pitch-pine stakes are used for the



Fig. 21.—  
Traverse of  
“horse.”

<sup>1</sup> *Mitteilungen*, 1901, p. 187.

preparation of these "horses," illustrated in Figs. 20 and 21. The stakes have a thickness of 8 to 10 cm., a length of 3.6 to 4 m., and the upper half of each has five to six holes, at intervals of 30 cm., through which wooden staves 70 cm. in length are thrust. The lower ends of the stakes or "horse-poles" are driven 1.8 m. into the bog, and are arranged in rows so that the stakes are 1.8 m. apart in the rows, which are 3.6 m. from one another. Two laths, each 2 m. in length and at least 3 cm. in thickness, are placed on each side of the cross-staves, and on these the sods, which generally have (for peat litter) a size of 30 x 12 x 12 cm., are laid crosswise. The peat is usually placed on the "horses" in autumn or winter for peat litter, and after collecting it in May or June the "horses" can be immediately covered again. This new layer is dry by autumn. Six thousand sods, or 44 cb. m. of peat, can be dried at the same time on a "horse" 100 m. in length.

The "horse-poles" are prevented from sinking into the soft bog by placing two boards under the cross-trees on the surface of the bog.

These "horses" could be provided with advantage, and without expense worth speaking of, with a simple roofing of boards, like that of the Carinthian drying structures, by means of which the drying would be made more certain.

The drying hurdles or drying frames in the Sebastiansberg Bog, in the Erzgebirge, are constructed in a quite similar manner.<sup>1</sup> These are removable wooden frames, 3½ m. long, 2 m. wide and 2 m. high, which, in six stages one over another, carry each four pairs of long poles or laths on which the freshly cut sods are placed edgewise. Somewhat larger sods are laid on the topmost laths, and thus a roof is formed, to a certain extent, for the underlying sods. The capacity of such a drying frame is 800 to 1,000 sods.

(e) *The Drying Huts of Styria.*—The drying huts in Styria, which are used especially at the peat works belonging to the Rottenmann Iron Works in Gampermoos and Wörschach, near Steinach, in the valley of the Enns, differ from the above-mentioned drying frames by their depth being greater; while the depth of the latter is arranged for only two double laths, or two sods, that of the former takes usually five to six pairs of laths, or five to six sods, behind one another (cf. Fig. 22). Each of the huts there is about 19 m. (10 cords, Austrian) long, seven laths high, and is divided by partitions into ten sections. The partitions, which are also formed of long laths, serve on their part as supports for the pairs of laths arranged in the seven compartments. Unlike those in the drying trestles, the pairs of laths in the drying huts are not fastened to their supports, but lie loosely on these, since the front rows must be removed when filling the drying huts, in order that the middle and back rows may be reached conveniently. Only when the latter have been filled from the top

<sup>1</sup> Cf. Hans Schreiber, "Das Moorwesen Sebastiansbergs," Staab, 1913.

to the bottom are the former brought into position and filled as required. The individual pairs of laths are 1.90 m. in length and carry each 18 sods, so that a drying hut with ten compartments is able to hold in all  $10 \times 7 \times 5 \times 18 = 6,300$  sods.

The winning operations are carried out by piece-work, each group of workmen being paid an inclusive rate for cutting the peat and putting it in the drying huts. When the rate of wages of the workmen was 3 to 4 kr. for 11 to 12 hours, the Company stated that the cost of the air-dry peat was 46 heller for a barrel containing 3 hl. = 42 to 43 kilos. This would correspond to 1.10 kr. for 100 kilos, and would nowadays be correspondingly higher.

One man with a male or female assistant can in good weather cut and put in the huts in one month enough peat for 10 to 12 huts (therefore, 75,600 sods).

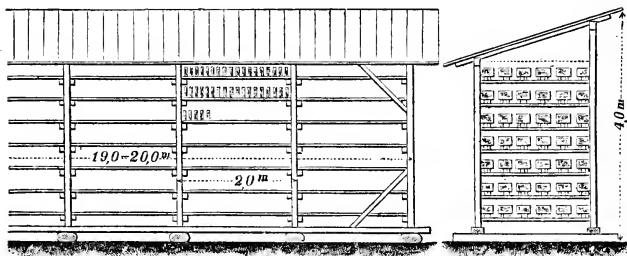

FIG. 22.—Drying hut.

Owing to the greater depth of these drying huts, attention must be paid to securing a more or less free circulation of air in and between them if the same degree of drying is to be obtained with them as with the less deep drying trestles. Hence the huts are not placed in large numbers (separated only by the spaces necessary for transit) on the drying ground itself, but are distributed at more or less distance from one another over the whole bog, and in such a way that the huts are arranged right and left of the roads, and so many of these so-called "lanes" are placed near one another in a bog that there is between every two of them a clear peat field of 80 m. to 100 m. in width. These peat plots, the length of which corresponds to the size of the bog, are the only places where peat is won and worked. Beginning at the middle of each, the peat is cut and brought to the drying huts on the right or left (cf. Fig. 23).

Even in the longitudinal direction, every two huts *h h* are separated from one another by nearly the length of a hut (about 14 m.), and they are also so placed that the positions of the huts on one side of the "lane" correspond to the gaps on the other side. If the locality of the bog permits of the "lanes" being made so that the huts are broadside to the usual direction of the wind, the drying is extraordinarily satisfactory.

At Gampermoos 700, and at Wörschach 140, of these drying huts, each of which costs 250 kr. and lasts twenty to thirty years, have been erected; at Gampermoos alone the capital employed for the drying huts is therefore 175,000 kr.

Fig. 23 shows roughly the arrangement at Gampermoos; the seven hundred huts mentioned are arranged right and left of 12 "lanes," so that there are 50 to 60 huts in each "lane." These "lanes" cut, nearly at right angles, the bog which stretches from east to west between the main road to Rottenmann and the Enns. The drains to the Enns run on the right and the left beside the "lanes." The peat, brought in direct from the bank, remains in the drying huts about four to five weeks, and is then removed either to the place where it is used or to storehouses. The huts are ordinarily filled only three or four times in a season.

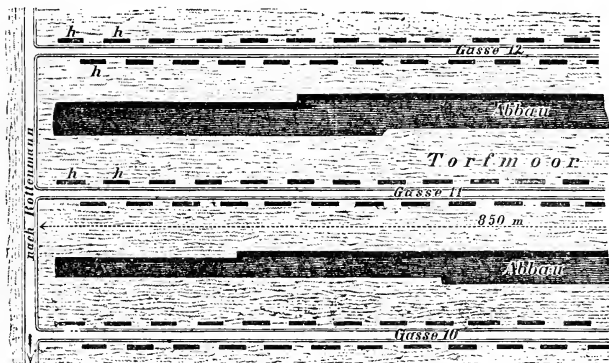

FIG. 23.

At Gampermoos the peat consists to the extent of one-fourth of grassy peat, one-half of intermediate peat and one-fourth of bituminous peat; the contraction of the peat sods during drying is therefore variable, so that 1 cb. m. of

Fibrous peat contains .. ..	304 sods (85 kilos)
Intermediate peat contains .. ..	340 sods (120 kilos)
Bituminous peat contains .. ..	504 sods (194 kilos)
And on the average, therefore, contains	372 sods (130 kilos)

whence the weight of 1,000 sods is, on the average, 360 kilos.

If each drying hut is filled three times a year, then in a single hut  $3 \times 6,300$ , or 18,900, sods can be dried for a capital outlay of 250M. or kr., which at 5 per cent. for interest and 5 per cent. for amortization amounts in all to 25M., or 1.40M. or kr. per 1,000 sods. In Wörschach the quantity required to fill each hut was 225 hl. or 75 barrels, each containing 42 to 43 kilos of dry peat, therefore altogether 3,150 kilos. Assuming that the filling occurs three times per annum, then the interest and amortization for every 100 kilos would be approximately 0.25 kr.

(f) *Drying on Drying Ramparts*.—Ekelund, at Jönköping, has recommended<sup>1</sup> that peat be dried on ramparts 1 m. in height, as he considers it necessary for the facilitation of drying to free the spread peat from the moist layer of air which lies immediately on the upper surface of a bog. As this layer is, as a rule, so saturated with moisture that it cannot take up any more water (as may be seen from the frequent occurrence of layers of fog in bogs), the drying of the peat must take place (if it is to occur quickly and with certainty) at least 1 m. above the surface of the bog. With the object of winning crude peat for coking, Ekelund therefore digs trenches in the drying ground with distances of at least 3 m. between their inner sides. The peat from the trenches is thrown up between them, and a rampart about 1 m. in height is formed from it. The peat, when cut, is piled on these ramparts, and, owing to the action of the dry fresh air which continually blows over the piles, "the peat dries in an astonishingly short time." When the peat has been on the ramparts so long that the surface of the sods is dried, it is made into more or less large heaps on the drying place proper, and covered by means of a light roof or boards. Ekelund states that he can construct (in Sweden) ramparts 1,000 m. long, 4 m. wide and 1 m. high for 270M. to 300M. Such ramparts could be used for many years, and 20,000 hl. of peat could be dried simultaneously on them. Since only a few days are generally necessary to dry the peat to the state required for his coking process, i.e., to 40 to 60 per cent. of moisture, a large amount of peat may be dried in a single summer on the surfaces of such ramparts.

### 7.—Size of the Drying Ground

In Sebastiansberg, Schreiber<sup>2</sup> has made experiments on the high bog peat of that locality with regard to the space required for drying by various methods as well as the costs of the various drying structures. As a result of these experiments, he states:—

(1) *Minimum size of drying ground required* for spreading at one time 55·5 cb. m. of raw peat corresponding to 10,000 kilos of air-dried fuel peat:—

	Ares.
Pulped peat, spread.. .. .	11
Machine-formed peat, spread .. .. .	6
Cut peat (according to position in bog and size of sods)	4-10
Cut peat, "poled" .. .. .	6
Cut peat, "spiked" .. .. .	7
Cut peat, on "horses" .. .. .	4
Cut peat, on hurdles, trestles, &c. . . . .	3

In the case of moss litter, for the same weight of dry peat the size of drying ground must be about doubled.

<sup>1</sup> "Die Herstellung Komprimierter Kohle aus Brenntorf," by H. Ekelund, Leipzig, 1892.

<sup>2</sup> *Oesterreich. Moorzeitschrift*, 1903, pp. 92, 93.

(2) *Maximum output from a hectare of drying ground* when this is used only once :—

(The output is given in metric tons of air-dried peat.)

	M. tons.
Pulped peat, spread .. .. .	94
Machine-formed peat, spread .. .. .	178
Cut peat, spread .. .. .	100-270
“Poled” .. .. .	185
“Spiked” .. .. .	148
On “horses” .. .. .	310
On hurdles, trestles, &c. .. .. .	477

The output in the case of moss litter is about half these figures.

### 8.—Cost of the various Drying Contrivances

Hans Schreiber has calculated the following table (see p. 52) of costs for the various methods of drying which chiefly occur in Austria and South Germany, and in which drying plant is employed.<sup>1</sup>

In the case of peat litter these figures also hold for 55·5 cb. m., but as the dry peat is then only about half as heavy as fuel peat, the figures for 100 kilos must be approximately doubled.

The other results obtained in these experiments are given in Section V, under the influence of mode of winning on the drying. In considering them, attention should be paid to the fact that the figures given are not to be taken as generally true, owing to the extraordinarily rough climate round the experimental district.

### 9.—Costs and Results in the Hand Peat Industry

From the results given up to the present, it is evident that the cost of winning the unit (100 kilos) of air-dried peat must vary a good deal with the character of the raw peat and that of the bog, with the local rates of wages, and the method of winning (size of sods, mode of drying, and weather). It must also vary according as light peat litter or denser fuel peat, which may be cut peat or as dough peat, is won from medium high bog or denser low bog peat.

While the utilitarian and commercial value of peat is best expressed for a given weight of the substance, the cost of winning is mostly agreed upon and paid for by the *thousand* or the *cubic metre* (in Bavaria the “ster”) of air-dried sods or by the cubic metre of raw peat cut, and therefore by the volume, which is more easily determined than the weight. How far in the case of different varieties of peat the same units of price affect the cost of winning, and therefore the price by weight, or the market price, may be seen from the following figures.

In a particular case 1,000 sods were obtained from 5 cb. m. of raw peat containing 80 per cent. of moisture, i.e., 200 sods from

<sup>1</sup> *Oesterreich. Moorzeitschrift*, 1904, p. 64.

TABLE OF COSTS FOR DIFFERENT METHODS OF DRYING.

Kind of drying contrivance.	Cost of each piece, Marks.	For 10 m. tons of air-dried fuel peat = 55.5 cb. m. crude peat.			Charges on 10 m. tons of fuel peat for interest and amortization per annum.			Costs on 100 kilos of fuel peat, Pfennige.		
		Number of contrivances.	Figures for plant.		Interest, 5 per cent.	Amortization.			Total, Marks.	
			Amount, Marks.	Number of fillings.		For a single filling, Marks.	Per cent.			Marks.
Drying huts	2.55	2½	595.00	4	148.75	7.44	4	5.95	13.39	13½
Lower Alp, sod stands :	..	..	..	..	..	..	..	..	..	..
Complete	8.50	23	246.50	5	49.30	2.47	10	4.93	7.40	7½
Tween-stands	2.55	20								
Hurdles :	..	..	..	..	..	..	..	..	..	..
Complete	6.80	9	77.80	4	19.60	0.98	10	1.96	2.93	3
Tween-hurdles	2.38	7								
“Horses” :	..	..	..	..	..	..	..	..	..	..
Complete	1.70	32	81.60	4	20.40	1.02	10	2.04	3.06	3
Tween-horses	0.85	32								
Spiked Stakes	0.42	203	85.26	4	21.32	1.06	10	2.12	3.19	3¼
Poles	0.08	348	29.58	3	9.86	0.51	6	0.60	1.10	1
Spears	0.03	1,388	46.92	3	15.64	0.76	10	1.53	2.30	2¼



1 cb. m., and 600 of the air-dried sods had a volume of 1 cb. m. = 10 hl. They weighed in the case of lighter peat 180 kilos and in that of denser peat 300 kilos. One hundred kilos of this air-dried peat, clamped on the bog, cost, at the same rate of wages for the thousand sods, with a sod weight of :—

300 grammes	..	..	..	..	..	0·70M.
400	..	..	..	..	..	0·50M.
500	..	..	..	..	..	0·40M.

The *weight of a cubic metre of air-dried sods of moss litter peat* varies between 40 and 75 kilos, and that of 1 cb. m. of air-dried *fuel peat* between 130 and 300 kilos.

The *cost of winning* (excluding incidentals) 100 kilos of air-dried cut peat (fuel peat) varies from 0·40M. to 1·00M., and for 100 kilos of air-dried moss peat (peat litter) from 0·30M. to 0·60M. As an average, 0·70M. may be taken as the cost of winning 100 kilos of fuel peat (hand peat) clamped or stored at the bog, but to this must be added the ground rent and general working expenses. How far these figures may vary in special cases may be seen from the industrial details in the preceding sections, and for the further consideration of this the following facts may serve :—

(1) *In the Oldenburg peat-cutting industries at Augustfehn and Elisabethfehn, &c.*, the prices per unit given on p. 27 are paid. According to these, the cost of winning 100 kilos amounts to 0·30M. to 0·40M., the total net cost being 0·50M. to 0·65M.

(2) *Feilenbach Peat Works at Aibling.*—The area of the bog is 350 ha., of which 17 ha. are grass and transition bog, and the remainder high bog, this having a depth of 3 to 6 m. In addition to 15,000 m. tons of machine peat, there are won every year 2,000 m. tons of cut peat and 800 m. tons of peat litter and peat mull. For 100 kilos of cut peat the labourers' wages alone amount to 0·65M., and including drainage and general expenses, 0·80M. The market price is 1·05M. to 1·25M. for quantities of a double wagon load; 100 kilos realize 2·40M. to 2·90M. at Munich, coal varying in price from 2·50M. to 5·00M. (according to quality). The rate of wages is 3M. for a ten-hour day, but by piece-work 5M. to 6M. can be earned. (Cf. the "Feilenbach Peat Factory" in Section V, G, "Description of some Large Machine Peat Factories.")

(3) *Peat Factory of the Rosenheim and Reichenhall Salt Works.*—  
(a) *Hochrunst Moss.*—This high bog, which belongs to the Rosenheim Salt Works and is connected with the Koller Moss, has an area of 297 ha. In the semi-gas furnaces hitherto employed at the Salt Works, about 100,000 cb. m. (ster) of peat are required every year for the production of 26,000 m. tons of salt from a 26 per cent. solution. Of this amount of peat about 20 per cent. is won in their own factory, while the winning of the remainder is handed over to a contractor. All the operations are paid for at prices per unit, the rates being agreed upon with the workmen at the commencement of the peat-cutting. The manner of working is, in the main, that described on p. 31. Two men, a cutter and his assistant, always work together. The peat is cut as far as the

loamy subsoil in sods 40 x 12 x 10 cm., and these are dried in the open. The cutter's assistant (the *wheeler*) brings the cut peat to the drying ground over a narrow gauge rail, 40 cm. in width, bringing each time 60 to 70 sods of peat. The sods are spread on the drying ground, later on "castled," 6 sods in each, and as the drying progresses they are "re-castled" and, if necessary, "poled," i.e., placed on top of one another to a height of 10 to 20 sods round a pole standing in the centre, whereas in "castling" only 3 or 6 sods lie on one another. When the peat is dry enough it is made into heaps (clamped), 2 m. to 2·3 m. wide, 3 m. high and 12 m. long, on socles raised 20 to 30 cm. above the ground. The clamps are provided with a roof of timber planks which projects 30 to 50 cm. over the side walls. (cf. Figs. 12 and 13).

The bog is connected by a narrow gauge line with the full gauge line leading to the neighbouring Koller Moss. The peat is tipped directly from cars of 3 cb. m. capacity into the railway wagons, by which it is conveyed to the heaters of the salt works. Loading the peat from the clamps on the bog is paid for at the rate of 0·15M. to 0·18M. per cubic metre, while the transport and unloading are reckoned at 0·35M. per cubic metre, excluding, however, amortization of the capital required for the railway plant, which includes two locomotives and forty tip-lorries.

The contract price per cubic metre of clamped cut peat amounts to 1·15M. to 1·20M., which gives, on the assumption that a ster of dry peat weighs, on an average, 225 kilos, 0·53M. as the cost of labour for 100 kilos. The selling price for the cut peat of the neighbouring peat works is 2·60M. per cubic metre of dry peat, or 1·20M. for 100 kilos f.o.r.

A 30 h.p. Wielandt dredger, electrically driven, has been working since 1913 on the Hochrunst Moss. The sod spreader has a length of 20 m. Without taking into account stoppages, which are, however, still very frequent, the output of the dredger is 40 cb. m. of raw peat per hour.

A peat-dredging machine with a Baumann automatic sod spreader has been undergoing tests there since 1914. In the case of this peat dredger, the peat sods, after being made compact in a forming machine, pass, one by one, to a spreading belt, which may be of any desired length. The belt used here has a length of 90 m. Excluding stoppages, the output of the Baumann dredger is also 40 cb. m. per hour.

Finally, for the same bog a cut peat machine, Gress's patent (D.R.P., No. 265684), has been procured since 1915 for the production of cut peat or, as it is better termed, *machine-cut peat*. The industrial working of the machine, which gave satisfactory results on trial, was to take place from 1916 onwards.

(b) *Kendlmühl Moss*.—The Kendlmühl Moss, which lies at the side of Chiemsee Bog, and which was used in the seventies of the past century for winning peat for the puddling and smelting furnaces of the Bergen Smelting Company, was again arranged for peat working in 1914. Each year 40,000 ster of cut peat and approximately 5,000 ster of machine peat are won. The peat is

intended for the use of the Royal Salt Works at Reichenhall. The mode of working is as described above.

The peat machine (a Sugg) is provided with a 50 m. long Strenge sod spreader. The regularity with which the issuing peat sods pass on to the spreading belt is attained by means of a Gress regulator (D.R.P., notified).

The bog is connected with Bernau Railway Station by means of a narrow gauge line 3·6 km. in length. At the station the peat is thrown into a pit, from which it is brought by a conveying belt to the railway wagons. The winning of the cut peat is handed over to a contractor. The rates of payment are as described above.

(4) *Bürmoos, near Salzburg*.—In this bog, which has an area of approximately 500 ha., 140,000 to 160,000 cb. m. of dry peat are won every year for use in four glass works and two circular furnaces for the manufacture of bricks. The cost of winning 1 cb. m. of dry peat, piled in heaps, is 1·30 kr. A cubic metre of dry peat weighs about 225 kilos and contains about 500 sods. During the working season, from about April 15th to the middle or end of November, generally 120 to 150 groups of two workers each (a cutter and a wheeler) are engaged, each of which in 140 to 150 working days produces 1,200 cb. m. of dry peat and receives therefor 1,560 kr., so that each of the labourers earns daily, by piecework,  $4\frac{1}{2}$  to 5 kr.

(5) *Rottenmann Peat Works, near Wörschach*.—The amount won annually is 45,000 cb. m. of cut peat, in sods 30 x 22 x 12 cm., which is dried entirely in the air in the huts described on p. 48. The net cost is stated to be 1·85 kr. for 1 cb. m. of dry peat, or 1·00 kr. to 1·20 kr. for 100 kilos (a cubic metre having a weight of 150 to 200 kilos). The rate of wages in the locality is  $2\frac{1}{2}$  kr. to  $3\frac{1}{2}$  kr. a day, or 4 kr. a day by piece-work.

(6) *Peat Works of the Aussee Salt Company*.—The bog has an area of 160 ha. and an average depth of 3 m. Only cut peat is made, and this is cut in two layers each 1·5 m. in depth. Twelve cutters are employed. The sods are cut to a size of 23 x 16 x 5 cm. The small thickness is owing to the great difficulty of drying the peat, due to the local weather conditions. The drying itself is carried out entirely in the drying trestles or sheds described on p. 45. Every man is required to bring the sods cut by him to the drying trestles. The cutting, the transport and the layering of the sods on the trestles are paid for by the day (2·60 kr. to 3·60 kr.) The average output of a workman in a day shift of ten hours, from 6 a.m. to 6 p.m., with intervals of  $1\frac{1}{2}$  hours at midday,  $\frac{1}{4}$  hour in the morning and  $\frac{1}{4}$  hour in the afternoon, is 2,000 sods. The drying on the trestles, each of which holds 5,000 sods, requires two to six weeks, according to the weather and the moisture content of the sods when cut. A drying trestle can be emptied about every four weeks during the season from May to September. The transport of the dried sods to the storage sheds is carried out by two men, who are paid 2·60 kr. to 3·60 kr. per day. In one shift three drying sheds can be emptied. Owing to high railway

rates the peat is transported from the bog to the salt factory, which is at a distance of 9 km. from the bog, in horse wagons, each of which takes a load of 18 to 20 double cwts. (metric). The transport from and the loading at the storage sheds is paid for at the rate of 43 heller per 100 kilos. The unloading at the salt works into the peat sheds is done, when required, by one man, who is paid by the day.

The total number of people engaged in the peat-cutting is : One superintendent, one timekeeper and tool repairer, and about twelve cutters, who also look after the emptying of the dry peat from the trestles into the storage huts, the clearing of the peat bank, the cutting of drains, the repairing of trestles, &c., making, therefore, fourteen men in all.

How far the yield of air-dried peat, by volume as well as by weight, is affected by the differences in the raw peat, in spite of the method of working being the same, may be seen from the following results :—

1,000 sods of the above-mentioned size weighed, air-dried—				
from bituminous peat	..	..	..	235 kilos
from fibrous peat	..	..	..	224 kilos ;
and 1 cb. m. of air-dried peat sods weighed—				
from bituminous peat	..	..	..	240 kilos
from fibrous peat	..	..	..	140 kilos ;

and as 84 to 90 sods went to 1 hl., therefore 1 cb. m. corresponded to 840 to 900 sods. The above weights are not invariable, but alter with the density of the peat used, as the terms bituminous peat, mould peat, and fibrous peat are not sharply defined.

The cost of production has increased more and more every year, and in the years 1912 to 1913 was, including all incidentals, 2·27 kr. for 100 kilos of dry peat, as against only 1·23 kr. in the year 1903.<sup>1</sup>

According to the statement given on p. 57, 6,554,600 sods, weighing 1,233,100 kilos, were produced in the years 1911, 1912, and 1913. The mean annual production amounted, therefore, to 2,184,866 sods, weighing, when air-dried, 405,800 kilos. These required :—

(1) In wages for cutting, placing on trestles, transport to storage huts, removal of the bushes and roots before and behind the cutting, making drains, covering the bank, repairing the drying and storage sheds, removal of the implements and tools at the conclusion of the cutting, watching during Sundays and holidays, as well as superintendence and unloading at the salt works for the 2,178 shifts of the average year	..	..	..	= 6,338·89 kr.
(2) For the loading and transport of the peat from the supply sheds to the salt works at 43 heller for 100 kilos	..	..	..	= 1,744·94 kr.
(3) For the building materials and substances employed at the bog as well as for repairing the drying huts and trestles	..	..	..	= 995·78 kr.
				<hr/>
Ground rent	..	..	..	9,079·61 kr.
				119·25 kr.
Total	..	..	..	<hr/> 9,198·86 kr.

So that, for an annual output of 405·8 m. tons, 100 kilos of the peat cost the above-mentioned 2·27 kr.

<sup>1</sup> Cf. the corresponding part in the second edition of this handbook, p. 68.

## THE AUSSEE PEAT INDUSTRY FOR THE YEARS 1911-1913.

Industrial year.	1911.	1912.	1913.	Total.	Mean.
1. Duration of season	May 8th to Oct. 27th	Apr. 30th to Oct. 9th	Apr. 29th to Sep. 25th	—	—
2. Number of shifts completed	2,474	1,964	2,098	6,536	2,178
3. Wages paid (in Kr.)	7,072·05	5,577·85	6,366·79	19,016·69	6,388·89
4. Output (in 100 kilo- Output in sods . .	4748 2,254,809	3735 1,924,768	3748 2,374,942	12231 6,554,600	4058 2,184,866
5. Average output in 100 kilos per man per shift	1·92	1·90	1·78	—	1·87
6. Cost of produc- tion for 100 kilos (in Kr.)	1·49	1·49	1·68	—	1·55
7. Cost for imple- ments and build- ing materials (in Kr.)	1,718·21	465·27	803·88	2,987·36	995·78
8. Ditto for 100 kilos (in Kr.)	0·36	0·12	0·21	—	0·244
9. Transport costs for 100 kilos (in Kr.)	0·43	0·43	0·43	—	0·43
10. Ground rent (in Kr.)	76·24	205·27	76·24	357·75	119·25
11. Total cost of pro- duction for 100 kilos (in Kr.)	2·30	2·10	2·33	—	2·27
12. Amount of fuel peat used for pre- paration of salt (in 100 kilos).	4864	3236	4233	12333	4111

The peat mixed with lignite was fired at the salt works in semi-gas furnaces provided with step and horizontal grates. For 100 kilos of salt the consumption of fuel was, approximately, 75 kilos of peat and 84 kilos of lignite. On account of the high cost of manufacturing the peat, its further production for use in the salt works was *abandoned* in 1914.

For example, lignite free in wagon loads at the Bad-Aussee Salt Works costs 1·27 kr.; brown coal and coal are not used there. For the production of salt 411·1 m. tons of fuel peat were used on an average every year.

#### 10.—Percentage of Water in various Bogs and kinds of Peat ; Quantities of Water to be evaporated in Drying, and Yield of Moist or Dry Substance

The water content of bogs and of the raw peat won from them varies, according to their situation and degree of drainage, between 70 and 95 per cent., so that peat won from, or under, water with cutting machines or dredgers seldom contains less than 90 to 95 per cent. of water. Peat lying above the water-level contains 85 to 90 per cent. of water, and only that taken from well-drained peat layers contains 80 to 85, in rare cases under 80 per cent. of water.

On the other hand, the moisture content of peat well air-dried is usually only about 15 to 20 per cent., though it may rise to 25 per cent. Peat fuel containing more than 25 per cent. of moisture has its calorific power considerably decreased thereby and cannot any longer be called an air-dry commercial substance. Peat intended for dry pressing or coking is generally dried beforehand until it contains 40 to 50 per cent. of moisture; "anhydrous peat" should not contain any moisture at all.

Very frequently, and especially when dealing with the artificial drying of peat described further on, and which appears to many to be an easy, simple, and cheap operation, the significance of these figures is too little and, even by so-called experts, incorrectly appreciated.

One hundred kilograms of air-dried peat fuel with, for example, 20 per cent. of moisture contain, with the 20 kilos of moisture, 80 kilos of dry substance. If, however, 100 kilos of this air-dried peat are to be won from a raw peat with 90 per cent. of water, then 800 kilos of the raw peat will correspond to the 80 kilos of dry substance, since 800 kilos of this raw peat contain only 10 kilos of dry matter, and of these 800 kilos of raw peat 720 kilos will be water. *It is necessary, therefore, to raise from the bog and bring to the working and drying grounds eight times the weight of the peat fuel capable of being utilized, and evaporate from this, by drying, 700 kilos of water (as the residual 100 kilos of air-dried peat should contain only 20 kilos of water), i.e., seven times the weight of the peat fuel.*

For the partial drying required for dry pressing or coking, for instance, 100 kilos of peat with 80 per cent. of water to peat containing 60 per cent. of water, it is not 20 kilos of water, as is sometimes assumed even in estimates of costs, but 50 kilos, i.e., more than double the former amount, which must be evaporated, and the resulting partially dried mass weighs, not 80, but only 50 kilos, since the 20 kilos of dry substance corresponding to the 100 kilos of crude peat give with 30 kilos of water 50 kilos of peat containing 60 per cent. of water. The difference between the above 80 kilos and this 30 kilos must be got rid of by drying.

From the extraordinary difference between percentages and weights it may be seen how important it is in the matter of costs or in regard to the commercial value of artificial drying to use correct figures in all calculations with regard to fuel requirements.

Owing to variation in the quantity of water in one and the same amount of peat at various degrees of drying, the amount of the dry, "half-dry," or moist peat also varies in weight, but the weight of dry peat substance in it does not alter, remaining always the same.

If by drying raw peat containing  $m$  per cent. of water, i.e., 100 kilos of the raw peat contain  $m$  kilos of water, peat with only  $n$  per cent. of water is to be prepared, the unknown weight  $x$  of this peat may be found from the equation:—

$$x - x \cdot \frac{n}{100} = 100 - m \therefore x = \frac{100 - m}{1 - \frac{n}{100}}$$

since the weight of dry matter in  $x$  kilos of peat containing  $n$  per cent. of water is  $x - \frac{x \cdot n}{100}$ , and this must be the same as that of the original solid matter in the peat, viz.,  $(100 - m)$  kilos.

The quantity of water  $y$ , which gives with a fixed amount of dry matter a moist or partially dried peat substance with a fixed amount, say  $n$  per cent., of water, is known, when  $g$  is the weight of the dry substance, from the equation:—

$$g + y - (g + y) \cdot \frac{n}{100} = g$$

$$\text{therefore } y = \frac{g \cdot n}{100 - n}$$

If one has, for instance, peat with 95 per cent. of water, 100 kilos of which, therefore, contain 5 kilos of dry matter, then with these 5 kilos in a partially dried product containing 40 per cent. of moisture there are still combined only  $y = \frac{5 \times 40}{100 - 40} = \frac{200}{60} = 3\frac{1}{3}$  kilos of water, and the substance then weighs  $5 + 3\frac{1}{3} = 8\frac{1}{3}$  kilos. The excess water, which must be removed in drying, evaporated is  $91\frac{2}{3}$  kilos.

The tables on pp. 60 and 61 have been calculated in this way.

## 11.—Shrinkage and “Condensation” of Hand Peat on Drying

The shrinkage of hand peat on drying and the “condensation” associated with this differ greatly in individual cases and depend chiefly on:—

- (a) The amount of water in the peat as won and worked.
- (b) The mode of winning.
- (c) The age and the character of the raw peat.

The more the process of winning breaks up the fibres and destroys their connexion with one another, and the more the raw peat is kneaded and ground, the more the “formed peat” made from it contracts or shrinks on drying. In this way trodden, dough, and dredged peat shrink more than stroked peat and the latter more than cut peat, while, moreover, a peat shrinks all the more the older it is and the wetter it is worked.

The shrinkage of different peat sods can best be measured and the influence of different modes of winning on this can best be compared by finding the ratio of the size of an air-dried piece to the size of the same piece in the freshly formed condition. If the volume of the former be  $v$  and that of the latter  $V$  the fraction  $\frac{v}{V}$  or  $\frac{V}{v}$  for different kinds of peat, or for different modes of winning, gives the desired basis for comparison.

In the following,  $\frac{v}{V}$  is called the “dry-volume ratio,” since it gives the volume, after drying, of a piece of peat, the original volume of which was equal to 1; while the value  $\frac{V}{v}$  is called the “contraction, or shrinkage effect,” because the number thus obtained tells us how many times a sod of peat, worked by a certain method and in the air-dried condition, is smaller than it was when freshly formed.

(a) The columns under the figures in heavy type give the weights of peat—containing the percentage of moisture at head of column—which may be produced (either by evaporation or addition of water) from 100 parts (by weight) of peat containing the percentage of moisture shown in column A.

	Percentage of moisture shown in column A.																			
	95	90	85	80	75	70	65	60	55	50	45	40	35	30	25	20	15	10	5	0
95%	100	50	33.3	25	20	16.7	14.3	12.5	11.1	10	9.1	8.3	7.7	7.1	6.7	6.3	5.9	5.6	5.3	5
90%	200	100	66.7	50	40	33.3	28.6	25.0	22.2	20	18.2	16.7	15.4	14.3	13.3	12.5	11.8	11.1	10.6	10
85%	300	150	100.0	75	60	50.0	42.9	37.5	33.3	30	27.3	25.0	23.1	21.4	20.0	18.8	17.6	16.7	15.8	15
80%	400	200	133.3	100	80	66.7	57.2	50.0	44.4	40	36.4	33.3	30.8	28.6	26.7	25.0	23.5	22.2	21.1	20
75%	500	250	166.7	125	100	83.3	71.5	62.5	55.5	50	45.5	41.7	38.5	35.7	33.3	31.3	29.4	27.7	26.3	25
70%	600	300	200.0	150	120	100.0	85.8	75.0	66.7	60	54.6	50.0	46.2	42.9	40.0	37.5	35.4	33.3	31.7	30
65%	700	350	233.3	175	140	116.7	100.0	87.5	77.8	70	63.7	58.3	53.9	50.0	46.7	43.7	41.2	38.9	36.8	35
60%	800	400	266.7	200	160	133.3	114.3	100.0	88.9	80	72.6	66.7	61.5	57.1	53.3	50.0	47.0	44.5	42.1	40
55%	900	450	300.0	225	180	150.0	128.6	112.5	100.0	90	81.8	75.0	69.2	64.3	60.0	56.0	53.0	50.0	47.3	45
50%	1,000	500	333.3	250	200	166.7	142.9	125.0	111.0	100	91.0	83.3	77.0	71.4	66.7	62.5	58.8	55.5	52.6	50
45%	1,100	550	366.7	275	220	183.7	157.1	137.5	122.2	110	100.0	91.6	84.6	78.6	73.6	68.8	64.7	61.1	57.9	55
40%	1,200	600	400.0	300	240	200.0	171.4	150.0	133.3	120	109.0	100.0	92.2	85.7	80.0	75.0	70.6	66.7	62.2	60
35%	1,300	650	433.3	325	260	216.7	185.7	162.5	144.4	130	118.2	108.3	100.0	92.9	86.7	81.2	76.5	72.2	68.4	65
30%	1,400	700	466.7	350	280	233.3	200.0	175.0	155.5	140	127.2	116.7	107.7	100.0	93.3	87.5	82.3	77.8	73.7	70
25%	1,500	750	500.0	375	300	250.0	214.3	187.5	166.7	150	136.3	125.0	115.4	107.1	100.0	93.8	88.2	83.3	79.0	75
20%	1,600	800	533.3	400	320	266.7	228.6	200.0	177.8	160	145.4	133.3	123.1	114.3	106.7	100.0	94.1	88.9	84.2	80
15%	1,700	850	566.7	425	340	283.7	242.9	212.5	188.9	170	154.5	141.7	130.8	121.4	113.3	106.3	100.0	94.5	89.5	85
10%	1,800	900	600.0	450	360	300.0	257.0	225.0	200.0	180	163.6	150.0	138.5	128.6	120.0	112.5	105.9	100.0	94.7	90
5%	1,900	950	633.3	475	380	316.7	271.4	237.5	211.1	190	172.7	153.3	146.1	135.7	126.7	118.8	111.8	105.6	100.0	95
0%	2,000	1,000	666.7	500	400	333.3	285.7	250.0	222.2	200	181.8	166.7	153.8	142.9	133.3	125.0	117.6	111.1	105.2	100

A.



(b) The amount of water in kilos which must be evaporated by drying to obtain a peat with :

		95	90	85	80	75	70	65	60	55	50	45	40	35	30	25	20	15	10	5	0
From 100 kilos of peat with a percentage of water of	95	0	50	66.7	75	80	83.3	85.7	87.5	88.9	90	90.9	91.7	92.3	92.9	93.3	93.8	94.1	94.5	94.7	95
	90	—	0	33.3	50	60	66.7	71.4	75.0	77.8	80	81.8	83.3	84.8	85.7	86.7	87.5	88.2	88.9	89.5	90
	85	—	—	0	25	40	50.0	57.1	62.5	66.7	70	72.7	75.0	76.9	78.6	80.0	81.3	82.3	83.3	84.2	85
	80	—	—	—	0	20	33.3	42.9	50.0	55.6	60	63.6	66.7	69.2	71.4	73.3	75.0	76.5	77.8	78.9	80
	75	—	—	—	—	0	16.7	28.6	37.5	44.5	50	54.6	58.3	61.5	64.3	66.7	68.8	70.6	72.2	73.7	75
	70	—	—	—	—	—	0	14.0	25.0	33.3	40	45.5	50.0	53.8	57.2	60.0	62.5	64.7	66.7	68.4	70
	65	—	—	—	—	—	—	0	12.5	22.2	30	36.4	41.7	46.2	50.0	53.3	56.3	58.8	61.0	63.0	65
	60	—	—	—	—	—	—	—	0	11.1	20	27.3	33.3	38.5	42.9	46.7	50.0	53.0	55.5	57.9	60
	55	—	—	—	—	—	—	—	—	0	10	18.2	25.0	30.8	35.7	40.0	43.8	47.0	50.0	52.2	55
	50	—	—	—	—	—	—	—	—	—	0	9.0	16.7	23.0	28.6	33.3	37.5	41.2	44.5	47.4	50
	45	—	—	—	—	—	—	—	—	—	—	0	8.3	15.4	21.4	26.7	31.3	35.3	38.9	42.1	45
	40	—	—	—	—	—	—	—	—	—	—	—	0	7.7	14.3	20.0	25.0	29.4	33.3	36.8	40
	35	—	—	—	—	—	—	—	—	—	—	—	—	—	7.1	13.3	18.8	23.5	27.8	31.6	35
	30	—	—	—	—	—	—	—	—	—	—	—	—	—	0	6.7	12.5	17.7	22.2	26.3	30
	25	—	—	—	—	—	—	—	—	—	—	—	—	—	—	0	6.3	11.8	16.7	21.0	25
	20	—	—	—	—	—	—	—	—	—	—	—	—	—	—	—	0	5.9	11.1	15.6	20
15	—	—	—	—	—	—	—	—	—	—	—	—	—	—	—	—	0	5.6	10.3	15	
10	—	—	—	—	—	—	—	—	—	—	—	—	—	—	—	—	—	0	5.3	10	
5	—	—	—	—	—	—	—	—	—	—	—	—	—	—	—	—	—	—	0	5	
0	—	—	—	—	—	—	—	—	—	—	—	—	—	—	—	—	—	—	—	—	0

Percentage of water is :—

This contraction is met in calculating the yield by volume from a bog, and the shrinkage on winning must be taken into account whenever peat fuel is to be sold by the thousand and the sods are to have, as far as possible, a prescribed size.

In a similar manner the different effects of different methods of winning for one and the same raw material, or of one and the same method of winning for different raw materials, on the density and the firmness of the peat fuel may be judged relatively to one another by determining and comparing the ratio by weight of a piece of "formed peat" to the weight of an equally large piece of cut peat, or, in other words, *the ratio of the density of the "formed peat" (moulded, trodden, or dough peat) to the density of cut peat from the same material, dried to the same degree (air-dried).*

Other things being the same, preference is to be given to that mode of winning by means of which the ratio of the density of the "formed peat" to that of cut peat from the same material is the greatest.

This influence may be called the "*condensing effect*" of the mode of winning and may be given a numerical value by determination of  $\frac{s}{s'}$ , where  $s$  is the density of the "formed" or "dough" peat" and  $s'$  is that of the cut peat from the same bog.

(This condensing effect is of great importance in the winning of machine peat and affects considerably estimations of output as well as the selection of suitable machines, as is shown later in more detail.)

If the above observations be applied to several communications with regard to measurements and weights of different kinds of peat in the wet and dry (air-dried) states, as, for instance, those of Engineer Wasserzieher, on peat from the Langenberg Bog, near Stettin, and of G. Thenius, on Bürmoos peat, which are to be found in *Dingler's Polytechn. Journal*, the values of the "dry-volume ratio," as well as the "shrinkage" and "condensation effects" of various methods of winning in the case of the various peats contained in the table (p. 63) will be obtained.

From the figures given it follows that the "dry-volume ratio" of cut peat, neglecting the pure "liss peat," is 20 to 35 per cent., and on the average may be taken as 28 per cent., while that of stroked peat is 16 to 24 per cent., and on the average 20 per cent. The yield (by volume), therefore, of air-dried peat from a bog, the volume of which has been measured *in situ*, would be only 28 per cent. of this in the case of cut peat, or 20 per cent. in the case of stroked peat.

At the same time it may be seen from the last vertical column of figures that the influence of the mode of winning on the condensation, i.e., the condensing effect, amounts to 1.43 to 1.94, and, therefore, may be assumed to be approximately  $1\frac{1}{2}$  to 2. By kneading and stroking peat, in the case of the raw peat noted in the table, a product  $1\frac{1}{2}$  to 2 times heavier and more solid than the cut peat from the same material is obtained.

DRY-VOLUME RATIO, SHRINKAGE, AND CONDENSING EFFECT WITH VARIOUS KINDS OF PEAT AND VARIOUS METHODS OF WINNING.\*

No.	Size in cubic inches (German) of the peat		Weight in kilograms of the peat.		Density of the air-dried peat.	Dry-volume ratio, $\frac{v}{V}$	Shrinkage effect, $\frac{v}{V}$	Condensing effect, $\frac{s}{S}$	Mode of winning.	Nature of the raw peat and site of the bog.
	Raw.	Air-dried.	Raw.	Air-dried.						
1	150	44.0	2.715	0.490	0.62	0.29	3.41	—	Cut peat	{ Brown peat { "Liss" Peat { Pure "liss" peat { Upper Middle Lower } Peat cut in Bürrmoos
2	150	30.9	2.800	0.535	0.96	0.21	4.85	1.53	Stroked peat	
3	150	35.2	2.565	0.355	0.56	0.23	4.26	—	Cut peat	
4	150	23.5	2.750	0.410	0.97	0.16	6.38	1.73	Stroked peat	
5	150	43.5	2.760	0.505	0.65	0.29	3.45	—	Cut peat	
6	150	32.9	2.820	0.550	0.93	0.22	4.56	1.43	Stroked peat	
7	150	52.8	2.305	0.275	0.29	0.35	2.84	—	Cut peat	
8	150	35.5	2.805	0.350	0.55	0.24	4.23	1.89	Stroked peat	
9	150	76.0	2.200	0.175	0.127	0.50	1.97	—	Cut peat	
10	150	58.0	2.800	0.260	0.247	0.39	2.58	1.94	Stroked peat	
11	192	60.0	3.990	0.350	0.32	0.31	3.20	—	Cut peat	
12	288	80.0	5.810	0.860	0.58	0.28	3.60	1.89	Kneaded peat	
13	192	39.0	4.590	0.385	0.54	0.20	4.93	—	Cut peat	
14	192	52.5	4.130	0.430	0.45	0.27	3.66	—	Cut peat	

\* Cf. also Section V, "Comparison of the Properties of Machine Peat and Cut Peat from the same Raw Material, and Influence of the various Modes of Winning on these Properties," also Section VI, 1, the same ratios for peat litter winning.

## 12.—Defects of Hand Peat

By noting the operations to be carried out in the various methods of winning hand peat and by taking into account the capacity of the air in different seasons for absorbing water vapour,<sup>1</sup> it will be seen that the success of these methods of winning and drying depends for the most part on the action of the air and on the weather conditions.

Moreover, crude peat is in itself, owing to its mode of origin and the nature of the bodies which form it, in most cases, especially in the upper layers of a bog, a very loose, felty, mossy mass. Owing to great variation in the density of the raw material and irregularity in its drying, the individual particles of the substance become loosely arranged and thus very many cavities are produced to which the low density (weight) and loose consistency of the cut peat are to be attributed. These defects cannot be decreased to a sufficient extent even by manufacturing kneaded or dough peat. In consequence of this, the drying of hand peat in uncertain weather can be effected only with great difficulty and loss of time, since, when perhaps only a few more days are required for its being clamped, it absorbs water again during every shower of rain, with the result that the drying must commence anew, and since it, moreover, possesses the property, common to all bodies of loose texture of not letting all its water be evaporated by air-drying, but of retaining a certain amount, and even of re-absorbing this amount from moist air when a portion of it has been removed in a hot season by drier air or by more or less prolonged lying in covered sheds. The property of retaining water is all the greater, the lighter, the more felty, and the looser the peat is.

For these reasons hand peat, especially cut peat, must lie for months in the open before it can be brought into sheds to finish the air-drying, provided sheds are there at all, and in a big peat-cutting industry this is usually not the case, as they would entail a considerable amount of extra capital.

Covered stands, sheds, &c., such as are employed to dry cut peat in some Austrian works, although they show very good results as regards the degree of drying, and the time required for it, have not everywhere proved commercially successful, the increase in expenses due to them proving too great for the market value of the peat. Hence it happens that, although thorough air-drying should produce in the case of cut peat a lowering of the water generally to 20 per cent. and even to 15 per cent., this degree of drying, on account of the difficulties mentioned, is attained only in the rarest cases. Much more frequently hand peat, if it has not been stored under cover for a long time, contains more than 20 per cent., and, especially in the case of cut peat, even up to 25 per cent. of water.

When, moreover, as frequently happens, the crude peat has only slight cohesive properties, the hand peat, even when made

---

<sup>1</sup> Cf. table in Section V, D.

as stroked or dough peat, falls to pieces or breaks into crumbs partly while in the clamps (even when fully dry), and partly while loading at the loading place or unloading at the place of utilization. The loss due to this cause is not inconsiderable. On the average it may be assumed as 15 to 20 per cent., but in the case of light cut peat it may be as much as 25 per cent.

The consequence of these properties is that :—

(1) In using hand peat as a fuel, its moisture (approximately one-fourth the weight of the fuel) decreases its calorific power considerably, as a considerable portion of the heat set free by the burning of the peat is used up in evaporating the water contained in the latter, and, therefore, becomes lost, so that the heat of combustion and the practically utilizable amount of heat can never be reached to the extent corresponding to the amount of carbon and hydrogen in the peat.

(2) Owing to the loose texture of ordinary peat a given volume can produce only a small amount of heat, and even large quantities of peat rapidly burn away. Hence, especially in the case of more or less large furnaces, almost continuous feeding and stirring of the fire is necessary, and this, apart from the inconvenience of stoking, causes considerable loss of heat owing to the frequent opening of the furnace doors and also owing to the size of the hearth.

(3) In consequence of the unfavourable ratio of volume to weight, transport is inconvenient and expensive, since a wagon, on account of the large volume required by the hand peat, cannot generally take its full load (by weight).

(4) On account of the friability of hand peat much breakage, and, therefore, much loss occurs on loading and unloading and also by vibration of the transport vehicles. Transport over distances of any length is scarcely feasible in places where there are no waterways or where somewhat frequent handling is necessary.

Moreover, when winning either cut peat or dough peat in protracted bad weather, a good deal of the winning, and, therefore, of the wages paid for it, is lost, and also in cutting peat a great loss of material arises owing to the upper layer of the bog not possessing sufficient cohering power for cut peat owing to the action on it during several years of cold and heat. It requires to be removed occasionally to a depth of half a metre and thrown aside as useless. Further, a number of pieces which break up while being cut fall back into the cutting trench. Again, "moulding" by hand labour can be carried out only with such kinds of peat as from their friable, short fibre character can be stroked into the forms (moulds) and which, after "moulding," do not again swell out, become loose, and crumble. Finally, the production of trodden, pulped, or dredged peat requires, relatively, too much human labour, which is either difficult to procure or too dear, and the treading of the wet bog surface with the feet is an operation which is difficult in itself and unhealthy.

For the reasons given above, and especially when the intention was to work a bog on a large scale, people soon directed their

*efforts to getting rid of all these defects, by preparing the peat, in large quantities, as dry and as dense as possible, from any raw peat by means of machines, thus obtaining a fuel as cheap, valuable, and transportable as possible, and able to compete in industry with brown coal or coal.*

The description of the methods adopted is given in the following section.

## SECTION IV

# WINNING OF ARTIFICIAL, PRESS, AND MACHINE PEAT FOR PRODUCTION ON A LARGE SCALE AND FOR GETTING RID OF THE DEFECTS OF HAND PEAT

### 1.—Summary of the Methods Proposed and on their Value in General

The following methods have been proposed for attaining the object mentioned above, and also for getting rid of the defects of hand peat already indicated.

(1) Ordinary air-dry cut peat, stroked peat, or dredged peat is subjected to artificial drying (dehydration) in order to remove the water (anhydrous peat).

(2) The peat, after addition of much water, is ground and torn into powder by machines, and then, before drying it, an effort is made to free it by a "washing-out" process from the earthy (ash) bodies with which it is mixed. (*Washed-out peat* : Methods of Challeton, Galecki, and others.)

(3) The peat is pressed through a sieve by means of machines, and in this way the real peat substance is separated from the plant residues (sedge, grass roots, and stones), which may be present in it, and is then formed into regular pieces by special machines. (*Sieve peat* : Versmann's method.)

(4) The peat, after maceration as far as possible for the purpose, is dehydrated in drying ovens, and the warm peat mould is pressed by means of powerful piston presses (crank or spindle presses) into smooth, regular pieces. (*Press peat* : Dry press methods of Exter-Gwynne, Stauber, Peters, and others.)

(5) An attempt is made to press the water out of the peat, freshly raised from the bog, by strong mechanical pressure, and at the same time to form it into sods, which are then dried under cover. (*Press peat* : Wet press methods of Koch and Mannhart, the Moor Cultivation and Peat Utilization Co., the Wet Carbonizing Co., Ltd., the Wet Press Co., Dr. Heine and Rudeloff, Dr. Ekenberg and Larson's Wet Carbonizing, &c.)

(6) Attempts are made by means of electrical currents to facilitate the dehydration of raw peat by pressure. (*Press peat* : Electrosmosis, methods of the Osmonde and Pentane Works, Bessey, Kittler, and others. *Hard peat* : Baron von Verschuer's method.)

(7) Raw peat is disintegrated and mixed by means of machines, as in (8) but the peat mass, which has a uniformly

thick and pulpy consistency, is formed in special machines into balls as big as a man's fist, which are then dried artificially in special drying shafts. (*Ball peat*: Eichhorn's method.)

(8) The freshly won peat is brought to machines which tear up the root and plant fibres, destroy the natural, uneven, felty formation of the peat, and by thorough mixing transform the peat into a thick mass, which is as uniform as possible, and which:—

(a) *Without previous addition of water* is, while thick and kneadable, stroked by hand into moulds or is formed by the mixing machines themselves into a thick, endless, sausage-like band, which is divided into sods before it is spread for air-drying (*machine-formed peat*: Weber's method); or

(b) *After previous addition of water*, is allowed to flow out as mud or pulp on an open, levelled ground in a layer of uniform thickness which is cut into sods before it is fully air-dried (*machine pulp* or *machine dough peat*, sometimes also called *machine mud peat*: Hanover-Oldenburg method).<sup>1</sup>

<sup>1</sup> Schreiber proposes in his Report ("Neues über Moorkultur und Torfverwertung," Second Annual Series) the term "machine-kneaded peat" for this, "because the name pulp peat would also do for machine-formed peat."

In the first place this term is not suitable, since machine-formed peat in order to be capable both of being "formed" and of giving firm sods is, as a rule, worked in so dry a state that it is not really a pulp, and is therefore not "pulped peat" (p. 30) in the sense in which this commonly accepted and unambiguous term is employed in general trade as well as in the peat world, even though a peculiar hardening effect may be ascribed to the pulpy (that is, viscous, moist, pasty) mass. A body may be "pulpy," that is, it may have one or other of the qualities of pulp without being "pulp" itself, just as a thing may be "woody" or "stony" without being wood or stone.

Machine-formed peat as it issues from the mouthpiece of the machine does not collapse on the sides as a real pulp would do, but, on the contrary, can be moulded into pieces with free vertical faces. Above all, however, no pronounced distinction between machine-pulped peat and machine-formed peat is introduced by the term "machine-kneaded peat." Machine-formed peat, since it is worked without addition of water, must be kneaded by the machine even more than the muddy, machine-pulped peat, which is generally worked with addition of water, and the term "machine-kneaded peat" is therefore even better suited for machine-formed peat. Just as in the more or less large peat districts the terms applied to different varieties of hand peat—cut peat, trodden peat, pulp peat or dough peat, and moulded or formed peat—are definite expressions which have been generally accepted for centuries, so also the corresponding terms machine pulp peat and machine-formed peat are applied to peats of a similar kind when spread on the drying ground if in working the raw peat into dough, or pulp peat, or into moulded, or formed peat, machines have been substituted for hand labour.

Hence in machine peat circles, especially in Germany and Holland, under the general term "machine peat" it is customary to distinguish between machine-formed and machine pulp peat. Consequently it has been adopted here in agreement with this practice. The general practice of foreign peat industries, for instance those of Denmark, should not be regarded as final for the German technical world, nor should it be assumed that the term "pulp peat," which is less ambiguous and therefore clearer for German technical journals, is sufficiently covered by "Aeltetorv" (kneaded peat), which would without a doubt be a rather hazy term for German experts to use when distinguishing between the various kinds of peat fuel.



(9) Peat is won by machinery in the form of powder or dust for firing in the well-known coal-dust furnaces. (*Machine dust*, or *machine powder*, *peat*: Ekelund's method.)

Of the above-mentioned methods only that mentioned under (8) has had any general commercial success, and that under (4) has had a quite limited one. According to the machines employed for performing the work and their peculiarities, the methods may be divided into several sub-groups, which have had much, or little, success. By a process mentioned under (8) we obtain a well-known fuel which is coming more and more into use under the name of "*condensed machine peat*," or briefly "*machine peat*." The name "*press peat*" is often applied to the latter, and the machines for producing it are called "*peat presses*." This use of the term is, however, incorrect, and leads to this peat being confused with the real press peats made according to method (4) or (5). In ordinary language we understand by the expression "*press peat*" only such a product as has been really pressed into a dry and dense condition by means of considerable mechanical pressure, just as we understand by the term "*press*" a machine by the aid of which a big mechanical force can be applied.<sup>1</sup>

---

<sup>1</sup> It is to be regretted that now and then, even in expert circles, the terms "*press peat*" and "*machine peat*," which, as we have explained above, are diametrically opposed, are not kept strictly separate, and that the expressions "*press peat*" and "*peat presses*" are used for "*machine peat*" and "*peat-forming machines*," although they are quite distinct both in their nature and in their commercial results. Just as in trade, industry, and domestic use a quite definite fuel really pressed from coal (coal briquettes) is known and universally understood under the expression "*press coal*"—the expression (coal briquettes), hitherto current for it, tending more and more to disappear—in the same way only the product (peat briquettes), prepared in the same manner from peat, can be logically understood by the term "*press peat*."

To give to quite a different product the same name as that given to a generally known commercial article is certainly not justifiable, and therefore not admissible for an expert. For, after all, it is the primary duty of the leading experts, and especially of the leading technical journals, to cater for the enlightenment and the instruction of the circles interested. Consequently also, in the present case, the final word on the former point should not be that in less instructed circles, and such as are therefore less careful with regard to both facts and words, and in which "*machine-(formed) peat*," which is quite a different thing from *press peat*, is often called "*press peat*." On that account it is rather the duty of experts, for the prevention of obscurity and confusion of ideas, to avoid, when possible, these expressions which are still used in minor circles, although admitted to be "*erroneous*" or "*badly chosen*," and to employ the clearer terms existing for the purpose in the leading expert circles.

The principal technical journals, such as the *Mitteilungen des Vereins zur Förderung der Moorkultur im Deutschen Reiche*, the *Vienna Zeitschrift für Moorkultur und Torfverwertung*, the *Berichte der Bremer Moorversuchstation*, and of the Technische Hochschule in Hanover, proceed in this way, which is also emphasized as the correct one in the conclusions of the *Begriffsbestimmungen wichtiger Torferzeugnisse* of the sixth session of the Bog Experimental Institutes, in which occurs the statement, "*Varieties of formed peat*: (a) *Machine peat* (wrongly called *press peat*)."

If in the leading expert circles any expression is recognized as, and

This is, indeed, the case in the methods (4) and (5) mentioned above and in the machines employed in these methods; but is not so in any of the methods mentioned under (6), since the pressure produced by these machines is barely sufficient for "forming" the soft peat mass. The condensation of machine peat is not brought about, as will be explained later on, by the pressure applied, but by the mixing action of the machine in question. Hence experts term the machines of method (6), according as they "form" the peat at the same time or merely tear it up and mix it, peat-forming machines or peat pulp or peat-preparing machines, or briefly *peat machines*, and in accordance with this, the product from them, to distinguish it from hand peat and press peat, is called machine-formed peat, or machine dough or machine-pulped peat.

In the case of the above-mentioned method of winning machine peat the facts *are not* as often asserted and accepted:—

"Any water enclosed in the peat fibres, as in capillaries, is let flow out by rupturing the tubes, and thus the machine peat is dried more rapidly than cut peat" (for water-retaining plant fibres or tubular water reservoirs of appreciable size, such as could be cut by the knives and blades of the peat machine, are not present in any considerable number in the peat). The water-retaining capillaries and cells are so small as to be almost imperceptible to the naked eye, and can in no case be cut through or torn to pieces by the mixing machines in question;

Or "the greater portion of its water is pressed out of the peat while it is being formed before it leaves the machine, and the

said to be, wrong (when used instead of another term), such an expression should be avoided on principle and replaced by the clearer one in standard technical writings. Also on p. 68 of the technical work "Neues über Moorkultur und Torfverwertung," Pilsen, 1903, it is stated under the heading "Machine-formed Peat" that it is wrongly called "press peat." Nowadays all experts agree that the name press peat is incorrect and misleading. They should therefore never use the name unless the words "wrongly called" are prefixed to them to prevent misconception. It would be still better and more effectual if the misleading name were not employed at all. At any rate, it is clear from this that only non-experts can now use the expression "press peat" for "machine-formed peat" without sinning against expert knowledge and expert custom arising therefrom. In his work, "Pressen und Formen von Brentorf," Wittenberg, 1912, Thamm takes the same view, and expressly states that "machines which only 'form' the peat are *wrongly* called *peat presses*," and that the name "press peat" or "briquette" is applicable only to a peat product really formed by means of strong pressure. Considering the doubtful success hitherto attained in the real peat press plants, in peat presses, and with press peat, those who manufacture and who sell peat-mixing and forming machines of proved excellence, which are not peat presses (the latter are usually uneconomical), should avoid applying the same name to their product. The doubt fostered thereby can only have an injurious effect—since it is becoming more and more recognized that only in the rarest instances are press peat factories successful—on the sale of the more suitable mixing or forming machines of proved excellence for which the name "peat machines," and for the product of which the name "machine peat," are very suitable and generally understood terms.

peat is, in consequence of the pressing action of the machine, transformed into a solid and valuable fuel like coal ” ;

Or “ by the mixing and stirring of the peat mass the plant gum, which is to bring about the hardening of the pulverized peat, is ‘ set free,’ also by tearing the ‘ peat straw,’ the pentosanes—the powerful cements enclosed with the peat water in the straw—are set free and then surround the peat pulp as it dries ” ;

But still less “ empyreumatic bodies contained in the peat are pressed to the surface of the pieces of peat, the surfaces becoming pasted over with a gelatinous layer of bitumen and humin and solidifying at once after gasification of carbon on exposure to the air.”

The same remark applies to other similar mental aberrations such as are frequently found in articles by so-called peat authorities in the price lists of peat machine manufacturers and of peat machine dealers, and in the literary effusions of the owners of peat bogs or peat machines who, with few exceptions have, through lack of detailed and expert investigation, only a very remote notion of the real nature of peat winning. In their excursions along the borders of technical and natural science they feel tempted, in spite of their lack of real expert knowledge, to explain the basis of the machine peat industry by a scientific jingle. Others aim at commercial exploitation, speculating as they do on the ignorance of certain circles.

As a matter of fact, the process of condensation which takes place in the winning of machine peat is simply as follows :—

“ The raw peat, which is at first of variable density, and which is working in the machines in question with a percentage of water ranging from 70 to 90, acquires (assuming that a correct selection of machines has been made) a uniformly dense and pulpy consistency by the thorough mixing which occurs while the plants and plant fibres are being torn up, and while the felty, spongy structure of the peat is being destroyed. The small particles of peat therefore acquire the natural tendency peculiar to such pulpy, finely divided, cellular or fibrous masses of adhering closely to one another during the subsequent evaporation of the water, and, in proportion as the water evaporates, the volume of the peat becomes smaller, that is, the peat contracts or becomes more dense. The cement, if such a term can be used at all, is the “ humic substances ” and the peat fibres themselves. If we consider the condensation only, it is almost a matter of indifference whether the peat pulp was pressed or not pressed, “ formed ” or not “ formed,” when it was leaving the machine. *Condensation during drying will be all the greater and more uniform the more minutely the peat is macerated and the better it is converted into a uniform pulpy mass.*

The condensation, due to the mixing action of the machines, and by means of which nearly all the above-mentioned defects of hand peat are at the same time removed, takes place when working light fibrous peat, as well as every other raw peat, to such an extent that when this machine peat is fully dried one can

cut, saw, and turn it like hard wood or heavy brown coal—the peat giving a perfectly smooth glistening section. To obtain peat as dense and firm as this from wet peat or from a partially dried powder by means of lever, piston, or roller presses would be possible only by the expenditure of great mechanical power, and the process would therefore be too costly for winning on a large scale.

For this reason the press methods mentioned under (4) to (6) may be generally described as uneconomical. Usually press peat (unnecessarily called peat briquettes), prepared by a dry method from peat mould or peat powder, has a further defect in that the peat blocks, which are in themselves very clean and firm, lose their firmness through the action of the heat in the fireplace, and fall into powder again before the actual process of burning sets in; in this way their utilization for industrial purposes is hampered, and that for carbonization is made quite impossible. Moreover, both the processes require, relatively speaking, high capital charges and entail great working costs, and give, therefore, also, on account of the preliminary drying and heating required for the raw substance, a very dear fuel, which is at the same time unequal to the demands made on it in industry.

Every artificial drying plant (dehydration plant) has up to the present, no matter how promising it seemed to be, always proved too expensive, both as regards plant costs and running expenses. For this reason the manufacture of anhydrous peat is out of the question (for particulars see Part II, Section I, D).

The “*washing-out process*” of Challeton, mentioned under (2), with which the process proposed some time ago by Galecki agrees even with respect to the “washing out,” is not one to be imitated, inasmuch as it must be termed an incorrect procedure to try to win and utilize as fuel a peat which contains such gross, and so great a quantity of, earthy impurities that an appreciable portion of these can, and must, be removed by a “washing-out” process. In this way a bad peat, very rich in ash, would be burdened with costs of winning which even a good peat, poor in ash and of which there were plenty in nature, could scarcely support, and this without the quality of the former being improved to an extent corresponding to the increase in cost.

The *manufacture of “ball peat,”* which was similar in principle to that of machine peat, required for its working a large plant which was difficult to construct. Owing to frequent interruption of the industry and high plant costs, as well as to the artificial drying associated with the process, the fuel produced was far too expensive.

This statement is even more applicable to *Versmann’s sieve process*.

Many other attempts to condense or to dehydrate peat by mechanical agents have either not got further than the experimental stage on the small scale, or the application for a patent; or the results obtained after working them did not correspond to the expectations entertained to such an extent as to allow of

hopes for a favourable commercial success, even after overcoming the difficulties which usually become apparent in the preliminary trials.

To this class belong all attempts to remove water from peat, enclosed in cloths, by water-pressure (or hydraulic) presses, which is in itself a roundabout method and which gave a very costly fuel with, at the same time, a low output, and also attempts to employ centrifugal force for the same purpose, which were made by Cobbold, Gwynne (London), Hebert (Rheims), and others.

In order to secure technical success for these attempts, it was found necessary to convert the peat into a uniform pulp before feeding it into the centrifuge, and also to "form" the dehydrated peat in machines. It is evident that there could be no question of commercial success for a process so complex as this.

This remark applies also to the process of removing water wholly or partially from peat by bringing the peat on a filter cloth over a place which has been previously made into a vacuum by means of an air pump and then forming the peat, either by pressing it between rollers or by pressing it by means of rollers and stamps, into moulds which could be moved under the latter.

Attempts such as these were made in very many cases, especially before Weber's process was generally known, and, particularly in England, several patents for such methods of winning out were taken out at that time. Some of these methods are described in detail in Muspratt's "Chemistry," and in Dr. Vogel's little book, "Der Torf, seine Natur und Bedeutung," Brunswick, 1857.

In more recent times many attempts have again been made to solve the peat problem by dry pressing, wet pressing, fore-pressing and after-pressing, in order to deprive the peat of its water by pressing, artificially heating, sucking away the air, and evaporation. No one of these *new* and *newest discoveries* deserves a detailed description, and they may all, without further consideration, be rejected as uneconomical. Experts conversant with the matter, knowing and taking into account the nature of peat, occupied themselves only with the further development and extension of the methods mentioned under (8) in all cases except that of installations of the kind described further on for power stations in bogs.

The method first employed in 1858-59 by von Weber at Staltach, in Bavaria, the machines used in the method, and the improved winning processes and plant developed from it form the subject of detailed discussion in the following sections, preceded by brief explanations of the other methods which had been used in their time, but which, being of little advantage, as we have already mentioned, have ceased to be employed.

Inasmuch as these methods have only historical value for the development of the peat industry, their description has been limited to that of the general methods employed and their results without entering into details.

The manufacture of anhydrous peat, which formerly appeared to be important for many branches of industry, especially for the smelting industry, is treated in Part II, Section I, D, of this handbook.

## 2.—Description of the various Methods

### A.—Manufacture of “Washed-out” Peat (Challeton’s Process)

According to the “*washed-out*” peat process employed by Challeton at Montauger, near Paris, and in various factories in the south of France and Switzerland, the freshly won peat after addition of water, was torn up and macerated by a series of rollers, each of which had a length of 125 cm., a diameter of 45 cm., and was mounted with hollander knives 100 mm. in length; after further addition of water the peat was converted into a thin pulp by means of stirrers.

At Montauger, the pulp, when freed from fibres by fine sieves, was elevated to the upper story of the machine house and then passed down through pipes into the “soaking pits.” The latter consisted of pits 5 sq. m. in area and 0·5 m. in depth, the permeable bottoms of which were covered with sedge and reeds, so that the water, by soaking through the bottom, could easily flow away from the mud, which became denser and was then cut into sods, which were subjected to a preliminary drying in covered sheds and finally to a complete drying in heated rooms.

A very dense peat was, of course, obtained by this process (its density being at least as great as that of condensed machine peat) and, indeed, the density of the anhydrous “washed out,” artificial peat, which still contained, however, a high percentage of ash, was up to 1·8. The ultimate object of this expensive “washing-out” process, viz., freeing the peat from its incombustible ingredients and decreasing the percentage of ash, was attained only either to a very small extent or not at all. Coarse sand, stones, &c., could, indeed, be removed by the process, but the quicksand, clay, lime, or gypsum, which were minutely distributed in the pulp, could not be separated in this manner.

Since such a process depends essentially on the weather and on the season (in wet summers from four to six weeks will elapse before the peat pulp can be cut in the soaking pits); since the washing out requires a large area round the machine house, and the peat has to be conveyed from a considerable distance to the pits; and since, owing to the removal of most of the fibres, the peat is destitute of good binding material and, therefore, the dry peat, like Exter’s press peat, easily crumbles when burning, the method is not suited for general use. Moreover, the capital and running expenses are by no means low. At Challeton’s works there were 800 pits, 50 of which were filled each day; the daily output of finished peat was about 8,500 kilos.

The same process was also employed at that time near Roy, in St. Jean, in Switzerland, in Würtemberg, and in several places in Russia.

According to Dr. Vogel, the method which Hebert adopted at Rheims agreed in the main with that of Challeton, but differed from the latter, however, in the manner of carrying it out. There also the peat was put into a machine by which it was worked, after addition of much water, into a thin pulp, and the pulp then passed through a sieve, which stopped all the coarser portions, into a pit from which, as from an ordinary washing pit, the water could be let flow away when the peat pulp had subsided. When the peat pulp had become quite dense it was raised from the pit and "formed" into sods by means of a machine, to which we shall return when dealing with the manufacture of machine-formed peat.

The "washed-out peat" factory, which formerly existed at Langenberg, near Stettin, was erected according to Challeton's plan, from which it differed only in the arrangement of the peat-disintegrating machines. When the factory was first started, the disintegrators consisted of four grinders, which were placed in the upper story of the machine-house and which were fed with wet peat by means of elevators. Each grinder contained two pairs of rollers, 750 mm. in diameter and 1,250 mm. in length. The two upper rollers were grooved to a depth of 55 mm. and the two lower to a depth of 20 mm. The rollers of each pair had equal velocities but revolved in opposite directions. With this arrangement the only possible result was that the peat remained almost unaltered even when it was passed several times through the grinders and therefore, this expensive plant, having had almost no action on the peat, had to be very soon replaced by another.

After many alterations, which necessarily destroyed all chances of profit from the enterprise, the following arrangement was adopted:—

The factory stood on a sand-dune which was raised to a height of 10 m. above the surface of the bog and was extended up to 400 m. on both sides of the factory.

A canal, 15 m. in width, led from the bog to one side of the building and the raw peat was brought to the latter in flat-bottomed boats over the canal. These pontoons were filled by a 20 h.p. steam dredger which worked in the bog and had a daily output of 1,000 cb. m. with a dredging depth of 5 m. Each of the pontoons was capable of holding 25 to 30 cb. m. of raw peat. The pontoons were hauled in pairs quite close to the factory, from the upper stories of which two elevators, 14 m. in length, were suspended at an angle of  $45^\circ$ ; by means of these the raw peat was raised to the disintegrating machines. The disintegrating machines for each elevator consisted of two wooden vats, side by side, each 3 m. in diameter and 0.6 m. in height. Inside each vat, at a distance of 250 mm. from the outer shell, there was an inner screen made of iron rods, 10 mm. in thickness and arranged in latticed fashion, into which the crude peat, mixed with much water, was brought. In the middle of each vat there was a vertical shaft provided with four arms, to the ends of which strong brushes were fastened which swept closely over the sieve-like or latticed

screen. The shafts made twenty revolutions a minute and the peat, to which water was added as required, was broken up by the stirrers attached to the shafts, the finely divided peat being centrifuged into the external cylindrical space, while the coarse fibres, roots, and other impurities remained in the inner compartment.

In front of each of the four vats there was a wooden mill, of which the fixed lower part was 200 mm. in height and the upper runner 500 mm. in height and 2·6 m. in diameter. The grinding surfaces were of cross-grained wood and were provided with deep feeding channels. The eye of the runner had a diameter of 1·2 to 1·5 m. and caught the peat mud as it came from the sieve vats. The mills worked well and gave, when running, a peat mud which was ground more or less finely as desired. The mud from the four mills collected in a channel, 1·5 m. in width, which had a natural fall towards a pit. The mud was raised by a centrifugal pump from the pit to a small reservoir about 6 m. higher than the pit. From the reservoir long wooden channels, 470 mm. wide and 600 mm. deep, led to the level sandy surface, 12 ha. in area, which was divided into main fields and these again into divisions of 25 ares each. Each of these fields was surrounded on three sides by an embankment, 0·6 m. in height; the fourth side was open and had a wall of planks (of various lengths) 0·8 m. in height when the field was full of peat mud.

Between every two fields there was a trench 0·5 m. in depth. The trenches were bounded by the embankments and were connected with the general discharging drains. In order to cover the various fields with peat mud, the main channels, which had falls of 1 in 100, had in each field three small side pipes opening at right angles to the direction of the main channel of the field and closed by wooden side valves. There were also at hand, small, portable wooden channels, 4 to 5 m. in length, 180 mm. in height, and with a width decreasing from 340 to 275 mm., together with portable trestles. The channel conduits, constructed from these, sloped downwards from the three side tubes of the main channel to near that end of the field which was closed by the boards.

Two fields were always covered with the peat mud at the same time and the channels stood ready for use in a third field. In two days, with the help of five men, 75 ares were laid out. The depth of the layer of thin fluid peat in the fields was 0·5 to 0·6 m. When, after four to eight days, the surface began to crack, the peat was trodden until firm with the aid of boards fastened under the workers' feet. After a further period of six to eight days the peat was cut into longitudinal strips, and after another six days it was cut crosswise, turned, and then dried in the air by the ordinary method.

At this factory the winning season had to end about the middle of July to ensure that the last portion run out could be dried. Hence, in about sixty working days about 140,000 hl. or 625,000 kilos of peat were won on the 12 ha.

The output from every 100 sq. m. of the surface covered by



the mud was 11·5 cb. m. of dry peat sods, 60 to 70 mm. square by 160 to 200 mm. in length. A hectolitre of these sods (including the spaces between the sods) weighed, in the case of litter peat, 40 kilos, and in that of brown peat, 53 kilos. The density of the dry peat was 0·73 to 0·90.

This "washed-out peat" process was given up even in the last century, and after many experiments and intermediate stages it evolved into a peat press method in which a Magdeburg dry press (cf. p. 84) was employed, but even this peat press factory (at Langenberg) has in turn closed down.

Galecki's "washed-out peat" process, which, in so far as it is really a "washing-out process," is just as uneconomical as Challeton's, is described more fully in the section on the Hanover-Oldenburg pulp peat winning (p. 152).

### B.—Versmann's Sieve Process

The essential part of this process, as in that of Buckland<sup>1</sup> (which was introduced into England about 1860 and brought from there to Germany by the chemist Versmann), consisted in the peat being first very finely divided in a disintegrating machine, the peat proper being separated from the impurities and plant remains (roots, fibres, &c.) which always accompany it and then formed into regular pieces in a special forming machine.

The machine for the preliminary preparation consisted<sup>2</sup> of an iron cylinder resting on a square stand with a funnel, likewise made of iron, fixed near the bottom of the cylinder. The wall of the funnel was pierced with a large number of holes, which were close beside one another and 3 mm. in width. A cast-iron cone rotated inside the funnel, and on its mantle two screw-threads were placed so that, when the cone was rotated, they glided round with their sharp external edges close to the inner, perforated wall of the funnel. In working the machine the raw peat was thrown into the upper feeding cylinder, where it was caught by the screws of the rapidly rotating cone and was pressed by the screw blades against the perforated wall of the funnel. The peat itself was pressed through the holes in the form of macaroni, while the fibres and coarse impurities (stones, pieces of wood, &c.) were said to have been left behind and to have been expelled through the lower cylindrical prolongation of the funnel.

The peat, which had been pressed out and purified, fell on a table which rotated with the vertical axle under the funnel and from which the peat was scraped by a stationary knife, this knife being screwed to the machine stand with its lower edge close to the upper surface of the table. The peat was pushed towards a forming machine which bore a resemblance to a brick machine.

Apart from the fact that with impure peat frequent stoppages occurred in the work owing to the choking of the sieve-holes, it is wrong to remove from a fibrous peat the fibres which are of value,

<sup>1</sup> *Journal of the Society of Arts*, 1860, p. 437.

<sup>2</sup> *Dingler's Polytechn. Journ.*, vol. 168, p. 306, and vol. 172, p. 332.

both as fuel and as "cementing constituents," in the "forming" and drying processes which are subsequently carried out. Moreover, since the manipulation, as may be seen even from the description, was more intricate than that of mixing and macerating machines, which are at the same time "forming" machines, and also since this process was usually combined with artificial drying, any expectation of favourable commercial results in the case of installations of this type was precluded from the very start. Consequently, all the factories which were erected at great expense to carry out this process, as, for instance, that at Neustadt-on-Rhine, ceased working after a very short time.

### C.—Manufacture of Press Peat (Peat Briquettes)

#### 1.—*The Exter-Gwynne Dry Press Process*

Dry pressing, agreeing in the main with the process elaborated by Gwynne in England in 1853, was carried out after a long series of very difficult experiments in 1856 by Exter, first at the State Peat Factory at Haspelmoor, between Munich and Augsburg, and afterwards at Aibling, in Bavaria, at Freiburg, in Switzerland, at Neustadt, in Hanover, at Miskolcz, in Hungary, and at many other places.

The peat was freed from water as far as possible by means of deep drains. It was then steam-ploughed lightly and, therefore, very finely divided by the tearing to pieces of the various fibres and roots. The mass obtained in this way was harrowed so that it might dry better in the sun and air, and when fully air-dry it was brought to the machine-house in small cars over a railroad. It was there thrown on a sieve, 25 mm. mesh width, and the peat mould which passed through the sieve was raised by an elevator to the top story of the building, and was again sifted in inclined cylindrical sieves, which were placed beside one another and decreased in width from 1 m. to 70 cm. over a length of 2 m. The fine-sifted portion passed directly to the drying ovens and the coarse portion was brought, by means of spiral screws, to the boiler-house, where it was employed for heating the steam boiler.

The drying oven was divided into several sections by shallow tin boxes, which were connected alternately in a zigzag fashion. The peat powder was driven through these by spiral screws and passed through them from above downwards alternately from right to left and left to right, while a current of hot steam passed in the opposite direction between the tin boxes and escaped at the top. At the temperature of the oven, which was from 40° to 50° C., the peat dried until the percentage of water in it was 10 to 12. It next passed from the oven through a funnel into the presses, and was pressed at a temperature of 50° C. into pieces 180 mm. long, 80 mm. wide and 15 mm. to 25 mm. thick, each of which weighed about 375 g.

The presses were double-acting ones, lever presses or crank presses, steam-driven, and with two pistons.

As the stroke of these presses was quite definite and did not

automatically regulate itself during action, frequent breakages of various parts of the machinery were caused by the peat fed into the machine not being of uniform density, and this, together with the heating of the machine due to the heat contained in the pressed peat and the complicated construction of the drying ovens, gave rise to the necessity for frequent repairs and, therefore, to troubles in the working. All these, together with high plant costs and high working expenses, were detrimental to the wide use of the process, and after a short time led to the closing down of all these factories.

The costs of the installations were at the time very considerable, and amounted, for instance, for steam ploughs, transport vehicles, drying ovens, machines, buildings, and site at:—

Locality.	Marks.
Haspelmoor .. .. with 4 Presses, to	300,000
Aibling .. .. „ 2 „ „	240,000
Freiburg .. .. „ 3 „ „	225,000

Gwynne's method, which was used at the time in England and Ireland, differed only in details and in the machines used from Exter's method, which has just been described, and did not give any better results from the commercial standpoint.

## 2.—*Resumption of Dry Pressing by Peters, Stauber, the Buckau and Zeitz Machine Factory, &c.*

(At the end of the last, and the beginning of this, century.)

In recent decades extraordinary success in the utilization of friable or earthy brown coal and inferior small coal was obtained everywhere owing to the employment of dry presses which have during this period been considerably improved (by Exter). A big market (even in the cases of long transport by rail or water) has also been opened up for clean "press coal" for domestic as well as industrial use. Under these circumstances it soon became apparent that steps would once more be taken to employ the plant which had proved successful in the "press coal" industry for the manufacture of an equally clean and marketable press peat from the raw peat, which was to be found almost everywhere and which apparently cost nothing. As sufficient attention was not paid either to the difference between the raw materials—mine-damp brown coal or pit coal containing 55 to 60 per cent. of moisture on the one hand, and raw peat raised from the bog with 85 to 90 per cent. of moisture on the other hand—or to local conditions, these attempts must, from the commercial point of view, end in failure, as the author of this handbook has always maintained. The manufacture of a good, clean press peat, similar to press coal, from peat mould by the process usually adopted for winning press coal (especially when the well-known Zeitz or Magdeburg stamp presses with plate or tubular drying ovens are employed),<sup>1</sup> presents no technical difficulties. With almost the

<sup>1</sup> Further particulars are contained in Preissig's "Die Presskohlen-industrie," Freiberg in Silesia, 1887, and in Dr. Friedrich Jünemann's "Die Brikettindustrie und die Brennmaterialein."

same plant "half-dry" peat mould, containing the same amount of moisture, can be worked without any special cement into clean, firm and transportable press peat (peat briquettes) with the same degree of technical success and at the same cost. The net cost, however, of the raw material required for the pressing is, in the case of the "half-dry" peat mould required, considerably higher than in the case of the pit coal, and therefore the net cost of press peat is considerably greater than that of press coal. Hence the question of commercial success for the press peat factory can only arise in the case of districts to which the cost of transport by car or rail is rather high, and into which pressed brown coal, for instance, cannot be delivered free at a price of 150M. for a double wagon load of 10,000 kilos.

By not bearing these circumstances sufficiently in mind, failure must inevitably result. Thus, at the end of the nineties, Stauber, in connection with a Schöning machine company, being mistaken as to the commercial value of such installations for the public, erected two press peat factories in the middle of the Province of Brandenburg, and therefore in a district where the brown coals of Anhalt and Lausatia are always to be had at the very lowest market prices, and intended these factories to serve as models for similar installations in all the larger peat districts.

The first installation, at Trebbin, could not be got to work at all, and the second, at Mittenwald, could only be got to work by replacing their own patented devices by the sifting and drying plants which had proved successful in the press brown coal industry. After the loss of much capital, the result arrived at here, which could have been predicted by any expert, was that the cost of the product, which *can be made* and *can be utilized*, is much too high in comparison with the ordinary prices of fuel in the immediately surrounding district, even when the industry is well organized and proceeds smoothly, and that, therefore, the industry could not be maintained with any prospect of commercial success. The peculiar characteristic of Stauber's plan was said to consist<sup>1</sup> in the emancipation of the industry from the air-drying required by other methods, and thus making it independent of wind, weather, and the season of the year, by a preliminary artificial drying of the raw peat (which contained 80 to 90 per cent. of moisture) in a drying drum with the aid of hot gases from fires until the "half-dry" body contained the 60 per cent. of moisture present in mine-damp brown coal powder. In this way it was hoped that the continuous working, both day and night, summer and winter, which is necessary for a large commercial industry, would be possible.

Owing to the importance which at the beginning of this century was once more attached by many (attracted by very promising but incorrect statements of some speculators) to the winning and utilization of peat in the form of press peat (peat

---

<sup>1</sup> Cf. E. Stauber, Berlin, "Torfbriketts als Ersatz für Kohle," and *Techn. Rundschau des Berliner Tageblattes*, Nos. 40 and 41, 1900.

briquettes), detailed accounts of the various peat factories of this class and of the results which are possible in the most favourable cases are given in the second edition of this handbook, to which reference must here be made.

In the present edition a detailed account<sup>1</sup> of these may well be dispensed with, since in the meantime the results obtained in all these press peat factories have once more shown that the working of such factories in a commercially remunerative manner cannot as a rule be attained. For even with the low wages of 2·50M. for the ordinary day labourer and 3M. to 4M. for artisans and mechanics (the rates of wages at present are considerably higher), the actual net costs, including interest and amortization of the capital, calculated when the industry went smoothly, were :—

In the case of a plant with one press, the capital being at least 200,000M.	In the case of a plant with two presses, the capital being 320,000M.
For 1,000 sods press peat .. .. .	For 1,000 sods press peat .. .. .
4·22M.	3·84M.
Or for one double wagon equal to 10,000 kilos..	Or for one double wagon equal to 10,000 kilos ..
105M.	97M.

These costs of production would be increased 30 to 40 per cent. by the considerable increases which have in the interval taken place in capital costs and in wages.

Press brown coal costs, on the other hand, according to its quality, at Senftenberg Station, 80M. to 100M. ; at Berlin Station, 113M. to 133M. ; and Saxon press coal at Meuselwitz, 90M. to 115M. a double wagon.<sup>2</sup>

Assuming 28,000 briquettes to a double wagon, then 1,000 briquettes cost 3½M. to 4½M. at Berlin, carriage paid. The so-called industrial press coal costs about 5M. less per double wagon.

In the manufacture of press peat, a given weight of the finished press peat, containing 12 to 15 per cent. of moisture, requires for the press peat itself and the fuel necessary for heating the boilers and the preliminary drying of the materials, a weight of raw peat, containing 90 per cent. of moisture, eleven times the weight of the finished product, and since in the manufacture of press brown coal the weight of raw material is not even double

<sup>1</sup> Further particulars with regard to details of the capital and working expenses may be seen in the second edition (1904) of this book.

<sup>2</sup> In summer, 1914, the net cost in the case of Senftenberg coal was 50M. to 55M., and in the case of Meuselwitz coal 60M. to 65M. for a double wagon at the works, the small coal costing 10M. to 14M. a double wagon, that is 7 Pfg. to 9 Pfg. a hectolitre (70 kilos) at Senftenberg and up to 10 Pfg. at Anhalt, according as day shifts only were worked or not.

In general it may be reckoned that 1 kilo of press coal will require in raw material and fuel : At Senftenberg, 2½ kilos pit coal ; at Anhalt, 3 kilos pit coal ; on the Rhine, 3½ kilos small coal ; and at an Anhalt press coal factory, which does not work under the most favourable conditions, there are required for 100 kilos of press coal—32 Pfg. for press coal, 13 Pfg. for fuel coal, 12 Pfg. for wages, 5 Pfg. for general working expenses = 62 Pfg. for 100 kilos, or 62M. for one double wagon.

Meuselwitz wet press coal, 14 Pfg. being paid for coal from a deep shaft, was manufactured for 55M. a double wagon, and sold in 1914 at 75M. to 80M.

that of the finished product, these relations must affect very considerably the commercial results of the two industries.

Even when instead of the artificially "half-dried" peat, which Stauber proposed to use, ordinary air-dried cut peat was employed as fuel for heating the boilers, it was found that the change in the method of working produced no material alteration, either in favour or against the cost of the process. While the use of cut peat as fuel simplifies the working of the concern, the use of "half-dried" peat renders it more independent of the weather and the season of the year.

Other processes which were also proposed for the winning of press peat, for the removal of fibres therefrom, and for the artificial drying of peat, have not, as might be foreseen by any expert, proved successful, but have indeed proved very expensive for the experimenters.<sup>1</sup> The above remarks also apply to the various wet press processes, by which indeed a marketable, firm and utilizable peat fuel can be obtained, but the commercial value of which, owing to the complexity of the process and the inferiority of every kind of peat to brown coal, may be predicted as out of the question.

A press peat factory can become remunerative only when the "half-dry" peat mould (containing at most 20 per cent. of moisture) required for the press peat costs, delivered at the press or the steam plate driers, no more than the pit coal required for press coal factories, and when, in the case of peat bogs at a considerable distance from coal-mines, the difference in freightage can be placed to the credit of the press peat factory. In the brown coal industry there are many factories in which brown coal, containing 60 per cent. of moisture and costing only 8 Pfg. to 12 Pfg. per 100 kilos, is made into press coal in a commercially remunerative manner. In the peat industry there is no method yet known by which it would be possible to win "half-dry" peat mould (containing 60 per cent. of moisture) in large quantities, and with a certainty which would guarantee continuous working for a large scale industry at approximately this price.

The Swede Ekelund estimated the "half-dry" cut, or crumb peat (containing 60 per cent. of moisture), required as raw material for his own coking process at only 3 öre to 4 öre per hl. (50 kilos),

---

<sup>1</sup> Especially Stauber's manufacture of press peat on the Dammersdorf Estate, near Marlow, in which the peat was to be dehydrated by being subjected to pressure between a movable piston and a perforated mantle, and was then to be pressed through hot forming tubes and after being cut into uniform sods, was to be converted by several days' drying into "an excellent, firm and dry press peat." Also his "Removal of fibres from, and artificial drying of peat for the production of press peat" (see E. Stauber, Berlin, "Torfbriketts als Ersatz für Kohle"), and his "solution" of the peat problem: "Drying peat in an air-tight canal by alternately pumping out the air and heating the peat and then coking the peat," as well as his artificial drying by destroying and bursting the capillaries and peat fibre vesicles by super-heated steam in the Blöstau Peat Factory, near Königsberg, in Prussia (*Techn. Rundschau des Berliner Tageblattes*, Nos. 40 and 41, 1900).

which is equivalent to 6 öre to 8 öre or 7 Pfg. to 9 Pfg. for 100 kilos, delivered at the factory. He also stated that it was easy to win anywhere such "half-dry" stuff at this price. In spite of every endeavour we have not succeeded in finding even in Sweden where peat of this kind could really be won at this cost in the large quantities which are being considered here.

Plans and detailed estimates for large press peat factories with artificial preliminary drying of the material to be pressed have also been made by others. In Oldenburg, for instance, peat containing 83 per cent. of moisture, raised from a drained bog, "formed" by machines into sods and dried in a shed until it contained 80 per cent. of moisture, was to be sent through drying canals (Möller and Pfeifer's method), which were to be heated by hot air or hot gases from fires, attention being paid to the recovery of the heat of evaporation. From the drying canals, in which the percentage of water in the peat was to be lowered from 80 to 72, the peat thus "fore-dried" was to be sent in drying cars direct to the drying rooms, one of which was to serve for drying while the finished dry peat was being removed from a second and a third was being filled with "fore-dried" sods. In the drying room the water in the peat was to be reduced in three to five days, by conducting hot air or hot gases (at 80° C.) from a fire through the room, to 17 per cent., a percentage which was said to be a suitable one for feeding the material to the presses. The hot air required for this, as well as for the preliminary drying, was to be obtained by mixing the hot gases from the boiler fires with the air of the boiler-house, and was to be driven by blowers into the rooms. We are not aware of the successful construction and working of any installation of this kind.

In spite of every effort, only the following press peat factories were actually at work or were in working order during the first decade of the present century:—

- (1) The Langenberg Press Peat Factory, near Stettin.
- (2) The Ostrach Peat Briquette Factory, in Hohenzollern.
- (3) Jrinowka Press Peat Factory, near Petrograd.
- (4) The Press Peat Factory of the Griendtsveen Moss Litter Company at Rotterdam.

A press peat factory near Königsberg, in Prussia, another at Schönau, near Stolzenberg, in Pomerania, and still another near Teterow, in Mecklenburg, were built, but, like the Mittenwald factory, they did not get any further than a few experiments on pressing. The peat factory erected by the Beuerberg Peat Briquette Company was *not* a press peat factory; it made, in so far as it worked at all, only machine peat with the aid of two Schlickeysen machines. Of the four press peat factories first mentioned not a single one, except the Russian one mentioned under (3), is at present working in spite of the prolonged efforts of the owners to make them commercially successful.<sup>1</sup> There is

<sup>1</sup> In the second edition of this handbook, pp. 107–110, further particulars are given with regard to details and working results of these factories.

now not even one peat press factory in Germany. At Langenberg it has been shown that, notwithstanding all attempts to improve the press peat industry, mere agricultural utilization of the bog gives a better return than the winning of press peat. The Ostrach Peat Briquette or Coal Works intends to procure other machines for another process in place of those of the press peat works which have been shut down, but at the present time it is running only its peat litter factory. In Finland, however, a large peat dust factory with presses (according to Ekelund's method) has been recently erected near Riihimäki. So far as its success is concerned nothing is yet known.

The erection of the Langenberg and the Ostrach Factories was due to the Buckau Machine Company, near Magdeburg, that of the Jrinowka Press Peat Factory to the Zeitz Foundry and Machine Company at Zeitz, and that of the Dutch factory to the Düsseldorf Iron Company at Düsseldorf-Grafenberg. The first two were single-press plants; the Russian one has two presses. The factories did not differ essentially from the well-known press brown coal factories. The Buckau Machine Company used a Schulze tubular drier, and the Zeitz Company its own plate drier. The Dutch press peat factory, instead of employing air-drying, which is commercially the only justifiable process and which was employed by the other factories, at the recommendation of the Düsseldorf Iron Company, resorted to pressure for the preparation of the "half-dry" press material, in order to ensure that the industry could be carried on throughout the year. In this method the raw peat was brought to a piston press, by which it was carried through a mouthpiece as a continuous band, 0.6 m. wide and 50 mm. thick, to a cutting contrivance by means of which it was divided into pieces 0.6 m. in length. Every thirty of these peat cakes, after being wrapped in filter cloths by a machine, passed automatically to a lift by which they were brought over a filter press in which these cakes were dehydrated, in about twenty minutes, between grooved press plates under a pressure of 100 atmospheres until their volume had been reduced to one-half and the percentage of water had fallen to about 50. It was stated that 0.14M. covered the cost of manufacture of 100 kilos of these pressed peat cakes, which formed the crude material for the subsequent dry pressing, and also that the power required for a press was 2 h.p. (!).

It is said that in spite of all efforts the "half-dry stuff" obtained by the fore-pressing contained 65 to 70 per cent. of water instead of the 50 per cent. which was expected. This difference is big enough to raise doubts as to the commercial value of the plant, as a whole, for the manufacture of press peat.

Only the Jrinowka Press Peat Factory in Russia is said to be still working, and this must be ascribed to local conditions and to the personal influence of the proprietor on his customers. The managing body of this press peat factory stated, for instance, that the factory works satisfactorily with two steam presses which are constructed for a yearly output up to one million pud



(16,380 m. tons) of press peat. It has been said that the two presses give every day 4,000 pud ( $6\frac{1}{2}$  double wagons) of press peat from cut peat containing 30 to 35 per cent. of moisture, and that, as a matter of fact, the sales amounted to 500,000 pud (8,190 m. tons, or approximately 820 double wagons) in six months. Under the unfavourable weather conditions which prevail there, the net cost was 16 copecs a pud, or 100 copecs for 100 kilos of press peat ready at press, that is, without freightage, amortization, &c. The selling price was 25 copecs a pud, or 150 copecs for 100 kilos, delivered in the city. The press peat is used there in the better circles of society for stoves in rooms and for kitchen fires; some of it is, however, used in Hoffmann circular furnaces for the manufacture of bricks. The Company hope to reduce still further the net cost of the press peat by means of a cheaper method of winning, which has been already introduced.

The scheme proposed by Amandus Kahl's Machine Company, of Hamburg, must be regarded as not differing essentially from the process of dehydrating by pressure used in the Dutch factory. According to it, the "half-dry" press stuff was to be obtained by employing artificial drying with suction of water and air instead of the natural method of drying. The raw peat, which was to be dredged and well mixed by a Strenge machine, was to be brought over a field railway from the dredger to the peat press factory, and then, after addition of water, was to be mashed by stirrers into a peat pulp containing 90 to 95 per cent. of water. This peat pulp was then to be dehydrated until it contained 60 per cent. of water by a suction drier—the so-called Hencke separator,<sup>1</sup> and in this condition was then to be used as "half-dry" stuff for the press peat factory. The suction drier may act quite well in other industries (for drying distillery, brewery, and starch residues, for instance), and in the present case may, as intended, "half dry" the peat. This dehydration of the peat entails, however, so great an expenditure for the machines and the working of the suction pumps and the suction drier itself, that peat dehydrated in this way should be too dear a "press stuff" for a press peat factory to allow of the remunerative manufacture of a marketable press peat. There are no reliable figures available with regard to the actual cost of "half-dry" peat which has been dehydrated according to this method.

### 3.—*The various Wet Press Methods*

The wet press method of Koch and Mannhart was employed in 1858 on the Riet Bog, at Schleissheim, in the neighbourhood of

---

<sup>1</sup> This suction drier consists of a revolving drum having a permeable perimeter, over which runs an endless filter cloth, to which the peat to be dehydrated is fed uniformly through a kind of sieve. The air is pumped out of the drum, and in this way, under the pressure of the external air, a part of the water of the peat becomes sucked out. The peat on the filter cloth, which has been to a large extent dehydrated, runs above the drum over some pressure and suction rollers, which are also said to remove water from the peat.

Munich. According to this method, the wet peat, as it comes from the bog, is pressed mechanically until it has lost as much as possible of its water and is then dried completely under cover, or in the case of unfavourable weather in hot drying chambers. The machine employed for this purpose consisted, according to Dr. Vogel, of two iron cylinders, 4 m. in diameter, having sieve-like surfaces round which closely woven press cloths passed. By means of a special contrivance the water which collected under the press cloth was able to flow away continuously through the cylinders as the pressing proceeded. A special distributor is said to have partially broken up the raw peat and to have fed it uniformly to the rollers. A wide band of peat, about 6 mm. thick, was thus formed, the peat at the same time losing a good deal of its water and acquiring a considerable amount of solidity. Two or more such bands were combined to a single band by pressing once more. When the band of peat was sufficiently thick it was cut into pieces of the desired size, and dried.

The peat bands, before they received their main pressing, on passing through the large cylinders dammed up and fouled the press cloths so that the latter ceased to act, thus giving rise to frequent stoppages. Moreover, if the press cylinders were really to exert a pressure, it would be necessary to allow them to revolve slowly. For these reasons the daily output of the machine must be small. For large outputs of pressed peat the number of the machines must be large, and the plant of such a factory would therefore be very costly. The interest and amortization due to this, together with the costs of repairing the machinery, could only result in considerable increase in the expenses of the industry.

All these disadvantages were experienced in a high degree at the first factory of this class, which was built at Schleissheim. Although efforts were constantly made at the time to remove the various defects and to decrease the working expenses of the process, they met with only slight success, since the process, owing to its cumbrous nature (repeated pressing with the object of increasing the thickness of the bands by combining them with one another), could not give a cheap product. Moreover, this press peat, on account of its shape (that of a thin plate), was not much adapted for burning economically. The factory, which was the only one of its kind, closed after a considerable amount of money had been wasted.

In this class we may also include all the unsuccessful proposals or contrivances of Stauber, Schöning-Heine, the Dusseldorf Iron Company, and others, in which peat, before further treatment, is to be freed from its excess of water by the pressure, in one or more stages, of grooved rollers, pistons, or plates against sieves or filter cloths, even when the peat is also to be warmed or otherwise treated with electricity (!).

It may be taken for granted that in a relatively short time, by a continuous pressure of several atmospheres which can be applied without difficulty, so much water can be pressed out from raw

peat containing, as a rule, 90 per cent. of water, that the amount of water in the peat is lowered to 80 per cent. The further dehydration of the peat does not, however, keep pace with the increase in the pressure or in its time of application, but becomes relatively smaller as the percentage of water becomes lowered by the pressure to 70 or less and, finally, when the amount of water in the peat has fallen to 65 to 60 per cent., it is not worth taking into consideration even when the pressure is 100 atmospheres or more. Indeed, owing to the gelatinous or pasty nature of the peat at this stage of dehydration, removal of the water by means of even these high pressures ceases almost altogether.

The removal of the water by pressure is facilitated by freezing and thawing the peat beforehand, by heating the raw peat or by mixing it with granular, pulverulent, porous, drier substances. Heating the material to be pressed is the basis of the Ekenberg process of the "Wet Carbonizing" Co., Ltd., of London. In Sweden and Germany attempts have also been made, with employment of much capital, and simultaneous loss of capital, to work factories of this kind, the commercial success of which cannot but appear impossible when we bear in mind the calorific power of peat and the unwieldy nature of the process.

According to Dr. Ekenberg and Engineer Larson the basis of this method, which is also called the "wet carbonization of peat," is:—

The peat (containing 85 to 90 per cent. of water), which has been worked into a pulp by a mixing machine (Anrep), is pumped through a number of tubes in which it is heated to 150 to 200° C., and at the same time it is subjected to a fairly high pressure, so that no development of steam can take place. Partial carbonization of the peat is said to occur without formation of tar and gaseous hydrocarbons, the calorific value of the peat increasing by about 1,000 calories. It is claimed that the fibres of the peat mass, subjected to this treatment, lose their colloidal properties, and that the water can then be driven out of them by pressure. This dehydrated peat is then converted by pressure into press peat, which is said to possess a calorific power equal (?) to that of coal. (Cf. the various methods and appliances under Patents in Section VII, 1.)

Every wet press method, even when it *can* be carried out and gives a marketable, convenient fuel, must from the nature of peat be uneconomic, i.e., too dear.

For the same reason scarcely any other result is to be expected from the process of the Wet Press Co., Ltd., of Wiesbaden, which has been referred to recently in several technical publications as worthy of attention. In this process some peat, which has been previously dried artificially, is added to the raw peat, after this has been disintegrated in a machine, and the mixture is exposed to a slowly increasing pressure between rollers and press cloths. It is claimed that in this way the amount of water in the peat can be lowered to 60 per cent., and that the peat can

then be used with advantage either for the production of power gas or for the manufacture of press peat.

By means of fairly large experimental machines it has indeed been shown at Dortmund, Neustadt-on-Haardt, and at the Malmoe exhibition of 1914, that the process can be carried out *technically* with production of a press peat similar to press coal in appearance, handiness, and transportability, and no one would expect that it could not, since all such operations are *technically* possible. It is, however, equally true that owing to the unwieldy nature of the process, the artificial drying required for the fairly considerable amount of the dry peat added, the high percentage of water in the raw peat in comparison with that in mine-damp brown coal, and the lower calorific power of, even well-dried peat in comparison with that of commercial "press brown coal" of medium quality, every expert must regard the commercial possibility of the process as out of the question in the case of every country, especially Germany, where brown coal and coal, which have higher calorific powers, are accessible to everyone in sufficient quantity and at the prevailing prices.

Dr. Heine and Rudeloff, of Berlin, wish to bring into operation a new method of pressing, in which, unlike that of the Wet Press Co., no addition of other substances is made to the peat, and to employ it in conjunction with the Heine artificial "carbonizing, in heaps" (mentioned in Part II, under Patents) for the utilization of bogs. According to this method, which is called the "*step-pressing*" one, the material to be pressed is brought between two conveying tracks to several presses, which operate independently and in which the moisture is driven out by pressure, which increases in stages. After two pressings the material is disintegrated and is then again subjected to two more pressings. This system of pressing, in which the pressure gradually increases in stages, is said to open somewhat the cavities in the peat owing to the resilience of the fibres, and to render it easy therefore to drive out the residual water during the later compressions.

What has been already said of the method of the Wet Press Co. with regard to its technical possibility and its commercial value should in general also apply to this case.

For the same reason the technical, but not the commercial, success of the processes for dehydrating peat of the Moor Reclamation and Peat Utilization Co., of Ober Schönevide, Berlin,<sup>1</sup> can be admitted. In this process the individual peat particles are kept moving continuously during the compression. The superposed peat fibres constantly change their position, while the ever-increasing pressure forces the water out of the fibres or capillaries. It is maintained that the motion of the mass produces natural channels through which the water can pass out and flow away. In this manner it is said that the percentage of water in peat can be reduced within 30 to 40 minutes from 90 to 50 (!),

---

<sup>1</sup> Ziegler, "Ueber Versuche der Torfpressung" (Proceedings of the 79th Meeting of the Central Moor Commissions, p. 19).

and that the peat can then without difficulty have its percentage of water reduced to 25 by means of waste heat or air-drying, yielding a very firm and thoroughly dry fuel. This method will scarcely advance beyond the experimental stage.

#### 4.—*Press Processes with Simultaneous Electrical Dehydration (Electrosmosis, Osmone, Pentane, &c.)*

The co-operation of the electric current (the so-called electrosmosis) has not in any way been able to alter the non-success of the dry or the wet pressing of peat. Electrosmosis depends on the fact that the passage of the electric current through a liquid produces a motion of particles of the mass and "therefore allows the enclosed liquid particles to ooze out through the cell walls of the fine peat fibres." On this principle Count Schwerin, of Wildenhoff, based his process for the *electrosmotic dehydration of peat*, which was adopted by the Hoechst Dyeworks, and brought into operation in Schwenzel Bog by the East Prussian Pentane Works (see under Patents, Section VII, 2). The product, which was brought into trade under the name "Osmone," was prepared from the crude peat which had been made into a uniform pulpy mass in the usual way by removing two-thirds of its water electrosmotically in presses with the aid of pressure or suction, and converting the air-dried product, by breaking up and sifting it, into a marketable and utilizable fuel consisting of sods or powder. The current consumption for the separation of 1,000 kilos of water was found to be 13 to 15 kw.-h. By electrosmosis for a quarter of an hour 1 cb. m. of "osmosed peat," containing 70 per cent of water, was obtained from 1.5 cb. m. of raw peat, containing 87 per cent. of water. When the product was air-dried under cover it gave 169 kilos of "osmone," with 15 per cent. of water, and therefore 1 cb. m. of raw peat gave 113 kilos of "osmone."

From the economic standpoint the results attained by this method bear no comparison with the running expenses and the cost of the equipment employed in connexion with it. Not only the Pentane Works, but also Osmone, Ltd., which was established in 1905 at Berne, with a share capital of 1,800,000 francs, have been shut down. A similar failure attended Bessey's method, in which a powerful alternating current, working intermittently, was employed (the water being pressed out in the intervals)—the "secret process" of Kittler and other electrical dehydrating processes.

#### 5.—*Hard Peat*

A dense, cube-shaped peat fuel, prepared at Bad Aibling according to the process of Baron von Verschuer, has been called "*hard peat*." It is in essence a dense machine peat, which has, however, during its preparation, been exposed to the action of an electrical current, and has been finally dried artificially. Its fracture is like that of the brown coal of Central Germany.

The peat, freshly cut in the ordinary way, is brought by means of a field railway and a conveyer to a mixing machine, from which it is, when well mixed, driven through an "electrical mouthpiece." By the action of the latter the watery and resinous constituents of the peat fibres are said to pass to the surface of the fibres, and the gelatinous pulpy state of the body is modified so as to allow the subsequent drying to proceed more effectively. The peat falls from the electrical mouthpiece into a forming machine, from which it emerges in two prisms, each of 8 x 8 cm. cross-section. These are cut by knives into cubes of 8 cm. side, caught on plates (1.05 x 0.22 m.) (pierced with holes), which are removed from the rolling table, placed in layers of ten over one another on the adjacent car, and brought to drying tunnels, which can be closed by means of sliding doors.

Every eight tunnels (each 27.5 m. long, 1.20 m. broad, and 2.00 m. high), which lie beside one another and hold fourteen cars each, are supplied uniformly with hot air, day and night, by means of a fan. The wagons and the air current traverse the tunnel in opposite directions. By this continuous and thorough removal of moisture the peat fuel, which is finished in the course of a week, is said to acquire a very high density which cannot be reached by ordinary machine peat. The amount of water in the peat is said to have fallen from the original 80 to 85 per cent. to 35 to 30 per cent., the cubes contracting to a volume of 6 x 4 x 3 cm. each. One hectolitre of this "hard peat" weighs 46 kilos, and 1 m. ton requires a storing space of 2.2 cb. m. "Hard peat" such as this is a solid body, almost as hard as stone, does not crumble, and bears transport well.

This mode of proceeding increases the duration of the peat season from 100 days to 250 days, and also renders the drying independent of the weather and the time of the year.

For daily outputs of 5, 12, 25 and 50 m. tons the costs of plant are given as 36,000, 90,000, 150,000, and 280,000M. respectively. When everything is written off the mean cost of the fuel is 8.6 to 9.09M., and its mean selling price is 18M. per metric ton.

No one doubts that this process can give a good, clean, transportable fuel, suitable for household use. Its economic success can, however, be questioned, since the cost of the "hard peat," according to the above particulars, is approximately the same as that of press peat (peat briquettes), which was an equally neat product and which, owing to its lower percentage of water, had a somewhat higher calorific power, but which was so unable to compete with commercial press coal in the most diverse districts of Germany that there is not a single one of the press peat factories proper any longer in operation.

It is said, however, that a fairly large "hard peat" factory is to be established at Augustfehn, an experimental factory on one of the Bavarian State bogs having proved the commercial value of the process.

## D.—Eichhorn's "Ball Peat"

This process, which was discovered, and much elaborated at the time, by the retired mining director, H. Eichhorn, at Wörschach, near Steinach, in the valley of the Upper Enns (Bavarian Patent of March 11th, 1860<sup>1</sup>), differs from all the hitherto described ways of manufacturing condensed machine peat less in its nature than in giving the peat the shape (spherical) most favourable for its utilization as a fuel and in the machinery and drying plant employed to attain this object and lower the percentage of water in the fuel.

According to the *Bayrische Industrie und Gewerbeblatt*, June and July, 1875, the following method was employed there:—

The peat coming from the trench in irregular pieces is worked to a pulp or dough, as uniform as possible, in any macerating machine (an ordinary crushing mill) suitable for the local conditions, and is raised or pushed to the forming machine by means of any ordinary elevator (windlass with rope and bucket, conveyer, or screw).

In its original form the machine consisted, according to the size of the factory, of one or more wooden or metallic drums

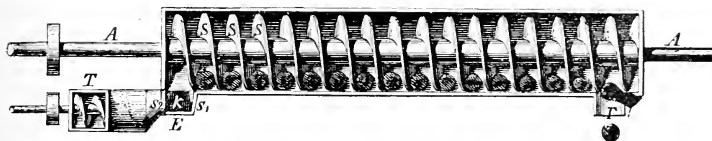

FIG. 24.—Eichhorn's "ball peat drum."

(Fig. 24) rotating round a shaft *A*. The cover of each drum had a screw-shaped passage *S S* inside; it also had one or two inlets *E*, and the same number of outlets *F*.

As the peat issues from the macerator it is pushed into the drum by means of a screw-shaft rotating in a funnel *T*.

Every portion *k* of the mass in and above the funnel, which is pushed forward by a single rotation of the drum, and which is sufficient for a single ball, is immediately separated (cut) from the mass in the drum by a cutter and counter-cutter *S*<sub>1</sub> and *S*<sub>2</sub>, which are attached like the two branches of a pair of scissors, one at the entrance to the drum and the other at the exit from the funnel. The piece falls directly into the drum and after a few rotations reaches the outlet *F*, where it has the form of a ball 100 to 130 mm. in diameter.

After arriving there this and all the succeeding balls fall or roll on the surface of a track, which is inclined at a suitable angle

<sup>1</sup> According to the pamphlet "Der Kugeltorf von Dr. G. Wentz, Dr. Lintner and H. Eichhorn, Freysing, 1867," H. Eichhorn had been engaged before 1867 in winning peat on an experimental scale by the method which was employed successfully later on by Weber and others, but was compelled to abandon it owing to his efforts to give the peat during its winning the form which is most advantageous for its combustion.

and played upon by a current of air heated to 50° C., and on which the balls, rolling forward automatically, are led through the drying rooms (drying shafts).

The drying rooms were immediately under the forming drums and consisted of a number (depending on the size of the peat factory) of stone or timbered shafts 5 to 6 m. in height and 3 to 5 m. in diameter. One of the tracks, mentioned above, opens into each of these shafts and runs in a continuous spiral to the sole or bottom of the shaft. The peat balls, all rolling automatically over this extension of the track, reach the bottom of the shafts, fill the latter gradually, and are subjected in them (in 12, 24, or 36 hours, according to the nature of the raw peat) to any desired degree of dehydration, by means of an ordinary hot-air apparatus under the bottom of the shafts from which the air, heated to the desired temperature, flows into the peat balls through flues or vents in the vault (shaft bottom). The air circulates round (enfilades) the peat balls on all sides, and finally, charged to a large extent with moisture taken up from the peat while drying, either escapes into the open through outlets immediately under the inclined surface, or else it can be used for the preliminary heating of the "unformed" peat.

According to the degree of dryness intended to be attained, the peat balls are gradually removed through several side openings in the lower part of the drying shaft and brought to their final destination—their place of utilization.

As the charge in the shafts decreased it was to be replaced from the drums and therefore forming, dehydration, removal and finishing of the product were to be continuously carried on.

Just as the natural quality of the peat (from the lightest fibrous to the heaviest bituminous peat, from marshy mud to earthy grass peat) and the local conditions and requirements of the customers varied among themselves, even so must the construction and installation of the forming machine be varied.

A great advantage of this process was said to consist of its being capable of being kept continuously working under all conditions of weather (even in the depth of winter) and also in a relatively small space.

According to calculations which were made, the following results were said to be attained:—

One forming drum, rotating round its axis with the moderate velocity of about 60 revolutions per minute and having only a single screw-thread which allows only one peat ball to fall after each rotation, gives in 24 hours about 86,000 balls, 100 to 130 mm. in diameter, which, in the wet state, weigh about an equal number of pounds and give at least 7,000 kilos of perfectly dry peat. In a year of 300 working days a single drum gives, therefore, sufficient peat balls for about 2,100,000 kilos of anhydrous peat. It requires for this output simply a machine of at most  $\frac{3}{8}$  h.p., since the power in the case of the very moderate velocity with which the drum rotates has only to keep up the pushing, running, or rolling of 17 to 20 balls having a total weight of 10 kilos,



and overcome the slight resistance due to the screw in *T* while this is gently pressing the soft peat required for one or two balls against the external wall of the drum.

For carrying out the whole process of "forming" and drying the peat under a single forming drum, only a simple shaft structure consisting of four light walls 3 to 4 m. in length, the same number of metres in width, and 11 m. in height, was said to have been required for the complete dehydration in 24 hours of the 86,000 balls produced by the drum in that time, or, therefore, for a yearly output of at least 2,100,000 kilos of anhydrous peat. From the beginning of the forming to the completion of the dehydration, with the exception of the stoker—that is, only one man—simply the above described machine of  $\frac{3}{4}$  h.p. (and the fuel necessary for the artificial drying) was required.

In arriving at the total power consumption for such a factory the power required for "forming" the peat, for driving the grinding and tearing machine, and for raising the macerated mass above the forming machines which are placed at the top of the building should be taken into account.

The "condensation" of the raw peat is at least the same as that obtained by the methods of winning machine-formed peat described later, the two "condensations" being due to similar causes.

The peat balls, which have at first diameters of 100 to 130 mm., contract until their diameters are from 50 to 60 mm., and then have densities depending on the variety of the raw peat. (Further particulars with regard to the "condensing action" of the process and as to the density of and the percentage of water in various ball peats are given in Section V, H.)

The expectations entertained on many sides from this process have nowhere been fulfilled from the commercial standpoint, in spite of all the sacrifices made by the inventor himself. The last peat ball factory,<sup>1</sup> which was erected under Eichhorn's supervision at Wörschach in the Enns valley (1874), after working for several years with slight success was abandoned and had to give way to the winning of ordinary machine peat.

Since the process was first elaborated at Eichhorn's peat ball factory at Feilenbach, near Aibling, which passed later on into other hands, several factories of this class were erected abroad in Russia, Sweden, and Norway, all of which, however, according to reports received, had such high working expenses and required so much capital, that they had to shut down after a short industrial life.

---

<sup>1</sup> For further particulars see H. Hausding's "Die Torfwirtschaft Süddeutschlands und Oesterreichs," Berlin, Paul Parey.

## E.—Manufacture of Condensed Machine Peat

I.—MANUFACTURE OF MACHINE-FORMED PEAT, WEBER'S  
(STALTACH) PROCESS1.—*Essence of the Process. Weber's Machine at Staltach, Gysser's Improvement, and the Peat-forming Machine of Hebert, of Rheims*

The mode of winning first elaborated by von Weber in 1858–59 at Staltach, in Bavaria, depends, as already mentioned, on the following processes in disintegrating by machines the peat pieces which contained roots and fibres, and had been won from the marsh or bog with every kind of texture from earthy to mossy; tearing up the roots and fibres as much as possible; destroying the felty, spongy character of the raw substance; and on transforming the mass which was not at first uniform in density into one which was quite uniform by mixing it well. When formed, the peat was subjected to the process of drying and to the natural condensation (inseparable from drying) effected by the process and common to all felted, pulpy bodies. This condensation depends on the contraction of the small fibres uniformly distributed in the pulp, and in it the "humic" portions of the peat play the part of a cement.<sup>1</sup>

The character of the raw peat, whether mountain, grass, pitch, or moss peat, is of no special significance for this treatment, as the process, when correctly carried out, has proved suitable for every kind of raw peat. The result is, in fact, an almost unexpected one; even light and poor moss peat gives, when treated in a very simple manner, a fuel which bears scarcely any resemblance to peat in its raw condition.<sup>2</sup>

---

<sup>1</sup> Dr. Breitenlohner, in his pamphlet "Der Backtorf," gives priority for the condensation of peat in a commercially correct way to the landowner Hasselgren, of Dalsland, in Sweden, who in the year 1845 had already taken out a patent in Scandinavia for his *crane-mill method*, which was employed later on in many districts of Sweden. According to this method, the peat is worked and ground into a stiff pulp in a vat like a pug-mill (called "Kran" in Swedish), and then, when converted into a thick pulp, it is formed or treated by the Hanoverian method. The process, therefore, in its nature corresponds to that of von Weber.

Even if von Weber knew of this process, and one would scarcely assume that he did owing to the incompleteness of his first experiments, no one could contest with him the honour, which is no less great, of having introduced this process into Germany and of having popularized it by the successful erection of the first large factory of this type which, as a specimen institute of the period, attracted visitors from far and wide. Without doubt it was only after the erection of the Staltach Works that the manufacture of machine peat, which depends on the natural condensation of a well-mixed raw peat, was taken up and became more widely spread.

<sup>2</sup> Details are given in Section V, F, of the properties of the condensed machine peat won in this way, and of its advantages over cut peat.

At Staltach the peat was raised from the bog with ordinary shovels; it was brought by means of cars on light railways to the machine-house, and in the latter was fed into the tearing and mixing machine, which was driven by a 10 to 12 h.p. engine. The feeding of the peat into the mixing machine was carried out by means of an elevator consisting of an inclined endless belt, which was also driven by the steam engine.

*Weber's machine*, as originally constructed, was fitted out as follows:—

By means of two bearings *l l*, the vertical shaft (Fig. 25) is let into an iron vat, which is wide at the top and narrow at the bottom.

The shaft has a number of crescent-shaped knives *m m* fastened to it so that they follow one another along a helical line. In

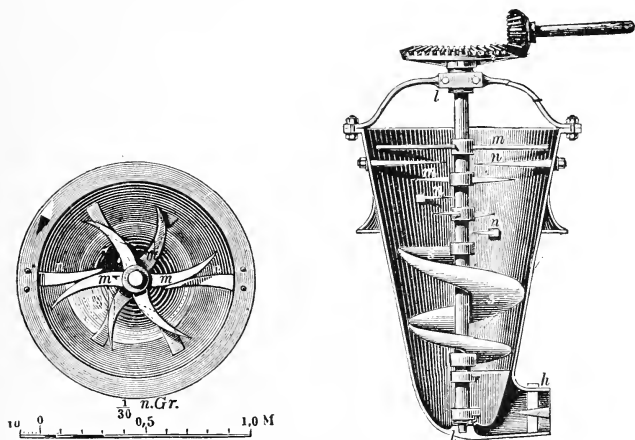

FIG. 25.—Weber's Peat Machine.

the conical cover of the vat there are also knives *n n*, arranged likewise in a helical line and placed at such intervals that each knife on the rotating shaft passes between two of those fixed to the cover of the vat and thus the peat caught between the knives is torn and cut during the rotation of the shaft. The disintegrated pieces, while being rotated and pressed downwards by the knives which are arranged spirally, are mixed intimately with other pieces which have already been similarly disintegrated.

In the earlier machines the last pair of fixed knives met in the centre and served as a point of support for a second shaft-bearing. Under this a screw *s s* made of sheet metal was fixed to the shaft and by means of it the peat was pressed towards an opening in the bottom.

The peat, which had been torn to pieces and mixed in this manner, then passed into a car which had been placed under the

machine. It was brought in the car to the forming table, where it was made into peat sods in ordinary moulds and then put into sheds in which it was dried.

After about three days the peat sods had become so firm that they could be turned, and after a further three to four days they could be footed or, for complete drying and to make room for freshly moulded peat, they could be "ringed," since, owing to the firmness they had by that time acquired, neither rain nor sunshine could any longer injure them. (All the peat won at Staltach was subjected to a further artificial drying for the purpose of being coked. Further particulars with regard to this are contained in the section on the Coking of Peat, Part II, "The Utilization of Peat.")

*Gysser's Improvement.*—The defect of the first machine, just described, was that the "forming" of the peat sods had to be done by hand, which led to loss of time and labour, i.e., money. This defect was removed by von Weber in conjunction with Gysser, Metallurgical Director at the time of the Grand Duchy of Baden, who, in 1860, at the request of the Government of Baden, erected a peat factory at Willaringen according to von Weber's model.

Gysser arranged the exit from the tearing and mixing machine so that, as shown already in Fig. 25, it ended in a funnel-shaped neck *h* through which the peat was pressed out in the form of a smooth band. In this way the mixing machine became at the same time a "forming machine."

In the case now discussed the mouthpiece had a diameter of 80 mm.; the peat bands had, therefore, a circular cross-section. They were cut at the mouthpiece into lengths of 310 mm. by means of sheet metal semi-cylindrical scoops, closed behind and provided with handles. The cutting was effected by a workman holding the hand-scoop before the mouthpiece, letting the required length of peat band run into it and then moving the scoop quickly from below upwards across the mouthpiece, a second workman being at the same time ready with another scoop to repeat the operation.

Two 6 h.p. steam engines were employed at the factory, each of which, with one peat machine, had an output of 14,000 peat sods of the size given above in twelve working hours.

This method of "forming"—the employment of a mouthpiece attached to a cylindrical or conical vessel in which a spiral or flat-bladed screw exerts a pressure on a mass (capable of being formed) contained in the vessel and compels this mass to pass through the mouthpiece in a continuous band—was not, however, a new one. It had been used many years before that time and, indeed, in a more fully elaborated form by Hebert, the previously mentioned director of the peat factory at Rheims. At the Paris Exhibition in 1855 Hebert had already shown fuel produced by his forming machine and he was, therefore, the first, so far as reliable information exists, who utilized the pressing action of

a rotating screw for "forming" peat and who constructed and employed such a machine. His process, however, received little attention until after the erection of the Staltach Peat Factory in Germany and it was also apparently unknown to the founder of this factory—the reason for this may well have been the early retirement of the inventor of the process from the direction of the above-mentioned factory. Dr. Vogel, in his book, which has already been mentioned, gives, from personal observation, details with regard to this process and an illustration and description of the machine in question. As this machine is to

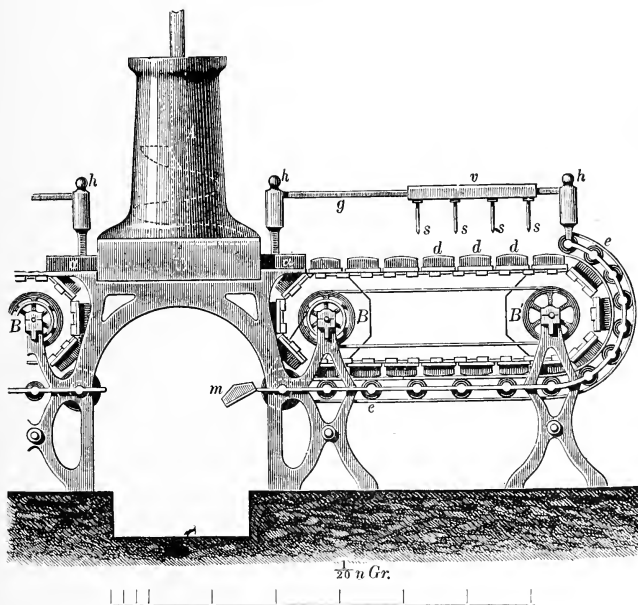

FIG. 26.—Hebert's peat machine.

be regarded as the precursor of all modern peat-forming machines, a description of it, taken from the above-named source, will now be given:—

*Hebert's Forming Machine* consists essentially of a cylindrical vessel *A*, widened at the base which is rectangular in shape (Fig. 26). It is 2.3 m. in height and in it a strong sheet-metal screw rotates round an axis. The peat pulp, thrown in at the top, is pressed by the motion of the screw towards the bottom, and as it cannot escape there it is compelled to pass out sideways through the openings *a a*. On each of two sides of the cylinder (or rectangle) there are 13 of these openings, so that, therefore, 26 bands of peat are continuously pressed out of the large

cylinder *A* through the tubes *a*, only one of which is visible on each side of the illustration.

As the peat issues from the tubes *a* it is caught in 26 rows of small boxes *d d*, which have the same size as the sods, are open at the top, and are kept in motion by means of two pulleys and an endless chain over two octagonal drums *B B'*. The division of the peat bands into sods is effected by the knives *s* of the contrivance *h h*, which consists of two cylinders *h*, in each of which is a spiral spring. The rod *g* can be pressed downwards until the knives *s* just cut through the peat and, when that has been effected, is raised automatically by the spiral springs. The knives themselves are fixed at suitable distances in the socket *v* and can be moved, together with this, on the rod *g*. At the end of the second drum *B'* the peat is pressed by the endless belt *e e*, which runs on rollers, into the little boxes *d d* until these reach the lower side of the first drum *B*, where they deposit their contents—the wet, pressed, peat sods—on the endless belt. At the last roller they are caught by workmen in peculiar small hand-boxes *m* and brought to their final destination.

While Hebert, when setting up his forming machine, required a special machine for tearing the peat, von Weber advantageously combined the two machines into one and thus simplified the process and decreased the cost of production.

## 2.—*Various Kinds of Peat-forming Machines*

Every more or less successfully conducted manufacture of machine peat which is at present in operation agrees with the Staltach process so far as method is concerned. The processes differ from one another only in the construction of the machines employed for tearing, mixing and “forming” the mass. The success of the enterprise and the quality of the machine peat depend mainly on the plant, its output, and the power required by it. We shall, therefore, describe more fully the machines constructed for, and used in, the industry from the date of the introduction and the improvement of the Staltach process to the present day. The quality of the peat produced by these machines depends mainly, as is shown later, on their mixing action on the raw peat, and the latter in turn on the rotation number of the knife shafts or screw shafts in the machines and on the number and kind of the knives fastened to the shafts. With reference to the former, which is the more important, we must distinguish “*Peat machines with slowly running knife shafts*” and “*those with rapidly running and double knife shafts.*” In nature and in effect the former may be compared with pug-mills and the latter with sausage machines or willows, both of which have obviously served as models for the kinds of machines introduced into the peat industry.

Of the peat machines hitherto most generally met, those with 1 to 30 revolutions per minute may be classed as machines

with slowly running knife shafts, and those with at least 60 revolutions per minute as rapidly running machines. The revolution numbers lying between these are not found, as a rule, in any noteworthy modification actually constructed, so that even manufacturers' practice seems to justify the above definition and characterization of the two chief varieties. The former are usually vertical machines, and in recent times are adapted for direct horse or capstan driving, the latter are horizontal machines for mechanical driving.

(a) *Vertical Peat Machines (with Slowly Running Knife Shafts)*

(1) *The Schlickeysen Machine and those related to it of R. Dolberg and Co., Gewert, Stützke Bros., Cegielski and Co., amongst others.*—E. Schlickeysen, machine manufacturer of Berlin-Rixdorf, made experiments in 1861 at first in a small model machine, with the object of employing his pug-mills or brick machines for the working and "forming" of peat. The main part of these machines (as of those described above)—some screw-blades fixed, however, in a definite order to a vertical shaft inside a vat—effected to a certain extent the mixing of the peat, and the screw formation of the knives was able to exert a pressure on the mixed peat in the same way as on brick-clay compelling it to pass as an endless smooth band of peat through a mouthpiece, attached to the lower end of the vat.

In accordance with this assumption and with the principles of the methods already mentioned in the preceding portion of this section, the experiment gave a result sufficiently satisfactory to justify the construction of peat machines of larger dimensions. The first of these, which were, indeed, intended for steam power, were delivered in 1862 to the peat factories of the Baron von Sina, at St. Miskolcz, in Hungary, von Krafft, at Laufen, in Salzach, the knight W. Rebhahn, at Żbiersk, near Kalisch, and many others. The circumstances that smaller machines like these were also made for horse-power and that relatively good results were obtained with the Schlickeysen machines when the *raw material was suitable* for them soon produced a big demand for the machines and a fairly wide extension of the manufacture of condensed machine peat, especially in the north of Germany.

The construction of the machines in the form in which they were ultimately delivered, after several alterations had been made in the original type, can be seen from Figs 27, 28, and 29, the first of which shows a machine for horse-power and the last a steam peat machine.<sup>1</sup>

Screw-blades, usually called "knives," are attached to a vertical shaft which rotates in bearings at  $a_1$ ,  $a_2$ ,  $a_3$  (Fig. 27). They generally consist of parts of a so-called Archimedean

---

<sup>1</sup> Schlickeysen's steam peat machines are no longer made in this earlier form, which was at the time much used, but are now made in the horizontal form seen in Figs. 50 and 51.

spiral, and each part extends over about a quarter to one-third of the circumference of the circle. In addition to these wide screw-blades *s s*, there are straight stirrers *b b* welded to some of the navies in order to assist the mixing action of the machine. The knives are 15 mm. thick at the circumference, and increase to a thickness of about 30 mm. towards the centre. They

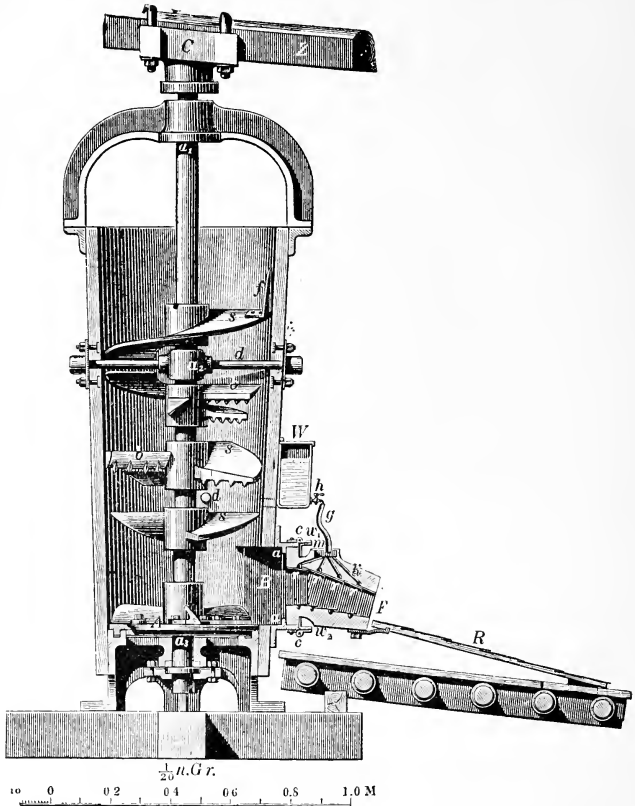

FIG. 27.—Schlickeysen's horse-driven peat machine.

differ, moreover, amongst themselves, as the projections  $M_1$ ,  $M_2$ ,  $M_3$ ,  $M_4$  (Fig. 28) of the first, second, third and fourth knives, counting from the top, show, and are fixed to the shaft in such a way that their external bounding line is not a continuous screw-thread. They are arranged so that when looked at vertically, the beginning of the screw surface of one knife is  $\frac{1}{8}$ th to  $\frac{1}{6}$ th the diameter of the circle from the lower end of the knife



immediately above it, and the latter knife covers the former by the same amount when viewed in the direction of the motion, that is, in the horizontal direction. In this way a mixing and a pushing (or pressing) action of the knives are simultaneously brought to bear on the added raw peat. The top knife is provided with a scraper *f*, which loosens any peat adhering to the circumference of the vat and exposes it to the action of the knives.

In order that the raw peat should not stick between the knives and rotate in the vat with the shaft, several stationary iron rods *d d*, the so-called "cross-stops," are passed through the vat between every two knives.

The base *A*, which closes the lower part of the vat, is generally keyed to the shaft, and therefore rotates with the latter. When compared with the fixed bases in the other machines used, it has the advantage that the main part of the pressure exerted by the knives on the peat mass, which would act in the machine as a pressure directed downwards on the shaft bearings and thus produce friction, is relieved by the mass, which is pressed downwards, exerting a counter-pressure on the base fixed to the shaft and thus relieving the shaft and its bearings to the same extent. Moreover, the peat on the revolving base rotates with the latter and becomes mixed with that which flows towards the exit *B* between the base *A* and the fourth knife, and thus receives a more intimate mixing than it would if the mass coming from the top were driven directly to the exit. In front of the exit is the "forming piece" *F*, by means of which the outgoing band is "formed." The coherence, the smoothness, and the cross-section of the band are due to the closed smooth surfaces of the sides of the "forming piece." The construction and the attachment to the exit of these forms are treated further on in a special article.

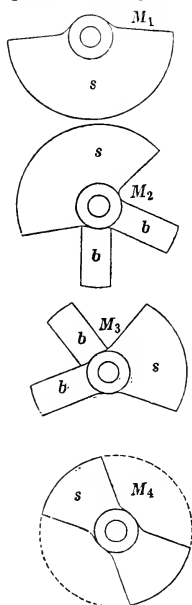

FIG. 28.

forms are treated

With machines worked by horses, as in the case of pug-mills and brick machines, the power is applied directly without intermediate gearing by means of a capstan head *C* keyed on the machine at the upper end of the shaft (cf. also Fig. 30). According to the size of the machine, the horse is yoked at a distance of 5 m. to 8 m. from the centre, and the knife shaft makes  $1\frac{1}{2}$  to 2 revolutions per minute.

The machine is fixed on a wooden frame, together with which it can be moved in the bog.

The steam peat machine, Fig. 29, which is also screwed on a wooden frame, is exactly similar to that just described so far

as the construction of the mixing and "forming" contrivance is concerned. Its shaft, which in the case of the larger machines makes 15, and in that of the smaller ones 25, revolutions a minute, is, however, driven by means of double reduction gearing

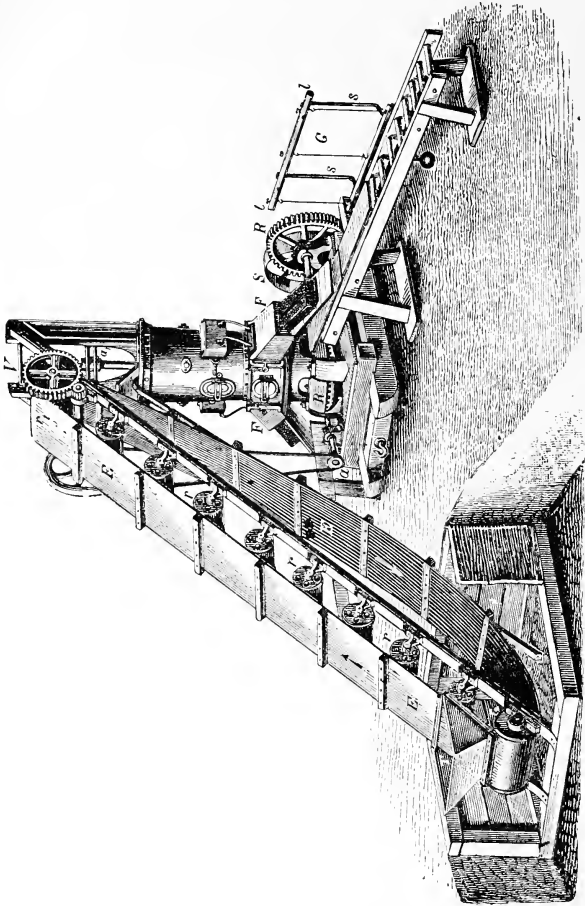

FIG. 29.—Steam-driven peat machine (older form) of E. Schlickeysen, Berlin-Rixdorf.

wheels *R R* and a belt-pulley *S* generally from the flywheel of a locomotive.

One or two men are sufficient for throwing in the peat required by a horse-driven machine. They shovel into the vat the peat which has been brought in barrows to the machine. In the case of machines driven by steam, either a platform is

erected at the level of the upper opening of the vat and the peat is brought there in barrows by means of an inclined plane (the barrow-way) and then thrown into the vat, or, as shown in Fig. 29, the machine is provided with an elevator *E E* consisting of an endless cloth running on rollers *rr*, or a scraper or bucket elevator, driven from the intermediate gearing of the machine by the aid of the belt pulley *a* and the intermediate gearing *V*. In the latter case the workmen who bring the peat empty the barrows or cars into the hopper *T*, which is attached to the strut beam of the elevator. The raw peat falls on the cloth, which runs under the hopper in the direction of the arrow, and is then thrown into the vat as it passes over the upper roller *r*, at a speed depending on the rate at which the cloth is moving. To prevent the peat from rolling back as the elevator cloth ascends, brackets 50 mm. in height are fixed on the latter.

These steam peat machines were generally provided with mouthpieces on two opposite sides of the vat. They worked, therefore, on two sides, as may be seen from Fig. 29, and this required for each working side, in addition to the labourers employed in bringing the raw peat and in taking the freshly formed peat to the drying ground as well as those (usually two men) engaged in throwing the peat into the vat or on the conveyer, one woman (or girl) for cutting the peat sods and one girl for putting them on the barrow or car. Since the end of the seventies these vertical machines have been more and more driven out of use by the more convenient machines with horizontal and rapidly running shafts constructed as shown in Fig. 51.

Machines worked by horses afforded an output of 500 to 1,000 sods an hour with a team of one or two horses.

Steam-driven vertical machines of 3 to 10 h.p. gave 10,000 to 50,000 sods, or 15 to 75 cb. m., of "formed peat" in a day.

The size of the freshly "formed" sods varies a good deal with the peculiarities of the different machines, the special points of view of the manufacturers, and the differences in the varieties of the raw peat. In order to be able to compare, therefore, the outputs of various machines, the yield of each machine is given by the number of cubic metres of freshly "formed" peat as well as by the number of sods made in a ten-hour day.

It is advisable for more rapid drying and for more advantageous combustion, as is pointed out further on, that the sods should not in general exceed 2,000 c.c. in volume, which corresponds to a length of 25 cm., a thickness of 8 cm. and a height of 10 cm., or to a length of 20 cm., a thickness of 10 cm., and a height of 10 cm. If estimates of amounts won or costs of winning are based on such peat sods, which in this book are called "*standard sods*," then 500 of these sods are contained in a cubic metre of formed peat, and it is therefore easy to calculate the output in number of sods (standard sods) from an output given in cubic metres.

These peat machines, which originated from the Schlickeysen pug-mills or brick machines, were soon imitated in Prussia,

Pomerania, and Mecklenburg by several other machines more or less modified (the modifications cannot, however, in all cases be called improvements). Some factories try to adapt their machines to various kinds of peat and also to make them available for work on a small scale, and therefore for wider circles and less wealthy bog-owners.

To machines of the class just described belong the peat machines of G. W. Gewert, of Potawern; Stützke Bros., of Lauenburg; R. Dolberg and Co., of Hamburg and Rostock; H. Cegielski and Co., of Posen; and several others.

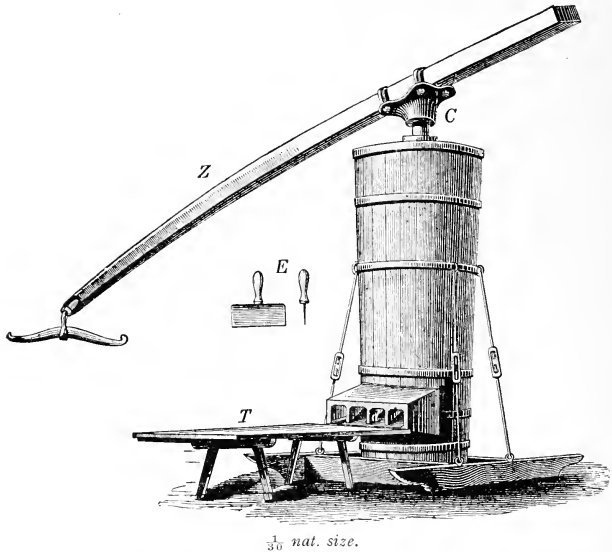

FIG. 30.—Horse-driven peat machine with a four-band mouthpiece.

Fig. 30 shows a horse-driven peat machine of this type set up in a bog. Driven by one horse and making two revolutions a minute, it gives 800 to 1,000 sods or  $2\frac{1}{2}$  to 3 cb. m. of wet, "formed" peat (therefore 1,200 to 1,500 standard sods of 2 l. each) per hour, and costs 300M. to 400M.<sup>1</sup>

The labour required for attending the machine is given as three men and four children or women. Two men are required to throw up the peat and bring it on barrows to the machine, which should be as near them as possible, while the third man

<sup>1</sup> The prices given for this and the following peat machines are taken from the price lists of the manufacturers concerned, current when the German edition was being written (1914). They vary with the place of sale, and should serve only as a general basis for comparison and for estimates of costs.

takes charge of the throwing in of the peat. One boy cuts the peat sods in front of the mouthpiece and places them on the transport cars which are removed to the drying ground by three or four girls or boys according to the distance to be traversed.

More recent machines have been made so as to let the peat out of the mouthpiece in only two bands (but with double the velocity). These bands pass directly to the spreading boards, which are pushed forward automatically on a roller track. The peat bands are cut on the boards.

The wooden vat is about 1.9 m. high and 63 cm. wide ; on its shaft, which is rotated by means of a capstan, there are generally two full screw-threads, and above these four quarter-screw knives, which are arranged so that they form a complete screw-thread.

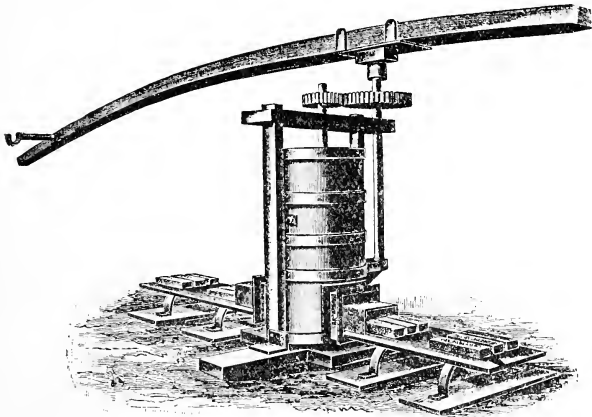

FIG. 31.—Horse-driven, single-shaft peat machine, with intermediate gearing wheels, of H. Cegielski and Co., Posen.

Sometimes in the case of these or similar machines a plate is fixed edgewise inside the vat and immediately behind the lower exit. The plate covers as much as possible of the space between the lower knife and the bottom disc, in order to prevent the peat from rotating with the bottom disc, so that on the further rotation of the shaft it is pressed out through the forming piece.

(2) *Peat Machines for Horse Driving with Intermediate Gearing Shafts.*—When working with horses, in order to obtain a better mixing effect than that given by the ordinary single-shaft machines in which the capstan is directly attached to the knife shaft, these machines have been provided with intermediate gearing shafts which support the capstan, and which, by means of proportional gear transmission, give a greater velocity to the knife shaft, and therefore have a better mixing action and give a greater output. Fig. 31 shows a machine of this type with

intermediate gearing wheels as constructed by H. Cegielski and Co., of Posen. It was built in two sizes, costing 470M. and 700M., with an output of 1,000 to 2,500 sods per hour in the case of very fibrous peat, a two-band mouthpiece, and one or two horses.

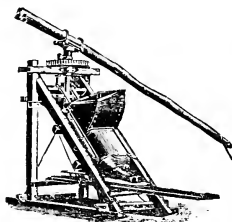

FIG. 32.—Horse-driven, double-shaft peat machine, with intermediate gearing wheels, of R. Dolberg and Co., Hamburg, and of H. Cegielski and Co., Posen.

With the same object, R. Dolberg and Co., of Hamburg and Rostock, have arranged the double-shaft, horizontal peat machine described further on in an obliquely upright direction and provided it with a trestle stand and intermediate gearing wheels as well as with a capstan, as shown in Fig. 32. The top half of the cover, together with the hopper, can easily be removed in case of a stoppage by loosening some cramps. Recently H. Cegielski and Co. have similarly constructed peat machines for working with horses. With the two horses required to drive the machine and 10 to 12 workmen,

the machine is said to give 2,000 to 2,500 standard sods (of 2,000'c.c.) or 4 to 5 cb. m. of formed peat per hour. The price of the machine, excluding the draught pole, is 800M. to 875M., and its weight 980 kilos.

### (b) Horizontal Peat Machines (with Slowly Running Knife Shafts)

(1) *The Simple Horizontal Peat Machine.*—Partly in order to avoid the necessity of feeding the peat into the high vats of peat machines with vertical knife shafts and partly to avoid the use of such heavy machines (especially those driven by steam) and therefore to replace them by machines which would be more easily moved from place to place in the bog, attention was quickly directed to the construction of the machine with a horizontal knife shaft, which we are now about to describe.

Such a machine can be understood from Fig. 33, in which *A* is the belt pulley, *B* is the body supported by the two feet *C C*, *M* is the knife shaft or screw shaft, *F* is the "forming piece," and *T* is the cutting table. The driving force exerted on the belt pulley *A* by a locomotive (more rarely by means of a horse capstan) is transmitted by double reduction gearing wheels *R*<sub>1</sub> and *R*<sub>2</sub> to the knife shaft, which makes 20 revolutions a minute. The body has a diameter of 300 mm. The knife shaft is provided with the double knife *M*<sub>1</sub> and seven single half spirals arranged so as to form a complete screw. The slope of the screw at the external circumference is 14° to 15°.

While these horizontal machines have many advantages over the vertical steam peat machines in regard to weight, price, installation, and ease of feeding them with the raw substance, they have the disadvantage, especially when working with impure peat which has a tendency to form lumps, that the screw knives do not automatically catch the raw peat fed into the funnel, so

that the peat may accumulate there forming an arch over the knife shaft. This affects the feeding of further quantities of the raw peat, and, therefore, the output of the machine is generally less than that of a vertical machine, in which both the screw blades and the weight of the peat continually press the peat towards the exit in the bottom of the vat, thus emptying the upper part of the vat so that more peat can be added.

(2) *Schlickeysen's Horizontal Machine with Feeding Rollers.*—In order to remove this defect of the earlier forms, E. Schlickeysen, of Berlin-Neukölln, put in the funnel *D* (see Figs. 34 and 35) of his older horizontal machines at a distance of 10 mm. from the external circumference of the knife blades a feeding roller *W*, which was rotated by the shaft by means of the cog wheels  $r_1$   $r_2$  and therefore revolved in the opposite direction to that of the

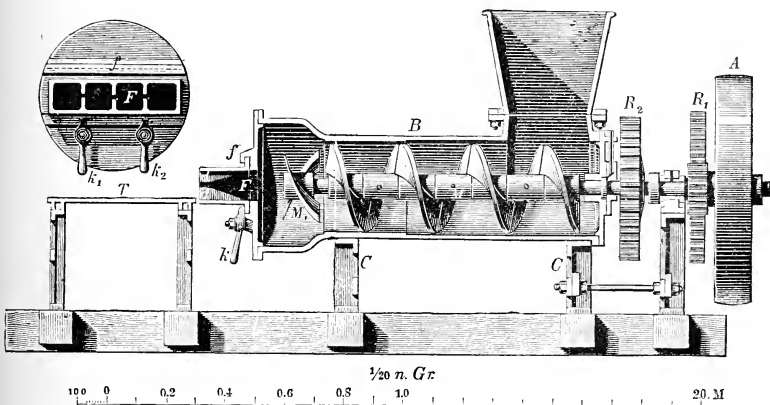

FIG. 33.—Simple horizontal peat machine.

shaft. The feeding roller and the periphery of the knives exerted the gripping action of a grinding machine, seized the peat mass fed into the funnel, and brought it to the screw knives in the cylinder *H*, which, in the case of this machine, consisted of separate, double- and triple-winged screw knives.

In this way the output of the horizontal machines was indeed generally increased, but when working with impure and fibrous raw peat the defect mentioned above remained and in the case of slippery raw material the roller glided by without gripping and bringing it to the knife shaft. In the first case, moreover, the knife shaft became surrounded by fibres and roots, so that stoppages of the machine ensued and more or less frequent cleaning was necessary.

Machines of this kind were shown at the Bremen Exhibition of 1874, and since then they have been employed in many peat factories. In more recent times, however, they are constructed

only in the form illustrated in Fig. 51, in which the gripping and tearing mechanism is more efficient.

(3) *The "Tube Peat" Machine of Ros, of Norköping.*—The machine constructed by J. J. Ros, of Norköping, also has a horizontal cast-iron cylinder which is divided into two halves,

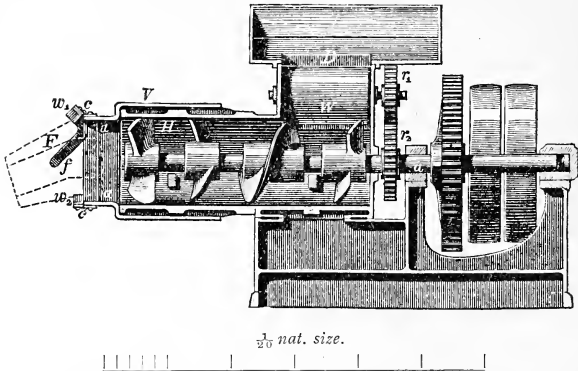

FIG. 34.—Older form of Schlickeysen's horizontal peat machine, with feeding roller.

and in which the peat is worked by a shaft furnished with knives. The shaft, which passes through the cylinder, is supported in three bearings and is rotated by means of a belt pulley. It is provided with eight cast-iron screw-shaped knives, which, in combination

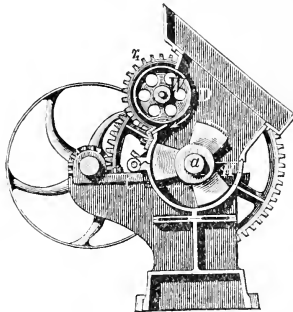

FIG. 35.—Cross-section of Fig. 34.

with wrought-iron knives fixed in the sides of the cylinder, cut up the peat and drive it towards the screw at the narrow end of the cylinder, which then presses the mass out through the mouth-piece. As the shaft is prolonged through the mouth-piece, the cylinder of peat which is pressed out has a hollow or tubular



shape. Six pieces of wood are fastened round the mouthpiece and project 37 cm. beyond the latter. The tube of peat is supported by these pieces of wood until suitable lengths of it can be taken up and removed by the so-called "gripper." The latter consists of a circular board having two handles; three wooden rods are fixed to the board by iron uprights; each of the rods has an iron hook at its end. The tubes of peat are taken off in lengths of 29 cm. to 36 cm. by inserting the iron points of the "gripper" between the wooden pieces through the peat tube and then taking the gripper away from the mouthpiece in a direction parallel to

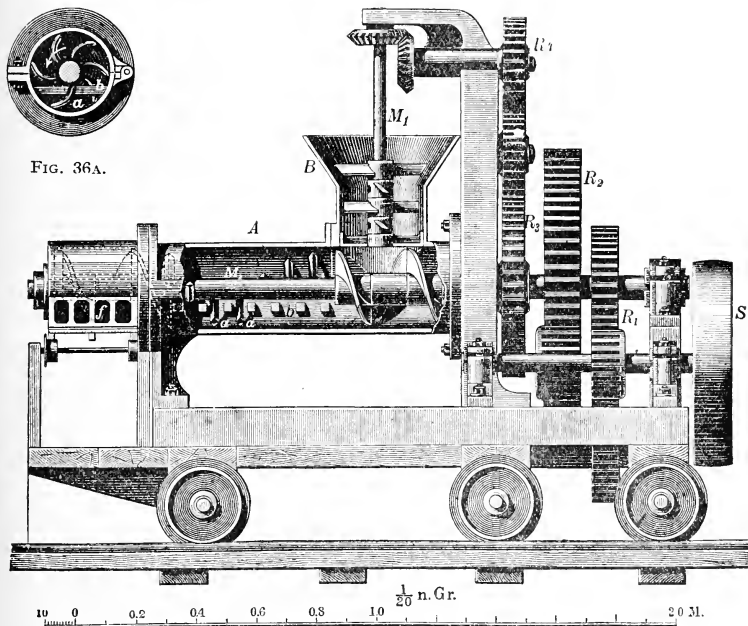

FIG. 36A.

FIG. 36.—Peat Machine of Henry Clayton, Son, and Hewlett, London.

the wooden pieces. The piece of peat torn off by the iron hooks is left on the wooden rods and is loaded on a peat-bier, ten of which are mounted on a frame provided with wheels and movable over rails. The pieces of peat are placed on the biers, and as each of the latter holds five pieces, every fully laden car holds fifty peat tubes. Each machine can keep four such cars going. The tubes are unloaded on the drying ground in an erect position and then either dried on supports or on simple trestles.

The driving of a machine of this type requires 2 to 2½ h.p. The labour requirements of each machine are three to four energetic workmen and eight women or striplings for transport to

and from the drying ground and for the drying operations. About 22 cb. m. of tubular peat sods can be won in an eleven-hour shift.

The pieces of peat are more bulky and more easily broken than ordinary machine peat sods owing to the hole in the middle, but, on the other hand, the facilitation of the drying by the cavity is by no means an unimportant matter under the conditions prevailing in Sweden.

Several machines of this type were employed at the time in Wermland and were said to have been both efficient and easily worked. This machine has not, however, been widely used even in Sweden.

(4) *Clayton's Peat Machine.*—The peat machine of the Atlas Factory of Henry Clayton, Son, and Howlett, of London, which is shown in Figs. 36 and 37 in two different forms (in the former as a “transportable machine” and in the latter as a “stationary machine”), belongs to the machines with wide horizontal cylinders and slowly running knife shafts.

The builders of this machine have tried to get rid of a disadvantage of the simple horizontal machines—that of not drawing the peat to be worked automatically from the hopper—by connecting the horizontal cylinder *A* with a vertical funnel *B*, which may be regarded as the vat of a vertical machine, and also by bringing into this funnel a stirring arrangement or knife shaft *M*, which, with the aid of the weight of the peat in the funnel and the action of the full screw *V* under the knife shaft, make it possible to withdraw the peat from the upper and feed it to the lower cylinder.

At the same time, however, owing to the height of the hopper, the advantage possessed by horizontal machines of enabling one or two men to feed the raw substance with shovels into the machine was lost. This machine was, therefore, provided with a peat elevator (Fig. 37), which was worked by the intermediate gearing shaft *E* and the belt pulley *H*. The elevator consisted of a chain and an elevating drum *K*. By means of the drum and chain the peat to be worked was conveyed in tipping cars up a track from the cutting trench to the machine and then up an inclined plane *S* to a platform from which it was fed into the machine.

The knife shaft  $M_2$  was provided over most of its length with several square iron bars *a*, which passed during the rotation of the shaft between the cross-bars *b* fixed in the cylinder. As every two of the latter leave only a narrow passage for the former the raw peat fed to the knives by the upright knife shaft and the full screw *V* is caught by the knives or bars *a* on the horizontal axle and forced against the edges of the fixed cross-bars *b*; in this way the longer fibres, roots, or reeds are torn up, and at the same time the whole of the raw peat becomes intimately mixed. The peat pulp which has been thus disintegrated and mixed is gradually pushed to the mouthpiece of the machine by the pressure of the horizontal screw. A screw-blade fixed at the end of the shaft presses out the pulp through four or five openings as smooth bands, which are caught on boards moving easily on a rolling

table, and cut into separate sods by a cutting grid *G* (containing six tightly strung wires) by pressing the grid round its axis of rotation until it strikes the spreading board.

The machine was made in two parts, so that in case of stoppage the horizontal cylinder could be easily cleaned. The upper half could be rotated round the hinges *cc*, and the machine could therefore be opened when a fastening screw or pin had been loosened. In order that fibres and roots might not remain adhering to the knives and that they might be stripped off during the motion of the knives, the latter were curved as may be seen in Fig. 36A, and had their convex surfaces in the direction of rotation, by which means any fibres adhering to the knives glided off

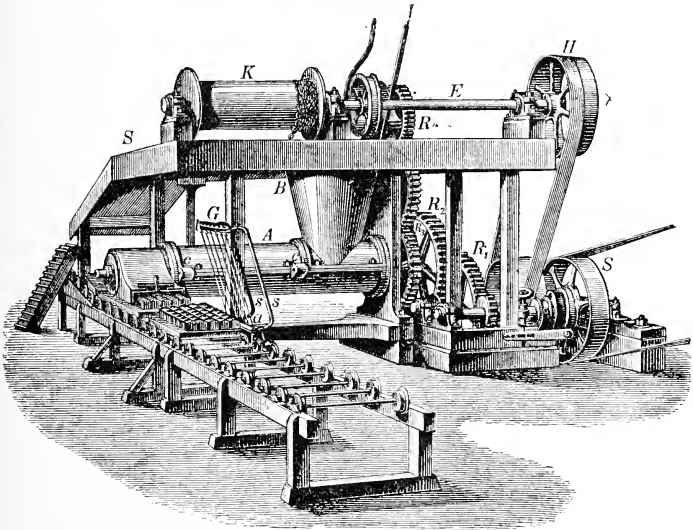

$\frac{1}{16}$  nat. size.

FIG. 37.—Clayton's peat machine with elevator.

automatically. Finally, in order that the resistance due to the passage of the rotating knives between the fixed ones would be as uniform as possible throughout a revolution, the knives *aa* were fixed screw-wise on the shaft, so that at any instant there were only two of them exerting the shearing action with the knives *bb* by which the peat fibres between them were disintegrated.

The peat machine shown in Fig. 36 was exhibited and worked at the Bremen Exhibition in 1874. The machine was, however, so massively constructed that it was too heavy to be transportable over bogs which had small bearing power and it was also too inconvenient to be used as a stationary machine. The following process was recommended at the time by the builders as peculiarly

suitable for winning "condensed peat" with their machine. The peat obtained in or under water, and with, therefore, at least 90 per cent. of water, was to be brought to the machine for further working. In order to remove a part of its water from the peat before working it up the raw peat was to be filled into Clayton's peculiar press cars, and during the transport of the peat from the bog to the machine so much water was to be driven out of it by a pressing contrivance that the residual crude substance would then be in the more or less dry state required for its further treatment.

Like all attempts to remove water from peat by pressure, this one could not prove other than a failure.

Machines of this type were introduced into the peat industry at the beginning of the seventies, and indeed, in Germany there was one on the Testorf estate at Schönwalde, in Holstein, and another at the peat factory of J. A. C. Pape, at Hamburg. Since then they have been replaced in Germany by home-manufactured machines, which, on the whole, are capable of giving a greater output and at the same time are lighter in construction.

(5) *General Characteristics of Peat Machines with Slowly Running Knife Shafts.*—The output of the peat machines just described, especially of the vertical machines with relatively wide cylinders and slowly running knife shafts, is generally satisfactory when treating marsh, pitch or bituminous peat, which is free from non-humified portions—wood, roots, and grasses—and which already has a certain amount of uniformity. Peat of this character is kneaded by the knives as much as is required for "forming," the plant residues are at the same time mixed with it, and the longer, humified fibres are torn up. The slowly rotating blades with their wide surfaces (the vertical machines having diameters of 500 mm. to 800 mm.) facilitate the motion of the mass towards the exit. This motion is assisted by the weight of the peat in the vat above the "forming piece" and hence it arises that in the case of a raw peat (bituminous peat, marsh peat) suitable for the machines, the output corresponding to the power applied is a satisfactory one. In the case of well-humified peat the bands fill the cross-section of the mouthpiece and a very firm, "formed" peat, suitable for sale, is produced.

If, however, the consistency of the peat varies, and if there are many hard, felted lumps, roots, reeds, grasses, or portions of wood in the soft mass, or if the crude substance is for the main part moss, root, or fibrous peat, the hard lumps have not time during the slow rotation (2 to 25 revolutions per minute) of the knife shafts to yield to the action of the knives, while the latter, both on account of their low velocity and their thickness, are unable either to tear or cut up the roots and grasses in the peat. The more or less long fibres and stems of grasses adhere to the knives, entwine the axle and the screws which fasten the knives to it, producing a blocking of the machine which the cross-bars in the vat are unable to prevent, and therefore they diminish still more the mixing action of the spiral knives, which in any case is

only a slight one. The output is unsatisfactory when we are dealing with a very fibrous moss peat.

The same statement holds also with regard to the *quality* of the machine peat when the peat worked is either fibrous or a mixture of different kinds.

It follows from the nature of the case, the experience of the author, and experiments which he made with this object,<sup>1</sup> that, *the more intimately the mixing and kneading takes place in machines in the case of one and the same peat, the more the fibres suspended in and felted with the peat are torn apart and disintegrated, the more closely arranged are the particles of peat on the subsequent evaporation of the water, the more the peat contracts on drying, and the greater the density of the peat made by the machine is when compared with that from unmixed peat.*

In the case of one and the same raw material its value increases with the density of the dry peat obtainable from it, since in one and the same volume both the quantity of the fuel and its firmness increase with the density, also its water-absorbing properties, which have a prejudicial effect on its combustion, *decrease, so that the defects of hand peat, mentioned earlier, appear to be the more completely removed, and therefore, other circumstances being the same, a machine peat appears to be all the more valuable according as the peat manufactured by the machines is denser (or heavier).*

*Hence the value of machine-made peat depends mainly on the amount of "condensation" that sets in "during the drying," and this in turn depends only on the degree of mixing attained by the machine, while the pressure itself which the screws or spirals in the machine exert on the peat is infinitely small and has no effect on the density of the machine peat.* It is only just sufficient for pressing out and "forming" the thick, pulpy peat, so that there can be no question of a real *pressing* (by means of mechanical force), and therefore of "press peat" and "peat presses" in this method of winning peat.<sup>2</sup>

Not only are the slowly running, thick knives (they have nothing in common with real knives except the name) unable to exert a cutting or tearing action on plants mixed with the peat which are not yet completely humified (and many kinds of peat mainly consist of only half-humified fibres, grasses and roots), but their mixing action is also very slight in itself (as we may easily see from a simple calculation) and is only just sufficient for specially pure and uniform marsh and mould peat.

The vertical steam peat machine in Fig. 29, for example, has, for an output of 30,000 peat sods, 80 x 80 x 235 mm. each, a vat diameter averaging 550 mm., the free cross-section of which is approximately 2,300 sq. cm. Hence every second a quantity of peat measuring 
$$\frac{30,000 \times 8 \times 8 \times 23 \cdot 5}{10 \times 60 \times 60} = 1,254 \text{ c.c.}$$
 must pass through,

<sup>1</sup> Cf. Section V, E and F.

<sup>2</sup> See the foot-note on pp. 69 and 70 with regard to the erroneous designation of these peat machines as peat presses.

and its velocity is, in consequence, approximately 0.6 cm. per second. The vat itself is filled at most to a height of 60 cm. above the exit, so that the charge requires approximately 1.66 minutes to pass through the machine. During this time the knife shaft rotates  $15 \times 1.66$ , that is, only 25 times (corresponding to 15 revolutions a minute)—a number of rotations insufficient to mix intimately a quantity of raw peat equal to  $2,300 \times 60$  or 138,000 c.c., that is, 138 l. For 100 l. of peat, this would give 18 revolutions of the screw shaft, while this *rotation number*, which characterizes the mixing action of a machine,<sup>1</sup> amounts to 50 to 150 per 100 l. in the case of machines with rapidly running knife shafts.

A figure which is still more unfavourable than that just calculated is obtained in the case of horse-driven machines making about two revolutions per minute.

*These and the above-mentioned defects of machines with slowly running knife shafts (blocking easily, too slight a disintegration and mixing of a peat which is not uniform in itself, and therefore a product which is poor in quality and small in quantity) quickly led, as the machine peat industry grew, to the construction of the machines described in the following article on machines with rapidly running or double knife shafts, with which machines, indeed, the more modern installations are alone concerned.*

Machines with special mixing or tearing contrivances are comparable with these machines so far as mixing action is concerned.

### (c) *Peat-forming Machines with Rapidly Rotating or Double Knife Shafts*

*General Characteristics.*—Owing to the horizontal arrangement peculiar to all these machines a small height is possible for the machine. (This is of advantage for feeding, and, moreover, enables the weight to be kept down.) Not only do the knife shafts rotate with a velocity of 75 to 250 revolutions per minute, but for the same output these machines have also a narrower diameter for the cylinder than the older ones. Hence, as the ratio of the volume of the cylinder to the surface of the cover along which the screw knives tear and grind the peat is small, the mixing action of the rapidly running knife shaft is still further increased.

The horizontal rapidly running machines, like the vertical machines, were at first constructed with a single shaft, which was provided with screw knives arranged in a continuous spiral for bituminous or "liss" peat and with separate knives arranged round the shaft along the curve of a screw for fibrous peat. In the first case, when working fairly pure and uniform peat, a big yield (in quantity) was obtained at the expense, however, of the mixing, while in the latter case the separate knives, usually striking past counter-knives, were intended only for cutting and tearing the

<sup>1</sup> Cf. Section V, A, 1, "On Knives and Screws."

fibres, and another part of the screw shaft, which generally consisted of a continuous screw, pressed out and "formed" the mass at the mouthpiece.

In some cases, however, and especially in that of unripe, fibrous peat, the knives became entwined with fibres and carried the peat round with them during their rapid rotation without pressing it through the mouthpiece, and, therefore, the output of the machine was decreased.

This disadvantage is overcome partly by means of the fixed counter-knives set in the wall of the cylinder and partly by a second shaft, placed near the knife shaft and which is fitted with screw knives wound in the opposite direction to those on the first shaft. The screw knives on the second shaft work into those of the first, and during rotation the two shafts clean one another, while at the same time both push the peat in the same direction towards the mouthpiece. In this respect we can divide rapidly running machines into those with a single knife shaft and those with two knife shafts.

Some of these machines are provided with special feeding and tearing contrivances.

(1) *Fundamental Types of Horizontal Machines.*—Starting from the principle, which to some extent was supported by the experience gained with the vertical slowly running machines, that a working substance which, like peat, occurs in nature and even in one and the same bog with much want of uniformity in quality, cannot be worked by one and the same machine of a fixed type (a universal machine) with even approximately the same degree of success in the different cases, the civil engineer Leo Seydl, of Berlin, at the end of the sixties invented a series of machines, the various members of which he proposed to employ for the manufacture of condensed machine peat. The machines were numbered according to the series in which the raw peats were arranged in order of consistency, beginning with uniform bituminous peat and ending with raw peat having the consistency of moss and fibrous peat, rich in roots.

Corresponding to this, the machines with the lower numbers had a more or less great mixing action, and those with the higher numbers had, in addition, a more or less great tearing action.

Seydl's peat machine No. 1 consisted of a single wrought-iron screw, 400 mm. in diameter and having a slope of  $9^\circ$  at the external curve of the screw. The shaft of the screw had a velocity of 220 revolutions per minute, and its main action was to crush the raw material against the inner surface of a plate-metal drum which surrounded it. The machine is shown in longitudinal section in Fig. 38.

It was screwed on a low wooden sledge in order that it could be more easily moved in the bog. The screw shaft *A* was rotated either by means of the hook-joint *a* and lay shaft from a horse gear or by a belt pulley, fixed on the screw shaft, which was driven by a steam engine (locomotive). The raw material was fed through the hopper *B*.

The hollow cylinder (plate-iron casing) *D* tapered like a funnel towards the exit *C* and ended in a mouthpiece *F*, which was 100 mm. long and 150 mm. wide. The peat band emerged from the machine through this mouthpiece in the form of a cylinder and passed to the spreading boards *L*, which were carried on movable rollers under the mouthpiece. The peat was cut into sods and brought to the drying ground on the boards.

This machine was recommended (and used) by its constructor

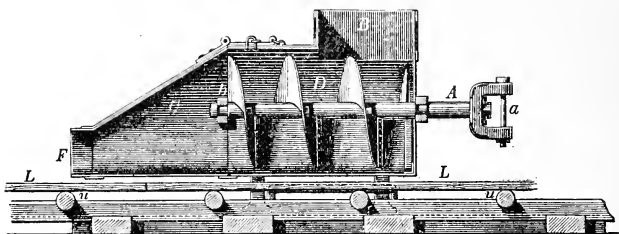

FIG. 38.—Seydl's machine for bituminous peat.

only for kneading black, friable, bituminous or marsh peat which was completely free from non-humified plant remains.

If the friable, bituminous peat was in part still permeated with slightly humified or non-humified plant residues the machine was no longer able to work the body with advantage. In the latter case a double-shaft machine was employed.

The latter machine, like that shown in Fig. 40, had two screws which lay near one another, but, unlike those in the figure, were quite smooth. The screws worked into one another throughout

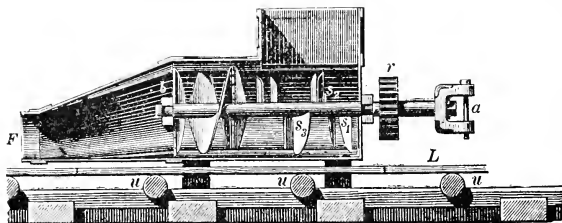

FIG. 39.—Seydl's mixing and forming machine for fibrous paste.

their whole lengths, so that when the two knife shafts *A* and *B* were rotated together by means of a pair of gear wheels *r r*, the screw blades of one shaft worked in the empty spaces between the screw blades of the other. Not only was a more intimate mixing of the peat to be treated possible by means of this machine, but a tearing up of half-humified fibres and a grinding of any knots and hard lumps present in the peat took place. The screw blades as they glided past one another freed themselves from fibres and thus prevented stoppage of the machine.



The various machines which followed these differed from one another less in their external appearance than in the arrangement of the screws and spirals. For tearing a fibrous peat they were arranged, as Figs. 39 to 41 show, so that separate portions of a discontinuous screw  $s_1$   $s_2$   $s_3$ , acting partly as knives and partly in conjunction with the others as a screw-thread, tore up the fibrous and woody peat as well as possible and at the same time pushed it to the exit.

According to the nature of the raw substance, that is, according as it was more or less felted and fibrous, the shafts were provided with a varying number of knives which were to exercise a cutting and tearing action on the peat. In this way the various modifications of the Seydl machines arose.

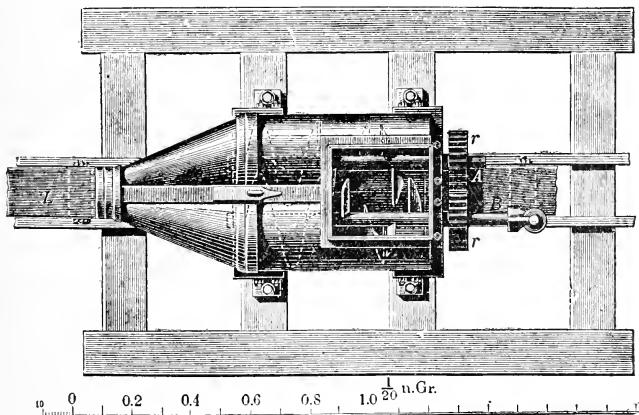

FIG. 40.—Ground plan for Fig. 39.

The first machine of this type, i.e., with two adjacent knife shafts and screws working into one another, was constructed at Powunden by Steenke, formerly of Zölp and later of Elbing, in conjunction with von Besser. In 1864–1865 they had one of these machines built, utilizing the contrivances employed in the well-known sausage machines. However, they had little success with it except for its use in working black mould peat.

All these machines, however correctly they were planned, suffered from various errors of construction and were altogether too lightly built. They were replaced by the improved forms about to be described.

(2) *The Modern Multiple-shaft Peat Machines of Dolberg, Heinen, Strenge, Wielandt, Schenck, Sugg and Co., Anrep, Åkermann, Koppel, &c.*—The circumstances, already mentioned, that the consistency of peat varies a good deal even in one and the same bog, that one will rarely be inclined to use a special machine for every special class of peat, and that even

then favourable results are not always obtained, have led to further improvements of these machines. The most widely employed types are illustrated in the following figures.

The cases and supports of the machines are usually made of cast-iron, the shafts of wrought-iron, and the knives of cast-steel. As a rule they have two adjacent knife shafts *M* and *N*, which rotate in opposite directions, and each of which is supported in two bearings *L L* fixed outside the cylinder (Figs. 42 to 45).

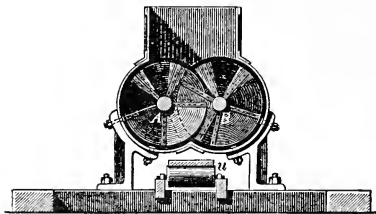
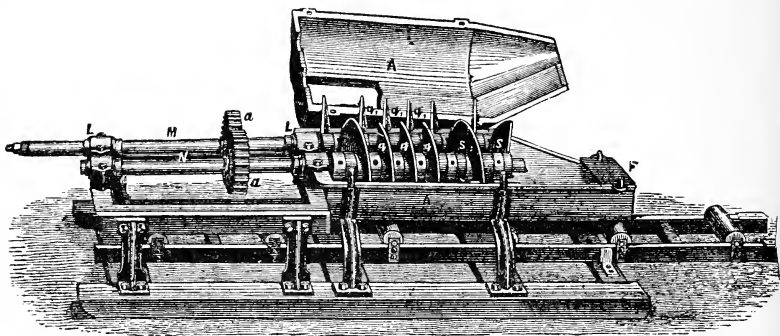

FIG. 41.—Cross-section for Fig. 38.

The use of the machines for different kinds of peat, which is to a certain extent feasible, is made possible by the fact that the knives, which consist of sectors, can be arranged by means of bosses and adjusting screws in various ways with respect to one another, and, indeed, from that of a continuous screw *s s* to that of quite separate knives *q q* and *q<sub>1</sub> q<sub>1</sub>*. The more the quarter



$\frac{1}{20}$  nat. size.

FIG. 42.—Double-shaft peat machine: general arrangement.

screws are separated from one another, that is, the more they act as striking or cutting knives, the more complete the destruction of the moss and the tearing and cutting of fibres and roots will be when the revolutions of the machine are 75 to 100 per minute. The more the quarter screws are pushed together, i.e., the more they tend to form a complete screw, the more powerfully the bituminous and friable peat will be kneaded and crushed at the

circumference of the double cover *A*, which closely surrounds the knives, and the more its forward movement towards the exit *F*, and therefore the output of the machine, will be affected. All intermediate positions between these may be realized, but obviously the knives *q q* and *q<sub>1</sub> q<sub>1</sub>* must be so arranged and set up that the blades of one shaft during every revolution of the two by the pair of cog-wheels *a a* will intermesh with the blades of the other shaft. The screws of one shaft must, therefore, have right-handed and those of the other left-handed threads. As in the case of the preceding machines the rotations of the two shafts in opposite directions never allow the peat contained in the machine to rotate with the shafts and also the various knives by their motion into and through one another usually clean themselves from roots, fibres, &c., and while continually cutting and

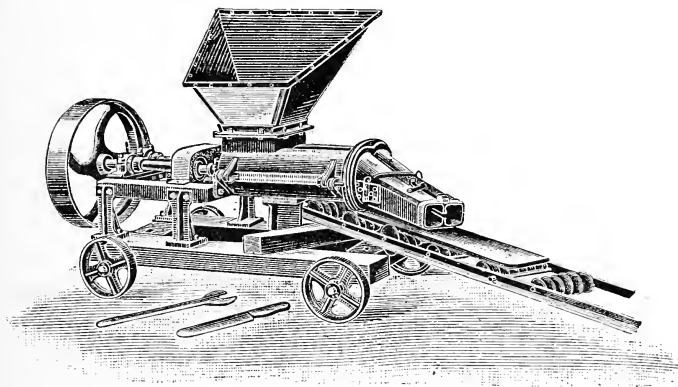

FIG. 43.—Double-spiral peat machine of R. Dolberg and Co., Rostock.  
For the same machine, with an elevator, see Fig. 46.

crushing the mass the two sets move it to the “forming piece” in the exit.

Machines of this kind were first manufactured in the seventies of the last century by Grotjahn and Pieau of Berlin, later Pieau of Munich. Figs. 42 and 43 show the general arrangement of the machines.

In later and more modern machines the central axis of the mouthpiece makes an obtuse angle with the axis of the machine, and it is thus made possible for the transport boards which catch the “formed peat” to be placed on the rollers from the side of the front part of the machine instead of being pushed from behind on the runners under the machine. Machines of this type are built by R. Dolberg and Co., of Hamburg and Rostock; Sugg and Co., of Munich; A. Heinen, of Varel; Stützke Bros., of Lauenburg; Dr. Wielandt, of Oldenburg; W. K. Strenge, of Ocholt (Oldenburg); Karl Schenck, of Darmstadt; Jähne and Son, of

Landsberg-on-Wartha ; H. Cegielski and Co., of Posen ; Aleph Anrep, of Emmelunga (Sweden), together with Munktell's mekaniska Verkstads Aktiebolag, of Eskilstuna, and Aadals Bruk's mekaniska Verkstad, of Christiania ; Aktiebolag Åkermann's Gjuterie and mek. Verkstad, of Eslöf ; Abjörn Anderson's mek. Verkstads Aktiebolag, at Svedala<sup>1</sup> ; Arthur Koppel, of Petrograd and Moscow, and others.

The machines, which are named after those who offer them for sale or who build them, agree in the main with one another in external form and internal arrangement and are illustrated by Figs. 42 to 45. They differ only in the greater or less care with which they have been constructed, in their solidity, and in the arrangement of the elevator, the driving gear, and the mouthpiece.

All these machines are delivered to order without or with

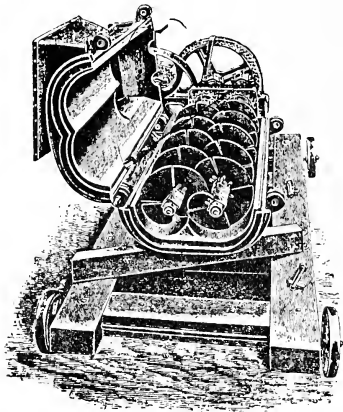

FIG. 44.—Double-spiral, rapidly rotating peat machine, with continuous screw-threads, for bituminous peat.

peat elevators (Figs. 43 or 46). The elevator usually consists of a transporting chain fitted with scrapers which glides in a channel delivering above the hopper of the machine. The raw peat thrown in at the lower end of the trough-shaped channel is raised until, having reached the end of the trough, it falls directly into the hopper. The elevator is driven from the intermediate gearing shaft.

The mouthpiece or forming piece usually consists of a single, double, triple, or even, in the Strenge machines, of a nine-chambered copper "forming piece." According to the nature of the peat the "forming piece" is square, arched, or circular in cross-section. Sometimes by means of double walls with scales

<sup>1</sup> For a detailed description of these single-axle Swedish peat machines and their output see *Osterr. Moorzeitschrift*, 1906, p. 8 et seq.

on the inside the issuing peat band can be moistened. (Further details are contained in Section V, A, 2, "On Forming Pieces and Mouthpieces.")

The screw has a slope of  $10^\circ$ , its diameter is generally from 25 to 35 cm. and is, as a rule, 32.5 cm.; the length of the double cylinder (without the mouthpiece) is up to 800 mm.; the outputs of these machines are given as follows:—

Size of the machine in terms of the horse-power required to drive it.	Per hour.			Approximate weight of machine in kilos.	Approximate price in Marks.	Price of elevator in Marks.
	Output.		Work-men required.			
	Standard sods, 10×10×20 cm.	Formed peat, cubic metres.				
4-6 h.p.	3-4,000	6- 8	12-14	500	600-650	700
8-10 h.p.	5-6,000	10-12	15-18	600	800-900	800
11-18 h.p.*	6-8,000	12-16	18-22	900	1,000-1,100	1,000
20-25 h.p.*	8-10,000	16-20	20-24	1,000-1,200	1,200-1,800	1,100
30-40 h.p.*	12-14,000	24-28	25-30	—	2,000-2,300	2,400†

\* Including side-driving of the elevator.

† 23 m. in length.

The sods actually made are, as a rule, bigger than the standard sods given in the table.

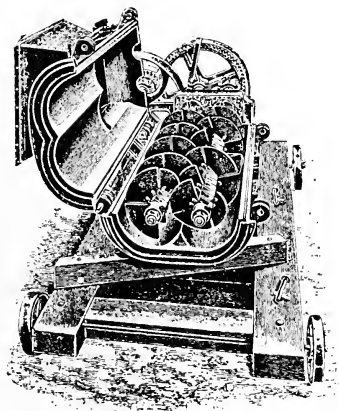

FIG. 45.—Double-spiral, rapidly rotating peat machine, with discontinuous screw-threads, for fibrous peat.

The iron chain elevator, which is 8 to 10 m. in length, is well able to feed the peat machine and replaces eight to ten men. The large machines with elevators further require: A support for the conveyor (130M. to 300M.), a side-driving gear for the chain elevator (160M. to 300M.), a wooden or iron transport contrivance

for the locomotive and peat machine with hand levers (450M. to 600M.), a transport contrivance for use with steam power (800M. to 900M.), and, finally, rails at 25M. to 30M. a metre.

The outputs given above are, however, attained only when the raw material is a suitable one; if this is not so, the actual figures are less than those quoted for these machines according to the experience of peat factories which work peat either very rich in fibre or containing roots and wood.

In recent times, in order to diminish the number of workmen and to decrease considerably the cost of winning the peat, the larger machines of this kind, especially those of Strenge, Wielandt, Dolberg, Schenck, Anrep (Svedala), amongst others, are provided with an automatic scoop dredger or with a dredger and conveyer instead of a conveyer only, and at the mouthpiece side of the machine with a sod spreader (in the case of machine peat) or a peat pulp spreader (in the case of machine pulp peat) and also with a cutting contrivance which is driven by the motor of the machine. For large outputs, especially for such as are essential for the smooth working of big power stations, these machines are said to have already proved very successful in the case of black, ripe mould peat which did not contain much wood. (See details with regard to these in this Section, E, III, under large scale industry peat machines, &c.)

The power required for a machine increases with the amount of fibre in the peat, and also according as the peat machine is or is not provided with special preliminary mixing and tearing contrivances (knife blades, counter-knives, "feeding rollers" and tearing rollers).

In the case of the machine with the dimensions given above, the peat moves through it with a velocity of—

$$\frac{150,000,000}{1.66 \times 830 \times 10 \times 60 \times 60} \text{ cm.}$$

or, approximately, 3 cm. per second, and requires, therefore, 27 seconds to traverse the length, 80 cm. In this time each of the two shafts makes  $\frac{100 \times 27}{60}$  or, approximately, 45 revolutions.

Hence 90 rotations of the shafts are made in a quantity of peat equal to  $\frac{830 \times 1.66 \times 80}{1,000}$  l., or, approximately, 110 l., so that 82 revolutions of the mixing contrivance correspond to every 100 l. of the peat. The mixing action of these machines can thus be compared with those of others.

It has been shown in many cases that, in spite of the inter-meshing spiral knives and their relatively good mixing action, these machines are not able to work a very fibrous moss peat which contains tough, non-humified roots mixed with it. The latter become firmly attached, as in the case of the machines already described, to the front periphery of the knife blades (which, of course, are not sharp, cutting knives) and, indeed, so firmly attached that they either decrease the yield of the

machine or break the knives if the work is not frequently interrupted in order to clean the machine. As may be seen from Fig. 42, the cleaning of the machine is facilitated as much as possible by making the upper half of the cylinder capable of being turned over.

To overcome this defect by better tearing and mixing, the double-shaft machines are sometimes provided with special cutting and tearing contrivances, as, for example, in the Dolberg peat machine, Model No. 1c, shown in Fig. 47. This also has two knife shafts, but is, on the whole, more or less strongly constructed. On each shaft there are eight knife blades, having hardened and sharpened cutting edges, which so work against counter-knives, fixed on the bottom of the machine that the peat fibres become well torn or cut. Towards the end of the shaft the knives are again arranged as a continuous spiral. These machines are also

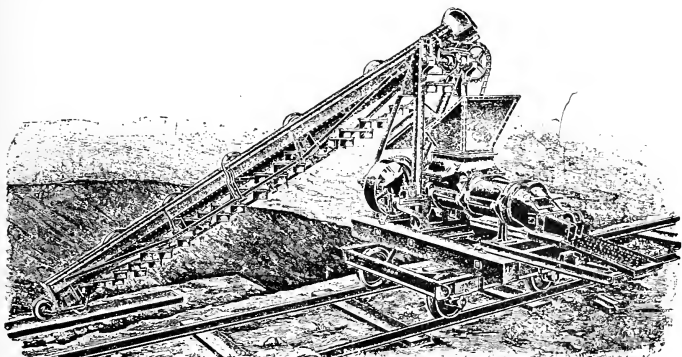

FIG. 46.—Double-spiral peat machine with elevator (in "back position").

provided with a preliminary crusher above the hopper when this is specially desired.

They are in use as follows :—

(a) *Dolberg Peat Machines in Germany.*—The Board of Control of the Wiesmoor, at Aurich, employs over 20 machines of the more recent type with the scraper conveyers, 16 to 20 m. in length, used in combination with them; the Hanoverian Colonization and Bog Utilization Society (the overland power station at Dammer Moor) employ eight machines, each having a daily output of 300 cb. m., or 120,000 to 140,000 sods, all of which are fitted with automatic sod spreaders; at the Aurich Wiesmoor one of the bigger machines, with a dredger and a sod spreader, 55 m. in length, is employed.

These machines are used in Austria by Moritz Fuchs at Szered on the Waag; in Russia by Leopold Riesberg at Petrograd, C. F. Schulze at Reppin, near Werro (Lithuania), the Mühlgraben Chemical Factory at Riga, Count Czapski at Minsk, the Russian

Company for the manufacture of explosives at Petrograd, Count von Menden at Rakiturja (Kursk); in Switzerland by the National Councillor Berger at Langenau; in Norway by Adalsog Hasle, of Brug, Fedge Torfbrug at Bergen, amongst others.

(b) *Heinen's Peat Machines*.—These machines are employed by Johann Free at Oldenburg, the Klein-Scharrel Peat Works at Oldenburg, H. Steinfeld at Augustfehn, Hinselmann and Lieken at Einfeld, near Neuminster, the Scherrebeck Press Peat Co., Ltd., at Scherrebeck, the Quarzbiehl Peat Factory, near Fletzen, in Bavaria, amongst others.

(c) *Peat Machines of Stütze Bros.*—These machines are employed on the Grüneberg demesne, near Lubichow (West Prussia), by Albert Rahn at Marienburg, Päske, Conraden, near Arnswalde, the Sebastiansberg Peat Works in Bohemia, at the Zollen demesne, near Soldin, the Terra Chemical Works at Rostock, Stengel at Gnewin (Lauenberg), J. Pinn at Melkendorf, near Eutin, Hugo Meyer at Riga, the Koppenow demesne, near Lauenburg, amongst others.

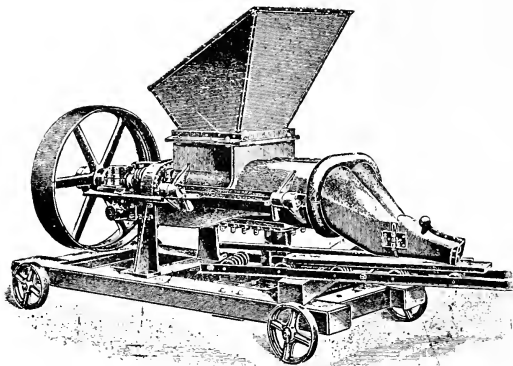

FIG. 47.—Double-shaft peat machine with counter-knives in the base of the cover. R. Dolberg and Co., Rostock.

(d) *Cegielski Machines*.—These are used at the Lussowko (Posen), the Pakoslaw (Neutomischel), the Rzadkowo (Colmar district, Posen,) and the Pomerzany (Gnesen) demesnes, and by the Goslawica Sugar Factory (Konin district of Russian Poland).

(e) *Anrep's Machines*.—These machines are used mainly in the peat factories of Sweden; and especially also in those of Russia.

(3) *Peat Machine of L. Lucht, of Kolberg*.—This machine, which is now constructed by the Kolberg Machine Company of Kolberg, consists, as may be seen from the longitudinal section, Fig. 48, and the cross-section, Fig. 49, of a *single* screw shaft *M*, lying in a hollow cylinder *A B*, which can be driven by a pair of conical wheels by electrical means or with the aid of a belt wheel by means of a steam engine (locomotive) or with the assistance of a cross-joint *U* and a capstan pole by means of horses.



The macerating and tearing contrivance is in the wider part *A* of the cylinder, and consists of a number of knives *a*, fastened to the shaft, which work against counter-knives *c* fixed in the external cover of the cylinder. The counter-knives prevent the peat from rotating with the shaft, and at the same time cut and tear the fibres and roots adhering to it.

The tearing or cutting knives *a a* are separate screw blades, the *straight* cutting edges of which strike closely past the fixed counter-knives and together with the latter exert a shearing action on the peat thrown in through the hopper, not only tearing the fibres but actually cutting them. The counter-knives are fixed on the one hand in the cover of the cylinder and are caught on the other hand in grooves turned in the nave of the shaft cover, and therefore the screw knives are always in close contact with the counter-knives along the cutting edges of which they glide. All wood, roots, fibres, &c., coming between them are, therefore, cut into small pieces.

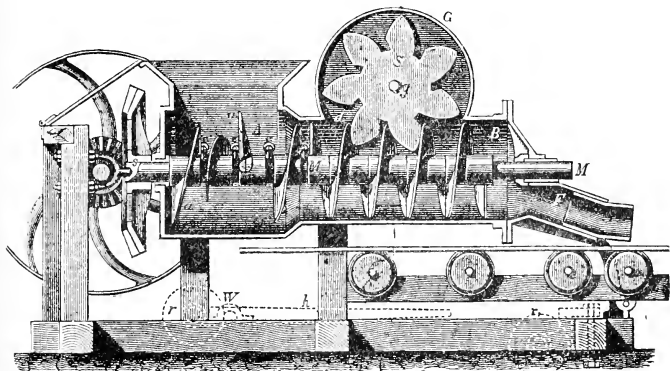

FIG. 48.—Peat machine of L. Lucht, of Kolberg.

The screw shaft can be moved in the longitudinal direction by utilizing the pivot *s* in the rear of the machine. To prevent fracture of the knife blades by their striking the counter-knives when the screw shaft is displaced, which would occur if they were rigidly connected with the shaft, the knives are fixed on pieces of cast-iron, which are fitted to the shafts by means of springs and slots so that they can move in the longitudinal direction of the shaft. In this way the pressure of the spiral on the shaft, even when the latter gives way to it, can never injure the knife blades, as the shaft can move through the latter without altering their position in relation to the fixed counter-knives.

In the narrower part *B* of the cylinder the spiral on the knife shaft is continuous. In addition to its crushing action against the cover of the cylinder, its main object is to catch the torn up and

mixed peat in the wider part of the cylinder, force it to the mouth-piece  $F$ , and press it out through the "forming piece" fixed to the latter. In order to remove a more or less inherent defect of all single-shaft and also in the case of very fibrous peat of double-shaft peat machines (the twining of fibres and roots round the knife shaft and the blocking of the machine due to this), Lucht has placed above the screw shaft a "cleaner"  $S$ , which is characteristic of his machines. This consists of a star-shaped wheel in a case  $G$ , which is closed externally and connected with the cylinder merely by a narrow slit  $d$ . The teeth of this wheel, the shape of which is shown in the illustration, work into the spaces of the screw so that they fill these as much as possible and when the screw rotates in the direction of the arrow they are moved forward—the star

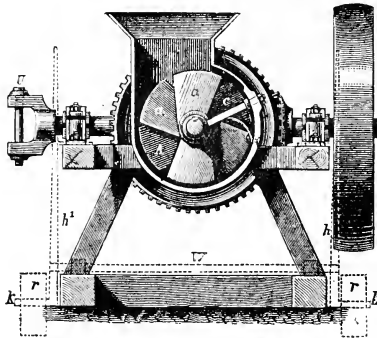

FIG. 49.—Peat machine of L. Lucht, of Kolberg. Cross-section of Fig. 48.

itself acquiring a rotatory motion—and in this way new teeth of the wheel are constantly meshing into the spaces of the screw. These teeth, which have a very intimate contact with the screw, in the first place clean this of all adhering fibres and roots, and in the next place, by stopping the peat in the spiral and thus making it impossible for the peat to share in the rotatory motion of the shaft, cause it to be moved to the mouthpiece  $F$  and to be pressed out of the latter.

In consequence of this ingenious arrangement, the output of the machine is relatively large even when the raw material is impure or very fibrous.

The back-pressure exerted by the screw shaft is taken up by a steel core pin  $s$ . The friction is thus diminished and easy running of the machine is attained.

The machine shown in Figs. 48 and 49 corresponds to No. 3 in the following list (p. 128); the diameter of its screw is 33 cm., and the total length of its cylinder is 100 cm.

The number of the revolutions of the knife shaft per minute is 30 to 40 when driven by horses, and 50 to 75 when driven by steam power. According to the quoted output, 86 cb. m. of

freshly formed peat in a ten-hour shift, the velocity of the peat in the cylinder is  $\frac{86,000,000}{10 \times 60 \times 60 \times 0.75 \times 855}$  cm., or 3.8 cm. per second, so that a charge of peat takes  $\frac{100}{3.8} = 26$  seconds to pass through the cylinder.

During this interval the knife shaft has been making  $\frac{50 \times 26}{60}$  that is, about 22 revolutions in the charge of the cylinder,  $\frac{0.75 \times 855 \times 100}{1,000}$  l., or approximately 64 l., so that, compared with the earlier machines, 34 to 35 revolutions of the knife shaft are made for every 100 l. of peat, a mixing action which is fair in itself, but which is increased by means of the shearing action due to the many knives of the cutting mechanism.

As may be seen from the illustration, the machine is made of iron with the exception of the supporting frame, which is made of wood. This is said to facilitate the transport of the machine in the bog, at the expense, however, to some extent, of the solidity of the whole machine.

A *transporter* is also supplied, when desired, with each machine, in order to increase its transportability in the bog. The transporter, which is indicated in the illustrations by the dotted lines, consists of a shaft  $W$  with two cranks  $k$ , two wheels  $r$ , two levers  $h$ , and a third movable wheel  $r_1$ . When the machine is to be moved from one place to another the lever  $h$  is raised, and the machine, thus placed on the wheels, can be moved easily by two men over planks placed under the wheels.

Wooden conveyers 7 m. in length and 500 to 900 kilos in weight cost 500M. to 900M.; iron chain elevators 10 m. in length and 2,600 to 3,200 kilos in weight, for machines Nos. 4-7, cost 3,250M. to 4,000M.

An iron transportable frame, on which the peat machine and the elevator can easily be moved as a whole, costs 1,000M. to 1,250M.

The larger machines are provided with a roller-way for removing the peat sods, by means of which the boards with the sods can be brought automatically to the drying ground and the empty boards again brought back to the machine. Such a roller-way costs 50M. to 60M. per linear metre; the driving contrivance with winch costs 840M.

Machines of this type with iron elevators and roller-ways are in operation at the peat works of E. Koy at Rosenort, East Prussia, and Lange and Gansowsky at Käberot, near Braunsberg, amongst others.

(4) *Schlickeysen's Horizontal Peat Machine with Gripping and Tearing Contrivance*.—To increase the mixing action and ensure a good output even in the case of peat which is very heterogeneous, slippery and fibrous, E. Schlickeysen, of Neukölln-Berlin, has

No.	Driving.		Revolutions of knife shaft per minute.	Output in ten hours.			Price in Marks of the		
	Mechanism.	Power, h.p.		In sods.	In cubic metres.		Machine.	Transporter.	
					Number	Size in centimetres.			Freshly formed.
1.	Horse	2	30	15,000	23.5 × 9.2 × 9.2	30	12	650	60
2.	Horse	3	30	15,000	23.5 × 9.2 × 9.2	30	12	950	60
3.	Steam	4.6	50	25,000	31.5 × 10.5 × 10.5	86	27	1,100	80
4.	Steam	6.8	60-75	32,000	31.5 × 10.5 × 10.5	110	33	1,540	90
5.	Steam	6.8	60-75	40,000	31.5 × 10.5 × 10.5	138	42	1,375	90
6.	Steam	8-10	60-75	70,000	31.5 × 10.5 × 10.5	258	78	1,800	100
7.	Steam	10-12	70-80	70,000	31.5 × 10.5 × 10.5	253	78	2,900	100

In kilos, dry, with density of 0.75-1.0.

provided his horizontal peat machine of the eighties with a special gripping and tearing contrivance instead of the feeding rollers of the older machine (Fig. 34) and has also equipped the front portion of the knife shaft with cast-steel knife blades which work between counter-knives. The front edges of the knife blades are constructed in a scientific manner with curved cutting edges.<sup>1</sup> As Figs. 50 and 51 show, a strong iron roller *D*, which is keyed to the belt pulley and driving axle *A*, lies in the hopper *B* above the knife shaft *C*. The roller is provided with narrow tearing teeth, which play between the six knives *F* rotating in the cylinder *B*. The teeth then pass through six counter-knives or "strikers" *H*, which are fixed on an axle *G*, and are kept continually pressed against the roller and the tearing teeth by means of a counter-poise lever *J* fastened to their axle. The raw peat

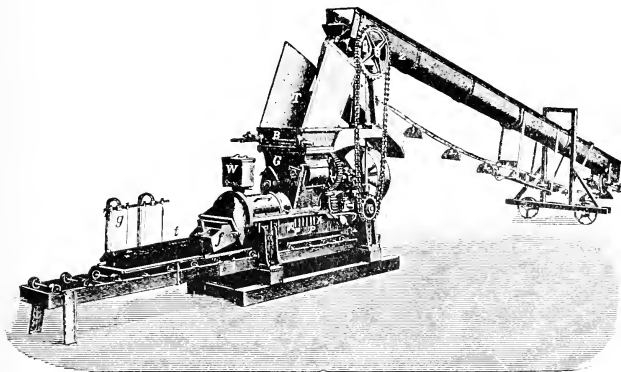

FIG. 50.—Schlickeysen's peat machine with gripping and tearing contrivance and elevator (in back position).

(consisting of sods which are not uniformly big and felted but hard and soft, friable and fibrous, and mixed with decayed roots) is thrown into the hopper *B* and is caught by the teeth, the shaft of which makes 200 to 240 revolutions per minute, and is partly thrown by these with a velocity of 3 to 4 m. to the knife blades *F* lying under them and partly carried round to the counter-knives or strikers *H*, where it is then torn to pieces, and any peat which may be entwined on the teeth is stripped off and fed to the screw knives *F*. The edges of the screw knives are turned accurately, so that the cutting action against the sharp-edged steel bars *P* may be as good as possible. The mass thus worked is pushed to the mouthpiece by the other screw blades or knife blades. By this arrangement all the coarse pieces of peat are uniformly broken up, the felty consistency of the peat is destroyed,

<sup>1</sup> Cf. Section V "On Knives and Screws."

and almost all the roots and fibres, which are only partially humified and slightly friable, are torn up or, in so far as they twine round the knives, they are cut as much as possible, stripped off these, mixed and worked with the rest of the peat. If the

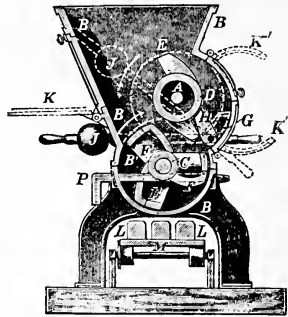

FIG. 51.—Schlickeysen's peat machine with gripping and tearing contrivance.

cylinder is in danger of being obstructed by the hopper becoming too full, then the strikers *H*, owing to the more or less strong pressure of the peat against them, are raised together with the counter-poising lever *J* into the position denoted by the dotted

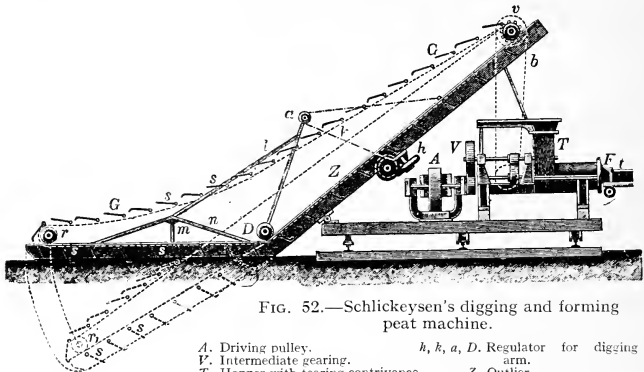

FIG. 52.—Schlickeysen's digging and forming peat machine.

- |                                       |   |
|---------------------------------------|---|
| A. Driving pulley.                    | <i>h, k, a, D.</i> Regulator for digging arm. |
| V. Intermediate gearing.              | Z. Outlier.                                   |
| T. Hopper with tearing contrivance.   | s. Automatically adjustable digging arm.      |
| F. Mouthpiece.                        | G. Digging and dredging chain.                |
| t. Peat band.                         |   |
| b. Driving mechanism for digging arm. |   |

lines. In this position the strikers stop stripping the peat off the teeth *E* which therefore do not feed new peat to the cylinder, so that the knives *F* in a short time again work freely. When this occurs, the increased pressure ceases to act on the strikers; these return to their usual position, and normal working is then restored in a few minutes.

By means of this arrangement the action of the feeding roller *D* (provided with the tearing teeth *E*) is made certain so far as the feeding of the peat is concerned, and at the same time the tearing and the mixing actions of the machine are increased to an extraordinary extent. The number of rotations (about 60 to 80 per minute) of the knife shaft corresponding to an output of 100 l. from the machine must be increased by a part of the rotations made by the toothed roller *A E* in the same amount of peat, when comparing the mixing action of the machine with those of the various machines mentioned in the earlier articles of this section. The "run of the machine" can be regulated to the consistency of the peat and for the power employed by moving the weight *J*. The trap-doors *K, K', K''*, allow of access to the interior of the machine. Stones, pieces of iron, and thick, hard wood may not get into the tearing and mixing mechanism without endangering the machine. The counter-knives *P P* can be withdrawn, cleaned, and again put back without opening the cover of the cylinder. These machines have a greater mixing and condensing action than those without any special tearing mechanism which have been already described. They are stoutly constructed, and are on sale, like all the other machines, with elevators and with special transport frames, as may be seen from Figs. 50 and 52. In a somewhat modified form they are now built by Schlickeysen's successors, the Rixdorf Machine Co., Ltd., of Berlin-Neukölln.

The prices, outputs, weights, &c., of the various sizes of machines may be seen from the following particulars:—

No. of machine	Width of cylinder. m.m.	Steam power required, h.p.	Rotations per minute of		Daily output (ten hours).				Approximate weight of	Price of
			Knife shaft.	Teeth shaft.	Sods (2 l.).	Raw peat, cb. m.	Formed peat.			
							Fresh, in kilos.	Air-dry, approximate number of kilos.	Kilos.	Marks.
1	200	3-5	} 60 to 80	180 to 200	8,000	24	16	4-5,000	600	800
2	300	5-6			30,000	90	60	15-20,000	1,000	1,500
2a	400	6-10			40,000	120	80	1-24,000	1,800	1,800
3	500	12-14			70,000	210	140	30-45,000	3,000	2,500

It is advisable to equip only the bigger machines with elevators. An iron chain elevator 10 m. in length, with an iron channel for the machine No. 3 costs 1,500M. Four axles with strong track wheels and supports, serving as a transportable frame for the peat machine and the locomotive, cost 440M. Two lever appliances for advancing the frame and the superincumbent machinery cost 100M. A No. 3 machine with all these

accessories costs, therefore, 4,550M. For working such a machine there are also required :—

	Marks.
50 m. of ordinary rails on which the supporting frame with the machines can be placed, and over which it can be moved	2,000
One 10 h.p. locomotive, for peat-firing .. .. .	6,000
400 m. of field rails, 50–60 cm. gauge .. .. .	1,500–2,000
4 turntables .. .. .	200–300
6 transport cars, each taking 15 boards, and these, in turn, each 12 sods	600–800
	<hr/>
	15,640
Sleepers, planks, winches, pumps, woodwork .. .. .	3,060
	<hr/>
Total .. .. .	18,700
Or approximately 19,000M. to 20,000M.	

According to particulars obtained from the factory, No. 3 machine requires, when working with good mould peat, the following labourers for :—

- (1) Stripping the peat and grubbing out the roots, &c. .. 2 men.
  - (2) Digging the peat and throwing it on the elevator .. 5 men.
  - (3) Placing in the boards to catch the formed peat .. 1 boy.
  - (4) Cutting the peat into sods .. .. . 1 man.
  - (5) Loading the boards on the cars .. .. . 2 men.
  - (6) Transporting the cars .. .. . 6 men.
  - (7) Tipping the boards on the drying ground .. .. 6 men.
- (This may also be done by women).

Total .. .. 23 labourers.

In Mid-Germany these operations are paid for at the rate of 16M. for a thousand boards (12,000 sods of 2 l. each, or 24 cb. m. of wet formed peat). For clamping and transporting to the storage sheds, 4M. per 1,000 boards are paid, i.e., altogether 20M. from the grubbing of the roots to the storage of the peat in the sheds. The wages paid for a day's output of 70,000 sods are approximately 120M. To this must be added the cost of :—

	Marks.
One engine driver per day .. .. .	6
Various operations, including two men (bringing fuel to the locomotive) .. .. .	12
Firing locomotive with waste peat .. .. .	5
	<hr/>
	23
Twelve women for turning the peat on the drying ground and for collecting it .. .. .	36
Interest, amortization, stand-by of machines, altogether 20 per cent. of 20,000M., i.e., 4,000M., or for the output of one of the 100 working days .. .. .	40
General expenses and ground rent together, about 4,000M., or for a single day's output .. .. .	40
Wages as calculated above .. .. .	120
	<hr/>
Total .. .. .	259

In the case of these machines 15 cb. m. of raw peat give, on the average, 10 cb. m. of wet machine peat, equivalent to 3 cb. m. of dry peat, weighing 2,300 to 3,000 kilos. Each of the fresh



sods has a volume of 2 l., measuring 8 x 10 x 25 cm., and contracts on drying to a sod measuring 6 x 6 x 18 cm., or 648 c.c., that is, to one-third of its original size.

With the output, given above, of 30,000 to 45,000 kilos of dry peat for a No. 3 machine the over all net cost of 100 kilos of dry peat is 0·58M. to 0·80M., according to the quality of the raw peat.

Machines of this type have been delivered to the Zintenhof Cloth Factory, late Wöhrmann and Son, of Zintenhof, near Pernau (Lithuania), to Baron Grevenitz for the Demesnes Department of Pernau, to Count Alexander Buxhöfden, of Cludowo (Russia), amongst others.

The better condensing action of these machines can be deduced from the fact that the dry sods from a "forming piece" 135 mm. square contracted to a cross-section of 80 x 70 mm., and were so dense and firm that they could be planed and polished, while sods from the *same* raw peat made by another (Russian) machine with the same forming piece contracted to only 120 x 110 mm., and were still so friable that they could be broken into crumbs by the hand.

(5) *Schlickeysen's Automatic Digging and Forming Peat Machine*.—In order to replace the costly operation of digging the peat required for a machine peat factory with a big daily output, for which it is sometimes difficult to procure a sufficient number of workmen, by the more independent, more rapid and cheaper machine labour, and, therefore, to facilitate the working of large bogs, Schlickeysen has proposed (as Mecke and Sander, of Oldenburg, did in the seventies) to combine an automatic dredger, or digging machine, with his horizontal steam peat machine.

The iron chain elevator well known in peat machines was made also to act as a dredger or peat scraper. Plate-steel scrapers *s s*, which have sharp front edges, revolve round pivots, and can place themselves into the working direction, are attached to an endless hinged chain (Fig. 52) driven by the working machine and passing by means of rollers round an outlier *Z* provided with a digging arm *s s*. When gliding over the bog the scrapers, by their own weight and that of the digging arm *m*, penetrate into the bog so deeply that, throughout their working widths, they shave or plane off thin layers of peat and raise it, thus loosened, in scraper cells which are enclosed on the sides, first to the hinge *D* of the arm at the surface of the bog and from there onwards through the ascending channel of the outlier *Z*, at the end of which the peat falls either into the hopper *T* of the peat machine or into cars placed under the end of the channel.

The digging arm *m* lies at first on the horizontal surface of the bog; when working, however, its free end sinks automatically, pressing by means of its own weight the digging scrapers into the bog, and it can thus dig the peat to a depth of 3 m.

The driving is so arranged that the conveying and digging arm can be rotated as desired round the axis of the hopper of the peat machine and can be raised or lowered with reference to this axis.

The whole machine can also be moved forward during the working.

The elevator with its digging arm when engaged at working digs in every position required, no matter whether it is rotating or lowering itself, standing or moving, and during each of these phases of working raises the substance which has been excavated.<sup>1</sup>

We do not know whether, after the death of Schlickeysen, who contributed much to the development of peat machines and brick machines, plants of this kind with digging machines, forming machines, and electrically driven, such as have been considered for some more or less large peat factories, have been constructed. The idea of peat-dredging machines for large scale industries has, however, been taken up and developed by others. This is discussed in more detail under E, III, of this Section.

(6) *Heinen's Peat Machine, with Preliminary Tearing and Mixing Contrivance.*—A. Heinen, of Varel, has, like Schlickeysen, provided his double-shaft peat machine (cf. Figs. 53 to 56) with a special preliminary tearing and mixing contrivance for working more or less ripe bogs or for getting a better mixing action. As the illustrations show, this contrivance consists of one or two pairs of knife shafts *a b* and *c d* placed between the hopper and the knife shafts proper and driven from the belt pulley shaft. The peat, thrown in at the top in irregular pieces, when partially broken up, torn and mixed by the upper knife shafts is fed by these to the spiral knife shaft *e f*.

In order to avoid obstruction of the machine by fibres and roots adhering to the knives, the tearing and mixing knives and blades are made in the curved form discussed more fully in the section on knives and spirals. The curved form of the knives favours the automatic removal of the fibres.

---

<sup>1</sup> E. Schlickeysen had previously intended to attain in another way the winning, on a large scale, of dense, handy fuel by automatic dredging or digging machines. A ploughing, mixing, and forming peat machine, similar to the well-known steam ploughs, was to be moved over the bog, and in this way the uppermost dried layer was to be simultaneously loosened, worked, and "formed." Instead of the ploughshare, he thought of using a peat screw, acting like a plough or a knife. The screws were to be arranged so that they could be raised or lowered, and a mixing spiral in a cylinder was to be attached to each of them. The whole machine was to run on wheels on a plank way. The mode of working was to be the following: Two locomotives, set up at the two sides of the working field, draw this peat-digging machine backwards and forwards by means of a wire cable and on each occasion the sunken front screw works by its open front part becoming pressed into the bog through the whole length of its course by the forward motion of the whole machine. In this way the screw cuts a piece of peat with a cross-section the same as that of the screw, works it at the same time in the closed part of the cylinder into a uniformly dense, doughy mass of peat, and again spreads it on the surface of the peat field, which has just been ploughed, as a long continuous band of peat "formed" by means of a mouthpiece placed at the rear of the cylinder. The band of peat is then to be cut into separate sods by hand. So far as is known this arrangement has never been employed. Even on account of the fact that the bog was to be worked from above downwards, and that its very moist upper surface was to be used as a drying ground, the process was not a suitable one for the purpose.

In determining the mixing action (cf. p. 122) of this machine part of the number of rotations of the fore-mixing knife shafts is to be added to the number of rotations of the knife shafts corresponding to 100 l. of the formed peat. The output of a 6 to

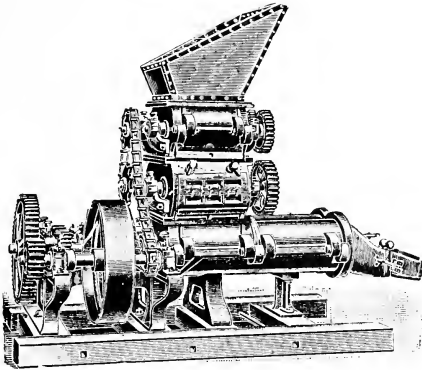

FIG. 53.—Double-shaft peat machine with preliminary tearing and mixing contrivance. A. Heinen, Varel.

8 h.p. machine of this type is, according to the manufacturer, 50,000 to 60,000 sods or 100 to 120 cb. m. of freshly "formed" peat in a ten-hour shift.

These machines have been acquired by the following peat factories: Johs. Free, formerly the International Company for

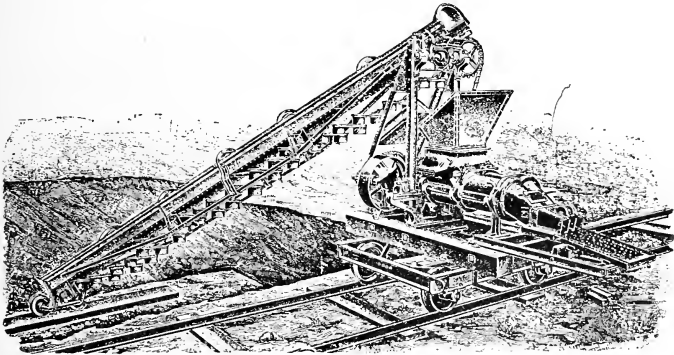

FIG. 54.—Peat machine with chain elevator (in back position). A. Heinen, Varel.

the Utilization of Peat, Ltd., of Oldenburg; the Brettberg Peat Factory, near Lohne, in Oldenburg; M. Damhof, of Gröningen; K. Lieken, the Einfeld Peat Factory, near Neuminster, in Holstein; Hermann Voigt, of Neudorf-Platendorf, near Gifhorn, and the Quarzbiehl Peat Factory, Munich.

## II.—MANUFACTURE OF MACHINE PULP OR MACHINE DOUGH PEAT IN HANOVER, OLDENBURG, DENMARK, AND SWEDEN

The process is in general that sketched in Section III, p. 30, for the manufacture of pulped, stroked, or trodden peat by the Hanoverian or Dutch method and differs from the latter process only by the kneading and mixing of the peat being effected by machines instead of by treading with the feet. The peat can be obtained in a denser and firmer condition and also in a greater output by means of the machines.

The raw peat is won by any of the known methods of digging, cutting, or dredging, and is thrown, after the addition of water if it does not contain sufficient of this (about 90 to 95 per cent.)

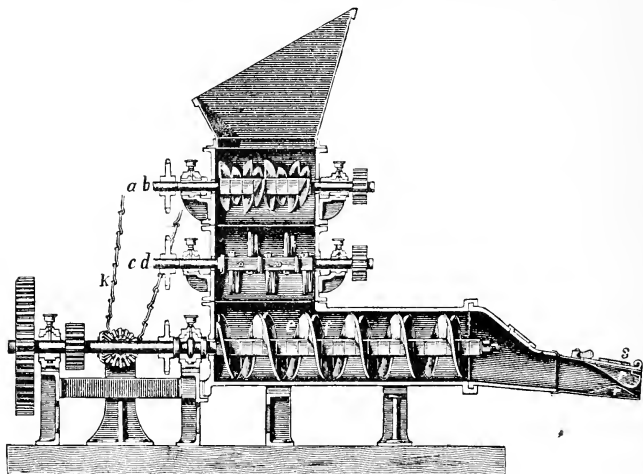

FIG. 55.—Preliminary tearing and mixing contrivance of A. Heinen's double-shaft peat machine.

to give a fluid pulp when ground in the machine, into a tearing machine with *rapidly running* knife shafts by which the fibres and roots are torn up or crushed and the whole mass of peat is converted into a uniform pulp. The latter flows out of the mouthpiece of the machine and is spread in a layer, 15 to 20 cm. high, over the peat field (which has been levelled beforehand) in the immediate neighbourhood of the machine. For this purpose the drying field is divided into sections by means of planks which prevent the pulp from flowing out. After some days, when the mass has lost a great part (approximately 40 per cent.) of its water, partly by evaporation and partly by soaking into the ground, it is trodden firm and levelled by workmen with boards strapped under their feet. Before it begins to split as the drying proceeds it is cut longitudinally and crosswise into regular,

rectangular sods of the usual sizes by slanes, cutting discs, or long knives, by hand or machine labour. The sods are left in the open air and frequently turned for further drying. In Denmark the peat is stroked into sods in moulds. Sometimes, especially in North-west Germany, the peat pulp, which has been spread and is ready for dividing, is cut in more or less large (30 sq. cm.) pieces and after some days each of these is again divided into three sods. These sods are "ringed," clamped, and when dry are collected into sheds in the usual way. As the disintegration and mixing of the peat are facilitated by addition of water and as a uniformly dense mass is more easily obtained when much water is present, and, further, as the evaporation of the water, therefore the drying

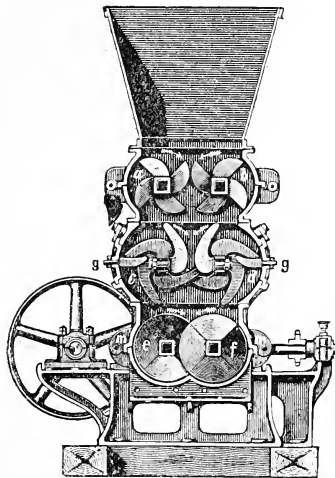

FIG. 56.—Preliminary tearing and mixing contrivance; cross-section.

of the peat, takes a relatively long time, the contraction of the peat and its increase in density are favoured in every respect. Although the fuel thus obtained in regular pieces is not quite smooth and clean externally, it is extraordinarily dense and firm and is very suitable for transport, for coking, &c.

The winning of this pulped peat can, however, take place only in the summer months (up to the end of July), since the pulped peat if made later rarely becomes dry owing to the large amount of water originally contained in it.

Unless the pulped mass which has been won late in the year is wintered between high banks for further working-up in the following spring, a winning season for this process of only ninety days can be relied on, while in the case of the manufacture of machine-formed peat a winning season of 100 to 125 days may be assumed.

The first man who carried out the manufacture of pulp peat and the preparation of dough peat by machinery was, so far as is known (and, indeed, in the year 1868), the father of the bog-owner R. J. Ruschmann, of Varel. He was driven to this process mainly by failures in the preparation of machine-formed peat. These failures led him to give up entirely the "forming" of the raw peat which had been worked in the machine, and to treat further the peat mass coming from the machine, after it had been made sufficiently fluid by the addition of water, exactly like the Hanoverian kneaded or trodden peat. The favourable results thus obtained soon procured an introduction for the process, especially

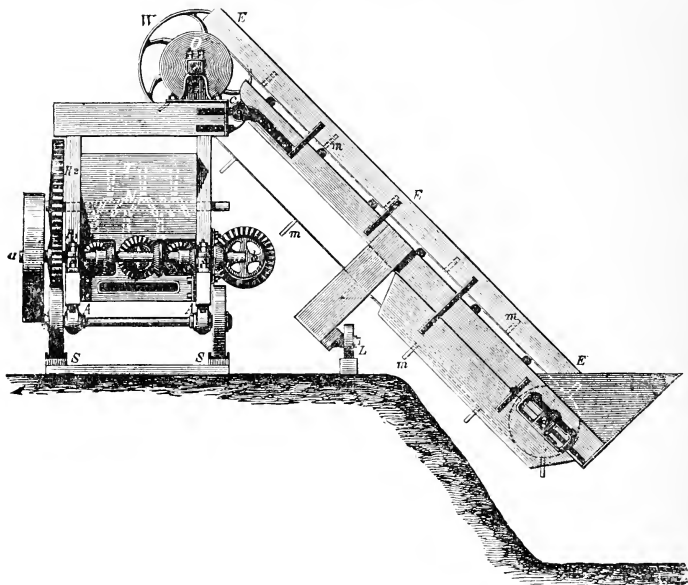

FIG. 57.—Triple-shaft pulp peat machine, with elevator.

into Oldenburg, Hanover, and Bremen, and from these districts into others which were situated farther away. The machines which gradually came into use for the manufacture of this pulp peat are almost as varied in construction as the peat-forming machines. The most important of them are the following:—

1.—*The Hanoverian Pulp Peat Machine.*

This peat machine, which was first constructed in 1868 by Cohen and Moritz, of Hanover,<sup>1</sup> for Ruschmann's Peat Factory, at Varel, and which in a similar form is still in use even at the

<sup>1</sup> This firm no longer exists.

present day, is shown in Figs. 57 and 58, in front and side views. It consists essentially of several tubes or cylinders *C*, 180 mm. in diameter, in each of which a screw shaft rotates, making 220 revolutions per minute.

These screw shafts are driven by a locomotive with the aid of a pair of conical wheels on the intermediate gearing shaft *a* and a belt pulley. A horizontal stirrer or mixer *N* is contained in the funnel *T*, into which the raw peat is fed, and is kept in motion, at the rate of 90 revolutions per minute, by the intermediate gearing shaft *a* with the help of the pair of spur-wheels *R*<sub>1</sub> *R*<sub>2</sub>; its object being to mix the raw peat put into the machine with the water which is at the same time made to flow into the funnel, usually by a pump driven by the locomotive, and feed the mixed mass in regular quantities to the working screws which lie under the funnel.

The machine is fixed on a frame *A A*, which is provided with four wheels and can be transported on a frame-rail *S S* placed

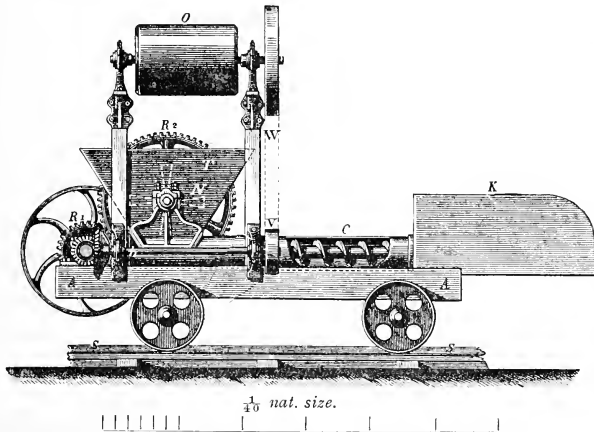

FIG. 58.—Side view for Fig. 57.

under the machine. At fixed intervals it can be moved, together with the locomotive employed in working it, beside the cut-out working trench. On the opposite side of the machine the peat is spread for drying. In this way the labour of transporting the raw peat to the machine and the peat pulp from the machine to the drying ground is made as small as possible.

The trenches are laid out 3 m. in width. When the depth of the trench is small the peat-diggers throw the raw peat directly into the hopper of the machine, but in the case of deeper bogs an elevator *E* is combined with the machine, as shown in Figs. 54 and 57. The outlier of the elevator can rotate round the axle *c* according to the depth of the trench and is supported by the roller-wheel *L* while the machine is being moved forwards.

The elevator consists of an endless cloth on which laths or boards *m m* are fixed. It is driven from the shaft *b* by means of the upper drum *O* and the belt pulleys *V* and *W*. The elevator *E* is now generally placed in the longitudinal direction of the machine (the so-called "back elevator" seen in Fig. 54).

The peat is converted into a uniform thin pulp while passing through the screw tubes. At the front the pulp flows into the box *K* or into cars moved under it and by means of which it is transported to the drying ground.<sup>1</sup> The latter has a width of about 25 m. and runs parallel to the peat trench, but is so situated that the peat machine is between the drying ground and the peat trench. In this way three men with hand barrows can remove from the machine and spread 200 cb. m. of raw peat in a day.

This quantity of peat gives about 40,000 sods or 35 to 40 cb. m. of air-dry peat, weighing 30,000 to 40,000 kilos. With 15 to 18 labourers the cost of winning alone, without ground rent and general expenses, is, therefore, 0·20M. to 0·30M. for 100 kilos.<sup>2</sup>

This machine, modified by F. J. Müller, of Prague, has come into use in several Austrian peat factories. In order that the raw peat might be torn and mixed more efficiently the horizontal shaft *N* of Figs. 57 and 58, on which some knives were fixed, was replaced in these machines by one or two grinding drums according to the nature of the raw peat. These drums, like the well-known beet rasps, were provided with saw blades on their covers. J. Müller has also fitted his machines with screw shafts working into each other, such as are described on pp. 118 to 121 for the double-shaft forming machines, in place of those of the above machine which were arranged separate from one another. In this way he obtained a very intimately kneaded and well-mixed peat pulp, a result which is of great importance for the subsequent condensation in the case of coarse-fibred raw peat containing much wood mixed with it; and in some cases, indeed, the final decision as to whether this method of winning is likely to be suitable or not will depend on the amount of this kneading and mixing.

## 2.—The Oldenburg Pulp Peat Machine

This machine was introduced by George Mahlstedt, who was at the time Director of the Oldenburg Canal Construction and Peat Manufacturing Co., Ltd., in a bog belonging to this Company. Several of these machines were constructed by the machine manufacturer Beeck, of Oldenburg; they may be regarded as modifications of the Ruschmann machine. As may be seen from Fig. 59, the machine consists of only *two* adjacent tubes and screw shafts. The bearings of the screw shafts also are in this case

<sup>1</sup> The pulp peat made in this way, even when the raw peat is worked with little or no addition of water, can be formed in moulds on the ground like dough peat, or by the machine itself (by means of a mouthpiece screwed on the front of the machine), as in the case of the forming machines described earlier.

<sup>2</sup> Cf. Section V, E.



fixed outside the cylinder, both in the front and in the rear, so that a stoppage due to clogging of the bearings with fibres cannot take place.

The machine, which is screwed on a frame provided with four wheels, can be easily moved in the bog on planks or rails placed under the wheels.

Such a machine is intended, when working regularly, to treat on an average 100 cb. m. of raw peat in ten hours and to require for attendance (including the bringing of the peat to the machine but excluding the drying operations) nine labourers and an engine-driver. A 5 to 6 h.p. locomotive is required to work the machine. The price of such a machine amounts to about 900M.<sup>1</sup>

Fig. 60 shows a triple-shaft peat machine of this kind with a preliminary tearer, as constructed by A. Heinen, of Varel. With an output in a ten-hour day of 50,000 to 60,000 sods, equivalent to 120 cb. m. of "formed" peat, and with a consumption of

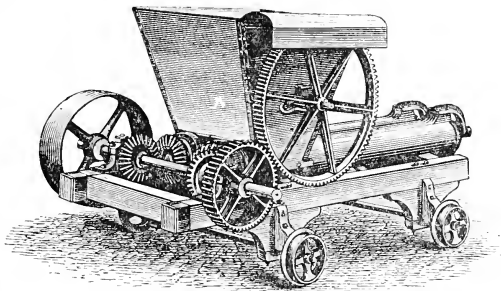

FIG. 59.—Double-spiral pulp peat machine.

power of 5 to 6 h.p., it costs 900M. Machines of this type have been used by Ruschmann and Co., of Varel, Suhren and Thien, of Bockhorn, in Austria, the Hahn Peat Factory, and by P. Thaden, of Rastede.

### 3.—Machine for making Pulp Peat, of A. Ingermann, of Koldmoos

For cases where a locomotive or other mechanical power is not available and the winning is not to be carried out on a large scale, A. Ingermann, of Koldmoos, near Gravenstein, has built the machine described below which can be driven with the aid of a horse.

<sup>1</sup> The output obtainable from the machine during a *short* trial may be far greater than this. On the occasion of the industrial contest at Bremen Exhibition in 1874 one of these machines worked 2 cb. m. of peat into peat pulp in three minutes, which corresponds, therefore, to an output of  $\frac{10 \times 60 \times 2}{3} = 400$  cb. m. in ten hours. When judging a machine all the credit should not, however, be given to outputs of this kind, obtained in short trials under specially favourable conditions.

The machine (Fig. 61) consists of a kneading mill *A* which is driven by one or two horses by means of a cross-joint on the shaft *W*, an axle-tree and a capstan. The square wooden body has a width of 55 cm., a height of 70 cm., and is plated on the inside. Six or seven crescent-shaped knives are fixed on a vertical shaft *aa* contained in the body. The knives move between several cast-iron ribs attached to one of the inner walls of the body, and in this way grind the peat. At the opposite side of the body there is another vertical shaft *bb* which is connected with the first by a pair of spur wheels  $r_1 r_2$ , on which there are several round, sharp cast-steel discs. These pass through the external wall of the body and are contained in a box fastened to this wall. As the shafts revolve in opposite directions the discs glide over the inner knives in such a way that they cut any fibres adhering to the knives and thus prevent stoppage of the machine or diminution in the cutting action of the knives. The knife shaft makes 24 and the disc shaft 8 revolutions per minute.

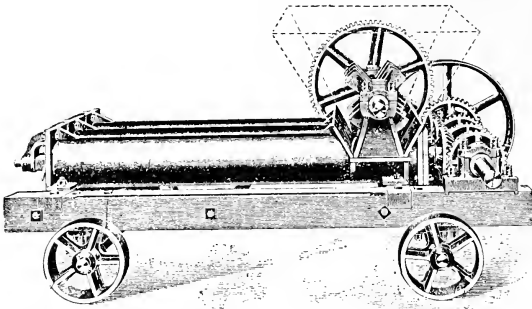

FIG. 60.—Heinen's triple-spiral pulp peat machine, with preliminary tearer and mixer.

The rectangular shape has been selected to allow of the machine being more easily and cheaply constructed of wood, of the ribs being conveniently fitted in, and also in order that more or less firm and tough pieces of peat, stones and roots, which might be a source of danger for the cutting knives and be likely to cause breakage, can be pushed by the curved knives into a corner. They either remain in the corner until the body is being cleaned or are gradually broken up as the rotation and crushing proceeds.

One side-wall can be raised, like a flap, to facilitate the cleaning of the machine. The motion of the knife shaft is effected by the horizontal axle lying under the body, with the aid of a pair of conical wheels. While the cross-joint for making union with the shaft of the capstan is at one end of the shaft *W*, a crank *k* is fixed on the other side, which can be seen in the illustration. By means of a rod the crank sets a suction and pressure pump *P* in

motion which feeds the water required for its working into the body of the machine. The stroke of the pump is adjustable and, therefore, the intake of the water can be regulated at will.

When the raw peat in the body has been converted into a uniform pulp by the rotation of the knife shaft it passes out through an opening, which can be closed by a flap by which the outflow can at the same time be regulated into a box *K* placed in front of the opening. The front wall of the box consists of a flap which can be lowered and in this way the peat can be allowed to flow into barrows placed underneath, or it can easily be withdrawn by a workman by means of a rake.

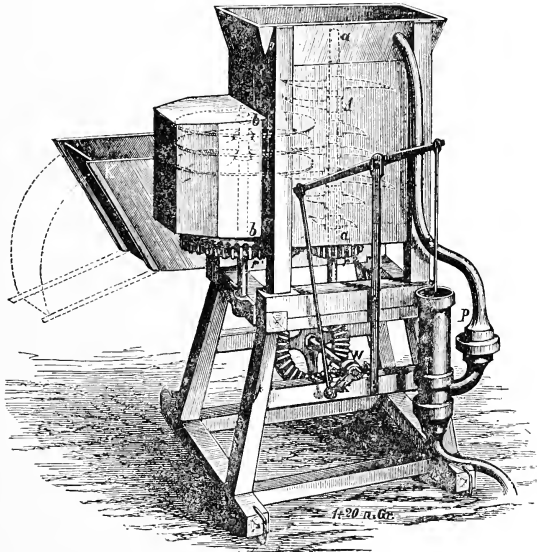

FIG. 61.—A. Ingermann's pulp peat machine.

The peat is brought to the drying ground and is further treated as described for the Oldenburg process, or, as frequently happens in more or less small industries, it is emptied into a forming barrow like that shown in Fig. 62, and by means of this—a workman pulling the barrow behind him—the pulp is moulded into sods by the rotation of the drum wheel and is at the same time spread for drying.

The "forming" barrow consists of a drum wheel *R* on the cover of which two rows of moulds are fixed. These glide during the motion of the barrow under its hopper and thus become filled with the pulp which has been thrown into the hopper. In order that the latter may not fall through the open moulds into the wheel there is an iron protecting plate on the latter and along this the pulp may be pressed. To prevent the peat sods from

falling out too soon a protecting plate is also fixed below and outside the moulds. This keeps the peat in the moulds until they reach the lowest point when it falls out of the moulds, forming two rows side by side.

According to its size the wheel contains 30 to 40 moulds; every time it rotates 30 to 40 sods are, therefore, moulded and spread

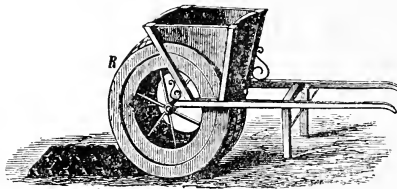

FIG. 62.—Forming barrow for pulped and moulded peat.

After three or four days pulp peat moulded in this way becomes so firm that it can be footed, and after further drying it may be “ringed.” Although machines of this type have proved very suitable when the industries and outputs are small, since with five men and one strong horse, or two more or less weak ones, up to 16,000 sods of peat can be moulded and spread in a day, they have, however, in the course of time been displaced by simpler band-forming machines or pulp peat machines.

#### 4.—Hodge's Peat Boat in Oldenburg, Peat Dredgers, &c.

Amongst the machines for winning machine-pulped or machine-kneaded peat must be included Hodge's peat boat, which was at first acquired by a private company in connexion with the construction of the Hunte-Ems Canal and later taken over from the company by the State of Oldenburg, the well-known dredgers, such as the Fimmen boat dredger, bucket dredgers, “wash” and “suction” dredgers, &c., in so far as these are combined with a special mixing or kneading machine.

Hodge's peat boat was first built in Canada.<sup>1</sup> In a peat boat of this class there are digging, elevating, and disintegrating machines, as well as distributing channels. There is a diagram of the boat in *Gartenlaube*, 1873, No. 37.

The peat-digging machine consisted of two large spirals, 3.5 m. in diameter, placed in the front of the boat and driven by the aid of cogwheels by the engine in the back portion of the boat. These screws cut their way through the level bog by excavating a canal 6 m. wide and  $1\frac{1}{4}$  to  $1\frac{3}{4}$  m. deep. The forward motion of the screws in the bog was about  $4\frac{3}{4}$  m. per hour. It decreased as the density of the bog increased, varying from

<sup>1</sup> *Engineer*, July and August, 1872, and *Polytechn. Zentralbl.*, 1872.

100 to 50 mm. a minute. The breadth and the depth of the cutting in the case of the Hunte-Ems canal were not sufficient for the purpose intended. Several cuttings were, therefore, made alongside one another and also under one another when the depth of the peat deposit allowed of this being done. The peat raised by the screws was brought to the bow of the boat from which it was conveyed by an elevator to the disintegrating machine. After addition of water it was disintegrated and intimately mixed with the latter. The pulped peat passed through a long tube, in which it was further disintegrated by revolving and fixed knives, to a considerable distance over the adjoining bank on which the peat was deposited. The bank was levelled and consolidated by workmen beforehand.

There were several openings provided with flaps at intervals along the tube. The peat could, therefore, be allowed to flow out of the tube at any desired distance from the bank. It was spread in a uniformly thick layer and levelled, the workmen using small boards provided with handles for this purpose. For spreading the peat on the surface beyond the discharging channel the aid of horses was required.

When a large amount of the water contained in the spread peat had soaked away or had been evaporated, the peat was cut into sods by special machines in order to dry it more fully. According to statements which have been received, a peat boat such as this raises  $6 \times 1.50 \times 4.75 = 42.75$  cb. m. per hour. The boat, together with machines, implements, wages, &c., for an output of 100 cb. m. of air-dried peat fuel every ten hours cost 35,000M. to 40,000M.

Although the peat boat is said to have worked quite well in grass and green bogs in Canada, the Canal Construction Co., of Oldenburg, was not commercially successful. When the Company wound up the State took over the boat, and in the service of the latter it worked with good results in the construction of the Hunte-Ems Canal. Considerable quantities of peat were raised every year. It was well mixed and spread on the side, and from it large quantities of a good mud peat were obtained and sold at a price slightly above the cost of production. The cutting of the canal, therefore, cost nothing.

In the construction of the Kaiser Wilhelm Canal the well-known bucket dredger and other dredgers of the same type working to a depth of 10 m. raised up to 300 cb. m. of raw peat per hour.

##### 5.—*Mecke and Sander's Peat-dredging Machine*<sup>1</sup>

At the end of the seventies Mecke and Sander, of Oldenburg, believed they had solved the problem of manufacturing, cheaply and on the large scale, a saleable and transportable machine peat by a process almost the same as this, in which their peat

<sup>1</sup> Compare the pamphlet, "Der Torf und dessen Massenproduktion nach dem zeitigen Stande der Wissenschaft und Technik," by Dr. H. Stierner, Engineer, Halle, 1883, in which there is also a diagram of the machine.

dredgers were utilized. The peat-pulping machine was a multi-spiral one, and was provided on one side with a peat dredger and on the other with a peat pulp distributor. The whole could be moved or transported along the trench on a latticed frame supported by wheels and rails. The dredger could be raised or lowered to suit the depth of the bog; it stopped automatically when obstacles were encountered and could be again set going when the obstacles were removed. It consisted of sharp, saw-edged dredger buckets, mounted on a chain which was set in motion from the power shaft by cogwheels and chain pulleys. The dredging buckets rasped the peat in thin layers from the face of the bank and brought it, when thus finely divided, to the mixing machine. The latter, like the Hanover-Oldenburg pulp peat machine, consisted of two shafts which were provided with winged screws and rotated in opposite directions in the same case. The peat, cut simultaneously through the whole height of the peat bank and conveyed by the dredger to the machine, was intimately mixed in the latter and the uniformly dense peat pulp thus obtained was pressed out through a wide mouthpiece to the distributor. The latter consisted of a belt formed of sheet-iron plates, 0.15 m. wide and 0.5 m. long, which were connected to two parallel guiding chains. The belt ran over drums and supporting rollers. It was driven from the main shaft and as it passed under the mouthpiece it was fed with peat pulp. The latter was thrown off the belt and spread on the underlying, levelled drying ground by a car, constructed like a snow plough, which was movable along the upper flange of the spreader. The width of the drying ground and the length of the distributor (usually 24 m. to 30 m.) corresponded to the depth to which the peat was cut. In consequence of the absorbing power of the drying ground, which had been freed beforehand from its grassy coat and the upper layers of which were already fairly free from excess of moisture, the drying of the pulp and the contraction and natural compression associated with it were said to be so facilitated that the upper surface of the peat pulp could, after two or three days, be levelled and compressed by boards placed under the feet of the workmen and the sods could then be cut longitudinally and transversely. The sods were said to have dried in five to six days to such an extent that they could be footed and, after a further twelve to fourteen days, clamped. It was not necessary that the peat should dry rapidly as the ground seldom required to be covered more than twice in the same year. The whole machinery moved forwards automatically and continuously during the operations and in this way the amount of the peat layer rasped off the trench wall could be regulated as desired. The average forward motion per hour was given as 15 m. During its work the machine was said to describe a serpentine course which, by means of loops at the ends, allowed the machine to turn and which stretched over the whole of the bog area worked. In bogs which contained roots and other obstacles to such an extent that the use of the dredger was not possible, an elevator,

fed by hand, was substituted for the latter, and the cost of winning the peat was, in consequence, somewhat increased. Even when it rained continuously for weeks the operation of the machine was not stopped—the peat pulp was spread beside the line of cutting and sufficient time for the drying and clamping of the peat was always available. When the surface of the bog would not bear the great weight of the machine the latter was mounted on a flat-bottomed boat, with the dredger in front, so that the machine by dredging and working the peat was able to cut its own canal.

The builders of these machines<sup>1</sup> guaranteed their daily output as 100,000 sods. The cost of the plant, including machinery, rails, and housing accommodation, was 36,000M., and the annual working capital was 17,500M. The cost of the peat was therefore 1.75M., or, after adding 0.25M. for trade expenses, 2.00M. for 1,000 sods. As 1,000 sods weighed 500 kilos when air-dried, 100 kilos of the air-dried peat cost 0.40M. Nevertheless, the peat-dredging machine of Mecke and Sander did not continue in use long, owing mainly to the machine having too weak a construction and to the dredger not being so completely automatic as it was supposed to be. In most cases the nature of peat bogs will render the smooth working of automatic digging machines very difficult. Owing to the frequent occurrence of wood and roots in bogs the dredger must be strongly constructed so as to suit the peat, and constant supervision, as well as the timely removal of large roots and tree stems, will be necessary.

#### 6.—*The Strenge Peat-dredging Machine*

This dredging and pulping peat machine was a further development of that of Mecke and Sander, just described, due to the late Oltmann Strenge, the owner of a peat factory at Elisabethfehn. Machines of this type were first used at the Strenge Peat Factory at Elisabethfehn and afterwards at the Schwaneburg Peat Factory at Ramsloh, in Oldenburg.

The machine in its earliest forms consisted of a dredger, a conveyer, a mixing machine, and a spreader, driven either by a 25 to 30 h.p. locomotive or electrically, and moving forward automatically during its work. The dredger or digger could be adjusted both for angle and depth of working, which took place at the side of the bog. It dredged the peat vertically, and as this took place simultaneously through the whole depth of the bog the different layers of peat were well mixed during the dredging. The peat was thrown on a conveyer consisting of a channel with a chain of plates or belt, by which it was brought to a double-spiral mixing and kneading machine. From the latter the peat fell on to a screw conveyer, which brought it to an

<sup>1</sup> Mecke and Sander, of Oldenburg. The firm has been extinct for several years, and therefore these dredging machines, on which great hopes were placed at the time, have disappeared from the market.

automatic spreader consisting of two troughs inclined at an angle to one another and the bottoms of which were pierced with holes. A roller moving in the trough levelled and distributed the peat. The trough case trailing behind over the spread peat pressed the pulp into a uniform layer, the height of which was 30 cm. to 40 cm., and the width 15 m. Several days after the spreading of the peat its surface was levelled by means of boards strapped under the workmen's feet, and the sods were then cut. For this purpose a workman, or a machine, drew a roller with cutting discs, about 20 cm. in diameter, across the peat layer. The distance apart of the cutting discs corresponded to the width of the sods, and the height of the layer to the length intended for them. During the further drying and contraction the peat strips separated from each other, and after six to eight days they were divided by a cutting disc, 1 m. in diameter (Fig. 63), supported on the peat layer by a broad roller on each side of the disc. In large factories, as, for instance, that of the Wiesmoor

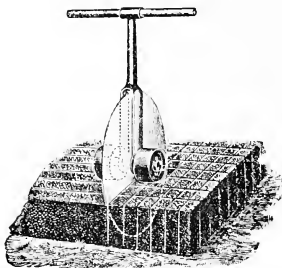

FIG. 63.—Cutting disc for pulp peat.

Power Station, where two Strenge dredging machines of the 1906 model were at work up to 1912, the cutting of the peat cake was effected by a hand-guided, electrically driven poly-disc cutter (Fig. 64). The further drying operations—footing, re-footing, clamping, castling—of this pulp peat were carried out in the usual manner.

By removing the spreader and connecting a screw conveyer, 10 m. to 15 m. in length, to the mixing machine, the peat could be worked after addition of water to a thinner pulp, and this mud peat (Schlammtoorf)<sup>1</sup> is allowed to flow either into wide trenches or between tree trunks so as to form a more or less high layer (about 1½ m. in height, which subsides to about 1 m.), where partially covered it is allowed to winter and in the following spring is cut into sods in the ordinary way. This process was used during the later summer and early autumn months (July to September), when there was a risk that the machine-pulped peat could not be sufficiently dried before the setting in of

<sup>1</sup>Not Schlammtoorf (washed-out peat), which has quite a different signification (see p. 67).



frosty weather, in which case it would be injured by freezing. In this way the usual season of 100 days was said to have been extended to 180 to 200 days.

After the death of Oltmann Strengé his son took over the construction and the further development of these machines as well as the erection of machine peat factories for the firm of W. K. Strengé, of Ocholt, in Oldenburg. Since about 1910 the Strengé "pulp peat" dredging machine with spreader has been converted, especially for large industries, into a "formed peat" dredging machine with automatic sod spreader. The Strengé pulp peat machines of the 1906 model are no longer in use, and the same may be said of the 1910-1912 models, which were provided with a sliding board by means of which the sods, cut into lengths, were laid crosswise on the spreading band and

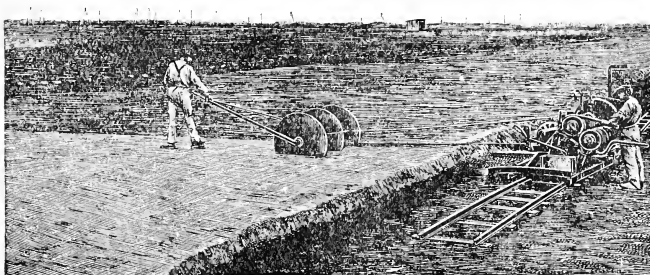

FIG. 64.—Multiple-disc cutting contrivance for pulp peat.

tipped on their ends on the drying ground. These machines have all been changed to machines like those at Wiesmoor of the 1914-1915 model described fully in the following section so that Strengé pulp peat machines are no longer manufactured.

### 7.—Danish (*Sparkjaer*) Machine-pulped Peat Winning

In Denmark, especially Jutland, peat is won in the large bogs mainly as machine peat, and, indeed, almost entirely as machine-pulped peat. The first of these factories was the Okjaer-Mosebrug Peat Works, which was erected in 1873, but was closed several years ago owing to the bog having been cut out. The director of the factory was the Danish nobleman, M. Rahbek, of Sparkjaer, who has rendered exceptional services for the extension and the commercial success of peat winning in Denmark.<sup>1</sup> There are about 90 machine peat works in Denmark, having altogether an annual output of about 90,000 tons of dry peat fuel. Only a few of these are machine-formed peat works, the others manufacturing machine-pulped peat, so that of the total annual output

<sup>1</sup> *Meddelelse No. 3 fra Moseindustri-Foreningen*, October, 1902, Viborg.

about 10,000 tons consist of machine-formed peat. The Danish (especially Jutland) bogs<sup>1</sup> are mostly high bogs overlying low bogs. Their depths are up to 10 m., and their contents consist of well-decomposed mould peat. The peat is dug and either brought to, and worked in, a vertical machine, or the machine can be moved on the bog, or it is screwed to a flat-bottomed boat which floats in the peat drain. In the latter cases the peat is thrown into the machines and worked up at the place in which it is won. In both cases the crude peat is worked into a pulp after the addition of water and is afterwards formed into sods.

According to Rahbek, the mixing machine consists, as a rule, of a wooden case  $2\frac{1}{4}$  m. to  $2\frac{1}{2}$  m. in length and about 55 cm. in width and depth. It is shaped like a closed trough, has an opening for filling in the peat, and is provided with a shaft, furnished with knives and blades and making about sixty revolutions a minute. A transporter carries the peat pulp, which issues from one end of the mixing trough through an adjustable opening, to a loader, from which it passes into the tipping car, which is drawn (generally by horses) to a "forming" and drying ground well drained, and situated at as high a point as possible.

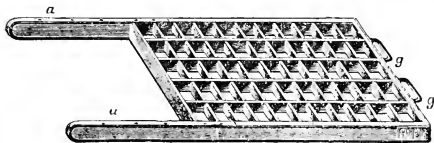

FIG. 65.—Moulding and stroking frame.

The peat pulp is moulded in frames, 183 cm. long, 141 cm. wide and 8 cm. high, each of which is divided into 55 spaces for the sods (Fig. 65). The surface of the drying ground acts as a bottom for the frame. In the smaller factories 80 to 90 of these frames, and in the Okjaer Factory 166, lie in a row along the front of which a temporary railway track is laid. The peat pulp is emptied from the tipping wagon into the forming frames over which it is spread (stroked) by means of large wooden shovels or stroking boards, so that each sod space becomes filled. When the row of frames has been filled and stroked, and therefore 4,400 to 9,130 sods have been formed, the railway track is moved sideways through the width of a frame, and the frames are tilted up and drawn after it. The frames are provided with handles *g g* in the front and with 50 cm. arms *a a* (formed by prolonging the sides of the frame) behind, on the extreme ends of which they are supported while being drawn forward, so that the frame itself moves over the moulded sods without touching them, the ends of the arms slipping along the surface of the

<sup>1</sup> For the Danish and Swedish machine peat factories, see Hans Schreiber in *Oesterr. Moorzeitschrift*, 1906 and 1913.

ground between the rows of sods. On an average, each sod has a volume of 3,000 c.c. = 3 l., and weighs when wet 3.5 and when dry 0.5 kilos.

The line of rails for the frames lies at right angles to the main line, with which it is connected by a pass-by or a small traverser.

The work of drying the sods is usually carried out by children, by whom the sods are placed, when (after four to fourteen days) they are sufficiently firm, on their narrow sides supporting one another in an inclined position. After a further eight to twenty days the sods, which are then only "half dry," are gathered into beehive-shaped heaps or stacks 2 m. in height, where they are fully dried and from which they are finally despatched to their place of utilization. Every two of these heaps contain 630 sods. This work is done by the bigger children and women.

The power required for converting the peat into a thin pulp is less than that required for making machine-formed peat and amounts to only 4 to 6 h.p. It is generally obtained from a steam engine and in a few cases from a petroleum engine. The work is carried out only in summer, from about the middle of April to the middle of August. During this period most of the factories have about 80 to 90 working days; a few, however, have over 100 working days. At the Okjaer Bog, for instance, a 2 to 3 h.p. peat-pulping machine, placed in a flat-bottomed boat and served by four men (one man digging and throwing up the crude peat, two men transporting the peat pulp, and one man moulding the pulp), produced every hour an amount of pulp corresponding to 1.2 to 1.4 m. tons of dry peat. The cost of drying was 18 öre = 0.20M. for every thousand sods, each of which weighed, when dry, 0.5 kilo or, therefore, 0.40M. per metric ton.

The total annual output of all these factories, in addition to 50,000 to 60,000 m. tons of hand peat, is easily disposed of, generally for use in factories (brick-making, glass furnaces, farms, &c.), and for household requirements. The selling price of the peat fuel is 9 to 12 kr. for 1 m. ton (in the case of truck-loads), being always about  $3\frac{1}{2}$  to  $4\frac{1}{2}$  kr. more than the cost of winning, and 10 to 12 kr. less than that of English coal. The winning of machine-pulped peat is being further extended in Denmark (Jutland) as a result of the experience gained during many years.

8.—*The Anrep-Jakobsson-Svedala Machine-pulped Peat Winning, or the Winning of Machine Field Peat by means of Jakobsson's Spreading, Stroking, and Cutting Machine*

In Sweden and Norway, where the winning of machine-pulped peat has extended considerably, a more or less remunerative winning of peat fuel on a large scale with a reduction in the number of labourers otherwise necessary is attained in a manner worthy of our attention. In this process, not only the transport of the peat from the working trench, but also the spreading, levelling and

cutting of the peat pulp on the drying ground are effected by machinery. For this purpose Abjörn Anderson's mek. Verkstads Aktiebolag, Svedala, have combined their Anrep-Svedala mixing machine (with dredger or elevator) with the spreading, stroking and cutting machine illustrated in Fig. 66, which has proved very useful. The peat pulp is brought in tipping wagons from the mixing machine to the drying ground where it is tipped on the rimmed platform of the spreader, which can be moved along the drying ground by means of a wire rope. The peat is spread in long layers, beside one another, each having the thickness of a sod and a width of  $1\frac{1}{2}$  to 2 m. Its surface is made smooth by means of a weighted leveller and it is then cut into 15 to 20 bands, each having

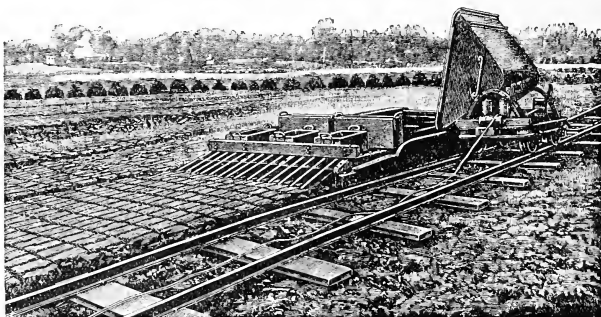

FIG. 66.—Jakobsson's spreading, stroking, and cutting contrivance for machine "field peat."

the thickness of a sod, by a mechanical cutter at the end of the platform. After some days the strips are cut crosswise into sods unless this has already been done by a mechanical cross-cutter attached to the spreader and leveller.

#### 9.—Galecki's Method of Winning Pulped Peat

We need not discuss in detail this process, which is said to have been tried on an experimental scale in Russia, since it would occur to no one in Germany to employ this troublesome and expensive method for the preparation of peat which in no case gives a product better than the well-known machine-pulped or machine-formed peat. It is considered briefly here only because it has been recommended<sup>1</sup> repeatedly by Peat Societies and in journals. The problem, "To prepare a fuel equal to coal in calorific power, but cheaper than the latter," is here solved only in reports, which show little technical knowledge, and are therefore open to objection. According to these reports, the peat is first to be purified from its "injurious admixtures," sand, clay, lime, and non-humified

<sup>1</sup> Further particulars will be found in *Dingler's Polytechn. Journ.*, 1900, p. 768, and 1901, p. 367.

fibres.<sup>1</sup> The winning of the peat from the undrained bog is effected by a kind of cutting machine. The peat block, cut by sinking a knife or cutting blade from above downwards, is worked with the peat water to a uniform pulp in a box which is connected with the cutting machine and the bottom of which can be closed by a slide. The stirring arrangement or mixer contained in the box consists, like all peat kneaders, mainly of several rotating knives or toothed rollers lying above, or alongside, one another. The projections of these rollers work into one another, tearing up the fibres and kneading the peat. The closed box is then elevated by means of chains, a trough is pushed under it, and the contents are emptied into the "wash-out." Every cut is supposed to raise 1 cb. m. of peat, and after each cut the machine is advanced by the thickness or width of a cut. The "wash-out" consists of a transportable box, which also contains a mixer, the rotating axle of which is kept in motion by hand or by the driving mechanism of the box. The washer is brought by two workmen or a horse to the filtering place, where the contents are continuously beaten up by the stirrer and the whole mass is converted into a uniform pulp. In this further treatment of the peat, the substances mechanically mixed or chemically combined with it which are soluble in water, are said to separate (!) from the peat. The "washed-out" material is to remain a short time in the filters to allow the heavy impurities to subside.

In the side of the "wash-out" about 18 cm. from the bottom there is an opening, which can be closed by a slide, the inner portion of which is covered by wire gauze by means of which the "washed-out" peat when it passes from the box to the filter is freed from roots, stones, fibres, more or less large pieces of peat, &c. The filter, which serves for converting the peat pulp into peat dough, consists of a bottomless frame, about 275 cm. in length, 150 cm. in width and 20 cm. in height. When the filter is freshly filled the layer has a height of 20 cm., but this, on drying, falls to 10 cm. The layer is then divided by means of wooden cross-bars into pieces 20 to 30 cm. in length and 15 to 20 cm. in width and spread, best on a well-mown sward (!) or on well-harrowed ground, any sand still adhering to it then falling off (!). After two or three days these peat sods, which in all the laudatory notices are wrongly called peat briquettes, could be stamped and placed on a movable "multi-drier," as the multiple drying frame used is called. After about six days the peat, which is then sufficiently dry, is brought to an adjacent "dry press" to be pressed (?) and kept (?) for use. The so-called dry press has, however, nothing in common with either the drying or the pressing of peat and is therefore as misleading a term for the contrivance as the name peat briquettes is for the product.

---

<sup>1</sup> If a peat should contain such admixtures as these it is better to let it rest quietly in the bog, going on with its conversion into coal; it should not be disturbed for conversion into peat fuel. In any case the peat fibres should be left as fuel in the peat.

The "dry press" consists of a beam with a board (!) over it, "weighted in all cases with some stones or bricks," between which the sods (in layers of 10 to 15) are placed, piled over one another, on their flat sides. "As all the edges were exposed to the air, the "briquettes" contracted gradually, while the edges of the flat sides, subjected to the counter-pressure, could not turn up. As they did not, however, contract suddenly, their splitting and crumbling were avoided."

No detailed consideration of this "solution of the peat problem" is necessary. It is to be deplored that reports and statements of this character have had circulation in serious German publications without attention being drawn to their errors. Just as inappropriate according to the above as the machinery and processes utilized appear to be for the winning of this mud or pulped peat, so also are the assumptions on which the table of costs is based. With one overseer, one night watchman, fourteen labourers and two horses, 20 cb. m. of dry peat, i.e., 10,000 to 12,000 kilos of dry sods, are said to be made in 11 hours from 150 cb. m. of peat pulp. For this purpose there were required: One cutting machine with a mixer and an elevating mechanism, four "wash-outs," 60 filter frames, four exit sieves, 20 wooden trellises, 300 drying trestles, two cars, 30 scrapers, three "schock" of boards, rails, sidings, utensils, &c., costing altogether 13,000M. In the estimate the wages for 11 hours are for a man 1.62M. and for a woman 1.08M., amounts which are not even half of the corresponding sums paid for eleven hours' work in every machine-formed peat factory. Nevertheless, even in this estimate the cost of manufacture, including petty expenses, for 100 kilos of the peat is 0.60M.

The product of Galecki's process is, as the above description clearly shows, simply a machine-pulped or machine-mud peat produced in a very roundabout manner by means of a cutting and a mixing machine, then cut into separate sods, and finally dried on trestles. It has no advantages over machine-pulped peat, and is also very much dearer than the latter.

### III.—FULLY AUTOMATIC OR LARGE SCALE INDUSTRY PEAT MACHINES WITH DREDGERS AND AUTOMATIC SOD SPREADERS

The idea of combining the peat machine with a dredger (see p. 130) in order to reduce the number of workmen employed was realized first by Mecke and Sander, and afterwards by Schlickeysen. It has since been taken up by others, who have still further diminished the number of workmen required by effecting the transport of the fresh sods to the drying ground and the spreading of them there by the machine itself, that is, by means of automatic sod spreaders. Owing to the increasing scarcity of labourers for agricultural industries, the necessity of putting the peat industry on a secure basis and of decreasing the cost of winning, especially in the case of great industries—for example, those of gasification, coking, bog power stations, &c.—this is to be regarded as a notable development of peat machinery

Although the employment of peat dredgers instead of human labour for cutting and throwing the peat into the conveyers is difficult in the case of unripe bogs abounding in wood and roots, and in many cases cannot be carried out at all, it may, however, be assumed that in the case of ripe, well-humified peat, free from considerable quantities of roots and wood, peat dredgers of this class give satisfactory results, especially when the bog consists mainly of bituminous or mud peat. If undecomposed roots or other woody parts are contained in the bog, these will cause considerable derangement for the whole industry, since disturbance of the working, both for the machinery and its attendants, occurs whenever the dredger fails or is temporarily thrown out of gear to allow of the obstacles being removed by hand. When the dredging peat machines are fitted with automatic sod transporters and spreaders, the many workmen otherwise required for wheeling and spreading the sods on the drying ground are dispensed with, and therefore a temporary cessation of disturbance of the industry, owing to the machine's inability to dredge, is no longer so important as it was in the case of the earlier dredging peat machines, which were not furnished with sod spreaders.

By contact of the dredging scrapers with more or less large obstacles (root stems, stones, &c.), parts of the dredger may be injured. To prevent this the driving gear may, with advantage, be provided with a friction clutch or safety pulley by means of which, when the occasion arises, the driving power is automatically thrown out of gear, if not completely stopped (as in the case of an electric motor), by the big resistance until the obstacle is removed.

Among fully automatic or large scale industry machines of this class, which are already in use apparently with good results, may be mentioned :—

### *1.—Wielandt's Peat-dredging and Forming Machine*

Dr. W. Wielandt, of Oldenburg, was one of the first to provide his peat-dredging and forming machine with a sod spreader. The machine (Fig. 67) rests on a frame which has a uniform forward motion of 15 to 20 m. an hour over a field railway of 60 cm. gauge. It consists of a double-spiral mixing and forming machine to which the peat is brought by a bucket dredger connected obliquely with the forming machine and working to a depth of 2 to 5 m. and a width of 0·8 to 1·2 m., of a sod cutter, and also of a sod spreader which is connected with the frame and is 20 to 30 m. in length. The latter consists of a conveyer belt, formed of plates, which catches the peat sods at the mouthpiece and as soon as the band, loaded with sods, has reached the end of the spreader throws the sods over the whole width of the drying ground.<sup>1</sup> The machine and frame at the same time move forwards.

<sup>1</sup> Although the peat sods on being tipped cannot be said to keep their shape so well as Fig. 67 indicates, they do so, however, to an extent which is amply sufficient for the operations of drying and utilizing the peat.

All the parts—dredger, mixing machine, sod cutter and spreader—are driven generally by electricity, by the machine itself. A revolving “stripper” is combined with the machine in the case of bogs which have not been “stripped.” By its means the layer to be stripped is shaved off and thrown sideways into the working trench.

A peat-dredging and forming machine of this class weighs (without the driving machine, electro-motor, gas-engine, or locomotive 8,000 to 10,000 kilos and costs 17,000M. to 22,000M. It requires 25 to 35 h.p. During the work the dredger can be elevated or lowered and inclined more obliquely or more acutely. It can be raised and placed crosswise when the machine is being moved from one trench to another. If the bog contains wood the slope of the narrow working trench (approximately 1 m.) must be searched by one or two workmen for any wood which may be contained in it, and this, if present, removed.

As the surface dredged has a width of only about 1 m. the peat fed to the machine is relatively drier than that from ordinary working trenches of 3 to 5 m. in width and, therefore, the formed peat thus won requires a shorter time for drying. Accordingly, it is said that peat winning with this machine can be continued until September, and that the season may, therefore, be assumed to have a duration of 140 days. The drying of the sods after spreading is facilitated by their pentagonal or oval cross-section, which allows the rain to flow away more or less easily. The length of the working day may, without difficulty, be increased to eighteen hours, since few labourers are required.

Experience gained by this method indicates that the peat spread by the machine can be clamped after one to two weeks. After a further two weeks it can be removed from the bog in an almost air-dry condition. The same drying ground may thus be used four to six times in a single season so that with a yearly output of 10,000 m. tons of fuel peat and a drying ground 30 m. in width one double-sided trench (two cutting surfaces) 3 km. in length appears to be sufficient.

Since 1909 several of these machines have been in operation at Wielandt's Peat Coking Factory at Elisabethfehn, and at the Johannesburg Peat Factory near Papenburg, also amongst others at the Oldenburg Clinker Works in Bockhorn, at the Royal Salt Works at Rosenheim, at the Hesep Peat Factory near Meppen. In the last-named factory the two machines first installed are said to have given such satisfaction that seven more have been ordered. A preliminary condition for a satisfactory output from this machine is that the bog should be as free as possible from wood and roots, otherwise the output of the dredger will be decreased.

The peat-dredging machines of the Elisabethfehn works were at first driven by benzine engines, which at the end of the season (September) were employed as locomotives for the transport of the peat over the railway to the factory, &c. Since 1914 the peat dredgers have been driven by electricity, the machines giving greater outputs and the cost of labour being decreased.



In the summer of 1914, apparently one such machine of the intermediate type, working on day shifts only, gave 5,370 m. tons of air-dried sods of peat. According to the statements of the manager the cost of dredging, mixing and spreading the wet sods on the drying field, so far as wages to labourers were concerned, was 0·61M. for every metric ton of air-dried peat. The drying required 13·05M., the delivery 9·77M., and other costs were 3·67M. for a railway wagon load (10 m. tons), so that 1 m. ton of air-dried peat delivered at the factory cost 3·26M. If we add the cost of electric current<sup>1</sup> and that due to amortization of the cost of the peat-winning plant, the total cost at the factory of the air-dried peat is about 4M. per metric ton, a price which may be diminished by increasing the size of the machine or by working better (i.e., denser) peat, free from roots.

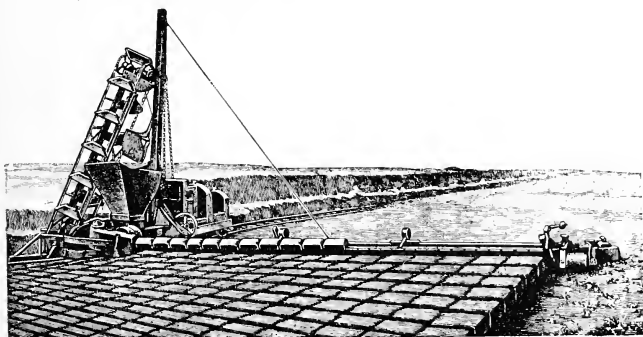

FIG. 67.—Wielandt's peat-dredging machine with sod spreader.

Professor Keppeler and Dr. Birk<sup>2</sup> obtained somewhat different results in a trial made with a similar machine in July, 1914, at the Peat Coke Company's bog at Elisabethfehn. The results of the trial, which lasted two days and was attended by unavoidable stoppages and interruptions, were calculated on the assumption that a full ten-hour day had been worked.

The dredger and the machine worked about 400 m. tons of raw peat and required the service of one dredger guide (5M. a day), one preparer (4M.), and three rail layers (3M. each).

The 400 m. tons of raw peat, the percentages of water and dry matter in which were 92·82 and 7·18 respectively, contained, therefore, 28·72 or, approximately, 29 m. tons of dry peat, and gave  $\frac{29 \times 100}{100 - 30} = 41·4$  m. tons of air-dried peat containing the 30 per cent. of water which was usually found in it.

<sup>1</sup> Most of the current could be generated from the excess coke-oven gases, and, moreover, on the average it was only 18 kw. costing approximately 25 Pfg.) for each machine.

<sup>2</sup> *Mitteilungen*, 1915, No. 10.

The sod conveyer and spreader laid on the drying ground 1,595 rows containing on an average 40 sods each and, therefore, 63,800 sods with an average weight of 6·26 kilos each.

With an initial cost of 15,000M. for the machine and 5,000M. for the motor, accessories and cable, that is altogether 20,000M., and allowing 3,000M., that is 15 per cent., for interest and amortization, we have :—

	Marks.
Interest for 1 shift of 10 hours .. ..	30·00
Current, 10 × 10 (?) kw.-h. at 0·45M. .. ..	4·50
Wages (as reckoned above) .. ..	18·00
	52·50
Total ..	52·50

and the cost of 1 m. ton of dry peat, spread wet on the field, was, therefore, about 2M.

When “stripping” is not effected by the machine itself, as happened in the trial, the wages of three more labourers must be added (9M.) making  $\frac{61\cdot5}{28\cdot72} = 2\cdot20M.$

To the cost of the drying operations we must add those for “heaping,” “rowing,” transporting, and storing, which amounts to 1·2M. for 1 m. ton of air-dried peat or 1·71M. for 1 m. ton of anhydrous peat. The total costs are, therefore, 2·2 plus 1·71 = 3·91M. for 1 m. ton of anhydrous, or 2·80M. for 1 m. ton of air-dried peat containing 30 per cent. of moisture.

We can see, however, from this, as also from the comparison of costs in Section V, F, that the cost of winning calculated from a more or less short trial, even when this lasts several days, will be below the cost actually found in a trial lasting a season and is, therefore, not to be taken unreservedly as the average cost for a whole year's operation.

## 2.—*The Strenge Large Scale Industry Machine with Sod Spreader*

As already mentioned on p. 149, W. K. Strenge, of Ocholt, has constructed the Strenge peat-dredging machine in its new form, Model 1910, Model 1912, and Model 1914–15, as a peat-forming machine and has at the same time changed the pulp peat spreader into a sod spreader to enable a large scale industry to become commercially more satisfactory. Originally, the Strenge peat-dredging machine was built and employed as a pulp peat machine. Fig. 68A shows such a machine with a sod spreader and also with peat sods tipped on the drying ground. In this, as in the older Strenge machines, the dredger is suspended by a pulley-block, as in Fig. 68, on the conveying channel, which is also suspended by pulley-blocks on its supporting brackets: In this way the dredger, which is driven by means of a removable square shaft by the power driving the whole machine, can be adjusted to the various depths of dredging. The dredger working with a vertical chain, being adjustable and displaceable, allows of a dredging depth up to 4 m. and a cutting breadth of 3 to 4 m.

Sometimes two dredgers work alongside one another with one conveyer. The mixing and forming machine is a double-spiral one and presses the kneaded peat mass through a seven to nine sod mouthpiece. As the peat bands issue from the mixing machine they pass, according to the 1912 model, to a sliding board inclined to the side at an angle of  $90^\circ$  and kept slippery by water dropping on it. In the 1914-15 model the peat passes to the sod spreader after it has been cut into sod lengths by an automatically moving paddle or water wheel. In the earlier types the sod spreader was usually only 30 m. in length, but in that of 1914-15 it can be constructed up to 75 m. in length according to the width of the drying ground. It consists of an endless Gall's chain which returns, when empty, to the mouthpiece of the machine, and the plates of which, when the whole tipping line is filled with sods, are tipped by means of a lever. In this way the sods are spread on the drying ground and, indeed, in the 1912 model the sods are

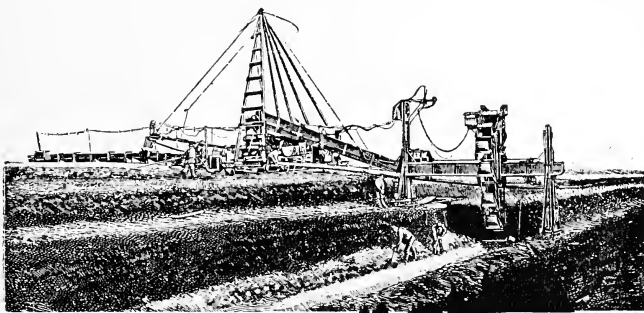

FIG. 68.—Strenge's peat-dredging machine with peat pulp spreader.

usually end on towards the front. The sods can also be laid flat, as in the 1914-15 model, which, having no sliding board, throws the sods directly on to the drying ground. The speed of the spreading belt can be adjusted by hand or electrically to the speed of the emerging peat band. This ensures uniformity and continuity of the peat band on the belt as it runs out. The sod-cutting wheel runs on ball bearings and can be set in motion only by the peat band. The frame which supports the moving Gall's chain is arranged in a transportable manner and is moved forward by a power winch as the dredger advances. As the machine digs trenches with vertical walls in the bog, it is possible to throw the stripped upper layer easily and with little expense on the cut-away surface. So far as position is concerned, the safety of the machine, which is heavy in itself, is ensured by laying the rails for the machine and motor about 7 m. from the edge of the bank and by putting the motor in front of the cut-out trench. The machine is said to win and work 20 cb. m. of raw bog every hour, and for this purpose a 35 to 40 h.p. locomotive or a 60 h.p.

electro-motor is required. All the operations are effected by power from a single source. In addition to the mechanic the operations require three labourers for laying the rails, two for stripping the bog, one for tipping the sod spreader, two or three girls at the machine to prevent more or less large roots or pieces of wood from getting into it, one girl at the pump for feeding the machine, and one girl for regulating the speed of the spreading belt. Altogether, there are the peat ganger and ten to twelve labourers, including five or six girls.

Machines of this type are also constructed for small industries. These have a dredger width of only 1 m., are adjustable for depth, and have sod spreaders 30 m. in length. The older machines of the 1910 and 1912 models have been recently altered to the 1914-15 type.

In the case of a large scale industry machine with an output of 5,000 m. tons of air-dry peat for a season, the expenses attached to 1 m. ton of air-dry peat, containing 20 to 30 per cent. of water, are given as follows (it is assumed that wages are 40 to 45 Pfg. an hour for men and 25 to 30 Pfg. for women, that a locomotive is used for driving, and that the width of the layer to be stripped is about 1 m.) :—

	Marks.
Wages for attendants at the machine .. ..	0·80
Wages for " piling " .. ..	0·55
Wages for " clamping " .. ..	0·40
" Waste " peat for heating .. ..	0·25
Transport of peat (2 km.) .. ..	0·45
Salary of overseer .. ..	0·20
Repairs .. ..	0·20
Contributions for insurance .. ..	0·05
Amortization of machine (30,000M. at 10 per cent.)	0·60
Amortization of bog .. ..	0·20
Contingencies .. ..	0·30
	-----
Total for 1 m. ton .. ..	4·00

(calculated on the basis of the usual daily output, which, however, according to practical experience, is greater than the average for the year's output, and therefore the average cost per metric ton of the peat for the whole year will be somewhat higher (cf. Section V, F.) A benzine locomotive with tip wagon is provided for drawing the dry peat to the stores or the place where it is utilized. The value of the bog has been assumed as 500M. for a hectare. One cubic metre of air-dry peat (loosely packed) weighs about 350 kilos.

These machines, with sod spreaders 30 to 50 m. in length, were used in 1912 at Strenge's Peat Factory at Ocholt, and similar machines, with sod spreaders 75 m. in length, were used in 1913-14 at a bog fairly rich in wood in Russia, and at the Schweger Moor Power Station near Osnabruck. A machine with a sod spreader 65 m. long and a double dredger, or with two dredgers working alongside one another at different depths in a bog rich in wood, and which was intended for day and night work, was used in 1914-15 at Raubling Peat Factory (Upper

Bavaria), and at Wiesmoor Peat Factory, near Aurich. In recent times these machines are also built with a rear stripper, which, as the dredger advances, places the layer, which has been stripped to a depth of 1 to 1½ m., back into the cut-away portion in a regular manner and as wide as is necessary for the subsequent agricultural industry. For such a machine (electrically driven) with an output every ten hours of 120,000 sods, 40 x 12 x 11 cm., a gang of five persons is said to be required, including one dredger guide, three rail layers (also employed in other work), and one spreader guide. Working day and night, the output of one of these machines may, according to the nature of the bog (!), amount to 10,000 m. tons of dry peat. The older machines have meanwhile been altered, as already stated, to the latest 1914-15 model. A large scale industry machine of this class with a spreader 75 m. in length weighs approximately 28,000 kilos and costs (without locomotive or electro-motor) about 30,000M.

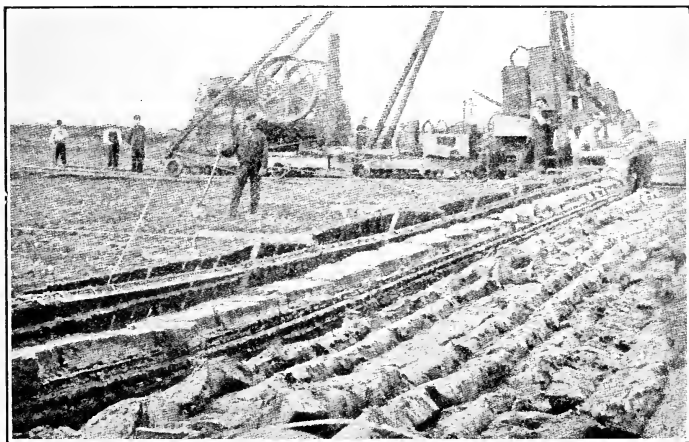

FIG. 68A.—Streng's large scale machine with sod spreader.

### 3.—*The Baumann-Schenck Peat-dredging Machine with Sod Spreader*

This machine (see Figs. 69 and 70), designed by Fr. Baumann, of Mannheim, and constructed at the machine factory of Charles Schenck, of Darmstadt, consists also of a dredger and conveyer for bringing the dredged peat to the double-spiral mixing and forming machine. The latter is provided with a sod former, by means of which the sods are "formed" by knives acting radially in an iron drum containing twelve chambers. By "forming" and arranging the sods at the side of the cover of the drum their separation is said to be facilitated and ensured.

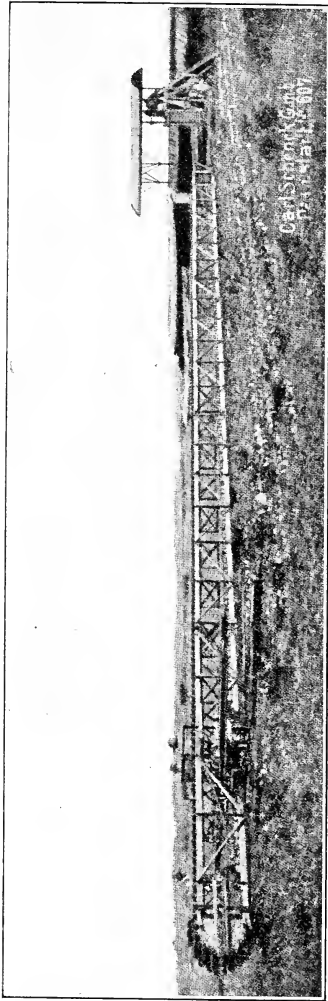

FIG. 69.—Baumann-Schenck peat-dredging machine with sod spreader.

The sods pass from the sod former under the drum to the lower belt of the sod spreader, which has a length of up to 100 m., and is described in more detail and also illustrated in Section V, A, 4. One of these machines has been installed in the peat factory of the Royal Rosenheim Salt Works at Raubling Bog.<sup>1</sup> It is said to deliver, form and spread in a second three sods having a volume of 5·4 l. and a length of 10 cm.

In spite of the unavoidable stoppages due to working troubles, the average hourly output of this machine amounts to 35 to 40 cb. m. of formed peat, and for this amount five labourers are required, viz., two men at the dredger, one man at the spreader, and two or three men for moving forward the rails. When the whole belt is full the motor is thrown out of gear and the sods (approximately 500) are spread by means of a hand wheel from the driver's box, the operation requiring about half a minute. In the new types the spreading is said to take place automatically during the working of the machine. The dredger, unlike those of the Wielandt and Strenge machines, which operate from below upwards, dredges from above downwards. The object of this is to disintegrate more fully the upper, tougher layer of peat and to mix it with the lower layers. The buckets of the dredger at Rosenheim are provided with sharp, rigidly fixed knives, so that roots of 5 cm. thickness, unless they give way and pass into the buckets, are easily cut into pieces 4 cm. in length. Searching for roots when these are present in the bog requires constant attention, and an attempt has been made to avoid it by replacing the dredger by a multiple-disc cutter. The price of the whole machine is about 30,000M. A 40 h.p. alternating current machine serves as motor for the mixing machine and the spreader and a similar one of 20 h.p. for the dredger.

Feeling that, especially in bogs containing wood, dredging peat is not the best way of working, Baumann is at present employed in constructing a peat-sawing machine which is supposed to be much cheaper and also to require fewer labourers than the large scale industry dredging machine. As the results of experiments which have been made, it may be expected that a uniform, well-mixed, heavy, air-dry peat, having a density of 1 to 1·1, will be won even in the case of a raw peat which is light and of little value. The characteristic digging implements are light saw drums, which are arranged over one another in groups of three or four on a movable beam placed against the side of the trench. The peat, after being cut, is delivered by means of a belt conveyer to the mixing and forming machine. To cut the necessary amount of peat from the side of the trench, the machine requires a forward motion of 1·5 to 2 cm. a second and this is also the depth of the cut. The screw-shaped, wound-up, angle-irons of the sawing wheels have a diameter of 2½ m. and are provided with sharp-edged ribbon saw blades. As each tooth describes a circle

<sup>1</sup> Cf. the description of the peat factory of the Rosenheim Salt Works in Section V, G.

different from the others, the whole surface is covered, the somewhat strongly grown roots being said to offer enough resistance to permit of their being chopped sufficiently small by the cutters. A group of cutters working the whole surface of the trench wall has over 100 m. of cutting edge and a mean velocity of 4 m. instead of the 2 to 3 m. of cutting edge and the 0·5 m. velocity of the buckets of the ordinary peat dredgers hitherto used. Hence a considerable increase in output, in addition to continuous working, is believed to be possible.

It remains to be seen whether these hopes will be realized in operations extending over a considerable period.

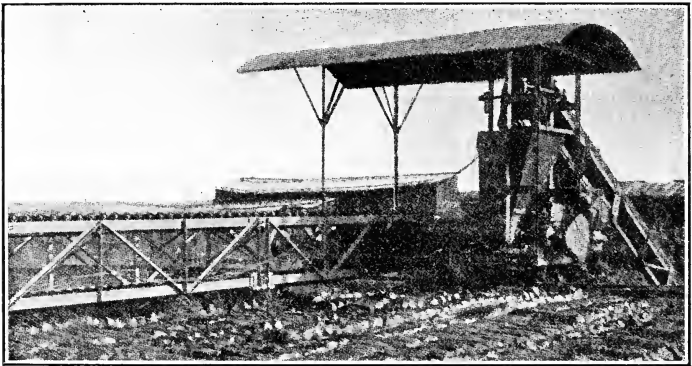

FIG. 70.—Baumann-Schenck large scale machine with sod spreader.

#### 4.—*The Large Scale Industry Peat Machine of R. Dolberg and Co.*

The machine, which is illustrated in Fig. 71 (only half the length of the sod spreader is, however, shown), consists, when viewed from left to right, of a transportable trestle support for a dredger bridge on which rest a dredger, moving in and out, and a rigid conveying channel of a peat-mixing and forming machine with a sod cutter, transportable support and railway track, and of the sod spreader, which has a length of 50 to 60 m. and which is supported by four cars and a railway track. The dredger bridge is suspended at the supporting car on two pulley-blocks and by this means the dredger can be raised or lowered. The bridge has a length of 16 m. whereby slipping of the vertical face of the bank is prevented since no violent vibration reaches the dangerous zone. The spreader starts from the mouthpiece where it is supported on the car under the machine. It consists of a latticed iron frame, carrying the endless band and capable of being rotated as a whole round its long axis. To prevent bending and to enable it to be moved forward with the dredging machine along the dredging bank, it is supported at its end and



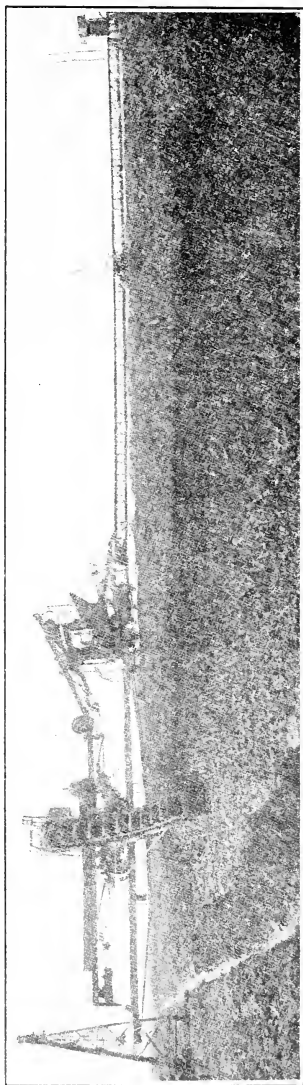

FIG. 71.—Large scale industry peat machine of R. Dolberg and Co.

at three intermediate points (therefore every 14 to 15 m.) in "turn rings" on field railway cars. The crude peat won and raised by the dredger from a face about 5 m. in width and up to 4 m. in depth is brought through the channel of the conveyer to the mixing machine, from the quintuple mouthpiece of which it emerges and passes, after division into separate sods by a cutter, to the conveying belt of the spreader. This consists of an endless Gall's chain driven by an electro-motor at the end of the spreader, and which can be held up at any moment either for tipping the spreader or owing to a stoppage due to any cause. With a suitable depth of bog (at Wiesmoor approximately 2 m.) the whole length of the spreader is filled within four minutes. When this is attained, the workman in the turret-shaped power car at the end of the belt signals the fact, the



FIG. 72.—Drying ground covered with sods from an automatic sod spreader.

mixing machine is thrown out of gear, and the whole spreader (latticed support and band) is rotated by a man on an elevated platform in the middle of the spreader, who at the same time puts into action the electro-motors in the supporting rings on the field railway cars. In this way the whole quintuple band of peat which has been cut into separate sods is spread on the drying field. The spreading of the peat band and the return of the spreader to its original position by further rotation in the same direction takes only forty seconds. The whole machine must then be moved forward 50 cm. to 60 cm. by automatic driving of the transporting frame of the mixing machine and of the four supporting cars of the spreader.

When the work proceeds smoothly and the band is emptied fifteen times every hour, the output of the machine is said to be 100 cb. m. of raw peat in ten hours. By exchanging the driving wheels this output may be further increased. The six railway tracks necessary for moving forward the whole machine must be

laid as the work proceeds, and this is best done once a day, either in the morning or in the evening. For working the machine the following are required: One man each at the supporting car, the dredger, the mixing machine, the middle of the spreader and the end of the spreader, making a total of five men and one overseer. The electro-motors required for driving are a 13 h.p. motor for the dredger, a 20 h.p. one for the mixing machine, a 10 h.p. one for the spreading band, and a 10 h.p. one for rotating the spreader and moving forward the dredger bridge support, amounting in all to about 50 h.p.

Fig. 72 shows a drying field covered with sods by means of an automatic spreader.

In order to ensure the greatest possible smoothness in working, it has been found from the experiments carried out at Wiesmoor with the first machine of this kind that several alterations were necessary.

#### 5.—Other Large Scale Industry Machines

In Sweden, Norway, Denmark, Russia, and Canada, the well-known forming or field press peat machines have been provided with the dredgers of Ekelund, Munktell, and Anrep, and the more or less automatic peat spreaders or sod transporters of Jakobsson, K rner, Esl f, Persson, and others, with a view to converting them into large scale industry machines. The details of these machines, with the exception of the Jakobsson spreader and sod cutter for field press peat described on p. 152, do not differ much from those just described. (See also particulars under Patents, Section VII.)

#### F.—Machine Peat Powder and Machine Peat Dust for Fuel Purposes

H. Ekelund, of J nk ping, believes he has solved the problem of burning peat by winning the peat by machines, not in the form of sods but in that of powder or dust, and burning it in furnaces as coal dust is burnt in the well-known coal-dust furnaces. The engineer E. Nystr m reports<sup>1</sup> on a factory of this class erected near B ck, in Sweden, by the Aktiebolaget Torg, as follows: "The peat is won with two different peat-dredging machines. One of them is on the upper surface of the bog. It consists of a dredger, a kneader, and a conveyer, which places the peat pulp into the tipping car for transport to the drying field. The machine, which weighs 18 to 20 m. tons, requires a gang of eight men and has an output of 40 cb. m. per hour. The other machine is on the cut-away surface, and has also an output of 40 cb. m. of peat per hour. The machines are driven electrically from the electric power station for which the peat winning is intended. The dredged and kneaded peat pulp is brought in tipping cars by

<sup>1</sup> "Anl ggning och Fabrikation of Torfpulver vid B ck," *Jara-Kontorettis Annaler*, 1910, No. 7, p. 587.

means of small petroleum locomotives to the drying field, where it is tipped, levelled with an electrically driven 'smoother' or 'leveller,' and cut first into strips and finally into sods. The dredging machine and the 'leveller' together require 75 h.p. The peat is next clamped, and when air-dry it is collected into the sheds. From here the air-dry peat (with 30 to 50 per cent. of moisture) is brought in tipping cars (holding 1 cb. m.) by means of a ropeway to the floor of the factory immediately above the crushing machine, where it is thrown into a coarse crusher, from which it passes to a fine crusher. By the aid of an elevator the well-ground and sifted peat powder is brought to the drying ovens, where it is dried until it contains about 15 per cent. of moisture. It is again ground and sifted, so that finally a very fine powder is obtained, which, when packed in closely woven sacks, is ready for transport. The factory is designed for a yearly output of 10,000 m. tons. The results show that in the case of peat dried beforehand to 50 per cent. of moisture the daily output is 15 m. tons of powder, containing 12 to 13 per cent. of moisture, and in the case of peat containing 40 per cent. of moisture the output in the same time is 21 m. tons. The powder required as fuel amounts in the first case to 12 per cent. and in the second to 9 per cent. of the finished product. Hence a metric ton of the peat powder containing 15 per cent. of moisture costs 8.50 to 9.50 kr., including interest, writing off, &c. The weight of 1 hl. of peat dust, packed in sacks, is 35 to 44 kilos. The installation costs are given as 150,000 kr."

The economic success of a factory of this kind is not impossible in Sweden, where coal is dear and wages low. In Germany the installation and working costs would be considerably higher, and even in Sweden these costs of manufacture would generally be greater than those given above, since the bog at Bäck is peculiarly adapted for the manufacture of peat powder.

After several experiments with peat-firing for locomotives, the Swedish State Railways Department has decided to acquire a peat bog at Hästhagen, not far from Lake Wetteren, with a view to manufacturing peat powder for continuous use on its railways. About 20,000 m. tons of peat powder are to be used yearly in the locomotives of the Falköping-Nässjö railway line, which is approximately 100 km. long and runs on the southern shore of Lake Wetteren. The bog contents will suffice for about twenty years, and at the end of this time the cut-away bog will, as arable land, have a value of 45,000M. The calorific power of peat powder is said to be two-thirds that of coal, and the manufacturing costs correspond to a price of 20M. (per metric ton) for coal at Jönköping railway station, or 17.55M. at Gothenburg (on the Cattegat). The costs of the whole lay-out are given at approximately 1,150,000M., including purchase of land and alteration of the locomotive furnaces (*Zeitung des Vereins Deutscher Eisenbahnverwaltungen*, April 29, 1916).

The statements in the foot-note on p. xix may be supplemented by the following: "The Vakö Bog belongs to a company for the

manufacture of peat powder by the method of Porat-Odelstierna (somewhat different from that of Ekelund), which was tested at Riihimacki, in Finland, and is perhaps somewhat better than that of Ekelund. The ground peat is dried by air heated by peat gas furnaces. The company obtained a loan of 500,000 kr. from the State. The Sölvosborg-Älmhut railway is not a State railway."

## SECTION V

# DETAILS OF WINNING AND PROPERTIES OF CONDENSED MACHINE PEAT

### A.—On some Important Particulars with regard to Peat Machines and their Use

In this Section we describe the component parts, such as knives, forming pieces and cutting contrivances common to all peat machines and on the nature of which the output of the machine depends both in quantity and in quality. Special importance is therefore to be attached to their being suitably constructed. The peat machines described in the previous sections in so far resemble each other that the chief component which is known to be suitable in the case of one kind of machine can be transferred either unchanged, as in the case of the cutting contrivances, or with unimportant alterations, as in the case of knives and forming pieces, to another type of machine.

In the following the contrivances hitherto employed, with their advantages and defects, will be described in detail so that by paying attention to the statements made here we shall, as occasion requires, be able to select the type which is best suited for the attainment of commercially successful results.

#### 1.—On Knives and Screws

If a peat machine is to provide from the very start for all the demands to be made on it, especially with regard to the treatment of *every* kind of peat, the mode of action of the knives or screws fixed on its main shaft must be a fourfold one, and must consist of—

(1) *Crushing* and *tearing* the lumps, hard or felted pieces of peat, and semi-humified plant remains contained in the raw peat.

(2) *Cutting* (in the proper meaning of the word) the fibres of moss, wood and sedge such as occur in a slightly humified fibrous peat or a humified peat containing a large amount of impurities of this kind.

(3) *Mixing* and *kneading* dissimilar peat layers into a mass of the greatest possible uniformity.

(4) *Pushing* the peat inside the machine from the hopper to the mouth and (in forming machines) pressing it out through the mouthpiece with the object of "forming" the peat.

In the case of the machines which are in use, these four conditions are only partially fulfilled—frequently only those mentioned under (1) and (4) are satisfied—and this is why many peat machines, even amongst those still employed, although

suitable for the treatment of marsh or mould peat are not so for that of fibrous peat.

In the machines which have been described in detail in the preceding section—

(1) The *mixing* and *kneading effect* is produced by the revolution of a shaft, provided with separate screws or knives, in a vat or cylinder which is filled with peat. Hence it depends on the number of revolutions made by the shaft for the amount of peat which passes through the machine, and *therefore in the case of different machines it is all the greater and the more complete the greater the number of the revolutions of the knife shaft for a given amount of peat*. In the case of the machines described above, 100 l. has been taken as the unit for this determination; the number of revolutions corresponding to this unit, according to the calculations made for the various machines,<sup>1</sup> is from 18 to 140, and the mixing actions of the machines are in the same ratio as these numbers. The knives and screws of the various machines differ so little from one another in construction and arrangement, so far as mixing is concerned, that we cannot attribute to the one or the other form a considerably greater or smaller action *for a single revolution of the screw shaft*. The rotation numbers determined for the different machines suffice therefore for the comparison of the mixing effects.

(2) The *crushing* and *tearing action* of the machines is due to the fact that the rough and broad surfaces of the knives or screws glide near fixed walls or parts of machines (counter-knives, cross-stops, &c.) specially made for this purpose and grind the peat through the narrow intervening space. They thus crush the peat, seize the fibres and roots adhering to fixed parts of the machine in the case of single-shaft machines or in the case of the double-shaft machines any that may adhere to parts of the machine which are in motion in opposite directions and (in the most favourable case) tear up these fibres. This action takes place chiefly owing to the motion of cast-iron or cast-steel screw blades, 15 to 20 mm. thick, inside a cylindrical cover fitting closely round them either at the counter-knives which have been inserted or where the various knives of one screw shaft strike through the corresponding spaces of a second shaft.

The action increases with the area of the gliding and crushing surfaces and with the number of striking edges to which the crushing and tearing are due. The action of the latter is again directly proportional to the rotation number of the knife shaft.

Consequently the crushing and tearing action of a peat machine, like its mixing action, increases with the number of revolutions of its knife shafts corresponding to a given amount of peat, and therefore for different machines their crushing actions are in the same ratio as their mixing actions. For mixing machines which differ in construction the number of striking edges or separate knives has also to be taken into account.

---

<sup>1</sup> Cf. pp. 112–135.

(3) A *cutting action*, which in the case of a fibrous raw material is indispensable for the quantity and the quality of the output, and also *certainty of tearing action*, can never be attained with the knives and knife shafts of peat machines by mere motion (even of knives as sharp as razors)<sup>1</sup> through the peat, but can only occur when—

(a) Either their sharp edges (sickles), like those of real knives, strike through peat which is held in position by some or other contrivance (cross-stops or counter-knives), or when the peat fibres are compelled to glide along the former, when they are cut as if by a saw; or

(b) When thick (blunt) knives, with edges like those of a pair of scissors, while rotating with the shaft are moved quite close past similarly shaped knives, which are either stationary or rotate in the opposite direction, at an angle which is less than  $40^\circ$ , as in the case of the long or the circular shears (Fig. 73).

The preservation of sharp, sickle-shaped edges, according to (a), is, in the case of peat machines, a very difficult if not quite an insoluble problem. Most of the cast-iron, wrought-iron, or cast-steel knives or screws met with in the peat machines hitherto employed have front edges from 3 to 10 mm. in thickness, and do not conform to the first condition. Therefore, a real cutting action can never be attained by their means although all the manufacturers ascribe this property in a more or less high degree to their machines; nor is this in any way improved by bringing either, as in the single-shaft machines, a stationary flat or round bar between two of these rotating knives past which the latter strike at a distance of 5 mm., or, as in the double-shaft machines, by letting them strike through at the same distance from the various knives of an adjacent shaft.

Of the other peat machines hitherto used only that of Lucht, the horizontal machines of Schlickeyesen and Heinen with preliminary tearers, the Dolberg machine, and machines like these with lower counter-knives contain knives which exert a cutting action according to paragraph (b), the front edges of which, as may be seen from Fig. 73, strike closely past the stationary counter-knives, thus trying to attain and render possible a shearing action and therefore a mincing and an advantageous working of fibrous peat.

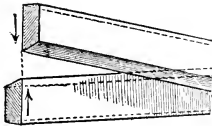

FIG. 73.—Shearing knife.

An estimate of the cutting and shearing action of different machines can be obtained from the number of clipping knives fastened to the knife shafts and the rotation number of the latter. For purpose of comparison, the figures to be used should be those obtained

<sup>1</sup> With the materials hitherto used for knives, cast-iron, wrought-iron, cast-steel, and the like, such sharp knives can neither be made nor kept sharp; these so-called knives therefore, always have working edges 3 to 10 mm. in thickness.



by multiplying the rotation number for 100 l. by the number of clipping knives.

*It can be seen, therefore, that in every case, in addition to the number of the several front edges of the screw blades which exert a shearing action, the number of revolutions of the knife shaft corresponding to a definite amount of peat (100 l.) which may be called the comparative rotation number of the knife shaft, directly affects the quality of the peat machine's output, and that therefore the rotation number is the chief thing to be considered when an opinion is to be formed with regard to either a peat machine already constructed or a new one about to be built.*

Nevertheless, the increase in the mixing and tearing action relative to that of the corresponding comparative rotation number has its limits, so that finally the expenditure of power required for the larger number of revolutions does not bear an economically favourable ratio to the increased mixing action due to it. Although a definite value cannot be assigned to this limit, which varies for different kinds of peat, it has been ascertained from results obtained with machines which were working well that in these cases 80 to 120 revolutions correspond to 100 l. of the peat. Of course, when making calculations, only that part of a machine and its volume in which there is a shaft provided with knives must be taken into consideration. A calculation such as this, when made for various machines, shows at once that, other conditions remaining the same, the mixing action, and therefore the quality of a machine peat produced from a given raw peat, are the poorer—

(a) The greater the diameter of the cylinder of the peat machine in question ;

(b) The shorter the part of its knife shaft or screw shaft which is mounted with knives ;

(c) The fewer the separate knives or blades present ;

(d) The greater the amount of the peat to be treated by the machine in a given time.

These are facts which, if not taken into account when the machine is being selected, usually become apparent only after close observation over a considerable working period and, sometimes, as experience again and again proves, in a manner by no means to the advantage of the winning.

The fact that with various kinds of machines otherwise famed for their large outputs the peat produced still leaves much to be desired, inasmuch as the sods during the earlier drying period may break up rather easily and fall apart owing to the action of rain and in the later drying may split, easily tearing and crumbling, *is to be attributed solely to the slight mixing and kneading action of the machines.* The greater the latter action the greater is the power of resistance towards rainfall of the freshly formed peat and the smoother, firmer and denser the dry peat will be and the more it will consist of unbroken sods.

Only in the case of pulp peat machines is the mixing of the knife shafts rotating in them considerably increased by addition

of water to the raw peat. By this treatment the peat, which in itself already contains 80 per cent. or more of water, is disintegrated by the rapid motion of the screw shafts, mixed intimately with the added water and minutely distributed by the circulation through it of a relatively large amount of water from which it can settle uniformly and become dense during the slow evaporation of the water which occurs later. In this way a fuel is obtained which is as good as machine-formed peat, although the crushing and cutting action of the pulp peat machines owing to the type of screw shaft hitherto used is nearly always considerably less than that of the machines now generally employed for the production of machine-formed peat.

The cross-stops and counter-knives inserted in the other machines at fixed distances from the rotating knives generally only prevent the peat from twining round the knife shaft and from rotating with the latter in the part of the cylinder in question. They have a beneficial action on the mixing power of the machine, and only in the most favourable case, when working with fibres, roots, and plant remains which have been already half humified, are they able to effect even a partial tearing of these.

A large portion of the fibres, especially when working with unripe fibrous and root peat, adhere to the front edges of the knives, which even at the present day are often *radial and bounded by straight lines*, during the continuous motion of the knives through the peat, and, indeed, they cling all the more firmly and in the greater number the longer the rotation lasts, until finally the knives, especially in the case of single-shaft machines without any special contrivances, become completely entwined and no longer answer their purpose.

Straight edges for the separate knives or screws which produce a mixing and tearing effect must be regarded as a great drawback in the case of all those forming machines to which an actual cutting action cannot be attributed, since they decrease the speed of working, or when the much entwined front edges strike against similarly entwined cross-stops and counter-knives, give rise to fracture of the knives and, therefore, to working troubles.

If we consider, for instance, the spiral knife, illustrated in Fig. 74, of a single-shaft peat machine, and if we assume the edge *a*, which is radial and bounded by straight lines as was formerly the case in all these machines, to be the moving front edge, it will be evident that the peat fibres met by this edge must necessarily adhere to it, in a clamped or hooked fashion, since the motion of the peat and its fibres is exactly at right angles to that of the knife-edge. If these fibres are not so decayed that they are torn to pieces as they pass by the cross-stop *b*, which is fixed in the cylinder at a distance of several millimetres from the moving knife-edge, they will be only still more firmly pressed to it, since the direction of the motion remains the same, and accumulating layer by layer must give rise to blocking of the machine and to breaking of the entwined knives as the space between these and the cross-stops will have become too narrow.

This disadvantage is to a large extent avoided by making the front edge of the knife curved as at *c*. The curve is so shaped that the motion of the peat takes place at an acute angle to the knife-edge. This helps any adhering fibres to glide off and enables the knife to rotate in the peat without catching and carrying round all the fibres it meets in its course. In this way the knife glides through the peat with the same mixing effect, and without

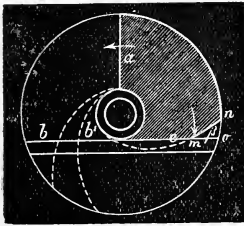

FIG. 74.—Shearing edge.

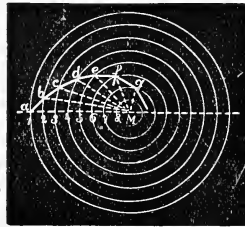

FIG. 75.—Shearing edge curve.

the disadvantageous action of the radial-edged knife. The removal of any fibres which adhere to the front knife-edge is greatly facilitated by the knife-edge emerging from the cross-stops at  $b\bar{b}^1$  almost in the direction of the curved edge. Also the tearing action of the edge *c* when it first meets the counter-bars is

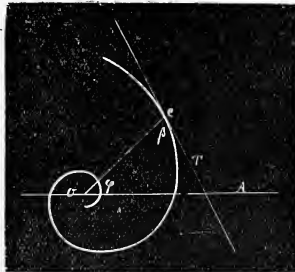

FIG. 76.

considerable, since it then makes with the counter-bar an angle  $\beta = \angle n m o$  (directed outwards), whereby any adhering fibres are either torn, cut, or stripped off. A partial cutting effect may be due to the latter operation, since even a rough, blunt knife is capable of cutting fibres drawn along its edge, while this is scarcely possible for even a sharp knife so long as the fibres are simply pressed perpendicularly to the cutting edge, as is the case during the rotation of the edge *a*.

The most suitable form for this curved edge is governed by the condition that the angle  $\alpha = \angle m n o$ , determined by experiments as the most favourable for peat, must be the same for every point of the curved line and, therefore, the direction in which a particle of peat or a fibre is struck by a portion of the rotating knife must always be the same.

The mathematical name for the curved line which satisfies this condition is the logarithmic spiral,<sup>1</sup> the exact form of which can be obtained without difficulty by means of the equation given in the note.

For constructive purposes the bounding line of the knife is obtained with a sufficient degree of accuracy by dividing the distance from the centre to the circumference into (as many as possible) equal parts, 1, 2, 3, 4 . . . describing circles (Fig. 75) through these points with the same centre  $M$ , drawing the radius  $M1$ , drawing a line  $ab$  from 1 until it cuts the circle marked 2 making an angle  $90^\circ - \alpha$  with the radius, where  $\alpha$  denotes the angle which every portion of the front edge of the knife is to make with the direction of rotation, in a similar drawing manner the line  $bc$  making the same angle with  $Mb$ , and so on until the broken line  $abcdefg$  is obtained. The curved line desired is then completed by drawing an enveloping line to which the various parts of the broken line are tangents.

According to experiments made by the author on this subject with various knives and curved edges, a suitable value for the edge angle for the knives of single-shaft machines is, in the case of those which do not work against cross-stops,  $30^\circ$ , and for those which work against cross-stops,  $35^\circ$  to  $40^\circ$ .

More or less prolonged working with peat rich in fibres and roots showed that with different types of knives fixed on one and the same shaft, the separate knives which had a straight, radial front edge were thickly covered with roots and fibres, and rotated in the machine as lumps without definite shapes, while the knives which had edges formed according to the given curved line remained almost free from adhering matter of this nature.

The disadvantages of straight, radial bounding lines as front edges of separate knives and screws, when working with peat rich in fibre, hold for double-shaft in exactly the same way as for single-shaft machines.

Fig. 77 shows in a simple manner the cross-section through the knife shafts of such a machine.  $M_1 M_2$  denote the two horizontal

<sup>1</sup> The logarithmic spiral (Fig. 76) is a curved line for which any radius vector  $oc$  always makes the same angle  $\beta$  with the tangent  $T$  at  $c$ , and therefore, at the same time the condition is fulfilled that the circle described with  $oc$  as radius, which in the present case represents the direction of motion of a particle of the knife-edge, always makes the same angle  $\alpha$  with the logarithmic spiral, i.e., the knife-edge line.

Its equation  $r = e^{m\varphi}$ , where  $r$  is the length of the radius vector  $oc$  for various points inclined at angle  $\varphi$  to  $oA$ ,  $e$  is the base (2.71828) of the natural system of logarithms, and  $m$  is  $\cot. \beta$  the cotangent of the angle between the radius vector and the tangent. This angle is the same as that considered in Fig. 74, i.e.,  $90^\circ - \alpha$ .

knife shafts,  $q^1$   $q^2$  the separate knives or quarter screws, which are fastened to them, work in opposite directions, and have front edges which are straight and radial. Even if the two knives worked quite close to each other, and even if they were provided with edges like those of a scissors or a reaping hook, a cutting or shearing action could never take place by the front edges  $b$  and  $c$  moving towards one another, since at the instant when the two edges meet—which occurs at the point marked 1 in Fig. 77—the angle between them is almost a right angle ( $90^\circ$ ), i.e., so great that the knife-edges, which form the angle and which, as the rotation proceeds, open out ever more and more from one another, can never exert a cutting action on the peat contained between them, but are merely able to strip this off one another and push it before them. As the rotation of the knife shaft proceeds and the knife-edges gradually move into the positions 2, 3, 4, &c., the angle between the edges becomes ever greater, therefore less favourable for cutting, until the knife-edges as they pass the position 8 again separate altogether.

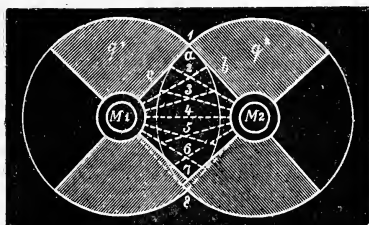

FIG. 77.—Screw knives with radial edges.

The knives, moreover, owing to inaccuracies which are unavoidable in their manufacture, and to reasons connected with their working, are fastened to the opposite shafts at distances of several millimetres from one another, so that even for this reason alone a cutting action cannot take place.

The action of the knives, therefore, in addition to that of mixing is limited to stripping off fibres adhering to their edges as the latter glide past one another during the rotation of the knives through the peat, tearing some of the fibres and preventing the peat from rotating in the cylinder. This action is, as many trials showed, sufficient for the working of mould peat and moss peat in which the fibres are in a semi-humified state, but it is not sufficient for the working of fibrous peat. Apart from the fact that a cutting action appears desirable in machines intended for working fibrous peat from the point of view of the quality of the machine peat, considerable working troubles occur, owing to blocking of the machine or fracture of the knives, when knife shafts and screw shafts constructed according to Fig. 77 are employed. This is easily deduced from the mode of

action of the separate knives and quarter screws hitherto employed and may be avoided to a large extent by using knives with curved front edges.

When the quarter screws are in the position 4, their straight, radial front edges are in contact over the maximum length and have freed one another from adhering fibres; from there on, in 5, 6, 7, they separate more and more until in position 8 they are completely separated, so that as the rotation of the knife shafts proceeds they take up most of the fibres contained in the peat which come in their way, hooking and holding them fast on the edges, since the fibres are struck and caught perpendicularly, i.e., exactly in the direction of the motion. These fibres cannot be cut by the edges even if these be sharp, since in order that this shall occur, the fibres must either glide, voluntarily or involuntarily, along the edge or must be prevented from rotating with the knives by a stationary knife or by one rotating in the opposite direction.

At each revolution of the knife shaft fibres are collected during more than three-quarters of the total path traversed,

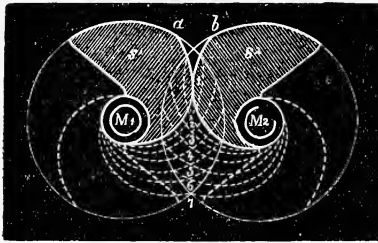

FIG. 78.—Screw knives with curved edges.

the edges being cleaned and brushed by one another during scarcely one-quarter of the revolution. Assuming even the most favourable case, viz., that the cleaning of the edges is complete, i.e., that after each rotation the edges when beginning a new revolution are free from fibres—in reality this is never so—then when working a peat consisting almost entirely of fibres and roots we can easily imagine the other case when fibres adhere firmly and tightly to the straight, radial edges during three-quarters of their revolution (i.e., while the edge *a* moves through the peat in the direction of the arrow from 8 to 1) in such quantities that the front edges having become converted into thick pads, are not able to force themselves into one another when they meet in the position 1, or past one another during the last quarter of the revolution. Under these circumstances the knives are not able to offer sufficient resistance to the great lateral pressure which thus arises and they snap, since a shearing action, by which the fibres would be cut and the edges released from the strain, does not take place, even in the case of good raw peat.

Hence, also, in the case of double-shaft machines it is desirable to replace the straight radial edges of the separate knives, even when working raw materials less rich in fibres, by the above-mentioned curved edges indicated in Fig. 78. The mixing effect of these knives is exactly the same as that of the quarter spirals shown in Fig. 77, and the cleaning of the edges by one another, if necessary at all, is equally good, as is evident from the various positions 1, 2, 3. Also, owing to the peculiar shape of the front edge, the catching of the peat fibres is avoided as far as possible from the very start. Moreover, the front edges, when they are suitably constructed, exert in part a shearing action on the peat contained between them over half their length from 1 to  $a$  and 1 to  $b$  owing to the angle  $\beta$  which forms between them constantly closing up, and in part a cutting action owing to the tendency of the fibres to glide along the curved edge during the rotation of the shaft.<sup>1</sup>

In these double-shaft machines the edge angle  $\alpha$ , i.e., the angle which every part of the curved edge makes with the direction of rotation (circular motion) may, with advantage, be chosen at  $30^\circ$  to  $35^\circ$ . The angle of curvature in Fig. 78 will then be  $60^\circ$  to  $55^\circ$ .

(4) *The action of the knives necessary for the forward motion inside the machine, and for the forming of the mass*, is attained, as is well known, by winding the knives in a spiral or screw-shaped manner round the shaft.

The slope of the external circumference of the spiral when the output is not too small and the power required is not to be too great should not be under  $80^\circ$  or over  $20^\circ$  and may, with advantage, be kept between  $10^\circ$  and  $15^\circ$ . In every machine the forward motion of the peat in the cylinder is smaller than that which would be calculated from the slope and the rotation number of its spiral, and therefore a part of the peat during the motion of the screw shafts lags behind in the space between their periphery and the cover of the cylinder, and in this way the mixing action is increased. The crushing effect of the knife shafts at the inside surface of the cylindrical cover is also to be attributed to this circumstance.

In constructing peat-forming machines it is advisable to arrange the parts which specially affect the output of the machine independently of those which affect the quality of the peat, that is, those which have as their main function the cutting and tearing of the peat. Therefore the cutting and shearing knives should not be arranged spirally, since by so doing a considerable portion of their action would be lost and, therefore, if they were to serve both purposes at the same time they could work only in an imperfect manner. It is, moreover, necessary to arrange the

---

<sup>1</sup> The examination of the action, and the most suitable shape of knives in mixing machines, which the author was the first to engage in, and which was first published in the first edition of this work, has attracted much attention; since then all the better class machines have been provided with knives of this type.

special disintegrating contrivance, or the part of the knife shaft destined for this purpose, so that it can always be inspected and, if necessary, cleaned, without requiring to open any part of the machine. This is best achieved by placing it directly in or under the funnel, as has been already done in the horizontal machines which have recently come into use. In an industry everything depends on being able to overcome any machine troubles as rapidly as possible and without its being necessary to take the machine to pieces.

## 2.—On Forming Pieces and Mouthpieces

The forming pieces are no less important for peat-forming machines than the knives and have a considerable effect, especially on the external appearance of the machine peat. Vertical machines have, according to their size, forming pieces either on one side, as in Figs. 25, 27 and 30, or on two opposite sides, as in Figs. 26, 29 and 31. Horizontal machines have them on one side only and, as a rule, at the end of the longitudinal axis of the machine opposite to that at which the hopper is placed. They are fixed in a mouthpiece suitably constructed for receiving them.

The contrivance for fixing the forming piece in the mouthpiece, which usually forms part of the cylinder of the machine, must be so devised that the forming piece can be loosened with the least possible expenditure of time and, therefore, can be quickly taken out and exchanged.

This requirement is necessary owing to frequent stoppages in the working, partly due to blocking of the machine, but still more frequently to blocking of the forming piece itself, and to remedy that due to the latter cause the forming piece must be taken off and cleaned or exchanged. *For the same reason it is necessary in the case of every machine to keep a reserve forming piece always ready for insertion.*

If the forming piece were inserted and fastened by means of screws and nuts, the loosening of these when taking out the forming piece, and the tightening when putting in the cleaned or reserve forming piece would cause too prolonged a disturbance of the work. A key, lever, or latch contrivance is, therefore, employed by means of which the loosening or tightening can be effected by a handle.

A contrivance of this kind is shown in Figs. 27, 33 and 34. Round the two hinges  $cc$  angle irons  $W^1 W^2$ , one on each of the upper and lower walls of the rectangular mouthpiece, can be rotated, and to their heads flat iron angles are riveted. The wooden forming piece is provided with a groove in its upper and lower walls (Figs. 27 and 34) into which the arms of the angle irons catch when the longer arms of the flat iron angles are tilted into a vertical position, and the forming piece is thus clamped tight against the shoulder  $a$  of the mouthpiece. In order that the angle irons may not loosen automatically, owing to the pressure of the peat as it comes out during the working, a peg is inserted in front of the vertical longer arms of the flat



iron angles where they overlap in the middle at each side of the mouthpiece. In order to free the forming piece, it is merely necessary to withdraw the peg and rotate the arms to the horizontal position.

A clamping device which is very simple and can be quickly loosened is shown on the mouthpiece of the machine in Fig. 33. In this, the forming piece is set by means of its upper, longer side into a groove  $f$  contained in the front plate of the machine and is prevented from falling out or being pressed out by two keys  $k^1 k^2$ , screwed on its lower side, a mode of fastening which combines sufficient certainty in action with great simplicity in construction and use.

The forming pieces of the horizontal double-shaft machines are loosened or clamped by means of an edge groove by opening or shutting the upper part of the mouthpiece which is divided horizontally and can be rotated round hinges.

All the three contrivances mentioned here answer their purpose. Quickness and certainty in handling are in every case the main requirements.

The forming pieces of the older vertical machines were made of oak and had a length of 150 to 220 mm. measured in the direction in which the band issued. The opening was divided by intermediate walls in such a way that for smaller machines 3, for larger machines 5, and for the Hebert machine even 13 band openings lay side by side, having whatever cross-section was required for the sods. In order that the pressure of the spirals may give smooth side walls to the bands, the forming pieces must become narrower as they extend outwards. The amount of this contraction and also the length of the forming pieces depend on the quality of the peat to be treated, the former varying from  $\frac{1}{8}$  to  $\frac{1}{12}$  and the latter from 80 to 300 mm. A mould peat requires a short forming piece and a fibrous peat a longer one which, however, contracts less than that necessary for a fat marsh or bituminous peat.

In order to be certain of getting smooth sides for the formed peat in the case of certain raw materials, the wooden forming pieces have in some cases been replaced by cast-iron, and, better still, by copper forming pieces, of which the side walls are as smooth as possible. This purpose is also served to a large extent, and therefore the friction in the forming piece, and with this the power required to drive the machine, is at the same time diminished by letting water flow drop by drop between the walls of the forming piece and the sides of the issuing band. This is done by means of rubber tubes and several holes bored in the walls of the forming piece.

Earlier (for the first time indeed at the Bremen Exhibition in 1874), C. Schlickeysen, of Berlin, had also applied to peat machines the "watering forming pieces" which had been previously used with success in his brick machines. These were made of wood which were lined with tin plates arranged overlapping one another like the scales of a fish. The longitudinal

section of such a "watering forming piece" may be seen in Fig. 27. The scaly layer covers water grooves  $r$  all over the inside of the wall of the forming piece. The grooves are connected by channels  $k$  with a trough  $m$  which is fed with water through the rubber tubes  $g$  from a tank  $W$  fixed on the machine. The flow of the water can be regulated by the cocks  $h$ . A "watering forming piece" such as this costs 30M. to 45M.

Many machines have only smooth, iron, or single-walled copper forming pieces, or iron forming pieces with copper scales.

These "watering forming pieces" must not, however, be regarded as a never-failing means for neatly moulding every raw material. Sometimes the forming pieces must be modified a good deal before a satisfactory result can be attained.

A mud peat, rich in humus, can be generally formed into neat bands by means of a short, smooth-walled, "watering forming piece," while a fibrous peat requires a longer, dry forming piece for the same purpose.

Cast-iron forming pieces must always be lined with copper or brass plate so as to prevent rusting.

If the peat band frequently tears when coming out of the mouth-piece and if in general it is not sufficiently smooth and neat, then, provided the mouthpiece is a good one, the mixing action of the peat machine is not great enough for the peat which has been fed into it, i.e., the latter does not work and mix the peat well enough; it may also happen that the material fed into the hopper is not sufficiently uniform. These defects are sometimes remedied by working the peat in a wetter condition.

*It is essential that the various layers of a peat bog should all be worked simultaneously and mixed with one another if we wish to obtain a dense machine peat which can be easily "formed," remain as uniform as possible in quality, and cake well.* This is best attained, not by gradually cutting out the bog from above downwards, but by excavating in the side of a suitably wide and deep trench which is divided into three or four steps, uniformly from all the layers and in the direction of the axis of the trench (Figs. 85, 86 and 87).

In the case of all multi-band forming pieces which are divided by several intermediate walls, a palpable defect is that the more or less long fibres or roots of impure fibrous peat catch on the front of the vertical intermediate walls of the forming pieces and quickly block the openings, which can be freed again only by taking off and cleaning the forming pieces and thus causing disturbance in the working, decrease in the output, and increase in the cost of winning.

To avoid this inconvenience the bog owner and landed proprietor von Kobylinski-Wöterkeim made in his time the important improvement seen in Figs. 30 and 33, the use of which has rapidly extended. As can be seen, the intermediate wall which divides the forming piece into separate sections has no rectangular surface inside but tapers into a triangle  $d$ , which starts from the inside of the upper wall of the forming piece, increases in height

as it extends outwards and leaves a small opening between it and the lower wall, as in Fig. 30, or between two such intermediate walls, as in Fig. 33. In this way the roots and grasses in the peat which reach the dividing walls are gradually pressed from above downwards and finally pushed out through the intermediate opening. The latter is 6 to 12 mm. in height, according to the amount of the roots and other clogging substances which are present. Should a more or less large piece of wood, moss, &c., be pressed into this cleft it can be quite easily taken out or moved aside into the wider opening with the aid of a hook.

By employing this improved forming piece, into which, moreover, every other forming piece can be easily converted, a smaller amount of power is required to drive the machine, since in this case each band has to overcome the friction at only half the ordinary number of surfaces, and the division of the various bands is effected by the intermediate wall, which exerts a gradual pressure and a greater cutting action than the vertical one to which all the fibres would necessarily adhere.

Von Kobylinski stated that with a peat machine which constantly clogged and was about to be discarded he easily obtained with two horses an output of 12,000 large sods per day after he had inserted the modified forming piece.

These forming pieces have been still further improved by sharpening the wedge-shaped intermediate walls, which slope inwards, and by making it possible to remove them from the forming piece for rapid and thorough cleaning without it being necessary to loosen the forming piece itself. This is effected either by drawing out the wedge through a slit in the upper wall of the forming piece after freeing a clamping contrivance, or by fastening all the wedge-shaped plates on a hinged frame which can be rotated round the front edge of the upper wall of the forming piece. By rotating this all the intermediate walls can be brought simultaneously from the inside to the outside of the forming piece and, when cleaned, allowed to fall back again, and fastened. This improvement is of great advantage for impure or fibrous peat on account of the diminution in working troubles effected by its means.

In the case of "watering forming pieces" it is very difficult to attach the thin intermediate walls required for the division of a wide peat band into several separate bands with cross-sections equal to those of ordinary sods. "Watering forming pieces" have, therefore, sometimes been constructed having the cross-section shown in the accompanying illustration (Fig. 79). The peat band, which has a width of 250 mm., is notched on its top and bottom to a depth of 25 mm. by the ridges *nn* which are soldered to the inner (scaly) wall and taper towards the inside of the forming piece. The peat pads which are cut into lengths of 250 to 300 mm. across their whole width tear asunder at these grooved places while drying and contracting, and three or four peat sods are, therefore, formed from each pad.

This tearing takes place, however, somewhat irregularly, and

is accompanied by partial crumbling of peat into small pieces, thus causing a loss. Consequently the external appearance of the peat sods is not so good and their sizes are also not as uniform as would be expected. This is not, however, of much importance in the case of peat intended either for one's own use or for use on a large scale. Since the peat pads sometimes remain for days in the form of a single piece, and since even after splitting the space intervening between two sods is initially very small, the surface which is exposed to the air and which renders the evaporation of the water contained in the peat possible is much more limited and, therefore, the drying itself is slower than when the peat sods are made separately from the start with a space of at least 10 mm. between them by a forming piece with intermediate walls and spread in this condition on the drying ground.

The shape of the cross-section of the sod is of great importance for the winning itself and for the neatness of the peat band, and is necessarily variable since every variety of peat cannot be equally well worked by one and the same forming exit. A circular cross-section would cause the fewest difficulties for all kinds of peat and it could also be recommended as that which would give the best results in the combustion of machine peat were it not that the subsequent handling during drying, piling and loading of sods of this kind is troublesome, since, owing to their narrow supporting bases, they have a tendency to slip out of a piled wall. It is employed, therefore, in rare cases and only for lean peat.

The "layering power" of peat sods, i.e., the property due to their shape which allows them to be placed in heaps, can be increased without giving up the form of the cross-section suited for obtaining a neat band and also for burning peat, if we select, instead of the circular cross-section, an oblong one, such as is obtained when we suppose a circle divided by a vertical diameter and a rectangle whose height is equal to the diameter of the circle inserted between the two semicircles, which will give a straight layering surface.

This cross-section is, however, better suited for forming pieces with undivided exits because the fixing of intermediate walls, as in Kobylinski's improvement, causes difficulties. The slit left for the passage of the fibres and impurities is transferred in this case, as indicated in Fig. 33, to the middle of the intermediate walls, and the latter taper both towards the upper and the lower wall of the forming piece. For divided forming pieces, and especially for fat marsh and moor peat or bituminous peat the square shape is selected as the one most suitable for the subsequent handling. Its corners are much blunted or rounded off, as can be seen from Figs. 30, 33, 36, and 43.

R. Dolberg, Ltd., of Rostock, and later A. Heinen, of Varel, amongst others, have recently improved this mouthpiece by inserting, as described below, a wedge-like and not quite continuous intermediate wall, which has proved very useful (Fig. 79A).

The upper portion of the knife-like intermediate wall projects downwards three-quarters of the height of the sod and the lower intermediate piece projects upwards over one-quarter at its highest point. The two portions of these knives which bulge most do not touch one another. The highest part of the lower knife lies behind the lowest part of the upper knife and a free passage out of the forming piece is left between the edges of the two knives for the woody, fibrous portions of the peat, which have not been worked up by the screws while, however, the complete cutting through of the peat bands, which is essential for the production of neat sides, is effected. The upper knives are fixed on a rotating spindle and can be tilted out through slits in the upper wall of the forming piece, the cutter automatically cleaning itself at the slit. After tilting out the upper knife the lower one can be conveniently cleaned by hand. The upper knife frame is kept in position either by a counterpoising weight *g* or by a revolving clip.

It is advisable to round off the corners of the mouthpiece. The advantages of this are that sharp edges, which break off easily on drying, are avoided, that the air will have better access

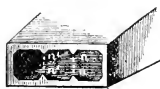
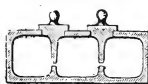

FIG. 79.—Triple-band mouthpiece.



Section at *a-b*

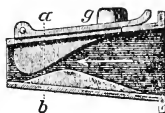

FIG. 79A.—Mouthpiece with intermediate walls.

into the multiple bands thrown from the boards on the drying ground, that the individual, adjacent bands (from a multiple-band forming piece) separate more easily, and that rain-water which may fall on them can flow away more easily. When the individual peat sods in the dry state still adhere together a higher rate of wages by piece or by day work must be paid for clamping during the drying operations, as separation of the sods from one another will then be necessary.

Just as the *shape* of the cross-section has a great influence on the moulding so has its *size* on the drying and the subsequent combustion of the peat. The drying of the sods takes place all the more quickly, and their combustion all the more completely, the more the entrance of air is facilitated, that is to say, *the greater the ratio of the surface of the sods to their mass*, or, other conditions being the same, the smaller their cross-section. The more the peat consists of small pieces the better it burns. We must not, however, exceed a certain limit, as the formation of very small pieces in large numbers would increase the expenses of the industry out of all proportion. Moreover, during rapid and good air-drying, peat sods of very small cross-section easily develop splits and clefts, where they easily break on subsequent

loading, producing a loss which should be most guarded against in the machine peat industry, due to the falling off of the smaller pieces. The most suitable thickness for freshly formed sods, so far as forming and drying are concerned, is 8 to 12 cm. and the most suitable length 25 to 30 cm. Sods more than 12 cm. in thickness should not be made at all, since these require far too long a time for drying, and access of the oxygen of the air is so impeded during their combustion that their heating power cannot be utilized to the full extent.

When drying peat on trestles or under cover, it is advisable to make the height of the sods greater than their width in order that the drying area may be more fully utilized. If a width of 30 cm. and a length of 1 m. be selected for the spreading boards, the forming piece may, with advantage, be a triple one, each hole being 8 cm. in width and 10 cm. in height and with intervening spaces of 15 mm. between the sods. If the length of the sods be made 25 cm. a spreading board will contain 12 sods each of 2,000 c.c. (2 l.) in volume.

These sods are the same size as the *standard sods* which entered into the calculation (p. 103) on the comparative estimation of the outputs of different machines. The sods, 500 of which are given by 1 cb. m. of formed peat, have proved very suitable both for the drying operations and for combustion in industrial and domestic fireplaces.

If the output of the peat machine depends, as it generally does, on the forming exit (assumed to be undivided) being as large as possible, then we can, without any special difficulties and without affecting the output of the peat machine, conform to this condition and at the same time produce sods of small volume (standard sods) when working with a suitable raw material (bituminous, marsh, or ripe, humified peat) or with a machine which has a good disintegrating action, by employing the "lath knife," or the "roll bed with grid cutter," or the "automatic cutter" described in (b) and (c) of the following subsection. In this case we give the opening of the forming piece the usual length of peat sods (20 to 25 cm.) as its width and construct it with a rounded or very blunt-edged cross-section. We allow the peat band to emerge undivided and insert the knives in the lath, or stretch the wires in the grid cutter, at so short a distance (10 cm.) from one another that they cut the peat sods of the *thickness* required. Every raw material and every peat machine does not, however, permit of the employment of the grid cutter, since, if the formed peat, issuing from the machine, still contains many undivided fibres (of cotton-grass for instance), these will remain attached to the wires of the grid cutter, and when the wires are withdrawn they will tear out pieces from the peat bands, causing a loss of formed peat and at the same time giving the bands an unsightly appearance. In the latter case, the only course left is to let several peat bands of smaller cross-section issue side by side (therefore through a divided forming piece), and to cut these lengthwise.

### 3.—On Chopping and Cutting Contrivances

These contrivances, necessary for all machines, depend less on the particular kind of machine as regards their choice and use than the other contrivances. Each of the contrivances described below can therefore be used directly with any of the above-mentioned machines.

The factors which have greatest weight in the selection of the most suitable form are the number of workmen required for a given daily output, the subsequent treatment of the freshly formed peat, and the degree of external neatness intended, or necessary, for the sods of peat.

Excluding the semi-cylindrical cutter mentioned under the Weber-Gysser process, the simplest of these contrivances and that first employed is:—

(a) *The Chopping Board and Chopper*, illustrated in Figs. 30 and 31. The board *T*, which is covered by a tin or glass plate, is placed in front of the mouthpiece in such a way that the issuing peat bands flow over it in a slightly inclined direction. A workman called "the cutter" at the same time keeps it in a slippery condition by moistening it with water. When the issuing bands have attained the required length the workman cuts them with the chopper *E*, shown in Fig. 30, which is kept moistened by dipping it into a tub of water, and catching the ends of the cut sods with his other hand, he puts about 10 to 20 of them side by side on a spreading board near at hand. Several boards filled in this way are then taken to the drying ground on a barrow or car, and there the boards with the sods are either tipped over or, when tipping is not possible owing to the nature of the peat, the sods are taken off separately and spread for drying.

It is easily seen that in this procedure, uniformity in the length of the sods, which is desirable when the sale of the machine peat takes place by the number of pieces, depends on the workman's eye and skill; and by the removal of the freshly formed sods from the chopping table to the spreading boards, and from the latter to the drying ground, their good external appearance, to attain which no pains were spared in the careful selection and construction of the forming piece, suffers considerably owing to the softness of the fresh machine peat, and this, in turn, has a bad effect on the product ultimately sold.

These defects are removed in part by the—

(b) *Rolling Table with Running Boards*.—As may be seen from Figs. 29, 32, 38 to 43, &c., this consists of a long frame, 20 to 40 cm. in width and 2 to 3 m. in length, which rests on feet or sleepers. Rollers *u* (Fig. 38) are carried by the side members of the frame, being either let into notches or into bearings secured to the members, and over these rollers boards, 1 to 2 m. in length, can run easily. The rolling table is placed under the mouthpiece of the machine in such a way that the running board is just freely movable between the mouthpiece and the rollers, and also that the long axis of the rolling table is in the same direction as that

in which the peat bands leave the mouthpiece. Before the peat comes out, the first running board is pushed underneath either from the rear or from the side, according to the construction of the machine, until the issuing peat bands begin to rest on the board. Owing to the subsequent forward motion, and also since the table is set up with a slight slope forwards, the peat bands draw the board with them, moving it forwards on the rolling bed by their own velocity. Before the end of one board reaches the mouthpiece the workman places a second board on the rolling bed immediately behind the first and pushes it until it also is caught and dragged forward by the issuing peat bands. While this is taking place, another workman, with a wide knife similar to that described above, chops through the peat bands at the line of contact of two boards. In this way boards covered with peat bands of equal length are obtained in continuous succession. These are placed in turn on transport barrows or cars, by which they are conveyed to the drying ground.

If there is only one thick band on each board, the latter can be emptied simply by tipping, and in this way the bands are spread side by side one after another. If the peat is to be coked as described in Part II of this work, the sods may retain their length of 1 m., since the longer the sods are the better they can be coked, but if the formed peat is to be used as fuel, then the sods are subdivided by means of a long knife or, better, by means of a lath, 1 m. in length, to which vertical knives are attached at suitable distances from one another.

These roller beds may be used with any machine, but in some cases where the construction of the machine does not allow of the insertion of the boards from behind, and the forming piece is too short to insert the boards easily from the side, the modification shown in Fig. 27 will be necessary. In this case the peat band emerges on to a slide board *R*, which is covered with a tin plate and kept moistened with water. The slide is fastened at the top to the forming piece, and is sloped downwards to the roller bed. It is of such a length that a spreading board can be placed under it from the side before the preceding board has quite passed the end of the slide. With the same object in view, the mouthpiece may be inclined towards the side, as shown in Figs. 43 and 47.

(c) *The Roller Bed with Grid Cutter*, which is an improved form of the above-mentioned roller table with running boards, makes it possible to cut the peat bands emerging from the mouthpiece into pieces, the length of which is equal to that of the spreading board, and these again into smaller sods of the desired length by means of a single movement of the so-called "*grid cutter*."

Grid cutters with several steel wires stretched at a fixed distance from one another may be seen in the roller bed of Schlickeysen's machine (Fig. 29) and in that of Clayton's machine (Fig. 37). The grid cutter consists (Figs. 29, 37 and 50) of a frame rotating round an axle *a*. The side rods *S* of the frame are usually made of iron and bent somewhat like a bow. Between its two long sides *l* and *a* a number of wires separated by distances equal to



the length of the sods are stretched by means of screw hooks and wing nuts. The distance from the first to the last wire is equal to the length of a spreading board.

To the axis *a a* an elliptical disc, a cam, or a falling latch is fastened, which in the downward motion of the grid and just before the wires enter the peat band, stops the motion of the spreading board until the downward cut is completed and the wires have been just raised out of the band by the upward motion of the grid. In this way the peat band receives a clean cut. In order that the band which emerges from the mouthpiece and moves forward continuously during the cut may not cause trouble by banking on the clamped spreading board, the cut must be made as quickly as possible during the interval from the instant of the insertion of the wires in the band to that of their emergence. After some practice this can be attained without difficulty.

The workman has time enough after each cut to clean the wires to which peat fibres usually adhere. A lad or a girl looks after the insertion of new boards.

With this contrivance 40,000 to 60,000 neat and uniformly long peat sods can be conveniently cut and removed in a day by one man and two lads, one of the latter placing the empty spreading boards under the mouthpiece and the other removing the filled boards from the roller bed to the barrows or cars. This contrivance has a great advantage over the two others described above in respect of the neatness of the operation and the saving of labour.

It can be used, however, with success only when it is a matter of working a peat which is quite fibre-free, or when the action of the preparing machine is so perfect that large pieces of wood and roots and long fibres and sedge stems are not contained in the formed peat. If these were present they would adhere to the wires and during their motion through the peat band pieces would be torn out of this and its shape would become irregular.

For the operation just described, the roller table should be so long that its length behind the cutting wire should be at least equal to that of a spreading board.

When the grid cutter is fixed at the end of the roller bed the cutting of the peat band can be effected more easily and without any special practice or skill on the part of the workman.

The cutting table in this case requires only one lad, who has simply to regulate, in the case of "watering forming machines," the addition of the water to the forming piece, to cut the peat band emerging from the forming piece, when it has covered a board, with a wide knife over the line of separation of two boards, and to move the filled board to the end of the rolling bed from which it is removed to the transport cars. Before, however, the person working the car or barrow removes the board covered by the peat band he cuts the layer into separate sods by depressing the cutting bow. The latter operation requires no particular care or skill, since the cutting takes place while the peat band, unlike that in the above method, is entirely at rest.

An automatic sod cutter of R. Dolberg and Co., of Hamburg and Rostock, is shown in Fig. 80.

A similar automatic sod cutter is attached to the large scale industry machine of Wielandt. The Strenge machine has a knife wheel or scraper wheel, which is set in motion by the peat band as it glides forward, while in the Schenck machine intermediate cross-cutting knives are fixed as sod cutters in the forming chamber attached to the mouthpiece.

Smooth, clean peat sods with good edges are not so important when the winning is on a large scale; the main point then is to produce pieces which hold together, do not crumble, and make rapid air-drying possible. These can be obtained with the machines described, provided a fair amount of care be shown in the selection, and even with the automatic sod spreaders described in the following subsection their manufacture is satisfactory.

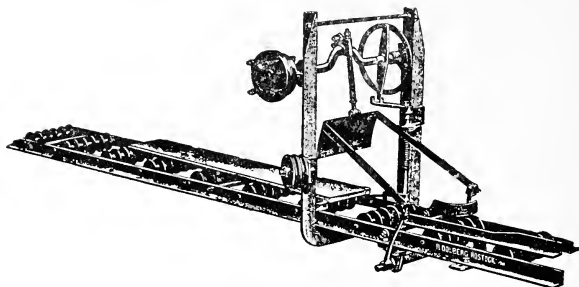

FIG. 80.—Cutting contrivance of R. Dolberg and Co., Rostock.

#### 4.—Automatic Sod Spreaders<sup>1</sup>

Attempts have been made, especially by large industrial concerns, to win a cheap fuel or moss litter peat with as few workmen as possible. In addition to the dredgers, already mentioned, for digging and conveying the raw peat and the contrivances for cutting the sods, workmen have hitherto been employed for transporting the cut sods as well as for spreading them on the drying field. By means of mechanical appliances directly connected with the peat machine and driven from a common source of power, an attempt has been made to dispense with these workmen. At the same time, a saving is also effected by the cars and the rails for the transport of the sods from the machine to the drying ground being no longer required.

We shall consider especially :—

(a) *The Wielandt Sod Spreader* (see Fig. 67).—In the case of this spreader, the peat band, which leaves the machine almost at right angles to the direction in which the machine is advancing,

<sup>1</sup> Details have been already given, on pp. 147–152, of spreaders, levellers and cutters for pulp peat.

is cut into separate sods by an up-and-down motion of the knife produced by the driving gear, and these are pushed by the peat band behind them to a conveyer formed of plates, flexibly connected and gliding over rollers. This belt carries the sods to the drying ground beside the working trench. It can be tipped round its long axis, but when not fully laden it is prevented from tipping by a counterpoise. When the part of the belt which is laden with sods has reached the end of the spreader, and therefore the whole "run" is covered with sods, the weight of the latter releases the belt clutch, the belt tips over and spreads the sods on the drying ground, the machine with the sod spreader driven by a gas or benzine locomotive moving forwards simultaneously along the trench. In this way the service of the entire machine, including the transport and the spreading of the sods, requires only a few workmen (three to five). (Cf. p. 157).

(b) *The Strenge Sod Spreader* (see Fig. 68A).—The sods, cut by a paddle or knife wheel, pass to an endless chain conveyer, which is up to 75 m. in length (Model 1914-15), and travels backwards and forwards. When the conveyer is sufficiently filled it is tipped by means of a lever, and the sods are thus placed flat on the drying ground. The speed of the spreading belt is regulated electrically, so as to correspond to that with which the band of peat issues from the machine. While the empty spreading belt is returning to the machine it lies in the same plane as the loaded belt.

(c) *The Baumann Spreader of Carl Schenck, of Darmstadt* (see Fig. 69).—The peat sods, formed and cut by the bucket wheel or cell wheel placed between the mixing machine and the spreader in the Schenck machines, are placed by the cell wheel on the lower part of the endless conveyer. The latter consists of separate plates, which can be tilted. The support for the belt and roller, which in front and rear rests on a slide bar and is moved forward with the machine, has a lattice-work formation. The lower loaded part of the conveyer lies near the ground. When the whole length of the conveyer is filled with sods, the separate plates tilt across the long axis of the spreader and lay the sods on the drying ground. The empty plates return to the machine over the upper roller railway. It is said that the spreader can be made for a drying ground up to 90 to 120 m. in width.

(d) *The Dolberg Spreader* (see Fig. 71) consists of an endless conveyer, formed of separate plates, supported on an iron lattice work and extending over the width of the drying ground. The belt catches the peat sods, formed by the sod cutter at the mouthpiece of the forming machine, and transports them sideways to the drying ground. The first of these sod spreaders constructed was up to 60 m. in length. To avoid bending the bearing frame, the latter is fixed in rings on cars at its two ends and at three intermediate points, therefore at every 15 m., in such a way that the frame and belt can be turned in the rings. The belt is driven electrically from its end and its motion automatically ceases when the machine for any reason stops. The rotation of the

band with that of the whole latticed bearing frame is effected, when the entire length of the band is full of sods, by means of electrical machines in the bearing rings on the cars. The peat sods are in this way tipped on the drying ground. The spreading of the band of sods and the return of the conveyer to its original position by further rotation in the same direction require altogether only forty seconds. It has been found that the output of the spreader is 600 cb. m. in ten hours. The belt is emptied fifteen times every hour.

(e) *The Swedish Sod Spreaders of Ernst A. Persson, Körner, Eslöf*, and others, resemble in the main the varieties described above. The Persson spreader, which is constructed at Abjörn Anderson's Mek. Verkstad A.B., in Svedala, resembles the Wielandt spreading belt (an endless belt running in a transportable frame), and is constructed to deliver to a distance of 150 m.

It is not yet possible to express a final opinion on these mechanical transporters and sod spreaders, which automatically transport the peat sods and spread them on the drying ground over distances of 30 to 150 m. They should all be useful, but nevertheless capable of improvement. Wielandt's spreaders are at work in Wielandt's Peat Factory at Elizabethfehn (Oldenburg) and at the Rosenheim Salt Works; Streng's and also Dolberg's at the Aurich Wiesmoor; Baumann's at the Raubling Bog of the Rosenheim Salt Works; and the Swedish spreaders in several Swedish peat factories—Persson's, for instance, at the Emmeljunga Peat Factory.

## B.—On Installing and Driving Machines in a Peat Bog

### 1.—Installation of Driving and Working Machines

Only in rare cases do the transport and the installation of the machines offer any difficulties, and even then only when it is not possible to drain the bog sufficiently, before beginning the work, to give adequate supporting power. In this case the pressure due to the weight of the machines set up in the bog should be distributed over greater surfaces than those afforded by the frame of the peat machine or the four wheels of a locomotive. The working machine, or driving machine, is placed on a wooden frame provided with rollers by means of which it is moved over temporary rails and is allowed to remain on these while the work is going on where it has been installed, as has already been indicated in the case of the Hanoverian transportable peat machine (Fig. 57 and also Fig. 86).

At least two pairs of these supporting rails must be procured so that one pair can be placed in front of the other when the machine is to be moved forward.

These wooden frames, which are partly mounted with iron, must not be too heavy to be lifted and moved forward, length by length, by the gang usually engaged in working the machine. In this way an artificial road is made by means of which at least

the peat machine, the weight of which should rarely exceed 1,000 to 1,500 kilos, can be brought to the working place.

This cannot always be done with the driving machines—locomotives, steam engines, &c.—which may have a weight of 4,000 to 5,000 kilos for 8 to 12 h.p.

In the latter case, in order to cut down the transport of the peat as much as possible, the only alternative remaining is to set up the peat machine at the working place in the bog and the driving machine on firm ground at the edge of the bog, transmitting the power to the working machines by means of a wire rope or, still better, in the form of electricity.

It is worth noting here the arrangement which the machine manufacturer, J. Müller, of Prague, devised in his time to enable the power machine and the working machine to be moved easily and quickly by means of steam. The peat machine is supported on two U-shaped carriers and rigidly connected to the front support of the locomotive so that when the machine is being moved forward for work at different places it all forms a rigid piece, and therefore when the forward motion has been completed it does not again require readjustment. When for any position of the machine the peat has been so far worked that the transporter or elevator can no longer be suitably and easily fed, the whole machine is moved forward. For this purpose a rope drum, driven by the locomotive when this is coupled to it, is placed under the frame of the peat machine; a wire rope is coiled round the drum and the other end of the rope is fastened to an anchor which is placed at any point of the bog situated in the desired direction of working. By driving the rope drum the locomotive, together with the peat machine, is moved forward on the underlying rails and when the forward motion ceases the machine can at once begin work.

The drainage of the bog will, meanwhile, as a rule, have so far advanced that the peat machine and the locomotive, screwed on a common frame provided with wheels, can be moved forward on rails placed under the wheels as the working of the bog progresses. The track is best made of ordinary (railway) rails supported on wide sleepers and should consist of separate sections which can be joined together. The machinery is moved forward either by hand-levers with ratchet wheels which are fixed as a driving shaft on one axle of the frame, or by a contrivance for moving the machine by which the locomotive or electro-motor works the driving shaft by means of a chain and toothed wheel intermediate gearing. It may also be moved by means of the above described anchor and rope.

The commoner plans for installation and working may be seen from the following figures (Figs. 81 to 87).

Figs. 81 and 82 each show a machine peat works for horse driving. In the former the raw peat is won from the dry peat trench by hand cutting, and in the latter it is raised from under water by a cutting machine.

Fig. 83 shows a steam-driven plant in which the peat, which

is to be worked by a machine, is raised by means of several cutting machines set up at the edge of the bog. The crude peat is brought in and the formed peat taken away over an endless track.

Fig. 84 shows a steam-driven plant with a cutting machine in a bog which cannot support the weight of a locomotive owing to

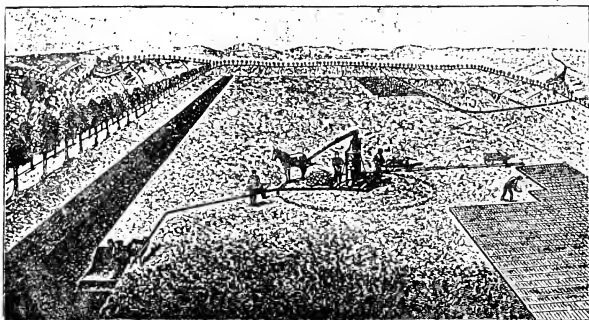

FIG. 81.—Installation of a horse-driven peat machine with a barrow track (high bog).

insufficient drainage. The locomotive is therefore mounted on a flat-bottomed boat from which it drives the cutting machine and the peat machine, which can be moved over rails. The cutting

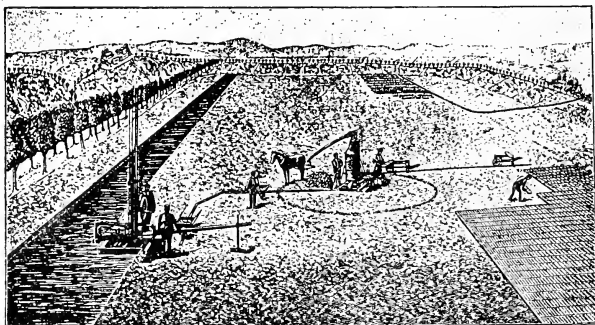

FIG. 82.—A peat machine, as in Fig. 81, in conjunction with a cutting machine (low bog).

machine and the peat machine are fixed on a bridge which is supported partly by the flat-bottomed boat and partly by two narrow gauge railway cars.

Figs. 85, 86 and 87 show steam-driven industries with raw peat elevators. According to Fig. 85, the machine with an elevator

trailing behind it—a “back elevator”—can be moved along the peat trench; in Figs. 86 and 87 the machine frame with its laterally fixed elevator—a side elevator—can be moved in front of the top of the cutting trench.

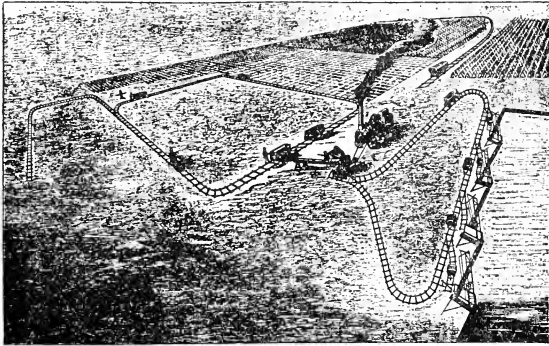

FIG. 83.—A steam-driven peat machine with cutting machines; endless transport track.

The labour required for the two arrangements of the elevator is the same and the peat can be always thrown on to the elevator

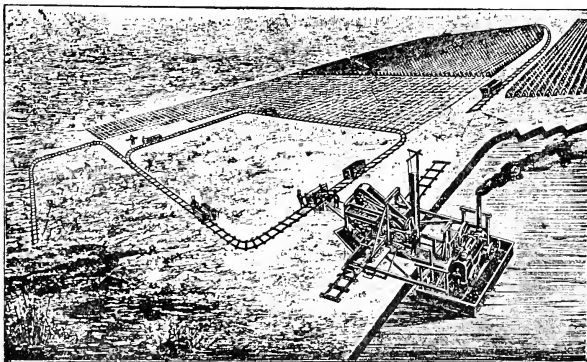

FIG. 84.—A peat machine with steam-driven cutting machine of R. Dolberg and Co.; endless transport track.

from both sides. In some cases, however, the forward motion of the machinery in the direction, and in front of the top of the cutting trench, which is possible with the back elevator arrangement, is more convenient than that along the side of the peat trench.

2.—*Driving Peat Machines by means of Draught Animals*

Little need be said about the driving of the working machines by means of draught animals (horses and oxen). The peat machines and the capstans (horse poles) which may be required to

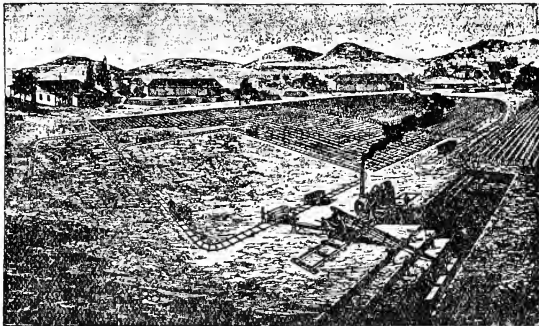

FIG. 85.—A peat machine with an elevator (in back position); endless transport track.

work them (in the case of machines with rapidly running knife shafts) are usually, for the sake of security, fixed on a platform of sleepers which is placed under them and prevented from moving or sliding in the bog by piles driven into the latter.

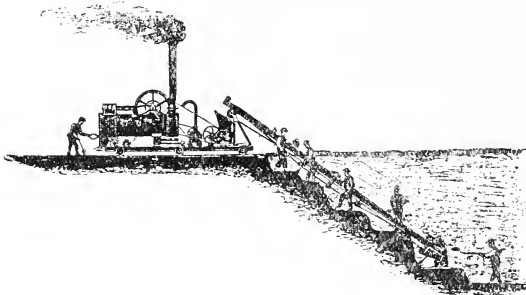

FIG. 86.—A peat machine with an elevator (in "side position"); advancing the machine in front of the top of the trench.

Owing to the constant motion and treading of the draught animals in a relatively small place in a bog which is only barely able to support traffic, a disadvantage will soon appear, inasmuch as the feet of the animals sink into the circular track which has been worn and softened by the constant treading. This tires the animals and makes continuous working impossible. In order



to avoid this, treading boards or clogs like those shown in Figs. 88 to 90, are fastened under the hoofs of the animals; still, in many cases this remedy is not sufficient. These clogs should be in contact with the shoes and not the hoofs of the animals, and may be fastened by wedges to the shoes. Sores due to chafing are avoided by putting rags under the straps. Improved horse clogs, in which wedges are dispensed with, and adjustment for different

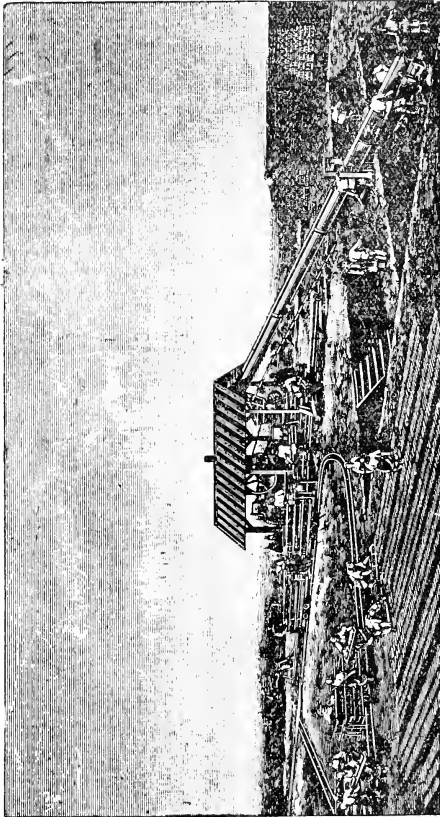

FIG. 87.—A peat machine with an elevator (in "side position") and the long track for the removal of the peat.

sizes of hoofs is provided for by an adjustment up to 5 cm., are sold by the master smith Westphal, of Bremen, at a price of 2·5M. per pair, including the wooden soles. H. Osmers, of Hinzendorf, near Langwedel (Hanover), sells wooden horse clogs. Bernhard Vogler, of Erfurt, makes horse clogs, as in Fig. 89, from Indian fibre. They cost 2·0M. and are said to have proved successful. If the treading boards are not sufficient for their

purpose the treading track is excavated to a depth of 0.5 to 0.6 m. and filled with sand or waste solid, or, if this cannot be obtained in the neighbourhood, with the roots or shrubs found in every bog, which are placed close together in as uniform layers as possible across the track in place on the excavated peat. The peat raised during the excavation is employed to level the surface of the track. In this way a safe and a sound track for draught animals is obtained, on which they do not become fatigued by the motion as do animals with treading boards buckled on their feet. The treading track may also be made of planks, which are for this purpose made ring-shaped and capable of being taken apart in several sections. In regard to cheapness and suitability of construction this arrangement is, however, inferior to that mentioned above.



FIG. 88.—Horse clog.



FIG. 89.—An Indian fibre horse clog, made for buckling on.



FIG. 90.—An Indian fibre horse clog, made for lacing on.

### 3.—Driving Peat Machines by means of Wire Ropes

A plant of this character offers no particular difficulties, but when it is employed frequent changing of the position of the peat machine during the season must be sacrificed. The length of the ropeway as well as the number of driving and supporting rollers depend on local conditions—the arrangement therefore, varying in every case.

Fig. 91 illustrates the arrangement of a wire rope plant for two peat machines which are to be driven by a locomotive.

At the edge of the bog which is unsuitable to support traffic the locomotive *A* is installed, and on its flywheel there is a rope pulley having a diameter of about 1,600 mm. From this the power is first transmitted by means of a wire rope, 15 mm. thick, to the intermediate shaft, which is at a distance of 40 m. and supported on a wooden trestle. On this shaft there are also the driving pulley for the first peat machine  $T_1$ , and a second rope pulley having a diameter of 1,200 mm., which transmits the rest of the power by means of a rope, 12 mm. thick, to the second rope shaft, which is 60 m. away, and by means of the belt pulley on this to the second peat machine  $T_2$ .

The loss of power in the case of such a wire rope plant is smaller than is usually supposed and when the plant is well

constructed it amounts at most to 1 per cent. for every 100 m., while the cost of erection, rope pulleys, supporting trestles, wire ropes, &c., amounts to 3M. to 6M. for every metre of the distance between the rope pulleys.

According to the experience hitherto gained a wire rope in continuous use lasts on an average one to two years, so that if it be used only in the summer season it should last for two to four years. If the ropes last a shorter time than this the installation must be a faulty one.

At present wire ropes are not used to work several peat machines situated at distances from each other. They have been replaced by *electrical driving*, which is simpler in working and easier to maintain.

#### 4.—Selection of Driving Power

If the amount of peat won permits, the driving of peat machines is best effected either by means of a steam engine or by electrical power if an electric power installation exists or can be erected with advantage for working several machines. Even if the outputs for horse driving given in the price lists of peat machine builders are attainable with every horse this is usually possible only for short working periods. In most cases the animals cannot stand the heavy labour of continuous work and either the output decreases or the horses break down and relays of horses must be provided; in any case, the cost of production is considerably increased and it will generally pay to procure a steam engine as driving power. For this purpose a locomotive is usually chosen. Although a locomotive consumes more fuel and requires a higher rate (12 to 15 per cent.) for amortization of its cost price than a stationary engine, it has, on the other hand, advantages in so far as it can be readily installed, easily attended, and readily moved from one place to another as the work progresses. In many cases, moreover, the owners of the peat bogs are at the same time more or less large agriculturists, and the locomotives can, therefore, be used for working threshing machines, distilleries, mills, &c., during the months when the peat industry is quiescent.

When selecting locomotives for driving peat machines attention must be paid to the fact that only peat mould and waste peat or incompletely dried sods, bog wood, &c., are usually employed as

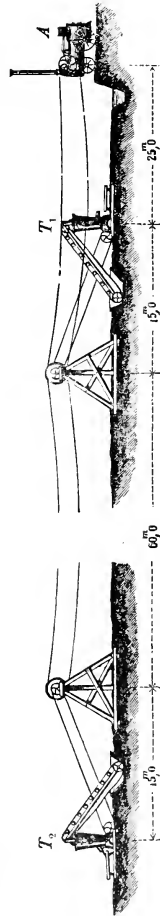

FIG. 91.—Driving two or more peat machines by means of a wire rope.



fuel in the bog. Not only a greater heating surface in proportion to the power of the locomotive is, therefore, required for the boiler, but also the firebox and the area of the grate must be larger than those generally used in locomotives.

While a boiler-heating surface of 1.4 to 1.7 sq. m. per horse-power is sufficient for a locomotive heated with coal or good dry machine peat, at least 1.8 to 2.0 sq. m. heating surface per horse-power is required in the case of the above-mentioned less valuable fuel. In the latter case also the firebox must be correspondingly increased in size. It will be well, therefore, if the locomotives to be selected from were not originally constructed with the more or less large firebox and heating necessary for an inferior fuel, to select a locomotive 20 to 25 per cent. more powerful (in amount of horse-power) than would be actually required for the driving of the peat machine.

The consignment weight (for transport) is about one-fifth more than that given above. Locomotives with fore-grates or step fore-grates for heating with peat cost 4 to 10 per cent. more and are about 5 per cent. heavier than the ordinary ones. The Lanz locomotive boilers with "Colonial fireboxes" are said to have proved suitable for peat-firing.

The above prices refer to locomotives provided with removable tubular boilers, reversible distributing valve motion and automatic regulation. Only the first two sizes have ordinary distributing valve motion and locomotive boilers.

Nominal outputs as an *indication of size* for sale do not enable us to form a reliable estimate of the size and output of machines or to compare tenders in a satisfactory manner. These nominal outputs are given too high by some and too low by other machine builders and traders. The cylinder measurements with a given working pressure, and the heating surface, serve as guides, and still better *the actual effective output, based on these, guaranteed by the seller for regularly conducted continuous working, when the steam pressure, the horse-power, the number of revolutions, and the maximum steam consumption are all given.* No purchaser of a locomotive should fail to obtain such a guarantee. In the more recently constructed locomotives the working pressure amounts to 8 to 10 atmospheres.

If the work is to be conducted economically by avoiding loss of heat, the steam cylinders and distributing box must lie entirely within the steam chamber of the boiler. Under these conditions the consumption of steam for a regular load is 13 to 11.5 kilos per horse-power hour, and that of fuel is 1.50 to 1.70 kilos of coal (calorific power 7,500 calories), the lower figures applying to the larger machines (up to 30 h.p.).

Further particulars with regard to locomotives for peat-firing are contained in Part II of this book.

It should be noted, moreover, that the German steam boiler industries prescribe two feeders for every locomotive; a locomotive which has only one feeding pump is not regarded in Germany as being in *proper working order*.

Either the migratory mode of working introduced for peat pulp machines, described on pp. 139 and 140, or the transmission of power to a propelling contrivance connected to the machine frame, such as has recently been generally employed in the case of horizontal peat machines, appears a suitable method for utilizing a locomotive.

If such a migratory industry be not practicable owing to existing local conditions (hilly or broken country), or on account of the surface being unable to support traffic, the bog is to be divided into several plots, which should be worked in turn and the site of the peat machine and the locomotive should be changed only at fairly long intervals. The transport of the raw and the formed peat is in this case best effected by means of the movable rail tracks, described below, and transport cars which together constitute the so-called *field railways*.

The direct connexion of the steam engine with a peat machine in such a way that the fly-wheel of a horizontal steam engine, by means of a pair of spur wheels, drives the knife shafts of the peat machine, which is fixed on the same frame as the steam engine—the steam (locomotive) boiler being at the same time set up separately from these—cannot be regarded as either a well-devised mode of working or as an improvement on the plan hitherto adopted.

Naturally, the parts of a peat machine which are in motion outside the mixing cylinder become soiled by particles of raw peat, waste matter, &c., scattered during the work. The earthy constituents—sand, stones, &c.—contained in these cause greater wear and tear of the machines than the latter would otherwise experience. This may be seen actually occurring in all peat bogs in spite of every precaution. All machines and parts of machines which are not absolutely and directly essential for the working of the peat machine should therefore be set up as far as possible from the latter. In this way they can be protected from evils which cannot be avoided in the case of the peat machine itself.

The electrical driving of several peat machines in a large peat factory may be carried out with great advantage from a central power station, like that, for instance, of the North German Peat Company at Triangel, near Gifhorn (Hanover), where ten peat machines are driven in this way. By this method it is possible to dispense with two men (a stoker and a water carrier for the locomotive) in the case of each peat machine. Moreover, the raising of steam at a single boiler installation, that of the electric power station, as well as the moving forward of the peat machines during their work, are more conveniently carried out, and are therefore less costly. No difficulties are experienced with regard to the transmission of the power to the peat machines, which are distributed in the bog, at any desired distances from the power station. Nor are any difficulties encountered either in driving the machines by electro-motors fixed on the frames of the machines or in shifting the cable when the machines move forward. Even ordinary agricultural labourers quickly learn how to deal

with the current conductors. Further particulars with regard to this may be seen in the description of the factory of the North German Peat Company contained in Subsection G of this Section. *When substituting electrical driving for steam power it must not be forgotten that the power required for a peat machine is generally given as lower than it really is,* and that locomotives are always able to give a few horse-power more than that corresponding to their nominal horse-power, while the nominal power of an electro-motor as a rule corresponds exactly to its actual power. If for working a peat machine a so-called 10 h.p. or a 15 h.p. locomotive, for instance, were sufficient, then for electrical driving instead of the latter a 13 h.p. or a 20 h.p. motor should be taken.

### C.—Transport of Raw Peat to the Machine and of Machine Peat to the Drying Ground or Sheds

Although the devising of a cheap and rapid mode of transporting the raw and the manufactured peat in a peat works may at first sight appear a simple matter, it is in reality a difficult one, especially that of removing the freshly formed peat sods from the machine to the drying place. Cases are known to the author in which a peat machine could not be kept going fully, because in spite of every effort the formed peat could not be removed from the machine as fast as it came from the mouthpiece, and also, with the means of transporting at hand, neither the loaded barrows could be taken away nor the empty barrows brought back quickly enough to keep the work going smoothly. The output of the machine had to be cut down in order that the work should be continuous.

The difficulties are due chiefly to the fact that relatively large quantities (40,000 to 80,000 peat sods per day) must be transported from a single working place to discharging stations, the positions and distances of which change quickly, especially when drying in the open is practised. They are also due to the surface of the bog being only in rare cases so smooth and firm that the loaded cars or barrows can be easily moved over it without a field railway. Owing to the nature of the bogs, field railways cannot in most cases be dispensed with. In order to increase as much as possible, with the expenditure of little labour, the quantity to be transported on them, it is essential that the positions of the field railways should be capable of being altered as those of the drying ground and the working place undergo change.

The following means are employed for this purpose :—

#### 1.—*Barrows and Barrow Tracks*

In the transport of large quantities such as are dealt with in the machine peat industry, the use of barrows for this purpose is admissible only when these quantities are not moved over a track through the long distances required in the case of a big factory with a large output, or, in an industry where the peat machine

is moved forward only at long intervals. On the other hand, transport by means of barrows can be employed with advantage when the output is small, or when the peat has to be moved only a short distance, as, for instance, when a migratory machine or a pulped peat machine is employed, and even then in most cases an artificial track, the so-called barrow track, must be employed. The track may with advantage be made of planks, 25 cm. wide and 5 cm. thick, and its position in the peat bog can be altered as required. Boards less than 5 cm. thick should not be used as planks for the barrows, otherwise the wear and tear and the loss due to their replacement, which very soon becomes necessary, would be abnormally high.

When pinewood costs 45M. per cubic metre, a linear metre of barrow track costs  $0.25 \times 0.05 \times 1.0 \times 45 = 0.60M.$ ; at least 25 per cent. should be allowed for wear and tear and loss per annum.

The barrows, wheel-barrows or box barrows are constructed according to various types which depend on local usage, but with regard to them we must rigidly adhere to the principle that the

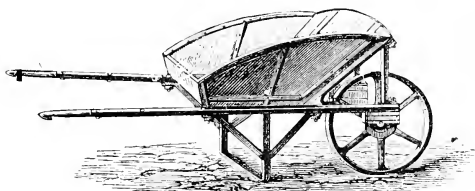

FIG. 92.—Peat barrow.

best are always the cheapest in the long run. On account of the ease with which barrows with sloping sides can be emptied, they are to be recommended for the transport of the raw peat to the machine. Such a barrow made of wood costs, according to price of materials and rate of wages, from 25M. to 30M. when its capacity is  $\frac{3}{4}$  hl.

Barrows made entirely of wrought iron are the most satisfactory. That shown in Fig. 92, having a capacity of  $\frac{3}{4}$  to 1 hl., costs 30M. to 40M.

Although their cost is considerably greater than that of wooden barrows, they can, with only a very slight expenditure for repairs, be used for at least ten years, whereas all wooden barrows have high running expenses, and after two years' use only bits of them remain. The position of the centre of gravity of a loaded barrow constructed according to Fig. 92 is also more favourable for the wheeler, and the barrow itself can be handled more conveniently than is usually the case with wooden barrows. The workmen therefore prefer these barrows, and, as they also load them better, this has a double advantage so far as the daily output is concerned.



Wheel-barrows are not so well suited for the removal of peat sods from the machine, since they afford only a relatively small loading space. For this purpose the barrows are made with more or less long, straight trees, on which the boards, covered with four or five sods each, are placed crosswise in two rows over one another. To prevent tilting and upsetting of the barrows two wheels, at a distance of 300 mm. from one another, are sometimes attached to the axle instead of the single wheel usually employed, but this, however, necessitates the widening of the barrow track, and at the same time makes it more difficult to turn corners with the barrow.

## 2.—Cars on Railways (*Field Railways and Transport Wagon Railways*)

In the case of a large industry or in that of a process which necessitates transport to long distances, it is advisable to install tracks and railway cars (field railways) both for the raw peat which is to be brought to the machine and for the peat sods to be

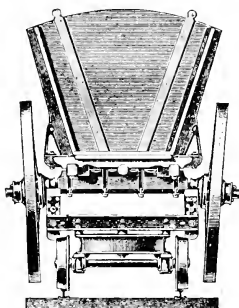

FIG. 93.—Wagon with a field railway bogie under it.

taken away from it. The gauge of the track most suitable is 600 mm. These field railways can also be used for the removal of ordinary agricultural or transport wagons, so that loads can be brought without unloading the wagons from the original or collecting station to the end of the field railway and from there to the place where the peat is utilized, or difficulties due to unavoidable interruptions in the field railway can be surmounted.

The wagons are brought over a pit through which the field railway passes, and bogies running on the field railway are placed under the wagons (transport wagon tracks), see Figs. 93 and 94.

As the sites of the working centres in a peat factory (peat bank, position of machine, drying ground and drying sheds) are liable to alter, the rails must be so constructed that they can be moved from one place to another without much expenditure of time and labour. The rails employed are generally either the so-called pit rails or flanged rails. Ease of removing the rails and their accessories—turntables, switches, traversers, &c.—is attained in various ways.

For the construction of such field railways and transport wagon railways it is best to apply to factories which make their manufacture and supply a speciality. Amongst these are Orenstein and Koppel and Arthur Koppel and Co., of Berlin, Bochum and Vienna, Ferrovia Railway Works, Vienna, Bochum Steel Foundry, R. Dolberg's Machine and Railway Works, Rostock, Berlin, and Hamburg, and others. For particulars as to the construction of tracks we must refer to the detailed illustrated price lists or instructions issued by the above-mentioned firms.

Generally speaking the following must be considered :—

(a) *Tracks, Crossings, Switches, Turntables, and Turning Plates.*—As in ordinary railways, it is also often necessary in the case of field railways that two tracks should intersect, or that a single track should branch into two tracks, or that two separate tracks should be connected together by means of a third, or, finally, that from a single track another should branch at a given point and at a given angle.

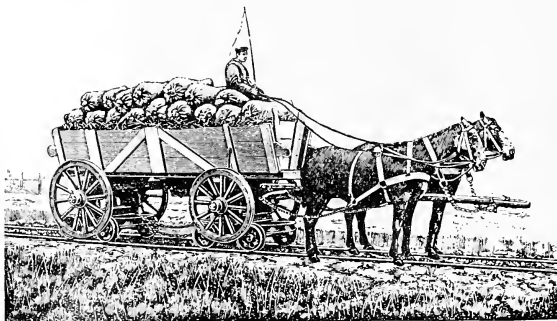

FIG. 94.—Wagon on bogies.

For the first three the so-called switches with crossings (cross-frogs) are necessary, and for the last we require turning plates and turntables. The switches and turntables are made either for letting into or for placing on the ground, forming the so-called by-passes or turntables.

The arrangement of the rails for these cases may be seen in Fig. 95, in which one track is split up into others by means of a switch at *a*, one track cuts another at *b*, and also each of the middle tracks connects the two outside tracks with one another. The turntable *c* and the turning plate *d* allow of passing from one track to another at a right angle or at any oblique angle desired.

As may be seen, it is not possible to arrange the switches and crossings without employing curved rails. The making of these, however, offers no difficulty as the pit rails which are employed for the purpose can be bent even when cold.

In narrow gauge tracks, such as these, on which the cars never attain any great velocity, the radius of curvature of the

bends in the switches may be as small as 1 m. To prevent the car wheels from becoming fixed in the bends it is necessary when the rails are much curved to increase the gauge by 10 to 15 mm.

Fig. 95 shows also the arrangement of two tracks at the working station of a peat machine the position of which is never altered. The peat machine *M* is between, or beside, two tracks on which the empty and the loaded sod cars are taken away and brought back

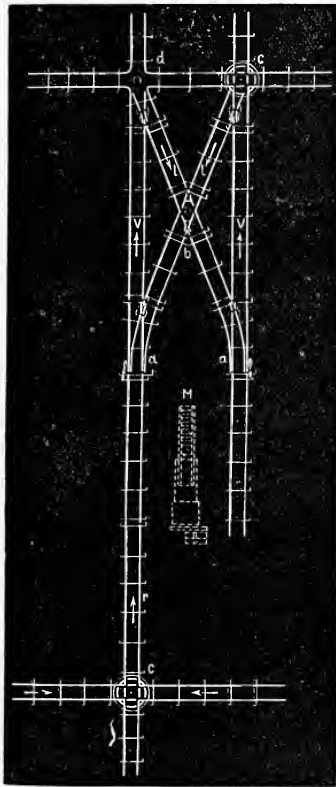

FIG. 95.—Scheme for changing from one track to another.

alternately. The loaded cars always pass over the straight side tracks to the turntables or switches and from there travel, according as required, to the right, left, or straight on to the drying ground. The returning empty cars pass from the turntables (which can also be replaced by turning plates) to the middle cross rails, and, when the loaded cars have been removed, are pushed from there to the cutting table of the peat machine, where they

can again be loaded with formed peat. The raw peat is transported to the machine over the track *r*, which is either connected by means of the turntable *c* with the track lying beside the peat bank or else lies beside the bank.

In places where, on account of want of room, the various tracks cannot meet at the small angle which is necessary when switches are employed, or where one track intersects several others at almost a right angle and it is necessary to be able to pass from it to the others, turntables *c* or turning plates *d* must be laid (Figs. 96 and 97).

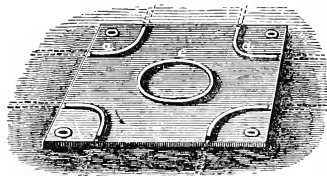

FIG. 96.—Turning plate.

The *turning plates* consist of wrought-iron or cast-iron plates, 1 to 1.5 m. square and lie fixed between the rails in contact with them. In reference to the upper edges of the rails the plates are so high that the flanged wheels run on them as they leave the rails. On these firmly fixed plates the cars are rotated round their vertical axes until their longitudinal axes coincide with the middle lines of the railways to be traversed. The turning of a car, during which operation the wheels must slip sideways on the fixed plate, can be accomplished when the car-load is about 1,000 kilos (everything included) only when the car attendant exerts all his strength; this is, therefore, a matter of considerable difficulty.

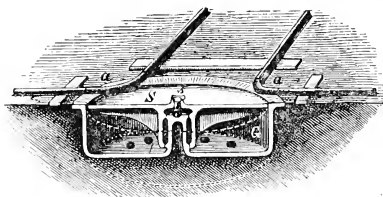

FIG. 97.—Turntable.

Owing to the unavoidable lateral pressure on the axles and bearings of the cars and the slipping of the wheels, this method of turning is in the long run injurious to the plant and occasions frequent extra work and rapid wear and tear. As, moreover, the time required for the turning is greater than that required when turntables are employed the latter are generally preferred in spite of their greater cost.

Wrought-iron turning plates consist mostly of smooth, square plates, 8 to 10 mm. thick, on the sides of which the somewhat

curved ends of the rails rest, supported transversely on sleepers. As shown in Fig. 96, a cast-iron turning plate has a turning ring *c* in its centre and short rail pieces to connect it with the rails of the track so that the cars can be accurately turned and pushed into the rail track to be traversed. Fig. 97 shows a *turntable* which is often constructed even for broader gauges and heavier loads than are met with in bogs. In the cast-iron case *G*, which acts both as a cover and a support, the disc *S*, strengthened by the ribs and supported by the steel pivot *s*, rotates by means of a hollow spindle round the upturned central column of the case. The pivot and the turntable can be easily lubricated from the outside by means of an oil-hole in the centre of the table.

This mode of construction has the advantage that the turntable, when buried and tamped in the ground or the bog, can be traversed by loaded cars as soon as it is connected to the railway track. This is of great importance when it is a question of changing the position of the railway.

The plates of these turntables can be made without rails and therefore quite smooth. It is thus possible, without being obliged to adjust the table for the axis of the rails and then fix it by a latch contrivance, to move a car from any track on to the turntable and after rotating the latter until the car is in the axis of the outgoing track to move it into the latter, after which the turntable is again ready to take any other car. This construction is to be recommended when many crossings at different angles occur in an extensive network of railways and when the traffic over one rail is to be made to pass in the desired direction over another rail by means of turntables all of which are made according to the same model. In this case the rail terminals only require to be screwed to the border round the turntables. When the turntable is constructed according to this type the advantage hitherto claimed for the smooth turning plates, viz., that they are capable of being used for any desired direction, is shared by the turntable, which is at the same time free from the defects of the turning plate already mentioned. These turntables have all the advantages of the turning plates and answer every demand made upon them.

When at all possible it is advisable, in the case of a large railway system, to lay separate tracks for the loaded and the empty cars, the so-called parallel tracks or auxiliary tracks. In this way disturbance in the working is most easily avoided and shorter transport distances are required. If this is not practicable, endless tracks (as in Figs. 83 to 85) or, in the case of only a single track, sidings are to be made. The points of the track, in the latter case, at which sidings are to be made will be determined by the number of cars to be moved and the length of the track. The connexion between the sidings and the main track is usually made by a hand-controlled switch. Special attention must be paid to these sidings when laying rails, as they give rise to frequent derailment of the cars, and, therefore, to working troubles if their construction is faulty. With the ordinary arrangement of switches

this may occur, especially when the cars enter the siding. The shock of running on to the siding rails and any faulty construction of the latter, together with the tendency of the car to remain on the straight track owing to its inertia, usually give rise either to derailment or to running ahead on the straight track and, therefore, to collision with any cars which it may meet on this.

In order to avoid this defect as far as possible, it is advisable to arrange the switches so that each car, no matter in what direction it is moving, should run straight into the siding. Only the

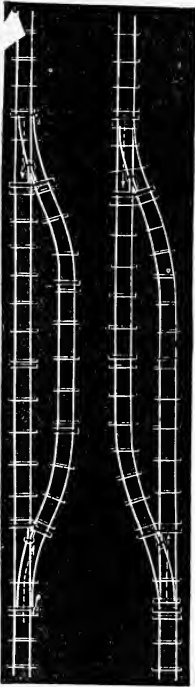

FIG. 98.

FIG. 99.

exit from the siding should be curved. This can be effected by arranging the siding as shown in Fig. 99. The tendency of the cars to run off the rails or to run on to the wrong track is so diminished by this arrangement that these sidings can be constructed without any movable rails, without endangering the safety of the traffic, and without the car attendants requiring to diminish the speed at these points or devote special attention to the guiding of the car. The cars automatically run into and out of the siding in the right track provided that the crossing places in the tracks for the flanges be left open, as shown in Fig. 99. The saving of the movable siding rails is important for the industry in so far as we can dispense with the pointsmen who would be required at these places in the event of much traffic; also, when there are no pointsmen the men pushing the cars, who are entrusted with the care of this contrivance, need waste no time with it and can run through the sidings at full speed, which is of great importance for the maintenance of a regular and undisturbed traffic.

A single track railway, 5,000 m. in length, was constructed in this way to carry wood. It had five loading stations and also sidings for cars passing one another without any movable switches, the changing of which with so long a track and with the constant daily use of the railway would have required at least five workmen. The wood cars, connected together in threes, passed automatically through the sidings without any disorganization, due to derailment, being experienced. The whole track lay downhill, so that once the cars were in motion they continued running of their own accord to the terminus. As an indication of the suitability of the siding arrangement we have the fact that the cars, which were let go by themselves from the hill and which on account of the steep incline traversed the

track with a speed of, say, 3 m. per second, passed through all the sidings (none of which had movable switches) in a regular manner (always running correctly) and arrived at their halting place without running off the rails. As a consequence of this the working was arranged, at first in an experimental manner for the first two stretches of the line, so that the loaded cars as they ran down the hill drew the empty cars up the hill by means of an endless rope passing round two drums and the trains could then be left without any attendants whatever. The cars passed through the sidings so safely that this method of working could be set up for the whole line, and in this way the working expenses were very considerably diminished. The ropeways ran on the ground on small wooden rollers right and left at the sides of the track.

The following method for conveying raw peat to the machine, which has already come into use in many peat works, may be indicated as a suitable one. It consists in driving from the locomotive both the peat machine and a capstan or windlass contrivance which, by putting into or throwing out of gear a coupling, can be set into or thrown out of action. A chain fastened at one end to the drum of the windlass is coupled at the other end by means of a hook and eye to the car loaded with raw peat in the bog. As soon as the capstan contrivance is set in motion the car is drawn on the track laid between the peat bank and the peat machine until it is close to the working place, where it is emptied and again pushed back. If the rail track from the peat bank to the machine runs up an incline of at least 1 in 100, the cars, when emptied and set in motion by a push, will run back of their own accord.<sup>1</sup>

(b) *Transport Cars for the Raw Peat and the Machine-formed Peat.*—The cars in use for transport are of the most diverse makes. Generally, cars of the same type serve for raw and for dry peat. These are usually made in the form of tipping cars on account

---

<sup>1</sup>The use of wire ropeways as a means of transporting raw peat or formed peat sods in a peat works is not to be recommended under ordinary conditions. Such an installation deserves consideration only when very undulating or very much intersected ground makes the construction of a firm railway track either impossible or too costly, or where waterways, roads, and valuable ground, which cannot be acquired, must be passed over without interfering with the traffic on the former and the utilization of the latter. In peat works, when we are dealing only with level ground, and when the length of railway connecting the peat bank, the machine, and the drying ground is relatively short, the laying of a firm railway track will always be preferred to a wire ropeway from the point of view of cheapness of the installation and security of the industry.

The matter assumes a different complexion when it becomes a question of sending peat from the bog to good roads, re-loading stations, places of consumption or distant centres where the peat is further worked. In these cases the great distances and land difficulties must be taken into consideration and the use of a wire ropeway may very well be substituted for that of a solid railway track, as, for instance, at the Dyckerhoff Peat Moss Litter Factory, at Neustadt, in Rügenberg, which has a wire ropeway 4 km. in length.

of the ease and the rapidity with which they can be emptied (see Fig. 100). Recently these cars have also been constructed in the form of "ring tumbler" or "ring tipper."

For removing the fresh sods from the machine to the drying ground or sheds the transport car, the construction of which is illustrated in Fig. 101, can be recommended.

The most important point is that such a car should be able to take so many spreading boards, 1 to 2 m. in length and covered

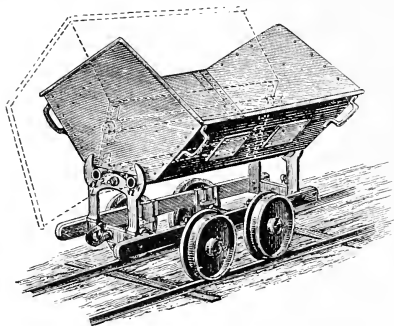

FIG. 100.—Peat car, tipper.

with "formed peat," that the car will have its full load, i.e., the pushing force of the workman will be fully utilized. To ensure regularity of working at the drying ground it is essential that all the boards may be put on and taken off easily from either side of the car.

The type of construction mentioned above fulfils these conditions, since such a car, according as it contains 3 or 4 tiers, is

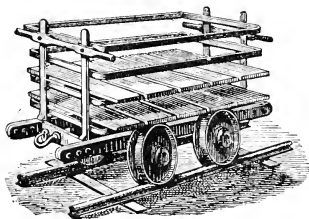

FIG. 101.—Transport cars for peat sods.

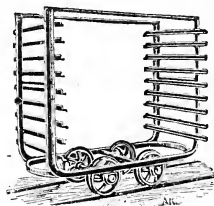

FIG. 102.

capable of taking 12 to 16 boards, each of which is 1 m. in length, 300 mm. in width, and can be loaded with 12 standard sods (2,000 c.c. volume).

This corresponds to a load of 144 to 192 sods of 3 to 4 kilos each and, therefore, to an effective weight of 500 to 790 kilos, which one man is able to move over an iron railway track. As the boards are laid across the longitudinal axis of the car they can be taken off and put on without difficulty at either side, which is not the case



with cars in which the boards lie in the direction of the longitudinal axis on both sides of central supports.

Fig. 102 shows another arrangement with boards lying in the direction of the length of the car, which can be recommended when the boards are more than 1 m. in length.

Cars like these, made altogether of iron, with roller bearings and lubricating caps for the wheels, weigh 180 to 200 kilos and cost 80M. to 100M.

The *diameters of the wheels* are chosen as large as possible, so that the cars may be the more easily moved; they may with advantage be from 300 mm. to 400 mm.

The *axle distance*, i.e., the distance apart of the centres of the axles, is to be arranged so as to leave a space of 30 to 50 mm. between the circumferences of the wheels. It must not, however, be made less than 350 mm., and it is generally 400 mm. The shorter the distance between the axles the more easily the cars traverse bends and the more conveniently they can be pushed on to turntables and turning plates.

In order to make the moving of the cars on the rails as easy as possible and to spare the transport gear it is necessary to keep the running surface of the rails free from waste matter, sand, or peat. This can be conveniently done by means of a scraper with which a workman cleans the rails at least once a day.

(c) *Prices of the Component Parts of a Field Railway.*—According to the price of iron, the greater or smaller demand, the place where required, and according as the rails for a 600 mm. gauge are chosen at 45 mm. or 50 mm. in height, the prices of the parts necessary for a field railway are approximately as follows :—

	Light tracks for hand or horse power. Marks.		Heavy tracks for locomotive power. Marks.
1 linear m. removable rail consisting of steel rails 5 m. in length with cast-steel sleepers, made from rails 65 mm. or (in the case of locomotive power) 70 mm. in height .. .. .	3·50-4·50	..	4·50-5·00
1 m. fixed track for wooden sleepers or as in the preceding with fish-plates and fish-bolts .. .. .	2·30-2·80*		3·50-3·80
1 removable rail crossing, right-angled .. . . .	35-40	..	60-65
1 removable rail crossing, acute-angled .. .. .	60-75	..	120-130
1 movable switch 5 m. long ..	45-55	..	70-75
1 complete set of points with switches 2·5 m. in length and adjusting block .. .. .	100-110	..	130-140
1 movable by-pass .. .. .	30-35	..	35-40
1 movable by-pass 5 m. long ..	50-55	..	70-80
1 turntable, 95 cm. diameter ..	60-80	..	—
1 cast-iron turning table, 1 m. diameter for 1,500 kilos weight ..	25-35	..	—

\* Waterproof sleepers for these cost 0·80M. or 1·20M. per metre for thicknesses of 10 x 12 cm. or 12 x 14 cm.

	Light tracks for hand or horse power. Marks,	Heavy tracks for locomotive power. Marks,
1 by-pass turntable with two pairs of sliding tongues .. ..	90-95	.. —
1 single track traverser, 100 cm. gauge width .. ..	110-130	.. —
1 cast-steel tipping car for raw peat, $\frac{1}{2}$ to $\frac{3}{4}$ cb. m. capacity .. ..	90-115	—
1 sod transport car with lubricating caps .. ..	85-125	.. —
1 box car with side flaps for transport of dry peat .. ..	150-170	.. —

One Montania benzine locomotive of 10 or 14 h.p. to draw 42 or 52 tons costs 7,500M. or 8,500M.

One Deutz benzine locomotive of 10, 14, or 20 h.p. may be obtained for about 7,000M., 7,900M., or 8,900M.

### 3.—*Belt Elevators, Conveyers, Automatic Spreaders, and Distributors*

To economize labour, the well-known belt elevators and chain conveyers (see Fig. 86) have in recent times also been used to transport horizontally to the peat machines the raw peat from the peat bank or the peat raised by cutting machines or dredgers in bogs which are difficult to drain. For this purpose almost horizontal conveyers, belts, chains, &c., supported by wooden pulleys or rolling latticed girders, up to 100 m. or more in length, are employed. The peat is thrown by them directly into the hopper of the peat machine, and in this way there is a saving of four or five workmen for each machine. These transporters or chain conveyers (for mud peat, tubes or channels with a screw conveyer) are also constructed as peat spreaders, i.e., they take the worked material from the mixing or forming machines to the drying grounds and deposit it there, as has been already stated in Subsection A, 4.

### 4.—*Comparison of the Powers required to move Loads over various Roads and Railway Tracks*

The power required to move a car over horizontal rails in good condition is generally 1 per cent. of the total weight of the car and its load. When working on a slight incline making an angle  $\alpha$  with the horizontal, the pushing or pulling power  $P$  required to move a total weight  $Q$  can be calculated from the formula :

$$P = Q (\mu \pm \sin \alpha)$$

where the + sign holds for motion uphill and the — sign for motion downhill, and  $\mu$  is the co-efficient of frictional resistance on the track in question, which, as above indicated, can be assumed to have an average value of 0.01.

When  $\alpha = 0^\circ$ , i.e., when the track is horizontal,  $P = Q\mu$  or  $\mu = \frac{P}{Q}$  so that the co-efficient of frictional resistance on a track

is equal to the ratio of the (minimum) moving force to the weight moved.

The following particulars may serve to compare the frictional resistance on a track with those occurring in other modes of locomotion. The co-efficient of frictional resistance is :—

For sleighs on snow .. .. .	0·02
For cars on good roads .. .. .	0·02-0·04
For cars on worn, muddy roads .. .. .	0·04-0·06
For cars on very bad roads with ruts 70 mm. to 80 mm. in depth	0·06-0·08
For cars on a wooden track .. .. .	0·02-0·03
For barrows on a wooden track .. .. .	0·02
For ordinary iron railings .. .. .	0·003-0·005
For flat-bottomed boats on water .. .. .	0·003
For auxiliary tracks, narrow gauge tracks with small wheels, field railways, &c.	0·008-0·015

In the case of the latter, when the down gradient is 1 in 100 the cars run of their own accord.

The average pulling or pushing force of a man may be assumed to be that required to give a velocity of 1 m. per second to a weight of 10 to 12 kilos, and that of a horse as that required to give a velocity of 1·3 m. to a weight of 50 to 55 kilos. According to the figures given above, one horse or one man for the same expenditure of power can move by means of a car on an iron railway track a load four times as big as they can respectively move on ordinary roads, and also at least twice as big as they can move with barrows or cars over wooden tracks.

#### D.—Drying Machine Peat

The drying of machine-formed peat or machine-pulped peat (divided into sods by hand or stroked in moulds) generally takes place like that of hand-cut peat in the open air and rarely on boards or trestles or in drying sheds. The latter method, as well as artificial drying and the manufacture of anhydrous peat, is also too expensive in the case of machine peat.

Drying peat by means of artificial heat is discussed in detail in the article on the resumption of dry pressing by Stauber and others, as well as in the subsection on the "Manufacture of Kiln-dried Peat," in Part II of this book.

Of methods for artificially drying peat two only need be mentioned. Some time ago these were called, like all such schemes, the "Solution of the Peat Problem." They were to be introduced into large peat factories.

(a) *Gehrcke's Tubular Steam Boiler* for drying peat. This is filled with wet peat. "The water of the peat is evaporated by heating, the peat contracts, passes through the tubes of the boiler, loses its water in the lower part and gradually falls into the fire, and then the automatic working of the boiler begins. The dry peat burns under the boiler, evaporating the water from a new charge of peat. The steam developed is to be used for driving machines." However, the fuel contained in raw peat which

usually has 90 per cent. of water, is not even capable of drying itself, and there is therefore no need to discuss excess steam pressure or an excess of dry fuel.<sup>1</sup>

(b) *Hannemann's Peat-drying Process* is similar to that just described. The peat, which has been passed through purifying and disintegrating machines, is to be moved by screws through an upper boiler, where it is dried. "After the substance passes the two upper spirals with a velocity of 1 m. per minute, it passes through a connecting tube into the large lower spiral, and from there to the dry press. The drying is to be effected by the heat of the water which surrounds the tubes. Only half of the dried peat should be required for drying purposes for an output of 1,500 kilos of dry peat from peat containing 75 per cent. of water with a boiler plant which has 100 sq. m. heating surface, so that the other half should be available for the manufacture of press peat. Moreover, 60 per cent. of the heat necessary for drying should be available for power purposes in the form of steam."

It is wrongly assumed here that ordinary raw peat contains only 75 per cent. of water; in the case of peat containing 85 per cent. of water 66.7 kilos more water must be evaporated in order to produce 100 kilos of peat containing 75 per cent. of water, and the dry fuel finally obtained is now not even sufficient for the whole drying operation.

In what follows, therefore, only the most important of the drying processes in which ordinary air and the heat of the sun are employed will be mentioned, in so far as the devices to be considered for ensuring the drying of machine peat are not identical with those more fully described in Section III.

### *1.—Drying in the Open Air*

The raw peat about to be worked in forming machines, which are at the same time good mixing machines, should be so far freed from excess of water that only a few drops of this can be pressed out of it by squeezing with the hand. This corresponds to a water percentage of 75 to 85, and peat freshly raised from the bog, having a higher percentage of water than this should lie for several days in the air and sun in order to lose as much as possible of the excess water by evaporation. The peat sods which then come from the machine are generally so firm that they can be laid on the drying ground in pairs over one another. This is best done by laying two sods on the ground at a distance of 50 mm. from one another and placing two others at the same distance apart, but crosswise, on the first pair. Similar heaps of four sods,

---

<sup>1</sup> In spite of the warning given in the second edition of this handbook, several more or less large experimental plants have been fitted with these Gehrcke peat steam boilers and have met with complete failure, as might have been predicted. The manufacture of these boilers has therefore been given up by the Nürnberg factory, which had taken them over. Compare also the reference to this in the remarks on furnaces in Subsection C, 3, of Part II.

sometimes also six sods, in layers over one another are placed 20 to 30 mm. apart in rows on the drying ground. It has been found by experience that the sods thus prepared and placed in small heaps resist the action of wet weather, provided they are not exposed to heavy rain during the first twelve hours.

As a result of the initial drying, their surfaces soon become as hard as leather so that in three to four days in good weather, and in six to eight days in bad weather, the sods can be turned and put into rings or walls eight to ten layers in height, thus to some extent clearing the drying ground, on which more sods may be again spread. Usually after fourteen days the sods are collected from the rings and walls into larger heaps in which, however, there are still small spaces left between the sods. The sods are allowed to remain in these clamps until they are fully air-dried, which as a rule will require from five to eight weeks, according to the weather and the locality.

If at all possible, as, for instance, by employing the temporary trestles described in the following subsection, the exposure of the peat sods which have just come from the machine to the influence of strong wind or the burning rays of the sun should be avoided. Usually in the heat of the sun, and especially in the case of certain dense and fatty (bituminous) peats, a hard crust forms on the surfaces of the sods owing to their rapid drying, and this, tending to contract, soon splits in many places, as the inner core, being still moist, does not contract to the same extent. The consequence of this is that these peat sods, on drying out, split still more, lose their good appearance, and fall into pieces, producing loss of material when being further handled or loaded. On the other hand, peat acquires greater firmness and density if it is not exposed during the first few days to the action of the sun, and for this reason peat dried slowly in the shade looks better and is firmer than that dried in the sun.

Under the name "*split-free quick drying*" a process was proposed by C. Schlickeysen, of Berlin, with a view to avoiding this defect. Small quantities of finely ground or sifted peat, coal or coke powder, or saw-dust are added to the raw peat when it is being thrown into the mixing and forming machine, and these, although not decreasing in any way the calorific power of the peat, prevent the splitting of the formed sods during the drying in the air and sun, just as a thinning medium does in the conversion of fat clay into bricks. This process is said to have frequently worked well. The time required for drying is shortened by this method, and the winning season is lengthened by some weeks. It can scarcely give rise to special costs, as the dry peat mould required for it will be found ready at hand in every peat works. The addition of chopped straw as a cementing substance was proposed earlier for the same object. Machine peat inclined to crumble might perhaps be prevented from doing so by the addition of this substance.<sup>1</sup>

<sup>1</sup> Cf. *Mitteil. d. Ver. z. Förd. d. Moork.*, 1900, p. 112.

*Machine peat on drying contracts the more, and splits and crumbles the less, the greater the mixing and kneading action of the machine.*

The rapid drying of machine peat is connected (1) with the amount of air to which the mass to be dried is exposed ; (2) with the time of the year and the average daily temperature ; (3) with local circumstances.

How these vary in different countries, and how that which has proved of use in winning peat in one place cannot be directly applied in another, may be seen from the fact that, for instance, peat fuel winning can take place without drying appliances and without sheds during eleven months of the year at Helenaveen in Holland, while at Sebastiansberg in the Erzgebirge, which is 480 m. above sea-level and has a high rainfall, it is possible for scarcely two months ; in the Enns valley, Carinthia, Styria, &c., for not much more than two and a half months ; and in the majority of the peat factories of West and North Germany for scarcely more than three and a half months (on an average, 100 working days).

When drying in the open air or in an open shed where the motion of the air and therefore the amount of air which takes up moisture cannot be increased, the drying on a given drying ground, which should be chosen in as open and windy a place as possible, takes place all the more rapidly the greater the ratio of the surface of the wet peat sods to their mass. For this reason, long, thin pieces dry better than short, thick ones, and therefore it is not desirable to manufacture sods having a cross-section more than 100 mm. square, although for other reasons this is generally done.

INFLUENCE OF THE SIZE OF PEAT SODS ON THE TIME REQUIRED FOR DRYING.

No.	Volume (c.c.) of the fresh peat sods.	Surface (sq. cm.)	Weight (g.)	Surface correspond- ing to every 100 c.c. of volume.	Percentage decrease in weight during the progress of the drying, after						
					2 days.	4 days.	6 days.	8 days.	10 days.	12 days.	14 days.
1	1,280	744	1352·0	58	12·1	25·3	35·4	47·0	59·9	65·6	68·7
2	448	344	471·0	80	17·0	37·4	50·7	62·7	69·0	71·0	72·4

The effect of different sizes of peat sods on the time required for drying may be seen from the accompanying figures, which are based on observations made with sods having cross-sections with different areas : The larger peat sods had 58 sq. cm. and the smaller 80 sq. cm. of surface for every 100 c.c. of volume. The various sods were taken successively from the same peat band, and therefore had the same density, texture, and percentage of water, and consisted of the same raw material. The figures given, therefore, may be regarded as establishing the advantage which the smaller sods with smaller cross-sections have while drying, especially as in the earlier stages they are several days ahead of

the others, and therefore can be footed and ringed sooner, so that for the same output by weight they require a smaller drying ground.

Moreover, in the case of a raw peat which is sensitive towards the sun and wind, the smaller sods, since they dry more uniformly, split less than the thicker (anything over 100 mm. square) ones.

Drying in the open air depends, however, a good deal on the time of the year and on the average daily temperature, because air at a given temperature is only able to take up a certain maximum amount of water vapour (moisture), and when this has been taken up the air is then said to be "*saturated with water vapour.*" A part of this maximum quantity is always already taken up by the air, and the amount of this varies from month to month. This "*degree of saturation*" of the air, by which its capacity to absorb more water vapour is determined, is at a maximum in Mid-Germany in December and at a minimum in August, amounting in the former case to 86 per cent. and in the latter to 61 per cent., while from April to the end of September the average value is 68 per cent. In the summer months the air is still able to take up at most 32 per cent., or approximately one-third of the total quantity of water required to saturate it at that time of the year.

This quantity, however, depends on the mean temperature of the air for the months in question, and at low temperatures it is very small, as may be seen from the accompanying table:—

WATER CONTAINED IN ONE CUBIC METRE OF SATURATED AIR AT VARIOUS TEMPERATURES.\*

Air temperature in degrees Cent.	Amount of water in grammes.	Air temperature in degrees Cent.	Amount of water in grammes.	Air temperature in degrees Cent.	Amount of water in grammes.
- 15	1·4	20	17·2	70	197·4
- 10	2·3	25	23·0	80	290·9
- 5	3·4	30	30·2	90	420·5
0	4·9	35	39·5	100	591·9
5	6·8	40	51·0	120	1,120·0
10	9·4	50	82·7	140	1,870·0
15	12·8	60	129·8	150	2,400·0

\* Calculated from the results of Regnault's observations on the tension of water vapour at various temperatures.

In our north temperate zone the mean daily temperature is lowest in the middle of January. It rises at first very slowly, but in April and May it rises fairly quickly, and after these months again more slowly until the end of July, when it reaches its highest point. It then falls at first slowly, and about autumn more rapidly. From the above table it follows that the months of May, June and July are the best times for drying peat, and that peat winning must cease all the sooner the wetter the peat is (corresponding to the mode of winning), when first exposed for drying, i.e., the longer the time required for drying it will be. This is also the reason why pulp peat winning must cease much earlier (as a matter

of fact, at the end of July) than the machine peat industry, which can be carried on until the middle of September.

The view hitherto generally taken and the statement often made, that condensed machine peat dries more rapidly and more completely than ordinary cut or stroked peat is erroneous, and has not been supported by any of the many investigations carried out by the author. On the contrary, hand or cut peat in good weather or under cover (covered trestles) dries not only more quickly than machine peat from the same raw material, but the hand peat, when fully air-dry, contains 1 to 3 per cent. less moisture than machine peat under the same conditions. (Cf. Subsection F of this Section.)

A difference in favour of machine peat is met only when the drying takes place in the open during unfavourable rainy weather or heavy fogs. Cut or stroked peat, on account of its loose, cellular texture, easily absorbs any rain falling on it or fog condensing on it, and during prolonged rain can again saturate itself like a sponge, until it contains its original percentage of water, so that in reference to its degree of dryness it thus retreats again and again by days or weeks. Even protracted and heavy rain cannot exert a similar action on machine peat, as the drops of water run off it on account of its smoother and more intimately kneaded surface and also are prevented from penetrating into the interior by its uniformly dense structure. When the rain or the damp weather ceases the moisture remaining on the surface of the machine peat again evaporates very quickly, and the progress of the drying from within outwards can continue its course without interruption. Under these circumstances, especially when they repeat themselves during the drying of one and the same "spreading," machine peat acquires a definite degree of dryness in a shorter time than hand peat from the same raw material.

Consideration cannot be withheld from the "split-free quick drying" mentioned above, in so far as it ensures the drying process for large scale winning, and especially when the winning aims at obtaining sods as smooth and free from cracks as possible.

Owing to the relatively large volume which hand peat occupies when compared with its weight, storing sheds for all the fully air-dried peat won in the middle of summer would cost too much. The cut or stroked peat is put into large clamps and is therefore always exposed to the action of adverse weather conditions. In consequence of the spongy, very porous, or fissured character it generally has after drying, it again readily absorbs moisture and, when actually used, it mostly contains a much higher percentage of water than corresponds to its really air-dried state. Machine peat, which can be kept under cover at a smaller expense, retains, either for this reason or, if clamped in the open air, owing to its denser and firmer texture in the dried condition causing all the raindrops to run off it as they do from coal, the degree of dryness attained by careful drying in the air or allows it to be altered within only such narrow limits that the peat contains on the average 18 to 25 per cent. of moisture.



The number and the size of the drying grounds for machine formed peat are calculated with reference to a drying period which is at most fourteen days, since even in unfavourable weather the peat is so dry and firm after this time that it can be brought into clamps.

The drying grounds are best laid out with lengths of 150 to 200 m., widths of 10 m., and with intervals of  $1\frac{1}{2}$  to 2 m. between every two. The intervening strips are levelled, and barrow tracks or portable rails are laid on them as required. These lead to the forming machine, where they are divided by means of switches into several tracks for the empty and loaded cars. The forming machine is placed between these tracks.

With the method given above for spreading the peat sods on the drying grounds, every four standard sods (8 x 10 x 25 cm.), having a volume of 2,000 c.c. each, piled in two tiers, require a surface of  $(0\cdot25 \text{ m.} + 0\cdot02 \text{ m.})^2$  or 0·72 sq. m. Every 1,000 sods therefore require  $\frac{0\cdot072 \times 1,000}{4} = 18$  sq. m. of drying ground, so that for every cubic metre of freshly formed peat 9 sq. m. of drying ground are required.

If the consistency of the freshly formed peat sods makes it possible to place them in three tiers, that is, in small heaps of 6 sods each, then for 1 cb. m. of formed peat only 6 sq. m. of drying ground will be necessary.

This degree of firmness is attained all the more readily the drier the peat machine is allowed to work the raw peat, and this happens all the more frequently the greater the mixing action of the machine.

The area of the drying grounds required for winning machine-pulp peat is larger owing to the addition of water which usually occurs in the manufacture, and for every cubic metre of raw peat it amounts approximately to 15 sq. m. In this case, even in the middle of summer, not less than fourteen days can be reckoned upon for each "spreading."

The total cost of the drying operations on the drying ground itself and of collecting the sods into clamps amounts for every 1,000 sods of air-dried machine peat to 0·60M. to 0·90M. when the average daily wages are 1·75M. for women or girls and 3·00M. for men, so that when the thousand sods of machine peat, dried in the open, weigh 600 kilos, then 10 to 15 Pfg. will be the cost corresponding to every 100 kilos of air-dried machine peat. In unfavourable weather this may increase to 18 Pfg.

## 2.—Drying on Boards and Trestles

The inconvenience (and the losses associated therewith) which became manifest when peat was won on a large scale by air-drying in unfavourable weather was to a great extent met by having recourse to the machine peat industry.

Nevertheless, after the introduction of the machine peat industry attention was again directed to freeing the peat from the

prejudicial effect of wet weather and the sun's rays and, in order to obtain a higher price for it, to giving the peat a neater external appearance by avoiding frequent turning and piling on the drying ground and the ruin to its regular shape associated with these operations.

In some machine peat industries attempts have been made to avoid removing the wet peat sods from the spreading boards, or tipping them on the drying ground, and, therefore, to dry the sods on the boards themselves, which are laid close to one another on the ground. The peat dries in this way far more rapidly than when it is placed directly on the ground itself.

In order to economize in drying ground, and at the same time to protect most of the peat won from the action of the weather, four to five boards can, as indicated in Fig. 103, be piled over one another by employing simple wooden trestles with cross-trees, the so-called "temporary trestles." The movable drying stands

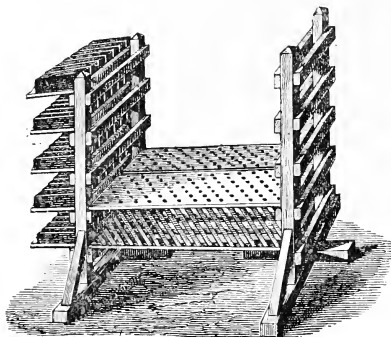

FIG. 103.—Movable trestles for drying boards.

obtained in this way can be moved forward with the machine in the bog, and the amount of transport for the formed sods made as small as possible.

It is advisable for this purpose to make the spreading boards (which are at the same time drying boards) in such a way that the air can also have access to the peat sods from underneath. This is attained by providing the boards, as in Fig. 104, with several wide air-holes 30 mm. in diameter, or still better by making the boards from a frame on which lathes, 30 to 40 mm. wide, are nailed in a slanting direction, with spaces of 15 to 20 mm. between them. The peat sods in this case do not require to be turned or even touched until they are quite dry, or until they are being collected into clamps. This method of drying is therefore not much dearer than that of drying in the open and on the bare ground, and is, moreover, much safer. There is no loss of peat or time, and in this respect it is indeed cheaper than the other method, but it requires a fairly large capital outlay for trestles and drying boards, and can only be worked on a small scale.

When 40,000 sods or 20,000 kilos of dry peat are won per day the drying plant costs approximately 18,000M. ; assuming 6 per cent. interest and 14 per cent. amortization, therefore altogether 20 per cent., and 150 working days, the cost for 100 kilos amounts to  $\frac{18000 \times 0.20}{150 \times 200} = 0.12M. = 12 \text{ Pfg.}$  For transporting the peat

boards to the trestles six men are required, and for placing the boards on the trestle two more men, who, at 3M. each, are paid in all 24M., and this distributed over the daily output of 20,000 kilos gives 12 Pfg. for 100 kilos, so that the total cost of drying amounts to 24 Pfg. or, including collection into clamps, to approximately 30 Pfg. for 100 kilos. When the daily output is 30,000 kilos the latter cost becomes 20 Pfg.

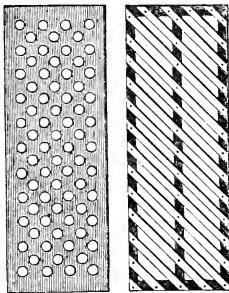

FIG. 104. FIG. 104A.  
Drying Boards.

### 3.—Drying under Cover

This method of drying has hitherto been seldom employed for peat on account of its cost. By correctly constructing and arranging the buildings and their internal equipment required for this method it ought to be possible to make the machine peat winning into a great industry as characteristically and as remuneratively independent of the weather as the winning of formed brown coal (not to be confused with press coal or briquettes), the calorific value of which is no higher than that of machine peat of average quality.

The brown coal sods made from coal dust or "smalls" with the aid of brick machines were originally also dried entirely in the open because it was believed that fuel which was of little value could not support the increase in price due to the expense of erecting drying sheds. The mine-owners, however, during rainy summers suffered a considerable decrease in their profits, partly owing to the action of rain on the coal sods spread for drying and partly owing to the increase in the length of time required for drying due to the constantly wet ground and the humid atmosphere. They therefore began to erect drying sheds, and since then these

have become more and more common wherever such brown coal sods are still manufactured, the owners finding their balance sheet better than it formerly was.

The drying sheds already described in Section III, "Winning and Properties of Hand Peat," may be regarded as forming a transition stage to these drying sheds.

To the latter also belong the movable drying houses, which Gysser erected at Willaringen for a small factory in which Weber's machines were employed and which can be used with advantage whenever, in the case of spreading and drying in the open, the injurious action of heavy rain is to be kept off the freshest and softest portion of the winning.

These houses consist of five hurdles, placed over one another, the uppermost of which is covered with a shingle roof. Each hurdle (Fig. 105) is formed of a frame of four roofing laths, nailed

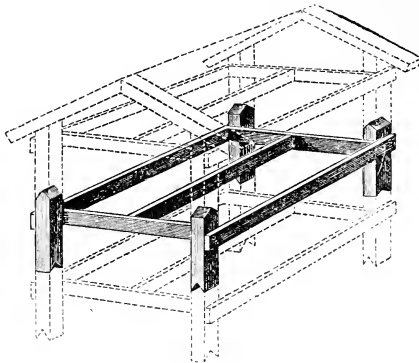

FIG. 105.—Drying hurdles.

at the four corners to short posts. These small posts have wedge-shaped upper ends and have corresponding portions cut out of their lower ends. The positions of these ends and cut-out portions are similar for all the posts over one another at any one corner, but those of the one corner are at right angles to those of the other in order that when several hurdles are placed on one another they may keep their positions firmly and without toppling over.

#### E.—Cost of Plant, and Working Expenses of Machine Peat Factories

The outputs given in the description of the various peat machines in Section IV are taken from the statements of their inventors or sellers and in actual work are rarely reached as average outputs. The reasons for this smaller output are partly due to the circumstance that the figures given in the price lists usually hold good only "*for suitable raw material.*" This suitable

raw material, under which expression generally root-free, ripe, well-drained, and uniform mould peat is understood, is, however, usually not present in the peat bogs to be worked. The reasons for the lower output are also partly to be sought in the incorrect use of this or that method of winning, and in the incorrect selection of the working machines, and in part also in faulty transport contrivances, bad management, &c.

Hence the actual costs of production are generally higher than those made out in the preliminary estimates in Section IV (without, however, questioning the utility of machine peat winning in itself). In every new installation there must be determined, in respect to local circumstances but especially in regard to the raw peat to be worked and the labour available, what method of winning and therefore what working machine will be most suitable for that case, and how closely we may expect to be able to reach the *possible* costs of winning calculated in Section IV.

Since in winning machine peat human labour is required for digging and transporting the raw peat as well as for layering the formed peat and the operations of drying (with a daily output of 40,000 to 60,000 sods 20 to 25 labourers are necessary), it follows, therefore, that the wages corresponding to this form the main portion of the costs of production, and the latter therefore increase or fall with the local rates of wages per day. With these costs must be combined the contributions for amortization of the cost of installation for machines and implements as well as the ground rent and, when calculating the net profit, the interest on the installation capital and the working capital.

The cost of the installation, when known for an already existing peat factory, can be easily calculated in the case of a new factory to be erected from the output intended with the aid of the statements made in the preceding sections. The error is usually made, however, of estimating the portion corresponding to interest and amortization (together about 10 per cent.) too low. This leads, we grant, to smaller costs of production, but at the same time to self-deception on the part of the owners of the factories.

In describing the means and the machinery for transport in Subsection C, only the amortization, which will depend on the types of machines selected for the various objects and which amounts to from 7 to 25 per cent., has been specially considered, locomotives being written off at 10 to 12 per cent. and peat machines at 15 per cent., including the annual cost of maintenance. If the small amount of attention and care given to a locomotive, and the rapid wear and tear of the working machines in a peat bog be taken into consideration, these rates ought not to be assumed lower in any estimate by an expert, since in the first case, while taking into account the annual contributions for running repairs, amortization is assumed in a period of ten to fifteen years, and general experience shows that this is not too long.

The ground rent corresponding to the amount won per annum varies a good deal with local circumstances, but necessitates, however, only a slight increase in price for every 100 kilos won.

It amounts to from 300M. to 1,000M. for 1 ha. of bog, according to its depth of 1 to 4 m., or in some cases to 1½ Pfg. to 2 Pfg. for every 100 kilos of dry peat won.

Under average circumstances, with an expertly planned installation, organized management, and ordinary high or low bogs having the usual admixtures of wood, the plant cost and working expenses are approximately as given below, where it is assumed that the bog is so far drained or so capable of supporting traffic that the peat machines and locomotive can be set up at once at the excavating edge (bank), and the peat, dug by hand in the bog, brought to the machine by a chain elevator connected with the latter. The average daily (10 hours) output of the peat machine is assumed to correspond to an output of at least 60,000 standard sods of 2 l. each (therefore sods with sizes, let us say, of 25 x 8 x 10 cm. or 20 x 10 x 10 cm.). These correspond to 120 cb. m. of formed peat, to which 168 cb. m. of excavated bog (raw peat) are required. This average output requires a peat machine with a greater nominal output, and as a rule it will be obtained only with a peat machine for which an output about one-fourth higher (therefore 75,000 to 80,000 sods, or 150 to 160 cb. m. of formed peat) is given by the machine factories, and which has also, indeed, been subjected to a working trial for some hours or days. In addition a 10 to 15 h.p. locomotive is required. The sods of formed peat contract on drying to one-third to one-sixth of their original volumes, and have in the air-dry state, according to the ripeness of the raw peat and the mixing and condensing action of the machine, a density of 0·7 to 1·2, and weigh 0·3 to 0·5 kilo each.<sup>1</sup> From 120 to 200 kilos of dry peat correspond to 1 cb. m. of fresh formed peat, or 300 to 500 kilos correspond to 1,000 standard sods. In the following estimate a raw peat is considered, the standard sods (2,000 c.c.) of fresh machine-formed peat from which weigh 0·3 kilo when air-dry, or 1 cb. m. of the formed peat gives 150 kilos of dry peat, so that the daily output of the machine is 18,000 kilos or 18 m. tons.

	(1) COST OF PLANT.	<i>Marks.</i>
1 Peat machine, with a daily output of 70,000 to 80,000 standard sods or 150 to 160 cb. m. of formed peat		2,000–3,500
1 Wrought-iron elevator, 10 m. in length .. .. .		1,100–1,500
1 Locomotive, 10 to 15 h.p. .. .. .		5,000–7,000
1 Pump for draining the bog trench .. .. .		450– 500
1 Iron transporting frame, with contrivance for moving it forward, for taking the machine		600– 800
50 m. of rail track for this transporting frame .. ..		1,000–1,000
6 Transport cars for sods, at 80–120M. each .. ..		480– 720
6 Turntables or turning plates, at 15–35M. each .. ..		90– 200
600 m. field railway track, at 1·8–2·5M. each .. ..		1,200–1,600
3 Box tipping cars for dry peat at 120–150M. each .. ..		360– 450
260 Spreading boards at 0·50M. each .. .. .		125– 125
Driving belts .. .. .		80– 120
Implements .. .. .		200– 300
Freightage of machines, bringing into and setting up in bog (not including taxes) and other miscellaneous charges		1,200–2,000
Total ..		13,885–19,815

<sup>1</sup> This weight is that of standard sods; the weight of the larger sods usually made is correspondingly greater.

## (2) WORKING EXPENSES (PER DAY).

	<i>Men.</i>	<i>Women or Girls.</i>
1. Stripping the bog, grubbing out roots and included wood, carrying water to the locomotive, &c.	2	—
2. Digging the peat and throwing it on to the elevator ..	4-6	—
3. Fetching the peat boards and placing them under the machine	—	2
4. Cutting the peat bands into sods.. .. .	—	1
5. Placing the boards on the cars .. .. .	2	—
6. Moving the sod cars .. .. .	4-6	—
7. Removing the boards from the cars and tipping them on to the drying ground	2	—
8. Spreading, ringing, &c., on the drying ground.. ..	—	4
9. Clamping .. .. .	—	2
Total .. .. .	14-18	9

*Marks.*

14 men at 4·00M. each and 9 women at 2·50M. each amounts per day (working period being 10 hours) to	78·50
10. 1 Engine driver and overseer .. .. .	5·00
11. Fuel for the engine—750 kilos of waste peat at 0·40M. for 100 kilos	3·00
12. Lubricating and cleaning materials .. .. .	3·00
13. Insurance of workers and medical benefits contributions	2·00
14. Repairs and contingencies .. .. .	2·50
Total ..	94·00

## (3) GENERAL EXPENSES.

	<i>Marks.</i>
1. Interest on plant capital—5 per cent. on 15,000–20,000M.	750–1,000
2. Interest on working capital (the amounts paid out per day for 100 working days must be extended over at least half a year, 5 per cent. for 9,000M. for half a year)	225– 225
3. Amortization of the cost of machinery, 10,000–14,000M., at 10 per cent.	1,000–1,400
4. Rails, 2,290–2,800M., at 5 per cent. .. .. .	115– 140
5. Means of transport, 840–1,170M., at 7 per cent. .. .. .	58– 82
6. Peat boards, 125M., at 20 per cent. .. .. .	25– 25
7. Driving belts at 20 per cent. .. .. .	16– 24
8. Implements at 10 per cent. .. .. .	20– 30
Total ..	2,209–2,926

Or approximately 22M. to 30M. per day for 100 working days. Therefore—

## (4) COSTS OF PRODUCTION ARE:—

	<i>Marks.</i>
1. Daily working expenses .. .. .	94
2. General expenses.. .. .	22– 30
Total ..	116–124

Or the cost of every 100 kilos of dry peat at the bog, when the daily output is 18,000 kilos, is 0·64M. to 0·70M., including interest and amortization, but excluding ground rent. To arrive at the net cost, free at place of sale, we must add the loading and freight charges or the charges due to auxiliary or field railways, as well as those for the preliminary preparation of the bog.

From the above estimate it is easy to see in how far the costs of production of the unit weight, and therefore of the ordinary

unit of sale, are affected, when on account of the nature of the raw peat or the faulty mixing and condensing action of the peat machine, the weight of the air-dry peat sod corresponding to a standard sod (2 l.) does not reach the weight of 0·3 kilo assumed above in the calculation of the net cost, or the weight of 1 cb. m. of the air-dry formed peat does not reach 150 kilos, or when the average daily output is less than the assumed output owing to difficulties in working the bog, or poor yield from, or smaller size of, the machine.

As a matter of fact, the machine peat bands are not always divided into sods with a volume of 2 l. each (standard sods). The size of the sods in the various peat factories is controlled by the kind of mouthpiece employed. The latter may be made either as single- or as multiple-band mouthpieces, according to the nature of the peat, or according as sods of greater or smaller cross-sections are required for the drying operations, or to meet the wishes of those who finally receive the peat. The work is usually given by contract for 1,000 peat boards (boards covered with sods), tipped and spread (on the drying ground). The contract price varies with the number and the size of the sods in the layer covering the board. The boards are 1 to 2 m. in length, and the layer on each of them is usually divided into 4 to 6 sods, according to the length, so that the length of a sod is from 25 to 40 cm. The following figures (see table, p. 229) from three different machine peat works for the industrial year 1914, as well as the particulars in Subsections F and G, give a good insight into the cost of production of machine-formed peat.

Particulars have already been given in the subsections on the manufacture of press peat and the manufacture of machine pulp or dough peat with regard to the costs of production of press peat and machine pulp peat by the Hanover-Oldenburg or Jutland method, and some installations of this kind have been described there in detail. As mentioned above, the working results, and, therefore, the net cost of the peat won in the case of factories with peat-forming machines, vary a good deal with the kind and the number of the machines, with the quality of the raw peat, and with the suitability of the installation. Before setting up a new installation it is advisable either to seek the advice of an experienced, disinterested expert or to examine thoroughly good machine peat factories. The names of several peat factories in which the various machines are at work are always appended to the description of the various machines. The owners of these factories are generally only too pleased to allow of a thorough inspection being made. Many machine peat factories now exist in all peat countries; some details with regard to three large North German and two South German peat works follow under Subsection G.



COST OF PRODUCTION OF MACHINE-FORMED PEAT.

Contract price for 1,000 peat boards for the operations set forth above under 1, 7 and 10 in the working expenses	In a North German peat factory (Githorn), 6½M.	In a Bavarian peat factory. 17M.	In a Württemberg peat factory. 15.5M.
Gang, including engine driver	13 men ..	13 men and 2 women	21 men and 2 women or boys
Character of bog ..	High bog, 4-5 m. in depth, not containing much wood	High bog, 3-6 m. in depth, not containing much wood	High bog, 3 m. in depth, containing much wood and roots
Length of each board	1.20 m. ..	1.30 m. ..	2 m.
Contents of each board	1 band with cross-section 10 × 13 cm. = 130 sq. cm.	2 bands, each with cross-section 10 × 12 cm. = 120 sq. cm.	1 cylindrical band with diameter 12.7 cm., therefore cross-section is 126 sq. cm.
Each board full is divided into	4 sods, each 30 cm. long	2 × 3 = 6 sods, each 43 cm. long	6 sods, each 33 cm. long
Amount of formed peat on each board	15,600 c.c.	31,200 c.c.	25,200 c.c.
Output of machine in 10 hours with 10-12 h.p. locomotive	10,000 boards or 156 cb. m.	6,600 boards or 206 cb. m.	5,000 boards or 140 cb. m.
1,000 boards give of	Fresh formed peat 15.6 cb. m. Standard sods of 21. each 7,800 Air-dry peat 1,750 kilos	31.20 cb. m. 15,600 4,800 kilos	25.20 cb. m. 12,600 3,200 kilos
Therefore 1 cb. m. of formed peat gives in dry peat	112 kilos	154 kilos	127 kilos
Weight corresponding to 1,000 dry standard sods*	230 kilos*	308 kilos*	254 kilos*
Wages alone per 100 kilos of dry peat for digging, forming and spreading	At 6½M. for 1,000 boards, 0.37M.	At 17M. for 1,000 boards, 0.36M.	At 15.5M. for 1,000 boards, 0.48M.
Drying labour for 1,000 full boards	Breaking and ringing 0.50M. Heaping 0.50M. Clamping 1.25M. } 2.25M.	1.20M. 0.60M. 1.15M. } 2.95M.	0.40M. 0.95M. 1.00M. } 2.35M.
Drying labour therefore for 100 kilos	0.13M.	0.07M.	0.07M.
Total for digging, forming, drying and clamping	0.37 + 0.13 = 0.50M.	0.36 + 0.07 = 0.43M.	0.48 + 0.07 = 0.55M.

\* The sods actually manufactured are larger and heavier.

## F.—Comparison of Costs in the Cases of Fully Automatic or Large Scale Industry Machines and Ordinary Peat Machines

In estimating the saving which can be attained in one and the same peat works by using a fully automatic machine, with dredger and sod spreader, instead of an ordinary peat machine with which workmen are required for digging the peat, and for transporting and spreading the sods on the drying field, the following comparison is worth attention.

During the summer of 1915 several simple peat machines of the ordinary type, having each a daily output of 50,000 sods, 33 x 10 x 10 cm. or 3·3 l. each, that is, 165 cb. m. of machine-formed peat (or 220 cb. m. of raw peat), weighing 24,000 kilos when air-dried, and therefore an output of 240 double wagons of dry peat for each machine during the season, worked in a Frisian high bog beside a "fully automatic machine," which for a ten-hour day had an output of 100,000 sods, 40 x 12 x 11 cm. or 5·3 l. each, that is, 530 cb. m. of machine-formed peat (or approximately 700 cb. m. of raw peat), weighing when air-dried about 76,000 kilos (corresponding to 145 kilos for 1 cb. m. of the formed mass), and therefore a calculated output of 760 double wagons of dry peat in 100 working days.

For approximately the same daily output three of the older peat machines, with a total output, however, of only 720 double wagons of dry peat, but requiring 15 men each, therefore 45 men in all, and an overseer, corresponded to one "fully automatic machine" (yielding 760 double wagons of dry peat and requiring 5 workmen and an overseer).

The cost of the large scale industry machine, including electrical power and other accessories, was about 38,000M., and that of the three *ordinary peat machines*, including rails, cars, electrical power, &c., was 21,000–24,000M., that is 7,000–8,000M. for each machine. In both cases interest may be charged at 5 per cent., and redemption of capital outlay at 10 per cent.

The expenses for rent of bog, draining and stripping the working field are the same in the two cases.

In the following comparison of the costs of winning, and general expenses, which differ from one another on account of differences in the machines employed, a double wagon load (10,000 kilos or 10 m. tons) of dry peat is taken as the unit. For this amount in the case of the large scale industry machine we require to win and dry 13,000 sods of 5·3 l. each, i.e., 68·9 cb. m. of dry machine-formed peat, and for the *ordinary peat machines* about 20,000 sods of 3·3 l. each, i.e., 66 cb. m. of dry peat.

The wages and other current expenses paid for these purposes in the summer of 1915 were :—

	(a) With the large scale industry machine.	(b) With the three ordinary peat machines.
1. Levelling drying field	1 ha. 40-50M., at 300 wagons to 1 ha., for each wagon, therefore 0·17M.	
2. Peat winning	13,000 sods at 0·40M. per 1,000 5·20M.	20,000 sods at 1·5M. per 1,000 30·00M.
3. Piling ..	13,000 sods at 0·25M. per 1,000 3·25M.	20,000 sods at 0·30M. per 1,000 6·00M.
4. Re-piling ..	13,000 sods at 0·20M. per 1,000 2·60M.	20,000 sods at 0·15M. per 1,000 3·00M.
5. Piling the bottom sods about 1 in 10	13,000 sods at 0·02M. per 1,000 0·26M.	20,000 sods at 0·015M. per 1,000 0·30M.
	11·48M.	39·30M.
6. Collecting into clamps and loading; the same in the two cases	—	—
7. Interest and amortization	15 per cent. of 38,000M. = 5,700M. for 760 wagons, therefore 1 wagon .. 7·50M.	15 per cent. of 24,000M. = 3,600M. for 720 wagons, therefore 1 wagon .. 5·00M.
8. Workmen's insurance for 17 weeks	5 persons at 0·48M. each = 40·80M. for 760 wagons, therefore 1 wagon .. 0·04M.	45 persons at 0·48M. each = 367M. for 720 wagons, therefore 1 wagon .. 0·51M.
9. One overseer, 800M.	For 1 wagon .. 1·10M.	For 1 wagon .. 1·10M.
10. Workmen's houses and equipment	For 5 persons 500M., 15 per cent. of which = 7·50M., or for 1 wagon .. .. 0·10M.	For 45 persons 3,600M., 15 per cent. of which = 540M., or for 1 wagon .. .. 0·80M.
	Total .. 20·22M.	Total .. 46·71m.
For 1 double wagon of 10 m. tons or for 1 m. ton	2·02M.	4·67M.

We must also observe that in the case of *fully automatic machines* the danger of a strike is less on account of the much smaller number of workmen employed, and that the carrying on of the work both by day and night, with increase in the output ( $1\frac{1}{2}$  to  $1\frac{3}{4}$  times the ordinary), is easier than in the case of machines requiring many workmen.

These numbers, calculated on the basis of a day's output, do not as a rule correspond to those actually met with in practice, since here, as in all such preliminary estimates, the actual output

of the machines during a full working season of 100 days is not 100 times that of a single day. For instance, in the case of a *fully automatic machine* with dredger and sod spreader, on account of various interruptions in the work owing to roots and trees in the peat, the output becomes smaller, and when these are taken into consideration for the above-mentioned bog we have:—

The actual summer output of a “fully automatic machine” is about 5,000 m. tons.

The actual summer output of an “ordinary peat machine,” with elevator, is about 2,000 to 2,500 m. tons.

The average costs per metric ton for the actual output during a season of 100 days in the case of a “fully automatic machine,” with dredger and sod spreader, are:—

$$\frac{760 \times 2.0}{500} = 3.1M \text{ and for an ordinary peat machine } \frac{24 \times 46}{22.5} = 5M.$$

When all the expenses are taken into consideration the actual cost of production of 1 m. ton (1,000 kilos) of air-dried peat in recent years was about 8-9M., which can, it is expected, be reduced to 6-7M.

## G.—Description of some Large Machine Peat Factories

### 1.—*The Peat Works of the North German Peat Moor Company of Triangel in the Gifhorn District*

This undertaking, which was begun in 1873, was under the direction of Agricultural Councillor Rothbarth (who died recently) until 1906. Since the latter year it has been managed by Rothbarth's son in conjunction with the son of the owner. The moor comprises an area of 5,000 acres (Prussian) or 1,250 ha. The company is a joint-stock one, all the shares of which are held by one man (Arnold Rimpau, of Brunswick).

The portion of the bog which is not likely to be used for the manufacture of fuel or moss litter within the next twenty years, and, therefore, the whole uncut part of the high bog, is employed for agricultural purposes, especially those connected with the rearing of cattle. In a similar way the cut-out bog is utilized by the Dutch Veen Reclamation Method by mixing on its surface a layer of the waste upper strippings from the bog, about 20 to 30 cm. in height with an equally high layer of the sand which lies immediately under the bog. Turnips, potatoes, rye, oats, clover and grass are cultivated in the soil thus prepared. Most of these give satisfactory crops, especially the potatoes, the yield of good quality specimens being rarely less than 5,000 kilos per Prussian acre.

The peat industry, which has been conducted here on a large scale with commercial success for over forty years, comprises the winning of peat fuel and peat charcoal, and since 1879-1880 the manufacture of peat moss litter, peat dust and peat meal, the latter substance having, indeed, been first introduced into commerce from this factory. The bog is all high bog containing

usually 4 to 5 m. of brown to good black mould peat, on which there is a layer of light yellow moss peat 1 to 1.25 m. in depth. Wood inclusions are met in veins. The part of the bog in use is well drained by a main canal, several secondary canals and trenches, so that the winning of the peat is carried on, even to the bottom of the bog, entirely *over* water.

Fuel peat is almost entirely won in the form of machine peat. Cut peat is dug only in the cases of small areas of less valuable peat or of shallow layers. Ten machines are employed for the preparation of machine peat and most of them are in operation from April until the end of July in each season.

The majority of these are uni-spiral machines from the Imperial Ironworks at Lauterberg, in the Harz. In addition to these, there are some bi-spiral machines from Oldenburg.

Each of the peat machines has a mouthpiece with only one opening, 10 x 13 cm., or 140 sq. cm., so that the mixed peat leaves the machine in only one band. This band, which runs on to boards, 1.20 m. in length, placed under the mouthpiece and moving forward automatically with the peat column, is cut on each board by a workman with the aid of a chopper into 4 parts of 30 cm. each in length. The boards with the sods are placed on cars, each of which will accommodate 30 boards, and transported to the drying ground, where the sods are spread in layers by tipping the boards.

Each machine requires the service of thirteen men distributed as follows: Four men for digging and throwing the peat on to the elevator, one man for placing the boards under the mouthpiece, one man for cutting and dividing the peat band, one man for taking away the boards and loading them on to the cars, three men for moving the cars to the drying ground, two men for emptying the boards on to the drying ground, and one man as a helper.

Each machine, attended by a gang such as this, yields on an average 1,000 boards every hour, i.e., 15.6 cb. m. of freshly formed peat or 4,000 sods, which weigh, when air-dry, 1,700 to 1,800 kilos. As the duration of the season is short the labourers always work twelve hours a day. The output of a machine is 187 cb. m. of formed peat, corresponding to 20,000 to 22,000 kilos of dry peat per day. With 10 machines, therefore, 200,000 to 220,000 kilos, or approximately 200 m. tons, of air-dried machine peat are won every day.

In the earlier years each of the machines had its own motive power, furnished by a locomotive which, together with the peat machine, was screwed to a strong transportable frame.

Since 1896, electrical power is supplied to most of the machines from a common power station. Here, indeed, the idea of converting the peat into electrical power and utilizing the latter at more or less great distances from the bog was first attempted practically. Instead of the automobile a small electric motor was placed on the carriage, and the power was transmitted to this over wires carried on poles placed in the various working fields. With this source of power, the daily and, in the case

of locomotive driving, the difficult forward motion of the machine with its driving agent was much facilitated, the weight being decreased by that of the locomotive (about 10,000 kilos). There is, moreover, a saving in fuel, and also in the case of each machine two men (one fireman and one water carrier) can be dispensed with.

The current is brought from the conductors to the machine by means of a cable, which must be re-hung about every three days. This can be easily done by the workmen ordinarily in attendance on the machine.

The electrical power station contains three tubular boilers fixed in stonework, provided with plain grates (step grates have not proved successful), and heated by the combustion of waste peat which could not be sold, and two steam engines (150 h.p. in all), which by means of a dynamo generate a current with a tension of 3,000 volts. The current is transmitted at this high tension to a transforming station 6 km. distant where the tension is lowered to 500 volts. From the transformer house the current at 500 volts passes through branch circuits to the various working fields and also, by means of a conductor 1 km. in length, to the manor house for use in driving agricultural machinery.

All the peat-winning operations are conducted by piece-work. The machine gang is paid in the case of locomotive driving 6·75M., and in the case of electrical driving 6·25M., for every 1,000 boards, of peat.

The further payments for drying operations are :—

	Marks.
Unloading and ringing 1,000 boards .. ..	0·5
Collecting into small clamps .. ..	0·5
Transporting to large clamps .. ..	1·25

The wages alone, therefore, for every 100 kilos of good, air-dry machine peat in large clamps or sheds in the high bog amount to 0·5M. to 0·55M. To this must be added the contributions for insurance of workmen, the salaries of the officials, interest, amortization and upkeep of machinery as well as of the junction line (8 km.) to Triangel railway station and the narrow gauge line (60 cm. gauge and 20 km. in length) which is laid in the bog as required. If we estimate 1 m. of the main line at 20M. and of the field line at 3M., this installation alone costs 220,000M. To this again must be added interest, amortization and maintenance of the main and secondary canals for the drainage of the bog.

About 2,500 double wagons of machine peat are won every year. Approximately one-fourth of this amount is coked in heaps, and the remainder is sold as fuel for industrial and household purposes in the neighbouring villages and towns of Brunswick and Hanover.

The price of one double wagon (10 m. tons) is now (1915) 120M. to 130M. This price is not quite reached in the case of the peat for coking. The latter is retained for the sake of a bigger trade by which the general expenses for the individual double wagons become smaller. The price of 10 m. tons of peat charcoal is 550M.

Each of the two peat-moss litter factories has four presses which are also driven electrically. The daily output is 10 to 15 double wagons (100 to 150 m. tons). The majority of these presses are horizontal spindle presses (Fig. 117) and the remainder angle-lever presses (Fig. 115). Some of the willows are provided with steel brushes and others with circular saws.

For cutting or digging the moss peat which is intended for the manufacture of peat litter, the rate of payment is, at present, 1·10M. for 1,000 sods, 30 x 15 x 8 cm. each, left in heaps of ten sods. In Oldenburg, 0·75M. is paid for the same amount of work. For drying and collecting the sods into large clamps another 0·5M. is added. One thousand sods of air-dried peat of this kind weigh about 300 kilos and give three bales of litter.

The pressed peat litter or peat mull bales are 1 m. long, 0·80 m. wide and 0·65 m. high. They weigh 100 kilos or more, according to the quality and the dryness of the peat. The lighter the material is the better it is, so that with an equal amount of pressing one double wagon, i.e., 10 m. tons, will contain 90 to 100 bales of litter or mull of the *first* quality, 80 to 90 bales of the *second*, and 70 to 80 bales of the *third*. Peat litter of the first quality at present sells at 180M., and of the *third* quality at 130M. for 10 m. tons. In years poor in straw, i.e., about every five or six years, the prices may rise, according to the demand, even to 400M. Peat mull bales are in general somewhat heavier than those of peat litter. For peat meal, i.e., a fine sifted dust, a somewhat higher price is obtained.

The peat litter bales for home use are usually bound with six laths and three wires (cf. Fig. 113).

This method of packing costs 0·15M. to 0·18M. for each bale. The workmen who manufacture the bales by piecework receive 0·25M. a bale for bringing the peat litter from the bog to and manufacturing it in the factory.

## 2.—Feilenbach Peat Factory

The Feilenbach Peat Factory at Aibling, in Upper Bavaria, belongs to a joint-stock company, which has been in existence since 1887 but which has worked with a profit only during the past nine years. For several years before the joint-stock company was established the peat factory belonged to a single proprietor. The bog has an area of 350 ha., of which about 17 ha. are grass and transition bog, the remainder being high bog of 3 to 6 m. in depth. It is situated in what was formerly a lake bed in the district bordering on the Alps at the foot of Wendelstein. About 10 ha. of cut-away bog, which is now cultivated ground, have been given over to agriculture since 1902, and on it potatoes (Snowflake, Walkersdorf, Early Roses, White Edelstein), oats, winter rye, winter wheat, Jerusalem artichokes, vetches, common beetroot, &c., are cultivated. The potato crop on the cultivated cut-away bog was said to have been very good in 1914.

The peat winning is carried out with ten peat machines, each of

which is driven by a locomotive. Nine of the peat machines were made by Krauss and Co., or Sugg and Co., Machine Factory, Munich, and one by R. Dolberg and Co., of Rostock. Some of the locomotives were delivered by Krauss and Co., some by R. Wolf, of Buckau-Magdeburg, and some by English factories. Each peat machine is provided with an elevator, 12 m. in length, which is fed by five or six peat diggers. To each machine four or five cars for transporting the sods are attached. The machines have double-band mouthpieces made of brass with double wedge-shaped partitions constructed like the four-band one shown in Fig. 30, and which give simultaneously two peat bands each 10 cm. wide and 12 cm. high. The spreading boards are 1.30 m. in length and 28 cm. in width. Each band on the board is divided into three lengths, and the whole contents of the board are, therefore, divided into six sods, each of which is 43 cm. long, 10 cm. wide and 12 cm. high. The gang for each machine consists, in addition to the machinist, of 13 males and 3 females. It comprises one engine-driver, five diggers, who cut the peat from the various layers lying one over another and throw it as regularly as possible on to the elevator, one female for placing in the boards, one female for cutting the sods, two men for loading the cars, four men for transporting the cars, two men for emptying the boards on to the drying ground and replacing the boards on the cars, and one female for bringing water and fuel peat to the locomotive. The total number of labourers at the works is, approximately, 220 in summer and 45 in winter. The engine-driver, who is selected and appointed by the labourers themselves, is captain and contractor for the gang; 17M. are paid him for every 1,000 boards (i.e., 6,000 sods), and of this each of the men, according to the difficulty of his work, gets 0.90M. to 1.25M., and each of the women 0.45M. to 0.50M. for every 1,000 boards. The average daily output for a nine-hour working period amounts to 6,000 boards, i.e., 36,000 sods or 186 cb. m. of machine-formed peat, in ten hours, therefore, 206 cb. m. The so-called "castling" (two upper sods crosswise on two lower ones) and "re-castling" (putting the lower sods over the upper ones) are done by women only. For the first 1.20M. and for the second 0.60M. are paid for every 1,000 boards. The approximate weight of 1,000 sods of air-dried machine peat is 800 kilos.

The finished peat is transported over a narrow-gauge railway to the station at Au, on the Bad-Aibling-Feilenbach electric railway line. For this purpose two Krauss locomotives, 8 km. of rails, and 30 wagons are employed.

Approximately 1,500 double wagon loads (15,000 m. tons) of machine peat, 200 double wagon loads of cut peat, and further about 80 double wagon loads of peat moss litter and peat dust are won annually. In 1910 the erection of a wet carbonizing factory according to the process of Dr. Ekenberg was projected, but was abandoned after more or less extensive experiments had been conducted. As is well known, there was formerly in Feilenbach an Eichhorn ball peat factory, which was not



a commercial success and which was closed down about thirty years ago. A thorough and expert drainage of the whole surface of the bog was carried out in 1906 and 1907.

Drying is effected in the open on drying fields, 9 m. wide and 200 m. long, which are separated by drains 80 cm. in depth. The cost of drying machine peat amounts to 6 to 7 Pfg. for 100 kilos of the dry peat. The average remuneration of a labourer for a ten-hour working period amounts at Feilenbach to 3M.; by piecework he earns, however, 5M. to 6M.

For clamping, including covering and binding with poles and wires, the men receive 35 Pfg. per cubic metre for clamps 2 m. wide and 3 m. high.

The locomotives, which are of an old type, are of 10 to 12 h.p., and require 600 to 700 kilos of machine peat every day. The Wolf locomotive, which was procured in 1903, on the other hand, is said to require scarcely 150 to 175 kilos. The machines are moved on sleepers provided with rails, by means of a toothed gear with latch levers, wheel catches, and traversing hand spikes.

According to the statement of the manager the wages paid to the workmen for one double wagon load of machine peat are 80M. Including fuel, drainage and general expenses the cost is 110M., the comparative cost of cut peat being 65M. to 80M. The selling price for 10,000 kilos of machine peat is 160M. to 180M., for cut peat 105M. to 125M., while at Munich it was 1·20M. to 1·45M. for 50 kilos. The region supplied includes Munich, Augsburg, Landshut, Freising, Nürnberg, Aibling, Traunstein, and Reichenbach. There are several Gienanth's stoves for heating with peat in use at Munich.

Coal costs, according to quality, 2·50M. to 5·00M. for 100 kilos in the district.

Similar peat industries exist at the Hochfilz and Panzerfilz, at Rosenheim, at Kolbermoor, at the City Peat Works, Ismaning, near Munich, and at other places.

### 3.—*Schussenried Peat Factory of the Royal Württemberg Peat Department*

The part of the high bog, known as Steinhauser Ried, which is here utilized has an area of 300 ha. and an average depth of 3 m. The upper four-tenths consist of yellow, light moss peat (from Sphagnum and Hypnum varieties), the centre four-tenths of tough fibrous peat (*Erica*, *Vaccinium*, &c.) rich in roots, and the lower two-tenths of good black mould peat. From the middle of April to the end of July, i.e., in about 90 working days of twelve hours each, 2,000,000 kilos of machine peat are won, in addition to large quantities of cut peat (10,000,000 sods), which are partly utilized as fuel, but for the most part (95 per cent.) are worked to peat litter and peat dust. The machine peat industry was begun in 1879, as an experiment, with a single machine. As the results were satisfactory two similar machines with the necessary accessories were afterwards procured. All three are

Pieau double-spiral machines (Fig. 42). Only two of them are in use, in turn, at any time. Each of the machines is driven by a 10 to 12 h.p. locomotive, fired with peat, and is mounted together with the locomotive on a transportable frame on which it moves along the trench as the work progresses. The drying fields along each working trench are 600 m. to 800 m. long and 200 m. wide. In spite of all attempts to utilize the drying fields twice in the year this could not be done. It is regarded as sufficient if the first layer spread can be brought in quite dry.

A field track with double rails has been laid for the peat cars ; shunting from one to the other track is now effected by traversers and turntables, many attempts having been made at first to effect this by a closed circular track.

The raw peat as it reaches the machine contains about 85 per cent. of water. Each of the machines is fitted with a chain elevator,  $11\frac{1}{2}$  m. long and 435 mm. wide, the lower end of which rests in the working trench on a trestle fitted with two iron rollers. In addition to screws several extra fittings are kept ready to replace the parts of the chain elevator most liable to wear and tear, as well as the wings of the left and right-handed rotating spirals, in order to avoid interruptions of the work as much as possible.

The peat machines, which tear, mix and knead the peat in a very satisfactory manner, even when it contains many roots and fibres, afford a continuous band of peat of circular cross-section and 127 mm. in diameter. The peat band is caught on boards, each 2 m. in length, on which it is brought to the drying ground, where it is spread by tipping the boards. During the run the peat band on each board is divided by means of a chopper into six pieces, which, however, separate completely from one another only during the subsequent drying. This facilitates the turning and footing of the bands on the drying ground.

With a gang of 23 labourers, each machine in a twelve-hour day gives 7,000 bands, 2 m. in length and 126 sq. cm. in cross-section, equivalent to 170 cb. m. of machine-formed peat, i.e., 14 cb. m. per hour. When air-dried 100 of these bands or rows of blocks weigh 320 kilos.

For a total yield of 2,000,000 kilos of dry machine peat in 90 working days the average daily output of each of the two machines is 22,000 kilos of dry peat or, with a cross-section of 126 sq. cm. for each of the 7,000 bands, 176 cb. m. of freshly formed peat in twelve hours, which is a very good average daily output for a whole season.

The gang consists of :—

- 1 Engine-driver.
- 8 Men for digging and throwing on the elevator peat which often contains wood and roots.
- 1 Woman for inserting the boards.
- 1 Boy for dividing the sods with the aid of a chopper.
- 2 Men for removing and loading the boards on the cars.
- 6 Attendants for the peat cars.
- 3 Men for spreading the bands on the drying ground.
- 1 Supernumerary.

The work of winning and drying is let at piece rates. For 1,000 bands (2 m. in length) the wages paid are:—

	Marks.
For digging, working in the machine, transport, including spreading on drying field (for the whole gang of 23), 14M. to 16M., therefore, on the average .. .. .	15.50
For drying—	
(a) Turning .. .. .	0.40
(b) Footing 0.90 to 1.00, on the average ..	0.95
(c) Clamping and transporting to the sheds, 1.00 to 3.00, on the average .. ..	2.00
Total (average) ..	18.85

In this way the labourers earn for a ten-hour day:—

	Marks by day.	Marks by piece-work.
Women .. .. .	2.00 to 2.20	2.50
Men .. .. .	3.00 to 3.50	5.00

The general expenses for oil, cotton-waste, fuel for engine, repairs, replacing parts, boards, stoppages, turning the machine, &c., amount to about 8 Pfg. for 100 kilos of dry peat.

The Royal Peat Department has entrusted the peat-winning to a contractor at a fixed price for 100 kilos of dry peat, which in the year 1915 was:—

For machine peat in sheds .. .. .	0.80–0.85M.
For peat litter and peat dust, packed in bales	1.00M.

the contractor being supplied free with the whole apparatus—machines, rails, sheds, &c. The plant costs for these amounted to 36,000M. to 40,000M., i.e., 12,000M. to 13,000M. for each of the three machines. The contractor is responsible for the maintenance of the machines only.

At the peat works machine peat was sold at the rate of 1.60M. for 100 kilos. The same amount loaded on railway trucks cost 1.80M. For 100 kilos of peat litter 2.00M. were paid, while the best coal (gas coal) at the same place cost 2.55M. for 100 kilos, Brown coal is not used in the district.

The peat litter factory has one willow, one mull mill and two presses, which are used for baling mull and fibre. The machinery was supplied by Francis Haas, Machine Factory, Ravensburg.

#### 4.—*The Elisabethfehn Peat Works of the Peat Coke Co., Ltd., Oldenburg*

This undertaking was founded by Dr. Wielandt in 1905, and passed into his sole possession in 1908.

With a view to improving the process for winning peat, the first Wielandt peat-dredging machine was installed there in 1909, and this was followed in 1910 by other machines of the same type. The amount of bog owned by him has been increased to 200 ha. The bog serves to provide the peat which is required by the Peat Coke Co., Ltd. In 1914, with a view to further decreasing the expenses, an electrical power station was erected to replace the

older locomotives. Electricity is generated at the power station, at almost no expense, by means of the waste gases from the coking furnaces, and is transmitted to the peat works at a tension of 3,000 volts, which is transformed to a tension of 500 volts for the machines.

The two Wielandt machines which are now working there together produce yearly 14,000 m. tons of air-dried peat with a power consumption, measured on the switch-board, of 20 h.p. for each machine.

The peat is light in colour and of low density, and the upper layer, to a depth of over 1 m., is almost white. This layer is cut in the form of sods, and worked to litter or mull in the peat litter factory belonging to the works, the output of which is at present about 600 railway wagons per annum.

The drainage of the bog is effected by an electrical pumping installation which has been set up for this purpose.

The peat dries rapidly, since the dredger digs the driest slope of the bank and the sods are spread flat with small spaces between them. Generally after eight days the sods may be placed in heaps, five sods in height, and after two to four weeks more they can be removed and put into small clamps for further drying—the operations being performed by piece-work. In the hot summer months the peat in good weather is already so far dried while in the first footing that it may be delivered direct to the coking works, with a considerable saving of expense.

The first peat dredged in the beginning of April is, as a rule, so dry in the footed state by the middle of May that it can be delivered to, and coked in, the coking works, the percentage of water in the peat being 25 to 35. Since in this way the peat can be utilized about two months earlier in the season, the winter supply is cut down by a two months' amount.

During the War in 1915, when able-bodied labourers were difficult to obtain, the service of one of these machines was so well maintained by one able-bodied engine-driver and three or four young people of from 16 to 18 years of age that the peat machines did not miss a single day's work from lack of labour. The total cost, including everything, for 100 kilos of air-dried peat, delivered free at the coking plant, was said to be 0·40M. Further particulars are given on p. 155, under the heading "Wielandt's Peat-dredging and Forming Machine," and also in Part II, Section II, 2, under "Wielandt's Peat-carbonizing Process."

### 5.—*The Wiesmoor Peat Works at Aurich*

Particulars with regard to the origin, equipment and utilization of this factory (the largest of all peat works), which was erected in 1908, are to be found under the heading, "The Wiesmoor Electric Power Station," in Part II, Section IV, 7. From 40,000 to 50,000 m. tons of peat fuel are won yearly, and for this purpose about 30 peat machines, amongst which are several Strenge fully automatic machines with dredgers and sod

spreaders, electrically driven, have been installed and give employment to 500 labourers.

In this factory various forms of machines, and therefore different methods, are employed to win the peat. The necessity of providing, without artificial drying, sufficient dry peat fuel to keep the electric power station working at its full capacity, and, moreover, the efforts of the board of control to utilize any new discoveries for winning and utilizing peat, especially on a large industrial scale, have made this factory of great importance for the peat world. This is true more especially with reference to the question of utilizing the immense, and hitherto neglected, peat bogs of Germany, and also with regard to rendering the bogs available for agricultural operations at practically no expense.

#### H.—Comparison of the Properties of Machine Peat and Cut Peat from the same Raw Material, and Influence of the various Modes of Winning on these Properties

Condensed machine peat has considerable advantages over cut peat from the same raw material, as has been already indicated in Section IV. Air-dry machine peat has such a density and firmness that a piece of it can scarcely be broken by the hands, and in order to break it up a more or less heavy implement—a hammer, an axe, or the like—is required. It is even difficult to cut small pieces off it by means of a knife.

Especially when machine-formed peat is won, the surface of the peat sods, even when these are not fully air-dry, has so dense and firm a crust that the peat, when taken in the hands, neither stains them nor crumbles easily. Machine-formed peat, in this respect far excelling coke, brown coal and coal, may be regarded as one of the cleanest of fuels for household purposes.

In conformity with the method of winning machine peat, the interior, like the surface, of the sods has such a uniformly dense consistency that a cut with a saw or a knife gives a smooth section with a waxy lustre, in which, apart from splits formed during the progress of the drying when the disintegration and mixing of the raw material has not been carried out with sufficient care, more or less large pores can scarcely be noticed.

By means of the great firmness and density produced in machine peat in consequence of the mixing action of the machine, almost all the defects of hand peat mentioned on pp. 64 and 65 are simultaneously removed, and in the successful attempt to increase its density, its water-absorbing properties decrease as the firmness and density of the machine peat increase.

The effect of different methods of winning, or of different machines for the same method of winning, on the contraction, the drying, the percentage of water in and the density of the machine peat when working the same raw material, depends mainly on the more or less great destruction of the fibrous character of the raw peat, on the disintegration of the peat fibres, and

on the thorough working of the whole mass. Generally it depends on the mixing and tearing action of the machines employed for carrying out the method of winning, and the amount of this effect can be expressed numerically by means of the "dry-volume ratio"  $\frac{v}{v'}$ , the contraction effect  $\frac{v}{v'}$ , and the condensing effect  $\frac{s}{s'}$  as in the winning of hand peat. (Cf. pp. 59 and 62.)

With this object the author instituted a series of experiments, the results of which are given in the following tables, and from which important conclusions may be drawn as to the method of winning machine peat which is economically the best.

According to the statements made under A, 1, of this section, the mixing action of a machine depends on the number of revolutions of its knife shaft corresponding to a definite amount of the raw material. Attempts were made to determine this effect by making the rotation of the knife shaft and the arrangement of the knives capable of being so altered that for the same output the comparative rotation number, i.e., the number of rotations of the knife shaft corresponding to 100 l., was at first 15 and later 75. Various raw peats were worked into formed peat in this machine while employing different speeds for the rotation of the knife shaft and noting exactly the volume and the weight relations in each case.

These experiments have confirmed the observations already made in peat factories, which showed that, owing to a greater mixing action, not only is the air-dry machine peat denser (due to greater contraction of the sods) than a machine peat made with a smaller mixing action of the knife shaft, but the *fresh* formed peat coming from the machine is also denser and more compact in the first case.

The peat sods made in the machine when it had a greater mixing action looked smoother and neater than those made from the same raw material and with the same mouthpiece when the machine had the smaller mixing action. In consequence of their greater uniformity, they also held together better in their later treatment—repeated weighing, spreading, turning, &c.—and kept their uniformly smooth surfaces even on drying. The sods of the less well-mixed peat, on the other hand, broke easily when being spread, lost shape on drying, and developed irregularities and fissure on their surfaces owing to undivided and more or less hard lumps or roots—disadvantages which may frequently be observed in many bogs as a consequence of too small a mixing action of the machines.

From numerous measurements and weighings a difference of 8 to 15 per cent. in weight—on an average, 10 per cent.—has been found in favour of the machine with the greater velocity (the higher comparative rotation number of the knife shaft was, as stated above, five times the lower), the fresh peat sods having the same size and being made from the same raw material in each case. It was also possible, with the machine having the greater mixing action, to work the raw peat with 15 to 20 per cent. less water, getting an equally dense and firm final product, which in many

cases is of great advantage so far as the time of drying and the area of the drying ground are concerned.

Examples of the average results obtained in the experiments with several peats from Königs-Wusterhausen district are given in the following table.

EFFECT OF THE GREATER MIXING ACTION OF PEAT MACHINES ON THE PRODUCT.

Character of the raw peat worked.	Mode of winning.	Rotations of knife shaft for 100 l. of peat.	Size	Weight	Increase of weight compared with cut peat.	Difference between the machine peats.	Density	Condensing effect
			of the freshly formed sods.				in the air-dry condition	
Brown grass peat with much intermixed humified wood, sedge, and wood fibres	Cut peat	—	cm. 25 × 7 × 4	g. 508·0	—	—	0·70	—
	Machine-formed peat	15	Do.	759·0	50 p.c.	} 10 p.c. {	1·12	1·6
		75	Do.	810·0	60 p.c.		1·30	1·71
Black humified peat with intermixed sedge remains and some not yet humified root fibres	Cut peat	—	15 × 4 × 4	237·60	—	—	0·88	—
	Machine-formed peat	15	Do.	298·70	26 p.c.	} 14 p.c. {	1·00	1·14
		75	Do.	334·40	40 p.c.		1·24	1·41

(Cf. also the following table, pp. 246-247, in which the figures given under 10 and 12 relate to the same raw peat, and the dry-volume ratios and dry weights of the sods here mentioned are indicated.)

It may be seen in the table that the machine peat made from one and the same raw material by a machine with a more or less high rotation number for the knife shaft contains in the one case 10 per cent. and in the other 14 per cent. more solid matter for sods of the same volume than those obtained from the same machine with a smaller rotation number.

Attention to this fact is of great importance for the success of a peat factory, since the labour required for forming and drying in machine peat winning is usually paid for by the thousand of the formed sods of a definite size, although the sale of the machine peat takes place only, and more correctly, by weight. For the same wages, on an average 10 per cent., in some cases even 15 per cent., more fuel is produced when a machine with the higher mixing action is employed, and therefore without further trouble 10 per cent. more is gained than in the other case where *apparently* (according to the number of sods) only the same output is obtained.

*In selecting a peat machine attention must therefore be paid not only to the nature of the raw material to be worked and the number of the total volume of sods the machine can produce per day, but especially to the amount of the mixing and condensing action of the machine.*

It follows from numerous experiments and observations that *the greater the mixing and condensing action of a peat machine, the denser the dry peat won from a given volume of formed peat, the greater its output of air-dry peat, and the drier the raw peat can be worked for the same ease of "forming"; and therefore for the same raw peat a greater weight of (and hence a cheaper) dry peat can be obtained from the partially dried material. Also, the less sensitive (because the firmer) the freshly formed peat is towards any rain which may fall on it during the early days of the drying period, the more securely it dries, the better the sods retain their regular shape, and the less they (on account of their more uniform texture) split and crumble during the process of drying.*

The direct effect of the machines on the condensation of the formed peat, i.e., the condensation of the *fresh* formed peat in reference to the raw peat, which is directly due to the mixing action in the machine, varies with the percentage of water and the nature of the raw peat, from 25 to 60 per cent., and with average peats it may be assumed as 30 to 40 per cent., so that for 1 cb. m. of freshly formed peat 1·30 to 1·40 cb. m. of raw peat are required. From 1 cb. m. of raw peat, therefore, 0·7 to 0·8 cb. m. of fresh machine peat is obtained, and this during air-drying contracts to one-fifth, that is, to 0·14 to 0·16 cb. m., which, when clamped in sods, has a volume of 0·20 to 0·30 cb. m.

In the case of machine pulp peat winning less raw material is required for 1 cb. m. of fresh pulp peat owing to the large amount of water which is added, but since, on the other hand, the fresh pulp peat does not give as much air-dry machine peat, the amount required for 1 cb. m. of air-dry pulp peat is in general the same as in the machine-formed peat winning.

A number of machine peats, some of which were made by different methods, and the corresponding cut peats from various peat bogs, have been subjected by the author to a thorough examination with a view to comparing other properties of machine peat with those of cut peat from the same raw material. The results are shown in the table on pp. 246-247.

The special objects of this examination were :—

(1) The condensation, the dry-volume ratio, and the contraction effect of the machine peat as well as the condensing actions of the different machines and methods of winning.

(2) The percentage of water in air-dry machine peat and in air-dry cut peat from the same raw material.

(3) The absorption of water by anhydrous machine peat and by anhydrous cut peat.

(4) The absorption of water by air-dry machine peat and air-dry cut peat when they are exposed under the same conditions to a moist atmosphere (rain).



The peat sods examined were all first air-dried in a covered place until two successive weighings at intervals of four days gave no appreciable difference in weight. The percentages of ash and the densities (vertical columns 2, 8 and 9) were then determined with one lot of the fully air-dried pieces of peat. A second lot of the pieces of peat was weighed exactly and heated in a drying oven with careful regulation of the temperature to 110° C. until, in two successive weighings at intervals of six hours, it showed no change in weight and was therefore to be regarded as anhydrous. From the weights of the anhydrous peat and the air-dried peats the percentages of water given in columns 13 to 16 were calculated in reference both to the weight of the air-dry peat and that of the anhydrous peat.

The pieces employed were chosen so as to have the different surfaces and nature of the cut peat on the one hand and of the machine peat on the other hand well maintained. These anhydrous pieces of peat were then all exposed to the effect of the air, and the new amounts of water absorbed by the anhydrous peats were determined (see columns 17 to 22) by making weighings at definite intervals. Finally, a third batch of the pieces of air-dry peat was exposed for twenty-four hours to the action of heavy rain to enable us to form an idea of the water absorption due to rainfall, of cut peat and machine peat when exposed to the action of the weather, as, for instance, when stored in the open. The increases in weight, found by means of weighings made an hour after the rain stopped, and also twenty-four hours later, are given in columns 23 to 26.

It follows from the table that :—

(a) The dry-volume ratio in the case of the winning of machine peat, i.e., the ratio of the size of an air-dry peat sod to the size of the same sod in its freshly made formed peat or pulped peat state varies from 14 to 30 per cent., and that its average value may be assumed to be 20 per cent. ; the contraction therefore amounts to approximately 80 per cent.

(b) The shrinkage effect varies from 7·28 to 3·40 and has an average value of 5, i.e., the volume of a piece of freshly made machine peat is five times as great as that which the same piece has when it is air-dry.

(c) The condensing effect varies with the different machines and processes from 1·14 to 4·90. The figures in the table cannot, however, be used for direct comparison of different modes of winning and of different machines with one another in respect to their condensing effects, since the action of one and the same machine varies for different raw materials. Only figures giving the condensing effects of different machines when working the same raw peat can be employed for the purposes of comparison.

*The condensing effect of one and the same method of winning or of one and the same machine for different raw peats is all the greater the less dense, the more felty, and the poorer in ash the raw peat is and the wetter it is worked.*

In the case of naturally dense, humified peats, even a machine

COMPARISON OF DRY-VOLUME RATIOS, SHRINKAGE AND CONDENSING EFFECTS, AS WELL

Column	1	2	3	4	5	6	7
No.	Raw substance.		Mode of winning.	Size of sods in cm.		Dry-volume ratio $\frac{v}{V}$	Shrinkage effect. $\frac{V}{v}$
	Kind and quality.	Ash p.c.		Wet. V	Air-dry v		
1	Oldenburg, light, dark brown and sedge peat, intermixed with much plant matter	1.8	Machine pulp peat	28×9.3×13	19×6.5×7.6	0.28	3.60
2	Hanoverian brown heather peat, mixed with much cotton-grass and wood roots	2.0	Machine pulp peat	30×15×12	20×7.5×6	0.17	6.00
3	Holstein, dense, brown, humified peat with few plant remains	10.3	Machine-formed peat	28.8×7.2×9.8	19.6×5.2×5.9	0.30	3.40
4	Gravenstein, brown, light peat having a bast-like texture	2.5	Machine pulp peat made with forming barrow	29×13×10	17×8×5	0.18	5.56
5	Light, brown, felty, moss peat . .	1.3	Eichhorn's ball peat	10 to 12 in. diameter	5.5 to 6.0	0.17	6.00
6	Dense, brown, humified peat with much cotton-grass sedge remains, &c.	2.7	Do.	10 to 12 in. diameter	5.5 to 6.0	0.17	6.00
7	Brunswick dark brown, humified peat, short and clean	16.5	Machine-formed peat	23.5×9×6.5	16×6×5	0.33	3.00
8	Brandenburg black, humified peat mixed with sedge remains and some not yet humified root fibres and containing 85 per cent. of water when worked	12.1	Machine-formed peat at 10 to 15 V (*)	15×4×4	9.9×2.2×2	0.18	5.50
9	Do. at 75 V (*)	—	Do. at 75 V (*)	15×4×4	9×1.8×2.5	0.17	6.05
10	Brown grass peat mixed with much semi-humified fibres of wood, sedge and roots, and containing 85 per cent. of water when worked	11.1	Machine-formed peat at 10 to 15 V (*)	Oval 25×7×4	14.8×4×2.3	0.19	5.32
11	Do. at 75 V (*)	—	Do. at 75 V (*)	25×7×4	14.2×3.8×1.8	0.14	7.28
12	The same peat as under 10 and 11, but it had been exposed as half-dried machine peat to the action of frost and, after thawing, had been dried in the air	—	—	25×7×4	19×5.5×2×5	0.37	.027

\* Number of revolutions of the knife shaft

S PERCENTAGES OF WATER AND ABSORPTION OF WATER FOR MACHINE AND CUT PEATS.

8	9	10	11	12	13	14	15	16	17	18	19	20	21	22	23	24	25	26
Density of air-dry		Density of anhydrous		Con- dens- ing effect  S — s	Water percentage in air-dry peat referred to				Percentage absorption of water by the anhydrous peat after						Percentage absorption of water by the air-dry peat in rainy weather			
Cut peat.  s	Machine peat.  s	Cut peat.	Machine peat.		Air-dry state.		Anhydrous state.		2 days.		4 days.		10 days.		1 hour after the rain.		After 24 hours.	
					Cut peat.	Machine peat.	Cut peat.	Machine peat.	Cut peat.	Machine peat.	Cut peat.	Machine peat.	Cut peat.	Machine peat.	Cut peat.	Machine peat.	Cut peat.	Machine peat.
20 to 29	0.98	0.18 to 0.26	0.84	3.27 to 4.9	10.45	14.40	11.68	16.81	6.8	2.1	7.3	2.9	8.7	6.3	29.0	1.5	5.9	1.1
37	1.03	0.32	0.89	2.80	12.80	13.73	14.68	16.00	7.7	2.6	9.5	3.6	12.8	6.1	9.5	2.0	4.3	1.0
64	1.20	0.53	0.98	1.90	17.70	18.20	21.50	22.41	10.3	2.9	14.2	5.7	20.1	13.3	9.8	5.2	5.4	3.0
31 to 44	0.67	0.27 to 0.38	0.57	1.52 to 2.16	13.70	14.70	15.93	17.27	8.3	7.0	9.5	9.0	12.3	12.3	17.2	6.1	4.3	3.6
15 to 38	0.74	0.13 to 0.33	0.63	2.85	13.90	14.30	16.01	16.68	9.5	5.9	11.3	8.1	12.8	12.2	29.0	5.5	8.0	3.2
48	1.00	0.41	0.88	2.10	13.26	11.98	15.29	13.59	8.8	1.05	10.9	1.6	13.4	4.1	11.3	3.9	5.2	1.7
74	1.10	—	0.93	1.50	?	15.80	—	18.88	—	3.80	—	5.90	—	11.9	—	3.9	—	1.7
88	1.00	0.76	0.86	1.14	14.0	13.80	16.36	15.92	6.5	5.8	9.1	8.4	14.3	14.1	6.3	3.9	4.0	2.8
88	1.24	0.76	1.07	1.41	14.0	13.70	16.36	15.74	6.5	3.1	9.1	5.1	14.3	7.2	6.3	1.7	4.0	1.5
70	1.12	0.60	0.95	1.60	14.40	15.30	16.85	18.01	7.5	2.6	10.5	4.3	15.7	9.5	10.4	4.7	5.8	3.0
70	1.30	0.60	1.09	1.71	14.40	16.40	16.85	19.59	7.5	1.5	10.5	2.5	15.7	7.2	10.4	3.8	5.8	2.5
70	0.56	0.61	0.48	0.80	13.00	14.79	14.94	17.35	7.5	9.0	10.5	11.2	15.7	12.78	10.4	10.6	5.8	4.7

per every 100 l. of peat (in an experimental machine).

with a good mixing action rarely attains a greater condensing effect than 1·5. In this respect the advantage of winning peat by machines increases with the lightness of the raw peat, and it is therefore of great importance for poor raw peat.

(d) The percentage of moisture in air-dry machine peat (the average value is 15 to 18 per cent.) is generally slightly greater for the same length of drying (under cover) than that of cut peat from the same bog.

(e) On the other hand, the tendency of machine peat to re-absorb moisture is considerably less than that of cut peat, so that the water absorbed by air-dry machine peat in the case of rain or heavy mists is to be regarded as zero, while the percentage of water in cut peat increases considerably.

The somewhat higher percentage of water in machine peat in the air-dry state, which state is, however, seldom attained by cut peat which is not dried under cover, can be explained by its dense and solid consistency, and especially when "watering forming pieces" are employed by the fully macerated, dense surface of the sods. Both of these increase the difficulty of evaporating the water from the interior of the machine peat, and to them is due the fact that the moisture of the core disappears only after storing for some months.

This solidity and density of machine peat, and the satisfactory maceration of its surface are the reasons why machine peat, no matter whether pulped or formed peat, does not dry more rapidly than cut peat with the same initial percentage of water, although the contrary is almost generally assumed or at least asserted in favour of machine peat by those engaged in the manufacture of the latter product.<sup>1</sup>

The numerous experiments carried out with great exactness by the author have in every case established the above fact, which is also evident from the nature of the change and the course taken by well-known natural processes. A body such as peat cannot in the dry state have a smaller absorptive power for moisture owing to its denser consistency, and at the same time this body

---

<sup>1</sup> To facilitate the drying of formed peat and increase its resistance towards the injurious action of an unfavourable atmosphere (formation of crust, splitting, bursting, crumbling), Schlickeysen proposed either to add finely divided bodies (coal dust, peat mould, saw-dust) to the raw peat, or to add bodies such as these to the surface layers of the sods. The peat bands were also to be heated a short time—i.e., until their surface water had been evaporated. The crusts thus formed round the still cold cores of the sods were supposed to make direct piling of the sods possible (cf. Patents 156025, 164225, and 166597). These processes have not, however, come into use on a large scale.

With a similar object, but with the intention rather of increasing the calorific power of the peat, Zailer (Vienna) has proposed to work the raw peat in the mixing and forming machine with the addition of crude petroleum in countries rich in oil. This oil peat is said not to take longer to dry, to become denser, and, according to the amount of oil added, to have its calorific power nearly doubled (up to 6,000 calories). The oil peat process is to be acquired by the German Naphtha Company, and to be carried out on a large scale in Galicia.

with the same dense consistency in the wet state gives off moisture by evaporation more rapidly than fibrous, loose, raw material with the same percentage of water, in which access of air, and therefore evaporation of water, is in every way favoured by the open and cleft structure of its loose, cellular and rough surface. As has been already indicated, no peat has closed cells and capillaries containing water so large that they can be torn up and opened by the thick knives of peat machines, which would thus set *free* in the machine peat the water which would remain *enclosed* in the cut peat. The same dense, dried crust, however, which within two days after the preparation of the machine peat is able to prevent the penetration into the peat of any rain which may fall on it, and which allows the rain to run off the surface, protecting especially the surface of the still moist sods from being washed out and carried away, that same crust, together with the great compactness of the core, impedes the free evaporation from the interior of the water contained in the sod, and therefore makes machine peat dry less readily than cut peat.

The table on p. 250 contains some data as to the course of the drying of cut peat and machine peat from the same raw material. The peat sods were taken with care from the same layer of peat and were chosen so that the specimens of machine peat and cut peat from the same raw material had as nearly as possible the same percentages of water, as shown by the calculations made when the specimens were completely dry. The sample of cut peat, No. II, in the third experiment, was taken from a very compact and heavy layer, which would probably allow its water to evaporate with great difficulty, but even in the case of this specimen the drying took place more rapidly than in that of the corresponding machine peat.

In a covered place the machine peats under 1 and 2 became air-dry about ten days, and that under 3 about twelve days, later than the corresponding cut peats.

Although machine peat in general dries more or less slowly, atmospheric conditions, as already pointed out on p. 216 in the section on the drying of peat, in protracted rainy weather, favour machine peat. The latter, owing to its more or less low absorptive power, retains in rainy weather that degree of dryness which it has previously attained, while cut peat, lacking this property, re-absorbs water and retreats in the drying. Hence it happens that a peat which is to be *dried and stored in the open* will attain and keep its air-dry state with 15 to 20 per cent. of moisture more certainly than cut peat from the same mass.

If cut peat is not stored in covered sheds in which it is exposed to the air, it will attain its proper air-dry condition, containing 12 to 15 per cent. of moisture, only in very rare cases, and never in winter.

The effect of frost on machine peat which is not air-dry is just as disadvantageous for the firmness of the peat as it is in the case of cut peat. If the machine peat contains more than 30 per cent. of water, and in this condition is exposed on the

PROGRESS OF THE DRYING IN THE CASES OF CUT PEAT AND MACHINE PEAT FROM THE SAME PEAT BOG.

No.	Nature of the raw peat.	Mode of winning.	Con- densing effect.	Volume, surface, and weight of the fresh peat sods.		Water evaporated, percentage by weight, after				Water evapo- rated in forming the air-dry peat. Per cent.	Weight of the air-dry peat. g.	
				c.c.	sq. cm.	2 days.	4 days.	6 days.	8 days.			14 days.
1	Black, humified peat, mixed with some sedge remains, &c., from Königswusterhausen district	Cut peat ..	—	265	206	28.0	50.2	63.7	72.9	80.5	84.8	39.80
		Machine peat	1.14	240	272	24.3	45.6	56.0	64.9	73.2	84.3	47.00
		Machine peat	1.41	240	272	20.4	38.0	52.1	62.3	73.0	84.5	51.80
2	Brown grass peat, mixed with wood sedge and root fibres, from Königswusterhausen district	Cut peat ..	—	335	347	22.3	39.5	47.4	53.4	78.3	86.3	36.30
		Machine peat	1.60	635	525	19.4	32.7	43.0	49.5	75.0	86.3	102.60
		Machine peat	1.71	635	525	16.6	27.3	37.6	44.9	71.7	85.0	120.85
3	Brown, mossy, humified peat, mixed with sedge and root remains, rich in ash, from Tempelhof, near Berlin	Cut peat I ..	—	450	324	30.9	54.3	65.9	74.0	80.6	80.7	52.00
		Cut peat II	—	650	440	17.4	33.6	45.7	58.7	77.6	81.2	97.60
		Machine peat	2.1	640	435	12.1	25.3	35.4	47.0	68.7	79.5	138.60

drying ground, in clamps or in open sheds, to a temperature below  $0^{\circ}$  C., the well-known expansion of the water as it becomes converted into ice increases the volume, and destroys the intimate connexion between the various small particles of the peat. After thawing, the small splits and clefts which form between the particles prevent mutual attraction, shrinkage and condensation during the early stages of the drying. In the case of very wet peats the sods, after thawing, fall to pieces, while those which are more advanced in the drying process, although they remain whole, do not contract any further, and when completely dry they give a very light, and therefore less valuable, peat which has more or less the properties of spongy cut peat.

The horizontal column 12 of the table on p. 246 contains the results of the experiments made with frozen peat sods. For this purpose some of the sods made for the experiments under 10 and 11 were kept at  $6^{\circ}$  C. for several days (the experiments took place at the end of October during a heavy frost which lasted for days) until they were frozen throughout their mass. The stage of drying at which the sods were frozen was such that their original length of 25 cm. had contracted to 19 cm. After thawing the surfaces of the sods they showed the well-known scaly appearance characteristic of such sods; some of them fell to pieces, but most of them held together; as the drying, however, proceeded in a covered place all further contraction ceased, so that the sods even when air-dry still had a length of 19 cm., while those which had not been exposed to frost, and which were also originally 25 cm. in length, had, when air-dry, decreased to 14.2 to 14.8 cm. in length. Hence, in the case of the frozen peat the shrinkage effect (cf. the vertical column 7) was 2.70, while that of equally large sods which had not been frozen, and which had been made from the same raw material and in the same machine was 7.28 and 5.32. The frozen machine peat gave very light sods, having a density of 0.56, which was therefore even lower than that (0.70) of its raw peat (air-dry), so that in this case the condensing effect was under 1, and, indeed, had the value 0.8. For the same reason the figures giving the behaviour of the peat towards moisture contained in the columns 13 to 26 show considerable alterations which are not in favour of the frozen machine peat.

It is therefore inadvisable to continue the winning of machine peat so far into the autumn that the last sods manufactured cannot be dried so as to contain not more than 30 per cent. of moisture before the time at which frosty weather is to be expected.

Frozen peat sods, containing 40 per cent. of moisture, when worked again and treated in the ordinary way in the machine, give a machine peat which hardens and shrinks as well as ordinary peat worked in the same machine. This has been the general experience when working frozen raw peat (which owing to insufficient watering has been "frozen out" over winter) which, in contrast to the failures in the cut peat winning, gives a fuel differing little or not at all from that made from unfrozen peat. In order that the winning may be, however, quite safe, the frozen

peat is always mixed with good (unfrozen) raw material when being worked in the machine.

Schreiber has made the following experiments<sup>1</sup> at Sebastiansberg with peat from the high bogs of that locality. The object of these experiments was to determine the effect of different methods of winning and drying on the quality (density, volume, dryness) of the peat and on the size of the drying ground required. The results of the experiments, however, especially with regard to the drying ground, are to be appraised and utilized with caution on account of the extraordinarily bad climate at the locality where the experiments were conducted.

Thirty-eight samples, each  $\frac{1}{8}$  cb. m., were taken from the Sebastiansberg bog. The samples weighed in each case from 136 to 140 kilos, without any difference in weight being perceptible between fuel peat (black, well-humified peat) and litter peat (young, light yellow moss peat). One cubic metre of raw peat had therefore, a weight of 1,088 to 1,120 kilos.

The experiments with this (Sebastiansberg) high bog peat gave :

(1) Percentage of *water* and *ash* in the peat :—

Percentage of	Fuel peat.				Litter peat.				
	Raw.	Air-dry.	Anhydrous.	Raw.	Air-dry.	Anhydrous.	Raw.	Air-dry.	Anhydrous.
Water ..	87	22	—	92	18	—	—	—	—
Ash ..	—	—	2.2	—	—	3.1	—	—	—

(2) *Density* of the air-dry peat :—

Mode of winning.	Fuel peat.		Litter peat.	
Cut peat .. .. .	0.55	..	0.22	..
Cut peat, after wintering .. .. .	—	..	0.14	..
Pulp peat (moulded and stroked peat) ..	0.70	..	—	..
Machine-formed peat .. .. .	0.95	..	0.35	..

(3) *Shrinkage* :—

100 l. of raw peat shrink during air-drying to :—

	Fuel peat.		Litter peat.	
Cut peat .. .. .	33	litres	45	litres.
Cut peat, after wintering .. .. .	—	..	80	..
Machine peat .. .. .	20	..	31	..

(4) *Contraction* of the lengths of the sod edges in percentages of their original lengths :—

	Fuel peat.		Litter peat.	
Cut peat .. .. .	74	..	77	..
Pulp peat .. .. .	69	..	—	..
Machine-formed peat .. .. .	61	..	70	..

(5) *Yields* of air-dry peat :—

	Fuel peat.		Litter peat.	
1 cb. m. of raw peat gives ..	182	kilos	107	kilos
1 ha. of bog, 1 m. in depth, gives ..	1,820	m. tons	1,070	m. tons.

(6) *Weight* in kilos of 1 hl. of the air-dry peat :—

	Fuel peat.		
	Cut peat.	Pulp peat.	Machine-formed peat.
Loosely filled .. .. .	22	33	36
Filled without intervening spaces ..	55	70	95

<sup>1</sup> Fourth "Jahresbericht der Moorkulturstation in Sebastiansberg," by Hans Schreiber, published by the Bog Utilization Station.



(7) *Minimum area of drying ground* required for a single spreading of the 55.5 cb. m. of raw peat required to give 10,000 kilos of air-dry fuel peat :—

	Are.
Pulp peat, spread .. .. .	11
Formed peat, spread .. .. .	6
Cut peat, according to locality and size of sods .. .. .	4-10
Cut peat, "poled" .. .. .	6
Cut peat, "spiked" .. .. .	7
Cut peat, on "horses" .. .. .	4
Cut peat, on trestles or hurdles .. .. .	3

(8) *Maximum yield of 1 ha. of drying ground* for a single spreading of air-dry fuel peat :—

	M. tons.
Pulp peat, spread .. .. .	94
Formed peat, spread .. .. .	178
Cut peat, spread .. .. .	100-270
"Poled" peat .. .. .	185
"Spiked" peat .. .. .	148
Peat on "horses" .. .. .	310
Peat on trestles, hurdles, &c. .. .. .	477

The yield from a bog of air-dry peat, which is marketable and can be utilized, varies a good deal with the nature of the peat and the mode of winning, as may be seen from the dry-volume ratios, the shrinkage effects, and the densities for the various peats given in the tables on pp. 63 and 246. Excluding abnormal kinds of peat, the figures with respect to yield vary within the following limits :—

From 1 cb. m. of raw peat, with a density from 1 to 1.1 and a percentage of water from 85 to 95, the following may be obtained, according as it consists mainly of light moss peat or of black humified peat :—

	When won as			
	Cut peat.		Stoked, pulped, or kneaded peat.	Machine-formed peat.
	Litter peat.	Fuel peat.		
Of air-dry peat (regarded as having no intervening spaces)	0.40-0.50	0.25-0.35	0.18-0.25	0.17-0.30 cb. m.
With a density of ..	0.15-0.30	0.30-0.80	0.60-1.00	0.65-1.30
Weighing (air-dry with 20 per cent. of moisture)	75-120	100-150	150-180	170-200 kilos

More reliable average figures for preliminary estimates with regard to the valuation of peat bogs or for projected peat factories cannot be given owing to great variation in the bogs. In order to guard against being misled it is emphatically to be recommended that in every case estimates should be based on well-conducted experiments made with the peat of the locality itself.

Vogel has made experiments in a rolling barrel, which had

a volume of three Bavarian buckets, with regard to the transportability of various kinds of peat, which is closely connected with the density of the peat. The results of these experiments were that the weight of light *cut peat* decreased 3·5 per cent., of dense Staltach machine peat 0·31 per cent., and of Schleissheim (roller) press peat 2·4 per cent., owing to waste, for the same amount of motion.

## J.—On the Selection of New Peat Machines and on Peat Machine Competitions

### 1.—General Observations on the Selection of New Peat Machines

In choosing machines for the manufacture of machine peat it will be necessary to take into account the amount of the projected annual output and the driving power, available or intended, as well as the nature of the peat to be worked and that of the bog. By referring, then, to what has been said in the preceding sections about the advantages and the defects of the various machines, that best suited for the given case can be selected.

Although rules applicable to all cases cannot be given, it will be easy, by paying attention to the general points of view described below, to decide in the special circumstances of each case as to the mode of winning to be adopted and the kind of machine to be acquired for carrying it out.

In choosing machines we must also consider what is the best degree of dryness or wetness in a bog for winning a raw peat which is to split and crumble as little as possible during the drying, and if necessary we must find this by experiment. Raw peat which is too dry gives a fuel which splits very easily if the mixing action of the machine is not satisfactory.

If the industry be a small one, i.e., with a daily output of 15,000 peat sods or 30 cb. m. of freshly formed peat, equivalent to 7,500 to 10,000 kilos of machine peat, the peat machines can, as a rule, be worked by horses, since a horse of average strength can, according to the type of the machine, turn out 7,000 to 10,000 sods, or 4,000 to 6,000 kilos, per day. If the industry is to be continuous and as great as possible, horses, if kept constantly at work, will break down, unless relays of them be maintained. In these cases, and also where horses cannot be bought cheaply, it is preferable to use steam (locomotive or wire-rope) or electrical power for driving the working machines, even for an output of 15,000 sods.

Vertical machines for direct driving by horses, with the aid of a capstan fastened to the knife shaft, have only a small mixing action. These machines can, therefore, be employed without disadvantage only when the material to be worked is a very uniform, humified peat without appreciable admixture of semi-humified roots, sedges, grasses, &c., and which even in its natural (air-dry) state has a high density (over 0·6) and in the winning

of which it is not so much a matter of obtaining a machine peat as dense as possible for transport or perhaps for coking as of converting the available peat into handy sods for one's own use either when it cannot be won at all as cut peat, or for want of skilled workmen, or when it is desired to become independent of them. In this case and when the capital required is small, the vertical machines with slowly rotating knife shafts described in Section IV meet the requirements.

The raw peat may, however, consist wholly or partly of fibrous, moss, or sedge peat, or the otherwise ripe, humified peat may be mixed more or less with wood, sedge, or grasses. It may also, when working pure bituminous peat, be a matter of obtaining a product as good and as dense as possible. In these cases weight must be mainly attached to the possibility of intimately mixing the raw peat, and machines are to be selected which do this either by means of thin knives passing by counter-knives or fixed to a rapidly rotating shaft, i.e., machines which give the greatest condensing action are to be chosen. When this is so direct driving with horses no longer gives a sufficiently large number of shaft rotations and an attempt must be made, by means of an intermediate gearing or a capstan with gear changing from slow to fast, to bring the rotation number of the knife shafts up to 20 to 30 revolutions per minute. (Cf. Figs. 31 and 32.)

When, however, horses are not available for driving and when it has been decided to adopt steam or electric power to keep the industry going properly, or when the output is to be so great that resource must be had to steam or electricity, one should in every case try to obtain the best fuel, and importance should be attached not only to the best output from the machine in volume and external appearance but also in weight. Real tearing and good mixing machines are indicated for use not only when working fibrous peat, light moss peat and peat mixed with semi-humified plant remains in order to avoid frequent stoppages through the knives becoming wrapped with fibres, stopping of the spirals, &c., but also for obtaining as heavy a product as possible from good humified peat or bituminous peat which is in itself naturally dense.

It cannot be denied that satisfactory results, at least by volume, have now and then been obtained with machines with slowly running shafts or with smooth spiral double-shaft machines, when working ripe, humified peat. There is, however, scarcely any raw peat which is free from impurities of the most varied kinds, especially from semi-humified wood and roots, and as the above-mentioned machines with their slowly running broad knives, which only push the peat forward, cannot exert a tearing, cutting and good mixing action without frequent stoppages, and the working troubles associated therewith, an insufficiently kneaded peat and, therefore, one which will split and crumble when drying, will inevitably be formed. These troubles increase the more closely the quality of the peat approaches that of light moss and grass peat, and the output of the machine becomes much smaller

when fibrous peat preponderates in the material worked. It has, moreover, been pointed out in the preceding section that in a properly organized peat industry the shrinkage effect for a given peat due to the mode of winning or to the working machine has had a good deal of influence on the prosperity of the industry. Here, as in all other cases, the "*best*" should always displace the "*good enough*." The horizontal, rapidly running machines require no greater driving power than the vertical. When properly chosen they work all kinds of peat, give a denser, heavier product, are easier to attend, and, owing to their smaller weight, are more easily moved in the bog itself than are vertical machines. It only requires some skill from the workmen, supervision from the manager, correct choice of means of transport and acquaintance with their special advantages in each case to prepare by means of these machines from any given raw material a product which is the cheapest for sale and the most valuable for use. How far the various modifications of the horizontal machine adapt themselves to special cases has been sufficiently indicated in the descriptions of them given in Section IV. According to the experience hitherto gained the pulp peat machines, which are also described in the section referred to, appear to be in general well able to compete with the rapidly running forming machines. The decisive factors in the selection of the one or the other mode of working are generally local circumstances and the customs of the owners or their workmen. There is no doubt, however, that the winning of formed peat requires a greater amount of knowledge from the manager, a more careful choice of the working machine, and better trained workmen than does that of pulp peat. On the other hand, the pulp peat winning requires a longer drying period, and therefore has a shorter working season each summer. This method gives a fuel which does not look so well and depends more on the weather, &c.

The question has often been asked how the different machines behave and wear when stones are contained in the raw material worked. The answer to this ought to be in favour of the vertical machines in so far as, owing to the small number of their knives, the width of their cylinders, and the slow rotation of their knife shafts any stones or pieces of wood in the peat have time to escape from the action of the knives and, not producing any resistance, cannot therefore exert any injurious back pressure on individual parts of the machines, especially the (cast-iron) knives.

It is more difficult to keep the stones out of the way, and this is also less likely to happen in the case of double-spiral machines with many intermeshing knives, as in the first portion of Lucht's machine and in the tearing and gripping parts of the new horizontal machines. The same stone, however, which breaks the knives or screws of these machines also breaks the heavier and, therefore, more expensive knives of the vertical machines when it becomes caught between the knife and the wall of the vat during the working. In the case of the horizontal machines, replacement of broken knives or screws is, as a rule, more easily effected since

all the knives and parts of screws are generally made according to the same type, and reserves may, therefore, be kept without much expense, and also as there are no bearings inside the machine the parts can, without difficulty, be taken off or placed on at the free end of the shaft and fixed in position by thumb-screws. Knives in the vertical machines can only be replaced when the crank-pin, by means of which the capstan is fixed, has been knocked out of the shaft and the upper shaft bearing has been removed.

If we remember, for a moment, that machines should be good peat-working machines *not* stone-working machines, the point made that one kind of machine does not resist the action of stones as well as another will have less significance. A peat machine with a good mixing and condensing action *must* be endangered by stones thrown in with the peat. If stones and pieces of wood pass through the machine easily, the tearing and mixing action certainly leave much to be desired. Hence, when stones are present in the peat to be worked it is better to take care to keep a sharp watch on the feeding of the raw peat, so as to avoid this working trouble, which, indeed, rarely occurs, than to try to prevent it altogether by means of a defective machine and, therefore, to content oneself indefinitely with a defective product.

## 2.—*Peat Machine Competitions*

The larger peat machine competitions hitherto organized have never led to a useful result, and under the conditions adopted could not do so. The author has already fully discussed in another place<sup>1</sup> the mistakes made in organizing these machine exhibitions and competitions.

Competitions such as these are only of value, and a correct judgment on the machines engaged can only be given, when the following conditions are fulfilled :—

The peat machines must be exhibited in a large peat bog and especially in such a one as can give large quantities of light, fibrous peat in one place and of pure humified peat (bituminous peat) at another, since it is desirable to examine the behaviour of every machine first in working separately the different kinds of peat and afterwards in working material consisting of mixtures of peats of various ages. It is also required to extend this observation for every kind of peat over a more or less long period with a view to determining how the various machines, in the *continuous* working of impure or light fibrous peat, behave with regard to stoppages and average outputs. The transport to the machine of the large quantities of raw peat then required and the removal from it of the finished product would, if the machines were set up outside the bog, waste at least as much money as would be required for setting up the various machines in the bog itself. It is only

---

<sup>1</sup> Cf. the first edition of this work and the "Bericht über die Gifhorner Torfmaschinen-Konkurrenz," by A. Hausding, 1877, published by Paul Parey, Berlin.

observation of machines set up and working in a bog itself which enables us to draw conclusions generally applicable to peat winning.

It is desirable that a bog be selected which lies near a railway. If this cannot be found it should be recommended that the funds for money prizes and any contribution by the State, agricultural societies, &c., should be divided amongst all the competitors, in part payment of their expenses, and that the best machines should be designated only by the verdict of the judges.

The following points should be exactly observed in the trial itself :—

(1) Early publication of all the conditions to be observed by those taking part in the competition as well as of the rules governing the procedure of the judges.

(2) Examination of the behaviour of every machine : (a) While working ripe humified peat ; (b) while working light, mossy and fibrous peat ; (c) while working a peat consisting of a mixture of the most commonly occurring kinds of raw peat.

(It is very easy to imagine a case where some machine proves the best for a peat consisting almost entirely of humified and marsh peat, while it is much behind others in its output for working fibrous peat, and conversely).

(3) The working of any one kind of peat must be extended to at least five hours with each machine in order to be able to determine the average output and any more or less frequent occurrence of disturbance in the working due to stoppages of the knife shafts or to faulty construction of the machine, forming pieces, &c.

(It is assumed here that a disturbance in the working is not caused by cleaning the machines twice a day (mid-day and evening) when working is not going on, but that all cleaning or repairing of the machines which occurs oftener than is essential is to be regarded as a disturbance in the working and a defect in the machine).

(4) Observation of the power required in each case to drive the machines during these five hours.

(5) Determination of the output by volume and by weight both in the freshly formed and in the air-dry state and, therefore, determination of the condensing action of each process and of each machine.

(6) Determination of the most suitable method of raising and of transporting the raw peat and of the best method of removing the formed peat and of spreading it for drying.

(7) The working expenses, in which the workmen required for attending the machine as well as the cost (amortization expenses) of the working and driving machines and of any implements and buildings, required for the carrying out of the mode of winning in question, are to be taken into account.

(8) Determination of the most suitable mode of dividing large peat bands, in the case of formed peat, and of cutting the spread peat, in the case of pulp peat winning.

(9) The most suitable mode of drying, the area required for it, and its cost are to be taken into account.

(10) Examination of ease of moving, installing and starting the machines in the peat bog.

(The average amounts paid for bringing the raw material and for taking away the product are lower the more easily the machine follows the progressive advance of the peat cutting and of the drying ground, and the more rapidly it can be restarted when for any reason it has been thrown out of gear).

(11) Examination of the machine (*a*) with respect to the quality and strength of its parts and the neatness of its work; (*b*) with respect to the simplicity of its construction as a whole and of its working parts individually as well as with regard to their probable costs of repair.

(12) That access be allowed to the bog a considerable time before the competition is held so that the competitors may be able to spend the time and care necessary for the installation of the machines, making trial runs and adapting the machines to the raw material.

(13) Publication of a well-founded decision of the judges in the papers named at the time of the invitation and making this report accessible by reprinting it.

If we suppose that 12 to 15 machines take part in such a contest and that they, working in threes, are all watched and examined by the judges, and that, further, *each* machine is to work three different kinds of peat (which in reality will not occur in the case of all the machines), the contest would require two to three weeks in all (each machine being in working order for at least two days). It would, however, probably enable us to form an opinion which might govern, and be of great importance for, further peat winning in which for want of general knowledge as to its nature and the correct way of carrying it out much money has been lost and is still being lost every year.

## SECTION VI

# WINNING OF PEAT LITTER AND PEAT MULL

### 1.—Preparatory Work, Preliminary Conditions, and Raw Material

“Peat litter” (i.e., disintegrated, long-fibred, pure fibrous peat or moss peat) is an excellent litter for stables, and “peat mull,” the powdery or dusty “*peat mould*” obtained when peat litter is sifted, is used for addition to closets, for purifying and deodorizing sewage, as an insulator for heat, for addition to molassine meal, &c.<sup>1</sup> The operations which precede the winning of these substances are the same as those which precede the winning of hand peat, or cut peat, intended for fuel purposes.

In the present case, unlike that of fuel peat, the product is all the better the lighter and the more fibrous the raw peat. Hence, the peat best suited for the winning of peat litter is light, incompletely humified, mossy or fibrous peat, consisting mainly of sphagnum moss (*Sphagnum*), cotton-grass (*Eriophorum*) and other vegetable fibres, such as is found, frequently several metres in thickness, in the upper, white, yellow to yellowish-brown layers of high bogs. It also sometimes occurs in thinner layers in the black or brown heather peat of low bogs and moss fens, and sometimes, indeed, only under or between these peats. The chief sources of moss peat suitable for peat litter are the high bogs and moss fens of North-eastern and North-western Germany, Holland, Sweden, and Russia, and occasionally the moss peat bogs of South Germany and Austria.

We distinguish the following six main varieties of peat litter, which are named after the plants from which the peat used for making the litter is mainly derived:—

*Sphagnum peat litter* (*Sphagnum* moss peat litter),

---

<sup>1</sup> The properties of peat litter and peat mull are described in Part II, “The Utilization of Peat,” in the section on the “Utilization of Peat Litter, &c.” Details with regard to peat litter are contained in the following publications:—

First, “Die Torfstreu und ihre Bedeutung für Stadt und Land,” Berlin, 1892.

Jünger, “Die Torfstreu in ihrer Bedeutung für die Landwirtschaft und Städtereinigung,” Berlin, 1890.

Von Mendel, “Die Torfstreu, ihre Herstellung und Verwendung,” 2nd edition, by Professor M. Fleischer, Bremen, 1890.

Schreiber, “Moostorf, seine Gewinnung und Bedeutung,” Prague, 1898, and *Oesterreich. Moorzeitschrift*, 1906.

Viktor Zailer, “Torfstreu und Torfstreuwerke,” Hanover, 1915.



*Cotton-grass peat litter* (Eriophorum peat litter),  
*Rush peat litter* (Scheuchzeria peat litter),  
*Reed peat litter* (Phragmites peat litter),  
*Sedge peat litter* (Reed-grass, or Carex, peat litter),  
*Ramified moss peat litter* (Brown moss, or Hypnum, peat litter).

Occasionally we also meet with *starry feather moss peat litter* (from Meesea, Paludella, Aulacomnium, Webera varieties, &c.) and brush moss litter derived from Polytrichum varieties.

Layers of moss peat in large or small amounts are also found in almost all the larger peat bogs. The heavier, the browner or blacker and the more compact a raw peat is the less is it suited for the winning of peat litter, on account of its smaller absorptive power. Other conditions being the same, then of various raw materials that moss peat is the best for this purpose in which the unit of volume, 1 l. or 1,000 c.c., has the smallest amount of solid matter in its natural state and which is, therefore, lightest when dried, or the unit of weight of which occupies the greatest volume. Peat litter is in great demand for many purposes on account of its excellent properties and has become quite indispensable for stables. Also, since the freezing of raw peat or of peat sods which have been already cut is rather an advantage than a disadvantage for the disintegration necessary in the manufacture of peat litter, the winning of the latter, when combined with that of peat fuel, allows not only of the utilization of the whole contents of the bog, especially of the moss peat layers which are too light for fuel and which were formerly thrown on one side, being regarded rather as an obstacle in the way of the development of the bog, but also of a better utilization of the working season and of the available power both of machines and men. Thus the winning of moss peat suitable for the manufacture of peat litter can be begun some weeks earlier in the spring and can be continued at the end of summer beyond the ordinary peat-winning season (this is generally confined to the period intervening between the beginning of May and the end of June until frosty weather sets in. Peat excavated for peat litter which has not by that time become dry and which is kept over winter dries, and can be worked all the more easily for this in the following spring.

In order that the winning of peat litter should be as profitable as possible from the commercial standpoint, good draining of the layers of peat is here even more important than in the case of the winning of fuel peat, owing to the high percentage of water and the low percentage of dry peat fibres in the light moss peat. Moss peat from swampy, undrained bogs may be regarded as almost saturated with water. Peat litter and peat mull as commercial substances should contain only 30 to 35 per cent., and in no case more than 40 per cent. of moisture, while the amount of moisture in them when they are well air-dried is only 20 per cent.

A comparison of the amount of dry material in 1 cb. m. of undrained raw peat with the amount of water contained in the peat and a consideration of the fact that as the drying or draining of

a bog proceeds its volume diminishes and that, therefore, 1 cb. m. of half-drained bog contains a considerably greater amount of utilizable peat fibres than 1 cb. m. of peat from the same bog in an undrained state, show us that for 1 cb. m. of excavated (cut) raw peat the weight of useless material to be raised and transported is not only much greater in the case of an undrained, or an insufficiently drained, bog, but that the yield of dry substance is at the same time smaller than in the case of an equally large volume of peat raised at the same expense from a properly drained bog. In this way the cost of production is increased without any corresponding benefit by not draining the bogs to a sufficient extent.

According to the investigations made at the Experimental Bog Station at Bremen, the weights of a given volume of various moss peats and their absorptive powers were as follows:—

1 CB. M. OF MOSS PEAT UNDRAINED OR SATURATED WITH WATER.

Moss peat from	Weight. Kilos.	Peat content.		Water absorbed by 100 parts of the dry moss peat Parts.
		Au- hydrous. Kilos.	Air-dry. Kilos.	
Bourtang Bog, at 15-47 cm. depth, with little heather remains	903	83	104	990
Bourtang Bog, at 112-147 cm. depth, with little heather remains	805	47	59	1,601
Hellweg Bog, at 31-57 cm. depth, with little heather remains	853	58	73	1,375
Hellweg Bog, at 58-86 cm. depth, with little heather remains	885	82	78	1,335
Great Moss Fen in East Prussia at 0-20 cm. depth, moss peat with some heather mould	526	93	116	1,140
The same at 20-100 cm. depth, almost pure moss peat	504	70	88	1,610
Karolinenhorst Bog (Stettin), at 15-30 cm. depth, moss peat fairly well decomposed	854	138*	173	1,775
The same, at 60-80 cm. depth, almost pure moss peat	969	106*	133	2,300

\* The substance was not quite saturated with water and had already shrunken somewhat.

Moss peats which have an absorptive power smaller than eight times their dry weight ought not to be worked into marketable peat litter in districts where more absorptive moss peats occur. For various economic reasons fibrous peats with a smaller absorptive power than this are still worked for private use, especially in bog districts where the only available fibrous peat is that of low bogs consisting of grass, reed or sedge peat.

According to Professor Fleischer, there was found in one and the same bog (Osterholz high bog) :—

At a depth of :—		Grammes of water absorbed by 100 g. of peat.
0-27 cm. ..	Well-decomposed heather humus and well-decomposed moss peat	890
27-43 cm. ..	Moss peat with little cotton-grass remains	1,390
43-61 cm. ..	Pure, undecomposed moss peat. . . .	1,560
61-76 cm. ..	One-half consisting of well-decomposed heather peat and the other of slightly decomposed moss peat	820
76-91 cm. ..	A mixture of heather humus, moss peat and cotton-grass remains	720
91-117 cm. ..	Much decomposed heather peat, with some undecomposed moss peat and cotton-grass remains	580
117-131 cm. ..	Almost ripe, mouldy heather peat, with some undecomposed heather stems	510
131-157 cm. ..	The same .. . . . .	400

In the manufacture of peat litter the amount of fine peat mould, the so-called peat mull, formed during the disintegration of the peat and separated by the sieves from the fibrous peat litter itself, depends on the degree of decomposition, or the amount of humification, of the moss peat and on the quantity of other plant residues, heather humus, or fuel peat mixed with it. According to the demand for peat mull, the one or the other raw material from the various layers of a peat bog will be worked unless the plant is so arranged that by putting certain contrivances (sieves, mill mills, &c.) into or out of gear, according as required, one and the same fibrous peat (or also suitable peat from selected layers) can be worked mainly to peat litter or to peat mull, as will be described more fully further on.

The absorptive power of sifted peat mull is not always the same as that of peat litter from the same raw peat. The earthy, mouldy admixtures, which are richer in peat and in which the decay and humification have already reached an advanced stage fall into mould and dust more easily than the fibres of the moss peat during the disintegration of the air-dry raw peat, and enrich the peat mull with substances of small absorptive power. If, however, the peat mull consists only of particles of fibres formed during the disintegration of the pure moss peat, its absorptive power may even be greater than that of peat fibres in large pieces (therefore less available for absorption). Investigations at the Experimental Bog Station have established the following :—

One hundred parts of dry moss peat from three different portions of Teufelsmoor, in the Osterholz district, absorbed water as follows :—

(a)	In rather coarse pieces :	717 parts ;	crushed :	909 parts.
(b)	„ „ „	511 „	„	794 „
(c)	„ „ „	781 „	„	1,019 „

One hundred parts of moss peat in the form of mull absorbed,

therefore, 182, 283, or 238 parts of water more than the same moss peat in pieces.<sup>1</sup>

Experiments with various sphagnum peats conducted by Carl von Feilitzen, Director of the Swedish Peat Utilization Society, have given the following results:—

Sphagnum peat from	Vapno, disintegrated into		Norrköping, disintegrated into		Skylberg, disintegrated into	
	Peat litter.	Mull.	Peat litter.	Mull.	Peat litter.	Mull.
Water absorption per 100 parts of peat	Anhydrous .. 1,080		1,490		2,060	
	Air-dry (with 20 per cent. of water) 850		1,170		1,630	
	1,280		1,660		2,390	
	1,000		1,310		1,890	

*Artificial drying* of peat litter at such temperatures as are on the whole suitable for artificial drying (up to 80° C.) does not affect its absorptive power, but complete drying at higher temperatures, say, 100° C. or higher, does affect it. Thus, for instance, von Feilitzen found:—

	Absorption of water by sample. Per cent.
A peat litter dried in the air (20 per cent. moisture) ..	2,060-2,080
The same peat litter dried for 3 hours at 70° C. ..	2,090
The same peat litter dried for 16 hours at 100° C. ..	1,460*

\* Probably a misprint for 2,460. Anhydrous peat litter has a higher absorptive power than the same peat litter has when air-dry.—TRANSLATOR.

Artificial drying of peat even with the best possible drying plant must, however, always prove unremunerative so long as the present market prices for peat litter remain unchanged.

The *chemical compositions* of peat litter and of peat mull may also differ somewhat; they agree less with one another the more the moss peat is permeated with heather humus and grass peat. Thus, for instance, the following results were found in the analysis of a specimen of moss peat which had been separated by machinery into litter and mull:—

Percentage of	Anhydrous peat.	
	Litter.	Mull.
Nitrogen .. .. .	1·40	1·62
Soluble ash .. .. .	4·77	8·60
Insoluble ash (silica, sand) .. .. .	2·32	6·06
" Potash " .. .. .	0·07	0·12
" Soda " .. .. .	0·04	0·09
Lime .. .. .	0·84	0·78
Magnesia .. .. .	0·27	0·27
" Phosphoric acid " .. .. .	0·13	0·17
" Sulphuric acid " .. .. .	0·25	0·34

<sup>1</sup> Professor M. Fleischer, " Die Torfstreu."

The *effect of frost* on peat in destroying its power of contracting, condensing, or shrinking can be appreciated from the statements of Dr. Fleischer. Of two sods, equally large and heavy, containing the same percentage (84) of water and made from heather peat, one was dried directly and the other after exposure for a more or less long time to heavy frost. The first sod contracted a good deal on drying and gave a solid, very hard mass; the second, on the other hand, contracted less and remained fairly soft.

The sod dried in the absence of frost had a volume of 134 c.c., and the sod dried after freezing, of equal size originally, had a volume of 278 c.c., or—

1 cb. m. of peat dried without freezing weighed 747 kilos.

1 cb. m. „ „ after „ „ 360 „

J. Nessler<sup>1</sup> allowed two equally large pieces from two freshly cut peat sods to dry after one of them had been repeatedly frozen in the open air. In this experiment 1,000 c.c. of wet peat gave :—

	Non-frozen.	Frozen.
Volume of dry peat .. .. .	333 c.c.	414 c.c.
Weight of 1 cb. m. of the dry peat ..	400 kilos	363 kilos.
Water absorbed by 100 parts of the dry mass during the first 6 hours	156 parts	338 parts.
Water absorbed by 100 parts of the dry mass during the first 24 hours	196 parts	373 parts.

The investigations which Hjalmar von Feilitzen<sup>2</sup> made with undecomposed sphagnum peat (the proper raw material for peat litter and peat mull) at Flahult (Sweden) are also worthy of note.

The average decreases in the volume and the weight of batches, ten peat sods in each, were :—

	Non-frozen peat.				Frozen peat.			
	Freshly cut in autumn, 1907.	Air-dry in spring, 1908.	Decrease in		Freshly cut in autumn, 1907.	Air-dry in spring, 1908.	Decrease in	
			Measurement.	Measurement, p.c.			Measurement.	Measurement, p.c.
Length of sods in cm. ..	32.5	29.6	2.9	8.9	32.9	32.0	0.9	2.7
Breadth .. .. .	27.1	24.5	2.6	9.6	26.2	25.0	1.2	4.6
Thickness .. .. .	10.7	8.7	2.0	18.7	10.9	10.1	0.8	7.3
Volume of sods in c.c. ..	9,423	6,323	3,100	32.9	9,383	8,087	1,296	13.8
Weight in grammes ..	9,565	1,333	8,232	86.1	9,169	1,134	8,035	87.6
Density (calculated) ..	1.02	0.21	0.81	79.4	0.98	0.14	0.84	85.7

While the weight of unit volume of the freshly cut sod was approximately 1.00, after air-drying, the weight of unit volume in the case of the frozen peat was 0.14, and for non-frozen peat 0.21; the absorptive power (calculated for the anhydrous state) was, in the case of the :—

Frozen peat .. .. .	1,082 per cent.
Non-frozen peat .. .. .	847 „

<sup>1</sup> *Wochenbl. des Landw. Vereins in Grand Duchy of Baden*, 1886, No. 3.

<sup>2</sup> *Mitteilungen*, 1908, p. 235.

The percentage of mull in the peat litter taken from the willow was, in the case of the frozen peat, 15 to 20, and in that of the non-frozen, 10·5.

From these results it is evident that peat frozen through and through not only dries quicker, remaining looser while doing so and therefore more easily torn up and disintegrated, but that it is also more absorptive than non-frozen peat from the same bog. As occasions arise, we should take full advantage of this property of frozen peat, in the manufacture of good and cheap peat litter, and also of peat suitable for insulating walls, sound-dampers and drying bricks. By allowing peat, otherwise unsuitable, to freeze, a peat litter quite serviceable as a bedding material for stables can be won on a small scale.

In addition to moss peat itself, when this and other suitable or valuable litter are lacking, undecomposed grass or sedge peat (fibrous peat) can also be worked into peat litter and peat mull. This is done especially in South Germany, Austria, and Switzerland. Such peats or portions of them consist mainly of tangled masses of reeds, sedges, grasses, semi-grasses, woody plants (*Phragmites communis*, *Eriophorum vaginatum*, *Carex*, *Juncus*, *Scirpus*, &c.), the undecomposed layers of which are formed of a body very similar to moss peat. Its absorptive power for water, and especially for ammonia, is indeed smaller than that of moss peat (the absorptive power of various Bavarian and Franconian grass or sedge peats believed to be suitable for conversion into peat litter was only 400 to 800, and that of some North German low bogs was between 1,000 and 1,800 parts per 100 of dry matter, while the percentage of ash varied between 1·0 and 18·0, that of the nitrogen between 0·75 and 3·20, and that of the lime was anything up to 4 per cent.). In accordance with the nature of the plants from which it is formed, its tendency to decompose in the ground is greater than that of pure moss litter. For this reason, and also owing to its percentage of nitrogen and lime, its manurial value is also greater. In judging from the point of view of sale or use the value of the one or the other kind, we must take into account the fact that the density of grass peat, and therefore of grass peat litter, is as a rule greater than that of moss peat, that a larger amount of grass peat litter than of moss peat litter is required for the same effect, since its absorptive power is generally smaller, and also that grass peat litter is neither so soft nor so elastic as moss peat litter.

In doubtful cases, and especially before proceeding with the erection of large factories, it is advisable to have a careful and expert examination made of the quality of the peat intended to be used for the manufacture of peat litter and peat mull, and for this purpose samples should be sent to the official bog experimental stations. Several peat litter factories have failed utterly owing to working a raw peat quite incapable of giving a good peat litter.

The cost of freightage and transport both of the raw peat to the peat litter factory and of the finished peat litter to the place of sale also affect the commercial success of a peat litter factory.

## 2.—The Winning of Peat Litter on a Manufacturing Scale

Besides the possibility of a market and the existence of good means of access to the factory, another condition which must be fulfilled before the factory is erected if this is to be commercially successful is that the bog should be a sufficiently large one, and should contain light mossy or fibrous peat, which alone gives a good peat litter. The fibrous peat may be present either as an upper layer on fuel peat or it may form the main portion of the bog. Experience has shown that it ought to be at least half a metre in depth, and on account of the amortization of capital the right of working it should run for not less than twenty years, the amount of litter peat contained in it being sufficient for at least the number of years. As a cubic metre of raw moss peat gives 80 to 120 kilos, on the average 100 kilos,<sup>1</sup> of air-dry peat litter, then for every 1,000 m. tons or 1,000,000 kilos of the output per annum, which will depend on the output per day and the number of working days, at least 1 ha. will be required every year, when the peat layer is 1 m. thick, and therefore 20 ha. for twenty years. If the thickness of the peat layer is greater or less than this, the area required will be correspondingly larger or smaller.

The manufacture of peat litter<sup>2</sup> begins as a rule with raw peat, cut by hand or machinery into separate pieces or sods and as air-dry as possible (25 to 30 per cent. of moisture). The manner of winning this cut peat is the same as that of the cut peat for fuel purposes described in Section III. It is only necessary to bear in mind that for the reasons mentioned above, spring (when, owing to danger of frost at night, the winning of fuel peat cannot commence) and autumn or winter (when the winning of fuel peat has been already stopped for want of sufficient time for drying) are the best seasons for winning raw peat for litter. In the winter, however, it can be continued only during the first or light frosts, when only the excavated peat freezes. This freezing of the excavated peat facilitates its maceration and improves the absorptive power of the litter formed from it.

The drying of cut peat for litter is best carried out in the way already described for the drying of fuel peat, and, indeed, as we must again point out, in no case should "artificial drying" contrivances be employed. Moreover, trials of new suggestions or discoveries of this kind should not be attempted. All such contrivances for removing water from peat, which in its natural state has a very high percentage of moisture or water (in 100 kilos of raw peat there are as a rule 85 kilos of water for every 15 kilos of dry matter), in any way other than by drying in the air, so that the product—fuel peat, peat litter, peat fibres, &c.—may be able to compete in the market with other commercial substances—brown coal, coal, straw litter, &c.—have failed to attain their object.

---

<sup>1</sup> Compare the figures given on p. 252.

<sup>2</sup> For balance sheets of moss litter factories, compare Schreiber, *Oesterr. Moorzeitschrift*, 1906, and Dr. Zailer, "Torfstreu und Torfstreuwerke," Hanover, 1915.

We must bear in mind that for winning even a partially dried raw peat, containing about 30 per cent. of moisture, from raw peat with 80 per cent. of moisture approximately 357 kilos of water for every 100 kilos of dry substance, or 250 kilos of water for every 100 kilos of the partially dried peat obtained, must be removed by spontaneous or artificial evaporation (pp. 60 and 61). Hence the heat, or other energy corresponding to it, theoretically required to evaporate this amount of water is so great that from the monetary or commercial standpoint complete failure must be inevitable, even when the technical contrivances are assumed to be as perfect as possible. *Whoever values his money should never attempt the artificial drying of raw peat.*

The absorption of water during showers is not inconsiderable, especially in the case of light fibrous peat. To make air-drying certain, it may therefore be necessary, according to the locality, to make use of the roofs of planks, the drying poles, the hurdles, the spiked poles, the trestles, or the huts employed, as already described,<sup>1</sup> in drying fuel peat. Drying sheds in the proper sense of the term are as a rule too dear. In simple air-drying on the ground it is very important, especially for moss peat sods, that the ground should be as dry as possible, and therefore should be so well drained that the sods, when spread, cannot absorb moisture from the underlying ground.

The sods, when sufficiently dry, are collected into more or less large clamps roofed with boards, or into large store houses for further working according as the sods are required. The clamps, as well as the store houses or sheds, ought to be protected on the weather side, and finally, in order to facilitate subsequent drying, provision should be made for the free passage of the air through the peat.

The owners of some peat litter factories prefer buying the peat, air-dry, from neighbouring peat cutters to winning it themselves. This may be done at any place where moss peat superposed on, or interposed between, layers of fuel peat must be removed when winning fuel peat in more or less big layers, the moss peat being then raised like the fuel peat in regular pieces which are spread for drying.

The operations of a peat litter factory comprise:—

(a) The tearing up or setting free of the fibres of the peat sods, together with the sifting and removal of mull from the torn-up peat.

(b) The pressing and packing of the peat litter and peat mull.

The disintegration of the air-dry peat sods is effected by a willow. The latter is a machine, in the mantle or body of which there is a rapidly rotating drum, provided with numerous pins or teeth or formed from several toothed discs (or circular saws) by

---

<sup>1</sup> Thus, for instance, in the peat litter works in Sebastiansberg (Erzgebirge) peat litter sods are successfully dried on hurdles similar to the Carinthian drying trestles shown in Fig. 19. Cf. Schreiber, "Das Moorwesen, Sebastiansberg," Staab, 1913.



the aid of which it tears up the pieces of peat thrown in through a hopper (Figs. 106 and 107). The degree of disintegration can be varied according to the quality of the fibrous peat and according as this is to be worked mainly to peat litter or to peat mull. Sometimes the inside of the body is also provided with pins or

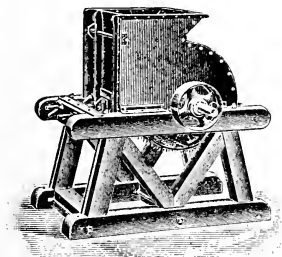

FIG. 106.—Willow for peat litter.

counter-teeth, between which the teeth of the working roller pass. The steel pins are fixed on the rollers in oblique lines or screwwise, and the work is thus better distributed and lighter, since only a few pins are, in turn, actually engaged at work at any time.

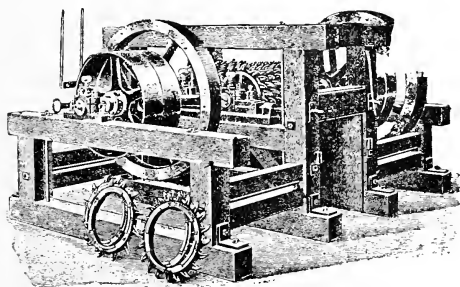

FIG. 107.—Double willow for peat litter. A. Heinen, Varel.

In order to avoid excess of dust and blocking of the machine, the number of revolutions per minute should be 500.

With the object of increasing the output, the willows have recently been generally constructed in the form of the so-called twin or double willows, with two adjustable tearing rollers moving in opposite directions with unequal velocities, which are either pin and toothed or circular saw tearing rollers, according to the nature of the raw peat to be disintegrated and the product intended to be manufactured. The individual saw-blades of the latter, which are separated from one another by intervening pieces, are formed like

those of circular saws, and can easily be taken out for sharpening. The slower running saw-blade willows are the more suitable for working cotton-grass peats and moss peats, as well as fibrous sedge peats which are not much decomposed, and the more rapidly running toothed and pin willows are the better adapted for working ripe, mouldy and crumbly kinds of peat. Double willows such as these give more litter and less mull than the single willows. Machines of this class are constructed, for example, by A. Heinen, of Varel; A. Beeck, of Oldenburg; R. Dolberg and Co., of Hamburg, Rostock, and Berlin, amongst others.

R. Dolberg and Co. provide the tearing rollers of their saw-blade willows with blades having peculiarly formed teeth, those of the one roller intermeshing with those of the other (Fig. 108). Usually the willows are driven from the shaft of a belt pulley, and in such a way that a cog-wheel on the shaft of the roller interlocks with another cog-wheel on the shaft of the counter-roller, the second roller therefore rotating in a direction opposite to that of the first.

A. Heinen, of Varel, has, as shown in Fig. 107, made a useful alteration in the mode of driving with the object of avoiding cog-wheels and the breakages associated with these. The shafts of the rollers are driven independently, and, in order that the rollers may grip the peat more firmly when it is fed rapidly or when the pieces are more or less hard each shaft is provided with a powerful flywheel. The working surfaces of the rollers consist of cast-steel toothed rings, which can be taken off when necessary.

Twin or double willows cost, according as they are saw-blade or toothed roller willows, the following amounts, the lower figures corresponding to the saw-blade willows:—

Driving power.	Output per hour in kilos.	Approximate weight in kilos.	Cost of willows alone in Marks.	Cost of willows with sieves in Marks.
Hand, for domestic use	Up to 300	100-250	125	220
Hand, for domestic use (two workmen)	„ 500	200-260	225-300	350-375
Horse and capstan . .	From 600-750	220-280	275-350	390-450
Steam-engine, 4 h.p.	„ 750-1,000	230-300	300-450	450-650
„ 6 h.p.	„ 1,000-1,200	500-600	450-600	650-800
„ 6-9 h.p.	„ 1,500-2,000	600-800	500-750	700-900
„ 9-10 h.p.	„ 3,000-4,000	950-1,100	800-1,000	1,200-1,400
„ 10-15 h.p.	„ 4,000-5,000	1,200-1,400	1,200-1,400	1,500-1,800

The machine factory of C. Weber and Co., of Artern, sells smaller disintegrating machines for the manufacture of peat litter, hand-driven at 75M., and power-driven at 120M.

Also, A. Beeck constructs for specially large factories having four to six balers a twin willow, the rollers of which consist of separate and easily removable pin plates and are driven independently from a belt pulley. Per metre length of the rollers, the output per hour is 8,000 to 10,000 kilos and the price 1,500M. without and 1,800M. with a sieve.

In addition to these, willows with horizontal rollers, so-called peat-grinding mills with vertical shafts, are made (Fig. 109) for small scale or hand working. They resemble coffee mills in their

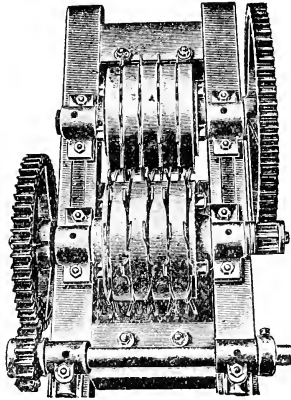

FIG. 108.—Saw-blade willow.

construction, and are used mainly for converting into mull pieces of peat of a more or less mouldy character or the siftings from the peat litter. Although peat mills can also be used for disintegrating peat sods, especially on farms, they are employed mainly for

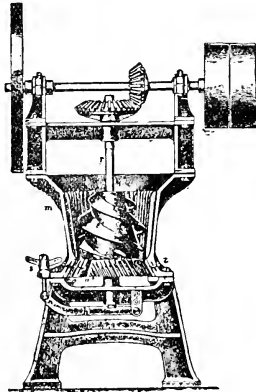

FIG. 109.—Peat mill.

making or grinding peat mull when the amount of peat mull obtained from the sieves in the manufacture of peat litter is insufficient to meet the demand. Peat mills are not well adapted for working fibrous or moss peat. With an output per hour of

500 to 2,000 kilos of mull and with a power of consumption of 2 to 10 h.p., they cost, according to the mode of construction and the design of the grinders, 500M. to 1,200M.

As a rule, a shaking sieve or a cylindrical sieve is used in conjunction with the willow or peat mill to sift the dusty or pulverulent peat mull from the fibrous peat litter, since these substances are used for different purposes, and therefore each is regarded as an impurity, or at least as an undesirable admixture, in the other in spite of the properties common to the two upon which the purposes for which they are used depend. The shaking sieve (Fig. 110) has a mesh width of 2 mm. to 3 mm., and the cylindrical sieve 2 mm. to 4 mm. The price of the shaking sieve is 250M. to 350M., and that of the larger cylindrical sieve 450M. to 550M.

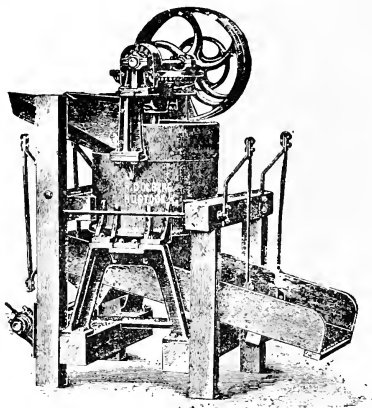

FIG. 110.—Peat mill with a shaking sieve.

For ordinary and well-dried moss peat, the amount of mull separated by the sieves during the manufacture of peat litter is 15 to 25 per cent.

Fig. 111 shows a peat mill or mull mill of R. Dolberg and Co., of Hamburg, which is used for working peat litter into mull. This mull willow gives 90 per cent. of peat mull and 10 per cent. of pure peat cotton or peat fibres from the moss or litter peat fed into it.

The machine costs :—

Power.	Output per hour in kilos.	Approximate weight in kilos.	Price in Marks.
Hand .. .. .	Up to 300	240	200
6 h.p. engine .. .. .	Up to 1,000	485	375
8 h.p. engine .. .. .	Up to 1,500	860	600

A special mull willow, which is also able to work peat sods directly, giving 80 to 90 per cent. of very finely divided mull, is used for the manufacture of large quantities of mull (for molassine meal, packing purposes, heat insulators and sound dampers, &c.). Fig. 112 shows a mull willow of this type made by R. Dolberg and Co., of Hamburg (D.R.P. 165464). It consists of a feeding drum and a grinding drum. The former is composed of discs of wood and saw blades, which seize the pieces of peat thrown into the hopper and feed them to the grinding drum. The peat tending to collect between the rows of teeth is pushed out by a comb and fed to the grinding drum. The latter consists of a large number of sharp annealed steel saws. It tears the pieces of peat fed to it into a fine mull, which is then sifted in order to separate the residual peat cotton or peat fibres.

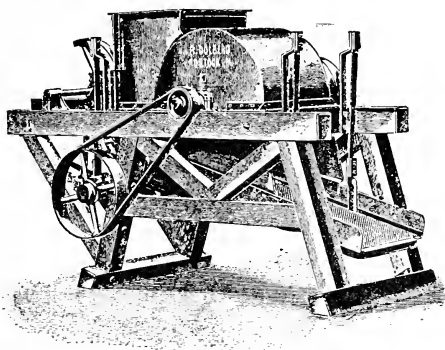

FIG. 111.—Willow for peat mull (mull willow) with shaking sieve.

The grinding drum makes 500 and the feeding drum 5 revolutions per minute.

The data for mull willows such as these are :—

Output per hour in kilos.	Weight.		Horse-power required.	Price.	
	Without sieve, in kilos.	With sieve, in kilos.		Without sieve, in Marks.	With sieve, in Marks.
1,000–1,500	1,250	1,450	15	1,400	1,550
2,000–2,500	1,400	1,750	21	1,650	1,850

A. Beeck, of Oldenburg, also constructs a peat mull mill for working peat litter suitable for large scale operations. A horizontal drum, which is surrounded by an easily removable sieve, is furnished with teeth over two-thirds of its length. The teeth are arranged along the lines of a screw, and in that part of their length from the feeding end to the middle they gradually decrease, so that the space between the toothed drum and the

cylindrical sieve gradually decreases and therefore the tearing and disintegrating action of the teeth increases. On the last third of the drum, which is furnished partly with small teeth and partly with oblique grooves, the remainder of the charge which has not already fallen through the sieve, by which the fineness of the mull is determined, is ground up to the required fineness, and at the same time the unground peat fibres pass out at the front end of the drum. These machines are on sale in three sizes, with outputs per hour from 500 to 4,000 kilos, and they cost :—

In Marks.. . . . .	1,000-1,100	1,700	3,275
For an output per hour in kilos of	500-700	1,500-2,000	3,500-4,000
With a required horse-power of	2-4	5-6	9-12

Such a combination of mull mill and willow for the direct working of large peat sods into peat mull with an output of 900 to 1,000 kilos per hour costs 2,500M., and the sieve costs 300M. to 600M., according to its size. The largest machine has, however, two drums, which rotate with different velocities, whereby the

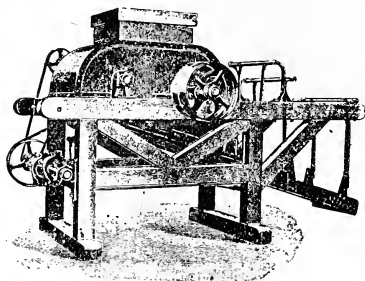

FIG. 112.—Mull willow. R. Dolberg and Co.

grinding of any fibrous peat present is facilitated. This machine is at work for the North Germany Peat Company at Triangel, near Gifhorn, and for L. Hornburg, Ltd., at Platendorf, in the neighbourhood of Triangel.

For working large peat sods into mull, a willow is combined with a mull mill by placing the former, by means of which the peat is disintegrated and torn up, over the drum of the mill. The peat then falls directly into the mull mill, in which it is further ground. The width of the mesh of the sieves, which can be interchanged, permits of any desired size of grain in the peat mull to be obtained.

*Pressing and packing* of peat litter and peat mull is necessary, in order to put those quantities of the substances not required at the producing station itself into a form both capable of being transported and suitable for the market. The light, loose and cumbrous material falling from the sieve is converted by strong pressure into regular, nicely trimmed bales, and retention of the power of holding together thus given to it is made still more secure by packing it suitably (Fig. 113).

For this purpose the loose peat litter is first pressed into cubical or rectangular bales by means of vertical or horizontal angle-lever presses or spindle presses until its volume is decreased to  $\frac{1}{2}$  to  $\frac{1}{3}$  when working by hand or with horse-capstans, or to  $\frac{1}{3}$  to  $\frac{1}{4}$  when working with steam power. While still in the press the bale is bound with strong wire with the aid of wooden laths laid on it. This packing is sufficient for bales intended for inland use. It generally consists of 6 to 8 wooden laths, 6 x 1.5 cm. thick, bound together by four wires, and costs 50 Pfg. per bale (Fig. 113). The pressing of a bale, including the packing, requires, in addition, the placing of the lower laths in the press box, the removal of intrusions above the press piston, the filling of the press box, levelling and putting the laths on the upper surface, closing the upper clapper, starting the power, pressing, opening the front and back clappers, pulling through and binding the wires, releasing the stops, and finally pulling out and sliding

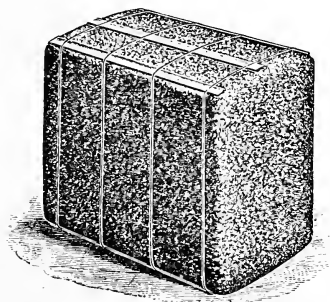

FIG. 113.—A peat litter bale, tied.

away the bales. The time required for these operations is, in all, from three to six minutes, according to the type of the press.

For export, and also in the case of the finer kinds of peat mull, the bales are, in addition, sewn up in jute.

Usually the bales are 100 to 125 cm. in length, 80 to 90 cm. in width, and 55 to 65 cm. in height, or their cross-section may be 70 to 75 cm. square, so that a bale contains 0.4 to 0.7 cb. m. of press litter or peat mull and weighs from 125 to 130 kilos. The manufacture of standard bales, each 0.5 cb. m. in size, has been attempted with a view to simplifying the trade. The standard bales, on the average, ought to weigh 125 kilos.

According to the amount of pressing, the quality and the dryness of the peat worked, the weight of a cubic metre of pressed peat litter varies between 200 and 250 kilos, and that of a cubic metre of pressed peat mull between 250 and 300 kilos; there is a similar variation in the weight of the individual bales even from one and the same factory.

Good pressing and cheap but firm packing cannot be neglected if the peat litter is to be turned out as a marketable and

transportable article. Well-dried peat litter is more difficult to compress than somewhat moist litter, and, moreover, if the compression is less than 1 : 2 the bales do not hold together sufficiently well. Moisture, however, diminishes the practical

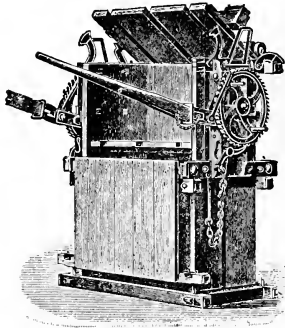

FIG. 114.—A hand-worked peat litter baler.

value of the peat litter. If the peat is well pressed by means of steam presses it is possible to put a full load (10,000 kilos) of it on a railway double wagon.

Fig. 114 shows a vertical press for hand working, Fig. 115 one for steam, Fig. 116 another with its driving gearing, and

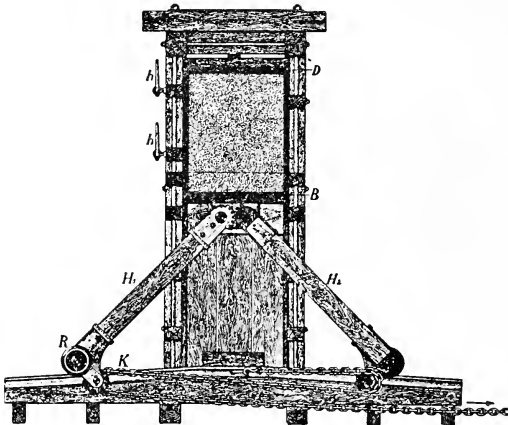

FIG. 115.—A steam-driven peat litter baler (angle-lever press).

Fig. 117 a horizontal peat litter press. The output of the latter is, other conditions being the same, somewhat greater than that of a vertical press. According as the trade requires that the litter be supplied in bales of a definite volume or bales of a definite



weight, the loose material to be pressed is filled into the press-box by hand or by machines (elevators, transporting belts, conveyers, spiral screws) until the amount in the press-box has a definite volume or a definite weight. The box is then closed by a lid *D* and the peat is strongly compressed by a piston worked by

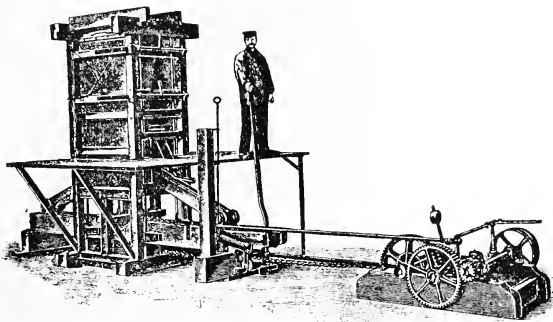

FIG. 116.—A steam-driven peat litter baler showing the driving gear.

a latch-lever, chain-lever, or angle-lever *K*, *H*<sub>1</sub>, *H*<sub>2</sub> (Fig. 115) or by a screw-spindle (Fig. 117).

Recently ratch and pinion presses, on account of the smaller space they require and the greater ease with which they can be installed. The consumption of the power is somewhat greater in their case than

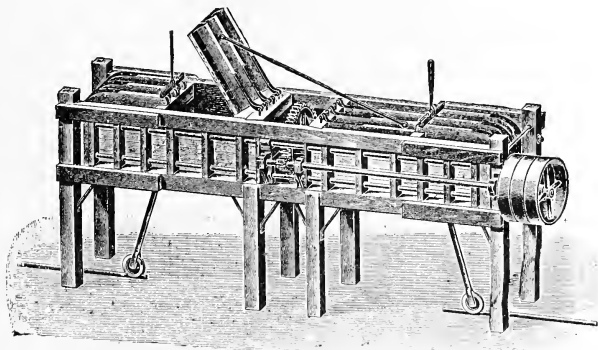

FIG. 117.—A steam-driven horizontal peat litter baler (spindle press).

in that of the angle-lever presses, but the output is also greater. It is still an open question which kind is to be preferred.

Presses such as these are constructed by the Lüneburg Iron Works; A. Heinen, of Varel; A. Beck, of Oldenburg; R. Dolberg and Co., of Hamburg and Rostock, and others.

A continuously acting press by J. A. Gustavsson, of Altomte, is working successfully for the Swedish Brown Peat Litter Company at Skyttorp.<sup>1</sup>

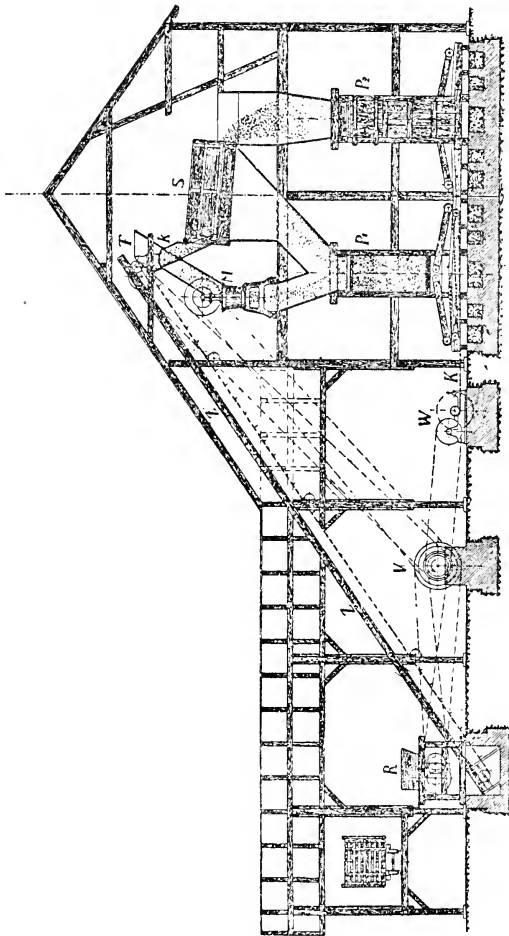

Fig. 118.—A peat litter and peat mull factory, according to A. Heinen, Vareel.

*R* willow, *Z* elevator, *T* hopper with adjustable flap-valve *k*, *S* cylindrical sieve, *M* mull mill, *P*<sub>1</sub> baler for peat mull, *P*<sub>2</sub> baler for peat litter, *V* driving gear, *W* driving gear for the balers.

A lever press worked by hand with a daily output of about 80 bales (100 x 60 x 70 cm.) costs 600M. to 700M. ; a similar one

<sup>1</sup>Described in the *Oesterr. Zeitschrift für Moorkultur und Torfverw.*, 1910, p. 44.

for steam power with an output of 10 to 15 bales per hour costs 1,200M. to 1,500M., and its driving winch 600M. to 800M.

When there are two presses in a factory, it is best to instal only one winch to drive the two. The piston of one press can be made to move downwards while that of the other is going upwards. A saving in cost, time, and wages will thus be effected. It is said that in this way 50 to 60 bales can be made per hour.

Ratch and pinion presses with an output per hour of 20 to 25 bales (from 100 x 65 x 70 to 122 x 60 x 80 cm.) cost 3,500M. to 3,800M., and require a 2 to 4 h.p. engine.

Fig. 118 shows a peat litter factory as planned by the machine manufacturer A. Heinen, of Varel. The litter peat, brought from the clamps in cars running over a track, is emptied into the willow *R*, from which the finely torn peat is carried by the elevator or conveyer *Z* to the upper story of the factory, and there fed into the hopper *T*. In the latter there is an adjustable flap-valve *k*, by means of which the torn material can be fed, according as the main product is to be peat litter or peat mull, either into the sieve *S* for peat litter and peat mull residue or into the mull mill *M* for peat mull exclusively. If the main product is to be peat litter, the press *P*<sub>1</sub> can be reversed, and it also can then be utilized for peat litter.

A. Beeck now constructs his peat litter factories so that the willow is on one side of the vertical conveyer or elevator and the mull mill on the other. Litter and mull are then brought up to the sieves by the elevator. The litter is next led directly to the presses, and the mull either collects on the upper floor or passes to the press. The sieve residues from the mull mill pass directly to the peat litter baler.

In some peat litter factories attempts have been made to convey, elevate, feed and sift the torn peat, especially when peat mull is the main product, by means of compressed air instead of by machines and sieves, and, for hygeinic reasons, to combine the plant with a dust-removing installation. What the advantage of this is time will show.<sup>1</sup>

The installation costs of a peat litter factory may be assumed at :—

for 1,	2,	3,	4 presses.
35,000–40,000,	65,000–75,000,	95,000–110,000	110,000–120,000M.

They vary with local conditions and with the foundation walls, drying trestles, drying sheds, storing sheds, field railways, &c., required. From one-third to half of these sums are to be provided as working capital.

<sup>1</sup> Such installations have been set up, e.g., not only by the Griendtsveen Company at Rotterdam, but also at the experimental station of the Edward Dyckerhoff Poggenmoor Utilization Co., Ltd., near Neustadt. The latter plant was destroyed by the burning of the factory in 1911, and has not been reinstalled in the present very large factory, which has an output of 600,000 kilos of peat per day, and is equipped with all the most recent appliances. For the description of this factory, see *Illustr. Landw. Ztg.*, 1914, No. 79.

Reliable average figures for the cost of production cannot be given, owing to the great differences in the rates of wages, in the nature of the bog, in the outputs, in the number of possible working days (200 to 300), in the drying procedure, &c. The net cost, including the necessary writing-off of buildings, machines and implements, as well as the interest on the cost of plant and the working capital, vary between 10M. and 15M. per metric ton or 1M. to 2M. per 100 kilos. It may be assumed that in successful peat litter factories the interest on the installation and working capital does not in general exceed 10 per cent.

The cost of winning the air-dry peat sods is the most important item in the total cost of manufacturing 100 kilos of finished peat litter. The cost of cut peat in the clamps varies, according to statements received, from 50 Pfg. to 90 Pfg. per 100 kilos.

In Hanover 1M. to 1·5M. per 1,000 sods, 35 x 12 x 15 cm. each, is paid for cutting the moss peat intended for peat litter, the sods being placed in heaps of 10 sods each; and in Oldenburg the rate is 0·75M. to 1M. per 1,000, while drying and collecting into large clamps cost a further sum of 0·50M. to 0·80M. In the air-dry state, 1,000 of these sods weigh about 300 kilos.

Transport to the factory, disintegrating, sifting and pressing the peat are reckoned at approximately 0·20M. to 0·30M. per bale or 100 kilos of transportable product. Packing is reckoned at 0·18M. to 0·22M. per 100 kilos.

At the end of 1914 the usual market price at the factory was: For good peat litter, 1·50M. to 2·20M., for good peat mull, 1·60M. to 3·00M., per 100 kilos, the higher prices being paid for the less dense material.<sup>1</sup>

In spite of the excellent qualities of moss peat as a litter and of peat mull as a mixing powder for closets and cesspools, as a preserving and packing material for fruit, as a complement for molassine meal, as a heat insulator, &c., the amount of peat litter and peat mull required per annum varies to an extraordinary extent. Both the amount used and its market price are much affected by variation in the output of straw from farms, by railway and other transport costs, by the state of the weather during the season in which the peat is dried, and by the yield from the bog of cheap moss peat suitable for litter. In years in which straw is abundant the demand for peat litter is considerably less than it is in other years, when, however, fodder also is perhaps deficient. Dry summers decrease the cost, and wet summers increase the difficulty, of manufacturing it. All these circumstances, as well as actual, or perhaps prospective, competition of neighbouring peat litter factories, the peat of which may be better suited for litter and, with the same cost of production and the same selling price, may be a more valuable article for the buyers, must be carefully considered when erecting new peat litter factories. Inattention to

---

<sup>1</sup> In 1915-16, during the War, the price was 220M. for 10,000 kilos, having a volume of at least 35 cb. m., with an extra 7·50M. per metric ton for every cubic metre more than the thirty-five.

any of the above points may entail the loss of the whole cost of the installation.

Of the larger peat litter factories of Germany and Austria-Hungary,<sup>1</sup> the following may be mentioned: The North German Peat Co., at Triangel, near Gifhorn (Arnold Rimpau, of Gifhorn); the Brunswick Peat Litter Factory, formerly Ed. Meyer and Co., of Brunswick; Edward Dyckerhoff Poggenmoor Peat Utilization, Ltd., near Neustadt; Peat Litter Co., formerly Fed. Wolff and Co., of Bremen; Meyer Bros. and Co., of Oldenburg; Bielewo Peat Litter Factory in the Kosten district; the East Prussian Peat Litter Factory at Heydekrug, in East Prussia; the Budda and Neuhoof Peat Litter Factories in West Prussia; the Westermoor Peat Litter Factory, near Owschlag; the Karolinenhorst Peat Moss and Mull Factory, near Stargard, in Pomerania; the factory of the Royal Peat Department of Württemberg at Schussenried; the Bavarian Peat Litter and Mull Factory at Haspelmoor; the Feilenburg Peat Co.; the Peat Litter Co. at Himmelspforten; Neudorf-Plattendorf Peat Litter Factory; the Peat Coke Co., Oldenburg; Pfungried Peat Works; the Saxon Peat Litter and Mull Factory at Reitzenhain; the Sebastiansberg Peat Co., Ltd. (Erzgebirge); that of Prince Schwarzenberg's Mining Co. at Schwarzbach, in Bohemia; Ignaz Glaser's Peat Litter Factory at Bürmoos, near Salzburg; Prince Esterhazy's Peat Litter Factory at Esterhaza; the First Carinthian Peat Litter and Mull Works at Buchscheiden, near Feldkirchen; the Laibach Peat Industry Co. at Laverca, near Laibach; O. M. Roberts van Son; Schrems Peat Litter and Mull Works at Schrems; Peter Wieser's Peat Litter Factory at Elzenbaum (Tyrol); Admont Peat Industry; Robert Weinlinger and Co. (Styria), amongst others.

In other countries, especially in Holland (Helenaveen and Hoopeveen), Sweden, and Norway, numerous large peat litter factories have been erected in recent years. These have a considerable export trade with countries poorer in peat, such as France and England.

### 3.—Winning Peat Litter for Use by Farmers

For owners of bogs who are also farmers, it is not so much a matter of manufacturing peat litter in large quantities as of making it in small quantities for use in their own farmyards, with the aid of their farm hands and horses. In such cases, instead of winning cut peat and employing peat mills or willows, the following simplified process, which for evident reasons is not, however, suitable for large scale operations, can be employed:—

---

<sup>1</sup> See also Dr. Zailer: "Die staatliche Förderung der Torfstreuherzeugung in den Österr. Alpenländern," *Zeitschrift für Moorkultur und Torfverwertung*, 1910, p. 73, as well as his book, "Torfstreu und Torfstreuwerke," Hanover, 1915, p. 314–15, and Hans Schreiber in *Mitteilungen*, 1907, as well as his account of Austria's peat litter factories, *VII. Jahresbericht der Moorkulturstation in Sebastiansberg*, 1905, Staab.

The upper layers of the bog, which has been sufficiently drained, are ploughed fairly deeply at the beginning of winter. The ploughed layer, which will have become frozen during the winter, is harrowed as finely as possible in spring, and broken up by frequent light harrowing in dry weather. When the upper layer is sufficiently dry it is collected into banks or ramparts with the aid of shovels, striking or scraping boards. The cleared areas (strips) lying between the peat ramparts are again torn up by means of a harrow, and the litter peat, loosened and dried after repeated harrowing, is heaped on the ramparts already formed. According to the amount required, this process is repeated, and in good weather the peat litter which is sufficiently dry is collected into more or less large covered sheds or clamps. In dry summers the harrowing may indeed take place ten times, and the dry litter may be heaped on the peat litter ramparts, which thus gradually and continuously increase in height. Any pieces which are too coarse can be separated by sifting and further disintegrated in a hand or capstan peat mill, for which purpose the peat litter disintegrating machine,<sup>1</sup> which resembles the peat mills and which is described in the section on the utilization of peat litter in Part II, can be employed with advantage.

#### 4.—Valuation of Peat Litter

Peat litter is—the amount of compression being constant—all the better the lighter it is per unit of volume, e.g., 1 cb. m., or a bale of a definite size. The degree of compression is, however, very hard to determine, and therefore in trade one is tempted to compress into a bale of a given size only just as much substance as is required for the coherence of the bale. On the other hand, for the same absorptive power the litter contained in unit volume is all the more valuable the greater its weight, but this weight increases also with the percentage of water and ash, which substances decrease the value of the article. Hence it is obvious that the determination of the quality of peat litter and its valuation as a commercial article is not a simple one. According to what has just been said, neither the total volume (the number and the size of the bales), the total weight, nor the determination of the weight of unit volume or its converse is alone sufficient for the valuation of the litter.

When dealing with peat litter deliveries, we should always examine :—

- (1) The external appearance of the litter.
- (2) The weight of the litter delivered and its volume.
- (3) The percentage of moisture and ash in the litter.
- (4) The absorptive power of the litter.

This examination can be carried out in a manner quite sufficient for trade, and without troublesome or expensive chemical analyses, as follows :—

---

<sup>1</sup> Constructed by the Kyffhäuser Machine Co., of Artern, in Saxony.

In external appearance good peat litter should consist entirely of loose, soft and elastic peat moss or peat grass fibres, as little decomposed as possible, without hard, mouldy or solid lumps or felted masses of much decomposed, humified peat, and should be free from dust or earthy admixtures. In doubtful cases the presence of these admixtures may be established by loosening and shaking the felted fibres over a sheet of white paper, or, better still, by placing the loosened sample in a glass vessel, pouring on water, and well stirring the mixture. The dusty and earthy admixtures fall to the bottom at once. Before the fibres become saturated with water and sink to the bottom they can be removed from the water, and the impurities left at the bottom can then be easily examined.

The weight delivered can be determined by weighing in the ordinary way. It ought to be noted, however, whether the weight given in the invoice has been delivered without appreciable loss, i.e., whether not too great a loss has occurred during transport owing to insufficient compression or faulty packing of a material the crumbling of which cannot be completely avoided. This loss often amounts to 10 per cent. and more. The total value can be obtained from the number of bales and the volume of each bale.

The percentages of moisture and ash, as well as the absorptive power, may be ascertained by taking specimens<sup>1</sup> from the interior of some of the bales (not from the exterior, as the external parts may be much drier or wetter according to the state of the weather).

From each of these average samples 100 g. are weighed on a delicate balance, and these are then dried in an oven, the temperature of which should not exceed 100° C., for five to six hours and again weighed. The decrease in weight of each sample in grammes is the percentage of moisture in the peat litter. Thus, if the weight were 70 g. the litter examined would contain 70 per cent. of dry matter and 30 per cent. of moisture. If the percentage of ash is also desired the 70 g. are ignited in a porcelain crucible over a gas burner or spirit lamp and kept stirred by a glass rod until all the combustible matter is burnt. The residue is then cooled and weighed. The number of grammes thus obtained is the percentage of ash in the *sample analysed*, and from this the percentage of ash in the anhydrous substance can be easily calculated. If the residual ash, for instance, weighed 4.2 g., the percentage of ash in the peat litter analysed would be 4.2 per cent.

---

<sup>1</sup> When sending average samples for examination these should be taken from at least 10 per cent. of the bales, and if the number of these be less than 100, from at least 15 per cent. of them. The samples should be taken from every part (the edge as well as the centre of the bale) by means of a special sampling auger. The specimens should be carefully mixed, and an average sample of at least 400–500 g. taken from the mixture should be sent for analysis in a perfectly dry and air-tight vessel. A peat auger, suitable for taking samples, and recommended by Professor B. Tacke, is made by Westphal, of 132, Johannistrasse, Bremen, and sold for 6M.

of the *weight as delivered*, or since 100 g. of the weight as delivered contain 70 g. of anhydrous matter, it is  $\frac{4.2 \times 100}{70} = 6$  per cent. of the anhydrous substance.

Another quantity of 100 g. from the same fresh sample is placed in a glass vessel and covered with water with a view to determining the absorptive power of the sample. After two to three days the water is poured off, the specimen is drained on a sieve, and again weighed. Its increase in weight in grammes (e.g., an increase of 1,500 g.) is the absorptive power "per 100" the peat litter has in the state in which it was *delivered and examined*. In the case mentioned this would be 1,500 per cent.<sup>1</sup>

Since, according to the first test, 70 g. of dry matter and 30 g. of moisture were contained in 100 g. of the specimen, then 1,500 plus 30 equals 1,530 g. of total water correspond to every 70 g. of anhydrous substance. The calculation gives, therefore,  $\frac{1,530 \times 100}{70} = 2,186$  per cent. as the absorptive power of the anhydrous matter of the peat litter or of the variety of raw peat employed for its manufacture.

The former determination is important for the purchaser of the peat litter in determining the practical value of the article bought, and the latter for the bog-owner or the peat litter manufacturer when examining varieties of peat as to their fitness for conversion into litter.

From this it follows that the most suitable basis for the peat litter trade is "by weight." It will be well, however, to fix the price for a maximum degree of moisture (e.g., 25 to 30 per cent.), a maximum degree of ash (e.g., 5 per cent.), and a minimum degree of absorptive power (e.g., 1,000 per cent.), and that for deliveries deviating from these standards in a manner prejudicial to the practical value of litter a corresponding diminution in the price to be paid for the article delivered should be made. With the ordinary good commercial article, moreover, 100 bales should have a volume of 50 cb. m.<sup>2</sup>

Thus, for instance, the Agricultural Society of Westphalia

<sup>1</sup> As a result of many comparative experiments with the various modes of carrying out this determination, the following method (the so-called Bremen method) has been adopted by the directors of the chief experimental bog stations as the standard process (see *Mitteilungen*, 1909, p. 185):—

*The absorptive power of a specimen of peat litter is determined by saturating a carefully selected average sample of 30 g. in weight, which should not contain pieces of more than 2 cm. in diameter, with water at room temperature in a vacuum such as can be obtained with a good water pump, and without the addition of ammonia. After standing for three days the specimen is filtered in a cubical wire basket of 10 cm. side lined with filter paper until drops cease falling from the wire basket, which is inclined at angle of 30° to a corner. The results are to be calculated for 100 g. of the specimen in the anhydrous state, and also for the degree of dryness in which the specimen was received as well as for the air-dry condition with 30 per cent. of moisture.*

<sup>2</sup> For the valuation of peat litter, compare also *Mitteilungen*, 1905, pp. 221 and 227, and 1909, pp. 177–188.



and Lippe has decreed in its regulations relating to dealings with peat litter factories that: "The delivering factory guarantees that the peat litter sold does not contain more than 25 per cent. of water and 2 per cent. of ash, and therefore contains at least 73 per cent. of vegetable dry matter. If the samples (taken and examined in a manner prescribed) contain higher percentages, the buyer is justified in deducting for every increase in 1 per cent. of water or ash one-thirtieth of the contract price as compensation therefor."

According to the decision arrived at by the representatives of the Experimental Bog Stations on February 18th, 1914, first grade commercial peat litter should not contain more than 35 per cent. of moisture, and, similarly, the percentage of moisture in second grade peat litter should not exceed 40. The percentage of moisture and the absorptive power are determined throughout the German Empire and Austria by the process of the Bremen Experimental Bog Station as modified by Tacke and Minssen.<sup>1</sup>

Good peat litter containing 30 per cent. of moisture can absorb at least eleven times, and other kinds at least six times, its own weight of water in each case. Good peat mull should, in addition to possessing these qualities, contain no pieces with diameters greater than 3 to 5 cm.

The determination of the *absorptive power for every delivery* of peat litter can be omitted only when the average absorptive power of the peat litter from a given bog or a given factory has been established in the case of samples to which no objection can be raised, and when this absorptive power is always maintained to a satisfactory extent. Even in this case an occasional check is desirable.<sup>2</sup>

To avoid the disadvantages and difficulties connected with sale by weight, due to variations in the degree of dryness which are often considerable, the Peat Litter Combine, E. V., Berlin, which was formed in 1915, during the War, and to which all the peat litter factories of Germany belong, has recently proposed that the sale and the delivery of the article should be "*by volume*," i.e., according to the number of bales pressed to a fixed volume (standard bales). While maintaining the degree of dryness which is in all cases necessary for the good quality of the article, the

<sup>1</sup> *Mitteilungen*, 1909, p. 177, and 1913, p. 131.

<sup>2</sup> It has been assumed that an absorptive power, in so far as it exceeds 1,200 per cent., cannot be fully utilized in a stable; peat litter, however, with an absorptive power materially under 1,000 per cent. is still, as we have already mentioned, quite capable of being used; it is simply a matter of its price as against the market price, the practical value and the available supply of other litters. In the air-dry state these litters have the following absorptive powers:—

Straw ..	200-350 per cent.	Saw-dust ..	360-500 per cent.
Heather ..	190-230 „	Wood cotton	133-333 „
Bracken ..	200-250 „		

Compare the statements in Part II, under the "Utilization of Peat Litter, &c." The absorptive powers for ammonia and the percentages of nitrogen of these litters are also less than those even of the most kinds of grass peat.

uniformity of the quantity of useful matter delivered in a number of standard bales is to be attained and guaranteed by a degree of compression (ratio of the volume of the pressed bale to the volume of the press-box) or degree of condensation (hitherto generally one-third to one-fourth) which is to be maintained by every factory.

## SECTION VII

# PATENTS<sup>1</sup> RELATING TO THE WINNING OF PEAT<sup>2</sup>

### Extracts from the German Letters Patent

*(The numbers of the patents given are the same as those of  
the various Letters Patent)*

The activity of the inventor has been fairly pronounced in the realm of peat, and patents have been granted for a number of discoveries. It would take us too far and it would not be of sufficient interest to the general reader of this book to describe individually and to discuss technically or commercially all these proposals, *most of which have, indeed, remained as mere proposals.*

In so far as one or other of these proposals has actually been adopted in the peat industry, has been experimented with on a large scale, no matter whether with or without success, and has seriously interested any circles, particulars of the contrivances relating to it have been considered in the foregoing sections of this book.

So far as regards the others it must be left to the individual to form an opinion as to their possibilities from the following extracts from the Letters Patent relating to the treatment of peat, and for any given case to acquaint himself more fully with it from the Letters Patent itself (each of these can be had for 1M. from the Imperial Patent Office in Berlin). From the following particulars he will generally be in a position to form his own opinion as to the objects, aims and practical values of the various proposals and as to the commercial success to be expected from them while taking into account the nature of peat and the statements made in the preceding sections.

---

<sup>1</sup> Only German patents are here considered, as experience shows that patents for all important discoveries are applied for first in Germany even by foreigners. With regard to the time during which the protection given by a patent lasts the following may be noted:—

A German patent lasts fifteen years from the date of notification, unless it expires during that interval from non-payment of the fees, or from renunciation by the holder, or has been nullified in the Courts, or has been withdrawn. Supplementary patents expire with the chief patent.

Anyone may consult without charge the official Patent Roll, which gives information with regard to the patents, as well as the Letters Patent at the Imperial Patent Office in Berlin. The Letters Patent are also placed for consultation, free of charge, with Corporations, Societies, &c., in many cities of Germany. The places where they are thus on view are notified publicly from time to time, and may be ascertained by inquiry at any Chamber of Commerce and any Chamber of Industry.

<sup>2</sup> Compare the corresponding section at the end of Part II on "The Utilization of Peat."

## I.—Dehydration of Peat by means of Machines

- P. 15172, February 9th, 1881, *R. Fösche*, Halle on the Saale :—Dehydration of cut peat by addition of ashes or slack, chaff, disintegrated straw or heather, saw-dust, wood charcoal, coke from coal, brown coal or peat, and
- P. 17098, July 30th, 1881, *the same* :—Warming of this mixture by compressing with the object of more completely dehydrating the peat.
- P. 59640, March 17th, 1891, *Gérard*, Paris :—The peat, after conversion into a uniform pulp, is to be passed slowly and in a thin layer between wire gauze surfaces, first through dropping or suction contrivances, then with its sides covered with surfaces of felt or similar body through roller presses, and finally through a drying chamber in which it is partially coked. After this the peat removed from the wire gauze surfaces is mixed in a kneading machine with liquid cements with the object of converting it into a mass which can be “formed.”
- P. 83025, February 27th, 1895, *Nottbeck*, Lielax :—A dehydrating roller in which the material to be dried is passed into the press rollers by means of a feeding cylinder which is hollow and pierced with holes, like a sieve.
- P. 88948, April 14th, 1896, *Schönemann and Co.*, Schöningen :—For the preliminary drying of peat it is to be made into a pulp of mud with the addition of water, pumped into filter presses, and there exposed to the action of compressed air.
- P. 89591, January 29th, 1896, *Kerminnes*, Jorksdorf :—The peat, which has already been passed through a peat machine, is to be partially dehydrated by rollers, with filter frames on their sides, and afterwards kneaded and formed once more by a peat machine.
- P. 90663, July 17th, 1896, *Stauber*, Berlin :—The transport car for the cut raw peat is to be furnished with sides which are pierced with holes and movable on hinges, and the hook to which the transporting power (machines, animals) is attached is, in order that the peat may be pressed during the journey, so placed that the applied power moves the walls of the box-car towards one another.
- P. 91810, August 2nd, 1896, *Filser*, Landsberg-on-Lech :—Peat dehydrating machine, with a press drum divided into cells by slides with the object of making it more easily emptied.
- P. 97526, March 6th, 1897, *Max Schöning*, Berlin :—The piston head of a dehydrating press, which works in a vessel pierced with holes, is to be provided underneath with hot chambers heated electrically.
- P. 101408, June 16th, 1897, *Count Schwerin*, Wildenhoff, and *Kerminnes*, Jorksdorf :—Flexible traverses are to be fixed both transversely and longitudinally on the upper filter cloth of a dehydrating press. These are to prevent the peat from damming in front of the rollers, and similar flexible supports

(rubber tubes and the like) are to effect the condensation at the sides in the longitudinal direction of the filter cloth.

- P. 109482, May 19th, 1899, *Düsseldorf Iron Co.*:—With the object of automatically adjusting the press plates for the thickness of the press cakes the plates, between which the cakes, enclosed in bags or cloths, fall automatically, are to be connected by ropes or the like with supports capable of an up-and-down movement. As the press piston moves forward these supports are lowered to such an extent that the press plates can move forward without hindrance during the time of application of the pressure, but during the backward motion of the piston the supports are raised so far that the press plates swing free and automatically adjust themselves to the distance apart required for the introduction of new press cakes.
- P. 117651, May 9th, 1899, *Bockfisch*, Teterow :—The raw peat is to be led on an endless filter belt between two rollers placed over one another and is to undergo a preliminary compression in a tapering space between a feeding base and the upper roller, and is then to be pressed by the stretched filter belt against the hollow walls of the rollers, which are bounded on the sides by flanges so that the substance cannot escape there.
- P. 132017, July 21st, 1900, *The Whittington Peat-Coal Syndicate, Ltd.*, London :—Peat is to be dehydrated by addition to it of quicklime, sugar, nitre, and soot.
- P. 133375, March 27th, 1901, *Estlander*, Jokkis and Humppila (Finland) :—A press with rotating discs, in which two smooth press rings obliquely inclined to one another form with two fixed circular walls a gradually contracting press chamber.
- P. 143404, January 8th, 1901, *Krupp*, of Hanover, and *Heine*, of Imbs (Norway) :—Non-disintegrated peat is to be separated from the peat pulp by means of a cylindrical sieve (like that of a paper machine) and then led to a heated drum in which it is dried.
- P. 148387, June 24th, 1902, *Hendunen*, Moscow :—Dehydration of peat by means of compressed air, a piston pierced with holes like a sieve being kept pressed in a vessel, against the peat according as the dehydration proceeds, by means of compressed air with the object of preventing the formation of cavities in the material pressed.
- P. 153965, March 5th, 1903, *Ruparti and Schloemann*, Düsseldorf :—A dehydrating press with endless press cloths and special enclosing pieces, fixed on the sides of the piston head or the press plate, and with flexible guides above as well as below, in which the filter cloths move.
- P. 160938, July 2nd, 1903, *Dyeworks, formerly Meister Lucius and Brüning*, Höchst-on-Main :—Dehydration of peat by means of presses after salts, such as sodium chloride, sodium or ferrous sulphate and the like, or acids (sulphuric, hydrochloric, &c.), have been added to the disintegrated peat.
- P. 161676, September 27th, 1902, *Ekenberg*, Stockholm :—Wet

- peat is to be made easily dehydrated, for the manufacture of press peat, by heating it in closed vessels to 150° C. or over.
- P. 166150, September 5th, 1903, supplementary to P. 148387, *Hendunen*, Moscow :—The pistons, pierced with holes like sieves, except at their ends, are made so that the compressed air can be introduced into them directly and the expressed water led away from the press cylinder, and also so that they can serve as lids or bottoms for the latter.
- P. 166721, May 7th, 1904, *the same* :—Bodies pierced with holes for placing in piston presses with double-walled cross-pieces, also pierced with holes, for dividing the press cake into separate portions.
- P. 169117, December 21st, 1902, *Ekenberg*, Stockholm :—The wet peat, kept in motion and continuously mixed in tubes open at both ends, is to be kept enclosed in compressed layers whereby with the use of a narrow and long tube a sufficient resistance is attained to prevent the scattering about of the peat.
- P. 172102, June 26th, 1903, supplementary to P. 169117, *the same* :—The tubes are heated so strongly that the mass moved forward in them carbonizes, the moist mass being introduced into and kept in the tubes under so high a pressure that neither gases nor vapours can escape.
- P. 179045, March 26th, 1905, *Hemmerling*, Dresden :—Peat dehydrating press, in which the charge is divided by hollow partitions so that the water can be led away. The hollow spaces and the tubes connecting them with the press space are arranged so that air, but not the liquid pressed out, can escape from the hollow spaces and at the same time the expressed liquid is prevented by the air pressure from carrying minute particles of the pressed material away with it.
- P. 217118, April 30th, 1907, *Alexanderson*, Stockholm :—Dehydration of raw peat after freezing and thawing by pressing out the water.
- P. 234424, December 8th, 1908, *Peat Coal Investment Co., Ltd.*, London :—Peat dehydrating press with a press box formed of thin pieces and in which a screw shaft is adjustable longitudinally so as to adapt the amount which is plugged in the press box in front of the screw, and to which increased pressure is due, to the more solid or looser consistency of the material to be pressed.
- P. 250367, November 3rd, 1910, *Franke, jun.*, London :—Peat dehydrating press with press cones which are pierced with holes and are also provided with teeth to tear up the material.
- P. 257558, September 28th, 1910, *Abresch*, Neustadt-on-Haardt :—Dehydration of raw peat with addition of bone-dry press peat.
- P. 258331, July 17th, 1910, *Brune and Horst*, Neustadt-on-Haardt :—Dehydration of raw peat by mixing it with coke and wet pressing in such a way that the coke after the pressing of the material is separated and employed again for addition to more peat.

- P. 258604, May 30th, 1911, *Abresch*, Neustadt-on-Haardt :—Press-belt rollers in which the boxes for the materials to be pressed, and which are attached to endless belts, have walls pierced with holes and lying free on all sides.
- P. 260316, August 14th, 1910, *Franke, jun.*, London :—Dehydrating presses with impermeable false bottoms which consist of combustible materials (wood, paste-board, and the like) and which remain in the material when pressed.
- P. 263722, April 7th, 1912, *Philip Roth*, Berlin :—Peat dehydration with discontinuous compression and formation of vacuum in such a way that the degree of compression and the degree to which the air is pumped out or that of each working operation return automatically to zero during the breaks in the process.
- P. 264002, February 26th, 1911, *Wet Carbonizing, Ltd.*, London :—The so-called wet carbonization of peat by Ekenberg's process is to be carried out in such a way that only a short portion of the tube is to be heated to 180° C.
- P. 267687, September 28th, 1910, *Abresch*, Neustadt-on-Haardt :—Press-belt rollers, in which rigid side-walls and cross-walls on the press-belts, pierced with holes from the mouth onwards, form moulding boxes (closed on all sides) for the pressed material, the side and cross-walls overlapping one another.
- P. 267865, March 19th, 1912, *Franke*, London :—A spiral spring-brush addition for fitting piston in dehydrating presses.
- P. 268374, April 7th, 1912, *Zahlmann*, Berlin-Lichterfelde :—Dehydrating press with a base which rests on the piston. It is connected with a supporting pole and can be moved independently of the piston.
- P. 268720, November 29th, 1911, *Wet Carbonizing, Ltd.*, London :—Dehydration of wet carbonized peat for direct use in a gas producer in such a way that the wet carbonized peat, without heating and without any addition of other material, is first pressed in a filter press until the cake formed contains about 70 per cent. of water, and the pressed material is then exposed to a continuous pressure in order to bring its percentage of water under 50.
- P. 269333, November 29th, 1911, *the same* :—To prevent the formation of residues in, and to remove them from, dehydrating vessels a vigorous motion of the mass in the vessel is to be produced, suddenly and for a short time, by mechanical means, and afterwards again adjusted.
- P. 270484, January 6th, 1912, *Wolters*, Weitmar, in Westphalia :—Preliminary preparation of peat for mechanical dehydration by heating and pressing, whereby steam, hot gases, &c., are so led in one direction through rooms through which peat is led in the opposite direction that after introduction of the peat they decrease in pressure and temperature.
- P. 271076, March 15th, 1912, supplementary to P. 250367, *Franke, jun.*, London :—In the peat-dehydrating press, according to P. 250367, in addition to the conical insets, there

are other surfaces which come in contact with the material to be pressed, and which are also provided with teeth, or the like, for tearing up the material.

- P. 273138, August 14th, 1912, *Franke, jun.*, London :—Peat dehydrating press in the oppositely moving surfaces of which press cones are fixed which have their apices turned towards one another, and which work between one another. They are also provided with filtering surfaces for the removal of the expressed water.
- P. 275386, November 10th, 1912, *the same* :—Dehydration of peat with the aid of other bodies which are added to it, whereby the added bodies are saturated with solid or liquid organic substances in order to prevent their absorbing liquid.
- P. 275887, September 1st, 1912, *Hirsch*, Berlin :—Dehydrating press with conical openings from the interior to the exterior for the expressed water, in which the walls containing the openings consist of several superposed, thin metallic plates in which holes, progressively increasing in size, are bored.
- P. 276763, February 26th, 1913, *Schülpe Peat Works, Ltd.*, Schülpe, near Nortorf (Holstein) :—A brush conveyer belt for peat dehydration contrivances made from coconut fibre.
- P. 279996, October 27th, 1912, *Lambrecht*, Berlin :—A centrifuge for dehydrating peat, consisting of two permeable cylinders which are fitted with striking pistons, lie inside one another and can be rotated in opposite directions.
- P. 282781, December 12th, 1913, *Jabs*, Zurich :—A roller press in which scrapers strike the peat from each roller so near the pressing zone that the water driven out into the mantle of the rollers cannot be again absorbed by the peat.
- P. 283823, June 18th, 1914, *Meyer*, Dortmund :—Dehydration of peat by letting the peat which is contained in baskets, slit or pierced with holes on all sides and tapering at the base, fall from a considerable height. The water given up when the concussion occurs is let flow away, and the removal of the dry material, as well as the bringing of new baskets to the points of falling, are effected with the aid of a horse-capstan.
- P. 287470, January 3rd, 1914, *Wet Press Co., Ltd.*, Wiesbaden :—Dehydration of raw peat by the aid of bodies which are added to it for the purpose. The peat is cut into powder, without grinding its fine fibres, and, without affecting its pulverulent nature, it is loosely incorporated with the added body, forming a powdery mixture, which retains this condition up to the pressing, which is effected by making the particles move towards one another as rectilinearly as possible.
- P. 288521, December 13th, 1913, *Dr. Charles Heine*, Dabendorf (Teltow) and *Julius Rudeloff*, Berlin :—Contrivance for dehydrating raw peat in which the material to be pressed, embedded between two transporting surfaces, is brought by means of these to presses in which the pressure on the material increases in steps, the pressure being released at intervals, the transport of the material to be pressed to the various presses,



which again set free the body after pressing it, taking place in steps, and the pressing of the material occurring every time the motion of the conveying surfaces stops.

## 2.—Electrical Dehydration of Peat

- P. 124509, April 4th, 1900, *Count Schwerin*, Windenhoff :—The raw peat which is to be dehydrated is to be brought in the form of mud or pulp in direct contact with the two electrodes.
- P. 124510, April 4th, 1900, *the same* :—The material which is to be pressed is to be moved by means of a spiral between two cylindrical electrodes fitted into one another, and of which at least the negative one is permeable for liquids.
- P. 128085, April 4th, 1900, *the same* :—Use of a box similar to that generally employed for moulding peat, the bottom of which is connected with the negative pole of a source of electrical current and is at the same time permeable for liquids, while connexion with the positive pole is made by means of plates or boxes lying on the mass to be dehydrated.
- P. 131932, September 26th, 1901, *the same* :—In carrying out the above process with boxes for holding peat, which are open at the top and provided with permeable bottoms serving as negative electrodes, positive electrodes, formed of a cell structure containing a number of peat boxes with their bottoms placed over one another, lying like plates above the negative electrodes, are to be arranged in such a manner that they can be raised or lowered simultaneously, and, when lowered, each plate is always in contact with the peat as the latter contracts.
- P. 150069, November 25th, 1902, *Dyeworks, formerly Meister Lucius and Brüning*, Höchst-on-Main :—Alkaline substances or salts are to be added to the peat to be treated according to P. 124509. The action of these during the electrolysis at the negative pole is the same as that of added alkali.
- P. 154114, October 10th, 1902, *Möller and Pfeifer*, Berlin :—A number of dehydrating cells, which are arranged over one another in the form of a prism so that the total weight of the cells at an electrode compresses the material enclosed between the electrodes, are connected with a switch under the cells, by means of which the whole prism of cells can be lowered by the height of a single cell so that the cells can be exchanged without stopping the dehydration.
- P. 155453, November 26th, 1902, *Dyeworks, formerly Meister Lucius and Brüning*, Höchst-on-Main :—Dehydration of peat by simultaneous employment of electrical osmosis and intermittent pressure.
- P. 163549, July 5th, 1904, *the same* :—The material between the electrodes, together with the two electrodes, or at least one of these, has a uniform, or discontinuous, forward motion during which fresh material is continually added to the electrodes at one side and the dehydrated material removed at the other.

- P. 166742, October 20th, 1904, *the same* :—The material to be dehydrated is led uniformly, or discontinuously, by means of endless belts of non-conducting, permeable material, between the electrodes, while the latter are kept stationary or are alternately brought nearer to and removed farther from the conveyer belt.
- P. 173630, June 24th, 1902, *Schwarzer, Diamant, Adler, and Kittler*, Memel :—Continuous dehydration of peat while the latter is kept in good motion, wherein, during the passage of the electrical current and the formation of a vacuum, hot air is led through the peat from the positive pole.
- P. 179985, December 10th, 1903, supplementary to P. 124509, *Dyeworks, formerly Meister Lucius and Brining*, Höchst-on-Main :—In the case of the process described in P. 124509 heat is to be added at the negative electrode.
- P. 185189, October 1st, 1902, *the same* :—As in the case of the process described in Patent 124509, the electrical current is to act in the presence of heat, but, during the passage of the current and the simultaneous formation of a vacuum, hot air is to be led through the peat from the positive pole, and also there is to be a stirrer which will serve to introduce hot air and act as the positive electrode.
- P. 207583, July 25th, 1905, *Byron Bessey*, London :—Preliminarily dehydrated peat is treated with an alternating current in such a manner that while strong heating of the mass is avoided, the action occurs intermittently, the water set free by the electrical current, being mechanically removed in the intervals.

### 3.—Disintegration and Sifting of Peat

- P. 1293, July 2nd, 1877, P. 4759, May 26th, 1878, *Brosowsky*, Jasenitz :—Peat disintegrating machine, in which the knives are curved and also to which water is added.
- P. 80014, April 11th, 1894, *Stauber*, Berlin :—The peat, loosened in the ordinary way by rollers, is to be freed from fibres by sifting, the sieve being provided for this purpose with a grate-like fibre-catcher.
- P. 89810, June 17th, 1896, *Stauber*, Berlin :—The raw peat, ground by rollers, is to be sifted more or less completely from fibres, branches, stones, &c., by arranging an obliquely inclined, flexibly suspended retarding plate over the exit of the obliquely inclined shaking sieve, so that it retards the substance shaken and at the same time makes the exit smaller. The coarse, sifted material coming from the exit slit is, in so far as the peat fibres are to be recovered, led to a rapidly rotating brush, which throws the hard impurities, stones, roots, &c., away from the end of the sieve, but retains the clinging fibres on its bristles and brings them to a ridge-shaped scraper meshing into the bristles, which lets them fall on a collecting plate.

- P. 106710, October 4th, 1898, *Kerinnes*, Jorksdorf:—The raw peat is to be pressed by a piston through a cylinder furnished with both rotating and stationary cutting arms. It can also be driven through a ball mill before it leaves the cylinder.
- P. 110746, February 3rd, 1899, *Ball*, London:—In a peat disintegrating machine the peat is to be pressed by means of curved rotating knives through metal plates, which are pierced with holes and arranged in tiers over one another, and it is at the same time to be cut or torn into small pieces by the wedge-shaped and the sickle-shaped knives.
- P. 129969, December 21st, 1900, *Lüdicke*, Prostkerhut:—Peat is to be finely ground by an arrangement consisting of a fixed grinding disc (pierced with holes) of a peat machine through which the peat is pressed by the screw of the machine and a grinding disc which is placed outside the cylinder and rotates with the shaft of the latter. The peat pressed through the fixed disc is disintegrated by means of the revolving disc.
- P. 170980, June 15th, 1905, *Dr. Frederick William Ferdinand Schultz*, Berlin:—An arrangement for the grinding of peat from a preliminary disintegrating machine, the cylinder of which ends in a tube of sufficient length to allow a grinding roller of more or less small diameter to work (under pressure) against the inner surface of the tube.
- P. 171786, March 27th, 1903, *the same*:—The peat coming from the preliminary disintegrating machine is pressed between the horizontal grinding surfaces of grinding stones, one of which forms a flange-like portion of the press cylinder.
- P. 282912, October 24th, 1913, *Verhoeven*, Utrecht:—Teeth, arranged spirally on the surface of a grinding drum, grind the peat thoroughly to powder against the inner grinding surface of a stationary sieve drum and press the powder out through holes in the sieve drum.

#### 4.—Peat Machines and their Components

- P. 466, August 21st, 1877, *Mecke and Sander*, Ocholt:—Combination of a dredger with a peat machine and conveyer, in which the dredger is so suspended that it delivers the raw peat directly to the mixing machine or distributor.
- P. 1293, July 2nd, 1877, and 4759, May 26th, 1878, *Brosowsky*, Jasenitz:—Peat disintegrating machine with cell drum, slides, drum knives and flap-valve knives.
- P. 3484, April 30th, 1878, *Grotjahn*, Berlin:—Peat machine mouthpiece, with intermediate walls capable of being drawn out of the mouthpiece.
- P. 4640, September 3rd, 1878, *Giffhorn*, Brunswick, and *Westerich*, Harberg:—Mouthpiece with intermediate walls, wedge-shaped inside, rounded underneath, and capable of being tilted outwards.
- P. 7492, November 3rd, 1878, *Schlickeysen*, Berlin:—Machine for digging, separating, lifting, working, forming, and spreading

- peat, consisting of two digging, mixing and forming machines (see p. 130), provided with screw and spiral knives and working in the same manner as steam ploughs.
- P. 8873, August 21st, 1877, *Mecke and Sander*, Oldenburg :—Peat-dredging and peat-mixing machine with distributor.
- P. 9412, October 17th, 1879, *Dolberg*, Rostock :—Sod-cutter, consisting of one or more circular knives arranged in front of the mouthpiece of the peat machine.
- P. 11232, April 11th, 1880, *the same* :—Sod divider, consisting of intermediate walls arranged in pairs over one another in the mouthpiece. The walls taper like wedges and do not quite reach one another so that blocking is avoided.
- P. 13057, November 3rd, 1878, *Schlickeysen*, Berlin :—Peat digging and mixing machine similar to that under P. 7492.
- P. 14645, February 13th, 1881, *Mecke and Sander*, Oldenburg :—Floating peat machine, with dredgers suspended freely on supports, for use in bogs which cannot be drained.
- P. 16790, January 21st, 1881, *Brosowsky*, Jasenitz :—Peat-digging machine with single or double intermediate gearing according as necessary.
- P. 19668, July 20th, 1881, *the same* :—Peat-digging machine with double intermediate gearing and intermediate gearing shafts lying beside one another horizontally, so that the machine will have a convenient height.
- P. 19670, March 14th, 1882, *Steeneck*, Gnarrenburg :—Sod-cutting machine, with circular knives for cutting trodden or dough peat.
- P. 20921, April 23rd, 1882, *Schultz Bros.*, Münster in Westphalia :—Peat sod willow for manufacture of peat litter. The knives on the drum move in the opposite direction to the peat sods which are pushed towards them in a channel.
- P. 36195, December 18th, 1885, *Müller*, Demmin :—Arrangement for driving peat-digging machines.
- P. 39509, November 25th, 1886, *the same* :—Alteration in the driving arrangement.
- P. 43106, August 21st, 1887, *Dolberg*, Rostock :—Improvements in peat-digging machines.
- P. 58030, December 6th, 1890, *Hausen*, Jasenitz :—Peat-digging machine with a digger which falls automatically and is lifted in the return stroke.
- P. 61816, August 30th, 1891, *Vollhering and Bernhardt*, Lübeck :—Dredger with a dredging ladder formed in three parts, which are connected together by hinges.
- P. 62424, October 19th, 1890, *Challeton*, Montauger :—Flap-valves on peat diggers which fall into place horizontally, when the digger is being hauled up, so that falling out of the cut peat prism is thereby prevented.
- P. 63737, September 17th, 1890, *Brosowsky*, Stettin :—Peat-digging machine with chain driving.
- P. 74031, July 19th, 1893, *Dürr*, Pfungenried :—Distributor for peat machines, consisting of two tubular cups placed opposite

one another on an axle and into which the peat pulp, coming from the peat machine, runs so that after filling the cup which at the moment happens to be on top, the pulp becomes scattered on the drying ground as the cup tilts, the other cup turning upwards at the same time to receive its charge in turn.

- P. 79798, April 17th, 1894, *Strenge*, Elisabethfehn:—A peat-digging and forming machine in which an endless chain is supported on a frame, which can be adjusted both vertically and horizontally. The cutting knives and the elevating buckets are arranged alternately on the chain. The frame supports an horizontal and also an inclined transport channel.
- P. 89591, January 29th, 1896, *Kerinnes*, Jorksdorf, East Prussia:—Manufacture of machine peat in such a manner that the peat which has been worked in the machine is partially dehydrated by means of rollers with filter frames at their sides, and is then worked once more in, and formed by, the peat machine.
- P. 93186, July 31st, 1896, *Dolberg*, Rostock:—A peat-digging machine with automatic releasing and steering of the digging mechanism.
- P. 98270, December 21st, 1897, *Karnot*, Riga:—A peat-winning machine, including a cylinder which can be moved sideways, upwards, and downwards, and a cutting and mixing contrivance consisting of a cone with cutting knives.
- P. 104745, February 16th, 1898, *Kerinnes*, Jorksdorf:—A peat machine in which the peat is dehydrated under continuous pressure, then mixed, again dehydrated and kneaded, and finally pressed through sod-forming pieces as a continuous band of peat.
- P. 104746, July 3rd, 1898, *Bartsch* and *Nitschke*, Jasenitz:—A peat-cutting machine with a double transport track in which the track of the car which takes away the peat is beside the track for the cutter and between the latter and the working platform.
- P. 106020, April 16th, 1899, *Logatni* and *Galecki*, Warsaw:—While digging peat a pit is made in the bog with the aid of a movable weir, and the peat, cut by the vertical plane method, is mixed in the pit.
- P. 108631, February 15th, 1898, *Kerinnes*, Tilsit:—A peat-working machine in which spiral blades, capable of being rotated, pierced with holes and with their ends formed into rubbers or scrapers, are fixed in the tubes intended for the dehydration of the peat, the object of these blades being to keep the filter walls clean and to push the peat, which has been already dehydrated, towards the centres of the tubes.
- P. 110602, October 5th, 1899, *Brosowsky*, Jasenitz:—A peat-digging machine in which the knife-box guide, reaching almost to the bottom of the bog, can be adjusted for depth. At its upper and lower ends it is furnished with rollers round which the driving chain runs.

- P. 114033, August 4th, 1899, *Dolberg*, Rostock :—A peat band cutter in which a click, set in action by the peat bands or the sod boards, sets free the knife shaft, the rotation of which is controlled by a friction clutch, when a cut is to take place.
- P. 120840, January 29th, 1899, *Brosowsky*, Jasenitz in Pomerania :—A contrivance for cutting and removing peat cubes from the peat prism consisting of a knife moving to and fro, which in its return through the peat cube, resting on it, pushes the previously cut peat cubes still farther on the transport cars.
- P. 128532, October 25th, 1900, *Galecki*, Warsaw :—A box-shaped peat cutter in the interior of which contrivances are arranged by means of which the cut peat contained in the box is mixed.
- P. 129040, March 15th, 1901, *Strenge*, Elisabethfehn :—A peat-cutting machine in which two or more circular knives, attached to a frame and at the same time acting as wheels for the frame, are so arranged that every two knives, separated from one another by the width of the peat band to be cut, are placed behind one another and therefore are not on the same axle. The axles are driven from a motor (a power machine) fixed on the frame.
- P. 134745, October 19th, 1901, *Galecki*, Warsaw :—A transportable peat machine in which a base supported on a transportable frame and capable of revolution round a vertical axis, carries several mixing cylinders which are arranged round its circumference, and which are fed in turn from a filling contrivance during the revolution of the base. The movable bottoms of the cylinders open and close automatically as they pass a notch in the supporting frame.
- P. 138027, February 8th, 1902, *Brosowsky*, Jasenitz :—A bearing frame for peat-digging machines, made in the form of an obtuse-angled triangle, so that the machine may stand more securely.
- P. 140122, August 5th, 1900, *Bade*, Bremen :—A dough peat divider in which an adjustable shaft, carrying several circular knives, runs parallel to the dividing roller. In the forward motion of the contrivance its knives are made to rotate rapidly by means of a chain so that the layer of peat to be operated upon, which was divided by the knives of the roller, is cut through by the rotating circular knives.
- P. 140726, July 13th, 1901, *the same* :—The above cutting contrivance is modified so that straight-cutting knives can be driven downwards into the peat in rapid succession by means of a crank-shaft or the like, and the lance-shaped cutting knives can receive an up-and-down motion in an oblique direction in reference to the surface of the peat, so that the peat may be more easily and more certainly cut, and damming in front of the knives may be prevented.
- P. 149571, March 29th, 1909, *Hansen*, Herning (Denmark) :—A peat machine with an endless sod-spreading belt, which passes over a supporting frame. The frame can be rotated

- round the horizontal axis and can be set in motion by a shaft which rotates the frame as soon as the end of the peat band strikes against a plate placed over the belt, the peat being then tipped on the drying ground.
- P. 153147, December 16th, 1900, *Krupp*, Hanover, and *Heine*, Jmbs (Norway):—A centrifugal pump dredger, the peat being separated under water by the knives of the dredger, and then raised in a continuous stream by the pump.
- P. 154577, September 29th, 1901, *Schlickeysen*, Neukölln:—A contrivance for digging and removing peat (see Fig 52).
- P. 156953, July 31st, 1903, *Dreyer*, Ostersode, near Gnarrenburg:—A transportable machine for dividing the upper layers of peat bogs into sods by means of cutting knives with an up-and-down motion. It is provided with a starting lever for the knives and rollers.
- P. 157121, November 8th, 1902, *Schlickeysen*, Neukölln:—Side and bottom knives for the peat-digging machine of P. 154577.
- P. 161169, July 26th, 1904, *Heyman* and *Poppe*, Bremen:—A floating peat-digging machine in which the cutters empty the peat through a side opening into the trough of an elevator. It is provided with an adjustable wall for shutting out water.
- P. 161953, March 9th, 1904, *Weitzmann*, Greifenhagen:—A peat machine with a special preliminary disintegrator (knife-drum and cutting blades in the hopper).
- P. 163368, January 5th, 1904, *Blomdahl*, Eskilstuna (Sweden):—A peat machine with counter-knives only in the ascending portion of the feeding neck, which is made to the full width of the machine cylinder.
- P. 163369, November 5th, 1904, *Oltmann Strenge and Sons*, Elisabethfehn, near Augustfehn:—A peat machine with parallel knife spirals, the first knife courses of which reach only to near the mantle, a resistance being thus opposed to the peat behind the lower knife courses, and the process of mixing being improved accordingly.
- P. 165805, November 5th, 1904, *Oltmann Strenge and Sons*, Elisabethfehn:—A peat dredger with cutting knives inclined obliquely outwards on both sides with the object of mixing the peat more uniformly.
- P. 166784, January 6th, 1904, *Dobson*, Beonerton (Canada):—A transportable peat-winning machine with a rotating cutter, the peat won by the machine being distributed over the drying ground by means of an endless conveyer belt.
- P. 168071, January 10th, 1905, *Marius Ib Nyeboe*, Copenhagen:—A floating, mixing, and kneading machine with two or more kneading and mixing channels which, starting from feeding points at different depths, unite at their other ends, giving always a uniform mixture of the various layers.
- P. 169185, January 5th, 1904, *Blomdahl*, Eskilstuna (Sweden):—A peat machine with spiral knives and counter-knives, the former of which are so made that they both press the peat

from the circumference to the axis of the cylinder and give it a forward motion in the direction of the knife shaft.

- P. 177446, December 28th, 1905, *Lührs*, Bokeloh, near Bremer-vörde:—A peat plough for winning machine-cut peat, in which a front roller, provided with transverse knives, divides transversely the peat strips which are to be raised, knife discs behind this cut them at the sides, and a toothed disc, resembling a circular saw, lying behind these, separate the strips from the underlying uncut peat.
- P. 180283, January 25th, 1906, *Charles F. M. Wiencke*, Rostock, in Mecklenburg:—A conveyer for the boards on which the peat sods are removed from a peat machine, consisting of two parallel endless chain conveyers, connected with one another by cross-bars supporting carriers which are suspended freely between transportable bearing frames at the sides and support the sod boards on the cross-bars, while the winch for working the bearing frames at the sides is driven by the conveyer chains, and these are kept in tension by a suspended weight.
- P. 200565, December 15th, 1906, *von Morsey-Picard* and *von Vershuer*, Cassel:—A mouthpiece for peat machines, with two side walls for the mouthpiece made of electrically conducting material.
- P. 214556, January 31st, 1908, *Bünting*, Jeddelloh, Oldenburg:—A peat distributor with an endless belt, which is provided with arms by means of which the peat is uniformly spread and levelled.
- P. 220291, June 29th, 1909, *Henry Albert Knopf*, Jaderberg, Oldenburg:—An endless conveyer for peat sods capable of being moved in the direction of its cross-section. The bearing frame of the conveyer can be rotated round the longitudinal axis so that it can be tilted to one side when it is fully charged with sods, which are thus spread on the drying ground.
- P. 225922, March 31st, 1909, *Beckmann*, Papenburg:—A machine for cutting peat, the cross-cuts being made with knives having an up-and-down motion and the longitudinal and bottom cuts by several angle-knives attached to a frame trailing behind the machine.
- P. 226216, May 9th, 1909, *Henkensiefken*, Geestemünde:—A peat-winning machine for vertical peat walls, with a cutting and elevating contrivance movable on a longitudinal girder, in which the cutting and elevating contrivance is provided with a vertical and a horizontal cutting disc and a dividing contrivance for the peat sods.
- P. 227083, May 29th, 1909, *Dr. William Wielandt*, Grand Duchy of Oldenburg:—A peat-spreading belt consisting of several plates, arranged so that they can be tilted, in which the plates which form the transporting course are supported by a vertical bearing rail, on the releasing of which the supported plates tilt down, and in this way all the sods on them glide off simultaneously. The releasing of the bearing rail takes place when the front sods come in contact with a back-stop.



- P. 231393, January 18th, 1910, *Koscielski*, Petrograd :—Specially formed slit openings for the cutting discs of peat machines.
- P. 233380, September 28th, 1909, *Knopf*, Jaderberg (Oldenburg) :—A peat-digging or dredging machine with vertically rotating spirals or blades, arranged in screw fashion, which are provided on the outside with teeth or knives which cut off the peat when they are pressed against the peat wall, and feed it to an elevator.
- P. 233381, June 19th, 1909, *Anrep*, Helsingborg (Sweden) :—A peat dredger, which is supported on a frame which can be pushed across the trench and is fixed on a bridge movable along the trench so that the dredger can be moved over the whole width and worked to any depth required for the dredging operations without putting too much weight on the external edge of the bank.
- P. 233809, November 7th, 1908, *Hendunen*, Moscow :—A peat machine with a centrifugal drum interposed between the hopper and the kneading spiral and with knives fixed trelliswise to the wall of the drum in order to disintegrate and condense the peat more thoroughly.
- P. 237905, July 14th, 1910, *Fred Baumann*, Mannheim :—A sod-spreading belt consisting of plates which are arranged in series, like the tiles on a roof, and can be tipped crosswise at one end. The dimensions of the various plates are such that when one plate is released all the following plates tip and empty.
- P. 239194, April 8th, 1909, *Treude*, Meppen :—A machine for cutting peat provided with transverse, longitudinal and bottom knives. The longitudinal and the bottom knives are supported by a bow which allows a certain amount of play so that the peat can be cut to various depths.
- P. 247489, March 23rd, 1909, *Dr. Wielandt*, Grand Duchy of Oldenburg :—A peat-dredging machine which moves parallel to the peat bank. The dredger beam, lying in a plane at right angles to the direction of motion, is inclined sideways so that its head lies above the transporting frame. The whole dredger beam can be moved any way desired round the horizontal and the vertical axis so that dredging can take place at any desired angle.
- P. 252639, February 20th, 1910, *Strenge*, Ocholt, Oldenburg :—A sod-cutting wheel for peat machines, the knives of which may be adjusted as desired by means of a rotating ring.
- P. 256892, August 8th, 1911, *Wet Carbonizing, Ltd.*, London :—A marsh peat dredger consisting of a digger, a pump and tubes. A contrivance, interposed between the digger and the pump, by cutting and grinding the peat adapts it for further transmission.
- P. 258603, December 29th, 1909, *Rogoff*, Gus Chrystalnyi, Russia :—A single-shaft peat machine, the cutting knives of which work against counter-knives, fixed in an adjustable manner as hoops round the shaft.

- P. 263771, September 19th, 1911, *Zelenay*, Twer, Russia :—A peat-digging machine with a cutting contrivance fixed at the lower end of an adjustable vertical cylinder and with a transporting spiral in the cylinder.
- P. 264003, June 5th, 1912, *Strengé*, Ocholt, Oldenburg :—A peat machine with sod cutter and sod spreader such that the sods emerge first on a sliding board and then in groups on a second cross-sliding board whereon a considerable number of such groups of sods are transported to the discharging place by means of a conveyer, which moves in the direction of the longitudinal axis of the second sliding board, and the whole series of sods is tipped, all together, on the drying ground in such a manner that the sods stand upright on their ends beside one another.
- P. 265412, March 9th, 1912, supplementary to P. 263771, *Zelenay*, Twer, Russia :—The conical cutter of the machine patented under 263771 is equipped with two or more screw-shaped ducts, the exit edges of which are provided below with broad knives, and above with a steel plate in which a hole is cut.
- P. 265684, November 30th, 1911, *Gress*, Rosenheim, Upper Bavaria :—A peat-cutting machine with slits for the longitudinal and the bottom knives and consisting of a curved plate supporting all these knives and their bearings.
- P. 269741, February 11th, 1912, *Wet Carbonizing, Ltd.*, London :—A pit made in a bog is to be used as a collecting station for cut and disintegrated peat suitable for pumping.
- P. 269993, November 27th, 1912, *Anderson*, Walentymow, near Raschkow :—A peat machine with a cutter which can be moved upwards, forwards or sideways, which, in addition to a lifting contrivance for the up-and-down courses, can be adjusted from the side by means of a slit in the cross-frame on which the cross-motion takes place.
- P. 272528, October 20th, 1910, *Wielandt*, Oldenburg :—A peat-cutting machine in which there is an up-and-down moving contrivance capable of cutting in three directions. By withdrawing a click at the proper time after a horizontal cut the contrivance falls through the height of a vertical cut.
- P. 274271, April 19th, 1913, *Strengé*, Ocholt, Oldenburg :—A sod spreader with an endless conveyer belt consisting of separate plates, capable of being rotated. In order to spread the sods the plates are swung down by automatic removal of a supporting rail, each plate rotating round a line through its centre. The loaded plates are kept in the horizontal position by means of a supporting rail which projects above the back edges of the plates and which, when the plates are to be swung down, is drawn back horizontally by the driving mechanism and thus releases the back edges of the laden plates.
- P. 279725, February 13th, 1913, *Hinrichsen*, Hermsdorf, near Berlin :—Mixing and pushing knives with a wave-like cutter, the blades of which are also wave-shaped.

- P. 280456, December 9th, 1913, *Mai*, Wiesmoor, East Frisia :—A sod-spreader formed from revolving chains, wherein one chain revolves in the reverse direction round the other and supports the receivers of the inner chain, but has now and then openings in its course so that the receivers of the inner chain separately lose their support at places lying continuously behind one another in a spreading line, and empty themselves by tipping.

### 5.—Peat Pressing ; Piston Presses and Stamp Presses (Briquette Presses)

- P. 2152, February 16th, 1878, *Hack*, Lauenburg :—A peat kiln with right-handed and left-handed distributing spirals, through which the peat mould, which has been previously sifted, is distributed on a wide box-shaped drying floor, heated by steam and consisting of upper and lower boxes. The peat is moved about on the floor of the kiln by an endless chain to which scrapers are attached and is at the same time turned. When the drying is finished the anhydrous peat again falls into a distributing spiral which feeds it into the well-known stamp presses.
- P. 53844, October 27th, 1889, *Ruederer, Loé, and Gumbart*, Munich :—Freshly slaked lime is added to the dried peat, the mixture is coked with recovery of the by-products, and then the residue, after addition of water, is compressed into press peat charcoal. An endless conveyer belt with flaps distributes and pushes the material to be dried over the drying plates.
- The coking oven contains chambers, the bottoms and covers of which taper obliquely, and an adjustable tube by regulating which the operations can take place with or without the recovery of by-products.
- P. 60627, 63923, 70638, June 17th, 1891, *Stauber*, Berlin :—A peat press in which the material to be pressed is driven through a compressing cylinder to forming rollers or forming tubes, the press material passing between the forming rollers only after it has been so much compressed that it has raised a valve which has a counterpoise regulated for the density to which it is intended to compress the peat.
- P. 91810, August 2nd, 1896, *Filser*, Landsberg-on-Lech :—A peat-pressing and drying machine having a pressing drum containing cells in its cover provided with slides which move up and down. When the peat is compressed the slides are pushed over by means of a pair of levers fixed on the common shaft, and after the compression the slides are pushed fully in by means of gearing, so that the pressed material can then fall down over a stripper.
- P. 103118, December 10th, 1896, *Stauber*, Berlin :—The raw peat after removal of fibres and other admixtures is to be dehydrated while hot by pressure, dried in a steam oven and again pressed.

- P. 103509, November 2nd, 1898, *Raoul de Faucheux d'Humy*, Liverpool:—The dehydrated peat is to be heated and stirred simultaneously by means of steam, then intimately mixed with oil, peat distillation products, mineral oil, and the like, and finally filled into forming pieces or pressed.
- P. 117152, August 11th, 1897, *Kerlnnes*, Tilsit:—In order to keep the cementing substances which expand in water in an active condition, the peat, in the manufacture of press peat from disintegrated material, at the ordinary temperature or when heated at most to 80° C., is to be treated in such a way that it contains not less than 60 per cent. of water, and is then to be pressed.
- P. 134974, August 12th, 1900, *Hasselmann*, Munich:—In manufacturing press peat from fibrous and mossy peat mixed with easily inflammable substances, oleic acid is to be added to the mixture, the constituents of the latter reacting with it to form oleic acid derivatives.
- P. 139625, September 22nd, 1901, *Helling*, Wandsbeck:—When milk of lime is employed in manufacturing press peat, powdered pyrolusite, or a similar manganese compound which can give off oxygen, is also to be added.
- P. 152217, August 6th, 1902, *Schwarzer, Diamant, Alder, and Kittler*, Memel:—A peat press in which a table is moved backwards and forwards under a hopper. At the end of each stroke the table moves under a stamping contrivance.
- P. 161415, June 10th, 1902, *Zschörner*, Vienna:—For making a uniformly grained peat (for press peat) a double-drum dehydrating press is to be attached to a peat band machine, and to the former a peat-disintegrating machine is likewise to be connected, which feeds the peat grains (mould) to a rotating cell-drum, from the interior of which hot compressed air is blown through the peat grains which fill the cells in the circumference of the drum.
- P. 163277, February 22nd, 1903, *Peters*, Langenberg:—Peat for the manufacture of press peat is disintegrated, made into heaps, allowed to stand some time to become spontaneously heated, and then worked up further in the well-known way.
- P. 164226, April 9th, 1904, *the same*:—In order that the decomposition may be quicker, the heaps of peat, prepared as in the last method, are heated artificially.
- P. 164274, March 22nd, 1904, *Kellond and Morrison*, Chicago:—A feeding contrivance for peat presses, wherein the mouth is opened and closed once during each compression by means of a sliding valve connected with the stamp of the press.
- P. 167548, August 16th, 1903, *White*, Toronto, and *Griffin*, Guelph (Canada):—Manufacture of press peat having a hard crust. The wet peat is first exposed to a small pressure in closed moulds, which are continuously heated and are provided with steam exits, so that the dried, porous parts of the external layer of the peat are kept in front of the exits; the pressure is then increased, step by step, until a hard crust is formed, and

is finally diminished so as to prevent the splitting of the crust and to make the press sod easily removable from the mould.

- P. 172504, November 4th, 1903, *Seemann, Tilsit*:—In order to manufacture press peat from wet peat in a single course of operations, wet peat is heated in a closed cylinder, provided inside with a transporting spiral, and passed into a press containing revolving moulds, in which the material is pressed and then pushed in the form of separate sods through the moulding table to the drying train, whereby the heat enters through the hollow cover of one end of the train and plays round it in a direction opposite to that in which the press sods are moving, after which it passes through the hollow cover of the screw cylinder and the hollow screw-shaft and finally is used to heat the peat in the hopper of the screw cylinder.
- P. 173928, February 7th, 1905, *MacGregor and Pearson, Old Charlton (England)*:—A peat press in which the press piston glides in a moulding tube which holds a more or less large number of the manufactured press sods.
- P. 177981, February 7th, 1905, *the same*:—A contrivance for manufacturing press peat from wet peat wherein an edgemill for disintegrating and kneading the peat is placed under a dehydrating contrivance and over a moulding press.
- P. 179814, June 24th, 1903, *Luedicke, Prostergut, near Marggrabowa, East Prussia*:—Manufacture of press peat in such a way that the peat is changed, by heating it to about 125° C., into a pulpy mass, and the various peat particles become covered and cemented by the resinous constituents, which become soft without coking of the peat and volatilization of the resinous constituents taking place, after which the peat pulp, without any further special treatment, is worked up in the usual manner.
- P. 182459, June 8th, 1906, supplementary to P. 179814, *the same*:—In the process just described, as soon as the peat has been heated to about 125° C., the muffle is opened and resin powder or resinous bodies are added to the peat to increase the percentage of resin in the latter, so that a thin, dense layer forms on the surface of the press peat.
- P. 220538, June 25th, 1907, *American Peat Machinery Co., Portland, America*:—The following contrivances are combined with the object of disintegrating and mixing peat for press peat machines: A feeding funnel with a transporting spiral and under it several short tubes, following one another, provided with screw courses and ending in a mouthpiece. A screw shaft passes through them, the lower portion of which is furnished with knives which work between curved blades.
- P. 253427, May 30th, 1909, *Peat Coal Investment Co., Ltd., London*:—Peat is to be dehydrated according to P. 161676, 169117, and 172102, then dried as completely as possible by heating to 120° C., and finally converted into press sods in the ordinary manner.

- P. 268721, May 11th, 1912, *Wet Carbonizing, Ltd.*, London :—For pressing wet carbonized peat, the material to be pressed is prepared by piling in layers so that it encloses as much air as possible.

### 6.—The Drying of Peat

- P. 22223, March 7th, 1882, *Rothbarth*, Gifhorn, and *Selwig and Lange*, Brunswick :—A peat drier in which the peat is spread on the surface (permeable to air) of a slowly moving conveyer belt, which is placed in a closed chamber and exposed both to the action of a current of hot air and the direct action of heat.
- P. 64962, 84458, 88429, and 89462, December 25th, 1891, *Stauber*, Berlin :—A drying contrivance with belt conveyers arranged like steps, between which peculiarly constructed plates, capable of being heated, are interposed. By means of crank pins the material to be dried is kept in motion on the plates.
- P. 68685, October 11th, 1891, *Kauffmann*, Soest :—A drying drum with a star-shaped heating drum in the centre and a larger drum, pierced with holes, provided with a spiral and scrapers and fixed on the same axis, which are arranged semicircularly round the heating tubes.
- P. 82038, November 13th, 1894, *Hansen*, Sandefjord (Norway) :—A peat-drying contrivance consisting of a series of elevators which alternately raise and let fall the peat in such a way that the peat which falls down from the scrapers of the one elevator is taken up by the scrapers of the other, a current of hot air passing at the same time through the plant.
- P. 108333, November 29th, 1898, *Kerimnes*, Jorksdorf :—A drying shed consisting of several stories, having a vertical shaft passing through it, in which is arranged a transporter, which can be elevated and lowered, from which the car boards carrying the peat sods are pushed on rollers sideways into the rooms in the various stories of the shed.
- P. 115007, June 4th, 1899, *Gehrcke*, Hamburg :—The water contained in peat, which is heated in a closed space, is to be converted into high-pressure steam suitable for power purposes. The dried peat is to serve for heating the closed space in which the steam is to be generated from the raw peat. The peat is to be fed continuously, under pressure, into the drying tubes at one side of a tubular boiler, separated there into steam and dry substance, and the latter, which comes out of the other side, is to be used for heating the drying boiler.
- P. 116293, October 18th, 1903, *Dunlap*, London :—A peat drier with a drum which can be heated and out of which the air can be pumped, wherein, in order to divide up the material to be dried and to press it in thin layers on the inner surface of the drum, a roller is arranged inside the drum, so that it can exert a regular and automatically adjustable pressure against the inner surface of the drum.
- P. 139056, March 7th, 1902, *Hannemann*, Berlin :—A drying

contrivance with tubes through which the peat is moved by spirals, and which are built into the steam or water chamber of a steam boiler.

- P. 59455, December 5th, 1890, *J. A. Soetje and Alb. Kahl*, Hamburg :—An oven for drying peat mould for press peat or peat charcoal, wherein, in order to obtain large drying surfaces, the material to be dried is kept in thin layers between latticed walls, between which it slowly descends while hot tubes pass through the surrounding space and the vapour produced is led away through special channels.
- P. 156025, June 25th, 1902, *Schlickeysen*, Steglitz :—The drying of formed peat is facilitated, and its resistance to the action of the weather or pressure is increased, by working the raw peat after addition to it of powders, such as coal-dust, peat mould, saw-dust, or the like.
- P. 164225, July 25th, 1903, *the same* :—A further modification of the process just mentioned, wherein these powders are also placed on the surface of the freshly formed peat.
- P. 166597, May 19th, 1903, *the same* :—The formed peat bands are heated for a short time, i.e., so long as only the surface water evaporates, whereby a crust forms round the still cold core of the sod, and it then becomes possible to pile the peat without further trouble.

### 7.—The Winning and the Treatment of Peat Fibres

(Cf. also "Peat as a Fibrous Material for Paper, Paste-board, Textiles, &c.," under Patents, Part II.)

- P. 11729, January 21st, 1880, *Thümmeler and Seidel*, Dresden :—Bleaching peat fibres and giving them a sheen by means of chlor-ether with subsequent separation of the fibres by sudden development of carbon dioxide, and by softening them by means of glycerine vapours.
- P. 18115, March 31st, 1881, *Friedrich*, Plagwitz-Leipzig :—For winning peat fibres from disintegrated fibrous peat, obtained in the ordinary way, use is made of a centrifuge (the staves of which are provided with oblique holes to unroll and flatten out the peat fibres) in combination with a sieve and a rake for winning the extended peat fibres, also a three-roller press for manufacturing formed peat by driving the sifted mouldy peat through a forming mouthpiece.
- P. 22905, October 31st, 1882, *Nehlmeyer*, Hanover :—For the disintegration of pieces of peat and the separation of the peat fibres from the peat litter and the peat mull, funnel-shaped vessels are to be employed, the side walls of which are to be provided with points or teeth and are to be rotated in opposite directions, while the peat thus pressed and ground falls on a moving endless sieve in order to separate its fibres.
- P. 23107, August 2nd, 1882, *Friedrich*, Plagwitz-Leipzig :—The disintegrated fibrous peat is stirred with water in a trough by

- means of rollers, just as in a hollander, from which the floating more or less long fibres are separated from the shorter by means of sieve-grids. After the sifting the different kinds of peat fibres are to be treated separately; the finer in a hollander, and the coarser in a finishing or tearing mill.
- P. 35900, November 25th, 1885, *Kleine*, Linden, Hanover :—A washing machine, wherein peat fibres are to be purified and made into paper stuff by the slow backward and forward motion of a grid.
- P. 37547, April 3rd, 1886, *the same* :—A machine for removing reeds from peat, the object of which is to win the reed grass contained in peat for commercial purposes, especially spinning, weaving, and the manufacture of paper and paste-board. A roller, equipped with blunt, closely packed, short teeth, works against a vertical surface contiguous to it. The peat thus torn up falls on a shaking sieve in which the mull and litter are sifted, and the material which has not gone through the holes of the sieve then passes under a second roller having teeth which are long, far apart, and mesh through a grid, the fibres being thus separated from the mould.
- P. 42200, June 21st, 1887, *Schleipen*, Cologne-on-Rhine :—The freshly cut peat is shaken in a funnel with a "porcupine" in order to disintegrate the peat and separate the fibres. The disintegrated peat is stirred in a vat until the fibres have separated from one another. The fine fibres are passed through the meshes of a sieve drum to a collecting vessel which has a sieve bottom, the collected and washed coarse fibres are raised by a water-engine to an endless sieve and led from this under a press roller.
- P. 50304, April 12th, 1880, *Bérand*, Bucklersburg (Baden) :—Working peat fibres in a special machine with pin-drums and water-blast.
- P. 50516, July 10th, 1889, *Beckmann*, Papenburg :—Peat fibre sifting by washing on a shaking, box-shaped sieve.
- P. 78845, June 9th, 1894, *Paul*, Hamburg :—A machine for cleaning peat fibres from earthy and woody constituents, wherein a grinding cone, furnished with bristle brushes, works against a similarly furnished, conical, grinding ring.
- P. 79389, April 28th, 1884, *Cannot*, Meppen :—A machine for peeling peat fibres provided with grooved peeling drums, which have a longitudinal as well as a rotary motion so that as complete as possible a peeling is attained.
- P. 83332, March 28th, 1895, *Rotten*, Berlin :—Peat is to be separated into fibres, mould, and other portions of plants, by allowing the peat, suspended in water, to flow in at the front side of a box provided with partitions which are not quite as high as the internal sides of the box, until it overflows the partitions and passes out at the rear, and then letting it, together with the water, fall on a sieve or a plate pierced with holes, the meshes or holes in which are of small dimension, with the object of separating the plant remains on the bottoms.



- of the compartments formed by the partitions, the peat fibres remaining on the sieve and the mould passing into a receiver which is placed under the sieve.
- P. 90483, July 3rd, 1895, *Stauber*, Berlin :—The peat is to be fed into two drums in turn, one of which effects the preliminary drying and disintegration of the peat as well as the separation into fibres and peat proper, while the other dries the peat proper and is to dry and disintegrate further the fibrous portion which it is also to further separate into peat proper and fibres.
- P. 92265, July 15th, 1896, *Cannot*, London :—To obtain unbroken peat fibres as free from dust as possible these are to be separated from the peat by the latter being raked backwards and forwards in a vat filled with water, whereby the earthy portions are separated from the fibres and are then removed by means of a false bottom, pierced with holes, which is fixed in the vat.
- P. 96540, October 20th, 1895, *Charles Geige*, Düsseldorf :—Manufacture of chemically pure fibres from peat by extracting crude peat fibres with alkalis, drying and breaking up the fibres which are brought first into an acid bath, with the object of converting the starch contained in the fibres into sugar and destroying the proteins, and afterwards into a fermenting bath to decompose the sugar into alcohol and carbon dioxide. The fibres are treated with an agent for removing fatty bodies, again washed, boiled with dilute acids or alkalis, washed once more, and finally bleached.
- P. 102988, September 6th, 1898, *Rom*, Liao (Norway) :—The peat is to pass between two belts, moving with different velocities in the same direction and provided with “points” or knives, whereby the more rapidly moving “points” are to take the peat fibres with them and from which they are to be taken off by a fan or a comb.
- P. 123785, January 1st, 1901, *Société Tempied et Dumartin*, Paris :—A spun material from peat containing pure peat fibres on the outside with an inner base of one or more fibres of cotton or the like.
- P. 127393, December 11th, 1900, *Dr. Beddies*, Berlin :—The raw peat, which has an acid reaction, is mixed and washed after addition of alkaline wash water in a mixing and pressing contrivance provided with blunt screws, and the mass of peat fibres is uniformly disintegrated. It is then bleached, &c., and worked to paste-board or paper in the usual way.
- P. 144830, January 30th, 1901, *Kalmann*, Rabenstein (Lower Austria) :—Separation and working of peat fibres: The cut peat is to be first purified by washing and rubbing and the material obtained is to be worked by repeated (but only for a short time) grinding and re-soaking in water first to half-stuff, and by a repetition of the treatment, under increased pressure, to full-stuff and finished paper.
- P. 150698, February 6th, 1903, *Garnholz*, Oldenburg, and *Kettler*,

- Osternburg :—Winning of peat fibres in such a manner that the peat bands as they came from a peat machine strike against prongs for removing the fibres.
- P. 154144, May 4th, 1916, supplementary to P. 142658, *Pollak and Esser*, Vienna :— In the contrivance protected by P. 142658 a to-and-fro moving table is to be employed instead of the revolving table there mentioned.
- P. 156842, November 8th, 1903, *the same* :—Manufacture by stamping from peat of a product suitable for half-stuff, wherein the peat is put in thin layers on a revolving support, where it is subjected to the action of pounders or hammers.
- P. 159284, July 9th, 1902, *Garnholz*, Oldenburg, and *Kettler*, Osternburg :—A fibre winner such that the peat mud is fed through a channel to an endless revolving cloth which is furnished with scrapers or tines for catching the peat fibres.
- P. 161667, November 23rd, 1902, supplementary to P. 159284, *the same* :—Revolving chain combs are placed in the above contrivance, the object of which is to take the fibres from the channel and carry them to the striking-off brushes.
- P. 161668, November 25th, 1902, supplementary to P. 159284, *the same* :—Rotatory or up-and-down moving grids or combs are arranged above the channel for the purpose of taking the fibres out of it.
- P. 162108, November 25th, 1902, supplementary to P. 159284, *the same* :—Several rollers with combs on their circumferences are employed to take the fibres out of the channel.
- P. 167831, December 30th, 1902, supplementary to P. 161668, *the same* :—The fibres are taken up from the peat mud as it flows from the vat through a supporting tube, by means of grids under one another and also under the mud vat.
- P. 168172, May 23rd, 1905, *Dr. Beddies*, Berlin :—The peat is ground until its short friable fibres are disintegrated and then the disintegrated portions are swept away from the durable long fibres by a current of water.
- P. 169381, January 8th, 1903, supplementary to P. 167831, *Garnholz*, Oldenburg :—Winning of peat fibres according to P. 167831, wherein the grids oscillate or rotate under the peat mud exits.
- P. 180397, July 9th, 1905, *Dr. Oswald John*, Cothen, Anhalt, and *Henry Wollheim*, Grunewald, Berlin :—Separation and bleaching of peat fibres, by bleaching with hydrogen peroxide the peat fibres which have been separated from one another by means of dilute hydrofluoric acid.
- P. 203269, June 6th, 1907, *Beck*, Hamburg :—A contrivance for manufacturing a half-stuff from peat by pounding, wherein the main shaft extends over the whole width of the revolving table and drives a set of pounders at each of its two ends while the driving of the other pounder shafts is effected by bevelled wheels, and the revolving table itself is driven from one of these pounder shafts.
- P. 208421, June 6th, 1907, *the same* :—Manufacture of half-stuff

from peat, whereby the peat which has been pounded on a revolving table is subjected, in regular succession, to a number of pulling or rubbing actions of different intensities.

- P. 209354, September 5th, 1907, *Reif and Dyckerhoff*, Hanover :—  
A machine for breaking up fibres in peat, wherein two tearing rollers, rotating in opposite directions, are provided with screw-knives having their courses wound in the same direction.
- P. 216203, September 8th, 1908, *Christeiner*, Munich :—A contrivance for separating disintegrated peat into its fibrous constituents consisting of an inclined revolving cylinder with several channels on its inner surface which are parallel to the longitudinal axis of the cylinder. The disintegrated peat is fed into the upper end of the cylinder together with water from a water-spraying tube, which projects into the cylinder, while the wash water and the earthy substance leave the cylinder through openings placed near its lower end and the purified and separated mass of fibres through openings at its lower end.
- P. 216934, July 2nd, 1908, *Franz*, Admont, Styria :—The cut, raw peat, before washing and separating the fibres, is pressed into an endless band and cut into discs of, approximately, equal thicknesses, the operation being in preparation for the later one by which the half-stuff is separated.
- P. 221712, May 20th, 1909, *Reif and Dyckerhoff*, Hanover :—  
A machine with a comb made from discontinuous rows of sharp teeth, having the same axis or parallel axes, which intermesh with a point-disc or point-roller and tear up the product coming from the cutting rollers without formation of powder.
- P. 258068, March 19th, 1912, *Granville*, New York :—Separation of fibres from peat, wherein a powerful current of water is employed to set free the peat and to bring the separated constituents to the place where they are to be further treated.
- P. 288210, February 5th, 1915, *Dr. Leo Ubbelohde*, Karlsruhe, Baden :—A contrivance for preparing peat for paper stuff consisting of a vat having a sieve bottom and a rake which is moved to and fro in the vat and which has its teeth directed upwards.

## SECTION VIII

### NOTES

#### From the Sections on the Winning of Peat

(The figures given in parentheses indicate the pages on which further particulars are to be found.)

Peat in its natural state, no matter whether it is black peat, mould peat, or fibrous peat, contains as a rule 80 to 90 per cent. of *water*, and even in peat from well-drained bogs the percentage of water is rarely under 80<sup>1</sup> (p. 57).

The percentage of water in air-dry peat should be only 20 for fuel peat, 25 for peat litter, and in either case it should not exceed 25 to 30, while in press peat the percentage of water should not exceed 15.

Hence *considerable* quantities of water must be raised and worked with the raw peat and removed from it by drying. It should be noted that 100 kilos of raw peat containing 80 per cent. of water (20 kilos of anhydrous substance and 80 kilos of water) give only 25 kilos of fuel, or litter, peat in the air-dry state containing 20 per cent. of moisture, or 26·7 kilos in the air-dry state containing 25 per cent. of moisture, and that in every 100 kilos of raw peat 75 or 73·3 kilos of water must be moved as if it were ballast, and must be evaporated during the drying<sup>2</sup> (pp. 60, 61).

This unusually high percentage of water increases the difficulty and also the cost of winning dry peat.

As the water evaporates, the volume and the weight of the peat which has been raised from the bog (raw peat) diminish. On an average, 1 cb. m. of raw peat containing 80 per cent. of water, and weighing approximately 1,000 kilos, gives only 0·28 cb. m. of air-dry cut peat weighing 250 kilos (pp. 60, 61, 63). In the case of machine peat, the decrease in volume is still greater, owing to the greater contraction of the peat (p. 244).

Many a peat, even when it has a good fatty or slippery appearance, often contains a high *percentage of ash* and has therefore little value as a fuel, while other fibrous peat, which may perhaps be considered suitable for peat litter, may have only a small *absorptive power* (pp. 262–264).

Before the working of a bog commences, it is essential that the quality of the peat from its various layers should be carefully

---

<sup>1</sup> On the other hand, moist brown coal, as raised from the mine, rarely contains more than 60 per cent. of water.

<sup>2</sup> On the other hand, 100 kilos of moist brown coal, as raised from the mine (60 per cent. of water), give 50 kilos of air-dry fuel—i.e., double the amount mentioned above—and in their formation only 50 kilos of water require to be evaporated.

examined<sup>1</sup> with a view either to organizing the best scheme for the development of the bog, or to protect oneself from delusion and loss (p. 282).

Industrial winning of peat is preceded with advantage by drainage of the bog during a period of one to two years, by which, as a rule, the water in the peat is lowered by 5 to 10 per cent. This apparently small decrease is of *considerable* importance, since owing to it, for the same total output (in raw peat raised), and, therefore, as a rule for the same amount paid in wages, the amount of dry peat finally obtained from the same weight of raw peat is materially increased, and, with it, the success of the undertaking. Even if the percentage of water in the raw peat be decreased from 90 to only 85, i.e., by only 5 per cent., then from 100 kilos of raw peat 20 kilos(!) instead of 13·3 kilos of air-dry peat will be obtained. This is an increase of one-half or 50 per cent. (pp. 60, 61, 244), and with the same expenses the total output, and, therefore, the earnings of the industry, is increased to the same extent. With reference to volumes, the difference is smaller, but in this case also it is still considerable (pp. 63, 246).

Large areas are required for the *drying grounds* (pp. 50, 216, *et seq.*, also p. 253), which should be dry, level, and situated as high as possible.

Transport and freightage should be cheap, and a large market should either exist or be capable of being created.

The only method of drying which has hitherto proved satisfactory is *air-drying*; in wet districts, or when production on a large scale is to be assured, air-drying may be assisted by contrivances such as spiked poles, open trestles, "horses," huts or sheds (pp. 45-49, 216, *et seq.*).

In order to make certain of a sufficient amount of raw peat for continuous working of peat by machines (machine peat) even when the weather is unfavourable, the necessary reserve of raw peat can be accumulated. This will not be injured in any way during the winter, since, when mixed and kneaded in machines, it regains its cohering and contracting powers. On the other hand, frost acts injuriously on freshly cut peat and freshly moulded peat or machine peat because frozen sods do not retain their power of cohering and contracting (pp. 65, 251, 265).

Every method of artificial drying is uneconomic so long as it is a matter, as is generally the case, of winning peat fuel, and peat litter or peat as a substitute for cheap materials for textiles, paste-board, artificial wood, artificial stones, &c. In this respect new experiments should be avoided even when the "new" drying process promises *technical* success, i.e., the plant is really able to turn out well-dehydrated or dry peat. As a commercial process, artificial drying is always *too dear*. The same may be said of a combination of artificial heating with air circulation (pp. 58, 82, 216, 268).

<sup>1</sup>Most of the official Bog Experimental Stations have stated that they are prepared to do this. With regard to the specimens to be sent for examination, attention should be paid to what was said on p. 283.

Dehydration of peat by compression, even when an electrical current is employed, is unscientific and does not lead to the goal desired. By strong compression, even with a pressure of 400 to 500 atmospheres for several hours, the percentage of water (85) in a peat could not be lowered below 63 (pp. 72, 85-89).

Compression of machine peat with a view to obtaining neat blocks of fuel similar to press coal is also too dear.

The fact that the artificial drying and the dehydration of peat by *wet* or *dry presses* with or without *electrical dehydration* are uneconomic is not affected in any way by the patenting of various contrivances or processes (mostly owing to some novel contrivance which has been found to be *technically* successful) (pp. 287-293).

The best raw material for peat fuel is black, humified peat, as dense as possible, while that intended for peat litter should be light-coloured fibrous or mossy peat of low density (pp. 260-266). As a fibre substitute for spinning and weaving materials, wadding, paper, paste-board, only peat containing a high percentage of humified cotton-grass (*Eriophorum vaginatum*) is a suitable raw material.

The simplest and as a rule the cheapest mode of winning is that of hand peat (p. 23 *et seq.*). Hand peat (cut, pulped, or moulded peat) is frequently good enough for ordinary household requirements. On account of its defects (p. 64), it is scarcely suitable as fuel for more or less large industrial furnaces and better-class dwelling houses, or for transport and trade on a large scale.

For winning large quantities of peat for conversion into peat litter or peat mull or for gasification (for gas engines, &c.) where it is not so essential to obtain a firm, dense product which can be improved by mixing and kneading and made suitable for transport over long distances, crumb peat winning and peat dust winning (pp. 35, 65) deserve attention. The same remark applies to the cut peat machines (p. 37) which have been recently constructed and which have done well in their trials.

For preparing a denser and better peat, capable of competing with brown coal and coal, only the uni- or multi-spiral peat-mixing machines and the machines required for the manufacture of machine-pulped peat or machine-formed peat, briefly termed machine peat, have proved successful, while the more recent fully automatic or large scale machines with dredgers and automatic sod spreaders are available for large installations, bog power stations, factories for the supply of fuel to railways in countries poor in coal, and the like (pp. 94-169).

With regard to the cost of winning machine peat, it should be noted that this cost varies within fairly wide limits according as the kind of machine used and the nature of the bog worked vary (see p. 227 *et seq.*). The average cost per metric ton of air-dry peat fuel calculated for the whole year's output is, owing to various industrial troubles which are still unavoidable in every industry, as a rule higher than the price per unit (metric ton) calculated from the actual output per hour or per day for even carefully conducted

experiments over a few days' systematic working (p. 229). Even in the case of large scale industries the average net cost per metric ton of air-dry peat fuel calculated from the output during the whole year is only in exceptional cases under 5M. (pp. 158, 160, 231).

Press peat can be made from peat by the aid of the contrivances (presses) used in the press coal manufacture in as good and neat a condition as that of the press coals from brown coal powder. Even years ago this operation offered no difficulties of a technical nature. Press peat is, however, as a rule *too dear* (p. 81), especially in districts in which press brown coal and press coal have succeeded in gaining a footing. These latter are usually more valuable and have a higher calorific power than press peat and are also well liked for heating purposes both in households and in factories. For this reason the installation of press peat factories and the manufacture of *press peat* are generally uneconomic. Only under quite definite conditions can the manufacture of press peat be taken into consideration. It always requires a large capital for plant and working expenses (pp. 79, 81).

To prevent the cost of production of the *press peat* being too heavily loaded by too short a time for amortization of the cost of the installation, the working life of a press peat factory must not be assumed as less than twenty years, and the bog must be sufficiently large and productive to last this period. Even with a single press industry having a yearly output of about 10,000 m. tons about 5 ha. of bog 2 m. in depth will be required per annum, so that altogether 100 ha. will be necessary, together with the corresponding amount of drying ground. Single press industries are, however, less remunerative than industries with several presses (p. 81).

In Germany and Scandinavia the few press peat factories which were working at the beginning of this century have all been shut down despite efforts, extending over many years, to keep them going (p. 83).

Only peat which is poor in ash is suitable for the winning of peat fuel. Peat containing more than 10 per cent. of ash can only in exceptional cases be utilized and sold in the market (p. 12). At the place of winning, and with low costs of manufacture, a peat rich in ash may be used in gas furnaces or for the production of power gas (see Part II).

For the manufacture of machine peat the machine must be carefully selected, taking into account the quality of the peat to be worked and the nature of the product, i.e., whether it is machine pulp or machine-formed peat (p. 94 or p. 136). Neither cheapness in the price of the machine nor its guaranteed output is the deciding factor.

The season for winning hand or machine peat may be assumed to be during the months from April to the end of July, i.e., lasting only 90 to 100 working days, while that for peat litter factories may be assumed to last up to 300 working days.

For winning for commercial purposes, the depth of the bog

should be at least 1 m. for hand peat and  $1\frac{1}{2}$  to 2 m. for machine peat. It is desirable to combine the winning of peat fuel with that of peat litter.

We should attach as much importance to the good condensing action of the machine, due to its thorough tearing, mixing, and kneading action (pp. 71, 113, 170-174, 241-254), as to its actual average output while operating in the bog to be worked during a run of at least one week's duration (pp. 226-229).

A peat machine which under the same conditions—with the same number of workmen, the same output per hour in cubic metres of formed peat, and the same or a somewhat higher consumption of power (fuel)—has a 5 per cent. greater condensing action and about a 5 per cent. greater average output during the week's working, shows in contrast to another machine having apparently the same output by volume a net gain of 10 per cent. in the total working expenses. This alone may frequently bring about the commercial success of the whole enterprise, especially when the increased output is associated with the better drainage of the bog (p. 245 *et seq.*).

The better the kneading and mixing action of a peat machine, the drier the peat from one and the same bog can be worked, the greater the output for the same expense, the less the machine peat splits and crumbles during drying (pp. 113, 170 *et seq.*, p. 243) and *the better is it able to withstand the action of rain during the first few days when drying on the ground.*

A big peat factory with several machines is more remunerative than a small factory with only one peat machine.

The driving of several peat machines in common from a single power-station (electrical) is to be preferred to driving them by separate engines (locomotive), both labour and capital being saved thereby (pp. 230-241).

In winning peat on a commercial scale, it is advisable, in order to lower the cost of production, to employ machines each of which has an output of at least 100 cb. m. of formed peat per day. When labour is scarce, it is desirable to install fully automatic or large scale machines (pp. 154-169, 230, 232-241).

The track and field railway system between the peat machine and the drying ground for the rapid transport of the loaded peat cars and for putting the unloaded peat cars again in the position required, has a great influence in preventing irregularity in the output of a machine peat factory (p. 203 *et seq.*). One should therefore visit, beforehand, successful large peat factories and also obtain expert advice. For large scale industries (bog power-stations) and for economizing labour, and therefore for decreasing the cost of winning, it is desirable to install peat-forming machines with peat dredgers and automatic sod spreaders. In this case careful selection should be made, taking into account the nature of the bog (whether it contains wood and roots) (p. 154 *et seq.*).

The installation capital required for the same output is, indeed, somewhat greater in the case of fully automatic machines than it is in that of ordinary peat machines, but, on the other hand, the



working expenses and the number of labourers required are smaller in the former case (pp. 230-239).

It is desirable when procuring new machines to obtain a guarantee not only of the mixing and condensing action but also of the minimum output of the peat machine under the given local conditions and including the maximum number of workmen and the maximum amount of power required, and to regard this guarantee as fulfilled only when it has been borne on trials of at least one week's duration at the given place. The question of a somewhat higher price for the machine cannot then arise. This average output during a more or less long working trial and the dry weight of the manufactured product are decisive factors in the success of the enterprise (pp. 157-169, 227, 230-254).

If a machine factory imposes the condition that its representative is to conduct the operations until the workmen have been trained and the average output of the machine mentioned in the agreement has been attained, it should, on the other hand, be required that these are to take place within a definite period from the date on which the machine is capable of starting operations, as otherwise if the machine does not satisfy the requirements the machine factory may refuse to take it back and to make restitution of any payments made on account. It is to be noted in this case that the working of one of these machines is of a satisfactory nature only when it does not demand too much skill from agricultural labourers and does not require too long a time to train them to carry out the operations. It is the business of the maker of the machine to so adapt it from the very start for the peat to be operated upon that the machine at the place in question will give even with ordinary labourers the output, promised and agreed upon, within a fixed period of time.

It is obvious that a machine which is to be delivered under conditions such as these will be more expensive than one delivered without such a guarantee. The experience of many years in peat factories is, however, in favour of obtaining such a guarantee.

So far as the product and the output from a machine are concerned in addition to the average output during at least a week's trial it is important to know (1) how much freshly formed peat (in cubic metres or in number of fully loaded boards) and (2) how many kilos of dry peat 10 or 100 cb. m. of the bog give, since the costs of winning and drying depend usually on the volume of the formed peat and the selling price on the weight of dry substance obtained.

It is desirable to manufacture peat litter and peat mull intended for sale, from light, mossy, and fibrous peat, the dry material of which has an absorptive power equal to at least eight times its own weight (p. 262).

We should be very careful, if not sceptical, when dealing with any "*recent*" or "*most recent invention*" in the peat world, even when this is "*patented*," as patenting is no proof of the commercial success of the discovery with which its industrial utilization is solely concerned. Whatever is suitable and applicable for the

winning of peat has been described in detail in the various sections of this book. Further developments or ideas, so far as they have been made the object of public recommendations and, therefore, of discussions in expert circles, have been duly considered in the corresponding sections. There are at present no other discoveries relating to the winning or the improvement of peat which are worthy of note and have at the same time undergone satisfactory trials. During the last twenty-five years not a single one of the many discoveries or inventions in the domain of peat winning has attained any considerable importance whatever or any success worth noting except the peat dredgers, which have already been mentioned and described in detail, the automatic sod spreaders or peat pulp distributors, and the cut peat machines.

Peat, like every other moist, fibrous, mouldable, compressible, loose, spongy, pulverulent, doughy, cohesive, miscible body, by the aid of machines (or suitable modifications thereof) employed for treating these substances, can be dehydrated, dried, have its fibres split up or removed, be compressed, partially or completely, smooth and neat, wet or dry, cold or warm, can be formed, thick or thin, solid or hollow, into plates, roofs, or bricks, be used to make paste-board, paper, or textiles, and be pressed into building wood or smooth, chocolate-coloured plates or blocks for the manufacture of ornaments. With the well-known artifices all this is, without further trouble, technically possible, but from the *commercial* standpoint these attempts and their *technical* possibility are of no value, as these products, owing to the nature of peat, are, as a rule, of too slight a value or are too dear in comparison with the corresponding products from the materials ordinarily and successfully employed in their manufacture—a competition in which the peat would be successful is, therefore, out of the question.

In any case, a peat discovery should be taken up only after very careful consideration and after procuring a statement of opinion from some independent expert consultant whom we know to have undoubtedly a deep knowledge of peat. Millions have already been invested in experiments on so-called “new solutions” of the peat problem and most recent peat inventions, and have been lost, even within the last ten years, *in spite of warnings by the author in the previous edition of this handbook (1904).*

## PART II

# THE UTILIZATION OF PEAT

### SECTION I

## THE UTILIZATION OF PEAT AS FUEL

### A.—General Remarks on Fuel and Combustion

#### 1.—On Fuel

IN every commercial fuel the only elements which function as heat producers are carbon and hydrogen; all the other constituents are of no advantage, and, moreover, require to be heated to the temperature of combustion without contributing anything to the heat evolved. Hence from the many substances which contain carbon and hydrogen those have been selected as fuel which contain the greatest amount of carbon or hydrogen, or carbon plus hydrogen, relative to the other constituents which injuriously affect combustion. So far at least as industry is concerned, almost the only body which fulfils this condition is plant fibre, which is composed of carbon, hydrogen, and oxygen in the ratio of 44·4, 6·2, and 49·4 per hundred parts by weight of the substance. This is employed either in the unchanged state as wood or in the form of its naturally humified products—peat, brown coal, or coal—or its carbonized or gasified products, coke and gas respectively.

These modifications or transformation products of plant fibres, which in industrial and domestic use are designated "*fuels*," contain more or less small amounts of sulphur derivatives which burn with evolution of heat, forming sulphur dioxide. They also contain incombustible, earthy constituents, which remain as *ashes* after the combustion and prejudicially affect the value of the fuel. The latter remark applies also to the combined sulphur, the products of combustion of which act injuriously upon any metallic surfaces with which they come in contact.

Combustion of these bodies can occur only by combination with the oxygen contained in the air admitted into the fire, since *all ordinary combustions* are merely *chemical interactions* between substances and oxygen. In every-day life a chemical combination is called a combustion only when it takes place with the evolution of a considerable amount of light and heat (fire).

In the combustion of plant fibre and its transformation products (fuel in general)—

The hydrogen burns to *water* by combining with eight times its weight of oxygen, and the carbon burns either to *carbon dioxide* when a sufficient amount of oxygen is present (complete

combustion), or to carbon monoxide when there is a deficiency in oxygen (incomplete combustion).

The weight of oxygen required for the combustion of every 3 g. of carbon is in the former case 8 g. and in the latter 4 g. Fuel generally consists of more or less large pieces, and, as it is only the surface of each piece that is in contact with the air, that is, therefore, the only place where combustion of the piece can occur. Gasification, however, takes place in the interior of the piece, owing to the heat developed at its surface. Combustible gases developed inside find their way out through splits or clefts originally present or formed by the bursting of the pieces. In this way they get into the fire, where they meet the oxygen of the added air, and reacting with this, burn with evolution of heat, making a by no means unimportant contribution to the combustion itself. As the results of gasification and incomplete combustion show, these gases consist of a mixture of carbon monoxide and hydrocarbons, and of greater or smaller amounts of sulphur dioxide and water vapour according to the percentages of sulphur and moisture in the fuel. The easily combustible hydrocarbons consist partly of so-called light carburetted hydrogen (marsh gas) and partly of heavy carburetted hydrogen (olefiant gas). When the gases formed in this manner ultimately burn in the fire they give the same final products—carbon dioxide and water—and produce the same heating effect as those obtained by direct combustion of the solid fuel.

The quantities of heat developed in the combustion of different fuels vary with the nature of the fuel. For purposes of comparison the heat developed is measured in *thermal units*, under which term we shall understand the amount of heat required to raise the temperature of 1 g. of water through 1° C. (1 calorie = c.).

(In finding the calorific powers of different fuels we determine the number of thermal units developed at 0° C. by the complete combustion of the different substances.)

According to the investigations of the physicists Favre and Silbermann, the heat developed in the combustion of—

	Calories.
Carbon to carbon dioxide is .. .. .	8,080
Carbon to carbon monoxide is .. .. .	2,473
Carbon monoxide to carbon dioxide is .. .. .	2,403
Hydrogen to water at 0° C. is .. .. .	34,462
Hydrogen to water vapour at 100° C. is .. .. .	29,000
Sulphur to sulphur dioxide is .. .. .	2,221
Sulphuretted hydrogen to sulphurous acid .. .. .	2,741

This means, for instance, that the heat developed by the combustion of 1 g. of carbon is able to raise the temperature of 8,080 g. of water through 1° C.

In the case of fuels which contain carbon, hydrogen and sulphur in different amounts, their calorific powers, i.e., the number of thermal units evolved by the combustion of unit weight of the fuel, can either be calculated (*calculated calorific power*) from the chemical composition of the fuel or determined by direct experiment in bomb calorimeters (*directly measured calorific power*).

In the first case it is assumed that *the amount of heat developed by the combustion of a compound is equal to the sum of the quantities of heat developed by the combustion of its separate components (carbon, "free hydrogen," sulphur)*. Here, however, it must be noted that the portion of the hydrogen which in the body may be regarded as combined with oxygen in the form of water, or rather which during combustion combines with the oxygen of the fuel forming "combined water" (i.e., one-eighth part of the weight of the oxygen in the fuel) is assumed to have no useful thermal effect, and, therefore, only the excess ("free hydrogen") of hydrogen above this amount is to be taken into account in the calculation of the calorific power. Accordingly the following formula, which is called the *Verbands formula*, or the modified Dulong formula, has been adopted for the calculation of the calorific powers of moist or air-dry fuels, for steam raising and for furnaces, by the German Engineering Society and the Union of Steam Boiler Superintendents:—

$$\text{The calorific power of a fuel} = 81 C + 290 \left( H - \frac{O}{8} \right) + 25 S - 6 W$$

where C, H, O, S, and W are the percentages of carbon, hydrogen, oxygen, sulphur, and water contained in the fuel. Hence, from the percentage composition of a given peat, or from that of a similar peat, the calorific power of a peat can be calculated within a degree of approximation sufficient for practical purposes. The heat actually developed during combustion (i.e., the directly measured calorific power) is about 5 per cent. greater than that calculated by means of the above formula. In case of necessity it is desirable to have the calorific power of a fuel determined by the Bog Experimental Stations or other public testing bureau. (Cf. also p. xviii.)

In these stations it has been the rule that calorific powers should be determined only by means of bomb calorimeters, therefore, the calculation of calorific powers from percentage compositions by means of formulæ which take into account certain corrections is not employed.<sup>1</sup>

In reports of such determinations the distinction between the terms "*heat of combustion*" or "*higher calorific power*" and "*lower or practical calorific power*" should be observed and clearly expressed.

## 2.—*Calorific Power per Unit Weight and per Unit Volume, and Temperature of Combustion*

The figures mentioned above, which give the amount of heat in thermal units that can be developed by the combustion of unit weight of a given fuel, are called the *calorific powers per unit weight* or the *absolute calorific powers*, in contradistinction to the *calorific power per unit volume* or *specific calorific power*, which is the number of thermal units developed by the combustion of unit

<sup>1</sup> Cf. *Mitteilungen*, 1910, No. 8.

volume of a fuel, and which can be calculated from the absolute calorific power by multiplying this by the density of the fuel.

In addition to these two we must also distinguish the *temperature of combustion* or the *pyrometric heat effect*, by which we mean the maximum temperature attained during the combustion of a substance in air at 0° C. and under normal barometric pressure.

The calorific powers obtained in accordance with the statements given above are simply the maximum values *calculated* or *measured* under the assumption that not even a trace of the heat developed in the combustion becomes lost by conduction or radiation to foreign bodies. In practice only 60 to 75 per cent. of the maximum or "higher calorific power" can be utilized owing to conduction by the walls of the fireplace, the impossibility of adding only the exact quantity of air necessary for the combustion and of preventing the heat from escaping with the products of the combustion. The amount of heat actually utilized in contradistinction to the calculated or measured maximum calorific power is called the *economic heat effect* or the *economic calorific power* of the fuel.

### 3.—Composition, Density, and Calculated Calorific Power of various Fuels

FUEL.	Carbon.	Free hydrogen.	Water.		Ash.	Density.	Calorific power of		Calculated temperature of combustion. Degrees Centigrade.
			Chemically combined.	Free.			Unit weight. Calories.	Unit volume. Calories.	
Wood, air-dry ..	40	—	39	20	1	—	3,232	—	—
Wood, half kiln-dry	45	—	44	10	1	{ 0.55— }	3,636	{ 1,800— }	1,790
Wood, kiln-dry ..	50	—	49	10	1	{ 0.80 }	4,040	{ 3,200 }	
Wood charcoal, air-dry	85	—	—	12	3	{ 0.15— 0.20* }	6,868	1,250	2,200
Wood charcoal, fully dried	97	—	—	—	3	—	7,837	1,500	2,450
Fibrous brown coal	45	1	29	20	5	{ 1.2 }	3,980	4,776	1,800
Earthy brown coal..	49	2	19	20	10	{ to }	4,648	5,600	1,975
Conchoidal brown coal	56	3	16	20	5	{ 1.3 }	5,557	7,224	2,050
Coal, non-caking ..	69	3	18	5	5	1.35	6,608	8,920	2,200
Cherry coal.. ..	75	4	11	5	5	1.30	7,438	9,670	2,250
Caking coal .. ..	78	4	8	5	5	1.25	7,680	9,600	2,300
Anthracite .. ..	90	3	2	3	2	1.50	8,305	2,457	2,350
Non-caked coke ..	{ 85 }	—	—	{ 5 }	{ 3 }	0.48	6,787	3,258	2,400
Cherry coke .. ..	{ to }	—	—	{ to }	{ to }	0.43	7,434	3,197	
Caked coke .. ..	{ 92 }	—	—	{ 10 }	{ 5 }	0.35	7,838	2,743	
Cut peat, ordinary..	42.5	1.5	26	25	5	{ 0.25 to 0.80 }	3,950	{ 987 to 3,160 }	1,720
Machine peat, air-dry	48	1.6	30.4	18	2	{ 0.80 to 1.20 }	4,430	{ 3,544 to 5,316 }	

\* In the powdered state it is 1.4 to 1.5.

The foregoing table contains the average chemical compositions, and the calorific powers calculated therefrom, of various fuels, and is intended to serve as a basis for the comparison of these fuels with the peats under consideration.

The following limits for the calorific powers are used for the comparison of various fuels, containing average percentages of moisture, by the directors of the more important Bog Experimental Stations :—

	Calories.
(1) Air-dry wood .. .. .	2,400–3,800
(2) Earthy brown coal .. .. .	1,500–3,400
(3) Press brown coal .. .. .	4,500–5,000
(4) Bohemian brown coal .. .. .	4,300–5,500
(5) Coal .. .. .	5,500–8,100
(6) Press coal.. .. .	6,200–7,600
(7) Coke .. .. .	5,900–7,500
(8) Peat charcoal .. .. .	7,300–7,600
(9) Wood charcoal .. .. .	6,900–7,500
(10) Good peat .. .. .	3,500–4,200
(11) Average peat .. .. .	2,800–3,500
(12) Mediocre peat .. .. .	2,000–2,800

## B.—Peat as Fuel

### 1.—*Calorific Power of Different Varieties of Peat and Influence of the mode of Winning on it*

By taking into account the figures given in the preceding tables as well as those in the tables on pp. 10 and 13 of Part I, it will be seen that peat when properly used will make a good fuel. Notwithstanding its very wide occurrence, peat is not generally used as a fuel, and in many districts it has either not been used at all or has been discontinued. The reasons for this are that the prices for wood and coal were too low in comparison with the cost of winning peat, and the better known, or, at least, the commoner peats—cut, stroked and dredged peat—had, owing to their low density, a low specific calorific power, and therefore only a small economic calorific power. Moreover, the low density and great friability of ordinary peat made it unsuitable for transport over long distances, so that its application as a fuel was confined to localities in the immediate neighbourhood of the places where it was won.

Owing to the low density of peat it was obvious that a large fireplace would be required for the combustion of a definite quantity of peat in a given time, and therefore that there would be an increase in the loss of heat in the firing, which loss could not in general be prevented. As this was combined with bad stoking arrangements and high percentages of water and ash in the peat, it can therefore be readily understood that industry, in order to save time and money, refrained from making protracted experiments with peat and resorted again to fuels such as wood and coal, which although more expensive were in all cases the more reliable.

The attempts to get rid of the above-mentioned defects of peat, to give it, by compression, a higher density and greater firmness and to remove its high percentage of water by artificial drying, generally led, as has been pointed out in Part I, to unfavourable

results. The products obtained by these methods—press peat (according to Exter and Gwynne) and kiln-dried peat—were found to be unable to compete with the other fuels when the costs of production were taken into consideration.

It was only when the prices of wood and coal had risen considerably and when we had learned how to manufacture, without big installation costs, a cheap and a better class fuel in the form of condensed machine peat, and had also learned, after the introduction of gas furnaces, how to burn with advantage a more or less poor peat, that we were obliged and were able to turn again to peat as a fuel. Since that time peat has been once more employed in industry and its use has extended from year to year.

The main requirements for favourable commercial results are the use of a peat—

- (1) As free from ash as possible.
- (2) As air-dry as possible.
- (3) As dense as possible (machine peat).
- (4) Suitable furnaces or a good gasification plant, especially when dealing with more or less moist and light "crumb" or "lump peat."

By not properly attending to any of these requirements, e.g., by examining the raw peat superficially or not at all, or by faulty drying contrivances, too short a drying period, faulty storing sheds, mistakes in the selection of the peat machine, or faulty arrangement of the furnace or gasification plant, a peat which may otherwise satisfy all the remaining conditions may become excluded from the group of commercially valuable fuels.

With regard to the first two points, the figures given further on show how disadvantageously the percentage of ash or water affects a peat which from its chemical composition would be classed as good, while the experiments on combustion mentioned there, together with actual experience extending over many years, show that a light, cut, or trodden peat is difficult to use in large furnaces with advantage and without prejudicially affecting the industry, and also that machine peat has a higher economic calorific power than hand peat made from the same raw material.

It is quite erroneous to suppose, as is sometimes done and as is sometimes stated in commendatory notices by peat machine manufacturers, that the calorific power of a given weight of a peat can be altered by the mode of winning or manufacturing the press or machine peat, and that it increases as the tearing up of the fibres and the mixing of the peat are the more thoroughly effected by the machines. The chemical composition, the percentages of carbon and hydrogen, on which alone the calorific power of a peat depends, cannot be altered by any machine nor can any machine decrease the percentage of ash in a peat. It is never possible, therefore, to make from an intrinsically poor peat by any machine, however good, "a fuel nearly as valuable as coal." The calorific powers of peat formed in the same way by one and the same machine are very variable and depend on the nature of the peat worked, but the absolute calorific power of 100 kilos of condensed



machine peat is exactly the same as that of 100 kilos of cut peat, if they are equally dry and are made from the same raw material.

Any change in calorific power which may occur refers only to that of the calorific power of unit volume and to the greater utilization of the calorific power of unit weight associated therewith. The objective of the machine peat industry is to increase the *efficiency* of a furnace fired with peat, and in addition to obtain a product with a smaller percentage of water by rendering it possible to dry the material more thoroughly and more certainly, as well as to make the formed peat transportable over long distances by increasing its firmness. Hence the statement "that the calorific power of a fuel increases with its density" is true only so far as the total unavoidable losses in a furnace due to radiation from the furnace walls, incomplete combustion, &c., decrease as the size of the fireplace decreases. The size of the fireplace is directly proportional to the total volume and inversely proportional to the density of the fuel. Hence the loss of heat from a fuel in an otherwise well-constructed furnace is all the smaller in comparison with its calculated calorific power the smaller it is possible to construct the furnace for a given amount of the fuel, i.e., the greater the density of the fuel, or, in the present case, *the greater the density of a machine peat, manufactured from a raw peat having a given composition, the greater its economic calorific power will be.*

This is a further reason why a peat-forming machine which aims at tearing up the fibres and mixing the peat as well as possible should be preferred to a simple forming machine when we want to get the best possible fuel for furnaces from a given raw peat.

The manner in which the density of machine peat, contrasted with that of cut peat from the same raw material, is affected by differences in the treatment of the peat in different machines is shown by the results of the author's experiments in Part I, pp. 243 and 246.

The calorific powers of different varieties of peat can be easily obtained with the aid of ultimate organic analysis, taking into account the principles set forth in the introduction to this section. Although the calculated values are only approximate, they are sufficiently accurate for all matters connected with the value and the utilization of different kinds of peat.

Professor Ritthausen calculates, for instance, for the varieties of peat examined by him, the compositions of which have been given in Part I, pp. 8-10, first the percentages of carbon and "free hydrogen," on which the development of heat depends, as follows :—

Peat No.	..	1	2	3	4	5	6
Carbon	..	43·61	45·16	44·33	45·86	41·02	46·83
Free hydrogen	..	0·68	0·85	0·79	0·83	1·30	1·17

and from these by means of Favre and Silbermann's calorific powers he calculates for the various peats :—

Peat No. ..	1	2	3	4	5	6
Calorific power ..	3,723	3,906	3,791	3,955	3,630	4,144 c.
Calorific power in round numbers	3,700	3,900	3,800	3,950	3,700	4,100 c.

Since experiment has shown that 652 c. are required to convert 1 g. of water at 0° C. into steam at 150° C. (at 4 atmospheres pressure), then the amounts of water which could be converted into steam at 150° C. by the combustion of 1 kilo of each of the various peats are :—

Peat No. ..	1	2	3	4	5	6
Water evaporated	5·67	5·98	5·22	6·05	5·67	6·59 kilos

In the cases of peats 5 and 6, the percentages of combustible matter in which do not differ much (Part I, p. 8), we can readily see how the percentage of ash affects the calorific power. Both peats should have almost the same calorific powers in the anhydrous, ash-free state ; owing, however, to the percentages of water and ash (11·92 in No. 5 and 5·18 in No. 6) in the samples the percentage of carbon in No. 5 is lowered to 41·02 and the calorific power of the peat to 3,700 c., while the carbon percentage of No. 6 is 46·83, and its calorific power is 4,100 c.

For this reason also the younger peats, Nos. 2 to 4, which contain very little ash, have higher calorific powers than the Waldau peat.

According to Dr. Victor Zailer<sup>1</sup> the average calorific power of the vegetable (organic) material in peat may be assumed as follows :—

Variety of Peat.	Calorific power.	
	Slightly humified.	Strongly humified.
	Calories.	Calories.
Reed .. .. .	5,000	Up to 5,500
Sedge or Carex .. .. .	5,200	.. 5,600
Hypnum .. .. .	4,900	.. 5,200
Alder or birch .. .. .	5,300	.. 5,700
Scheuchzeria and Eriophorum .. .. .	5,200	.. 5,500 & over
Sphagnum .. .. .	4,400	.. 5,400
Heather .. .. .	4,600	.. 5,200
Liver .. .. .	5,100	.. 5,800

<sup>1</sup> *Mitteilungen*, 1908, p. 40.

Results of detailed experiments on the calorific powers of various peats have also been published<sup>1</sup> by Dr. von Feilitzen (Jönköping). They refer to 57 specimens from various districts of Sweden, of which 2 were cut peat, 1 dough peat, 9 (machine) mud or pulp peat, and 45 machine peat. Of these samples:—

- 56 per cent. consisted of Sphagnum peat, containing in the anhydrous state 3·86 per cent. of ash.
- 15 per cent. consisted of Hypnum peat, the ash content of which is unknown.
- 65 per cent. consisted of Eriophorum peat, containing in the anhydrous state 3·31 per cent. of ash.
- 20 per cent. consisted of bog-wood peat, containing in the anhydrous state 6·78 per cent. of ash.
- 33 per cent. consisted of grass peat, containing in the anhydrous state 5·62 per cent. of ash.
- 16 per cent. consisted of reed peat, containing in the anhydrous state 5·13 per cent. of ash.

The average percentage of ash in the anhydrous samples was 4·59. The average calorific power of the specimens was:—

	Calories.
Anhydrous, ash-free .. .. .	5,526
Anhydrous .. .. .	5,266
Air-dry, with 27·17 per cent. of moisture ..	3,463
Air-dry, with 25 per cent. of moisture (calculated) ..	3,531

The average density of the finished products was 0·74.

At the Bog Experimental Station near Bremen, Dr. H. Minsen examined 51 different specimens of peat in a calorimetric bomb and obtained the results given below. According to the chemical analyses the compositions of the anhydrous, ash-free peats were:—

Percentage of	In the whole of the 51 specimens.			In the 44 low bog peats.			In the 7 high bog peats.		
	From	to	Average.	From	to	Average.	From	to	Average.
Carbon ..	50·16	60·10	56·14	50·16	60·10	56·00	55·38	58·88	57·02
Hydrogen ..	4·44	5·86	5·44	4·44	5·86	5·43	5·10	5·83	5·50
Oxygen ..	30·61	39·41	34·19	30·61	39·41	33·90	33·46	38·03	36·09

And the calorific powers found by means of the bomb varied for the anhydrous specimens, which had very different percentages of ash, approximately from 3,000 to 5,000 c.<sup>2</sup> It may be assumed, therefore, that the calorific power of the best German peats in the ash-free, anhydrous condition is about 5,200 c. (rarely more), or, including the ash, about 5,100 c., and in the air-dry state, with 20 per cent. of moisture, it is about 4,000 c.

<sup>1</sup> *Mitteilungen*, 1905, v, p. 156 *et seq.*

<sup>2</sup> For further particulars with regard to the mode of carrying out these experiments and their results, as well as for the origin, age, consistency, and chemical composition of the various samples of peat investigated, see *Mitteilungen*, 1907, p. 335.

2.—*Influence of the Percentages of Moisture and Ash on the Calorific Power of Peat*

How unfavourably a more or less high percentage of ash or water affects the calorific power in the case of one and the same peat or of different peats containing equal amounts of combustible material, may be seen still more clearly from the following figures.

If we suppose that the combustible portion of different kinds of peat has an average composition of, let us say, 60 per cent. of carbon, 2 per cent. of free hydrogen, and 38 per cent. of "chemically bound" water, then its combustion should give in the following cases :—

	Calorific power.	Temperature of combustion.*
	Calories.	
Anhydrous peat without ash . . . .	5,440	2,210° C.
" " with 4 p.c. ash . . . .	5,222	2,200° C.
" " " 12 p.c. " . . . .	4,787	2,180° C.
" " " 30 p.c. " . . . .	3,808	2,150° C.
Peat with 25 p.c. moisture . . . .	3,930	2,000° C.
" " 15 p.c. ash & 0 p.c. moisture	4,624	1,976° C.
" " 0 p.c. " 25 p.c. " . . . .	3,930	1,750° C.
" " 10 p.c. " 30 p.c. " . . . .	3,084	1,575° C.

\* The temperatures of combustion are not consistent with one another and are obviously incorrectly calculated.—TRANSLATOR.

Dr. G. Minsen states, as a result of his calorific power determinations, that the decrease in the calorific power is not proportional to the increase in the percentage of ash, the calorific power decreasing somewhat more rapidly (and, indeed, in a fairly regular manner) than the percentage of ash increases. He calculates the calorific power for peat, the ash-free, dry matter of which has a calorific power  $H_w$ , and which, in the anhydrous state contains  $a$  per cent. of ash, from the following formula, which he has found to be generally applicable :—

Calorific power of anhydrous peat containing ash ( $a$ )

$$= \frac{(100-a)(H_w-10a)}{100}$$

Since it is chiefly the percentage of moisture which causes a diminution in the calorific power of a peat, it will be seen how important it is to employ in the winning of peat every means by which the amount of water can be decreased or removed without great expense. It has been sufficiently emphasized in Part I of this book that this is best effected by working the peat in tearing machines, destroying the cohesion of the plant fibres, setting them free, and intimately mixing the whole mass. In this way machine peat, no matter how it has been moulded, dries with greater certainty, and at the same time it loses, at least to a large extent, the property cut peat possesses of absorbing water from

moist air after drying. Whenever possible the drying is to be facilitated by installing drying sheds and by storing the peat in dry situations.

The *evaporating powers* of various peats, the calorific powers of which have been calculated or measured, can be obtained for commercial purposes as follows :—

If, for instance, the calorific power of a peat fuel is 4,250 c., then this is to be divided by 652, since 652 c. are required to change 1 g. of water at 0° C. into steam at 150° C. (corresponding to a pressure of 4 to 5 atmospheres). The calculated evaporating power of the above peat is therefore :—

$$\frac{4250}{652} = 6.5$$

i.e., 1 kilo of the above peat is theoretically sufficient to convert 6.5 kilos of water into steam at 150° C.

Owing to unavoidable losses, the calculated amount of steam is never obtained in furnaces actually constructed, and even when these are well designed only  $\frac{2}{3}$  to  $\frac{3}{4}$  of the calculated quantity is obtained.

With 1 kilo of average air-dry machine peat (containing 5 per cent. of ash and 15 per cent. of moisture) ( $\frac{2}{3}$  to  $\frac{3}{4}$ ) x 6.4 = 4.2 to 4.8 kilos of water can actually be evaporated.

In order to make it possible to institute a comparison in this respect between peat and other fuels, the following table contains the evaporating powers actually determined in many carefully conducted experiments with various fuels in well-constructed furnaces :—

PRACTICAL EVAPORATING POWERS OF VARIOUS FUELS.

1 kilo of air-dry	Water evaporated in kilos.
Wood .. .. .	3.0-3.4
Brown coal .. .. .	3.5-4.9
„ „ Bohemian .. .. .	4.5-6.0
Cut peat .. .. .	2.8-4.0
Machine peat .. .. .	4.5-5.0
Coal, poor .. .. .	4.0-6.0
„ medium .. .. .	6.0-7.0
„ best .. .. .	7.0-8.0
Coke, with 15 per cent. of ash .. .. .	5.0-6.0

In trials which were carried out many years ago, with great care and under conditions as comparable as possible, at the instigation of the Bavarian State Railway Department, nearly equal amounts of water were evaporated by means of various coals, peat, and wood on the same grate and with the same strength of draught. The trials lasted for several hours, and in most cases were made in duplicate.

The results obtained were as follows:—

Fuel.	Percentage of		Kilos of water evaporated by 1 kilo of the fuel.	Weight in kilos of 1 cb. m. of the loosely packed fuel.
	Moisture.	Ash.		
Steam coal .. .. .	—	15·00	8·00	933·8
Saxon coal .. .. .	11·6	10·00	6·34	787·5
Bohemian brown coal ..	—	9·86	6·59	759·4
Miesbach coal .. .. .	4·8	9·25	5·19	817·6
Traunthal brown coal ..	12·20	5·78	3·88	576·9
Haspelmoor press peat ..	16·20	5·30	4·07	633·4
Kolbermoor press peat ..	12·00			
Lodron's "sausage peat" ..	20·00	2·71	3·86	281·3
Eichhorn's "ball peat" ..	15·50			
Karolinenfeld cut peat ..	18·66	3·0	4·10	245·3
Burgau cut peat .. .. .	13·60			
Aitrang cut peat .. .. .	17·10	3·0	4·10	319·5
Olching cut peat .. .. .	29·70			
Lochhaus cut peat .. .. .	15·00	3·0	4·10	183·0
Pine wood .. .. .	8·70			
		0·4	3·88	207·0
				351·5

If the evaporating power (6·34) of Zwickau coal be taken as the average value for the better-class coals, and if that of air-dry peat, containing up to 5 per cent. of ash, be assumed to be on the average 4·1, then, according to the results of the above trials, so far as heating value is concerned—

100 kilos of coal =	79·2 kilos of steam coal.
	= 96·2 kilos of Bohemian brown coal.
	= 122·0 kilos of Miesbach coal.
	= 163·0 kilos of Traunthal brown coal.
	= 154·0 kilos of peat.
	= 163·4 kilos of pine wood.
or 100 kilos of peat =	51·5 kilos of steam coal.
	= 64·7 kilos of Saxon coal.
	= 62·2 kilos of Bohemian coal.
	= 79·0 kilos of Miesbach coal.
	= 106·0 kilos of Traunthal brown coal.
	= 106·0 kilos of pine wood.

The following results of experiments, which were made at the Imperial Dockyards at Wilhelmshaven at the request of the Oldenburg Railway Department with reference to the possibility

of utilizing the peats (press, machine, and cut) which had been won from the bog near the Hunte-Ems Canal and had been employed in trial journeys on the railway, are also worthy of notice :—

Fuel.	1 cb. m. broken up weighed. Kilos	Quantity burnt in experiment. Kilos	Ash Per cent.	Quantity burnt per hour per sq.m. grate area. Kilos	Water evaporated from 0° C.		Temperature of flue gases.  Degrees Centigrade
					Per hour per sq.m. grate area. Kilos	Per kilo of fuel. Kilos	
1. Press peat* (Lauwer's briquettes), moisture 5 per cent.	580	3,300	7·83	164	601	3·66	250-350
2. Machine peat (Ruschmann, Varel), moisture 9·03 per cent.	432	3,200	4·09	165	670	4·05	280-370
3. Cut peat from the Wehne bog, moisture 18·83 per cent.	240	3,470	0·99	164	605	3·68	280-370
4. Bituminous coal (Central mine)	752	2,100	5·64	96	837	8·69	—

\* The press peat employed by the Oldenburg Railway Department in their locomotive heating trials in December, 1900, was made from peat from the same bog as that from which the cut peat given under 3 was obtained (cf. the section on the utilization of peat in the railway industry.)

### 3.—Commercial Values of Peats containing Different Percentages of Water and Ash. Comparison of these Values with those of other Fuels.

The figures given in the preceding table may also serve for the determination of the selling or the buying price of a peat having a known evaporating power when the price and the calorific power of another fuel are known, inasmuch as the prices of equal weights of different fuels must be in the same ratio as their evaporating powers if the fuels are to be equivalent for the working of a furnace.

It may very easily happen that a business man who meets his peat requirements by purchase from a single peat works may require to calculate what the selling price of one and the same peat with a different percentage of water will be when its price with a given percentage of water is known. In this calculation we must take into account not only the solid matter of the peat, which is smaller in the wetter peat than it is in the same weight of the drier substance, but also the loss of heat due to the necessity for evaporating the excess of water present in the wetter material.

If, for instance, the price of an air-dry machine peat with 15 per cent. of moisture has been agreed upon and if the seller owing, let us say, to an insufficient stock of air-dry peat delivers a peat containing 25 per cent. of moisture, then 100 kilos of the latter body

will not only contain 10 kilos of peat less (instead of 85 kilos only 75 kilos of anhydrous peat, corresponding to a loss of 11·8 per cent. of the anhydrous peat and, therefore, to a decrease in the price of 11·8 per cent.), but also in the case of the wetter fuel the heat of the air-dry peat which is required to evaporate the extra 10 kilos of water present, i.e.,  $10 \times 640 = 6,400$  kilo-calories, will become wasted so far as useful evaporation (steam-raising) is concerned.

If the known evaporating power of the air-dry peat (containing 15 per cent. of moisture) contracted for were “ $n$ ” and if 100 kilos of the peat cost “ $K$ ” Marks, then the equivalent price “ $K_1$ ” of a peat won from the same bog, but containing 25 per cent. of moisture, would be given by:—

$$K_1 = \frac{88 \cdot 2}{100} K - \frac{640 \times 10}{100 \times n \times 652} K = K (0 \cdot 882 - \frac{640}{n \times 6520})$$

$$\text{or, if } \frac{640}{6520} \text{ be assumed equal to } \frac{1}{10}, K_1 = K (0 \cdot 882 - \frac{1}{10n}).$$

The formula shows that the loss during the combustion due to the evaporation of the excess water is all the greater the smaller the calorific power of the peat. While, for example, in the case of a machine peat, which in the air-dry state may have an evaporating power of 5·0, the value of  $\frac{1}{10n}$  corresponding to this is  $\frac{1}{50}$ , or 2 per cent., in the case of a poorer cut peat with an evaporating power of 3 the loss is  $\frac{1}{10n} = \frac{1}{30} = 3\frac{1}{3}$  per cent.

Hence, in the former case the contract price must be lowered by 11·8 plus 2 = 13·8 per cent., and in the latter by 11·8 plus 3·33 = 15·13 per cent.

From this we see once more what effect water in a peat has on the value of the peat and how important it is on the one hand to get rid of the water as much as possible and on the other to take it into account when purchasing peat.

The inconvenience and the difficulty hitherto assumed to exist in the correct determination of the percentage of moisture in a given sample of peat and in the selling price which is calculated therefrom have in various districts given rise to the custom of selling and buying peat not by weight but by volume, and, indeed, either according to a definite unit of volume (a vat, cord, or clamp, &c.<sup>1</sup>) or “per thousand” sods manufactured in definite sizes. In this case, however, we make the still greater mistake of paying most for the lightest and least valuable kind of peat at the same time receiving a much less valuable fuel, which contains a more or less high percentage of moisture and with which the value will vary, than that obtained when the peat fuel is purchased in the air-dry state. In addition to the loss of calorific power mentioned above due to the evaporation of

<sup>1</sup> 1 cord =  $\frac{1}{3}$  clamp = 80 vats = 108 cb. ft. =  $3\frac{1}{2}$  cb. m.; it contains 72 per cent. of peat and 28 per cent. of intervening space. 1 barrel (Austrian) = 3 hl. and 1 ster = 1 cb. m. including intervening spaces.



the excess water contained in a moist peat (which, however, can be avoided by prolonged storing) one receives and pays for in the moist peat (containing about 25 to 30 per cent. of moisture) 15 per cent. more volume than the same mass of peat would have when air-dry. Hence, for the same price we get 15 per cent. less useful fuel, since every incompletely dried peat has a larger volume, corresponding to its greater content of moisture, and, therefore, equal volumes of fuel peats may contain very different weights of fuel owing to differences in their degrees of dryness, notwithstanding the fact that the peats may have been obtained from one and the same bog. For an exact determination of the calorific power of a peat and for taking this into account in calculating the value of the fuel, knowledge of the percentage of water is not less necessary when the peat is sold by volume than it is for the case where the purchase of peat takes place by weight. Since, moreover, in the sale of peat by volume or by number of sods it is very difficult to ensure that the correct volume is received, and the whole process being, therefore, haphazard and inconvenient, it does not afford the purchasers as good a basis for judging the wares acquired by them as that given by the sale of peat by weight. In the former case, in order to be able to form an approximate idea as to the fuel value of a clamp or a "thousand" of peat the weight of this unit must first be determined. This mode of sale would make the bog-owners direct their attention mainly not to a product which would be as dense and as uniform as possible, but to a light, formed peat possessing more or less the defective properties of ordinary, light, cut peat, and would, therefore, *not* be suitable for introduction into the machine peat industry.

For these reasons it is advisable that the sale of peat should, in general, take place *only* by weight. The same conclusion also follows from considerations regarding the utilization of peat. For several years past it has been sold in this way in Hanover, Oldenburg, Bremen, and the adjoining peat districts. In the wholesale trade a procedure has been introduced which consists of taking into account the percentages of moisture in different peats by means of a variable deduction from the contract price, which, but in somewhat more exact form, is worth attention.

In this case an agreement for the delivery of an air-dry peat at a fixed price per 100 kilos is concluded between the seller and the purchaser. At every delivery, however, a number of test sods are broken, and by eye and touch (?) it is shown that either the peat is up to the standard or that it contains a higher percentage of water than that agreed upon. In the latter case a small, or big, deduction is made by agreement from the contract price.

No objection would be raised to the suitability of this procedure if the determination of the percentage of water were more exactly carried out, and this indeed could always be done without great inconvenience by any seller or purchaser of peat.

In every household, in every industry, there is a heating place or fireplace (baking tubes, frying tubes, oven, stove, boiler cover, &c.), in which (after fixing a movable false bottom, or the like,

to prevent charring) the artificial drying (kiln-drying) of small quantities of peat can be carried out (in factories which use large quantities of fuel it would be advisable to procure a small drying oven, or the like, for this purpose). If we select several pieces (about ten) from various parts of a large clamp of peat, the percentage of water in which is to be estimated, weigh these on not too rough a balance, dry them artificially, for which generally twelve hours and in all cases twenty-four hours will be sufficient, as the drying can be facilitated by breaking up the pieces, and then determine the weight of the dried pieces; anyone, with the aid of a simple calculation from these two weights, can find in every case the percentage of moisture in the test pieces, and therefore the average percentage of moisture in the whole amount of the peat in question. This can be done in a relatively short time, and with as much accuracy and certainty as is desired for the required purpose, i.e., to allow for the effect of moisture on the selling price and the calorific power of the peat.

Since the difference between the two weighings corresponds to the moisture which was originally in the test pieces, the weight of water in 100 parts of the peat, or in other words the percentage of water  $W$  in the peat, is given by the formula:—

$$W = \frac{(G - g) 100}{G},$$

where  $G$  is the original weight, and  $g$  the weight when dried, of the pieces of peat.

In other words, the percentage of water in peat is obtained when the product of 100 by the difference between the weights of a given amount of peat in its undried and dried states is divided by the weight of the undried peat.

If, for instance, 10 test pieces from a clamp weighed 7·40 kilos before and 5·55 kilos after drying in an oven, the water which was contained in them was 7·40—5·55 kilos, and the percentages of water was therefore:—

$$\frac{1 \cdot 85 \times 10}{7 \cdot 40} = \frac{185}{7 \cdot 4} = 25 \text{ per cent.}$$

In more or less large households and furnace installations where the payments for peat as fuel form large items, such a regular testing of peat about to be purchased for its percentage of water and the slight trouble connected therewith will quickly pay for itself, when the selling price for a given kind of peat is corrected according to the rules mentioned in this section, or when, by taking into account the prices and the percentages of water, the most valuable kind is found from amongst several samples tendered.

Similar investigations should be made with reference to the percentage of ash in peats and these should also be considered when fixing prices. In this case, however, the matter is simpler, inasmuch as this test for peat, especially machine peat from one and the same peat works, requires only to be made *once*, since we may assume that the percentage of ash in peat from one and the

same layer is constant within certain limits. It can be easily estimated by burning the peat, and as a rule will have been already determined in, and known from, earlier experiments on occasions when the same peat was already used.

### C.—Design and Construction of Fireplaces suitable for Burning Hand Peat and Machine Peat

#### 1.—On the Air necessary for Combustion and on the Flue Gases

It is necessary to indicate how the furnaces employed for the combustion of cut, stroked, and machine peat are constructed so as to combine the best utilization of the calorific power of a peat, corresponding to its chemical composition, with as careful as possible a preparation and drying of the substance.

It has been mentioned already in the introduction to this section that the oxygen of the air is always employed for the combustion of the carbon and hydrogen contained in the fuel, the carbon being burnt to carbon monoxide or carbon dioxide, and the hydrogen to water vapour. The combustion gases, together with the nitrogen of the added air (four-fifths of which is nitrogen), acquire a high temperature and escape as the so-called "*flue gases*" when they have given most of their heat to objects (steam boiler, oven walls, &c.) on which they impinge. The aim of a furnace is to so regulate the addition of the air necessary for the combustion and the withdrawal of the combustion gases according to definite empirical principles, which vary with the fuel and the use to which the furnace is being put, that the greatest possible useful effect may result from a given amount of fuel.

The most important parts of such a plant, i.e., fireplace, grate or hearth, ash-pit, flues and chimney, depend as regards shape and size not only on the amount of fuel to be burnt in a given time, but also on the most suitable amount of air to be added for the combustion.

The amount of fuel required in a given time for a furnace is determined by experience extending over many years in the various industries, according to the work to be done by the furnace (e.g., in boiler installations according to the amount of water to be evaporated per hour, in brick kilns according to the number of bricks to be burnt, in drying and heating installations according to the number of cubic metres in the room to be heated, &c.). At the same time, the exact amount of air necessary for the complete combustion of a fuel can be calculated from the chemical composition of the fuel and the amount of the flue gases to be led away through the chimney, from that of the added air, the chemical composition and the temperature of the gaseous combustion products.

Experience shows, however, that the calculated (theoretical) quantity of air is in reality never sufficient for the complete combustion of the fuel. The distribution of the air in the first place

## AMOUNT OF AIR NECESSARY FOR BURNING 1 KILO OF VARIOUS FUELS,

FUEL.	Amount of			The carbon			The
	Carbon.	Free Hydrogen.	Chemically bound water and moisture	requires	and gives		requires
				oxygen	therewith		oxygen
	$\frac{a \times 16}{6}$	carbon dioxide.*		$8 \times b$ .			
kilos.	kilos.	kilos.	kilos.	kilos.	kilos.	kilos.	
<i>a</i>	<i>b</i>	<i>c</i>	<i>d</i>	<i>e</i>	<i>f</i>	<i>g</i>	
Wood, air-dry, with 20 p.c. of moisture ..	0·40	—	0·59	1·067	1·467	0·742	—
Wood, half kiln-dried, with 10 p.c. of moisture	0·45	—	0·54	1·200	1·650	0·835	—
Wood, anhydrous .. .. .	0·50	—	0·49	1·333	1·833	0·927	—
Wood charcoal, air-dry, with 12 p.c. of moisture	0·85	—	0·12	2·267	3·117	1·577	—
Wood charcoal, anhydrous .. .. .	0·97	—	—	2·553	3·523	1·783	—
Brown coal, fibrous, with 20 p.c. of moisture..	0·45	0·01	0·49	1·200	1·650	0·835	0·080
Brown coal, earthy, as last .. .. .	0·49	0·02	0·39	1·307	1·797	0·909	0·160
Brown coal, conchoidal, with 20 p.c. of moisture	0·56	0·03	0·36	1·493	2·053	1·039	0·240
Non-caking coal with 5 p.c. of water ..	0·69	0·03	0·23	1·840	2·530	1·280	0·240
Cherry coal .. .. .	0·75	0·04	0·16	2·000	2·750	1·392	0·320
Caking coal .. .. .	0·78	0·04	0·13	2·080	2·860	1·447	0·320
Anthracite .. .. .	0·90	0·03	0·05	2·400	3·300	1·670	0·240
Non-caked coke .. .. .	} 0·85	—	0·05	2·270	3·120	1·579	—
Cherry coke .. .. .		to	to	to	to	to	.
Coke .. .. .		0·92	0·10	2·450	3·370	1·705	—
Cut peat, air-dry, with 25 p.c. of water ..	0·42	0·014	0·51	1·120	1·530	0·774	0·112
Machine peat, air-dry, with 18 p.c. of water..	0·465	—	0·47	1·240	1·705	0·863	0·120
Anhydrous peat .. .. .	0·57	0·02	0·63	1·520	2·090	1·058	0·160
Peat charcoal .. .. .	0·90	0·015	0·05	2·400	3·300	1·670	—

\* 1 cb. m. of carbon dioxide weighs 1·978 kilos.

† 1 cb. m. of water vapour weighs 0·803 kilo.

## AMOUNT OF THE GASEOUS PRODUCTS FROM THE COMBUSTIONS.

free hydrogen and gives therewith water vapour.†		Hence total oxygen‡		Nitrogen§ present with the oxygen in the added air.		Hence total theoretical amount of air.¶		Water vapour formed from moisture in the fuel.		Total volume of gases formed in the combustion by addition of the theoretical amount of air.		Total volume of gases formed in the combustion by addition of double the theoretical amount of air.	
<i>d + g</i>		<i>d + g</i>								<i>f + i + n + r</i>		<i>f + i + n + r + p</i>	
kilos.	cb. m.	kilos.	cb. m.	kilos.	cb. m.	kilos.	cb. m.	kilos.	cb. m.	at 0° C.	at 300° C.	at 0° C.	at 300° C.
<i>h</i>	<i>i</i>	<i>k</i>	<i>l</i>	<i>m</i>	<i>n</i>	<i>o</i>	<i>p</i>	<i>q</i>	<i>r</i>	<i>s</i>	<i>t</i>	<i>u</i>	<i>v</i>
—	—	1·067	0·748	3·552	2·812	4·619	3·560	0·59	0·735	4·289	9·007	7·849	16·483
—	—	1·200	0·840	3·989	3·158	5·189	3·998	0·54	0·672	5·496	11·542	9·494	19·937
—	—	1·333	0·933	4·431	3·508	5·764	4·441	0·49	0·610	5·045	10·595	9·486	19·921
—	—	2·267	1·587	7·529	5·967	9·796	7·554	0·12	0·149	7·693	16·155	15·247	32·019
—	—	2·553	1·787	8·486	6·719	11·039	8·506	—	—	8·502	17·845	17·008	35·717
0·090	0·112	1·280	0·896	4·255	3·369	5·535	4·265	0·49	0·610	4·926	10·345	9·191	19·301
0·180	0·224	1·467	1·027	4·876	3·861	6·343	4·888	0·39	0·486	5·480	11·508	10·368	21·773
0·270	0·336	1·733	1·213	5·761	4·561	7·494	5·774	0·36	0·448	6·384	13·406	12·158	25·532
0·270	0·336	2·080	1·456	6·915	5·475	8·995	6·931	0·23	0·286	7·377	15·492	14·308	30·047
0·360	0·448	2·320	1·624	7·712	6·106	10·032	7·730	0·16	0·199	8·145	17·105	15·875	33·338
0·360	0·448	2·400	1·680	7·978	6·317	10·378	7·997	0·13	0·162	8·374	17·585	16·371	34·379
0·270	0·336	2·640	1·848	8·775	6·948	11·415	8·796	0·05	0·062	9·016	18·934	17·812	37·405
—	—	2·270	1·589	7·536	5·975	9·806	7·564	0·05	0·062	7·616	15·994	15·180	31·878
—	—	to	to	to	to	to	to	to	to	to	to	to	to
—	—	2·450	1·715	8·144	6·448	10·594	8·163	0·10	0·124	8·277	17·382	16·440	34·524
0·126	0·157	1·132	0·862	4·093	3·241	5·325	4·103	0·51	0·635	4·807	10·095	8·910	18·711
0·135	0·168	1·360	0·952	4·522	3·580	5·882	4·532	0·47	0·585	5·196	10·912	9·728	20·429
0·180	0·224	1·680	1·176	5·585	4·422	7·265	5·598	0·36	0·448	6·152	12·919	11·750	24·675
—	—	2·400	1·680	7·978	6·317	10·378	7·997	0·05	0·062	8·049	16·901	16·046	33·697

‡ 1 cb. m. of oxygen weighs 1·427 kilos.

§ 1 cb. m. of nitrogen weighs 1·263 kilos.

¶ 1 cb. m. of air weighs 1·294 kilos at 0° C. and 760 m.m.p.

is not good enough, and the velocity of the current of air through the fuel is too great, to allow of every particle of air coming into such intimate contact with the fuel that every particle of oxygen in the air can contribute to the combustion of a particle of fuel. It is assumed, therefore, that the amount of air which must be added through the hearth for the complete combustion of a given amount of fuel is *double* the theoretical quantity.

The calculated amount of air required for the complete combustion of a kilogram of peat is 4 cb. m., but in practice it would be necessary to add double this amount, i.e., 8 cb. m. of air per kilogram of peat.

In the preceding table are given the amounts of air required for combustion and also the amounts of flue gases formed in the cases of peat and other fuels. A comparison of these shows how they vary for different fuels. It follows from the figures that a furnace in which coal, brown coal, or the like has been hitherto burnt with good results under given conditions of draught and arrangement of fireplace may not, without alteration of the conditions for draught, be employed for the advantageous combustion of peat.

## 2.—*Grate, Height of Layer of Fuel, and Shape of the Fire Chamber*

As everyone knows, the objects for which a grate is intended are to receive layers of the fuel, to be burnt in a given time, of a suitable height and as uniform as possible, to admit enough air for the combustion, and during the combustion to separate the residual ashes from the still active fuel. As a rule a grate consists of a number of firebars lying close to one another. The surface of the grate—the *total grate area*—corresponds to the first of the above-mentioned objects, while the sum of the areas of the clefts between every two bars—the *free grate area*—corresponds to the last two objects.

The *total grate area* depends upon the amount of fuel to be burnt in a given time, and, indeed, it may be assumed that in general the combustion of 100 kilos of fuel will require a total grate area equal to 1 to 2 sq. m. in the case of peat, 1.5 sq. m. for coal, and 1.2 to 1.4 sq. m. for brown coal. The most convenient height of the layer of fuel in a furnace is 20 to 25 cm. for peat, while for coals it should be smaller, as a matter of fact, 15 cm. for brown coal and 10 to 12 cm. for ordinary coal. For a given fuel the combustion takes place the more rapidly but the less completely the deeper the layer of the fuel.

Adjustment of the *free grate area* is regarded by many as the chief means of controlling the amount of air to be admitted for the advantageous combustion of a fuel. While taking into account the figures given in the above table they recommend making the free grate areas for the different fuels definite fractions of the total grate areas. This fraction is, as a rule, to be  $\frac{1}{6}$  to  $\frac{1}{5}$  for peat-firing,  $\frac{1}{5}$  to  $\frac{1}{3}$  for brown coals, and  $\frac{1}{4}$  to  $\frac{1}{3}$  for coals. On the other hand, very good results have always been obtained by regulating the

amount of air admitted by means of a damper, i.e., a smoke slide-valve set in the flue between the furnace and the chimney. The latter is the better way of regulating the air, since the width of the spaces between the bars of a fireplace depends mainly on the character of the fuel, while the thickness of the bars, so far as regards their strength and manufacture, depends on the length of the hearth, and at the same time the free grate area for advantageous combustion of *every* fuel, and, therefore, the width of the spaces between the bars, is to be made as large as possible, i.e., as wide as the fuel in question will allow, so that admission of the air to the fuel spread on the grate may be as little impeded as possible. The free grate area, therefore, varies with the character of the fuel while the bars must at the same time be made as thin as possible.

If the general rule given above were to be observed in the construction of fireplaces it would lead us, especially in the case of peat furnaces, to dimensions that would be almost impossible, and certainly disadvantageous so far as good combustion is concerned. Peat varies a good deal in its percentage of ash, and this, in turn, varies considerably in character. Sometimes the ash, being light and finely divided, falls through the spaces between the bars, and at others, being more compact, blocks the openings in the grate. The peat is used sometimes in the form of mould, sometimes as crumby, light cut peat, sometimes as firm, dense machine peat. Hence, in designing the grate and in determining the free grate area, i.e., the width of the spaces between the bars, more attention must be paid to the peculiarities of the material to be burnt in the case of peat than in that of any other fuel. Many kinds of peat, especially when in the form of condensed machine peat, retain to some extent their sod shape during combustion and fall into powdery ashes only when all the combustible constituents have burnt away. It is necessary, therefore, especially in the case of peat rich in ash, to make certain that the spaces between the bars are large enough to allow the ashes to escape from the furnace and the air required for combustion to enter it. Boiler furnaces for peat such as this may, with advantage, have spaces of 20 mm. or more between the bars and the latter may be 10 mm. thick (according to the rule given above it would be necessary to give the bars a thickness of 80 to 100 mm. (!) each); on the other hand, when a peat mould or a press peat, which crumbles easily in the fire, is being burnt the maximum width for the spaces between the bars should be 8 mm.

The minimum free grate area, with which the total grate area will vary when the thickness of the bars for a given case is taken into account, can easily be calculated from the figures for the amount of air required for the combustion given in the above table, by means of the formula:—

$$F = \frac{Q}{v \times 60 \times 60},$$

where  $F$  is the free grate area,  $Q$  is the quantity of air given in the table, which is double the theoretical amount, and  $v$  is the velocity

of the air current (the draught) through the grate, which may be assumed as 0.7 to 1.0 m. per second for ordinary fires and boiler furnaces. This calculation can be used to find whether the spaces between the bars are wide enough for the fuel in order to be certain that incomplete combustion may not occur, even when the damper is fully opened, by the quantity of air being insufficient owing to the free grate area being too small.

It is clear that the air must be brought in contact with the fuel as uniformly and as intimately as possible if the combustion is to be complete. As this desired effect can be produced only by a grate which allows the ashes to escape from the peat during the combustion and at the same time admits the air uniformly from below the grate, all fireplaces in which combustion takes place on a *flat hearth without a grate* are to be regarded as not suited for industrial work and should be avoided especially in the case of peat.

Only light cut peat can be used in defective furnaces such as these, since machine peat, which, as stated above, has the highest efficiency, can be kept burning well only by means of special care. (It is, for instance, difficult to ignite.) It is only when furnaces of this class are taken into consideration that a bog-owner would be induced to forgo attempts to obtain as dense a product as possible when manufacturing machine peat.

Recently stoves for living rooms have been used with success in which peat is burnt on a flat hearth. A sufficient amount of air is maintained in these by means of a double supply of air at the front and the back side of the box-shaped layer of fuel, as, for instance, in the peat stove of Winter and Co., of Hanover.

The *size and the height of the fireplace*, i.e., the space above the grate which serves for receiving the fuel and developing the hot gases, are very important, especially for good commercial installations. In plants where the heat is to be given to a vessel suspended in the fireplace, as, for instance, in evaporating boilers, heating ovens, steam boilers, &c., the height of the fireplace must be chosen so that the flame can develop properly and so that its hottest portions may come in contact with the wall of the vessel. The best distance between the grate and the bottom of the vessel to be heated may be assumed to be 50 to 60 cm. for peat-firing, 30 to 35 cm. for coal-firing, and 40 to 45 cm. for brown coal-firing.

The *shape of the fireplace* varies with the purpose for which the firing is employed. It would take us too long to go into the manifold variations for the different purposes, and we shall consider more closely only steam boiler furnaces which are of general importance for industry as a whole. As regards the others, it is always advisable when constructing anew or modifying these installations for peat-firing to consult an expert of standing, since it may be seen from what has been said above how greatly many conditions for good peat-firing differ from those which have proved suitable for firing with other fuels, and how the differences in the properties of natural peats, or of peats obtained by different methods of winning, necessitate modifications of the average



figures given above. Unfortunately, one can see again and again how such installations are constructed by laymen and ordinary artisans according to a fixed pattern, depending on the eye and good luck, and it is no wonder that on the same hearth on which perhaps coal or brown coal has previously been burnt successfully peat cannot be *so advantageously* consumed. The blame for this is only too frequently attributed to the peat, which is said to be either "bad or too dear in comparison with coal," and often a peat is put aside as worthless which would have given good results if the firing had been carried out in an expert manner. The difference in the consumption of fuel and in the heating effect between a good and a bad firing installation may amount to 50 per cent. or more.

While direct combustion furnaces such as these show, in the case of a firm peat which is not rich in ash and which, above all things, is thoroughly air-dry, a heating power which allows peat to enter into competition with other fuels, the results, especially in the case of large scale industries and big furnaces, are not always favourable when light, cut, or dredged peat, peat mould, ashy, earthy or similar peat is employed, which, owing to unfavourable atmospheric or local conditions, cannot acquire a degree of dryness sufficient for its advantageous combustion. It is then advisable to gasify the fuel before burning it. The combustible constituents of the peat are first developed as gases, and are then led to the fireplace, where they are burned after addition of air. This so-called gas-firing, which is, however, somewhat involved as regards both plant and mode of working and which we shall discuss later in a special section, enables us to employ successfully a peat of little value, which can therefore be claimed as being capable of utilization as a fuel.

*What makes peat specially valuable as a fuel and distinguishes it from almost every other fuel is the circumstance that the longer flame from peat, distributing itself better over the boiler, evaporator, &c., being purer, and in general more free from smoke and sulphur, does not attack the metallic walls, or only slightly, and indeed allows the boiler to be used twice as long as in the case of coal-firing.*

### 3.—Furnaces suitable for Steam Boilers, Locomotives, Evaporating Pans, &c.

It is exactly in the case of these furnaces, which are so important and so often met with in industry, that the error is usually made of not taking into account sufficiently the peculiarities of commercial peat. In most cases, indeed, people demand that the peat, the heating power of which they wish to examine before deciding to use it as the sole fuel in their industries, should burn at least as well as or, if possible, with greater commercial success than coal in a furnace in which coal has perhaps been hitherto burnt with advantage, alteration of the grate and fire chamber, if this is done at all, being made only after they have convinced themselves of the advantages of peat as a fuel. In these cases figures favouring

peat will rarely be obtained, while undoubtedly other results would be arrived at if they adopted the reverse procedure of first constructing a suitable new furnace, or of properly altering the old one, and then carrying out the combustion experiments.

The properties of peat, which are very different from those of coal and brown coal, demand quite different dimensions for the furnaces from those required by the coals, in the same way as do the various peats themselves, owing to natural differences and those due to modes of winning. For instance, a light, moist, fibrous peat having a density of 0.3 requires a quite different fire chamber and quite different grate dimensions from a heavier, bituminous peat more or less rich in ash and having a density of 0.8 to 1.3. Taking into account these peculiarities, corresponding alterations of the numbers given in the preceding portion of this section will be required in the two cases in order to get the best combustion for a given fuel. We should not, as unfortunately still happens frequently, rely for the width and the height of the fire chamber on the opinion of a mason or plumber "renowned" for setting boiler foundations, or for the grate dimensions on the models which a foundry may happen to have and for which they usually quote per 100 kilos, nor should we depend for the height of the chimney on the length of the scaffolding poles at our disposal.

The general arrangement and shape of the fireplace and its position relative to the walls of the boiler are even more important than the parts of the furnace just mentioned if combustion is to be good and evaporation at a maximum. Moreover, the high percentage of moisture, which in cut peat averages 25 and in machine peat 18, should be specially taken into account.

The influence of this moisture on the development of heat during combustion is given on p. 332, where it is shown that 640 c. are required for the evaporation of every gramme of water contained in the fuel, so that for 100 kilos of peat containing 25 per cent. of moisture  $25 \times 640 = 16,000$  kilo-calories may be regarded as wasted.

Let us imagine a furnace, such as that shown in Fig. 119, with an ordinary flat grate under a cylindrical boiler, and let a fresh layer of fuel be added through the door of the furnace; then an amount of heat corresponding to that calculated above and to that required for the pre-heating of the fresh fuel is first withdrawn from the layer burning on the hearth, which thus becomes cooled, as the freshly added peat cannot at once develop of itself the heat required for the evaporation of its moisture. Owing to the high specific volume of light cut peat, time is necessary for adding the required weight of fresh fuel to the grate, and during this period a large amount of cold air, pressing into the fire chamber through the open furnace door, cools the fire, and therefore the walls of the boiler.

The generation of steam is disturbed, and a complete, i.e., a smokeless, combustion on the hearth is made impossible through this twofold (and considerable) degree of cooling of the combustion gases, and also through the cooling action which the fresh layer

of fuel exerts on the boiler immediately above it. A considerable amount of time is required before the new layer is so far ignited that it can help the combustion and the evaporation due to this. An incomplete combustion, such as this, is always associated with loss of fuel, and therefore with a greater consumption of fuel, without, however, making it possible to maintain a vigorous development of steam.

Hence it follows that an ordinary flat grate which is fixed immediately under the boiler, and on which, as experience shows, coal can be burned with advantage, is not well suited for peat-firing, although installations of this type may still be frequently met with.<sup>1</sup>

These defects are partially removed by means of the so-called Fairbairn double grate, which may be regarded as a flat grate divided into two parts by a fire-brick partition, 12 to 25 cm. in thickness. Each compartment is closed by a special fire door and the combustion gases from the two compartments unite either

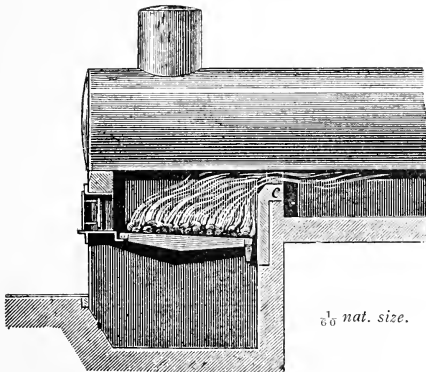

FIG. 119.—Ordinary grate furnace.

directly in front of, or over, the fire bridge *c* (Fig. 119). The main condition for obtaining a real success and the best possible development of steam in the boiler during the working of this furnace is that one compartment of the fire chamber be filled with fresh fuel while the other is in active glow. In the freshly filled compartment the defects of the ordinary flat grate firing again occur.

The fire becomes cooled owing to the incomplete combustion, and thick black smoke is given off from the freshly added fuel, together with the gases, such as carbon monoxide, formed by the

<sup>1</sup> Ordinary back-flame firing, a shaft-firing, generally without a grate. In which the combustion gases strike downwards round a scob into the combustion chamber, is also unsuitable for peat-firing. An insufficient supply of air, an irregular and smoky combustion, and a low heating effect are characteristic of it.

incomplete combustion of the fuel. These products, however, meet, above the fire bridge, the hot gases from the other compartment, become again ignited and help in the development of steam. It is advisable to let in air from the outside at this point through vents in the fire bridge, by which means the combustion becomes more complete and almost free from smoke. A considerable portion of the heat becomes lost, however, owing to the cold air which enters through the repeated opening of the furnace doors, and when the peat is somewhat wet it is difficult to keep the fire and therefore the generation of steam going well, because the cool combustion gases, in so far as they find but little heat stored in the boiler walls, which are always made of iron, exert a cooling action on the boiler, and conversely the walls of the boiler, consisting of good conductors, are at so relatively low a temperature that they

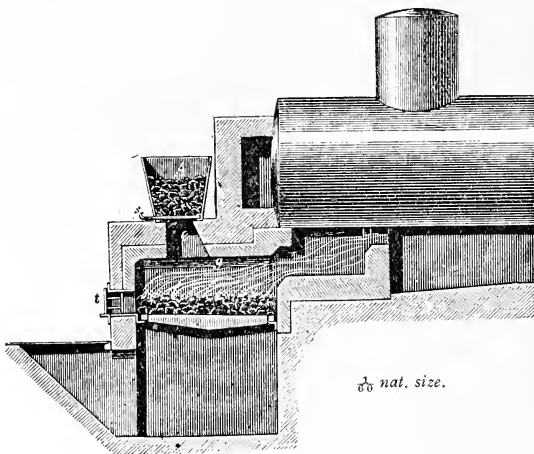

FIG. 120.—A fore-set double-grate furnace with hopper.

are unable to ignite and assist the combustion of the freshly added fuel.

If combustion is to be made as regular and as perfect as possible, it is very important that the freshly added fuel should be almost completely surrounded with heating surfaces, which may be regarded as heat reservoirs, the heat radiated from which suffices to dry the freshly added peat quickly, so that heat need not be withdrawn from the glowing layer to evaporate the water in the fresh peat, and therefore cooling of the combustion gases and the boiler is avoided as much as possible.

This may be effected by means of a so-called fore-placed furnace (fore-furnace), the grate of which lies in front of and not under the boiler (Figs. 120 and 121). Its combustion chamber has a roof *g* made of firebrick (non-conducting material). This

acts as a heat reservoir, since it becomes heated to glowing when the fuel on the grate is burning brightly and counterbalances the cooling of the hot gases and of the boiler, when the furnace is being refilled, by radiation of the heat stored in it to the fresh layer of fuel, whereby the moisture is evaporated rapidly, the fresh peat becomes ignited, and the fire in a very short time again burns brightly.

If such a furnace is installed, as shown in Fig. 121, according to the method already mentioned for the Fairbairn double grate, it will in all cases give good results, other conditions being favourable. The plant may be considerably improved by feeding the furnace through hoppers *A* and special openings *e* in the roof instead of through the fire doors. The amount of air entering the

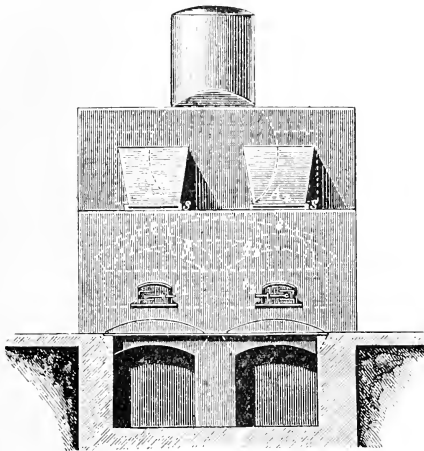

FIG. 121.—A fore-set double-grate furnace with hoppers.

fire chamber during the refilling may in this way be reduced to a minimum. The lighter the peat the longer the refilling will require, and during this process a large quantity of cold air may enter the fire chamber, the ill-effects of which will generally become evident very quickly in the manometer readings. This defect is almost completely avoided by means of the arrangement shown in Figs. 120 and 121. The fire doors *t* are opened in this case only for stirring the fire, which does not often occur and requires little time. Moreover, the doors may be made much smaller for this purpose (15 cm. x 10 cm.) than for feeding fuel (32 cm. x 26 cm.), so that for this twofold reason the amount of cold air which may stream in is relatively small. The hoppers *A*<sub>1</sub>, *A*<sub>2</sub>, are closed just above the roof by sliding doors *s*, and are always kept full of peat. At various intervals the stoker pulls out the slides, and the charge falls according as desired, either wholly or partially, on the grate, on

which it distributes itself. It is evident that the whole operation of charging the furnace takes only a few seconds, and that the amount of cold air which enters is reduced to a minimum, since the sliding door is again closed directly the hopper has emptied itself.

For more or less long grates two hoppers are arranged behind one another, so that each (double) hearth has  $2 \times 2$ , i.e., 4 hoppers. The hoppers over any one of the grates are used alternately instead of both together, so that the combustion becomes as regular as possible.

Instead of putting the hoppers above the stonework we may, according to Scholl, arrange them as indicated in Fig. 122, where the hopper *a* is built into the stonework near the stoking end of the furnace. The sliding valve *s* can be moved by means of a handle through an opening in the side wall. The peat is placed on the stonework above the hopper. The stoker draws it from there with a kiln rake and feeds it through the hopper into the fireplace. The inclined chute must be so made that the lower side *cd* points to the middle of the grate, and therefore makes an angle of at least  $50^\circ$  with the horizontal.

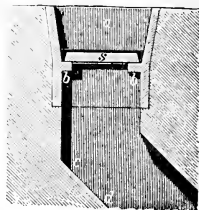

FIG. 122.—Hopper.

An equally good firing arrangement for peat is afforded by *step grates*, which have an inclination of  $40^\circ$  to  $45^\circ$ ,<sup>1</sup> with intervals of 80 mm. to 100 mm. between the steps (Bolzano's grate). This is especially the case with the *Langen step grate*, the construction of which (Fig. 123) makes it possible to feed the fresh peat into the fire chamber under instead of over the fuel already burning there.

The smoke from the fresh peat and the carbonic oxide gas due to incomplete combustion of the fuel are then obliged to pass through the brightly glowing layer of peat, where they are fully burnt by means of the oxygen of the added air and therefore utilized for the development of heat.

The grate has an inclination corresponding to the size and the quality of the pieces of peat and is divided into several steps, so that between every two steps there extends, across the whole width of the grate, a gap, 120 mm. to 200 mm. in height, through which the fresh fuel can be pushed into the fire chamber. Two side plates *a* limit the width of the furnace. These are connected at their upper ends with a head-plate *c*, and at their lower ends, on the boiler side, with two grate supports *c*<sub>1</sub> and *c*<sub>2</sub>. They are provided with supports *m m*, on which the plates *d*<sub>1</sub>, *d*<sub>2</sub>, *d*<sub>3</sub> for receiving the fresh peat rest. These plates extend as far as the surfaces where the combustion occurs. The combustion surfaces consist of bent grate bars *e f*, which are carried on the hollowed cast-iron bars *b b*, resting on the supports of the side plates. In

<sup>1</sup> See Figs. 124 and 143.

connexion with the grate bars *g* of the lowest step there are two flap-doors *z z* formed of grate surfaces, which can be let down or closed by means of the lever *h*. The pivots of these doors rest on the trunnions *i* of the grate support *c*<sub>2</sub>, and between the latter and the grate support *c*<sub>1</sub> there is an ordinary flat grate surface, which is bounded behind by the stonework of the boiler.

The peat thrown on the plates *d* is pushed, by means of the fire-iron, through the long narrow opening between the inclined grate and the plate. The fuel from *e* to *w* is thus pressed inwards, it slides downwards over the inclined surface, and the portion from *e* to *w* becomes filled with fresh peat. The fire remains in this state until refilling with fresh peat is necessary. The coals previously pushed in between *e* and *w* owing to the action of the superimposed layer have in the interval evolved their most volatile constituents, moisture, &c., in the form of vapours, and

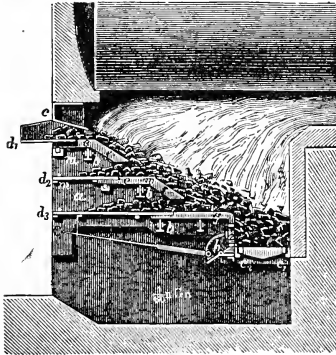

$\frac{1}{60}$  nat. size.

FIG. 123.—A step grate for peat-firing.

on being moved farther inwards, burn with an intense flame and as high a temperature as possible.

Boiler furnaces such as this, fed solely with peat, worked well for a number of years at the Augustfehn Iron Works.

The well-known Cornelius, Kudliez, and similar fire-grates with special air inlets and air distributors, the ingenious chain or sliding grates, the horizontal grates with fore-feeders, the Fränkel trough grates (Fränkel and Viebahn, Leipzig), the step grates of Kowalsky, Keilmann and Völkers, amongst others, as well as the dust furnaces of Schwartzkopff, de Camp, Wägener, and others, can without trouble be utilized for peat-firing, as might be expected from some recent reports.<sup>1</sup> We have not been able

<sup>1</sup> See "Handbuch der Trocken- und Brenn-öfen," by Francis Rauls, Cologne-on-Rhine, 1915, for combustion, furnaces, grates, gasifiers, and the various ovens and furnaces for the different industries.

to find definite cases in which these peat-firing plants have already worked satisfactorily. In any given case thorough preliminary experiments will always be necessary in order to determine particulars such as size of grate, width between the bars, and rate of admission of air, and the advice of a real furnace expert will also be essential before a plant which has proved successful for coal or brown coal firing can be employed with advantage for peat-firing. Some of these furnaces, e.g., peat-dust furnaces, can be employed with advantage even with coal-firing only in the case of some very definite kinds of coal, which are not always available; and, as every expert knows, there are considerable technical or commercial difficulties experienced in procuring sufficient quantities of coal-dust of the required degree of uniformity and fineness for dust furnaces.

Although great hopes were expressed in technical circles<sup>1</sup> with regard to the Gehrcke peat boiler (cf. p. 306, Patent 115007), with which artificial drying of the peat is associated, and although the artificial preliminary drying of the peat on which it is based was regarded as a great advance, the plant has not proved successful, and after many failures its construction has been abandoned.

For further particulars with regard to successful semi-gas furnaces with peat-firing for boilers and evaporators, see Section IV, on "Peat Gas Furnaces for Boiler Installations," &c.

Mixtures of peat and coal have been used in boiler furnaces with success in very many cases, and without any considerable alteration in the existing firing plant.

After the outbreak of the French War in 1870 experiments were made on a large scale in Würtemberg as, owing to the commandeering of all the railways for the transport of troops, coal became scarce there, and supplies were cut off for a long period.

A report of the Imperial Central Institute for Industry and Trade indicates that, apart from social economic reasons, the chief advantages of employing a mixture of peat and coal for more or less large furnaces are:—

(1) The prevention of clinkering of the grate in the case of certain kinds of coal.

(2) Greater sparing of the boilers, since the longer flame produced by mixing peat with coal is better distributed over the boilers than in the case of pure coal and coke firing, which give more powerful but smaller flames and attack certain parts of the boilers more strongly and therefore gradually burn through them.

According to the report, the best mixture was 2 parts of coal to 1 part of peat, but 1 part of coal to 1 part of peat also acted well, and indeed in some cases mixtures of 1 part of coal with 2 parts of peat were employed.

With reference to the firing arrangements, it is pointed out that pure peat firing requires the same grate width as pure wood firing.

<sup>1</sup> Cf. the Jubilee number, "Die Entwicklung der Moorkultur in dem letzten 25 Jahren," of the *Vereins zur Förd. d. Moork.* (1908), pp. 215–220.



For pure coal firing the grate is, as is well known, kept narrower, and therefore in the case of mixed peat and coal firing the distances between the grate bars must be adjusted to suit the ratio of the components in the mixture.

*Peat Powder or Peat Dust Firing.*—The boiler furnace employed in Sahlström Factory for firing peat dust, won by Ekelund's process, is operated as follows: the sacks of peat dust are emptied into a reservoir over the boiler. The dust passes from the reservoir through a channel into a tube which ends in the fire chamber inside the combustion hearth of an igniting oven. The igniting oven is placed on transport rails in front of the boiler so that it can be readily moved aside whenever auxiliary firing with coal is desired. The powder introduced into the fire chamber meets a hot-air blast and is ignited by the flame from the igniting oven, the powder being immediately gasified and burning with a bright flame. The amounts of powder and compressed air added can be regulated.<sup>1</sup> According to comparative experiments made in February 1911, by R. Torneberg, with three different samples, 1 kilo of peat dust generated as a rule 4·87 kilos of steam, while the same weight of coal produced 6·81 kilos of steam, and therefore 1 kilo of coal corresponded to 1·40 kilos of peat dust.<sup>2</sup>

For particulars with regard to peat dust firing for locomotives, see Section IV, on "Peat in the Railway Industry."

*Peat-firing for Locomotives and Locomobiles.*—The use of peat for firing locomotives obviously requires not only alteration in the dimensions of the fire-box, but also in those of the tender, both of which must be made considerably bigger for peat than they are when coal and coke are used. When light, cut and stroked peat are used for more or less long railway tracks, even a big tender will not be able to carry all the peat required for the journey, and one or two goods wagons loaded with peat must be coupled to the tender unless peat depôts are set up at various intermediate points where the tender can be refilled.

After much indecision on the part of railway companies in peat districts, and after it had been shown that only in the case of a few favourably situated railways and during periods when coal was dear could any saving in expenses be made by firing locomotives with peat instead of coal, the use of peat in the German railway industry decreased more and more at the end of the preceding century. This was due to the desirability of uniformity in the industry over the greatly extended railway systems of the various districts, to the difficulty of procuring the very large quantities of fuel required annually if peat in a sufficiently dry condition were to be regarded as an essential part of the annual supply, and to the ever-growing demands made on the capacity of the railways.

---

<sup>1</sup> Wallgren, Chief Peat Engineer of the Government, has submitted a report on the installation and its working costs. This report is given in the *Osterr. Moorzeitschrift*, 1911, p. 71.

<sup>2</sup> *Mitteilungen*, 1912, p. 33.

In Germany, for instance, peat is no longer employed<sup>1</sup> for firing locomotives, except in the case of some goods trains in Bavaria and on a few local lines.

In the present edition we have therefore refrained from giving details with regard to the construction of locomotives for peat-firing such as are contained in the second edition.

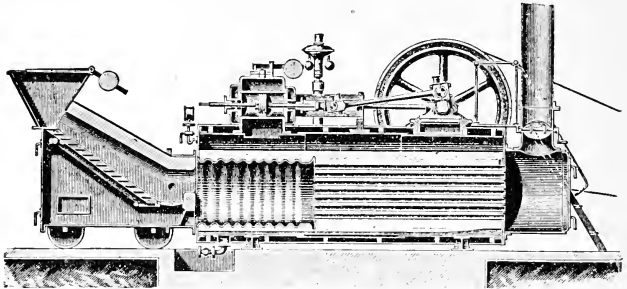

FIG. 124.—A locomobile boiler with a fore-set step grate for peat-firing.  
Henry Lanz, Munich.

The attempts which have recently been made in Sweden to utilize Ekelund's peat powder firing for locomotives and the modification of locomotive furnaces rendered necessary by it have

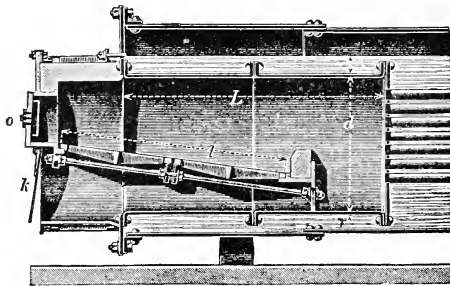

FIG. 125.—A locomobile boiler with fore-set fireplace for peat-firing.  
R. Wolf, Magdeburg-Buckau.

not so far led to a decisive result. The same may be said of the more recent attempts made in Prussia to utilize peat more widely than hitherto for firing locomotives.

The use of an ordinary locomobile boiler with peat-firing, if it has not initially been adapted for this purpose by providing it with a specially large fire-box and a large grate area, can be made possible in various ways by suitably extending the fire chamber.

<sup>1</sup> Cf. the subsection "Peat in the Railway Industry," in Section IV, "Application of Peat-firing in various Branches of Industry," &c.

Fig. 124 shows a step grate with a hopper added to a locomobile boiler as constructed by Henry Lanz, of Munich,<sup>1</sup> and Fig. 125 shows an extension containing the grate and fire chamber screwed to the boiler as employed by R. Wolf, of Magdeburg-Buckau, in his locomobile boilers for peat-firing.

The absence, as a rule, of sulphur from peat and the uniform flame which necessarily results when peat is used contribute largely to the life of the boiler of a locomobile or a locomotive. The fire-boxes last much longer for peat-firing than for coke or coal-firing. From the experiences hitherto gained it may be assumed that a locomotive fire-box can be used with peat-firing two or three times as long as with coke-firing, and that the renewal of the grate bars, which is so expensive in the case of coke and coal-firing, is quite unnecessary in that of peat.

### D.—Methods and Plants for Increasing the Calorific Effect of Air-dry Peat

In order to avoid the considerable losses of heat due mainly to the moisture content of the peat it has been found necessary, especially for smelting purposes, where it is chiefly a matter of attaining high temperatures, and for competing with wood charcoal and coke, to remove the moisture from the peat either by means of external heat, i.e., by artificial drying (kiln drying), or by carbonization.

We obtain therefore—

either by completely or partially removing the moisture, "*kiln-dried peat*,"

or by removing the moisture and the "chemically bound water," and at the same time driving out other volatile constituents (distillation, carbonization), "*peat charcoal*."

Attempts have recently been made to utilize and increase the heating effect of peat by gasifying it in gasifiers (unnecessarily called generators).

Owing to the importance of kiln-dried peat, peat charcoal, and peat gasification for industry, details with regard to these and their commercial value are given in the following sections.

#### Manufacture of Kiln-dried Peat

##### 1.—*Various Modes of Drying*

The artificial drying of peat always takes place in closed rooms, called drying kilns, which are usually made of stones, and which are filled with the peat sods to be dried, leaving spaces between the sods for the passage of the gases and vapours. The drying itself, i.e., the introduction and distribution of the heat produced in a separate hearth, and the driving out of the moisture contained in the peat by this heat, takes place in the following ways:—

<sup>1</sup> From 50 to 60 per cent. of the calorific power of the fuel was utilized in a 75 to 100 h.p. locomobile of this type by the Count von Landsberg Peat Litter Co., Ltd., of Velen (Westphalia). *Mitteilungen*, 1911, p. 327.

- (1) By radiation from the drying walls, heated by the combustion gases and by flues in the bottom or sides of the room.
- (2) By direct action of the escaping combustion gases.
- (3) By a current of hot air.

In all cases it is necessary to see that sufficient attention is paid to the natural circulation of the hot gases, or the hot air, and also to that of the gases which escape from the kiln saturated with water vapour.

While the hot combustion gases and the dry hot air have a tendency to ascend and to occupy the highest point of the drying room, they sink down when they cool by giving up their heat, or when their weight gradually increases as they become cooled, by absorbing water vapour. The cold and moist gases should always have an exit at the bottom of the drying room. The various currents of the warm and dry gases, on the one hand, and the cold and moist gases on the other, should interfere with one another as little as possible, and the gases, once they have become saturated with water vapour, should be led away at once without giving them time and opportunity to give up their moisture again to the colder parts of the room or to peat which has not yet become sufficiently heated, since this moisture would have to be removed again by the incoming hot gases.

The various methods of drying mentioned above take this circumstance into account only to a limited extent, and the defects due to this, as well as the greater or smaller utilization of the heat of the fuel required for the drying, which varies with the different arrangements, gave, especially for the first and the second processes, a result which was scarcely satisfactory.

Since, according to the conclusions in the following subsection, the commercial value of the kiln drying of peat is ordinarily either a doubtful or a zero quantity, the manufacture of kiln-dried peat may in general be regarded as now out of date.

The author is not aware that there are ovens or appliances for the manufacture of kiln-dried peat now in use anywhere. For this reason detailed description of the older plants is not given here.<sup>1</sup>

Some more recent proposals are contained in the Section on Patents at the end of Part I, under the headings "The Dehydration of Peat," &c., and "Drying of Peat."

## 2.—*Commercial Value of Kiln Drying*

The commercial advantage of kiln drying or artificial drying is debatable in every case where it is merely a question of getting the greatest possible heating effect from a given kind of peat, i.e., where the fuel made from it is to be used mainly for the development of quantity of heat (number of calories), as for instance in boiler installations for the evaporation of water, in drying contrivances for warming large quantities of air, &c., and where it is not largely a matter of the temperature of the gases developed

---

<sup>1</sup> These plants are described more fully in the first edition of this work.

in the combustion, which temperature is the chief thing to be taken into account in smelting operations in ironworks.

We can see from the figures given at the beginning of the preceding section that the calorific intensity of one and the same kind of peat decreases considerably as the amount of water in it increases. A peat, which in the anhydrous state, i.e., thoroughly dried, gives a temperature of  $2,000^{\circ}$  C. on combustion, will, when it contains 25 per cent. of moisture, give a maximum temperature of  $1,750^{\circ}$  C., which temperature cannot indeed be raised by increasing the amount of the fuel burnt in unit time. If we want to attain the minimum temperature necessary for certain purposes, as for instance in ironworks, the temperature  $1,500$  to  $1,600^{\circ}$  C. required for melting iron, we must improve the quality of the fuel by drying it still more. Recourse will therefore be had to the kiln drying of peat only when estimates show that kiln-dried peat is cheaper than the substances—coal, coke, peat, charcoal, &c.—for which it is substituted, and for existing ironworks, owing to their proximity to the coal districts, this can scarcely be the case.

If the temperature of the combustion gases is not to be taken into consideration or is only of secondary importance, and if the number of calories can be increased by increasing the consumption of fuel, as happens in the case of all steam installations, kiln-dried peat will be in an unfavourable position from the very start. In this case the amount of water evaporated will depend mainly on the amount of peat burnt, and it will then be a matter of determining whether the advantage obtained by the kiln drying of air-dry peat, that is, the increase in calorific effect due to this, corresponds to the more or less high expenses for the kiln-drying plant and process.

In this examination let us assume the favourable case that in a well-devised oven the 25 per cent. of moisture in air-dry peat may be lowered to about 5 per cent. by a fuel consumption of 10 per cent. of the quantity to be dried, which, however, will in reality be rarely attained.

We shall assume also that a calorific power of 4,500 corresponds to the chemical composition of anhydrous peat, so that 1 kilo of this peat, containing 25 per cent. of water, can develop  $0.75 \times 4,500 = 3,375$  kilo-calories. Assuming that peat at a temperature of  $20^{\circ}$  C. is fed into the fireplace, the amount of heat just mentioned must be decreased by  $0.25 \times (640 - 20) = 155$  kilo-calories which are required to convert into steam the 0.25 kilo of water contained in the peat, neglecting the small amount of heat necessary to heat the evaporated water to the temperature of the escaping combustion gases.

From 1 kilo of the above peat with 25 per cent. of moisture  $0.75 \times 4,500 - 0.25 \times 620 = 3,220$  kilo-calories can be produced. If its moisture has been lowered to 5 per cent. by kiln drying, this weight of peat will give:  $0.75 \times 4,500 - 0.05 \times 620 = 3,344$  kilo-calories. To do this, however, a further 10 per cent. of air-dry peat will be required, and if this, together with the original amount of

air-dry peat, were burnt directly we should get :  $3,220 + 0.10 \times 3,200 = 3,542$  kilo-calories, or a 6 per cent. greater heating effect than can be obtained from the kiln-dried peat. Moreover, all the working expenses and installation costs would still have to be taken into account, to the detriment of the kiln drying.

Even in the case where the peat burnt for the kiln drying can be regarded as not so valuable as the peat to be dried and can be estimated at a cost which is only 50 per cent. of the latter, direct utilization of the air-dry peat is still more advantageous than kiln drying, since in the first case, without any further expense,  $3,220 + 0.50 \times 0.10 \times 3,220 = 3,381$  kilo-calories are obtained as against 3,344 in the latter. It is a mistake not to take into account in estimates of costs of winning for the working of a bog the fuel required for machines and drying contrivances, because it is taken from one's own bog and has not to be paid for. All so-called waste can be worked into valuable fuel, especially when machine peat is being manufactured, otherwise the plant would be a very defective one if the amount required for the working became waste. At any rate, the cost of raising and transporting the peat from the trench to the point of utilization and the cost of drying it must be taken into the estimate, and these will always amount to more than 50 per cent. of the net cost of the same weight of air-dry peat. The above estimate may therefore be regarded as corresponding to the actual existing circumstances. Only in cases where such an amount of wood remains and roots (which must be regarded as impurities in the peat and separated from it) is obtained in winning peat as will be sufficient to cover completely the expenditure of fuel, and where this wood cannot be otherwise disposed of, could the fuel for the kiln drying be left out of account. In the latter case the kiln drying would increase the heating effect by  $3,344 - 3,220 = 124$  kilo-calories, i.e., by about 4 per cent., a gain which in most cases would be counterbalanced by the increased installation and working expenses.

While therefore kiln-dried peat has to compete so far as calorific intensity is concerned with coal and coke, it must also, whenever heating effect is considered from the point of view of thermal units, enter into competition with air-dry, cut, stroked, or machine peat, which according to the foregoing must be unfavourable for the kiln-dried peat and could be taken into account only when a careful calculation showed that transport costs from the bog to the place of use or sale constituted a considerable portion of the selling price of the fuel.

Since in transporting 100 kilos of air-dry peat 25 kilos of water must be carried as ballast, useless for combustion, and since this useless ballast per 100 kilos is decreased by 15 to 20 per cent. in the case of kiln-dried peat, the freightage for the same amount of actual peat substance would on an average be 18 per cent. cheaper. According as the fuel required for the kiln drying in reference to the mode of winning is to be assumed in the estimate as of the same value as the fuel to be dried or as of no value, kiln drying or artificial drying can be recommended as economical :—

(a) When fuel of equal value is used for kiln drying, if 18 per cent. of the freightage amounts to more than 6 per cent. of the cost of production of the air-dry peat at the place where it is used, together with the working expenses and the amortization of the kiln-drying plant.

(b) When fuel at half the cost is used for kiln drying, if 18 per cent. of the freightage amounts to more than the working expenses and the amortization of the kiln-drying plant.

(c) When fuel at no extra cost is used for kiln drying, if 18 per cent. of the freightage amounts to more than the working expenses and the amortization costs of the kiln-drying plant after deducting 4 per cent. of the cost of production of the air-dry peat from these expenses.

By paying attention to local conditions and to the cost of winning given earlier in this handbook, this calculation can be made without difficulty in every case.

In the kiln drying of peat we must always take into account the fact that the water cannot be permanently removed from the peat, but that, even after drying, the peat still retains its tendency to absorb water, and when exposed to the open air it can re-absorb a portion of the water expelled, so that after some considerable time it will again contain 12 to 15 per cent. of moisture. This property increases with the lightness and sponginess of the dry peat, and is present to a greater extent in cut and stroked peat than in condensed machine peat, which is, moreover, better adapted for kiln drying, since for the same installation costs it allows a much greater amount of peat by weight to be put into the drying rooms and therefore gives a greater output for a smaller cost of production.

The author has made numerous experiments on the re-absorption of moisture by anhydrous peat, the results of which are given in the table on pp. 246 and 247. From these it follows that the re-absorption of water by anhydrous peat in general, especially by anhydrous cut peat, is very considerable in a relatively short time after the drying, and that after six to eight days the effect of the drying will have almost completely disappeared. When this circumstance is taken into account, it is necessary, and indeed this is generally the case, that the kiln-dried peat when used in ironworks should be won directly at the place of use and should not be stored. In cases where in reference to transport costs it was advisable to submit the peat to an artificial drying, it was found best not to lower the moisture in the peat below 10 per cent.

For all these reasons, artificial drying—the manufacture and the utilization of peat in the kiln-dried state—is in general to be rejected as uneconomical.

## SECTION II

# MANUFACTURE OF PEAT CHARCOAL

### 1.—The Various Methods of Carbonizing Peat

With a view to making peat better adapted for employment as a fuel, especially for smelting purposes, and to making it therefore more generally useful, attempts have been made to decrease, as far as possible, not only its moisture content, but also its "chemically bound water," nitrogen, &c., which prejudicially affect combustion and cannot be removed by mere drying, and, therefore, to increase the percentage of carbon, in exactly the same way as it is increased during the carbonization of wood into wood charcoal, or that of coal into coke.

This is attained by strongly heating the peat in a limited supply of air, or in the absence of the latter. In the decomposition of the vegetable constituents thus effected only the carbon and the ash of the peat ultimately remain in the form of peat charcoal, which is sometimes called peat coke.<sup>1</sup>

During the heating the moisture contained in the peat escapes first; acetic acid, light and heavy hydrocarbons, and ammonia are then evolved, the latter bodies being supposed to be formed by decomposition of the "chemically bound water" of the peat into hydrogen and oxygen, with re-combination of these with part of the carbon and the nitrogen contained in the peat. A part of the combustible gases is burnt immediately after their formation in order to produce the heat necessary for the further carbonization and the remainder mixes with the other gasification products, and these partly condense to tar and ammonia water and partly, in so far as they are non-condensable, escape in the gaseous state.<sup>2</sup>

The main essential for the winning of the maximum amount of charcoal is to avoid as much as possible the formation of these by-products, in so far as they are carbon compounds, and to conduct the carbonization so as to reduce the consumption of the carbon or fuel necessary to produce the heat of carbonization to a minimum.

---

<sup>1</sup> The expressions "coal" and "coke," which, as a matter of fact, are quite clear and unambiguous, should not be used in a different sense in expert circles when referring to peat carbonization. Peat charcoal and peat carbonization, so far as relates to the product intended to be obtained, bear exactly the same relation to peat as wood charcoal and wood carbonization do to wood, and coke and coking do to coal. If we wish to refer to the incomplete carbonization of peat and the product obtained in the process, we should not employ the incorrect expression "peat charcoal," for the latter, which, as in the case of wood charcoal, simply denotes the product of complete carbonization, and in the present case we should call the product peat semi-charcoal, or partially carbonized peat.

<sup>2</sup> See the products of distillation in Part II, Sections III and V.



Carbonization, which may be regarded as a protracted drying at a high temperature (air being excluded as much as possible), can therefore take place in the ways already indicated for drying, excluding, however, the hot-air method, as air at a high temperature would ignite and burn the peat, thus causing total loss of the carbon. For the operation we have, therefore :—

(a) Carbonization by means of direct heat—i.e., by means of combustion gases.

(b) Carbonization by means of radiated or conducted heat.<sup>1</sup>

Following the methods used for the carbonization of wood, the former of these operations is carried out in a limited supply of air in ordinary piles, heaps, or in stonework ovens (pile ovens), and the latter in closed stonework or iron muffles (retorts). We may distinguish, therefore, between pile, heap, oven, and muffle or retort carbonization.

In the first two cases either a part of the peat burns in the presence of air at the beginning of the process, as in piles, or cheaper (valueless) fuel is burnt, as in some kinds of ovens, on grates lying outside the ovens, and the heat thus produced decomposes another portion of the peat, so that the combustible hydrocarbons, formed when the air-holes are partially closed, serve to develop the heat necessary for the further carbonization of the peat as the process continues. (The only exception is when the combustion gases are taken from an already existing furnace plant—as, for instance, gases from puddling, re-heating or blast furnaces, which can be led into and ignited in the carbonizing ovens.)

The heat necessary for the carbonization in muffles or retorts is always generated in a separate furnace, and the combustion gases are led round the walls of the muffle.

In addition to the above-mentioned decomposition products, carbon dioxide and carbon monoxide are always formed during carbonization in the presence of a limited supply of air by the combustion of carbon, and free hydrogen is formed by the interaction of carbon monoxide and steam. The yield of charcoal depends a good deal on the amount of air admitted.

Experience shows that in all cases :—

(1) The longer the carbonization lasts, and the higher the temperature at which it occurs, the freer the residual charcoal will be from oxygen and hydrogen.

(2) The yield of charcoal is the smaller, and its percentage of carbon is the greater, the higher the temperature of the carbonization.

(3) For the same temperature of carbonization the yield of charcoal is smaller the longer the time during which the carbonization proceeds.

---

<sup>1</sup> Attempts have also been made to effect carbonization by means of superheated steam. A process by Vignole is described in detail in Dr. Vogel's "Der Torf," p. 131. All such processes remained in the experimental stage, their development being prevented by the installation and working expenses being too high.

*(a) Carbonization in Piles*

The construction and the manipulation of the piles are the same as for the carbonization of wood, but the supervision of the piles and the correct carrying out of the process of carbonization are much more difficult for peat than for wood.

In most cases the piles are made in the bog itself, and for this purpose the site of the pile is levelled and surrounded by a trench so that it may be properly drained and dried. A so-called chimney pole or chimney shaft is erected at the centre of the site. The base of the pile slopes from the centre to the circumference, so that the water vapour or other volatile products, which may condense below during the carbonization, can drain away the more easily. If the base cannot be well dried, and therefore the lower layers of peat remain uncarbonized on account of the moisture coming up from the ground, or if there is danger of the pile sinking somewhat through its own weight, wooden poles 10 cm. in diameter are laid radially close beside one another from the circumference to the central stake, and these when covered with charcoal dust or dry sand form a good dry base for the pile and last for several carbonizations. A quantity of easily inflammable material—wood, straw, saw-dust, &c.—sufficient to ignite the pile, is made into a heap at the foot of the chimney pole, and round this the lower layer of the pile is built of upright peat sods inclined slightly to the chimney pole. The various layers are then heaped over one another on these sods, but in such a way that the surface of the pile tapers like an egg at the top. A firing channel extending to the circumference must be left in the lower layers so that the pile can be ignited from the centre outwards. Moreover, care must be taken to see that the sods are laid in rows so close and so regular with respect to one another that intervening spaces filled with air do not occur.

According as strong twigs of trees and shrubs or sods are available, the whole external surface of the pile is covered with these so that the layer of earth or charcoal dust which is next put on and which cuts off the pile completely from the air will not sink into the peat. The thickness of this cover may decrease from 30 cm. at the base to 15 cm. at the top.

When the combustion of the pile has been started by firing the fuel in the igniting channel and that round the chimney pole, and when after a few hours the fire has progressed upwards round the chimney pole so that the carbonization can begin, the cover of the pile, which up to that time has been kept open for 30 cm. round the pole, and the igniting channel are closed. The pile is then left to itself for several hours in order that all the layers of the peat in it may become uniformly heated ("sweated"). Any holes or depressions formed during this time by irregular burning and settling of the peat layers round the pole must be refilled with fresh peat, after removing the cover at the spot, which must be again replaced.

The fire is led from the centre towards the circumference and gradually from above downwards by means of several air holes.

30 mm. in diameter, made in the cover, until the mass is uniformly carbonized.

Owing to the many interstices which are unavoidably produced in spite of the greatest care during the building of the pile, and which become still bigger as the peat contracts during the carbonization, and owing to the irregular sinking of the various peat layers due to want of uniformity in the contraction, especially when carbonizing cut peat from bogs, the layers of which differ a good deal from one another, the peat pile settles in a very irregular manner, producing clefts and fissures in its cover. It is very difficult therefore to keep it compact, and in spite of the "green" cover one can scarcely prevent a good deal of the earthy coating from slipping into the pile and endangering the draught. Since when re-making the pile, and also when the cover becomes torn, air always gets into the carbonizing space, decrease in the output of the pile is associated with this, and the charcoal burner has to watch a peat pile with much greater care and circumspection than a wood pile if he is to obtain equally good results.

Moreover, we have still the difficulty of extinguishing the pile when the carbonization is finished. Peat charcoal keeps burning longer than wood charcoal, and also it cannot be extinguished with water, as wood charcoal generally is, since the water sprayed on some peat charcoals runs off them without producing any effect, and the water which penetrates other peat charcoals is converted into steam, breaking up and crumbling the charcoal, which is always friable. The only way usually left for cooling the pile and completely extinguishing the glowing charcoal is to put a coating of wet clay, 15 to 20 cm. thick, round it, and to make this compact by striking it with a shovel so that all entry of air will be prevented, and the fire will consequently go out.

The cooling of the fire nevertheless lasts two days, and the whole carbonization, the burning and the cooling of a pile, lasts from eight to twelve days.

To prevent the occurrence of the evils mentioned above, peat sods as large, dry, and compact as possible should be employed in the formation of the piles, which generally have a volume of 80 cb. m.

The output of charcoal when the carbonization is carried out in piles amounts to 28 to 35 per cent., averaging 30 per cent. (by weight), but in the case of good, dry machine peat it may reach 40 per cent.<sup>1</sup>

---

<sup>1</sup> Occasionally in Sweden a process is employed for the production of small quantities of peat charcoal, which process has been adopted in North Germany, rather owing to its simplicity than to the yield obtained, and which must therefore be mentioned here.

The owner of the Wartofta estate in Skaraborgs Lehen, Lieutenant C. Storkenfeld, wrote as follows in his pamphlet "Om Brännorf":—

"A very simple method, and one which never fails after some experience of it has been acquired, is to burn the charcoal in a trench dug in the ground, lined with stones like a shaft. Pieces of wood laid on the bottom of the trench are ignited and more or less small pieces of peat are thrown on these until the layer is 30 to 40 cm. in height. When this layer is burning so

*(b) Carbonization in Clamps*

Carbonization of peat in clamps, like that in piles, takes place, on the whole, in the same way as the carbonization of wood. The clamps are 2 m. in breadth and 15 to 20 m. in length. Air passages are left from the various chimney poles to the sides of the heap so as to give a better draught. In order to control the direction of the combustion, holes are opened in the layers at various heights. The precautions necessary are exactly the same as those for carbonization in piles. The fire, which is started at one of the narrow faces, advances about 0·5 to 0·8 m. each day. The whole time required for the carbonization depends therefore on the length of the clamp. The output of charcoal is the same as that for carbonization in piles and in both processes the quality of the charcoal depends on the nature of the peat carbonized.

*(c) Carbonization in Ovens*

This process was introduced in the last century in order to counteract the difficulties occurring, and not always capable of being overcome, in ordinary carbonization in piles or heaps.

The ovens employed for this purpose generally consist of fixed pile walls of stonework or cast-iron, the form of which is cylindrical in order to facilitate their construction. Each oven has an opening in its straight, or vaulted, roof for the addition of fresh peat, and another at its base for removing the charcoal. It has, moreover, a fireplace under, or in front of, it with a fire door where the fuel necessary for starting the carbonization is burnt. As soon as the oven is filled with peat the latter is ignited through the lower fire opening. When the contents of the oven are burning uniformly, which can be the more easily secured by opening or closing air holes which are sometimes made in the lower part of the oven, entrance of air into the interior of the oven is prevented by closing all the fire holes, draught holes, and air holes in the lower part of the oven. The peat gradually glows, settles to about one-third of its original volume, to which it is again restored by filling in fresh peat through the upper opening, and when smoke ceases to escape

---

well that the flame rises between the pieces of peat, the whole trench is gradually filled with peat, and finally a heap of the latter is made on top. The trench should not be filled too quickly, one to one and a half hours being required for the operation, according to the dryness of the peat. When the combustion has proceeded until the heap, as it settles, becomes level with the ground, the pile is extinguished by laying on it some flags over which clay is thrown.

“ The pile cools in four days and the charcoal, which contains not even the slightest (?) admixture of ash, is then taken out. This charcoal is so active that it corresponds to three times (?) its weight of wood charcoal, and is therefore of great advantage in the forge.”

Unfortunately particulars with regard to the output of the peat charcoal by weight are wanting. According to other reports the output in this process is 30 per cent. by volume, which would be a very low one, as 60 per cent. by volume is obtained by the ordinary process of carbonization in piles.

through the latter this also is closed. The carbonization is usually completed in four days, and the cooling requires at least the same amount of time.

Although most of the evils encountered in carbonization in piles are avoided by working with these ovens, the yield is not appreciably improved. The ovens suffer still more from the defect observed in the case of piles, that the contraction of peat which is ignited and gradually carbonized from below upwards produces a diminution in volume and therefore more or less large interstices, which generally give rise to irregular slipping of the upper layer of peat. This slipping, together with the weight of the peat layer, which is several metres in height, acts very injuriously on the compactness of the peat charcoal already formed farther down, and which, in the glowing condition, has not much strength. This is also the reason why many small pieces of charcoal, much waste and dust are formed.<sup>1</sup>

In order to remove this defect ovens were constructed in which the peat burned from above downwards instead of from below upwards, as in the arrangement just mentioned.

(1) *Hahnemann's oven* (Fig. 126) is one of the oldest furnaces of this kind. It consists of a shaft oven, open at the top, 5 m. clear height and 2 to 2½ m. clear width. The sole of the hearth is spherical in section. On one side, and at the lowest part of the shaft, an opening *C* is left for removing the charcoal. On the opposite side there is a tube *r*, passing outwards through the stonework from the lowest point of the sole, through which the gaseous products are led into a receiver placed outside the oven. An earthenware pipe *E*, glazed internally, 6 m. in height and 40 cm. in diameter, is placed in the centre of the shaft and is fixed in the sole. Just above the sole this pipe has several air holes and draught holes corresponding to the internal cross-section of the tube.

When such a carbonizing oven is filled with peat and the discharging opening *C* is closed, the peat is then ignited at the top. When the upper layer of peat is glowing uniformly, the top of the shaft is closed by means of an iron cover, made in two halves, and all the crevices are plastered. The gases formed by the combustion and carbonization are thus compelled to pass down through the whole of the peat to the sole, and from there they escape through the draught holes and the tube *E*. When the glow has reached the sole the fire is extinguished by closing the oven everywhere as air-tight as possible, and then letting it cool of its own accord.<sup>2</sup>

The irregular slipping of the non-carbonized peat into the interstices which are constantly being formed under it as the

---

<sup>1</sup> Ovens such as these, which did not give particularly good results, and which were gradually abandoned, are described in Dr. Vogel's "Der Torf," pp. 108-117, Muspratt's "Chemie," iii, Dr. Schenck's "Rationelle Torfverwertung," p. 34, and other publications.

<sup>2</sup> A carbonizing oven of this type, constructed entirely of iron, has been made by Moreau and Sons. An illustration of one of these ovens is given in Dr. Vogel's "Der Torf," p. 119.

carbonization progresses in the case of the older ovens already mentioned, as well as the injurious effect of this on the charcoal. are not experienced during the working of this oven, which is very simple in construction, since the charcoal is always on top of the

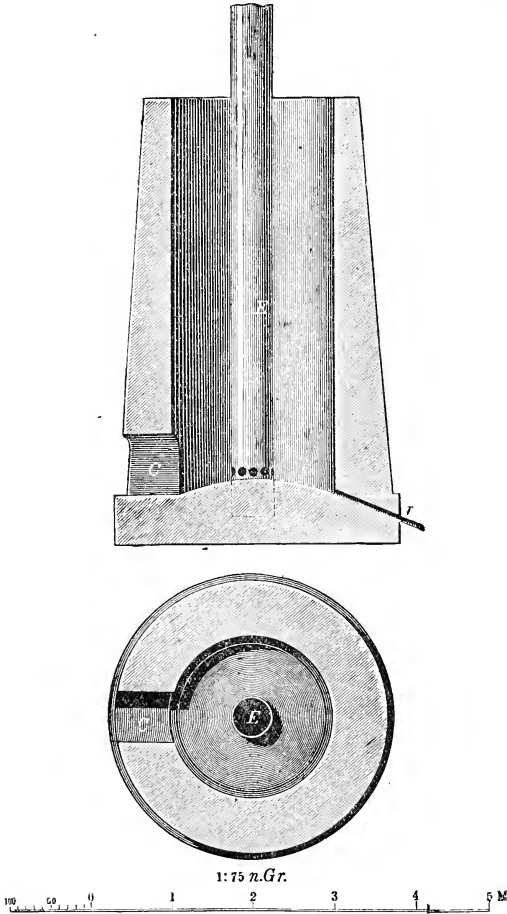
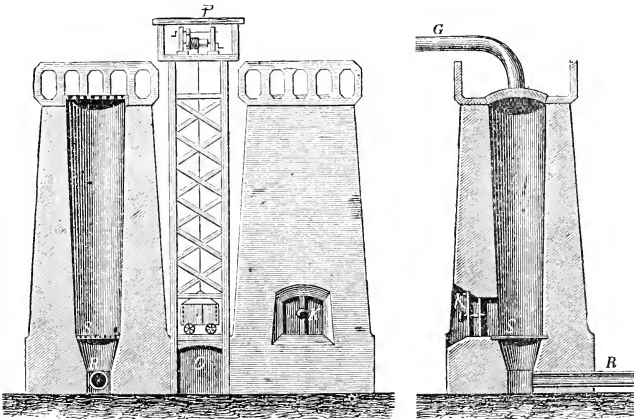

FIG. 126.—Hahnemann's peat-carbonizing oven.

raw material and the contraction associated with the carbonization gradually goes on from above downwards, and owing to the slight pressure between the pieces of charcoal these always lie on one another more or less lightly.

(2) *Wagenmann's oven*<sup>1</sup> (Figs. 127 and 128) may be regarded as an improved form of oven in so far as the shaft tapers from above downwards according to the degree to which the peat contracts on carbonization (if the peat does not contract too much the ratio in which the oven tapers is 5 : 4), and therefore the gentle subsidence of the various pieces of charcoal is assisted, inasmuch as the charcoal presses from behind into a tapering space, the decrease in the size of which corresponds to that due to the contraction associated with the carbonization of the peat.

This oven differs from the others also by the carbonizing chamber ending in a grate *S* instead of a hearth, and by the combustion gases being led away through a tube *R* which is connected with an air-pump. The mouth of the shaft is covered by



Figs. 127 and 128.—Wagenmann's peat-carbonizing oven.

a plate provided with air holes, the openings of which can be regulated or completely closed by means of a slide. The opening *R* can also be closed tightly by a plate.

The working of this oven is started in the same way as that of the preceding, but here there is still another advantage, inasmuch as the draught can be adjusted as required both by means of the slide in the upper cover plate and by the greater or lesser action of the pump. The oven shown in Figs. 127 and 128 is a double one. The peat is raised to the top of the oven by means of an elevator *O P*.

For the same raw material the yield of valuable, large pieces of charcoal from these ovens was far better than that from piles or ovens in which the direction of the draught was from below upwards. The yield by weight was on the whole 40 per cent.

In the case of one of these ovens in good working order, even

<sup>1</sup> Dr. Schenck's "Rationelle Torfverwertung," p. 35.

if a less valuable fuel than that to be carbonized (usually the best of the winning) is added as fuel to produce the carbonization we are still unable to prevent a part of the more valuable peat from being

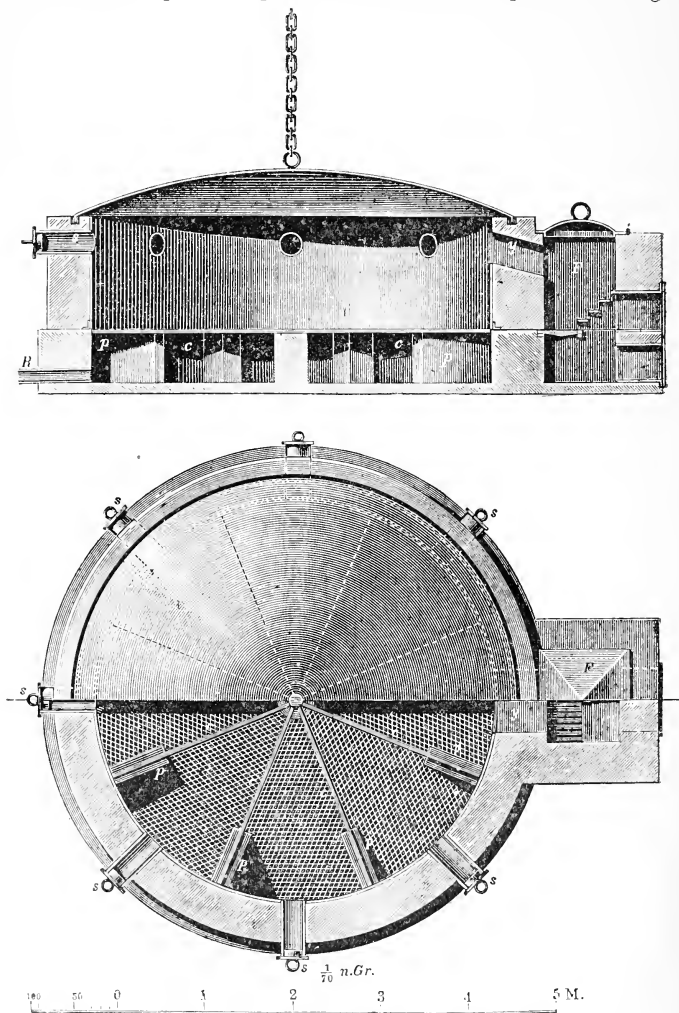

FIGS. 129 and 130.—Weber's peat-carbonizing oven.

lost by combustion so long as the gases necessary for the carbonization are developed in the carbonizing chamber itself by the combustion of a portion of the charge in a limited supply of air.



To avoid this loss and to be able to utilize the least valuable material in a bog for producing the heat required for the carbonization Dr. Schenck generated gases from this less valuable material in a special furnace, provided the top of Wagenmann's oven with a tightly fitting cover (Fig. 128), and led the gases from the gas furnace by means of a tube *G* through this cover into the carbonizing chamber.

By regulating the current of gas the temperature of the oven could be raised or lowered as required and the entrance of excess of oxygen into the carbonizing chamber could be prevented. The useful fuel contained in the peat remained, therefore, unburnt and a better yield of charcoal was obtained.

(3) *Weber's Carbonizing Oven* as used at Staltach (Figs. 129 and 130), was constructed in a similar manner. In this case also less valuable fuel was burnt for the carbonization of the peat in a fireplace *F* alongside the carbonizing oven. The combustion gases entered through *y* into the carbonizing chamber, spread through this and carbonized the peat from above downwards. The progress of the carbonization could be inspected through the stirring holes *s*, all round the oven, which were 15 cm. in diameter and could be closed tightly by lids. By opening one or other of the stirring holes for a more or less long time and by poking the peat with an iron bar the combustion could also be regulated.

The oven itself was built of stones and was cylindrical in shape. It had a diameter of 4.5 m., a height of 1.3 m., and could take a charge of 20 cb. m. of peat. At the level of the base and across the whole section of the oven wire nets were stretched, and on these, which rested on iron rods *c* supported on pillars *p*, the peat was thrown.

The bottom was excavated to a depth of 50 cm. under the wire frame, and in the cavity thus made the heavy tarry vapours, formed during the carbonization, collected and were led away through a wide tube *R*, which was connected with the air-pump, and when the latter was working these vapours, together with the other combustion gases, were drawn out of the oven.

The lid of the oven was made of plate-iron. Its edge, which was turned to a depth of 80 mm., fitted into a groove in the oven which was filled with sand, and in this way it was possible to make the joint air-tight. The lid was raised by means of a chain which was fastened to the centre of the lid and ran over a shaft fixed in the roof. When the oven was full the lid could be again lowered.

The fire was kept going in the fireplace for twenty-four hours, after which time the carbonization was complete. The oven was then left cooling for the same period and finally emptied.

Two men could charge the oven in a day and empty it in half a day. The yield was 50 per cent. by weight and 76 per cent. by volume. As condensed, moulded peat was employed at Staltach, the peat charcoal obtained there, which was used in cupola furnaces, was very strong and compact. Its density was 0.30.

(d) *Carbonization of Peat in Muffles by means of Radiated or Conducted Heat*

Partly in order to cut down the expenses by using less valuable fuel for producing the heat required for carbonization, partly in order to obtain a better yield of charcoal by carbonizing in the total absence of air, and partly to be able to collect with greater certainty and convenience the by-products of the gasification—tar, acetic acid, ammonia, &c. (by the utilization of which, increase in the earnings was to be expected)—closed stonework or iron muffles or retorts for containing the peat to be carbonized were constructed. Round these the combustion gases, produced in a fireplace in front of, alongside, or under the muffles, were led so that their heat was imparted as fully as possible to the walls of the muffles. Owing to the heat developed in the muffles, from which air was completely excluded, the carbonization of the peat took place with separation of the above-mentioned decomposition products, the volatile constituents (tar, peat oil, and ammonia) of which were led through a tube to a condenser while the charcoal was left in the muffle.

The results did not, however, altogether correspond to expectations, as the consumption of fuel was relatively high (33 per cent. of the peat to be carbonized) and the output of charcoal, both as regards quality and quantity, was not appreciably better than that obtained by carbonization in piles. Moreover, the gain due to the utilization of the by-products (see the following section) did not correspond to the expense incurred in their further treatment.

Only under particularly favourable conditions, when the prices for wood, charcoal, or coke were high, when the fuel required for the carbonization could be assumed not to cost much and when the yield of tar was good, was this carbonizing process able to secure a permanent footing in a few localities.

The oven described below may be regarded as typical of the better contrivances of this class employed in their time.<sup>1</sup>

These carbonizing plants, which are provided with separate firing arrangements, are called muffle or retort ovens in order to distinguish them from the pile ovens mentioned in the preceding subsection, and are subdivided into vertical and horizontal muffles. The vertical ovens are usually made of fire-bricks or stones and the horizontal of iron.

These ovens were constructed (a) with vertical axes by Jüngst, of Lingen, in Hanover, and (b) with horizontal axes by Lottmann, of Josefthal, in Bohemia, amongst others.

---

<sup>1</sup> Several of the older contrivances will be found in Dr. Vogel's "Der Torf."

(1) *Jüngst's Peat-carbonizing Oven*

Figs. 131 and 132 show several ovens of this type arranged in a row beside one another.

The carbonizing chambers *A* have a height of 5 m. and a clear width of 3 m. at the bottom and 1.5 m. at the top. The heating holes *c* and the grates *d* have a width of 52 cm., a height of 60 cm., and a combustion surface of 0.1 sq. m. The discharging openings *b* are 0.6 m. wide and 0.9 m. high. The space intervening between the cover of the oven and the shaft itself is 0.5 m. at the base. The cover is  $1\frac{1}{2}$  bricks and the muffle shafts  $\frac{1}{2}$  a brick in thickness.

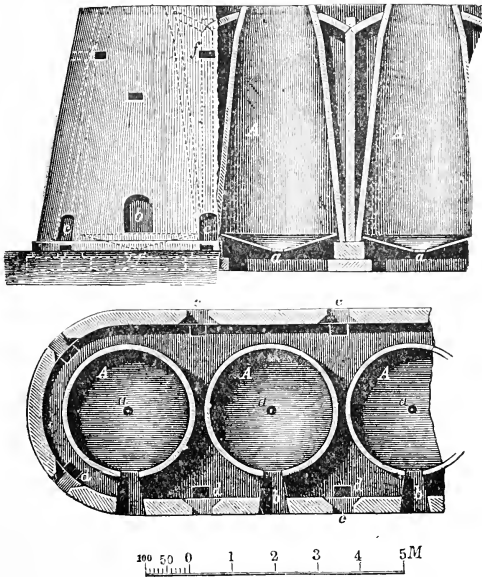

FIGS. 131 and 132.—Jüngst's peat-carbonizing oven.

The gases from the fires play round the muffles and escape through the draught holes *f*. The exit *a* for the volatile gasification products in the funnel-shaped bottom of the muffle is arched over with peat when the oven is being set and then the muffle is filled from the top, the opening *b* is walled up and the upper mouth is closed by a lid sealed with sand. The fire ignited on the grate *d* is at first kept burning gently for twenty-four hours and is then made burn strongly for sixty hours, the liquid flowing out of *a* being kept under observation all the time. At first the liquid is aqueous, later it becomes tarry, and when it begins to smell all the heating and draught openings are closed. The charcoal can be removed after three days, and the whole carbonization lasts, therefore, about seven days.

Attempts have been made in the case of this mode of carbonization to drive out the water separately during the gentle heating to which the peat is first subjected and to retain the tarry constituents in the upper part of the muffle, so that they may be re-absorbed by the porous charcoal as this cools, thus making the charcoal more compact, but these attempts have been only partially successful. The charcoal in the upper layer is, nevertheless, the best.

At the Alexis Works, at Lingen, where these ovens were used for some time, cut peat from Burtang Bog and dredged peat from Rupenest Bog were carbonized. The weekly output of an oven was 1,150 kilos of charcoal with a fuel consumption equivalent to 25 to 30 per cent. of the peat carbonized. The yield of charcoal by weight is said to have been 40 per cent. for light peat and 60 per cent. for dredged peat.

### (2) *Lottmann's Peat-carbonizing Oven*

The chamber ovens erected at the Josefsth Iron Works by the Mining Superintendent Lottmann, fifteen of which were in regular operation in 1860, each consisted, as Figs. 133 and 134 show, of a vaulted room having an egg-shaped plan, which was 2.8 m. in width at the wider and 2.3 m. at the narrower end. The chamber itself was formed by the inner cover *h*, which tapered at the top into the stonework of the outer cover. The firing was carried out on the central grate *a* and on the two side grates *b b*.

The combustion gases formed at the grate *a* were led to the chimney *g* through the conduit *f*, not, however, directly, but, in order that the peat in the centre should be also heated and carbonized, they were forced by interposed partitions to pass through U-shaped cast-iron tubes *r*, 24 cm. wide, and to give up a portion of their heat to these. The gases developed on the side grates *b b* played round the thin walls of the chamber through the intervening spaces *m*, and then escaped through the slide valves into the chimney.

The charging of the oven, which required 25 cb. m. of peat, was effected through the door *t* and the charging holes *o o*. When the oven was full the carbonizing chamber was slowly heated. As the temperature increased the valves, which at first were all open, were closed as far as the lowest. The gasification products escaped through two waste pipes, 20 cm. wide, which were attached near the crown of the arch and which ended in a condenser. After six to eight hours' heating peat was again added through the charging holes *o o*, and this operation was repeated once more later on. The heating lasted fifty to sixty hours and could be regarded as finished when the waste pipes, in spite of the heating, began to grow cold and the condensed gasification products, together with the outflowing tar, consisted of a liquid which had a wine-red colour. The air holes in the surrounding walls were then opened and the oven was cooled in about three days by the cold air streaming between the chamber and the surrounding masonry

to the chimney. The work was regulated so that the oven was filled on Tuesday, the carbonization was finished on Thursday, and then on the following Monday, when the oven was cold, the charcoal was withdrawn.

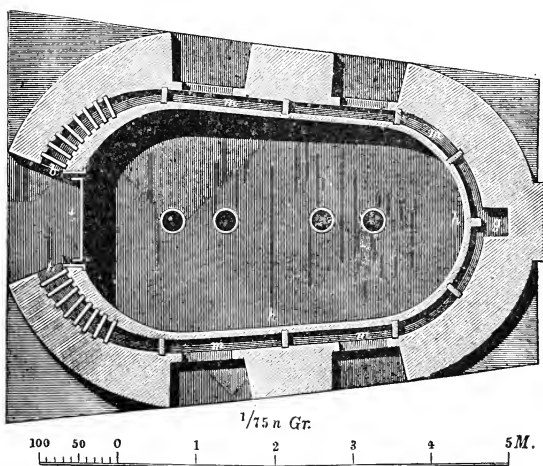
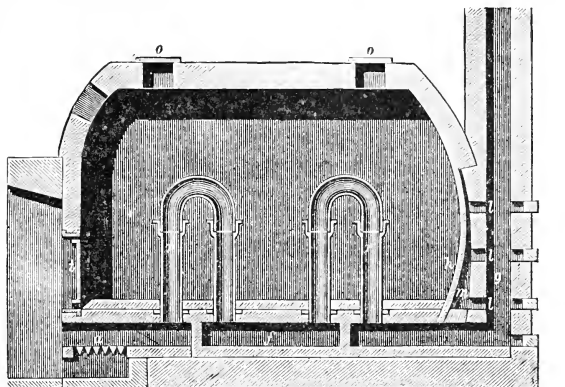

FIGS. 133 and 134.—Lottmann's peat-carbonizing oven.

The volume of the oven was 20 cb. m., but in the early stages of the operations another 5 cb. m. of peat were added. One thousand sods, 26 x 13 x 13 cm., when heated by means of 460 sods (i.e., 45 per cent.), for which, as a rule, waste peat was employed, gave 25 cubic feet (German) or 8 hl. of charcoal, 1 cubic foot of which

weighed 3·5 kilos when fibrous peat and 6 kilos when bituminous peat was used for the carbonization.

For use in blast furnaces the charcoal was mixed to the extent of half to two-thirds with wood charcoal. It was also employed with advantage for smelting iron, the peat charcoal from the bituminous peat of the locality completely displacing soft wood charcoal billets for this purpose. The following table indicates the nature of the peat and of the product obtained from it by carbonization.

Substances carbonized.	Light fibrous peat.	Compact fibrous peat.	Bituminous peat.
	Per cent.	Per cent.	Per cent.
Water .. .. .	18	26	20
Charcoal .. .. .	30·00	33·43	30·34
Tar .. .. .	6·00	4·68	6·96
Tar-water .. .. .	33·00	42·50	37·50
Gases .. .. .	31·00	19·29	25·20
Percentage of ash in the peat ..	1·34	1·35	1·87
Percentage of ash in the charcoal ..	3·33	2·99	4·93
Density of the peat .. .. .	0·26	0·52	0·48
Density of the charcoal .. .. .	0·230	0·208	0·355

The working of these chamber ovens can scarcely be said to be economical, since with a fuel consumption of 45 per cent. the yield of charcoal, between 30 and 40 per cent., is obviously small, while equally good, and even better, results are obtained with the above-described pile ovens without any special expenditure for firing.

### (3) *Carbonizing Ovens with Horizontal Iron Muffles*

The shape and the stonework setting for these are the same as for the muffles and retorts for coal-gas factories, to which a general reference is therefore given. As an example we shall give below only the chief dimensions of, and the results obtained in working, a peat charcoal factory erected by Dr. G. Thenius, for the Salzburg Peat Bog Utilization Company, which was, however, very quickly given up as it proved to be uneconomical.

The main building of the factory had a length of 38 m., a width of 13·3 m. and a height of 7·6 m. The peat carbonized was all kiln-dried, and for this purpose a drying installation was constructed with underground hot-air furnaces. The oven house was so large that it could conveniently take 12 ovens in 2 rows with 3 to 5 muffles in each oven, that is, 36 to 60 muffles in all. Wrought-iron muffles (Figs. 135 and 136) were employed to carbonize the

peat. Each muffle had a length of 2.20 m., a width of 0.93 m., and a height of 0.3 m. The pipe *R* was intended for the escaping tarry vapours and the ammonia water and was provided with a valve *s* for blocking off the vapours when desired. In the interior of the muffles and in front of the descending pipe there was a sieve *E* formed from a 20 mm. iron plate containing holes 26 mm. in diameter, the object of which was to prevent pieces of peat from falling down the pipe. It was found necessary to test the sieve plate frequently by means of pointed iron rods to see whether its holes were blocked or not.

Wrought-iron muffles were selected by the inventor because they do not crack so easily as cast-iron, because they are cheaper, and, also, when peat is used as fuel, last much longer than cast-iron

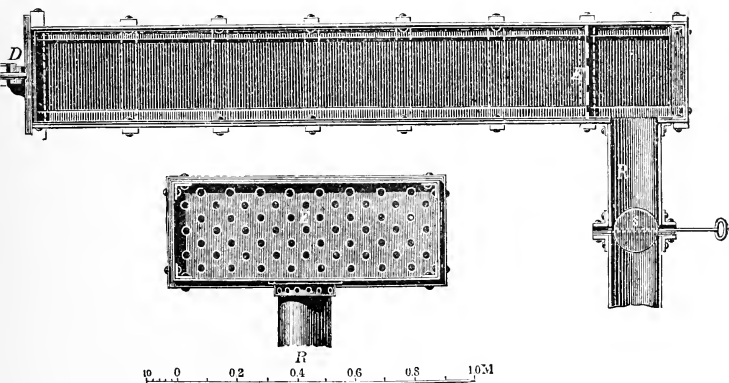

Figs. 135 and 136.—A wrought-iron peat carbonizer.

muffles, especially when they are surrounded by a thin covering of a refractory material.<sup>1</sup>

## 2.—Recent Methods of Carbonizing Peat

The progress of technics, especially of the art of firing and the advances made thereby in recent years in the coking and gasification of coal and brown coal, could not fail to have an effect on peat carbonization, which for the reasons given above had formerly been regarded as uneconomic, and therefore abandoned. The renaissance of peat carbonization was regarded as a "new solution of the peat problem." Several plans for the improvement of the process were proposed, and some were even put into operation on a large scale, but most of them after a short time were again given up as failures. Of these only the following

<sup>1</sup> For particulars with regard to manipulation of the retorts and the results obtained, see George Thenius's "Die Torfmoore Oesterreichs."

are worth mentioning, either because they were given in technical journals a quite unjustifiable importance by their discoverers and therefore the attention of peat owners was directed to them, or because the impossibility of their technical and commercial success cannot be predicted by mere consideration of the methods proposed for their application.

### 1.—*Process of Gumbert and Loe*

According to this process freshly slaked lime is to be added to the dried peat and the mixture is to be carbonized, with recovery of the by-products, then powdered, mixed with water, and made into press peat charcoal. The carbonizing oven contains several compartments, with sloping bottoms and tops, and a movable tube, according to the position of which the operation can occur with or without recovery of by-products.

The press peat charcoal is apparently intended to compete with press brown coal and coal for ordinary domestic or industrial firing.

It is *a priori* evident that this cannot be done with commercial success. Considering the prevalent prices for the commoner fuels (especially press brown coal and ordinary machine peat), as well as the decrease in weight due to the carbonization itself, the price of unit weight of the residual peat charcoal is much too high in comparison with the increase in the calorific power due to the carbonization.

Peat charcoal can be considered commercially only in relation to wood charcoal and coke, but the product obtained by this process would not, however, be able to compete with these substances. (Cf. the general statements with regard to the commercial value of peat carbonization.)

### 2.—*Ekelund's Process*<sup>1</sup>

Ekelund, of Jönköping, Sweden, bases his peat-carbonizing process, which is to bring about "the greatest possible utilization of large peat bogs, even those of Germany," on the experience that carbonization in ovens is the best of the older processes, but that it requires well-dried peat of as great a density as possible, and therefore machine peat, which is too dear for many purposes; while, on the other hand, it necessitates a great consumption of fuel for the carbonization itself, and nevertheless gives a poor yield and a very porous charcoal. In order to obtain a peat charcoal which could be generally used and would be marketable when in competition with coal (!) we should not regard good air-dried or indeed kiln-dried peat as a preliminary essential for the manufacture of peat charcoal on a large scale, nor should we use the

---

<sup>1</sup> Further particulars are contained in the pamphlet "Die Herstellung komprimierter Kohle aus Brenntorf," by H. Ekelund, Leipzig, 1892.



more or less dear machine peat for this purpose. We should rather employ ordinary half-dry cut or hand peat such as can be won in almost unlimited quantities in any bog during summer and winter even in unfavourable weather conditions, or may be bought locally at very low prices.

According to Ekelund's process, by employing suitable ovens with a fore-drying chamber,<sup>1</sup> hand peat with 60 per cent. of moisture can be carbonized with the same consumption of fuel as was required for peat with 30 per cent. of moisture in the other ovens. Since the carbonization in the oven with direct heating does not require more than one-tenth of the fuel necessary for retort or muffle carbonization, the result is that he can carbonize in his oven the same quantity of peat with, however, 60 per cent. of moisture, by means of one-tenth of the fuel with which this amount of peat containing 30 per cent. of moisture can be carbonized in a muffle.

Ekelund estimated the income of a factory with a yearly output of 100,000 hl. (8,000 m. tons) of a dense peat charcoal from the results of large scale experiments as follows :—

	Kronor. <sup>2</sup>
760,000 hl. of raw peat at 5 öre .. ..	38,000
50,000 hl. fuel peat (machine peat) at 12 öre..	6,000
3,000 days' work by labourers at 2 kr. ..	6,000
Cost of supervision .. ..	5,000
Interest and amortization .. ..	11,000
Sundries .. ..	4,000
Total .. ..	70,000

This gives for 100,000 hl., when these are sold at the low price of 1 kr. for 1 hl., or 12·50 kr. per metric ton, a gain of 30,000 kr.

Ekelund calculated the installation costs for such a single-oven plant at only 16,500 kr., and for a double-oven plant, with twice the output, only a further 6,500 kr. would be required.

The expectations based on these proposals and estimates have not been realized. The experimental factory, which was erected at the time, was very soon obliged to shut down. Ekelund himself and his fellow-countrymen have not pursued the matter any further.

<sup>1</sup> For this purpose Ekelund provides his carbonizing oven with an upper compartment in which the fresh peat, packed into the oven for carbonization, is heated and dried beforehand, also with another compartment under the oven into which the finished charcoal is let fall while the fore-dried peat is being filled into the oven from the upper compartment. Continuous working is thus made possible. The heat withdrawn from the finished charcoal as it cools in the lower compartment is utilized by means of suitable contrivances for carbonizing in the middle, and fore-drying in the upper, compartment.

<sup>2</sup> 1 Swedish krone = 100 öre = 1·125 M. ∴ 1 öre = 1½ Pfg.

### 3.—*Jebsen's Electrical Process and other Electrical Processes*

According to this process the peat when dried in the air or to some extent artificially is carbonized completely by heating it by means of an electrical current in air-tight muffles (retorts). The gases which are formed are led through the cover of the muffle and utilized for heating the drying rooms. From 100 kilos of air-dry peat, 33 kilos of peat charcoal, 4 kilos of peat tar, 40 kilos of tar-water, and 33 kilos of gases are obtained. The charcoal, which is very compact and has a deep black colour, contains 76·91 per cent. carbon, 4·64 per cent. hydrogen, 8·15 per cent. oxygen, 1·78 per cent. nitrogen, 3 per cent. ash, 0·70 per cent. sulphur, and 4·82 per cent. volatile matter. The electric current is generated by five dynamos, each of which has an output of 80 kw. and is driven by a 128 h.p. turbine.

This process, which was at first reported upon very favourably in Norway, can perhaps be utilized there where the electric current may be generated by means of water power which cannot be otherwise utilized at the given locality. Under other conditions the process cannot be regarded as affording any prospect of commercial success. Even the factory in Norway has already been shut down.

Similarly, other electrical processes for carbonizing peat, e.g., that of the Electro-Peat-Coal Syndicate in England, that of the Pentane Works at Tilsit, and of the Osmone Works in Switzerland, have not proved successful. The factories erected in 1908 to 1910 by the above-named companies have ceased working, and the companies have been dissolved.

### 4.—*Ziegler's Process*

As a result of the experience gained by him in brown coal distillation, the civil engineer Ziegler, of Berlin, has devised a peat-carbonizing process by applying and suitably modifying contrivances which have proved successful for the gasification of brown coal. The process was first tried at Oldenburg during the years 1894 to 1897, and after having been repeatedly improved it remained in use up to 1913. Notwithstanding the favourable report of the deputy sent by the State to examine and report on the factory<sup>1</sup> it has not met with a satisfactory commercial success. The factory belonging to the International Peat Utilization Company, later called the Oldenburg Peat Coke Works and Chemical Factory, which was equipped with five ovens for work on a large scale, produced a good marketable charcoal, was said to show a satisfactory profit, and gave rise to the construction of

---

<sup>1</sup> This report is published in the October number of the *Verhandlungen des Vereins zur Beförderung des Gewerbflusses*, 1903, Berlin, and is supplemented by some remarks by Ziegler in the December number. See also *Mitteilungen d. V. z. F. d. Mh.*, 1904, pp. 14 and 32.

similar factories at Redkino (Russia), Beurenberg (Bavaria), and other places, which, however, have not fulfilled the expectations entertained with regard to them.

Ziegler, like Ekelund, strove to utilize the heat of the non-condensable gases, given off during the carbonization, for coking the peat so that for heating the carbonizing ovens no fuel should be required except these gases. Ziegler, however, laid great stress, for the commercial success of his process, on the winning and utilization of the condensable substances—tar, ammonia, acetic acid, &c.—carried over in the waste gases, since otherwise the peat charcoal won would be too dear. He also considered it important that the work should be continuous, and that the charcoal obtained should be compact and suitable for smelting purposes.

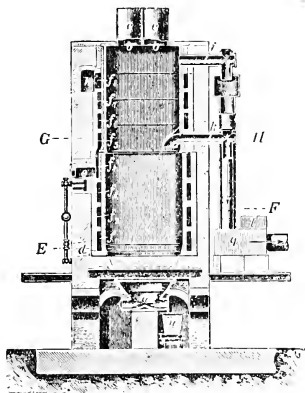

FIG. 137.—Ziegler's peat-carbonizing oven. Vertical section.

The heat set free during the carbonization is used for concentrating the by-products, and the waste combustion gases from the fire, employed to heat the oven, are mixed with air and used to dry the peat. Here, as in Ekelund's process, an attempt is made to utilize for large scale operations a raw peat which is not quite air-dry, and thus make the process independent of the weather in so far as relates to the winning of the raw material.

The problem of producing a charcoal sufficiently strong for metallurgical purposes is solved in Ziegler's process, as is made clear on p. 389, by carbonizing only machine peat in as dense a condition as possible.

The Ziegler peat-carbonizing oven<sup>1</sup> contains, according to a pamphlet on the process distributed by the Peat Coke Industry Co., Ltd., of Berlin, two adjacent muffle shafts, oval in cross-section, the lower portions of which are made of fire-brick and the upper of cast-iron surrounded by fire-brick (Figs. 137 to 139).

<sup>1</sup> Compare the Letters Patent 101482 and 103507.

The muffle or retort shafts rest on a common cast-iron base *d*, which is provided with two discharging openings *a* for removing the charcoal. The two shafts are provided at the top with hoppers *c*, which can be tightly closed. Between the two walls there are

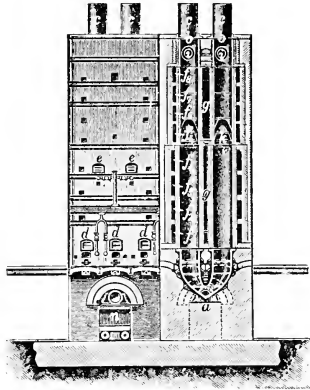

FIG. 138.—Ziegler's peat-carbonizing oven. Outside view and section.

passages  $f_1$  to  $f_8$  for the combustion gases. The dimensions of the ovens are such that in twenty-four hours 18 m. tons, or in a year 5,000 m. tons, of air-dry peat, containing 20 to 25 per cent.

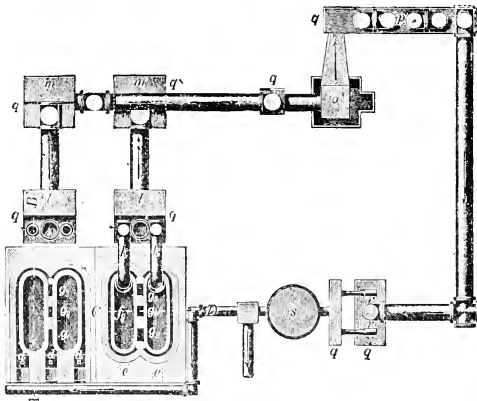

FIG. 139.—Ziegler's peat-carbonizing oven. Horizontal section.

of moisture, can be carbonized. Experience shows that the amount of non-condensable gases formed is sufficient for heating the ovens and boilers in the factory. The ovens have three lower *d* and two

upper *e* fires for heating them. The combustion gases pass successively through the passages  $f_1$  to  $f_8$ , lying over one another, and then go through the flue *h* into the drying rooms or the chimney. In order to be able to watch the ovens and measure the temperature during the operation, each fire passage has a spy-hole in the front and in the rear side of the ovens. In the lower fire passages the temperatures are about  $1,100^\circ$  C., and in the upper  $600^\circ$ ,  $500^\circ$ , and  $400^\circ$  C. (The combustion gases, escaping with a temperature of  $300^\circ$  C, are used in the new installations for drying, in separate drying rooms, any peat which may be too moist for use.)

In the interior of the oven the temperature rises to  $600^\circ$  C. The heat contained in the gasification products (water vapour and tarry gases), which escape from the oven shafts through the tubes *i* and *k* at a temperature of  $200^\circ$  to  $300^\circ$  C., serves for evaporating in the pans *l* and *m* the ammonium sulphate and calcium acetate solutions obtained from the tar-water.

The ovens, after they have been charged with raw peat, are heated at first by means of peat. After forty-eight hours so much non-condensable gases are evolved that the firing with peat can be stopped and the heating continued by the combustion of the gases given off. The air required for the combustion is previously heated in the cast-iron chamber under the oven, and at the same time the finished charcoal is cooled there. The regular working now begins; every hour the charcoal is allowed to fall through the discharging openings right and left alternately into cars *n*, which can be closed air-tight and in which the charcoal must be left until quite cold. Fresh peat is added to the ovens through the hoppers *c c* after each withdrawal of the charcoal from the ovens, and the work is therefore continuous. The water vapour and tarry gases formed by the carbonization of the peat in the oven shafts are drawn off by an air-pump *o* and driven through a tubular receiver *p* in which they are cooled by the air, with condensation of tar and tar-water. The non-condensable gases are driven through a safety contrivance, and then utilized for heating the ovens, boilers, &c. Fuel is therefore required only for starting the firing of the ovens and boilers. The gases can develop about 1,200 kilo-calories per cubic metre, and may also be utilized in gas engines.

In addition to the peat charcoal, a product termed by Ziegler "peat-heating coke" or "brown coke," but better named "semi-coke" or "oven-charcoal," could be prepared in the Ziegler carbonizing oven without modifying the plant. This was an incompletely carbonized product from which, in addition to water, only small quantities of tar and gases had been removed. It resembled the peat charcoal and was almost as strong and compact as the latter. Even when allowed to remain for a long time in water it did not absorb the water. The peat-heating coke was obtained by allowing the peat to pass through the oven more rapidly than it did when peat charcoal was being won. It was therefore not fully carbonized.

In carbonizing (coking) air-dry machine peat (containing 20 to

25 per cent. of moisture) the Ziegler ovens gave on an average the following results :—

	During the manufacture of peat charcoal.	During the manufacture of semi-charcoal.
1. Peat charcoal or peat semi-charcoal ..	35	50
2. Peat tar .. .. .	4	2
3. Peat tar-water .. .. .	40	36
4. Gases .. .. .	21	12
	100	100

The peat charcoal as it came from the oven was a perfect substitute for wood charcoal and in many cases even for coke. It was obtained in large, sod-shaped pieces. This peat charcoal was porous like coke, but rang hard, and could be so far sintered in the Ziegler ovens that, unlike wood charcoal, it withstood pressure as well as coke.

On examination of peat charcoal, peat semi-charcoal and wood charcoal, the following results were obtained :—

	Peat charcoal from a high-bog peat poor in ash.	Peat semi- charcoal	Wood charcoal.
Carbon .. .. .	84·23	73·50	85·18
Hydrogen .. .. .	1·93	3·59	2·88
Nitrogen .. .. .	1·49	—	—
Oxygen .. .. .	6·28	14·41	3·44
Sulphur .. .. .	—	0·20	—
Ash .. .. .	3·09	2·50	2·46
Moisture .. .. .	4·47	4·34	6·04
	100·00	100·00	100·00
Calorific power.. .. .	7,042 c.	6,776 c.	7,670 c.

The peat tar obtained by this process resembles brown coal tar, and differs from it only by containing considerably more creosote.

Like brown coal tar, it can be separated by distillation into wax and illuminating oil.

The commercially saleable products from 100 kilos of tar are, according to Ziegler :—

- 10 kilos of paraffin wax melting at 48° C.
- 58 kilos of illuminating oil.
- 12 kilos of creosote oil.

The peat tar-water contained, so far as useful constituents are concerned, ammonia, acetic acid, and methyl alcohol.

From 1 cb. m. of the tar-water about 10 kilos of ammonium sulphate, 15 kilos of calcium acetate, and 15 kilos of methyl alcohol were recovered.

In a carbonizing factory of this type the following substances are obtained from peat in the order given :—

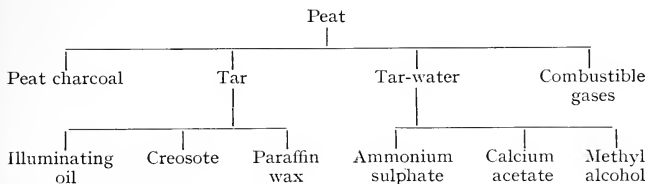

From the nature of the process there can be no doubt that the well-burnt peat charcoal thus obtained is generally equal in value to good wood charcoal both as regards its utility and its calorific power. According to a report from the Bleymüller blast-furnace works at Schmalkalden, it will withstand the pressure in blast furnaces having heights up to 12 m.

The saleability of the charcoal, as well as the commercial value of the whole process, depends on the cost of production of the peat charcoal, including freightage to the place where it is utilized, the selling prices of the by-products (tar, ammonia, &c.), as well as on the market price of the wood charcoal competing with it, or in the case of peat charcoal for heating purposes on the prices of brown coal and coal.

From the above particulars it follows that the commercial success of Ziegler's peat-carbonizing process depends on the winning and utilization of the tar and other volatile products, since if this is not done the charcoal will, without doubt, be too dear. If this is not sufficiently borne in mind, or if the utilization of the gasification products meets with difficulties, the profit expected from the undertaking will be endangered. This has been the case in the Ziegler factories which have so far been constructed, for instance at the large Russian factory at Redkino, which has eight carbonizing ovens and was intended for a yearly output of 500,000 pud, and at the factories at Beurenberg, where the winning of the quantity of air-dry machine peat necessary to keep the carbonizing plant working fully appears to have proved too troublesome and too expensive on account of the machines employed there being insufficient for the purpose.

##### 5.—Bamme's Peat-carbonizing Process

Bamme, like Ziegler, tried to utilize peat by carbonizing it, with recovery of the by-products. Carbonizing ovens for his process have been erected at Augustfehn (Oldenburg) and Stickhausen (East Frisia). Bamme's oven differs somewhat from Ziegler's. It is a chamber oven consisting of a number of compartments lying beside one another, which are provided with heating flues under it as well as in its two sides. The base of the chamber consists of a plane sloping at such an angle that isolated pieces of peat or charcoal will not remain lying on it. The main

effect of the inclined surface is that the peat which has already been carbonized to some extent continually slides to the lowest and at the same time the hottest place, where it remains about four hours, and becomes fully carbonized at the more or less high temperature which is constantly maintained there. The fires for heating the ovens are inside the stonework of the ovens and on a level with the base of the oven house. By using only refractory stones for the inside of the chamber and for the fireplaces we can prevent the walls of the chamber from burning away and keep them air-tight. In this process also, peat containing 25 to 30 per cent. of moisture is used. The charging takes place through a hopper which can be closed at the top and the bottom. When the chamber is full the heating of the oven with peat is continued until carbonization with development of gas sets in. The gases pass through the condenser, in which tar and tar-water separate, and the non-condensable gases are again led to the fires. After some time the amount of these gases is sufficient for the heating of the chambers, no other fuel being required for the continuation of the process. When part of the charcoal is finished, which may be seen by looking through the spy-holes, it passes into a cooling chamber which has movable shutters at its top and bottom, and from which it is withdrawn every four hours. According as the finished charcoal is removed from the oven fresh peat is fed into it and the work is thus made continuous. The discharging opening is above the sole of the oven house, so that working rooms lying under the surface of the bog are thus avoided.

The capacity of a chamber is 27 cb. m., corresponding to a charge of 8,000 kilos of peat containing 30 per cent. of moisture, which, when the carbonization lasts twenty-four hours, would give about 2,700 kilos of peat charcoal or "peat coke" by withdrawing it six times, i.e., every four hours. Bamme stated that the carbonization required only sixteen to twenty hours and that the output of a chamber was about 3,000 kilos in twenty-four hours.

He gave the yield as follows: Peat containing 30 per cent. of moisture gave:—

30	per cent.	water.				
35	"	peat charcoal or	50	per cent.	of the dry substance.	
4	"	tar	5.8	"	"	"
20	"	tar-water	28.6	"	"	"
9	"	gases	12.8	"	"	"
2	"	loss	2.8	"	"	"

1,000 kilos of the dry peat were said to give on an average 215 cb. m. of non-condensable gases, 1 cb. m. of which weighs 0.6 kilo and gives 5,000 kilo-calories on combustion.

According to the table on pp. 60–61, however, 143 kilos of peat containing 30 per cent. of moisture correspond to 100 kilos of dry peat, so that in the carbonization  $10 \times 43 = 430$  kilos of water must first be separated from the 1,000 kilos of dry peat, and the evaporation of this water would require  $430 \times 650 = 279,500$  kilo-calories. We have at our disposal in the non-condensable



(combustible) gases  $215 \times 5,000 = 1,075,000$  kilo-calories, so that 795,500 kilo-calories remain for the carbonization of the peat and the evaporation of the solutions, i.e., for the complete manufacture of 500 kilos of charcoal and the working up of  $58 + 286 = 344$  kilos of tar and tar-water.

With an installation capital of 200,000M. the profit was estimated at 45 per cent.

In this case also the hopes entertained with regard to the process were not fulfilled.

The actual profit derivable from a plant such as this is greatly affected by the factors and conditions which we have indicated already under Ziegler's carbonizing process.

### 6.—*Wielandt's Peat-carbonizing Process*

Dr. Wielandt, of Oldenburg, also regards peat carbonization with recovery of the by-products as a suitable mode of utilizing large quantities of peat. The peat-carbonizing factory at Elisabethfehn, which belongs to the Peat Coke Co., Ltd., and which has worked apparently with success since 1907,<sup>1</sup> contains three carbonizing ovens for the manufacture of about 10 m. tons of peat charcoal in twenty-four hours from approximately 34 m. tons of peat. It also contains the installations necessary for winning and storing the peat, a peat-tar still for working up the peat-tar to creosote oil, illuminating oil, paraffin wax, and pitch, and an evaporating plant for recovering calcium acetate and ammonium sulphate. The peculiarity of the process is that by means of a connecting tube between the top portion of the oven and the lower chamber in which the charcoal cools, and by displacing at the same time the point where the gas is drawn off towards the middle of the oven, connexion is made between the places where the steam and the gases are respectively generated. In this way it is only the considerable quantities of water vapour formed by the drying of the peat in the upper part of the oven which are drawn, as a natural consequence of the pressure relations, into the funnel in which the charcoal collects, pass through the middle portion of the oven in which the permanent gases and tar vapours are developed, and leave the oven together with these. This has valuable results, inasmuch as the glowing charcoal is cooled inside the oven itself before it leaves the latter. Also more ammonia is obtained by the action of the water vapour on the peat to be carbonized, the tar vapours are protected from too great a decomposition, and, finally, the temperature of the distillation is lowered. At the same time this results in an automatic regulation of the working of the oven. It is, moreover, said to be possible to carry out not only the heating of the ovens and

---

<sup>1</sup> Especially since 1914, when electrical driving of the peat dredgers for winning the peat was substituted for the driving with the benzine locomobiles used earlier. This resulted in considerably greater outputs from the peat machines and a saving in wages (cf. p. 155).

the recovery of the by-products by means of the gas itself, even in the case of more or less moist peat, but also to supply electrical power, cost free, for the peat machines on the bog.

Dr. Wielandt gives the costs of production for the charcoal as follows :—

For a factory with a yearly output of 12,000 m. tons of peat charcoal, including the writing off of the plant and deducting the income from the by-products, 1 m. ton of the peat charcoal would cost 18 to 20M., but if the factory had an output of 30,000 m. tons the cost would be less than 10M. per metric ton. The installation costs, excluding purchase of site, would amount to about 400,000M. for an annual output of 6,000 m. tons, to 700,000M. for 12,000 m. tons, and 1,500,000M. for 50,000 m. tons.

From the Elisabethfehn peat the yield is said to be 30 per cent. charcoal,  $2\frac{1}{2}$  per cent. tar, 30 to 35 per cent. gas liquor. The tar is said to give 60 per cent. of oil, 10 per cent. of paraffin wax, and 20 per cent. of good pitch. Most of the peat charcoal or peat coke (in large pieces) is sold to coppersmiths, dockyards, and machine factories at a price of 60 to 70M. per metric ton, excluding freightage, medium-sized pieces of charcoal (about 20 to 50 mm. in size) are disposed of as nut charcoal to foundries for drying the moulds, &c., at 40M. to 60M. per metric ton, and the waste charcoal (pieces under 20 mm. in size) fetches 25M. to 40M. per metric ton when made into "smokeless press coal" for mixing with tempering powder and for chemical purposes.

The demand for large quantities of peat charcoal for addition (to the extent of 25 per cent.) to "wood charcoal" blast furnaces, for use in cupola furnaces, reverberatory furnaces, &c., for which purposes experiments show that peat charcoal is well suited, is said to have increased so much from year to year that it could not be met.

According to the locality the peat tar is either sold to large tar distillation factories or is worked into crude intermediates (illuminating oil, disinfectants). The pitch, it is said, is sold to press coal factories, and the paraffin is sent into the market as crude paraffin scales.

#### 7.—*Peat Carbonizing by means of Hot Rollers, Plates, Presses, &c.* (*Fritz and Schöning's Process*)

Schöning, of Stamsund (Norway), intended to compress air-dry peat between iron rollers, plates, &c., under strong pressure, and at the same time to heat it until it was carbonized, the volume diminishing to about one-fifth that of the peat. This decrease in volume is possible, but in addition to the effect of the partial carbonization of the peat it is, as in the well-known dry-press methods, mainly due to the strong compression. In the first contrivances and experiments with a hand-press the development of explosive gas mixtures during the heating of the peat contained in the moulds of the press caused so much difficulty and danger

that, notwithstanding the improvements effected by the engineer Fritz, the process was unable to give a satisfactory result. The German Peat Charcoal Company, Ltd., of Berlin, which adopted this process, modified it as a result of further experiments. Air-dry cut or lump peat, disintegrated in a tearing machine, was dried and so far carbonized by heating to 200° C. in tubes, muffles, or retorts, that in the carbonization of the peat or fibrous matter which ensued, all the moisture and some of the combustible gases, but not all the tarry substances, were driven off. The semi-carbonized peat powder passed from the carbonizing muffle directly to a stamp press, provided with heated compression moulds, in which, when raised to a high temperature, it was converted by a hydraulic pressure of 200 atmospheres into pieces which resembled press brown coal and were 0.5 kilo in weight. The pieces remained exposed to this pressure for twelve to fifteen seconds, during which time, by the action of the pressure, the temperature and the tarry cements produced or set free by these two agents, the semi-carbonized peat cemented together so well that the pressed pieces could not be broken apart by the hand, were very resistant to moisture, and retained their shape in the fire. The press peat charcoal made in this way, which somewhat resembled Ziegler's peat semi-charcoal so far as its state of carbonization is concerned, was not intended as a substitute for wood charcoal or coke, as the carbonization had not proceeded far enough for this, but was intended for competition with coal and press brown coal for domestic and industrial firing.

The pieces, which were still glowing when leaving the press, were allowed to cool with careful exclusion of air, since otherwise they would ignite and burn away.

The yield of this press charcoal from the air-dry peat carbonized amounted to 60 per cent., according to the tests made at the Company's experimental factory at Halensee railway station, in the suburbs of Berlin. The firing of the oven was said to require about 10 per cent. of the fuel carbonized.<sup>1</sup>

The Company's hopes that the process could be applied successfully on a commercial scale have not been fulfilled. The Company has dissolved, with loss of its capital.

#### 8.—Carbonization of Peat by Pressure or in Mounds

(a) A. Born's "Mound-carbonizing" Process.—A. Born, of Friedenau (Berlin), noticed that "half wet" crumbs or even sods of slick or lowland peat, when piled in heaps or mounds 8 m. in height, become very hot, cake together, and contract a good deal, the water of the various peat layers becoming uniformly distributed and much of it evaporating, and the product obtained after about nine to twelve months being a much drier, black, granular mass resembling coal. On this observation he bases the new

---

<sup>1</sup> A more detailed account is contained in the second edition of this book, 1904, p. 404.

peat-carbonizing process proposed by him, which he calls carbonization by pressure. He attributes<sup>1</sup> this phenomenon to fermentation of the peat due to piling in a high mound, the peat cells bursting by the heat produced, so that the peat falls into a powder, which then, as the humification proceeds, cakes firmly together owing to the pressure of the mound.

This process, therefore, effects a considerable diminution in the amount of water (i.e., a drying) of the mound peat and a uniform distribution of the otherwise very heterogeneous mass of peat fibres and peat grains, and, therefore, in conjunction with the contraction and condensation of the mass already mentioned, gives as a final product a uniformly dense fuel peat resembling coal, sufficiently dry and suitable, without further trouble, for gasification or for firing. If the freshly won peat sods be protected from rain during the earlier weeks, as can easily be done by means of movable hurdles, they become impervious to moisture, and even in bad weather become so far dried that they can be brought into mounds, where they contract to half to a quarter of their original size in one to two years, and have then a calorific power equal to that of good dense pieces of brown coal. In the case of unformed, dredged, or pulped peat, the wet and dry portions must be mixed together. Even in wet years a mound peat can be obtained in this way very cheaply, and at the same time well suited for gasification.

From the description itself, it follows that in this process there is no question of a real "carbonization" of the peat and therefore of the manufacture of peat charcoal such as are the objectives of the processes described above and such as occur in the manufacture of wood charcoal as well as in the carbonization (coking) of coal and brown coal. The process cannot be regarded as other than a further decay or humification of the various layers of the peat, helped by the spontaneous heating of the mound, the product from which within a reasonable interval of time can never be, or become, real peat charcoal, and should therefore be simply called "condensed mound peat."

But even if this process merely afforded a method of winning half-dry peat, suitable for gasification or firing on a large scale, that would be commercially sound and independent of human labour and of the weather, it would be in the highest degree worth attention for the winning and utilization of peat. The future must show how far this is the case.

That this storing in mounds, when it is combined with the other processes generally used for winning peat, offers advantages in the case of large scale industries is apparent from the fact that every autumn at the Aurich Wiesmoor raw peat is made into large heaps and left there until the following summer, with a view to ensuring a sufficient supply of peat for the working of the electric power station. (See the description of the electric power station at Wiesmoor, Part II, Section IV, 7.)

---

<sup>1</sup> *Mitteilungen*, 1912, p. 429, and 1913, p. 227.

A. Born hopes that by combining the winning of mound peat with the use of his peat gasifier there will be a big extension in the utilization of peat bogs. (See Part II, Section III, 3 and 4.) Works of this nature have not yet been constructed, but some experiments which were instituted have either failed or have not yet been concluded. He says that in the slick bog at Ludwigshof, the peat of which was worked for ammonium sulphate, the metric ton of anhydrous "mound peat" (containing 40 per cent. of water) costs 5.50M., and that this cost could be reduced in the case of a modern large scale industry to 4M. (including amortization of the plant). A large scale industry winning plant (including dredgers, field railways, platforms for mounds), with an output of 100 to 300 m. tons of peat (anhydrous) per day and with continuous working of the gasifying plant, would cost 200,000 to 500,000M.

(b) *Heine's Carbonization in Mounds.*—This process is an extension of that just described, and is based on the assumption that moist peat, being spread in the air, in layers on top of one another, rapidly absorbs oxygen and becomes hot. This spontaneous heating promotes the decomposition of the vegetable fibres, and at the same time the absorption of oxygen and the heating assist each other. Ozonized air exerts a peculiarly good effect on the decomposition of the piled peat. While in the case of ordinary pressure or mound carbonization of peat the time of storage to be reckoned upon is from one to two years, it is claimed that the new process keeps the internal carbonization completely under control, so that even after a few weeks a considerable amount of drying is attained without spontaneous ignition occurring. In this process peat, dehydrated by pressure until it contains 60 per cent. of moisture, is to be used. This is to be made into mounds, and to be converted by ozonized air into a fuel richer in carbon (therefore not a real peat charcoal), the ozonized air being introduced at the base of the mound through tubes which can be closed when desired. (Compare the extract from the patent in Section IX.)

We are not aware that this process has been carried out with commercial success.

### 9.—*The so-called Wet Carbonization*

Details have already been given on p. 87, in the section on wet press processes, of the Ekenberg-Larson method of the Wet Carbonizing Company, Ltd., of London, in which also no real carbonization occurs.

More or less detailed experiments on "wet carbonization" were made by E. W. Paulson at the Norwegian Technical High School.<sup>1</sup> These experiments establish the influence of the process on the advantageous alteration of the properties of the peat (due

---

<sup>1</sup> Cf. *Mitteilungen*, 1915, p. 430.

to the more or less great heating) with regard to the pressing out of the water, the increase of the calorific power to 7,600 c., the compressibility, and in some cases the greater strength of the carbonized press peat. They also show that all the peat produced by wet pressing gave, when carbonized, only a loose, pulverulent coke, and that at best the process could only be regarded as technically possible. They do not, however, alter in any way the improbability of the commercial success of the process due to its great inconvenience in comparison with the small increase in calorific power or value of the peat.

### 3.—Best kind of Raw Peat for Carbonization; Economic Value of Carbonization; Calorific Power and Properties of Peat Charcoal

That quantity of fuel which is wasted in evaporating moisture during the combustion of air-dry peat is also required for the same purpose during the carbonization of peat unless the charge has been previously kiln dried. In the carbonization of moist peat, a more or less large loss of carbon can also occur in so far as during the passage of water vapour over the glowing charcoal, which cannot be avoided in piles and muffle ovens, the water vapour reacts with a corresponding amount of carbon, forming carbon monoxide and hydrogen, which are evolved.

Hence if the peat is not sufficiently air-dry, the yield of charcoal is subjected to a twofold diminution, and in any event it is advisable to employ only good dry peat for carbonization, so as to avoid these losses and to work in as advantageous a manner as possible.

In order that peat charcoal may compete with wood charcoal and coke from the point of view of general utility in the iron industry, it is necessary in the first place that, apart from the cost of production, it should be manufactured in large pieces as dense and as strong as possible, and with a maximum of calorific power. Although the construction of the ovens and the attendance on the piles to some extent affect the nature of the charcoal won, this depends most of all on the properties of the raw peat employed for the carbonization.

The denser the raw peat is, the denser the charcoal obtained from it will be. If the charcoal hitherto manufactured could not be used in smelting because it did not offer sufficient resistance to the force of the blast, the pressure of the ores to be smelted, &c., i.e., because it was too brittle, the main cause of this was that the peat employed for carbonization was ordinary air-dry cut peat. In rare cases trodden or dredged peat, and only in a few exceptional cases condensed machine peat, was used for carbonization.

Cut peat is by no means firm, and, moreover, has a low density. It contains on an average 25 per cent. of moisture, which has to be removed completely during the carbonization, and has a further 25 per cent. of oxygen, hydrogen, and nitrogen, most of which must

also be expelled. It follows, therefore, that even when the peat is very good or very rich in carbon it must give a light, porous, and therefore a loose, charcoal ill adapted for the iron industry. Better results are obtained from the denser, stroked and dredged peat, but a good strong charcoal, capable of being used for most of the operations of the iron industry even without admixture of wood charcoal or coke, can only be obtained from machine peat, and, indeed, this charcoal is all the better the greater the condensing action of the peat machine by which it has been made.

This is another reason for paying special attention, when selecting a peat machine, not only to the forming power, but still more to the condensing power of the machine, and for giving the preference unreservedly to those machines which, other circumstances being equal, give the densest dry peat, i.e., which have the greatest mixing and tearing action.

Real press peat (press peat or peat briquettes formed from peat powder by strong mechanical pressure), which may have the same or even a greater density than machine peat, is nevertheless not suitable for carbonization, since the cohesion between its components is completely destroyed by the action of heat, and this results in the formation of small pieces of a very loose charcoal.

In order to avoid as far as possible the irregular settling and the falling in of the piles as well as the slipping in ovens, which occur when cut peat is carbonized, and the decrease in yield connected with these, it is necessary to keep the peat from the various layers of the bog separate during its winning and to charge a pile or oven at a given time only with peat of the same character.

The percentage and the nature of the ash in the peat to be carbonized has a great effect on the calorific power of the charcoal won, and therefore on its utility. If we bear in mind that the yield of charcoal is only 30 to 40 per cent. of the charge, that all the ash of the latter remains in the former, that the charcoal therefore

contains  $\frac{100}{30}$  to  $\frac{100}{40}$ , i.e.,  $3\frac{1}{3}$  to  $2\frac{1}{2}$  times as much ash as the same weight of the peat from which it is formed, and that the ash lowers the calorific power of a fuel considerably, it will be evident that it is very necessary that only peat poor in ash, i.e., containing 8 per cent. of ash as a maximum, should be used for the manufacture of charcoal of good quality.

Peat containing 10 per cent. of ash is not suited for the manufacture of charcoal, as this will contain 30 per cent. of ash when the yield of charcoal from the peat is 33 per cent., and therefore the percentage of carbon in it may be lowered to 60 if we assume the peat contains, in addition to the ash, 10 per cent. of other constituents (hydrogen, oxygen, nitrogen, &c.).

The high temperature required in the iron industry depends solely on the percentage of carbon in the charcoal. Scheerer has observed that by the combustion of a good charcoal which contained 86 per cent. of carbon, 10 per cent. of hydrogen and

oxygen, and 4 per cent. of ash, a combustion temperature of 2,380° C. was obtained, while kiln-dried peat free from ash and moisture gave 2,210° C., and the same peat in the air-dry state (i.e., with 25 per cent. of moisture) gave only 2,000° C.

A peat charcoal from Upper Franconia examined by Fikentscher had the following composition:—

Carbon	..	..	..	..	..	..	89·9 <sup>1</sup>
Nitrogen	..	..	..	..	..	..	2·4
Hydrogen	..	..	..	..	..	..	1·7
Ash	..	..	..	..	..	..	4·2
Loss	..	..	..	..	..	..	1·8
							100·0

while a wood charcoal made at a temperature of about 400° C. (i.e., at a temperature favouring the percentage of carbon) contained:—

	(a) Anhydrous.	(b) With 13 p.c. of moisture.
Carbon	.. .. 81·64	70·45
Hydrogen	.. .. 1·96	1·68
Oxygen	.. .. 15·24	13·10
Ash	.. .. 1·16	1·00
Moisture	.. .. —	13·76
100·0		99·99

Generally, the heating effects of the fuels used for smelting purposes in the iron industry vary within the following limits:—

Peat charcoal	.. ..	Calorific power.	..	Calorific intensity.
Wood charcoal	.. ..	0·83–0·85*	..	2,050–2,400° C.
Coke, with not more than 5 per cent. of ash	.. ..	0·64–0·97	..	2,100–2,450° C.
		0·84–0·97	..	2,350–2,450° C.

\* The calorific power of pure carbon (8,080° C.) is taken as 1.

From this it can be seen that peat charcoal, which can be made more cheaply than wood charcoal, has a heating effect at least as good as that of the latter and little inferior to that of coke. The lower limits give, indeed, lower figures for peat charcoal since peat with *medium* ash content gives, after carbonization, a charcoal *rich* in ash, while wood charcoal on an average contains only 2 to 3 per cent. of ash and the coke is assumed here to have a maximum value of 5 per cent. of ash. If, however, only peats poor in ash be selected for carbonization for smelting purposes, the

<sup>1</sup> Note by Translator: According to K. Birnbaum, "Die Torf-Industrie," p. 237, the results obtained by Fikentscher were:—

Carbon	..	..	..	..	..	..	79·9
Hydrogen	..	..	..	..	..	..	1·7
Nitrogen	..	..	..	..	..	..	2·4
Ash	..	..	..	..	..	..	4·2
Oxygen, &c.	..	..	..	..	..	..	11·8
							100·0



charcoals from them will give the figures mentioned above, and by paying attention to the directions given for the manufacture of a peat charcoal, which can be utilized for most purposes, we shall obtain a product which will in every respect be saleable for smelting and forge purposes.

The constituents of the ash are important for the utilization of the peat charcoal for smelting and forge operations in so far as the ash sometimes contains admixtures of sulphur and phosphorus—compounds which may prejudicially affect the quality of the iron. According to the investigations of peat ashes given on p. 15, these injurious substances are present in such small quantities that the utilization of peat charcoal for smelting iron need cause us little concern on this head, provided, however, that in every case where the charcoal is to be used for more or less larger and important operations we subject it to a chemical analysis in order to be quite certain that it is *not* injurious. In most cases where peat charcoal is employed for smelting iron the nature of the ash indeed facilitates the formation of an easily fusible slag, and, so far as its advantageous action on the iron is concerned, the ash is more closely related to that of wood charcoal than to that of coke. This property has made peat charcoal highly esteemed by the workmen and the owners of iron factories and would, undoubtedly, have very quickly extended its use had the ovens for manufacturing it been properly chosen and had the requisite attention in selecting the peat for carbonization been paid in the past to the above-mentioned conditions which are essential for the manufacture of a cheap and good peat charcoal, and this result might still be attained with the necessary attention. One such essential condition is always to *employ for carbonization only a dry machine peat as poor in ash and as dense as possible.*

Peat charcoal alone is but little employed for smelting iron in Germany. Although its use has often been tried, it has generally been given up again for the reasons just stated. On the other hand, peat charcoal mixed with wood charcoal or coke is used more frequently and with advantage for the quality of the product, since peat charcoal, when the industry is properly conducted, can be made at a smaller expense and of a more uniform character than wood charcoal.

In Clumetz, near Wittingau, some time ago, two-thirds of the charcoal charge in the blast furnace was peat charcoal (from Lottmann's ovens), very satisfactory results being obtained with it. The works were closed later on, as the crude iron, obtained from the poor ores which occur there, was found to be too dear when compared with Styrian refined iron or English foundry pig-iron.

In Bleymüller's blast furnaces, near Schmalkalden, peat charcoal, prepared from good machine peat, together with wood charcoal, has been employed for several years past. Further particulars with regard to this are given in the section dealing with the results obtained in iron and steel works.

*Heating Charcoal.*—For heating railway carriages, hot pipes,

smoothing irons, &c., a heating substance is made by mixing peat charcoal powder with a cement consisting of tar, pitch and brown dextrine, adding a 5 per cent. solution of saltpetre and pressing the mixture.

Carbonization of peat for use in ordinary fires, with a view to utilizing air-dry peat economically, can never—when the income from the by-products obtained during the carbonization is not taken into account—give a commercially favourable result even when the expenses of the carbonization are left out of the reckoning.

The charcoal formed from 110 kilos of air-dry peat can under no circumstances have a higher heating value than the 100 kilos of peat from which it is obtained. The carbonization is attended by a consumption, and therefore by a loss, of heat.

If we consider, for instance, an air-dry peat containing 20 per cent. of water and 5 per cent. of ash, 100 kilos of it, if the pure peat in it has the average composition—carbon 60, “free hydrogen” 2, “chemically bound water” 38—will contain 45 kilos of carbon, 1.5 kilos of “free hydrogen,” 28.5 kilos of “chemically bound water,” 20 kilos of moisture, and 5 kilos of ash.

The heat obtainable from it will be:  $45 \times 8,080 + 1.5 \times 34,462 = 415,293$  kilo-calories, of which  $(28.5 + 20) \times (640 - 15) = 30,312.5$  kilo-calories will be required for the evaporation of the total water present in the products. The useful heating effect will, therefore, be  $415,293 - 30,312.5 = 384,980.5$  kilo-calories.

If the same 100 kilos of peat were converted into charcoal the yield in the most favourable case would be 40 kilos, of which, however, 5 kilos would be ash, as the peat charcoal would contain all the ash present in the charge from which it was made. The remainder of the 35 kilos is assumed to consist of pure carbon, although complete carbonization is never actually obtained, a small amount of hydrogen, oxygen, and nitrogen always being left, the latter two of which decrease the calorific power of the fuel.

The charcoal from the above amount of peat would, therefore, in the most favourable case give a heating effect of  $(40 - 5) 8,080 = 282,800$  kilo-calories, that is  $384,980.5 - 282,800 = 102,180.5$  kilo-calories less than would be obtained from the corresponding amount of peat. The fuel value of the peat, therefore, suffers a loss of about 30 per cent. owing to the carbonization.

It has already been pointed out above that the relation is otherwise, and, in fact, in favour of carbonization, if the calorific intensity only is taken into consideration, as happens when the peat charcoal is in competition with wood charcoal, coal and coke for smelting, welding and forge purposes.

In addition to its use as fuel, peat charcoal, like wood charcoal, can be employed in another way, and one in which it can also compete with wood charcoal. Peat charcoal has in a high

degree the property of absorbing dyes, of removing fusel oil from brandy, and of absorbing ammonia formed by putrefaction ; on account of the last property peat mould may with advantage be added to manure.

Comparative experiments, instituted by Stenhouse, have given the following results for the absorptive powers of different charcoals :—

	Ammonia.	Hydrochloric acid.	Sulphuretted hydrogen.	Carbon dioxide.	Oxygen.	Sulphur dioxide.
Wood charcoal ..	98·5	45·0	30·0	14·0	0·8	32·5
Peat charcoal ..	96·0	60·0	28·5	10·0	0·6	27·5
Tar coke.. ..	43·5	—	9·0	5·0	0·5	27·5

### SECTION III

## GASIFICATION OF PEAT FOR FUEL AND POWER PURPOSES

### 1.—General Remarks on the Gasification of Fuel and on Gas Furnaces<sup>1</sup>

The following principle, which has been derived from experience and has, moreover, a scientific basis, is applicable to all good furnace installations: *A heating contrivance is all the better the more completely the combustion of the fuel takes place in a minimum excess of air.*

In order to attain this the contact of the fuel with the oxygen of the air supporting the combustion must be made as intimate as possible. We must also be always able to keep the temperature so uniformly high that the combustion will be as complete as possible, and the entrance of air must be so regulated that, after its admixture with the gases formed in the fire and the combustion of these, the escaping combustion gases will not contain excess of air.

Hence the object of all gas furnaces is to convert all the fuel into combustible gases at a place distinct from that at which the gases are finally burnt. These gases are then led to the heating chamber where they are burnt, after being mixed with the air necessary for their combustion. We are thus in a position to add to the gases, developed quantitatively from the fuel, only that amount of air which is theoretically required for their complete combustion. The loss of heat (owing to the heat carried away by the excess of air) due to the addition of double the theoretical quantity of air, which is necessary when the fuel is burnt in ordinary fireplaces, does not occur under these circumstances.

The contrivance in which gasification of the fuel occurs is called

---

<sup>1</sup> The construction of independent gas furnaces arose from the use of blast furnace gases for smelting purposes. The gases escaping at the top of blast furnaces were used in France in 1814 in re-heating and puddling furnaces. In Germany the earliest experiments in this direction were made at Wasseralfingen in 1835 by the Württemberg Mining Councillor Fabre du Faur.

The defects of the system, especially the dependence of two important heating installations on one another, induced the Royal Ironworks at Jenbach, in the Tyrol, in 1839-40, to experiment with independent gas furnaces. These, which must be regarded as the first of their kind, were quickly abandoned, as explosive combustion of the gas could not be prevented. They were, however, resumed again, and also with more success, at the St. Stephan Royal Foundry in Styria.

About the same period (1839) Bischoff, the manager of an ironworks at Magdeburg, greatly improved gas furnaces, and these were still further improved later by Thoma, Schinz, and recently by Siemens (see Steinmann's "Compendium der Gasfeuerung").

a gas producer or gas developer (generator), and the gas developed therein which is to be burnt later is called power gas or fuel gas (generator gas).

In making the gas, the fuel is always filled into the generator to such a height over the grate that the air passing through it from below is not sufficient for the complete combustion of the fuel, and the flame itself does not actually pass through the layer of fuel. In this way it is only the fuel lying directly on the grate which glows brightly, burning completely into ashes, carbon dioxide, and water. Owing to the heat thus developed, the upper layers of fuel are subjected to a dry gasification, the constituents of the fuel being mainly converted into combustible gases and escaping as such. The reactions which occur may be represented as follows:—

At the points where the air comes into immediate contact with the fuel on the grate, carbon dioxide, water, and ash are formed. The carbon dioxide, the nitrogen of the combustion gases and the unused oxygen of the added air press their way up into the glowing layers, where the remainder of the oxygen is used up and the carbon dioxide is reduced to carbon monoxide. As the carbon dioxide is in this way converted into carbon monoxide, the volume of the latter is double the volume of the former. The carbon monoxide passes through the upper layers of fuel, and there becomes mixed with the gases, light and heavy hydrocarbons, formed by the action of heat on the fuel. The mixture of gases is then led away to the gas furnace.

According to Ebelmen, who, from 1842 onwards, carried out much valuable work in France on independent gas furnaces, the figures given below show the composition of gases, such as these, from various fuels:—

Gases from	Wood charcoal.	Wood.		Peat.		Coke.		Wood charcoal.	Wood.		Peat.		Coke.	
		I.	II.						I.	II.				
Nitrogen .. ..	63·4	50·1	50·0	61·5	64·1	64·9	53·2	55·5	63·1	64·8				
Carbon monoxide ..	33·3	32·5	19·0	21·8	33·5	34·1	11·6	22·0	22·4	33·8				
Carbon dioxide ..	0·5	7·2	13·2	9·1	0·8	0·8	34·5	21·2	14·0	1·3				
Hydrogen .. ..	2·8	10·2	17·8	7·6	1·5	0·2	0·7	1·3	0·5	0·1				

By volume.
By weight.

These gas furnaces have a further advantage, inasmuch as it is possible to gasify a peat in them having so high a percentage of ash that it could not be used at all for carbonization or used only with difficulty in an ordinary fire. Even from peats rich in ash good fuel gas can be produced in a suitable generator with an economic efficiency of 80 per cent., provided the ashes be removed from the grate at intervals, which can be done, without stopping the generation of the gases and without letting in too much air, more easily than when grate-firing is employed.

While in ordinary, and even in the better class, grate-firing the loss of heat is 25 to 30 per cent., in the case of gas-firing it is only 15 to 25 per cent.

Good fuel gas contains approximately 25 per cent. of carbon monoxide (CO), 8 per cent. of hydrogen (H<sub>2</sub>), 2 per cent. of hydrocarbons (CH<sub>4</sub> and C<sub>2</sub>H<sub>4</sub>), 59 per cent. of nitrogen (N<sub>2</sub>), and 6 per cent. of carbon dioxide (CO<sub>2</sub>), and has a calorific power of 1,100 to 1,300 kilo-calories per cubic metre.

When peat, brown coal and coal are gasified in the anhydrous condition, the results generally obtained are :—

	Peat.	Brown coal.	Coal.
Carbon monoxide ..	21	22	22
Hydrogen ..	8	8	9
Hydrocarbons ..	2	2	2
Nitrogen ..	60	62	61
Carbon dioxide ..	9	6	6
	100	100	100

Hence it follows that by gasifying peat a gas can be obtained as good as that from brown coal and coal. When gasifying ordinary air-dry peat containing 25 to 30 per cent. of moisture we must, however, cool the generated gas in order to remove (as ammonia water) the water vapour which, if left in it, would affect its combustion prejudicially. While in the case of brown coal and coal the height of the layer of fuel in the generator is 60 to 120 cm., in the case of peat gasifiers it is 150 to 200 cm.

The gases evolved collect in the upper portion of the generator and are led thence, by means of tubes or pipes, to the furnace.

In order to be able to stop or adjust the current of gas almost every gas generator is provided with a tightly closing cut-out at the beginning of the gas-pipe. Sand-sealed or water-sealed valves are generally preferred for this purpose as they give a tight seal, which in the case of flap-valves or slide-valves is very quickly affected by tar settling on the surfaces of the seal.

Next in importance for the installation, especially when the furnace is at some distance from the generator, is *the piping for the gas*, which should have a suitable cross-section, be always inclined upwards whenever possible, and have no contractions or bends worth mentioning. Just at the entrance to the furnace the necessary amount of air should be added to, and intimately mixed with, the generator gas. The gas and the air enter the mixing chamber either by pipes which lie opposite, behind, or alongside one another, or through several nozzles surrounding one another, according to the place where it is being used and the possibilities existing there. In their arrangement, however, the main thing is to see that an intimate mixture of the gas with the air is obtained.

In order to obtain the best possible effect, it is also necessary to be able to regulate the addition of the air, as, for instance, by means of a slide valve in the air-duct. Since combination of the oxygen with the carbon takes place more rapidly and more completely the higher the temperature, it is necessary to heat the air beforehand. This can be done by letting the waste combustion gases play round the air-duct or by letting the air-duct take a spiral course through the combustion gases.

Directly after or at the moment when the heated air meets the gases, complete combustion sets in with the development of a bright flame and great heat, so that the furnace therefore becomes a working place, where the heat developed can be utilized for commercial purposes.

Such furnace installations, the chief characteristics of which are the generation of the gases in a furnace shaft and as direct as possible a transmission of these with the air necessary to support their combustion to the fireplace, are called *simple gas furnaces*. The air draught required for the incomplete combustion (dry gasification) in the gas generator is produced, according to the situation and the purpose of the installation, sometimes by a natural chimney flue draught, and at other times by tuyeres (compressed air, under-grate blast). The latter mode is chiefly employed in simple gas-firing when large amounts of gas are to be burnt at the highest possible temperature, which can be realized in the case of ordinary shaft furnaces only by very careful pre-heating of the air required for the combustion.

In these simple gas furnaces a part of the heat contained in the escaping combustion gases is utilized for the pre-heating of the air supporting the combustion, and this has a very great effect on the commercial success of the whole installation. Complete utilization of the "waste heat" of the escaping gases is, however, only possible by means of "alternate draught" gas furnaces (regenerators), the peculiarity of which is that all the heat developed from the fuel remains at the place where it was generated, or returns there, inasmuch as all the heat of the combustion gases escaping from the furnace with the exception of the amount of heat required to produce the flue draught serves to pre-heat the new currents of air and gas introduced into the fireplace. The heat contained in them is first taken up in chambers, the pre-heaters (regenerators), which are formed of heat-absorbing surfaces, as large as possible, and usually consist of arched rooms fitted with a large number of refractory stoves arranged trellis-wise, the incoming air and combustible gas being led through these chambers. As the gas and the air are to be heated simultaneously, but separately, it follows that both air and gas pre-heaters must be installed, and as the same chambers must serve during one interval for removing the combustion gases and absorbing the heat contained in them, and during the next for introducing and pre-heating the currents of gas and air going to the fireplace, the whole installation must consist of two similar sections (each having one air heater and one gas heater) with the

fireplace in the centre. Also for changing the mode of action of the two air or gas pre-heaters (as each of these must be used in turn for the escaping combustion gases) it is necessary to provide two similar pre-heaters with adjustable flaps or valves (the *air* and *gas flaps* or *valves*).

The essence of regenerative gas-firing may be easily understood from Fig. 140. In this illustration  $l_1$   $l_2$  are the two air pre-heaters,  $g_1$   $g_2$  the two gas pre-heaters,  $v$  the air valve,  $w$  the gas valve,  $a$  the gas-duct from the generator,  $b$  the air-duct, and  $d$  the exit to the chimney flue. The arrows indicate the directions of the currents of air and gas, which, after their passage through the pre-heaters  $g_1$  and  $l_1$  unite in the flue over  $f_1$ , and then in the form of a flame strike through the fireplace over  $d$ , escaping on the right through the flue  $f_2$  into the two compartments  $l_2$  and  $g_2$ , and from these to

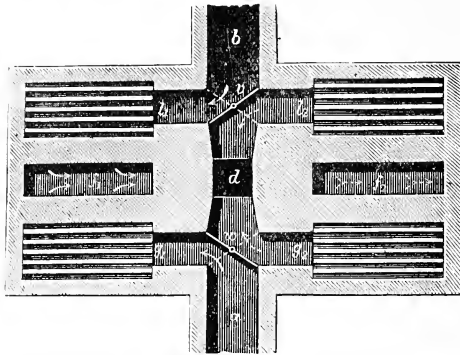

FIG. 140.—Regenerative gas furnace of Siemens.

the chimney flue  $d$ . When the pre-heating compartments  $l_2$  and  $g_2$  have been made hot enough by the escaping gases, the valves are reversed so that the new currents of gas and air pass through the compartments  $l_2$  and  $g_2$ , where they become heated before they enter the fireplace, while the escaping combustion gases once more heat the compartments  $l_1$  and  $g_1$ , and so on alternately at definite intervals.

The possibility of fulfilling approximately the conditions theoretically required for complete combustion in the case of gas fires and of realizing this without an excess of air constitutes the great advantage of gas furnaces. Even with fuel which is otherwise poor, good results can be obtained, so that in these installations dusty, wet, earthy substances can be burnt with a degree of success far greater than that obtained by utilizing the same fuel in ordinary furnaces.



## 2.—Production of Fuel Gas and Power Gas from Peat

### (a) Fuel Gas

The production of fuel gas from peat and its combustion in suitable ovens led, for the reasons given above, to the use of peat as a fuel in a number of large scale industries into which its introduction had previously been attempted in vain, notwithstanding the many attempts made and the expenditure of much money for the manufacture of a suitable fuel from a given raw peat.

Amongst these industries are all installations with continuous firing and those in which the temperature of the combustion gases is the main concern, as, for instance, soda factories, lime works, pottery factories, as well as iron, steel, and glass industries.

Statements with regard to the installation and the size of the gas furnaces applicable to the various cases of the individual industries cannot be made here. These gas furnaces have in

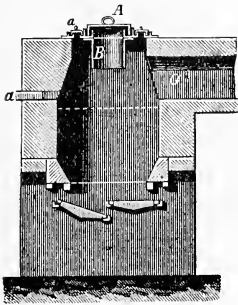

FIG. 141.—Gas generator.

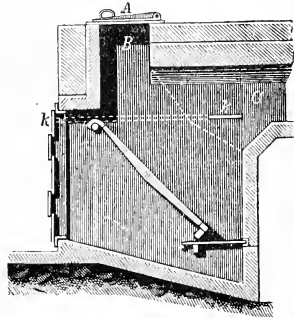
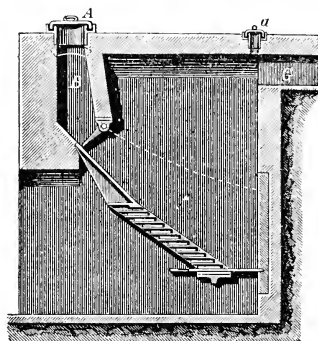

FIG. 142.—Gas generator.

recent years been much improved and simplified. It must be left to experts to devise installations in accordance with the laws of science and experience, while taking into account the many details which must be considered in any particular case. For our purpose it will be sufficient to explain these installations more fully only in so far as the peculiarity of the peat to be employed as fuel may affect them, and this really occurs only in the case of the generator. We shall then proceed to draw attention to the advantage of this mode of utilizing peat by indicating the results obtained with it in various branches of industry.

The arrangement of the gas generator, more especially the depth and the character of the hearth, depends, as in ordinary furnaces, on the form and the quality of the peat intended for gasification. This refers, however, less to the heating effect to be attained than to ensuring a continuously uniform and good generation of gas without special attention from a workman being necessary.

Figs. 141 to 145 show a number of gas generators which have proved successful with various peats, and, as a matter of fact, the arrangement in Figs. 141, 144, and 145, with flat or slightly inclined grates and a fairly deep position of the grate or height of



$\frac{1}{80}$  nat. size.

FIG. 143.—Gas generator.

fuel layer, is intended for dense cut peat or machine peat. The arrangement in Fig. 144 with a deep position of the grate can be recommended for more or less light cut peat, while that in Figs. 142 and 143 is for peat mould or crumb peat. The grate

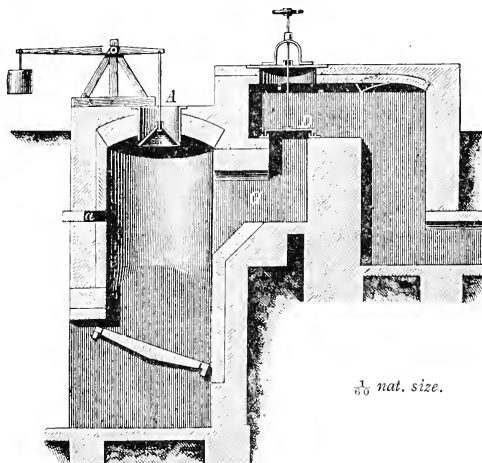

$\frac{1}{80}$  nat. size.

FIG. 144.—Gas generator, with valve in gas main.

dimensions will depend on the richness or poorness of the peat in ash, and the cross-section of the shaft on the amount of fuel used in unit time.

The different methods of sealing the charging holes *B* may also be understood from the figures. Figs. 141 and 143 show a cap and sand seal, Fig. 142 a flap seal, and Fig. 144 a conical seal.

It is advisable to provide every gas generator with a spy-hole *a*, which can be closed when not in use, and which, when arranged as in Fig. 143, can be utilized when the fire is being stirred.

The dotted lines denote the approximate height and the position of the fuel in the generator. The gas collecting above the layer of fuel is led through the ducts *G* to the fireplace (in the case of simple gas furnaces), or to the pre-heater (in the case of regenerator furnaces). For regulating the current of gas, and also for cutting it off when several gas generators belong to a common fireplace, a valve *D* is shown in Fig. 144. In the case of simple gas furnaces, the generators of which are usually directly in front of the working hearth (the fireplace), adjusting and cutting-out valves are rarely employed.

If in such a case hot air be let into the gases, formed by the incomplete combustion (gasification), through a slit *k* (indicated in Fig. 142) suitably placed in each of the two sides of the shaft combustion immediately sets in with production of a bright flame and much heat, which can be utilized for commercial purposes, development of steam in boilers, heating evaporating pans, burning lime in kilns, &c. Simple installations of this kind are also called semi-gas furnaces.

*Ziegler's peat gasifier* (Fig. 146) consists of a fire-brick shaft surrounded by brickwork in which the layer of peat, resting on the grate, has a height of about 2 m. The roof of the shaft is arched and provided with a hopper *h*, while the base consists of two or more grates *c d* and *c<sub>1</sub> d<sub>1</sub>*, each formed of a flat grate *c* and a vertical auxiliary grate *d*. The grates are arranged step-wise, with intervening partitions, and access to them may be had through the door *b*. In order that no unreduced or so-called "wild" gas (carbon dioxide) may take the more convenient path along the sides of the shaft and thus escape reduction, the shaft *a* is contracted somewhat in the centre so that the gas must pass through the peat, where its carbon dioxide will be reduced by the glowing charcoal to carbon monoxide. Under each grate there is an air inlet *f* through which the air is forced,

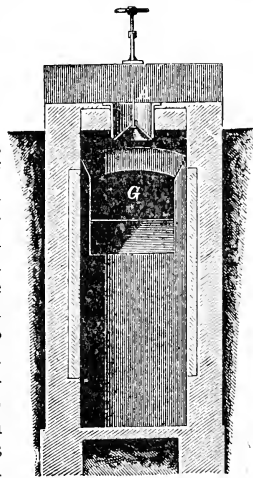

FIG. 145.—Gas generator.

most conveniently by means of a water-blast. When charging the generator the lid *i* is lifted off, the hopper *h* is filled with peat, the lid is again replaced, the cylinder *l* is raised, and the peat falls into the shaft.

The gas is led through a bent tube *n* into the condenser *o*, where it is freed from ammonia water and tar.

A gasifier with 9 sq. m. grate area will produce in an hour 2,500 cb. m. of gas from 900 kilos of peat, i.e., 2.8 cb. m. of gas from 1 kilo of peat. The calorific power of the gas is 1,200 kilo-calories per cubic metre.

It is evident from the illustration that the gas developed in this gasifier does not pass through the glowing layer of peat charcoal, but escapes at the top in a tarry condition. The Ziegler gasifiers are provided with special tar condensers and purifiers *p* when it is required to separate the tarry substances from the gas, as, for instance, in the manufacture of power gas. In addition to one of these gasifiers on the Fleiss Bog in Scheleken,

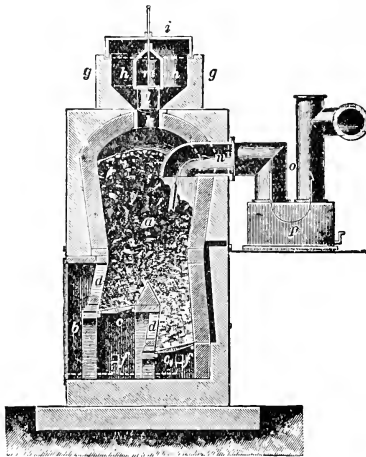

FIG. 146.—Ziegler's peat gas generator.

two have been at work since 1909 in the factory of Lapp Bros. at Rottenmann (Styria). The peat gas is used there in the manufacture of refined sheet metal.

(b) *Power Gas and the Gasifiers of the Deutz Gas Motor Factory, Körting Bros. and Co., Görlitz Machine Factory, &c.*

The available energy of a fuel is much better utilized (about 25 to 30 per cent. of the thermal energy in the fuel being converted into work) in gas engines than in the power machine hitherto most widely used—the steam engine and boiler (the maximum efficiency of which is 12 per cent.). Fuel gas of a definite composition or produced in a suitable manner is called power gas, "mixed gas," or "Dowson gas," and can be used for developing power in gas

engines quite as successfully as the illuminating gas hitherto employed for this purpose. These facts have opened up a wide field for the utilization of fuels by or in the generation of power gas. In the case of small single cylinder steam engines the utilization of the thermal energy by the boiler and engine is far from being as good as that given above, and frequently amounts to scarcely 5 per cent. of the thermal energy of the coal, while in the case of gas engines the amount of the heat transformed into energy varies little with the size of the engine.

Fuel gas for power purposes is won in shaft-like gas producers by blowing air and water vapour continuously through a layer of glowing coal. The oxygen of the air combines with the carbon of the coal, forming carbon monoxide, and the steam is decomposed at the glowing surface of the coal into its constituents, oxygen and hydrogen; the latter remains in the free state, and the former is converted by the carbon into carbon monoxide. The "run" of the furnace and the production of gas may without difficulty be adapted almost exactly to the gas consumption, so that large gasometers, as in the case of coal gas or "water gas," are not essential. While in the older power gas installations, the so-called "*pressure power gas producers*," the steam required had to be generated in a separate boiler and the air and steam mixture to be introduced under the grate of the gasifier by a blower, the process is much simplified, and therefore the cost of the plant is decreased by the replacement of these by suction gas plants. The latter require neither a separate boiler for the generation of steam nor a blower. As a rule, an evaporator filled with water is connected to the gasifier and is heated by radiation from the glowing coal and the escaping gases. One side of the evaporator is connected with the external air and the other connected by means of a tube with the grate of the gasifier, the latter being similarly connected with the gas washer and the engine. The suction of the engine draws the air and steam through the layer of glowing coal, the amount of gas formed at any time being therefore exactly that required by the engine at the moment. Installations such as this are subject neither to restrictions nor to official supervision. These facts, together with constant attendance on the plant being unnecessary, make it well adapted for small industries. Even when the power is as low as 6 h.p., the consumption of coal may be kept under 0.5 kilo per effective hour, for which one would otherwise require two or three times the amount of coal in an ordinary steam engine plant.

In the older of these installations, of which there are now a good many, only certain expensive kinds of fuel, especially anthracite and coke, were used. However, the experiments carried out by the more important factories—Deutz Gas Motor Factory of Deutz, Julius Pintsch and Co., of Berlin, Körting Bros. and Co., of Hanover, Görlitz Machine Building and Ironfoundry Company, Görlitz, and others, with a view to making peat available for this purpose, show that an efficient power gas can be obtained in a commercially satisfactory manner from more

or less air-dry peat without making the plant much more inconvenient.

The unavoidable losses of heat in the production of power gas consist only of the heat radiated from the gasifier and the sensible heat of the power gas itself, which becomes lost, since the gas must be as cold as possible when it is sent into the engine. These losses of heat amount to 15 to 20 per cent. of the total heat of the fuel, so that 80 to 85 per cent. of the heating power of the fuel is therefore contained in the gas. As the gas engine transforms 25 to 27 per cent. of this into external work, 20 to 23 per cent. of the heating power is actually made available in the form of energy. In the case of anthracite and coke it was sufficient to subject the gas coming from an ordinary shaft furnace gasifier to a good purification. In the gasification of friable, tarry fuels, such as peat, in ordinary gasifiers, a good deal of tar vapours passed into the purifier, and these, later, settled as tar and

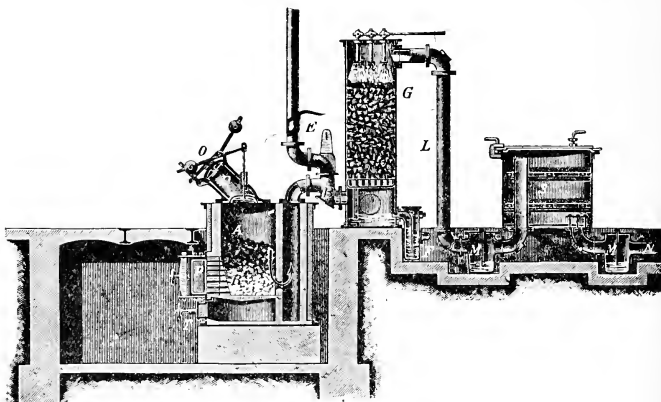

FIG. 147.—Suction gas plant for peat. Körting Bros. and Co.

paraffin in the pipes, blocking the latter so that the plant had to be cleaned very frequently. The main problem of a good gasifier is, therefore, to convert these tar vapours into permanent, non-condensable gases, and this problem is to be regarded as now solved.

*It is a very important fact that peat containing 40 to 50 per cent. of moisture can be used with good results in these gasifiers, and we are not therefore obliged, as in the case of ordinary peat furnaces, to use peat as air-dry as possible, the procuring of which, as is well known, causes considerable trouble in large scale industries.*

Fig. 147 illustrates one of these gasifiers of Körting Bros. and Co., and at the same time shows the whole arrangement of one of these suction plants.

The air required for the combustion passes into the fuel *A* through the ante-chamber *P*, the grate *R*, and the opening *T*. The peat is filled at the top into the hopper *D* and gradually slides downwards as it burns away below. The distillation gases, formed on top, in order to get into the gas main, must pass through the glowing lower layers of charcoal, where the tarry vapours are decomposed and converted into permanent gases. The gas coming from the gasifier escapes through the valve *E*, and, as soon as good gas is present, it is sent through the tube *B* into the purifier (scrubber) *G*, the pipe *L*, the water-pot *M*, the sawdust scrubber *S*, and from this through another water-pot to the gasometer or the engine.

These plants have recently been improved by converting them into "double-fire" producers. In the latter, as shown in Fig. 148, the fuel issuing from one or more feeding shafts *d* is not allowed to go directly to the fire on the grate *r*, but passes through an upper fire *o*, where all the tarry distillation gases are expelled from it, and therefore only pure peat charcoal or coke, free from gas and tar, is fed to the lower fire. The distillation gases formed in the upper fire are introduced, while still hot, by means of the connecting pipe *u* into the lower fire, where they are completely decomposed and converted into a permanent gas such as is required for the smooth working of a gas engine. After passing through the lower fire the gases are brought through the exits *a* to the purifiers. A pure gas, suitable for driving engines, can be made from peat containing 30 per cent. of moisture by means of these gasifiers. According to statements made by K rting Bros. and Co., these plants work continuously and smoothly even with peat containing 40 to 50 per cent. of moisture. In the case of a peat containing 45 per cent. of moisture, the gas had a heating effect of 1,029 kilo-calories per cubic metre and gave the following results<sup>1</sup> on analysis:—

Carbon dioxide (CO <sub>2</sub> ) .. ..	13.3
Carbon monoxide (CO) .. ..	17.6
Hydrogen (H <sub>2</sub> ) .. ..	10.9
Methane (CH <sub>4</sub> ) .. ..	2.5
Nitrogen (N <sub>2</sub> ) .. ..	55.7
	100.0

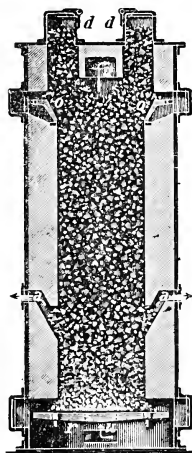

FIG. 148.—A double-fire producer.

<sup>1</sup> The average composition of fuel gas or power gas made from anthracite is generally as follows:—

Carbon monoxide (CO) .. ..	23	} With a heating effect of 1,300 kilo-calories per cb. m. The heating effect of ordinary power gas is 900 to 1,200 kilo-calories, that of coke oven gas is 4,000 kilo-calories, and that of illuminating gas is 5,000 kilo-calories per cb. m.
Hydrogen (H <sub>2</sub> ) .. ..	17	
Methane (CH <sub>4</sub> ) .. ..	2	
Carbon dioxide (CO <sub>2</sub> ) .. ..	6	
Nitrogen (N <sub>2</sub> ) .. ..	52	
	100	

In another plant a peat having the following composition :—

Moisture .. .. .	29.0	} Heating effect, 3,065 kilo-calories per kilogram,
Ash .. .. .	6.1	
Carbon .. .. .	37.5	
Hydrogen .. .. .	3.7	
Oxygen and nitrogen .. .. .	23.7	
	<hr/> 100.0	

gave on gasification a power gas consisting of :—

Carbon dioxide (CO <sub>2</sub> ) ..	11.2	} Heating effect, 1,187 kilo-calories per cb. m.
Oxygen (O <sub>2</sub> ) .. .. .	0.3	
Carbon monoxide (CO) ..	17.0	
Methane (CH <sub>4</sub> ) .. .. .	6.2	
Hydrogen (H <sub>2</sub> ) .. .. .	5.9	
Nitrogen (N <sub>2</sub> ) .. .. .	59.4	
	<hr/> 100.0	

Several plants of this type have been erected in Denmark, Sweden, and Canada, and are said to have proved successful. According to the manufacturers, they require approximately 1 kilo of a peat having the rather low calorific power of 3,000 to 3,200 c. for 1 h.p.-hour.

The Deutz Gas Motor Factory obtained similar results with their shaft-gasifiers for peat (see Patents 157729, 169088, 169378, 198295, in the section on Patents). These results may be summarized as follows :—

Cut peat from Hanover				Peat from Giengen (Württemberg)			
having the following composition :—							
Carbon .. .. .	41.46	Carbon .. .. .	30.30				
Hydrogen .. .. .	3.88	Hydrogen .. .. .	2.71				
Oxygen and nitrogen ..	18.85	Oxygen and nitrogen ..	17.63				
Sulphur .. .. .	0.25	Sulphur .. .. .	0.16				
Ash .. .. .	3.26	Ash .. .. .	4.78				
Moisture .. .. .	32.30	Moisture .. .. .	44.42				
	<hr/> 100.00		<hr/> 100.00				

on gasification gave a power gas consisting of :—

	Per cent.		Per cent.
Carbon monoxide (CO) ..	30.6	Carbon monoxide (CO) ..	30
Hydrogen (H <sub>2</sub> ) .. .. .	6.1	Hydrogen (H <sub>2</sub> ) .. .. .	10
Carbon dioxide (CO <sub>2</sub> ) ..	5.7	Carbon dioxide (CO <sub>2</sub> ) ..	6
Methane (CH <sub>4</sub> ) .. .. .	5.1	Methane (CH <sub>4</sub> ) .. .. .	2
		Olefines (C <sub>n</sub> H <sub>2n</sub> ) .. .. .	0.4

From 1 kilo of peat the volume of gas was :—

1.9 cb.m.		1.3 cb. m.
and the consumption of peat for an effective h.p.-hour was		
1.2 kilos.		1.1 kilos.

Gas engines and peat gasifiers made by the Deutz Company are at work in Sweden and Russia. The maker states that the moisture of the peat may be as high as 60 per cent. (?) without



injuriously affecting the production of the gas or its purity, and, therefore, the working of the gas engines.<sup>1</sup>

The Görlitz Machine Factory and Iron Foundry construct a suction gas producer which, together with their gas engines, is to serve for the utilization of peat in power stations. They state that good results are to be obtained with it even when peat containing up to 50 per cent. of moisture is employed. The drier the peat is, however, the better the return from its use. The consumption of peat for the h.p.-hour is again given as averaging 1 kilo. The grateless producer (Fig. 149) has a double-walled

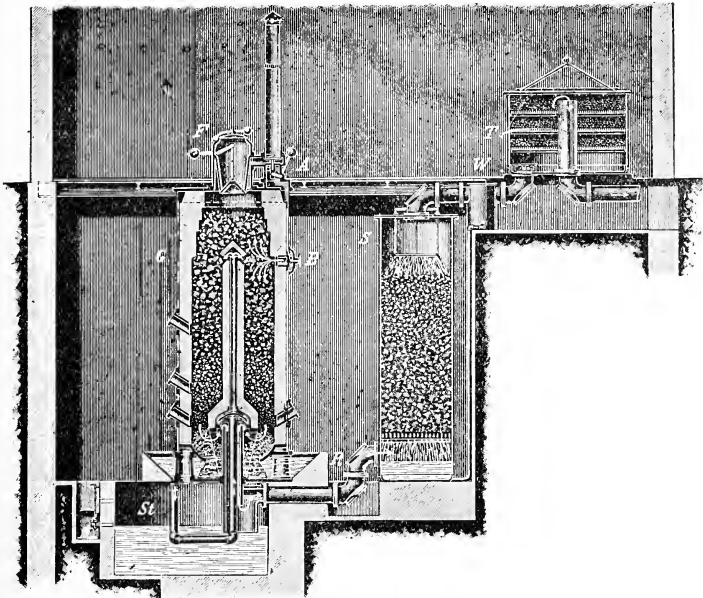

FIG. 149.—Peat gasifier with central gas exit, as constructed by the Görlitz Machine Factory and Iron Foundry.

cover made of steel plates and lined with fire-brick. It is closed at the top by an adjutage with a reversing contrivance *A* and a hopper *F*, which can be opened by means of a counterpoise lever;

<sup>1</sup> Further experiments made with a Dutch peat from Venlo, Helenaveen, have shown that even with a peat containing 59 to 60 per cent. of moisture, and having the extraordinary low calorific power of 1,800 c., the consumption of peat for the effective h.p.-hour is 2.35 kilos, corresponding to 3,725 kilo-calories, the gas being well purified in a very small space, and with low capital costs. For a more detailed report, see the Dutch journal *De Ingenieur*, 1912, p. 42.

and is sealed at the bottom by a water pan. The exit tube for the gas, the pre-heater for the air and the inner air pipe are all placed in the centre of the shaft.

The combustion proceeds from below upwards, the peat and air are admitted from the top, and the gas is sucked out from the centre of the shaft. The peat filled in at the top is heated strongly, and, therefore, deprived of its volatile matter by the combustion occurring farther down. The distillation gases or tarry vapours thus formed pass down with the air and are converted into permanent gases by the high temperature existing below. The carbon first burns in the oxygen of the air to carbon dioxide, but the latter, on passing through the layer of glowing charcoal, combines with more carbon, forming carbon monoxide. The conservation of the heat set free in the gasification is of great importance, as on it the successful gasification of moist peat mainly depends. With this object all the air required for the combustion is at first taken from the lower duct, in which the gas-delivering tube lies and by which it is pre-heated. Then one portion is led by means of a tube through the water seal at the bottom and up through the middle of the gas-delivering tube. The air tube, which is surrounded on all sides by the hot gases, absorbs the heat contained in the latter. This portion of the air then passes through the so-called pre-heater and then, when heated to a high temperature passes into the fuel in the upper portion of the gasifying shaft. The heat contained in the gas is, therefore, fairly completely returned to the gasifier. The other portion of the air required for the combustion passes from the lower duct through the double-walled cover up into the shaft, over the whole of which it becomes distributed. In this way the heat, which would otherwise become lost by radiation, is also returned to the gasifier. By this arrangement it is possible to work continuously and successfully even with very wet earthy fuels.

Whenever, owing to special circumstances, e.g., charging the furnace with a very wet peat, the fire drops off in the shaft, the stoker connects the flue with the interior of the shaft by opening the reversing valve *A*. The entrance of air at the top is then cut off, the hot air in the double-walled cover passes directly into the shaft when the valve *B* is opened, and a very energetic combustion sets in. When the fire is once more burning well the valve is again reversed. Ashes and slack can be removed by means of shovels from the water seal *St* without any development of dust. The water seal also acts as a dust-catcher for the outgoing gas. The washer *S* is filled with pieces of coke decreasing in size from below upwards and has a water sprayer at the top. *W* is a water separator, and finally *T* is a saw-dust scrubber from which the gas, which is by this time washed, purified, and dried, flows into the gasometer, from which it is drawn off for driving the power machine or for other purposes.

The peat gas plant is always so arranged that the hopper of the producer is level with the surface of the ground, the shaft

itself being, on the other hand, in a basement or cellar. This has the great advantage that the peat, which has to be charged in large quantities, can be brought in and unloaded on the level without requiring to be elevated, as otherwise happens, to shaft hoppers at a considerable height above the surface of the ground.

The thorough experiments carried out by Professor Baer, of Breslau, with one of these 300 h.p. peat gas installations, which was set up at the Posen Exhibition of 1911, and was used there for continuously generating electricity, showed that with a double-acting, quadruple cycle gas engine having an actual efficiency of 82.9 per cent. and 260 effective h.p. the peat consumption was 258 kilos per hour or 1.55 kilos per kilowatt-hour on the switch-board, or 0.99 kilo for 1 effective h.p.-hour or 0.82 for the piston h.p.-hour.<sup>1</sup>

The analysis of the gas gave the following results :—

	Experiment I.	Experiment II.
	Per cent.	Per cent.
Methane .. .. .	1.35	1.74
Heavy hydrocarbons .. .. .	0.11	0.15
Hydrogen .. .. .	17.13	17.00
Carbon monoxide .. .. .	15.85	12.80
Oxygen .. .. .	1.02	1.31
Carbon dioxide .. .. .	12.34	14.00
Nitrogen .. .. .	52.20	53.00

Power gas plants of this type are working successfully for S. G. Gratschoff and A. C. Bortschaninoff and Co., at Ekaterinburg (Russia), amongst others. The plant at Ekaterinburg is of 450 to 500 h.p.

The gasifier of the Julius Pintsch Company, of Berlin, has a tube which is suspended in the centre of the oven shaft and into which the peat passes from the hopper. The tube is open at the bottom and serves for the distillation and carbonization of the peat. In this case also the distillation gases are burnt in the gasification zone. The freshly charged peat is heated by the finished power gas, which flows round the outside of the suspended tube, and then, when fully carbonized, passes down into the gasifier where power gas formation is effected by means of the mixture of air and steam passed up through the grate. While this gas is led away through a tube, separated as well as possible from the centre of the gasifier, the distillation gases formed in the gasifier are drawn out through a tube intended specially for them, and, after addition to them of the quantity of air necessary for their combustion, they are again introduced into the gasifier by means of a by-pass tube, ending under the grate.

<sup>1</sup> *Maschinen-Zeitung*, 1911, No. 24.

### 3.—The Frank-Caro-Mond Process for Gasifying Peat with Recovery of Nitrogen; and the Gasifiers of Hoering-Wielandt, A. Born, &c.

The ordinary method of utilizing peat is beset with difficulties which everyone knows, and the economic working of large peat factories, the satisfactory disposal of fuel peat or peat charcoal, and, therefore, the successful utilization of large bogs are specially affected by:—

(1) The inconvenience associated with the winning and drying of peat, lack of labour, &c.

(2) The low heating power of ordinary air-dry hand peat, or machine peat, in relation to its volume.

(3) The non-utilization of the nitrogen of the peat which, though valuable in itself, does not increase the calorific power of the peat.

These facts led Professors Frank and Caro, of Charlottenburg, near Berlin, to work out a special gasification process based on that of Mond,<sup>1</sup> the object of which<sup>2</sup> is to recover the valuable nitrogen in the form of ammonia, in addition to producing a cheap power gas from (crumb, cut, or dredged) peat even when the latter is only "half dry."

High bog peats contain 0·8 to 1·5 per cent. of nitrogen and low bog peats up to 3 to 4 per cent. of this element. If, in the well-known shaft gasifiers or gasification ovens for the production of power gas from peat, care be taken to keep the temperature of the gasifier as low as possible and to remove the gases from it as rapidly as possible, the ammonia, which is formed from the nitrogen of the peat during the combustion, can be prevented from decomposing owing to increase of temperature and won in the undecomposed state, provided little air, but much steam, be let into the gasifier. Under these conditions about 70 per cent. of the nitrogen contained in the peat can be won in the form of ammonia. If the peat is more or less rich in nitrogen the yield of ammonia, and the profit arising from this, are so considerable that the power gas won at the same time becomes an extraordinarily cheap fuel. This power gas is to be used in electrical power stations for local factories or in overland power stations for generating an electrical current, which can be transmitted and distributed over long distances (without great loss) by cables in the well-known manner. In this way the utilization of peat is to be made feasible in the bog itself without incurring heavy expenses for drying and freightage. The heating value of the gas thus obtained varies from 1,100 to 1,300 kilo-calories per cubic metre. It is said that peat containing 50 to 60 per cent. (and even 70 per cent.) of moisture can be employed with advantage in this process and also even when it is in the form of mould (i.e., sods are not necessary). It is claimed that this peat can be

<sup>1</sup> See Patent 130884 in the section on Patents.

<sup>2</sup> See Patents 238829 and 255291 in the section on Patents.

won cheaply, and that the industry can be carried on during at least nine months of the year.

According to the improved process the peat is filled into the shaft gasifier, which is sealed underneath from the air by means of water. Hot air, saturated with water vapour, is forced under pressure into the charge, which has been ignited from below. The peat above the glowing layer then undergoes gasification. The gas is washed and freed from tar, and then the ammonia contained in it is absorbed by sulphuric acid. The lye thus obtained is evaporated and the ammonium sulphate, which is separated by centrifuging, has a high value as a fertilizer. The gas is further purified in the ordinary way, cooled by imparting its heat to the air-blast required for the gasification, and is then capable of being used in gas engines. The essential part of the Frank-Caro improvement in the "Mond gas" process is the very high temperature ( $400^{\circ}$  to  $450^{\circ}$  C.) of the air-blast blown into the gasifier, owing to which temperature the drying layer is brought as near as possible in the furnace to the burning layer, and the yield of ammonia, therefore, increased.

The German Mond Gas Company, which was founded in conjunction with leaders of industry and financiers of the Rhineland for the utilization of the process improved by Frank and Caro, erected at considerable expense a big experimental plant at Sodingen, in Westphalia, and then formed the Hanoverian Colonization and Bog Utilization Company at Osnabruck, which acquired 1,000 ha. of the Schweger Moor, near Osnabruck, in addition to extensive bog areas near Papenburg. In 1910 this Company built a 3,000 h.p. power gas and electricity station in the Schweger Moor, which began work in October, 1911, after initial difficulties of various kinds had been experienced. In addition to utilizing the bogs, which had previously been more or less derelict, and supplying electricity to the town of Osnabruck and the surrounding districts, they hoped that by means of this factory they would have given an incentive for extensive colonization of the bogs by agricultural labourers and for the installation in the district of large chemical and other industrial works.

According to Frank the average composition of the power gas obtained from peat containing 50 to 55 per cent. of moisture was:—

	Per cent. by volume.	
Carbon dioxide ..	17.4 - 18.8	} The total combustible constituents were therefore 36 to 39 per cent. (by volume), and their heating value was, on an average, 1,300 to 1,400 kilocalories per cubic metre.
Carbon monoxide ..	9.4 - 11.0	
Hydrogen ..	22.4 - 25.6	
Methane ..	2.4 - 3.6	
Nitrogen ..	42.6 - 46.6	
Oxygen ..	Traces	

Each effective horse-power of a gas engine required 2.4 cb. m. of the gas. The peats gasified at Sodingen, which on the average contained 1.15 per cent. of nitrogen, gave up to 40 kilos of ammonium sulphate per metric ton of dry peat. A deduction

must be made in the case of large installations by taking into account the amount of gas necessary for generating the steam required for the gasifier, so that for the metric ton of dry peat, corresponding to 2 m. tons of peat containing 50 per cent. of moisture, the power produced should be assumed as only 650 to 700 h.p.-hours. For every 1,000 h.p.-years, of 8,000 h.p.-hours each, then at 650 to 700 h.p.-hours, or with continuous working 900 h.p.-hours, for the metric ton of dry peat, the fuel consumption would require each year the cutting out of 4 ha. of bog 3 m. in depth. The cost of winning 1 m. ton of peat containing 50 to 55 per cent. of moisture is assumed to be 3M. For the 3,000 h.p. station in the Schweger Moor 12 ha. of bog would require to be cut away every year, and the subsoil, made available for tillage by the Dutch method, could be handed over to colonists for agricultural purposes. Special importance was attached to the winning of the nitrogen of the peat in the form of ammonium sulphate (33 to 35 kilos per metric ton of dry peat), both from the point of view of the shareholder and also to meet, as far as possible by home manufacture, the German agriculturists' requirements of nitrogenous fertilizers. It was also expected that with the cheap power gas thus won the utilization of atmospheric nitrogen for the production of fertilizers (calcium cyanamide, &c.) by the process discovered by Frank and Caro would be greatly facilitated. About 800,000 to 1,000,000 h.p. would be required in the case of the calcium cyanamide process to meet Germany's ever-growing requirements of combined nitrogen.

In this process for gasifying peat with recovery of by-products the consumption of dry peat necessary to produce, electrically, 1,000 h.p.-hours is 1.25 m. tons, while in the other processes without by-product recovery (Deutz, Körting, Görlitz) it is 0.6 to 0.75 m. tons, or with peat containing 50 per cent. of moisture it is 2.5 as against 1.2 to 1.5 m. tons. Counterbalancing the increased consumption of 1 to 1.3 m. tons of "half-dry" peat (costing 3M. to 4M.) for 1,000 h.p.-hours, 10 kilos of nitrogen in the form of ammonium sulphate (worth 10M.) are obtained. This profit from the ammonium sulphate; which is, however, subject to a deduction due to the higher interest and amortization of the higher capital required, serves, therefore, for decreasing the cost of the power obtained.

As far as is known, the carrying out of this process on the large scale of the Schweger Moor power station met with considerable difficulties, so that the peat gasification plant had to be shut down. The estimates of the probable working results based on the very complete experiments made in the bog and the hopes for the commercial success of the installation, entertained even by the world of experts, have not as yet been fulfilled. With regard to the reasons for this, the public is not clear whether it is due to the "half-dry" peat (containing 50 to 60 per cent. of moisture) being too dear and also insufficient in amount for the yearly requirements of the station, or to the character of the Schweger Bog, inadequacy of the peat-winning machines,

unfavourable utilization of the steam and heat in the gasification of the by-products, or to an unsatisfactory yield and utilization of these by-products, or, what is most probably the case, to the co-operation of several of these causes.<sup>1</sup>

In addition to the experimental installation near Osnabruck two more or less large plants of this type are said to be working, and indeed satisfactorily, at Orentano and Codigoro, both of which belong to the Società per l'utilizzazione dei combustibili Italiani. The latter plant is said to be able to produce 10 to 12 m. tons of ammonium sulphate per day from 150 m. tons of artificially (?) dried peat. The total expenditure of the Company at Orentano and Codigoro is said to have been 4,859,400M. and the cost of production of 100 kilos of ammonium sulphate to have been only 10M. to 11·50M., as against a selling price of 24M.<sup>2</sup>

The purpose of the peat gasifiers which we are now about to mention is essentially the same as that of the gasifier just described.

The *Hoering-Wielandt Gasifier*<sup>3</sup> consists of a combination of the Hoering carbonizing muffle<sup>4</sup> with a gasifier in which the destructive distillation occurs at a different place from that at which the gasification is carried out. It is claimed that it is possible in this way to win all the by-products of the coking or carbonizing process without destroying the tarry constituents by burning them. The heat contained in the glowing charcoal is absorbed by the steam, which is forced through the oven to cool the charcoal, and is then employed for the recovery of the by-products and the pre-heating of the air required for the combustion.

*A. Born's Peat Gasifier.*—In this shaft producer the peat is to be gasified in the crumb instead of in the sod form. The air is led in all directions through the peat, while this is gradually sinking during the gasification, so as to avoid the great resistance offered by a high column of crumbly peat to the passage of air and fuel gas through it. With this object the air supply chambers are displaced to the side of the shaft, separated by greater intervals than usual, and are provided with inlets and outlets so that the air is compelled to pass through the crumbly mass of peat instead of up the side of the latter. Also in the case of this gasifier, in addition to the production of gas for fuel or power purposes, the main object is the recovery of as much as possible of the by-products (up to 90 per cent. of the nitrogen of the fuel and 10 per cent. of the tar) and at the same time the commercial solution (?) of the problem of the utilization of peat even when this contains 40 per cent. of moisture. One of these gasifiers is at present set up at the State Mine Works at Glodbeck.

The same remarks apply to the gasifier of the Upper Bavarian

---

<sup>1</sup> Cf. also *Mitteilungen*, 1913, p. 209 *et seq.*; also p. 231 or pp. 320–328 and 371–372 for A. Born's statements and the reply thereto of the Hanoverian Colonization and Bog Utilization Company.

<sup>2</sup> *Mitteilungen*, 1914, p. 376.

<sup>3</sup> See Patent 176231 in the section on Patents.

<sup>4</sup> See Patents 158032, 176364, and 176365 in the section on Patents.

Coke Works and Chemical Products Factory at Beuerberg. This gasifier is mentioned in more detail under Patent 213852 in Section IX, 3.

#### 4.—Economic Value of the various Peat Gasifying Installations

The question has often been asked in reference to the technical utilization of peat by gasification for power purposes whether a down-draught or an up-draught producer, and also whether simple generation of power gas, according to the method described on p. 400, or gas generation with recovery of by-products according to the process of Mond, Frank, and Caro, is the more economical and, therefore, the more correct. This question cannot be answered in general. The size of the power station projected or intended to be used, as well as the nature of the peat to be employed, especially its percentage of nitrogen, have important bearings on these points. Well-purified gas, which will not clog the gas pipes or the engine, is absolutely necessary if the power machines are to work without interruptions. In an up-draught producer, the gas exit of which is above the layer of fuel, the tarry vapours, formed in all cases, pass with the gas to the purifier in which they must be subjected to a thorough mechanical purification which necessitates a corresponding expenditure of power. In the "Mond gas" manufacture the purification of the gas is effected during the recovery of the by-products, and this in itself requires a more or less large expenditure of power and capital. The down-draught producers, amongst which that described on p. 405 may be mentioned, aim at the production of gas which can be used without further purification in engines. The tarry vapours, formed also in this case from the freshly charged peat at the top of the producer and not being able to escape there, are obliged to pass with the air necessary for the gasification through the underlying layers of glowing peat, where they are converted into permanent gases suitable for engines, and from which they escape with the power gas itself. The recuperation of the more or less large amount of heat contained in the gases formed in this process is effected by utilizing it in a suitable manner to pre-heat the air required for the gasification. In comparing the different power gas installations with one another it is not the quantity of gas produced in the plant and its content of carbon which are the deciding factors, but rather that quantity which is available as power for use outside the factory together with the simplicity, the ease of supervision, the purpose and the cost of the installation. "Mond gas" plants require a larger capital on account of their wider scope and more workmen and officials for the recovery of the by-products (ammonia, &c.). As the "Mond gas" installation also requires more peat for the development of unit power than the simple power gas plant, a bigger installation and working capital is necessary for the larger amount of peat to be won, and the interest and amortization of this must be taken into account in the estimate. More or less



small "Mond gas" plants could, therefore, scarcely prove commercially successful. For such installations it will, as a rule, be a matter of several hundred thousand Marks capital which, when the peat is cheap and rich in nitrogen and when there is an assured market for the by-products, should yield a good interest.

The statement that in one or other plant more or less wet peat (containing up to 70 per cent. of moisture) can be gasified successfully without interfering with the continuity of the working can only be accepted with reserve. Too high a moisture content requires a large expenditure of heat for its evaporation, and in any event makes the gasification more difficult to effect, the gas won having at the same time a lower heating power. The larger amount of heat thus lost and the increased consumption of fuel necessary for the recovery of the by-products are partly compensated by the greater yield of ammonia, &c., the value of which, and, therefore, the final economic verdict on the possibility of working a more or less wet peat, will depend on the market price of the by-products.

Regarding the question whether it is better to use power gas or fuel gas for a plant, especially when the load is variable, as, for instance, in the case of electric lighting and power stations, it must be observed that gas engines have their full and maximum efficiency only when working at full load, while steam engines and steam turbines are able to adapt themselves to a varying load without considerable loss of efficiency.

In large installations it will be well, therefore, to combine the two methods in such a way that the probable constant load will be provided for by gas engines and power gas producers and the variable excess load by steam engines and steam turbines, developing the steam necessary for the latter in boilers heated by fuel gas furnaces.

## SECTION IV

# APPLICATION OF PEAT-FIRING IN VARIOUS BRANCHES OF INDUSTRY RESULTS

### I.—General Heating Installations and Domestic Fires

In North and South Germany, Holland, Switzerland, Sweden, and Norway, as well as in Russia, peat is used extensively as a fuel, both for sitting-room fires and kitchen fires, as well as for industrial purposes—for instance, for boilers in breweries and salt-works, for furnaces in glass-works and potteries, and also for the manufacture of peat charcoal. In Austria, on the other hand, it is mainly used in factories, especially ironworks, glass factories, and potteries. The use of peat for firing locomotives and smelting iron, with regard to which details are given later, is everywhere on the decline. The construction of domestic fireplaces for peat has been recently improved in South and North Germany, as well as in Denmark, Sweden, and Norway. These are either grate fireplaces with doors, capable of being made air-tight, for the fire itself as well as for the opening through which the ashes fall, or else intermediate shell fireplaces for continuous firing. We must once more point out that a stove suitable for other fuels cannot, without further trouble, be employed with advantage for peat-firing, and that this can be done only when the stove, having a sufficient heating surface and a suitable draught with air regulators, is able to separate the ashes easily from the still burning fuel and to allow just the right amount of air to pass freely to every part of the burning peat. In these peat stoves for living rooms the heating is generally conducted so that all the fuel required to warm the room in question is put in one batch into the stove and ignited. When it is burning freely the fire-door and the ash-door are closed tight. The charge then burns out gradually, and the retention of the heat thus developed makes it possible for a single firing to suffice for the whole of a cold winter's day.

The modern intermediate shell and continuous combustion stoves, well known for coal-firing, have been suitably modified for peat-firing. In the absence of a grate they have been provided with two air inlets on the front and rear sides of a box-shaped layer of fuel, and we are thus enabled to keep the firing going well for several days with peat, just as in the case of coal or coke. Amongst good stoves, constructed specially for peat, may be mentioned the "Danish continuous combustion stoves for peat-firing," of Gienanth Bros., of Hochstein and Eisenberg (Palatinate), of Christensen and Co., of Nykjöbing, of Lange Jensen and Co.,

of Svenborg, of A. B. Recks, Opvarmings Co., of Copenhagen, of H. Andersson, of Laholm, and the new peat continuous combustion stoves of Winter and Co., of Hanover, as well as the peat stoves of Alfred Christensen, of Munich.

For central heating the Strelbel Works of Mannheim provide their well-known hot-water and steam-heating boilers with special firing and draught contrivances for those cases where brown coal and peat are used as the fuel. These appliances have proved successful. The trials gave, for instance, with the so-called "Brico boiler" of the factory, using machine peat in sods of the ordinary size and quality, a nearly complete combustion and a heat development of 7,000 to 8,000 kilo-calories per square metre of the heating surface. A good draught in the chimney (which should be at least 10 m. in height and have a draught of at least 3.5 mm. of water) is, however, absolutely necessary, as the moisture content of the peat is generally high.

The following results have been obtained in the different industries :—

## 2.—Iron and Steel Industry

The use of peat for the manufacture of iron and steel progressed to an extraordinary extent *pari passu* with the development of gas-firing in the middle of the last century, and the ironworks, erected mainly with a view to utilizing large peat bogs, in Oldenburg, Styria, Carinthia, and the Tyrol, for instance, showed during the seventies and eighties in regard to peat utilization almost entirely satisfactory, in some cases indeed very good, results. By employing the improved Siemens gas furnaces a temperature sufficient for smelting steel was attained, and in forging, welding and puddling operations, as well as in the Martin process, peat could, in bog districts, compete favourably with any other form of fuel.

In the first edition of this book, as well as in the report on visits made by the author, which appeared in 1878 under the title "Die Torfwirtschaft Süddeutschlands und Oesterreichs," Berlin, Paul Parey, and in the *Landw. Jahrbücher*, vol. vii, Nos. 4 and 5, detailed accounts are given of the plants employed and the results obtained.

The fuel consumption for 100 kilos of the finished product, e.g., in the Siemens regenerating furnaces of the Josefthal Ironworks, near Chlumetz, amounted to 120 kilos of peat in the case of re-heated plate-iron, wire, or refined iron. In the Siemens re-heating furnaces of the Buchscheiden Ironworks, in Carinthia, the fuel required was 58 kilos. In a double furnace, indeed, only 36.3 kilos of cut peat were required for every 100 kilos of twice-heated rolled steel rails. This double furnace gave 93,000 kilos per week, corresponding to 4 to 4½ heatings in twelve hours for eight ingots of 240 kilos each.

In the peat gas re-heating furnaces of the Marien Ironworks, at Dantzig, the peat required per 100 kilos of twice re-heated iron was estimated at 90 kilos, similar results being obtained about that

time in the re-heating and steam-hammer operations of the Berlin Machine Co., formerly owned by L. Schwartzkopff.

In the Nothburga Ironworks, near Klagenfurt, where approximately 18,000 cb. m. of peat were consumed annually, but which ceased operations several years ago, the output of a double puddling furnace charged with 450 kilos of "white Carinthian wood charcoal cast-iron" was 405 kilos, the peat consumption being 165 kilos per 100 kilos of iron. At the Rottenmann Ironworks, in the Enns valley, for every 100 kilos of finished sheet metal, 150 kilos of peat were required for puddling, 45 kilos for re-heating to mill-bar, and 90 kilos in the reverberatory furnace.

The best results of the period were obtained at the Oldenburg Ironworks, at Augustfehn, which at the beginning of the eighties had in addition to 3 coal puddling furnaces and 1 coal re-heating furnace, 11 peat gas puddling furnaces and 4 peat gas re-heating furnaces (Siemens furnaces), together with 9 steam boilers fired with peat. The fuel burnt consisted of 4,750,000 kilos of coal and 18,300,000 kilos of peat, of which 14,300,000 kilos were cut by the Company itself and the remainder purchased from neighbouring bog-owners. The annual net profit of the Company at the time amounted to 38 per cent., but on the average was 20 per cent. It was found that in the puddling furnaces every 100 kilos of unfinished rails required 120 to 130 kilos of coal in the coal furnaces, and 190 to 230 kilos of peat in the peat gas furnaces (including the steam generation), which in the years 1873-1874, when the price of coal, free at the factory, was 2·24M. per 100 kilos and that of cut peat was 0·57M. per 100 kilos, made a difference in the cost of production of 1·50M. per 100 kilos of the finished product in favour of the peat gas furnaces.<sup>1</sup>

Since then, however, partly owing to extensions in railways and waterways, partly owing to better utilization for metallurgical purposes of the waste gases from carbonizing and coking ovens, partly because the smelting of poor bog-iron ores became unremunerative in the face of pig-iron from England, Alsace and Lorraine, Spain, or Sweden, the circumstances of the iron and steel industry so altered that, quite apart from the fuel question, the continued existence of all the smaller ironworks became endangered. These, owing either to remoteness from trade centres or to difficulty in obtaining the raw or semi-raw materials, or to distance from the market for their products, or to labour difficulties, &c., were much less favourably situated than the many factories in the centre of the well-known iron and coal districts which were well capitalized and equipped with the best technical contrivances for the work. Hence the ironworks erected at that time for the utilization of peat in the larger bog districts which are generally at a considerable distance from commercial centres were gradually abandoned, as, for instance, the Neustadt Works in Hanover, the Josefthal

<sup>1</sup> All the working results as well as the details with regard to the contrivances at the ironworks are given in the first edition of this book "Industrielle Torfgewinnung und Torfverwertung," Berlin, 1877.

Ironworks near Chlumetz, the ironworks of the Vordernberger-Radmeister community in the Enns valley, the Buchscheiden Ironworks in Carinthia, &c.; and even the Augustfehn Ironworks, which had considerably better results in the eighties with its peat gas re-heating and puddling furnaces than it did with coal furnaces and which gave rise to great hopes for peat utilization in the future, has in the interval given up the peat industry. The directors were obliged to adopt this course owing to the nature of the peat and to the shutting down of their puddling industry. Their own peat became every year less dense, and for several successive years it was not sufficiently dry; dry peat from outside sources was offered at too high a price and in too small a quantity; the puddling became therefore no longer remunerative, the pig-iron having become too dear. Re-heating with peat gas was given up, as the manufacture of re-heated iron in the new coal gas re-heating furnaces proved more economical than in the peat furnaces; the steam for the rolling mill engine was obtained, moreover, without any special expenditure of fuel.

The neighbouring Augustfehn Steelworks, on the other hand, now, as heretofore, uses peat for firing its boilers.

The peat industry itself in these factories, notwithstanding the shutting down of the ironworks, has not been given up nor has it decreased in extent. The peat won there is used in dwelling houses or in the furnaces of neighbouring potteries and glass-works.

The bogs of the earlier Josefthal Ironworks, for instance, have passed into the possession of the glass-manufacturing Company of C. Stölzle and Sons, of Nagelberg, which also carries on a machine factory, an iron foundry, a wire-mill, and a wire-tack industry at Chlumetz, near Wittingau. This Company uses in its various industries, including the glass-works, 50 to 60 million sods of peat per annum, in addition to 800 double wagons of brown coal and 40,000 cb. m. of wood. According to the quality of the peat, i.e., whether fibrous or bituminous, 1,000 sods weigh 220 to 400 kilos, so that the annual consumption of peat amounts to about 1,700 double wagons. In Bohemia their works are in the Oberplan, Wittingau, Schweinitz region, and in Lower Austria in that of Gmünd, Weitra, Schrems. The combustion is carried out in gas furnaces with flat grates and also on step grates.

In other works peat-firing has maintained itself to some extent, e.g., in the Untersberg Iron Refinery, near Salzberg, and in the iron-works at Rottenmann (Styria) of Lapp Bros., formerly belonging to the Pesendorf representatives. The latter uses annually, in addition to 200 to 240 m. tons of "smiths' coal" in the forge fires and about the same amount of brown coal in reverberatory fires for the manufacture of 1,500 to 2,000 m. tons of axle-trees, 1,400 m. tons of brown coal in tempering furnaces, 360 m. tons of coke in cupola furnaces, and 45,000 to 48,000 hl. of wood charcoal, 10,000 to 12,000 m. tons of brown coal, and 450,000 hl., or 9,000 m. tons, of peat from Gamper and Wörschach moors

(in the Enns valley), in re-heating furnaces with flat grates and in gasifiers for the manufacture of 8,500 m. tons of refined sheet metal, cold-rolled band-iron, and ordinary sheet metal. According to the thickness of the sheet metal, 150 to 200 kilos of cut peat are required for 100 kilos of the refined plate. All the cut peat is dried in the sheds described on p. 47; the cost of winning is 0·50 kr. per 100 kilos of dry peat, to which 0·50 kr. must be added for the construction and repair of the drying sheds, transport, &c.<sup>1</sup> Fohnsdorf coal costs 2·80 kr. and Lankowitz brown coal 2·00 kr. per 100 kilos, delivered free at Rottenmann railway station.

Industrially, peat charcoal, made from good machine peat, is in ready demand as a substitute for wood charcoal for copper-smiths, machine manufacturers, locksmiths, &c., and also even for the blast furnace industry. The proprietor of the Schmal-kalden blast furnace works (Bleymüller) reported, as the result of many years' experience of peat charcoal and wood charcoal in his blast furnaces, that a good, dense, and firm peat charcoal, when obtained from layers of pure peat and free from sulphur and phosphorus, as is generally the case with the East Frisian peat charcoal, is very well adapted for the replacement of beech charcoal in blast furnaces, and that it has a crushing strength equal to that of the latter. So far from the iron being in any way prejudicially affected, it is rather of a more uniform character when made with peat charcoal than with wood charcoal, which frequently, owing to rainy weather, is brought in wet, and therefore in an unreliable condition.

Whether peat charcoal can be used successfully for blast furnace purposes depends entirely on the price and the strength of the charcoal. While some are of opinion that the height of the furnace, when peat charcoal is used, should not exceed 12 to 13 m., experiments in Bosnia have shown that Ziegler's peat charcoal can stand the pressure in furnaces up to 18 m. in height. After each "running-off" the hearth must be carefully freed from dust, but a special form of furnace is not necessary.

According to the experiments of Professor Odelstierna, the peat powder of Ekelund is said to have worked very well in Swedish iron and steel smelting furnaces. Thus, for instance, the melting of 1 kilo of crucible steel required only 0·8 kilo of peat powder as against 1 kilo of coal.

### 3.—Glass-works Industry

Peat-firing has maintained itself better in glass-works than it has in the iron industry. With the introduction of peat gas firing into the glass industry, the two following conditions, important for good working, were simultaneously fulfilled:—

<sup>1</sup> The factory reckons that a 3 hl. barrel = 60 to 65 kilos of air-dry fuel peat, costs 55 heller (hence 100 kilos cost approximately 1 kr.), including all charges, interest, &c.

(1) The production of a sufficiently high temperature even when a comparatively poor fuel was employed.

(2) The preservation of the glass from attack by injurious fumes, which is made possible in the case of ordinary firing by employing only closed melting pots and by using only wood or coal of a good quality to attain the high temperature required for these.

With the aid of ordinary grates and peat-firing common and semi-white glass were manufactured in a few cases when the fuel was of specially good quality. The glass had, however, to be made 20 to 30 per cent. softer than that made in wood charcoal, coal, or gas furnaces. This placed the manufacturer at a disadvantage, and, moreover, the glass was less brilliant and less resistant to chemical agents than that obtained in the ordinary furnaces.

The window glass made in this way very quickly becomes dull and is not much sought after. On the other hand, gasification of the peat, for which purpose even a peat of little value may be used on account of the purity of the flame, which is of very great value in the manufacture of glass, enables us to smelt extra-fine glass without any special difficulty and helps to impart a beautiful brilliancy to the product, thus increasing its market value.

The possibility of using peat for this industry allows of the latter being introduced into countries containing all the necessary raw materials—sand, ashes, spar, and lime—and in which the establishment of glass factories has hitherto been impossible owing to lack of wood or too great distance from coal districts, while at the same time peat is present there in almost inexhaustible quantities, as, for instance, in the Baltic provinces, Posen, Poland, Bohemia, Styria, West Russia, &c.

The advantage which peat gas firing has over ordinary firing with wood charcoal or coal is considerable and amounts to a saving of at least 30 to 40 per cent. in fuel costs, as may be seen from the following particulars.

According to statements made many years ago by the Neufriedrichstal Glassworks, near Uscz, a glass-smelting furnace fired with peat gas, having 8 glass-smelting pots and giving 3,200 kilos of glass in each batch required in 7 days or 7 x 24 hours :—

77 cords <sup>1</sup> of light peat at 6M.	..	..	..	..	462M.
7 cords of faggots at 9·0M.	..	..	..	..	63M.
					525M.
Total	..	..	..	..	525M.

On the other hand, a glass-smelting furnace of the same dimensions fired with wood, therefore, with 8 pots, each giving 800 kilos of bottle glass in 7 x 24 hours or 1 week, required :—

56 cords of logs at 13·50M.	..	..	..	..	756M.
7 cords of faggots at 9·0M.	..	..	..	..	63M.
					819M.
Total	..	..	..	..	819M.

<sup>1</sup> A cord of peat is 108 cubic feet (German) = 3½ cb. m., and contains 2,000 sods of peat, weighing altogether 1,500 to 2,000 pounds (German) = 750 to 1,000 kilos of cut peat.

and therefore the fuel for the latter furnace cost an extra 294M. per week for the same output.

According to Steinmann,<sup>1</sup> a furnace such as this, with a fuel consumption of 180,960 sods of light peat per week, in six batches gave 18 m. tons = 18,000 kilos of glass, so that with the cheaper charge (the thousand of peat sods is estimated at 2M.) the fuel per 50 kilos of glass was 1·01M., or for 100 kilos 2·02M., while in a wood furnace with ordinary firing the fuel cost for 50 kilos of glass amounted to 2·17M.

On an average we may assume that 100 kilos of finished bottles (160 ordinary Rhine wine or red wine bottles) require 250 kilos of air-dry peat, or, if 100 sods of peat be supposed to weigh 35 kilos, then 100 kilos of bottles will require 700 sods of cut peat. The daily consumption of a glass furnace, having 8 pots of 400 kilos each, is 4,500 kilos of peat in 24 hours, with a melting period of 15 hours, so that in the week six workings and smeltings can be carried out.

In cistern furnaces the peat consumption is even more favourable. In a glass-works near Kolbermoor, which manufactured only glass bottles in a Schinz cistern furnace, 20,000 bottles were made in 7 batches, with a fuel consumption of 2,000 to 2,500 kilos in the week, and, therefore, for each batch, including cooling, 36 cb. m. of peat were required, corresponding approximately to 12 cb. m. of peat for 1,000 bottles, or with a price of 1·40M. for a cubic metre at the place, to a fuel cost of 16·80M.

Good brown coal for the same purpose would have cost at that time and place 1·50M. per 100 kilos, or 30 to 40M. for the same output.

At the Ignaz Glaser Works, in the Bürmoos, near Salzburg, which manufactures exclusively plate-glass in Siemens gas furnaces, 10,000 sq. m. of plate-glass (2 mm. thick) are manufactured per month in each of four furnaces, and therefore 40,000 sq. m. altogether of plate-glass per month. For this purpose, including flattening kilns, heating the pots and firing a steam engine for driving small working machines, the furnace installation requires 17,000 cb. m. of fuel peat per annum, or for 100 kilos of plate-glass 3·6 cb. m. of peat (200 kilos each), i.e., 720 kilos of peat are required.

There are at present many glass factories using peat fuel. In Austria, for instance, at Suchental, Georgenthal, Aalfang, Sofienwald, Althütte, Neuhütte, Eugenhütte, near Schrems, Nagelberg, Salzburg, and in Bavaria at Kolbermoor, &c.

The Glass Manufacturing Company of C. Stölzle and Sons, of Nagelberg (Lower Austria), gave their peat consumption as 300 to 600 kilos per 100 kilos of glass, according to the nature of the glass made. As mentioned above, the Company required 50 to 60 million sods (17,000 tons) of cut peat per annum in their various works.

The installation expenses of a modern peat gas furnace do not

<sup>1</sup> Steinmann's "Compendium der Gasfeuerung."



exceed those of an ordinary smelting furnace with the same size of hearth, while, on the other hand, its maintenance costs less, and when its foundations have been made with the requisite care, the furnace may easily last ten to twelve seasons without any great repair being required. The increased expenditure due to the substructure is very rapidly repaid by the saving of fuel and also by other advantages of the furnace. Sometimes this will be paid off even within the first two seasons' work.

Two of the gasifiers shown in Figs. 142 and 144 will be ample for a glass furnace with 4,000 kilos pot capacity or for a cistern furnace, the cisterns of which can take from 5,000 to 7,000 kilos of glass.

For the manufacture of hollow glass ware not only the smelting furnaces but also all the auxiliary furnaces (including even the annealing ovens), which require a lower temperature, can be constructed for gas-firing. The peat consumed in these may be taken as usually 25 per cent. of that used in smelting when plate-glass is being made, and 8 to 12 per cent. for hollow glass ware.

#### 4.—Peat-firing for Burning Earthenware, Bricks, Lime, &c.

The successful use of peat as fuel in the above-named industries is made possible, in the case of continuous working, by means of Hoffmann's annular kilns in addition to the gas furnaces already mentioned.

If these Hoffmann annular or zigzag kilns are combined with drying chambers specially adapted for the wet bricks, commercial success of the industry will be assured. According to Patent No. 283248 of the brickworks engineer Rauls, of Cologne-on-Rhine, a zigzag kiln may be constructed with its drying chambers built either on or in front of its burning chambers and co-axial with these, which are provided with doors at their ends, and with a track going through each of the burning and igniting chambers and extending from the brick-way house to the place where the finished bricks are loaded, the filling and the emptying of the kiln being at the same time made entirely automatic.

In such a kiln it is said that 1,000 bricks or tiles can be manufactured for 8·80M. (the cost was formerly 15 to 16M.), the particulars being as follows:—

Annual output: 10 million bricks and tiles.

Daily output: 40,000.

Size of factory: 33 x 60 m. (1,710 sq. m. site, ground-level).

Number of workmen: 21 men, including those in the clay-pit.

Installation costs: 260,000M.; including cost of clay-pit, 42,500M., working capital, 20,000M., and peat industry, 20,000M.

Cost of production for 1,000 bricks loaded at the brick-kilns:—

(a) Writing-off and interest, 1·87M.

(b) Peat and coal used, 2·76M.

(c) Wages, 2·17 M.

(d) Other expenses, 2·00M.

Total, 8·80M.\*

\* See Rauls, "Handbuch der Trockner und Brennöfen," Cologne, 1915.

The cost of 4,000,000 kilos (4,000 m. tons) of peat was :—

Wages, 6,900M., overseer, 480M., interest, 800M.

Writing-off, 400M., wear and tear, 1,000M., raw material, 2,100M., lubricants, 200M., stoker, 300M., Total, 12,180M.; or in round numbers, 13,000M., with an installation capital of 20,000M. (50 kilos of peat cost, therefore, 0·163M.).

The plan adopted for automatically feeding the peat is that in the German patent of O. von Wilucki, Director of the Brick School at Zwickau, in Saxony.

The peat burnt consists of more or less small pieces of formed peat or mould, but in order that the operations may run smoothly it is essential that it should be as dry as possible. With this object the Rauls peat gas producer is combined with new and ingenious driers so that no peat except that which is almost dry enters into the producer. The drier is run at no expense, all the fuel required for it being obtained from the gas producer itself.

In the Kolbermoor earthenware factory, which is mainly concerned with the manufacture of ridge-tiles, pipes, hollow and ornamental bricks, &c., 1,000 ridge-tiles were burnt in shaft kilns having narrow (Mehl's patent) grates with the aid of 5 cb. m. (215 to 220 kilos each) of peat won by the factory itself. Here also gas-firing has been installed for the better utilization of the fuel.

In most cases, especially for the manufacture of roofing tiles, the peat, as in the Raul's plant, is mixed with coal in order to facilitate combustion.

In the Ingaz Glaser annular kiln brickery at Bürmoos, near Salzburg, the burning of 7 million bricks (29 x 14 x 6·5 cb. m.) requires 15,000 cb. m. of cut peat, i.e., 3,000,000 kilos of peat, (each cubic metre weighing 200 kilos), and therefore 428 kilos would be required for 1,000 bricks.

In the steam tilerly at Husum, near Jever, in Oldenburg, where Dutch bricks are made from an excellent, rich, blue clay, surprisingly good, hard, brown-finished bricks were produced with a fuel one-half of which was machine peat and the other half coal, the product previously obtained with coal alone not having given satisfaction. Equally good results are obtained in the "Scharrel Annular Kiln Brickery" where the output is 10 to 12 millions per annum.<sup>1</sup>

While for continuous working Schütt's annular kilns are the simplest firing installations for the utilization of peat in burning ordinary earthenware bricks, pipes, &c., gas furnaces provided with special gasifiers are necessary when, as in the case of high-class glazed potter's ware, facing bricks, stoneware, &c., we require that the flame should be as pure and as uniform as possible and when we wish to prevent the ill-effects due to contact of the wares to be burnt with the fuel and to the influence on the wares of smoke and ashes, which might injuriously affect the colour of the product, even in the case of bricks.

For this purpose a gas furnace is combined with a Hoffmann chamber kiln (Mendheim type) for production on a large scale, or

<sup>1</sup> *Mitteilungen*, 1906, p. 168.

one or more kilns, grouped together, are provided with gasifiers and a hot blast is forced into the combustion hearth (types of Kleinwächter, Nehse, Möldner, &c., for stoneware, porcelain and

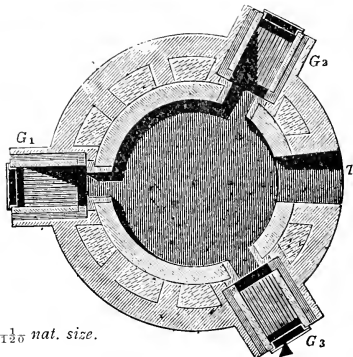
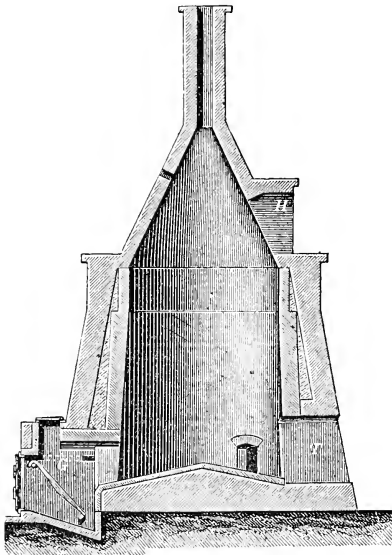

$\frac{1}{12}$  nat. size.

FIGS. 150 and 151.—Lime-kiln with semi-gas firing for peat.

fire-brick) when the working temperature is to be as high as possible.

The description of kilns such as these would take us outside the limits of this handbook ; we can dispense with it all the more

readily as it is not advisable to construct plants of this type without the co-operation of experts.<sup>1</sup>

For a smaller output kilns of a simpler character can be constructed with semi-gas furnaces for the combustion of the peat. Figs. 150 and 151 show, for instance, a lime-kiln with semi-gas firing built many years ago for a lime-burning works at Danzig. It consists of a triple fire shaft-kiln with three gasifiers  $G_1$ ,  $G_2$ ,  $G_3$ , the construction of which is like that shown in Fig. 142.

Immediately before the generated gases enter the shaft the air required for their combustion is passed into them through the air passages left in the side walls of the gasifiers.  $H$  is the upper charging door to which the limestone is wheeled up an inclined plane,  $T$  is the lower charging and discharging door. The kiln, which is simple in construction, gives good results.

In the more modern lime-kilns with semi-gas firing the entire process of burning a charge takes thirty-six to forty hours and for every 100 kilos of burnt lime 50 kilos of peat, or (when 1 cb. m. of burnt lime weighs 1,200 kilos) for 1 hl. of lime 60 kilos of peat having a heating effect of 3,700 kilo-calories, are gasified.

Semi-gas peat-firing can also be used with advantage in more or less small arched kilns for burning good-class earthenware pipes, fire-bricks, &c., in which case the inner cylindrical chamber of the kiln should be suitably widened and arched at the top. As in all arched kilns, the necessary number of air holes should be left in the sole and these can be connected by a duct, under the sole, with a chimney, which is best erected near the kiln and to which, later on, other kilns may also be connected. According as desired the kiln flame may be an ascending or a reverberatory one and the flame itself will have an oxidizing or a reducing action according to the amount of air mixed with the fuel gas.

### 5.—Peat Gas Furnaces for Boiler Installations, Digesters, Evaporators, &c.

As in all industrial operations in which the fuel consumption has a considerable effect on the working expenses, so also for the working of steam-raising, boiling and evaporating plants, efforts have been made to introduce gas-firing wherever the simple grate furnaces described on pp. 341 to 349 have proved inefficient, especially in localities where the peat was of a poor quality.

The simple gas furnace mentioned at the beginning of this Section was that generally used, and attempts were made to improve it so that the results would approach as closely as possible those obtained with hot-blast gas-firing.

A gas furnace for boilers in which the air required for the combustion is added to and mixed with the fuel gas in a very simple

---

<sup>1</sup> Further information with regard to the construction of these kilns and their outputs are contained in *Die Deutsche Töpfer- und Ziegler-Zeitung* and in the *Tonindustrie-Zeitung*.

manner was constructed by H. Pütsch (see Figs. 152 and 153.) This furnace, which resembles the semi-gas furnaces mentioned in the introduction to this section, has given satisfaction, being both simple and cheap.

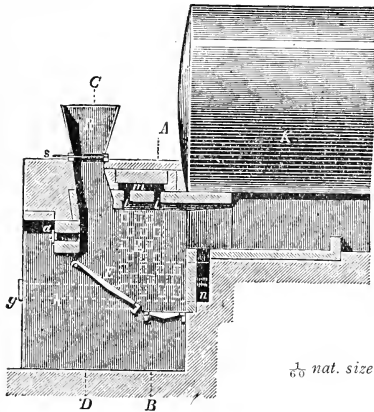

FIG. 152.—Semi-gas peat furnace for steam boilers.

Fig. 152 shows a longitudinal section through the centre of one of the two gasifiers, which are placed side by side ; Fig. 153 a cross-

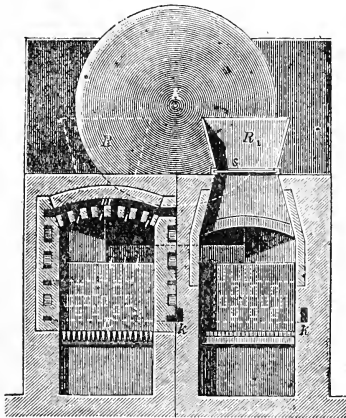

FIG. 153.—Semi-gas peat furnace for steam boilers.

section through the two (through the left gasifier along the line *A-B* and through the right gasifier along *C-D.*, Fig. 152).

*R, R<sub>1</sub>* are the hoppers through which, in turn, after withdrawal of the slide *s*, the gasifier is charged with peat, which forms

a high layer on the grate *E* where, after ignition from below, it becomes gasified. In each section there is a spy-hole or stirring hole *a*. The gases, as they force their way up through the fuel, are drawn by the chimney draught from the two gasifiers into the common flue, which passes under the centre of the boiler *K*, after the necessary combustion air has been added to them through the nozzles *i, i, i*, in the arched roof and in the back wall of the gasifiers. The side walls of the gasifiers and the parts of the furnace in contact with the hot gases are made of fire-brick; in each of the former there is an air chamber *L*, partially obstructed with fire-bricks arranged lattice-wise and connected on the one hand by the duct *h* with the external air and on the other through the passages *m* and *n* with nozzles opening into the interior of the gasifiers. The

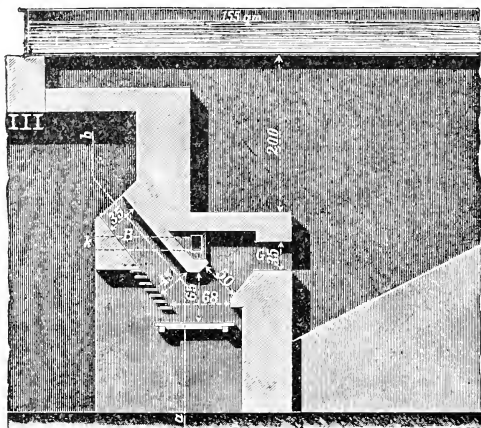

FIG. 154.—Semi-gas furnace for evaporating pans.

mouth of the air-duct *h* is closed outside by an adjustable slide *g*. According to the position of the latter the required amount of air enters through the ducts *h* into the air chambers *L L*, and, its passage through these being impeded by the latticed arrangement of the bricks, it is afforded an opportunity to become heated by the hot walls of the gasifiers before entering the latter through the various nozzles. As the air thus enters the gasifier at a relatively high temperature and there comes in contact with the hot gases which have just been generated, the main conditions for a good and energetic combustion of the two are fulfilled and at the entrance to the common flue an almost perfect combustion sets in with development of an intense heat and flame. The further course of the flues is similar to that of an ordinary boiler installation.

The furnace shown in Figs. 154 and 155 has proved suitable for

burning peat, alone or mixed with brown coal, for heating evaporating pans in boiler-houses and salt works. It is a combination of a step grate with a flat grate. Immediately in front of the fire bridge *G*, the air which is necessary for an energetic combustion and has been heated by the walls of the furnace is added to the combustion gases by means of the air-ducts *k*. Furnaces of this type have been used successfully for many years past under evaporating pans and boilers in the Aussee Salt Works. The width of the furnace is 60 cm. for coal and 35 cm. for a mixture of peat and coal. Six furnaces are built beside one another for a pan 155 sq. m. in area.



FIG. 155.

Semi-gas furnaces made by C. Reich, of Hanover, and used with success for peat-firing are shown in Figs. 156 to 158. Fig. 156 represents a semi-gas furnace for evaporating pans, and Figs. 157 to 159 furnaces for boilers for steam-raising or for hot water and steam heating installations. Their satisfactory action, which is at the same time nearly smokeless, is due to the combined effect of the four main parts, viz., the feeding shaft *A* (*a*), the inclined step grate, the burner *O R* (*o r*), and the gas chamber *B* (*b*), with the air supply and air chamber *M* (*m*). (Figs. 156 to 158.)

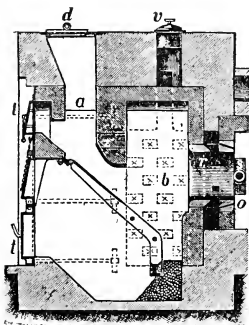

FIG. 156 —Reich's semi-gas peat furnace for evaporating pans.

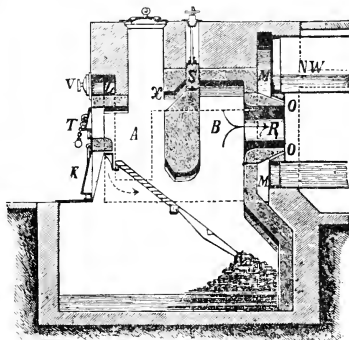
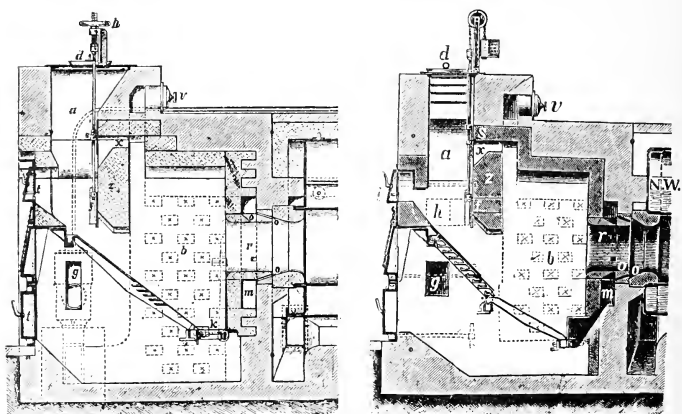

FIG. 157.—Reich's semi-gas peat furnace for steam boilers.

The upper portion of the inclined grate and the feeding shaft *A* (*a*) serve for the preliminary heating and the destructive distillation of the fuel, charged through the hopper *T* or *d*. Direct combustion occurs on the lower portion of the grate where the necessary amount of air is admitted. The flame thus formed mixes in the gas chamber *B* (*b*) with the gases drawn from *A* (*a*) through the connecting passage *x*. These gases can be produced continuously and uniformly by adjusting the gas slide *S* (*s*) for the width of the connecting passage *x*. The dividing wall *z* between the chambers

*A* (*a*) and *B* (*b*) is heated to a high temperature, and, as it at the same time acts as a heat reservoir, it facilitates the uniform separation of the volatiles from the fuel. Strongly heated, "fire bridge air" is added through the air passages *O* (*o*) to the gas mixture in order that the combustion of the latter in the burner *R* (*r*) may be energetic.

The air is heated either in compartments in the furnace walls or in special air-heating chambers *M* (*m*). The amount of upper or "fire-bridge air" admitted can be regulated by means of a valve *V* (*v*). The hot-air current issuing from the pre-heating chamber *M* (*m*) circulates round the burner *R* (*r*), passes through inclined slits *O* (*o*) in these and mixes, when very hot, with the burning mixture of gases, producing, especially behind the burner, a turbulent motion with intimate mixing of the two masses, and therefore an almost complete combustion without any formation



FIGS. 158 and 159.—Reich's semi-gas peat furnace for central heating installations.

of smoke worth mentioning. In order that it may be the more easily cleaned, the furnace can be provided either with an open ash-hole (as in Figs. 156 and 157) or with a tilting grate *h* (as in Fig. 158).

Semi-gas furnaces of this type for peat-firing were constructed for the boiler-house of the Papenteich Sugar Factory, at Meine, for the still-house of Charles Köster, at Borgstedt, near Kirchof, in Hanover, for the boiler-house of the Kolomma Machine-building Company, for the Kulebacki Smelting Works, near Murow (Russia), for the central heating installations of Attl Monastery, near Wasserburg, in Bavaria (installed by Käferle, of Hanover), and that of Gundlach-on-Leizen, near Dambeck in Würtemberg (installed by Käuffer and Co., of Mayennes).

In the peat furnace of the Papenteich Sugar Factory at Meine, analyses of the gaseous products of combustion have shown a



content of carbon dioxide equal to 17.5 per cent. and an average of 0.3 per cent. of oxygen when the flue draught was 6.5 mm. of water. The steam-raising power of the peat, which was not quite air-dry, was 3.42 kilos of water per-kilo of the peat and 17.8 kilos per square metre of heating surface per hour. At the Kulebacki smelting works, with Reich's semi-gas furnace, 1 kilo of the peat employed raised 4.0 to 4.2 kilos of steam, while in the furnaces previously used there (ordinary step grate furnaces) the evaporating power was only about 2 kilos.

Fig. 160 shows a semi-gas peat furnace which can be installed somewhat more simply and which has been constructed for steam-raising by the Okjaer Mosebrug Peat Works in Jutland. With it the evaporating power of a peat containing 4.4 per cent. of ash and

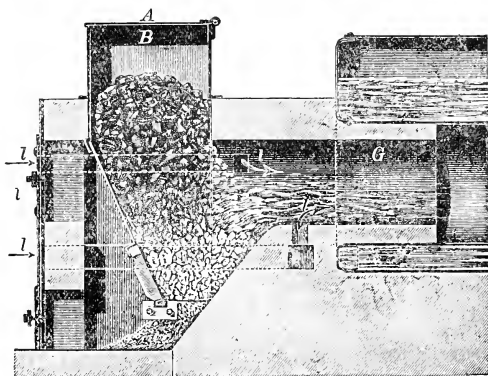

FIG. 160.—Okjaer Mosebrug's semi-gas peat furnace for steam raising.

24.6 per cent. of moisture was 3.9, and that of a peat containing 1.4 per cent. of ash and 20 per cent. of moisture was 4.

It has been shown that when peat is burnt on grates under boilers, the latter are not much corroded and therefore last a long time. This is even still more the case with gas-firing installations, in which a perfect or nearly perfect combustion occurs as the gases in contact with the plates of the boiler contain neither free oxygen nor free carbon and the flame cannot therefore corrode the iron. The result of this is that the plates last longer and are always quite free from soot, which is of great advantage also so far as the steam raising is concerned.

In steam-raising furnaces 1 kilo of air-dry peat, poor in ash, evaporates 4.0 to 4.5 kilos of water. It replaces, therefore, 0.75 kilo of medium coal and is equal in value to ordinary brown coal, having a somewhat higher percentage of moisture.<sup>1</sup>

<sup>1</sup> Cf. also M. Arland, "Verdampfungsversuche mit Stich- und Maschinen-torf und gemischte Brennstoffe," *Mitteilungen*, 1916, p. 239, and A. H. W. Hellemons, "Wirtschaftlichkeit des Torf-Dampfkesselbetriebes," *Mitteilungen*, 1916, p. 357.

Owing to the uniform character and the long flame of the combustion, and, therefore, to the longer life of the metallic walls of boilers, pans, and ovens, peat-firing has proved very suitable, for instance, for the boiler-houses of salt works and breweries in Württemberg, in Upper Bavaria, and in the Salt Department demesnes. The latter statement holds for the Bavarian salt works, which make "crystal salt." In the Austrian salt works, where the product is lump salt, which is dried by direct contact with the burnt gases led through the drying chambers from the furnace for the evaporating pans, the general use of peat is made more difficult in so far as the combustion must be kept almost entirely smokeless. Owing to variations in the character of the peat and in its percentage of moisture it is difficult to keep the combustion smokeless in simple grate furnaces, but by first gasifying the peat, mixed if necessary with good coal, we can, as was the case at Aussee, get a uniform, smokeless combustion.

The choice of peat as a fuel in an industry and further applications of it depend, and always will depend, mainly on the cost of the peat.

In the Royal Salt Works at Rosenheim, 22,100 m. tons of salt were won every year from a 26 per cent. salt solution by means of 65,000 cb. m. of cut peat fired in semi-gas furnaces,<sup>1</sup> 60,000 cb. m. of the peat being won by the Company itself. (See p. 53.) The amount of peat required, therefore, for 100 kilos of salt was 0.3 to 0.33 cb. m. = 75 kilos.

In the Aussee Salt Works the peat gas furnaces installed at the time (in the eighties) worked very satisfactorily, 100 kilos of peat being sufficient for the winning of 128 kilos of "lump salt." The high charges for the installation and the upkeep of the furnaces induced the Company, however, to return to simple furnaces with step grates (see Fig. 154), and to burn in these a mixture of Trauntal brown coal and peat in the ratio 1 : 2, with which it has been estimated that 100 kilos of peat produce about 132 kilos of salt or that 80 kilos of peat are required for 100 kilos of salt. (See p. 55 for the Aussee Salt Works peat industry, which is no longer working.)

In the boiler-houses of breweries the following results have been obtained :—

At the Weihenstephan State Brewery, for a single boiling of 31 hl. of malt, 1,610 kilos of good Freising or 1,458 kilos of Feilenbach cut peat were required under the copper. Hence for 10 hl. of malt for mere, but nevertheless vigorous, ebullition 520 kilos of Freising or 470 kilos of Feilenbach cut peat were required. On the other hand, a single boiling of 36 hl. of malt at Aibling, including the firing of the steam boiler, required on an average 15 cb. m. of the local peat of medium quality which, for an average weight of 240 kilos per cubic metre, corresponds to 1,000 kilos of peat for 10 hl. of malt, including the working of the steam boiler.

---

<sup>1</sup> These semi-gas furnaces are described in "Die Siedesalzerzeugung," by Charles Baltz (Edlen von Boltzenberg),

## 6.—Peat in the Railway Industry

The question of the utilization of peat in the railway industry, as far as Germany and the neighbouring countries are concerned, can be regarded as finally answered. In spite of every effort and of the painstaking experiments on the utilization of peat on railroads, which were repeated again and again over a period of many years and which were constantly being made as the railway systems developed, partly with a view to decreasing the working expenses and partly for national economic reasons, the conclusion has been arrived at that peat should not be employed as fuel for firing locomotives. Apart altogether from light cut peat and press peat, which crumbles very easily in the fire, even the best machine peat is not able to compete with coal in meeting the great demands on locomotives due to the extraordinarily increased and constantly increasing requirements of the passenger and goods traffic of our railways. Not only were the working expenses generally higher in the case of peat-firing than in that of coal, but the firing itself, as well as the procuring and the carriage of the much more bulky peat fuel, proved considerably more troublesome. These disadvantages were in general sufficient to outweigh the national economic advantages—employment of agricultural labourers and utilization of waste moorlands. Hence, after trials extending over many years throughout Prussia, Bavaria, Württemberg, Hanover, Oldenburg, &c., the railway boards were obliged to give up gradually, and in most cases entirely, the use of peat in their industry except for a few short lines passing through peat districts.

It is unnecessary, therefore, to repeat here all the trials and their results, which have been mentioned in detail in the second edition<sup>1</sup> of this book (pp. 443–452); they are now only of historical interest.

In Sweden also the State Railway Department, by means of exhaustive trials made in 1910, showed that the introduction of peat for firing locomotives would make the cost considerably higher than that incurred with English coal, the Department finding as a result of the trials made abroad (in Germany) that it requires 1.95 m. tons of peat to replace 1 m. ton of coal. The peat required to fire the locomotives would have been approximately 80,000 m. tons per annum, and to cover this new installations would have been necessary, the increased cost of which would have to be borne by the difference between the price at the time of the coal (11.25M. per metric ton) and the peat (5.6M. per metric ton). The conclusion reached was that the introduction of peat-firing was not to be recommended for railway and public financial reasons.

Influenced by the favourable results obtained with Ekelund's peat powder firing in several Swedish factories, several of the railway boards in Sweden have again considered the firing of

---

<sup>1</sup> Published 1905. Cf. also A. Hausding, "Die Torfwirtschaft Süddeutschlands und Oesterreichs," Berlin, 1878, Paul Parey.

locomotives with peat powder. For this purpose, however, the locomotives must be provided with special contrivances. The comparison trials, which, as a matter of fact, were made with an eight wagon goods engine with tender, 27 m. tons in weight, 56.1 sq. m. heating surface, 14 sq. m. Schmidt's super-heater, 1.1 sq. m. grate area, and 32 km. maximum speed, have given the following results: The steam pressure being kept the same, the super-heating was greater in the case of peat powder firing than in that of coal, the temperature of the escaping waste gases was 310 to 320° C. in the case of the peat powder and 340 to 360° C. in that of the coal. Owing to the nearly complete combustion of the peat powder, there was in this case no evolution of smoke and sparks and the surface of the boiler exposed to the heat remained quite free from soot or other deposit. The ratio of the power returns from the peat powder and the coal were as 1 : 1½. The labour of stoking the peat powder was almost *nil*, as this was done automatically, so that the fireman could pay more attention to the line and the signals. With peat powder firing the locomotive could meet the demands made on it as well as with coal-firing.<sup>1</sup> These experiments are not to be regarded as yet concluded and the final result is therefore still uncertain.

These efforts to utilize peat have again been made owing to the extraordinary increase in the price of coal and the difficulty of obtaining enough fuel for the railways in 1914–1915 at the beginning of the War. For the same reasons the Swedish State Railways Department have taken into consideration the building of an experimental factory for which 500,000 kr. have been voted by the Government. For this purpose the Vaköe Bog in the Selvesberg–Aalenhut district near Hökön has been purchased, and peat powder is to be made there by the new process of von Porat and Odelstierna. Press peat is also to be made from the peat powder.

In other countries poor in coal and rich in peat, as, for instance, Russia, Canada, &c., attempts have also been made to get peat more widely adopted in the railway industry than hitherto.

For firing experiments with various fuels in the railway industry see p. 330.

## 7.—Erection of Power Stations in Bog Districts

It is possible to transmit electricity and, therefore, electric power, over conducting wires or cables from a collecting or producing station to centres of utilization in districts separated from one another by considerable distances without considerable loss, i.e., without considerable expense. Owing to this, electrical power stations in bogs are well adapted for taking advantage

---

<sup>1</sup> Report by Captain Wallgren in the *Jahrbuch der Moorkunde*, 1913, p. 70.

of the large quantities of peat fuel stored in the bogs and at the same time for securing for agriculture, without expense, extensive areas of bogs. This is important in the case of places where other methods of winning and utilizing peat have hitherto proved quite uneconomic and impracticable owing to high cost of transport to and from the places or in consequence of too high a cost of winning on the small scale.

The State has great interest in this matter on the one hand because it is itself the owner of almost immeasurable bog areas, very rich, owing to their depth, but not hitherto workable, owing to their remoteness, and on the other hand, because it is especially called upon to improve the condition of the people and, therefore, to promote the cultivation and colonization of our waste lands, both bog and moor, even when these are in the possession of private owners. It is in a position to give powerful support to this method of utilizing moors by handing over State bogs at low rents for the winning of peat to undertakings of this class directed to the common-weal, and by providing loans, repayable over long periods, for the erection of the works.

Holland, and to some extent East Frisia, show how green meadows and thriving villages can be made out of immense waste moors by the cutting away of peat on a large scale during several years. Attention must always be paid, however, to ensuring that the technical utilization of the bogs should not prejudicially affect the later agricultural operations. The canals and trenches serving to drain the bogs and to provide the necessary means of access are, as in the case of Holland, to be laid out so as to divide the surface of the bog into settlements of 5 to 15 ha. each. The smaller (open) drains, usually  $\frac{1}{2}$  m. in depth and 10 to 20 m. apart, should, if possible, be replaced by covered drains in order that the land may be worked with machines. As is customary, care should be taken to see that the strippings, so valuable for agriculture, should be preserved and distributed with care over the surface to be tilled.

So far as is known, only three of these bog super-power stations have come into operation. Two of these are in Germany (one in the Wiesmoor, near Aurich, the other in the Schweger Moor, near Osnabruck—in Memel a similar factory has been planned by Mayor Altenberg), and one in Russia, the "Bogorodsk Peat Electric Station" near Moscow.

In addition, the following peat electrical power stations are said to be in operation in Sweden: The power stations at Skaberjö and Slätteröd, at Sperlingsholm (with Lutter's suction gas plant), as well as the power station of the Visby Cement Factory, which is capable of giving 1,500 h.p. and in which, according to Larson, the consumption of peat fuel containing 41.7 per cent. of water and having a calorific value of 2,400 calories is 1.42 kilos, corresponding to 0.842 kilo of dry substance, per h.p.-hour. Further particulars are not known about these factories, but with regard to the first three works the following may be reported:—

*(a) The Wiesmoor Electric Power Station near Aurich*

The origin of this station is to be found in the efforts of the Prussian Estates Department to render large surfaces of bogs available for agriculture and to the exertions of Dr. Ramm, Privy Councillor, of the Prussian Ministry of Agriculture, for the realization of these objects. In as short a time as possible the contiguous parts of the Aurich, the Neudorf and the Friedeburg Wiesmoor, having an approximate area of 10,000 ha., are to be made available for agriculture, especially for high bog cultivation. In order to lower the expenses of draining, making roads and canals, tilling, &c., the peat raised in these operations, not inconsiderable in amount, and especially that contained in suitable parts of the bog, was to be used at the same time for the winning of more or less large quantities of utilizable fuel. The bog surfaces, which in this way would have been deprived of peat, were to be made available for agriculture after a suitable time, by cultivation ("fenning") of the earthy subsoil by covering and mixing it with the moss peat removed from the upper surface.

In the case of the large quantities here dealt with, the winning of peat fuel could be effected by machinery. A part of the peat was to be employed for producing the power necessary for working the peat machines. The disposal of the excess, and the larger part, of the peat for household fires and industrial plants did not appear very hopeful owing to the great distance of the bog from inhabited, more or less large districts, and on account of the lack of sufficient large industries in the neighbourhood of the bog. After several unsatisfactory attempts, to drive the peat-winning machines separately by locomotives, electrical driving by a system common to all was decided upon. For this purpose a power station was erected in the bog and equipped with a 200 h.p. steam engine which drove a 5,000 volt alternating current generator. The factory started operations in 1908. Simultaneously, however, negotiations were begun between the State and the Siemens Electrical Company, Ltd., for the erection of a large overland power station after the initiation of proposals for the co-operation of a number of surrounding places such as Wilhelmshaven, Bant, Happens, Neuende (Rüstringen), Leer, and Emden, as well as the towns and parishes of the Grand Duchy of Oldenburg. In the expectation that it would be better to have the plant, the working, and the management of such a factory in the hands of a company, an agreement was concluded according to which the Siemens Electrical Company, Ltd., through the Siemens-Schuckert Company, should erect the machinery and the conductors for an overland power factory (exclusive of the buildings) at its own expense and that it should itself conduct the industry. The peat was to be bought from the State, and the electrical power required for the peat winning and the opening up of the bog was to be sold to the State.

The large overland power station thus built was able to start

operations in August, 1910, after the original 200 h.p. steam engine had been replaced by a steam turbine plant of 5,400 h.p. It is situated at the point on the road between Bagband and Wiesederfehn where the main canal (not yet constructed) leading from the Ems-Jade Canal through the Markard Bog (the reclamation of which has already been begun) to the North Georgsfehn Canal will cross the road.

In the boiler-house there are eight water-tube boilers, each with 300 sq. m. heating surface, constructed for a working pressure of 12.5 atmospheres and fired with peat. Four of these boilers have each a super-heating surface of 100 sq. m., and the other four have each 70 sq. m. All the eight boilers have each 12 sq. m. grate area. The boilers in the second set of four are provided with two Steinmüller pre-heaters, each of which has a heating surface of 285 sq. m. There are also two water-tube boilers, each having 330 sq. m. heating surface and 77.5 sq. m. super-heating surface, constructed for a working pressure of 12.5 atmospheres and fired with coal. The latter boilers are also fitted with a Steinmüller pre-heater having approximately 450 sq. m. heating surface. The feeding of the boilers is provided for by three steam pumps and two double-stage, high-pressure, centrifugal pumps, which draw the water from the feeding tank, in which the condensed steam from the turbines has been mixed with water which has been passed through a purifier. The water which is taken from the North Georgsfehn Canal is, as usual, purified in the ordinary water purifier with addition of a little soda and lime. In the machine house there are five turbine current machines (turbo-dynamos), two of which generate each 1,250 kw., and two others give each 1,550 kw. at a tension of 5,000 volts and one machine which gives 1,720 kw. at 1,150 volts. The machines run at 3,000 r.p.m. The turbines are all of the Zölly type.

In the nature and arrangement of its rooms and fittings the factory does not in general differ from the other electric stations recently constructed by the Siemens-Schuckert Works. (Further particulars are contained in the memoir "Das Kraftwerk im Wiesmoore," by S. Teichmüller, in the *Elektrotechnische Zeitschrift*, 1912.) Only the special measures taken in the working of the factory for the winning and the utilization of the fuel peat are of importance for this handbook.

Two Strenge peat-dredging machines, each with an automatic sod conveyer, and twenty-six ordinary Dolberg peat machines, are used at present for winning the peat. One Dolberg peat-dredging machine<sup>1</sup> was worked as an experiment in 1914. In the case of the Strenge machines the peat was brought, up to 1912, by an elevator over a conveying channel to the mixing machine, after which it was spread through two side channels as peat pulp on the surface of the bog. After some time it was cut into sods, placed in small heaps (Wienjes), and dried in the air. Since

<sup>1</sup> According to Figs. 68A and 71 on pp. 161 and 165.

1912 these machines have been converted into forming machines, and, like the new Dolberg automatic machine, are equipped with

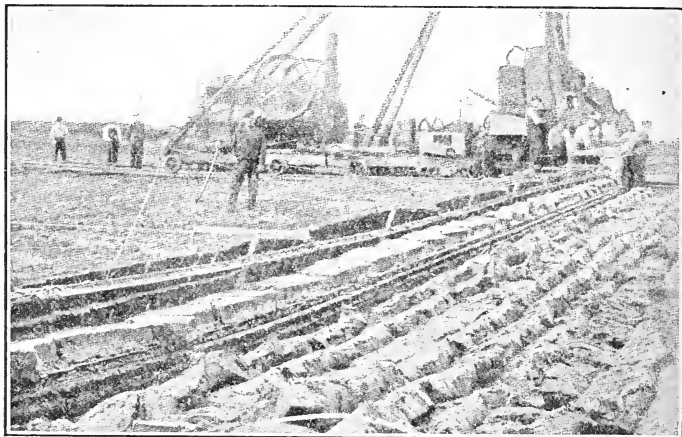

FIG. 161.—Strengé's large scale machine with sod spreader.

automatic sod spreaders (see Fig. 161). In the other Dolberg peat-forming machines (see Fig. 162) the peat is dug by three or four men and thrown on to a conveyer, which takes it up an incline



FIG. 162.—Dolberg's peat machine, with conveyer.

to the mixing and forming machine. The triple or quintuple peat bands as they leave the machine are divided into sods and transported on boards in cars, tipped and dried in the ordinary way. A Dolberg machine can form 60,000 to 80,000 sods in ten hours.

According to a somewhat different method, the peat from the mixing and forming machine is pressed on a conveying belt and without being divided into sods is thrown from the band into high heaps, from which, after the winter, it is cut and brought to the furnace house (manufacture of the so-called "autumn peat").

In the season from April to August the machines yield altogether about 50,000 m. tons of air-dried peat. The air-dried



peat has 25 to 30 per cent. of water; in the hot summer of 1911 it had only 18 to 22 per cent. The sods, which measure at first  $33 \times 10 \times 12$  cm., contract to  $26 \times 6 \times 6$  cm. As the demands of the factory are continually growing it is intended to increase the amount of peat won per annum to 60,000 m. tons, thus providing for a current production of 10,000,000 kw.-h.

The air-dried peat is transported over field railways<sup>1</sup> to the power station by means of benzine locomotives. The distances to which the peat is transported are fairly great, amounting on the average to  $1\frac{1}{2}$  km. In the power station the peat is either fed directly above the boilers into hoppers leading to the boiler fires or is stored in sheds so as to ensure that a sufficient amount of dry peat should be always at hand. This is an essential condition for the regular and economical working of a factory of this magnitude. The fulfilling of this condition caused considerable difficulties at first, but, in the main, it can now be regarded as satisfactorily solved. The capacity of the sheds is

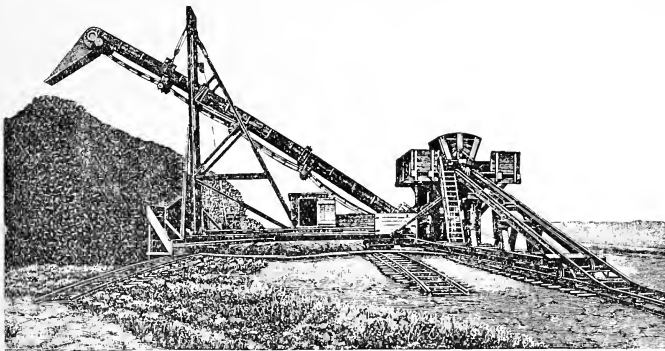

FIG. 163.—Clamping peat in the Wiesmoor by means of an elevator.

2,600 m. tons of peat. Another portion of the peat sods is formed into large clamps on the bog by means of a transportable Dolberg conveyer lift, the inclination of which can be adjusted to heights up to 10 m. (see Fig. 163) and which can be driven and transported by a 15 h.p. electro-motor. The feeding of the peat in the power station offered considerable difficulties. The fuel peat during the loading, unloading, and slipping from the hopper showed a tendency to "lock," due to the form of the sods necessary for its winning. Attempts to break or cut the peat by machinery failed, as too much dust formed in these operations. Often no peat at all fell out of the lower mouth of the hopper and on being stirred up after a "block" it passed on in larger quantities and more rapidly than was desirable. After long and

<sup>1</sup> The rails (60 cm. gauge) rest on a layer of sand, 20 to 25 cm. in height, on which a layer of slack (from the peat fires) is thrown.

costly experiments, success in feeding the peat was attained in an entirely satisfactory degree by a slight alteration in minor details.

About 500 men were engaged here (in the years 1914–1915) in winning peat. The rates of wages were 30 Pfg. an hour for ordinary labourers and 40 Pfg. an hour for skilled workmen, who earned, however, 4 to 5M. a day by piece-work.

A step grate serves for burning the peat. This has been given its present form, which ensures good combustion, only after many difficulties were experienced and many alterations were effected. The grate is in two parts. Its two halves are inclined at an angle of  $36^\circ$  and can be fed in turn (compare Fig. 164) from the chute (of a hopper), which is placed in front of the whole grate.

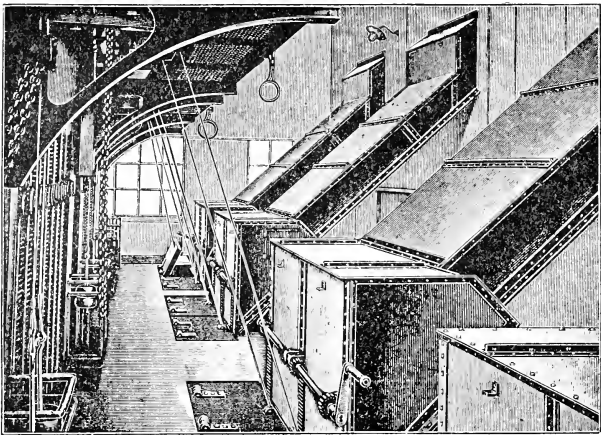

FIG. 164.—Hoppers for the boiler furnaces in the Wiesmoor power station.

In the more recent arrangement entrance of excess of air during the charging is avoided, the peat blocking the entrance of the air during its rapid fall from the hopper. This is of importance, since the air-dried peat has the low heating effect of 2,500 to 3,500 calories and therefore requires to be frequently charged, especially as the fuel is somewhat bulky. 100 kilos of fuel peat, thrown in as sods, occupy a volume of at least 0.4 cb. m., corresponding to a heating effect of 620,000 kilo-calories for a cubic metre. Many difficulties with regard to burning and charging the peat, depending mostly on want of uniformity of the fuel (too much moss peat; or, because too deeply dredged, too much sandy, and, therefore, slack-forming constituents; in part, also, too wet a peat), had to be overcome.

In December, 1910, exact experiments gave the following as mean results:—

The quantity of water evaporated was 44,982 and 43,092 kilos, and the peat burned for this purpose was 15,266 and 14,027 kilos. From this the evaporative power is  $\frac{44,982 + 43,092}{15,266 + 14,027} = 3.01$ , and the amount of heat utilized is  $653.6 \times 3.01 = 1,967$  calories. From this it follows that with 2,680 calories as the mean calorific value found for the peat the efficiency of the boiler is  $\frac{1,967}{2,680} = 73.5$  per cent., while the efficiency guaranteed by the factory was 65 per cent. The steam pressure at a temperature of  $247.5^{\circ}$  C. was 12.1 atmospheres.

Percentage of carbon dioxide in the flue gases ..	12.8
Percentage of carbon dioxide and oxygen in the flue gases .. .. .	19.6
Temperature of the hot gases in the flue .. ..	$330^{\circ}$ C.
Temperature of the air draught .. ..	$28^{\circ}$ C.
Draught above the grate .. ..	5.6 mm.
Draught in the flue above the damper .. ..	8.3 mm.
Draught in the main flue .. ..	17.6 mm.
Temperature of the feed water .. ..	$47.7^{\circ}$ C.
Heat of formation of the steam .. ..	653.6 c.

The high efficiency given here is not attainable in everyday practice. As a rule (up to 1912) the consumption of peat was 2.7 kilos per 1 kw.-h. Sometimes, however, it was 2.4 kilos per kilowatt-hour; in wet weather 3 kilos or more have been used. If the price of the peat be assumed to be 5M. per metric ton, then with a peat consumption of 2.4 to 2.8 kilos for 1 kw.-h., the fuel cost for 1 kw.-h. will be 1.2 to 1.4 Pfg., which is approximately the same as when coal is used for firing. By further improvements it is hoped that the fuel number 2.5 kilos (air-dried peat) will certainly be attained in ordinary practice.

The idea put forward some time ago of replacing steam boilers fired with peat by gas engines operated by gasification of the peat according to the Frank-Caro "Mond gas" method, or at least of making thorough experiments with this object in view, has been dropped for the present on account of the hitherto unsuccessful results obtained in the Schweger Bog. On the other hand, efforts have been made to lower still more the costs of winning machine peat and those of the existing furnace plant by introducing, for the first mentioned, apparatus for automatically spreading the wet peat sods, and in the case of the furnace plant by improving its conveyers, feeders, and shakers, and therefore the heating effect of the boilers.

With regard to the reclamation (cultivation) of the Wiesmoor which proceeds hand in hand with the winning of the peat and forms the State's special task, the following may be briefly cited:—

For twenty or thirty years the peat works can be provided with fuel from the transport and drainage canals alone, which are dug through the whole depth of the fuel peat to a width of 50 m. After the cutting of the main canal the adjacent bog

becomes drained so far as to allow the peat to be spread for drying on the canal banks and some roads to be made alongside the canal and also for a short distance into the bog. These roads, in accordance with the plan of division and colonization, are laid out in widths of about 7 m. at right angles to the length of the canal so that they will lie later on between every two colonies but are so far apart from one another that they serve their primary object of assisting the agricultural utilization. The colonies are each 100 m. in width, so that the distance between the roads was, therefore, selected at 400 to 500 m., thus corresponding to four or five colonies. Following this we have the cutting and the clearing of the drains to a depth of 1 to  $1\frac{1}{2}$  m. The bog is then left alone for three to six months, during which period it drains considerably. When the draining pipes have been laid and the trenches filled in, the working of the bog is at once begun with Kemna steam ploughs and electrically driven tilting ploughs, from the Siemens-Schuckert works, with Kemna's supporting wheels. Each of the latter is driven by means of a windlass car and a Schweizer anchor car. Their most recent forms are provided with wheels so broad (up to 80 cm. felloe width) that they can travel over soft bogs even without supporting planks.

In spite of the cheapness of the electric current (4 Pfg. per kilowatt) the steam plough is preferred because it is more easily moved and worked more cheaply. In the case of the electrically driven plough displacement of the cable, the bringing forward of the current transformer, and the connexion with the electrical conductors, are found sources of trouble. When the furrows have been allowed to remain some time, the disc harrow (of Kemna) begins operations, and finally the Kemna roller follows. On the ground which has been thus consolidated lime and artificial manure are scattered. These are harrowed in thoroughly and immediately afterwards the sowing takes place.

The working of the machines on the bog amounts to:—

Worked by the plough	.. ..	5-6 ha. daily.
Worked by the harrow (double stroke)	.. ..	10 ..
Worked by the roller	.. ..	15 ..

A set of machines is able to work 750 to 800 ha. in a year of 200 working days. The expenses of the reclamation amounted at Wiesmoor (1912) to approximately 600M. to 700M. a hectare.

When a site for the dwelling house has been cleared of peat and the colonies are in good working order, they are assigned to the settlers. The further cutting of the peat is the task of the settler himself. The disposal of the peat is an easy matter, as the power station has been designed to use this fuel.

The peat super-power station, which has been planned on a broad basis, affords proof that commercially successful utilization of large bogs by the erection of big power industries in which peat only is employed as fuel is possible even when this can only be attained by overcoming many difficulties, some of quite considerable magnitude. Further development of enterprises of this nature is certain to take place. It is a matter of the

cost of winning peat with regard to which, unfortunately, the results hitherto obtained have not yet been satisfactory. Here, as in every other case, we must always approach "very promising novelties" only after very thorough and trustworthy special experiments have been made.

The experiences of recent years in this large scale industry have shown that although the dredging machines win peat somewhat more cheaply, ordinary peat machines, requiring digging by labourers, are, on the whole, more convenient and more generally in use. The peat-dredging machines hitherto manufactured are difficult to move and are not suitable for every bog. Even for the conditions existing at Wiesmoor there is as yet no peat-winning machine which satisfies all the requirements. The actual average yield of air-dry peat in a summer from a large scale peat-dredging machine is 5,000 m. tons, the ordinary Dolberg peat machine giving 2,000 to 2,500 m. tons. On an average the cost of manufacturing a metric ton of air-dry machine peat is now 8M. to 9M., but may later be reduced to 6M. to 7M.

#### (b) *The Schweger Moor Electric Power Station*

In spite of all attempts, authentic details as to this, the second large peat power station, could not be obtained.<sup>1</sup> After experiencing obstacles of many kinds the industry began operations in 1912. It is divided into two parts, one of which is the electric station and the other the peat works, the object of the latter being to supply power gas to the former for all the machinery, and, as already mentioned on p. 409, it was based on the Frank-Caro "Mond gas" process with recovery of the by-products (ammonia, &c.). It is said to have four gas engines, each of 1,000 h.p., and that for every metric ton of dry peat 40 kilos of ammonium sulphate, gas for 800 kw.-h., and 30 to 40 kilos of tar have been obtained, and this with a peat containing up to 70 per cent. (?) of water. The winning of the peat, for conversion into the gas required for the projected industry of the electrical station, is said to have met with such great difficulties, partly owing to the nature of the bog and partly owing to the large amount of the "half-dry" peat required and its cost being too high, that the peat producer gas plant has ceased working since 1913, and the electrical station has since then been worked with coal. The peat producer gas company is said to have been wound up and millions (of Marks) to have been lost. It has been represented that the yield of ammonia during the production of the gas was too small and, therefore, the manufacture of the peat power gas was too costly. The factory erected for winning the peat is at present employed in manufacturing and selling machine peat for fuel purposes.

---

<sup>1</sup> Some details by Dr. Hamers are to be found in the report by Dr. Bersch, *Zeitschrift für Moorkultur und Torfverwertung*, 1912, p. 175.

In 1914, it is said that the cost of the peat required by the factory has been not inconsiderably reduced in consequence of the employment of sod spreaders worked by machines, and also that the nitrogen percentage of the peat being now on the average 1·8 to 1·9 an improvement in the yield of ammonia is expected, and with it the success of the whole enterprise.

(c) *The Bogorodsk Electric Power Station near Moscow*

The power station has been erected by the Moscow Company for the transmission of electrical power. The head office of the Company is in Petrograd and its fully paid-up capital is 6,000,000 roubles. It began work at the end of 1914 and at present has a capacity of 10,000 kw. Three steam turbines, each with a rotatory current generator for 50 periods, have been set up. Each machine has a capacity of 5,000 kw. Two of them are in operation, the third being kept in reserve. The steam turbines are Zölly turbines, supplied by Escher, Wyss and Co., of Zurich, and the rotatory current machine was supplied by the Siemens-Schuckert Co., of Berlin. It was proposed before the War to increase the capacity of the plant by a further 10,000 kw. Within distances of 50 km. all round the station current was supplied for lighting places and as a source of power for factories (mainly spinning and weaving) as well as for the numerous looms in the local houses. A fairly large amount of current is supplied to the electric station at Moscow, which is 70 km. from the bog.

The only fuel which has been taken into consideration for the industry is peat, that is machine peat, which is won with well-known machines of various types, amongst which are twenty-five Anrep and Hendune machines. The peat is for the greater part raised by hand and brought to the machines by conveyers; one Strenge dredger and one scoop dredger are, however, at work there.

The connexion of the peat power station with the electrical station at Moscow allows as much current to be given at any time, even at night, to the precincts of Moscow as can be spared from the supply of the 10,000 kw. in the other system of conductors. The output of the power station, when working day and night for the whole year, and, therefore, for about 8,000 hours per annum, can in this way be fully utilized, a circumstance which is of great importance for the industry and for its commercial success. The yearly output is, therefore, approximately, 80,000,000 kw.-h.

It has been calculated that 1·8 kilos of peat, containing 25 per cent. of moisture, must be burnt under the boilers to generate 1 kw.-h. According to the experience of other stations—for instance, at Wiesmoor, where 2·5 to 2·8 kilos are required—this is too low an assumption since, even if for no other reason, air-drying on a large scale to an average of 25 per cent. of water is scarcely attainable. Assuming, however, 2·0 kilos, then the year's output of 80,000,000 kw.-h. requires 160,000,000 kilos, i.e., 160,000 m. tons of air-dried peat.

The average daily output of the peat machines during a season of about eighty days (from the middle of May to the end of July) must, therefore, amount to at least  $\frac{160,000}{80} = 2,000$  m. tons of air-dried peat.

The peat is burnt under the steam boilers (tubular boilers). The fuel is brought from the clamps on the bog over a railway to the boiler-house and is then raised to the bunkers of the steam boilers by lifts and conveyers. The air-dried peat is very hard, dark brown in colour, and has in the air-dried condition (25 per cent. of water) a calorific power of about 4,500 c.

The bog which has been acquired and is being worked by the Company has an area of 40 sq. km., i.e., 4,000 ha. ; the bog is up to 12 m. in depth, but, on the average, is only 3 to 4 m.

The power station is on a sand ridge in a small lake situated in the middle of the bog. The cut-out bog is at present left waste. On account of the confusion due to the War particulars as to the working results could not be obtained.

In the Bogorodsk district bogs have been largely utilized for many years. The peat serves in general as fuel for neighbouring factories, in which there ought to be at present steam boilers for about 150,000 h.p. fired with peat.

## SECTION V

# THE UTILIZATION OF PEAT FOR ILLUMINATING PURPOSES

### 1.—Substances formed by the Distillation of Peat

Various substances, such as gases, tar, an aqueous liquid, and charcoal (or peat coke), depending on the age of and the percentage of moisture in the peat, are formed by its distillation, that is, by heating it in closed vessels usually made of iron. The peat charcoal is left in the retort while the gases, the tar and the aqueous liquid escape as volatile substances, while hot, through the exit tube of the retort. When the mixture of gases and vapours is led through condensers and receivers, the tarry and aqueous ammoniacal vapours subside, and the gases can then be collected in another vessel.

In this distillation process fresh peat behaves like wood, and dense, old peat like coal. The yield of the one or the other of the above-mentioned substances depends largely on the temperature of distillation; at a low red heat the amount of tar, aqueous liquid and charcoal is larger, and at a high temperature gaseous products preponderate.

The gases consist of light hydrocarbons, a small amount of an oil-forming gas, carbon monoxide, carbon dioxide, hydrogen and nitrogen, hydrocyanic acid and vapours of volatile oils (light photogen, peat oil), which can be condensed by heavy cooling. On account of its high content of carbon these combustible gases have, in the purified condition, considerable illuminating power and for this reason may be used for illuminating purposes.

The tar is an oily, dark brown liquid, sp. g. 0·870 to 0·965, with a very unpleasant odour, and contains hydrocarbons in the form of light oil (the so-called "peat oil"—peat photogen), and heavy oil (solar oil, gas oil, or lubricating oil), in addition to impurities such as sulphuretted hydrogen, hydrocyanic acid, &c.

If the distillation is commenced at a red heat and if the temperature be raised according as the distillation proceeds, a tar is obtained which, in addition to the substances just named, contains "paraffin," a body much in demand and of value for the manufacture of candles.

The aqueous liquid (ammonia water) contains ammonia, acetic, butyric, and valeric acids, phenol, methyl alcohol, &c., and can be utilized with advantage for the preparation of acetic acid and ammonia.

The charcoal (peat charcoal), according to the raw material employed, the course and the main object of the distillation, may be



either of a firm, ringing quality suited for fuel and forge purposes, or of a loose, powdery nature of little value as a fuel, but capable of being employed as a manure, or it may be of an intermediate type suited for the one or the other purpose.

After further treatment and purification of the crude distillation products a series of valuable substances adapted for illuminating purposes is obtained. This includes *illuminating gas*, *photogen*, *solar oil*, *paraffin*, and the by-products *asphalt*, *charcoal*, *ammonia*, *acetic acid*, *methyl alcohol*, &c. The total value of these substances, obtained from a given amount of peat, has again and again given rise to efforts being made to win them on a large scale and in this way to utilize peat bogs. According to the local conditions and the special properties of the raw peat the main object of the enterprise is sometimes the winning of illuminating gas, and at other times that of the combustible oils and the paraffin, while the other substances are won and utilized as by-products.

The results obtained on a large scale have not been as good as was expected from experiments carried out on a small scale. The most important of these results are given in the two following sub sections.

## 2.—Illuminating Gas from Peat

If peat is distilled, by subjecting it to the action of heat in a vessel, only its moisture is first given off. At 150 to 180° C. light oil vapours begin to pass over. These are characterized by a strong, acrid odour. The amount formed is still greater at an incipient red heat. They are followed, as the temperature rises, by tar vapours mixed with ammonia and acetic acid vapour. Towards the end of the distillation not inconsiderable quantities of ammonium cyanide and small amounts of sulphuretted hydrogen are given off, together with the oxides of carbon. The oil vapours, mixed with various gases, burn with a flame which is in itself only slightly luminous, like that of the gas produced from wood. They acquire, however, strong illuminating properties when the oily and tarry substances produced during the distillation are brought, according to the method of Professor Pettenkofer, for considerable time<sup>1</sup> into contact with a glowing metallic surface, by which they are changed into heavy hydrocarbons having a high illuminating power. The vapours developed from the peat in the retorts are led, therefore, through a series of white hot tubes before entering the condenser. The oil vapours are thus completely decomposed and converted into illuminating gas.

The figures given on the following page may be taken as average results for the yield of gas obtained in experiments carried out on a large scale by the ordinary process with different varieties of peat.

---

<sup>1</sup> See *Dingler's Polytechn. Journ.*, 145, p. 21, for a paper by Pettenkofer, "Ueber die wichtigsten Grundsätze der Bereitung und Benutzung des Holzleuchtgases."

## YIELD OF ILLUMINATING GAS, ETC., FROM 100 KILOS OF PEAT.

Variety of raw peat.	Illuminating gas.	Percentage of			Observer.
		Char-coal.	Tar.	Ammonia water.	
Bavarian pitch peat, poor in ash, with 19 per cent. of moisture	cb. m. 21·68	30	4·5	15-20	Dr. W. Reissig (late), Peat Gas Factory at Utersen.
Light, yellowish-brown, fibrous peat from Holstein	23·87	25	2·34	—	
Compressed and artificially dried Bürmoos peat	25·11	43	6·7	24-25	Gräser (Eng.).
English peat .. .. .	28·80	33·5	—	—	—
Air-dried peat from Königsau Bog	30·36	20	3·1	24	F. Schuppler.
Dark brown, dried, grass peat with 21 per cent. of ash	22·09*	—	—	—	Dr. C. Stammer.

\* Containing 30 per cent. of carbon dioxide.

The yield of these substances from 100 kilos of coal is as follows:—

Variety of coal.	Illuminating gas.	Percentage of			Observer.
		Coke.	Tar.	Ammonia water.	
	cb. m.				
Saxon coal .. .. .	24·0	50-60	4·75	} 6-7	—
Westphalian coal .. .. .	28·4	65	4·25		—
Silesian coal .. .. .	28·4	55-60	4·75		—
Newcastle coal .. .. .	28·4	65	4·25		—

According to Dr. W. Reissig, purified peat gas prepared from good raw peat contained:—

		(1)	(2)
Heavy hydrocarbons .. .. .	.. .. .	9·52	12·16
Methane .. .. .	.. .. .	42·65	33·00
Hydrogen .. .. .	.. .. .	27·50	35·18
Carbon monoxide .. .. .	.. .. .	20·33	18·34
Carbon dioxide and sulphuretted hydrogen .. .. .	.. .. .	Traces	0·00
Nitrogen .. .. .	.. .. .	0·00	0·32
		100·00	99·00

From these figures it may be seen that the yield of gas from peat is relatively great, while that of coke and tar, both in quantity and in quality, is considerably poorer than that obtained in the manufacture of coal gas; also the dilute ammonia formed in the peat gasification cannot be utilized so well as that obtained in the gasification of coal. On the other hand, the illuminating power of peat gas is somewhat greater than that of wood or coal gas of

the same degree of purity (percentage of carbon dioxide), and this circumstance, together with the good yield of gas obtained in gasification experiments on the large scale, led to the erection of several peat gas works at the end of the fifties and the beginning of the sixties. Some, as in Salzburg, were wood gas works altered for peat gasification, others, as in Utersen, Heide, and several other towns in peat districts, were newly erected factories. The muffles or retorts were usually constructed to take a charge of 40 to 50 kilos of peat. The gasification required one to one and a half hours, and the fuel necessary for it amounted to 40 to 45 per cent. of the charge which was distilled, assuming that the peat coke remaining after the gasification was utilized otherwise.

The high percentage of carbon dioxide in peat gas, increasing as it does with the percentage of moisture and the light, porous nature of the peat, made the cost of purification greater, and almost everywhere threw obstacles in the way of the success of the peat gas factories. There is scarcely one of these factories working now, or which has not been changed into a coal gas factory.

The same result was obtained from experiments conducted at a later date in the neighbourhood of Hamburg.

At the Utersen gas factory<sup>1</sup> the purification of 1,000 cb. m. of gas required 1,370 kilos of shell lime, while for the same purpose in the case of wood gas 840 kilos, and in that of coal gas 88 to 90 kilos of lime were sufficient.

According to experiments of Dr. Stammer,<sup>2</sup> the purification of 1,000 cb. m. of peat gas required only 1,100 kilos of lime. Even with this lower amount the lime required for purifying equal amounts of illuminating gas from peat, wood, and coal would be in the ratio 12 : 9 : 1.

The high cost of purification of peat gas, which was out of all proportion to that of coal gas, led to the peat gas factories erected at Utersen (1861), at Heide (1864), at Salzburg, and other places being shut down after very short periods and to their being changed into coal gas factories.

In the present state of technics, it is as a rule more economical to employ the peat in a suitable boiler and engine plant, or in a power gas plant, to generate electricity and utilize the latter for power and illuminating purposes.

### 3.—Recovery of Peat Oil, Paraffin, &c., from the Distillation Products

Numerous experiments have been instituted by Wagenmann, Dr. H. Vohl, Dr. Thenius, and Professor Dr. Hoering on the gasification of various peats with the object of obtaining by slow heating and at a low temperature the largest possible yield of tar for the preparation of combustible oils, paraffin, &c.

---

<sup>1</sup> For the arrangement and working of the Utersen gas factory see *Dingler's Polytechn. Journ.*, 152, p. 352.

<sup>2</sup> *Dingler's Polytechn. Journ.*, 174, p. 130.

YIELD OF TAR, PEAT OIL, PARAFFIN, ETC., IN THE DISTILLATION OF VARIOUS PEATS.

No.	Variety of peat.	Volatile products, per cent.				100 parts of tar gave				Observer.	
		Tar.	Ammonia water.	Gases and vapours.	Coke.	Light oil.	Heavy oil.	Paraffin.	Asphalt.		Crucible and loss.
1	Commercial, dense, dark brown cut peat* ..	4.89	50.01	17.40	27.70	8.90	22.56	33.73	22.60	6.21	L. Wagenmann.
2	Brown, mossy, dredged peat† ..	5.19	58.03	11.11	25.77	7.32	21.66	46.03	12.77	12.22	Do.
3	Bürmoss peat, air-dried ..	4.70	36.00	19.30	40.00	20.00	22.50	2.50	16.00	39.00	Dr. G. Themius.
4	Oldenburg cut peat, fairly dense ..	9.06	40.00	15.63	35.31	19.46	19.55	3.32	17.19	40.49	Dr. H. Vohl.
5	Swiss, light moss peat from Zurich ..	5.38	52.00	17.62	25.00	14.40	8.67	0.42	42.42	35.09	Do.
6	Dutch, dense, compact cut peat, air-dried ..	6.70 (0.980)	46.95	17.33	29.02	11.44	12.21	1.70	55.19	19.46	Do.
7	The same, dried 48 hours at 50° C. . .	10.73 (0.986)	29.17	17.84	42.26	(0.825)	(0.84-0.87)				
8	Peat from Celle, air-dried ..	5.6	37.53	23.31	33.56	34.60 (0.820)	36.00 (0.860)	8.01	—	—	Do.

NOTE.—The numbers in brackets are the densities of the corresponding substances.

\* With 33.58 per cent. of water and 6.67 per cent. of ash.

† With 36.23 per cent. of water and 5.40 per cent. of ash.

‡ Crude paraffin from which the pure paraffin is separated. All the other figures refer to pure commercial paraffin.

Recently Ziegler and Bamme have drawn attention to the combining of peat coking with the winning of the volatile products, which is necessary from the economic standpoint, for the advantageous utilization of bogs.

According to Vohl, the manufacture of illuminating substances from a peat was remunerative only when the yield of tar was at least 4 per cent. of the weight of the peat, and when the distillation was not in general carried out in costly distilling plants, but by means of retorts or coking kilns on the bog itself. The tar manufacture took place either with the winning of all the volatile products and the charcoal, or all the volatile gases were collected, the charcoal being sacrificed by the peat being completely burnt, leaving ash only as residue, or finally the volatile substances, except the tar and the gases evolved, were neglected, a valuable charcoal, however, being obtained when the raw substance was of a suitable nature therefor.

The quantities of the crude products—tar, ammonia water, and charcoal—obtained from various peats, and of the pure commercial illuminants, asphalt, &c., prepared from 100 parts of the tar, are shown in the table on the preceding page.<sup>1</sup>

In numerous experiments, H. Vohl obtained from brown coal tar :—

33.41 per cent. of light oil (0.820),
40.06 per cent. of heavy oil (0.860), and
6.70 per cent. of paraffin as <i>maximum yield</i> ;
10.62 per cent. of light oil,
19.37 per cent. of heavy oil, and
1.20 per cent. of paraffin as <i>minimum yield</i> .

The aqueous solution obtained in the distillation of the peats mentioned under 6 and 7 was also investigated, and the substances contained in 100 parts by weight were :—

Acetic acid (concentrated)	.. = 1.5800 of sp. g. 1.063.
Wood spirit (methyl alcohol)	.. = 0.7639 of sp. g. 0.870.
Ammonia (anhydrous)	.. = 0.0860, corresponding to 0.242 of sal ammoniac.
Butyric and valeric acids	.. = 0.2069
	2.6368
Water .. .. .	.. 97.3632
	100.0000

The charcoals, like that from wood, contain :—

Carbon (with small quantities of nitrogen and hydrogen) or combustible substances	93.231
Ash .. .. .	9.769
	100.000*

\* There is a misprint in the German text in this place, the sum of the percentages of the ash and the carbon being 103, not 100.—TRANSLATOR.

<sup>1</sup> For the plant and details of the process employed for the preparation and the purification of the volatile products from peat, compare the papers by Dr. Vohl, *Annalen der Chem.*, 97, p. 9 ; *Dingler's Polytechn. Journ.*, 140, p. 63, and 183, p. 321 ; Löbel, "Beitrag zur Kenntnis des Torfteers," 1911. For the composition and the properties of the by-products see especially Dr. Paul Hoering, "Moornutzung und Torfverwertung," 1915.

Of the factories which were working at that time on a large scale, that of Bermuthsfeld, near Aurich, obtained 6 to 8 per cent. of tar from the peat employed, and from this got 20 per cent. of its weight of photogen (sp. g. 0·83) and 0·75 per cent. of paraffin. The factory at Zeitz obtained 0·72 cb. m. of anhydrous tar, 42 cb. m. of coke, for firing the furnaces, and 5·39 cb. m. of gas water, containing 6 per cent. of ammonium sulphate, from 250 kilos of air-dried peat in twenty-four hours. The 0·72 cb. m. of tar (sp. g. 0·86) gave 119 kilos of photogen (sp. g. 0·83), 303 kilos of solar oil, 208·5 kilos of a crude substance containing paraffin, 40·5 kilos of creosote, and 174·5 kilos of asphalt. The yield of tar from the peat was 4·65 per cent. Peat oil, light peat oil, or peat photogen is a very fluid oil, clear as water, with a not unpleasant odour and completely volatile. Its density does not exceed 0·835. It is a good solvent for resins, is free from oxygen, and consists of carbon and hydrogen only. In any photogen, or oil, lamp the peat oil burns emitting a beautiful white light without the slightest odour or formation of smoke. During the burning the wick is scarcely charred. The nitro derivative of peat oil has an agreeable odour, resembling that of musk and oil of almonds. Alone, or mixed with alcohol, it is excellent for removing stains. The chief use, however, of the oil is for illuminating purposes.

Heavy peat oil, gas oil, or lubricating oil has a light brown or pale yellow colour and a slight odour. It is less volatile than peat oil and has a density up to 0·885. In any good oil lamp it burns with a dazzling white light, charring the wick, however, after several hours' combustion. It can be used advantageously in resin gas and oil gas factories for the production of an excellent gas. It is not solidified by either cold or by resinification, and is therefore used as a lubricant in England, especially for the spindles (highflyers) of the cotton-wool factories, for which purpose it commands a high price.

The asphalt obtained from peat has a beautiful black colour, and is employed in iron lacquering, making lampblack, &c.

The paraffin is of good quality, transparent as alabaster, and can, without detriment, be mixed with 10 per cent. of stearine for the production of candle material.

According to Anderson, the composition of the paraffin is as follows:—

	From boghead coal.	From peat.	From petroleum.
Carbon..	.. 85·00 ..	84·5 -85·23 ..	85·15
Hydrogen	.. 15·36 ..	15·05-15·16 ..	15·29

Assuming that the peat mentioned under 6 and 7 in the table on p. 448 is dried in the retorts by radiant heat before distilling, and that it gives on the average 7 per cent. of tar and 30 per cent. of coke, then, according to Dr. Vohl, the following quantities of products would be obtainable from 1,000 kilos of peat.

						Kilos.
Peat oil .. .. .	..	..	..	..	..	= 7·9094
Solar oil .. .. .	..	..	..	..	..	= } 8·5463
Lubricating oil .. .. .	..	..	..	..	..	= }
Paraffin .. .. .	..	..	..	..	..	= 1·1893
Creosote and carbolic acid .. .. .	..	..	..	..	..	= 19·8114
Sal-ammoniac .. .. .	..	..	..	..	..	= 0·9196
Acetic acid .. .. .	..	..	..	..	..	= 6·0040
Wood spirit .. .. .	..	..	..	..	..	= 2·9028
Coke .. .. .	..	..	..	..	..	= 300·0000
Butyric and valeric acids .. .. .	..	..	..	..	..	= 0·7862

The application of peat in the manufacture of illuminating substances has not, however, been hitherto attended by the success which one would be justified in expecting from the experiments carried out even on a large scale. The winning of tar and tarry substances from peat in combination with peat carbonization according to the methods proposed by Ziegler and Bamme, which have already been tried on a large scale, are likely to give, under certain circumstances, better results in the utilization of bogs. The same may be said of the recovery of by-products (ammonia) in the case of the Frank-Caro gasification of peat for power purposes. Nevertheless, an assured commercial success does not seem to have been hitherto made possible by this method. For the yields of tar and tar water in this process, see the details on pp. 378-81 and 409-11.

Attempts have also been made to obtain bitumen, or wax, from peat, but these can be attended by commercial success only when they form a side industry to another recognized peat industry such as those of distillation or coking. The Ziegler-Frank (condenser) is said to have worked well for this purpose.

In the crude state the bitumen is dark brown to black in colour, but when distilled, pressed, &c., it is dazzlingly white and melts at 78° C.

According to the *Berichte der Deutschen chemischen Gesellschaft* (1902), the percentages of wax, referred to dry peat, in the case of several specimens were as follows:—

Aibling bog .. .. .	..	..	..	..	7·5	per cent. of wax.
Kolbermoor .. .. .	..	..	..	..	6·7-8·0	„ „
Feilenbach bog .. .. .	..	..	..	..	5·5	„ „
Oldenburg .. .. .	..	..	..	..	3·8	„ „
Franzenbad .. .. .	..	..	..	..	4·1	„ „
Peat litter from Lüneburg Moor .. .. .	..	..	..	..	2·8	„ „
Peat from Salzwedel .. .. .	..	..	..	..	1·3	„ „
Peat from Tangsehl, from the surface to 3 m. in depth, gave gradually increasing amounts from ..	..	..	..	..	1·92-10·0	„ „

Comprehensive accounts of numerous results of recent researches on peat carbonization and peat gasification are to be found in the Section “*Chemie der Destillations-produkte*,” in Dr. Hoering’s “*Moornutzung und Torfverwertung*,” Berlin, 1915, to which we can here only refer. Further consideration of this subject would exceed the limits of the purpose and range of this book.

## SECTION VI

# UTILIZATION OF PEAT LITTER AND PEAT MULL<sup>1</sup>

### 1.—Peat Litter and Peat Mull for the Absorption and Deodorization of Manures and Waste Substances

The possibility of utilizing light mossy, fibrous peat and peat mould as litter for stables and as a deodorizer for human and animal excreta has been known for a long time, and this use of peat has been therefore, for many years past, in actual operation on the farms of persons dwelling in the neighbourhood of bogs. In spite of the excellent results it gave, this use could only become general when, in the manufacture of peat litter on a large scale, it became possible by judiciously selecting the raw peat, by uniformly working it in machines, and by specially pressing and packing it, to introduce the peat litter to trade as a handy, fairly uniform, transportable, and cheap product, well suited for the purposes to which it was put.

According to a report of the Agricultural Councillor Horn, light moss peat had, even in the seventies, especially in the Grand Duchy of Baden, become indispensable as litter. For use in this way the moss peat was cut into thin slices, in so far as the waste small peat obtained during the winning of fuel peat did not suffice to meet the want. On the Grenzhof and Helmdorf estates moss peat was at that time regularly used as litter, 0·30 to 0·45 hl. per day being required for each animal, with a corresponding amount of straw over the layer of peat. In the parish of Klufbern there was not a single homestead in which peat litter was not used during three to five months of the year; the manure obtained at the same time was held in much higher esteem than ordinary stable manure.<sup>1</sup>

The credit for starting, in 1878–79, the use of peat litter on a large scale by winning the litter in a factory as described in detail in Part I, and of having facilitated this by means of the machines discovered by him is due to the bog-owner, W. Hollmann, of Gifhorn. As a result of the undoubted success of the first peat litter factory at Gifhorn, others, with improved machinery, very quickly followed it in Bremen and Oldenburg, and to-day factories of this type exist in almost all the larger peat bogs.<sup>2</sup>

There is an acute demand for litter in many districts where little corn is raised, for instance, in portions of West and South

---

<sup>1</sup> In addition to the publications mentioned on p. 260, see also Haupt's "Torfstreu als Desinfektions und Düngemittel," Halle, 1884, and Vogel's "Die keimtötende Wirkung des Torfmulls," Berlin, 1894.

<sup>2</sup> Some of the larger peat litter factories are mentioned on p. 281.



Germany, in the Tyrol, Carinthia, Styria, as well as in some parts of Bohemia, Upper Austria, Italy, &c. This leads to a heavy demand on the forest litter in the districts in question, and therefore to the destruction of the forests. This evil can be successfully met by utilizing the high bogs, which occur almost everywhere, for the winning of peat litter.

In the utilization of peat as litter and mull, we must consider its extraordinary high absorptive power for liquids, its power of absorbing ammonia and other volatile sweet or ill-smelling substances, its disinfecting and preserving power (due to the destruction of injurious bacteria), and its content of plant food or fertilizing substances.

With regard to the absorptive power of different varieties of peat, details have already been given in Part I, p. 262. According to these the mossy and fibrous peats which are converted into peat litter have as a rule absorptive powers of 800 to 2,000 per cent., i.e., 8 to 20 times their own weights. Investigations of peat litter samples from well-known factories, made in 1891 during the Bremen Exhibition for Bog Utilization, gave an absorptive power as high as 2,200 to 2,500 per cent.

It is generally assumed that an absorptive power above 1,200 per cent. cannot be fully utilized in a stable, and that good peat litter should therefore have an absorptive power of 800 to 1,000 per cent. In some cases, however, especially for one's own use, peat with a much smaller absorptive power than 800 can be employed as litter. The determining circumstances are the demand and the market price of other litters, account being taken of the fact that the absorptive powers of other litters are considerably smaller than those of peat. In the case of straw this is 200 to 350 per cent., heather 190 to 230 per cent., bracken 200 to 250 per cent., saw-dust 360 to 500 per cent., and wood-cotton 133 to 333 per cent.

According to Nessler, 100 parts of peat will *absorb* 1.6 to 2.5 parts of *ammonia*, while the same weight of rye-straw will absorb only 0.26 part of ammonia. In another case 100 kilos of peat absorbed as much ammonia as 225 kilos of straw. Hence it happens that in stables and closets in which peat litter and peat mull are used, we notice scarcely any bad odour which, if present, would pollute the air to be breathed by animals and men. With the absorption of the urine and the retention of the ammonia by the peat the most valuable constituents of the manure, which would otherwise be lost by the decomposition or evaporation of the sewage, are preserved for agricultural use. Dr. Fleischer estimated the loss of valuable fertilizers, due to decomposition of the urine in the cesspools, at 140M. for every ten head of cattle per annum.

According to Dr. A. König's experiments<sup>1</sup> the absorptive power of peat for ammonia varies with the nature of the peat.

---

<sup>1</sup> "Landw. Lehrbücher," 1882, p. 1, &c.

With 20 g. of dry peat and a solution of ammonium carbonate the following results were obtained :—

Peat.	Ash.	Percentage of the nitrogen of the solution absorbed.	100 parts of dry peat absorbed the following amounts of nitrogen.
	Per cent.		
Pure moss peat .. ..	2·2	73·6	1·55
" " .. ..	2·5	65·3	1·37
Humified, heather peat ..	6·9	47·7	1·00
Grassy and woody peat ..	22·0	39·8	0·84
" " " ..	37·5	32·1	0·68

Just as peat litter and peat mull absorb ammonia, they also absorb other sweet-smelling or ill-smelling substances or injurious gases, such as sulphuretted hydrogen, carbon dioxide, &c., and when they are employed for this purpose wherever such substances are being developed they keep the air pure.

*Chemical Composition of Moss Peat.*—Investigations by the Bog Experimental Stations have shown that moss peat, contrary to what is generally believed, is by no means free from acid. All the layers of the German high bogs contain large amounts of free acids. The nitrogen content of completely dry moss peat, free from grass residues, varies, according to Professor Fleischer, from 0·5 to 1·0 per cent., but otherwise the compositions of moss peats from various sources do not differ considerably from one another. The variations in the composition of 100 parts of dry peat are, according to Professor Fleischer :—

Nitrogen	Ash	Sand (insoluble)	Potash	Lime
0·5–2·3	1·0–1·55	0·2–0·6	0·01–0·04	0·1–0·3
Magnesia	Iron oxide and alumina	Phosphoric acid	Sulphuric acid	
0·2–0·4	0·11–0·22	0·02–0·04	0·15–0·24	

Moss peat from North-west Germany has generally a higher percentage (up to 0·43) of lime.

Straw, on the other hand, has a lower percentage of nitrogen, but somewhat higher percentages of potash, lime, and phosphoric acid.

The *disinfecting power* of peat litter and peat mull depends both on the absorption and retention by the peat of injurious waste products, and on its power of inhibiting decomposition and putrefaction by preventing the development of injurious bacteria.

In 1894 Dr. J. H. Vogel<sup>1</sup> submitted to the German Agricultural Society four detailed reports on the bactericidal action of peat mull made by Professors Stutzer, of Bonn; Fränkel, of Marburg; Gärtner, of Jena; and Löffler, of Griefswald. According to these reports, *peat mull when mixed with human excreta*

<sup>1</sup> Dr. J. H. Vogel, "Die keimtötende Wirkung des Torfmulls." Four reports to the German Agricultural Society, 1894.

*prevents the development of the bacteria which produce epidemic diseases, e.g., the cholera bacillus, if the peat mull is saturated with 2 to 5 per cent. sulphuric acid and is well mixed with the excreta.*

The various uses to which peat litter and peat mull are put and the results obtained thereby are given below.

## 2.—Peat Litter for Use in Stables

As litter for stables only (fibrous) peat litter, never peat mull, is employed as the latter develops too much dust, making the air impure and soiling the cattle by adhering to their coats. It is estimated that 100 kilos of peat litter will be required per annum for every 100 kilos live weight of the animal (e.g., cattle); draught animals, which are not always in the stalls, require less. It is assumed that a horse will require per month about 75 to 90 kilos of moss peat litter, and correspondingly more of grass peat litter, sometimes up to 200 kilos. The litter must be stored dry and used dry.<sup>1</sup> It is spread to a depth of 10 to 20 cm., and at first, until the animals have been accustomed to it, it is covered with some straw. For every square metre of the stable floor 9 kilos of peat are therefore required. The dung should be removed once or twice a day, moist litter should be uniformly distributed, and fully saturated litter should be removed and replaced by 1 to 2 kilos of fresh litter for each animal (2 to 3 kilos in the case of horses). The bed should be renewed when the air of the stable has become impure, or when the animals show either a disinclination to lie down or wet their coats when they do so. A bed lasts four to five weeks in the case of horses, and two to three weeks in that of cattle. Sewage channels in the stalls are filled with peat litter to prevent the urine from flowing away, which, absorbed by the peat, makes an excellent manure.

In the case of new stalls where peat litter is to be used, drains may be omitted altogether, and also the bed for the animals may be made quite horizontal, as contrivances to aid the escape of the urine are no longer necessary.

Peat litter stalls are almost odourless if properly managed, as the excreta are at once absorbed and the ill-smelling substances are retained by the litter. On the estate at Kreuzberg, near Berlin, for instance, the air in a byre containing 250 cows was kept quite pure by means of 1,000 to 1,250 kilos of peat litter per day.

Chief Forester von Steuben states that 4 kilos of peat litter are enough for one cow per day. If the dung is removed three times a day and the beds are re-made every morning, mid-day, and evening, the cows will then have a drier standing place and a cleaner bed than in the case of straw. Daily removal of the dung from a stall containing young cattle is not necessary.

The animals become accustomed to peat litter very quickly,

---

<sup>1</sup> The habit of many peat litter dealers, and also of many agriculturists, of storing their peat litter reserves in the open is strongly to be deprecated. If *good* peat litter is to be kept *good* it must be protected from rain and moisture.

when this is used properly, as it gives them a soft, elastic bed ; even for the stall attendants it has advantages, as the well-known injurious odour, the acid vapours, the dirty beds, approaches, &c., are completely got rid of. Sickness of the cattle and the attendants from inflammation of the lungs, nose and eyes decreases considerably, and the cattle, moreover, keep themselves cleaner on peat litter than on any other form of litter.

Peat litter has a peculiarly advantageous effect on the hoofs of horses. Disease of the fetlock is almost banished by it. The number of horses lame from hoof troubles is about 30 per cent. less in the case of peat litter than in that of straw litter.

Wet litter, or litter saturated with urine, must, however, be removed at the proper time and replaced by dry litter.

Only in the case of sheep is peat litter not very applicable, as the long peat fibres adhere to the fleece. On the other hand, it can be very highly recommended for pig-styes or fowl-houses. It appears to be advisable to leave the portion of a pig-stye in front of the feeding trough free from peat litter.

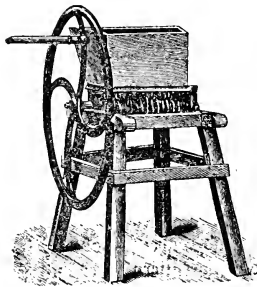

FIG. 165.—A disintegrating mill for peat litter.

Peat litter manure has also a smaller volume than stable manure. For the same number of horses the year's manure has for peat litter (about 20 cb. m. per horse) only half the volume which it has for straw litter (40 to 50 cb. m. per horse).

A peat litter is also in most cases cheaper than straw litter. It ought to be widely used owing to the advantages mentioned. Since straw, however, gives a manure which rots somewhat more quickly and acts more rapidly, it is preferable for wet, peaty soils.

Sometimes strongly compressed peat litter bales, which have perhaps become wet during transport, cannot be sufficiently broken up by a pitch-fork or shovel, so that many hard lumps remain in them. Peat litter in this condition cannot afford the animals the soft, comfortable, and therefore healthy bed to which they are accustomed. Moreover, in the lumpy condition peat is not so absorptive as it is in a uniformly loose state. It is advisable, therefore, in order to avoid these defects and also to prevent the formation of a lumpy manure, to employ a peat litter disintegrating

machine for which hand-driving will generally suffice. These peat mills (Fig. 165) are constructed by C. Weber and Co., amongst others. Those for hand driving cost 75M., and power-driven machines, with an output of 5 to 8 bales per hour, cost 120M. The disintegrating machine converts uneven or hard bales into a thoroughly uniform, loose litter, having a more or less large volume and a high absorptive power. The better, and therefore the more economic utilization of the otherwise lumpy peat litter rendered possible by means of the disintegrating machine soon pays for the cost of the latter.

It has been already mentioned under the winning of peat litter that it is not advisable in practice to utilize the absorptive power of peat litter to its full extent. Prolonged lying of the wet litter in the stables is also to be avoided as well as prolonged exposure of the uncovered peat litter manure in the ploughed fields and meadows, as drying and evaporation of ammonia, which then occur, prejudicially affect the value of the manure.

### 3.—Peat Mull for Water-closets, Town Sewage Disposal, &c.

According to the experience gained in various towns and large institutions in the disinfection and deodorization of human excreta and waste water from houses, as well as in the conversion of offensive human excreta into a convenient, inoffensive form, no substance is more suitable than peat mull, because it acts with certainty, is easily handled, and is cheap. It is equally good for cesspools, privy buckets, or tubs, as well as for commodes, &c., for bedrooms or house closets. The emptied or cleaned vessel is filled with peat mull to a height of 10 to 20 cm., a cesspool to a height of 30 to 50 cm., and each time it is used some mull is scattered over its contents. For household use 30 to 50 kilos, for factories 20 kilos, and for schools 4 kilos, of good moss peat mull are sufficient for each individual per annum. The closets or close-stools are then almost odourless. The appearance of the contents and the operations of emptying them out and taking them away do not excite disgust. The latter operation, being quite odourless, can be carried out even in broad daylight without offending the susceptibilities of the workmen or the people of the neighbourhood. When mixed with peat powder, human excreta give a quite odourless, valuable manure, resembling black mould in appearance, easily handled, and conveniently transported. While urine, inasmuch as it is a valuable constituent of manure, should always be added to the excreta with which peat mull is mixed, it is not advisable to let the other waste water of the household into the closets, since the value of the excreta would then be decreased and too much peat mull would be required for its absorption.

Regular supervision and management of these mull installations, especially the regular addition of mull after use of the installation, are absolutely necessary for their success.

*From public health considerations every closet installation for town and country which is not connected with a public sewage*

*disposal system, or which is not provided with other contrivances acting with certainty, should not only be obliged by the police to have the excreta contained in them disinfected by peat mull and to have their contents mixed by means of suitable contrivances with a quantity of peat mull sufficient for the operations of emptying and transporting them, but also the regular and conscientious maintenance and working of the installations should be closely supervised by the police.* The disgusting conditions which are found in almost all (even better-class) dwellings, institutions, and hotels of the smaller and middle-sized towns, which are not provided with a public water supply or have not compulsory powers, conditions which have been indeed described as illegal, but have not been treated as such by the police, would in this way be at once removed, with great advantage to the public. At the same time the permeation into the soil around dwelling places of sewage and the injurious microbes associated with it (which would take place in the course of time even if it has not already occurred) as well as the pollution of rivers and springs, the source of our drinking water, would be prevented.

*It is astonishing that the public health authorities have not devoted their attention to this defect of thousands of dwelling houses, public institutions, &c., and invoked legal aid to deal with it.* By means of peat mull, anyone can get rid of this universal evil with very little expenditure for the installation and maintenance of the contrivances. The value of the excellent manure obtained covers in most cases in a short time the installation costs and many times the cost of upkeep.

The carrying out of a general measure of this type would require, however, exceptional freightage on the railways, so that cheap peat litter powder could be placed at the disposal of every community and of every householder.

In schools, factories, and much frequented public closets the addition of the peat mull can be made by attendants at certain definite intervals. In house closets it is better to provide the seats with automatic arrangements for the addition of the mull, or, in the case of new installations, to set up automatic peat mull closets or peat stools.<sup>1</sup>

Well-made contrivances of this type are on sale by the Chemical Factory, formerly Rud. Grevenberg and Co., of Hemelingen, near Bremen; O. Poppe, of Kirchberg, in Saxony; Karl Fischer, of Bremen; Kleucker and Co., of Brunswick; Schmidt Bros., of Weimar; Franz Bros., of Königsberg, in Prussia; Umrath and Co., of Bubna, near Prague; E. Gildzinski, of Vienna; B. Grünhut, of Gratz, &c. Reference must be made to the price lists of the firms mentioned above for details as to the construction and prices of the contrivances. Automatic peat stools cost 20M., "scatterers" 12M., and the buckets or tubs 6M.

---

<sup>1</sup> According to Pettenkofer, the daily excreta from a fully grown man are 1,500 g. of liquid motions and 120 g. of solid stools, therefore approximately 600 kilos per annum, so that the average amount from fully grown men and children may be assumed to be 500 kilos per annum.

Police regulations with regard to the use of peat mull for closets exist in Brunswick, Stade, Magdeburg-Neustadt, Emden, Christiania, Malmö, Gothenburg, to some extent also in Küstrin, Greifswald, Neumünster, Flensburg, Losancz (Hungary), Groningen, Bremen, Hanover, Minden, Rendsburg, &c.<sup>1</sup> According to Dr. J. H. Vogel, 212 out of the 564 towns in Germany with more than 10,000 inhabitants were using peat mull closets in 1896. In some of these, however, the number in use was small.

The German Agricultural Society, in 1902, awarded a first prize of 5,000M. to the town of Minden, in Hanover, and a second prize of 2,000M. to the town of Rendsburg, for the best peat closet process with removable buckets.<sup>2</sup>

#### 4.—Peat Litter Manures

In spite of all doubts as to the expediency of using large quantities of peat litter manures in agriculture, as, for instance, owing to the difficulty with which peat fibres decompose, the inability of the peat to loosen the soil, the low content of peat manure in lime, potash, phosphoric acid, &c., it has become a very valuable manure, much in demand for agriculture owing to the universally favourable experience gained with these peat manures, both peat litter stable manure and peat mull closet manure. Its power of absorbing and retaining urine (rich in plant food) has, perhaps most of all, popularized the use of peat litter. In the case of straw litter, a good deal of this liquid manure becomes lost. The ammonia also, which is formed by the decomposition of animal excreta, and which is valuable as a manure on account of the nitrogen contained in it, is fixed almost completely by the peat litter, while a good deal of it becomes lost by volatilization in the case of straw litter.

Experiments instituted by the Bog Experimental Station, as well as comparative trials made by numerous landowners, have proved that when the quantities of the litters used in each case are just sufficient to completely absorb the urine, the drains being blocked, straw manure contains, indeed, 7 to 10 per cent. more of potash, lime, and phosphoric acid than peat litter manure, and, on the other hand, 4 to 5 per cent. less of not easily soluble, and 80 to 85 per cent. of freely soluble, nitrogen. With ten head of cattle, the amounts required per day for each beast were, 4·6 kilos of straw (cut into pieces 10 to 12 cm. in length) or 3·5 kilos of peat litter. The amount of manure obtained was much the same in both cases, being 55 to 58 kilos per day with 16 to 18 per cent., i.e., 9 to 10 kilos of dry substance.

When it is not desired to forgo the higher percentages of potash and lime, Dr. Fürst recommends the addition of kainit and

<sup>1</sup> See statistics by Hans Schreiber in the *Osterr. Moorzeitschrift*, 1906.

<sup>2</sup> See types of peat closet processes for small and medium-sized towns, "Bericht der Deutschen Landwirtschaftsgesellschaft," 1902, Berlin, No. 74 of the Proceedings of the Society.

Thomas slag to the peat litter manure—100 kilos of these to 2,000 kilos of the manure.

Wherever, owing to conservatism, peat litter has not yet been adopted, the urine collecting in the drains should at least be absorbed by means of peat litter and its full manurial value retained. The urine thus fixed forms with the peat litter a thick, curdy or mouldy mass, which can be easily and conveniently brought to tillage fields and meadows, or, in suitable cases, even dispatched to a distant district. Ten hectolitres or 1 cb. m. of liquid manure give in the case of good peat litter (with an absorptive power of about 1,000 per cent.) little more than 1 cb. m. of solid, easily handled manure, 1 cb. m. of the liquid manure requiring 100 kilos of good peat litter.

The reports as to the effects of peat litter manures as fertilizers are also all favourable. In the Bog Experimental Station at Bremen, the crops per hectare were as follows :—

Straw litter manure	..	..	Oats. 3,210 kilos	..	Straw. 5,155 kilos.
Peat litter manure	..	..	3,705 „	..	5,955 „

So that with peat litter manure, 500 kilos more grain and 800 kilos more straw were obtained than were with straw litter manure.

With peat litter manure the potato crop was about 1,000 kilos per hectare more than with straw litter manure, and the increased quantity was mostly due to the potatoes being larger. With horse beans and capuchin peas, 700 kilos more grain per hectare were obtained with peat litter than with straw litter, the straw crops being the same in the two cases.

According to C. Haupt, on the Harting estate near Regensburg 5 m. tons of peat closet manure gave the same amount of rye (grain) and 250 kilos more straw than were obtained with 20 m. tons of straw litter manure from cow-sheds, and with peat closet manure the yield of potatoes per hectare was 5 m. tons more than without manure.

In the prison at Vechta a sandy soil fertilized with peat closet manure gave  $15\frac{1}{2}$  times the seed sown, while an equally large amount of straw litter manure gave only  $10\frac{3}{4}$  times the seed.

The results observed in vineyards, vegetable gardens and fruit gardens where peat closet manure has been used have also in all cases been good ; for instance, in manuring asparagus, raspberries, gooseberries, all kinds of vegetables, radishes, cauliflowers, &c., where, in addition to giving well-flavoured and fine crops, it gave a return of 50 to 100 per cent. more than with the same amount of ordinary farmyard manure.

Fürst attributes the cause of this remarkable increase in the crops fed with peat closet manure in comparison with those with ordinary farmyard manure to two things—firstly, because human excreta being a product from a vegetable and a meat diet is about one-third more effective than animal excreta, and secondly, because peat litter possesses the property of absorbing more efficiently and retaining for a longer time the plant food contained in the excreta than the other absorbing agents do.



### 5.—Various Industrial Applications of Peat Litter

On account of its remarkable power of preventing decomposition and destroying bacteria, as well as of its loose, bulky, elastic, pliable properties, and especially on account of its low thermal conductivity, peat in the form of litter and mull has been used with great success for many years for the following commercial purposes:—

(a) *For Packing and Preserving Perishable Objects*, for instance, for the wintering or the preservation of soft or hard fruit, grapes, beet, potatoes, onions, &c.,<sup>1</sup> for packing eggs, fish, meat, sausages, &c., and for preserving bodies and parts of bodies in mortuaries. Hard fruit, packed in peat mull in boxes, keeps its fresh appearance for months without becoming withered or decayed; the same may be said of beet, potatoes, onions, &c., which, moreover, do not sprout prematurely. After an eighteen days' journey, fish packed in peat appeared as fresh as when they had just come from the water.

How far fibrous peat or peat mull can compete commercially with wood cotton as a packing material depends on their costs of production; as a packing and filling material, loose peat is at least as good as wood cotton, straw, or similar substance.

(b) *As a Bandaging and Padding Material*.—Dr. Neuber, of Kiel, employed at first—with complete success—peat mull saturated with carbolic acid and iodoform in gauze bags of various sizes and about two fingers thick as antiseptic bandages in surgery. Later a peat cotton, highly valued for many years past for bandaging and healing purposes, was made from fibrous peat and from the fibres of cotton-grass (*Eriophorum vaginatum*). This is used like the well-known surgical wadding, but is preferred to the latter by many medical men on account of the greater certainty of its action.<sup>2</sup>

On account of its great absorptiveness and its power of preventing decomposition, peat litter or peat cotton is a suitable filler for bed pillows and mattresses for the sick room or nursery.

(c) *As an Absorbent and Filling Material, as a Sound Damper, and as a Heat Insulator*.—For the rapid drying of damp rooms (cellars) fibrous peat or peat mull is of the greatest use on account of its high absorptive power. Similarly, owing to its low thermal conductivity, it serves well for covering, or surrounding, ice-cellars, refrigerating or heating rooms, incubators, &c. According to Dr. Fürst, a heap of ice covered with peat was made in the open at Bockelholm Bog, in 1888–89, and, without replenishing the store, this ice was taken out in an unthawed condition in the summer of 1891.

<sup>1</sup> "Peat felt," which was introduced to commerce by the Felt Factory of the Zimmermann family of Eupen, is an excellent packing and preserving material for fish, flesh, soft fruit, &c. It costs 0·30M. per square metre and is sold in widths of 50, 75, and 100 cm., with a thickness of  $\frac{1}{2}$  to 1 cm.

<sup>2</sup> Surgical peat cotton, peat cotton cushions, peat felt, &c., are sold, for instance, by the apothecary G. Beckstroem, of Neustrelitz.

For covering heating chambers or heat conductors, steam or hot-water pipes, reservoirs, &c., peat bricks, plates, or cylindrical shells are made and are now on sale. For insulating walls, as a rule, peat mull, or better, peat litter, is loosely filled between double walls. As sound dampers, walls pressed from fibrous peat or made from peat mull bricks and peat mull plates have proved suitable for telephone compartments, doors, &c. As cement, the usual building materials, lime, cement, clay, mud, &c., are used.

Peat litter is a good substance for filling spaces between covers, and for this purpose it should be saturated with milk of lime and again well dried.

Lime-sand bricks or clay bricks which are made from a suitable mixture containing fibrous peat or peat mull give, in the dry unburnt condition, a badly conducting brick—in the burnt condition, a very light porous brick. In Sweden, for instance, the walls of cabins built in bogs are made of these peat bricks and mortar, and are then boarded both inside and outside.

Garden plants are protected against frost by a covering of peat mull, which, at the same time, prevents mildewing of the covered plants.

(d) *For the Manufacture of Peat Molassine Meal.*—Peat mull, on account of its great absorptive power and its property of preventing decomposition, is peculiarly adapted for the manufacture of peat molassine meal, which in recent years has come more and more into demand. Peat molasses consist of 70 to 80 per cent. of molasses and 20 to 30 per cent. of good peat mull. The peat in it has no nutritive value, but experience shows that it is, on the other hand, quite harmless. It converts the syrupy crude molasses (a waste product from the sugar factories) into a convenient and stable product, which, as a foodstuff, is easily digested by animals.

When the peat mull, made by means of mull machines (p. 264), is not directly used for this purpose the peat mull intended for the preparation of the peat molassine meal is manufactured by means of special machines, such as those sold by C. Weber and Co., of Artern, amongst others. A power-driven machine weighing 250 kilos costs 245M.

(e) *Other Uses.*—Peat litter and peat mull have been used instead of saw-dust with success on an experimental scale for cleaning and drying metallic articles for nickelling or for metal baths, for filtering oil or liquids, for thickening lyes (e.g., the so-called elution lye of the sugar factories which, absorbed in peat mull, forms a valuable fertilizer) as well as for preserving in a powdery condition caking fertilizers (superphosphate, kainit, &c.), or other pulverulent substances which absorb moisture from the air (a quantity of mull equal to  $2\frac{1}{2}$  per cent. of the weight of the manure is sufficient for this purpose). Peat mull is said to be an excellent material for propagating beds in gardens, as it keeps uniformly warm and moist and prevents rotting. The plants shoot more rapidly and root satisfactorily.<sup>1</sup>

---

<sup>1</sup> *Deutsche Landwirtschaftliche Presse*, 1884, No. 38.

## SECTION VII

# OTHER METHODS OF UTILIZING PEAT

### 1.—Textile Fibres and Cotton from Peat

Attempts have long been made to utilize the tough, elastic, fibrous plant residues, found in large quantities in some peat layers, as spinning and weaving materials, like the well-known hemp, flax, and nettle fibres. It was believed that the working substance, the fibres, which, in the form of wool, cotton, hemp, or linen, cost a good deal, would require to be merely dug or hacked out of valueless bogs. Only the fibres of the cotton-grass (*Eriophorum vaginatum*) have, however, actually proved suitable for this purpose. These fibres do not undergo decomposition during the humification of the other plant components in which they are contained, and in many bogs they occur in a special fibrous layer, called cotton-grass peat, in considerable quantities under the litter and fuel peat. From their admitted capability of being utilized as a spinning and weaving material they invite development, but they are, nevertheless, neither cheap enough in their winning nor extensive enough in their occurrence for a large scale industry.

In Holland and Oldenburg there are large bog areas in which, under a cover of 10 to 15 cm. of heather soil, there is a layer of moss or litter peat 40 to 80 cm. thick, and under this a layer of humified or fuel peat 70 to 100 cm. thick, with finally a layer of cotton-grass peat, 50 to 150 cm. thick, generally resting on sand. The cotton-grass layer contains workable fibres of the plant in well-preserved tufts, in which the structure of the plant can still be recognized, and in such quantities that, from every cubic metre of the peat itself, i.e., fibre layer, including the upper layers which must be removed, 17 to 20 kilos of dry cotton-grass fibres can be won on the large scale. In the further treatment to which they must be subjected before they are capable of being spun they lose about half of this weight. Four cubic metres of crude fibrous layer gave, when washed, 2 cb. m. of peat cotton fibres, and when worked into cotton 1 cb. m. of the latter, weighing 150 kilos, i.e., 1 cb. m. of fibre layer gave  $37\frac{1}{2}$  kilos of cotton.

The difficulty encountered in working these peat cotton fibres, that of converting the woody and to some extent friable and earthy raw fibres into smooth, elastic, absorptive fibres capable of being spun and dyed, could only be overcome by chemical means.

The peat fibres, under which term the sifted cotton-grass (*Eriophorum vaginatum*) residues alone are understood in this

section, are digested<sup>1</sup> in a solution of caustic soda, potassium carbonate, or sodium carbonate, or boiled under pressure and washed with lukewarm water. Dilute sulphuric or hydrochloric acid may be used instead of the alkaline solutions. When treated in this way, however, the fibres remained brittle, were only slightly absorptive, could not be bleached, could be dyed only in dark shades, and could be spun only into coarse yarn. In the middle of the nineties, Charles Geige, of Düsseldorf, introduced a considerably improved process for winning chemically pure peat fibres which could be spun and dyed. In his process the crude peat fibres are extracted with alkalis by stirring them for several hours in a dilute alkaline bath. The fibres are then dried and split up in machines resembling the ordinary willows of the cotton industry. The fibres are next placed in a fermenting bath to decompose the starch contained in them, and then in another digesting bath containing sulphuric acid to decompose any vegetable proteins still remaining in the substance. When the decomposition products have been removed by washing with water the peat fibres are exposed to the action of hot ether, benzine, or other fat-extracting solvent in closed digesters under pressure, until a sample shows that all the resins, oils and fats of the fibres have been extracted. The fat-free peat fibres, which are removed from the boiler when cold, are thoroughly washed, then boiled with dilute acids or alkalis (the last portions of tannic acid being thus extracted), and finally washed once more, and, when desired, bleached in the ordinary way.

The peat cotton fibres, treated as above, are chemically pure, quite neutral, soft, and pliable. They can be bleached, dyed in bright shades, and spun into very fine yarn. It was intended to weave the fibres into all kinds of textile articles, clothes, carpets, covers, &c., and this could, indeed, be done, as was proved at the time in the experimental factory erected at Düsseldorf for the exploitation of Geige's peat products.

Wadding, made from peat fibres thus treated, on account of its purity, innocuousness, and extraordinary absorptive nature, is an excellent dressing material which can be employed in large quantities with advantage from the health standpoint, in surgery.<sup>2</sup> It can, moreover, be used for making absorptive cushions and drying cushions for young children and sick persons.

Peat wadding or peat cotton fibres can also be mixed and spun in any desired proportion with wool, linen, cotton, &c., for the preparation of mixed fabrics for various uses, such as the manufacture of cloth, &c.

Unfortunately commercial success in this case, also, has not been able to keep pace with the technical success. In spite of the cheap raw material (fibrous peat), and notwithstanding all the

---

<sup>1</sup> Cf. "Die Abscheidung und die Charakteristik der Torffaser," by Dr. Karl Linsbauer, in *Dingler's Polytechn. Journ.*, 1900, p. 439, *et seq.*

<sup>2</sup> This peat bandaging cotton or wadding, &c., is sold by the apothecary C. Beckstroem, of Neustrelitz.

attempts hitherto made and the support given to Geige's process by well-known experts of the spinning and weaving industry, the washing and the purification of the fibres and their conversion into spinning fibres could not be effected so cheaply that the peat yarn could compete in price with other well-known spinning materials, even when it was intended for use in combination with these.

In the case of mixed yarns double dyeing was, moreover, necessary, as the peat fibres did not take the same tint as the other yarn fibres in a single dip. The experimental factory at Düsseldorf was therefore closed several years ago and the projected erection of larger factories in Holland and Oldenburg was not proceeded with.

In 1903, a new company was formed in Oldenburg under the name German Peat Cotton Works the object of which, again, was to win and utilize peat cotton. It erected an experimental factory near Moslesfehn, which was visited by various societies. Arising out of one of these visits the following report has been published in the *General Advertiser* for Oldenburg and East Frisia<sup>1</sup>:—

“The Eriophorum fibres, from which the peat cotton is won, are found in large quantities in the middle and lower layers of peat. The freshly dug peat is first washed in a current of water to isolate the fibres from the peat. The peat fibres are taken out of the current of pulp by means of forks, which are fastened like dredger buckets to an endless chain. The fibres thus obtained are brought into large vats where they are washed mechanically several times, taken out, and wrung. The purified fibres are subjected to a boiling and to a fermenting process by which any portions of tissues still adhering to them are removed. The mass is then dried by centrifuging and blowing air through it. The dried fibres are freed from dust by a sieve and are then ready for the further treatment to which they are subjected. Several willows, provided with slender feathering points, effect the disintegration into the ‘fine’ and ‘very fine’ fibres required for the various kinds of peat cotton. The peat cotton is handed over to the spinning and weaving factories for further working, alone or mixed with ordinary cotton. Felt and paste-board can be made from the peat cotton, &c. As the experience gained in the experimental factory gives rise to hopes for the success of a large scale industry several peat cotton factories are to be erected there and elsewhere provided the Government authorities rise to the occasion. Such an industry could employ many hands and lead to the utilization of bogs which have hitherto been valueless; it would have great significance for a country which is rich in non-utilized bogs.”

So far the report. The factory is, however, no longer in existence.

In Austria, Charles A. Zschörner, of Vienna, tried to utilize peat as a spinning and weaving material. In an article in the

---

<sup>1</sup> *Mitteilungen*, 1903, p. 297.

*Zeitschrift für die gesamte Textilindustrie*<sup>1</sup> the statement is made that "the fibres employed—extracted from certain kinds of peat—are mainly reed-grass threads (?). The reed-grass, which constitutes the upper layers of the bog, after it has been separated (?) from the peat, dried, and mechanically purified, passes to the Zschörner carding machine, from which it is wound off as threads and made into felt, carpets, and other woven fabrics."

This process also, about which much was written and many opinions expressed at the time,<sup>2</sup> did not get beyond the experimental stage, since, as everywhere else in the industry, the decisive factor in this case also, is not *technical success*, i.e., the possibility of manufacturing spinning and weaving materials from peat fibres, but *commercial success*, i.e., the suitability and the *price* of the products.

## 2.—Manufacture of Paper and Mill-board

The many attempts to employ peat (light, mossy and fibrous peat) as raw material, or complement, for paper or mill-board have not hitherto led to any striking results although some of the experiments have given mill-board little inferior in quality to that made with wood or straw and rags. It is difficult to free the fibrous constituents, by beating, sifting and washing, from the earthy bodies (fine sand, &c.) mixed with them, and from the humic substances. These cause trouble during the further treatment of the fibres and prejudicially affect the quality and the durability of the mill-board, especially the elasticity and pliability that are required for the treatment to which it is later subjected.

Thus, for instance, experiments conducted on a large scale in a paper factory at Leer with very porous, light-coloured moss peat (from the Oldenburg high bogs) have shown that the earthy constituents of the peat are very detrimental and that consequently the mill-board obtained was too brittle. A considerable proportion of rags would have to be added to obtain a product as firm as that from wood or straw and the article would then cost too much.

Experiments formerly carried out at Volprechtsweyer with a moss peat from Zehlen Bog, near Königsberg, gave results which were in general satisfactory for ordinary thick mill-board. The specimens of packing paper and mill-board submitted to the Polytechnical Society at Berlin were of good quality. The mill-board was 8 cm. thick and so firm that it could be polished. The paper made from pure moss peat was just as short and fragile as that from pure wood or straw; addition of 15 kilos of rags to 100 kilos of moss was sufficient to remove this defect, which, moreover, in

---

<sup>1</sup> 1899–1900, Nos. 5 and 6, "Der Torf als Spinn- und Web-stoff," by Desiderius Schatz, Engineer Assistant in the Mechanical-Technology Institute of the Technical High School, Dresden. Cf. also "Mikroskopisch-technische Untersuchungen über Torffaser und deren Produkte," by Karl Linsbauer, in *Dingler's Polytechn. Journ.*, 1900, p. 437.

<sup>2</sup> See also the second edition of this book, p. 477.

the case of thick, flat boards was scarcely, or not at all, perceptible, owing to the repeated layering and the inter-connexion of the long fibres under and over one another.

At present, wherever wood and straw form a relatively cheap complement for mill-board factories, peat is not able to compete with them for this purpose, since it is either much too impure or its fibrous constituents are not uniform enough, or when these are purified to the required extent they are much too dear.

A large mill-board factory (Scholten in Groningen) erected in Holland has, it is generally believed, been closed.

A. von Feszty, of Eszterháza in Hungary, has also carried out extensive experiments on the manufacture of paper from peat; he has also succeeded in making, in an experimental factory, a product capable of being utilized. Here, however, we have again the same question, how does its price compare with those of similar products from other materials? It is a matter of indifference whether mill-board or paper can be made *entirely* from moss peat or peat fibres as is sometimes demanded when the use of peat as half-stuff for paper or mill-board is under discussion, or whether for this purpose it requires to be mixed with the other half-stuffs of the paper and mill-board industry. Mill-board and paper are not made entirely from wood, nevertheless, wood is a valuable half-stuff for the paper industry.<sup>1</sup> Hitherto almost everywhere peat fibres, insufficiently treated and purified, have proved incapable of being utilized, and, on the other hand, purified and utilizable peat fibres have proved too dear a half-stuff for mill-board and paper.

Charles A. Zschörner, of Vienna, claims that a fibrous material suitable for the manufacture of paper can be won by extracting the previously washed fibrous peat under the highest possible pressure with a weak alkali solution (not more than 2 per cent.), or several times with alkali solutions of continually decreasing strengths, and, after separation of the lye, washing with a weak solution of an oxidizing agent (calcium hypochlorite or sodium hypochlorite solution 1 to 2° Bé), which at the same time bleaches the fibres. These are finally extracted with an alkali solution weaker than that used at first.

On the occasion of the Course on Bog Industry and Peat Utilization at Admont, in September, 1903, those who participated in that course visited a peat mill-board factory erected for the Zschörner process by Esser and Pollak, at Frauenburg, near Admont, in Styria. According to the report then made<sup>2</sup> a very favourable impression is said to have been produced on the visitors by the factory and its equipment.<sup>3</sup>

All the peat mill-board factories erected in Ireland, Scotland, and America during the period 1904 to 1910 have closed after loss of their capital.

<sup>1</sup> See also "Charakteristik der Torfpapiere," by Karl Linsbauer, in *Dingler's Polytechn. Journ.*, 1900, p. 441.

<sup>2</sup> *Zeitschrift für Moorkultur und Torfverwertung*, Vienna, 1903, p. 99.

<sup>3</sup> For failures in the manufacture of peat mill-board see, however, *Mitteilungen*, 1907, p. 164.

### 3.—Peat as a Substitute for Wood and as a Building Material

Helbing in Wandsbeck—Hamburg, and Hemmerling in Dresden, have made artificial wood from a mixture of 90 to 95 volumes of freshly cut peat and 5 to 10 volumes of a cement (slaked lime with alumina compounds) by subjecting it to a pressure of 450 to 500 atmospheres and then drying the mass. As the product was supposed to be "proof" against water, temperature, and fire, to be hard and to resist wear and tear, it was to be used as a material for street pavement, railway sleepers, ship-building, railway wagons, inlaid floors, roofs, tables, and all kinds of carpenters' products, for furniture, &c.

According to statements made at the General Meeting of the Bog Cultivation Society in 1903, the freshly cut peat is intimately mixed in machines, and in that state, i.e., containing 80 to 90 per cent. of moisture, it is compressed into the desired objects, generally wall-plates and floor-plates, street pavement, &c. The drying of the plates then requires at most four to five days. For the same strength and durability with greater resistance to wear and tear, their price is said to be 33 to 50 per cent. less than that of oak wood; if ornamentation is to be carried out, the price is said to be 75 per cent. that of oak wood. Plates such as these are extraordinarily difficult to burn, and if they really could be prepared cheaply enough they could be used as building plates on account of their dryness, their power of damping sound, and their low thermal conductivity. Further particulars with regard to them are not known, especially the fact as to whether the process is commercially successful or is extensively carried out.

Stuck, cut, or sawed brick-like pieces, plates, &c., from raw peat are much used for the walls of light buildings, for heat insulators, and for partitions or roofs. Similarly, thin plates of peat are used as supports, on which objects of instruction (butterflies, beetles) are fixed; suitably cut or formed pieces of peat are also used for stuffing, filling, or embedding objects (e.g., loose, folded, skinny, or fragile bodies).

Lang, at Sebastiansberg in the Erzgebirge, Weigend, at Dux, Hoffmann, at Heydekrug, amongst others, have manufactured balls, small pillars and stands capable of being polished from black, bituminous peat, as well as letter weights, fancy boxes, cigar cabinets, picture frames, &c., from brown, pressed, moss peat.

*Peat for Roofing Purposes.*—In order to avoid the evils attached to paste-board roofs—repeated tarring, tearing of the paste-board, and then leaking of the roof, frequent repairs, &c.—which are generally due to the low absorptive power of the pasteboard, von Wangenheim devised a moss peat roof, originally for his own buildings, and, when it had proved very successful in his own case, the commercial utilization of this method of roofing was handed over to Louis Lindenberg, of Stettin, and the roofing expert, Duckert, of Freienwald, in Prussia.<sup>1</sup>

<sup>1</sup> *Mitteilungen*, 1897, p. 107.



The roof consists of two portions—the under support and the peat layer. The former is made by rolling a light roofing paste-board on an ordinary support, gluing it all round at the bottom and sides, so that no nails are required and it is at the same time quite tight. The warm peat mixture is thrown on this, levelled and made smooth with a heavy hot iron. During the operation care should be taken to see that the peat layer is everywhere at least 1 to 1½ cm. thick. The moss peat mixture for roofing purposes consists mainly of moss peat mull, coal tar, resin, pitch, and a substance which tends to make the mixture fireproof. Only moss peat mull is used ; it should be as free as possible from earthy matter and contain a large amount of plant fibres. A thin skin forms on the surface of the mixture during the levelling with the hot iron. Red-hot gravel, the size of lentils, is then thrown on it. Owing to its weight and the heat contained in it, the gravel sinks into the mass, a light crust being formed, which impedes the volatilization of the oils. The latter are retained therefore in the mixture, and the paste-board remains soft and pliable for years and, therefore, firm and tight. The cost of such a roof is stated to be 2 to 2½M. per square metre. while a double-layered paste-board or wood-cement roof costs about the same amount. When good materials are used and the costs of repairs and maintenance for a period of fifteen years are taken into account all the other roofs are, however, more expensive. The double-layered paste-board roof suffers, however, from the defect that in hot summers the tarry mass softens and runs off, and also the paste-board when dry or brittle in cold winters tears readily ; the wood-cement roof requires, moreover, a much stronger support. The weight of a square metre of a moss peat roof, 18 to 20 kilos, is the same as that of a good paste-board roof. The slope of the roof may be made 1 : 30 with great advantage.

*Moss Peat Insulating Walls.*—Moss peat sods or plates cut from moss peat made into walls in the same way as bricks, earthenware or cork plates, are excellent sound dampers (for telephone boxes, doors, &c.), heat-insulating walls (for ice cellars, hot rooms, incubators), lagging for boilers and tubes, floors, &c. Lang, of Sebastiansberg,<sup>1</sup> in manufacturing walls for rooms, cut moss peat sods into plates of a uniform size by means of a circular saw and morticed these by means of glue into a wooden frame in place of the wall. The partitions thus formed were plastered or papered. The walls are excellent dampers of sound, easily constructed, have a thickness of only 4 cm., are extraordinarily light, and require no supporting walls under them.

Bricks of lime-sand, gypsum, or clay, made from a paste into which fibrous peat or peat mull has been stirred, give in the dry, unburnt condition a sound damping, non-conducting structure, and in the burnt condition one which is very light and permeable in respect to air. In Sweden, cabins are constructed in bogs by

---

<sup>1</sup> Hans Schreiber, "Neues über Moorkultur und Torfverwertung," second year, p. 153.

forming their walls of these peat bricks and mortar and rough-casting them both within and without.

It may here be pointed out once more that with the technical aid at our disposal we can overcome all the difficulties encountered in converting peat into any artistic or useful object, but that in doing so we have by no means solved the problem of peat utilization. It is rather a matter, in the first place, of whether it is wise to work peat for purposes other than burning, bedding, filling or packing, or to convert it into objects for which other substances are more suited by their nature and in general can be more conveniently obtained; and, secondly, whether the final product, however perfect from the technical standpoint, is not much too dear in comparison with products obtained from materials that are already used and are as a rule better for the purpose. Taking into account the well-known nature of peat, the latter question will generally be answered in the affirmative, and therefore all new peat discoveries are to be regarded with much caution, notwithstanding the recommendation that the product "is only half as dear as hitherto."

#### 4.—Manufacture of Alcohol from Peat

For this purpose the peat is heated under pressure with dilute sulphuric acid, the vegetable fibres or cellulose of the peat being converted into fermentable sugar. The acid solution is neutralized, filtered, mixed with yeast, and the spirit is distilled from the fermented liquid. The yield of alcohol is about 6 l. per 100 kilos of dry peat. In Denmark and Sweden exhaustive experiments have been recently made with the patented process of Reymud, which resulted, however, in confirming the earlier conclusion that the spirit made from peat is much too dear in comparison with that made from ordinary materials. The cost of producing 1 l. of alcohol from peat was 25 to 35 öre. Peat alcohol cannot, therefore, compete commercially with the other substances employed for generating power, light, or heat.

#### 5.—Peat for Mud Baths

Peat is used to a limited extent for mud baths, but only under certain conditions and when it has a particular composition. Only a few bogs are suitable for this purpose, and this use of peat cannot be regarded as a general commercial one.<sup>1</sup>

---

<sup>1</sup> For further particulars see "Moor und Moorbäder," by Dr. Helenkampff, Bad Elster, Leipzig, 1903.

## SECTION VIII

# THE AGRICULTURAL UTILIZATION OF PEAT AND OF BOGS

A detailed description of the agricultural utilization of bogs and peat would extend beyond the limits of this book.<sup>1</sup> The agricultural utilization of peat or of bogs will therefore be considered only briefly. It will sometimes supplement the industrial utilization, but in most cases will immediately follow the latter process, and take the form of reclaiming the bog cut away, if the simultaneous tillage of the portion of the bog not immediately required for industrial purposes does not commend itself.

### (a) *The Use of Raw Peat as a Manure*

It is well known that a sandy ground is not directly utilizable in agriculture, since it affords neither a firm hold for the roots of the plants, owing to its loose texture, nor nutritive material for them. If, however, peat be mixed with the sand, then, as may be seen from the composition of various peats given in the tables on pp. 11 and 13, under certain circumstances a soil results which is well adapted for growing certain plants.

Conversely, many a peaty soil is not directly suitable for agricultural utilization; it requires to be improved by admixture with sand. Details with regard to this are given in subsections (c) and (d).

Peat ashes as manure for meadows may be considered wherever, owing to lack of trade and a market, the utilization of large peat deposits by other methods is not possible.

### (b) *Moor Burning and the Moor-burning Industry*

Moor burning and the cultivation of buckwheat on the burnt moors associated with it has been known since about the middle of the seventeenth century, and was probably first carried out

---

<sup>1</sup> Further particulars with regard to this subject are to be found in the publications on the cultivation of bogs mentioned on pp. xxii and xxiii. Valuable summaries are also given in the reports of Professor Tacke, Dr. Fleischer, Beseler, the President of the Hove, Dr. Buhlert, Baron von Wangenheim, Dr. Ramm, Privy Councillor, and others, on the cultivation of bogs and moors in Prussia, Bavaria, Oldenburg, Emsland, &c., in the *Mitteilungen* 1911, p. 165 *et seq.*; also by E. Stumpfein "Die Beseidlung der deutschen Moore," Leipzig, 1903; in "Die deutschen Moore und ihre Bedeutung für die deutsche Volkswirtschaft," Ministry of Agriculture, Berlin, 1911; in M. Fleischer's "Die Anlage und Bewirtschaftung von Moorwiesen und Moorweiden," Berlin, 1912; in the article on the cultivation of bogs in Prussia by the Minister for Agriculture (No. 56 of the publications of the House of Deputies, 1912-13).

in the Wildervank fen colony, which was founded in 1647. Its object and advantage consist of the temporary removal of those injurious properties of peaty soil which prejudicially affect the cultivation of agricultural products on bogs, and of making fertile, in an easy manner and for several years the otherwise sterile soil of high bogs. As is well known, peaty soil, owing to its excessive content of humus and the acid substances contained in this, is almost barren. Owing to the humus in the soil the latter is spongy from above downwards, absorbs and retains water, and is very cold. Vegetable growth on it is hampered by lack of plant food. Wherever the fire attacks the soil the humus is destroyed and an ash is produced, which, when incorporated in the peat, improves the latter both in its external characteristics and in its composition and alters the food ratio in favour of plant growth. The power of retaining water is decreased; the air enters more freely; the soil becomes more easily warmed; and the insoluble earthy foodstuffs partially dissolve and accumulate larger amounts, especially after the burning of the humus.

The total area of bog burnt for the cultivation of buckwheat in North Germany and the Netherlands amounted from 90,000 to 100,000 German acres (2,500 ha.), of which about 30,000 to 40,000 German acres were in the Ems bogs of Prussia, 6,000 in Oldenburg, and 45,000 to 50,000 in Holland. As a surface, after being burnt two or three times, must be left fallow for thirty years, about 900,000 German acres, or 45 square miles (German) (20,000 ha.), were required for the purpose.

Moor burning is also the chief cause of the atmospheric phenomenon known as dust-haze, and when we consider the figures given above with regard to the extent of the industry (often termed a pirate industry) no further proof of this is required.

The land intended for burning, if it is to be sown in the spring, is divided in the autumn into beds, 4 to 5 m. in width, which are separated from one another by parallel drains, 0·6 to 1·0 m. in depth and breadth. The surfaces are then re-dug or re-hoed, and left during the winter for the freezing and drying of the soil, for which purpose it is essential that the layer should be as loose as possible. In spring the drains are cleared so that the water may flow away, and the beds are again hoed. More or less large pieces of peat are placed in rows two paces apart along the beds, where they dry quickly. The bog is then left until the middle of May, when night frosts are no longer to be feared and when, in fine weather, the burning can commence. For this purpose, when the dew has evaporated, the heaps on the windward side, which contain the driest peat, are set on fire. When half the peat contained in these has burnt, the ignited pieces of peat are scattered on each side over the surface, and in this way the latter ignites and the whole surface becomes burnt. While the ashes are still warm the buckwheat is sown and quite lightly harrowed. The tillage is distributed between May and June; if in any year the weather in June is bad, the surface is not sown in that year.

The burnt ground can be re-burnt and sown for only three to five successive years, since after frequent hoeing and burning of the surface of the bog a hard coating is formed which cannot be made loose and will not burn, the soil, moreover, becoming impoverished, especially in respect to potash. The exhausted soil must be left fallow for thirty to forty years, so that the surface necessary for the burning may again form.

The buckwheat crop on bogs is very variable and on an average amounts to 8 to 10 bushels an acre (German), that is, 16 to 20 times the quantity of seed sown; the minimum crop may be taken as 3 to 4, the maximum is 15 to 20 bushels an acre.<sup>1</sup>

The disadvantages which moor burning, in its agricultural and social aspects, inflicts on the population of the districts where it is practised and the dangers to the public welfare caused by the burning have, apart from the offensiveness and the generally admitted injuriousness of the moor smoke or dust-haze, in recent times obliged the Government and its deputies in the country to oppose this method of cultivation, to check its growth by opening up other lines, to limit it, and, where possible, to get rid of it altogether. For attaining this object one way, which is not to be underestimated and is perhaps the best of all, is the industrial utilization of the peat bogs for winning peat fuel and moss litter, and, for the facilitation of this as well as for the drainage of the bogs and the creation of a market and transport route, the construction of canals and waterways at the expense of the State. Moor burning is therefore no longer practised to a noteworthy extent.

### (c) *The Dutch Moor, Fen, or Fehn Industry*

The fen industry, which originated in Holland in the sixteenth century and which has since then systematically embraced all the Dutch bogs, presupposes the cutting away of the bogs.

It was very necessary in Holland, which is poor in wood and coal, to win peat as a fuel, and this also was the primary reason for the utilization of the bogs in that country. Regular, systematic drainage was a necessary preliminary for the winning of the peat and the subsequent agricultural utilization of the cutaway surfaces (fehns). A catchment drainage, i.e., a main outlet or main canals, had to be formed, into which the drains (Grippen) would lead and which would at the same time serve as waterways. As such catchment drains the Ems-Vechte, the North and South, the Harm-Rueten, and the Rhine-Ems canals have been constructed. Side canals or catchment drains (Hoofdwieken), which are also navigable, discharge at right angles into these main canals, and into these in turn still smaller drains (Inwieken) discharge. The former are 1,500 to 2,000 m. and the latter 200 to 250 m. apart. The bog surfaces, bounded by the canals, drains, and roads lying between them, have areas of about

<sup>1</sup> The prize essay, "Uber das Moorbrennen," by Dr. Birnbaum, Glogau, 1872, contains further particulars about this matter.

10 ha. and form the divisions of colonies, which in each case after the cutting away of the peat and its reclamation form a holding capable of being tilled by the family of a small peasant without outside help and at the same time large enough for their support. When a given area has been cut away the strippings, that is, the light, fibrous upper layer of peat, which had been first cut and which is useless as a fuel, is again spread on the sandy subsoil of the bog, the ground is manured with sand (from the subsoil), mud and town refuse (brought as return cargo by the peat boats), and is then worked, sown, and planted in the usual way. It thus happens that in Holland, and to some extent in East Frisia and Oldenberg, populous districts, prosperous and fertile, have arisen where desolate wastes formerly existed. For the attainment of this result, however, in the case of such bog areas as those of Holland, hundreds of years have been necessary.

(d) *The Rimpau Ridge Industry and other Methods of Cultivating Bogs*

H. T. Rimpau, dissatisfied with the results of the moor-burning industry and intent on the better utilization of his bogs, successfully devised, as the result of his endeavours, the ridge industry, or the so-called "ridge calculation" method. He did this on his Cunrau estate, which lies north of Drömling (a bog of 180,000 German acres, situated in Saxony, Brunswick, and Hanover), containing about 6,650 acres (German) of good land and about 2,000 acres (German) of grass.

The essence of this method is that a layer of sand, which can be taken from the subsoil of the bog by means of trenches, is spread to a height of 10 cm. quite level and uniform over the bog and this sand layer, in spite of its non-fertilizing character, is employed for the growth of plants.

In carrying out the process, beds (ridges) 20 to 25 m. in width are made by cutting parallel trenches in the bog. The trenches are 5 m. wide at the top and 3.5 to 4 m. at the bottom, and are so deep that a layer of sand, 10 to 12 cm. in height, for the beds, can be taken from the sand under the bog, and the water-level be lowered by at least 1.0 to 1.3 m. The peat won in making the trenches is thrown on the beds on each side, where it is spread out, the level of these being thus raised by 15 to 20 cm. This peat is then covered with a similarly thick layer of sand, so that, in fact, "ridges" in the proper sense of the word, and from which the name "ridge industry" comes, are formed.

The trenches between the ridges conduct the water which collects in them into a main drain which lies at right angles to them, but they do not open into it, a rampart of 7.5 to 9.5 m. being left between them and the main drain. The water from the side-drains is led into the main drain through wide earthenware pipes under the rampart. This arrangement is necessary in order that access from one ridge to the next, during tillage and harvesting, may not be impeded.

The object of the trenches is to provide the excavated material necessary to increase the height of the soil surface, to make the land dry better, and then, when necessary in dry weather, to irrigate the soil by damming the water. The layer of sand spread on the surface of the ridge makes this suitable for the growth of plants. The layer is moist enough for the roots to develop and compact enough for them to become firmly fixed in it. It moreover exerts a pressure on the underlying peat, in consequence of which the latter becomes denser and retains its moisture, so that the roots penetrating into it can obtain a good grip of and draw their food from the peat.

When suitable sand is not present in the subsoil or when too much of the useful surface of the bog would be lost in raising the required amount of sand, the layer of the latter may be obtained from other places in the neighbourhood. Preliminary experiments have also been made with the object of introducing a system of closed pipes instead of the open trenches.

After investigations extending over a long period, the following conclusions have been reached with regard to the rotation and the manuring of the crops.

Just as the preparation of the bog ridges is exceedingly easy and simple, so also are the rotation and the selection of fertilizers for them. At Cunrau, attempts were at first made to grow most of the cultivated plants with suitable artificial and farmyard manure, and finally those crops were selected which gave the surest return and at the same time fodder and litter for the cattle in largest amount. All the crops which gave uncertain returns or together with the direct gain from them too small an amount of fodder or litter, or required too much labour for their cultivation, were gradually excluded, e.g., crops of poppies, yellow mustard, caraways, and beans, which are otherwise very remunerative. In manuring, the rule holds that when the first crop is drilled oats, plenty of potash and soluble phosphates should be applied, about one and a half times the amount removed by a good crop, i.e., 20 kilos of pure potash and 15 kilos of soluble phosphoric acid per acre (German), or 80 and 60 kilos per hectare.

Addition of nitrogen in the form of artificial manure is nowadays quite out of the question, since abundant manuring with potash and phosphates and the vigorous plant growth produce an amount of ammonia and nitrates from the undissolved nitrogen of the Drömling bog more than sufficient for the rankest growth of the plants, which, as a matter of fact, in good harvests has the disadvantage of making the corn lodge. Drömling bog contains an abundance of all the plant foods except potash and phosphates; the latter can, however, without hesitation be given in the above-mentioned large quantities if good crops are to be always obtained until the plants grow too vigorously, when it is advisable to give only so much of it as, according to Wolff's tables, the last crop will have removed. As it is well known that peat has a very strong absorptive power for potash and phosphates, there is no danger that any excess of these applied will pass to the

subsoil and be removed with the drainage water. A few inches of peat are sufficient to absorb the above fertilizers, even when these are very heavily applied, and to retain them in an easily soluble form for the succeeding crops.

Farmyard manure is applied only for certain crops and only to a small extent, 3 to 5 m. tons per acre (German), i.e., 12,000 to 20,000 kilos per hectare. Generally some potash and phosphates, about half the above quantities, are applied at the same time. The crops raised consist of peas, vetches, potatoes, beet, rape, oats, and clover.

Generally the first crop was oats, the second peas or vetches, the third rape, followed by rape or winter barley, oats, or potatoes. The latter crops preceded peas or summer corn, and, together with rape, occurred the most frequently in the rotation.

At Cunrau, later on, 50 per cent. of the surface of the bog was laid out in grain crops, 46 per cent. in root crops, and only 4 per cent. with grass or hay, the chief rotation being root crops, grain.

As necessary conditions for the successful prosecution of the ridge industry we have :—

- (1) A bog depth between 0·4 m. and 1·5 m.
- (2) Certainty of drainage to a depth of 1·0 m.
- (3) A subsoil suitable for covering the bog (a sandy bottom, loamy sand or sandy loam).

As a rule, a moor is, moreover, all the better suited for the ridge industry the denser, firmer and the more decomposed the peat. A loose, spongy, moss peat (the upper surface of high bogs) is scarcely, or not at all, adapted for this system, for which meadow or grass bogs alone are suited.

The basis of the fertilizer used every year at Cunrau for all the crops was 250 kilos of kainit and 50 kilos of Thomas phosphate per acre (German), or  $\frac{1}{4}$  ha. The potatoes received 100 kilos less kainit in order that the starch formation should not be decreased too much. The yield of potatoes per acre (German) in 1900 was 7,900 kilos.

According to the Bog Experimental Station at Münster, the amount of manure, which is best spread in the autumn, varies per hectare from 200 to 600 kilos of kainit and 100 to 300 kilos of Thomas phosphate according to the amount of potash and phosphates contained in the bog.

A large number of ridge fields were laid out according to this method in different years in districts of various types, and the good returns have fully established the value and the appropriateness of the ridge industry.<sup>1</sup>

According to an experience extending over more than ten years,

<sup>1</sup> Details with regard to these are contained in "Die moderne Moorkultur," by W. Peters, Osnabruck, 1874, and in the *Zeitschrift für Kultur des Moor- und Heidebodens*, by W. Peters, Osnabruck, and in von Massenbach's "Praktische Anleitung zur Rimpauschen Moordammkultur," 2nd edition, Berlin, Paul Parey, 1904, in "Der forst- und landwirtschaftliche Anbau der Hochmoore," by K. Brünings, Berlin, Springer, 1881, and in the *Mitteilungen*, 1901, especially p. 61, &c.



the net gain at Cunrau averaged 36M. per acre (German), or 142M. per hectare. The conditions were, however, specially favourable there, but nevertheless in all cases good net profits should be expected, since the gross profit is generally not less than that from good heavy soil or reclaimed and marshy ground, while the working costs of the peat ridge fields are very much less than those of the heavier soil.

The initial costs are redeemed, as a rule, by the crops of the first two years, certainly a favourable result.

The costs of the tillage, in wages, artificial manures, drilling, harrowing, rolling, seed corn, mowing, drawing to the barns, threshing and sifting, marketing, and interest were 412M. at Cunrau, 320M. at Zion, and 480M. at Münster per hectare, while the produce (per German acre) amounted to:—

	Marks.
27 bushels of oats at 3·70M. .. .. .	= 99·90
900 kilos of straw .. .. .	= 27·00
	126·90

According to this, there was a gain of 6·40M. per acre (German) even in the first year after deducting all the initial costs.

Under other and less favourable conditions, the initial costs may be assumed to be even double those at Cunrau without endangering the profit of the undertaking.

The average returns per acre (German) for various crops suitably manured are given as follows:—

Oats .. .. .	27-30 bushels.
Victoria pea .. .. .	13 "
Rye .. .. .	16-22 "
Wheat .. .. .	16-19 "
Potatoes .. .. .	100-110 "
Barley .. .. .	18-20 "
Beet (fodder) .. .. .	15,000-20,000 kilos.
Clover .. .. .	750 kilos (first crop).

In recent years, owing to improvements in the ridge cultivation method, the returns from some of the crops at Cunrau have been greatly increased.

At Drömling, near Cunrau, labourers prepare the ridges for the farmers in return for one or two years' use of these ridges.

Ridge cultivation can also be employed in most cases for the reclamation of cut-out high bogs, so that these extensive areas, after their use for industrial purposes, can be handed over to agriculture, which by suitable treatment will again be able to utilize them.

Great extensions of the ridge cultivation industry and elaborate experiments on various details of the process, manures, rotations of crops, &c., have recently been made in many places, especially at Cunrau itself. The results have shown that what was found suitable for Cunrau Bog could not, without trouble, be applied to other bogs. The depths of draining, ploughing, and covering, the nature of the fertilizers, and the crops selected, with their rotation, must be varied with the nature of the bog and that of the

covering material at hand if good harvests are to be won every year. Further discussion of these results would, however, exceed the limits of this book. Details with regard to them are contained in the writings mentioned above, in which they can be consulted.<sup>1</sup>

The ridge cultivation method cannot, however, be employed under all circumstances. If ridge fields are to work well and give continuous satisfaction, the depth of the completely decomposed and mouldy layer must be at least 30 cm. in the case of shallow bogs (1½ m. deep) and at least 40 cm. in that of deep bogs. Good drainage and side aeration of the upper layer of the bog by means of deep tillage, deepening and loosening of the bottoms of the furrows, careful disintegration of the material thrown up from the trenches and the furrows, &c., are important conditions which should be observed.

(e) *Reclamation of Low Bogs for Meadows, &c.*

Large bogs in the State forests, which have resisted attempts at afforestation made regardless of expense, have been converted into excellent meadows by a suitable treatment partly with and partly without the use of sand.

In most cases drainage to a depth of 50 cm. suffices for those grass and low bogs which are to be used as meadows, and this necessitates the lowering of the water-level in the main drains to a depth of 0·8 to 1·0 m. A covering of coarse sand or earthy soil, loam, marl, limestone, or mud to a depth of 10 to 12 cm., is to be recommended.

A germinating bed better than that formed by harrowing can be obtained in the case of "uncovered" surfaces more cheaply by ploughing. Closet or farmyard manure is used as a fertilizer. For "covered" surfaces an artificial manure can be used, and, as a matter of fact, 400 kilos of Thomas phosphate and 800 kilos of kainit can be distributed over each hectare in the autumn. In following years the Thomas phosphate can be cut down to 200 kilos, and in the case of bogs rich in iron and phosphates it may even be omitted altogether. Special seed mixtures are to be recommended.<sup>2</sup>

(f) *Reclamation of High Bogs*<sup>3</sup>

The methods mentioned above, which have proved efficient for the reclamation of "low" and "transition" bogs, are not applicable to high bogs on account of their different nature. The amount of plant food in the high bogs being small (on an average there is 1·2 per cent. of nitrogen, 0·35 per cent. of lime, and 0·10

---

<sup>1</sup> A balance sheet for a ridge cultivation farm, 108 ha. in area, at Lobeofund, for 1900, is given in the *Mitteilungen*, 1901, p. 124.

<sup>2</sup> *Mitteilungen*, 1901, p. 258.

<sup>3</sup> "On the Utilization of Prisoners of War for the Reclamation of Bogs." See report on the 33rd, 34th and 35th meetings of the Verein zur Förderung der Moorkultur in the *Mitteilungen*, 1915, 1916 and 1917.

per cent. of phosphoric acid in the peat), a greater amount of manure is required, and, moreover, the sand necessary for the "ridge process" is not, as a rule, available. For these reasons extensive agricultural industries on high bogs were rare up to the beginning of this century. The chief object aimed at was the conversion of the coarse soil into a finer one by repeated ploughing, harrowing, and rolling, and the preparation of it in this way for growing plants. An important factor in this case is the correct amounts of farmyard and artificial manure to be added. The Experimental Bog Station at Bremen owns at Meybusch a large high bog experimental field of over 100 acres (German), i.e., 25 ha.

The Experimental Agricultural Station at Münster was the first to discover a method of cultivating high bog<sup>1</sup> by which it is possible to render high bog fertile without removing the peat, burning, or sanding the surface. The method consists in dividing the bog, when the water-level is high, into banks 8 to 10 m. in breadth by means of small drains similar to the "ridge cultivation method" at Rimpau. The drains are 50 to 60 cm. in depth, 50 to 60 cm. wide at the top, and 30 to 40 cm. at the bottom. After laying out the drains, the levelling and the working of the humic layer of heather and the loosening of the "soil" to a depth of 15 cm. are commenced in the spring. From the end of May to the beginning of June the ground is limed with 4,000 kilos of slaked lime for each hectare, and the lime harrowed in. After harrowing two or three times, from the beginning of July to the beginning of August, the soil is manured at the end of August or the beginning of September with 1,200 to 1,500 kilos of kainit and 600 to 800 kilos of Thomas phosphate meal. At the end of September or the beginning of October the cultivation of winter grain can be commenced, or the surface may be left fallow until the following spring. Unlike low bogs, high bogs require, in addition to the above-mentioned manures, treatment with nitrogenous manures. For summer crops Chili saltpetre and for winter crops ammonium sulphate are employed; 200 to 400 kilos of Chili saltpetre or 150 to 300 kilos of ammonium sulphate are applied to each hectare. The amount of manure applied can be decreased later on.

The costs for 1 ha. are given as follows:—

(1) For levelling, opening drains, dividing into banks, &c., 90–100M.

(2) For lime and artificial manures in the earlier years, 120–130M.

(3) For lime and artificial manures in the latter years, 80–90M.

As a set-off against this expenditure the produce in the earlier years realizes from 280M. to 400M. per hectare. The crops harvested, for instance, are for each acre (German), i.e.,  $\frac{1}{4}$  ha., as follows: Potatoes, 4,250 to 6,000 kilos; rye, 450 to 550 kilos; oats, 350 to 450 kilos; peas and beans, 250 to 500 kilos; and hay, 1,250 to 2,000 kilos.

This method has been further improved and has also been

<sup>1</sup> *Mitteilungen*, 1901, p. 273.

employed for many years with success on a large scale. By its means the vast amount of waste land in our German high bogs has been made available for agricultural use, securing the nation's foodstuffs by means of home-grown products.<sup>1</sup> Mechanical or motor ploughs (such as those constructed by J. Kemna, of Breslau, the Lößnitz Iron Co., of Stettin, Eberhardt Bros., of Ulm, on the Danube, amongst others) have become very important and are much employed in the agricultural utilization of large bogs.

---

<sup>1</sup> Compare reports on the cultivation of the Wiesmoor, p. 440.

## SECTION IX

# PATENTS<sup>1</sup> RELATING TO THE UTILIZATION OF PEAT<sup>2</sup>

### Extracts from the German Letters Patent

(The numbers prefixed are those of the various Letters Patent.)<sup>3</sup>

#### 1.—Peat Furnaces

- P. 287837, May 8th, 1913, *Charles Hjalmer William von Porat*, of Stocksund, Sweden :—A peat powder furnace for locomotives, in which the supply of the fuel is regulated by the starting contrivance for the admission of steam to the cylinder of the engine and the auxiliary steam blower in such a way that the peat powder is not let in until the draught in the fire-box and the fuel supply tube is of the required strength; the supply of the powder ceases when, or before, the draught falls off. Details of the furnace are given.

#### 2.—Peat Carbonization, Carbonizing Ovens, and Carbonizing Presses

- P. 14923, December 14th, 1880, *Schott*, of Kreiensen :—Preparation of peat charcoal for the purification of liquids from coloured and other foreign admixtures, as well as for the purification of air in closed rooms.
- P. 16961, June 5th, 1881, *Count zur Lippe*, of Villa Friedegg (Austria) :—A peat-carbonizing oven, containing a boiler furnace, in conjunction with a boiler and a super-heater, with steam nozzle and iron charging cars, the boxes of which consist of a lattice-work, thus allowing the steam to act on their contents from all sides.
- P. 28512, August 29th, 1883, *Angerstein*, of Schalke :—A peat-carbonizing oven, consisting of a number of vertical muffles which are heated by the carbonization gases from auxiliary muffles. They have cooling chambers under them and pipes to supply the air required for the combustion.
- P. 53617, January 5th, 1890, *Ekelund*, of Jönköping :—A peat-carbonizing oven with three chambers lying over one another, the middle one of which can be filled from the upper and

---

<sup>1</sup> See the footnote on p. 287.

<sup>2</sup> See the corresponding section at the end of Part I, on "The Winning of Peat."

<sup>3</sup> The Letters Patent may be procured from the Imperial Patent Office at Berlin at a cost of 1M. each.

- emptied into the lower one, while the hot air, introduced into a side chamber, can pass through the middle chamber and then, together with the gas evolved, pass, either direct or through a condenser, into the upper chamber.
- P. 56492, September 12th, 1890, *Burgdorf Bros.*, of Altona :—  
A peat-carbonizing oven with several gas combustion chambers, lying over one another, from which the hot gases enter the adjacent layers of peat and then escape with the steam from the zone at the top of the oven.
- P. 59237, October 19th, 1890, *Challeton*, of Montauger :—A contrivance for purifying and carbonizing peat for the manufacture of a fuel similar to coke. It consists of a steam vat, from which the steamed peat is led to a roller and then passes to a mixing vat provided with a stirrer. After removal from the vat it is dried and then brought into closed muffles, which are moved on rails through a gas-fired carbonizing oven, divided into two compartments. The finished product is exposed to a steam blast, with which alkali is sprayed in order to fix any sulphurous acid still present, the charcoal being in this way freed from any bad odour it may have.
- P. 59455, December 5th, 1890, *Soetje and Kahl*, of Hamburg :—  
A drying oven in which the peat to be dried and carbonized is brought in thin layers between open-work walls, so that the drying surfaces may be large, and the peat allowed to sink slowly between these walls. The portion of the oven which is not occupied by the peat contains heating pipes. Suitable exits for the water, formed during the drying, are arranged in the oven.
- P. 63407, December 24th, 1891, *Ekelund*, of Jönköping :—  
A contrivance for carbonizing ovens by means of which the hot combustion gases may be led upwards through the peat from the fireplaces.
- P. 63409, of January 1st, 1892, *Angel*, of Jönköping :—Formed peat is to be first heated in tightly closed vessels with the object of carbonizing it and is then allowed to cool in such a way that the volatiles developed, instead of being let out, are retained as far as possible in the vessels so that they condense to tarry products during the cooling, which, owing to their very intimate contact with the particles of peat charcoal, are absorbed by the latter, binding these together so that the product, without any further addition of cements, forms a compact mass.
- P. 70010, October 1st, 1892, *Dr. Steimer*, of Berg, and *Ziegler*, of Nachterstedt :—A peat charcoal igniter, made by saturating peat charcoal with saltpetre.
- P. 78312, November 1st, 1892, *Liander*, of Petrograd, and *Haig*, of Paisley :—A step plate oven in which uniformity in charging the oven is attained by means of several scrapers placed under the cover, the fixed and rotating discs.
- P. 85837, October 18th, 1895, *Schöning*, of Stamsund :—  
Carbonization of peat by pressing the peat between plates

or rollers which are heated so highly that carbonization takes place.

- P. 88947, April 10th, 1896, *Jebson*, of Dale (Norway):—Carbonization of peat by means of electrical heaters, which are fixed inside the vessel containing the peat.
- P. 98007, April 18th, 1897, *Vilen*, of Gothenburg:—A peat-carbonizing oven, in which flap valves, differing in weight and separated by partitions, are so connected inside the muffle to the gas exit leading to the fireplace, that the lifting of the lighter valve connects the interior of the muffle with a tube, which can be closed by a stopcock, so that the gases can be led from the muffle outside its fireplace, into the gas-duct leading to the fireplace of another muffle, while the heavier flap valve regulates the connexion of the muffle with a gas-duct leading to its own fireplace.
- P. 100414, April 3rd, 1897, *von Heidenstam*, of Skönvik (Sweden)—Peat carbonization in which the raw peat, led or pressed into tubes or channels, is heated gradually during the pressing, the evolved gases being at the same time removed. The product emerges as a continuous, firm band of charcoal, retaining this consistency even when it has left the tube.
- P. 101482, June 27th, 1897, *Ziegler*, of Berlin:—A peat-carbonizing oven, with winning and utilization of the gaseous and liquid by-products. It consists of two adjacent shaft-muffles, the lower halves of which are made of fire-brick and the upper of cast-iron, with fire channels between their opposing walls. They are built on a common, boiler-like, cast-iron foundation, surrounded by air-ducts. These air-ducts are arranged in the cast-iron middle and lower portions so that as the burnt peat charcoal contained in the lower portion cools the air required for the combustion becomes heated.
- P. 103507, June 27th, 1897, *Ziegler*, of Berlin:—A peat-carbonizing oven, with recovery of the by-products (see No. 101,482), in which the hot gases escaping from the muffles are led through channels, lying side by side, which are used in turn, and to each of which a super-heater or boiler and a chamber for kiln-drying the peat are connected.
- P. 103922, March 15th, 1898, *von Heidenstam*, of Stockholm:—An appliance for manufacturing firm pieces of charcoal from formed peat under pressure, in which the pressure can be adjusted as required, so that it always acts with the same force on the substance to be carbonized, thus forming pieces of charcoal of the desired strength and firmness.
- P. 106960, January 21st, 1899, *Osann*, of the Concordia Iron Works, near Bendorf-on-Rhine:—A muffle oven with a draught reverser for peat carbonization, in which two furnaces facing one another let the fire gases into the left and right fireplaces alternately.
- P. 114551, February 3rd, 1900, *von Heidenstam*, of Skönvik (Sweden):—Peat carbonization with a piston in the carbonizing muffle, the pressure of which can be adjusted. The

- substance to be carbonized is filled into the muffle in layers, separated by plates, so that it does not touch the sides of the muffle, and jamming is thus prevented. (See No. 100414.)
- P. 132961, July 4th, 1900, *Holm*, of Aalborg :—A multi-chamber peat-carbonizing oven with a mixing and distributing chamber in the centre, in which gases produced outside the oven are mixed with cold gases and from which the mixed gases are led to the carbonizing compartments, where carbonization is effected at a temperature neither too high for nor injurious to the process.
- P. 133832, March 3rd, 1901, *Hartmann*, of Munich :—The defects alleged to exist in the process for carbonizing press peat, or in the heating of air-dry peat to redness in the absence of air, are to be overcome by increasing the calorific power of disintegrated peat by heating it slowly to about 220° C. in open vessels in the presence of air. The less volatile, tarry substances, which have a high calorific power, are to remain in the roasted and carbonized product. The peat powder thus roasted is to be pressed in moulds in the ordinary way.
- P. 141807, August 12th, 1901, *Laurenus*, of Göteborg :—The fuel gases developed in the carbonization of peat, issuing from a burner fixed in the bottom of the muffle, are to be used for heating the muffle, and by lowering the rotating grate the flame from the burner of the muffle is to be led through a duct connecting the ash-pit with the chimney, so that the hot gases, when the carbonization is finished, may be allowed to escape directly into the chimney.
- P. 142251, August 28th, 1901, *Laurenus*, of Göteborg :—A gas-burner for peat-carbonizing ovens, in which the gaseous products are led into the fire for heating the muffle through an inlet in the lower part of the latter, so arranged that the bottom of the muffle is provided with cup-shaped depressions at the inlet for the gaseous products into which the cover of the inlet is so fitted by means of ribs that a zigzag passage is formed through which the gaseous products pass into the fire. The spaces between the depressions and the ribs are filled with asbestos. In this way the temperature of the fuel gases passing through the intervening spaces is raised.
- P. 144149, September 27th, 1901, *Ziegler*, of Schöneberg, near Berlin :—A vertical muffle oven in which partitions are fixed in the upper portion of the oval muffles. These contract, step by step, towards the bottom, so that lattice-like openings are formed and the fuel chamber increases in width towards the base.
- P. 149959, July 8th, 1900, *Fritz*, of London :—Carbonization in the absence of air in such a way that the peat still retains the tarry substances evolved above 400° C. and is sent to the press in this condition. The mass is pressed and aerated alternately so as to remove the gases and vapours still contained in it.
- P. 151136, April 30th, 1901, *Banme*, of Leer :—A peat-carbonizing oven with an inclined sole fired from below upwards, and with



- a nose which presses back the unfinished pieces of charcoal, the object of the oven being to make the carbonization uniform.
- P. 157338, June 10th, 1902, *von Gröling*, of Vienna :—A peat-carbonizing press, consisting of two endless chains of plates in which only the returning portions of the chains are directly heated so as to spare the tracks and the rollers of the chains, and the members of the chains of the press tracks, which are provided with ventilating grooves, are intermittently raised and lowered so that at every discharge of the peat exits are left free.
- P. 157691, January 14th, 1905, *Marcotty*, of Schöneberg, near Berlin, and *Karlson*, of Copenhagen :—A contrivance for holding forming boxes in peat-carbonizing presses provided with conveyers.
- P. 159415, August 22nd, 1902, *the same* :—A carbonizing press with heated press plates arranged in the hearth of a furnace.
- P. 158032, June 27th, 1903, *Dr. Hoering*, of Berlin, and *Dr. Mjoen*, of Christiania :—Carbonization, in which the water vapour developed from the fresh fuel in the colder zone of the oven is led into the carbonizing zone and is drawn off along with the gaseous products.
- P. 163266, September 30th, 1903, *Sellnow*, of Berlin :—A vertical peat-carbonizing oven, with heating tubes inside it which have openings at their lower ends, through which the flue draught exerts a suction on the interior of the oven, drawing the gases and vapours through the layers of peat charcoal.
- P. 169924, December 20th, 1903, *Wiesner*, of Ötzsch-Gautzsch, near Leipzig :—A muffle oven for carbonizing peat, consisting of a number of vertical muffles separated by hot walls and arranged round a central axis, in which the intervening space is divided by means of horizontal floors into a number of groups of channels lying over one another.
- P. 172677, September 10th, 1905, *von Hatten*, of Lemitten, near Wormditt :—A shaft oven in which the gases are led into the fire. To make the gas pass more easily, steam, which is produced by the heat of the carbonizing chamber and is super-heated in a tube, is led into the gas outlet and inlet tubes.
- P. 173237, January 20th, 1905, *Müller*, of Sundbyberg, Sweden :—A chamber oven in which each compartment contains one or more shafts (open above and below) for receiving the substance to be carbonized, the walls of which are formed of hot bodies superimposed on one another.
- P. 175786, May 21st, 1905, *The Upper Bavarian Cokeworks and Chemical Products Co.*, of Beuerberg :—Peat carbonization in a shaft oven, consisting of an upper and a lower portion, in which alternately hot gases are led through the peat, at about 250° C. when it is in the upper, and at 350° C. when it has reached the lower portion. The hot gases and vapours are led off separately.
- P. 176364, June 15th, 1905, supplementary to No. 158032, *Peat Charcoal Co., Ltd.*, of Berlin :—Carbonization according to

- No. 158032, in which only part of the water vapour developed in the colder zone of the oven is led, either directly or after super-heating, through the carbonizing zone itself or through a neighbouring oven, from which it is drawn off together with the gaseous products.
- P. 176365, January 15th, 1905, supplementary to No. 158032, *Peat Charcoal Co., Ltd.*, of Berlin :—Carbonization according to No. 158032, in which the water vapour developed in the colder zone of the oven is introduced into the carbonizing zone at the centre of its cross-section, and is withdrawn from the zone together with the gaseous products at the circumference of the oven chamber.
- P. 186935, May 1st, 1906, *The Upper Bavarian Cokeworks and Chemical Products Co.*, of Beuerberg :—A vertical carbonizing muffle with a cellular gas shaft inside it and with a star-shaped cross-section for the muffle and gas-clearing shaft.
- P. 196603, December 14th, 1905, *Kittler*, of Memel :—A process for manufacturing gas from press peat in muffles with recovery of the by-products. The muffles are charged from a feeding chamber by means of movable slides ; the gas and air which penetrate into the feeding chamber when one slide is opened are drawn out by a pump before the other slide of the feeding chamber is opened in its turn.
- P. 196935, October 21st, 1906, *The Upper Bavarian Cokeworks and Chemical Products, Ltd.*, of Beuerberg :—A muffle carbonizing oven in which the part of the muffles intended for the body to be carbonized is divided by a contraction in the centre into two partially separated shafts.
- P. 204399, February 2nd, 1908, *Lorenz*, of Berlin :—A distilling oven with distilling cylinders pushed into one another and heated externally, and with funnel-shaped bells having a special arrangement for leading away the distillation gases.
- P. 210342, August 26th, 1906, *Müller*, of Gothenburg, Sweden :—A carbonizing plant with several oven chambers, in which several carbonizing shafts are combined in sections and are connected at their lower ends by collecting tubes, of which there is one for each section.
- P. 229606, October 16th, 1909, *Wolters*, of Weimar, Westphalia :—A peat distillation oven with a gas producer built into it so that both the producer and the distilling retort can be charged separately.
- P. 238254, September 30th, 1909, *von Mentzer*, of Regenhildsborg, Sweden :—A carbonizing press with an oscillating press plate, which has special air-duct inlets in addition to special heating channels.
- P. 245309, January 19th, 1909, *Wengler*, of Zwickau, Saxony :—A carbonizing shaft oven with gas-accelerating nozzles, in which the gas reservoir is placed underneath in the cooling chamber of the oven. The gas serves for the generation of steam for the glowing charcoal and for the concentration of the by-products.

- P. 245310, June 21st, 1910, *the same* :—A multi-compartment oven with a removable partition between the two parts of the oven, one of which is fixed behind the other.
- P. 247774, February 12th, 1911, *The Pluder Chemical Factory, Ltd.*, of Pluder, East Silesia :—A carbonizing oven with an inclined sole and a hood-shaped tongue fixed on this, which is made hollow for letting in the fuel gases, required to heat the oven chamber, through gas inlets on its sides.
- P. 253561, February 10th, 1911, *Société Anonyme Huilerie et Savonnerie de Lurian*, of Salon, France :—A carbonizing oven divided horizontally into two compartments, the upper of which serves for burning the gases evolved and the lower for the carbonization.
- P. 260095, October 25th, 1911, *Hart and Deschamps*, of Beulach, Austria :—A pile oven, in which openings, capable of being closed by slides, lie over one another in the sides of the walls and serve to introduce the air required for the combustion and to remove the gases evolved.
- P. 260800, May 25th, 1911, *Dr. Bergius*, of Hanover :—The winning of peat charcoal in the form of powder in the following way : The peat is heated above 300° C. with water under pressure until complete separation of the solid residue (charcoal in the form of powder) from the aqueous portion takes place in the closed vessel.
- P. 265041, August 31st, 1911, *Fritz*, of Bremen :—A pile oven with several chambers lying side by side and with openings in their side walls, which can be closed when required.
- P. 274780, February 11th, 1912, *Wet Carbonizing, Ltd.*, of London :—Heating of wet carbonized peat, whereby in a separate boiler furnace such a quantity of fuel is burnt that sufficient heat for a boiler and for the contrivance for the wet carbonization is produced, the combustion gases from the furnace being led into the carbonizing contrivance.
- P. 283535, January 21st, 1911, *Industrial Ovens Manufacturing Company, Poppe and Co.*, of Berlin :—Pressure carbonization of unformed moist peat by means of a combination of air-drying and storage in mounds.

### 3.—Peat Gasification and Peat Gasifiers

- P. 120051, May 10th, 1900, *Martin Ziegler*, of Schöneberg, near Berlin :—A gas producer for peat in which two or more flat grates, accessible from one side, are arranged in steps with a partition between every two grates. The grate can also be made in the form of a basket grate, as in No. 164438.
- P. 136884, August 10th, 1901, *Dr. Mond*, of London :—Production of gas from moist fuel, in which a part of the generated gas is again led through the glowing zone, in which, moreover, the gases before being led away pass through a chamber containing a chequered filling which is strongly heated so as to

- convert the volatile products into permanent gases, while avoiding loss of ammonia.
- P. 157729, January 22nd, 1904, *Deutz Gas Motor Factory*, of Cologne-Deutz:—A gas producer with an upper and lower fire, the gas exit being between the two. The gases are led away through a vertical grate which forms part of the side wall.
- P. 164571, December 15th, 1903, P. 176645, May 6th, 1904, P. 202375, September 26th, 1905, *Körting Bros. and Co.*, of Linden, near Hanover. A gas producer with air inlets at top and bottom and with an upper (second) grate which is inclined, but so slightly that the fuel cannot slip down into the shaft, and sliding of the fire under the upper zone where air is admitted is thus prevented.
- P. 169008, June 3rd, 1905, *Deutz Gas Motor Factory*, of Cologne-Deutz:—A gas producer with an upper and a lower fire. The power gas and the distillation gas are drawn off between the two fires, but the mouth of the pipe for the distillation gas is so far removed from that for the power gas that the layer of glowing fuel between them is sufficiently thick to bring about the combination of any oxygen entering the shaft, through a leak in the gas-duct, with carbon before it reaches the point where the gas is to be utilized.
- P. 169378, September 20th, 1905, *the same*:—A gas producer with an upper and lower fire, the gas being taken off between the two. The shaft of the gas producer is pierced at a suitable height by a trough (or pipe), open below, and the gas is withdrawn through the passage formed by the channel and the fuel sloping towards it. From the trough, however, one or more shafts, with stops, are led to the bottom layer of the fuel so that the fire can be stirred through these shafts.
- P. 176231, January 31st, 1905, *Dr. Hoering and Dr. Wielandt*, of Berlin:—Gasification of peat which has been previously carbonized, whereby the carbonized peat is cooled in the carbonizer, thus becoming loose before it is introduced into the gasifier.
- P. 176233, February 18th, 1905, *Stauber*, of Königsberg, Prussia, and *Buch*, of Berlin:—A producer for power gas from peat, in which the tarry constituents of the gas are partly separated by a water-seal and partly decomposed by heating. The gas exit tube, which is cooled by water, passes down outside the gasifier and then up through the middle of the latter.
- P. 177988, May 5th, 1905, *The Görlitz Machine Manufacturing and Iron Foundry Co.*, of Görlitz:—A grateless gas producer with a gas exit tube in the middle of the gasifier, an air pipe or water pipe being so arranged round the gas pipe that the air becomes heated and streams through a pipe into the fuel layer, or the water becomes evaporated by the escaping gases and the steam enters through several openings into the hottest zone of the gasifier.
- P. 198295, August 26th, 1905, *Dr. Caro*, of Berlin:—An application of the Mond gas process, wherein substances containing

- nitrogen and carbon are treated in a gasifier with a limited amount of air and excess of water, for the recovery of ammonia from the waste products.
- P. 206576, May 2nd, 1907, *Jabs*, of Zürich :—A gasifier in which the moist fuel is dried and deprived of its gas in a shaft which is pierced fanwise and lies outside the gasifier. It has also heating chambers, which are situated between the shaft and its wall.
- P. 209387, August 21st, 1908, *Julius Pintsch and Co.*, of Berlin :—A gas producer for moist fuel with a drying chamber heated by the evolved gases and a pumping contrivance in circuit with the duct for removing the water vapour.
- P. 213852, May 6th, 1908, *The Upper Bavarian Cokeworks Co.*, of Beuerberg, Upper Bavaria :—For gasifying peat with more than 45 per cent. of water, three gasifiers are arranged in series in such a way that one works at a high temperature, another acts regularly, and the third receives the fresh fuel, the water vapour evolved from the latter is led into the glowing layer of fuel in the hottest gasifier and there reacts with the glowing carbon, forming "water gas," while the tarry and ammoniacal vapours are collected separately.
- P. 238554, January 5th, 1908, and its supplementary Patent No. 243810, of July 16th, 1911, *Asmus Jabs*, of Zürich :—Before gasifying peat for gas engines the moisture is to be removed from the peat by direct contact with the waste gases of the engine in the following manner : The hot gases first meet the wettest portion of the peat at the mouth of the drier, passing through the latter in the same direction as the peat and leaving it, together with the water vapour, at the exit for the dried peat.
- P. 238829, December 18th, 1906, *Dr. Caro*, of Berlin :—Winning of ammonia from peat by gasifying peat in shaft gasifiers by means of a mixture of air and an excess of water vapour in such a manner that separation of the processes of distillation and formation of producer gas does not occur, and also that air and water vapour are present in every part of the gasifier.
- P. 255291, January 24th, 1909, *Dr. Caro*, of Berlin :—Gasification of peat for winning ammonia and power gas by addition of limited quantities of air and excess of water vapour (No. 238829) in such a way that by addition of the air-steam mixture, in a super-heated condition, or by increasing the size of the combustion zone in the gasifier a temperature of at least 250° C. is maintained in the dehydrating zone and, therefore, the decomposition of the peat and the formation of the ammonia occur in the same place and at the same time as the dehydration of the peat.
- P. 274011, December 13th, 1912, *Sachs*, of Carlsruhe :—In order to increase the yield of ammonia the gases of a producer are led through tubes from the interior of the fuel layer, where they are formed, the temperature of the tubes being kept, by means of condensers, so low that decomposition of the gases does not occur.

- P. 279550, September 20th, 1913, *Koppers*, of Essen :—In the Mond gas process in gas producers, with addition of a combustible gas as a diluent, in order to increase the yield of ammonia, the process is to be carried out at so high a temperature that the combustible gas (hydrogen, producer gas) burns continuously, and thus maintains the temperature of the decomposition zone.
- P. 282579, August 18th, 1911, *Klinner*, of Berlin-Carlshorst :—The gas formed in the gasifier is led through the fresh fuel, contained in the drier, by mean of one or more spiral tubes, set in the wall of the shaft, while the volatiles are driven out of the fuel in a separate lower chamber and burnt under the grate.

#### 4.—Peat as a Fibrous Material for Paper, Paste-board, Textiles, &c.

(For the winning of peat fibres, see the list of Patents on p. 307)

- P. 96540, October 20th, 1905, *Charles Geige*, of Düsseldorf :—Manufacture of chemically pure fibres from peat by extracting raw peat fibres with alkalis, drying and loosening the fibres, which are then brought into an acid bath with the object of converting the starch contained in the fibres into sugar and of decomposing the proteins. The sugar is then fermented into alcohol and carbon dioxide. The residual product is freed from fats, again washed, boiled with dilute acids or alkalis and, after another washing, is bleached.
- P. 102616, July 3rd, 1897, *Zschörner*, of Vienna :—Paper material for peat prepared by extracting the washed peat under the highest possible pressure first with a weak alkali solution (not more than 2 per cent.), or several times with alkali solutions of continuously decreasing strengths, then washing, breaking up the fibres with a weak solution of an oxidizing agent which at the same time bleaches them and then treating them once more with an alkali solution (about 1 per cent.).
- P. 123785, January 1st, 1901, *Société Tempied et Dumartin*, of Paris :—A spun material from peat which contains peat fibres on the outside and one or more threads of cotton, or the like as an inner core.
- P. 144830, January 30th, 1901, *Kalman*, of Rabenstein (Lower Austria) :—Breaking up and working peat fibres. The cut peat is to be first purified by washing and rubbing and the product is to be converted into half-stuff by repeated grinding and soaking in water for short intervals. The half-stuff is to be converted into paper pulp and finished paper by repetition of this treatment under increased pressure.
- P. 172288, April 13th, 1905, *Kirner*, of Admont (Styria) :—Preparation of half-stuff from peat by grinding and rubbing the disintegrated and sifted peat between several pairs of rollers which are adjusted to correspond with the sizes of the different sifted materials.

- P. 173357, September 24th, 1905, supplementary to No. 172288, *the same* :—In the case of the roller press mentioned in No. 172288 the rollers which rotate with different velocities are pushed towards one another longitudinally during their rotation.
- P. 180397, July 9th, 1905, *Dr. John*, of Cothen (Anhalt), and *Henry Wollheim*, of Grunewald (Berlin) :—Breaking up and bleaching peat fibres by dilute hydrofluoric acid and subsequent bleaching of the well-washed fibres by means of hydrogen peroxide.

### 5.—Utilization of Peat in the form of Mull, Litter, and Manure

- P. 13143, August 20th, 1880, *Duke*, of Plains Totnes (England) :—Sewage, gas water, urine and other waste waters containing fertilizing materials are absorbed by means of soluble silicates, phosphates, peat charcoal or peat powder, with the object of winning a manure.
- P. 14016, May 23rd, 1880, *Ernst*, of Beesenlaublingen :—A process for converting "molasses waste" into a dry mass, with retention of its nitrogen content, by addition of sulphuric acid and peat mull.
- P. 20590, January 14th, 1882, *Cobley*, of Dunstable (England) :—A process for the preparation of horse manure by addition of peat ashes, peat powder, and the like to wet stable litter.
- P. 23251, November 12th, 1882, *Starck*, of Mayennes :—Manufacture of a fibrous, tanning agent by saturating moss peat with extracts of tannins.
- P. 25995, April 24th, 1883, and P. 31330, September 19th, 1884, *Starck*, of Mayennes :—Moss peat as an admixture for petroleum, fats, and oils, when these are being treated with superheated steam, and when they are being bleached or when they are being converted into lampblack.
- P. 29564, 42071, January 30th, 1884, *Dr. Karsch*, of Berlin :—A precipitating powder for artificial manures is made by slaking freshly burnt lime with a vegetable fibre paste (peat pulp, urine, wood refuse, &c.), or the plant, or peat, fibres are broken up by strong acids and then freed from acid by magnesia, alumina, iron, or manganese compounds.
- P. 40360, October 27th, 1886, *Rohkrämer and Son*, of Erfurt :—Use of peat for the manufacture of a nitrogenous manure which can be spread.
- P. 44510, November 15th, 1887, *Classen*, of Ansbach :—An odourless sewage valve with a peat mill sieve.
- P. 52834, February 17th, 1890, *Dr. Weigelt*, of Berlin :—Preparation of dry manures from fish and flesh refuse. When drying the fleshy parts, which decompose owing to the action of potash or magnesium salts, the salted parts are mixed with peat, peat litter, peat mull, or bog stuff.
- P. 82580, July 14th, 1894, *von Domarus*, of Barmen :—A disinfectant from peat mull and calcium chloride.

- P. 88519, March 1st, 1895, *Riensch*, of Wiesbaden :—Boiled peat mull as a clarifying agent.
- P. 121526, February 21st, 1900, *Wenck*, of Magdeburg :—Manufacture and dehydration of manures from sewage by production from calcium carbonate and acid of a continuous current of carbon dioxide in the liquids to be dried.
- P. 165976, January 17th, 1902, *Gerdes*, jun., of Bremen :—Peat and the like treated with alkalis are mixed, while moist, with alkali silicates or phosphates.
- P. 209157 February 12th, 1904, supplementary to No. 165976, *the same* :—The humic substances are made soluble by alkaline phosphates instead of by caustic alkalis.
- P. 220213, June 5th, 1909, *Julia Wolters*, of Ildehausen-on-Haardt :—Manufacture of manures from peat mould by mixing this with carbonates of the alkaline earths or generally with such substances which although they are neither acid nor alkaline are nevertheless able to neutralize acids.
- P. 282532, March 19th, 1914, *Louis Wilkening*, of Hanover :—A process for preparing a stable manure, which can be spread and will not absorb water, by subjecting any kind of "molasses waste," mixed with peat, to fermentation with a view to destroying the water-absorbing constituents.
- P. 283461, December 2nd, 1913, *A. Gasser*, of Neumühle (Württemberg) :—Peat and wood are ground up together and the mass is further treated in the same way as cellulose for the manufacture of bodies having high anti-putrefactive and bactericidal properties.

#### 6.—Peat for Building Purposes, Artificial Wood, &c.

- P. 2872, January 17th, 1878, *Gercke*, jun., of Hamburg :—Fibrous layers of peat are to be strongly compressed after drying, and after impregnation with tar, asphalt, &c., or milk of lime, water-glass, or cementing substances, they are to be employed for the manufacture of substitutes for wood, paste-board, paper, or roofing material.
- P. 27472, December 21st, 1883, *Vibrans*, of Ufingen :—Heat-insulating covers from moss peat.
- P. 36751, January 15th, 1886, *von Wendland*, of Bernied :—A jelly-like, compressible or mouldable, "setting" mass made from disintegrated peat by boiling it with addition of glue, water-glass, or the like.
- P. 39335, April 18th, 1886, *Nussbaum*, of Munich :—A filling material consisting of disintegrated peat, which is impregnated with milk of lime and then dried in the air.
- P. 77178, August 10th, 1893, *Geige*, of Broich, near Mülheim-on-Ruhr :—Manufacture of artificial wood from peat by digesting the raw peat and breaking up its fibres, then mixing the moist felty mass, when dry, with calcium sulphate solution and pressing it in moulds.
- P. 78047, May 27th, 1893, *von Wangenheim*, of Klein-Spiegel,



- near Grossmellen (Pomerania):—A peat product for roofing purposes from peat mull and tar, to which cements such as resin, pitch, gum, and the like are added.
- P. 114414, November 11th, 1898, *Zeland*, of Stockholm:—Peat as a building material. The raw peat is to be pressed and warmed between bands or plates, pierced with holes, and the drying of the more or less large plates, &c., which are thus made is to be completed by electrical decomposition of the moisture.
- P. 115145, August 3rd, 1899, *Reif*, of Hanover:—A process and a contrivance for manufacture from peat and the like of articles resembling those made of wood or stone, substances being added to the peat while it is being dried and disintegrated which, during the preparation, pressing, and forming, afford the necessary cementing or impregnating materials either alone or in combination with those already existing in the peat.
- P. 128728, October 31st, 1900, *Helbing*, of Wandsbeck:—Manufacture of artificial wood by mixing the washed peat, while preserving its fibrous nature, with milk of lime and an alumina compound, and then compressing the moist product.
- P. 130238, May 29th, 1901, *John v. d. Kammer*, of Chicago:—A germinating material made mainly from peat or peat moss, with substances inserted in it made of material permeable to the air.
- P. 133253, November 20th, 1900, *Decker*, of Mittweida, in Saxony:—Artificial wood from wood shavings, sawdust, chopped straw, and the like, which are boiled in a solution of a metallic salt and are then mixed with powdered brown coal and peat with addition of aluminium sulphate, whereby the mass, when dried, is acted upon by a bath of sodium borate and is then mixed with cements and formed in the ordinary way.
- P. 142432, July 11th, 1902, *Dr. Classen*, of Aix:—In order to be able to compress peat into a dense, heavy material capable of being worked, the raw material is moistened and heated with a mineral acid so dilute that a chemical change in the body is excluded and the product is then washed and dried.
- P. 145251, October 5th, 1902, *Factonite Works of Reif and Co., Ltd.*, of Wunstorf:—A substance capable of being worked is made from peat by pressing liquid cements such as tar, or its mixture with oil and resin, under high pressure in a finely divided condition, into the fibrous material, which is kept in continuous motion, and converting them when necessary into the solid state by the addition of oxidizing agents, in order to provide the fibres in a simple and cheap manner with a very thin coating of cement. The fibres are then pressed, according as required, in moulds.
- P. 159651, March 19th, 1903, *Stölzel*, of Thorn:—Building materials, pipes, and the like from peat, mixed in such a quantity and in so moist a state with cement that setting

takes place with the aid of the water withdrawn from the peat.

- P. 286082, January 17th, 1913, *Charles Narr*, of Munich :—  
 Manufacture of artificial stones from peat mull, which is prepared from frozen peat.
- P. 287704, June 5th, 1914, *William Schütz*, of Königsberg, in Prussia :—Manufacture of peat stones with suitable cements by first partially dehydrating the peat, then grinding it well, mixing it intimately with cements, moulding the mixture, allowing it to dry in the air, and thus become loose in the moulds.

### 7.—Peat for the Manufacture of Alcohol, Feeding Stuffs, &c.

- P. 66158, November 15th, 1891, *Kappesser*, of Carlsruhe :—  
 Manufacture of solutions containing sugar and alcohol from peat.
- P. 79932, June 5th, 1894, *Wagner*, of Sehnde, near Lehrte :—  
 Disintegrated peat is mixed with molasses or the like in any desired proportion for feeding purposes, and is then pressed in moulds of any desired form.
- P. 88546, December 22nd, 1894, *M. de Cuyper*, of Mons :—  
 Manufacture of alcohol by fermentation of molasses and peat.
- P. 112617, November 21st, 1897, *Schwartz*, of Hanover :—A feeding stuff consisting of skim milk mixed with peat and molasses.
- P. 237806, October 20th, 1908, *Joseph*, of Berlin :—Manufacture of peat molasses with addition of alkali, whereby the peat, before it is mixed with the molasses, is made very faintly alkaline by means of alkali lyes (soda lye).
- P. 241380, April 14th, 1909, supplementary to No. 237806, *the same* :—A process similar to No. 237806, whereby, after the addition of the soda lye, part of the liquid is separated with the object of removing to some extent the humic acid salts which are formed.

## SECTION X

### NOTES

#### From the Sections on the Utilization of Peat <sup>1</sup>

(The figures given in parentheses indicate the pages on which further particulars are to be found.)

Hitherto in great commercial industries peat has been used with success only in the following ways :—

(1) *As fuel*, in competition with wood, brown coal, and coal, especially when converted into fuel gas or power gas.

(2) In the form of *charcoal*, as a substitute for wood charcoal and coke, but *not* as a substitute for brown coal and coal.

(3) In the form of fibrous peat, as *peat litter* and *peat mull* for stables and closets, and as a preserving agent and a packing medium.

(4) In the form of peat, *peat mull* and *peat wool* as a bandaging, packing, insulating, and drying material.

The use of peat fibres (cotton-grass, *Eriophorum vaginatum*) as raw material for paper and paste-board for spun and woven fabrics and the like has hitherto proved to be indeed technically possible, but in spite of every effort and great sacrifice of money, no striking success has yet been obtained commercially in this way. Great care should be exercised with regard to new experiments of this type (pp. 466-467).

See what has been stated on p. 470 with regard to the treatment and the utilization of peat for various purposes and the manufacture of articles of the most diverse nature.

The calorific powers of various fuels may be seen on pp. 320-323, 326-331, and that for peat on pp. 326-327. The percentages of water and ash in peat have an extraordinary effect on its calorific power (pp. 328, 332).

By no method of treatment can peat be made a fuel equal in value to good brown coal or coal. *By no method* of treatment, including that of carbonization, *can either the calorific effect of a given weight of the dry peat be increased, or its ash content be decreased* (pp. 325, 388).

Peat cannot, without alteration, be burnt in a furnace adapted for coal with the same degree of success as the latter fuel. If this is to be attained a special furnace, in the construction of which the peculiarities of peat are taken into consideration, is always necessary.

Furnaces well adapted for peat may be divided into :—

(a) Ordinary grate furnaces (p. 343), peat powder furnaces (pp. 349, 432).

---

<sup>1</sup> See the Notes from the sections on the Winning of Peat, p. 312, *et seq.*

(b) Semi-gas furnaces (pp. 398, 424); locomotive furnaces (pp. 349, 432).

(c) Pre-heater gas furnaces (pp. 396, 425).

(d) Fuel gas and power gas installations (pp. 392, 397, 400).

In various branches of industry perfectly satisfactory results have been obtained with peat furnaces—for instance with semi-gas and gas furnaces for steam-raising and boilers (p. 424), for glass-works (p. 418), as well as for lime-kilns and potteries (p. 421). The use of peat as a fuel in the railway industry of Germany is out of the question (p. 431). Similarly in iron and steel works—in so far as it is not a question of peat charcoal as a substitute for wood charcoal (p. 389)—peat has fallen and more more out of use (pp. 415–418) in recent years.

Artificial drying of fuel peat—i.e., the manufacture of kiln-dried peat—is not economically sound (p. 355).

Peat charcoal or peat coke is equal in value to wood charcoal, and in general may be more cheaply prepared than the latter (pp. 356, 379–382). Although the calorific power of peat charcoal is greater than that of the same weight of air-dry, cut, machine, or press peat for the same raw material, *the heating effect of a given weight of air-dry peat* can never be increased by carbonization. The heating effect of the weight of peat charcoal obtained from it (only 30 to 40 per cent. of that of the peat) is always less than that of the peat from which it is obtained, although the calorific power of 1 kilo of peat charcoal is considerably more than that of 1 kilo of air-dry peat (pp. 386–391). Only machine peat, as dense and firm as possible, should be used for the manufacture of peat charcoal (p. 389).

In order to make the selling price of peat charcoal for large deliveries as low as possible, carbonizing ovens should be installed in which the waste, combustible gases from the charge of peat could be used for heating the ovens while the by-products (tar-water, tar, gas) could be recovered and utilized (pp. 374, 385, 408, 451).

Only under favourable conditions and in exceptional cases can semi-carbonized peat, powdered and pressed in moulds, compete with press brown coal, as a clean, pressed, peat charcoal for household use, unless the press brown coal is abnormally dear owing to high freightage (pp. 372, 383).

By means of *power gas* installations a new way is opened up for the utilization of peat for illuminating and power purposes (p. 400), especially for electric stations erected at or in a bog (p. 432).

*Peat litter* and *peat mull* have hitherto, without exception, proved excellent for the absorption and the winning of manures in stalls, closets, &c. (p. 452 *et seq.*). In this case also the raw material should be subjected to expert examination before factories for commercial products are erected.

Fibrous peat, waste peat, and peat mull are good *packing*, *storing*, and *preserving* agents (p. 461).

Peat as a *building material* has hitherto found only limited

use. The same remark applies to peat for mud baths (pp. 468 and 470).

*The manufacture of peat gas for illuminating purposes is technically possible, but is as a rule too expensive in comparison with that of coal gas (p. 444 et seq.).*

The use of *peat fibres* or *fibrous peat* as a *spinning* and *weaving* material and for the manufacture of *paper* and *mill-board* has not yet proved commercially remunerative (pp. 463 and 466).

*The winning of tar, tar products, pitch, wax, &c., from peat is commercially remunerative only when it is combined with the winning and utilization of peat charcoal (pp. 378, 451).*

Both uncut and cut-out bogs can, when suitably worked and manured, be used with great advantage for *agricultural* purposes. In the industrial utilization of bogs, therefore, the improvement of the surface of the ground for agricultural purposes should not be left out of consideration (pp. 471-480).

In Section IX, on Patents (p. 481), &c., it may be noted that in the case of furnaces and carbonizing and gasifying plants we should accept as suitable for peat not those which *can be used in common* for different fuels (wood, coal, coke, and peat), but only those contrivances *exclusively* or specially intended for peat and therefore peculiar to it.



# INDEX

NOTE.—Only the more important proper names or those most frequently referred to have been indexed.

- Abjörn Anderson machine, 152.  
Absorption of water by anhydrous peat, 244, 247, 355.  
Absorptive power of peat, 262-265, 283, 317, 452-462.  
Absorptive power of peat charcoal, 391.  
Acetic acid. *See* By-products.  
Age of bogs, 3.  
Agricultural implements used for winning peat, 35.  
Agricultural utilization of bogs, 410, 434, 440, 471-480, 497.  
Agricultural utilization of peat, 471-480.  
Air-dried peat, water content, 58.  
Air-dried peat, yield from a bog, 62.  
Åkermann peat machine, 117, 120.  
Alcohol from peat, 470. Patents, 494.  
Alder peat, 326.  
Algæ as "peat formers," 1.  
Ammonia. *See* By-products.  
Ammonium sulphate. *See* By-products.  
Analysis of peat, 7-14.  
Anhydrous peat, 58, 67, 72, 351-355.  
Anrep machine, 87, 117, 120, 122, 301, 442.  
Anrep-Jakobsson-Svedala machine, 151-152.  
Anthracite, 322, 336, 402, 403.  
Antiseptic bandages from peat, 461, 495.  
Area of peat bogs, 6.  
Artificial drainage, 20-22.  
Artificial drying, 72, 264, 267, 313, 351-355.  
Ash in peat, 5, 15, 245, 246, 252, 264, 266, 283, 312, 319, 322-331, 334, 339, 356, 370, 374, 378, 387-388, 389, 390, 454, 495.  
Asphalt from peat tar, 445, 448, 450.  
Augustfehn peat industry, 53.  
Augustfehn Steelworks, 416, 417.  
Aussee Peat Industry, 36, 55-57.  
Aussee Salt Works, 430.  
Austria, winning of cut peat in, 31-35, 64.  
Automatic machines (*see also* Machines), 154-167.  
"Autumn peat," 436.  
Bactericidal action of peat mull, 454-455.  
Bales of peat, 274-279.  
"Ball peat," 68, 72, 91-93, 330.  
Bamme's peat-carbonizing process, 379-381.  
Barrows and barrow tracks, 203-205.  
Baumann-Schenck peat-dredging machine, with sod spreader, 54, 161-164, 191.  
Beeck, peat willows, 270, 273, 277.  
Birch peat, 326.  
Birnbaum, K., 388.  
Blast furnaces, use of peat in, 370, 379, 389, 418.  
Bogorodsk electric power station, 433, 442-443.  
Bogs, agricultural utilization of, 410, 434, 440, 471-480, 497.  
Bogs, classification of, 4-9.  
Boilers, use of peat in steam, 400, 413, 424-430, 435, 438, 439, 443, 496.  
Bolzano's grate, 346.  
Bomb calorimeters, 321.  
Born's "mound-carbonizing" process, 383-385.  
Born's peat gasifier, 411.  
Brick manufacture, use of peat for, 421-424.  
Briquettes, peat, 23, 70, 78.  
Brosowsky, peat-cutting machine, 38-41, 294-298.  
Brown peat, 14, 63.  
Buchscheiden peat works and iron works, 34, 43, 44, 46, 415.  
Buckwheat, cultivation of, 24, 471, 472.  
Building material, use of peat as, 468-470, 496. Patents, 492-494.  
Burning of moors, 471-473.  
Butyric acid. *See* By-products.  
By-products (ammonia, tar, &c.), 356, 366, 367, 370, 374, 375, 378, 382, 385, 399-403, 408-413, 441, 444-451, 497.  
Calcium acetate, 377, 378, 381.  
Calcium cyanamide, 410.  
Calorie, 320.  
Caloric powers, 65, 320-329, 352-355, 378, 386, 388, 495.  
Carbolic acid. *See* By-products.  
Carbonization of peat, 356-391, 451, 496.  
Carbonization of peat by pressure, 383-385. Patents, 481-487.  
Carbonization of peat by pressure in heaps, 88.  
Carbonizing plants, 370-371, 497.  
Carbonizing processes—  
Bamme, 379-381.  
Born, 383-385.  
Ekelund, 372-373.  
Ekenburg and Larson, 67, 87, 385.  
Fritz and Schöning, 382-383.  
Gumbert and Loe, 372.  
Heine, 385.  
Jebsen, 374.  
"Wet," 67, 87, 385.  
Wielandt, 381-382.  
Ziegler, 374-379.

- Carbon monoxide. *See* Power and fuel gas.
- Carex peat, 1, 261, 326.
- Carinthia, drying of peat in, 43, 45, 218.
- "Castling" peat, 32, 54.
- Cegielski peat machine, 104, 105, 124.
- Centrifuges, dehydrating peat in, 73.
- Challeton process, 67, 72, 74-75.
- Charcoal, peat, 351, 353, 356-391, 418, 444-446, 449, 495, 496.
- Chemical composition of peat, 8-13, 264, 388, 454.
- Chemical process for conversion of fibres into cotton, 463-464.
- Chopping contrivances, 187-190.
- Clamping peat, 27, 32, 33, 53.
- Clamps, carbonization in, 360.
- Classification of bogs, 4-9.
- Clayton peat machine, 109, 110-112, 188.
- Clogs for horses, 197, 198.
- Closets, use of peat mull in, 457-459, 495.
- Coal compared with peat, 79, 223, 322, 323, 329-331, 336, 338, 356, 384, 394, 495.
- Coal, distillation of, 446, 447.
- Coal mixed with peat for firing, 348.
- Coal, press, compared with press peat, 79-82.
- Coke, 322, 323, 329, 336, 356, 393, 402, 446, 448, 451.
- Coke, peat. *See* Charcoal.
- Combustion, 335-341.
- Combustion, heat of, 319-323, 388.
- Commercial values of peat as a fuel, 331-335.
- Competitions between peat machines, 30, 257-259.
- Composition of peat, 7, 8-13, 264, 322-324, 327, 328, 335, 388, 454.
- Compression of peat, 314, 385.
- "Condensation" of peat on drying, 59, 62, 63, 71.
- Condensed machine peat, 69.
- Condensing action of machines, 241-254, 315, 316, 387.
- "Condensing effect," 62, 63, 241, 244, 245, 246.
- Conditions of peat formation, 2.
- Conductivity, thermal, 461, 468, 469.
- Constituents of peat, 7-14.
- "Contraction effect," 241, 244-246, 252.
- Contraction of peat on drying, 59, 62, 71.
- Conveyers, chain and belt, 214.
- Costs, large-scale machines and ordinary peat machines compared, 230-232.
- Costs of peat in hand peat industry, 36, 51-57.
- Costs of peat plants, installation and working, 224-229.
- Cotton from peat, 461, 463-466.
- Cotton-grass, 260, 463, 465, 495.
- Counter-knives, 172, 173-180.
- Croosote. *See* By-products.
- Cross-stops, 172-180.
- Crossings for light railways, 236.
- Crumb peat, 35-37, 324, 398, 408, 411.
- Crushing of peat, 171.
- Cultivation of bogs, 24, 25, 433, 439, 474-480.
- Cut peat, 62, 63, 64, 322, 323, 325, 327, 329, 331, 336, 387, 398, 408.
- Cut peat compared with machine peat, 244-253.
- Cut peat machines, 37-42, 54.
- Cutting away bogs, advantages of, 433.
- Cutting contrivances, mechanical, 187-190.
- Cutting disc for pulp peat, 148, 149, 164-167.
- Cutting peat, 23, 26, 31, 37, 49, 53, 170-180.
- Decomposition of plants, products of, 2, 3.
- Defects of hand peat, 64-66.
- Dehydration, electrical, 89. Patents, 293-294.
- Dehydration of peat, 67, 72, 313, 314, 351-355. Patents, 288-293.
- Density of raw and air-dried peat, 14, 15, 63, 77, 244, 245, 247, 252, 266, 322, 323, 370, 386, 389.
- Deodorizing powers of peat, 452-459.
- Depreciation of peat machines, costs, 225, 227.
- Disc for cutting pulp peat, 148, 149.
- Disinfecting powers of peat, 453-459.
- Disintegrating machines, 75, 77-78.
- Disintegrating mill for peat litter, 456-457.
- Disintegration of peat. Patents, 294-295.
- Distillation of peat, 444-451.
- Dolberg, automatic sod cutter, 190, 296, 298.
- Dolberg, elevator for clamping peat, 437.
- Dolberg, large scale peat machine, 164-166.
- Dolberg, macerating machine, 41-42, 99, 106, 117, 119, 122, 123, 296.
- Dolberg, peat litter machine, 270-273.
- Dolberg sod spreader, 191-192.
- Domestic use of peat, 414-415.
- Double-shaft peat machines, 119-123, 134, 135, 255, 256.
- Dough peat, 2, 4, 14, 29, 30, 68, 136, 327.
- "Dowson gas," 400.
- Drainage of bogs, 17-22, 24, 25, 31, 36, 76, 261-262, 313, 433, 473-479.
- Dredged peat, 7, 30, 323, 408.
- Dredgers, 42, 54, 74, 154-167, 316, 318, 435, 441, 442.
- Driers for peat, 422.
- Driving of peat machines, 192-203, 316.
- Dry peat from raw peat, yield of, 57-59, 60, 61.
- Dry press processes, 67, 78-85.
- "Dry volume ratio," 59, 62, 63, 242, 244-246, 253.
- Drying, artificial, 264, 267, 313, 496.
- Drying contrivances for peat, 42-52, 221-224.
- Drying, Gehrcke's tubular steam boiler, 215.



- Drying ground required, area of, 50, 221, 253, 313.
- Drying, Hannemann's peat-drying process, 216.
- Drying in open air, 216-223.
- Drying, machine and cut peat, compared, 219, 220, 245, 248-250.
- Drying machine, suction, 85.
- Drying of machine peat, 215-224.
- Drying peat by pressure, 78-89.
- Drying peat. Patents, 306-307.
- Dulong formula for calorific power, 321.
- Dust, peat, 69, 167-169, 349.
- Dutch moor fen industry, 473-474.
- Earthenware, use of peat for burning, 421-424.
- Economic calorific power, 322.
- Eichhorn's "ball peat," 68, 91-93.
- Ekelund, 50, 82, 84, 167, 169, 372, 373, 418, 431, 481, 482.
- Ekenberg-Larson wet carbonization process, 67, 87, 385.
- Electric power for driving machines, 22, 199, 202, 203, 233-234, 254, 255, 316.
- Electric power stations in bog districts, 432-433.
- Electrical dehydration, 67, 89. Patents, 293-294.
- Electro-Peat-Coal Syndicate, 374.
- Electrosmosis, 67, 89.
- Elevators, peat, 110, 120-122, 129, 135, 138, 139, 196, 197, 214.
- Elisabethfehn Peat Works, 239-240.
- Erica, 1, 4.
- Eriophorum peat, 1, 4, 260, 326, 327, 463, 465, 495.
- Evaporative powers of peat, 329, 332, 439.
- Evaporative powers of various fuels compared, 329-331.
- Evaporators, 424, 426-430.
- Exter-Gwynne dry press process, 67, 78-79, 324.
- Factories, peat litter, 280-281.
- Fairbairn double grate, 343-344.
- Feeding stuffs from peat. Patents, 494.
- Feilenbach Peat Factory, 53, 235-237.
- Feilitzen, von, 264, 265, 327.
- Felt from peat cotton, 465.
- Fen canals, 24.
- Fen industry for cultivation of bogs, 473-474.
- Fermentation of peat, 384.
- Fertilizers for cultivation of bogs, 475-477.
- Fertilizing properties of peat, 453-460.
- Fibres from peat. Patents, 307-311, 490-491.
- Fibres in peat, 77, 463-466.
- Fibrous peat, 4, 14.
- Field railways, 202, 203, 205, 213, 316, 437.
- Filling material, peat mull, 461-462.
- Filtering liquids, use of peat mull for, 462.
- Fireplaces for burning peat, 325, 335, 342.
- Firing peat, 342-351, 414-443.
- Flat bogs, 4, 5.
- Fleischer, 5, 9, 17, 263, 265, 453, 454.
- Flue gases, 335, 338, 439.
- Forest peat, 1, 10, 11.
- Forging, use of peat for, 415, 444.
- Fork, placing, 25.
- Formation of peat, 1-2, 4.
- "Forming barrow," 143, 144.
- Forming machines, peat, 59, 63, 68-71, 77-78, 98-135, 170, 180.
- Forming pieces, 180-186.
- Frames for moulding peat, 29, 30, 150.
- Frank-Caro-Mond process for gasification, 408-411, 412, 439, 441, 451.
- Freudenberg bog, 34, 45-46.
- Friability of hand peat, 65.
- Fritz and Schöning's carbonized press peat process, 382-383.
- Frost, effect on peat, 22, 34, 87, 249, 251, 261, 265, 266, 313.
- Fuel gas, 397-400, 413.
- Fuel, peat, 16, 53, 58, 314, 315, 318-355, 495.
- Furnaces, 325, 335, 350, 392-413, 417, 422, 424-430, 495, 496.
- Furnaces for peat powder. Patents, 481.
- Galecki's "washed-out peat," process, 67, 72, 77, 152-154.
- Gampermoos drying huts, 47-49.
- Gardens, use of peat mull in, 462.
- Gas-firing, 341, 391, 424-430.
- Gas, fuel and power, 397-413.
- Gas furnaces, 392-413, 417, 422, 424-430.
- Gas producer or generator, 392, 397-413.
- Gases from various fuels, composition of, 403-404.
- Gasification for illuminating purposes, 445-447.
- Gasification. Patents, 487-490.
- Gasification of peat, 16, 320, 351, 392-413, 419, 439, 451.
- Gasifier, 392-413, 422-424, 497. Patents, 487-490.
- Gasifier, Korting Bros., 400-403.
- Gasifier, Ziegler's, 399-400.
- Gehrcke's tubular steam boiler, 215.
- Glass industry, use of peat in, 418-421, 496.
- Görlitz machine factory, gasifier, 405-407.
- Grass peat, 1, 14.
- Grates, 338, 339, 342-348, 438.
- Gress's patent cut peat machine, 38, 54.
- "Grid cutter," 186, 188-189.
- Griendtsveen press peat factory, 83.
- Grinding mills, 76, 271.
- Growths of plants in peat formation, 2.
- Gumbert and Loe process for carbonization, 372.
- Gwynne dry press process, 73, 78.
- Gysser's improved peat machine, 94, 96.
- Hahnemann's oven, 361-362.
- Hand implements for winning peat, 25.
- Hand peat, winning of, 23-66, 314, 335-341.

- Hannemann's peat-drying process, 216.  
 "Hanover peat" or mud peat, 30.  
 Hanoverian pulp peat machine, 138-140, 192.  
 "Hard peat," 67, 89-90.  
 Harrow, Kemna, 440.  
 Hearths, 339, 340.  
 Heather peat, 1, 10, 11, 326.  
 Heating of peat, spontaneous, 383-384.  
 Hebert's forming machine, 75, 97-98, 181.  
 Heine and Rudeloff process, 67, 88.  
 Heine, "carbonization in mounds," 88, 385.  
 Heinen's peat litter factory, 270, 278, 279.  
 Heinen's peat machines, 124, 134-135, 141, 172, 184-185.  
 Hencke separator, 85.  
 Hendune machines, 442.  
 High bog, 4, 7, 9.  
 High bogs, reclamation of, 478, 479.  
 Hochrunst factory, 38, 53, 54.  
 Hodge's peat boat, 144-145.  
 Hoering, Dr., 447, 449, 451.  
 Hoering-Wielandt gasifier, 408.  
 Hoffmann kiln, 85, 421, 422.  
 Hoofs of horses, effect of peat litter on, 456.  
 Horizontal cutting of peat, 23.  
 Horizontal peat machines, 99, 106-114.  
 Horse-clogs, 197-198.  
 Horse-driven peat machine, 99-102, 103-107, 198-198.  
 "Horse poles," 47.  
 Horses for driving machines, 196-198, 199, 254, 255.  
 "Horses" for drying peat, 46-47, 52.  
 Humic substances in peat, 2, 3, 7, 8, 71, 472.  
 Humification, 2, 4, 384.  
 Hurdles for drying peat, 47, 52, 224.  
 Huts for drying peat, 47-49, 52.  
 Hydrocarbons from peat, 320, 356, 393, 394, 407, 444, 446.  
 Hypnum peat, 1, 261, 326, 327.  
 Illuminating oil from peat, 378, 382.  
 Illuminating purposes, use of peat for, 444-451, 496.  
 Implements for hand winning of peat, 25.  
 Industrial use of peat, 414-443.  
 Ingemann's pulp peat machine, 141-143.  
 Insulating material, peat as, 469, 495.  
 Intermediate peat, 10.  
 Iron industry, use of peat in the, 415-418, 493.  
 Irrigation, 24, 474.  
 Jakobsson's peat machine, 152.  
 Jebson's electrical process for carbonization, 374.  
 Jrinowka press peat factory, 83, 84.  
 Jungst's peat-carbonizing oven, 367-368.  
 Kahl's Machine Company, method of drying peat of, 85.  
 Kainit as a fertilizer for bogs, 459, 476, 478, 479.  
 Kemna steam ploughs, 440.  
 Kiln-dried peat, 351-355, 496.  
 Kiln for brick burning, 421-424.  
 Kittler, 67, 89.  
 Kneaded peat, 29, 62, 63, 68, 170, 171, 315, 316.  
 Knife-shafts of peat-forming machines, 98, 106-115, 255, 257.  
 Knives, peat machine, 170-180.  
 Kobylinski-Wöterkeim, 182, 183, 184.  
 Koch and Mannhart, wet press process, 67, 85-86.  
 Kolbermoor glass-works and earthenware factory, 420, 422.  
 Korting Bros.' gasifier, 402-404.  
 Langen step grate, 346-347.  
 Langenberg peat factory, 75-77, 83, 84.  
 Larson, 67, 87, 433.  
 Laws for the preservation of bogs, 17.  
 Levellers of pulp peat, 164-167.  
 Lignite, 57.  
 Lime as a fertilizer, 459, 478, 479.  
 Lime burning, use of peat for, 421-424.  
 Liss peat, 62, 63.  
 Litter from peat. Patents, 491-492.  
 Litter, peat, 51, 53, 235, 260-286, 314, 317, 452-462, 495, 496.  
 Liver peat, 4, 10, 11, 326.  
 Locomotives, firing with peat, 349-351, 431-432.  
 Lottmann's peat-carbonizing oven, 368-370.  
 Low bogs, 4, 5, 9.  
 Low bogs, reclamation of 478.  
 Lucht peat machine, 124-127, 172.  
 "Lump peat," 35, 324.  
 Maceration of peat. *See* Mixing.  
 Machine-cut peat, Gress's patent, 38, 55.  
 Machine dough peat, 68, 70, 136-138.  
 Machine peat, 63, 67-71, 314-316, 386.  
 Machine peat, composition and calorific power of, 322-335.  
 Machine peat, drying of, 215-216.  
 Machine pulp peat, 68, 70, 136-138, 173-174.  
 Machine peat compared with cut peat, 244-254.  
 Machine peat, factors affecting quality of, 173-174.  
 Machines—  
 Anrep, 87.  
 Anrep-Jakobsson-Svedala, 151-152.  
 Baumann-Schenck peat-dredging machine, with sod spreader, 161-164.  
 Brodnitz and Seydel, centrifugal pump for draining, 19, 20.  
 Brosowsky, 38-41, 42.  
 Cegielski, 124.  
 Clayton, 109, 110-112.  
 Dolberg, 41-42, 117, 119, 122, 123, 435, 436.  
 Dolberg automatic peat machine, 164-167.  
 Eichhorn's "ball peat," 91-93.  
 Galecki's peat pulp machine, 152-154.

Machines—*cont.*

- Gehrcke's tubular steam boiler, 215.  
 Grotjahn and Pieau, 119.  
 Hannemann's peat-drying process 216.  
 Hanoverian pulp peat, 138-140.  
 Heinen, 124, 134-135.  
 Hodge's peat boat, 144-145.  
 Ingermann's pulp peat machine, 141-144.  
 Jakobsson's peat machine, 151-152.  
 Lucht, 124-127.  
 Mecke and Sander's peat-dredging machine, 145-147.  
 Oldenburg pulp peat machine, 140-141.  
 Ros, 108-110.  
 Schlickeysen, 83, 99-110, 127-134.  
 Seydl, 115-117.  
 Strenge automatic peat machine, 158-161.  
 Strenge peat-dredging machines, 147-149.  
 Stütze, 124.  
 Sugg, 55.  
 Weber, 94-96, 98.  
 Wielandt automatic peat machine, 155-158.
- Machines, automatic peat, costs, 230-232.  
 Machines, choice of, 254-257.  
 Machines, costs of peat, 230-232.  
 Machines, double-shaft, 119-123, 255, 256.  
 Machines for winning peat under water, 42.  
 Machines, horizontal and vertical, 99-112.  
 Machines, installation of peat, 192-195.  
 Machines, patents for peat, 295-303.  
 Machines, peat-forming, 69, 99-135.  
 Machines, rate of rotation of knife shafts in peat, 255, 256.  
 Machines, willows for peat litter, 268-273.
- Magdeburg presses, 77, 79.  
 Manufacture of peat litter, 267-281.  
 Manure, peat. Patents, 491-492.  
 Manure, peat charcoal as a, 444.  
 Manures, peat litter, 459-460.  
 Manuring of crops on bogs, 440, 475-479.
- Marine peat, 1.  
 Marsh peat, 1, 4, 10, 11.  
 Measurement of peat for sale, 332, 334.  
 Mecke and Sander's peat-dredging machine, 145-147.
- Methyl alcohol. *See* Distillation of peat.
- Mill-board from peat, 466-467, 497.  
 Mill for grinding peat, 76.  
 Mill for grinding peat litter, 456-457.  
 Mixed bogs, 5.  
 "Mixed gas," 400.  
 Mixing action of machines, 71, 113, 241-245, 316.  
 Mixing contrivances of peat machines, 122, 170, 171.  
 Moist peat from raw peat, yield of, 57-61.
- Moisture in air-dried peat, percentage of, 8, 12, 57-61, 64, 244-248, 252, 267-268, 312, 370, 380.  
 Moisture in peat for producers, 413.  
 Moisture in peat litter, 283-284.  
 Moisture in raw peat, percentage of, 57-61, 252, 312.  
 Moisture, its effect on calorific power, 319-329.  
 Moisture, its effects on selling price, 331-335.  
 Molassine meal, peat, 462.  
 Möller and Pfeifer's method of drying, 83.  
 Mond process for gasification, 408, 409, 412, 413.  
 Moor-burning industry, 25, 471-473.  
 Moss litter peat, area of ground required for drying, 50.  
 Moss peat, 1, 4, 8-11, 14, 452.  
 Mould peat, 14, 30, 65, 260, 388, 408, 452.  
 Moulding frame, 150.  
 Mouthpieces, 180-186.  
 Mud baths, peat, 470, 497.  
 Mud peat, 2, 4, 10, 11, 14, 30, 68.  
 Muffles, carbonization in, 366-371.  
 Mull from peat. Patents, 491-492.  
 Mull, peat, 235, 260-282, 314, 317, 452-462, 495, 496.  
 Müller's contrivance for moving machines, 193.
- Nessler, 13, 265.  
 Nitrogen, 5, 8-13, 374, 378, 388, 408, 409, 442, 454, 478.  
 North German Peat Moor Company, 232, 233.  
 Nyström, 167.
- Oil, addition to peat fuel of, 248.  
 Oil, illuminating, 378, 382.  
 Oils from peat, 445, 447-451.  
 Oldenburg, 5, 6, 14, 19, 24-27, 53, 83, 140-141, 416.  
 Origin of peat, 1-4.  
 "Osmosed peat," 67, 89, 374.  
 Ostrach Peat Briquette Factory, 83, 84.  
 Output of hand-cut peat, 35, 51-57.  
 Output of machines, factors affecting, 172-175.  
 Output of machines, theoretical, 224.  
 Output with different methods of drying peat, 51.
- Ovens—  
 Hahnemann's, 361-362.  
 Jungst's, 367-368.  
 Lottmann's, 368-370.  
 Thenius's, 370-371.  
 Wagenmann's, 363-365.  
 Weber's, 365.
- Ovens, carbonization in, 360-365.  
 Ovens, carbonizing. Patents, 481-487.  
 Ozonized air, its effect on humification, 385.
- Packing, use of peat in, 461, 495, 496.  
 Paper from peat, 466-468, 495, 497, Patents, 490-491.

- Paraffin from peat, 378, 379, 382, 402, 445, 447-451.
- Paste-board from peat, 465, 495.  
Patents, 490-491.
- Patents. Utilization of peat, 481-494.  
Patents. Winning of peat, 287-311.
- Peat-firing, 342-351, 414-433.
- Peat-forming plants, 1.
- Peat litter, 16, 235, 260-286, 314, 317, 452-462.
- Peat machine competitions, 257-259.
- Peat meal, 235.
- Peat mixed with coal for firing, 348.
- Peat mull, 16, 235, 260-281, 314, 317, 452-462.
- Peat oil, 447-451.
- Peat powder, 167-169, 348.  
"Peat presses," 69, 70.
- Peat pressing. Patents, 303-306.
- Pentosanes, 71.
- Persson sod spreader, 192.
- Pettenkofer, 445.
- Phanerogams as "peat formers," 1.
- Phenol. *See* By-products.
- Phosphorus, comparative freedom of peat from, 418.
- Photogen, 444, 445, 450.
- Piles, carbonization in, 358-359.
- Pintsch Co., gasifier of, 407.
- Piston presses, 72. Patents, 303-306.
- Pitch from peat, 381, 382, 390, 497.
- Pitch peat, 4, 14.
- Plant gum in peat, 71.
- Ploughs, electrically driven, 440, 480.  
"Poles, horse," 47.  
"Poling," 29, 32, 42, 43, 50, 52, 54.
- Porous bodies, effect of their admixture with peat, 86, 87.
- Powder, peat, 69, 167-169, 348, 418, 432.
- Power gas, 393, 397, 400-413, 496.
- Power station, electrical, 233-235, 432-443.
- Powers required on various roads and railway tracks, 214-215.
- Preserving power of peat, 3, 453-462, 495, 496.
- Press coal compared with press peat, 79-83.
- Press, peat, 67, 69, 70, 71-73, 315-324, 330, 331, 387, 432.
- Presses, carbonizing. Patents, 481-486.  
Presses for baling peat, 274-280.  
Presses, peat, 69, 70, 71, 79.
- Pressing of peat, dry and wet, 67, 78-89.
- Pressing. Patents, 303-306.
- Pressure for drying peat, 72, 89.
- Producer, gas, 323, 400-413.
- Producer gas plant, 441.
- Producer, Raul's gas, 421, 422.
- Production of peat on a large scale, summary of methods, 67-68.
- Proteins in peat, 464.
- Pulp peat, 30, 50, 68, 71, 149-151, 173-174, 327.
- Pulp peat machines, 136-144.
- Pulp peat process, Galecki, 152-154.
- Pulsometers, use of, in drainage, 20, 21.
- Pumps, centrifugal, use of, in drainage, 19, 20.
- Pütsch gas furnace, 425.
- Pyrometric heat effect, 322.
- Rails in bogs, 193-194, 206-211, 316, 437.
- Railway industry, use of peat in, 431-432, 496.
- Ramparts for drying, 50.
- Rate of drying in different countries, 218.
- Raul's peat gas producer, 421, 422.
- Reclamation of bogs, 471-480.
- Reclamation of Wiesmoor Bog, 439.
- Reed peat, 1, 10, 11, 261, 326, 327.
- Regenerative gas furnace, 395-396.
- Reich's semi-gas peat furnace, 427-428.
- Resin, 7, 8.
- Ridge cultivation of bogs, 474-478.
- Rimpau ridge industry for cultivation, 474-478.
- "Ringing" of peat, 27.
- Roller, presses, 72.
- Rolling table with running boards, 187-189.
- Roofing purposes, peat, for, 468-469.  
Patents, 492-494.
- Ros, "tube peat" machine of, 108-110.
- Rosenheim and Reichenhall Salt Works Peat Factory, 38, 53, 55, 430.
- Rotation of crops, 475-479.
- Rotation of knife shaft, rate of, 242-243.
- Rottenmann Peat Works, 55.
- Running board, 187-188.
- Ruschmann machine, 140, 141.
- Rush peat, 1, 261.
- Sale of peat, measurement for, 332-333.
- Sand, 7, 11, 15, 454, 471, 474, 478.
- Saturation of the air, effect on drying of peat, 218, 219.
- Sausage peat, 330.
- Schenck peat machine, 117, 119, 122, 191.
- Scheuchzeria peat, 1, 261, 326.
- Schlickeysen peat machines, 83, 99-108, 127-134, 172, 181, 188, 217, 248, 295.
- Schreiber, Hans, 50, 51, 68, 150, 252, 267, 268, 459, 469.
- Schussenried Peat Factory, 237-239.
- Schweger Moor Electric Power Station, 410, 433, 441-442.
- Screw knives with curved and radial edges, 174-179.
- Screws in peat machines, action of, 170-180.
- Seaweed as "peat former," 1.
- Sedge peat, 1, 10, 11, 261, 326.
- Separator, Hencke, 85.
- Sewage, use of peat mull, 457-459.
- Seydl's peat machines, 115-117.
- Shaft, double, peat machines, 117-123, 134-137, 255, 256.
- Shafts, construction of, 170-180.
- Sheds for drying, 46-47, 215, 223, 224.
- Shrinkage effect, 242, 244-246, 252.

- Shrinkage of hand peat on drying, 59, 62, 63.
- Siemens' regenerative furnace, 396, 415, 416, 420.
- Sieve process, Versmann's, 67, 77-78.
- Sieves for mull willows, 272, 273.
- Sifting of peat. Patents, 294-295.
- Slane, 23, 25, 26.
- Sluices in drainage, use of, 22.
- Smelting, use of peat for, 54, 55, 351, 353, 370, 375, 386, 388, 389, 390, 415-418.
- Sod cutters, automatic, 190.
- Sod spreaders, automatic, 54, 55, 154-167, 190-192, 316, 318, 442.
- Sods of peat, standard size and form of, 185-186, 218.
- Sound damper, use of peat mull as a, 461, 468, 469.
- "Spearing" peat, 42, 52.
- Sphagnum peat, 1, 4, 8, 10, 11, 260, 326, 327.
- "Spiking" peat, 29, 43-45, 50-51.
- Spinning of peat fibres, 463-466, 497.
- Spiral, double, peat machines, 117-123, 134-137, 255, 256.
- Spiral knives, 174, 177.
- "Split-free quick drying," 217-220.
- Spreaders, automatic, 54, 55, 154-167, 190-192, 214, 316, 318, 442.
- Spreading board, 189.
- Spreading peat, 23, 26, 167.
- Stables, use of peat litter in, 455-457, 496.
- "Stage" of step-pressing, 88.
- Stamp presses, 79.
- Stamp pressing. Patents, 303-306.
- Stauber, 67, 79, 80, 86, 288, 294, 303, 306, 309.
- Steam dredger, 74.
- Steam power for driving peat machines, 41-42, 103-110, 193-195, 199, 254, 255.
- Steam production from peat, 400, 413, 424, 430, 435, 438, 439, 442, 443, 496.
- Steam turbines, 435, 442.
- Steel industry, use of peat in, 415-418, 496.
- Steinmüller pre-heaters, 435.
- Step grates, 346-351.
- Stones in raw peat, effect on machines, 256-257.
- Stoves for peat-firing, 414-415.
- Strenge automatic machine with sod spreader, 158-161.
- Strenge forming machines, 117, 119, 122, 435-436.
- Strenge peat-dredging machine, 85, 147-149, 435.
- Strenge sod spreader and cutter, 55, 190, 191.
- Stripping spade, 25.
- Stroked peat, 29, 30, 31, 59, 62, 323.
- Stroking frame, 29, 30, 150.
- Styrian peat works, 34, 47-49, 218.
- Suction drier, 85.
- Suction gas plants, 401, 405-406.
- Sugg peat machine, 55, 117, 119.
- Sulphur, 319-321, 341, 351, 374, 378, 389, 404, 418.
- Sun drying of peat, 216-217.
- "Sweating," 358.
- Sweden, drying of peat in, 46-47.
- Switches in field railways, 206, 207, 209, 210, 213.
- Tannic acid in peat, 464.
- Tar from peat. *See* By-products.
- Temperature effects on the drying of peat, 219.
- Temperature of combustion, 321, 328.
- Textiles from peat, 463-466, 497. Patents, 490-491.
- Thickening lyes, use of peat mull for, 462.
- Thomas phosphate as a fertiliser for bogs, 460, 476, 478, 479.
- Tile manufacture, use of peat in, 421-424.
- Timber in bogs, 38.
- Tipping cars, 211, 212, 214.
- Tracks in bogs, 193-196, 197, 198, 206.
- Transition bogs, 5, 9.
- Transport of machines, 127, 128, 192-196.
- Transport of peat, 65, 203-215, 313.
- Transport railways, 205-213.
- Tree roots in bogs, 38.
- Trestles for drying of peat, 45-46, 217, 221-222.
- Trials of peat machines, 257-259.
- Triple-shaft pulp peat machines, 138-140.
- Trodden peat, 30, 31, 324.
- Turntables in transport railways, 206-211, 213-214.
- Vacuum used for removing water from peat, 73.
- Varieties of peat, 1.
- Verschuer's, Baron von, process for dehydration of peat, 67, 89-90.
- Versmann's sieve process, 67, 72, 77-78.
- Vertical cutting of peat, 23.
- Vertical peat machines, 99-105.
- Vogel, Dr., 73, 75, 86, 97, 253, 357, 361, 366, 452, 454, 459.
- Vohl, Dr. H., 447, 448, 451.
- Volatile products of peat, 447-451.
- Volume ratio, dry, 59, 62, 63, 242, 244-246.
- Volume ratio to weight affecting use of peat, 65.
- Volume, selling peat by, 332, 333.
- Wadding from peat, 461.
- Wagenmann's oven, 363, 365, 447.
- Wagons for transport of peat, 205, 206.
- "Washing out process" of peat, 67, 72-77.
- Water-closets, use of peat mull in, 457-459.
- Water content of saturated air, 219.
- Water from peat, pressure used to remove, 72, 89.
- Water in peat, effect on economic value. *See* Moisture.
- Water in raw and air dried-peat. *See* Moisture.
- Water-retaining properties of peat, 62, 64.

- Waterways, a necessity for transport of peat, 65.
- Wax from peat, 7, 8, 379, 382, 451, 497.
- Weather conditions affecting peat drying, 62, 64, 65.
- Weaving material from peat, 463, 464, 466, 497.
- Weber's oven, 364-365.
- Weber's process, 68, 73, 94-96, 98.
- Weber-Gysser process, 187.
- Weight ratio to volume affecting use peat, 65.
- Weight, selling peat by, 332-333.
- "Wet carbonization of peat," Ekenberg and Larson, 67, 87, 385.
- Wet-press process, 67, 85-89.
- Weilandt automatic sod cutter and spreader, 190-191.
- Weilandt dredger, 54.
- Weilandt peat-carbonizing process, 381-382.
- Weilandt peat dredger and forming machine, with sod spreader, 117, 119, 155-158, 239.
- Wiesmoor electric power station, 148, 240, 434-441.
- Willows, 268-274.
- Winning of hand peat, 23-66.
- Winning of machine peat, 66-260.
- Winning of machine peat, erroneous explanation of facts, 69-71.
- Winning of peat litter, 260-282.
- Winning of peat. Patents, 287-311.
- Winning of peat under water, 38, 42.
- Wire ropes for driving of peat machines, 198-199, 211.
- Wood compared with peat, 322, 323, 329, 330, 336, 393.
- Wood from peat, artificial, 468-469.
- Wood from peat. Patents, 492-494.
- Wood in bogs, 38.
- Wood peat, 1, 2, 11.
- Wool grass peat, 1.
- Zailer, 25, 248, 267, 323.
- Ziegler, 449, 451, 482, 483, 484, 487.
- Ziegler's peat charcoal, 418.
- Ziegler's peat gasifier, 399-400.
- Ziegler's process for carbonization, 374-379.
- Ziegler-Frank condenser, 451.
- Zschörner, Charles A., 465, 467.

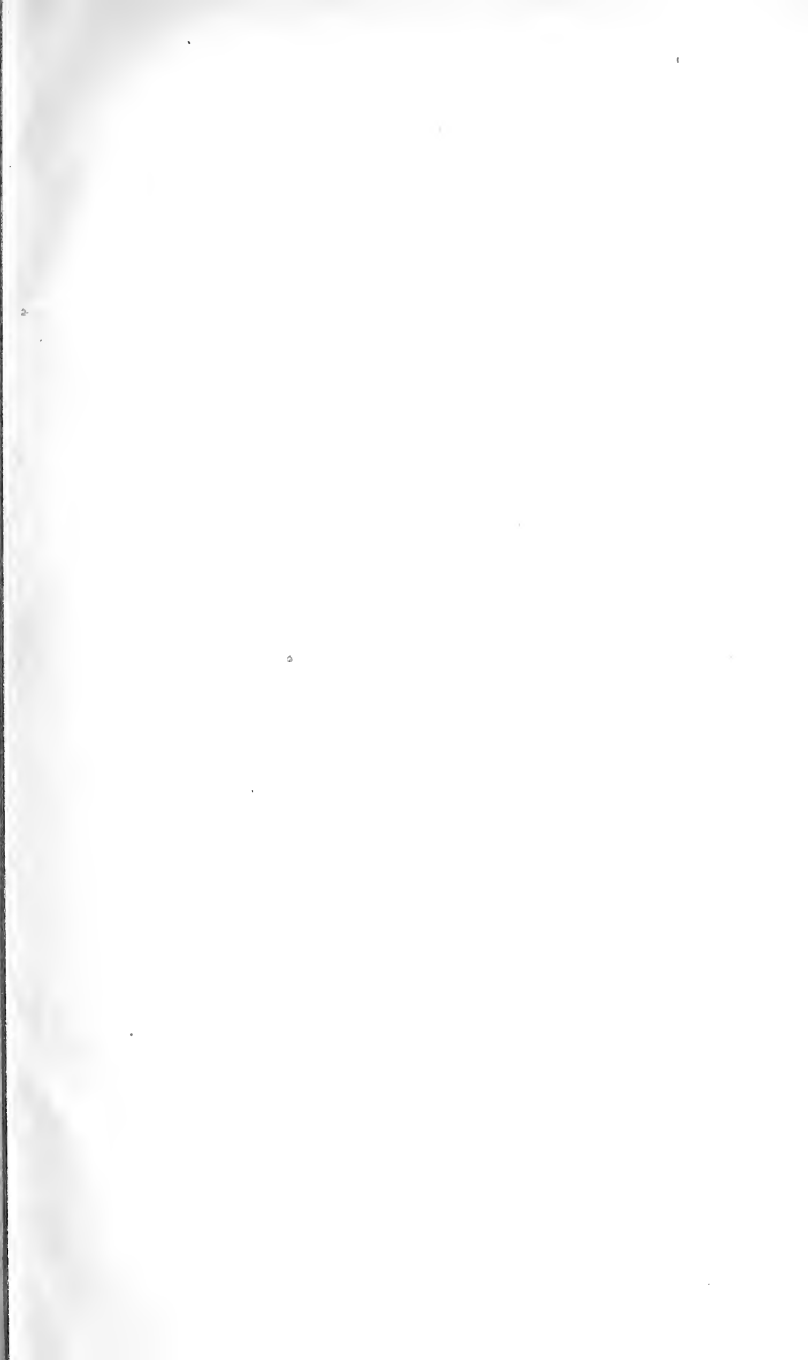







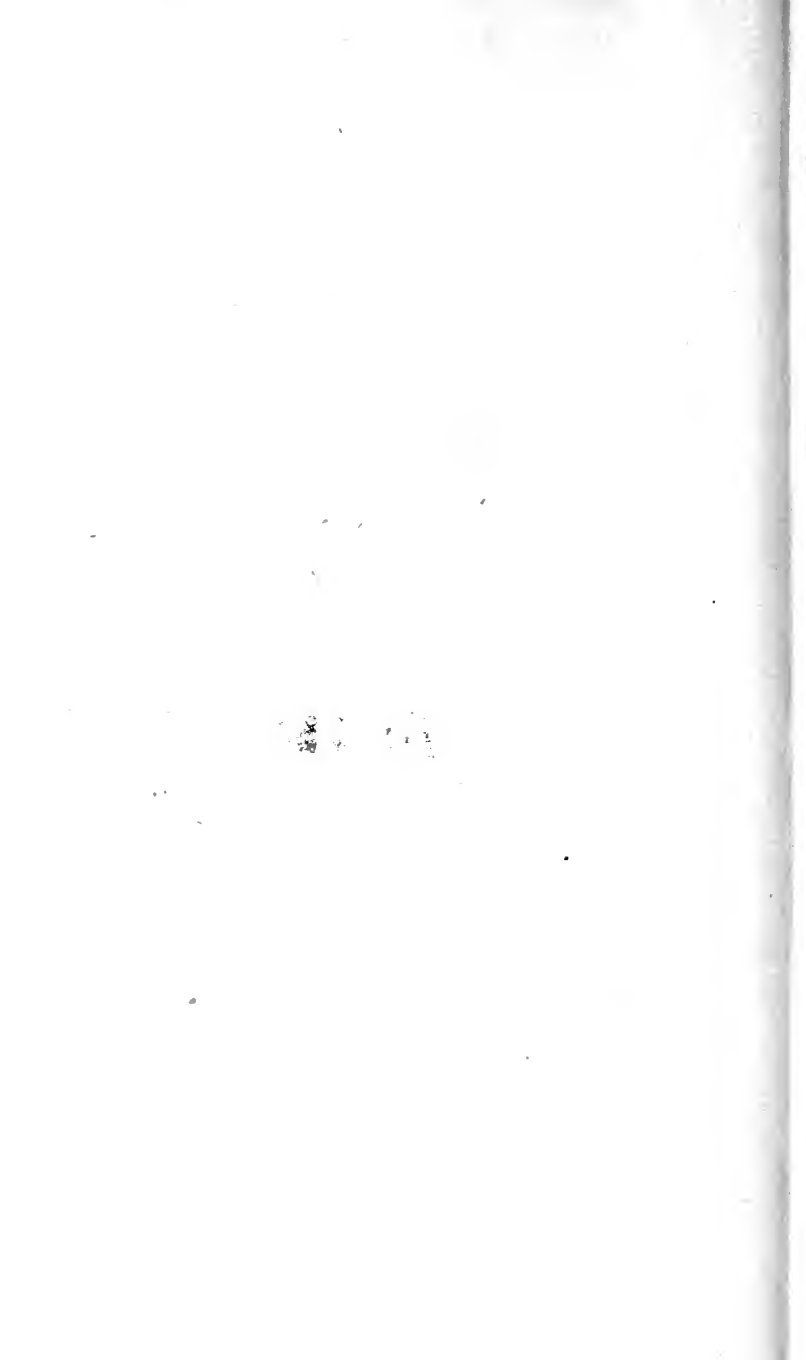

LIBRARY  
FACULTY OF FORESTRY  
UNIVERSITY OF TORONTO

TN  
837  
H313  
1921

Hausding, Alfred  
A handbook on the  
winning and the utilization  
of peat

For

DEC - 9 1995

[173743]

