

UC-NRLF



6B 661 669



DEMING
PUMPS
FOR HAND & POWER
CATALOGUE
NO. 26



GIFT OF
James Koeber

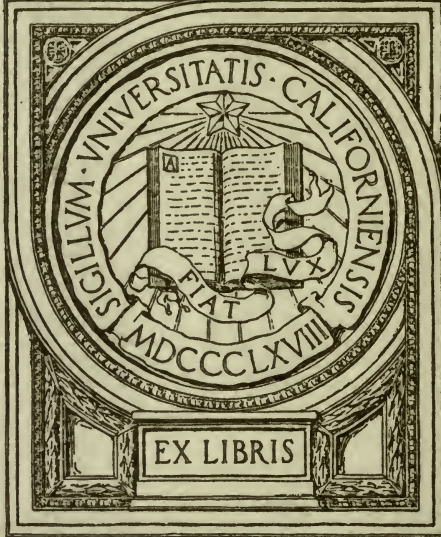

UNIVERSITY FARM

James Koebel,

2-3-1922,



Digitized by the Internet Archive
in 2007 with funding from
Microsoft Corporation

HAND & POWER PUMPS FOR ALL USES



Cistern and Force Pumps
Well Pumps and Cylinders
Spray Pumps and Nozzles
Hydraulic Rams and
Pneumatic Water Systems
Rotary, Centrifugal and
Power Deep Well Pumps
Triplex Power Pumps
Air Compressors and
Pumps for Special
Duties



THE DEMING COMPANY
SALEM, OHIO, U.S.A.

ESTABLISHED 1880



Works No.1 Hand and Power Pumps for all uses

Works No.2 Sprayers Nozzles and Accessories

The "World's Best" Equipped Pump Factories

The above bird's-eye views represent the plants of The Deming Company, where are produced the "World's Best" Hand and Power Pumps for all Uses. The upper view shows the Main Plant (Works No. 1), in which are made the Hand, Windmill and Power Pumps—the large Triplex and Deep Well Power Pumps and Hydraulic Machinery are made in building at the right. The lower view, in oval panel, shows the department of Spray Pumps, Nozzles and Accessories (Works No. 2), in which also are produced brass goods entering into the Deming lines.

ANNOUNCEMENT

THIS edition of our General Catalogue is ready for distribution in the beginning of our forty-first year as Pump Manufacturers. In March, 1880, our first pump patterns were ready for the foundry—a number two cistern and a pitcher spout pump, some millions of which have subsequently been turned out from our factory and shipped to all parts of the world. These two simple types were soon followed by set-length pumps and the common types of well and windmill standards and cylinders. Each year the line was increased in variety and volume of product until now there is hardly a pumping condition that is not met by some one of the many pumps made in the Deming factory, embracing a great variety of types, and sizes, for various uses, from the smallest Hand Pump to the most ponderous Power Pump.

Deming Pumps are designed for durability and efficiency by expert engineers and are made of the best materials by experienced mechanics. Modern Machine Tools of the best makes are used, the equipment in our various manufacturing departments being the best obtainable. For the convenience of dealers we issue, in addition to this General Catalogue, separate departmental catalogues, booklets and circulars; principally our Power Pump Bulletins, Spray Pump Catalogue, and Hydro-Pneumatic Water Supply Catalogue.

The division into distinct chapters or sections, each embracing a class of Pumps, or Accessories, we believe will be appreciated, as this arrangement enables one by referring to the Table of Contents to easily and quickly find the page on which the Pump or other article is shown. In addition to this general Table of Contents and the division into classified chapters we have the usual Figure Index and the Alphabetical Index. The Engineering Tables and Information relating to Hydraulics, and the Telegraph Cipher Code are useful to the dealer in Pumps.

In this Catalogue No. 26, we have eliminated certain pumps that are superseded by similar more recent productions. Every pumping requirement is, however, met by the articles shown herein.

Read carefully and take note of the following

EXPLANATIONS AND INSTRUCTIONS

CORRESPONDENCE

In order to insure prompt replies to communications, all letters should be addressed to the Company and not to individuals. Orders should be specific—mention of the Figure and Number or Size, and the Fitting only being necessary. *Please do not mutilate this Catalogue.*

PRICES AND TERMS

Prices are given to the trade in discount sheets with exception of Triplex and Deep Well Power Pumps which are quoted on application. Trade prices and special quotations are subject to change without notice. Parties not known to us commercially should accompany their orders with cash, or with satisfactory reference. Orders are accepted contingent upon unavoidable delays.



HAND AND POWER PUMPS FOR ALL USES



EXPLANATIONS AND INSTRUCTIONS—Continued

ORDERS AND SHIPMENTS

Unless otherwise specified in the order, we will ship by freight, delivery being made F. O. B. cars at factory, except in cases where such shipment had best be made by express or parcel post; and unless specifically mentioned we will in such cases use our judgment. In ordering, the Figure and Number or Size should be specified. We pay particular attention to properly packing goods for exportation and we maintain an export office in New York City.

ESTIMATES AND RECOMMENDATIONS

Prospective purchasers will be given estimates on pumping outfits and recommendations as to what is adaptable. This applies particularly to Power Pumping Outfits, Hydro-Pneumatic Water Supply Systems, Hydraulic Rams and Power Spraying Outfits. Special designs and adaptations of power pumps will be made, under agreement, for certain purposes and to meet special requirements.

SOME POWER PUMPS NOT SHOWN

Our line of Triplex and Deep Well Power Pumps is not complete in this catalogue; only the principal types being shown. The complete line is covered by individual Power Pump Bulletins. The list prices of many Power Pumps illustrated herein are omitted but will be quoted on application.

RETURNED GOODS

Pumps and other goods that are returned will not be accepted unless arrangements for their return have been previously made. Always mark your name and address distinctly on the package when returning goods, and send us by mail a memorandum of the same with bill of lading.

ALLOWANCE OF CLAIMS

All claims for corrections or deductions should be made within ten days after receipt of the goods. We are not responsible for breakages after goods are delivered to the transportation company in good condition.

INSPECTION AND TESTING

We take great care in inspecting Deming Pumps as to material and workmanship so that defects are very rare. All Power Pumps are tested in the factory. Charges for labor or expense required to repair defective goods will not be allowed. The amount of damage allowed in such case is only the price of the defective goods, which should be returned to us.

ILLUSTRATIONS AND IMPROVEMENTS

As we are constantly making improvements in design and construction of Deming Pumps, the goods ordered, when received, may possibly not be exactly like the engravings in the catalogue. In our old catalogues are shown certain articles not illustrated in later editions. On receipt of specific description, the repairs for such goods may usually be procured from us.

DISTRIBUTING AGENCIES

In the principal cities we have Distributing Agencies for handling Deming Hand and Power Pumps and Water Systems. These agencies have been established for the convenience of dealers in the adjacent territory.

IN CONCLUSION

This catalogue is self-explanatory and is arranged to save unnecessary correspondence. It supersedes all former issues of our General Catalogue. The List and Trade Prices are subject to change without notice.



TABLE
of
CONTENTS

Each Chapter or Classified Section embraces the Pumps or other articles which are related to each other in their most essential points.

When the Figure number of an article is known the same may be found by referring to the Figure Index; and if the name of the article is known it may be found by referring to the Alphabetical Index; both contained in the last chapter of this catalogue.

TITLE OF SECTIONS

	PAGES
HOUSE LIFT AND FORCE PUMPS	9 to 28
Pitcher Spout and Cistern Lift Pumps for Shallow Wells and Cisterns.	
House Force Pumps for Hand Use in Domestic Water Supply.	
SET LENGTH LIFT AND FORCE PUMPS	29 to 48
Non-Freezing Outdoor Pumps for Shallow Wells and Cisterns. Complete Lift and Force Pumps for Hand and Windmill Use with Three-Foot Set-Length between Standard and Cylinder.	
WELL AND WIND MILL PUMP STANDARDS	49 to 68
Lift and Force Pump Standards, Stuffing-box Heads, etc., for either Shallow or Deep Wells; the Cylinder or Working Barrel being separate and usually submerged.	
"STRAIGHT LINE" PUMPS AND WORKING HEADS.	69 to 76
For Shallow or Deep Wells. May be Operated by Hand, Windmill, Gasoline Engine or Electric Motor; the Cylinder or Working Barrel in most cases being separate and usually submerged.	
CYLINDERS AND PUMP LEATHERS	77 to 94
Iron, Brass and Brass-lined Cylinders, Used with Hand and Windmill Lift and Force Standards, Power Working Heads, etc. For general water supply; the Cylinder being usually submerged.	
PIPE, SUPPLIES AND PUMP FIXTURES	95 to 110
Strainers, Float, Check and Foot Valves; Air Chambers, Pump Rod and Couplings, Drive Points, Pipe and Fittings, Sinks, Brass Goods, Hose, Pump Fitters' Tools, Oil and Grease Cups, etc.	
MISCELLANEOUS HAND AND POWER PUMPS	111 to 136
Pumps for the Farm and Factory, Garage, Plumbing Shop, etc., including Thresher Tank Pumps, Contractors' Pumps, Bilge Pumps, Plumbers' Pumps, Factory and Village Fire Pumps, Air Compressors, Hydraulic Rams, Test Pumps, Creamery Pumps, Pump Jacks, etc.	



HAND AND POWER PUMPS FOR ALL USES



TITLE OF SECTIONS—(Continued)

CENTRIFUGAL AND ROTARY PUMPS	137 to 150
Hand and Power Rotary Pumps for Use in Oil Refineries, Creameries, Breweries, Canning Factories, Paint and Chemical Works, etc., also Horizontal and Vertical Centrifugal Power Pumps for Contractors' Use, Draining and Irrigating, etc.	
TRIPLEX POWER PUMPS, SINGLE AND DOUBLE-ACTING.	151 to 162
For Boiler Feeding, Mine Pumping, Water Works, Sewage Pumping, Brine Circulation, Paper Mill Pumping, Hydraulic Pressure Accumulators, Fire Protection Service, Railway Water Supply, Hydraulic Elevator Service, Private Water Supply, Irrigating, etc., for Operation by Electric or Other Power.	
HORIZONTAL DOUBLE-ACTING POWER PUMPS	163 to 174
Double-Acting Power Pumps for Various Duties Operated from any Power Source for Mine Pumping, Contractors' Use, Water Tank Service in Factories and Mills, Pneumatic Tank Service, etc.	
DEEP WELL WORKING HEADS	175 to 186
For Use with Brass Artesian Well and Other Types of Cylinders. For Operation by Electric Motor, Gas or Gasoline Engine, Steam Engine, Horse Power and Windmill; Using Belt, Gearing or Connecting Rod.	
HYDRO-PNEUMATIC WATER SYSTEMS	187 to 198
For Supplying Water to Farm Homes, Suburban Residences, Country Clubs, Summer Homes, Greenhouses, etc., the Tank Pressure in Many Cases being Automatically Controlled, and the Pump Operated by Electric Motor, Gasoline Engine or by Hand.	
SPRAY PUMPS AND ACCESSORIES	199 to 216
Bucket, Knapsack, Barrel, Tank, Compressed Air, and Cart Sprayers for the Garden, Greenhouse and Orchard; Independent Power Spray Pumps and Complete Power Spraying Outfits for Extensive Operations; Field Sprayers, Spray Nozzles, Spraying Attachments, etc.	
REPAIRS OR EXTRA PARTS	217 to 238
Descriptive Tabulated Price Lists of Extra Parts for Deming Hand, Windmill and Power Pumps; Iron and Brass Cylinders, Spray Pumps and Accessories.	
TECHNICAL DATA AND ENGINEERING TABLES	239 to 248
Information for the Engineer, Architect and Manufacturer; Also for Dealers In and Users of Pumps in General; Such as Facts, Formulas and Rules Relating to Hydraulics and Pneumatics; Including Capacities, Power and Speed of Pumps, and Their Operating Factor.	
TELEGRAPH CIPHER CODE AND INDEXES	249 to 254
Embracing Figure Index Arranged by Figure Numbers, Consecutively; and Alphabetical Index Arranged by Name of Article. The Telegraph Cipher Code Defines Sentences Relating to Class of Goods, Inquiries and Prices, Terms and Shipments; Also to Orders and their Execution.	



HOUSE LIFT
AND
FORCE PUMPS

FOR CISTERNS AND WELLS

PITCHER SPOUT AND CISTERN
LIFT PUMPS FOR SHALLOW
WELLS AND CISTERNS. HOUSE
FORCE PUMPS FOR HAND USE
IN DOMESTIC WATER
SUPPLY.





A Typical Deming House Force Pump

Fig. 508

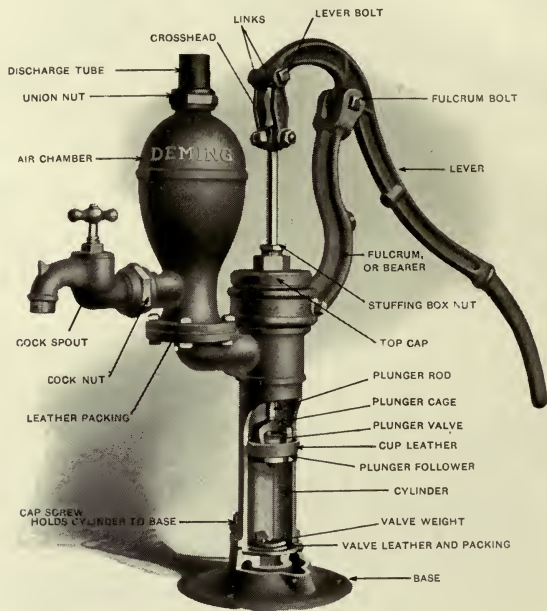

(Descriptive Illustration)

The names of the various parts are indicated in the illustration to give dealers and users a general idea of the component parts of pumps shown in this section or chapter of the catalogue. These pumps are complete integral force pumps ready for attaching of suction and discharge tubing.

The pumps designated as house force pumps will satisfactorily lift water by suction a vertical distance of 25 ft. calculated from the surface of the water to the pump cylinder. A reasonable horizontal distance from the water supply to the cylinder does not materially affect the working of the pump, but all pipe connections should be screwed up tight and the horizontal part of suction pipe should always incline a trifle upward toward the pump. This will prevent air pockets, which are troublesome.

With a house force pump water can be lifted and forced to a point above the surface of supply, (called the total lift) from a cistern, well, spring, dam or creek, as given below for various dimensions of cylinder.

Approximate Duty of House Force Pumps (The Leverage Being About 6 to 1)

Diameter of Cylinder Inches	Stroke Inches	Capacity per Stroke Gallons	Will Lift and Force Feet
2	6	.0816	90
2½	6	.1275	75
3	6	.1836	50
3½	8	.3332	35
4	8	.4352	30

Complete Table of Contents and General Classification of Pumps, Pages 7 and 8



How to Install Deming House Lift and Force Pumps

Shown on the Following Pages



Typical Installation showing well a horizontal distance from pump

Before placing the pump in working position, it is best to soak the stock in water for an hour or so. This will expand the cup leather and cause it to fit the walls of the cylinder more snugly. The pump should always rest firmly on the well curb or platform, and should not be supported by the suction pipe. The lower end of the suction pipe should never be permitted to touch the bottom of the well.

The pump always works easier after a few days' use. If the plunger leathers should be thick, the pump may work hard and stiff at first. It is almost impossible to adjust leathers exactly right at the factory because of the difference in expansion and thickness of the leathers.

All pipe joints should be well threaded and screwed together snugly so as to secure a perfect suction. The connecting rod in deep well pumps should be well threaded and screwed together tightly to make good, strong joints.

If a bucket of water is held to the spout and the handle is worked rapidly, the pump will prime itself.

It is possible to draw water horizontally any reasonable distance, provided the vertical suction distance does not exceed 25 feet. This is illustrated by the "Typical Installation" in which the water is drawn vertically from the well, then horizontally to a point beneath the pump, and again vertically into the pump cylinder which is located in the stock or body of the pump. When the suction pipe is laid horizontally, it should be placed underground a distance of three feet to prevent freezing, and the pipe leading vertically to the pump should be carefully boxed in for the same reason.

Where the water is more than 25 feet below the pump, Deming Set-Length Pumps, with additional pipe, or Deming Well Pump Standards should be used.



HAND AND POWER PUMPS FOR ALL USES



Deming Close Top Pitcher Spout Pump

With Adjustable Lever and Cut-Off Base
For a Vertical Suction Lift of 25 Feet

Fig. 125



This is our Fig. 125 improved pitcher spout pump with close top. It is in universal favor for house use, where a low priced but substantial cistern pump is required. Fig. 125 has a cut-off base so that a bucket or vessel when set under the spout, will catch the water.

The cylinder is polished on a special machine which insures a smooth surface for the plunger and at the same time leaves intact the chilled face of the casting. All parts are made to exact gauges so that repairs will always fit. An iron valve seat is regularly furnished. Brass valve seat instead of iron, will be furnished if desired, but at extra cost.

On the projecting hub at the bottom of the base, is screwed a coupling nut which is threaded for iron pipe. When so ordered, either a brass tube or a galvanized iron tube for soldering to lead pipe, will be furnished, but at extra charge. Fig. 125 is made with either iron or brass-lined cylinder as listed below.

Furnished, when so ordered, with Brass Valve Seat at extra cost.

Quantity, Dimensions and Weights of Fig. 125, Packed for Export

Sizes	No. 2	No. 3	No. 4	No. 5
Number in Case	25	24	16	12
Cubic Feet	16.2	18.4	15	17.1
Gross Weights, Pounds	685	775	570	570

Sizes and Prices

No.	Size Cylinder Inches	Fitted for Pipe Inches	Stroke Inches	IRON		BRASS-LINED CYLINDER		Weight in Pounds
				Cipher	Price	Cipher	Price	
2	3	1½	4	ASSAYED	\$4.75	ASTRAY	\$7.25	23
3	3½	1½	4	ASSENT	5.25	ASUNDER	8.00	26
4	4	1½	4	ASSIGN	6.25	ATONING	9.00	31
5	4½	2	5	ASSUAGE	9.50	ATTAIN	12.50	41

Complete Table of Contents and General Classification of Pumps, Pages 7 and 8



The Deming "Domestic" Kitchen Pump
With Close Top
For Vertical Suction Lift of 25 Feet

Fig. 102



This is a splendid pump for kitchen use. The close top and large water chamber prevent the water from splashing out at the top. A spout of this type keeps the water from dripping back on the pump stand. The "horn" on the spout provides a means of supporting the bucket. By unscrewing the two bolts in the bearer, the lever can be swung around to the right or left as desired.

The "Domestic" is very durable. It is not expensive and is a staunch and efficient pump for cistern use. The cylinder is iron. On the projecting hub at the bottom of the base, is screwed a coupling nut which is threaded for iron pipe. If specified, a brass or galvanized iron tube for soldering to lead pipe will be supplied at extra cost. All parts are made to exact gauges so repairs will always fit.

Furnished, when so ordered, with Brass Valve Seat at extra cost.

Sizes and Prices

Size of Cylinder Inches	Fitted for Pipe Inches	Stroke Inches	Cipher	Price	Weight Pounds
3	1¼	4½	ACC RUE	\$5.00	22

Alphabetical Index, Figure Index and Telegraph Cipher Code, Pages 249 to 254



Deming Brass Cylinder Pitcher Spout Pumps

With Close Top and Adjustable Lever
For Vertical Suction Lift of 25 Feet

Fig. 101

Fig. 115

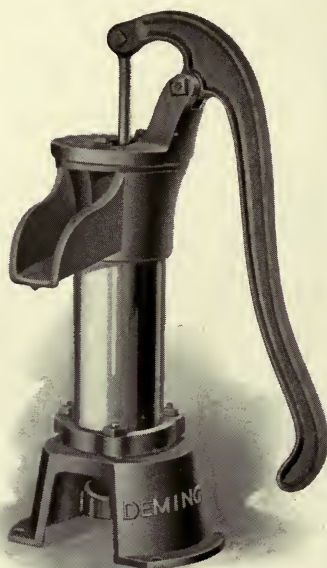

These pumps have the cylinder or stock constructed of SEAMLESS BRASS TUBING which makes them extremely durable. On the projecting hub at the bottom of the base, is screwed a coupling nut which is threaded for iron pipe. If so ordered, a brass or galvanized iron tube for soldering to lead pipe will be supplied at extra cost.

Fig. 101 can be furnished with either nickel plated or brass finished cylinder as listed below.

Fig. 115 has all-brass plunger.

The bearers may be set at any angle to the spout. The construction of the bases makes it possible to place a vessel directly beneath the spout.

Wherever a cistern pump of neat appearance and high quality is desired, either Fig. 101 or Fig. 115 will fulfill the requirements in every respect.

Brass Valve Seats are regularly furnished on these pumps.

Figure	Size Cylinder Inches	Fitted for Pipe Inches	Cylinder	Stroke Inches	Weight Pounds	Cipher	Price
101	3	1¼	(Polished Brass) (Nickel Plated)	4	17	ANTIPATHY ANTIGRAPH	\$7.00 8.00
115	3	1¼	Polished Brass	4	22	ASSAYER	8.00

Complete Table of Contents and General Classification of Pumps, Pages 7 and 8



HAND AND POWER PUMPS FOR ALL USES



Deming Revolving Top Cistern Pumps With Bolted Base and Polished Cylinder For Vertical Suction Lift of 25 Feet or Less



Fig. 120



Detail View of
Base Furnished on
These Pumps



Fig. 124, With Wall Brackets

These pumps have the cylinder in the stock and are ready to use when connected to pipe. The cylinder is bolted to the base. The top is held in place by a set screw so that the lever may be swung around to any desired position.

The cylinder is water polished up to the spout, which prevents wear on the pump leather and insures a good suction.

The base on these pumps is tapped for iron pipe as listed below. When so ordered, tubes for soldering to lead pipe will be furnished at extra price.

Fig. 124 is identical with Fig. 120 except that it is fitted with brackets for attaching to plank or wall.

Sizes and Prices

Fig.	No.	Size Cylinder Inches	*Fitted for Pipe Inches	Stroke Inches	IRON		BRASS-LINED CYLINDER		Weight Pounds
					Cipher	Price	Cipher	Price	
120	2	2½	1¼	5	ABBOT	\$4.50	AIDANT	\$ 6.50	23
120	3	2¾	1¼	6	ABBREVIATE	5.00	AIDER	7.25	26
120	4	3	1½	7	ABDICATE	5.50	AIGRE	8.00	34
120	5	3¼	1½	7	ABDICATION	6.50	AIMER	9.50	42
120	6	3½	2	8	ABDOMEN	8.00	AIMLESS	11.50	51
120	8	4	2½	8	ABDUCE	10.00	AIRING	15.00	56
124	2	2½	1¼	5	ADJUTOR	4.50	ALBURN	6.50	25
124	3	2¾	1¼	6	ADJUTRIX	5.00	ALBURNUS	7.25	28
124	4	3	1½	7	ADMONISH	5.50	ALCADE	8.00	37
124	5	3¼	1½	7	ADOBE	6.50	ALCAIC	9.50	48
124	6	3½	2	8	ADONEAN	8.00	ALCANNA	11.50	53
124	8	4	2½	8	ADONIS	10.00	ALCEDO	15.50	58

*For export, when so ordered, we fit these pumps for English pipe thread.



Deming Special Cistern Force Pumps

With Brass Cylinder
Will Lift and Force 50 Feet

Fig. 518

Fig. 519

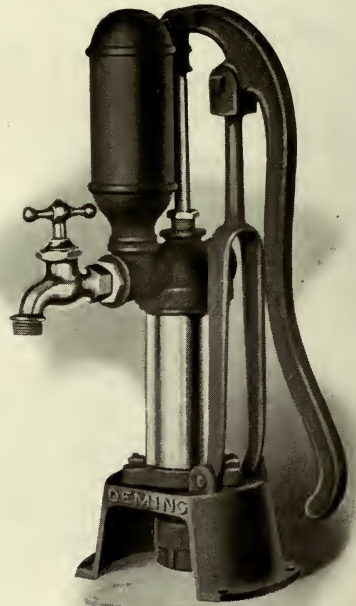

The above cuts represent a type of our more recent cistern force pumps with Brass cylinder. They will be found useful in elevating water to bathroom, tank or any part of the house by running pipes from the back outlet. We furnish this pump with either plain or cock Spout and with or without air chamber. The long swinging fulcrum (on Figs. 518 and 519) reduces the wear on plunger rod and stuffing box to a minimum. These pumps can be fitted for lead or iron pipe, but always furnished for iron pipe unless otherwise specified.

In ordering, always state style of spout. For Nickel-plated Cylinders add \$1.00 to list.

Brass Valve Seats are regularly furnished on these pumps.

Sizes and Prices

Fig.	Cylinder Inches	Suction Fitted for Pipe Inches	Stroke Inches	Cipher	Spout	Price	Weight in Pounds
518	3	1 1/4	6	ENDOGEN	Plain	\$ 8.50	20
518	3	1 1/4	6	ENDOCARP	Cock	11.00	20
519	3	1 1/4	6	ENDODERM	Plain	10.00	25
519	3	1 1/4	6	ENFILADE	Cock	12.50	25

Complete Table of Contents and General Classification of Pumps, Pages 7 and 8



Deming "New Era" Double-Acting House Force Pumps
 With Differential Plunger
 Will Lift and Force from 35 to 50 Feet

Fig. 540



Fig. 544



For house use these are very popular pumps to lift and force water from cisterns and shallow wells where the water is within easy vertical suction distance. If water is to be discharged into an elevated tank, Fig. 544 must be used, because it has a cock spout adapting it especially to this purpose.

The suction plunger below the spout, and the differential plunger above the spout produce a double acting effect as the suction plunger is twice the area of the differential.

On the projecting hub at the bottom of the base, is screwed a coupling nut which is threaded for iron pipe. When so ordered a brass tube or galvanized iron tube for soldering to lead pipe, will be furnished at additional cost.

The spouts are threaded for 3/4-inch hose coupling. The back outlet is tapped for 1-inch pipe. The bearers are adjustable so the levers can be turned at any angle with the spout. By removing the brass plug in the air chamber, Figs. 540 and 544 may be converted into lift pumps.

Brass Valve Seats are regularly furnished on these pumps.

Sizes and Prices

Fig.	No.	Diameter Cylinder	Suction Fitted for Pipe Inches	Stroke Inches	BRASS-LINED CYLINDER		Weight Pounds
					Cipher	Price	
540	4	3	1 1/4	3 1/2	EARLESS	\$ 8.50	30
540	6	3 1/2	1 1/2	3 1/2	EARLOCK	10.00	35
544	4	3	1 1/4	3 1/2	EAGLESS	10.50	32
544	6	3 1/2	1 1/2	3 1/2	EARWIG	12.00	37

Alphabetical Index, Figure Index and Telegraph Cipher Code, Pages 249 to 254



HAND AND POWER PUMPS FOR ALL USES



Deming Hand Force Pump on Base

With Cock Spout and Air Chamber
Will Lift and Force 35 to 75 Feet

Fig. 508



This is an extremely popular pump. It has an air chamber and cock spout on the side discharge. The upward discharge is supplied with a union nut and galvanized malleable iron tube threaded for pipe as listed. Brass cased plunger rod is regularly furnished.

The base is tapped for iron suction pipe. All parts are made to exact gauges and repairs will always fit.

The bearer is adjustable to any angle with the spout. The bolt holes in the air chamber are so spaced that the spout can be turned 90 degrees in either direction.

To prevent freezing, raise the lever to extreme height.

If upward discharge ONLY is to be used, deduct \$2.50 for cock spout from list price.

Brass Valve Seat is regularly furnished on this pump.

Sizes and Prices

No.	Size Cylinder Inches	Suction and Discharge Fitted for Pipe, Inches	Will Lift and Force Feet	Stroke Inches	IRON		BRASS LINED		Weight in Pounds
					Cipher	Price	Cipher	Price	
2	2½	1¼	75	6	ELFISH	\$12.50	EMBREW	\$15.00	60
4	3	1¼	50	6	ELICIT	14.50	EMBROGLIO	17.00	64
6	3½	1½	35	8	ELICITED	21.50	EMBRYO	25.00	83

Complete Table of Contents and General Classification of Pumps, Pages 7 and 8



Deming Hand Force Pump on Plank

With Cock Spout and Upward Discharge
Will Lift and Force 35 to 75 Feet

Fig. 509



The pump here illustrated is in every respect similar to Fig. 508, shown on opposite page, except that it is provided with brackets for attaching to plank or wall.

The upward discharge is supplied with a union nut and galvanized malleable iron tube threaded for pipe as listed.

Base is tapped for iron pipe as listed below. When so ordered, tubes for soldering to lead pipe will be furnished at extra price.

The bolt holes in the air chamber are so spaced that the spout can be turned 90 degrees in either direction. Brass cased plunger rod is regularly furnished. All parts are made to exact gauges so that repairs will always fit.

Should the plank not be desired, deduct \$1.00 list.

If cock spout is not desired, deduct \$2.50 from list price.

Sizes and Prices

No.	Size Cylinder Inches	Suction and Discharge Fitted for Pipe, Inches	Will Lift and Force Feet	Stroke Inches	IRON		BRASS LINED		Weight in Pounds
					Cipher	Price	Cipher	Price	
2	2½	1¼	75	6	ELOPEMENT	\$13.50	ENCHISEL	\$16.00	69
4	3	1¼	50	6	ELOQUENCE	15.50	ENCHASE	18.00	72
6	3½	1½	35	8	ELOQUENT	22.50	ENCLOISTER	26.00	89

Engineering Tables and Information Relating to Hydraulics, Pages 239 to 248



Deming "Blue Special" House Force Pump

With Brass Tube Cylinder
Will Lift and Force 50 Feet

Fig. 516

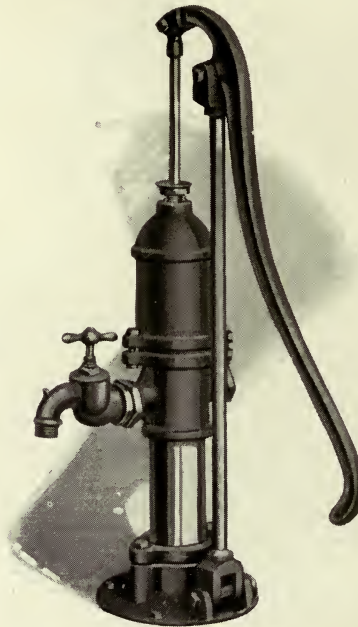

This is one of our latest and best designed pumps for house use. It has a long swinging fulcrum which puts on the base, all the strain of pumping. The suction pipe screws into the base. This type of bolted base is very convenient to install and makes the suction valve easy of access when the cylinder is removed from the base.

Fig. 516 has brass tube cylinder and large air chamber, also compression bibb cock and a back outlet tapped for one inch pipe. The plunger rod is brass cased and operates through a brass stuffing box gland. Fig. 516 is painted blue and gold and presents a very neat appearance. The unusually long lever makes pumping easy.

Brass Valve Seat is regularly furnished on this pump.

Sizes and Prices

Size Cylinder Inches	Suction Fitted for Pipe Inches	Back Outlet Fitted for Pipe	Stroke Inches	Cipher	Price	Weight in Pounds
3	1¼	1 Inch	6	EXPLODE	\$10.00	40

Complete Table of Contents and General Classification of Pumps, Pages 7 and 8



Deming House Force Pump on Plank

With Fly-Wheel and Crank
Will Lift and Force 35 to 75 Feet

Fig. 523



This pump is firmly bolted to the wall plank. The spout can be set at different angles by removing the bolts in the base of the air chamber.

The fly-wheel is 20 inches in diameter and will be found of great assistance in pumping large quantities of water.

The plunger rod is brass cased and operates through a brass stuffing box gland.

The upward discharge is supplied with a union nut and galvanized malleable iron tube threaded for pipe as listed.

Base is tapped for iron pipe as listed below. When so ordered, tubes for soldering to lead pipe will be supplied at extra cost.

The plank on which the pump is mounted is nicely finished in natural wood. Deduct \$1.00 from list price if plank is not desired.

If cock spout is not desired, deduct \$2.50 from list price.

Brass Valve Seat is regularly furnished on this pump.

Sizes and Prices

No.	Diam. Cyl. Inches	Stroke Inches	Capacity per Stroke Gallons	Will Lift and Force Feet	Suction Inches	Upward Discharge	Weight in Pounds	IRON CYLINDER		BRASS-LINED CYLINDER	
								Cipher	Price	Cipher	Price
2	2½	6	.127	75	1¼	1¼	135	EROSE	\$31.50	ENTREATY	\$34.00
4	3	6	.183	50	1¼	1¼	165	EROSIVE	37.00	ENTREE	40.50
6	3½	6	.249	35	1½	1½	175	EROTEME	45.00	ENTRENCH	49.50.

Alphabetical Index, Figure Index and Telegraph Cipher Code, Pages 249 to 254



Deming House Force Pump on Plank
 With Upward Discharge
 Will Lift and Force 35 to 75 Feet

Fig. 520

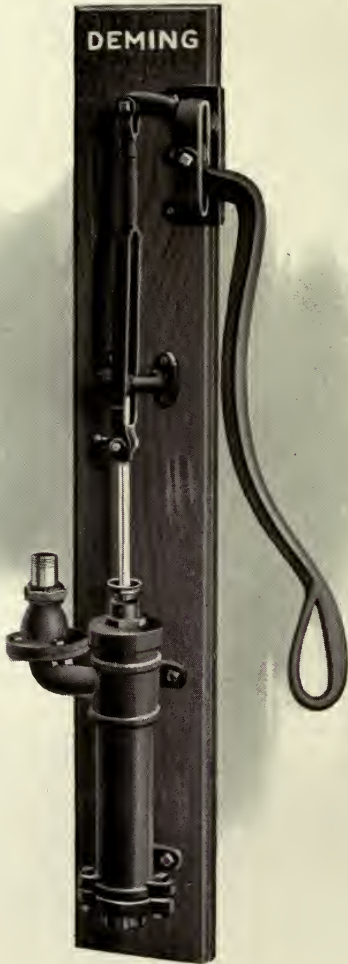

Fig. 520 has a brass cased piston rod with pitman and rod guide, and long lever. The lever is furnished for either right or left hand, but is always arranged right handed, as illustrated, unless otherwise ordered.

All parts are made to exact gauges so that repairs will always fit.

The discharge of Fig. 520 is fitted with a galvanized malleable iron tube threaded for iron pipe, this tube being attached to the discharge funnel with a coupling nut.

Base is tapped for iron pipe as listed below. When so ordered, tubes for soldering to lead pipe will be supplied at extra cost.

Fig. 520 is regularly mounted on a handsome plank and presents a very fine appearance. If this plank is not desired, deduct \$1.00 list.

Brass Valve Seat is regularly furnished on this pump.

Sizes and Prices

No.	Size Cylinder Inches	Suction and Discharge Fitted for Pipe, Inches	Will Lift and Force, Feet	Stroke Inches	IRON		BRASS LINED		Weight in Pounds
					Cipher	Price	Cipher	Price	
2	2½	1¼	75	7	EPIDEMIC	\$15.50	ENTUNE	\$18.00	95
4	3	1¼	50	7	EPIDEMY	16.50	ENURE	20.00	100
6	3½	1½	35	7	EPIGRAM	22.00	ENVAULT	26.50	105

Complete Table of Contents and General Classification of Pumps, Pages 7 and 8



Deming House Force Pump on Plank
 With Air Chamber and Cock Spout
 Will Lift and Force 35 to 75 Feet

Fig. 524



In all respects this is the same pump as Fig. 520, except that an air chamber and cock spout have been added. The bolt holes in the air chamber are so spaced that the spout can be turned 90 degrees.

The upward discharge is supplied with a union nut and galvanized malleable iron tube threaded for pipe as listed.

Base is tapped for iron pipe as listed below. When so ordered, tubes for soldering to lead pipe will be supplied at extra cost.

All parts are made to exact gauges so that repairs will always fit.

Should plank not be desired, deduct \$1.00 list.

Deduct \$2.50 from list price if cock spout is not wanted.

Brass Valve Seat is regularly furnished on this pump.

Sizes and Prices

No.	Size Cylinder Inches	Suction and Discharge Fitted for Pipe, Inches	Stroke Inches	Will Lift and Force, Feet	IRON		BRASS LINED		Weight in Pounds
					Cipher	Price	Cipher	Price	
2	2½	1¼	7	75	ERECTED	\$20.00	ENVY	\$22.50	109
4	3	1¼	7	50	ERECTION	21.00	ENVYING	24.50	114
6	3½	1½	7	35	ERGOT	28.00	ENVIER	32.50	115



Deming "Ideal" Double-Acting Oscillating Force Pump

With Brackets

Will Lift and Force 20 to 90 Feet

Fig. 570

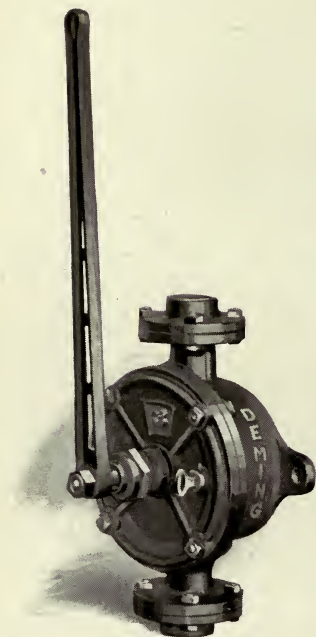

Fig. 570 is well suited for pumping hot liquid, oils, wines, cider, etc., as it has no leather packing.

To secure the best results, the vertical distance from the pump to the liquid should not exceed 20 feet. A foot valve on the end of the suction pipe may be used to advantage where freezing is not liable to occur. The pump lever may be worked from either a vertical or horizontal position. The construction of Fig. 570 is such as to cause a minimum of friction. All parts are made to exact gauges so that repairs will always fit. The following parts are regularly made of brass:

Oscillating wing or piston, valves, which are brass swing type, suction valve deck and valves, stuffing-box gland.

Following are the parts regularly made of iron, any or all of which will be made of brass when specified at extra cost: Shell, lid, stuffing-box nut and pipe flanges.

The piston shaft is steel but will be made of brass if specified, but at extra cost. Lever is regularly malleable iron but can be furnished with an iron socket and wood lever if so specified. The interior view shown on opposite page will explain the construction, also method of operation.

We can furnish air chamber with cock spout at additional list prices as on opposite page.

Sizes and Prices

No.	Suction and Discharge Flanges Fitted for Pipe, Inches	Outside Diameter of Cylinder Inches	Inside Diameter of Cylinder Inches	Capacity at 50 Strokes per Minute Gallons	Will Lift and Force When Operated by One Man	Weight in Pounds	Iron (includes brass wing and valves; brass suction deck and valves; brass stuffing-box gland)	
							Cipher	Price
0	1/2	5 1/4	4 1/8	4	90	17	GABLED	\$18.00
1	3/4	6 1/2	4 3/8	5	72	23	GADDED	19.00
2	1	7 3/4	5 1/8	6	60	27	GAINSAID	20.00
3	1 1/4	9	6 3/8	9	40	39	GALLANTLY	25.00
4	1 3/4	10 1/4	7 1/8	13	27	50	GALLED	30.00
5	1 1/2	11 1/2	8 3/8	19	20	58	GALLERIES	38.00
6	1 3/2	12 1/2	9 3/8	22	17	67	GALLOPED	44.00

Complete Table of Contents and General Classification of Pumps, Pages 7 and 8



Deming "Ideal" Double-Acting Oscillating Force Pump

Mounted on Base

Will Lift and Force 20 to 90 Feet

Fig. 670

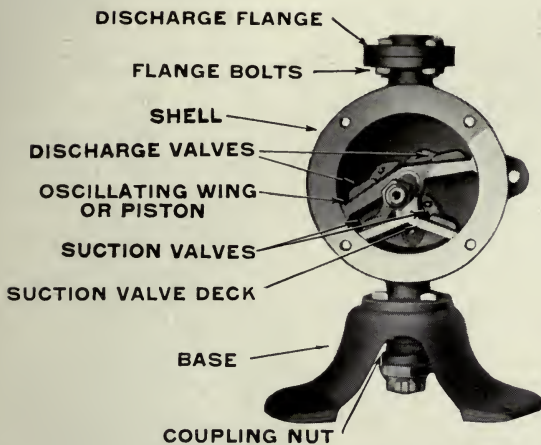

DETAIL OF FIGURE 670

Fig. 670 is same as Fig. 570 shown on opposite page, but mounted on a cast-iron base.

We can furnish air chamber with cock spout at additional list as given below:

Iron Air Chamber and Brass Bibb Cock

No. 0	\$6.50	No. 2	\$6.50	No. 5	\$9.00
No. 1	6.50	No. 3	8.00	No. 6	9.00
		No. 4	8.00		

Sizes and Prices

No.	Suction and Discharge Flanges Fitted for Pipe, Inches	Outside Diameter of Cylinder Inches	Inside Diameter of Cylinder Inches	Approximate Capacity per Minute Gallons	Will Lift and Force, Feet	Weight in Pounds	Iron (includes brass wing and valves; brass suction deck and valves; brass stuffing-box gland)	
							Cipher	Price
0	1/2	5 1/4	4 1/8	4	90	25	GADFLY	\$20.00
1	3/4	6 1/2	4 3/8	5	72	30	GAGGING	21.00
2	1	7 3/4	5 1/8	6	60	35	GALLOT	22.50
3	1 1/4	9	6 3/8	9	40	51	GAMUT	27.50
4	1 3/4	10 1/4	7 1/4	13	27	60	GARBAGE	33.00
5	1 3/2	11 1/2	8 3/8	19	20	70	GARDENER	41.50
6	1 1/2	12 1/2	9 3/8	22	17	76	GAUFFER	48.00

Alphabetical Index, Figure Index and Telegraph Cipher Code, Pages 249 to 254



Deming "Climax" Double Acting House Force Pumps For Open Tank Water Systems Will Lift and Force 50 to 75 Feet

Fig. 608



Fig. 600



These are two of our most popular pumps for elevating water to upper floors and attic tanks. Access to the valves is obtained by removing the two bolts, one on each end of the pump. The air chamber and suction attachment can then each be separated from the valve chamber, leaving the valves exposed. As shown in the illustration, the valve chamber is cast on the side of the cylinder. Both cylinder heads are bolted on, making the plunger easily accessible.

Water is discharged on both strokes and a steady even stream is insured because of the large air chamber. Figs. 608 and 600 are especially

suited to *open tank* water systems. For pumps to be used with the hydro-pneumatic (compressed air tank systems) see next page. All "Climax" pumps have bronze wing valves and bronze valve seats. Many thousand "Climax" pumps are now in use.

Fig. 600 is fitted with cog lever. In this respect only does it differ from Fig. 608 which has plain lever.

Sizes and Prices

No.	Size of Cyl. Inch	Suction Inch	Dis. Inch	Stroke Inch	Weight Pounds	Fig. 608				Weight Pounds	Fig. 600			
						Iron		Brass-Lined Cyl.			Iron		Brass-Lined Cyl.	
						Cipher	Price	Cipher	Price		Cipher	Price	Cipher	Price
1	2½	1¼	1	4	55	FABLE	\$16.00	FABULIST	\$18.00	60	FRANTIC	\$18.00	FRAUD	\$20.00
2	3	1½	1¼	4	61	FABRIC	18.00	FABULIZE	21.00	67	FRAP	20.00	FRAUDFUL	23.00

Complete Table of Contents and General Classification of Pumps, Pages 7 and 8



HAND AND POWER PUMPS FOR ALL USES



Deming "Climax" Double Acting House Force Pumps

For Hydro-Pneumatic Systems
Will Lift and Force 50 to 75 Feet

Fig. 608½

With Air Cock and Plain Lever



Fig. 600½

With Air Cock and Cog Lever



Except that to each of these pumps is fitted a small check valve and air cock, they are identical with Figs. 608 and 600 shown on the opposite page. This air valve which is attached to the cylinder head, adapts these pumps for use with hydro-pneumatic systems of water supply (commonly known as compression tank water systems).

The hydro-pneumatic systems are fully explained on pages 187 to 198. With the air cock just mentioned the amount of air to be pumped into the tank with the water, can be easily governed by adjusting the cock. If it is desired to

pump water only, then the air cock can be shut off. Fig. 600½ "Climax" is the Fig. 608½ "Climax" with cog lever instead of plain lever.

Sizes and Prices

No.	Size of Cyl. Inch	Suction Inch	Dis. Inch	Stroke Inch	Weight Pounds	Fig. 608½				Weight Pounds	Fig. 600½			
						Iron		Brass-Lined Cyl.			Iron		Brass-Lined Cyl.	
						Cipher	Price	Cipher	Price		Cipher	Price	Cipher	Price
1	2½	1¼	1	4	55	FRANK	\$17.00	FRANKING	\$19.00	60	FRAY	\$19.00	FRECKLE	\$21.00
2	3	1½	1¼	4		FRANKED	19.00	FRANKLY	22.00		67	FRAYING	21.00	FRECKLY

Engineering Tables and Information Relating to Hydraulics, Pages 239 to 248



Deming Double-Acting House Force Pump

For Hydro-Pneumatic Service

For Wells and Cisterns 25 Feet Deep or Less

Fig. 606



Fig. 606, with Patented Internal Air Cylinder

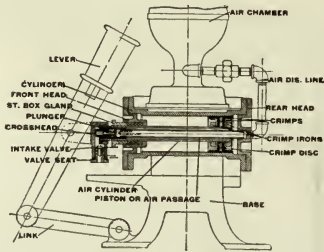

Section of Fig. 606 (Patented)

In general construction, this pump is similar to those illustrated and described on the two preceding pages. It is, however, fitted with a special internal air cylinder which is connected directly to the air chamber or compression tank as desired, by an air discharge pipe. With this device, air is not taken directly into the suction; therefore the efficiency of the pump is not impaired. The piston rod is hollow and forms the internal air cylinder. If water only is desired, close the air cock on plunger rod. THIS INTERNAL AIR CYLINDER IS FULLY COVERED BY OUR PATENTS. The view of this pump in section shows clearly the method of operating.

FIG. 606 IS, ESPECIALLY ADAPTED FOR USE WHERE THE SUPPLY IS HIGHER THAN THE PUMP, but can also be used to good advantage where the supply is lower than the pump.

FIG. 606 is, without doubt, the most efficient hand pump on the market for hydro-pneumatic systems.

Sizes and Prices

No.	Size Cylinder Inches	Stroke Inches	Suction Inches	Discharge Inches	WITH BRASS-LINED CYLINDER		
					Cipher	Price	Weight Pounds
1	2½	4	1¼	1	FAITH	\$25.00	56

Complete Table of Contents and General Classification of Pumps, Pages 7 and 8



SET-LENGTH LIFT

AND

FORCE PUMPS

FOR HAND AND WINDMILL

NON-FREEZING OUTDOOR
PUMPS FOR SHALLOW WELLS
AND CISTERNS. COMPLETE LIFT
AND FORCE PUMPS FOR HAND
AND WINDMILL USE WITH
THREE-FOOT SET-LENGTH
BETWEEN STANDARD
AND CYLINDER





A Typical Deming Set Length Force Pump

Fig. 442 (In Section)

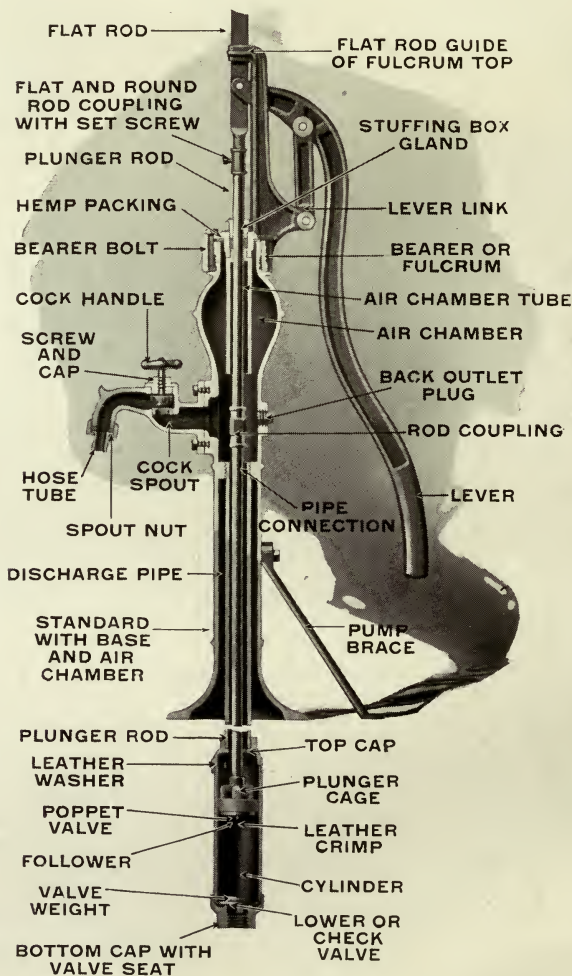

Approximate Sizes of Cylinders for Hand and Windmill Pumps

Depth of Well in Feet (This Depth or Less)	25	50	75	100	150	200
Diameter of Cylinder in Inches (This Size or Less)	3½	3	2½	2¼	2	1¾
Diameter of Suction and Discharge in Inches (This Size or Greater)	1½	1¼	1¼	1¼	1	1

Complete Table of Contents and General Classification of Pumps, Pages 7 and 8



Deming Set Length Lift and Force Pumps Suggestions For Installing Them

Any pump stock which is connected to an independent cylinder by sufficient pipe to place the top of the cylinder three feet below the base of the pump, is known as a "Set Length pump." By the use of this fixed set length, the cylinder is brought below the frost line. All the pumps illustrated in this section are furnished with a three-foot set length and a cylinder.

To prevent freezing, we drill a small hole in the set length pipe just above the cylinder, which permits the water to drain out of the pipe after pumping. Care should be taken that this drip hole does not become clogged while the pump is being installed.

The set length pump is intended for use in wells 28 feet deep or less or in any place where the vertical suction lift does not exceed 25 feet. A set length pump is very easy to install since it is necessary only to screw sufficient pipe into the lower end of the cylinder to reach to the bottom of a well. However, the distance from the bottom of the cylinder to the surface of the water should not be greater than 25 feet. All pipe joints should be well threaded and screwed up tight. The weight of the pump and pipe should be carried by the well platform or curb, and not upon the suction pipe, as the suction pipe should never rest upon the bottom of the well. When the pump is to be used in a shallow well, it is advisable to soak the cylinder in water for an hour or so. This will cause the plunger leathers to swell and fit more snugly the walls of the cylinder.

By lengthening the pipe and lowering the cylinder into or near the water, this type of pump may be used in wells up to 200 feet deep, depending upon the size of the cylinder and the construction of the pump. For instance, it is not advisable to use Figs. 198, 182, 183, 166 and other light weight pumps shown in this section in wells more than 50 feet deep, while the heavier pumps with longer levers, such as Figs. 211, 290, 219, 442, the "Peerless" Pumps, etc., may be used in wells of much greater depth.

We recommend that a foot valve be placed on the end of the suction pipe if the cylinder cannot be submerged. The foot valve will keep the cylinder and the pipe below the cylinder, full of water at all times, so that the pump will require no priming. However, if the cylinder can be placed in the water, the pump will always be primed and a foot valve will not be necessary. We advise that the cylinder be submerged wherever possible.

On the succeeding pages are described lift and force pumps with cast iron stocks; pipe stocks and adjustable bases; hand, windmill and cog lever tops. The table on opposite page showing the size cylinder which should be used in wells up to 200 feet, will be found useful when figuring a pump installation.



Deming Special Anti-Freezing Lift Pumps

With Set Length Connected Under Spout
For Wells 28 Feet Deep or Less

Fig. 398
Windmill Top

Fig. 198
Open Top



These are the lightest pattern of set length pumps which we manufacture. They are extremely popular and have for many years been favorites with dealers and users. We have made thousands of them.

By lengthening the pipe and lowering the cylinders into the water, this type of pump can be used in wells 50 feet deep or less, with very satisfactory results.

Fig. 198 has pump rod $\frac{3}{8}$ inch diameter.

Fig. 398 has windmill rod 1 inch x $\frac{3}{8}$ inch, threaded $\frac{7}{16}$ inch. Plunger rod is $\frac{3}{8}$ inch. Coupling is $\frac{7}{16}$ inch x $\frac{3}{8}$ inch.

Fig. 398 has the same standard and set length as Fig. 198; the only difference between the two pumps is that Fig. 398 has revolving windmill top instead of hand top.

A drip hole in the set length pipe three feet below base allows the water to flow back into the well and prevents freezing.

Brass Valve Seats are regularly furnished on these pumps.



Sizes and Prices

Fig.	No.	Size of Cylinder Inches	Fitted for Pipe Inches	WITH IRON CYLINDER		WITH BRASS-LINED CYLINDER		Weight in Pounds
				Cipher	Price	Cipher	Price	
198	2	2½	1¼	BRAZENLY	\$7.50	BLANCHING	\$10.00	56
198	4	3	1¼	BREACH	8.00	BLANCARD	10.50	60
398	2	2½	1¼	BUTLER	8.50	BLASTING	11.00	63
398	4	3	1¼	BUTMENT	9.00	BLASTED	11.50	69

Complete Table of Contents and General Classification of Pumps, Pages 7 and 8



Deming Special Open Top Hand Lift Pump

With Cog Lever Top and Guarded Gear
For Wells 28 Feet Deep or Less

Fig. 298
Hand Top

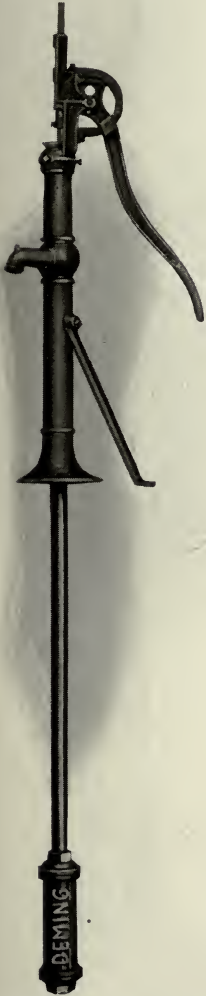

This is the same standard as Fig. 198, on opposite page, but is fitted with cog lever top for hand operation. It makes a very light but serviceable cog lever pump which we are able to sell at a low price. Fig. 298 is the simplest form of COG LEVER set length lift pump.

As illustrated, Fig. 298 is adapted for wells 28 feet deep or less; but if the pipe is lengthened and the cylinder lowered into or near the water, it may be used in wells 50 feet deep or less with very satisfactory results. The cylinder rod is $\frac{3}{8}$ of an inch in diameter.

We construct this pump so that the plunger rod is given a direct vertical motion and will not get out of line, which makes it very easy to operate.

The gear guards afford absolute protection from the gears, which are entirely enclosed by the guards.

A drip hole in the set length pipe, three feet below the base, allows the water to flow back into the well and prevents freezing.

Brass Valve Seat is regularly furnished on this pump.

Sizes and Prices

Fig.	No.	Size of Cylinder Inches	Fitted for Pipe Inches	WITH IRON CYLINDER		WITH BRASS-LINED CYLINDER		Weight in Pounds
				Cipher	Price	Cipher	Price	
298	4	3	1 1/4	BROACH	\$10.00	BURGOO	\$12.50	68

Alphabetical Index, Figure Index and Telegraph Cipher Code, Pages 249 to 254



Deming "Mascot" Pipe Standard Lift Pumps

With Adjustable Base and Brace
For Wells 28 Feet Deep or Less

Fig. 182
Open Top

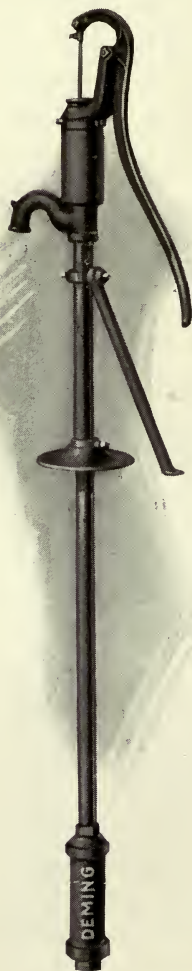

Fig. 482
Open Top



The "Mascot" pump is made with plain and cog lever top as illustrated. That part of the standard below the spout is made of pipe and is fitted with adjustable base which makes it possible to have the pump spout any desired distance above the well platform or sink. The brace is also adjustable and the bearer is of the revolving type.

As illustrated, these pumps are adapted for wells 28 feet deep or less; by lengthening the pipe and lowering the cylinder into or near the water, they are equally serviceable in wells up to 50 feet deep. The stock and set length on each pump is constructed of 1¼-inch pipe. The cylinder rod is ¾ of an inch in diameter.

The cog lever top on Fig. 482 insures frictionless operation. The plunger rod receives a direct vertical motion which makes the operation extremely easy. The gears are entirely enclosed by gear guards.

A drip hole in the set length pipes of each of these pumps, three feet below the base, allows the water to flow back into the well and prevents freezing. Figs. 182 and 482 have six-inch stroke.

Brass Valve Seats are regularly furnished on these pumps.

Sizes and Prices

Fig.	Diam. of Cylinder Inches	Fitted for Pipe Inches	WITH IRON CYLINDER		WITH BRASS-LINED CYLINDER		Weight in Pounds
			Cipher	Price	Cipher	Price	
182	3	1¼	BACHELOR	\$7.50	BADGER	\$10.00	50
482	3	1¼	BROMAL	9.75	BREWING	12.25	58

Complete Table of Contents and General Classification of Pumps, Pages 7 and 8



Deming Special Well Hand Lift Pumps

With Adjustable Base
For Wells 28 Feet Deep or Less

Fig. 166
Open Top



FIG. 166 "NEW MODEL" has a large spout casting which provides a receptacle of sufficient size to prevent the water from spurting out at the top. The curved siphon spout insures a uniform discharge. A heavy split base is furnished, so that a brace is not needed. The bearer can be set at any angle to the spout, and the base being adjustable, permits the standard to be any desired height. The cylinder rod is $\frac{7}{16}$ inch diameter.

FIG. 183 also has an adjustable base and brace, permitting the standard to be any desired height. The base is cup-shaped and will fit over the top of any size casing up to six inches diameter. Pump rod is $\frac{1}{2}$ -inch cold-rolled steel, welded to $\frac{3}{8}$ -inch plunger rod.

The standards and set lengths of these pumps are constructed of $1\frac{1}{4}$ -inch pipe. As illustrated, Figs. 166 and 183 are adapted for use in wells 28 feet deep or less, but if the pipe is lengthened and the cylinder lowered into or near the water, they may be used in wells 50 feet deep or less. A drip hole in the set length pipe three feet below the base allows the water to flow back into the well and prevents freezing.

Brass Valve Seats are regularly furnished on these pumps.

Fig. 183
Lift Pump

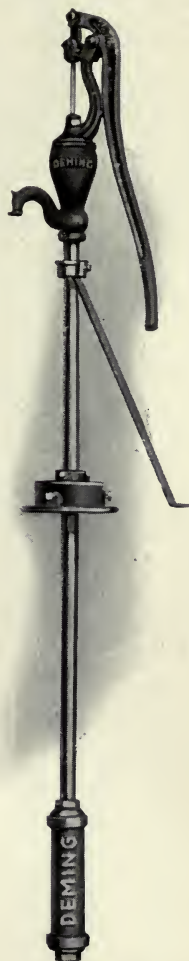

Sizes and Prices

Fig.	No.	Size Cylinder Inches	Fitted For Pipe Inches	Stroke Inches	WITH IRON CYLINDER		WITH BRASS-LINED CYLINDER		Weight in Pounds
					Cipher	Price	Cipher	Price	
166	4	3	$1\frac{1}{4}$	6	BANDON	\$8.00	BANDY	\$10.50	59
183	4	3	$1\frac{1}{4}$	6	BEZAN	9.00	BEZANTLER	11.50	62



Deming Improved Non-Freezing Hand Lift Pump
 With Open Top
 For Wells 28 Feet Deep or Less

Fig. 211



One of our best known and most popular lift pumps. A well-balanced, medium-weight pump. The base is cast solid on the stock and set length pipe is connected under the spout, insuring delivery of the water after a few strokes of the handle. Suitable for open or drilled wells.

Pump rod is $\frac{7}{16}$ -inch steel and is fastened to lever with a rod eye and set screw. This rod eye is furnished to enable repairs to be made by any person equipped to thread the rod.

The lever may be set at any angle to the spout. Bearer is secured to the stock by three set screws.

As illustrated, Fig. 211 may be used in wells 28 feet deep or less.

However, by lengthening the pipe and lowering the cylinder into or near the water, it may be used in wells 50 to 75 feet deep, depending upon the size of the cylinder--see table on page 30.

A drip hole in the set length pipe three feet below the base allows the water to flow back and prevents freezing.

Brass Valve Seat is regularly furnished on this pump.

Sizes and Prices

SIZES AND FITTINGS			Stroke Inches	CIPHER AND PRICE				Weight
No.	Size Cylinder Inches	Fitted for Pipe Inches		With Iron Cylinder		With Brass-Lined Cylinder		
2	2½	1¼	6	BEGRUDGE	\$ 8.50	BIGOTRY	\$11.00	72
4	3	1¼	6	BEMOAN	9.00	BILLIARDS	11.50	77
6	3½	1½	6	BEQUEST	10.00	BIRTHDAY	13.00	82
8	4	2	6	BEQUOTE	11.50	BIRTHING	15.00	90

Complete Table of Contents and General Classification of Pumps, Pages 7 and 8



Deming Non-Freezing Windmill Lift Pump

Fig. 421

With Tight Top
For Wells 28 Feet Deep or Less

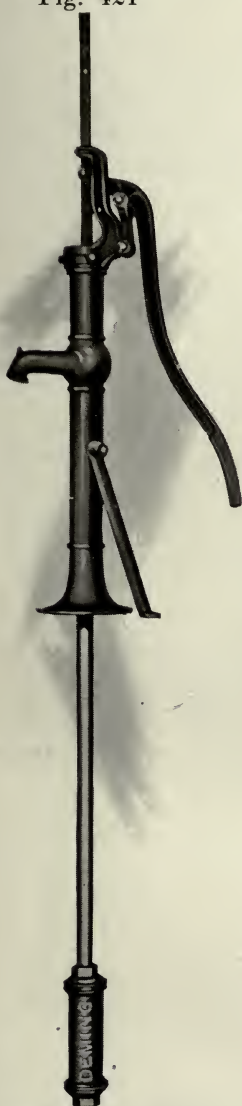

This pump is similar to Fig. 211 shown on the opposite page except that it is fitted with windmill top. The addition of this windmill top gives a vertical motion to the piston rod, preventing an uneven action of the plunger in the cylinder and adapts the pump for operation by windmill.

The flat rod of Fig. 421 fits the top snugly and prevents dirt, stones, or other foreign substances from getting into the pump.

As illustrated, Fig. 421 may be used in wells 28 feet deep or less. However, by lengthening the pipe and lowering the cylinder into or near the water, they may be used in wells 50 to 75 feet deep, depending upon the size of the cylinder—see table on page 30. Fig. 421 has windmill rod, 1 x $\frac{3}{8}$ inch, threaded $\frac{7}{16}$ inch. Plunger rod is $\frac{7}{16}$ inch. Coupling is $\frac{7}{16}$ x $\frac{3}{8}$ inch.

A drip hole in the set length pipe just above the cylinder prevents freezing. Length of stroke is six inches.

Brass Valve Seats are regularly furnished on these pumps.

Sizes and Prices

SIZES AND FITTINGS			Stroke Inches	CIPHER AND PRICE				Weight
No.	Size Cylinder Inches	Fitted for Pipe Inches		With Iron Cylinder		With Brass-Lined Cylinder		
2	2½	1¼	6	BOATSWAIN	\$ 9.50	BOGGISH	\$12.00	75
4	3	1¼	6	BOBBINET	10.00	BOILING	12.50	78
6	3½	1½	6	BOBOLINK	11.00	BOLDLY	14.00	84
8	4	2	6	BOBANCE	12.50	BOLDNESS	15.50	92

Alphabetical Index, Figure Index and Telegraph Cipher Code, Pages 249 to 254



Deming Pipe Standard Hand Force Pump
 With Adjustable Base and Brace
 Will Lift and Force 50 Feet

Fig. 185
Force Pump

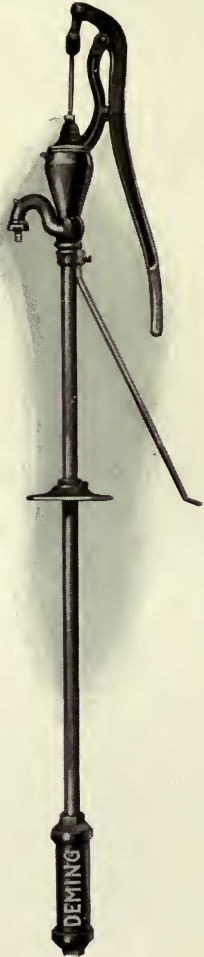

FIG. 185 SINGLE-ACTING FORCE PUMP is a very good light weight pump, popular with dealer and user alike. The standard and set length consists of 1¼-inch pipe. Base and brace may be quickly adjusted for varying distances between well platform and spout. Pump rod is ½-inch cold-rolled steel, welded to ¾-inch plunger rod.

FIG. 184 DOUBLE-ACTING FORCE PUMP is one of our latest designs of force pumps, the construction permitting adjustment of the spout to any desired height. It can be used in either open or drilled wells. The cup-shaped base will fit over the top of any size casing up to six inches in diameter.

Fig. 184 has a differential plunger which causes a continuous flow of water at the spout. The cylinders furnished with Fig. 184 are sufficiently long to give full six-inch stroke, either in iron, brass-lined or brass tube, capped inside or outside, as listed. Fig. 184 has ½-inch plunger rod fitted with ½ x ¾-inch coupling.

Both pumps are regularly supplied with hose nut and tube. A drip hole in the set length pipe just above the cylinder prevents freezing. Length of stroke is six inches.

Brass Valve Seats are regularly furnished on these pumps.

Fig. 184

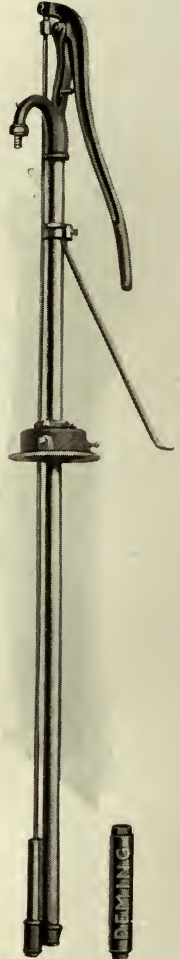

Sizes and Prices

Fig.	Size Cyl-inder Inches	Fitted for Pipe Inches	Stroke Inches	WITH IRON CYLINDER		WITH BRASS-LINED CYLINDER		BRASS CYLINDER		Weight in Pounds
				Cipher	Price	Cipher	Price	Cipher	Price	
185	3	1¼	6	BITTER	\$11.00	BITTERN	\$13.50	62
184	2½	1¼	6	BREVE	14.00	BRILLE	16.50	BIGAM	\$18.00	75

Complete Table of Contents and General Classification of Pumps, Pages 7 and 8



Deming Non-Freezing Hand Force Pumps

With Revolving Top

Fig. 219

Will Lift and Force 35 to 75 Feet

Fig. 223



The pumps illustrated on this page are similar in most respects. They differ principally in the construction of the air chamber, which in Fig. 219 is in the standard and cast integral with it. Fig. 223 has a separate air chamber, bolted to the standard, this air chamber being fitted with upward discharge for forcing water into elevated tanks. They are furnished with hose tubes, as shown. As listed, they are adapted to wells 28 feet deep, but when the cylinder is lowered into or near the water, they may be used in wells up to 100 feet deep if a cylinder of smaller diameter is used than listed below—see table on page 30. The rod on these pumps is $\frac{5}{8}$ -inch cold-rolled steel, welded to $\frac{7}{16}$ -inch plunger rod.



A drip hole in the set length pipe, three feet below base, allows the water to flow back into the well and prevents freezing.

Repairs for our pumps will always fit.

If Fig. 223 is wanted with plain spout instead of cock spout, deduct \$2.50 from list.

Fig. 219 has back outlet tapped for $1\frac{1}{4}$ -inch pipe.

Fig. 219 furnished with cock spout at \$2.50 extra, list.

Brass Valve Seats are regularly furnished on these pumps.

Sizes and Prices

Fig.	No.	Size Cylinder Inches	Fitted for Pipe Inches	Weight Pounds	Stroke Inches	Will Lift and Force Feet	IRON CYLINDER		BRASS-LINED CYLINDER	
							Cipher	Price	Cipher	Price
219	2	2½	1¼	82	6	75	BOOZING	\$12.50	BOWING	\$15.00
219	4	3	1¼	84	6	50	BOOSER	13.00	BOVINE	15.50
219	6	3½	1¼	90	6	35	BOOTING	14.00	BOUTANT	17.00
223	2	2½	1¼	98	6	75	BORER	16.50	BOWLING	19.00
223	4	3	1¼	100	6	50	BORDERER	17.50	BOWER	19.50
223	6	3½	1¼	106	6	35	BOREAL	18.50	BOWET	21.50



Fig. 290 Deming "Premium" Hand Force Pumps Fig. 291

With Adjustable Base

Will Lift and Force 35 to 75 Feet

For yard use we consider these pumps to have no equal. They are very easy to operate and are so substantially built as to be practically exempt from breakage.

Figs. 290 and 291 have adjustable bearers, braces and bases, so that the standards may be lengthened or shortened as desired and the levers swung around to any angle with the spouts. The heavy metal balls on the extra long wooden levers makes pumping easy.

In Fig. 290 the stock is made of 1½-inch pipe while the set length is 1¼-inch pipe, with the exception of No. 6 size, which has 1½-inch set length pipe.

Fig. 291 differs from Fig. 290 in the following respects. It is fitted with a cock spout instead of plain spout; has a back outlet tapped for 1¼-inch pipe; the standard and set length are respectively constructed of 2-inch and 1¼-inch pipe except the No. 6 size which has 1½-inch set length. The back outlet makes it possible to force water into elevated tanks. The base is cup-shaped and will fit over the top of any size casing up to six inches diameter. If plain spout is wanted, deduct \$2.50 from list price.

Plunger rod through stuffing box is 5⁄8-inch cold-rolled steel, welded to 3⁄8-inch steel rod, coupled to 3⁄8-inch stub rod on cylinder. On No. 6 size, lower end of plunger rod and stub rod on cylinder is 1⁄16 inch.

Both pumps have hose nut and tube.

As illustrated, Figs. 290 and 291 are adapted for use in wells 28 feet deep or less, but by lengthening the pipe and lowering the cylinder into or near the water, they may be used in wells up to 200 feet deep, provided a cylinder of smaller diameter is used than listed below—see table on page 30. A drip hole in the set length pipe three feet below the base allows the water to flow back into the well and prevents freezing.

Brass Valve Seats are regularly furnished on these pumps.

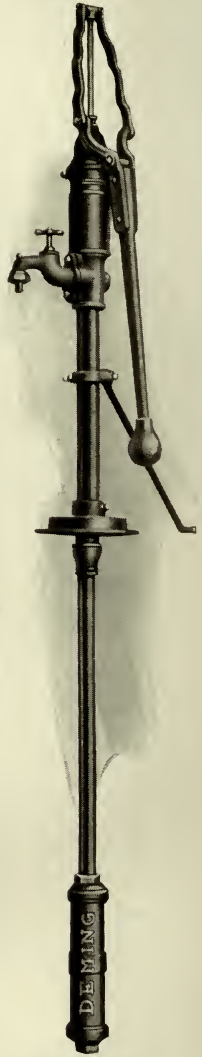
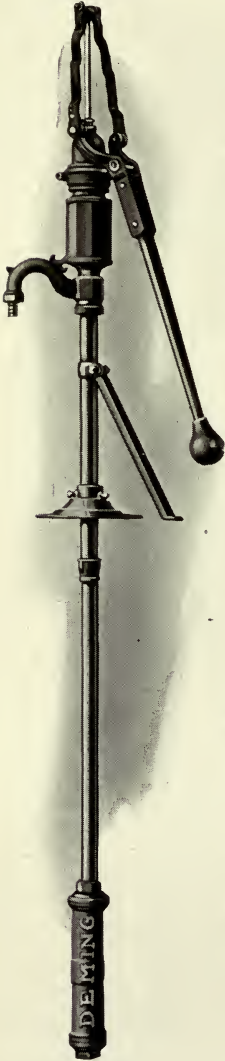

Brass-Lined

Brass-Lined

Sizes and Prices

Fig.	No.	Diameter and Length of Cylinder Inches	Fitted for Pipe Inches	Stroke Inches	Will Lift and Force Feet	BRASS-LINED CYLINDER		BRASS CYLINDER		Weight in Pounds
						Cipher	Price	Cipher	Price	
290	2	2½x14	1¼	10	75	BAGGY	\$16.50	BANDBOX	\$18.00	80
290	4	3 x14	1¼	10	50	BAGNET	18.00	BANANA	19.50	80
290	6	3½x14	1½	10	35	BAILED	20.50	BANKING	22.50	85
291	2	2½x14	1¼	10	75	BAVIN	21.50	BEAGLE	22.50	90
291	4	3 x14	1¼	10	50	BAWBLE	23.00	BEAKED	24.50	90
291	6	3½x14	1½	10	35	BAWD	25.50	BEAMY	27.50	95

Complete Table of Contents and General Classification of Pumps, Pages 7 and 8



Deming Non-Freezing Windmill Force Pump

With Cock Spout and Back Outlet
Will Lift and Force 35 to 75 Feet

Fig. 442



This popular set length pump is adapted for hand or windmill use. It has the same standard as Figs. 440 and 444. The windmill top gives a direct vertical motion to the plunger, thus wearing the cylinder smoothly and evenly. Fig. 442 has revolving tight top and brass stuffing box gland. Accurate and permanent alignment of the piston rod is secured by casting the stuffing box and rod guide in one piece.

The lever can be disconnected when the pump is to be operated by windmill. Spout is flanged and bolted to the standard. Hose tube and nut are regularly furnished. Bearer is clamped to the stock by three hook bolts. Fig. 442 has windmill rod 1 x 3/8 inch, threaded 1/2 inch. Plunger rod through stuffing box is 3/4-inch cold-rolled steel, coupled to 7/8-inch plunger rod. Back outlet is regularly tapped for 1 1/4-inch pipe.

Fig. 442 may be installed in wells up to 200 feet if a smaller diameter cylinder is used than listed below — see table on page 30.

A drip hole in the set length pipe, three feet below the base, allows the water to flow back into the well and prevents freezing.

Deduct \$2.50 from list price if plain spout is desired instead of cock spout.

Brass Valve Seat is regularly furnished on this pump.

Sizes and Prices

No.	Size Cylinder Inches	Stroke Inches	Fitted for Pipe Inches	Will Lift and Force Feet	Weight in Pounds	IRON CYLINDER		BRASS-LINED CYLINDER	
						Cipher	Price	Cipher	Price
2	2 1/2	6	1 1/4	75	87	BOTHNIAN	\$16.00	BREME	\$18.50
4	3	6	1 1/4	50	91	BOTTLING	16.50	BREN	19.00
6	3 1/2	6	1 1/2	35	98	BOULLION	17.50	BREWIS	20.50

Alphabetical Index, Figure Index and Telegraph Cipher Code, Pages 249 to 254



Deming "Peerless" Double-Acting Force Pumps

A Brief Description of this Famous Complete Line of Pumps

"Peerless" Pumps are made for either shallow, deep or drilled wells, and with or without three-way attachment — with or without windmill top. Any of them may be had with cog lever top. We make the cog lever pumps WITH WINDMILL OR HAND TOP and we can furnish them either way at the same price, since the extra length of windmill rod is the only difference between the hand and windmill cog lever pumps.

EASY TO OPERATE: "Peerless" Pumps are so often found in country school yards and railway stations, because they are so easy to operate. Directly under the lever of every "Peerless" Pump is an air chamber pipe which compresses the supply of air and acts as an elastic cushion, keeping the same amount of water in the discharge pipe so that the water flows from the spout in a steady stream without spurting or splashing.

THE DIFFERENTIAL CYLINDER EQUALIZES THE LOAD: On the up stroke of the plunger the water from the lower cylinder is lifted through the cylinder pipe and pump passages. One-half is forced through the spout and the other half follows the differential piston into the differential cylinder. On the downward stroke, the differential piston forces down and

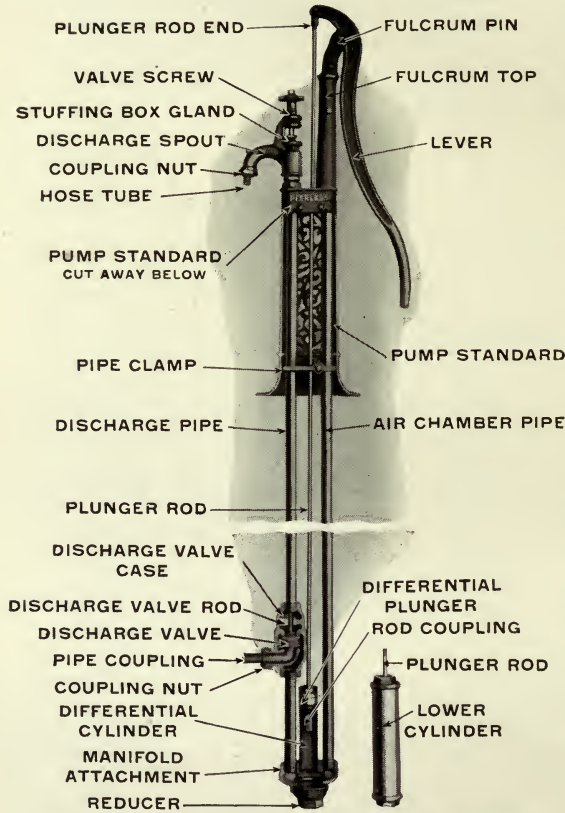

Illustration (in Section) of Fig. 283 "Peerless" Force Pump.

out through the spout the water that followed it on the up stroke and half on the down stroke.

Because of the differential cylinder, no stuffing boxes are used. There is nothing, therefore, to hinder the passage of the plunger rod. When garden hose is attached to the spout, there will be no leakage at top of air chamber.

When windmill power is to be applied to the "Peerless" windmill pumps, it is necessary to remove just one pin, and the handle drops down. When this operation is reversed, the pin will always FIT.

The stock is a single casting. The pipes are held rigidly in place by an ingenious clamp which prevents them from swinging. THE DISCHARGE AND AIR CHAMBER PIPES ARE GALVANIZED. On the succeeding six pages the "Peerless" pumps are illustrated and further described.

Complete Table of Contents and General Classification of Pumps, Pages 7 and 8



Deming Double-Acting "Peerless" Force Pumps

For Shallow Wells

Will Lift and Force 35 to 75 Feet

Fig. 450
Windmill Top

Fig. 280
Hand Top



Dealers will find that these pumps are a great convenience because the Shallow Well Pumps, Figs. 280 and 450, can readily be made into the Deep Well Pumps, Figs. 281 and 451, see page 44. This is accomplished by simply detaching the lower cylinder and connecting to it the attachment "B" and to the lower pump casting the attachment "A." This feature of adjustability is an advantage that gives the dealer four styles of pumps by carrying two styles; together with the attachments. When fitted for deep wells these pumps may be used in wells up to 200 feet deep, if a smaller diameter cylinder is used than is listed below—see table on page 30.

Fig. 280 has 1/2-inch plunger rod fitted with 1/2 x 3/8-inch coupling.

Fig. 450 has windmill rod 1 x 3/8 inch, welded to 1/2-inch steel rod, and connected to plunger rod with union coupling. Plunger stub rod is threaded 3/8 inch.

Nos. 2 and 4 "Peerless" Pumps, Figs. 280 and 450, are the most popular size, as they will go in 5 5/8-inch well casing.

Attachments "A" and "B" to make "Peerless" shallow well pumps into deep well pumps, \$1.00 per pair.

A drip hole in the discharge pipe, three feet below base, allows the water to flow back into the well and prevents freezing.

Brass Valve Seats are regularly furnished on these pumps.

Sizes and Prices

Fig.	No.	Diameter Lower Cylinder Inches	Stroke Inches	Fitted for Pipe Inches	Will Go In Drilled Wells Inches	Will Lift and Force Feet	Weight in Pounds	WITH BRASS-LINED CYLINDER	
								Cipher	Price
280	2	2 1/2	6	1 1/4	5 3/8	75	82	BANKRUPT	\$14.00
280	4	3	6	1 1/4	5 3/8	50	83	BARBARIAN	14.00
280	6	3 1/2	6	1 1/2	6 3/8	35	90	BARBECUE	16.00
450	2	2 1/2	6	1 1/4	5 3/8	75	88	BARLEY	15.00
450	4	3	6	1 1/4	5 3/8	50	90	BARNACLE	15.00
450	6	3 1/2	6	1 1/2	6 3/8	35	102	BAROMETER	17.00



Deming "Peerless" Double-Acting Force Pumps

For Deep Wells
Will Lift and Force 35 to 75 Feet

Fig. 451
Windmill Top

Fig. 281
Hand Top



Instead of having the cylinder attached to the set length as is the case in Figs. 280 and 450, described on the preceding page, Figs. 281 and 451 are furnished with the deep well attachments "A" and "B," and a separate brass-lined cylinder (Fig. 308) which can be dropped down into the well, thereby adapting the pump to wells 200 feet deep or less, if a smaller diameter cylinder is used than is listed below—see table on page 30.

Fig. 281 has $\frac{1}{2}$ -inch plunger rod fitted with $\frac{1}{2} \times \frac{3}{8}$ -inch coupling.

Fig. 451 has windmill rod $1 \times \frac{3}{8}$ -inch, welded to $\frac{1}{2}$ -inch steel rod and connected to plunger rod with union coupling. Plunger stub rod is threaded $\frac{3}{8}$ inch.

If the lower cylinder is placed in the water, the pump will not require priming.

A drip hole in the discharge pipe, three feet below the base, allows the water to flow back into the well and prevents freezing.

Brass Valve Seats regularly furnished on these pumps.



Sizes and Prices

Fig.	No.	Diameter Lower Cylinder Inches	Fitted for Pipe Inches	Stroke Inches	Will Go In Drilled Wells Inches	Will Lift and Force Feet	Weight in Pounds	WITH BRASS-LINED CYLINDER	
								Cipher	Price
281	2	2½	1¼	6	5½	75	83	BARRICADE	\$15.00
281	4	3	1¼	6	5½	50	86	BASTINADO	15.00
281	6	3½	1½	6	6½	35	90	BAYONET	17.00
451	2	2½	1¼	6	5½	75	89	BEDLAM	16.00
451	4	3	1¼	6	5½	50	92	BEDOUIN	16.00
451	6	3½	1½	6	6½	35	96	BEGGAR	18.00

Complete Table of Contents and General Classification of Pumps, Pages 7 and 8



Deming "Peerless" Double-Acting Force Pumps

For Drilled Wells

Will Lift and Force 50 to 75 Feet

Fig. 282
Hand Top



Since most drilled wells are of small diameter, we make this "Peerless" type with air chamber and suction pipe close together.

The two cylinders are not connected by pipe, but are left separate so that the lower cylinder may be dropped down to any desired depth. Better results are usually obtained if the lower cylinder is placed in the water. These pumps may be used in wells up to 200 feet deep if a smaller diameter cylinder is used than is listed below—see table on page 30.

Fig. 282 has $\frac{1}{16}$ -inch galvanized steel pump rod and fitted with $\frac{7}{16}$ x $\frac{3}{8}$ -inch coupling.

Fig. 452 has windmill rod 1 x $\frac{3}{8}$ inch, threaded $\frac{1}{8}$ inch, and coupled to $\frac{1}{16}$ -inch plunger rod with compression coupling. Lower end of rod is furnished with $\frac{7}{16}$ x $\frac{3}{8}$ -inch coupling for cylinder rod.

The lower cylinder furnished with this type of "Peerless" pump is our flush capped cylinder, Fig. 322.

A drip hole in the discharge pipe, three feet below the base, allows the water to flow back into the well and prevents freezing.

Brass Valve Seats are regularly furnished on these pumps.

Fig. 452
Windmill Top



Sizes and Prices

Fig.	No.	Diameter Lower Cylinder Inches	Stroke Inches	Fitted for Pipe Inches	Will Go In Drilled Wells Inches	Will Lift and Force Feet	Weight in Pounds	WITH BRASS CYLINDER	
								Cipher	Price
282	2	2½	6	1¼	3¾	75	85	BELAY	\$16.00
282	4	3	6	1¼	4	50	92	BEHOLDEN	16.00
452	2	2½	6	1¼	3¾	75	91	BELAYING	17.00
452	4	3	6	1¼	4	50	98	BELLOWS	17.00

Alphabetical Index, Figure Index and Telegraph Cipher Code, Pages 249 to 254



Deming "Peerless" Double-Acting Force Pumps

With Three-Way Valve for Underground Discharge
Will Lift and Force 50 to 75 Feet

Fig. 283
Hand Top



Fig. 453
Windmill Top

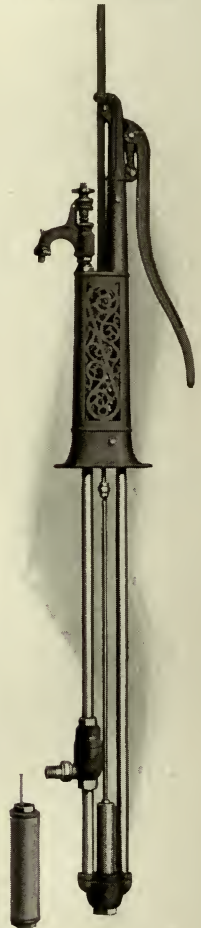

With this style of the "Peerless" pumps, the water may be discharged through the spout or through the underground discharge pipe by simply turning a hand-wheel at the top of the spout which operates the distributing valve in the discharge pipe.

Well casing must come only to the UPPER cylinder attachment, 4 feet, 3 inches below the base of the pump, and a pit of that depth should be dug to accommodate the distributing valve. Our new distributing valve is the acme of perfection. With it the water may be discharged through the underground discharge pipe, into a tank at house or barn, a considerable distance from the well.

The lower cylinder furnished with this type of "Peerless" pump is our flush capped cylinder, Fig. 322. These pumps may be used in wells up to 200 feet deep, if a smaller diameter cylinder is used than is listed below—see table on page 30.

Fig. 283 has $\frac{1}{2}$ -inch plunger rod fitted with $\frac{1}{2}$ x $\frac{3}{8}$ -inch coupling.

Fig. 453 has windmill rod 1 x $\frac{3}{8}$ -inch, welded to $\frac{1}{2}$ -inch steel rod and connected to plunger rod with union coupling. Plunger stub rod is threaded $\frac{3}{8}$ inch.

A drip hole in the discharge pipe, 3 feet below the base, allows the water to flow back into the well and prevents freezing.

Brass Valve Seats are regularly furnished on these pumps.

Sizes and Prices

Fig.	No.	Diameter Lower Cylinder Inches	Fitted for Pipe Inches	Stroke Inches	Under-ground Discharge Inches	Diam. Well Lower Cyl. Goes In Inches	Weight in Pounds	WITH BRASS CYLINDER	
								Cipher	Price
283	2	2½	1¼	6	1	3	106	BELVEDERE	\$19.00
283	4	3	1¼	6	1	3½	109	BENEFACITOR	19.00
453	2	2½	1¼	6	1	3	115	BENGAL	20.00
453	4	3	1¼	6	1	3½	116	BETHEL	20.00

Complete Table of Contents and General Classification of Pumps, Pages 7 and 8



Deming "Peerless" Cog Lever Force Pumps

Fig. 450½, for Shallow Wells

For Shallow and Deep Wells
Will Lift and Force 50 to 75 Feet

Fig. 451½ For Deep Wells

These two pumps are fitted with the Deming Cog Lever Top, but otherwise they are the same as Figs. 450 and 451, pages 43 and 44, respectively.

No. 2 can be used by hand in wells up to 75 feet deep; No. 4 in wells up to 50 feet deep; No. 6 in wells up to 35 feet deep or less, than the depth mentioned. Our Fig. 308 cylinder is furnished with these pumps. For deeper wells a smaller cylinder should be used than is listed below—see table on page 30.

Figs. 450½ and 451½ have windmill rod 1 x ¾ inch, threaded ⅞ inch and coupled to ½-inch plunger rod with compression coupling. Lower end of rod is furnished with ⅞ x ¾-inch coupling for cylinder rod.

The "Peerless" pumps with cog lever can be used either by hand or windmill. The gear guard ABSOLUTELY PREVENTS possibility of CHILDREN'S FINGERS becoming caught in the cogs.

When used as a hand pump, a pin is inserted at the opening "C." When used as a windmill pump the pin is taken out, which allows the handle or lever "E" to drop down, and in addition a windmill slide rod is attached.

Brass Valve Seats are regularly furnished on these pumps.



Detail Cut of Cog Lever

Key to Engraving

- A—Wood rod of windmill.
- B—Hercules windmill connection.
- C—Opening for steel pump pin used always with hand pumps.
- D—Combination coupling for connecting flat and round rod.
- E—Lever, which hangs down when pin is removed from "C."
- F—Gear guard, partly broken away to show cogs "G" on lever and rack.
- G—Cog mechanism, a part of lever "E."
- H—Actuating rack for hand use.
- When used by hand the pin must be inserted at "C."
- J—Bolt for supporting air chamber pipe.

Sizes and Prices

Fig.	No.	Diameter Lower Cylinder Inches	Fitted for Pipe Inches	Stroke Inches	Will Go In Drilled Wells Inches	Weight in Pounds	WITH BRASS-LINED CYLINDER	
							Cipher	*Price
450½	2	2½	1¼	6	5½	99	BURIAL	\$16.50
450½	4	3	1¼	6	5½	101	BURIER	16.50
450½	6	3½	1½	6	6½	103	BURKE	18.50
451½	2	2½	1¼	6	5½	91	BURKED	17.50
451½	4	3	1¼	6	5½	103	BURKING	17.50
451½	6	3½	1½	6	6½	105	BURKER	19.50

*Extra list for Fig. 390 "Hercules" Windmill connection, \$1.00.

Engineering Tables and Information Relating to Hydraulics, Pages 239 to 248



Deming "Peerless" Cog Lever Windmill Force Pumps

Fig. 452½
For Drilled Wells

For Drilled Wells; and with Three-Way
Distributing Valve

Fig. 453½
With Three-Way
Discharge Valve

Will Lift and Force 50 to 75 Feet



Figs. 452½ and 453½ are the same as pumps illustrated on pages 45 and 46, respectively, except that these pumps are fitted with cog lever tops instead of the plain windmill top.

These cog lever "Peerless" pumps are made WITH WINDMILL OR HAND TOP and we can furnish them either way at the same price, since the extra length of windmill rod is the only difference between the hand and windmill cog lever pumps. They may be used in wells up to 200 feet deep, if smaller diameter cylinders are used than listed below—see table on page 30.

All "Peerless" pumps are furnished with hose tubes so that garden hose can be used.

The lower cylinder furnished with this type of "Peerless" pump is our flush capped brass body cylinder, Fig. 322.]

Figs. 452½ and 453½ have windmill rod 1 x 3/8 inch, threaded 1/8 inch and coupled to 1/2-inch plunger rod with compression coupling. Lower end of rod is furnished with 7/16 x 3/8-inch coupling for cylinder rod.

A drip hole in the set length pipe, three feet below the base, allows the water to flow back into the well and prevents freezing.

Brass Valve Seats are regularly furnished with these pumps.

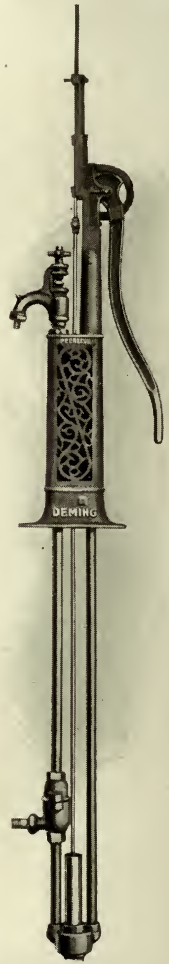

Sizes and Prices

Fig.	No.	Diameter Lower Cylinder Inches	Fitted for Pipe Inches	Stroke Inches	Set Length and Lower Cylinder Will Go In Drilled Well Inches	Weight in Pounds	WITH BRASS CYLINDER	
							Cipher	Price
452½	2	2½	1¼	6	3½	91	BURL	\$18.50
452½	4	3	1¼	6	4	98	BURLACE	18.50
					Lower Cyl. Will Go In Drilled Wells, Inches			
453½	2	2½	1¼	6	3	115	BURLY	21.50
453½	4	3	1¼	6	3½	116	BURLESQUE	21.50

Complete Table of Contents and General Classification of Pumps, Pages 7 and 8



W E L L P U M P S T A N D A R D S

FOR HAND AND WINDMILL

LIFT AND FORCE PUMP STAND-
ARDS, STUFFING-BOX HEADS,
ETC., FOR EITHER SHALLOW OR
DEEP WELLS; THE CYLINDER
OR WORKING BARREL BEING
SEPARATE AND USUALLY
PLACED IN THE
WATER





Typical Deming Force Pump Standard (in Section)

For Operation By Hand or Windmill

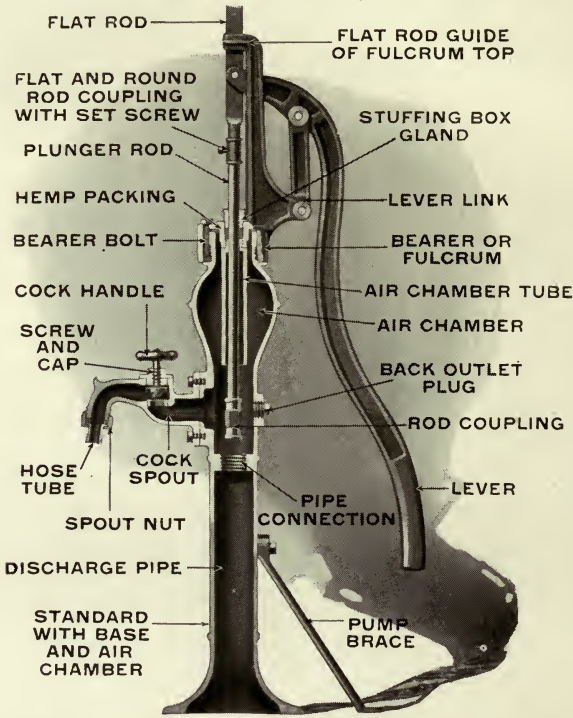

This illustration will serve to identify the parts entering into the construction of a pump standard. It portrays our Fig. 444 windmill force pump standard, which is a representative type of the classification to which this particular section of our Catalogue is devoted.

The term "Standard," as applied to pumps, indicates a pump stock with bearer, lever and rod connection fitted for pipe and adapted for use with any ordinary independent cylinder when pipe and rod are added. "Standards" are classified as follows: Hand lift pump standard; Windmill lift pump standard; Hand force pump standard; Windmill force pump standard; Deep well force pump standard, also hand and windmill standards with underground discharge, all of which are described on the following pages of this section.

The dealer can fit a pump for a well of any depth by securing the proper standard and cylinder and supplying the pipe and rod from his stock. Many dealers do this in preference to buying the complete set length pump.

When standards are required for wells 75 feet deep or more, well pipe should be carried by independent supports in the well, so that the weight of the pipe will not be carried entirely by the thread in the standard. The cylinders should in no case be placed a greater distance than twenty feet above the water to secure good suction, and wherever possible they should be submerged. The size of cylinder to be used with each standard is determined by the depth of the well. (See table on page 30.)

Deming standards with six inch stroke are fitted regularly for 1 1/4 inch pipe; with ten inch and adjustable stroke, for two inch pipe. However, we will tap them for other sizes of pipe, when so ordered, and will also thread the stub of the rods of both the standards and cylinders for such sizes of couplings as may be specified.

Deming standards are the result of years of experience. They are well proportioned and practical, and are as near perfection as it is possible to make them.

Complete Table of Contents and General Classification of Pumps, Pages 7 and 8



Deming Improved Well Lift Pump Standard

With Pipe Connection Under Spout
For Wells 70 Feet Deep or Less

Fig. 224—Open Top



This pump standard is suited for use in wells up to 70 feet deep. It has solid base and is threaded for pipe under the spout.

Attached to the lever of Fig. 224 is a rod eye connection for $\frac{7}{16}$ -inch well rod. A set screw on this connection holds the rod in place. When the pump is installed, the complete length of $\frac{7}{16}$ -inch or $\frac{3}{8}$ -inch rod may be used from cylinder to top of pump, without coupling. *For this reason we do not furnish Fig. 224 with stub rod.*

Fig. 224 is tapped in the standard for 2-inch pipe. A combination bushing, however, is regularly furnished for $1\frac{1}{4}$ -inch or $1\frac{1}{2}$ -inch pipe, thus adapting it for varying conditions.

Cylinders or working barrels for use with this pump will be found elsewhere.

Sizes and Prices

No.	Fitted for Pipe	Length of Stroke Inches	Height Inches	Weight Pounds	Cipher	Price
4	$1\frac{1}{4}$	6	45	50	BELCH	\$5.50



Deming Deep Well Lift Pump Standard
With Bolted Pipe Flange

For Wells 150 Feet Deep or Less

Fig. 230



Fig. 230 is an extra heavy lift pump standard, which will give good service in wells 150 feet deep, provided a two-inch cylinder is used. It is, of course, more desirable to install the pump in wells of lesser depth.

Fig. 230 is made in two sections, with pipe flange bolted between so that the upper section can be removed while connection is being made to the well pipe. After the operation is completed, the upper section can be replaced.

With such a heavy pump as Fig. 230, the flange construction will be found very convenient, because, when making the connection to well pipe, there is only the lower section to be handled. The lever is long and weighted.

Pump rod is $\frac{7}{8}$ -inch piston rod steel, threaded $\frac{7}{16}$ -inch and fitted with $\frac{7}{16} \times \frac{3}{8}$ -inch reducing coupling for connecting to $\frac{3}{8}$ -inch well rod.

Fitted for $1\frac{1}{4}$, $1\frac{1}{2}$, or $2\frac{1}{2}$ -inch pipe when so ordered. Extra pipe flanges, 50 cents extra list.

Sizes and Prices

Stroke Inches	Fitted for Pipe Inches	Height Inches	Weight Pounds	Cipher	Price
7	2	51½	83	BRAMBLE	\$10.00

Complete Table of Contents and General Classification of Pumps, Pages 7 and 8



Deming Deep Well Force Pump Standards
With Upward Discharge

Fig. 231 Will Lift and Force 35 to 150 Feet Fig. 1231



Provided a two-inch cylinder is used, Figs. 231 and 1231 will lift and force 150 feet, but of course it is more desirable to install them where the duty is not quite so heavy, and then use 2½ or 3-inch cylinders. These are very heavy and substantial force pump standards, and are very often used as school pumps, town pumps, etc. They are especially well adapted to coal mining sections, or wherever unusually hard service is to be expected.

These pumps are made in two sections with pipe flange bolted between, so that the upper section can be removed while connection is being made to well pipe. After the operation is completed, the upper section can be replaced.

This makes it necessary to handle only the lower section, during the installation. In the case of such heavy pumps, dealers and well drillers will much appreciate this feature.

Fig. 1231 is furnished regularly with cock spout, and with nut on upward discharge, tapped for pipe. Fig. 231 has plain spout fitted with hose nut and tube. Air chamber of Fig. 231 is fitted with cap nut on upward discharge.

Pump rod is 7/8-inch piston rod steel, threaded 7/8-inch and fitted with 7/8 x 3/8-inch reducing coupling for connecting to 3/8-inch well rod.

Sizes and Prices

Fig.	Fitted for Pipe Inches	Stroke Inches	Height Inches	Upward Discharge Fitted for Pipe Inches	Weight Pounds	Cipher	Price
231	2	7	51½	Cap Nut	115	BRANCHED	\$13. 00
1231	2	7	51½	1¼	120	BURRY	15. 50

Alphabetical Index, Figure Index and Telegraph Cipher Code, Pages 249 to 254



Deming Improved Well Force Pump Standards
 With Air Chamber in the Stock
 Will Lift and Force 35 to 100 Feet

Fig. 1229

Fig. 1229



Well force pump standards with solid base, Figs. 1229 and 1229, when used in connection with cylinders of the proper sizes will lift and force 35 to 100 feet. To prevent freezing, the pipe should be provided with a drip hole three feet below the base, which allows the water to flow back after pump has been used.

The air chamber is formed by enlarging the stock above the spout. By loosening one set screw, the lever may be set at any angle to the spout. The spout is flanged and bolted to the standard, and is furnished with nut and 3/4-inch hose tube.

Pump rod is 5/8-inch cold rolled steel, threaded 1/8-inch and fitted with reducing coupling for 3/8-inch well rod.

Fig. 1229 is regularly furnished with cock spout. Cylinders or working barrels for use with these standards are listed elsewhere.

Sizes and Prices

Fig.	Stroke Inches	*Fitted for Pipe Inches	Height Inches	Back Outlet Tapped for Pipe Inches	Weight Pounds	Cipher	Price
229	6	1 1/4	48 1/2	1 1/4	58	BRAINED	\$ 9.00
1229	6	1 1/4	48 1/2	1 1/4	63	BURROW	11.50

*Fitted for 1 1/2 or 2-inch pipe when so ordered.

Complete Table of Contents and General Classification of Pumps, Pages 7 and 8



Deming Improved Well Force Pump Standards
With Air Chamber Bolted on the Standard
Will Lift and Force 35 to 100 Feet

Fig. 239

Fig. 1239



Well force pump standards with solid base, Figs. 239 and 1239 when used in connection with cylinders of the proper sizes, will lift and force 35 to 100 feet. To prevent freezing, the pipe should be provided with a drip hole, three feet below the base, which allows the water to flow back into the well after pumping.

The air chamber is separate and bolted to standard. The upward discharge of Fig. 239 is furnished with a cap nut, spout, hose nut and tube. Air chamber of Fig. 1239 is fitted with nut tapped for pipe on upward discharge.

By loosening one set-screw, the lever may be set at any angle with the spout. Fig. 1239 is regularly supplied with cock spout. Otherwise it is same as Fig. 239.

Pump rod is $\frac{5}{8}$ -inch piston rod steel, threaded $\frac{1}{8}$ -inch and fitted with reducing coupling for $\frac{3}{8}$ -inch well rod.

Cylinders or working barrels for use with these standards are listed elsewhere.

Sizes and Prices

Fig.	Stroke Inches	Fitted for * Pipe Inches	Height Inches	Upward Discharge Fitted for Pipe Inches	Weight Pounds	Cipher	Price
239	6	1 $\frac{1}{4}$	49	Cap Nut	80	BRAINLESS	\$11.00
1239	6	1 $\frac{1}{4}$	49	1 $\frac{1}{4}$	85	BURSAR	13.50

*When so ordered. can be fitted for 1 $\frac{1}{2}$ or 2-inch pipe.



Deming Windmill Lift Pump Standards
For Wells 100 Feet Deep or Less

Fig. 403



Fig. 394

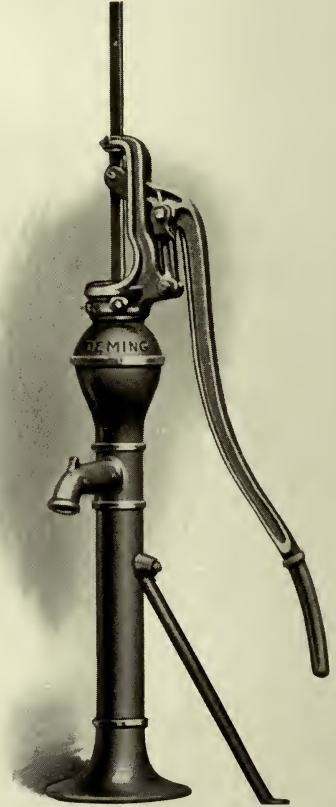

FIG. 403 is one of our most popular windmill lift pump standards. It is strong and substantial, and symmetrical in design. The pipe screws into the stock under the spout. Fig. 403 is regularly tapped in the standard for 2-inch pipe. To adapt it for 1¼-inch or 1½-inch pipe we will furnish a combination bushing when specified.

FIG. 394 is a swell top windmill lift pump standard adapted for either tubular or drilled wells. The enlarged top forms a water chamber which prevents the water from escaping at the top. Furnished regularly with solid windmill rod. Base is cast solid on the stock.

Both of the standards have adjustable bearers. Pump rod is threaded 7/8-inch and is supplied with a coupling for reducing to 3/8-inch. Cylinders or working barrels for use with these standards will be found elsewhere.

Sizes and Prices

Fig.	No.	WITH SIX-INCH STROKE			WITH TEN-INCH STROKE				WITH ADJUSTABLE STROKE 6, 8 or 10-INCH				
		*Fitted for Pipe Inches	Cipher	Weight Pounds	Price	*Fitted for Pipe Inches	Weight Pounds	Cipher	Price	*Fitted for Pipe Inches	Cipher	Weight Pounds	Price
403	4	1½	DAINTY	56	\$7.50	2	63	DAMNABLE	\$8.50	2	DENTIL	64	\$9.00
394	..	1¼	DABBING	58	8.00	2	60	DABBING	9.00	2	DEMY	62	9.50

Complete Table of Contents and General Classification of Pumps, Pages 7 and 8



Deming Windmill Force Pump Standards
With Adjustable Stroke and Solid Rod

Fig. 484

For Wells 80 Feet Deep or Less

Fig. 1444



Fig. 484 is a very useful Force Pump Standard, with windmill top and swivel spout. This pump can be used with any of our independent cylinders shown elsewhere. In certain cases there are advantages in using a pump of this kind, since the position of the spout and lever can be changed at will after the pump is set in the well. The fulcrum top and the spout can be placed in any desired position with relation to each other. A separate flange between the base and the top permits the well pipe to be easily attached. Windmill rod is 1 x 3/8 inch, welded to 1 1/8-inch cold-rolled steel, threaded 7/8-inch, and supplied with coupling for reducing to 3/8-inch. This pump, as shown, has solid rod, which can be removed without disturbing the fulcrum top or stuffing-box. This is a great advantage when installing the pump. If plain spout is wanted, instead of cock spout, deduct \$2.50 from list.

Fig. 1444 is similar to our Figs. 440 and 444, illustrated elsewhere, except that it is fitted with a solid rod, the same as Fig. 484.

Sizes and Prices

Fig.	*Fitted for Pipe Inches	†Stroke	Back Outlet Tapped for Pipe Inches	Side Outlet Tapped for Pipe Inches	Height to Top of Rod Guide Inches	Weight Pounds	Cipher	Price
484	1 1/4	Adjustable	...	1 1/4	53	77	DEPOSER	\$16.00
1444	1 1/4	6, 8 or 10-inch	1 1/4	...	50	74	DERM	15.00

*Fitted for 1 1/2 or 2-inch pipe when especially so ordered.

†When especially ordered, adjustable stroke pumps will be fitted for 12-inch windmill stroke.

Alphabetical Index, Figure Index and Telegraph Cipher Code, Pages 249 to 254



Deming Windmill Lift Pump Standard
With Long Fulcrum
For Wells 35 to 100 Feet Deep

Fig. 494



Our improved Windmill Lift Pump Standard, with extra long fulcrum, will be greatly appreciated by pump dealers and users. The long fulcrum throws all the strain of the lever when pumping, on the base of the pump instead of the pump top. By this arrangement the pump top and rod guide will always remain rigid and in place.

The illustration shows Fig. 494 with adjustable stroke. It is also made with six-inch stroke, as listed below.

The pump rod is threaded $\frac{7}{16}$ -inch, and is fitted with a $\frac{7}{16} \times \frac{3}{8}$ -inch coupling, so that $\frac{7}{16}$ or $\frac{3}{8}$ -inch rod may be used. Pumps that are tapped for two-inch pipe will, when specified, be fitted with one-inch wood rod fork.

Cylinders or working barrels for use with this standard are illustrated and listed elsewhere.

Sizes and Prices

Fig.	Stroke Inches	*Fitted for Pipe Inches	Weight Pounds	Cipher	Price
494	6	$1\frac{1}{4}$	65	DEITY	\$ 8.50
491	6, 8 and 10	2	70	DEJECTION	10.00

*Fitted for 1, $1\frac{1}{4}$, $1\frac{1}{2}$ or 2-inch pipe, but always as listed, unless otherwise ordered.

Complete Table of Contents and General Classification of Pumps, Pages 7 and 8



Deming Windmill Force Pump Standards

With Long Fulcrum and Back Outlet
Will Lift and Force 35 to 200 Feet

Fig. 496



Fig. 498



The long fulcrum or bearer throws all of the lever strain on the base when pumping, instead of putting it on the pump top.

Accurate and permanent alignment of the piston rod is secured by casting the stuffing-box and rod guide in one piece. The levers can be disconnected when the pump is to be operated by windmill. The spout is flanged and bolted to the standard. Hose tube and nut are regularly furnished.

Back outlet is tapped regularly for 1¼-inch pipe, for discharging into elevated tank. Pump rod is made of ¾-inch piston rod steel. It is threaded 7/16-inch and is furnished with a 7/16 x 3/8-inch coupling so that 7/16 or 3/8-inch well rod may be used.

Where there is no liability to danger from freezing, we recommend the use of foot valves with these standards. Figs. 496 and 498 are made to exact gauges so that repairs will always fit.

Fig. 498 is regularly furnished with cock spout. Otherwise it is exactly like Fig. 496.

Cylinders or working barrels for use with these standards are illustrated and listed elsewhere.

Sizes and Prices

WITH SIX-INCH STROKE							WITH ADJUSTABLE STROKE—6, 8 OR 10-INCH				
Fig.	Spout	Fitted for Pipe Inches	Weight Lbs.	Back Outlet Tapped for Pipe Inches	Cipher	Price	Fitted for Pipe Inches	Weight Lbs.	Back Outlet Tapped for Pipe Inches	Cipher	Price
496	Plain	1¼	80	1¼	DELIGHT	\$11.00	2	80	1¼	DELUSION	\$12.50
498	Cock	1¼	83	1¼	DELIRIUM	13.50	2	83	1¼	DEMAGOGUE	15.00



Deming Windmill Force Pump Standards

With Back Outlet

Will Lift and Force 35 to 200 Feet

Fig. 440



Fig. 444



These popular Standards are adapted for hand or windmill use. They have revolving tight top. The piston rod is always in line because the stuffing-box and rod guide are made in one casting. Stuffing-box gland is brass. The lever can be disconnected when the pumps are to be operated by windmill. The spout is flanged and bolted to the Standard. Hose tube and nut are regularly furnished. The bearer is secured with strong hook bolts.

The back outlet on each pump is tapped for 1¼-inch pipe.

The pump rod is made of ¾-inch piston rod steel; is threaded 1/8 inch and is furnished with a 7/16 x 3/8-inch coupling, so that 7/8 or 3/8-inch well rod may be used.

Where there is no liability to danger from freezing, we recommend the use of foot valves and strainers with these standards. Figs. 440 and 444 are made to exact gauges, so that repairs will always fit.

Cylinders or working barrels for use with these standards are illustrated and listed elsewhere.

Sizes and Prices

WITH SIX-INCH STROKE						WITH ADJUSTABLE STROKE—6, 8 OR 10-INCH				
Fig.	Fitted for Pipe Inches	Height Inches	Weight Lbs.	Cipher	Price	Fitted for Pipe Inches	Height Inches	Weight Lbs.	Cipher	Price
440	1¼	46	63	DUBBER	\$10.00	2	50	70	DUBBING DUBIOUSLY	\$11.50
444	1¼	46	65	DUBIOUS	12.50	2	50	72		

Complete Table of Contents and General Classification of Pumps, Pages 7 and 8



Deming Windmill Force Pump Standard

With Cog Lever Top
Will Lift and Force 35 to 200 Feet

Fig. 444½



This is a standard for hand or windmill use, equipped with cog lever top instead of plain windmill top. The gear action is well guarded to prevent accidents. The rack can be disconnected when the pump is to be operated by windmill.

The bearer is adjustable and is secured to the stock by three hook bolts. The piston rod is always in line because the stuffing-box and rod guide are made in one casting. Stuffing-box gland is brass. The spout is flanged and bolted to the standard. Hose tube and nut are regularly included. Back outlet is tapped for 1¼-inch pipe.

The pump rod is made of ¾-inch piston rod steel; is threaded 7/16-inch and is furnished with a 7/16 x 3/8-inch coupling, so that 7/16 or 3/8-inch well rod may be used.

Where there is no liability of freezing, we recommend the use of a foot valve and strainer with this standard.

Deduct \$2.50 from list price if plain spout is desired instead of cock spout.

Cylinders or working barrels for use with this standard are illustrated and listed elsewhere.

Sizes and Prices

Figure	Stroke Inches	Fitted for Pipe Inches	Height Inches	Weight Pounds	Cipher	Price
444½	6	1¼	52	75	DIVULGE	\$13.50

Alphabetical Index, Figure Index and Telegraph Cipher Code, Pages 249 to 254



Deming Windmill Force Pump Standard
 With Renewable Guide Bushing and Patented Windmill Top
 Will Lift and Force 35 to 200 Feet

Fig. 445



Complete View of Fig. 445

Detail View of Patent Windmill Top

This is a good heavy windmill standard suitable for operation by pump jack or windmill. The windmill top is of new design and is heavily reinforced at the points where in other pumps of this type breakage is most liable.

The detail view (illustration to the left) shows our new patented windmill top and air chamber tube. The patented feature consists of a loose ring which keeps the three bolts in place and prevents them from falling to the ground or into the well, should it be necessary to remove the top.

The bushing on the windmill slide rod can be renewed when worn. In many pumps it is necessary to buy an entire new top when the guide wears out.

Fig. 445 is tapped in the standard for 2-inch pipe. A combination bushing, however, is regularly furnished for 1¼ and 1½-inch pipe, thus adapting it for varying conditions. The pump rod is made of ¾-inch piston rod steel. It is threaded 7/16-inch and is furnished with a 7/16 x 3/8-inch coupling so that 7/16-inch or 3/8-inch rod may be used.

Where there is no liability to danger from freezing, we recommend the use of foot valve and strainer with this standard.

The spout is provided with a hose nut and tube. Deduct \$2.50 from list price if cock is not desired.

Cylinders or working barrels for use with this standard are shown and listed elsewhere.

Sizes and Prices

Figure	Fitted for Pipe Inches	Height Inches	Back Outlet Inches	Stroke	Weight Lbs.	Cipher	Price
445	1¼, 1½ and 2	52	1¼	Adjustable 6, 8 or 10 Inches	77	DIVORCE	\$15.00

Complete Table of Contents and General Classification of Pumps, Pages 7 and 8



Deming Windmill Force Pump Standard

With Flanged Base and Patented Bearer

Will Lift and Force 35 to 200 Feet

Fig. 441



Complete View of Fig. 441

Detail View of Patent
—Windmill Top

This is a very strong, durable and convenient standard. The bearer is clamped to the stock by three hook bolts. Should it become necessary for any reason to remove the bearer, the bolts will be kept in place by a loose ring, which prevents them from dropping to the ground or in the well. The detail cut explains this construction. This style of bearer is fully covered by our patents.

A separate flange between the base and the stock permits the well pipe to be easily attached. This makes it possible to remove the standard while connection is being made to the well pipe, which is a very much easier method of installing, than if the entire heavy pump had to be handled during the setting.

Fig. 441 is regularly furnished with $\frac{3}{4}$ -inch brass cased plunger rod, threaded at the bottom $\frac{7}{8}$ -inch and furnished with a $\frac{7}{16} \times \frac{3}{8}$ -inch coupling so that either $\frac{7}{8}$ or $\frac{3}{8}$ -inch steel rod may be used.

Fig. 441 has a brass packing gland. When tapped for two-inch pipe and larger, our artesian well cylinders, Figs. 311 and 324, may be used to advantage in connection with this pump. Other cylinders or working barrels for use with this standard are listed elsewhere.

The bushing on the windmill slide rod can be renewed when worn. In many pumps it is necessary to buy an entire new top when the guide wears out. The heavy metal ball will be found an aid to pumping — especially if the well is very deep. Cock spout is fitted with hose nut and tube.

Fig. 441 is made with adjustable stroke only. Deduct \$2.50 if plain spout is wanted instead of cock spout.

Where there is no danger from freezing, we recommend the use of foot valve and strainer with this standard.

Sizes and Prices

Figure 441	*Fitted for Pipe Inches	Height Inches	Back Outlet Inches	†Stroke	Weight Lbs.	Cipher	Price
Standard Complete With Cock Spout	2	55	1¼	Adjustable 6, 8 or 10 Inch	92	DIVINING	\$16.00

*Fitted for 1¼, 1½, 2, 2½ or 3-inch pipe, but always as listed, unless otherwise ordered.

†When especially ordered, adjustable stroke pumps will be fitted for 12-inch windmill stroke.

Engineering Tables and Information Relating to Hydraulics, Pages 239 to 248



Deming Windmill Force Pump Standard

With Air Chamber, Cock Spout and Flanged Base
Will Lift and Force 35 to 200 Feet

Fig. 407



Fig. 407 has a flange for pipe, located near the base. This makes it possible to remove a large part of the pump while connection is being made to the well pipe, which is a very much easier method of installing the pump, than if the entire heavy pump had to be handled during the setting. The bolts in the air chamber are so spaced that the spout can be turned 90 degrees in either direction.

Fig. 407 has an upward and back outlet or discharge. This pump can be attached to pipe up to three inches, which especially adapts it for use with artesian well cylinders. Air chamber is fitted with a nut tapped for pipe on upward discharge.

Where there is no danger from freezing, we would recommend the use of foot valve and strainer with this standard.

Pump rod is made of $\frac{3}{4}$ -inch piston rod steel, threaded $\frac{1}{8}$ -inch at the bottom and furnished with a reducing coupling for $\frac{3}{8}$ -inch well rod.

Fitted for $1\frac{1}{4}$, $1\frac{1}{2}$, 2, $2\frac{1}{2}$ or 3-inch pipe, but always as listed, unless otherwise ordered. Extra flanges, 50 cents each.

Cylinders or working barrels for use with this standard are shown and listed elsewhere.

Sizes and Prices

Figure 407	WITH SIX-INCH STROKE					*WITH ADJUSTABLE STROKE—6, 8 or 10-Inch				
	Fitted for Pipe Inches	Height Inches	Weight Lbs.	Cipher	Price	Fitted for Pipe Inches	Height Inches	Weight Lbs.	Cipher	Price
Standard Complete	$1\frac{1}{4}$	49	110	DEANERY	\$16.00	2	53	115	DEANSHIP	\$18.00

*When especially ordered, adjustable stroke pumps will be fitted for 12-inch windmill stroke.

Complete Table of Contents and General Classification of Pumps, Pages 7 and 8



Deming Special Windmill Force Pump Standard

Will Lift and Force 35 to 200 Feet
With Underground Discharge

Fig. 408

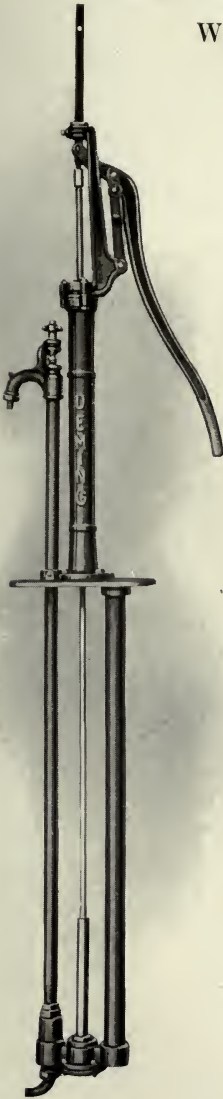

Fig. 408 has been heavily reinforced in the places which are most liable to breakage in a pump of this kind, so that it is well adapted for operation by pump jack. The stock is of uniform diameter — three inches — between the two rings so that all makes of jacks can be used.

Should it be necessary to remove the bearer, the three hook bolts can be loosened and the top taken off, but the bolts are kept from dropping to the ground or into the well by the loose ring which holds them securely in place. This feature is patented.

The air chamber of Fig. 408 is two inches in diameter. A $1\frac{1}{4}$ -inch differential cylinder is furnished instead of a stuffing-box. The pump rod is $\frac{3}{4}$ -inch and is one complete rod, unbroken by couplings, except where it is coupled to the guide rod at top of pump. Lower end of pump rod is furnished with $\frac{1}{2} \times \frac{3}{8}$ -inch coupling. The bushing for the guide rod is renewable. In many pumps a complete new bearer has to be secured when the guide wears out.

The plunger and valve may be withdrawn from two-inch tubular wells after stuffing-box is removed. The union elbow coupling for underground connections can be turned the direction of the pipe.

Fitted for other sizes of suction pipe when especially ordered.

Cylinders or working barrels for use with this pump are listed elsewhere.

Sizes and Prices

Figure	Stroke	Suction Fitted for Pipe Inches	Underground Discharge Fitted for Pipe Inches	Weight Pounds	Cipher	Price
408	Adjustable 6, 8 or 10 Inch	$1\frac{1}{4}$	1	145	DIASPORE	\$23.00



Fig. 260
Plain
Windmill Top

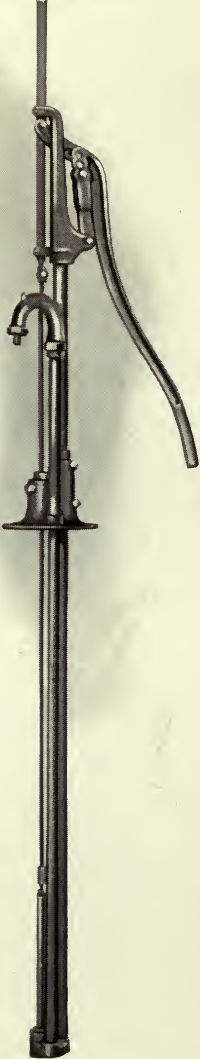

Deming Force Pump Standards
With Adjustable Base
Will Lift and Force 35 to 200 Feet

In these pumps the standard is formed of pipe; the pipe to which the windmill top is attached, acting as an air chamber.

The differential plunger in the set length helps to make a smooth, uniform flow since the water is discharged at each stroke.

The one inch differential plunger is used instead of a stuffing box.

These pumps have a 1¼-inch air chamber pipe and 1-inch discharge pipe.

The base is adjustable so that the pump standard may be made any desired length. Fig. 258 is identical with Fig. 260, except that it is fitted with a cog lever top for hand or windmill use and with enclosed gears. The spout can be swung to the left or right. Either pump will go into 5⅝-inch casing.

Fig. 260 is fitted with adjustable stroke lever for 6, 8 or 10-inch stroke. The cylinder is not included in the list price.

Figs. 260 and 258 have windmill rod 1 x ⅜ inch, threaded ⅞-inch and coupled to ⅞-inch plunger rod with compression coupling.

The ⅞-inch rod is coupled to ⅞-inch piston stub rod which is threaded on the bottom ⅜-inch.

Cylinders or working barrels for use with these standards are illustrated and listed elsewhere.

Fig. 258
Cog Lever
Windmill Top

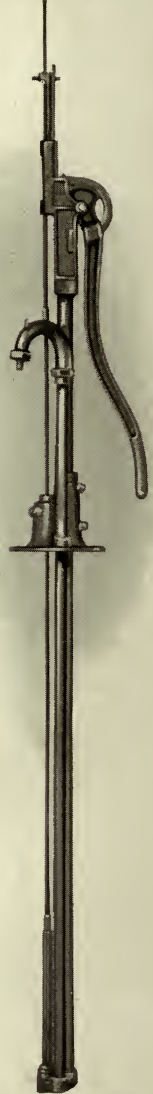

Sizes and Prices

Figure	Fitted for Pipe	Stroke	Weight in Pounds	Cipher	Price
260	1¼	Adjustable 6, 8 or 10 Inch	60	BUSTLE	\$11.50
258	1¼	6 Inch Hand 10 Inch Mill	60	BUSTARD	12.50

Complete Table of Contents and General Classification of Pumps, Pages 7 and 8



Deming Force Pump Standards

Fig. 261
Plain
Windmill Top

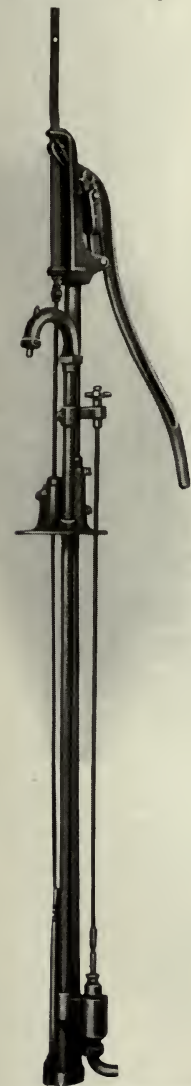

Will Lift and Force 35 to 200 Feet
With Three Way Distributing Valve

Except for the addition of the three way distributing valve for underground discharge to tank, Figs. 261 and 259 are the same as Figs. 260 and 258 on the opposite page.

The three way valve being on the **outside** of the discharge pipe gives free passage to the water and greatly lessens the effort required for operation.

The stuffing-box for the three way valve is located **below the frost line**.

The gears on Fig. 259 are completely enclosed, making the pump entirely safe for children to operate. The cog lever insures a straight line movement of the piston rod.



Sectional View of
Three Way Valve

The elbow on the three way valve can be turned either to the right or left as desired. The cylinder is not included in the list price.

Figs. 261 and 259 have windmill rod 1 x $\frac{3}{8}$ inch, threaded $\frac{1}{16}$ -inch and coupled to $\frac{7}{16}$ -inch plunger rod with compression coupling. The $\frac{1}{16}$ -inch rod is coupled to $\frac{7}{16}$ -inch piston stub rod which is threaded on the bottom $\frac{3}{8}$ -inch.

Fig. 259
Cog Lever
Windmill Top



Sizes and Prices

Figure	Fitted for Pipe Inches	Stroke	Weight in Pounds	Cipher	Price
261	1 1/4	Adjustable 6, 8 or 10 Inch	65	BUSTER	\$13.50
259	1 1/4	6 Inch Hand 10 Inch Mill	65	BUSKY	14.50



Deming Windmill Force Pump Standards

Fig. 415

With Underground Discharge

Fig. 415½

Will Lift and Force 35 to 200 Feet

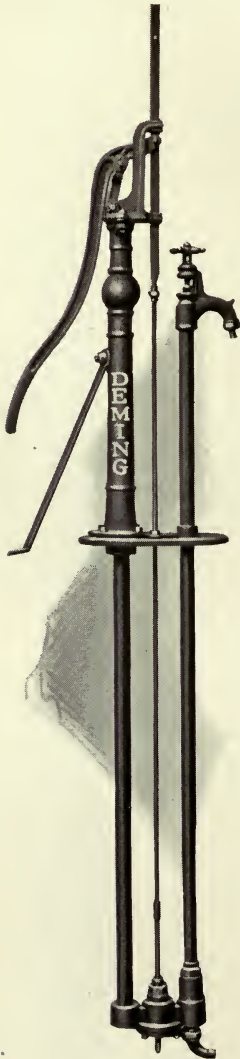

These pumps were perfected to meet the requirements of the principal windmill manufacturers in the United States for better windmill force pumps with three-way valves than had heretofore been produced.

They have won their reputation on their merits, are the original pumps of this type and have been in use for more than thirty years.

The especial feature of these pumps is their distributing valve. The union elbow coupling for underground connection can be turned to suit the direction of the pipe, so that water can be discharged underground without danger from freezing. The distributing valve is operated by the hand wheel above the discharge spout.

The air chamber pipe on these pumps is 1½ inches diameter.

With Fig. 415, the plunger can be withdrawn from 2-inch tubular wells by removing the stuffing box.

Fig. 415½ has differential plunger 1¼ inches diameter instead of stuffing box and gland. When used with 2-inch tubular wells the valves may be withdrawn without disturbing the pipe connections.

These standards may be fitted for 1, 1¼, 1½ or 2-inch suction pipe and ¾, 1 or 1¼-inch underground discharge pipe, but always as listed unless otherwise ordered. Fitted with 7/16-inch steel well rod and reducing coupling, so that ¾-inch rod can be used if desired.

Cylinders or working barrels for use with these standards will be found elsewhere.

Sizes and Prices

WITH SIX-INCH STROKE					WITH ADJUSTABLE STROKE (6, 8 or 10-Inch)			
Pump Standard as Illustrated	Fitted for Pipe Inches	Weight Pounds	Cipher	Price	Fitted for Pipe Inches	Weight Pounds	Cipher	Price
Figure 415	1¼ Suction	122	DEBAUCH	\$17.00	2 Suction	132	DECAY	\$18.50
415½	1¼ Suc. 1 Disch.	122	DEFER	18.00	2 Suc. 1 Disch.	129	DEL F	20.50

Complete Table of Contents and General Classification of Pumps, Pages 7 and 8



**“STRAIGHT LINE”
PUMPS
AND
WORKING HEADS**

FOR
SHALLOW AND DEEP WELLS

A DISTINCTIVE TYPE OF CON-
STRUCTION WHICH INSURES
UNUSUAL EASE OF OPERATION,
ACCESSIBILITY, CONVENIENCE,
SIMPLICITY AND DURABILITY.
MAY BE OPERATED BY HAND,
WINDMILL, GASOLINE ENGINE
OR ELECTRIC MOTOR.





Deming "Straight-Line" Working Heads

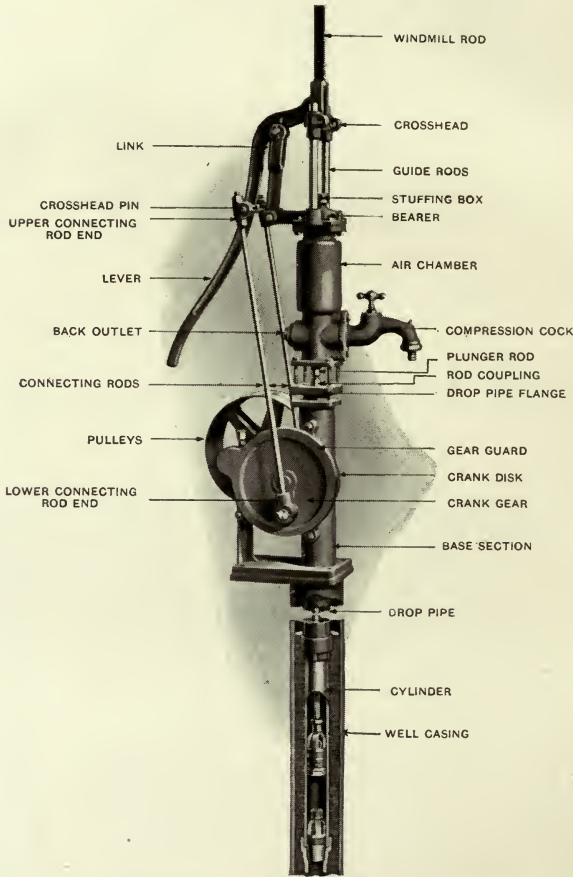

Illustration shows Fig. 1717, No. 1, with Air Chamber about to be replaced, after installation has been made

Suggestions for Installing

Our "Straight Line" pumps and working heads possess especial features of accessibility, ease of operation, convenience, simplicity and durability unequalled by any other pumps on the market. The illustration shows how easily this type of pump may be installed. Following are a few simple directions.

To install in well put a length of pipe and rod on cylinder and remove air chamber from base. Place pipe and cylinder in well, using necessary tools to hold pipe while installation is being made; then place base over well and draw pipe and rod up through base. Add desired lengths of pipe and rod, dropping them down through base; screw pipe flange to last thread of pipe. Pump base will then support entire weight of cylinder and pipe. Remove plunger rod from crosshead; connect it to cylinder rod, then place air chamber in position and bolt fast.

Complete Table of Contents and General Classification of Pumps, Pages 7 and 8



Deming "Straight-Line" House Force Pump For Operation by Hand, Windmill or Pump Jack Fig. 1700

Ease of operation, accessibility, convenience, simplicity and durability are the outstanding features of this pump. This "Straight Line" construction reduces the friction to a minimum, causes the pump to work smoothly and easily, and makes it practically proof against wear.

As illustrated, it may be operated by hand or windmill, but is also adapted for connection to any standard pump jack.

Fig. 1700 is intended for use in wells where the vertical suction distance is not greater than 25 feet. For discharge elevations see table below.

Specifications

CROSSHEAD is designed for use with hand, windmill or jack. The jack may be attached direct to crosshead or to windmill flat rod but preferably to crosshead.

STUFFING BOX AND GUIDE SUPPORTS are cast integral to insure permanent alignment.

STUFFING BOX is of the nut and gland type with brass gland.

PLUNGER has one leather, brass cage and valve, and iron follower. **PLUNGER ROD** is 3/4-inch brass-cased steel.

LOWER VALVE is a rubber-faced wing valve, guided by the cylinder bore, and can be easily lifted out with a piece of ordinary fence wire having bent end, after bearer and plunger are removed. See detail illustration of base.

UPWARD DISCHARGE on air chamber is fitted with union nut and galvanized malleable iron pipe tube.

BASE is bolted to the cylinder for convenience when installing.

BEARER AND AIR CHAMBER are each adjustable to three different positions.

ANTI-FREEZING. The lower valve is so constructed that it will trip upon contact with the plunger, permitting the water to drain from the cylinder back into the well. Therefore, to drain the pump see that the cock spout is open and raise the lever to its extreme height.

If pump is discharging into overhead tank, we recommend that a check valve be installed in the discharge line to prevent contents of tank from draining on such occasions.

Price below includes 1-inch Brass Bib Cock. If upward discharge only is wanted, deduct \$6.00 from list price.

Brass Valve Seat is regularly furnished on this pump.

Sizes and Prices

No.	Diam. Cyl. Inches	Suction and Upward Discharge Fitted for Pipe Inches	Stroke Inches	Discharge Elevation Feet		IRON		BRASS LINED		Weight Pounds
				Hand	Power	Cipher	Price	Cipher	Price	
4	3	1 1/2	6	50	100	ORVAL	\$27.50	ORYX	\$30.50	77

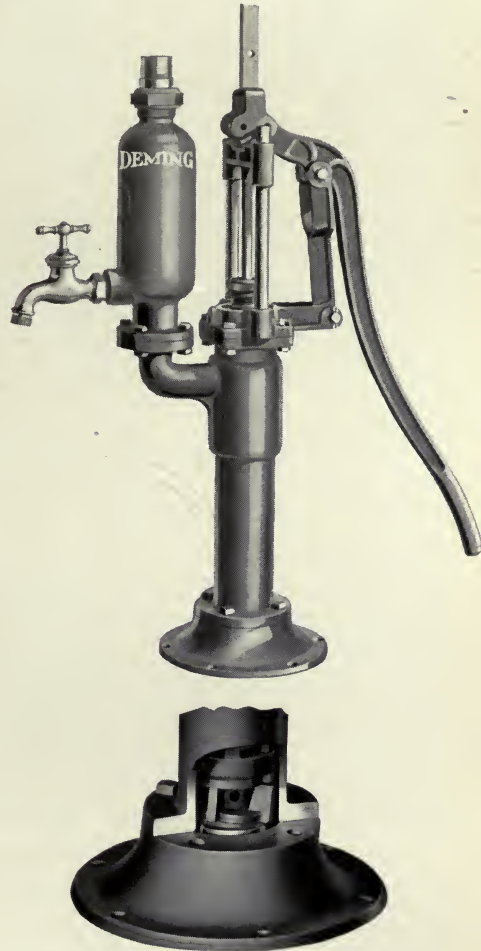

Cross Section of Base and Lower Part of Cylinder, Showing Construction and Operation of the Trip Valve.



Deming "Straight-Line" Windmill Force Pump Standard
For Wells 200 Feet Deep or Less

Fig. 1716

As illustrated, Fig. 1716 may be operated by hand, windmill or pump jack. Our distinctive "Straight Line" construction reduces friction to a minimum, causes the pump to work smoothly and easily and makes it practically proof against wear.

Specifications

CROSSHEAD is designed for use with hand, windmill or jack. The jack may be attached direct to crosshead or to windmill flat rod, but preferably to crosshead.

PISTON ROD, No. 1 is 3/4-inch cold-rolled steel; No. 2, 7/8-inch.

GUIDE SUPPORTS AND STUFFING BOX are cast integral to insure permanent alignment.

STUFFING BOX is of the nut and gland type with brass gland.

BEARER is adjustable to three different positions.

SEPARATE FLANGE BETWEEN BASE AND AIR CHAMBER for attaching drop pipe.

BACK OUTLET placed opposite discharge, for connecting to elevated tank.

Price includes one iron body compression cock. If plain spout is desired instead of cock spout, deduct \$2.50 from list price.

We recommend that Deming iron, brass-lined or brass cylinders be used with this standard.

The largest size plunger which can be withdrawn through the No. 1 size is 1 3/4-inch; through the No. 2 size is 2 3/4-inch.

Fig. 1716 may be fitted with air compressor at \$15.00 extra list (Cipher, OILET), as shown on page 76, for use with pneumatic water systems.

For information concerning how to install this standard, see page 70.

Fig. 1716 may be arranged to discharge into underground pipe by using a tee in the drop pipe the required distance below the ground. A shut-off should be placed in the underground pipe to check the flow when desired.



Illustration shows No. 1 size

Sizes and Prices

No.	Largest Drop Pipe Inches	*Plunger Rod Fitted for	Back Outlet Inches	†STROKE, INCHES	Outside Diameter Base Section Inches	Weight Pounds	Cipher	Price
				Hand				
1	2	5/8" Wood Rod Coupling 1/2 x 7/16" Steel Rod	2	6, 8, 10	3 1/4	82	OWSER	\$22.50
2	3	7/8" Wood Rod Coupling 1/2" Steel Rod	2	6, 8, 10	4 1/2	112	OYEZ	27.50

*When pump is used with wood rod, stub end for steel rod should be cut off.

†When especially ordered, can be furnished for 12-inch windmill stroke.

Complete Table of Contents and General Classification of Pumps, Pages 7 and 8



Fig. 1717



Illustration shows No. 2 size

Deming "Straight-Line" Working Head

For Wells 200 Feet Deep or Less

This is a self-contained high grade power working head for operation by hand, windmill, gasoline engine or electric motor. Our distinctive "Straight-Line" construction, so called from the two guide rods on which the crosshead operates, insures minimum wear on packing and piston rod. It also prevents cramping of connecting rods which often occurs with the ordinary pump jacks, due to the twisting of the crosshead out of alignment.

Specifications

STANDARD: Cast iron, with bronze-bushed shaft bearings.

DROP PIPE FLANGE between base and air chamber.

GUIDE SUPPORTS AND STUFFING BOX are cast integral to insure permanent alignment.

STUFFING BOX is of the nut and gland type with brass gland.

CROSSHEAD: Cast iron; arranged to attach lever for hand operation. Can be supplied with windmill rod. By removing pins, connecting rods may be laid back for operation by hand or windmill.

CONNECTING RODS: Cold-rolled steel with cast-iron ends. Lower end babbitted.

DISCHARGE COCK: Cast iron, compression type, with brass valve seat and brass nut and screw.

CRANK DISC: Cast iron.

CRANK GEAR: Cast iron. Teeth cut from the solid.

PINION: Steel; teeth cut from the solid.

CRANK AND PINION SHAFTS: Cold-rolled steel.

OIL CUPS: For crank shaft and pinion shaft bearings.

CRANK PINS: Steel.

GEAR GUARD: Cast iron, enclosing gear and pinion.

CRANK SHAFT AND PINION SHAFT BEARINGS have removable bronze bushings.

PISTON ROD: Size No. 1 is $\frac{3}{4}$ -inch; No. 2 is $\frac{7}{8}$ -inch cold-rolled piston rod steel, threaded for both wood and steel pump rod. *When using wood rod, cut off steel rod thread.*

No. 1 size is fitted for $\frac{5}{8}$ -inch wood rod coupling and $\frac{1}{8}$ -inch steel rod; No. 2 size for $\frac{3}{4}$ -inch wood rod coupling and $\frac{1}{2}$ -inch steel rod. The largest size plunger which can be withdrawn through the No. 1 size is $2\frac{1}{4}$ -inch; through the No. 2 is $2\frac{3}{4}$ -inch.

Fig. 1717 may be equipped with air compressor at \$15.00 extra list (Cipher, OILET), as shown on page 76, for use with pneumatic water systems. On page 195, the No. 2 size of this head is listed with complete hydro-pneumatic system. If desired to operate head by windmill power, specify windmill flat rod at 60 cents extra list.

For information concerning how to install this head see page 70.

Sizes and Prices

No.	Largest Drop Pipe In.	Back Outlet Inches	Stroke Inches	Gear Ratio	Tight & Loose Pulleys Regular Inches	Maximum Diameter Pulleys which May be Used Inches	Diam. Pinion Shaft Inches	Dimensions of Base Inches	Wght. Lbs.	Cipher	Price
1	2½	2	6	5-1	12 x 3	22	1	8½x11½	164	OUTPOT	\$70.00
2	3	2	6, 8, 10	6-1	14 x 3	24	1	10 x 16	235	OBIT	\$85.00

Capacities

Diameter and Stroke of Cylinder Inches	Gallons per Revolution of Crank Shaft	Maximum Revolutions per Minute	Gallons per Minute	Maximum Lift in Feet Surface of Water to Point of Discharge
2¼ x 10	.172	40	7	200
2¾ x 10	.257	40	10	150
3¼ x 10	.359	40	14	110
4 x 10	.544	40	21.7	75

Alphabetical Index, Figure Index and Telegraph Cipher Code, Pages 249 to 254



Deming "Straight-Line" Power Working Head

Fig. 1718

With Underground Discharge

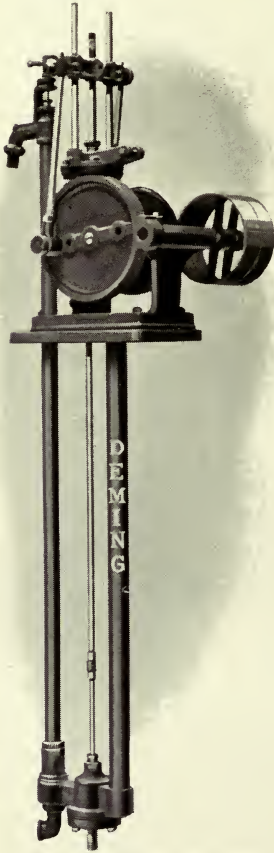

Fig. 1718 is a very substantial working head for operation by windmill, gas engine or electric motor. It is good for 400 pounds plunger load. The large pipe air chamber enables pump to discharge into long discharge pipe without undue strain on the working parts.

Specifications

BASE AND SHAFT BEARINGS are cast integral. Bearings are equipped with removable brass bushings.

GUIDE SUPPORTS AND STUFFING BOX are cast integral to insure accurate and permanent alignment.

CROSSHEAD: Cast iron; arranged for attaching lever for hand operation. Can be supplied with windmill rod. By removing pins, connecting rods may be laid back for operation by hand or windmill.

GUIDE RODS: Cold-rolled steel.

CONNECTING RODS: Cold-rolled steel with cast-iron ends, and lower end babbitted.

CRANK GEARS: Cast iron; teeth cut from the solid.

CRANK DISC: Cast iron.

CRANK AND PINION SHAFTS: Cold-rolled steel.

GEAR GUARD: Encloses gear and pinion.

Underground is a cast-iron manifold to which is attached stuffing box with brass gland, air chamber pipe, hydrant pipe, underground discharge, hydrant valve and case, drop pipe flange, plunger rod through stuffing box, threaded for $\frac{7}{16}$ -inch steel rod.

Fig. 1718 may be equipped with air compressor at \$15.00 extra list (Cipher, OILET), as shown on page 76, for use with pneumatic water systems. If desired to operate head by windmill power, specify windmill slide rod at 60 cents extra list.

Sizes and Prices

No.	Largest Drop Pipe In.	Underground Discharge Inches	Stroke Inches	Gear Ratio	Tight & Loose Pulleys Regular Inches	Maximum Diameter Pulleys which May be Used Inches	Diam. Pinion Shaft Inches	Dimensions of Base Inches	Wght. Lbs.	Cipher	Price
1	2½	1	6	5-1	12 x 3	22	1	10 x 14½	230	OUTRAGE	\$ 80.00
2	3	1½	6, 8, 10	6-1	14 x 3	24	1	11½x19½	320	OATEN	100.00

Capacities

Diameter and Stroke of Cylinder Inches	Gallons per Revolution of Crank Shaft	Maximum Revolutions per Minute	Gallons per Minute	Maximum Lift in Feet Surface of Water to Point of Discharge
2¼ x 10	.172	40	7	200
2¾ x 10	.257	40	10	150
3¼ x 10	.359	40	14	110
4 x 10	.544	40	21.7	75

Complete Table of Contents and General Classification of Pumps, Pages 7 and 8



Deming "Straight-Line" Power Working Head With Underground Discharge For Wells 200 Feet Deep or Less

Fig. 1719

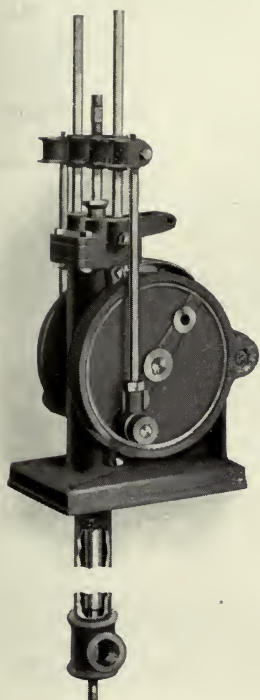

Fig. 1719, as illustrated above, is adapted for use where a discharge spout at the well is not required.

The machine is substantially made with well guarded gears cut from the solid, and 2-inch outlet located three feet below the base. The drop pipe acts as an air chamber.

The connecting rods may be detached and the head operated by windmill in connection with our windmill slide head, Fig. 390. Windmill connection furnished when specified at \$1.50 extra list.

When specified, Fig. 1719 will be equipped with air compressor (Cipher, OILET) as shown on page 76 for use in Hydro-Pneumatic systems at \$15.00 extra list.

If it is desired to operate this head by windmill power, specify windmill flat rod, at 60 cents extra list.

No. 1 size is fitted for $\frac{5}{8}$ -inch wood rod coupling and $\frac{1}{16}$ -inch steel rod; No. 2 size for $\frac{3}{8}$ -inch wood rod coupling and $\frac{1}{2}$ -inch steel rod. *When using wood rod, cut off steel rod thread.*

Plunger rod No. 1 is $\frac{3}{4}$ -inch cold-rolled steel; No. 2 is $\frac{7}{8}$ -inch.

Sizes and Prices

No.	Largest Drop Pipe In.	Underground Discharge Inches	Stroke Inches	Gear Ratio	Tight & Loose Pulleys Regular Inches	Maximum Diameter Pulleys which May be Used Inches	Diam. Pinion Shaft Inches	Dimensions of Base Inches	Wght. Lbs.	Cipher	Price
1	2½	2	6	5-1	12 x 3	22	1	8½ x 11½	160	OUTRAY	\$64.50
2	3	2	6, 8, 10	6-1	14 x 3	24	1	10 x 16	215	ODYLE	80.00

Capacities

Diameter and Stroke of Cylinder Inches	Gallons per Revolution of Crank Shaft	Maximum Revolutions per Minute	Gallons per Minute	Maximum Lift in Feet Surface of Water to Point of Discharge
2¼ x 10	.172	40	7	200
2¾ x 10	.257	40	10	150
3¼ x 10	.359	40	14	110
4 x 10	.544	40	21.7	75



Deming "Straight-Line" Shallow Well Power Pump

For 22 Feet Suction Lift and 125 Feet Discharge Elevation

Fig. 1720

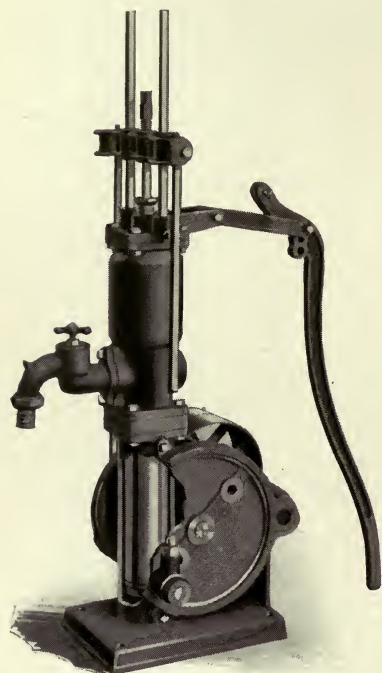

Fig. 1720 is for use in shallow wells, 22 feet deep or less. It is especially suited for tank service, creameries, pneumatic water systems and general water supply.

Specifications

BASE AND SHAFT BEARINGS are cast integral. Bearings are equipped with removable brass bushings.

CYLINDER: Brass, with one leather brass plunger.

GUIDE SUPPORTS AND STUFFING BOX: Cast integral.

STUFFING BOX: Nut and gland type with brass gland.

GUIDE RODS: Cold-rolled steel.

CONNECTING RODS: Cold-rolled steel with cast-iron ends. Lower end babbitted.

CROSSHEAD: Cast iron; arranged to attach lever for hand operation. Can be supplied with windmill rod. By removing pins, connecting rods may be laid back for operation by hand or windmill.

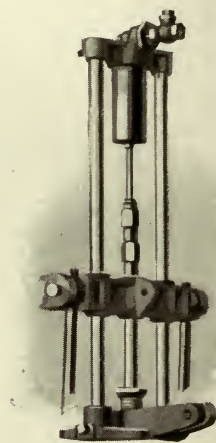

SPECIAL AIR COMPRESSOR
Furnished at Extra Cost
(See reference below)

CRANK DISC: Cast iron.

CRANK GEAR: Cast iron; teeth cut from the solid.

PISTON: Steel; teeth cut from the solid.

PISTON ROD: Cold-rolled steel.

When specified, we will equip Fig. 1720 with air compressor (Cipher, OILET), see illustration above, for hydro-pneumatic service, at \$15.00 extra list.

If it is desired to operate this head by windmill power, specify windmill flat rod at 60 cents extra list.

Sizes and Prices

No.	Diameter Cylinder Inches	Back Outlet Inches	Stroke Inches	Gear Ratio	Tight and Loose Pulleys Regular Inches	Max. Diam. Pulleys which May be Used Inches	Diam. Pinion Shaft Inches	Dimensions of Base Inches	Wght. Lbs.	Cipher	Price
1	2¾	2	6	5-1	12 x 3	22	1	8½x11½	174	OUTROOT	\$82.50
2	3½	2	6, 8, 10	6-1	14 x 3	24	1	10 x 16	240	ODOR	95.00

Complete Table of Contents and General Classification of Pumps, Pages 7 and 8



CYLINDERS
OR
WORKING BARRELS
AND
PUMP LEATHERS

FOR
SHALLOW AND DEEP WELLS

IRON, BRASS AND BRASS-LINED
CYLINDERS, USED WITH HAND
AND WINDMILL LIFT AND
FORCE STANDARDS, POWER
WORKING HEADS, ETC. FOR
GENERAL WATER SUPPLY; THE
CYLINDER BEING USUALLY
SUBMERGED





Deming Cylinders or Working Barrels

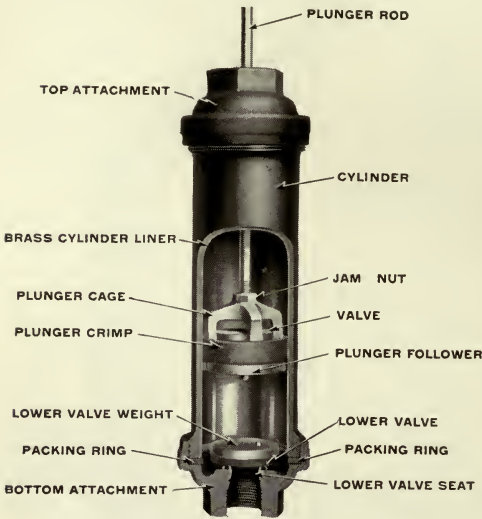

Section of a Typical Brass-Lined Cylinder

The thought which is responsible for the old adage "A chain is no stronger than its weakest link," may be well applied when speaking of pump construction, for no pump is better than its cylinder. If the cylinder is defective, the pump is certain to be condemned.

The pump cylinder is sometimes designated as the "working barrel" or "working section" because it performs the actual work of bringing the water from the depths of the well to the surface. The pump top or standard is of secondary importance to the cylinder.

Attention is directed to the detail view on this page showing a typical cylinder. This will give a clear understanding of the location and function of each of the necessary parts of the cylinder. The engraving represents our brass-lined cylinder, Fig. 308, with leather lower valve.

We are extremely careful in the manufacture of Deming cylinders, making all parts to exact gauges so that repairs, should they be needed, will always fit. All cylinders undergo a rigid inspection before they leave our factory.

The lists on the following pages give the sizes of pipe for which the cylinders are fitted, but if other sizes of pipe are to be used, we can generally fit the cylinder attachments to suit, for which we will make an extra charge. However, we recommend that the cylinders be fitted as listed, as we have found from experience that they are best adapted for the sizes of pipe as given in the lists. In order that the pump operates properly, all parts of the cylinder must be in perfect condition, and the joints should be air tight.

Deming Iron Cylinders

Deming iron cylinders are finished on special machines, leaving a high polish in the bore and retaining the chilled surface of the iron. This makes a cylinder which is not easily affected by rust and which wears longer than iron cylinders finished in the ordinary way. Only skilled workmen — men who have been in our employ for years — are permitted to work on Deming cylinders.

Deming Brass-Lined Cylinders

When rust accumulates on an iron cylinder, the plunger leathers are apt to become more or less affected by it. To overcome this difficulty, the brass-lined cylinder was originated about 1876 and was a tremendous success right from the start. Deming brass-lined cylinders are made similar to the iron cylinders, the shell being bored out smoothly and enough to insert a piece of seamless drawn polished brass tubing which is forced into the iron shell and then expanded at both ends—"swaged"—to position. These cylinders possess the smoothness of the brass tube cylinders and are not so likely to become injured by external pressure. They will not rust, "pit" or break.

Deming Brass Tube Cylinders

Many of our customers prefer brass tube cylinders for the reason that the brass threads do not rust, and it is therefore less trouble to take off the caps when new leathers are needed or other repairs are to be made. The iron threads are likely to be rusty and offer some difficulty when the caps are to be removed. The shell of a Deming brass tube cylinder consists of a heavy seamless drawn polished brass tube with iron or brass attachments as desired.

Complete Table of Contents and General Classification of Pumps, Pages 7 and 8



Plungers for Deming Cylinders

The plunger constitutes a very important part of the cylinder. Great care must be exercised in the manufacture of the plunger and its valve, or the cylinder will fail to give good service. Deming plungers are constructed by workmen especially skilled in making and assembling this particular article.



"A"
(One Leather)
Plunger

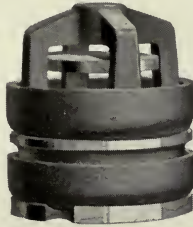

"J"
(Two Leather)
Plunger



All Brass
Plunger Used
With Fig. 311



All Brass
Plunger Used
With Fig. 324

Specifications of Deming Plungers

"A" PLUNGER HAS ONE CUP LEATHER and $\frac{3}{8}$ -inch follower, as illustrated.

"J" PLUNGER HAS TWO CUP LEATHERS and $\frac{1}{2}$ -inch follower, as illustrated.

The "A" and "J" Plungers may be had as follows:—either all iron; or with iron follower, brass cage and valve; or all brass.

Plunger used in Fig. 311 artesian well brass cylinder has two cup leathers, and ball valve. FURNISHED REGULARLY ALL BRASS.

Plunger used in Fig. 324 artesian well brass cylinder has four cup leathers and ball valve. FURNISHED REGULARLY ALL BRASS.

Deming Brass Valve Seat

Will not break, chip, flatten, corrode, wear out or become loosened from the cap.

Furnished regularly on all Deming Cylinders except Fig. 314.

The construction of this seat is such that no particles of sand and gravel will find permanent lodgment upon it. The Deming brass valve seat is swaged to position—expanded at both ends—which insures its permanence. This seat is so constructed that an extra hard surface is secured for the face, making it impervious to the action of the water or the pounding of the valve.

Many times we have had Deming cylinders returned to us in which the valve leathers had worn out after long usage, leaving iron valve weight to pound upon the brass seat, *but without affecting the seat in any way whatever* because the Deming seat has a harder surface than *any iron or cast brass seat.*

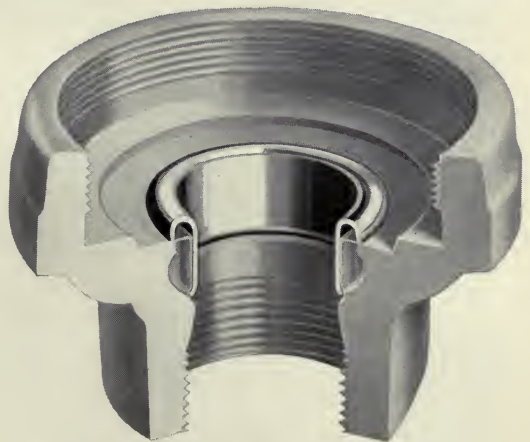

Bottom attachment of a Deming cylinder cut open to show Deming Brass Valve Seat. This clearly illustrates how it is impossible for the seat to "break, chip, flatten, corrode, wear out or become loosened from the cap."



Deming Lower Valve and Brass Valve Seat

Special Lower Cylinder Valve, Fig. 335 Western Style



Fig. 335

The special lower cylinder valve, Fig. 335, is for use with our iron, brass-lined and brass body cylinders having OUTSIDE ATTACHMENTS, Figs. 300, 308 and 312, listed elsewhere. Any of these cylinders will be furnished with Fig. 335 when so ordered, at extra list prices given below. The poppet valve is leather faced, insuring a perfect seat. Many dealers find it desirable to carry this cage and valve in stock as an extra.

Sizes and Prices, Fig. 335

Size in inches (Diam. Cyl.)	2	2¼	2½	2¾	3	3¼	3½	4	4½	5	6
Extra list added to Cyl. list.	\$0.50	\$0.50	\$0.50	\$0.50	\$0.50	\$0.60	\$0.60	\$0.75	\$0.75	\$1.00	\$1.25

Deming Improved Deep Well Air Cylinder

Fig. 306

(Patented)

For Pneumatic Water Supply in Connection with Compression Tank Systems

The use of compressed air tanks supplied from deep wells by windmill or other power pumping appliances has hitherto been seriously hindered by lack of a reliable contrivance to supply air for recharging the tank. This hindrance has recently been overcome by the use of an auxiliary air pumping cylinder located in the discharge pipe between the working barrel and the pumping head.

We offer the best cylinder of this type in our Fig. 306 Auxiliary Air Pumping Cylinder. The illustration shows a sectional view with an air cock in center casting. The air cock must be located above the water, or piped to some point above to prevent cylinder from pumping water instead of air.

These cylinders may be used with any size of working barrels, but we advise their use with the size of pipe for which they are fitted.

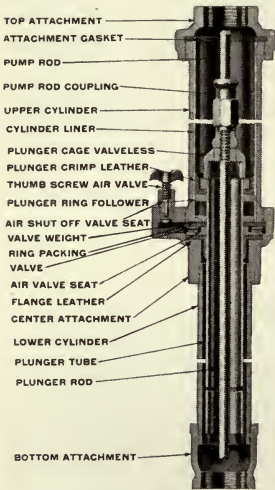

Fig. 306
Detail View



Fig. 306

Sizes and Prices

Size Pipe Fitted for Inches	Stroke Inches	Extreme Outside Width Inches	Weight Pounds	Cipher	Price	Size Pipe Fitted for Inches	Stroke Inches	Extreme Outside Width Inches	Weight Pounds	Cipher	Price
1¼	7	4½	12	CAREFUL	\$13.50	1¼	14	4½	14½	CAROL	\$15.50
1½	7	4¾	18	CAREER	14.50	1½	14	4¾	21	CARNY	17.50
2	7	5¼	19	CARET	15.50	2	14	5¼	25	CAROUSE	18.50

Complete Table of Contents and General Classification of Pumps, Pages 7 and 8



Lower Caps and Valves for Deming Cylinders

Hinged Leather Lower Valve

The hinged leather valve which we use on all our cylinders with outside caps is too well known to require detailed description. The very best of material and workmanship is used in the construction of this valve which has for many years given the best of satisfaction.

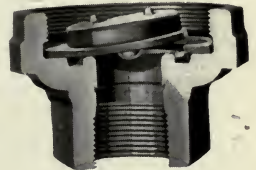

Hinged Leather Lower Valve

Lower Cap and Disc Valve with Split Cage For Inside Capped Cylinder, Fig. 322 (Patented)

Our special leather faced disc valve with split cage is furnished regularly on our Fig. 322 inside capped cylinder. The split cage makes it impossible for the valve to get out of place when in the cylinder. The valve is very easy to remove and repair when the cap is unscrewed from the cylinder. The cage and valve are made of iron on the cylinders with iron attachments. Cylinders with brass attachments have brass cage and valve. The Deming brass valve seat is furnished on this iron lower cap.



Special Lower Cap and Disc Valve with Split Cage (Patented)

Lower Valve for Fig. 311 Artesian Well Brass Cylinder

This ball valve is made tapered to fit the lower attachment of the cylinder. As an added safeguard against leakage, it is also supplied with leather cup packing. With this construction, the valve can be drawn through the top of the cylinder without removing the attachments.



Lower Valve for Fig. 311

Lower Valve for Fig. 324 Artesian Well Brass Cylinder

This valve is in all respects similar to the valve used in the Fig. 311 cylinder except that we pack it with rings of leather which are turned to fit the cylinder, which adapts Fig. 324 for heavier duty than Fig. 311.



Lower Valve for Fig. 324



Deming Improved Iron Cylinders or Working Barrels
With Outside Caps and Brass Valve Seats

Fig. 300

Fig. 300 is made with hinged leather lower valve and with Deming BRASS VALVE SEAT. The construction of the Deming brass valve seat prevents particles of sand and gravel from finding lodgement and interfering with the proper working of the valve.

Fig. 300—10" in length is fitted with "A" (One Leather) Plunger. Longer than 10" have "J" (Two Leather) Plungers.



Fig. 300, with "A" Plunger

With "A" Plunger (One Leather)

Inside Diameter and Length Inches	Stroke Inches	Fitted for Pipe Inches	Well Rod Inches	Capacity per Stroke Gallons	Approximate Weight Pounds	Extreme Outside Diameter Inches	Price With Iron "A" Plunger (CIPHER, CHILL)
2½ x 10	6	1¼	¾	.128	9½	3¾	\$ 4.35
3 x 10	6	1¼	¾	.184	11	4¼	5.00
3½ x 10	6	1½	7/16	.25	14½	4¾	7.00
4 x 10	6	2	5/8	.326	18	5¼	9.00



Fig. 300, with "J" Plunger

With "J" Plunger (Two Leathers)

2½ x 12	8	1¼	¾	.17	11	3¾	6.00
3 x 12	8	1¼	¾	.245	13	4¼	7.00
3½ x 12	8	1½	7/16	.333	18	4¾	9.00
4 x 12	8	2	5/8	.435	21	5¼	11.50
2½ x 14	10	1¼	¾	.213	12	3¾	6.50
3 x 14	10	1¼	¾	.306	14	4¼	7.50
3½ x 14	10	1½	7/16	.417	19	4¾	10.00
4 x 14	10	2	5/8	.544	23½	5¼	13.00
2½ x 16	12	1¼	¾	.255	13	3¾	7.00
3 x 16	12	1¼	¾	.367	15	4¼	8.00
3½ x 16	12	1½	7/16	.5	20½	4¾	11.25
4 x 16	12	2	5/8	.653	24½	5¼	14.50

Complete Table of Contents and General Classification of Pumps, Pages 7 and 8

Deming Improved Brass-Lined Iron Cylinders
With Outside Caps and Brass Valve Seat

Fig. 308

Fig. 308 has hinged Leather Lower Valve and Deming Brass Valve Seat. The construction of the Deming brass valve seat prevents particles of sand and gravel from finding lodgement and interfering with the proper working of the valve. See description and illustration on page 79.

A brass lined cylinder will not pit or rust, and presents always a smooth surface for the plunger leathers; lengthening greatly their life and insuring a full amount of water at each stroke.

Fig. 308—10" in length is fitted with "A" (One Leather) Plunger. Longer than 10" have "J" (Two Leather) Plungers.

With "A" Plunger (One Leather)

Inside Diameter and Length Inches	Stroke Inches	Fitted for Pipe Inches	Well Rod Inches	Capacity per Stroke Gallons	Approximate Weight Pounds	Extreme Outside Diam. Inches	Price Iron Caps, Iron Plunger, (Cipher, CARSE)	Price Iron Caps, Iron Follower, Brass Cage and Valve (Cipher, CASS)
2½ x 10	6	1¼	¾	.128	9½	3¾	\$ 7.25	\$ 8.00
3 x 10	6	1¼	¾	.184	11	4¼	7.75	9.00
3½ x 10	6	1½	7/8	.25	14½	4¾	8.75	10.50
4 x 10	6	2	5/8	.326	18	5¼	10.50	13.00



Fig. 308, with "A" Plunger

With "J" Plunger (Two Leathers)

2½ x 12	8	1¼	¾	.17	11	3¾	7.75	8.50
3 x 12	8	1¼	¾	.245	13	4¼	8.25	9.50
3½ x 12	8	1½	7/8	.333	18	4¾	9.50	11.25
4 x 12	8	2	5/8	.435	21	5¼	11.75	14.25
2½ x 14	10	1¼	¾	.213	12	3¾	8.50	9.25
3 x 14	10	1¼	¾	.306	14	4¼	9.00	10.25
3½ x 14	10	1½	7/8	.417	19	4¾	10.50	12.25
4 x 14	10	2	5/8	.544	23½	5¼	13.25	15.75
2½ x 16	12	1¼	¾	.255	13	3¾	9.50	10.25
3 x 16	12	1¼	¾	.367	15	4¼	10.00	11.25
3½ x 16	12	1½	7/8	.5	24½	4¾	11.75	13.50
4 x 16	12	2	5/8	.653	26	5¼	15.00	17.50



Fig. 308, with "J" Plunger



Deming Seamless Brass Body Cylinders

With Outside Caps and Brass Valve Seat

Fig. 312

On this cylinder we use our hinged leather lower valve and the famous Deming brass valve seat. For descriptions see pages 79 and 81.

The construction of the Deming brass valve seat prevents particles of sand and gravel from finding lodgement and interfering with the proper working of the valve.

Fig. 312—10" in length is fitted with "A" (One Leather) Plunger. Longer than 10" have "J" (Two Leather) Plungers.



Fig. 312,
with "A"
Plunger

With "A" Plunger (One Leather)

Inside Diameter and Length Inches	Stroke Inches	Fitted for Pipe Inches	Well Rod Inches	Capacity per Stroke Gallons	Approximate Weight Pounds	Extreme Outside Diam. Inches	Price Iron Caps, Iron Follower Brass Cage and Valve (Cipher, CHOIR)	Price Iron Caps, All Plunger (Cipher, CHOCK)	Price All Brass (Cipher, CHODE)
2 x 10	6	1	3/8	.082	7	3	\$ 7.50	\$ 8.00	\$10.75
2 1/2 x 10	6	1 1/4	3/8	.128	8	3 1/2	8.00	8.50	12.25
3 x 10	6	1 1/4	3/8	.184	9 1/2	4	9.00	9.75	13.50
3 1/2 x 10	6	1 1/2	1/2	.25	12	4 1/2	10.50	11.50	16.75
4 x 10	6	2	5/8	.326	14 1/2	5	13.00	15.50	21.50



Fig. 312,
with "J"
Plunger

With "J" Plunger (Two Leathers)

2 x 12	8	1	3/8	.109	7 1/2	3	8.00	9.25	11.25
2 1/2 x 12	8	1 1/4	3/8	.17	8 1/2	3 1/2	8.50	9.75	12.75
3 x 12	8	1 1/4	3/8	.245	10	4	9.50	11.00	14.00
3 1/2 x 12	8	1 1/2	1/2	.333	12 1/2	4 1/2	11.25	13.75	17.50
4 x 12	8	2	5/8	.435	15 1/2	5	14.25	18.00	22.50
2 x 14	10	1	3/8	.136	10	3	8.50	9.75	13.00
2 1/2 x 14	10	1 1/4	3/8	.213	13	3 1/2	9.25	10.50	14.75
3 x 14	10	1 1/4	3/8	.306	16	4	10.25	11.75	16.25
3 1/2 x 14	10	1 1/2	1/2	.417	18	4 1/2	12.25	14.75	21.00
4 x 14	10	2	5/8	.544	25	5	15.75	19.00	26.50
2 x 16	12	1	3/8	.163	11	3	9.00	10.50	13.75
2 1/2 x 16	12	1 1/4	3/8	.255	15	3 1/2	10.25	11.75	16.00
3 x 16	12	1 1/4	3/8	.367	17 1/2	4	11.25	12.75	17.25
3 1/2 x 16	12	1 1/2	1/2	.5	19	4 1/2	13.50	16.00	22.25
4 x 16	12	2	5/8	.653	26	5	17.50	20.50	28.00
2 x 20	16	1	3/8	.218	14 1/2	3	9.50	11.50	14.75
2 1/2 x 20	16	1 1/4	3/8	.34	17	3 1/2	11.25	13.50	17.75
3 x 20	16	1 1/4	3/8	.49	19	4	12.25	14.75	19.25
3 1/2 x 20	16	1 1/2	1/2	.666	21	4 1/2	14.75	19.00	25.25
4 x 20	16	2	5/8	.87	28	5	19.25	24.00	31.50



HAND AND POWER PUMPS FOR ALL USES



Deming Seamless Brass Body Cylinders

With Inside Caps and Special Patented Disc Lower Valve

Fig. 322

In these cylinders the top and bottom attachments screw *INSIDE* the cylinder, which brings the attachments flush with the shell of the cylinders and adapts them for use in wells of smaller diameter than the corresponding size of cylinder fitted with outside caps.

The Deming brass valve seat is furnished on this cylinder. Our special disc lower valve as described on page 81, is used with this cylinder instead of the hinged leather lower valve.

Fig. 322—12" in length is fitted with "A" (One Leather) Plunger. Longer than 12" have "J" (Two Leather) Plungers.

With "A" Plunger (One Leather)

Inside Diameter and Length Inches	Stroke Inches	Fitted for Pipe Inches	Well Rod Inches	Capacity per Stroke Gallons	Approximate Weight Pounds	Extreme Outside Diam. Inches	Price Iron Caps Iron Follower Br'ss C'ge and Valve (Cipher, CAUL)	Price Iron Caps, All Brass Plunger (Cipher, CAVE)	Price All Brass (Cipher, CAXON)
2 x 12	6	1	3/8	.082	5 1/2	2 1/4	\$ 8.00	\$ 9.25	\$11.25
2 1/4 x 12	6	1 1/4	3/8	.103	7	2 1/2	8.25	9.50	11.50
2 1/2 x 12	6	1 1/4	3/8	.128	7 1/2	2 3/4	8.50	9.75	12.75
2 3/4 x 12	6	1 1/4	3/8	.154	8	3	9.00	10.50	13.25
3 x 12	6	1 1/4	3/8	.184	9	3 1/4	9.50	11.00	14.00
3 1/2 x 12	6	1 1/2	1/2	.25	14	3 3/4	11.25	13.75	17.50
4 x 13	6	2	3/8	.326	18	4 1/4	14.75	18.00	22.50



Fig. 322, "A" Plunger

With "J" Plunger (Two Leathers)

2 x 14	8	1	3/8	.109	7	2 1/4	8.50	9.75	13.00
2 1/4 x 14	8	1 1/4	3/8	.138	8	2 1/2	9.00	10.25	13.50
2 1/2 x 14	8	1 1/4	3/8	.17	8 1/2	2 3/4	9.25	10.50	14.75
2 3/4 x 14	8	1 1/4	3/8	.206	9 1/2	3	9.75	11.25	15.50
3 x 14	8	1 1/4	3/8	.245	10 1/2	3 1/4	10.25	11.75	16.25
3 1/2 x 14	8	1 1/2	1/2	.333	13 1/2	3 3/4	12.25	14.75	21.00
4 x 15	8	2	3/8	.435	20	4 1/4	15.75	19.00	26.50
1 3/4 x 16	10	1	3/8	.104	6	2	13.75
2 x 16	10	1	3/8	.136	7	2 1/4	9.00	10.50	13.75
2 1/4 x 16	10	1 1/4	3/8	.172	8	2 1/2	9.75	11.25	14.50
2 1/2 x 16	10	1 1/4	3/8	.213	9	2 3/4	10.25	11.75	16.00
2 3/4 x 16	10	1 1/4	3/8	.257	10	3	10.75	12.25	16.50
3 x 16	10	1 1/4	3/8	.306	11	3 1/4	11.25	12.75	17.25
3 1/2 x 16	10	1 1/2	1/2	.417	14	3 3/4	13.50	16.00	22.25
4 x 17	10	2	3/8	.544	27	4 1/4	17.50	20.50	28.00
1 1/2 x 18	12	1	3/8	.092	4 1/2	1 3/4	14.25
1 3/4 x 18	12	1	3/8	.125	6 1/2	2	14.25
2 x 18	12	1	3/8	.163	8	2 1/4	9.50	11.00	14.25
2 1/4 x 18	12	1 1/4	3/8	.206	9	2 1/2	10.50	12.00	15.25
2 1/2 x 18	12	1 1/4	3/8	.255	10 1/2	2 3/4	11.25	12.75	17.00
2 3/4 x 18	12	1 1/4	3/8	.309	12	3	11.75	13.25	17.50
3 x 18	12	1 1/4	3/8	.367	15	3 1/4	12.25	13.75	18.25
3 1/2 x 18	12	1 1/2	1/2	.5	17 1/2	3 3/4	14.75	17.25	23.50
4 x 19	12	2	3/8	.653	22	4 1/4	19.25	22.25	29.75
1 1/2 x 22	16	1	3/8	.122	4 1/2	1 3/4	15.25
1 3/4 x 22	16	1	3/8	.167	6 1/2	2	15.25
2 x 22	16	1	3/8	.218	8	2 1/4	10.50	12.00	15.25
2 1/4 x 22	16	1 1/4	3/8	.275	9	2 1/2	12.00	13.50	16.75
2 1/2 x 22	16	1 1/4	3/8	.34	10 1/2	2 3/4	13.25	14.50	18.75
2 3/4 x 22	16	1 1/4	3/8	.411	12	3	13.75	15.25	19.50
3 x 22	16	1 1/4	3/8	.49	15	3 1/4	14.25	15.75	20.25
3 1/2 x 22	16	1 1/2	1/2	.67	17 1/2	3 3/4	17.75	20.50	26.75
4 x 23	16	2	3/8	.87	22	4 1/4	22.75	25.75	33.25



Fig. 322, with "J" Plunger

Alphabetical Index, Figure Index and Telegraph Cipher Code, Pages 249 to 254



The Deming "Whitecap" Seamless Brass Body Cylinder
 With Inside Attachment and Iron "A" Plunger
 For Small Diameter Wells

Fig. 314

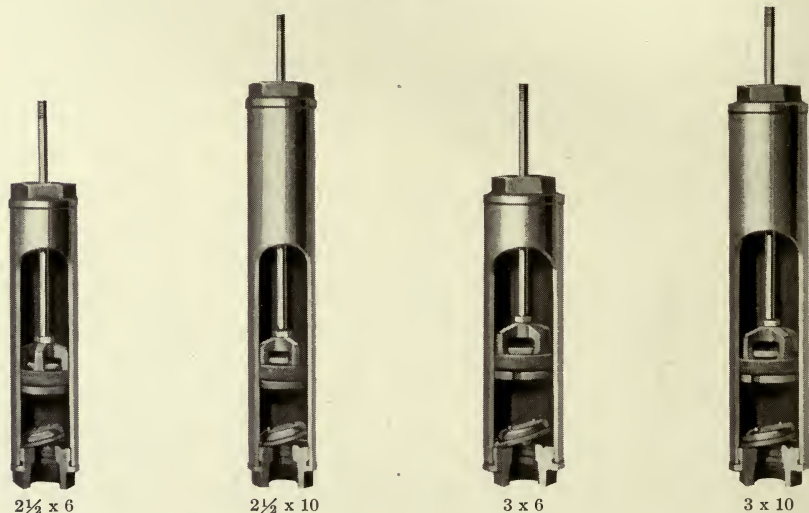

For the benefit of pump dealers, we have gotten up this special line of brass body cylinders designated as Fig. 314. These cylinders will be seen by the specifications are made in the popular sizes — 2¼-inch, 2½-inch, 2¾-inch and 3-inch, and in two lengths of stroke, 6-inch and 10-inch. The longer stroke cylinders are adapted for adjustable stroke windmill pumps, and as these cylinders are all made with inside attachments, they will give the greatest capacity for drilled wells of small diameters. As this is intended to be a popular line of cylinders, they are made only as listed and as shown in the engravings with iron parts excepting the brass tube shell. The cylinder attachments are all fitted for 1¼-inch pipe. All details in connection with these cylinders have been carefully considered as to the convenience of the Dealer and the User. It is a thoroughly practical line of cylinders and embraces the sizes that are in most common use.

To distinguish the Deming Special "Whitecap" Brass Body Cylinders from our standard line, the Caps of these Specials will be painted white. For our standard cylinders, made in varied sizes and lengths of stroke, see other pages in this section of the Catalogue.

Price List with "A" Plunger (One Leather)

Diameter Inches	Stroke Inches	Extreme Outside Diameter Inches	For Pipe Inches	Pump Rod Inches	Capacity per Stroke Gallons	Approximate Weight Pounds	Price (Ciper, CHINE)
2¼	6	2½	1¼	3/8	.103	6½	\$ 7.50
2½	6	2¾	1¼	3/8	.128	7	7.75
2¾	6	3	1¼	3/8	.154	7½	8.00
3	6	3¼	1¼	3/8	.184	8½	8.25
2¼	10	2½	1¼	3/8	.172	7½	9.00
2½	10	2¾	1¼	3/8	.213	8½	9.25
2¾	10	3	1¼	3/8	.257	9½	9.50
3	10	3¼	1¼	3/8	.306	10½	10.25

Complete Table of Contents and General Classification of Pumps, Pages 7 and 8



Deming Seamless All Brass Cylinder
With Inside Caps and Brass Poppet Valves

Fig. 1315

Price List with "J" Plunger (Two Leathers)

Fig. 1315 is made of brass and has "J" (two leather) plunger. The plunger and lower valve are constructed with single finger, metal faced, ground poppet valve. The lower valve has brass cage SCREWED onto bottom cap. Rods are fitted with lock nuts.

Inside Diam. of Cylinder	Stroke Inches	Length Over all Inches	Extreme Outside Diam. Inches	Fitted for Pipe Inches	Well Rod Inches	Capacity per Stroke Gallons	Approximate Weight Pounds	Price All Brass (Cipher, CAMEL)
2	12	21½	2¼	1¼	½	.163	8	\$ 16.00
2½	12	21	2¾	1¼	½	.255	10	20.00
3	12	21½	3¼	1½	½	.367	15	22.00
3½	12	22	3¾	1½	½	.5	20	28.50
4	12	22½	4¼	2	5/8	.653	25	34.00
4½	12	23½	4¾	2½	5/8	.837	31	45.00
5	12	24	5¾	2½	5/8	1.02	37	59.50
5½	12	24½	5¾	3	¾	1.234	45	69.00
6	12	26	6¾	3	¾	1.469	58	78.50
6¾	12	27	7¼	4	¾	1.858	73	100.00
7	12	27	7¾	4	¾	1.999	77	126.50
2	16	25½	2¼	1¼	½	.218	9	17.50
2½	16	25	2¾	1¼	½	.34	11	22.00
3	16	25½	3¼	1½	½	.49	16½	24.50
3½	16	26	3¾	1½	½	.666	21½	31.50
4	16	26½	4¼	2	5/8	.87	27	37.50
4½	16	27½	4¾	2½	5/8	1.12	33	50.00
5	16	28	5¾	2½	5/8	1.36	39	65.00
5½	16	28½	5¾	3	¾	1.646	48	75.00
6	16	30	6¾	3	¾	1.958	60	93.00
6¾	16	31	7¼	4	¾	2.479	77	107.00
7	16	31	7¾	4	¾	2.666	81	135.00
2	20	29½	2¼	1¼	½	.272	10	19.00
2½	20	29	2¾	1¼	½	.425	12	24.00
3	20	29	3¼	1½	½	.612	18	27.00
3½	20	30	3¾	1½	½	.833	23	34.00
4	20	30½	4¼	2	5/8	1.088	29	40.50
4½	20	31½	4¾	2½	5/8	1.394	36	55.00
5	20	32	5¾	2½	5/8	1.7	42	70.00
5½	20	32½	5¾	3	¾	2.057	51	81.00
6	20	34	6¾	3	¾	2.448	63½	100.00
6¾	20	35	7¼	4	¾	3.098	81	115.00
7	20	35	7¾	4	¾	3.332	85	143.00
2	24	33½	2¼	1¼	½	.326	11	20.50
2½	24	33	2¾	1¼	½	.51	13	26.00
3	24	33½	3¼	1½	½	.734	19½	29.00
3½	24	34	3¾	1½	½	1.	24½	37.00
4	24	34½	4¼	2	5/8	1.306	31	44.00
4½	24	35½	4¾	2½	5/8	1.673	38	60.00
5	24	36	5¾	2½	5/8	2.04	45	75.00
5½	24	36½	5¾	3	¾	2.468	54	87.00
6	24	38	6¾	3	¾	2.938	67	106.50
6¾	24	39	7¼	4	¾	3.716	85	122.50
7	24	39	7¾	4	¾	3.998	89	151.00



Fig. 1315
Made only with
"J" Plunger

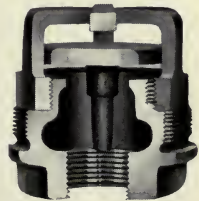

Bottom Attachment
for Fig. 1315.
Brass Cage
Screws onto
Bottom Cap



Deming Special Artesian Well Brass Cylinder

With Bronze Ball Valves

Fig. 311



Fig. 311 Cylinder is made of seamless drawn brass tubing with cast bronze attachments, the top attachment being threaded for standard pipe of the next size larger than the inside diameter of the cylinder, to permit the withdrawing of the plunger and lower valve without the necessity of removing the pipe and cylinder. The bottom attachment is threaded for suction pipe or strainer. The plunger and lower valve are made of bronze, with bronze ball valves, and the plunger has two cup leather packings. The plunger is provided with a steel pin connection for wood rod coupling as listed unless ordered otherwise.

These cylinders are somewhat lighter and shorter than Fig. 324 cylinders of the same diameter and stroke, though in every way equal in the high quality of material and workmanship. They are suitable for use in wells of medium depth with any power or steam-driven working head.

NOTE.—For convenience in shipping the plunger and lower valve are screwed together, and must be disconnected before cylinder is lowered in the well.

Sizes, Capacities, Prices, Etc.

Inside Diam. of Cyl. Inches	Stroke Inches	Capacity per Stroke Gallons	Pipe for Top Attachment Inches	Pipe for Bottom Attachment Inches	Extreme Length of Cyl. Inches	Extreme Outside Diam. Inches	Stem of Plunger Fitted with Pin Connection Inches	Approximate Weight Pounds	CYLINDER COMPLETE	
									Cipher	Price
1 3/4	10	.11	2	2	24	2 3/4	5/8	13	CAPTIVITY	\$17.50
1 3/4	16	.17	2	2	30	2 3/4	5/8	15	CHAMPION	19.00
2 1/4	10	.17	2 1/2	2	25	3 1/2	3/8	17	CARESS	26.00
2 1/4	16	.27	2 1/2	2	31	3 1/2	3/8	19	COLLISION	28.00
2 1/4	24	.41	2 1/2	2	39	3 1/2	3/8	22	CABOOSE	32.00
2 3/4	10	.26	3	2	26	4	3/8	23	CELEBRATED	34.00
2 3/4	16	.41	3	2	32	4	3/8	26	COLOSSAL	36.00
2 3/4	24	.61	3	2	40	4	3/8	29	CACTUS	38.00
2 3/4	30	.77	3	2	46	4	3/8	32	CADET	40.00
3 1/4	10	.36	3 1/2	2 1/2	29 1/2	4 3/4	1	30	COERCE	45.00
3 1/4	16	.57	3 1/2	2 1/2	35 1/2	4 3/4	1	33	COMMERCE	48.00
3 1/4	24	.86	3 1/2	2 1/2	43 1/2	4 3/4	1	37	CADDY	52.00
3 1/4	30	1.08	3 1/2	2 1/2	49 1/2	4 3/4	1	40	CAITIFF	55.00
3 3/4	10	.47	4	3	31	5 1/2	1 1/8	43	CAIRN	65.00
3 3/4	16	.77	4	3	37	5 1/2	1 1/8	46	CABINET	70.00
3 3/4	24	1.15	4	3	45	5 1/2	1 1/8	50	CADENZA	75.00
3 3/4	30	1.43	4	3	51	5 1/2	1 1/8	53	CALABASH	80.00

Complete Table of Contents and General Classification of Pumps, Pages 7 and 8



Deming Standard Artesian Well Brass Cylinder

Fig. 324—With Bronze Ball Valves

Fig. 324 Cylinder, or Working Barrel, is made of seamless drawn brass tubing with cast bronze top and bottom attachments, the top attachment being threaded for standard wrought iron pipe connections the next size larger diameter than the cylinder, to admit of withdrawing the plunger and lower valve. The bottom attachment is threaded for suction pipe or strainer. The plunger and check are of bronze, with bronze ball valves, and the plunger has four cup leather packings. With these cylinders we recommend using Fig. 636 wood sucker rod, listed on page 99, the plunger being provided with a steel pin connection for wood rod coupling as listed unless ordered otherwise. *For convenience in shipping, the plunger and lower valve are screwed together, and must be disconnected before cylinder is lowered in well.*

Unless otherwise specified top and bottom attachments of cylinders will always be threaded for standard pipe as listed below. *When so ordered the 5¼ inch cylinder will be fitted for 5½ inch casing, and the 6¼ inch cylinders for 6½ inch casing.*

Sizes, Capacities, Prices, Etc.

Inside Diam. of Cyl. Inches	Stroke Inches	Capacity per Stroke Gallons	Pipe for Top Attachment Inches	Pipe for Bottom Attachment Inches	Ex-treme Length of Cyl. Inches	Ex-treme Outside Diam. Inches	Plunger Fitted with Pin Connection Inches	Ap-proximate Weight Pounds	CYLINDER COMPLETE	
									Cipher	Price
1½	10	.064	1½	1½	28½	2¾	5/8	11	COFFER	\$ 13. 50
1½	16	.103	1½	1½	32½	2¾	5/8	12	COLLATOR	15. 00
1¾	10	.104	2	2	28½	2¾	5/8	16	COLLATE	17. 50
1¾	16	.167	2	2	32½	2¾	5/8	17	COLLEAGUE	19. 00
2¼	10	.172	2½	2	31	3½	7/8	21	COLLATING	26.00
2¼	16	.275	2½	2	35	3½	7/8	23	COLLEGIAN	28. 00
2¾	10	.257	3	2	38	4¼	7/8	32	COLLECT	34. 00
2¾	16	.411	3	2	42	4¼	7/8	34	COLLIDE	36. 00
2¾	24	.617	3	2	59	4¼	7/8	37	COLLODION	38. 00
2¾	30	.771	3	2	56	4¼	7/8	39	COLUMBINE	40. 00
3¼	10	.359	3½	2½	37	4¾	1	43	COLIC	45. 00
3¼	16	.575	3½	2½	43	4¾	1	45	COLLIERY	48. 00
3¼	24	.862	3½	2½	51	4¾	1	48	COLLUDE	52. 00
3¼	30	1. 077	3½	2½	57	4¾	1	50	COMATOSE	55. 00
3¼	36	1. 294	3½	2½	63	4¾	1	52	COMEDY	58. 00
3¾	10	.478	4	3	41	5½	1½	59	COLLARING	65. 00
3¾	16	.765	4	3	45	5½	1½	62	COLLECTIVE	70. 00
3¾	24	1. 147	4	3	53	5½	1½	66	COLLUSION	75. 00
3¾	30	1. 434	4	3	59	5½	1½	69	COMBAT	80. 00
3¾	36	1. 722	4	3	65	5½	1½	72	COMFORT	85. 00
4¼	16	.982	4½	3	46¼	6	1½	81	COLISEUM	90. 00
4¼	24	1. 473	4½	3	54¼	6	1½	87	COLOGNE	95. 00
4¼	30	1. 842	4½	3	60¼	6	1½	92	COMBINED	100. 00
4¼	36	2. 210	4½	3	66¼	6	1½	97	COMICAL	105. 00
4¾	24	1. 840	5	3	56¼	6½	1½	105	COLONIAL	135. 00
4¾	30	2. 300	5	3	62¼	6½	1½	110	COMBING	142. 50
4¾	36	2. 760	5	3	68¼	6½	1½	115	COMMA	150. 00
5¼	24	2. 248	6	3½	57¼	7½	1½	124	COLUMBIAN	160. 00
5¼	30	2. 811	6	3½	63¼	7½	1½	130	COMMANDING	170. 00
5¼	36	3. 372	6	3½	69¼	7½	1½	137	COMMUTING	180. 00
5¾	24	2. 696	6	3½	57¼	7½	1½	148	COMBATANT	195. 00
5¾	30	3. 372	6	3½	63¼	7½	1½	156	COMEDIAN	207. 50
5¾	36	4. 044	6	3½	69¼	7½	1½	164	COMMANDER	217. 50
6¼	24	3. 186	7	4	60¼	8½	1½	205	COMBINE	250. 00
6¼	30	3. 984	7	4	66¼	8½	1½	212	COMMENTED	260. 00
6¼	36	4. 780	7	4	72¼	8½	1½	220	COMPARED	275. 00
6¾	24	3. 716	7	4	61¼	8½	1½	253	COMBINE	300. 00
6¾	30	4. 645	7	4	67¼	8½	1½	261	COMMENTING	320. 00
6¾	36	5. 576	7	4	73¼	8½	1½	269	COMPARATIVE	335. 00
7¾	24	4. 900	8	4½	72	9½	1½	290	COMFORTED	450. 00
7¾	30	6. 126	8	4½	78	9½	1½	310	COMMITTED	480. 00
7¾	36	7. 348	8	4½	84	9½	1½	330	CONSTRUCTED	500. 00
8½	24	5. 880	9	5	72	11	1½	295	COMIC	725. 00
8½	30	7. 350	9	5	78	11	1½	320	COMMON	775. 00
8½	36	8. 820	9	5	84	11	1½	345	CONSTRUCTED	825. 00
9½	24	7. 344	10	6	72	12	1½	525	COMICALITY	915. 00
9½	30	9. 180	10	6	78	12	1½	540	COMMUNE	955. 00
9½	36	11. 016	10	6	84	12	1½	555	CONSTRUCTING	1000. 00





Deming Seamless Brass Tube Cylinder With Removable Lower Valve

Fig. 1311

Fig. 1311 cylinder is made of seamless drawn brass tubing with cast-iron attachments, the top attachment being threaded for standard casing of the next size larger than the inside diameter of the cylinder, to permit the withdrawing of the plunger and lower valve without the necessity of removing the pipe and cylinder. *Bronze attachments furnished at extra cost.* The bottom attachment is threaded for suction pipe or strainer. The plunger and lower valve are made of machine-finished, bronze castings and are designed with the largest possible waterway.

The plunger has two cup leather packings and the lower valve one. The valves, valve seats and followers are interchangeable; valves are leather-faced. The lower valve is held securely in place by stiff springs which are so designed that they lock the lower valve seat and make it impossible for it to unscrew and drop off of the valve stem. To remove plunger and lower valve, simply draw out the plunger. The lower valve rod, which extends up through the plunger and is fitted with lock nuts, will, in turn, draw out the lower valve.

This simple construction does away with the difficulty so often experienced in trying to screw the plunger down onto the lower valve cage, as it is necessary to do on nearly all other makes of cylinders.



Sizes, Capacities, Etc.

Inside Diam. of Cylinder Inches	Stroke Inches	Capacity per Stroke Gallons	Top Attachment Fitted for Casing I. D. Inches	Bottom Attachment Fitted for Pipe Inches	Extreme Length of Cylinder Inches	Extreme Outside Diameter of Cylinder Inches	Plunger Fitted with Iron Pipe Connec. Inches	Approximate Weight Pounds	Price (Cipher. CHIME)
2 1/2	12	.255	2 3/4	1 1/2	23 1/2	4 1/2	1	14	\$30.40
2 1/2	16	.340	2 3/4	1 1/2	27 1/2	4 1/2	1	16	33.65
2 1/2	20	.425	2 3/4	1 1/2	31 1/2	4 1/2	1	18	38.25
2 1/2	24	.510	2 3/4	1 1/2	35 1/2	4 1/2	1	20	39.40
3	12	.367	3 1/4	2	24 1/2	4 3/8	1	24	33.65
3	16	.489	3 1/4	2	28 1/2	4 3/8	1	26	37.15
3	20	.612	3 1/4	2	32 1/2	4 3/8	1	28	41.25
3	24	.734	3 1/4	2	36 1/2	4 3/8	1	30	43.95
3 1/2	12	.499	3 3/4	2	26	4 7/8	1 1/2	32	42.75
3 1/2	16	.666	3 3/4	2	30	4 7/8	1 1/2	34	45.75
3 1/2	20	.833	3 3/4	2	34	4 7/8	1 1/2	36	48.00
3 1/2	24	1.000	3 3/4	2	38	4 7/8	1 1/2	38	50.65
4	16	.870	4 1/4	2 1/2	31 1/2	5 1/2	1 3/4	40	53.65
4	20	1.088	4 1/4	2 1/2	35 1/2	5 1/2	1 3/4	42	56.25
4	24	1.306	4 1/4	2 1/2	39 1/2	5 1/2	1 3/4	44	59.25
5	16	1.360	5 5/8	3	33	7 1/4	1 3/4	62	77.65
5	20	1.700	5 5/8	3	37	7 1/4	1 3/4	68	81.00
5	24	2.040	5 5/8	3	41	7 1/4	1 3/4	74	84.40
6	20	2.448	6 5/8	4	38 1/2	8 1/4	2	100	99.00
6	24	2.938	6 5/8	4	42 1/2	8 1/4	2	105	121.50
7	20	3.332	7 5/8	5 5/8 ID	39 1/2	9 1/2	2	112	153.00
7	24	3.998	7 5/8	5 5/8 ID	43 1/2	9 1/2	2	117	168.65
8	24	5.222	8 5/8	6 5/8 ID	45	10 1/2	2	127	219.40

Complete Table of Contents and General Classification of Pumps, Pages 7 and 8



Deming Windmill Irrigating Cylinders
For Wells 100 Feet Deep or Less



Fig. 380
For Spiral Riveted Pipe
(Flange of Cylinder Fits
Flange of Pipe)

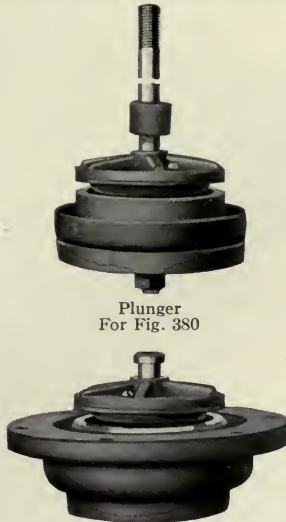

Plunger
For Fig. 380

Lower Valve
For Fig. 380



Fig. 1380

These cylinders may be operated by windmill or other power. They are intended for use in raising large quantities of water for irrigation or drainage purposes.

Fig. 380 has suction and discharge fitted for wrought iron pipe as listed. The top flange is regularly drilled for Abendroth and Root Special Riveted pipe as listed below.

Fig. 1380 has an extra heavy brass liner; all brass plunger; brass poppet lower valve and brass valve seat. The extended flange at top is drilled for supporting the cylinder on a framework to relieve the connecting pipe of the weight of the cylinder. Flanges on the 6 and 8-inch cylinders have $\frac{9}{16}$ -inch holes; the 10-inch and 12-inch cylinders have $\frac{5}{8}$ -inch holes.

Sizes and Prices, Fig. 380

Nom'l Inside Diam. Inches	Actual Inside Diam. Inches	Length of Stroke Inches	Total Length Inches	Flange for. Iron Pipe	Ex-treme Outside Diam. Inches	Plunger Rod Fitted for Pipe Inches	Nom'l Cap. per Stroke Gals.	Weight Pounds	IRON		BRASS-LINED	
									Cipher	Price	Cipher	Price
5	4 $\frac{5}{8}$	16	26	2 $\frac{1}{4}$	8	1	1 $\frac{1}{4}$	100	CAZIC	\$19.00	CAWKY	\$25.00
6	5 $\frac{5}{8}$	16	26	4	9	1	1 $\frac{3}{4}$	125	CEDRY	22.50	CELT	30.00
8	7 $\frac{5}{8}$	16	26	6	11	1	3 $\frac{1}{4}$	180	CELLA	31.00	CENSE	41.00
10	9 $\frac{5}{8}$	16	26	8	14	1 $\frac{1}{4}$	5 $\frac{1}{4}$	280	CHOWDER	45.00	CASSINO	57.00
12	11 $\frac{5}{8}$	16	34	8	16	2	7 $\frac{3}{4}$	400	CACHET	65.00	CADDICE	90.00
6	5 $\frac{5}{8}$	24	34	4	9	1	3	150	CARPEL	25.00	CARRYALL	37.00
8	7 $\frac{5}{8}$	24	34	6	11	1	5	225	CARPOLITE	33.00	CARTILAGE	49.00
10	9 $\frac{5}{8}$	24	34	8	14	1 $\frac{1}{4}$	7 $\frac{3}{4}$	375	CARPUS	53.00	CASCADE	71.00
12	11 $\frac{5}{8}$	24	42	8	16	2	11 $\frac{5}{8}$	600	CARRACK	75.00	CASEMENT	112.50

Sizes and Prices, Fig. 1380

Diameter and Stroke (Inches)	Capacity per Stroke (Gallons)	Suction and Discharge Pipe (Inches)	Plunger Connections Pipe (Inches)	Lift and Force Feet	Approximate Weight Pounds	BRASS LINED	
						Cipher	Price
6 x 16	1.958	3	1	100	150	CERES	\$ 55.00
8 x 16	3.482	4	1	75	225	CUTTY	80.00
10 x 16	5.44	5	1 $\frac{1}{4}$	50	320	CYCAS	120.00
12 x 16	7.833	6	2	50	380	CYCLE	160.00

*Refers to the diameter of spiral riveted pipe, through which the plunger can be drawn.

Engineering Tables and Information Relating to Hydraulics, Pages 239 to 248



Deming Oak Tanned Pump Leathers
Packed in Cartons of One Dozen Each



Showing Carton of One Dozen
Lower Valve Leathers



Showing Carton of One Dozen
Cup Plunger Leathers

Good leathers are just as essential to the success of a cylinder as a good cylinder is essential to the success of a pump. By some manufacturers, very little attention is given to the matter of leathers, although it is a subject of supreme importance, since much depends upon the performance of the leathers.

It is possible to buy pump leathers at a very low price, made up from scrap or clippings, but in the manufacture of Deming leathers, we use only the very highest grade of material. We buy the full sides from a tannery which makes a specialty of pump leather, and cut our own plungers and valve leathers, washers, etc. As the sides are especially treated for us, durability is assured, and by cutting them ourselves, we secure absolute accuracy. We have been cutting our own pump leathers for more than thirty years.

Deming cup and valve leathers are packed in pasteboard cartons. Dealers find these cartons to be very convenient. The kind, quantity and size of leathers contained are printed plainly on the front of each box so that the leather inventory can be taken at a glance. Being square cornered, these cartons will not roll around on the shelves and can be stacked one above the other.

Complete Price Lists are given on the opposite page for lower valve leathers, ring packings, flat plunger leathers and cup or crimped plunger leathers.

Complete Table of Contents and General Classification of Pumps, Pages 7 and 8



Deming Oak Tanned Pump Leathers
For Standard Deming Cylinders



Ring Packing

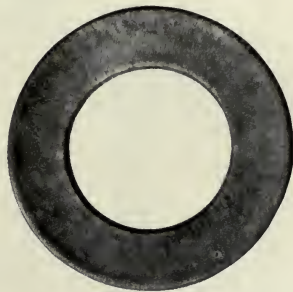

Flat Plunger Leather



Lower Valve Leather

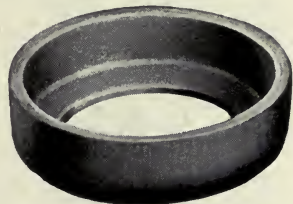

Cup or Crimped Leather

Price List Per 100

Inside Diameter of Pump Cylinder Inches	Cupped Plunger Leathers (Furnished with Our Regular Iron, Brass Lined and Brass Tube Cylinders)	Canvas Cups (For Spray and Special Fitted Pumps)	Flat Plunger Leathers	Lower Valve Leathers	Ring Packing	CUP LEATHERS FOR ARTESIAN WELL CYLINDERS — FIGS. 311 AND 324	
						Inside Diameter of Pump Cylinder Inches	Price Per 100
1	\$ 2.45	1 ³ / ₈	\$ 5.50
1 ¹ / ₄	3.15	1 ³ / ₄	6.60
1 ¹ / ₂	4.15	\$ 4.15	2 ¹ / ₄	9.40
1 ³ / ₄	5.55	5.55	2 ³ / ₄	12.85
2	6.25	6.25	\$ 4.50	\$ 4.50	\$ 3.15	3 ¹ / ₄	16.65
2 ¹ / ₄	6.95	6.95	5.50	5.50	3.50	3 ³ / ₄	27.40
2 ¹ / ₂	9.00	9.00	5.90	5.90	4.20	4 ¹ / ₄	36.00
2 ³ / ₄	10.50	10.50	7.00	7.00	4.85	4 ³ / ₄	49.00
3	11.50	11.50	7.30	7.30	5.55	5 ¹ / ₄	62.50
3 ¹ / ₄	12.85	12.85	9.00	9.00	6.60	5 ³ / ₄	76.40
3 ¹ / ₂	17.00	17.00	10.75	10.75	8.00	6 ¹ / ₄	90.00
4	21.85	21.85	12.50	12.50	9.00	6 ³ / ₄	104.00
4 ¹ / ₂	27.75	14.50	14.50	10.50	7 ³ / ₄	132.00
5	34.00	34.00	18.00	18.00	13.25	8	139.00
6	50.00	50.00	24.50	24.50	17.40	8 ¹ / ₂	160.00
8	115.00	9 ¹ / ₂	205.00
8 ¹ / ₂	130.00	10	222.00
10	175.00	10 ¹ / ₂	243.00
12	255.00	11	264.00
.....	11 ¹ / ₂	285.00
.....	12	305.00

Alphabetical Index, Figure Index and Telegraph Cipher Code, Pages 249 to 254



Deming "Marine" Irrigating Pumps

Will Lift 20 Feet

Fig. 475

With Bottom Suction

Fig. 476

With Side Suction



Fig. 475 is adapted for raising large quantities of water, short distances, with windmill or other power. It has a flanged base to fasten to platform or foundation. The bottom flange is threaded for suction pipe. The plunger can be withdrawn after removing the top cap. The plunger valve is metal, leather faced.

Fig. 476 is like Fig. 475 except that it is made with a tall base and has a flange at one side threaded for suction pipe.

Sizes and Prices

Fig.	Diam. of Cylinder Inches	Length of Stroke Inches	Suction Fitted for Pipe Inches	Capacity per Stroke Gallons	Weight Pounds	IRON CYLINDER		BRASS-LINED CYLINDER	
						Cipher	Price	Cipher	Price
475	6	12	3	1½	125	CAKLER	\$ 25.00	CALIPH	\$ 33.00
475	8½	12	4	3	215	CAJOLE	35.00	CALLIOPE	45.00
475	12	16	6	7¾	520	CABBLING	105.00	CABOB	130.00
476	6	12	3	1½	145	CABESSE	28.00	CABOTAGE	36.00
476	8½	12	4	3	270	CABIRIC	40.00	CABURN	50.00
476	12	16	6	7¾	540	CABLET	115.00	CACAO	140.00

Complete Table of Contents and General Classification of Pumps, Pages 7 and 8



PIPE, SUPPLIES
AND
PUMP FIXTURES

VARIOUS ACCESSORIES

INCLUDING STRAINERS, FLOAT,
CHECK AND FOOT VALVES; AIR
CHAMBERS, ROD COUPLINGS,
DRIVE POINTS, PIPE AND FIT-
TINGS, SINKS, BRASS GOODS,
HOSE, PUMP FITTERS' TOOLS,
OIL AND GREASE
CUPS, ETC.





HAND AND POWER PUMPS FOR ALL USES



Standard Weight and Extra Strong "Spellerized" Steel Pipe Black and Galvanized

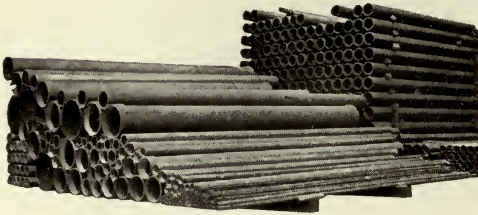

"SPELLERIZING"

In order to lessen the natural tendency of pipe to corrode, all sizes of "NATIONAL" Pipe below 4 inches are "Spellerized." This is a special roll-knobbling process whereby the heated bloom is subjected to the action of rolls having regularly shaped projections on their working surfaces, and then to the action of smooth-faced rolls. These successive operations are repeated until a uniform and dense texture is obtained, the metal as a consequence becoming better adapted to resist corrosion, especially in the form of pitting.

"Spellerizing" is NOT a mere experiment, but after several years in actual service, results have proved the value of uniform material for pipe, and this is the effect of "Spellerizing."

The larger sizes of pipe are also uniform in texture as the result of special manufacturing processes, but the smaller sizes only are "Spellerized" to counteract the greater danger from corrosion to the thinner walls.

We carry large stocks of all sizes up to and including 4 inches, and can make shipment the same day order is received.

REVISED LISTS, ADOPTED JANUARY 1, 1913. SIZES, WEIGHTS, ETC.

STANDARD PIPE					DIMENSIONS OF STANDARD PIPE COUPLINGS		
Nominal Size Inches	Price Per Foot Black or Galvanized	Actual Outside Diameter	Nominal Weight Per Foot Pounds	No. Threads Per Inch	Size Pipe Inches	Outside Diameter Inches	Length Inches
1/8	.055	.405	.24	27	1/8	1 1/8	1 1/8
1/4	.06	.54	.42	18	1/4	1 3/8	1
3/8	.06	.675	.56	18	3/8	1 1/2	1 1/4
1/2	.085	.84	.85	14	1/2	1 7/8	1 1/8
3/4	.115	1.05	1.13	14	3/4	2 1/8	1 3/8
1	.17	1.315	1.67	11 1/2	1	2 3/8	1 1/2
1 1/4	.23	1.66	2.27	11 1/2	1 1/4	2 7/8	2
1 1/2	.275	1.9	2.71	11 1/2	1 1/2	3 1/8	2 1/4
2	.37	2.37	3.65	11 1/2	2	3 7/8	2 3/4
2 1/2	.585	2.87	5.79	8	2 1/2	4 1/8	3 1/8
3	.765	3.5	7.57	8	3	4 7/8	3 3/8
3 1/2	.92	4.0	9.10	8	3 1/2	5 1/8	3 7/8
4	1.09	4.5	10.79	8	4	5 7/8	3 3/4
4 1/2	1.27	5.0	12.54	8	4 1/2	6 1/8	3 3/8
5	1.48	5.56	14.61	8	5	6 7/8	3 3/8
6	1.92	6.62	18.97	8	6	7 7/8	3 1/2
7	2.38	7.62	23.54	8	7	8 7/8	4
8	2.88	8.62	28.55	8	8	9 7/8	4

X STRONG PIPE

Nominal Size Inches	Price Per Foot	Actual Outside Diameter	Nominal Inside Diameter	Nominal Weight Per Foot Pounds	Nominal Size Inches	Price Per Foot	Actual Outside Diameter	Nominal Inside Diameter	Nominal Weight Per Foot Pounds
1/8	.12	.405	.215	.314	2 1/2	.77	2.87	2.323	7.661
1/4	.075	.54	.302	.535	3	1.03	3.5	2.90	10.252
3/8	.075	.675	.423	.738	3 1/2	1.25	4.0	3.364	12.505
1/2	.11	.84	.546	1.087	4	1.50	4.5	3.826	14.983
3/4	.15	1.05	.742	1.473	4 1/2	1.80	5.0	4.29	17.611
1	.22	1.315	.957	2.171	5	2.08	5.56	4.813	20.778
1 1/4	.30	1.66	1.278	2.996	6	2.86	6.62	5.761	28.573
1 1/2	.365	1.9	1.50	3.631	7	3.81	7.62	6.625	38.048
2	.505	2.37	1.939	5.022	8	4.34	8.62	7.625	43.388

The permissible variation in weight is 5 per cent. above and 5 per cent. below.

Furnished with threads and couplings and in random lengths unless otherwise ordered.

For cut lengths, an extra charge will be made above random lengths.

For pipe smoothed on the inside, known as reamed and drifted, an extra charge will be made above standard pipe.

For galvanized, or coated pipe, an extra charge will be made above black.













Complete Table of Contents and General Classification of Pumps, Pages 7 and 8



HAND AND POWER PUMPS FOR ALL USES



Revised Price List of Pipe Fittings

Sizes, Inches	¼	⅜	½	¾	1	1¼	1½	2	2½	3	3½	4	4½	5	6	
Elbows, Malleable, 45°	\$.08	\$.10	\$.12	\$.18	\$.26	\$.36	\$.54	\$.82	1.25	2.50	3.25	4.50	5.25	6.00	7.50	
Elbows, Galvanized, 45°12	.15	.20	.25	.40	.50	.85	1.35	1.90	3.75	4.75	6.75	9.00	11.00		
Elbows, Malleable07	.08	.10	.15	.22	.25	.35	.50	.90	1.50	2.25	3.00				
Elbows, Galvanized09	.11	.14	.20	.32	.40	.60	.90	1.50	2.60	3.75	5.00				
Street Elbows, Malleable10	.10	.12	.20	.25	.40	.55	.90	1.50	2.25	3.50					
Street Elbows, Galvanized12	.12	.15	.28	.35	.55	.80	1.30	2.25	3.50						
Tees, Malleable08	.09	.11	.15	.25	.30	.45	.60	1.05	1.70	2.50	3.40				
Tees, Galvanized10	.13	.16	.20	.38	.50	.70	1.00	1.90	3.00	4.25	5.75				
Crosses, Malleable09	.10	.16	.20	.30	.40	.60	1.00	1.75	3.00	3.25	5.25				
Crosses, Galvanized25	.29	.45	.60	.90	1.50	2.75	4.50		8.00				
Couplings, Wrought05	.06	.07	.10	.13	.17	.21	.28	.40	.60	.80	1.00	1.50	1.65	2.40	
Couplings, Galvanized06	.08	.10	.13	.18	.25	.32	.40	.55	.80	1.05	1.40	2.00	2.25	3.25	
Couplings, Malleable, R. & L.04	.06	.08	.12	.16	.25	.36	.52								
Couplings, Galvanized, R. & L.06	.09	.10	.17	.25	.35	.55	.75								
Nipples, Short04	.04	.05	.06	.08	.11	.13	.18	.39	.48	.75	.85	1.25	1.55	1.85	
Nipples, Long06	.06	.07	.09	.13	.17	.20	.27	.59	.72	1.05	1.20	1.70	2.45	2.90	
Nipples, Short, Galvanized06	.06	.06	.08	.11	.17	.21	.27	.56	.70	1.20	1.35	1.85	2.30	2.80	
Nipples, Long, Galvanized11	.11	.11	.14	.19	.29	.35	.47	.86	1.10	1.70	1.87	2.60	3.15	4.25	
Bushings, Plain04	.04	.05	.06	.07	.09	.14	.21	.30	.40	.50	.75	.93	1.25	
Bushings, Galvanized08	.08	.10	.12	.14	.18	.28	.42	.60	.80	1.00				
Plugs, Plain02	.02	.02	.03	.04	.05	.07	.10	.18	.25	.38	.42	.65	.88	1.20	
Plugs, Galvanized04	.04	.04	.06	.08	.10	.14	.20	.36	.50	.76	.84	1.30	1.75	2.40	
Reducers, Cast													1.85	2.00	2.70	
Reducers, Malleable05	.06	.07	.10	.16	.20	.28	.45	.70	1.00	1.50	1.85				
Reducers, Galvanized10	.15	.25	.35	.45	.75	1.05	1.65	2.40	3.05				
Caps, Cast													1.05	1.20	1.55	
Caps, Malleable03	.04	.05	.08	.12	.16	.24	.32	.45	.85	1.00	1.20				
Caps, Galvanized04	.05	.08	.12	.17	.24	.38	.52	.76	1.30	1.60	2.00				
Locknuts, Malleable02	.03	.04	.05	.07	.09	.11	.18								
Locknuts, Galvanized03	.04	.05	.07	.10	.14	.20	.30								
Locknuts, Cast27	.34	.47	.64	.85	.90	1.30		
Unions, Malleable18	.20	.22	.27	.33	.46	.58	.75	1.55	2.10	3.65	4.35				
Unions, Galvanized27	.30	.33	.40	.50	.70	.90	1.15	2.35	3.15	5.50	6.50				
Flanged Unions40	.46	.52	.64	.78	1.00	1.25	1.50	1.80	2.10	2.70	3.15	3.95	

Alphabetical Index, Figure Index and Telegraph Cipher Code, Pages 249 to 254



Deming Steel Pump Rod and Couplings

Steel Pump Rod

Size, Inches	$\frac{3}{8}$	$\frac{7}{16}$	$\frac{1}{2}$	$\frac{5}{8}$
Weight, Per Foot	6 Oz.	8 Oz.	11 Oz.	16 Oz.
Price, Per Pound, Galvanized	\$0.10	\$0.10	\$0.10	\$0.10

Couplings for Steel Pump Rod

HEXAGON MALLEABLE IRON ROD COUPLINGS



Hexagon Malleable Iron Rod Coupling

Size, Inches	$\frac{3}{8}$	$\frac{7}{16}$	$\frac{1}{2}$	$\frac{5}{8}$	$\frac{3}{4}$	$\frac{7}{8}$
Approx. No. Per Pound	9	7	7	6	6	6
Threads to the Inch	14	12	12-14	12	12-14	12-12
Price, Black, Per Pound	\$0.16	\$0.16	\$0.16	\$0.16	\$0.16	\$0.16
Price, Galvanized, Per Pound20	.20	.20	.20	.20	.20

These couplings are tapped $\frac{1}{32}$ -inch over size unless otherwise ordered.

Heavy Duty Rod Coupling

HEAVY DUTY ROD COUPLINGS



Rod Coupling for Heavy Duty

Size, Inches	Price Galvanized Per Pound	Price Plain Per Pound
$\frac{5}{8}$	\$0.22	\$0.18
$\frac{5}{8} \times \frac{3}{8}$.22	.18
$\frac{5}{8} \times \frac{7}{16}$.22	.18

Beaded Rod Coupling



Beaded Rod Coupling

Size Rods, Inches	Threads to the Inch	Galvanized Per Pound	Plain Per Pound	Brass Per Pound
$\frac{3}{8}$	14, regular	\$0.20	\$0.16	\$0.50
$\frac{3}{8}$	16, to order	.20	.16	.50
$\frac{3}{8} \times \frac{7}{16}$	12x14	.20	.16	.50
$\frac{7}{16}$	12	.20	.16	.50
$\frac{1}{2}$	12	.20	.16	.50
$\frac{1}{2} \times \frac{7}{16}$	12	.20	.16	.50



Combination Pipe and Rod Coupling

Combination Pipe and Rod Couplings

PIPE AND ROD COUPLING FOR $\frac{3}{8}$ -INCH IRON PIPE

Size Rod, Inches	$\frac{3}{8}$	$\frac{7}{16}$	$\frac{1}{2}$
Approximate Number in Pound	5	5	5
Price per Pound, Galvanized	\$0.30	\$0.30	\$0.30



Deming Wood Sucker Rods and Pin Connections



Fig. 636 Wood Sucker Rods are made of the best material obtainable, octagon in shape, and are lighter than solid steel or pipe rods. Prices include rods with couplings attached, and are for standard lengths of from 18 to 20 feet each. Shorter lengths furnished at proportionate increase in price. When wanted, rods are furnished with galvanized couplings and copper rivets at extra price. Fig. 636 Rod Couplings are of forged wrought iron with threaded box and pin joints.

Sizes and Prices of Fig. 636 Rods and Couplings

Size of Octagon Wood Rods Inches	Diameter of Box and Pin Inches	Number of Threads per Inch	Approximate Shipping Weight per Foot Pounds	RODS WITH COUPLINGS IN ABOUT 20-FOOT LENGTHS			COUPLINGS ONLY, PER PAIR			Adapted for Working Barrel Diameter Inches (Depending Upon the Depth of Well)
				Cipher	Price per Foot		Cipher	Price		
					With Plain Coupl'g	With Galv'd Coupl'g		Plain	Galv'd	
1 1/4	5/8	12	1/2	SACRED	\$0.19	\$0.25	SACRUM	\$1.65	\$2.25	From 1 3/4 to 2 1/4
1 3/8	7/8	10	3/4	SADNESS	.28	.37	SAGGER	2.75	3.75	From 2 1/4 to 3 1/4
1 7/8	1	10	1	SACREDLY	.30	.40	SADDLE	2.75	3.75	From 2 3/4 to 3 3/4
2	1 1/8	10	1 1/4	SAFFRON	.50	.60	SAGGING	3.75	3.45	From 3 1/4 to 4 1/4
2 1/4	1 1/8	8	1 3/4	SAGELY	.55	.80	SAGO	3.75	3.45	From 3 3/4 to 5 1/4
2 3/4	1 1/8	8	2	SABINE	.85	1.05	SACKER	6.25	9.25	From 4 1/4 to 5 3/4
3	1 1/8	8	2 1/4	SAGENITE	.90	1.25	SAGOIN	6.25	9.25	From 4 3/4 to 6 1/4
3 1/4	1 1/8	8	3 1/4	SACQUE	1.40	1.85	SADLY	13.50	16.50	From 5 3/4 to 7 3/4
3 1/2	1 1/8	8	4 1/2	SABOT	1.60	2.05	SACKAGE	13.50	16.50	From 6 3/4 to 9 1/2



Fig. 1637 (Cipher, "Sanity") Pin connections, or steel substitutes, are for making connection between Figs. 324 and 311 cylinder plungers and wood rod couplings. One end is threaded to fit the plunger and the other end threaded the same as pin on the coupling of Fig. 636 sucker rod, unless otherwise specified.

Sizes and Prices of Fig. 1637 Steel Pin Connection

Trade No.	Size of Pin	Threads per Inch	Size of Pin	Threads per Inch	Price	Trade No.	Size of Pin	Threads per Inch	Size of Pin	Threads per Inch	Price
1	5/8	12	5/8	12	\$0.50	7	1 1/8	8	3/8	10	\$2.50
2	7/8	10	7/8	12	1.00	8	1 3/8	8	1	10	2.50
3	1	10	1	10	1.00	9	1 5/8	8	1 1/8	8	2.50
4	1	10	1 1/8	12	2.00	10	1 7/8	8	1 3/8	8	4.00
5	1	10	1 3/8	10	2.00	11	1 7/2	8	1 7/8	8	4.00
6	1	10	1	10	2.00



Deming Suction Strainers for Pipe and Hose

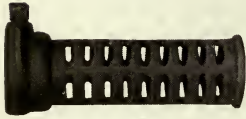

Fig. 338



Fig. 339



Fig. 340

Fig. 338 — Suction strainer for iron pipe. Fastens to pipe with set screw. For use where pipe is not threaded.

Fig. 339 — Female thread. Screws on end of pipe.

Fig. 340 — Male thread. Screws into pipe coupling or into bottom of cylinder.

Size, Inches	1	1¼	1½	2	2½	3	
Figs. 338, 339, 340	Plain	\$0.36	\$0.40	\$0.48	\$0.72	\$0.80	\$1.00
	Galvanized44	.48	.52	.80
	Galvanized and Gauze Covered56	.64	.72	1.00

*Two and one-half inch and 3-inch made only in Fig. 340 plain.



Fig. 334
Strainer for Hose

Fig. 334 — Suction strainer for hose. Stem is forced into hose and held therein by hose band. *Fig. 334 is furnished regularly with capped end hose, but will be furnished for enlarged end hose when specified.*



Fig. 341
Strainer for Pipe

Fig. 341 — Extra heavy bell-shaped strainer for iron pipe. Female thread.

Size, Inches	1	1¼	1½	2	2½	3	3½	4	4½	5	6	7	8
Fig. 334, Plain	\$0.20	\$0.25	\$0.35	\$0.50	\$0.75	\$1.00	\$1.50
Fig. 334, Galv.25	.30	.45	.60	1.00	1.50	2.50
Approx. Weight, Pounds	2	2½	3	3¾	5½	5¼
Fig. 341, Screwed, Plain22	.29	.40	.54	.80	1.05	1.70	1.90	2.25	2.40	3.40	5.00	6.60
Fig. 341, Screwed, Galvanized32	.42	.56	.75	1.10	1.60	2.60	2.90	3.50	3.80	5.00	7.25	9.75
Approx. Weight, Pounds	1½	2	3	4	6	7½	8	11	16¾	13¾	17½	27	33

Complete Table of Contents and General Classification of Pumps, Pages 7 and 8



Deming Strainers, Check and Foot Valves

Vertical and Horizontal Check Valves

Where the suction lift is high or the suction pipe long it is desirable to use a foot valve as this will insure quick starting of the pump by maintaining the suction pipe full of water.



Fig. 325, Vertical

Size, Inches	¾	1	1¼	1½	2	2½	3	3½	4
Fig. 325/Plain	\$1.50	\$1.75	\$2.00	\$2.50	\$3.00	\$4.25	\$6.00	\$7.50	\$10.00
(Galv.)	2.00	2.25	2.75	3.50	4.50	6.00	9.00	12.00	15.00
Fig. 326/Plain	1.00	1.25	1.50	2.00	2.75	4.00	6.00	7.50	9.00
(Galv.)	1.50	1.75	2.25	3.00	4.00	5.50	8.00	10.00	12.00



Fig. 326, Horizontal



Fig. 328, Foot Valve and Strainer, 6-inch and Smaller, Screwed

Foot Valves With Bolted Strainer

It is well also to have a strainer at the end of the suction pipe to prevent the intake of the larger particles of foreign matter which would tend to clog the pump valve. Fig. 328 combined foot valve and strainer answers this purpose to very good advantage. We can furnish sizes larger than 2-inch in either the screwed or flanged type.



Fig. 328, Foot Valve and Strainer, 7-inch and Larger, Flanged

Size, Inches	1	1¼	1½	2	2½	3	3½	4	4½	5	6	7	8
Fig. 328													
Will Go In Pipe, Inches	5	5	6	7	8	9	10	10	10	12	12	14	14
Screwed, Plain	\$0.48	\$0.48	\$0.62	\$0.82	\$1.20	\$1.70	\$2.50	\$2.75	\$4.00	\$4.25	\$7.00	\$16.00	\$16.00
Screwed, Galvanized	.75	.75	1.00	1.45	2.00	2.70	3.90	4.25	6.00	6.50	10.00	30.00	30.00
Flanged, Plain					2.10	2.25	3.00	3.60	4.75	5.00	8.00	16.50	16.50

Foot Valves with Screwed Strainers

These foot valves are for use in open wells and also in drilled wells of diameters given in table below.

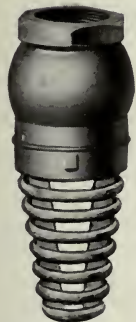

Fig. 330, Foot Valve and Strainer

Size, Inches	¾	1	1¼	1½	2	2½
Will Go In Pipe	2½	2½	3	3½	4	5
Fig. 330/Plain	\$1.50	\$1.75	\$2.00	\$2.50	\$3.00	\$4.25
(Galvanized)	2.00	2.25	2.75	3.50	4.50	6.00

Size, Inches	1¼	1½	2	2½	3	4
Fig. 336						
Screwed for Pipe, Inches	1¼	1½	2	2½	3	4
Outside Diameter, Inches	2¾	2¾	2¾	3¾	4½	5¾
Will Go In Pipe, Inches	2½	3	3	4	5	6
Approximate Weight, Pounds	3	4	4	7	11	17
Price, Plain, Each	\$2.25	\$2.50	\$3.00	\$3.50	\$4.50	\$8.00
Price, Galvanized, Each	3.00	3.50	4.00	4.50	5.50	10.00



Fig. 336, Foot Valve and Strainer



HAND AND POWER PUMPS FOR ALL USES



Float Valves, Air Chambers, Water Conductors, Etc. Float and Outlet Valves and Floats



Fig. 350

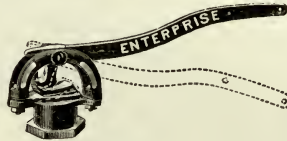

Fig. 1079

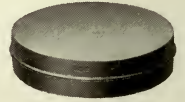

Fig. 1078

Fitted for Pipe, Inches	3/4	1	1 1/4	1 1/2	2	2 1/2	3
Fig. 350 Float Valve, Each	\$0.80	\$0.80	\$1.00	3.00	5.00	7.50	\$10.00
Fig. 1079 Enterprise Float and Outlet Valve	1.25	1.38	1.50				
Fig. 1078, Copper, 9 1/2 x 2 3/4 Inches, Each							\$1.25
Fig. 1078, Copper, 12 x 3 Inches, Each							1.75
Fig. 1078, Galvanized Iron, 12 x 3 Inches, Each							1.50

HYDRAULIC AIR CHAMBERS, FIG. 369

These Air Chambers are adapted for attaching to the conducting pipe where pumps are required to work against great pressure or force water through a long lead of pipe. Their use will greatly lessen the wear on the pumps. They are fitted with tee connection.

SIZES AND PRICES

Size, Inches	3/4	1	1 1/4	1 1/2	2	2 1/2
Price Each	\$3.00	\$3.00	\$4.00	\$4.00	\$6.50	\$12.00



Fig. 369



Fig. 389

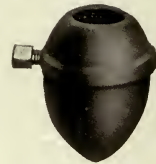

Fig. 343

ROLLER PISTON ROD GUIDES FIG. 389

HANDLE BALLS FIG. 343

For Pipe, Inches	1	1 1/2
Price	\$2.50	\$3.50

Weight, Lbs.	2 3/4	4 1/2	6	8	12 1/2
Price, Each.	\$0.30	\$0.45	\$0.60	\$0.80	\$1.25

WATER CONDUCTORS, FIG. 344

The Water Conductor is a great convenience for conveying water from the spout of pumps to troughs and tanks situated at a distance. It is made to swivel and conduct the water in any direction desired. For 1 1/4 or 1 1/2-inch Conducting Pipe, as ordered. Price, each, \$1.00



Fig. 344
Water Conductor



Fig. 368
Malleable Hose Clevis
for Pump Spout



Fig. 362
Goose Neck

MALLEABLE
HOSE CLEVIS, FIG. 368
FOR PUMP SPOUT
Price, each, 3/4 or 1-in. \$0.50

GOOSE NECK, FIG. 362

Size Inches	Fitted for Hose Coupling Inches	WITHOUT HOSE COUPLING		WITH HOSE COUPLING	
		Cipher	Price	Cipher	Price
3/4	3/4	COMPETENT	\$0.60	COMPLIMENT	\$0.90
1	1	COMPLIER	.60	COMPONENT	1.25
1 1/4	1 1/4	COMPLACENT	.80	COMPOSER	1.50
1 1/2	1 1/2	COMPLEX	.90	COMPREHEND	1.80
2	2	COMPLEXITY	1.00	COMPULSION	2.50

Complete Table of Contents and General Classification of Pumps, Pages 7 and 8



Deming Pump Bracket and Cast Iron Sinks

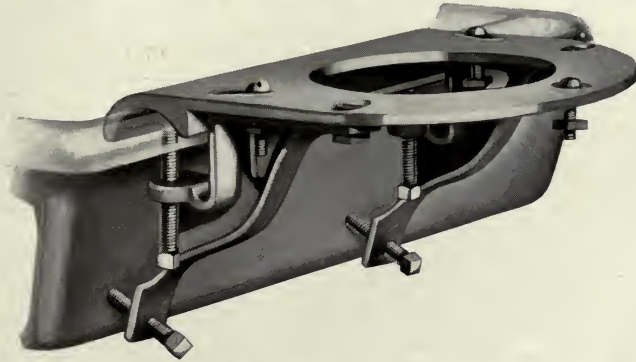

Pump Bracket for Flat and Roll Rim Sinks

Will attach to the rim of an ordinary painted or enameled flat or roll rim sink for supporting a pump, and can be placed on either end. The shelf is substantial and neat in design. The combination consists of the pump shelf and bracket, and has a bead around the outer and inner edges, so that all waste water will drain into the sink. It can be quickly placed in position by means of the set screws, and it can also be adjusted to the proper level. A small piece of sheet rubber packing or leather should be placed between the shelf and the sink so as to prevent marring the enamel. The suction pipe of the pump passes through opening of the shelf.

Dimensions	Weight Pounds	PRICE PER DOZEN		
		Aluminum	Galvanized	White Enameled
Length, 9½ inches Top of Plate to Bottom of Bracket, 5½ inches	7½	\$18.00	\$24.00	\$36.00

Porcelain Enameled Iron Kitchen Sinks

WITH FLAT RIM, NICKEL PLATED BRASS STRAINER AND COUPLINGS

The sizes listed below are carried in stock for immediate shipment

- 16 x 24 x 6 inches
- 18 x 24 x 6 inches
- 18 x 30 x 6 inches
- 18 x 36 x 6 inches
- 20 x 30 x 6 inches
- 20 x 36 x 6 inches

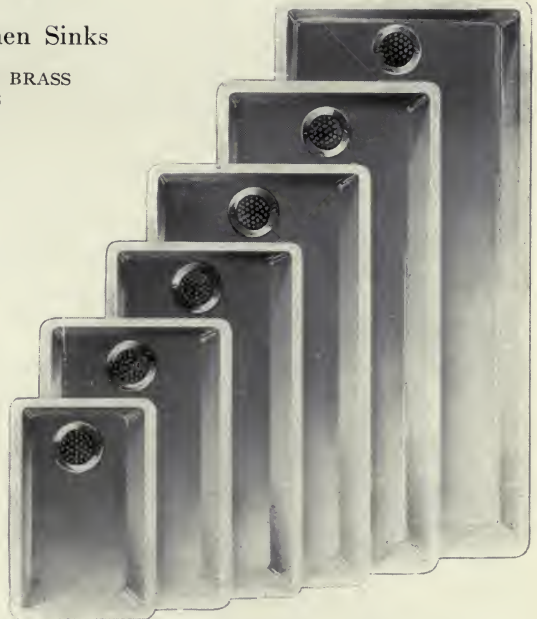



Brass Goods — Cocks and Valves



Fig. 900

GLOBE VALVE, FIG. 900

Size, Inches	1/8	1/4	3/8	1/2	3/4	1	1 1/4
Price, Each	\$0.72	\$0.72	\$0.77	\$1.00	\$1.26	\$1.80	\$2.52



Fig. 908

STRAIGHT-WAY DOUBLE-GATE VALVES, FIG. 908

Size, Inches	1/2	3/4	1	1 1/4	1 1/2	2	2 1/2	3
Price, Each	\$1.65	\$2.05	\$2.80	\$3.70	\$5.00	\$7.30	\$13.00	\$19.00



Fig. 904

HORIZONTAL CHECK VALVES, FIG. 904

Size, Inches	1/8	1/4	3/8	1/2	3/4	1	1 1/4	1 1/2	2	2 1/2	3
Price, Each	\$0.65	\$0.65	\$0.70	\$0.90	\$1.15	\$1.60	\$2.25	\$3.15	\$4.75	\$9.00	\$13.00

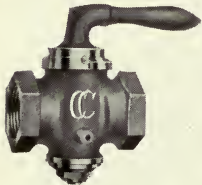

Fig. 913

LEVER HANDLE, ROUGH STOP, FIG. 913

Size, Inches	1/2	3/4	1	1 1/4	1 1/2
Rough Stops, Lever Handle, Per Dozen	\$21.00	\$36.00	\$52.80	\$89.40	\$149.40
Rough Stops, Lever Handle, Check and Waste, Per Dozen	21.60	36.60	54.00	91.20	152.40



Fig. 917

LEVER HANDLE BIBB COCKS, FIG. 917

Size, Inches	3/8	1/2	5/8	3/4	1	1 1/4	1 1/2	2
Finished Bibbs, Per Dozen	\$25.20	\$25.80	\$35.40	\$45.00	\$64.80	\$107.40	\$179.40	\$300.00
Finished Bibbs for Hose, Per Dozen	28.80	38.40	48.00	72.00	118.20	194.40	322.20	



Fig. 919

COMPRESSION BIBBS, FIG. 919

Size, Inches	3/8	1/2	5/8	3/4	1
Compression Bibbs, Finished, Per Dozen	\$18.60	\$19.80	\$25.20	\$33.00	\$60.00
Compression Bibbs, Finished, for Hose, Per Dozen	22.80	28.20	36.00	67.20	

Complete Table of Contents and General Classification of Pumps, Pages 7 and 8



HAND AND POWER PUMPS FOR ALL USES



Pump Accessories — Metal and Glass



Fig. 1545

COMBINATION CHECK VALVE AND AIR COCK

Fig. 1545

For Pumping Air and Water, for Use with Hydro-Pneumatic Water Systems

Price, \$1.00



Fig. 788

Tee Handle Air Cock

Sizes for Iron Pipe, Inches	1/8	1/4	3/8	1/2
Fig. 788, Air Cock, Tee Handle.	\$0.40	\$0.45	\$0.50	\$0.60

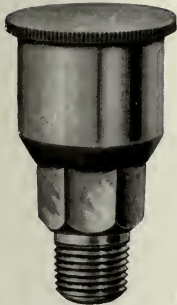

Plain Brass Oil Cup



Glass Body with Set-Feed



Glass Body with Sight-Feed, Set-Feed and Stop-Feed



Blued Steel Grease Cup

Sizes for Iron Pipe, Inches	1/8	1/4	1/4	3/8	3/8	1/2	1/2
Outside Diameter of Bodies, Inches	3/8	1	1 1/4	1 1/2	1 3/4	2
Plain Brass, Price	\$0.35	\$0.40	\$0.60	\$0.90	\$1.25	\$1.75
Outside Diameter of Glass, Inches	1 1/4	1 1/2	1 3/4	2	2 1/4	3	3 1/2
With Set-Feed, Finished Brass, Price	\$0.80	\$1.00	\$1.25	\$1.50	\$1.90	\$3.10	\$4.00
With Set-Feed, Finished Nickel, Price95	1.20	1.50	1.75	2.30	3.50	4.50
With Sight-Feed, Finished Brass, Price	3.00	3.25	3.50	3.75	4.25	7.25	9.25
With Sight-Feed, Finished Nickel, Price	3.50	3.75	4.00	4.25	4.75	8.00	10.25

PRICE LIST OF "MOON" GREASE CUPS



Number	0	1	2	3	4	5
Inside Diameter, Inches	7/8	1 1/8	1 1/2	1 3/4	2 1/4	3
Outside Diameter, Inches	1 1/4	1 1/2	1 3/4	2	2 3/4	3 3/8
Height Over All, Plunger Raised, In.	3 3/4	4 1/2	4 3/4	5 1/4	6 1/2	8
Capacity, Ounces	1/2	1	1 1/2	2 1/2	4 1/2	10
Shank Pipe Thread, Inches	3/8	1/4	1/4	3/8	1/2	1/2
Finished Cast Brass, Each	\$1.50	\$2.00	\$2.50	\$3.20	\$4.30	\$6.00
Finished Nickel, Each	1.75	2.25	2.80	3.60	5.00	6.75

PRICE LIST OF BLUED STEEL GREASE CUPS

Number	00	0	1	2	3	4
Inside Diameter, Inches	1	1 1/4	1 1/2	2	2 1/2	3
Shank Pipe Thread, Inches	1/2	1/2 or 1/4	1/4	1/4 or 3/8	3/8 or 1/2	1/2
Capacity, Ounces	1 1/2	2 1/2	1	2	3 1/2	5
Blued Steel, Each	\$0.90	\$1.15	\$1.40	\$1.80	\$2.60	\$3.50

"Moon" Grease Cup

Alphabetical Index, Figure Index and Telegraph Cipher Code, Pages 249 to 254



Rubber Suction and Discharge Hose



"Deco" 1/2-inch Special High Pressure Hose for Spraying—Good for 250 Pounds Working Pressure

"DECO" 1/2-INCH SPECIAL SPRAY HOSE FOR 250 POUNDS WORKING PRESSURE

This is a high grade continuous web hose made up especially for us and according to our specifications. It is used with hand and power sprayers and is guaranteed for 250 pounds working pressure to the square inch. We can furnish this hose in any desired lengths. Standard reel, 500 feet. List price per foot 1/2-inch \$0.25



Spiral Wire Suction Hose

SPECIAL WIRE SUCTION HOSE

We carry in stock spiral wire lined suction hose as follows:

- 1-inch and 1 1/4-inch in 10-foot lengths.
- 2-inch in 15, 20 and 25-foot lengths.
- 2 1/2-inch and 3-inch in 15-foot lengths.

Size, Inches	1	1 1/4	1 1/2	2	2 1/2	3
Price per Foot	\$0.75	\$0.93	\$1.13	\$1.50	\$3.10	\$4.00



Red "CI" 3/8-inch Tubing for Bucket and Knapsack Spray Pumps

RED "CI" 3/8-INCH RUBBER TUBING

For use with bucket and knapsack sprayers, etc. Furnished in lengths of 50 feet or less. List price per foot \$0.15



Three-Ply Hydrant Hose

THREE-PLY HYDRANT HOSE

This is the very best quality of hose for hydrant and pump service where the pressure does not exceed 75 pounds.

Size, Inches	3/4	1	1 1/4	1 1/2
3-Ply Hydrant	\$0.30	\$0.40	\$0.50	\$0.60

FOR HOSE COUPLINGS AND BANDS, SEE PAGE 312

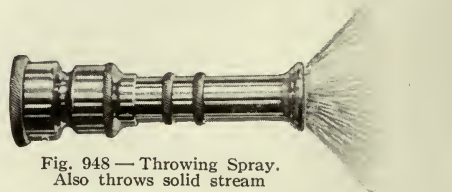

Fig. 948 — Throwing Spray. Also throws solid stream

"GEM" HOSE NOZZLE, FIG. 948

Size, Inches	3/4	1
"Gem" Hose Nozzles, with graduating spray. Price, Dozen	\$10.00	\$15.00



Pipe Pullers, Fitters' Tools, Etc.



JACK SCREW PIPE PULLER, FIG. 861

Holds Pipe, Inches . . .	1	1 1/4	1 1/2	2	2 1/2	3
No. 2, with 1, 1 1/4, 1 1/2 or 2-in. Dies				\$2.75		
Extra Dies for No. 2	\$0.80	\$0.75	\$0.50	.50		
No. 3, with 2, 2 1/2 or 3-in. Dies						\$5.00
Extra Dies for No. 380	.75	.75

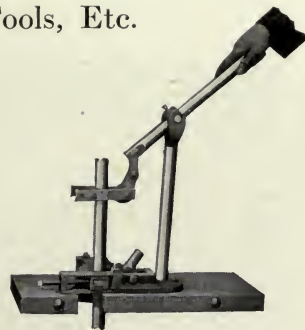

BABCOCK'S PIPE LIFTER AND HOLDER, FIG. 884

Price, complete for 1 and 1 1/4-in. Pipe, \$6.50

Holds Pipe, Inches . . .	3	3 1/2	4	4 1/2	5	6
No. 4, with 3 1/2 or 4-in. Dies			\$8.50			
Extra Dies for No. 4	\$2.25	\$2.00	\$1.75			
No. 5, with 4, 4 1/2 or 5-in. Dies					\$10.00	
Extra Dies for No. 5	3.25	3.00	2.75	\$2.50	2.00	
No. 6, with 4, 4 1/2, 5 or 6-in. Dies						\$12.00
Extra Dies for No. 6			3.00	2.75	2.50	2.25

HANDY PIPE VISE, FIG. 858

Fig. 858, Capacity from 3/8-inch Rod to 2-inch Pipe. Each \$3.00

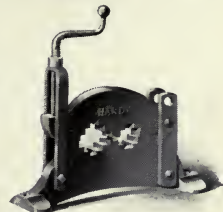

STILLSON WRENCH, FIG. 844

Length, Open, . . .	6 In.	8 In.	10 In.	14 In.	18 In.	24 In.
Takes Pipe, In., . . .	1/8 to 1/2	1/8 to 3/4	1/8 to 1	1/4 to 1 1/2	1/2 to 2	1/2 to 2 1/2
Price . . . Each . . .	\$2.00	\$2.25	\$2.50	\$3.50	\$5.00	\$7.25
Extra Jaws, "75	.80	.85	1.15	1.75	2.25
Extra Nuts, "12	.15	.20	.30	.35	.55
Ex. Frames "38	.42	.50	.60	.75	.95



BARNES' CUTTER, FIG. 855

Numbers	1	2	3	4	5
Cuts Pipe, In., . . .	1/8 to 1	1/2 to 2	1 1/2 to 3	2 1/2 to 4	4 to 6
Price . . . Each . . .	\$4.50	\$6.00	\$10.00	\$20.00	\$30.00
Ex. Wheels, "25	.30	.40	.50	.75
Wheel Pins, "10	.10	.10	.20	.20



DIE STOCKS WITH SOLID DIES, FIG. 848

Number	0	1	1 1/2	1 3/4	2	3
Dies with Each Stock	1/8 to 1/2	1/4 to 1	3/4 to 1 1/4	1 to 1 1/2	1 1/4 to 2	2 1/2 to 3
Dimensions of Dies	2 x 1 1/2	2 1/2 x 3/4	3 x 3/4	3 x 3/4	4 x 3/8	5 x 1 1/4
Complete with Right-hand Dies. . . Each . . .	\$8.00	\$10.50	\$9.50	\$9.50	\$14.50	\$35.00
Stocks without Dies or Guides	3.00	3.50	4.00	4.00	8.50	20.00
Extra Dies, Right or Left	1.40	1.60	2.00	2.00	2.50	9.00
Extra Guides.30	.40	.60	.60	.75	2.00
Die Frames30	.40	.40	.50	.60

No. 2 and larger have Leaded Screw.

Engineering Tables and Information Relating to Hydraulics, Pages 239 to 248



HAND AND POWER PUMPS FOR ALL USES



Brass Jacket Drive Well Points



FIG. 630

Trade No.	Size Inches	Length Feet	Jacket Inches	Holes	PRICES BY THE DOZEN			
					No. 60 Gauze	No. 80 Gauze	No. 90 Gauze	No. 100 Gauze
74	1	2	18	70	\$ 33.00	\$ 46.00	\$ 52.00	\$ 62.00
76	1	2½	24	100	42.00	56.00	64.00	78.00
78	1	3	30	120	51.00	66.00	76.00	94.00
80	1	3½	36	140	60.00	76.00	88.00	120.00
82	1	4	42	160	69.00	86.00	100.00	136.00
84	1	4½	48	190	78.00	96.00	112.00	152.00
86	1½	1½	14	80	30.00	42.00	50.00	64.00
90	1½	2	18	100	36.00	52.00	60.00	80.00
94	1½	2½	24	125	46.00	64.00	75.00	100.00
98	1½	3	30	150	56.00	76.00	90.00	120.00
100	1½	3½	36	175	66.00	88.00	105.00	140.00
102	1½	4	42	200	76.00	100.00	120.00	160.00
106	1½	4½	48	225	86.00	112.00	135.00	180.00
110	1½	5	54	250	96.00	124.00	150.00	200.00
112	1½	5½	60	275	106.00	136.00	165.00	220.00
136	1½	2	18	120	48.00	65.00	78.00	94.00
140	1½	2½	24	160	60.00	80.00	96.00	118.00
144	1½	3	30	200	72.00	95.00	114.00	142.00
146	1½	3½	36	230	84.00	110.00	132.00	166.00
148	1½	4	42	270	96.00	125.00	150.00	180.00
150	1½	4½	48	310	108.00	140.00	168.00	204.00
152	1½	5	54	350	120.00	155.00	186.00	228.00
154	1½	5½	60	390	132.00	170.00	204.00	252.00
160	2	2	18	140	75.00	94.00	110.00	130.00
164	2	2½	24	200	90.00	112.00	132.00	160.00
168	2	3	30	260	105.00	130.00	154.00	190.00
170	2	3½	36	290	120.00	148.00	176.00	220.00
172	2	4	42	330	135.00	166.00	198.00	250.00
174	2	4½	48	380	150.00	184.00	220.00	280.00
176	2	5	54	430	165.00	202.00	242.00	310.00
178	2	5½	60	480	180.00	220.00	264.00	340.00
180	2	6	66	530	195.00	238.00	286.00	370.00
184	2½	3	30	300	180.00	230.00	260.00	300.00
188	2½	4	42	360	230.00	300.00	340.00	400.00
192	2½	5	54	420	280.00	370.00	420.00	500.00
196	2½	6	66	480	330.00	440.00	500.00	600.00
200	3	3	30	300	240.00	310.00	340.00	410.00
204	3	4	42	420	300.00	390.00	430.00	520.00
208	3	5	54	540	360.00	470.00	520.00	630.00
212	3	6	66	660	420.00	550.00	610.00	740.00
216	4	4	36	360	480.00	560.00	600.00	700.00
220	4	6	60	600	630.00	760.00	840.00	1,000.00
224	4	8	84	840	780.00	960.00	1,080.00	1,300.00
228	4	10	108	1,080	930.00	1,160.00	1,320.00	1,600.00



Fig. 898

MALLEABLE IRON DRIVE CAP, FIG. 898

These caps are made for driving well points. They are extra heavy and especially designed for driving pipe. They are much stronger than the ordinary cap.

Size, Inches	1¼	1½	2
Fig. 898, Malleable Drive Cap . . .	\$0.20	\$0.24	\$0.44

Complete Table of Contents and General Classification of Pumps, Pages 7 and 8



Gauges, Current Breakers, Automatic Switches, Etc.

WATER RELIEF VALVES—FIGS. 1526-A AND 1995

Fig. 1995 Relief Valve is designed especially for Pneumatic Water Supply Service. It is substantially made, having brass valve and brass seat. The Standard Brass Relief Valve, Fig. 1526-A, has brass body as well as brass valve seat.



Fig. 1995



Fig. 1526-A

SIZES AND PRICES

Size, Inches	$\frac{3}{4}$	1	$1\frac{1}{4}$
Fig. 1995	\$4.00
Fig. 1526-A	\$11.00	\$13.00	\$16.00
Nickel Plated	12.00	14.00	18.00

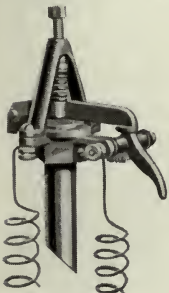

Fig. 1540

CURRENT BREAKER FOR GASOLINE ENGINE FIG. 1540

Automatically cuts out battery current when pressure in tank reaches a predetermined point. Simple—Durable—Reliable.

Price, for $\frac{1}{2}$ -in. pipe\$6.00



Fig. 688

WATER GAUGE, FIG. 1535—To fit $\frac{1}{2}$ -inch openings. Has $\frac{3}{8}$ -inch glass and hand-wheel. Should glass break, ball check valve closes and prevents air and water from escaping.

Price.\$3.00

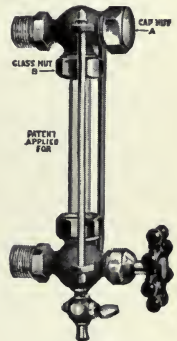

Fig. 1535 Water Gauge

WATER PRESSURE GAUGE, FIG. 688—Imitation hard rubber. Price, including cock ($3\frac{1}{2}$ -inch)\$3.00



Fig. 390

THE HERCULES PATENTED WINDMILL CONNECTION, FIG. 390

Holds the pump rod firmly in position. The weighted wrench forces the set screw in hole of slide iron and clamps it firmly to the pump rod. Wrench cannot detach itself. Two complete turns to the left allows the pump rod to play freely in the slide iron, and the connection is made again by turning twice to the right.

Fig.	For Pump With	Cipher	Price
390	6 to 10-inch Stroke	DEFEND	\$1.25



Deming Automatic Pressure Regulators

For Small D. C. and A. C. Motors

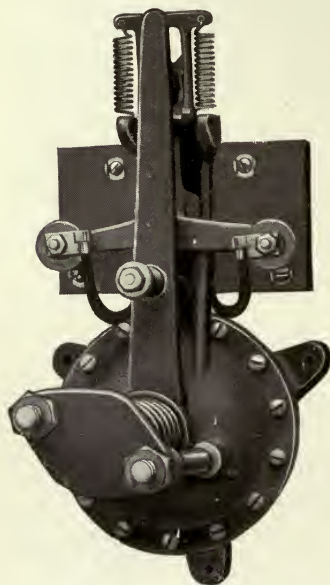

Fig. 1508
List Price, \$24.00



Fig. 1608

Designed for the automatic control of electric motors which drive pumps operating in connection with hydro-pneumatic water systems. Positive in operation and absolutely reliable. Suited for use with motors which may be thrown directly across the line and of capacities not to exceed the listing below.

Connection with the pressure tank should be by an independent pipe from the tank and not from the discharge pipe from the pump. Fig. 1508 is fastened to the wall, or other vertical support, by screws, while Fig. 1608 is supported by the $\frac{3}{8}$ -inch supply pipe and requires no other support.

They are suitable for use with motors which may be thrown directly across the line, and of capacities not exceeding the following:

The Fig. 1508 switch is regularly furnished on all of our electric-driven water systems except the "Marvel" outfits, Nos. 1685 and 2085, on which the Fig. 1608 switch is regularly supplied.

ON A. C. CIRCUITS				ON D. C. CIRCUITS		
Phase	Voltage	Horse Power		Voltage	Horse Power	
		Fig. 1508	Fig. 1608		Fig. 1508	Fig. 1608
1	110	2	$\frac{1}{4}$	115	1	$\frac{1}{4}$
1	220	4	$\frac{1}{2}$	230	1	$\frac{1}{4}$
1	440-550	5	$\frac{1}{2}$	500	1	$\frac{1}{4}$
2-3	110	3	$\frac{1}{4}$
2-3	220-550	5	$\frac{1}{2}$

Complete Table of Contents and General Classification of Pumps, Pages 7 and 8



MISCELLANEOUS HAND AND POWER PUMPS

FOR VARIOUS USES

PUMPS FOR THE FARM AND
FACTORY, GARAGE, PLUMBING
SHOP, ETC., INCLUDING THRESH-
ER TANK PUMPS, CONTRACTORS'
PUMPS, BILGE PUMPS, PLUMB-
ERS' PUMPS, FACTORY AND
VILLAGE FIRE PUMPS, AIR
COMPRESSORS, HYDRAULIC
RAMS, TEST PUMPS, CREAMERY
PUMPS, ETC.





Typical Deming Double-Acting Force Pump

Fig. 601 (In Section)

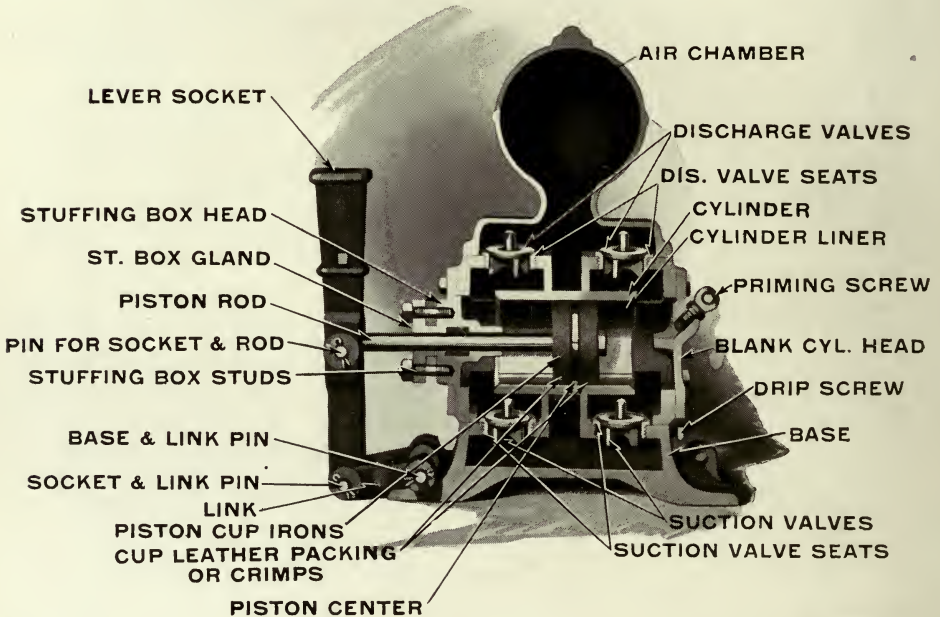

Detail of Triumph Pump

The pumps in this section are so varied in their construction and use that it is impossible to show a sectional view of any one pump which will be representative of all. However, on this page we have illustrated Fig. 601 as being a typical double-acting force pump. It discharges water on both strokes of the lever and will lift and force from 60 to 75 feet, depending upon conditions. All of the pumps listed in this section have the cylinder or working parts located in the body of the pump so that no independent cylinder will be required.

None of these pumps, therefore, are intended for a greater suction distance than 22 feet, and in the case of diaphragm pumps, not more than 20 feet. In most instances, when using pumps shown in this section, it will be found advisable to attach a strainer to the suction pipe or hose to keep particles of sand, gravel, etc., from being drawn into the pump.



Deming "Triumph" Double-Acting Force Pumps

Fig. 601



Flat Air Chamber

Fig. 602

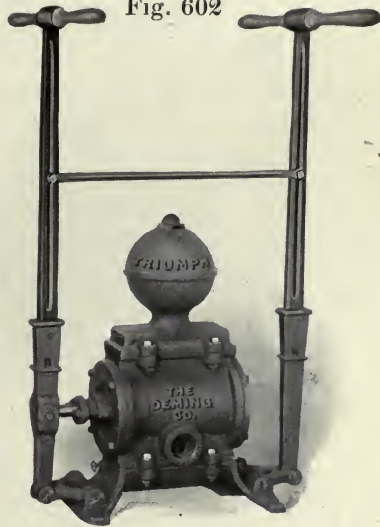

Fig. 601 is a heavy duty double-acting force pump, fitted with single malleable iron lever with wood handle, and is particularly well adapted for use in mines, factories, warehouses, for fire protection, and for use on vessels, in pumping either hot, cold, acid or salt water. The piston rod is brass, and works through a bolted stuffing box and gland. The piston is regularly fitted with leather crimps, but for hot water is furnished with canvas crimps. Valves and seats are of brass, and the cylinder is brass lined. All brass cylinder, or entire water end of brass, furnished as ordered. Standard air chamber is round, but flat air chamber is furnished to order without extra charge. All pumps are provided with brass vent plugs to prevent freezing.

Fig. 602 is identical in construction with Fig. 601, except that it is provided with two malleable iron levers, and is made in the three larger sizes only. The No. 4, with 5-inch diameter cylinder, has a displacement somewhat in excess of 100 cubic inches, thereby more than meeting the requirements of the U. S. Steamboat Inspection Service, which calls for one pump of 100 cubic inches capacity on vessels of 200 tons or less, and two pumps on vessels of over 200 tons. These pumps are suitable for pressures up to 50 pounds.

The suction and discharge of Figs. 601 and 602 are regularly fitted for iron pipe; fitted with brass hose couplings at extra price. *Extreme suction lift should not exceed 25 feet.*

Net weights of these pumps are as follows: Fig. 601 No. 1, 94 lbs.; No. 2, 96 lbs.; No. 3, 115 lbs.; No. 4, 175 lbs.; No. 5, 220 lbs.; Fig. 602 No. 3, 150 lbs.; No. 4, 200 lbs.; No. 5, 270 lbs.

Sizes and Prices

Fig.	No.	Diam. Cyl., In.	Length Stroke, In.	Gals. per Rev.	Diam. Suc. Pipe, In.	Diam. Dis. Pipe, In.	BRASS LINED		BRASS CYLINDER		*BRASS		Extra for Brass Hose Coupling
							Cipher	Price	Cipher	Price	Cipher	Price	
601	1	2½	4½	.190	1¼	1	FACADE	\$27.00	FACING	\$55.00	FACET	\$75.00	\$2.00
601	2	3	4½	.275	1¼	1	FACETIOUS	28.00	FACTORY	55.00	FACETTE	75.00	2.00
601	3	4	4½	.490	1½	1¼	FACIAL	30.00	FACULTY	60.00	FACIENT	90.00	3.00
601	4	5	5½	.935	2	1½	FACILITY	40.00	FADING	90.00	FACILE	150.00	4.20
601	5	6	5½	1.224	2½	2	FACIALLY	50.00	FACIES	120.00	FACTIVE	185.00	7.50
602	3	4	4½	.490	1½	1¼	FACINGLY	35.00	FACT	65.00	FACTO	95.00	3.00
602	4	5	5½	.935	2	1½	FAGGING	45.00	FAILING	95.00	FACTUM	155.00	4.25
602	5	6	5½	1.224	2½	2	FAGOT	55.00	FAINTED	125.00	FACTUAL	190.00	7.50

*Brass pumps are made entirely of brass, except levers, links and bolts.

Alphabetical Index, Figure Index and Telegraph Cipher Code, Pages 249 to 254



Deming "Giant" Double-Acting Thresher Tank Pumps Will Lift and Force 60 Feet



Fig. 554



Fig. 554½ with Cog Lever

For the use of threshermen in filling their wagon tanks quickly with water for the purpose of supplying the steam engine boiler; for a contractor's ditch pump; for garden irrigating, and for mine and tank service, the "Giant" is unexcelled.

Discharge spout is fitted with hose tube for hose. For use with iron pipe, we will furnish when specified, tubes threaded for iron pipe, instead of spout and hose tubes, as illustrated. This gooseneck may be turned for discharge on either side of the pump. The capacity is from one to two barrels per minute, depending on the number of strokes. Valves are metal, faced with rubber. Cylinder is highly polished. The long wood lever insures easy operation. The polished steel piston rod operates through a brass stuffing-box gland.

The caps over the discharge valves can be removed to examine or repair the discharge valves by inserting a stick or rod between the projections. No wrench is necessary. These pumps are double-acting and deliver water on every stroke.

Figs. 554 and 554½ are identical except that Fig. 554½ has cog lever instead of plain lever. The cog lever makes it possible to operate the pump with a minimum degree of friction. Iron cylinder is regularly supplied on these pumps, but if specified brass-lined cylinder will be furnished at \$5.00 extra list.

For Fig. 554½ add \$2.00 to list prices below.

Sizes and Prices, Fig. 554

Fig. 554	Cylinder	Suction	Discharge	Stroke	Weight Pounds	Capacity per Stroke	Cipher	Price
	5 in. Diam.	2 in. hose	1 in. hose	5 inch	90	⅞ gal.		
Pump Only	Includes suction strainer, suction and discharge hose tubes.						FALCADE	\$18.00
Outfit A	Pump complete, with 15 feet of 2-inch spiral-wire suction hose and strainer; 12½ feet of 1 inch 3-ply discharge hose and nozzle.						FALDAGE	40.00
Outfit A A	Same as Outfit "A," less discharge hose and nozzle.						FALLOW	35.00
Outfit B	Pump complete, with 20 feet of 2-inch spiral-wire suction hose and strainer; 12½ feet of 1 inch discharge hose and nozzle.						FALSEHOOD	45.00
Outfit B B	Same as Outfit "B," less discharge hose and nozzle.						FAMBLE	40.00
Outfit C	Pump complete, with 25 feet of 2-inch spiral-wire suction hose and strainer; 12½ feet of 1 inch 3-ply discharge hose and nozzle.						FAMOUSLY	50.00
Outfit C C	Same as Outfit "C," less discharge hose and nozzle.						FANCYING	45.00
Outfit D	Pump complete, with 25 feet of 2-inch spiral-wire suction hose and strainer; 25 feet of 1 inch 3-ply discharge hose and nozzle.						FANGLE	54.00

Complete Table of Contents and General Classification of Pumps, Pages 7 and 8



Deming "Marine" Bilge Pumps

For Suction Lift of 20 Feet or Less

Fig. 470
Bottom Suction

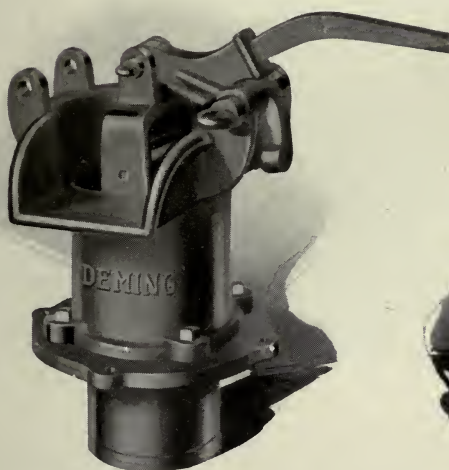

Fig. 471
Side Suction



These Pumps are adapted for raising large quantities of water by hand from the bilge well of vessels, from stone quarries and coal mines, cellars and ditches, and for irrigating purposes, where the water is not over 20 feet vertically below the pump. They are much used by contractors in removing water from excavations of various kinds.

There are three fulcrums, as shown on the engraving, whereby the pump may be operated with the lever in any one of three positions. The lever is substantially constructed of wrought iron, bent, so that its position may be reversed in the socket and thus it becomes a vertical lever which, in some instances, will be found quite convenient.

The Valves are rubber-faced, and are made large so as to give ample water way. They are easily removed for repairing. The Cylinder is brass lined. A flange, threaded for suction pipe, is bolted to the base of the pump. At a slight additional cost, we fit these pumps, when ordered, for suction hose.

The Suction may be fitted for other sizes of pipe, but is always fitted as listed, unless otherwise ordered.

Suction Hose Nipples furnished when ordered. Extra list for No. 2, \$3.75; No. 4, \$5.00.

Sizes and Prices

No.	Diam. of Cylinder Inches	Suction Fitted for Pipe Inches	Length of Stroke Inches	Capacity per Stroke Gals.	Fig. 470			Fig. 471		
					Weights Pounds	Cipher	Price	Weights Pounds	Cipher	Price
2	6	3	4	.49	125	GRACING	\$23.00	145	GRADUATING	\$26.00
4	8½	4	6	1.47	240	GRACEFULLY	30.00	280	GRACIOUSLY	35.00

Engineering Tables and Information Relating to Hydraulics, Pages 239 to 248



Deming Improved Diaphragm Suction Pumps

Fig. 472, Bottom Suction

Fig. 473, Side Suction



Fig. 472 Bottom Suction Pump is made with diaphragm of the best quality of rubber; iron suction and discharge valves are rubber faced, both being easily removable. The waterways are large and practically non-chokable. The suction is fitted for iron pipe.

Fig. 473 Side Suction Pump is similar in construction to Fig. 472, but the suction connection is at the side, and is fitted with nipple for connecting iron pipe, which is also the thread generally used for hose coupling.

A strong wrought iron lever is furnished with each pump, the lever being bent so that it can be used in a vertical or horizontal position, and the pump operated from either side.

For the use of contractors and others these pumps are invaluable for pumping out sewers, trenches, excavations, or places containing muddy or gritty water.

Fig. 337 Galvanized Strainer furnished without hose at \$1.90 list for 2½-inch, and \$2.65 for 3-inch. Hose couplings, extra diaphragms and gaskets furnished at reasonable prices.

Figs. 472 and 473, Sizes and Prices

No.	Diam. of Diaphragm Inches	Suction fitted for Pipe Inches	Gals. per Stroke	Fig. 472			Fig. 473			Extra for 15 feet of Suction Hose with Coupling and Galvanized Strainer
				Cipher	Price Pump only	Approx. Weight	Cipher	Price Pump only	Approx. Weight	
1	9	2½	¾	GURGLE	\$36.00	70	GUZZLER	\$38.00	75	\$24.00
2	12½	3	1¼	GURNARD	42.00	150	GUSSET	45.00	165	30.00

Complete Table of Contents and General Classification of Pumps, Pages 7 and 8



Deming Power Diaphragm Pumping Outfit

Fig. 1473

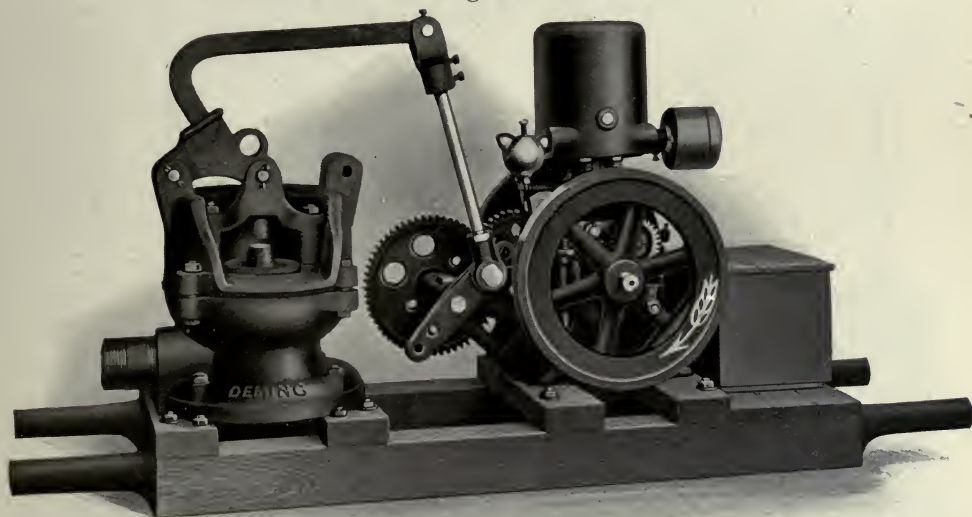

Fig. 1473 Power Diaphragm Pump is especially recommended for the use of contractors or others, when it is necessary to handle quickly and economically large quantities of muddy or gritty water. The diaphragm is 12½ inches in diameter of best quality of rubber and the valves are of metal, rubber faced, both being easily renewable. The waterways are large and practically non-chokable.

Unless otherwise specified the side suction pump illustrated is furnished, and is fitted with nipple for connecting iron pipe, which is also the thread generally used for hose coupling. When ordered for bottom suction the list price is \$3.00 less than given below.

These outfits are furnished with either 1-H.P. or 1½-H.P. engines of the four-cycle type, with hit-and-miss governor and cooling hopper, these being very reliable and simple. The gears of the jack are machine cut from solid blanks to reduce friction and noise to a minimum.

The pump and engine are mounted on substantial wooden skids, as shown, for easy handling.

Fig. 1473, Prices, Etc.

Outfit No.	Pump Diaphragm Inches	Suction Inches	Capacity per Hour Gallons	Horse Power Engine	Cipher	Price	Approximate Weight Pounds	Extra for 15 feet of Suction Hose Including Coupling and Galvanized Strainer
1	12½	3	3500	1	GUNNER	\$155.00	535	\$30.00
2	12½	3	3500	1½	GUNNERY	175.00	585	30.00



Deming Improved Siphon Force Pumps

With Brass Cylinder and Brass Piston Rod
Will Lift and Force 25 to 100 Feet

Fig. 385



Our Siphon Pumps are so constructed that the cylinder and valves are at all times submerged and consequently always primed.

In Fig. 385 the outer case is provided with a hand-hole at the base, covered by a plate. To gain access to the lower valves, remove the hand-hole plate. Access to the plunger may be secured by removing the stuffing-box cap. Plunger may then be withdrawn. This construction makes possible the removal of the plunger and lower valve without in any way disturbing the pipe connections.

Swing jointed rod coupling will be furnished when so ordered at extra list prices as follows: 3-inch and smaller, \$1.00 extra; 3½ and 4-inch, \$1.50 extra; 5 and 6-inch, \$2.00 extra.

Fig. 386



Fig. 386 is in all respects identical with Fig. 385, except for the addition of a hand lever.

Gooseneck spouts furnished at \$1.00 extra list.

Sizes and Prices

Size Cylinder	Stroke Inches	Fitted for Pipe Inches	Fig. 385			Fig. 386		
			Weight in Lbs.	Cipher	Price	Weight in Lbs.	Cipher	Price
2½	6	1½				155	DECROWN	\$28.50
3	6	1½				165	DECROWN	31.00
2½	8	1½	125	DENIZEN	\$25.00			
3	8	1½	130	DENTISTRY	27.50			
2½	10	1½	130	DEPRAVE	27.50	165	DACAPO	31.00
3	10	1½	135	DEPRAVITY	30.00	170	DACOIT	33.50
3½	10	2	205	DEPONENT	37.50	240	DECURY	42.50
4	10	2	215	DEPRIVING	42.50	260	DEFECCATE	47.50
2½	12	1½	135	DESPOTIC	30.00			
3	12	1½	140	DESTROYER	32.50			
4	12	2	210	DELTOID	40.00			
3½	12	2	215	DATARY	45.00			
5	12	2½	305	DECAGON	65.00			
6	12	3	315	DECALCIFY	85.00			
5	16	2½	325	DECISORY	80.00			
6	16	3	340	DECORY	105.00			

Complete Table of Contents and General Classification of Pumps, Pages 7 and 8



Deming Improved Siphon Force Pumps

With Submerged Cylinder

Will Lift and Force 25 to 75 Feet

Fig. 320



Fig. 321



Fig. 320, Submerged Cylinder Pump, for use in places where it can be located within twenty-five feet of the water, has been for years a favorite. It is always primed, therefore will draw water a longer distance than ordinary pumps. It must be protected from frost. The piston-rod is arranged for power, and a forked coupling for attaching to a wind mill wood-rod is also furnished.

Fig. 321 is identical with Fig. 320, except that it has windmill top and lever for hand use. Goose neck spout will be furnished at an extra list price of \$1.00 for Nos. 1 to 4.

Sizes and Prices

SPECIFICATION OF SIZES				Fig. 320 BRASS-LINED CYLINDER			Fig. 321 BRASS-LINED CYLINDER		
Size Cyl. Inches	Stroke Inches	Suction Pipe Inch	Discharge Pipe Inch	Weight in Lbs.	Cipher	Price	Weight in Lbs.	Cipher	Price
2½	8	1½	1½	80	DECKER	\$20.00	110	DECREASE	\$23.50
3	8	1½	1½	88	DECLAIM	22.00	118	DECREPIT	26.50
3½	10	2	2	113	DECLAIMER	30.00	148	DECRIED	35.00
4	10	2	2	135	DECLARED	34.00	170	DEDICATE	39.00
5	12	2½	2½	194	DECLENSION	52.00	229	DEDUCED	59.50
6	12	3	3	212	DECLINABLE	70.00	247	DEEDED	77.50



Deming Siphon Windmill Force Pump

With Brass Cylinder
Will Lift and Force 25 to 75 Feet

Fig. 387



In this pump the brass working barrel is suspended in the iron case, thus forming a reservoir.

This reservoir is always filled with water and the pump is therefore always primed. In freezing weather this water can be drained off by removing drip screw and operating pump until water is all out of cylinder. Near the top of the iron case the pump is tapped for suction pipe. The plunger rod is brass cased, and the plunger, suction valve cage and seat are all brass.

The discharge pipe may be turned either to the right or to the left to suit conditions. All of the working parts may be removed by taking off the top cap which is fastened to the outer case by means of four bolts. The inner cylinder is of heavy seamless brass tubing.

Add \$1.00 to the list price if malleable forked rods are wanted instead of windmill slide.

Sizes and Prices

Diam. of Cylinder Inches	Suction and Discharge Fitted for Pipe Inches	8-INCH STROKE				12-INCH STROKE			
		Capacity per Stroke Gal.	Approximate wt. Lbs.	Cipher	Price	Capacity per Stroke Gal.	Approximate wt. Lbs.	Cipher	Price
2½	1½	.17	70	DISTURB	\$18.50	.26	75	DITONE	\$20.00
3	1½	.24	75	DISTURBER	21.00	.37	80	DITCHER	22.50
3½	2	.33	110	DISTYLE	25.00	.50	115	DIVAN	27.50
4	2	.43	112	DITATION	30.00	.65	120	DIVINE	32.00

Complete Table of Contents and General Classification of Pumps, Pages 7 and 8



Deming Windmill Force Pumps on Base

With Air Chamber and Cock Spout
Will Lift and Force 30 to 75 Feet

Fig. 430



Fig. 1430

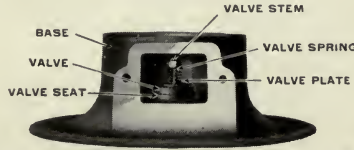

Fig. 430 is a very heavy pump which may be used in connection with a windmill. It is also arranged for operation by hand. The base is tapped for iron suction pipe and is bolted to the stock. The air chamber is provided with an upward discharge.

When used in cold climates, freezing may be prevented by raising the lever to its extreme height which trips the valves and allows the water to escape from the cylinder. The working barrel or cylinder is located in the stock.

Fig. 430 has brass valve seat, brass cased piston rod and a cock spout threaded for hose. The bolt holes in the air chamber are so spaced that the spout can be turned 90 degrees either way. The bearer is also adjustable.

Fig. 1430 is similar to Fig. 430 except that it has a hand-hole in the base, giving easy access to the suction valve for examination or repairs.

Deduct \$2.50 from list price if cap nut on side discharge is wanted instead of cock spout. Brass Valve Seats are regularly furnished on these pumps.

Sizes and Prices

Fig.	No.	Size Cylinder Inches	Suction and Discharge Fitted for Pipe, Inches	Will Lift and Force Feet	Stroke Inches	IRON		BRASS LINED		Weight in Pounds
						Cipher	Price	Cipher	Price	
430	2	2½	1¼	75	6	ENRAPTURE	\$15.50	ENDARK	\$18.00	78
430	4	3	1½	50	6	ENRICH	16.00	ENDIVE	18.50	78
430	6	3½	1½	35	8	ENRICHED	23.00	ENDOSS	26.50	100
430	8	4	2	30	8	ENROBE	24.50	ENDURE	29.50	105
1430	2	2½	1¼	75	6	ENMESH	16.50	ENOUNCE	19.00	78
1430	4	3	1½	50	6	ENMEW	17.00	ENRIDGE	19.50	78
1430	6	3½	1½	35	8	ENODE	24.00	ENROOT	27.50	100
1430	8	4	2	30	8	ENOMOTY	25.50	ENSAFE	30.50	105

Alphabetical Index, Figure Index and Telegraph Cipher Code, Pages 249 to 254



Deming "Little Giant" Hydraulic Pressure Test Pump

With Detachable Lever
For 800 Pounds Pressure

Fig. 566



This pump is built for pressures up to 800 pounds per square inch. All parts coming in contact with the liquid are made of brass. Fig. 566 has an extra long and powerful forged steel lever. It is much used for testing boilers, pipe lines, castings or for steam gauges, in connection with a master gauge.

Fig. 566 is regularly fitted for iron pipe but can be fitted with hose nipples at extra price when so ordered.

Sizes and Prices

Size of Piston Inch	Length of Stroke Inches	Length of Lever Inches	Suction Pipe Inch	Discharge Pipe Inch	Weight in Pounds	WITHOUT GAUGE		WITH 1,000-POUND PRESSURE GAUGE	
						Cipher	Price	Cipher	Price
3/8	3	24	3/4	1/2	26	HORSEMAN	\$25.00	HULLING	\$35.00

Complete Table of Contents and General Classification of Pumps, Pages 7 and 8



Deming Hydraulic Force Pump for Plumbers

With Brass Valves
For 400 Pounds Pressure

Fig. 594



This pump is very convenient for plumbers to use for removing obstructions from drain pipes, etc. It is also well adapted for use as a reserve hand boiler feed pump on traction outfits. Should the injector refuse to work, then Fig. 594 would be available to pump water into the boiler and prevent an explosion. In certain localities the laws require an auxiliary feed pump, and Fig. 594 meets the requirements of these laws.

It has an extra long and powerful lever which may be turned so as to operate from either side. The suction and discharge valves are screwed to the cylinder.

Fig. 594 is very convenient for making a cold water test on boilers as a maximum pressure of 400 pounds can be obtained by its use.

Price List

Cylinder Inches	Stroke Inches	Lever Inches	Suction Inches	Discharge Inches	Height Inches	Weight Pounds	Cipher	Price
1½	3	24	¾	¾	11½	17	HEDDLE	\$10.00



Deming Gasoline Plunger Pumps

For Private Garages

Will Lift and Force 50 Feet

Figs. 725 and 726

To anyone desiring a low priced gasoline pump of small and medium capacity, these two pumps will commend themselves.

Fig. 725 will handle about 1¾ gallons of gasoline per minute when operated at 42 strokes. It has a special foot valve fitted for ¾-inch suction pipe. When furnished without cock, the discharge connection is adapted for ¼-inch pipe or ⅜-inch and ½-inch hose,

The base is adjustable, and the pump is, with the exception of the handle, made almost entirely of brass. The brass air chamber insures a steady stream. If a chain and padlock are used on the handle, thefts of gasoline will be prevented. It is fitted for ½-inch bibb cock. When ordered with stop cock, the cock is threaded for hose.

Fig. 726 has an all brass piston with cup packing. The stuffing-box is of the nut and gland type. The base is in two parts and is clamped to the cylinder so that pipe connections may be made without disturbing



Fig. 725

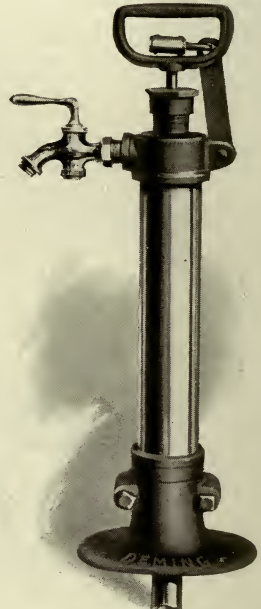

Fig 726

the pump. When ordered with stop cock, the cock is threaded for hose.

Fig. 726 also has a safety locking device which prevents children and others from wasting the gasoline and thereby endangering the garage. It is fitted for 1-inch suction pipe.

When the handle is pushed entirely down to locking position, the brass valve trips and the liquid flows back into the tank, leaving the pump entirely free.

On page 149 is shown a typical installation of a gasoline pump for garage use.

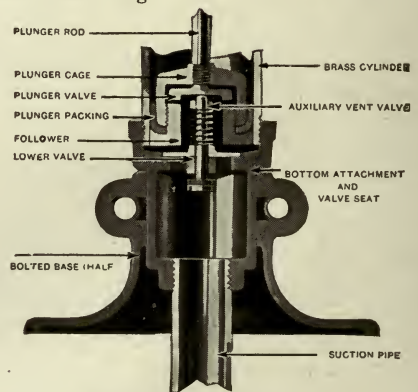

Detail View of Fig. 726

Sizes and Prices

Fig.	Diameter Cylinder Inches	Stroke Inches	Capacity per Stroke Gal.	Capacity per Min. 40 Strokes Gal.	Weight Pounds	Without Cock		With Cock	
						Cipher	Price	Cipher	Price
725	1	12	.0408	1.632	10	GESTING	\$6.50	GESTIC	\$8.00
726	2	10	.136	5.44	15	GAUCHO	9.00	GARRETT	11.50

Complete Table of Contents and General Classification of Pumps, Pages 7 and 8



Deming Fire Protector

For Factories, Warehouses, Construction Camps, Etc.

Fig. 1668

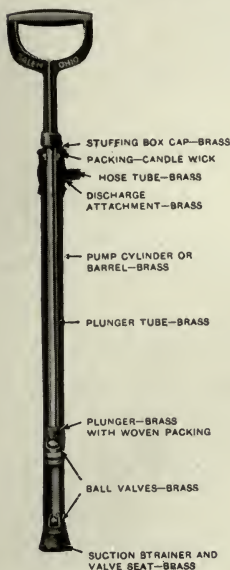

Detail View of Pump



This handy little fire protector affords an ever ready means for the control of incipient blazes. Many thousands of these fire protectors have been supplied to the U. S. Government for use in camps and cantonments in this country and abroad; also on transports and other types of vessels.

Filling the tank of Fig. 1668 with a brine solution (or plain water where there is no danger of freezing) provides an effective means of fire control. A chemical fire extinguisher may not work in time of need, but this Fig. 1668 outfit *is always ready and will not fail.*

Specifications

TANK—Capacity 5 gallons; strongly and substantially built of galvanized iron and assembled with riveted joints. Ends of tank rolled over No. 9 wire. One-half of tank cover is hinged and provided with a catch. Bale is extra heavy and very rigid. Foot rest on tank keeps outfit immovable while pump is being operated. Tank is painted inside with two coats of "Insulite" and painted outside with one coat flat vermilion red and one coat bright red enamel.

PUMP—Is our "Prize" double-acting brass force pump with special air chamber; and "D" shaped handle. Has brass cylinder; brass ball valves; brass fittings and strainer and is securely fastened to the tank. May be easily removed from the tank by loosening three screws.

PERFORMANCE—Pump will throw solid stream 35 feet vertically. Three minutes of rapid pumping will empty the tank.

DIMENSIONS AND WEIGHT—Diameter of tank, 9 5/8 inches. Height of tank, 17 1/2 inches. Height overall with plunger on extreme down stroke, 27 inches. Weight complete, 8 3/4 pounds; boxed for shipment, 25 pounds.

EQUIPMENT—Three feet of 3/8-inch hose and brass fire nozzle for throwing solid stream only.

Outfits

Fig. 1668—With galvanized iron tank, as illustrated Cipher, KORET
Alphabetical Index, Figure Index and Telegraph Cipher Code, Pages 249 to 254



Deming Southern Well Force Pump

With Polished Cylinder in Stock
Will Lift and Force 35 to 100 Feet

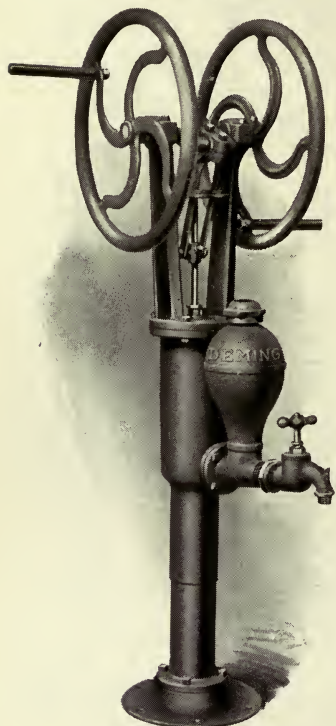

Fig. 1274

Fig. 1274 is made with two fly-wheels; a crank shaft; babbitted bearings, and a guided rod. The air chamber is provided with an upward discharge fitted for the same size of pipe as the suction.

For pumping large quantities of water, the fly-wheel and crank are preferred in some localities to the usual lever, because all strokes are of equal length, and the pump discharges the full capacity at each revolution.

When equipped with either 2, 2½, 3 or 3½-inch cylinder, Fig. 1274 will lift and force, respectively, 100, 75, 50 and 35 feet. For Fig. 1274 fitted with independent cylinders for deep wells, see list below.

Where there is liability to danger from freezing, Fig. 1274 should not be used, except when in service as a deep well pump. If plain spout is wanted instead of cock spout, deduct \$2.50 from list.

Sizes and Prices

No.	Size Cyl. Inches	Fitted for Pipe Inches	Stroke Inches	Cap. per Rev. Gals.	WITH TWO FLY WHEELS			WITH ONE FLY WHEEL ONLY		
					Weight Lbs.	Cipher	Price	Weight Lbs.	Cipher	Price
4	3	1¼	6	.18	195	BELDAM	\$35.00	127	BENDING	\$32.00
6	3½	1½	6	.25	195	BENCH	40.00	130	BENDY	37.00

For Deep Wells (With Two Fly Wheels)

(Complete With Independent Cylinder, but Without Pipe and Well Rod)

IRON CYLINDER					BRASS-LINED CYLINDER			
No. 4			No. 6		No. 4		No. 6	
Size Cylinder Inches	Cipher	Price	Cipher	Price	Cipher	Price	Cipher	Price
2	BIAS	\$35.00	BISE	\$40.00	BICORN	\$37.00	BIGHT	\$42.00
2½	BIASED	36.00	BICEPS	41.00	BIDDEN	38.50	BIGOT	43.50
3	BIASING	36.50	BICKER	41.50	BIDE	39.00	BILBO	44.00
3½	BIBBER	38.00	BICOLOR	43.00	BIFOLD	41.00	BILE	46.00

Complete Table of Contents and General Classification of Pumps, Pages 7 and 8



Deming "Colonial" Quick Return Force Pump

With Fly-Wheel and Compensating Lever
Will Lift and Force 35 to 100 Feet

Fig. 277

By the combination of the slotted yoke or lever, and roller crank pin, the leverage is greater on the up stroke than with the ordinary crank, which makes it very easy to operate the pump. The arrow on the face plate indicates the direction in which the crank shaft should be revolved.

The cylinder and plunger are in the stock. If wanted for other than wrought iron suction pipe, the purchaser can easily arrange suction flanges to fit the bottom flange of the pump. The three-way discharge cock makes it possible to force water to an elevated tank or through the spout opening, as desired. For Fig. 277, fitted with independent cylinders for deep wells, see list below. When equipped with either 2, 2½, 3 or 3½-inch cylinder, Fig. 277 will lift and force, respectively, 100, 75, 50 and 35 feet. If plain spout is desired instead of cock spout, deduct \$5.00 from list.



Sizes and Prices

No.	Size Cylinder Inches	Fitted for Pipe Inches	Length Stroke Inches	Weight in Pounds	Cap. per Revolution Gallons	Cipher	Price
4	3	1½	6	251	.18	BONESET	\$35.00
6	3½	2	6	260	.25	BONFIRE	40.00

For Deep Wells

(Complete With Independent Cylinders, but Without Pipe and Well Rod)

IRON CYLINDER					BRASS-LINED CYLINDER			
No. 4			No. 6		No. 4		No. 6	
Size Cylinder Inches	Cipher	Price	Cipher	Price	Cipher	Price	Cipher	Price
2	BILLOW	\$35.00	BINDER	\$40.00	BINOT	\$37.00	BIPONT	\$42.00
2½	BILLY	36.00	BINE	41.00	BIOLOGY	38.50	BIRCH	43.50
3	BINARY	36.50	BING	41.50	BIOTINE	39.00	BIREME	44.00
3½	BINATE	38.00	BINOCE	43.00	BIPOLAR	41.00	BIRT	46.00



Deming "Century" Complete Whitewashing Outfit

With Brass Working Parts

Fig. 644

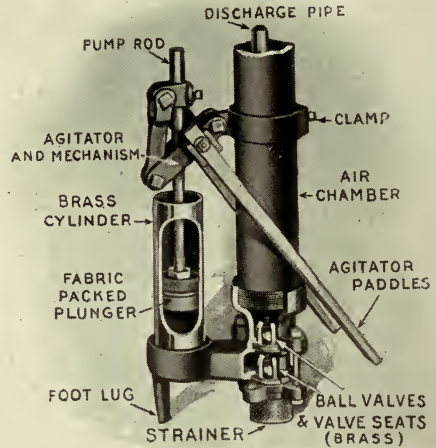

The better the light, the more work an employee will do, and "brightening up" with whitewash has therefore been found to bring very satisfactory results in factories where the light is not good. Artificial lighting bills have been very materially decreased; in some cases as much as 25 per cent., by the application of whitewash or cold water paint.

When applied with a brush, the process is slow, laborious and often unsatisfactory. Using a Deming whitewashing outfit, the operation is simplified and is quickly completed. The "Century" is very much used in factories, mills, warehouses, abattoirs, stock farms, etc.

The detail of the working parts (shown above) gives a very clear idea of the construction of the pump.

A mechanical agitator keeps the mixture in suspension. Valves are brass balls. They will not clog nor corrode. Pump can be worked at 100 pounds pressure.

Brass cylinder is $2\frac{1}{4}$ inches in diameter, and is always submerged. The long leverage and large air chamber capacity make the "Century" very easy to operate.

The tank is a 50-gallon barrel, and the wheels are broad and strong. The caster at front end facilitates turning. Twenty-five feet of $\frac{3}{8}$ -inch hose, 4-foot extension pipe, and our "Bordeaux" nozzle (the best whitewashing nozzle) are furnished.

*OUTFIT "A" — same as above, but with two 25-ft. sections of $\frac{3}{8}$ -inch hose, each with 4-ft. pipe and "Bordeaux" nozzle.

Price List

Diameter Cylinder Inches	Stroke Inches	Weight in Pounds	Cipher	Price	*OUTFIT "A"	
					Cipher	Price
$2\frac{1}{4}$	$4\frac{1}{2}$	200	KAISER	\$35.00	KANAKA	\$41.50

Complete Table of Contents and General Classification of Pumps, Pages 7 and 8



Deming Adjustable Stroke Single-Acting Power Pump

Fig. 582

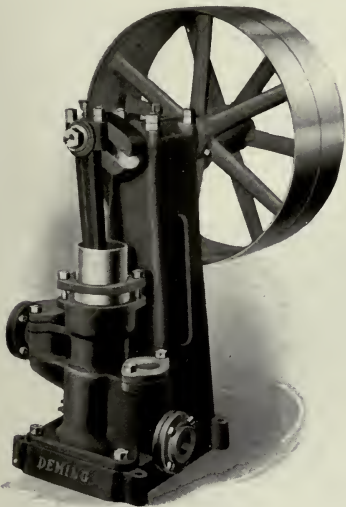

Fig. 582, Sizes 5 x 5 and larger

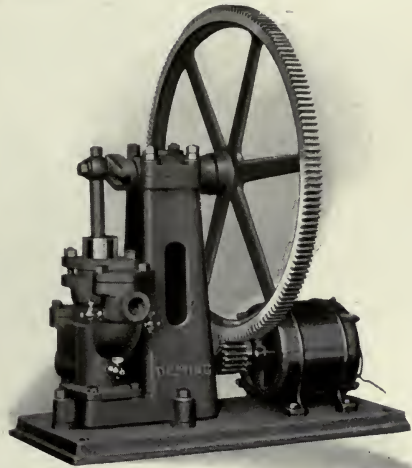

Fig. 582, Size 2 1/2 x 2 to 4 x 4 with Type "B" Drive

Fig. 582 is a single cylinder, outside packed plunger pump with adjustable stroke, and is designed especially for supplying jacket water for cooling gas engines or for other service where pressure does not exceed 50 pounds.

MAIN STANDARD is of cast iron and includes babbitted main shaft bearing and base to which cylinder is bolted. Plunger is outside packed with bolted stuffing box gland.

VALVES are of rubber on bronze grid seats and are quickly accessible.

Type "B" Drive (Cipher, "TYPEB") includes cast iron sub-base, pump gear and rawhide motor pinion for connecting an electric motor, the speed of which should not exceed 900 R. P. M.

Type "C" Drive (Cipher, "TYPEC") includes cast iron sub-base, short belt and spring belt tightener for connecting SLOW SPEED electric motor (not illustrated).

Fig. 582, Sizes, Capacities, Prices, Etc.

PLUNGERS		CAPACITY			DIAMETER OF PIPES		Tight Pulley	Cipher
Diam. Inches	Stroke Inches	Gallons per Revolution Max. Stroke	Usual Revs. per Min.	Gallons per Min.	Suction Inches	Discharge Inches		
2 1/2	2	.042	70	2.94	1	1	14 x 3	HINDOO
3	3	.091	65	5.91	1 1/4	1 1/4	18 x 3	HILLOCK
3 1/2	4	.166	60	9.96	1 1/2	1 1/2	18 x 4	HILLY
4	4	.217	60	13.02	1 1/2	1 1/2	20 x 4	HILTED
5	5	.425	50	21.25	2	2	28 x 5	HINNY
6	5	.612	50	30.60	2	2	30 x 6	HINTED

PLUNGERS		LIST PRICES				
Diam. Inches	Stroke Inches	With Tight Pulley	Extra for Brass Cylinder, Plunger and Gland	Extra for Tight and Loose Pulleys	*Extra for Type "B" Drive	*Extra for Type "C" Drive
2 1/2	2	\$78.00	Price on Application	\$10.00	\$75.00	\$75.00
3	3	122.00		\$12.00	88.00	88.00
3 1/2	4	158.00		15.00	110.00	110.00
4	4	165.00		16.00	110.00	110.00
5	5	288.00		20.00	142.00	142.00
6	5	310.00		25.00	145.00	145.00

*When telegraphing with reference to Type "B" or "C" Drive, place cipher word "TYPEB" or "TYPEC," respectively, immediately following the cipher word for the standard pump.

Alphabetical Index, Figure Index and Telegraph Cipher Code, Pages 249 to 254



Deming Improved Hand and Power Piston Pump

With Crank Shaft, Pulley and Handle
Will Lift and Force 75 Feet

Fig. 585

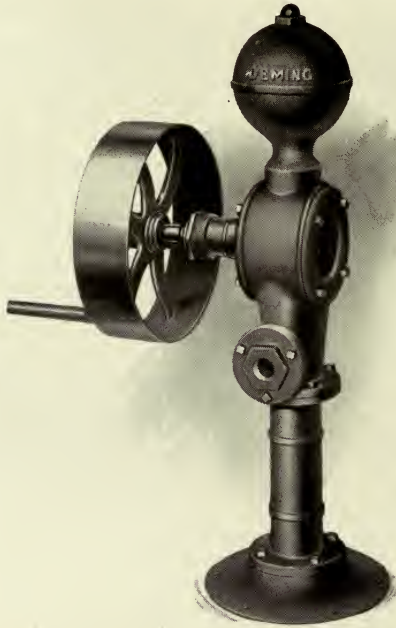

This Pump is constructed with cylinder in the stock, the plunger being operated by a steel crank shaft and pitman, which are inclosed below the air chamber. Fig. 585 is well adapted for use in cheese factories and creameries. It is suitable for raising water from shallow wells, springs and cisterns, by hand or power, and will force it to any point desired; or for filling boiler supply tanks, etc.

The cylinder is in a separate casting, and can be renewed when worn.

Fig. 585 will be fitted with stub rod to connect with independent cylinders, for deep wells when specified, at same list price. Cylinders are extra.

Fig. 585, when furnished with tight and loose pulleys for power only, is designated as Fig. 590. See list below.

Sizes and Prices

Fig.	No.	Size Cylinder Inches	Suction Fitted for Pipe Inches	Discharge Fitted for Pipe Inches	Stroke Inches	Pulleys Inches	Weight Pounds	Cipher	Price
585	4	3	1½	1¼	5	16 x 4	122	HADDOCK	\$27.00
585	6	3½	1½	1¼	5	16 x 4 Tight and Loose	125	HAGGARD	30.00
590	4	3	1½	1¼	5	16 x 3	140	HAGGISH	32.00
590	6	3½	1½	1¼	5	16 x 3	145	HAGGLING	35.00

Complete Table of Contents and General Classification of Pumps, Pages 7 and 8



Deming Improved Power Piston Pump

With Tight and Loose Pulleys
Will Lift and Force 75 Feet

Fig. 591



Fig. 591 is similar in design to our Fig. 590, but is constructed for more severe duty. The crank-shaft extends entirely through the body of the pump, with bearings on both sides, adding greatly to the durability. It is very generally used in creameries, cheese factories, cotton gins, shops and factories, for pumping water from wells for the boiler supply tank. For deep wells we supply it with an independent cylinder of suitable size for the additional cost of the cylinder.

Sizes and Prices

No.	Size Cylinder Inches	Suction Fitted for Pipe Inches	Discharge Fitted for Pipe Inches	Stroke Inches	Pulleys Inches	Weight Pounds	Cipher	Price
4	3	1½	1¼	5	16 x 3	150	HABENDUM	\$37.00
6	3½	1½	1¼	5	16 x 3	155	HABITANT	40.00
4	3	1½	1¼	5	24 x 3	180	HACKSTER	44.00
6	3½	1½	1¼	5	24 x 3	165	HAIRBELL	47.00



The Deming Hydraulic Ram, Fig. 690



The Hydraulic Ram in Operation

A DEMING HYDRAULIC RAM installed at a spring means a constant supply of fresh water in the home at practically no operating expense. Below is briefly explained the construction of the Hydraulic Ram; its method of operation; and the conditions under which it may be installed.

It is impossible in a general catalogue like this to give exact specifications of the various conditions under which a Hydraulic Ram will operate successfully. The illustration above will give a general idea of the utility of this wonderful machine in supplying water to a suburban or country residence. IN A SEPARATE BULLETIN, THIS SUBJECT IS MORE FULLY TREATED.

Operation

Deming Hydraulic Rams are used to elevate a part of the water supply to a point higher than the level of supply. The machine in its simple form consists of a body to which is attached an impetus or overflow valve, and an air chamber under which is a check valve. In operation the supply water flows into the ram body through a drive pipe leading from a spring to the ram; the water then passes out through the impetus valve until the column attains sufficient speed to raise the impetus valve to its seat. This stops the column of water in the drive pipe and the pressure produced by stopping this column forces a small quantity through the check valve into the air chamber compressing the air slightly, when the check valve closes and prevents it from returning to the drive pipe. The air, being now at a pressure greater than that due to the head in the discharge line, forces the small quantity into the supply tank.

At the moment the check valve closes, the column of water in the drive pipe rebounds a short distance which removes the pressure from the impetus valve and permits it to open of its own weight. This completes one cycle. These movements continue automatically.

Suggestions for Installing

The LENGTH of the drive or supply pipe should be about five times the FALL. The Hydraulic Ram is MOST EFFICIENT when the VOLUME of the AIR CHAMBER is EQUAL to the VOLUME of the DISCHARGE PIPE.

The upper end of the drive pipe should always be a foot or more below the surface of the water. It should be located six or more inches above the bottom of reservoir and a strainer placed on end of pipe.

Pipes should be laid straight to reduce friction. Where turns are necessary, long bends are better than abrupt angles.

Locate the Ram in a masonry-lined pit, and bolt it on a LEVEL FOUNDATION. Provide drainage for waste water from the bottom of pit. Place all pipes below the frost line.

No two installations are alike; therefore we much prefer to make suggestions and give information covering each individual case.

Complete Table of Contents and General Classification of Pumps, Pages 7 and 8



The Deming Hydraulic Ram, Fig. 690

Tables of Efficiency, Etc.

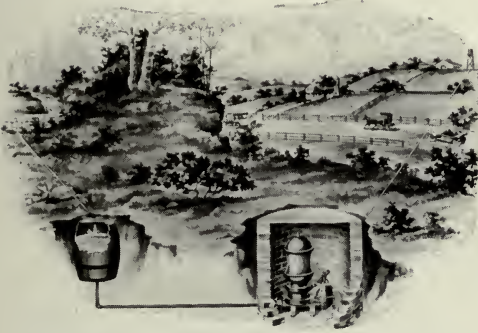

Ideal Arrangement for Installing Hydraulic Ram where the fall is too great or the Reservoir located considerable distance from the Ram



Three Popular Sizes of the Seven Deming Rams

No. 8

Information We Should Have

FALL IN FEET vertically from surface of water in the supply reservoir to level of the Hydraulic Ram.

NUMBER OF GALLONS of water per minute supplied to the Ram.

ELEVATION OR HEIGHT in feet (vertically above level of Ram) at which water is to be discharged.

QUANTITY OF WATER per day of 24 hours (in gallons) required to be discharged into storage tank.

LENGTH OF DRIVE PIPE in feet. It should not be less than five times the fall to give best results. It may, however, be longer.

LENGTH IN FEET OF DISCHARGE PIPE.

ESTIMATE OF EFFICIENCY: To find the quantity of water a Deming Ram will deliver, multiply the fall in feet (from spring to Ram) by the number of gallons per minute supplied; divide the product by twice the height to which the water is to be forced; the result will be the quantity per minute discharged.

EXAMPLE OF EFFICIENCY: With a fall of six feet to the Ram from a spring flowing ten gallons per minute, and a height of 40 feet from the Ram to the point of delivery, the estimate is made as follows: $\frac{6 \times 10}{40 \times 2} = \frac{60}{80}$ or $\frac{3}{4}$, being the quantity (in gallons) per minute the Ram should deliver. This condition requires a No. 4 or 5 Ram.

Sizes and Prices

No.	Quantity of Water supplied to the Ram Gals. per Minute	Length the Drive Pipe should be Feet	DIAMETER OF PIPE		Weights Pounds	Cipher	Price
			Drive Inches	Discharge Inches			
2	1/2 to 2	12 to 50	3/4	1/2	28	HAUTBOY	\$ 20.00
3	1 1/2 to 4	12 to 50	1	1/2	37	HAVOC	22.00
4	3 to 7	12 to 50	1 1/2	3/4	50	HAVERSACK	27.00
5	6 to 14	25 to 100	2	1	74	HAWSER	37.00
6	12 to 25	25 to 100	2 1/2	1 1/4	142	HAZARD	70.00
7	20 to 60	25 to 125	4	2	350	HAZARDOUS	138.00
8	30 to 120	25 to 150	6	2 1/2	615	HEADLONG	235.00

Alphabetical Index, Figure Index and Telegraph Cipher Code, Pages 249 to 254



The Deming "Hydraeram"

A Modern Hydraulic Ram

Fig. 695

The apparatus represented by the annexed engraving is our new Automatic Hydraulic Pumping Engine, or Hydraulic Ram, which we designate as Fig. 695 and have given the name of "HYDRAERAM." This name has been registered at the patent office as a trade mark. We have been granted a design patent.



THE HYDRAERAM IS MORE EFFICIENT than other machines of the kind. It is new in design and construction, as may be seen by the illustration. The air chamber, base, and impetus valve chamber are cast integral. The facility with which the Hydraeram may be adapted to various conditions surpasses everything in the line of automatic pumping apparatus. The Hydraeram can be regulated without detaching any of the parts, and under favorable conditions will discharge water to a height of fifteen times the amount of fall.

THE AUTOMATIC AIR SUPPLY is attained by the valve construction, and is so regulated as to give the most efficient results.

IN ORDERING A "HYDRAERAM," care should be exercised in giving us as near as possible the amount of WATER PER MINUTE that can be supplied to the machine; the amount of WATER REQUIRED every twenty-four hours; the NUMBER OF FEET FALL (vertically) that can be obtained from the reservoir to the "Hydraeram," and the length of drive pipe; also the VERTICAL and horizontal DISTANCE the water must be DISCHARGED, i. e., height water is elevated, and length of discharge pipe. DIRECTIONS FOR SETTING AND STARTING FURNISHED WITH EACH MACHINE.

Sizes and Prices

No.	Quantity of Water Supplied per Minute to which Hydraeram is Adapted Gallons	Approximate Length of Drive Pipe Feet	SIZES OF PIPE		Extreme Height Inches	Diameter of Base Inches	Weights Pounds	Cipher	Price
			Drive Inches	Dis-charge Inches					
10	1½ to 3	10 to 40	¾	½	12½	5½	16	HYDRUM	\$24.00
11	2 to 5	10 to 50	1	½	17	8	40	HYDRIC	28.00
12	3 to 10	15 to 50	1½	¾	23	10	45	HYDRIDE	48.00
13	6 to 15	25 to 75	2	1	29	12	150	HYDROGEN	75.00
14	10 to 25	25 to 100	2½	1¼	35	16	300	HYDROMEL	125.00

Complete Table of Contents and General Classification of Pumps, Pages 7 and 8



Deming Power Air Compressor or Vacuum Pump

Fig. 680



Fig. 680 Single-Acting Power Air Compressor and Vacuum Pump is well adapted to pumping into receivers for starting gas or gasoline engines, for use in connection with dry pipe sprinkler systems, in garages, chemical works, potteries, hospitals, and by artists and dentists.

This compressor is made in the best manner possible from the best of materials. The crank shaft is of steel, and the bearings are of large dimensions, lined with the best babbitt metal. The piston is of iron, packed with iron bronze rings, and the valves are of steel, seating vertically on bronze seats, thereby insuring the least possible wear and minimum clearance. Oil cups are furnished.

The cylinder is thoroughly water jacketed to enable the pump to be operated continuously at the maximum rated speed and pressure. For intermittent service these compressors may be operated at one-third higher speeds and pressures than listed.

Fig. 680 standard construction includes heavy rim belt fly-wheel, as illustrated, but is also furnished with loose pulley at extra price as listed.

Fig. 680 with Type "B" Drive (Cipher, "TYPEB") consists of the standard compressor without pulley, but with sub-base and gearing connection for electric motor.

Fig. 680 with Type "C" Drive (Cipher, "TYPEC") consists of the standard pump with fly-wheel pulley, and with sub-base, short belt and spring belt tightener for connecting electric motor.

Motor is not included with Types "B" and "C" Drives, but can be furnished at extra price.

Fig. 680, Sizes, Capacities, Prices, Etc.

PISTON		Cu. Ft. Displacement Free Air per Rev.	Revs. per Minute	Cu. Ft. Displacement Free Air per Min.	Discharge Pressure Pounds	Suction Pipe Inches	Discharge Pipe Inches	Water Jacket Piping Inches	Belt Fly-Wheel	H. P. Required at Rated Speeds
Diam. Inches	Stroke Inches									
2¾	4	.0137	200	2.74	125	½	½	½	18 x 3	.70
3½	5	.0278	175	4.86	125	1	¾	½	24 x 4	1.15
4	6	.0436	150	6.54	125	1¼	1	½	30 x 4	2.00
5	6	.0681	150	10.21	125	1¼	1	½	36 x 5	2.90

PISTON		*Cipher	PRICES AND WEIGHTS							
Diam. Inches	Stroke Inches		With Fly-Wheel Pulley	Approximate Weight in Lbs.	*With Tight and Loose Pulleys	Approximate Weight in Lbs.	†With Type "B" Drive	Approximate Weight in Lbs.	†With Type "C" Drive	Approximate Weight in Lbs.
2¾	4	HUNGER	\$110.00	135	\$120.00	160	\$185.00	250	\$185.00	290
3½	5	HUNTSMAN	145.00	260	180.00	325	245.00	400	245.00	425
4	6	HURDEN	190.00	370	235.00	450	320.00	525	320.00	550

*When telegraphing about compressor with tight and loose pulleys, place cipher word "LOOSPUL" immediately following cipher word for standard Fig. 680.

†When telegraphing with reference to Type "B" or "C" Drive, place the cipher word "TYPEB" or "TYPEC," respectively, immediately following the cipher word for the standard Fig. 680.



Deming Improved Pumping Jacks

For Operating Pump Standards

Fig. 747

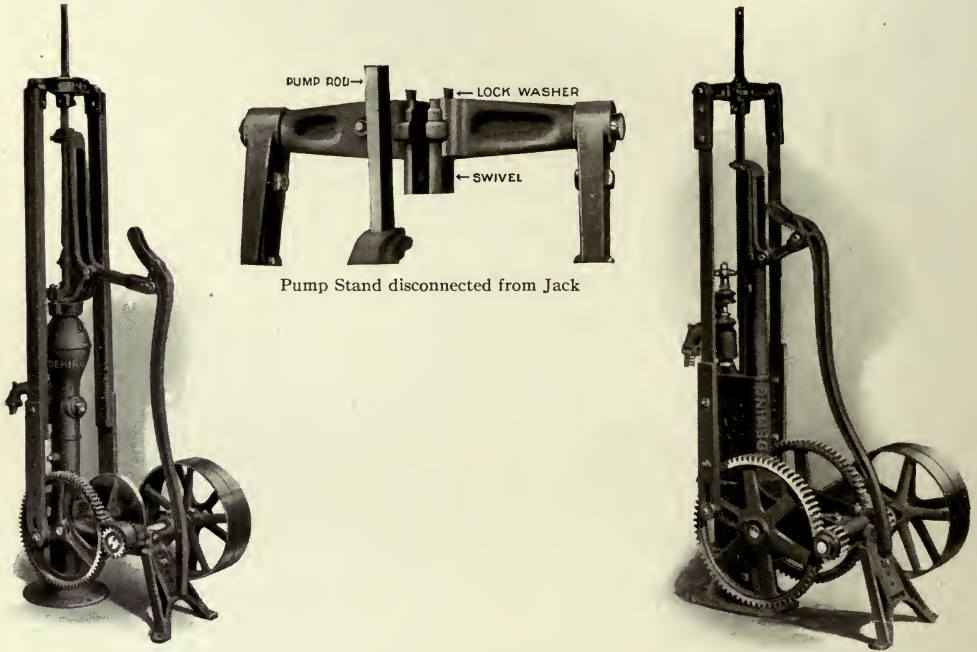

View of No. 1 size, connected to Deming Windmill Pump Standard, Fig. 440.

View of No. 2 size connected to Standard of Fig. 453.

In these jacks the rests bolt securely to platform and serve as a brace to help support the jack and brace the pump stand. The pump connection is designed to make quick change from jack to windmill or hand pumping without removing any bolts. When the pump is set directly under a windmill it can be operated by hand, by windmill or by gasoline engine.

No. 0 is not illustrated, but is in general appearance very much like No. 1, except that it is double geared.

No. 1 is single geared.

No. 2 is double geared, equally dividing the load. Has adjustable foot rest. Shafts are extra heavy.

Sizes and Prices

No.	Adjustable Stroke Inches	Gear Ratio	Tight and Loose Pulleys	Weight Pounds	Cipher	*Price
0	5, 7 or 10	4 to 1	13 x 2	90	HAAF	\$10.00
1	5, 7 or 10	4 to 1	13 x 2	95	HAAK	12.00
2	5, 7 or 10	5½ to 1	13 x 2	155	HABLE	17.00

*List Prices do not include the pump shown with each of these Jacks.

Complete Table of Contents and General Classification of Pumps, Pages 7 and 8



CENTRIFUGAL
AND
ROTARY PUMPS

FOR VARIOUS PURPOSES

INCLUDING HAND AND POWER
ROTARY PUMPS FOR USE IN OIL
REFINERIES, SOAP FACTORIES,
GARAGES, BREWERIES, CANNING
FACTORIES, CREAMERIES, PAINT
AND CHEMICAL WORKS, ETC.
ALSO HORIZONTAL AND VERTI-
CAL CENTRIFUGAL POWER
PUMPS FOR CONTRACTORS'
USE, DRAINING AND
IRRIGATING, ETC.





Typical Deming Rotary Force Pump

Fig. 577 (In Section)

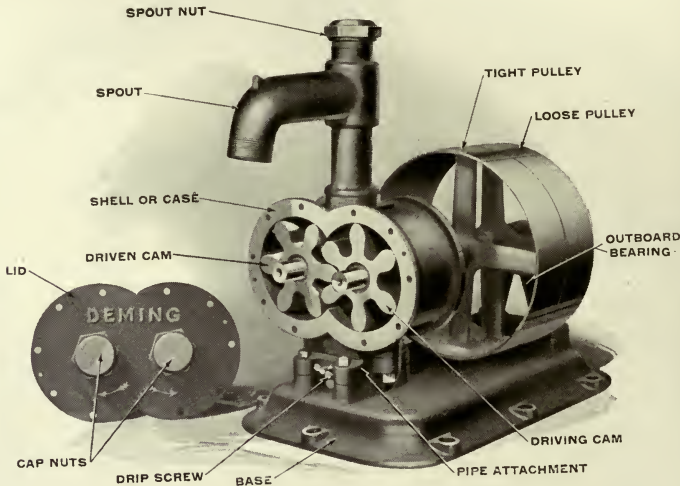

Deming Rotary Force Pumps are adapted for a suction lift of 12 to 15 feet. As a rule they may be used for a total lift and force of 60 feet, depending of course upon the conditions.

Liquids can be drawn horizontally any reasonable distance. In such case, the suction pipe should incline upward a trifle. Deming Rotary Pumps are very easy to install; it being necessary only to attach the required lengths of suction and discharge pipe to the openings in the pump.

As shown in the illustration, the working parts consist of a pair of toothed pinions, which when they revolve, mesh into each other and secure the required suction. The discharge from a rotary pump is uniform and constant. However, they are not adapted to very heavy duties. They are very much used for circulating cooling water for gasoline engines; pumping cider, vinegar, wine, milk, etc.; pumping oil, chemicals, gasoline, kerosene, etc. They are easy to clean and for that reason are often used where food products are handled in liquid form.

If hot liquids are to be pumped, we should be advised, for the reason that vapor arising from a hot liquid will prevent the pump from forming a vacuum. For priming purposes, there is a hole in the top of the pump. There is also a drain plug at the bottom. Wherever aciduous liquids are to be handled, we recommend that bronze pumps be used.

If a small quantity of oil is run through the pump before and after using, it will prevent rusting.

In order that rotary pumps be operated with maximum efficiency, they have to be very accurately made. With our special machinery for manufacturing this type of pump, we are in position to make rotary pumps which will operate to the very best advantage, under the conditions for which they are recommended.

Complete Table of Contents and General Classification of Pumps, Pages 7 and 8



Deming Improved Rotary House Force Pumps

Will Lift and Force 60 Feet



Fig. 578

Fig. 578

The base of this pump is flat and square, with a cast hub projecting below. Both suction and discharge are fitted for hose couplings but will be fitted for iron or lead pipe if so ordered. Fig. 578 has flat fly-wheel and is generally mounted on a table or bench. It is well adapted for pumping cider, vinegar, wine, milk, cream, water or oil.

Fig. 579

Rotary force pump, Fig. 579, is the same type as Fig. 578 except that it is made with a hand crank instead of fly-wheel. It is also provided with brackets for attaching to post or wall. The suction is regularly fitted for iron pipe, but will be arranged for lead pipe or hose, when so ordered, at a slight additional cost. If Fig. 579 is wanted with hand fly-wheel, add \$2.00 to the list price. By removing cap on top of spout and attaching it to end of spout, Fig. 579 is adapted to upward discharge, as also is Fig. 578.



Fig. 579

Sizes and Prices—Fig. 578

No.	Suction Fitted for Hose Inches	Capacity at 50 Revs. per Min. Gallons	Diam. Fly-Wheel Inches	Dimensions of Base Inches	Weight Pounds	IRON		BRONZE CASE AND CAMS		BRONZE	
						Cipher	Price	Cipher	Price	Cipher	Price
1	1¼	5½	14	10¼ x 7	58	GARLAND	\$19.50	GAULISH	\$41.50	GALBAN	\$51.00
2	1¼	7½	14	10¼ x 7	58	GARLIC	22.50	GARRISON	46.50	GALENIC	56.00
3	1½	10	14	14 x 9	78	GARMENT	26.75	GARRULITY	51.75	GALIPOT	64.00

Fig. 579

No.	Suction Fitted for Pipe Inches	Discharge Fitted for Pipe Inches	Capacity at 50 Revs. per Min. Gallons	Weight Pounds	IRON		BRONZE CASE AND CAMS		BRONZE	
					Cipher	Price	Cipher	Price	Cipher	Price
1	1	1	5½	38	GRILLY	\$17.00	GRIEVOUS	\$39.00	GRIPE	\$49.00
2	1	1	7½	48	GRIEVING	20.00	GRIFFON	44.00	GRIMY	54.00
3	1¼	1¼	10	58	GRIEVER	24.00	GRIFFLADE	49.00	GRIST	61.00

Engineering Tables and Information Relating to Hydraulics, Pages 239 to 248



Deming Improved Hand Rotary Force Pump

With Fly-Wheel and Crank
Will Lift and Force 60 Feet

Fig. 575



This is one of our most popular types of hand rotary force pumps and is largely used by brewers, wine producers, distillers, gas companies, etc. Being metallic fitted, it is especially adapted for their requirements.

As is explained at the beginning of this chapter, our rotary pumps are most accurately and carefully manufactured, the cases and cams of each size being made to exact gauges and templates. The peculiar construction of the rotary pump requires the utmost accuracy in fitting every part.

When used for handling acids, the working parts should be made of bronze metal. In such event the pump is made all bronze except the fly-wheel and base, and extra price is charged for which see list below. For pumping oil or fermented and acetous liquids Fig. 575 is very efficient, and for pumping hot or cold water, it can be used in place of an ordinary piston pump.

The fly-wheel is 20 inches in diameter. A 36-inch fly-wheel will be furnished on Nos. 4, 5 and 6 at \$4.50 extra list, when specified. Fig. 575 is regularly fitted for iron pipe.

Sizes and Prices

No.	Suction Fitted for Pipe Inches	Discharge Fitted for Pipe Inches	Capacity at 50 Revs. per Min. Gallons	Weight Pounds	IRON		BRONZE CASE AND CAMS		*BRONZE	
					Cipher	Price	Cipher	Price	Cipher	Price
1	1¼	1	5½	70	GALLANTRY	\$20.00	GAMMON	\$42.00	GAUZY	\$ 52.00
2	1¼	1	7½	77	GALLERY	23.00	GANDER	47.00	GAVEL	57.00
3	1½	1¼	10	90	GALLOP	27.00	GANGRENE	52.00	GAWKY	64.00
4	2	2	12½	123	GALLOW	35.00	GANGWAY	65.00	GEATY	87.00
5	2	2	18	139	GAMBOL	40.00	GARGLE	75.00	GECKO	105.00
6	3	2½	24	192	GAMESTER	50.00	GARGOYLE	100.00	GEMINY	140.00

*All parts coming in contact with the liquid are made of bronze.

Complete Table of Contents and General Classification of Pumps, Pages 7 and 8



Deming Improved Hand Rotary Force Pump

With Barrel Attachment
Will Lift and Force 60 Feet

Fig. 576



Fig. 576

Usual method of operating Fig. 576

This is an ideal pump for dealers in oils and liquors. With it, the liquid can be transferred from the cellar to any part of the building. It is a positive suction and force pump — simple in construction and easily operated. It is furnished with top discharge and spout, crank handle and iron suction pipe, the latter being fitted with a barrel attachment which will fit the bung-hole of steel drums when tapped for 1½ or 2-inch pipe. This can also be used for bungholes of wooden barrels by simply screwing it into the wood. By forcing the tapered end into the bung-hole, the pump is held firmly in place. A hook for holding discharge hose on edge of tank is also included. Hose is not furnished regularly with the pump but we can supply it in any lengths at additional cost. List prices include hose couplings.

Sizes and Prices

No.	Suction Fitted for Pipe Inches	Dis-charge Fitted for Hose Inches	Capacity at 50 Revs. per Min. Gallons	Weight Pounds	IRON		BRONZE CASE AND CAMS		BRONZE	
					Cipher	Price	Cipher	Price	Cipher	Price
1	1	1	5½	43	GASEOUS	\$17.00	GASTRIC	\$39.00	GENEVAN	\$49.00
2	1	1	7½	50	GASOMETER	20.00	GATHER	44.00	GENTIAN	54.00
3	1¼	1¼	10	60	GASPED	24.00	GATHERED	49.00	GENTILE	61.00

Alphabetical Index, Figure Index and Telegraph Cipher Code, Pages 249 to 254



Deming Power Rotary Force Pumps
With Bottom Suction
Fig. 577

Fig. 577 with Tight and Loose Pulleys

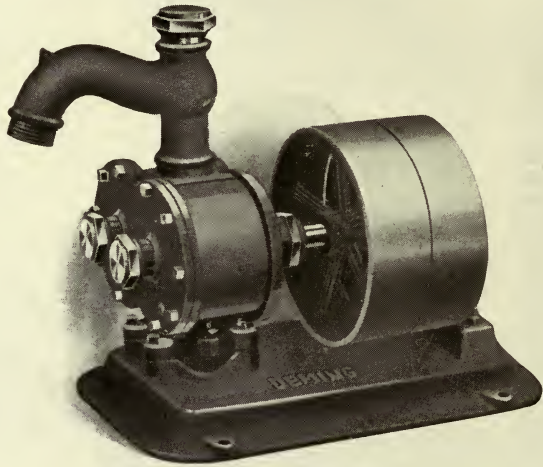
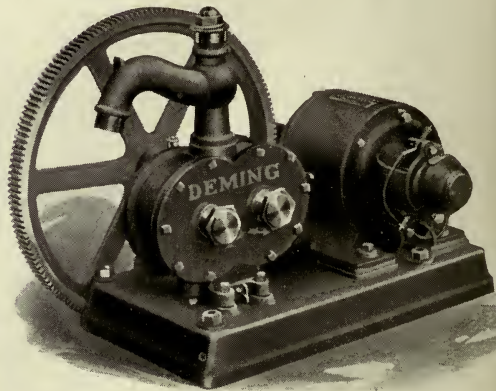

Fig. 577½ with Tight and Loose Pulleys



Fig. 577 with Type "B" Drive





Deming Power Rotary Force Pumps

With Bottom Suction
Will Lift and Force 60 Feet

Figs. 577 and 577½

Fig. 577 Rotary Force Pump is used largely in oil refineries, distilleries, creameries, wine cellars, and wherever water or other liquids must be rapidly elevated by power. It is essential that the liquid being pumped is entirely free from gritty substances, and that the suction lift should not exceed 15 feet.

Fig. 577½ is the same as Fig. 577, except is furnished for upward discharge without spout.

This pump is mounted on heavy cast iron base frame and furnished with tight and loose pulleys, while beyond the pulleys the drive shaft runs in a heavy babbitted bearing. Drip cock is provided to prevent freezing. Unless otherwise ordered, leather packed suction valve is provided.

The case which receives the cams is carefully turned and bored, and is perfectly true and smooth, while the cams are accurately machined to the form which years of experience has demonstrated will produce the minimum of friction and wear, and at the same time give the best results in pumping.

For vertical discharge with Fig. 577, the cap shown in the illustration should be placed on the spout and pipe connection made on top.

This pump with Type "B" Drive (Cipher, "TYPEB") consists of the standard pump without pulleys, but with sub-base and gearing connection for electric motor HAVING SPEED OF 1200 REVOLUTIONS PER MINUTE, OR LESS. Unless otherwise specified, the motor piston is made of rawhide. Motor can be furnished, if desired, at extra price.

Fig. 577, Sizes, Capacities, Prices, Etc.

Number	*Capacity at 100 Revs. per Min., Gal.	DIAM. OF PIPES		Elevation above Supply, Feet	Size Pulleys	Approximate Weight in Pounds	PRICES OF STANDARD FIG. 577 WITH PULLEYS						†† Extra for Type "B" Drive	Approximate Weight With Type "B" Drive
		Suction Inches	Discharge Inches				IRON		BRONZE CASE AND CAMS		†BRONZE			
							Cipher	Price	Cipher	Price	Cipher	Price		
1	11	1¼	1	60	8 x 2½	70	GAZETTEER	\$27.00	GENIAL	\$49.00	GROPER	\$60.00	\$25.00	160
2	15	1¼	1	60	8 x 2½	75	GELATINE	32.00	GENITIVE	56.00	GROTTO	67.00	27.00	170
3	20	1½	1¼	60	8 x 2½	85	GENDER	38.00	GENIUS	63.00	GROVEL	75.00	30.00	185
4	25	2	2	60	12 x 3	130	GENERATE	48.00	GENTEEL	78.00	GROWLER	100.00	35.00	250
5	36	2	2	60	12 x 3	145	GENEROUS	54.00	GENTILITY	90.00	GROZZER	120.00	40.00	275
6	48	3	2½	60	16 x 4	200	GENESIS	80.00	GENTLEMAN	135.00	GUFFLY	175.00	45.00	340

Fig. 577½, Sizes, Capacities, Prices, Etc.

Number	*Capacity at 100 Revs. per Min., Gal.	DIAM. OF PIPES		Elevation above Supply, Feet	Size Pulleys	Approximate Weight in Pounds	PRICES OF STANDARD FIG. 577½ WITH PULLEYS						†† Extra for Type "B" Drive	Approximate Weight With Type "B" Drive
		Suction Inches	Discharge Inches				IRON		BRONZE CASE AND CAMS		†BRONZE			
							Cipher	Price	Cipher	Price	Cipher	Price		
1	11	1¼	1¼	60	8 x 2½	65	GRADED	\$26.00	GRAFTED	\$48.00	GRAINAGE	\$58.00	\$25.00	155
2	15	1¼	1¼	60	8 x 2½	70	GRADING	31.00	GRAFTING	55.00	GRAINY	65.00	27.00	165
3	20	1½	1½	60	8 x 2½	80	GRADELY	37.00	GRAFTER	62.00	GRAITH	73.00	30.00	180
4	25	2	2	60	12 x 3	120	GRADIENT	46.00	GRAIL	76.00	GRALLIC	96.00	35.00	240
5	36	2	2	60	12 x 3	130	GRAFF	52.00	GRAINED	88.00	GRAM	116.00	40.00	260
6	48	3	2½	60	16 x 4	180	GRAFT	77.50	GRAINING	132.50	GRAMPLE	170.00	45.00	320

*For pumping oil against head of 30 feet or less, these pumps may be operated at 150 revolutions per minute.

†In the "Bronze" Pumps all parts which come in contact with the liquid are made of bronze.

††When telegraphing about Type "B" Drive, place cipher word "TYPEB" after cipher word for pump.

Engineering Tables and Information Relating to Hydraulics, Pages 239 to 248



Deming Power Rotary Force Pumps With Side Suction

Fig. 532 with Tight and Loose Pulleys

Fig. 531 with Tight and Loose Pulleys



These pumps are identical in construction with Figs. 577 and 577½, illustrated and described on preceding two pages, except that they are fitted for side suction instead of bottom suction. Fig. 531 is threaded for suction and discharge pipe as listed. Fig. 532 is made with discharge spout. For types of drive, see Figs. 577 and 577½.

Fig. 531, Sizes, Capacities, Prices, Etc.

Number	*Capacity at 100 Revs. per Min., Gal.	DIAM. OF PIPES		Elevation above Supply, Feet	Size Pulleys	Approximate Weight in Pounds	PRICES OF STANDARD FIG. 531 WITH PULLEYS						†† Extra for Type "B" Drive	Approx. Weight with Type "B" Drive
		Suction Inches	Discharge Inches				IRON		BRONZE CASE AND CAMS		†BRONZE			
							Cipher	Price	Cipher	Price	Cipher	Price		
1	11	1½	1¼	60	10 x 2½	70	GASHFUL	\$29.00	GELDED	\$51.00	GENTLE	\$ 62.00	\$25.00	160
2	15	1½	1¼	60	10 x 2½	75	GAVOT	34.00	GELDING	58.00	GENTLEST	69.00	27.00	170
3	20	1½	1¼	60	10 x 2½	85	GAWBY	40.00	GELDER	65.00	GENTLY	77.00	30.00	185
4	25	2	1½	60	16 x 3	130	GAYER	52.00	GELLY	82.00	GENTUS	104.00	35.00	250
5	36	2	1½	60	16 x 3	140	GAYEST	58.00	GEMARA	94.00	GHERKINS	124.00	40.00	270
6	48	3	2½	60	24 x 4	205	GAZEFUL	87.50	GENERAL	142.50	GILDING	183.00	45.00	345

Fig. 532, Sizes, Capacities, Prices, Etc.

Number	*Capacity at 100 Revs. per Min., Gal.	DIAM. OF PIPES		Elevation above Supply, Feet	Size Pulleys	Approximate Weight in Pounds	PRICES OF STANDARD FIG. 532 WITH PULLEYS						†† Extra for Type "B" Drive	Approx. Weight with Type "B" Drive
		Suction Inches	Discharge Inches				IRON		BRONZE CASE AND CAMS		†BRONZE			
							Cipher	Price	Cipher	Price	Cipher	Price		
1	11	1½	1	60	10 x 2½	75	GLEAN	\$30.00	GLOOMILY	\$52.00	GNOME	\$ 64.00	\$25.00	165
2	15	1½	1	60	10 x 2½	80	GLEANER	35.00	GLOSSIST	59.00	GNOMIC	71.00	27.00	175
3	20	1½	1	60	10 x 2½	90	GLEANING	41.00	GLOSSY	66.00	GNOMICAL	79.00	30.00	190
4	25	2	1½	60	16 x 3	140	GLOOM	54.00	GLUTEN	84.00	GOPPISH	108.00	35.00	260
5	36	2	1½	60	16 x 3	155	GLOOMED	60.00	GLUTENATE	96.00	GORGET	128.00	40.00	285
6	48	3	2½	60	24 x 4	225	GLOOMING	90.00	GLUTINOUS	145.00	GORHEN	188.00	45.00	365

*For pumping oil against head of 30 feet or less, these pumps may be operated at 150 revolutions per minute.

†In the "Bronze" Pumps all parts which come in contact with the liquid are made of bronze.

††When telegraphing about Type "B" Drive, place cipher word "TYPEB" after cipher word for pump.

Complete Table of Contents and General Classification of Pumps, Pages 7 and 8



Deming Automobile Rotary Gasoline Pump

With Tall Base

Will Lift and Force 60 Feet

Fig. 776

The "Typical Installation" below shows how Fig. 776 may be installed and connected up to underground tank.

The working parts of Fig. 776 consist of a set of cams enclosed in an iron case and mounted on a tall base. To operate, if a cock is on the spout, open the cock and turn the crank in the direction indicated by the arrows on the face of the pump. When through pumping, turn the crank in the opposite direction several revolutions, after which the cock should be closed, thus preventing the escape of gasoline and reducing fire risk to a considerable degree. For the price, no better pump is made.

In this "Typical Installation" the tank is 24 inches in diameter, 36 inches long; has 1-inch suction pipe; $\frac{1}{4}$ -inch air vent pipe and air cock and 2-inch filling pipe.

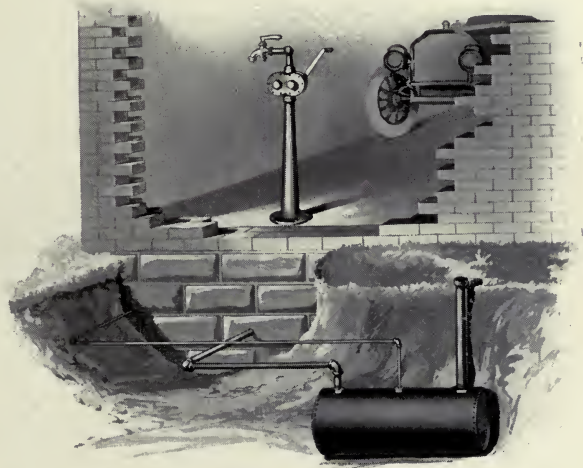

Typical Installation

The tank should be buried outside the garage. This illustration is shown as a guide to those desiring to install such an outfit. Prices on storage tanks, fittings, etc., will be quoted on application.

Sizes and Prices

Suction Fitted for Pipe, Inches	Discharge Fitted for Bibb Cock Inches	Capacity at 50 Revolutions per Minute Gallons	Weight Pounds	Pump only, Iron			
				Without Cock		With Cock	
				Cipher	Price	Cipher	Price
1	$\frac{3}{4}$	$5\frac{1}{2}$	78	GARAGE	\$22.50	GARUM	\$25.00

Alphabetical Index, Figure Index and Telegraph Cipher Code, Pages 249 to 254



Deming Power Rotary Force Pump

Will Lift and Force 100 Feet

Fig. 595

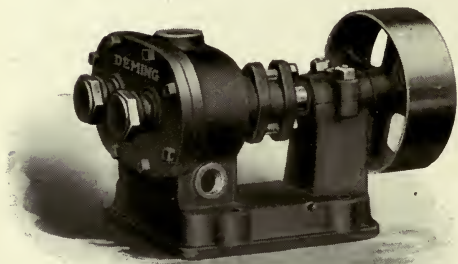

Fig. 595

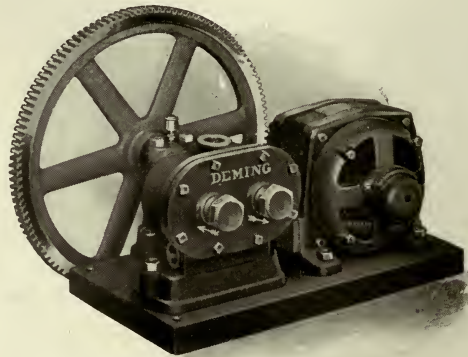

Fig. 595 with Type "B" Drive

Fig. 595 Rotary Pump is designed to meet the demand for pumps for pumping small quantities of oil or gasoline. It is also recommended for pumping water for house supply or other purposes where power is available, and the liquid is entirely free from gritty substances.

It is simple in construction, consisting of a pair of special machine-cut gears running together in a tight case. It is mounted on a substantial iron base frame with babbitted bearing for shaft. Suction connection at either side, and discharge at the top. Price includes tight pulley only, but loose pulley will be supplied to order.

Fig. 595 with Type "B" Drive (Cipher, "TYPEB") is identical in construction with the Fig. 595, except that it is mounted on a substantial cast iron base with electric motor and connected to the motor by gearing. The motor speed should not exceed 1,800 revolutions per minute for the maximum pump speed of 200. Motor is not included in price, but will be furnished at extra charge.

Fig. 595, Prices, Etc.

No.	Capacity at 200 Revs. per Min. Gallons	Suction Inches	Dis-charge Inches	Pulley	Maximum Dis-charge Pressure Pounds	IRON		*BRONZE		Extra for Loose Pulley	†Extra for Type "B" Drive
						Cipher	Price	Cipher	Price		
1	10	1	1	10 x 2½	50	GOURD	\$25.00	GOUT	\$55.00	\$5.00	\$25.00

*All parts which come in contact with the liquid are made of bronze.

†When telegraphing with reference to Type "B" Drive, place the cipher word "TYPEB" immediately after the cipher word for the standard belt driven pump.

Complete Table of Contents and General Classification of Pumps, Pages 7 and 8.



Deming Special Power Rotary Oil Pump

For Lubricating Machine Tools
Will Lift and Force 60 Feet

Fig. 580

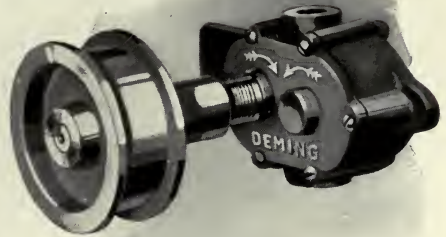
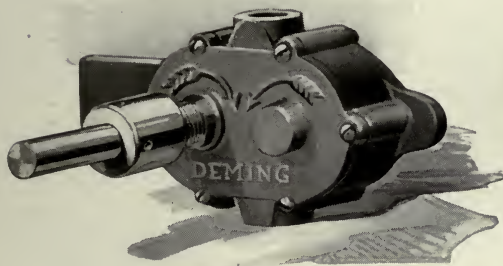

With Pulley

Fig. 580 is a Rotary Force Pump which has been designed to meet the requirements of machine tool manufacturers, for lubricating special screw threading and tapping tools. A bracket is attached to the pump, by means of which it may be bolted to the machine.

This pump may also be used for pumping small quantities of water for house supply where it can be operated by electric motor or other power, such as small gas engine. It is compact and takes up but little space. The pump should not be set more than 10 to 15 feet above the liquid, preferably as near to it as possible.

This little pump can be run with safety as high as 150 revolutions per minute, but 100 is about the proper speed. It is made in bronze only on special order. The diameter of shaft is $\frac{3}{4}$ inch, and the length $2\frac{3}{4}$ inches from stuffing-box to outer end.

A pulley of proper size should be attached to the shaft and the Pump Bracket fastened rigidly to the machine tool if thus used, or to a wall or upright timber if used for water supply as suggested above.

Can be used as either a right or left hand pump.

When fitted with $1\frac{1}{2}$ x 4-inch flanged pulley, add \$2.00 to the list price.

Sizes and Prices

Suction Fitted for Pipe Inches	Discharge Fitted for Pipe Inches	Capacity per Minute at 100 Rev. Gallons	Weight Pounds	IRON		BRONZE	
				Cipher	Price	Cipher	Price
$\frac{1}{2}$	$\frac{1}{2}$	1	12	GARROT	\$15.00	GARROTER	\$25.00



Deming Standard Horizontal Centrifugal Pump

Fig. 598

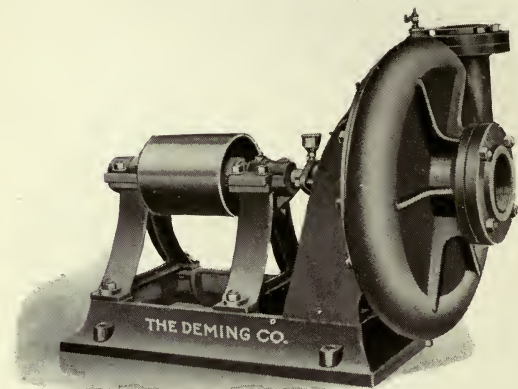

Fig. 598 Horizontal side suction centrifugal pump is the style most extensively used and, with the exception of the two smaller sizes, is adapted for elevations up to 100 feet, or equivalent pressure. It is designed and constructed throughout on very liberal lines. The case or shell is of the solid type, and the runner is of large diameter, adapting the pump for slow speeds.

The inside of the case is machine-finished and the runner machined and accurately fitted to it. The shaft is large and the bearings, which are self-oiling in sizes No. 1½ and larger are generously proportioned. An ample stuffing-box and gland are provided. All parts are accurately interchangeable, and any part can be readily duplicated.

The pumps are furnished for discharge at any angle desired, and, when so ordered, any of these pumps can be supplied with the discharge necks increased so that the discharge opening is the same size as the suction opening.

NOTE—The illustration on the opposite page shows Fig. 598 with hand suction primer.

Fig. 598, Sizes and Capacities

No. Pump	SIZE OF PIPE INCHES		Economical Capacity Gallons per Minute	H.P. Required per Foot Elevation	Diam. and Face Pulley Inches	Shipping Weight Without Primer Pounds	Shipping Weight With Primer Pounds
	Dis.	Suct.					
¾	¾	1	10	.010	3 x 2	27	
1	1	1½	30	.025	4 x 3	40	
1½	1½	2	70	.058	5 x 5	95	120
1¾	2	2½	90	.075	6 x 5	170	215
2	2	3	120	.10	6 x 6	245	310
2½	2½	3½	185	.15	7 x 6	300	370
3	3	4	265	.22	7 x 8	370	465
3½	3½	4½	360	.26	8 x 8	380	495
4	4	5	470	.30	10 x 8	505	665
5	5	6	735	.45	10 x 10	770	915
6	6	8	1060	.59	14 x 12	1150	1380
8	8	10	2000	1.00	20 x 12	1550	1790
10	10	12	3000	1.52	24 x 12	2400	2750
12	12	15	4300	2.00	30 x 14	2800	

Fig. 598, Prices, Etc.

No. Pump	PUMP WITHOUT PRIMER		PUMP WITH PRIMER		*Extra for Brass Fittings
	Cipher	Price Iron	Cipher	Price Iron	
¾	GODWIT	\$25.00			\$ 5.00
1	GOBLET	30.00			6.00
1½	GOBBLE	45.00	GLITTER	\$60.00	15.00
1¾	GODLY	60.00	GLOAMING	75.00	18.00
2	GOOGLE	75.00	GLOAT	95.00	22.00
2½	GOLDEN	90.00	GLOATED	110.00	27.00
3	GONDOLA	110.00	GLOBULAR	135.00	30.00
3½	GONOPH	120.00	GLOPPEN	145.00	40.00
4	GONDOLIER	130.00	GLOBULE	160.00	48.00
5	GOODNESS	165.00	GLOOMY	200.00	72.00
6	GOODY	225.00	GLORIFY	270.00	108.00
8	GOPHER	310.00	GLOARIOUS	375.00	130.00
10	GORDIAN	395.00	GLOSSARY	470.00	265.00
12	GORING	500.00			

*Brass-fitted pumps have runner and shaft of brass.

Prices of pumps with entire water end of brass are furnished on application.

Complete Table of Contents and General Classification of Pumps, Pages 7 and 8



Deming Standard Horizontal Centrifugal Pump

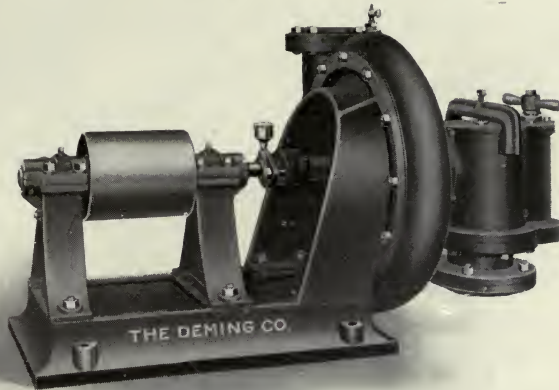

Fig. 598, With Hand Suction Primer

Revolution Table

Speeds at which Fig. 598 pumps should operate to raise water to various heights.

No. Pump	Cap. Gals. Min.	5 Ft.	10 Ft.	15 Ft.	20 Ft.	25 Ft.	30 Ft.	35 Ft.	40 Ft.	50 Ft.	60 Ft.	70 Ft.	80 Ft.	90 Ft.	100 Ft.
¼	10	1000	1275	1490	1690	1860	2020								
1	30	963	1176	1357	1515	1625	1790	1911	2028						
1½	70	642	784	904	1010	1104	1193	1274	1352	1493	1622	1742	1864	1968	2069
1¾	90	473	570	651	724	790	850	906	959	1058	1147	1230	1317	1392	1461
2	120	364	443	511	570	623	672	718	762	840	913	980	1054	1111	1167
2½	185	389	448	500	547	590	630	667	703	770	830	886	949	1000	1048
3	265	286	359	419	475	517	559	599	636	704	766	824	888	939	986
3½	360	352	413	455	513	555	595	632	667	733	793	847	911	961	1007
4	470	324	390	445	493	539	580	618	654	721	781	837	901	951	998
5	735	311	368	418	462	502	538	574	606	666	722	773	836	881	924
6	1060	247	300	345	385	421	433	484	513	566	615	658	712	751	789
8	2000	293	345	390	430	466	500	532	561	617	667	714	768	810	849
10	3000	160	226	278	320	358	392	424	456	506	555	603	650	696	741
12	4300	133	188	230	266	298	326	352	376	421	461	500	538	575	611



Deming Electric-Driven Horizontal Centrifugal Pump

Fig. 599

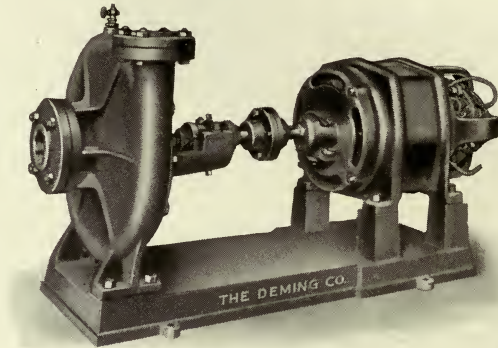

Fig. 599 arranged for direct connected motor drive.

The smaller sizes have both pump and motor mounted on a cast iron bed-plate, while the larger sizes are mounted on a steel frame instead.

The pump is provided with a bracket bearing of the ring-oiling type, which is outside of and separate from the stuffing-box.

Flexible couplings, connecting the pump and motor shafts, can be furnished at an extra price when so ordered.

To adapt these pumps to the various motor speeds, special construction is always necessary; therefore, inquiries should always state the voltage and the kind of current used, amount of liquid to be pumped, the length and sizes of piping and the total height to which liquid is to be raised.

Fig. 599, Sizes, Capacities, Prices, Etc.

No. Pump	SIZE OF PIPE INCHES		Economical Capacity Gallons per Min.	Approximate Shipping Weight Pounds	STANDARD IRON PIPE		*Extra for Brass Fittings
	Disch.	Suction			Cipher	Price	
3/4	3/4	1	5- 10	75	GABEL	\$60.00	\$ 5.00
1	1	1 1/2	10- 30	100	GAB	70.00	6.00
1 1/2	1 1/2	2	50- 70	150	GABBLED	80.00	15.00
1 3/4	2	2 1/2	70- 90	250	GABBLER	110.00	18.00
2	2	3	100- 120	300	GABELLE	140.00	22.00
2 1/2	2 1/2	3 1/2	150- 185	400	GADDER	160.00	27.00
3	3	4	225- 285	500	GADDISH	180.00	30.00
3 1/2	3 1/2	4 1/2	300- 360	600	GALLOW	190.00	40.00
4	4	5	400- 470	750	GADORD	210.00	48.00
5	4	6	600- 735	1200	GAEL	250.00	72.00
6	6	8	900-1060	1500	GAFFLE	320.00	108.00
8	8	10	1800-2000	2000	GAINAGE	410.00	130.00

*Brass-fitted pumps have runner and shaft of brass.

Prices are for pump complete with coupling and bedplate to receive motor, but do not include motor.

Complete Table of Contents and General Classification of Pumps, Pages 7 and 8



TRIPLEX POWER PUMPS

SINGLE AND DOUBLE-ACTING

FOR BOILER FEEDING, MINE
PUMPING, WATER WORKS,
SEWAGE PUMPING, BRINE CIR-
CULATION, PAPER MILL PUMP-
ING, HYDRAULIC PRESSURE
ACCUMULATORS, FIRE PROTEC-
TION SERVICE, RAILWAY WATER
SUPPLY, HYDRAULIC ELEVATOR
SERVICE, PRIVATE WATER
SUPPLY, IRRIGATING, ETC., FOR
OPERATION BY ELECTRIC
OR OTHER POWER



SEPARATE BULLETINS

Descriptive of our complete line of triplex power pumps and comprising many different types and sizes, will be sent upon request. However, to give a general idea of the appearance and construction of these pumps, a few representative types are listed in this section of the Catalogue.



Deming Triplex Power Pumps For Operation By Any Power

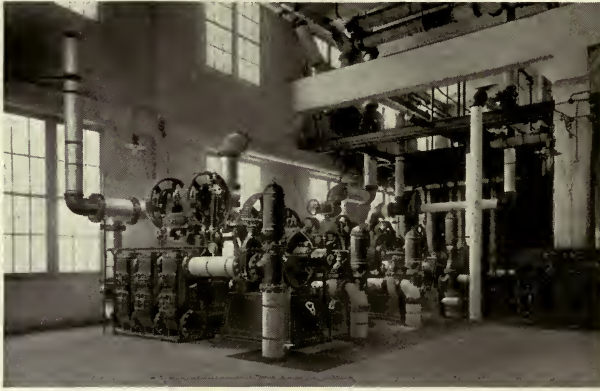

Installation of Deming Triplex Power Pumps in the plant of the Eastman Kodak Co., Rochester, New York

Our complete line of triplex power pumps is covered by a number of individual Bulletins. However, to give a general idea of the construction of these pumps, we illustrate in this section a few of the most popular types.

Deming Triplex Power Pumps are for operation by electric motors, gas, gasoline or steam engines, water wheels, etc., either belt driven or direct connected to the driver. They are very much more economical to operate than the direct acting steam pump and will show savings of two-thirds and often more when compared with costs of steam pumping. When electric driven, they can be installed in any convenient place without reference to the location of a central power plant.

Deming Triplex Pumps embody the principle of the three-throw crank shaft, with the crank pins at an angle of 120 degrees with each other, by which arrangement the strokes follow and overlap one another. This results in a continuous and uniform action upon the fluid being pumped, and insures an easy flow through the delivery pipe, with a corresponding high degree of efficiency in the operation of the pump.

They are regularly made with capacities from 300 gallons to 60,000 gallons per hour, and on special orders will be built in much larger sizes. A brief summary of the many different uses for Deming Triplex Pumps is given below:

BELT DRIVEN: For waterworks, boiler feeding, paper and pulp mills, and for all kinds of factory pumping.

ELECTRIC DRIVEN: For waterworks, compression and open tank pumping for private water supply, fire service, boiler feeding, brine circulating, hydraulic elevators, hydraulic pressure accumulators, mine pumping, irrigating, etc.

GAS OR GASOLINE DRIVEN: For waterworks, railway tank service, private water supply, mine pumping, irrigating, etc.

WATER WHEEL DRIVEN: For irrigating and other purposes.

We invite correspondence with reference to special pumping equipment, and will gladly prepare and submit estimates on pumps to satisfactorily meet existing conditions.

Complete Table of Contents and General Classification of Pumps, Pages 7 and 8



Information We Should Have to Furnish an Intelligent Estimate on Deming Triplex Power Pumps

It will greatly facilitate correspondence if our customers, in writing for quotations, will advise us fully of their requirements. In order that we may recommend and quote on the best pump to meet these requirements, IT IS NECESSARY THAT WE KNOW:

FIRST: For what purpose the pump is to be used.

SECOND: The maximum quantity to be pumped per minute, per hour, or per day of twenty-four hours.

THIRD: To what height the liquid is to be lifted by suction, and the diameter and length of the suction pipe.

FOURTH: The height, or pressure, against which liquid is to be discharged, also diameter and length of discharge pipe.

FIFTH: Whether the liquid to be pumped is hot or cold, salt or fresh, acid, clear, thick or gritty.

SIXTH: Power available for driving the pump.

IF THE PUMP IS TO BE DRIVEN BY ELECTRIC MOTOR, WE SHOULD KNOW:

FIRST: Whether the current available is direct or alternating. If direct, state the voltage, and if alternating, state voltage, number of cycles and phase.

SECOND: Whether the pump is to be driven by belt from motor, or to have same direct connected by gearing, or otherwise.

IF THE PUMP IS TO BE DRIVEN BY GAS OR GASOLINE ENGINE, WE SHOULD KNOW:

FIRST: Whether it is to be driven by belt from engine, or direct connected by friction cut-off coupling.

SECOND: If by friction coupling, whether pump and engine are each to be mounted on masonry foundations, or furnished with cast iron bed plate extending under both, also the speed of the engine.

IF PUMP IS TO BE DRIVEN BY STEAM ENGINE, WE SHOULD KNOW:

FIRST: The steam pressure available at the engine.

SECOND: Whether vertical or horizontal engine is wanted.

THIRD: Whether connection is to be made by flanged coupling or by friction coupling.

Alphabetical Index, Figure Index and Telegraph Cipher Code, Pages 249 to 254



Deming Single-Acting Triplex Plunger Pump

Fig. 50, for General Service

Fig. 50 Single-Acting Triplex Pump is designed for water works, hydraulic elevator service, boiler feeding, pulp grinders and for general water supply.

Specifications

FRAME consists of two standards, and includes crosshead guides and main crank shaft bearings, the latter being lined with best anti-friction metal. In sizes 4 x 4 and smaller the frame is cast in one piece with the cylinders.

CRANK SHAFT is of best open hearth steel casting in one piece.

GEARING is machine cut, and is double in 9 x 10 and 10 x 10 sizes, and in sizes 11 x 12 and larger. Other sizes made with double gearing at extra price.

PINION SHAFT is of steel, running in boxes lined with best anti-friction metal, and bolted to the main housings.

CONNECTING RODS, in sizes 4 x 6 and larger, have bronze boxes with wedge and screw adjustment at crosshead end, and marine type babbitted boxes at crank end. Smaller sizes have bronze bushings at crosshead ends.

CROSSHEADS run in bored guides, sizes 4 x 6 and larger having adjustable bronze shoes.

PLUNGERS are of hard, close-grained cast iron, finished true and smooth, and reciprocate through packing of ample depth.

CYLINDERS AND BASE are in one casting in sizes 10 x 10 and smaller, and in larger sizes the cylinders are in three separate castings bolted to the base.

VALVE CHAMBERS, in sizes 3½ x 4 and larger, are separate castings bolted to the cylinders.

They are of liberal proportions, affording large valve area, and all valves are readily accessible.

VALVES for cold water are rubber discs, protected on top from cylindrically wound springs by brass plates. For hot water, either special hard composition valves or bronze valves are furnished as ordered.

VALVE SEATS are of bronze, screwed into decks, and are of the grid type. Iron seats and valves furnished when conditions require.

AIR CHAMBER furnished when specified. Vacuum Chamber to order.

GREASE CUPS, or Oil Cups if specified, and wrenches furnished with all pumps.

SPECIAL CONSTRUCTION: Pumps furnished with brass cased or solid bronze plungers, and bronze lined stuffing boxes and glands, with rawhide pinions, or otherwise varied from standard construction, at extra price.

For different Types of Drive for pumps direct connected with electric motor, gas engine, or other motive power, see pages 155 to 162, inclusive.

Fig. 50, Standard Sizes, Capacities, Etc.

PLUNGERS		CAPACITY			Maximum Working Pressure Pounds	DIAM. OF PIPES		Gear Ratio	*Tight and Loose Pulleys	Cipher
Diam. Inches	Stroke Inches	Gallons per Rev.	Usual Revs. per Min.	Gallons per Min.		Suction Inches	Disch. Inches			
2	2	.081	70	5.67	150	1½	1	5 to 1	8 x 2	OBESH
2½	2	.127	70	8.89	150	1½	1	5 to 1	10 x 2	OBELIZE
2½	3	.19	60	11.4	150	2	1½	5 to 1	12 x 3	OAKEN
3	3	.27	60	16.2	150	2	1½	5 to 1	14 x 3	OATH
3½	3	.37	60	22.	150	2	1½	5 to 1	16 x 3	OAKLING
3½	4	.50	60	30.	150	2½	2	5 to 1	16 x 4	OBELUS
4	4	.65	60	39.	150	2½	2	5 to 1	18 x 4	OAKUM
4	6	.98	60	59.	160	2½	2	5 to 1	20 x 5	OAKSMAN
4½	6	1.24	60	74.	150	3	2½	5 to 1	20 x 5	OAKY
5	6	1.53	60	91.	150	3	2½	5 to 1	24 x 5	OASIS
5½	8	2.46	60	147.	150	4	3	5 to 1	28 x 6	OATMEAL
6	8	2.94	55	161.	140	4	3	5 to 1	30 x 6	OBODURATE
7	8	4.00	55	220.	150	5	4	5 to 1	30 x 8	OBIDURATE
8	8	5.22	55	287.	150	5	4	5 to 1	36 x 8	OBITER
8	10	6.52	50	326.	140	6	5	5 to 1	36 x 8	OVERCOAT
9	10	8.26	50	413.	160	8	6	5 to 1	42 x 10	OBLOQUY
10	10	10.20	45	459.	150	8	6	5 to 1	42 x 12	OBIGNATE
10	12	12.24	42	514.	140	8	8	5 to 1	42 x 14	OBJURATION
11	12	14.81	42	622.	160	10	8	5 to 1	48 x 14	OBDUCT
12	12	17.62	42	740.	150	10	8	5 to 1	48 x 16	OBDUCTION
12	14	20.56	40	822.	150	12	10	5 to 1	48 x 18	OBSERVANCE
13	14	24.12	40	965.	140	12	10	5 to 1	48 x 20	OBSERVANT

*Note.—Sizes 9 x 10 and larger regularly furnished with tight pulley only.



Deming Single-Acting Triplex Plunger Pump

Fig. 50, for General Service

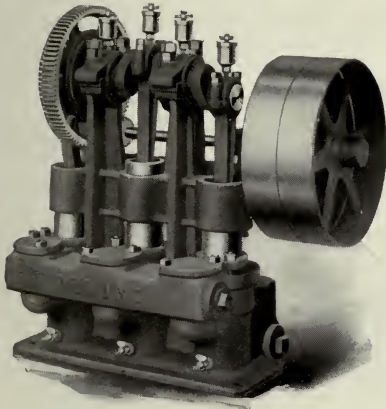

Fig. 50, Sizes $3\frac{1}{2} \times 3$ and smaller

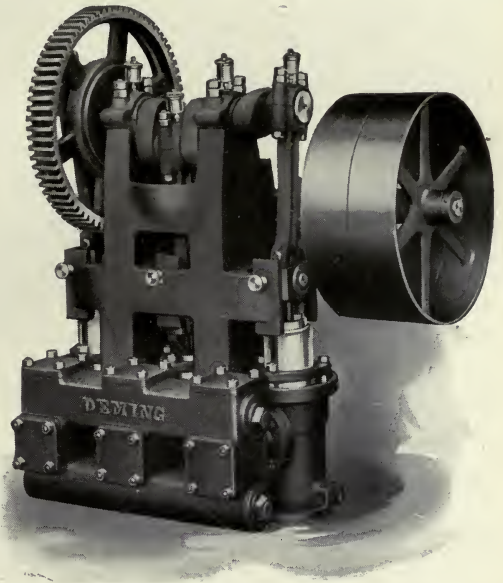

Fig. 50, Sizes 4×6 to 5×6

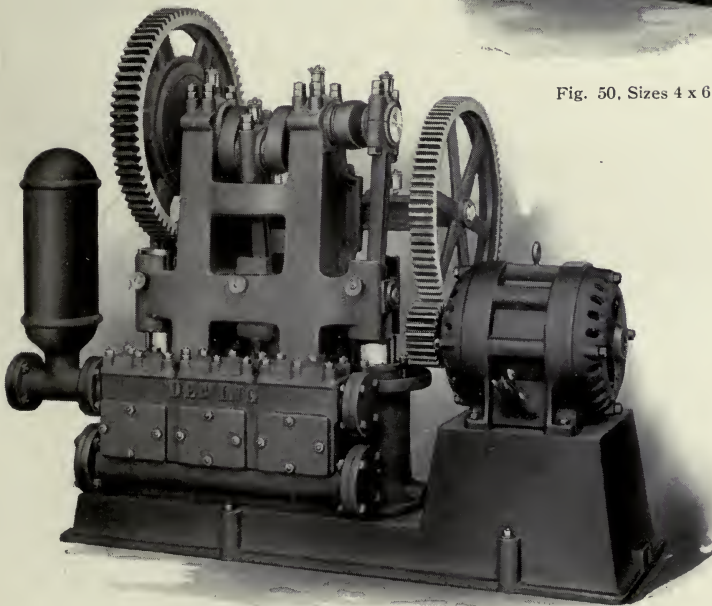

Fig. 50, Sizes $5\frac{1}{2} \times 8$ to 8×10 with Type "B" Drive

Type "B" Drive (Cipher, TYPEB) consists of intermediate pump gear, rawhide, or fibre, motor pinion, and bedplate under both pump and motor, except in the larger sizes, which have separate motor bedplate bolted to the pump base. Recommended where space for installation is limited and some noise due to high speed gearing is not objectionable.

Engineering Tables and Information Relating to Hydraulics, Pages 239 to 248



Deming Single-Acting Triplex Plunger Pump

Fig. 40, for Medium Service

Fig. 40 Single-Acting Triplex Pump is designed for medium heavy service, such as circulating brine, tank supply for factories, railway stations, etc.

Specifications

FRAME consists of two standards, and includes the crosshead guides and main crank shaft bearings, the latter being lined with best anti-friction metal. In sizes 5½ x 6 and smaller the frame is cast in one piece with the cylinders.

CRANK SHAFT is of best open hearth steel casting in one piece.

GEARING is machine cut, and is double in sizes 12 x 14 and larger.

PINION SHAFT is of steel, running in boxes lined with best anti-friction metal and bolted to main housings.

CONNECTING RODS, in sizes 7 x 8 and larger, have bronze boxes with wedge and screw adjustment at crosshead ends, and marine type babbitted boxes at the crank ends. Smaller sizes have bronze bushings at crosshead ends.

PLUNGERS are of close-grained gray iron, turned and ground true and smooth, and have crossheads with bronze shoes adjustable for wear.

CYLINDERS and base are in one casting, except in 12-inch stroke sizes which have cylinders in separate castings.

VALVE CHAMBERS in all sizes except 5½ x 8 and 6 x 8 are in separate castings bolted to cylinders. They have large valve area, and all valves are readily accessible.

VALVES for cold water are rubber discs, protected on top from cylindrically wound springs by brass plates. For hot water, either special composition valves or bronze valves are furnished as ordered.

VALVE SEATS are of bronze, grid type, screwed into the decks. Iron seats and valves furnished when conditions require.

AIR CHAMBER furnished when specified. Vacuum Chamber to order.

GREASE CUPS, or Oil Cups if specified, and wrenches furnished with all pumps.

SPECIAL CONSTRUCTION: Pumps furnished with brass cased or solid bronze plungers, and bronze lined stuffing boxes and glands, with rawhide pinions, or otherwise varied from standard construction, at extra price.

For different Types of Drive for pumps in connection with electric motor, or other motive power, see pages 155 to 162, inclusive.

Fig. 40, Standard Sizes, Capacities, Etc.

PLUNGERS		CAPACITY			Max. Working Pressure Pounds	DIAM. OF PIPES		Gear Ratio	*Tight and Loose Pulleys	Cipher
Diam. Inches	Stroke Inches	Gallons per Rev.	Usual Revs. per Min.	Gallons per Min.		Suction Inches	Dischg. Inches			
4	6	.98	60	59	100	2½	2	5 to 1	16 x 4	OBCORDATE
4½	6	1.24	60	74	95	3	2½	5 to 1	18 x 4	OBTUSION
5	6	1.53	60	91	90	3	2½	5 to 1	18 x 4	OJECTOR
5½	6	1.85	60	111	75	3½	3	5 to 1	18 x 4	OBEYING
5½	8	2.46	60	147	85	4	3	5 to 1	20 x 5	OBITUARY
6	8	2.94	55	161	75	4	3	5 to 1	20 x 5	OBFIRM
7	8	4.00	55	220	100	5	4	5 to 1	28 x 6	OBLATION
8	8	5.22	55	287	100	5	4	5 to 1	30 x 6	OBTDUN
8	10	6.52	50	326	90	6	5	5 to 1	30 x 6	OBSEQUENT
9	10	8.26	50	413	90	6	5	5 to 1	30 x 8	OBTRUSIVE
10	10	10.20	45	459	90	8	6	5 to 1	36 x 8	OBEAH
11	12	14.81	42	622	90	10	8	5 to 1	36 x 10	OBI
12	12	17.62	42	740	75	10	8	5 to 1	36 x 10	OBITUAL
12	14	20.56	40	822	100	12	10	5 to 1	44 x 10	OJECT
13	14	24.12	40	965	85	12	10	5 to 1	44 x 10	OJECTING
14	14	27.98	40	1119	75	12	10	5 to 1	46 x 10	OJECTIVE

*NOTE.—Sizes 10 x 10 and larger furnished with tight pulley only.

Complete Table of Contents and General Classification of Pumps, Pages 7 and 8



Deming Single-Acting Triplex Plunger Pump

Fig. 40, for Medium Service

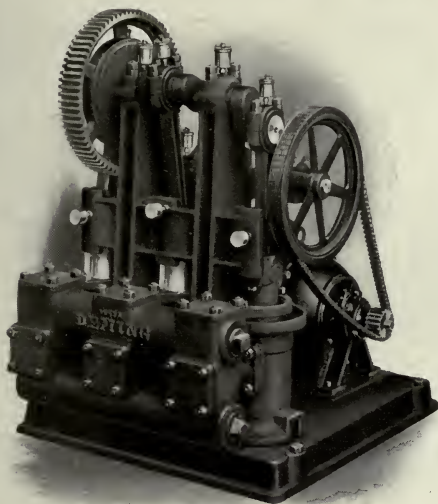

Fig. 40, Sizes 4 x 6 to 5½ x 6

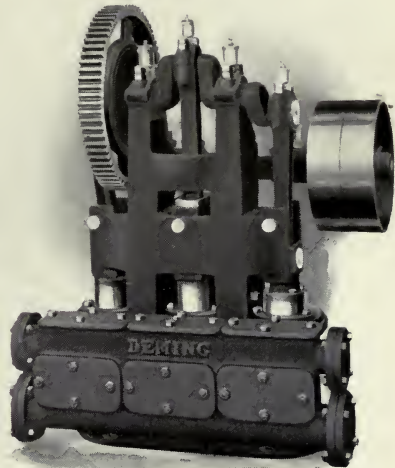

Fig. 40, Sizes 5½ x 8 and 6 x 8

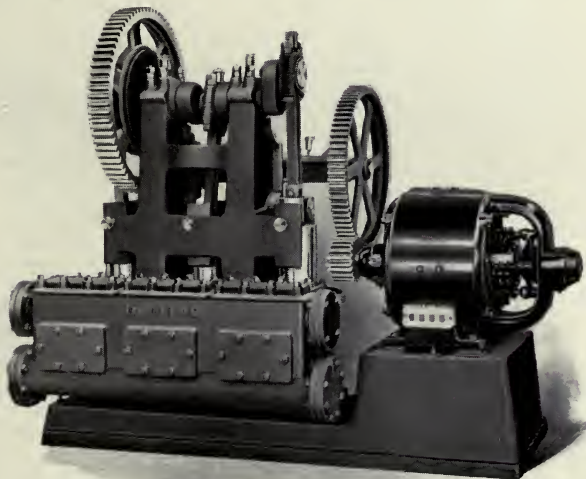

Fig. 40, Sizes 7 x 8 to 9 x 10 with Type "B" Drive

Type "B" Drive (Cipher, TYPEB) consists of intermediate pump gear, rawhide, or fibre, motor pinion, and bedplate under both pump and motor, except in the larger sizes, which have separate motor bedplate bolted to the pump base. Recommended where space for installation is limited and some noise due to high speed gearing is not objectionable.

Alphabetical Index, Figure Index and Telegraph Cipher Code, Pages 249 to 254



Deming Single-Acting Triplex Plunger Pump

Fig. 52, for Heavy Duty

Fig. 52 Single-Acting Triplex Pump is designed for working pressures of from 200 to 400 pounds, or equivalent elevations. It is especially adapted for general water supply, boiler feeding, hydraulic elevators and mine pumping, where the pressures do not exceed the ratings given below.

FRAME consists of two standards, and includes crosshead guides and main crank shaft bearings, the latter being lined with best anti-friction metal.

CRANK SHAFT is of best open hearth steel casting in one piece.

GEARING is machine cut, and is double in size 6 x 8 for 300 pounds pressure and larger sizes; smaller sizes made with double gearing at extra price.

PINION SHAFT is of steel, running in boxes lined with best anti-friction metal and bolted to main housings.

CONNECTING RODS have bronze boxes with wedge and screw adjustment at the crosshead end, and marine type babbitted boxes at the crank end.

CROSSHEADS run in bored guides, and have bronze shoes adjustable for wear.

PLUNGERS are of hard close-grained cast iron, finished true and smooth, and reciprocate through deep stuffing boxes.

CYLINDERS and base are in one casting in sizes 8 x 10 and smaller, and in larger sizes are in three separate castings bolted to the base.

VALVE CHAMBERS are separate from and bolted to the cylinders. They are of liberal proportion, affording large valve area, and all valves are readily accessible.

VALVES for 300 pounds pressure or less are of special composition rubber with bronze seats of the grid type, unless specified otherwise. For higher pressure, valves are of bronze.

AIR CHAMBER supplied with pumps. Vacuum Chamber to order.

GREASE CUPS, or Oil Cups if specified, and wrenches furnished with pump.

SPECIAL CONSTRUCTION: Solid bronze plungers, bronze lined stuffing boxes and glands rawhide pinions, or other variations from standard construction, at extra price.

For different Types of Drive for pumps direct connected with electric motor, gas engine, or other motive power, see pages 155 to 162, inclusive.

Fig. 52, Standard Sizes, Capacities, Etc.

PLUNGERS		CAPACITY				DIAM. OF PIPES		Gear Ratio	*Tight and Loose Pulleys	Cipher
Diam. Inches	Stroke Inches	Gallons per Rev.	Usual Revs. per Min.	Gallons per Min.	Maximum Working Pressure Pounds	Suction Inches	Dischg. Inches			
3	6	.55	50	27.5	400	2½	2	5 to 1	24 x 5	OULONG
3½	6	.75	50	37.5	300	2½	2	5 to 1	24 x 5	OUPHE
4	6	.98	50	49.0	230	2½	2	5 to 1	24 x 5	OUPHEN
4	8	1.30	45	58.5	325	3	2½	5 to 1	28 x 6	OURETIC
6	8	2.93	45	131.	250	5	4	5 to 1	30 x 8	OUSEL
6	8	2.93	45	131.	300	5	4	5 to 1	36 x 8	OUST
6½	8	3.44	45	155.	260	5	4	5 to 1	36 x 8	OUTLOOK
7	8	4.00	45	180.	220	5	4	5 to 1	36 x 8	OUSTED
7	10	5.00	42	210.	300	6	5	5 to 1	42 x 10	OUSTING
8	10	6.52	42	273.	220	6	5	5 to 1	42 x 10	OUSTER
8	12	7.83	40	313.	340	8	7	5 to 1	48 x 14	OUTING
9	12	9.91	40	396.	275	8	7	5 to 1	48 x 14	OUTER
10	12	12.24	40	489.	225	8	7	5 to 1	48 x 14	OUTERLY

*Sizes 7 x 10 and larger are furnished with tight pulley only.



Deming Single-Acting Triplex Plunger Pump

Fig. 52, for Heavy Duty

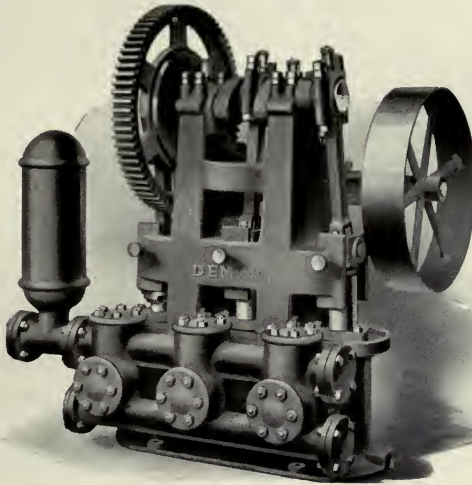

Fig. 52, Size 4 x 8

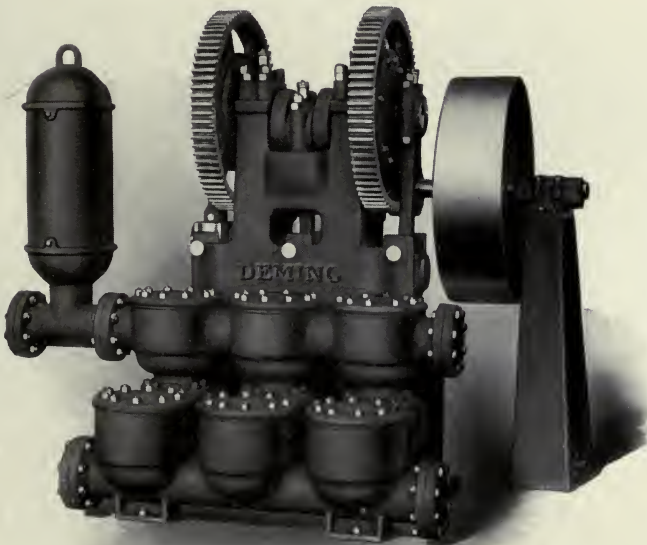

Fig. 52, Size 6 1/2 x 8



Deming Single-Acting Triplex Plunger Pump

Fig. 48

Especially designed for pumping into open or compression tanks in apartment houses, residences, office buildings, or wherever quietness of operation is essential. These pumps have unusually large valve area, which permits operating at much higher speeds than is the usual practice with geared pumps, resulting in much greater capacity for the space occupied.

FRAME consists of three standards, which include the crosshead guides and the main crank shaft bearings, the latter being lined with best anti-friction metal.

CRANK SHAFT is of best open hearth steel in one piece, and extended to receive driving pulley.

CONNECTING RODS, in sizes 4 x 6 and larger, have bronze boxes with wedge and screw adjustment at the crosshead ends, and marine type babbitted boxes at the crank end. Smaller sizes have bronze bushings at crosshead end.

CROSSHEADS run in bored guides, and sizes 4 x 6 and larger have bronze shoes adjustable for wear.

PLUNGERS are of close grained cast iron, finished true and smooth, and reciprocate through packing of ample depth.

CYLINDERS in sizes 5 x 6 and smaller are integral with the main guide frame.

VALVE CHAMBERS in sizes 3½ x 4 and larger are separate castings bolted to the cylinders. All valves are readily accessible.

VALVES for cold water are rubber discs protected on top from cylindrically wound springs by brass plates. Bronze or hard rubber valves furnished for hot water when specified.

VALVE SEATS are of bronze, and in sizes 2 x 2 and larger are of grid type, screwed into the decks.

GREASE CUPS, or Oil Cups if preferred, and wrenches furnished with all pumps, also air chamber if specified. Vacuum Chamber to order at extra price.

SPECIALS: Pumps furnished with brass cased plungers, or solid bronze plungers, and bronze lined stuffing boxes and glands at extra price.

For different Types of Drive for Fig. 48 pumps in connection with electric motor and gas engine, see opposite page.

Fig. 48, Standard Sizes, Capacities, Etc.

PLUNGERS		CAPACITY			Maximum Working Pressure Pounds	DIAM. OF PIPES		*Pulley	Cipher
Diam. Inches	Stroke Inches	Gallons per Rev.	Usual Revs. per Min.	Gallons per Min.		Suction Inches	Discharge Inches		
1½	1½	.034	140	4.8	100	1¼	1	16 x 3	OXPECK
2	2	.081	120	9.7	100	2	1½	24 x 3	OXALITE
2½	2	.127	120	15.2	100	2	1½	30 x 3	OXAMIDE
3	3	.191	110	21.0	100	2½	2	36 x 3	OXIDATE
3½	3	.275	110	30.2	100	2½	2	42 x 3	OXIDATION
3½	3	.375	110	41.2	100	2½	2	48 x 3	OXIDATOR
3½	4	.499	95	47.4	100	3	2½	42 x 4	OXIODIC
4	4	.65	95	61.7	100	3	2½	48 x 4	OXONIAN
4	6	.98	85	83.3	100	3½	3	48 x 5	OXEN
4½	6	1.24	85	105.4	100	3½	3	48 x 5	OXBOW
5	6	1.53	85	130.0	100	3½	3	48 x 6	OXEYED
5½	8	2.46	75	184.5	100	5	4	54 x 8	OXPITH
6	8	2.94	75	220.5	100	5	4	60 x 8	OXYTONE
7	8	4.00	75	300.0	100	6	5	60 x 10	OXIDABLE

*Pumps regularly furnished with tight pulley only; loose pulley at extra price.



Deming Single-Acting Triplex Plunger Pump

Fig. 48



Fig. 48, Sizes 2 x 2 to 3 1/2 x 3

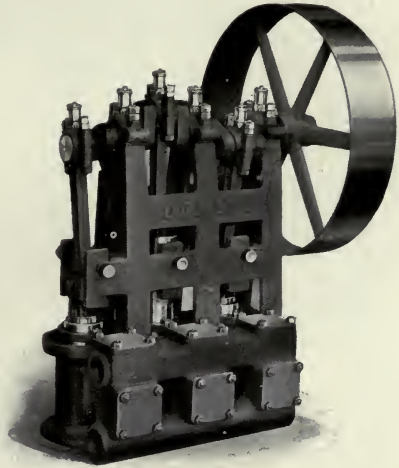

Fig. 48, Sizes 3 1/2 x 4 to 5 x 6



Fig. 48, Sizes 2 x 2 to 3 1/2 x 3 with Type "C" Drive

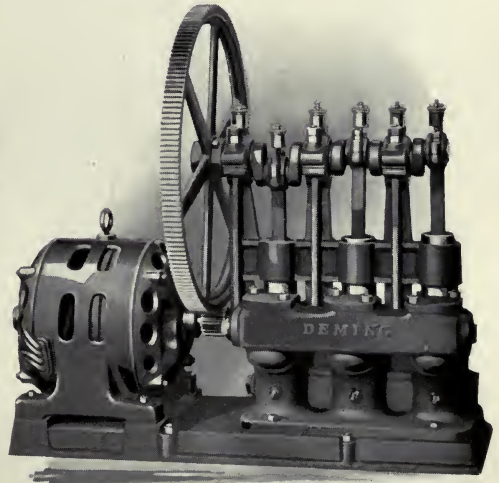

Fig. 48, Sizes 2 x 2 to 3 1/2 x 3, with Type "B" Drive

Type "C" Drive (Cipher, TYPEC) includes cast-iron bedplate under pump and motor, with connection by short belt and spring belt tightener. Very desirable outfit where limited space is available for installation and quietness in operation is essential.

Type "B" Drive (Cipher, TYPEB) includes cast-iron bedplate on which both pump and motor are mounted with connection by gear and rawhide, or fibre, motor pinion. Recommended where space for installation is limited and some noise due to gearing is not objectionable.

Alphabetical Index, Figure Index and Telegraph Cipher Code, Pages 249 to 254



Types "C" and "D" Drives for Deming Geared Power Pumps

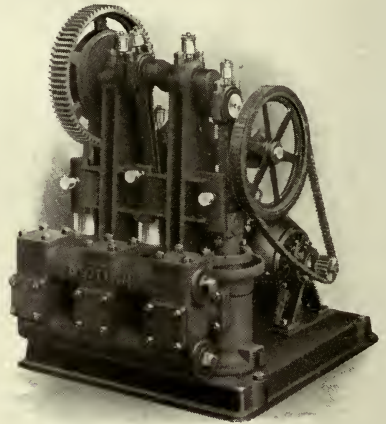
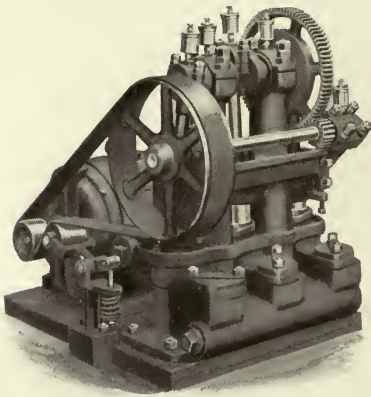

Fig. 50, Sizes 2 x 2 to 3½ x 3 with Type "C" Drive] Fig. 40, Sizes 4 x 6 to 5½ x 6 with Type "D" Drive

Type "C" Drive (Cipher, TYPEC) consists of bedplate under pump and motor, with connection by short belt and spring belt tightener. Recommended where limited space is available and quiet running is essential. With rawhide pump pinion, practically all noise is eliminated.

Type "D" Drive (Cipher, TYPE D) consists of bedplate under pump and motor in smaller sizes, and motor bed plate bolted to pump bed plate in larger sizes, with motor connected to pump by silent chain drive. More quiet in operation than the geared drive and occupies small space.

Type "K" Drive for Deming Geared Power Pumps

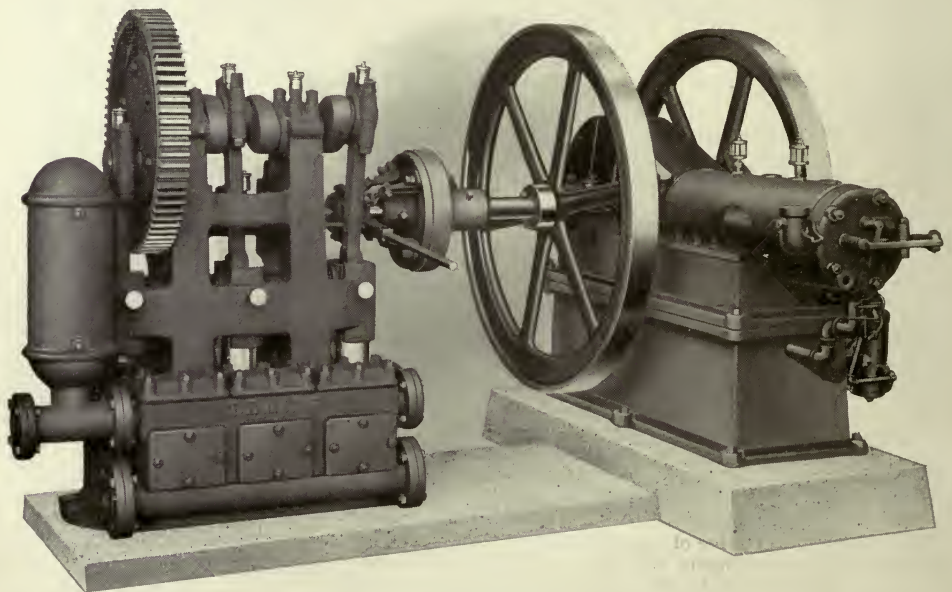

Fig. 50, Size 5½ x 8 with Type "K" Drive

Type "K" Drive (Cipher, TYPEK) furnished with friction cut-off coupling for direct connecting to gas engine on masonry or other foundations. No bedplate furnished.

Complete Table of Contents and General Classification of Pumps, Pages 7 and 8



HORIZONTAL DOUBLE - ACTING POWER PUMPS

FOR

VARIOUS DUTIES

DOUBLE-ACTING POWER PUMPS
OPERATED FROM ANY POWER
SOURCE FOR MINE PUMPING,
CONTRACTORS' USE, WATER
TANK SERVICE IN FACTORIES
AND MILLS, PNEUMATIC TANK
SERVICE, ETC.



SEPARATE BULLETINS

Descriptive of our complete line of horizontal power pumps and comprising many different types and sizes, will be sent upon request. However, to give a general idea of the appearance and construction of these pumps, a few representative types are listed in this section of the Catalogue.



Deming "Atlas" Double-Acting Power Piston Pump

Fig. 691

For Hydro-Pneumatic Water Systems and
General Water Supply

Especially Adapted to Hydro-Pneumatic Service

The "Atlas" Pump is regularly fitted with an air-charging device for supplying air to pneumatic tank for hydro-pneumatic water supply. If the pump is to be placed lower than the source of supply, we recommend that it be fitted with air compressor (see illustration at bottom of opposite page); but if water supply is located at a lower level than the pump, the regular air-charging device will be entirely satisfactory.

Suited for Long Distance Pumping

The "Atlas" Pump is DOUBLE-ACTING and discharges water at each stroke of the pump. It will lift water vertically by suction, a distance of 25 feet or less.

It will draw water horizontally from 200 to 300 feet; will force it vertically 150 feet; and will also force water horizontally for two or three miles, provided the discharge pipe is large enough to prevent excessive friction. With a 1¼-inch discharge pipe the "Atlas" Pump can usually be depended upon to force water horizontally for approximately one mile. However, for hydro-pneumatic service, the pump should be placed as near the tank as possible. The "Atlas" is built for 75 pounds maximum pressure.

Smallest Size Easy to Operate With Hand Attachment

The "Atlas" may be operated by gasoline engine or electric motor. The 2¼ x 5-inch size will be fitted with hand attachment when specified. This is often done as a precaution against failure of engine or motor. When operated by hand the "Atlas" works no harder than the ordinary hand tank pump.

Suction and Discharge Valves Easy to Reach

Each of the two valve chambers contains one set of discharge and suction valves. To gain access to these valves, remove the three cap screws from each of the valve chamber covers. The opening thus made is plenty large enough to admit inserting the hand for withdrawal of one set of the discharge valves. A set of suction valves is located directly under the discharge valves in each valve chamber. These suction valves may be withdrawn through the same opening as the discharge valves.

Other Points of Advantage

Cylinder is brass lined. On the two larger sizes the liner may be easily removed. All bearings are babbitted, insuring long life and minimum friction. Gears are fully enclosed by cast iron gear guard. Cylinder and valve decks are cast in one piece. They cannot pull apart.

Crank end of connecting rod has adjustable boxes which permits taking up of all wear. Valves are metal, faced with rubber, and have BRASS VALVE SEATS. Oil pockets and grease cups insure thorough lubrication.

The "Atlas" is made in three sizes, 2¼ x 5, 3 x 6, and 4 x 8, with capacities of 600, 1200 and 2400 gallons per hour respectively. "Atlas" Pumps are painted "Quaker Gray" and trimmed in gold.

Shipping weights are as follows: 2¼ x 5—140 lbs. 3 x 6—275 lbs. 4 x 8—350 lbs.

For Types of Drives, Capacities, Sizes, Prices, Etc., of Fig. 691, see Pages 170 and 171.

Complete Table of Contents and General Classification of Pumps, Pages 7 and 8



Deming "Atlas" Double-Acting Power Pump

For Wells and Cisterns 25 Feet Deep or Less

Fig. 691

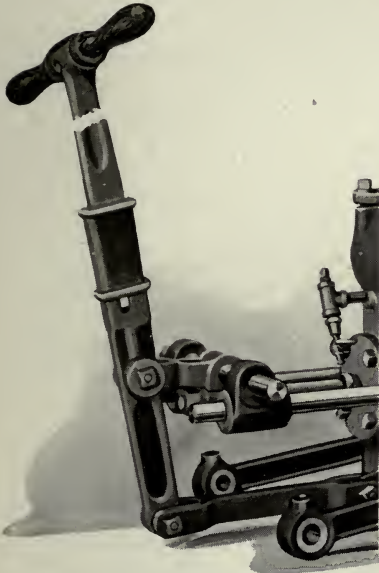

Hand Lever Attachment for Fig. 691.
Furnished on the $2\frac{1}{4}$ x 5 size only

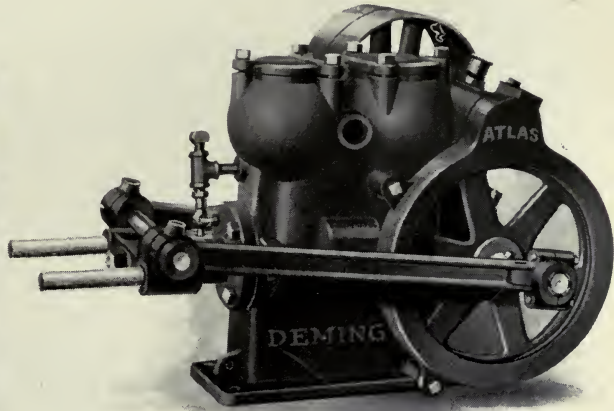

Fig. 691, with Tight and Loose Pulleys, also Air Charging Device

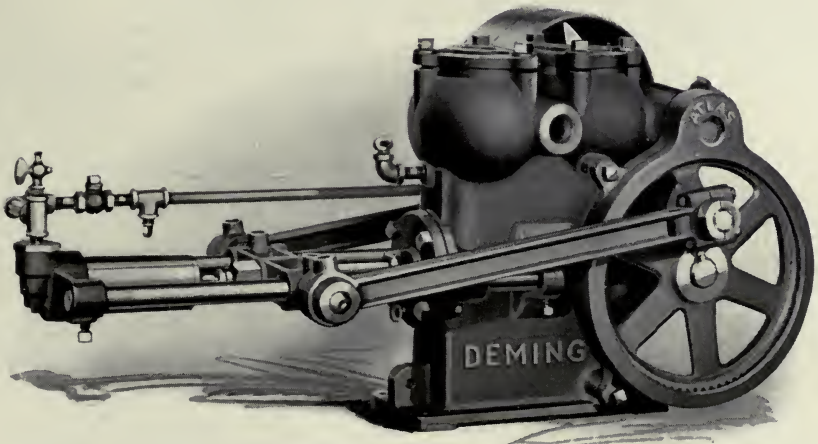

Fig. 691, with Air Compressor

Alphabetical Index, Figure Index and Telegraph Cipher Code, Pages 249 to 254



Deming "Atlas" Double-Acting Power Pump

For Wells and Cisterns 25 Feet Deep or Less

Fig. 691

(Continued from two preceding pages)

A few of the reasons for the popularity of the "Atlas" pump are mentioned on page 164. Further specifications, also list prices, descriptions and illustrations of various types of drives, will be found on this and the opposite page.

Complete hydro-pneumatic systems in which the "Atlas" pump is used are illustrated and described on pages 192 and 193.

A SPECIAL AIR COMPRESSOR will be supplied (see illustration at bottom of page 165) when desired, at extra price, as listed below.

Type "B" Drive (Cipher, "TYPEB"). Includes cast iron sub-base, intermediate gear and rawhide pinion for connecting electric motor.

Type "C" Drive (Cipher, "TYPEC"). Same as Type "CI" Drive with addition of cast iron sub-base under pump and motor. Belt is included. Motor furnished at extra price.

Type "CI" Drive (Cipher, "TYPECI"). Includes tight pulley, 20 inches diameter or smaller, with belt tightener of gravity type for driving by electric motor or gas engine with short belt pulley centers. Larger diameter pulley supplied at extra price. Belt is not included.

Type "G" Drive (Cipher, "TYPEG"). Includes a horizontal or vertical water-cooled, or a vertical air-cooled, gasoline engine mounted on a cast iron sub-base with pump and connected by gearing. See below for prices of outfits with different styles of engines.

HAND OPERATION: Size 2½ x 5 is furnished, when desired, with lever, link and attachments as illustrated, for operating by hand in case of emergency. (Cipher, "HANDOP.")

Capacities, Sizes, Prices, Etc.

PISTONS		Revs. per Minute	Gallons per Min. at Maximum Speed	Maximum Working Pressure Pounds	DIAMETER OF PIPES		Tight and Loose Pulleys	*Cipher	PRICES		
Diam. Inches	Stroke Inches				Suction Inches	Discharge Inches			With Standard Pulleys	Extra for Hand Operating Attachment	Extra for Air Compressor
2½	5	60	9.6	75	1½	1	8 x 2½	FLAUNT	\$ 60.00	\$6.00	\$15.00
3	6	55	19.2	75	2	1½	14 x 3	FLAG	165.00	18.00
4	8	50	42.5	75	2½	2	16 x 4	FLAGGING	200.00	22.50

PISTONS		PRICES CONTINUED							
Diam. Inches	Stroke Inches	MOTOR OR ENGINE NOT INCLUDED				WITH "G" DRIVE — ENGINE INCLUDED			
		With "B" Drive	With "C" Drive	With "CI" Drive	With "G" Drive	Prices on Application			
2½	5	\$115.00	\$105.00	\$ 68.00	\$120.00				
3	6	245.00	235.00	185.00	250.00				
4	8	330.00	320.00	245.00	335.00				

*When telegraphing with reference to either of the types of drive, place the cipher word representing the type of drive immediately following the cipher word for the standard pump.

Complete Table of Contents and General Classification of Pumps, Pages 7 and 8



Deming Types of Drives for "Atlas" Double-Acting Power Piston Pump

Fig. 691

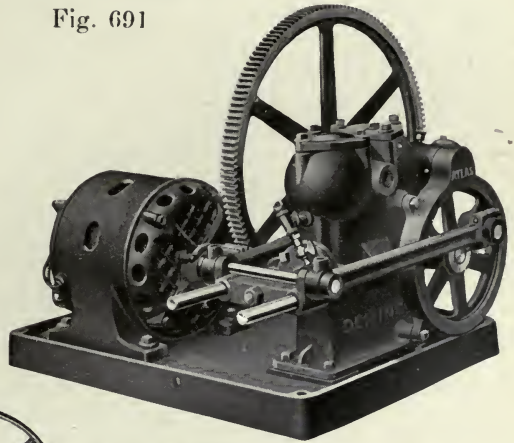

Fig. 691, with Type "B" Drive and Electric Motor

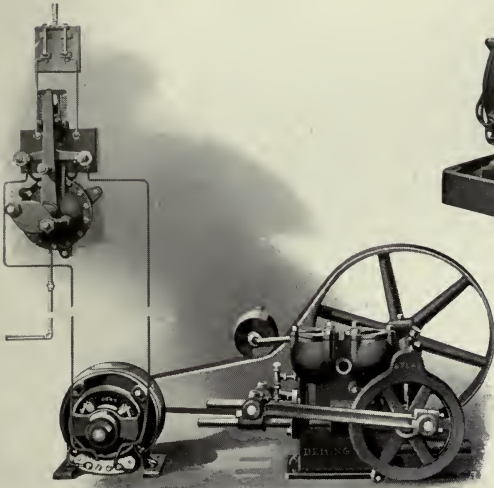

Fig. 691, with Type "CI" Drive, also Motor and Automatic Control

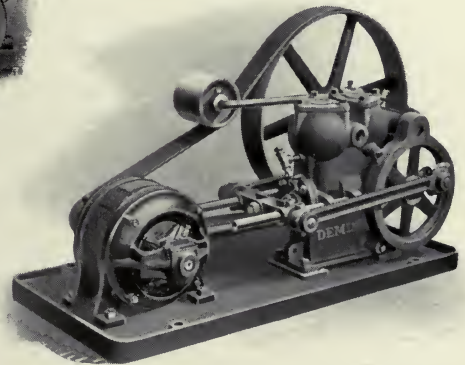

Fig. 691, with Type "C" Drive and Motor

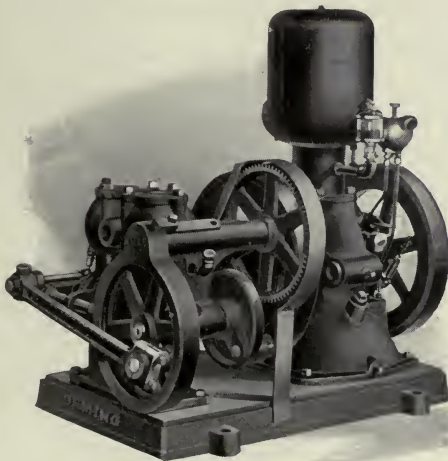

Fig. 691, with Type "G" Drive and Water-Cooled Vertical Engine

Engineering Tables and Information Relating to Hydraulics, Pages 239 to 248



Deming Double-Acting Power Pump
 With Attachment for Pumping Air
 Fig. 708

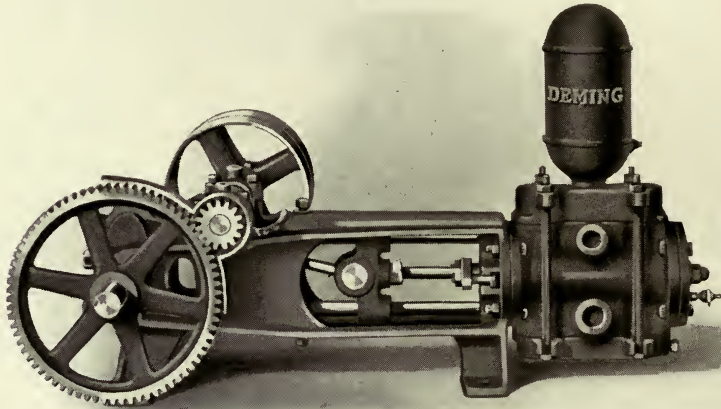

Fig. 708 is a double-acting power pump, made in three sizes, and good for pumping against pressures up to 200 pounds, which makes it an admirable pump for contractor's service and hydro-pneumatic water supply systems.

It is adapted for a suction lift of 24 feet or less.

Any available power may be used to drive the pump, such as gasoline engine, electric motor, etc. Air chamber has ample capacity.

There are no air pockets in this pump so it cannot become "air bound."

CYLINDER is reversible, so suction and discharge pipes may be arranged for either side. CYLINDER LINER: Brass and removable.

PISTON PACKING: Special fibrous cup packing.

SUCTION VALVE DECK is removable, to give access to suction valves.

GEARS: Ratio 5 to 1. Machine-cut from the solid; not cast teeth.

PULLEYS: See list below.

VALVES: Brass balls; are accessible without interference with the piping.

VALVE SEATS are cast bronze, and removable.

PISTON ROD: Cannot buckle or get out of line as it is double rod guided.

Type "B" is used to indicate direct connected motor drive.

Type "CI" Drive: Includes tight pulley, as follows: No. 1, 8 x 4; No. 2, 16 x 4; No. 3, 16 x 4. With belt tightener of the gravity type. Pulleys of different diameters furnished at extra price.

Dimensions

No.	Height Inches	Length Inches	Width Inches
1	25	36	15
2	33	40	18
3	33	40	18

Capacities, Sizes, Prices, Etc.

PISTON		Rev-olutions per Minute	Capacity per Minute at Maximum Speed	Maximum Working Pressure in Pounds	DIAMETER OF PIPES		Gear Ratio	Tight and Loose Pulley	Wgt.	PRICE			*Cipher
Diam. Inches	Stroke Inches				Suction Inches	Dis-charge Inches				With Tight and Loose Pulley	With "CI" Drive	Extra for Type "B" Drive	
2	5	60	8.16	200	1	¾	5 to 1	14 x 3	150	\$ 60.00	\$ 62.00	\$50.00	FRIEZE
2½	5	60	12.78	200	1¼	1	5 to 1	16 x 4	230	90.00	93.00	60.00	FRIEZER
3	5	60	18.36	200	1½	1¼	5 to 1	16 x 4	250	110.00	114.00	65.00	FRIEZED

*In telegraphing, if motor drive is wanted, add "TYPEB" to cipher word. If "CI" drive is desired, add "TYPECI" to cipher word.

Complete Table of Contents and General Classification of Pumps, Pages 7 and 8



Deming Horizontal Double-Acting Piston Pump
 For Heavy Duty
 Fig. 1696

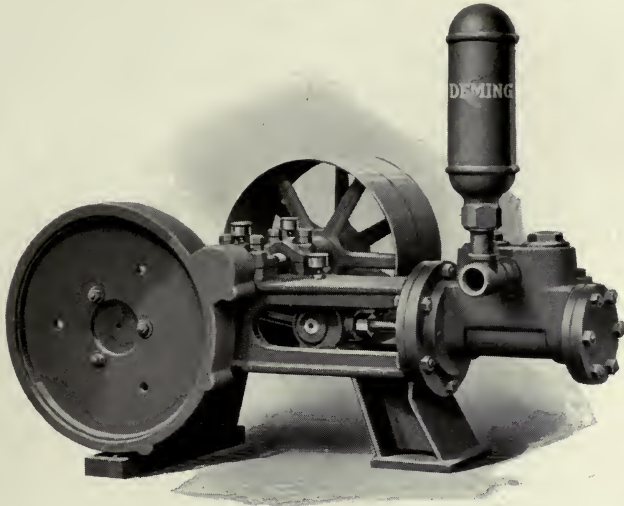

FIG. 1696 is especially recommended for pumping oils and other liquids where a pump for high pressure is required.

MAIN FRAME is of heavy box type, and includes bored crosshead guide and babbitt-lined shaft bearings.

CYLINDER is of cast iron fitted with spring ring piston.

CRANK SHAFT is of best open hearth steel casting, accurately machined.

GEARING is machine-cut from the solid and entirely enclosed in substantial gear guard.

CONNECTING ROD has babbitt-lined adjustable bearing at the crank end and bronze bushing at the crosshead end.

CROSSHEAD reciprocates through a bored guide and has shoes adjustable for wear.

PISTON is of cast iron with spring ring packing.

PISTON ROD is of steel working through deep stuffing box with bolted gland.

VALVES are bronze balls on bronze seats screwed into the decks and are easily accessible.

STANDARD CONSTRUCTION includes tight and loose pulleys, grease cups and companion pipe flanges of sizes listed.

Type "B" Drive (Cipher, TYPEB) for connecting to an electric motor, includes a substantial cast-iron sub-base under pump and motor, with an intermediate gear and rawhide motor pinion for connecting motor to pump. See illustration of Fig. 716 Type "B" Drive, page 173.

Sizes, Prices, Etc.

PISTON		Capacity per Revol'ns Gallons	Revol'ns per Minute	Capacity per Min. at Max. Speed Gallons	Max. Working Pressure Pounds	DIAMETER OF PIPES		Gear Ratio	Tight and Loose Pulleys Inches	*Cipher
Diam. Inches	Stroke Inches					Suction Inches	Disch'ge Inches			
3	6	.368	45 to 55	20	300	1½	1½	6 to 1	18x4	FLAWLESS

*When telegraphing with reference to Type "B" Drive, place cipher word "TYPEB" immediately following cipher word for the standard belt-driven pump.

Alphabetical Index, Figure Index and Telegraph Cipher Code, Pages 249 to 254



Deming "Triumph" Double-Acting Piston Pump

Fig. 609, for Medium Service

Fig. 609 "TRIUMPH" Piston Pump has been on the market for many years, and has gained great popularity as a gathering pump in mines where a pump of but small capacity is required. It is also well adapted to use in circulating brine, tank supply and boiler feeding where pressures do not exceed the ratings below.

The pump cylinder is securely bolted to a substantial bed plate, and the crank shaft, rod guide, yoke and pitman are so arranged as to keep all parts in perfect alignment. All standard pumps have piston with hydraulic cup packing, tight and loose pulleys, cut gearing and babbitted bearings. The piston rod, stuffing box, valves and valve seats are made of brass, and cylinders are brass lined except in "bronze cylinder" and "all bronze" pumps.

Modification of standard construction to suit special requirements can be made at extra price.

Fig. 609 with Type "B" Drive (Cipher, "TYPEB") is the standard pump without pulleys, but with sub-base and gearing connection for electric motor, as illustrated on opposite page.

NOTE. Fig. 609 can also be furnished mounted on portable truck with motor.

Fig. 609, Sizes, Capacities, Etc.

PISTONS		CAPACITY			Maximum Working Pressure Pounds	DIAM. OF PIPES		Gear Ratio	Tight and Loose Pulleys	Height with Type "B" Drive Inches
Diam. Inches	Stroke Inches	Gallons per Rev.	Usual Revs. per Min.	Gallons per Min.		Suction Inches	Dis-charge Inches			
2½	4½	.19	40	7.6	100	1¼	1¼	3 to 1	16 x 4	31
3	4½	.27	40	10.8	80	1½	1¼	3 to 1	16 x 4	31½
4	4½	.48	40	19.2	65	2	1½	3 to 1	16 x 4	33
5	4½	.76	40	30.4	50	2½	2	3 to 1	16 x 4	34½

List Prices of Standard Pump

PISTONS		BRASS LINED		*BRONZE CYL. AND PISTON		*ALL BRONZE		†Extra for Type "B" Drive
Diam. Inches	Stroke Inches	Cipher	Price	Cipher	Price	Cipher	Price	
2½	4½	FATE	\$185.00	FATHERLY	\$245.00	FATLING	\$275.00	\$105.00
3	4½	FATAL	190.00	FATHOM	255.00	FATNER	300.00	105.00
4	4½	FATALITY	195.00	FATIGUE	275.00	FATNESS	330.00	115.00
5	4½	FATEFUL	200.00	FATTY	330.00	FATLY	390.00	115.00

*Pumps with "Brass Cylinder and Piston" also have brass cylinder and valve decks, while "All Brass" pumps have all parts which come in contact with the water made of brass.

†When telegraphing with reference to Type "B" Drive, place cipher word "TYPEB" immediately following the cipher word for the standard pump.

Complete Table of Contents and General Classification of Pumps, Pages 7 and 8



Deming "Triumph" Double-Acting Piston Pump

Fig. 609, for Medium Service

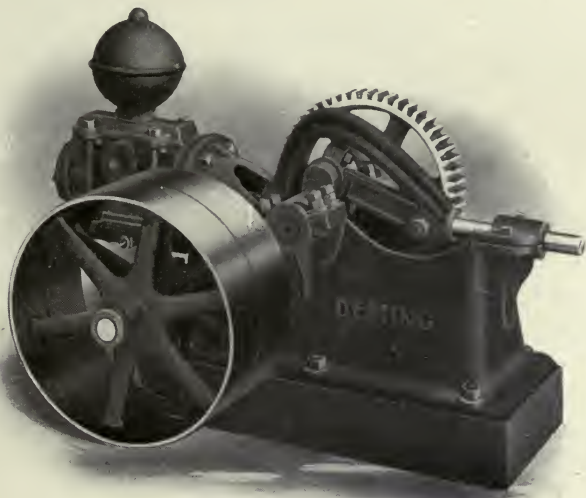

Fig. 609, All Sizes

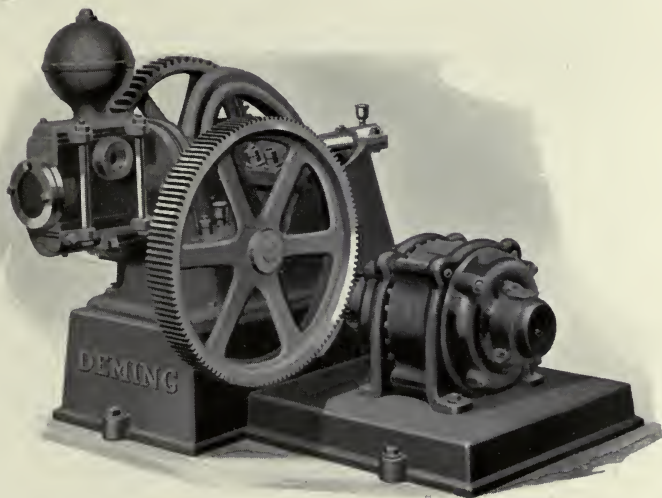

Fig. 609 with Type "B" Drive



Deming "Ajax" Double-Acting Piston Pump Fig. 716, for Medium Service

Fig. 716 is especially recommended as a gathering pump and for other use in mines where the maximum discharge pressure does not exceed that for which it is rated. It is also a very desirable pump for brine circulation and for tank supply for factories, railway water stations, etc.

MAIN FRAME is of heavy box type, and includes bored crosshead guide and babbitt-lined shaft bearings.

CYLINDER is of cast iron with cast bronze liner, and contains the valves which are readily accessible without disturbing pipe connections.

CRANK SHAFT is of best open hearth annealed steel casting, accurately machined.

GEARING is machine cut from the solid.

CONNECTING ROD has babbitt-lined adjustable bearing at the crank end, and bronze bushing at the crosshead end.

CROSSHEAD reciprocates through a bored guide, and has shoes adjustable for wear.

PISTON is fibrous packed.

PISTON ROD is of bronze working through deep stuffing box, with bolted gland.

VALVES are of rubber, on bronze grid seats, which are screwed into the decks.

STANDARD CONSTRUCTION includes tight and loose pulleys, grease cups, wrenches and companion pipe flanges of sizes listed. Modifications of standard construction furnished at extra price.

TYPE "B" DRIVE (Cipher, "TYPEB") for connecting an electric motor includes a substantial cast iron sub-base under pump and motor, with an intermediate gear and rawhide pinion for connecting motor to the pump as illustrated.

NOTE. The 5 and 6-inch stroke pumps can also be furnished mounted on portable truck with motor.

TYPE "BA" DRIVE (Cipher, "TYPEBA") includes an intermediate gear and rawhide pinion for connecting an electric motor, the main frame being altered on top to permit mounting the motor thereon. This drive is only furnished with 10-inch stroke sizes and only for motors having frames of comparatively small dimensions.

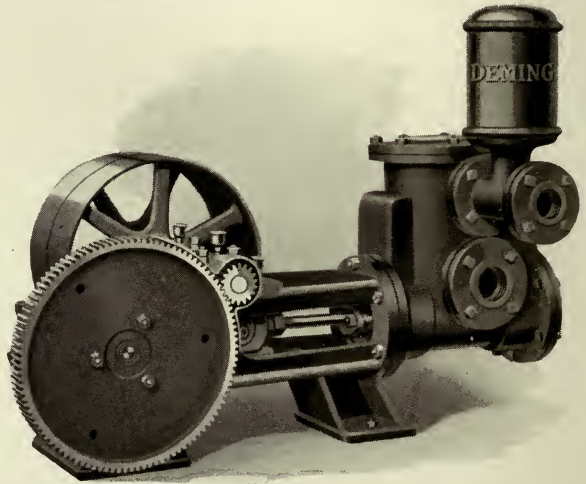

Fig. 716, All Sizes

Fig. 716, Sizes, Capacities, Etc.

PISTONS		Cap. per Rev. Gal.	Revol'ns per Minute	Capacity per Minute at Maximum Speed Gallons	Maximum Working Pressure Pounds	DIAM. OF PIPES		Gear Ratio	Tight and Loose Pulleys	Height with Type "B" Drive Inches	*Cipher
Diam. Inches	Stroke Inches					Suc'n Inches	Dis-charge Inches				
4	5	.534	50 to 60	31.04	75	2	2	6 to 1	14 x 3	35	FLATIVE
5	5	.833	50 to 60	49.98	75	2½	2	6 to 1	16 x 4	35½	FLATLING
5	6	1.000	45 to 55	55.00	75	3	2½	6 to 1	18 x 4	39½	FLATLY
6	6	1.448	45 to 55	79.64	75	3	2½	6 to 1	20 x 5	37½	FLATNESS
6	10	2.395	40 to 50	119.75	75	4	3	6 to 1	24 x 5	46	FLATTEN
7	10	3.279	40 to 50	163.95	75	5	4	6 to 1	28 x 5	56	FLATTERV
8	10	4.275	40 to 50	213.75	75	6	5	6 to 1	30 x 6	57	FLATTERER

*When telegraphing with reference to type "B" or "BA" Drive, place Cipher word "TYPEB" or "TYPEBA," respectively, immediately following the cipher word for the standard belt-driven pump.

Complete Table of Contents and General Classification of Pumps, Pages 7 and 8



Deming "Ajax" Double-Acting Piston Pump

Fig. 716, with Types "B" and "BA" Drives

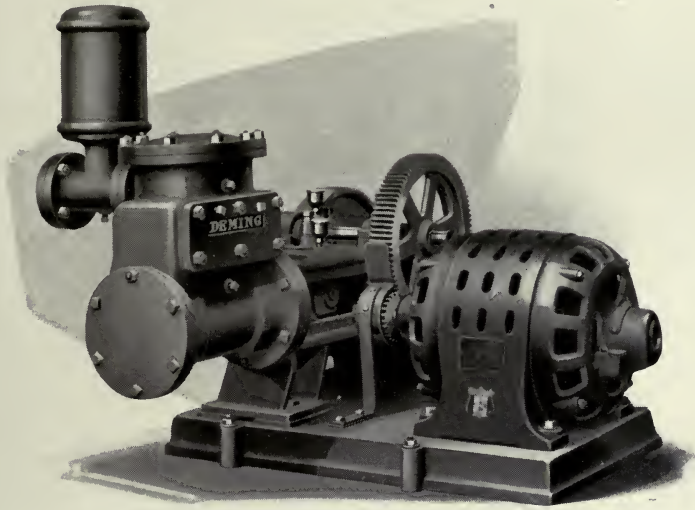

Fig. 716 with Type "B" Drive

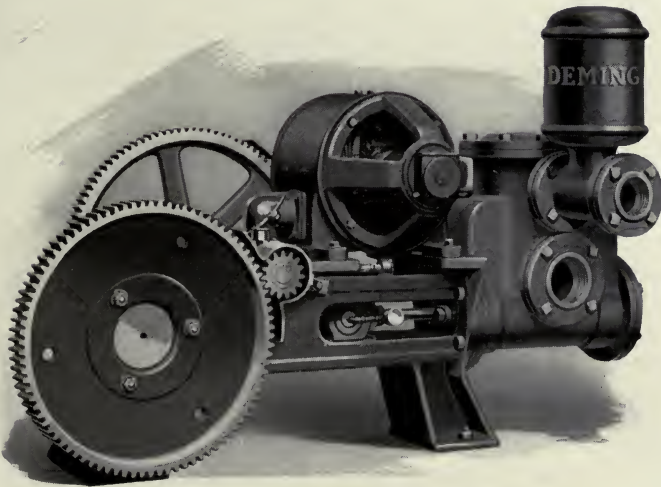

Fig. 716 with Type "BA" Drive



Deming "Neptune" Double-Acting Piston Pump
Fig. 696, for Medium Service

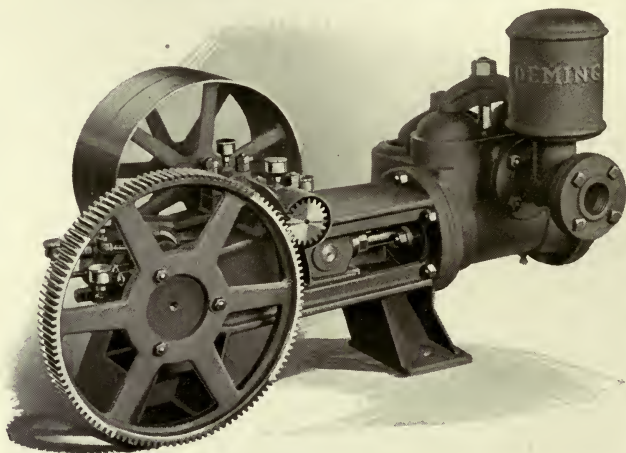

Fig. 696, All Sizes

Fig. 696 differs from our other types of horizontal piston pumps in that all valves are quickly accessible from the top by loosening two nuts. This is especially desirable in handling mine water where small particles of coal or other foreign substances are liable to clog the valves. This pump is also well suited for brine pumping and general water supply where pressure does not exceed 75 pounds.

MAIN FRAME is of heavy box type, and includes bored crosshead guide and babbitt-lined shaft bearings.

CYLINDER is of cast iron with cast bronze liner, and contains all valves.

CRANK SHAFT is of best open hearth annealed steel casting, accurately machined.

GEARING is machine cut from the solid.

CONNECTING ROD has babbitt-lined, divided bearing at the crank end and bronze bushing at the crosshead end.

CROSSHEAD reciprocates through a bored guide, and has shoes adjustable for wear.

PISTON is fibrous packed.

PISTON ROD is of bronze working through deep stuffing box, with bolted gland.

VALVES are of rubber, on bronze grid seats, which are screwed into the decks.

STANDARD CONSTRUCTION includes tight and loose pulleys, grease cups, wrenches and companion pipe flanges of sizes listed. Modifications of standard construction furnished at extra price.

Types "B" and "BA" Drives

Fig. 696 is furnished with Type "B" Drive in all sizes the same as Fig. 716, and with Type "BA" Drive in size 6 x 10 only. See illustration and description on pages 172 and 173.

NOTE. The 5 and 6-inch stroke pumps can be furnished on portable truck with motor.

Fig. 696, Sizes, Capacities, Etc.

PISTONS		Cap. per Rev. Inches	Revol'n's per Minute	Capacity per Min. at Maximum Speed Gallons	Maximum Working Pressure Pounds	DIAM. OF PIPES		Gear Ratio	Tight and Loose Pulleys	Height with Type "B" Drive Inches	*Cipher
Diam. Inches	Stroke Inches					Suction Inches	Discharge Inches				
5	5	.833	50 to 60	49.98	75	2	2	6 to 1	16 x 4	29½	FRILL
6	6	1.448	45 to 55	79.64	75	3	2½	6 to 1	20 x 5	34	FRILLED
6	10	2.395	40 to 50	119.75	75	4	3	6 to 1	24 x 5	40	FRILLING

*When telegraphing with reference to type "B" or "BA" Drive, place the cipher word "TYPEB" or "TYPEBA," respectively, immediately following the cipher word for the standard belt-driven pump.

Complete Table of Contents and General Classification of Pumps, Pages 7 and 8



DEEP WELL WORKING HEADS

FOR

SPECIAL WATER SUPPLY

EMBRACING VARIOUS TYPES OF
POWER WORKING HEADS FOR
USE WITH DEMING BRASS ARTE-
SIAN WELL AND OTHER TYPES
OF CYLINDERS; ADAPTED FOR
OPERATION BY ELECTRIC
MOTOR, GAS, OR GASOLINE EN-
GINE, STEAM ENGINE AND
WINDMILL; USING BELT, GEAR-
ING OR CONNECTING ROD.



SEPARATE BULLETINS

Descriptive of our complete line of working heads and comprising many different types and sizes, will be sent upon request. However, to give a general idea of the appearance and construction of these pumps, a few representative types are listed in this section of the Catalogue.



Deep Well Pumping

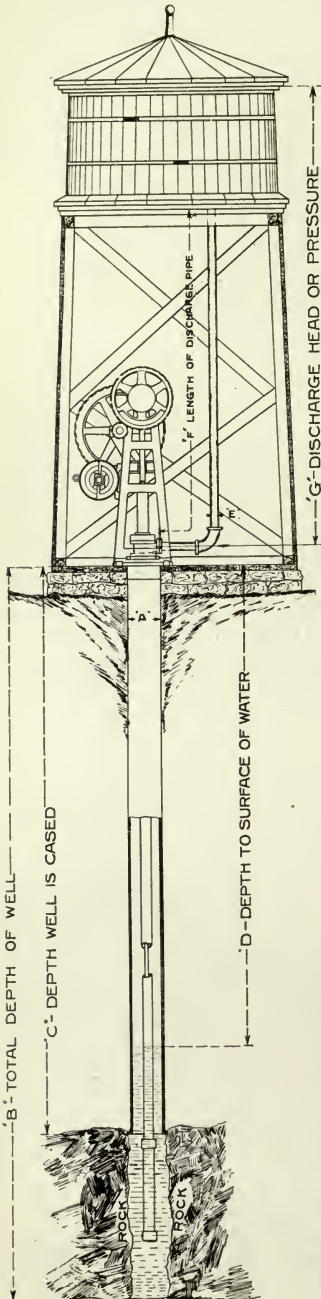

Information Desired to Enable Us to Intelligently
 Recommend the Best Style of
 Deep Well Pump

- "A" Inside diameter of well casing inches.
- "B" Total depth of well feet.
- "C" Depth well is cased feet.
- "D" Depth to surface of water feet.
- "E" Inside diameter of discharge pipe inches.
- "F" Length of discharge pipe feet.
- "G" Discharge head . . feet (or discharge pressure . . pounds per square inch).

Does water level recede when well is pumped, and how much?

What capacity in gallons per minute is wanted at discharge?

What power is available to operate pump?

If electric power is available, and price on electric motor is wanted, state whether current is direct or alternating, and if alternating, state phase and cycles.

Suggestions Concerning the Installation of Deep Well Pumps

The cylinder should be placed at such depth as to insure its being constantly submerged, and unless tests show that the water level does not recede materially it is advisable to place the cylinder near the bottom of the well.

In placing the cylinder in the well special care should be taken to make all pipe and sucker rod joints tight.

For convenience in shipping, cylinders are usually sent with the plunger and lower valve screwed together, and these must be disconnected before lowering the cylinder in the well.

We are not liable for damage done or trouble caused by sand, gravel, chips or any substance other than clear water. The well is supposed to have a straight clear bore of the size specified so that the pump parts will go into it when reasonable clearance is allowed, and also to furnish sufficient clear water to supply the pump.



Deming Deep Well Pump Heads

With Double Rod Guides and Power Attachment
For Wells 35 to 300 Feet Deep

Fig. 439

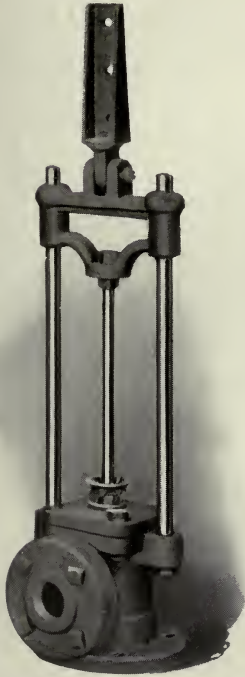
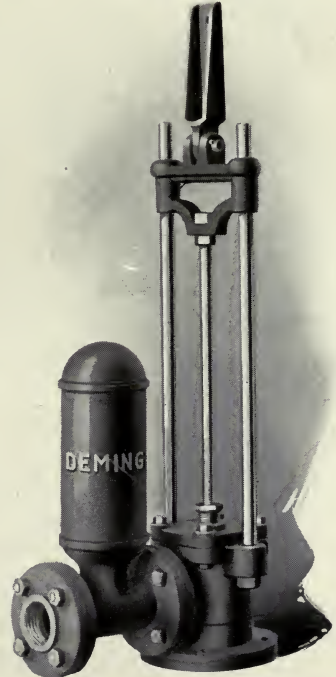

Fig. 1439



These pump heads have crossheads with babbitted bearings working on double heavy steel rod guides. The stuffing-box gland is of brass. The power attachment is hinged to the crosshead and is designed to fit wood rod of windmill, although it can be altered for other style connection when desired.

Fig. 439 has flanged base to bolt to platform or foundation, and the base is threaded for pipe that connects with cylinder. When so ordered, a separate flange threaded for drop pipe, will be furnished at additional cost.

Fig. 1439 is exactly the same as Fig. 439, but with the addition of a large flanged air chamber.

For use with Figs. 439 and 1439 pump heads, we recommend our Figs. 311 and 324 artesian well cylinders, listed elsewhere and connecting with pipe of larger diameter than the cylinder, which will permit the withdrawal of the plunger and valve by the removal of the stuffing-box flange.

Plunger rods are regularly threaded on lower end, $\frac{3}{4}$ -inch U. S. Standard, but will be threaded otherwise if so specified. In ordering always specify size of suction and discharge pipe wanted.

Sizes and Prices

Figures	Stroke Inches	Threaded for Cylinder Pipe Inches	Discharge Inches	Weight in Pounds	Cipher	Price
439	16	4½ or less	2½ or less	92	DEFACEMENT	\$20.00
439	24	4½ or less	2½ or less	95	DEFIANCE	23.00
439	30	4½ or less	2½ or less	100	DEFRAYING	25.00
1439	16	4½ or less	2½ or less	167	DEFT	30.00
1439	24	4½ or less	2½ or less	170	DEIFY	33.00
1439	30	4½ or less	2½ or less	175	DEIST	35.00

Alphabetical Index, Figure Index and Telegraph Cipher Code, Pages 249 to 254



Deming Geared Deep Well Working Head

Fig. 569



Fig. 569

Fig. 569 illustrates our Pump Standard for wells of medium depth. It has adjustable stroke (6, 8 and 10-inch) and is furnished with machine cut gearing having a ratio of three to one, and with tight and loose pulleys for operating by power. Fly wheel pulley 36 inches diameter can be furnished, if desired, in place of the tight and loose pulleys.

The illustration shows the No. 2 Pump with air chamber by which water can be forced upward through the top of the air chamber, or through the spout.

In connection with this standard we recommend the use of our Fig. 311 cylinders, or any other type of brass, brass lined or iron deep well cylinder.

In corresponding, give as fully as possible the particulars asked for on page 176, and if working head only is wanted, specify sizes of drop pipe and discharge pipe and also threads on sucker rod.

Fig. 569, Sizes, Prices, Etc.

No.	Stroke Inches	*Suction Fitted for Pipe Inches	Discharge	Gear Ratio	Tight and Loose Pulleys
1	6, 8 and 10	1¼ to 3	{ With Flange for 1¼ to 2-inch pipe { With Double Discharge Air Chamber, as illustrated { With Air Chamber and Cock	3 to 1	20 x 5
2	6, 8 and 10	1¼ to 3		3 to 1	20 x 5
3	6, 8 and 10	1¼ to 3		3 to 1	20 x 5
†Lift and Force		WITH PULLEYS		WITH FLY WHEEL	
		Cipher	Price	Cipher	Price
2¼-inch cylinder, 175 feet }		BRAVO	\$140.00	BRAVNY	\$140.00
2½-inch cylinder, 120 feet }					
3¼-inch cylinder, 80 feet }					
3¾-inch cylinder, 60 feet }					
4¼-inch cylinder, 50 feet }		BRAWL	145.00	BRAVER	145.00
		BRAWLER	150.00	BRAZEN	150.00

*Unless otherwise specified, suction is fitted for 1½-inch pipe and discharge for 1¼-inch pipe.

†From lowest surface of water in well to highest point of delivery.

Complete Table of Contents and General Classification of Pumps, Pages 7 and 8



Deming Geared Deep Well Power Working Head

For Wells 375 Feet Deep or Less

Fig. 66

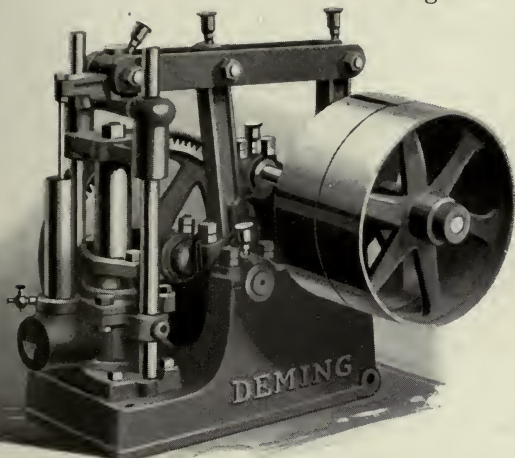

This head is adapted especially for pumping water from deep wells for suburban homes and other places requiring a moderate water supply. All parts are readily accessible.

The sucker rod and cylinder valves can be withdrawn without disturbing any pipe connections.

The standard head includes cut gearing, tight and loose pulleys and oil cups. For hydro-pneumatic service an air compressor will be supplied at extra cost. When desired, an extended walking beam and counterweight, for equalizing the plunger load, will be furnished at extra cost as listed below.

Our Figs. 311 or 324 cylinders are recommended for use with this head.

TYPE "B" DRIVE (Cipher, TYPEB) consists of a cast-iron bedplate, on which working head and electric motor are mounted, with motor direct-connected by gearing.

TYPE "CS" DRIVE (Cipher, TYPECS) consists of a cast-iron shelf hinged to the back of working head frame, the motor being mounted on the shelf and belted to the working head. Quieter in operation than Type "B" Drive.

On page 194 this head is shown in connection with a complete hydro-pneumatic water supply system.

Specifications, Prices, Capacities, Etc.

Stroke Inches	MAXIMUM DIAMETER OF PIPES		Gear Ratio	Tight and Loose Pulleys	Maximum Height Inches	Weight With Tight and Loose Pulleys Pounds	*Cipher
	Suction Inches	Discharge Inches					
6	3	1½	6 to 1	12 x 3	25	215	ORRIS
Diameter of Cylinder Inches	CAPACITY			‡Maximum Lift, Feet			
	Gallons per Rev. of Crank Shaft	Usual Revs. per Minute	Gallons per Minute				
	1¾	.063	40		2.52	375	
	2¼	.103	40		4.12	225	
	2¾	.154	40		6.16	140	
3¼	.215	40	8.60	100			
With Tight and Loose Pulleys	Without Tight and Loose Pulleys	Extra for Type "B" Drive (Motor not included)	Extra for Type "CS" Drive including Belt (Motor not included)	Extra for Extended Walking Beam and 100-Lb. Counterweight	Extra for Air Compressor Including Piping Connections		
\$70.00	\$65.00	\$35.00	\$20.00	\$15.00	\$9.00		

*When telegraphing with reference to working head with Types "B" or "CS" Drive, place cipher word "TYPEB" or "TYPECS" respectively, immediately following cipher word "ORRIS."

‡Refers to vertical distance from surface of water to point of delivery or equivalent pressure.



Deming Deep Well Power Working Head Fig. 62, with Differential Plunger

Fig. 62 is adapted especially for supplying water from deep wells for private estates, manufacturing plants, farms, etc. It is very substantially built, and the "low-down" design, as well as other features, make it the most accessible deep well pump on the market. By disconnecting the differential plunger from the crosshead and the walking beam from the connecting rod, and removing the stuffing box cap, the plunger can be readily withdrawn without disturbing the pipe connections. The stroke is adjustable, thereby permitting the easy regulation of the pump capacity to the flow of the water in the well.

The main base is of cast iron, and carries the crank and pinion shaft bearings, which are lined with best babbitt metal.

The gearing is machine cut, the main gear being bolted to a flange integral with the crank shaft.

The crosshead is babbitt lined, and the guide rods are of polished steel.

Each pump has a differential plunger which discharges part of the water on the down stroke, thus equalizing the load and giving a more uniform flow of water. The stuffing box is very easy of access for repacking, the gland being of the bolted type. Air chamber furnished at extra price.

Fig. 62 with Type "B" Drive (Cipher, ТУРВВ) is the standard pump without pulleys, but with extended base and gearing connection for electric motor.

Fig. 62 with Type "C" Drive (Cipher, ТУРЕС) is the standard pump mounted on sub-base for connection to electric motor, and including short belt and belt tightener. Adaptable to 10-inch stroke size only.

On page 196, Fig. 62 is illustrated in connection with hydro-pneumatic System No. 2018.

With these working heads we recommend using our Fig. 324 or Fig. 311 artesian well cylinders and Fig. 636 octagon wood sucker rod.

Fig. 62, Sizes, Etc.

Stroke Inches	MAXIMUM DIAMETER OF PIPES		Gear Ratio	Tight and Loose Pulleys	Maximum Height, Inches	*CIPHER Standard Pump with Pulleys
	Suction Inches	Discharge Inches				
8, 9 and 10	4½	2½	6 to 1	16 x 3	40½	ODIN
12, 14 and 16	6	3	7 to 1	20 x 5	51	ODIUM
20, 22 and 24	8	4	6¾ to 1	28 x 6	73	ODIZE

*When telegraphing with regard to the Type "B" or "C" Drive, place the cipher word representing the Type of Drive immediately following the cipher word for the standard pump.

Fig. 62, Capacities

Diam. and Stroke of Cylinder	CAPACITY			†Maximum Lift, Feet
	Gallons per Rev. of Crank Shaft	Maximum Revs. per Min.	Gallons per Min.	
2¼ x 10	.257	40	10.2	300
2¼ x 6	.411	35	14.3	300
2¼ x 24	.617	28	17.2	400
3¼ x 10	.478	40	19.1	175
3¼ x 16	.765	35	26.7	175
3¼ x 24	1.147	28	32.1	215
4¼ x 10	.614	40	24.5	130
4¼ x 16	1.227	35	42.9	100
4¼ x 24	1.841	28	51.5	135
5¼ x 16	1.798	35	62.9	70
5¼ x 24	2.696	28	75.4	90
6¼ x 24	3.716	28	104.0	70
7¼ x 24	4.900	28	137.2	50

†From lowest surface of water in well to highest point of delivery. For the rated speeds it is recommended that the cylinder be located not more than 200 feet below the surface. When placed at greater depth, operate the working head at 20 per cent slower speed.

Complete Table of Contents and General Classification of Pumps, Pages 7 and 8



Deming Deep Well Power Working Head

Fig. 62, with Differential Plunger



Fig. 62, 24-inch Stroke with Tight and Loose Pulleys



Fig. 62, 10-inch Stroke with Fig. 63 Air Pumping Attachment



Fig. 62, 16-inch Stroke with Type "B" Drive

Alphabetical Index, Figure Index and Telegraph Cipher Code, Pages 249 to 254



Deming Deep Well Power Working Head

Fig. 61 with Differential Plunger

Fig. 61 Deep Well Working Head is of very rigid construction throughout, and its "low down" design, together with other features, make it one of the most desirable deep well pumps on the market for the work for which it is adapted. Access to the well for repairing cylinder or rod is quickly and easily made. The stroke is adjustable, permitting the regulation of the pump capacity to the supply of water in the well.

MAIN FRAME is of cast iron of very heavy design, and contains both the crank and pinion shaft bearings which are lined with best anti-friction metal.

GEARING is machine cut, the crank gear being bolted to a large flange integral with the crank shaft and located between the main bearings, thereby eliminating torsional strains.

CRANK SHAFT, Connecting Rod, Link and Walking Beam are all of steel.

CROSSHEAD is babbitt lined with provision for lubrication, and the guide rods are of polished steel held in rigid alignment by stay rods extending to the main standard.

DISCHARGE HEAD is located above the base and can be readily turned to discharge to the front as illustrated, or to the right or left as desired.

DIFFERENTIAL PLUNGER works through an outside packed stuffing box with bolted gland.

FIG. 61 WITH TYPE "B" DRIVE (Cipher, TYPEB) is furnished with extended cast iron bed plate and gearing connection for electric motor. Motor can be furnished at extra charge.

FIG. 61 WITH TYPE "K" DRIVE (Cipher TYPEK) is furnished with friction cut-off coupling for direct connecting with gas or gasoline engine when speed of engine is not too great to permit this drive. When engine speed exceeds 200 R. P. M., provision is made for a double reduction of gearing and an extra bearing for a secondary shaft to which a higher speed engine can be connected by friction coupling. Prices for Type "K" Drive are quoted on application with statement of engine horse power and speed.

In connection with Fig. 61 working head we recommend using our Fig. 324 Artesian Well Cylinder and Fig. 636 octagon wood sucker rod.

In corresponding, give as fully as possible conditions under which working head is to be operated, and if working head only is required, specify size of cylinder in use and also threads on sucker rod. See page 176.

Fig. 61, Sizes, Etc.

Stroke Inches	MAXIMUM DIAMETER OF PIPES		Standard Gear Ratio	Tight and Loose Pulleys	Maximum Height Inches	*Cipher
	Suction Inches	Discharge Inches				
20, 22 & 24	9	4	6.5 to 1	30 x 6	79	ODONTOID

*When telegraphing with regard to Type "B" or "K" Drive, place the cipher word representing the Type of Drive immediately following the cipher word for the standard pump.

Diameter and Stroke of Cylinder, Inches	CAPACITY			†Maximum Lift, Feet	Diameter and Stroke of Cylinder, Inches	CAPACITY			†Maximum Lift, Feet
	Gals. per Rev. of Cr. Shaft	Max. Revs. per Min.	Gallons per Min.			Gals. per Rev. of Cr. Shaft	Max. Revs. per Min.	Gallons per Min.	
3¼ x 24	.862	28	24	900	5¼ x 24	2.696	28	75	300
3¾ x 24	1.147	28	32	690	6¼ x 24	3.190	28	89	250
4¼ x 24	1.470	28	41	540	6¾ x 24	3.716	28	104	210
4¾ x 24	1.841	28	51	450	7¼ x 24	4.900	28	137	150
5¼ x 24	2.250	28	63	360	8½ x 24	5.880	28	164	130

†From lowest surface of water in well to highest point of delivery. For the rated speeds it is recommended that the cylinder be located not more than 200 feet below the surface. When placed at greater depth, operate the working head at 20 per cent slower speed.

Complete Table of Contents and General Classification of Pumps, Pages 7 and 8



Deming Deep Well Power Working Head

Fig. 61, with Differential Plunger

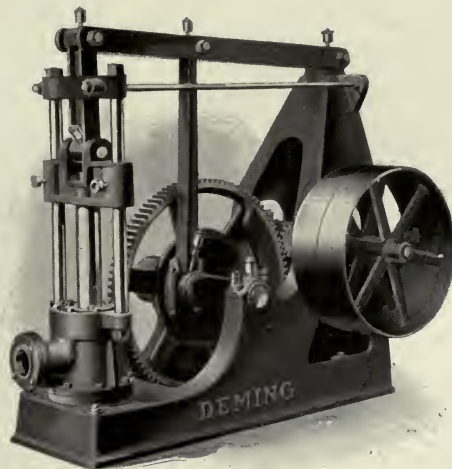

Fig. 61 with Pulleys

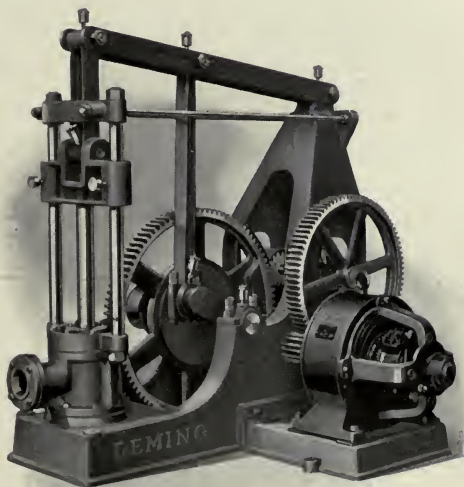

Fig. 61 with Type "B" Drive



Deming Deep Well Power Working Heads

Figs. 80 and 82, with Differential Plunger

Figs. 80 and 82 Deep Well Working Heads are designed for the operation of deep well cylinders, and have incorporated such desirable features as our extensive experience in this line of pumping machinery indicates as the best.

Fig. 82 differs from Fig. 80 (illustrated on opposite page) in having double crank gears, and outboard bearing and stand.

BEARINGS are lined with best anti-friction metal, the pinion shaft bearings being bolted to the main housings.

GEARING is machine cut, the main gear (or gears) being bolted to a large flange (or flanges) integral with the crank shaft.

CONNECTING ROD is of steel with marine type box at the crank end, and bronze bushing at the crosshead end.

CROSSHEAD has bronze shoe adjustable for wear, and runs in polished guides.

DIFFERENTIAL PLUNGER is furnished and equalizes the flow of water, with consequent greater economy and ease of operation.

AIR CHAMBER is supplied; also Grease Cups, or Oil Cups if preferred, and wrenches furnished with all pumps.

Discharge can be connected at either front or back of pump.

When electric motor or steam engine is to be direct connected, we can furnish these working heads with the different Types of Drive as described below and illustrated on pages 90 and 91.

Type "B" Drive (Cipher, TYPEB) consists of connecting an electric motor by an intermediate gear and rawhide, or other quiet running pinion, the pump being provided with a heavy cast iron shelf at the back, on which shelf the motor is mounted.

Motor for Type "B" Drive can be furnished, if wanted, at extra charge.

Fig. 324 Single-Acting Cylinders with Fig. 636 Wood Sucker-Rod, with extra strong pipe sucker-rod, are recommended for use with Figs. 80 and 82.

In corresponding, give the information asked for on page 176, and if working head only is wanted, specify sizes of drop pipe and discharge pipe and also threads on sucker rod.

Figs. 80 and 82, Sizes, Etc.

Stroke Inches	MAXIMUM DIAM. OF PIPES		Gear Ratio	TIGHT AND LOOSE PULLEYS		Height Inches	*CIPHER	
	Suction Inches	Discharge Inches		Fig. 80	Fig. 82		Fig. 80	Fig. 82
16	9	4	6 to 1	28 x 6	76	ORIENT
24	9	4	5¼ to 1	36 x 6	36 x 8	98½	ORIENTAL	ORNAMENTAL

*When telegraphing with reference to Type "B" Drive, place the cipher word "TYPEB" immediately following the cipher word for the standard pump.

MAXIMUM SPEED AND CAPACITY PER MINUTE WITH FIG. 324 SINGLE-ACTING CYLINDERS

Diam. of Cylinder Inches	16-Inch Stroke		24-Inch Stroke		†MAXIMUM LIFT, FEET	
	Revs.	Gallons	Revs.	Gallons	Fig. 80	Fig. 82
4¼	35	34	28	41	540	725
4¾	35	42	28	51	450	600
5¼	35	52	28	63	360	485
5¾	35	62	28	75	300	400
6¼	35	74	28	89	250	335
6¾	35	86	28	104	210	285
7¼	35	114	28	137	150	215
8¾	35	137	28	164	130	170

†From lowest surface of water in well to highest point of delivery. For the rated speeds it is recommended that the cylinder be located not more than 200 feet below the surface. When placed at greater depth, operate the working head at 20 per cent slower speed.

Complete Table of Contents and General Classification of Pumps, Pages 7 and 8



Deming Deep Well Power Working Head

Figs. 80 and 82, with Differential Plunger



Fig. 80, 24-inch Stroke



Fig. 82, 24-inch Stroke



Deming Single-Acting Triplex Piston Pump

For Deep Open Wells

Fig. 710

Fig. 710 is designed for use in deep open wells where the water is too low to be reached by suction from the surface. The power end is mounted on "I" beams or other supports at the surface and the cylinders are secured to the supports in the well, within suction distance of the water.

When depth of well requires, the well rods should be guided by Fig. 389 double roller guides. See list below.

Air chamber and discharge check valve; grease cups or oil cups, and wrenches, are included in the regular equipment.



Fig. 710, All Sizes



Fig. 389

ROLLER PISTON ROD GUIDES
FIG. 389

For Pipe, Inches	1	1½
Price	\$2.50	\$3.50

Fig. 710, Sizes, Capacities, Etc.

PISTONS		CAPACITY			*Max. Elevation Feet	DIAM. OF PIPES		Gear Ratio	Pulleys	Outside Dimensions Water End Inches	Cipher
Diam. Inches	Stroke Inches	Gals. per Rev.	Usual Revs. per Min.	Gals. per Min.		Suction Inches	Discharge Inches				
3	10	.91	40	36.4	300	3	3	5 to 1	20 x 5	21 x 14	ODORATE
3½	10	1.25	40	50.0	225	3	3	5 to 1	20 x 5	21 x 14	ODORLESS
4	10	1.63	40	65.2	170	3	3	5 to 1	20 x 5	21 x 14	OFFERTORY
5	10	2.55	40	102.0	300	4	4	5 to 1	28 x 6	24 x 17	OFFICIATE
6	10	3.67	40	145.8	210	5	4	5 to 1	28 x 6	24 x 18¼	OFFSPRING

*Elevation includes total lift from surface of supply to highest point of delivery.

Complete Table of Contents and General Classification of Pumps, Pages 7 and 8



DEMING HYDRO-PNEUMATIC WATER SYSTEMS

INCLUDING PUMP

AND

COMPLETE EQUIPMENT

FOR SUPPLYING WATER TO
FARM HOMES, SUBURBAN RESI-
DENCES, COUNTRY CLUBS, SUM-
MER HOMES, GREENHOUSES,
ETC., THE TANK PRESSURE IN
MANY CASES BEING AUTOMATI-
CALLY CONTROLLED, AND THE
PUMP OPERATED BY ELECTRIC
MOTOR, GASOLINE ENGINE
OR BY HAND



A SEPARATE CATALOGUE

Of our complete line of hydro-pneumatic water systems, comprising many different types and sizes, will be sent upon request. However, to give a general idea of the appearance and construction of these systems, a few representative types are listed in this section of the Catalogue.



Deming Water Supply Systems



A representative group of "Deming equipped" homes. Conclusive proof of the adaptability of Deming Systems of water supply to the needs of the modest house or the most elaborate establishment.

No matter how small or how large the home, building or institution may be, there is a Deming system to exactly fit the requirements.

Many thousands of Deming Water Systems are today giving dependable, satisfactory service, covering a range of conditions that is almost without limit. In the tiny bungalow, and in the magnificent country homes of some of the world's richest men, Deming systems are daily proving to the owners the wisdom of their choice.

In the smallest Deming system, the pump has a capacity of 180 gallons per hour with a tank of 53 gallons capacity. The pump in the largest system will deliver 60,000 gallons per hour with a tank capacity 20,000 gallons. In very large installations several tanks are often used.

Each Installation Is Handled As a Separate Proposition

To secure the best results from any water supply system, it is necessary that each outfit be planned to suit the particular conditions under which it must give service. The size of pump, tank and power unit should be based upon the conditions actually prevailing in every case. Upon receipt of a statement of conditions we will be glad to have our experts tell you just which outfit will best do your work. This service is given absolutely without charge and is distinctly understood to place the prospective customer under no obligation whatever.

Note Carefully

WHEN QUOTING ON DEMING OUTFITS, THE SUCKER ROD, PIPE AND PIPE FITTINGS, SUCH AS ELLS, TEES, UNIONS, ETC., ARE NOT INCLUDED, UNLESS SO SPECIFIED, SINCE EACH INSTALLATION IS, AS A RULE, DIFFERENTLY SITUATED AND REQUIRES, THEREFORE, DIFFERENT FITTINGS AND VARYING LENGTHS OF PIPE.

Hand-holes and man-holes in tank ARE FURNISHED ONLY WHEN SPECIFIED, but we recommend that a hand-hole at least be included. For prices see page on which tanks are listed. The water capacity of a tank is approximately two-thirds the total capacity.

Complete Table of Contents and General Classification of Pumps, Pages 7 and 8



Deming "Climax" Water System No. 2001 For Wells and Cisterns 25 Feet Deep or Less

With the "Climax" System, sufficient water may be stored at one pumping to last a family of four or five about one day for ordinary requirements. The pump can be easily operated against a pressure of 40 pounds in the tank. The pump is provided with air valve so that air and water can be forced into the tank at the same time. If water only is desired, the air valve on the cylinder head can be closed. We recommend that a foot-valve be placed on the end of the suction pipe. Should the supply be higher than the pump, we recommend the use of Fig. 606, described on page 28, instead of the Fig. 608½ pump, listed below.

Equipment Specifications of System No. 2001

- One 30-in. x 6-ft. vertical tank.
- One Fig. 608½ "Climax" double-acting pump with brass-lined cylinder.
- One Fig. 904 1-in. check valve.
- One Fig. 900 1-in. globe valve.
- One Fig. 913 ¾-in. stop and waste valve.
- One Fig. 688 pressure gauge.
- One Fig. 917 ½-in. hose bibb.
- One glass water gauge.

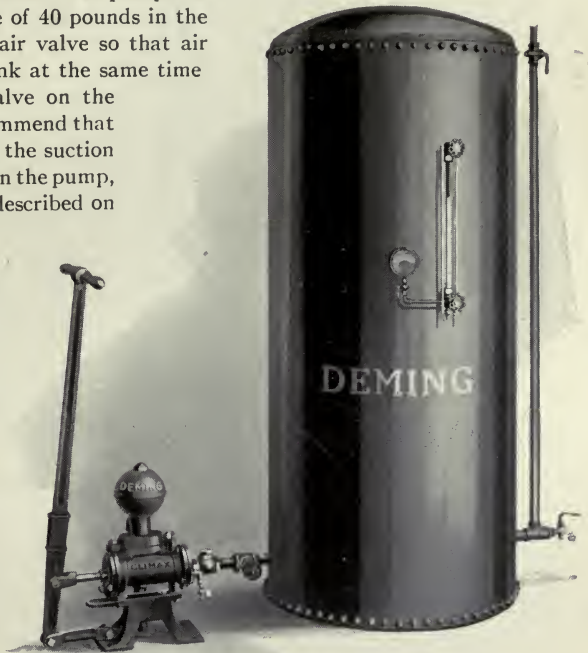

Sizes, Capacities, Etc.

PUMP			TANK			Complete Weight of Outfit Pounds	Cipher
Diameter of Cylinder Inches	Stroke Inches	Capacity per Minute 30 Strokes Gallons	Capacity of 30-in. x 6-ft. Tank Gallons	Water 30-in. x 6-ft. Tank Gallons	Weight of Tank Pounds		
2½	4	5	220	150	575	650	SERF

Variations of the "Climax" Outfit

- System No. 2002, with 30-in. x 8-ft. HORIZONTAL tank (total capacity, 295 gallons), otherwise same as above (Cipher, SERGE)
- System No. 2003, with 30-in. x 6-ft. VERTICAL tank (total capacity, 220 gallons), and Fig. 606 pump, as described on page 28; otherwise the same as System No. 2001 (Cipher, SERIAL)
- System No. 2004, with 30-in. x 8-ft. HORIZONTAL tank (total capacity, 295 gallons), otherwise the same as System No. 2003 (Cipher, SERIES)

Hand Hole in Tank, furnished at extra cost

Alphabetical Index, Figure Index and Telegraph Cipher Code, Pages 249 to 254



Deming "Marvel" Electric House Pumping Outfit

For Wells and Cisterns 25 Feet Deep or Less
System No. 2085

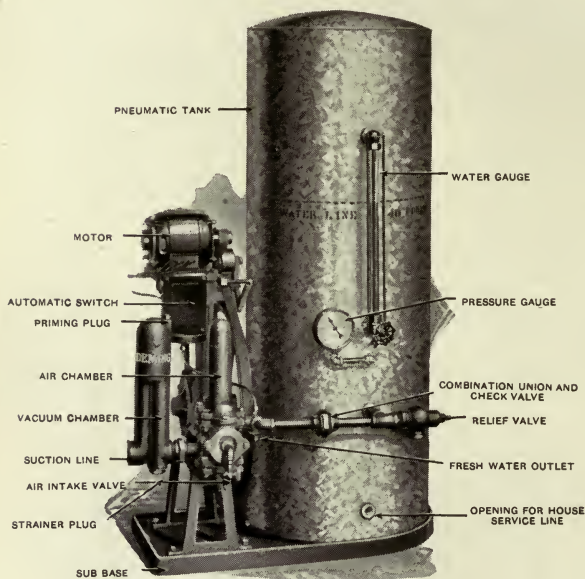

The "Marvel" system is intended for supplying the requirements of bathroom, laundry and kitchen, in farm and suburban homes, summer cottages and other places where a moderate quantity of water is used.

System No. 2085 is self-starting, self-stopping, self-oiling, self-priming—self-operating in all respects. A complete set of instructions for installing is furnished with every outfit.

Fresh Drinking Water— Direct From the Well

Every electric-driven "Marvel" outfit has a fresh water outlet which automatically shuts off the pressure from the tank when the faucet in the fresh water line is opened and starts up the pump, delivering cold water direct from the well.

Equipment Specifications of System No. 2085

"Marvel" electric house pump with electric motor; automatic switch; pulley; spring belt tightener, flat belt; pressure gauge; water glass; relief valve; fresh water outlet; cast-iron sub-base or floor plate.

When Pump is Wanted Without the Tank

Frequently owners of hand-operated systems desire to replace their hand pump with a power-driven pump. For such installations, we have arranged to supply the "Marvel" pump only, without the tank, sub-base or piping connections, designated as Fig. 1685, and including the following equipment:

Equipment Specifications of Fig. 1685

"Marvel" electric house pump with electric motor; automatic switch; pulley; spring belt tightener and belting; air-charging device; fresh water outlet and pump stand.

Prices, Capacities, Etc.

Fig.	Capac. per Hour Gal.	DIAMETER OF PIPES		Capac. of Galv. Tank Gal.	Max. W'k'g. Press. Lbs.	Sh'pg. W'ght. Lbs.	Overall Dimensions Inches	Cipher	PRICE	
		Suc'n Inches	Disch. Inches						With D3 Single-Phase 60-Cycle 110-Volt A. C. Motor	Furnished with A. C. Two or Three-Phase, 60-Cycle, 110 or 220-Volt, or D. C. 32 or 110-Volt Motor at Same Price.
1685	180	1	½	..	50	180	31 high 27 long 10 wide	SALIX	\$140.00	Other Frequency Motors at Additional Price.
2085	180	1	½	53	50	340	53 high 27 long 31 wide	SALTY	\$200.00	

When desired, No. 2085 will be furnished with 120-gallon galvanized iron tank at extra cost.

Complete Table of Contents and General Classification of Pumps, Pages 7 and 8



Deming "Marvel" House Pumping Outfit
 Gasoline Engine Driven
 For Wells and Cisterns 25 Feet Deep or Less
 System No. 2086

Where electric current is not available, we recommend the use of our gasoline engine driven "Marvel" outfit. This consists of the same pump used in System No. 2085 (see opposite page), ½ H. P. engine, 30-inch x 6-foot black steel tank; spring belt tightener and belting; air charging device; pressure gauge; water glass; circuit breaker and relief valve. Pump and engine are mounted on a heavy plank base.

The engine is provided with a foot lever for starting, which, when pressed down upon with the foot, spins the engine. After testing and experimenting with different makes of gasoline engines, we have found that this engine is not only the most economical in operation, but is so simply constructed that anyone can learn to run it in a few minutes' time.

The automatic circuit breaker supplied with this system stops the engine when the tank is pumped up to 40 pounds pressure.

The steel tank in System No. 2086 is coated inside with a special anti-rust paint.

A complete set of instructions for installing and operating is furnished with every "Marvel" outfit.

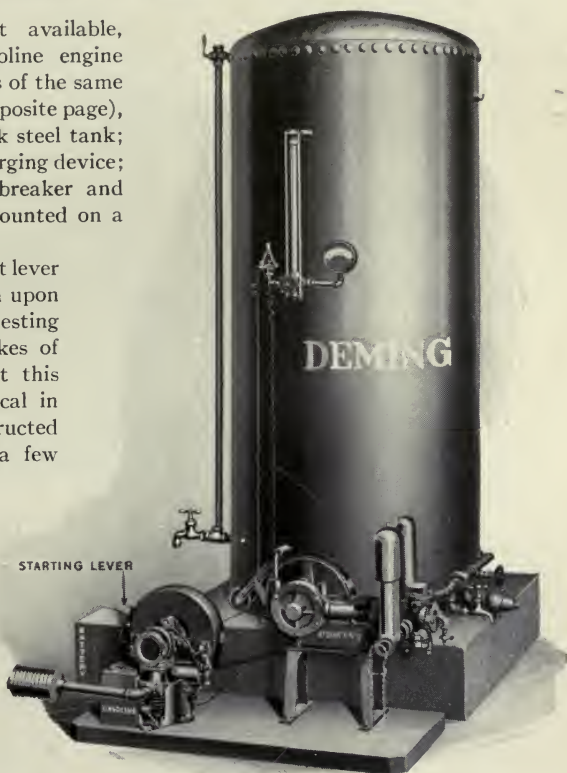

When the Pump is Wanted Without the Tank

When desired, we will ship the "Marvel" pump and engine, *without the tank*, including equipment as below. This outfit is designated as Fig. 1686.

Equipment Specifications of Fig. 1686

"Marvel" house pump; ½ H. P. air-cooled gasoline engine; spring belt tightener and belting; air-charging device; all mounted upon a heavy plank base.

Prices, Capacities, Etc.

Fig.	DIAMETER OF PIPES		Maximum Working Pressure Pounds	Overall Dimensions Inches Fig. 1686 Only	TANK			Shipping Weight Pounds	Cipher	Price
	Suct. Inches	Disc. Inches			Total Capac.	Water Capac.	W'ght			
1686	1	½	50	25 high 16 wide 43 long	240	SOPITE	\$140 00
2086	1	½	50	25 high 16 wide 43 long	220	150	575	825	SOPOR	285.00



HAND AND POWER PUMPS FOR ALL USES



Deming "Atlas" Water System No. 2009 With Gasoline Engine and "Atlas" Power Pump For Wells and Cisterns 25 Feet Deep or Less

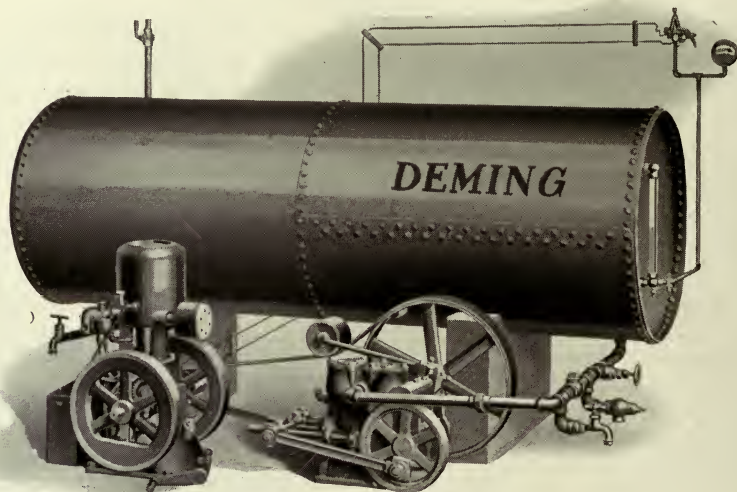

This system will store water under 75 pounds pressure or less. The pump has a capacity of 575 gallons per hour at 60 revolutions per minute, and is fully described on the preceding pages. The engine is of the hopper-cooled type; four cycle; has hit-and-miss governor; will not freeze; has machine-cut gears; jump spark ignition; operates at 600 revolutions per minute. Diameter of engine pulley, 10 inches; face, 3 inches. It is one of the very best engines on the market. Book of instructions for operating engine is included with each "Atlas" system.

Amount of air to be pumped can be regulated by the air charging device on the pump. The usual maximum pressure maintained is 45 to 50 pounds. This makes a very good outfit for farms, suburban residences, factories, warehouses, etc.

Equipment Specifications of System No. 2009

One 30-in. x 8-ft. horizontal pressure tank.
One Fig. 691 "Atlas" double-acting power pump, 2¼ in. x 5 in.; with air charging device and brass-lined cylinder; also Type "CI" drive; 20-in. x 3-in. pulley.
One 1½ horse-power reliable vertical gasoline engine with 10 feet of canvas belting.
One Fig. 904 1-in. check valve.

One automatic gasoline engine stop or circuit breaker.
One Fig. 900 1-in. globe valve.
One Fig. 1995 ¾-in. relief valve.
One Fig. 688 pressure gauge.
Two Fig. 917 ½-in. hose bibbs.
One Fig. 913 ¾-in. stop and waste cock.
One glass water gauge.

For complete details of the "Atlas" pump, see pages 164-167.

Sizes, Capacities, Etc.

PUMP					TANK			Complete Weight of Outfit Lbs.	Cipher
Diam. of Cylinder Inches	Stroke Inches	Good for Maximum Pressure Lbs.	Capacity per Min. at 60 Strokes Gallons	Weight Lbs.	Capacity of 30" x 8' Tank Gallons	Water Capacity of 30" x 8' Tank Gallons	Weight of Tank Lbs.		
2¼	5	75	9.6	140	295	198	725	1175	SELION

If automatic gasoline engine stop is not wanted, a reduction in price will be made. Hand Hole in Tank, furnished at extra cost.

Complete Table of Contents and General Classification of Pumps, Pages 7 and 8



Deming "Atlas" Water System No. 2012
 With $\frac{3}{4}$ Horse-power Electric Motor and "Atlas" Power Pump
 For Wells and Cisterns 25 Feet Deep or Less

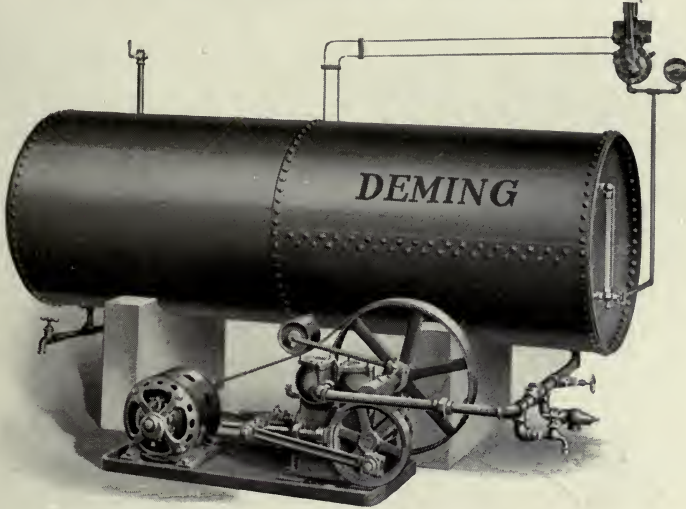

The pump is belted to the motor in this system, which practically eliminates all noise. System No. 2012 is, therefore, our most popular motor driven outfit. The automatic pressure regulator starts and stops the motor when the pressure falls or rises beyond a predetermined point. The "Atlas" pump has a capacity of 575 gallons per hour and is fully described on the preceding pages. Pump and motor are mounted upon a cast-iron sub-base, and are connected by a short belt. The cast-iron base insures permanent alignment of pump and motor.

We should be fully informed regarding the kind of current and the voltage available.

Equipment Specifications of System No. 2012

- One 30-in. x 8-ft. horizontal tank.
- One Fig. 691, $2\frac{1}{4}$ in. x 5 in. "Atlas" double-acting power pump with air charging device and brass-lined cylinder; with Type "C" drive (including cast-iron sub-base and 20-in. x 3-in. pulley).
- One $\frac{3}{4}$ horse-power, A. C., single-phase, 60-cycle, 110-220 volt electric motor. Price will vary slightly, depending upon the kind of motor required. See list below.
- One Fig. 1508 automatic pressure regulator.
- One Fig. 904 1-in. check valve.
- One Fig. 900 1-in. globe valve.
- One Fig. 1995 $\frac{3}{4}$ -in. relief valve.
- One Fig. 688 pressure gauge.
- Two Fig. 917 $\frac{1}{2}$ -in. hose bibbs.
- One Fig. 913 $\frac{3}{4}$ -in. stop and waste cock.
- One glass water gauge.

For complete details of the "Atlas" pump, see pages 164-167.

Sizes, Capacities, Etc.

P U M P					Capacity of 30" x 8' Tank Gallons	Weight of Complete Outfit Pounds	Cipher	Regularly furnished with $\frac{3}{4}$ HP, A. C. Single-Phase, 60-Cycle 110-220 Volt Motor.
Diam of Cylinder Inches	Stroke Inches	Capacity per Min. at 60 Strokes Gallons	Weight Pounds	Good for Maximum Pressure Pounds				
$2\frac{1}{4}$	5	9.6	140	75	295	1100	SELVES	When desired, D. C. Motor or A. C. Two or Three-Phase Motor can be furnished.

Hand Hole in Tank, furnished at extra cost.

Alphabetical Index, Figure Index and Telegraph Cipher Code, Pages 249 to 254



Deming Deep Well Water System No. 2016
With Electric Motor and Fig. 66 Power Working Head
For Wells 75 Feet Deep or Less

In this system the air is supplied to the tank by means of an air compressor, which is constructed as a part of the power working head, and which is operated from the pump crosshead.

Should no air be desired while the head is operating, a pet cock may be opened which will permit the escape of the air. This system has a capacity of about 250 gallons per hour, when working against a tank pressure of 60 pounds, and using a 2¼-in. x 10-in. artesian well cylinder in a 75-foot well. We should be fully informed regarding the kind of current and the voltage available.

Since conditions affecting deep well installations may vary greatly, different sizes of cylinders and motor are often required. It is best, therefore, to send us complete details before ordering a deep well outfit. However, for many installations, System No. 2016 will be satisfactory without alteration in equipment specified below.

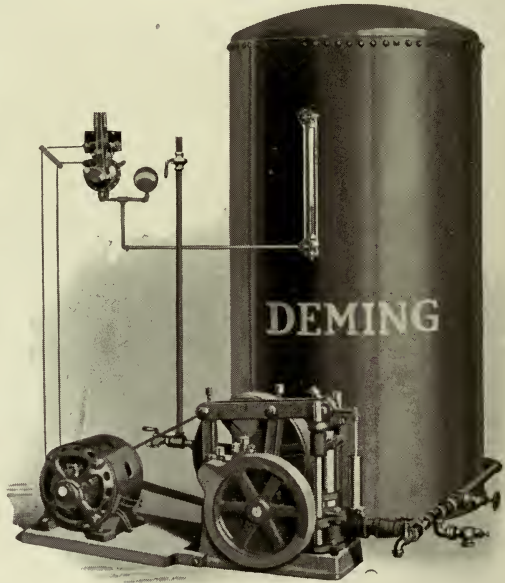

Equipment Specifications of System No. 2016

- One 36-in. x 6-ft. vertical tank.
- One Fig. 66 deep well power working head with air compressor and "CS" drive.
- One 1½ horse-power, A. C., single-phase, 60-cycle, 110-220-volt electric motor. Price will vary slightly, depending upon the kind of motor required. See list below.
- One Fig. 1508 automatic pressure regulator.

- One Fig. 311 2¼x10 in. special brass cylinder.
- One Fig. 1995 ¾-in. relief valve.
- One Fig. 688 pressure gauge.
- One Fig. 904 1-in. check valve.
- One Fig. 900 1-in. globe valve.
- Two Fig. 917 ½-in. hose bibbs.
- One Fig. 913 ¾-in. stop and waste cock.
- One glass water gauge.

For complete details of Fig. 66, see page 179.

Sizes, Capacities, Etc.

WORKING HEAD			CYLINDER		Capacity of 36" x 6' Tank Gallons	Complete Weight of Outfit Pounds	Cipher	Furnished regularly with 1½ HP, A. C. Single-Phase 60-Cycle Motor. When desired, D. C. Motor or Two or Three-Phase A. C. Motor can be supplied.
Stroke Inches	Suction Fitted for Pipe Inches	Discharge Fitted for Pipe Inches	Diam. and Length Inches	Gallons per Min. at 40 Revs.				
6	2½	1	2¼x10	4.12	315	1300	SERE	

Hand Hole in Tank, furnished at extra cost

Complete Table of Contents and General Classification of Pumps, Pages 7 and 8



Deming "Straight Line" Water System No. 2020
With Gasoline Engine and Fig. 1717 Head
For Wells 100 Feet Deep or Less

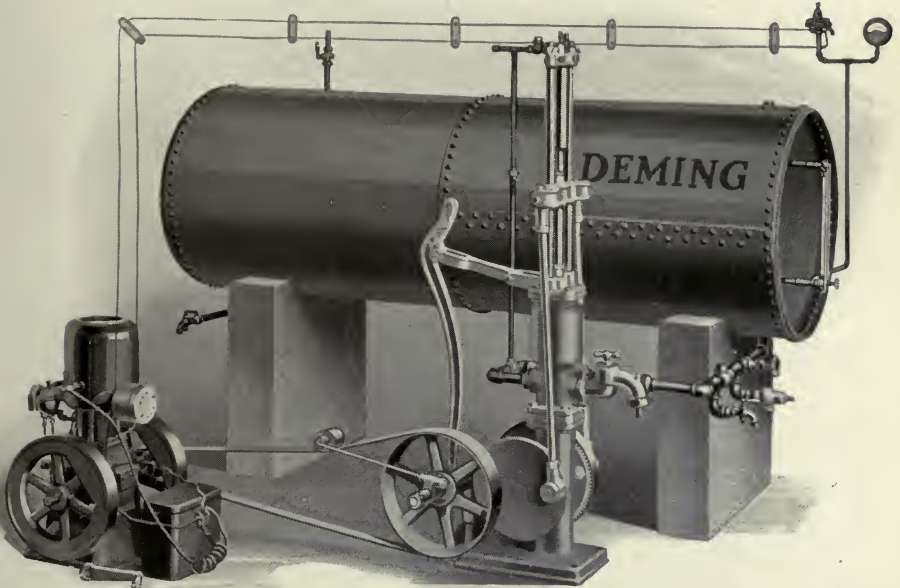

In this system the air is supplied to the tank by means of an air compressor, which is located between the guide rods at top of the pump head, and is operated from the crosshead. Should no air be desired while the pump is running, a pet cock may be opened which will permit the air to escape.

Operating our Fig. 311, 2¼ x 10-inch brass cylinder at a depth of 100 feet, System No. 2020, when driven by 1½ H. P. gasoline engine, will deliver 420 gallons of water per hour against 50 pounds pressure in the tank.

An automatic gasoline engine stop cuts out battery switch when pressure reaches desired point. Should power fail, lever is provided for hand operation. In deep well outfits it is advisable to send us complete details, since a cylinder of larger capacity may be used in wells of lesser depths than 100 feet. For complete details of Fig. 1717, see page 73.

Equipment Specifications of System No. 2020

- One 30-inch x 8-foot vertical tank.
- One Fig. 1717 deep well working head, with tight pulley, 20 x 3 inches, and special air-compressor.
- One Fig. 311, 2¼ x 10-inch special brass cylinder.
- One 1½ horse-power, water-cooled, vertical gasoline engine.
- One 12-ft. belt.
- One automatic engine stop or circuit breaker.
- One Fig. 1995 ¾-inch relief valve.
- One Fig. 688 pressure gauge.
- One Fig. 900 1-inch globe valve.
- One Fig. 904 1-inch check valve.
- One Fig. 913 ¾-inch stop and waste cock.
- One Fig. 917 ½-inch hose bibb.
- One glass water gauge.

Sizes, Capacities, Etc.

Tight Pulley Inches	Back Outlet Inches	Working Head Stroke Inches	CYLINDER		Total Capacity of 30-Inch x 8-Foot Tank Gallons	Weight of Complete Outfit Pounds	Cipher
			Diameter and Length Inches	Capacity per Minute at 40 Rev. Gallons			
20 x 3	2	6, 8, 10	2¼ x 10	7	295	1400	STAPES

Hand Hole in Tank, furnished at extra cost.

Engineering Tables and Information Relating to Hydraulics, Pages 239 to 248



Deming Deep Well Water System No. 2018
With Electric Motor, and Fig. 62 Power Working Head
For Wells 150 Feet Deep or Less

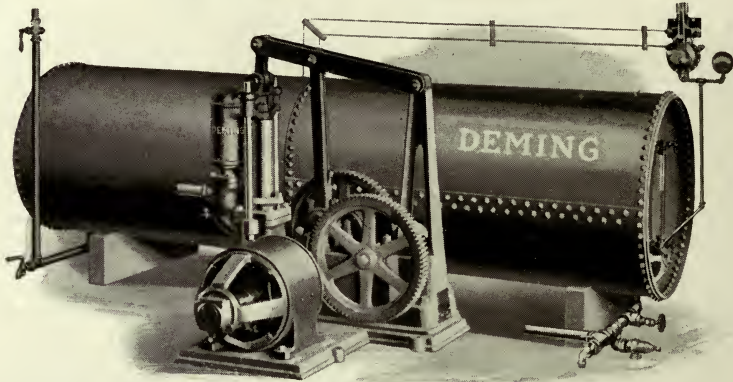

In deep well installations the pump head is usually located some distance away from the tank. For this reason, the piping in the above illustration is shown disconnected from the head

With a Fig. 311, 2 3/4-in. x 10-in. cylinder at a depth of 150 feet below the surface, this system will supply 600 gallons of water per hour against 60 pounds pressure in the tank.

When preferred, the connection between working head and motor is made by a short belt with tightener instead of gearing at the same price, this being designated as Type "C" drive.

Air for the pneumatic tank is supplied by the Fig. 63 air pumping device in the discharge head when the well cylinder does not exceed 3 1/4 inches inside diameter, but when a cylinder larger than 3 1/4 inches diameter is used, Fig. 64 air compressor attachment is furnished.

While the System No. 2018 as listed below will be satisfactory for most conditions where a capacity of not more than 600 gallons per hour is required (from a deep well), we nevertheless advise that full information as to the depth of the well, inside diameter of same and the discharge pressure required should be sent with the order.

For complete details of Fig. 62, see pages 182-183.

Equipment Specifications of System No. 2018

- One 36-in. x 12-ft. horizontal tank.
- One Fig. 62 power working head, with Type "B" drive and Fig. 63 air pumping device.
- One Fig. 311, 2 3/4-in. x 10-in. brass cylinder.
- One 3 H. P. A. C. single phase, 60 cycle, 110-220 volt motor.
- One Fig. 1508 automatic pressure regulator.
- One Fig. 1995 3/4-in. relief valve.
- One Fig. 688 pressure gauge.
- One Fig. 900 1 1/2-in. globe valve.
- One Fig. 913 3/4-in. stop and waste cock.
- Two Fig. 917 1/2-in. hose bibbs.
- One glass water gauge.

Sizes, Capacities, Etc.

WORKING HEAD	CYLINDER		Total Capacity of 36" x 12' Tank Gallons	Weight of Complete Outfit Pounds	Cipher	Regularly furnished with 3 H. P., A. C. Single-Phase, 60-Cycle Motor.
	Stroke Inches	Diameter and Length Inches				
8, 9 or 10	2 3/4 x 10	10.2	635	2200	SERIN	When desired, D. C. Motor or Two or Three-Phase A. C. Motor can be supplied.

Hand Hole in Tank, furnished at extra cost

Complete Table of Contents and General Classification of Pumps, Pages 7 and 8



Deming Triplex Pumps for Hydro-Pneumatic Service

For Use Where a Large Quantity of Water is Required

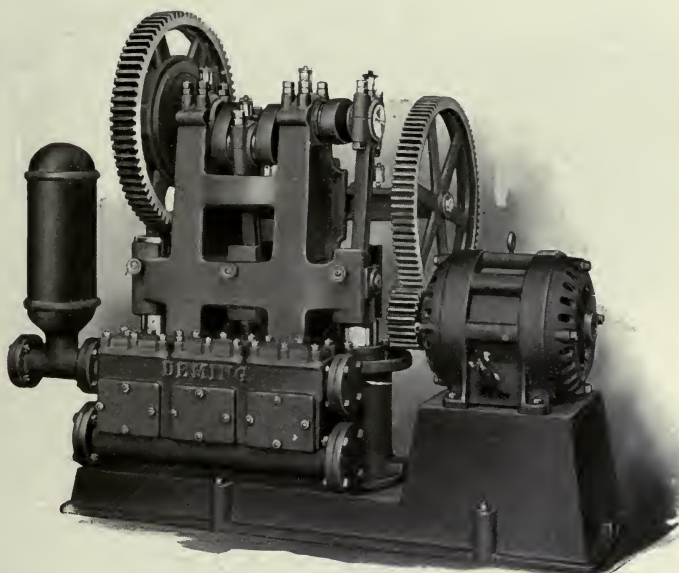

Fig. 50, Sizes $5\frac{1}{2} \times 8$ to $8\frac{1}{2} \times 8$ with Type "B" Drive
Capacity $5\frac{1}{2} \times 8$ size, 8800 gallons per hour

For installations where very large quantities of water are necessary, we recommend the use of our triplex pumps. These are made in capacities up to 60,000 gallons per hour. We also can supply hydro-pneumatic tanks with capacities of 20,000 gallons or less.

When the source of supply is at a much lower elevation than the point where the water is to be used, and also a considerable distance away, our triplex pumps are preferred.

We do not list any complete hydro-pneumatic outfits in which triplex pumps are used, for the reason that in large installations the conditions vary so very much that we prefer to handle such propositions as individual cases in order to determine the outfit best suited to existing conditions.

Such outfits usually consist of a Deming triplex pump, hydro-pneumatic tank, electric motor or gasoline engine, with the Deming air pumping device, and the necessary valves, gauges, etc.

Deming triplex pumps are especially adapted for hydro-pneumatic service in hotels, country estates, etc. When electric current is available, they may be automatically controlled. They are made in a great many different styles and sizes for varying conditions.

To quote intelligently we should know the quantity of water required per day; vertical distance from surface of water to the pump suction inlet and length of suction pipe; elevation from surface at well to point of delivery and length of discharge pipe. Give kind of motive power preferred; if electric current, state kind of current and voltage.

Alphabetical Index, Figure Index and Telegraph Cipher Code, Pages 249 to 254



Standard Hydro-Pneumatic Steel Tanks

With Convex and Concave Heads



These tanks are made of best open hearth flange steel with double riveted longitudinal seams, and are all tested to 125 lbs. air pressure. The prices below do not include water and pressure gauges or other accessories, but holes for pipe connections are tapped to suit conditions. *All tanks are painted inside with a special anti-rust paint.*

Sizes, Capacities, Prices, Etc.

Diam. Inches	Length Feet	THICKNESS		Weight	Cap. in Gals.	LIST PRICE	Diam. Inches	Length Feet	THICKNESS		Weight	Cap. in Gals.	LIST PRICE
		Shell	H'ds						Shell	H'ds			
24	6	$\frac{3}{16}$	$\frac{1}{4}$	425	140	\$121.00	42	8	$\frac{1}{4}$	$\frac{5}{16}$	1425	575	\$364.00
24	8	$\frac{3}{16}$	$\frac{1}{4}$	535	190	155.00	42	10	$\frac{1}{4}$	$\frac{5}{16}$	1625	720	406.00
24	10	$\frac{3}{16}$	$\frac{1}{4}$	645	235	178.00	42	12	$\frac{1}{4}$	$\frac{5}{16}$	1850	865	460.00
30	6	$\frac{3}{16}$	$\frac{1}{4}$	575	220	154.00	42	14	$\frac{1}{4}$	$\frac{5}{16}$	2150	1000	543.00
30	8	$\frac{3}{16}$	$\frac{1}{4}$	725	295	195.00	42	16	$\frac{1}{4}$	$\frac{5}{16}$	2350	1150	605.00
30	10	$\frac{3}{16}$	$\frac{1}{4}$	840	365	227.00	48	12	$\frac{1}{4}$	$\frac{5}{16}$	2200	1130	539.00
30	12	$\frac{3}{16}$	$\frac{1}{4}$	960	440	259.00	48	14	$\frac{1}{4}$	$\frac{5}{16}$	2500	1315	600.00
36	6	$\frac{3}{16}$	$\frac{1}{4}$	735	315	199.00	48	16	$\frac{1}{4}$	$\frac{5}{16}$	2800	1500	698.00
36	8	$\frac{3}{16}$	$\frac{1}{4}$	900	420	249.00	48	18	$\frac{1}{4}$	$\frac{5}{16}$	3100	1700	769.00
36	10	$\frac{3}{16}$	$\frac{1}{4}$	1050	525	284.00	48	20	$\frac{1}{4}$	$\frac{5}{16}$	3400	1880	822.00
36	12	$\frac{3}{16}$	$\frac{1}{4}$	1200	635	320.00	48	24	$\frac{1}{4}$	$\frac{5}{16}$	4000	2260	951.00

EXTRAS—Hand Holes, \$6.25; Manhole in Shell, \$45.00; Manhole in Head, \$30.00.

The water capacity is two-thirds of the capacities given above.

An additional charge will be made for tappings other than standard.

Complete Table of Contents and General Classification of Pumps, Pages 7 and 8



SPRAY PUMPS
AND
ACCESSORIES

FOR ALL

SPRAYING CONDITIONS

INCLUDING BUCKET, KNAPSACK, BARREL, TANK, COMPRESSED AIR, AND CART SPRAYERS FOR THE GARDEN, GREENHOUSE AND ORCHARD; INDEPENDENT POWER SPRAY PUMPS AND POWER SPRAYING OUTFITS FOR EXTENSIVE OPERATIONS; FIELD SPRAYERS, SPRAY NOZZLES, SPRAYING ATTACHMENTS, ETC.



A SEPARATE CATALOGUE

Of our complete line of spray pumps, nozzles and accessories, comprising many different types and sizes, will be sent upon request. However, to give a general idea of the appearance and construction of these pumps, a few representative types are listed in this section of the Catalogue.

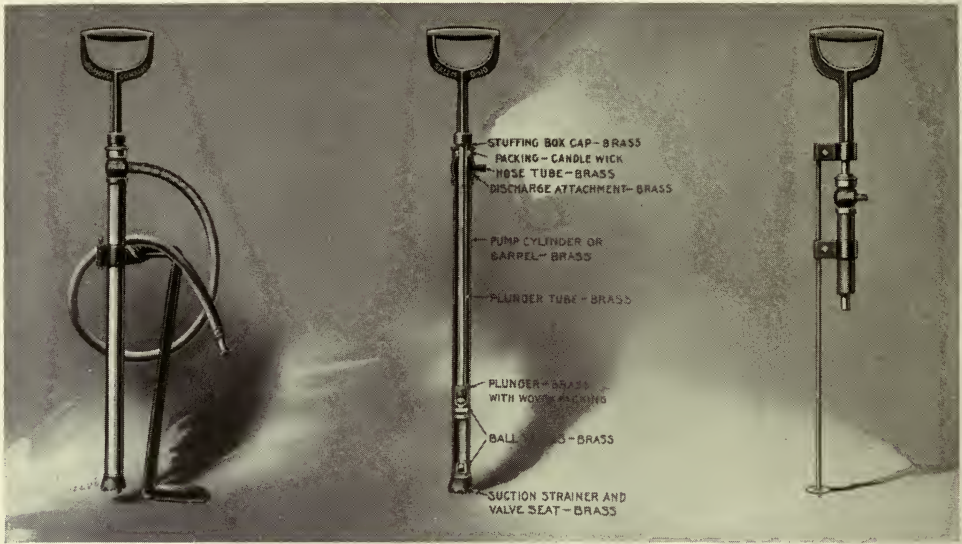

The "Prize" Bucket Sprayer, Fig. 669

For Garden and Greenhouse Spraying

Without some type of bucket spray pump, no assortment of garden tools may be said to be complete. The "Prize" is much used for spraying small trees, garden truck, flowers and shrubbery; washing windows, porches, autos and buggies; applying whitewash and disinfectants in barns and poultry houses; applying cattle-fly oil, stock dip, etc.

This is our lowest priced spray pump, but it is often referred to as "much in little." The "Prize" is double acting, discharging one-half the solution on both the up and down stroke, giving a continuous spray. It is light; easy to carry; and is "built for business;" will develop a good pressure; is easy to operate; is practically non-breakable and will last for years.

Specifications

PUMP: The working parts of the pump are brass, including cylinder, plunger tube, plunger, valve seats and valve cages. The valves are solid brass balls, a true sphere to one one-thousandth of an inch. Nothing to rust or corrode. The ball valves insure a free movement of the liquid, as they are practically non-chokable.

AIR CHAMBER: The hollow plunger tube acts as an air chamber. The discharge chamber is brass.

HANDLE: The handle is made of malleable iron similar to that used on the "Success" Pumps.

HOZE AND NOZZLE: The "Acme" spray nozzle, our simplest, is used with 3 feet of $\frac{3}{8}$ -inch hose. The "Bordeaux," our patented adjustable nozzle for all spraying conditions, is furnished at additional cost.

FOOT REST is of malleable iron, 12 inches high, and clamps to the cylinder of pump.

SHIPPING WEIGHT, crated, is about nine pounds. The pump is put up in a strawboard box.

Outfit and Extras

Fig. 669 — "Prize" bucket pump, as illustrated Cipher, KAFIR

Fig. 669 — With "Bordeaux" nozzle instead of "Acme" Cipher, KINEMATIC

Seven-foot section of $\frac{3}{8}$ -in. hose with couplings and pole holder, for tree spraying. CIPHER, KEDLACK

AGITATOR—Dash Disc, Fig. 759, ready to attach to "Prize" and "Success" Pumps.

See illustration above. CIPHER, KINGLING

Complete Table of Contents and General Classification of Pumps, Pages 7 and 8

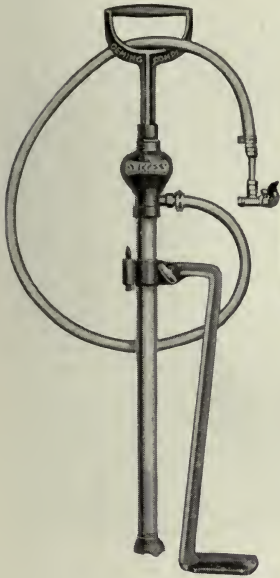

Fig. 659
"Success"



Fig. 689
"Perfect Success"



Fig. 968
"Handy Success"

Deming Bucket Spray Pumps

Fig. 659 is without doubt the most popular bucket spray pump on the market. Hundreds of thousands are in use all over the civilized world. It is similar to the "Prize" (see opposite page), except that it has a large brass air chamber, which produces a more uniform stream. For spraying a small number of trees; for flower and vegetable gardens, greenhouses, etc.; for washing windows, porches, autos and buggies; for applying whitewash and disinfecting barns and poultry houses, it is very useful.

HANDLE AND FOOT REST are malleable iron. Foot rest is clamped to cylinder and is 15 inches high—sufficient for any tall bucket.

HOSE AND NOZZLE—Furnished with three feet of 3/8-inch hose and "Bordeaux" nozzle. Hose is attached with a hose band and is not wired on. Shipping weight, crated, is about 10 pounds. Each pump is packed in a separate strawboard box.

Fig. 659—"Success" Pump, as illustrated CIPHER, KORAN

Fig. 689—"Perfect Success," same as above, but with 4 feet of 3/8-inch hose, also malleable iron bucket clamp for holding pump firmly in bucket (see illustration above), so entire outfit may be carried from place to place by the bail when bucket is full of mixture CIPHER, KELTER

Fig. 968, "Handy Success," consists of the "Success" pump mounted in a four-gallon tank, which may be had in brass or galvanized iron. This is a very popular outfit among florists, gardeners, stockmen and poultrymen. HOSE AND NOZZLE: Four feet of 3/8-inch hose and "Bordeaux" nozzle. Weight, boxed for shipment, is about 25 pounds.

Fig. 968—With galvanized iron tank CIPHER, KIVER

Fig. 968—With brass tank CIPHER, KRIS

Alphabetical Index, Figure Index and Telegraph Cipher Code, Pages 249 to 254



The Deming Knapsack Sprayers, Figs. 675, 654

For Garden, Vineyard and Greenhouse

FIG. 675 — The "Success" Knapsack sprayer (the cut to the left) is a useful implement for the florist and grower of vegetables and small fruits. As a vineyard sprayer it is much used, but sprayers of large capacity are now more in use for this purpose. The brass tank is suitable for using lime-sulfur and bordeaux solutions.

FIG. 654 — "Prize" Knapsack sprayer (cut to the right) is similar to Fig. 675, except that the tank is of galvanized iron, and the "Prize" pump is used.

Specifications

PUMP: The working parts are same as the "Prize" and "Success" pumps shown on preceding pages. The cylinder, plunger, valves and valve seats being brass, corrosion and rust are eliminated. The lever is wrought iron and with malleable iron link, steel rod and wood handle.

TANKS are five gallons capacity. Fig. 675 has BRASS tank and dash disc agitator, operated from the pump lever. Fig. 654 may be fitted with agitator, when desired, at extra cost. Both outfits have drip cup for possible leakage; wide shoulder straps; and a gauze strainer under filling hole. Figs. 675 and 654 have carrying handles on top of tank and wide foot rest at bottom, for convenience when used like bucket pumps. When so used, lever may be detached and the extra handle affixed to the plunger rod. Fig. 654 has GALVANIZED IRON tank.

HOSE AND NOZZLE: These outfits have 4 feet of 3/8-inch hose with extension pipe 24 inches long; undersprayer, Fig. 962 (see page 215) and our "Bordeaux" nozzle (see page 214).

SHIPPING WEIGHT: The weights boxed for shipment are about 40 pounds.

Outfits

- Fig. 675 — With brass tank, as described Cipher, KETTLE
- Fig. 654 — With galvanized tank Cipher, KETCHUP
- Seven-foot section 3/8-inch hose couplings and pole holder, for tree spraying . . Cipher, KEDLACK

Complete Table of Contents and General Classification of Pumps, Pages 7 and 8



The Deming "Aerospra," Fig. 663

(Patented. Trade-Mark Registered)
For Garden, Vineyard and Greenhouse

The "Aerospra" is the best and most durable compressed air hand sprayer on the market. It is convenient in all respects. *If the plunger is removed from the cylinder, it can be replaced without interference with the crimped plunger leather by placing it in the recessed cap of tank until the cap is attached again ready for operations.* The straps are for carrying it on the shoulders—or it can be carried by the handle, when carrying lock is attached—see the sectional view. The operator can pump up and spray at rest, until the reduced pressure requires pumping again. The tanks are tested up to 100 pounds pressure—more than twice the pressure which is obtained by the average operator. The sprayer is patented and the NAME "AEROSPRA" IS A REGISTERED TRADE-MARK.

Specifications

AIR PUMP: Brass tube cylinder, diameter 2 inches, stroke 12 inches. Top cap of tank attached to cylinder. A special rubber-packed flange tightens with the pressure. The locking and carrying clamp is of unique design. The cylinder valve is rubber and is very simple. The pump can be instantly removed for filling the tank.

TANK: MADE EITHER OF THE BEST QUALITY OF GALVANIZED SHEET STEEL OR SHEET BRASS. The carrying straps are wide for ease in handling. The diameter is 7½ inches and height 18½ inches, with about 3½ gallons capacity. The tank should be about two-thirds filled.

HOZE AND NOZZLE: There is a 3-foot section of 3/8-inch hose with shut-off cock and fine spray nozzle.

SHIPPING WEIGHT: When boxed with all parts snugly packed ready for freight or express, the weight is about 20 pounds.

Outfit and Extras

Fig. 663 — "Aerospra" with brass air pump and BRASS TANK, as illustrated and described, CIPHER, KOORD

Fig. 663 — "Aerospra," as above, but with GALVANIZED STEEL TANK CIPHER, KING

For extension pipe see Fig. 1165, page 216.

For nozzle with automatic shut-off we recommend a special size, Fig. 1152, as illustrated above, 24 inches long. For general description, see page 216 CIPHER, KING

Engineering Tables and Information Relating to Hydraulics, Pages 239 to 248



The "Gardener's Choice" Sprayer, Fig. 651

For Garden and Field Work, Small Orchards, Etc.

This is one of the most convenient spraying outfits for general use. As an all-round utility sprayer it cannot be beaten. It is particularly adapted for both the garden and greenhouse, also for orchard use, as well as for spraying livestock in the barn and livery stable. It is a splendid whitewashing outfit, as the pump is strong and durable and has a good agitator. The working parts, including agitator, are shown in the sectional view above.

Specifications

PUMP has 1¼-inch brass cylinder, brass ball valves with brass seat and cage, brass plunger and our special plunger packing. The leverage is six to one; can be worked against pressure of 100 pounds. The air chamber is ample, the base adding considerably to the capacity of the pipe air chamber.

AGITATOR: Twin paddle type, simple and effective; stirs the liquid thoroughly.

TANK AND CART: Twenty-four-gallon wood tank with steel hoops and hinged wood top. Leg, tongue and handle of wrought pipe. Metal wheels, diameter 24 inches, with staggered spokes and 2-inch tires. Special axle of wrought iron pipe held by long through bolts. Hub-to-hub measurement, 33 inches. Height to top of tank, 30 inches. Height to top of pump, 42 inches.

HOSE AND NOZZLE: Six feet of ½-inch "Deco" discharge hose and our "Bordeaux" nozzle are furnished. See list below for extra section of hose.

SHIPPING WEIGHT, including cart, when crated, is about 120 pounds.

Outfits and Extras

Fig. 651 — "Gardener's Choice," with equipment as described above CIPHER, KIDDER
Section of ½-inch "Deco" sprayer hose 12½ feet long, with couplings and "Simplex" angle
nozzle CIPHER, KNAVISH
Additional price for extra lengths of hose. For extension pipes, etc., see pages 215 and 216.

Complete Table of Contents and General Classification of Pumps, Pages 7 and 8

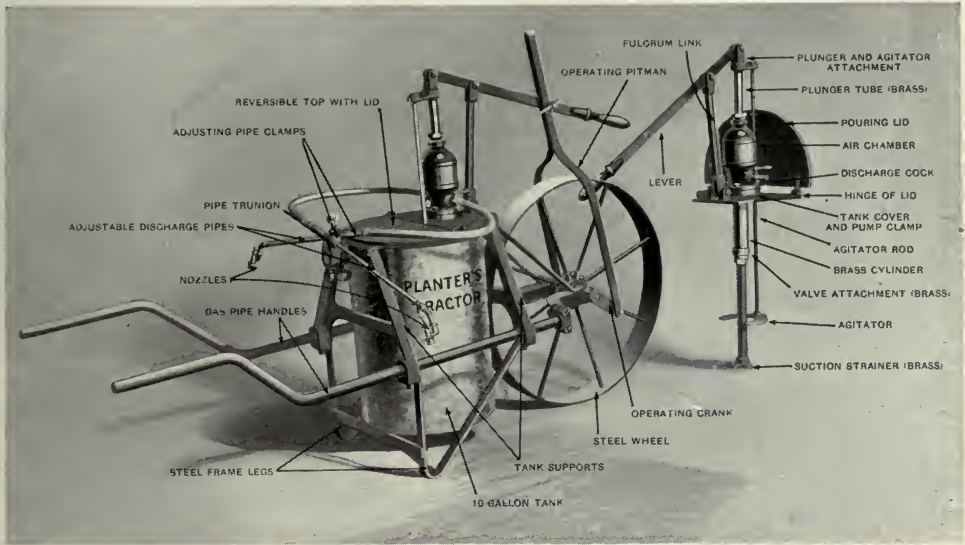

The "Planter's Tractor" Sprayer, Fig. 822

(Patented)

For Garden and Field Crops

FOR SPRAYING GARDEN AND FIELD CROPS two rows at a time, this is a splendid machine. It is a "one-man power" outfit, in which the pump is automatically operated from the wheel. OPERATES UNDER 40 POUNDS PRESSURE WHEN PUSHED AT ORDINARY SPEED.

When used for TREE SPRAYING ONLY the crosshead pin and connecting rod should be removed from the axle and pump lever, REVERSING THE PUMP AND TANK. This brings the pump lever convenient to the user, who can then attach an extra section of 3/8-inch hose and proceed to spray his trees and shrubbery.

Specifications

PUMP: 1 1/2-inch brass cylinder, stroke is adjustable, 3 3/4, 2 3/8 or 1 1/2 inches. Air chamber is augmented by hollow brass plunger tube. The plunger, valves and seats are brass. Lever is steel. The agitator is of dash-disc type operated from rod attached to plunger tube.

TANK: GALVANIZED OR BRASS, 10-GALLON; detachable. Iron top and lid; bottom reinforced.

FRAME: Handles of steel pipe bent to shape, and attached to uprights, carrying the tank. Axle bearings clamped to ends of handles, forming the frame. Structure rigidly supported by steel braces, forming the legs.

WHEEL: Diameter, 24 inches, with 3-inch tire. Hub is welded to axle.

DISCHARGE EQUIPMENT: Two sections of 3/8-inch hose 2 feet long; two 3/8-inch stop cocks; two 1/4-inch hose pipes 18 inches long; two "Demorel" nozzles with angle discharge for rows up to 48 inches apart; forward or backward spray for shorter or taller plants.

SHIPPING WEIGHT, when crated, about 150 pounds.

Outfits and Extras

Fig. 822 — "Planter's Tractor," complete with galvanized tankCipher, KINGCRAB

Fig. 822 — "Planter's Tractor," with brass tankCipher, KIRKYARD

For extension pipes, see page 216.

Seven-foot section of 3/8-inch hose with couplings and pole holder, for trees. . Cipher, KEDLACK

Alphabetical Index, Figure Index and Telegraph Cipher Code, Pages 249 to 254



The "Major" Barrel Sprayer, Fig. 832

For Spraying Small and Medium-Size Orchards

For the farmer who has either a young or old family orchard, this is an excellent pump. It has a smaller diameter cylinder than the "Century" (see following page), and for this reason is adapted for use with one lead of hose and one nozzle only. The "Major" clamps to the chime of the barrel and is also firmly secured to the bottom of barrel by an anchor pin which fits into a recess in the pump. This device may be quickly and easily attached to any barrel. Other pumps of this type without this anchor device will not remain rigid and are very annoying to operate.

The "Major" is also much used for disinfecting the farmyard, barns, poultry houses and stock pens; spraying stock dip and cattle-fly oil; for whitewashing buildings and fences; for deodorizing and purifying cellars, vegetable bins, dairy rooms, etc. The "Major" will develop a powerful pressure; is practically proof against corrosion, as all working parts are brass; is easy to operate; and is the best pump on the market for the price. *The barrel is not furnished; any good barrel may be used.*

Specifications

PUMP: Sets low in barrel. Fastens to chime of barrel by turning one clamp screw. Held rigid by anchor pin on bottom of barrel.

CYLINDER: Removable 2-inch seamless drawn brass; always submerged and primed.

PLUNGER has special fabric packing—chemically treated. Will not require replacing for two or three seasons.

VALVES: Solid bronze ball valves and bronze valve seats. By removing two bolts, both suction and discharge valves may be taken out for examination or repair.

AIR CHAMBER: Two-inch heavy steel tubing. Ample capacity for one section hose. Reduces effort of pumping.

AGITATOR: Twin paddle type. Simple and effective for stirring solution.

FITTINGS: Brass gauze strainer; discharge connection fitted for one lead of ½-inch hose.

SHIPPING WEIGHT: Pump only, about 50 pounds.

Outfits and Extras

Fig. 832 — "Major" sprayer only; discharge fits regular ½-inch female half hose coupling
 Cipher, KEEL

Outfit "A" — "Major" sprayer with one 12½-foot section of ½-inch hose, couplings, and
 "Simplex" angle nozzle Cipher, KEELING

Additional price for extra lengths of hose. Extension pipes with stop cock, and other extras on pages 215 and 216 showing accessories.

Complete Table of Contents and General Classification of Pumps, Pages 7 and 8

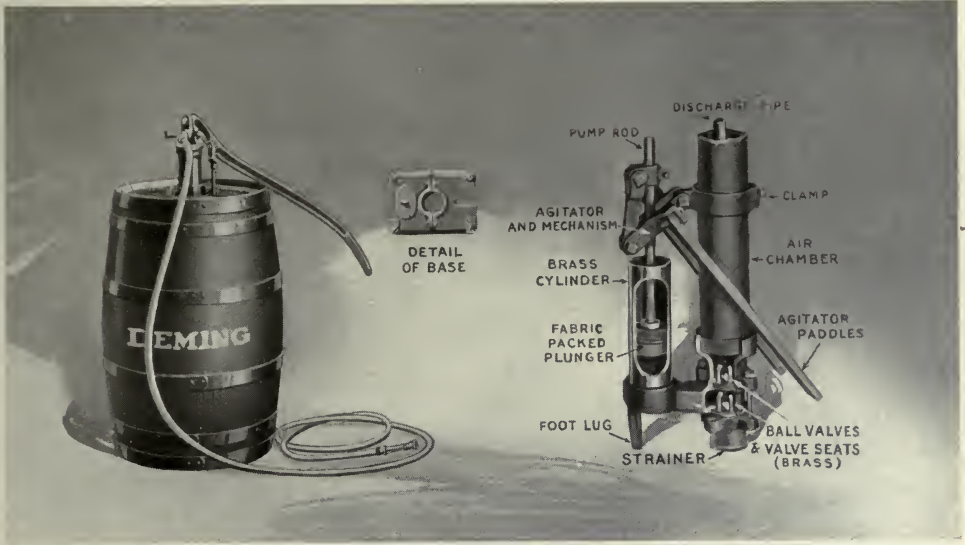

The "Century" Barrel Sprayer, Fig. 645

The Premier of all Barrel Sprayers

For more than twenty years, the "Century" has maintained its leadership among barrel sprayers. Thousands of "Centuries" are now in use all over the civilized world. Leading growers and horticultural experts all combine in pronouncing it the "best all-around barrel sprayer on the market." At the National Horticultural Congress, the "Century" was awarded first honors, winning out over six other well-known makes.

It has a larger capacity than the "Major" (see preceding page), and will supply two leads of hose and two nozzles. In addition to spraying orchards, etc., it is widely used for disinfecting farmyards, barns, poultry houses and stock pens; spraying stock dip and cattle-fly oil; white-washing buildings and fences; disinfecting and purifying cellars, vegetable bins, dairy rooms, etc.

The "Century" is proof against corrosion, as all working parts are brass; is so substantially constructed as to be practically exempt from breakage; is easy to operate and is absolutely the best barrel pump that money can buy. *The barrel is not furnished.*

Specifications

PUMP: Sets low in barrel. *Universal iron base*—adjustable to any size or depth of barrel—fits the flat head or curved side of barrel. This, with foot lug, keeps pump absolutely rigid during operation. Base fits 7 x 10-inch hole. Liquid is poured through a filling hole in base. Four hook bolts with large thumb nuts attach base to barrel head. Easy to remove pump from barrel.

CYLINDER: Renewable 2¼-inch seamless drawn brass. Four-inch stroke. Always submerged and primed. Plunger has special fabric packing, chemically treated.

VALVES: Solid bronze ball valves and bronze valve seats. By removing four bolts, both suction and discharge valves may be taken out for examination or repair.

AIR CHAMBER: 2½-inch heavy steel tubing, 32 inches long. Reduces effort in pumping.

AGITATOR: Twin paddle type. Simple and effective for stirring solution.

FITTINGS: Brass gauze strainer. Brass discharge "Y" for two leads of ½-inch hose.

SHIPPING WEIGHT: Pump only, carefully boxed, 75 pounds.

Outfits and Extras

Fig. 645 — "Century" barrel sprayer only, with "Y" connection, Fig. 364 . . . Cipher, KINATE
Outfit "A," as above, with one 12½-foot section of ½-inch "Deco" hose, couplings and
"Simplex" angle nozzle Cipher, KERNISH

Outfit "B," with two 12½-foot sections of hose, nozzles, etc. Cipher, KNIGHTLY
Additional price for extra lengths of hose. For extension pipes, etc., see page 216.

Engineering Tables and Information Relating to Hydraulics, Pages 239 to 248



The "Farmer's Friend" Sprayer, Fig. 647

For Spraying Field Crops, Orchards, Etc.

A most convenient outfit for either field, vineyard or orchard work. The U. S. Government is using large numbers of these outfits at home and abroad for spraying, disinfecting and white-washing.

No lifting of heavy barrels of mixture into and out of farm wagons. The "Farmer's Friend" is always ready for business as soon as barrel is filled.

For spraying field crops, our four-row field sprayer, Fig. 653 (see opposite page) is recommended.

Specifications

PUMP: The "Century" barrel pump. For complete description of pump see page 207.

AGITATOR: Twin paddle type. Keeps liquid well stirred.

TANK AND FRAME: The tank is a 50-gallon barrel set lengthwise on strong steel supports. Hills and platform are of wood and well constructed. Shafts and platform are of hardwood with plenty of space for a man to stand on platform for driving and pumping.

WHEELS AND AXLE: Wheels are steel; diameter, 44 inches; width of tire, 3 inches. Axle is 1½-inch steel shafting. Wheels are fitted for 56-inch tread.

FITTINGS: A three-way stop cock is fitted to pump discharge so that two leads of hose may be used if necessary, although but one 12½-foot section of ½-inch "Deco" hose and "Simplex" angle nozzle are regularly supplied. We recommend the use of an extension pipe with this outfit when used for orchard spraying. See page 216.

SHIPPING WEIGHT: Knocked down and crated, is about 500 pounds.

Outfits and Extras

Fig. 647 — "Farmer's Friend" sprayer, complete with pump, hose, etc., as illustrated and described CIPHER, KERNING

Additional price for extra lengths of hose. Extension pipes, stop cocks, etc., on pages 215 and 216.

Complete Table of Contents and General Classification of Pumps, Pages 7 and 8

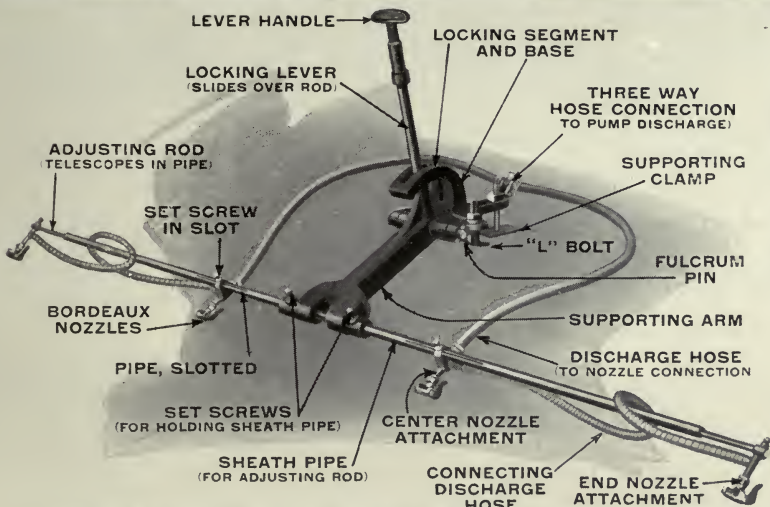

The Deming Four-Row Field Sprayer, Fig. 653

For Potato Plants and Other Field Crops

For spraying potatoes, strawberries, small nursery stock, cotton fields, etc., this is a very convenient device, as it is easily and quickly attached to any wagon.

The nozzle holders can be adjusted to rows of any width from 22 to 40 inches for forward or backward spraying. They may be raised or lowered and brought together to pass through gate. OUR "CENTURY" OR LARGER SPRAYERS CAN BE USED.

Specifications

ATTACHMENT: For any wagon or cart. Can be securely clamped on with set screws and bolts which are furnished.

ADJUSTMENT: Height for spraying and width of rows can be easily arranged by the lock lever. Width of rows from 22 to 40 inches.

HOSE AND NOZZLES: There are two sections of $\frac{3}{8}$ -inch hose connecting to the outer nozzles and two sections of $\frac{1}{2}$ -inch hose connecting to coupling in center, to which discharge hose of pump is attached. Four "Simplex" nozzles are used.

SHIPPING WEIGHT: Partially crated to prevent breakage, is about 80 pounds.

Outfits

Fig. 653 — With four "Simplex" nozzles and hose sections, also coupling for discharge hose connecting to pump as per detail engraving CIPHER, KATYDID
 Section of $\frac{1}{2}$ -inch "Deco" sprayer hose, 8 feet long, with couplings for attaching field sprayer to discharge of spray pump CIPHER, KANTRY

Alphabetical Index, Figure Index and Telegraph Cipher Code, Pages 249 to 254

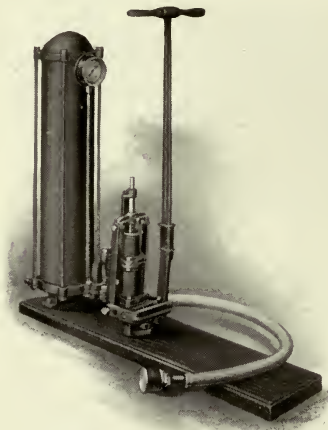

Fig. 633



Fig. 933

“Samson” Double-Acting Sprayer, Fig. 633 and Outfit, Fig. 933

The next best outfit to a power machine, and the easiest working hand sprayer on the market. Will develop a pressure of 150 to 175 pounds while supplying two leads of hose, and at the same time, permit the operator to rest between strokes, because of the unusually large air chamber and extra long lever. Is proof against corrosion and practically exempt from breakage.

Does speedy, thorough work. Thousands now in use. Positively the latest and best development in hand spraying, and a decided success from the start.

Specifications Fig. 633

PUMP: Differential plunger, discharging equal amount of water at each stroke. Working parts accessible; brass cylinder linings and ball valves easily removed. Furnished with wood platform, 10 feet of 1-inch suction hose and strainer; pressure gauge and double discharge attachment. Discharge hose, nozzles, etc., extra; see pages showing accessories.

CYLINDER: Differential; brass; solid bronze ball valves and seats; special fabric packing—chemically treated to resist corrosion.

AIR CHAMBER: Steel tube; seven gallons capacity; makes pumping easy.

SHIPPING WEIGHT, crated, about 175 pounds.

Specifications Fig. 933

PUMP on large platform with following additional equipment: 50-gallon barrel; 1-inch suction pipe (instead of hose) and strainer; agitator, operated from lever; 25 feet 1/2-inch “Deco” discharge hose with double spraying attachment and two “Simplex” nozzles; Fig. 751 bamboo extension, 10 feet long, with drip shield. A wrench is provided with which to loosen the suction pipe, thus preventing siphonage of the mixture from the pump.

Outfits and Extras

Fig. 633 — As illustrated and described CIPHER, KNOBED

Fig. 933 — Complete with equipment as illustrated and described CIPHER, KECKLE

Additional charge for extra hose



Deming Duplex Plunger Pump, Fig. 761 For Operation by Any Gasoline Engine

This is the pump regularly supplied on our complete power sprayers. Many growers who already have an engine prefer to assemble their own outfits and we, therefore, list this pump separately. The pulley may be changed to fit any engine speed.

MAIN CASTINGS ARE SEPARATE.

The base, columns and air chamber on Fig. 761 are separate castings. Should breakage occur because of accident, this construction reduces cost of repairs.

CYLINDERS AND PLUNGERS: Deming cylinders are made of cast bronze, bored absolutely true. The plungers are of close-grained gray foundry iron. Plunger packing consists of a chemically-treated leather crimp which wipes the cylinder free from solution at every stroke.

THE VALVES: Deming valves consist of solid bronze balls. The valve seats are cast bronze and will not break, chip, corrode, wear out or become loosened from the seat.

THE SUCTION VALVE COVERS are not screwed in but are held in place by a yoke. This yoke can be removed by unscrewing *one nut*. The valve covers can then be lifted out, exposing the suction valves. The discharge valves are of the same construction. Nothing could be simpler.

DRAINAGE: Suction and discharge ports are equipped with drainage plugs to prevent freezing.

Equipment Furnished With Fig. 761

Belt tightener; pressure gauge; relief valve; double discharge cock; 10 feet of 1-inch suction hose and strainer.

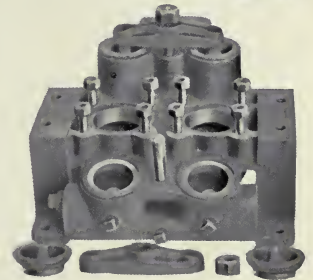
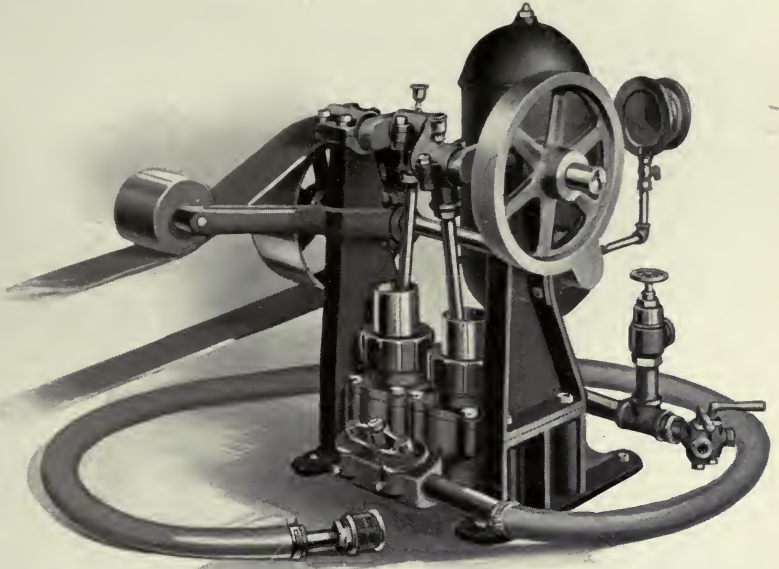

Sizes, Capacities, Etc.

No.	Maximum Revs. per Minute	Diameter Cylinder and Stroke Inches	Horse-power of Engine Recommended	Capacity per Minute at 70 Revs. Gallons	Shipping Weight Pounds	Size Pulleys	Cipher
1	70	2 x 2½	2	4¼	225	12 x 3	KYAN
2	70	2½ x 3½	3	9	310	14 x 4	KEYAGE

For discharge hose, nozzles, extension pipe, etc., see pages 214 to 216.

Engineering Tables and Information Relating to Hydraulics, Pages 239 to 248



Deming "Victory Junior" Power Sprayer, Fig. 729
With 4¼-gal. Pump, 2 H. P. Engine and 150-gal. Tank



The Deming "Victory Junior"—View From Right Side

For spraying orchards of 8 to 10 acres or more, a power rig is essential. Deming Power Sprayers may be mounted on any standard farm wagon truck, as they are furnished with adjustable bolster pieces. In the construction of the "Victory Junior" we use the Fig. 761, No. 1 pump, described on preceding page; 2 H. P. Novo engine and 150-gallon tank.

The pump is good for 250 pounds pressure—more than is required for successful spraying.

NOTE: *The "Victory Junior" will supply two nozzles with large hole discs or four nozzles with small hole discs. Nozzles with large hole discs are regularly furnished.*

If it is desired to use two leads of hose, the small hole discs should be specified.

We recommend the use of our "Comet" spray gun, *with small hole disc*, in connection with "Victory Junior."

Equipment Regularly Supplied with the "Victory Junior"
Power Sprayer, Fig. 729

DUPLEX PUMP: Capacity, 4¼ gallons per minute at 70 revolutions.

ENGINE: 2 H. P. Novo; batteries and wiring.

TANK: 150 gallons with manhole and propeller agitator; a hinged cab encloses both the pump

ACCESSORIES: Suction box and clean-out strainer; double discharge cock for two leads of hose; One 25-foot section of ½-inch "Deco" high pressure discharge hose, with couplings, double spraying attachment and two "Simplex" angle nozzles;

One Fig. 751 brass-lined bamboo extension pipe, 10 feet long, with leakless stop cock; Pressure regulator; pressure gauge; tool box containing oil can, monkey wrench and spanner for stuffing box of pump; hooks for coiling hose when not in use; holders on top of tank for extension pipes; foot rest; all complete as illustrated, ready to mount on any wagon truck and commence operations.

Capacities, Etc., of Fig. 729

PUMP			H.P. of Engine	Net Weight of Outfit Pounds	Shipping Weight of Outfit Pounds	Cipher
Diameter Cylinder and Stroke Inches	Capacity per Minute at 70 Revolut'ns Gallons	Good for Maximum Pressure Pounds				
2x2½	4¼	250	2	1000	1200	KNUR

Complete Table of Contents and General Classification of Pumps, Pages 7 and 8



**Deming "Victory" Power Sprayer, Fig. 730
With 8-Gallon Pump; 3-H. P. Engine and 200-Gallon Tank**

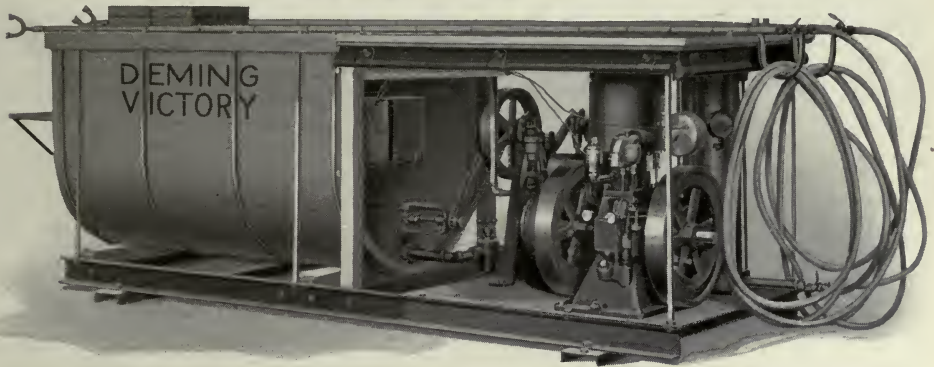

The Deming "Victory"—View from Left Side

In the "Victory," we have used Fig. 761, No. 2 (page 211) with 3 H. P. Novo engine and 200-gallon tank.

This makes a larger and more powerful outfit than the "Victory Junior" and is especially adapted to large commercial orchards.

Inspection and Test

A rigid test and inspection of each Deming Power Sprayer is made before it is permitted to leave the factory—the pump being subjected to a high pressure that would inevitably disclose any flaws or weaknesses. Both the pump and engine are most carefully adjusted. Unless such precautions are taken, annoying delays are apt to be experienced the first few times the outfit is used. But Deming outfits will be found "ready for business" as soon as uncrated.

Equipment Regularly Supplied with the "Victory," Fig. 730

DUPLEX PUMP: Capacity, 8 gallons per minute at 60 revolutions.

ENGINE: 3 H. P. Novo; batteries and wiring.

TANK: 200 gallons with manhole and propeller agitator; hinged cab enclosing pump and engine with roll curtains to further protect machinery.

ACCESSORIES: Suction box and clean-out strainer; double discharge cock for two leads of hose; Two 25-foot sections of 1/2-inch high pressure "Deco" discharge hose, with couplings, double spraying attachment and four "Simplex" angle nozzles;

Two Fig. 751 brass-lined bamboo extension rods, 10 feet long, with leakless stop cock on each; Pressure regulator; pressure gauge; tool box containing oil can, monkey wrench and spanner for stuffing box on pump; hooks for coiling hose when not in use; holders on top of tank for extension pipes; foot rest; all complete as illustrated, ready to mount on any wagon truck and commence operations.

OPTIONAL EQUIPMENT: One 50-foot section of hose and fittings as above, and one Deming "Comet" spray gun.

Capacities, Etc., of Fig. 730

Diameter Cylinder and Stroke Inches	PUMP		H.P. of Engine	Net Weight of Outfit Pounds	Shipping Weight of Outfit Pounds	Cipher
	Capacity per Minute at 60 Revolutions Gallons	Good for Maximum Pressure Pounds				
2 1/2 x 3 1/2	8	250	3	1400	1600	KILLAS

Alphabetical Index, Figure Index and Telegraph Cipher Code, Pages 249 to 254

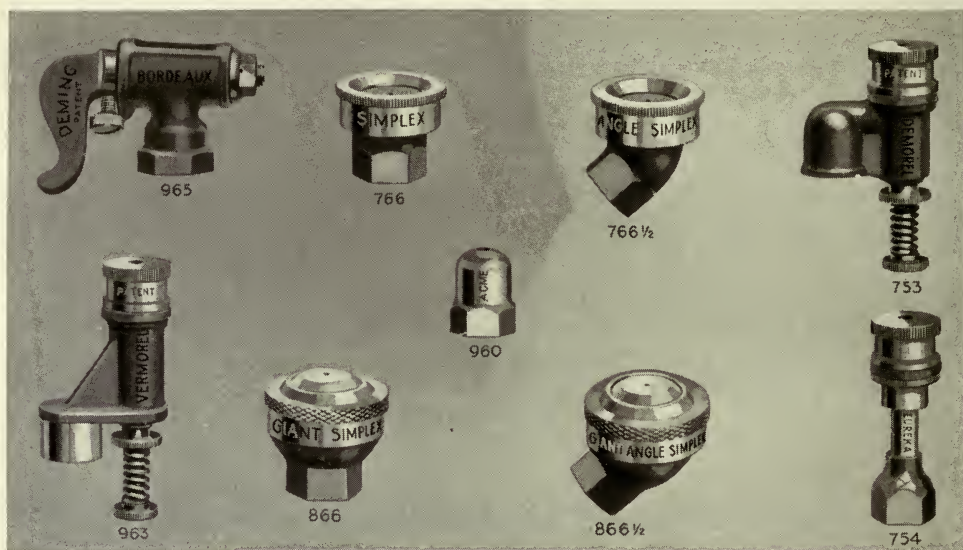

The Deming Spraying Nozzles

THE MANUFACTURE OF SPRAY NOZZLES requires great care in the machine work. Special machinery and tools enable us to make perfect nozzles. Perfect brass castings only are used and EVERY NOZZLE IS TESTED before it leaves our works.

A SPRAYER'S EFFICIENCY IS IN THE NOZZLE — THE "BUSINESS END." Without a good nozzle any spraying outfit is inefficient. The Deming patent spray nozzles, shown above, are "The World's Best." They can be used with any spray pump.

HOW DEMING NOZZLES ARE PUT UP: — All the DEMING NOZZLES illustrated above are put up in individual paper boxes except Fig. 960, as listed below. Complete directions for using the nozzles are printed on each nozzle box. The "BORDEAUX" patent nozzle, when so ordered, is put up for dealers in cartons containing a dozen nozzles.

- Fig. 965 — "Bordeaux" is furnished with many of our sprayers. It is the best general purpose spray nozzle ever produced. Throws a solid stream, coarse long-distance spray, or a fine mist; or it may be shut off. It is an excellent nozzle also for whitewashing, disinfecting, etc. Easily disgorger. THE NAME "BORDEAUX" IS A REGISTERED TRADE-MARKCipher, KEEPSAKE
- Fig. 766 — "Simplex," light, durable and compact. Adapted for high pressure. Has two interchangeable steel spray discs, one coarse and one medium-fine spray. Does not waste liquidCipher, KEMPTV
- Fig. 766½—"Simplex" angle nozzle, similar to Fig. 766. Cipher, KILT
- Fig. 753 — "Demorel," similar to "Vermorel," but somewhat lighter in weight, with caps for fine and coarse sprays. Steel caps, instead of brass, when ordered. (PAT-ENTED)Cipher, KERONA
- Fig. 963 — "Vermorel," with caps for fine and coarse sprays. Obstructions readily forced out with spring disgorger. Steel caps, instead of brass, when specified. (PAT-ENTED)Cipher, KEFFEL
- Fig. 866 — "Giant Simplex" nozzle, with strainer and arch spray disc, similar to Fig. 766, but larger, for extensive operations and high pressureCipher, KNAGGED
- Fig. 866½—"Giant Simplex Angle" nozzle, with strainer, similar to Fig. 866Cipher, KNOCK
- Fig. 754 — "Eureka," throws conical-shaped spray; disgorges by pushing against fence or tree. A good whitewasher.Cipher, KNITCH
- Fig. 960 — "Acme," will throw a solid stream or a fine spray. Furnished on "Prize" bucket sprayers.Cipher, KELPIE

Complete Table of Contents and General Classification of Pumps, Pages 7 and 8

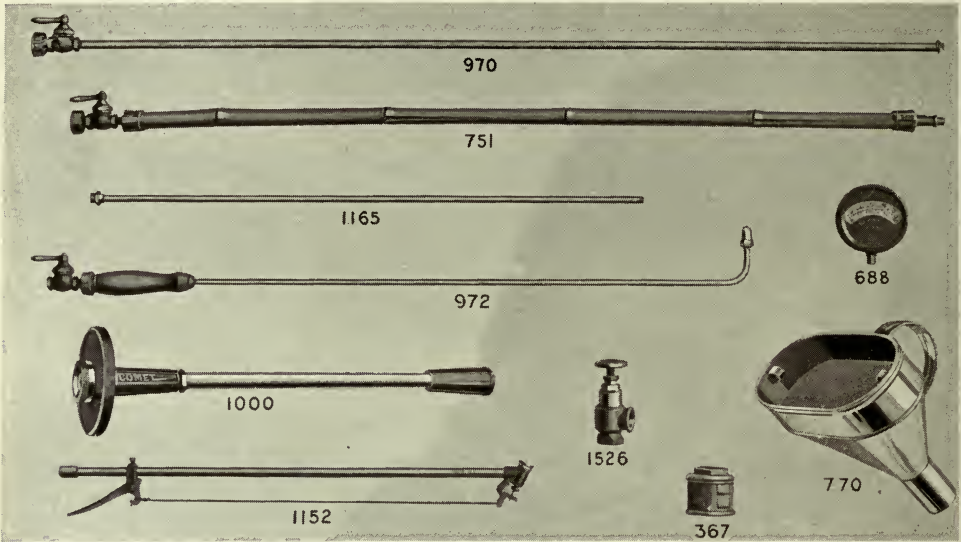

Deming Spraying Accessories

- Fig. 970 — Galvanized Extension Pipe 8 feet long with leakless stop cock. CIPHER, KALAND
- Fig. 751 — Bamboo Extension Pipe, 10 feet long, light and strong. Brass lined, with leakless stop cock; longer pipes extra CIPHER, KALENDER
- Fig. 1165 — Brass Spray Pipe, two feet long, 1/4 inch with 1/4-inch iron pipe connections, male one end, female other end. Male end fits all standard nozzles. CIPHER, KALENDS
- Fig. 1165 — Three feet long CIPHER, KALEYARD
- Fig. 1165 — Four feet long CIPHER, KALI
- Fig. 972 — The "Acme" brass Spray Lance with stop cock, strainer, handle and Acme nozzle, especially for ground crops, such as melons, cucumbers, etc. CIPHER, KIBED
- Fig. 1000 — "COMET" Spray Gun CIPHER, KUMISS
- Fig. 1152 — "ADJUSTOP" Spray Pipe Extension, 6 feet long, with wood hand-hold, adjustable spray nozzle and automatic shut-off. The spray is adjustable in distance; throws coarse spray 25 feet; shortening distance broadens spray CIPHER, KNARLED
- Fig. 1152 — Twenty-four inches long (as illustrated) CIPHER, KINIE
- Fig. 1526 — "B" — "Special" Brass Adjustable Relief Valve for power sprayers CIPHER, KYLOES
- Fig. 688 — Pressure Gauge, used on power sprayers and largest hand sprayers. For 1/4-inch pipe CIPHER, KAMSIN
- Fig. 367 — Galvanized Strainer with Brass Gauze, for 1-inch pipe CIPHER, KANTIST
- Fig. 770 — Filling Funnel (with removable brass gauze strainer), size, 10 x 6 x 10 inches, Brass Funnel as above CIPHER, KYMNEL
- Fig. 752 — Seven-foot section 3/8-inch hose with pole holder and couplings (not illustrated) CIPHER, KEDLACK
- DIS-CHARGE HOSE SECTIONS { 12 1/2-foot section of 1/2-inch "Deco" sprayer hose, couplings and "Simplex" angle nozzle CIPHER, KNAVISH
- { 25-foot section of 1/2-inch "Deco" hose, with couplings, double attachment and two "Simplex" angle nozzles CIPHER, KESLOP
- { 50-foot section of 1/2-inch "Deco" sprayer hose; couplings, double spraying attachment; two "Simplex" angle nozzles CIPHER, KABOB
- HOSE WITHOUT COUPLINGS { "Deco" sprayer hose, 1/2-inch, for 250 pounds pressure, any length.
- { Rubber tubing, 3/8-inch, for Bucket and Knapsack sprayers, any length.
- { Wire-lined suction hose, 1-inch, in 10-foot sections.

Complete Table of Contents and General Classification of Pumps, Pages 7 and 8



REPAIRS
OR
EXTRA PARTS

FOR

HAND AND POWER PUMPS

EMBRACING DESCRIPTIVE
TABULATED PRICE LISTS OF
EXTRA PARTS FOR DEMING
HAND, WINDMILL AND POWER
PUMPS, IRON AND BRASS
CYLINDERS, SPRAY PUMPS, ETC.
A CONVENIENCE TO DEALERS
AND USERS. PRICES ON RE-
PAIRS NOT LISTED FUR-
NISHED ON REQUEST





HAND AND POWER PUMPS FOR ALL USES



REPAIRS OR EXTRA PARTS

The repair parts listed in this section embrace our most popular hand and windmill pumps; iron and brass cylinders, hydraulic rams, power pumps, spray pumps, etc.

If repairs are desired for a pump not given in this repair list, we should be informed concerning the symbol number which is cast on the pump part; and any other details such as descriptive diagram, weight, etc. The comprehensive figure index below will make it possible to quickly find the page on which the desired repairs are listed.

FIGURE INDEX TO REPAIR PARTS

FIGURE	PAGE	FIGURE	PAGE	FIGURE	PAGE	FIGURE	PAGE
66.	234	311.	228	482.	221	609.	234
101.	218	312.	227	494.	224	633.	238
102.	218	314.	227	496.	224	645.	237
115.	218	320.	230	498.	224	651.	237
120.	219	321.	230	508.	220	653.	238
124.	219	322.	227	509.	220	654.	236
125.	219	324.	228	516.	220	659.	236
166.	221	398.	221	518.	219	669.	236
182.	221	403.	224	519.	219	670.	220
183.	222	415.	225	540.	219	675.	236
184.	222	415½.	225	544.	219	689.	236
185.	221	421.	222	554.	229	690.	231
198.	221	430.	230	554½.	229	691.	233
211.	222	440.	224	570.	220	695.	231
219.	224	441.	224	575.	232	761.	238
223.	224	442.	224	576.	232	776.	232
224.	224	444.	224	577.	232	832.	237
229.	224	444½.	224	577½.	232	1229.	224
239.	224	445.	224	578.	232	1239.	224
258.	225	450.	223	579.	232	1430.	230
259.	225	450½.	223	585.	230	1444.	224
260.	225	451.	223	590.	230	1473.	229
261.	225	451½.	223	591.	230	1685.	235
280.	222	452.	223	595.	231	1686.	235
281.	222	452½.	223	600.	221	1717.	226
282.	222	453.	223	600½.	221	1718.	226
283.	222	453½.	223	601.	228	1719.	226
290.	222	470.	229	602.	228	1720.	226
291.	222	471.	229	606.	221	2085.	235
298.	221	472.	229	608.	221	2086.	235
300.	227	473.	229	608½.	221		
308.	227						

"DOMESTIC" KITCHEN PUMP, FIG. 102

NAME OF PART	PRICE	NAME OF PART	PRICE
Cylinder	\$1.25	Plunger only	\$0.55
Bearer	.40	Plunger Rod	.10
Lever	.40	Brass Tube for Lead Pipe	.45
Base	.65	Valve Weight and Screw	.06
Base Nut	.20		

BRASS CYLINDER PITCHER SPOUT PUMPS, FIGS. 101 AND 115

FIGURE NUMBER	101	115	FIGURE NUMBER	101	115
Cylinder, Brass	\$2.25	\$2.75	Base	\$0.75	\$1.15
Cylinder, Nickel Plated	2.50	Base Nut	.20	.20
Spout Section	1.00	1.40	Plunger only	.55	* 2.00
Bearer	.40	.40	Plunger Rod	.10	.10
Lever	.40	.40	Valve Weight and Screw	.06	.06
Cylinder Ring	.30	.30	* Brass.		

Complete Table of Contents and General Classification of Pumps, Pages 7 and 8



HAND AND POWER PUMPS FOR ALL USES



PITCHER SPOUT PUMPS, FIG. 125

SIZE NUMBER	1	2	3	4	5	6
Cylinders, Iron	\$1.00	\$1.10	\$1.20	\$1.60	\$2.00	\$3.50
Cylinders Brass-lined	2.00	2.25	2.75	3.00	4.25	7.50
Bearer40	.40	.50	.50	.65	1.25
Lever30	.30	.40	.40	.40	1.00
Base60	.65	.80	.90	1.75	2.75
Base Nut20	.20	.20	.25	.50	.75
Plunger only45	.55	.65	.85	1.25	2.00
Plunger Rod10	.10	.10	.10	.10	.10
Valve Weight and Screw06	.06	.07	.10	.10	.20

CISTERN PUMPS, FIGS. 120 AND 124

SIZE NUMBER	1	2	3	4	5	6	8
Cylinder, Fig. 120, Iron	\$1.75	\$1.75	\$2.00	\$2.25	\$2.50	\$2.75	\$4.50
Cylinder, Fig. 120, Brass-lined	2.75	2.75	3.25	4.00	5.00	6.00	8.00
Cylinder, Fig. 124, Iron	2.25	2.25	2.50	2.75	3.00	3.50	5.00
Cylinder, Fig. 124, Brass-lined	3.25	3.25	3.75	4.50	5.50	6.75	8.50
Base, Fig. 12075	.75	.85	1.00	1.25	1.50	1.75
Base, Fig. 12450	.50	.50	.65	.75	.85	1.00
Bearer40	.40	.50	.60	.70	.85	1.00
Lever50	.50	.50	.60	.70	.75	.75
Base Nut15	.15	.15	.20	.20	.30	.40
Brass Suction Tube for Iron Pipe60	.75	.75	.95	.95	1.25	2.00
Galv. Suction Tube for Iron Pipe15	.20	.20	.25	.25	.35	.50
Brass Tube for Lead Pipe25	.35	.35	.45	.45	.65	1.15
Galvanized Tube for Lead Pipe15	.15	.15	.20	.20	.25
Plunger only40	.45	.50	.55	.60	.65	.85
Plunger Rod12	.12	.12	.15	.15	.15	.20
Valve Weight and Screw06	.06	.06	.06	.07	.07	.10

SPECIAL CISTERN FORCE PUMPS WITH BRASS CYLINDERS, FIGS. 518 AND 519

FIGURE NUMBER	518	519	FIGURE NUMBER	518	519
Cylinder, Brass	\$2.25	\$2.25	Spout for Fig. 518	\$0.35
Top Section85	1.10	Cock Spout for Fig. 519	\$2.00
Air Chamber, Fig. 519	1.00	Plunger Rod, Brass Cased60	.60
Stuffing-box Gland35	.35	Rod End or Cross Head15	.15
Lever40	.40	Plunger only55	.55
Fulcrum or Link50	.50	Cylinder Ring30	.30
Base	1.25	1.25	Valve Weight and Screw06	.06
Base Nut20	.20			

"NEW ERA" DOUBLE-ACTING HOUSE FORCE PUMPS, FIGS. 540 AND 544

SIZE NUMBER	2	3	SIZE NUMBER	2	3
Cylinders	\$4.50	\$5.25	Plain Spout, Fig. 540	\$0.50	\$0.50
Base	1.00	1.25	Cock Spout, Fig. 544	2.50	2.50
Bearer30	.35	Hose Nut and Tube50	.50
Lever50	.50	Rod Eye25	.25
Link10	.10	Cylinder Ring with Set Screws50	.50
Plunger60	.70	Rubber Valves (half ball) for		
Differential Plunger40	.50	Spout20	.20
Plunger Rod10	.10	Wheel for Cock Spout15	
Lower Valve25	.35	List		



HAND AND POWER PUMPS FOR ALL USES



HAND FORCE PUMPS, FIGS. 508 AND 509

SIZE NUMBER	0	2	4	6	8
Cylinder, Iron, Fig. 508	\$3.00	\$3.25	\$3.75	\$4.50	\$5.25
Cylinder, Iron, Fig. 509	3.75	4.00	4.50	5.25	6.00
Cylinder, Brass-lined, Fig. 508	4.00	4.50	5.50	7.00	8.25
Cylinder, Brass-lined, Fig. 509	4.75	5.25	6.25	7.75	9.00
Air Chamber, Figs. 508 and 509	2.50	2.50	2.50	3.00	3.00
Stuffing-box Cap35	.35	.40	.50	.50
Stuffing-box gland50	.50	.50	.50	.50
Bearer	1.00	1.00	1.25	1.50	1.50
Lever	1.00	1.00	1.00	1.25	1.25
Cross Head35	.35	.35	.35	.35
Links for Cross Head, per pair15	.15	.15	.15	.15
Base for Fig. 508	1.00	1.10	1.25	1.50	1.75
Bottom Flange, Fig. 50950	.50	.55	.65	.75
Suction and Discharge Nuts, each15	.15	.15	.20	.30
Brass Tubes for Iron Pipe75	.75	.75	.95	2.00
Cock Spout with Coupling Nut	2.50	2.50	2.50	2.75	2.75
Coupling Nut for Cock Spout25	.25	.25	.35	.35
Plunger only40	.45	.55	.65	.85
Plunger Rod, Brass Cased85	.85	.85	1.00	1.00
Valve Weight and Screw06	.06	.06	.07	.10
Plank for Fig. 509	1.25	1.25	1.25	1.25	1.25

"BLUE SPECIAL" HOUSE FORCE PUMP, FIG. 516

NAME OF PART	PRICE	NAME OF PART	PRICE
Brass Cylinder	\$4.00	Base	\$1.00
Spout Section	1.15	Cock Spout with Coupling Nut	2.50
Air Chamber	1.85	Coupling Nut for Cock Spout25
Air Chamber Gland50	Plunger55
Lever	1.00	Plunger Rod, Brass Cased85
Fulcrum Rod (Pipe), only30	Plunger Rod Cross Head25
Fulcrum Rod Cross Head, each15	Valve Weight and Screw06
Cylinder Ring35		

DOUBLE-ACTING OSCILLATING FORCE PUMPS, FIGS. 570 AND 670

SIZE NUMBER	0	1	2	3	4	5	6	7	8
Shell Iron	\$6.00	\$6.50	\$7.00	\$8.00	\$ 9.00	\$10.50	\$12.00	\$19.00	\$30.00
Lid Iron	2.50	2.50	2.50	3.00	3.25	3.75	4.50	6.00	9.00
Pipe Flanges, Iron, each15	.15	.15	.20	.20	.20	.20	1.00	1.00
Suction Valve Seat ("A")—Piece Complete with Valves)	3.00	4.00	4.50	5.00	5.50	7.50	9.50	12.00	15.00
Valves, each40	.60	.65	.70	.75	.80	.90	1.25	1.25
Wing Plunger (Steel Shaft), Complete with Valves	5.75	6.75	7.50	8.50	10.00	13.00	16.00	20.00	24.00
Stuffing-box Nut75	1.00	1.00	1.00	1.25	1.25	1.25	2.00	2.00
Stuffing-box Gland35	.55	.55	.55	.75	.75	.75	.85	.85
Malleable Lever35	.50	.50	.50	.60	.60	.60	.75	.75
Base for Fig. 670	2.75	2.75	2.75	2.75	3.25	3.25	3.25	6.00	10.00
Air Chamber	3.50	3.50	3.50	4.50	4.50	4.75	4.75	6.50	7.00
Cock Spout	2.25	2.25	2.25	2.50	2.50	2.50	2.75	2.75	2.75

Complete Table of Contents and General Classification of Pumps, Pages 7 and 8



HAND AND POWER PUMPS FOR ALL USES



DOUBLE-ACTING HOUSE FORCE PUMP, FIG. 606

NAME OF PART	PRICE	NAME OF PART	PRICE
Base	\$1.30	Stuffing Box Gland	\$1.10
Crosshead	1.85	Stuffing Box Nut	.40
Air Chamber	2.10	Plunger	.95
Cylinder	5.00	Valve Seat	.75
Crimp Iron	.45	Valve	.55
Funnel	.85	Lever	2.75
Back Cylinder Head	2.25	Air Chamber Packing	.20
Front Cylinder Head	2.20	Ring Packing	.05
Link	.30	Wood Handle	.30
Crimp Disc	.15	Piston Rod	.40
Lever Socket	.55	Cylinder Head Packing	.15
Air Cylinder	1.00	Air Discharge Pipe	.50
Follower	.30	Pipe Plug	.10

"CLIMAX" DOUBLE-ACTING FORCE PUMPS, FIGS. 600, 600½, 608 AND 608½

SIZE NUMBER	1	2	SIZE NUMBER	1	2
Bearer for Figs. 600, 600½	\$3.50	\$3.50	Crosshead for Plunger Rod	\$0.25	\$0.25
Cylinder with Valve Seats, Iron	4.00	4.00	Malleable Lever	1.25	1.25
Cylinder with Valve Seats, Brass Lined	6.00	7.50	Wood Handle	.25	.25
Stuffing Box Head	.50	.75	Lever Socket for Figs. 600, 600½	1.50	1.50
Rear Head	.25	.50	Lever Rack for Figs. 600, 600½	.75	.75
Base	1.25	1.25	Link	.25	.25
Suction Chamber with Valve Seats	1.50	1.50	Stuffing Box Gland	.40	.40
Air Chamber	1.50	1.75	Brass Valve Seats, each	.35	.35
Plunger with Crimps	.50	.60	Brass Valves, each	.40	.40
Air Cock for Figs. 600½, 608½	.75	.75	Thumb Screw, each	.10	.10
Plunger Rod for Figs. 600, 600½	2.25	2.25	Lever Socket for Figs. 608, 608½	.50	.50
Plunger Rod Complete for Figs. 608 and 608½	1.50	1.50			

SPECIAL ANTI-FREEZING WELL PUMPS, FIGS. 198, 298 AND 398

FIGURE NUMBER	198	298	398	FIGURE NUMBER	198	298	398
Stock or Standard Only	\$3.00	\$3.00	\$3.00	Plunger Rod Coupling	\$0.30	\$.30	\$0.75
Bearer	.50	1.50	1.00	Rod Eye	.15
Lever	.75	1.00	.75	Brace	.25	.25	.25
Rack25	Link25
Gear Guard	0.45				

ADJUSTABLE STANDARD LIFT AND FORCE PUMPS, FIGS. 166, 182, 185 AND 482

FIGURE NUMBER	166	182	185	482	FIGURE NUMBER	166	182	185	482
Spout Casting	\$1.50	\$1.25	\$3.25	\$1.25	Base	\$1.25	\$0.75	\$0.75	\$0.75
Bearer	1.00	.50	1.50	1.50	Stuffing Box Nut50
Lever	.75	.75	1.25	1.00	Stuffing Box Gland50
Plunger Rod	.30	.30	.75	.30	Brace25	.40	.25
Rod Eye	.20	.15	Brace Ring20	.40	.20
Crosshead50	Bearing Pins, each15
Link25					

Alphabetical Index, Figure Index and Telegraph Cipher Code, Pages 249 to 254



HAND AND POWER PUMPS FOR ALL USES



PIPE FORCE PUMPS, FIGS. 183 AND 184

FIGURE NUMBER	183	184	FIGURE NUMBER	183	184
Acorns	\$0.20	Cylinder or Head Casting	\$0.85
Air Chamber	1.50	Differential Plunger25
Bearer85	\$1.65	Differential Tube	2.50
Bearer Nut20	Plunger Rod	\$0.60	.75
Lever	1.25	1.25	Rod Connection25
Base	1.85	2.00	Rod Link60
Brace Ring25	.25	Rod Eye15
Brace50	.50	Steel Pins with Cotters, each10	.10

ANTI-FREEZING WELL PUMPS, FIGS. 211 AND 421

FIGURE NUMBER	211	421	FIGURE NUMBER	211	421
Stock or Standard only	\$4.00	\$4.00	Crosshead for Rod	\$0.20
Bearer	1.00	1.50	Brace25	\$0.25
Bearer Link25	Malleable Crimp Pin10
Lever	1.25	1.00	Steel Pins with Cotters15
Plunger Rod35	.90			

"PREMIUM" HAND FORCE PUMPS, FIGS. 290 AND 291

FIGURE NUMBER	290	291	FIGURE NUMBER	290	291
Air Chamber	\$4.00	\$6.00	Stuffing-box Gland	\$0.50	\$0.50
Bearer with Bolt60	.60	Base	1.00	2.00
Rod Links, each25	.25	Brace35	.35
Lever Links, each30	.30	Brace Ring25	.50
Cross Head25	.25	Cock Spout	2.50
Wood Lever50	.50	Plunger Rod	1.00	1.00
Handle Ball50	.50	Cross Head Pin15	.15

"PEERLESS" DOUBLE-ACTING HAND PUMPS

FIGURE NUMBER	280 and 281			282		283	
	2	4	6	2	4	2	4
Stock	\$5.00	\$5.00	\$5.00	\$5.00	\$5.00	\$5.00	\$5.00
Lever	1.00	1.00	1.00	1.00	1.00	1.00	1.00
Spout60	.60	1.00	.60	.60	1.00	1.00
Spout Nut15	.15	.15	.15	.15	.15	.15
Union Coupling for Spout25	.25	.30	.25	.25
Hose Tube, Malleable05	.05	.05	.05	.05	.05	.05
Pipe Clamps in Base, per pair15	.15	.15	.15	.15	.15	.15
Head or Cylinder Castings, Iron	1.25	2.00	1.50	1.50
Head or Cylinder Casting (Mall.)	1.50
Differential Cylinder Tube	1.50	2.00	2.50	1.50	2.00
Differential Cylinder Plunger35	.40	.60	.35	.40	.35	.40
Differential Cylinder with Cap	7.00	7.50
Plunger Rod50	.50	.50	.75	.75	1.00	1.00
Eye for Plunger Rod20	.20	.20	.20	.20	.20	.20
Cap for Air Chamber Pipe20	.20	.20	.20	.20	.20	.20
Steel Pins with Cotters, each15	.15	.15	.15	.15	.15	.15

Parts for Fig. 283 only

SIZE NUMBER	2	4	SIZE NUMBER	2	4
Shut-off Rod	\$1.00	\$1.00	Rubber Gaskets for Three-way Valve, each	\$0.20	\$0.20
Hand Wheel and Screw50	.50	Nut for Three-way Discharge20	.20
Stuffing-box Gland50	.50	Brass Discharge Three-way Tube60	.60
Lower Half of Three-way Casting	2.00	2.00			
Upper Half of Three-way Casting	1.35	1.35			
Brass Disc for Three-way Valve60	.60			

Complete Table of Contents and General Classification of Pumps, Pages 7 and 8



HAND AND POWER PUMPS FOR ALL USES



"PEERLESS" DOUBLE-ACTING PUMPS WITH PLAIN WINDMILL TOP

FIGURE NUMBER	450 & 451			452		453	
	2	4	6	2	4	2	4
Stock	\$5.50	\$5.50	\$5.50	\$5.50	\$5.50	\$5.50	\$5.50
Lever75	.75	.75	.75	.75	.75	.75
Bearer Link25	.25	.25	.25	.25	.25	.25
Spout60	.60	1.00	.60	.60	1.00	1.00
Spout Nut15	.15	.15	.15	.15	.15	.15
Malleable Hose Tube05	.05	.05	.05	.05	.05	.05
Union Coupling for Spout25	.25	.30	.25	.25
Pipe Clamp in Base, per pair15	.15	.15	.15	.15	.15	.15
Head or Cylinder Casting, Iron	1.25	2.00	1.50	1.50
Head or Cylinder Casting, Malleable	1.50
Differential Cylinder Tube	1.50	2.00	2.50	1.50	2.00
Plunger for Differential Cylinder35	.40	.60	.35	.40	.35	.40
Differential Cylinder with Cap	7.00	7.50
Upper Plunger Rod85	.85	.85	.60	.60	.85	.85
Lower Plunger Rod25	.25	.25	.50	.50	.25	.25
Caps for Air Chamber Pipe20	.20	.20	.20	.20	.20	.20
Steel Pins with Cotters15	.15	.15	.15	.15	.15	.15
Malleable Pump Pins10	.10	.10	.10	.10	.10	.10
Shut-off Rod	1.00	1.00
Hand Wheel and Screw50	.50
Stuffing-box Gland50	.50
Lower Half of Three-way Casting	2.00	2.00
Upper Half of Three-way Casting	1.35	1.35
Brass Disc for Three-way Valve60	.60
*Rubber Gaskets for 3-way Valve, ea.20	.20
*Nut for Three-way Discharge20	.20
*Brass Tube for Three-way Discharge60	.60

"PEERLESS" WINDMILL PUMPS WITH COG LEVER TOPS

FIGURE NUMBER	450½, 451½ & 452½			453½
	2	4	6	2 & 4
Stock	\$6.00	\$6.00	\$6.00	\$6.00
Lever	1.25	1.25	1.25	1.25
Gear Guard45	.45	.45	.45
Rack on Plunger Rod40	.40	.40	.45
Spout60	.60	1.00	1.00
Spout Nut15	.15	.15	.15
Malleable Hose Tube05	.05	.05	.05
Union Coupling for Spout25	.25	.30
Pipe Clamp in Base, per pair15	.15	.15	.15
Head or Cylinder Casting, Iron	1.25	2.00	1.50
Head or Cylinder Casting, Malleable	1.50
Differential Cylinder Tube	1.50	2.00	2.50	2.00
Plunger for Differential Cylinder35	.40	.60	.40
Differential Cylinder with Cap	7.00	7.50
Upper Plunger Rod60	.60	.60	.60
Lower Plunger Rod50	.50	.50	.50
Caps for Air Chamber Pipe20	.20	.20	.20
Steel Pins with Cotters15	.15	.15	.15
Malleable Pump Pins10	.10	.10	.10
Shut-off Rod	1.00
Hand Wheel and Screw50
Stuffing-box Gland50
Lower Half of Three-way Casting	2.00
Upper Half of Three-way Casting	1.35
Brass Disc for Three-way Valve60

*Same prices as for Fig. 453. (See the last three items in table above this one.)



HAND AND POWER PUMPS FOR ALL USES



HAND AND WINDMILL STANDARDS, FIGS. 224 AND 403

FIGURE NUMBER	224	403	FIGURE NUMBER	224	403
SIZE NUMBER	4	4	SIZE NUMBER	4	4
Stock	\$4.00	\$4.00	Lever 6"	\$1.00
Bearer	1.00	Lever 10"	1.25
Bearer 6"	1.50	Plunger Rod	\$0.30	.50
Bearer 10"	1.75	Cross Head for Rod	.20
Bearer Link 6"25	Brace	.25	.25
Bearer Link 10"35	Malleable Pump Pin10
Lever	1.25	Steel Pins with Cotters15

HAND PUMP STANDARDS, FIGS. 219, 223, 229, 239, 1229 AND 1239

NAME OF PART	PRICE	NAME OF PART	PRICE
Stock or Standard only	\$4.50	Stuffing Box Cap	\$1.00
Bearer	1.25	Stuffing Box Gland	.75
Lever	1.25	Plain Spout	.50
Lever Links, per pair	.25	Cock Spout for Figs. 223, 1229 and 1239	2.50
Crosshead	.50	Brace	.25
Piston Rod	.60	Spout Nut	.25
Air Chamber for Figs. 223, 239 and 1239	2.50	Hose Tube	.15

WINDMILL FORCE PUMP STANDARDS, FIGS. 441 AND 445

FIGURE NUMBER	441	445	FIGURE NUMBER	441	445
Base	\$1.70	Comb. Bushing	\$0.40
Bearer	2.40	2.40	R. & F. Rod Coup.	\$0.15	.15
Bush	.10	.10	Pump Pin	.10	.10
Brace	.20	.20	Pump Key	.05	.05
Lever	1.00	1.00	Nut Ring	.05	.05
Pipe Flange 2"	.60	Link Pin	.10	.10
Link	.35	.35	Flat Rod	.80	.80
Retaining Ring	.10	.10	B. C. Rod	2.00
Stock	5.50	3.75	Round Rod50
Cock Spout	2.50	2.50	Rod Coupling	.25	.25
Bearer Tube	.50	.50	Pipe Plug	.05	.05
Handle Ball 4 1/2"	.50	Eccentric Hd. Bolt	.20	.15
Gland	.50	.50	Hose Tube	.05	.05
Priming Screw	.10	.10			

WINDMILL PUMP STANDARDS, FIGS. 494, 496 AND 498

FIGURE NUMBER	494		496		498	
	6"	ADJ.	6"	ADJ.	6"	ADJ.
Stock	\$4.25	\$4.25	\$6.00	\$6.00	\$6.00	\$6.00
Bearer Complete	2.50	2.75	2.50	2.75	2.50	2.75
Lever	1.50	2.00	1.50	2.00	2.00	2.50
Base Connection for Fulcrum	.35	.35	.35	.35	.35	.35
Fulcrum Link	.75	1.00	.75	1.00	1.25	1.50
Pipe Connection for Fulcrum	.40	.40	.40	.40	.35	.35
Pipe for Fulcrum	.60	.60	.60	.60
Plain Spout50	.50	.50
Steel Pin	.20	.20	.20	.20
Cock Spout	2.50	2.50
Spout Nut25	.25	.25	.25
Hose Tube15	.15	.15	.15
Flat Rod	.75	.75	.60	.60	.60	.60
Round Polished Rod60	.60	.60	.60
Flat & Round Rod Couplings50	.50	.50	.50
Stuffing-box Gland85	.85	.85	.85
Bearer Ring25	.25
Base Stand30	.30

WINDMILL PUMP STANDARDS, FIGS. 440, 442, 444, 444 1/2 AND 1444*

STROKE, INCHES	6		STROKE, INCHES	6	
	ADJ. 6, 8 or 10	ADJ. 6, 8 or 10		ADJ. 6, 8 or 10	ADJ. 6, 8 or 10
Stock or Standard only	\$4.75	\$4.75	and 1444	\$2.50	\$2.50
Bearer	1.75	2.00	Spout Nut	.20	.20
Bearer Link	.35	.50	Malleable Hose Tube	.05	.05
Lever	1.00	1.50	Flat Rod	.50	.60
Lever for Fig. 444 1/2	1.25	Round Rod	.50	.60
Rack on Rod, Fig. 444 1/2	.40	Solid Rod for 1444	3.25
Gear Guard, Fig. 444 1/2	.45	Flat and Round Rod Couplings	.25	.25
Bearer Ring	.25	.25	Malleable Pump Pin	.10	.10
Bearer Tube	.50	.50	Link Pin (Steel) each	.15	.15
Gland	.50	.50	Brace	.25	.25
Spout for Fig. 440	.75	.75	Combination Bushing, 2 to 1 1/2 to 1 1/4 inches	.50	.50

*Fig. 1444 repair parts same as 440 and 444, but made with adjustable stroke only

Complete Table of Contents and General Classification of Pumps, Pages 7 and 8



HAND AND POWER PUMPS FOR ALL USES



THREE-WAY WINDMILL FORCE PUMPS, FIGS. 415 AND 415½

STROKE, INCHES	6	ADJUST. 6, 8, 10	STROKE, INCHES	6	ADJUST. 6, 8, 10
Standard Complete with Lever, Bearer, etc.	\$ 8.50	\$ 9.50	Platform Base only	\$2.00	\$2.00
Stock or Standard only	4.00	4.00	Platform Guide Plate15	.15
Bearer	1.25	1.50	Hydrant Spout	1.00	1.00
Link25	.35	Spout Nut15	.15
Lever	1.00	1.25	Malleable Hose Tube05	.05
Brace50	.50	Valve Screw in Hydrant Top50	.50
Flat Rod50	.60	Spout Gland50	.50
Malleable Pump Pin10	.10	Shut-off Rod	2.00	2.00
Link Pins, each15	.15	Brass Cased Rod75	1.00
Bottom Section Complete with Hydrant Top	15.00	15.50	Center Rod45	.45
Bottom Section only	1.25	1.25	Air Chamber Pipe, Fig. 415	1.25	1.25
Stuffing-box Cap50	.50	Discharge Pipe	1.50	1.50
Stuffing-box Gland40	.40	Wood Rod Coupling20	.20
Pipe Sleeve Valve Rod Guide75	.75	Union for Rod20	.20
Brass Disc for Two-way Valve60	.60	Differential Cylinder, Fig. 415½	1.50	2.00
Rubber Valves for Two-way, each20	.20	Differential Cylinder Cap, Fig. 415½50	.50
Pipe Sleeve Lock Nut15	.15	Differential Plunger and Rod, Fig. 415½50	.55
Union Nut Ell20	.20	Suction Pipe Flange75	.75
Malleable Ell25	.25			

PIPE FORCE PUMPS, FIGS. 258, 259, 260 AND 261

FIGURE NUMBER	258	259	260	261
Bearer	\$1.75	\$1.75	\$1.50	\$1.50
Lever	1.25	1.25	1.00	1.00
Link25	.25
Rack40	.40
Gear Guard45	.45
Spout60	.60	.60	.60
Spout Nut15	.15	.15	.15
Hose Tube05	.05	.05	.05
Shut-off Screw2020
Shut-off Clamp7575
Iron Shut-off Rod4545
Brass Shut-off Rod with Coupling7575
Base Piece, "AA-201"	1.40	1.40	1.40	1.40
Base Piece, "BB-201"	1.60	1.60	1.60	1.60
Three-way Casting	2.25	2.25
Three-way Discharge Plug8585
Malleable Ell2525
Malleable Ell Nut2020
Three-way Valve Disc6060
Three-way Valve Rubbers, each2020
Three-way Valve Gland5050
Bottom Casting	1.25	1.25	1.25	1.25
Differential Cylinder Tube	1.10	1.10	1.10	1.10
Differential Cylinder Plug60	.60	.60	.60
Differential Plunger Complete65	.65	.65	.65
Flat Plunger Rod60	.60	.60	.60
Round Plunger Rod50	.50	.50	.50
Flat and Round Rod Coupling25	.25	.25	.25
Union Coupling Spout25	.25	.25	.25
Malleable Pump Pin10	.10	.10	.10
Steel Pins, Each15	.15	.15	.15

Alphabetical Index, Figure Index and Telegraph Cipher Code, Pages 249 to 254



HAND AND POWER PUMPS FOR ALL USES



"STRAIGHT LINE" WORKING HEADS, FIGS. 1717, 1718, 1719 AND 1720

FIGURE NUMBER	1717	1718	1719	1720
Base	\$15.25	\$15.25	\$15.25	\$15.25
Bearer	3.00	3.00	3.00	3.00
Crosshead	2.40	2.40	2.40	2.40
Pinion Shaft Collar20	.20	.20	.20
Crank Disc	4.10	4.10	4.10	4.10
Suction Flange	2.15	2.15	2.15	2.15
Crank Gear	7.50	7.50	7.50	7.50
Gear Guard	1.50	1.50	1.50	1.50
Tight Pulley	6.00	6.00	6.00	6.00
Loose Pulley	6.00	6.00	6.00	6.00
Crank Shaft	1.25	1.25	1.25	1.25
Crank Pin70	.70	.35	.70
Connecting Rod Complete	2.80	2.50	2.50	2.80
Connecting Rod Pin40	.40	.40	.40
Pinion Shaft	1.25	1.25	1.25	1.25
Pinion	3.00	3.00	3.00	3.00
Plunger Rod	1.40	.40	1.40	1.40
Guide Rod85	.85	.85	.85
Pump Pin15	.15	.15	.15
Pump Pin Key05	.05	.05	.05
Air Chamber Pipe60	3.00	2.20	.60
Air Chamber	5.50	5.50
Lever	1.40	1.40	1.40
Link	1.00	1.00	1.00
Cock Spout Complete	3.75	3.75
Stuffing-box Gland	1.00	.45	.90	1.00
Stuffing-box Gland, for Spout40
Crank Disc Pin, each1515
Platform Plate	6.75
Three-way Casting	7.25
Pipe Flange	1.85
Plug	1.25
Spout	2.75
Shut-off Screw90
Tube or Rod Guide	1.85
Shut-off Rod and Valve Complete	3.50
Brass Cased Rod	1.35
Discharge Pipe	3.25
Drop Pipe	4.85
Bottom Attachment	1.35
Plunger Complete90
Valve Complete35
Spun Valve Seat15
Cylinder Tube	7.90
Piston Rod	2.00

AIR PUMPING ATTACHMENT FOR FIGS. 1717, 1718, 1719 AND 1720

NAME OF PART	PRICE	NAME OF PART	PRICE
Air Cylinder Attachment	\$3.15	Expansion Spring	\$0.10
Adjustable Sleeve Nut	1.10	Suction Valve45
Plunger	1.70	Crimp20
Cylinder Tube	1.85	Plunger Rod20
Valve Chamber Cap70	Guide Rod	1.20
Piston Follower35		

Complete Table of Contents and General Classification of Pumps, Pages 7 and 8



HAND AND POWER PUMPS FOR ALL USES



CYLINDER REPAIRS, FIGS. 300, 308, 312 AND 322

SIZE, INCHES	1½ & 1¾	2	2¼	2½	2¾	3	3½	4	5	6
CYLINDER SHELLS, IRON										
Fig. 300	10 inches	\$0.90	\$1.00	\$1.10	\$1.20	\$ 1.30	\$ 1.60	\$ 2.00
	12 inches	1.00	1.10	1.20	1.40	1.50	1.90	2.50
	14 inches	1.15	1.25	1.40	1.60	1.75	2.20	3.00
	16 inches	1.40	1.50	1.60	1.85	2.00	2.50	3.50
CYLINDER SHELLS, BRASS LINED										
Fig. 308	10 inches	2.00	2.25	2.50	2.75	3.00	3.50	4.00
	12 inches	2.35	2.60	2.85	3.10	3.35	4.00	5.00
	14 inches	2.70	2.95	3.25	3.50	3.80	4.75	6.00
	16 inches	3.00	3.35	3.75	4.00	4.50	5.50	7.00
CYLINDER SHELLS, BRASS TUBE										
Figs. 312 and 322	10 inches	4.00	4.40	4.70	5.10	5.50	6.50	7.80
	12 inches	4.65	5.10	5.50	6.00	6.50	7.65	9.20
	14 inches	5.30	5.80	6.30	6.90	7.50	8.80	10.60
	16 inches	5.40	5.95	6.50	7.10	7.80	8.50	10.00	\$21.50	\$27.00
	18 inches	6.00	6.65	7.20	7.90	8.70	9.50	11.25	13.40	25.00
	20 inches	6.50	7.25	7.90	8.70	9.60	10.50	12.40	15.00	31.50
TOP ATTACHMENT OR CAPS FOR Figs. 300, 308, 312, 322, Iron										
		.40	.40	.40	.40	.50	.60	.80	2.00	2.50
Figs. 312, 322, Brass										
		1.25	1.50	1.75	2.00	2.50	3.00	3.75	5.00	6.50
BOTTOM ATTACHMENT OR CAP FOR Figs. 300, 308, 312, Iron										
		.60	.60	.60	.60	.75	.90	1.10	3.50	4.00
Fig. 312, Brass										
		1.50	1.75	2.00	2.25	2.75	3.50	4.25	6.00	8.00
BOTTOM ATTACHMENT COMPLETE WITH VALVE AND CAGE, Fig. 322, Iron										
		.95	.95	.95	1.00	1.05	1.30	1.65	2.00	5.25
Attachment only, Iron										
		.75	.75	.75	.75	.95	1.15	1.40	4.25	5.00
Valve with Leather, Iron										
		.10	.10	.10	.10	.15	.25	.30	.40	.65
Cage, two pieces, Iron										
		.10	.10	.10	.15	.15	.20	.25	.30	.65
BOTTOM ATTACHMENT COMPLETE WITH VALVE AND CAGE, Fig. 322, Brass										
		2.50	2.50	3.00	3.50	3.75	4.50	5.50	6.50	9.25
Attachment only, Brass										
		1.75	1.75	2.25	2.50	2.50	3.00	3.75	4.50	6.50
Valve with Leather, Brass										
		.35	.35	.35	.40	.50	.60	.65	.75	1.25
Cage, two pieces, Brass										
		.40	.40	.40	.60	.75	.90	1.10	1.25	1.50
PLUNGERS ONLY, NO RODS										
"A" Style, All Iron										
		.40	.40	.45	.50	.55	.65	.85	2.00
Brass Cage and Valve										
		.85	1.00	1.25	1.50	1.75	2.00	2.75
All Brass										
		1.00	1.25	1.50	1.75	2.00	2.50	3.50
"J" Style, All Iron										
		.75	.75	.90	1.00	1.15	1.50	2.00	4.50	6.50
Brass Cage and Valve										
		1.25	1.50	1.75	2.00	2.25	3.00	3.75	9.50	14.00
All Brass										
		2.00	2.00	2.25	2.50	2.75	3.00	4.00	12.00	17.50
Plunger Cage, Iron										
		.10	.12	.12	.15	.15	.25	.30	.80	1.35
Plunger Cage, Brass										
		.55	.65	.75	.80	.90	1.40	1.80	4.00	6.00
Plunger Follower, "A" Style, Iron										
		.08	.10	.13	.15	.18	.25	.30
Plunger Follower, "A" Style, Brass										
		.40	.50	.60	.70	.75	1.15	1.40
Plunger Follower, "J" Style, Iron										
		.12	.15	.20	.20	.25	.30	.45	1.00	1.50
Plunger Follower, "J" Style, Brass										
		.60	.65	.75	.85	1.00	1.40	1.85	4.25	6.50
Plunger Ring, "J" Style, Iron										
		.05	.05	.05	.05	.07	.12	.15	.25	.45
Plunger Ring, "J" Style, Brass										
		.20	.25	.30	.40	.50	.60	.75	1.00	1.50
Plunger Valves, Iron										
		.05	.05	.05	.08	.10	.12	.15	.25	.45
Plunger Valves, Brass										
		.15	.18	.25	.30	.35	.50	.65	1.25	1.75
Suction Valve Weights and Screw, Iron										
		.05	.05	.06	.06	.06	.07	.10	.15	.20
Suction Valve Weights and Screw, Brass										
		.20	.20	.25	.30	.40	.40	.50	.60	1.00

"WHITE CAP" BRASS BODY CYLINDER, FIG. 314

SIZE	2¼x6	2¼x10	2½x6	2½x10	2¾x6	2¾x10	3x6	3x10
Top Attachment	\$0.40	\$0.40	\$0.40	\$0.40	\$0.40	\$0.40	\$0.50	\$0.50
Bottom Attachment95	.95	1.00	1.00	1.05	1.05	1.30	1.30
Plunger Complete45	.45	.50	.50	.60	.60	.60	.60
Valve Complete45	.45	.45	.45	.45	.45	.45	.45
Cylinder Tube	2.95	3.85	3.25	4.30	3.55	4.65	3.80	5.00
Cylinder Ring05	.05	.10	.10	.10	.10	.10	.10
Stub Rod15	.15	.15	.15	.15	.15	.15	.15



HAND AND POWER PUMPS FOR ALL USES



BRASS ARTESIAN DEEP WELL CYLINDER, FIG. 324

INSIDE DIA. CYLINDER, INS.	1¾	1¾	2¼	2¾	3¼	3¾	4¼	4¾	5¼	5¾	6¼	6¾
Top Attachment	\$2.00	\$2.00	\$ 2.75	\$ 3.50	\$ 5.25	\$ 7.25	\$ 9.00	\$12.00	\$15.75	\$15.75	\$22.00	\$ 22.00
Bottom Attachment	2.75	3.00	3.75	4.50	7.00	9.50	12.00	15.00	18.00	18.00	27.00	27.00
Plunger Complete	8.00	8.50	10.50	18.00	27.00	33.00	40.00	52.00	70.00	75.00	90.00	100.00
Lower Valve Complete	3.50	4.00	6.00	10.00	14.00	18.00	26.00	35.00	45.00	50.00	70.00	80.00
Plunger Cage	2.00	2.25	2.50	4.00	6.00	7.50	10.00	12.00	15.00	18.00	23.00	30.00
Plunger Stock	1.75	2.00	2.50	4.25	6.50	8.00	10.00	13.00	16.00	18.00	23.00	30.00
Plunger Nut75	.85	1.00	2.00	3.50	4.50	5.00	6.00	7.00	8.00	9.00	10.00
Plunger Rings, each60	.60	.80	1.00	1.25	1.50	1.75	2.50	3.00	3.50	4.00	4.75
Lower Valve Cage	1.50	2.50	3.00	4.00	5.50	7.00	10.00	12.00	14.00	16.00	22.00	28.00
Lower Valve Seat or Stock	1.50	1.50	2.00	2.75	4.00	4.50	7.00	8.50	10.00	12.00	16.00	20.00
Brass Ball Valves35	.45	.80	2.00	3.25	4.25	5.25	6.50	7.25	10.00	12.00	13.50
Steel Adapter or Wood Rod Coupling75	.75	1.00	1.00	1.10	1.25	1.25	1.25	1.25	1.25

BRASS ARTESIAN DEEP WELL CYLINDER, FIG. 311

INSIDE DIAMETER CYLINDER, INCHES	1¾	2¼	2¾	3¼	3¾
Top Attachment	\$2.00	\$2.75	\$ 3.50	\$ 5.25	\$ 7.25
Bottom Attachment	3.00	3.75	4.50	7.00	9.50
Plunger Complete	6.00	8.00	11.00	15.00	22.00
Lower Valve Complete	4.00	6.00	8.50	12.50	17.00
Plunger Cage	2.00	2.50	3.50	4.00	5.50
Plunger Stock	1.50	2.00	2.50	3.50	5.00
Plunger Nut85	1.00	1.50	2.25	3.00
Lower Valve Cage	2.00	2.50	3.50	4.00	5.50
Lower Valve Seat or Stock	1.50	2.00	2.75	4.00	4.50
Brass Ball Valve45	.80	1.25	2.15	3.75
Steel Adapter or Wood Rod Coupling75	1.00	1.00	1.10	1.25

"TRIUMPH" DOUBLE-ACTING FORCE PUMPS, FIGS. 601 AND 602

SIZE NUMBER	1	2	3	4	5
Brass-lined Cylinders with Brass Valve Seats	\$11.50	\$12.50	\$14.50	\$20.00	\$28.00
Base with Valve Seats	6.25	6.50	6.75	7.75	15.00
Air Chamber	5.00	5.00	5.00	6.00	8.00
Stuffing-box Head	1.00	1.25	1.50	1.75	2.50
Rear Head65	.65	.65	.75	1.75
Bolted Stuffing-box Gland	1.50	1.50	1.50	1.50	1.50
Brass Valve Seats, each40	.50	.60	.75	1.00
Brass Valves, each40	.50	.65	.90	1.00
Piston with Leathers65	.75	1.10	1.50	2.50
Piston Rod	3.75	3.75	3.75	3.75	5.00
Lever Socket	1.25	1.25	1.25	1.75	1.75
Lever Link35	.35	.35	.50	.90
Malleable Lever with Wood Handle, each	1.50	1.50	1.50	2.50	2.50
Malleable Cross Bar60	.60
Drip Screws10	.10	.10	.10	.10
Priming Screws15	.15	.15	.20	.25
Steel Pins15	.15	.15	.15	.15

Complete Table of Contents and General Classification of Pumps, Pages 7 and 8



HAND AND POWER PUMPS FOR ALL USES



"GIANT" DOUBLE-ACTING FORCE PUMPS, FIGS. 554 AND 554½

NAME OF PART	PRICE	NAME OF PART	PRICE
Cylinder, Iron	\$7.50	Lever Socket for Fig. 554½	\$1.35
Brass-lined Cylinder	11.00	Wood Lever50
Stuffing-box Head	1.00	Lever Rack for Fig. 554½60
Rear Head75	Socket Link35
Stuffing-box Gland50	Plunger with Crimps	1.75
Valve Caps, each25	Plunger Center, Iron20
Goose Neck75	Plunger Follower Irons, each20
Suction Nut40	Piston Rod Complete75
Suction Tube35	Rod for Fig. 554½75
Goose Neck Nut40	Crosshead for Piston Rod15
Hose Nut15	Drip Screws, each10
Hose Tube20	Hose Nozzle, Iron50
Valves, each15	Bearer for Fig. 554½	4.00
Lever Socket60		

"MARINE" BILGE PUMPS, FIGS. 470 AND 471

FIGURE NUMBER	470		471	
	2	4	2	4
Brass-lined Cylinder	\$24.00	\$32.00	\$24.00	\$32.00
Base	8.75	10.50	14.00	22.00
Plunger Complete	8.00	13.00	8.00	13.00
Plunger Casting	6.50	10.50	6.50	10.50
Plunger Pin40	.40	.40	.40
Plunger Valve75	1.50	.75	1.50
Suction Valve80	1.25	.80	1.25
Rubber Facing for Valves, each25	.40	.25	.40
Flange	1.50	1.75	1.50	1.75
Lever	3.25	3.75	3.25	3.75
Lever Socket	1.75	2.00	1.75	2.00
Lever Pin with Cotters40	.50	.40	.50
Stop Pin for Valves10	.10	.10	.10

DIAPHRAGM PUMPS, FIGS. 472, 473 and 1473

FIGURE NUMBER	472		473		1473
	1	2	1	2	2
Base	\$7.50	\$10.50	\$8.00	\$11.50	\$11.50
Spout Section	6.50	9.50	6.50	9.50	9.50
Forged Levers	1.75	4.00	1.75	4.00	4.00
Lever Socket65	1.00	.65	1.00	1.00
Plunger Cage50	1.25	.50	1.25	1.25
Plunger Top Ring40	.50	.40	.50	.50
Plunger Bottom Ring50	1.00	.50	1.00	1.00
Rubber Diaphragm	2.50	3.50	2.50	3.50	3.50
Plunger Valve40	.60	.40	.60	.60
Suction Valve25	.35	.25	.35	.35
Valve Stop Pin05	.10	.05	.10	.10
Rubber Facing for Plunger Valve25	.45	.25	.45	.45
Rubber Facing for Suction Valve20	.35	.20	.35	.35
Steel Pins with Cotters20	.25	.20	.25	.25
Connecting Rod	1.25
Rod End	2.00
Lever for Fig. 1473	4.00
Crosshead Pin20

Alphabetical Index, Figure Index and Telegraph Cipher Code, Pages 249 to 254



HAND AND POWER PUMPS FOR ALL USES



IMPROVED "SYPHON" FORCE PUMPS, FIGS. 320 AND 321

SIZE NUMBER	1	2	3	4	5	6
Air Chamber	\$6.00	\$6.00	\$9.00	\$9.00	\$10.00	\$12.00
Air Chamber Gland	1.00	1.00	1.25	1.25	1.50	2.00
Air Chamber Tube	.50	.50	1.00	1.00	1.50	2.00
Check Valve Case only	1.00	1.00	1.25	1.25	1.50	2.00
Check Valve Tube	1.00	1.25	1.50	2.00	2.50	3.00
Check Valve Nut	.50	.50	.75	.75	1.00	1.50
Suction Pipe Flange	.75	1.00	1.25	1.25	1.50	1.75
Outside Cylinder	4.00	4.00	5.50	5.50	7.00	7.00
Base Plate	2.00	2.00	2.50	2.50	3.00	4.00
Inside Cylinder, Brass Lined	3.00	3.50	4.00	5.00	6.00	7.00
Bottom Attachment for Inside Cyl.	.75	.85	1.00	1.25	1.50	1.75
Brass Plunger	2.50	3.00	3.50	4.00	4.50	5.00
Brass Valve Seat	.25	.30	.40	.50	.75	1.00
Piston Rod (only) Brass	4.80	1.25	1.50	1.50	2.00	2.00

WINDMILL FORCE PUMPS ON BASE, FIGS. 430 AND 1430

SIZE NUMBER	2	3	4	5
Cylinder	\$5.00	\$5.00	\$7.00	\$8.00
Bearer	2.00	2.00	2.00	2.00
Lever	1.50	1.50	1.50	1.50
Lever Link	.50	.50	.50	.50
Flat Rod	.60	.60	.60	.60
Round Rod	1.00	1.00	1.00	1.00
Coupling for Connecting Rods	.50	.50	.50	.50
Plunger	1.00	1.00	1.50	1.50
Stuffing-box Gland	1.00	1.00	1.00	1.00
Base for Fig. 430	1.00	1.25	1.50	1.50
Air Chamber	2.50	2.50	3.00	3.00
Cock Spout	2.00	2.00	2.50	2.50
Coupling Nut for Spout	.35	.35	.50	.50
Discharge Nut	.35	.35	.50	.50
Discharge Tube, Brass	.65	.65	.80	1.25

HAND AND POWER PISTON PUMPS, FIGS. 585, 590 AND 591

FIGURE NUMBER	585		590		591	
	4	5	4	5	4	5
SIZE NUMBER						
Cylinder	\$5.00	\$5.50	\$ 5.00	\$ 5.50	\$ 5.00	\$ 5.50
Base	3.25	3.25	3.25	3.25	3.25	3.25
Crank Case	6.50	6.50	6.50	6.50	11.50	11.50
Stuffing-box Lid	3.00	3.00	3.00	3.00
Outside Lid	.50	.50	.50	.50	3.00	3.00
Stuffing-box Nut	.50	.50	.50	.50
Stuffing-box Gland	1.00	1.00	1.00	1.00	1.25	1.25
Air Chamber	4.00	4.00	4.00	4.00	4.00	4.00
Crank Shaft	5.00	5.00	5.50	5.50	10.00	10.00
Plunger Complete	4.00	5.00	4.00	5.00	4.00	5.00
Connecting Rod	2.50	2.50	2.50	2.50	3.00	3.00
Discharge Flange	.50	.50	.50	.50	.50	.50
Lower Valve Complete	.85	.85	.85	.85	.85	.85
Pulley only, 16 x 3 inches, each	7.00	7.00	7.00	7.00
Pulley only, 24 x 3 inches, each	11.00	11.00	11.00	11.00
Pulley only, 15 x 4 inches, each	6.00	6.00
Handle	.75	.75

Complete Table of Contents and General Classification of Pumps, Pages 7 and 8



HAND AND POWER PUMPS FOR ALL USES



HYDRAULIC RAM, FIG. 690

SIZE NUMBER	2	3	4	5	6	7	8
Brass Impetus Valve and Case Compl.	\$6.00	\$7.00	\$9.00	\$11.00	\$20.00
Brass Case only	3.00	3.50	5.00	7.00	11.00
Brass Impetus Valve only	1.10	1.50	2.00	2.50	5.00
Brass Nut on end of Valve30	.30	.35	.35	.75	\$ 1.25	\$ 1.75
Brass Adjusting Nut50	.60	.65	.65	1.25	3.50	3.75
Brass Lock Nut25	.25	.35	.35	.75	.75	1.50
Brass Screws, each25	.25	.25	.25
Base with Valve and Seats Complete except Nos. 7 and 8	3.00	3.50	4.00	8.00	14.00	21.00	50.00
Inside Valve Complete, each80	.80	1.00	1.50	1.50	4.25	3.25
Air Chamber	4.00	4.50	5.00	7.50	18.00	22.00	40.00
Cap Nut15	.15	.15	.20	.30
Discharge Nut15	.15	.15	.20	.30
Brass Discharge Tube for Iron Pipe50	.50	.55	.60	.75
Drive Nut15	.20	.30	.40	.50
Brass Drive Tube for Iron Pipe60	.65	1.00	1.25	2.00
Rubber Bumper Ring05	.05	.05	.05	.10	.20	.20
Brass Impetus Valve Follower	4.50	8.50
Brass Impetus Valve Stem	6.00	8.25
Brass Binder Nut75	1.25
Rubber Impetus Valve	1.50	3.50
Iron Washer for Impetus Valve25	.30
Water Chamber with Valve Seats	19.25	34.75
Impetus Valve Case, Iron	10.00	15.00
Cap for Impetus Valve Case with Brass Bush	9.00	12.50
Blank Flange	1.50	1.75
Discharge Flange	1.75	2.00
Drive Flange	3.50	7.00

DEMING HYDRAERAM, FIG. 695

SIZE NUMBER	10	11	12	13	14
Impetus Valve Complete	\$7.00	\$ 7.50	\$10.00	\$12.00	\$18.00
Impetus Valve Cover with Seat	2.00	3.00	4.00	4.50	9.00
Impetus Valve Arm	1.25	1.00	1.00	1.25	1.50
Impetus Valve Weight50	.15	.15	.20	.30
Impetus Valve and Stem75	1.00	1.50	2.00	3.00
Impetus Valve Adjusting Nut50	.50	.75	.85	1.00
Impetus Valve Locking Screw25	.25	.50	.50
Impetus Valve Fulcrum Pin15	.15	.15	.20	.30
Impetus Valve Seat and Ring15	.20	.50	.50
Base	28.00
Air Chamber	8.00	11.00	23.00	17.00	75.00
Discharge Cap Nut10	.15	.15	.20	.30
Discharge Coupling Nut10	.15	.15	.20	.30
Discharge Tube Brass50	.50	.60	.65	.75
Drive Coupling Nut10	.20	.30	.40
Drive Tube, Brass60	.65	1.00	1.25
Discharge Valve (Leather and Weight)85	1.00	1.25	1.50	2.75

POWER ROTARY FORCE PUMP, FIG. 595

NAME OF PART	PRICE	NAME OF PART	PRICE
Base	\$7.00	Shell	\$14.00
Main Bearing Cap35	Lid Packing05
Cams and Shafts, one set	20.00	Gland Packing05
Cover	5.75	Cam Pin05
Gland75	Studs—Shell to Base15
Cap Nut10	Gland Studs20
Pulley	4.75	Main Bearing Studs20

Engineering Tables and Information Relating to Hydraulics, Pages 239 to 248



HAND AND POWER PUMPS FOR ALL USES



HAND ROTARY FORCE PUMPS, FIGS. 575, 576, 578 AND 579

SIZE NUMBER	1	2	3	4	5	6
Case only	\$5.00	\$7.00	\$8.50	\$10.50	\$13.00	\$18.50
Lid or Cover	1.75	2.00	2.25	2.50	3.00	4.00
Cams with Short Shaft	4.00	4.50	4.75	5.25	6.50	9.50
Cams with Long Shaft	4.25	4.75	5.00	5.50	6.75	9.75
Stuffing-box Nut25	.25	.25	.35	.35	.35
Cap Nuts for Bearings, each10	.10	.10	.15	.15	.15
Spout with Cap Nut	1.00	1.00	1.25	2.00	2.75	4.25
Base for Fig. 575	4.00	4.00	4.25	11.00	11.00	13.00
Base for Fig. 578	4.00	4.00	5.50
Fly-wheel, Fig. 575, with Handle	4.50	4.50	4.50	5.00	5.00	5.00
Fly-wheel with Handle, Fig. 578	3.00	3.00	3.00
Drip Plug20	.20	.20	.20	.20	.20
Priming Plug15	.15	.15	.15	.15	.15
Barrel Attachment for Fig. 57650	.50	.75
Goose Neck or Hook for Fig. 57625	.25	.35
Suction Nut for Figs. 576 and 57935	.35	.40
Crank Complete for Figs. 576 and 57960	.60	.60
Bracket for Fig. 579	1.75	1.75	2.00

AUTOMOBILE ROTARY GASOLINE PUMP, FIG. 776

NAME OF PART	PRICE	NAME OF PART	PRICE
Case only	\$8.00	Cap Nuts for Bearings, each	\$0.10
Lid or Cover	4.25	Spout with Cap Nut70
Cams with Short Shaft	6.25	Base	7.25
Cams with Long Shaft	6.50	Drip Plug15
Stuffing-box Nut60	Crank Complete	1.00

POWER ROTARY PUMPS, FIGS. 577 AND 577½

SIZE NUMBER	1	2	3	4	5	6
Case, Cover, Cams and Shaft Complete	\$17.50	\$20.50	\$23.00	\$27.50	\$33.00	\$46.00
Case only	5.00	7.00	8.50	10.50	13.00	18.50
Lid or Cover	1.75	2.00	2.25	2.50	3.00	4.00
Cam with Short Shaft	4.00	4.50	4.75	5.25	6.50	9.50
Cam with Long Shaft	4.50	5.00	5.25	5.75	7.00	10.00
Stuffing-box Nuts25	.25	.25	.35	.35	.35
Cap Nuts for Bearings, each10	.10	.10	.15	.15	.15
Spout with Cap Nut	1.00	1.00	1.25	2.00	2.75	4.25
Small Base with Drip Screw	1.25	1.25	1.50
Valve Seat with Drip Screw	2.25	2.25	5.00
Metallic Valve35	.35	.40	.65	.65	1.15
Bed Plate	2.00	2.00	2.00	5.00	5.00	7.50
Outboard Bearing	1.00	1.00	1.00	1.00	1.00	2.00
Pulleys, each	2.00	2.00	2.00	4.00	4.00	6.25
Drip Plug20	.20	.20	.20	.20	.20
Priming Plug15	.15	.15	.15	.15	.15

Complete Table of Contents and General Classification of Pumps, Pages 7 and 8



HAND AND POWER PUMPS FOR ALL USES



"ATLAS" DOUBLE-ACTING POWER PISTON PUMP, FIG. 691

SIZE, (DIAMETER AND STROKE), INCHES	2¼ x 5	3 x 6	4 x 8
Brass-lined Cylinder with Valve Seats	\$20.00	\$50.00	\$75.00
Brass Liner only for Cylinders,	3.00	4.50	8.00
Brass Ring for Cylinder Liner, each	1.25	1.35
Suction Valve Seats40	.50	.75
Discharge Valve Seats60	.75	1.65
Suction Valve Cap and Wing15	.20	.20
Discharge Valve Cap and Wing20	.20	.30
Suction Valve Rubber, each10	.10	.20
Discharge Valve Rubber, each15	.20	.35
Valve Chamber Covers25	.40	1.75
Rear Cylinder Head and Bearing	5.75	7.25
Stuffing-box Head70	2.50	3.00
Brass Stuffing-box Nut85	1.00
Brass Stuffing-box Gland35	.60	1.00
Piston or Plunger Complete	2.50	6.75	8.00
Piston Followers, each45	2.50	3.25
Piston Center25
Piston Head	1.25	4.25	4.50
Piston Rod	2.75	4.00	6.50
Main Gear	2.85	5.25	10.00
Pinion	1.00	3.50	4.25
Crank Shaft75	1.35	2.00
Pinion Shaft60	1.40	1.50
Connecting Rods and Caps, each	1.25	2.25	4.75
Cross Head	1.50	4.75	8.00
Crank Disc	1.00	2.50	2.75
Crank Pins, each25	1.20	1.60
Guide Rods, each35	1.10	1.30
Gear Guard75	3.75	4.25
Main Bearing Box Covers20	.20
Pinion Bearing Box Covers25	.25
Shaft Collars, each15	.20	.25
HAND ATTACHMENT FOR "ATLAS" FIG. 691			
Cross Head	1.75
Long Link50
Short Link25
Lever Socket50
Malleable Lever	1.25
Wood Handle25
Cross Head Pin25
AIR PUMPING ATTACHMENT FOR "ATLAS" FIG. 691			
Air Chamber Attachment	2.25	4.25	5.50
Cylinder Tube	1.50	1.75	4.00
Guide Rods, each40	1.50	2.00
Piston Rod10	.10	.10
Valve Cap85	.85	.85
Piston Follower25	.25	.25
Cross Head Nut50	.50	.50
Suction Valve25	.25	.25
Discharge Valve30	.30	.30
Piston90	.90	.90
Crimp Spring05	.05	.05
Air Cock75	.75	.75
BELT IDLER FOR "ATLAS" FIG. 691			
Idler Complete	6.00	7.50	9.00
Idler Pulley	3.75	3.75	4.00
Idler Arm85	.95	1.25
Idler Cross Head85	2.00	3.00
Shaft Collar, each15	.15	.15

Alphabetical Index, Figure Index and Telegraph Cipher Code, Pages 249 to 254



HAND AND POWER PUMPS FOR ALL USES



"TRIUMPH" DOUBLE-ACTING POWER FORCE PUMP, FIG. 609

SIZE NUMBER	1	2	3	4
Bed Plate with Caps	\$68.00	\$68.00	\$68.00	\$68.00
Crank Shaft	11.25	11.25	11.25	11.25
Pinion Shaft	2.50	2.50	2.50	2.50
Gear Wheel	20.00	20.00	20.00	20.00
Pinion	7.00	7.00	7.00	7.00
Connection Rod with Caps	4.75	4.75	4.75	4.75
Yoke	11.50	11.50	11.50	11.50
Pulleys, each	16.00	16.00	16.00	16.00
Cylinder with Valve Seats	22.75	28.50	28.50	35.00
Suction Chamber with Valve Seats	8.75	9.25	9.25	10.75
Air Chamber	8.50	9.00	9.00	10.00
Piston Rod	3.75	3.75	3.75	4.50
Piston with Leathers75	.85	1.50	2.10
Front Cylinder Head	5.85	5.85	5.85	5.85
Rear Head	1.50	1.50	1.50	1.75
Stuffing-box Cap	1.75	1.75	1.75	2.00
Stuffing-box Gland	1.10	1.10	1.10	1.35
Brass Valves55	.65	1.00	1.10
Brass Valve Seats50	.65	.75	.80
Water End Complete	72.00	75.00	75.00	84.00

DEEP WELL POWER WORKING HEAD, FIG. 66

NAME OF PART	PRICE	NAME OF PART	PRICE
Base with Caps	\$40.00	Differential Plunger	\$5.50
Crank Shaft	6.50	Walking Beam	1.75
Pinion Shaft	1.00	Guide Rods, each75
Main Gear	3.75	Cross Head Pin25
Pinion	1.65	Rod Link	1.25
Main or Plunger Cross Head	3.25	Rod Link Pin15
Crank Cross Head and Cap	6.75	Gear Guard	2.50
Sliding Cross Head End of Beam	2.25	Pulleys, each	6.00
Discharge Head	6.00	AIR PUMPING DEVICE	
Stuffing-box	2.00	Crosshead Attachment25
HAND ATTACHMENT		Bottom Attachment for Air Cylinder	5.50
Cross Head for Lever	4.25	Plunger Complete without Rod	1.95
Bearer	4.25	Plunger Top	1.25
Bearer Rack40	Plunger Follower60
Lever Socket	1.25	Air Valve, Complete20
Guide Rods, each	1.75	Plunger Rod75
Wood Handle50	1/8" Air Cock45
Stuffing-box Gland	1.75		



HAND AND POWER PUMPS FOR ALL USES



"MARVEL" HOUSE PUMPING OUTFITS

Nos. 1685, 2085, 1686 and 2086

FIGURE NUMBER	1685, 2085	1686, 2086
Cylinder, Brass Lined	\$8.50	\$8.50
Air Chamber	2.75	2.75
Suction Chamber	2.50	2.50
Valve Seat60	.60
Rubber Valves05	.05
Valve Stem15	.15
Valve Spring05	.05
Steel Washers10	.10
Piston	1.00	1.00
Piston Follower50	.50
Piston Rod25	.25
Piston Valve10	.10
Piston Washer20	.20
Leather Crimp15	.15
Stuffing-box Head	1.50	1.50
Stuffing-box Gland25	.25
Stuffing-box Nut50	.50
Back Head85	.85
Bed Plate	11.50	11.50
Crank Cover	3.00	3.00
Bed Plate Bushing	1.75	1.75
Crank Cover Bushing90	.90
Eccentric and Shaft	4.00	4.00
Crosshead	2.15	2.15
Crosshead Pin10	.10
Connecting Rod Complete	1.25	1.25
Vacuum Chamber	3.50	3.50
Strainer Cap75	.75
Strainer40	.40
Mal. Galv. Tube40	.40
Union Tube Nut25	.25
Idler Complete	2.15	2.55
Idler Arm50	.70
Idler Pulley	1.00	1.00
Idler Arm Pin25	.45
Idler Pulley Bolt25	.25
Idler Spring15	.15
Pulley	9.50	9.50
Motor Pulley	1.25
Endless Belt	2.50	4.25
Motor Shelf	1.75
Motor Shelf Supports20
Feet, each75	.75
Check Valve	2.00	2.00
Ball Check Air Cock75	.75
Drip Plug05	.05
Surface Packing50	.50
Controller Disc or Plug10
Controller Shelf	1.00
Sub Base for Fig. 2085	14.00
Controller Tube, Brass40
Pipe Nipple25
Battery Box	2.25



HAND AND POWER PUMPS FOR ALL USES



BUCKET SPRAY PUMPS, FIGS. 669, 659 AND 689

FIGURE NUMBER . . .	669	659	689	FIGURE NUMBER . . .	669	659	689
Air Chamber	\$0.75	\$1.75	\$1.75	Foot Rest Complete . . .	\$0.65	\$0.65	\$1.15
Stuffing Cap25	.25	.25	Malleable Foot Rest . .	.50	.50
Cylinder Tube	1.50	1.50	1.50	Malleable Foot Rest Clamp10	.10
Plunger Tube	1.00	1.00	1.00	Thumb Screw05	.05
Plunger Complete with Ball Valve50	.50	.50	Cylinder Clamp only50
Foot Valve and Strainer with Ball Valve75	.75	.75	Clamping Hinge10
Brass Ball Valves, each	.15	.15	.15	Clamping Screw10
Plunger Packing05	.05	.05	Adjusting Screw10
Stuffing-box Packing . .	.05	.05	.05	Hinge-screw10
Handle25	.35	.35	Foot Rest with Ad- justing Rod25
				Bail Hook05

KNAPSACK SPRAY PUMP, FIG. 675

NAME OF PART	PRICE	NAME OF PART	PRICE
Agitator, Complete	\$0.85	Hose Coupling Tube	\$0.20
Drip Cup40	Plunger Tube90
Extra Handle30	Cylinder Tube	1.15
Hose Coupling Nut15	Brass Tank	17.00
Pump Collar55	Carrying Handle60
Crosshead40	Lever Link25
Air Chamber	1.90	Shoulder Straps, Complete, one set .	2.60
Stuffing-box Gland25	Lever55
Strap Link20	Swinging Handle, Complete45
Plunger, Complete60	Lance90
Saddle	2.00	Foot Rest	1.10
Foot Valve, Seat and Strainer40	Gland Packing10

KNAPSACK SPRAY PUMP, FIG. 654

NAME OF PART	PRICE	NAME OF PART	PRICE
Galv. Tank with Saddle, Strap Holders, etc., Complete	\$7.50	Carrying Straps, each	\$0.60
Drip Bowl	1.00	Malleable Wrench15
Carrying Handle25	Lid for Tank	1.00
Lever Complete50	(For Repair Parts for Pump, see Repair List of Fig. 669)	



HAND AND POWER PUMPS FOR ALL USES



THE "GARDENER'S CHOICE" SPRAYER, FIG. 651

NAME OF PART	PRICE	NAME OF PART	PRICE
Base or Air Chamber	\$4.00	Agitator Yoke	\$0.30
Bottom Casting Complete, with Valves	2.00	Agitator Cross Head25
Bottom Casting only50	Agitator Clamp Complete30
Foot Valve and Strainer with Ball Valve85	Agitator Yoke Pin10
Valve Seat and Ball Valve65	Agitator Paddles, per set (2)15
Ball Valves, each30	Plates for Base Bolts10
Lever75	Half Barrel or Tank with Cover	10.00
Cylinder Tube, Brass	1.50	Wheels, each	3.00
Air Chamber Tube, Iron65	Axle Pipe50
Discharge Pipe15	Cast Iron Handle40
Piston Rod20	Foot Casting15
Piston Rod Cross Head25	Barrel Support or Frame Casting, each75
Piston Complete with Crimps60	Axle Collar, each25
Piston Center Casting10	Axle Caps, each20
Piston Follower Castings, each10	V-Bolt, Front of Barrel40
Agitator Complete	1.25	Bolts, Barrel to Axle Collar, each10

"MAJOR" BARREL SPRAY PUMP, FIG. 832

FIGURE NUMBER	832	FIGURE NUMBER	832
Bearer with Clamp	\$1.50	Piston Rod	\$0.25
Lever75	Piston Rod Cross Head25
Bottom Casting Complete with Valves	2.50	Plunger Complete with Crimps	1.25
Bottom Casting only	1.15	Plunger Center Casting25
Strainer35	Plunger Follower Casting, each35
Valve Cage05	Agitator Complete	1.25
Ball Valves, each30	Agitator Yoke30
Valve Seats, each35	Agitator Cross Head25
Air Chamber Tubing	1.25	Agitator Yoke Pin10
Discharge Pipe25	Agitator Paddles, per set15
Brass Cylinder Tube	1.50	Agitator Pipe Clamp Complete30

THE "CENTURY" BARREL SPRAYER, FIG. 645

NAME OF PART	PRICE	NAME OF PART	PRICE
Bearer or Top	\$0.75	Plunger Follower Casting, each	\$0.20
Lever	1.00	Plunger Rod30
Air Chamber Tube	1.75	Plunger Rod Cross Head25
Discharge Pipe25	Agitator Complete	1.50
Bottom Attach. for Air Chamber50	Pipe Clamp25
Bottom Casting only75	Agitator Yoke25
Strainer35	Agitator Link15
Valve Seats, each35	Agitator Cross Head15
Ball Valves, each35	Agitator Paddles, per set15
Cylinder Tube	2.50	Base for Barrel Complete	1.50
Plunger Complete with Crimps	1.00	Filling Cap10
Plunger Center Casting15		



HAND AND POWER PUMPS FOR ALL USES



FOUR-ROW FIELD SPRAYER, FIG. 653

NAME OF PART	PRICE	NAME OF PART	PRICE
Locking Segment and Base	\$1.50	Three-way Hose Connection	\$0.90
Supporting Arm	4.25	Sheath Pipe	1.25
Supporting Clamp and Bolt25	Adjusting Rods, each10
"L" Bolts with Nuts, each45	Center Nozzle Attachments, each	1.10
Locking Lever Complete with Handle	1.00	End Nozzle Attachment, each55
Handle only50	Hose Spring, each35
Fulcrum Pin.35		

"SAMSON" DOUBLE-ACTING SPRAYER, FIG. 633.

NAME OF PART	PRICE	NAME OF PART	PRICE
Air Chamber Tube	\$7.50	Crosshead Links, each	\$1.50
Air Chamber Cap	1.00	Valve Chamber Covers, each25
Air Chamber Rods, each25	Guide Rod	2.00
Base, with Suction Valve Seat	6.50	Differential Plunger with Crimps60
Lower Cyl. Castings with Valve Seat	4.25	Lower Plunger Complete	3.50
Lower Cylinder Liner	2.75	Lower Plunger Cage	2.25
Upper Cylinder Liner	3.25	Lower Plunger Follower	1.00
Guide or Bearing Casting	1.50	Malleable Lever	1.75
Brass Valve Seats, each60	Wood Handle25
Brass Ball Valves, each	1.00	Suction Hose Tube50
Lever Socket	1.50	Suction Hose Nut20
Crosshead35	Cylinder Bolts, each20

DUPLEX PLUNGER POWER SPRAY PUMP, FIG. 761

SIZE NUMBER	1	2	SIZE NUMBER	1	2
Base with Valve Seats	\$14.00	\$20.00	Cross Head Nuts, each		\$0.60
Valve Seats only, each50	.60	Cross Head Pins10
Brass Ball Valves, each35	1.00	Plungers and Connecting Rods Complete, each	\$8.00	
Right or Left Column with Caps	6.50	7.50	Connecting Rod and Caps, each		4.00
Crank Shaft	7.50	10.00	Air Chamber	4.25	6.50
Main Gear	2.75	5.00	Plunger Covers, per set15
Pinion	1.25	1.65	Belt Tightener Complete	6.00	8.00
Pinion Shaft65	1.00	Belt Tightener Pulley	2.50	3.75
Gear Guard85	2.25	Belt Tightener Yoke	1.00	1.25
Valve Covers, each15	.20	Belt Tightener Arm90	1.15
Valve Cover Bars, each20	1.25	Belt Tightener Collar10	.10
Cylinders, each	1.50	2.00	Belt Tightener Oil Cup Collar25	.25
Stuffing-box Nuts, each40	.50	Pump Pulley	6.50	7.50
Stuffing-box Glands	1.10	1.35	Gaskets for Valve Caps, each10	.10
Plungers only, each		7.50	Gaskets for Cylinders, each15	.20
Plunger Cross Heads, each		1.25			

SPECIAL NOTICE

Repair Parts for Pumps and Accessories not listed in the foregoing section will be quoted on request, which should be accompanied by symbol number; or a dimension diagram, complete description and weight of the part. The figure number and size should be given, if known.

Complete Table of Contents and General Classification of Pumps, Pages 7 and 8



VALUABLE
TECHNICAL DATA
AND
ENGINEERING
TABLES

EMBRACING INFORMATION
USEFUL TO THE ENGINEER,
ARCHITECT AND MANUFACTUR-
ER; ALSO TO DEALERS IN AND
USERS OF PUMPS IN GENERAL,
SUCH AS FACTS, FORMULAS AND
RULES RELATING TO HYDRAU-
LICS AND PNEUMATICS, INCLUD-
ING CAPACITIES, POWER, AND
SPEED OF PUMPS AND THEIR
OPERATING FACTOR





HAND AND POWER PUMPS FOR ALL USES



Useful Technical Information

THE AREAS OF CIRCLES are to each other as the square of their diameters. Doubling the diameter of a pipe or cylinder increases its capacity four times. Friction of liquids in pipes increases as the square of the velocity.

ATMOSPHERIC PRESSURE at sea level is usually estimated at 14.7 pounds per square inch, and this pressure will maintain a column of water 33.9 feet high when the normal pressure in the column is relieved by the creation of a vacuum. This is the theoretical distance that water may be drawn by suction. In practice, however, pumps should not be placed over 20 to 25 feet above the water supply, and nearer if possible.

EVERY FOOT OF HEIGHT in a column of water represents .434 pounds pressure to the square inch. It is common practice to estimate that every foot in height is equal to one-half pound pressure per square inch, as this allows for ordinary friction in pipes.

A GALLON OF WATER WEIGHS 8.33 pounds, and contains 231 cubic inches. A cubic foot of water weighs 62.36 pounds, and contains 1,728 cubic inches, or 7.48 gallons.

A MINER'S INCH OF WATER is approximately equal to 11½ U. S. gallons per minute.

Rules to Determine the Size and Speed of Pulleys or Gears

The Driving pulley is called the Driver, and the Driven pulley the Driven.

If the number of teeth in gears is used instead of diameter in these calculations, number of teeth must be substituted wherever diameter occurs.

TO FIND THE DIAMETER OF THE DRIVER, the diameter of Driven and its revolutions, and also revolutions of Driver being given: Multiply the diameter of Driven by its revolutions, and divide the product by the revolutions of Driver; the quotient will give the diameter of Driver.

TO FIND THE DIAMETER OF THE DRIVEN, the revolutions of Driven, also diameter and revolutions of Driver being given: Multiply the diameter of Driver by its revolutions, and divide the product by the revolutions of Driven; the quotient will give the Diameter of the Driven.

TO FIND THE REVOLUTIONS OF THE DRIVER, the diameter and revolutions of the Driven, also diameter of the Driver being given: Multiply the diameter of Driven by its revolutions, and divide the product by the diameter of Driver; the quotient will give the revolutions of Driver.

TO FIND THE REVOLUTIONS OF THE DRIVEN, the diameter and revolutions of the Driver, also diameter of the Driven being given: Multiply the diameter of Driver by its revolutions, and divide the product by the diameter of Driven; the quotient will give the revolutions of Driven.

Data on Air Compression

FRANK RICHARDS, M. E.

AIR COMPRESSION FROM ONE ATMOSPHERE,
AT SEA LEVEL, 60° FAHRENHEIT

Gauge Press. Lbs.	Volume		Mean pressure per stroke		Final temper. Air not cooled	HORSE POWER (THEORETICAL)	
	Air const. temper.	Air not cooled	Air const. temper.	Air not cooled		To compress 1 cu. ft. free air per minute	
						Air const. temper.	Air not cooled
0	1.	1.	0	0	60.		
1	.936	.95	.96	.97	71.		
2	.88	.91	1.87	1.91	80.4		
3	.83	.87	2.72	2.80	88.9		
4	.786	.84	3.53	3.67	98.		
5	.746	.81	4.3	4.5	106.	.0187	.0196
10	.595	.69	7.62	8.27	145.	.0332	.0360
15	.495	.606	10.33	11.5	178.	.0450	.0502
20	.423	.543	12.62	14.4	207.	.0550	.0628
25	.370	.494	14.59	17.01	234.	.0636	.0742
30	.328	.463	16.34	19.4	255.	.0713	.0846
35	.295	.42	17.92	21.6	281.	.0782	.0942
40	.268	.393	19.32	23.66	302.	.0843	.1032
45	.246	.37	20.52	25.59	321.	.0895	.1116
50	.227	.35	21.79	27.39	339.	.0950	.1195
55	.210	.331	22.77	29.11	357.	.0993	.1270
60	.196	.314	23.84	30.75	375.	.1040	.1341
65	.184	.301	24.77	31.69	389.	.1080	.1402
70	.173	.288	26.00	33.73	405.	.1124	.1471
75	.163	.276	26.65	35.23	420.	.1162	.1537
80	.155	.267	27.33	36.6	432.	.1192	.1597
85	.147	.256	28.05	37.94	447.	.1224	.1655
90	.140	.248	28.78	39.18	459.	.1255	.1709
95	.134	.24	29.53	40.4	472.	.1288	.1762
100	.128	.232	30.07	41.6	485.	.1312	.1815

NOTE.—Losses by machine friction, heating the air, clearance, etc., reduce the efficiency to about 60 per cent. for single stage and 75 per cent. for two-stage compression.

Complete Table of Contents and General Classification of Pumps, Pages 7 and 8



HAND AND POWER PUMPS FOR ALL USES



Table Showing Capacity of Pumps per Stroke Figures are for One Single-Acting Cylinder

Diam. of Cylinder Inches	Area Square Inches	LENGTH OF STROKE IN INCHES AND CAPACITY IN GALLONS												
		2	3	4	6	8	10	12	14	16	20	24	30	36
3/8	.307	.003	.004	.005	.008	.011	.013	.016	.019	.021	.027	.032	.040	.048
3/4	.442	.004	.006	.008	.011	.015	.019	.023	.027	.031	.038	.046	.057	.068
7/8	.601	.005	.008	.01	.016	.021	.026	.031	.036	.042	.052	.062	.078	.094
1	.785	.007	.01	.014	.02	.027	.034	.041	.048	.054	.068	.082	.102	.122
1 1/8	.994	.009	.013	.017	.026	.034	.043	.052	.06	.069	.086	.103	.129	.154
1 1/4	1.227	.011	.016	.021	.032	.043	.053	.064	.074	.085	.106	.127	.159	.192
1 3/8	1.485	.013	.019	.026	.039	.051	.064	.077	.089	.103	.128	.154	.192	.232
1 1/2	1.767	.015	.023	.031	.046	.061	.077	.092	.107	.122	.153	.184	.231	.276
1 3/4	2.405	.021	.031	.042	.063	.083	.104	.125	.146	.167	.208	.25	.312	.374
2	3.142	.027	.041	.054	.082	.109	.136	.163	.19	.218	.272	.326	.408	.49
2 1/4	3.976	.034	.052	.069	.103	.138	.172	.206	.241	.275	.344	.413	.516	.62
2 1/2	4.900	.043	.064	.085	.128	.17	.213	.255	.298	.34	.425	.51	.639	.766
2 3/4	5.94	.051	.077	.103	.154	.206	.257	.309	.36	.411	.514	.617	.771	.926
3	7.069	.061	.092	.122	.184	.245	.306	.367	.428	.49	.612	.734	.918	1.102
3 1/4	8.296	.072	.108	.144	.215	.287	.359	.431	.503	.575	.718	.862	1.077	1.294
3 1/2	9.621	.083	.125	.167	.25	.333	.417	.5	.583	.666	.833	1	1.251	1.50
3 3/4	11.045	.095	.143	.191	.287	.382	.478	.574	.669	.765	.956	1.147	1.434	1.722
4	12.566	.109	.163	.218	.326	.435	.544	.653	.762	.87	1.088	1.306	1.632	1.958
4 1/4	14.186	.123	.184	.246	.368	.491	.614	.737	.86	.982	1.228	1.473	1.842	2.21
4 1/2	15.904	.138	.207	.275	.413	.551	.689	.825	.964	1.102	1.377	1.652	2.067	2.478
4 3/4	17.721	.153	.23	.307	.46	.614	.767	.92	1.073	1.227	1.534	1.84	2.301	2.76
5	19.635	.17	.255	.34	.51	.68	.85	1.02	1.19	1.36	1.7	2.04	2.55	3.06
5 1/4	21.648	.187	.281	.375	.562	.75	.937	1.124	1.311	1.499	1.874	2.248	2.811	3.372
5 1/2	23.758	.206	.309	.411	.617	.823	1.029	1.234	1.44	1.646	2.057	2.468	3.087	3.702
5 3/4	25.967	.225	.337	.45	.674	.899	1.124	1.348	1.573	1.798	2.248	2.696	3.372	4.044
6	28.274	.245	.367	.49	.734	.979	1.224	1.469	1.714	1.958	2.448	2.938	3.672	4.406
6 1/4	30.68	.266	.398	.531	.797	1.062	1.328	1.593	1.859	2.124	2.656	3.186	3.984	4.78
6 1/2	33.183	.287	.431	.574	.861	1.149	1.436	1.796	2.011	2.298	2.873	3.447	4.308	5.178
6 3/4	35.785	.309	.465	.62	.929	1.239	1.549	1.858	2.168	2.479	3.098	3.716	4.647	5.576
7	38.485	.333	.5	.666	1.1	1.333	1.666	1.999	2.332	2.666	3.332	3.998	4.998	5.998
7 1/2	44.179	.383	.574	.765	1.148	1.53	1.913	2.295	2.678	3.06	3.825	4.59	5.739	6.886
7 3/4	47.173	.408	.613	.817	1.225	1.633	2.042	2.45	2.858	3.266	4.084	4.9	6.126	7.348
8	50.266	.435	.653	.87	1.306	1.741	2.176	2.611	3.046	3.482	4.352	5.222	6.528	7.834
8 1/2	56.745	.49	.735	.98	1.47	1.96	2.45	2.94	3.43	3.92	4.9	5.88	7.35	8.82
8 3/4	60.132	.52	.78	1.04	1.56	2.08	2.6	3.12	3.64	4.16	5.2	6.24	7.8	9.36
9	63.617	.551	.826	1.101	1.652	2.203	2.754	3.305	3.856	4.406	5.508	6.61	8.262	9.91
9 1/2	70.882	.612	.918	1.224	1.83	2.448	3.06	3.672	4.284	4.896	6.12	7.344	9.18	11.02
9 3/4	74.662	.646	.97	1.293	1.939	2.586	3.232	3.878	4.525	5.171	6.464	7.757	9.696	11.636
10	78.54	.68	1.02	1.36	2.04	2.72	3.4	4.08	4.76	5.44	6.8	8.16	10.2	12.24
10 1/2	86.590	.750	1.125	1.500	2.250	3.000	3.750	4.500	5.250	6.000	7.500	9.000	11.250	13.50
11	95.033	.823	1.234	1.645	2.464	3.291	4.114	4.937	5.76	6.582	8.228	9.874	12.44	14.81
11 1/2	103.869	.90	1.351	1.80	2.701	3.60	4.505	5.406	6.30	7.2	9	10.8	13.515	16.2
12	113.098	.979	1.468	1.958	2.938	3.917	4.896	5.875	6.854	7.833	9.792	11.75	14.688	17.626
12 1/2	122.718	1.062	1.593	2.124	3.186	4.244	5.310	6.372	7.434	8.488	10.620	12.744	15.930	19.116
13	132.733	1.149	1.723	2.297	3.445	4.596	5.745	6.894	8.042	9.192	11.49	13.78	17.235	20.68
13 1/2	143.139	1.238	1.857	2.476	3.714	4.852	6.190	7.428	8.666	9.704	12.38	14.856	18.57	22.284
14	153.938	1.332	1.998	2.665	3.997	5.33	6.663	7.994	9.328	10.66	13.32	15.98	19.989	23.98
14 1/2	165.13	1.43	2.142	2.865	4.284	5.718	7.148	8.578	10.0	11.424	14.28	17.136	21.444	25.704
15	176.715	1.529	2.294	3.059	4.589	6.119	7.649	9.178	10.7	12.23	15.29	18.35	22.947	27.52
16	201.062	1.74	2.61	3.48	5.22	6.96	8.703	10.44	12.18	13.92	17.40	20.88	26.109	31.32
18	254.47	2.202	3.303	4.404	6.606	8.808	11.01	13.21	15.41	17.61	22.02	26.42	33.03	39.72
20	314.16	2.720	4.08	5.44	8.16	10.88	13.6	16.32	19.04	21.76	27.2	32.64	40.8	48.96

Doubling the DIAMETER of a pipe or cylinder increases its capacity four times.

Alphabetical Index, Figure Index and Telegraph Cipher Code, Pages 249 to 254



HAND AND POWER PUMPS FOR ALL USES



Theoretical Horse Power Required to Raise Water to Different Heights

Feet Elevation	5	10	15	20	25	30	35	40	45	50	60
Gallons per Min.											
5	.006	.012	.019	.025	.031	.037	.044	.05	.06	.06	.07
10	.012	.025	.037	.050	.062	.075	.087	.10	.11	.12	.15
15	.019	.037	.056	.075	.094	.112	.131	.15	.17	.19	.22
20	.025	.050	.075	.100	.125	.150	.175	.20	.22	.25	.30
25	.031	.062	.093	.125	.156	.187	.219	.25	.28	.31	.37
30	.037	.075	.112	.150	.187	.225	.262	.30	.34	.37	.45
35	.043	.087	.131	.175	.219	.262	.306	.35	.39	.44	.52
40	.050	.100	.150	.200	.250	.300	.350	.40	.45	.50	.60
45	.056	.112	.168	.225	.281	.337	.394	.45	.51	.56	.67
50	.062	.125	.187	.250	.312	.375	.437	.50	.56	.62	.75
60	.075	.150	.225	.300	.375	.450	.525	.60	.67	.75	.90
75	.093	.187	.281	.375	.469	.562	.656	.75	.84	.94	1.12
90	.112	.225	.337	.450	.562	.675	.787	.90	1.01	1.12	1.35
100	.125	.250	.375	.500	.625	.750	.875	1.00	1.12	1.25	1.50
125	.156	.312	.469	.625	.781	.937	1.094	1.25	1.41	1.56	1.87
150	.187	.375	.562	.750	.937	1.125	1.312	1.50	1.69	1.87	2.25
175	.219	.437	.656	.875	1.093	1.312	1.531	1.75	1.97	2.19	2.62
200	.250	.500	.750	1.000	1.250	1.500	1.750	2.00	2.25	2.50	3.00
250	.312	.625	.937	1.250	1.562	1.875	2.187	2.50	2.81	3.12	3.75
300	.375	.750	1.125	1.500	1.875	2.250	2.625	3.00	3.37	3.75	4.50
350	.437	.875	1.312	1.750	2.187	2.625	3.062	3.50	3.94	4.37	5.25
400	.500	1.000	1.500	2.000	2.500	3.000	3.500	4.00	4.50	5.00	6.00
500	.625	1.250	1.875	2.500	3.125	3.750	4.375	5.00	5.62	6.25	7.50

Feet Elevation	75	90	100	125	150	175	200	250	300	350	400
Gallons per Min.											
5	.09	.11	.12	.16	.19	.22	.25	.31	.37	.44	.50
10	.19	.22	.25	.31	.37	.44	.50	.62	.75	.87	1.00
15	.28	.34	.37	.47	.56	.66	.75	.94	1.12	1.31	1.50
20	.37	.45	.50	.62	.75	.87	1.00	1.25	1.50	1.75	2.00
25	.47	.56	.62	.78	.94	1.09	1.25	1.56	1.87	2.19	2.50
30	.56	.67	.75	.94	1.12	1.31	1.50	1.87	2.25	2.62	3.00
35	.66	.79	.87	1.08	1.31	1.53	1.75	2.19	2.62	3.06	3.50
40	.75	.90	1.00	1.25	1.50	1.75	2.00	2.50	3.00	3.50	4.00
45	.84	1.01	1.12	1.41	1.69	1.97	2.25	2.81	3.37	3.94	4.50
50	.94	1.12	1.25	1.56	1.87	2.19	2.50	3.12	3.75	4.37	5.00
60	1.12	1.35	1.50	1.87	2.25	2.62	3.00	3.75	4.50	5.25	6.00
75	1.40	1.69	1.87	2.34	2.81	3.28	3.75	4.69	5.62	6.56	7.50
90	1.68	2.02	2.25	2.81	3.37	3.94	4.50	5.62	6.75	7.87	9.00
100	1.87	2.25	2.50	3.12	3.75	4.37	5.00	6.25	7.50	8.75	10.00
125	2.34	2.81	3.12	3.91	4.69	5.47	6.25	7.81	9.37	10.94	12.50
150	2.81	3.37	3.75	4.69	5.62	6.56	7.50	9.37	11.25	13.12	15.00
175	3.28	3.94	4.37	5.47	6.56	7.66	8.75	10.94	13.12	15.31	17.50
200	3.75	4.50	5.00	6.25	7.50	8.75	10.00	12.50	15.00	17.50	20.00
250	4.69	5.62	6.25	7.81	9.37	10.94	12.50	15.72	18.75	21.87	25.00
300	5.62	6.75	7.50	9.37	11.25	13.12	15.00	18.75	22.50	26.25	30.00
350	6.56	7.87	8.75	10.94	13.12	15.31	17.50	21.87	26.25	30.62	35.00
400	7.50	9.00	10.00	12.50	15.00	17.50	20.00	25.00	30.00	35.00	40.00
500	9.37	11.25	12.50	15.62	18.75	21.87	25.00	31.25	37.50	43.75	50.00

The theoretical horse power required to elevate water is found by multiplying the gallons pumped per minute by the total lift (including friction) in feet, and dividing by 4000. To get the actual horse power required, divide the theoretical power obtained from the table above by the efficiency of the pump expressed as a decimal.

Complete Table of Contents and General Classification of Pumps, Pages 7 and 8



HAND AND POWER PUMPS FOR ALL USES



Comparative Equivalents of Liquid Measures and Weights

Measures and Weights for Comparison	MEASURE AND WEIGHT EQUIVALENTS OF ITEMS IN FIRST COLUMN								
	U. S. Gallon	Imperial Gallon	Cubic Inch	Cubic Foot	Cubic Metre	Litre	*Vedro	*Pood	Pound
U. S. Gallon	1.	.833	231.	.1337	.00378	3.785	.308	.231	8.33
Imperial Gallon	1.20	1.	277.27	.1604	.00454	4.542	.369	.277	10.
Cubic Inch	.0043	.00358	1.	.00057	.000016	.0163	.00132	.001	.0358
Cubic Foot	7.48	6.235	1728.	1.	.02827	28.312	2.304	1.728	62.355
Cubic Metre	264.17	220.05	61023.	35.319	1.	1000.	81.364	61.023	2200.54
Litre	.26417	.2200	61.023	.0353	.001	1.	.08136	.06102	2.2005
* Vedro	3.249	2.706	750.1	.4344	.01228	12.29	1.	.7501	27.06
* Pood	4.328	3.607	1000.	.578	.01636	16.381	1.333	1.	36.07
Pound	.12	.1	27.72	.016	.00045	.454	.0369	.0277	1.

*Vedro and Pood are a Russian measure and weight respectively.

CONVENIENT TO KNOW { A common water pail holds 19 pounds, or 2.272 U. S. gallons.
 { A miner's inch of water equals approximately 1½ U. S. gallons per minute.
 { One metre equals 39.37 inches, or 3.281 feet.

Relative Quantities of Water

Delivered in 24 Hours, in 1 Hour, and in 1 Minute.

Gallons in 24 hours	Gallons in 1 hour	Gallons in 1 min.	Gallons in 24 hours	Gallons in 1 hour	Gallons in 1 min.	Gallons in 24 hours	Gallons in 1 hour	Gallons in 1 min.
2500000	104166.0	1736.0	650000	27083.3	451.3	150000	6250.0	104.1
2000000	83333.3	1388.0	600000	25000.0	416.7	100000	4166.6	69.4
1500000	62500.0	1041.7	550000	22916.6	381.9	75000	3125.0	52.9
1000000	41666.6	694.3	500000	20833.3	347.2	60000	2500.0	41.6
950000	39583.3	659.7	450000	18750.0	312.5	50000	2083.3	34.7
900000	37500.0	625.0	400000	16666.6	277.7	25000	1041.6	17.3
850000	35416.6	590.2	350000	14583.3	243.0	20000	833.3	13.8
800000	33333.3	555.5	300000	12500.0	208.3	15000	625.0	10.4
750000	31250.0	520.8	250000	10416.7	173.6	10000	416.6	6.9
700000	29166.6	486.1	200000	8333.3	138.8	5000	208.3	3.4

Strokes to Piston Speed of 100 Feet per Minute

Length of Stroke Inches	Number of Strokes	Length of Stroke Inches	Number of Strokes	Length of Stroke Inches	Number of Strokes
				Length of Stroke Inches	Number of Strokes
4	300	12	100	24	50
5	240	14	86	26	46
6	200	16	75	28	43
7	172	18	67	30	40
8	150	20	60	36	33
10	120	22	55	40	30

Deep Well Pump Plunger Loads—in Pounds

Lift in Feet	DIAMETER OF CYLINDERS AND LOAD IN POUNDS											
	2¼	3¼	3¾	4¼	4¾	5¼	6¼	7½	8½	9	9½	10
50	129	180	240	307	384	562	775	956	1228	1377	1535	1700
75	195	270	360	460	576	845	1162	1435	1840	2065	2300	2550
100	260	360	480	615	770	1125	1550	1910	2455	2755	3070	3400
125	320	450	600	770	960	1405	1940	2390	3070	3440	3835	4250
150	385	540	720	920	1150	1685	2325	2870	3685	4130	4600	5100
200	515	720	960	1230	1535	2250	3100	3825	4910	5510	6135	6800
250	645	900	1200	1535	1920	2810	3875	4780	6140	6885	7670	8500
300	775	1080	1440	1840	2305	3370	4650	5740	7370	8260	9200	10200
350	900	1260	1680	2150	2690	3935	5425	6690	8600	9640	10740	11900
400	1030	1440	1920	2455	3075	4500	6200	7650	9825	11015	12270	13600
500	1290	1800	2400	3070	3840	5620	7750	9560	12280	13770	15340	17000

Alphabetical Index, Figure Index and Telegraph Cipher Code, Pages 249 to 254



HAND AND POWER PUMPS FOR ALL USES



Table Showing Head in Feet and Pressure in Pounds

HEAD OF WATER AND EQUIVALENT PRESSURE						PRESSURE OF WATER AND EQUIVALENT HEAD					
Feet Head	Lbs. Press.	Feet Head	Lbs. Press.	Feet Head	Lbs. Press.	Lbs. Press.	Feet Head	Lbs. Press.	Feet Head	Lbs. Press.	Feet Head
5	2.17	70	30.3	200	86.6	5	11.5	70	161.6	180	415.6
10	4.33	80	34.6	250	108.2	10	23.0	80	184.7	190	438.9
15	6.50	90	39.0	300	129.9	15	34.6	90	207.8	200	461.7
20	8.66	100	43.3	350	151.5	20	46.2	100	230.9	225	519.5
25	10.83	110	47.6	400	173.2	25	57.7	110	253.9	250	577.2
30	12.99	120	52.0	500	216.5	30	69.3	120	277.0	275	643.0
35	15.16	130	56.3	600	259.8	35	80.8	130	300.1	300	692.7
40	17.32	140	60.6	700	303.1	40	92.3	140	323.2	325	750.4
45	19.49	150	65.0	800	346.4	45	103.9	150	346.3	350	808.1
50	21.65	160	69.2	900	389.7	50	115.4	160	369.4	400	922.6
60	26.09	180	78.0	1000	433.0	60	138.5	170	392.5	500	1154.5

Table of Effective Fire Streams

Using 100 feet of 2½ inch ordinary best quality Rubber-Lined Hose between Nozzle and Hydrant or Pump.
J. R. FREEMAN, C. E.

Smooth Nozzle, Size	¼ Inch						½ Inch						1 Inch					
	32	43	54	65	75	86	34	46	57	69	80	91	37	50	62	75	87	100
Pressure at Hydrant, lbs.	30	40	50	60	70	80	30	40	50	60	70	80	30	40	50	60	70	80
Pressure at Nozzle, lbs.	2	3	4	5	5	6	4	6	7	9	10	11	7	10	12	15	17	20
Press. lost in 100ft. 2½ in. hose	48	60	67	72	76	79	49	62	71	77	81	85	51	64	73	79	85	89
Vertical Height, feet	37	44	50	54	58	62	42	49	55	61	66	70	47	55	61	67	72	76
Horizontal Distance, feet	90	104	116	127	137	147	123	142	159	174	188	201	161	186	208	228	246	263
Gallons Discharged per min.																		
Smooth Nozzle, Size	1½ Inch						1¾ Inch						1¾ Inch					
	42	56	70	84	98	112	49	65	81	97	113	129	58	77	96	116	135	154
Pressure at Hydrant, lbs.	30	40	50	60	70	80	30	40	50	60	70	80	30	40	50	60	70	80
Pressure at Nozzle, lbs.	12	16	20	24	28	32	9	25	31	37	43	49	28	37	46	56	65	74
Press. lost in 100 ft. 2½ in. hose	52	65	75	83	88	92	53	67	77	85	91	95	55	69	79	87	92	97
Vertical Height, ft.	50	59	66	72	77	81	54	63	70	76	81	85	56	66	73	79	84	88
Horizontal Distance, feet	206	238	266	291	314	336	256	296	331	363	392	419	315	363	406	445	480	514
Gallons Discharged per min.																		

250 gallons per minute gives a good standard fire stream with 80 pounds pressure at the hydrant.

Table for Open Weir Measurement

Giving Cubic Feet of Water per minute that flows over an open Weir one inch wide and from ¼ to 20¾ inches deep.
PELTON W. W. Co.

INCHES	¼	½	¾	1	1½	2	2½
0	.00	.01	.05	.09	.14	.19	.26
1	.40	.47	.55	.64	.73	.82	.92
2	1.13	1.23	1.35	1.46	1.58	1.70	1.82
3	2.07	2.21	2.34	2.48	2.61	2.76	2.90
4	3.20	3.35	3.50	3.66	3.81	3.97	4.14
5	4.47	4.64	4.81	4.98	5.15	5.33	5.51
6	5.87	6.06	6.25	6.44	6.62	6.82	7.01
7	7.40	7.60	7.80	8.01	8.21	8.42	8.63
8	9.05	9.26	9.47	9.69	9.91	10.13	10.35
9	10.80	11.02	11.25	11.48	11.71	11.94	12.17
10	12.64	12.88	13.12	13.36	13.60	13.85	14.09
11	14.59	14.84	15.09	15.34	15.59	15.85	16.11
12	16.62	16.88	17.15	17.41	17.67	17.94	18.21
13	18.74	19.01	19.29	19.56	19.84	20.11	20.39
14	20.95	21.23	21.51	21.80	22.08	22.37	22.65
15	23.23	23.52	23.82	24.11	24.40	24.70	25.00
16	25.60	25.90	26.20	26.50	26.80	27.11	27.42
17	28.03	28.34	28.65	28.97	29.28	29.59	29.91
18	30.54	30.86	31.18	31.50	31.82	32.15	32.47
19	33.12	33.45	33.78	34.11	34.44	34.77	35.10
20	35.77	36.11	36.45	36.78	37.12	37.46	37.80

In making Weir measurements, place a board or plank in the stream at the point so that a pond will form above it. A rectangular notch is cut in it large enough so that all the water will flow over the notch. The length of the notch should be from two to four times its depth. The edges should be beveled to slope outward in the direction of the flow of the water. In the pond about six feet above the Weir a stake should be driven so that its top is precisely level with the bottom of the notch, and at some convenient point for measuring. The depth of the water flowing over the Weir may then be ascertained by an ordinary rule, placed on top of the stake, measuring to the surface of the water, and the quantity figured from the table above.

Complete Table of Contents and General Classification of Pumps, Pages 7 and 8



HAND AND POWER PUMPS FOR ALL USES



Friction of Water in Pipes

Loss of head in feet due to Friction, per 100 feet of smooth, straight cast iron pipe

Gallons Per Minute	1/2-Inch Pipe		3/4-Inch Pipe		1-Inch Pipe		1 1/4-Inch Pipe		1 1/2-Inch Pipe		2-Inch Pipe		2 1/2-Inch Pipe		3-Inch Pipe		4-Inch Pipe								
	Vel.	Frict.	Vel.	Frict.	Vel.	Frict.	Vel.	Frict.	Vel.	Frict.	Vel.	Frict.	Vel.	Frict.	Vel.	Frict.	Vel.	Frict.							
2	2.10	5.30	1.20	1.40							
3	3.16	11.30	1.80	2.90	1.12	0.90							
4	4.21	19.20	2.41	5.00	1.49	1.52	0.86	0.40	0.63	0.187							
5	5.26	29.00	3.01	7.50	1.86	2.32	1.07	0.60	0.79	0.283							
10	10.52	105.00	6.02	27.10	3.72	8.40	2.14	2.18	1.57	1.02	1.02	.36	0.65	0.12	0.45	0.05							
15	9.02	57.00	6.13	18.90	3.92	4.65	2.72	2.25	1.53	0.81	0.98	0.25	0.68	0.11							
20	12.03	97.00	7.44	30.10	4.29	7.90	3.15	3.70	2.04	1.29	1.31	0.43	0.91	0.18							
25	9.30	45.50	5.36	11.90	4.56	5.60	2.55	1.96	1.63	0.66	1.13	0.27							
30	11.15	64.00	6.43	16.90	4.72	7.80	3.06	2.73	1.96	0.92	1.36	0.38							
35	13.02	85.00	7.51	22.30	5.51	10.30	3.57	3.66	2.29	1.23	1.59	0.51							
40	14.88	109.00	8.58	28.50	6.30	13.30	4.08	4.68	2.62	1.57	1.82	0.65	1.02	0.16							
45	9.68	35.20	7.08	16.60	4.60	5.80	2.95	1.97	2.02	0.80	1.17	0.20							
50	10.72	43.20	7.87	20.20	5.11	7.10	3.30	2.38	2.27	0.98	1.28	0.24							
70	15.01	81.00	11.02	37.60	7.15	13.20	4.60	4.42	3.18	1.83	1.79	0.45							
75	11.80	42.70	7.66	14.90	4.93	5.07	3.41	2.11	1.92	0.52							
100	15.74	73.00	10.21	25.60	6.54	8.60	4.54	3.52	2.55	0.88							
120	12.25	36.00	7.84	12.00	5.45	4.97	3.06	1.22							
125	12.75	38.90	8.16	13.01	5.68	5.40	3.19	1.33							
150	15.30	54.00	9.80	18.72	6.80	7.72	3.84	1.82							
175	11.43	23.70	7.92	9.75	4.45	2.40							
200	13.07	30.90	9.08	12.80	5.11	3.12							
225	10.42	16.00	6.32	4.72							
250	11.28	19.70	6.40	4.80						
270	12.45	22.70	6.90	5.50						
275	12.70	23.60	7.03	5.71					
300	13.62	27.10	7.66	6.70					
350	8.90	8.80					
400	10.20	11.30				
450	11.50	14.10			
470	12.16	16.00		
475	12.30	16.40	
500	12.77	17.20

Gallons Per Minute	5-Inch Pipe		6-Inch Pipe		8-Inch Pipe		10-Inch Pipe		12-Inch Pipe		16-Inch Pipe		20-Inch Pipe		24-Inch Pipe		30-Inch Pipe	
	Vel.	Frict.	Vel.	Frict.	Vel.	Frict.	Vel.	Frict.	Vel.	Frict.	Vel.	Frict.	Vel.	Frict.	Vel.	Frict.	Vel.	Frict.
70	1.14	0.15
100	1.63	0.29	1.14	0.10
120	1.96	0.41	1.42	0.18
125	2.04	0.46	1.48	0.20
150	2.45	0.63	1.71	0.23
175	2.86	0.84	2.00	0.34
200	3.27	1.06	2.28	0.44
225	3.67	1.33	2.57	0.53
250	4.08	1.60	2.80	0.66	1.60	0.16
270	4.42	1.86	3.03	0.81	1.70	0.18
275	4.50	1.94	3.06	0.82	1.73	0.19
300	4.90	2.25	3.40	0.92	1.90	0.26
350	5.72	2.99	3.98	1.21	2.20	0.29
400	6.54	3.81	4.54	1.58	2.60	0.40
450	7.35	4.75	5.12	1.96	2.92	0.46	1.80	0.150
470	7.78	5.30	5.49	2.23	3.07	0.55	1.92	0.170
500	8.17	5.80	5.60	2.33	3.20	0.58	2.04	0.200	1.42	0.08
550	8.99	6.90	6.16	2.81	3.52	0.70	2.25	0.236	1.57	0.098
600	9.80	8.10	6.72	3.36	3.84	0.83	2.46	0.282	1.71	0.106
650	10.62	9.40	7.28	3.93	4.16	0.96	2.66	0.327	1.85	0.134
700	11.44	10.80	7.84	4.56	4.46	1.10	2.86	0.368	2.00	0.154
750	12.26	12.30	8.50	5.00	4.80	1.24	3.06	0.422	2.13	0.170
800	9.08	5.64	5.12	1.41	3.28	0.476	2.27	0.196
850	9.58	6.25	5.48	1.63	3.48	0.534	2.41	0.22
900	10.30	7.22	5.75	1.76	3.68	0.592	2.56	0.24
950	10.72	7.65	6.06	2.05	3.88	0.653	2.70	0.25
1000	11.32	8.60	6.40	2.16	4.08	0.718	2.84	0.295
1100	12.50	10.22	7.03	2.51	4.50	0.860	3.13	0.35
1200	13.52	11.92	7.67	3.04	4.91	1.040	3.41	0.41
1500	9.60	4.48	6.10	1.490	4.20	0.61	2.39	0.171
2000	12.70	7.65	8.10	2.500	5.60	1.02	3.19	0.280
2500	10.10	3.810	7.00	1.56	3.99	0.397
3000	12.10	5.300	8.40	2.42	4.79	0.568	3.08	0.191
3500	14.10	7.200	9.80	2.80	5.59	0.745	3.59	0.251
4000	11.35	3.80	6.38	0.956	4.10	0.323
5000	14.20	5.82	7.96	0.144	5.13	0.488	3.55	0.199	2.27	0.067

When pipe is slightly rough, add 15 per cent. When very rough, add 30 per cent.
 Vel.—Velocity feet per second. Frict.—Friction head in feet.

Alphabetical Index, Figure Index and Telegraph Cipher Code, Pages 249 to 254



HAND AND POWER PUMPS FOR ALL USES



Friction of Water in Elbows

Loss of head in feet, due to friction in various sizes of smooth 90° elbows when discharging the given quantities of water.

Gals. per Minute	1-Inch		1¼-Inch		1½-Inch		2-Inch		2½-Inch		3-Inch		4-Inch		5-Inch		6-Inch		8-Inch		10-Inch		12-Inch		
	Vel.	Fric.	Vel.	Fric.	Vel.	Fric.	Vel.	Fric.	Vel.	Fric.	Vel.	Fric.	Vel.	Fric.	Vel.	Fric.	Vel.	Fric.	Vel.	Fric.	Vel.	Fric.	Vel.	Fric.	
5	2.04	0.06	1.30	0.14	
10	4.08	0.22	2.60	0.21	
15	6.12	0.49	3.90	0.29	2.73	0.09	
20	8.16	0.87	5.20	0.52	3.64	0.16	
25	10.20	1.35	6.50	0.80	4.55	0.25	2.60	0.09	
30	12.24	1.95	7.80	1.15	5.46	0.36	3.06	0.13	
35	14.28	2.65	9.10	1.60	6.37	0.50	3.57	0.18	2.29	0.09	
40	16.32	3.46	10.40	2.05	7.28	0.64	4.05	0.23	2.62	0.11	
45	11.70	2.70	8.19	0.81	4.60	0.29	2.95	0.14	2.02	0.06	
50	9.10	0.99	5.11	0.35	3.30	0.18	2.27	0.08	
75	12.74	1.98	7.15	0.70	4.60	0.34	3.18	0.19	1.79	0.05	
100	10.20	1.41	6.54	0.74	4.54	0.29	2.55	0.10	1.96	0.06	
120	12.25	2.24	7.84	1.17	5.45	0.46	3.06	0.15	
150	15.30	3.20	9.80	1.58	6.80	0.66	3.84	0.22	2.45	0.09	
175	11.43	2.16	7.92	0.90	4.45	0.30	2.86	0.12	2.00	0.06	
200	13.07	2.96	9.08	1.18	5.11	0.40	3.27	0.16	2.28	0.07	
250	11.28	1.84	6.40	0.62	4.08	0.25	2.80	0.12	1.60	0.04
300	12.45	2.55	6.90	0.70	4.42	0.25	3.03	0.14	1.70	0.05
350	13.62	2.63	7.66	0.89	4.90	0.36	3.40	0.18	1.90	0.06
400	8.90	1.24	5.72	0.50	3.98	0.24	2.20	0.09
450	10.20	1.59	6.54	0.63	4.54	0.29	2.60	0.10
470	11.50	2.01	7.35	0.81	5.12	0.39	2.92	0.13	1.80	0.05
500	12.16	2.26	7.78	0.90	5.49	0.46	3.07	0.14	1.92	0.06
570	12.77	2.47	8.17	1.01	5.60	0.48	3.20	0.16	2.00	0.07	1.40	0.04	...
750	12.26	2.24	8.40	1.09	4.80	0.36	3.00	0.15	2.10	0.07	...
1050	12.57	2.41	7.04	0.76	4.40	0.29	3.08	0.14
1250	14.10	3.02	8.00	1.00	5.00	0.40	3.50	0.20
1500	9.60	1.44	6.10	0.58	4.20	0.29

When pipe is slightly rough, add 15 per cent. When very rough, add 30 per cent.

Vel.—Velocity in feet per second. Fric.—Friction head in feet.

Table shows loss for one elbow, and is based on Weisbach's Formula for short radius bends.

Water Required per Minute to Feed Boilers

(Using the "Centennial Standard"—30 pounds or 3.6 gallons of water per horse power per hour, evaporated from 100° F. to 70 pounds steam pressure per square inch.)

H. P. Boiler	Feed Water Gallons	H. P. Boiler	Feed Water Gallons	H. P. Boiler	Feed Water Gallons	H. P. Boiler	Feed Water Gallons	H. P. Boiler	Feed Water Gallons
20	1.2	60	3.6	110	6.6	190	11.4	400	24.0
25	1.5	65	3.9	120	7.2	200	12.0	450	27.0
30	1.8	70	4.2	130	7.8	225	13.5	500	30.0
35	2.1	75	4.5	140	8.4	250	15.0	600	36.0
40	2.4	80	4.8	150	9.0	275	16.5	700	42.0
45	2.7	85	5.1	160	9.6	300	18.0	800	48.0
50	3.0	90	5.4	170	10.2	325	19.5	900	54.0
55	3.3	100	6.0	180	10.8	350	21.0	1000	60.0

Sizes of Single-Acting Triplex Pumps Recommended to Feed Boilers

While 30 pounds of water per horsepower per hour is the usual basis of estimate, this table is based on 36.6 pounds per hour, giving a reasonable amount of excess supply.

Horse Power of Boiler	FEED WATER AT 212°		Size of Pump	Revolutions per Minute	Horse Power of Boiler	FEED WATER AT 212°		Size of Pump	Revolutions per Minute
	Pounds per Hour	Gallons per Minute				Pounds per Hour	Gallons per Minute		
50	1830	3.6	2½ x 2	29	600	21960	43.8	4½ x 6	35
75	2745	5.4	2½ x 3	29	700	25620	51.3	5 x 6	34
100	3660	7.3	3 x 3	28	800	29280	58.5	5½ x 8	24
150	5490	10.9	3½ x 3	30	1000	36600	73.2	5½ x 8	30
200	7320	14.6	3½ x 4	28	1200	43920	87.8	6 x 8	30
250	9150	18.3	3½ x 4	37	1500	54900	109.	7 x 8	28
300	10980	21.9	4 x 4	34	1800	65880	131.	8 x 8	25
350	12810	25.6	4 x 6	27	2000	73200	146.	8 x 8	29
400	14640	29.3	4 x 6	30	2500	91500	183.	8 x 10	28
500	18300	36.6	4½ x 6	30	3000	109800	219.	9 x 10	26

Complete Table of Contents and General Classification of Pumps, Pages 7 and 8



HAND AND POWER PUMPS FOR ALL USES



Irrigation Quantity Tables

Amount of water required to cover one acre to given depths.			*Second Feet reduced to Gallons and Acre Feet.				Gallons required to cover a given number of acres to a depth of one foot (Acre foot)	
Depth in inches and feet (Acre inches and acre feet)	Cubic feet (or second feet) contained in one acre to depths given in first column	Gallons	Second foot	Gallons per minute	Gallons per pumping day of 12 hours.	Acre feet per pumping day of 12 hours	Acres (or number of acre feet)	Gallons
ft. in.								
1	3630	27154	1/4	112.2	80790	2479	1	325851
2	7260	54309	1/2	224.4	161579	4959	2	651703
3	10890	81463	3/4	336.6	242369	7438	3	977554
4	14520	108617	1	448.8	323158	9917	4	1303406
5	18150	135771	1 1/4	561.0	403948	12307	5	1629257
6	21780	162926	1 1/2	673.2	484738	14876	6	1955109
7	25410	190080	1 3/4	785.5	565527	17355	7	2280960
8	29040	217234	2	897.7	646317	19835	8	2606812
9	32670	244389	2 1/2	1122.1	807896	24793	9	2932663
10	36300	271543	3	1346.5	969475	29752	10	3258515
11	39930	298697	4	1795.3	1292634	39669	15	4887772
1 00	43560	325851	5	2244.2	1615792	49586	20	6512029
1 2	50820	380160	6	2693.0	1938951	59503	25	8146286
1 4	58080	434469	7	3141.8	2262109	69421	30	9775544
1 6	65340	488777	8	3590.6	2585268	79338	40	13034058
1 8	72600	543086	9	4039.5	2908426	89255	60	19551087
1 10	79860	597394	10	4488.3	3231585	99173	80	26068116
2 00	87120	651703	20	8976.6	6463170	198345	160	52136232

*One cubic foot of water per second (exact 7.48052 gallons) constant flow is known as the "Second Foot." The "Acre Foot" is the quantity of water required to cover one acre to a depth of one foot.

Contents of Round Tanks in U. S. Gallons for Each Foot in Depth

Inside Diameter Ft.	Inches	Gallons One foot in depth	Inside Diameter Ft.	Inches	Gallons One foot in depth	Inside Diameter Ft.	Inches	Gallons One foot in depth.
1	0	5.87	5	9	194.19	10	6	653.69
1	3	9.17	6	0	211.44	10	9	678.88
1	6	13.21	6	3	229.43	11	0	710.69
1	9	17.98	6	6	248.15	11	3	743.36
2	0	23.49	6	9	267.61	11	6	776.77
2	3	29.73	7	0	287.80	11	9	810.91
2	6	36.70	7	3	308.72	12	0	848.18
2	9	44.41	7	6	330.38	12	3	881.39
3	0	52.86	7	9	352.76	12	6	917.73
3	3	62.03	8	0	375.90	12	9	954.81
3	6	73.15	8	3	399.76	13	0	992.62
3	9	82.59	8	6	424.36	13	3	1031.17
4	0	93.97	8	9	449.21	13	6	1070.45
4	3	103.03	9	0	475.80	13	9	1108.06
4	6	118.93	9	3	502.65	14	0	1151.21
4	9	132.52	9	6	530.18	14	3	1192.69
5	0	146.83	9	9	558.45	14	6	1234.91
5	3	161.88	10	0	587.47	14	9	1277.86
5	6	177.67	10	3	617.17	15	0	1321.54

Atmospheric Pressures, Equivalent Heads and Suction Lift

ALTITUDE	Barometric Pressure Per Sq. In. Pounds	Equivalent Head of Water Feet	Practical Suction Lift of Pumps Feet
Sea Level.....	14.70	33.95	22
1/4 mile (1320 feet) above sea level.....	14.02	32.38	21
1/2 mile (2640 feet) above sea level.....	13.33	30.79	20
3/4 mile (3960 feet) above sea level.....	12.66	29.24	18
1 mile (5280 feet) above sea level.....	12.02	27.76	17
1 1/4 miles (6600 feet) above sea level.....	11.42	26.38	16
1 1/2 miles (7920 feet) above sea level.....	10.88	25.13	15
2 miles (10560 feet) above sea level.....	9.88	22.82	14

NOTE.—Barometer in inches multiplied by 0.4908 equals pressure per square inch.

Alphabetical Index, Figure Index and Telegraph Cipher Code, Pages 249 to 254



HAND AND POWER PUMPS FOR ALL USES



Theoretical Discharge of Nozzles in U. S. Gallons Per Minute

HEAD		Velocity of Discharge Feet per Sec.	DIAMETER OF NOZZLE IN INCHES								
Pounds	Feet		1/8	1/4	3/8	1/2	5/8	3/4	7/8		
10	23.1	38.6	0.37	1.48	3.32	5.91	13.3	23.6	36.9	53.1	72.4
15	34.6	47.25	0.45	1.81	4.06	7.24	16.3	28.9	45.2	65.0	88.5
20	46.2	54.55	0.52	2.09	4.69	8.35	18.8	33.4	52.2	75.1	102.
25	57.7	61.0	0.58	2.34	5.25	9.34	21.0	37.3	58.3	84.0	114.
30	69.3	66.85	0.64	2.56	5.75	10.2	23.0	40.9	63.9	92.0	125.
35	80.8	72.2	0.69	2.77	6.21	11.1	24.8	44.2	69.0	99.5	135.
40	92.4	77.2	0.74	2.96	6.64	11.8	26.6	47.3	73.8	106.	145.
45	103.9	81.8	0.78	3.13	7.03	12.5	28.2	50.1	78.2	113.	153.
50	115.5	86.25	0.83	3.30	7.41	13.2	29.7	52.8	82.5	119.	162.
55	127.0	90.4	0.87	3.46	7.77	13.8	31.1	55.3	86.4	125.	169.
60	138.6	94.5	0.90	3.62	8.12	14.5	32.5	57.8	90.4	130.	177.
65	150.1	98.3	0.94	3.77	8.45	15.1	33.8	60.2	94.7	136.	184.
70	161.7	102.1	0.98	3.91	8.78	15.7	35.2	62.5	97.7	141.	191.
75	173.2	105.7	1.01	4.05	9.08	16.2	36.4	64.7	101.	146.	198.
80	184.8	109.1	1.05	4.18	9.39	16.7	37.6	66.8	104.	150.	205.
85	196.3	112.5	1.08	4.31	9.67	17.3	38.8	68.9	108.	155.	211.
90	207.9	115.8	1.11	4.43	9.95	17.7	39.9	70.8	111.	160.	217.
95	219.4	119.0	1.14	4.56	10.2	18.2	41.0	72.8	114.	164.	223.
100	230.9	122.0	1.17	4.67	10.5	18.7	42.1	74.7	117.	168.	229.
105	242.4	125.0	1.20	4.79	10.8	19.2	43.1	76.5	120.	172.	234.
110	254.0	128.0	1.23	4.90	11.0	19.6	44.1	78.4	122.	176.	240.
115	265.5	130.9	1.25	5.01	11.2	20.0	45.1	80.1	125.	180.	245.
120	277.1	133.7	1.28	5.12	11.5	20.5	46.0	81.8	128.	184.	251.
125	288.6	136.4	1.31	5.22	11.7	20.9	47.0	83.5	130.	188.	256.
130	300.2	139.1	1.33	5.33	12.0	21.3	48.0	85.2	133.	192.	261.
135	311.7	141.8	1.36	5.43	12.2	21.7	48.9	86.7	136.	195.	266.
140	323.3	144.3	1.38	5.53	12.4	22.1	49.8	88.4	138.	199.	271.
145	334.8	146.9	1.41	5.62	12.6	22.5	50.6	89.9	140.	202.	275.
150	346.4	149.5	1.43	5.72	12.9	22.9	51.5	91.5	143.	206.	280.
175	404.1	161.4	1.55	6.18	13.9	24.7	55.6	98.8	154.	222.	302.
200	461.9	172.6	1.65	6.61	14.8	26.4	59.5	106.	165.	238.	323.

HEAD		Velocity of Discharge Feet per Sec.	DIAMETER OF NOZZLE IN INCHES								
Pounds	Feet		1	1 1/8	1 1/4	1 3/8	1 1/2	1 3/4	2	2 1/4	2 1/2
10	23.1	38.6	94.5	120	148	179	213	289	378	479	591
15	34.6	47.25	116.	147	181	219	260	354	463	585	723
20	46.2	54.55	134.	169	209	253	301	409	535	676	835
25	57.7	61.0	149.	189	234	283	336	458	598	756	934
30	69.3	66.85	164.	207	256	309	368	501	655	828	1023
35	80.8	72.2	177.	224	277	334	398	541	708	895	1106
40	92.4	77.2	189.	239	296	357	425	578	756	957	1182
45	103.9	81.8	200.	253	313	379	451	613	801	1015	1252
50	115.5	86.25	211.	267	330	399	475	647	845	1070	1320
55	127.0	90.4	221.	280	346	418	498	678	886	1121	1385
60	138.6	94.5	231.	293	362	438	521	708	926	1172	1447
65	150.1	98.3	241.	305	376	455	542	737	964	1220	1506
70	161.7	102.1	250.	317	391	473	563	765	1001	1267	1565
75	173.2	105.7	259.	327	404	489	582	792	1037	1310	1619
80	184.8	109.1	267.	338	418	505	602	818	1070	1354	1672
85	196.3	112.5	276.	349	431	521	620	844	1103	1395	1723
90	207.9	115.8	284.	359	443	536	638	868	1136	1436	1773
95	219.4	119.0	292.	369	456	551	656	892	1168	1476	1824
100	230.9	122.0	299.	378	467	565	672	915	1196	1512	1870
105	242.4	125.0	306.	388	479	579	689	937	1226	1550	1916
110	254.0	128.0	314.	397	490	593	705	960	1255	1588	1961
115	265.5	130.9	320.	406	501	606	720	980	1282	1621	2005
120	277.1	133.7	327.	414	512	619	736	1002	1310	1659	2050
125	288.6	136.4	334.	423	522	632	751	1022	1338	1690	2090
130	300.2	139.1	341.	432	533	645	767	1043	1365	1726	2132
135	311.7	141.8	347.	439	543	656	780	1063	1390	1759	2173
140	323.3	144.3	354.	448	553	668	795	1082	1415	1790	2212
145	334.8	146.9	360.	455	562	680	809	1100	1440	1820	2250
150	346.4	149.5	366.	463	572	692	824	1120	1466	1853	2290
175	404.1	161.4	395.	500	618	747	890	1210	1582	2000	2473
200	461.9	172.6	423.	535	660	799	950	1294	1691	2140	2645

NOTE.—The actual quantities will vary from these figures, the amount of variation depending upon the shape of nozzle and size of pipe at the point where the pressure is determined. With smooth taper nozzles the actual discharge is about 94 per cent. of the figures given in the tables.

Complete Table of Contents and General Classification of Pumps, Pages 7 and 8



TELEGRAPH CODES
AND
INDEXES

FOR

CONVENIENCE OF PATRONS

EMBRACING FIGURE INDEX ARRANGED BY FIGURE NUMBERS, CONSECUTIVELY; AND ALPHABETICAL INDEX ARRANGED BY NAME OF ARTICLE. THE TELEGRAPH CIPHER CODE DEFINES SENTENCES RELATING TO ENQUIRIES AND PRICES; ALSO ORDERS AND THEIR EXECUTION.





Telegraph Cipher Code

For the accommodation of those desirous of making inquiries, or placing orders by telegraph, we append the following code, the use of which will often save considerable expense.

A great part of the articles listed in this catalogue are given cipher words by which they may be ordered by telegraph.

OUR CABLE ADDRESS IS "DEMING, Salem, Ohio."

We also use Lieber's, Bentley's, the A. B. C. 4th and 5th Edition, and Western Union Telegraphic Codes. When using either of these special Codes, add to telegram the word "Lieber" for the Lieber Code; the word "Alphabet" for A. B. C. 4th and 5th Editions, and the word "Western" for Western Union Telegraphic Code, etc.

Concerning Orders, Quotations and Shipments

PADDLING . . . How soon could you ship if ordered at once?	PINAFORE . . . We have no reply to our telegram of.
PADDLE . . . We have in stock.	PIPPIN . . . Have you received our letter of regarding
PALENESS . . . When will you ship?	PISTOLET . . . We do not understand your telegram by cipher code, repeat it using regular language.
PASTORATE . . . Enter our order for specifications for which follow by mail.	PITCHING . . . Write us fully in regard to matter in our letter of
PASSWORD . . . Do not ship our order of until advised by us.	PITIABLE . . . When you receive our letter of please telegraph reply.
PASTRY . . . Ship what you have in stock, and let balance follow as soon as possible.	PROBATE . . . Referring to your letter of
PATHETIC . . . Ship immediately by freight.	PROBE . . . Referring to our letter of
PATHOS . . . Ship immediately by express.	PROBOSCIS . . . Answer by telegraph.
PEERDOM . . . We can ship. . .	PROCLAIM . . . Mail blue-print of
PEEVISH . . . We will ship. . . .	PROCTOR . . . Referring to your telegram of
PETULANT . . . Answer by telegraph at our expense.	PRODDING . . . Referring to our telegram of
PINDAR . . . We have received no letter from you in regard to	PROFFER . . . Answer by mail.

Concerning Classes of Goods

PACATION . . . Pump fitted with bronze plungers and bronze-lined stuffing boxes and glands.	PLATOON . . . Fitted for 1½-inch Suction Pipe.
PACING . . . Pump fitted with brass cased plungers and bronze-lined stuffing boxes and glands.	PLATTER . . . Fitted for 2-inch Suction Pipe.
PIMENT . . . Pump with all-bronze water end.	PLAUDIT . . . Fitted for 2½-inch Suction Pipe.
PADRA . . . Complete with H. P. motor.	PLAUSIBLE . . . Fitted for 3-inch Suction Pipe.
PAGODA . . . For volt, direct current.	PLAUSIVE . . . Fitted for 1-inch Discharge Pipe.
PALING . . . For volt, alternating current. . . . phase, cycles.	PLASTRON . . . Fitted for 1¼-inch Discharge Pipe.
PLATEN . . . Fitted for 1 -inch Suction Pipe.	PLAYFUL . . . Fitted for 1½-inch Discharge Pipe.
PLATONIC . . . Fitted for 1¼-inch Suction Pipe.	PLAYING . . . Fitted for 2-inch Discharge Pipe.
	PLEADING . . . Fitted for 2½-inch Discharge Pipe.
	PLEADER . . . Fitted for 3-inch Discharge Pipe.

Complete Table of Contents and General Classification of Pumps, Pages 7 and 8



Alphabetical Index

	PAGE		PAGE
Accessories, Metal and Glass, for Pumps	105	Drive Well Points	108
Accessories, Spraying	213-215	Drive Well Pumps	32-41
Acid Pumps	139-147	“Duplex” Outside-Packed Plunger Spraying Pump	211
“Acme” Spraying Nozzle	214	Electric Mine Pumps	154-157, 170-174
“Aerospra” Compressed Air Sprayer	203	Electric Driven Pumps	142-144, 154-162, 164-174
Air Chambers for Discharge Pipe	102	Electric House Pumps	160-161, 164-167, 190-191
Air Compressors	135	Elevator Pumps	154-155
Air Cylinder for Deep Wells	80	“Eureka” Spraying Nozzle	214
“Ajax” Double Acting Piston Pump	172-173	Factory Pumps, Miscellaneous Hand and Power	122, 125, 128-129, 154-155, 164-186
Artesian Well Cylinders	88-89	“Farmer’s Friend” Sprayer	208
Artesian Well Plungers and Valves	79, 81	Field Sprayer, Four-Row	209
“Atlas” Double-Acting Power Pump	164-167	Fire Extinguishers	125
“Atlas” Hydro-Pneumatic Water Systems	192-193	Fittings for Pipe	97
Automobile Rotary Gasoline Pumps	145	Foot and Float Valves	101-102
Automobile Plunger Gasoline Pumps	124	Force Pumps for Plumbers’ Use	122-123
Bilge Pumps	115, 116	Force Pumps, Hand Rotary	139-141
“Blue Special” House Force Pump	20	Force Pumps, Hand and House	16-28
Boiler Feed Pumps, Hand, Single Plunger	123	Force Pumps, Power Rotary	142-144, 146-147
Boiler Feed Pumps, Power	154-155	Force Pump Standards, Hand and Windmill	50, 57-68
Boiler Testing Pumps	122-123	Force Pumps, Well, Hand	38-48
“Bordeaux” Spraying Nozzle	214	Garage Pumps, for Gasoline	124, 145
Bottom Cylinder Cap with Valve	81	Garden Pumps, for Spraying	204-205
Brass and Brass-lined Cylinders	83-90	Garden Pumps, Hand, Irrigating	26-27, 113-116
Brass Goods	104-105	“Gardener’s Choice” Sprayer	204
Brass Valve Seat	79	Gas Engine Cooling Pumps	142-144
Brine Circulating Pumps 142-144, 154-157, 160-161, 169-174		Gasoline Garage Pumps	124, 145
Centrifugal Pumps	148-150	Gate Valves, Globe Valves and Check Valves	104
“Century” Barrel Sprayer	207	Gauges, Water and Pressure	109
“Century” Whitewashing Outfit	128	“Gem” Hose Nozzle	106
Cistern Pumps, Lift and Force	15-16	“Giant” Double-Acting Thresher Tank Pumps	114
“Climax” Double-Acting House Force Pumps	26-27	“Giant Simplex” Spraying Nozzle	214
“Climax” Water Systems	189	Goose Neck Spouts	102
“Clock Pumps,” with Wing Valves	24-25	Grease and Oil Cups	105
Cocks and Valves, Brass	104	Greenhouse Pumps for Water Supply	164-167, 189-196
Cog Lever Pumps	33, 47-48, 61, 66-67, 114	Greenhouse Pumps, for Spraying	200-207
“Colonial” Quick Return Force Pump	127	Hand and House Force Pumps	16-28
“Comet” Spray Gun	216	Hand and Power Pumps, Miscellaneous	113-136
Compressed Air Sprayers	203	Handle Balls	102
Contractors’ Pumps	116-117, 148-150	“Handy Success” Bucket Sprayer	201
Creamery Pumps	130-131, 142-144	Heads, Power Working	177-185
Current Breakers	109, 110	Horizontal Hand Force Pumps	26-27, 114
Cylinders and Accessories	78-94	Horizontal Double-Acting Piston Pumps, Power	164-174
Cylinders, Artesian Well, Brass	88-89	Hose, “Deco” Special Spraying	106, 216
Cylinders, Brass-lined, Iron	83, 91	Hose Couplings	215
Cylinders, Iron	82, 91	Hose, Discharge and Suction	106
Cylinders, Irrigating	91, 94	House Force Pumps	16-28
Cylinders, Seamless Brass Body	84-90	House Lift Pumps	12-15
“Deco” Special Spraying Hose	106, 216	House Pumping Outfits	189-196
Deep Well Pump Standards	72-75, 178	How to Install Deming House Lift and Force Pumps	11
Deep Well Power Working Heads	177-185	Hydraeram	134
Deep Well Pump Heads	177	Hydraulic Hand Pumps for Plumbers	122-123
Deep Well Triplex Pumps	186	Hydraulic Rams	132-133
“Demorel” Spraying Nozzle	214	Hydro-Pneumatic Steel Tanks	198
Diaphragm Suction Pumps for Hand and Power 116-117		Hydro-Pneumatic Water Systems	189-198
Discharge Hose	106	“Ideal” Double-Acting Oscillating Pumps	24-25
“Domestic” Kitchen Pump	13	Iron Cylinders	83, 91
Double-Acting Belt-Driven Spray Pump	211	Irrigating Pumps	94, 148-150
Double-Acting Hand Force Pumps	24-27, 113, 114	Knapsack Sprayers	202
Double-Acting House Force Pumps	24-27	Leathers for Plungers and Lower Valves	92-93
Double-Acting Power Pumps	164-174	Lever Handle Bibbs and Stops	104
Drives for Power Pumps, Types of	155, 157, 161-162	Lift Pumps, Set-Length	32-37
Drive Cap, Malleable	108		

Engineering Tables and Information Relating to Hydraulics, Pages 239 to 248



HAND AND POWER PUMPS FOR ALL USES



Alphabetical Index—Continued

	PAGE		PAGE
"Little Giant" Hydraulic Pressure Test Pump	122	Rubber Hose and Tubing	106, 216
Lower Valves and Valve Seats	81	"Samson" Double-Acting Sprayer	210
"Major" Barrel Sprayer	206	Set-Length Lift and Force Pumps	32-48
Malleable Fittings	97	Ship's Deck Pumps	26-27, 113-115
"Marine" Bilge Pumps	115	"Simplex" Spraying Nozzle	214
"Marine" Irrigating Pumps	94	Single-Acting Triplex Plunger Pumps	154-161
"Marvel" Electric House Pump	190	Sink Bracket for Pitcher Pumps	103
"Marvel" Water Systems	190-191	Sinks, Cast Iron, Enameled	103
"Mascot" Pipe Standard Lift Pumps	34	Siphon Force Pumps, Hand and Windmill	118-120
Mine Pumps	154-155, 164-174	Southern Lift and Force Pump	126
"Neptune" Double-Acting Piston Pump	174	Spout Hose Clevis	102
"New Era" Double-Acting House Force Pumps	17	Sprayers, Barrel	206-207, 210
Non-Freezing Hand and Windmill Pumps	32-48	Sprayers, Bucket	200-201
Nozzles, Spraying	214	Sprayers, Field	208-209
Oil Pumps, Power Rotary,	147	Sprayers, Compressed Air and Knapsack	202-203
Oil Pumps, Horizontal Power	169	Sprayers, Power, and Outfits	211-213
Orchard Sprayers	206-213	Spraying Accessories	215-216
Oscillating Force Pumps, with Wing Valves	24-25	Spraying Nozzles	214
Outlet Valves	102	Stop Cocks, for Spraying Outfits	215
Paper Mill Pumps	154-159	"Straight Line" Pumps and Working Heads	71-76
"Peerless" Cog Lever Force Pumps	47-48	Strainers, Suction, for Pipe and Hose	100
"Peerless" Windmill Force Pumps	43-48	"Success" Bucket and Tank Sprayers	201
"Peerless" Double-Acting Force Pumps	43-48	Suction Strainers	100
"Perfect Success" Bucket Sprayer	201	Sucker Rod and Joints	99
Pipe Fittings	97	Suction Hose	106
Pipe Holders, Lifters and Pullers	107	Sugar House Pumps	154-161, 170-174
Pipe Standard Lift and Force Pumps	34-35, 38, 40, 60-67	Tanks for Hydro-Pneumatic Systems	198
Pipe, Spellerized Steel	96	Three-Way Force Pumps	46, 48, 65, 68
Pipe Cutters and Die Stocks	107	Thresher Tank Pumps	114
Pipe Vises and Wrenches	107	Triplex Mine Pumps	154-157
Piston Pumps, Hand and Power	164-174	Triplex Power Pumps, Single Acting	154-161
Piston Pumps, Horizontal Double-Acting	164-174	Triplex Deep Well Power Pumps	186
Piston Rod Roller Guides	102, 186	Triplex Pumps for Hydro-Pneumatic Service	197
Pitcher Spout Pumps	12, 14	"Triumph" Double-Acting Force Pump, Hand	112-113
"Planters Tractor" Sprayer	205	"Triumph" Double-Acting Piston Pump, Power	170-171
Plungers for Cylinders	79	Vacuum Pumps	135
Plunger and Valve Leathers	92-93	Valves, Check, Foot and Float, Iron	101-102
Plunger Pump, Hand and Power	211	"Vermorel" Spraying Nozzle	214
Pneumatic Pumps	135	"Victory Junior" Power Sprayer	212
Power Pumps, Single-Acting, Triplex	154-161	"Victory" Power Sprayer	213
Power Pumps, Double-Acting, Horizontal	164-174	Vises, Pipe	107
Power Spray Pumps	211-213	Water Systems, "Marvel"	190-191
Power Spraying Outfits	212-213	Water Systems, "Climax"	189
Power Working Heads for Deep Wells	72-75, 176-185	Water Systems, Deep Well	194-196
"Premium" Hand Force Pumps	40	Water Systems, Hydro-Pneumatic	189-196
Pressure Regulators for Electric Motor Circuits	110	Water Works Pumps	154-161
"Prize" Bucket Sprayer	200	Well Lift and Force Pumps, for Hand	32-48
Pump Bracket, for Sinks	103	Well Force Pump Standards	53-55
Pump Heads, Deep Well	177	Well Lift Pump Standards	51-52
Pumping Jacks	136	Whitewashing Outfits	128
Pump Leathers, Oak Tanned	92-93	Windmill Connections	109
Pump Rods, Steel and Wood	98-99	Windmill Force Pumps on Base	121
Pump and Cylinder Valves	80-81	Windmill Force Pump Standards	57, 59-68
Railway Water Supply Pumps	154-159, 170-174	Windmill and Power Irrigating Cylinder	91
Rams, Hydraulic	132-133	Windmill Lift Pump Standards	56, 58
Repairs or Extra Parts	217-238	Windmill Three-Way Force Pumps	65, 67, 68
Relief Valves	109, 216	Wing-Valve Pumps, Oscillating	24-25
Rod Couplings and Steel Rod	98	Wood Sucker Rods and Pin Connections	99
Rods, Wood Sucker and Connections	99	Working Heads, Deep Well, Geared	178-185, 73-75
Rotary Force Pumps, Hand and Power	139-147	Working Heads, Deep Well, Triplex	186
Rotary Gasoline Pumps, Automobile	145	Yard Pumps	32-48
Rotary Oil Pumps, for Lubricating Machine Tools	147	"Y" Discharge Connection and Stop Cock	215

Complete Table of Contents and General Classification of Pumps, Pages 7 and 8



Index to Figures

Articles in this Catalogue are generally designated by a Figure number. This Index should be used when the Figure number is known; otherwise the Alphabetical Index, preceding, should be used to find description and list when the name is known.

FIG.	PAGE	FIG.	PAGE	FIG.	PAGE	FIG.	PAGE
40	156-157, 162	306	80	415½	68	566	122
48	160, 161	308	83	421	37	569	178
50	154-155, 162, 198	311	88	430	121	570	24
52	158-159	312	84	439	177	575	140
61	182-183	314	86	440	60	576	141
62	180-181	320	119	441	63	577	138, 142-143
63	181	321	119	442	30, 41	577½	142-143
66	179	322	85	444	50, 60	578	139
80	184-185	324	89	444½	61	579	139
82	184-185	325	101	445	62	580	147
101	14	326	101	450	43	582	129
102	13	328	101	450½	47	585	130
115	14	330	101	451	44	590	130
120	15	334	100	451½	47	591	131
124	15	335	80	452	45	594	123
125	12	336	101	452½	48	595	146
166	35	338	100	453	46	598	148, 149
182	34	339	100	453½	48	599	150
183	35	340	100	470	115	600	26
184	38	341	100	471	115	600½	27
185	38	343	102	472	116	601	112, 113
198	32	344	102	473	116	602	113
211	36	350	102	475	94	606	28
219	39	362	102	476	94	608	26
223	39	364	215	482	34	608½	27
224	51	366	215	484	57	609	170-171
229	54	367	216	494	58	630	108
230	52	368	102	496	59	633	210
231	53	369	102	498	59	636	99
239	55	380	91	508	10, 18	644	128
258	66	383	215	509	19	645	207
259	67	384	215	516	20	647	208
260	66	385	118	518	16	651	204
261	67	386	118	519	16	653	209
277	127	387	120	520	22	654	202
280	43	389	102, 186	523	21	659	201
281	44	390	109	524	23	663	203
282	45	394	56	531	144	669	200
283	42, 46	398	32	532	144	670	25
290	40	403	56	540	17	675	202
291	40	407	64	544	17	680	135
298	33	408	65	554	114	688	109, 216
300	82	415	68	554½	114	689	201



HAND AND POWER PUMPS FOR ALL USES



Index to Figures—Continued

FIG.	PAGE	FIG.	PAGE	FIG.	PAGE	FIG.	PAGE
690	132-133	844	107	970	216	1540	109
691	164-167	848	107	972	216	1545	105
695	134	855	107	980	215	1608	110
696	174	858	107	981	215	1637	99
708	168	861	107	1000	216	1668	125
710	186	866	214	1078	102	1685	190
716	172-173	866½	214	1079	102	1686	191
725	124	884	107	1140	215	1696	169
726	124	898	108	1150	215	1700	71
729	212	900	104	1152	216	1716	72
730	213	904	104	1165	216	1717	73
733	215	908	104	1229	54	1718	74
747	136	913	104	1231	53	1719	75
749	215	917	104	1239	55	1720	76
751	216	919	104	1274	126	1995	109
752	216	933	210	1311	90	2001	189
753	214	948	106	1315	87	2002	189
754	214	949	215	1380	91	2003	189
759	200	951	215	1430	121	2004	189
761	211	955	215	1439	177	2009	192
766	214	960	214	1444	57	2012	193
766½	214	962	215	1473	117	2016	194
770	216	963	214	1508	110	2018	196
776	145	965	214	1526-A	109	2020	195
788	105	966	215	1526-B	216	2085	190
822	205	968	201	1535	109	2086	191
832	206						



THIS BOOK IS DUE ON THE LAST DATE
STAMPED BELOW

AN INITIAL FINE OF 25 CENTS

WILL BE ASSESSED FOR FAILURE TO RETURN
THIS BOOK ON THE DATE DUE. THE PENALTY
WILL INCREASE TO 50 CENTS ON THE FOURTH
DAY AND TO \$1.00 ON THE SEVENTH DAY
OVERDUE.

JAN 20 50

FE 25 '56

CU

NOV 20 1963

LIBRARY, BRANCH OF THE COLLEGE OF AGRICULTURE
UNIVERSITY OF CALIFORNIA 5m-8,'37(s)

24507		TJ902
Deming company.		D4
Hand & power pumps		
for all uses.		
JAN 20 '50		
NOV 20 1963		

Deming company

*TJ902
D4*

24507
LIBRARY, BRANCH OF THE COLLEGE OF AGRICULTURE, DAVIS
UNIVERSITY OF CALIFORNIA

