

EX LIBRIS





*green*  
-HEAT ENGINES-

STEAM, GAS, STEAM TURBINES  
AND THEIR AUXILIARIES

BY

JOHN R. ALLEN

PROFESSOR MECHANICAL ENGINEERING  
UNIVERSITY OF MICHIGAN

-AND-

JOSEPH A. BURSLEY

JUNIOR PROFESSOR MECHANICAL ENGINEERING  
UNIVERSITY OF MICHIGAN

SECOND EDITION

THOROUGHLY REVISED AND ENTIRELY RESET

---

TOTAL ISSUE 6,000

UNIVERSITY OF  
CALIFORNIA

McGRAW-HILL BOOK COMPANY, INC.  
239 WEST 39TH STREET, NEW YORK  
6 BOUVERIE STREET, LONDON, E. C.

1914

TJ255  
A6  
1914

COPYRIGHT 1914, BY THE  
MCGRAW-HILL BOOK COMPANY, INC.

---

COPYRIGHT 1910, BY THE  
MCGRAW-HILL BOOK COMPANY.

THE  
MCGRAW-HILL  
BOOK COMPANY

## PREFACE TO SECOND EDITION

The advancement in heat engines during the past four years has been such as to make it desirable to publish a new edition of this text. Among the new subjects treated are the Stumpf Uniflow Engine, the Humphrey Gas Pump, and recent developments in steam turbines and gas engines. It has been found also desirable to rewrite many of the chapters in order to clear up the points which experience has shown need more detailed explanation than was given in the first edition. At the same time an effort has been made not to increase materially the size of the book.

The authors desire to thank those members of the faculty of the mechanical engineering department of the University of Michigan who have assisted in the preparation of this text by their timely suggestions, and the manufacturers who have kindly supplied many of the new cuts used.

JOHN R. ALLEN.  
JOSEPH A. BURSLEY.

ANN ARBOR, MICHIGAN  
*Sept. 1, 1914.*

## PREFACE TO FIRST EDITION

In preparing this book, it has been the intention of the authors to present an elementary treatise upon the subject of Heat Engines, considering only those engines which are most commonly used in practice. It is written primarily as a text-book, the subject-matter having been used in the classes at the University of Michigan for a number of years.

The forms of heat engines discussed include the steam engine with its boiler plant and auxiliaries, the gas engine with its producer, oil engines, and the principal types of steam turbines. Under each division of the text, problems have been worked out in detail to show the application of the subject-matter just treated, and, in addition, a large number of problems have been introduced for class-room work. The use of calculus and higher mathematics has been largely avoided, the only place where it is used being in the chapter on thermo-dynamics, which subject has been treated in its elementary phases only. The matter of the design of engines has been left untouched, as it was felt that that subject did not properly come within the scope of this work.

The authors wish to express their thanks to Messrs. H. C. Anderson, A. H. Knight, and J. A. Moyer, for their assistance in compiling this work, to Mr. W. R. McKinnon who made a number of the drawings, and to the various manufacturers who have very kindly furnished illustrations and descriptions of their apparatus.

JOHN R. ALLEN.

JOSEPH A. BURSLEY.

ANN ARBOR, MICHIGAN  
*Sept. 1, 1910.*



# CONTENTS

	PAGE
PREFACE . . . . .	v-v
LIST OF TABLES . . . . .	xii

## CHAPTER I

### HEAT

THEORY AND MEASUREMENT OF HEAT . . . . .	1
SPECIFIC HEAT . . . . .	5
RADIATION, CONDUCTION, AND CONVECTION . . . . .	7
DEFINITIONS OF ENERGY, WORK, AND POWER . . . . .	8

## CHAPTER II

### ELEMENTARY THERMODYNAMICS

FIRST AND SECOND LAWS OF THERMODYNAMICS . . . . .	10
EQUATION AND LAWS OF PERFECT GASES . . . . .	11
ABSORPTION OF HEAT . . . . .	13
JOULE'S LAW . . . . .	14
RELATION OF SPECIFIC HEATS . . . . .	15
EXPANSIONS IN GENERAL . . . . .	17
WORK OF EXPANSION . . . . .	18
GENERAL CASE OF HEAT ADDED . . . . .	20
HEAT ADDED AT CONSTANT VOLUME OR CONSTANT PRESSURE . . . . .	22
ADIABATIC EXPANSION . . . . .	24
ISOTHERMAL EXPANSION . . . . .	25
RELATION OF PRESSURE, VOLUME AND TEMPERATURE DURING EXPANSION . . . . .	27
THEORETICAL HEAT ENGINE . . . . .	29
CARNOT CYCLE . . . . .	29
PROBLEMS . . . . .	34

## CHAPTER III

### PROPERTIES OF STEAM

FORMATION OF STEAM . . . . .	38
PROPERTIES OF STEAM . . . . .	40
STEAM TABLES . . . . .	42

## CHAPTER IV

### CALORIMETERS AND MECHANICAL MIXTURES

CALORIMETERS . . . . .	48
SEPARATING CALORIMETERS . . . . .	48
THROTTLING CALORIMETERS . . . . .	50

	PAGE
QUALITY OF STEAM . . . . .	53
PROBLEMS . . . . .	55
MECHANICAL MIXTURES . . . . .	56
PROBLEMS . . . . .	61

## CHAPTER V

## COMBUSTION AND FUELS

COAL ANALYSIS . . . . .	64
HEATING VALUE OF FUELS . . . . .	66
COAL CALORIMETERS . . . . .	68
AIR REQUIRED FOR COMBUSTION . . . . .	70
SMOKE . . . . .	71
ANALYSIS OF FLUE GASES . . . . .	71
THEORETICAL TEMPERATURE OF COMBUSTION . . . . .	74
FUELS . . . . .	75
PROBLEMS. . . . .	79

## CHAPTER VI

## BOILERS

RETURN TUBULAR BOILERS. . . . .	82
INTERNALLY FIRED BOILERS . . . . .	87
WATER-TUBE BOILERS . . . . .	91
HORSE-POWER OF BOILERS . . . . .	97
HEATING SURFACE, GRATE SURFACE, AND BREECHING . . . . .	98
BOILER ECONOMY . . . . .	99
BOILER EFFICIENCY . . . . .	100
BOILER LOSSES . . . . .	101
BOILER ACCESSORIES . . . . .	105

## CHAPTER VII

## BOILER AUXILIARIES

MECHANICAL STOKERS . . . . .	109
INCLINED GRATE STOKERS . . . . .	110
CHAIN GRATE STOKERS . . . . .	113
UNDER-FEED STOKERS . . . . .	115
BOILER FEEDERS . . . . .	119
FEED-WATER HEATERS . . . . .	122
ECONOMIZERS . . . . .	125
SUPERHEATERS . . . . .	127
CHIMNEYS. . . . .	128
MECHANICAL DRAFT. . . . .	132
PROBLEMS . . . . .	133

# CONTENTS

ix

## CHAPTER VIII STEAM ENGINES

	PAGE
THE SIMPLE STEAM ENGINE . . . . .	139
HORSE-POWER OF A STEAM ENGINE . . . . .	142
LOSSES IN THE STEAM ENGINE . . . . .	144
METHODS OF REDUCING INITIAL CONDENSATION. . . . .	147
CLEARANCE AND COMPRESSION . . . . .	149
PROBLEMS . . . . .	150

## CHAPTER IX TYPES AND DETAILS OF STEAM ENGINES

CLASSIFICATION OF ENGINES . . . . .	153
ENGINE DETAILS . . . . .	160

## CHAPTER X TESTING OF STEAM ENGINES

STEAM ENGINE INDICATOR . . . . .	168
INDICATED HORSE-POWER . . . . .	172
DETERMINATION OF INITIAL CONDENSATION . . . . .	174
ECONOMY OF VARIOUS FORMS OF ENGINES . . . . .	177
BRAKE HORSE-POWER . . . . .	178
MECHANICAL EFFICIENCY . . . . .	179
ACTUAL HEAT EFFICIENCY . . . . .	180
DUTY . . . . .	180
PROBLEMS . . . . .	184

## CHAPTER XI VALVE GEARS

PLAIN D-SLIDE VALVES . . . . .	187
DEFINITIONS OF LAP, LEAD, ANGULAR ADVANCE, AND ECCENTRICITY . . . . .	188
RELATIVE POSITION OF VALVE AND PISTON . . . . .	190
ZEUNER VALVE DIAGRAM . . . . .	191
EFFECT OF CONNECTING ROD . . . . .	196
VARIOUS TYPES OF VALVES . . . . .	198
CORLISS VALVES . . . . .	205
REVERSING GEARS . . . . .	209
VALVE SETTING . . . . .	212
INDICATOR DIAGRAMS . . . . .	213

## CHAPTER XII GOVERNORS

TYPES . . . . .	216
GOVERNOR MECHANISM . . . . .	217

	PAGE
ISOCHRONISM . . . . .	222
HUNTING . . . . .	222
FLY WHEEL . . . . .	223

## CHAPTER XIII

## COMPOUND ENGINES

COMPOUND ENGINES . . . . .	225
TANDEM COMPOUND ENGINES . . . . .	226
CROSS COMPOUND ENGINES. . . . .	227
RATIO OF CYLINDERS . . . . .	228
HORSE-POWER OF COMPOUND ENGINES . . . . .	229
COMBINED INDICATOR CARDS . . . . .	232
PROBLEMS . . . . .	234

## CHAPTER XIV

## CONDENSERS AND AIR PUMPS

JET CONDENSERS. . . . .	237
SURFACE CONDENSERS . . . . .	240
AIR PUMPS . . . . .	240
COOLING WATER . . . . .	240
PROBLEMS . . . . .	242

## CHAPTER XV

## STEAM TURBINES

HISTORY . . . . .	244
CLASSIFICATION . . . . .	246
ACTION OF STEAM IN TURBINE . . . . .	247
TURBINE NOZZLES . . . . .	248
SPEED OF TURBINES . . . . .	249
DE LAVAL TURBINE . . . . .	251
CURTIS TURBINE . . . . .	255
RATEAU TURBINE . . . . .	257
KERR TURBINE . . . . .	259
STURTEVANT TURBINE . . . . .	260
PARSONS TURBINE . . . . .	262
DOUBLE-FLOW TURBINE . . . . .	264
LOW-PRESSURE TURBINES . . . . .	266
MIXED-FLOW TURBINES. . . . .	267

## CHAPTER XVI

## GAS ENGINES

HISTORY . . . . .	269
CLASSIFICATION . . . . .	270
THEORETICAL EFFICIENCY . . . . .	275
LOSSES . . . . .	282

# CONTENTS

xi

	PAGE
GAS-ENGINE FUELS . . . . .	283
GAS PRODUCERS . . . . .	284
LIQUID FUELS . . . . .	286
FUEL MIXTURES . . . . .	287
RATED HORSE-POWER . . . . .	288
ACTUAL HORSE-POWER . . . . .	292

## CHAPTER XVII

### DETAILS OF GAS-ENGINE CONSTRUCTION

DESCRIPTION OF PARTS . . . . .	294
METHODS OF IGNITION . . . . .	295
METHODS OF GOVERNING . . . . .	300
CARBURETORS . . . . .	302
OIL ENGINES FOR SHIPS . . . . .	305
HUMPHREY' GAS PUMP . . . . .	305
PROBLEMS . . . . .	307

## CHAPTER XVIII

### ECONOMY OF HEAT ENGINES

RELATIVE ECONOMY . . . . .	309
COMMERCIAL ECONOMY . . . . .	310
INDEX . . . . .	313



## LIST OF TABLES

		PAGE
TABLE	I. TEMPERATURE COLORS . . . . .	4
TABLE	II. SPECIFIC HEATS OF GASES . . . . .	6
TABLE	III. RADIATING POWER OF BODIES . . . . .	7
TABLE	IV. CONDUCTING POWER OF BODIES . . . . .	8
TABLE	V. HEAT AND TEMPERATURE CHANGES DEPENDENT UPON VALUE OF $n$ DURING EXPANSION . . . . .	18
TABLE	VI. SPECIFIC HEATS OF SUPERHEATED STEAM . . . . .	40
TABLE	VII. PROPERTIES OF SATURATED STEAM . . . . .	42
TABLE	VIII. SPECIFIC HEATS OF LIQUIDS AND SOLIDS . . . . .	57
TABLE	IX. COMBUSTION PROPERTIES OF ELEMENTS . . . . .	67
TABLE	X. CALORIFIC VALUE OF WOODS . . . . .	76
TABLE	XI. CALORIFIC VALUE OF PEATS . . . . .	77
TABLE	XII. CALORIFIC VALUE OF LIGNITES . . . . .	77
TABLE	XIII. CALORIFIC VALUE OF BITUMINOUS COALS . . . . .	78
TABLE	XIV. CALORIFIC VALUE OF SEMI-BITUMINOUS COALS . . . . .	78
TABLE	XV. CALORIFIC VALUE OF ANTHRACITE COALS . . . . .	79
TABLE	XVI. DIAMETER OF BOILER TUBES . . . . .	99
TABLE	XVII. HEAT BALANCE IN BOILER PLANT . . . . .	101
TABLE	XVIII. CHIMNEY HEIGHTS . . . . .	131
TABLE	XIX. STEAM CONSUMPTION OF VARIOUS CLASSES OF ENGINES	178
TABLE	XX. DUTY OF VARIOUS FORMS OF PUMPS . . . . .	181
TABLE	XXI. RELATIVE CHANGES IN VELOCITY, SPECIFIC VOLUME AND PRESSURE OF STEAM FLOWING THROUGH A NOZZLE . . . . .	249
TABLE	XXII. CALORIFIC VALUE OF GASEOUS AND LIQUID FUELS . . . . .	287
TABLE	XXIII. VOLUMETRIC EFFICIENCIES, $\nu_v$ , OF GAS ENGINES . . . . .	289
TABLE	XXIV. ECONOMIC EFFICIENCIES, $\nu_w$ , AND AIR CONSUMPTION, OF GAS ENGINES . . . . .	290
TABLE	XXV. THERMAL EFFICIENCIES OF PRIME MOVERS . . . . .	309
TABLE	XXVI. COMPARATIVE COSTS PER RATED HORSE-POWER . . . . .	311





# HEAT ENGINES

## STEAM—GAS—STEAM TURBINES—AND THEIR AUXILIARIES

### CHAPTER I

#### HEAT

1. **Heat** being the source of energy for the devices considered in this book, a short discussion of the nature and the more important properties of heat will assist the student to a better understanding of the subject-matter of this text. These phenomena will be considered only as they affect perfect gases, steam, and water.

2. **Theory of Heat.**—The accepted theory of heat at the present time is that it is a motion of the molecules of a body. Physical experiments indicate this to be the fact. The intensity of the heat, or the temperature, is supposed to depend upon the velocity and amplitude of these vibrations.

Most bodies when heated expand. This expansion is probably due to the increased velocity of the molecules which forces them farther apart and increases the actual size of the body.

The vibration may become so violent that the attraction between the molecules is partly overcome and the body can no longer retain its form. In this case the solid becomes a liquid. If still more heat is added, the attraction of the molecules may be entirely overcome by their violent motion, and the liquid then becomes a gas.

The phenomena of heat is then a form of motion. This is often stated in another way, that is, heat is a form of kinetic energy. As heat is a form of motion, it must be possible to transform heat into mechanical motion. In the following pages, therefore, the most important methods of making this transformation will be discussed.

3. **Temperature and Temperature Measurement.**—The velocity of the vibration of the molecules of a body determines the intensity of the heat, and this intensity is measured by

the temperature. If the molecules of a body move slowly it is at a low temperature; if they move rapidly it is at a high temperature. The temperature of a body is then determined by the rapidity of the motion of its molecules.

*Temperature* is sometimes defined as *the thermal state of a body considered with reference to its ability to transmit heat to other bodies*. Two bodies are said to be at the same temperature when there is no transmission of heat between them. If there is transmission of heat between them, the one from which the heat is flowing is said to have the higher temperature.

In mechanical engineering work, temperatures are usually measured on the Fahrenheit scale, and in this text, unless otherwise stated, the temperature will be taken on this scale. There is, however, an increasing use of the Centigrade scale among engineers, and certain quantities, such as the increase in temperature in a dynamo, are always expressed in Centigrade units.

In the Fahrenheit scale the graduations are obtained by noting the position of the mercury column when the bulb of the thermometer is placed in melting ice, and again when it is placed in boiling water under an atmospheric pressure corresponding to sea level barometer. The distance between these two points is divided into 180 equal parts. The freezing point is taken as  $32^\circ$ , making the boiling point  $32^\circ + 180^\circ = 212^\circ$  above zero.

In the Centigrade scale the distance between the freezing point and the boiling point is divided into 100 equal parts or degrees, and the freezing point on the scale is marked  $0^\circ$ . The boiling point is then  $100^\circ$ .

Both the Fahrenheit and Centigrade scales assume an arbitrary point for the zero of the scale.

Since in the Fahrenheit scale there are 180 divisions between the freezing and boiling points and on the Centigrade 100 divisions, it follows that  $1^\circ \text{ F.} = \frac{5}{9}^\circ \text{ C.}$ , or  $1^\circ \text{ C.} = \frac{9}{5}^\circ \text{ F.}$  As, however, the freezing point on the Fahrenheit scale is marked 32 and on the Centigrade scale 0, it is necessary to take account of this difference when converting from one scale to the other. If the temperature Fahrenheit be denoted by  $t_F$  and the temperature Centigrade by  $t_C$ , then the conversion from one scale to the other may be made by the following equations:—

$$t_F = \frac{9}{5} t_C + 32; \quad (1)$$

$$t_C = \frac{5}{9} (t_F - 32). \quad (2)$$

The measurement of temperature is not so simple a process as is generally supposed. The mercury of the ordinary glass thermometer does not expand equal amounts for equal increments of heat, and the bore of the thermometer is not absolutely uniform throughout the whole length of the tube. These inaccuracies must be allowed for by accurate calibration. In measuring the temperatures of liquids, the depth to which the thermometer is immersed affects the reading, and it should be calibrated at the depth at which it is to be used. If a thermometer is used to measure the temperature of the air in a room in which there are objects at a higher temperature, its bulb must be protected from the radiant heat of those hot bodies. When accurate temperature measurements are desired, a careful study should be made of the errors of the instrument and the errors in its use.

The ordinary form of mercury thermometer is used for temperatures ranging from  $-40^{\circ}$  F. to  $500^{\circ}$  F. For measuring temperatures below  $-40^{\circ}$  F, thermometers filled with alcohol are used. These are, however, not satisfactory for use at high temperatures. When a mercury thermometer is used for temperatures above  $500^{\circ}$  F., the space above the mercury is filled with some inert gas, usually nitrogen or carbon-dioxide, placed in the thermometer tube under pressure. As the mercury rises, the gas pressure is increased and the temperature of the boiling point of the mercury is raised, so that it is possible to use these thermometers for temperatures as high as  $1000^{\circ}$  F. This is the limit, however, as the melting point of glass is comparatively low.

For temperatures exceeding  $800^{\circ}$  F., some form of *pyrometer* is generally used. The simplest of these is the *metallic* or *mechanical pyrometer*. This consists of two metals having different rates of expansion, such as iron and brass, attached to each other at one end and with the other ends free. By a system of levers and gears the expansion of the metals is made to move a hand over a dial graduated in degrees. This should not be used for temperatures over  $1500^{\circ}$  F.

There are two types of *electrical pyrometers* in use to-day. In one, the *thermo-electric couple* is employed and the difference in temperature of the junctions of the two metals forming the couple produces an electric current which is proportional to this difference, and which is measured on a galvanometer calibrated in

degrees. By keeping one junction at a known temperature, the other may be computed. This may be used up to 2500° F.

The second type, the *electrical resistance pyrometer*, depends upon the increase in electrical resistance of metals due to a rise in temperature.

For still higher temperatures the *optical pyrometer* gives the most satisfactory results. This is based on the results of experiments made by Pouillet which show that incandescent bodies have for each temperature a definite and fixed color, as follows:—

TABLE I. TEMPERATURE COLORS

Color	Temp. C.	Temp. F.
Faint red.....	525	977
Dark red.....	700	1292
Faint cherry.....	800	1472
Cherry.....	900	1652
Bright cherry.....	1000	1832
Dark orange.....	1100	2012
Bright orange.....	1200	2192
White heat.....	1300	2372
Bright white.....	1400	2552
Dazzling white.....	{ 1500 1600	{ 2732 2912

**4. Absolute Zero.**—In considering heat from a theoretical standpoint, it is necessary to have some absolute standard of comparison for the scale of temperature, so that the *absolute scale* is largely used.

A perfect gas contracts  $\frac{1}{491.6}$  of its volume at 32° F. for each degree that it is reduced in temperature. Hence if the temperature be lowered to a point 491.6° below 32°, its volume will become zero. This point is called the *absolute zero* and is manifestly an imaginary one. (The lowest point so far actually reached by experiment is about -488.9° F.) For ordinary usage it is sufficiently accurate to consider absolute zero as 492° below the freezing point in the Fahrenheit scale. In other words, to convert to the absolute scale, add 460 to the temperature expressed in degrees Fahrenheit. In this text absolute temperatures will be denoted by  $T$  and temperatures in degrees Fahrenheit by  $t$ .

On the Centigrade scale the absolute zero is 273.1° below the

freezing point, and for all practical purposes, temperatures on the absolute scale may be found by adding 273 to the thermometer reading expressed in degrees Centigrade.

**5. Unit of Heat.**—Heat is not a substance, and it cannot be measured as we would measure water, in pounds or cubic feet, but it must be measured by the effect which it produces. The unit of heat used in mechanical engineering is the heat required to raise a pound of water one degree Fahrenheit. The heat necessary to raise a pound of water one degree does not remain the same throughout any great range of temperature. For physical measurements where accuracy is required, it is necessary to specify at what point in the scale of temperatures this one degree is to be taken. The practice of different authors varies; the majority, however, specify that *the heat unit is the amount of heat required to raise a pound of water from 39° to 40° Fahrenheit*. The range from 39° F. to 40° F. is used because at this temperature water has its maximum density. This unit is called a British Thermal Unit, and is denoted by B.T.U. The heat unit used in Marks and Davis tables is the “mean B.T.U.,” that is  $\frac{1}{180}$  of the heat required to raise one pound of water from 32° to 212° at atmospheric pressure (14.7 pounds per square inch absolute).

**6. Specific Heat.**—If the temperature of a body is raised or lowered a definite amount, a definite amount of heat must either be added to or given up by the body.

Then

$$dH = Cdt. \quad (3)$$

where  $C$  is the heat necessary to change the temperature of the body one degree.

Let a body of unit weight at a temperature  $T_1$  be heated to a temperature  $T_2$ , and at the same time let its heat content be increase from  $H_1$  to  $H_2$ . Then the heat,  $H$ , added to cause this increase in temperature will be found by integrating equation (3) between the limits  $T_1$  and  $T_2$ , or

$$H = H_2 - H_1 = \int_{T_1}^{T_2} Cdt.$$

If  $C$  is a constant and is equal to the heat necessary to raise the temperature of a unit weight one degree

$$H = C \int_{T_1}^{T_2} dt = C(T_2 - T_1). \quad (4)$$

$C$  in equation (4) represents the *heat capacity* of the body, or the heat required to raise the temperature of a unit weight of the body one degree.

The heat capacity of any substance compared with that of an equal weight of water is called its *specific heat*.

Expressed in English units, the heat capacity of one pound of water is one B.T.U., and specific heat may be defined as *the heat necessary to raise the temperature of one pound of a substance one degree Fahrenheit expressed in British Thermal Units*.

Since a B.T.U. is the amount of heat required to raise a pound of water from  $39^{\circ}$  to  $40^{\circ}$  the specific heat will then represent the ratio of the heat necessary to raise the temperature of a unit weight one degree to the heat necessary to raise the temperature of the same weight of water from  $39^{\circ}$  to  $40^{\circ}$ .

TABLE II. SPECIFIC HEATS OF GASES

Gas	Symbol	Expressed in B.T.U.		Expressed in Ft. Lbs.		$R = K_p - K_v$	$\gamma = \frac{K_p}{K_v} = \frac{c_p}{c_v}$
		Constant pressure $c_p$	Constant volume $c_v$	Constant pressure $K_p$	Constant volume $K_v$		
Air.....		.2375	.1689	184.77	131.40	53.37	1.406
Alcohol.....	$C_2H_6O$	.4534	.400	352.75	311.20	41.55	1.133
Ammonia gas.....	$NH_3$	.5084	.350	395.54	272.30	123.24	1.452
Carbonic oxide.....	CO	.2450	.174	190.61	135.37	55.24	1.408
Carbonic acid.....	$CO_2$	.2169	.167	168.75	129.93	38.82	1.299
Carbon disulphide..	$CS_2$	.1569	.131	122.07	101.92	20.15	1.197
Ether.....	$C_4H_{10}O$	.4797	.450	373.21	350.10	23.11	1.066
Hydrogen.....	H	3.4090	2.412	2652.20	1876.54	775.66	1.413
Nitrogen.....	N	.2438	.1727	189.68	134.36	55.32	1.412
Oxygen.....	O	.2175	.1551	169.22	120.67	48.55	1.402
Superheated steam.	See Table VI, Page 40.						

In solid and liquid substances it is necessary to consider but one specific heat, as the change in volume when a solid or a liquid substance is heated is so small that its effect may be neglected. In gases the change in volume when the gas is heated is large, and if it is heated under a constant pressure this change is directly proportional to the change in the absolute temperature. If there is a change in volume there must be external work done. On the other hand, when gas is con-

fined and is heated, it cannot expand. If it does not expand, there is no external work done. Therefore, in considering the specific heat of a gas, we must consider two cases: one in which the pressure remains constant and the gas expands when it is heated; and the other where the volume remains constant and the pressure increases when the gas is heated. Hence, in the case of a gas, there are two specific heats, the *specific heat of constant pressure* and the *specific heat of constant volume*. The specific heat of constant volume will be denoted by  $c_v$  and the specific heat of constant pressure by  $c_p$ , both being expressed in B.T.U. When expressed in foot-pounds they will be denoted by  $K_v$  and  $K_p$  respectively.

**7. Radiation.**—The heat that passes from a body by radiation may be considered similar to the light that is radiated from a lamp. There is always a transfer of radiant heat from a body of a high temperature to a body of lower temperature. The amount of heat radiated will depend upon the difference in temperature between the bodies and upon the substances of which they are composed. The following table gives the radiating power of different bodies.

TABLE III. RADIATING POWER OF BODIES

Radiating power of bodies, expressed in heat units, given off per square foot per hour for a difference of one degree Fahrenheit. (PECLET.)

	B.T.U.
Copper, polished.....	.0327
Iron, sheet.....	.0920
Glass.....	.595
Cast iron, rusted.....	.648
Building stone, plaster, wood, brick.....	.7358
Woolen stuffs, any color.....	.7522
Water.....	1.085

**8. Conduction.**—The heat transmitted by conduction is the heat transmitted through the body itself. The amount of heat conducted will depend upon the material of which the body is composed and the difference in temperature between the two sides of the body, and is inversely proportional to the thickness of the body. Heat may be conducted from one body to another when they are placed in contact with each other.

The following table gives the conducting power of different bodies.

TABLE IV. CONDUCTING POWER OF BODIES

The conducting power of materials, expressed in the quantity of heat units transmitted per square foot per hour by a plate one inch thick, the surfaces on the two sides of the plate differing in temperature by one degree. (PECLET.)

	B.T.U.
Copper.....	515
Iron.....	233
Lead.....	113
Stone.....	16.7
Glass.....	6.6
Brick work.....	4.8
Plaster.....	3.8
Pine wood.....	.75
Sheep's wool.....	.323

**9. Convection.**—Loss by convection is sometimes called loss by contact of air. When air or other gas comes in contact with a hot body it is heated and rises, carrying away heat from the body. Heat carried off in this manner is said to be lost by convection. The loss by convection is independent of the nature of the surface—wood, stone, or iron losing the same amount—but it is affected by the form and position of the body.

**10. Energy, Work, and Power.**—*Work* is the overcoming of resistance through space and is measured by the resistance multiplied by the space through which this resistance is overcome. The simplest form of work is the raising of a body against the force of gravity.

Let  $M$  = the mass of the body.

$g$  = the force of gravity.

$w$  = the weight.

$l$  = the distance through which the weight is moved.

$W$  = work.

Then  $Mg = w$ , and  $wl = W$ .

If  $w$  is expressed in pounds and  $l$  in feet, then the unit of work will be the foot-pound (ft.-lb.).

If we consider the work done by a fluid, let the volume be increased from  $v$  to  $v + \delta v$ , and the pressure against which the increase takes place be  $p$ , then the work done will be

$$p [(v + \delta v) - v] = p \delta v = \delta W.$$



If a pressure  $p$  acts upon an area  $a$  through a distance  $l$ , then the work

$$W = pla.$$

*Work* may also be expressed as mass times acceleration times space.

*Energy* is the capacity for doing work.

*Power* is the time rate of doing work. The unit of power is the horse-power (H.P.). *A horse-power is equivalent to raising 33,000 lbs. one foot in one minute.* This is the unit employed in determining the power of a steam engine. If  $r$  equals the resistance expressed in pounds,  $l$  the distance in feet through which the resistance  $r$  is overcome, and  $m$  the time in minutes in which the space is passed over, then the horse-power exerted is

$$\frac{l \times r}{33,000 \times m}$$

Power is often expressed in electrical units. This is usually the case where an engine is used to drive a generator. An *ampere* is the unit of current strength or rate of flow. The *volt* is the unit of electromotive force or electrical pressure. The *watt* is the product of the amperes and the volts. One horse-power equals 746 watts, or one kilowatt equals 1.34 horse-powers.

## CHAPTER II

### ELEMENTARY THERMODYNAMICS

**11. First Law of Thermodynamics.**—"When mechanical energy is produced from heat, a definite quantity of heat goes out of existence for every unit of work done; and conversely, when heat is produced by the expenditure of mechanical energy, the same definite quantity of heat comes into existence for every unit of work spent."

The relation between work and heat was first accurately determined by Joule in 1850. More recently Professor Rowland of John Hopkins University redetermined its equivalent with great accuracy. His results show that *one British Thermal Unit is equivalent to 778 foot-pounds*. This factor is often called the *mechanical equivalent of heat*, and is usually denoted by *J*. Heat and work are mutually convertible in the ratio of 778 foot-pounds equals one B.T.U.

**12. Second Law of Thermodynamics.**—The second law of thermodynamics may be stated in different ways. Clausius states it as follows: "It is impossible for a self-acting machine, unaided by any external agency, to convey heat from one body to another of higher temperature." Rankine states the second law as follows: "If the total actual heat of a homogeneous and uniformly hot substance be conceived to be divided into a number of equal parts, the effects of those parts in causing work to be performed are equal." It follows from the second law that no heat engine can convert more than a small fraction of the heat given to it into work. From this law we derive the expression for the efficiency of a heat engine, *i. e.*,

$$E = \frac{\text{heat added} - \text{heat rejected}}{\text{heat added}}$$

The second law is not capable of proof but is axiomatic. All our experiments with heat engines go to show that this law is true.

**13. Laws of Perfect Gases.**—There are two laws expressing the relation of pressure, volume, and temperature in a perfect gas: the law of Boyle and the law of Charles.

*Boyle's Law.*—"The volume of a given mass of gas varies inversely as the pressure, provided the temperature remains constant."

If  $p_0$  = the pressure, and  $v_0$  = the volume of the initial condition of the gas, and  $p$  and  $v$  any other condition of the same gas, then

$$p_0 v_0 = pv = \text{a constant.}$$

*Charles' Law.*—"Under constant pressure equal volumes of different gases increase equally for the same increment of temperature. Also if the gas be heated under constant pressure equal increments of its volume correspond very nearly to equal increments of temperature by the scale of a mercury thermometer."

This law may also be stated as follows: *When a gas receives heat at a constant volume the pressure varies directly as the absolute temperature, or when a gas receives heat at a constant pressure the volume varies directly as the absolute temperature.*

Letting a gas receive heat at a constant volume  $v_0$ , the pressure and absolute temperature varying from  $p_0$ ,  $T_0$  to  $p$ ,  $T'$ , then

$$\frac{p}{p_0} = \frac{T'}{T_0} \quad \checkmark$$

If the gas now receives heat at this pressure  $p$ , the volume and temperature changing to  $v$  and  $T'$ , then

$$\frac{v}{v_0} = \frac{T'}{T_0} \quad \checkmark$$

**14. Equation of a Perfect Gas.**—Combining these two laws we have the equation of a perfect gas. Let one pound of a gas have a volume  $v$ , a pressure  $p$ , and be at an absolute temperature  $T$ . From Boyle's Law, if the pressure is changed to  $p_1$  and the volume to  $v'$ , the temperature  $T$  remaining constant, then we have the following equation:

$$\frac{p_1}{p} = \frac{v}{v'}, \text{ or } p_1 = \frac{pv}{v'} \quad \checkmark \quad (1)$$

From the law of Charles, if the volume remains constant at  $v'$  and the temperature be changed to  $T'$  and the pressure to  $p'$ , then

$$\frac{p_1}{p'} = \frac{T}{T'}, \text{ or } p_1 = \frac{p'T}{T'} \quad \checkmark \quad (2)$$

Combining equations (1) and (2), we have

$$\frac{pv}{v'} = \frac{p'T'}{T'}$$

Hence,

$$\frac{pv}{T} = \frac{p'v'}{T'} = \frac{p''v''}{T''} = \text{a constant} \quad (3)$$

Denoting this constant by  $R$ , then

$$pv = RT, \quad p'v' = RT', \quad \text{and} \quad p''v'' = RT'' \quad (4)$$

The value of  $R$  given in this equation is for one pound of the gas. If we wish to state this law for more than one pound, let  $w$  equal the weight of the gas, then the law becomes

$$pv = wRT \quad (5)$$

This equation is called the *equation of the gas* and holds true for any point on any expansion line of any perfect gas.

These laws were first determined for air, which is almost a perfect gas, and they hold true for all perfect gases. A *perfect gas* is sometimes defined as a gas which fulfils the laws of Boyle and Charles. It is probably better to define it as a gas in which no internal work is done, or in other words, a gas in which there is no friction between the molecules under change of conditions.

In the above expressions,  $p$  is the *absolute* pressure in pounds per square foot,  $v$  is the volume in cubic feet, and  $T$  is the absolute temperature in degrees Fahrenheit.

*Absolute pressure* must not be confused with *gage* pressure. The ordinary pressure gage reads the difference in pressure between the atmospheric pressure outside the gage tube and the applied pressure inside the gage tube. *The absolute pressure is equal to the gage pressure plus the barometric pressure.*

The value of  $R$  for any given substance may be determined, provided we know the volume of one pound for any given condition of pressure and temperature. For example, it has been found by experiment that for air under a pressure of 14.7 lbs. per square inch absolute, and at a temperature of 32° F., the volume of 1 lb. is 12.39 cu. ft. Substituting these values in equation (4) we have

$$\begin{aligned}
 R &= \frac{pv}{T} \\
 &= \frac{14.7 \times 144 \times 12.39}{32 + 460} \\
 &= 53.37 \text{ (compare with the value of } R \text{ for air given in} \\
 &\quad \text{Table II).} \tag{6}
 \end{aligned}$$

Therefore for one pound of air with the units we have taken,

$$pv = 53.37 T. \tag{7}$$

or for  $w$  pounds,

$$pv = 53.37 wT. \tag{8}$$

This equation is always true for air at all times and under all conditions, as long as it remains a gas.

**Example.**—A tank contains 5 lbs. of air at 75° F., under a pressure of 100 lbs. per square inch gage. Find the volume of the air.

**Solution.**—

$$pv = wRT.$$

$$p = (100 + 14.7)144 = 114.7 \times 144 \text{ lbs. per square foot absolute.}$$

$$T = 75 + 460 = 535^\circ \text{ absolute.}$$

Therefore, substituting in the equation of the gas, we have

$$114.7 \times 144 \times v = 5 \times 53.37 \times 535$$

$$v = \frac{142760}{16520}$$

$$v = 8.64 \text{ cu. ft.}$$

**Example.**—Ten pounds of air under a pressure of 50 lbs. per square inch gage occupy a volume of 10 cu. ft. Find the temperature.

**Solution.**—

$$pv = wRT$$

$$p = (50 + 14.7)144 = 64.7 \times 144 \text{ lbs. per square foot absolute.}$$

Therefore

$$64.7 \times 144 \times 10 = 10 \times 53.37 \times T$$

$$T = \frac{93200}{533.7}$$

$$T = 174.5^\circ \text{ absolute}$$

$$T = 174.5 - 460 = -285.5^\circ \text{ F.}$$

**15. Absorption of Heat.**—When a gas receives heat this heat may be dissipated in one or all of three ways; by increasing its temperature, by doing internal work, or by doing external work.

Let  $dH$  denote the heat absorbed,  $dS$  the heat used in increasing the temperature,  $dI$  the heat used in doing internal work, and  $dW$  the heat equivalent of the external work done. Then

$$dH = dS + dI + dW \quad \checkmark \quad (9)$$

The heat utilized in changing the *internal energy* of the substance is represented by  $dS + dI$ , and  $dI + dW$  represents the heat equivalent of the *total work* done.

By "internal work" is meant work done in overcoming changes in the physical state of the substance, and in overcoming the attraction of the molecules for each other, thus changing the potential energy of the body.

An example of this is shown in the case of water at the boiling point being changed into steam. In this case  $dS$  in equation (9) becomes zero since the temperature remains constant. Therefore all the heat added goes to doing internal and external work. The external work will be equal to the change in volume from water to steam times the pressure under which the steam is being formed. This will be only a small part of the total heat added to accomplish the change, the balance being the heat going to internal work or  $dI$ .

Since no internal work is done in heating a perfect gas, the second term in equation (9) becomes zero and all the heat absorbed goes either to increasing the temperature or doing external work. Therefore in the case of a perfect gas

$$dH = dS + dW$$

$$\therefore \int_{H_1}^{H_2} dH = \int_{S_1}^{S_2} dS + \int_{v_1}^{v_2} dW.$$

Integrating

$$H_2 - H_1 = S_2 - S_1 + \int_{v_1}^{v_2} pdv$$

Let  $H = H_2 - H_1$ ,  $S = S_2 - S_1$  and  $W = \int_{v_1}^{v_2} pdv$

Then

$$H = S + W. \quad (10)$$

and a change in internal energy is indicated by a change in temperature alone.

**16. Joules Law.** *When a perfect gas expands without doing external work and without taking in or giving out any heat, its temperature remains unchanged and there is no change in its*

*internal energy.*—This law was established by the following experiment performed by Joule.

Two vessels *a* and *b*, Fig. 1, connected by a tube containing a stop-cock *c* were placed in a water-bath. One vessel contained air compressed to a pressure of 22 atmospheres, while a vacuum was maintained in the other. After the vessels had remained in the bath long enough so that the air and water were at the same temperature and there could therefore be no further flow of heat from one to the other, the stop-cock *c* was opened and the air allowed to flow from one vessel to the other until the pressure in each was 11 atmospheres. The temperatures of the air and

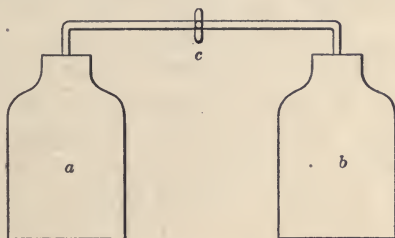

FIG. 1.—Joule's apparatus.

water were then read again and found to be unchanged. From the conditions of the apparatus no work external to the two vessels could have been done. As the gas had done no work and had neither gained nor lost any heat, its internal energy must have remained unchanged. Although the pressure and volume of the gas had changed the temperature had not, thus proving that a change in internal energy depends upon a change in temperature only.

**17. Relation of Specific Heats.**—If one pound of a perfect gas is heated at a constant pressure from a temperature  $T_1$  to a temperature  $T_2$ , and the volume is changed from a volume  $v_1$  to a volume  $v_2$ , the heat absorbed would equal

$$K_p(T_2 - T_1) \quad (11)$$

and the work done,

$$W = \int p dv.$$

Integrating between limits

$$w = \int_{v_1}^{v_2} p dv = p \int_{v_1}^{v_2} dv = p(v_2 - v_1),$$

Since from the equation of a perfect gas

$$pv_2 = RT_2, \text{ and } pv_1 = RT_1,$$

substituting these values in the above expression for the work done, we have

$$p(v_2 - v_1) = R(T_2 - T_1). \quad (12)$$

Since from equation (10),  $S = H - W$ , then the difference between equation (11) and equation (12) would be the heat which goes to increasing the temperature, which equals

$$(K_p - R)(T_2 - T_1). \quad (13)$$

If the gas is heated at a constant volume from a temperature  $T_1$  to a temperature  $T_2$ , then the heat added would be

$$K_v(T_2 - T_1), \quad (14)$$

and as no external work is done this heat all goes to increasing the temperature. But since equation (13) also represents the heat which goes to increasing the temperature, equations (13) and (14) are equal to each other, or

$$(K_p - R)(T_2 - T_1) = K_v(T_2 - T_1),$$

therefore

$$K_v = K_p - R, \quad (15)$$

or

$$R = K_p - K_v. \quad (16)$$

The difference between the two specific heats,  $R$ , is the amount of work in foot-pounds done when one pound of a gas is heated one degree Fahrenheit at constant pressure.

The ratio of the two specific heats, that is  $\frac{K_p}{K_v}$ , is denoted by  $\gamma$ .

Since  $K_p - K_v = R$ , and  $\frac{K_p}{K_v} = \gamma$ ,

then

$$\frac{K_p}{K_v} - 1 = \frac{R}{K_v},$$

or

$$\gamma - 1 = \frac{R}{K_v},$$

and hence

$$K_v = \frac{R}{\gamma - 1}. \quad (17)$$

Similarly

$$K_p = \frac{R\gamma}{\gamma - 1} \quad (18)$$



For air

$$R = 184.77 - 131.40 = 53.37 \text{ (compare equation 6)}$$

and

$$\gamma = \frac{K_p}{K_v} = \frac{184.77}{131.40} = 1.406. \tag{19}$$

**18. Expansions in General.**—When air, steam, or any other gas is used as the working substance in an engine, the gas is allowed to expand, doing work for a portion of the working stroke of the engine. The variation in pressure and volume during this expansion may be graphically represented by a mathematical curve on the pressure-volume plane. The same is true in the compression of these gases. On this plane the ordinates of any curve represent pressures and the abscissæ represent volumes.

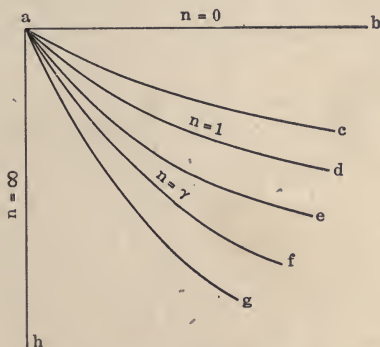

FIG. 2.—Paths of an expanding gas.

Almost all the expansion or compression curves ordinarily occurring in steam, or gas engines, or the various forms of compressors, can be represented by the equation

$$pv^n = \text{a constant}. \tag{20}$$

During expansion, or compression,  $n$  in equation (20) may have any value between zero and infinity, but is constant for any given curve. Fig. 2 shows how the path of a gas will vary during expansion depending upon the value of  $n$ .

The value of  $n$  will determine whether heat must be added, rejected, or remain constant, and whether the temperature will rise, fall, or remain constant during the expansion, or compression, of a gas. These varying conditions are clearly shown in Table V.

TABLE V.—HEAT AND TEMPERATURE CHANGES DEPENDENT UPON VALUE OF  $n$  DURING EXPANSION

Value of $n$	Equation of path of gas	Path as shown in Fig. 2	Heat	Temperature
$n = 0$ .....	$p = \text{constant}$	$ab$	Added	Rises
$n > 0$ and $< 1$ .....	$pv^n = \text{constant}$	$ac$	Added	Rises
$n = 1$ .....	$pv = \text{constant}$	$ad$	Added	Constant
$n > 1$ and $< \gamma$ .....	$pv^n = \text{constant}$	$ae$	Added	Falls
$n = \gamma$ .....	$pv^\gamma = \text{constant}$	$af$	Constant	Falls
$n > \gamma$ and $< \infty$ .....	$pv^n = \text{constant}$	$ag$	Rejected	Falls
$n = \infty$ .....	$v = \text{constant}$	$ah$	Rejected	Falls

For any path lying between  $ad$  and  $af$ , heat is added and yet the temperature falls. In other words the specific heat is *negative*.

In case the gas is being compressed instead of expanding, the changes in heat and temperature will be just the opposite of those shown in the table.

**19. Work of Expansion.**—The curve  $ab$  in Fig. 3 represents graphically the relation between pressure and volume during expansion. Let the equation of this curve be

$$pv^n = \text{a constant.}$$

In this figure pressures are represented by ordinates and volumes by abscissæ. The gas expands from a point  $a$ , where the pressure is  $p_1$  and the volume  $v_1$ , to the point  $b$  where the pressure is  $p_2$  and the volume  $v_2$ . The area  $abcd$  represents the work done during this expansion.

Let  $W$  equal the work done during expansion. Then as

$$W = \int_{v_1}^{v_2} pdv. \quad (21)$$

Since every point in the curve must fulfil the original conditions for the equation of the curve,

$$pv^n = p_1v_1^n = p_2v_2^n, \text{ hence} \\ p = \frac{p_1v_1^n}{v^n}. \quad (22)$$

Substituting this expression in equation 21

$$W = p_1v_1^n \int_{v_1}^{v_2} \frac{dv}{v^n}. \quad (23)$$

$$\text{Integrating, } W = p_1 v_1^n \frac{(v_2^{1-n} - v_1^{1-n})}{1-n}. \quad (24)$$

Multiplying out the parenthesis, we have

$$\begin{aligned} W &= \frac{p_1 v_1^n v_2^{1-n} - p_1 v_1}{1-n}, \\ &= \frac{p_1 v_1^{n-1} v_2^{1-n} - 1}{1-n} = \frac{p_1 v_1 \left( \frac{v_2^{1-n}}{v_1^{1-n}} - 1 \right)}{1-n}. \end{aligned} \quad (25)$$

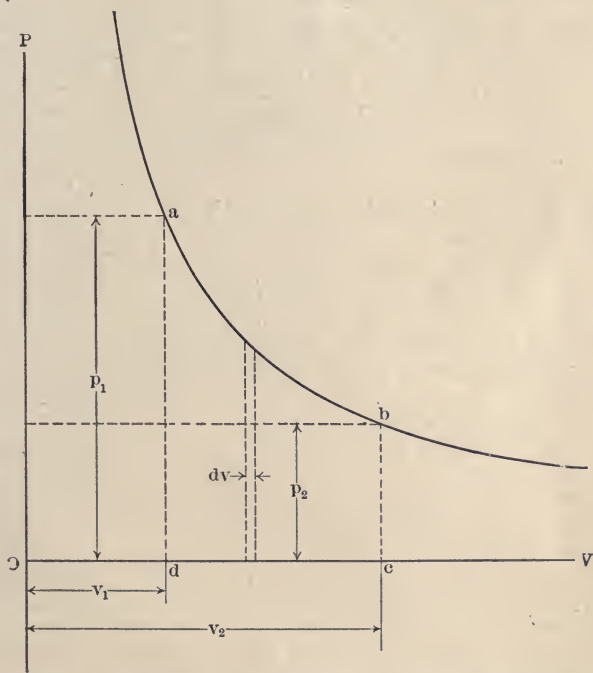

FIG. 3.—Pressure-volume diagram of an expanding gas.

But  $\frac{v_2}{v_1} = r$ , the ratio of expansion for the gas,

therefore

$$W = \frac{p_1 v_1 (1 - r^{1-n})}{n-1}, \quad (26)$$

or substituting  $p_2 v_2^n$  for  $p_1 v_1^n$  in equation (25), we have

$$W = \frac{p_1 v_1 - p_2 v_2}{n-1}. \quad (27)$$

Substituting for  $pv$  its value in terms of  $R$  and  $T$ , equation (27) becomes

$$W = \frac{R(T_1 - T_2)}{n - 1} \quad (28)$$

If  $w$  pounds of the gas is expanded, then equation (28) becomes

$$W = \frac{wR(T_1 - T_2)}{n - 1} \quad (29)$$

**20. Heat Added—General Case.**—In the case of any expansion, the heat added is equal to the algebraic sum of heat equivalent of the work done and the change in internal energy. As has been previously shown, the change in internal energy of a gas depends upon the change in temperature only and is equal to the heat necessary to change the temperature at constant volume.

Therefore in the case of a perfect gas

$$H = S + W$$

$$= wK_v(T_2 - T_1) + \frac{p_1v_1 - p_2v_2}{n - 1} \quad (30)$$

$$= \frac{K_v}{R}(p_2v_2 - p_1v_1) + \frac{p_1v_1 - p_2v_2}{n - 1}$$

$$= \frac{p_2v_2 - p_1v_1}{\gamma - 1} + \frac{p_1v_1 - p_2v_2}{n - 1}$$

$$= (p_1v_1 - p_2v_2) \left( \frac{1}{n - 1} - \frac{1}{\gamma - 1} \right) \quad (31)$$

This result will be expressed in foot-pounds since  $p_1$  and  $p_2$  are expressed in pounds per square foot, and  $v_1$  and  $v_2$  are expressed in cubic feet. To find the equivalent B.T.U., divide equation (31) by 778.

Equation (30) may also be changed to read as follows:—

$$H = wK_v(T_2 - T_1) + \frac{p_1v_1 - p_2v_2}{n - 1}$$

$$= wK_v(T_2 - T_1) + wR \left( \frac{T_1 - T_2}{n - 1} \right)$$

$$= wK_v(T_2 - T_1) + wK_v(\gamma - 1) \left( \frac{T_1 - T_2}{n - 1} \right)$$

$$H = wK_v(T_1 - T_2) \left( \frac{\gamma - 1}{n - 1} - 1 \right) \quad (32)$$

The answer in this case is also expressed in ft.-lbs. since  $K_v$  represents the specific heat when expressed in ft.-lbs., and, as in equation (31), the result must be divided by 778 to find the equivalent B.T.U.

In equations (30), (31) and (32),  $p_1$ ,  $v_1$  and  $T_1$  refer to the original state of the gas and  $p_2$ ,  $v_2$  and  $T_2$  to the final state.

**Example.**—Five cubic feet of air under a pressure of 75 lbs. per square inch are expanded to 25 lbs. per square inch along a curve the equation of which is  $pv^{1.2} = \text{a constant}$ .

(a) Find the final volume of the air. (b) Find the work in foot pounds done during the expansion. (c) Find the heat in B.T.U., added during the expansion.

**Solution.**—(a) From equation (20)

$$p_1 v_1^n = p_2 v_2^n$$

or 
$$v_2^n = \frac{p_1}{p_2} v_1^n$$

$$\begin{aligned} \text{Therefore } v_2^{1.2} &= \frac{(75 + 14.7) \times 144}{(25 + 14.7) \times 144} \times 5^{1.2} \\ &= 2.26 \times 5^{1.2} \end{aligned}$$

$$\begin{aligned} 1.2 \log v_2 &= \log 2.26 + 1.2 \log 5 \\ &= .354 + 1.2 \times .699 = .354 + .839 \end{aligned}$$

$$1.2 \log v_2 = 1.193$$

$$\log v_2 = .994$$

$$v_2 = 9.86 \text{ cu. ft.}$$

(b) From equation (27)

$$\begin{aligned} W &= \frac{p_1 v_1 - p_2 v_2}{n - 1} \\ &= \frac{89.7 \times 144 \times 5 - 39.7 \times 144 \times 9.86}{1.2 - 1} \\ &= \frac{64650 - 56370}{.2} = \frac{8280}{.2} \\ &= 41400 \text{ ft.-lbs.} \end{aligned}$$

(c) From equation (31)

$$\begin{aligned} H &= (p_1 v_1 - p_2 v_2) \left( \frac{1}{n - 1} - \frac{1}{r - 1} \right) \\ &= (89.7 \times 144 \times 5 - 39.7 \times 144 \times 9.86) \left( \frac{1}{1.2 - 1} - \frac{1}{1.406 - 1} \right) \end{aligned}$$

$$\begin{aligned}
 &= 8280 \left( \frac{1}{.2} - \frac{1}{.406} \right) = 8280 (5 - 2.463) = 8280 \times 2.537 \\
 &= 21000 \text{ ft.-lbs.} \\
 &= 27 \text{ B.T.U.}
 \end{aligned}$$

**21. Expressions for Heat added at Constant Volume and at Constant Pressure.**—The heat added at constant volume may be determined from the volume and pressure, when the temperature is not given, in the following manner:

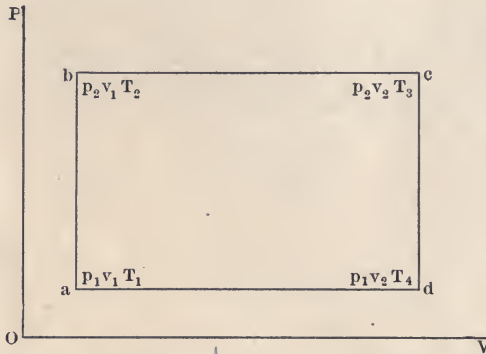

FIG. 4.—Pressure-volume diagram when heat is added to a gas at constant volume and at constant pressure.

Let  ${}_aH_b$  represent the heat added along the line  $ab$ , Fig. 4  
Then

$$\begin{aligned}
 {}_aH_b &= c_v w (T_2 - T_1) \text{ in B.T.U.,} \\
 &= K_v w (T_2 - T_1) \text{ in ft.-lbs.}
 \end{aligned} \tag{33}$$

But

$$wT_2 = \frac{p_2 v_1}{R} \text{ and } wT_1 = \frac{p_1 v_1}{R}.$$

Substituting these values in equation (33), we have

$${}_aH_b = \frac{K_v v_1}{R} (p_2 - p_1). \tag{34}$$

But from equation (17),  $\frac{K_v}{R} = \frac{1}{\gamma - 1}$ .

Hence substituting in equation (34),

$${}_aH_b = \frac{v_1 (p_2 - p_1)}{(\gamma - 1) \times 778}, \text{ expressed in B.T.U.} \tag{35}$$

In the same manner we may derive the following expression for the heat added at a constant pressure,

$${}_bH_c = \frac{p_2\gamma(v_2 - v_1)}{(\gamma - 1) \times 778}, \text{ expressed in B.T.U.} \quad (36)$$

**Example.**—Suppose that in Fig. 4,  $p_1 = 15$  lbs. per square inch absolute,  $p_2 = 75$  lbs. per square inch absolute,  $v_1 = 5$  cu. ft., and  $v_2 = 25$  cu. ft. (a) Find the heat added in B.T.U. (b) Find the heat rejected in B.T.U.

**Solution.**—(a) Heat added =  $H_1 = {}_aH_b + {}_bH_c$ .

From equation (35),

$$\begin{aligned} {}_aH_b &= \frac{v_1(p_2 - p_1)}{(\gamma - 1) \times 778} \\ &= \frac{5(75 - 15) \times 144}{(1.406 - 1) \times 778} = \frac{5 \times 60 \times 144}{.406 \times 778} = \frac{43200}{316} \\ &= 136.7 \text{ B.T.U.} \end{aligned}$$

From equation (36).

$$\begin{aligned} {}_bH_c &= \frac{p_2(v_2 - v_1)\gamma}{(\gamma - 1) \times 778} \\ &= \frac{75 \times 144(25 - 5) \times 1.406}{(1.406 - 1) \times 778} = \frac{75 \times 144 \times 20 \times 1.406}{.406 \times 778} \\ &= \frac{303700}{316} = 961 \text{ B.T.U.} \end{aligned}$$

$$H_1 = 136.7 + 961 = 1097.7 \text{ B.T.U.}$$

(b) Heat rejected =  $H_2 = {}_cH_d + {}_dH_a$ .

$$\begin{aligned} {}_cH_d &= \frac{v_2(p_2 - p_1)}{(\gamma - 1) \times 778} \\ &= \frac{25(75 - 15) \times 144}{(1.406 - 1) \times 778} = \frac{25 \times 60 \times 144}{.406 \times 778} = \frac{216000}{316} \\ &= 683 \text{ B.T.U.} \end{aligned}$$

$$\begin{aligned} {}_dH_a &= \frac{p_1(v_2 - v_1)\gamma}{(\gamma - 1) \times 778} \\ &= \frac{15 \times 144(25 - 5) \times 1.406}{(1.406 - 1) \times 778} = \frac{15 \times 144 \times 20 \times 1.406}{.406 \times 778} \\ &= \frac{60740}{319} = 192 \text{ B.T.U.} \end{aligned}$$

$$H_2 = 683 + 192 = 875 \text{ B.T.U.}$$

**22. Adiabatic Expansion.**—*Adiabatic expansion is one in which the expanding gas does not receive or reject any heat except in the form of external work.* That is, there is no radiation or conduction of heat to or from the expanding gas, and the external work is done at the expense of the internal energy in the gas. If compressed adiabatically, the work done upon the gas goes to increasing its internal energy. Since any change in the internal energy of a gas depends upon a change in temperature, it is impossible to have an increase in the internal energy without an increase in temperature, or a decrease in internal energy without a decrease in temperature.

Adiabatic expansion could only be produced in a cylinder made of a perfectly non-conducting material with the working fluid itself undergoing no chemical change. In actual engines, or compressors, this is never the case, and adiabatic expansion is only approximated.

Taking the expression

$$W = \frac{R(T_1 - T_2)}{n - 1}$$

we have now to find the value of  $n$  for adiabatic expansion. In paragraph 17 it was shown that the loss of energy due to a change of temperature equals

$$K_v(T_2 - T_1),$$

or expressed in B.T.U.,

$$c_v(T_2 - T_1).$$

Equation (10), paragraph 15, is

$$H = S + W.$$

In adiabatic expansion no heat is absorbed or rejected, hence  $H$  becomes zero and  $W = -S$ . That is, all the heat lost, due to a change in temperature, goes to doing work. (It must be understood that the negative sign before  $S$  does not mean negative work, but does mean a decrease in internal energy.)

But 
$$S = K_v(T_2 - T_1);$$

therefore the work done,

$$W = K_v(T_1 - T_2); \tag{37}$$

but

$$K_v = \frac{R}{\gamma - 1}.$$



and hence substituting this value in (37) we have

$$W = \frac{R(T_1 - T_2)}{\gamma - 1} \tag{38}$$

Comparing equations (28) and (38), both of which express the value for work done in an adiabatic expansion, we see that  $n = \gamma$ . Therefore the equation for adiabatic expansion is

$$pv^\gamma = p_1v_1^\gamma = p_2v_2^\gamma = \text{a constant.} \tag{39}$$

**Example.**—Five cubic feet of air under a pressure of 75 lbs. per square inch are expanded adiabatically until the pressure is 25 lbs. gas

(a) Find the final volume of the air. (b) Find the work done during the expansion. (See example, paragraph 20).

**Solution.**—(a) From equation (39),

$$p_1v_1^\gamma = p_2v_2^\gamma,$$

or

$$v_2^\gamma = \frac{p_1}{p_2}v_1^\gamma.$$

Therefore

$$v_2^{1.406} = \frac{(75 + 14.7) \times 144 \times 5^{1.406}}{(25 + 14.7) \times 144} = 2.26 \times 5^{1.406}$$

$$1.406 \log v_2 = \log 2.26 + 1.406 \log 5$$

$$= .354 + 1.406 \times .699 = .354 + .983$$

$$1.406 \log v_2 = 1.337$$

$$\log v_2 = .95$$

$$v_2 = 8.915 \text{ cu. ft.}$$

(b) From equations (38) and (4),

$$W = \frac{p_1v_1 - p_2v_2}{\gamma - 1}$$

$$= \frac{89.7 \times 144 \times 5 - 39.7 \times 144 \times 8.915}{1.406 - 1}$$

$$= \frac{64650 - 50950}{.406} = \frac{13700}{.406}$$

$$= 33700 \text{ ft.-lbs.}$$

**23. Isothermal Expansion.**—A gas expands or contracts isothermally when its temperature remains constant during a change of volume. Since the temperature remains constant during isothermal expansion no heat is absorbed in increasing the temperature, and in the case of a perfect gas,  $S$  in equation(10) becomes zero and  $H$  equals  $W$ , or all the heat absorbed during isothermal expansion of a perfect gas goes to doing external

work. Hence for isothermal expansion, equation (4) becomes

$$pv = \text{a constant} \quad (40)$$

(which is the equation of a rectangular hyperbola).

Equation (40) is of the same form as equation (20), and the exponent  $n$  is in this case equal to 1. Substituting 1 for the value of  $n$  in equation (28), we derive an indeterminate expression. In order to derive an expression for the work done in isothermal expansion it is necessary therefore to proceed differently.

Assume the curve  $ab$ , Fig. 3, to be an isothermal curve, or an equilateral hyperbola. The work done by the gas in expanding isothermally from volume  $v_1$ , represented at the point  $a$ , to the volume  $v_2$ , represented at the point  $b$ , is the area  $abcd$ ;

$$\text{or} \quad W = \int_{v_1}^{v_2} p dv. \quad (41)$$

To integrate this expression the pressure must be expressed in terms of volume. From equation (40) we have

$$p_1 v_1 = p_2 v_2 = pv;$$

hence

$$p = \frac{p_1 v_1}{v}. \quad (42)$$

Substituting equation (42) in equation (41) we have

$$W = p_1 v_1 \int_{v_1}^{v_2} \frac{dv}{v}.$$

Integrating,

$$W = p_1 v_1 (\log_e v_2 - \log_e v_1);$$

hence

$$W = p_1 v_1 \log_e \frac{v_2}{v_1}. \quad (43)$$

Since  $p_1 v_1 = RT$ , then

$$W = RT \log_e \frac{v_2}{v_1},$$

but  $\frac{v_2}{v_1} = r$ , the ratio of expansion,

and  $p_1 v_1 = pv$ ;

hence

$$W = RT \log_e r \quad (44)$$

$$= pv \log_e r. \quad (45)$$

If  $w$  pounds of gas is expanded, then equation (44) becomes

$$W = wRT \log_e r. \quad (46)$$

During the isothermal expansion there is no change in the internal energy, since the temperature remains constant. Hence the gas takes in, during isothermal expansion, an amount of heat equivalent to the work done during the expansion. Equations (44), (45), and (46) then represent not only the work done, but the equivalent amount of heat taken in or rejected during isothermal expansion or compression.

In actual practice, when gas is suddenly compressed, the compression curve is approximately an adiabatic, and when slowly compressed may be approximately isothermal.

**Example.**—If in the example given in paragraph 20, the air expands isothermally, find (a) the final volume of the air; (b) the work done in foot-pounds; (c) the heat added in B.T.U.

**Solution.**—(a) From equation (40),

$$p_1 v_1 = p_2 v_2$$

or 
$$v_2 = \frac{p_1 v_1}{p_2}$$

Therefore 
$$v_2 = \frac{89.7 \times 144}{39.7 \times 144} \times 5 = 2.26 \times 5$$

$$v_2 = 11.30 \text{ cu. ft.}$$

(b) From equation (45),

$$W = p_1 v_1 \log_e r,$$

but 
$$r = \frac{v_2}{v_1} = \frac{11.30}{5} = 2.26.$$

Therefore

$$\begin{aligned} W &= 89.7 \times 144 \times 5 \log_e 2.26 \\ &= 89.7 \times 144 \times 5 \times 2.3 \times .354 \\ &= 54,200 \text{ ft.-lbs.} \end{aligned}$$

(c) Heat added 
$$= \frac{54200}{778}$$
  

$$= 69.5 \text{ B.T.U.}$$

**24. Relation between  $p$ ,  $v$ , and  $T$  during Expansion or Compression.**—Since the equation of a gas during expansion or compression is

$$p v^n = \text{a constant, (see equation 20).}$$

then

$$p_1 v_1^n = p_2 v_2^n, \quad (47)$$

$$\frac{p_2}{p_1} = \left( \frac{v_1}{v_2} \right)^n, \quad (48)$$

and 
$$\frac{v_1}{v_2} = \left(\frac{p_2}{p_1}\right)^{\frac{1}{n}}. \quad (49)$$

From the equation of a perfect gas,

$$\frac{p_2 v_2}{T_2} = \frac{p_1 v_1}{T_1}, \text{ or } \frac{p_2 v_2}{p_1 v_1} = \frac{T_2}{T_1}. \quad (50)$$

Multiplying equation (47) by (50), we have

$$\frac{T_2}{T_1} = \frac{p_2 v_2 p_1 v_1^n}{p_1 v_1 p_2 v_2^n}$$

Hence 
$$\frac{T_2}{T_1} = \left(\frac{v_1}{v_2}\right)^{n-1}. \quad (51)$$

Substituting in equation (51) the value of  $\frac{v_1}{v_2}$  in terms of  $p_1$  and  $p_2$  from equation (49), we have

$$\frac{T_2}{T_1} = \left(\frac{p_2}{p_1}\right)^{\frac{n-1}{n}}. \quad (52)$$

Equations (48), (49), (51), and (52) give the relations between pressure, volume, and temperature in any expansion or compression.

In the case of adiabatic expansion or compression, the value of  $n$  in these equations become  $\gamma$ , (see paragraph 22).

**Example.**—Five cubic feet of air under a pressure of 75 lbs. per square inch and at 60° F. are expanded adiabatically until the pressure is 25 lbs. (See example, paragraph 20.) Find the temperature at the end of expansion.

**Solution.**—Since the expansion is adiabatic, equation (52) becomes

$$\frac{T_2}{T_1} = \left(\frac{p_2}{p_1}\right)^{\frac{\gamma-1}{\gamma}}$$

$$\text{or } T_2 = T_1 \left(\frac{p_2}{p_1}\right)^{\frac{\gamma-1}{\gamma}}$$

$$= (60 + 460) \left(\frac{39.7 \times 144}{89.7 \times 144}\right)^{\frac{1.406-1}{1.406}} = 520 \times .442^{.29}$$

$$\log T_2 = \log 520 + .29 \log .442$$

$$= 2.716 + .29 \times \bar{1}.645 = 2.716 - .104$$

$$\log T_2 = 2.612$$

$$T_2 = 410^\circ \text{ abs.}$$

$$= 410 - 460 = -50^\circ \text{ F.}$$

**25. Heat Engine.**—Any device used to convert heat into work is called a *heat engine*. The ideally perfect heat engine would convert all the heat which it receives into useful work, but this can never be the case. This conclusion follows from the second law of thermodynamics, *i.e.*, that all the heat which is received by the engine cannot be converted into useful work. In fact a major portion of it is rejected. The ratio of the useful work done to the heat received is called the *heat efficiency* of the engine, or

$$\text{Efficiency} = \frac{\text{Heat equivalent of the work done}}{\text{The heat taken in by the engine}}. \quad (53)$$

In every heat engine there must be a working medium for transferring the heat. The working substance may be solid, liquid, or gaseous. In all of the commercial heat engines now in use the working substance is a gas. In the theoretical engine the working substance is supposed to go through a cycle of changes, returning to its original condition at the end of the cycle. Each working cycle involves: first, taking in the heat of the working substance; second, the doing of work by the working substance; and third, the rejection of heat by the working substance. For example, take a condensing steam plant including the boiler. Water is fed into the boiler from the hot well of the condenser. In the boiler the water receives heat from the coal and is transformed into steam. The steam carries the heat to the engine, part of which heat is used in doing useful work, the balance being lost when the steam is condensed in the condenser. The condensed steam is discharged into the hot well and the cycle is completed. In this cycle of operations the following equation must hold good:

$$\text{Heat taken in} - \text{Heat rejected} = \text{Heat equivalent of work done}. \quad (54)$$

**26. Carnot Cycle.**—The most efficient means for converting heat into work for any given difference in the temperatures of the *heat taken in* and *heat rejected* was first described by the French engineer, Sadi Carnot, in 1824.

In the cycle as described by him the gas first expands isothermally as from *A* to *B* in Fig. 5, then expands adiabatically from *B* to *C*, is then compressed isothermally from *C* to *D*, and is finally compressed adiabatically from *D* to *A*.

To understand more clearly the action of an engine working

in this cycle, imagine a hot body,  $H$ , Fig. 6, as an infinite source of heat at the temperature  $T_1$ ; a cold body,  $C$ , at a temperature  $T_2$  which is lower than  $T_1$ , and with an infinite capacity for absorbing heat without any change in temperature; a non-conduct-

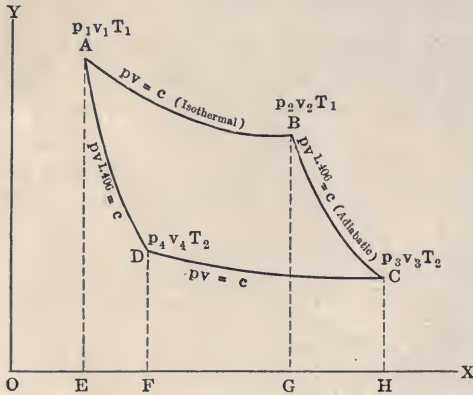

FIG. 5.—Carnot cycle.

ing cover,  $N$ ; and a cylinder covered, except on the outer end, with a perfectly non-conducting material and containing a non-conducting, frictionless piston. The outer end of the cylinder is assumed to be a perfect conductor.



FIG. 6.—Engine working in Carnot cycle.

The cylinder containing  $v_1$  cubic feet of a perfect gas under a pressure  $p_1$  is first placed so that the conducting end is in contact with the hot body  $H$  and the gas allowed to expand to a volume  $v_2$  and pressure  $p_2$ . Since the supply of heat is infinite,

the temperature will remain constant and the expansion will be isothermal. The cylinder is next placed against the non-conducting cover,  $N$ , and the gas allowed to expand adiabatically to a volume  $v_3$  and pressure  $p_3$ . At the same time the temperature falls to  $T_2$ °. Then the cold body,  $C$ , is placed in contact with the cylinder head, and the gas is compressed, rejecting heat to  $C$ , the temperature of which remains constant at  $T_2$ , so that the compression is isothermal. Finally the non-conducting cover is again placed on the cylinder head and the gas compressed adiabatically to the original conditions of pressure, volume and temperature. The third step, or isothermal compression is carried to such a point,  $D$ , Fig. 5, that the adiabatic through  $D$  will pass through  $A$ .

The heat absorbed along the isothermal  $AB$ , Fig. 5, is equal to  $\frac{p_1 v_1}{J} \log_e \frac{v_2}{v_1}$ , and the heat rejected along  $CD$  is equal to  $\frac{p_3 v_3}{J} \log_e \frac{v_3}{v_4}$ . As  $BC$  and  $DA$  are adiabatics there will be no heat received or rejected along these lines, and all the heat will be received along  $AB$  and all the heat rejected along  $CD$ .

Since the temperature along  $AB$  is  $T_1$ , and along  $CD$  is  $T_2$ , then

$$\frac{T_1}{T_2} = \left(\frac{v_3}{v_2}\right)^{\gamma-1} = \left(\frac{v_4}{v_1}\right)^{\gamma-1}.$$

Hence

$$\frac{v_3}{v_4} = \frac{v_2}{v_1}.$$

Let  $H_1$  equal the heat added, and  $H_2$  the heat rejected, and let  $\frac{W}{J}$  equal the heat equivalent of the work done. Then

$$\frac{W}{J} = H_1 - H_2,$$

and the efficiency is

$$E = \frac{W}{JH_1} = \frac{H_1 - H_2}{H_1} \tag{55}$$

Substituting in this expression, the expression for the heat absorbed and the heat rejected as given above, we have the efficiency

$$E = \frac{\frac{p_1 v_1}{J} \log_e \frac{v_2}{v_1} - \frac{p_3 v_3}{J} \log_e \frac{v_3}{v_4}}{\frac{p_1 v_1}{J} \log_e \frac{v_2}{v_1}}$$

Substituting for  $\frac{v_3}{v_4}$  its value in terms of  $v_2$  and  $v_1$ , and simplifying the expression,

$$E = \frac{p_1 v_1 - p_3 v_3}{p_1 v_1} \quad (56)$$

From the equation of a perfect gas,

$$p_1 v_1 = RT_1, \text{ and } p_3 v_3 = RT_2.$$

Substituting in equation (56),

$$E = \frac{T_1 - T_2}{T_1}. \quad (57)$$

This expression for efficiency is general for all engines using perfect gases, as in deriving the expression we have not assumed any special conditions dependent upon the nature of the gas.

Equation (57) can only be unity when  $T_2 = 0$ , that is, when the temperature of the condenser, or cold body, is absolute zero. The nearer unity equation (57) becomes, the higher the efficiency of the engine. In order to obtain this result,  $T_1 - T_2$  must be made as large as possible. This can only be attained by making  $T_1$  larger, or  $T_2$  smaller. In actual practice there are limits to the values of  $T_1$  and  $T_2$  which may be available in the different forms of engines.

It may also be shown by the following demonstration that in any working medium in which equal increments of temperature represent equal increments of heat, the expression for efficiency applies.

Assume a scale of temperature so that each degree on the temperature scale represents one heat unit, then heat and temperature would be represented by the same quantity numerically. From equation (55)

$$E = \frac{H_1 - H_2}{H_1};$$

but on the assumed temperature scale

$$H_1 = T_1, \text{ and } H_2 = T_2,$$

hence  $E = \frac{T_1 - T_2}{T_1}$  (compare equation 57)

All experience in testing engines using either perfect or imperfect gases as their working medium goes to show that this law applies to all forms of engines no matter what the working medium may be.



**27. Reversibility of Carnot Cycle.**—The Carnot cycle is a reversible one as the gas may be considered to first expand adiabatically along  $AD$  and then isothermally along  $DC$ , then to be compressed adiabatically along  $CB$ , and finally compressed isothermally along  $BA$ . It is thus possible to work around the cycle in the reverse direction.

Having proved that the Carnot cycle is reversible and that its efficiency is equal to  $\frac{T_1 - T_2}{T_1}$ , it is now necessary to show that no cycle can be more efficient than a reversible one, and that no reversible cycle can have a greater efficiency than that of the Carnot cycle.

Assume a non-reversible engine  $A$  and a Carnot engine  $B$ , both working between the same limits in temperature. Engine  $A$  takes  $Q_A$  heat units from the hot body and rejects  $Q'_A$  heat units to the cold body, while engine  $B$  takes  $Q_B$  heat units from the hot body and rejects  $Q'_B$  heat units to the cold body.

If engine  $A$  is more efficient than engine  $B$ , it must take less heat from the hot body and reject less to the cold body, or in other words

$$Q_A < Q_B$$

and

$$Q'_A < Q'_B.$$

Now assume that  $B$  is to run in the reverse direction and that  $A$  is to drive  $B$ , which acts as a heat pump. Since  $B$  is a reversible engine, it will reject to the hot body, when running in a reverse direction, the same amount of heat that it takes from that body when running direct. Therefore the combined unit of  $A - B$  will, in each cycle, take from the hot body the quantity of heat  $Q_A$  and reject to the hot body the quantity of heat  $Q_B$ .

But

$$Q_B > Q_A$$

which means that this "self-acting machine unaided by any external agency" is transferring heat from a body of lower to one of higher temperature. This is contrary to the Second Law of Thermodynamics. It is, therefore, impossible for engine  $A$  to be more efficient than engine  $B$ . As these represent any engines of these particular types, no non-reversible engine can be more efficient than a reversible one working in the Carnot cycle.

Now assume engine  $A$  to be a reversible engine also. It can

be similarly proven that it cannot be *more* efficient than the Carnot engine.

The conclusion is therefore reached that no cycle can be *more* efficient than the Carnot cycle.

It can also be proven that this cycle is the *most* efficient cycle that any engine can follow when working between any given temperature limits. This necessitates, however, a more thorough exposition of the principles of thermodynamics than it is deemed wise to include in this text, and will therefore be omitted.

### PERFECT GAS PROBLEMS

1. One pound of air under a pressure of 100 lbs. per square inch absolute occupies .3 of a cubic foot in volume. What is its temperature in degrees F.?

2. Ten pounds of air under a pressure of 10,000 lbs. per square inch absolute have a temperature of 100° F. Find the volume occupied.

3. Five pounds of air at a temperature of 60° F. occupy a volume of 50 cu. ft. Find the gage pressure per square inch.

4. A tank containing air has a volume of 300 cu. ft. The pressure in the tank is 100 lbs. per square inch absolute and the temperature is 70° F. Find the weight of air in the tank.

5. What is the weight of the quantity of air which occupies a volume of 10 cu. ft. at a temperature of 100° F. under a pressure of 50 lbs. per square inch absolute?

6. What is the temperature of a pound of air when its volume is 5 cu. ft. and the pressure is 35 lbs. per square foot absolute?

7. What is the weight of a cubic foot of air when the pressure is 50 lbs. per square inch absolute and the temperature 160° F.?

8. A quantity of air at a temperature of 60° F. under a pressure of 14.7 lbs. per square inch absolute has a volume of 5 cu. ft. What is the volume of the same air when its temperature is changed to 120° F. at constant pressure?

9. The volume of a quantity of air at a temperature of 60° F. under a pressure of 14.7 lbs. per square inch absolute is 10 cu. ft. What is the volume of the same air when the pressure is changed at constant temperature to 60 lbs. per square inch absolute?

10. A tank contains 200 cu. ft. of air at a temperature of 60° F. and under a pressure of 200 lbs. absolute. (a) What is the weight of the air? (b) How many cubic feet will the air occupy at atmospheric pressure?

11. A tank containing 1000 cu. ft. is half full of air and half full of water. The pressure in the tank is 60 lbs. absolute and the temperature is 60° F. If half the water is withdrawn from the tank, what will be the resulting pressure, assuming the temperature to remain constant?

12. The volume of a quantity of air at 70° F. under a pressure of 16 lbs. per square inch absolute is 20 cu. ft. What is the temperature of this air when the volume is 4 cu. ft. and the pressure is 70 lbs. per square inch absolute?

13. A compressed air pipe transmission is 1 mile long. The pressure at entrance is 1000 lbs. per square inch absolute; at exit, 500 lbs. The velocity at entrance to pipe, which is 12 in. in diameter, is 100 ft. per second. (a) What must be the diameter of the pipe at the exit end to have the same velocity as at entrance, the temperature of the air in the pipe remaining constant? (b) What, if the velocity at exit is to be 90 ft. per second?

14. A street car has an air storage tank for its air brakes with a volume of 400 cu. ft. The pressure in the tank at starting is 200 lbs. absolute and the temperature is  $60^{\circ}$  F. The air-brake cylinders take air at 40 lbs. absolute and have a volume of 2 cu. ft. How many times can the brakes be operated on one tank of air, assuming the temperature of the air to remain constant?

15. To operate the air brakes on a car requires 1 cu. ft. of air at 40 lbs. gage pressure. The car has a storage tank containing 100 cu. ft. of air at 250 lbs. gage pressure. How many times will the tank operate the brakes?

16. The compressed air tank on a street car has a volume of 250 cu. ft. The pressure in the tank is 250 lbs. gage and the temperature is  $60^{\circ}$  F. There are two air cylinders each  $8'' \times 10''$ . The brakes take air at 40 lbs. gage pressure and  $60^{\circ}$  temperature. How many times will the tank operate the brakes?

17. How many B.T.U. will be required to double the volume of 1 lb. of air at constant pressure from the temperature of melting ice?

18. A tank filled with 200 cu. ft. of air at atmospheric pressure, and at  $60^{\circ}$  F. is heated to  $150^{\circ}$ . What will be the resulting air pressure in the tank and how many B.T.U. will be required to heat the air?

19. A tank contains 200 cu. ft. of air at  $60^{\circ}$  F. under a pressure of 40 lbs. absolute. If the air has 1000 B.T.U. added to it, what will be the resulting temperature and pressure in the tank?

20. A tank contains 100 cu. ft. of air at  $60^{\circ}$  F. under a pressure of 50 lbs. absolute. If the air in the tank receives 100 B.T.U. of heat, what will be the resulting temperature and pressure?

21. Ten pounds of air enclosed in a tank at  $60^{\circ}$  F. under a pressure of 100 lbs. absolute are heated to  $100^{\circ}$  F. (a) What is the volume of the air? (b) What will be the final pressure? (c) How many B.T.U. will be required to heat it?

22. A tank contains 200 cu. ft. of air at  $60^{\circ}$  F. under a pressure of 50 lbs. absolute. (a) How many pounds of air in the tank? (b) How many B.T.U. will be required to raise the temperature of the air in the tank to  $100^{\circ}$  F.? (c) What will be the pressure in the tank when the air has been heated to  $100^{\circ}$  F.?

23. A certain auditorium will seat 3000 people. If each person is supplied with 2000 cu. ft. of air per hour for ventilation, the outside temperature being  $0^{\circ}$  F. and that in the hall being  $70^{\circ}$ , how many pounds of air will be admitted per hour, and how many B.T.U. will be required to heat it? Weight of 1 cu. ft. of air at  $0^{\circ}$  F. is .0863 lbs.; at  $70^{\circ}$  is .075 lbs.

24. A piece of iron weighing 5 lbs. is heated to  $212^{\circ}$  F. and then dropped into a vessel containing 16.5 lbs. of water at  $60^{\circ}$  F. If the temperature of the water is increased five degrees by the heat from the iron, what is the specific heat of the iron?

25. How many foot-pounds of heat must be absorbed by 2 lbs. of air in

expanding to double its initial volume at constant temperature of  $100^{\circ}$  F.?

26. How many B.T.U. of work must be expended in compressing 3 lbs. of air to one-fourth its initial volume at a constant temperature of  $15^{\circ}$  C.?

27. If 1 cu. ft. of air expands from a gage pressure of 4 atmospheres and a temperature of  $60^{\circ}$  F. to an absolute pressure of 1 atmosphere without the transmission of heat, find the final temperature.

28. An air compressor, the cross-section of which is 2 sq. ft., and stroke 3 ft., takes in air at 14 lbs. absolute pressure and  $60^{\circ}$  F. and compresses it to 60 lbs. gage pressure without the transmission of heat. Find the final temperature.

29. In problem 28, if the air at 60 lbs. gage pressure and  $70^{\circ}$  F. expands adiabatically to a final pressure of 20 lbs. gage, find the final temperature.

30. Two cubic feet of air at  $60^{\circ}$  F. and an initial pressure of 1 atmosphere absolute are compressed in a cylinder to 5 atmospheres gage pressure. If there be no transference of heat, find the final temperature and volume.

31. A cylindrical vessel, the area of the base of which is 1 sq. ft., contains 2 cu. ft. of air at  $60^{\circ}$  F. when compressed by a frictionless piston weighing 2000 lbs. resting upon it. Find the temperature and volume of the air if the vessel be inverted, there being no transmission of air or heat.

32. Given the quantity of air whose volume is 3 cu. ft. at  $60^{\circ}$  F. under a pressure of 45 lbs. absolute. (a) Find the volume and temperature of this air after it has expanded adiabatically until its pressure is 15 lbs. absolute. (b) What is the work done during the expansion? (c) What is the heat in B.T.U. converted into work?

33. Given a quantity of air whose volume is 2 cu. ft. at  $60^{\circ}$  F. under a pressure of 80 lbs. absolute. (a) What is the weight of the air? (b) What will be the final temperature and pressure if the air be expanded adiabatically until its volume is 8 cu. ft.? (c) How much work will be done during this expansion? (d) How much work will be done if the air be expanded isothermally until its volume is 8 cu. ft.?

34. Given a quantity of air whose volume is 2.2 cu. ft. at  $80^{\circ}$  F. under a pressure of 100 lbs. absolute. It is made to pass through the following Carnot cycle: it is expanded isothermally until its volume is 4 cu. ft.; then expanded adiabatically until its temperature is  $30^{\circ}$  F.; then compressed isothermally; and finally it is compressed adiabatically until its volume, pressure, and absolute temperature are the same as at the beginning of the cycle. (a) Find the total heat added in B.T.U. (b) Find the total heat rejected in B.T.U. (c) Find the work done in foot-pounds during the cycle. (d) Find the efficiency of the cycle.

35. Given a quantity of air whose volume is 10 cu. ft. at  $60^{\circ}$  F. under a pressure of 20 lbs. absolute. Heat is added at constant volume until its pressure is 200 lbs. absolute; then added at constant pressure until its volume is 40 cu. ft.; then rejected at constant volume until its pressure is 20 lbs. absolute; and then rejected at constant pressure until its volume is the same as at the beginning of the cycle. (a) Find temperature at end of first step. (b) Find temperature at end of second step. (c) Find temperature at end of third step. (d) Find total heat added in B.T.U. (e) Find total heat rejected in B.T.U. (f) Find work done in foot-pounds. (g) Find the efficiency of the cycle.

36. Given a quantity of air whose volume is 20 cu. ft. at 60° F. under a pressure of 20 lbs. absolute. Heat is added at constant volume until its pressure is 200 lbs. absolute; then the air is expanded adiabatically until its pressure is 20 lbs. absolute; and then compressed at constant pressure until its volume is the same as at the beginning of the cycle. (a) Find temperature at end of first step. (b) Find temperature at end of second step. (c) Find total heat added in B.T.U. (d) Find total heat rejected in B.T.U.

37. Given a quantity of air whose volume is 1 cu. ft. under a pressure of 100 lbs. absolute. It is expanded under a constant pressure to 3 cu. ft. (a) What external work has been done during the expansion? (b) What heat has been added?

38. Two pounds of air occupying a volume of 6 cu. ft. under a pressure of 60 lbs. absolute are expanded isothermally until the pressure is 20 lbs. absolute. (a) What external work has been done during the expansion? (b) What heat has been added?

39. 1.3 cu. ft. of air under a pressure of 15 lbs. absolute are heated at constant volume to 80 lbs. absolute; then expanded adiabatically to a volume of 4.26 cu. ft. and a pressure of 15 lbs. absolute; then compressed at a constant pressure to the original volume. (a) What is the total heat added in B.T.U.? (b) What is the work done in foot-pounds? (c) What is the efficiency of the cycle?

40. Two cubic feet of air under a pressure of 15 lbs. per square inch absolute are heated at constant volume to a pressure of 100 lbs. per square inch absolute; then heated at constant pressure to a volume of 4 cu. ft.; then expanded to the original pressure; and finally compressed at constant pressure to the original volume. The expansion is  $pv^{1.2} = \text{a constant}$ . (a) Find the heat added in B.T.U. (b) Find the heat rejected in B.T.U. (c) Find the work done in foot-pounds. (d) Find the efficiency of the cycle.

41. One pound of air is made to pass through the following cycle: it is expanded at constant pressure; then expanded isothermally; then compressed at constant pressure; and then compressed isothermally until the cycle is complete. Derive the expressions in terms of pressure and volume for, (a) the heat added in B.T.U.; (b) the heat rejected in B.T.U.; (c) the work done in foot-pounds; (d) the efficiency of the cycle.

9. a tank 4ft in diam & 10ft long  
 2/3 of its vol is filled with H<sub>2</sub>O & 1/3 with  
 air. The Press in tank is 100 lb/sq in  
 How much H<sub>2</sub>O must be withdrawn  
 from the tank to reduce the  
 pressure to 40 lb/sq in abs.

## CHAPTER III

### PROPERTIES OF STEAM

**28. Formation of Steam.**—In order to understand the operation of a steam engine it is necessary to study the nature and properties of steam. Steam as produced in the ordinary boiler is a vapor, and often contains a certain amount of water in suspension, as does the atmosphere in foggy weather. Let us suppose that we have a boiler partly filled with cold water, and that heat is applied to the external shell of the boiler. As the water in the boiler is heated its temperature slowly rises. This increase of temperature continues from the initial temperature of the water until the temperature of the boiling point is reached, this latter temperature depending upon the pressure in the boiler. When the boiling point is reached small particles of water are changed into steam. They rise through the mass of water and escape to the surface. The water is then said "to boil." *The temperature at which the water boils depends entirely on the pressure in the boiler.* The steam produced from the boiling water is at the *same temperature* as the water, and under this condition the steam is said to be *saturated*. If we keep on applying heat to the water in the boiler, the pressure remaining the same, the temperature of the steam and the water will *remain constant* until all the water is evaporated. If more heat is added after all the water is converted into steam, the pressure still being kept unchanged, the temperature will rise. Steam under this condition is said to be *superheated*.

In the formation of steam we divide the heat used into three different parts:

(1) The heat which goes to raising the temperature of the water from its original temperature to the temperature of the boiling point, called "Heat of the Liquid."

(2) The heat which goes to changing the water at the temperature of the boiling point into steam at the temperature of the boiling point, called "Latent Heat."

(3) The heat which goes to changing the saturated steam at the temperature of the boiling point into steam at a higher

temperature but at the same pressure, called "Heat of Superheat."

**29. Dry Saturated Steam.**—*Saturated steam always exists at the temperature of the boiling point corresponding to the pressure.* If this saturated steam contains no moisture in the form of water, then it is said to be *dry saturated steam*, or, in other words, *dry saturated steam is steam at the temperature of the boiling point and containing no water in suspension.* Water so contained is often called entrained moisture. If heat is added to dry saturated steam, not in the presence of water it will become superheated. If heat is taken away from dry saturated steam it will become wet steam. Dry saturated steam is not a perfect gas, and the relation of pressure, volume, and temperature for such steam does not follow any simple law, but has been determined by experiment.

The properties of dry saturated steam were originally determined by Regnault between sixty and seventy years ago, and so carefully was his work done that no errors in his results were apparent until within very recent years, when the great difficulty in obtaining steam which is exactly dry and saturated became appreciated, and new experiments by various scientists proved that Regnault's results were slightly high at some pressures and slightly low at others. The steam tables given in this book are based upon these recent experiments, and are probably correct to a fraction of 1 per cent.

**30. Wet Steam.**—*Wet steam is saturated steam which contains entrained moisture.* When saturated steam is used in a steam engine, it almost always contains moisture in the form of water, so that the substance used by the engine as a working fluid is a mixture of steam and water. The steam and water in this case are at the same temperature.

**31. Superheated Steam.**—*Superheated steam is steam at a temperature higher than the temperature corresponding to the pressure of the boiling point at which it was formed.* It is sometimes called steam gas. If water were to be mixed with superheated steam, this water would be evaporated as long as the steam remains superheated. Superheated steam at the *same pressure* as the boiling point at which it was produced can have *any temperature higher* than that of the boiling point. When raised to any considerable temperature above the temperature of the boiling point, it follows very closely the laws of a perfect

gas, and may be treated as a perfect gas. The equation for superheated steam, considered as a perfect gas, is

$$pv = 85.5 T', \text{ approximately.}$$

The specific heat of superheated steam is a variable and depends upon the pressure of the steam and the temperature to which the steam is superheated. For approximate calculations, the following values for the specific heat of superheated steam may be taken.

TABLE VI. SPECIFIC HEATS OF SUPERHEATED STEAM

Abs. press. in lbs. per sq. in.	14.7	25.0	50.0	75.0	100.0	125.0	150.0	175.0	200.0	225.0	250.0	275.0	300.0
Temp. of boiling point, F.°	212.0	240.1	281.0	307.6	327.8	344.4	358.5	370.8	381.9	391.9	401.1	409.5	417.5
Actual Temp. of Steam.													
250°	.47	.48	.....	.....	.....	.....	.....	.....	.....	.....	.....	.....	.....
275	.47	.48	.....	.....	.....	.....	.....	.....	.....	.....	.....	.....	.....
300	.47	.48	.50	.....	.....	.....	.....	.....	.....	.....	.....	.....	.....
325	.47	.48	.50	.53	.....	.....	.....	.....	.....	.....	.....	.....	.....
350	.47	.48	.49	.52	.55	.58	.....	.....	.....	.....	.....	.....	.....
375	.47	.47	.49	.51	.53	.56	.60	.66	.....	.....	.....	.....	.....
400	.47	.47	.49	.50	.52	.54	.57	.60	.65	.72	.....	.....	.....
425	.47	.47	.48	.50	.51	.52	.54	.56	.59	.63	.67	.74	.82
450	.47	.47	.48	.49	.50	.51	.52	.53	.55	.57	.60	.64	.67
475	.47	.47	.48	.49	.50	.50	.51	.52	.53	.54	.55	.56	.58
500	.47	.47	.48	.49	.49	.50	.50	.51	.52	.52	.53	.53	.54
525	.47	.47	.48	.48	.49	.49	.50	.50	.51	.51	.51	.52	.52
550	.47	.47	.48	.48	.49	.49	.50	.50	.50	.50	.51	.51	.52
600	.47	.47	.48	.48	.48	.49	.49	.49	.49	.50	.50	.50	.50
650	.47	.47	.48	.48	.48	.48	.49	.49	.49	.49	.50	.50	.50
700	.47	.47	.48	.48	.48	.48	.49	.49	.49	.49	.49	.50	.50
800	.48	.48	.48	.48	.48	.48	.48	.49	.49	.49	.49	.49	.49

When more accurate results are desired the value of specific heat should be taken from results given in Peabody's, or Marks and Davis's Steam Tables.

The value of  $\gamma$  for superheated steam is approximately 1.3.

**32. Heat of the Liquid.**—*The heat necessary to raise one pound of water from 32° to the temperature of the boiling point is called the heat of the liquid.* This may be expressed numerically as follows: let  $c$  be the specific heat of the water,  $t$  the temperature of the boiling point, and  $h$  the heat of the liquid; then

$$h = c(t - 32). \quad (1)$$

For approximate results  $c$  may be taken as 1, but where great accuracy is required the heat of the liquid should be taken from



the steam tables as shown in Column 3. During this operation the change in the volume of the water is extremely small, and the amount of external work done may be neglected and all the heat of the liquid may be considered as going to increasing the heat energy of the water.

**33. Latent Heat of Steam.**—When the water has reached the boiling point, more heat must be added to convert this water into steam. *The heat necessary to convert one pound of water at the temperature of the boiling point into steam at the same temperature is called the latent heat.* We will denote the latent heat by  $L$ . Experiments show that the latent heat of steam diminishes as the pressure increases.

When water is changed into steam, the volume is increased rapidly so that a considerable portion of the latent heat goes to external work. Let  $P$  equal the pressure at which the steam is formed;  $V$  equal the volume of the steam, and  $v$  equal the volume of the water; then the external work done equals

$$P(V - v). \tag{2}$$

The volume of one pound of water under those conditions may be taken as approximately .017 cu. ft. At  $212^\circ$  the external work done in producing one pound of steam is equivalent to 73 heat units or about one-thirteenth of the latent heat.

Experiments show that the latent heat of steam diminishes about .695 heat units for each degree the temperature of the boiling point is increased: If  $t$  be the temperature of the boiling point, then, approximately,

$$L = 1072.6 - .695(t - 32). \tag{3}$$

In condensing steam the same amount of heat is given up as was required to produce it.

**34. Total Heat of Steam.**—*The total heat of steam is the heat necessary to change one pound of water at  $32^\circ$  to one pound of steam at the temperature of the boiling point.* The total heat of dry saturated steam will be designated by  $H$ .

$$H = h + L. \tag{4}$$

The experimental results as given in the table for the value of the total heat may be approximated very closely by the formula

$$H = 1072.6 + .305(t - 32). \tag{5}$$

It is more accurate, however, to take the values of the total heat from the tables than it is to compute them from the formula given.

If we let  $q$  represent the percentage of dry steam in a mixture of steam and water, then the latent heat in one pound of wet steam equals

$$qL \quad (6)$$

and the total heat of one pound of wet steam equals

$$h + qL. \quad (7)$$

**35. Steam Tables.**—The following table shows the properties of dry saturated steam. More complete tables will be found in Peabody's Steam Tables, Marks and Davis's Steam Tables, or in the Engineering Hand Books. Column 1 gives the absolute pressure of the steam in pounds per square inch. Column 2 gives the corresponding temperature of the steam in Fahrenheit degrees. Column 3 gives the heat of the liquid, or the heat necessary to raise one pound of water from 32 degrees to the boiling point corresponding to the pressure. Column 4 gives the latent heat, or the heat necessary to change a pound of water at the temperature of the boiling point into steam at the same temperature. Column 5 gives the total heat of the steam, and is the sum of the quantities in Column 3 and Column 4. Column 6 is the volume of one pound of steam at the different temperatures. Column 7 is the weight of one cubic foot of steam at the different temperatures.

TABLE VII.—PROPERTIES OF SATURATED STEAM  
ENGLISH UNITS

Abs. Pressure Pounds per Sq. in.	Temperature Degrees F.	Heat of the Liquid	Latent Heat of Evapora- tion	Total Heat of Steam	Specific Volume Cu. Ft. per Pound	Density Pounds per Cu. Ft.	Abs. Pressure Pounds per Sq. In.
$p$	$t$	$h$	$L$	$H$	$v$	$\frac{1}{v}$	$p$
.0886	32	0	1072.6	1072.6	3301.0	.000303	.0886
.2562	60	28.1	1057.4	1085.5	1207.5	.000828	.2562
.5056	80	48.1	1046.6	1094.7	635.4	.001573	.5056
1	101.8	69.8	1034.6	1104.4	333.00	.00300	1
2	126.1	94.1	1021.4	1115.5	173.30	.00577	2
3	141.5	109.5	1012.3	1121.8	118.50	.00845	3
4	153.0	120.9	1005.6	1126.5	90.50	.01106	4
5	162.3	130.2	1000.2	1130.4	73.33	.01364	5
6	170.1	138.0	995.7	1133.7	61.89	.01616	6
7	173.8	144.8	991.7	1136.5	53.58	.01867	7
8	182.9	150.8	988.1	1138.9	47.27	.02115	8

PROPERTIES OF SATURATED STEAM—Continued

ENGLISH UNITS

Abs. Pressure Pounds per Sq. In.	Temperature Degrees F.	Heat of the Liquid	Latent Heat of Evapora- tion	Total Heat of Steam	Specific Volume Cu. Ft. per Pound	Density Pounds per Cu. Ft.	Abs. Pressure Pounds per Sq. In.
<i>p</i>	<i>t</i>	<i>h</i>	<i>L</i>	<i>H</i>	<i>v</i>	<i>ρ</i>	<i>p</i>
9	188.3	156.3	984.8	1141.1	42.36	.02361	9
10	193.2	161.2	981.8	1143.0	38.38	.02606	10
11	197.7	165.8	979.0	1144.8	35.10	.02849	11
12	202.0	170.0	976.4	1146.4	32.38	.03089	12
13	205.9	173.9	974.0	1147.9	30.04	.03329	13
14	209.6	177.6	971.7	1149.3	28.02	.03568	14
14.7	212.0	180.1	970.4	1150.4	26.79	.03733	14.7
15	213.0	181.1	969.5	1150.6	26.27	.03806	15
16	216.3	184.5	967.4	1151.9	24.77	.04042	16
17	219.4	187.7	965.4	1153.1	23.38	.04277	17
18	222.4	190.6	963.5	1154.1	22.16	.04512	18
19	225.2	193.5	961.6	1155.1	21.07	.04746	19
20	228.0	196.2	959.8	1156.0	20.08	.04980	20
21	230.6	198.9	958.0	1156.9	19.18	.05213	21
22	233.1	201.4	956.4	1157.8	18.37	.05445	22
23	235.5	203.9	954.8	1158.7	17.62	.05676	23
24	237.8	206.2	953.2	1159.4	16.93	.05907	24
25	240.1	208.5	951.7	1160.2	16.30	.0614	25
26	242.2	210.7	950.3	1161.0	15.71	.0636	26
27	244.4	212.8	948.9	1161.7	15.18	.0659	27
28	246.4	214.9	947.5	1162.4	14.67	.0682	28
29	248.4	217.0	946.1	1163.1	14.19	.0705	29
30	250.3	218.9	944.8	1163.7	13.74	.0728	30
31	252.2	220.8	943.5	1164.3	13.32	.0751	31
32	254.1	222.7	942.2	1164.9	12.93	.0773	32
33	255.8	224.5	941.0	1165.5	12.57	.0795	33
34	257.6	226.3	939.8	1166.1	12.22	.0818	34
35	259.3	228.0	938.6	1166.6	11.89	.0841	35
36	261.0	229.7	937.4	1167.1	11.58	.0863	36
37	262.6	231.4	936.3	1167.7	11.29	.0886	37
38	264.2	233.0	935.2	1168.2	11.01	.0908	38
39	265.8	234.6	934.1	1168.7	10.74	.0931	39
40	267.3	236.2	933.0	1169.2	10.49	.0953	40
41	268.7	237.7	931.9	1169.6	10.25	.0976	41
42	270.2	239.2	930.9	1170.1	10.02	.0998	42
43	271.7	240.6	929.9	1170.5	9.80	.1020	43
44	273.1	242.1	928.9	1171.0	9.59	.1043	44
45	274.5	243.5	927.9	1171.4	9.39	.1065	45
46	275.8	244.9	926.9	1171.8	9.20	.1087	46

PROPERTIES OF SATURATED STEAM—*Continued*

ENGLISH UNITS

Abs. Pressure Pounds per Sq. In.	Temperature Degrees F.	Heat of the Liquid	Latent Heat of Evapora- tion	Total Heat of Steam	Specific Volume Cu. Ft. per Pound	Density Pounds per Cu. Ft.	Abs. Pressure Pounds per Sq. In.
<i>p</i>	<i>t</i>	<i>h</i>	<i>L</i>	<i>H</i>	<i>v</i>	$\frac{1}{v}$	<i>p</i>
47	277.2	246.2	926.0	1172.2	9.02	.1109	47
48	278.5	247.6	925.0	1172.6	8.84	.1131	48
49	279.8	248.9	924.1	1173.0	8.67	.1153	49
50	281.0	250.2	923.2	1173.4	8.51	.1175	50
51	282.3	251.5	922.3	1173.8	8.35	.1197	51
52	283.5	252.8	921.4	1174.2	8.20	.1219	52
53	284.7	254.0	920.5	1174.5	8.05	.1241	53
54	285.9	255.2	919.6	1174.8	7.91	.1263	54
55	287.1	256.4	918.7	1175.1	7.78	.1285	55
56	288.2	257.6	917.9	1175.5	7.65	.1307	56
57	289.4	258.8	917.1	1175.9	7.52	.1329	57
58	290.5	259.9	916.2	1176.1	7.40	.1351	58
59	291.6	261.1	915.4	1176.5	7.28	.1373	59
60	292.7	262.2	914.6	1176.8	7.17	.1394	60
61	293.8	263.3	913.8	1177.1	7.06	.1416	61
62	294.9	264.4	913.0	1177.4	6.95	.1438	62
63	295.9	265.5	912.2	1177.7	6.85	.1460	63
64	297.0	266.5	911.5	1178.0	6.75	.1482	64
65	298.0	267.6	910.7	1178.3	6.65	.1503	65
66	299.0	268.6	910.0	1178.6	6.56	.1525	66
67	300.0	269.7	909.2	1178.9	6.47	.1547	67
68	301.0	270.7	908.4	1179.1	6.38	.1569	68
69	302.0	271.7	907.7	1179.4	6.29	.1591	69
70	302.9	272.7	906.9	1179.6	6.20	.1612	70
71	303.9	273.7	906.2	1179.9	6.12	.1634	71
72	304.8	274.6	905.5	1180.1	6.04	.1656	72
73	305.8	275.6	904.8	1180.4	5.96	.1678	73
74	306.7	276.6	904.1	1180.7	5.89	.1699	74
75	307.6	277.5	903.4	1180.9	5.81	.1721	75
76	308.5	278.5	902.7	1181.2	5.74	.1743	76
77	309.4	279.4	902.1	1181.5	5.67	.1764	77
78	310.3	280.3	901.4	1181.7	5.60	.1786	78
79	311.2	281.2	900.7	1181.9	5.54	.1808	79
80	312.0	282.1	900.1	1182.2	5.47	.1829	80
81	312.9	283.0	899.4	1182.4	5.41	.1851	81
82	313.8	283.8	898.8	1182.6	5.34	.1873	82
83	314.6	284.7	898.1	1182.8	5.28	.1894	83
84	315.4	285.6	897.5	1183.1	5.22	.1915	84
85	316.3	286.4	896.9	1183.3	5.16	.1937	85

PROPERTIES OF SATURATED STEAM — *Continued*

ENGLISH UNITS

Abs. Pressure Pounds per Sq. In.	Temperature Degrees F.	Heat of the Liquid	Latent Heat of Evapora- tion	Total Heat of Steam	Specific Volume Cu. Ft. per Pound	Density Pounds per Cu. Ft.	Abs. Pressure Pounds per Sq. In.
<i>p</i>	<i>t</i>	<i>h</i>	<i>L</i>	<i>H</i>	<i>v</i>	$\frac{1}{v}$	<i>p</i>
86	317.1	287.3	896.2	1183.5	5.10	.1959	86
87	317.9	288.1	895.6	1183.7	5.05	.1980	87
88	318.7	288.9	895.0	1183.9	5.00	.2002	88
89	319.5	289.8	894.3	1184.1	4.94	.2024	89
90	320.3	290.6	893.7	1184.3	4.89	.2045	90
91	321.1	291.4	893.1	1184.5	4.84	.2066	91
92	321.8	292.2	892.5	1184.7	4.79	.2088	92
93	322.6	293.0	891.9	1184.9	4.74	.2110	93
94	323.4	293.8	891.3	1185.1	4.69	.2131	94
95	324.1	294.5	890.7	1185.2	4.65	.2152	95
96	324.9	295.3	890.1	1185.4	4.60	.2173	96
97	325.6	296.1	889.5	1185.6	4.56	.2194	97
98	326.4	296.8	889.0	1185.8	4.51	.2215	98
99	327.1	297.6	888.4	1186.0	4.47	.2237	99
100	327.8	298.4	887.8	1186.2	4.430	.2257	100
101	328.6	299.1	887.2	1186.3	4.389	.2278	101
102	329.3	299.8	886.7	1186.5	4.349	.2299	102
103	330.0	300.6	886.1	1186.7	4.309	.2321	103
104	330.7	301.3	885.6	1186.9	4.270	.2342	104
105	331.4	302.0	885.0	1187.0	4.231	.2364	105
106	332.0	302.7	884.5	1187.2	4.193	.2385	106
107	332.7	303.4	883.9	1187.3	4.156	.2407	107
108	333.4	304.1	883.4	1187.5	4.119	.2428	108
109	334.1	304.8	882.8	1187.6	4.082	.2450	109
110	334.8	305.5	882.3	1187.8	4.047	.2472	110
111	335.4	306.2	881.8	1188.0	4.012	.2493	111
112	336.1	306.9	881.2	1188.1	3.977	.2514	112
113	336.8	307.6	880.7	1188.3	3.944	.2535	113
114	337.4	308.3	880.2	1188.5	3.911	.2557	114
114.7	337.9	308.8	879.8	1188.6	3.888	.2572	114.7
115	338.1	309.0	879.7	1188.7	3.878	.2578	115
116	338.7	309.6	879.2	1188.8	3.846	.2600	116
117	339.4	310.3	878.7	1189.0	3.815	.2621	117
118	340.0	311.0	878.2	1189.2	3.784	.2642	118
119	340.6	311.7	877.6	1189.3	3.754	.2663	119
120	341.3	312.3	877.1	1189.4	3.725	.2684	120
121	341.9	313.0	876.6	1189.6	3.696	.2706	121
122	342.5	313.6	876.1	1189.7	3.667	.2727	122
123	343.2	314.3	875.6	1189.9	3.638	.2749	123

PROPERTIES OF SATURATED STEAM—*Continued*

ENGLISH UNITS

Abs. Pressure Pounds per Sq. In.	Temperature Degrees F.	Heat of the Liquid	Latent Heat of Evapora- tion	Total Heat of Steam	Specific Volume Cu. Ft. per Pound	Density Pounds per Cu. Ft.	Abs. Pressure Pounds per Sq. In.
<i>p</i>	<i>t</i>	<i>h</i>	<i>L</i>	<i>H</i>	<i>v</i>	$\frac{1}{v}$	<i>p</i>
124	343.8	314.9	875.1	1190.0	3.610	.2770	124
125	344.4	315.5	874.6	1190.1	3.582	.2792	125
126	345.0	316.2	874.1	1190.3	3.555	.2813	126
127	345.6	316.8	873.7	1190.5	3.529	.2834	127
128	346.2	317.4	873.2	1190.6	3.503	.2855	128
129	346.8	318.0	872.7	1190.7	3.477	.2876	129
130	347.4	318.6	872.2	1190.8	3.452	.2897	130
131	348.0	319.3	871.7	1191.0	3.427	.2918	131
132	348.5	319.9	871.2	1191.1	3.402	.2939	132
133	349.1	320.5	870.8	1191.3	3.378	.2960	133
134	349.7	321.0	870.4	1191.4	3.354	.2981	134
135	350.3	321.6	869.9	1191.5	3.331	.3002	135
136	350.8	322.2	869.4	1191.6	3.308	.3023	136
137	351.4	322.8	868.9	1191.7	3.285	.3044	137
138	352.0	323.4	868.4	1191.8	3.263	.3065	138
139	352.5	324.0	868.0	1192.0	3.241	.3086	139
140	353.1	324.5	867.6	1192.1	3.219	.3107	140
141	353.6	325.1	867.1	1192.2	3.198	.3128	141
142	354.2	325.7	866.6	1192.3	3.176	.3149	142
143	354.7	326.3	866.2	1192.5	3.155	.3170	143
144	355.3	326.8	865.8	1192.6	3.134	.3191	144
145	355.8	327.4	865.3	1192.7	3.113	.3212	145
146	356.3	327.9	864.9	1192.8	3.093	.3233	146
147	356.9	328.5	864.4	1192.9	3.073	.3254	147
148	357.4	329.0	864.0	1193.0	3.053	.3275	148
149	357.9	329.6	863.5	1193.1	3.033	.3297	149
150	358.5	330.1	863.1	1193.2	3.013	.3319	150
152	359.5	331.2	862.3	1193.5	2.975	.3361	152
154	360.5	332.3	861.4	1193.7	2.939	.3403	154
156	361.6	333.4	860.5	1193.9	2.903	.3445	156
158	362.6	334.4	859.7	1194.1	2.868	.3487	158
160	363.6	335.5	858.8	1194.3	2.834	.3529	160
162	364.6	336.6	858.0	1194.6	2.801	.3570	162
164	365.6	337.6	857.2	1194.8	2.768	.3613	164
166	366.5	338.6	856.4	1195.0	2.736	.3655	166
168	367.5	339.6	855.5	1195.1	2.705	.3697	168
170	368.5	340.6	854.7	1195.3	2.674	.3739	170
172	369.4	341.6	853.9	1195.5	2.644	.3782	172
174	370.4	342.5	853.1	1195.6	2.615	.3824	174
176	371.3	343.5	852.3	1195.8	2.587	.3865	176

PROPERTIES OF SATURATED STEAM—*Concluded*

ENGLISH UNITS

Abs. Pressure Pounds per Sq. In.	Temperature Degrees F.	Heat of the Liquid	Latent Heat of Evapora- tion	Total Heat of Steam	Specific Volume Cu. Ft. per Pound	Density Pounds per Cu. Ft.	Abs. Pressure Pounds per Sq. In.
<i>p</i>	<i>t</i>	<i>h</i>	<i>L</i>	<i>H</i>	<i>v</i>	$\frac{1}{v}$	<i>p</i>
178	372.2	344.5	851.5	1196.0	2.560	.3907	178
180	373.1	345.4	850.8	1196.2	2.532	.3949	180
182	374.0	346.4	850.0	1196.4	2.506	.3990	182
184	374.9	347.4	849.3	1196.7	2.480	.4032	184
186	375.8	348.3	848.5	1196.8	2.455	.4074	186
188	376.7	349.2	847.7	1196.9	2.430	.4115	188
190	377.6	350.1	847.0	1197.1	2.406	.4157	190
192	378.5	351.0	846.2	1197.2	2.381	.4200	192
194	379.3	351.9	845.5	1197.4	2.358	.4242	194
196	380.2	352.8	844.8	1197.6	2.335	.4284	196
198	381.0	353.7	844.0	1197.7	2.312	.4326	198
200	381.9	354.6	843.3	1197.9	2.289	.4370	200
202	382.7	355.5	842.6	1198.1	2.268	.4411	202
204	383.5	356.4	841.9	1198.3	2.246	.4452	204
206	384.4	357.2	841.2	1198.4	2.226	.4493	206
208	385.2	358.1	840.5	1198.6	2.206	.4534	208
210	386.0	358.9	839.8	1198.7	2.186	.4575	210
212	386.8	359.8	839.1	1198.9	2.166	.4618	212
214	387.6	360.6	838.4	1199.0	2.147	.4660	214
216	388.4	361.4	837.7	1199.1	2.127	.4700	216
218	389.1	362.3	837.0	1199.3	2.108	.4744	218
220	389.9	363.1	836.4	1199.5	2.090	.4787	220
222	390.7	363.9	835.7	1199.6	2.072	.4829	222
224	391.5	364.7	835.0	1199.7	2.054	.4870	224
226	392.2	365.5	834.3	1199.8	2.037	.4910	226
228	393.0	366.3	833.7	1200.0	2.020	.4950	228
230	393.8	367.1	833.0	1200.1	2.003	.4992	230
232	394.5	367.9	832.3	1200.2	1.987	.503	232
234	395.2	368.6	831.7	1200.3	1.970	.507	234
236	396.0	369.4	831.0	1200.4	1.954	.511	236
238	396.7	370.2	830.4	1200.6	1.938	.516	238
240	397.4	371.0	829.8	1200.8	1.923	.520	240
242	398.2	371.7	829.2	1200.9	1.907	.524	242
244	398.9	372.5	828.5	1201.0	1.892	.528	244
246	399.6	373.3	827.8	1201.1	1.877	.532	246
248	400.3	374.0	827.2	1201.2	1.862	.537	248
250	401.1	374.7	826.6	1201.3	1.848	.541	250
275	409.6	383.7	819.0	1202.7	1.684	.594	275
300	417.5	392.0	811.8	1203.8	1.547	.647	300
350	431.9	407.4	798.5	1205.9	1.330	.750	350

## CHAPTER IV

### CALORIMETERS AND MECHANICAL MIXTURES

**36. Calorimeters.**—As we have already seen, steam may be either wet, dry and saturated, or superheated. By “*quality*” of steam is meant *the per cent. of dry and saturated steam in the sample.*

The percent of *moisture* in the steam is found by subtracting the quality from 100 per cent.

The quality is determined by means of a Calorimeter. There are two classes of these instruments in general use at the present time, the Separating Calorimeter and the Throttling Calorimeter. In each of these classes there are several types or makes, but it will suffice to describe only one or two of each.

As will be seen in Paragraph 39, the American Society of Mechanical Engineers recommend the use of a *sampling nozzle*, or *calorimeter nipple*, in connection with the calorimeter. This nipple is a piece of pipe extending nearly across the steam main, as shown in Fig. 9, with a cap on the end and a series of  $\frac{1}{8}$ -inch holes along and around its cylindrical surface. As the steam to be tested must enter the calorimeter through this nipple, a fair sample of the steam is insured. The sampling nozzle should be inserted in the steam main at a point where the entrained moisture is likely to be most thoroughly mixed.

**37. Separating Calorimeters.**—The weight of the dry steam that will pass through a given size of orifice in a given time depends upon the pressure on the two sides of the orifice. If  $A$  is the area of the orifice in square inches,  $P$  the absolute pressure in pounds per square inch, and  $W$  the pounds of steam passing through the orifice into the atmosphere per second, then

$$W = \frac{PA}{70} \text{ (Napier's Rule).} \quad (1)$$

From Napier's Rule the weight of steam flowing through an orifice of known area is proportional to the absolute steam pressure. This law holds true until the lower pressure equals or exceeds .6 of the higher pressure.



The amount of steam flowing through any orifice may, therefore, be determined. Professor R. C. Carpenter has a calorimeter based upon this principle. Wet steam enters the calorimeter, Fig. 7, through the pipe 6, and is projected against the cup 14. The steam and water are then turned through an angle of 180°, which causes the water to be thrown outward by centrifugal force through the meshes in the cup into the inner chamber 3. Causing the steam to strike the cup, instead of flowing directly into the chamber 3, prevents any moisture already thrown out being picked up again and carried on. The steam after leaving the cup passes upward and enters the top of the outer chamber 7. It then flows down around the inner chamber in the annular space 4, and is discharged through the orifice 8. The area of this orifice, which is known, is so small that there is no loss in pressure of the steam as it flows through the calorimeter. The pressure in the two chambers being the same, the temperature is the same, and there is no loss of heat from the inner chamber by radiation. The gage glass 12, connected with the inner chamber, is graduated in *hundredths of pounds*, so that the weight of moisture separated from the steam can be read directly. The gage 9 is so calibrated as to read directly the number of *pounds* flowing through the orifice 8 in a given time (generally ten minutes). These readings are not proportional to the pressure readings on the gage, which has two scales, for the latter readings are proportional to the pressures above the atmosphere and not to the absolute pressures. The accuracy of the results obtained by using the gage may be checked at any time by condensing and weighing the discharge from orifice 8 for a given period of time.

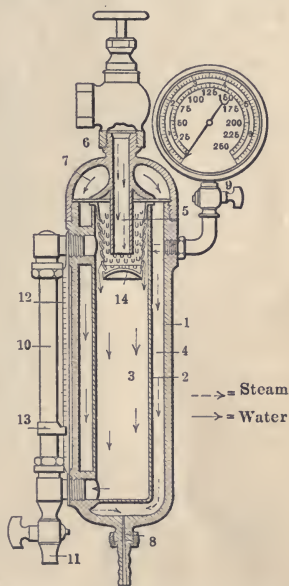

FIG. 7.—Carpenter's improved separating calorimeter.

If now we call  $w$  the weight of dry steam discharged from the orifice 8 in any given period of time,  $W$  the weight of mois-

ture collected in 3 in the same period of time, and  $q$  the quality of the steam, then

$$q = \frac{w}{w + W} \quad (2)$$

$w$  may be obtained either from the reading of the gage 9, or by actually weighing the steam, and  $W$  is found by taking the difference between the readings on scale 12 at the beginning and end of the test.

**38. Throttling Calorimeter.**—This form of calorimeter was invented by Prof. C. H. Peabody, and is the form recommended

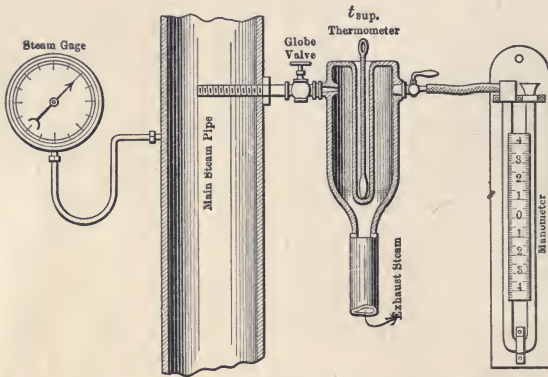

FIG. 8.—Carpenter's throttling calorimeter.

by the A.S.M.E. Committee on Standards (see paragraph 39 below). It is the most accurate form of calorimeter where it can be used, but is unsuitable for use in determining the quality of the steam if the steam contains over 3 or 4 per cent. of moisture, or if the temperature of the lower thermometer is below  $225^{\circ}$ , which will be the case if the steam is at a very low pressure (below 5 or 6 lbs. gage).

The principle of its operation is as follows: a pound of saturated steam at a high pressure contains more heat than a pound of saturated steam at a lower pressure. If steam at a high pressure pass through an orifice into a space at a lower pressure without doing any external work, some of this heat must be given up, and as the only object that can absorb heat is the steam itself, it takes up this heat. If this steam contained some moisture at the higher pressure, part of the heat liberated when the pres-

sure is lowered will go to evaporating this moisture, and the excess will go to superheating the steam.

Let  $q$  = the quality of the steam.

$t_1$  = the temperature of the wet steam before passing through the orifice.

$p_1$  = the absolute pressure of the wet steam in the main.

$t_2$  = the temperature corresponding to the absolute pressure on the low-pressure side of the orifice.

$t_{sup.}$  = the temperature of the steam as shown by the thermometer on the low-pressure side of the orifice.

$h_1$  and  $L_1$  = heat of liquid and latent heat corresponding to the temperature  $t_1$ , or the absolute pressure  $p_1$ .

$h_2$  and  $L_2$  = heat of liquid and latent heat corresponding to the temperature  $t_2$ .

The heat contained in 1 lb. of the mixture of steam and water at temperature  $t_1$ , or pressure  $p_1$ , would be

$$h_1 + qL_1.$$

The heat contained in 1 lb. of the steam on the low-pressure side of the orifice after expansion would be

$$h_2 + L_2 + c_p(t_{sup.} - t_2) = H_2 + c_p(t_{sup.} - t_2),$$

where  $c_p$  is the specific heat of superheated steam. But since the heat in a pound of the substance must be the same on one side of the orifice as it is on the other,

$$h_1 + qL_1 = H_2 + c_p(t_{sup.} - t_2). \quad (3)$$

Solving for  $q$ ,

$$q = \frac{H_2 + c_p(t_{sup.} - t_2) - h_1}{L_1}. \quad (4)$$

The percentage of moisture equals  $1 - q$ . (5)

Ordinarily  $t_2$  is found from the tables by looking up the temperature corresponding to the absolute pressure in the calorimeter, *i.e.*, the sum of the atmospheric pressure and the pressure shown by the manometer. This practice, however, is not permitted by the A.S.M.E. rules for finding the quality of steam, since  $t_{sup.}$  is taken with a thermometer that has part of

its stem exposed, and is thus subject to radiation,\* nor does it take account of the radiation from the calorimeter itself, which may be considerable even though well covered. Therefore for accurate work it is necessary that we take a "normal reading" of the thermometer, as described in paragraph 39 to correct for these errors.

The calorimeter shown in Fig. 9 differs from the one shown in Fig. 8 in that the *temperature* of the steam being admitted to the calorimeter is observed instead of the *pressure*. In other

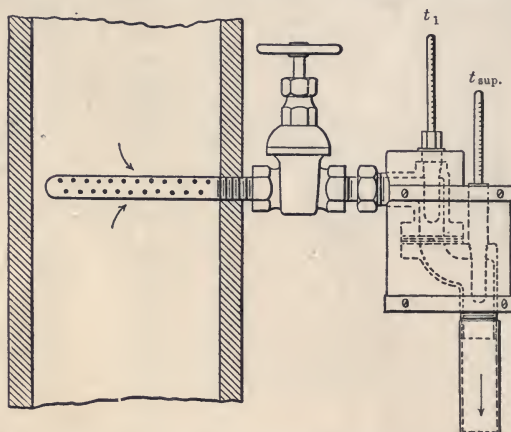

FIG. 9.—Barrus' throttling calorimeter.

words,  $h_1$  and  $L_1$  correspond to the temperature  $t_1$  rather than to the absolute pressure  $p_1$ . Another difference is that in the Barrus calorimeter, the exhaust is made very free and the pressure,  $p_2$ , on the lower side of the orifice is assumed to be atmospheric. A long exhaust pipe will cause a back pressure in the calorimeter where we have assumed the pressure to be atmospheric.

In case the atmospheric pressure is not known, it can be

\*When a considerable portion of the mercury column of a thermometer measuring high temperatures is exposed to the air, a correction  $K$  must be added to the readings to obtain the true temperature.

Let  $t$  = the observed reading of the thermometer.

$t'$  = the temperature of the air surrounding the exposed stem of the thermometer.

$D$  = number of degrees on the scale from the surface of the liquid in the thermometer cup to the upper end of the mercury column.

Then  $K = .000088 D (t - t')$ , in Fahrenheit degrees.

assumed as 14.7 lbs. per square inch. If the barometer reading is given, however, it should always be used. This reading, as well as that of the manometer giving the pressure in the calorimeter, will be given in inches of mercury. To change this to pounds per square inch, multiply the inches of mercury by .491.

**39. Quality of Steam.**—The following are the standard rules for finding the quality of steam as adopted by the A.S.M.E., and published in the Transactions of that society, Vol. 21, p. 43, and Vol. 24, p. 740:

“The percentage of moisture in the steam should be determined by the use of either a throttling or a separating steam calorimeter. The sampling nozzle should be placed in the vertical steam pipe rising from the boiler. It should be made of  $\frac{1}{2}$ -in. pipe, and should extend across the diameter of the steam pipe to within half an inch of the opposite side, being closed at the end and perforated with not less than twenty  $\frac{1}{8}$ -in. holes equally distributed along and around its cylindrical surface, but none of these holes should be nearer than  $\frac{1}{2}$  in. to the inner side of the steam pipe. The calorimeter and the pipe leading to it should be well covered with felting. Whenever the indications of the throttling or separating calorimeter show that the percentage of moisture is irregular, or occasionally in excess of 3 per cent., the results should be checked by a steam separator placed in the steam pipe as close to the boiler as convenient, with a calorimeter in the steam pipe just beyond the outlet from the separator. The drip from the separator should be caught and weighed and the percentage of moisture computed therefrom added to that shown by the calorimeter.

“Superheating should be determined by means of a thermometer placed in a mercury-well inserted in the steam pipe. The degree of superheating should be taken as the difference between the reading of the thermometer for superheated steam and the readings of the same thermometer for saturated steam at the same pressure, as determined by a special experiment, and not by reference to steam tables.”

“If it is necessary to attach the calorimeter to a horizontal section of pipe, and it is important to determine the quantity of moisture accurately, a sampling nozzle should be used which has no perforations, and which passes through a stuffing-box applied to the bottom of the pipe so that it can be adjusted up and down, and thereby draw a sample at different points ranging from the top to the bottom.

“To determine the ‘normal reading’ of the calorimeter, the instrument should be attached to a horizontal steam pipe in such a way that the nozzle projects upward to near the top of the pipe, there being no perforations and the steam entering through the open end. The test should be made when the steam in the pipe is in a quiescent state, and when the

steam pressure is constant. If the steam pressure falls during the time when the observations are being made, the test should be continued long enough to obtain the effect of an equivalent rise of pressure. When the normal reading has been obtained, the constant to be used in determining the percentage of moisture is the latent heat of the steam at the observed pressure divided by the specific heat of superheated steam at atmospheric pressure, which is forty-six hundredths (.46). To ascertain this percentage, divide the number of degrees of cooling by the constant, and multiply by 100.

“To determine the quantity of steam used by the calorimeter in an instrument where the steam is passed through an orifice under a given pressure, it is usually accurate enough to calculate the quantity from the area of the orifice and the absolute pressure. If it is desired to determine the quantity exactly, a steam hose may be attached to the outlet of the calorimeter, and carried to a barrel of water placed on a platform scale. The steam is condensed for a certain time, and its weight determined, and thereby the quantity discharged per hour.”

**Example.**—Steam at 100 lbs. pressure blows through a throttling calorimeter. The temperature of the lower thermometer is 275° and the manometer reading is 5.6 in. of mercury. Barometer reading 29 in. Find the quality of the steam.

**Solution.**—First find the atmospheric pressure and the pressure in the calorimeter.

$$\text{Atmospheric pressure} = .491 \times 29 = 14.25 \text{ lbs.}$$

$$\text{Pressure in calorimeter} = .491 \times 5.6 = 2.75 \text{ lbs.}$$

Now from the steam tables find  $h_1$  and  $L_1$  corresponding to the pressure in the main, 114.25 lbs. absolute, and also  $H_2$  and  $t_2$  corresponding to the pressure in the calorimeter, 17 lbs. absolute.

Then from equation (4),

$$\begin{aligned} q &= \frac{H_2 + c_p (t_{sup.} - t_2) - h_1}{L_1} \\ &= \frac{1153.1 + .46 (275 - 219.4) - 308.5}{880.1} \\ &= \frac{1153.1 + .46 \times 55.6 - 308.8}{880.1} = \frac{869.6}{880.1} = .988. \end{aligned}$$

*Answer:* — 98.8 per cent.

**Example.**—(a) Find the quality of the steam in the preceding problem as shown by a separating calorimeter, if the data is as follows: weight of dry steam escaping through orifice, 4.5 lbs.; weight of moisture collected, .05 lbs.

(b) Find the diameter of the orifice if the length of the run is 20 minutes.

Solution.—(a) From equation (2),

$$q = \frac{w}{w + W}$$

$$= \frac{4.5}{4.5 + .05} = \frac{4.5}{4.55} = .988.$$

(b) Find weight of steam flowing through orifice per second, and call it  $w'$ . Then

$$w' = \frac{4.5}{20 \times 60} = \frac{4.5}{1200} = .00375 \text{ lbs.}$$

From equation (1),

$$w' = \frac{PA}{70}$$

$$A = \frac{70w'}{P} = \frac{70 \times .00375}{100 + .491 \times 29} = \frac{.26250}{114.25}$$

$$A = .0023$$

$$\pi r^2 = .0023$$

$$r^2 = \frac{.0023}{3.1416} = .000732$$

$$r = .027$$

$$d = .054$$

Answer: (a) 98.8 per cent

(b) .054 in.

PROBLEMS

1. Steam at 100 lbs. pressure passes through a Barrus calorimeter. Temperature after passing through orifice is 246°. What is the quality of the steam?

2. Steam at 110 lbs. blows through an orifice into the atmosphere. The temperature of the steam after passing through this orifice is 240°. What per cent. of moisture is in the original steam?

3. One pound of a mixture of steam and water containing 2 per cent. moisture at 150 lbs. absolute pressure expands through an orifice to 15 lbs. absolute pressure. What will be the temperature at the lower pressure?

4. Steam at a pressure of 100 lbs. and a quality of 98 per cent. blows through an orifice to 15 lbs. absolute. What will be its temperature?

5. Steam at 95 lbs. pressure containing 2½ per cent. moisture blows through an orifice into a chamber where the pressure is 8.2 in. of mercury above the atmosphere. What is the temperature of the steam after passing through the orifice? Barometer, 29.8 in.

6. Find the quality of the steam if, when tested with a separating calorimeter, 4.5 lbs. of dry steam blow through the orifice while 1.5 lbs. of mois-

Handwritten notes: "steam pres" with an arrow pointing to the denominator of the area calculation; "Barometer reading Ats. pressure" with an arrow pointing to the denominator of the area calculation.

ture are separated out. If the run is thirty minutes long and the steam pressure is 100 lbs., determine the diameter of the orifice.

7. Steam at 10 lbs. pressure blows through a separating calorimeter. The run is forty-five minutes long, 10.5 lbs. of dry steam flow through the orifice and .5 lbs. of moisture are collected. Find the quality of the steam and the area of the orifice.

**40. Mechanical Mixtures.**—Problems involving the resulting temperature and final condition when various substances are mixed mechanically are often met with. They are best treated by first determining the heat in B.T.U. that would be available for use if the temperature of all the substances were brought to 32° F., and then using this heat (positive or negative) to raise (or lower) the total weight of mixture to its final temperature and condition.

Another method of solving mixture problems is by equating the heat absorbed to the heat rejected and letting  $x$  represent the resulting temperature. It is often difficult to decide upon which side of the equation a material should be placed. In such a case a trial calculation should be made, and the temperature determined by this trial will settle this question.

In the mixture of substances which pass through a change of state during the mixture process, it is almost necessary to make a trial calculation. Take, for example, the mixing of steam with other substances. The steam may all be condensed and the resulting water cooled also; the steam may be condensed only; or the steam may be only partially condensed. The equations in each case would be different.

If one pound of dry saturated steam at a temperature  $t_1$  is condensed and then the temperature of the condensed steam is lowered to a temperature  $t_2$ , the amount of heat  $H'$  given off would be

$$H' = L_1 + c(t_1 - t_2). \quad (6)$$

where  $L_1$  is the latent heat corresponding to the temperature  $t_1$ .

If the steam was condensed only, the heat given off would be

$$H' = L_1 \quad (7)$$

and the temperature of the mixture is the temperature corresponding to the pressure.

If the steam is only partly condensed, let  $q$  equal the per cent. of steam condensed. Then

$$H' = qL_1 \quad (8)$$

and the temperature of the mixture is the temperature corresponding to the pressure.



The general laws of thermodynamics do not apply in the case of mixtures as the equations become discontinuous. The general expression for heat absorbed in passing from a solid to a gaseous state may be stated as follows:

Let  $c_1$  be the specific heat in the solid,  $c_2$  in the liquid and  $c_3$  in the gaseous state,  $w$  the weight of the substance,  $t$  the initial temperature,  $t_1$  the temperature of the melting point,  $t_2$  the temperature of the boiling point,  $t_3$  the final temperature,  $H_f$  heat of liquefaction, and  $L$  heat of vaporization.

$$H' = w[c_1 (t_1 - t) + H_f + c_2 (t_2 - t_1) + L + c_3 (t_3 - t_2)] \quad (9)$$

TABLE VIII. SPECIFIC HEATS OF LIQUIDS AND SOLIDS

Substances	Specific heat, $c$ .
Mercury.....	.0333
Alcohol.....	.615
Turpentine.....	.462
Wrought iron.....	.114
Cast iron.....	.129
Copper.....	.095
Ice.....	.504
Spermaceti.....	.320
Sulphur.....	.177
Glass.....	.187
Graphite.....	.200

Latent heat of fusion of ice = 144 B.T.U.

**Example.**—Find the final temperature and condition of the mixture after mixing 10 lbs. of ice at 20°; 20 lbs. of water at 50°, and 2 lbs. of steam at atmospheric pressure. Mixture takes place at the pressure of the steam.

**Solution.**— **First Method**

Heat to raise ice to 32° = 10 × .5 (32 - 20)	= 60
Heat to melt ice = 10 × 144	= 1440
Total heat necessary to change the ice to water at 32°	= 1500 B.T.U.
Heat given up by water when temperature is lowered to 32° = 20 × (50 - 32)	= 360
Heat in steam above 32° (from tables)	
= 2 × 1150.4	= 2300.8
Total heat given up in lowering water and steam to 32°	= 2660.8 B.T.U.
Heat available for use = 2660.8 - 1500	= 1160.8 B.T.U.

$$\text{Degrees this heat will raise the mixture} = \frac{1160.8}{32} = 36.3.$$

$$\therefore \text{final temperature of mixture} = 36.3 + 32 = 68.3^\circ \text{ F.}$$

*Ans.* 32 lbs. water at 68.3° F.

### Second Method

Assume that the steam is all condensed and that the temperature of the mixture is  $t^\circ$ . Then the heat necessary to raise the ice to the melting point equals

$$10 \times .5 (32 - 20).$$

The heat necessary to melt the ice equals  $10 \times 144$ ; the heat necessary to raise the melted ice to the temperature of the mixture equals  $10(t - 32)$ ; the heat necessary to raise the water to the temperature of the mixture equals  $20(t - 50)$ ; the heat given up by the steam in changing to water at the temperature of the boiling point equals  $2 \times 970.4$ , and the heat given up by the condensed steam when its temperature is lowered to the temperature of the mixture equals  $2(212 - t)$ .

Combining the preceding parts into one equation, we have

$$10 \times .5 (32 - 20) + 10 \times 144 + 10(t - 32) + 20(t - 50) = 2 \times 970.4 + 2(212 - t)$$

$$60 + 1440 + 10t - 320 + 20t - 1000 = 1940.8 + 424 - 2t$$

$$32t = 2184.8$$

$$t = 68.3^\circ$$

Since  $t$  is less than the temperature of the boiling point corresponding to the pressure at which the mixture takes place, all the steam is condensed.

*Ans.* 32 lbs. water at 68.3° F.

**Example.**—Find the resulting temperature and condition after mixing 10 lbs. of ice at  $20^\circ$ , 20 lbs. of water at  $50^\circ$ , 40 lbs. of air at  $82^\circ$ , and 20 lbs. of steam at 100 lbs. pressure and containing 2 per cent. moisture. Mixture takes place at the pressure of the steam.

**Solution.**—

**First Method**

$$10 \times .5(32 - 20)$$

$$= 60$$

$$10 \times 144$$

$$= 1440$$

1500 B.T.U. = heat to raise ice to water at  $32^\circ$ .

$$\begin{aligned}
 20 \times (50 - 32) &= 360 \\
 40 \times .2375(82 - 32) &= 475 \\
 20(308.8 + .98 \times 879.8) &= 23420 \\
 &24255 \text{ B.T.U.} = \text{heat given up by air,} \\
 &\quad 1500 \quad \text{water, and steam.} \\
 &22755 \text{ B.T.U.} = \text{heat available.} \\
 40 \times .2375(337.9 - 32) &= 2905 \text{ B.T.U.} = \text{heat to raise air to } 337.9^\circ. \\
 &19850 \text{ B.T.U.} = \text{heat available to raise the} \\
 &\quad \text{water.} \\
 50 \times 308.8 &= 15440 \text{ B.T.U.} = \text{heat to raise water to} \\
 &\quad 337.9^\circ. \\
 &4410 \text{ B.T.U.} = \text{heat available to evaporate} \\
 &\quad \text{water.} \\
 \frac{4410}{879.8} &= 5.01 \text{ lbs. steam.}
 \end{aligned}$$

*Ans.* 40 lbs. air  
 44.99 lbs. water  
 5.01 lbs dry saturated steam } at 337.9°.

### Second Method

Assume the steam to be all condensed and let the temperature of the mixture be  $t^\circ$ . Equating the heat gained by the ice, water and air, and the heat lost by the steam, we have

$$10 \times .5(32 - 20) + 10 \times 144 + 10(t - 32) + 20(t - 50) + 40 \times .2375(t - 82) = 20 \times .98 \times 879.8 + 20(337.9 - t)$$

$$60 + 1440 + 10t - 320 + 20t - 1000 + 9.5t - 779 = 17250 + 6758 - 20t$$

$$\begin{aligned}
 59.5t &= 24670 \\
 t &= 413.6^\circ \text{ F.}
 \end{aligned}$$

This result is of course absurd, as the temperature of the mixture cannot be higher than the temperature of the boiling point corresponding to the pressure at which the mixture takes place. Therefore our assumption that all the steam is condensed must be wrong, and we know that part of it remains in the form of steam, and hence the temperature of the mixture is equal to the temperature of the boiling point corresponding to the pressure at which the substances are mixed.

Then substituting for  $t$  its value, and letting  $x$  represent the number of pounds of steam condensed, we have

$$\begin{aligned}
 10 \times .5(32 - 20) + 10 \times 144 + 10(337.9 - 32) + 20(337.9 - 50) \\
 + 40 \times .2375(337.9 - 82) = 879.8x
 \end{aligned}$$

$$60 + 1440 + 3059 + 5758 + 2431 = 879.8x$$

$$879.8x = 12748$$

$$x = 14.49 \text{ lbs. condensed.}$$

$$20 \times .98 = 19.6 \text{ lbs.} = \text{original weight of dry steam.}$$

*Ans.* 40 lbs. air

$$\left. \begin{aligned} 10 + 20 + (20 - 19.6) + 14.49 &= 44.89 \text{ lbs. water} \\ 19.6 - 14.49 &= 5.11 \text{ lbs. dry saturated steam} \end{aligned} \right\} \text{ at } 337.9^\circ.$$

The difference between the results obtained in these two methods of working this problem is due to the fact that in the first method we took account of the variation in the specific heat of water by using the heat of the liquid,  $h$ , from the tables, in place of  $(t - 32)$  wherever possible, while in the second method we assumed this specific heat to be constant and equal to 1.

**Example.**—Find the resulting temperature and condition after mixing 10 lbs. of ice at  $20^\circ$ , 20 lbs. of water at  $50^\circ$ , and 30 lbs. of steam at 100 lbs. pressure and  $400^\circ$  temperature. Mixture takes place at 25 lbs. pressure.

**Solution.**—

**First Method**

$$10 \times .5(32 - 20)$$

$$= 60$$

$$10 \times 144$$

$$= 1440$$

1500 B.T.U. = heat to raise ice to water at  $32^\circ$ .

$$20 \times (50 - 32)$$

$$= 360$$

$$30 \times .57(400 - 337.9) = 1062$$

$$30 \times 1188.6$$

$$35658$$

37080 B.T.U. = heat given up by water and steam.

$$\underline{1500}$$

35580 B.T.U. = heat available.

$$60 \times 235.7$$

$$= 14142 \text{ B.T.U.} = \text{heat to raise water to } 266.8^\circ.$$

21438 B.T.U. = heat available to evaporate water.

$$\underline{21438}$$

$$\frac{21438}{933.3} = 22.97 \text{ lbs. steam}$$

*Ans.* 37.03 lbs. water

22.97 lbs. dry saturated steam

} at  $266.8^\circ \text{ F.}$

### Second Method

Assume the steam to be all condensed and let the temperature of the mixture be  $t^\circ$ . Then

$$10 \times .5(32 - 20) + 10 \times 144 + 10(t - 32) + 20(t - 50) = 30 \times .57(400 - 337.9) + 30 \times 879.8 + 30(337.9 - t)$$

$$60 + 1440 + 10t - 320 + 20t - 1000 = 1062 + 26394 + 10137 - 30t$$

$$60t = 37413$$

$$t = 623.6^\circ$$

This result is, of course, impossible and we see at once that only part of the steam is condensed, and that the temperature of the mixture must be that of the boiling point corresponding to the pressure at which the mixture takes place.

This problem differs from the previous ones in that the pressure of the mixture is different from the original steam pressure, and we must proceed in a slightly different manner.

Assume for the moment that the steam has all been condensed and that we have 60 lbs. of water at 623.6° F. Then assume that the temperature of the water is dropped to the temperature of the boiling point (266.8°) corresponding to the pressure (25 lbs.) at which the mixture is made. Each pound will give up, approximately (623.6 - 266.8) B.T.U. This heat can then be used to re-evaporate part of the water. Therefore since the latent heat corresponding to 25 lbs. is 933.3, we have

$$\frac{60(623.6 - 266.8)}{933.3} = \frac{60 \times 356.8}{933.3} = \frac{21408}{933.3} = 22.94 \text{ lbs. re-evaporated.}$$

Ans. 37.06 lbs. water

22.94 lbs. dry saturated steam } at 266.8° F

### PROBLEMS

1. Required the temperature after mixing 3 lbs. of water at 100° F., 10 lbs. of alcohol at 40° F., and 20 lbs. of mercury at 60° F.
2. Required the temperature and condition after mixing 5 lbs. of ice at 10° F. with 12 lbs. of water at 60° F.
3. Required the temperature and condition after mixing 10 lbs. of ice at 15° F. with 1 lb. of steam at 212° F.
4. Required the temperature and condition of the mixture after mixing 5 lbs. of steam at 212° F. with 20 lbs. of water at 60° F.
5. One pound of ice at 32° is mixed with 10 lbs. of water at 50° and 20 lbs. of steam at 212°. What is the temperature and condition of the resulting mixture?
6. Ten pounds of steam at 212° are mixed with 50 lbs. of water at 60° and 2 lbs. of ice at 32°. What will be the resulting temperature and condition of the mixture?
7. Ten pounds of steam at atmospheric pressure, 5 lbs. of water at 50° and 10 lbs. of ice at 32° are mixed together. (a) What will be the resulting temperature of the mixture? (b) What will the condition of the mixture be? (c) If the steam is not all condensed, determine what per cent. of the steam will be condensed.

7 8. Five pounds of steam at atmospheric pressure, 10 lbs. of water at  $60^\circ$ , and 2 lbs. of ice at  $20^\circ$  are mixed at atmospheric pressure. What will be the resulting temperature?

9. Ten pounds of ice at  $10^\circ$ , 20 lbs. of water at  $60^\circ$  and 5 lbs. of steam at atmospheric pressure are mixed at atmospheric pressure. Find the resulting temperature and condition of the mixture.

7 10. Twenty pounds of steam at atmospheric pressure, 10 lbs. of water at  $60^\circ$  and 50 lbs. of air at  $100^\circ$  are mixed together at the pressure of the steam. (a) What will be the resulting temperature? (b) If the steam is not all condensed, determine what per cent. of the steam will be condensed.

11. A mixture is made of 10 lbs. of steam at atmospheric pressure, 5 lbs. of ice at  $20^\circ$ , 10 lbs. of water at  $50^\circ$ , 30 lbs. of air at  $60^\circ$ . (a) What will be the temperature of the resulting mixture? (b) What will be the percentage by weight of air, steam, and water in the mixture?

+ 12. What would be the resulting temperature and condition of a mixture of 10 lbs. of water at  $40^\circ$ , 20 lbs. of water at  $60^\circ$ , and 8 lbs. of steam at 5 lbs. pressure? Mixture takes place at 5 lbs. pressure.

13. Ten pounds of steam at 5 lbs. pressure, 1 lb. of ice at  $32^\circ$ , and 20 lbs. of water at  $60^\circ$  are mixed at 5 lbs. pressure. What will be the temperature and condition of the resulting mixture?

+ 14. Five pounds of ice at  $5^\circ$ , 10 lbs. of water at  $50^\circ$ , 20 lbs. of air at  $80^\circ$ , and 5 lbs. of steam at 20 lbs. pressure are mixed at the pressure of the steam. Find the resulting temperature and condition of the mixture.

15. Required the temperature and condition of the mixture after mixing 10 lbs. of steam at a pressure of 30 lbs. absolute and a temperature of  $250.3^\circ$  F., 2 lbs. of ice at  $10^\circ$  F., and 20 lbs. of water at  $40^\circ$  F. Mixture takes place at the pressure of the steam.

16. Fifty pounds of air at  $100^\circ$ , 10 lbs. of steam at atmospheric pressure, and 10 lbs. of water at  $60^\circ$  are mixed at atmospheric pressure. What is the temperature of the mixture and how much steam is condensed?

17. Required the final temperature and condition after mixing at the pressure of the air 100 lbs. of air at a temperature of  $500^\circ$  and a pressure of 100 lbs. absolute, and 2 lbs. of steam at 100 lbs. absolute having a quality of 98 per cent.

206) 21  
+ 18. Five pounds of steam at 5 lbs. gage pressure are mixed at atmospheric pressure with 10 lbs. of water at  $60^\circ$ . What is the temperature and condition of the resulting mixture?

19. Thirty pounds of water at  $60^\circ$ , 10 lbs. of steam at 115 lbs. absolute and a temperature of  $400^\circ$  F., and 10 lbs. of ice at  $20^\circ$  are mixed at atmospheric pressure. What will the resulting temperature be? What is the condition of the mixture?

20. Ten pounds of ice at  $20^\circ$  F., 18 lbs. of water at  $80^\circ$ , and 10 lbs. steam at 75 lbs. pressure and 90 per cent. quality, are mixed at atmospheric pressure. What is the resulting temperature and condition of the mixture?

21. Two pounds of steam at 150 lbs. absolute and a temperature of  $400^\circ$ , 5 lbs. of ice at  $22^\circ$ , and 10 lbs. of water at  $60^\circ$  are mixed at atmospheric pressure. Find the final temperature and condition of mixture.

22. Required the final temperature and condition after mixing at atmos-

spheric pressure 3 lbs. of ice at  $22^{\circ}$  and 3 lbs. of steam at 100 lbs. pressure and containing 2 per cent. moisture.

+ 23. Find the resulting temperature and condition of a mixture of 10 lbs. of steam at 150 lbs. absolute and a temperature of  $400^{\circ}$  F., 10 lbs. of water at  $60^{\circ}$  F., and 50 lbs. of air at  $112^{\circ}$  F. Mixture takes place at atmospheric pressure.

24. Five pounds of ice at  $0^{\circ}$ , 20 lbs. of water at  $75^{\circ}$ , and 15 lbs. of steam at 50 lbs. absolute and 95 per cent. quality are mixed at 20 lbs. absolute. What is the resulting temperature and condition of the mixture?

+ 25. How many pounds of water will 10 lbs. of dry steam heat from  $50^{\circ}$  to  $150^{\circ}$  if the steam pressure is 100 lbs. gage?

+ 26. If 10 lbs. of steam at 100 lbs. gage raises 93 lbs. of water from  $50^{\circ}$  to  $140^{\circ}$ , what per cent. of moisture is in the steam, radiation being zero?

+ 27. A pound of steam and water occupies 3 cu. ft. at 110 lbs. absolute pressure. What is the quality of the steam?

## CHAPTER V

### COMBUSTION AND FUELS

**41. Coal Analysis.**—The source of heat which is used to produce steam in a boiler is the fuel. The principal ingredients of all fuels are carbon and hydrogen.

For the purpose of making comparison between the product of various mines, and to determine the relative value of these fuels for different uses, coal is subjected to an *ultimate* and a *proximate* analysis, and it is tested in a coal calorimeter to ascertain its *calorific* or *heating value*.

In the *ultimate analysis* the proportions of carbon, hydrogen, oxygen, nitrogen and sulphur are determined.

In the *proximate analysis* determinations are made of the amounts of moisture, volatile matter, fixed carbon and ash. The volatile gases are hydrocarbons such as marsh or olefiant gas, pitch, tar and naphtha. All of these must be distilled from the fuel before being burned. The fixed carbon and ash are left after all the volatile gases have been driven off. The ash consists of the incombustible material which remains after the fuel has been completely burned.

It should be noted that the term "proximate" does not mean that the analysis is only "approximate," the facts being actually to the contrary.

The analyses are made of air-dried coal. Therefore, the various percentages of carbon, hydrogen, etc., in the ultimate analysis, and of fixed carbon, ash, etc., in the proximate analysis of "coal as received," "moisture free" or "dry coal," and "coal, moisture and ash free," as given, for example, in the U. S. Bureau of Mines Bulletin No. 22 on the "Analyses of Coals in the United States," "were not obtained directly but were calculated from the values obtained by the analyses of air-dried coal."



“Calculations from ‘Air Dried’ to ‘Moisture Free’ Condition ”\*

‘Air dried’ condition		‘Moisture free’ condition
Volatile matter	$\times \frac{100}{100 - \text{moisture}}$	= volatile matter
Fixed carbon	$\times \frac{100}{100 - \text{moisture}}$	= fixed carbon
Ash	$\times \frac{100}{100 - \text{moisture}}$	= ash
Sulphur	$\times \frac{100}{100 - \text{moisture}}$	= sulphur
Hydrogen (– 1/9 moisture)	$\times \frac{100}{100 - \text{moisture}}$	= hydrogen
Carbon	$\times \frac{100}{100 - \text{moisture}}$	= carbon
Nitrogen	$\times \frac{100}{100 - \text{moisture}}$	= nitrogen
Oxygen (– 8/9 moisture)	$\times \frac{100}{100 - \text{moisture}}$	= oxygen
Calorific value	$\times \frac{100}{100 - \text{moisture}}$	= calorific value

“The analyses are calculated to the ‘moisture and ash free’ basis by taking 100 – (moisture + ash) as a divisor and proceeding otherwise exactly as in the calculation to the ‘dry coal’ or ‘moisture free’ basis.

“The air-drying loss of a mine sample indicates to some degree the loss in weight after mining from the evaporation of loosely retained moisture. The analysis of the coal ‘as received’ shows the actual composition of the coal in the mine. After the coal has left the mine its moisture content lies between the limits of coal ‘as received.’ and coal ‘air dried.’

“The analysis on a ‘moisture free’ basis represents the composition of the coal after drying at 221° F. (105° C.).

“The analysis stated on a ‘moisture and ash free’ basis represents approximately the heating value and composition of the dry organic matter. This relation seems to be fairly constant for the same coal bed in certain districts, especially in the Appalachian region. Comparison of numerous analyses shows that the ‘moisture and ash free’ calorific values of different samples from the same mine and bed usually agree closely, provided the proportion and the character of the ash and the sulphur do not vary greatly.

“For the commercial valuation of coals a proximate analysis and a calorific value determination are usually sufficient. Moisture and ash are of importance; they not only displace their own weights of combustible matter, but the evaporation of the moisture wastes heat.

\* U. S. Bureau of Mines Bulletin No. 22.

A high percentage of ash increases the cost of handling coal in a power plant and decreases the efficiency of the furnace.

“The ratio of the volatile matter to the fixed carbon indicates in a way the type of furnace best adapted for burning a coal with maximum efficiency.

“The smokeless combustion of coal containing a low percentage of volatile matter is not difficult in furnaces of ordinary types, but to burn a high volatile coal without smoke requires a suitably designed furnace. A high percentage of sulphur is undesirable in coal used for the manufacture of coke and gas. For ordinary steaming purposes sulphur is not a serious drawback unless associated with elements, such as iron or lime, that promote clinkering.”

**42. Heat of Combustion.**—The term *combustion* as applied here refers to the union of oxygen with some other substance producing heat. The perfect combustion of ordinary fuel should result in carbon dioxide, nitrogen, water vapor, and a trace of sulphur dioxide.

“*The calorific power, or heating value, of a fuel is the total amount of heat developed by the complete combustion of a unit weight of fuel.*” The calorific power as determined by a calorimeter is the *higher heating value*. When a fuel is burned water vapor is formed, and this will be condensed only when the temperature falls below the boiling point. So long as this water remains in the form of vapor, the heat necessary to maintain it as such, *i.e.*, the latent heat of steam at atmospheric pressure times the weight of vapor, is unavailable for use.

The difference between the higher heating value and this latent heat is called the *lower heating value*. This is the “available calorific value” in nearly all cases. For example, in a boiler plant the temperature of the stack gases, and in a gas engine the temperature of the exhaust, are both above the temperature of the boiling point of water, and therefore the heat actually available for use in either case is the lower heating value of the fuel.

The heat given off per pound by the elements ordinarily met with in fuels, together with the air required for combustion and the combining volumes and weights, are shown in Table IX.

TABLE IX.—COMBUSTION PROPERTIES OF ELEMENTS

Combustion	Combustion formula	Combining volumes	Combining weights	Higher heating value per lb., B. T. U.	Air required per pound, pounds
H to H <sub>2</sub> O (Water)	2H <sub>2</sub> + O <sub>2</sub> = 2H <sub>2</sub> O	2 vol. H + 1 vol. O = 2 vol. H <sub>2</sub> O	$\left\{ \begin{array}{l} 2 \text{ lb. H} + 16 \text{ lb. O} = 18 \text{ lb. H}_2\text{O} \\ 1 \text{ lb. H} + 8 \text{ lb. O} = 9 \text{ lb. H}_2\text{O} \end{array} \right\}$	62,100	34.8
C to CO <sub>2</sub> (Carbon dioxide)	C <sub>2</sub> + 2 O <sub>2</sub> = 2 CO <sub>2</sub>	1 vol. C + 2 vol. O = 2 vol. CO <sub>2</sub>	$\left\{ \begin{array}{l} 12 \text{ lb. C} + 32 \text{ lb. O} = 44 \text{ lb. CO}_2 \\ 1 \text{ lb. C} + 2.66 \text{ lb. O} = 3.66 \text{ lb. CO}_2 \end{array} \right\}$	14,650	11.6
C to CO (Carbon monoxide)	C <sub>2</sub> + O <sub>2</sub> = 2CO	1 vol. C + 1 vol. O = 2 vol. CO	$\left\{ \begin{array}{l} 12 \text{ lb. C} + 16 \text{ lb. O} = 28 \text{ lb. CO} \\ 1 \text{ lb. C} + 1.33 \text{ lb. O} = 2.33 \text{ lb. CO} \end{array} \right\}$	4,430	5.8
CO to CO <sub>2</sub>	2CO + O <sub>2</sub> = 2CO <sub>2</sub>	2 vol. CO + 1 vol. O = 2 vol. CO <sub>2</sub>	$\left\{ \begin{array}{l} 28 \text{ lb. CO} + 16 \text{ lb. O} = 44 \text{ lb. CO}_2 \\ 2.33 \text{ lb. CO} + 1.33 \text{ lb. O} = 3.66 \text{ lb. CO}_2 \\ 1 \text{ lb. CO} + .57 \text{ lb. O} = 1.57 \text{ lb. CO}_2 \end{array} \right\}$	$\left( \begin{array}{l} 10,220 \\ 2,330 \\ 4,380 \end{array} \right) =$	2.5
S to SO <sub>2</sub> (Sulphur Dioxide)	S <sub>2</sub> + 2O <sub>2</sub> = 2SO <sub>2</sub>	1 vol. S + 2 vol. O = 2 vol. SO <sub>2</sub>	$\left\{ \begin{array}{l} 32 \text{ lb. S} + 32 \text{ lb. O} = 64 \text{ lb. SO}_2 \\ 1 \text{ lb. S} + 1 \text{ lb. O} = 2 \text{ lb. SO}_2 \end{array} \right\}$	4,000	4.35
CH <sub>4</sub> (Methane)	CH <sub>4</sub> + 2O <sub>2</sub> = CO <sub>2</sub> + 2H <sub>2</sub> O			23,840	17.3
C <sub>2</sub> H <sub>2</sub> (Acetylene)	2C <sub>2</sub> H <sub>2</sub> + 5O <sub>2</sub> = 4CO <sub>2</sub> + 2H <sub>2</sub> O			21,430	13.35
C <sub>2</sub> H <sub>4</sub> (Ethylene)	C <sub>2</sub> H <sub>4</sub> + 3O <sub>2</sub> = 2CO <sub>2</sub> + 2H <sub>2</sub> O			21,430	14.95

When a coal is analyzed the percentage of hydrogen shown includes not only the free hydrogen in the sample but also that which existed in combination with the oxygen in the form of water (for all the oxygen in the coal will be united with hydrogen). As 16 parts by weight of oxygen unite with 2 parts of hydrogen, the weight of hydrogen which was in combination with the oxygen will be equal to one-eighth the total weight of oxygen. The balance of the hydrogen is available for producing heat, and in determining the heat value of a fuel, the number of B.T.U. in the coal may be found from the ultimate analysis by the following formula:

Heat value of fuel in B.T.U. per pound

$$= 14,650 C + 62,100 \left( H - \frac{O}{8} \right) + 4000 S, \quad (1)$$

where the symbols  $C$ ,  $H$ ,  $O$  and  $S$  represent the weights of carbon, hydrogen, oxygen and sulphur in 1 lb. of the fuel. This is called Du Long's formula.

The heat value obtained from equation (1) is only an approximate result, and where greater accuracy is desired it is necessary actually to test the coal experimentally in a *coal calorimeter*.

**43. Coal Calorimeters.**—One form of calorimeter very commonly used for determining the heating value of solid fuels is the Mahler Bomb Calorimeter. This consists of a strong steel vessel into which a known weight (usually 1 gram) of finely powdered air-dried coal is introduced. This coal is placed in a platinum cup or dish suspended from the cover of the bomb by a wire electrode. Another wire passes through the cover, although well insulated from it, and extends down into the coal. The cover is then screwed down tight and the bomb charged with oxygen to a pressure of from 150 to 250 lbs. This allows a considerable excess of oxygen over that theoretically required for the combustion of the coal. After the bomb has been charged it is placed in a vessel containing a known weight of water and an electric current is passed through the wire electrodes, igniting the coal. While the combustion is going on, the water in the containing vessel is kept thoroughly stirred by the apparatus.

The rise in temperature of the water is carefully noted, and after making allowances for radiation, the heat generated by the electric current, etc., the heating value of the coal can be com-

puted, since the heat gained by the water must equal the heat given up by the coal (after the allowances just mentioned have been made).

Another type which has found considerable use in cases where it is not convenient to secure a supply of oxygen under pressure,

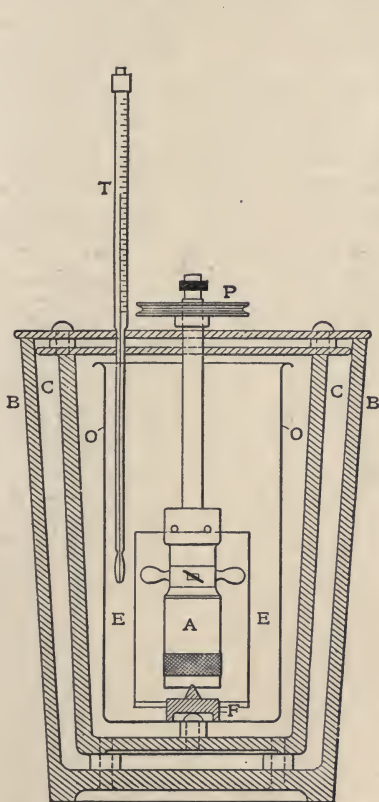

FIG. 10.—Parr coal calorimeter.

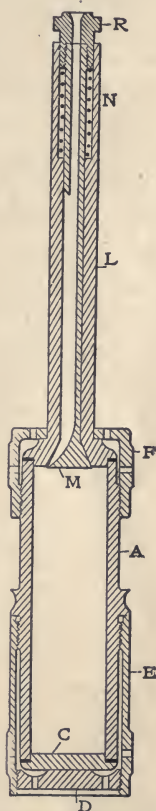

FIG. 11.—Cartridge in Parr calorimeter.

is the Parr Calorimeter shown in Fig. 10. This is simpler to use than a bomb calorimeter, but the results obtained are not as accurate. The charge consists of .004 of a pound of finely powdered coal and eighteen times as much by weight of sodium peroxide to supply the oxygen for combustion. After the charge has been placed in the cartridge, Fig. 11, and A, Fig. 10, and the cover has been tightly screwed down, it should be thoroughly

mixed by shaking. The calorimeter is then immersed in a vessel containing water and a short piece of white hot wire is dropped in the top of the long neck and a blow on the upper end opens the valve at *M*, Fig. 10, and allows the wire to drop into the charge igniting it. The water is stirred by fins attached to the sides of the cartridge which is turned on a pivot bearing at the bottom by a belt run by an electric motor. The rise in temperature of the water due to the combustion of the coal is carefully noted. After making allowances for the heat radiated, the heat given up by the combustion of the sodium peroxide and by the wire used for ignition, the heating value of the coal is found just as in the case of the bomb calorimeter.

**44. Air Required for Combustion.**—The oxygen furnished to the fuel in order to burn it is obtained from the air. Air is a mechanical mixture containing by weight 23 per cent. oxygen and 77 per cent. nitrogen, and by volume 21 per cent. oxygen and 79 per cent. nitrogen. The oxygen only is used in the combustion of the fuel, the nitrogen being an inert gas and having no chemical effect upon the combustion.

For the complete combustion of 1 lb. of hydrogen there is required 8 lbs. of oxygen, and for the complete combustion of 1 lb. of carbon to carbon dioxide there is required  $32 \div 12 = 2.66$  lbs. of oxygen. For each pound of hydrogen there will be required  $\frac{8}{.23} = 34.8$  lbs. of air, and for each pound of carbon  $\frac{2.66}{.23} = 11.6$  lbs. of air to produce combustion.

As has already been stated, the oxygen in the fuel unites with its equivalent of hydrogen to form water and in determining the weight of air theoretically required for combustion this hydrogen should be disregarded. The air required for the complete combustion of any fuel may then be found from its analysis by the following expression:

$$\begin{aligned} & \text{Weight of air per pound of fuel} \\ & = 11.6 C + 34.8 \left( H - \frac{O}{8} \right) + 4.35 S \end{aligned} \quad (2)$$

In equations (1) and (2) it has been assumed that each atom of hydrogen and carbon comes in contact with a proper proportion of oxygen. In actual practice this condition does not exist and an excess of air is furnished in order to insure com-

plete combustion. Theoretically most coals require for complete combustion approximately 12 lbs. of air. In actually burning coal under a boiler with natural draft we find that the coal requires about 24 lbs. of air per pound of coal. For forced draft there is usually required about 18 lbs. per pound of coal. If insufficient air is admitted to the fire, only a portion of the carbon will unite with the oxygen to form  $\text{CO}_2$ , the balance forming  $\text{CO}$ .

In the actual operation of a boiler plant, one of the most important considerations is the admission of a proper quantity of air to the fire. As will be seen later, the less the quantity of air given to the fire the better the efficiency of combustion, provided enough air enters so that all the carbon is burned to  $\text{CO}_2$ .

**45. Smoke.**—Smoke is unburned carbon in a finely divided state. The amount of carbon carried away by the smoke is usually small, not exceeding 1 per cent. of the total carbon in the coal. Its presence, however, often indicates improper handling of the boiler, which may result in a much larger waste of fuel. Smoke is produced in a boiler when the incandescent particles of carbon are cooled before coming into contact with sufficient oxygen to unite with them. It is necessary that the carbon be in an incandescent condition before it will unite with the oxygen. Any condition of the furnace which results in carbon being cooled below the point of incandescence before sufficient oxygen has been furnished to unite with it, will result in smoke. Smoke once formed is very difficult to ignite, and the boiler furnace must be handled so as not to produce smoke. Fuels very rich in hydrocarbons are most apt to produce smoke. When the carbon gas liberated from the coal is kept above the temperature of ignition and sufficient oxygen for its combustion added, it burns with a red, yellow, or white flame. The slower the combustion the larger the flame. When the flame is chilled by the cold heating surfaces near it taking away heat by radiation, combustion may be incomplete, and part of the gas and smoke pass off unburned. If the boiler is raised high enough above the grate so as to give room for the volatile matter to burn and not strike the tubes at once, the amount of smoke given off and of coal used will both be reduced.

**46. Analysis of Flue Gases.**—In all large power houses and carefully conducted power plants the flue gases leaving the

boilers are analyzed from time to time. In some cases records are kept, by an automatic device, of the percentage of carbon dioxide in the flue gases. In analyzing the flue gases it is customary to use some modification of the Orsat apparatus. This consists of three pipettes, a measuring tube, and a wash bottle, as shown in Fig. 12. The first pipette *D* contains a saturated solution of potassium hydrate and absorbs  $\text{CO}_2$ , the second pipette *E* contains potassium pyrogallate and absorbs  $\text{O}$ , and the third pipette *F* contains cuprous chloride and absorbs  $\text{CO}$ . The gas is passed through the pipettes in the order named, and

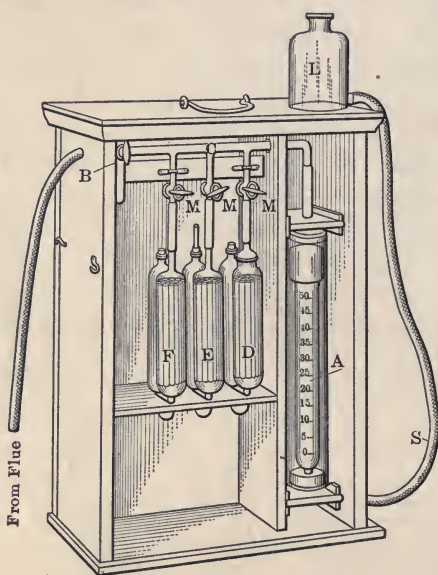

FIG. 12.—Orsat apparatus.

the remainder is assumed to be nitrogen. The readings obtained from this apparatus give the per cent. composition of the gases by volume.

The following directions will show how the reagents used in the Orsat apparatus are prepared.

*Potassium Hydrate.*—(1) For the determination of  $\text{CO}_2$ , dissolve 500 grams of the commercial hydrate in 1 liter of water.

1 c.c. of this solution will absorb 40 c.c. of  $\text{CO}_2$ .

(2) For the preparation of potassium pyrogallate for use in case the per cent. of oxygen is high, dissolve 120 grams of the commercial hydrate in 100 c.c. of water.



*Potassium Pyrogallate.*—Put 5 grams of the solid pyrogallic acid in a funnel placed in the neck of the pipette *E*, and pour over this 100 c.c. of potassium hydrate, solution (1) or (2). Solution (1) may be used in case there is not more than 25 per cent. of O in the gas. Otherwise solution (2) must be used or CO may be given up.

1 c.c of this solution absorbs 2 c.c. of O.

*Cuprous Chloride.*—Pour from  $\frac{1}{4}$  to  $\frac{1}{2}$  an inch of copper scale into a 2-liter bottle and also place in the bottle a number of long pieces of copper wire. Then fill the bottle with hydrochloric acid of 1.10 sp. gr. (1 part muriatic acid to 1 part water). Let the bottle stand, shaking it occasionally until the solution becomes colorless. Then pour the liquid into the pipette *F*, which is filled with copper wires.

1 c.c of this solution will absorb from 1 to 2 c.c of CO.

**Example.**—A stack gas shows the following analysis: CO<sub>2</sub>, 12 per cent.; CO, 1 per cent.; O, 7 per cent.; N, 80 per cent. Find the air used in burning a pound of coal, if the coal contains C, 80 per cent.; H, 4 per cent.; O, 2 per cent.

**Solution.**—

	Vol. in 100		Density	Weight
	cu. ft.			
Carbonic acid, CO <sub>2</sub> .....	12	×	.12341	= 1.481
Carbonic oxide, CO .....	1	×	.07806	= .078
Oxygen, O .....	7	×	.08928	= .625

One pound of carbon dioxide contains  $\frac{8}{11}$  of a pound of oxygen, and 1 lb. of carbonic oxide contains  $\frac{4}{7}$  of a pound. The weight of the oxygen in 100 cu. ft. of the flue gases would therefore be:

In carbonic acid .....	$\frac{8}{11}$	×	1.481	= 1.077
In carbonic oxide .....	$\frac{4}{7}$	×	.078	= .045
Free oxygen .....				= <u>.625</u>
Total weight of oxygen				= 1.747 pounds

and the weight of the carbon would be:

In carbonic acid .....	$\frac{3}{11}$	×	1.481	= .404
In carbonic oxide .....	$\frac{3}{7}$	×	.078	= <u>.033</u>
Total weight of carbon				.437 pounds

Air contains 23 per cent. of oxygen by weight; hence the pounds of air required to burn .437 lbs. of carbon would be

$$1.747 \div .23 = 7.6,$$

and the pounds of air to burn 1 lb. of carbon under the conditions of the flue gases would be

$$7.6 \div .437 = 17.4$$

The pounds of air used to burn a pound of coal of the given analysis would be

$$\begin{aligned} & 17.4 \text{ C} + 34.8 \left( H - \frac{O}{8} \right) \\ &= 17.4 \times .80 + 34.8 \left( 0.4 - \frac{.02}{8} \right) = 13.92 + 1.31 \\ &= 15.23 \text{ lbs.} \end{aligned}$$

It should be noted here that in this solution the weight of air *theoretically* required to burn the hydrogen has been added to the weight *actually* required to burn the carbon as shown by the stack gas analysis. While this is, of course, not exactly correct, it is approximately so, and the error is slight, as the amount of air used to burn the hydrogen is small as compared with the total amount required.

The above results are such as might be expected in a boiler plant using induced draft.

**47. Theoretical Temperature of Combustion.**—If the total and specific heats of the materials of a given coal are known, the temperature that might result from their combustion may be approximately calculated.

The calculated temperatures are often very much higher than can be obtained in practice, this being probably due to the fact that the specific heat of the products of combustion is very much larger at the high temperatures, and also to the fact that carbon and oxygen will no longer unite above a given temperature, probably about 3500° Fahrenheit.

**Example.**—Assume the following composition of coal: Carbon, 75 per cent.; hydrogen, 5 per cent.; oxygen, 3 per cent.; nitrogen, 2 per cent.; the ash and sulphur may be disregarded. Find the theoretical and actual rise in temperature of the products of combustion.

**Solution.**—A coal of the above composition has a heat value of 13,860 B.T.U. The theoretical amount of air required to burn 1 lb. of it is 10.62 lbs. 10.62 lbs. of air contain  $10.62 \times .77 = 8.18$  lbs. nitrogen, to which must be added the .02 lbs. of nitrogen in the coal, giving us a total of 8.2 lbs. nitrogen.

$$\left. \begin{aligned} \text{Total CO}_2 \text{ formed} &= .75 \times 3.66 = 2.745 \text{ lbs.} \\ \text{Total H}_2\text{O formed} &= .05 \times 9 = .45 \text{ lbs.} \end{aligned} \right\} \begin{array}{l} \text{(See} \\ \text{Table IX)} \end{array}$$

The thermal units required to raise the products of combustion through 1° would be

	Sp. ht.	B.T.U.
Carbonic acid.....	$2.75 \times .217 =$	.596
Water vapor.....	$.45 \times .460 =$	.207
Nitrogen.....	$8.2 \times .244 =$	2.000
		<hr style="width: 100px; margin-left: auto; margin-right: 0;"/>
Total.....		2.803

The theoretical rise in temperature of the products of combustion would be

$$13,860 \div 2.8 = 4950^\circ$$

In the actual operation of a boiler it is found necessary to add 50 to 100 per cent. more air than is required for combustion. This additional air, as the following calculation shows, materially reduces the theoretical temperature of combustion. Assuming 100 per cent. more to be required, there would then be added 10.62 additional pounds of air. The heat to raise this 1 degree would be

	$10.62 \times .2375 =$	2.522
Add for undiluted products.....		2.803
		<hr style="width: 100px; margin-left: auto; margin-right: 0;"/>
Total B.T.U. per degree.....		5.325

The theoretical rise in temperature would be, then,

$$13,860 \div 5.325 = 2600^\circ$$

This is more nearly the temperature obtained in a boiler plant with hand firing.

If the temperature of the boiler room is given, the final temperature of the products of combustion may be found by adding to this temperature the rise in temperature as found above, the assumption being made that the temperature of the coal is the same as that of the boiler room.

In boilers operated by automatic stokers, temperatures in the fire of over 3000° F. have been observed. Such temperatures are usually obtained when the boilers are being crowded to their full capacity and their operation is being given careful attention, especially with reference to the amount of air admitted to the furnace.

**48. Fuels.**—Fuels may be divided into three general classes, solid, liquid, and gaseous.

The larger proportion of the fuels used are in solid form. The principal solid fuels are wood, peat, lignite, and coal. Coal may be divided into three principal kinds, anthracite, semi-bituminous and bituminous coal.

The liquid fuels are usually some of the mineral oils, generally unrefined petroleum. In some gas plants liquid tar is used.

The most commonly used gaseous fuel is natural gas, but there are a good many plants using gas which is a waste product from a manufacturing operation. In the steel mills the "down comer" gases from the blast furnaces are often used as a fuel for the steam boilers. Coke-oven gases are similarly used. In some cases the coal is distilled in a gas producer, and this producer gas used as a fuel.

**49. Woods.**—Woods may be divided into two general classes, soft and hard. The commonest hard woods are oak, hickory, maple, beech, and walnut. The commonest soft woods are pine, elm, birch, poplar, and willow. When first cut, wood contains about 50 per cent. of moisture, but after being dried this is reduced from 10 to 20 per cent. The following table gives the chemical composition and heat value of some of the more common woods. (From Pople's *Calorific Value of Fuels*.)

TABLE X.—CALORIFIC VALUE OF WOODS

Name	C	H	O	N	Ash	B.T.U. per lb. combustible
Ash.....	49.2	6.3	43.9	.07	.57	8480
Beech.....	49.0	6.1	44.2	.09	.57	8590
Birch.....	48.9	6.0	44.7	.10	.29	8590
Elm.....	48.9	6.2	44.3	.06	.50	8510
Oak.....	50.2	6.0	43.4	.09	.37	8320
Pine.....	50.3	6.2	43.1	.04	.37	9150

In boiler tests a pound of wood is usually assumed as equal to .4 of a pound of coal.

**50. Peat.**—Peat is an intermediate between wood and coal. It is formed from the immense quantity of rushes, sedges, and mosses that grow in the swampy regions of the temperate zone. These in the presence of heat and moisture are subject to a chemical change which leaves behind the hydrocarbons, fixed carbon, and 70 to 80 per cent. of moisture. It is usually cut in blocks and air dried. Good air-dried peat contains about 60 per cent. of carbon, 6 per cent. of hydrogen, 31 per cent. of oxygen and nitrogen, and 3 per cent. of ash. The following table gives the heat value of some of the different peats:

TABLE XI. CALORIFIC VALUE OF PEATS

Location	Fixed carbon	Volatile matter	Ash	B.T.U. per lb. combustible
Northern Michigan.....	.....	.....	4.4	11,000
Southern Michigan.....	33.3	61.2	5.5	8,900
Southern Michigan.....	29.0	68.5	2.3	9,500
New York.....	29.2	65.6	8.25	10,200
Wisconsin.....	27.6	60.5	11.8	8,250

**51. Lignite Coal.**—Lignite is coal of very recent formation, and its analysis is similar to peat. It usually resembles wood in appearance, and is of brownish color. It is uneven of fracture and of a dull luster. It is found quite generally west of the Mississippi River. The composition is given in the following table:

TABLE XII. CALORIFIC VALUE OF LIGNITES

Location	Fixed carbon	Volatile matter	Ash	B.T.U. per lb. combustible
California.....	.....	.....	.....	9,063
Colorado.....	46	32.7	2.74	11,360

**52. Bituminous Coal.**—Coals that contain over 20 per cent. volatile matter are usually classed as bituminous coals. Bituminous coals are divided into coking, non-coking, and cannel coals.

“Coking coal” is a term used in reference to coals that fuse together on being heated and become pasty. These coals are used in gas manufacture, and are very rich in hydrocarbons. Non-coking coals are free burning and the lumps do not fuse together on being heated. “Jackson Hill” is an example of this kind of coal. Cannel coal is very rich in carbon, ignites readily, and burns with a bright flame. It is very homogeneous, breaks without any definite line of fracture, and has a dull, resinous luster. It is very valuable as a gas coal so that it is little used for steaming purposes.

The principal bituminous coals used are mined in Ohio, West Virginia, Pennsylvania, and Illinois. The following table gives the properties of the commonest varieties of the bituminous coals used for steaming purposes:

TABLE XIII. CALORIFIC VALUE OF BITUMINOUS COALS

Location	Fixed carbon	Volatile matter	Ash	B.T.U. per lb. combustible	Water
<i>Illinois:</i>					
Big Muddy.....	53.7	30.1	9.2	13,610	.....
Streator.....	44.0	39.2	12.3	13,690	4.5
Wilmington.....	44.9	36.8	13.3	14,050	13.3
<i>Michigan:</i>					
Saginaw.....			6.1	13,470	.....
<i>Ohio:</i>					
Brier Hill.....	59.1	36.4	4.5	14,200	.....
Hocking Valley.....	49.1	36.1	8.5	13,980	6.4
Jackson.....	54.6	34.3	7.0	13,955	4.1
<i>Pennsylvania:</i>					
Pittsburg No. 8.....	54.6	35.5	9.9	14,200	.....
Turtle Creek.....	56.6	34.4	8.0	15,080	1.0
Youghiogheny.....	54.7	32.6	12.7	15,000	.....
<i>West Virginia:</i>					
Clover Hill.....	56.8	31.7	10.1	14,265	.....
Thacker.....	56.2	35.5	6.8	15,240	.....

**53. Semi-Bituminous.**—This is a softer coal than anthracite, but in appearance it looks like the latter. It is lighter than anthracite and burns more rapidly, and is a valuable coal where it is necessary to keep a very intense heat. Its composition is given in the following table:

TABLE XIV. CALORIFIC VALUE OF SEMI-BITUMINOUS COALS

Location	Fixed carbon	Volatile matter	Ash	B.T.U. per lb. combustible
Blassburg, Pa.....	73.0	15.0	11.0	13,500
Cumberland, Md.....	80.8	13.0	5.0	16,320
Pocahontas, W. Va.....	74.5	18.1	6.6	15,740

A semi-bituminous coal should not contain, usually, more than 20 per cent. volatile matter as compared with the fixed carbon.

**54. Anthracite.**—This coal ignites very slowly and burns at a high temperature. Its principal component is fixed carbon. Consequently it gives off almost no smoke and the flame is very short. Owing to its smokeless burning, it is almost all consumed for domestic purposes. Nearly all anthracite used in this country comes from Pennsylvania. An anthracite coal should contain not

less than 92 per cent. of fixed carbon as compared with the volatile matter. The following is a table of the composition of various anthracite coals:

TABLE XV. CALORIFIC VALUE OF ANTHRACITE COALS

Location	Fixed carbon	Volatile matter	Ash	B.T.U. per lb. combustible
Lackawanna.....	84.0	5.0	11.0	13,900
Lykens Valley.....	81.0	5.0	14.0	13,650
Seranton.....	84.4	6.5	9.0	13,800

**55. Efficiency of Fuels.**—The commercial value of a fuel is determined by the number of pounds of water it will evaporate into steam per hour from and at  $212^{\circ}$ . This, however, involves the efficiency of the boiler, so that to compare fuels in actual use, they should be burned in the same boiler. In practice the value of a fuel in any given plant is affected by the form and character of the furnace, the amount of air supplied, and the intensity of the draft. There are, in fact, so many variables entering into the problem that it is difficult to make an accurate comparison of the value of the different coals.

It is easy to burn either anthracite or semi-bituminous coal in almost any boiler. For bituminous coals containing less than 40 per cent. volatile matter, plain grate bars with a fire-brick arch over the fire give very good results. With coals containing over 40 per cent. volatile matter, it is desirable to use some form of furnace arranged so that the gases are mixed with warm air, and with these a large combustion chamber should be provided.

The commercial results obtained from a given coal are usually determined by the cost to evaporate 1000 lbs. of water into steam from and at  $212^{\circ}$ . This cost varies from 10 cents to 18 cents. Where the principal cost of the coal is in the freight rate, it is usually more economical to burn a good grade of coal than a cheap grade.

### PROBLEMS

1. An anthracite has the following composition: C, 90 per cent.; H, 2 per cent.; O, 2 per cent. Find the heating value of the coal.
2. A semi-bituminous coal has the following composition: C, 80 per cent.; H, 5 per cent.; O, 3 per cent. Find the heat units in the coal.

3. A Pennsylvania bituminous coal contains: C, 75 per cent.; H, 5 per cent.; O, 12 per cent. Find the heat value of the coal and the air required to burn 1 lb.

4. An Illinois bituminous coal has the following composition: C, 62 per cent.; H, 5 per cent.; O, 15 per cent. Find the heat units in the coal and the air required to burn 1 lb.

5. A coking coal has the following composition: C, 85 per cent.; H, 5 per cent.; O, 4 per cent. Find the heat value of the coal and the air required to burn 1 lb.

6. A coal contains C, 80 per cent.; H, 2 per cent.; O, 6 per cent. What is its heat value and how many pounds of air will be required to burn 1 lb. of it?

7. A coal contains C, 70 per cent.; H, 5 per cent.; O, 8 per cent. What is its heat value and how much air will be required to burn 1 lb. of it?

8. A coal has the following composition: C, 80 per cent.; H, 3 per cent.; O, 4 per cent. How much heat will be lost if one-half of the carbon is burned to CO and the balance to CO<sub>2</sub>, and what is the weight of air required to burn 1 lb. of the coal under these conditions?

9. A coal contains C, 90 per cent.; H, 1 per cent.; O, 2 per cent. If three-quarters of the carbon is burnt to CO<sub>2</sub> and the balance to CO, what will be the B.T.U. given off per pound, and what will be the air required to burn 1 lb. under the above conditions?

10. A flue-gas shows the following composition: CO<sub>2</sub>, 8 per cent.; CO, 0 per cent.; O, 14 per cent.; N, 78 per cent. Find the pounds of air used per pound of coal if the coal contains C, 80 per cent.; H, 5 per cent.; O, 3 per cent.; and N, 1 per cent.

11. A flue gas shows the following composition: CO<sub>2</sub>, 8.1 per cent.; CO, 0 per cent.; O, 10.1 per cent.; N, 75.8 per cent. Find the pounds of air used per pound of coal, if the coal contains C, 75 per cent.; H, 5 per cent.; O, 8 per cent.

12. A flue gas shows the following composition: CO<sub>2</sub>, 5 per cent.; CO, 0 per cent.; O, 15 per cent.; N, 80 per cent. Find the pounds of air used per pound of coal if the coal contains C, 75 per cent.; H, 5 per cent.; O, 8 per cent.

13. A flue gas shows the following composition: CO<sub>2</sub>, 4.1 per cent.; CO, 0 per cent.; O, 16 per cent.; N, 79.9 per cent. Find the pounds of air used per pound of coal if the coal contains C, 75 per cent.; H, 5 per cent.; O, 8 per cent.

14. A flue gas shows the following composition: CO<sub>2</sub>, 4.3 per cent.; CO, 0 per cent.; O, 12.7 per cent.; N, 83 per cent. Find the pounds of air required per pound of coal if the coal contains C, 75 per cent.; H, 5 per cent.; O, 8 per cent.

15. A flue gas shows the following composition: CO<sub>2</sub>, 8.3 per cent.; O, 10.8 per cent.; N, 80.9 per cent. How much air is burned per pound of coal if the coal contains C, 75 per cent.; H, 6 per cent.; O, 4 per cent.?

16. A coal contains C, 80 per cent.; H, 5 per cent.; O, 3 per cent.; N, 1 per cent. Find the theoretical temperature of combustion if 30 per cent. more air is used in the combustion than is necessary. Temperature of boiler room, 70°.



17. A coal has C, 80 per cent.; H, 5 per cent.; O, 3 per cent.; and N, 1 per cent. Find the theoretical temperature of combustion if 50 per cent. more air is used than is necessary for the combustion. Temperature of boiler room, 80°.

18. A coal gives the following analysis: C, 75 per cent.; H, 6 per cent.; O, 4 per cent.; and N, 2 per cent. Seventy-five per cent. excess of air is used in burning it. What is the ideal rise in temperature of the gases?

## CHAPTER VI

### BOILERS

**56. Boilers** may be divided, from the path taken by the fire, into *fire-tube or tubular* boilers and *water-tube or tubulous* boilers. In the fire-tube boiler the hot gases from the fire pass *through* the tubes, while in the water-tube boiler these gases pass *around* the tubes.

Boilers are also divided into two classes depending on the position of the fire; these are known as *externally fired* and *internally fired* boilers.

In the externally fired boiler, the fire is entirely external to the boiler and is usually confined in a brick chamber. These boilers are largely used for stationary plants.

The internally fired boiler is most commonly used for locomotive and marine boilers. The fire is entirely enclosed in the steel shell of the boiler and no brick setting is necessary. These boilers are more expensive per horse-power than the ordinary forms of stationary boilers.

The various forms of boilers under proper operating conditions give essentially the same economical results.

**57. Return Tubular Boilers.**—Fig. 13 shows the plan and elevation of the setting of a fire-tube boiler of the return type. The coal burns upon the grates, which rest upon the front of the boiler setting and upon the bridge wall. The flames pass under and along the boiler shell, then turn in the back combustion chamber *D* and pass through the tubes of the boiler, then out through the smoke nozzle *N* and through the breeching to the chimney. The smoke nozzle is shown at the front of the boiler setting.

There are usually two man-holes in the boiler, one in front under the tubes and one in the top of the boiler. These openings are reënforced with flanged steel reënforcements. The shells are made of boiler steel having a tensile strength of 55,000 to 66,000 lbs. The shell of the boiler is rolled to form and riveted together. The heads of the boiler which form the tube sheet

and into which the tubes are fastened are made of flanged steel of about 55,000 lbs. tensile strength. The tubes are made of steel, usually lap welded. Charcoal iron tubes are the best, but are difficult to get, so that most manufacturers use a hot-rolled, lap-welded steel tube.

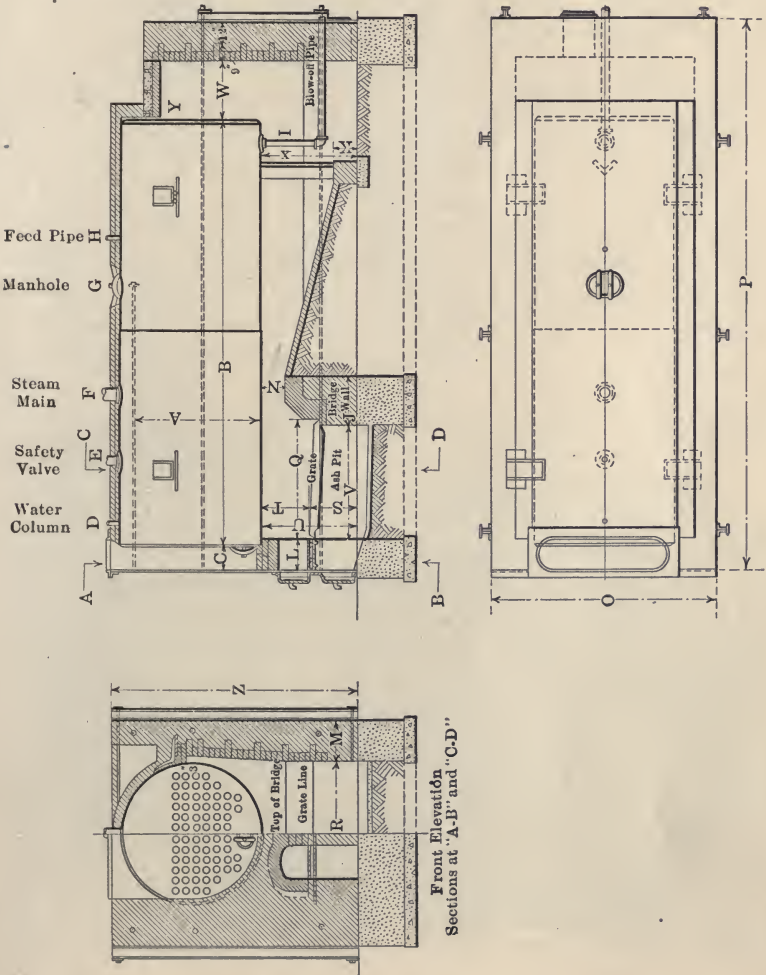

Fig. 13.—Return tubular boiler.

These boilers are set in brick settings, and in all brick-set boilers great care should be taken in building the setting. Air leaks in the brick work should be carefully avoided as they cause serious loss in economy. All brick should be set with full flush

mortar joints so as to make the setting strong and avoid leakage. Fig. 13 shows the return flue boiler with the boiler resting upon the brick work.

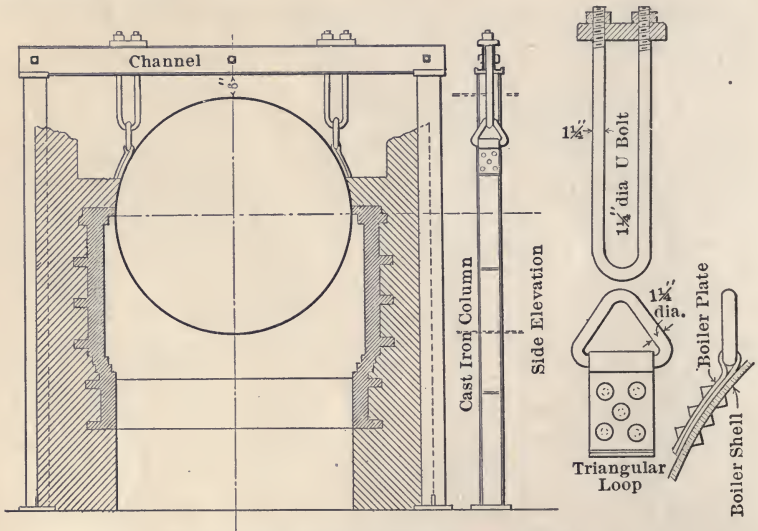

FIG. 14.—Steel frame boiler support.

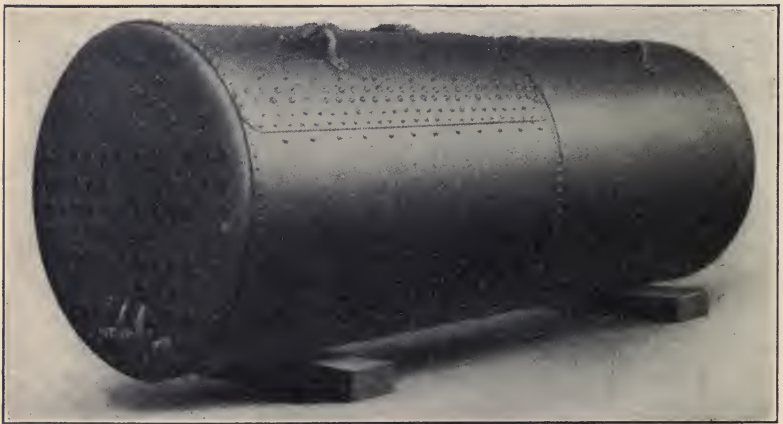

FIG. 15.—Return tubular boiler with loops for suspension setting.

Boilers of this type are often supported by a steel framework as shown in Figs. 14 and 15. This method is preferable as it leaves the boiler independent of the setting. The brick setting of

a boiler has very little strength and this arrangement leaves the boiler setting free from all strain due to the weight of the boiler.

In earlier boiler construction it was customary to place a steam dome on all boilers. The object of doing this was to

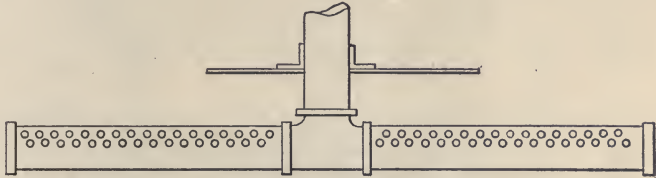

FIG. 16.—Dry pipe.

provide dry steam. Most engineers have discarded the use of steam domes on high-pressure boilers as they weaken the boiler shell and add to the expense of the boiler construction. To avoid getting wet steam from the boiler a *dry-pipe* is provided as shown in Fig. 16.

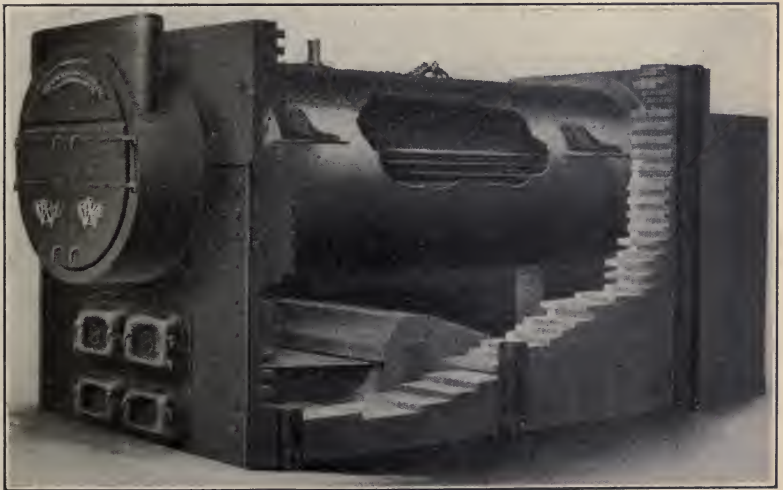

FIG. 17.—Brick setting for fire-tube boiler with overhanging shell.

Fig. 17 shows a return flue boiler and solid brick setting. Some engineers prefer a setting having a 2-in. air space in the center of the wall. The brick walls enclosing a fire-tube boiler are made very heavy so as to give good heat insulation, preventing an excessive loss of heat from the boiler, and also to prevent the

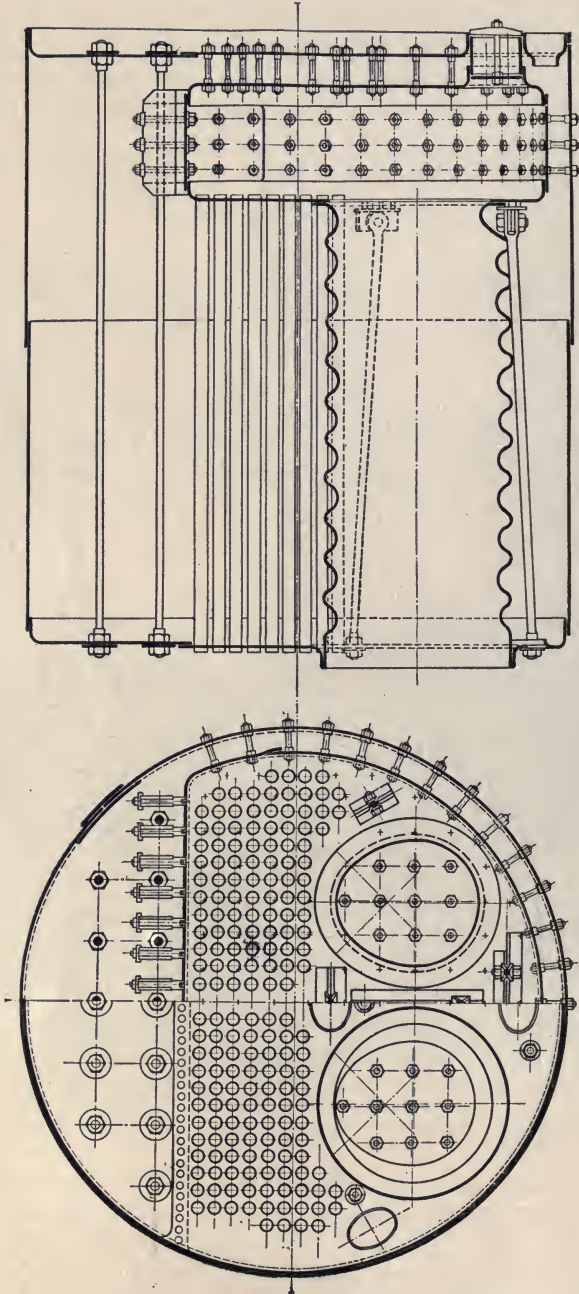

Fig. 18.—Cross-section of Scotch marine boiler with steel combustion chamber.

filtration of air through the setting and the consequent cooling of the hot gases passing away from the fire.

**58. Internally Fired Boilers.**—Another large class of return tubular boilers are the internally fired boilers. These boilers have been extensively used for marine purposes. Fig. 18 shows an internally fired Scotch marine boiler. The cut shows two internal furnaces. In the larger sizes these boilers are often

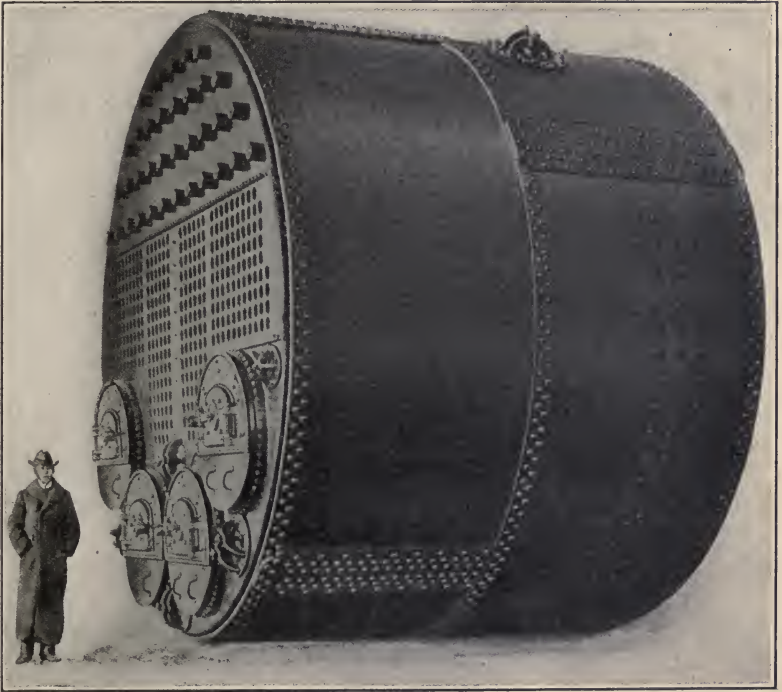

FIG. 19.—Scotch marine boiler.

made with three or even four furnaces (see Fig. 19). These can be built in large sizes, and are very compact, making them particularly suitable for marine work.

Fig. 20 shows one of these boilers built for stationary purposes. The steel back combustion chamber used in marine work, shown in Fig. 18, is replaced by brick construction in Fig. 20. In very large boilers of this type, furnaces are provided at each end, opening into a common combustion chamber in the middle of the boiler.

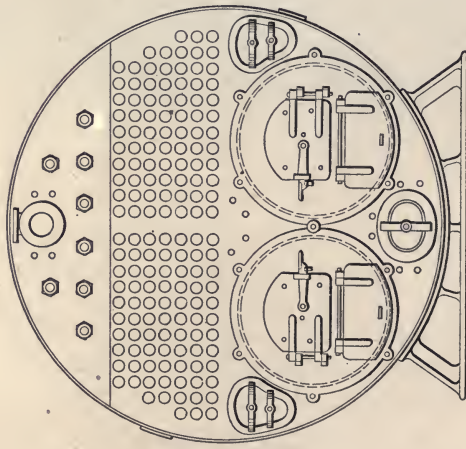
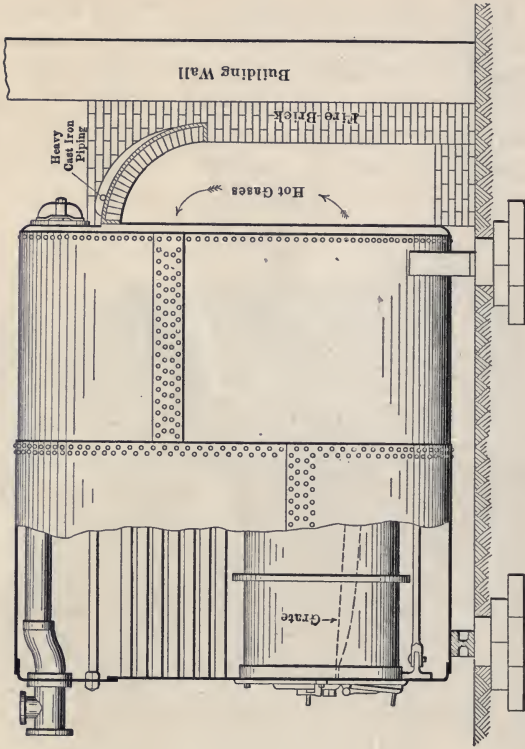

FIG. 20.—Scotch marine boiler with brick combustion chamber.  
*PRY BACK BOILER*



**59. Locomotive Type of Boiler.**—A special type of fire-tube boiler is used on locomotives. In this boiler the combustion space, including the grates, and the sides of the ash pit are surrounded by a water space. The gases pass directly from the fire through the tubes and up the stack. As in the internally fired boiler, the hot gases do not come in contact with the shell of the boiler. This permits of the use of higher pressures in these boilers, often as high as 225 lbs. Modifications of this type of boiler are used for threshing and other types of portable boilers. They are sometimes used for stationary purposes, particularly

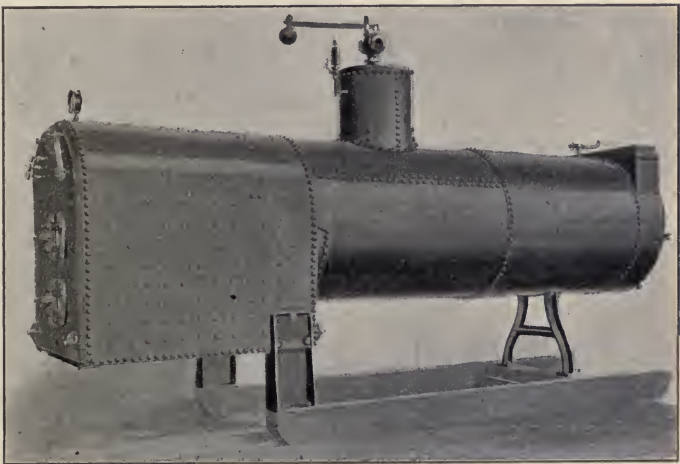

FIG. 21.—Locomotive type of boiler.

for heating where a compact form of boiler is desirable. Fig. 21 shows the side elevation of a boiler of this class designed for stationary use.

**60. Use of Tubular Boilers.**—The fire-tube boiler, as shown in Fig. 13, has certain limitations in use. Its construction is such that hot gases pass outside the shell, with cold water on the inside of the shell. This produces a large difference of temperature on the two sides of the shell, and a strain is produced in the metal of the shell, owing to this difference of temperature. The thicker the shell the greater is the difference in temperature between the two sides of the shell. In practice it is found that the thickness of the shell should not exceed  $\frac{1}{2}$  in. This limitation in the thickness of the shell limits the diameter of the boiler and the pressure that the boiler can carry. It is customary to use this

class of boilers for pressures not to exceed 125 lbs. per square inch and in sizes not larger than 125 boiler horse-power.

A majority of the more recent plants are being operated at over 125 lbs. pressure and therefore a fire-tube boiler cannot be used. In addition the horse-power of each boiler unit is so small that a very large number of boiler units would be necessary. In a power plant of say 50,000 horse-power, such as exists in the larger cities, if this type of boiler were used, there would be required 400 boilers and the space required for this number of units would make it almost impossible to install such a plant.

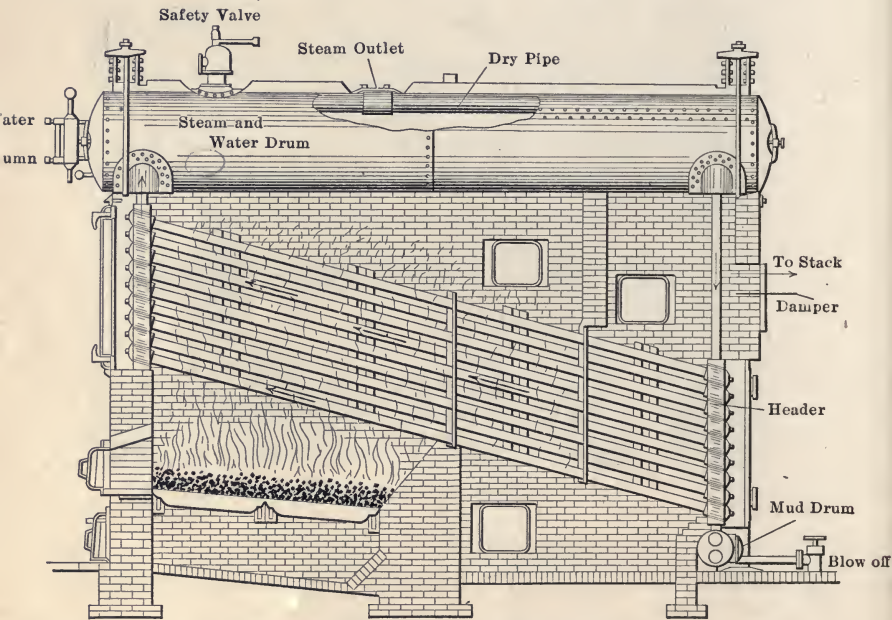

FIG. 22.—Babcock and Wilcox boiler.

The internally fired boiler is not as limited in the pressure that it can carry as is the return fire-tube type, since the fire does not come in contact with the boiler shell and the shell can be made thicker. The increased thickness of shell permits the building of larger boilers of this type than of the return fire tube, and they have been built in units of 500 horse-power carrying 200 lbs. pressure. They have not been much used for stationary purposes owing to their first cost and the cost of repairs where conditions are not favorable to their use.

**61. Water-tube Boilers.**—The demand for increased pressure and for larger sized boiler units has led to the introduction of water-tube boilers, and all the larger power stations to-day are using water-tube boilers almost exclusively. The principal reasons for using the water-tube boilers in large power stations are: adaptability to high pressure, reduced space taken by the boiler, and greater safety in operation. There are a great many different makes of water-tube boilers on the market of various types, both vertical and horizontal.

Fig. 22 shows a Babcock and Wilcox boiler in longitudinal cross-section. Gases from the fire pass up through the tubes, being deflected vertically by a baffle wall located between the tubes and directly above the bridge wall. They then pass down around the tubes to the space back of the bridge wall, being deflected by another baffle, then up between the tubes and out through the smoke opening which is in the rear of the boiler setting and above the tubes.

As it is heated, the water in the tubes tends to rise toward their upper, or front end, then rises through the front header and connection into the steam and water drum, where the steam separates from the water, and the latter flows back in the drum and down through the rear header. The feed water enters the boiler through a pipe passing through the front end of the drum and extending back about one third its length.

Fig. 52 shows a Babcock and Wilcox boiler with a superheater attached.

Fig. 23 shows the front and side views of a header in a Babcock and Wilcox boiler and indicates clearly the way the tubes are "staggered."

This class of boiler gives very satisfactory service for high-pressure work, having large disengaging surfaces for the steam to leave the water, and ample steam space.

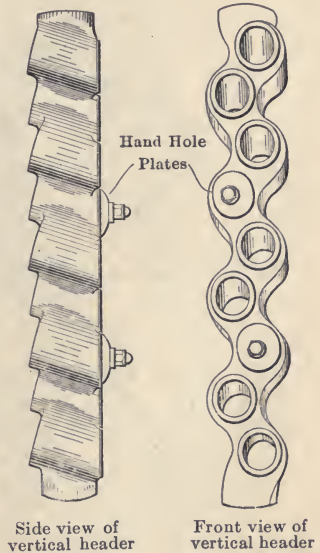

FIG. 23.—Tube header in Babcock and Wilcox boiler.

Fig. 24 shows a sectional side elevation of a Stirling boiler.

"This consists of three transverse steam and water drums set parallel and connected to one mud drum by water tubes so curved that their ends enter the tube sheets at right angles to the surface. This curvature of the tubes gives ample and efficient provision for expansion and contraction. The front and middle steam drums are connected by curved equalizing tubes

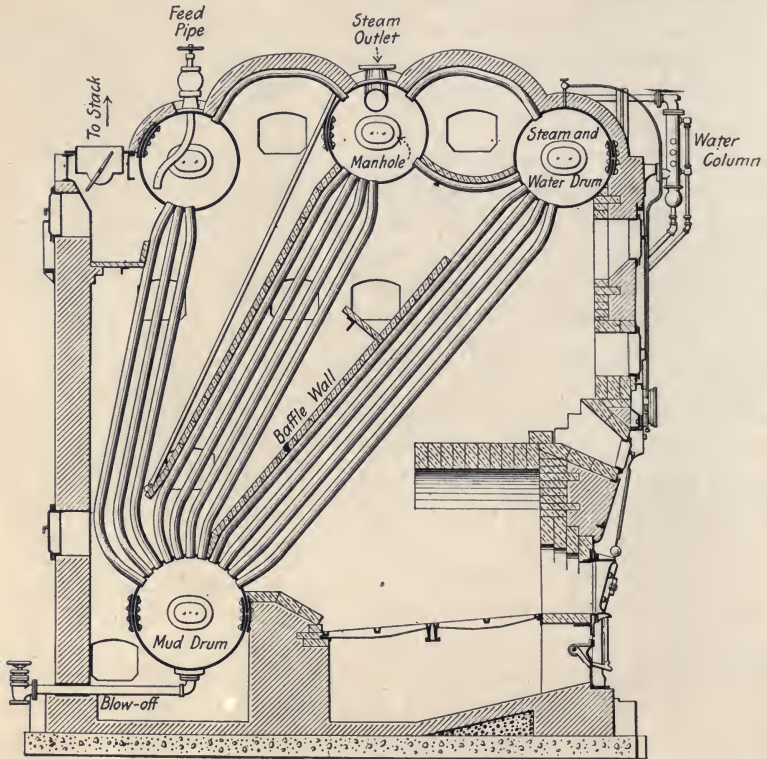

FIG. 24.—Stirling boiler.

above the water line and curved circulating tubes below the water line, while the rear and middle drums are connected by curved equalizing tubes above the water line only.

The steam generated in the three banks of tubes passes into the middle drum, which is set higher than the other two to give additional steam space, thence it passes through the main steam outlet, which may be located anywhere along the top of the drum.

The safety valves are located on the top of the middle steam drum. The feed pipe connection passes through the top of the rear drum into a trough by which the water is distributed along the whole length of the drum. The blow-off connection is attached to the bottom of the mud drum at the center and passes out through a sleeve in the rear wall, just outside of which the blow-off valve is located. The water column, located at one side of the front of the boiler, is connected to one head of the center steam and water drum. The feed water enters the upper rear drum and passes downward through the rear bank of tubes to the lower drum, thence upward through the front bank to the forward steam and water drum. The steam formed during the passage upward through the front bank of tubes becomes separated from the water in the front drum, and passes through the upper row of cross tubes into the middle drum, from which point it enters the steam main. The water from the front drum passes through the lower cross tubes into the middle drum, and thence downward through the middle bank of tubes to the lower drum, from which it is again drawn up the front bank to retrace its former course. The steam generated in the rear bank of tubes passes through the cross tubes to the center drum. In its passage down the rear bank of tubes the feed water is heated so that much of the scale-forming matter is precipitated and gathers in the rear bank of tubes and in the mud drum, where it is protected from high temperatures and can be washed and blown out as frequently as the case demands."

The hot gases circulate in the reverse direction. On leaving the fire they are deflected by baffle walls so as to pass up between the tubes to the first drum, then down around the tubes from the second drum, and again up between the tubes to the rear drum. The burned gases leave the boiler at the rear near the upper end of the last bank of tubes. This boiler represents the ideal circulation as far as the paths of the water and gases are concerned; that is, the coldest gases come in contact with the coldest water in the boiler, and the hottest gases come in contact with the hottest water. The drums with their connecting tubes are supported by a steel frame built into the brick work of the boiler. The brick setting only serves to enclose the gases and is under no strain due to the weight of the boiler.

There is a man-hole in one end of each of the four drums and by the removal of the man-hole plates the drums may be entered.

Fig. 25 shows a cross-section of a Heine water-tube boiler. In this boiler the gases of combustion pass over the bridge wall into the combustion chamber, where they are completely burned. They then pass upward back of the lower baffle wall (which consists of a row of tiling) and then forward around the tubes, and parallel to them, to the front of the boiler, where they turn up in front of the forward end of the upper baffle wall and then

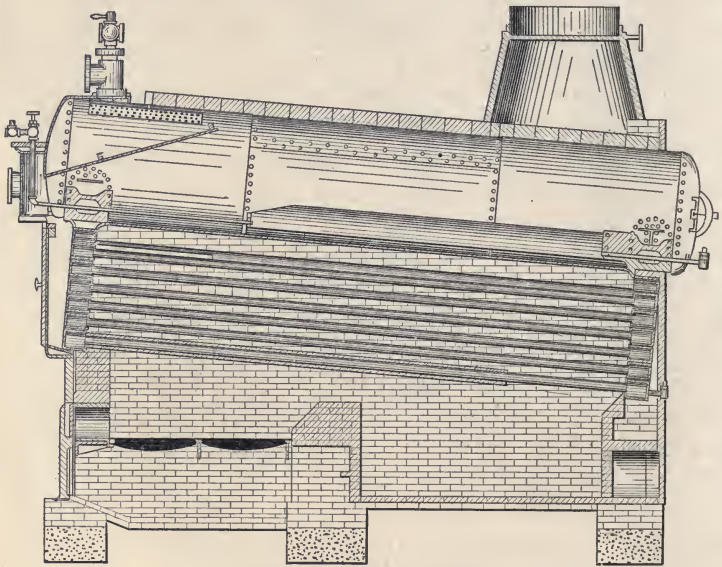

FIG. 25.—Heine boiler.

pass back around the shell to the opening to the breeching. The feed water enters the boiler through the front head, passing into the mud drum where the dirt and sediment are deposited, then flows back along the bottom of the drum and then forward along the top and out of the drum at the front end. From here the circulation is toward the back of the boiler, down the rear water-leg, forward through the tubes, and up the front water-leg into the boiler again. The steam, which is formed very largely in the tubes, is carried along with the water and discharged into the boiler from the front water-leg.

Fig. 26 shows a side elevation of the water-legs, shell and tubes in the Heine boiler.

Where a plant is very limited in the floor space available, it is often desirable to use a vertical water-tube boiler. Fig. 27 shows a cross-section of the Wickes vertical boiler. The grates are located in a "Dutch Oven" front built out from the main boiler setting. The gases pass up around the tubes in the forward half of the boiler and down around them in the rear half, leaving the boiler in the rear near the lower drum. The water inside the tubes flows in the same direction as the gases, in both the front and rear compartments. These boilers are quick steamers and occupy relatively small floor space.

Fig. 28 shows a vertical boiler of the Rust type. The furnace and combustion chamber project from the front of the boiler as a "Dutch Oven" front.

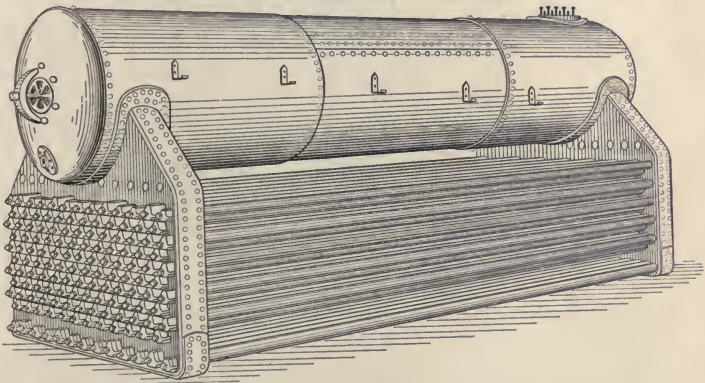

FIG. 26.—Heine boiler showing water-legs, shell and tubes.

"The products of combustion travel up the first pass, down the second pass and out to the stack.

"The water, which is fed into the center of the rear water-and-mud drum, passes across through the circulating tubes to the front water-and-mud drum, up the vertical tubes in the front pass to the front steam-and-water drum where the steam generated in the front pass is separated from the water. The water then passes over through the circulating tubes to the rear steam-and-water drum and down the rear bank of tubes to the starting place.

"The steam liberated in the front steam-and-water drum passes through the steam tubes into the steam space of the rear steam-and-water drum, the entrained moisture dropping into the

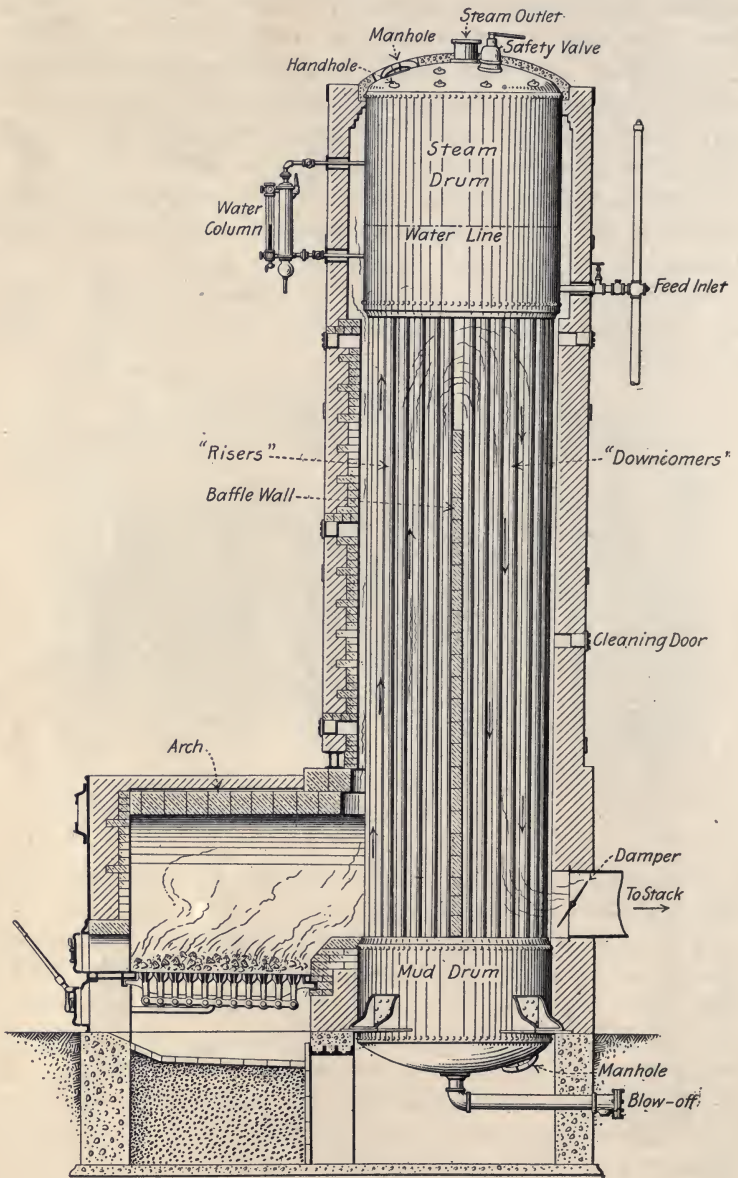

FIG. 27.—Wickes boiler.



water space, while the steam passes along the top of the drum through the dry pipe to the steam outlet."

**62. Horse-power Rating of Boilers.**—The term "horse-power," as applied to boilers, has no definite value and is only used as a matter of convenience. The ability of a boiler to

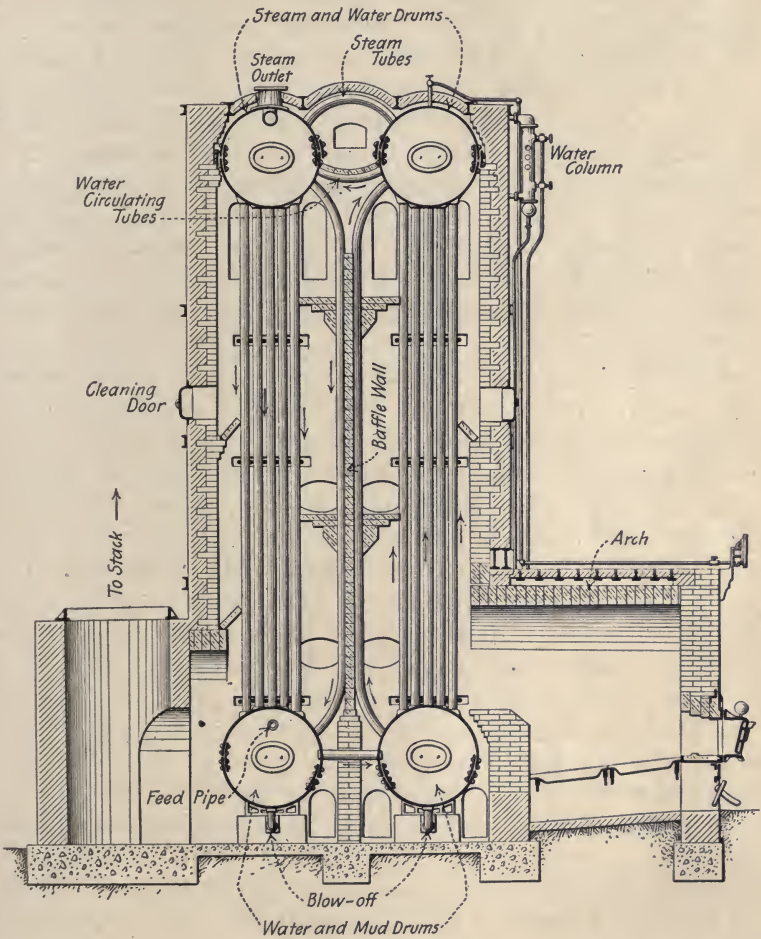

FIG. 28.—Rust boiler.

make steam depends on the amount of heating surface in it. Experience has determined that for the best results in the ordinary form of boiler, a square foot of heating surface should not evaporate more than 3 lbs. of water per hour (if economy

is highly desired). In writing specifications for boilers, it is customary to state the number of square feet of heating surface the boiler is to contain and the pounds of water it is to evaporate per hour under the given conditions, rather than the boiler horse-power. In order to give the term "boiler horse-power" a definite meaning, the American Society of Mechanical Engineers has adopted the following rating for boilers: A "boiler horse-power" is 34.5 lbs. of water evaporated per hour from and at 212° into dry and saturated steam. Most boilers will produce from 25 to 50 per cent. more steam than their rating, depending upon the amount of heat generated in the furnace and the amount of heat that is given to the water in the boiler. The amount of heat given off by the fuel will depend upon the kind of fuel used, the area of the grate, the amount of draft, and the skill of the fireman. A very rapid rate of combustion usually results in a large escape of heat to the stack and reduced economy.

*There is no relation between a boiler horse-power and an engine horse-power.* The number of boiler horse-power required to supply steam for a given engine horse-power will be determined by the number of pounds of steam the engine requires to develop a horse-power. The steam required per horse-power hour varies through a wide range in the different types of engines.

**63. Heating Surface, Grate Surface, and Breeching.**—*The water heating surface in a boiler is that part of the boiler which has water on one side and hot gases on the other. Superheating surface has steam on one side and hot gases on the other.* In both cases the side in contact with the hot gases is the one to be measured. The proportion of grate surface to heating surface depends upon the kind of fuel and the intensity of the draft. In small boilers such as are used for heating purposes, with light draft and hard coal it is usual to allow 1 sq. ft. of grate to from 20 to 30 sq. ft. of heating surface. In large power boilers the ratio of grate surface to heating surface varies from 1 to 50, to from 1 to 70. In locomotive boilers with forced draft the ratio is from 1 to 50, to 1 to 100.

The rate of combustion varies with the kind of coal and with the draft. With anthracite coal and moderate draft, not exceeding five-tenths of an inch of water, it is from 12 to 15 lbs. per square foot of grate surface per hour, and with bituminous coal from 15 to 20 lbs. The air opening in the grate depends

upon the kind of coal and usually does not exceed 50 per cent. of the grate area. Anthracite and the better grades of bituminous coal require less air opening than the poorer grades of coal.

The following rule is used for determining the heating surface of a horizontal return flue fire-tube boiler: *the heating surface is equal to two-thirds the cylindrical surface of the shell, plus the internal area of all the tubes, plus two-thirds the area of both tube sheets, minus twice the combined external cross-sectional area of all the tubes, all expressed in square feet.*

In water-tube boilers it is customary to allow 10 sq. ft. of heating surface per boiler horse-power, and in fire-tube boilers 12 sq. ft.

The connection for carrying the hot gases from the boiler to the chimney is called the *breeching*. The area of the breeching is from  $\frac{1}{6}$  to  $\frac{1}{8}$  of the area of the grates, depending on the strength of the draft. The breeching is usually made of sheet steel well braced, and should be provided with a door for cleaning and inspection.

TABLE XVI. DIAMETER OF BOILER TUBES

Outside		Inside	
Inches	Feet	Inches	Feet
2	.167	1.80	.150
2½	.208	2.28	.190
3	.250	2.78	.232
3½	.292	3.26	.272
4	.333	3.74	.312
4½	.375	4.24	.353
5	.417	4.72	.393

**64. Boiler Economy.**—The economy of a boiler is usually expressed as the number of pounds of water fed to the boiler per pound of coal fired.

The water evaporated by a boiler is equal to the weight of water fed to the boiler (corrected for leakage), provided that the steam formed is dry and saturated. If the steam is wet, it is necessary to make a correction in order to determine how much dry and saturated steam might have been formed. When the percentage of moisture is less than 2 per cent. this correction may be made by simply subtracting the moisture from the total weight of water fed. If the percentage is more than 2 per cent.

or if great accuracy is desired, the weight of water fed must be multiplied by a "factor of correction" which is equal to

$$q + (1 - q) \left\{ \frac{h - (t - 32)}{H - (t - 32)} \right\}$$

where  $q$  is the quality of the steam,  $h$  is the heat of the liquid and  $H$  the total heat of the steam at the given pressure, and  $t$  the temperature of the feedwater.

In order to compare boilers working under different conditions of feed temperature and steam pressure and with different coals, it is better to reduce them all to the same conditions, and the economy may be expressed as the number of pounds of equivalent evaporation from and at 212° per pound of combustible burned. By "equivalent evaporation from and at 212°" is meant the number of pounds of water that would be evaporated from a feed temperature of 212° into dry and saturated steam at 212° by the expenditure of the same amount of heat as is actually used in evaporating the water under the given conditions. The "factor of evaporation" is that factor by which the water evaporated, corrected for moisture in the steam, must be multiplied in order to get the equivalent evaporation. It is equal to the heat necessary to make 1 lb. of dry and saturated steam under the given conditions divided by the heat necessary to make 1 lb. from and at 212°.

With a good boiler and high-grade bituminous coal, a boiler will evaporate from 9 to 12 lbs. of water per pound of coal. The average performance under usual working conditions is from 8 to 10 lbs. of water per pound of coal. The economy of boiler operation depends not only upon the construction of the boiler, but also upon the skill of the fireman. This is particularly true with hand firing, and a careful record of the fireman should be kept, in order to prevent a waste of coal due to improper handling of the fires.

**65. Efficiency of Steam Boilers.**—The efficiency of boiler, furnace and grate is the ratio of the heat absorbed per pound of dry coal fired, to the heating value of a pound of dry coal.

The efficiency of boiler and furnace is the ratio of the heat absorbed per pound of combustible burned to the heating value of a pound of combustible.

The "heat absorbed" per pound of dry coal or combustible is found by multiplying the equivalent evaporation from and at 212° F. per pound of dry coal, or combustible, by 970.4.

The "dry coal fired" is found by deducting the moisture in the coal from the total weight of coal supplied to the grates.

The "combustible burned" is determined by deducting from the weight of coal fired, the weight of moisture in the coal plus the weight of ash and refuse taken from the ash pit plus "the weight of dust and soot, if any, withdrawn from the tubes, flues and combustion chamber, including ash carried away in the gases, if any, determined from the analysis of coal and ash."

The "heating value of a pound of combustible" is equal to the heating value of a pound of dry coal divided by 1 minus the percentage of ash in the dry coal as shown by analysis.

Actual tests of various boilers show that the efficiency under ordinary working conditions varies from 60 to 80 per cent. Seventy per cent. might be considered as a good average efficiency.

**66. Losses in Boiler.**—The principal losses in a boiler are the heat that is carried away by the flue gases, the loss due to hydrogen in the coal, the loss through the grates, and the loss by radiation. Of these, the largest is the heat carried up the chimney by the stack gases. The following table shows the relative proportions of these losses in a well-operated boiler plant, and is termed the *heat balance*. The total heat in 1 lb. of combustible in the coal was 15,070 B.T.U.

TABLE XVII. HEAT BALANCE IN BOILER PLANT

Distribution of heat of dry coal	B.T.U.	Per cent.
1. Heat absorbed by the boiler.....	10,982	77.82
2. Loss due to evaporation of moisture in the coal..	27	.19
3. Loss due to heat carried away by steam formed by the burning of hydrogen in the coal	628	4.45
4. Loss due to heat carried away in dry chimney gases.	1,635	11.57
5. Loss due to carbon monoxide.....	96	.68
6. Loss due to combustible in ash and refuse.....	319	2.26
7. Loss due to heating moisture in the air.....	40	.28
8. Loss due to unconsumed hydrogen and hydrocarbons, to radiation, and unaccounted for.	388	2.75
Total.....	14,115	100.0

The heat carried away by the chimney gases depends upon the amount of air admitted to the fire and upon the temperature at which the gases leave the boiler. In a properly operated plant, the gross loss of heat up the chimney should not exceed

20 per cent. It is often much more than this owing to the fact that the fireman admits too much air to the coal; more than is necessary for its complete combustion. This excess of air is heated from the temperature of the boiler room to the temperature of the stack gases, and all the heat used for this purpose passes up the chimney and is wasted. It is, therefore, very important that the amount of air admitted to the fire should not be more than is absolutely necessary. This is determined by the amount of carbon dioxide in the stack gas analysis which has been previously described. In a well-operated plant, the  $\text{CO}_2$  as shown by the analysis varies from 9 to 10 per cent., and under exceptional conditions an analysis showing 16.8 per cent. of  $\text{CO}_2$  has been obtained. It is usually undesirable to have more than 12 to 13 per cent. of  $\text{CO}_2$  in the stack gases. Larger percentages generally indicate the presence of CO.

**Example.**—A 48 in.  $\times$  12 ft. return flue fire-tube boiler has thirty 4-in. tubes. It evaporates 1400 lbs. of water per hour from a feed temperature of  $120^\circ$  into steam at 100 lbs. What per cent. of its rating is the boiler developing?

**Solution.**—First find heating surface from the rule in paragraph 63. H.S. of cylindrical portion of shell

$$= \frac{\pi}{4} \times 3.1416 \times 4 \times 12 = 100.6 \text{ sq. ft.}$$

$$\text{H.S. of tubes} = 30 \times 3.1416 \times \frac{3.74}{12} \times 12 = 352.5 \text{ sq. ft.}$$

$$\begin{aligned} \text{H.S. of tube sheets} &= 2\left[\frac{\pi}{4}(3.1416 \times 2 \times 2)\right] - \left(30 \times 3.1416 \times \frac{1}{8} \times \frac{1}{8}\right) \\ &= 2(8.38 - 2.62) = 11.5 \text{ sq. ft.} \end{aligned}$$

$$\text{Total heating surface} = 464.5 \text{ sq. ft.}$$

$$\text{From paragraph 63, the rated horse-power} = \frac{464.5}{12} = 38.7$$

Now find actual horse-power developed.

The heat actually used in evaporating a pound of water is equal to the total heat in a pound of steam at the given pressure minus the heat already in the feed water.

The heat used in evaporating water under actual conditions

$$= 1400 [1188.6 - (120 - 32)] = 1,541,000 \text{ B.T.U.}$$

From paragraph 64, the equivalent evaporation from and at  $212^\circ$

$$= \frac{1,541,000}{970.4} = 1588 \text{ lbs. per hour,}$$

and from paragraph 62, the boiler horse-power

$$= \frac{1588}{34.5} = 46.$$

$$\frac{46.}{38.7} = 1.19 = 119 \text{ per cent.}$$

*Ans.* Boiler is developing 19 per cent. overload.

**Example.**—A boiler evaporates 8.23 lbs. of water per pound of coal fired. Feed temperature, 120°; steam pressure, 100 lbs. Coal as fired contains 2 per cent. moisture. Dry coal contains 5 per cent. ash and has a heating value of 12,800 B.T.U. per pound. Twelve per cent. of coal fired is taken from ash pit in form of ash and refuse. (a) Find the efficiency of the boiler, furnace and grates combined. (b) Find the efficiency of the boiler and furnace.

**Solution.**—(a) Heat necessary to evaporate 1 lb. of water

$$= 1188.6 - (120 - 32) = 1100.6 \text{ B.T.U.}$$

Water evaporated per pound of dry coal fired

$$= \frac{8.23}{1.00 - .02} = \frac{8.23}{.98} = 8.4 \text{ lbs.}$$

Heat utilized per pound of dry coal fired

$$= 8.4 \times 1100.6 = 9245 \text{ B.T.U.}$$

120  
32  
—  
88

Efficiency of boiler, furnace and grates combined

$$= \frac{\text{Heat utilized per pound of dry coal fired}}{\text{Heating value of 1 lb. of dry coal}}$$

$$= \frac{9245}{12800} = .7223 = 72.23 \text{ per cent.}$$

(b) Heating value of 1 lb. of combustible

$$= \frac{12800}{1.00 - .05} = \frac{12800}{.95} = 13,474 \text{ B.T.U.}$$

Water evaporated per pound of combustible burned

$$= \frac{8.23}{1.00 - (.02 + .12)} = \frac{8.23}{.86} = 9.57 \text{ lbs.}$$

Heat utilized per pound of combustible burned

$$= 9.57 \times 1100.6 = 10,533 \text{ B.T.U.}$$

Efficiency of boiler and furnace

$$= \frac{\text{Heat utilized per pound of combustible burned}}{\text{Heating value of 1 lb. of combustible}}$$

$$= \frac{10533}{13474} = .7817 = 78.17 \text{ per cent.}^*$$

$$\text{Ans. } \begin{cases} (a) & 72.23 \text{ per cent.} \\ (b) & 78.17 \text{ per cent.} \end{cases}$$

**Example.**—If 26 lbs. of air are used to burn a pound of coal containing 13,500 B.T.U., and the temperature of the stack gases is  $550^\circ$ , what per cent. of heat is lost up the stack, if the temperature of the boiler room is  $70^\circ$ ?

**Solution.**—If there were no ash in the coal, each pound burned would give off a pound of gas and the total weight of stack gas per pound of coal fired would be  $26 + 1 = 27$  lbs. This, however, is never the case as there is always some ash and unburned coal, and hence the actual weight of stack gas per pound of coal is something a little less than 27 lbs. The average of the specific heats of the various components of the stack gases is a little higher than that of air, .2375. To be absolutely correct, then, it would be necessary to multiply the weight of each of the various gases in the stack gas by its particular specific heat, and then add these products together to get the B.T.U. necessary to raise the products of combustion one degree. This, however, is never done, the method used being to assume the specific heat of the stack gases to be the same as that of air, .2375, although really it is slightly higher, and to assume that 1 lb. of gas is given off from 1 lb. of coal, although in reality it is a little less. Thus one assumption practically offsets the other, and the result is approximately correct.

Hence, the heat necessary to raise the products of combustion one degree

$$= .2375(26 + 1) = 6.41 \text{ B.T.U.}$$

Rise in temperature of the stack gases

$$= 550 - 70 = 480^\circ.$$

\* This answer may be checked as follows:

Efficiency of grate alone

$$= \frac{\text{Combustible burned per pound of coal fired}}{\text{Combustible fired per pound of coal fired}}$$

$$= \frac{1.00 - (.02 + .12)}{1.00 - \{ .02 + .05(1.00 - .02) \}} = \frac{.86}{.931} = .9237 = 92.37 \text{ per cent.}$$

Efficiency of boiler and furnace

$$= \frac{\text{Efficiency of boiler, furnace and grate}}{\text{Efficiency of grate alone}}$$

$$= \frac{.7223}{.9237} = .7819 = 78.19 \text{ per cent.}$$



$$\begin{aligned} \text{Heat necessary to raise the stack gases } 480^\circ \\ = 480 \times 6.41 = 3080 \text{ B.T.U.} \end{aligned}$$

Per cent. of heat lost up the stack

$$= \frac{3080}{13500} = .2281 = 22.81 \text{ per cent.}$$

**67. Boiler Accessories.**—In order to determine the physical condition of the steam and water in a boiler, all boilers are provided with a *steam gage* showing the pressure per square inch in the boiler, a *gage glass* to indicate the water level in the boiler, and a *safety valve* which automatically relieves the pressure in the boiler should it exceed the safety point. The *feed-water pump*, or other feeding device, supplies the boiler

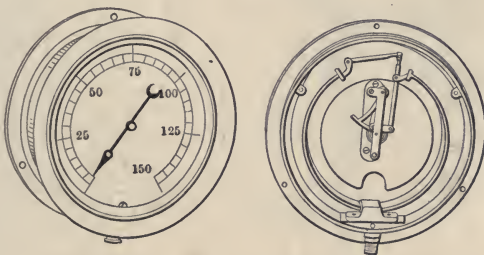

Elevation.

Interior mechanism

FIG. 29.—Pressure gage.

with water to take the place of water which has been made into steam. The *blow-off cock* is attached to the lowest point of the boiler and drains the water from the boiler. This is usually opened from time to time to blow the mud and settlings out of the boiler.

The ordinary form of pressure gage is shown in Fig. 29. Pressure gages should be placed at a convenient point for easy observation, and the piping should be as short as possible. *The gage should always be provided with a siphon containing water so that the hot steam cannot enter the gage.* If hot steam enters the gage it changes the length of the copper gage-tube, which changes the calibration of the instrument. It should also have a gage cock and union so that it may be easily removed. The operating portion of the gage consists of a flattened copper tube bent in a circle and closed at the end. One end is fixed, or, as shown in Fig. 29, there are two such tubes. When fluid pressure is

applied to the inside of the tube, its cross-section tends to assume a circular form and the tube tends to straighten. The greater the pressure the more the straightening of the tube. By proper mechanism this change of form due to pressure is registered on a dial, which when properly calibrated shows the pressure in the boiler.

Fig. 30 shows the elevation and cross-section of a *water column* with its gage glass. The section shows the float so arranged that it will blow a whistle when the water in the boiler is too high or too low. This is called a "high and low water alarm."

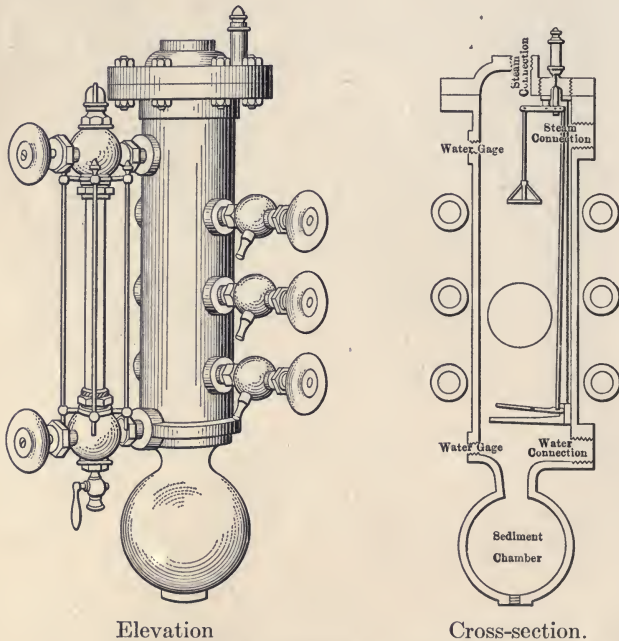

FIG. 30.—Water column.

The water gage and water column to which it is attached are important accessories in boiler operation. The length of the water gage on the boiler should be such as to cover the ordinary fluctuations of water in the boiler. It should always be attached to a water column. On this water column are placed tri-cocks, or gage cocks, used as a check upon the water column, as the water column is sometimes clogged with dirt. The lowest point in the gage glass should be set about 3 in. above

the highest point of the tubes in tubular boilers. The position of the gage glass in water-tube boilers is usually determined by the manufacturers. The top of the water column should be attached to the steam space so that it will get dry steam, and the bottom of the water column to the water space at a point in the boiler. There should be blow-off valves on both the water column and the water gage. The water columns and gage cocks should be blown off frequently. Fig. 30 shows the ordinary arrangement of water column, water gage, and tri-cocks.

Safety valves are constructed in a great many different forms, but in general they consist of a valve opening outward and held in place by a spring, and in the old forms by an arm and weight. Fig. 31 shows the construction of the ordinary safety valve. The size of the safety valve is usually determined by the grate surface and the steam pressure carried. The following rule may be used:

Let  $G$  = the grate surface in square feet;

$P$  = the pressure in pounds per square inch gage;

$A$  = the total area of safety valve, or valves, in square inches.

Then,

$$A = \frac{22.5 G}{P + 8.62}$$

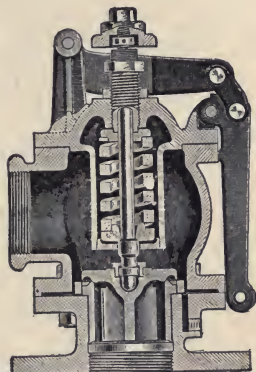

FIG. 31.—Safety valve.

Some authorities allow in spring-loaded safety valves 1 sq. in. of safety valve for every 3 sq. ft. of grate surface. Formerly the lever safety valve was the type most used, but it was easily tampered with. At the present time the pop safety valve is almost universally used. Safety valves are adjusted so as to blow at one pressure, and seat at a pressure usually 2 lbs. less than that at which they open. The safety valve on the boiler should be tried once a day at least, to see if it is in working condition.

In an article presented to the A.S.M.E., the following expressions have been developed for determining the size of safety valves to be used on boilers:

For 45° valve seats

$$D = .0095 \frac{E}{L \times P};$$

For locomotives

$$D = .055 \frac{H}{L \times P};$$

For fire-tube and water-tube stationary boilers

$$D = .068 \frac{H}{L \times P};$$

For marine boilers

$$D = .095 \frac{H}{L \times P}.$$

$E$  = Pounds of steam discharged, or boiler-evaporation, per hour.

$L$  = Vertical lift of the valve in inches.

$P$  = Steam pressure (absolute) in pounds per square inch.

$D$  = Nominal diameter of valve (inlet) in inches.

$H$  = Total boiler heating surface in square feet.

The average lift for a safety valve is about .1 of an inch. More exact results may be obtained by reference to a paper on this subject by P. G. Darling in the A.S.M.E. Proceedings for 1909.

The feed pipe to the boiler is always provided with a valve and check valve. In case of accident to the feed valve the check valve will close and prevent the water from leaving the boiler.

It sometimes happens that a boiler shell may become overheated and a boiler explosion results from this accident. Such accidents are avoided by having screwed into the boiler a plug consisting of a brass bushing filled with a metal, which melts before any damage can be done to the boiler. These plugs are called *fusible plugs* and are often used.

## CHAPTER VII

### BOILER AUXILIARIES

**68. Mechanical Stokers.**—In firing a boiler the best results are obtained by firing the coal in small quantities, or by progressive burning of the coal. With hand firing these results are difficult to accomplish. Most firemen prefer to shovel the

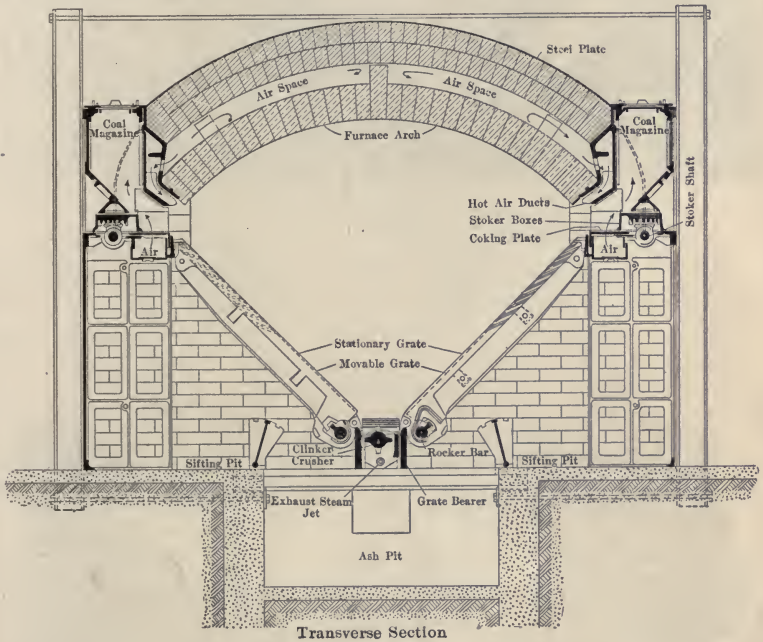

FIG. 32.—Murphy stoker—cross-section.

coal into the furnace in relatively large amounts and then rest. It is difficult to get them to give the proper attention to the handling of their fires. With mechanical stokers it is possible to introduce small quantities of coal frequently, or so arrange the stoker that there may be progressive burning of the coal.

The first stoker was introduced into England by Brunton in 1822, and at nearly the same time by Stanley. These were

both of the sprinkling type. The first chain grate was brought out by John Juckes. The first American stoker was invented

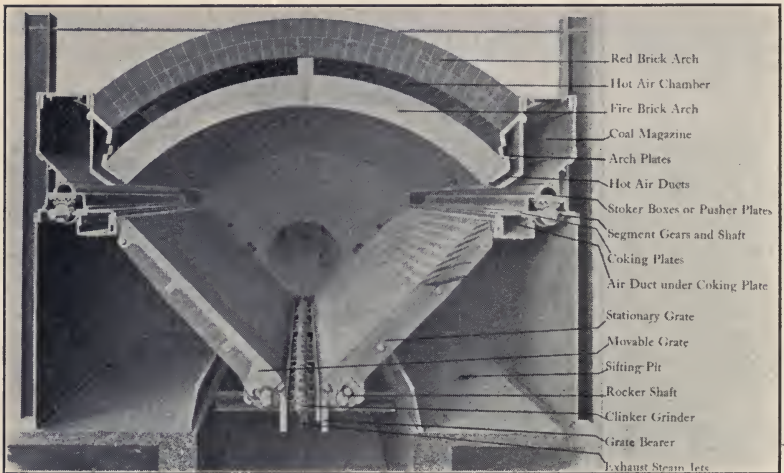

FIG. 33.—Murphy stoker—view from rear of furnace.

by Thomas Murphy of Detroit, Mich. in 1878, and it was probably the first to have a sloping grate.

Stokers may be divided into three principal classes: the inclined grate, the chain grate, and the under-feed.

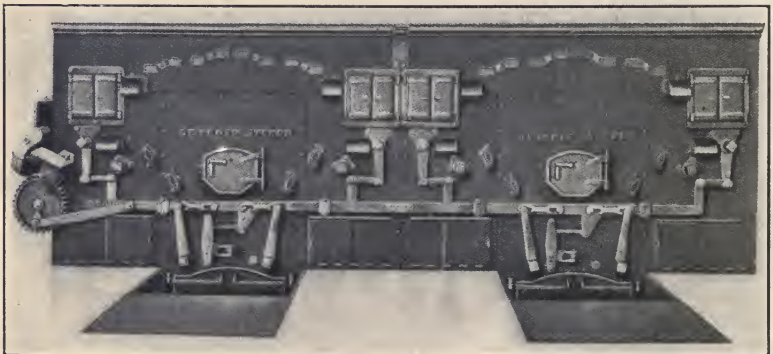

FIG. 34.—Elevation of Detroit stoker.

**69. Inclined Grates.**—The Murphy stoker, shown in Figs. 32 and 33, is an example of the inclined grate known as the side overfeed or opposed type.

“At either side of the furnace, extending from front to rear, is a coal magazine into which the coal may be introduced either mechanically from conveyors, or by hand. At the bottom of this magazine is the coking plate, against which the inclined grates rest at their upper ends. The stoker boxes, operated by segment gear shaft and racks, push the coal out over the coking plate and on to the grates.

The grates are made in pairs—one fixed, the other movable. The movable grates, pinioned at their upper ends, are moved by a rocker bar at their lower ends, alternately above and below the surface of the stationary grates. The stationary grates rest upon the grate bearer, which also contains the clinker or ash grinder. This grate bearer is cast hollow and receives the

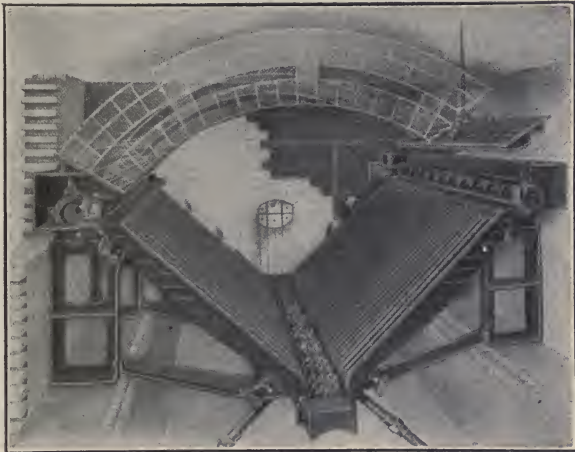

FIG. 35.—Detroit stoker—view from rear of furnace.

exhaust steam from the stoker engine. This steam escapes through small openings at regular intervals on either side of the clinker grinder and lower ends of the grates, to soften the clinker and so assist the cleaning process.”

Figs. 34 and 35 show the elevation and rear view of a Detroit stoker. This is very similar to the Murphy. In small plants a worm conveyor type of feed is used (see Fig. 35). These conveyors revolve through the hoppers and feed the coal in through the magazines. This is a convenient arrangement where the coal is shoveled into the hoppers from the floor by hand.

Both the Murphy and Detroit stokers are adaptable to all

grades of bituminous coal, but are not suited to the use of lignite or anthracite.

The Dutch oven, or extension settings, are generally regarded as the most effective both as to efficiency and as to the elimination of smoke.

Still another form of inclined grate stoker is the Roney, shown in Fig. 36, in which the coal is fed into a hopper in front of the boiler, and is pushed upon an inclined grate from the front. The feeding mechanism is shown in Fig. 37. To the

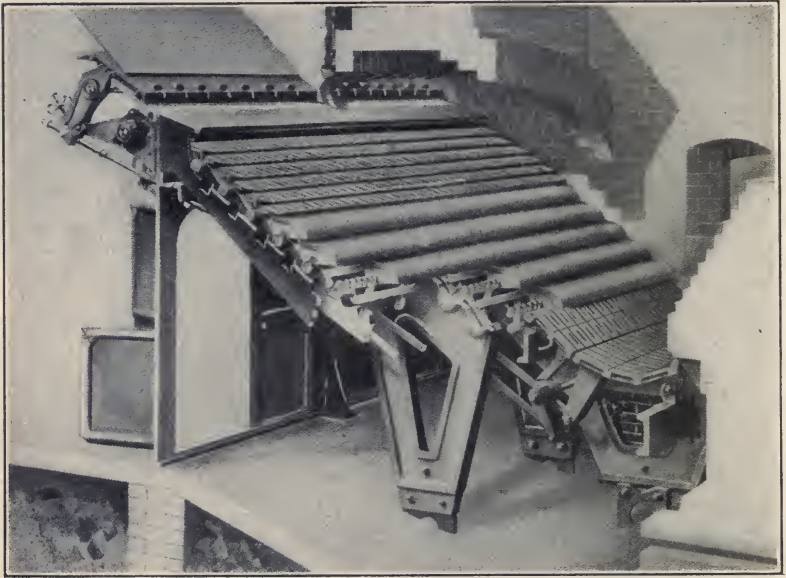

FIG. 36.—Roney stoker—side view.

main operating shaft which runs horizontally just beneath the hopper, is keyed an eccentric which gives a pendulum motion to the agitator. This agitator is connected with the grates, giving to them a rocking movement. It also, through the rock-shaft, imparts a reciprocating motion to the pusher, the length of this motion being regulated by a hand-wheel. As the pusher recedes, the fuel in the hopper settles down in front of it, and as it advances the fuel is pushed into the furnace. As the main operating shaft runs at constant speed, the quantity of fuel fed is proportional to the travel of the pusher.

The reciprocating motion of the rocker bar is imparted through



a connecting rod, the free end of which works freely through a sliding bearing in the lower end of the agitator—an adjusting nut on the connecting rod makes it possible to regulate the reciprocating motion of the rocker bar, and consequently the amplitude of the rocking motion of the grate bars.

The inclined grate stoker has given excellent satisfaction, particularly in using diversified coals. In conditions of excessive loads this is probably not so smokeless as some other forms of stoker, but when carefully operated is one of the most satisfactory forms.

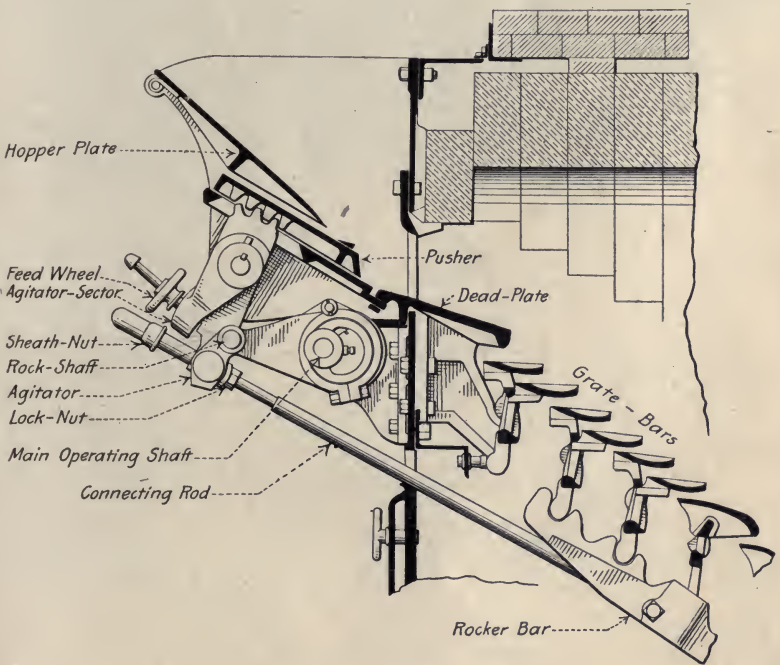

FIG. 37.—Roney stoker—feed mechanism.

**70. Chain Grates.**—Fig. 38 shows the elevation of a chain grate. The coal is fed into a hopper, the bottom of which is open to the chain grate, composed of a series of flexible links rotating upon two cylinders, one at each end of the grate. The grate is driven by a small engine the speed of which can be adjusted to the particular form of fuel burned and the load on the boiler. This speed should be regulated so that the fuel is completely burned just as it reaches the back of the grate. If

the speed is too fast, unburned coal will be carried over the back of the grate into the ash pit. If it is too slow, there will be holes

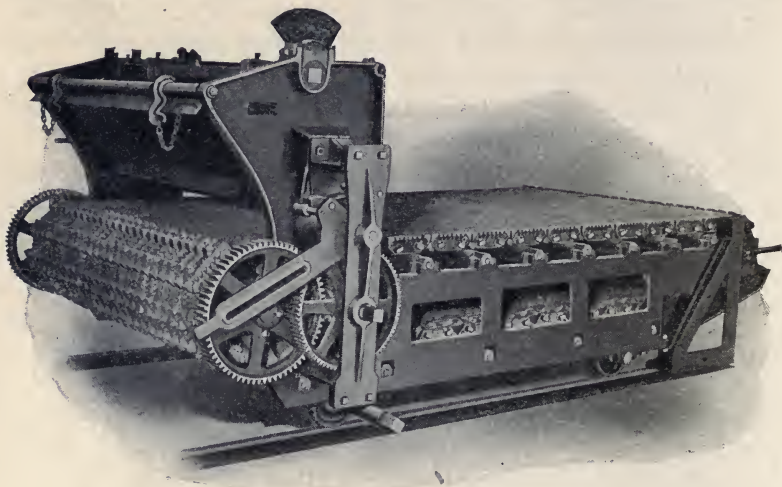

FIG. 38.—Green chain grate.

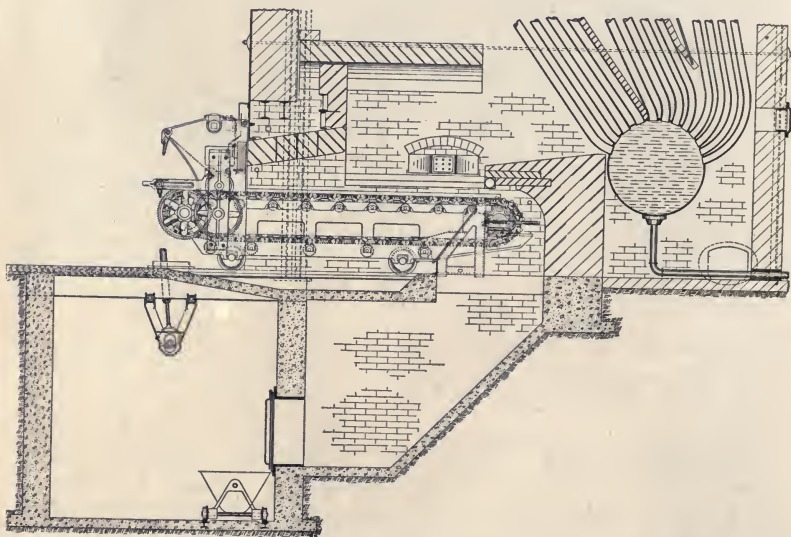

FIG. 39.—Green chain grate stoker applied to Stirling boiler.

in the fire toward the rear, allowing an excess of air to pass through the grate. The coal drops from the hopper upon this slowly moving grate, the thickness of the bed of coal being ad-

justed by an apron at the front of the boiler. This form of grate gives excellent satisfaction with non-coking coals and uniform loads on the boiler, and will be almost smokeless under proper conditions of operation. It is not adapted to the use of semi-bituminous, or anthracite, coal. The greatest difficulty is improper installation, which will permit of the passing of an excess of air through the grate. This, however, may be avoided by careful setting. In installing these grates, provision should be made for the easy removal of the ashes. Fig. 39 shows the

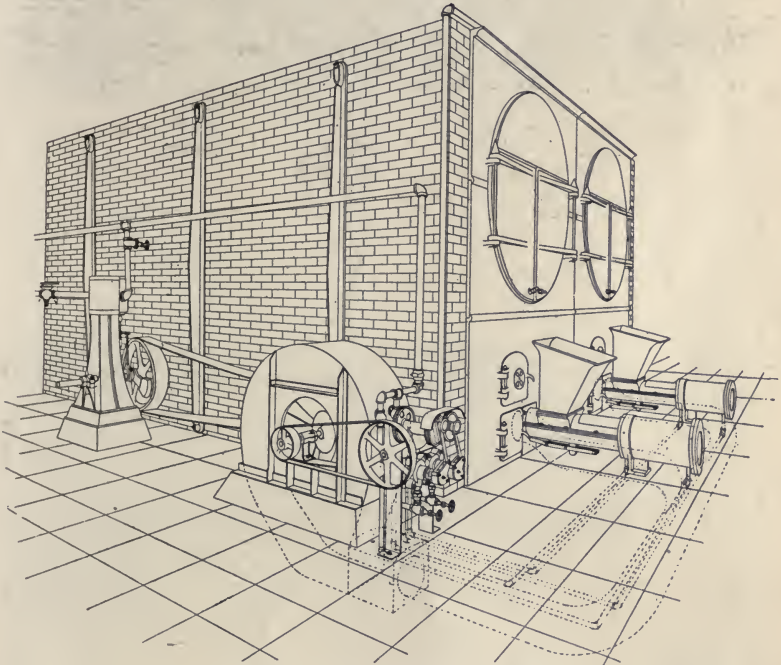

FIG. 40.—Jones under-feed stoker.

cross-section of a chain grate installed under a Stirling boiler. It also shows the ash pit and sub-basement for easy removal of the ashes. This is a desirable arrangement with most forms of stokers.

**71. Under-feed Stokers.**—One of the commonest forms of under-feed stokers is the Jones, shown in Fig. 40 applied to a boiler plant, and in Fig. 41 in cross-section. In this form, coal is dropped down from hoppers in front of a piston at regular intervals depending upon the load. This piston moves forward

and pushes the coal in under the burning fuel. In this way coal is always introduced under the fire, and all the gases are

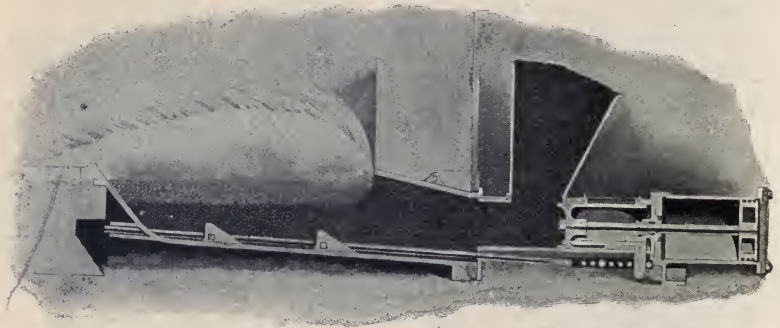

FIG. 41.—Section of Jones under-feed stoker.

passed through the incandescent fuel. This is the most smokeless form of stoker.

Fig. 42 shows the American type of stoker, which is similar

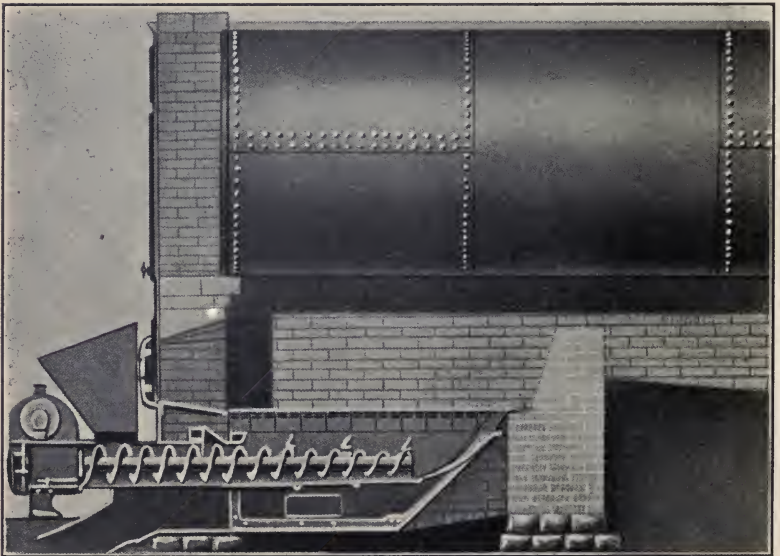

FIG. 42.—American under-feed stoker.

in operation, but in this stoker the piston of the Jones is replaced by a worm which continuously feeds the coal underneath the fire.

The under-feed form of stoker produces a very intense heat directly above the fire. The ash accumulates on the top of the fire and falls over to the sides of the furnace, from where it is taken out. Owing to the ashes being raised to a high temperature, coal containing ash which is high in sulphur and iron should not be used in a stoker of this type, as it will produce very large, hard clinkers.

In under-feed stokers, the resistance of the fuel bed to the passage of air is so great that it is necessary to use a blower

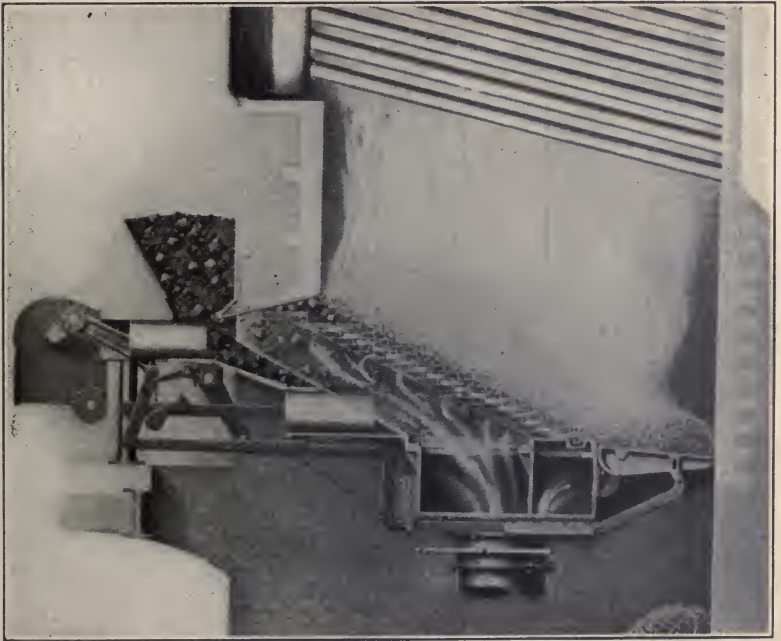

FIG. 43.—Taylor stoker—cross-section.

to force the air through the fuel bed. This blower is usually driven by a steam engine, and the excessive amount of steam used is one of the objections offered to the use of these stokers.

The Taylor, Figs. 43 and 44, is an inclined under-feed stoker.

“Coal from the hopper is fed into the retort, from which two cylindrical rams, assisted by gravity, introduce it into the furnace at an angle to the fire surface. Movement of the upper

ram pushes the green coal outward and upward, properly distributing it in the coking zone. The action of the lower ram is similar, but instead of bringing in fresh coal it pushes the fuel bed and refuse toward the dump plates at the rear.

The retort or fuel magazine is formed by two tuyère boxes. Air for combustion enters the tuyère boxes from the wind box, and escaping from the tuyère openings mingles with the gases distilled from the coal and with the coked fuel pushed outward and upward by the rams. Both rams are actuated by connecting rods and links from a crank shaft which is driven from the speed shaft. The speed shaft in turn is driven by the fan engine.

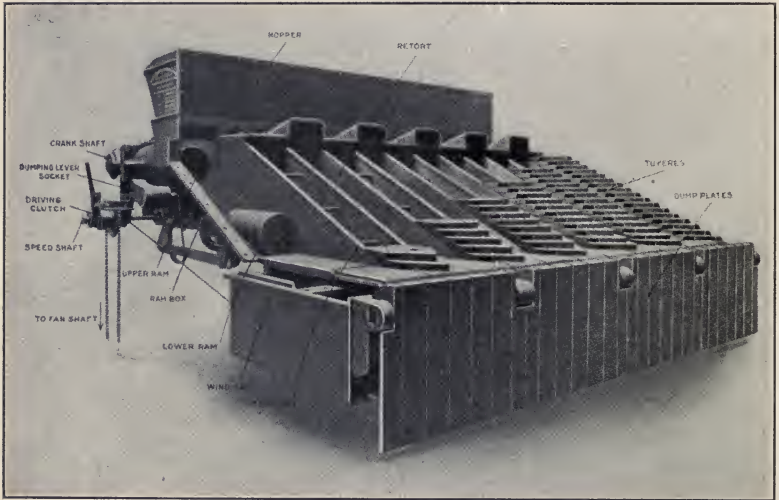

FIG. 44.—Taylor stoker—perspective, showing dumping plates down.

“The dump plates, which are combination dump plates and fire guards, are hung on the rear of the wind box; these plates receive the burned out refuse and are dumped periodically, as the conditions of service may require. The dump plates are operated from the front of the stoker, raised, latched in position and released by a hand lever.”

**72. Grate Surface in Stokers.**—The grate surface in a stoker with an inclined grate is taken as the area of the horizontal projection of the grates, and is termed *projected area*. The ratio of projected grate area in the stoker to the heating surface in the boiler varies from 1 to 55, to 1 to 65.

**73. Advantages and Disadvantages.**—The principal advantages of mechanical stokers are: smokeless operation of the furnace, adaptability to the burning of cheaper grades of coal, uniformity of furnace conditions and steam pressure, which adds to the economy of the plant, and in larger plants, a saving in the labor charge for plant operation. Their disadvantages are: high initial cost, large repair bills, cost of operating stoker mechanism, which in most stokers is from  $\frac{1}{2}$  to 3 per cent. of the steam generated, and, if fan blast is used, from 3 to 5 per cent. of the steam generated.

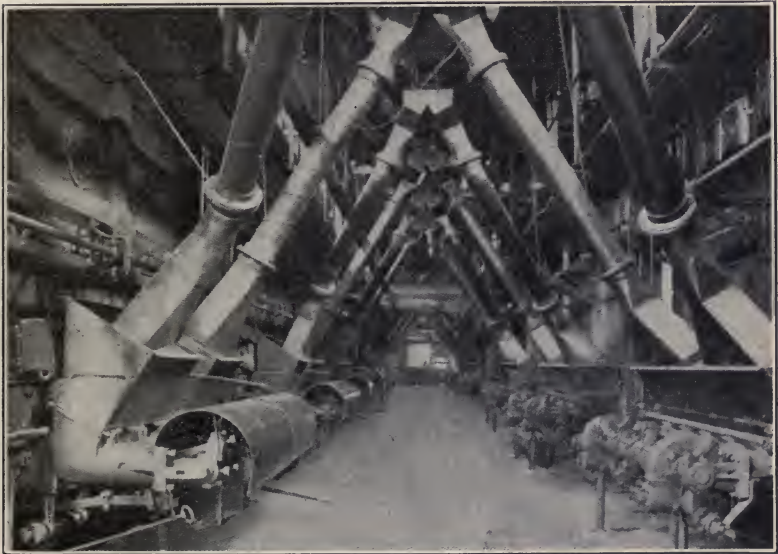

FIG. 45.—General arrangement of a modern boiler room.

In small plants where coal-handling machinery is not provided, stokers will not reduce the labor charge. In large plants where the coal is delivered mechanically to the stoker hoppers, stokers will materially reduce this charge. Fig. 45 shows a plant with stokers fed from overhead hoppers. In such plants the ash is usually removed from a basement under the boiler room floor.

**74. Boiler Feed Pumps.**—The feed water is forced into a boiler either by a *feed pump* or an *injector*. There are two general types of feed pumps: *belted feed pumps* which may

be driven from the machinery, or by independent motor; and *independent pumps* driven by their own steam cylinders.

The independent feed pump is most commonly used as it has the advantage of being independent of the operation of the main engine, and in addition its speed can be adjusted so as to give uniform feeding. Its principal disadvantage is in the large steam consumption of pumps of this type. Small feed pumps use from 150 to 300 lbs. of steam per indicated horse-power per hour; large steam pumps, from 80 to 150 lbs.; compound condensing feed pumps of the direct-acting type, from 60 to 75 lbs. The mechanical efficiency of these pumps is about 80 per cent.

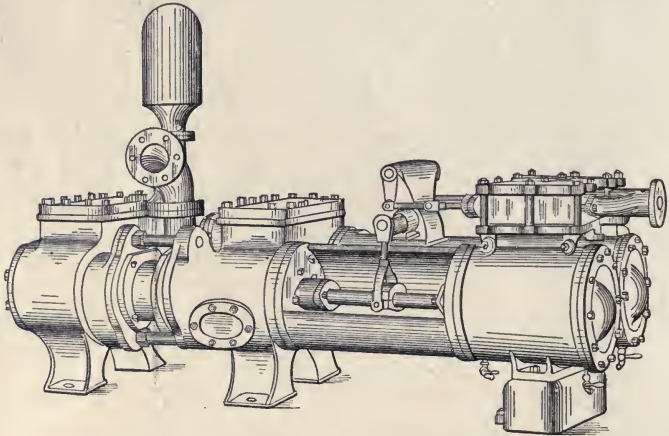

FIG. 46.—Worthington boiler feed pump.

Fig. 46 shows a modern form of feed pump having four single-acting water cylinders. This pump has two plungers working in these cylinders. The plungers are in the center of the pump and have the packing glands outside the cylinder. This type of pump is called an *outside center packed pump*.

The belt-driven pump is often used to overcome the steam wasted when using the independent direct-acting pump. These pumps may be driven from the shaft of the main engine or from the line shafting. In some cases they are driven by an electric motor. This arrangement has its disadvantages. The speed of the pump being constant, it is necessary to regulate the amount of water pumped by a by-pass allowing part of the water pumped to go back from the pressure to the suction side of the pump.



If the feed is suddenly shut off from all the boilers, provision must be made for the discharge from the pump being turned back to the suction automatically. It is not possible to use a belted feed pump except when the engine is running, and there must be an auxiliary feeding device provided that can be operated when the main engine is shut down.

In very large plants steam turbine driven, turbine pumps are being used. These pumps being of the centrifugal type, it is not necessary to change the speed of the pump for changes of load. The speed of a turbine pump determines the pressure

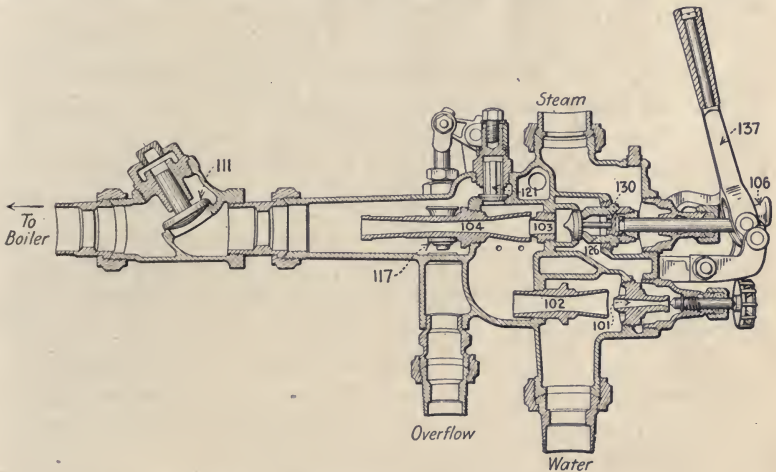

FIG. 47.—Steam injector—cross section.

only and the amount of water pumped depends upon the demand. This is, therefore, automatic and requires very little attention.

**75. Steam Injectors.**—Boilers are often fed by an *injector*, a device invented by M. Giffard, a French engineer.

Fig. 47 shows the cross-section of an injector, the operation of which is as follows: The handle, 137, is pulled back slightly, thus raising valve 130 from its seat and admitting steam through valve 126 to the lifter nozzle 101. "The discharge of steam from this nozzle into the lifter combining tube, 102, entrains the air in the suction pipe finally producing sufficient vacuum to lift the water. The flow of water passes through both the intermediate overflow, 121, and the forcer combining tube, 104, and out of the final overflow, 117. A further movement of the lever opens the forcer steam valve, 126, and admits

steam to the forcer steam nozzle, 103, while at the same time the final overflow valve is approaching its seat, producing a consequent increase of pressure in the delivery chamber. This pressure closes the intermediate overflow valve, 121, and opens the intermediate or line check valve, 111, and when the final overflow valve, 117, is brought to its seat the injector will be in full operation. The intermediate overflow valve, 117, operates automatically, its only function being to give direct relief to the lifter steam nozzle when lifting or priming, and comes to its seat when the forcer steam is applied and is held there by the pressure exerted by the forcer."

There are many different forms of injectors made for different conditions. The injector, however, is a very inefficient pump for general pump purposes. It is installed, however, as an auxiliary method of feeding the boiler in case of accident to the regular feed pump. As a boiler feeder it has a thermal efficiency of almost 100 per cent. since all the heat of the steam used by the injector, except that lost by radiation, goes into the feed water.

In locomotives, injectors only are used for feeding the boiler, as they take very little space and warm the feed water. Each locomotive is provided with two injectors.

**76. Pump Connection.**—When a pump or injector is handling cold water, the lift on the suction side of it should not exceed 25 ft. Most engineers try to install pumping apparatus with a head on the suction not more than 15 ft.

When hot water is to be handled, the pump should be below the level of the water on the suction side. By hot water is meant water exceeding  $120^{\circ}$ . Injectors are seldom used to handle hot water as they are very difficult to start with water exceeding  $100^{\circ}$ . Where pumps are installed handling hot water from a feed-water heater, the level of water in the heater should be 5 ft. above the center line of the pump cylinders if possible. Hot water cannot be raised by a pump, as the lowering of the pressure in the suction pipe lowers the temperature of the boiling point of the water in the suction pipe, the water in the suction boils and all the pump draws from the suction is steam.

**77. Feed-water Heaters.**—It is very important that a boiler be fed with warm water, usually at a temperature over  $180^{\circ}$ . This saves part of the heat necessary to make steam, and in addition prevents strains in the boiler due to a difference in

temperature of different parts of the boiler shell. Feeding a boiler with cold water often causes a leak.

In all modern power plants some means is provided for heating the feed water before entering the boilers. This is usually accomplished in one of two ways; by heating the water with the exhaust steam from the engine, which is by far the commonest method used, or with waste gases from the boilers. Devices for using the exhaust steam for heating the water are called *feed-water heaters*, and the device for using the gases from the boiler for heating the feed water is termed an *economizer*.

The principal advantages of the feed-water heater are the saving in B.T.U. due to the increase in the temperature of the feed, and the saving in wear and tear on the boiler due to introducing hot instead of cold water, thereby reducing the strain on the boiler. A heater which increases the temperature of the feed water from 70° to 200° will save about 12 per cent. of the fuel, and the installation of a heater will usually pay for itself in a few months.

**78. Types of Feed-water Heaters.**—There are two general types of heaters: the *open* and the *closed*. The open feed-water heater, Fig. 48, consists of a cast- or wrought-iron shell into which the exhaust steam is led. The cold water is admitted at the top of the heater, and is allowed to pass through the exhaust steam in streams or sheets of water. In this type of heater the feed water and exhaust steam come into direct contact with each other. The water usually passes over pans, or trays, upon which any scale-producing matter can be deposited. When it is desired to clean the heater, it is only necessary to take out these pans and clean them. Before entering the heater the exhaust steam should be passed through an oil separator. The hot feed water is usually passed through some form of filter before going to the feed pumps. The feed-water heater should be located at a sufficient height above the feed pump so that the water will enter at a pressure. This distance should be 5 ft. or more. The heater may also be used as a receptacle for the hot water which is drained from the steam mains, and for other hot condensed steam which does not contain oil. A uniform water level is maintained in the heater by a float valve which automatically allows water to enter the heater when the level gets below a certain point.

The closed heater shown in Fig. 49 consists of a cylindrical

shell of cast iron, or steel, containing tubes extending from the header at one end of the heater to the header at the other end,

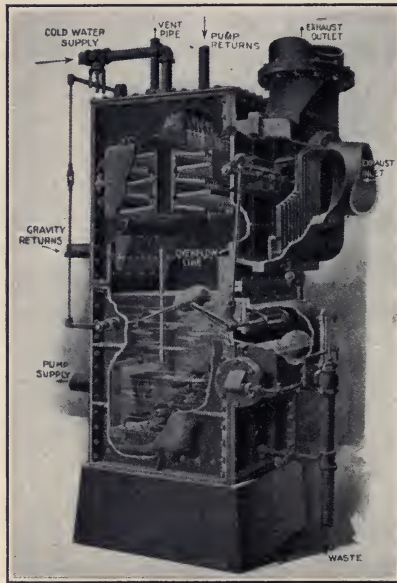

FIG. 48.—Open feed-water heater.

or tubes in the form of coils of pipe. The exhaust steam is admitted on one side of the tubes and the feed water on the other. In a closed heater the feed water and the steam used

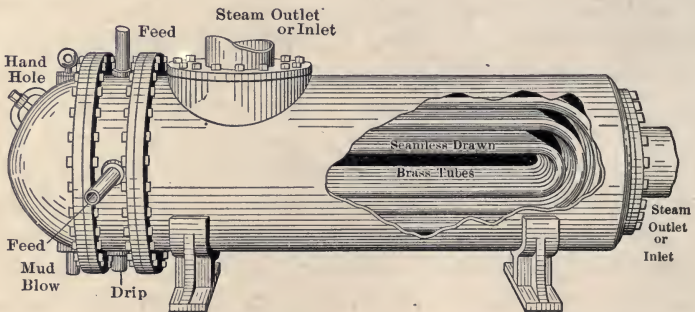

FIG. 49.—Closed feed-water heater.

do not come in contact with each other. The closed heaters are usually used where it is desired to pass the water through

the heaters under pressure. They are more expensive than the open heaters and are more difficult to clean. Where possible it is better to use an open heater.

**79. Installation of Heaters.**—Open heaters are placed on the *suction* side of the feed pump, and the feed water must be brought to the heater. The level of the water in an open heater should be at least 5 ft. above the center of the feed-pump cylinder as a feed pump cannot lift hot water. Injectors are never used with an open heater as they cannot be used with hot water.

Closed heaters are placed on the *discharge* side of the pump and the feed pump may lift its supply directly from the source of water. An injector may be used with a closed heater.

Heaters cost from \$2 to \$4 per boiler horse-power served by them.

**80. Economizers.**—Any device which heats the feed water by means of the heat in the gases which leave the boiler is termed

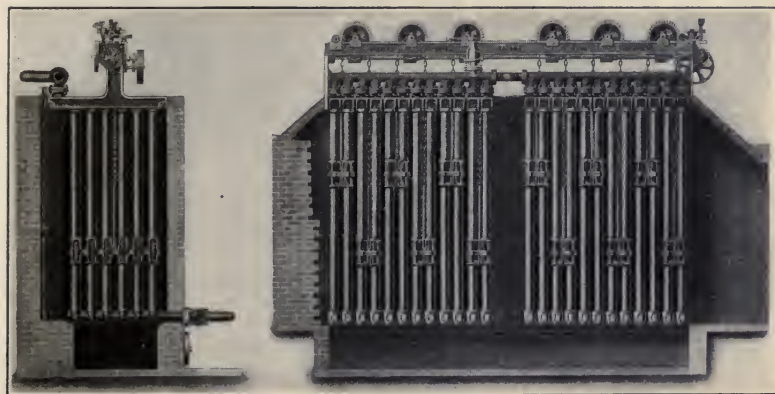

End elevation.

Side elevation.

FIG. 50.—Economizer.

an economizer. Fig. 50 shows the elevations of an economizer. The cold water is pumped into the lower pipe header, and after being heated, passes out from the upper header to the boiler. The flue gases from the boiler pass around the pipes and headers containing the feed water. The tubes as shown in the cut are provided with scrapers operated from time to time to remove the soot from the pipes. The general arrangement of an economizer is shown in Fig. 51. An economizer is always provided

with a duct, or by-pass, passing around it, so that it can be cleaned without shutting down the plant. The economizer is placed in a brick or sheet metal flue which carries the gases from the boiler to the chimney. Economizers are installed so as to make use of the heat in the gases leaving a boiler and thus reduce the waste in heat going up the stack. Economizers may be installed also to increase the capacity of a boiler plant which is too small for its services. They deliver the water to the

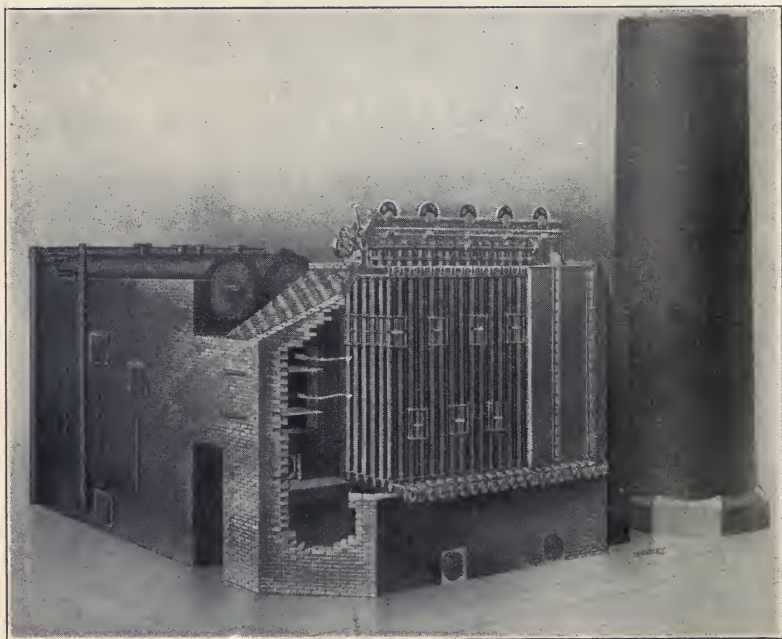

FIG. 51.—Economizer, showing location in breeching.

boiler at a high temperature, reducing the strain and the leakage caused by the admission of cold water. Their particular disadvantage is in reducing the strength of the draft owing to the fact that the economizer causes additional friction. Economizers should never be used except with chimneys having a strong draft or with mechanical draft.

The first cost of the economizer is very high, varying from \$5 to \$6<sup>00</sup> per horse-power for plants of 1000 horse-power or over. A number of tests have been made of the economizer where a

net saving of 10 per cent. was shown, allowing for cost of economizer, cost of operation, interest, depreciation, and repairs.

From 4 to 5 sq. ft. of economizer surface should be allowed per boiler horse-power.

**81. Superheaters.**—In the past few years the use of superheated steam with both reciprocating engines and turbines has become very general. The benefits derived are many. The steam remains in a dry condition until all the superheat is lost. The heat lost by the steam while passing through the piping from the superheater to the place where it is to be used, does not

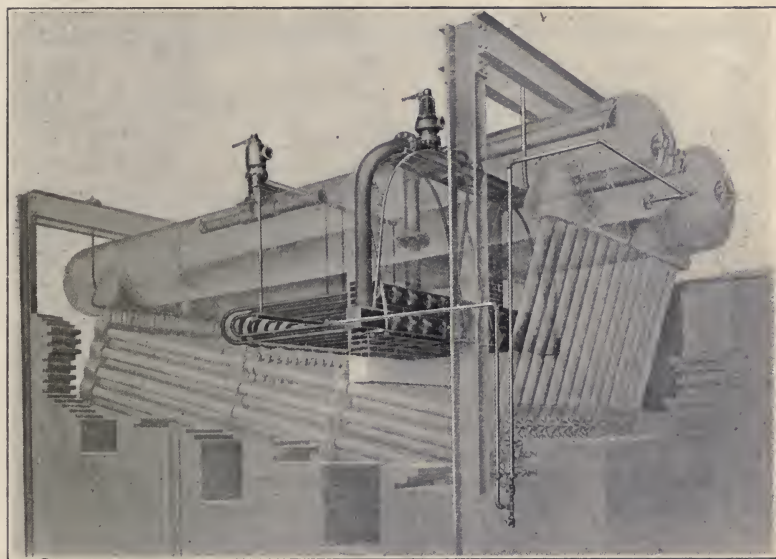

FIG. 52.—Superheating coil in Babcock and Wilcox boiler.

cause condensation as it is simply superheat which is given up. The initial condensation loss in reciprocating engines is greatly reduced, or entirely eliminated, depending upon the amount of superheat in the steam. In turbines the absence of moisture is particularly desirable, as the water coming in contact with the blading at a high velocity has an eroding effect, thus increasing the clearance between the blades and the casing and consequently increasing the steam consumption.

Recent experiments have shown that when steam is superheated from  $0^{\circ}$  to  $100^{\circ}$  F. there is a saving of 1 per cent. in

steam consumption for every 10 degrees of superheat, and when superheated from 100° to 200° F. there is a saving of 1 per cent. for every 12 degrees of superheat. These results are based on a comparison between superheated and dry saturated steam. If the steam is wet, the saving will, of course, be much larger.

The degree of superheat to be used will depend largely upon the conditions. In the majority of cases it has been found that the highest commercial efficiency is secured by the use of from 125° to 150° of superheat in turbine plants and slightly less in the case of reciprocating engine plants.

A superheating coil placed in a Babcock & Wilcox boiler is shown in Figure 52.

It has been frequently stated that cast-iron fittings and valves should not be used with superheated steam, as the iron deteriorated at the high temperatures. Recent developments have shown that the trouble has been caused by fluctuating rather than high temperatures.

In the transactions of the A.S.M.E., Vol. 31, page 1037, Professor Hollis states:

“When the temperature is constant, even though as high as 600° or 700° F., the change in cast iron is not serious enough to prohibit us from its use, but where the temperature varies considerably, the metal is certain to develop cracks and distortion that render it unsuitable for steam pipes and other parts under steam pressure.

“The use of cast-iron fittings for superheated steam is inadvisable where the temperature is likely to fluctuate, but it can be safely used where the temperature is to be constant.”

**82. Chimneys.**—The chimney is a very important part of a steam-power plant, and the operation of the plant depends upon the draft and capacity of the chimney.

**83. Draft.**—The draft in a chimney is produced by the difference in weight between the column of hot gases inside the chimney and a column of gases of the same dimensions outside the chimney. The hot gases, being light, are forced up the chimney by the cold gases coming through the grates.

The height of the chimney then determines the intensity of the draft. The draft is always measured in inches of water, and for a given height of stack may be determined as follows:



Let  $H$  = the height of the chimney.

$T^\circ$  = the absolute temperature of the gases outside the chimney.

$T'$  = the absolute temperature of the gases inside the chimney.

$w^\circ$  = the weight of a cubic foot of air at a temperature  $T^\circ$ .

$w'$  = the weight of a cubic foot air at a temperature  $T'$ .

Then assuming the chimney to have an area of 1 sq. ft., the weight of the hot gases equals

$$Hw' = Hw^\circ \frac{T^\circ}{T'} \quad (1)$$

The weight of the cold gases equals

$$Hw^\circ = Hw' \frac{T'}{T^\circ} \quad (2)$$

Hence the force of the draft,

$$F' = Hw^\circ - Hw' = Hw^\circ - Hw^\circ \frac{T^\circ}{T'}$$

Therefore

$$F' = Hw^\circ \left( 1 - \frac{T^\circ}{T'} \right). \quad (3)$$

This is in pounds per square foot. To reduce to inches of water this must be multiplied by .192. Hence the force of the draft in inches of water,

$$F = .192 Hw^\circ \left( 1 - \frac{T^\circ}{T'} \right). \quad (4)$$

The intensity of the draft as shown in equation (4) is determined by the height of the chimney and the temperature inside and outside the chimney.

**84. Chimney Capacity.**—The capacity of a chimney is the quantity of gases that it will pass per hour, and upon the capacity of a chimney depends the number of pounds of coal that the plant will burn. The theoretical quantity of coal that a chimney will burn may be found as follows:

Let  $h$  = the head producing velocity. Then the weight of the gases producing the head equals  $hw'$ , and

$$hw' = Hw^\circ - Hw' = Hw' \frac{T'}{T^\circ} - Hw'. \quad (5)$$

Therefore

$$h = H \left( \frac{T'}{T^\circ} - 1 \right) \quad (6)$$

Let  $u^\circ$  = the velocity of the entering gases and  $u'$  = the velocity of the leaving gases in feet per second. Then the velocity of the leaving gases

$$u' = \sqrt{2gh} = \sqrt{2gH \left( \frac{T'}{T^\circ} - 1 \right)}. \quad (7)$$

Let  $W^\circ$  = the total weight of the gases passing up the chimney per second, then

$$\begin{aligned} W^\circ &= w^\circ u^\circ = w' u' = w' \sqrt{2gH \left( \frac{T'}{T^\circ} - 1 \right)}. \\ &= w^\circ \frac{T^\circ}{T'} \sqrt{2gH \left( \frac{T'}{T^\circ} - 1 \right)} \end{aligned}$$

or

$$W^\circ = w^\circ \sqrt{2gH \left[ \frac{T^\circ}{T'} - \left( \frac{T^\circ}{T'} \right)^2 \right]}. \quad (8)$$

For an outside temperature of  $70^\circ \text{ F.}$ ,  $w^\circ = .075$  and  $T^\circ = 530$ . Assume the temperature in the chimney to be  $500^\circ \text{ F.}$  Then  $T'$  equals  $960^\circ$ .

Substituting these values in equation (8),

$$\begin{aligned} W^\circ &= 8.025 \times .075 \sqrt{H \left( \frac{530}{960} \right) - \left( \frac{530}{960} \right)^2} \\ &= .602 \sqrt{H} \times .247. \end{aligned} \quad (9)$$

If  $A$  = area of the chimney in square feet, then

$$W^\circ = .30A \sqrt{H} \text{ in pounds per second,} \quad (10)$$

or in pounds per hour

$$W^\circ_1 = 3600 \times .30A \sqrt{H}. \quad (11)$$

This assumes the efficiency of a chimney to be 1, but experience shows the average efficiency of a chimney to be about 35 per cent., so that the actual weight of air passed per hour is

$$W^\circ_a = 3600 \times .35 \times .30A \sqrt{H} = 378A \sqrt{H}. \quad (12)$$

Each pound of coal requires 24 lbs. of air to burn it, and as each boiler horse-power requires about 5 lbs. of coal, the boiler horse-power of a chimney is

$$B.H.P. = \frac{378}{24 \times 5} A \sqrt{H} = 3.15A \sqrt{H}. \quad (13)$$

Various authors give values of the constant in this expression varying from 3.5 to 3.0.

**85. Height of a Chimney.**—The height of a chimney is always measured from the level of the grate and, in any given case, depends upon the kind of fuel that is to be burned under the boiler. The following table gives the minimum height of chimney for various kinds of fuels:

TABLE XVIII. CHIMNEY HEIGHTS

For straw or wood.....	35 feet.
“ bituminous lump, free burning .....	100 “
“ ordinary slack.....	100 “
“ ordinary bituminous coal.....	115 “
“ small slack or anthracite.....	125 “
“ anthracite pea coal.....	150 “

The height of the chimney should not be too short for its diameter. A very large diameter of chimney in proportion to the height may show reduced capacity. As an example, a chimney 100 ft. high should not exceed 6.5 ft. in diameter. In general the inside diameter of a chimney should not exceed 8 per cent. of its height.

**86. Materials Used.**—Brick or hollow tile is more extensively used in building chimneys than any other material where permanent chimneys are desired. The life of a brick chimney is probably forty or fifty years. These materials are used in plants where few changes are expected.

In most plants the station is not expected to remain without extensive changes more than twenty or twenty-five years, and the expense of a brick chimney is not warranted. Many of the recent power houses are using self-sustaining steel chimneys.

For temporary use the unlined sheet steel chimney is very commonly used. It is necessary to brace these chimneys with steel guy wires. The life of these chimneys is short, at the best not more than ten years, and where the coal contains much sulphur not more than five years.

**87. Brick Chimneys.**—Brick chimneys, as shown in Fig. 53, are built in two parts, an outer shell and an inner shell, usually lined with fire-brick which forms a flue for the burned gases. There should be an air space between the outer and the inner shells so that the inner shell is free to expand. Brick chimneys are expensive to erect, but very permanent in character. Care should be taken in investigating the ground which is to support

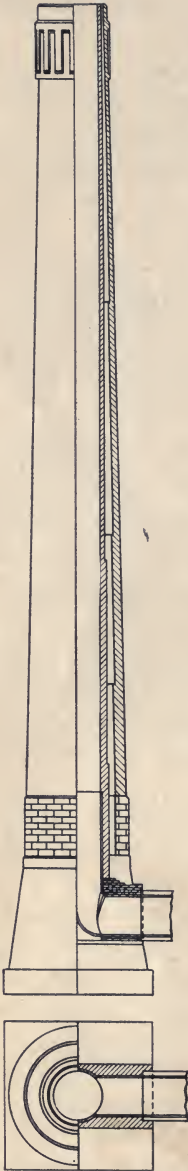

FIG. 53.—Brick chimney.

a chimney, as unequal or excessive settlement may endanger the chimney.

The radial brick chimney is constructed of hollow tile and has no lining. These chimneys are much lighter than the solid brick chimney. They are much less expensive than the brick and cost but little more than a self-sustaining steel chimney.

**88. Steel Chimneys.**—Steel chimneys of the self-sustaining type are built of boiler plates riveted together. They are supported on ample foundations to which they are bolted by very heavy anchor bolts. The pressure of the wind against the chimney is carried to the foundation by these bolts, and the foundation must be of sufficient size and weight to prevent overturning. Chimneys of this type are lined with fire-brick usually for their full length.

**89. Mechanical Draft.**—In some cases conditions will not permit of the construction of a tall chimney, and in other cases the draft required is more than the ordinary chimney will give. It is then necessary to resort to some form of forced or mechanical draft.

Mechanical draft is entirely independent of the temperature inside or outside of the chimney. Where economizers are used, the temperature in the chimney may be so low and the resistance of the economizer such as to require mechanical draft.

**90. Systems of Mechanical Draft.**—There are three systems that may be used to produce mechanical draft.

(1) A steam jet may be used to force air into the ash pit.

(2) A fan may be used to force air into the ash pit.

Both of the above systems require a closed ash pit and are termed *forced draft*, as the air is forced through the fire.

(3) The third system, or *induced draft*, is more commonly used. With this system a fan is placed in the smoke connection to the chimney, or, as in the case of locomotives, the cylinders exhaust directly into the stack, and air is drawn through the fire. The action in this case is analogous to the action of the chimney.

Under ordinary conditions the rate of combustion may be taken as from 15 to 30 lbs. of coal per square foot of grate surface per hour with mechanical draft. With mechanical draft the air required to burn a pound of coal may be reduced to 18 lbs. With induced draft the pressure of the draft usually varies from 1.5 to 2 in. of water. The operation of an induced draft plant may be made partially automatic. This is done by driving the fan with an engine and having the speed of the engine controlled by the steam pressure in the boilers.

#### PROBLEMS

1. Calculate the factor of evaporation for a gage pressure of 75 lbs. and an initial temperature of the feed water of 135°.
2. A boiler evaporates 500 lbs. of water per hour from a feed temperature of 145° into steam at 80 lbs. pressure. What is the equivalent-water evaporated per hour from and at 212°?
3. A boiler evaporates 8½ lbs. of water per pound of coal. Pressure in boiler, 125 lbs.; feed temperature, 150°. What will it evaporate from and at 212°?
4. A boiler evaporates 8 lbs. of water per pound of coal. Pressure, 100 lbs.; feed temperature, 100°. What will it evaporate if the pressure is 80 lbs. and feed 200°; and what will it evaporate from and at 212°?
5. A boiler evaporates 8 lbs. of water per pound of coal. Steam pressure, 120 lbs.; feed temperature, 150°. What will it evaporate with a steam pressure of 5 lbs. and a feed temperature of 200°?
6. A boiler evaporates 9 lbs. of water per pound of coal. Steam pressure, 100 lbs.; feed temperature, 50°. What will it evaporate if the steam pressure is 200 lbs. and the feed temperature 150°?
7. A boiler evaporates 8000 lbs. of water per hour. Steam pressure, 120 lbs.; feed temperature, 180°. What would it evaporate if the steam pressure were 60 lbs. and the feed temperature 60°?
8. A boiler plant evaporates 6 lbs. of water per pound of coal. Steam pressure, 150 lbs.; feed temperature, 120°. What will it evaporate if an economizer is added increasing the feed temperature to 230°?
9. A boiler evaporates 5000 lbs. of water per hour from a feed-water-temperature of 70° into steam at 120 lbs. pressure. What is the evaporation from and at 212°? If the efficiency of the boiler, furnace and grate is 70 per cent. and coal that contains 13,500 B.T.U. per pound is used, how many pounds of water will be evaporated from and at 212° per pound of coal?
10. A coal contains 14,000 B.T.U. per pound dry. If all the heat in this

coal should be utilized, how many pounds of water would be evaporated per pound of dry coal? Steam pressure, 200 lbs.; feed temperature, 250°.

- 11. Efficiency of a boiler, furnace and grate is 65 per cent. Coal burned contains 12,000 B.T.U. per pound. Steam pressure, 200 lbs.; feed temperature, 180°. How many pounds of water will be evaporated per pound of coal?
- 12. A boiler burns coal containing 13,000 B.T.U. per pound. Steam pressure, 200 lbs.; feed temperature, 200°; efficiency of the boiler, furnace and grate, 75 per cent. What would be evaporated from and at 212°?
13. One hundred pounds of coal containing 13,000 B.T.U. per pound will evaporate how many pounds of water at 200° into steam at 100 lbs. pressure? What will it evaporate from and at 212°? Efficiency of the boiler, furnace and grate, 70 per cent.
- 14. How many pounds of water can be evaporated from and at 212° by the heat evolved by the complete combustion of 1 lb. of dry coal containing C, 65.2 per cent.; H, 4.92 per cent.; O, 8.64 per cent.?
- 15. A coal contains C, 75 per cent.; H, 5 per cent.; O, 4 per cent. Efficiency of the boiler, furnace and grate, 70 per cent.; feed temperature, 180°; steam pressure, 150 lbs. absolute. Steam contains 2 per cent. moisture. (a) What is the actual evaporation per pound of coal? (b) What is the equivalent evaporation from and at 212° per pound of coal?
- 16. A coal contains C, 80 per cent.; O, 7 per cent.; H, 3 per cent.; and ash, 10 per cent. It is used in a boiler carrying 100 lbs. pressure with a feed temperature of 180°. The efficiency of the boiler, furnace and grate is 70 per cent. What will be the evaporation per pound of coal?
- 17. If 40 per cent. of the heat of combustion of coal containing 12,750 B.T.U. per pound is lost, how many pounds of coal will be required to evaporate 5650 pounds of water from an initial temperature of 130° and under a pressure of 80 lbs.?
18. A coal contains 12,500 B.T.U. and requires 24 lbs. of air per pound to burn it. Temperature of boiler room, 70°; temperature of stack gases, 500°. What per cent. of the heat of the coal goes up the stack?
- 19. If the temperature of the boiler room is 70° and the temperature of the stack gases is 500° and 30 lbs. of air are used per pound of coal, what per cent. of heat is lost up the stack, if the coal contains 14,500 B.T.U. per pound?
- 20. A boiler evaporates 3500 lbs. of water per hour from an initial temperature of 120° and under a pressure of 80 lbs. A second boiler evaporates 4000 lbs. of water from an initial temperature of 110° and under a pressure of 60 lbs. Which of the two boilers utilizes the greater amount of heat per hour?
- 21. A boiler evaporates 6000 lbs. of water per hour. Coal contains 13,000 B.T.U. Steam pressure, 100 lbs.; feed temperature, 180°; efficiency of boiler and grate, 70 per cent. How many pounds of coal will the boiler burn per hour?
- 22. An engine uses 30 lbs. of steam per I.H.P. per hour. Feed temperature, 120°; steam pressure, 120 lbs. The boiler evaporates 9 lbs. of water per pound of coal. How many pounds of coal are required per I.H.P. per hour?
23. A boiler evaporates 7.5 lbs. of water per pound of coal. Steam

pressure, 150 lbs.; feed temperature, 200°. Coal costs \$2.50 per ton. What is the cost to evaporate 1000 lbs. of water from and at 212°?

- 24. A 72-in. return tubular boiler 18 ft. long has seventy 4-in. tubes. Find the heating surface and rated B.H.P. (Boiler Horse-power).

25. A 66-in. boiler 16 ft. long has ninety-eight 3-in. tubes. Find the heating surface and rated B.H.P.

- 26. A 60-in. boiler 16 ft. long has forty-four 4-in. tubes. Find the heating surface and rated B.H.P.

27. A 60-in. boiler 16 ft. long has fifty-six 3½-in. tubes. Find the heating surface and rated B.H.P.

28. A 48-in. boiler 12 ft. long has twenty-six 4-in. tubes. Find the heating surface and rated B.H.P.

29. A 36-in. boiler 12 ft. long has twenty-six 3-in. tubes. Find the heating surface and rated B.H.P.

- 30. A boiler evaporates 4000 lbs. of water per hour from a feed temperature of 60° into steam at 150 lbs. pressure and 100° of superheat. What is the factor of evaporation, boiler H.P., and number of pounds of coal used per hour, if the boiler, furnace and grates combined have an efficiency of 70 per cent. and the coal contains 14,000 B.T.U. per pound dry.

31. A boiler evaporates 9000 lbs. of water per hour. Steam pressure, 150 lbs.; feed temperature, 120°. How many boiler horse-power is it developing?

- 32. What is the H.P. of a boiler which evaporates 3080 lbs. of water per hour from an initial temperature of 135°, and under a pressure of 100 lbs.?

- 33. A 1000-H.P. engine uses 15 lbs. of steam per H.P. per hour. Steam pressure at boiler, 180 lbs.; feed water temperature, 120°. What boiler H.P. should we have to supply steam for the engine?

34. A boiler evaporates 4000 lbs. of water per hour at 100 lbs. pressure from a feed temperature of 120°. Quality of steam, 98 per cent. What is the boiler H.P.?

35. A fire-tube boiler is 60 in. × 16 ft. and has fifty-four 4-in. tubes. If it evaporates 3000 lbs. of water per hour, is it working over or under its rated H.P. and how much? Steam pressure, 100 lbs.; feed temperature 200°

+ 36. A return fire-tube boiler is 60 in. in diameter, 16 ft. long, and has fifty-two 4-in. tubes. It evaporates 4000 lbs. of water per hour. Steam pressure, 100 lbs.; feed temperature, 150°. Is it working above or below its rated H.P., and how much?

37. A boiler is reported to evaporate 12.5 lbs. of water per pound of coal. Coal contains 13,000 B.T.U. and uses 24 lbs. of air per pound to burn it. Temperature of the boiler room, 70°, and of the stack, 550°. Steam pressure, 100 lbs.; feed temperature, 70°. Would this result be possible? If not, how many pounds of water could the boiler evaporate per pound of coal?

- 38. A plant burns 1500 lb. of coal per hour. The height of the stack is 130 ft. Temperature of boiler room is 70° and of the stack gases, 500°, and 24 lbs. of air are used to burn 1 lb. of coal. Coal contains 12,000 B.T.U. per pound. What should be the area of the stack? What per cent. of heat is lost up the stack? What is the pressure of the draft in tenths of inches of water?

11.11. P. 13  
 70.65 18.74  
 B.H.P. 13  
 F.H.U. = 5  
 N/6

39. A boiler is to evaporate 12,000 lbs. of water per hour. Steam pressure, 100 lbs.; feed temperature, 200°. (a) What should be the horse-power of the boiler? (b) How many square feet of heating surface should the boiler contain? (c) How many square feet of grate surface should it have? (d) What should be the area of the breeching?

- 40. In a 100 H.P. boiler plant what should be the area of the grates, and the diameter of the stack, if the stack is 125 ft. high? If the plant carries 130 lbs. gage pressure, would a water or a fire-tube boiler be used, and why?

- 41. A 400 H.P. Corliss engine uses 26 lbs. of steam per H.P. per hour. The auxiliaries use 25 per cent. as much as the engine. The boilers to supply the plant should contain how many square feet of heating surface and grate surface, and about what should be the area of the flue? Pressure, 150 lbs.; feed temperature, 200°. How many pounds of coal will the plant burn per hour if the coal contains 13,500 B.T.U. per pound and the efficiency of the boiler, furnace and grate is 70 per cent.?

- 42. A boiler evaporates 7 lbs. of water per pound of coal. Steam pressure, 100 lbs.; feed temperature, 50°. A feed-water heater is added increasing the feed-water temperature to 200°. Heater costs \$400. Allowing 5 per cent. interest and 5 per cent. for depreciation and repairs, would it pay to install the heater if the plant burns 750 tons of coal per year, coal costing \$2.50 per ton?

- 43. A boiler evaporates 10 lbs. of water per pound of dry coal from and at 212°. Dry coal contains 13,000 B.T.U. per pound. What is the combined efficiency of the boiler, furnace and grate?

- 44. A boiler evaporates 7.5 lbs. of water per pound of coal. Coal contains 13,000 B.T.U. Steam pressure, 100 lbs.; feed temperature, 150°. What is the combined efficiency of the boiler, furnace and grate?

- 45. What is the combined efficiency of a boiler, furnace and grate that evaporates 8 lbs. of water per lb. of coal from a feed temperature of 150° into steam at 150 lbs. pressure? Coal contains 13,000 B.T.U. per pound.

- 46. A boiler evaporates 9 lbs. of water per pound of dry coal containing 13,500 B.T.U. per pound. Steam pressure, 100 lbs.; feed temperature, 200°. What is the combined efficiency of the boiler, furnace and the grate?

- 47. A coal contains C, 80 per cent.; H, 4 per cent.; O, 2 per cent. What is the heat value of the coal? If this coal is used in a boiler carrying 100 lbs. pressure with a feed temperature of 190° and evaporates 8 lbs. of water per pound of coal, what is the combined efficiency of the boiler, furnace and grate?

- 48. A boiler evaporates 15,000 lbs. of water per hour into steam at 100 lbs. pressure; temperature of feed, 200°. Nine pounds of water are evaporated per pound of dry coal containing 13,000 B.T.U. per pound. (a) What is the H.P. developed by the boiler? (b) What is the combined efficiency of the boiler, furnace and grate?

- 49. A boiler evaporates 11 lbs. of water from and at 212° F. per pound of dry coal containing 14,000 B.T.U. per pound. What is the combined efficiency of the boiler, furnace and grate? At the same efficiency, what will it evaporate with a steam pressure of 200 lbs. and feed temperature at 200°?

- 50. A boiler uses 1 lb. of dry coal containing 13,000 B.T.U. to evaporate 6 lbs. of water. Steam pressure, 100 lbs.; feed temperature, 100°. (a)



What is the efficiency of the boiler plant? (b) What will be the efficiency of the plant if a heater is added which heats the feed to 200° F.? (c) What will be the evaporation per pound of coal after the feed-water heater is installed?

51. A boiler evaporates 9 lbs. of water per pound of coal fired. Feed temperature, 70°; steam pressure, 150 lbs. Coal as fired contains 3 per cent. moisture. Dry coal contains 14,000 B.T.U. per pound and has 6 per cent. ash by analysis. Twelve per cent. of coal fired is taken from the ash pit in form of ash and refuse. (a) What is the efficiency of the boiler and furnace? (b) What is the efficiency of the boiler, furnace and grates combined?

52. A boiler plant burns coal which contains C, 75 per cent.; H, 6 per cent.; and O, 8 per cent. Two-thirds of the carbon is burned to CO<sub>2</sub> and the balance to CO. The evaporation is 8 lbs. of water per pound of coal. Steam pressure, 100 lbs.; feed temperature, 170°. (a) What is the efficiency of the boiler and furnace? (b) What is the efficiency of the boiler, furnace and grates combined?

53. A boiler evaporates 20,000 lbs. of water per hour from a feed temperature of 180° into dry saturated steam at 115 lbs. pressure absolute. Dry coal contains 4 per cent. ash by analysis and 13,000 B.T.U. per pound. Ten per cent. ash and refuse are taken from the ash pit. The actual evaporation per pound of dry coal is 9 lbs. (a) What H.P. is being developed by the boiler? (b) What is the efficiency of the boiler, furnace and grates combined? (c) What is the efficiency of the boiler and furnace alone?

54. Given the following data from a boiler test: Duration of test, 24 hours; total amount of water fed to boilers, 240,000 lbs.; total weight of dry coal fired, 30,000 lbs.; total weight of ash and refuse, 3000 lbs.; temperature of feed water, 180° F.; steam pressure, 150 lbs. absolute; quality of steam, 98.5 per cent.; dry coal contains 13,000 B.T.U. per pound and 3 per cent. ash by analysis. (a) What H.P. is the boiler developing? (b) What is the evaporation from and at 212° per pound of dry coal? (c) What is the combined efficiency of the boiler, furnace and grates? (d) What is the efficiency of the boiler and furnace alone? (e) What should be the heating and grate surfaces in this boiler?

55. A boiler received 10,000 lbs. of water per hour at 100° F. Steam pressure, 150 lbs. absolute; quality of steam, 98½ per cent. Dry coal burned per hour, 1250 lbs., each pound containing 13,000 B.T.U. Per cent. of ash by analysis, 3 per cent.; ash and refuse taken from ash pit per hour, 125 lbs. Coal costs \$3 per ton. Plant runs 10 hours a day, 300 days in the year. (a) What H.P. is the boiler developing? (b) What is the efficiency of the boiler, furnace and grates combined? (c) What is the efficiency of the boiler and furnace alone? (d) If the interest and depreciation is 10 per cent., how much could you pay for a heater that would increase the temperature of the feed water to 212°?

56. A boiler evaporated 9000 lbs. of water per hour from a feed temperature of 80° into steam at 145.8 lbs. absolute. Coal contains 13,500 B.T.U. and costs \$2.50 per ton. Efficiency of the boiler, furnace and grate, 70 per cent. If we add a feed-water heater that will increase the temperature to

212°, what will be the saving in coal cost per year, if the plant operates 10 hours a day, 300 days in the year?

57. A boiler plant evaporates 30,000 lbs. of water per hour. Feed temperature, 70°; steam pressure, 150 lbs. The evaporation is 8 lbs. of water per pound of coal, and coal costs \$2.50 a ton. If a feed-water heater is installed that will increase the temperature of the feed water to 180°, how much money will be saved per year and how much can be paid for the heater if the interest and depreciation are 10 per cent.? Plant runs 10 hours per day, 300 days in the year.

58. A feed-water heater increases the temperature of the feed from 100° to 200°. Steam pressure, 100 lbs. The plant evaporates 10,000,000 lbs. of steam per year. The cost to evaporate 1000 pounds of steam without the heater is 15 cents. What can we afford to pay for a heater allowing 5 per cent. interest and 8 per cent. depreciation and repairs?

59. A boiler plant develops 500 B.H.P. and uses 4 lbs. coal per H.P. per hour. Coal contains 13,000 B.T.U. per lb. Steam pressure, 150 lbs. Feed temperature, 120°. A feed-water heater is added raising the temperature of water from 120° to 200°. Heater costs \$500. The plant operates 10 hours a day for 300 days a year. The cost of coal is \$3 per ton. (a) Allowing 7 per cent. depreciation, what interest will the owner make on the investment? (b) If later an economizer is added which raises the feed water from 200° to 300°, allowing 5 per cent. interest and 7 per cent. depreciation, how much can the owner pay for the economizer? (c) What would be the efficiency of the plant under this last condition?

60. A boiler plant runs 24 hours per day for 300 days in the year. It burns 30 tons of coal per day costing \$3 per ton. The analysis of the stack gases is CO<sub>2</sub>, 5 per cent.; O, 15 per cent.; N, 75 per cent. The coal contains C, 80 per cent.; H, 6 per cent.; and O, 4 per cent. The plant is changed so that the stack gas analysis is CO<sub>2</sub>, 14 per cent.; O, 6 per cent.; N, 75 per cent. What will be the saving in dollars per year? Stack gas temperature, 600 F. Boiler room temperature, 70°. Boiler radiation loss, 4 per cent.

After this change is made, an economizer is installed which reduces the temperature of the stack gases from 600° to 400°. The evaporation is 9 lbs. of water per pound of coal. Feed-water temperature is 120° F. What will be the final temperature of the feed water? What will be the saving in dollars per year after this second change is made?

## CHAPTER VIII

### STEAM ENGINES

**91. The Simple Steam Engine.**—A simple form of stationary steam engine and one in general use is shown in Fig. 54. It is a small direct double-acting engine with a balanced slide valve and a cast-iron cylinder closed at its ends by cylinder heads bolted on. The engine has no steam jacket and is surrounded on the outside by non-conducting material and cast-iron lagging. Fig. 55 shows the steam chest containing the valves and the ports leading from the steam chest to the cylinder. The

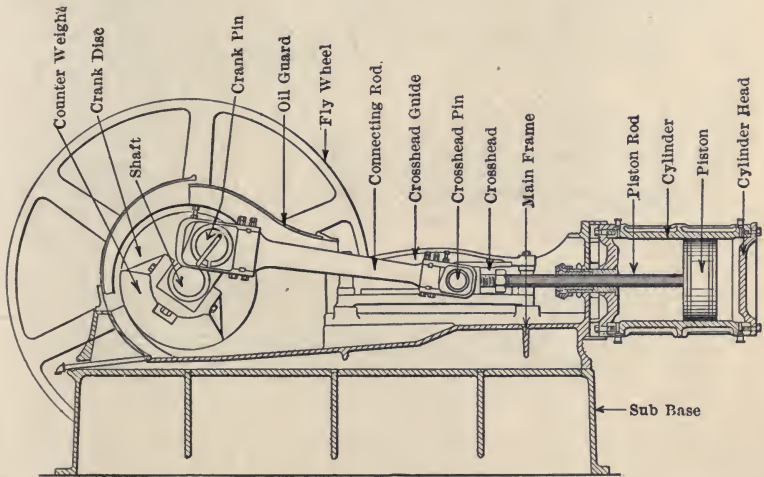

FIG. 54.—Vertical section of Skinner engine.

steam is admitted and exhausted through these ports. The piston is made a loose fit in the cylinder. The spring rings shown in the piston serve to prevent leakage from one side of the piston to the other. The piston rod is usually fastened into the piston head by means of a taper-ended rod and nut, and is then carried through the cylinder head, the gland and packing serving to make a steam-tight joint. The other end of the piston rod is connected with the cross-head. The power is

communicated from the connecting rod to the crank, which is attached to the main shaft. To this main shaft the eccentric is fastened by means of set-nuts. The valve of the engine is driven by the eccentric through the eccentric rod and the valve stem. The valve stem passes through the steam chest, being made tight by the glands and packing, as in the case of the piston rod, and is fastened by lock nuts to the valve. The function of this valve is to admit the steam surrounding the valve to each end of the cylinder alternately. On the opposite stroke,

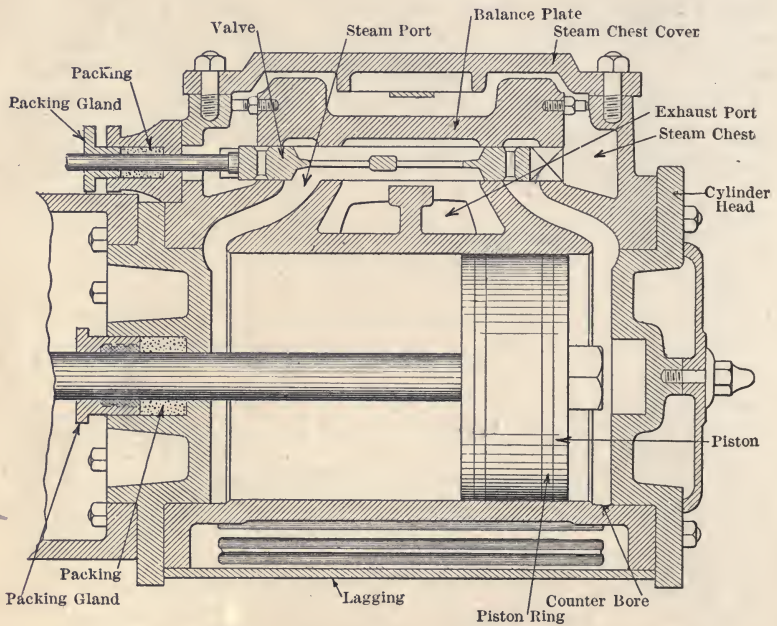

FIG. 55.—Section through steam engine cylinder and valve.

the valve opens up the ends of the cylinder to the exhaust space in the center of the valve, this space being connected to the exhaust pipe of the engine, and the space outside of the valve being connected to the steam pipe admitting the steam to the engine. Fig. 55 shows the slide valve in a position admitting steam to the head end of the cylinder. On the crank end, the cylinder is open to exhaust. As the steam enters behind the piston, the steam in the space on the opposite side of the piston is forced out through the space under the valve and out of the exhaust port. When the piston reaches the opposite end of the stroke, the valve

will have been moved to a similar position at the opposite end. Steam will then be admitted at that end, and the end previously receiving steam will be open to exhaust.

**92. Action of the Steam in the Steam Engine.**—In the simplest form of steam engine, the steam is admitted for the full stroke of the piston and, when the valve opens the cylinder to exhaust, the steam is exhausted at nearly full boiler pressure. This action of the engine is, of course, very uneconomical, and early in the development of the engine it was found desirable to allow the steam to expand in the cylinder. This is accomplished by having the valve close the entrance port before the piston has reached the end of its stroke, then, for the balance of the stroke, as the piston is forced out, the steam pressure in the cylinder is greatly reduced, due to the increased volume of the cylinder.

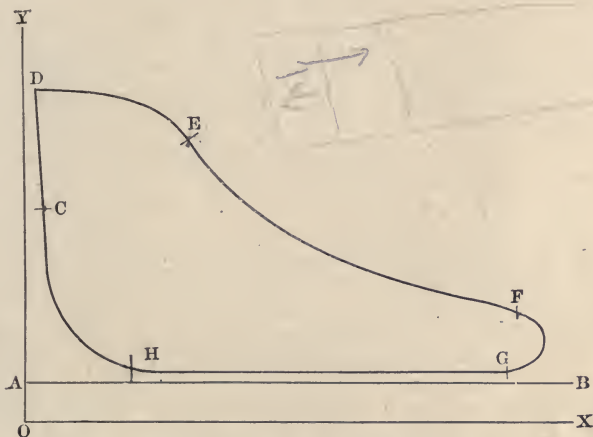

FIG. 56.—Indicator diagram.

Fig. 56 shows graphically the action which goes on in the cylinder. The ordinates of the diagram represent the steam pressure, and the abscissas represent cylinder volumes as the piston moves out. The steam enters along the line  $CDE$ , the pressure at  $D$  being a little below boiler pressure. At the point  $E$ , known as the point of cut-off, the valve closes. The steam expands from the point  $E$  to  $F$ , along the expansion line  $EF$ . At the point  $F$ , called the point of release, the valve opens, and from the point  $F$  to the point  $H$  the exhaust occurs. At the point  $H$  the valve closes the exhaust port and compression of the steam left in the cylinder begins, continuing along the line  $HC$  to the

point *C*. At this point steam is again admitted to the cylinder. A similar action occurs on the opposite end of the cylinder, so while the steam is being admitted at one side, at the opposite side of the piston we have exhaust pressure. Such a diagram is termed an indicator diagram and may be graphically produced by an instrument known as the indicator.

**93. Theoretical Horse-power of a Steam Engine.**—In determining the theoretical horse-power of a steam engine it is assumed that there is no clearance, that the full pressure of steam is maintained during admission, that the cut-off and release occur instantly, and that the engine acts without compression. Then the indicator card of the engine would be as shown in Fig. 57.

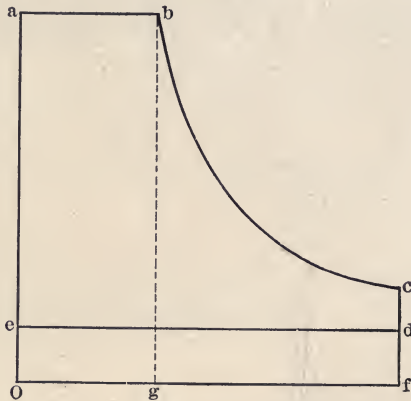

FIG. 57.—Theoretical indicator card.

The curve of expansion is assumed to be a rectangular hyperbola, the equation of which is  $pv = a$  constant, as this is the curve which coincides most nearly with the actual expansion curve in a simple non-condensing engine.

Let the pressure at the point of cut-off *b* be  $p_1$ , and the volume  $v_1$ ; and let the pressure at the point *d* be  $p_2$ , and the volume,  $v_2$ . The area of work is represented by the area

$$abcde = oabg + gbcf - oedf.$$

$$\text{Area } oabg = p_1v_1. \quad \text{Area } gbcf = \int_{v_1}^{v_2} pdv. \quad \text{Area } oedf = p_2v_2.$$

Substituting these values in the previous equation, the area of work,

$$abcde = p_1v_1 + \int_{v_1}^{v_2} pdv - p_2v_2. \quad (1)$$

As  $v_1$  and  $v_2$  are the volumes before and after expansion, the ratio of expansion,

$$r = \frac{v_2}{v_1} \tag{2}$$

Since the expansion curve  $bc$  is a rectangular hyperbola,

$$pv = p_1v_1.$$

Hence substituting for  $p$  its value in terms of  $p_1$  and  $v_1$ , the equation for work becomes

$$abcde = p_1v_1 + p_1v_1 \int_{v_1}^{v_2} \frac{dv}{v} - p_2v_2 = p_1v_1 \left( 1 + \int_{v_1}^{v_2} \frac{dv}{v} \right) - p_2v_2.$$

Integrating, and substituting  $r$  for  $\frac{v_2}{v_1}$ , we have

$$abcde = p_1v_1(1 + \log_e r) - p_2v_2. \tag{3}$$

The average pressure on the card, which is termed the *mean effective pressure*, is found by dividing this by the length of the card  $v_2$ , or

$$M.E.P. = p_1 \frac{1 + \log_e r}{r} - p_2. \tag{4}$$

In actual practice, however, the assumptions made are not fulfilled, and the actual mean effective pressure is less than the theoretical mean effective pressure. The proportion borne by the actual M.E.P. to the theoretical M.E.P. is termed the *diagram factor*,  $e$ . (Trans. A.S.M.E., Vol. 24, p. 751.)

The actual mean effective pressure is

$$M.E.P. = e \left\{ \frac{p_1 (1 + \log_e r)}{r} - p_2 \right\}. \tag{5}$$

This diagram factor is found by experiment and varies from 70 to 90 per cent.

To determine the indicated horse-power of a steam engine, it is necessary to find the work done in the engine cylinder. Assume the engine to have a cylinder  $a$  square inches in cross-section and 1 ft. long, that it is double-acting and makes  $n$  revolutions per minute (r.p.m.), and that the mean effective pressure determined from equation (5) acting on the piston is  $p$  pounds per square inch. Then the total pressure against the piston will be  $pa$  pounds and the space traveled per minute by the piston will be  $2ln$ ; hence the foot-pounds of work done per

2 HP

minute is 2 *plan*. Since 1 horse-power equals 33,000 ft.-lbs. per minute, the indicated horse-power of the engine is

$$I.H.P. = \frac{2 \text{ plan}}{33,000} \quad (6)$$

**Example.**—A 12'' × 15'' double-acting engine runs 200 r.p.m. Cut off,  $\frac{1}{4}$  stroke; steam pressure, 100 lbs.; back pressure, 2 lbs. absolute-Card factor, 80 per cent. Find the rated horse-power of the engine.

**Solution.**—From equation (2), the ratio of expansion,

$$r = \frac{v_2}{v_1} = \frac{1}{\frac{1}{4}} = 4,$$

and from equation (5) the

$$\begin{aligned} M.E.P. &= e \left\{ \frac{p_1}{r} (1 + \log_e r) - p_2 \right\} \\ &= .80 \left\{ \frac{114.47}{4} (1 + \log_e 4) - 2 \right\} = .80 \{ 28.7(1 + 1.39) - 2 \} \\ &= .80 \{ 68.5 - 2 \} = .80 \times 66.5 \\ &= 53.2 \text{ lbs.} \end{aligned}$$

The cross-sectional area of the cylinder,

$$\begin{aligned} a &= \pi r^2 = 3.1416 \times 6^2 \\ &= 113.3 \text{ sq. in.} \end{aligned}$$

From equation (6), the

$$\begin{aligned} I.H.P. &= \frac{2 \text{ plan}}{33,000} \\ &= \frac{2 \times 53.2 \times 1.25 \times 113.3 \times 200}{33,000} \end{aligned}$$

$$A-12 = 91.4.$$

Ans. 91.4 rated horse-power.

**94. Losses in a Steam Engine.**—The action of the steam in the steam engine is different from that which has been assumed as the ideal action. The action of the ideal engine is useful, however, as a basis of comparison for the action of the steam in actual engines. In the actual engine the steam is never expanded completely, and has at the end of the expansion a higher pressure than the back pressure in the exhaust pipe. It is not advisable to give the steam complete expansion, as there will be no added work due to the complete expansion of this steam, the pressure being insufficient to overcome the friction of the engine. Qwing



to the fact that we do not have complete expansion, it is necessary to open the exhaust valve before the end of the stroke so as to bring the pressure at the end of the stroke down to the back pressure. Comparing the ideal diagram, Fig. 57, with the actual diagram, Fig. 56, it will be noticed that the steam during admission in the actual diagram does not remain at full boiler pressure, but that there is a reduction of the pressure due to wire drawing of the steam through the ports of the valve. In the ideal engine there is no transmission of heat to the steam except in the boiler, but in the actual engine there is a transfer of heat from the steam to the cylinder walls during a portion of the stroke, and during other portions of the stroke from the cylinder walls to the steam.

In an actual engine the back pressure in the cylinder is always greater than the vacuum in the condenser owing to the resistance of exhaust valve and passage. In the ideal engine the whole volume of the cylinder is swept through by the piston, and in the actual engine there must be a space at the end of the cylinder to prevent the piston striking the head.

The principal losses of heat from an engine are given as follows, as nearly as possible in the order of their importance.

1. Heat lost in the exhaust. This loss is usually 70 per cent. or more of the entire heat admitted to the engine.
2. Initial condensation.
3. Wire drawing at admission and in exhaust valve.
4. Condensation in the clearance space during compression.
5. Radiation and conduction from the cylinder.
6. Leakage past the piston and valves.

**95. Heat Lost in the Exhaust.**—Most of the heat brought to the engine by the steam is rejected by the engine in the exhaust. This loss varies from 70 per cent. of the heat of the steam in the best engines to over 90 per cent. in the poorer types. In many steam plants this heat is partly recovered by using the exhaust for heating or manufacturing purposes. The steam leaving the exhaust of an engine usually contains from 10 to 20 per cent. of water.

**96. Initial Condensation and Re-evaporation.**—Early experimenters in steam-engine economy found that the surfaces of the cylinder wall and steam ports played a very important part in the economy of the steam engine. The inner surfaces exposed to the action of the steam in the engine naturally have a temperature very close to that of the steam itself. When the steam

enters the cylinder, it comes in contact with the walls of the cylinder which have just been exposed to exhaust steam and are necessarily at a lower temperature. A part of this steam will, therefore, be condensed in warming the walls, and as the piston moves out more, more of the walls will be exposed, so that condensation increases to a point even beyond the point of cut-off. After the point of cut-off the steam expands, the pressure falls, and the temperature drops until a point is reached where the temperature of the cylinder walls is about the same as the temperature of the steam in the cylinder. Condensation ceases at this point and the cylinder walls are by this time covered with a film of moisture. If the expansion of the steam is still further increased, the temperature in the cylinder corresponding to the steam pressure will be less than the temperature of the cylinder walls, and this film of moisture on the surface will begin to re-evaporate. Usually the amount of re-evaporation is very much smaller than the initial condensation and the cylinder walls are still wet when the exhaust valves open. This re-evaporation also continues during the exhaust stroke. It is very desirable that all the moisture on the surface of the cylinder be evaporated before the end of the exhaust. If it is not evaporated, the cylinder walls will be wet when steam is again admitted to the cylinder and the initial condensation will be greatly increased. The transfer of heat from the steam to the walls of the cylinder is always increased by the presence of moisture.

In the average non-condensing engine, initial condensation is from 15 to 20 per cent., in small reciprocating steam pumps an initial condensation as high as 75 per cent. sometimes occurs, and in the most perfect engines it is from 10 to 12 per cent.

**97. Factors Affecting Initial Condensation.**—Initial condensation is always increased by increasing the *range of temperature* in the cylinders.

It also increases as the *proportion of the area of the cylinder walls to the volume of the cylinder* increases. The greater this ratio, the less the economy, as the more wall that is exposed the more heat the wall will take up. This accounts for the large consumption of steam shown by most rotary engines.

*Time* is also important, and other conditions being the same, the slower the speed of the engine, the greater the initial condensation, as the whole action depends upon the time during which the heat has an opportunity to be taken up or given off by

the cylinder walls. As the element of time during which the steam is in contact with the walls of the cylinder increases, the initial condensation increases. The changes of temperature only affect the inner surfaces of the cylinder, and the greater the time, the greater the depth of cylinder walls that will be affected.

Initial condensation increases as the *ratio of expansion* is increased, that is, as the cut-off becomes shorter. This is easily explained; as the cut-off is shortened, the weight of steam admitted to the cylinder becomes less and the amount of heat taken up by the cylinder walls remains substantially the same, so that the proportion of steam condensed increases. With very short cut-offs this initial condensation becomes very large. When the cut-off is reduced below a certain point, the increased initial condensation offsets the increase in economy due to longer expansion. If the cut-off is shortened to less than this point, the steam consumption of the engine will be increased. The point of greatest economy in most single-cylinder engines is from one-quarter to one-fifth stroke. In an engine having a short cut-off and using a high steam pressure, the economy may often be increased by reducing the steam pressure, thereby increasing the cut-off.

**98. Steam Jacket.**—The action of initial condensation is increased by the loss of heat through the cylinder wall by conduction. This may be reduced by surrounding the cylinder with steam at boiler pressure. Such an arrangement is called a *steam jacket*. The effect of the steam jacket is to reduce initial condensation and to increase the re-evaporation. The steam used by the steam jacket is always charged to the engine as though it had been used in the cylinder. Engines with jackets show increased economy, particularly when operated at slow speed. The higher the speed of the engine, the less is the element of time during which the jacket can affect the steam in the cylinder and the less effective the jacket becomes. In cases of slow-speed engines with large ratios of expansion, the use of the jacket will show a saving of from 10 to 20 per cent.

**99. Superheating.**—Superheating the steam previous to its admission to the engine is used as a means of reducing initial condensation. A sufficient amount of superheat should be given to the steam so that on admission of steam to the cylinder, the cylinder walls take up this superheat instead of condensing the

steam. The effect of this is to leave the cylinder walls entirely dry, reducing the amount of heat which would be conducted to the walls, as dry gas is one of the best non-conductors of heat. The experiments of Professor Gutermuth show that with sufficient superheat the economy of a simple non-condensing engine may be made to equal that of a compound condensing engine.

**100. Compound Expansion.**—By increasing the steam pressure and using a longer range of expansion, the range of temperatures in the cylinder of a steam engine is much increased, thereby increasing the initial condensation. In order to reduce the range of temperatures in the cylinder, it has been found more economical partially to expand the steam in one cylinder and then exhaust the steam into a second cylinder in which the expansion is completed. By this means the range of temperature in each cylinder is reduced and initial condensation reduced. Compound cylinders are only used when the steam pressure is sufficiently high so that the initial condensation would be excessive if the steam were expanded in one cylinder. With steam pressures less than 100 lbs., compound engines are seldom used. It is not necessary to use compound engines for less than 125 lbs. pressure unless the ratio of expansion is very large.

**101. Wire Drawing.**—The resistance offered by the valves, ports, and passages lowers the pressure of the steam in the cylinder during admission and raises the pressure during exhaust. As the valves do not close instantly when the valve nears the point of closing, or cut-off, the pressure is reduced owing to the small port opening. This is shown by the rounded corners at cut-off and release. This resistance is often called "*throttling*" or "*wire drawing*." The effect of this throttling of the steam is to slightly dry the steam and, if it were absolutely dry to start with, there would be a small amount of superheating. It will be noticed in the indicator diagram, Fig. 56, that the initial line *DE* is not absolutely horizontal, but that there is a gradual reduction of pressure from *D* to *E*. The initial pressure line is always lower than the boiler pressure, owing to the resistance of the passages between the boiler and the cylinder.

The steam in passing through the piping leading to the engine loses a certain quantity of heat, with a corresponding condensation. It is customary to place a separator in the main just before it reaches the engine so that this water of condensation can be removed from the steam.

**102. Clearance and Compression.**—In order that the piston may not strike the end of the cylinder, it is necessary to leave a small space between the piston and the cylinder head. In addition there is always some space in the steam ports between the valve and the cylinder. The volume of the ports between the valves and the cylinder, together with the space between the piston at the end of its stroke and the cylinder head, is called the *clearance*. It is usually determined by placing the piston at the extreme end of its stroke and filling the clearance space with water. Knowing the weight and temperature of the water put into the clearance space, the volume of the water may be determined. Dividing the volume of the clearance by the volume of

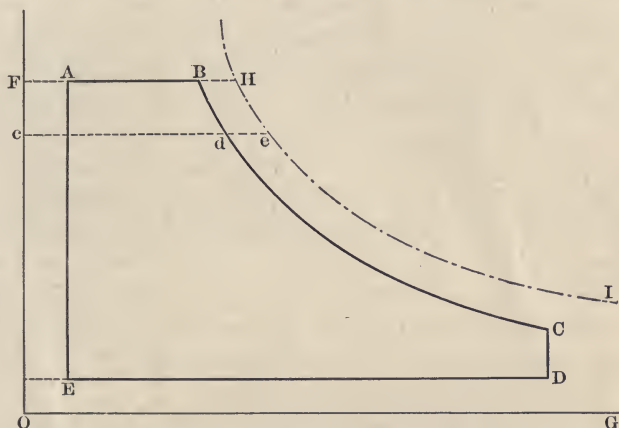

FIG. 58.—Theoretical indicator card showing clearance.

the piston displacement gives the *per cent. of clearance*. The clearance in engines varies from 1 to 10 per cent. The steam in the clearance affects the expansion curve of the engine.

In Fig. 58,  $ED$  represents the piston displacement, and  $AB$  represents the volume of the steam admitted to the cylinder. The apparent ratio of expansion is

$$\frac{ED}{AB} \quad (7)$$

Actually, however, the steam expanding includes not only the steam admitted from the boiler, but also the steam left in the clearance, so that the real ratio of expansion is

$$\frac{ED + AF}{AB + AF} \quad (8)$$

The clearance of the engine alters the amount of steam consumed per stroke of the engine. In order to reduce the amount of live steam to fill the clearance at each stroke, the exhaust valves of the engine are closed before the end of the stroke, and for the balance of the stroke the steam is compressed. This compression of the steam serves to fill the clearance space with steam at a higher pressure than the exhaust pressure. In addition, compression of steam in the clearance space serves to retard the reciprocating masses in the engine and bring them to rest at the end of the stroke. If an engine is operated with too little compression, it will be found to pound at the end of the stroke. The effect of compression, or the cushioning of the piston, is materially increased by the *lead* of the engine. The lead is the amount the valve is open when the piston reaches the end of its stroke. In order to have lead it is necessary to open the valves before the end of the stroke, and this steam admitted before the end of the stroke serves to assist in cushioning the piston and reciprocating parts.

We may consider the steam occupying the cylinder as composed of two parts: the part that has been left in the clearance, which is called *cushion steam*; and the part that has been admitted from the boiler, which is called *cylinder feed*. If it is desired to determine the amount of steam that is expanding in an engine, it is necessary to add to the weight of the steam fed from the boiler the weight of the steam left in the clearance space. The sum will be the total steam expanding in the engine.

The compression of the steam in the clearance space always involves a loss. Just previous to compression, the cylinder walls have been exposed to the exhaust steam. During compression the steam compressed has its temperature increased, and when the temperature of the compressed steam exceeds the temperature of the walls, condensation begins to occur. The action is similar to initial condensation.

### PROBLEMS

1. An electrical plant runs a factory having five 10 H.P. motors, two 20 H.P. motors, four 30 H.P. motors. Efficiency of the motors, 80 per cent.; transmission, 80 per cent.; of the engine and dynamo combined, 80 per cent. What should be the H.P. of the engine plant and kilowatts of the generator?

2. A street car plant uses ten cars each requiring an average horse-power of 75 at the wheels. Efficiency of car is 60 per cent.; of transmission, 75 per cent.; of sub-stations, 75 per cent.; and of main engines and dynamo, 75 per cent. M.E.P. of engine, 40 lbs.; r.p.m., 150. Plant has two engines

of equal size. What are the dimensions of their cylinders? Assume 600 ft. per minute piston speed.

3. Assume the mean effective pressure to be 40 lbs., the number of revolutions to be 75 per minute, and the length of the stroke to be 42 in., and determine the diameter of the cylinder of a double-acting engine which will develop 200 H.P.

4. An engine is  $18'' \times 36''$  and runs 100 r.p.m. Initial pressure, 100 lbs.; back pressure, atmospheric; cut-off,  $\frac{1}{4}$  stroke. What H.P. will be developed? Assume card factor of 85 per cent.

5. An engine is  $8'' \times 12''$ ; initial steam pressure, 100 lbs. gage; back pressure, 3 lbs. gage; cut-off,  $\frac{1}{4}$ ; the expansion curve is an isothermal of a perfect gas; r.p.m., 250. What is the horse-power of the engine? Card factor, 85 per cent.

6. Determine the horse-power of a  $13'' \times 18''$  double-acting engine when making 220 r.p.m. while taking steam at 80 lbs. gage and cutting off at  $\frac{1}{4}$  stroke. Neglect the clearance and assume that the mean back pressure is 20.5 lbs. absolute, and that the card factor is 80 per cent.

7. An engine is  $18'' \times 30''$ ; cut-off,  $\frac{1}{4}$  stroke. It runs 100 r.p.m. Initial steam pressure, 80 lbs. Exhaust, atmospheric. What would be the increase of horse-power if the cut-off was increased to  $\frac{1}{2}$  stroke and initial pressure to 150 lbs.? Card factor, 80 per cent.

8. An engine is  $8'' \times 12''$  and makes 300 r.p.m.; cut-off,  $\frac{1}{4}$  stroke; exhaust, atmosphere. What would be the horse-power of the engine at the following gage pressures: 60, 80, 100, and 120 lbs.? Card factor, 75 per cent.

9. What would be the horse-power developed under the different conditions stated in Problem 8, if a condenser were added and the back pressure reduced to 2 lbs. absolute?

10. An engine is  $18'' \times 30''$ ; runs 100 r.p.m., and initial pressure is 100 lbs. Atmospheric exhaust. A condenser is added bringing the exhaust down to 2 lbs. absolute. In both cases cut-off occurs at  $\frac{1}{4}$  stroke. Card factor, 80 per cent. (a) How much is the horse-power of the engine increased? (b) If the power is sold for \$60 per horse-power per year, how much could be paid for a condenser, allowing 5 per cent. for interest and 6 per cent for depreciation?

11. An engine is to develop 600 H.P. at a piston speed of 600 ft. per minute. Initial steam pressure, 100 lbs. Exhaust pressure, 1 lb. gage. Cut-off at  $\frac{1}{4}$  stroke. Speed, 100 r.p.m. Card factor, 85 per cent. (a) What should be the stroke and diameter of the cylinder? (b) What should be the diameter if the back pressure is 2 lbs. absolute?

12. An engine is to develop 1000 H.P. at  $\frac{1}{4}$  cut-off and 120 r.p.m. Initial steam pressure, 125 lbs; back pressure, atmospheric; piston speed not to exceed 720 ft. per minute. What should be the dimensions of the cylinder? Card factor, 70 per cent.

13. The cylinders of a locomotive are 19 in. in diameter and have a 24-in stroke. The driving wheels are 7 ft. in diameter, and the mean back pressure against which the piston works is 19 lbs. absolute. Determine the horse-power developed by the locomotive when taking steam at 150 lbs. gage

and cutting off at  $\frac{5}{8}$  stroke, while traveling at a speed of 40 miles per hour Card factor, 75 per cent.

14. An engine has a clearance volume which is 0.08 of the volume swept through by the piston per stroke. If the steam be cut off at  $\frac{1}{8}$  stroke, what will be the number of times it is expanded?

15. A 12"  $\times$  14" double-acting engine develops 97 H.P. when running 260 r.p.m. and at  $\frac{3}{8}$  cut-off. Pressure, 70 lbs. What is the weight of steam actually used per I.H.P. per hour, assuming that one-quarter of that theoretically required is lost through condensation, radiation, etc.

16. A tank contains 1000 cu. ft. of air at a pressure of 1000 lbs. per square inch absolute and a temperature of 60° F. This tank is used to run an 8"  $\times$  12" double acting air engine;  $\frac{1}{4}$  cut-off; 200 r.p.m. The initial pressure of air entering the engine is 60 lbs. per square inch absolute. How long will the tank run the engine?

17. A tank contains 200 cu. ft. of air at 200 lbs. absolute and a temperature of 60° F. How long will it operate a 4"  $\times$  6" double-acting air engine running 100 r.p.m.? Cut-off  $\frac{1}{4}$  stroke. Engine takes air at 60 lbs. absolute. Temperature constant.

18. A double-acting compressed air locomotive has two air tanks each 3'  $\times$  12'. These tanks supply two 8"  $\times$  12" cylinders. The cylinders take their air through a pressure reducing valve at 100 lbs. per square inch absolute, the original pressure in the tanks being 1000 lbs. per square inch absolute. (a) If the air acts at a constant temperature of 60° F. and the expansion in the engine is isothermal, how long will the tanks run the engine at  $\frac{1}{4}$  cut-off in the cylinder? (b) How many horse-power will be developed when the engine runs 150 r.p.m., assuming a card factor of 90 per cent.?

Yosemite Lodge Co  
 CAMP CARRIERY  
 Yosemite Valley  
 CALIF  
 1920



## CHAPTER IX

### TYPES AND DETAILS OF STEAM ENGINES

**103. Classification.**—Engines may be classified according to whether they exhaust into the atmosphere or into a condenser, into:

1. Non-condensing engines.
2. Condensing engines.

In the non-condensing engine the exhaust passes directly to the atmosphere. In condensing engines the exhaust steam passes into a cold chamber where, by means of a cooling medium, the steam is changed to water. This produces a vacuum so that the exhaust occurs at a pressure lower than that of the atmosphere. The condensed steam is removed and the vacuum is sustained by means of an air pump.

Another classification may be made according to the way in which their speed is governed, as:

1. Throttling engines.
2. Automatic engines.

In the throttling engines the speed of the engine is controlled by means of a valve in the steam pipe which regulates the pressure of the steam entering the engine. In the automatic engine the pressure of the entering steam remains constant and the governor controls the amount of steam admitted to the cylinder.

Engines may also be classified according to the number of cylinders in which the steam is allowed to expand successively as:

1. Simple engines.
2. Compound engines.
3. Triple expansion engines.
4. Quadruple expansion engines.

In a simple engine the steam expands in but one cylinder, and is then allowed to exhaust. In a compound engine a portion of the expansion occurs in the high-pressure cylinder, and from there the steam passes to the low-pressure cylinder, where it is further expanded to a pressure approximating the exhaust pressure. In the triple-expansion engine the steam expands successively in three cylinders, and in the quadruple in four.

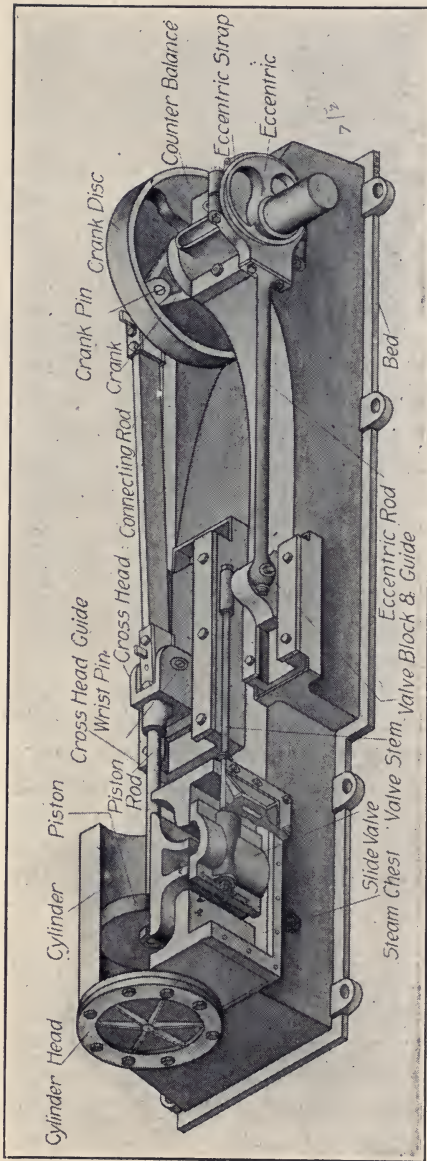

FIG. 59.—Block plan of steam engine.

A fourth classification depends upon the position of the cylinder, as:

1. Vertical engines.
2. Horizontal engines.

**104. Plain Slide Valve Engine.**—The simplest form of engine is the plain D-slide valve engine, as shown in Fig. 59.

The valve is shown in its normal position in the steam chest. A cross-section of a valve of this type showing the steam ports is shown in Fig. 90.

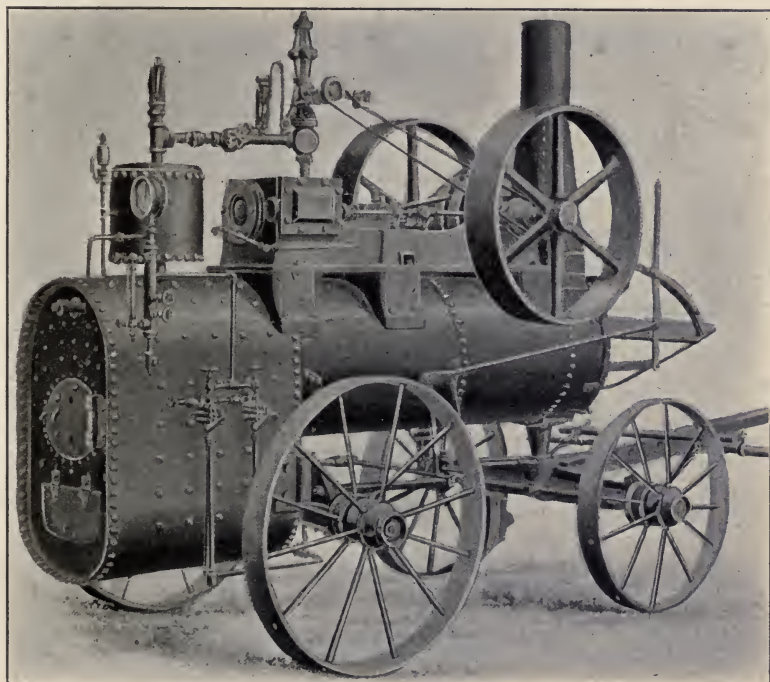

FIG. 60.—Portable engine and boiler.

This type of engine is used where high economy is not necessary. It requires little attention, and is easily repaired and adjusted. Fig. 60 shows a boiler and engine of this type arranged so as to be portable. These engines are governed by a throttling governor of the fly-ball type, as shown in Fig. 60, which controls the speed of the engine by changing the pressure of the steam in the steam chest.

**105. Automatic High-speed Engine.**—This class of engines has developed rapidly since the introduction of electrical lighting machinery, and is designed primarily for the direct driving of

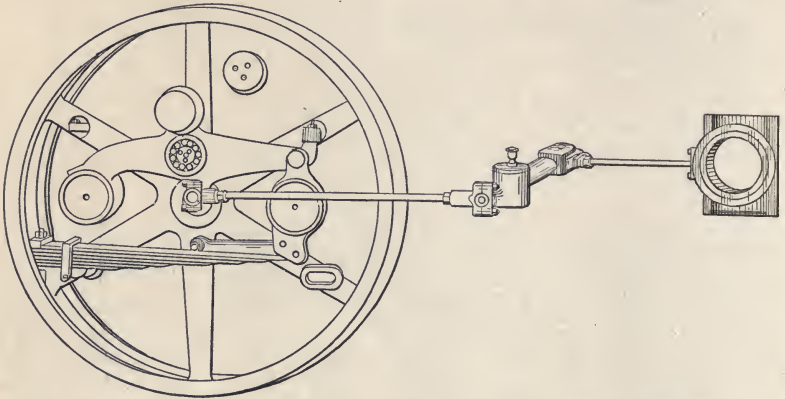

FIG. 61.—Governor, eccentric rod, rocker shaft, valve and valve stem.

electric generators. These engines have balanced slide valves such as are shown in Fig. 55. The governors in this class of engines control the valve directly, and it is necessary that the

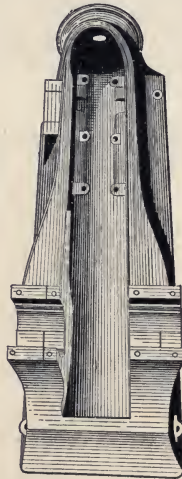

FIG. 62.—Bed of high-speed, center-crank engine.

valve be balanced so that it may be moved easily by the governor. Fig. 61 shows the governor, eccentric rod, rocker shaft, valve stem, and valve.



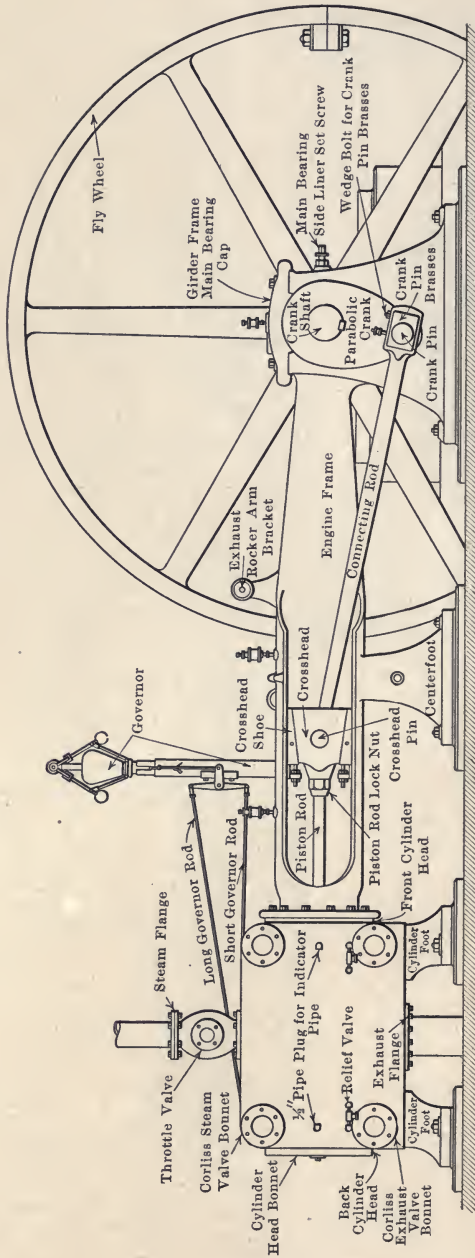

FIG. 64.—Elevation of Corliss engine.

Engines of this class are well adapted to a high rotative speed. The stroke of these engines is usually short, so that the average piston speed may exceed 600 ft. per minute when the engine runs at a large number of revolutions per minute.

Most engines of this class are of the center crank type so that all parts of the engine are supported on one casting.

Fig. 62 shows the bed of a center-crank high-speed engine. This bed is so designed that all parts are accessible and may be removed. It may be machined at one setting. This insures perfect alignment of the various parts of the engine. This bed casting is bolted to a suitable brick or cement foundation.

**106. Corliss Engine.**—These engines are described and the action of their valves explained in paragraph 136. Figs. 63 and 64 show a plan and side elevation of a Corliss engine.

**107. The Stumpf Uniflow Engine.**—In 1910 Professor Stumpf of Charlottenburg, Germany, brought out an engine which he called a uniflow engine and which promises to give materially better economy than the ordinary reciprocating engine. This engine was not new in principle as the patent had been taken out in 1886 but had not been used. It obtains its economy largely through reducing the initial condensation losses. It is of the four-valve type.

Fig. 65\* shows a section through the cylinder. This cylinder has no exhaust valves but in the middle of the cylinder there is a ring of ports which are uncovered by the piston at the end of each stroke so that the piston is the exhaust valve. There are two steam valves *A* in the cylinder heads, and the steam spaces over the valves have the clearance pockets *B* which completely steam jacket the heads. In the uniflow engine, the piston faces and cylinder heads are exposed to exhaust temperature only during the short time that the piston uncovers and covers the exhaust ports. On the return stroke the steam remaining in the cylinder is compressed in the clearance spaces up to the admission pressure. The temperature also increases in the compression space, not only due to compression but also to the absorption of heat from the jacketed head.

The cylinder Fig. 65 is a simple cylindrical casting with a belt cast in the middle for the exhaust passage. The steam chest is integral with the cylinder and provided with two drums *C* to take up expansion without distorting the cylinder. Each cylinder has

\* Taken from *Power*, June 11, 1912, vol. 35, No. 24, p. 830.

a large valve *D* open into a pocket *D* in the cylinder head. This valve opens automatically to serve as a relief valve to let out entrained water. It also serves as extra clearance to prevent excessive pressure if the vacuum should be lost when the engine is operating non-condensing. In the particular form of inflow engine described the valves are Corliss valves and operated by the usual Corliss valve mechanism. These engines have shown very low steam consumption particularly with superheated steam. In a recent test a simple single-cylinder engine, non-condensing, developed a horse-power with  $11\frac{1}{4}$  lbs. of steam. In addition they have a flat economy curve and are capable of taking very heavy overloads.

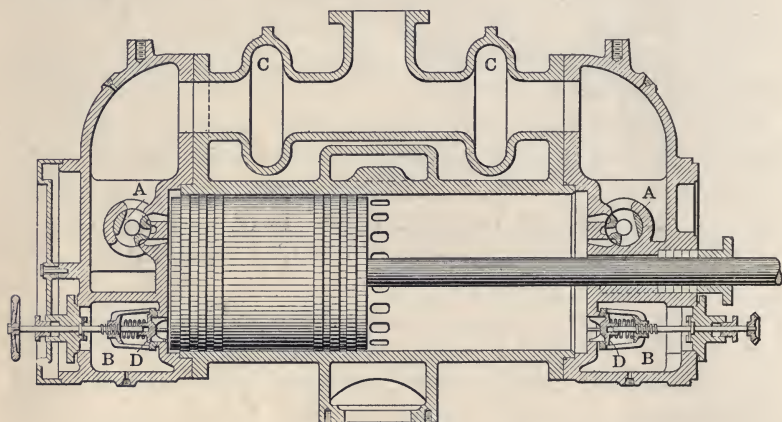

FIG. 65.—Section of Stumpf engine.

**108. Engine Details.**—Fig. 66 shows the piston and piston rod. The piston is turned a little smaller than the cylinder, and is made tight in the cylinder by means of spring rings. These rings are shown in the figure leaning against the piston rod. They are made of cast iron and are so constructed that they have to be compressed in order to get them into the cylinder, and when the piston is in place, the rings bear firmly against the cylinder walls. The piston with rings in place is shown in Fig. 67. In Fig. 68 is shown a piston, piston rod, and cross-head. The piston is attached to the piston rod by a taper pin and lock-nut, and the other end of the piston rod is screwed into the cross-head and fastened by a lock-nut. The cross-head pin is also shown in the cross-head.



Fig. 69 shows a solid-ended connecting rod. These rods are usually made of forged steel. The bearings that enclose the pin are made of brass and fitted into the ends of the rods. These

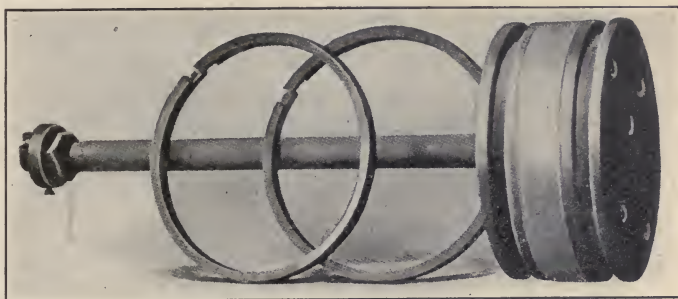

FIG. 66.—Piston and piston rings.

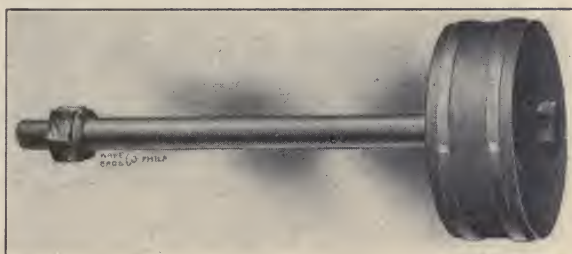

FIG. 67.—Piston with rings in place.



FIG. 68.—Piston, piston rod and crosshead.

bearings, or brasses, are taken up when they wear by means of wedges held by lock-nuts as shown in the cut.

Fig. 70 shows a strap-ended connecting rod. In this form of rod the brasses are held in place by steel straps that encircle them. These straps are fastened to the body of the connecting

rod by means of a taper key and a cotter. The brasses in this rod are shown lined with babbitt metal which is much softer than the steel pins themselves.

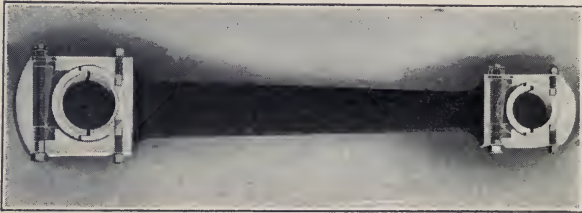

FIG. 69.—Solid end connecting rod.

Fig. 71 shows the crank-shaft and its counterbalance weights which are bolted to the crank. The crank-shaft is a solid forging of open-hearth steel. The counterweights are made of cast iron.

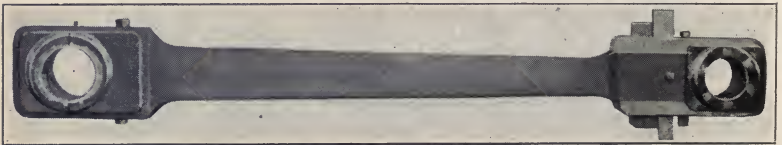

FIG. 70.—Strap end connecting rod.

The crank-shaft shown in the figure is designed for a center-crank engine.

Fig. 72 shows one of the main bearings for the crank-shaft. The figure shows what is called a four-part bearing. The

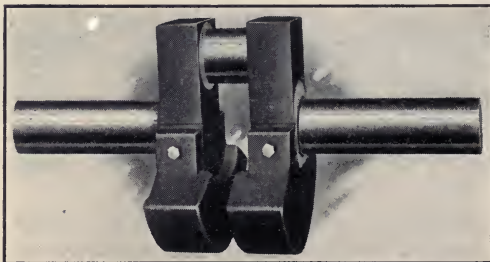

FIG. 71.—Counter-balanced crank.

bearing proper is made up of four pieces. The two side pieces, or brasses, take up most of the wear in the bearing and are

adjusted by means of set screws fastened with lock-nuts. The upper part of the brasses is adjusted by a screw in the top of the bearing. The brasses are supported by the main frame of

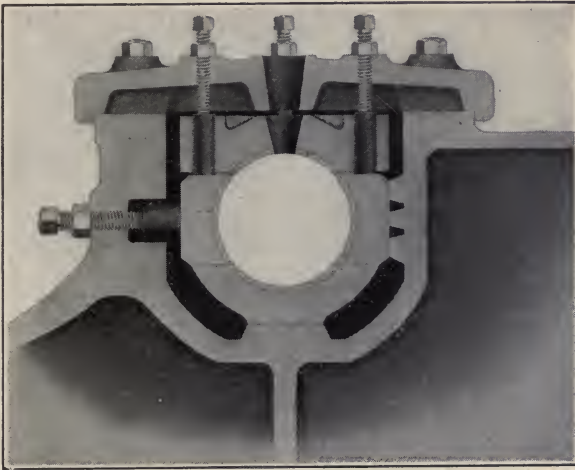

FIG. 72.—Main bearing, four part.

the engine and held down by a main bearing cap bolted to the main frame of the engine.

Fig. 73 shows the eccentric strap and eccentric rod. The eccentric strap is driven by an eccentric sheave the position of

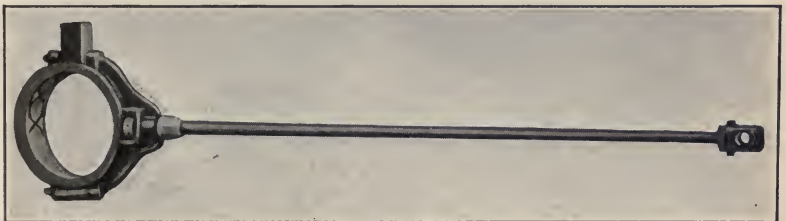

FIG. 73.—Eccentric strap and eccentric rod.

which is determined by the governor. Fig. 74 shows the eccentric sheave.

In Fig. 75 is shown the eccentric strap more in detail. The strap is split in two parts and bolted together so that it can be placed over the sheave.

In Fig. 76 is shown the main frame for a side-crank engine.

This cut shows a main bearing with a three-part box. The side brasses in this box are adjusted by wedges moved by set-nuts on the top of the bearing.

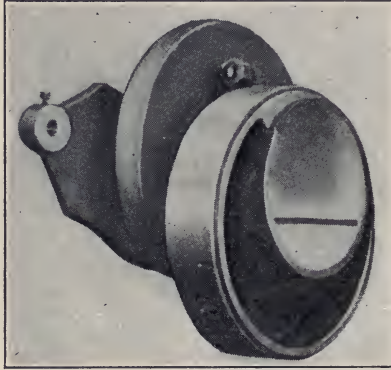

FIG. 74.—Eccentric sheave for shaft governor.

Figs. 77 and 78 show two views of a main engine-bearing having an oil cellar. The lower part of the cellar is filled with oil which is carried up onto the bearing by means of a chain

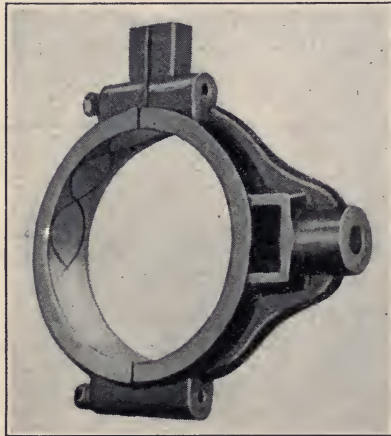

FIG. 75.—Eccentric strap.

which hangs over the shaft and dips into the cellar. The chain is moved by the rotation of the shaft, bringing the oil up on to the shaft.

109. Lubricators.—Although not a part of the engine itself, the lubricator is so intimately associated with it that it seems desirable to describe its action at this point.

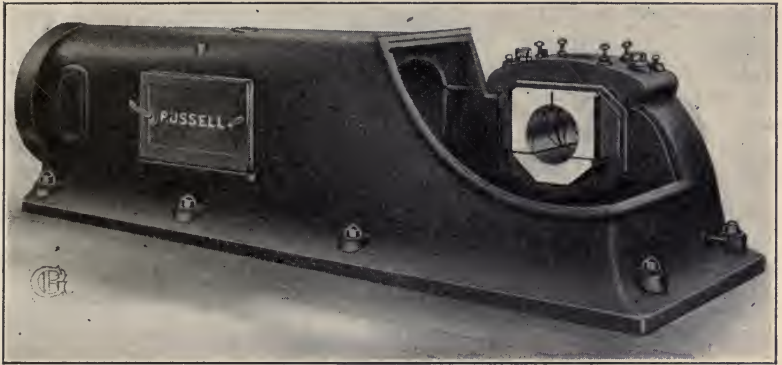

FIG. 76.—Frame for side crank engine.

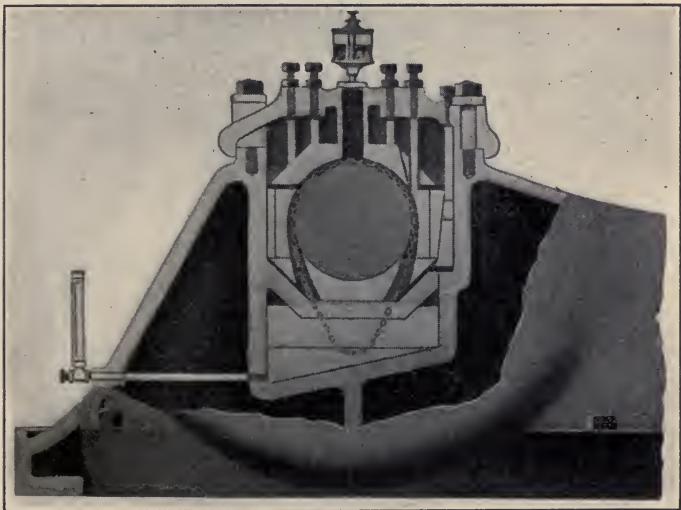

FIG. 77.—Main engine bearing with oil cellar—cross-section.

A cross-section of a sight feed lubricator is shown in Fig. 79. The lubricator is connected to the steam main just before the main enters the steam chest, and its purpose is to supply oil for

lubricating the engine cylinder. This oil is carried into the cylinder by the entering steam.

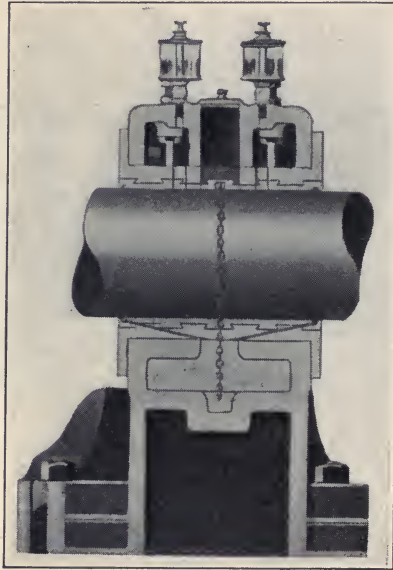

FIG. 78.—Main bearing with oil cellar—transverse-section.

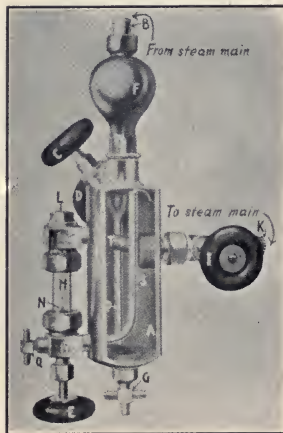

FIG. 79.—Sight-feed lubricator.

“Steam being admitted into pipe ‘B’ and condenser ‘F’ condenses, thus forming a column of water which exerts a pressure

equal to its head plus the difference in specific gravity between oil and water, through the tube 'P' on the oil in reservoir 'A.' By this excess pressure the oil is forced from reservoir 'A' through the tube 'S' and sight feed nozzle 'N' into the sight feed chamber 'H.' The sight feed chamber being filled with water, the drop of oil floats to the top and passes to the point to be lubricated through the passage 'T' and support arm 'K.'"

## CHAPTER X

### TESTING OF STEAM ENGINES

**110. The Indicator.**—The indicator is a device by which the pressure of the steam for each point in the stroke of the engine is graphically recorded. It was first invented by James Watt and has since reached a high state of perfection.

There are three principal things determined by an indicator:

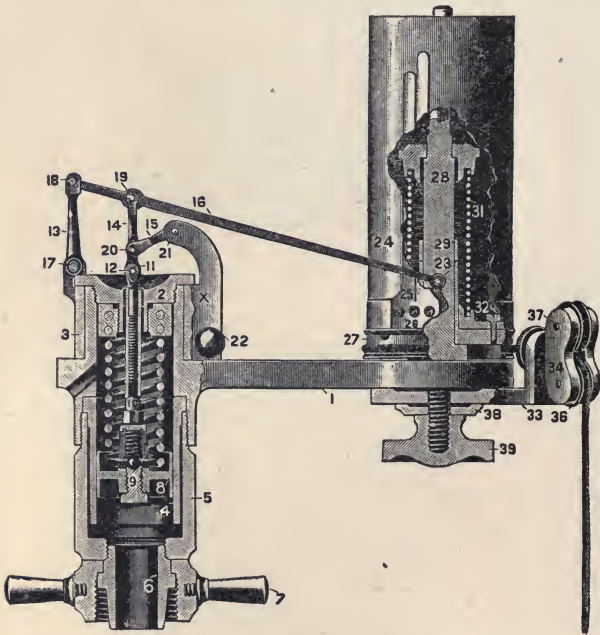

FIG. 80.—Crosby indicator.

*First*, the average pressure of the steam acting against the piston, which is called the mean effective pressure (M.E.P.).

*Second*, the distribution of the steam in the engine; that is, the point at which the valves of the engine are opened and closed. By the use of the indicator we are able to determine whether or not the engine has a proper distribution of steam.



*Third*, from the indicator we may determine the actual weight of steam which is being worked in the engine cylinder. The indicator makes possible a complete analysis of the action of the steam engine.

Fig. 80 shows a cross-section of a Crosby steam-engine indicator. This instrument is attached to the engine cylinder, and the space under the piston 8 is in direct communication with the

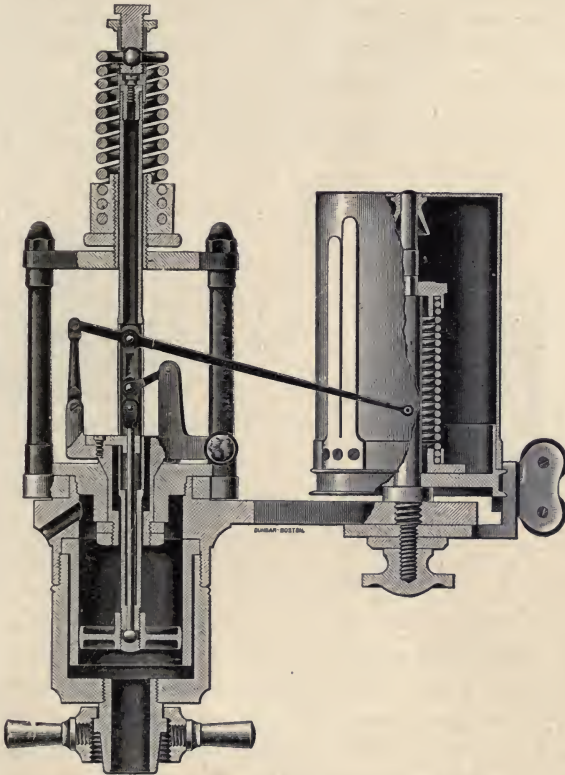

FIG. 81.—Crosby indicator with outside spring.

engine cylinder. The pressure of the steam acts against the piston 8, compressing a spring above it. The pressure of the steam raises an arm 16, and the attached pencil at 23. The drum 24 is covered with a sheet of paper; a cord passing over a pulley 34 is attached to the engine cross-head through a reducing motion, so that with each stroke of the engine the drum makes almost a complete revolution. The movement of the drum corresponds

to the movement of the piston, and the upward movement of the pencil corresponds to the pressure in the cylinder. We have a diagram, therefore, of the pressure in the cylinder for each point in the stroke of the engine. The springs used above the piston are of various strengths. What is termed a 40-lb. spring would be one of such strength that a pressure of 40 lbs. per square inch under the piston would move the pencil one inch. These springs are carefully calibrated so that certain movements of the piston give a corresponding movement of the pencil on the paper.

A brass stylus is sometimes used in place of a pencil. This has the advantage of always keeping a sharp point. In this case the indicator cards are taken on a specially prepared paper with a metallic surface, as no mark would be made on ordinary paper.

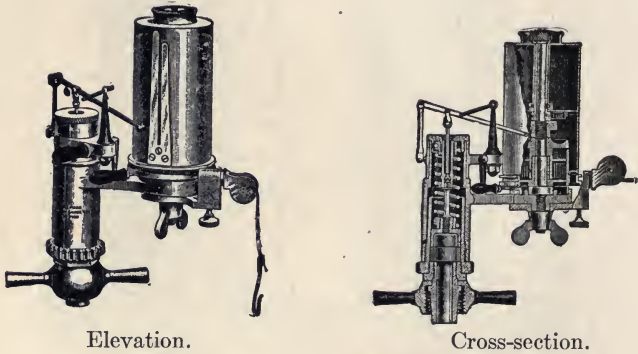

FIG. 82.—Thompson indicator.

One disadvantage of the use of the stylus and metallic surfaced paper is that the outline traced by the brass point is not permanent, but will fade out in a comparatively short time.

Fig. 81 shows a similar indicator with the spring external to the indicator piston. The temperature of the spring in this indicator is independent of the steam pressure. The spring in this indicator may easily be changed without removing the indicator piston. This form is particularly adapted for indicator work where great accuracy is desired.

Fig. 82 shows the elevation and cross-section of the Thompson indicator. This form of indicator is particularly well adapted to hard service.

**111. Use of Indicator.**—The accuracy of an indicator depends upon the accuracy with which the pressure in the cylinder is

recorded on the indicator drum, and also upon the accuracy with which the motion of the piston is conveyed to the indicator drum. In order to have the pressure recorded properly, the following conditions should be observed: the piping leading to the indicator should not be more than 18 in. long, and should be  $\frac{1}{2}$  in. in diameter; the indicator should never be connected to a pipe through which a current of steam is passing; the holes connecting the indicator with the cylinder should be drilled into the clearance space so that the piston will not cover the opening; the indicator should, if possible, be placed in a vertical position.

Where great accuracy is desired the indicator spring should be calibrated before and after the test.

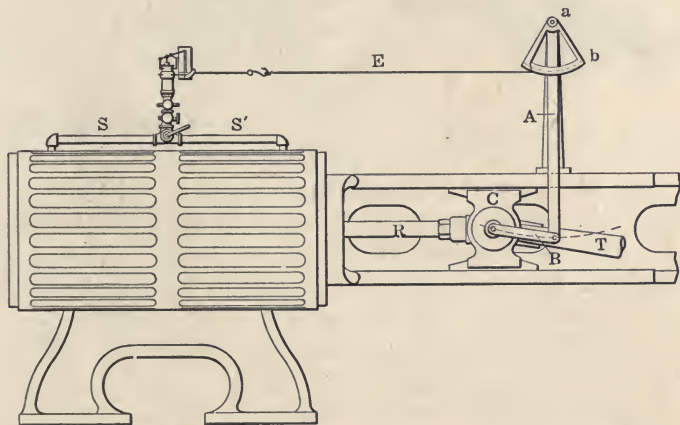

FIG. 83.—Reducing motion, showing method of attachment.

The motion of the drum may be taken from any part of the engine which has the same relative motion as the engine piston. The movement of the drum, which is usually taken from the cross-head, must be reduced to the length of the indicator diagram by some form of mechanism which makes the reduced motion an exact ratio to the movement of the engine piston. The indicator drum is then connected with this reduced motion of the piston by means of a cord. A reducing lever and segment is one of the commonest means used to accomplish this reduction. There are also on the market various forms of reducing wheels which make the reduction by means of gearing and pulleys. These reducing motions are more satisfactory when they are provided with a clutch so that the drum may be disengaged without

removing the cord connection from the reducing motion to the engine.

Fig. 83 shows a simple form of reducing motion made of hard wood splines and a brass segment. It is better to use a segment of a circle at the point *b*, so that *ab* is the same distance for every point of the stroke.

Fig. 84 shows a reducing wheel having a clutch, so that it is not necessary to disconnect the motion from the cross-head when the paper on the drum is replaced.

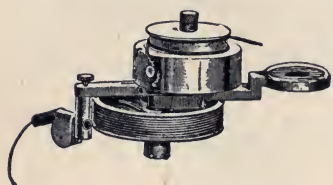

FIG. 84.—Reducing wheel.

Cord that has been stretched should be used on the indicator and reducing motion, so that the give of the cord will not reduce the length of the card. Wherever very long cords are found necessary, it is better to replace the cord with piano wire.

#### 112. Taking an Indicator Card.—

Before attaching the indicator, oil the parts of the mechanism with watch oil and the piston with cylinder oil. Be sure the piston is working freely in the cylinder. The piston should drop by gravity in the cylinder when the spring is removed. The pencil should have a smooth, fine point. Be sure there is no lost motion in the instrument.

The reducing motion should be adjusted so that the length of the card is from  $2\frac{1}{2}$  to 3 in. The higher the speed, the shorter should be the card. The tension of the indicator drum spring should be just sufficient to prevent slackness in the cord. Before taking a card, try the indicator and see that it does not strike the stops at either end of the stroke. The cord should run to the indicator over the center of the guide pulleys. Steam should be turned on the indicator a few moments before taking the card so as to warm up the instrument.

**113. To Find the Power of the Engine.**—The piston area is the cross-section of the cylinder. The diameter of the cylinder should be obtained with a caliper and the corresponding area is the piston area *a*. The piston area is not the same at both ends of the stroke, as on the crank end the area of the piston rod must be subtracted.

The travel of the piston in feet per minute for each end of the stroke is found by multiplying the length of the stroke by the revolutions of the crank-shaft per minute.

The mean effective pressure is obtained from the indicator card. The usual method is to measure the area of the card with an instrument called a planimeter.

In Fig. 85 is shown a standard form of planimeter. In using a planimeter the point *B* is placed on a point on the indicator card to be measured and the vernier *E* set at zero. The point *B* is then made to trace the card in a clockwise direction, going all around the card and returning to the starting-point. The reading of the scale on the rotating wheel *C* will then show the number of square inches enclosed by the diagram. Dividing the area of the

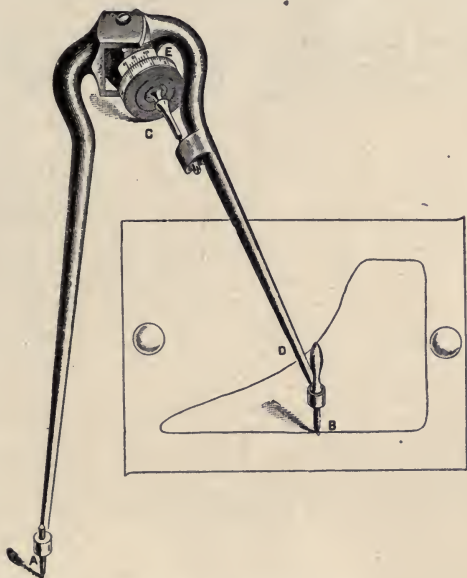

FIG. 85.—Polar planimeter.

card by the length of the diagram will give the average height of the card in inches, and this multiplied by the value of the spring gives the mean effective pressure, M.E.P. The M.E.P. should be determined for each end of the cylinder separately.

The mean ordinate from the card may also be obtained by dividing the card into ten spaces by vertical lines drawn equidistant apart. Then measure the distance from the back pressure line to the forward pressure line at the center of each space. The average of these lengths will be approximately the mean ordinate.

Let  $p_h$  be the mean effective pressure for the head end, and  $p_c$ , for the crank end;  $a_h$ , the cross-sectional area of the piston in square inches for the head end, and  $a_c$ , for the crank end;  $l$ , the length of the stroke in feet; and  $n$ , the number of revolutions per minute. Then the indicated horse-power will be

$$I.H.P. \begin{cases} \text{Head end} = \frac{p_h l a_h n}{33000} & (1) \\ \text{Crank end} = \frac{p_c l a_c n}{33000} & (2) \end{cases}$$

The total *I.H.P.* of the engine is the sum of the *I.H.P.* for the head end and the crank end.

**114. Indicator Diagrams.**—The indicator is very often used to determine the setting of the valve and the distribution of steam

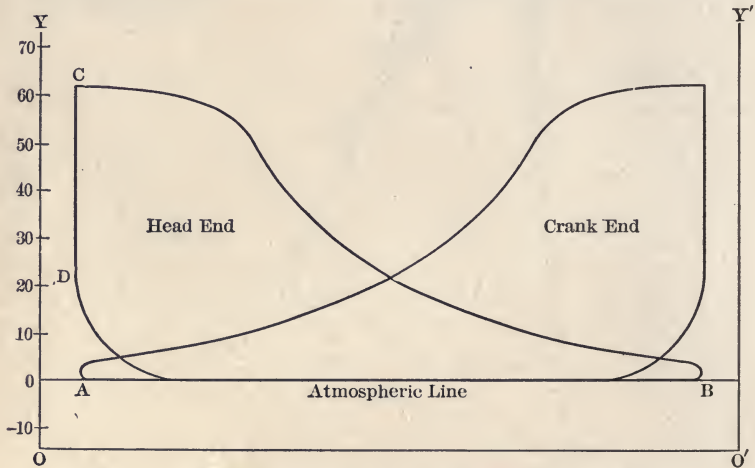

FIG. 86.—Indicator card from non-condensing Corliss engine.

in the cylinder. Fig. 86 shows a typical indicator card from a Corliss engine running non-condensing.  $AB$  is the atmospheric line, and  $OO'$ , the line of absolute vacuum, or zero pressure absolute.  $OY$  is the line of no volume for the head end, and  $O'Y'$  for the crank end of the cylinder. The horizontal distance between the lines  $OY$  and  $CD$  represents the clearance volume for the head end of the cylinder. The clearance on the crank end is similarly shown.

**115. Graphical Determination of Initial Condensation.**—Initial condensation may be determined graphically from the

indicator card. In determining the amount of steam working in the engine cylinder, the amount supplied to the engine per stroke is determined by either weighing the water entering the boiler, which passes over as steam into the engine, or by weighing the steam condensed in a condenser attached to the exhaust of the engine.

This total quantity of steam used by the engine is then reduced to the amount of steam used per stroke, and this is called the cylinder feed. To this must be added the cushion steam. To determine the amount of cushion steam, an average indicator card is selected, and at a point after compression has begun and it is certain that the valve is closed, the pressure is measured and the volume determined. This volume must include the volume of the clearance. From this pressure and volume, by reference

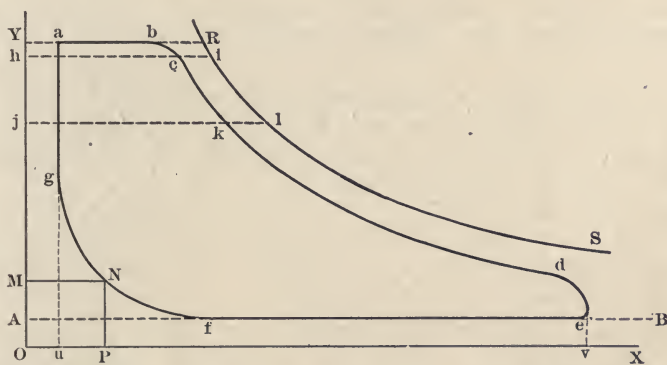

FIG. 87.—Indicator card and saturation curve, showing effect of initial condensation.

to the steam tables, the weight of the cushion steam may then be calculated, assuming the steam to be saturated. The total steam in the cylinder during expansion is then found by adding this cushion steam to the cylinder feed. A curve of saturation for this total quantity of steam can then be drawn upon the indicator diagram, and this curve will represent at each point of the stroke the volume of steam if no initial condensation has occurred.

Fig. 87 shows a saturation curve constructed on an indicator card. *YR* represents the volume of the steam as supplied to the engine per stroke, or in other words, it represents the volume of the total steam in the cylinder at boiler pressure if all the steam entering remained steam. The curve *RS* represents the volume

of this same weight of steam for the varying pressures of expansion. The difference in the volume between this theoretical expansion line and the actual expansion line represents the loss in volume due to condensation. The percentage of initial condensation at the point of cut-off would be  $\frac{ci}{hi}$ , and at any other point, such as  $k$ , would be  $\frac{kl}{jl}$ .

**Example.**—An 8"  $\times$  12" engine runs 230 r.p.m. and uses 700 lbs. steam per hour. Steam pressure, 100 lbs.; exhaust, atmospheric; clearance, 10 per cent.; scale of indicator spring, 60 lbs. Find the total weight of steam in the cylinder during expansion.

**Solution.**—First find the cylinder feed, or amount of steam supplied by the boiler to the engine per stroke.

$$\text{Strokes per hour} = 230 \times 2 \times 60 = 27,600.$$

$$\text{Cylinder feed} = 700 \div 27,600 = .02536 \text{ lbs.}$$

To find the amount of cushion steam, first lay off from  $u$ , Fig. 87, the distance  $uO$  equal to 10 per cent. of  $uw$ , since the clearance is 10 per cent. and  $uw$  represents the volume of the cylinder. If the length  $wv$  of the card is 2.9 in., the total length  $Ov$  is 3.2 in.

The volume swept through by the piston is  $3.1416 \times 4 \times 4 \times 12 = 602.4$  cu. in. The clearance volume is then 60.2 cu. in., and the total volume 662.6 cu. in. In other words, each inch of length of the line  $Ov$  represents  $662.6 \div 3.2 = 207$  cu. in.

Now take a point on the compression curve after the exhaust valve has closed, such as  $N$ . The ordinates of this point measured from the axes  $OY$  and  $OX$  are,  $p = 34.8$  lbs. absolute, and  $v = 124.2$  cu. in. = .07187 cu. ft. From the steam tables we find that 1 cu. ft. of dry saturated steam at 34.8 lbs. absolute weighs .0836 lbs.

The weight of .07187 cu. ft., or the cushion steam, will then equal  $.07187 \times .0836 = .006$  lbs.

The total weight of steam in the cylinder during expansion is therefore

$$.0254 + .006 = .0314 \text{ lbs.}$$

Finally plot the curve of saturation for .0314 lbs. of steam. To do this, take any pressure such as 80 lbs. absolute and from the steam tables find the volume of 1 lb. of steam at that pressure. This equals 5.47 cu. ft. The volume of .0314 lbs. would then be

$$.0314 \times 5.47 = .1718 \text{ cu. ft.} = 297 \text{ cu. in.}$$



Hence the ordinates of this point will be

$$p = \frac{80}{60} = 1.33 \text{ in.}$$

and 
$$v = \frac{297}{207} = 1.43 \text{ in.}$$

This point is then plotted, and others are found and plotted in the same way. A curve drawn through these points will be the saturation curve.

**116. Determination of Steam Consumption.**—When the engine is used with a surface condenser, the steam consumption may be determined by weighing the steam condensed. It is seldom, however, that this can be done, and usually it is necessary to measure the amount of feed water going to the boiler which supplies steam to the engine to be tested. When this is done, great care should be taken to see that all the steam produced from this feed water goes to the engine. If all the steam does not go to the engine, the amount going to other purposes should be measured and deducted from the total feed, the difference being the engine feed. Tests of this character should be at least 10 hours in length, and still better 24 hours, so as to allow for the effect of varying conditions such as level of water in the boiler. The engine should be credited with the moisture in the steam. The engine should be operated for some time before the test begins so that the heat conditions may be uniform. During the test the engine should be run as nearly as possible at a uniform load. Indicator cards are usually taken every 10 or 15 minutes, and the average horse-power shown by the cards is taken as the average horse-power developed during the test. As has already been stated, to determine the number of pounds of steam used by a steam engine per horse-power per hour, the water entering the boiler is weighed and all the water that actually goes to the engine is charged to the engine. This weight of water reduced to pounds per hour is divided by the average horse-power developed by the engine; the result is the number of pounds of steam used by the engine per horse-power per hour. The American Society of Mechanical Engineers has adopted a standard method of testing steam engines, which will be found in Volume XXIV of their Proceedings.

The number of pounds of steam used by the various forms of

engines are summarized in the following table. These results are very general for the various classes of engines.

TABLE XIX. STEAM CONSUMPTION OF VARIOUS CLASSES OF ENGINES

	Pounds
Simple throttling engine, non-condensing.....	44 to 45
Simple automatic engine, non-condensing.....	30 to 35
Simple Corliss engine, non-condensing.....	26 to 28
Simple automatic engine, condensing.....	22 to 26
Simple Corliss engine, condensing.....	22 to 24
Compound automatic engine, non-condensing.....	25 to 30
Compound automatic engine, condensing.....	18 to 20
Compound Corliss engine, condensing.....	14 to 16
Triple Corliss engine, condensing.....	12.25 to 13
Uniflow engine, simple condensing, superheat.....	11.25 to 12

**117. Brake Horse-power.**—All of the economies given in Table XIX are based on the indicated horse-power of the engines. But this does not represent the actual useful work that can be

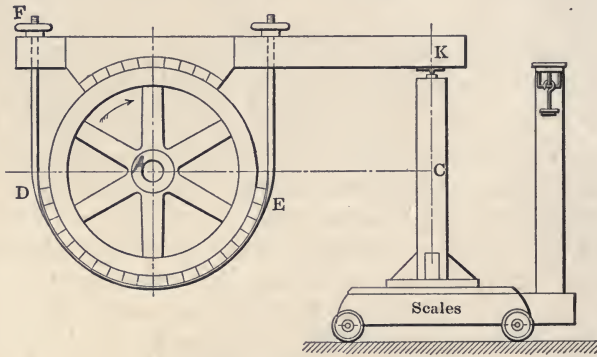

FIG. 88.—Prony brake.

obtained from the engine, as part of this power must be used in overcoming the friction of the engine itself. The actual power of the engine delivered upon the fly-wheel is usually measured by a Prony brake or some similar device. The horse-power obtained at the brake is termed the "brake," or "effective" horse-power.

The brake used to determine the brake horse-power usually consists of an adjustable strap which encircles the rim of the brake wheel which is fastened to the crank-shaft of the engine. The brake wheel should be provided with interior flanges for holding water used for keeping the rim cooled. To the strap encircling the brake wheel is rigidly fastened an arm which rests on a platform scales. The friction of the strap *DE*, Fig. 88,

tends to carry the arm  $FK$  in the direction of rotation of the wheel. The force tending to depress the arm  $FK$  is measured on the scales. The net force on the scales times the distance  $AC$  is the moment of friction, and this multiplied by the angular velocity equals the rate of doing useful work. The weight of the lever on the scales must either be counterbalanced, or else found by suspending the lever on a knife-edge vertically over  $A$  and noting the scale reading. This weight plus the weight of the standard  $C$  is called the *tare*, and is then subtracted from the weight shown on the scales to determine the net weight due to the force of friction. The standard  $C$  must be of such a length that when the engine is running the arm  $FK$  is held in a horizontal position.

Let  $w$  = the net weight on the scales,  $n$  the revolutions of the shaft per minute,  $l$  the horizontal distance  $AC$  in feet, or the brake arm, and  $B.H.P.$  the brake horse-power. Then

$$B.H.P. = \frac{2\pi l w n}{33000} \quad (3)$$

**118. Mechanical Efficiency.**—The brake horse-power divided by the indicated horse-power is the *mechanical efficiency* of the engine, and the indicated horse-power minus the brake horse-power is called the *friction horse-power*. The mechanical efficiency of an engine is usually about 85 per cent., and in well-built engines may be as high as 90 per cent. and over.

In large engines it is not possible to obtain the brake horse-power, as such an engine would require a very elaborate brake. In such cases it is customary to obtain the horse-power lost in friction, approximately, by what is termed a friction card. A friction card is obtained by removing all the load from the engine so that the only load acting upon the engine is the friction of the engine itself. An indicator card is taken from the engine under these conditions, and the horse-power shown by this card is called the friction horse-power. A card so taken does not give the actual friction of the engine, as the friction increases with an increase of load. After finding the friction horse-power, the actual output of the engine may be determined by subtracting this friction horse-power from the indicated horse-power. If the power taken by the friction card is more than 10 per cent. of the full-load capacity of the engine, the friction of the engine is considered to be excessive. Where an engine is used to drive a dynamo, the mechanical efficiency of the engine may be deter-

mined from the electrical output of the generator, if the electrical efficiency of the generator is known.

**119. Actual Heat Efficiency.**—*The actual thermal efficiency of an engine is the heat equivalent of one horse-power per hour divided by the number of heat units consumed by the engine per H.P.-hour, either indicated or brake.*

Since a horse-power is 33,000 foot-pounds per minute, then the heat equivalent of one horse-power per hour is

$$\frac{33000 \times 60}{778} = 2545 \text{ B.T.U.} \quad (4)$$

Let  $S$  equal the steam consumption of an engine per horse-power per hour,  $q$  the quality of the steam,  $L$  the latent heat,  $h$  the heat of the liquid above  $32^\circ$ , and  $t$  the temperature of the feed-water. (The British practice assumes this temperature to be the temperature corresponding to the exhaust, or back, pressure.) Then the actual thermal efficiency would be

$$\frac{2545}{S\{h + qL - (t - 32)\}} \quad (5)$$

**120. Duty.**—The economy of pumping engines is usually expressed not as the number of pounds of steam per I.H.P. per hour, but in terms of “*duty*.”

In the earlier history of pumping engines, the definition of duty was the number of foot-pounds of work done in the pump cylinder per 100 lbs. of coal burned in the boiler. The objection to this method of determining duty is that it includes both boiler and engine economy. In purchasing a pumping engine it was necessary to allow the contractor to furnish the boilers also.

To obviate this difficulty it is better to express duty as the number of foot-pounds of work obtained in the pump cylinders per 1000 pounds of steam furnished to the engine. The specifications state at what pressure this steam must be furnished.

Duty may also be expressed as the *number of foot-pounds of work done in the pump cylinders per 1,000,000 B.T.U. consumed by the engine.* This is the best way of expressing duty, as it eliminates all considerations of the steam pressure. Engines working under widely different conditions may be compared when their duty is based on foot-pounds developed in the pump cylinder per 1,000,000 B.T.U. furnished to the engine.

The amount of “work done” is equal to the weight of water pumped times the “head” pumped against. The total head is made up of the pressure shown by the gage on the discharge line plus that on the suction line, both reduced to feet, plus the

vertical distance between the center of the pressure gage and the point of attachment of the suction gage to the main.

The duty that may be obtained in the various forms of pumping engines is given in the following table:

TABLE XX. DUTY OF VARIOUS FORMS OF PUMPS

	Ft. lbs.
Small duplex non-condensing pumps.....	10,000,000
Large duplex non-condensing pumps.....	25,000,000
Small simple fly-wheel pumps, condensing.....	50,000,000
Large simple fly-wheel pumps, condensing.....	65,000,000
Small compound fly-wheel pumps, condensing.....	85,000,000
Large compound fly-wheel pumps, condensing.....	120,000,000
Large triple-expansion fly-wheel pumps, condensing.....	165,000,000
Large triple-expansion pumps, condensing, of exceptional economy.....	180,000,000

The *capacity* of a pump is the number of gallons pumped in 24 hours.

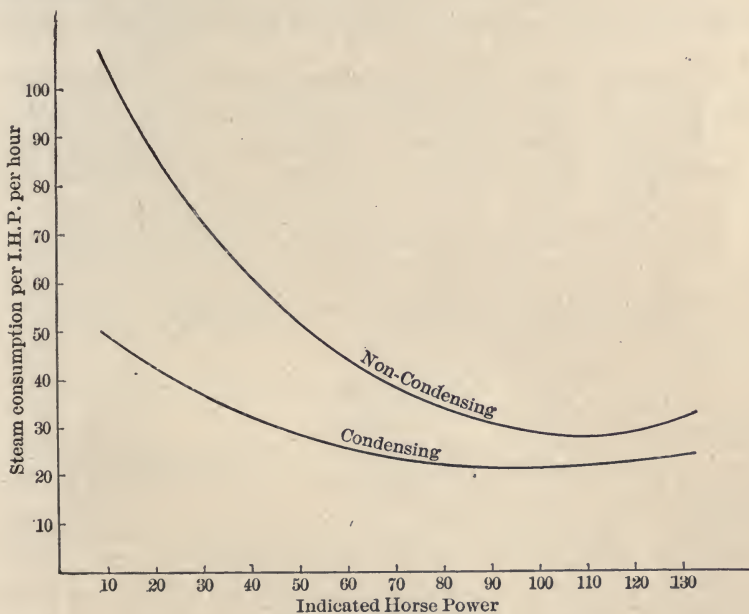

FIG. 89.—Curves showing steam consumption.

**121. Variation of Steam Consumption.**—Most engines work at a varying load, so that it is important to know the steam consumption of the engine at the different loads. Fig. 89 shows the variation of steam consumption in a 100 horse-power engine at

various loads. The upper curve shows the steam consumption when the engine was running non-condensing, and the lower curve when it was running condensing.

In these curves the ordinates represent the steam consumption per horse-power per hour, and the abscissæ represent the indicated horse-power.

**Example.**—The area of the indicator card from the head end of an 8" × 12" double-acting steam engine running 227 r.p.m. is 1.34 sq. in., and from the crank end 1.16 sq. in. The length of both cards is 2.19 in., and the scale of the spring used was 60 lbs. The diameter of the piston rod is 1½ in. A Prony brake was attached to the engine and the gross weight on it was 103.5 lbs. The length of the brake arm is 54 in., and the tare 28.5 lbs.

Find the (a) I.H.P., (b) B.H.P., (c) F.H.P., and (d) mechanical efficiency.

**Solution.**—(a) The average height, or mean ordinate, of the card is equal to the area divided by the length, and this multiplied by the scale of the spring used will give the mean effective pressure. Hence,

$$\begin{aligned} \text{M.E.P.} & \left\{ \begin{array}{l} \text{Head end} = \frac{1.34}{2.19} \times 60 = 27.7 \text{ lbs.} \\ \text{Crank end} = \frac{1.16}{2.19} \times 60 = 23.95 \text{ lbs.} \end{array} \right. \\ \text{Area} & \left\{ \begin{array}{l} \text{Head end} = 3.1416 \times 4 \times 4 = 50.26 \text{ sq. in.} \\ \text{Crank end} = (3.1416 \times 4 \times 4) - (3.1416 \times .75 \times .75) \\ \qquad \qquad \qquad = 48.50 \text{ sq. in.} \end{array} \right. \end{aligned}$$

The indicated horse-power for each end equals  $\frac{plan}{33000}$ .

Hence,

$$\text{I. H. P.} \left\{ \begin{array}{l} \text{Head end} = \frac{27.7 \times 1 \times 50.26 \times 227}{33000} = 9.58. \\ \text{Crank end} = \frac{23.95 \times 1 \times 48.5 \times 227}{33000} = 8.02. \end{array} \right.$$

$$\text{Total I.H.P.} = 9.58 + 8.02 = 17.6.$$

$$(b) \text{ Net weight on brake} = 103.5 - 28.5 = 75 \text{ lbs.}$$

$$\text{Length of brake arm} = \frac{54}{12} = 4.5 \text{ ft.}$$

$$\text{B.H.P.} = \frac{2\pi n w}{33000} = \frac{2 \times 3.1416 \times 4.5 \times 227 \times 75}{33000} = 14.6.$$

$$(c) \text{ F.H.P.} = \text{I.H.P.} - \text{B.H.P.} = 17.6 - 14.6 = 3.$$

$$(d) \text{ Mech. Eff.} = \frac{\text{B.H.P.}}{\text{I.H.P.}} = \frac{14.6}{17.6} = .829 = 82.9 \text{ per cent.}$$

**Example.**—If the engine in the preceding problem used 35 lbs. of dry steam per I.H.P. per hour at 100 lbs. pressure and exhausted it at atmospheric pressure, find (a) the theoretical maximum thermal efficiency, and (b) the actual thermal efficiency of the engine (based on I.H.P.), if the temperature of the feed water is 212° F.

**Solution.**—(a) The theoretical maximum thermal efficiency is the efficiency of the Carnot cycle working in the limits given. Hence, theoretical efficiency

$$\begin{aligned} &= \frac{T_1 - T_2}{T_1} = \frac{(337.9 + 460) - (212 + 460)}{(337.9 + 460)} \\ &= \frac{797.9 - 672}{797.9} = \frac{125.9}{797.9} \\ &= .1575 = 15.75 \text{ per cent.} \end{aligned}$$

(b) Actual thermal efficiency

$$\begin{aligned} &= \frac{2545}{S \{H - (t - 32)\}} \\ &= \frac{2545}{35 \{1188.6 - (212 - 32)\}} = \frac{2545}{35 \times 1008.6} \\ &= \frac{2545}{35300} = .0721 = 7.21 \text{ per cent.} \end{aligned}$$

**Example.\***—A 500 H.P. engine pumps 18,000,000 gallons of water in 24 hours against a total head of 70 lbs. per square inch. The steam consumption is 15 lbs. per I.H.P. per hour. Steam pressure, 100 lbs.; feed temperature, 120°. (a) What is the duty per 1000 pounds of steam? (b) What is the duty per 1,000,000 B.T.U.?

**Solution.**—(a) Weight of water pumped in 24 hours

$$= 8\frac{1}{2} \times 18,000,000 = 150,000,000 \text{ lbs.}$$

Head pumped against = 70 × 2.31 = 161.7 ft.

Work done in 24 hours = 150,000,000 × 161.7 = 24,255,000,000 ft.-lbs.

Work done per hour = 24,255,000,000 ÷ 24 = 1,010,625,000 ft.-lbs.

Steam used per hour = 500 × 15 = 7500 lbs.

Duty per 1000 lbs. of steam = 1,010,625,000 ÷ 7.5 = 134,750,000 ft.-lbs.

(b) Net heat supplied to engine per pound of steam

$$= 1188.6 - (120 - 32) = 1100.6 \text{ B.T.U.}$$

Total heat furnished to engine by boiler

$$= 1100.6 \times 7500 = 8,255,000 \text{ B.T.U.}$$

Duty per 1,000,000 B.T.U. = 1,010,625,000 ÷ 8.255 = 122,400,000 ft.-lbs.

\*A gallon of water weighs 8½ lbs.

A water pressure of 1 lb. per square inch equals a head of 2.31 feet.

One inch of mercury equals a pressure of .491 lbs.

## PROBLEMS

1. An engine is  $8'' \times 12''$  and runs 250 r.p.m. The indicator card of the head end has an area of 2 sq. in. and of the crank end, 2.5 sq. in. Length of both cards, 3 in.; spring, 80 lbs. Diameter of the piston rod,  $1\frac{1}{2}$  in. What horse-power does the engine develop?

2. An  $8'' \times 12''$  engine runs 250 r.p.m. The indicator card from the head end has an area of 1.5 sq. in. and length of 3 in.; from the crank end an area of 1.7 sq. in. and length of 3 in. The scale of spring is 80 lbs. Diameter of piston rod, 2 in. What horse-power is the engine developing?

3. A double-acting engine is  $12'' \times 12''$  and runs 250 r.p.m. The area of the average indicator card is 1.5 sq. in. and the length is 3 in. Scale of spring, 60 lbs. What is the I.H.P. of the engine?

4. The area of the indicator card on the head end of an engine is 2.3 sq. in.; area of crank end card, 2 sq. in.; length of each 3 in. Scale of spring, 80 lbs. Engine is  $18'' \times 24''$  and runs 100 r.p.m. Diameter of piston rod, 3 in. What is the I.H.P. of the engine?

5. The indicator card from the head end of an engine is 2.1 sq. in. in area and 3 in. long; from the crank end the area is 2.2 sq. in. and the length 3 in. The cards were taken with a 100-lb. spring. The engine is  $18'' \times 24''$  and runs 150 r.p.m. Piston rod is 3 in. in diameter. What horse-power is the engine developing?

6. An engine is  $18'' \times 36''$ ; r.p.m., 100; diameter of piston rod, 3 in. Area of head end card, 3 sq. in.; length, 2.5 in.; area of crank end card, 2.8 sq. in.; length, 2.5 in.; scale of spring, 60 lbs. Find the I.H.P.

7. An engine is  $24'' \times 36''$  and runs 100 r.p.m. The diameter of the piston rod is 4 in. The area of the head end card is 1.5 sq. in. and the length 3.2 in. Area of crank end card is 1.7 sq. in. and length 3.5 in. Scale of spring, 100 lbs. Find the I.H.P.

8. The indicator card from the head end of an engine is 2.1 sq. in. in area and 3 in. long. From the crank end it is 1.8 sq. in. in area and 3 in. long. The card is taken with an 80-lb. spring. The engine,  $24'' \times 36''$ , runs 100 r.p.m.; piston rod, 4 in. in diameter. What horse-power is the engine developing?

9. A  $12'' \times 15''$  engine runs 250 r.p.m. The area of the head-end card is 1.314 sq. in.; of the crank-end card, 1.168 sq. in.; the length of each being 2.92 in. The cards are taken with a 50-lb. spring. Diameter of piston rod, 2 in. The engine is fitted up with a Prony brake with an arm 4 ft. 9 in. long. The tare of the brake is 25 lbs. and the gross weight on it, 178 lb. Find the I.H.P.; B.H.P.; F.H.P.; and the mechanical efficiency.

10. A  $12'' \times 15''$  engine runs 240 r.p.m. The area of the head-end card is 1.341 sq. in.; of the crank-end card, 1.49 sq. in.; the length of each being 2.98 in. The cards are taken with a 50-lb. spring. Diameter of piston rod, 2 in. The engine is fitted with a Prony brake having an arm 4 ft. 9 in. long. The tare of the brake is 23 lbs. and the gross weight on it, 213 lbs. Find the I.H.P.; B.H.P.; F.H.P.; and the mechanical efficiency.

11. An  $8'' \times 12''$  engine runs 220 r.p.m. Area of head-end card is 2.1 sq. in.; of the crank-end card, 2.04 sq. in.; the length of each being 2.91 in. The cards are taken with a 40-lb. spring. Diameter of piston rod, 1.5 in.



The engine is fitted with a Prony brake having an arm 54 in. long. The tare of the brake is 29.25 lbs. and the gross weight on it, 100.25 lbs. Find the I.H.P.; B.H.P.; F.H.P.; and the mechanical efficiency of the engine.

12. An 8"  $\times$  12" engine runs 221 r.p.m. Area of head-end card, 2.32 sq. in.; of the crank-end card, 2.34 sq. in.; the length of each being 2.84 in. The cards are taken with a 40-lb. spring. Diameter of piston rod, 1.5 in. The engine is fitted with a Prony brake having an arm 54 in. long. The tare of the brake is 20.25 lbs. and the gross weight on it, 120.25 lbs. Find the I.H.P.; B.H.P.; F.H.P.; and mechanical efficiency.

13. An engine uses 14 lbs. of steam per I.H.P. per hour. Initial steam pressure, 125 lbs.; feed temperature, 125° F. What is the actual and theoretical thermal efficiency of the engine?

14. An engine uses 25 lbs. of steam per I.H.P. per hour. Steam pressure, 100 lbs.; feed temperature, 200° F. Find the actual and the theoretical thermal efficiency of the engine.

15. An engine uses 30 lbs. of steam per I.H.P. per hour. Steam pressure, 120 lbs.; feed temperature, 125° F. Find the actual and theoretical thermal efficiency of the engine.

16. An engine uses 35 lbs. of steam per I.H.P. per hour. Initial steam pressure, 100 lbs.; feed temperature, 200° F. Find the actual and theoretical thermal efficiency of the engine.

17. An engine uses 24 lbs. of steam per I.H.P. per hour. Steam pressure, 100 lbs.; feed temperature, 125° F. What is the actual and theoretical thermal efficiency?

18. Given a 500 k.w. generating set; efficiency of the engine and generator, 85 per cent. Steam pressure, 150 lbs.; feed temperature, 180°. The engine uses 20 lbs. of steam per I.H.P. per hour. Evaporation from and at 212° is 10 lbs. of water per pound of dry coal. Dry coal contains 13,000 B.T.U. per pound. What is the heat efficiency of the plant?

19. A 500 I.H.P. engine is direct connected to a generator. Efficiency of engine and generator is 85 per cent. Engine uses 10,000 lbs. of steam per hour. Steam pressure, 150 lbs.; feed temperature, 180°. Evaporation from and at 212° per pound of dry coal is 10 lbs. Dry coal contains 13,000 B.T.U. per pound. What is the heat efficiency of this plant?

20. A pumping engine pumps 15,000,000 gal. of water per day (24 hours) against a head of 70 lbs. per square inch. It uses 6000 lbs. of steam per hour. Steam pressure, 125 lbs.; feed temperature, 150° F. What is the duty per million B.T.U.?

21. A pumping engine pumps 15,000,000 gal. of water in twenty-four hours against a head of 65 lbs. per square inch. It develops 450 H.P. with a steam consumption of 13 lbs. per I.H.P. per hour. (a) What is the duty per 1000 lbs. of steam? (b) What is the mechanical efficiency? (c) If the steam pressure is 125 lbs. and the feed temperature 130°, what is the duty per 1,000,000 B.T.U.?

22. An engine develops 450 I.H.P. and uses 6300 lbs. of steam per hour. It pumps 600,000 gallons of water an hour against a head of 70 lbs. (a) What is the mechanical efficiency of the engine and pump? (b) What is its duty per 1000 lbs. of steam? (c) If the initial steam pressure is 125 lbs. and the feed temperature is 130°, what is its duty per million heat units?

23. A 20,000,000 gallon pumping engine pumping against a head of 70 lbs. has a duty of 120,000,000 foot-pounds. If the steam pressure is 180 lbs. and feed temperature 180°, how many pounds of steam will be used per hour?

24. A 40,000,000 gallon pumping engine pumping against a head of 70 lbs. has a duty of 160,000,000 foot-pounds. If the steam pressure is 180 lbs. and feed temperature 180°, what boiler horse-power will be required for the plant?

25. A 40,000,000 gallon pumping engine has a duty of 120,000,000 foot-pounds per 1,000,000 heat units. Steam pressure, 150 lbs. absolute; exhaust 2 lbs. absolute; feed temperature, 120° F.; pressure pumped against, 70 lbs. per square inch gage. What boiler horse-power will be required to operate the pump?

26. The duty of a 12,000,000 gallon pumping engine is 160,000,000 foot-pounds. Steam pressure, 180 lbs. absolute; exhaust, 2 lbs. absolute; feed temperature, 120° F.; reading of pressure gage, 60 lbs. per square inch; reading of suction gage, 20 in. of mercury; distance between center of pressure gage and point of attachment of suction gage, 10 feet. (a) What boiler horse-power will be required to operate the plant? (b) If the mechanical efficiency of the pump is 90 per cent., what will be the steam consumption per I.H.P. per hour? (c) If the boiler efficiency is 70 per cent. and the coal contains 13,000 B.T.U. per pound and costs \$3 per ton, what will be the coal cost per year, if the plant operates twenty-four hours a day for three hundred and sixty-five days per year?

## CHAPTER XI

### VALVE GEARS

122. AN essential part of every steam engine is the valve. The function of the valve is to admit steam to the cylinder at the proper time in the stroke, and on the return stroke to open the cylinder to the exhaust and let the steam escape either to the atmosphere or to the condenser. The proper action of the engine depends very largely upon the proper distribution of steam in the cylinder.

In a *single-acting* engine, steam is admitted to one side of the piston only, while in the *double-acting* engine it is admitted alternately, first to one side and then to the other. Most steam engines in common use are double-acting.

In the simpler forms of steam engines, only one valve is used, which is so arranged that it admits steam to either end of the cylinder and also controls the exhaust.

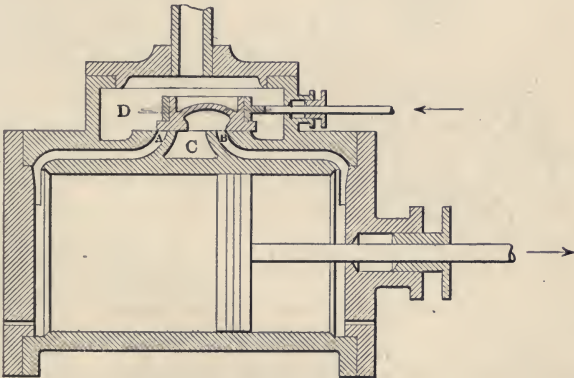

FIG. 90.—D-slide valve.

123. **Plain D-slide Valves.**—Fig. 90 shows a plain D-slide valve, so called from its longitudinal cross-section. In the figure shown, the space *D* is filled with live steam under pressure, and the space *C* is open to the exhaust. In the position shown, steam has just ceased flowing from the space *D*, through the steam

port *A*, into the cylinder. On the other side of the piston, steam is exhausting through the steam port *B* into the exhaust space *C*. The valve is moving to the left and the piston to the right, and the point of cut-off has just been reached. The steam will now expand in the cylinder until the valve has moved far enough to the left to uncover port *A*, placing it in communication with the exhaust port *C*, when exhaust will begin. Compression in the right end of the cylinder will begin when the valve has moved far enough to the left to cover port *B*. When it has moved still further to the left, port *B* will again be uncovered and steam will be admitted to the right end of the cylinder, driving the piston toward the left. A plain D-slide valve will, therefore, if given a proper reciprocating motion, control the admission and the exhaust of the steam so that the piston will be given a reciprocating motion.

**124. Lap, Lead, Angular Advance, and Eccentricity.**—Consider a valve such as is shown in Fig. 91. This valve is con-

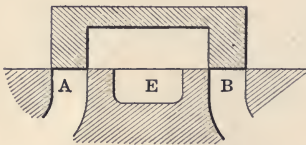

FIG. 91.—Simple valve without lap.

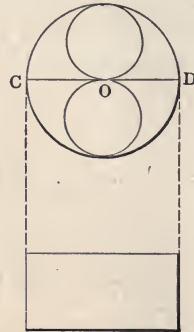

FIG. 92.—Indicator card and Zeuner diagram from valve shown in Fig. 91.

structed so that it just covers the steam ports *A* and *B*. If the valve is moved to the right, or to the left, steam will be admitted to the cylinder at one end or the other, and exhaust from the opposite end. A valve constructed as shown will admit steam to the end of the stroke and permit the exhaust to continue to the end of the stroke at the opposite side of the piston. There would then be no expansion of the steam on the working stroke and no compression of steam on the exhaust stroke.

The ideal indicator card for a valve such as is shown in Fig. 91 is shown in Fig. 92.

In certain steam pumps, the indicator card is very similar to the one shown. The economy, however, of such a pump must be very poor. In order partially to expand the steam and to have compression at the end of the exhaust stroke, it is necessary that the valve be lengthened as shown in Fig. 93. The lengthening of the valve on the steam side causes the port to be closed before the end of the stroke, and for the balance of the stroke the steam expands. The increased length of the valve on the steam side of the valve is called the *steam lap*. The steam lap in Fig. 93 is the distance  $S$ . Steam lap may be defined as: *the distance that the valve, when in its mid-position, extends beyond the edge of the steam port toward that side from which it takes steam*. It is equal to the distance the valve must move from its mid-position before steam is admitted to the cylinder. The lap is not always the same for the two ends of the cylinder.

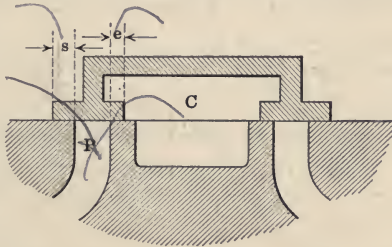

FIG. 93.—Valve with steam and exhaust lap.

In order to have compression at the end of the exhaust stroke, the valve must extend beyond the exhaust port as shown in Fig. 93, by an amount called the *exhaust lap*, which may be defined as follows: *exhaust lap is the distance that the valve, when in its mid-position, extends beyond the edge of the steam port toward that side into which it exhausts*. It is equal to the distance the valve must move from its mid-position before exhaust begins. The exhaust lap may be *negative*, in which case it is equal to the amount the port  $P$ , Fig. 93, would be open to the exhaust chamber  $C$ , when the valve is in the mid-position.

If the valve did not begin to admit steam until just as the engine was on the dead center, full steam pressure in the cylinder would not be attained until the piston had travelled some distance on the next stroke. In order to have full steam pressure in the

cylinder at the beginning of each stroke, it is necessary for the valve to open just before the piston reaches the end of the previous return stroke, thus causing *pre-admission*. This opening before the end of the stroke is called the *lead*.

*Lead is the amount the steam port is open when the piston is at the end of its stroke.*

If the valve were to be constructed as shown in Fig. 91, the eccentric would be set exactly  $90^\circ$  in advance of the position of the crank. But with the valve having both lap and lead, it is necessary to set the eccentric ahead of the crank an angle greater than  $90^\circ$  by an amount sufficient to move the valve a distance equal to the lap and the lead. This angle is called the *angle of advance*.

*The angle of advance is the angle which the perpendicular to the line of motion of the piston makes with the center line of the eccentric when the engine is on the dead center; or it is the angle between the center lines of the eccentric and the crank minus  $90^\circ$ .*

*Eccentricity is the distance between the center of the shaft and the center of the eccentric.*

*The throw of the eccentric is equal to the travel of the valve, or to twice the eccentricity.*

**125. Relative Position of Valve and Piston.**—In order to study the action of the valve, it is necessary to know its exact

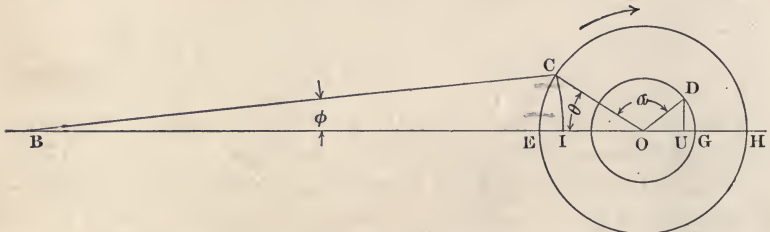

FIG. 94.—Relative position of valve and piston.

position for each position of the piston. The valve is driven by an eccentric (see paragraph 108), which is really a crank in which the crank-pin is enlarged until it includes the shaft. As the size of the crank-pin has nothing to do with the motion produced in the rod attached to it, any two cranks having the same arm, or distance between the shaft center and the crank-pin center, will produce the same motion. In the eccentric the arm is called the *eccentricity*. As the eccentric is equivalent to a crank, our

problem consists in finding the simultaneous positions of two reciprocating pieces, driven by two cranks upon the same shaft.

In Fig. 94 let  $OC$  represent any position of the crank,  $OD$  the center line of the eccentric,  $\alpha$  the angle between the two, and  $BC$  the connecting rod. Drawing the arc  $CI$  with  $B$  as a center, we find that the piston has moved a distance  $EI$  from its extreme position at the left, or its distance from its mid-position is  $OI$ . Similarly, by dropping a perpendicular from  $D$  upon  $EH$ , the valve is found to be at the distance  $UG$  from its extreme right position, or distance  $OU$  from its mid-position.

To be absolutely correct an arc should be struck through  $D$  with a radius equal to the length of the eccentric rod and with the center on the line  $OB$ , or  $OB$  extended to the left, and the point  $U$  found as the intersection of this arc with the line  $EH$ , rather than as the foot of the perpendicular dropped from  $D$ . However, as the ratio of the length of the eccentric rod to the length of the eccentric arm, or eccentricity, is so great, the error caused by using the perpendicular instead of the arc is negligible.

**126. Valve Diagrams.**—The above method, although the most apparent way of attacking the problem, is inconvenient in practice, and simpler constructions known as valve diagrams are commonly used. Of the many forms of valve diagrams which have been designed, the one due to Zeuner is perhaps the best known, and will, therefore, be used in the present discussion.

**127. Zeuner Diagram.**—Let  $XY$ , Fig. 95, represent the stroke of the piston and  $DE$  the travel of the valve. Let  $OA$  represent any position of the crank, the cylinder being assumed to be to the left of the figure;  $OB$ , the corresponding position of the eccentric; and  $\alpha$  the angle between the crank and the eccentric. Then the angle  $BOJ$ , or  $\delta$ , is the angle of advance ( $\alpha - 90^\circ$ ).

Drop a perpendicular from  $B$  to the line  $DE$ . Then  $OC$  represents the displacement of the valve from the mid-position when the crank is in the position  $OA$ . Draw  $OF$  so that the angle  $FOG$  equals the angle of advance,  $\delta$  ( $= \alpha - 90^\circ$ ). Then

$$\begin{aligned} FOA &= 90^\circ - DOA - FOG \\ &= 90^\circ - \theta - (\alpha - 90^\circ) \\ &= 180^\circ - \theta - \alpha. \end{aligned}$$

$$\text{But } 180^\circ - \theta - \alpha = BOE.$$

$$\text{Therefore } FOA = BOE.$$

As  $\alpha$  is a constant, this relation will hold for all values of  $\theta$ . Draw  $FH$  from  $F$  perpendicular to  $OA$ . Then the triangles  $FOH$  and  $BOC$  are equal and  $OH$  will equal  $OC$ , or the displacement of the valve from its mid-position. Since  $FH$  is perpendicular to  $OA$ ,  $FHO$  will be a right angle for any value of  $\theta$ , and the locus of the point  $H$  will be a circle described on  $OF$  as a diameter. Therefore, as  $OA$  represents any position of the crank, the corresponding displacement of the valve from its mid-position may be found by measuring the length intercepted by the circle  $FHO$ . Thus with the crank at  $KO$ , the intercept is zero and the valve is at its mid-position; at  $PO$  the intercept is a maximum and the valve is at its extreme position toward the right; at  $LO$  the intercept is again zero and the valve has returned to its mid-

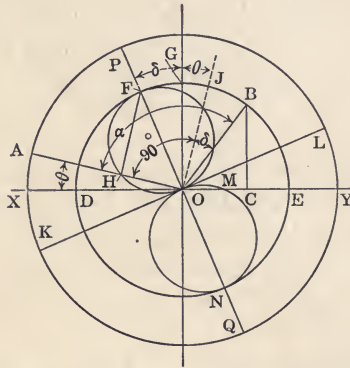

FIG. 95.—Elementary Zeuner diagram.

position. Beyond this point the crank does not intersect the circle, and it is necessary to draw a second circle  $OMN$ , from which we obtain the location of the valve when on the left side of its mid-position. The circles  $FHO$  and  $OMN$  are known as valve circles. It is important to note that in the arrangement which we have selected (clockwise rotation with the cylinder at the left of the shaft) the intercepts on the crank line made by the upper valve circle represent the displacements of the valve toward the right, while those made by the lower valve circle indicate displacements toward the left.

**128. Effect of Lap.**—In a valve having lap, it is evident the valve will have to be moved from its mid-position a distance equal to the lap before admission begins, and on returning to



its mid-position will close the steam port when its distance from that position is equal to the lap. The effect of the lap is to close off the steam before the end of the stroke and, with a very large lap and a small port, the time of admission of steam might be reduced to zero.

The amount by which the port is open at any instant is called the *port opening*, and for the valve in Fig. 91 is equal to the displacement of the valve from its mid-position. Since the addition of lap makes it necessary to move the valve a distance equal to the lap before any port opening is obtained, the port opening is found by subtracting the lap from the displacement of the valve. This is most conveniently done by drawing the circular arc  $DBW$ , Fig. 96, with a radius equal to the steam lap. Then for any crank position, as  $OE$ , the opening of the port is  $BC$ . A further

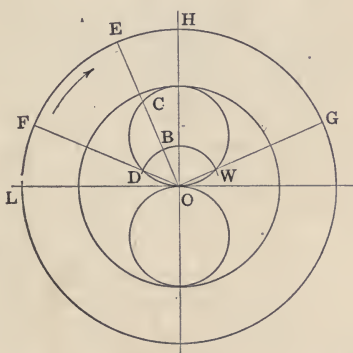

FIG. 96.—Zeuner diagram, showing effect of steam lap.

examination of this diagram shows that admission begins with the crank at  $OF$ , and ends at  $OG$ . This arrangement is not practicable since admission must occur before the piston begins its stroke, by the amount of the lead. This result may be obtained by revolving the circle  $DCWO$  in a counter-clockwise direction about  $O$  as a center until  $D$ , the point of intersection of the valve circle with the steam lap circle, falls below the horizontal axis  $OL$  as shown in Fig. 97.

In rotating the valve circle to its new position, the eccentricity remains the same, but the angular position of the eccentric relative to the crank has been altered. To see what change in the actual engine corresponds to a rotation of the valve circle center to  $E$ , we have only to remember that  $FOG$ , Fig. 97, equals

the angular advance, or  $\alpha - 90^\circ$ . Consequently, any increase in the angle  $FOG$  corresponds to an equal increase in the angle between the crank and the eccentric. An examination of the figure shows that with any given lap, an increase in the angular advance increases the lead and makes cut-off earlier. Also, that for a given angle of advance an increase in the steam lap reduces the lead and causes cut-off to occur sooner.

In Fig. 97 the valve is in its mid-position when the crank is in the position  $OJ$ . This would therefore be the crank position at the time of admission if there were no steam lap. Similarly

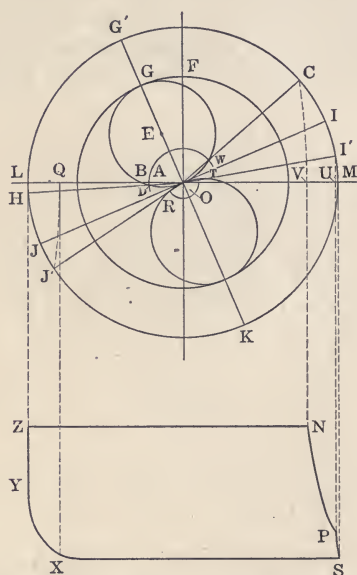

FIG. 97.—Zeuner diagram showing effect of lap.

the crank position at cut-off would be  $OI$ . As there is steam lap, the crank positions at admission and cut-off are  $OH$  and  $OC$ . These are found by drawing lines from  $O$  through  $D$  and  $W$ , the points of intersection of the valve circle and steam lap circle.  $AB$  is the lead.

If the valve had no exhaust lap, the port would begin to open to exhaust when the crank is in the position  $OI$ , reaching its maximum opening at  $OK$  and finally closing again at  $OJ$ , when the valve resumes its mid-position. Beyond  $OJ$ , the continued movement of the crank compresses the steam remaining in the

left-hand end of the cylinder until  $OH$  is reached, when the admission of live steam begins.

**129. Exhaust Lap.**—The valve shown in Fig. 93 is extended on the exhaust side so as to give it exhaust lap. The effect of this is similar to the steam lap and causes the exhaust valve to close before the end of the exhaust stroke, giving the engine compression at the end of the exhaust stroke of the engine. On the valve diagram the exhaust lap is treated in the same way as the steam lap. In Fig. 97, with a radius  $OR$  equal to the exhaust lap, the lap circle  $RT$  is drawn, and through the points where this circle cuts the valve circle, as  $T$  and  $R$ , are drawn the lines  $OI'$  and  $OJ'$ , giving the position of the crank at the time the port is opened to exhaust, called the point of release, and at the time the port is closed, called the point of compression.

The indicator card resulting from the steam distribution brought about by the valve analyzed in Fig. 97 is shown below the valve diagram and is obtained as follows:

Take any crank position, as for example,  $OC$ , the cut-off position. Draw the arc  $CV$  with the length of the connecting rod as a radius and with the center on the line  $OL$ . Then  $LV$  represents the distance which the piston has moved from the beginning of its stroke up to cut-off, and  $V$  may be projected downward, thus locating  $N$ . The other points of the diagram corresponding to the different events are found in a similar way. The actual indicator card for the engine we are considering would probably have its corners rounded off, due to wire drawing. In examining actual indicator cards, the point of cut-off is the point of contraflexure of the curve.

**130. Crank End Diagram.**—Thus far we have confined our investigations to the head end of the cylinder, but as it is necessary to see what takes place in both ends of the cylinder, we must be able to draw the valve diagrams for the crank end also. Fig. 93 shows that by moving the valve to the left, steam will be admitted to the crank end of the cylinder as soon as the valve has been moved a distance equal to the steam lap on the right end of the valve.

Fig. 98 shows the valve diagram for both the head and crank ends of the engine. In this figure,  $LZ$  and  $Z'L'$  represent both the stroke of the piston and, to a different scale, the travel of the valve. As the lower circle of the crank diagram shows the displacement to the left, the diagram for the admission stroke on

the crank must be drawn below the line  $O'L'$ . Similarly the valve diagram for the exhaust end must be drawn above the line  $O'L'$ .

**131. Effect of Connecting Rod.**—In Fig. 98 the lead has been taken the same for both the head and the crank end. It is easily seen in the figure that the cut-off at the two ends of the cylinder is not the same. In drawing the arcs of a circle,  $CQ$  and  $C'Q'$ , to project the positions of the piston at the time of

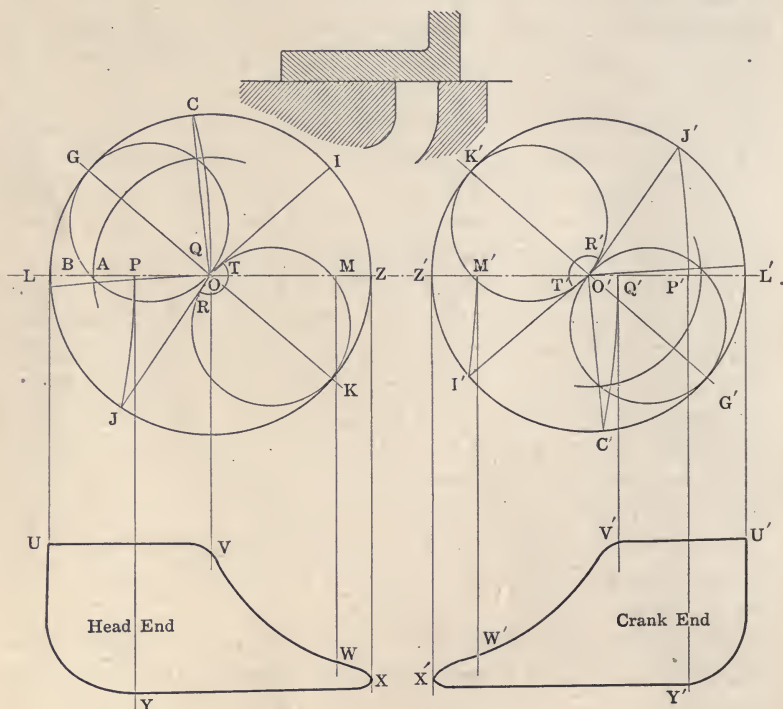

FIG. 98.—Zeuner diagrams showing effect of connecting rod.

cut-off upon the line  $LZ$  and  $L'Z'$ , it will be noticed that the points  $Q$  and  $Q'$  fall on the opposite sides of the feet of the perpendiculars from the points  $C$  and  $C'$ , measured in the direction in which the piston is moving, due to the angularity of the connecting rod. This difference in the angularity of the rod on the two sides of the cylinder makes the cut-off on the crank end less than on the head end. In order to correct this inequality of the cut-offs, it is necessary to have a smaller lap on the crank

end than on the head end. The points of compression and release are also made unequal for the two ends of the cylinder by the action of the connecting rod, but can be approximately equalized by a proper variation in the exhaust laps.

**132. Determination of Lap, Lead, and Angular Advance.**—Aside from its use as a means of exhibiting the action of the valve in an existing engine, the Zeuner valve diagram may also be used for the purposes of design. This may best be shown by an example. Let it be required to determine the *steam and exhaust-laps, lead, angle of advance, and point of release*, having given the *points of admission, cut-off and compression*, and the *travel of the valve*.

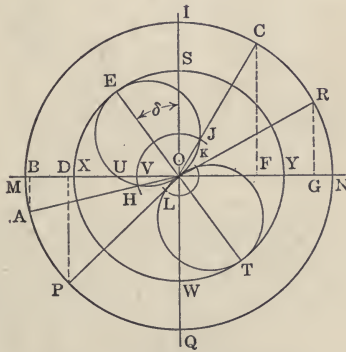

FIG. 99.—Use of Zeuner diagram for design of valve.

The lines  $OD$  and  $OW$ , Fig. 97, are equal, being radii of the same circle and therefore the arcs  $OD$  and  $OW$  are equal. Hence the arc  $DG$  is equal to the arc  $WG$  and the line  $G'O$  bisects the angle between the crank positions at admission and cut-off.

Draw the circle  $MINQ$ , Fig. 99, with a diameter,  $MN$ , equal to the stroke of the piston, and the circle  $XSYW$  with a diameter,  $XY$ , equal to the travel of the valve. Through  $O$  draw  $IQ$  perpendicular to  $MN$ . Lay off on  $MN$  the distance  $NB$  equal to the per cent. of the stroke at which admission begins;  $MF$ , the per cent. at which cut-off occurs; and  $ND$ , the per cent. at which compression begins. Erect perpendiculars at  $B, F$  and  $D$  cutting the crank circle at  $A, C$  and  $P$ . (The angularity of the connecting

rod has been neglected.) Draw the lines  $OA$ ,  $OC$  and  $OP$  representing respectively the crank positions at admission, cut-off and compression. Bisect the angle  $AOC$  with the line  $EOT$ . Then the angle  $EOS$  equals the angle of advance. Draw the valve circles  $EJO$  and  $TLO$  on  $OE$  and  $OT$  as diameters, intersecting the lines  $OA$  at  $H$ ,  $OM$  at  $U$ ,  $OC$  at  $J$ , and  $OP$  at  $L$ . Then  $OH$  equals  $OU$  equals the steam lap, and  $OL$  equals the exhaust lap. With  $O$  as a center and the radius  $OH$  draw the steam lap circle  $HVJ$  intersecting the line  $OM$  at  $V$ . Then  $UV$  will equal the lead. With  $O$  as a center and the radius  $OL$  draw the exhaust lap circle intersecting the valve circle  $TLO$  at  $K$ . Draw the line  $OKR$  from  $O$  through  $K$ . This line represents the crank position at release. From  $R$  drop the perpendicular  $RG$  on to the line  $MN$  (neglecting the angularity of the connecting rod). Then  $MG$  equals the distance the piston has travelled at the time of release.

**133. Piston Valves and Other Balanced Valves.**—The plain D-slide valve, while entirely satisfactory under certain condi-

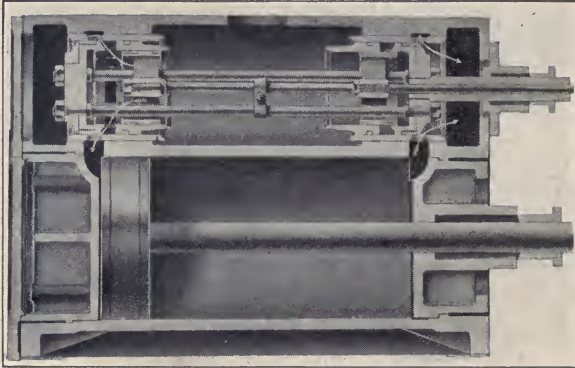

FIG. 100.—Riding cut-off, piston valve.

tions, has a number of inherent faults which preclude its use in many cases. Prominent among these is the amount of resistance to movement which it offers when used with high-pressure steam. An examination of Fig. 90 shows that the entire back of the valve is exposed to live steam, with the result that it is pressed against its seat with great force and in consequence a large frictional resistance must be overcome in moving it.

By using a piston valve, examples of which are shown in Figs. 100, 101, and 102, this difficulty is overcome, and, as it is commonly expressed, the valve is perfectly "balanced," since the pressure upon the valve acts radially around its entire circumference. In the plain D-slide valve, leakage of steam past the

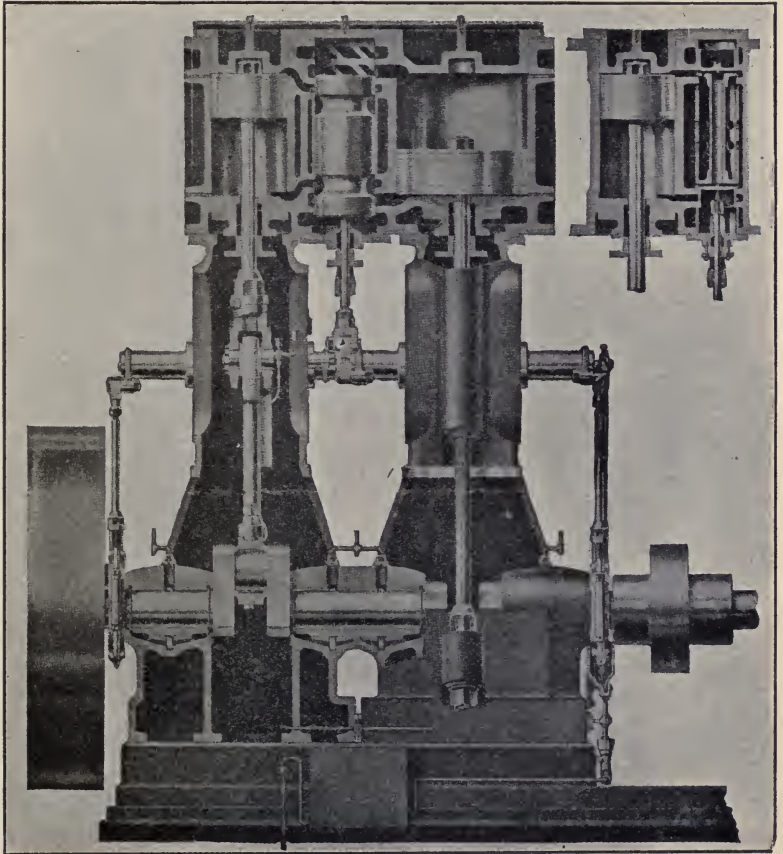

FIG. 101.—Compound engine with piston valve.

valve is prevented by the fact that it is held tightly against its seat by the steam pressure. In the piston valve no such force is present, and in stationary engines it is customary to rely upon an accurate fit of the valve for tightness. This makes it necessary to replace the valve when the wear has made the leakage excessive. In marine practice, tightness is obtained by the use

of spring rings similar to those used on a piston. So far as the valve diagram is concerned, the piston valve is the exact equivalent of the plain D-valve, since we may consider it formed by rolling the flat working surface of the plain D-valve into a cylindrical form. The piston valve is used extensively in marine

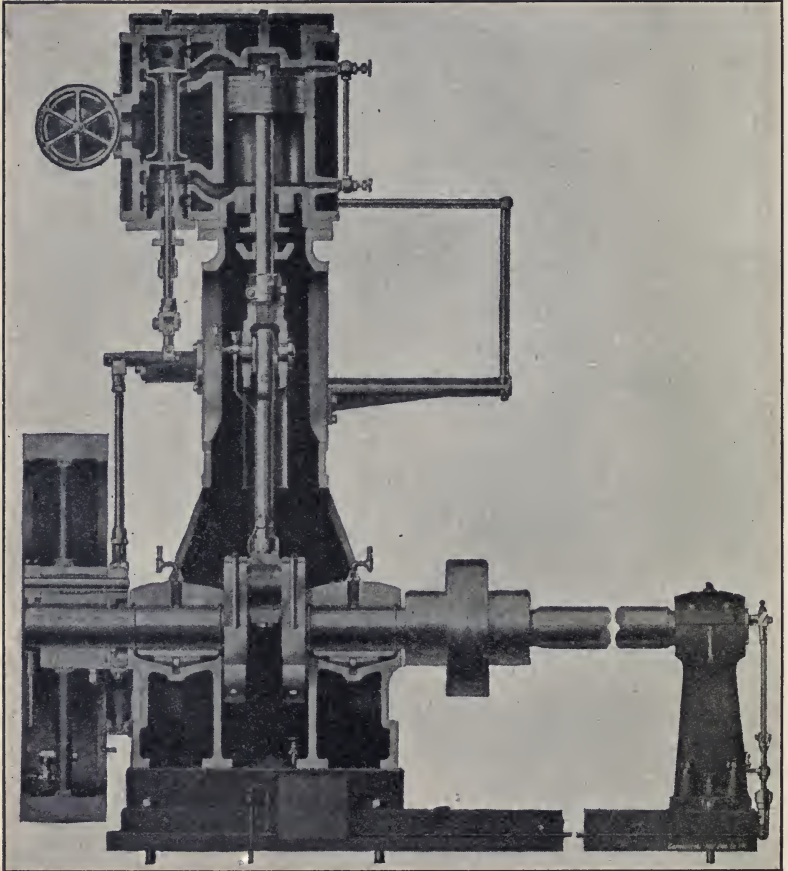

FIG. 102.—Simple engine with piston valve.

engines, compound locomotives, and also in a number of types of high-speed stationary engines.

The engine shown in Fig. 101 is a vertical compound engine having piston valves on both low and high pressure cylinders. The sectional view of the high-pressure piston is shown more in detail in the upper right-hand corner of the figure. The piston



valve on the high-pressure cylinder is a double-ported valve. The valves are driven by a simple eccentric. The governor in this engine is a shaft governor which controls the action of the high-pressure valve.



FIG. 103.—Double ported valve with cover plate.

Fig. 102 shows a simple engine with similar valve.

The valve often used in high-speed engines is the one shown on the left in Fig. 103. To the right in Fig. 103 is shown the cover plate. This cover plate is made a scraping fit when it is

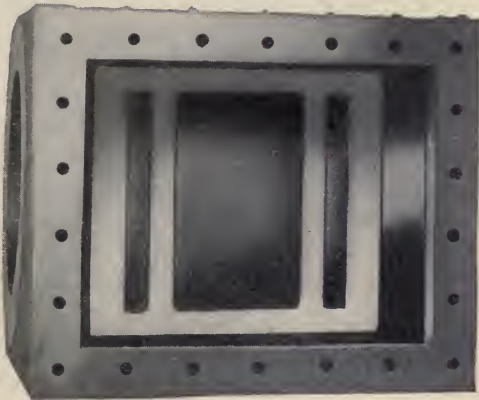

FIG. 104.—Steam chest showing valve seat.

placed over the valve. This prevents any steam pressure on top of the valve, making it a balanced valve.

Fig. 104 shows the valve seat in the steam chest. The valve and its cover plate are fitted to this seat. The whole arrange-

ment is shown in cross-section in Fig. 55. The steam ports are at the ends of the steam chest, and the exhaust port between them.

**134. Double-ported Valves.**—It will be noticed that all valve diagrams so far discussed in this text have been drawn for a cut-off later than half stroke. It is important to notice the difference introduced in the valve gear in changing from a late cut-off to an earlier one. If a valve diagram is constructed so that the cut-off in the cylinder is at  $\frac{1}{4}$  stroke, the results obtained will show that so short a cut-off in the D-slide valve is a practical impossibility. The eccentricity and steam lap for  $\frac{1}{4}$  cut-off are entirely too large for practical use, although a  $\frac{1}{4}$  cut-off is not extraordinarily early, but is the working cut-off used in the majority of high-speed engines. It is thus quite evident that a simple

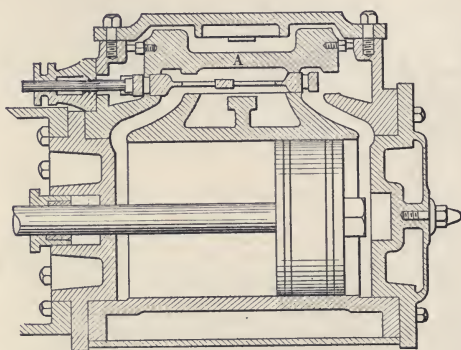

FIG. 105.—Modern high-speed engine valve.

D-valve is not at all suitable for early cut-offs and some modification must be made to obtain a satisfactory form.

In Fig. 105 is shown a modern high-speed engine valve suitable for early cut-off. At the right end of the valve, admission is begun and the steam is entering the port past the end of the valve in the ordinary manner. At the same time a flow of steam past the upper corner is taking place. This steam passes through a port in the valve and enters the cylinder with the steam coming directly past the lower corner. The advantage of this arrangement lies in the fact that for any given movement of the valve, the port opening is twice as large as for the simple *D*-valve, since we have two ports instead of one. In other words, for a double-ported valve with a given cut-off, port opening, and lead,

the eccentricity and the steam lap are one-half as large as for a plain D-slide valve giving the same steam distribution.

Another important feature of this valve is the pressure plate *A*, which extends over the entire back of the valve, thus relieving it from the action of the steam pressure, and consequently reducing wear and friction. The pressure plate extends around the side of the valve and rests upon the valve seat. It is held in its place by a flat spring at the back when there is no steam present in the steam chest. In case of a large quantity of water being present in the cylinder during compression, the spring allows the pressure plate and the valve to lift from its seat, thus permitting the water to escape instead of bursting the cylinder as it would otherwise do. This form of valve may be restored to a tight condition when worn by planing off the faces of the pressure plate which bear against the valve seat, thus reducing the clearance between the valve and pressure plate.

The governor usually fitted in engines having this type of valve controls the speed by alternating the point of cut-off as the load changes. This variation in cut-off is effected by changing the position of the eccentric center in one of three ways.

*First.*—By revolving the eccentric around the shaft, thus keeping the eccentricity constant while varying the angle of advance.

*Second.*—By moving the eccentric in a straight line at right angles to the crank, thus altering both the eccentricity and the angle of advance, but keeping the lead constant.

*Third.*—By moving the eccentric center in a circular arc, the center of which is on the opposite side of the arc from the shaft center, and very frequently directly opposite the crank. In this case the angle of advance and the eccentricity are both varied, but not in the same way as in the second type.

Of these three forms, the third is the commonest, largely because it is the most convenient. By drawing a series of valve diagrams corresponding to the various positions of the eccentric center, the changes produced in the four events of the steam distribution are easily seen. With the eccentric swung from a point opposite the crank, the diagrams show that as the cut-off is shortened, the lead is reduced, while the points of release and compression are made earlier. For cut-off as early as one-fourth stroke, the points of release and compression are very much too

early for low-speed engines, but not objectionably so for the high-speed engines in which this valve gear is used.

**135. Meyer Riding Cut-off.**—In an engine having but one valve, any change in the position of the valve affects all the operations of the valve. A change in the angular advance not only changes the steam lead, but also the exhaust lead as well as the

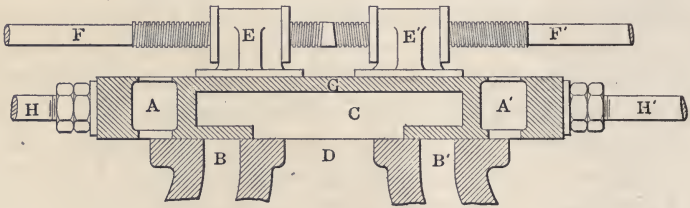

FIG. 106.—Meyer riding cut-off valve.

cut-off. In the same way the release and compression depend upon each other, and one cannot be changed without changing the other. In order to regulate the speed of the engine by the cut-off, it is desirable to have some means of changing the cut-off without changing any other operation of the valve.

This may be done by having a separate valve controlling the cut-off. The Meyer valve is an example of how this may be done.

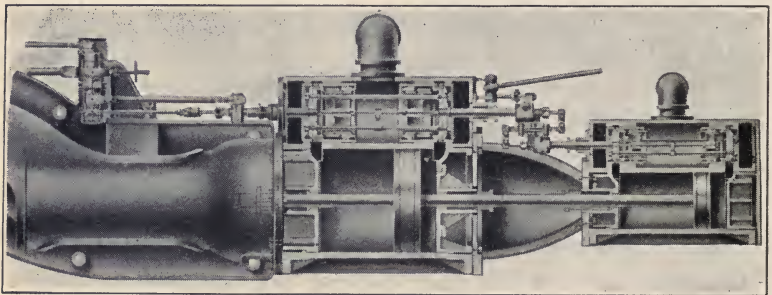

FIG. 107.—Cross-section of Buckeye valve gear for tandem compound engine.

Such a valve is shown in Fig. 106. The main valve is very similar to a D-slide valve, except that the steam ports,  $AA'$ , pass through the body of the valve and the steam enters the cylinder through these ports. The cut-off valve consists of two blocks that are fastened together by a rod threaded through one with a left-hand thread, and through the other with a right-hand thread.

By turning this rod, the two blocks forming the cut-off valve may be drawn together or forced apart. The two valves are operated by separate eccentrics and are so designed that when admission begins, the cut-off valve does not obstruct the port in the main valve. At the point of cut-off, the riding or cut-off valve covers the steam port in the main valve. If the cut-off valve blocks are moved farther apart, and the other operations of the valve are left the same, the blocks will cover the port earlier in the stroke, and the point of cut-off comes earlier.

In Fig. 107 is shown the riding cut-off valve used by the Buckeye Engine Company. This is similar to the Meyer gear except the blocks of the riding cut-off are rigidly fastened to each other. The governor controls the cut-off valve, and a change in the position of the governor changes the relative position of the two valves, so as to shorten or lengthen the cut-off.

**136. Corliss Valves and Valve Gear.**—The Corliss engine, invented by George H. Corliss in 1849, and in its more recent

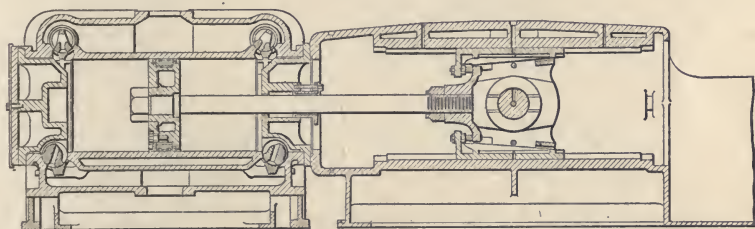

FIG. 108.—Corliss engine—cylinder and frame section.

forms varying only slightly from the original engine of this type, is one of the most commonly used forms of reciprocating engines, particularly in large sizes, in the United States to-day. They give as high an economy as any form of engine made. The distinctive features of this engine are the valves and the valve gear.

Valves of the form shown in Figs. 108 and 109 are used in the Corliss engine, each end of the cylinder being provided with separate admission and exhaust valves. Instead of sliding upon their seats with a straight line motion like a common slide valve, these valves have an oscillatory motion about the common axis of the cylindrical seat and valve. In horizontal cylinders the admission, or steam valves, are placed above with their axes at right angles to the axis of the cylinder, while the exhaust valves are similarly placed below. All four valves have spindles which

extend through stuffing-boxes to the outside of the cylinder, where they are rigidly connected to short cranks called valve arms. As shown in Fig. 109, these valve arms all derive their motion from the *wrist plate*, which is in turn oscillated by the eccentric rod. Valve rods permanently connect the arms of the exhaust valves to the wrist plate, but for the steam valves a trip gear is provided, which disengages the valve arm at the point of cut-off and allows the valve to close with a rapid motion. This sudden closure of the valve is due to its connection to the *dash-pot* piston. As the valve opens, the dash-pot piston is raised, producing a partial vacuum in its cylinder, so that as soon as the

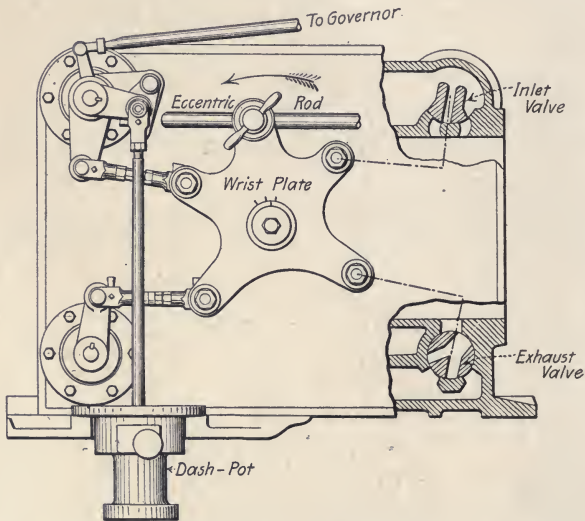

FIG. 109.—Corliss engine, showing arrangement of valves.

trip gear releases the valve arm from its connection with the wrist plate, atmospheric pressure forces the dash-pot piston down and closes the valve.

In Figs. 110 and 111 the trip gear for the steam valve is shown. The steam arm is keyed to the valve stem, and, as the outer end of the arm is raised or lowered, the valve is turned on its seat. The knock-off cam lever and the bell-crank lever are both free to oscillate about the valve stem as an axis. The valve rod connects one end of the bell-crank lever with the wrist plate, and as the wrist plate oscillates back and forth, the bell-crank is given a rocking motion about the valve stem. The other arm of the

bell-crank lever carries a steam hook, the inner leg of which is kept in close contact with the knock-off cam lever by a spring. In the position shown in Fig. 110 the steam hook has engaged with a block on the outer end of the steam arm, and, as the valve rod is moved to the left, the steam hook is raised pulling up with it the outer end of the steam arm and turning the valve on its seat, opening it. When the bell-crank lever has been turned about its axis until the point is reached where the inner leg of the steam hook strikes the knock-off cam, the outer leg will be forced to the

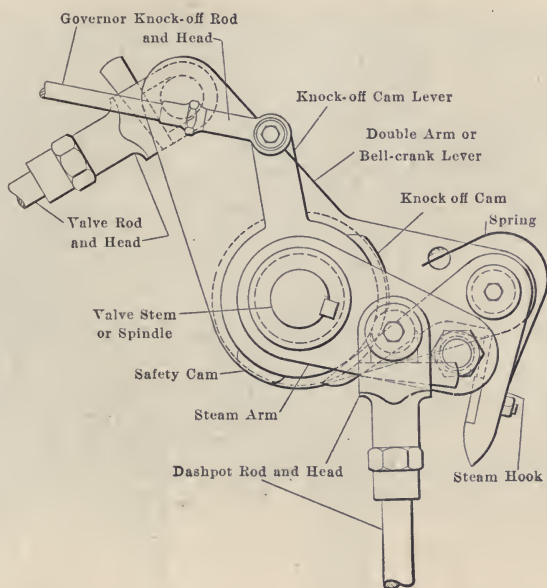

FIG. 110.—Line diagram of Corliss trip mechanism.

right releasing the steam arm which will suddenly be pulled downward by the dash-pot rod which is attached to it. This sudden movement of the steam arm closes the valve and gives a sharp cut-off. The governor controls the position of the knock-off cam, thus determining the point at which the steam hook releases the valve arm and cut-off takes place. A safety cam is provided so that in case the governor belt breaks, the dropping of the governor balls will rotate the safety cam in a counter-clockwise direction, causing cut-off to occur so early that the engine will stop.

An analysis of the motion of a properly designed Corliss valve reveals two important points:

*First.*—That the valve is moving at nearly its greatest velocity when the edge of the valve crosses the edge of the port.

*Second.*—That during the period when the valve is closed its motion is very slight.

The first of these features reduces the wire-drawing effect and makes the corners of the indicator card more sharply defined than is the case with simple slide valves. The second reduces

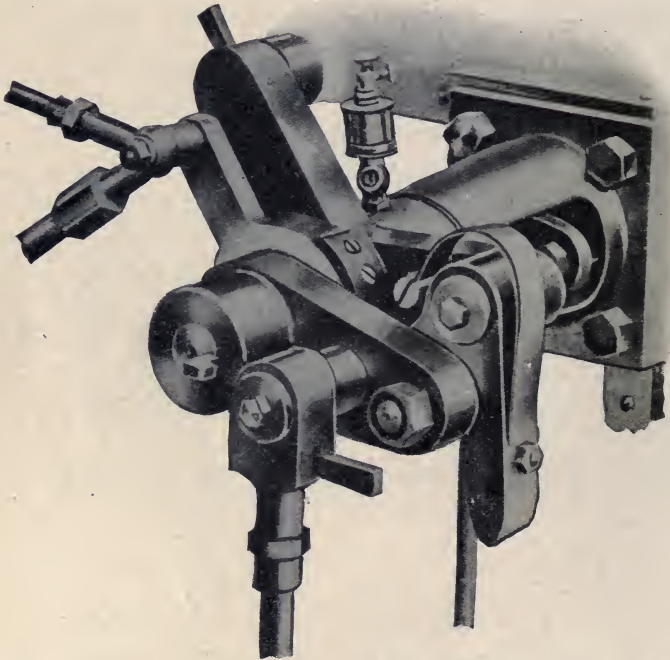

FIG. 111.—Corliss trip mechanism for steam valve.

the friction and the wear, since the valve is pressed against its seat by the full steam pressure during the large part of the period when the port is closed. The use of the trip gear makes the cut-off independent of all the other events, and consequently the lead and points of compression and release remain the same for all loads. With the Corliss valve gear the combination of excellent steam distribution, slight leakage and wire drawing, with a minimum amount of clearance, is obtained, resulting in a high degree of economy.



A complete Corliss engine direct-connected to an electric generator is shown in Fig. 112. This cut shows the rods passing from the governor to the valve motion. These engines are always side-crank engines, having only one bearing on the engine frame. The end of the shaft away from the crank is supported by a bearing separate from the engine frame, often called the "outboard" bearing. When this bearing is on the right side, looking from the cylinder toward the fly-wheel, the engine is said to be "right-hand," when on the left side, to be "left-hand."

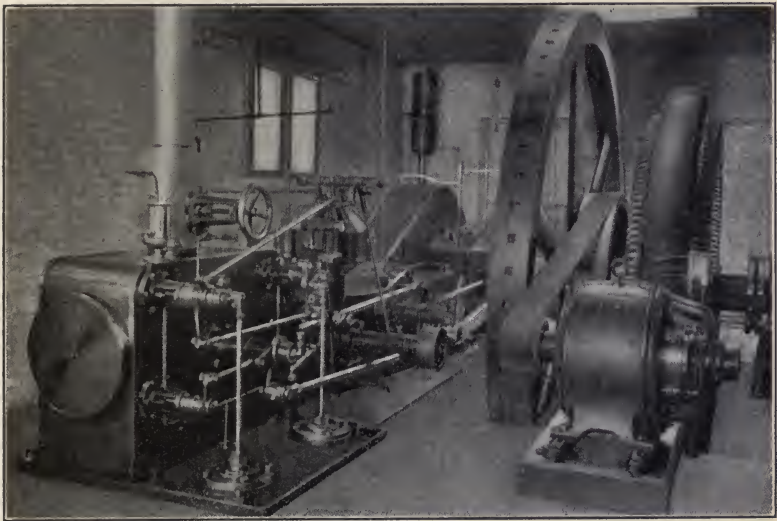

FIG. 112.—Corliss engine and alternating current generator.

**137. Changing the Direction of Rotation.**—In all the preceding valve diagrams, the cylinder has been taken at the left of the shaft and rotation in a clockwise direction has been assumed. Horizontal engines rotating in this direction, or in other words taking steam in the head end of the cylinder while the crank passes through the upper half of its path, are said to "run over." To produce rotation in the opposite direction, or to make the engine "run under," it is only necessary to lay off the angle  $\alpha$  in the opposite direction from the crank. That is, to set the eccentric at an angle of  $90^\circ + \delta$  from the crank, measured in a counter-clockwise direction. By constructing the corresponding valve diagram, all the events will take place at the same percentage

of stroke as before, and nothing is changed except the direction of rotation.

For many purposes engines are required which can be reversed, or made to run in either direction, at the will of the operator. By arranging the eccentric so that it could be revolved through an angle of  $180^\circ - 2\delta$ , the engine would be made reversible. This arrangement has actually been used, though it is now practically obsolete. Instead of this construction, mechanisms known as *reversing gears* are used, which beside making the engine reversible, permit a variation in the point of cut-off.

**138. Stephenson Link Motion.**—In 1842 Robert Stephenson and Company applied to their locomotives a form of reversing gear which has received the name of the Stephenson link motion. This has been more widely used than any other type of reversing gear. This gear, as shown in Fig. 113, has as its essential feature a curved piece, or link, connected at its ends to the rods of the

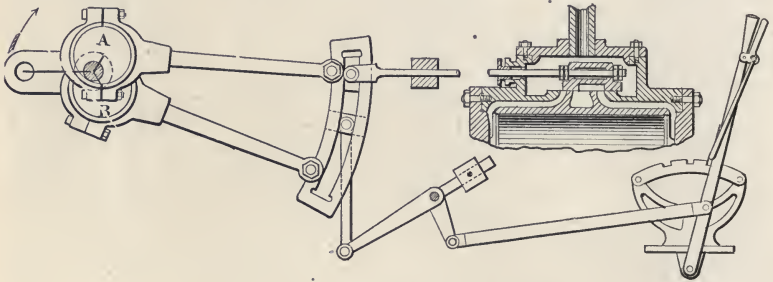

FIG. 113.—Stephenson link motion.

two eccentrics. On the end of the valve stem is a block, fitted to slide in the link and free to turn on a pin carried by the valve stem. By means of a bell crank and suspension rods connecting it to the link, it is possible to raise or lower the link, and so cause the valve to take its motion from any desired point along the arc of the link. One end of the link is connected to an eccentric for the “go-ahead” position, and the other end of the link to an eccentric set for the “back-up” position. When the block is thrown to the end controlled by the go-ahead eccentric, the valve is moved so as to drive the engine forward, and when thrown to the opposite end, the engine reverses. As the block is moved nearer the middle of the link, both eccentrics affect the motion of the valve, and the cut-off is shortened. When the middle of the link is reached, admission and cut-off are found to occur at

equal crank angles on either side of the dead center position and the engine has no motion. Beyond the mid-position, the motion of the engine is in the opposite direction.

In American locomotives a rocker arm is always placed between the link block and the valve stem. This arrangement causes the valve and the link block to move in opposite directions. For this reason each of the eccentrics is placed at an angle of  $180^\circ$  from the position shown in Fig. 113. In marine practice the link block is usually carried on the end of the valve stem as shown in the figure.

**139. Radial Gears.**—In addition to the Stephenson Link Motion, a number of other types of reversing gear are in more or less common use. One class of these, known as *radial gears*, have either one eccentric and derive part of their motion from the connecting rod, or are entirely without an eccentric and derive

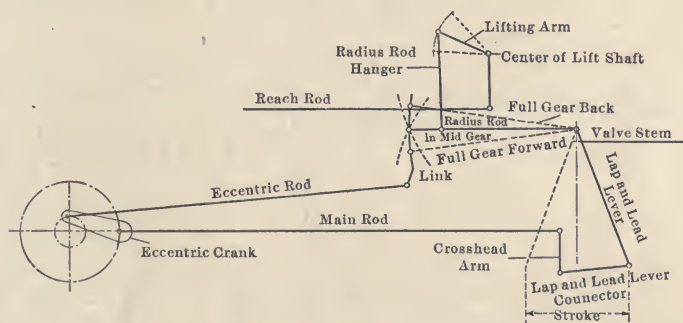

FIG. 114.—Diagram of Walschaert valve gear.

their entire motion from the connecting rod. The most important of these is the Walschaert gear, which is now being fitted to a large number of American locomotives. A diagrammatic sketch of this gear is shown in Fig. 114. On the outer end of the crank pin, a second crank is carried, which is connected with the link in such a way as to cause it to oscillate about its point of support. The valve stem is connected to the vertical lever which derives its motion both from the block, carried on the link, and from the cross-head of the engine. By setting the block at different points along the link, the cut-off may be varied or the engine reversed. With the Walschaert gear, the lead remains the same for all cut-offs, instead of increasing when the cut-off is made earlier, as in the Stephenson gear.

Another type of radial gear occasionally met with is the Joy gear, shown in Fig. 115. In this gear the valve motion is derived from the connecting rod through a linkage. The point *S* is permanently fixed. With this gear the steam distribution is almost exactly the same for both ends of the cylinder, and the lead is constant for all cut-offs.

Another method which may be used for reversing engines having a balanced slide valve is to change, by means of a three-way cock, the steam ports into exhaust ports and the exhaust ports into steam ports.

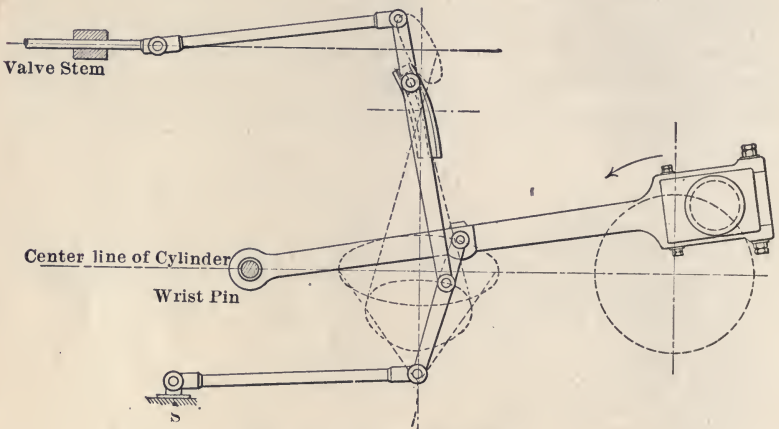

FIG. 115.—Joy radial gear.

**140. Setting the Valve by Measurement.**—In setting a valve, the first step is to place the engine on *dead center*, that is, the piston at the extreme end of its stroke. To do this, proceed in the following way: Place the engine near the center and turn it away from the center about  $15^\circ$ . Measure with a tram from a fixed point on the frame to the fly-wheel and mark the wheel. While in the same position, mark a line across the cross-head and the cross-head guide. Now turn the engine past the center until the lines on the cross-head and the cross-head guide again coincide. From the same point on the frame, mark the fly-wheel again with the tram. Bisect the distance between the tram marks, and turn the fly-wheel until this point of bisection is just the length of the tram from the fixed point on the frame. The engine will now be on center. The opposite center can be determined in the same way.

The next step is properly to place the valve on the valve stem. The engine being on center, move the eccentric on the shaft until the valve has a slight lead. Measure this lead very carefully. Now place the engine on the opposite center, and again measure the lead. If the lead is not the same, move the valve on the stem one-half of the difference. Then repeat the operation until the lead at both ends is the same. The valve is now traveling equally over both steam ports. Now move the eccentric on the shaft, the engine being kept on the center, until the port is just closed, and then move it ahead to the amount of the lead desired. The lead is set anywhere from "line and line" to  $\frac{3}{16}$  of an inch, depending upon the speed and size of the engine.

**141. Setting the Valve by the Indicator.**—It is difficult to set the valve exactly by measurement. After the valve has been set by measurement, it is best to check the setting with the indicator.

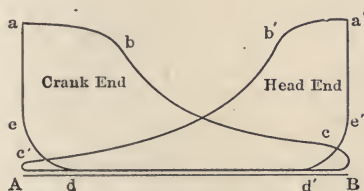

FIG. 116.—Indicator card showing unequal distribution of work in the two ends of the cylinder.

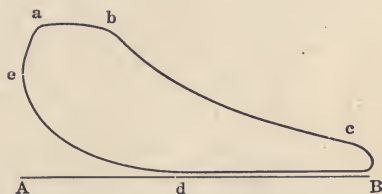

FIG. 117.—Indicator card showing effect of insufficient lead.

When the valve is not set in the proper position on the stem, the steam admission at the two ends of the cylinder will not be alike, and the indicator card will appear as shown in Fig. 116. The objection to this card is that one end of the cylinder is doing more work than the other. In single-valve engines, this condition may be remedied by changing either the position of the valve on the stem, or the length of the valve-stem. In the Corliss engine, it is changed by varying the relative length of the governor rods to the two admission valves.

Fig. 117 shows an indicator card taken on an engine where the valve has insufficient lead. This card can usually be corrected by changing the position of the eccentric on the shaft. The eccentric should be changed in position until the line *ea* is a vertical line.

Fig. 118 shows an indicator card with too much lead. As before, this card may be corrected by changing the eccentric.

Fig. 119 shows an indicator card with too much compression.

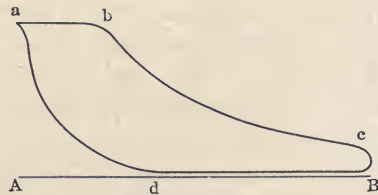

FIG. 118.—Indicator card showing effect of too much lead.

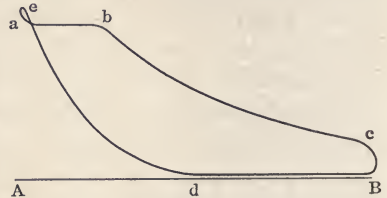

FIG. 119.—Indicator card showing effect of too much compression.

In single-valve engines with automatic governors this often occurs at light load. In Corliss engines it may be corrected by changing the length of the rod connecting the valve and wrist plate.

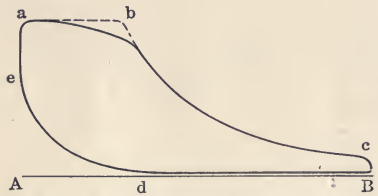

FIG. 120.—Indicator card showing effect of "wire-drawing".

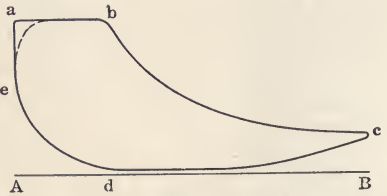

FIG. 121.—Indicator card showing effect of insufficient exhaust lead.

Fig. 120 shows an indicator card in which the admission line *ab* is a falling line. This is due to friction in the admission valve, which is usually caused by the valves opening slowly. With

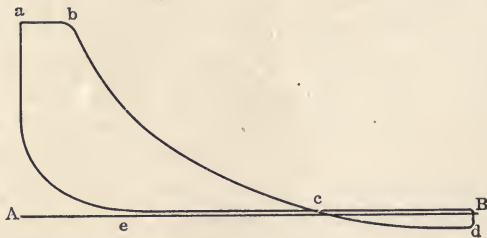

FIG. 122.—Indicator card showing effect of too short cut-off.

rapidly opening valves, such as a Corliss valve, the admission line will have the dotted position.

The indicator card shown in Fig. 121 has insufficient exhaust lead; that is, the point of release is too late. With a single-valve engine this condition of exhaust lead will usually be accompanied by insufficient steam lead, and the admission line will be as shown in the dotted position. Correcting the steam lead will correct the exhaust lead. In a four-valve engine, the lead of the exhaust valve should be increased.

When an engine is operated with a very light load, the cut-off may be so short that the steam will be expanded below atmospheric pressure before the valve opens to exhaust. As shown in Fig. 122, this gives a loop of negative work from *c* to *d*, and shows an uneconomical condition of operation. When this occurs regularly the engine is too large for the work it has to do. The best way to correct it is by reducing the steam pressure until the cut-off is long enough so that expansion is not carried below atmospheric pressure.

## CHAPTER XII

### GOVERNORS

**142.** In stationary engine practice it is essential that the engine operate at a uniform speed irrespective of the power which it develops. In most cases the load on the engine is continually varying, requiring a constant change in the amount of power given by the engine. There are two general forms of governors used for this purpose: the *throttling* governor which regulates the pressure of steam entering the engine; and the *automatic* or *cut-off* governor which regulates the volume of steam admitted, but does not change the pressure of the steam entering.

In addition to the changes of speed brought about by the change of external load on the engine, there is also a change of speed during each revolution of the engine due to the variable effort of the steam on the crank pin of the engine, and to the effect of the reciprocating parts of the engine. This variation of speed is taken care of by the *fly-wheel* of the engine.

**143. Throttling Governors.**—In a throttling governor a valve, usually of the poppet type or other form of balance valve, is located in the steam pipe near the engine. This valve is controlled by the governor in such a manner that, when the speed of the engine increases, the area of opening through the valve is reduced, thereby increasing the velocity of the steam through the valve and reducing the pressure of steam entering the engine. This governor regulates the speed of the engine by varying the pressure of the entering steam, the cut-off remaining constant.

**144. Automatic or Variable Cut-off Governors.**—These governors are attached to the valve mechanism of the engine and, as the load on the engine is reduced, the length of time during which steam is admitted to the engine is reduced by making the cut-off come earlier. Thus, as the load becomes less, less steam is admitted to the engine, but the pressure of the steam remains unchanged.

**145. Relative Economy.**—The indicator cards shown in Fig. 123 are taken from an engine using a throttling governor. This



figure shows a number of cards taken at different loads. Under a light load, owing to the action of the governor, the steam pressure is very low, while under a heavy load the card shows high pressure. At the light load the steam is expanded almost to atmospheric pressure, but at the heavy load, the cut-off being kept the same, there is a very small expansion. This condition is not favorable to economical operation.

Fig. 124 shows a card similar to Fig. 123, but taken from an automatic engine. In this form of governing the initial pressure remains the same for all loads and the cut-off varies. This enables the engineer to select a load giving a cut-off at which an engine using a given steam pressure will show maximum economy. In most engines this is found to be about one-fourth stroke; therefore an automatic engine should be operated with a load

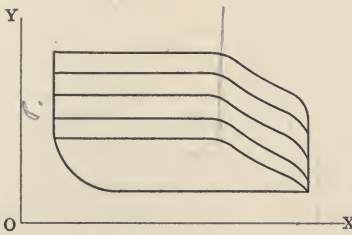

FIG. 123.—Indicator card showing effect of throttling governor when load on engine is varied.

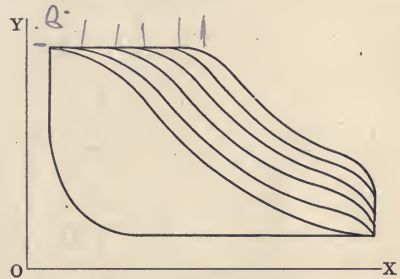

FIG. 124.—Indicator card showing effect of automatic governor when load on engine is varied.

requiring the governor to maintain the cut-off as nearly as possible at this point.

Under most conditions this form of governor is more economical in its operation than the throttling governor. Actual experiment with an engine having both an automatic and throttling governor shows the automatic governor to give a steam consumption of about 75 per cent. of the steam consumption of the same engine operated with a throttling governor.

**146. Governor Mechanism.**—The mechanism of the governor which is to maintain the speed of the engine uniform must be such that the change of speed will cause a change in the position of the parts of the governor. There are two general types of mechanism used for this purpose. The *fly-ball* governor is the first type and consists of two balls fastened to pivoted arms and rotated by the engine, and as the speed of the engine increases,

the balls move out and change either the throttle valve or the valve mechanism.

In the second type, the *shaft* governor, the governor is fastened to the fly-wheel of the engine. It usually consists of two weights attached to the fly-wheel of the engine by arms. These arms being pivoted, as the engine speed increases, the governor weights move out against the resistance of a spring. The governor arms are attached to the eccentric, and as the weights move out the position of the valve changes.

**147. Fly-ball Governors.**—Fig. 125 shows a line diagram of a fly-ball governor.  $BB$  are the balls of the governor. These balls are suspended by arms  $AB$ , and are also attached to the

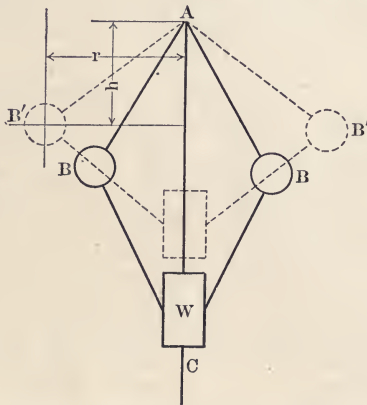

FIG. 125.—Line diagram of a fly-ball governor.

weight  $W$  by the arms  $BC$ . The arms and balls of the governor rotate around the vertical spindle  $AC$ , and are pivoted at the point  $A$ . The weight  $W$  is free to move in a vertical direction along the axis  $AC$ . As the speed of the engine increases, the balls of the governor move out into the dotted positions  $B'B'$ . Let the force acting on each one of the balls in a vertical direction be  $P$ ,  $w$  the weight of each ball, and the height through which the balls are lifted,  $dh$ . The heavy weight  $W$  will move through a greater distance,  $kdh$ . As the work put in must equal the work done, we have the following equation

$$2Pdh = 2wdh + Wkdh.$$

$$\text{Therefore } P = w + \frac{kW}{2}. \quad (1)$$

(If the upper and lower arms are the same length, then  $k = 2$ .) The horizontal work will be zero. Let  $F$  be the centrifugal force acting on each ball to maintain it in the dotted positions; then taking moments about  $A$ ,

$$Pr = Fh. \quad (2)$$

Substituting for  $P$ , in equation (2), its value in equation (1), and for  $F$  the expression for the centrifugal force,  $\frac{wv^2}{gr}$ , the equation becomes

$$\left(w + \frac{kW}{2}\right)r = \frac{wV^2}{gr}h, \quad (3)$$

where  $V$  is velocity in feet per second.

$$\text{If } W = 0, \text{ then } wr = \frac{wV^2}{gr}h, \text{ or}$$

$$\frac{V^2}{g} = \frac{r^2}{h}. \quad (4)$$

This equation shows that theoretically the action of the governor is independent of the weight of the balls. Practically, there is considerable friction in the mechanism of the governor, and the balls must have considerable weight in order easily to overcome the friction of the governor. If the number of revolutions of the governor balls be  $n$  per minute, then

$$V^2 = \left(\frac{2\pi rn}{60}\right)^2. \quad (5)$$

Substituting in equation (4), the value of  $V^2$  as found from (5), and solving for  $n$

$$n = \frac{60}{2\pi} \sqrt{\frac{g}{h}}. \quad (6)$$

Substituting equation (5) for  $V^2$  in equation (3), and letting  $k = 2$ , then

$$w + W = \frac{w4\pi^2n^2h}{60^2g}, \quad (7)$$

$$\text{or} \quad 2936 \left(1 + \frac{W}{w}\right) = n^2h. \quad (8)$$

This expression gives the relation of the principal items of the governor design.

**148. Shaft Governor.**—There are two forces that may be utilized to control the speed of an engine by means of a shaft governor. In the earlier form of governors, the principal force was *centrifugal force*.

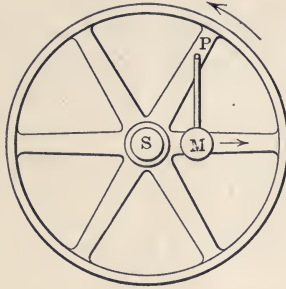

FIG. 126.—Elementary centrifugal governor.

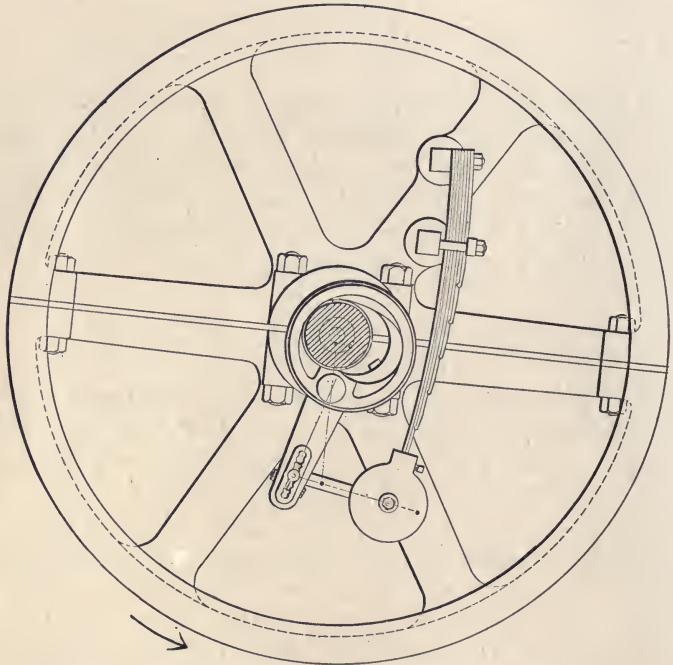

FIG. 127.—Actual construction of centrifugal governor.

In Fig. 126, the governor weight is so suspended that it moves approximately in a radial direction due to the action of centrifugal force. In the actual construction of the governor, the centrifugal

force acts against the resistance of a spring. In this figure, as the speed of the wheel increases, the centrifugal force increases

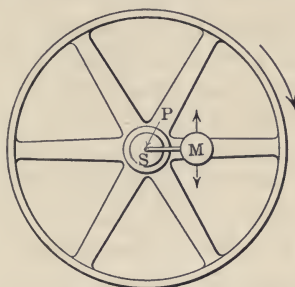

FIG. 128.—Elementary inertia governor.

and the weight  $M$  will move out against the resistance of the spring.

Fig. 127 shows the actual construction of a governor which is

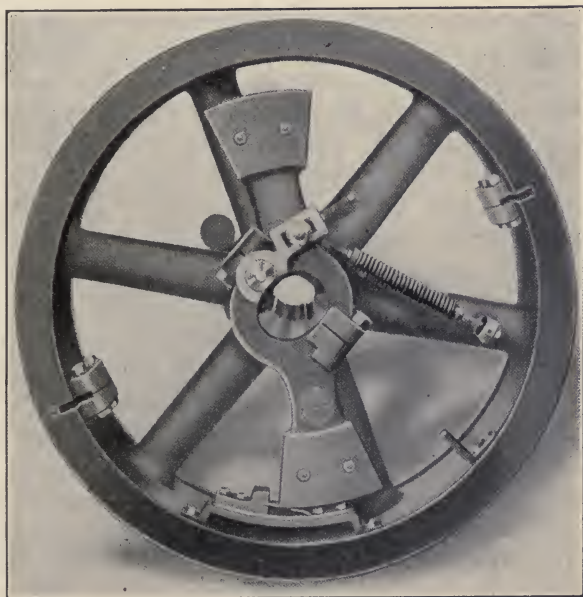

FIG. 129.—Actual inertia governor.

actuated by centrifugal force. The governor in this case regulates the position of the eccentric, as is shown by the dotted lines.

The angular advance and eccentricity are changed at the same time, leaving the lead almost constant for all positions of the governor.

In Fig. 128 the weight  $M$  is fastened so that centrifugal force has no effect upon the movement of the weight, but only produces a stress in the arm  $SM$ . But, if the wheel were suddenly stopped, the weight would continue to move, due to the *inertia*, and exert a force upon a spring (not shown) against the resistance of which the governor ball acts. The motion of this weight is arranged to change the position of the valve. Inertia alone is not used as the actuating force, but a combination of centrifugal force and inertia is used. Fig. 129 shows a form of governor combining these two forces. The two governor weights are fastened to a single arm which rotates around a pin (shown shaded). One weight has a longer arm than the other, and is the dominating weight. As the engine revolves, this weight tends to take a radial position. This action gives the governor its initial position and determines the position of the valve. The governor weights are suspended so that if the speed of the engine changes, the inertia of the weights moves the governor against one or the other of the stops shown. The governor weights act against the resistance of a spring. The speed at which the engine is to run may be changed by changing the tension of this spring. The valve is driven by a pin fastened to the governor arm.

**149. Isochronism.**—For a given governor,  $w$  and  $W$  are fixed quantities, and if the governor is so constructed that  $h$  is constant, then  $n$  must be constant, and the governor becomes *isochronous*. An isochronous governor is one in which the balls are in equilibrium at one speed and only at one, except for friction, and any variation from this speed will send them to the limit of their travel in one direction or the other. The friction of the governor makes it impossible for a governor to be perfectly isochronous. This result is approximately obtained by using crossed arms so that the governor balls have a parabolic path, and the height  $h$  will remain approximately constant. In some forms of governors the balls are guided in a parabolic guide so that their motion is an exact parabola and give  $h$  a uniform value.

**150. Hunting.**—Over-sensitive governors often exhibit the phenomena known as "*hunting*." No matter how quickly a governor may change its position in response to a demand for more or less steam, the engine does not respond instantly. This

is in consequence of the energy stored in the moving parts of the engine, and in the element of time that must elapse between the moment when the steam is admitted by the governor and the time that it acts on the piston. Therefore when a sudden demand for power is made on an engine in which the governor is too sensitive, or too nearly isochronous, the drop in speed will be sufficient to force the governor into a position of over-control, so that too much steam is admitted. This causes the revolutions to increase beyond the desired point and the same over-control is exercised in the opposite direction. In other words, the governor balls fly first in one direction and then the other, "hunting" for the position of equilibrium. The effect is to make the speed of engine change rapidly, first having an excess of speed, and then a speed below the normal. This trouble may be overcome by adding a small weight to one of the governor balls, and changing the tension of the governor spring.

**151. Practical Considerations.**—When a properly designed engine does not govern properly, the trouble is often due to undue friction in the valve mechanism, which may be caused by a tightening of the glands or the journals, or by friction in the dash pot and springs. It may also be due to excessive leakage in the valve, unbalancing it, or by the valve being too tight. The governor should also be examined to see that the weights have not been changed. The tension of the springs should be uniform, if more than one spring is used.

If the engine operates at a lower speed than that desired, the tension of the governor spring should be increased. If this tension has been increased to the limit of the spring, then additional weight should be placed in the governor balls.

In all forms of governors it is necessary that the friction of the valve mechanism be made as small as possible, and it should, if possible, be a constant quantity. It is better to have balanced valves, where they are directly operated by the governor, and the valves should have a small travel. In the D-slide type of valve, small travel is obtained by using a double-ported valve.

In direct connected engines, 2 per cent. variation in speed is the maximum allowable, and most specifications require the variation to be less than 1 per cent. In mill engines a variation of 5 per cent. is sometimes allowed.

**152. Fly-wheel.**—The governor of an engine controls the speed within certain limits by controlling the action of the valve. It

takes a few revolutions, however, to bring the governor into action.

The steam engine, however, has fluctuations of speed that occur in the fraction of a revolution, and these fluctuations must be controlled by the fly-wheel. These fluctuations of speed are due to three principal causes:

*First.*—The pressure of steam is not the same at all points of the stroke.

*Second.*—The motion of the piston is carried to the shaft by means of the connecting rod and crank. This means of changing reciprocating into rotary motion causes a turning effort which varies from zero to a maximum.

*Third.*—The reciprocating motion of the engine piston and other parts necessitates these parts being brought to rest and started again twice each revolution. The overcoming of the inertia effect, caused by the action described, causes a variable force to be transmitted to the crank.

A fly-wheel is fastened to the main shaft of the engine to reduce the variation of speed of the engine in the fraction of a revolution. The inertia of the fly-wheel serves to carry the engine at those portions of the stroke where the piston is not giving sufficient power to the shaft to carry the load.

The effectiveness of the fly-wheel depends upon the energy stored in it. As most of the weight of the wheel is in the rim, we may consider, for an approximation, the action of the rim as giving the fly-wheel effect. If  $W$  is the weight of the fly-wheel rim in pounds, and  $R$  is the average radius in feet, and the wheel makes  $n$  revolutions per minute, then the energy of the rim

$$\begin{aligned}
 &= \frac{1}{2}mv^2 \\
 &= \frac{W}{2g} \left( \frac{2\pi RN}{60} \right)^2 \\
 &= \frac{wR^2N^2}{2g \times 3600} \\
 &= \frac{WR^2N^2}{5874} \text{ ft. lbs.} \qquad (9)
 \end{aligned}$$

The expression shows that the effectiveness of a fly-wheel depends upon the weight of the rim, the square of the radius of the wheel, and the square of the number of revolutions that it makes.



## CHAPTER XIII

### COMPOUND ENGINES

**153. Compound Engines.**—Any engine in which the expansion of steam is begun in one cylinder and continued in another is called a *compound engine*; although this term as commonly used refers to an engine in which the expansion takes place in *two* cylinders *successively*. A *triple-expansion* engine is one in which the steam is expanded *successively* in *three* cylinders.

When steam is expanded in two or more cylinders successively, the number of expansions per cylinder is less than when only one is used, and therefore the range of temperature in each cylinder is less. Reducing the range of temperature in the cylinder reduces the condensation losses. *The principal object of compounding is to reduce the amount of steam used per horse-power per hour*, and, under proper conditions, compounding accomplishes this, owing to the reduction of initial condensation. The radiation losses from a compound\* engine are usually larger than from a simple engine, and very often the mechanical losses are increased by compounding.

The tendency, then, in a compound\* engine, is to increase the radiation loss and to increase the mechanical losses. On the other hand, compounding decreases the thermodynamic losses by decreasing the range of temperature in each cylinder. With low pressure and a small number of expansions, a single-cylinder engine is more economical than a compound\* engine, but with high-pressure steam and a larger number of expansions, the reverse is the case. The higher the pressure and the larger the number of expansions the greater the economy of the compound\* engine.

For pressures under 100 lbs., the single-cylinder condensing engine is more economical than the compound engine. But for pressures above 100 lbs. the compound engine is usually more economical. In the case of the non-condensing engine, the com-

\*The term "compound" as here used includes triple-expansion, quadruple-expansion, etc.

pound engine does not show any economical advantage until the pressure reaches 150 lbs. The compound condensing engine becomes less economical than the triple-expansion engine for pressures greater than 150 lbs.

The single-cylinder engine, Fig. 112, is more economical than the compound engine when the number of expansions of the steam is less than four. When there are from four to six expansions there is very little difference in the economy. With from six to fifteen expansions the compound engine is more economical. When the number of expansions exceeds fifteen it is usual to use a triple-expansion engine.

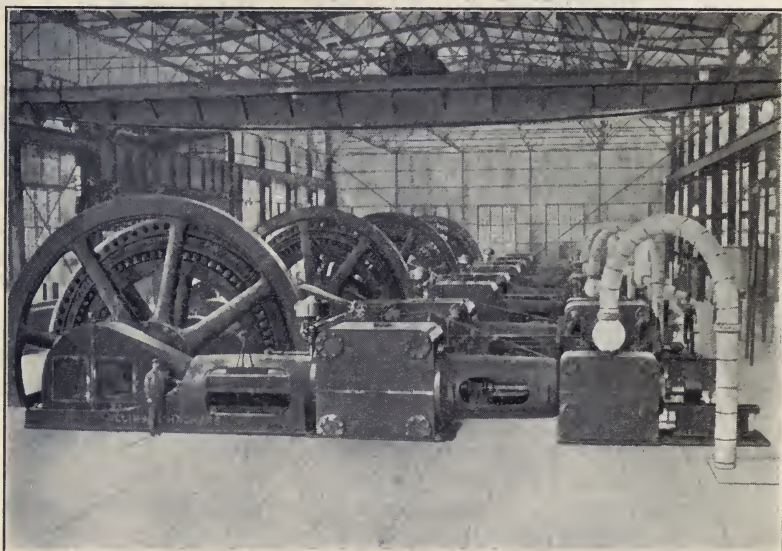

FIG. 130.—Tandem arrangement of cylinders.

**154. Tandem Compound Engines.**—A *tandem compound engine*, Fig. 130, is one in which the two cylinders are placed one in front of the other. The pistons of the two cylinders are attached to the same piston rod, and there is but one connecting rod and crank. The steam flows directly from the high-pressure cylinder into the low-pressure cylinder, and the connecting pipes are relatively small, there being no receiver except the piping between the cylinders. The tandem compound engine occupies less space than the cross compound. The principal objection to this form of engine is the difficulty of getting at

the cylinder which is nearest the crank-shaft. This is the earliest form of compound engine used.

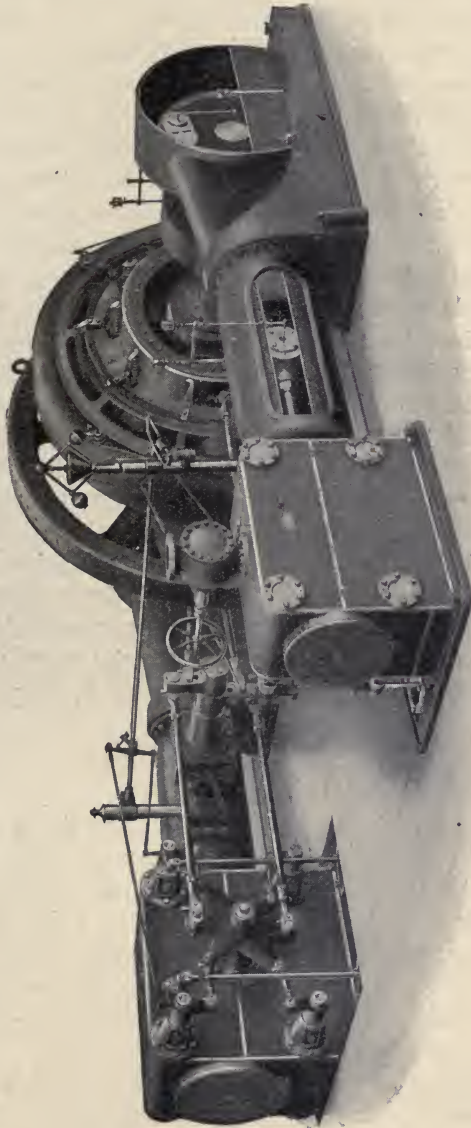

Fig. 131.—Cross compound engine.

**155. Cross-compound Engine.**—In the *cross-compound engine*, Fig. 131, the two cylinders are placed side by side, and each

cylinder has its separate piston rod, connecting rod, and crank. The steam, after leaving the high-pressure cylinder, usually enters a steam reservoir called a *receiver*, and from this receiver the low-pressure cylinder takes its steam. The cranks in a cross-compound engine are usually set  $90^\circ$  apart, so that when the high-pressure cylinder is at the beginning of its stroke the low-pressure cylinder is at mid-stroke. A cross-compound engine with cranks at  $90^\circ$  must always be provided with a receiver, as the low-pressure cylinder may be taking steam when the high-pressure cylinder is not exhausting. The cross-compound engine occupies a much larger space than the tandem engine, but the parts are lighter. Each piston, cross-head, connecting rod, and crank does only approximately one-half the work that they would do in a tandem engine. The turning effort on the crank-shaft is made more uniform by placing the crank at  $90^\circ$ . This reduces the size of the fly-wheel necessary to overcome the fluctuation of the speed of the engine, and also assists the governing.

A vertical cross-compound engine is often termed a "fore and aft" compound.

**156. Ratio of Cylinders in the Compound Engine.**—In the compound engine the strokes of the two cylinders are usually the same. If we represent the ratio of the volumes of the two cylinders by  $L$ , and the diameter of the high-pressure cylinder by  $d$ , and that of the low-pressure cylinder by  $D$ , then

$$L = \frac{D^2}{d^2} \quad (1)$$

The value of  $L$  should be such as to avoid a fall in pressure, termed "drop," between the exhaust pressure in the high-pressure cylinder and the admission pressure in the low-pressure cylinder. The value of  $L$  varies from  $2\frac{1}{4}$  to 4 for automatic high-speed engines, and from 3 to  $4\frac{1}{2}$  for engines of the Corliss type.  $L$  is equal to the quotient of the number of times the steam is expanded in the engine divided by the number of expansions in the high-pressure cylinder.

The *ratio of expansion*,  $r$ , in a compound\* engine is equal to the *ratio of the total volume of the low-pressure cylinder, or cylinders, to that of the high up to the point of cut-off*. That is, it is, as in

\* See note at bottom of page 225.

the case of a single-cylinder engine, the ratio of the *final* to the *initial* volume occupied by the steam while in the engine.

This ratio,  $r$ , may be varied in an engine by varying the point of cut-off in the high-pressure cylinder. It is customary to proportion an engine and so set the valves that each cylinder does an equal amount of work. This, however, is not always the case, some engines being designed to give equal ranges of temperatures in the cylinders. Theoretically this gives the best economy.

*The proportion of work that is done by each cylinder may be adjusted by changing the low-pressure cut-off.* The shorter the cut-off in the low-pressure cylinder, the less the steam taken from the receiver and the higher the pressure in the receiver. Increasing the pressure in the receiver causes a higher back pressure for the high-pressure cylinder, and consequently less work done by that cylinder. Increasing the low-pressure cut-off will decrease the work done by the low-pressure cylinder. Theoretically, *changing the cut-off in the low-pressure cylinder does not change the gross horse-power developed by the engine*, but in actual practice this does not hold absolutely true, although the change is very slight. The equalization of the work in the two cylinders cannot be accomplished in most engines, as in equalizing the work at different loads an excessive drop may be produced between the cylinders.

**157. Horse-power of a Compound\* Engine.**—In determining the horse-power of a compound\* engine from the indicator cards, the card from each end of each cylinder is worked up and the horse-power calculated for each, and the sum of the horse-powers determined from each card will be the horse-power of the engine.

In determining the horse-power that a compound\* engine ought to develop it is necessary to know the absolute initial steam pressure, the total number of expansions of steam, the number of strokes per minute, the length of the stroke, and the diameter of the high- and low-pressure cylinders.

*The horse-power is then determined as though there were but one cylinder, and that one the size of the low-pressure cylinder, and the total expansion of steam took place in that cylinder.* The reason for this is apparent when we consider that the power of any engine per stroke depends on the weight of steam admitted and its

\* See note at bottom of page 225.

ratio of expansion, and that all the power of the compound\* engine could be developed in its low-pressure cylinder if we admitted into that cylinder the same weight of steam as was admitted to the high-pressure cylinder, expanded the steam in this cylinder the same number of times as it was expanded in the whole engine, and exhausted against the same back pressure. If the horse-power obtained by assuming all the work done in the low-pressure cylinder be multiplied by a card factor, the result will be equal to the horse-power of the engine. This may be expressed mathematically as follows:

- Let  $D$  = the diameter of the low-pressure cylinder.  
 $d$  = the diameter of the high-pressure cylinder.  
 $A$  = the area of the low-pressure cylinder in square inches.  
 $l$  = the length of stroke of the engine in feet.  
 $p$  = the mean effective pressure for the whole engine.  
 $n$  = number of revolutions per minute.  
 $x$  = the per cent. of the stroke to the point of cut-off in the high-pressure cylinder.  
 $r$  = ratio of expansion for the whole engine.  
 $e$  = the card factor.  
 $p_1$  = initial pressure steam entering the engine.  
 $p_2$  = pressure of the exhaust.

Then 
$$r = \frac{\pi \frac{D^2}{4}}{x \pi \frac{d^2}{4}} = \frac{D^2}{x d^2}, \quad (2)$$

and 
$$p = e \left\{ \frac{p_1 (1 + \log_e r)}{r} - p_2 \right\}. \quad (3)$$

$$\text{Horse-power} = \frac{2 p l A n}{33000}. \quad (4)$$

The value of the factor  $e$  depends upon the type of the engine, and varies from .70 to .80 for automatic high-speed engines, and from .75 to .85 for a Corliss engine.

**Example.**—A  $15'' \times 24'' \times 36'' \times 30''$  engine runs 100 r.p.m. Cut-off in the H.P. cylinder,  $\frac{3}{8}$  stroke; in the intermediate cylinder,  $\frac{3}{8}$  stroke; in the L.P. cylinder,  $\frac{1}{2}$  stroke. Steam pressure, 225 lbs.

\* See note at bottom of page 225.

Engine exhausts into a condenser having a vacuum of 26 in. Barometer reading, 28.65 in. Assume a card factor of .80.

Indicator cards were taken from the engine with the following areas: H.P. cylinder, head end, 1.32 sq. in., crank end, 1.35 sq. in.; intermediate cylinder, head end, 1.8 sq. in., crank end, 1.71 sq. in.; L.P. cylinder, head end, 2.01 sq. in., crank end, 2.04 sq. in. Length of all cards, 3 in. A 160 lb. spring was used on the H.P. cylinder, a 50 lb. spring on the intermediate, and a 20 lb. spring on the L.P. The diameters of the piston rods were as follows: H.P. cylinder 2 in.; intermediate cylinder, 2½ in.; L.P. cylinder, 3 in.

(a) What is the rated H.P. of the engine?

(b) What per cent. of the rated H.P. is being developed?

**Solution.**—(a)

Atmospheric pressure

$$= 28.65 \times .491 = 14 \text{ lbs.}$$

Exhaust pressure,  $p_2$ , =  $(28.65 - 26) \times .491 = 1.3$  lbs.

$$r = \frac{D^2}{xd^2} = \frac{36 \times 36}{\frac{3}{8} \times 15 \times 15} = \frac{8 \times 36 \times 36}{3 \times 15 \times 15} = 15.35.$$

$$\text{M.E.P.}_r = e \left\{ \frac{p_1}{r} (1 + \log r) - p_2 \right\}.$$

$$\begin{aligned} \text{M.E.P.} &= .8 \left\{ \frac{239}{15.35} (1 + \log 15.35) - 1.3 \right\} = .8 (58.1 - 1.3) \\ &= 45.46 \text{ lbs.} \end{aligned}$$

Area L.P. cylinder =  $3.1416 \times 18 \times 18 = 1018$  sq. in.

$$\text{Rated I.H.P.} = \frac{2 \times 45.46 \times 2.5 \times 1018 \times 100}{33000} = 701.$$

Practically a 700-H.P. engine.

(b)

M.E.P.	{	H.P., H.E., $\frac{1.32}{3} \times 160 = 70.3$ lbs.
		H.P., C.E., $\frac{1.35}{3} \times 160 = 72$ "
		M.P., H.E., $\frac{1.8}{3} \times 50 = 30$ "
		M.P., C.E., $\frac{1.71}{3} \times 50 = 28.5$ "
		L.P., H.E., $\frac{2.01}{3} \times 20 = 13.4$ "
		L.P., C.E., $\frac{2.04}{3} \times 20 = 13.6$ "

*length of card.*  
*160# Spring*  
*50# Spring*

$$\text{Area} \left\{ \begin{array}{ll} \pi 7.5^2 & = 176.7 \text{ sq. in.} \\ \pi(7.5^2 - 1^2) & = 173.6 \text{ " " } \\ \pi 12^2 & = 452 \text{ " " } \\ \pi(12^2 - 1.25^2) & = 447 \text{ " " } \\ \pi 18^2 & = 1018 \text{ " " } \\ \pi(18^2 - 1.5^2) & = 1011 \text{ " " } \end{array} \right.$$

$$\text{Constant} = \frac{LN}{33000} = \frac{2.5 \times 100}{33000} = .007575.$$

$$\text{I.H.P.} \left\{ \begin{array}{ll} \text{H.P., H.E.} & = 70.3 \times 176.7 \times .007575 = 94.4 \\ \text{H.P., C.E.} & = 72 \times 173.6 \times .007575 = 94.7 \\ \text{M.P., H.E.} & = 30 \times 452 \times .007575 = 102.5 \\ \text{M.P., C.E.} & = 28.5 \times 447 \times .007575 = 96.5 \\ \text{L.P., H.E.} & = 13.4 \times 1018 \times .007575 = 103.5 \\ \text{L.P., C.E.} & = 13.6 \times 1011 \times .007575 = 104.2 \end{array} \right.$$

Total = 595.8

Per cent. of rated H.P. developed

$$= \frac{595.8}{700} = .851 = 85.1 \text{ per cent.}$$

$$\text{Ans.} \left\{ \begin{array}{l} (a) \text{ 700 H.P.} \\ (b) \text{ 85.1 per cent.} \end{array} \right.$$

**158. Combined Indicator Cards.**—The combined diagram is a hypothetical figure which would be obtained if the admission, expansion and exhaust all took place in one cylinder, and that the low-pressure cylinder of a compound\* engine. It is a diagram on which may be measured the pressure of the steam at any point in the stroke of any of the cylinders, and the volume of that steam. In it the indicator card from each cylinder appears in its true proportion.

When combining the cards from a compound\* engine, it is first necessary to reduce them all to the same scale of pressures and volumes. It is generally more convenient to use the diagram from the low-pressure cylinder as the basis to which to change the other diagrams.

On each of the diagrams lay off a vertical line back of the admission line a distance equal to the clearance volume for that particular cylinder. These lines represent the lines of zero volume.

Divide the high and intermediate diagrams into any convenient

\* See note at bottom of page 225.



number of parts by vertical lines spaced equidistant apart. Multiply the distance from the atmospheric line of each of the

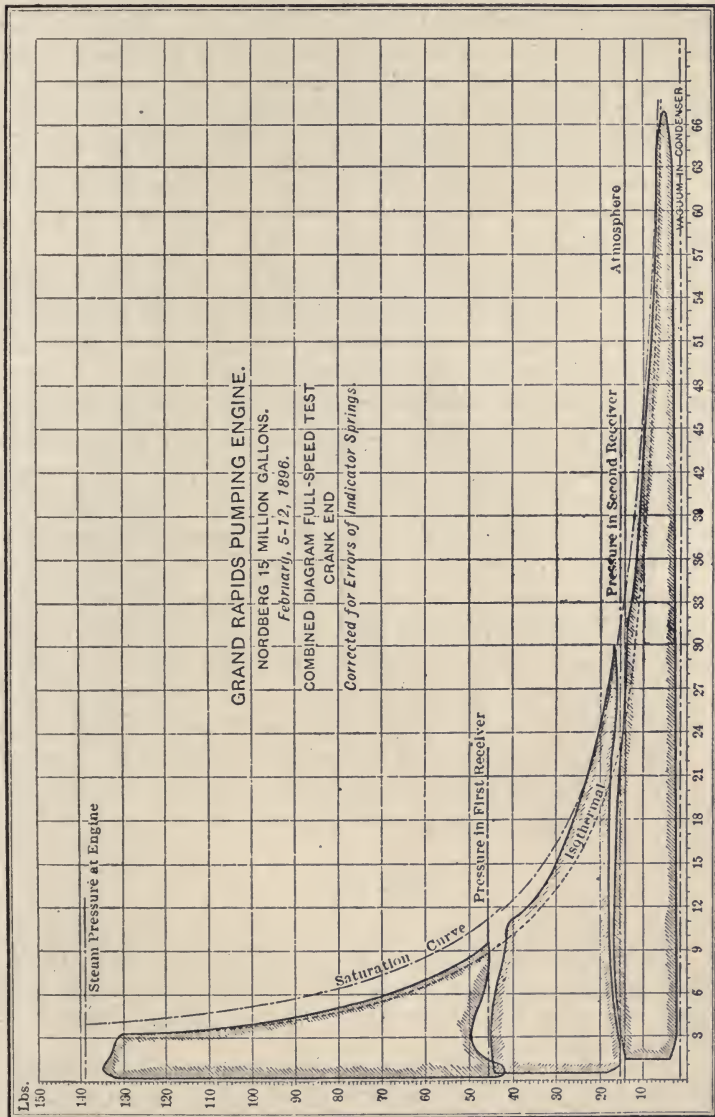

Fig. 132.—Combined indicator cards for triple-expansion pumping engine.

points where these vertical lines cross the diagrams, by the ratio of the scale of the spring used in the cylinder being considered to

that used in the low-pressure cylinder. The results will be the ordinates of the points to be plotted when drawing the combined diagram. (The pressure in each cylinder at any point in the stroke may be determined from the indicator card for that cylinder, knowing the value of the spring used and the position of the atmospheric line). Multiply the horizontal distances from the zero volume line to the points of intersection of the vertical lines and the diagram, by the ratio of the volume of the cylinder under consideration to the volume of the low-pressure cylinder. The results obtained will be the abscissæ of the points on the combined diagram.

Now plot the results using the atmospheric line and line of zero volume on the low-pressure diagram as the horizontal and vertical axes from which to measure the ordinates and abscissæ. Through the points so plotted, draw the combined diagram.

Fig. 132 shows the combined diagram from a triple-expansion pumping engine. The indicator cards for the high, intermediate, and low-pressure cylinders, have all been reduced to the same scale of volumes and pressures. The ordinates in this diagram are absolute pressures and the abscissæ are volumes. The indicator card from each cylinder was divided into an equal number of parts and the pressure and volume at each of these points was computed and plotted in the figure. The indicator card for each cylinder, it will be noticed, does not begin at the zero volume line, the difference between zero volume of the indicator card and the zero of volumes representing the volume of the clearance. The dotted saturation curve shows what the curve of expansion would have been if the actual weight of steam expanding in the engine had remained saturated.

### PROBLEMS

1. A compound engine is  $8'' \times 16'' \times 12''$  and runs 300 r.p.m. Initial steam pressure, 150 lbs. absolute; back pressure, 2 lbs. absolute. Cut-off in high-pressure cylinder at  $\frac{1}{4}$  stroke. If the steam expands along an isothermal of a perfect gas and the card factor is 70 per cent., what I.H.P. will the engine develop?

2. A single-acting compound engine is  $9'' \times 15'' \times 9''$ ; initial pressure, 125 lb. gage; back pressure, atmospheric; cut-off in high-pressure cylinder,  $\frac{1}{4}$  stroke; r.p.m., 250. Assume card factor of 80 per cent. What would be the horse-power rating of the engine?

3. A compound engine is  $27'' \times 35'' \times 48''$  and runs 80 r.p.m. Initial pressure, 125 lbs.; back pressure, 2 lbs. absolute; cut-off in the high-pressure

cylinder,  $\frac{1}{2}$  stroke; card factor, 80 per cent. What will be its horse-power if each cylinder develops an equal number of horse-power?

4. A triple-expansion engine is  $20'' \times 27'' \times 40'' \times 36''$ . Cut-off in high-pressure cylinder,  $\frac{1}{4}$  stroke; in intermediate cylinder,  $\frac{1}{2}$  stroke; and in low pressure cylinder,  $\frac{1}{2}$  stroke. Steam pressure, 135 lbs.; back pressure, 2 lbs. absolute. Engine is double acting and runs 50 r.p.m. Assuming a card factor of 80 per cent., what is the rated horse-power of the engine?

5. A city pumping engine is  $27'' \times 35'' \times 55'' \times 48''$ ; cut-off in high-pressure cylinder,  $\frac{1}{4}$  stroke. Steam pressure, 130 lbs.; back pressure, 2 lbs. absolute; r.p.m., 40. Assume card factor of 85 per cent. What is its rated horse-power?

6. An engine is  $9'' \times 15'' \times 9''$  and runs 320 r.p.m., the cut-off in the high-pressure cylinder being  $\frac{1}{4}$  stroke. Steam pressure, 125 lbs.; back pressure, 3 lbs. absolute. Engine is single acting and the area of the indicator card from high-pressure cylinder is .9 sq. in.; from the low-pressure cylinder, 9. sq. in. The length of each is 2.35 in. An 83-lb. spring is used in indicator on high-pressure cylinder and a 40-lb. spring in indicator on low-pressure cylinder. The engine is fitted with a Pony brake carrying a gross weight of 120 lbs. The tare of the brake is 20 lbs. and the length of the brake arm is 51 in. Find the I.H.P.; B.H.P.; F.H.P.; and mechanical efficiency.

7. A triple-expansion engine is  $18'' \times 28'' \times 36'' \times 24''$  and runs 180 r.p.m. Steam pressure, 200 lbs. absolute; vacuum, 28 in. Diameter of piston rod for H.P. cylinder, 2 in.; for M.P. cylinder, 3 in.; for L.P. cylinder, 4 in. Indicator spring for H.P. cylinder, 160 lbs.; for M.P. cylinder, 60 lbs; for L.P. cylinder, 20 lbs. The area and lengths of indicator cards are as follows:

H.E., H.P. Cyl.,	area	2	square	inch,	length	3	in.
C.E.	"	"	"	"	"	"	3
H.E., M.P.	"	"	"	"	"	"	$2\frac{1}{2}$
C.E.	"	"	"	"	"	"	$2\frac{1}{2}$
H.E., L.P.	"	"	"	"	"	"	3
C.E.	"	"	"	"	"	"	$3\frac{1}{4}$

Find the total I.H.P.

## CHAPTER XIV

### CONDENSERS AND AIR PUMPS

159. There are two general forms of condensers in use, the *jet condenser* and the *surface condenser*. In condensers of the

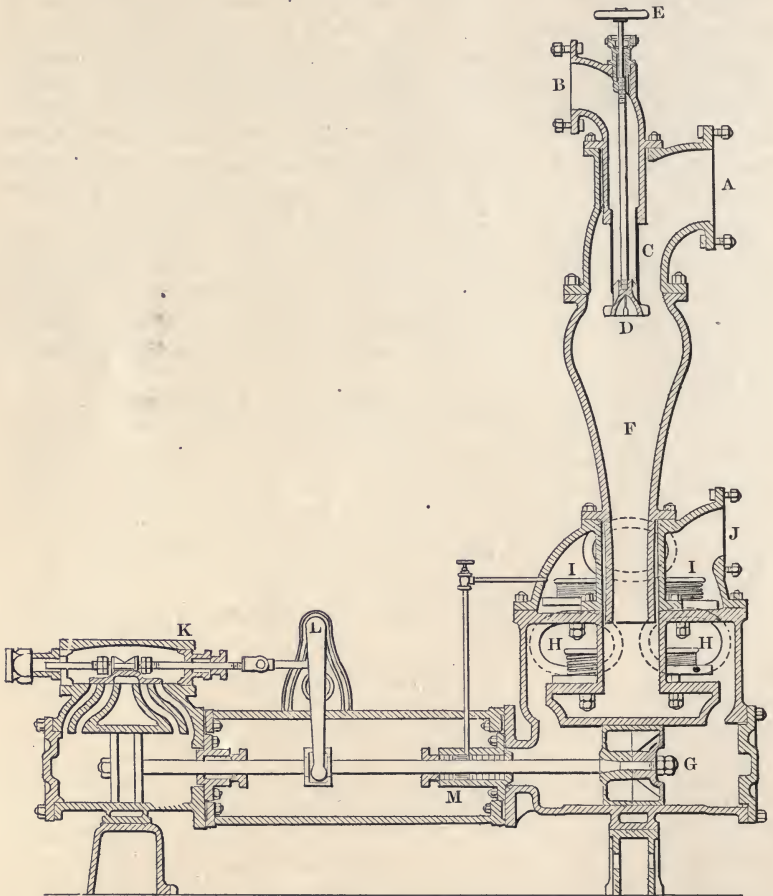

FIG. 133.—Jet condenser.

jet type, the condensing water and the steam are brought into contact with each other, while in the surface condensers the con-

condensing water and the steam condensed do not come in direct contact.

**160. Jet Condensers.**—There are two principal types of jet condensers, the *regular jet* type and the *barometric condenser*.

Fig. 133 shows a jet condenser of the regular type. The exhaust steam from the engine enters at *A*, and the injection water at *B*. These are mixed in the combining chamber *F*. The water in entering the combining chamber is sprayed by a rose-head on the end of the injection pipe at *D*. The condensation of the steam

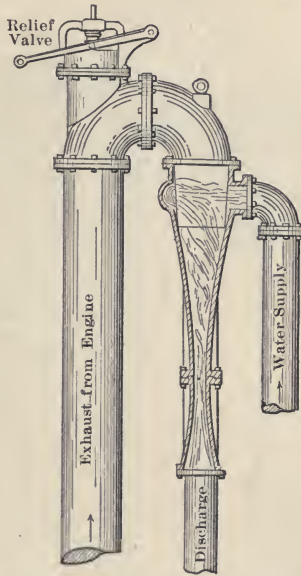

FIG. 134.—Barometric condenser.

reduces its volume many times, and this reduction of volume forms a vacuum in the chamber *F*. This vacuum is maintained by the pump *G*, which removes the condensing water, and air which is present in small quantities.

In the position shown in the figure, the piston is moving toward the left, forcing the water in the crank end of the cylinder out through valve *I* into the discharge pipe *J* and holding valve *H* closed. At the same time the suction in the head end of the cylinder closes valve *I'* and opens valve *H'* drawing in the water and air from the combining chamber *F*. If the source of condensing water is not more than 15 ft. below point *B*, it is pos-

sible to draw the water into the condenser by the vacuum in the chamber *F*.

In the barometric condenser, Figs. 134 and 135, the water and steam, after coming in contact, pass as water through a narrow opening in the throat of the condenser. The water passing through this narrow throat carries the air with it. The condensation of the steam forms a vacuum, but the condensing water must be pumped into the combining chamber, as this chamber is ele-

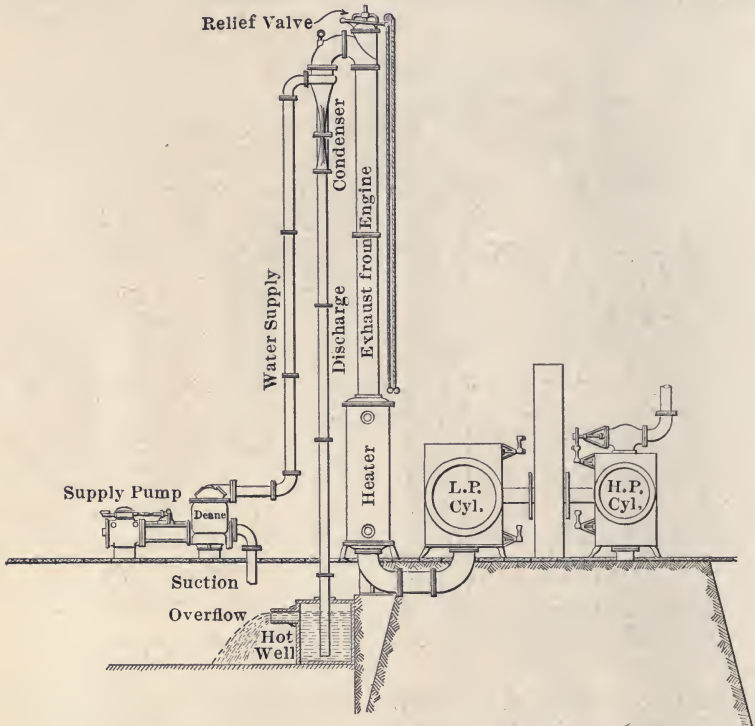

FIG. 135.—Complete installation of barometric condenser.

vated at least 35 ft. above the hot well, so that the pressure of the atmosphere upon the surface of the water in this well cannot force it up into the chamber. The quantity of water passing through the throat of the condenser cannot be decreased very much, as, if the velocity of the water passing is reduced to any extent, it will be insufficient to maintain the vacuum. For this reason the barometric condenser is not adapted to variable loads.

The jet condenser is the form most used in stationary plants,

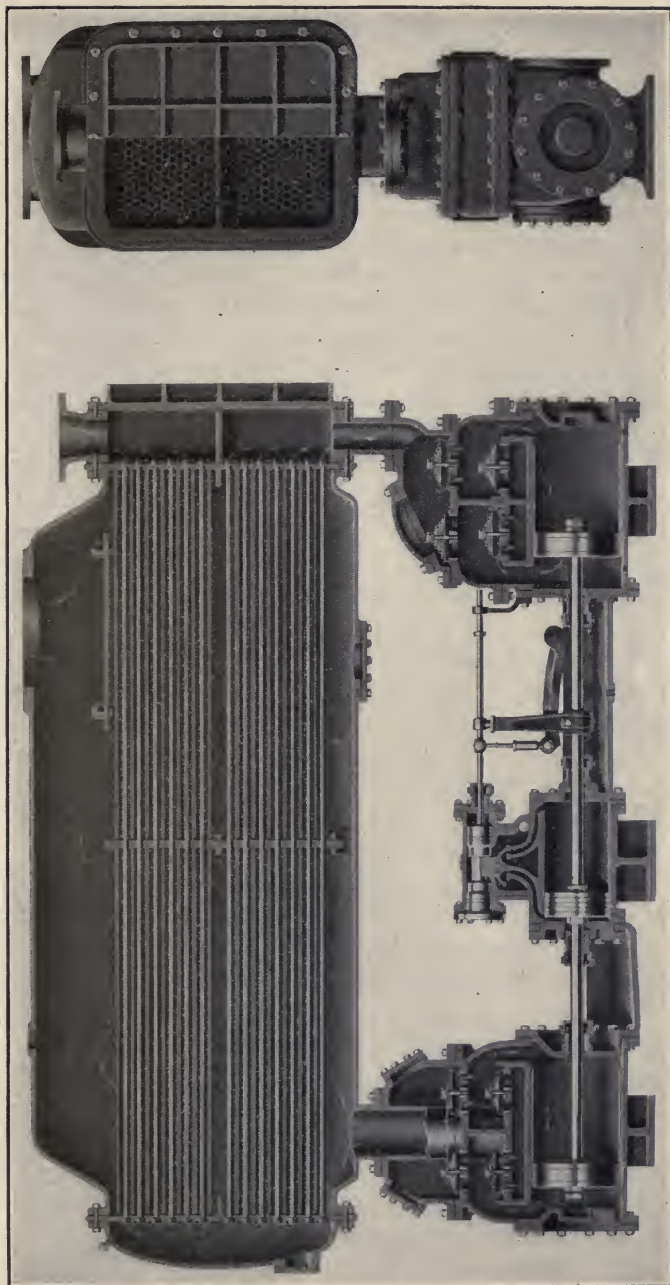

FIG. 136.—Surface condenser.

as it is less expensive to install, requires less repairs, and, where clean water is available, gives as good results as the surface condenser.

**161. Surface Condensers.**—In a surface condenser, Fig. 136, the steam to be condensed and the cooling water do not come in direct contact with each other. The cooling water is circulated on one side of a series of tubes, and the steam is condensed by coming in contact with the other side of the tubes. The condensed steam is drawn off by the air pump. The condensing water is drawn or forced through by the circulating pump. The surface of the tubes which come in contact with the steam is the condensing surface. The tubes are always of small diameter, and the metal is made as thin as possible and usually of brass. A surface condenser is used where the cooling water is not suitable for feed water, and it is necessary to use the same water over and over again for making steam in the boilers. The condensed steam being distilled water, contains no scale-forming matter and is excellent for feed water. Care must be taken, however, to see that none of the oil contained in the exhaust steam is allowed to go back to the boiler. With the surface condenser, the nature of the cooling water is immaterial as none of it will be used as feed water. This is the form of condenser always used in salt water marine practice.

**162. Air Pumps.**—The air pump is sometimes operated directly from the engine. This is done to avoid the use of steam by the independent condenser pump, which is always uneconomical, using from 70 to 120 lbs. of steam per I.H.P. per hour.

The water and air are usually discharged through the discharge pipe into a tank, or well, called the *hot well*, and the overflow from this hot well runs into the sewer, or river. The feed water for the boilers in a condensing plant is usually taken from the hot well.

In many plants, when very high vacuum is desired, there is added a dry air pump, in addition to the devices already described. This is attached to the combining chamber so as to remove the air from it, the regular vacuum pump removing only the water. Vacuums as high as 28 in. and over are maintained in these plants.

**163. Amount of Cooling Water.**—The amount of cooling water required in a condenser depends upon the temperature of the water and the degree of vacuum desired. If the temperature in the condenser is too high, low vacuum cannot be obtained, as the



pressure in the condenser cannot be less than the pressure corresponding to the temperature of the boiling point in the condenser. If the temperature of the water in the hot well is  $120^{\circ}$ , the corresponding pressure as given in the steam tables is 1.7 lbs., which is the lowest possible pressure that can be obtained. If a lower vacuum is desired, the temperature of the water leaving the condenser must be lowered. This can be done in two ways, by increasing the amount, or decreasing the temperature, of the cooling water.

- If we let  $t_1$  = the initial temperature of the cooling water;  
 $t_2$  = the final temperature of the cooling water (and, in a jet condenser, of the condensed steam also);  
 $t_3$  = the temperature of the condensed steam leaving a surface condenser;  
 $H$  = heat (above  $32^{\circ}$ ) in the steam entering the condenser;  
 $W$  = the weight of the cooling water entering per minute;  
 $w$  = the weight of steam condensed per minute;

then the heat given up by the steam in a jet condenser

$$= w\{H - (t_2 - 32)\}, \quad (1)$$

and the heat received by the water

$$= W(t_2 - t_1). \quad (2)$$

But these two expressions must be equal, and equating and solving,

$$W = \frac{w\{H - (t_2 - 32)\}}{t_2 - t_1} \quad (3)$$

The amount of cooling water per pound of steam entering a surface condenser is larger than that used in a jet condenser, as the temperature of the condensed steam is higher than the temperature of the cooling water leaving the condenser. Substituting  $t_3$  for  $t_2$  in equation (1), equation (3) becomes,

$$W = \frac{w\{H - (t_3 - 32)\}}{t_2 - t_1}, \quad (4)$$

which is the expression for the weight of cooling water used to condense  $w$  pounds of steam per minute in a surface condenser.

In ordinary stationary practice, 1 sq. ft. of cooling surface is allowed for every 10 lbs. of steam condensed per hour, except in the case of turbines using high vacuum, where 1 sq. ft. is allowed for every 4 to 8 lbs. of steam. In navy practice, from 1 to  $1\frac{1}{4}$  sq. ft. of surface are allowed for every indicated horse-power.

**164. Increase of Power by Use of Condenser.**—Condensing the exhaust steam diminishes the back pressure by creating a partial vacuum in the exhaust system. This vacuum is generally measured in inches of mercury. It is seldom that the vacuum maintained in the condenser exceeds 26 in., and 24 in. is more common. In the expression for mean effective pressure,

$$\text{M.E.P.} = e \left\{ p_1 \left( \frac{1 + \log_e r}{r} \right) - p_2 \right\},$$

the quantity affected by the vacuum is the term  $p_2$ . In a non-condensing engine this is usually about 15 lbs. and the M.E.P. about 40 lbs., but in the condensing engine the effect of adding a condenser is to lower  $p_2$  to about 2 lbs., and increase the M.E.P. for a single cylinder engine to 53 lbs., adding to the horse-power of the engine about 20 per cent.

**165. Condensers for Steam Turbines.**—In most steam turbine plants, surface condensers are used, principally for the reason that the exhaust from the steam turbine does not contain oil, and when condensed is an ideal feed water, as it contains no scale-producing matter. It is also possible in a surface condenser to use very large quantities of circulating water, and thus reduce the temperature of the condenser.

In turbine plants an increase in the vacuum increases the economy of the turbine materially, and every means is used to get the highest possible vacuum.

### PROBLEMS

1. A 150 H.P. engine has a guaranteed steam consumption of 20 lbs. per I.H.P. per hour. On being tested, it was found that it took 21.6 lbs. The engine operates 10 hours per day, 300 days per year, and cost \$4500 to install. The steam costs 25 cents per 1000 lbs. to produce. How much should be deducted from the cost price to compensate the purchaser for the increased cost of operation above that required under the guarantee? Allow 6 per cent. interest and 5 per cent. depreciation. (Suggestion: Find the present worth of an annuity equal to the loss per year due to the excess steam consumption.)

2. Given a plant equipped with two 5000 H.P. engines that use 20 lbs. of steam per horse-power per hour. Feed temperature,  $70^\circ$ ; steam pressure,

150 lbs. Boilers evaporate 9 lbs. of water per pound of coal. Coal cost \$2.25 per ton. Engines run 10 hours a day, 300 days in the year. If these engines are taken out and sold for \$5 per horse-power and new ones using only 12 lbs. of steam per horse-power per hour are installed; (a) how many boiler horse-power will be saved; (b) how much will be saved per year on the coal bill; (c) how much can be paid for the new engines if they are to return 6 per cent. on the investment, the depreciation of the engines being 4 per cent.?

3. A 100 H.P. automatic engine uses 32 lbs. of steam per I.H.P. per hour and costs \$1500. A 100 H.P. Corliss engine uses 26 lbs. of steam per I.H.P. per hour and costs \$2200. Steam in the plant costs 20 cents per 1000 lbs. The plant runs 10 hours per day and 300 days per year. Allowing 5 per cent. interest, 10 per cent. depreciation on the high-speed engine, and 7 per cent. on the Corliss, (a) which will be the most economical engine to buy? (b) How much will the one engine save over the other per year in operation?

4. A power plant is to deliver 1000 K.W. at the switch board. A steam engine can be installed which will give an economy of  $14\frac{1}{2}$  lbs. steam per I.H.P. per hour. Steam pressure, 145 lbs.; feed water,  $150^{\circ}$ ; dry steam. Engine efficiency, 92 per cent.; generator efficiency, 95 per cent. A steam turbine can be installed which will give a steam consumption of 20 lbs. per K.W. per hour. Steam pressure, 145 lbs.;  $150^{\circ}$  superheat. Feed water,  $150^{\circ}$ . Cost of generating steam in each case, 20 cents per 1,000,000 heat units. Which is the more economical installation and how much is saved by this one per hour over the other?

## CHAPTER XV

### STEAM TURBINES

**166. Historical.**—From the earliest time attempts have been made to produce a rotary motion by steam without converting a reciprocating motion into the rotary motion. Devices for doing this have, with the exception of the steam turbine, been a failure.

The modern steam turbine is the revival of the earliest form of steam motor. The first contrivance of this kind dates back to Hero's turbine, shown in Fig. 137, which was designed two centuries before the birth of Christ. Hero's turbine consisted

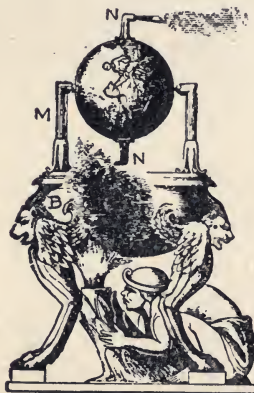

FIG. 137.—Hero's turbine.

of a hollow spherical vessel pivoted on a central axis. It was supplied with steam from a boiler through the support *M* and one of the pivots. The steam escaped from the spherical vessel through bent pipes or nozzles, *N, N*, facing tangentially in opposite directions. Rotation was produced by the *reaction* due to the steam discharged from the nozzles, just as a Barker's mill is moved by the water escaping from its arms. Hero's turbine was moved by the reaction of the steam jets alone, so that it is called a *reaction turbine*.

Giovanni Branca in 1629 designed a steam turbine as shown in Fig. 138. Steam issues from the nozzle in the mouth of the figure in the form of a jet. This jet strikes the blades of a wheel and causes it to rotate. The wheel is moved by the *impulse* of the steam jet exerted upon the blades of the turbine wheels. The Branca turbine is then of the *impulse type*.

**167. Forces of Impulse and Reaction.**—Fig. 139 illustrates the force of both impulse and reaction. A tank filled with water is suspended from above, and from one side a jet of water is allowed to escape through a nozzle. This issuing jet impinges against a block of wood having a curved surface which turns the jet of water back against its original direction.

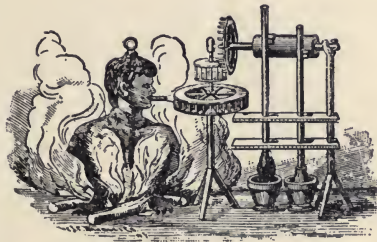

FIG. 138.—Branca's turbine.

The water striking the block produces a force which tends to move the block in the original direction of the jet, and which is the result of the jet being turned in direction by the curved surface. This force may be termed an impulsive force. At the same time the stream issuing from the tank exerts a reaction upon it, tending to move it to the left. This may be termed the force of reaction, and is caused by the fact that the particles of water are accelerated in velocity from practically zero inside the tank to a maximum at the mouth of the nozzle. In doing this accelerating a continuous force must be impressed upon the particles, and the tank and its contents must at the same time, sustain a reactive force of the same amount. This reactive force corresponds to the recoil or kick of a gun. In the case of the gun, however, the discharge is irregular; while in the case of the nozzle it is continuous. Reactive force accompanies the generation of velocity; and impulsive force accompanies destruction of it, or the deflection of a jet. Either one or both of the forces above

described may be used to give the driving impetus in a steam turbine.

**168. Classification.**—The two types of turbines described in paragraph 166 are typical of the modern classification of turbines, viz:

*Impulse turbines*, in which the expansion of the steam takes place only in the stationary nozzles or guide vane passages, the pressure on both sides of the moving blades or wheel being the same, and

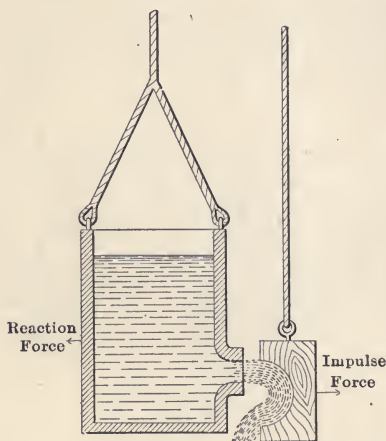

FIG. 139.—Diagram illustrating forces of impulse and reaction.

*Reaction turbines*, in which the expansion takes place either partially or completely, in the moving blades or buckets.

In Fig. 140 is shown an actual impulse turbine nozzle and blades. In this wheel, the motion is produced by the impulsive action of the steam striking the blades. The entire expansion of the steam takes place in the nozzle there being no expansion in the blades.

The blades and nozzle of a partial reaction turbine are shown in Fig. 141. Here the expansion of the steam is not complete in the nozzle, which is so designed that it cannot fully expand the steam by the time the jet has left it. The remainder of the expansion is completed in the blade passages. The nozzles are shaped like the blades, and are called stationary blades. But they expand the steam as nozzles would, and are therefore essentially equivalent to nozzles. The passageways through the blades are conver-

gent in cross-sections. In commercial impulse turbines blade passages are usually made slightly divergent.

**169. Action of Steam in Turbine.**—The steam turbine uses steam in a manner fundamentally different from that in which the steam reciprocating engine uses it. The purpose of both machines is to convert the potential or pressure energy of the steam into mechanical work. The reciprocating engine accomplishes this by allowing the steam to exert a pressure

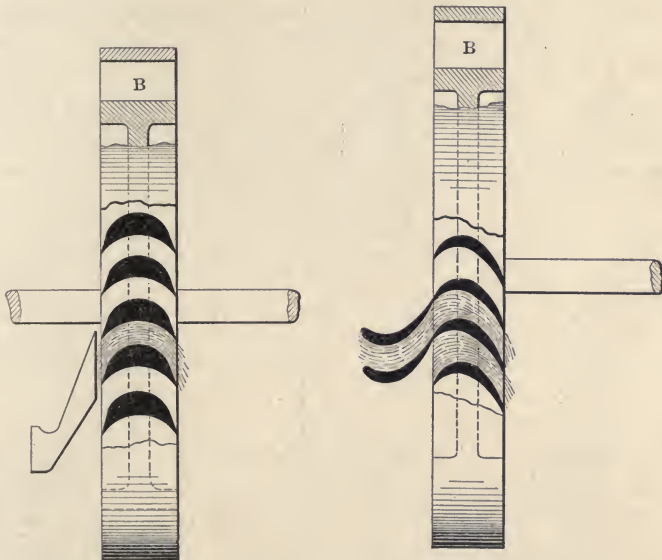

FIG. 140.—Impulse type.

FIG. 141.—Reaction type.

Turbine nozzle and blades.

directly upon its piston. In the steam turbine, there are two steps in the transformation. First, the potential energy of the steam is converted into kinetic energy; and second, the kinetic energy of the jet is changed into mechanical or useful work. The first of the two operations is performed by the nozzles whose function it is to expand the steam from one pressure to another in such a way as to produce the maximum velocity of jet possible, and at the same time to direct this jet properly upon the blades. The second operation is accomplished by the blades or moving elements whose functions it is to abstract the energy of velocity from the steam, and convert it into a useful form.

Sometimes, the steam is allowed to expand partly in the blades, in addition to the expansion which has already taken place in the nozzle. When this is the case, the turbine belongs to the partial reaction, or Parsons type.

**170. Turbine Nozzles.**—As steam flows through a nozzle its pressure is gradually reduced. At the same time the velocity of the particles of steam is correspondingly increased. The volume of the steam also grows as the steam proceeds at a continually diminishing pressure. The area of the nozzle at any particular cross-section is dependent upon the velocity and volume of the steam as well as upon the total weight passing per second. Since the weight is the same for all cross sections, if the velocity and specific volume increased at the same rate, then the area of a nozzle at all cross-sections would be the same and the nozzle would be nothing more than a tube of

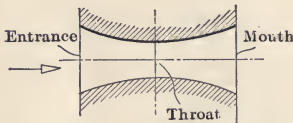

FIG. 142.—Turbine nozzle—longitudinal cross-section.

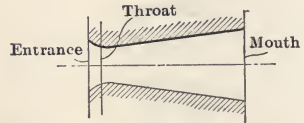

FIG. 143.—Ordinary form of nozzle.

uniform diameter. As a matter of fact, however, the velocity and specific volume do not increase at the same rate. During the first part of the expansion the velocity increases more rapidly than the specific volume; while during the latter part of the expansion the specific volume increases more rapidly than the velocity. The cross-sectional area of the nozzle is determined by the ratio of velocity to volume, and should diminish at first to a minimum value and then increase to a maximum at the end. The point of least cross-section is called the *throat* and is that place in the steam's progress through the nozzle at which the rate of increase in specific volume overtakes the rate of increase in velocity. Fig. 142 shows the general shape of a nozzle on a longitudinal cross-section. The nozzle, as ordinarily constructed is shown in Fig. 143, and differs from the nozzle of Fig. 142 in that the throat cross-section has been moved very near the entrance end. The convergent portion of the nozzle consists merely of a rounding or fillet. The divergent portion is comparatively long and of a straight taper. All nozzles have a convergent portion. When



the back pressure against which the nozzle is discharging is 58 per cent. or more of the initial pressure, the nozzle should be wholly convergent or it should be uniform in cross-section from the throat to the discharge end. But when the back pressure is less than 58 per cent. of the initial pressure then the nozzle should have a divergent part also. The size of the nozzle at the mouth or the relation of the area at the mouth to the area at the throat is a function of the relation between the back pressure and the initial pressure.

The following table shows how the velocity and specific volume increase as the pressure falls during adiabatic expansion:

TABLE XXI

RELATIVE CHANGES IN VELOCITY, SPECIFIC VOLUME AND PRESSURE OF STEAM FLOWING THROUGH A NOZZLE

1 Pressure, lbs. per sq. in. abs.	2 Available energy, B.T.U.	3 Velocity, ft. per sec. (theoretical)	4 Quality, per cent.	5 Specific volume of dry steam	6 Actual spec. vol. (= col. 4 $\times$ col. 5)
150	0.0	0	100.0	3.012	3.012
135	9.5	689	99.1	3.331	3.301
120	19.5	986	98.3	3.726	3.663
105	30.0	1225	97.4	4.23	4.12
90	42.0	1450	96.3	4.89	4.70
75	56.0	1675	95.2	5.81	5.53
60	72.5	1905	93.9	7.17	6.73
45	93.5	2160	92.3	9.39	8.66
30	121.5	2460	90.2	13.74	12.40
15	168.5	2900	87.0	26.27	22.87

**171. Speed of Turbine.**—The speed at which the blades of the turbine wheel will give the best efficiency shows the velocity at which the steam impinges upon the blade. In Fig. 144 the direction of the steam jet as it leaves the nozzle is represented by *ab*. Suppose the velocity of this jet to be 2000 ft. per second and let the blade be of such a form that the jet is turned any direction through an angle of  $180^\circ$ . Assuming the blade to be stationary, that is the turbine wheel blocked, then the speed of the steam relative to the blade will be 2000 ft. per second as it enters, or it is the same as the absolute velocity with which the steam left the nozzle. Assuming the blade to be frictionless the steam will be gradually deflected in direction without loss of velocity and will emerge with the same speed at which it entered, namely, 2000 ft. per second. An impulsive force will have been exerted upon

the blade, but no energy will have been taken from the steam jet because there has been no motion of the blade. Now assume another case in which the blade moves with a speed of 500 ft. per second. Then the speed of the jet as it enters the blade will be only 1500 ft. per second relative to the blade, although the absolute velocity, that is the velocity at which the steam leaves the nozzle, is still 2000 ft. per second. The jet will continue along the blade as before and will emerge from it with the same speed

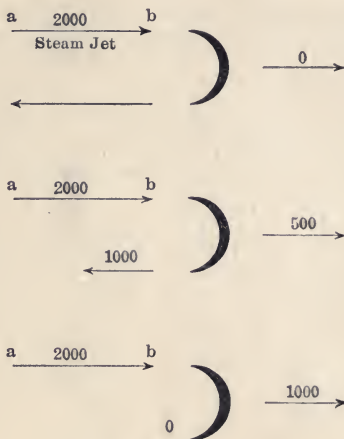

FIG. 144.—Diagram showing relative velocities of steam jet and blade.

with which it entered, that is, 2000 ft. per second. But since the blade is traveling at 500 ft. per second in a direction opposite to that of the leading jet, the actual absolute velocity of the jet at exhaust from the blade will be only 1000 ft. per second. All the energy is not abstracted from the jet because the steam still has left an amount of energy represented by the velocity of 1000 ft. per second. It is evident then that in order to abstract all the energy from the jet it will be necessary for the steam to leave the blade with no velocity.

Let us assume another case in which the blade speed is 1000 ft. per second. Then, reasoning as before, the velocity of the jet as it enters the blade will be 1000 ft. per second relative to the blade and in this case the steam will leave the blade with a relative velocity of 1000 ft. per second. But since the blade itself is now traveling 1000 ft. per second, the steam will be dis-

charged having no absolute velocity. In this case, then, all the kinetic energy of the steam has been abstracted by the blade and it is, therefore, operating under the most efficient speed. It may therefore be said in general that for turbines with a single row of blades and excluding friction, the peripheral speed of the blades for greatest efficiency should be one-half the speed of the jet. In actual practice the steam cannot usually be deflected through an angle of  $180^\circ$  nor can the blade be so designed as to avoid friction. Both these causes tend toward reducing the speed of the blade below one-half the speed of the jet for maximum efficiency, this speed reduction being from 10 to 15 per cent.

In a nozzle expanding steam under a pressure of 160 lbs. absolute to a pressure of 1 lb. absolute, the theoretical velocity of the issuing jet may be as high as 4000 ft. per second. This would give a blade speed of from 1700 to 1000 ft. per second, which is almost prohibitive even under the best mechanical construction. It is this condition that has led to the development of the multiple pressure stage and multiple velocity stage turbines, which are described later and whose primary purpose is the attainment of a high efficiency with a much lower blade speed.

**172. De Laval Turbines.**—The De Laval single-stage turbine consists of a group of nozzles located around the periphery of a wheel to which the blades are attached. The blades and jets of this form of turbine are shown diagrammatically in Fig. 145, and a plan of the turbine together with its gearing is shown in Fig. 146. The turbine wheel *W* is supported upon a light flexible shaft between the bearing *Z*, provided with a spherical seat, and a gland or stuffing-box *P*. The purpose of this flexible shaft is to permit the wheel, when running at high speeds, to revolve about its center of gravity instead of its geometrical center, thus reducing vibration and wear. Teeth are cut into the metal of the shaft to make the pinions on each side of *K* fit the gear wheels *A* and *B*.

Fig. 145 shows the diverging nozzles of the De Laval turbine. The function of these nozzles is to reduce the pressure of the steam by expanding it. At the same time the velocity of the steam is increased. In other words, the energy of pressure which the steam contains before entering the nozzles is changed in the nozzles into the energy of velocity. The steam issues from the nozzles at a very high velocity. It has been shown that

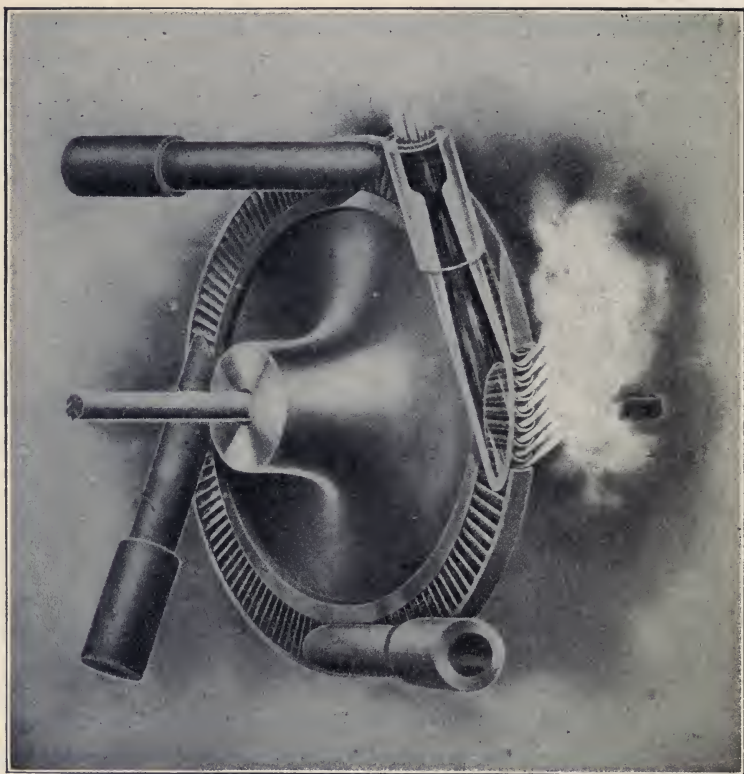

FIG. 145.—De Laval turbine wheel.

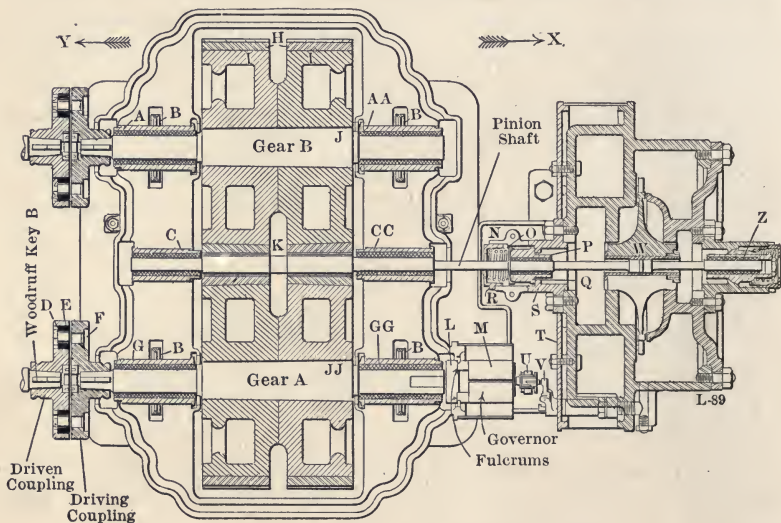

FIG. 146.—Cross-section of De Laval turbine.

the best efficiency of the turbine of this type occurs when the peripheral speed of the wheel is about half the speed of the steam leaving the nozzles. The peripheral speed of the wheel must then be very high in order to obtain good efficiency.

In order to bring the speed of the turbine wheel within practical limits for utilizing the power, the reduction gears *A* and *B* in Fig. 146 are required. This reduction is usually about ten to one, and is accomplished by means of small pinions in the shaft meshing with the gear wheels. The teeth are cut spirally, on one side with a right-hand, and on the other with a left-hand spiral. This method effectually prevents any movement of the shaft in the direction of the axis and balances the thrust of the gears.

On account of the very high speeds at which De Laval turbines operate, blade wheels, shaft, and bearings require very careful designing. The strength of the disk, or a wheel of a disk type, in which there is a hole at the center, is at best not more than half as great as one without a hole.\* On this account the larger sizes of De Laval turbine wheels are made without a hole at the center. The shaft is made with large flanged ends which are bolted into suitable recesses in the hub.

A simple throttling governor is used for speed regulation in the De Laval turbines. By reducing the pressure of the steam admitted to the nozzles at light loads, the steam is discharged upon the blades at a lower velocity than when it is at the higher pressure, and correspondingly less energy is given to the turbine wheel so as to maintain a constant speed.

Fig. 147 shows the variation of the velocity and the pressure in the nozzles and blades of a De Laval single-stage turbine. Curve II shows the velocity for each point in the nozzle. The ordinates represent the velocity, and the abscissæ the position in the nozzle

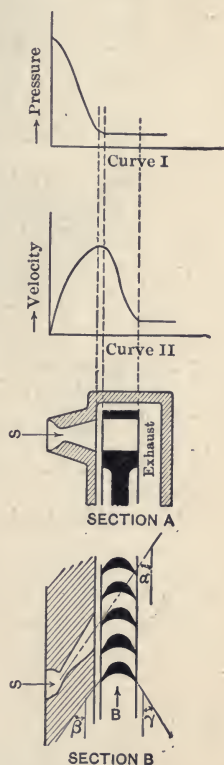

FIG. 147.—Variation of velocity and pressure in a De Laval turbine.

\* See Moyer's The Steam Turbine, page 333.

or blade. In a similar manner, the change of the pressure is shown in Curve I. The figure shows that the velocity at the entrance to the nozzle is almost zero and the pressure a maximum.

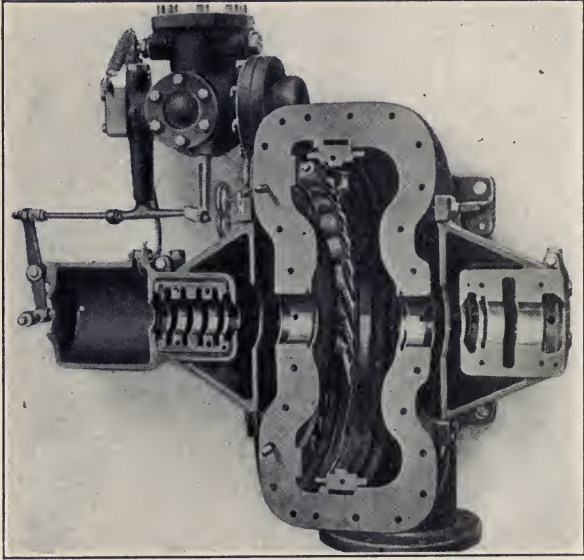

FIG. 148.—Casing of De Laval velocity-stage impulse turbine.

When the steam issues from the nozzle, the velocity is maximum and the pressure minimum.

De Laval turbines are also made of the *velocity-stage impulse* type in which the steam is expanded from the initial to the final

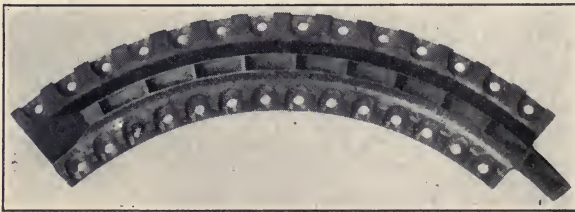

FIG. 149.—Nozzles of Curtis turbine.

pressure in one set of nozzles, but the velocity is absorbed in two sets of moving blades with a set of stationary ones between; and in the *pressure-stage impulse* or *multicellular* type where the steam expands through "successive sets of nozzles with corre-

sponding pressure steps, the velocity produced in each stage being expended upon a corresponding row of moving buckets." This is really a "series of single-stage wheels each enclosed in a separate cell or compartment and all mounted upon a common shaft."

These two types of De Laval turbines are similar respectively to a single-stage Curtis turbine and a Rateau turbine, both of which will be described later on.

Fig. 148 shows the casing of a velocity-stage turbine after the rotor has been removed. The individual nozzles by which steam is directed upon the first row of moving buckets and the intermediate stationary guide vanes by which the steam is redirected upon the second row of moving buckets are seen in place.

**173. The Curtis Turbine.**—In the Curtis turbine as in the De Laval, the steam is expanded in nozzles before reaching the moving blades, but the complete expansion from the boiler to the exhaust pressure occurs usually in a series of stages, or steps, as the steam passes through a succession of chambers separated from each other by diaphragms. In very small sizes of the Curtis turbines, there is usually only one pressure stage, but in larger sizes there are from two to five.

The nozzles of the Curtis turbine are generally rectangular in cross-section, and, because they are always grouped close together, they are either cast integral with the diaphragms or in separate nozzle plates (Fig. 149), which in assembling are bolted to the diaphragms. Most Curtis turbines are made with horizontal shafts, though the larger sizes often have the shafts placed vertically. In these vertical turbines the weight of the turbine is supported on a special foot-step bearing which carries the shaft on a thin film of oil supplied to the bearing under pressure.

It is typical of these turbines that there are always three or more rows of blades, or "buckets," following each group of noz-

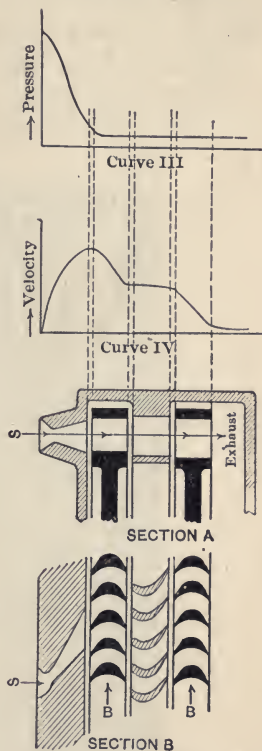

FIG. 150.—Variation of velocity and pressure in a single-stage Curtis turbine.

zles, and one of these rows is stationary. This arrangement in the single-stage turbine is illustrated in Fig. 150. No expansion takes place in the stationary blades, and the object in using several rows of blades is only to reduce the velocity to be absorbed per row, and consequently to reduce the peripheral speed of the wheels necessary to attain the best efficiency.

Fig. 151 shows the path of the steam through the blades or buckets in a Curtis turbine, and Fig. 152 shows the plan and elevation of a two-stage Curtis turbine.

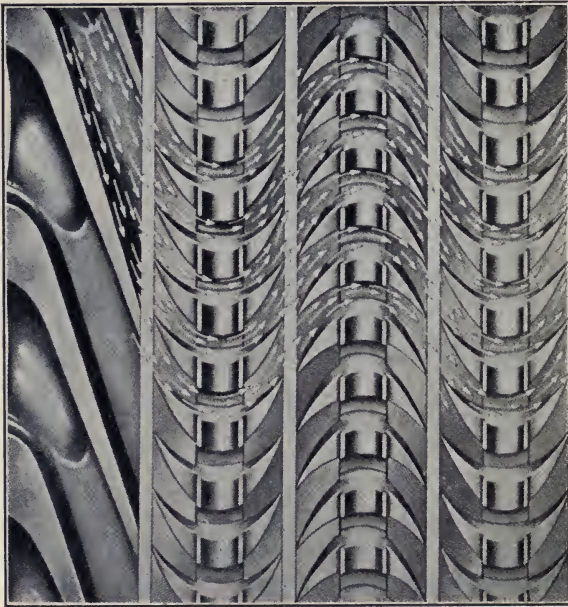

FIG. 151.—Path of steam through moving and stationary buckets in a Curtis turbine.

The speed of the turbine is controlled by a governor that “cuts out” the nozzles, the number of nozzles discharging steam through the turbine blades being determined by the governor. The Curtis turbine is made in a large range of sizes, being sold in sizes from 15 to 30,000 kw. The most common application of these turbines is to the driving of electric generators.

A section of a 9000 kw. Curtis vertical turbine generator is shown in Fig. 153. This figure shows the electric generator at the top of the figure, the diaphragms and the wheels of the five pres-



sure stages immediately below, and at the bottom, the step-bearing at the end of the vertical shaft.

174. **The Rateau Turbine.**—The Rateau turbine has been termed “Multicellular,” that is, it consists of a large number of cells, or pressure stages, of which each stage is like a separate

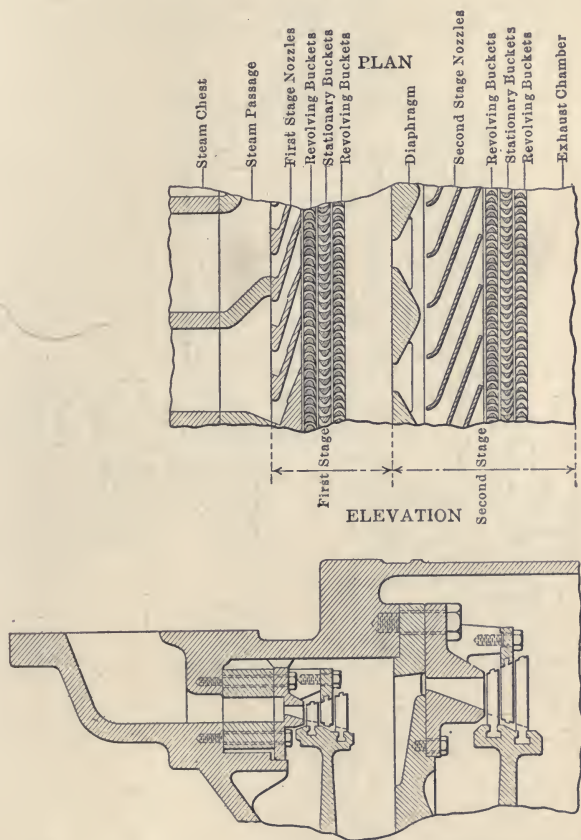

FIG. 152.—Plan and elevation showing path of steam in a two-stage Curtis turbine.

single-stage De Laval turbine. Each stage contains one row of blades, so that the velocity that can be absorbed efficiently by each stage is less than in the Curtis, and the turbine must contain a larger number of stages between the same limits of pressure.

Fig. 154 shows diagrammatically a Rateau turbine with two groups of nozzles, and therefore with two pressure stages. Steam

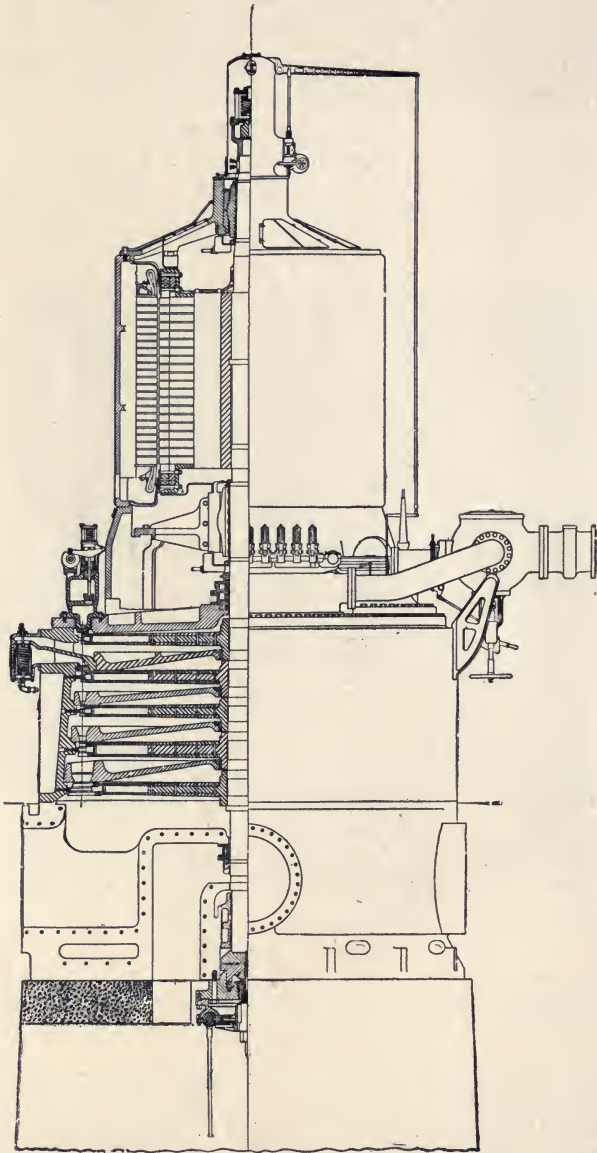

FIG. 153.—Section of 9,000 kilowatt Curtis turbine-generator.

at the initial pressure enters the first group of nozzles and expands to the pressure of the first stage. In this expansion it delivers a portion of its energy to the blades. It then expands to the exhaust pressure in the second group of nozzles, shown in the diagram between the first and second stages.

In the commercial turbines of this type the pressure drop at each stage is small and the nozzles are always made with a uniform

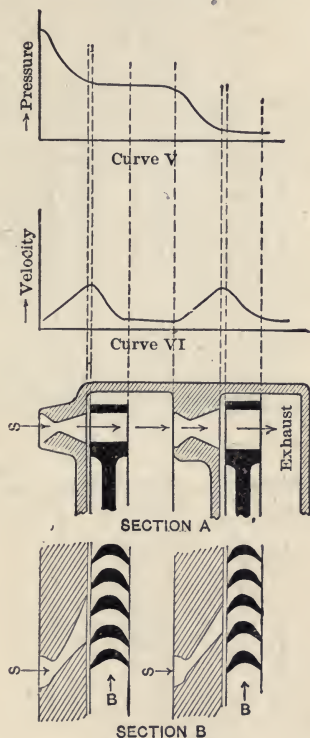

FIG. 154.—Variation of velocity and pressure in a two-stage Rateau turbine.

cross-section along their length; or in other words, they are “non-expanding.”

Fig. 155 shows four typical stages of a Rateau turbine, and Fig. 156 shows a cross-section of a Southwark-Rateau turbine.

**175. Kerr Turbine.**—Impulse turbines with bucket wheels of the Pelton type have been developed to the commercial stage. The Kerr turbine was formerly of the Pelton type and was the most characteristic. But as constructed at the present time it is

practically of the Rateau type. Fig. 157 shows a bucket wheel and nozzles of the older type, and Fig. 158 shows the new type of Kerr turbine.

**176. The Sturtevant Turbine.**—Another steam turbine in which the steam jets are discharged in a radial direction upon the bucket wheel is known as the Sturtevant turbine. In this respect it resembles the older Kerr turbine. Fig. 159 is a good illustration of this turbine, showing the buckets on the wheel and the “reversing” buckets on the inside of the casing. These re-

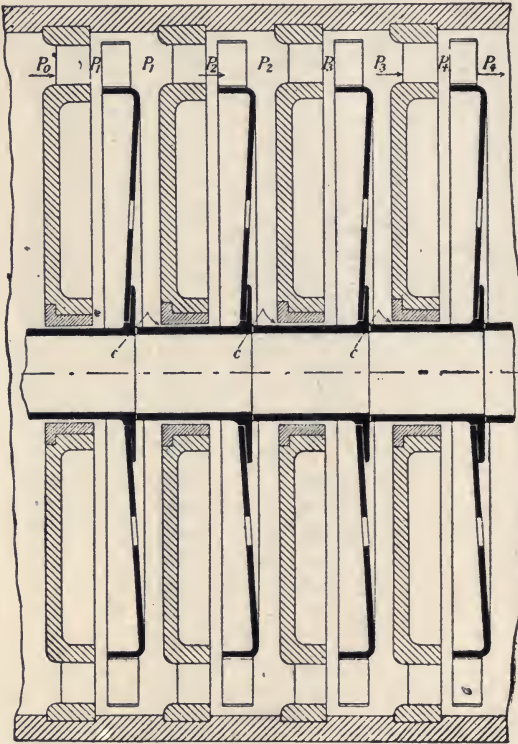

FIG. 155.—Four stages of Rateau turbine.

versing buckets are not cut all the way around the circumference, but three, four, or five are cut following each nozzle, depending on the velocity of the steam. The buckets are cut out of the solid metal of the rim of the wheel, which is a single forging of open-hearth steel. By this construction a wheel of great strength is secured and blade breakage is practically eliminated. This

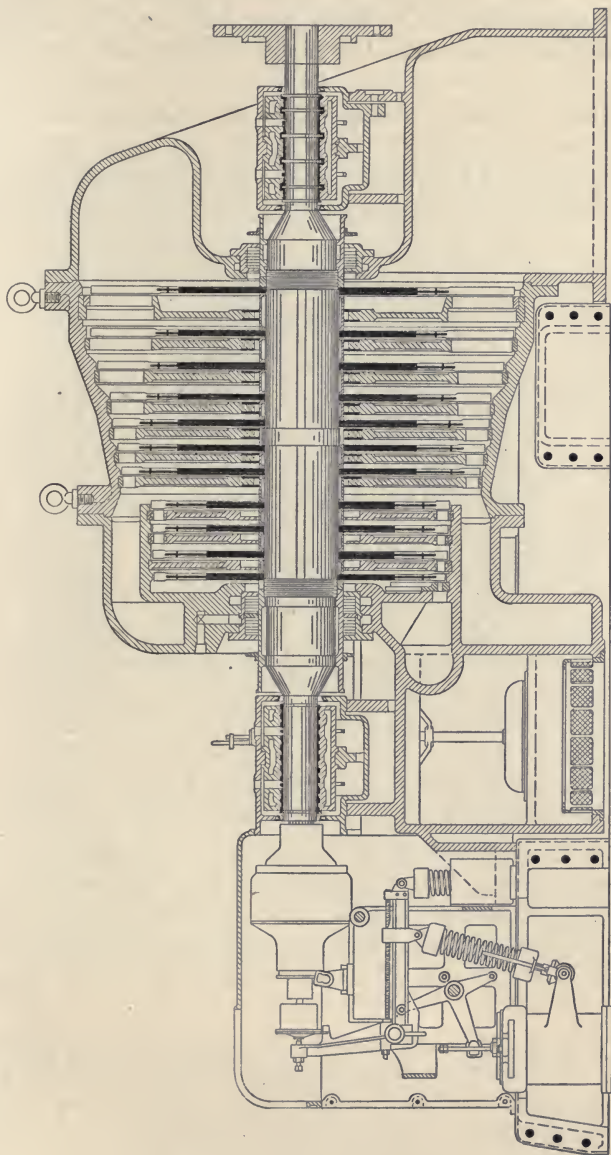

FIG. 156.—Cross-section of Southwark-Rateau mixed-flow turbine.

turbine was designed in all its parts to require the minimum amount of attention and repairs. It is stated that it can be operated continuously under ordinary conditions with little more attention than that required for filling the oil-wells once a week.

**177. The Parsons Turbine.**—The Parsons turbines are the only commercial turbines of the reaction type, and these operate only partially on this principle. In these turbines the stationary blades take the place of the nozzles in other forms, and direct the

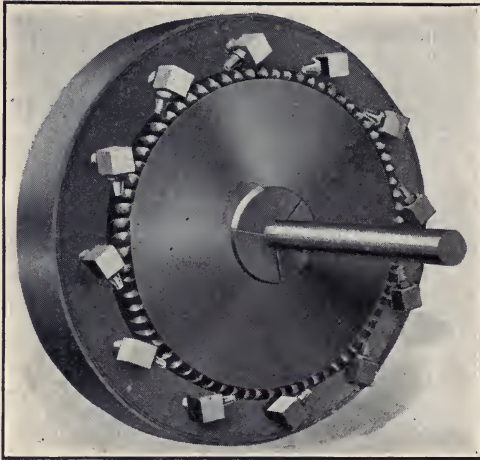

FIG. 157.—Bucket wheel of a Kerr turbine.

steam upon the moving blades. The system of blading in the Parsons turbine is shown in Fig. 160. Steam enters from the admission space as shown in the figure, and passes through the stationary blades where it expands with an increased velocity. From these blades it is passed to the first set of moving blades, in which it again expands. The variation of velocity and pressure in passing through one of these turbines is clearly shown in Fig. 160.

A section of one of the simplest Parsons turbines is shown in Fig. 161. The rotating part is a long drum of three different sections supported on two bearings—one at each end. Rows of moving blades are mounted on the circumference of this drum and corresponding stationary blades are fitted to the inside of the turbine casing. An annular space *A* is a steam chest which receives high-pressure steam from the steam mains. From this

annular space, the steam passes through alternate rows of moving and stationary blades to the exhaust at *B*. There are also two other annular spaces where the section of the drum, or rotor, is increased in diameter, and at these places is an unbalanced pressure, or thrust toward the right (in this design) caused by the pressure of the steam. This thrust is increased by the expansion

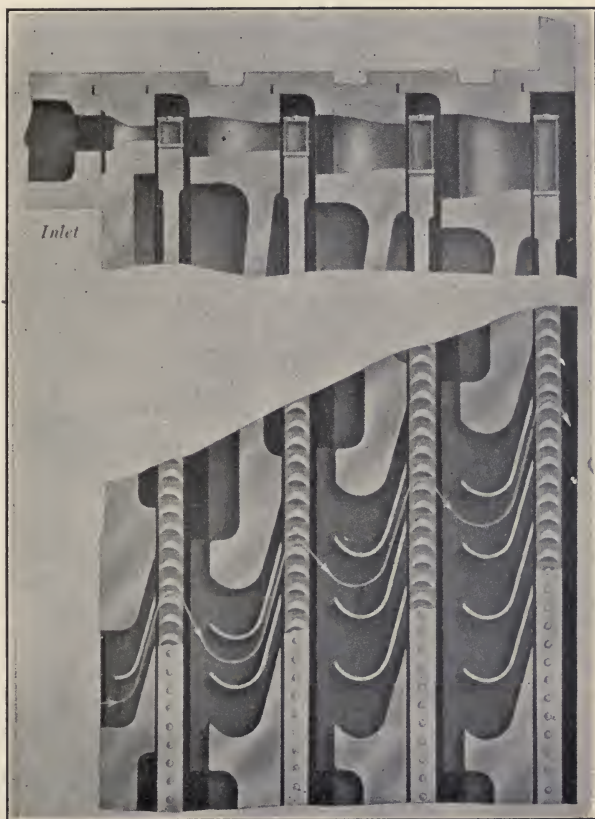

FIG. 158.—Cross-section of new type Kerr turbine.

of the steam in unsymmetrical blades. To balance this axial pressure, three balance pistons are provided at the left end of the casing—one for each section of the rotor. Passages are cored out in the casing to make each balance-piston communicate with its corresponding section of the rotor, so that the steam pressure on each piston is approximately the same as that in the correspond-

ing section. Except for some differences in the design of mechanical details, the turbine shown in Fig. 161 represents very well the usual Parsons type. The Parsons turbine is governed by admitting the steam in puffs. The interval of time between the puffs decreases as the load increases, until, when the overload capacity of the turbine is reached, the steam is admitted in a practically continuous stream.

178. "Impulse and Reaction" Double-flow Turbines.—Recently a design

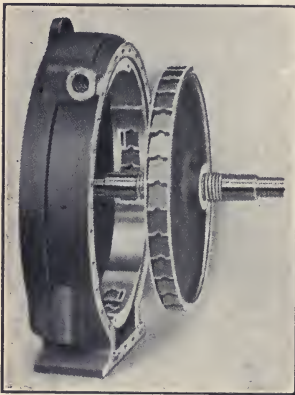

FIG. 159.—Sturtevant turbine.

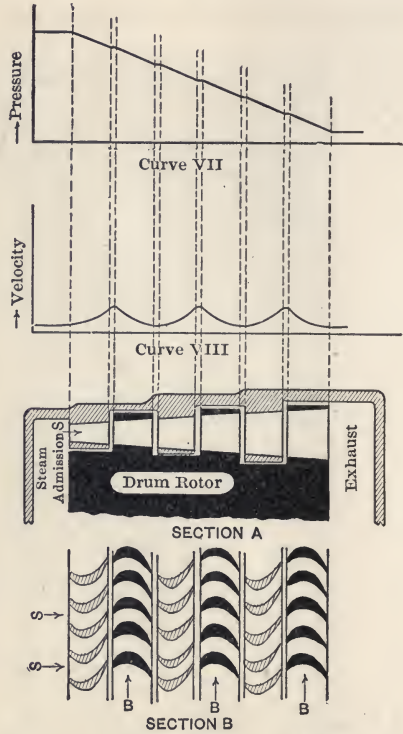

FIG. 160.—Variation of velocity and pressure in a Parsons turbine.

of *double-flow* turbine has been adopted by the Westinghouse Company for large sizes to replace the single-flow Parsons type. There are two principal advantages resulting from this change: (1) end thrust is practically eliminated; and (2) the impulse element reduces very considerably the length of the turbine.

Fig. 162 illustrates such a double-flow turbine with an impulse element. In its essential parts this turbine consists of a group of nozzles, an impulse wheel, with three rows of blades—two moving and one stationary,—and two intermediate and two low-



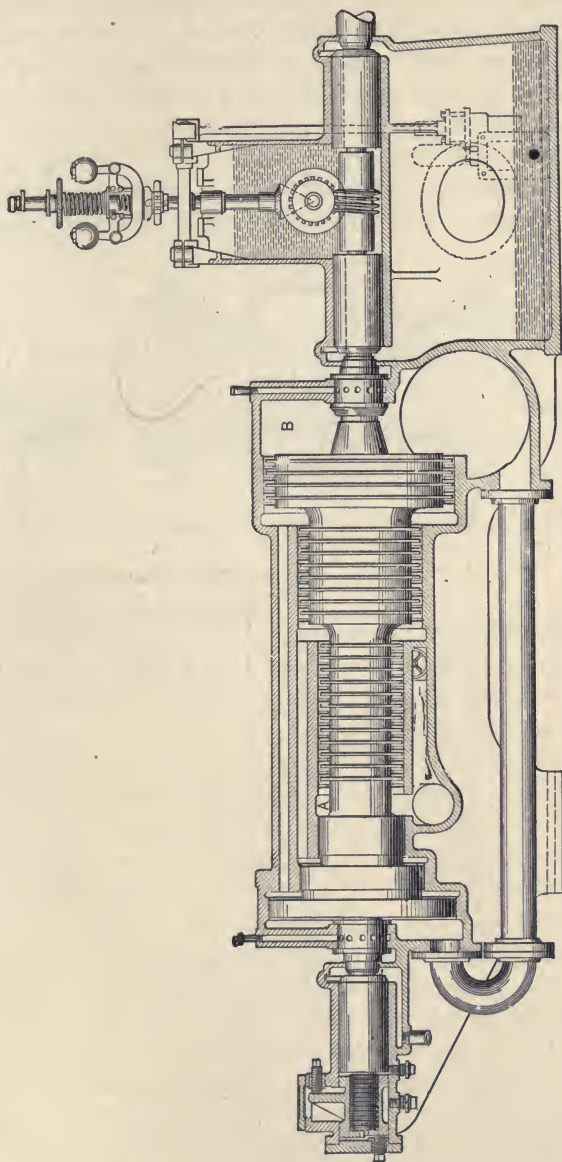

FIG. 161.—Westinghouse-Parsons turbine.

pressure sections of typical Parsons, or "reaction" blading. Steam is admitted to the turbine through the nozzle block or chamber at the bottom of the figure, and is discharged from the nozzles at a very high velocity to impinge on the impulse blades. After passing through these blades, it divides, one half expanding through the intermediate and low pressure Parsons blading at the right of the impulse wheel, and the other half expanding through the blading to the left. After leaving the low-pressure blading it exhausts through the passages *E, E* into the condenser.

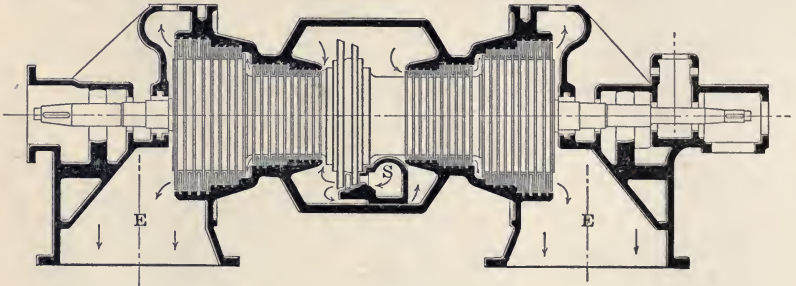

FIG. 162.—Double-flow Westinghouse turbine.

**179. Low-pressure Turbines.**—The high vacuums that can be obtained with the modern condenser have led to the development of the *low-pressure* turbine in which the pressure range is entirely below atmospheric pressure.

“A pound of steam, expanded in a perfect heat motor from ordinary boiler pressures to a 28-in. vacuum, will develop about one-half of the total work in the range of expansion above atmospheric pressure and the other half in the range of expansion from atmospheric pressure to vacuum. The ordinary reciprocating engine operates with fair efficiency in the range above atmospheric pressure, but fails to develop more than about one-third of the work theoretically available below atmospheric pressure. This is partly because of the narrowness of the exhaust ports and the alternate cooling and heating of the cylinder walls, but principally because of the restricted volume of the low-pressure cylinder, or rather, the limitations which are placed on the ratio of expansion. The steam turbine, on the other hand, is not hampered in this way, as it is a simple matter to provide all the area required by the steam at the lowest condenser pressure, and the alternate heating and cooling of metal surfaces

are avoided. With most types of turbines the efficiency ratio below atmospheric pressure is better than that obtainable with any other type of steam motor through any range of pressure. It thus comes about that low-pressure steam turbines used in conjunction with efficient high-pressure reciprocating engines at present hold the published record for highest efficiency ratio in large sizes."

"In practice it is found that a low-pressure turbine of, say, 300 horse-power capacity, will develop a horse-power hour on about 28 lbs. of steam at atmospheric pressure, exhausting into a vacuum of 28 in. In other words, the output of reciprocating engine plants, at present running non-condensing, can be increased 100 per cent. through the use of exhaust turbines, without requiring the generation of more steam or the burning of more fuel. Where simple engines are at present running condensing, the output of power per pound of steam can be increased by 60 per cent. and the output of compound condensing engines by a somewhat less amount—about 25 per cent. By lengthening the period of admission of the engines, the power-producing capacity can be increased in a still greater ratio."

**180. Mixed Flow or Mixed Pressure Turbines.**—"Turbines in which low pressure steam is admitted to an intermediate stage from some exterior source, as the exhaust of a steam engine, are known as *mixed flow* or *mixed pressure* turbines. They are usually designed to operate normally with low pressure steam, admitting high pressure steam only as required in case of a deficiency of the low pressure steam supply. They differ from standard high pressure condensing turbines principally in the different proportioning of the areas through the two parts of the turbines and in the provision of a special governing gear for automatically controlling the admission of the live steam. In case of complete failure of the low pressure steam supply, the turbine will operate with good economy on high pressure steam alone. Other arrangements are also supplied to meet special conditions."

**181. Bleeder Turbines.**—Turbines from which steam is drawn from an intermediate stage for use in heating, raising the temperature of the feed water, etc., are called *bleeder* turbines.

**182. Application of the Steam Turbine.**—The steam turbine is adapted primarily to the driving of machines which require a high rotative speed. They are not applicable where a large

starting effort is required, as the forces acting in the turbine are relatively small. Their use is therefore principally in driving machines which start without load, such as electric generators, centrifugal fans, and propeller wheels. The turbine is not suited to the propelling of vehicles, or to the driving of mills by belt drive. Such applications of power require more initial starting effort than the turbine is capable of producing. The steam turbine is also coming into extensive use in marine work. Its uniform torque and freedom from vibration are points which make it highly suitable to this field.

## CHAPTER XIV

### THE INTERNAL COMBUSTION ENGINE

**183. Historical.**—The internal combustion engine has now been in commercial use for over fifty years. During this time many improvements have been made in its certainty of operation, regulation and fuel economy. In the earlier engines the gas consumption was about 100 cu. ft. per horse-power for each brake horse-power developed; to-day the consumption of gas in the most economical engines has been reduced to as low as 14 cu. ft. per brake horse-power per hour. This may be expressed in another way, that is, the heat efficiency of the internal combustion engine has been increased in fifty years from 4 per cent. to 30 per cent. The regulation has been slowly improved so that now it is possible to operate gas engines for service requiring most exacting speed control and its certainty of operation is almost as satisfactory as that of the steam engine.

During the first twenty years of the development of internal combustion engines most of the engines built were small in size, not exceeding 10 horse-power; but to-day this type of engine is being built in sizes of over 5000 brake horse-power. There are in use in the world to-day over 800,000 internal combustion engine installations. The history of the development of the gas engine is extremely interesting and profitable reading and is well treated in the works of Dugald Clerk, Hugo Güldner and others.

The first important commercial gas engines were placed on the market by Otto in 1878 and the Otto engine was the first engine in which the gases were compressed in the cylinder previous to compression, and this type of engine has been the prevailing type in use. In 1898 an engine built in accordance with the principles laid down by Rudolf Diesel and using fuel oil showed a much higher efficiency than had been obtained heretofore. This engine has opened up a still wider field for the use of the gas engine and is now being extensively used in stationary practice and is being introduced in marine practice. The internal combustion engine is also being used in connection with the pro-

duction of power from the waste gases of blast furnaces and coke ovens. There are still many other applications of internal combustion engines which will, in the future, increase its already extensive use as a prime mover.

**184. Classification of Gas Engines.**—Gas engines may be divided into two general types;

- (1) those in which the ignition occurs at constant volume;
- (2) those in which the ignition occurs at constant pressure.

Theoretically it is possible to conceive of an engine working so that ignition would occur at constant temperature, but practically an engine working in such a cycle has not been constructed. Engines of the first type may be sub-divided into two classes;

- (a) those in which the charge is ignited without previous compression, and
- (b) those in which the charge is ignited with previous compression.

The first internal combustion engine built belonged to type (1), class (a) of which the Lenoir was a good example; but owing to its low efficiency, this class of engine is no longer used.

**185. Type (1), Class (a).**—In an engine of this class, the charge of gas and air is drawn in at atmospheric pressure for a part of its stroke, then the valve is closed and the charge ignited. The pressure rises rapidly, forcing the piston forward for the remainder of the stroke. On the return stroke, the products of ignition are forced out of the cylinder. The working cycle consists of: (1) feeding the cylinder with explosive mixture; (2) igniting the charge of gas and air; (3) expanding the gases after explosion; (4) expelling the burned gases. Fig. 163 shows an indicator card taken from an engine of this class. Line *AB* is the atmospheric line. From *A* to *C* the charge is drawn in, from *C* to *D* explosion occurs, from *D* to *E* the gases expand, and along the lines *EB* and *BA* the gases are expelled from the cylinder. Owing to the lack of previous compression, the pressure at *D* must always be comparatively low, seldom exceeding 40 lbs. This, of course, means lower initial temperature at the maximum point of explosion and correspondingly reduced economy. This type of engine uses about 60,000 B.T.U. per horse-power per hour.

A very interesting modification of this type of engine is the *free piston engine* of Otto and Langen, which was first shown at the Paris Exposition in 1867. The idea was not original with

them but the engine was an adaptation of an engine originally proposed (but never built) by Barsanti and Matteucci in Italy in 1854. In this particular type of engine the cylinder is set vertically and the piston is shot up by the explosion of the gases, without resistance. On its return stroke it engages, through suitable mechanism, with the fly-wheel which is rotated by the forces of gravity and atmospheric pressure acting against the piston on this downward or working stroke.

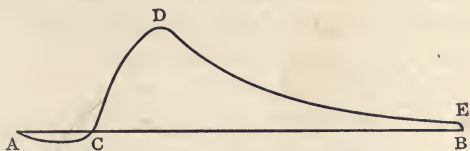

FIG. 163.—Type (1), class (a).

**186. Type (1), Class (b).**—In this engine, explosion occurs at a constant volume with previous compression. This cycle was first proposed by Beau de Rochas in 1862, and was first put into successful operation by Otto in 1876. In the Otto engine a charge of gas and air is drawn in with the first out stroke of the engine, and on the return stroke this charge is compressed. Near the end of the compression stroke, the

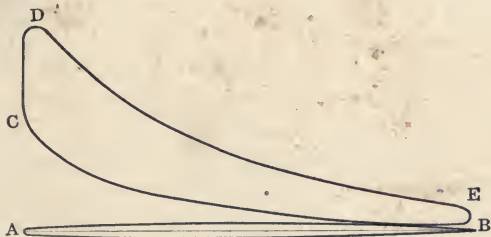

FIG. 164.—Type (1), class (b)—Otto cycle.

charge is ignited, and on the following out stroke, expands. On the next return stroke the charge is expelled from the cylinder. There are five operations in this cycle: (1) charging the cylinder with gas and air; (2) compressing the charge in the clearance space; (3) igniting the mixture; (4) expanding the hot gases after ignition; (5) expelling the burned gases on the exhaust stroke. A diagram of this cycle is shown in Fig. 164. Along the line *AB* the charge is drawn in; along the line *BC* it is compressed;

along  $CD$  it is ignited; along  $DE$  it is expanded; and along  $EA$  it is expelled from the cylinder.

Otto compressed the gases previous to ignition but did not realize that this was in itself the reason for the marked economy which his engine showed over all other engines that had previously been built. He attributed the economy of his engine to the compression of the gas producing a thorough mixture and preventing the gas and air from being in layers in the cylinder.

The cycle just described is that of a *four-cycle* engine, that is, to complete the cycle of the gases requires four strokes of the engine. In the *two-cycle* engine the same cycle of events for the gases is completed in two strokes.

The method of obtaining the full cycle of events in two strokes in the smaller types of engines is illustrated in Fig. 165.

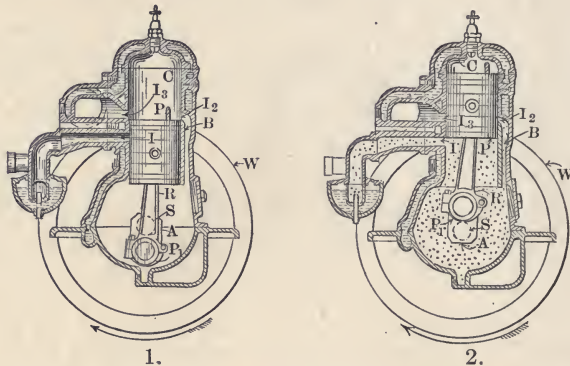

FIG. 165.—Cross-section of two-cycle engine.

Figure 165-1 shows the engine in its initial position. The fly-wheel has previously been rotated, drawing a charge of gas and air through port  $I$  into the engine base and partly compressing it there. In the larger engines this charge of gas and air is externally compressed. In the position shown the fuel charge previously compressed in the base is entering the cylinder through the port  $I_2$ . At the same time the burned gases are leaving the cylinder through the exhaust port  $I_3$ . A deflecting plate  $P$  on the head of the cylinder prevents the incoming gases from passing out of the exhaust port. As the piston moves up it covers ports  $I_2$  and  $I_3$ , and further compresses the gas into the clearance space. As the piston approaches the upper dead center, shown in Fig. 165-2, the gases are ignited. This ignition



occurs when the piston is practically stationary so that it may be said to occur at constant volume. The pressure produced by the rapid heating of the gases due to ignition, forces the piston down as soon as the dead center is passed. While the piston is in the position shown in Fig. 165-2, port *I* is fully uncovered and the vacuum produced by the upward movement of the piston draws air and gas through the carbureter into the crank case so as to furnish fresh gas and air for the next cycle of the engine. During the following downward stroke of the piston the burned gases above the piston are allowed to expand, and the fresh charge below it is compressed. This stroke brings the piston to the position shown in Fig. 165-1 and the cycle of operations is thus completed in two strokes instead of four, as described for a four-cycle engine.

**187. Type (2).**—The most representative engine of this type in commercial use is the Diesel. A typical indicator card of this engine is shown in Fig. 166.

In this engine air is drawn in on the downward stroke and then compressed on the next upstroke to a pressure of about 500 lbs. per square inch. The compression of the gas to this high pressure increases its temperature to over 1000° F. At the beginning

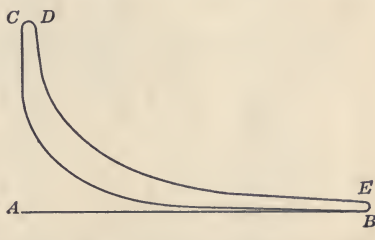

FIG. 166.—Indicator card of Diesel engine.

of the next down stroke of the engine fuel oil previously compressed to a pressure of about 800 lbs. is injected into the cylinder and owing to the high temperature of the air in the cylinder, the oil on entering is ignited. The heat produced by this ignition of the oil maintains the pressure in the cylinder up to the point at which the oil supply is cut off by the governor. For the remainder of this stroke the gases in the cylinder are expanded. On the fourth stroke of the engine the gases are exhausted from the cylinder. The cycle of operation is shown in Fig. 166 in which the line *AB* represents admission, *BC* compression, *CD* the period of fuel admission controlled by the governor, *DE* expansion, and *EA* represents exhaust. The cycle just described is for a four-cycle motor, but this same cycle may be used in a two-cycle motor. In the two-cycle motor during the first stroke the air will be compressed, on the next stroke expansion, (for about 75 per cent.

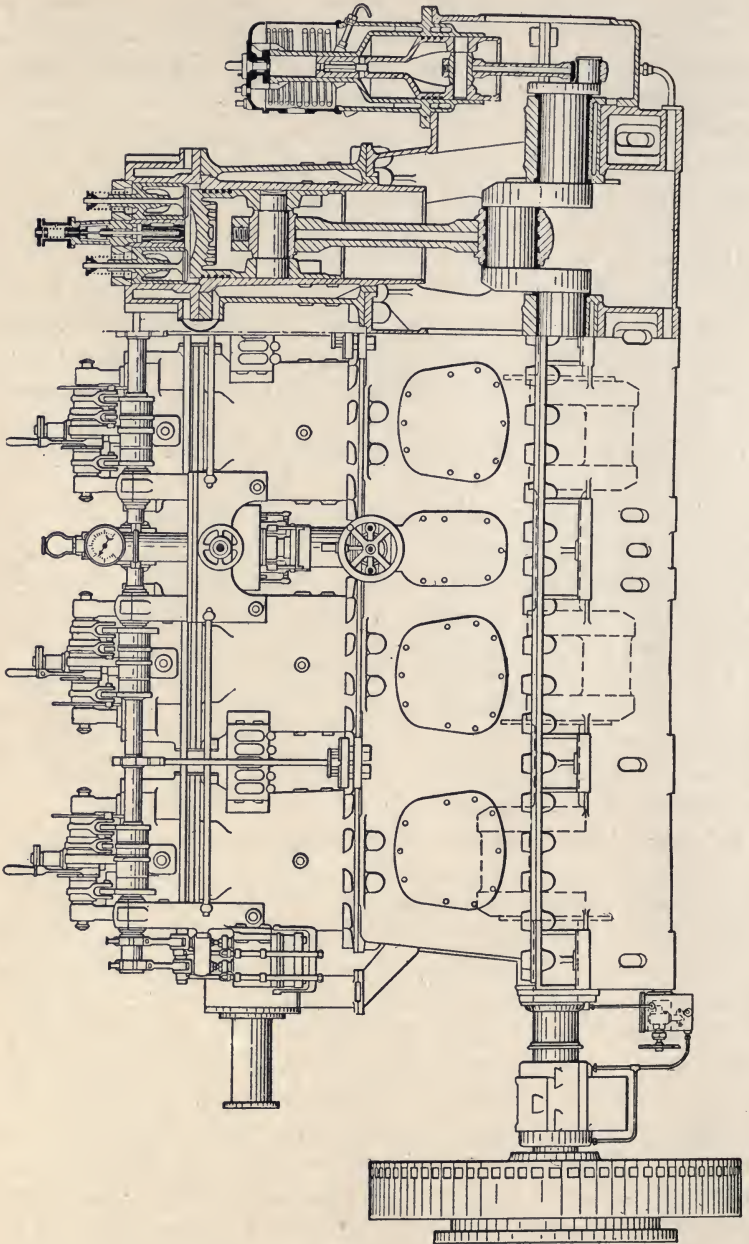

FIG. 167.—Vertical Diesel engine.

of the stroke), exhaust and admission will occur. For the two-cycle Diesel engine the air entering the cylinder is compressed by the external pump to about 8 lbs. and this air assists in driving out the burned gases or, as it is called, scavenging the cylinder.

Until recently the Diesel engines have been vertical, but now horizontal engines are also being made of this type.

Fig. 167\* shows a four-cylinder Diesel engine for marine purposes. A vertical air pump is coupled to one end of the crank shaft and compresses air in two stages from 750 to 1000 lbs. pressure. A governor is provided that adjusts the speed from 150 to 400 r.p.m. By reducing the quantity of fuel delivered by the pumps the speed can be still further reduced. The working cycle and details of operation are essentially the same as in the older types of stationary Diesel engine. The engine shown in the figure is a recent type of high-speed Diesel engine and develops about 250 H. P., is 11 ft. 10 in. long, 39 in. wide and 7 ft. high. The weight of the engine is about 26,000 lbs. The actual test of this engine showed a consumption of about  $\frac{1}{2}$  lb. of fuel oil per brake horse-power per hour at 350 r.p.m. and a full load. The mechanical efficiency at full load was about 78 per cent. This engine converted about 34 per cent. of the total heat of the fuel into available mechanical energy. Its theoretical efficiency was 56 per cent., so that about 60 per cent. of the theoretically available heat was actually utilized in the engine.

**188. Theoretical Cycles.**—In determining the mathematical expression for efficiency from the theoretical cycles for the two principal types of engine we must in each case distinguish two conditions; one in which the gas is expanded completely to the exhaust pressure and one in which the gas is partially expanded and exhaust begins at a pressure higher than the exhaust pressure line.

Fig. 168 represents an engine of type (1), class (b) working with complete expansion. Lines  $DE$  and  $CB$  are assumed to be adiabatics, line  $CD$  is a constant volume line, line  $BE$  is a constant pressure line. All the heat will be absorbed along the line  $CD$  and all the heat will be rejected along the line  $EB$ . Let the heat received along line  $CD$  be represented by  $H_1$  and the absolute temperature at  $C$  by  $T_c$  and at  $D$  by  $T_d$ ; let the heat rejected

\* Figure taken from *Power*, August 15, 1911, p. 248.

along  $EB$  be represented by  $H_2$  and the absolute temperature at  $E$  by  $T_e$  and at  $B$  by  $T_b$ ; and let the weight of the charge =  $w$ .

$$\text{Then} \quad H_1 = wc_v(T_d - T_c)$$

$$\text{and} \quad H_2 = wc_p(T_e - T_b)$$

$$\text{The work done} = H_1 - H_2 = wc_v(T_d - T_c) - wc_p(T_e - T_b)$$

$$\begin{aligned} \text{Efficiency} &= \frac{H_1 - H_2}{H_1} = \frac{wc_v(T_d - T_c) - wc_p(T_e - T_b)}{wc_v(T_d - T_c)} \\ &= 1 - \gamma \frac{T_e - T_b}{T_d - T_c} \end{aligned} \quad (1)$$

From Fig. 168 it will be seen that for any compression temperature  $T_c$  and given rise in temperature during ignition there is a

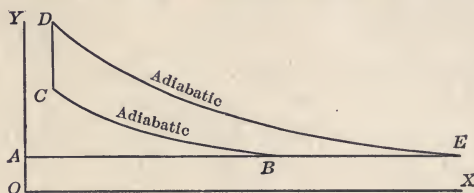

FIG. 168.—Type (1), class (b)—with complete expansion.

temperature  $T_e$  at which the adiabatic line touches the back pressure line  $AB$ . We can, therefore, establish a relation between  $T_b$ ,  $T_c$ ,  $T_d$  and  $T_e$ . If we allow the pressure and volume at each particular point to be represented by  $P$  and  $V$  respectively, with a subscript corresponding to the letter at that point, then

$$P_d V_d^\gamma = P_e V_e^\gamma \quad (2)$$

$$\text{and} \quad P_c V_c^\gamma = P_b V_b^\gamma \quad (3)$$

Dividing (2) by (3)

$$\frac{P_d V_d^\gamma}{P_c V_c^\gamma} = \frac{P_e V_e^\gamma}{P_b V_b^\gamma}$$

$$\text{But} \quad V_d = V_c \text{ and } P_e = P_b,$$

$$\text{therefore} \quad \frac{P_d}{P_c} = \frac{V_e^\gamma}{V_b^\gamma},$$

$$\text{and since} \quad \frac{P_d}{P_c} = \frac{T_d}{T_c} \text{ and } \frac{V_e}{V_b} = \frac{T_e}{T_b}$$

$$\text{then} \quad \frac{T_b}{T_c} = \frac{T_e^\gamma}{T_b^\gamma}$$

$$\text{and} \quad T_e = T_b \left( \frac{T_d}{T_c} \right)^{\frac{1}{\gamma}} \quad (4)$$

Although this represents the best cycle of type (1), class (b) engine, it is not one commonly used and as yet no engine has been put upon the market using this cycle.

Fig. 169 represents the ideal diagram of the Otto engine. In this diagram the expansion is only carried far enough so that exhaust commences when the volume in the cylinder is the same as that before compression.

The lines *BC* and *DE* are assumed to be adiabatics. All the heat must then be absorbed along the line *CD* and all rejected along *EB*. Let the heat received along *CD* be represented by

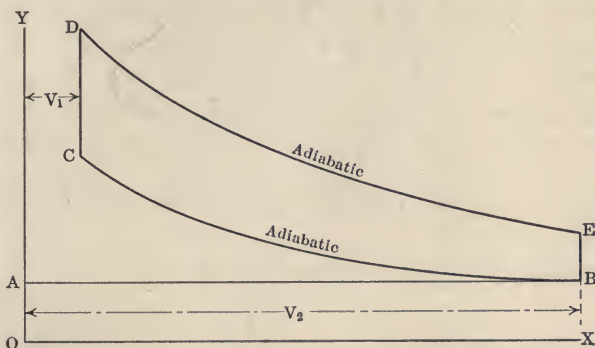

FIG. 169.—Theoretical Otto cycle.

$H_1$ , and the absolute temperature at *C* by  $T_c$ , and at *D* by  $T_d$ ; let the heat rejected along *EB* be represented by  $H_2$ , and the absolute temperature at *E* by  $T_e$  and at *B* by  $T_b$ ; and let the weight of the charge =  $w$ .

$$\begin{aligned} \text{Then } H_1 &= wc_v(T_d - T_c) \\ \text{and } H_2 &= wc_v(T_e - T_b). \end{aligned}$$

The work done =  $H_1 - H_2 = wc_v(T_d - T_c) - wc_v(T_e - T_b)$ .

$$\begin{aligned} \text{Efficiency} &= \frac{H_1 - H_2}{H_1} = \frac{wc_v(T_d - T_c) - wc_v(T_e - T_b)}{wc_v(T_d - T_c)} \\ &= \frac{(T_d - T_c) - (T_e - T_b)}{T_d - T_c} \\ &= 1 - \frac{T_e - T_b}{T_d - T_c}. \end{aligned} \tag{5}$$

Both curves are adiabatic, hence

$$\left(\frac{T_e}{T_d}\right) = \left(\frac{V_d}{V_e}\right)^{\gamma-1} = \left(\frac{V_c}{V_b}\right)^{\gamma-1} = \left(\frac{T_d}{T_c}\right).$$

Therefore

$$\frac{T_e}{T_d} = \frac{T_b}{T_c},$$

and by subtraction,

$$\frac{T_e}{T_d} = \frac{T_e - T_b}{T_d - T_c} = \frac{T_b}{T_c}. \quad (6)$$

Substituting equation (6) in equation (5),

$$\text{Efficiency} = 1 - \frac{T_b}{T_c}. \quad (7)$$

This is the most important expression in connection with the gas engine. It shows that the efficiency of a gas engine working in the Otto cycle depends upon the temperature before and after compression. The knowledge of this fact, first demonstrated by Dougal Clerk, has led to the production of the modern high-efficiency engine. The same fact will also be proved for the other types of engines.

The efficiency of the Otto cycle may also be expressed in terms of volume or pressure.

Since the compression curve is an adiabatic,

$$\frac{T_b}{T_c} = \left(\frac{V_c}{V_b}\right)^{\gamma-1} = \left(\frac{V_1}{V_2}\right)^{\gamma-1}.$$

Substituting this value of  $\frac{T_b}{T_c}$  in equation (7), we have

$$\text{Efficiency} = 1 - \left(\frac{V_1}{V_2}\right)^{\gamma-1}. \quad (8)$$

$$= 1 - \left(\frac{1}{r}\right)^{\gamma-1} = 1 - \frac{1}{r^{\gamma-1}} \quad (9)$$

where  $r = \frac{V_2}{V_1}$  = the ratio of compression.

Equation (8) shows that the efficiency depends upon and varies with  $V_1$ , the clearance volume.

Finally since  $BC$  is an adiabatic,

$$\frac{T_b}{T_c} = \left(\frac{P_b}{P_c}\right)^{\frac{\gamma-1}{\gamma}}.$$

Substituting this value in equation (7), we have

$$\text{Efficiency} = 1 - \left(\frac{P_b}{P_c}\right)^{\frac{\gamma-1}{\gamma}} \quad (10)$$

From equation (10) it is seen that the efficiency increases as the compression pressure,  $P_b$ , increases, since the pressure  $P_c$  will remain nearly constant.

In developing the expression for the efficiency of an engine working in the Type (2) cycle, it is best to assume that the compression takes place in the same cylinder as the expansion and exhaust, although in the actual engine two cylinders are used. Fig. 170 shows the theoretical diagram under this assumption, when there is complete expansion. The lines  $BC$  and  $DE$  are assumed to be adiabatics. All the heat must then be absorbed along the line  $CD$  and all rejected along the line  $EB$ . Let the heat received along  $CD$  be represented by  $H_1$ , and the absolute temperature at  $C$  by  $T_c$ , and at  $D$  by  $T_d$ ; let the heat rejected along  $EB$  be represented by  $H_2$ , and the absolute temperature at  $E$  by  $T_e$ , and at  $B$  by  $T_b$ ; and let the weight of the charge =  $w$ .

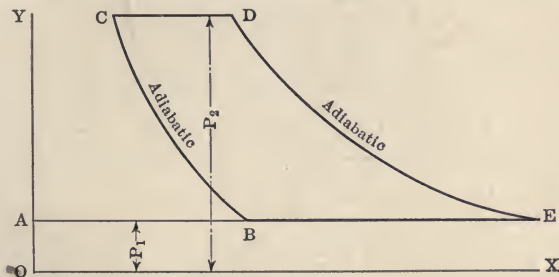

FIG. 170.—Type (2)—with complete expansion.

Then  
and

$$H_1 = wc_p(T_d - T_c)$$

$$H_2 = wc_p(T_e - T_b)$$

The work done =  $H_1 - H_2 = wc_p(T_d - T_c) - wc_p(T_e - T_b)$

$$\text{Efficiency} = \frac{H_1 - H_2}{H_1} = \frac{wc_p(T_d - T_c) - wc_p(T_e - T_b)}{wc_p(T_d - T_c)}$$

$$= \frac{(T_d - T_c) - (T_e - T_b)}{T_d - T_c}$$

$$= 1 - \frac{T_e - T_b}{T_d - T_c} \tag{11}$$

Both curves are adiabatic, hence

$$\frac{T_e}{T_d} = \left(\frac{P_e}{P_d}\right)^{\frac{\gamma-1}{\gamma}} = \left(\frac{P_b}{P_c}\right)^{\frac{\gamma-1}{\gamma}} = \frac{T_b}{T_c}$$

Therefore

$$\frac{T_e}{T_d} = \frac{T_b}{T_c},$$

and by subtraction,

$$\frac{T_e}{T_d} = \frac{T_e - T_b}{T_d - T_c} = \frac{T_b}{T_c} \tag{12}$$

Substituting equation (12) in equation (11),

$$\text{Efficiency} = 1 - \frac{T_b}{T_c}. \quad (\text{see equation 7}) \quad (13)$$

Since the compression curve is an adiabatic

$$\frac{T_b}{T_c} = \left(\frac{V_c}{V_b}\right)^{\gamma-1} = \frac{1}{r^{\gamma-1}}$$

$$\text{and } \frac{T_b}{T_c} = \left(\frac{P_b}{P_c}\right)^{\frac{\gamma-1}{\gamma}} = \left(\frac{P_1}{P_2}\right)^{\frac{\gamma-1}{\gamma}}$$

Substituting these values for  $\frac{T_b}{T_c}$  in equation (13), we have

$$\text{Efficiency} = 1 - \left(\frac{V_c}{V_b}\right)^{\gamma-1} \quad (\text{see equation 8}) \quad (14)$$

$$= 1 - \frac{1}{r^{\gamma-1}} \quad (\text{see equation 9}) \quad (15)$$

$$= 1 - \left(\frac{P_1}{P_2}\right)^{\frac{\gamma-1}{\gamma}} \quad (\text{see equation 10}) \quad (16)$$

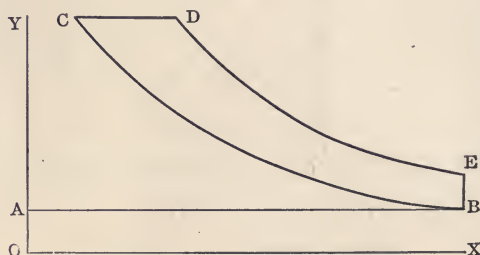

FIG. 171.—Theoretical Diesel cycle.

In the Diesel engine as now built ignition occurs at constant pressure and the heat is rejected at constant volume. The cycle is approximately that shown in Fig. 171. The lines  $BC$  and  $DE$  are assumed to be adiabatics. All the heat must then be absorbed along the line  $CD$  and all rejected along  $EB$ . Let the heat received along  $CD$  be represented by  $H_1$ , and the absolute temperature at  $C$  by  $T_c$  and at  $D$  by  $T_d$ ; and let the heat rejected along  $EB$  be represented by  $H_2$ , and the absolute temperature at  $E$  by  $T_e$  and at  $B$  by  $T_b$ . Assume the weight of the charge to be constant for the cycle and equal to  $w$ . This assumption is permissible since the fuel is oil and the increase in weight of the charge is small.

Then  $H_1 = wc_p(T_d - T_c)$

and  $H_2 = wc_v(T_e - T_b).$



The work done =  $H_1 - H_2 = wc_p(T_d - T_c) - wc_v(T_e - T_b)$ .

$$\begin{aligned} \text{Efficiency} &= \frac{H_1 - H_2}{H_1} = \frac{wc_p(T_d - T_c) - wc_v(T_e - T_b)}{wc_p(T_d - T_c)} \\ &= \frac{c_p(T_d - T_c) - c_v(T_e - T_b)}{c_p(T_d - T_c)} \\ &= 1 - \frac{T_e - T_b}{\gamma(T_d - T_c)}. \end{aligned} \quad (17)$$

Since  $CD$  is a constant pressure line and  $EB$  a constant volume line

$$T_d = T_c \frac{V_d}{V_c} \quad (18)$$

$$\text{and } \frac{T_e}{T_b} = \frac{P_e}{P_b}. \quad (19)$$

$$\text{But } P_e = P_d \left( \frac{V_b}{V_e} \right)^\gamma \quad (20)$$

$$\text{and } P_b = P_c \left( \frac{V_c}{V_b} \right)^\gamma = P_d \left( \frac{V_c}{V_e} \right)^\gamma. \quad (21)$$

Substituting equations (20) and (21) for  $P_e$  and  $P_b$  in equation (19) we have

$$\frac{T_e}{T_b} = \frac{P_d \left( \frac{V_d}{V_e} \right)^\gamma}{P_d \left( \frac{V_c}{V_e} \right)^\gamma} = \left( \frac{V_d}{V_c} \right)^\gamma$$

$$\text{or } T_e = T_b \left( \frac{V_d}{V_c} \right)^\gamma \quad (22)$$

Substituting equations (18) and (22) for  $T_d$  and  $T_e$  in equation (17) we have

$$\begin{aligned} \text{Efficiency} &= 1 - \frac{T_b \left( \frac{V_d}{V_c} \right)^\gamma - T_b}{\gamma \left( T_c \frac{V_d}{V_c} - T_c \right)} \\ &= 1 - \frac{T_b \left\{ \left( \frac{V_d}{V_c} \right)^\gamma - 1 \right\}}{T_c \gamma \left( \frac{V_d}{V_c} - 1 \right)} \end{aligned} \quad (23)$$

$$= 1 - \frac{1}{r^{\gamma-1}} \left\{ \frac{\left( \frac{V_d}{V_c} \right)^\gamma - 1}{\gamma \left( \frac{V_d}{V_c} - 1 \right)} \right\}, \quad \begin{array}{l} \text{(compare} \\ \text{with equations (24)} \\ \text{9 and 15)} \end{array}$$

since  $\frac{T_b}{T_c} = \left( \frac{V_c}{V_b} \right)^{\gamma-1} = \frac{1}{r^{\gamma-1}}$ .

From equation (24) it is seen that the efficiency of the Diesel cycle depends not only upon the ratio of compression,  $r$ , but also upon the ratio  $\frac{V_d}{V_c}$ , or the ratio of the volume at cut-off to the clearance volume.

**189. Losses in the Gas Engine.**—Fig. 172 shows the theoretical card of a gas engine in full lines, and the actual card in dotted lines. The difference between the actual and theoretical card is largely due to the losses. The actual compression line  $BF$  differs from the theoretical line  $BC$  because of the loss of heat to the cylinder walls during compression. The theoretical line  $CD$  assumes the combustion of the gas to take place instantly, while in actual operation, as shown by the line  $FG$ , the burning of the gas takes an appreciable length of time, and may continue to mid-



FIG. 172.—Difference between actual and theoretical indicator cards.

stroke. Due to this fact, it is impossible to obtain full theoretical pressure at the beginning of the stroke. During this operation there is also a loss of heat to the walls. The expansion line  $DE$  in the theoretical card is assumed to be an adiabatic. The actual line  $GH$  is not an adiabatic, as after-burning always occurs along this line, and in addition there is a large loss of heat to the water-jacket surrounding the cylinder of the engine.

There are other losses in the gas engine which are not so apparent from the indicator card.

(a) The largest of all losses is the loss of heat in the exhaust

gases, which leave the engine at a high temperature, usually over 500°.

(b) The next largest loss is the heat carried away by the water-jacket. This water-jacket is necessary in all stationary engines to prevent overheating of the cylinder. A similar loss occurs in all air-cooled cylinders.

(c) The loss due to the charge of gas and air entering the cylinder being heated by coming into contact with the hot parts of the engine. This heating of the charge increases its volume and the engine receives less weight of gas and gives a correspondingly reduced horse-power.

(d) There is a loss of effective pressure in the working medium due to the resistance in inlet and exhaust valves.

The following is a statement of the distribution of heat in a gas engine taken from actual tests and expressed in per cent.

Heat used in indicated work.....	25 per cent.
Heat lost in exhaust .....	37 per cent.
Heat lost in jacket water.....	33 per cent.
Heat lost in radiation and conduction.....	5 per cent.

The relative loss from the exhaust and in the jacket varies widely in different engines. In some engines the exhaust and jacket losses are nearly the same amount, and in some the jacket loss is even higher than the loss in the exhaust. The loss in the jacket may be appreciably decreased and the efficiency increased by running the jacket water as warm as successful operation will permit.

**190. Gas-engine Fuels.**—The fuel used by gas engines may be classified under three different heads:

1. Solid fuels.
2. Liquid fuels.
3. Gaseous fuels.

The fuel, no matter what its original state may be, must be changed to a gaseous form before it can be used in an engine. With the first two forms of fuel, it is necessary that some means be provided for vaporizing them before they are used in the engine.

In the solid fuels, they are vaporized in some form of gas producer. They are then used in the engine as producer gas. In the liquid fuels, vaporization takes place in some form of carbureter, or vaporizer, or in the cylinder itself.

**191. Gas Producers.**—In the gas producer, the heat of the fuel bed distils the volatile gases from the fresh coal, leaving coke. This coke is burned to CO by introducing insufficient air. A small portion of the carbon is changed to CO<sub>2</sub>. Producers using anthracite coal have been in successful use for a number of years, and bituminous producers are now coming into use. The principal difficulty in using bituminous coal as a fuel for producers is in removing, or preventing, the formation of tar. The future success of the bituminous producer depends upon the thorough removal of the tar.

There are two types of producers: (a) *pressure*, and (b) *suction* producers. In the pressure type, the air and steam are furnished

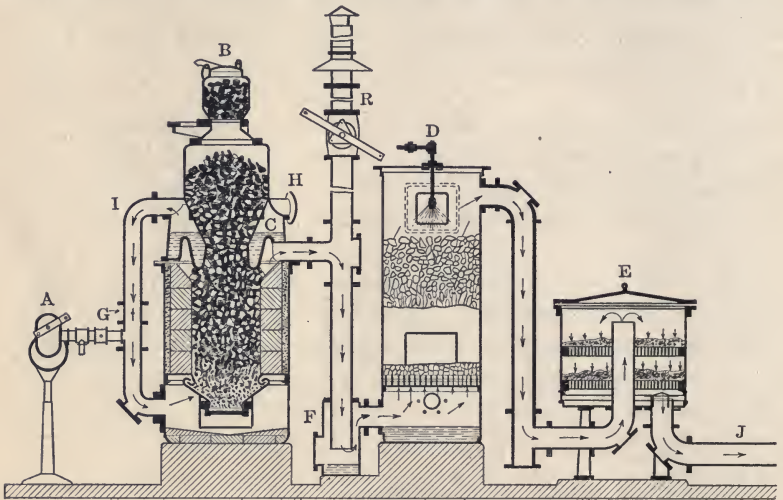

FIG. 173.—Cross-section of suction gas producer.

to the producer by a fan. The rate of production is independent of the engine's demand and the gas must be stored. The gas is furnished to the engine at the pressure produced by the fan, usually equivalent to a pressure of a 2- or 3-in. column of water.

In the suction type, the air is drawn through the producer by the suction formed in the engine cylinder, so that the rate of production of gas in the producer depends upon the demand of the engine. The producer then automatically furnishes the necessary amount of gas for the operation of the engine, so that no storage tank is required.

The suction producer is becoming very popular for use with the gas engine, particularly in the smaller sizes. The pressure pro-

ducer is more expensive in installation than the suction type, as it involves a gas holder, but it can be used with inferior grades of fuel. The suction producer occupies less space and costs less than the pressure type. It is best adapted to the use of high-grade fuels. The most successful suction producers use anthracite coal.

Fig. 173 shows a cross-section of a suction producer. *A* is a blower which is used to furnish draft during the starting of the fires. *B* is the generator with a double-valved hopper for admitting the coal to the fuel bed of the producer. *C* is a vaporizer in which steam is formed, the steam being mixed with the air entering the producer. *D* is the scrubber, consisting of a coke tower with a spray of water for washing the gas. *E* is the cleaner containing trays filled with wood shaving, through which the gas passes to remove dust and dirt. *F* is the cleaning pot which collects the heaviest dust and dirt coming over with the gas. By the admission of water to the cleaning pot on shutting down, the rest of the apparatus is water sealed and the gas remaining in it is kept for use in starting up again. *G* is a damper which is closed while the blower is running. After the blower has been shut down, the damper *G* is opened and the air enters the producer at *H*, passes over the surface of the water in the vaporizer *C* and down the pipe *I*, entering the generator *B* at the bottom. The pipe *J* leads to the engine.

To operate the plant, a fire is lighted just as in an ordinary coal stove, and the blower is run until a good fire is burning, with the relief valve *R* open. After fifteen or twenty minutes, the fire is sufficiently hot to give off gas. The relief valve is then closed and the gas allowed to pass through the apparatus to the engine, the blower being kept running until the proper quality of gas is obtained at the test cock near the engine. The engine is then started, the blower stopped and the formation of gas becomes automatic, the suction of the engine furnishing the draft through the fire.

The efficiency of the gas producer should be a little higher than that of a steam boiler. Actual tests show efficiencies as high as 85 per cent., but efficiencies ordinarily do not exceed 80 per cent. The consumption of fuel in a gas engine operating with gas producers does not usually exceed 1 lb. per horse-power per hour, and in large installations is less than one pound. The heat value of producer gas varies from 100 to 150 B.T.U. per cubic foot.

**192. Vaporization of Oil.**—The lighter oils, such as gasoline, are easily vaporized by either spraying the oil into a current of air, or allowing a current of air to pass over the surface of the oil. This vaporization may be increased or assisted in four ways:

- (a) By the application of heat;
- (b) By increasing the surface of the oil exposed to the air;
- (c) By reduction of pressure or increase in vacuum;
- (d) By keeping the air which is in contact with the gasoline as fresh or as far from the saturation point as possible.

With the heavier oils, such as distillates and crude oil, it is necessary to provide some other means of vaporizing the oils. There are two general methods to accomplish this purpose. In engines such as the Hornsby-Akroyd, the oil is injected into a cylinder against hot plates, or a hot ball, and is almost instantly vaporized by the contact with the red-hot surface. In other engines the oil is vaporized in a heated chamber external to the engine. Initial vaporization is often produced by artificially heating the chamber, and after the engine is in operation, the oil is heated by means of the exhaust passing through pipes located in this chamber. Engines have been placed on the market which used crude oil just as it comes from the wells, and have given fair satisfaction. The difficulty in using crude oils is in taking care of the heavier ingredients, such as paraffine and asphalt, that occur in them. The hot surface must be at a sufficient temperature so that in vaporizing these heavier oils they will be broken up into lighter compounds which are more easily vaporized. Asphalts cannot be broken up and must be removed.

**193. Alcohol.**—Alcohol is similar in its nature to kerosene, except that it will stand a very much higher compression, so that, while alcohol does not contain the heat value of the petroleum oils, it will, nevertheless, give almost as much power per pound, owing to the fact of the higher efficiency which may be obtained by its higher compression. In this country, alcohol has not yet been extensively used, but it has been largely used in Europe and Central America. In using alcohol in connection with the engine, it is usually necessary to provide some means of heating it so as to produce more rapid vaporization. Commercial alcohol usually contains not less than 5 per cent. water, and the percentage may be much higher. For satisfactory operation in a gas engine, it should not contain more than 10 per cent. water.

194. **Heating Value of Fuels.**—The heating values of the various fuels are given in the following table:

TABLE XXII.  
CALORIFIC VALUE OF GASEOUS FUELS

	Lower heating value per cu. ft., B.T.U.	Least air required for combustion per cu. ft., cu. ft.
Oil gas (Pintsch).....	1000	9.5
Natural gas.....	950	9.1
Illuminating gas.....	565	5.25
Coke-oven gas.....	545	5.0
Producer gas (from soft coal).....	145	1.25
Producer gas (from anthracite)....	145	1.15
Producer gas (from coke).....	135	1.0
Blast-furnace gas.....	100	0.7

CALORIFIC VALUE OF LIQUID FUELS

	Lower heating value per cu. ft. of oil gas, B.T.U.	Least air required for combustion per cu. ft., cu. ft.	Heating value B.T.U. per pound
Heavy crude oil (West Virginia).	94.6	15.0 lbs.	18,320
Light crude (West Virginia)....	95.0	15.0 "	18,400
Heavy crude (Pennsylvania)....	99.2	15.0 "	19,210
Kerosene.....	95.8	15.0 "	18,520
Gasoline.....	97.7	15.0 "	19,000
Benzol, C <sub>6</sub> H <sub>6</sub> .....	99.3	13.4 "	17,190
Alcohol, 100 per cent.....	103.0	8.6 "	11,664
Alcohol, 90 per cent.....	104.0	7.8 "	10,080

195. **Fuel Mixtures.**—The mixture of air and gas in internal combustion engines is very important. The possible power derived from an engine depends upon obtaining the proper mixture of air and gas. Under ordinary conditions of pressure and temperature, a mixture of CO and air will be explosive when the range is from 16 to 74 per cent., by volume, of CO. With illuminating gas, the range of mixture is from 8 to 19 per cent.; with gasoline, from 2½ to 5 per cent. It will be noticed that the possible range of mixtures varies very widely with the nature of the gas used. Experiments show that the best results are obtained when the air in the cylinder is slightly in excess of the theoretical mixture.

196. **Flame Propagation.**—A very important point in gas engine operation is the rate of flame propagation through the mass of the gas. If this rate is slow, the pressure will not be obtained

quickly enough for the engine to give its maximum horse-power. The rate of flame propagation depends upon the mixture of the gas and upon the method of ignition. In large engines it is becoming a custom to put more than one igniter upon an engine so as to produce more rapid flame propagation. High compression has a tendency to reduce the rate of flame propagation. On the other hand, however, compression of the gases increases the ease with which they may be ignited, and the range of the explosive mixture. Owing to slow flame propagation, ignition takes place before the beginning of the working stroke.

**197. Rated Horse-power.**—The determination of the power of a gas engine from its dimensions is much more difficult than of a steam engine. The theoretical diagram, although quite definitely defined is not of much value in determining the horse-power. The actual diagram is influenced by so many conditions such as the quality and purity of gas, temperature of the mixture, conditions of combustion, heat losses, location and kind of ignition, form of combustion chamber and other items, that it is possible to obtain almost any result. The card factor as applied to the steam engine is of little value as it shows variations under different conditions as high as 100 per cent. It is not surprising therefore that numerous methods exist for determining the principal dimensions of internal combustion engines, all of these based on assumptions giving only approximate results.

One of the best methods is based on the amount of air necessary for combustion and on the thermal and volumetric efficiencies when the engine is operating with the quantity of air assumed. This method was developed by Hugo Güldner and for many years this has been used with success for all sizes and types of engines and for various fuels.

Let  $N_n$  = normal or rated horse-power.

$n$  = r.p.m.

$H$  = the lower heating value of the fuel in B.T.U.—  
per cubic foot for gas—per pound for liquids.

$C_h$  = fuel consumption per hour at normal output—  
in cubic feet for gas—in pounds for liquids.

$\eta_w$  = economic or thermal efficiency at the brake.

$$\text{Then, } \eta_w = \frac{N_n \times 33000 \times 60}{778 \times C_h \times H} = \frac{2545 \times N_n}{C_h \times H} \quad (25)$$

$$\text{whence } C_h = \frac{2545 \times N_n}{\eta_w \times H} \quad (26)$$



Let  $C_{st}$  = fuel consumption per suction stroke.

$L_{st}$  = air consumption per suction stroke.

$L$  = proper amount of air in cubic feet required per cubic foot of gas or per pound of liquid fuel.

$D$  = diameter of the cylinder.

$S$  = stroke of the engine.

$\eta_v$  = volumetric efficiency.

Then, for a single acting four-cycle engine

$$C_{st} = \frac{C_h}{30 \times n} = \frac{84.8 \times N_n}{n \times H \times \eta_w} \quad (27)$$

$$L_{st} = \frac{C_h \times L}{30 \times n} = \frac{84.8 \times N_n \times L}{n \times H \times \eta_w} \quad (28)$$

For two-cycle engines equations (27) and (28) must be divided by 2.

During one suction stroke the volume of the actual charge drawn in is

$$\begin{aligned} V = C_{st} + L_{st} &= \frac{D^2 \times \pi \times S}{4 \times \eta_v} = \frac{\text{actual piston displacement}}{\text{volumetric efficiency}} \\ &= \frac{84.8 \times N_n \times (1 + L)}{n \times H \times \eta_w} \text{ in cubic feet} \end{aligned} \quad (29)$$

Solving for  $D$ ,  $S$ , and  $n$ , we get for engines using gaseous fuels:

$$D = \sqrt{\frac{108 \times N_n (1 + L)}{S \times n \times H \times \eta_w \times \eta_v}} \text{ ft.} \quad (30)$$

$$S = \sqrt{\frac{108 \times N_n \times (1 + L)}{D \times n \times H \times \eta_w \times \eta_v}} \text{ ft.} \quad (31)$$

$$n = \frac{108 \times N_n \times (1 + L)}{D^2 \times S \times H \times \eta_w \times \eta_v} \text{ r.p.m.} \quad (32)$$

For liquid fuel engines the term  $(1 + L)$  may be put equal to  $L$ , as the volume of fuel is very small compared with the volume of air.

In view of the amount of experimental data available a selection of the efficiencies  $\eta_w$  and  $\eta_v$ , and the air consumption for different-types and sizes of engines can be easily made. For this purpose Tables XXIII and XXIV are inserted.

TABLE XXIII.—VOLUMETRIC EFFICIENCY— $\eta_v$ , OF GAS ENGINE

$\eta_v = .88 - .93$	For slow speed engines with mechanically operated inlet valve.
$\eta_v = .80 - .87$	For slow speed engines with automatically operated inlet valves.
$\eta_v = .78 - .85$	For high speed engines with mechanically operated inlet valve.
$\eta_v = .65 - .75$	For high speed engines with automatic inlet valve.
$\eta_v = .50 - .65$	For very high speed automobile engines with automatic inlet valves and air cooling.

TABLE XXIV.—ECONOMIC EFFICIENCIES,  $\eta_w$ , AND AIR CONSUMPTION OF GAS

Fuel	1		2		3		4		5		6		7		8		9					
	Lower heating value H, B.T.U. per		Air required, L.		Theoretically per		Actually per		Consumption of fuel, 'C <sub>h</sub> ' per B.H.P. per hr. on the basis of 29" Hg. and 59° F.		Thermal efficiency at brake, $\eta_w$ , if $N_n =$		200 B.H.P.		100 B.H.P.		50 B.H.P.					
	Ft. <sup>3</sup>	Lbs.	Ft. <sup>3</sup>	Lbs.	Ft. <sup>3</sup>	Lbs.	Ft. <sup>3</sup>	Lbs.	C <sub>h</sub> , Ft. <sup>3</sup>	$\eta_w$	C <sub>h</sub> , Ft. <sup>3</sup>	Lbs.	$\eta_w$	C <sub>h</sub> , Ft. <sup>3</sup>	Lbs.	$\eta_w$	C <sub>h</sub> , Ft. <sup>3</sup>	Lbs.	$\eta_w$	C <sub>h</sub> , Ft. <sup>3</sup>	Lbs.	
I Illuminating gas																						
a. Lean.....	505		5.0		7.5		22.5	.22	20.7	.24	19.4	.26	18.8	.27	17.9	.28	17.4	.29				
b. Ordinary... {	561		↑		↑		20.4	.22	18.6	.24	17.2	.26	16.9	.27	16.1	.28	15.6	.29				
	618		↓		↓		18.6	.22	17.2	.24	15.8	.26	15.4	.27	15.1	.28	14.3	.29				
c. Rich.....	674		6.0		9.0		17.0	.22	15.8	.24	14.3	.26	14.0	.27	14.3	.28	13.1	.29				
II Producer gas.																						
a. On basis of anthracite*	13,500									1.296	.15	1.12	.17		1.005	.19	.895	.21				.85
b. Anthracite gas	140		.9-1.1		1.5		96.8		96.8	.19	86.0	.21	78.9	.23	75.2	.24	71.6	.26				
c. On basis of coke*	12,600								1.452	.14	1.25	.16	1.12	.18	1.005	.20	.92	.22				
d. Coke gas.....	129		85-1.0		1.25		104		104	.19	93.2	.21	86.0	.23	82.3	.24	78.9	.25				
e. On basis of lignite b'k's.*	8,670									1.63	.18	1.5	.20		1.41	.21	1.34	.22				
f. Lignite gas....	129		.9-1.0		1.3						89.6	.22	86.0	.23	82.3	.24	78.9	.25				
III Blast-furnace gas.	106		.75		.9-1								100.		24.95		25.91.3	.26				
IV Coke-oven gas	505		5.3		7								21.5	.23	19.8		26.18.6	.27				
V Kerosene-expl..	18,900		185		256-353		256-	1.117	.12	1.03	.13	.895	.15									
Eng.					288-320			.54	.26	.492	.29	.447	.32		.425	.33	.415	.34				
VI Crude oil - Diesel.	18,000		176		240-272			.65	.20	.582	.22	.56	.23									
VII Gasoline benzol.	19,800		185		128-192			1.07	.23	1.007	.25	.962	.26									
VIII Alcohol, 90 per cent.	10,300		96.5																			

\* Including 10 to 15 per cent. of the full daily fuel consumption for firing up. The consumption of a gas-producer banked through the right is from one-third to one-half of this amount.

Diameter  $D$ , stroke  $S$  and speed  $n$  have a certain relation to each other. Present-day engines can safely be built with  $\frac{S}{D} = 1$  to 2.5, and with piston speeds up to 800 ft. per minute for large engines and 1200 for smaller ones.

**Example.**—Determine the cylinder diameter, stroke and revolutions per minute of a four-cycle, single-acting, one-cylinder anthracite producer gas engine of 170 H.P., having a piston speed of 800 ft. per minute and a stroke-diameter ratio  $\frac{S}{D} = 1.35$

**Solution.**—From table XXIII use  $\eta_v = .90$   $L = 1.5$  cu. ft.  
From table XXIV use  $\eta_w = .26$

$$H = 140 \text{ B.T.U. and since } n = \frac{c}{2S} = \frac{c}{2.7D}$$

solving for  $D$

$$D = \sqrt{\frac{108 \times N_n(1 + L)}{S \times n \times H \times \pi_w \times \eta_v}} = \sqrt{\frac{108 \times 170 \times 2.5 \times 2.7}{1.35 \times 800 \times 140 \times .26 \times .9}}$$

$$= 1.877' \text{ feet} = 22.5 \text{ inches}$$

$$S = 1.35 \times 22.5 \cong 30 \text{ inches}$$

$$\eta = \frac{800}{2 \times 30} = 133 \text{ r.p.m.}$$

**Example.**—Determine the diameter and stroke of a two-cycle, single-acting, 4-cylinder Diesel Oil Engine of 150 H.P., having 350 r.p.m. and a piston speed of 700 ft. per minute.

**Solution.**—

From table XXIII  $\eta_v = .80$   $L = 312$  cu. ft.  $H = 18,009$  B.T.U.  
From table XXIV  $\eta_w = .32$

Each cylinder must develop  $\frac{150}{2 \times 4} = 18.75$  H.P. per cycle.

$$S = \frac{700 \times 12}{2 \times 350} = 12''$$

$$D = \sqrt{\frac{108 \times 18.75 \times 312}{1 \times 350 \times 18,000 \times .32 \times 0.80}} \cong 7.5''$$

The American Association of Automobile Manufacturers determines the normal output of four-cycle automobile engines by the formula—

$$\text{B.H.P.} = \frac{d^2 \times N}{2.5} \tag{33}$$

where  $d$  = the diameter of the cylinder in inches, and  $N$  the number of cylinders. This rule is based on a piston speed of 1000 ft.

per minute and has, of course, an arbitrary and conventional value only.

The rated horse-power of a gas engine to drive a given size electric generator is quite different from that of a steam engine to drive the same machine. This is due to the fact that a gas engine as rated has very little overload capacity, while a steam engine can carry a 25 per cent. overload continuously and a 50 per cent. overload for a short period of time. In order to allow for the overload capacity of the generator, the gas engine must be sufficiently large to drive the generator under that condition.

As an example, to drive a 2000 k.w. generator, a 4500 H.P. gas engine is used, while to drive the same generator with a steam engine, a 3000 H.P. engine is used.

It should be noted that, at present, gas engines are rated on their output, or brake horse-power, while steam engines are rated on their indicated horse-power, and that, as stated above, gas engines are rated at practically their maximum capacity, while steam engines are rated at the I.H.P. at which they give the best economy.

**198. Actual Horse-power.**—The actual indicated horse-power (I.H.P.) of a gas engine already built and in operation may be determined in almost exactly the same way as was done in the case of the steam engine, the only difference being that in the formula,

$$\text{I.H.P.} = \frac{plan}{33000}, \quad (34)$$

$n = \text{explosions}$  per minute, when finding the horse-power of the gas engine, while when finding the power of the steam engine, it was equal to the *revolutions* per minute.

In both cases,  $l =$  the length of stroke in feet, and  
 $a =$  the cross-sectional area of the piston in square inches.

The mean effective pressure  $p$  is found by taking indicator cards from the engine and then multiplying, by the scale of the spring used, the quotient found by dividing the area of the card by its length.

The cross-sectional area of the piston in the gas engine indicator is usually one-fourth of a square inch, while that of the

steam-engine indicator is one-half a square inch, the difference being due to the fact that the initial pressure in the gas-engine cylinder is so much greater.

The brake horse-power (B.H.P.) of a gas engine is found in exactly the same manner as the B.H.P. of a steam engine, the expression being

$$\text{B.H.P.} = \frac{2\pi l n w}{33000}, \tag{35}$$

where  $l$  = the length of the brake arm in feet,  
 $w$  = the net weight on the brake, and  
 $n$  = the number of *revolutions* per minute.

It is thus seen that in making a test of a gas engine to obtain the I.H.P. and B.H.P., both the *explosions* per minute and the *revolutions* per minute must be noted.

**Example.**—A  $10\frac{3}{8}'' \times 16\frac{7}{8}''$  single-acting gas engine runs 200 r.p.m. and makes 96 explosions per minute. The gross weight on the brake was 140 lbs., the tare 20 lbs., and the length of the brake arm, 60 in. The area of the indicator card was 1.07 sq. in. and the length 3 in., and the scale of the spring used was 219 lbs. Find the (a) I.H.P.; (b) B.H.P.; (c) F.H.P.; and (d) mechanical efficiency.

**Solution.**—

$$(a) \text{ M.E.P.} = \frac{1.07}{3} \times 219 = 78.1 \text{ lbs.}$$

$$a = \pi \times 5\frac{3}{16} \times 5\frac{3}{16} = 84.5 \text{ sq. in.}$$

$$l = 16\frac{7}{8} \div 12 = 1.406 \text{ ft.}$$

$$\text{I.H.P.} = \frac{\text{plan}}{33000} = \frac{78.1 \times 1.406 \times 84.5 \times 96}{33000} = \frac{885000}{33000} = 27.$$

$$(b) \text{ Net weight} = 140 - 20 = 120 \text{ lbs.}$$

$$\text{Length of brake arm} = 60 \div 12 = 5 \text{ ft.}$$

$$\begin{aligned} \text{B.H.P.} &= \frac{2\pi l n w}{33000} = \frac{2 \times 3.1416 \times 5 \times 200 \times 120}{33000} \\ &= \frac{755000}{33000} = 22.85 \end{aligned}$$

$$(c) \text{ F.H.P.} = \text{I.H.P.} - \text{B.H.P.} = 27 - 22.85 = 4.15.$$

$$(d) \text{ Mech. Eff.} = \frac{\text{B.H.P.}}{\text{I.H.P.}} = \frac{22.85}{27} = .846 = 84.6 \text{ per cent.}$$

## CHAPTER XVII

### DETAILS OF GAS-ENGINE CONSTRUCTION

**199.** In general, the frame and working parts of the gas engine are heavier in construction than the corresponding parts of a steam engine. This is largely due to the fact that the number of impulses given the gas engine for the same power is less than those given the steam engine, and hence each impulse in the gas engine must exert more force.

**FRAME.**—Fig. 174 shows the frame of a modern gas engine of medium size. The barrel of the cylinder is cast with the frame. The main bearing supports are cast in the same frame.

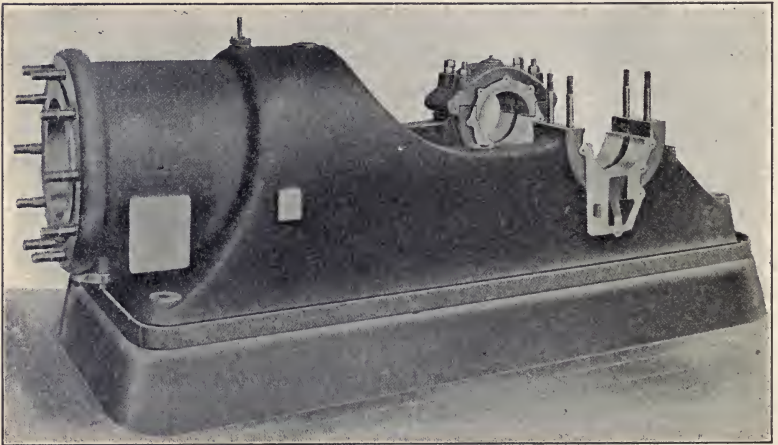

FIG. 174.—Gas engine frame.

**CYLINDER AND PISTON.**—The inner lining of the cylinder is inserted in the frame as a separate piece, except in the smaller engines.

Fig. 175 shows the piston and piston rings. Three rings, at least, and often six or seven, are used in a gas engine. It is very important that the piston fit the cylinder as closely as possible so as to hold the compression. The piston shown is for a single-

acting engine, and serves both as piston and cross-head. The cross-head pin is shown at the top of the figure, and is placed in the hole shown in the side of the piston. This is the most commonly used construction for small and medium size engines.

**CONNECTING RODS.**—The connecting rods used in gas engines are similar to those in steam-engine practice.

**VALVE MECHANISM.**—The valves used have been almost the same for all types of gas engines, and are of the poppet type. The exhaust valves are always mechanically operated, but the inlet valves may be either automatic or mechanically operated.

Fig. 176 shows the cross-section of a four-cycle gas engine, and shows both inlet and exhaust valves. These valves are operated from a cam shaft at the side of the engine by means of roller cams. In some engines these cams are replaced by eccentrics.



FIG. 175.—Piston and rings for gas engine.

**WATER-JACKET.**—In all except small air-cooled engines, the cylinder and cylinder head are cooled by being surrounded by a water-jacket, and in the best engines the valves are also water-jacketed. The water-jackets are shown in Fig. 176, surrounding the valves and reaching between the valves.

**200. Ignition.**—One of the most important details of gas-engine construction has been the development of a suitable means of ignition. The first successful form of ignition was by means of an open flame which was drawn into the cylinder at the proper time. Flame ignition, however, is uncertain and difficult of application, and is not economical and so has been abandoned in recent engines.

The next form of ignition was the hot tube, in which a closed tube connected with the engine cylinder was kept at red heat

by means of an external flame. The compression of the gases into the hot tube ignites them at the proper time in the stroke. The time of ignition is more or less regulated by the temperature of the tube. In some cases the admission of the gas into the hot tube was controlled by a valve. This form of ignition

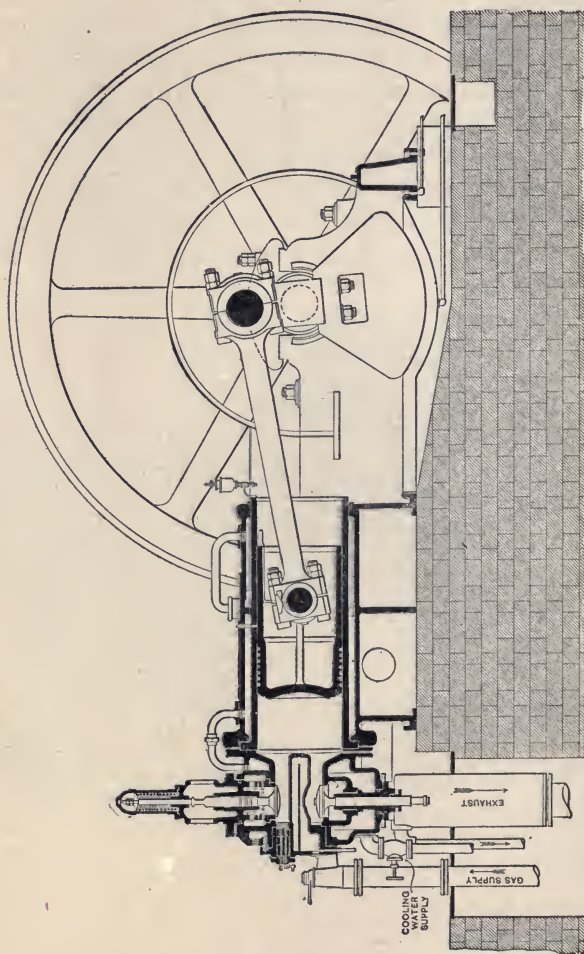

Fig. 176.—Longitudinal section of Koerting four-cycle gas engine, showing cylinder construction and valves.

is satisfactory in small engines, but is hardly sufficient to ignite a large volume of gas such as is admitted to a large engine, and does not admit of a change in the time of sparking.

One of the simplest forms of igniters is that used by the Deisel Engine Company. In this engine the air is compressed to a very



high pressure and the temperature is then sufficient to ignite the entering charge of oil, or gas, which is delivered to the cylinder at a pressure slightly higher than the compression pressure. This then requires no special igniting apparatus, and the time of ignition is controlled by the time of admission to the cylinder. In the Hornsby-Akroyd oil engine, a hot bulb, used for vaporizing the entering oil, serves also as an igniter.

At the present time, the most used and the most successful form of ignition is by electric spark. This has proven to be the

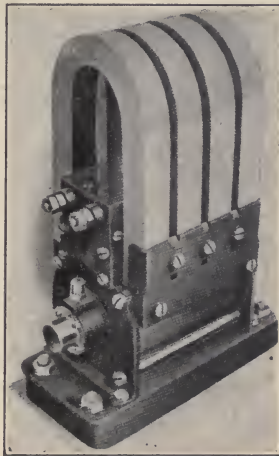

FIG. 177.—Magneto.

most satisfactory in the large majority of internal combustion engines and in automobiles it is used exclusively. It is by far the most reliable and flexible method in use. There are various means of generating the current used in electrical ignition, such as a battery, dynamo, or magneto, the one most commonly employed at present being the *magneto*, Fig. 177. This is a piece of apparatus consisting of a permanent steel magnet bent in the form of a letter *U*, with a coil of wire revolving in the opening between the poles or ends of the magnet. As the wire revolves it cuts the magnetic lines of force and an electric current is set flowing through the wire.

When the armature is in a position such that the magnetic lines flow through the core, this core becomes magnetized. If the armature is then turned so that the lines no longer flow through

the core, the core loses its magnetism and it is this dying away of the magnetism of the core that produces an electric current in the winding.

A magneto thus gives a current only at certain points in the

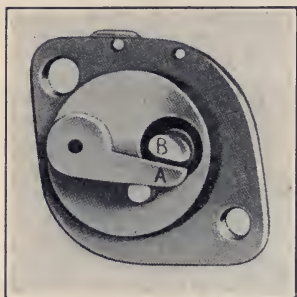

FIG. 178.—Bottom of make-and-break ignitor block, showing contact points.

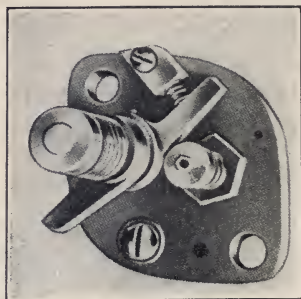

FIG. 179.—Top of make-and-break ignitor block.

revolution of the armature and it must be so driven that it will give this current at the time the engine needs a spark.

The more suddenly the magnetism changes strength the more intense the current will be. If the armature is turned slowly, the current may not be strong enough to form a spark.

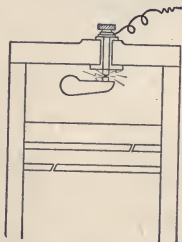

FIG. 180.—Section of cylinder head showing make-and-break ignition system.

A *battery* of dry cells is frequently used to furnish current for ignition of small engines.

There are two forms of electric ignition; viz. the *make-and-break* or *low tension*, and the *jump spark* or *high tension* systems. Of these, the *make-and-break* is the simpler.

In the *make-and-break* system there are two *contact points*, as shown in Figs. 178 and 180, located inside of the cylinder, and

in addition, in series with the circuit is placed what is called a *spark coil*. This consists of a number of turns of comparatively heavy wire wrapped around a core composed of iron wires. This coil acts as an inductive resistance, and when the circuit is broken it serves to cause a hot spark at the point of the break. The circuit of the make-and-break igniter, then, consists of a battery, or magneto, and a spark coil, both of which are placed in series with two contact points in the engine. Just before the point of sparking, the two contact points *A* and *B*, Fig. 178, are brought together, and at the point of sparking the mechanism is so constructed (see Fig. 179) that the two

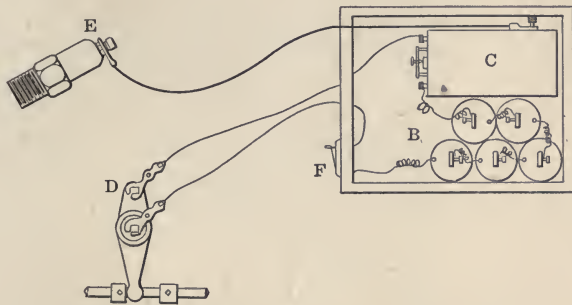

FIG. 181.—Diagram of jump-spark ignition.

points are quickly separated, producing a sufficient spark to ignite the charge.

The advantages of the make-and-break system are: (a) hot spark ensuring ignition; (b) little trouble with insulation. The disadvantages are: (a) moving mechanism required in the cylinder; (b) points of contact become foul and wear away.

The make-and-break igniter is used in a great many engines, and is advocated by many, owing to the low tension at which it is operated. It is the most common form of ignition on stationary engines.

In *jump-spark* ignition, Figs. 181 and 182, the current is taken from a battery *B*, Fig. 181, or generator at a low voltage and passed through an induction coil *C*, having an interrupter. The induction coil has a primary and secondary coil. The interrupted current passing through the primary coil induces a high-tension current in the secondary coil. This current at a high voltage is carried to what is known as a *spark plug E*, located in the engine cylinder.

This spark plug contains two points about  $\frac{1}{32}$  in. apart, across which a high-tension current is made to jump at the time of ignition. The time of ignition is controlled by a timer *D*, fastened to the engine shaft, and, at the proper time of the stroke, this timer closes the battery circuit, the high-tension current is generated in the induction coil, and the spark jumps across the air gap causing ignition in the cylinder. There are a great many detailed modifications of this device, but the above description covers the general construction of them all. In some cases the current is furnished by an alternating-current magneto. With an alternating current, no interrupter is necessary. This system is almost universally used on automobiles.

The advantages of the jump-spark system are: (a) absence of moving parts in the cylinder; (b) easy adjustment of the time of

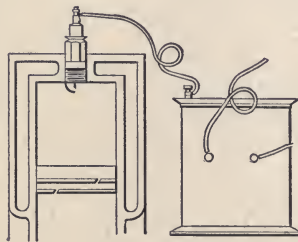

FIG. 182.—Section of cylinder head showing jump-spark ignition system.

ignition. The disadvantages are: (a) high insulation required; (b) liability of spark plug becoming fouled with oil or dirt; (c) intensity of spark varies with pressure in cylinder.

In all forms of gas-engine igniters, some means should be provided for changing the time of ignition, so that the pressure may reach a maximum at the proper time in the stroke. In the jump-spark igniter this is done by moving the position of the *commutator* relative to the piston position. The proper time for ignition depends upon the mixture and the speed of the engine.

Ignition is not instantaneous and in order to have the greatest pressure against the piston when it begins the power stroke, the mixture must be set on fire before the completion of the compression stroke. This is called *advancing the spark*.

**201. Governing.**—The aim of all governors is to obtain the maximum thermal efficiency at all loads. The governing of a gas engine is different from that of a steam engine. In a steam engine under a constant load, each cycle of the engine is

practically the same, while in the gas engine, even with a constant load, there is always some change in the cycle of the engine. This is due to changes of mixture and time of ignition. This makes the problem of governing in the gas engine more difficult than in the steam engine.

The following general methods of governing are used in gas engines:

I. The "*hit and miss*" system.

II. Variation in the *quantity* of charge entering the cylinder, the mixture of gas and air being constant.

III. Variation of the mixture of gas and air, the load determining the *quality* of the mixture.

IV. Governing by changing the time of *ignition*.

V. Combinations of the above methods.

1. *Hit and Miss*.—The most common of all these systems of governing is the "hit and miss." In this form of governing, when the speed exceeds the normal, the supply of gas is cut off and the engine gets no explosion, causing the engine to "miss." The loss of the explosion causes the speed to slacken, the governor opens the inlet valve and the engine again receives an impulse, or a "hit."

This is most economical and simplest method of governing, but does not provide the closest regulation in speed. In this system the "miss" may be occasioned by (a) holding the exhaust valve open and thus allowing no suction, or (b) by failing to open the gas valve. There may be considerable variation in speed.

This method of governing is not desirable for large engines because of the high pressures after a "miss."

2. *Quantity governing* may be accomplished by varying the weight, or quantity, of the mixture of gas and air entering the cylinder. This result may be obtained in two ways.

1. By cutting off the charge before the piston reaches the end of the suction stroke.

2. By throttling the charge during the suction stroke.

The disadvantage of this system is that the compression varies with the size of the charge. Reducing the compression reduces the efficiency, and hence this form of governing is not as universally efficient as the "hit and miss."

3. *Quality Governing*.—In this system the weight of the charge remains the same, but the proportion of gas to air is varied—the governor usually controlling the supply of gas.

As the load decreases, the amount of gas is reduced for the same total charge. This system has the advantage over *Method No. 2*, that the pressure of the compression always remains the same. On light loads, however, it is not so economical as *Method No. 2*, for when the load is very light the mixture may be so weak that the charge will not ignite.

*Method No. 4.*—Controlling the speed by changing the time of ignition is used on automobile engines. As the load diminishes, the time of sparking is brought nearer to the working stroke, that is, it is advanced, and it may even occur after the dead center (just previous to the working stroke). As the spark is advanced, the engine develops less and less power. The quantity and quality of the charge, however, remains the same. This system of speed control is very uneconomical at light loads.

*Method No. 5.*—A great many different combinations of the above systems have been used. Often engines having "quantity" and "quality" governors for the heavy and medium loads change the governing system to "hit and miss" for light loads. A combination largely used in electric lighting work, on account of the close regulation obtained, is quality governing at high loads and quantity governing at low loads.

The governing of an automobile is a combination of quality governor by the throttle, and governing by spark advance with the ignition device.

Kerosene and fuel oil engines are commonly governed by bypassing the fuel so that a greater or less amount of it is injected into the cylinder.

Gas-engine governing is at present almost as perfect as governing in the steam engine. There is no difficulty in obtaining sufficiently accurate governing so that alternators driven by gas engines may be operated in parallel.

**202. Carburetors.**—A carburetor is a device used for vaporizing oil, particularly gasoline. It is largely used in connection with automobile or small launch engines. In a carburetor the air may be passed over or through the gasoline, or the gasoline may be mechanically sprayed into the current of incoming air.

Fig. 183 shows a cross-section of one type of Stromberg carburetor. A float *M* operates a pair of levers and through them the needle valve *K*, thus controlling the supply of gasoline to the spray nozzle *C*. The gasoline enters the carburetor from the source of supply through *O* and the dirt in it is removed by the

strainer *N*. The hot water in the jacket *J* keeps the carburetor warm and assists in vaporizing the gasoline.

At each charging stroke of the engine, air is drawn in through the fixed air inlet *S* and passes at a high velocity up through the venturi tube *D* and around the nozzle *C*. The gasoline is sucked in a jet from this nozzle and is mixed with the air in the mixing chamber 1. The throttle valve *H* regulates the supply of the mixture to the engine.

As the speed of the engine increases, the proportion of air to gasoline must be increased. This is taken care of by the auxiliary

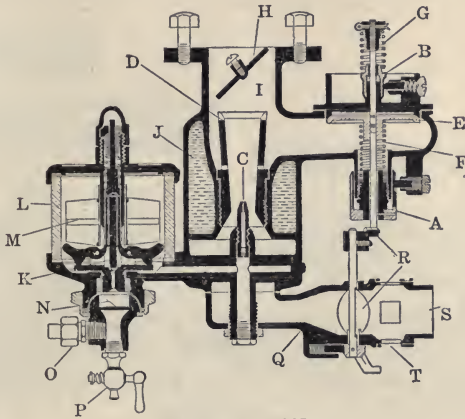

EXPLANATION

- |                              |                               |
|------------------------------|-------------------------------|
| A - Low speed adjusting nut  | K - Needle valve              |
| B - High speed adjusting nut | L - Glass float chamber       |
| C - Spray nozzle             | M - Metal float               |
| D - Venturi tube             | N - Gasoline strainer         |
| E - Auxiliary air valve      | O - Gasoline line coupling    |
| F - Low speed spring         | P - Drain cock                |
| G - High speed spring        | Q - Hot air horn              |
| H - Throttle valve           | R - Air shut-off for starting |
| I - Mixing chamber           | S - Fixed air inlet           |
| J - Water jacket             | T - Season adjustment         |

FIG. 183.—Cross-section of Stromberg gasoline carburetor.

air valve *E*, which is opened or closed a greater or less amount as the speed of the engine increases or decreases.

**203. Vertical Versus Horizontal Engines.**—The advantages of the vertical engine are: higher rotative speed, better balancing, occupy less floor space, less wear on the cylinders and pistons. The advantages are obtained because multi-cylinder engines are more easily built of the vertical type. Therefore more cylinders, each of smaller size, may be used for the same power than would

be the case with a horizontal engine. This means a shorter stroke and hence higher rotative speed for the same power. An increase in the number of cylinders means better balancing and less vibration. The reciprocating masses of the horizontal engine tend to cause the engine to move on its foundation and heavier foundations are necessary than in case of vertical engines.

The disadvantages of the vertical engine are: increased first cost, and, in the enclosed type, too much oil may get in the cylinder, causing trouble. The open end of the cylinder on the horizontal engine assists in cooling the piston. In the larger size

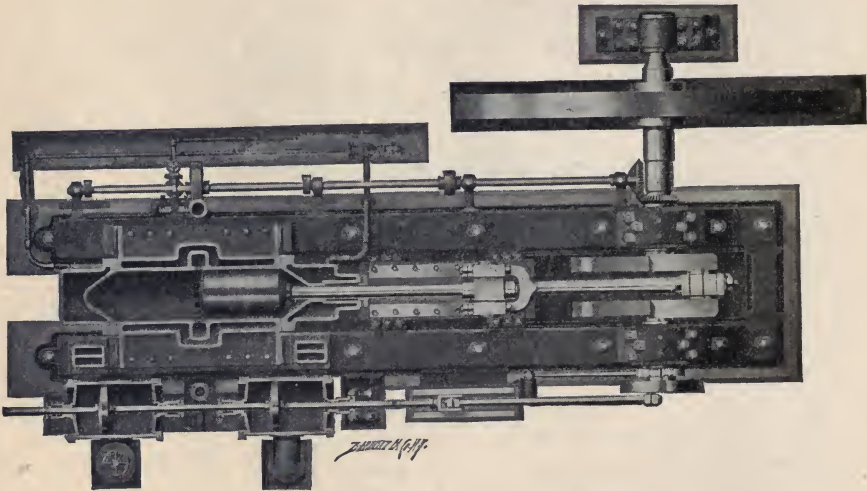

FIG. 184.—Koerting two-cycle gas engine.

engines, the cylinders are generally horizontal, while most automobile and small launch engines have vertical cylinders.

**204. Large Gas Engines.**—In the large sizes, the single-acting engine has been replaced by the double-acting engine, similar in its arrangement to the steam engine. Fig. 184 shows a block plan of a modern two-cycle gas engine of the double-acting type. In this figure, the device for cooling the piston and piston rod is not shown. In most large engines, however, of the double-acting type, the piston and piston rod are cooled by allowing a circulation of water through them. Usually the water enters through a flexible pipe connected to the cross-head, and is removed by a tail rod projecting through the cylinder head.



**205. Oil Engines for Ships.**—For use in marine work certain conditions are required for successful operation of the engine.

1. It should be able to be started quickly from any position without having to be barred round.
2. It should be capable of rapid reversal.
3. It should be able to run continuously for long periods without a stop.
4. It should work economically at various speeds.
5. It should start under a load.
6. It should admit of easy inspection and adjustment.
7. It should work smoothly in a rough sea when the propeller is sometimes partly out of the water.

The relative advantages and disadvantages of Diesel engines as compared with steam engines and boilers for use on large ships are as follows:

Advantages:

- (a) Have much higher thermal efficiency;
- (b) Weigh about half as much and occupy about two-thirds the space for the same power;
- (c) Make possible cleaner, quicker and easier "coaling;"
- (d) Require less attendants;
- (e) Eliminate funnels and dirt;
- (f) Start quicker;
- (g) Eliminate stand-by losses.

Disadvantages.

- (a) Are not so easily reversed or maneuvered in harbors;
- (b) Fuel is more expensive in most places and not so readily available;
- (c) There is an absence of steam for working the auxiliary devices.

**206. Humphrey Gas Pump**—During the Brussels Exposition in 1910 there was exhibited a new type of pumping engine known as the Humphrey Gas Pump. Since that time this gas pump has gained a world-wide reputation. It has been successfully introduced into this country and has been greatly improved by American designers. The largest pump in the world, pumping water for the City of London, is of this type. Its operation can best be understood by reference to Fig. 185.

The pump consists of a vertical gas cylinder *A* with inlet and outlet valves *B* and *C*. These valves interlock with each other. On the water side of the pump there is a suction pipe *D*,

a suction valve  $S$ , and a pressure pipe  $E$  connecting the cylinder with the pressure tank  $F$ . The water column  $G$  forms a gas-tight piston. The operation of the pump is as follows:

We will assume at the beginning that the gas cylinder is filled with a mixture of gas and air. This charge of gas and air is ignited and the pressure is suddenly increased. While this takes place the volume will scarcely change so that combustion practically takes place at constant volume. The water column

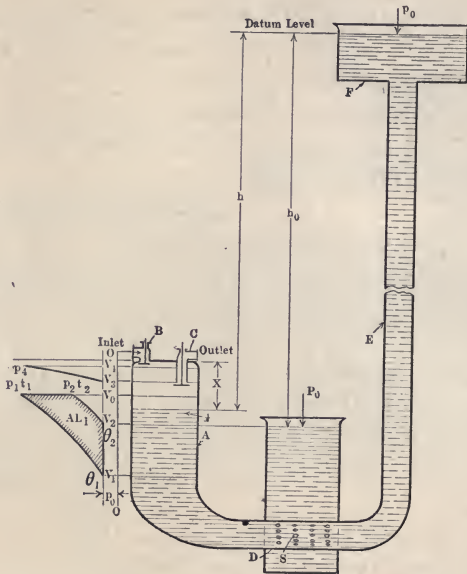

FIG. 185.—Diagram of Humphrey gas pump.

owing to the increased pressure on its surface is rapidly accelerated by the pressure in the gas cylinder and the gases undergo adiabatic expansion. When the gas has reached a predetermined pressure the exhaust valves on the top of the cylinder and the suction valves on the water inlet begin to open automatically. The inflowing water follows the moving water column and fills the gas cylinder, replacing the burned gases. The hydrostatic pressure from the water tank reverses the water column closing the water inlet valves and forcing out the burned gases through the exhaust valve. When the water level reaches the position  $V_3$ , the exhaust valve closes and the water column compresses the remaining burned gases to the volume  $V_4$ . Now the water column reverses

again. Reexpansion of the compressed gases takes place and the pressure falls below the atmospheric pressure. The mixing inlet valve opens and the new charge is taken in until the volume  $V_1$  is filled. The water column again reverses and compresses the charge to the volume  $V_2$ . Ignition takes place and the whole cycle is started over again. The engine works on the four-cycle principle, the expansion and contraction occurs adiabatically and the cycle is carried on by the oscillation of the water column due to the changes of pressure. The action of the pump is not altered if instead of delivering into the elevated tank it is discharged into an open air vessel or into an open tower. The pump has the advantage of being capable of handling enormous quantities of water. In the large pump installed in the City of London, 15 tons of water are discharged at each discharge of the pump, the pump having a capacity of 150 million gallons.

### PROBLEMS

1. A gasoline engine uses 1 lb. of gasoline per I.H.P. per hour. If the gasoline contains 19,500 B.T.U. per pound, what is the actual heat efficiency of the engine?

2. A gas engine uses 20 cu. ft. of gas per horse-power per hour. Each cubic foot of gas contains 600 B.T.U. Initial temperature in the engine is  $2000^\circ$  and the final temperature  $800^\circ$ . What is the actual and theoretical thermal efficiency of the engine?

3. What is the mechanical efficiency of an  $8\frac{1}{4}'' \times 14''$  single-acting gas engine if it runs 225 r.p.m., makes 106 explosions per minute, has a net weight of 50 lbs. on the brake, and the M.E.P. is 76.8 lbs.? The length of the brake arm is 62.75 in. and the tare of the brake is 19 lbs.

4. A card from an  $8\frac{1}{4}'' \times 14''$ , single-acting gas engine has an area of .9 sq. in. and its length is 3 in. Scale of spring, 240 lbs.; r.p.m., 225. Explosions per minute, 100. There is a Prony brake on the engine, the length of the brake arm being 63 in. and the net weight on the brake 42 lbs. Find the I.H.P.; B.H.P.; F.H.P.; and the mechanical efficiency.

5. An  $8'' \times 10''$ , single-acting steam engine running 250 r.p.m. and having an average M.E.P. of 35 lbs. uses 20 lbs. of steam per I.H.P. per hour. Steam pressure, 100 lbs.; feed temperature,  $200^\circ$ ; coal costs \$2.50 a ton and contains 13,500 B.T.U. per lb. Efficiency of the boiler plant, 70 per cent. A gas engine is being considered for the place. The engine is  $8\frac{1}{4}'' \times 14''$ , single acting, running 223 r.p.m. and making 75 explosions per minute. It uses  $2\frac{1}{4}$  lbs. coal per I.H.P. per hour. The area of the average indicator card is 1.04 sq. in. and the length 3.33 in. Scale of spring, 240 lbs. The engines are to run ten hours a day, three hundred days in the year. Gas producer uses the same coal as the boiler plant. Which would be the cheaper to run and how much per year? If a Prony brake is placed on each engine, that on the steam engine having a length of 4 ft. and carrying a net weight of 50 lbs.,

and that on the gas engine having a length of .63 in. and carrying a gross weight of 58 lbs., the tare being 19 lbs., which engine will develop the larger output and how much? Which has the greater mechanical efficiency and how much?

6. A steam engine uses 20 lbs. of steam per I.H.P. per hour and develops 200 H.P. A 20"  $\times$  24" single acting gas engine running 220 r.p.m. is being considered for the place. It uses 10,000 B.T.U. per I.H.P. per hour when making 105 explosions per minute and developing an average M.E.P. of 100 lbs. Efficiency of the boiler plant, 70 per cent.; efficiency of gas producer, 80 per cent. Steam engine plant costs \$20,000. Gas engine and gas producer plant costs \$30,000. Cost of labor is the same for both plants. Coal costs \$3 a ton and contains 13,000 B.T.U. per lb. The steam pressure in the boiler plant is 100 lbs., and the temperature of the feed water, 180°. If the interest charges are 5 per cent., and the repairs and the depreciation, 10 per cent., which would be the cheaper plant, and how much, to run ten hours a day for three hundred days a year?

## CHAPTER XVIII

### ECONOMY OF HEAT ENGINES

207. **Relative Economy of Heat Engines.**—Primarily the efficiency, and in most cases, the economy, of heat engines depends upon the range of temperature of the working medium in the engine. As has been shown, the thermal efficiency of an engine theoretically equals

$$\frac{T_1 - T_2}{T_1},$$

where  $T_1$  is the initial *absolute* temperature of the working medium and  $T_2$  is its final *absolute* temperature. In practice it is found that the best heat engines are able to realize actually only about 60 per cent. of the theoretical efficiency.

An examination of the range of temperatures in the various forms of heat engines will give some clue to their probable actual efficiency. The following table gives a general idea of the possible efficiency of some of the more important prime movers.

TABLE XXV. THERMAL EFFICIENCIES OF PRIME MOVERS

	Range of tempera- ture in cylinders	Theore- tical efficiency	Probable actual efficiency
Average non-condensing steam engine.....	116	14.5	8.7
Average condensing steam engine.....	226	27.8	16.7
High-pressure non-condensing steam engine...	194	22.4	13.4
High-pressure condensing steam engine.....	279	32.2	19.3
High-pressure steam engine, superheated steam	381	39.6	23.8
Average condensing steam turbine, saturated steam.....	381	39.6	23.8
High-pressure condensing steam turbine, super- heated steam.....	429	43.3	25.7
Small gas engine.....	900	39.5	19.5
Large gas engine.....	1300	47.0	28.0
Large gas engine, high compression.....	1400	52.2	31.6
Diesel motor, very high compression.....	1900	60.0	36.0

This table gives some idea of the development and future

possibilities of the various prime movers considering them from a standpoint of heat efficiency. The internal combustion engine is theoretically approximately twice as efficient as the steam engine.

**208. Commercial Economy.**—Heat efficiency, however, is not the only consideration. In actual operation, the important thing is the cost to produce a horse-power for a given period of time. A convenient unit of time is one year.

This cost of production involves a great many considerations. In determining this cost the following items should be considered:

- (1) Interest on the capital invested;
- (2) Depreciation of machinery and building structures;
- (3) Insurance and taxes;
- (4) Fuel cost;
- (5) Labor of attendance;
- (6) Maintenance and repairs;
- (7) Oil, waste, water, and other supplies.

The first three of these items are called the "fixed charges," and remain the same no matter what the load on the plant may be. The last four items are the "operating expense," and vary with the conditions of operation. The sum of the fixed charges and operating expense is the total operating cost.

In most plants the cost of coal is from 25 to 30 per cent. of the total operating expense. A saving in the coal cost of operating is not always a saving in the total cost of operating. This saving may involve so much increased cost of installation that the additional fixed charges on the new capital invested will more than offset the saving in coal. This is well illustrated by the condition which exists in localities having very cheap coal.

A careful comparison of plant-operating costs for a condensing and a non-condensing plant often shows that the cost of operating the non-condensing is less than that of the condensing plant, due to the fact that the increased cost of the condensing plant adds more to the interest and depreciation charges than is saved on the cost of coal used, which is less than in a non-condensing plant.

The following table gives the comparative itemized costs of operating for a compound condensing engine, a gas engine with gas producer, and a steam turbine. These are assumed to be operating an electric generating unit.

Comparison of a 1000 B.H.P. compound condensing engine, a 1000 B.H.P. bituminous gas producer and gas engine plant, and a 1000 B.H.P. steam turbine. Bituminous coal assumed to cost \$3 per ton, with lower heat value of 12,000 B.T.U. per pound

TABLE XXVI. COMPARATIVE COSTS PER RATED HORSE-POWER

	Reciprocating engine	Gas engine	Steam turbine
<i>Installation.</i>			
Engine.....	\$18.00	\$40.00	\$15.00
Piping.....	8.00	3.50	6.00
Condensers and pumps.....	3.50	—	5.00
Engine plant.....	29.50	43.50	26.00
Producer.....	—	20.00	—
Boiler.....	12.00	—	10.00
Chimney, breeching and pumps	10.00	—	9.00
Stokers.....	5.00	—	4.50
Boiler, or producer, plant...	27.00	20.00	23.50
Generator, switchboard and connections.....	18.00	18.00	14.00
Building.....	10.00	10.00	7.50
Total cost of plant.....	\$84.50	\$91.50	\$71.00
<i>Operation.</i>			
Interest, 5 per cent.....	4.25	4.58	3.55
Depreciation, 7 per cent.....	5.95	6.40	4.79
Insurance and taxes.....	1.70	1.83	1.42
Fixed charges.....	11.90	12.81	9.76
Coal per brake horse-power per year .....	27.00	16.20	21.60
Repairs, 3 per cent.....	2.55	2.75	2.13
Attendance, oil, waste and supplies .....	13.50	12.90	13.00
Operating expense.....	43.05	31.85	36.73
Total cost of operation.....	\$54.95	\$44.66	\$46.49

The above table assumes the plant to operate 24 hours per day and 300 days per year, and the average load to be one-half of the full rated load.

As the cost of coal increases, the gas engine and gas producer will make a more favorable showing. If full load could be carried for the 24 hours, the showing will be more favorable to the reciprocating engine. With smaller units the cost of operation is less for the gas engine, as small gas engines are more economical than small reciprocating steam engines, or steam turbines. With large gas engines the first cost is high and the upkeep expensive.



## INDEX

- Adiabatic expansion, definition of, 24  
change of temperature during, 28
- Advance angle, 188, 190
- Advancing the spark, 300
- Air, composition of, 70  
pump, 240
- Alcohol, use of in gas engines, 286
- Ampere, 9
- Angle of advance, 188, 190
- Anthracite coal, 78
- A. S. M. E. rule for finding,  
horse-power rating of boilers, 98  
quality of steam, 53
- Automobile engines, rated horse-  
power of, 291
- Babcock and Wilcox boiler, 91
- Barker's mill, 244
- Barrus, 52
- Barsanti, 271
- Bearing, 162
- Bituminous coal, 77
- Blow-off cock, 105
- Boiler accessories, 105
- Boiler,  
A. S. M. E. rule for horsepower  
rating of, 98  
Babcock and Wilcox water-tube, 91  
classification of, 82  
dry-pipe, 85  
economy, 99  
efficiency, 100  
feed pump (*see* Feed pump)  
fire-tube, 82  
heating surface of return fire-tube,  
99  
Heine water-tube, 94  
horse-power, actual, 98  
rated, 97  
internally fired, 87  
locomotive, 89  
losses, 101  
problems, 133
- Boiler, Rust water-tube, 95  
Scotch marine, 87  
setting, 83, 85  
Stirling water-tube, 92  
tubes, diameter of, 99  
tubular, 82  
tubulous, 82  
use of tubular, 89  
vertical, 95  
water-tube, 91  
when use fire-tube and when  
water-tube, 89  
Wickes water-tube, 95
- Boyle's law, 11
- Brake horse-power (*see* Horse-power,  
brake).
- Branca's, Giovanni, turbine, 245
- Brasses, 163
- Breeching, definition of, 99  
ratio of to grate surface, 99
- British Thermal Unit (B.T.U.), 5
- Brunton, 109
- Buckeye riding cut-off valve, 205
- Calorific power of fuel, 66, 76, 77,  
78, 79
- Calorimeter, 48  
Barrus throttling, 52  
Carpenter separating, 49  
throttling, 50  
coal, 68  
nipple, 48  
"normal reading" of, 48  
Peabody throttling, 50  
problems, 55  
separating, 48  
throttling, 48, 50
- Capacity of pump, 181
- Carburetor, 302
- Carnot cycle, description of, 29  
most efficient cycle, 34  
reversibility of, 33
- Carpenter, 49

- Charles' law, 11
- Chimneys, boiler horse-power of, 130  
brick, 131  
capacity of, 129  
draft of, 128  
efficiency of, 130  
height of, 131  
materials used in, 131  
steel, self-sustaining, 132  
unlined, 132
- Clausius, 10
- Clearance, 149  
per cent. of, 149
- Clerk, Dougal, 269, 278
- Coal analysis, 64  
proximate, 64  
ultimate, 64
- Coal, anthracite, 78  
bituminous, 77  
calorimeter, 68  
dry, 64  
semi-bituminous, 78
- Cock, blow-off, 105  
gage, 106  
three-way, reversing by means of, 212  
tri-, 107
- Combustion, air required for, 70  
heat of, 66  
problems, 79  
rate of, 98  
theoretical temperature of, 74
- Compound engines, combined diagram from, 232  
cross, 227  
cut-off in low-pressure cylinder of, 229  
"fore and aft," 228  
horse-power of, 229  
number of cylinders in, 225  
problems, 234  
ratio of cylinders in, 228  
tandem, 226
- Compound expansion, effect upon initial condensation, 148
- Compounding, gains due to, 225  
losses due to, 225  
principal object of, 225
- Compression, 149
- Condensation, initial (*see* Initial condensation).
- Condensers, barometric, 238  
cooling surface required in, 242  
cooling water used by, 240  
for steam turbine use, 242  
increase in power due to, 242  
jet, 237  
location of hot-well for use with, 238  
surface, 240  
types of, 236
- Conduction, 7
- Connecting rod, effect of on Zeuner diagram, 196  
solid-ended, 161  
strap-ended, 161
- Convection, 8
- Cover plate, 201
- Corliss engine card, 174  
trip gear, 206  
valve, 205  
effect of using, 208
- Counter-balance, 162
- Crank-shaft, 162
- Crosby indicator, 169
- Cross-compound engine, 227
- Cross-head, 160, 161  
pin, 161
- Curtis turbine, 255
- "Cushion steam," 150
- Cut-off valve (*see* Valve, cut-off).
- Cycle, Beau de Rochas, 271  
Carnot, 29  
four-, 272  
Otto, 271  
two-, 272
- "Cylinder feed," 150
- Dash-pot, 206
- Davis, 5, 40, 42
- Dead center, method of placing engine on, 212
- De Laval turbine, 251
- Diagram factor, 143
- Diesel, 269  
motor, 273, 296

- Draft, chimney, 128  
 forced, 132  
 induced, 133  
 mechanical, 132  
 systems of, 132  
 "Dutch Oven," 95, 112  
 Duty, 180
- Eccentric rod, 163  
 sheave, 163  
 strap, 163  
 throw of, 190  
 Eccentricity, 188, 190  
 Economizers, cost of, 126  
 description of, 125  
 size of, 127  
 Economy, engine, commercial, 310  
   relative, 309  
 governor, relative, 216  
 Efficiency, boiler, 100  
 boiler and grates combined, 100  
 chimney, 130  
 fuel, 79  
 gas engine, 275  
                   producer, 285  
 heat engine, 10, 29, 32  
                   actual, 180  
 mechanical, 179  
 turbine, best, 249  
 Energy, 8  
 change in internal, due to change  
 in temperature, 15  
 Engine, automobile (*see* Automobile  
 engine).  
 commercial economy of, 310  
 Corliss (*see* Corliss engine).  
 gas (*see* Gas engine).  
 heat (*see* Heat engine).  
 steam (*see* Steam engine).  
 Equivalent evaporation, 100  
 Evaporation, equivalent, 100  
 factor of, 100  
 per pound of coal, 100  
 Exhaust, heat lost in, 145  
 lap, 189  
   effect of on Zeuner diagram, 195  
 Expansion, adiabatic, 24  
 change of temperature during, 27  
 Expansion, compound, effect of upon  
   initial condensation, 148  
   general case, 17  
   isothermal, 25  
   ratio of, 26, 147  
   work of, 18
- Factor, diagram, 143  
 of evaporation, 100  
 Feed pump, location of, 122  
 use of, 119  
 Worthington boiler, 120  
 Feed-water heaters, advantages of,  
 123  
 closed, 123  
 cost of, 125  
 location of, 125  
 open, 123  
 types of, 123  
 use of, 123  
 "Fixed charges," 310  
 Flame propagation, 287  
 Flue gas, analysis of, 71  
 Fly-wheel, 223  
 Forces of impulse and reaction, 245  
 Frame, 164  
 "Free-piston" gas engine, 270  
 "Fore and aft" compound engine,  
 228  
 Fuel, air required for combustion of,  
 70  
 classification of, 75  
 composition of, 64  
 efficiency of, 79  
 gas engine, 283  
 heating value of gas and oil, 287  
   value of, theoretical, 68  
 mixtures, proper, 287  
 Fusible plug, 108
- Gage cocks, 106  
 glass, 105  
 Gas engine,  
 Barsanti and Matteucci's, 271  
 classification, 270  
 construction, details of, 294  
 Diesel's, 273, 280, 296  
 efficiency of, 275

- Gas engine, four-cycle, 272  
 "free-piston," 270  
 fuels, 283  
 governors, types of, 300  
 history of the, 269  
 horizontal *vs.* vertical, 303  
 horse-power, actual, 292  
   rated, 288  
 ignition, kinds of, 295  
 Langen's, Otto and, 270  
 Lenoir's, 270  
 losses in a, 282  
 Otto (and Langen's), 270  
 problems, 307  
 two-cycle, 272  
 use of alcohol in, 286  
 vertical *vs.* horizontal, 303
- Gas producers, 283  
 efficiency of, 285  
 pressure, 284  
 suction, 284
- Gas pump, Humphrey, 305
- Gear, Corliss trip, 206  
 Joy, 212  
 radial, 211  
 reversing, 209, 210  
 Walschaert, 211
- Giffard, M., 121
- Governor, automatic, 216  
 centrifugal, 220  
 design, relation of items in, 219  
 fly-ball, 218  
 "hit and miss," 301  
 inertia, 221  
 isochronous, 222  
 mechanism, 217  
 quality, 301  
 quantity, 301  
 shaft, 218, 220  
 throttling, 216  
 used with double-ported valve,  
 203  
 variable cut-off, 216
- Governors, gas-engine, types of, 300  
 practical considerations in con-  
 nection with, 223  
 relative economy of, 216  
 variation in speed allowable, 223
- Grate surface in stokers, 118  
   ratio of, to breeching, 99  
   to heating surface, 98
- Gutermuth, 148
- Güldner, 269
- Heat, absorption of, 13  
   added at constant pressure, 22  
     at constant volume, 22  
     general case, 20  
 balance in boiler plant, 101  
 capacity, 6  
   lost in exhaust, 145  
   up stack, 101  
 of fusion of ice, latent, 57  
 of liquid, 38, 40  
 of steam, latent, 38, 41  
   total, 41  
 of superheat, 38  
 relation between, and work, 10  
 between specific, of constant pres-  
 sure and of constant volume, 15  
 specific (*see* Specific heat).  
 theory of, 1  
 unit of, 5
- Heat engines, efficiency of (*see* Effi-  
 ciency, heat engine).  
   ideal, 29  
   relative economy of, 309
- Heater, feed-water (*see* Feed-water  
 heaters).
- Heating surface, definition of, 98  
 of fire-tube boilers, rule for finding,  
 99  
 ratio of, to grate surface, 98  
 to rated boiler horse-power, 99
- Heating value of fuel, 66, 287  
   higher, 66  
   lower, 66  
   of combustible, 101
- Heine boiler, 94
- Hero's turbine, 244
- "Hit and miss" governor, 301
- Hollis, 128
- Horse-power, boiler,  
 actual, 98  
 heating surface per, 99  
 rated, 97

- Horse-power, brake, gas engine, 293  
     steam engine, 178  
 chimney, 130  
 comparison of rated, for steam and  
 gas engines, 292  
 engine, automobile, rated, 291  
     compound, 229  
     definition of, 9  
     gas, actual, 292  
     rated, 288  
     steam, indicated, 143, 173  
     theoretical, 142  
 friction, 179  
 of gas and steam engines, how  
 rated, 292  
 Hornsby-Akroyd oil engine, 286, 297  
 Hot-well, 238  
 Humphrey gas pump, 305  
 "Hunting," 222
- Ice, latent heat of fusion of, 57
- Ignition, flame, 295  
     hot tube, 295  
     jump-spark, 299  
     kinds of gas engine, 295  
     "make and break," 298
- Impulse, 245
- Indicator, accuracy of, 170
- Indicator cards, 174  
     combined, 232  
     method of taking, 172  
     various forms of, 213
- Indicator,  
 Crosby, 169  
 difference between steam and gas  
 engine, 292  
 external spring, 170  
 manner of connecting to engine,  
 171  
 reducing motions, 171  
 setting valve by, 213  
 things determined by, 168  
 Thompson, 170  
 use of, 170
- Initial condensation, action of, 145  
 amount of, 146  
 factors affecting, 146  
 graphical determination of, 174
- Injectors, description of, 121  
     location of, 122
- Isochronous governor, 222
- Isothermal expansion, 25
- Joule, 10, 14
- Joy gear, 212
- Juckles, John, 110
- Jump-spark ignition, 299
- Kerr turbine, 259
- Knock-off cam, 206
- Langen, 270
- Lap, exhaust, 189  
     effect of on Zeuner diagram, 195
- Lap steam, 189  
     effect of on Zeuner diagram, 192
- Lead, 150, 188, 190
- Lenoir, 270
- Lignite, 77
- Losses, boiler, 101  
     due to compounding, 225  
     gas-engine, 282  
     steam-engine, 144
- Lubricators, 165
- Magneto, 297
- Mahler bomb coal calorimeter, 68
- "Make and break" igniter, 298
- Marks, 40, 42
- Matteucci, 271
- Mean effective pressure, 143, 173
- Mechanical draft, 132  
     systems of, 132  
     efficiency, 179  
     equivalent of heat, 10  
     mixtures, 56  
     stokers (*see* Stokers, mechanical).
- Meyer riding cut-off valve, 204
- Mines, U. S. Bureau of, 64, 65
- Mixture problems, 61
- Mixtures, fuel, 287  
     mechanical, 56
- Moisture in steam, 48
- Murphy, Thomas, 110
- Napier's rule, 48

- Nozzle, turbine, 248  
 "Normal reading" of calorimeter, 53
- Oil, vaporization of, 286  
 engine, Hornsby-Ackroyd, 286, 297  
 for ships, 205  
 "Operating expense," 310  
 Orsat apparatus, 72  
 Otto, 269
- Parr coal calorimeter, 68  
 Parsons turbine, single-flow, 262  
 Peabody, 40, 42, 50  
 Peat, 76  
 Peclet, 7, 8  
 Perfect gases, definition of, 12  
 equation of, 12  
 laws of, 11  
 problems in, 34  
 Piston, 160, 161  
 position of relative to valve, 190  
 rod, 160, 161  
 valve, 198
- Planimeter, 173  
 Port opening, 193  
 Power, 9  
 Pressure, absolute, 12  
 gage, 12  
 gas producer, 284  
 heat added at constant, 22  
 mean effective, 143, 173  
 relation between volume, temperature, and, 12, 27  
 specific heat of constant, 7
- Problems, boiler, 133  
 calorimeter, 55  
 combustion, 79  
 economic, 242  
 engine, gas, 307  
 steam, actual, 184  
 compound, 234  
 theoretical, 150  
 mixture, 61  
 perfect gas, 34
- Producers, gas (*see* Gas producers).
- Pumps, capacity of, 181  
 circulating, 240  
 Pumps, dry air, 240  
 feed (*see* Feed pumps).  
 Pyrometers, 3
- Quality of steam, 48, 53
- Radial gears, 211  
 Radiation, 7  
 Rankine, 10  
 Rateau turbine, 257  
 Ratio of expansion, 147, 228  
 Re-action, 245  
 Reducing motion, indicator, 171  
 Re-evaporation, 145  
 Regnault, 39  
 Reversing gear, 209, 210  
 by means of three-way cock, 212  
 Rochas, 271  
 Rotation, changing direction of, 209  
 Rowland, 10  
 "Run over," 209  
 "Run under," 209  
 Rust boiler, 95
- Safety valve, size of, 107  
 Sampling nozzle, 48, 53  
 Saturation curve, 175  
 Semi-bituminous coal, 78  
 Smoke, 71  
 Southwark-Rateau turbine, 259  
 Specific heat, definition of, 6  
 of constant pressure, 7  
 and of constant volume, relation between, 15  
 of superheated steam, 40  
 of constant volume, 7  
 theory of, 5
- Stanley, 109  
 Steam, action of, in turbine, 247  
 A. S. M. E. rules for finding quality of, 53  
 boiling point of, 38  
 consumption, determination of, 177  
 variation of at different loads, 181  
 cushion, 150  
 dry saturated, 39



UNIVERSITY OF CALIFORNIA LIBRARY  
BERKELEY

Return to desk from which borrowed.  
This book is DUE on the last date stamped below.

APR 23 1948

LD 21-100m-9,'47 (A5702s16)476

NOV 23 1939

NOV 2 1928



LC 12749

U. C. BERKELEY LIBRARIES



C042437842

302928

TJ 255

A6

1974

UNIVERSITY OF CALIFORNIA LIBRARY

