

QUESTIONS OF THE DAY.—XVII.

# HEAVY ORDNANCE

FOR

# NATIONAL DEFENCE

BEING A CONSIDERATION OF THE PRESENT DEFENCELESS CONDITION OF THE COAST CITIES OF THE UNITED STATES AND OF THE NECESSITY FOR THE IMMEDIATE PRODUCTION OF HEAVY GUNS ADAPTED TO MODERN WARFARE, TOGETHER WITH SUGGESTIONS CONCERNING THE BEST TYPE TO ACCEPT, AND THE MOST ADVANTAGEOUS SYSTEM OF CONSTRUCTION.

BY

WILLIAM H. JQUES

LIEUTENANT, U. S. NAVY.

UF  
523  
J37  
1885  
C.1  
ROBA

NEW YORK & LONDON  
G. D. PUTNAM'S SONS  
The Knickerbocker Press  
1885

UNIVERSITY OF TORONTO



3 1761 01345013 5

## WORKS FOR CITIZENS AND STUDENTS.

**THE AMERICAN CITIZEN'S MANUAL.** By WORTHINGTON C. FORD.

*Part I.*—Governments (National, State, and Local), the Electorate, and the Civil Service. "Questions of the Day," Volume IV. Octavo, cloth . . . . .75

*Part II.*—The Functions of Government, considered with special reference to Taxation and Expenditure, the Regulation of Commerce and Industry, Provision for the Poor and Insane, the Management of the Public Lands, etc. "Questions of the day," Volume V. Octavo, cloth . . . . .75

A work planned to afford in compact form a comprehensive summary of the nature of the organization of the Government of the United States, National, State, and Local, and of the duties, privileges, and the responsibilities of American citizens.

"Mr. Ford writes thoughtfully, carefully, impartially, and furnishes one of the best imaginable manuals that could be prepared for circulation on either side of the Atlantic."—*N. Y. World.*

**SIX CENTURIES OF WORK AND WAGES.** The History of English Labor (1250-1883). By JAMES E. THOROLD ROGERS, M.P. Large octavo . . . . . \$4.00

PRINCIPAL CONTENTS.—Rural England, Social Life, Agriculture, Town Life, The Distribution of Wealth and Trade, Society, Wages, Profit, Discontent, Combinations, Insurrection, The Development of Taxation, Labor, and Wages, Agriculture and Agricultural Wages in the Eighteenth Century, Wages in the Nineteenth Century, Present Situation, etc.

"The author supports his arguments by so many strong considerations, that he is entitled to the patient study of all who are interested in economic subjects, and especially of those who feel that the social problem is by no means solved, in the accepted Political Economy, and needs other and more organic remedies than are suggested in the orthodox treatises."—*Commercial Advertiser*, N. Y.

**ELEMENTS OF POLITICAL ECONOMY.** By EMILE DE LAVELEYE, Professor of Political Economy in the University of Liege. Translated by ALFRED W. POLLARD, of the University of Oxford. Edited with an introduction and supplementary chapter by F. W. TAUSSIG, Instructor in Political Economy. 12mo, cloth . . . \$1.50

**POLITICS.** An Introduction to the study of Comparative Constitutional Law. By WILLIAM W. CRANE and BERNARD MOSES. 8vo, cloth . . . . . \$1.50

"The work is an arsenal of facts, precedents, incidents, and argument, and will give the student of national affairs much basic instruction altogether meritorious."—*Commonwealth*, Boston.

**G. P. PUTNAM'S SONS,**

**NEW YORK.**

# HEAVY ORDNANCE

FOR

## NATIONAL DEFENCE

BEING A CONSIDERATION OF THE PRESENT DEFENCELESS CONDITION OF THE COAST CITIES OF THE UNITED STATES AND OF THE NECESSITY FOR THE IMMEDIATE PRODUCTION OF HEAVY GUNS ADAPTED TO MODERN WARFARE, TOGETHER WITH SUGGESTIONS CONCERNING THE BEST TYPE TO ACCEPT, AND THE MOST ADVANTAGEOUS SYSTEM OF CONSTRUCTION.

BY

WILLIAM H. JAQUES

LIEUTENANT, U. S. NAVY

PHOTOCOPIED BY  
PRESERVATION  
SERVICES

DATE..... JAN 1 0 1991.....

NEW YORK & LONDON

G. P. PUTNAM'S SONS

The Knickerbocker Press

1885

DEDICATED  
TO  
SENATOR JOHN F. MILLER  
OF CALIFORNIA  
BY  
THE AUTHOR

12906  
4/3/91



45  
323  
337  
1875  
.6

COPYRIGHT  
W. H. JAUQUES  
1804

# HEAVY ORDNANCE FOR NATIONAL DEFENCE.

BY

LIEUTENANT W. H. JAQUES, U. S. NAVY.

---

Too great prominence cannot be given to the exposed state of our harbors, and the utterly defenceless condition of the United States, and if we are not to remain utterly helpless there must be inaugurated and developed an efficient torpedo service, and adequate means for supplying quickly heavy guns and armor adapted to modern warfare.

In suggesting a remedy, all the requisites should undoubtedly be considered ; but the *great length of time* needed in which to manufacture the material for, and fabricate, the heavy guns and armor of a type accepted by the principal powers as the best weapons of offence and defence, makes it pertinent to give their supply preëminence over the construction of ships and fortifications.

Already much attention has been paid the subject, and investigations continue. Two Congressional Committees, one of the Senate and one of the House of Representatives, are making inquiries to learn

the capacity of steel-producing establishments in the United States to furnish suitable and sufficient material for heavy guns of high power, acting under the following resolutions :

*Resolved*, That a select committee of five be appointed by the Chair to inquire as to the capacity of steel-producing works in the United States to make steel of suitable quality and sufficient in quantity to furnish metal for guns of high power, and metal plates and other material for the construction of vessels of war, and for the armor or sheathing for such vessels.

2.—That said committee shall also inquire as to the character and sufficiency of machinery and machine tools in the navy yards, and also in private foundries and machine-shops in the United States, \* \* \* for manufacturing guns for the proper armament of such vessels, and of the sea-coast defences. \* \* \*

3.—Said committee shall also inquire into the best locations in the United States for manufacturing guns and armor for vessels, \* \* \* and the best method of manufacturing and building the same, whether by the Government or by contract with private persons.

The Gun-Foundry Board was reconvened by Departmental order, and its supplementary report has presented additional information that, it is hoped, will assist the solution of this most important question.

With the small appropriations allowed, the Chiefs of Ordnance of the War and Navy Departments have made advance in experiment; and at the Washington Navy Yard a few modern steel guns up to and including ten inches calibre are being fabricated.

Since Congress, at the present session, will be urged to make suitable provision for an armament, a consideration of the following details may be useful and interesting :

I.—Are guns needed ?

II.—If needed, what type shall be accepted ?

III.—Are there any establishments in the United States possessing sufficient plant and experience to manufacture the heaviest guns of the accepted type ?

IV.—If not, what is the best method of supply ?

I.—Are guns needed ?

Many leading representatives of both political parties have protested in Congress against leaving "the fortifications of this country in an absolutely worthless condition for all purposes of warfare."

The present helpless state of our sea-coast fortifications, the impossibility of producing at home at the present time the requisite gun and armor material, and the pressing need of modern ships and guns, have all received prominence in the very important campaign that preceded the late Presidential election.

Recalling the absence of guns, fast cruisers, and armored vessels, and "with not one high-powered cannon afloat in the Navy, the importance of action for the procurement of naval armament seems apparent, if the Navy is to longer survive."

The Chief of Army Ordnance, in his annual report for the fiscal year ending June 30, 1884, says: "The condition of our coast defences is a matter of grave concern and calls for immediate action, and I indulge the hope that before the end of the ensuing session Congress will show to the country its appreciation of these national wants by a liberal and permanent appropriation."

The report of the Chief of Army Engineers for the same year shows: "It is manifest that with the addition of guns of heavy calibre properly protected in their batteries the entrance to our harbors can be made impregnable to attack, and in case of disaster through neglect of making arrangements so manifestly effectual, a terrible responsibility must rest somewhere. Some of the guns on land should at least equal the most powerful afloat on the fleet. The armor on land should be made much heavier than that carried by ships.

\* \* \* \* \*

"It would appear that the time has at length come to be supplied with the best modern type, with the confident assurance that before the list of our armament shall have been completed we will be



possessed of guns all of which will be valuable and a number of them the best that can be manufactured.

“Those persons are greatly in error who imagine that by diplomatic delays war may be averted until proper preparations for defence can be made. Were we as well prepared as many other nations this might be true, but while a diplomatic delay of a few months might be necessary for a naval power to commission its ships, it would require a great many years for us to get together modern guns, without reference to constructing forts and batteries for their reception. It seems to be forgotten that a descent upon our coast to hold our unprotected cities under the guns of a hostile fleet would consume but a few months. The modern system is to make war sudden, sharp, and decisive, and to make the beaten party pay expenses.”

A committee of the Chamber of Commerce of New York, on the Harbor and Shipping, have made a report upon the warning sounded by the Chief of Army Engineers, in his annual report on the defenceless state of our seaports, notably of New York, and have submitted a memorial to Congress asking for an appropriation and prompt action upon these suggestions.

“It is admitted,” said the committee, “that there are afloat war cruisers of a type which would enable them to easily enter our lower bay, and, stationing themselves outside of Coney Island, or just below

the Narrows, could demand from the cities of New York and Brooklyn a ransom of an immense sum of money, limited only by the ability to raise it, and this without the possibility of an impediment being made worthy of the name. The unanimity with which the chiefs of the different departments repeat the warning, and admit this helpless state of affairs, should carry conviction to the minds of merchants that steps should at once be taken to in some degree remedy this state of things."

The committee reviewed the developments of the experiments which have been conducted at the expense of other nations on the subject of harbor defence, and announced, as "the opinion of eminent authority," that the following armament is necessary to render the protection of our harbor absolute: Sixteen turrets, mounting 32 100-ton guns; 50 rifled mortars; 100 6- to 8-inch rifled cannon; 50 Hotchkiss and Nordenfeldt cannon; 50 torpedo boats, and 12 miles of submarine mines.

The Gun-Foundry Board reported of the present condition of the Artillery of the United States:

"To recite under this heading the present armament of the country is unnecessary. Before the introduction of rifled cannon and the use of steel as the material for their construction, the United States boasted of her Dahlgren and Rodman cast-iron guns, which were the models for imitation and the standards for comparison of all nations.

“ While the rest of the world has advanced with the progress of the age, the artillery of the United States has made no step forwards. Its present condition of inferiority is only the natural result of such want of action.”

And the President, in his annual message, again calls attention to the “ necessity of providing means for the construction of guns of the highest power, both for the purpose of coast defence and for the armament of war vessels. The report of the Gun-Foundry Board, appointed April 2, 1883, in pursuance of the act of March 3, 1883, was transmitted to Congress in a special message of February 8, 1884. In my message of March 26, 1884, I called attention to the recommendation of the Board that the Government should encourage the production at private steel works of the required material for heavy cannon, and that two Government factories—one for the Army and one for the Navy—should be established for the fabrication of guns from such material. No action having been taken, the Board was subsequently reconvened to determine more fully the plans and estimates necessary for carrying out its recommendation. It has received information which indicates that there are responsible steel manufacturers in this country who, although not provided at present with the necessary plant, are willing to construct the same and to make bids for contracts with the Government for the supply of the requisite material for the heavi-

est guns adapted to modern warfare, if a guaranteed order of sufficient magnitude, accompanied by a positive appropriation extending over a series of years, shall be made by Congress. All doubts as to the feasibility of the plan being thus removed, I renew my recommendation that such action be taken by Congress as will enable the Government to construct its own ordnance upon its own territory, and so to provide the armaments demanded by considerations of national safety and honor."

A further convincing and powerful argument that guns are needed is presented in the careful estimate of the Chief of Engineers that \$60,000,000 will be needed to fortify and arm "all harbors on the coast of the United States of sufficient importance to tempt an enemy," and that \$25,000,000 is not an excessive estimate for heavy guns and emplacements needed for the defence of New York, Philadelphia, Boston, and Baltimore.

Congress is laboring under a most grievous error if it supposes that our torpedo system is efficient. In truth, it is wanting in almost every requisite of a useful and effective system; and even were it efficient, heavy guns are imperative to prevent countermining, removal and destruction of the interior and channel torpedo defences.

The interests that our Government should protect are so vast that immediate action should be taken by Congress to provide a suitable defence. It has been

estimated that "the contribution which could be levied from New York alone would probably pay four or fivefold the cost of all the fortifications of the important harbors of the country," while the national humiliation of its destruction would be immeasurable.

II.—If needed, what type shall be accepted?

To one accustomed to deal with commercial affairs this would not be a difficult problem. He would go into the market and purchase the type that was most generally accepted by the people who were using the greatest number of guns, or who were preparing, after unlimited expenditures for experiment, to defend their estates against a neighbor.

But the majority of ordnance officers and inventors are so confident of the success of their proposed systems of gun construction, that it is difficult—aye, next to impossible—to unite upon a type.

Of the many proposed systems in the United States,

The converted rifle has met the tests of endurance.

The experiments with the varied constructions of cast-iron bodies tubed and hooped with steel, made available by the French during their late war, but now being gradually discarded by them, have been continued.

The Woodbridge 10-inch muzzle-loading wire rifle "burst into two parts, just behind the trunnions," parting "under longitudinal strain," "the separation of the wire giving warning of the rupture." Since its

destruction, Mr. Woodbridge has departed from the principal feature of his system—winding wire in successive layers upon a steel tube,—and now proposes to introduce longitudinal bars, surrounding part of the tube with a broken jacket instead of the well-forged solid jacket so generally accepted. Though the Ordnance Board recommended that another 10-inch gun, “after the model presented by Dr. Woodbridge,” should be made for trial, it suggested that this “method of strengthening the walls of the gun as against longitudinal strains” should be adopted in its construction. This experimental gun has not yet been completed, but artillerists will look forward to its trials with interest, to see if it will meet the same fate as the Schultz wire gun in France, where the unequal tension of the longitudinal bars caused the failure of the gun at the first fire.

The cast-iron body for a 12-inch experimental rifle has wrecked its mould and surroundings.

The results of the experiments with the Lyman-Haskell multi-charge gun “are very far from fulfilling expectations; indeed, the actual power thus far realized is small in proportion to the weight of the gun, and to the weight of its charge, as compared with the results from contemporary single-charge steel guns.”

The breech of the Mann gun was blown off.

The Yates gun is uncompleted, because of the “difficulties experienced in procuring suitable material for this peculiar construction.”

The results of an experimental cast-steel cylinder "were not very satisfactory."

And the conception of the gun "carrying out a purely American idea"—a cast-steel gun, on the Rodman principle—has reached a "rough sketch, not ready for immediate practical embodiment, but to be developed by hard study and careful experiment,"—under such circumstances surely a gun of the future.

Some of these have given better results than the cast-iron smooth bore, but not one has approached the merits of the all-steel, built-up gun.

If Congress is willing to appropriate large sums for experiments—and other nations do this without hesitation,—some of these systems *may* be perfected and perhaps prove superior to the one now almost universally accepted; but if the country is to be placed in a suitable condition of defence within a reasonable time, that type must be accepted which has proved the most effective in the trials, for which European nations have so generously provided.

The type most generally adopted is constructed on the system of Mr. J. Vavasseur, of London, England. It consists of a tube of suitable strength; a long jacket J, shrunk on to provide longitudinal strength; and layers of superimposed cylinders or hoops A-I, shrunk on, the size of the gun governing the number of layers. (Plate I.)

PLATE I.

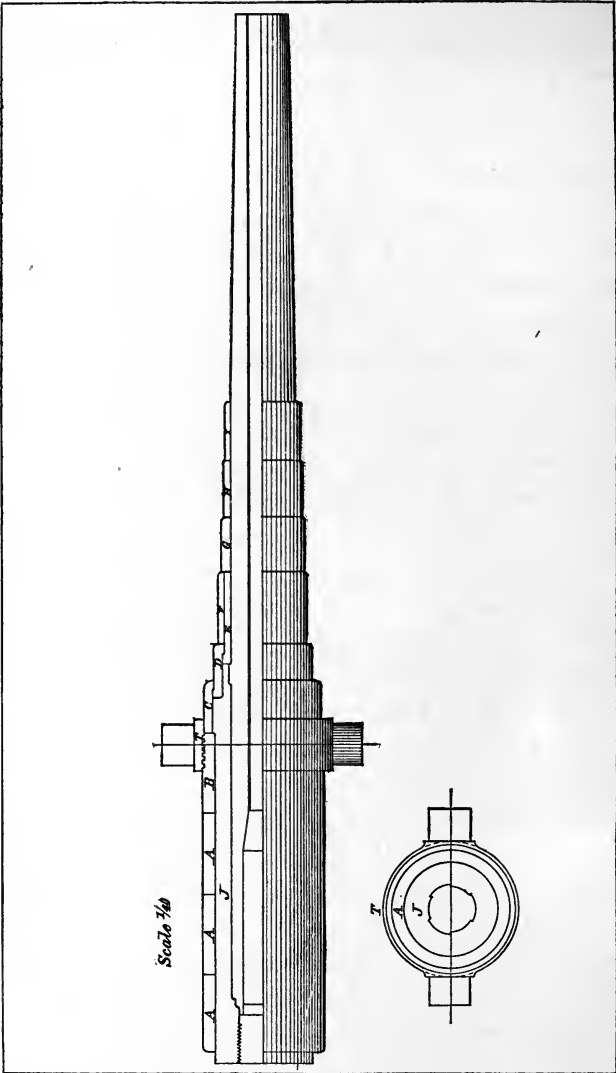

3-Inch Hooped B. L. R.—Bureau of Ordnance, Navy Department.



Most authorities concur that open-hearth steel is the best material, and it was the unanimous opinion of the Gun-Foundry Board, "that the system of Sir Joseph Whitworth surpasses all other methods of forging, and that it gives better promise than any other of securing that uniformity so indispensable in good gun-metal." In fact, all authorities concur that steel, *homogeneous* metal, is the best material for ordnance; and breech-loading is universally accepted.

The system of breech-loading (Plate II.) most

PLATE II.

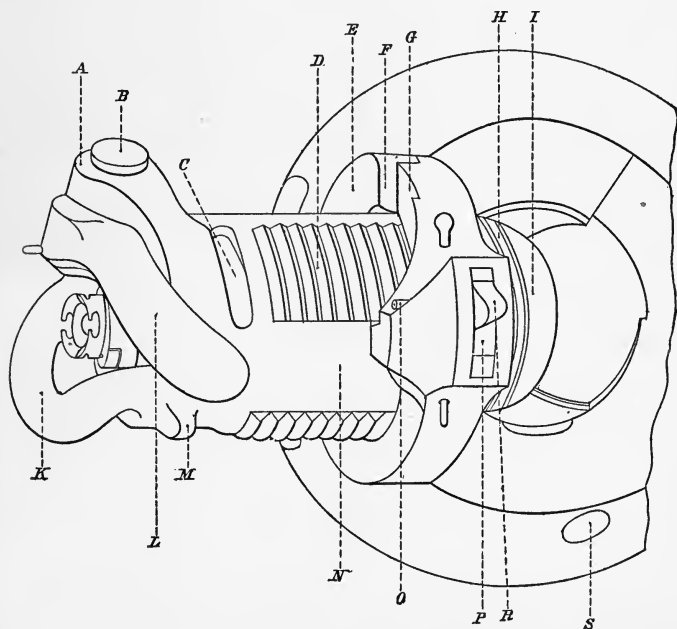

generally preferred is the interrupted-screw, "commonly known as the French system."

It comprises the breech-screw, the tray, the movable head, and the gas-check.

A, Lug of the breech-block.	I, Mushroom movable head.
B, Lever-bolt.	K, Fixed handle.
C, Notch for latch-butt.	L, Lever-handle.
D, Screwed sector.	M, Butt of breech-block.
E, Support for the cam of the lever-handle.	N, Smooth sector or guide.
F, Safety slot.	O, Latch-bolt.
G, Abutment of tray.	P, Latch-recess.
H, Gas-check.	R, Latch.
	S, Spring to release lever-handle.

All the parts of the breech-mechanism are assembled by pins, kept in place by friction.

By this means the entire mechanism can be easily taken to pieces. Moreover, if any of the pins are lost, they can be readily replaced, on account of their simple form.

When the breech is closed, the screwed sectors of the breech-block engage the screwed sectors in the breech. In this position the head of the lever-handle L enters the safety slot F of the tray, and prevents any rotary motion of the screw during fire.

To open the breech, disengage the lever-handle from the safety slot F, and turn the breech-block until its movement is stopped. In this position, the screwed sectors of the block face the smooth sectors of the breech, and the breech-block can be withdrawn. When the screw is turned, the butt of the latch is pushed by a projection, its upper nib being raised, and its lower engaging in its recess. At the end of this movement the tray is secured to the breech-hoop, and the latch is freed from the breech-block.

In disengaging the lever, its cam bears against the tray, and starts the gas-check from its seat, facilitating the withdrawal of the breech-block by hand. During this last movement, limited by a key-bolt, the breech-block is held and directed by the guides, the butt of the latch bearing against the body of the screw, keeping the lower nib in its recess. At the end of the movement, the block being withdrawn to its full limit, the latch is released, and the tray swings on its hinge, throwing open the breech.

To close the breech the tray is swung into its place and the breech-block thrust forward until its screwed sectors are opposite those of the breech.

The screw is then turned, and if the breech is well closed, the lever-handle will fall by its own weight and engage in the safety slot.

For the heavy calibres, the breech-block is fitted with a double handle to facilitate the operations of closing and opening.

“In the heavier guns, at least, the breech-screw will not engage in the tube, but in the cylinder (jacket) immediately surrounding it, thus relieving the tube from that portion of the longitudinal strain which tends to blow out the breech. The number of interruptions increases with the calibre.”

All authorities, except Sir Joseph Whitworth, who adheres to the polygonal system, agree that the rifling should be polygroove, and that the grooves should be numerous and shallow.

It may be pertinent to add, in reply to any question that may arise in relation to the employment of wire gun construction, that, although the advocates of the system claim many advantages for it, and an improved winding-machine has given some good results, no method of longitudinal winding has proved satisfactory, no solution of protecting the wire from injury has been applied, and the system has not passed out of the experimental stage. Therefore it cannot be presented as a developed type. In fact, presenting the question from its strongest-claimed point—the reduction of weight,—Colonel Maitland, the able superintendent of the Royal Gun Factories, Woolwich, England, in a recent paper on the heavy guns of 1884, has raised the inquiry, whether any further reduction of weight in proportion to power

in forged-steel guns may not necessitate more than a corresponding increase in the carriage. He says : "Should experience prove this to be the case, there will be little advantage in the introduction of wire, except in certain special cases."

III.—Are there any establishments in the United States possessing adequate plant and experience to manufacture the heaviest guns of the accepted type?

The Gun-Foundry Board has made a very thorough investigation of this question, and reported that :

"Previous to and during the Civil War the armaments of the United States were supplied from—

"The Cold Spring Foundry, West Point, N. Y.

"The South Boston Iron Works, Boston, Mass.

"The Fort Pitt Foundry, Pittsburgh, Pa.

"The Reading Iron Works, Reading, Pa.

"The Builders' Iron Foundry, Providence, R. I.

"The Phœnix Iron Company, Phœnixville, Pa.

"The Ames Manufacturing Company, Chicopee, Mass.

"Since the termination of the war the Fort Pitt Foundry has ceased to exist. The South Boston Iron-Works Company has manufactured a few experimental guns, and with the West Point Foundry has executed some small orders of the Government in the conversion of cast-iron smooth bores into rifle guns by inserting and rifling a coiled wrought-iron tube.

“None of the companies mentioned above have ever made steel guns, and virtually the United States is destitute of a source from which such an armament as the age demands can be supplied.

“With a view to such experiments as their appropriations would justify, the Ordnance Bureaus of the War and Navy Departments have from time to time addressed the steel manufacturers of the country on the subject of furnishing steel for cannon, but thus far have met with only a partial success.

“The fact is here stated to emphasize the conclusion that the immense steel works of the United States, from lack of demand for this special material, have not the necessary plant for forging, and are in no condition at present to manufacture steel for cannon in such quantities and in such sizes as are essential for a suitable armament for the country.”

Again, during the discussion of the appropriations for the steel cruisers now building, it was shown that “we are not prepared in any of our navy-yards, or in any of the workshops or manufacturing establishments of the United States to supply the guns that should be used on the steel cruisers when constructed.”

Since that time the Midvale Steel Company has been able to supply the steel parts of a few six-inch breech-loading rifles, and its plant has been increased to a capacity which, its administration believes, will produce the parts for eight-inch steel rifles.

The required plants must be equal to a *rapid* and *efficient* production, and it would seem that they will be most effectively inaugurated by the means proposed by the Gun-Foundry Board.

A few steel companies have adequate casting capacity, but are destitute of proper forging apparatus; and while the naval ordnance officers at the Washington Navy Yard have fabricated, even with limited means, a few of these modern guns of from five-inch to ten-inch calibre, inclusive, the heavier forgings were supplied by foreign steel manufacturers, and the fabricating plant is not capable of sufficiently rapid production to provide the guns required for the armament of the four steel cruisers, within the time contemplated for their completion.

IV.—If not, what is the best method of supply?

Of the following propositions :

1.—To purchase the finished guns of foreign makers.

2.—To purchase the forged steel abroad and fabricate the guns in the United States.

3.—To manufacture the guns in a national foundry.

4.—To depend entirely upon the private industries of the United States.

5.—To purchase the forged steel of home manufacturers, and fabricate the guns in Government gun factories.

The first two are readily answered, inasmuch as

no method would be sanctioned that would permit a declaration of war to cut off the supply. Any *dependence*, therefore, upon a foreign market, for either the steel or the finished guns, is out of the question.

In reply to the remaining propositions, the opinions and recommendations of the Gun-Foundry Board are direct and comprehensive.

It reported that:—"As examples of a practical partnership between a Government and a private company in working toward a national object the experiences in England and in Russia are very instructive, and warn against the adoption of such a system. In England, the Government, in addition to paying, during several years, very high prices for articles delivered, was forced to pay £65,000 to close an agreement; while the company, besides the profits on manufacture, came into possession of a complete working plant at a mere nominal valuation.

"In Russia, the Government finds itself involved with a stock company, paying excessive prices for what it receives, and discovers no way of relief except by buying up shares and operating the establishment as a Government foundry.

"As an example of depending almost entirely on private works, Germany is a perfect instance. The works of Mr. Krupp are practically the sole source of supply of the German artillery. It needs no argument to show the dependent condition of the

Government under such a rule : it might prove a source of the greatest embarrassment.

“As an example of depending alone on Government works, France was a perfect instance before the Franco-German war. During the period referred to, the Government foundries were the sole source of supply of the armament of the country ; the officers charged with the work formed a close corporation ; their action was never exposed to the public ; their ideas were never subjected to criticism ; the ingenuity and inventive talent of the country were ignored and resisted, and no precaution was thought necessary to provide a supply in case of need of re-armament. The result is well known ; a great crisis came ; the Government works were inadequate to meet the additional demands made upon them, and the patriotic efforts of private establishments were inadequate to produce all the material that was needed. How entirely France has now altered her system is shown in a previous part of this report ; her present practice is theoretically perfect, and it has proved to be practically efficient. Her Government establishments are still retained, but as gun *factories* simply, in which the parts are machined and assembled, but for *foundry* work she depends upon the private industries of the country, and many of these works have found it to their profit to establish gun factories which supplement the Government factories to a great extent.



“The conclusions of the Board on this subject accord with the plain teachings of these historical instances. It accepts the system now pursued in France as the proper standard for imitation, and recommends that in inaugurating the manufacture of war material in our own country a conformity as close as circumstances will admit to the plans which have proved so successful in France should be observed.

“Having reached this conclusion, the Board is prepared to dispose of the propositions into which the second interrogatory in the Act of Congress was divided.

“The first proposition was thus presented, viz. :

“That the Government should supplement the plants of some of the steel-workers of the country with such additional tools and implements as would enable them to turn out finished steel cannon.

“The adoption of this proposition would involve the Government in the embarrassments which now exist in Russia, and which we have seen were so costly to the English Government in its partnership with the Elswick Ordnance Company.

“The Board does not approve of such joint action.

“The second proposition was thus presented, viz. :

“That the Government should give contracts of sufficient magnitude to enable the steel-workers of the country to supply the finished guns without its direct aid.

“This proposition, if adopted without any qualifica-

tion, would make the Government dependent entirely upon the private industries of the country, which might combine to the detriment of the public service. The Government would have no guard against extortion and would be powerless against a combination. An actual instance of such a combination is cited as having taken place in France, but the independent position of the Government made the effort futile.

“The Board does not approve of this proposition taken by itself.

“The third proposition was thus presented, viz.:

“That the Government should establish on its own territory a plant for the fabrication of cannon, and should contract with private parties to such amounts as would enable them to supply from the private industries of the country the forged and tempered material.

“This proposition is approved by the Board and is regarded as the foundation upon which our system of manufacture should be built up.

“If this be done, and the Government made secure by the possession of works of its own, there is every reason to adopt in addition the idea embodied in the second proposition, in order to *supplement* the Government establishments.

“It is not considered judicious to concentrate in the Government establishments all the work of fabrication, or to include within their operations the preparation of such material as can be provided by the

private industries of the country. In the case under consideration the purchase of the steel required for cannon will stimulate our own manufacturers and interest them in the operations of the Government.

“The Board is thus led to the conclusion that it is not advisable to embark in the establishment of a gun *foundry*, properly so called, but that it is more judicious to establish gun *factories*, and to purchase the material from our manufacturers.

“At present the steel manufacturers of our country are not prepared to produce the material required for the larger calibres, and the important question arises, what means shall be adopted to induce them to study the subject and embark in the manufacture on a large scale. They cannot be expected to do this at a sacrifice of their own interests. This object can only be achieved by holding out a fair prospect of ultimate remuneration for the expenditures necessary to undertake the work, and this can only be done by the action of Congress.

“If, then, Congress shall conclude to arm the country it will be necessary that a sum of money shall be fixed as a permanent appropriation to be expended for this purpose, the amount to be assigned between the War and Navy Departments. With such a guaranty against loss the Board is satisfied that the required material for cannon will be forthcoming from our own steel-works.

“It would not be necessary for the Government to

be associated with a large number of firms for the supply of its material, for it is probable that the private establishments that would take up the subject would only be those with large available funds which they would be willing to put into a special plant, and for remuneration on which they would be willing to wait a reasonable time. The permanent appropriation would give them surety of ultimate profit, the only condition being success in providing the material that would be indicated in their contracts. From personal intercourse, fully sustained by letters, with some of the leading manufacturers, the Board is led to believe that the plan will have the effect of guiding the private industries of the country to the aid of the Government in developing this work of national importance.

“ It may be added that although the manufacture of armor-plates for ships and fortifications was not referred to this Board for investigation, the erection of plant for providing modern cannon would go far towards reducing the outlay requisite to enable our great steel manufacturers to meet another pressing want of the Government.

“ The chief expense to be considered by private parties is that of the *forge*, but by the substitution of the hydraulic press for the hammer, economy will be consulted and better results obtained. The Board is unanimous in approving the use of the press for all forging purposes, and recommends it to all who may

embark in the manufacture of gun-metal for the Government.

“The Board does not recommend the establishment of a Government foundry, properly so called, which shall provide for the manufacture of steel and the fabrication of cannon. It considers that every inducement should be offered to attract the private industries of the country to the aid of the Government in providing ordnance for the Army and Navy, and that the steel manufacturers should be called upon to provide the material.

“The Board recommends the establishment of two gun factories under the control of the Government, and is unanimous in recommending that the Army and the Navy should be provided with separate establishments. This has always been the custom in France, producing good results ; the reverse has been the practice in England, producing bad results.

“With Government gun *factories* established for both the Army and the Navy, there will be still needed the hearty coöperation of the private industries of the country. This cannot be aroused unless there is held out to them a fair prospect of remuneration. The Board does not approve of a partnership in business between the Government and private firms. *All history warns against such a course.* But it does believe that joint, and at the same time independent, action between them can be made to work harmoniously toward the common national purpose. This

can only be done by a permanent and liberal appropriation by Congress for the specific purpose of providing the country with modern artillery ; which appropriation shall be a guaranty against loss to the companies who elect to undertake the work.

“ This is entirely consistent with the action of Congress in providing for the supply of arms to the militia. The act authorizing this practice was passed in 1808, and since that time the yearly disbursement has been made from the Treasury without interruption. A similar act providing for the supply of heavy ordnance for the regular services will be but a farther development of the same idea.

“ The approximate cost of plant for producing the tempered parts of guns up to 100 tons, ready for delivery at gun factory, is :

Casting . . . . .	\$250,000
Forging (hydraulic press) . . . . .	150,000
Rough boring and turning . . . . .	210,000
Tempering . . . . .	50,000
	<hr/>
Total . . . . .	\$660,000
Additional cost if liquid compression be adopted . . . . .	175,000
	<hr/> <hr/>

“ Approximate cost of plant for gun factories :

Guns up to 6-inch calibre . . . . .	\$50,000
Guns from 6-inch to 12-inch calibre . . . . .	150,000
Guns from 12-inch to 16-inch calibre . . . . .	350,000
Buildings and shrinking pit . . . . .	350,000
	<hr/>
Total . . . . .	\$900,000

“ Such a factory will be able to turn out per year

fifty 6-inch, seventeen 12-inch, and twelve 16-inch guns, or a proportionally larger number of smaller calibres.

“ The figures cannot be pronounced exact, but the Board is confident that they closely approximate accuracy. The calculations are based upon estimates obtained abroad and do not include ocean freight and customs dues.

“ Though the Act of Congress replied to in the above report is one of inquiry, the Board desires to emphasize the necessity of a proper encouragement to the private steel manufacturers, which shall ensure the supply of gun material without loss to the Government or private companies ; and is of opinion, if Congress shall be pleased to appropriate an adequate sum for providing modern artillery for the Army and Navy, to be held in the Treasury to be expended under the authority of the President, that (with such a prospect of remuneration) there are steel manufacturers in the United States who will undertake the production of gun-metal on a large scale, on the sole condition that their steel shall meet the required tests.

“ The fact that the United States is destitute of the means of fabricating the modern guns so urgently needed for national defence would seem to demand an immediate appropriation of the amount estimated for the establishment of the proposed gun factories.”

Recalling the Senate's favorable acceptance of the

report, and the excellent opportunities under which the Board examined the sources of supply of those European countries where heavy modern ordnance exists, its conclusions are justly entitled to careful consideration.

In conclusion, therefore, it is evident :

That guns are sadly needed.

That breech-loading, chambered guns, from 5-inch to 17-inch calibre and from 30 to 35 calibres in length, should be constructed on the principle of Mr. Vavasseur, of open-hearth steel made by the Whitworth process, and fitted with the interrupted-screw breech mechanism and polygroove or polygonal rifling.

That we have no manufactories where the forged steel required for the parts of guns of more than 8-inch calibre can be produced, none where parts even for this calibre can be manufactured in sufficient quantities to meet the demand, and no gun factories where the heaviest guns adapted to modern warfare can be fabricated.

That the guns should be manufactured in the United States of American material.

That the tempered steel should be supplied by the private steel industries of the United States, and that a large appropriation should be made, to be expended under the authority of the President for the purchase of this material.

This appropriation should be made immediately,



that the steel manufacturers who will undertake the supply may complete a forging-plant in time to meet the demands of the gun factories for material.

That the guns should be fabricated—*i. e.*, the parts machined and assembled, and the guns finished and sighted—in two gun factories to be established under the control of the Government, one for the Army and one for the Navy.

The fact that England has made a definite proposition to establish a gun factory in Canada ought to be a conclusive argument why our Government should make adequate appropriations immediately to provide the much-needed heavy-steel forging-plants and gun factories.

With adequate appropriations, to be expended under the direction of an advisory board, confirmed by Congress; with the understanding that the remuneration of the steel manufacturers shall "be derived solely from the price paid by the Government for the material after passing the tests required"; and with the establishment of the two gun factories, as recommended by the Gun-Foundry Board, the United States will no longer be destitute of a means of providing proper ordnance for modern warfare, but will see her private industries producing the best gun and armor material in the world, her gun factories equal to every demand made upon them, and her guns *again* "the models for imitation and the standards for comparison of all nations."

DEFENCE.

which

## TOPICS OF THE TIME.

---

series of representative essays on questions of the day. Principally selected from the leading British and Continental journals. Published in handsomely printed 16mo volumes. Price each, in paper, 25 cents; in cloth, flexible, 60 cents. The set, six volumes, in box, \$3 50.

Vol. I. **SOCIAL PROBLEMS.** Comprising Giffen on "World-Crowding," Labouchère on "The Coming Democracy," Laveleye on "The European Trade," Mill on "Klanagan on "Trouble in the Straits

Vol.  
" Gam  
' Bish

and  
" G

V  
Mat  
ney  
" T  
ous

V  
Rev  
Cap  
Osc  
eral

V  
says  
ralit  
ney

V  
oph  
ism  
Lan  
Im  
Ed

UF  
523  
J37  
1885  
C.1  
ROBA

## QUESTIONS OF THE DAY.

- I.—**THE INDEPENDENT MOVEMENT IN NEW YORK**, as an element in the next Elections and a Problem in Party Government. 1 JUNIUS. Octavo, cloth . . . . . \$1 00
- II.—**FREE LAND AND FREE TRADE.** The Lessons of the English Corn-Laws Applied to the United States. By SAMUEL S. COX. Octavo, cloth, 75
- III.—**OUR MERCHANT MARINE.** How it rose, increased, became great, declined and decayed; with an inquiry into the conditions essential to its resuscitation and prosperity. By DAVID A. WELLS. Octavo, cloth. \$1 00
- IV.—**THE ELECTIVE FRANCHISE IN THE UNITED STATES.** By D. C. McMILLAN. 12mo, cloth . . . . . \$1 00
- V.—**THE AMERICAN CITIZEN'S MANUAL.** Edited by WORTHINGTON C. FORD. *Part I.*—Governments (National, State, and Local), the Electorate and the Civil Service. Octavo, cloth . . . . . 75
- VI.—**THE AMERICAN CITIZEN'S MANUAL.** *Part II.*—The Functions of Government, considered with special reference to taxation and expenditure, the regulation of commerce and industry, provision for the poor and insane, the management of the public lands, etc. Octavo, cloth 75
- VII.—**SPOILING THE EGYPTIANS.** A Tale of Shame. Told from the British Blue-Books. By J. SEYMOUR KEAY. Octavo, cloth . . . . . 75
- VIII.—**THE TAXATION OF THE ELEVATED RAILROADS IN THE CITY OF NEW YORK.** By ROGER FOSTER. 8vo, paper . . . . . 25
- IX.—**THE DESTRUCTIVE INFLUENCE OF THE TARIFF UPON MANUFACTURE AND COMMERCE, AND THE FACTS AND FIGURES RELATING THERETO.** By J. SCHOENHOF. Octavo, cloth, 75 cents; paper . . . . . 40
- X.—**OF WORK AND WEALTH.** A Summary of Economics. By R. R. BOWKER. Octavo, cloth . . . . . 75
- XI.—**PROTECTION TO YOUNG INDUSTRIES AS APPLIED IN THE UNITED STATES.** A Study in Economic History. By F. W. TAUSSIG. Octavo, cloth . . . . . 75
- TERMINAL FACILITIES.** By W. N. BLACK. 12mo, paper . . . . . 25
- PUBLIC RELIEF AND PRIVATE CHARITY.** By J. SEPHINE SHAW LOWELL. 8vo, cloth.
- "**THE JUKES.**" A study in Crime, Pauperism, Disease, and Heredity. By R. L. DUGDALE. 8vo, cloth.
- PROTECTION AND COMMUNISM.** By WM. RATHBONE.
- THE TRUE ISSUE.** By E. J. DONNELL.
- FREE TRADE.** By DAVID A. WELLS. In preparation.

G. P. PUTNAM'S SONS, PUBLISHERS,  
New York and London.