





LIBRARY  
OF THE  
UNIVERSITY  
OF ILLINOIS

Q 510.7

IL 63h1

1959

v. 3

EDUCATION





Digitized by the Internet Archive  
in 2011 with funding from  
University of Illinois Urbana-Champaign

<http://www.archive.org/details/highschoolmathemat03univ>





27

# HIGH SCHOOL MATHEMATICS

## **Unit 3.**

EQUATIONS AND INEQUALITIES

---

UNIVERSITY OF ILLINOIS COMMITTEE ON SCHOOL MATHEMATICS

MAX BEBERMAN, *Director*

HERBERT E. VAUGHAN, *Editor*

UNIVERSITY OF ILLINOIS PRESS · URBANA, 1959





9-7107  
226311  
1157  
113

[i]

3/1

[3-A]

1]

## TEACHERS COMMENTARY

The major purpose of this unit is to teach students how to solve equations. Skill in solving equations is one of the basic skills in elementary algebra, and students must become proficient in this activity. We have provided ample opportunities for practice. In order to facilitate checking and thereby release time for more practice in solving equations, we have kept the number of equations with nonintegral roots to a minimum. We also have included a considerable number of equation-solving exercises in which students must simplify algebraic expressions. These exercises will help maintain the skills developed in Unit 2. The types of linear equations to be solved in this unit are illustrated on page ii of the Table of Contents. In addition to these, students learn to solve quadratic equations by factoring, and to solve linear and quadratic inequations of the kinds illustrated on page iv of the Table of Contents. To do this, they need some preliminary work on expanding and factoring, as illustrated on page iii.

Apart from the need of students for proficiency in the mechanics of equation-solving, students need to understand what is meant by 'solving an equation'. To solve an equation is not to write a sequence of steps ending with ' $x = \dots$ '. To solve an equation is to find all those numbers which satisfy the equation. The methods which a student uses to do this are varied. In the early part of the unit, he is expected to invent his own methods for solving equations and inequations. This work is informal and must be kept informal in order to drive home the point that one is seeking roots when he solves an equation. To be sure, we want students to reach the point where they can find roots of an equation in a completely mechanical fashion. They will have ample opportunity to develop such mechanical approaches beginning with Section 3.05 when they undertake the formal work on transforming equations. But, even there, we still try to keep uppermost in the mind of the student the notion that when one solves an equation by transforming it, he is simply deriving another equation which has the same roots as the given one. We have sprinkled the drill work in Section 3.05 with equations which have no roots and with equations which have all real numbers as roots. Such exercises are included in order to show that the theory of transforming equations holds in cases such as these.

We have provided a large number of verbal problems, and have included many illustrative examples. But, we have not found a



panacea for enabling all students to solve verbal problems with ease. We believe that the ability to solve verbal problems is positively correlated with the student's intelligence. Moreover, we do not believe that any real gain is made by using gimmicks which enable students to solve various types of verbal problems in a mechanical fashion. This may be a desirable teaching procedure if the only goal is to enable students to solve certain types of problems on standardized examinations. But, if our goal is the improvement of problem-solving ability of a general nature, the only sensible teaching procedure is to give students plenty of practice in solving verbal problems.

Most mathematics teachers can remember that they enjoyed the work on verbal problems in their own days as students. Yet, it seems to be difficult to get students to the place where they can solve verbal problems with the same facility that they demonstrate in solving equations. Part of the difficulty can be attributed to the fact that the student and the teacher are frequently working at cross-purposes. The student is eager to find an answer to the problem [assuming that he wants to solve the problem at all], and he is not overly concerned with the method used in finding the answer. The teacher, on the other hand, is anxious about the student's ability to use an equation in obtaining his answer. We submit that the student is very much like the applied mathematician in his approach to problem-solving. He feels that he should use whatever method he can in finding the answer. The contribution that Unit 3 makes to the student is to add another weapon to his problem-solving arsenal. This is the method by which relevant facts of a problem are bound up in an equation. Indeed, it is a very powerful method in solving verbal problems, but it is not the only one. We must show students the power of this method by using it to solve really tough problems early in the game, and then telling him that he can gain skill in its use by practicing on problems which may be simple enough to yield to methods which he learned in earlier grades. Admittedly, this is a somewhat artificial situation, and it may be helpful to let students know that you regard it as artificial. They won't object, provided that the pay-off is not too long delayed. [This is one of the reasons we have placed traditionally difficult verbal problems rather early in the list of exercises.]

\*

In Unit 3 the student encounters the notion of set on a formal basis. By 'formal' we mean that the student will use set-notation. The underlying motivation for bringing in the set-notation is that it provides abbreviations for long-winded expressions. The reason for bringing in the notion of set at all is that this notion helps us in developing the theory behind the method of transformation of equations.



## TABLE OF CONTENTS

<u>Introduction</u>	[3-A]
3.01 <u>Graphs and coordinates</u>	[3-1]
Graphs of real numbers	[3-1]
Coordinates of points	[3-1]
Computing the midpoint of a line segment	[3-2]
3.02 <u>Solution set of a sentence</u>	[3-5]
Satisfying an open sentence -- the solution set	[3-5]
The empty set	[3-6]
Verbal descriptions of sets	[3-8]
Set abstraction operator notation, $\{ \dots : \underline{\hspace{2cm}} \}$	[3-9]
3.03 <u>Graph of a sentence</u>	[3-11]
Sentences and their graphs	[3-12]
Sketching the graphs of sentences	[3-13]
Writing a description from a graph	[3-14]
Locus of a sentence	[3-15]
Intervals, segments, and half-open intervals	[3-15]
Half-lines, rays, unit sets, couples, and $\emptyset$	[3-16]
Using geometric language to name loci	[3-17]
Using brace-notation to name loci	[3-18]
3.04 <u>Equations</u>	[3-19]
Equations and inequations	[3-19]
Roots [solutions] of an equation	[3-19]
Solution of equations	[3-19]
Deriving a new equation from a given equation by simplification of the sides	[3-22]
Exploration Exercises --	[3-26]
Subsets	[3-26]
Equations which have the same solution set	[3-28]
Equations which have the same roots	[3-29]
Transforming an equation by addition	[3-30]
Transforming an equation by multiplication	[3-31]

3.05	<u>Equivalent equations</u>	[3-32]
	Equivalent equations are equations which have the same solution set	[3-33]
	Transforming an equation to an equivalent one	[3-34]
	Transforming equations like '7t - 8 = 3 + 4t'	[3-36]
	Transforming equations like ' $\frac{a}{2} + 2 + \frac{a}{4} = 7 + \frac{a}{3}$ '	[3-37]
	Solution sets of statements	[3-38]
	Transforming equations like '4x - 3 + 2x = 5 - 10x'	[3-39]
	Transforming equations like '7(x - 3) + 4 = 3x + 3'	[3-41]
	Transforming equations like ' $\frac{x - 7}{5} + 2 = \frac{x + 8}{10}$ '	[3-42]
	Transforming equations like ' $\frac{3}{a} = 2 - \frac{2 + a}{a}$ '	[3-44]
	Equations whose solution sets are not the same as the solution set of a derived equation	[3-45]
	Necessity for restricting the values of the pronumeral when transforming an equation	[3-45]
	Transforming equations like ' $13 - \frac{2}{x + 2} = \frac{4x + 6}{x + 2}$ '	[3-47]
	Transforming equations like ' $3 + \frac{7}{x - 5} = \frac{2x + 1}{x - 5}$ '	[3-48]
	Transforming equations like $' \frac{3x - 4}{2x} - \frac{x + 1}{3x} + \frac{x + 2}{5x} = \frac{2}{5} '$	[3-48]
	Transforming equations like ' $\frac{6}{5b} = \frac{2}{b + 4}$ '	[3-49]
3.06	<u>Transforming a formula</u>	[3-51]
	The Fahrenheit-centigrade formula	[3-51]
	Equivalent formulas	[3-54]
	Transforming formulas	[3-55]
	Exploration Exercises --	[3-58]
	Arithmetic problems preparing for "worded" problems	[3-58]
3.07	<u>Solving problems</u>	[3-64]
	Solving a "coin" problem	[3-64]
	Solving a "ticket" problem	[3-66]
	Problems to solve	[3-68]
	Preparatory completion exercises	[3-69]

Solving an "arithmetic" problem	[3-75]
Solving a "distance" problem	[3-76]
Solving a "mixture" problem	[3-78]
Solving an "investment" problem	[3-78]
Solving a "work" problem	[3-79]
More problems to solve	[3-79]
Exploration Exercises --	[3-83]
Computing "special" products	[3-83]
"Expanding" pronomeral expressions	[3-85]
Expanding expressions like ' $(x + 5)(x + 3)$ '	[3-86]
Expanding expressions like ' $(y - 3)(y + 7)$ '	[3-86]
Expanding expressions like ' $(3x + 7)(2x + 5)$ '	[3-86]
Expanding expressions like ' $(2y - 5)(3y + 4)$ '	[3-87]
The exponent symbol	[3-88]
Expanding expressions like ' $(x + 3)^2$ '	[3-89]
Expanding expressions like ' $a(2b - 3)^2$ '	[3-90]
Expanding expressions like ' $x(3y - 2)(y + 5)$ '	[3-90]
Factoring pronomeral expressions	[3-90]
Factoring expressions like ' $30a + 6$ '	[3-91]
Factoring expressions like ' $x^2 + 7x - 8$ '	[3-92]
Factoring expressions like ' $n^2 + 10n + 25$ '	[3-92]
Factoring expressions like ' $6x^2 + 23x + 20$ '	[3-93]
Factoring expressions like ' $3a^2n - 12n$ '	[3-94]
Factoring expressions like ' $12a^2b - 4ab - 40b$ '	[3-95]
3.08 <u>Quadratic equations</u>	[3-96]
' $ab = 0$ ' is equivalent to ' $a = 0$ or $b = 0$ '	[3-96]
Standard form of a quadratic equation in ' $x$ '	[3-97]
Solution of quadratic equations	[3-99]
3.09 <u>Solving inequations</u>	[3-100]
Three transformation principles for equations	[3-100]
The addition transformation principle for inequations	[3-101]
The multiplication transformation principle for inequations	[3-102]

The factoring transformation principle for inequations	[3-103]
Solving inequations like ' $5x - 4 > 7x + 9$ '	[3-103]
Solving inequations like ' $x^2 + 4 > 5(2 - x)$ '	[3-104]
Solving inequations like ' $7 \leq \frac{5x - 2}{4} < 17$ '	[3-104]
Solving inequations like ' $ 3x - 5  < 13$ '	[3-105]
☆ Proving theorems about >	[3-106]
Exploration Exercises--	[3-107]
Graphing inequations	[3-107]
Subsets	[3-107]
 3.10 <u>Square roots</u>	[3-108]
Existence and uniqueness of positive square roots	[3-108]
The radical sign	[3-109]
Simplifying radical expressions	[3-110]
Degrees of approximation	[3-112]
"correct to ___ decimal places"	[3-112]
"correct to the nearest ___"	[3-114]
Estimates of errors	[3-118]
Computing approximations to square roots	[3-121]
☆ More on dividing-and-averaging	[3-124]
Using approximations to $\sqrt{2}$ , $\sqrt{3}$ , and $\sqrt{5}$ to find approximations to other square roots	[3-129]
Finding approximations to the roots of quadratic equations	[3-130]
Principal square root	[3-131]
$\forall_x \sqrt{x^2} =  x $	[3-132]
Simplifying expressions like ' $\sqrt{x^2 - 6x + 9}$ '	[3-132]
Solving quadratic equations and inequations by transforming to standard form	[3-133]
Solving worded problems which lead to quadratics	[3-134]
 <u>Miscellaneous Exercises</u>	[3-137]
A. Solving equations and inequations	[3-137]
B. Solving proportions	[3-138]



C.	Solving an equation for an indicated pronumeral	[3-139]
D.	Stating and proving generalizations	[3-139]
E.	Evaluating pronumeral expressions which contain radical signs	[3-140]
F.	Sentence completion--worded problems	[3-141]
G.	Solving worded problems	[3-150]
H.	Expanding pronumeral expressions	[3-155]
I.	Factoring pronumeral expressions	[3-155]
J.	Simplifying pronumeral expressions	[3-156]
<u>Test</u>		[3-160]
<u>Supplementary Exercises</u>		[3-165]
A.	Graphing sentences	[3-165]
B.	Solving equations by inspection	[3-166]
C.	Solving equations by first simplifying the left side	[3-167]
D.	Solving equations like ' $4x - 3 + 2x = 5 - 10x$ '	[3-168]
E.	Solving equations like ' $7(x - 3) + 4 = 3x + 3$ '	[3-169]
F.	Solving equations like ' $\frac{x - 7}{5} + 2 = \frac{x + 8}{10}$ '	[3-170]
G.	Solving equations like ' $\frac{3}{a} = 2 - \frac{2 + a}{a}$ '	[3-171]
H.	Transforming formulas	[3-173]
I.	Solving equations for an indicated pronumeral	[3-173]
J.	Completion exercises	[3-174]
K.	Solving worded problems	[3-181]
L.	Expanding	[3-186]
M.	Factoring	[3-187]
N.	Solving quadratic equations	[3-189]
O.	Finding approximations to square roots	[3-189]
P.	Simplifying radical expressions	[3-189]
Q.	Simplifying expressions like ' $\sqrt{x^2 + 2xy + y^2}$ '	[3-190]
R.	Solving quadratic equations and inequations by transforming to standard form	[3-190]



the

7

Some of your students will be able to solve this problem by "arithmetic". Check their solutions individually in class without revealing them to the rest of the students. Our purpose here is to give the students a moderately difficult problem so that they will discover that considerable ingenuity is required if they try to solve the problem by methods learned in earlier grades. It is likely that most of your students will be unable to solve the problem. Do not solve it for them. Instead, promise them that by the time they finish this unit, they will be able to solve problems like this without much effort at all. It is best to do this work in class so that students will not be unnecessarily tempted to get help from home. If a student discovers an algebraic method, acknowledge his success but do not try to explain the method to the class.

\*

You may be surprised by the cleverness of the solutions offered by some of your students. Here is a typical arithmetic solution.

An adult ticket costs more than a student ticket. If 167 student tickets were sold, the total collected would be  $(167 \times 39)$  cents or \$65.13. But, a total of \$79.17 was collected. So the difference between the totals, \$14.04, must be due to the fact that some adult tickets were sold. An adult ticket costs 27 cents more. Therefore, divide 14.04 by .27. You get 52. This is the number of adult tickets that were sold.

A report on a ticket sale. -- Betty Morris, who is chairman of the committee in charge of selling tickets for the play at Zabbranchburg High School, gave a financial report to the Student Council:

The ticket committee sold 167 tickets to the school play. We charged \$.66 for an adult ticket and \$.39 for a student ticket and we collected a total of \$79.17.

John Sanders, a member of the Student Council, had been critical of the expensive advertising used to interest adults in coming to the play. After Betty gave her report, he said:

I wonder if all of our advertising was worth the money. I didn't see many adults at the play. Just how many adults did attend the play, Betty?

The Council president asked Betty if she could tell them the number of adult tickets sold. Betty said that she couldn't give this information immediately because her records were at home. If the Council didn't mind waiting, she would call home and ask her mother to read the figures to her over the telephone. Bill Smith, another Council member, said:

That won't be necessary, Betty. As soon as John asked his question, I used the information you gave us and computed the number of adult tickets sold. It was easy to find the answer.

Can you tell how many adult tickets were sold?

The problem Bill solved is not an easy one if you try to solve it by methods you have used in earlier grades. It can be solved by those methods, but there is a faster method which makes this problem a very simple one. You will learn this faster method later in this unit and be able to solve even more complicated problems.



[3-1]

ould

- |                       |                     |                      |
|-----------------------|---------------------|----------------------|
| 11. $6x$              | 12. $4k$            | 13. [Given in text.] |
| 14. $12 + 13x$        | 15. $7 - 6r - 7t$   | 16. $-4 + 7r$        |
| 17. $-4 - 3x + 5y$    | 18. $-14$           | 19. $-7$             |
| 20. $12x$             | 21. $13t + 10$      | 22. $13a - 7b$       |
| 23. $-16x + 19y - 17$ | 24. $8 - 39x + 53y$ |                      |

\*

By the time students have finished these exercises they should be able to state the generalization:

$\forall x \forall y$  the midpoint of the number line segment whose end points are  $x$  and  $y$  is  $\frac{x+y}{2}$ .

Some students may protest that they "didn't do it that way", and explain that they subtracted one end point from the other and added half this difference to the subtrahend. In other words, they arrived at the generalization:

$\forall x \forall y$  the midpoint of the number line segment whose end points are  $x$  and  $y$  is  $x + \frac{y-x}{2}$ .

After such a student has stated this generalization, ask him whether he can simplify ' $x + \frac{y-x}{2}$ ', that is, whether he can derive the previous generalization from this and basic principles.



[3-1]

ould

following: There can't be such a point to the right of L because points to the right of L are farther from Q than from L, and, so, can't be twice as far from L as from Q. Now, points which are very near Q are much more than twice as far from L as from Q. If we start at Q and consider points farther and farther to the left, we see that there is just one point to the left of Q which satisfies the given condition. And, considering points between Q and L we see that there is just one point there which satisfies the given condition. [In each case, try several points, and see how, as one takes points farther from Q, one obtains smaller multipliers. ] Ask students why we shifted, in Exercises 26 and 27, from the definite article 'The' to the indefinite article 'A'.

\*

Answers for Part B [on pages 3-3 and 3-4].

1. 2                                      2.  $10\frac{1}{2}$                                       3.  $10\frac{1}{2}$

\*

Exercise 3 asks for the same information as does Exercise 2. Its purpose is to introduce the words 'midpoint' and 'end point' which we need to simplify the statement of Exercises 5 through 24. Note that a segment of the number line is a set of real numbers, and that its end points and midpoint are real numbers. More will be made of this and of related notions on pages 3-15ff.

4.  $\frac{1}{2}$                                       5. 20                                      6. -9                                      7. 10  
8. 300                                      9. 0                                      10.  $15 + x$

\*

Exercise 10 and most of the following exercises of Part B differ from the earlier exercises in that pronomeral expressions are used instead of numerals. Point out to students that Exercise 10 really requires him to complete the following generalization:

$\forall_x$  the midpoint of the number line segment whose end points are  $10 + x$  and  $20 + x$  is \_\_\_\_\_.

\*

[3-1]

ould

At this point we suggest that you reread TC[1-99]a and TC[1-99]b. The discussion on those pages will be helpful to you in handling Sections 3.01 and 3.02.

Notice that when we use the word 'point' in referring to a picture of a straight line, we mean a mark on the picture. You can translate 'point of the picture' to 'dot'. So, the graph of a real number is a dot, and a real number is a coordinate of a dot.

\*

Answers for Part A [on pages 3-2 and 3-3].

- |   |                    |                     |                    |
|---|--------------------|---------------------|--------------------|
| 1. Z  | 2. J               | 3. A                | 4. R               |
| 5. A dot which is halfway between H and Z.  |                    |                     |                    |
| 6. A dot which is one fourth of the way from A to G.  |                    |                     |                    |
| 7. A dot which is .9 of the way from B to E.  |                    |                     |                    |
| 8. A dot which is .8 of the way from F to A.  |                    |                     |                    |
| 9. A dot which is .99 of the way from B to E.   |                    |                     |                    |
| 10. A dot which is .1 of the way from R to Q.   |                    |                     |                    |
| 11. L   | 12. B              | 13. 9               | 14. -7             |
| 15. 0   |                    |                     |                    |
| 16. -4  | 17. 6              | 18. $2\frac{1}{2}$  | 19. 1              |
| 20. -1  |                    |                     |                    |
| 21. -2.6  | 22. $7\frac{2}{3}$ | 23. $-2\frac{3}{4}$ | 24. $-\frac{1}{2}$ |
| 25. 0   |                    |                     |                    |
| 26. The coordinate of a point such that the distance between it and L is twice the distance between it and Q is either $-1/3$ or $-3$ . [So, a short answer is: $-1/3$ or $-3$ .] |                    |                     |                    |
| 27. 1 or 4  |                    |                     |                    |

\*

Note that Exercise 26 is not answered correctly if the student gives the coordinate of only one point. He must give the coordinates of two points,  $-1/3$  and  $-3$ . Needless to say, he should find these coordinates intuitively. [Similarly, there are two points to be considered in Exercise 27.] Challenge the students to give a convincing argument that there are no more than two points which satisfy the description in Exercise 26. [Such an argument might boil down to something like the

3.01 Graph and coordinates. --In Unit 1 you learned that you could think of the real numbers as being "lined up". You can make a picture of this "line-up" by drawing a straight line,

---

marking any one of the points on it and labeling it with a '0',

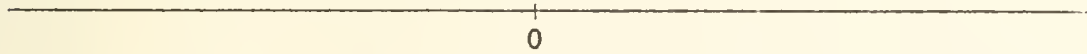

marking another point and labeling it with a '1',

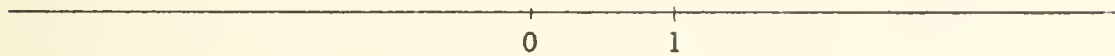

and using a uniform scale to assign points to the rest of the real numbers.

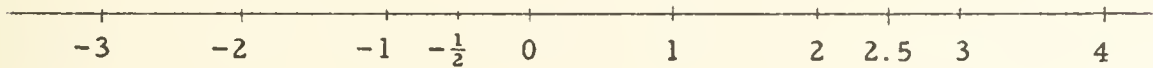

This diagram is a picture of [part of] the number line. Each point you mark on the picture corresponds with a real number, and this real number is the coordinate of the point. Each mark is the graph of the real number which is its coordinate.

[Once you have drawn a picture of the number line, you can make a mark corresponding with any real number whose graph falls within the boundaries of the picture. But, for a given picture, no matter what the scale, there are bound to be two real numbers whose difference is so small that you cannot mark different dots. So, no picture of the number line can be "accurate" in the sense that there is a one-to-one correspondence between the real numbers and their graphs. Nevertheless, pictures of the number line are helpful in visualizing properties of real numbers.]

## EXERCISES

- A. Here is a picture of the number line. Some of the points of the picture are labeled with letters as well as with numerals. [Notice, for example, that the point labeled 'Z' is the graph of the real number 3, and that the coordinate of point Z is 3.]

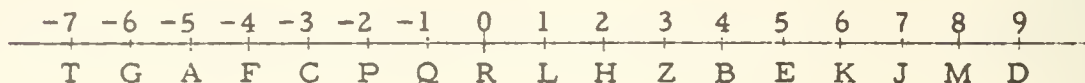

Sample 1. Which point is the graph of +6?

Solution. Point K.

Sample 2. Which point is the graph of  $-\frac{10}{3}$ ?

Solution. The point which is  $\frac{1}{3}$  of the way from point C to point F.

Sample 3. What is the coordinate of the point A?

Solution. -5.

Sample 4. What is the coordinate of the point halfway between L and P?

Solution. The coordinate of L is 1 and the coordinate of P is -2. The number we are looking for is the midpoint of the number line segment whose end points are 1 and -2. Since the distance between the end points is 3, the distance between the midpoint and either end point is 1.5. Hence, the midpoint is -0.5, and this is the coordinate of the point halfway between L and P.

What are the graphs of the listed numbers?

- |                    |              |                            |
|--------------------|--------------|----------------------------|
| 1. 3               | 2. +7        | 3. -5                      |
| 4. 0               | 5. 2.5       | 6. $-5\frac{1}{4}$         |
| 7. $\frac{49}{10}$ | 8. -4.8      | 9. 4.99                    |
| 10. -0.1           | 11. $4 + -3$ | 12. $-2 \div -\frac{1}{2}$ |

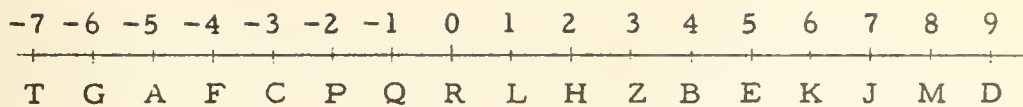

Give the coordinates of the points described in these exercises.

13. The point D.
14. The point T.
15. The point R.
16. The point 1 unit to the right of A.
17. The point 2 units to the left of M.
18. The point halfway between D and F.
19. The point halfway between D and T.
20. The point halfway between F and H.
21. The point 40% of the way from A to L.
22. The point one third of the way from M to J.
23. The point one fourth of the way from P to A.
24. The point which is as far from C as it is from H.
25. The point between G and Z which is twice as far from G as it is from Z.
26. A point such that the distance between it and L is twice the distance between it and Q.
27. A point which is three times as far from P as it is from H.

B. Complete into true sentences.

1. If the coordinate of a point A on a picture of the number line is 7, and the coordinate of a point B on this picture of the number line is -3, then the coordinate of the point halfway between A and B is \_\_\_\_\_.
2. If the coordinate of a point T is 9, and the coordinate of a point V is 12, then the coordinate of the point halfway between T and V is \_\_\_\_\_.

(continued on next page)

3. The midpoint of the number line segment whose end points are 9 and 12 is \_\_\_\_\_.
4. The midpoint of the number line segment whose end points are 11 and -10 is \_\_\_\_\_.

\*

Use the simplest expression you can to complete the table.

	<u>end point</u>	<u>end point</u>	<u>midpoint</u>
5.	9	31	_____
6.	-2	-16	_____
7.	8	12	_____
8.	200	400	_____
9.	-10	10	_____
10.	$10 + x$	$20 + x$	_____
11.	$3x$	$9x$	_____
12.	$2k + 7$	$6k - 7$	_____
13.	$3a + 2b$	$7a - 16b$	<u>[Answer: <math>5a - 7b</math>]</u>
14.	$2(5 - x)$	$7(2 + 4x)$	_____
15.	$3 - 5r + 7t$	$11 - 7r - 21t$	_____
16.	$5 - (7 + 3n)$	$9n - (6 - 8n)$	_____
17.	$-(3 - x + 2y)$	$-(5 + 7x - 12y)$	_____
18.	-6	_____	-10
19.	_____	1	-3
20.	$2x$	_____	$7x$
21.	_____	$3t$	$8t + 5$
22.	$a + 3b$	_____	$7a - 2b$
23.	$2x - 3y + 5$	_____	$-7x + 8y - 6$
24.	$2 - 3(x - y)$	_____	$5 - 7(3x - 4y)$





3.

3/7

The expressions 'satisfy', 'solution', and 'solution set' are important. You should spend enough time on the underlying concepts to be sure that students use the words properly. One very useful classroom technique for developing understanding of the underlying concepts is to engage in a bit of dramatics. Tell the story of the sentence:

$$x + 3 > 15$$

which is waiting for numbers to satisfy it. All the real numbers are waiting in line, each to introduce itself to the sentence and ask the question:

Do I satisfy you?

When 7 asks this question, the sentence answers 'no'. Why? Because the new sentence ' $7 + 3 > 15$ ' is false. But, 27.5 gets the yes-answer because ' $27.5 + 3 > 15$ ' is true. When each real number has been answered, we find that the sentence has separated these numbers into two sets, the set of those numbers which satisfy it and the set of those numbers which do not satisfy it. The "satisfying set" is called the solution set of ' $x + 3 > 15$ '. Each number in the "nonsatisfying set" is either 12 or smaller than 12. [Technically, the "nonsatisfying set" is called the complement of the solution set of ' $x + 3 > 15$ '. You may want to introduce the word 'complement' at this time.]

So, each open sentence of the type we shall be considering separates the set of real numbers into two subsets. [There are some open sentences which, in effect, separate the set of real numbers into three subsets, the set of all numbers which satisfy it, the set of all numbers which do not satisfy it, and the set of all numbers which would render the open sentence meaningless. For example, the open sentence:

$$\frac{1}{x} > 2$$

is neither satisfied nor "not satisfied" by the number 0. Reverting back to the dramatic approach, the number 0 is not even allowed in the room with the rest of the real numbers who are introducing themselves to the open sentence in question. This matter need not be taken up until the first occurrence of this type of sentence.]

\*

The use of the word 'convert' in the second paragraph on page 3-5 is colloquial. The open sentence is converted into a statement by substituting for 'x' a numeral for one of its values.

3.02 Solution set of a sentence. -- Consider the open sentence:

$$x + 3 > 1.$$

We know that this open sentence is neither true nor false, but that we can generate a statement from it by substituting a numeral for 'x'. Here are some of the true statements and some of the false ones.

<u>True</u>	<u>False</u>
$5 + 3 > 1$	$-2 + 3 > 1$
$9 + 3 > 1$	$-5 + 3 > 1$
$172 + 3 > 1$	$-17 + 3 > 1$
$-1.4 + 3 > 1$	$-2.5 + 3 > 1$

Each value of 'x' can be used to convert the open sentence ' $x + 3 > 1$ ' into a true statement or into a false statement. A value of 'x' which converts it into a true statement is said to satisfy the open sentence or to be a solution of the open sentence. The set of all real numbers which satisfy the sentence is called the solution set of the sentence. So, the solution set of the sentence:

$$x + 3 > 1$$

is the set of all real numbers which are greater than -2.

## EXERCISES

A. Describe the solution set of each of the following sentences.

Sample 1.  $3t = 12$

Solution. There is just one real number which satisfies this sentence. This is the number 4. So, we write:

the solution set is the set of real numbers  
which consists of just the number 4.

Sample 2.  $k > k + 1$

Solution. There are no numbers which satisfy this sentence. We express this fact by writing:

the solution set is the empty set.

Sample 3.  $5x < 30$

Solution. Each real number less than 6 is a solution of this sentence, and each number which is not less than 6 does not satisfy it. So, our answer is:

the solution set is the set of all real  
numbers which are less than 6.

Sample 4.  $2 < x$  and  $x < 6$

Solution. To find solutions for this sentence is to find numbers which are both greater than 2 and less than 6. These are the numbers which are between 2 and 6. So, we write:

the solution set is the set of all  
real numbers between 2 and 6.

[Note: An abbreviation of the sentence ' $2 < x$  and  $x < 6$ ' is ' $2 < x < 6$ ', which is read as ' $2$  is less than  $x$  is less than  $6$ '.]

The dramatic approach should be used for each of the samples on pages 3-6 and 3-7. In Sample 1, the sentence ' $3t = 12$ ' separates the set of all real numbers into two sets, one consisting of just the number 4, the other consisting of all numbers different from 4. A set which consists of a single element is often called a unit set or a singleton. [Students may object to admitting that there are sets with fewer than two elements. However, it is necessary to admit such sets if one is to say that each open sentence has a solution set. Once students are convinced that it is convenient to speak of unit sets, they may then object that there is no difference between a unit set and its member. That this is a mistaken notion can be shown by discussing the set whose only member is the set of students in your classroom. Since this set has just one member it is certainly different from the set of students in your classroom.]

In Sample 2, we find our first opportunity to deal with the notion of the empty set [sometimes called: the null set]. Each real number which introduces itself to the sentence ' $k > k + 1$ ' is assigned to the category of the nonsatisfying set. There are no numbers which satisfy the sentence. This fact is expressed by saying that the solution set is the empty set. Students may ask why we use the definite article 'the' in 'the empty set'. The answer is that, since a set is determined by its membership, there is just one empty set. The set of all unicorns in your classroom is  $\{x: x = x + 1\}$ . There is no member of either set which is not also a member of the other.

Sample 4 deals with a compound sentence. The dramatic approach is effective here and is of considerable help in Sample 5. As each real number introduces itself to the open sentence:

$$2 < x \text{ and } x < 6,$$

it asks the question: Do I satisfy you? This question requires a one-word answer. If the answer is 'yes', the number goes into the solution set; if the answer is 'no', the number goes into the nonsatisfying set. In order to supply this one-word answer, the sentence asks of each number: Are you greater than 2 and smaller than 6? It is easy to see that a yes-answer can be given only for those numbers between 2 and 6.

[3-6]

A.

[3-7]

ller

A.

3/12

' $x > 5$ ' is an appropriate sentence. Now write:

$$x + 3 >$$

on the board, and ask students to complete it. You should get either:

$$x + 3 > 5 + 3, \text{ or: } x + 3 > 8.$$

Then write:

$$y + ^{-}12 >$$

and ask that it be completed [' $y + ^{-}12 > 5 + ^{-}12$ ' or ' $y + ^{-}12 > ^{-}7$ '].  
Then write:

$$3k >$$

and expect it to be completed to ' $3k > 3 \cdot 5$ ' or ' $3k > 15$ '. [Avoid verbalizations like 'Do the same thing to both sides.'].]

\*

Answers for Part B are given on TC[3-8]. You can use the answers we have given there to make a quiz following the assignment of Part B. Just take these 36 sentences, write them at random, on the board, number them, and ask students to sort them into categories of sentences which have the same solution set.



[3-7]

ller

A.

3/11

Here is the truth-table for conjunction sentences. [We use notation commonly found in logic texts: 'T' for 'true', 'F' for 'false', and 'p' and 'q' in place of sentences.]

Conjunction sentences

<u>p</u>	<u>q</u>	<u>p and q</u>
T	T	T
T	F	F
F	T	F
F	F	F

As an example of how the table is used, consider the sentence:

$$(1c) \quad 2 < 7 \text{ and } 7 < 6$$

Replacing 'p' by ' $2 < 7$ ' and 'q' by ' $7 < 6$ ', we note that the second line of the table applies in this case. So, the sentence (1c) is called 'False'. Do you see that the first line of the table applies to sentence (1a) and that the third line applies to sentence (1b)?

Here is the truth-table for alternation sentences.

Alternation sentences

<u>p</u>	<u>q</u>	<u>p or q</u>
T	T	T
T	F	T
F	T	T
F	F	F

Sentence (2a) is covered by the second line of the table, (2b) by the third line, and (2c) by the fourth line.

Students should copy these tables in their textbooks and refer to them as needed in Units 3 and 4.

\*

The purpose of the exercises in Part B is to begin building the concept of equivalent sentences. Here is an effective way to get students to write equivalent sentences. Consider Sample 1. It is easy to see that

[3-7]

ller

A.

3/10

12. the solution set is the set of all real numbers.
13. the solution set is the set of all real numbers between 1 and 3.
14. the solution set is the set of all real numbers between -2 and 0.
15. the solution set is the set of all real numbers which are less than 1 and all real numbers which are greater than 4.

\*

Open sentences such as:

$$(1) \quad 2 < x \text{ and } x < 6$$

and:

$$(2) \quad 2 > x \text{ or } x > 3$$

may pose special teaching problems. We have already described ways in which students can be helped in thinking of the solution sets of such sentences. By the time they have completed Exercises 13, 14, and 15, they should have formulated agreements for deciding between truth and falsity for statements such as:

(1a)	$2 < 5 \text{ and } 5 < 6,$	[True]
(1b)	$2 < 1 \text{ and } 1 < 6,$	[False]
(1c)	$2 < 7 \text{ and } 7 < 6,$	[False]
(2a)	$2 > 1 \text{ or } 1 > 3,$	[True]
(2b)	$2 > 5 \text{ or } 5 > 3,$	[True]
(2c)	$2 > 2.5 \text{ or } 2.5 > 3.$	[False]

Such agreements are consequences of the way the words 'and' and 'or' are used. These agreements are usually exhibited in tables [commonly called in logic texts 'truth-tables']. The words 'and' and 'or' are sentence connectives. They are used to make compound sentences. A compound sentence formed by flanking an 'or' with two other sentences is called an alternation sentence. A compound sentence formed by flanking an 'and' with two other sentences is called a conjunction sentence. Sentences (1), (1a), (1b), and (1c) are conjunction sentences; (2), (2a), (2b), and (2c) are alternation sentences.

ller

A.

3/9

In Sample 5, the relevant question is: Are you less than 2 or greater than 3? For the number 1, the answer is 'yes'. Also, for the number 5, the answer is 'yes'. The only numbers for which a no-answer is correct are 2, 3, and all those numbers between 2 and 3. The answer given for Sample 5 was chosen to exemplify a use of the word 'and' which is quite different from the use of this word in Sample 4. In Sample 4 'and' is used to construct the compound sentence ' $2 < x$  and  $x < 6$ ' by connecting two simpler sentences. [In Sample 5, the word 'or' serves a similar purpose.] But, in the answer displayed for Sample 5 the word 'and' has the meaning of 'together with'. Perhaps the clearest form of answer for Sample 5 is:

The solution set consists of all real numbers which are less than 2 together with all real numbers which are greater than 3.

\*

Answers for Part A [which begins on page 3-6].

1. the solution set is the set of all real numbers which are greater than 2.
2. the solution set is the set of all real numbers which are greater than 7.
3. the solution set is the set of all real numbers which are less than 2, and the real number 2.
4. the solution set is the set of real numbers which consists of just the number -3.
5. the solution set is the set of real numbers which consists of the numbers -10 and 14.
6. the solution set is the set of all real numbers which are greater than 4.
7. the solution set is the set of all real numbers which are greater than 0. [or: the set of positive real numbers.]
8. the solution set is the set of real numbers which consists of the numbers 1 and 0.
9. the solution set is the set of all real numbers which are less than  $2\frac{1}{2}$ .
10. the solution set is the empty set.
11. the solution set is the set of all real numbers which are greater than 0.

Sample 5.  $2 > x$  or  $x > 3$

Solution. Here we are looking for numbers which are smaller than 2 or greater than 3. Such a number is 1, for  $1 < 2$  even though it is not larger than 3. Also, 6 is such a number. So, the answer is:

the solution set is the set of all real numbers which are less than 2 and all real numbers which are greater than 3.

[Note: Would it make sense to abbreviate ' $2 > x$  or  $x > 3$ ' to ' $2 > x > 3$ '? Why? Does the sentence ' $1 < x$  and  $x < 5$ ' have the same solution set as the sentence ' $1 < x$  or  $x < 5$ '?]

- |                         |                   |                        |
|-------------------------|-------------------|------------------------|
| 1. $x + 5 > 7$          | 2. $y - 3 > 4$    | 3. $3m \leq 6$         |
| 4. $10 + x = 7$         | 5. $ y - 2  = 12$ | 6. $5t + 1 > 21$       |
| 7. $8y > 0$             | 8. $x(x - 1) = 0$ | 9. $y + y < 5$         |
| 10. $x = x + 3$         | 11. $x + 4 > 4$   | 12. $x + 4 = 4 + x$    |
| 13. $1 < y$ and $y < 3$ | 14. $-2 < x < 0$  | 15. $1 > x$ or $x > 4$ |

B. Each exercise describes a set of numbers. For each exercise, write three sentences which have the given set as solution set.

Sample 1. the set of all numbers greater than 5

- Solution.
- (1)  $x > 5$
  - (2)  $x + 4 > 9$
  - (3)  $y - 7 > -2$

[Note: Suppose someone writes ' $x > 10$ ' as one of the answers, and defends this answer by saying that each number in the solution set of ' $x > 10$ ' is a number which is greater than 5. How would you show him that ' $x > 10$ ' is not a correct answer?]

Sample 2.  $\{4\}$

Solution. ' $\{4\}$ ' is a short way of describing the set which consists of just the number 4. So, three sentences which have  $\{4\}$  as solution set are:

$$(1) \quad x = 4$$

$$(2) \quad 3y = 12$$

$$(3) \quad 7z + 91 = 119.$$

1. the set of all numbers less than 2
2. the set of all numbers less than 0
3. the set of all numbers not less than 3
4. the set of all numbers between (but not including) 1 and 7
5. the set of all numbers between (and including) 1 and 7
6. the set of all numbers greater than 5 and all numbers less than 4
7. the set of all numbers greater than 1 and all numbers less than 3
8.  $\{2\}$
9.  $\{-2\}$
10.  $\{1, 3\}$
11. the set of all numbers
12. the empty set

C. Each of the following 12 exercises describes a set of numbers. Altogether, just 4 sets are described. Tell which descriptions refer to the same set.

- (1) the set of all numbers such that each is greater than 3
- (2) the set of all numbers such that each is less than 5
- (3) the set of all numbers such that each is 7
- (4) the set of all numbers such that the product of 2 by each is greater than 6



Answers for Part B [which begins on page 3-7].

[Of course there are many sentences which students could write which would, in each case, have the given set as solution set. We give three for each exercise which we think will be fairly typical of the kind submitted by your students.]

- |                            |                            |                                |
|----------------------------|----------------------------|--------------------------------|
| 1. (1) $x < 2$             | (2) $x + 1 < 3$            | (3) $x - 2 < 0$                |
| 2. (1) $x < 0$             | (2) $3x < 0$               | (3) $x - 84 < -84$             |
| 3. (1) $x \geq 3$          | (2) $2x \geq 6$            | (3) $x + 5 \geq 8$             |
| 4. (1) $1 < x < 7$         | (2) $-2 < x - 3 < 4$       | (3) $-5 < -6 + x < 1$          |
| 5. (1) $1 \leq x \leq 7$   | (2) $-2 \leq x - 3 \leq 4$ | (3) $-5 \leq -6 + x \leq 1$    |
| 6. (1) $x > 5$ or $x < 4$  | (2) $5 < x$ or $4 > x$     | (3) $x + 1 > 6$ or $x + 1 < 5$ |
| 7. (1) $1 < x$ or $x < 3$  | (2) $x > 1$ or $3 > x$     | (3) $3 < x + 2$ or $x - 1 < 2$ |
| 8. (1) $x = 2$             | (2) $2x = 4$               | (3) $5 - x = 3$                |
| 9. (1) $x = -2$            | (2) $-2x = 4$              | (3) $x + 6 = 4$                |
| 10. (1) $x = 3$ or $x = 1$ | (2) $ x - 2  = 1$          | (3) $(x - 3)(x - 1) = 0$       |
| 11. (1) $x = x$            | (2) $x + 3 = x + 3$        | (3) $1 + 2x = 2x + 1$          |
| 12. (1) $x = x - 5$        | (2) $x > 2$ and $x < 1$    | (3) $x < x - 1$                |

\*

The purpose of Part C is to develop a need for abbreviated descriptions of sets. The brace-notation, in which the names of the elements [not the elements themselves] of the set are separated by commas and placed between two braces, is one such abbreviated description. Clearly, we cannot list the elements of an infinite set [such as the sets described in sentences (1) and (2) of Part C]. However, we do use braces to construct a name for an infinite set, and this is shown on page 3-9. The brace-notation is a standard one for naming sets.

\*

Answers for Part C [on pages 3-8 and 3-9].

Descriptions (1), (4), (11), and (12) refer to the same set  $\{x: x > 3\}$ .

Descriptions (2), (6), and (8) refer to the same set  $\{y: y < 5\}$ .

Descriptions (3) and (9) refer to the same set  $\{7\}$ .

Descriptions (5), (7), and (10) refer to the same set  $\{2\}$ .

[3-8]

2

[3-9]

duct of

names for sets in an admirable fashion since the notation itself provides us with a method for determining of each thing in the universe whether it belongs to the set or not. So, as in Sample 1, we use the symbol:

$$\{x: 2xx + 13 = 63\}$$

itself to determine whether this symbol names the set which consists of the numbers 5 and -5. First, we determine if the set so named contains the numbers 5 and -5. We do this by determining whether the numbers 5 and -5 satisfy the open sentence '2xx + 13 = 63'. We find that they both do satisfy the open sentence. This knowledge is not sufficient to conclude that the symbol:

$$\{x: 2xx + 13 = 63\}$$

names the set which consists of just the numbers 5 and -5. For the set named by this symbol may contain other numbers. So, we convince ourselves intuitively that 5 and -5 are the only solutions of the sentence '2xx + 13 = 63'. On the basis of these two items of information--that 5 and -5 belong to the set in question, and that no other numbers belong to it--we conclude that '{x: 2xx + 13 = 63}' is a name for the set {5, -5}. Thus, we can write the true sentence:

$$\{x: 2xx + 13 = 63\} = \{5, -5\}.$$

Sample 2 shows more strongly the need for investigating numbers other than 5 and -5. The work in Sample 2 enables us to conclude that

$$\{n: |n| > 4.8\} \neq \{5, -5\}.$$

\*

Answers for Part D [on pages 3-9 and 3-10].

- |   |  |
|---|--|
| 1. $\{x: xx = 25\} = \{5, -5\}$                             | 2. $\{y: yy - 25 = 0\} = \{5, -5\}$          |
| 3. $\{k: 25 + kk = 0\} \neq \{5, -5\}$                      | 4. $\{m: m + 5 = 0\} \neq \{5, -5\}$         |
| 5. $\{t: (t - 5)(t + 5) = 0\} = \{5, -5\}$                  |  |
| 6. $\{x: x \text{ is the opposite of } -x\} \neq \{5, -5\}$ |  |
| 7. $\{\square: 4\square\square = 100\} = \{5, -5\}$         | 8. $\{\Delta: 5\Delta = -5\} \neq \{5, -5\}$ |
| 9. $\{x: x + 3 \neq 9\} \neq \{5, -5\}$                     | 10. $\{y: 5 + y \neq 10\} \neq \{5, -5\}$    |

[3-9]

duct of

The 'x' in sentence (a), line 9, should be deleted.

\*

In description (a), 'all numbers' and 'each of them' play the role of linked pronouns and can advantageously be replaced by a pronomeral. The result is:

(b) the set of x such that  $x + 4 < 9$ ,

and we abbreviate this to:

(c)  $\{x: x + 4 < 9\}$ .

The notation:

$\{x: \quad \}$

is, according to our convention, to be interpreted as meaning that each real number of the set of all real numbers is to be introduced to an open sentence. The open sentence in question then serves to select from the set of all real numbers all those numbers which satisfy it [for this reason, the open sentence in question is often called a set selector]. When the open sentence is inserted between the colon and the right brace, the resulting symbol becomes a name for a set of real numbers. It is important that students learn to regard this symbol as a name of a set. Note the analogy between ' $\{x: \quad \}$ ' and ' $\forall^x$ '. Each is an operator which can be applied to a sentence. Even more important, note the difference. When the first is applied to a sentence which contains no pronomeral other than 'x', the resulting expression is a noun. When the second is applied to such a sentence, the resulting expression is a statement.

\*

After completing Part C, students should return to descriptions (1) through (5) and write equivalent descriptions in brace-notation. [Respectively:

$\{x: x > 3\}$ ,  $\{x: x < 5\}$ ,  $\{y: y = 7\}$ ,  $\{z: 2z > 6\}$ ,  $\{a: 3a + 1 = 7\}$ .]

\*

The purpose of Part D is to acquaint students with how the brace-notation just introduced serves as a name for a set. Since the important aspect of a set is the fact that one knows which things in the universe belong to it, one cannot regard a symbol as a name for a set unless the members of the set are "known". The brace-notation provides

- (5) the set of all numbers such that 1 more than the product of 3 by each is 7
- (6) the set of all numbers such that 4 more than each is less than 9

\*

We can simplify these descriptions of sets of numbers by using pronumerals. For example, here is a restatement of the description given in Exercise (6):

- (a) the set of all numbers  $x$  such that each of them plus 4 is less than 9.

Now, let's abbreviate this to:

- (b) the set of  $x$  such that  $x + 4 < 9$ ,

and, finally, to:

- (c)  $\{x: x + 4 < 9\}$ .

[Read (c) as you do (b).]

\*

Now, continue sorting the descriptions.

- |                          |                            |
|--------------------------|----------------------------|
| (7) $\{x: 9x - 1 = 17\}$ | (8) $\{x: 10 - x > 5\}$    |
| (9) $\{y: 3y = 21\}$     | (10) $\{a: 6a + 1 = 13\}$  |
| (11) $\{z: 7 - z < 4\}$  | (12) $\{k: 33 > 51 - 6k\}$ |

D. Which of the following describe the set  $\{5, -5\}$ ?

Sample 1.  $\{x: 2xx + 13 = 63\}$

Solution. To determine whether this describes the set  $\{5, -5\}$ , we must decide whether the solution set of the sentence ' $2xx + 13 = 63$ ' consists of 5 and  $-5$ , and nothing else. We replace the 'x's in the sentence by '5's:

$$2 \cdot 5 \cdot 5 + 13 = 63$$

$$50 + 13 = 63.$$

Since 5 gives us a true statement, 5 is a solution of the

sentence. Next, we try substituting '-5' for 'x':

$$2(-5)(-5) + 13 = 63$$

$$50 + 13 = 63.$$

Again we get a true statement, so we know that -5 is a solution. Can you think of any other number which would satisfy ' $2xx + 13 = 63$ '? [Could a number greater than 5 be a solution?]

Having found that both 5 and -5 are solutions of the sentence ' $2xx + 13 = 63$ ', and believing that there are no other solutions, we would conclude that ' $\{x: 2xx + 13 = 63\}$ ' describes the set  $\{5, -5\}$ .

Sample 2.  $\{n: |n| > 4.8\}$

Solution. We substitute '5' for 'n':

$$|5| > 4.8,$$

and note that we get a true sentence because  $|5| = 5$ , and  $5 > 4.8$ . So, 5 is a solution of the sentence ' $|n| > 4.8$ '.

Substituting '-5' for 'n', we get:

$$|-5| > 4.8,$$

and we know that this is true since  $|-5| = 5$ . So, -5 is a solution.

But, are there other numbers which might be solutions also? Yes, 6 is such a number; so is -4.9.

Therefore, we conclude that ' $\{n: |n| > 4.8\}$ ' does not describe the same set as does ' $\{5, -5\}$ ' because the solution set of ' $|n| > 4.8$ ' contains numbers other than 5 and -5.

- |   |  |
|---|--|
| 1. $\{x: xx = 25\}$                     | 2. $\{y: yy - 25 = 0\}$                      |
| 3. $\{k: 25 + kk = 0\}$                 | 4. $\{m: m + 5 = 0\}$                        |
| 5. $\{t: (t - 5)(t + 5) = 0\}$          | 6. $\{x: x \text{ is the opposite of } -x\}$ |
| 7. $\{\square: 4\square\square = 100\}$ | 8. $\{\triangle: 5\triangle = -5\}$          |
| 9. $\{x: x + 3 \neq 9\}$                | 10. $\{y: 5 + y \neq 10\}$                   |



re

Note the definition of 'the graph of a sentence'. A graph is a picture. In particular, a graph is not a set [although you may think of it as a picture of a set]. A set is not, as is a picture, a physical object. In particular, a set is not a heap! For example, we could easily think of the set consisting of the books which Stan owns and the books which Al owns. The fact that some of these books are in Alaska and some are in, say, Ohio is completely irrelevant to the question of our being able to think of the set. If Stan moves his books to Alaska, the set in question does not change. The elements of the set may have been moved, but the set still consists of the same elements as before. Unfortunately, much of what is now being written about sets for popular consumption would lead the reader to believe that one forms sets by bringing things together, where 'together' has a physical connotation.

\*

Strictly speaking, one should not speak of the graph of, say, ' $x + 4 > 5$ ', because this sentence has at least as many graphs as there are copies of page 3-11.

\*

In this unit we consider only sentences which contain at most one pronumeral. In this context, the definition displayed near the bottom of page 3-11 is a satisfactory one. The following is a more generally suitable definition.

The picture made up of the graphs of the members of the solution set of a sentence is called the graph of a sentence.

\*

The '[' at the graph of  $-2$  in illustration (I) on page 3-12 means that  $-2$  does not belong to the solution set.

The '•' at the graphs of  $-2$  and  $3$  respectively, in illustration (III), means that  $-2$  and  $3$  do belong to the solution set.

In illustration (VI), the '•' at the graphs of  $0$  and of  $3$  indicate that the solution set consists of just  $0$  and  $3$ .

3.03 Graph of a sentence. --Suppose you mark on a picture of the number line the points corresponding with the numbers in

$$\{x: 3x + 1 = 7\}.$$

The picture you get is this:

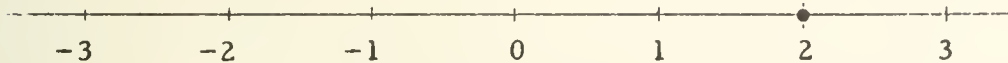

If you mark the graphs of the numbers in

$$\{x: x + 4 \geq 5\},$$

the picture you get is this:

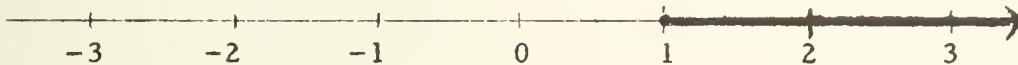

The set of numbers described by ' $\{x: 3x + 1 = 7\}$ ' is the solution set of the sentence ' $3x + 1 = 7$ ', and the set of numbers described by ' $\{x: x + 4 \geq 5\}$ ' is the solution set of the sentence ' $x + 4 \geq 5$ '.

The picture made up of the graphs of the numbers in the solution set of a sentence is called the graph of the sentence.

So, the graph of ' $3x + 1 = 7$ ' consists of a single point, the heavy dot in the first picture. The graph of ' $x + 4 \geq 5$ ' is the shaded portion of the second picture. [Notice the arrowhead in the second picture. What does it tell you?]

Here are several sentences and their graphs.

(I)  $2y > -4$



[Is  $-2$  a solution of ' $2y > -4$ '? What does the ' $)$ ' at the graph of  $-2$  show?]

(II)  $-1 < x$  and  $x < 2$

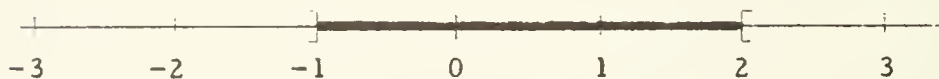

(III)  $-2 \leq y \leq 3$

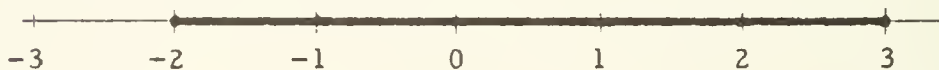

(IV)  $-3 \leq k < 1$

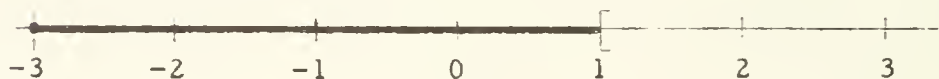

(V)  $t < -1$  or  $t > 2$

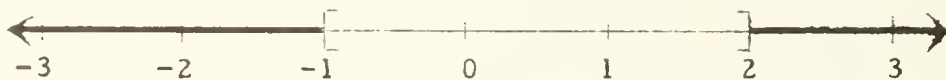

(VI)  $x(x - 3) = 0$

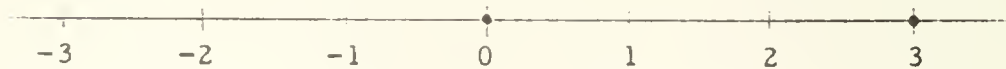

(VII)  $a + 1 < a$

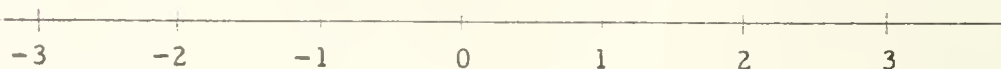

[Note: Since the solution set is the empty set, the graph of ' $a + 1 < a$ ' contains no points. Therefore, there is nothing to picture.]



Here are

(I)

Answers for Part A.

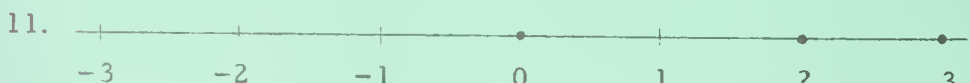
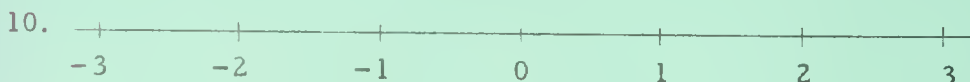
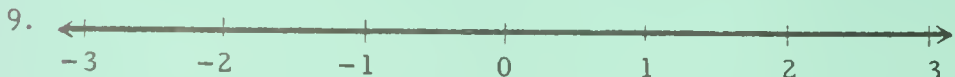
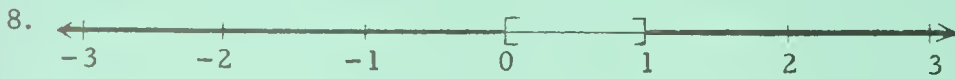
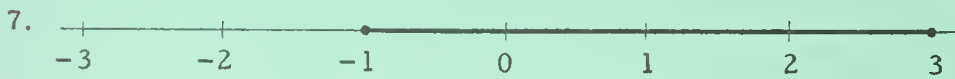
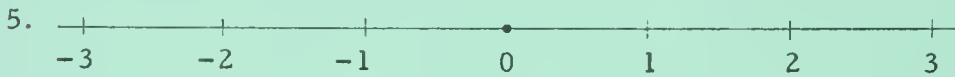
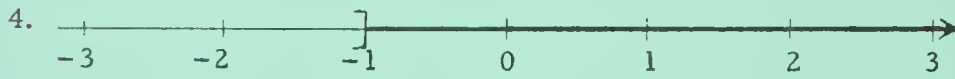
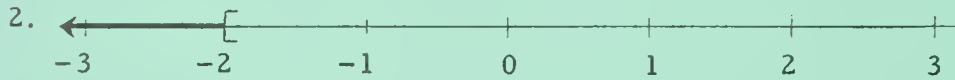
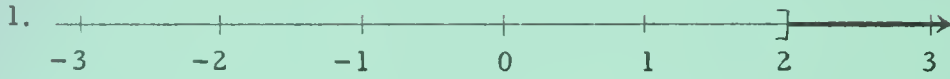

A. Sketch the graph of each of the following sentences.

1.  $3x > 6$

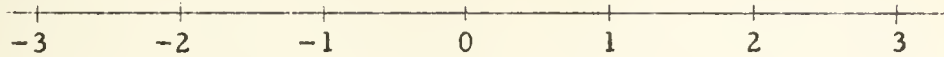

2.  $2x < -4$

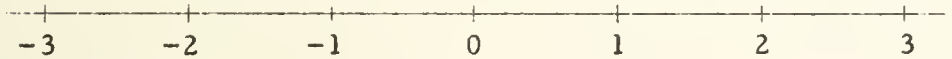

3.  $t + 5 \geq 5$

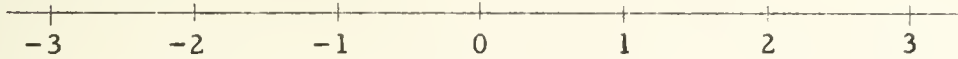

4.  $-x < 1$

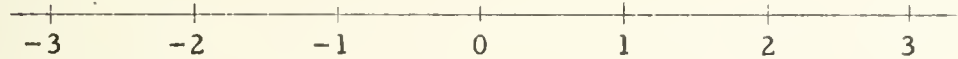

5.  $x = -x$

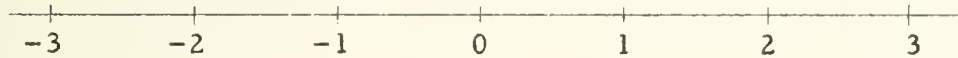

6.  $2k \geq 0$

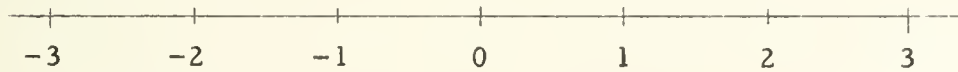

7.  $-1 \leq x \leq 3$

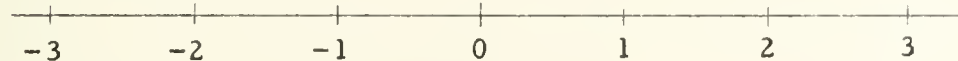

8.  $x > 1$  or  $x < 0$

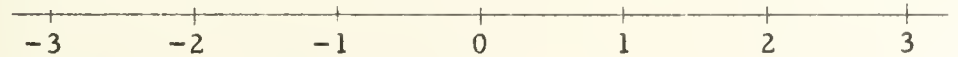

9.  $x > 0$  or  $x < 1$

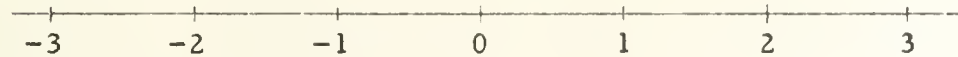

10.  $-1 \geq x \geq 3$

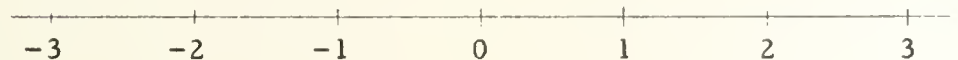

11.  $x(x - 2)(x - 3) = 0$

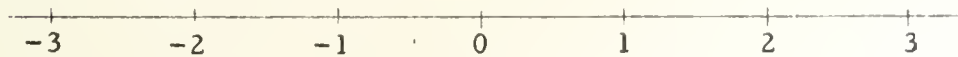

12.  $|x - 1| = 1$

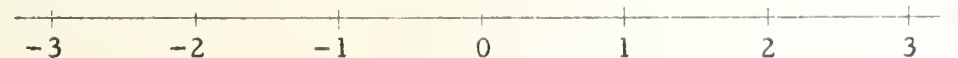

[More exercises are in Part A, Supplementary Exercises.]

B. Each exercise contains a picture of the number line with a graph marked on it. For each exercise, give three descriptions of the set of numbers which are the coordinates of the points on the graph.

Sample.

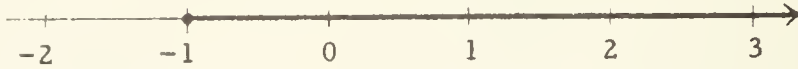

Solution. This graph consists of all the points with coordinate not less than  $-1$ . So, here are three descriptions of the set of numbers which are the coordinates of these points.

$$(1) \{x: x \geq -1\}$$

$$(2) \{k: 3k \geq -3\}$$

$$(3) \{y: 2y + 1 \neq -1\}$$

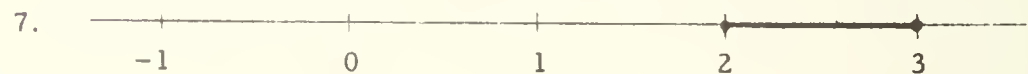
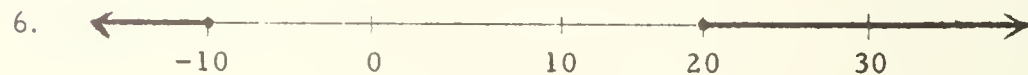
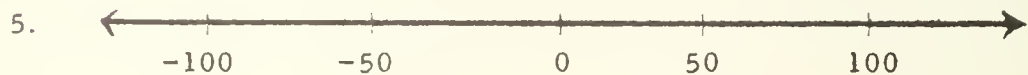
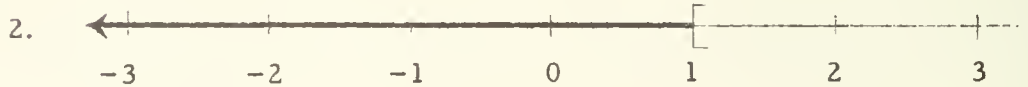
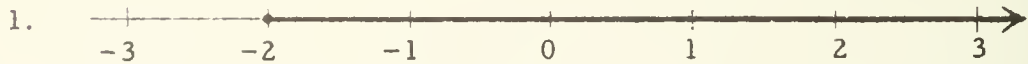



## Answers for Part B.

[Again, there are many sentences which students could write which would have the same graph as the one given in each exercise. Each such sentence could be used to describe the set of numbers which are the coordinates of the points on the graph. We give three descriptions for each exercise; your students will doubtless suggest others.]

1.  $\{x: x \geq -2\}$ ,  $\{a: 2a \geq -4\}$ ,  $\{n: 3n + 1 \neq -5\}$
2.  $\{k: k < 1\}$ ,  $\{a: 2a < 2\}$ ,  $\{n: 3 > 3n\}$
3.  $\{s: -2 \leq s \leq 3\}$ ,  $\{x: -1 \leq s + 1 \leq 4\}$ ,  $\{x: -2 \leq x \text{ and } x \leq 3\}$
4.  $\{n: -10 < n < -8\}$ ,  $\{r: -8 > r > -10\}$ ,  $\{a: -20 < 2a < -16\}$
5.  $\{x: x + 1 = 1 + x\}$ ,  $\{a: a \cdot 1 = a\}$ ,  $\{s: s = s\}$
6.  $\{y: y \leq -10 \text{ or } y \geq 20\}$ ,  $\{n: n + 3 \leq -7 \text{ or } n + 3 \geq 23\}$ ,  
 $\{r: r - 2 \leq -12 \text{ or } r - 2 \geq 18\}$
7.  $\{q: 2 \leq q \leq 3\}$ ,  $\{y: 0 \leq y - 2 \leq 1\}$ ,  $\{t: t \geq 2 \text{ and } t \leq 3\}$
8.  $\{x: x = 1\}$ ,  $\{y: y - 1 = 0\}$ ,  $\{z: 6z + 7 = 13\}$
9.  $\{u: u = 1 \text{ or } u = 2\}$ ,  $\{y: (y - 1)(y - 2) = 0\}$ ,  $\{r: |r - \frac{3}{2}| = \frac{1}{2}\}$

\*

Here is a suggestion for a quiz to follow Part B. Scatter the 27 names given above, number them, and ask students to sort them into categories of descriptions of the same set.

[3-14]

B. Each  
m

s,

B. Each

$\pi$

3/20

Students may ask why we don't use raised arrows which point to the left in addition to those which point to the right. There is no completely defensible excuse for not using both kinds of raised arrows. However, in seeking a name for a half-line or a ray, it is natural first to write a name for its vertex and then, following our customary method of writing from left to right, to write a name for another point of the set. Since it is suggestive to place the tail of the arrow above the name of the vertex, the raised arrows we use point to the right.

\*

Note, near the bottom of page 3-16, the symbol introduced as a name for the empty set. This symbol is formed by writing a capital 'O' together with a '/'. It is not a Greek letter. [It is a Scandinavian letter.] It is a symbol which occurs in the International Phonetic Alphabet, and is there pronounced as one pronounces the 'eu' in the French word 'bleu'. However, it is customary to read ' $\emptyset$ ' as 'the empty set'. We introduce this symbol because it is one of the standard ones. A more appropriate symbol might be to write a pair of braces with a space between them like this:

{ }.

You should suggest this latter symbol to the students and let them use it occasionally for ' $\emptyset$ '.

Of course, ' $\{\emptyset\}$ ' is not a name for the empty set.  $\{\emptyset\}$  is a set consisting of just one element, and this element is the empty set. Here is a good example of the difference between a unit set and the element it contains.  $\{\emptyset\}$  is a set with just one member,  $\emptyset$ . But  $\emptyset$  has no members. If a student claims that  $\{\emptyset\}$  is the solution set of, say, ' $x = x + 1$ ', point out his error as follows. The solution set of ' $x + 3 = 8$ ' consists of just the number 5; so a simple name for the solution set of ' $x + 3 = 8$ ' is ' $\{5\}$ '. This means that if we replace the 'x' in the given sentence by a '5', the sentence becomes true. If you claim that  $\{\emptyset\}$  is the solution set of ' $x = x + 1$ ', this means that if we replace the 'x' in ' $x = x + 1$ ' by a ' $\emptyset$ ', we should get a true sentence. Instead, we get nonsense.

s,

B. Each  
m

3/19

On pages 3-15 and 3-16 we introduce geometric terminology. In particular, we pave the way for our use of the word 'locus', in geometry, by equating it with 'solution set'; and we give names to some of the kinds of sets whose pictures students have seen on pages 3-12 and 3-14.

\*

Notice that an interval "has" end points, even though they do not belong to it. If this use of 'has' bothers your students, point out that, analogously, a set of points of the kind we call a circle "has" a center, although the center is not one of the points which belongs to the circle.

\*

Before proceeding to class discussion of page 3-16 you might have students identify those graphs on pages 3-12 and 3-14 which are pictures of intervals, segments, and half-open intervals, respectively.

Intervals: (II) on page 3-12 and Exercise 4 on page 3-14.

Segments: (III) on page 3-12 and Exercises 3 and 7 on page 3-14.

Half-open intervals: (IV) on page 3-12.

[We have not defined 'interval', 'segment', or 'half-open interval' in the text. From the examples which are given of these kinds of sets, students can form concepts which are adequate for the purposes at hand. However, the question may arise as to whether, for example,  $\{x: 2 < x < 2\}$  [that is, the empty set] is an interval and whether  $\{x: 2 \leq x \leq 2\}$  [that is, the set whose only member is 2] is a segment. For your information, in case these questions should arise, the answer to both is 'yes'; also, the empty set is a half-open interval.]

\*

The following is an effective classroom gimmick for getting students to understand the difference between a half-line and a ray. Ask students to imagine that they have plucked out a point from a line. This removal of a point separates the line into two pieces. Each piece is a half-line. Of course, each half-line "goes on forever". Now, if they take the point which they removed and restore it to one of the half-lines, the resulting figure is a ray. A half-line is named by referring to two points, the point which was removed and any other point on the half-line. A ray is named in a similar manner. The raised arrow notation is quite appropriate.

## LOCUS OF A SENTENCE

When people think of the set of real numbers in geometric terms, they call it 'the number line'. And, they often use another geometric term, locus, in place of 'solution set'. The locus of a sentence is the solution set of the sentence.

Consider the sentence ' $1 < x < 3$ '. The locus of this sentence is an interval of the number line, that is, it is the set of all those numbers which are between two numbers, in this case, between the two numbers 1 and 3. The graph of the sentence ' $1 < x < 3$ ' is a picture of this interval.

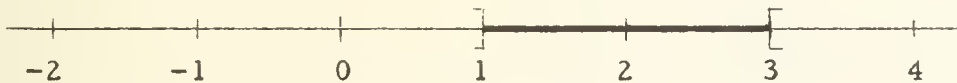

One name for this interval is:

$$\{x: 1 < x < 3\}.$$

Shorter names for this interval are:

$$\overline{1, 3} \quad \text{and:} \quad \overline{3, 1}.$$

[Read as 'interval one three' and as 'interval three one'.]

Consider, next, the sentence ' $1 \leq x \leq 3$ '. Here is a graph of this sentence.



The locus of this sentence is a segment of the number line. It is an interval together with its end points. One name for this segment is:

$$\{x: 1 \leq x \leq 3\}.$$

Shorter names are:

$$\overline{\bullet 1, 3} \quad \text{and:} \quad \overline{\bullet 3, 1}.$$

[Read as 'segment one three' and as 'segment three one'.]

The locus of ' $1 \leq x < 3$ ' is a half-open interval of the number line. A name for it is ' $\overline{\bullet 1, 3}$ ', which is read as 'half-open interval one three'. The locus of ' $1 < x \leq 3$ ' is another half-open interval, ' $\overline{3, \bullet 1}$ '. Make a picture of ' $-2, 3$ ' and a picture of ' $2, -3$ '.

Here is a graph of the sentence ' $2y > 2$ '.



Its locus is a half-line of the number line. Short names for this half-line are:

$$\overrightarrow{1, 2}, \quad \overrightarrow{1, 3}, \quad \overrightarrow{1, 7.3}, \quad \overrightarrow{1, 86}, \quad \text{etc.}$$

[Read as 'half-line one two', etc.] Write three other short names for this half-line. Draw a picture of  $\overrightarrow{2, 1}$ . Do you see that  $\overrightarrow{1, 2} \neq \overrightarrow{2, 1}$  ?

Let's look at a graph of ' $2y \leq 2$ '.

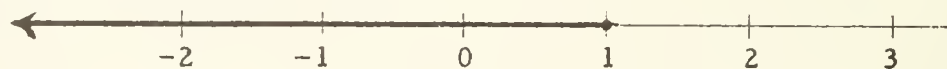

The locus of this sentence is a ray of the number line [a half-line together with its vertex], and is named by:

$$\overleftarrow{1, 0}, \quad \overleftarrow{1, -1}, \quad \overleftarrow{1, -2.3}, \quad \overleftarrow{1, -581}, \quad \text{etc.}$$

[Read as 'ray one zero', etc.]

If the solution set of a sentence consists of just one number, the locus of the sentence is a unit set or a singleton. For example, the locus of ' $3x + 1 = 7$ ' is  $\{2\}$ . The locus of ' $x^2 = 9$ ' is the couple  $\{3, -3\}$ .

The locus of ' $x = x + 1$ ' is the empty set. A short name for the empty set is ' $\emptyset$ '. Hence we could write 'the locus of ' $x = x + 1$ ' is  $\emptyset$ '. The locus of ' $x = x$ ' is the number line itself. [So, we can use ' $\{x: x = x\}$ ' as a name for the number line.]

### EXERCISES

A. Sketch pictures of these sets.

1.  $\overline{-2, 2}$

2.  $\overline{2, -2}$

3.  $\overline{-2, 2}$

4.  $\overline{-2, 2}$

5.  $\overrightarrow{-2, 5}$

6.  $\overrightarrow{5, -2}$

7.  $\overrightarrow{2, 1}$

8.  $\overline{3, 3}$

9.  $\overline{3, 3}$





1 2

-2 -1 0 1 2

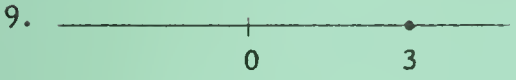

Here is a graph of the sentence ' $2y > 2$ '.



Its locus is a half-line of the number line. Short names for this half-line are:

$\overrightarrow{1, 2}$ ,  $\overrightarrow{1, 3}$ ,  $\overrightarrow{1, 7.3}$ ,  $\overrightarrow{1, 86}$ , etc.

[Read as  
for this  
 $\overrightarrow{1, 2} \neq \overrightarrow{2, 1}$

Let

The locus  
to

[Read as

locus of

locus of

empty

The locus

'{x: ...

A. S

1

4.

7.

q510.7  
I63h1  
1959  
v. 3

LOCATION Educ.

DATE 12 Aug.'63

VOLUMES 11 1/4

HEIGHT 11 1/4

A (STANDARD) 2557

B (NO COLLATION)

C (CRITERION)

D (LUM)

BIND IN ATTACHED SLIP

STUB MISSING PART

NONE BOUND BEFORE

SEE SAMPLE BACK

NO LETTERING

DO NOT COLLATE

BINDING CHARGE

SHELF NOS

EXTRA THICKNESS

STUBBING

HINGING, ETC

EXTRA TIME PREPARING, ETC

HAND SEWING

Write three other short names  
University of Illinois committee on school mathematics

High school mathematics

Teachers' edition

3

q510.7  
I63h1  
1959  
v. 3

book.

PLEASE PEEL OFF AT EXTENDED CARBON  
PLEASE INSERT COPIES 1 AND 2 IN BOOK

UNIV. OF ILLINOIS LIBRARY

$\overleftarrow{-2, 2}$

$\overrightarrow{5, -2}$

$\overleftarrow{3, 3}$

5.  $\overleftarrow{-2, 5}$

8.  $\overleftarrow{3, 3}$

4.  $\overleftarrow{-2, 2}$

7.  $\overrightarrow{2, 1}$

6.

9.

3/21

## Answers for Part A.

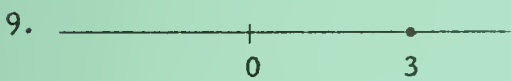
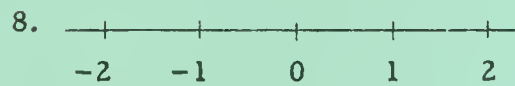

[3-16]

Here :

---

[3-17]

language

Answers for Part B [on pages 3-17 and 3-18].

[As mentioned on pages 3-15 and 3-16 there is more than one way to name the locus of a sentence. [The Sample gives other names for the half-line in question.] We give just one name for each exercise. However, students will doubtless suggest others. For example, Exercise 7 and Exercise 8 might be answered by  $\overline{1, -1}$  and  $\overline{4, -4}$ , respectively.]

- |                              |                                     |                              |                         |                               |
|------------------------------|-------------------------------------|------------------------------|-------------------------|-------------------------------|
| 1. $\overrightarrow{-4, 0}$  | 2. $\overrightarrow{3, 0}$          | 3. $\overrightarrow{4, 5}$   | 4. $\overline{3, 5}$    | 5. $\overline{-1, 4}$         |
| 6. $\{2, -2\}$               | 7. $\overline{-1, 1}$               | 8. $\overline{-4, 4}$        | 9. $\overline{2, -2}$   | 10. $\overrightarrow{-4, -6}$ |
| 11. $\overrightarrow{2, 3}$  | 12. the number line                 | 13. $\overline{-2, 3}$       | 14. $\overline{-5, -2}$ |                               |
| 15. $\overline{0, 4}$        | 16. $\overline{-6, 5}$              | 17. $\overline{-1, 1}$       | 18. $\emptyset$         | 19. $\overrightarrow{4, 5}$   |
| 20. $\overrightarrow{-5, 0}$ | 21. $\emptyset$                     | 22. $\overrightarrow{-3, 0}$ | 23. $\overline{-4, 5}$  | 24. $\overline{-4, 5}$        |
| 25. $\overline{-3, 3}$       | 26. $\overline{6, 6}$ , or: $\{6\}$ | 27. $\{3, -3\}$              | 28. $\overline{-3, 3}$  |                               |
| 29. $\emptyset$              | 30. $\overline{0, 0}$ , or: $\{0\}$ | 31. $\emptyset$              | 32. $\{5, -5\}$         |                               |
| 33. $\overline{-5, 5}$       | 34. the number line                 | 35. $\emptyset$              |                         |                               |
| 36. the number line          | 37. $\{5, -1\}$                     | 38. $\{1, 5\}$               |                         |                               |
| 39. the number line          | 40. $\overline{1, 1}$ , or: $\{1\}$ | 41. $\{0\}$                  |                         |                               |
| 42. $\emptyset$              | 43. $\{0\}$                         | 44. $\emptyset$              |                         |                               |
| 45. the number line          | 46. the number line                 | 47. the number line          |                         |                               |
| 48. $\{0\}$                  | 49. $\overrightarrow{0, 1}$         | 50. $\overrightarrow{0, -1}$ |                         |                               |
| 51. $\overrightarrow{0, -1}$ | 52. $\overrightarrow{0, 1}$         | 53. the number line          |                         |                               |
| 54. $\{0\}$                  | 55. $\overrightarrow{0, -1}$        |                              |                         |                               |

\*

As answers for Exercises 12, 34, 36, 39, 45, 46, 47, and 53, students may suggest  $\overleftrightarrow{-4, 4}$ ,  $\overleftrightarrow{0, 1}$ ,  $\overleftrightarrow{7, 2}$ , etc., as synonyms for 'the number line'. Although we have not felt it necessary to introduce this notation here, students may adopt it if they wish to do so.

\*

B. Name the loci of the following sentences using geometric language wherever possible. ['loci' is the plural of 'locus'.]

Sample.  $x + 2 < 5$

Solution.  $\overrightarrow{3, -8}$

[Other correct answers are:  $\overrightarrow{3, 0}$ ,  $\overrightarrow{3, -100}$ ,  $\overrightarrow{3, 2.999}$ .]

- |                        |                           |
|------------------------|---------------------------|
| 1. $x > -4$            | 2. $y \leq 3$             |
| 3. $x + 1 > 5$         | 4. $3 < y < 5$            |
| 5. $-1 \leq k \leq 4$  | 6. $ x  = 2$              |
| 7. $ x  < 1$           | 8. $ y  \leq 4$           |
| 9. $xx \leq 4$         | 10. $-y > 4$              |
| 11. $-y \leq -2$       | 12. $y > -4$ or $y < 4$   |
| 13. $-2 < x < 3$       | 14. $x > -5$ and $x < -2$ |
| 15. $0 \leq x < 4$     | 16. $-6 < n < +5$         |
| 17. $1 > t > -1$       | 18. $1 > s > 5$           |
| 19. $-3 < x > 4$       | 20. $-5 < x > -5$         |
| 21. $6 < x < 6$        | 22. $-x < 3$              |
| 23. $-4 \leq x < 5$    | 24. $-4 < x \leq 5$       |
| 25. $-3 \leq x \leq 3$ | 26. $6 \leq x \leq 6$     |
| 27. $xx = 9$           | 28. $xx \leq 9$           |
| 29. $xx < 0$           | 30. $xx \leq 0$           |
| 31. $kk = -4$          | 32. $k(-k) = -25$         |
| 33. $ x  < 5$          | 34. $ x  \geq 0$          |
| 35. $ x  < -5$         | 36. $ x  > -5$            |
| 37. $ k - 2  = 3$      | 38. $ 3 - m  = 2$         |

(continued on next page)

39.  $x + 1 = 1 + x$

40.  $x - 1 = 1 - x$

41.  $-x = 0$

42.  $0 \cdot x = 5$

43.  $t = 2t$

44.  $x - 2 = x - 3$

45.  $\square + 2\square = 3\square$

46.  $5g - 3g = 2g$

47.  $3t \times 5t = 15tt$

48.  $6 \times 3y = 9y$

49.  $\square$  is a positive number50.  $\square$  is a negative number51.  $-\square$  is a positive number52.  $-\square$  is a negative number53.  $-\Delta\Delta$  is a nonpositive number54.  $-\Delta\Delta$  is not a negative number55.  $\Delta\Delta\Delta$  is a negative number

C. Each exercise contains a geometric name of a set. Write a sentence which has this set for its locus, and then use brace-notation together with the sentence to write a name for the set.

Sample.  $\xrightarrow{\bullet} -3, 6$

Solution. [This is the ray which consists of  $-3$  and all numbers greater than  $-3$ .] A sentence whose locus is this ray is:

$$x \geq -3.$$

Using brace-notation, a name for the ray is:

$$\{x: x \geq -3\}.$$

Answer.  $x \geq -3, \{x: x \geq -3\}$

1.  $\xrightarrow{\bullet} -5, 4$

2.  $\xrightarrow{\bullet} 1, -8$

3.  $\{-2\}$

4.  $\xrightarrow{\bullet} -6, 6$

5.  $\xrightarrow{\bullet} 4, -8$

6.  $\overline{4, -4}$

7.  $\xrightarrow{\bullet} -6, 6$

8.  $\emptyset$

9.  $\xrightarrow{\bullet} 100, 101$

10.  $\xrightarrow{\bullet} 101, 100$

11.  $\overline{0, 1}$

12.  $\overline{1, 0}$

13.  $\{0\}$

14.  $\{-1, 0\}$

15.  $\{-1, 0, 1\}$



## Answers for Part C.

[Each exercise has many correct answers. We give just one.]

1.  $x \geq -5$ ,  $\{x: x \geq -5\}$
2.  $x \leq 1$ ,  $\{x: x \leq 1\}$
3.  $x = -2$ ,  $\{x: x = -2\}$
4.  $x > -6$ ,  $\{x: x > -6\}$
5.  $x < 4$ ,  $\{x: x < 4\}$
6.  $-4 < x < 4$ ,  $\{x: -4 < x < 4\}$
7.  $-6 \leq x \leq 6$ ,  $\{x: -6 \leq x \leq 6\}$
8.  $x = x + 1$ ,  $\{x: x = x + 1\}$
9.  $x > 100$ ,  $\{x: x > 100\}$
10.  $x < 101$ ,  $\{x: x < 101\}$
11.  $0 \leq x < 1$ ,  $\{x: 0 \leq x < 1\}$
12.  $0 < x \leq 1$ ,  $\{x: 0 < x \leq 1\}$
13.  $x = 0$ ,  $\{x: x = 0\}$
14.  $x(x + 1) = 0$ ,  $\{x: x(x + 1) = 0\}$
15.  $x(x + 1)(x - 1) = 0$ ,  $\{x: x(x + 1)(x - 1) = 0\}$

39.

4'

3/26

\*

When a student gives an incorrect answer, the only way to correct him is to replace the pronumeral in the equation by a name for the alleged root. For example, if a student claims that 2 is the root for Exercise 2, you can respond by asking: Does  $15 = 2 + 17$ ?

\*

Note that Exercises 9, 10, and 11 of Part A are equations which need to be solved just as the other equations need to be solved. Of course, students will conclude that equations such as these are "the world's easiest equations". Nevertheless, they do have roots. [In this connection, one of our colleagues pointed out an exercise in a rather well known textbook which asks students to solve the equation ' $x = \log_2 2$ '. We suppose that UICSM students would be able to divine the author's intention, but it does seem as though this author was not acquainted with the word 'simplify'.]

\*

Answers for Part A [on pages 3-19 and 3-20].

- |                        |                     |             |                     |                    |
|------------------------|---------------------|-------------|---------------------|--------------------|
| 1. 6                   | 2. -2               | 3. -4       | 4. -3               | 5. 1.4             |
| 6. -9.4                | 7. 26               | 8. -11      | 9. -1               | 10. 1.5            |
| 11. 17                 | 12. -5              | 13. 16      | 14. 7               | 15. -1             |
| 16. 9                  | 17. 2               | 18. 8       | 19. -2              | 20. 3              |
| 21. 3                  | 22. 4               | 23. $16/9$  | 24. -3              | 25. no roots       |
| 26. $-9/2$             | 27. 0               | 28. -9      | 29. 40              | 30. -6             |
| 31. 10                 | 32. -8              | 33. 0       | 34. -15             | 35. -8             |
| 36. -6                 | 37. 8               | 38. 10      | 39. 9               | 40. -10            |
| 41. 3                  | 42. 3               | 43. 3       | 44. $1/3$           | 45. -3             |
| 46. 30                 | 47. 43              | 48. -79.3   | 49. $\frac{93}{12}$ | 50. $\frac{19}{9}$ |
| 51. $\frac{17.3}{8.5}$ | 52. $71\frac{1}{4}$ | 53. 10, -10 | 54. no roots        | 55. 7, -7          |
| 56. 6, -6              | 57. no roots        | 58. 0       | 59. no roots        | 60. no roots       |

ing

\*

The bracketed remarks following the Solution of the Sample of Part A should get some attention. Although we do not expect students to ask and answer such questions about each of the equations they solve in Parts A and B, they should spend a little time pondering the question of how they know that 5 is the only root of the equation ' $x + 3 = 8$ '. The cancellation principle for addition answers this question for us. For if there were another root than 5, then this root's sum with 3 would equal the sum of 5 with 3. The cancellation principle for addition tells us that, for each  $a$ , if  $a + 3 = 5 + 3$  then  $a = 5$ . So, the alleged other root is 5. In other words, the equation has no other root than 5.

\*

It is good practice to discuss the first 12 exercises in class. 'discuss' in this case means asking individual students for roots. The student must focus his complete attention on the fact that he is seeking numbers which satisfy the equation. He is not trying to "find out what  $x$  is" or "find out what the unknown number is" or "find out what number  $x$  stands for". Recall that pronumerals do not represent or stand for numbers. They simply occupy places in expressions which can be occupied by numerals. They do not represent or stand for numerals which can be written in place of them. When a student is solving an equation, he is searching for numbers whose numerals can take the place of letters to make true sentences. Consequently, if you ask a student for the roots of the equation in Exercise 1, he should say that the root is 6. He should not say that " $x$  is 6" or that " $x = 6$ ". Thus, when students solve these equations as part of their homework, they should be required only to give the roots. This means that if they write answers in their textbook, all they need do is to write next to each equation a numeral for its root. [If they do not write answers in their textbook, then they should simply write the numerals for the exercise numbers, and next to each write a numeral for the corresponding root for the 60 exercises in Part A.] If the equation has two roots, the students should write names for both, and separate the names by a comma. If the equation has no roots, students should write 'no roots'. [They should not write ' $\emptyset$ ' because they are not asked to give the solution set.]

\*

Some students may recall mechanical rules for solving equations, rules which they learned in an earlier grade. Do not make a fuss over this. They will tend to stop using these rules when you ask only for roots [no work to be shown, please] and put a premium on speed in giving answers.

ing

Please note carefully the definition we give for 'equation'. An equation is a sentence, and therefore an equation is something which one looks at. We believe that conventional definitions of 'equation' are confusing. What can it mean to say, for example, that an equation is a statement that two numbers [or: quantities] are equal? It cannot be the case that two numbers are equal, since the only thing to which a number is equal is itself. When we assert:

$$3 + 4 = 6 + 1,$$

what we are asserting is that when you add 4 to 3, you get the same number as when you add 1 to 6.

Also, the truth or falsity of a sentence is entirely irrelevant to whether the sentence is an equation. The word 'equation' refers to the form of a sentence, and not to its "content". In view of the experience your students have had with true sentences, false sentences, and open sentences in Units 1 and 2, we do not anticipate that they will have difficulty in accepting this definition of 'equation'. To make sure that they feel at home with the concept, you might ask students to give you several examples of true equations, several examples of false equations, and several examples of equations which are neither true nor false [that is, open equations]. In view of this definition of 'equation', it is clear that statements such as:

an equation is like a balance,  
both sides of the equation must be kept the same,  
both sides of an equation stand for the same thing,

make no sense.

\*

Students should be able to solve the equations in Parts A and B without any prior instructions other than those given in the discussion at the top of page 3-19 and in the Sample for Part A. We hope that, by now, you will not be surprised by the fact that students are able to solve these equations without such formal devices as "equation axioms". If you should find a student who has difficulty with one of these problems, say, Exercise 5 of Part A, you may help him to this extent. Ask him to imagine that the 'm' in the given equation ' $9 + m = 10.4$ ' is really a hole in the paper. [In view of Unit 2, this will not be a strange thing for him to imagine.] His job in solving the equation, then, consists in finding what he must put in the hole to make the resulting sentence a true one. A number whose name when put in the hole converts the sentence into a true one is a root of the equation, or a solution of the equation. [Note well that a root or a solution of an equation is a number, not a numeral.]

3.04 Equations. --An equation is a sentence obtained by connecting expressions by an equality sign. Examples of equations are:

(1)  $3 + 5 = 4 \times 2,$

(3)  $x + 4 = 9 - x,$

(2)  $9 + 7 = 7 \times 3,$

(4)  $x = x - 1.$

An equation can be a statement such as (1) and (2), or open sentences such as (3) and (4). [Sentences obtained by connecting expressions by inequality signs like '>', ' $\neq$ ', '<', ' $\not<$ ', and '>' are called inequations.]

The numbers which satisfy an equation are called the roots of the equation [or: the solutions of the equation].

To solve an equation is to find all of its roots.

### EXERCISES

A. Solve.

Sample.  $x + 3 = 8$

Solution. To solve ' $x + 3 = 8$ ' is to find each number whose sum with 3 is 8. 5 is such a number. So, a root is 5. All you need write is:

5.

[How do we know that 5 is the only root? Does the cancellation principle for addition help you answer this question?]

1.  $x + 9 = 15$

2.  $15 = y + 17$

3.  $a + 4 = 0$

4.  $t + 12 = 9$

5.  $9 + m = 10.4$

6.  $18 + p = 8.6$

7.  $\square + 2 = 28$

8.  $12 + \Delta = 1$

9.  $x = -1$

10.  $y = 1.5$

11.  $\square = 17$

12.  $-\square = 5$

(continued on next page)

13.  $7 = x - 9$

15.  $A - 2 = -3$

17.  $3 - x = 1$

19.  $4 - q = 6$

21.  $15 = 5\Delta$

23.  $9x = 16$

25.  $2x = 1 + 2x$

27.  $-4\Delta = 0$

29.  $\square \div 8 = 5$

31.  $\frac{x}{5} = 2$

33.  $0 = \frac{t}{17}$

35.  $\frac{-\square}{8} = 1$

37.  $\frac{1}{2}\square = 4$

39.  $\frac{5}{3}t = 15$

41.  $\frac{3}{\square} = 1$

43.  $\frac{21}{x} = 7$

45.  $5 = 8 + x$

47.  $y - 17.8 = 25.2$

49.  $12x = 93$

51.  $17.3 = 8.5k$

53.  $xx = 100$

55.  $2AA = 98$

57.  $2 + y = 3 + y$

59.  $2 - y = 3 - y$

14.  $y - 4 = 3$

16.  $K - 9 = 0$

18.  $26 - y = 18$

20.  $-8 = -5 - t$

22.  $3\square = 12$

24.  $8y = -24$

26.  $2r = -9$

28.  $+27 = -3\square$

30.  $\Delta \div -2 = 3$

32.  $\frac{y}{4} = -2$

34.  $\frac{y}{-3} = 5$

36.  $-\frac{\Delta}{6} = 1$

38.  $\frac{3}{5}\Delta = 6$

40.  $\frac{7}{2}z = -35$

42.  $2 = \frac{6}{\Delta}$

44.  $24 = \frac{8}{y}$

46.  $20 = y - 10$

48.  $18.3 = z + 97.6$

50.  $18z = 38$

52.  $x - 22\frac{1}{2} = 48\frac{3}{4}$

54.  $-81 = tt$

56.  $yy - 12 = 24$

58.  $2y = 3y$

60.  $2 \div y = 3 \div y$





Do not fail to point out the similarity between the equations in Exercises 23 and 25 and those in Exercises 24 and 26. Ask students if the equation in Exercise 23 has the same roots as the equation ' $\frac{t+6}{2} = 9$ '. Try to elicit from them the statement that they could tell this without solving the equations by noticing that ' $\frac{1}{2}(t+6)$ ' and ' $\frac{t+6}{2}$ ' are equivalent pronumeral expressions. A bit of review on what is meant by 'equivalent pronumeral expressions' would fit in well here because Part D requires a good understanding of this term.

\*

- |            |              |                   |                                 |                      |
|------------|--------------|-------------------|---------------------------------|----------------------|
| 26. 11     | 27. 29       | 28. 26            | 29. -10                         | 30. -72              |
| 31. 4      | 32. 2        | 33. $\frac{1}{2}$ | 34. $\frac{64}{13}$             | 35. $\frac{129}{52}$ |
| 36. -19/92 | 37. 2        | 38. 35/53         | 39. 10, 0                       | 40. 1, 2             |
| 41. -1, 3  | 42. no roots | 43. 3, -3         | 44. $\frac{1}{3}, -\frac{1}{3}$ |                      |

\*

Your class may enjoy playing with the equation:

$$\frac{3 + |x|}{8 + |x|} = \frac{2}{3}$$

and variations of it obtained by replacing the ' $\frac{2}{3}$ ' in it by a ' $\frac{1}{2}$ ', a ' $\frac{3}{4}$ ', a ' $\frac{5}{6}$ ', and a ' $\frac{7}{8}$ '.



Part B contains so-called two-step and three-step equations. No formal instruction is necessary for these exercises. Students should work many of these exercises in class. Give individual help only when asked [or when a student is making consistent errors], and make this help intuitive only. By 'intuitive help' we mean help such as the following:

Suppose a student is having trouble with Exercise 10. You might place your thumb over '12m' and ask him what numeral could be written in place of '12m' so that the resulting sentence would be true. Let him think about this until he replies that '-24' would "work". It is not necessary to ask him how he obtained '-24'. Then, direct his attention to the '12m'. Ask about the numeral that could be written in place of 'm' so that the resulting expression would be a name for -24. This should be enough help. If the student needs help on another equation of the same type, say, Exercise 21, tell him to review the thinking he did in Exercise 10.

It may be necessary to ask the students to refrain from getting help from students in other classes or from their parents. They should understand that the purpose of these exercises is to get them to develop their own methods for solving equations. They will be operating at a disadvantage later on if they use a rule someone has given them. Students should feel very confident in solving equations of the type given in Part B before they attack Part D.

\*

Answers for Part B.

- |                   |                    |                    |        |                    |
|-------------------|--------------------|--------------------|--------|--------------------|
| 1. 3              | 2. 4               | 3. 3               | 4. 5   | 5. 3               |
| 6. 9              | 7. -3              | 8. -8              | 9. -1  | 10. -2             |
| 11. -2            | 12. 0              | 13. 2              | 14. -2 | 15. $\frac{11}{5}$ |
| 16. $\frac{3}{2}$ | 17. $\frac{11}{3}$ | 18. $\frac{13}{9}$ | 19. 38 | 20. 21             |
| 21. 15            | 22. 16             | 23. 12             | 24. 10 | 25. 13             |

\*

B. Find the roots of the following equations.

1.  $3x = 9$

2.  $3x + 4 = 16$

3.  $1 = 2x - 5$

4.  $7x + 8 = 43$

5.  $5 + 8x = 29$

6.  $2 + 3q = 29$

7.  $5x + 4 = -11$

8.  $-12 = 3y + 12$

9.  $7k + 9 = 2$

10.  $15 + 12m = -9$

11.  $2x - 12 = -16$

12.  $7 + 3x = 7$

13.  $5 - 2x = 1$

14.  $9 - 2x = 13$

15.  $5x + 7 = 18$

16.  $9 = 3 + 4x$

17.  $6y - 5 = 17$

18.  $9z - 8 = 5$

19.  $\frac{1}{2}x - 7 = 12$

20.  $\frac{2}{3}y + 2 = 16$

21.  $\frac{2}{5}x - 8 = -2$

22.  $\frac{1}{8}k - 1 = 1$

23.  $9 = \frac{1}{2}(t + 6)$

24.  $\frac{1}{3}(s - 4) = 2$

25.  $\frac{x + 2}{5} = 3$

26.  $\frac{y + 7}{2} = 9$

27.  $\frac{m - 5}{8} = 3$

28.  $\frac{n - 2}{4} = 6$

29.  $2 = \frac{4 - \square}{7}$

30.  $\frac{8 - \triangle}{10} = 8$

31.  $\frac{2a + 7}{3} = 5$

32.  $\frac{5z - 4}{-3} = -2$

33.  $3 = 2\frac{1}{2}x + 1\frac{3}{4}$

34.  $3\frac{1}{4}y - 7\frac{1}{5} = 8\frac{4}{5}$

35.  $5.2y - 4.3 = 8.6$

36.  $9.2b - 3.8 = -5.7$

37.  $7.8 - 3.9z = 0$

38.  $5.2 = 8.7 - 5.3u$

39.  $|x - 5| = 5$

40.  $|3 - 2y| = 1$

41.  $2 + |3 - 3x| = 8$

42.  $5 + |7 - 4x| = 2$

43.  $15 = 2ZZ - 3$

44.  $9kk - 3 = -2$

[More exercises are in Part B, Supplementary Exercises.]

C. Each exercise contains descriptions of sets of numbers. For each exercise, tell which descriptions refer to the same set as the first description. [The first description is underlined.]

1. {x:  $2x + 3x + 7 = 17$ }  
 (a) {x:  $2x + 10 = 17$ }  
 (b) {x:  $5x + 7 = 17$ }  
 (c) {x:  $12x = 17$ }
2. {r:  $5r + 3 - 2r - 12 = 12$ }  
 (a) {r:  $5r + r - 12 = 12$ }  
 (b) {r:  $3r - 9 = 12$ }  
 (c) {r:  $5r - 11 = 12$ }
3. {x:  $3x + 4(2x + 7) = 83$ }  
 (a) {x:  $7x + 2x + 7 = 83$ }  
 (b) {x:  $3x + 8x + 7 = 83$ }  
 (c) {x:  $3x + 8x + 28 = 83$ }  
 (d) {x:  $11x + 28 = 83$ }
4. {k:  $2(k - 3) + 7(k + 1) = 46$ }  
 (a) {k:  $2k - 6 + 7k + 1 = 46$ }  
 (b) {k:  $2k - 6 + 7k + 7 = 46$ }  
 (c) {k:  $9k - 13 = 46$ }  
 (d) {k:  $9k + 1 = 46$ }
5. {y:  $5y - 3 + 4y + 5 = 20$ }  
 (a) {y:  $2y + 4y + 5 = 20$ }  
 (b) {y:  $5y + y + 5 = 20$ }  
 (c) {y:  $5y - 7y + 5 = 20$ }  
 (d) {y:  $9y - 3 + 5 = 20$ }  
 (e) {y:  $9y + 2 = 20$ }
6. {t:  $3(t - 4) - 5(3 - 2t) = 38$ }  
 (a) {t:  $3t - 4 - 15 - 10t = 38$ }  
 (b) {t:  $3t - 4 - 15 + 10t = 38$ }  
 (c) {t:  $3t - 19 + 10t = 38$ }  
 (d) {t:  $3t - 9t = 38$ }  
 (e) {t:  $13t - 27 = 38$ }
7. {y:  $6y - 5(2 - 3y) = 32$ }  
 (a) {y:  $y - 2 - 3y = 32$ }  
 (b) {y:  $6y - 10 - 15y = 32$ }  
 (c) {y:  $6y - 10 + 15y = 32$ }  
 (d) {y:  $21y - 10 = 32$ }
8. {z:  $8z + 3 + 2z + 9 = -28$ }  
 (a) {x:  $8x + 2x + 3 + 9 = -28$ }  
 (b) {a:  $10a + 12a = -28$ }  
 (c) {k:  $10k + 12 = -28$ }  
 (d) {z:  $8z + 3 + 11z = -28$ }
9. {y:  $8(9 - 3y) + 5(6 - 7y) - 2y = 15$ }  
 (a) {y:  $72 - 3y + 30 - 7y - 2y = 15$ }  
 (b) {y:  $72 - 24y + 30 - 35y - 2y = 15$ }  
 (c) {y:  $102 - 61y = 15$ }

3/29

The exercises in Part C are really exploratory exercises for Part D. Students are supposed to discover that two equations which agree in their right members have the same roots if the left member of one is equivalent to the left member of the other. You should not ask for justifications for the answers students give to these exercises since, as is the case with Exploration Exercises, all we want the student to do is to build a good intuitive feeling that two equations have the same roots if the members of one are simplifications of the members of the other. [Introduce the phrase 'member of an equation' when it seems convenient to do so.]

What should be done if the student gives a wrong answer? For example, what if a student claims that in Exercise 1 the solution set described in (a) is the same as the set of numbers described by the underlined name? To show that the sets in question are different, all one need do is show that an element of one of them is not an element of the other. It is easy to see that an element of the set described in (a) is 3.5. Substituting '3.5' for 'x' in the open sentence ' $2x + 3x + 7 = 17$ ' shows immediately that 3.5 is not an element of the set named by the underlined description.

\*

In discussing these exercises [or other exercises involving the solution of equations] a student may assert, for example, that ' $2x + 3 + 7 = 17$ ' is the same equation as ' $2x + 10 = 17$ ', or he may even say that the two equations are equal. This kind of talk about equations should be stopped as soon as it occurs. One way to do this is to write the two equations on the blackboard, one about twelve inches below the other. Then ask: If a first grader walked into the room and looked at the blackboard, would he say that those two equations are the same or would he say that they were different? Of course, they are different equations. A student tends to say that they are the same because he is referring to the fact that they have the same roots. But, since an equation is a sentence composed of an equality sign flanked by expressions, the given two equations are not the same. [On the other hand, it is not necessary to be completely precise here. We shall often consider two equations [or expressions, generally] to be the "same" when one is a copy of the other.]

\*

Answers for Part C [on pages 3-22 and 3-23].

[We give just the identifying letters of the descriptions which refer to the same set as the underlined description.]

- |             |                   |                   |             |
|-------------|-------------------|-------------------|-------------|
| 1. (b)      | 2. (b)            | 3. (c), (d)       | 4. (b), (d) |
| 5. (d), (e) | 6. (e)            | 7. (c), (d)       | 8. (a), (c) |
| 9. (b), (c) | 10. (b), (c), (d) | 11. (a), (c), (d) |             |

[3-22]

C. Each  
ea





C. Each

3/31

will ask them again and again throughout Unit 3. If he can answer 'yes' to both questions then he can conclude that the equations have the same solution set. It is a good idea to write this explicitly:

$$\{x: 5x - 3 + 4x + 5 = 20\} = \{x: 9x + 2 = 20\}.$$

\*

Note the checking procedure. Since we know that the two equations have the same roots, there is no logical need for checking the roots of the derived equation by substituting in the given equation. However, there is a practical need, since students may have made errors in deriving equation (2). The reason that we check in cases like this is to make sure that there have been no errors in simplification.

\*

Answers for Part D [on pages 3-23, 3-24, and 3-25].

- |              |             |                                |              |        |
|--------------|-------------|--------------------------------|--------------|--------|
| 1. 1         | 2. 3        | 3. -2                          | 4. 0         | 5. 5   |
| 6. -2        | 7. 3        | 8. -5                          | 9. 19        | 10. 3  |
| 11. 5        | 12. 1/4     | 13. 3                          | 14. 4        | 15. -5 |
| 16. 0        | 17. -2      | 18. -3                         | 19. 4        | 20. -2 |
| 21. 3        | 22. 43      | 23. each real number is a root |              |        |
| 24. no roots | 25. 1/3     | 26. 1/2                        | 27. 8        | 28. 6  |
| 29. 5        | 30. 11, -11 | 31. 10                         | 32. no roots |        |



C. Each

3/30

The discussion in the Solution of Sample 1 of Part D is very important. We are faced with the problem of finding the roots of the equation:

$$(1) \quad 5x - 3 + 4x + 5 = 20.$$

In order to solve this equation, we give ourselves the job of solving the equation:

$$(2) \quad 9x + 2 = 20.$$

It is clear how equation (2) was obtained. We simplified the left member of (1), wrote the simplified expression, followed it by an equality sign, and followed that by the expression '20'. The vital question here is: Are the roots of equation (2) precisely the roots of equation (1)? Or, in other words, is the solution set of equation (2) the solution set of equation (1)? The questions asked in the text lead to the conclusion that each value of 'x' which satisfies (1) will satisfy (2), and each value of 'x' which fails to satisfy (1) will fail to satisfy (2). [Do you see that if each value of 'x' which fails to satisfy (1) also fails to satisfy (2) then each value of 'x' which satisfies (2) will also satisfy (1)?] If each value of 'x' either satisfies both (1) and (2) or satisfies neither (1) nor (2), then equations (1) and (2) have the same roots.

Now, the question which we raised only indirectly in the text and which should be handled in class is this: How do you know that each substitution for 'x' will convert both (1) and (2) into true sentences or both (1) and (2) into false sentences? The answer to this question depends on the fact that '5x - 3 + 4x + 5' and '9x + 2' are equivalent expressions. This means that each substitution for 'x' converts the expressions into names for the same number. If the substitution converts both expressions into names for a number different from 20, then that substitution converts both (1) and (2) into false sentences.

As indicated in the text, the sole reason for deriving equation (2) is that it is easier to solve than equation (1) and that it has the same roots as equation (1). You may want to ask two questions which are equivalent to the two asked in the text. They are: Do you think that any number which is a root of equation (1) must also be a root of equation (2)? and: Do you think that any number which is a root of equation (2) must also be a root of equation (1)? These two questions about a pair of equations will become very familiar to the student, since he

10.  $\{k: 5k - 2(k - 3) - 5(4 - 5k) = 144\}$
- (a)  $\{k: 5k - 2k - 3 - 20 - 5k = 144\}$
- (b)  $\{k: 5k - 2k + 6 - 20 + 25k = 144\}$
- (c)  $\{k: 5k + -2k + 25k + 6 + -20 = 144\}$
- (d)  $\{k: 28k - 14 = 144\}$
11.  $\{x: 8xx - 2x(3 + 4x) = -12\}$
- (a)  $\{x: 8xx - 6x - 8xx = -12\}$
- (b)  $\{x: 2x - 8xx = -12\}$
- (c)  $\{x: 8xx - 8xx - 6x = -12\}$
- (d)  $\{x: -6x = -12\}$

D. Solve.

Sample 1.  $5x - 3 + 4x + 5 = 20$

Solution. If we simplify the pronumeral expression '5x - 3 + 4x + 5', we get '9x + 2'. Does the given equation:

$$(1) \quad 5x - 3 + 4x + 5 = 20$$

have the same roots as the equation:

$$(2) \quad 9x + 2 = 20 \quad ?$$

Suppose you pick a value of 'x' and substitute a numeral for it in both (1) and (2). If the new sentence you get from (1) is true. will the sentence you get from (2) be true? If the sentence you get from (1) is false, will the sentence you get from (2) be false? Which equation is easier to solve, (1) or (2)?

Equation (2) has the root 2. So, equation (1) should have the root 2. We check this by substituting '2' for 'x' in (1):

$$5(2) - 3 + 4(2) + 5 = 20. \quad \text{True?}$$

$$10 - 3 + 8 + 5 \mid 20$$

$$20 = 20 \quad \checkmark \quad \text{Yes!}$$

Sample 2.  $3(x - 4) - 5(3 - 2x) = 38$

Solution. Derive a new equation which has the same roots but is easier to solve by simplifying the left side of ' $3(x - 4) - 5(3 - 2x) = 38$ '.

$$3(x - 4) - 5(3 - 2x) = 38$$

$$3x - 12 - 15 + 10x = 38$$

$$13x - 27 = 38$$

This last equation has the root 5. So, the given equation has the root 5.

Check.  $3(5 - 4) - 5(3 - 2 \cdot 5) = 38$  True?

$$\begin{array}{r} 3 \cdot 1 - 5 \cdot -7 \\ 3 + 35 \end{array} \quad \left| \begin{array}{l} 38 \\ 38 \end{array} \right.$$

$$38 = 38 \checkmark \text{ Yes!}$$

Sample 3.  $2x - 3(4 - x) = 7$

Solution.  $2x - 3(4 - x) = 7$

$$2x - 12 + 3x = 7$$

$$5x - 12 = 7$$

The root is  $\frac{19}{5}$ .

Check.

$$2 \cdot \frac{19}{5} - 3(4 - \frac{19}{5}) = 7 ?$$

$$\begin{array}{r} \frac{38}{5} - 3 \cdot \frac{1}{5} \\ \frac{35}{5} \end{array} \quad \left| \begin{array}{l} 7 \\ 7 \end{array} \right.$$

$$7 = 7 \checkmark$$

1.  $7y - 2 + 5y = 10$
2.  $8a - 3 - 2a = 15$
3.  $5z + 4 - 3z + 2 = 2$
4.  $1 = m + 2m + 1 + 4m$
5.  $3k - 2 - k = 8$
6.  $-21 = 4x + 5 + 9x$
7.  $3x + 2(x - 2) = 11$
8.  $8(7 - k) + 12(3 + 2k) = 12$
9.  $x - (2 - x) = 36$
10.  $3y - (12 - 2y) = 3$
11.  $x - (x - 1) - (x - 2) + 2 = 0$
12.  $5m - 2(m - 3) - 5(4 - 5m) = -7$
13.  $5(2r - 3) - 3(r + 7) = -15$
14.  $7(3 - 5s) - 2(2s - 4) = -127$
15.  $2a - 2(3a - 1) = 22$
16.  $3b - 5(2 - 4b) = -10$
17.  $4(B - 6) + 3(2B + 1) = -41$
18.  $26 = 3y + 5(4 - y)$
19.  $5 - 7(2 - x) + 4(2x - 5) = 31$
20.  $224 = 8(9 - 3y) + 5(6 - 7y) - 2y$
21.  $5(3 - 2z) - 6(5z - 2) + 8(3z - 5) = -61$
22.  $5.3(4 + 3m) - 8.2(2m - 1) = 7.9$
23.  $4x + 2(5 - 2x) = 10$
24.  $2x - 2(x - 3) = 7$
25.  $3(x + 2) + 2(5 - x) + 8x = 19$
26.  $2(y - 3) + 3(3 + 2y) = 7$
27.  $\frac{1}{2}(2x - 6) + \frac{1}{3}(3x + 9) = 16$
28.  $\frac{1}{3}(9x + 12) + \frac{1}{5}(5x - 15) = 25$
29.  $x(x - 5) + 2x(3 - x) + xx = 5$
30.  $3y(2 - y) - 4y(3 - y) + 6y - 5 = 116$
31.  $6(a - 3) + 7(a - 3) - 8(a - 3) - 4(a - 3) = 7$
32.  $5(bb - 3) - 8(bb - 3) + 3(bb - 3) = 6$

[More exercises are in Part C, Supplementary Exercises.]

## EXPLORATION EXERCISES

The solution set of the sentence ' $x + 4 > 6$ ' is the set of numbers greater than 2. Here is its graph.

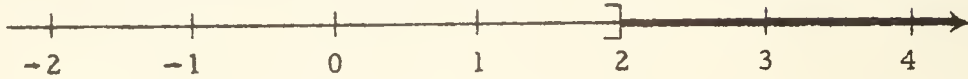

The solution set of the sentence ' $x + 4 > 5$ ' is the set of numbers greater than 1, and its graph is:

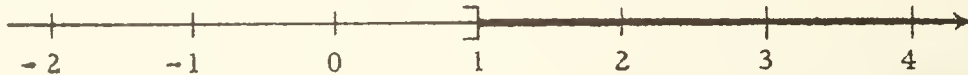

It is easy to see that each member of the solution set of ' $x + 4 > 6$ ' is a member of the solution set of ' $x + 4 > 5$ '. A quick way to express this fact is to say:

the solution set of ' $x + 4 > 6$ '  
is a subset of  
the solution set of ' $x + 4 > 5$ ',

which can be abbreviated to:

$$\{x: x + 4 > 6\} \subseteq \{x: x + 4 > 5\}.$$

Is the solution set of ' $x + 4 > 5$ ' a subset of the solution set of ' $x + 4 > 6$ '? The answer to this question is 'no' because the solution set of ' $x + 4 > 5$ ' contains at least one member which is not a member of the solution set of ' $x + 4 > 6$ '. For example, \_\_\_ is such a member.

A. True or false?

Sample 1.  $\{7, 9, 13\} \subseteq \{7, 9, 13, 17\}$

Solution. True, because each member of  $\{7, 9, 13\}$  is a member of  $\{7, 9, 13, 17\}$ .

Sample 2.  $\{5, 8, 71\} \subseteq \{1, 2, 5, 7, 8, 69, 70\}$

Solution. False, because 71 is a member of  $\{5, 8, 71\}$  but is not a member of  $\{1, 2, 5, 7, 8, 69, 70\}$ .



3/32

The set of Exploration Exercises which is concluded on page 3-31 seeks to carry the student from the notion of a pair of solution sets one of which is a subset of the other to the notion of transforming an equation to a second equation which is equivalent to the first. The student has already had experience in transforming an equation by simplifying one of its members. In that case, the equivalence of the resulting pair of equations is a consequence of the fact that the corresponding members are equivalent expressions.

In the transformation procedure developed in these Exploration Exercises, the fact that the derived equation is equivalent to the given equation depends upon other principles. The discussion of how the equivalence follows from other principles is a rather wordy affair, and one which is more readily carried out between teacher and class than in the textbook. [After all, the teacher can point to an equation.] We shall give a sketch of this discussion in the COMMENTARY as a guide for what you will be doing in class.

\*

In Sample 1 we point out that a first set is a subset of a second set if each member of the first set is a member of the second set. [Another way of saying this [which will be helpful in treating Exercise 15 on page 3-27] is to say that a first set is a subset of a second set if it is the case that there is no member of the first set which is not a member of the second set.]

Sample 2 is an example of how to prove that a first set is not a subset of a second.

Sample 3 on page 3-27 is important in that it exemplifies the generalization that each set is a subset of itself. The justification for this is, again, the fact that each member of the first set is a member of the second set or, alternatively, that there is no member of the first set which is not a member of the second set.

Another way of showing that the sentence in Sample 4 on page 3-27 is true is to show that the first set [that is, the set named on the left] is a subset of the second set and the second set is a subset of the first. This point is made in the middle of page 3-31. It is a good idea to prepare students for the work on page 3-31 by using this alternative method in solving Sample 4. You may also want to employ this alternative method in Exercises 18 and 20.





second set. Then it can be determined that the first set is a subset of the second, because if it has members they are real numbers and if it has no members it is the empty set. [You may be worried about the possibility that the set selector in the description of the first set may have complex number roots. Even if you change the domain of 'x' from the set of real numbers to the set of complex numbers, the sentence will still be true. ]]

20. T [The second set is the empty set. The equation in the description of the first set:

$$y + \frac{1}{y-8} = 8 + \frac{1}{y-8}$$

has no roots [Try values of 'y' other than 8.] So, the first set is the empty set. [Note what happens when you remove the 'and  $y \neq 8$ 's from the set selectors. ]]

\*

As explained in Unit 4, ' $\{x: \frac{xx}{x} = \frac{x}{x} \text{ and } x \neq 0\}$ ' is notationally somewhat unsatisfactory. A better name for the set in question is ' $\{x \neq 0: \frac{xx}{x} = \frac{x}{x}\}$ '. Briefly, just as in the case of restricted quantification [see TC[2-84]], we should restrict the admissible values of 'x' to those which convert ' $\frac{xx}{x} = \frac{x}{x}$ ' to a statement. Similarly, we should use ' $\{y \neq 8: y + \frac{1}{y-8} = 8 + \frac{1}{y-8}\}$ ' in Exercise 20.



10. T [This can be decided in a manner similar to that described for Exercise 9.]
11. T
12. T [Both 10 and -10 are members of each set, and they are the only members. So, the sentence ' $\{z: |z| = 10\} \subseteq \{z: zz = 100\}$ ' is also true. Hence the sentence ' $\{z: zz = 100\} = \{z: |z| = 10\}$ ' is true.]
13. T [2 and -2 are the only members of each set. So, it is the case that  $\{a: 9aa = 36\} \subseteq \{a: aa = 4\}$ ; it is also the case that  $\{a: aa = 4\} \subseteq \{a: 9aa = 36\}$ . Hence, we really have two names for the same set.]
14. F [Both 0 and 1 are members of the first set, but 0 is not a member of the second set.]
15. T [This sentence contains two names for the empty set. Since each set is a subset of itself, the sentence is true. Also, since there is no member of  $\{x: x = x + 1\}$  which is not a member of  $\{x: x = x + 2\}$ , it follows that  $\{x: x = x + 1\} \subseteq \{x: x = x + 2\}$ .]
16. F [All real numbers are members of the first set; 8 is the only member of the second set.]
17. T [The first set named is the empty set; since it contains no members, there is no member of the first set which is not a member of the second set.]
18. T [1 is the only member of each set. Hence, each set is a subset of the other, and therefore we have two names for the same set. It is interesting to compare this exercise with the following sentence:

$$\{x: xx = x\} = \{x: \frac{xx}{x} = \frac{x}{x}\}.$$

This sentence is false because the first set is not a subset of the second. The first set contains 0 but the second set does not.]

19. T [At the outset, students may claim that they cannot determine the answer to this question because they do not have a way of finding the members of the first set. Ask them to consider the members of the second set; a few moments reflection will surely elicit the comment that all real numbers are members of the



Answers for Part A [which begins on page 3-26].

1. F [1 is not a member of {2, 3}.]
2. T
3. F [At least one member of {2, 5} is not a member of {4, 9}.]
4. F [8 and 10 are not members of {7, 9, 11}.]
5. T [It may help students if they think about graphs of the sentences ' $x > 5$ ' and ' $x > 3$ '. If one attempts to draw graphs of both sentences on the same picture of the number line, it is clear that the graph of the first sentence is part of the graph of the second sentence. So, each member of the solution set of the first sentence also belongs to the solution set of the second sentence. It is, of course, sufficient for a student to point out that each number greater than 5 is also greater than 3.]
6. F [There are some numbers, e.g., 3.5, which belong to  $\{x: x < 5\}$  but which are not members of  $\{x: x < 3\}$ .]
7. T [Ask students if  $\{t: tt = \frac{1}{9}\} \subseteq \{t: 3t = 1\}$ .]
8. F [-4 is a member of the first set, but it is not a member of the second set. Ask if  $\{y: y = 4\} \subseteq \{y: yy = 16\}$ .]
9. T [This exercise and Exercise 10 provide students with an opportunity to explore the addition transformation principle which will be fully developed in the exercises of Part E on pages 3-30 and 3-31. In the present case, they should determine that 1 is the only member of the second set. They can use substitution to show that it is also a member of the first set. But, this is not sufficient to show that the first set is a subset of the second. They must also be convinced that 1 is the only member of the first set. One way to do this is to substitute names of values of 'a' greater than 1 and compare the corresponding values of the two sides of ' $8a - 6 = 2a$ '.

a	$8a - 6$	$2a$
1	2	2
2	10	4
3	18	6
4	26	8

It is easy to see that ' $8a - 6 = 2a$ ' has no root greater than 1 since, for increasing values of 'a', the corresponding values of the two sides become more discrepant. Similarly, treat values of 'a' less than 1.]



Sample 3.  $\{4, 31\} \subseteq \{4, 31\}$

Solution. True. [Why?]

Sample 4.  $\{x: xx = 1\} = \{x: |x| = 1\}$

Solution.  $\{x: xx = 1\}$  contains just the numbers 1 and  $-1$ .

Also,  $\{x: |x| = 1\}$  contains just the numbers 1 and  $-1$ . So, the given sentence is true.

1.  $\{1, 2\} \subseteq \{2, 3\}$
2.  $\{3, 5, 6\} \subseteq \{3, 5, 6, 7\}$
3.  $\{2, 5\} \subseteq \{4, 9\}$
4.  $\{8, 9, 10\} \subseteq \{7, 9, 11\}$
5.  $\{x: x > 5\} \subseteq \{x: x > 3\}$
6.  $\{x: x < 5\} \subseteq \{x: x < 3\}$
7.  $\{t: 3t = 1\} \subseteq \{t: tt = \frac{1}{9}\}$
8.  $\{y: yy = 16\} \subseteq \{y: y = 4\}$
9.  $\{a: 8a - 6 = 2a\} \subseteq \{a: 8a - 6 - 2a = 0\}$
10.  $\{x: 4x + 2 = 3x\} \subseteq \{x: 4x + 2 - 3x = 0\}$
11.  $\{x: x = -5\} \subseteq \{x: 3xx = 75\}$
12.  $\{z: zz = 100\} \subseteq \{z: |z| = 10\}$
13.  $\{a: 9aa = 36\} = \{a: aa = 4\}$
14.  $\{x: xx = x\} \subseteq \{x: x = 1\}$
15.  $\{x: x = x + 1\} \subseteq \{x: x = x + 2\}$
16.  $\{x: 2 \cdot |x| = |2x|\} \subseteq \{x: x = 8\}$
17.  $\{x: x = x + 1\} \subseteq \{x: 2x = 160\}$  [Hint: Is there a member of  $\{x: x = x + 1\}$  which is not a member of  $\{x: 2x = 160\}$ ? You must believe that the answer to this question is 'yes' if you claim that the sentence is false.]
18.  $\{x: xx = x \text{ and } x \neq 0\} = \{x: \frac{xx}{x} = \frac{x}{x} \text{ and } x \neq 0\}$
19.  $\{x: 3xx - 2xxx + 5x - 7 = 8x - 9xx + 5\} \subseteq \{x: x + 1 = 1 + x\}$
- ★20.  $\{y: y + \frac{1}{y-8} = 8 + \frac{1}{y-8} \text{ and } y \neq 8\} = \{y: y = 8 \text{ and } y \neq 8\}$

B. Each exercise contains descriptions of solution sets of sentences. For each exercise, tell which descriptions refer to the same set as the first description. [The first description is underlined.]

1. {x:  $4x + 7 + 2x = 1$ }
  - (a) {x:  $[4x + 7 + 2x] + 3 = [1] + 3$ }
  - (b) {x:  $[4x + 7 + 2x] - 7 = [1] - 7$ }
  - (c) {y:  $6y + 7 = 1$ }
  - (d) {k:  $6k + 7 - 7 = 1 + 7$ }
  
2. {b:  $11b - 8 = 7b$ }
  - (a) {b:  $[11b - 8] - 7b = [7b] - 7b$ }
  - (b) {b:  $4b - 8 = 0$ }
  - (c) {b:  $b = -2$ }
  - (d) {b:  $b[11b - 8] = b[7b]$ }
  
3. {x:  $5x - 6 = 3x + 8$ }
  - (a) {x:  $[5x - 6] - 3x = [3x + 8] - 3x$ }
  - (b) {x:  $2x - 6 = 8$ }
  - (c) {x:  $[5x - 6] - 5x = [3x + 8] - 5x$ }
  - (d) {x:  $[5x - 6] - 3x = [3x + 8] - 5x$ }
  
4. {y:  $3y - 2 = 2y - 7$ }
  - (a) {y:  $[3y - 2] - 2y = [2y - 7] - 2y$ }
  - (b) {y:  $y - 2 = -7$ }
  - (c) {y:  $[3y - 2] - 3y = [2y - 7] - 3y$ }
  - (d) {x:  $5(3x - 2) = 5(2x - 7)$ }
  
5. {t:  $7t - 8 = 10 - 2t$ }
  - (a) {t:  $[7t - 8] - 2t = [10 - 2t] - 2t$ }
  - (b) {t:  $[7t - 8] + 2t = [10 - 2t] + 2t$ }
  - (c) {t:  $9t + 8 = 10$ }
  - (d) {t:  $-8 = [10 - 2t] - 7t$ }

Parts B and C [Part C is on page 3-29] deal directly with the problem of transforming an equation into an equivalent one by means of certain transformation principles. Part B deals with this problem in terms of equality of solution sets; Part C deals with it in terms of equivalence of equations. We state here the two basic theorems:

I. Addition transformation principle

(a)  $\forall_x \forall_y \forall_z$  if  $x = y$  then  $x + z = y + z$ .

(b)  $\forall_x \forall_y \forall_z$  if  $x + z = y + z$  then  $x = y$ .

II. Multiplication transformation principle

(a)  $\forall_x \forall_y \forall_z \neq 0$  if  $x = y$  then  $xz = yz$ .

(b)  $\forall_x \forall_y \forall_z \neq 0$  if  $xz = yz$  then  $x = y$ .

You will note that I(a) is the uniqueness principle for addition. Also, II(a) is a consequence of the uniqueness principle for multiplication. In stating II(a) we have used the quantifying phrase ' $\forall_z \neq 0$ ' [although we would be justified in using ' $\forall_z$ '] because we are interested in using II to justify cases of equivalence between equations. Although the uniqueness principle for multiplication does tell us, for example, that each root of ' $2x - 3 = 5 - x$ ' is also a root of ' $(2x - 3)0 = (5 - x)0$ ', the two equations are not equivalent. You will recognize I(b) and II(b) as the cancellation principles for addition and multiplication, respectively. Students should state the two transformation principles, and write them in their textbooks, by the time they have finished Part F on page 3-31. They should not be stated all at once before the class does Parts B and C, although the various parts of the principles will be referred to and stated as the students need them in giving justifications.

\*

It is a good idea to let students go through the exercises in Part B in class as well as individually. Discuss the six exercises when the students have completed them. Here is a suggestion for carrying out the discussion. Consider Exercise 1 of Part B. Suppose a student claims that the description in (a) refers to the same set as the underlined description, that is, suppose a student claims that

$$\{x: 4x + 7 + 2x = 1\} = \{x: [4x + 7 + 2x] + 3 = [1] + 3\}.$$

What justification can we give for this assertion? To say that the first

[3-28]

B. Each

r

3/37

named set [in class, you can point instead of saying 'first named set'] and the second named set are the same set is to say that the first named set is a subset of the second and the second named set is a subset of the first. So, first we establish that the first named set is a subset of the second. Each number which belongs to the first named set must satisfy the sentence ' $4x + 7 + 2x = 1$ '. If we substitute a name for the root of ' $4x + 7 + 2x = 1$ ' for ' $x$ ' in that sentence, we get a true sentence. In other words, we convert the expression ' $4x + 7 + 2x$ ' into a name for 1. Now, does this number [root] which belongs to the first named set also belong to the second named set? That is, if in the sentence:

$$[4x + 7 + 2x] + 3 = [1] + 3,$$

we substitute for ' $x$ ' a name for this number, do we convert this open sentence into a true sentence? The answer is 'yes'. Why? Since we already know that a name for the number in question converts ' $4x + 7 + 2x$ ' into a name for 1, it follows that substituting for ' $x$ ' a name for this number in the open sentence:

$$[4x + 7 + 2x] + 3 = [1] + 3$$

will convert this sentence into one whose sides are names for the same number [4, in this case]. The uniqueness principle for addition is the justification. It tells us that, for each  $x$ ,

$$\begin{array}{l} \text{if} \qquad \qquad 4x + 7 + 2x = 1 \\ \text{then} \qquad [4x + 7 + 2x] + 3 = [1] + 3. \end{array}$$

So, we know that the first named set is a subset of the second named set.

Now, how do we know that the second named set is a subset of the first named set? To know this, we must show that each number which belongs to the second named set also belongs to the first named set. If we substitute for ' $x$ ' in:

$$[4x + 7 + 2x] + 3 = [1] + 3,$$

a name for a number which belongs to the second named set, this open sentence will be satisfied. The bracketed expression ' $4x + 7 + 2x$ ' will be converted into a name for a number, and the fact that the sentence thus obtained is true means that when 3 is added to the number named in the brackets on the left, you get the same sum as when 3 is added to 1. The cancellation principle for addition assures us that we must be adding 3 to the same number both times; that is to say, the number named by substituting for ' $x$ ' in ' $4x + 7 + 2x$ ' is 1. It tells us that, for each  $x$ ,

$$\begin{array}{l} \text{if} \qquad \qquad [4x + 7 + 2x] + 3 = [1] + 3 \\ \text{then} \qquad \qquad 4x + 7 + 2x = 1. \end{array}$$

[3-28]

B. Each

r

3/38

But, this is the same as saying that the number which satisfies the equation in the description of the second set, also satisfies the equation in the description of the first set. So, the second set is a subset of the first set. Therefore, the first set is equal to the second set.

A similar argument can be used to show that the set referred to by the underlined description is the same as the set described in (b). However, one needs first to apply the principle for subtraction so that the set selector in the description in (b) becomes:

$$[4x + 7 + 2x] + -7 = [1] + -7.$$

And, this sentence is equivalent to the one given originally in the description in (b) since the members of this new equation are equivalent to the members of the given equation.

The description in (c) refers to the same set as the underlined description despite the fact that ' $4x + 7 + 2x$ ' and ' $6y + 7$ ' are not equivalent expressions. It is easy for the student to see that  $\{y: 6y + 7 = 1\} = \{x: 6x + 7 = 1\}$ , and that ' $4x + 7 + 2x$ ' and ' $6x + 7$ ' are equivalent expressions.

\*

Exercise 2 presents the opportunity for a discussion of the ideas behind the multiplication transformation principle. Consider the set referred to in the underlined description and the set referred to in (d). The uniqueness principle for multiplication justifies the assertion that the first named set is a subset of the second named set. [You will want to bring this point home by talking in terms of substitutions as we did above.] However, the second named set is not a subset of the first named set. We establish this by showing that 0 belongs to the second named set but not to the first. This is an important idea and is recognized in the 0-exception part of the statement of the cancellation principle for multiplication. Some of the mystery which surrounds the topic of "extraneous roots" in conventional courses can be explained away by a precise statement of the uniqueness principle for multiplication and the cancellation principle for multiplication.

\*

Incidentally, the phrase 'extraneous root' is misleading and you should avoid using it. Actually, an extraneous root of an equation is just any number which is not a root of the equation. For example, 37 is an

[3-28]

B. Each

r



3/39

extraneous root of the equation ' $x + 2 = 3$ ' because it is not a root of this equation but is a root of the "derived equation":

$$(x + 2)(x - 37) = 3(x - 37).$$

Surely, calling a number which is not a root 'an extraneous root' is not helpful! [We owe this remark on 'extraneous root' to Professor A. D. Wallace.]

\*

It should be of interest to students to note that they can explain why the set referred to in the underlined description in Ex. 3 [or in Ex. 2] is the same as the set referred to in (a) without being able to tell which numbers belong to this set. It is easy for them to find the members of the set referred to in (b). After noting that the sets referred to in (a) and in (b) are the same set, they then know the members of the set referred to in (a) and in the underlined description. They should be asked to explain why the sets referred to in (a) and (b) are the same set. Their work in simplifying members of an equation should lead them to say immediately that the sets referred to in (a) and (b) are the same set since the sides of the set selector in the description in (b) are merely simplifications of the corresponding sides of the set selector in the description in (a).

It is easy to show that the underlined description does not refer to the same set as the description in (d). 7 belongs to the set referred to in the underlined description but it does not belong to the set named in (d).

\*

In Exercise 4 students are expected to show that the first named set is the same as the set referred to in (d) [as well as in (a), (b), and (c)]. And, in showing this, they should refer to both parts of the multiplication transformation principle. They should contrast Exercise 4(d) with Exercise 2(d).

\*

In discussing Exercise 5, after noting that the sets referred to in (a) and (b) are the same set, ask the students which description is more useful in telling the numbers which belong to the set. Give them sufficient time to study both descriptions.

\*

[3-28]

B. Each

r

Note that in Exercise 6 of Part B on page 3-29 we have omitted the brackets in the various set selectors. Students will probably supply these brackets mentally in order to make more evident the patterns they have noted in the preceding exercises.

\*

Answers for Part B [on pages 3-28 and 3-29].

[As a summary for your convenience, we give the identifying letters of the descriptions which refer to the same set as the underlined descriptions.]

- |                       |                  |                  |
|-----------------------|------------------|------------------|
| 1. (a), (b), (c)      | 2. (a), (b)      | 3. (a), (b), (c) |
| 4. (a), (b), (c), (d) | 5. (a), (b), (d) | 6. (a), (d)      |

[3-28]

B. Each

r



B. Each

3/45

\*

Answers for Part D.

[We give 3 equations which have the same roots as the given equation; but, of course, your students will suggest others.]

$$\begin{aligned} 1. \quad 5x + 7 - 7 &= 17 - 7 \\ 5x &= 10 \\ x &= 2 \end{aligned}$$

$$\begin{aligned} 2. \quad 3 - 2y + 2y &= 1 + 2y \\ 3 &= 1 + 2y \\ y &= 1 \end{aligned}$$

$$\begin{aligned} 3. \quad 6x + 1 - 1 &= 9 - 2x - 1 \\ 6x + 2x &= 8 - 2x + 2x \\ 8x &= 8 \end{aligned}$$

$$\begin{aligned} 4. \quad 8y + 7 - 7 &= 5 - 7y - 7 \\ 8y + 7y &= -2 - 7y + 7y \\ 15y &= -2 \end{aligned}$$

$$\begin{aligned} 5. \quad 5 - 3x + 3x &= 8x + 9 + 3x \\ 5 - 9 &= 11x + 9 - 9 \\ -4 &= 11x \end{aligned}$$

$$\begin{aligned} 6. \quad 11y + 3 - 3 &= 8 + 5y - 3 \\ 11y - 5y &= 5 + 5y - 5y \\ 6y &= 5 \end{aligned}$$

\*

As with other exercises of the type of Part D, you can take the 18 equations given above, scramble them, and make a sorting exercise. Students should be asked to sort the equations into as few categories as possible such that each category contains equations which have the same roots.



B. Each

3/44

[The right member of the second equation for each of the preceding exercises is given below.

1.  $9 - 2x + 2x$

2.  $5 + 7x - 7x$

3.  $7 + 3x - 3x$

4.  $(5 - x) \times 7$

5.  $2 - 15x - 5x$

In each case, these will convert the second equation into one which is equivalent to the first.]

\*

One word of caution concerning a colloquialism which students are very quick to invent. Consider the equations:

(a)  $7y + 3 = 31$

(b)  $[7y + 3] + 87 = [31] + 87.$

In describing how one obtained equation (b) from equation (a), the student is likely to say that "87 was added to both sides of equation (a)". Now, this is an improper use of the word 'add'. We can add a number to a number, but we cannot add a number to a side of an equation because the side of an equation is an expression, not a number. A description of what was done in obtaining equation (b) from equation (a) is the following:

The sides of equation (a) were enclosed in brackets and a '+ 87' was written to the right of each of the bracketed expressions.

Of course, it is unreasonable to expect students to use such precision. Thus, you should be willing to accept the colloquialisms of the form 'add ... to both sides' and 'multiply both sides by ...'. But, the first time either of these colloquialisms is used, you should stop and mention that it is really a slang expression which we shall accept in place of the more precise one, and then you give the precise expression. Within a very short while students will learn the expressions 'addition transformation principle' and 'multiplication transformation principle', so that there will be little need for you to ask them questions concerning how they derived an equation equivalent to the given equation. Instead of asking how, the question you should ask is:

What principle tells you that the given equation and the derived one are equivalent?





B. Each

3/43

if it is equivalent to the first, and writing the chorused answer next to the given equation. You should include equations such as the following:

$$\begin{aligned}8y + 7 - 7 &= 5 - 7y + 7, \\-7 + 8y + 7 &= 5 - 7y - 7, \\(8y + 7) \times 2 &= (5 - 7y) \times 2, \\5(8y + 7) &= (5 - 7y) \times 5, \\8y + 7 - 8y &= 5 - 7y + 8y, \\8y + 7 + y &= 5 - 7y + y, \\(8y + 7) \times y &= (5 - 7y) \times y, \\(8y + 7) \times \frac{1}{2} &= (5 - 7y) \div 2.\end{aligned}$$

Here is another procedure which tests whether students have learned the mechanical process for producing equivalent equations. Start with an equation such as:

$$5 - 3x = 8x + 9.$$

Then, write one of the sides of a second equation and have students tell what the other side should be so that the second equation is equivalent to the first. For example, you might start the second equation as follows:

$$5 - 3x + 4x =$$

and the student's job is to complete this so that the second equation is equivalent to the first. In the following exercises the right side of the second equation is to be completed so that the completed equation is equivalent to the first.

1.  $6x + 1 = 9 - 2x$

$6x + 1 + 2x = \underline{\hspace{2cm}}$

2.  $8 - 3x = 5 + 7x$

$8 - 3x - 7x = \underline{\hspace{2cm}}$

3.  $9 - 5x = 7 + 3x$

$9 - 8x = \underline{\hspace{2cm}}$

4.  $\frac{4x}{7} = 5 - x$

$(\frac{4x}{7}) \times 7 = \underline{\hspace{2cm}}$

5.  $3 + 5x = 2 - 15x$

$3 = \underline{\hspace{2cm}}$



B. Each

3/42

the pair of equations:

$$2x + 1 = 4x + 2$$

$$5(2x + 1) = 10(4x + 2).$$

These equations are equivalent.

\*

Answers for Part C [on page 3-29].

[We give the identifying letter of the equations which have the same roots as the first equation.]

1. (b), (d), (e), (f)      2. (b), (c), (e), (f)      3. (b), (e), (f)  
 4. (c), (d), (e), (f)      5. (b), (c)

\*

Part D provides the student with an opportunity to give evidence of his understanding of some of the ideas underlying Parts B and C. To make sure that he can quickly recognize pairs of equivalent equations, you may want to carry out the following exercise with your class. Write an equation on the board, for example:

$$8y + 7 = 5 - 7y.$$

Then write a second equation under the first, for example:

$$8y + 7 + 10 = 5 - 7y + 10,$$

and ask the class to tell if the first equation and the second are equivalent. Encourage them to give the answer in chorus. The answer to this question is 'yes'; so, write the word 'yes' to the right of the second equation. The blackboard should now have on it the following:

$$8y + 7 = 5 - 7y$$

$$8y + 7 + 10 = 5 - 7y + 10 \quad \text{yes}$$

Then, write a third equation under the others, say:

$$8y + 7 + 9y = 5 - 7y + 9y,$$

and ask if this third equation is equivalent to the first. The class should again say, in chorus, 'yes'. Write 'yes' to the right of the third equation. Continue this process of writing an equation, asking



B. Each

3/41

As in the case of Part B, students should be asked to go through the exercises in Part C by themselves, and then there should be class discussion of the exercises.

As noted earlier, Part C deals with the same ideas as Part B but works directly with equations rather than with solution sets of equations. Notice the corresponding change in instructions for the two parts. In discussing the exercises in Part C, instead of talking about equality of solution sets, you now talk about equations having the same roots.

In showing that equations (a) and (b) of Exercise 1 have the same roots, you must show both that each root of (a) is a root of (b) [the justification here is the uniqueness principle for addition] and that each root of (b) is a root of (a) [the justification here is the cancellation principle for addition]. Similarly, each root of (a) is a root of (f) by virtue of the uniqueness principle for multiplication, and each root of (f) is a root of (a) by virtue of the cancellation principle for multiplication [and the fact that  $9 \neq 0$ ; we also use, in both cases, the fact that  $9 \times 10 = 90$ .]

\*

Note that in Exercise 2 all of the equations except (c) involve the pronumeral 'y'. The change of pronumeral in (c) should not disturb your students. It would probably disturb the student who thought that the job of solving an equation is "to find what x is or what y is". Our emphasis on getting students to understand that solving an equation is to find numbers which satisfy it should pay off at this time.

\*

Exercise 5 presents an interesting problem in comparing the equations in (a) and (c). At first glance, you might conclude that (a) and (c) are not equivalent. However, the root of (a) is 0, and 0 is also the root of (c). This illustration should destroy the generalization that students might have been forming that "you've got to add the same thing to both sides in order to get equations with the same roots". The roots of equation (a) are roots of equation (f) ["even though the same thing was not done to both sides"] but not all roots of (f) are roots of (a). In fact, (f) is satisfied by each real number.

Another example along these lines in connection with multiplication is

6.  $\{s: 6s + 9 = -2 - 5s\}$

(a)  $\{s: 6s + 9 + 5s = -2\}$

(b)  $\{s: 6s + 9 - 6s = -2 - 5s + 6s\}$

(c)  $\{s: s(6s + 9) = s(-2 - 5s)\}$

(d)  $\{s: 6s + 9 + 5s - 9 = -2 - 5s + 5s - 9\}$

C. In each exercise pick out the equations which have the same roots as the equation in (a).

1. (a)  $3x + 4 = 10$

(b)  $[3x + 4] + 2 = [10] + 2$

(c)  $3x + 5 = 15$

(d)  $[3x + 4] + 2x = [10] + 2x$

(e)  $[3x + 4] - 3x = [10] - 3x$

(f)  $9(3x + 4) = 90$

2. (a)  $7y + 3 = 31$

(b)  $[7y + 3] + 87 = [31] + 87$

(c)  $[7x + 3] - 159 = [31] - 159$

(d)  $[7y + 3] + 16y = [31] + 16$

(e)  $7y + 3 - y = 31 - y$

(f)  $783(7y + 3) = 783 \cdot 31$

3. (a)  $5t - 9 = 5 - 2t$

(b)  $16(5t - 9) = 16(5 - 2t)$

(c)  $[5t - 9] + 10 = [5 - 2t] + 15$

(d)  $[5t - 9] + 4 = [5 - 2t] - 4$

(e)  $[5x - 9] + 2x = [5 - 2x] + 2x$

(f)  $[5t - 9] + 2t = 5$

4. (a)  $7 - 3x = 5 - 9x$

(b)  $[7 - 3x] + 3x = [5 - 9x] + 4x$

(c)  $7 = 5 - 6x$

(d)  $700 - 300x = 500 - 900x$

(e)  $[7 - 3x] + 9x = [5 - 9x] + 9x$

(f)  $7 + 6x = 5$

5. (a)  $9 - 6x = 8x + 9$

(b)  $[9 - 6x] + 15 = [8x + 9] + 15$

(c)  $[9 - 6x] + 71x = [8x + 9] + 83x$

(d)  $10(9 - 6y) = 100(8y + 9)$

(e)  $[9 - 6x] + 6x = [8x + 9] + 6$

(f)  $[9 - 6x] + 6x = [8x + 9] - 8x$

D. For each of the following equations, write 3 equations which have the same roots as the given equation.

1.  $5x + 7 = 17$

2.  $3 - 2y = 1$

3.  $6x + 1 = 9 - 2x$

4.  $8y + 7 = 5 - 7y$

5.  $5 - 3x = 8x + 9$

6.  $11y + 3 = 8 + 5y$

E. Do the equations:

$$(1) \quad 2x + 4 = 46 - x$$

and:

$$(2) \quad [2x + 4] + x = [46 - x] + x$$

have the same roots?

1. (a) Suppose you know a root of (1). If you substitute for 'x' a numeral for this root in equation (1), will the new sentence you get be true? Will the numerical expressions on both sides of the equality sign in the new sentence be names for the same number?

(b) Suppose you substitute for 'x' in equation (2) a name of this root of equation (1). Will the numerical expressions you get in the brackets be names for the same number? How can you tell? Will the new sentence you get from (2) be a true sentence?

2. Your answers to parts (a) and (b) of Exercise 1 should tell you that each root of (1) is a root of (2). Another way of saying this is [complete the sentence]:

{x:  $2x + 4 = 46 - x$ } \_\_\_\_\_ {x:  $[2x + 4] + x = [46 - x] + x$ }.

3. (a) Suppose you know a root of (2), and you substitute one of its numerals for 'x' in (2). Will the new sentence you get be true? Will the numerical expressions on both sides of the equality sign be names for the same number? Will the numerical expressions you get in the brackets be names for the same number? What principle learned in Unit 2 tells you this?

(b) Suppose you substitute for 'x' in (1) a name for this root of (2). Will you get a true sentence from (1)? How can you use your answers to part (a) to show this?



Parts E and F are summaries of discussions in which the class engaged in connection with Parts B and C. These exercises should culminate in precise statements of the addition and multiplication transformation principles [See TC[3-28]a.].

\*

For Exercise 1 of Part F on page 3-31, the justifying theorem is the left uniqueness principle for multiplication. In view of the commutativity of addition and multiplication, we shall not, in applying the transformation principles, make any great point of the distinction between the uniqueness or cancellation principles and the corresponding left uniqueness or left cancellation principles.

\*

Answers for Part E [on pages 3-30 and 3-31].

1. (a) Yes; yes. (b) Yes, because the expressions in the brackets are copies of the members of the equation in (a) which we said is a true sentence. The new sentence which we get from (2) will be true because of the uniqueness principle for addition.
2.  $\{x: 2x + 4 = 46 - x\} \subseteq \{x: [2x + 4] + x = [46 - x] + x\}$ .
3. (a) Yes; yes; yes; cancellation principle for addition.  
(b) Yes; in (a) we decided that, after substituting, the numerical expressions in the brackets will be names for the same number.
4.  $\{x: [2x + 4] + x = [46 - x] + x\} \subseteq \{x: 2x + 4 = 46 - x\}$ .

\*

Answers for Part F [on page 3-31].

1.  $\{x: 7x + 1 = 3x - 6\} \subseteq \{x: 5(7x + 1) = 5(3x - 6)\}$  because of the left uniqueness principle for multiplication.
2.  $\{x: 5(7x + 1) = 5(3x - 6)\} \subseteq \{x: 7x + 1 = 3x - 6\}$  because of the left cancellation principle for multiplication.
3.  $\{x: 7x + 1 = 3x - 6\} \subseteq \{x: x(7x + 1) = x(3x - 6)\}$  because of the left uniqueness principle for multiplication.  
 $\{x: x(7x + 1) = x(3x - 6)\} \not\subseteq \{x: 7x + 1 = 3x - 6\}$  because 0 belongs to the first set, but it does not belong to the second set. [Remember the 0-restriction in the left cancellation principle for multiplication.]

[3-30]

E. Do t'

[3-31]

tell

E. Do t'

3/47

Before undertaking the work in Section 3.05 on page 3-32, you may want to give students a brief quiz [the one below, or a similar one of your own] to test their understanding of how the parts of the two transformation principles are used. The test should contain precise statements of both parts of each of the two principles.

Quiz

Tell which of the two transformation principles, or which part of which principle, justifies each of the following true statements.

A. T. P.

(a)  $\forall_x \forall_y \forall_z$  if  $x = y$  then  $x + z = y + z$ .

(b)  $\forall_x \forall_y \forall_z$  if  $x + z = y + z$  then  $x = y$ .

M. T. P.

(a)  $\forall_x \forall_y \forall_{z \neq 0}$  if  $x = y$  then  $xz = yz$ .

(b)  $\forall_x \forall_y \forall_{z \neq 0}$  if  $xz = yz$  then  $x = y$ .

StatementJustification

1. $\{x: 3x + 1 = 7 - x\} \subseteq \{x: (3x + 1)6 = (7 - x)6\}$	[MTP(a)]
2. $\{x: (\frac{3-x}{7})7 = (9-x)7\} \subseteq \{x: \frac{3-x}{7} = 9-x\}$	[MTP(b)]
3. $\{x: 5 + x + 3x = 9 + 3x\} \subseteq \{x: 5 + x = 9\}$	[ATP(b)]
4. '5x - 3 = 7' and '5x - 3 + 3 = 7 + 3' have the same roots	[ATP]
5. '6x $\times$ $\frac{1}{6}$ = 42 $\times$ $\frac{1}{6}$ ' and '6x = 42' have the same roots	[MTP]
6. $\{x: x + 4 = 9\} \subseteq \{x: (x + 4)x = 9x\}$	[MTP(a)]
7. $\{x \neq 0: x + 4 = 9\} = \{x \neq 0: (x + 4)x = 9x\}$	[MTP]

4. Your answers to parts (a) and (b) of Exercise 3 should tell you that each root of (2) is a root of (1). In other words, [complete the sentence]:

$$\{x: [2x + 4] + x = [46 - x] + x\} \text{ \_\_\_\_\_\_ } \{x: 2x + 4 = 46 - x\}.$$

\* \* \*

In Exercise 2 you found that

$$(*) \quad \{x: 2x + 4 = 46 - x\} \subseteq \{x: [2x + 4] + x = [46 - x] + x\},$$

and, in Exercise 4 that

$$(**) \quad \{x: [2x + 4] + x = [46 - x] + x\} \subseteq \{x: 2x + 4 = 46 - x\}.$$

These statements tell you that each member of a first set is a member of a second set, and that each member of the second set is a member of the first set. Do you see that this is just another way of saying that the first set is the same as the second set? So, it follows from (\*) and (\*\*) that

$$\{x: 2x + 4 = 46 - x\} = \{x: [2x + 4] + x = [46 - x] + x\}.$$

In other words, the equations:

$$(1) \quad 2x + 4 = 46 - x$$

$$\text{and:} \quad (2) \quad [2x + 4] + x = [46 - x] + x$$

have the same roots.

\* \* \*

- F. 1. Tell why  $\{x: 7x + 1 = 3x - 6\} \subseteq \{x: 5(7x + 1) = 5(3x - 6)\}$ .
2. Tell why  $\{x: 5(7x + 1) = 5(3x - 6)\} \subseteq \{x: 7x + 1 = 3x - 6\}$ .
3. Tell why  $\{x: 7x + 1 = 3x - 6\} \subseteq \{x: x(7x + 1) = x(3x - 6)\}$ ,  
and  $\{x: x(7x + 1) = x(3x - 6)\} \not\subseteq \{x: 7x + 1 = 3x - 6\}$ .

3.05 Equivalent equations. -- You have solved many equations so far in this unit. The method you used may have been something like this.

To solve the equation:

$$3x + 4 = 19,$$

I must find a number such that 4 more than its product with 3 is 19. But,  $15 + 4$  is 19. So, it follows [from what principle?] that the product of this number with 3 is 15. By the principle of division,  $\frac{15}{3}$  is the number whose product with 3 is 15. So, 5 is the solution of the equation.

Now, let's try to solve the equation:

$$(1) \quad 5x + 9 = 13 - 2x.$$

You must find a number such that 9 more than its product with 5 is the difference of twice the number from 13! This is a much more difficult job than the first example.

We could make some guesses.

(1) Try 7.

$$5(7) + 9 = 13 - 2(7)?$$

$$44 \neq -1.$$

(2) Try 2.

$$5(2) + 9 = 13 - 2(2)?$$

$$19 \neq 9.$$

(3) Try 1.

$$5(1) + 9 = 13 - 2(1)?$$

$$14 \neq 11.$$

(4) Try 0.

$$5(0) + 9 = 13 - 2(0)?$$

$$9 \neq 13.$$

It seems that the root is between 0 and 1 [Why?]. Is it closer to 0 than to 1? You could get to the root by continuing this process of guessing and "closing in" on it. But, there is a faster procedure.

3/48

In line 8, 'the principle of division' refers to the division theorem.

\*

Now that students have a reasonably good acquaintance with the two equation transformation principles, and know how to apply them in deriving equations which are equivalent to a given one, they are ready to make use of this knowledge and skill in solving equations. The whole point of this development of transformation principles which justify the equivalence of two equations is to give students a method for solving an equation such as:

$$\frac{x+9}{9} + \frac{1}{3} = \frac{x-7}{2} - 1.$$

Up to now, students have been able to solve certain types of equations [primarily those in which the pronumeral occurs in just one of the members] by what students like to call 'common sense'. But, common sense doesn't seem to be strong enough to enable them to solve an equation such as the one displayed above, or such as equation (1) on page 3-32. [We have been pleasantly surprised on numerous occasions by the fact that common sense and ingenuity do enable students to devise their own methods for handling such equations.] Our purpose here is to develop a mechanical procedure which is applicable to a great many equations.

The guessing procedure illustrated on page 3-32 is a natural first step for your students. A few of them might even be able to use the results of the third and fourth guesses to tell you that the root is  $4/7$ . [If you would like to investigate for your own interest what may be the basis of their intuition, you may find it helpful to draw the graphs of equations ' $y = 5x + 9$ ' and ' $y = 13 - 2x$ '. Then use a property of similar triangles to tell you how to find the x-coordinate of the crossing point of the graphs.]

We dismiss this guessing procedure as inefficient, and begin, on page 3-33, to develop a more effective procedure.

[3-32]

3.05 E

in th

th





The goal in using the equation transformation principles to solve an equation is expressed briefly in the first paragraph at the top of page 3-33. Since it is not easy to use common sense to find the roots of equation (1), we look around for another equation which has the same roots as equation (1) but which we can solve by common sense. In other words, solve a new problem by reducing it to an old problem. As expressed at the bottom of page 3-33, the reducing job consists in transforming an equation with the pronumeral occurring in both members to an equivalent equation in which the pronumeral occurs in only one member.

\*

Equation (2) on page 3-34 is an equation of the type we are seeking. It is equivalent to equation (3), and equation (3) is one in which the pronumeral occurs in one side only. Notice the question: Are (2) and (3) equivalent? The answer to this question is 'yes', and the justification for this answer is that each side of equation (3) is equivalent to the corresponding side of equation (2). This justification is different from the one supporting the assertion that equations (1) and (2) are equivalent. [The difference in justifications is explored more thoroughly on page 3-35.]

Notice that in solving an equation by using the transformation principles, one [sensibly] stops when he has reached an equation which he can solve by common sense. For your students, this means equation (3). But, in the text, we have carried out the transforming process until we reached equation (7) which students like to call 'one of the world's easiest equations'. Moreover, when they are solving equations mechanically, they may not use the "method of common sense" until they have reached an equation such as (7).

\*

The bracketed paragraph on page 3-35 makes an important point. When you solve a sentence by using the transformation principles, you obtain a series of sentences which are equivalent to each other. The fact that they are equivalent to each other is revealed by the all-true-or-all-false test. A value of the pronumeral which satisfies any one of the sentences will satisfy all of them, and a value of the pronumeral which does not satisfy one of them will satisfy none of them.

What we should like to do is to find another equation which is easier to solve than:

$$(1) \quad 5x + 9 = 13 - 2x$$

but which has the same roots as (1). An equation whose roots are the same as the roots of (1) is said to be equivalent to (1) [and (1) is equivalent to it].

Now, there are many equations which are equivalent to equation (1). Here are just a few of them:

$$(a) \quad [5x + 9] + 15 = [13 - 2x] + 15,$$

$$(b) \quad [5x + 9] - 78 = [13 - 2x] - 78,$$

$$(c) \quad 10[5x + 9] = 10[13 - 2x],$$

$$(d) \quad [5x + 9] + 4x = [13 - 2x] + 4x.$$

But, even if you simplify the sides of these equations to get:

$$(a') \quad 5x + 24 = 28 - 2x,$$

$$(b') \quad 5x - 69 = -65 - 2x,$$

$$(c') \quad 50x + 90 = 130 - 20x,$$

$$(d') \quad 9x + 9 = 13 + 2x,$$

none of the simplified ones seems to be easier to solve.

What is there about these equations and equation (1) which makes them harder to solve than the equations you solved on pages 3-21 and 3-25? Look at the equations on those pages. Notice that in none of them do you find a pronumeral in both sides. Equation (1) [as well as (a'), (b'), (c'), and (d')] has the pronumeral occurring in both sides:

$$(1) \quad 5x + 9 = 13 - 2x,$$

and this is what makes it harder to solve than the equations you worked with earlier. So, what we need to do is to get an equation equivalent to (1) with the pronumeral in one side only. Do you see how this can be done?

Here is one possibility. If we write a '+ 2x' on both sides of equation (1), we get:

$$(2) \quad 5x + 9 + 2x = 13 - 2x + 2x,$$

which is equivalent to (1). Will (2) be of more help to us than any of (a), (b), (c), and (d)? We can simplify the sides of (2) to get:

$$(3) \quad 7x + 9 = 13.$$

Are (2) and (3) equivalent? Since (1) is equivalent to (2), and (2) is equivalent to (3), do you think that (1) is equivalent to (3)?

Equation (3) is just like those we solved earlier. Its root is  $\frac{4}{7}$ , and since (3) and (1) are equivalent, we know that  $\frac{4}{7}$  is a root of (1).

Instead of stopping with equation (3), we could continue getting equivalent equations which are easier to solve. We write a '+ -9' on both sides of (3) to get:

$$(4) \quad 7x + 9 + -9 = 13 + -9.$$

Is (4) equivalent to (3)? Simplify the sides of (4) to get:

$$(5) \quad 7x = 4.$$

Is (5) equivalent to (4)? It is easy to see that the root of (5) is  $\frac{4}{7}$ .

We can continue this process of getting easier equivalent equations. Write a ' $\times \frac{1}{7}$ ' on both sides of (5) to get:

$$(6) \quad 7x \times \frac{1}{7} = 4 \times \frac{1}{7}.$$

Is (6) equivalent to (5)? Finally, simplify the sides of (6) to get:

$$(7) \quad x = \frac{4}{7}.$$

Is (7) equivalent to (6)? Equation (7) is the easiest to solve!



He  
of e

Students should be able to justify quickly the equivalence of successive pairs of equations in the list on page 3-35 since they know the terms 'addition transformation principle' and 'multiplication transformation principle'. They might give justifications for the list as follows:

- (1) and (2)... addition transformation principle
- (2) and (3)... equivalent expressions
- (3) and (4)... addition transformation principle
- (4) and (5)... equivalent expressions
- (5) and (6)... multiplication transformation principle
- (6) and (7)... equivalent expressions

Then, you should also consider the question of how these facts tell us that equations (1) and (7) are equivalent. Since equivalent equations are those which have the same solution set, it follows that equation (1) has the same solution set as equation (2), and equation (2) has the same solution set as equation (3), etc. So, it turns out that we are talking about the same solution set all the way through from the first equation to the last.

\*

The justification 'equivalent expressions' refers in part to the pair of theorems:

- (a)  $\forall_x \forall_y \forall_u \forall_v$  if  $x = u$  and  $y = v$  then if  $x = y$  then  $u = v$ .
- (b)  $\forall_x \forall_y \forall_u \forall_v$  if  $x = u$  and  $y = v$  then if  $u = v$  then  $x = y$ .

[Actually, (a) and (b) say the same thing by virtue of the symmetry of equality. These are logical theorems and are proved by using the substitution rule.] When one justifies the equivalence of, say, (2) and (3) by saying 'equivalent expressions', he has these theorems in mind along with the appropriate theorems ' $\forall_x 5x + 9 + 2x = 7x + 9$ ' and ' $\forall_x 13 - 2x + 2x = 13$ '.

Let us summarize the steps involved in solving the given equation '5x + 9 = 13 - 2x'.

$$(1) \quad 5x + 9 = 13 - 2x$$

$$(2) \quad 5x + 9 + 2x = 13 - 2x + 2x$$

$$(3) \quad 7x + 9 = 13$$

$$(4) \quad 7x + 9 + -9 = 13 + -9$$

$$(5) \quad 7x = 4$$

$$(6) \quad 7x \times \frac{1}{7} = 4 \times \frac{1}{7}$$

$$(7) \quad x = \frac{4}{7}$$

Equations (1) and (2) are equivalent, equations (2) and (3) are equivalent, (3) and (4) are equivalent, (4) and (5) are equivalent, (5) and (6) are equivalent, and (6) and (7) are equivalent. So, (1) and (7) are equivalent.

[Suppose you substitute a numeral for 'x' in all these equations. If one of these equations is converted into a true sentence, what can you say about the sentences obtained from the rest of the equations? If you substitute a numeral for 'x' in all these equations and find that one of the sentences obtained is false, what can you say about the rest?]

Notice that the left sides of equations (2) and (3) are equivalent expressions, and that the right sides of (2) and (3) are equivalent expressions. Do these facts tell you that (2) and (3) are equivalent equations? What tells you that (4) and (5) are equivalent equations? What tells you that (6) and (7) are equivalent equations?

Are the left sides [and right sides] of (1) and (2) equivalent expressions? How do we know that (1) and (2) are equivalent equations? That (3) and (4) are equivalent equations? That (5) and (6) are equivalent? Your work in Part E on page 3-30 and in Part F on page 3-31 should help you answer these questions.

## EXERCISES

A. Solve these equations by transforming the given equation to an equivalent one whose root is obvious.

Sample 1.  $7t - 8 = 3 + 4t$

Solution.  $7t - 8 = 3 + 4t$   
 $7t - 8 + -4t = 3 + 4t + -4t$   
 $3t - 8 = 3$   
 $3t - 8 + 8 = 3 + 8$   
 $3t = 11$   
 $\frac{1}{3} \times 3t = 11 \times \frac{1}{3}$   
 $t = \frac{11}{3}$

The root is  $\frac{11}{3}$ .

[Since we believe that each of these equations is equivalent to each of the others, we believe that the root of the equation ' $t = \frac{11}{3}$ ' is the root of the equation ' $7t - 8 = 3 + 4t$ '. However, sometimes in transforming equations we may make an error in simplification or computation [especially if in a hurry--or quite sleepy!]; so, it is a good idea to check the root of the last equation by substituting in the given equation.]

Check.  $7 \cdot \frac{11}{3} - 8 = 3 + 4 \cdot \frac{11}{3} \quad ?$

$$\begin{array}{r|l} \frac{77}{3} - 8 & 3 + \frac{44}{3} \\ \hline \frac{77 - 24}{3} & \frac{9 + 44}{3} \\ \frac{53}{3} & = \frac{53}{3} \quad \checkmark \end{array}$$

Sample 2.  $8 - 4x = 7 - 9x$

Solution.  $8 - 4x = 7 - 9x$   
 $8 - 4x + 4x = 7 - 9x + 4x$   
 $8 = 7 - 5x$   
 $8 + -7 = 7 - 5x + -7$   
 $1 = -5x$   
 $-\frac{1}{5} \cdot 1 = -\frac{1}{5} \cdot -5x$   
 $-\frac{1}{5} = x$

The root is  $-\frac{1}{5}$ . [Check this!]





A.

3/52

is the same as adding the opposite' and 'dividing is the same as multiplying by the reciprocal' will suffice to make clear what is happening.

Exercises 13 and 14 on page 3-37 are really exploratory exercises. They are discussed in detail on pages 3-38 and 3-39.

\*

Answers for Part A.

- |                      |                   |                                |              |         |
|----------------------|-------------------|--------------------------------|--------------|---------|
| 1. 2                 | 2. 5              | 3. -2                          | 4. 3         | 5. -1   |
| 6. 4                 | 7. $\frac{3}{4}$  | 8. 1                           | 9. -60       | 10. 120 |
| 11. $\frac{168}{11}$ | 12. $\frac{3}{5}$ | 13. each real number is a root | 14. no roots |         |

\*

A word about checking. As indicated on page 3-36, this method of solving equations by deriving equivalent ones does not require the checking of roots. However, it is good practice to have students acquire the habit of checking as a safeguard against computational errors arising in simplifying. On the other hand, the requirement that students carry out a check for each equation they solve will add substantially to the amount of written work, and will thereby decrease the amount of time available for practice in solving equations. Some teachers require students to check only some of the equations in a given assignment and even designate those which are to be checked. Some teachers require that all equations on a test must be checked and assign point-credits to the check.

To facilitate your work in checking checks, we are including "check equations" in the COMMENTARY. These are the equations one obtains when he substitutes in each of the given equations a name for its root, and then simplifies the members.

\*

Check equations for Part A on page 3-37.

- |                |               |                                       |                                       |
|----------------|---------------|---------------------------------------|---------------------------------------|
| 1. $4 = 4$     | 2. $30 = 30$  | 3. $-6 = -6$                          | 4. $5 = 5$                            |
| 5. $1 = 1$     | 6. $17 = 17$  | 7. $0 = 0$                            | 8. $-7.5 = -7.5$                      |
| 9. $-20 = -20$ | 10. $45 = 45$ | 11. $\frac{192}{11} = \frac{192}{11}$ | 12. $-\frac{17}{50} = -\frac{17}{50}$ |
| 13. - - -      | 14. - - -     |                                       |                                       |



A.

Urge students to supply all of the steps in Exercises 1 through 14 on page 3-37. Assure them, as we do in the note at the top of page 3-37, that in the future they will be encouraged to use short cuts and to omit steps. Now we want to be sure they know how to apply the transformation principles, and that they know the difference between showing the equivalence of a pair of equations by using the transformation principles, and showing the equivalence by noting the fact that the corresponding members of the equations are equivalent expressions. In fact, you may want to require the students to supply the reasons on their homework paper for a few of the exercises. Here is a suggested arrangement.

$$\begin{array}{rcl}
 3m - 2 = 8 - 2m & & \\
 3m - 2 + 2m = 8 - 2m + 2m & \left. \vphantom{\begin{array}{l} 3m - 2 = 8 - 2m \\ 3m - 2 + 2m = 8 - 2m + 2m \\ 5m - 2 = 8 \\ 5m - 2 + 2 = 8 + 2 \\ 5m = 10 \\ 5m \times \frac{1}{5} = 10 \times \frac{1}{5} \\ m = 2 \end{array}} \right\} \begin{array}{l} \text{atp} \\ \text{ee} \\ \text{atp} \\ \text{ee} \\ \text{mtp} \\ \text{ee} \end{array} \\
 5m - 2 = 8 & & \\
 5m - 2 + 2 = 8 + 2 & & \\
 5m = 10 & & \\
 5m \times \frac{1}{5} = 10 \times \frac{1}{5} & & \\
 m = 2 & & 
 \end{array}$$

The root is 2.

We hasten to point out that this procedure should be employed for just a few of the exercises. If you make a general practice of this throughout the work on equations, you will find that students develop a marked distaste for solving equations. Our experience has been that, with the presentation we advocate, students develop a genuine liking for solving equations.

You may find some students who, for example, may write as their first derived equation in Exercise 5:

$$3 + 2x - 2x = 7 + 6x - 2x$$

instead of:

$$3 + 2x + -2x = 7 + 6x + -2x.$$

Also, students may write [in their solution for Exercise 1]:

$$5m \div 5 = 10 \div 5$$

instead of:

$$5m \times \frac{1}{5} = 10 \times \frac{1}{5}.$$

This is permissible, and the justifications for these steps should still be the addition transformation principle and the multiplication transformation principle, respectively. Brief remarks such as 'subtracting

[Note: In doing the exercises which follow, it is a good idea to put in all of the steps as shown in the samples. Later, you will discover and use many short cuts.]

1.  $3m - 2 = 8 - 2m$

2.  $7t - 5 = 15 + 3t$

3.  $4 + 5s = 3s$

4.  $8 - k = 5k - 10$

5.  $3 + 2x = 7 + 6x$

6.  $5y - 3 = 9 + 2y$

7.  $4m - 3 = 3 - 4m$

8.  $3k - 10.5 = 4.5 - 12k$

Sample 3.  $\frac{a}{2} + 2 + \frac{a}{4} = 7 + \frac{a}{3}$

Solution. This equation is complicated because it contains several fractions. We can transform it into an equivalent equation which does not contain any fractions by enclosing the sides in parentheses, writing a '12·' on both sides [Why '12'?), and then simplifying.

$$\frac{a}{2} + 2 + \frac{a}{4} = 7 + \frac{a}{3}$$

$$12 \cdot \left( \frac{a}{2} + 2 + \frac{a}{4} \right) = 12 \cdot \left( 7 + \frac{a}{3} \right)$$

$$12 \cdot \frac{a}{2} + 12 \cdot 2 + 12 \cdot \frac{a}{4} = 12 \cdot 7 + 12 \cdot \frac{a}{3}$$

$$6a + 24 + 3a = 84 + 4a$$

$$9a + 24 = 84 + 4a$$

$$-4a + 9a + 24 = 84 + 4a + -4a$$

$$5a + 24 = 84$$

$$5a + 24 - 24 = 84 - 24$$

$$5a = 60$$

$$\frac{1}{5} \times 5a = 60 \times \frac{1}{5}$$

$$a = 12$$

The solution is 12. [Check this!]

9.  $\frac{x}{4} - 5 = \frac{x}{3}$

10.  $\frac{t}{4} + \frac{t}{8} = 5 + \frac{t}{3}$

11.  $\frac{3y}{4} + 6 = \frac{8y}{7}$

12.  $\frac{k}{2} + \frac{3k}{5} - 1 = \frac{k}{10} - \frac{2k}{3}$

13.  $2(x + 1) = 2 + 2x$

14.  $3 + x = x$

\* \* \*

In doing Exercise 13 on the preceding page, you probably recognized immediately that since the two sides of the equation are equivalent pronumeral expressions, it has each real number as a root. And in Exercise 14, you no doubt knew at once that the equation had no roots. But, what would happen if you tried to solve these equations by the method of equivalent equations?

Let's try Exercise 13.

$$(1) \quad 2(x + 1) = 2 + 2x$$

$$(2) \quad 2(x + 1) + -2x = 2 + 2x + -2x$$

$$(3) \quad 2x + 2 + -2x = 2$$

$$(4) \quad 2 = 2$$

Equations (1), (2), (3), and (4) are supposed to be equivalent equations. This means that these equations have the same roots. Now, it may be easy to see that (1) and (2) have the same roots [each substitution for 'x' in (1) and (2) gives you a pair of sentences which are both true], and that (2) and (3) have the same roots, but what does it mean to say that (3) and (4) have the same roots? Equation (4) doesn't even have a pronumeral in it!

In order to make sense out of this we shall extend our idea of what a root is. We said earlier that a root of an equation is a number which satisfies the equation, and we used the word 'satisfy' just in connection with open sentences. We said nothing about whether statements [such as:  $3 > 1 + 0$ ,  $3 \neq 17 - 14$ ,  $2 = 2$ ,  $18 = 19$ ] can be satisfied. It seems strange to think about whether sentences like ' $5 = 4$ ' and ' $2 = 2$ ' can be satisfied. But, let's stretch our meaning of the word 'satisfy' and agree that every number satisfies a true statement and that no number satisfies a false statement. Under this agreement, we can say that

$$'2(x + 1) = 2 + 2x' \text{ is equivalent to } '2 = 2'.$$



Students should begin to develop short cuts in solving equations on page 3-40. Once in a while you can ask for justifications regarding the equivalence of pairs of equations [“Are these equations equivalent? How do you know?”]. But, do not require students to write such justifications on their homework papers. Similar remarks hold for the rest of the exercises through page 3-50. The 153 exercises in Part B can be assigned in fairly large chunks. For example, students will have no difficulty in doing Exercises 1 - 25 as one assignment. Exercises 26 - 50 make a comfortable assignment, and Exercises 51 - 75 also make a manageable load, as do Exercises 76 - 103. You may want to use two assignments to cover Exercises 104 - 153. You will doubtless want students to do part of each assignment during the class period. You may want to pass out duplicated lists of answers after students have completed an assignment. Furthermore, it is well to give a brief daily quiz as a means of determining the progress of the students.

As you can tell from the answers, we have taken pains to include only a small number of equations which have nonintegral roots. Also, as you can tell from some of the exercises on page 3-41 and on page 3-43, we have included many of the equations which arise in solving verbal problems. So, if students have difficulty in solving verbal problems later in the unit, it is unlikely that the cause of this difficulty is their inability to solve equations!

\*

Many of the equations can be solved by “common sense” rather than by the method of transformation. Do not insist upon the use of transformation principles when a simpler procedure will do the job.

It is interesting to let students solve the equation in Exercise 32 by common sense and also by transformation principles. Students in conventional classes have much difficulty with this kind of equation.



Now, let's consider the equation in Exercise 14 on page 3-37, ' $3 + x = x$ '. We proceed according to the familiar method.

$$(1') \quad 3 + x = x$$

$$(2') \quad 3 + x + -x = x + -x$$

$$(3') \quad 3 = 0$$

Under the agreement we just made, (3') has no roots because it is a false sentence. We observed at the outset that (1') does not have a root. So, under our agreement, we say that

' $3 + x = x$ ' is equivalent to ' $3 = 0$ '.

\* \* \*

B. Solve these equations. Look for short cuts.

Sample 1.  $4x - 3 + 2x = 5 - 10x$

Solution.  $4x - 3 + 2x = 5 - 10x$

$$6x - 3 = 5 - 10x$$

$$10x + 6x - 3 = 5 - 10x + 10x$$

$$16x - 3 = 5$$

$$16x = 8$$

$$x = \frac{1}{2}$$

The root is  $\frac{1}{2}$ .

Check.  $4 \cdot \frac{1}{2} - 3 + 2 \cdot \frac{1}{2} = 5 - 10 \cdot \frac{1}{2} ?$

$$2 - 3 + 1 \quad | \quad 5 - 5$$

$$0 = 0 \quad \checkmark$$

1.  $4x + 3 = 2x + 7$
2.  $6k - 2 = 8 - 14k$
3.  $3 - 7r = 17 + 7r$
4.  $8t - 3 = 12 - 2t$
5.  $10k + 3 = 16 - 3k$
6.  $4 - 7y = y - 20$
7.  $18 + 4x = x$
8.  $17 + 2y = 9$
9.  $5m = 5 - 5m$
10.  $7y = 3y + 8$
11.  $17b = 2b - 120$
12.  $4x = 3x + 4$
13.  $360 + 36t = 30t$
14.  $17r = -5r + 66$
15.  $-20A = 208 + 6A$
16.  $15 - 3z = 12z$
17.  $25t = 16 - 7t$
18.  $5b - 1 = 3b + 3$
19.  $d + 2 = 10 - d$
20.  $3x - 6 = 14 - x$
21.  $2c + 4 = c - 2$
22.  $3a + 2 = 7 - 2a$
23.  $80 + x = 79$
24.  $500 + 15s = 5s$
25.  $5n + 6 = 3n + 7$
26.  $15k = 25k + 65$
27.  $7p - 2 = 4p + 10$
28.  $2 - 7m = 11 - 7m$
29.  $x + 3x = 3x + 1$
30.  $3 - x = 3 + x$
31.  $3x = 5x + 1$
32.  $3x = 5x$
33.  $-6x + 11 = 2x + 43$
34.  $5c - 3 = 8c - 16$
35.  $3n - 7 = 2n + 7$
36.  $4n - 10 = 3n + 5$
37.  $8x + 3 = 5x + 30$
38.  $12y - 1 = 4y + 3$
39.  $7t - 3 = 6t + 1$
40.  $11k - 3 = 7k + 9$
41.  $8r - 7 = 6r + 1$
42.  $4x - 11 = x + 4$
43.  $4y - 5 = 3y + 5$
44.  $103 - x = x + 3$
45.  $s + 10 = 7s - 20$
46.  $8n - 5 = 23n - 35$
47.  $4s - 4 = s + 20$
48.  $13n + 5 = 8n + 40$
49.  $S = 14.70 + .30S$
50.  $S = 13.20 + .20S$

[More exercises are in Part D, Supplementary Exercises.]

Answers for Part B [which begins on page 3-39 and ends on page 3-50].

- |             |           |              |            |           |
|-------------|-----------|--------------|------------|-----------|
| 1. 2        | 2. $1/2$  | 3. -1        | 4. $3/2$   | 5. 1      |
| 6. 3        | 7. -6     | 8. -4        | 9. $1/2$   | 10. 2     |
| 11. -8      | 12. 4     | 13. -60      | 14. 3      | 15. -8    |
| 16. 1       | 17. $1/2$ | 18. 2        | 19. 4      | 20. 5     |
| 21. -6      | 22. 1     | 23. -1       | 24. -50    | 25. $1/2$ |
| 26. $-13/2$ | 27. 4     | 28. no roots | 29. 1      | 30. 0     |
| 31. $-1/2$  | 32. 0     | 33. -4       | 34. $13/3$ | 35. 14    |
| 36. 15      | 37. 9     | 38. $1/2$    | 39. 4      | 40. 3     |
| 41. 4       | 42. 5     | 43. 10       | 44. 50     | 45. 5     |
| 46. 2       | 47. 8     | 48. 7        | 49. 21     | 50. 16.5  |

\*

- |                                |                                |              |        |       |
|--------------------------------|--------------------------------|--------------|--------|-------|
| 51. -2                         | 52. -3                         | 53. $1/2$    |        |       |
| 54. each real number is a root | 55. no roots                   |              |        |       |
| 56. each real number is a root | 57. 2                          | 58. 2        |        |       |
| 59. 7                          | 60. each real number is a root | 61. 24       |        |       |
| 62. 300                        | 63. each real number is a root | 64. no roots |        |       |
| 65. 4                          | 66. 28                         | 67. $1/5$    | 68. 11 | 69. 7 |
| 70. each real number is a root | 71. 14                         | 72. 7        |        |       |
| 73. 1                          | 74. $1/4$                      | 75. $-2/5$   |        |       |

\*

Check equations for Exercises 1 - 75 on pages 3-40 and 3-41.

- |              |                |              |            |
|--------------|----------------|--------------|------------|
| 1. $11 = 11$ | 2. $1 = 1$     | 3. $10 = 10$ | 4. $9 = 9$ |
| 5. $13 = 13$ | 6. $-17 = -17$ | 7. $-6 = -6$ | 8. $9 = 9$ |

[3-40]

1.

3/55

- |                   |                     |                     |
|-------------------|---------------------|---------------------|
| 9. $2.5 = 2.5$    | 10. $14 = 14$       | 11. $-136 = -136$   |
| 12. $16 = 16$     | 13. $-1800 = -1800$ | 14. $51 = 51$       |
| 15. $160 = 160$   | 16. $12 = 12$       | 17. $12.5 = 12.5$   |
| 18. $9 = 9$       | 19. $6 = 6$         | 20. $9 = 9$         |
| 21. $-8 = -8$     | 22. $5 = 5$         | 23. $79 = 79$       |
| 24. $-250 = -250$ | 25. $8.5 = 8.5$     | 26. $-97.5 = -97.5$ |
| 27. $26 = 26$     | 28. $---$           | 29. $4 = 4$         |
| 30. $3 = 3$       | 31. $-1.5 = -1.5$   | 32. $0 = 0$         |
| 33. $35 = 35$     | 34. $56/3 = 56/3$   | 35. $35 = 35$       |
| 36. $50 = 50$     | 37. $75 = 75$       | 38. $5 = 5$         |
| 39. $25 = 25$     | 40. $30 = 30$       | 41. $25 = 25$       |
| 42. $9 = 9$       | 43. $35 = 35$       | 44. $53 = 53$       |
| 45. $15 = 15$     | 46. $11 = 11$       | 47. $28 = 28$       |
| 48. $96 = 96$     | 49. $21 = 21$       | 50. $16.5 = 16.5$   |
| 51. $-7 = -7$     | 52. $15 = 15$       | 53. $18 = 18$       |
| 54. $---$         | 55. $---$           | 56. $---$           |
| 57. $8 = 8$       | 58. $4 = 4$         | 59. $16 = 16$       |
| 60. $---$         | 61. $5280 = 5280$   | 62. $19500 = 19500$ |
| 63. $---$         | 64. $---$           | 65. $0 = 0$         |
| 66. $16 = 16$     | 67. $1 = 1$         | 68. $9 = 9$         |
| 69. $15 = 15$     | 70. $---$           | 71. $806 = 806$     |
| 72. $359 = 359$   | 73. $3 = 3$         | 74. $-72.5 = -72.5$ |
| 75. $18 = 18$     |                     |                     |

[3-40]

1.

Sample 2.  $7(x - 3) + 4 = 3x + 3$

Solution.  $7(x - 3) + 4 = 3x + 3$

$$7x - 21 + 4 = 3x + 3$$

$$7x - 17 = 3x + 3$$

$$4x = 20$$

$$x = 5$$

The root is 5.

Check.  $7(5 - 3) + 4 = 3 \cdot 5 + 3 ?$

$$14 + 4 \quad | \quad 15 + 3$$

$$18 = 18 \checkmark$$

51.  $3(y - 2) + 5 = 3 + 5y$

52.  $5(2x + 9) = 3(4x + 17)$

53.  $9(3 - 2z) = 2(12 - 6z)$

54.  $4x + 4 = 4(x + 1)$

55.  $5(3 - x) - 1 = 13 - 5x$

56.  $4(x - 5) + 3x + 1 = 2(x - 2) + 5(x - 3)$

57.  $7(2 - x) + 4x = 2 + 3x$

58.  $8 - 5x + 6 = 7(x + x) - 12x$

59.  $8x = 2(3x + 4) + 6$

60.  $3x + 5 - x = 2(2 + x) + 1$

61.  $80(60 - n) + 100n = 88(60)$

62.  $50p + 60(75) = 52(p + 75)$

63.  $(5x - 24) - 6 = 5(x - 6)$

64.  $2x + 3(5 - x) = 6(3 - x) + 5x$

65.  $7(x - 2) - 2(3 + x) = 0$

66.  $-7a + 4(2a - 3) = 16$

67.  $7r - 2(1 - 4r) = 1$

68.  $-3y + 6(y - 4) = 9$

69.  $3(2a - 9) = 5(10 - a)$

70.  $3(2x - 5) + 2(5 - x) = 4(x - 1) - 1$

71.  $20x + 10(2x) + 5(2x + 6) + (5x + 6) = 806$

72.  $25y + 10y + 5(y + 11) + (y + 17) = 359$

73.  $-4x + 2(5x + 1) - 5 = 6 - 3(2x - 1)$

74.  $10(3b - 4) - 5(4b + 7) = 10(5b - 6) - 25$

75.  $18(c + 7) - 14(7c + 10) = 7c(4c - 7) - 4c(7c - 1)$

[More exercises are in Part E, Supplementary Exercises.]

Sample 3.  $\frac{x-7}{5} + 2 = \frac{x+8}{10}$

Solution. Transform to an equation which has no fractions.

$$10 \times \left( \frac{x-7}{5} + 2 \right) = \left( \frac{x+8}{10} \right) \times 10$$

$$10 \cdot \frac{x-7}{5} + 10 \cdot 2 = x + 8$$

$$2(x-7) + 20 = x + 8$$

$$2x - 14 + 20 = x + 8$$

$$2x + 6 = x + 8$$

$$x = 2$$

The solution is 2.

Check.  $\frac{2-7}{5} + 2 = \frac{2+8}{10} ?$

$$\begin{array}{r|l} -1 + 2 & 1 \\ \hline 1 & = 1 \checkmark \end{array}$$

Sample 4.  $.25x + .50(70 - x) = 25.00$

Solution.

Method I

$$.25x + .50(70 - x) = 25.00$$

$$.25x + 35 - .50x = 25.00$$

$$-.25x + 35 = 25.00$$

$$-.25x = -10$$

$$x = \frac{-10}{-.25}$$

$$x = 40$$

Method II

$$.25x + .50(70 - x) = 25.00$$

$$100[.25x + .50(70 - x)] = 100[25.00]$$

$$25x + 50(70 - x) = 2500$$

$$25x + 3500 - 50x = 2500$$

$$-25x + 3500 = 2500$$

$$-25x = -1000$$

$$x = 40$$

The root is 40.

The root is 40.

Check.  $.25(40) + .50(70 - 40) = 25.00 ?$

$$\begin{array}{r|l} 10 + 15 & 25 \\ \hline 25 & = 25 \checkmark \end{array}$$

$$25 = 25 \checkmark$$





At this point in the unit you may want to start spiralling assignments. For example, along with the exercises on page 3-43, you could include some from Parts D and E of the Supplementary Exercises, and some from pages 3-58 through 3-64. [You may want to hold off on the material in pages 3-44 through 3-50 until students have developed considerable skill in solving equations like those in Parts D, E, and F of the Supplementary Exercises.]

\*

Answers for Part B, continued.

76. 7	77. $1/6$	78. 28	79. 30	80. 400
81. 7500	82. 225	83. 1500	84. 1500	85. 62.5
86. $18/5$	87. 300	88. 260	89. 6	90. -42
91. $-13/2$	92. 1	93. 15	94. 1	95. 3
96. 2	97. -2	98. $1/2$	99. 0	100. 0
101. 1	102. 5	103. no roots		

[Exercises 102 and 103 are exploratory exercises. The relevant concepts are discussed on pages 3-44ff.]

\*

Check equations for Exercises 76 - 103.

76. $2 = 2$	77. $1/6 = 1/6$	78. $4 = 4$	79. $24 = 24$
80. $4.5 = 4.5$	81. $12500 = 12500$	82. $67.5 = 67.5$	83. $175 = 175$
84. $60 = 60$	85. $175 = 175$	86. $6/5 = 6/5$	87. $72 = 72$
88. $550 = 550$	89. $63 = 63$	90. $-16 = -16$	91. $-5 = -5$
92. $0 = 0$	93. $3 = 3$	94. $3 = 3$	95. $3 = 3$
96. $13/3 = 13/3$	97. $-6/5 = -6/5$	98. $2/3 = 2/3$	99. $0 = 0$
100. $31/6 = 31/6$	101. $-0.5 = -0.5$	102. $3/5 = 3/5$	103. - - -

76.  $\frac{a-1}{3} = 2$
77.  $m = \frac{1}{10} + \frac{1}{15}$
78.  $\frac{1}{7}n = \frac{1}{2}n - 10$
79.  $\frac{1}{2}y + \frac{1}{10}y + \frac{1}{5}y = y - 6$
80.  $\frac{x}{200} + \frac{x}{160} = \frac{9}{2}$
81.  $a + \frac{3}{5}a + 500 = 12500$
82.  $c - .70c = 67.5$
83.  $.05x + .04(4000 - x) = 175$
84.  $.04n = .05(n - 300)$
85.  $2(100 - p) + 1.6p = 1.75(100)$
86.  $2n - 6 = \frac{1}{3}n$
87.  $\frac{k}{4} - 3 = 12 + \frac{k}{5}$
88.  $\frac{1}{2}(970 - a) + \frac{3}{4}a = 550$
89.  $10x + (-3 + x) = \frac{7}{4}(-30 + 10x + x)$
90.  $\frac{x}{3} - 2 = 5 + \frac{x}{2}$
91.  $\frac{2x+3}{2} = -5$
92.  $\frac{y+11}{6} - \frac{10-y}{3} + 1 = 0$
93.  $\frac{x+9}{9} + \frac{1}{3} = \frac{x-7}{2} - 1$
94.  $\frac{a+2}{3} + \frac{1}{2}(a+3) = 3$
95.  $\frac{x+5}{2} - \frac{x+1}{4} = 3$
96.  $\frac{2x}{3} + \frac{3x}{2} = \frac{13}{3}$
97.  $\frac{3x}{5} = \frac{19}{5} + \frac{5x}{2}$
98.  $\frac{8y}{7} + \frac{2}{21} = 1 - \frac{2y}{3}$
99.  $\frac{4m}{3} + \frac{3m}{5} = \frac{7m}{2}$
100.  $\frac{1}{3}(5 - 7x) + \frac{1}{2}(4x + 7) = \frac{1}{6}(3x + 31)$
101.  $\frac{2}{5}(8 - 3x) + \frac{5}{2}(6 - 7x) = \frac{3}{10}(4x + 15) - \frac{31}{5}$
102.  $\frac{3}{a} = 2 - \frac{2+a}{a}$
103.  $\frac{5}{x} = 4 - \frac{3x-5}{x}$

[More exercises are in Part F, Supplementary Exercises.]

\*

Let's reconsider the equations in Exercises 102 and 103 on page 3-43. Both of these equations contain fractions. So, as we have seen, a useful first step in solving them is to transform them into equations which do not contain fractions.

$$\begin{array}{l|l}
 \frac{3}{a} = 2 - \frac{2+a}{a} & \frac{5}{x} = 4 - \frac{3x-5}{x} \\
 a\left(\frac{3}{a}\right) = \left(2 - \frac{2+a}{a}\right)a & x\left(\frac{5}{x}\right) = \left(4 - \frac{3x-5}{x}\right)x \\
 3 = 2a - \frac{2+a}{a} \cdot a & 5 = 4x - \frac{3x-5}{x} \cdot x \\
 3 = 2a - (2+a) & 5 = 4x - (3x-5) \\
 3 = 2a - 2 - a & 5 = 4x - 3x + 5 \\
 5 = a & 0 = x
 \end{array}$$

Now, although 5 is a root of the first equation, 0 is not a root of the second equation. [Substitute '0' for 'x' in the second equation. Do you get a true statement?] How do we explain the fact that our usual method of solving gave a root in the first case but did not give a root in the second?

We shall be in a better position to answer this question if we look more closely at what happens when we transform an equation as we did in the two examples. Consider the equation:

$$(1) \quad 3x = 21.$$

Suppose we transform this equation by writing a ' $\cdot x$ ' on both sides. We get:

$$(2) \quad 3x \cdot x = 21 \cdot x.$$

Both 0 and 7 are roots of (2) because  $3 \cdot 0 \cdot 0 = 21 \cdot 0$  and  $3 \cdot 7 \cdot 7 = 21 \cdot 7$ . Equation (1), on the other hand, has just the root 7. So, (1) and (2) are not equivalent. [However, the solution set of (1) is a subset of the solution set of (2). [See Part F on page 3-31.]]



having the value 0, however. The fact that in this case it cannot be irrelevant.] Hence, we should agree that the set of values of 'x' is the set of real numbers different from 7, and indicate this agreement by writing an ' $x \neq 7$ ' at the right of the second equation. Thus, the given equation and the last equation are equivalent with respect to the set of real numbers different from 7. That is,

$$\{x \neq 7: 2x - \frac{1}{x-7} = 14 - \frac{1}{x-7}\} = \{x \neq 7: 2x = 14\}.$$

With respect to the set of real numbers different from 7, the solution set of both the given equation and the last equation is the empty set. So, there are no numbers in the restricted set of values of 'x' which satisfy the given equation. The only real number which can be a root is 7. Substitution shows that 7 is not a root of the given equation. So, the given equation has no roots.



Let's complete the procedure for solving ' $xx = 2x$ '.

- (a)  $xx = 2x$
- (b)  $xx \cdot \frac{1}{x} = 2x \cdot \frac{1}{x}, [x \neq 0]$
- (c)  $x(x \cdot \frac{1}{x}) = 2(x \cdot \frac{1}{x})$
- (d)  $x \cdot 1 = 2 \cdot 1$
- (e)  $x = 2$

Now, equations (b) and (c) are equivalent [with respect to the set of nonzero real numbers] by virtue of the fact that the pairs of corresponding members are pairs of equivalent expressions, and this equivalence is justified by the associative principle for multiplication. Equations (c) and (d) are equivalent [with respect to the set of nonzero real numbers] by virtue of "equivalent expressions". The cpm and the pq justify the equivalence of the pairs of corresponding members, and the pq has been applied correctly in view of the restriction ' $x \neq 0$ '. [It is not necessary to repeat the restriction when we apply the principle of quotients.]

Now, since equations (a) and (e) are equivalent with respect to the set of nonzero real numbers, and since 2 is the root of equation (e), and since 2 belongs to the set of nonzero real numbers, we conclude that 2 is a root of equation (a). But, our original job was to find all the roots of this equation. The only numbers which can be roots of equation (a) are those which are roots of equation (e) or those which are real numbers but not in the set of nonzero real numbers. We already know that 2 is a root. Since 0 is a real number and not a member of the set of nonzero real numbers, we must investigate the possibility that 0 is a root of equation (a). We substitute and find that it is. So, the roots of equation (a) are 2 and 0.

\*

The bracketed section at the bottom of page 3-47 is included to show that transforming an equation by multiplication is not the only transformation which requires that attention be paid to the matter of admissible values of the pronumeral. In the case in question, we must restrict the values of ' $x$ ' to those for which the expression ' $1/(x - 7)$ ' has values. [We need not worry about the expression





The second paragraph on page 3-45 should be illustrated by referring to the pair of equations (1) and (2) on page 3-44 and to the pair (1') and (2') on page 3-45. The pair (1) and (2) illustrate picking up a root, and the pair (1') and (2') illustrate losing a root. [Note the colloquial usage of 'multiplier'. A multiplier is a number, but we are here referring to expressions as multipliers.]

The clause 'if we restrict the set of values of the pronumeral to those for which the multiplier has nonzero values' [which occurs in the second half of the second paragraph] says two things. We want to restrict the set of values of the pronumeral to those for which the multiplier has values and for which none of these values is 0. So, for example, in the case of equations (1) and (2), since the multiplier is 'x', if we declare that the set of values of 'x' is the set of nonzero real numbers, then those numbers in the set of values of 'x' which satisfy (1) also satisfy (2), and vice versa. Similarly, in the case of equations (1') and (2'), since the multiplier is '1/x', let us agree to restrict the set of values of 'x' to the set of nonzero real numbers. [For each of these nonzero real numbers, '1/x' has a nonzero value.] Then, each number in the set of values of 'x' which satisfies (1') also satisfies (2'), and vice versa. We can say, in the case of (1) and (2), that (1) and (2) are equivalent with respect to the set of nonzero real numbers. Also, we could say that (1') and (2') are equivalent with respect to the set of nonzero real numbers. [Heretofore, when we have said that two equations are equivalent, it was tacitly understood that they were equivalent with respect to the set of all real numbers.] We can express these ideas in a succinct way by using the notation suggested on TC[3-27]c. Thus,

$$\{x \neq 0: 3x = 21\} = \{x \neq 0: 3x \cdot x = 21 \cdot x\},$$

and

$$\{x \neq 0: xx = 2x\} = \{x \neq 0: xx \cdot \frac{1}{x} = 2x \cdot \frac{1}{x}\}.$$

In practice, we indicate the fact that the values of the pronumeral are to be restricted to those of a proper subset of the set of all real numbers by writing a restriction next to the derived equation. For example:

$$\begin{array}{l} 3x = 21 \\ 3x \cdot x = 21 \cdot x, [x \neq 0] \end{array} \quad \parallel \quad \begin{array}{l} xx = 2x \\ xx \cdot \frac{1}{x} = 2x \cdot \frac{1}{x}, [x \neq 0] \end{array}$$

\*

Take another example. Transform the equation:

$$(1') \quad xx = 2x$$

by writing a  $\cdot \frac{1}{x}$  on both sides. This gives us:

$$(2') \quad xx \cdot \frac{1}{x} = 2x \cdot \frac{1}{x}.$$

(1') has the roots 0 and 2, but (2') has only the root 2. So, (1') and (2') are not equivalent. [However, the solution set of (2') is a subset of the solution set of (1').]

From these two examples we see that when we transform an equation by multiplication, we may not get an equivalent equation. In fact, we may "pick up" roots or "lose" them. The first occurs only if the "multiplier" has 0 as a value. The second occurs only if there are values of the pronumeral for which the multiplier has no value [ $\frac{1}{x}$  has no value which corresponds with the value 0 of 'x']. So, in transforming an equation by multiplication, if we restrict the set of values of the pronumeral to those for which the multiplier has nonzero values, we can be sure that those numbers in the restricted set of values of the pronumeral which satisfy the given equation will satisfy the derived equation, and vice versa.

Let's consider some more examples. Take the equation:

$$\frac{x-1}{x+1} = 2x - \frac{x+3}{x+1}.$$

We would like to transform this equation into one which has the same roots but which does not contain fractions. Previous exercises suggest that a first step is to transform by multiplying by 'x + 1'.

$$(x+1)\left(\frac{x-1}{x+1}\right) = \left(2x - \frac{x+3}{x+1}\right)(x+1).$$

Now, since 'x + 1' has the value 0 only for the value -1 of 'x' and, in fact, has nonzero values for all values of 'x' different from -1, we can be sure that this equation and the given one are equivalent with respect to the set of real numbers different from -1. That is, we can be sure that they are satisfied by the same members of this restricted set. To indicate this fact we usually write an '[x ≠ -1]'

at the right of the second equation. Here is how we might write the steps in solving the equation.

$$\begin{aligned}\frac{x-1}{x+1} &= 2x - \frac{x+3}{x+1} \\ (x+1)\left(\frac{x-1}{x+1}\right) &= \left(2x - \frac{x+3}{x+1}\right)(x+1), \quad [x \neq -1] \\ x-1 &= 2x(x+1) - (x+3) \\ &= 2xx + 2x - x - 3 \\ &= 2xx + x - 3 \\ (x-1) - (x-1) &= (2xx + x - 3) - (x-1) \\ 0 &= 2xx - 2\end{aligned}$$

The roots of this last equation are 1 and -1. Of these, only 1 belongs to the restricted set of values of 'x'. So, we know that 1 is a root of the given equation, and that the given equation has no other roots in the restricted set. If the given equation has roots other than 1, they must be outside the restricted set. The only such number is -1, and we discover by substitution that -1 is not a root of the given equation. So, the solution set of the given equation is {1}.

Now, consider the equation:

$$3(x+1) = (x+2)(x+1).$$

We might transform this equation into a simpler one by multiplying by ' $\frac{1}{x+1}$ ', first getting:

$$\left(\frac{1}{x+1}\right)[3(x+1)] = [(x+2)(x+1)]\left(\frac{1}{x+1}\right),$$

and then simplifying both sides to get:

$$3 = x + 2.$$

Since ' $\frac{1}{x+1}$ ' has values [nonzero ones, at that] for all values of 'x' except -1, we can be sure that the given equation and the next one are equivalent with respect to the set of real numbers different from -1. [As before, we would show this by writing an ' $[x \neq -1]$ ' next to the second equation.] The only root of the third equation is 1. So,

since 1 belongs to the restricted set, we know that 1 is a root of the given equation. The only other numbers which could be roots of the given equation are numbers outside the restricted set. There is only one such number. It is -1. By substitution, we find that -1 is a root of the given equation. So, its solution set is {1, -1}.

\*

Sample 5.  $13 - \frac{2}{x+2} = \frac{4x+6}{x+2}$

Solution.  $13 - \frac{2}{x+2} = \frac{4x+6}{x+2}$

$$(x+2)\left(13 - \frac{2}{x+2}\right) = \left(\frac{4x+6}{x+2}\right)(x+2), \quad [x \neq -2]$$

$$(x+2)13 - 2 = 4x+6$$

$$13x + 26 - 2 = 4x + 6$$

$$9x = -18$$

$$x = -2$$

The given equation has no roots in the restricted set. Obviously, -2 is not a root. So, the given equation has no roots at all.

\*

[Consider the equation:

$$2x - \frac{1}{x-7} = 14 - \frac{1}{x-7}.$$

We write a  $+\frac{1}{x-7}$  on both sides to get:

$$2x - \frac{1}{x-7} + \frac{1}{x-7} = 14 - \frac{1}{x-7} + \frac{1}{x-7},$$

and then simplify to get:

$$2x = 14.$$

The root of this last equation is 7, but 7 is not a root of the given equation. What happened?]

\*

Sample 6.  $3 + \frac{7}{x-5} = \frac{2x+1}{x-5}$

Solution.  $3 + \frac{7}{x-5} = \frac{2x+1}{x-5}$

$$(x-5)\left(3 + \frac{7}{x-5}\right) = \left(\frac{2x+1}{x-5}\right)(x-5), \quad [x \neq 5]$$

$$3(x-5) + 7 = 2x + 1$$

$$3x - 15 + 7 = 2x + 1$$

$$x = 9$$

The root is 9.

Check.  $3 + \frac{7}{9-5} = \frac{2 \cdot 9 + 1}{9-5} ?$

$$3 + \frac{7}{4} \quad \left| \quad \frac{19}{4}$$

$$\frac{19}{4} = \frac{19}{4} \quad \checkmark$$

Sample 7.  $\frac{3x-4}{2x} - \frac{x+1}{3x} + \frac{x+2}{5x} = \frac{2}{5}$

Solution.  $\frac{3x-4}{2x} - \frac{x+1}{3x} + \frac{x+2}{5x} = \frac{2}{5}$

$$30x\left(\frac{3x-4}{2x} - \frac{x+1}{3x} + \frac{x+2}{5x}\right) = \left(\frac{2}{5}\right)30x, \quad [x \neq 0]$$

$$15(3x-4) - 10(x+1) + 6(x+2) = 12x$$

$$45x - 60 - 10x - 10 + 6x + 12 = 12x$$

$$41x - 58 = 12x$$

$$29x = 58$$

$$x = 2$$

The root is 2.

Check.  $\frac{3 \cdot 2 - 4}{2 \cdot 2} - \frac{2 + 1}{3 \cdot 2} + \frac{2 + 2}{5 \cdot 2} = \frac{2}{5} ?$

$$\frac{2}{4} - \frac{3}{6} + \frac{4}{10} \quad \left| \quad \frac{2}{5}$$

$$\frac{2}{5} = \frac{2}{5} \quad \checkmark$$



Sa

3/61

122.  $\frac{96}{19} = \frac{96}{19}$

123. - - -

124.  $0 = 0$

125.  $0.75 = 0.75$

126.  $\frac{4}{3} = \frac{4}{3}$

127.  $\frac{7}{9} = \frac{7}{9}$

128.  $2 = 2$

129.  $1 = 1$

130.  $\frac{3}{2} = \frac{3}{2}$

131.  $\frac{3}{2} = \frac{3}{2}$

132.  $\frac{3}{8} = \frac{3}{8}$

133.  $\frac{1}{4} = \frac{1}{4}$

134.  $16 = 16$

135.  $2 = 2$

136.  $1 = 1$

137.  $4 = 4$

138.  $58 = 58$

139.  $10 = 10$

140. - - -

141.  $-\frac{66}{31} = -\frac{66}{31}$

142.  $1 = 1$

143.  $\frac{1}{7} = \frac{1}{7}$

144.  $2 = 2$

145.  $18 = 18$

146. - - -

147. - - -

148.  $-\frac{3}{2} = -\frac{3}{2}$

149.  $-2 = -2$

150.  $-\frac{17}{2} = -\frac{17}{2}$

151.  $\frac{5}{4} = \frac{5}{4}$

152.  $-40 = -40, 0 = 0$

153.  $\frac{121}{3} = \frac{121}{3}, 0 = 0$

\*

Unit 5 treats the notion of proportionality in considerable detail. However, some students will need a rudimentary knowledge of the subject [at least to the extent of being familiar with the phrase 'solve a proportion'] before they reach this topic in Unit 5. Hence, we have included some work on proportions in Part B of the Miscellaneous Exercises on page 3-138. You may want to introduce this work at this time. We hope that students will discover the "cross-multiply" shortcut and the theorems mentioned in the COMMENTARY on TC[3-56]a.





Sa

3/60

- |   |                       |                       |               |
|---|-----------------------|-----------------------|---------------|
| 104. $2/3$  | 105. $-3/4$           | 106. 6                | 107. 6        |
| 108. -5   | 109. 5                | 110. 2                | 111. 3        |
| 112. no roots                                     | 113. 0                | 114. $1/5$            | 115. $5/2$    |
| 116. $11/12$                                      | 117. $-\frac{103}{3}$ | 118. -1               | 119. $-1/3$   |
| 120. no roots                                     | 121. $17/5$           | 122. $19/60$          | 123. no roots |
| 124. $4/3$  | 125. 0.25             | 126. $-1/3$           | 127. $1/3$    |
| 128. 5  | 129. 2                | 130. 4                | 131. -6       |
| 132. 5  | 133. 10               | 134. $\frac{295}{27}$ | 135. 50       |
| 136. 5  | 137. 30               | 138. 25               | 139. 12       |
| 140. no roots                                     | 141. $\frac{11}{104}$ | 142. 9                | 143. 10       |
| 144. $1/4$  | 145. $16/9$           | 146. no roots         |               |
| 147. The roots are the real numbers other than 3. | 148. -3               |                       |               |
| 149. -4   | 150. -6               | 151. $-1/2$           | 152. 2, 7     |
| 153. $-\frac{2}{3}, \frac{5}{9}$                  |                       |                       |               |

\*

Check equations for Exercises 104 - 153 on pages 3-49 and 3-50.

- |                                      |  |                                      |                                    |
|--------------------------------------|--|--------------------------------------|------------------------------------|
| 104. $3 = 3$                         | 105. $-4 = -4$                         | 106. $\frac{1}{9} = \frac{1}{9}$     | 107. $2 = 2$                       |
| 108. $-1 = -1$                       | 109. $\frac{1}{2} = \frac{1}{2}$       | 110. $2 = 2$                         | 111. $\frac{11}{6} = \frac{11}{6}$ |
| 112. ---                             | 113. $0 = 0$                           | 114. $13 = 13$                       | 115. $\frac{13}{5} = \frac{13}{5}$ |
| 116. $\frac{34}{11} = \frac{34}{11}$ | 117. $-\frac{2}{515} = -\frac{2}{515}$ | 118. $-17 = -17$                     |                                    |
| 119. $-13 = -13$                     | 120. ---                               | 121. $\frac{40}{17} = \frac{40}{17}$ |                                    |

Sample 8.  $\frac{6}{5b} = \frac{2}{b+4}$

Solution.  $\frac{6}{5b} = \frac{2}{b+4}$

$$5b(b+4)\left(\frac{6}{5b}\right) = \left(\frac{2}{b+4}\right) 5b(b+4), \quad [b \neq 0 \text{ and } b \neq -4]$$

$$(b+4)6 = (2)5b$$

$$6b + 24 = 10b$$

$$24 = 4b$$

$$6 = b$$

The root is 6.

Check.

$$\frac{6}{5 \cdot 6} = \frac{2}{6+4} \quad ?$$

$$\frac{1}{5} = \frac{1}{5} \quad \checkmark$$

104.  $\frac{2}{b} = 3$

105.  $\frac{3}{x} = -4$

106.  $\frac{2}{3d} = \frac{1}{9}$

107.  $\frac{d}{d-3} = 2$

108.  $\frac{2}{x+3} = \frac{5}{x}$

109.  $\frac{y}{y+5} = \frac{1}{2}$

110.  $\frac{5}{x} - \frac{1}{2} = 2$

111.  $\frac{4}{k} + \frac{3}{2k} = \frac{11}{6}$

112.  $\frac{x}{3} + 4 = \frac{x}{2} - \frac{x}{6}$

113.  $\frac{x}{7} + \frac{x}{3} = \frac{x}{21}$

114.  $\frac{3}{a} - 2 = \frac{2}{a} + 3$

115.  $\frac{4}{x} + \frac{5}{2x} = 3 - \frac{1}{x}$

116.  $\frac{5}{2y} + \frac{1}{3y} = \frac{1}{y} + 2$

117.  $\frac{7}{k} + \frac{1}{5} = \frac{2}{15k}$

118.  $\frac{8}{x} - 9 = \frac{17}{x}$

119.  $\frac{3}{a} - 4 = \frac{7}{a} + 8$

120.  $\frac{1+y}{y} - 5 = \frac{1-3y}{y}$

121.  $\frac{6}{5x} + 2 = \frac{8}{x}$

122.  $\frac{7}{2b} - 6 = 9 - \frac{5}{4b}$

123.  $\frac{3x+8}{2x+5} - \frac{x+3}{2x+5} = 20$

(continued on next page)

124.  $\frac{x}{2} - \frac{x}{4} + \frac{2-3x}{6} = 0$

125.  $\frac{m+2}{3} = m + .5$

126.  $\frac{m+3}{2} = \frac{m+7}{5}$

127.  $\frac{4a+1}{3} = \frac{5-a}{6}$

128.  $\frac{3x-5}{x} = 2$

129.  $\frac{5}{y+3} = \frac{2}{y}$

130.  $\frac{c-1}{c-2} = \frac{3}{2}$

131.  $\frac{3}{2} = \frac{a}{a+2}$

132.  $\frac{k-2}{k+3} = \frac{3}{8}$

133.  $\frac{m-7}{m+2} = \frac{1}{4}$

134.  $\frac{x+2}{2} + \frac{3x}{5} + \frac{x+1}{4} = 16$

135.  $\frac{500}{5t} = \frac{500}{t} - 8$

136.  $\frac{b+11}{6} + \frac{b-10}{3} = 1$

137.  $\frac{180}{\frac{3}{2}x} = \frac{180}{x} - 2$

138.  $x + \frac{x+1}{2} + \frac{4x}{5} = 58$

139.  $\frac{x}{4} + \frac{x+2}{2} = 10$

140.  $\frac{44}{11-x} = \frac{4x}{11-x} - \frac{19}{3}$

141.  $\frac{5}{2} \left( \frac{1}{x-1} \right) + \frac{2}{3} = \frac{39x-3x}{2(x-1)}$

142.  $\frac{7}{x-2} = \frac{9}{x}$

143.  $\frac{2}{x+4} = \frac{1}{x-3}$

144.  $\frac{3}{2x+1} = \frac{8}{4x+3}$

145.  $\frac{4}{2-x} = \frac{6}{3x-5}$

146.  $\frac{5}{x-1} = \frac{5}{1-x}$

147.  $\frac{2}{x-3} = \frac{2}{x-3}$

148.  $x + \frac{3x}{x-3} = \frac{9}{x-3}$

149.  $x - \frac{16}{x-4} = \frac{-4x}{x-4}$

150.  $2x + \frac{7x}{x-6} = \frac{72-5x}{x-6}$

151.  $\frac{2xx}{2x-1} - 3x = 1 + \frac{x}{2x-1}$

152.  $8(x-7) = (x-7)(3x+2)$

153.  $(9x-5)(x-3) = (2x+5)(5-9x)$

[More exercises are in Part G, Supplementary Exercises.]

3.06 Transforming a formula. -- Sally Prentiss, a freshman at Zabbranchburg High, is planning a summer trip to Europe with her parents. She is concerned about the kind of clothes she should take with her. So, she writes to a friend who lives in France and asks questions about the weather in various cities which they expect to visit. Her friend sends her the following list of average July temperatures in these cities.

Madrid . . . . .	23.2°
Rome . . . . .	24.5°
Athens . . . . .	27.4°
Istanbul . . . . .	23.6°
Vienna . . . . .	18.8°
Copenhagen . . . . .	16.5°
Oslo . . . . .	17.0°
Glasgow . . . . .	14.5°
Amsterdam . . . . .	17.2°
Paris . . . . .	18.5°

Sally is slightly surprised at these temperatures. Does it really get that cold in Europe in July? Then she remembers that they use a different kind of thermometer in Europe, something called 'a centigrade thermometer', and that people in the United States use a Fahrenheit thermometer. She even remembers that in science she learned a formula about the thermometers. She hunts up her notebook and finds this formula:

$$C = \frac{5}{9}(F - 32).$$

She decides that she can use this formula to figure out the Fahrenheit temperatures in these cities. She starts with Madrid, substituting '23.2' for 'C' to get the equation:

$$23.2 = \frac{5}{9}(F - 32).$$

UNIVERSITY OF  
LIBRARY

Next, she solves this equation.

$$\begin{aligned}
 9 \times 23.2 &= 9 \times \frac{5}{9}(F - 32) \\
 208.8 &= 5(F - 32) \\
 208.8 &= 5F - 160 \\
 208.8 + 160 &= 5F - 160 + 160 \\
 368.8 &= 5F \\
 \frac{1}{5} \times 368.8 &= 5F \times \frac{1}{5} \\
 73.76 &= F
 \end{aligned}$$

So, the Madrid temperature in July is almost  $74^\circ$  Fahrenheit.

Now, how about Rome? Substitute again in the formula

$$C = \frac{5}{9}(F - 32):$$

$$\begin{aligned}
 24.5 &= \frac{5}{9}(F - 32) \\
 9 \times 24.5 &= 9 \times \frac{5}{9}(F - 32) \\
 220.5 &= 5(F - 32) \\
 220.5 &= 5F - 160 \\
 220.5 + 160 &= 5F - 160 + 160 \\
 380.5 &= 5F \\
 \frac{1}{5} \times 380.5 &= 5F \times \frac{1}{5} \\
 76.1 &= F
 \end{aligned}$$

The July temperature in Rome is about  $76^\circ$  Fahrenheit.

By now, Sally is annoyed at the prospect of having to solve so many equations. There must be an easier way! She sees that she followed exactly the same steps in solving the equations for Madrid and for Rome. And, she realizes that she would follow the same steps each time she tried to compute the Fahrenheit temperatures for the rest of the cities. So, there must be a pattern. She takes

the original formula:

$$C = \frac{5}{9}(F - 32)$$

and treats the 'C' as if it were a numeral.

$$9 \times C = 9 \times \frac{5}{9}(F - 32)$$

$$9C = 5(F - 32)$$

$$9C = 5F - 160$$

$$9C + 160 = 5F - 160 + 160$$

$$9C + 160 = 5F$$

$$\frac{1}{5}(9C + 160) = (5F) \frac{1}{5}$$

$$\frac{1}{5}(9C + 160) = F$$

Now, if she substitutes for 'C' in this last equation, she can find the Fahrenheit temperature very quickly. To be sure that this will work, she checks the Madrid temperature again.

$$F = \frac{1}{5}(9 \cdot 23.2 + 160)$$

$$= \frac{1}{5}(208.8 + 160)$$

$$= \frac{1}{5}(368.8)$$

$$= 73.76.$$

Sure enough, this is what she got the first time! There seem to be fewer steps, although the actual amount of computing is the same. She notices that she could cut down the amount of computing if she simplified the formula:

$$F = \frac{1}{5}(9C + 160)$$

to:

$$F = 1.8C + 32.$$

Compare the formulas :

$$(1) \quad C = \frac{5}{9}(F - 32)$$

and :

$$(2) \quad F = 1.8C + 32.$$

Do you see that when you substitute for 'C' in both formulas a numeral for the same number, the equations you get are equivalent? Also, do you get equivalent equations when you substitute a numeral for 'F' in both formulas? Formulas such as (1) and (2) are often called equivalent formulas. Either of two equivalent formulas can be transformed into the other by using the methods you learned in the preceding section.

You can see that knowing how to transform a formula makes it possible for you to have many formulas available without having to memorize them or even have them all written down. For example, Sally had just the formula 'C =  $\frac{5}{9}(F - 32)$ ' written in her notebook. This formula is most useful in computing centigrade temperatures when you are given Fahrenheit temperatures. The job Sally wanted to do required computing Fahrenheit temperatures from centigrade temperatures. A formula for this purpose would start:

$$F = \dots$$

And, Sally could have derived such a formula immediately by transforming 'C =  $\frac{5}{9}(F - 32)$ '.

Here is a formula for computing the perimeter of a rectangle :

$$P = 2(\ell + w).$$

If you know the measures of the length and width of a rectangle, you can use this formula to compute the perimeter.

But, suppose you know the perimeter and the width of a rectangle; is there a formula which you can use to compute the measure of the length of this rectangle? The answer is 'yes', and we can derive such



[3-55]

erts

Note that the word 'solve' is used with a different meaning in connection with the exercises in Part A. Up to now we have been using 'solve' to mean the same as 'find the numbers which satisfy'. Now, we are using 'solve for' to mean the same as 'find an equivalent equation beginning with'.

\*

Some remarks are called for in connection with the formula ' $P = 2(\ell + w)$ '. We have previously said that measures such as perimeters, and length and width measures, are numbers of arithmetic [rather than real numbers]. However, in solving problems concerning such measures, it is often convenient to think of them "as if they were real numbers". [This can safely be done because, as shown in Unit 1, the system of the non-negative real numbers is isomorphic with the system of the numbers of arithmetic.] It is convenient to do this because the real number system is simpler than the system of the numbers of arithmetic. [Subtraction is always possible in the former.] Because this change from numbers of arithmetic to real numbers is made in carrying out the solution of most problems which are actually concerned with numbers of arithmetic, we shall usually not bother to call attention to it. In fact, we shall often speak of measures as if they actually were real numbers.

The case of relative measures, such as what are commonly called 'temperatures' is slightly different. These are numbers which measure differences [directed trips] between absolute temperatures.

\*

Answers for Part A [on pages 3-55 and 3-56].

$$1. \quad b = P - 2a$$

$$2. \quad a = \frac{P - b}{2}$$

$$3. \quad s = \frac{P}{4}$$

$$4. \quad d = \frac{C}{\pi}$$

$$5. \quad x = \frac{P - 3y}{3}$$

$$6. \quad b = \frac{P - 2a}{3}$$

$$7. \quad y = \frac{x + z}{3}$$

$$8. \quad z = x - 2y$$

a formula by transforming ' $P = 2(\ell + w)$ ' into a formula which starts ' $\ell = \dots$ '.

$$\begin{aligned} P &= 2(\ell + w) \\ P &= 2\ell + 2w \\ P - 2w &= 2\ell \\ \frac{P - 2w}{2} &= \ell \\ \ell &= \frac{P - 2w}{2} \end{aligned}$$

This process is sometimes called 'solving an equation for one pronumeral in terms of the other pronumerals'. In the example just given, we solved the equation ' $P = 2(\ell + w)$ ' for ' $\ell$ ' in terms of ' $w$ ' and ' $P$ '.

### EXERCISES

A. Solve each of the following equations for the pronumeral indicated.

Sample 1.  $P = a + b + c$ ;  $b$

Solution. [We wish to transform the given equation into one whose left side is ' $b$ ' and whose right side is a pronumeral expression in which ' $b$ ' does not occur.]

$$\begin{aligned} P &= a + b + c \\ P &= b + (a + c) \\ P - (a + c) &= b + (a + c) - (a + c) \\ b &= P - a - c \end{aligned}$$

- |                        |                        |
|------------------------|------------------------|
| 1. $P = 2a + b$ ; $b$  | 2. $P = 2a + b$ ; $a$  |
| 3. $P = 4s$ ; $s$      | 4. $C = \pi d$ ; $d$   |
| 5. $P = 3x + 3y$ ; $x$ | 6. $P = 2a + 3b$ ; $b$ |
| 7. $x = 3y - z$ ; $y$  | 8. $x = 2y + z$ ; $z$  |

Sample 2.  $k = 5m - n$ ;  $n$

Solution.  $k = 5m - n$   
 $k - 5m = 5m - n - 5m$   
 $k - 5m = -n$   
 $-1(k - 5m) = -1(-n)$   
 $n = -k + 5m$  [or:  $n = 5m - k$ ]

9.  $A = 5b - c; c$

10.  $K = 2g - 3h; h$

11.  $x = 2v - 3u + w; v$

12.  $y = 2p + q - r; r$

13.  $P = 2(a + b) - c; c$

14.  $P = 3(x - y) - 5z; y$

Sample 3.  $A = hb; b$

Solution.  $A = hb$

$$A \cdot \frac{1}{h} = hb \cdot \frac{1}{h}, [h \neq 0]$$

$$b = \frac{A}{h}$$

Sample 4.  $i = prt; r$

Solution.  $i = prt$

$$i = (pt)r$$

$$r = \frac{i}{pt}, [pt \neq 0]$$

Sample 5.  $A = p + prt; p$

Solution.  $A = p + prt$

$$A = p(1 + rt)$$

$$p = \frac{A}{1 + rt}, [rt \neq -1]$$

[Why would you be wrong if you gave as the answer:

$$p = A - prt \quad ?]$$

15.  $c = np; n$

16.  $b = \frac{P}{r}; p$

17.  $A = \frac{1}{2}bh; b$

18.  $r = \frac{E}{I}; E$

19.  $x = y + yz; z$

20.  $x = y + yz; y$

21.  $l = a + (n - 1)d; d$

22.  $l = a + (n - 1)d; n$

23.  $A = \frac{1}{2}h(b_1 + b_2); h$

24.  $A = \frac{1}{2}h(b_1 + b_2); b_1$

[More exercises are in Part H, Supplementary Exercises.]

9.  $c = 5b - A$       10.  $h = \frac{2g - K}{3}$       11.  $v = \frac{x + 3u - w}{2}$
12.  $r = 2p + q - y$       13.  $c = 2(a + b) - P$       14.  $y = \frac{3x - 5z - P}{3}$
15.  $n = \frac{c}{p}, [p \neq 0]$       16.  $p = br, [r \neq 0]$
17.  $b = \frac{2A}{h}, [h \neq 0]$       18.  $E = Ir, [I \neq 0]$
19.  $z = \frac{x - y}{y}, [y \neq 0]$       20.  $y = \frac{x}{1 + z}, [z \neq -1]$
21.  $d = \frac{\ell - a}{n - 1}, [n \neq 1]$       22.  $n = \frac{\ell - a + d}{d}, [d \neq 0]$
23.  $h = \frac{2A}{b_1 + b_2}, [b_1 \neq -b_2]$       24.  $b_1 = \frac{2A - hb_2}{h}, [h \neq 0]$

\*

Answers for Part B [on page 3-57].

1.  $y = -2x + 9$       2.  $y = 5x + -15$       3.  $y = 1x + 7$
4.  $y = -\frac{3}{7}x + 3$       5.  $y = \frac{1}{7}x + -4$       6.  $y = \frac{3}{2}x + 9$
7.  $y = 3x + -\frac{7}{3}$       8.  $y = \frac{9}{2}x + -\frac{7}{2}$
9.  $y = -\frac{4}{5}x + 10$       10.  $y = \frac{2}{5}x + -\frac{3}{2}$

\*

In connection with Method II of Sample 2, you might ask students if they see a short cut which would enable them to go directly from:

$$\frac{1}{y} = \frac{5x - 1}{x} \text{ to: } y = \frac{x}{5x - 1}.$$

This is an application of the theorems:

- (a)  $\forall x \neq 0 \forall y \neq 0$  if  $x = y$  then  $\frac{1}{x} = \frac{1}{y}$ ,
- (b)  $\forall x \neq 0 \forall y \neq 0$  if  $\frac{1}{x} = \frac{1}{y}$  then  $x = y$ .

The first of these can be called 'the uniqueness principle for reciprocation'. As in the case of other uniqueness principles, it is a logical

[3-56]

9

3/64

theorem. [Suppose  $x = y$ . Since  $1/x = 1/x$ , it follows from the substitution rule that  $1/x = 1/y$ .] The second theorem is analogous to the cancellation principles. [Suppose  $1/x = 1/y$ . Then, by the uniqueness principle for reciprocation,  $1/(1/x) = 1/(1/y)$ . So, by Theorems 74 and 50,  $x = y$ .]

\*

Strictly speaking, the answer for Sample 2 should include all restrictions on the values of 'x' and 'y':

$$y = \frac{x}{5x - 1}, [x \neq 0 \neq y, x \neq \frac{1}{5}]$$

\*

[As indicated by the answer for Sample 2, when solving the remaining exercises of Part B, students should not expect to obtain an answer of the form:  $y = \dots x + \dots$ .]

\*

$$11. y = \frac{4x}{5x - 6}, [0 \neq x \neq \frac{6}{5}, y \neq 0]$$

$$12. y = \frac{3x - 63}{7}$$

$$13. y = \frac{pq}{p + q}, [p \neq 0 \neq q \neq -p, y \neq 0]$$

$$14. y = \frac{pq}{p - q}, [y \neq 0 \neq p \neq q \neq 0]$$

$$15. y = \frac{a}{6a - 1}, [y \neq 0 \neq a \neq \frac{1}{6}]$$

$$16. y = \frac{9n}{10 - n}, [y \neq 0 \neq n \neq 10]$$

$$17. y = \frac{x}{7 - x}, [0 \neq y \neq -1, x \neq 7]$$

$$18. y = -\frac{a}{11}, [a \neq y \neq -a]$$

[3-56]

9



B. Solve each of these equations for 'y' to obtain an equation of the form:  $y = \dots x + \dots$ .

Sample 1.  $3x - 2y = 7$

Solution.  $3x - 2y = 7$

$$-2y = 7 - 3x$$

$$y = \frac{7 - 3x}{-2}$$

$$y = \frac{3}{2}x + -\frac{7}{2}$$

1.  $2x + y = 9$

2.  $5x - y = 15$

3.  $x - y + 7 = 0$

4.  $3x + 7y = 21$

5.  $x - 7y = 28$

6.  $2y - 3x = 18$

7.  $4x + 2 - 6y = 9 - 3y - 5x$

8.  $7x + 6y - 3 = 8y - 2x + 4$

9.  $4(x - 5) + 5(y - 3) = 15$

10.  $3(x + y - 2) + 7(y - x + 3) = 0$

Sample 2.  $\frac{1}{x} + \frac{1}{y} = 5$

Solution.

Method I.

$$\frac{1}{x} + \frac{1}{y} = 5$$

$$xy\left(\frac{1}{x} + \frac{1}{y}\right) = 5xy, [x \neq 0 \neq y]$$

$$y + x = 5xy$$

$$y + x - y = 5xy - y$$

$$x = y(5x - 1)$$

$$y = \frac{x}{5x - 1}, [x \neq \frac{1}{5}]$$

Method II.

$$\frac{1}{x} + \frac{1}{y} = 5$$

$$\frac{1}{y} = 5 - \frac{1}{x}, [x \neq 0 \neq y]$$

$$\frac{1}{y} = \frac{5x - 1}{x}$$

$$xy\left(\frac{1}{y}\right) = \left(\frac{5x - 1}{x}\right)xy$$

$$x = (5x - 1)y$$

$$y = \frac{x}{5x - 1}, [x \neq \frac{1}{5}]$$

11.  $\frac{3}{4x} + \frac{1}{2y} = \frac{5}{8}$

12.  $3 = \frac{x}{7} - \frac{y}{3}$

13.  $\frac{1}{p} + \frac{1}{q} = \frac{1}{y}$

14.  $\frac{1}{p} + \frac{1}{y} = \frac{1}{q}$

15.  $\frac{1}{y} + \frac{1}{a} = 6$

16.  $\frac{2}{3n} - \frac{3}{5y} = \frac{1}{15}$

17.  $\frac{x}{y} = \frac{7}{1 + y}$

18.  $\frac{5}{a + y} = \frac{6}{a - y}$

[More exercises are in Part I, Supplementary Exercises.]

## EXPLORATION EXERCISES

Complete with the simplest expression you can to make true sentences.

1. The sum of 5 and 9 is \_\_\_\_\_.
2. The sum of 3 and the number which is 4 more than 3 is \_\_\_\_\_.
3. The sum of 7 and the number which is 5 less than 7 is \_\_\_\_\_.
4. The number which is 2 more than 10 is \_\_\_\_\_.
5. The number which exceeds 5 by 3 is \_\_\_\_\_.
6. The number which exceeds 3 by 5 is \_\_\_\_\_.
7. Mary is 14 and Mike is twice as old as Mary; in 7 years Mike will be \_\_\_\_\_ years old and Mary will be \_\_\_\_\_ years old.
8. The sum of three consecutive integers, of which the first is  $+5$ , is \_\_\_\_\_. [An integer is a real number whose absolute value is a whole number of arithmetic. Examples:  $-6$ ,  $0$ ,  $2$ , and  $100$ .]
9. The integer between  $-6$  and  $-8$  is \_\_\_\_\_.
10. The difference of 12 from 15 is \_\_\_\_\_.
11. The difference of 15 from 12 is \_\_\_\_\_.
12. The difference of 12 from the number which is 3 more than 12 is \_\_\_\_\_.
13. The number by which 73 exceeds 62 is \_\_\_\_\_.
14. If Teresa weighs 101 pounds after gaining  $2\frac{1}{2}$  pounds during March, she weighed \_\_\_\_\_ pounds at the beginning of March.
15. Mr. Petrini bought a home for \$12,350 and sold it the next year for \_\_\_\_\_ which was \$750 less than he had paid for it.

3/65

The purpose of these Exploration Exercises is to prepare students for the ideas [and language] they will encounter in verbal problems.

\*

Answers for Exploration Exercises [on pages 3-58 through 3-64].

- |  |                     |         |                     |              |
|--|---------------------|---------|---------------------|--------------|
| 1. 14  | 2. 10               | 3. 9    | 4. 12               | 5. 8         |
| 6. 8   | 7. 35, 21           | 8. +18  | 9. -7               | 10. 3        |
| 11. -3   | 12. 3               | 13. 11  | 14. $98\frac{1}{2}$ | 15. \$11,600 |
| 16. 7  | 17. -2              | 18. 30  | 19. 54              | 20. 48       |
| 21. 3  | 22. 1500            | 23. 35  | 24. 4.5             | 25. 125      |
| 26. 80   | 27. 33              | 28. 66  | 29. 77              | 30. 60       |
| 31. 63   | 32. 53              | 33. 21  | 34. 6920            | 35. 180      |
| 36. 264  | 37. 2.10            | 38. 40  | 39. 30              | 40. -25      |
| 41. 35   | 42. 17              | 43. 7   | 44. 18              |              |
| 45. The sentence does not contain sufficient information.  |                     |         |                     |              |
| 46. 70   | 47. 3               | 48. 155 | 49. 530             | 50. 2.40     |
| 51. The date given in this sentence are inconsistent, so it can not be completed to a true sentence.   |                     |         |                     |              |
| 52. 1529   | 53. $87\frac{1}{7}$ |         |                     |              |
| 54. The data are inconsistent if one assumes that the value of the blend should be the same as the sum of the values of the components. 70 pounds of 85¢ coffee is worth \$59.50. But, the components are worth \$61.80. |                     |         |                     |              |

\*

Students may object to the negative answers for Exercises 17 and 40. In these exercises the real number answers can be interpreted as measuring differences in status ["directed trips"]. Alternatively, the absence of nonnegative solutions may be interpreted as indicating that the problems as stated have no solutions. Ned is not older than his sister; the man does not make anything on the housing deal. Even with this interpretation it should be clear that Ned is 2 years younger than his sister, and that the man loses \$25 on the deal.

[3-58]

se

16. If Pete is 12 years old now, he was \_\_\_\_\_ years old 5 years ago.
17. If Ned was born 5 years ago and his sister was born 7 years ago, Ned is \_\_\_\_\_ years older than his sister.
18. The product of 6 and 5 is \_\_\_\_\_.
19. The product of 6 and the number which is 3 more than 6 is \_\_\_\_\_.
20. The product of 4 and the number which is the product of 3 and 4 is \_\_\_\_\_.
21. The number which is 10% of 30 is \_\_\_\_\_.
22. The product of 150 and  $\frac{1}{2}$  of 20 is \_\_\_\_\_.
23. The quotient of 70 by 2 is \_\_\_\_\_.
24. The number which is 3 more than the quotient of 15 by 10 is \_\_\_\_\_.
25. 75 is \_\_\_\_\_ per cent of 60.
26. 60 is \_\_\_\_\_ per cent of 75.
27. The number which exceeds 30 by 10% [of 30] is \_\_\_\_\_.
28. The number which exceeds 60 by 10% [of 60] is \_\_\_\_\_.
29. The number which exceeds 70 by 10% is \_\_\_\_\_.
30. The number which is 20% greater than 50 is \_\_\_\_\_.
31. The number which is 30% less than 90 is \_\_\_\_\_.
32. The sum of 50% of 70 and 60% of 30 is \_\_\_\_\_.

(continued on next page)

33. Joe has 36 pigeons; if Abe has 3 more than half this number of pigeons then Abe has \_\_\_\_\_ pigeons.
34. Mr. Abercrombie earns \_\_\_\_\_ dollars a year which is \$720 more than twice the earnings of Mr. Sussman who earns \$3100 yearly.
35. Phil added 60 stamps to his Switzerland collection; if this was  $\frac{1}{2}$  as many as he already had, then altogether he has \_\_\_\_\_ Swiss stamps.
36. If unlined paper costs 15 cents a pad and lined paper costs 7 cents more per pad than unlined paper, the cost of a dozen pads of lined paper is \_\_\_\_\_ cents.
37. If a paper boy earns one cent for each paper delivered, and if he delivers papers to 35 customers each day except Sunday, then he earns \_\_\_\_\_ dollars per week.
38. If Amos buys pencils three for a dime, and sells them to his classmates at 5 cents each, then his profit on two dozen pencils is \_\_\_\_\_ cents.
39. If the cost price of an article is 25 dollars, and the margin is 20% of the cost price, the selling price is \_\_\_\_\_ dollars.
40. A man buys a house for \$10,000 and sells it for 5% more than it cost; but, he pays 5% commission on the selling price. So, he makes \_\_\_\_\_ dollars.
41. The difference of 7 from the number which is 7 times as large as 6 is \_\_\_\_\_.
42. Carla is 10 years old now, and 3 years ago Dick was twice as old as Carla was then; Dick is \_\_\_\_\_ years old now.
43. If Butchie is now 5 years old and if Barbie's age is 3 years less than twice Butchie's age, Barbie is now \_\_\_\_\_ years old.

44. If white bread costs 3 cents less per loaf than whole wheat bread, six loaves of whole wheat bread cost \_\_\_\_\_ cents more than the same number of loaves of white bread.
45. If Rudolph is 7 years old, and Rupert is 12 years older than Rhoda, then Rudolph is \_\_\_\_\_ years younger than Rupert.
46. If the length of each side of a regular pentagon is 7 inches more than twice the length of each side of an equilateral triangle, and if the perimeter of the equilateral triangle is  $10\frac{1}{2}$ , then the perimeter of the pentagon is \_\_\_\_\_.
47. A rectangle is \_\_\_\_\_ inches wide if its perimeter is 20 and its length is 7 inches.
48. Martin has 3 dimes and 2 more quarters than dimes [and no other money]; so, he has \_\_\_\_\_ cents.
49. If the number of dimes in a sack of nickels and dimes is 3 more than twice the number of nickels, and if the sack contains 20 nickels, then all the coins in the sack are worth \_\_\_\_\_ cents.
50. Six quarters, six nickels and six dimes are together worth \_\_\_\_\_ cents.
51. In a sum of money consisting of just dimes and nickels there are 13 nickels. If the sum amounts to \$1.00 then there are \_\_\_\_\_ dimes.
52. 10 pounds of coffee at 85 cents per pound and 7 pounds of coffee at 97 cents per pound will cost \_\_\_\_\_ cents.
53. If a coffee blend is made using 30 pounds of a 90-cents-a-pound grade and 40 pounds of an 85-cents-a-pound grade, then one pound of this blend is worth \_\_\_\_\_ cents.
54. A grocer makes 70 pounds of a coffee blend to sell at 85 cents per pound by mixing 30 pounds of a 90-cents-a-pound grade with \_\_\_\_\_ pounds of an 87-cents-a-pound grade.

(continued on next page)

55. The simple interest per year on \$700 invested at an annual rate of 4% is \_\_\_\_\_ dollars.
56. If a total of \$1400 is invested, with \$1000 at 3% and the rest at 4%, the annual return on the total investment is \_\_\_\_\_.
57. The annual income on \$3000 of which \$1000 is invested at 4.5% and the rest at 5.5% is \_\_\_\_\_ dollars.
58. There are \_\_\_\_\_ pints in 3 quarts.
59. There are \_\_\_\_\_ quarts in 7 pints.
60. Two gallons and three quarts together make \_\_\_\_\_ pints.
61. Mrs. Swenson needs \_\_\_\_\_ gallons of tomato juice to fill 5 pint jars and twice as many quart jars.
62. There are \_\_\_\_\_ feet in 48 inches.
63. There are 48 feet in \_\_\_\_\_ inches.
64. If a man can do a certain job in 12 minutes, then by working at the same rate he can do \_\_\_\_\_ of the job in 1 minute, \_\_\_\_\_ of the job in 2 minutes, \_\_\_\_\_ of the job in 9 minutes and \_\_\_\_\_ of the job in 12 minutes.
65. If a man can do a certain piece of work in 10 minutes, then he can do \_\_\_\_\_ part of the job in 6 minutes.
66. If Art can do a certain job in 3 hours, and Joe can do the same job in 4 hours, then in 1 hour Art can do \_\_\_\_\_ of the job and Joe can do \_\_\_\_\_ of the job and, so, in one hour together they can do \_\_\_\_\_ of the job.
67. If Bill can do a certain job in 2 hours and Bob can do the same job in half the time, then in 3 hours they can do \_\_\_\_\_% of the job.
68. You can walk \_\_\_\_\_ miles in 3 hours at the average rate of 4 miles per hour.



3/66







[Correction for Exercise 65. Delete 'part'.]

\*







55. 28            56. \$46            57. 155            58. 6            59.  $3\frac{1}{2}$
60. 22            61.  $3\frac{1}{8}$             62. 4            63. 576
64.  $\frac{1}{12}, \frac{1}{6}, \frac{3}{4}, 1$  [or: all]    65.  $\frac{3}{5}$             66.  $\frac{1}{3}, \frac{1}{4}, \frac{7}{12}$
67. The data given here are somewhat ridiculous, but no doubt you will have students who will complete the blank with a '450'. 'doing 450% of the job' can be interpreted to mean that they completed 4.5 jobs in 3 hours.
68. 12            69.  $2\frac{1}{3}$             70.  $1\frac{1}{3}$             71.  $1\frac{3}{7}$             72. 1.5
73. The data given are insufficient.    74. 2            75. 6
76. 1.9            77. 6, 50            78. 4.5            79. 60
80. The data given are inconsistent.

\*

Use Exercise 76 to lead into a more intensive treatment of "mixtures". The following exercise proved helpful in one of our schools.

If a man starts with  quarts of  % of alcohol and adds  quarts of  % alcohol, then he has  quarts of  % alcohol.

Complete the table.

						
(1)	5	30	15	20	—	—
(2)	10	25	—	15	—	<u>18</u>
(3)	15	30	20	—	—	50
(4)	—	100	40	30	—	23.5
(5)	16	—	30	45	—	70

[3-62]

55. T'

3/67

Construct similar exercises for the candy mixtures [Exercise 78] and the nut mixtures [Exercise 79]. [We have been reminded that the volume of a mixture obtained by adding a quart of water to a quart of alcohol is less than 2 quarts. You may point this out to your students, and add that we live in a world of fantasy!]

Mixture problems are traditionally difficult. One aspect which causes difficulty is undoubtedly the reference to percentage. So, spend some time in analyzing mixture problems by referring to the components, thereby showing students how to use the percentage descriptions. Consider Exercise 76.

	<u>Total</u>	<u>Alcohol</u>	<u>Water</u>
20% Solution has:	5 qts.	1 qt.	4 qts.
30% Solution has:	3 qts.	.9 qt.	2.1 qts.
Mixture will have:	8 qts.	<u>1.9 qts.</u>	6.1 qts.

Here is a similar analysis for Exercise 77.

	<u>Total</u>	<u>Alcohol</u>	<u>Water</u>
Pure alcohol solution has:	2 qts.	2 qts.	0 qts.
25% solution has:	4 qts.	1 qt.	3 qts.
Mixture will have:	<u>6 qts.</u>	<u>.3 qts.</u>	3 qts.

3 is 50% of 6

Here is an analysis for Exercise 78.

	<u>Total</u>	<u>Peppermint</u>	<u>Other</u>
Original mixture has:	3 lbs.	$1\frac{1}{2}$ lbs.	$1\frac{1}{2}$ lbs.
Candy to be added:	_____	_____	0 lbs.
New mixture has:	3 + _____	$1\frac{1}{2}$ + _____	$1\frac{1}{2}$ lbs.

Since the new mixture is to be 80% peppermint candy, it must also contain 20% of its weight in other candy. We know that the other candy in the new mixture weighs 1.5 lbs. Since this is  $\frac{1}{5}$  of the total, the total must weigh 5 times as much, or 7.5 lbs. So, we must add 4.5 lbs. of peppermint candy.

[3-62]

55. T

69. You can walk 7 miles in \_\_\_\_\_ hours at the average rate of 3 miles per hour.
70. You can walk 4 miles in 3 hours at the average rate of \_\_\_\_\_ miles per hour.
71. If Kathy's average rate of walking is 1 mile per hour more than Marilyn's average rate, and if Marilyn walks 5 miles in 2 hours, then Kathy walks 5 miles in \_\_\_\_\_ hours.
72. If Bill's wages are \_\_\_\_\_ dollars an hour, he receives \$60 for 40 hours of work.
73. If Martha receives \$8 more than Richard for working 4 hours less, Richard receives \_\_\_\_\_ dollars an hour.
74. If 5 quarts of an alcohol solution contain 4 quarts of water and 1 quart of alcohol, then 10 quarts of this same solution will contain \_\_\_\_\_ quarts of alcohol.
75. If an alcohol solution is 25% alcohol [and the rest water] then 8 quarts of this solution contain \_\_\_\_\_ quarts of water.
76. If you add 3 quarts of a 30% alcohol solution to 5 quarts of a 20% alcohol solution, you get 8 quarts of solution containing \_\_\_\_\_ quarts of alcohol.
77. If you add 2 quarts of pure alcohol to 4 quarts of a 25% alcohol solution, then the mixture contains a total of \_\_\_\_\_ quarts of liquid, of which \_\_\_\_\_ per cent is alcohol.
78. If you have 3 pounds of a candy mixture, 50% of which is peppermint candy, and you want to make a mixture which contains 80% peppermint candy, you can add \_\_\_\_\_ pounds of peppermint candy to the original mixture.

(continued on next page)

79. If 28 ounces of shelled peanuts are combined with 2 pounds of a nut mixture which contains 25% shelled peanuts, then \_\_\_\_\_ per cent of the new mixture is shelled peanuts.
80. Five gallons of 15% -alcohol are poured into 7 gallons of 12% -alcohol. The resulting solution contains \_\_\_\_\_ gallons of 3% -alcohol.

3.07 Solving problems. -- The very best way of becoming a good problem solver is to solve lots of problems. In this section you will get lots of practice in solving problems. There is no one method which is best for solving all problems. There may be several very good ways of solving the same problem, as well as several poor ones. A "good" method of solving a problem is usually a method which takes less computing and which gives you ideas for solving other problems of the same kind. Sometimes you will find it helpful to take an easy problem and solve it in two or three different ways in order to get practice with these different methods, so that you will have a variety of tools available when you attempt more difficult problems.

Many of the problems you will practice on in this section are twentieth century versions of problems mathematics students have been doing for thousands of years. Most of them are really puzzles, but a few are of a practical nature. In either case, the important thing for you is that you read carefully and think clearly. And the more problems you work, the easier it will be to do both of these things.

Example 1.

A jar of coins contains 3 times as many dimes as nickels and twice as many quarters as nickels. The total value of the quarters, dimes, and nickels in the jar is \$21.25. How many nickels are there in the jar?

One way to attack this problem is to imagine yourself putting coins into a jar and following the conditions of the problem. Can you picture yourself doing this?

3/68

As far as we know there is no universal formula for solving worded [or verbal] problems. It appears that the most effective teaching technique is to give the students plenty of practice. We urge that you do not insist upon excessive formality in the student's work. If you require a certain amount of description to be written by the student on his homework paper or on his test paper so that you have something to use in grading him or in pointing out his errors, we suggest that you inform him of your purposes in requiring the written description.

\*

The article by Henderson and Pingry on problem-solving in the 21st Yearbook of the National Council of Teachers of Mathematics contains a number of helpful suggestions. Of particular importance is the research they summarize regarding the formation of mental sets. In order to avoid formation of inhibitory mental sets, we have not "typed" our problems.

\*

Some of the ancient problems referred to are found in a document called 'the Rhind Papyrus'. Most recent histories of elementary mathematics include a discussion of the Rhind Papyrus. [See, for example, Howard Eves, An Introduction to the History of Mathematics (New York: Rinehart and Company, 1953) page 46. James R. Newman has an excellent article on the Rhind Papyrus in the August 1952 issue of Scientific American. This article may be more readily accessible to you in its reprinted form in Volume I of The World of Mathematics (pages 170-178) published by Simon and Schuster and edited by Newman.]

\*

Teachers sometimes have difficulty in getting some students to make the transition from the "guessing-method" to the "equation-method". Part of the difficulty, we believe, can be attributed to the word 'guessing'. Actually, we are not concerned here with obtaining a guess in solving a worded problem. [If a student can make intelligent guesses, then he is probably the kind of student who can use the equation-method whenever he is called upon to do so.] Instead of a guess, what we want is a sample answer. Then, checking the sample answer against the problem itself and using the frames as we illustrate should result in the student's constructing the required equation. In order to obtain this equation, all the student need do is erase the sample answer from the frames.

What needs to be stressed is the fact that we want to obtain an equation containing a pronumeral, rather than trying to guess the correct answer.

[3-64]

79. I



3/69

\*

As we indicated above, there is no easy road to solving worded problems. We think that a student's facility in solving problems is highly correlated with his native intelligence. All of us know that it is possible to get students to solve certain kinds of worded problems in a fairly mechanical manner. Elementary algebra textbooks of 30 years ago [and some of the more recent ones] are full of teaching devices which succeed in getting students to solve certain kinds of worded problems in a mechanical way. There is very little to be gained by using such techniques. They do nothing whatsoever to increase the student's power in mathematics; they simply make him an "expert" in solving restricted types of worded problems. If he is given a worded problem which differs only slightly from the type he has learned to solve mechanically, he may be lost.

\*

The problem of Example 1 is concerned with finite cardinal numbers such as 0, 1, 2, 3, . . . . These numbers form a system isomorphic with the system of the nonnegative real integers 0, +1, +2, +3, . . . . [The system of the finite cardinal numbers is also isomorphic with (but different from) the system of the whole numbers of arithmetic.] By analogy with our treatment of measures as though they were nonnegative real numbers [see TC[3-55]], you can see that we can treat finite cardinal numbers as if they were nonnegative real integers. This means that when we solve the equation:

$$5x + 30x + 50x = 2125$$

by means of our transformation principles [which refer to real numbers], we are in effect solving a different equation:

$$+5x + +30x + +50x = +2125.$$

In this equation the numerals are names for real numbers and the domain of 'x' is the set of real numbers rather than, as in the case of the original equation, the set of finite cardinals. If this equation has nonnegative integral roots then the corresponding finite cardinals are roots of the original equation. If the new equation has no such roots then the original problem has no solution.

[Note: The finite cardinal numbers are those which are mentioned in answering the question: How many?, whereas the whole numbers of arithmetic are among those which are referred to in answering questions dealing with measures.]

[3-64]

79. I

Suppose you decide that you ought to put 10 nickels into the jar. The problem tells you that the jar is to contain 3 times as many dimes as nickels, and twice as many quarters as nickels. So, when you finish putting in the coins, the jar will contain

10 nickels  
 $3 \times 10$  dimes  
 $2 \times 10$  quarters.

Is the value of these coins \$21.25?

10 nickels are worth  $5 \times 10$  cents,  
 $3 \times 10$  dimes are worth  $10 \times (3 \times 10)$  cents,  
 $2 \times 10$  quarters are worth  $25 \times (2 \times 10)$  cents,

and, altogether the coins are worth

$5 \times 10 + 10 \times (3 \times 10) + 25 \times (2 \times 10)$  cents.

You have solved the problem correctly if this many cents is 2125 cents. And, we find this out by seeing whether the following sentence is true:

$$5 \times 10 + 10 \times (3 \times 10) + 25 \times (2 \times 10) = 2125.$$

50	+	300	+	500		2125
						850 = 2125.

This sentence is not true, so 10 is not the right number of nickels.

Try again. This time put in, say, 19 nickels. Then the jar will contain

19 nickels,  
 3 19 dimes,  
 2 19 quarters,

and these coins would be worth

$$5 \text{ 19 } + 10 \cdot 3 \text{ 19 } + 25 \cdot 2 \text{ 19 } \text{ cents.}$$

Let's check to see whether this is right.

$$\begin{array}{r}
 5 \boxed{19} + 10 \cdot 3 \boxed{19} + 25 \cdot 2 \boxed{19} = 2125? \\
 95 + 570 + 950 \quad | \quad 2125 \\
 1615 = 2125?
 \end{array}$$

No, wrong again!

Instead of trying another number of nickels, let's take a look at what has been done so far. For the number 10, you checked to see if the following was a true sentence:

$$(1) \quad 5 \boxed{10} + 10 \cdot 3 \boxed{10} + 25 \cdot 2 \boxed{10} = 2125,$$

and, for the number 19, you tested the following sentence:

$$(2) \quad 5 \boxed{19} + 10 \cdot 3 \boxed{19} + 25 \cdot 2 \boxed{19} = 2125.$$

It turned out that both (1) and (2) are false. How could you get a true sentence with the same pattern as (1) and (2)? Just by putting in the ' $\square$ 's numerals for the correct number of nickels. In other words, the correct number of nickels is a root of the equation:

$$5 \square + 10 \cdot 3 \square + 25 \cdot 2 \square = 2125.$$

Solve this equation [you can use 'x's instead of ' $\square$ 's if you prefer], and see if the root is the correct number of nickels.

### Example 2.

A committee sold 120 tickets for a school play. Some of the tickets were sold to adults at \$.70 each; the remaining tickets were sold to students at \$.50 each. A total of \$70.40 was collected from ticket sales. How many adult tickets were sold?

Imagine yourself selling these 120 tickets. Suppose you sell  $\boxed{40}$  adult ones. Then, how many do you sell to students?  $120 - \boxed{40}$ . From the adults you collect  $70 \times \boxed{40}$  cents, and from the students you collect  $50 \times (120 - \boxed{40})$  cents. Altogether, then, you collect

$$70 \times \boxed{40} + 50 \times (120 - \boxed{40}) \text{ cents.}$$

And, if 40 adult tickets were sold, the following sentence should be true.

$$70 \times \boxed{40} + 50 \times (120 - \boxed{40}) = 7040.$$

Instead of taking the time to check this sentence [it's probably false, anyway], we study the pattern of the sentence. Notice that the right answer to the problem would convert the open sentence:

$$(*) \quad 70 \boxed{\phantom{00}} + 50(120 - \boxed{\phantom{00}}) = 7040$$

into a true one. So, let's solve this equation, but using 'x's instead of ' $\boxed{\phantom{00}}$ 's. [It's easier to write 'x's than to write ' $\boxed{\phantom{00}}$ 's.]

$$70x + 50(120 - x) = 7040$$

$$70x + 6000 - 50x = 7040$$

$$20x + 6000 = 7040$$

$$20x = 1040$$

$$x = 52$$

So, 52 is the solution of (\*). We could check our computations by substituting in (\*). This would tell us only whether we had solved (\*) correctly. But, it is more important to check whether we solved the ticket problem correctly. And this we can tell by going back to the original statement.

How much money would 52 adult tickets bring in? How many student tickets were sold, and how much would they bring? How much is this all together? Is it \$70.40?

52	120 - 52 = 68	3640
× 70	× 50	3400
3640	3400	7040 ✓

## EXERCISES

A. Solve these problems.

1. Agnes bought 140 stamps for \$4.95. Some were 3-cent stamps and the rest were 4-cent stamps. How many 3-cent stamps did she buy?
2. Mary is 3 years older than Bill. Ten years ago Mary was three times as old as Bill. How old is Bill now?
3. Taking  $\frac{1}{5}$  of a certain number gives the same result as subtracting the number from 27. What is the number?
4. A rectangle is twice as long as it is wide. The width of a second rectangle is 3 units more than the width of the first, and the length of the first is half the length of the second. The second rectangle has a perimeter which is 8 less than twice the perimeter of the first. Find the width of the first.
5. John has a handful of dimes and nickels totaling \$3.55. He has 7 more dimes than nickels. How many nickels does he have?
6. Delivered milk costs 30 cents a quart. This price is 20% higher than last year's price. What did delivered milk cost last year?
7. Taking 50% of a certain number is the same as adding 7 to that number. What is the number?
8. Three more than a certain number is six less than twice the number. What is the number?
9. A square and an equilateral triangle have equal perimeters. A side of the triangle is two inches longer than a side of the square. How long is a side of the square?
10. A salesman sold a number of pairs of shoes at \$8 a pair, and 5 more than that number of pairs at \$6 a pair. He received \$184 for all the shoes sold. How many pairs did he sell at each price?

3/70

You will note that the ten exercises in Part A are fairly difficult, especially when one realizes that these are beginning exercises in verbal problems. However, we want to encourage students to use the "equation-method" to solve verbal problems. If the beginning exercises are so simple that the problems can be solved mentally, or by easy "arithmetic-methods", there will be no motivation to use the equation-method. It may still be the case, however, that students will display considerable ingenuity in solving these problems by arithmetic rather than by using the equation-method. Such students should be complimented for their ingenuity, and encouraged to solve the problems in a second way "just for practice".

We illustrate below [with Exercise 1]

- (a) the use of a sample answer to obtain an equation,
- (b) a nonalgebraic procedure based on an intelligent guess, and
- (c) the use of a straight-forward arithmetic procedure.

(a) the equation-method

Suppose Agnes bought  $\textcircled{100}$  3-cent stamps. Then she must have bought  $(140 - \textcircled{100})$  4-cent stamps. The 3-cent stamps are worth  $3 \times \textcircled{100}$  cents and the 4-cent stamps are worth  $4(140 - \textcircled{100})$  cents. So, altogether, the stamps are worth

$$3 \times \textcircled{100} + 4(140 - \textcircled{100}) \text{ cents.}$$

In other words, if our sample answer happens to be correct, the equation:

$$3 \times \textcircled{100} + 4(140 - \textcircled{100}) = 495$$

should be a true statement. Now, we really don't care whether this equation is a true statement. All we care about is the fact that the correct answer must be a root of:

$$3 \times \textcircled{\quad} + 4(140 - \textcircled{\quad}) = 495.$$

So, we solve this equation to find the solution of our problem.

[3-68]

A



3/71

(b) an intelligent guess method

We know that Agnes bought less than 140 3-cent stamps. Let us say she bought 100 of them. Then, she must have bought 40 4-cent stamps. But 100 3's and 40 4's are worth \$4.60 which is 35 cents less than she actually spent. So, if we "change" 35 3's into 35 4's, we shall make up this difference. Therefore, she bought 65 3's.

(c) a straight-forward arithmetic method

140 4's are worth 560 cents which is 65 cents more than she spent. Since the difference in value between a 4-cent stamp and a 3-cent stamp is 1 cent, the 65-cent difference can be made up by "changing" 65 4's into 65 3's. So, she must have bought 65 3's.

Note that method (c) actually involves the steps taken in solving the equation obtained by the equation-method:

$$\begin{aligned}4(140 - x) + 3x &= 495 \\4 \cdot 140 - 4x + 3x &= 495 \\560 - 495 &= (4 - 3)x \\65 &= x\end{aligned}$$

It should be clear to the student that you are trying to teach him to use method (a). Moreover, it ought to be the case that each of method (b) and method (c) takes longer than (a). If a student can demonstrate to you that he is consistently successful and faster with either (b) or (c) than with (a), then either our problems are too easy, or the method (a) is indeed a less efficient method.

\*

Answers for Exercises 2 - 10.

2. Suppose Bill is  $\boxed{12}$  years old. Then, Mary is  $\boxed{12} + 3$  years old. Ten years ago, Mary was  $(\boxed{12} + 3) - 10$  years old, and Bill was  $\boxed{12} - 10$  years old. So, since Mary was three times as old as Bill 10 years ago, if our sample answer is correct, the following sentence should be true:

$$(\boxed{12} + 3) - 10 = 3(\boxed{12} - 10).$$

[3-68]

A

3/72

In any event, what we want is a root of the equation:

$$(\square + 3) - 10 = 3(\square - 10).$$

If you prefer, you can use the pronumeral 'x' instead of the pronumeral ' $\square$ '.

$$(x + 3) - 10 = 3(x - 10)$$

$$x - 7 = 3x - 30$$

$$23 = 2x$$

$$11.5 = x$$

So, Bill is now 11.5 years old.

Check. If Bill is 11.5 years old, Mary is 14.5 years old. Ten years ago, Mary was 4.5 years old and Bill was 1.5 years old.  $4.5 = 3 \times 1.5$ .

3. [Students will find it easy to write an equation for this problem.] If  $x$  is the certain number then  $\frac{1}{5}x$  is  $27 - x$ . Hence, we are looking for a number  $x$  such that

$$\frac{1}{5}x = 27 - x.$$

$$x = 135 - 5x$$

$$6x = 135$$

$$x = 22.5$$

The number in question is 22.5.

4. The work the student did in Unit 2 on perimeters will help in this problem. If the width of the first rectangle is  $x$  units then its length is  $2x$  units. The width of the second rectangle is  $x + 3$  units, and the length of the second rectangle is  $2(2x)$ . The perimeter of the first is  $2(2x + x)$ , and the perimeter of the second is  $2[2(2x) + (x + 3)]$ . Since the perimeter of the second is 8 less than

[3-68]

A

3/73

twice the perimeter of the first, our job is to find a number  $x$  such that

$$2[2(2x) + (x + 3)] = 2[2(2x + x)] - 8.$$

$$2(5x + 3) = 2(6x) - 8$$

$$10x + 6 = 12x - 8$$

$$-2x = -14$$

$$x = 7$$

The first rectangle is 7 units wide.

5. [At this point, students should find it easier to list the data (in terms of a pronumeral) than to write a paragraph. In fact, it will probably be impossible to get them to write a paragraph!]

If  $x$  is the number of nickels

then  $x + 7$  is the number of dimes.

$5x$  is the number of cents in  $x$  nickels, and

$10(x + 7)$  is the number of cents in  $x + 7$  dimes.

355 is the number of cents in the handful of coins.

So, we want a number  $x$  such that

$$5x + 10(x + 7) = 355.$$

$$15x + 70 = 355$$

$$15x = 285$$

$$x = 19$$

John has 19 nickels.

6. Here is a problem which catches many students. They tend to find 20% of 30 and subtract, thus concluding that last year's price was 24 cents. Their error will be revealed through checking, since the number which is 20% more than 24 is 28.8, not 30.

If  $x$  cents is last year's price.

then  $x + .20x$  cents is this year's price.

So, we want a number  $x$  such that

$$x + .20x = 30.$$

$$1.20x = 30$$

$$x = 25$$

A quart of milk cost 25 cents last year.

[3-68]

A

3/74

7. If  $x$  is the number in question then

$$.50x = x + 7.$$

$$-.50x = 7$$

$$x = -14$$

The number we are looking for is  $-14$ .

[This problem is an unsettling one until the student realizes that he is working with real numbers rather than numbers of arithmetic.]

8. If  $x$  is the certain number then

$$x + 3 = 2x - 6.$$

$$9 = x$$

The number is 9.

9. If  $x$  inches is the length of a side of the square then  $x + 2$  inches is the length of a side of the triangle, and the perimeters are  $4x$  and  $3(x + 2)$ , respectively.

$$4x = 3(x + 2)$$

$$4x = 3x + 6$$

$$x = 6$$

A side of the square is 6 inches in length.

10.  $x$  pairs at \$8 a pair  
 $x + 5$  pairs at \$6 a pair

8x dollars received from sale of \$8 shoes

6(x + 5) dollars received from sale of \$6 shoes

$$8x + 6(x + 5) = 184$$

$$8x + 6x + 30 = 184$$

$$14x = 154$$

$$x = 11$$

He sold 11 pairs at \$8 a pair, and 16 pairs at \$6 a pair.

\*

We hasten to point out that you should not expect mastery of verbal problems as a result of the 10 problems in Part A. Nor should you expect all students to work these problems by means of the equation-method. Your objectives here are to get students interested in puzzles of this type, and to give them an opportunity to see how powerful the equation-method is.

[3-68]

A





Point out to the students that the purpose of Part B is to practice writing pronumeral expressions, and that such skill will be useful in setting up equations in connection with solving verbal problems.

\*

Answers for Part B [on pages 3-69 through 3-75].

- |                 |                   |                   |
|-----------------|-------------------|-------------------|
| 1. $2x - 7$     | 2. $4x - 2$       | 3. $-5x$          |
| 4. $5x$         | 5. $y + 2$        | 6. $\frac{z}{10}$ |
| 7. $1.05k$      | 8. $2.2p$         | 9. $.2r$          |
| 10. $.5s + .6t$ | 11. $75x$         | 12. $z - 9$       |
| 13. $-4v - 2$   | 14. $\frac{4}{x}$ | 15. $x + 6$       |

\*

Note, in Exercise 15, the quantifier:

For each number  $x$  of arithmetic, .

Here we are just making explicit the fact that the numbers dealt with in age problems are numbers of arithmetic rather than real numbers.

\*

Also, note in Exercise 17 the restriction ' $z > 2$ '. This restriction is necessary to insure that the expression ' $2z - 4$ ' leads to sensible expressions upon replacements for ' $z$ '. It serves the same purpose as the restriction ' $x \neq 0$ ' in, for example, 'for each  $x \neq 0$ ,  $\frac{x}{x} = 1$ '.

\*

- |                    |                    |           |
|--------------------|--------------------|-----------|
| 16. $2y + 7$       | 17. $2z - 4$       | 18. $x$   |
| 19. $11x + 30$     | 20. $2k$           | 21. $18m$ |
| 22. $\frac{t}{12}$ | 23. $91x$          | 24. $5m$  |
| 25. $5p + 10t$     | 26. $\frac{d}{10}$ |           |

B. Complete with the simplest expressions you can to make true sentences.

1. For each  $x$ , the sum of  $x$  and the number  $-7$  more than  $x$  is \_\_\_\_\_.
2. For each  $x$ , the sum of  $x$  and the number which is 2 less than the product of 3 and  $x$  is \_\_\_\_\_.
3. For each  $x$ , the number which is  $-5$  times as large as  $x$  is \_\_\_\_\_.
4. For each  $x$ , the difference of  $x$  from a number 6 times as large as  $x$  is \_\_\_\_\_.
5. For each  $y$ , the number which is 2 greater than  $y$  is \_\_\_\_\_.
6. For each  $z$ , the number which is 10% of  $z$  is \_\_\_\_\_.
7. For each  $k$ , 15% of the number which is 7 times as large as  $k$  is \_\_\_\_\_.
8. For each  $p$ , the number which is 120% greater than  $p$  is \_\_\_\_\_.
9. For each  $r$ , the number which is 80% less than  $r$  is \_\_\_\_\_.
10. For each  $s$ , for each  $t$ , the sum of 50% of  $s$  and 60% of  $t$  is \_\_\_\_\_.
11. For each  $x$ , the product of  $\frac{1}{2}x$  and 150 is \_\_\_\_\_.
12. For each  $z$ , 9 less than  $z$  is \_\_\_\_\_.
13. For each  $v$ , the product of 3 and  $-v$  exceeds the sum of 2 and  $v$  by \_\_\_\_\_.
14. For each  $x \neq 0$ , the quotient of 8 by the product of 2 and  $x$  is \_\_\_\_\_.
15. For each number  $x$  of arithmetic, if Bill is  $x$  years old now, he will be \_\_\_\_\_ years old 6 years from now.

(continued on next page)

16. For each number  $y$  of arithmetic, if Carl is  $y$  years old now and Andy is twice as old as Carl then Andy will be \_\_\_\_\_ years old 7 years from now.
17. For each number of arithmetic  $z > 2$ , if Mary is now  $z$  years old and Bill's age is 4 years less than twice Mary's age, Bill is now \_\_\_\_\_ years old.
18. For each number  $x$  of arithmetic, if the difference of Jim's age from Andy's age is  $x$  years then the difference of Jim's age from Andy's age 4 years ago was \_\_\_\_\_ years.
19. For each number  $x$  of arithmetic, if unlined paper costs  $x$  cents a pad, and a pad of lined paper costs 5 cents more than a pad of unlined paper, the cost of 6 pads of lined paper and 5 pads of unlined paper is \_\_\_\_\_ cents.
20. For each number  $k$  of arithmetic, there are \_\_\_\_\_ pints in  $k$  quarts.
21. For each number  $m$  of arithmetic,  $m$  quarts and twice that many gallons together contain \_\_\_\_\_ pints.
22. For each number  $t$  of arithmetic, there are \_\_\_\_\_ feet in  $t$  inches.
23. For each number  $x$  of arithmetic,  $x$  yards, 4 times as many feet, and 7 times as many inches (as yards) together make \_\_\_\_\_ inches.
24. For each whole number  $m$  of arithmetic, there are \_\_\_\_\_ cents in  $m$  nickels.
25. For each whole number  $p$  of arithmetic, for each number  $t$  of arithmetic, there are \_\_\_\_\_ cents in a total of  $p$  nickels and  $t$  dimes.
26. For each whole number  $d$  of arithmetic, there are \_\_\_\_\_ dollars in  $d$  dimes.

[3-71]

pencils

s

n-

16.

3/76

27.  $3p$                       28.  $1.25x$                       29.  $6w$                       30.  $4x$
31.  $4k - 6$                       32.  $7x(3 + x)$                       33.  $2\frac{1}{5}y$                       34.  $\frac{2}{3}N + 520$
35.  $4h$                       36.  $3r$                       37.  $rh$                       38.  $\frac{x}{30}$
39.  $\frac{s}{2}$                       40.  $.03x$                       41.  $.045(1400 - y)$
42.  $.03k + .04(2000 - k)$                       43.  $3x + 4$                       44.  $\frac{33t}{\pi}$
45.  $4(\frac{x}{3} + 4)$                       46.  $\frac{1}{x}$                       47.  $\frac{1}{3}, \frac{x}{3}$
48.  $\frac{5}{6}x$                       49.  $\frac{1}{3} - \frac{1}{x}$                       50.  $\frac{20}{x}$
51.  $5n + 25(2n) + 10(2n + 10)$                       52. The data given are inconsistent.
53.  $\frac{1}{3}x - 10$                       54.  $\frac{6}{5}t$
55.  $\frac{32x + 37(2x + 4)}{3x + 4}$                       56. The data given are inconsistent.
57.  $93x + 89(27 - x)$                       58.  $n + 1$                       59.  $n - 2$
60.  $2m + 3$                       61.  $.30x$                       62.  $.80x$
63.  $1 + .30x$                       64.  $\left(\frac{.03y + .14}{y + 2}\right)100$
65.  $\frac{x}{16} + .60$                       66.  $.3x + 1.2x$                       67.  $\left(\frac{.10x + 3}{13}\right)100$
- 68.\*  $\frac{7t}{14 + t}$                       69.  $\frac{17}{x}(2x + 7)$

---

\* A too strict interpretation of this exercise leads one to say that the data are insufficient; but the normal interpretation would supply, at the end, the word 'did'.

27. For each whole number  $p$  of arithmetic, if John buys pencils at the rate of 3 pencils for 12 cents and sells them to his classmates at 5 cents each, his profit on the sale of  $3p$  pencils is \_\_\_\_\_ cents.
28. For each number  $x$  of arithmetic, if the cost price of an article is  $x$  dollars and the margin is 25% of the cost price, then the selling price is \_\_\_\_\_ dollars.
29. For each number  $w$  of arithmetic, if the width of a rectangle is  $w$  units and the length is twice the width then the perimeter is \_\_\_\_\_.
30. For each number  $x$  of arithmetic, if a shorter side of a rectangle is  $x$  units long and a side of a square has the same length as this shorter side, then the perimeter of the square is \_\_\_\_\_.
31. For each number of arithmetic  $k > 3$ , if a longer side of a rectangle is  $k$  units, and a shorter side of this rectangle is 3 units less than a longer side, then the perimeter of the rectangle is \_\_\_\_\_.
32. For each  $x$ , the product of 7 by  $x$  multiplied by the sum of 3 and  $x$  is \_\_\_\_\_.
33. For each  $y$ , the sum of  $\frac{1}{5}$  of  $y$  and the product of 2 by  $y$  is \_\_\_\_\_.
34. For each number  $N$  of arithmetic, if Mr. Ronk earns  $N$  dollars a year and Mr. Dunlap earns \$520 more than two thirds of what Mr. Ronk earns, then Mr. Dunlap earns \_\_\_\_\_ dollars a year.
35. For each number  $h$  of arithmetic, you can walk \_\_\_\_\_ miles in  $h$  hours at the average rate of 4 miles per hour.
36. For each number  $r$  of arithmetic, you can travel \_\_\_\_\_ miles in 3 hours at the average rate of  $r$  miles per hour.

(continued on next page)

37. For each number  $r$  of arithmetic, for each number  $h$  of arithmetic, you can travel \_\_\_\_\_ miles in  $h$  hours at the average rate of  $r$  miles per hour.
38. For each number  $x$  of arithmetic, it takes \_\_\_\_\_ hours for a freight train to travel  $x$  miles if its average rate is 30 miles per hour.
39. For each number  $s$  of arithmetic, you must walk at an average rate of \_\_\_\_\_ miles per hour to travel  $s$  miles in 2 hours.
40. For each number  $x$  of arithmetic, the annual income (interest) on  $x$  dollars invested at 3% is \_\_\_\_\_ dollars.
41. For each number of arithmetic  $y \leq 1400$ , the annual income on  $(1400 - y)$  dollars invested at 4.5% is \_\_\_\_\_ dollars.
42. For each number of arithmetic  $k \leq 2000$ , the total annual income on \$2000 of which  $k$  dollars are invested at 3% and the rest at 4%, is \_\_\_\_\_ dollars.
43. For each number  $x$  of arithmetic, if the length of each of the two sides of equal length of an isosceles triangle is 2 inches more than the length of the base, and if the base is  $x$  inches long, then the perimeter is \_\_\_\_\_.
44. For each number  $t$  of arithmetic, if the circumference of a circle is  $33t$ , a diameter measures \_\_\_\_\_.
45. For each number  $x$  of arithmetic, if an equilateral triangle has perimeter  $x$  then a square whose side is 4 units longer than a side of this triangle will have perimeter \_\_\_\_\_.
46. For each number of arithmetic  $x > 0$ , if Abe can do a certain job in  $x$  hours, he can do \_\_\_\_\_ of the job in 1 hour.
47. For each number  $x$  of arithmetic, if Bob can mow a lawn in 3 hours then he can mow \_\_\_\_\_ of the lawn in 1 hour, and \_\_\_\_\_ of the lawn in  $x$  hours.



48. For each number  $x$  of arithmetic, if Bob can mow a lawn in 3 hours and Tom can mow this lawn in 2 hours then together, they can mow \_\_\_\_\_ of the lawn in  $x$  hours.
49. For each number of arithmetic  $x \geq 3$ , if an inlet pipe can fill a tank in 3 hours and an outlet pipe can empty the tank in  $x$  hours, then, when both pipes are turned on [starting with an empty tank], \_\_\_\_\_ of the tank is filled at the end of 1 hour.
50. For each nonzero number  $x$  of arithmetic, if Raymond hops  $\frac{3}{4}$  as fast as Harold and if Harold hops  $x$  feet per second, then Raymond takes \_\_\_\_\_ seconds to hop 15 feet.
51. For each whole number  $n$  of arithmetic, a pile of nickels, dimes and quarters which contains  $n$  nickels, twice as many quarters, and 10 more dimes than quarters is worth \_\_\_\_\_ cents.
52. For each number  $x$  of arithmetic, if the measure of the width of a rectangle is  $\frac{2}{3}$  the perimeter  $x$ , then the length measures \_\_\_\_\_.
53. For each whole number of arithmetic  $x > 30$ , if 15 more than one half of the total number  $x$  of passengers in a bus get off at the first stop, and one third of the remaining passengers get off at the second, there are \_\_\_\_\_ passengers left.
54. For each number  $t$  of arithmetic, if a person can climb a mountain in  $t$  hours and descend 5 times as fast, the total time required for the trip up and down [no resting at the top] is \_\_\_\_\_ hours.
55. For each number  $x$  of arithmetic, if  $x$  pounds of nuts at 32 cents per pound are mixed with 4 more than twice as many pounds of nuts at 37 cents per pound, the resulting mixture is worth \_\_\_\_\_ cents per pound.

(continued on next page)

56. For each number  $x$  of arithmetic, if  $x$  pounds of nuts at 85 cents per pound are mixed with 15 pounds of nuts at 70 cents per pound, the resulting mixture contains \_\_\_\_\_ pounds worth 90 cents per pound.
57. For each number of arithmetic  $x \leq 27$ , the total cost of  $x$  pounds of coffee at 93 cents per pound and  $(27 - x)$  pounds of coffee at 89 cents per pound is \_\_\_\_\_ cents.
58. For each number  $n$  of arithmetic, if  $n$  is a whole number, \_\_\_\_\_ is the next larger whole number.
59. For each number of arithmetic  $n \geq 3$ , if  $n$  is an odd whole number, \_\_\_\_\_ is the largest odd whole number smaller than  $n$ .
60. For each number  $m$  of arithmetic, if  $m$  is a whole number, the sum of the next two consecutive whole numbers is \_\_\_\_\_.
61. For each number  $x$  of arithmetic,  $x$  gallons of a 30% alcohol solution contain \_\_\_\_\_ gallons of alcohol.
62. For each number  $x$  of arithmetic,  $x$  gallons of a 20% alcohol solution contain \_\_\_\_\_ gallons of water.
63. For each number  $x$  of arithmetic, if 4 gallons of a 25% alcohol solution are added to  $x$  gallons of a 30% alcohol solution, the new mixture contains \_\_\_\_\_ gallons of alcohol.
64. For each number  $y$  of arithmetic, if  $y$  pints of a 3% iodine solution are added to 2 pints of a 7% iodine solution, the new mixture is a \_\_\_\_\_ per cent iodine solution.
65. For each number  $x$  of arithmetic, if  $x$  ounces of shelled peanuts are added to 2 pounds of a nut mixture which contains 30% shelled peanuts, the new mixture contains \_\_\_\_\_ pounds of shelled peanuts.
66. For each number  $x$  of arithmetic, if  $x$  gallons of a 30% alcohol solution are mixed with twice as many gallons of a 60% alcohol solution, the result is a mixture containing \_\_\_\_\_ gallons of alcohol.

67. For each number  $x$  of arithmetic, if 10 ounces of an  $x\%$  gold alloy are combined with 3 ounces of pure gold, the new alloy is \_\_\_\_\_ per cent gold.
68. For each number of arithmetic  $t \neq 0$ , if it takes Benjamin  $t$  hours to walk 7 miles and if Theodore can walk  $\frac{1}{2}$  mile per hour faster than Benjamin, then it takes Theodore \_\_\_\_\_ hours to walk half as far as Benjamin.
69. For each whole number of arithmetic  $x \neq 0$ , if  $x$  people share equally in the cost of a \$17 picnic, a picnic for 7 more than twice this number of people should cost \_\_\_\_\_ dollars.

[More exercises are in Part J, Supplementary Exercises.]

\* \* \*

You have seen how to solve some problems by picking some number as a possible answer, going through the steps necessary to check this possible answer [but not simplifying], and arriving at a pattern. This pattern is expressed easily by an equation, and a root of the equation leads to the solution of the problem.

You may also have found in Part A that you could write the equation immediately without going through the process of checking possible answers. Of course, it is faster if you can write down the equation immediately, and you should practice doing this in the next set of problems. But, you can always use the procedure of checking a possible answer if this helps you get the "feel" of the problem.

Example 3.

If you increase a certain number by 17, you get the same result as if you had subtracted  $\frac{1}{2}$  the number from 5. What is this number?

Solution. We know that, for each number  $x$ , if you increase  $x$  by 17, you get  $x + 17$ , and if you subtract  $\frac{1}{2}x$  from 5, you get  $5 - \frac{1}{2}x$ . So, we want to find a number  $x$  such that

$$(1) \quad x + 17 = 5 - \frac{1}{2}x.$$

If there is a number which meets the conditions of this problem,

it is a root of (1). So, we solve (1):

$$\begin{aligned}x + 17 &= 5 - \frac{1}{2}x \\2x + 34 &= 10 - x \\3x &= -24 \\x &= -8\end{aligned}$$

Instead of checking to see whether the root of (1) is  $-8$ , we check to see whether  $-8$  fits the conditions of the problem [Why do this?].

Check.

$-8$  increased by 17 is 9;  
the difference of  $\frac{1}{2} \cdot -8$  from 5 is 9.  $\checkmark$

Answer. The number in question is  $-8$ .

Example 4.

John usually takes 40 minutes to ride his bicycle from home to school. When he is pressed for time, he can increase his average speed by 6 miles per hour and save 16 minutes. How far does John live from school?

Solution. For each number  $x$  of arithmetic, if John lives  $x$  miles from school and it takes him  $\frac{2}{3}$  of an hour [40 minutes] at his usual rate to make the trip from home to school, his usual rate is  $\frac{x}{2/3}$  [or:  $\frac{3x}{2}$ ] miles per hour. If he increases this rate by 6 miles per hour, the new rate is  $\frac{3x}{2} + 6$  miles per hour. At this new rate the time required for the trip is 16 minutes less than the usual time of 40 minutes. That is, the new time is 24 minutes, or  $\frac{2}{5}$  of an hour. So, we are looking for a number  $x$  of arithmetic such that

$$\left(\frac{3x}{2} + 6\right)\frac{2}{5} = x.$$

3/77

Here is an alternative solution for Example 4. [Notice that instead of writing a paragraph, we simply write the relevant expressions and the equation to be solved.]

$x$  miles per hour is usual rate

$\frac{2}{3}x$  is distance [in miles] from home to school

$x + 6$  miles per hour is increased rate

$\frac{2}{5}(x + 6)$  is distance [in miles] from home to school

$$\frac{2}{3}x = \frac{2}{5}(x + 6)$$

$$15\left(\frac{2}{3}x\right) = 15\left[\frac{2}{5}(x + 6)\right]$$

$$10x = 6(x + 6)$$

$$10x = 6x + 36$$

$$4x = 36$$

$$x = 9$$

Distance from home to school is  $\frac{2}{3}(9)$  or 6[miles].

Students should understand that there are often several ways of solving a given problem and that one of the ways may lead to a very simple equation. The ability to hit upon the most elegant way comes as a result of extended experience; maybe it is one of those skills that can be learned but not taught!

[3-76]

it is

Let's solve this equation.

$$\left(\frac{3x}{2} + 6\right)\frac{2}{5} = x$$

$$\frac{3x + 12}{2} \cdot \frac{2}{5} = x$$

$$\frac{3x + 12}{5} = x$$

$$\frac{3x + 12}{5} \cdot 5 = x5$$

$$3x + 12 = 5x$$

$$12 = 2x$$

$$6 = x$$

Check. If John lives 6 miles from school and it takes 40 minutes to make the trip from home to school, his usual rate is  $6 \div \frac{2}{3}$  miles per hour; that is, 9 miles per hour. Now, if he increases his usual rate by 6 miles per hour, his new rate will be 15 miles per hour. Will this new rate make it possible for him to get to school in 16 minutes less time [i. e., in 24 minutes], as the problem stated? Well, if he lives 6 miles from school, and travels at a rate of 15 miles per hour, it will take him  $6 \div 15$  hours to get there.  $6 \div 15$  is  $\frac{2}{5}$  hours, or 24 minutes -- which is 16 minutes less than 40 minutes!

Answer. John lives 6 miles from school.

Example 5.

How many quarts of a 30% alcohol solution should be added to 8 quarts of a 40% alcohol solution to make a new solution which is 38% alcohol?

Solution. Suppose you add  $x$  quarts of the 30% alcohol solution to the 8 quarts of the 40% alcohol solution. Since what you add contains  $.3x$  quarts of alcohol, and since the original 8 quarts of solution contain  $.4(8)$  quarts of alcohol, the new solution contains  $[\ .3x + .4(8) ]$  quarts of alcohol. But, the new solution contains a total of  $(x + 8)$  quarts of liquid. So, we are looking for a number  $x$  of arithmetic such that

$$.3x + .4(8) = .38(x + 8).$$

We solve this equation.

$$100[.3x + .4(8)] = [.38(x + 8)]100$$

$$30x + 320 = 38x + 304$$

$$16 = 8x$$

$$x = 2$$

Check. 2 quarts of a 30% alcohol solution contain .6 quarts of alcohol. 8 quarts of a 40% alcohol solution contain 3.2 quarts of alcohol. So, the new mixture of 10 quarts of solution contains 3.8 quarts of alcohol, and 3.8 is 38% of 10.

Answer. 2 quarts of a 30% alcohol solution should be added.

Example 6.

Mr. Alders invests a total of \$3800 in two enterprises, one giving an income of 3% and the other an income of 5%. If the total income from these investments is \$166, how much is invested in each enterprise?

Solution. Suppose he invests  $x$  dollars at 3%. Then he invests  $(3800 - x)$  dollars at 5%. The income from these investments is

$$.03x + .05(3800 - x) \text{ dollars.}$$

So, we are looking for a number  $x$  of arithmetic such that

$$.03x + .05(3800 - x) = 166.$$

[Finish the solution and check.]



3/78

A schematic diagram such as the following may help with Example 5.

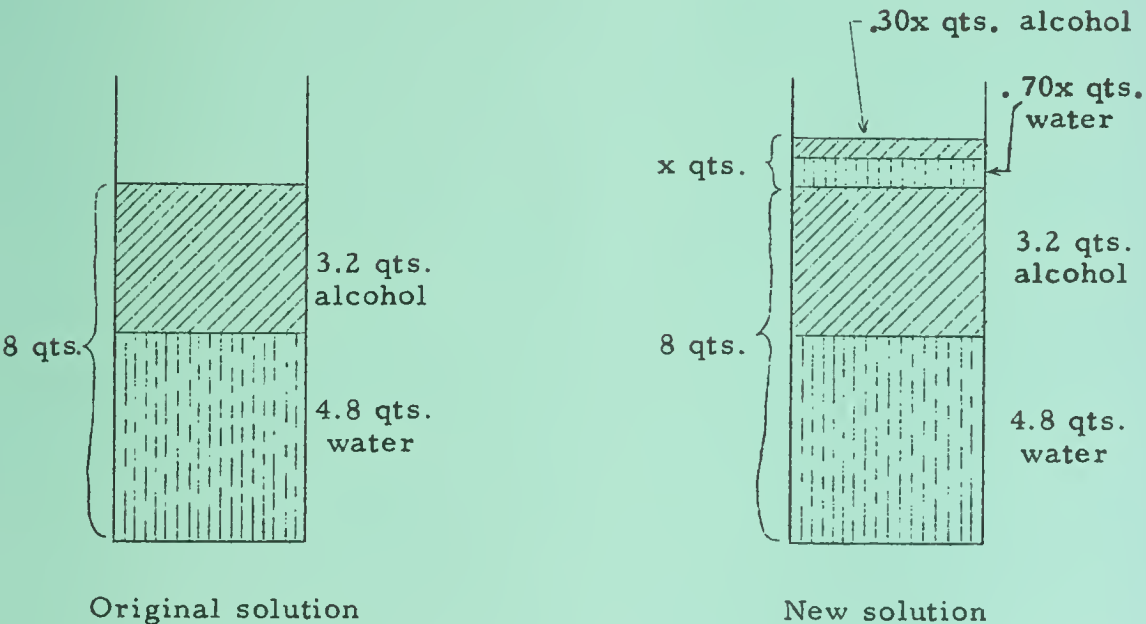

In the new solution, we want the number of quarts of alcohol to be 38% of the total number of quarts of solution. So, we seek a number  $x$  such that

$$.30x + 3.2 = .38(x + 8).$$

\*

In Example 7, there is a tendency for students to want to average the "times", and thus state that it would take the boys  $2\frac{1}{2}$  hours to do the job if they worked together. Point out that the job should require less time than that required by the faster boy since he is being helped by the slower one. [Of course, in practice it might take much longer since boys are prone to engage in conversation. They might even decide to give up the job and go fishing!]

Here is an interesting alternative solution for Example 7 [which might better be presented after the students have practiced setting up an equation for Exercise 9 of Part C]:

Suppose the boys work together for 6 hours. Then Albert would mow 3 such lawns and Bill 2 such lawns in the 6-hour period. So, together they would mow 5 lawns in 6 hours. Hence, it would take them  $6/5$  hours to mow one such lawn together.

[3-78]

Example



Example

3/79

Answers for Part C [on pages 3-79 through 3-82].

1.  $\frac{4}{13}$  of a pint [If  $x$  pints of pure alcohol are added to the pint of 15% alcohol solution, the new solution contains  $x + 0.15$  pints of pure alcohol and  $x + 1$  pints of solution. So, we are looking for a number  $x$  such that  $x + 0.15 = 0.35(x + 1)$ .]
2.  $12[(3x + 4)/8 = 5]$
3. Charles is 13 and Edward is 15. [ $x$  years...Charles' age,  $x + 2$ ...Edward's age;  $(x + 2) - 11 = 2(x - 11)$ ]

\*

You may want to spread the work on verbal problems over a longer period of time. This can be readily accomplished by assigning problems from pages 3-79 through 3-82 [and from Part K of the Supplementary Exercises] together with exercises from pages 3-83 through 3-95.

\*

4. This is a fooler! Since the taxi traveled 4 miles at 30 miles per hour, it took  $\frac{4}{30}$  of an hour, or 8 minutes to travel this distance. Hence, the train had departed before the taxi had covered half the distance. [If a student works the problem in a formal manner, he might get the equation:  $(\frac{4}{30}) + (\frac{4}{x}) = \frac{7}{60}$ , which has the root  $-240$ . Since he is looking for a number of arithmetic which satisfies the equation, this result shows that there is none.]
5. cashews, 12 pounds; almonds, 18 pounds [ $x$  pounds of cashews,  $30 - x$  pounds of almonds;  $0.90x + 0.75(30 - x) = 0.81(30)$ ]  
[Interesting questions which can be asked in connection with this problem are:
  - (a) If you use more than 12 pounds of cashews, how will the price per pound of the 30-pound mixture change?
  - (b) Suppose you wanted to make a mixture which would sell for 71 cents a pound. What kind of root would you get for the equation?
  - (c) If you decrease the price per pound of the mixture, what changes take place in the amounts of almonds and cashews?]

Example 7.

If Albert can mow a lawn in 2 hours and Bill can mow this lawn in 3 hours, how long will it take them to mow the lawn if they work together?

Solution. Method I

You know that Albert will mow  $\frac{1}{2}$  of the lawn in one hour, and Bill will mow  $\frac{1}{3}$  of it in one hour, if they work at steady rates. Suppose they work together for  $x$  hours. Then, together, they would mow  $\frac{1}{x}$  part of the lawn in 1 hour. So, we are looking for a number  $x$  of arithmetic, such that

$$\frac{1}{2} + \frac{1}{3} = \frac{1}{x}.$$

[Solve this equation and check.]

Method II

Suppose it takes  $x$  hours to mow the lawn if both boys work together. Then Albert would mow  $\frac{x}{2}$  part of the lawn during this time, and Bill would mow  $\frac{x}{3}$  part of it at the same time, and they would be finished. So, we need to find a number  $x$  of arithmetic such that

$$\frac{x}{2} + \frac{x}{3} = 1.$$

[Solve this equation and check.]

\* \* \*

C. Solve these problems.

1. One pint of an alcohol solution contains 15% alcohol. How much pure alcohol [100% alcohol solution] must be added to make a solution which contains 35% alcohol?
2. Jim picked a number, tripled it, added 4 to the result, divided the sum by 8, and got 5. What number did he pick?
3. Edward is two years older than Charles. Eleven years ago Edward was twice as old as Charles. How old is each boy now?

(continued on next page)

4. A business man has 7 minutes to catch a train at a station which is 8 miles from his home. His taxi covers half of this distance traveling at an average speed of 30 miles per hour. What should be the average speed of the taxi during the second half of the trip to enable the man to catch the train?
5. A confectioner is making a mixture of almonds and cashews. The cashews are worth \$.90 a pound and the almonds are worth \$.75 a pound. How many pounds of each kind of nut should be used to make 30 pounds of a mixture worth \$.81 per pound?
6. Two boys start around a 1300-foot track, running in opposite directions. If one boy runs 6 feet more per second than the other, and they meet in 24 seconds, what is the rate of the faster boy?
7. Two cyclists start at the same time and from the same place and travel in opposite directions. In twenty minutes they are 11 miles apart. The faster cyclist travels at an average speed which is 3 miles per hour more than the average speed of the slower cyclist. What is the average speed of each cyclist?
8. A freight train and a passenger train on parallel tracks are 7 miles apart at 1:00 p. m. and are traveling in opposite directions. The passenger train's average speed is 35 miles per hour more than the average speed of the freight train. If they maintain their average speeds and are 45 miles apart at 1:24 p. m., what is the average speed of the freight train?
9. Bill can mow a lawn in 35 minutes and his brother can do the same job in 40 minutes. If they were to work together, how long would they take to mow the lawn?
10. A tank has two inlet pipes. One pipe by itself can fill the tank in 17 minutes; the other pipe by itself can fill the tank in 21 minutes. How long will it take to fill the tank if both pipes are opened?

the  
in

3/80

6.  $361/12$  feet per second [assuming that the boys started running from the same point at the same time]

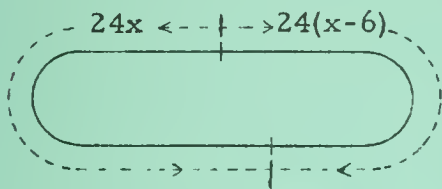

$$24x + 24(x - 6) = 1300$$

7. slower, 15 m.p.h.; faster, 18 m.p.h.

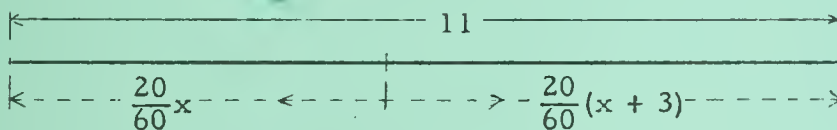

[Ask students how far apart the cyclists will be at the end of 1 hour if they maintain these rates. At the end of  $3/2$  hours.]

8. 30 m.p.h. [assuming that the trains do not pass each other];  
47.5 m.p.h. [assuming that the trains do pass each other]

First Assumption

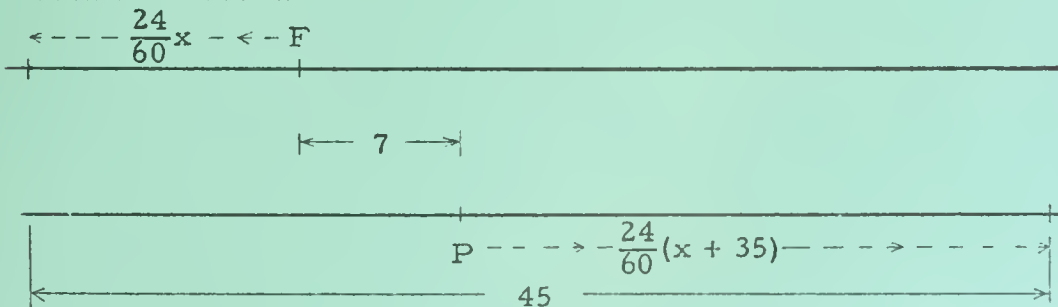

$$\frac{24}{60}x + 7 + \frac{24}{60}(x + 35) = 45$$

[A diagram for the second assumption is on TC[3-80, 81]b.]

[3-80]

4.



the  
in

Second Assumption

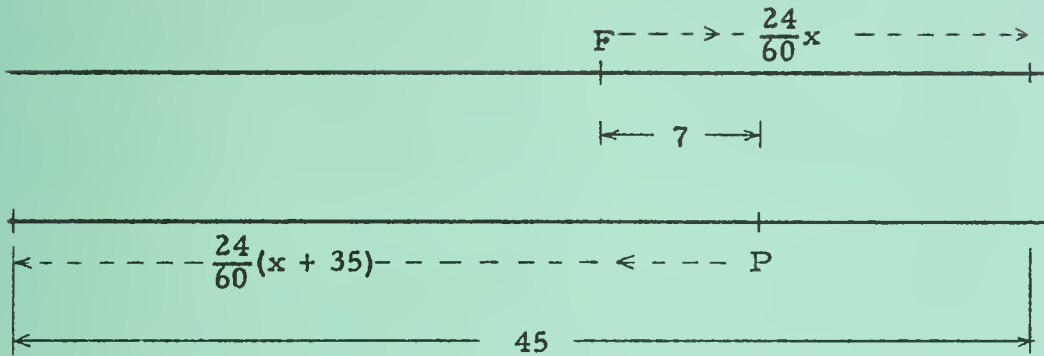

$$\frac{24}{60}(x + 35) - 7 + \frac{24}{60}x = 45$$

9. 56/3

[Our experience indicates that students may want to solve problems of this kind by an arithmetic method, reasoning somewhat as follows.

Each minute Bill can mow 1/35 of the lawn, and his brother can mow 1/40 of the lawn. Thus, if the two boys work together, in one minute they will mow (1/35) + (1/40), or 3/56 of the lawn. So, in order to have the entire lawn mowed, the boys would have to work together for 56/3 minutes.

We do believe, however, that the students should try to use the equation-method for problems of this kind, at least part of the time. Here is a solution which they can readily follow.

$x$  minutes is the time boys spend working together in mowing the lawn.

$\frac{1}{x}$  is that part of the lawn mowed in 1 minute when both boys are working together, [ $x \neq 0$ ].

1/35 is the part mowed by Bill in 1 minute.

1/40 is the part mowed by brother in 1 minute.

So, we want a number  $x$  of arithmetic such that

$$\frac{1}{35} + \frac{1}{40} = \frac{1}{x}.$$

⋮

[Another solution is on TC[3-80, 81]c.]

[3-80]

4.

3/82

Some students may prefer the following solution.

$x$  minutes is the time they spend working together in mowing the lawn.

$x/35$  is the part of the lawn Bill will mow in  $x$  minutes.

$x/40$  is the part of the lawn brother will mow in  $x$  minutes.

So, we want a number  $x$  of arithmetic such that

$$\frac{x}{35} + \frac{x}{40} = 1.$$

$$\vdots$$

Students should have an opportunity to compare these solutions.]

10. 357/38 minutes [(1/17) + (1/21) = 1/x]

11. 348 [5x girls, 4x boys; 5x + 4x = 783]  
[Alternatively: x boys, 783 - x girls; (783 - x)/x = 5/4]

12. 5%, \$2500; 6%, \$500 [x dollars at 5%, 3000 - x dollars at 6%;  
0.05x + 0.06(3000 - x) = 155]

13. 1 m.p.h.

[Students need to recognize the fact that the effective rate of rowing with the current ["downstream"] is the sum of the still water rate and the rate of the current, and the effective rowing rate against the current ["upstream"] is the difference of the rates. In these days, you might make the point by talking about airplanes flying with a tailwind or against a headwind!]

$$\begin{array}{l} \text{----- } 3(5 - x) \text{ -----} \\ \leftarrow \text{ upstream} \text{ -----} \\ \text{----- } 2(5 + x) \text{ -----} \\ \text{----- } 2(5 + x) \text{ -----} \end{array}$$

$$3(5 - x) = 2(5 + x)$$

[3-80]

4.

the

in

4.

3/84

After students have struggled with Exercise 19 [and succeeded], they may enjoy the famous problem about the sailors and the coconuts. As a starter, give them this easy version:

Two sailors on a desert island gather coconuts one day. Upon going to sleep that night they decide that they will share the coconuts the next morning. During the night one of the sailors awakens and [not having too much confidence in the honesty of his partner!] decides to take half the coconuts in the pile and hide them. After dividing the pile into two piles, each containing the same number of coconuts, he finds that he has one left over. He eats this extra one right then and there, hides one of the piles in a nearby cave, and goes back to sleep. Later that night, the other sailor awakens, and repeats the performance of the first sailor. That is, after eating one of the coconuts, he divides the remainder into two piles, each with the same number of coconuts, and hides one of the two piles. Morning arrives, both sailors awaken, and although the pile is noticeably smaller, neither sailor calls attention to the discrepancy. They just divide the pile [more than one!] equitably between them, with no coconuts left over.

Problem: How many coconuts were there in the original pile?

Since students will quickly discover that any of the numbers 11, 19, 27, 35, ... could be the number of coconuts in the original pile, you will have to alter your problem to one which asks for the smallest possible number of coconuts in the original pile. Then, for homework ["extra credit"], modify the problem to one which deals with 3 sailors, each of whom awakens once during the night and steals  $1/3$  of what he finds after eating one coconut. In the morning, the number of coconuts left is exactly divisible by 3.

\*

Another problem with an ancient history which students might enjoy when working on liquid-mixture problems is this one:

A wine [orange juice] merchant has two casks of the same capacity. One is half-full of wine, the other is half-full of water. He dips a pint of wine from the wine cask and pours it into the water cask. Then he dips a pint of this wine-water mixture into the wine cask. Is the per cent of water in the wine cask the same as the per cent of wine in the water cask?

[3-81]

the

n

4.

3/83

14. The data are inconsistent. [Suppose Paul's usual reading rate is  $x$  pages per hour. Then Howard's is  $1.5x + 4$  pages per hour. If Paul were to increase his rate by 20%, his new rate would be  $1.2x$  pages per hour. If Howard were to decrease his rate by 50%, his new rate would be  $0.5(1.5x + 4)$  pages per hour. But, these new rates would be the same  $[397/12$  pages per hour]. So, we want a number  $x$  of arithmetic such that  $1.2x = 0.5(1.5x + 4)$ . The only such number is  $40/9$ . So, it seems that Paul's usual rate is  $40/9$  pages per hour. If he increased this rate by 20%, he would be able to read  $16/3$  pages per hour, and in 12 hours he would be able to read just 64 pages rather than 397 pages. So, the data are inconsistent.] [Another way of discovering that the data are inconsistent is to recognize that we want a number  $x$  of arithmetic such that  $12(1.2x) = 397$  and  $12[0.5(1.5x + 4)] = 397$ . There is no such number since  $\{x: 12(1.2x) = 397 \text{ and } 12[0.5(1.5x + 4)] = 397\}$  is the empty set.]
15. dimes, 5; quarters, 12 [ $x$  dimes,  $17 - x$  quarters;  
 $10x + 25(17 - x) = 100(3.50)$ ]
16. \$5 to A, \$35 to B, \$10 to C, and \$105 to D [ $x$  dollars to A,  $40 - x$  dollars to B,  $2x$  dollars to C,  $3(40 - x)$  dollars to D;  
 $x + (40 - x) + 2x + 3(40 - x) = 155$ ]
17. 42 [ $0.5x + -6 = 15$ ]
18. \$1.45 [ $3x + 0.15 = 4.50$ ]
19. 180

The flight has  $x$  steps.

First climb:  $\frac{1}{2}x - 6$  steps

Second climb:  $\frac{1}{3}(\frac{1}{2}x + 6) + 4$  steps

Third climb:  $\frac{1}{4}[x - (\frac{1}{2}x - 6 + \frac{1}{3}[\frac{1}{2}x + 6] + 4)] - 3$  steps

$$[\frac{1}{2}x - 6] + [\frac{1}{6}x + 2 + 4] + [\frac{1}{4}(x - \frac{1}{2}x - \frac{1}{6}x) - 3] = x - 48$$

\*



11. There are 783 pupils in Zabbranchburg High School. If the ratio of girls to boys is 5 to 4, how many boys are there in the school? [If there are  $4x$  boys, there are  $5x$  girls.]
12. A man has a total of \$3000 earning interest, some at 5% and the remainder at 6%. The amount of annual interest on both investments is \$155. How much is invested at each rate?
13. A man who can row 5 miles an hour in still water rows up a stream for 3 hours and then rows back to his starting point in 2 hours. At what rate does the stream flow?
14. Howard can read at a rate which is 4 pages an hour more than one and a half times Paul's rate. If Howard were to decrease his rate by 50% and if Paul were to increase his by 20%, each would read a book of 397 pages in 12 hours. What is Paul's usual reading rate?
15. A man has \$3.50 in dimes and quarters. He has 17 coins in all. How many coins of each denomination does he have?
16. Divide \$155 among A, B, C, and D so that A and B together receive \$40, C receives twice as much as A, and D receives three times as much as B.
17. If  $-6$  is added to half a certain number, the result is 15. What is the number?
18. Jack wants a sweater that costs \$.15 more than 3 times the amount of money he now has. If the sweater costs \$4.50, how much money does Jack have now?
19. Herbert is walking up a long flight of steps. He climbs 6 less than half the total number, then he climbs 4 more than a third of the number remaining. He rests for a while, and then climbs 3 less than a fourth of what still remains. There are 48 steps left to reach the top. How many steps are there in the flight?

(continued on next page)

20. Noodles, Bismark, and Clem are three dachshund puppies. Noodles is one hour more than half as old as Bismark, and 3 hours older than Clem. Four hours ago Bismark's age was  $4\frac{2}{3}$  Clem's age. How old is each puppy?
21. Two grades of coffee were accidentally mixed, and thus produced a new grade. To meet the cost of advertising this new grade, the coffee distributor had to pay 7% of the gross income he had expected to receive from the sale of the original two grades [11.7 tons for \$17,550 and 8.3 tons for \$14,940]. How much [to the nearest cent] per pound must he charge for the new grade to meet the advertising costs, and to give him his originally expected income?
22. How many pounds of coffee at 75 cents per pound should be mixed with 337 pounds of coffee at 90 cents per pound to produce 1000 pounds of mixture worth 80 cents per pound?
23. How many pounds of coffee at 75 cents per pound should be mixed with 337 pounds at 90 cents per pound to produce a mixture worth (a) 50 cents per pound, (b) 80 cents per pound, (c) \$1.00 per pound?
24. Andrew has twice as much money as Scott. If Andrew were to lend Scott a quarter then both boys would have the same amount of money. How much money does each boy have?
25. (a) Two bees working together, can gather nectar from 100 hollyhock blossoms in 30 minutes. Assuming that each bee works the standard eight-hour day, five days a week, how many blossoms do these bees gather nectar from in a summer season of fifteen weeks?
- (b) In working on a batch of 100 blossoms, one of the bees stops after 18 minutes [just to smell the flowers], and it takes the other bee 20 minutes to finish the batch. How long would it take the diligent bee to gather nectar from 100 blossoms if she worked all by herself?

3/85

20. Bismark, 18 hours; Noodles, 10 hours; Clem, 7 hours [ $x$  hours... Bismark,  $0.5x + 1$  hours... Noodles,  $0.5x + 1 - 3$  hours... Clem;  $x - 4 = (14/3)(0.5x + 1 - 3 - 4)$ ]

21. 87 cents [originally expected income is  $17550 + 14940$  dollars, 20 tons at  $x$  cents a pound are worth  $40000x/100$  dollars;  $40000x/100 = 1.07(17550 + 14940)$ ; the root is 86.91075]

22. This is a tricky one. Since we want a total of 1000 pounds of mixture, and since we have 337 pounds of 90 cents-per-pound coffee, we must use 663 pounds of the 75 cents-per-pound grade.

$$663 \times .75 = 497.25$$

$$337 \times .90 = \underline{303.30}$$

$$800.55$$

The 1000 pounds of mixture is worth \$800, not \$800.55. So, it is impossible to make the mixture according to the given specifications.

23. (a) and (c) are tricky. See COMMENTARY for Exercise 5 on TC[3-79, 80]. (b) 674 [ $75x + 90 \cdot 337 = 80(x + 337)$ ]

24. Scott, 50 cents; Andrew, 1 dollar [ $x$  dollars... Scott,  $2x$  dollars... Andrew;  $2x - 0.25 = x + 0.25$ ]

25. (a)  $15 \times 5 \times 8 \times 2 \times 100$ , or 120000; (b) 50 minutes

The diligent bee processes  $x$  flowers per minute; so, this bee processes  $30x$  flowers in 30 minutes. Hence, the "lazy" bee processes  $100 - 30x$  flowers in 30 minutes, or  $\frac{100 - 30x}{30}$

flowers per minute. Thus, in 18 minutes the two bees, together, process

$$18x + 18\left(\frac{100 - 30x}{30}\right) \text{ flowers.}$$

In the next 20 minutes, the diligent bee processes 20 flowers.

So, we want a number  $x$  such that

$$18x + 18\left(\frac{100 - 30x}{30}\right) + 20x = 100.$$

The only such number is 2. Hence, the diligent bee processes 2 flowers per minute, that is, 100 flowers in 50 minutes.

[Alternative solutions for (b) are on TC[3-82]b.]

[3-82]

20.

3/86

Alternative solutions for (b)

- I. When the lazy bee stops,  $18/30$  of the job has been finished. So, the diligent bee takes 20 minutes to do  $12/30$ , or  $2/5$ , of the job. It would take her 10 minutes to do  $1/5$  of the job. Therefore, it would take her 50 minutes to do the whole job.
- II. The diligent bee has to work 8 minutes overtime [ $38 - 30 = 8$ ] to do the work which it would have taken the lazy bee 12 minutes to do. So, the diligent bee does  $3/2$  times as much work in 1 minute as the lazy bee does. So, in processing 100 flowers in 30 minutes, the diligent bee takes care of 60 flowers and the lazy bee takes care of 40 flowers. If the diligent bee processes 60 flowers in 30 minutes, she processes 2 flowers per minute, or 100 flowers in 50 minutes.

[3-82]

20.



These Exploration Exercises are designed to prepare the students for the process of "multiplying binomials". Students should study the examples and note the short cuts which are successively introduced. Then they should practice on the exercises in Part A on page 3-84 until they can find the products without writing any of the intermediate steps.

\*

There is an interesting geometric representation of this procedure for finding a product. Take the problem:  $24 \times 26 = ?$  Consider the rectangle whose dimensions are 24 units and 26 units.

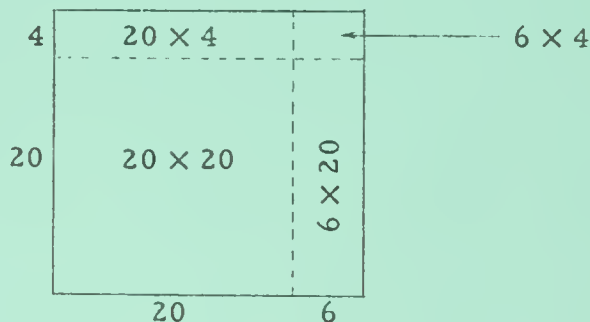

The area-measure of the rectangle is the sum of the area-measures of the component rectangles.

\*

Answers for Part A [on pages 3-83 and 3-84].

- |          |          |          |          |          |
|----------|----------|----------|----------|----------|
| 1. 204   | 2. 528   | 3. 198   | 4. 638   | 5. 288   |
| 6. 621   | 7. 1088  | 8. 2021  | 9. 3025  | 10. 2016 |
| 11. 4154 | 12. 7304 | 13. 7128 | 14. 8648 | 15. 5550 |



## EXPLORATION EXERCISES

Can you do these problems mentally?

$$13 \times 18 = ?$$

$$24 \times 26 = ?$$

$$17 \times 15 = ?$$

$$42 \times 47 = ?$$

Study the following examples. They may suggest a short cut.

Example 1.  $13 \times 18 = ?$

$$\begin{aligned} (10 + 3) \times (10 + 8) &= (10 + 3)10 + (10 + 3)8 \\ &= 10 \cdot 10 + 3 \cdot 10 + 10 \cdot 8 + 3 \cdot 8 \\ &= 100 + (3 + 8)10 + 24 \\ &= 100 + 11 \cdot 10 + 24 \\ &= 100 + 110 + 24 \\ &= 210 + 24 \\ &= 234. \end{aligned}$$

Example 2.  $24 \times 26 = ?$

$$\begin{aligned} (20 + 4)(20 + 6) &= (20 + 4)20 + (20 + 4)6 \\ &= 20 \cdot 20 + 4 \cdot 20 + 20 \cdot 6 + 4 \cdot 6 \\ &= 400 + (4 + 6)20 + 24 \\ &= 400 + 10 \cdot 20 + 24 \\ &= 600 + 24 \\ &= 624. \end{aligned}$$

Example 3.  $17 \times 15 = ?$

$$\begin{aligned} (10 + 7)(10 + 5) &= 100 + (7 + 5)10 + 35 \\ &= 100 + 12 \cdot 10 + 35 \\ &= 100 + 120 + 35 \\ &= 220 + 35 \\ &= 255. \end{aligned}$$

Example 4.  $42 \times 47 = ?$

$$\begin{aligned} 42 \times 47 &= 1600 + 9 \cdot 40 + 14 \\ &= 1960 + 14 \\ &= 1974. \end{aligned}$$

A. Simplify mentally.

- |                    |                    |                    |
|--------------------|--------------------|--------------------|
| 1. $12 \times 17$  | 2. $22 \times 24$  | 3. $18 \times 11$  |
| 4. $22 \times 29$  | 5. $16 \times 18$  | 6. $23 \times 27$  |
| 7. $32 \times 34$  | 8. $43 \times 47$  | 9. $55 \times 55$  |
| 10. $48 \times 42$ | 11. $62 \times 67$ | 12. $83 \times 88$ |
| 13. $88 \times 81$ | 14. $94 \times 92$ | 15. $74 \times 75$ |

B. Tell which is larger and by how much.

- |   |  |
|---|--|
| 1. $23 \times 25$ or $22 \times 26$                         | 2. $39 \times 31$ or $38 \times 32$      |
| 3. $43 \times 47$ or $45 \times 45$                         | 4. $68 \times 62$ or $67 \times 63$      |
| 5. $72 \times 76$ or $71 \times 77$                         | 6. $33 \times 35$ or $36 \times 32$      |
| 7. $84 \times 87$ or $89 \times 82$                         | 8. $91 \times 99$ or $96 \times 94$      |
| 9. $76 \times 76$ or $78 \times 74$                         | 10. $87 \times 88$ or $86 \times 89$     |
| 11. $372 \times 374$ or $371 \times 375$                    | 12. $891 \times 894$ or $893 \times 892$ |
| 13. $5873 \times 5876$ or $5874 \times 5875$                |  |
| 14. $92585 \times 92583$ or $92586 \times 92582$            |  |
| 15. $92588 \times 92582$ or $92584 \times 92584$            |  |
| 16. $9462593 \times 9462598$ or $9462597 \times 9462594$    |  |
| 17. $(50 + 2)(50 + 4)$ or $(50 + 3)(50 + 3)$                |  |
| 18. $(60 + 8)(60 + 3)$ or $(60 + 9)(60 + 2)$                |  |
| 19. $(67 + 8)(67 + 3)$ or $(67 + 9)(67 + 2)$                |  |
| 20. $(983 + 4)(983 + 5)$ or $(983 + 1)(983 + 8)$            |  |
| 21. $(983 + 40)(983 + 10)$ or $(983 + 30)(983 + 20)$        |  |
| 22. $(60052 + 99)(60052 + 1)$ or $(60052 + 27)(60052 + 83)$ |  |
| 23. $(-5 + 7)(-5 + 8)$ or $(-5 + 9)(-5 + 6)$                |  |
| 24. $(-27 + 1)(-27 + 5)$ or $(-27 + 2)(-27 + 4)$            |  |

3/88

In Part B students should discover an easy way to compare the two numbers. Here is what we had in mind.

$$23 \times 25 = 20 \times 20 + (3 + 5)20 + 3 \cdot 5$$

$$22 \times 26 = 20 \times 20 + (2 + 6)20 + 2 \cdot 6$$

Since  $15 > 12$ , it follows that  $23 \times 25 > 22 \times 26$ , and since  $15 - 12 = 3$ , it follows that  $23 \times 25 - 22 \times 26 = 3$ .

Exercise 15 does not follow the same pattern.

$$92588 \times 92582 = 92580 \times 92580 + (8 + 2)92580 + 8 \cdot 2$$

$$92584 \times 92584 = 92580 \times 92580 + (4 + 4)92580 + 4 \cdot 4$$

Obviously, the first number is the larger, and it exceeds the second by  $2 \cdot 92580$ , or 185160.

Exercise 22 also breaks the pattern. [Exercise 32 breaks the pattern of Exercises 29-31, and it introduces the work immediately following.]

\*

Answers for Part B [on pages 3-84 and 3-85].

1.  $23 \times 25 > 22 \times 26$ ;  $23 \times 25$  exceeds  $22 \times 26$  by 3.
2.  $38 \times 32 > 39 \times 31$ ;  $38 \times 32$  exceeds  $39 \times 31$  by 7.

For the rest of the answers, we list the number which is the larger, and the number which is the difference of the smaller from the larger.

- |                                   |   |                              |
|-----------------------------------|---|------------------------------|
| 3. $45 \times 45$ ; 4             | 4. $67 \times 63$ ; 5                   | 5. $72 \times 76$ ; 5        |
| 6. $33 \times 35$ ; 3             | 7. $84 \times 87$ ; 10                  | 8. $96 \times 94$ ; 15       |
| 9. $76 \times 76$ ; 4             | 10. $87 \times 88$ ; 2                  | 11. $372 \times 374$ ; 3     |
| 12. $893 \times 892$ ; 2          | 13. $5874 \times 5875$ ; 2              | 14. $92585 \times 92583$ ; 3 |
| 15. $92588 \times 92582$ ; 185160 | 16. $9462597 \times 9462594$ ; 4        |                              |
| 17. $(50 + 3)(50 + 3)$ ; 1        | 18. $(60 + 8)(60 + 3)$ ; 6              |                              |
| 19. $(67 + 8)(67 + 3)$ ; 6        | 20. $(983 + 4)(983 + 5)$ ; 12           |                              |
| 21. $(983 + 30)(983 + 20)$ ; 200  | 22. $(60052 + 27)(60052 + 83)$ ; 602662 |                              |
| 23. $(-5 + 7)(-5 + 8)$ ; 2        | 24. $(-27 + 2)(-27 + 4)$ ; 3            |                              |

\*

- |       |       |       |       |
|-------|-------|-------|-------|
| 25. T | 26. T | 27. T | 28. F |
|-------|-------|-------|-------|

\*

- |       |        |         |          |
|-------|--------|---------|----------|
| 29. 5 | 30. 12 | 31. -72 | 32. $3x$ |
|-------|--------|---------|----------|

[3-84]

A. S

\*

True or false?

25.  $(72 + 3)(72 + 7) > (72 + 2)(72 + 8)$ .
26. For each  $x$ ,  $(x + 3)(x + 7) > (x + 2)(x + 8)$ .
27. For each  $x$ ,  $(x + 9)(x + 8) > (x + 5)(x + 12)$ .
28. For each  $k$ ,  $(k + 1)(k + 18) > (k + 9)(k + 10)$ .

\*

Complete to true sentences.

29. For each  $x$ ,  $(x + 3)(x + 7) - (x + 2)(x + 8) = \underline{\hspace{2cm}}$ .
30. For each  $x$ ,  $(x + 9)(x + 8) - (x + 5)(x + 12) = \underline{\hspace{2cm}}$ .
31. For each  $k$ ,  $(k + 1)(k + 18) - (k + 9)(k + 10) = \underline{\hspace{2cm}}$ .
- ☆32. For each  $x$ ,  $(x + 10)(x + 2) - (x + 5)(x + 4) = \underline{\hspace{2cm}}$ .

## "EXPANDING" PRONUMERAL EXPRESSIONS

Let's look again at Exercise 32 of Part B above. The expressions

$$'(x + 10)(x + 2)' \text{ and } '(x + 5)(x + 4)'$$

can be simplified by using principles for real numbers.

$\begin{aligned} &(x + 10)(x + 2) \\ &(x + 10)x + (x + 10)2 \\ &xx + 10x + 2x + 20 \\ &xx + (10 + 2)x + 20 \\ &xx + 12x + 20 \end{aligned}$	$\begin{aligned} &(x + 5)(x + 4) \\ &(x + 5)x + (x + 5)4 \\ &xx + 5x + 4x + 20 \\ &xx + (5 + 4)x + 20 \\ &xx + 9x + 20 \end{aligned}$
---	---

So, for each  $x$ ,

$$\begin{aligned} &(x + 10)(x + 2) - (x + 5)(x + 4) \\ &= (xx + 12x + 20) - (xx + 9x + 20) \\ &= 3x. \end{aligned}$$

[Did you get this answer in Exercise 32?]

## EXERCISES

A. Transform each of the following expressions into an equivalent one which does not contain grouping symbols. [This procedure is sometimes called expanding.]

- |     |                  |                           |                   |
|-----|------------------|---------------------------|-------------------|
| 1.  | $(x + 5)(x + 3)$ | [Answer: $xx + 8x + 15$ ] |                   |
| 2.  | $(x + 2)(x + 7)$ | 3.                        | $(x + 6)(x + 2)$  |
|     |                  | 4.                        | $(x + 1)(x + 7)$  |
| 5.  | $(x + 8)(x + 9)$ | 6.                        | $(x + 3)(x + 5)$  |
|     |                  | 7.                        | $(x + 2)(x + 2)$  |
| 8.  | $(x + 7)(x + 7)$ | 9.                        | $(x + 11)(x + 9)$ |
|     |                  | 10.                       | $(x + 1)(x + 1)$  |
| 11. | $(y + 3)(y + 7)$ | 12.                       | $(y + 4)(y + 5)$  |
|     |                  | 13.                       | $(a + 1)(a + 15)$ |

Sample 1.  $(y - 3)(y + 7)$

Solution.

$$\begin{aligned} & (y - 3)(y + 7) \\ &= (y + -3)(y + 7) \\ &= yy + (-3 + 7)y + -3 \cdot 7 \\ &= yy + 4y - 21. \end{aligned}$$

- |     |                    |     |                  |     |                    |
|-----|--------------------|-----|------------------|-----|--------------------|
| 14. | $(x - 3)(x + 5)$   | 15. | $(x + 9)(x - 2)$ | 16. | $(z - 8)(z + 12)$  |
| 17. | $(a - 11)(a + 15)$ | 18. | $(a + 6)(a + 7)$ | 19. | $(a - 10)(a + 9)$  |
| 20. | $(b + 4)(b - 3)$   | 21. | $(b + 6)(b - 6)$ | 22. | $(b - 11)(b + 11)$ |
| 23. | $(b + 6)(b - 15)$  | 24. | $(m + 2)(m - 3)$ | 25. | $(m - 6)(m + 20)$  |
| 26. | $(x - 8)(x - 2)$   | 27. | $(x - 7)(x - 6)$ | 28. | $(x - 3)(x - 11)$  |
| 29. | $(x - 3)(x - 3)$   | 30. | $(x + 5)(x - 7)$ | 31. | $(x - 2)(x + 19)$  |
| 32. | $(m - 4)(m - 7)$   | 33. | $(m + 8)(m - 8)$ | 34. | $(m - 5)(m - 50)$  |

Sample 2.  $(3x + 7)(2x + 5)$

Solution.

$$\begin{aligned} & (3x + 7)(2x + 5) \\ &= (3x + 7)2x + (3x + 7)5 \\ &= 3x \cdot 2x + 7 \cdot 2x + 3x \cdot 5 + 35 \\ &= 6xx + (7 \cdot 2 + 3 \cdot 5)x + 35 \\ &= 6xx + (14 + 15)x + 35 \\ &= 6xx + 29x + 35. \end{aligned}$$

3/89

Work Exercise 1 of Part A with the class as follows.

$$\begin{array}{l}
 (x + 5)(x + 3) \\
 = (x + 5)x + (x + 5)3 \\
 = (xx + 5x) + (x3 + 15) \\
 = xx + (5x + x3) + 15 \\
 = xx + (5x + 3x) + 15 \\
 = xx + (5 + 3)x + 15 \\
 = xx + 8x + 15.
 \end{array}
 \left. \begin{array}{l} \\ \\ \\ \\ \\ \\ \\ \end{array} \right\} \begin{array}{l} \text{dpma} \\ \text{dpma, } 5 \cdot 3 = 15 \\ \text{apa, apa} \\ \text{cpm} \\ \text{dpma} \\ 5 + 3 = 8 \end{array}$$

Point out that you have proved the following generalization:

$$\forall_x (x + 5)(x + 3) = xx + 8x + 15.$$

To make sure students see that they have proved a generalization, have them check a few instances [using negative numbers and fractional numbers] by substituting for 'x' in the testing pattern.

Encourage students to find short cuts in Part A.

\*

In studying Samples 1, 2, and 3, students should see that short cuts have been used. You may want to assign the odd-numbered exercises of Part A in one block. These should be checked, any misconceptions corrected, and then the even-numbered exercises assigned.

\*

Answers for Part A [on pages 3-86 and 3-87].

- |                      |                     |                     |
|----------------------|---------------------|---------------------|
| 1. $xx + 8x + 15$    | 2. $xx + 9x + 14$   | 3. $xx + 8x + 12$   |
| 4. $xx + 8x + 7$     | 5. $xx + 17x + 72$  | 6. $xx + 8x + 15$   |
| 7. $xx + 4x + 4$     | 8. $xx + 14x + 49$  | 9. $xx + 20x + 99$  |
| 10. $xx + 2x + 1$    | 11. $yy + 10y + 21$ | 12. $yy + 9y + 20$  |
| 13. $aa + 16a + 15$  | 14. $xx + 2x - 15$  | 15. $xx + 7x - 18$  |
| 16. $zz + 4z - 96$   | 17. $aa + 4a - 165$ | 18. $aa + 13a + 42$ |
| 19. $aa - a - 90$    | 20. $bb + b - 12$   | 21. $bb - 36$       |
| 22. $bb - 121$       | 23. $bb - 9b - 90$  | 24. $mm - m - 6$    |
| 25. $mm + 14m - 120$ | 26. $xx - 10x + 16$ | 27. $xx - 13x + 42$ |
| 28. $xx - 14x + 33$  | 29. $xx - 6x + 9$   | 30. $xx - 2x - 35$  |
| 31. $xx + 17x - 38$  | 32. $mm - 11m + 28$ | 33. $mm - 64$       |
| 34. $mm - 55m + 250$ |                     |                     |

[3-86]

A





A

- |                       |                       |                       |
|-----------------------|-----------------------|-----------------------|
| 35. $12yy + 35y + 18$ | 36. $6xx + 19x + 10$  | 37. $14xx + 43x + 20$ |
| 38. $12xx + 40x - 63$ | 39. $27xx + 3x - 2$   | 40. $16gg + 26g - 35$ |
| 41. $aa - 10a + 21$   | 42. $aa - 7a$         | 43. $aa - 3a + 2$     |
| 44. $16aa + 26a + 3$  | 45. $6xx + 35x + 25$  | 46. $6aa + 49a + 88$  |
| 47. $10xx - 29x + 10$ | 48. $56yy - 53y + 12$ | 49. $27ss - 78s + 35$ |
| 50. $aa - 13a - 68$   | 51. $xx - x - 420$    | 52. $xx - 6400$       |
| 53. $7aa + 50a + 7$   | 54. $3bb + 20b + 32$  | 55. $27bb + 48b + 5$  |
| 56. $35 + 12x + xx$   | 57. $24 - 5x - xx$    | 58. $49 - xx$         |
| 59. $40uu + 21u - 27$ | 60. $100xx - 4$       | 61. $35 + 11x - 6xx$  |

\*

After the class has worked Part A, and answers have been checked, you should give a short quiz in which the examples are not categorized.

Suggested quiz.

Expand.

- |                       |                       |                       |
|-----------------------|-----------------------|-----------------------|
| 1. $(x + 7)(x + 9)$   | 2. $(y - 3)(y + 5)$   | 3. $(z + 1)(z - 1)$   |
| 4. $(a - 4)(a - 5)$   | 5. $(3 + x)(2 + x)$   | 6. $(5 + y)(y - 7)$   |
| 7. $(2x + 1)(3x - 1)$ | 8. $(6y + 3)(2y + 5)$ | 9. $(5x - 1)(3x - 2)$ |

\*

We do not have supplementary exercises for Part A because we want students to attain consummate skill in this type of expansion only after they have learned how to use the exponent symbol ' $^2$ '.

\*

Part B contains exploratory exercises in factoring trinomials in preparation for the work in Part C on page 3-92.

\*

Answers for Part B.

- |               |              |              |             |             |
|---------------|--------------|--------------|-------------|-------------|
| 1. $x + 2$    | 2. $n + 3$   | 3. $y + 3$   | 4. $z + 8$  | 5. $g - 7$  |
| 6. $a + 3$    | 7. $b + 5$   | 8. $s - 6$   | 9. $x + 2$  | 10. $c - 9$ |
| 11. $10y + 1$ | 12. $3b + 2$ | 13. $4m + 5$ | 14. $x - 5$ |             |

Sample 3.  $(2y - 5)(3y + 4)$

Solution.  $(2y - 5)(3y + 4)$   
 $= 6yy + (-15 + 8)y - 20$   
 $= 6yy - 7y - 20.$

- |                        |                          |                         |
|------------------------|--------------------------|-------------------------|
| 35. $(4y + 9)(3y + 2)$ | 36. $(2x + 5)(3x + 2)$   | 37. $(7x + 4)(2x + 5)$  |
| 38. $(6x - 7)(2x + 9)$ | 39. $(9x - 2)(3x + 1)$   | 40. $(2g + 5)(8g - 7)$  |
| 41. $(a - 7)(a - 3)$   | 42. $(a - 0)(a - 7)$     | 43. $(a - 1)(a - 2)$    |
| 44. $(2a + 3)(8a + 1)$ | 45. $(6x + 5)(x + 5)$    | 46. $(3a + 8)(2a + 11)$ |
| 47. $(2x - 5)(5x - 2)$ | 48. $(8y - 3)(7y - 4)$   | 49. $(9s - 5)(3s - 7)$  |
| 50. $(a + 4)(a - 17)$  | 51. $(x - 21)(x + 20)$   | 52. $(x - 80)(x + 80)$  |
| 53. $(a + 7)(7a + 1)$  | 54. $(b + 4)(3b + 8)$    | 55. $(9b + 1)(3b + 5)$  |
| 56. $(5 + x)(7 + x)$   | 57. $(3 - x)(8 + x)$     | 58. $(7 - x)(7 + x)$    |
| 59. $(5u - 3)(8u + 9)$ | 60. $(10x - 2)(10x + 2)$ | 61. $(5 + 3x)(7 - 2x)$  |

B. Complete to make true sentences.

- For each  $x$ ,  $xx + 5x + 6 = (x + 3)(\quad)$ .
- For each  $n$ ,  $nn + 8n + 15 = (\quad)(n + 5)$ .
- For each  $y$ ,  $yy + 7y + 12 = (y + 4)(\quad)$ .
- For each  $z$ ,  $zz + 2z - 48 = (\quad)(z - 6)$ .
- For each  $g$ ,  $gg - 16g + 63 = (g - 9)(\quad)$ .
- For each  $a$ ,  $aa - 9 = (a - 3)(\quad)$ .
- For each  $b$ ,  $bb + 10b + 25 = (b + 5)(\quad)$ .
- For each  $s$ ,  $ss - 12s + 36 = (\quad)(s - 6)$ .
- For each  $x$ ,  $xx - 7x - 18 = (x - 9)(\quad)$ .
- For each  $c$ ,  $cc - 11c + 18 = (\quad)(c - 2)$ .
- For each  $y$ ,  $30yy + 43y + 4 = (3y + 4)(\quad)$ .
- For each  $b$ ,  $15bb - 2b - 8 = (\quad)(5b - 4)$ .
- For each  $m$ ,  $20mm + 17m - 10 = (5m - 2)(\quad)$ .
- For each  $x$ ,  $xx - 25 = (\quad)(x + 5)$ .

\* \* \*

People often abbreviate expressions like '(xx)' and '(yy)' to ' $x^2$ ' and ' $y^2$ '. [Read ' $x^2$ ' as 'x squared' or as 'the square of x'.] So, for example,  $6^2 = 36$ ,  $3^2 = 9$ ,  $(.01)^2 = .0001$ , and  $(\frac{1}{3})^2 = \frac{1}{9}$ . The raised numeral is called an exponent symbol, or, for short, an exponent.

\* \* \*

C. True or false?

1.  $(6 \times 3)^2 = 6^2 \times 3^2$

2.  $(6 + 3)^2 = 6^2 + 3^2$

3.  $(6 \div 3)^2 = 6^2 \div 3^2$

4.  $(6 - 3)^2 = 6^2 - 3^2$

5.  $(5 + 2)^2 = (5 + 2)(5 + 2)$

6.  $(4 + 3)^2 = 4^2 + 2(4)(3) + 3^2$

7.  $(\frac{12}{2})^2 = \frac{12^2}{2^2}$

8.  $(\frac{5 + 9}{2})^2 = \frac{5^2 + 9^2}{2^2}$

9.  $(\frac{3 \times 4}{2})^2 = \frac{3^2 \times 4^2}{2^2}$

10.  $(\frac{14 - 4}{2})^2 = \frac{14^2 - 2(14)(4) + 4^2}{2^2}$

11.  $(2 \cdot 7)(3 \cdot 7) = 6 \cdot 7^2$

12.  $9 \cdot 5^2 = 9 \cdot 9 \cdot 5 \cdot 5$

13.  $(-5)^2 = 5^2$

14.  $-5^2 = -25$

D. Write an equivalent expression (as simple an expression as you can) which does not contain an exponent symbol.

1.  $3^2$

2.  $(-3)^2$

3.  $-3^2$

4.  $-(3^2)$

5.  $(2 \times 3)^2$

6.  $(2 + 3)^2$

7.  $(2 - 3)^2$

8.  $(2 \div 3)^2$

9.  $(.001)^2$

10.  $(-.001)^2$

11.  $(6 - 6)^2$

12.  $(6 + 6)^2$

13.  $(\frac{4 \times 3}{5})^2$

14.  $(\frac{5 + 2}{3})^2$

15.  $(\frac{6 - 4}{3})^2$

E. Expand.

1.  $(x + 3)(x + 8)$

2.  $(y - 4)(y + 9)$

3.  $(y - 3)(y + 17)$

4.  $(a - 4)(a + 12)$

5.  $(a - 2)(a + 3)$

6.  $(2x - 3)(5x + 7)$

3/91

Notice our use of 'exponent' as an abbreviation for 'exponent symbol'. In a later unit we shall instead use the word 'exponent' to refer to a number named by an exponent symbol. We do not think this ambiguity will cause a serious problem.

\*

Parts C and D are extremely important. They are designed to indicate certain properties of squaring, to forestall the formation of false generalizations, and to establish conventions. Exercises 1 and 3 suggest that squaring is distributive with respect to multiplication and division; Exercises 2 and 4 show that squaring is not distributive with respect to addition and subtraction. Exercises 5-10 emphasize these points.

The expected answers for Exercise 11 [True] and Exercise 12 [False] imply the acceptance of a convention which should be explicitly formulated at this time. [For a relevant discussion see TC[1-82]a.] Just as ' $-7x$ ' is an abbreviation for ' $(-7)x$ ' so ' $xy^2$ ' is an abbreviation for ' $x(y^2)$ '. So, ' $6 \cdot 7^2$ ' is an abbreviation for ' $6 \cdot (7^2)$ ', and ' $9 \cdot 5^2$ ' is an abbreviation for ' $9 \cdot (5 \cdot 5)$ '. A colloquial description of this convention is 'an exponent affects only what it's hitched to'. Stated this way, the convention clearly applies to Exercise 14. The exponent ' $^2$ ' is hitched to the numeral '5'. So,  $-5^2 = -(5^2)$  rather than  $(-5)^2$ . This convention may appeal more to students if you ask them to decide about the equivalence of, say, ' $10 - 3^2$ ' and ' $10 + -3^2$ '.

\*

Answers for Part C.

- |       |       |       |       |       |
|-------|-------|-------|-------|-------|
| 1. T  | 2. F  | 3. T  | 4. F  | 5. T  |
| 6. T  | 7. T  | 8. F  | 9. T  | 10. T |
| 11. T | 12. F | 13. T | 14. T |       |

\*

Answers for Part D.

- |       |         |                      |                    |                   |
|-------|---------|----------------------|--------------------|-------------------|
| 1. 9  | 2. 9    | 3. -9                | 4. -9              | 5. 36             |
| 6. 25 | 7. 1    | 8. $\frac{4}{9}$     | 9. .000001         | 10. .000001       |
| 11. 0 | 12. 144 | 13. $\frac{144}{25}$ | 14. $\frac{49}{9}$ | 15. $\frac{4}{9}$ |



3/92

Part E gives more practice in expanding, and in "squaring binomials". Sample 2 on page 3-89 requires careful study. A troublesome point is that of replacing  $(3x)^2$  by  $9x^2$ . Students are prone to go in one step from

$$(3x + 5)^2 \text{ to } 3x^2 + 30x + 25.$$

We suggest that you assign half the exercises in Part E on pages 3-88 through 3-90, check results, and assign the other half. Follow this by a quiz. Then give the supplementary exercises [Part L, pages 3-186 and 3-187] a day later when the students are doing the factoring exercises on pages 3-93 through 3-95.







Answers for Part E [which begins on page 3-88 and ends on page 3-90].

- |  |  |                             |
|--|--|-----------------------------|
| 1. $x^2 + 11x + 24$                                  | 2. $y^2 + 5y - 36$   | 3. $y^2 + 14y - 51$         |
| 4. $a^2 + 8a - 48$                                   | 5. $a^2 + a - 6$   | 6. $10x^2 - x - 21$         |
| 7. $x^2 + 2x + 1$                                    | 8. $a^2 + 10a + 25$  | 9. $k^2 + 4k + 4$           |
| 10. $m^2 - 2m + 1$                                   | 11. $n^2 - 8n + 16$  | 12. $y^2 - 22y + 121$       |
| 13. $9x^2 + 42x + 49$                                | 14. $4y^2 + 20y + 25$  | 15. $9z^2 + 18z + 9$        |
| 16. $16y^2 - 8y + 1$                                 | 17. $9k^2 - 24k + 16$  | 18. $49n^2 - 42n + 9$       |
| 19. $4 - 16j + 16j^2$                                | 20. $36 - 96r + 64r^2$   | 21. $9x^2 - 60x + 100$      |
| 22. $b^2 + 2b - 143$                                 | 23. $12x^2 + 8x - 15$  | 24. $7x^2 - 11x - 6$        |
| 25. $12a^2 + 32a - 35$                               | 26. $15b^2 - 22b + 8$  | 27. $12r^2 - 4r - 21$       |
| 28. $t^2 + 10t + 25$                                 | 29. $r^2 + 14r + 49$   | 30. $z^2 + 18z + 81$        |
| 31. $m^2 - 6m + 9$                                   | 32. $m^2 + 6m + 9$   | 33. $a^2 - a + .25$         |
| 34. $49m^2 + 28m + 4$                                | 35. $4a^2 - 12ab + 9b^2$   | 36. $25 + 90s + 81s^2$      |
| 37. $16x^2 + 26x + 3$                                | 38. $35 - 31y + 6y^2$  | 39. $12 - 44y - 45y^2$      |
| 40. $-x^2 + 8x - 15$                                 | 41. $15r^2 + 29r + 12$   | 42. $-12j^2 + 38j + 40$     |
| 43. $r^2 - r + \frac{1}{4}$                          | 44. $s^2 + \frac{2}{3}s + \frac{1}{9}$   | 45. $t^2 + t + \frac{1}{4}$ |
| 46. $4a^2 + 12ab + 9b^2$                             | 47. $16 + 24p + 9p^2$  |                             |
| 48. $9x_1^2 - 30x_1x_2 + 25x_2^2$                    |  | 49. $25x^2 - 4$             |
| 50. $64y^2 - 9$                                      | 51. $9z^2 - 6z + 1$  | 52. $ca^2 + 2cab + cb^2$    |
| 53. $4xy^2 - 20xy + 25x$                             | 54. $da^2 - 2dab + db^2$   | 55. $9ax^2 - ay^2$          |
| 56. $6nx^2 - 5nxy - 25ny^2$                          | 57. $rx_1^2 - 2rx_1x_2 + rx_2^2$   |                             |
| 58. $25m^2 - 4n^2$                                   | 59. $9a^2 - 16b^2$   | 60. $15b + 2ba - ba^2$      |
| 61. $x^2 + (\bigcirc + \square)x + \bigcirc\square$  | 62. $x^2 + 2\Delta x + \Delta^2$   |                             |
| 63. $\bigcirc^2x^2 + 2\bigcirc\square x + \square^2$ | 64. $\bigcirc\square x^2 + (\bigcirc\bigcirc + \square\Delta)x + \bigcirc\Delta$ |                             |

Sample 1.  $(x + 3)^2$

Solution.  $(x + 3)^2 = (x + 3)(x + 3)$   
 $= xx + 6x + 9$   
 $= x^2 + 6x + 9.$

Sample 2.  $(3x + 5)^2$

Solution.  $(3x + 5)^2 = (3x + 5)(3x + 5)$   
 $= (3x + 5)3x + (3x + 5)5$   
 $= (3x)^2 + 5 \cdot 3x + 3x \cdot 5 + 25$   
 $= 9x^2 + (5 + 5)3x + 25$   
 $= 9x^2 + 10 \cdot 3x + 25$   
 $= 9x^2 + 30x + 25.$

- |                           |                           |                           |
|---------------------------|---------------------------|---------------------------|
| 7. $(x + 1)^2$            | 8. $(a + 5)^2$            | 9. $(k + 2)^2$            |
| 10. $(m - 1)^2$           | 11. $(n - 4)^2$           | 12. $(y - 11)^2$          |
| 13. $(3x + 7)^2$          | 14. $(2y + 5)^2$          | 15. $(3z + 3)^2$          |
| 16. $(4y - 1)^2$          | 17. $(3k - 4)^2$          | 18. $(7n - 3)^2$          |
| 19. $(2 - 4j)^2$          | 20. $(6 - 8r)^2$          | 21. $(3x - 10)^2$         |
| 22. $(b - 11)(b + 13)$    | 23. $(6x - 5)(2x + 3)$    | 24. $(7x + 3)(x - 2)$     |
| 25. $(6a - 5)(2a + 7)$    | 26. $(5b - 4)(3b - 2)$    | 27. $(6r + 7)(2r - 3)$    |
| 28. $(t + 5)^2$           | 29. $(r + 7)^2$           | 30. $(z + 9)^2$           |
| 31. $(m - 3)^2$           | 32. $(m + 3)^2$           | 33. $(a - .5)^2$          |
| 34. $(7m + 2)^2$          | 35. $(2a - 3b)^2$         | 36. $(5 + 9s)^2$          |
| 37. $(8x + 1)(3 + 2x)$    | 38. $(5 - 3y)(7 - 2y)$    | 39. $(6 + 5y)(2 - 9y)$    |
| 40. $(-x + 3)(x - 5)$     | 41. $(-5r - 3)(-3r - 4)$  | 42. $(-6j - 5)(-8 + 2j)$  |
| 43. $(r - \frac{1}{2})^2$ | 44. $(s + \frac{1}{3})^2$ | 45. $(t + \frac{1}{2})^2$ |
| 46. $(2a + 3b)^2$         | 47. $(4 + 3p)^2$          | 48. $(3x_1 - 5x_2)^2$     |
| 49. $(5x - 2)(5x + 2)$    | 50. $(8y + 3)(8y - 3)$    | 51. $(3z - 1)(3z - 1)$    |

Sample 3.  $a(2b - 3)^2$

Solution.  $a(2b - 3)^2 = a(2b - 3)(2b - 3)$   
 $= a(4b^2 - 12b + 9)$   
 $= 4ab^2 - 12ab + 9a.$

Sample 4.  $x(3y - 2)(y + 5)$

Solution.  $x(3y - 2)(y + 5)$   
 $= x(3y^2 + 13y - 10)$   
 $= 3xy^2 + 13xy - 10x.$

52.  $c(z + b)^2$

53.  $x(2y - 5)^2$

54.  $d(a - b)^2$

55.  $a(3x + y)(3x - y)$

56.  $n(2x - 5y)(3x + 5y)$

57.  $r(x_1 - x_2)^2$

58.  $(5m - 2n)(2n + 5m)$

59.  $(3a + 4b)(3a - 4b)$

60.  $b(3 + a)(5 - a)$

61.  $(x + \bigcirc)(x + \square)$

62.  $(x + \triangle)^2$

63.  $(\hexagon x + \square)^2$

64.  $(\square x + \hexagon)(\bigcirc x + \triangle)$

[More exercises are in Part L, Supplementary Exercises.]

## FACTORING PRONUMERAL EXPRESSIONS

The process of transforming an expression such as:

$$x^2 + 6x + 8$$

into the equivalent one:

$$(x + 4)(x + 2)$$

is called factoring. Some other examples of factoring are transforming

'12' into '3 · 4'

'100' into '10 · 10'

'100' into '20 · 5'

'60' into '3 · 20' [or: '3 · 4 · 5']

'80a' into '4 · 20a'

' $x^2 + 3x$ ' into ' $x(x + 3)$ '

' $x^2y + xy^2$ ' into ' $xy(x + y)$ '

' $24a^2 - 60a$ ' into ' $a(24a - 60)$ '

' $24a^2 - 60a$ ' into ' $4a(6a - 15)$ '

' $24a^2 - 60a$ ' into ' $12a(2a - 5)$ '.



3/95

\*

Part B prepares the student for Part C on page 3-92.

\*

Answers for Part B.

- |              |               |                           |              |
|--------------|---------------|---------------------------|--------------|
| 1. $x + 3$   | 2. $x + 9$    | 3. $y + 1$                | 4. $y + 17$  |
| 5. $a + 4$   | 6. $a - 7$    | 7. $t + 3$                | 8. $t - 2$   |
| 9. $m - 10$  | 10. $z - 3$   | 11. $3z + 4$              | 12. $2x + 3$ |
| 13. $2x - 3$ | 14. $10t + 3$ | 15. $a^2 - 5a + 6, a - 2$ |              |

\*

You may want to put the following demonstration on the board. It is one of the familiar "proofs" that all numbers are equal.

Suppose:

$$\begin{array}{rcl}
 a + b = c & & \\
 (c - a)[a + b] = (c - a)[c] & \left. \begin{array}{l} \\ \\ \end{array} \right\} & \begin{array}{l} \text{uniqueness of multiplication} \\ ee \end{array} \\
 ca + cb - a^2 - ab = c^2 - ac & & \\
 [ca + cb - a^2 - ab] - bc = [c^2 - ac] - bc & \left. \begin{array}{l} \\ \\ \end{array} \right\} & \begin{array}{l} \text{uniqueness of addition} \\ ee \\ ee \end{array} \\
 ca - a^2 - ab = c^2 - ac - bc & & \\
 a(c - a - b) = c(c - a - b) & & \\
 a = c & \left. \begin{array}{l} \\ \end{array} \right\} & \begin{array}{l} \text{cancellation principle} \\ \text{for multiplication} \end{array}
 \end{array}$$

So, if  $a + b = c$  then  $a = c$ .

We have [apparently] proven that

$$\forall_a \forall_b \forall_c \text{ if } a + b = c \text{ then } a = c.$$

The fallacy results from unrestricted application of the cancellation principle for multiplication in deriving the last equation from the one immediately preceding it. What the pattern really establishes is:  $\forall_a \forall_b \forall_c \neq a + b$

if  $a + b = c$  then  $a = c$ . The fallacy becomes quite evident if you substitute numerals for the pronumerals in the demonstration. [Note that we are not claiming equivalence of equations in this demonstration. For example, the set of triples  $(a, b, c)$  which satisfy the first equation is a subset of the set of triples  $(a, b, c)$  which satisfy the second equation, but not conversely.]



The topic of factoring is treated in much greater detail in Unit 4. Students should view factoring as a process which relies basically upon the distributive principle for multiplication over addition just as does expansion.

Note carefully that there are no exercises in Part A which have uniquely correct answers. Here we are interested merely in whether the student can take a given expression and find an equivalent one for which the principal operator is a times sign. Thus, other correct answers for the Sample on page 3-91 are:

$$2(15a + 3), \quad 3(10a + 2), \quad \text{and:} \quad \frac{1}{2}(60a + 12).$$

In checking answers in class, encourage students to give more than one correct answer. In using factoring in later problems, the student will want to factor an expression in such a way that the factors are of a form most useful for the problem under consideration. Thus, it is important that the student have a flexible attitude toward factoring.

\*

Answers for Part A.

[We give three of the possible ways that Exercises 1-8 may be factored. Your students will doubtless suggest others.]

- |  |  |
|--|--|
| 1. $2 \cdot 6, 3 \cdot 4, 1 \cdot 12$              | 2. $12 \cdot 12, 4 \cdot 36, 2^4 \cdot 3^2$                |
| 3. $5 \cdot 7, 35 \cdot 1, 11 \frac{2}{3} \cdot 3$ | 4. $1 \cdot 51, 3 \cdot 17, 2 \cdot 25 \frac{1}{2}$        |
| 5. $3 \cdot 11x, 11 \cdot 3x, 33 \cdot 1x$         | 6. $3 \cdot 9 \cdot xy^2, 3(9xy^2), 3^3 \cdot x \cdot y^2$ |
| 7. $2 \cdot 12y, 3 \cdot 8y, 4y \cdot 6$           | 8. $10y \cdot 6z, 4 \cdot 15yz, 2y \cdot 30z$              |

[We give two of the possible ways for factoring Exercises 9 - 20.]

- |  |  |
|--|--|
| 9. $7(x + 4), 28(\frac{1}{4}x + 1)$      | 10. $8(y - 5), 4(2y - 10)$                         |
| 11. $7(3x + 10), \frac{1}{3}(63x + 210)$ | 12. $3(x + 4y), 12(\frac{1}{4}x + y)$              |
| 13. $4(4a - 5b), 2(8a - 10b)$            | 14. $5(m - 2p + 5q), \frac{1}{2}(10m - 20p + 50q)$ |
| 15. $x(y + 3), \frac{1}{3}(3xy + 9x)$    | 16. $5y(x - 2), 5(xy - 2y)$                        |
| 17. $2a(x - 3y + 5z), 2(ax - 3ay + 5az)$ | 18. $ab(a + b), a(ab + b^2)$                       |
| 19. $3a(t + 3a), a(3t + 9a)$             | 20. $2a^2b(4c - 1), 2a^2(4bc - b)$                 |



## EXERCISES

A. Factor.

- |        |             |        |           |
|--------|-------------|--------|-----------|
| 1. 12  | 2. 144      | 3. 35  | 4. 51     |
| 5. 33x | 6. $27xy^2$ | 7. 24y | 8. $60yz$ |

Sample.  $30a + 6$ Solution.  $6(5a + 1)$ 

[Check the result of factoring by seeing whether you can transform ' $6(5a + 1)$ ' into ' $30a + 6$ '.]

- |                   |                  |                        |
|-------------------|------------------|------------------------|
| 9. $7x + 28$      | 10. $8y - 40$    | 11. $21x + 70$         |
| 12. $3x + 12y$    | 13. $16a - 20b$  | 14. $5m - 10p + 25q$   |
| 15. $xy + 3x$     | 16. $5xy - 10y$  | 17. $2ax - 6ay + 10az$ |
| 18. $a^2b + b^2a$ | 19. $3at + 9a^2$ | 20. $-2a^2b + 8a^2bc$  |

B. Complete to make true sentences.

- For each  $x$ ,  $xx + 7x + 12 = (x + 4)(\quad)$ .
- For each  $x$ ,  $x^2 + 11x + 18 = (\quad)(x + 2)$ .
- For each  $y$ ,  $y^2 + 10y + 9 = (y + 9)(\quad)$ .
- For each  $y$ ,  $y^2 + 7y - 170 = (\quad)(y + -10)$ .
- For each  $a$ ,  $a^2 - 16 = (a - 4)(\quad)$ .
- For each  $a$ ,  $a^2 - 49 = (a + 7)(\quad)$ .
- For each  $t$ ,  $t^2 + 6t + 9 = (\quad)(t + 3)$ .
- For each  $t$ ,  $t^2 - 4t + 4 = (t - 2)(\quad)$ .
- For each  $m$ ,  $m^2 - 20m + 100 = (\quad)(m - 10)$ .
- For each  $z$ ,  $z^2 + 4z - 21 = (z + 7)(\quad)$ .
- For each  $z$ ,  $6z^2 + 23z + 20 = (2z + 5)(\quad)$ .
- For each  $x$ ,  $10x^2 + 33x + 27 = (\quad)(5x + 9)$ .
- For each  $x$ ,  $12x^2 - 4x - 21 = (6x + 7)(\quad)$ .
- For each  $t$ ,  $30t^2 - 91t - 30 = (\quad)(3t - 10)$ .
- For each  $n$ , for each  $a$ ,  $na^2 - 5an + 6n = n(\quad)$   
 $= n(a - 3)(\quad)$ .

C. Factor.

Sample 1.  $x^2 + 7x - 8$

Solution. We suspect that factoring ' $x^2 + 7x - 8$ ' will lead to an expression of the form:

$$(x + \triangle)(x + \hexagon).$$

Now, if we expand this last expression, we get:

$$x^2 + (\triangle + \hexagon)x + \triangle \times \hexagon.$$

Compare this with the expression to be factored:

$$x^2 + (7)x + (-8).$$

What we want to find are numbers  $\triangle$  and  $\hexagon$  such that

$$\triangle \times \hexagon = -8 \quad \text{and} \quad \triangle + \hexagon = 7.$$

Do you see that such numbers are 8 and -1? So, factoring ' $x^2 + 7x - 8$ ' gives us ' $(x - 1)(x + 8)$ ', or:

$$(x - 1)(x + 8)$$

[Check by expanding ' $(x - 1)(x + 8)$ '. Do you get ' $x^2 + 7x - 8$ '?]

Sample 2.  $n^2 + 10n + 25$

Solution.  $(n + \square)(n + \circ)$   
 $= n^2 + (\square + \circ)n + \square \times \circ.$

What we want to find are numbers  $\square$  and  $\circ$  such that

$$\square \times \circ = 25 \quad \text{and} \quad \square + \circ = 10.$$

$$5 \times 5 = 25 \quad \text{and} \quad 5 + 5 = 10.$$

So, factoring ' $n^2 + 10n + 25$ ' gives:

$$(n + 5)(n + 5)$$

or, for short:

$$(n + 5)^2.$$



Students may have to be told that the search for factors is essentially a trial-and-error process as far as their technical knowledge is concerned. Of course, one can reduce the search to a strictly mechanical procedure when he knows the quadratic formula. [Suggestions for dealing with the problem of helping a student who, for example, factors ' $a^2 + 3a - 10$ ' and gets ' $a(a + 3) - 10$ ' are given on TC[4-76, 77, 78]a.]

Students should discover [but not be asked to verbalize their discovery] that "if the middle term is negative and the third term is positive then both factors are negative, etc."

The factoring exercises [through Exercise 76 on page 3-95] should be handled in two assignments with necessary reteaching between the assignments.

\*

Answers for Part C [which begins on page 3-92 and ends on page 3-95].

- |   |   |                          |
|---|---|--------------------------|
| 1. $(y - 5)(y + 7)$   | 2. $(y - 3)(y + 9)$   | 3. $(x + 9)(x - 11)$     |
| 4. $(x - 1)(x - 12)$  | 5. $(r + 3)(r + 3)$   | 6. $(p - 11)(p - 11)$    |
| 7. $(y - 2)(y + 6)$   | 8. $(n - 8)(n - 8)$   | 9. $(x - 4)(x - 5)$      |
| 10. $(a + 2)(a + 8)$  | 11. $(y + 10)(y + 10)$  | 12. $(d - 6)(d - 6)$     |
| 13. $(3a + 1)(a + 2)$   | 14. This expression has no binomial factors with integral coefficients. |                          |
| 15. $(5p - 1)(p + 7)$   | 16. $(5m + 1)(5m + 1)$  | 17. $(3r - 1)(3r - 1)$   |
| 18. $(11t + 1)(t - 3)$  | 19. $(d + 5)(d + 1)$  | 20. $(b - 5)(b + 9)$     |
| 21. $(7a + 3)(a - 2)$   | 22. $(r + 2)(r + 3)$  | 23. $(2r + 7)(5r + 2)$   |
| 24. $(2x + 1)(3x - 1)$  | 25. $(4m - 2)(3m + 1)$  | 26. $(3p + 1)(5p + 8)$   |
| 27. $(5p + 1)(3p + 8)$  | 28. $(d - 6)(d - 6)$  | 29. $(q + 13)(q + 13)$   |
| 30. This expression has no binomial factors with integral coefficients. |   |                          |
| 31. $(y - 12)(y - 12)$  | 32. $(7x + 3)(7x + 3)$  | 33. $(n - 5)(n + 5)$     |
| 34. $(n + 3)(n - 3)$  | 35. $(x + 10)(x + 9)$   | 36. $(d + 3)(d + 7)$     |
| 37. $(a - 3)(a - 7)$  | 38. $(m + 7)(m - 4)$  | 39. $(7 - t)(7 + t)$     |
| 40. $(a + b)(a - b)$  | 41. $(2x + 5)(7x + 2)$  | 42. $(12t + 20)(2t + 1)$ |
| 43. $(6r + 5)(6r - 5)$  | 44. $(3 + 4s)(3 - 4s)$  | 45. $(b + 8)(b - 2)$     |
| 46. $(c - 16)(c + 1)$   | 47. $(9t + 3)(2t + 1)$  | 48. $(7k + 3)(3k - 2)$   |
| 49. $(3x + 5y)(3x - 5y)$  | 50. $(3x - 5y)(3x - 5y)$  |                          |

- |                       |                      |
|-----------------------|----------------------|
| 1. $y^2 + 2y - 35$    | 2. $y^2 + 6y - 27$   |
| 3. $x^2 - 2x - 99$    | 4. $x^2 - 13x + 12$  |
| 5. $r^2 + 6r + 9$     | 6. $p^2 - 22p + 121$ |
| 7. $y^2 + 4y - 12$    | 8. $n^2 - 16n + 64$  |
| 9. $x^2 - 9x + 20$    | 10. $a^2 + 10a + 16$ |
| 11. $y^2 + 20y + 100$ | 12. $d^2 - 12d + 36$ |

Sample 3.  $6x^2 + 23x + 20$

Solution. Factoring will lead to an expression of the form:

$$(\square x + \bigcirc)(\triangle x + \hexagon).$$

If we expand this last expression we get:

$$(\square \times \triangle)x^2 + (\square \times \hexagon + \bigcirc \times \triangle)x + \bigcirc \times \hexagon.$$

Compare this with the given expression:

$$(\quad 6 \quad )x^2 + (\quad \quad 23 \quad \quad )x + \quad 20 \quad .$$

We try various factorings for '6' and for '20'.

$\underline{\square \times \triangle = 6}$	$\underline{\bigcirc \times \hexagon = 20}$	$\underline{\square \times \hexagon + \bigcirc \times \triangle = 23}$
$6 \times 1$	$10 \times 2$	$6 \times 2 + 10 \times 1 \neq 23$
$6 \times 1$	$2 \times 10$	$6 \times 10 + 2 \times 1 \neq 23$
$6 \times 1$	$5 \times 4$	$6 \times 4 + 5 \times 1 \neq 23$
$6 \times 1$	$4 \times 5$	$6 \times 5 + 4 \times 1 \neq 23$
$3 \times 2$	$5 \times 4$	$3 \times 4 + 5 \times 2 \neq 23$
$3 \times 2$	$4 \times 5$	$3 \times 5 + 4 \times 2 = 23$

So, factoring ' $6x^2 + 23x + 20$ ' leads to:

$$(3x + 4)(2x + 5).$$

Check this by expanding.

(continued on next page)

13.  $3a^2 + 7a + 2$

15.  $5p^2 + 34p - 7$

17.  $9r^2 - 6r + 1$

19.  $d^2 + 6d + 5$

21.  $7a^2 - 11a - 6$

23.  $10r^2 + 39r + 14$

25.  $12m^2 - 2m - 2$

27.  $15p^2 + 43p + 8$

29.  $q^2 + 26q + 169$

31.  $y^2 - 24y + 144$

33.  $n^2 - 25$

35.  $x^2 + 19x + 90$

37.  $a^2 - 10a + 21$

39.  $49 - t^2$

41.  $14x^2 + 39x + 10$

43.  $36r^2 - 25$

45.  $b^2 + 6b - 16$

47.  $18t^2 + 15t + 3$

49.  $9x^2 - 25y^2$

14.  $2a^2 - 5a + 1$

16.  $25m^2 + 10m + 1$

18.  $11t^2 - 32t - 3$

20.  $b^2 + 4b - 45$

22.  $r^2 + 5r + 6$

24.  $6x^2 + x - 1$

26.  $15p^2 + 29p + 8$

28.  $d^2 - 12d + 36$

30.  $c^2 + 7c - 6$

32.  $49x^2 + 42x + 9$

34.  $n^2 - 9$

36.  $d^2 + 10d + 21$

38.  $m^2 + 3m - 28$

40.  $a^2 - b^2$

42.  $24t^2 + 52t + 20$

44.  $9 - 16s^2$

46.  $c^2 - 15c - 16$

48.  $21k^2 - 5k - 6$

50.  $9x^2 - 30xy + 25y^2$

Sample 4.  $3a^2n - 12n$

Solution.  $3a^2n - 12n$

$= 3n(a^2 - 4)$

$= 3n(a - 2)(a + 2).$

[Check this by expanding.]



13.

3/97

- |                             |                                  |                         |
|-----------------------------|----------------------------------|-------------------------|
| 51. $4a(a - 3b)$            | 52. $x(x + 5)$                   | 53. $6(n^2 + 3)$        |
| 54. $2(r + 3)(r - 3)$       | 55. $y(x + 8)(x + 8)$            | 56. $2(y + 12)(y + 3)$  |
| 57. $b(y + 11)(y + 10)$     | 58. $(m + 17)(m - 3)$            | 59. $(N - 2)(N + 5)$    |
| 60. $(P - 3Q)(P - 6Q)$      | 61. $n(4m + 3)(5m - 6)$          | 62. $z(2x + y)(3x - y)$ |
| 63. $3(15y^2 - 5xy - 2x^2)$ | 64. $(y + 20)(y + 2)$            |                         |
| 65. $x(3y - 5)(3y + 5)$     | 66. $2x(3y - 5z)(3y + 5z)$       |                         |
| 67. $(y + 5)(y + 8)$        | 68. $(y + 4)(y + 10)$            | 69. $3(r - 5)(r - 7)$   |
| 70. $a(t + 4)(t - 7)$       | 71. $(12 + r)(3 + r)$            | 72. $(6 - u)(7 - u)$    |
| 73. $(7u - v)(7u - v)$      | 74. $(10t - r)(10t + r)$         |                         |
| 75. $(2z - 3x)(6z + x)$     | 76. $(2x_1 - 3x_2)(5x_1 + 4x_2)$ |                         |

\*

Part D provides exploratory work for the next section.

\*

Answers for Part D.

- |                      |                                |           |         |
|----------------------|--------------------------------|-----------|---------|
| 1. 3, 5              | 2. -4, 7                       | 3. -3, -7 | 4. 0, 5 |
| 5. $\frac{5}{2}, -8$ | 6. $-\frac{5}{3}, \frac{7}{2}$ | 7. 6, -6  | 8. 2, 3 |



Sample 5.  $12a^2b - 4ab - 40b$

Solution.  $12a^2b - 4ab - 40b$   
 $= 2b(6a^2 - 2a - 20)$   
 $= 2b(3a + 5)(2a - 4).$

[Check this by expanding.]

51.  $4a^2 - 12ab$

52.  $x^2 + 5x$

53.  $6n^2 + 18$

54.  $2r^2 - 18$

55.  $x^2y + 16xy + 64y$

56.  $2y^2 + 30y + 72$

57.  $by^2 + 21by + 110b$

58.  $m^2 + 14m - 51$

59.  $N^2 + 3N - 10$

60.  $P^2 - 9PQ + 18Q^2$

61.  $20m^2n - 9mn - 18n$

62.  $6x^2z + xyz - y^2z$

63.  $45y^2 - 15yx - 6x^2$

64.  $y^2 + 22y + 40$

65.  $9xy^2 - 25x$

66.  $18xy^2 - 50xz^2$

67.  $y^2 + 13y + 40$

68.  $y^2 + 14y + 40$

69.  $3r^2 - 36r + 105$

70.  $at^2 - 3at - 28a$

71.  $36 + 15r + r^2$

72.  $42 - 13u + u^2$

73.  $49u^2 - 14uv + v^2$

74.  $100t^2 - r^2$

75.  $12z^2 - 16zx - 3x^2$

76.  $10x_1^2 - 7x_1x_2 - 12x_2^2$

[More exercises are in Part L, Supplementary Exercises.]

D. Solve these equations.

1.  $(x - 3)(x - 5) = 0$

2.  $(x + 4)(x - 7) = 0$

3.  $(y + 3)(y + 7) = 0$

4.  $x(x - 5) = 0$

5.  $(2x - 5)(x + 8) = 0$

6.  $(3y + 5)(2y - 7) = 0$

7.  $x^2 - 36 = 0$

8.  $x^2 - 5x + 6 = 0$

3.08 Quadratic equations. --Let's try to solve the following problem.

Ed is 3 years older than Mary,  
and 5 years ago the product of  
their ages was 180. How old  
are they now?

Suppose that Mary is now  $x$  years old. Then Ed is now  $(x + 3)$  years old. Five years ago, Mary was  $(x - 5)$  years old and Ed was  $(x + 3 - 5)$  [or:  $(x - 2)$ ] years old. Hence, we are looking for a number  $x$  such that

$$(x - 5)(x - 2) = 180,$$

or,

$$(1) \quad x^2 - 7x + 10 = 180.$$

So, we try to solve equation (1). The exercises in Part D on page 3-95 give us a clue to how this can be done.

Transform (1) into an equation which has one side '0':

$$x^2 - 7x + 10 - 180 = 180 - 180.$$

$$(2) \quad x^2 - 7x - 170 = 0.$$

Then, factor the left side of (2) to get:

$$(3) \quad (x - 17)(x + 10) = 0.$$

Now, we are looking for a number  $x$  such that the product of  $x - 17$  by  $x + 10$  is 0. The 0-product theorem tells us that if the product of a number by a number is 0 then one of these numbers is 0. Also, the principle for multiplying by 0 [and the commutative principle for multiplication] tells us that the product of a number by a number is 0 if one of the numbers is 0. So, equation (3) is equivalent to the sentence:

$$(4) \quad x - 17 = 0 \quad \text{or} \quad x + 10 = 0.$$

And, (4) is equivalent to the sentence:

$$(5) \quad x = +17 \quad \text{or} \quad x = -10.$$

The numbers which satisfy (5) are +17 and -10.

Do you see that sentence (5) is equivalent to equation (3), that

[3-97]

(1)

In line 8 on page 3-97 we ask why 17 is the only number of arithmetic which satisfies equation (1). When we used principles about real numbers to solve equation (1), we did so because we remembered from Unit 1 that the nonnegative real numbers behaved just like the numbers of arithmetic with respect to addition and multiplication. Since, in terms of the stated problem, we are looking for numbers of arithmetic in the first place, we are interested only in the nonnegative roots of equation (1). And, the numbers of arithmetic which correspond with such roots are the only numbers which can be solutions of the given problem. We could have recognized this explicitly by saying that we are looking for a solution of the sentence:

$$x^2 - 7x + 10 = 180 \text{ and } x \geq 0.$$

Then we would have derived the equivalent sentence:

$$(x = +17 \text{ or } x = -10) \text{ and } x \geq 0$$

and from this the equivalent sentence:

$$x = +17.$$

\*

Students who have had experience with the connectives 'or' and 'and' such as that gained in the early part of this unit should not be troubled by the statement:

the solutions of ' $x = \frac{1}{3}$  or  $x = -5$ ' are  $\frac{1}{3}$  and  $-5$ .

In conventional elementary algebra classes, there are students who wonder how " $x$  can be  $\frac{1}{3}$  and  $-5$  in the same problem". This difficulty arises from thinking of the ' $x$ ' as a number [general or otherwise] instead of as a pronumeral.

\*

We have introduced here another equation transformation principle which we call [on page 3-100] the factoring transformation principle. It consists of a pair of theorems:

(a)  $\forall_x \forall_y$  if  $xy = 0$  then  $x = 0$  or  $y = 0$ ,

(b)  $\forall_x \forall_y$  if  $x = 0$  or  $y = 0$  then  $xy = 0$ .

State both theorems at this time and introduce the name of the principle.

is, that they are satisfied by the same numbers? So, equation (1) and sentence (5) are equivalent. Hence, the solutions of (1) are  $+17$  and  $-10$ .

But the number we are looking for in the age problem is the number of years in Mary's present age. This is a number of arithmetic. And it must satisfy equation (1). Since  $+17$  and  $-10$  are the only real numbers which satisfy (1), it must be the case that 17 is the only number of arithmetic which satisfies (1) [Why?].

So, Mary is now 17 years old. [Check. Ed is 20 if Mary is 17. Five years ago they were 15 and 12, and the product of 15 and 12 is 180.]

\* \* \*

Notice that solving this problem involved solving the equation:

$$x^2 - 7x - 170 = 0.$$

This equation is called a quadratic equation. Other examples of quadratic equations are:

$$3x^2 + 11x - 4 = 0,$$

$$x^2 - 3x = 0,$$

$$x^2 + 6x + 9 = 0,$$

$$8x^2 - 392 = 0.$$

In fact, any equation you get from the open sentence:

$$\square x^2 + \triangle x + \hexagon = 0$$

by substituting numerals for the frames [but not substituting a name of 0 for ' $\square$ '] is called a quadratic equation in 'x'. [Sometimes, quadratic equations like these are said to be in standard form, and other equations which can be transformed into quadratic equations in standard form are also called 'quadratic equations'. For example, we can call the equation:

$$x^2 - 7x + 10 = 180$$

a quadratic equation' because we can transform it into a quadratic equation in standard form:

$$x^2 - 7x - 170 = 0.]$$

As you have seen, one way of trying to solve a quadratic equation

is to transform it to one of standard form and then try to factor the left side. Consider this example:

$$(1) \quad 2x(x + 6) = 5 - x(x + 2).$$

We expand to get:

$$(2) \quad 2x^2 + 12x = 5 - x^2 - 2x.$$

Next, transform (2) to get a quadratic equation in standard form:

$$(3) \quad [2x^2 + 12x] + -5 + x^2 + 2x = [5 - x^2 - 2x] + -5 + x^2 + 2x.$$

Simplify the sides to get:

$$(4) \quad 3x^2 + 14x - 5 = 0.$$

Now, factor the left side:

$$(5) \quad (3x - 1)(x + 5) = 0.$$

Notice that equation (1) and equation (5) are equivalent.

To solve (5) is to find numbers  $x$  such that the product of the number  $3x - 1$  and the number  $x + 5$  is 0. But, we know that, given a first number and a second number, if one of these numbers is 0 then their product is 0, and if their product is 0 then one of them is 0. So, equation (5) is equivalent to the sentence:

$$(6) \quad 3x - 1 = 0 \quad \text{or} \quad x + 5 = 0,$$

which is equivalent to the simpler sentence:

$$(7) \quad x = \frac{1}{3} \quad \text{or} \quad x = -5.$$

Since the numbers which satisfy sentence (7) are just the numbers  $\frac{1}{3}$  and  $-5$ , it follows from the fact that (7) and (1) are equivalent that the roots of (1) are  $\frac{1}{3}$  and  $-5$ .

We check to make sure our computations are correct.

$$\begin{array}{l} 2x(x + 6) = 5 - x(x + 2) \\ 2 \cdot \frac{1}{3}(\frac{1}{3} + 6) = 5 - \frac{1}{3}(\frac{1}{3} + 2)? \\ \frac{2}{3} \cdot \frac{19}{3} \quad | \quad 5 - \frac{7}{9} \\ \frac{38}{9} = \frac{38}{9} \checkmark \end{array} \quad \left\| \quad \begin{array}{l} 2x(x + 6) = 5 - x(x + 2) \\ 2 \cdot -5(-5 + 6) = 5 - -5(-5 + 2)? \\ -10 \cdot 1 \quad | \quad 5 - 15 \\ -10 = -10 \checkmark \end{array} \right.$$



is to tra  
the lo

3/100

There may be a few students who will ask about the quadratic formula or even for help in solving a quadratic which has irrational roots. [The quadratic formula and "completing the square" are treated in Unit 5.] Suppose a student presents:

$$x^2 + 6x + 4 = 0$$

for solution. Postpone your answer until a convenient out-of-class time and show him the following sequence:

$$x^2 + 6x + 4 = 0$$

$$x^2 + 6x + 9 - 9 + 4 = 0$$

$$x^2 + 6x + 9 - 5 = 0$$

$$(x + 3)^2 - 5 = 0.$$

Now the problem becomes one of factoring ' $(x + 3)^2 - 5$ '. Do not show him how to do this, but instead start with a new equation:

$$x^2 + 6x + 5 = 0.$$

He can easily find the roots of this equation, but solve it by completing the square:

$$x^2 + 6x + 9 - 4 = 0$$

$$(x + 3)^2 - 4 = 0$$

$$[(x + 3) - 2][(x + 3) + 2] = 0.$$

⋮

Then, tell him to apply the same kind of reasoning in solving ' $(x + 3)^2 - 5 = 0$ '.





is to tra

the l

3/99

Exercise 4 provides an example of a quadratic equation which has only one root.

$$\begin{aligned}x^2 + 10x + 25 &= 0 \\(x + 5)(x + 5) &= 0 \\x + 5 = 0 \text{ or } x + 5 &= 0 \\x = -5 \text{ or } x &= -5 \\x &= -5\end{aligned}$$

The solution set of the last equation is the solution set of the next-to-last equation, and so it is the solution set of the given equation.

You may have been accustomed to telling your students that each quadratic equation has exactly two roots but that they are not necessarily distinct. Of course, in our program 'two' means two, and such a phrase as 'two, not necessarily distinct, roots' is inappropriate. In a later UICSM unit we will take care of this matter by introducing the notion of multiplicity. Then we shall state that the sum of the multiplicities of the [complex number] roots of a quadratic equation is 2. [If the quadratic equation has just one root, this root has multiplicity 2.] While you should not try to formulate such a generalization for your students at this time, it is appropriate to tell them that -5 is a "double root" of the equation in Exercise 4.

\*

Answers for Exercises.

- |                        |                         |                                    |                                    |
|------------------------|-------------------------|------------------------------------|------------------------------------|
| 1. 1, 2                | 2. -6, -1               | 3. 1, -1                           | 4. -5                              |
| 5. $\frac{3}{2}$ , -4  | 6. $\frac{5}{3}$ , -3   | 7. -7, 2                           | 8. -9, $\frac{1}{2}$               |
| 9. 7, -7               | 10. 0, 8                | 11. $-\frac{1}{2}$ , $\frac{2}{3}$ | 12. $-\frac{7}{4}$ , $\frac{3}{2}$ |
| 13. $-\frac{7}{2}$ , 6 | 14. $\frac{10}{3}$ , -9 | 15. $\frac{2}{3}$ , $\frac{3}{2}$  | 16. $-\frac{1}{5}$ , 3             |
| 17. 0, $\frac{7}{3}$   | 18. -4, -2              | 19. -4, -2                         | 20. 4, 3                           |
| 21. 1                  | 22. -6, -2              | 23. -5, 2                          |                                    |

\*

## EXERCISES

Solve these equations.

Sample 1.  $x^2 - 3x - 40 = 0$

Solution. [The quadratic equation is in standard form.]

So, we try to factor the left side.]

$$x^2 - 3x - 40 = 0$$

$$(x - 8)(x + 5) = 0$$

$$x - 8 = 0 \text{ or } x + 5 = 0$$

$$x = 8 \text{ or } x = -5$$

The roots are 8 and -5.

Check.

$$\begin{array}{r|l} 8^2 - 3 \cdot 8 - 40 = 0 ? & (-5)^2 - 3 \cdot -5 - 40 = 0 ? \\ 64 - 24 - 40 \mid 0 & 25 - -15 - 40 \mid 0 \\ 0 = 0 \checkmark & 0 = 0 \checkmark \end{array}$$

1.  $x^2 - 3x + 2 = 0$

2.  $x^2 + 7x + 6 = 0$

3.  $x^2 - 1 = 0$

4.  $x^2 + 10x + 25 = 0$

5.  $2x^2 + 5x - 12 = 0$

6.  $3x^2 + 4x - 15 = 0$

7.  $x^2 + 5x = 14$

8.  $9 - 17x = 2x^2$

9.  $x^2 = 49$

10.  $x^2 = 8x$

11.  $6x^2 - x - 2 = 0$

12.  $8y^2 = 21 - 2y$

13.  $42 + 5z - 2z^2 = 0$

14.  $3x^2 - 90 + 17x = 0$

15.  $6x^2 = 6(2x - 1) + x$

16.  $y(5y + 1) = 3(5y + 1)$

17.  $28x = 12x^2$

18.  $2(x^2 + 6x + 8) = 0$

19.  $2x^2 + 12x + 16 = 0$  [Hint: See Exercise 18.]

20.  $7y^2 - 49y + 84 = 0$

21.  $5x^2 = 10x - 5$

22.  $\frac{1}{2}x^2 + 4x + 6 = 0$

23.  $\frac{1}{3}x^2 + x - \frac{10}{3} = 0$

[More exercises are in Part N, Supplementary Exercises.]

3.09 Solving inequations. -- You have used basic principles and theorems in solving equations. Particularly useful ones are these.

The addition transformation principle

$$(a) \quad \forall_x \forall_y \forall_z \quad \text{if } x = y \text{ then } x + z = y + z,$$

$$(b) \quad \forall_x \forall_y \forall_z \quad \text{if } x + z = y + z \text{ then } x = y.$$

The two parts of this principle are often combined into the single sentence:

$$\forall_x \forall_y \forall_z \quad (x + z = y + z \text{ if and only if } x = y).$$

The multiplication transformation principle

$$\forall_x \forall_y \forall_z \neq 0 \quad (xz = yz \text{ if and only if } x = y).$$

The factoring transformation principle

$$\forall_x \forall_y \quad [(x = 0 \text{ or } y = 0) \text{ if and only if } xy = 0].$$

You might suspect that there are similar principles which are useful for solving inequations. Let's try solving an inequation by transforming, as we did in solving equations, and see how we come out.

$$(1) \quad 2b + 3 > 9$$

$$(2) \quad 2b + 3 + -3 > 9 + -3$$

$$(3) \quad 2b > 6$$

$$(4) \quad 2b \cdot \frac{1}{2} > 6 \cdot \frac{1}{2}$$

$$(5) \quad b > 3$$

So, it appears that the solution set of (1) is  $\{x: x > 3\}$ . Do you believe that it is? In order to justify the procedure, we need to show that (1) and (2) are equivalent sentences, that (2) and (3) are equivalent, etc.

(2) and (3) are equivalent sentences because '2b + 3 + -3' and '2b' are equivalent expressions and so are '9 + -3' and '6'.

Similarly, (4) and (5) are equivalent sentences.

3/101

(1) a  
m-

Students should learn that there are transformation principles which can be used in solving inequations. Perhaps the best way to introduce this topic is to give them an inequation to solve as a class exercise and let them state principles as they need them. The addition transformation principle for inequations is entirely analogous to that for equations, but the multiplication principle is more complicated. The students should discover the similarities and the differences through working one or two examples.

Example 1. Solve:  $3x + 4 > 14 - 7x$

- Solution.
- (1)  $3x + 4 > 14 - 7x$
  - (2)  $3x + 4 + 7x > 14 - 7x + 7x$
  - (3)  $10x + 4 > 14$
  - (4)  $10x + 4 + -4 > 14 + -4$
  - (5)  $10x > 10$
  - (6)  $10x \cdot \frac{1}{10} > 10 \cdot \frac{1}{10}$
  - (7)  $x > 1$

So, the solution set is  $\{x: x > 1\}$ .

[Students will move from step to step quite mechanically by analogy with what they would do with the equation ' $3x + 4 = 14 - 7x$ '. Students should check one or two values of ' $x$ ' which exceed 1, and also one or two values which do not exceed 1. Some students will notice that, since the root of the equation ' $3x + 4 = 14 - 7x$ ' is 1, values of ' $x$ ' greater than 1 will convert the left member into an expression for a number larger than 7 and the right member into an expression for a number smaller than 7. It might help to make a table in which these results are listed.

$x$	$3x + 4$	$14 - 7x$
3	13	-7
1.5	8.5	3.5
1	7	7
0.5	5.5	10.5
0	4	14
-2	-2	28

After completing this much of the table you might ask whether a value of ' $x$ ', greater than 3 will convert ' $14 - 7x$ ' into a name for a number less than -7; also consider values of ' $x$ ' less than -2.]

[3-100]

3.09 So

theor

3/102

Now, refer to Example 1 on the preceding page. When students are intuitively sure that the solution set of sentence (7) is the solution set of sentence (1), you can ask for a formulation of the principles which justify asserting that the successive pairs of sentences are equivalent. The principle which justifies asserting that (1) and (2) are equivalent may be called the addition transformation principle for inequations and stated in two parts.

$$(a) \quad \forall_x \forall_y \forall_z \quad \text{if } x > y \text{ then } x + z > y + z.$$

$$(b) \quad \forall_x \forall_y \forall_z \quad \text{if } x + z > y + z \text{ then } x > y.$$

[These theorems are intuitively obvious. Locate two numbers on the number line. Take a trip from each, with each trip measured by the same real number. The ending points are in the same relative positions as the starting points. A more formal approach is the following. Recall [page 2-109] that, for each  $x$ , for each  $y$ ,  $x > y$  if and only if  $x - y$  is positive, that is, if  $x > y$  then  $x - y$  is positive, and if  $x - y$  is positive then  $x > y$ . Since, for each  $x$ , for each  $y$ , for each  $z$ ,  $x - y = (x + z) - (y + z)$ ,  $x - y$  is positive if and only if  $(x + z) - (y + z)$  is positive.]

Sentences (2) and (3) [as well as (4) and (5), and (6) and (7)] are equivalent by virtue of the fact that their corresponding members are equivalent expressions.

Sentences (3) and (4) are equivalent by virtue of the addition transformation principle for inequations.

The equivalence of (5) and (6) follows from the multiplication transformation principle for inequations. In stating and discussing this principle you will find opportunities for some creative teaching. Arguing from analogy, a student might make the following statement:

$$(a) \quad \forall_x \forall_y \forall_z \quad \text{if } x > y \text{ then } xz > yz,$$

$$(b) \quad \forall_x \forall_y \forall_z \quad \text{if } xz > yz \text{ then } x > y.$$

[3-100]

3.09 Sc

theor



3/103

If this happens, let them apply the principle to the solution of the sentence ' $-3x > 12$ '.

$$(1) \quad -3x > 12$$

$$(2) \quad -3x \cdot -\frac{1}{3} > 12 \cdot -\frac{1}{3}$$

$$(3) \quad x > 4$$

The claim is that the solution set of (3) is the solution set of (1). But, substituting, say '5' for 'x' in both (3) and (1) shows that this claim is false. Hence, the generalizations (a) and (b) stated above cannot both be true; as a matter of fact, both are false. Here are some examples which show that the generalizations are false.

(a) Although  $3 > 2$ , it is not the case that  $3 \cdot -7 > 2 \cdot -7$ .

Although  $-5 > -7$ , it is not the case that  $-5 \cdot 0 > -7 \cdot 0$ .

(b) Although  $3 \cdot -4 > 9 \cdot -4$ , it is not the case that  $3 > 9$ .

But,  $3 > 2$  and  $3 \cdot 7 > 2 \cdot 7$ . Also,  $9 \cdot 4 > 3 \cdot 4$  and  $9 > 3$ . So, it is intuitively clear that multiplying [or dividing] each of two numbers by a positive number "preserves the sense of the inequality" while multiplying [or dividing] by a negative number "reverses the sense of the inequality". You can bring this out more clearly by using the number line. The result of multiplying each real number by say,  $+3$ , can be pictured as follows.

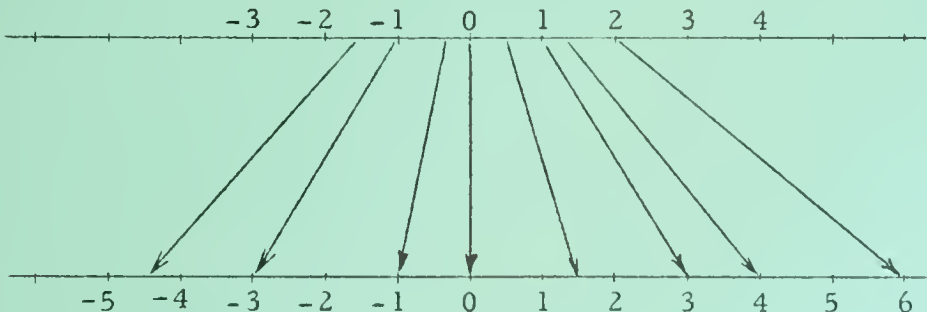

[3-100]

3.09 Sc

theor

3/104

The result of multiplying each real number by, say,  $-1$ , can be pictured as follows.

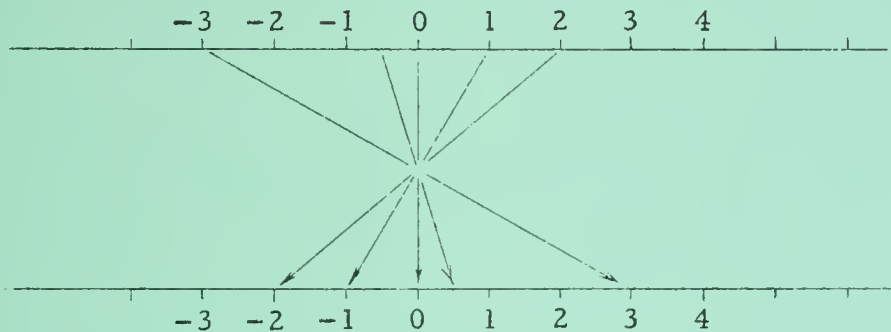

Multiplying by a positive number preserves the order; multiplying by a negative number reverses the order.

A correct formulation of the multiplication transformation principle for inequations has four parts:

$$(a_+) \quad \forall_x \forall_y \forall_z > 0 \quad \text{if } x > y \text{ then } xz > yz.$$

$$(b_+) \quad \forall_x \forall_y \forall_z > 0 \quad \text{if } xz > yz \text{ then } x > y.$$

$$(a_-) \quad \forall_x \forall_y \forall_z < 0 \quad \text{if } x > y \text{ then } xz < yz.$$

$$(b_-) \quad \forall_x \forall_y \forall_z < 0 \quad \text{if } xz > yz \text{ then } x < y.$$

Here is a sample in which the principles are cited.

$$\begin{array}{rcl}
 5x - 4 > 7x + 9 & \left. \vphantom{\begin{array}{l} 5x - 4 > 7x + 9 \\ 5x - 4 + 4 > 7x + 9 + 4 \\ 5x > 7x + 13 \\ 5x + -7x > 7x + 13 + -7x \\ -2x > 13 \\ -2x \cdot -\frac{1}{2} < 13 \cdot -\frac{1}{2} \\ x < -6.5 \end{array}} \right\} \begin{array}{l} \text{atpi} \\ \text{ee} \\ \text{atpi} \\ \text{ee} \\ \text{mtpi [(a_-) and (b_-)]} \\ \text{ee} \end{array} \\
 5x - 4 + 4 > 7x + 9 + 4 & \\
 5x > 7x + 13 & \\
 5x + -7x > 7x + 13 + -7x & \\
 -2x > 13 & \\
 -2x \cdot -\frac{1}{2} < 13 \cdot -\frac{1}{2} & \\
 x < -6.5 &
 \end{array}$$

So, the solution set is  $\{x: x < -6.5\}$ .

[3-100]

3.09 S

theor

Are (1) and (2) equivalent? That is, is the solution set of (1) a subset of the solution set of (2), and conversely? Given a first number  $[2b + 3]$  and a second number  $[9]$  such that the first number is greater than the second, if you add a third number  $[-3]$  to each, will the sum of the first and third be greater than the sum of the second and third? And, conversely, suppose the sum of the first and third is greater than the sum of the second and the third. Does it follow that the first is greater than the second? In other words, is it the case that

- (i)  $\forall_x \forall_y \forall_z$  if  $x > y$  then  $x + z > y + z$ ,  
 and (ii)  $\forall_x \forall_y \forall_z$  if  $x + z > y + z$  then  $x > y$ ?

It is easy to see that (i) is the case. Think of it geometrically.

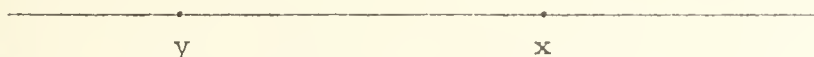

If  $x > y$  then the graph of  $x$  is to the right of the graph of  $y$ . Now, suppose you add the same number  $z$  to each of  $x$  and  $y$ . You can think of adding  $z$  as jumping the graphs of  $x$  and  $y$  either to the right [if  $z$  is positive] or to the left [if  $z$  is negative]. In either case, the graph of  $x + z$  is to the right of the graph of  $y + z$ .

Similarly, if the graph of  $x + z$  is to the right of the graph of  $y + z$  then the graph of  $x$  is to the right of the graph of  $y$ . So, (ii) is the case.

Generalizations (i) and (ii) together give us

The addition transformation principle for inequations.

$$\forall_x \forall_y \forall_z (x + z > y + z \text{ if and only if } x > y).$$

[Since ' $x > y$ ' means the same thing as ' $y < x$ ', and ' $x + z > y + z$ ' means the same thing as ' $y + z < x + z$ ', this principle tells us that

$$\forall_x \forall_y \forall_z (y + z < x + z \text{ if and only if } y < x).$$

So, the addition transformation principle for inequations is applicable to "<-tions" as well as to ">-tions". Also, you can combine this principle with the one for equations to get a principle which is applicable to "≤-tions" and to "≥-tions".]

Now, consider sentences (3) and (4):

$$(3) \quad 2b > 6,$$

$$(4) \quad 2b \cdot \frac{1}{2} > 6 \cdot \frac{1}{2}.$$

One is tempted to say that these are equivalent by virtue of the generalization:

$$(*) \quad \forall_x \forall_y \forall_z \neq 0 (xz > yz \text{ if and only if } x > y).$$

Let's try to justify this generalization as we did the one for addition.

If we multiply a number by  $1/2$ , we get a number whose graph is halfway between the graph of 0 and the graph of the original number. So, the result of multiplying by  $1/2$  is to jump the graphs of numbers toward the graph of 0 but to leave the graphs in the same order. Multiplying by 2 jumps the graphs away from the graph of 0 but still leaves them in the same order. Multiplying by 1 does nothing. [What would multiplying by 0 do?] Does this convince you that (\*) is the case? It shouldn't. Consider what multiplying by a negative number does to the order of the graphs.

So, here is the generalization which tells us that (3) and (4) are equivalent:

$$(a) \quad \forall_x \forall_y \forall_z > 0 (xz > yz \text{ if and only if } x > y).$$

Now, suppose we want to solve the inequation:

$$-3x > 12.$$

If we try to apply (\*), we get after simplifying:

$$x > -4$$

which is not equivalent to the given inequation. But, the simple inequation which is equivalent to the given one is:

$$x < -4.$$

If you experiment with multiplying numbers by a negative number and observing what happens to the order of their graphs, you will no doubt arrive at this generalization:

$$(b) \quad \forall_x \forall_y \forall_z < 0 (xz < yz \text{ if and only if } x > y).$$

Together, (a) and (b) constitute the multiplication transformation principle for inequations.

There is also an analogue for the factoring transformation principle. Since you are well acquainted with the facts on which it is based, we merely state it, and ask you to convince yourself of it by experimenting.

The factoring transformation principle for inequations

- (a)  $\forall_x \forall_y \forall_z (xy > 0 \text{ if and only if } [(x > 0 \text{ and } y > 0) \text{ or } (x < 0 \text{ and } y < 0)])$ .
- (b)  $\forall_x \forall_y \forall_z (xy < 0 \text{ if and only if } [(x > 0 \text{ and } y < 0) \text{ or } (x < 0 \text{ and } y > 0)])$ .

Let us now use the inequation transformation principles.

Example 1. Find the solution set and draw the graph of:

$$5x - 4 > 7x + 9.$$

Solution.

$$5x - 4 > 7x + 9$$

$$5x - 4 + 4 > 7x + 9 + 4$$

$$5x > 7x + 13$$

$$5x + -7x > 7x + 13 + -7x$$

$$-2x > 13$$

$$-2x \cdot -\frac{1}{2} < 13 \cdot -\frac{1}{2}$$

$$x < -6.5$$

The solution set is  $\{x: x < -6.5\}$ . Here is the graph.



\* \* \*

Now, before reading any further, you should make up some inequations like the one given in Example 1, solve them, and graph. [Throughout your study of mathematics, you will find it helpful to make up your own examples to illustrate new ideas and techniques.]

\* \* \*

Example 2. Find the solution set and draw the graph of:

$$x^2 + 4 > 5(2 - x).$$

Solution. [This appears to be a quadratic inequation, so we'll transform to standard form.]

$$x^2 + 4 > 5(2 - x)$$

$$x^2 + 4 > 10 - 5x$$

$$x^2 + 5x - 6 > 0$$

$$(x + 6)(x - 1) > 0$$

$$(x + 6 > 0 \text{ and } x - 1 > 0) \text{ or } (x + 6 < 0 \text{ and } x - 1 < 0)$$

$$\left. \begin{array}{l} (x > -6 \text{ and } x > 1) \text{ or } (x < -6 \text{ and } x < 1) \\ x > 1 \quad \text{or} \quad x < -6 \end{array} \right\} \text{ [Why?]}$$

So, the solution set is  $\{x: x > 1 \text{ or } x < -6\}$ . Here is the graph.

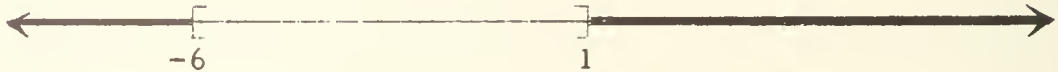

Example 3. Find the solution set and draw the graph of:

$$7 \leq \frac{5x - 2}{4} < 17.$$

Solution. [This sentence is a conjunction of the two inequations:

$$7 \leq \frac{5x - 2}{4}, \text{ and: } \frac{5x - 2}{4} < 17.$$

If a number satisfies the given sentence then it satisfies both inequations, and conversely.]

Since solving the given sentence amounts to solving two inequations simultaneously, we proceed as follows.



3/105

Example 2 on page 3-104 illustrates the use of the factoring transformation principle for inequations. The answer to the 'Why?' is that the sentences ' $x > -6$  and  $x > 1$ ' and ' $x > 1$ ' are equivalent [that is, have the same solution set] and the sentences ' $x < -6$  and  $x < 1$ ' and ' $x < -6$ ' are equivalent. Students have the correct idea if they say, in connection with the first pair of sentences, that each number greater than 1 is bound to be greater than -6. You might test their understanding by asking them to "simplify" the following sentences. [Students will find it helpful if they consider the graphs of the compound sentences.]

$$x > 2 \text{ and } x > 1, \quad [\text{Ans: } x > 2]; \quad x < -5 \text{ and } x < 0, \quad [x < -5];$$

$$x < 0 \text{ and } x < 3, \quad [x < 0]; \quad x > -1 \text{ and } x > -2, \quad [x > -1].$$

Proofs of such equivalences depend on the transitivity principle for  $>$  [or, for  $<$ ]:

$$\forall_x \forall_y \forall_z \text{ if } x > y \text{ and } y > z \text{ then } x > z.$$

[See (7) on TC[3-106]b.] For example, it follows from this and ' $1 > -6$ ' that, for each  $x$ , if  $x > 1$  then  $x > -6$ . So, if  $x > 1$  then ( $x > -6$  and  $x > 1$ ). And, obviously, if ( $x > -6$  and  $x > 1$ ) then  $x > 1$ .

\*

In Example 3, the transformation principles are applied to solve a "≤-tion" and a "<-tion". The possibility of doing this was pointed out at the bottom of page 3-101.

\*

The solution for Example 4 on page 3-105 can be explained by recalling that the absolute value of a real number is the distance between it and 0. [See pages 1-103 ff.] So, for example, the numbers whose absolute values are less than 13 are just the numbers between  $-13$  and  $+13$ . [An alternative approach is to recall that, since the absolute value of the difference of two real numbers is the distance between them, ' $|3x - 5| < 13$ ' is a short way of saying 'the distance between  $3x$  and  $+5$  is less than 13'. And this is equivalent to ' $3x$  is between  $+5 - +13$  and  $+5 + +13$ '. This approach would lead at once from the given inequation to ' $5 - 13 < 3x < 5 + 13$ '.]

[3-104]

Exa



than 1. So, the solution set of the given inequation is  $\{x: x - 1 < 0$  or  $x - 1 > 1\}$ .

Formal solution.  $(x - 1)^2 > x - 1$

$$(x - 1)^2 - (x - 1) > 0$$

$$(x - 1)[(x - 1) - 1] > 0$$

$$(x - 1)(x - 2) > 0$$

$$(x - 1 > 0 \text{ and } x - 2 > 0) \text{ or } (x - 1 < 0 \text{ and } x - 2 < 0)$$

$$x > 2 \text{ or } x < 1$$

★23.  $\{x: x < -2 \text{ or } 4 < x < 5\};$  

This inequation can be solved in several ways. One way is to use the theorem:

$$\forall_x \forall_{y \neq 0} \left( \frac{x}{y} < 0 \text{ if and only if } [(x > 0 \text{ and } y < 0) \text{ or } (x < 0 \text{ and } y > 0)] \right),$$

and then apply the factoring transformation principle. Another way is to use the tabular or graphical procedure shown in the COMMENTARY for Exercise 21. Still a third way is to first note that  $\forall_{x \neq 4} (x - 4)^2 > 0$ , and use the multiplication transformation principle for inequations:

$$\frac{(x + 2)(x - 5)}{x - 4} < 0$$

$$\frac{(x + 2)(x - 5)}{x - 4} \cdot (x - 4)^2 < 0 \cdot (x - 4)^2$$

$$(x + 2)(x - 5)(x - 4) < 0$$

This last inequation is equivalent to the given one, and can be solved in the way illustrated for Exercise 21.

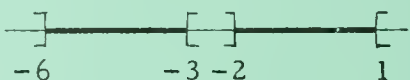
★24.  $\{x: -2 < x < 1 \text{ or } -6 < x < -3\};$  

Solution.  $|x^2 + 5x| < 6$

$$-6 < x^2 + 5x < 6$$

$$x^2 + 5x + 6 > 0 \text{ and } x^2 + 5x - 6 < 0$$

$$(x + 3)(x + 2) > 0 \text{ and } (x + 6)(x - 1) < 0$$

$$(x > -2 \text{ or } x < -3) \text{ and } -6 < x < 1$$

$$(x > -2 \text{ and } -6 < x < 1) \text{ or } (x < -3 \text{ and } -6 < x < 1)$$

$$-2 < x < 1 \text{ or } -6 < x < -3$$



Exa.

3/110

' $x - 4$ ' and transforming each simple inequation, we get:

$$(x > 2 \text{ and } x > -3 \text{ and } x > 4) \text{ or } (x < 2 \text{ and } x < -3 \text{ and } x > 4)$$

$$\text{or } (x > 2 \text{ and } x < -3 \text{ and } x < 4) \text{ or } (x < 2 \text{ and } x > -3 \text{ and } x < 4),$$

which is equivalent to:

$$x > 4 \text{ or } (x < -3 \text{ and } x > 4) \text{ or } (x < -3 \text{ and } x > 2) \text{ or } (x > -3 \text{ and } x < 2),$$

which is equivalent to:

$$x > 4 \text{ or } -3 < x < 2.$$

A shorter procedure, based on the same principle, is to note that a value of ' $x$ ' satisfies the inequations just if, of the corresponding values of ' $x - 2$ ', ' $x + 3$ ', and ' $x - 4$ ', all three are positive or one is positive and two are negative. These possibilities can be displayed in a table.

$x - 2$	$x + 3$	$x - 4$		
+	+	+	$x > 4$	
-	-	+	$x < -3 \text{ and } x > 4$	[impossible]
+	-	-	$x < -3 \text{ and } x > 2$	[impossible]
-	+	-	$x > -3 \text{ and } x < 2$	

So, the given inequation is equivalent to ' $x > 4$  or  $(-3 < x < 2)$ '.

There is a still simpler graphical procedure based on the same idea.

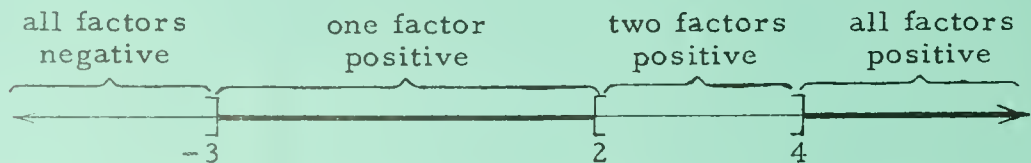

☆22.  $\{x: x < 1 \text{ or } x > 2\}$ ;

Intuitive solution. Consider the inequation:  $y^2 > y$ . The solution set consists of each number which is less than its square. Such numbers are the negative numbers and the numbers greater



Exa

3/109

the first part of the factoring transformation principle:

$$\forall_x \forall_y \left( \frac{x}{y} > 0 \text{ if and only if } [(x > 0 \text{ and } y > 0) \text{ or } (x < 0 \text{ and } y < 0)] \right).$$

[The quotient is positive if and only if the dividend and the divisor are both positive or both negative.] This theorem tells us that the last inequation:

$$\frac{1 - 2x}{x} > 0$$

is equivalent to:

$$(1 - 2x > 0 \text{ and } x > 0) \text{ or } (1 - 2x < 0 \text{ and } x < 0),$$

$$\text{and so, as before, to: } 0 < x < \frac{1}{2}.$$

★20.  $\{x: x < 0 \text{ or } x > 5\};$  

There are several ways of handling this problem. One way is to reduce it to one which is just like Exercise 19:

$$\frac{3x - 5}{x} > 2, \quad 3 - \frac{5}{x} > 2, \quad \frac{5}{x} < 1.$$

Another way is to multiply both sides by 'x', using both parts of the multiplication transformation principle. Still other ways are illustrated in the COMMENTARY for Exercise 19.

★21.  $\{x: -3 < x < 2 \text{ or } x > 4\};$  

Inequations of this kind can be solved formally by repeated use of the factoring transformation principle. Let's use 'abc > 0' instead of '(x - 2)(x + 3)(x - 4) > 0' to show the pattern to be followed in transforming the latter.

(1)  $abc > 0$

(2)  $(ab > 0 \text{ and } c > 0) \text{ or } (ab < 0 \text{ and } c < 0)$

(3)  $\left\{ \begin{array}{l} \{[(a > 0 \text{ and } b > 0) \text{ or } (a < 0 \text{ and } b < 0)] \text{ and } c > 0\} \\ \text{or } \{[(a > 0 \text{ and } b < 0) \text{ or } (a < 0 \text{ and } b > 0)] \text{ and } c < 0\} \end{array} \right.$

(4)  $\left\{ \begin{array}{l} (a > 0 \text{ and } b > 0 \text{ and } c > 0) \text{ or } (a < 0 \text{ and } b < 0 \text{ and } c > 0) \\ \text{or } (a > 0 \text{ and } b < 0 \text{ and } c < 0) \text{ or } (a < 0 \text{ and } b > 0 \text{ and } c < 0) \end{array} \right.$

Now, replacing in (4), 'a' by 'x - 2', 'b' by 'x + 3' and 'c' by





Exa:

3/108

set of the given inequation is  $\{x: 0 < x < \frac{1}{2}\}$ . The following is a convenient arrangement of the work.

$$\frac{1}{x} > 2$$

$$\frac{1}{x} \cdot x > 2x \quad [x > 0]$$

$$1 > 2x$$

$$\frac{1}{2} > x$$

$$x > 0 \text{ and } \frac{1}{2} > x$$

$$\frac{1}{x} > 2$$

$$\frac{1}{x} \cdot x < 2x, \quad [x < 0]$$

$$1 < 2x$$

$$\frac{1}{2} < x$$

$$\text{or } x < 0 \text{ and } \frac{1}{2} < x$$

An alternative procedure is to make use of the theorem ' $\forall_{x \neq 0} x^2 > 0$ ' [cf. (13) on TC[3-106]d].

$$\frac{1}{x} > 2$$

$$\frac{1}{x} \cdot x^2 > 2x^2$$

$$x > 2x^2$$

$$x - 2x^2 > 0$$

$$x(1 - 2x) > 0$$

$$(x > 0 \text{ and } 1 - 2x > 0) \text{ or } (x < 0 \text{ and } 1 - 2x < 0)$$

$$0 < x < \frac{1}{2} \text{ or } 0 > x > \frac{1}{2}$$

$$0 < x < \frac{1}{2}$$

Still another possibility is to proceed as follows:

$$\frac{1}{x} > 2$$

$$\frac{1}{x} - 2 > 0$$







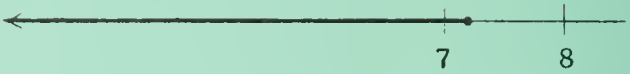

$$\frac{1 - 2x}{x} > 0$$

Then, either "multiply" both sides by ' $x^2$ ', and use the factoring transformation principle for inequations, or use the analogue to

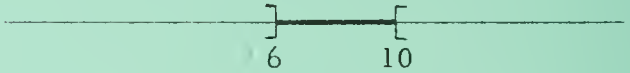

Exa

3/107

11.  $\{z: z \leq 7.2\}$ ; 
12.  $\{p: p \leq \frac{4}{5}\}$ ; 
13.  $\{x: 6 < x < 10\}$ ; 
14.  $\{x: 4 \leq x \leq 10\}$ ; 
15.  $\{x: 3 \leq x \leq 5\}$ ; 
16.  $\emptyset$  [“Nothing is larger than  $14/13$  and smaller than  $19/6$ .”]
17.  $\{x: -14 \leq x \leq 9\}$ ; 
18.  $\{y: 0.1 \leq y \leq 0.3\}$ ; 
- ★19.  $\{x: 0 < x < \frac{1}{2}\}$ ; 

Since 0 is not a solution of the given inequation, the latter is equivalent to the sentence:

$$(x > 0 \text{ or } x < 0) \text{ and } \frac{1}{x} > 2$$

and, so, to the sentence:

$$(x > 0 \text{ and } \frac{1}{x} > 2) \text{ or } (x < 0 \text{ and } \frac{1}{x} > 2).$$

The solution set of the given inequations will consist of the numbers which satisfy ' $x > 0$  and  $\frac{1}{x} > 2$ ' together with those which satisfy ' $x < 0$  and  $\frac{1}{x} > 2$ '. By the multiplication transformation principle, these two sentences are equivalent to ' $x > 0$  and  $\frac{1}{x} \cdot x > 2x$ ' and ' $x < 0$  and  $\frac{1}{x} \cdot x < 2x$ ', respectively. The solution set of the first is  $\{x: x > 0 \text{ and } \frac{1}{2} > x\}$ , and that of the second is  $\{x: x < 0 \text{ and } \frac{1}{2} < x\}$ . Since the latter set is  $\emptyset$ , the solution



Answers for Part A [on pages 3-105 and 3-106].

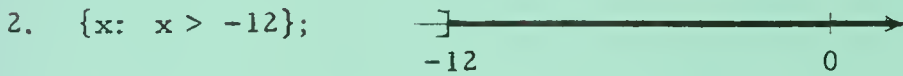
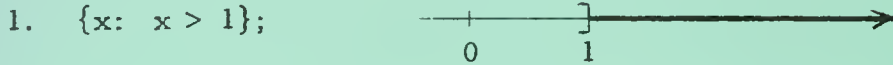

5.  $\emptyset$  [Students may discover the answer by inspection. "When you subtract  $\frac{5}{2}$  from a number you can't get a larger number than the one you get by adding  $\frac{4}{3}$  to it." If so, check for a false generalization on the students' part by asking if similar reasoning applies to ' $x - 3 > x + 2$ ' and to ' $x - 2 > x + 3$ '. Students who use the transformation principles should find that the given inequation is equivalent to the false statement ' $-15 > 8$ '. So, as in the corresponding case concerning equations [see page 3-39], the solution set is  $\emptyset$ .]



[Again, the answer may be obvious on inspection. "When you add 12 to a number you're bound to get a larger sum than when you add the number to 9." Students who use the transformation principles should find that the given inequation is equivalent to the true statement ' $12 > 9$ ' [cf. page 3-38].]



10. Same answer as for Exercise 9. [Students may recognize, without solving both, that the inequations of Exercises 9 and 10 are equivalent. If so, they need solve only one of the two.]

$$7 \leq \frac{5x - 2}{4} < 17$$

$$7 \leq \frac{5x - 2}{4} \quad \text{and} \quad \frac{5x - 2}{4} < 17$$

$$28 \leq 5x - 2 \quad \text{and} \quad 5x - 2 < 68$$

$$30 \leq 5x \quad \text{and} \quad 5x < 70$$

$$6 \leq x \quad \text{and} \quad x < 14$$

$$6 \leq x < 14$$

So, the solution set is  $\{x: 6 \leq x < 14\}$ . Here is the graph.



[You could save some extra writing by writing the steps this way:

$$7 \leq \frac{5x - 2}{4} < 17$$

$$28 \leq 5x - 2 < 68$$

etc.]

Example 4. Find the solution set and draw the graph of:

$$|3x - 5| < 13.$$

Solution. The sentence ' $|3x - 5| < 13$ ' is equivalent to:

$$-13 < 3x - 5 < +13.$$

So, we could proceed as in Example 3. Finish the problem.

### EXERCISES

A. Solve each of the following inequations and draw its graph. [To solve an inequation means to give the simplest description of its solution set, as illustrated in the preceding examples.]

- |                       |                              |
|-----------------------|------------------------------|
| 1. $3x + 4 > 14 - 7x$ | 2. $2x + 5 > x - 7$          |
| 3. $2x + 6 < 4 - 6x$  | 4. $\frac{x}{2} - 1 > 3 - x$ |

(continued on next page)

5.  $\frac{2y - 5}{2} > \frac{3y + 4}{3}$

6.  $2x^2 - 9x - 35 > 0$

7.  $x^2 + 2(x - 2) < x + 8$

8.  $3(x + 4) > 9 + 3x$

9.  $2x - 3 > 3x + 5$

10.  $3x + 5 < 2x - 3$

11.  $6.6 - 1.5z \geq 3 - z$

12.  $8p + 9 \leq 21 - 7p$

13.  $5 < 2x - 7 < 13$

14.  $-8 \leq 12 - 2x \leq 4$

15.  $10 \leq \frac{3x + 11}{2} \leq 13$

16.  $\frac{14}{3} < \frac{1}{2}(5 - x) + \frac{2}{3} < \frac{19}{6}$

17.  $|2x + 5| \leq 23$

18.  $|1 - 5y| \leq 0.5$

★19.  $\frac{1}{x} > 2$

★20.  $\frac{3x - 5}{x} > 2$

★21.  $(x - 2)(x + 3)(x - 4) > 0$

★22.  $(x - 1)^2 > x - 1$

★23.  $\frac{(x + 2)(x - 5)}{(x - 4)} < 0$

★24.  $|x^2 - 5x| < 6$

★B. 1. Use ' $\forall_x \forall_y \forall_z$  if  $x > y$  then  $x + z > y + z$ ' together with the basic principles and theorems to prove:

$$\forall_x \forall_y \forall_z \text{ if } x + z > y + z \text{ then } x > y.$$

2. Take as a basic principle the generalization:

$$(G) \forall_x \forall_y (x > y \text{ if and only if } x - y \text{ is positive}),$$

and use it to prove:

$$\forall_x \forall_y \forall_z (x + z > y + z \text{ if and only if } x > y).$$

\*

[In order to prove more theorems about  $>$ , you would need other basic principles about positive numbers in addition to (G). The following four are sufficient:

$$(P_1) \forall_x \text{ if } x \neq 0 \text{ then } x \text{ is positive or } -x \text{ is positive,}$$

$$(P_2) \forall_x \text{ not both } x \text{ and } -x \text{ are positive,}$$

$$(P_3) \forall_x \forall_y \text{ if } x \text{ and } y \text{ are positive then } x + y \text{ is positive,}$$

$$(P_4) \forall_x \forall_y \text{ if } x \text{ and } y \text{ are positive then } xy \text{ is positive.}$$

From these you can, for example, derive the transformation principles for inequations.]



3/112

The theorems which make up the transformation principles for inequations were obtained informally in the foregoing discussion. This level of understanding is adequate for most students at this time. However, you, yourself, will want to pursue the matter further, and perhaps some of the brightest students will want to go with you on this extra-curricular excursion. Provision for this is made in Part B on page 3-106.

You will recall that the transformation principles for equations are consequences of basic principles. Up to this point our basic principles are the commutative and associative principles for addition and multiplication, the distributive principle for multiplication over addition, the principle for adding 0, the principle for multiplying by 1, the principle of opposites, the principle for subtraction, and the principle of quotients. These principles characterize the structure which mathematicians call a field. [Sometimes, the principle ' $1 \neq 0$ ' is required in the characterization. Also, in some descriptions of a field you will find closure requirements listed among the principles. We don't include such closure principles because we think they more properly belong in a meta-linguistic description of the language of field theory.] The real number system--that is, the set of real numbers together with the operations of addition, multiplication, opposition, subtraction, and division--is an example of a field. It is the principal example with which your students are acquainted. [In a later course, students will see that the rational number system and the complex number system are also fields. Incidentally, the system of numbers of arithmetic is not a field.] If we introduce into the real number system the relation  $>$  [with its usual properties], the real number system becomes an example of an ordered field. The principles which characterize this structure must include certain statements concerning order. The definition of ' $>$ ' in the real number system:

$$(G) \quad \forall_x \forall_y [x > y \text{ if and only if } x - y \text{ is positive}],$$

suggests that we need to adjoin to the basic principles for a field some principles dealing with the property of being positive. These principles together with (G) and the previous basic principles characterize an ordered field:

$$(P_1) \quad \forall_x \text{ if } x \neq 0 \text{ then } x \text{ is positive or } -x \text{ is positive.}$$

$$(P_2) \quad \forall_x \text{ not both } x \text{ and } -x \text{ are positive.}$$

$$(P_3) \quad \forall_x \forall_y \text{ if } x \text{ and } y \text{ are positive then } x + y \text{ is positive.}$$

$$(P_4) \quad \forall_x \forall_y \text{ if } x \text{ and } y \text{ are positive then } xy \text{ is positive.}$$

[We assume it understood that, for example, ' $2 < 3$ ' means the same

[3-106]

5.

3/113

as ' $3 > 2$ ', and we assume also an understanding of ' $\geq$ ', ' $\leq$ ', ' $\neq$ ', and ' $\not\prec$ '. [See Part D on pages 1-100 and 1-101.]]

These principles can be used together with the earlier principles to prove many theorems, including the transformation principles for inequations. Here is a quick sketch of such theorems and their proofs.

Note, first, that it follows from  $(P_2)$  [and the theorem:  $-0 = 0$ ] that

$$(1) \quad 0 \text{ is not positive.}$$

Using this and  $(G)$  [and the theorem:  $\forall_x x - x = 0$ ] it follows that

$$(2) \quad \forall_x x \not\prec x.$$

Other simple and useful consequences of  $(G)$  are, first, that

$$(3) \quad \forall_x [x > 0 \text{ if and only if } x \text{ is positive}],$$

and, second, that

$$(4) \quad \forall_x \forall_y [x > y \text{ if and only if } x - y > 0].$$

From  $(P_1)$ ,  $(P_2)$ , and  $(P_3)$ , respectively, follow three important theorems:

$$(5) \quad \forall_x \forall_y \text{ if } x \neq y \text{ then } x > y \text{ or } y > x,$$

$$(6) \quad \forall_x \forall_y \text{ not both } x > y \text{ and } y > x, \text{ and:}$$

$$(7) \quad \forall_x \forall_y \forall_z \text{ if } x > y \text{ and } y > z \text{ then } x > z.$$

Proof of (5): Suppose that  $x \neq y$ . Then  $x - y \neq 0$ , so, by  $(P_1)$ ,  $x - y$  is positive or  $-(x - y)$  [that is,  $y - x$ ] is positive. Hence, by  $(G)$ , either  $x > y$  or  $y > x$ .

Proof of (6): By  $(P_2)$ , not both  $x - y$  and  $-(x - y)$  [that is,  $y - x$ ] are positive. Hence, by  $(G)$ , not both  $x > y$  and  $y > x$ .

Proof of (7): Suppose that  $x > y$  and that  $y > z$ . By  $(G)$ ,  $x - y$  and  $y - z$  are positive; so, by  $(P_3)$ ,  $(x - y) + (y - z)$  [that is,  $x - z$ ], is positive. Hence, by  $(G)$ ,  $x > z$ .

[Notice that (2) is an immediate consequence of (6) [substitute ' $x$ ' for ' $y$ '], and is equivalent to the more complicated, but sometimes handy,

[3-106]

5.

3/114

statement:  $\forall_x \forall_y$  if  $x = y$  then  $x \not> y$ . Also, notice that (7) can be strengthened to:

$$(7') \quad \forall_x \forall_y \forall_z \text{ if } x > y \text{ and } y \geq z \text{ then } x > z.]$$

Another consequence of  $(P_3)$  is that

$$(8) \quad \forall_x \forall_y \forall_u \forall_v \text{ if } x > y \text{ and } u > v \text{ then } x + u > y + v.$$

Proof of (8): Suppose that  $x > y$  and that  $u > v$ . By (G),  $x - y$  and  $u - v$  are positive, so, by  $(P_3)$ ,  $(x - y) + (u - v)$  [that is,  $(x + u) - (y + v)$ ] is positive. Hence, by (G),  $x + u > y + v$ .

[Again, there is a trivially stronger form:

$$(8') \quad \forall_x \forall_y \forall_u \forall_v \text{ if } x > y \text{ and } u \geq v \text{ then } x + u \geq y + v.]$$

Here is a derivation of the addition transformation principle for inequations.

$$(9) \quad \forall_x \forall_y \forall_z [x > y \text{ if and only if } x + z > y + z].$$

[This is an easy consequence of (G).]

Proof of (9):  $x - y = (x + z) - (y + z)$ , so,  $x - y$  is positive if and only if  $(x + z) - (y + z)$  is positive. Hence, by (G),  $x > y$  if and only if  $x + z > y + z$ .

As an application of (9) one can easily derive:

$$(10) \quad \forall_x \forall_y [x > y \text{ if and only if } -y > -x]$$

[or, one can derive (10) directly from (G) by using the fact that  $\forall_x \forall_y x - y = -y - -x$ ].

From (10) one sees immediately that

$$(10') \quad \forall_x [x < 0 \text{ if and only if } -x > 0].$$

The multiplication transformation principle for inequations is somewhat more complicated than the corresponding principle for equations.

It is easy to prove that

$$\forall_x \forall_y \forall_z > 0 \text{ if } x > y \text{ then } xz > yz.$$

For, suppose that  $x > y$ , and that  $z > 0$ , then  $x - y$  is positive [Why?] and  $z$  is positive [Why?]. So, by  $(P_4)$ ,  $(x - y)z$  [that is,  $xz - yz$ ] is

[3-106]

5.

3/115

positive. Hence,  $xz > yz$ . In order to prove that

$$(11) \quad \forall_x \forall_y \forall_z > 0 [x > y \text{ if and only if } xz > yz]$$

it remains to be shown that

$$\forall_x \forall_y \forall_z > 0 \text{ if } xz > yz \text{ then } x > y.$$

To do so, suppose that  $xz > yz$  and that  $z > 0$ . Then, by (4),  $xz - yz > 0$ , that is,  $(x - y)z > 0$ . It follows from (3) and (1) that  $(x - y)z \neq 0$ , so  $x - y \neq 0$  [Why?]. Hence, by (5),  $x > y$  or  $y > x$ . But, if  $y > x$  then, since  $z > 0$ ,  $yz > xz$ . And this, by (6), contradicts the assumption that  $xz > yz$ . Hence,  $x > y$ .

It still remains to prove the other half of the transformation principle:

$$(12) \quad \forall_x \forall_y \forall_z < 0 [x > y \text{ if and only if } xz < yz].$$

This follows fairly easily from (10) and (11). For, if  $z < 0$  then, by (10')  $-z > 0$ . So, by (11),  $x > y$  if and only if  $x(-z) > y(-z)$ , that is, if and only if  $-(xz) > -(yz)$ . But, by (10), this is the case if and only if  $yz > xz$ .

A simple and important consequence of (11) and (12) is that

$$(13) \quad \forall_x \neq 0 \quad x^2 > 0.$$

Proof of (13): Suppose that  $x \neq 0$ . By (5),  $x > 0$  or  $x < 0$ . If  $x > 0$  then, by (11),  $x^2 > 0$ . If  $x < 0$  then, by (12),  $0 < x^2$ .

From (13) and (11) it follows [using the principle of quotients] that

$$\forall_x \forall_y \forall_z \neq 0 \left[ \frac{x}{z} > \frac{y}{z} \text{ if and only if } xz > yz \right],$$

and, combining this with (11) and with (12), we see that

$$(11') \quad \forall_x \forall_y \forall_z > 0 [x > y \text{ if and only if } \frac{x}{z} > \frac{y}{z}]$$

and

$$(12') \quad \forall_x \forall_y \forall_z < 0 [x > y \text{ if and only if } \frac{x}{z} < \frac{y}{z}].$$

Finally, we note that

$$(14) \quad \forall_x \forall_y \text{ if } xy > 0 \text{ then } [(x > 0 \text{ and } y > 0) \text{ or } (x < 0 \text{ and } y < 0)],$$

and that

$$(15) \quad \forall_x \forall_y \text{ if } xy < 0 \text{ then } [(x > 0 \text{ and } y < 0) \text{ or } (x < 0 \text{ and } y > 0)].$$

[3-106]

5.



3/116

Proof of (14): Suppose that  $xy > 0$ . It follows, by (3) and (1), that  $xy \neq 0$ , so,  $x \neq 0$  and  $y \neq 0$ .

Hence, by (5),  $(x > 0 \text{ or } x < 0)$  and  $(y > 0 \text{ or } y < 0)$ . So, by (10'),

$$x > 0 \text{ or } -x > 0,$$

and

$$y > 0 \text{ or } -y > 0.$$

Now, there are four possibilities.

$$x > 0 \text{ and } y > 0,$$

$$x > 0 \text{ and } -y > 0,$$

$$-x > 0 \text{ and } y > 0,$$

$$-x > 0 \text{ and } -y > 0.$$

From (3) and  $(P_4)$  we know, in these cases, respectively, that

$$xy > 0,$$

$$x(-y) > 0,$$

$$-xy > 0,$$

$$(-x)(-y) > 0,$$

that is, that

$$xy > 0,$$

$$-(xy) > 0,$$

$$-(xy) > 0,$$

$$xy > 0.$$

From (10') it follows that

$$xy > 0,$$

$$xy < 0,$$

$$xy < 0,$$

$$xy > 0.$$

But, by (6), the second and third possibilities contradict the assumption that  $xy > 0$ . So, if  $xy > 0$  then  $(x > 0 \text{ and } y > 0)$  or  $(x < 0 \text{ and } y < 0)$ .

The proof of (15) is similar to the proof of (14). If we suppose that  $xy < 0$ , we arrive at the same four possibilities and, now, the first and fourth lead to a contradiction of our assumption. Hence, if  $xy < 0$  then  $(x > 0 \text{ and } y < 0)$  or  $(x < 0 \text{ and } y > 0)$ .

\*

As alternative basic principles for  $>$  [in place of (G),  $(P_1)$ ,  $(P_2)$ ,  $(P_3)$ , and  $(P_4)$ ] one can take theorems (5), (6), and (7) [on TC[3-106]b],

' $\forall_x \forall_y \forall_z$  if  $x > y$  then  $x + z > y + z$ ', and ' $\forall_x \forall_y$  if  $x > 0$  and  $y > 0$  then  $xy > 0$ '. One can proceed on this basis without introducing the phrase 'positive number'.

\*

[3-106]

5.

3/117

## Answers for Part B.

1. Suppose that  $x + z > y + z$ .Then  $x + z + -z > y + z + -z$ , [ $\forall_x \forall_y \forall_z$  if  $x > y$  then  $x + z > y + z$ ]

$$x + (z + -z) > y + (z + -z), \quad [\text{apa}]$$

$$x + 0 > y + 0, \quad [\text{po}]$$

and  $x > y.$  [ $\text{pa0}$ ]

Hence, if  $x + z > y + z$  then  $x > y$ .

[Compare the proof above with that given on page 2-65 for the cancellation principle for addition.]

2. [The theorem to be proved is (9) on TC[3-106]c, and its proof is given there.]

\*

Quiz.

Find the solution set of each sentence and draw its graph.

1.  $5x - 4 > 7x + 9$

2.  $|x| < 10$

3.  $|n| \geq 4$

4.  $|2x + 5| \leq 23$

5.  $2x + 6 < 4 - 6x$

6.  $\frac{x}{2} - 1 > 3 - x$

7.  $|c| < -2$

8.  $\frac{x-3}{x} < 3$

9.  $\frac{2y-5}{2} > \frac{5y+4}{5}$

10.  $|x+4| \geq 6$

11.  $|x+4| > 6$

12.  $|x+4| < 6$

13.  $|x+4| > 6$  or  $|x+4| < 6$

14.  $2x + 3 > 2(x - 1)$

15.  $|x| > 3$  and  $|x| > 5$

16.  $|x| < 3$  or  $|x| > 5$

\*

Answers for Quiz. [We do not show graphs.]

1.  $\{x: x < -6.5\}$

2.  $\{x: -10 < x < 10\}$

3.  $\{n: n \leq -4 \text{ or } n \geq 4\}$

4.  $\{x: -14 \leq x \leq 9\}$

5.  $\{x: x < -(1/4)\}$

6.  $\{x: x > 8/3\}$

7.  $\emptyset$

8.  $\{x: x < -1.5 \text{ or } x > 0\}$

9.  $\emptyset$

10.  $\{x: x \leq -10 \text{ or } x \geq 2\}$

11.  $\{x: x < -10 \text{ or } x > 2\}$

12.  $\{x: -10 < x < 2\}$

13.  $\{x: x < -10 \text{ or } x > 2 \text{ or } -10 < x < 2\}$

14.  $\{x: x = x\}$

15.  $\{x: x < -5 \text{ or } x > 5\}$

16.  $\{x: -3 < x < 3 \text{ or } x < -5 \text{ or } x > 5\}$

[3-106]

5.



5.

3/120

11. T [Since  $0.33 \leq 1/3$  and  $2/3 \leq 0.67$ , this exercise is just like Exercises 4 and 9. Another way to work Exercise 11 is to recognize that the first set is  $\{x: 1 < 3x < 2\}$ , and that the second set is  $\{x: 0.99 < 3x < 2.01\}$ . Now, use the same idea as the one used in Exercises 4 and 9.]
12. F [One method is to note that the first set is  $\{x: 1 < 7x < 2\}$  and that the second is  $\{x: 1.0003 < 7x < 2.002\}$ . Each number which belongs to  $\{x: 1 < 7x \leq 1.0003\}$  belongs to the first set but not the second. Another way to do this exercise is to consider the decimal names for  $1/7$  and  $2/7$ .  $1/7 = 0.142857142857\dots$ ,  $2/7 = 0.285714285714\dots$ . (Repeating decimals will be treated in some detail in Unit 4, but now is a good time to make sure students know how to use a division algorithm to obtain them.) Since  $0.1429 > 0.1428$ , it follows that the first set is not a subset of the second.]
13. F [Recall that  $1/9 = 0.111\dots$ . Each point in  $\{x: 0.11 < x \leq 1/9\}$  belongs to the first set but not to the second. Another way is to transform the set selectors by multiplying by 72.]



5.

3/119

2. F [For example,  $3.5 \leq 4.1 < 4.5$ , but it is not the case that  $3 \leq 4.1 < 4$  since  $4.1 \not< 4$ .]
3. T [Since  $6.25 < 6.26$  and  $6.28 < 6.35$ , it is the case that, for each  $x$ , if  $6.26 < x < 6.28$  then  $6.25 < x < 6.35$  and, so,  $6.25 \leq x < 6.35$ . Again, in students' spoken language: if a number is between 6.26 and 6.28, it is bigger than 6.25 and smaller than 6.35, and so it is also between 6.25 and 6.35.]
4. T [Intuitively, if you move the left end point of an interval to the left (smaller) and the right end point to the right (larger), you get a new interval (or a new half-open interval, or a new segment) which contains the original interval. Since  $5.3 < 5.31$  and  $5.39 < 5.4$ , it is the case that, for each  $x$ , if  $5.31 < x < 5.39$  then  $5.3 < x < 5.4$  and, so,  $5.3 \leq x < 5.4$ .] [Note that the half-open interval 5.3, 5.4 is not a bigger set than the interval 5.3, 5.4 in any accepted sense of the word 'bigger'. Both sets contain the same "number" of points even though one set contains 1 more point than the other.]
5. F [7.39845 belongs to the first set, but not to the second.]
6. T [Each number less than 1 is less than or equal to 1. In geometric terminology, an interval is a subset of the segment which is the union of the interval and the set consisting of its end points.]
7. F [The first set is the half-open interval 4.5, 5.5, and the second is the interval 4.5, 5.5. The left end point of the first does not belong to the second.]
8. T [An interval is a subset of each of its "corresponding" half-open intervals. Be sure that students see the connection between Exercises 7 and 8.]
9. T [Compare with Exercise 4.]
10. T [By the multiplication transformation principle for inequations,  $\{x: 1.414 < x < 1.415\} = \{x: 4.242 < 3x < 4.245\}$ . Since  $4.24 \leq 4.242$  and  $4.245 \leq 4.25$ , it follows that  $\{x: 4.242 < 3x < 4.245\} \subseteq \{x: 4.24 \leq 3x < 4.25\}$ .]





5.

3/118

The Exploration Exercises prepare students for the work on approximations which follows page 3-112.

\*

Answers for Part A.

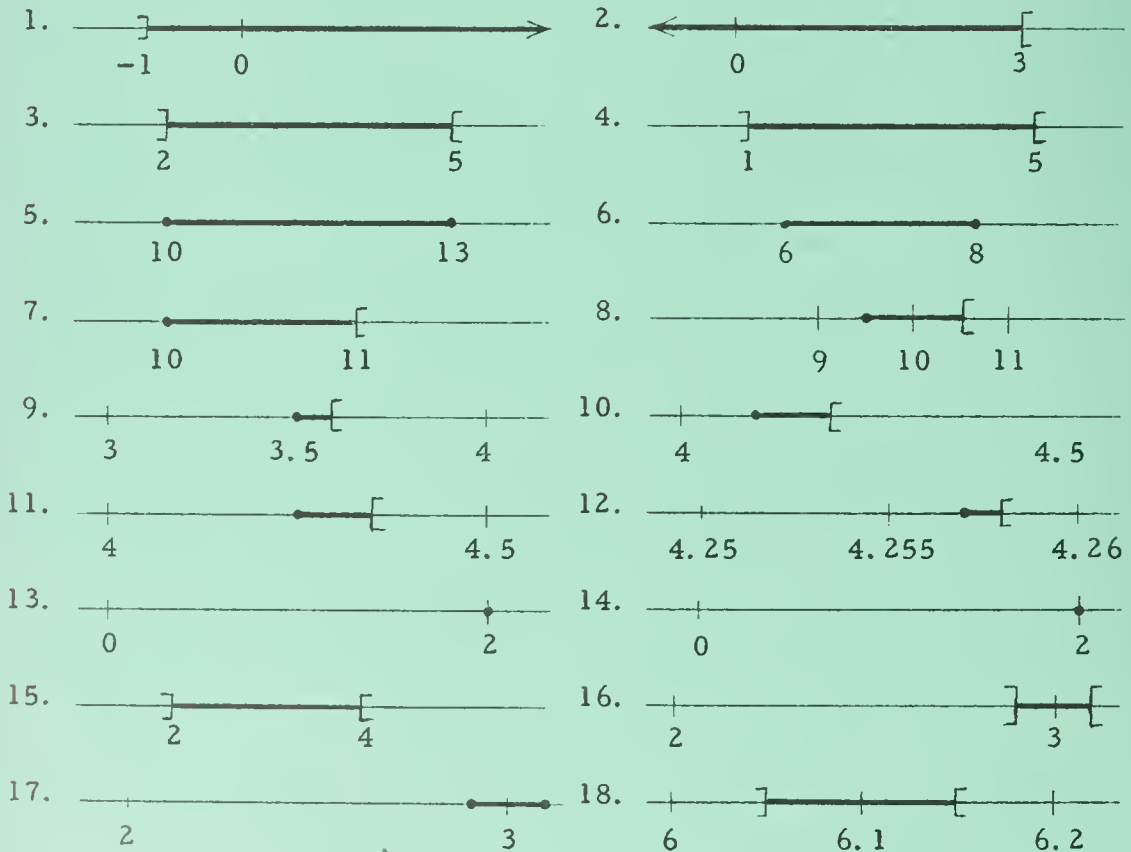

\*

Answers for Part B.

[Make generous use of pictures in dealing with the exercises.]

1. T [“Any number from 3 up to but not including 4 is a number from 3 up to but not including 5 because 4 is not bigger than 5.” More formally: since  $4 \leq 5$ , it is the case that, for each  $x$ , if  $3 \leq x < 4$  then  $3 \leq x < 5$ .]

## EXPLORATION EXERCISES

A. Graph each of the following sentences.

Sample.  $2x + 30 > 70$

Solution.



- |                           |                           |                              |
|---------------------------|---------------------------|------------------------------|
| 1. $5y + 9 > 4$           | 2. $3x - 2 < 7$           | 3. $2 < x < 5$               |
| 4. $3 < y + 2 < 7$        | 5. $9 \leq x - 1 \leq 12$ | 6. $-11 \leq 2y + 1 \leq 17$ |
| 7. $10 \leq x < 11$       | 8. $9.5 \leq y < 10.5$    | 9. $3.5 \leq x < 3.6$        |
| 10. $12.3 \leq 3x < 12.6$ | 11. $4.25 \leq x < 4.35$  | 12. $4.257 \leq x < 4.258$   |
| 13. $ x - 2  = 0$         | 14. $ x - 2  \leq 0$      | 15. $ x - 3  < 1$            |
| 16. $ x - 3  < 0.1$       | 17. $ x - 3  \leq 0.1$    | 18. $ x - 6.1  < 0.05$       |

B. True or false?

- $\{x: 3 \leq x < 4\} \subseteq \{x: 3 \leq x < 5\}$
- $\{x: 3.5 \leq x < 4.5\} \subseteq \{x: 3 \leq x < 4\}$
- $\{x: 6.26 < x < 6.28\} \subseteq \{x: 6.25 \leq x < 6.35\}$
- $\{x: 5.31 < x < 5.39\} \subseteq \{x: 5.3 \leq x < 5.4\}$
- $\{x: 7.3984 < x < 7.3992\} \subseteq \{x: 7.3985 \leq x < 7.3995\}$
- $\{x: |x - 3| < 1\} \subseteq \{x: |x - 3| \leq 1\}$
- $\{x: 4.5 \leq x < 5.5\} \subseteq \{x: |x - 5| < 0.5\}$
- $\{x: |x - 6.3| < 0.05\} \subseteq \{x: 6.25 \leq x < 6.35\}$
- $\{x: 5.477 < x < 5.478\} \subseteq \{x: 5.47 < x < 5.48\}$
- $\{x: 1.414 < x < 1.415\} \subseteq \{x: 4.24 \leq 3x < 4.25\}$
- $\{x: \frac{1}{3} < x < \frac{2}{3}\} \subseteq \{x: 0.33 < x < 0.67\}$
- $\{x: \frac{1}{7} < x < \frac{2}{7}\} \subseteq \{x: 0.1429 < x < 0.286\}$
- $\{x: 0.11 < x < 0.12\} \subseteq \{x: \frac{1}{9} < x < \frac{1}{8}\}$

3.10 Square roots. --Consider the equation:

$$x^2 - 25 = 0.$$

To solve this equation is to find all numbers each of which when squared gives 25. Since ' $x^2 - 25 = 0$ ' is equivalent to ' $(x - 5)(x + 5) = 0$ ', it follows that the solution set of the given equation is  $\{5, -5\}$ . Now, consider the equation:

$$x^2 - 30 = 0.$$

What is its solution set? If there is a number whose square is 30, this number belongs to the solution set. Also, its opposite belongs to the solution set. So, if we knew the positive numbers which satisfy the equation then we would know the solution set of the equation. This solution set consists just of the positive numbers which satisfy the equation together with their opposites. Let us first ask how many positive numbers satisfy the equation. Can there be two? Must there be at least one?

The first question ["Can there be two positive roots?"] is easy to answer; let's answer it. Suppose  $m$  and  $n$  are positive numbers whose squares are 30. Then  $m^2 = n^2$ . So,  $m^2 - n^2 = 0$ . Hence,  $(m - n)(m + n) = 0$ . Thus,  $m = n$  or  $m = -n$ . But, since  $m$  and  $n$  are positive,  $m$  cannot be the opposite of  $n$ . So,  $m = n$ . There can't be two positive roots of ' $x^2 - 30 = 0$ '.

Now, let's consider the second question: Must there be a positive number whose square is 30? Let's try to find one. Since  $30 > 25$ , and since  $5^2 = 25$ , it is reasonable to expect that if there is a positive number whose square is 30, the number is greater than 5. Also, since  $36 > 30$ , and since  $6^2 = 36$ , if there is a positive number whose square is 30, this number is less than 6. Let's consider some numbers between 5 and 6 along with their squares.

$$(5.1)^2 = 26.01$$

$$(5.2)^2 = 27.04$$

$$(5.3)^2 = 28.09$$

$$(5.4)^2 = 29.16$$

$$(5.5)^2 = 30.25$$

You can see that if there is a positive number whose square is 30, this

3/121

The section on square roots provides opportunities for inspired teaching in the course of which students will be led to think about important notions, see some theorems proved, and learn an important iterative process for computing square roots. We suggest that you start by considering the equation:

$$x^2 - 25 = 0.$$

To solve this equation means to find numbers each of which has 25 as its square. Students will quickly tell you that 5 and -5 are such numbers. Ask, next, if they think that there might be a positive number other than 5 whose square is 25. Students will feel pretty sure that 5 is the only such positive number. Generalize by going through the following routine.

Ask a student to think of a number and then square it. Ask a second student to think of a number and to square it. Then, ask the class to pretend that both students announced their squares and that the squares were the same. What conclusion can be reached concerning the numbers the students chose? Students should tell you that either the first and second numbers were the same, or else the first and second numbers were opposites. Now, change the game a bit by asking each of two students to pick a positive number and square it. If the squares are equal, what conclusion can be reached? The numbers chosen were the same.

Now, state the two generalizations involved:

$$(i) \quad \forall_a \forall_b \text{ if } a^2 = b^2 \text{ then } a = b \text{ or } a = -b,$$

$$\text{and: } (ii) \quad \forall_a \forall_b \text{ if } a > 0, b > 0, \text{ and } a^2 = b^2, \text{ then } a = b.$$

#### Proof of (i)

Suppose  $a^2 = b^2$ . Then  $a^2 - b^2 = 0$ . So,  $(a - b)(a + b) = 0$ . From this it follows that  $a = b$  or  $a = -b$ .

#### Proof of (ii)

Suppose  $a^2 = b^2$ . Then, from (i), it follows that  $a = b$  or  $a = -b$ . Now, if  $a > 0$  and  $b > 0$ ,  $a \neq -b$ . So,  $a = b$ .

[3-108]

3.10 Sq

Generalization (ii) tells us that each [positive] number is the square of at most one positive number. [Students should realize that, by the pm0 and the 0-product theorem, 0 is the only number whose square is 0, and that by the mtpi, the square of each nonzero real number is positive.]

\*

Few students will doubt the reasonableness of the assertion that if there is a positive number whose square is 30 then, since  $30 > 5^2$ , this positive number is greater than 5. However, the assertion can be proved, and students might enjoy seeing the proof.

Theorem

$\forall_x \forall_y$  if  $x > 0$ ,  $y > 0$ , and  $x^2 > y^2$ , then  $x > y$ .

Suppose  $x^2 > y^2$ . Then  $x^2 - y^2 > 0$ . So,  $(x - y)(x + y) > 0$ . Now, since  $x > 0$  and  $y > 0$ , it follows that  $x + y > 0$ . But, since  $(x - y)(x + y)$  is positive [ $> 0$ ], and  $x + y$  is positive [ $> 0$ ], it follows that  $x - y$  is positive. That is,  $x - y > 0$ . So,  $x > y$ .

This theorem also tells us that since  $6^2 > 30$ , if there is a positive number whose square is 30 then this positive number is less than 6.

The squaring procedure illustrated on 3-108 and 3-109 shows how we can find positive numbers whose squares differ from 30 by as little as we wish. As stated in the text, this is not evidence that there is a positive number whose square is 30. [In fact, this procedure will never produce such a number. A short proof that there is no number whose square is 30 which can be named by a terminating decimal proceeds as follows. Since all decimal numerals for 30 have '0's to the right of the decimal point ['30.0', '30.00', '30.000', etc.], if there is a number named by a terminating decimal, whose square is 30, then the final digit in any of the decimal numerals for this number must be a '0' because 0 is the only number whose square is 0. But, this means that the number in question must be an integer. And, there is no integer whose square is 30.]

In order to prove that each positive number is the square of at least one positive number, one needs in addition to the basic principles and those on order [in Part B on page 3-106], a further principle concerning the completeness of the real number system. Principles about completeness are generalizations about sets of real numbers. An example is the principle which tells us that each bounded and nonempty set of real numbers has a least upper bound. Our basic principles

[3-108]

3.10 So



and the order principles are generalizations about real numbers rather than about sets of real numbers, and for this reason are simple enough to be studied in a beginning algebra course. Your students are probably not ready for a study of the completeness of the real number system [at any rate, we are not ready to include this in the students' edition of Unit 3], but you may want to make such an extracurricular excursion yourself. Some textbooks which you may find useful in this regard are Begle's Introductory Calculus (New York: Holt, 1954), Apostol's Mathematical Analysis (Reading, Mass.: Addison-Wesley, 1957), Thurston's The Number-System (London: Blackie, 1956), The Anatomy of Mathematics by Kershner and Wilcox (New York: Ronald, 1950), and Russell's Introduction to Mathematical Philosophy (London: Allen and Unwin, 1919).]

\*

Even though we have not proved it, there is just one positive number whose square is 30. Since there is such a number, we are entitled to introduce a name for this number. One such name is:

the positive number whose square is 30.

A shorter name [and the standard one] is:

$$\sqrt{30} .$$

As in the case of all numerals, students need to regard ' $\sqrt{30}$ ' as a name for a number rather than as a command to do something. Commands and questions such as:

- (a) Find  $\sqrt{81}$ ,
- (b) Find  $3 + 2$ ,
- (c) Find  $\sqrt{30}$ ,
- (d) What is  $\sqrt{16}$  ?
- (e) What is  $7 \times 5$  ?

really involve colloquialisms. In some cases, the student is expected to write a numeral which is simpler than, but equivalent to, the one used. It is difficult to know what is intended in example (c). Perhaps the student is to write:  $\sqrt{30}$ , thereby indicating that ' $\sqrt{30}$ ' is the simplest name he knows for  $\sqrt{30}$ . Or else, he is supposed to give an approximation to  $\sqrt{30}$ , in which case the exercise is incomplete in that the degree of approximation has not been specified. To give students

[3-108]

3.10 So

practice in using the radical sign, you might ask questions like these:

- (1) What is the simplest name for the positive number whose square is 30? [Spoken answer: a radical sign with a numeral thirty under it.]
- (2) What is the simplest name for the positive number whose square is 25? [Spoken answer: a numeral five.]

\*

In some contexts ' $\sqrt{30}$ ' names the number of arithmetic whose square is the number 30 of arithmetic. In this sense,  $\sqrt{30} = |\sqrt{+30}|$ , and  $\sqrt{+30} = +\sqrt{30}$ . In general,

$$\forall_{x \geq 0} (\sqrt{|x|} = |\sqrt{x}| \text{ and } \sqrt{x} = +\sqrt{|x|}).$$

So, when, as in the first paragraph on page 3-110, we wish to find an approximation to  $\sqrt{30}$ , where '30' is a numeral for a number of arithmetic, we can instead think of '30' as a numeral for a positive number. This is the natural extension of our earlier procedures for treating problems dealing with numbers of arithmetic as though they dealt with nonnegative real numbers [See TC[3-55].].

[3-108]

3.10 So

number must be between 5.4 and 5.5 [Why?]. [If there is a positive number whose square is 30, then the only other number whose square is 30 is a negative number. What can you say about this negative number?]

Here is another list.

$$(5.41)^2 = 29.2681$$

$$(5.42)^2 = 29.3764$$

$$(5.43)^2 = 29.4849$$

$$(5.44)^2 = 29.5936$$

$$(5.45)^2 = 29.7025$$

$$(5.46)^2 = 29.8116$$

$$(5.47)^2 = 29.9209$$

$$(5.48)^2 = 30.0304$$

Do you see that if there is a positive number whose square is 30, this number is between 5.47 and 5.48? After more tedious multiplication, we find that

$$(5.477)^2 = 29.997529$$

and that

$$(5.478)^2 = 30.008484.$$

We leave to you the job of showing that the number we are seeking [if there is such a number] is between 5.4772 and 5.4773.

It appears that we can find positive numbers whose squares are as close to 30 as we wish. [For most applications of mathematics this is enough.] However, nothing we have done helps to show that there is a positive number whose square is 30. To prove that there is such a positive number is a difficult task and requires additional basic principles about real numbers. You may study such a proof in a later course. It is enough for present purposes that you accept the statement that there is such a number. The usual name for this number is:

$$\sqrt{30}.$$

[' $\sqrt{30}$ ' is read as 'the principal square root of 30', or as 'the square root of 30'. The ' $\sqrt{\quad}$ ' is called 'a radical sign'.] The negative number whose square is 30 is

$$-\sqrt{30}.$$

[' $-\sqrt{30}$ ' is read as 'the negative square root of 30'.]

So, the solutions of the equation:

$$x^2 - 30 = 0$$

are  $\sqrt{30}$  and  $-\sqrt{30}$ . The check is easy. Since  $\sqrt{30}$  is the positive number whose square is 30,  $(\sqrt{30})^2$  is 30, and  $30 - 30 = 0$ . And, since  $(-\sqrt{30})^2 = (\sqrt{30})^2$  [Why?],  $(-\sqrt{30})^2$  is 30, and  $30 - 30 = 0$ .

### EXERCISES

A. Find the solution sets of these equations.

1.  $x^2 - 17 = 0$  [Answer:  $\{\sqrt{17}, -\sqrt{17}\}$ .]
2.  $x^2 - 38 = 0$
3.  $y^2 - 91 = 0$
4.  $y^2 = 71$
5.  $0 = z^2$
6.  $x^2 = 81$
7.  $50 - a^2 = 0$

B. True or false?

Sample.  $\sqrt{600} = 10\sqrt{6}$

Solution. We are trying to determine whether ' $\sqrt{600}$ ' and ' $10\sqrt{6}$ ' are names for the same number. We know that ' $\sqrt{600}$ ' is a name for the positive number whose square is 600. So, we must determine whether  $10\sqrt{6}$  is the positive number whose square is 600. Since 10 and  $\sqrt{6}$  are positive numbers, and since the product of two positive numbers is positive, it follows that  $10\sqrt{6}$  is a positive number. Also,

$$\begin{aligned} (10\sqrt{6})^2 &= (10\sqrt{6})(10\sqrt{6}) \\ &= 10^2 \cdot (\sqrt{6})^2 \\ &= 100 \cdot 6 \\ &= 600. \end{aligned}$$

So, the sentence ' $\sqrt{600} = 10\sqrt{6}$ ' is true. [Is the sentence ' $-\sqrt{600} = 10\sqrt{6}$ ' true?]

1.  $\sqrt{5000} = 10\sqrt{50}$
2.  $\sqrt{2000} = 100\sqrt{2}$
3.  $\sqrt{8} = 2\sqrt{2}$
4.  $\sqrt{9} = 3$

3/125

Answers for Part A.

2.  $\{\sqrt{38}, -\sqrt{38}\}$       3.  $\{\sqrt{91}, -\sqrt{91}\}$       4.  $\{\sqrt{71}, -\sqrt{71}\}$   
 5.  $\{0\}$       6.  $\{9, -9\}$       7.  $\{\sqrt{50}, -\sqrt{50}\}$

\*

Mention to students that some people list the roots of, say, the equation in Exercise 3 by writing:  $\pm\sqrt{91}$ . This is an abbreviation for ' $\sqrt{91}$  and  $-\sqrt{91}$ ', and also an abbreviation for ' $\sqrt{91}$  or  $-\sqrt{91}$ '. In neither case is ' $\pm\sqrt{91}$ ' a numeral. Because of the ambiguity and because it is likely to be taken as a numeral, we avoid this expression.

\*

The problem in the Sample of Part B is this. In determining the truth or falsity of the sentence ' $\sqrt{600} = 10\sqrt{6}$ ', we are trying to find out whether it is the case that ' $\sqrt{600}$ ' and ' $10\sqrt{6}$ ' are names for the same number. By definition, ' $\sqrt{600}$ ' is a name for the positive number whose square is 600. So, we must determine if ' $10\sqrt{6}$ ' is a name for the positive number whose square is 600. Thus, there are two jobs, (1) to show that  $10\sqrt{6}$  is a positive number, and (2) to show that  $(10\sqrt{6})^2$  is 600.

[The procedure illustrated in the Solution is a useful one to accustom your students to, since they will use it when they deal with the inverses of exponential and circular functions in later courses. For example, suppose the student wants to show that

$$\log_2(8 \cdot 4) = \log_2 8 + \log_2 4.$$

Since, by definition,  $\log_2(8 \cdot 4)$  is the exponent of that power of 2 which is  $8 \cdot 4$ , in order to show that  $\log_2 8 + \log_2 4$  is  $\log_2(8 \cdot 4)$ , the student shows that

$$2^{(\log_2 8 + \log_2 4)} = 8 \cdot 4.$$

As a second example, suppose a student is to show that

$$\sin^{-1} \frac{1}{2} = \frac{\pi}{6}.$$

By definition,  $\sin^{-1}(1/2)$  is the number between  $-(\pi/2)$  and  $\pi/2$  whose sine is  $1/2$ . So, to show that  $\sin^{-1}(1/2) = \pi/6$ , the student shows that  $\pi/6$  is between  $-(\pi/2)$  and  $\pi/2$  and then shows that  $\sin(\pi/6) = 1/2$ . ]

Contrast this procedure in the Solution with the conventional one in which the student shows that  $\sqrt{600} = 10\sqrt{6}$  by "squaring both sides"

[3-110]

Sr



3/126

and arriving at the true sentence:  $600 = 600$ . [The student still needs to show that  $10\sqrt{6}$  is a positive number. Otherwise, the same procedure could be used to show that the false sentence ' $-\sqrt{600} = 10\sqrt{6}$ ' is true.] A proper use of the squaring-both-sides-procedure depends on the theorem:

$$\forall_x \forall_y \text{ if } x > 0, y > 0, \text{ and } x^2 = y^2 \text{ then } x = y.$$

[This theorem is proved on page 3-108. The related theorem ' $\forall_x \forall_y$  if  $x^2 = y^2$  then  $x = y$  or  $x = -y$ ' is proved at the same time]. The procedure in the Solution depends directly on the definition of ' $\sqrt{600}$ ' and is conceptually much simpler than the conventional procedure just described.

\*

Answers for Part B [on pages 3-110 and 3-111].

1. T      2. F      3. T      4. T      5. F      6. T  
 7. T      8. F [ $\sqrt{4} + \sqrt{9} = 5$  and  $5 \neq \sqrt{13}$ ]      9. T      10. T  
 11. T      12. F      13. T      14. T

\*

Students may want to generalize some of the results of Part B. For example, they may want to state that the square root of a product of two numbers is the product of the square roots of these numbers. This generalization is meaningless in the context of real numbers, as can be seen from the meaningless sentence:

$$\sqrt{-4 \cdot -9} = \sqrt{-4} \cdot \sqrt{-9}.$$

' $\sqrt{-4 \cdot -9}$ ' stands for 6, but ' $\sqrt{-4}$ ' and ' $\sqrt{-9}$ ' have no referents among the real numbers. [The generalization is false in the context of complex numbers.] The correct generalization is:

$$\forall_x \geq 0 \forall_y \geq 0 \sqrt{xy} = \sqrt{x} \sqrt{y},$$

and may be called 'the distributive principle for square rooting over multiplication'. The proof follows quickly from the definition of ' $\sqrt{\quad}$ '. Since  $\sqrt{x} \geq 0$  and  $\sqrt{y} \geq 0$ ,  $\sqrt{x} \sqrt{y} \geq 0$ . Also,  $[\sqrt{x} \sqrt{y}]^2 = (\sqrt{x} \sqrt{y})(\sqrt{x} \sqrt{y}) = (\sqrt{x} \sqrt{x})(\sqrt{y} \sqrt{y}) = xy$ . Since  $\sqrt{x} \sqrt{y} \geq 0$  and  $[\sqrt{x} \sqrt{y}]^2 = xy$ , it follows that  $\sqrt{x} \sqrt{y} = \sqrt{xy}$ .

[3-110]

Sc

3/127

Another generalization of importance is suggested by Exercise 14.

$$\forall x > 0 \quad \frac{x}{\sqrt{x}} = \sqrt{x}.$$

This is an immediate consequence of the division theorem. Since, by definition  $[x \geq 0]$ ,  $\sqrt{x} \cdot \sqrt{x} = x$ , it follows that  $\sqrt{x} = x \div \sqrt{x}$ ,  $[x > 0]$ . [In applying the division theorem we must introduce the restriction ' $\sqrt{x} \neq 0$ '. The final restriction, ' $x > 0$ ', implies this. To see how, note that, for each  $x \geq 0$ ,  $\sqrt{x} \cdot \sqrt{x} = x$ . So, by the pm0, if  $\sqrt{x} = 0$  then  $x = 0$ . Contrapositively, if  $x \neq 0$  then  $\sqrt{x} \neq 0$ . But, ' $x > 0$ ' implies ' $x \neq 0$ '. So,  $\sqrt{x} \neq 0$ .]

[3-110]

Sc



Parts C and D provide practice in working with radical expressions. In the Solution for the Sample of Part C, students may feel that ' $8\sqrt{2} + 7$ ' should be further simplified. Please do not say that you can't add  $8\sqrt{2}$  and 7. Obviously you can, and the sum is  $8\sqrt{2} + 7$ . What you can't do is simplify ' $8\sqrt{2} + 7$ '. Suppose a student claims that  $8\sqrt{2} + 7 = 15\sqrt{2}$ . One way to dispute this is to show by squaring that  $\sqrt{2}$  is between 1.4 and 1.5. So,  $8\sqrt{2} + 7 < 8(1.5) + 7$ ; that is,  $8\sqrt{2} + 7 < 19$ . Also,  $15\sqrt{2} > 15(1.4)$ ; hence,  $15\sqrt{2} > 21$ . So we know that  $8\sqrt{2} + 7 < 19 < 15\sqrt{2}$ . Another way to dispute the student's claim is to ask him whether he believes that  $8\sqrt{9} + 7 = 15\sqrt{9}$ .

\*

Answers for Part C.

1.  $8\sqrt{3}$       2.  $10\sqrt{5}$       3.  $5\sqrt{7}$       4.  $11\sqrt{2} + 3$       5.  $5\sqrt{5} + 8$   
 6.  $10\sqrt{3} - 10\sqrt{2}$  [or:  $10(\sqrt{3} - \sqrt{2})$ ]      7.  $15 + 17\sqrt{2}$       8.  $-7\sqrt{2} + 9\sqrt{3}$

\*

Answers for Part D.

1.  $15 + 7\sqrt{3}$       2.  $-33 - 2\sqrt{2}$       3.  $5 + 2\sqrt{13}$   
 4.  $194 + 7\sqrt{17}$       5. 1      6. -2  
 7.  $21 + 8\sqrt{5}$       8.  $21 + 8\sqrt{5}$       9.  $8 + 2\sqrt{7}$   
 10.  $19 - 6\sqrt{10}$       11.  $11 + 4\sqrt{7}$       12.  $x^2 - y$ , [ $y \geq 0$ ]  
 13.  $12a^2 - 10b + 7a\sqrt{b}$ , [ $b \geq 0$ ]      14.  $x + y^2 - 2y\sqrt{x}$ , [ $x \geq 0$ ]  
 15.  $4a + 9b^2 + 12b\sqrt{a}$ , [ $a \geq 0$ ]

[In giving their answers to Exercises 12 - 15, students should mention the restrictions on the admissible values of the pronumerals.]

- |   |   |
|---|---|
| 5. $\sqrt{16} = -4$                             | 6. $\sqrt{50} = \sqrt{25} \cdot \sqrt{2}$ |
| 7. $\sqrt{4 \cdot 9} = \sqrt{4} \cdot \sqrt{9}$ | 8. $\sqrt{4 + 9} = \sqrt{4} + \sqrt{9}$   |
| 9. $\sqrt{75} = 5\sqrt{3}$                      | 10. $\sqrt{7500} = 50\sqrt{3}$            |
| 11. $\sqrt{.02} = .1\sqrt{2}$                   | 12. $\sqrt{.002} = .01\sqrt{2}$           |
| 13. $\sqrt{89} \times \sqrt{89} = 89$           | 14. $89 \div \sqrt{89} = \sqrt{89}$       |

C. Simplify.

Sample.  $5\sqrt{2} + 3\sqrt{2} + 7$

Solution.  $5\sqrt{2} + 3\sqrt{2} + 7$   
 $= (5 + 3)\sqrt{2} + 7$   
 $= 8\sqrt{2} + 7.$

- |                                   |  |                                 |
|-----------------------------------|--|---------------------------------|
| 1. $6\sqrt{3} + 2\sqrt{3}$        | 2. $9\sqrt{5} + \sqrt{5}$                              | 3. $7\sqrt{7} - 2\sqrt{7}$      |
| 4. $4\sqrt{2} + 3 + 7\sqrt{2}$    | 5. $3\sqrt{5} + 2\sqrt{5} + 8$                         | 6. $5\sqrt{3} - 10\sqrt{2} + 5$ |
| 7. $5(3 + 2\sqrt{2}) + 7\sqrt{2}$ | 8. $4(2\sqrt{2} + \sqrt{3}) - 5(3\sqrt{2} - \sqrt{3})$ |                                 |

D. Expand.

Sample:  $(\sqrt{5} + 2)(\sqrt{5} + 3)$

Solution. Use the short cuts you developed earlier in the unit.  
 $(\sqrt{5} + 2)(\sqrt{5} + 3)$   
 $= (\sqrt{5})^2 + (2 + 3)\sqrt{5} + 6$   
 $= 5 + 5\sqrt{5} + 6$   
 $= 11 + 5\sqrt{5}.$

- |   |   |                        |
|---|---|------------------------|
| 1. $(\sqrt{3} + 4)(\sqrt{3} + 3)$               | 2. $(\sqrt{2} + 5)(\sqrt{2} - 7)$               |                        |
| 3. $(\sqrt{13} - 2)(\sqrt{13} + 4)$             | 4. $(3\sqrt{17} - 2)(4\sqrt{17} + 5)$           |                        |
| 5. $(\sqrt{3} - \sqrt{2})(\sqrt{3} + \sqrt{2})$ | 6. $(\sqrt{5} - \sqrt{7})(\sqrt{5} + \sqrt{7})$ |                        |
| 7. $(\sqrt{5} + 4)(\sqrt{5} + 4)$               | 8. $(\sqrt{5} + 4)^2$                           |                        |
| 9. $(\sqrt{7} + 1)^2$                           | 10. $(\sqrt{10} - 3)^2$                         | 11. $(2 + \sqrt{7})^2$ |
| 12. $(x + \sqrt{y})(x - \sqrt{y})$              | 13. $(3a - 2\sqrt{b})(4a + 5\sqrt{b})$          |                        |
| 14. $(\sqrt{x} - y)^2$                          | 15. $(2\sqrt{a} + 3b)^2$                        |                        |

## DEGREES OF APPROXIMATION

In some of the applications of mathematics it is important to be able to compute an approximation to the square root of a number. For example, suppose you wanted a carpenter to make a square table top, 30 square feet in area. The carpenter would need to know the number of feet in each side of the square. You could tell him that the table top should be  $\sqrt{30}$  feet on each side, but this information would be of little help to him since the carpenter's rule is not marked with numerals like ' $\sqrt{30}$ '. It would be more helpful for him to know that the sides should be approximately 5.5 feet long, or 5.48 feet long, or 5.477 feet long. Which approximation to  $\sqrt{30}$  he would use would depend upon how accurate a job he planned to do.

So, what we want to consider now are ways of computing approximations to square roots of numbers. Before doing this, we need to discuss different degrees of approximations to positive numbers. For example, we need to agree on what is meant by statements such as:

- 0.33 is the approximation to  $1/3$  correct to 2 decimal places,
- 0.88 is the approximation to  $7/8$  correct to the nearest 0.01,
- 0.55 is the approximation to  $5/9$  correct to 2 decimal places,
- 0.56 is the approximation to  $5/9$  correct to the nearest 0.01,
- 2 is the approximation to  $7/3$  correct to the units place,
- 5.4 is the approximation to  $\sqrt{30}$  correct to 1 decimal place,
- 5.4 is the approximation to  $\sqrt{30}$  correct to the nearest 0.1,
- 9.258 is the approximation to 9.25875 correct to 3 decimal places,
- 9.259 is the approximation to 9.25875 correct to the nearest 0.001.

A careful reading of the foregoing examples may have shown you what we mean by such phrases as 'correct to the nearest 0.01' and 'correct to 3 decimal places'. But, let's be explicit.

For each positive number  $x$ , there is just one integer  $y$  such that

$$y \leq x < y + 1.$$

This number  $y$  is the approximation to  $x$   
correct to the units place.



3/129

The purpose of pages 3-112 through 3-120 is to teach students what is meant by statements such as:

- (a) 5.47 is the approximation to  $\sqrt{30}$  correct to two decimal places,
- (b) 5.48 is the approximation to  $\sqrt{30}$  correct to the nearest 0.01,
- (c) 5.48 is a better approximation to  $\sqrt{30}$  than is 5.47.

To understand such statements, students need to be familiar with inequalities, absolute values, and the decimal system of numeration.

We give here a rationale for estimating errors in approximations. This rationale is implicit in the text discussion. We leave to you how explicit to make it. Consider the subset of the set of nonnegative real numbers which consists of just the nonnegative integers. If we consider each integer as the left end point of a half-open interval of length 1, then each nonnegative real number belongs to just one such interval. For example, the real number 1.7 belongs to  $\{x: 1 \leq x < 2\}$ ,

$$\pi \in \{x: 3 \leq x < 4\},$$

$$5 \in \{x: 5 \leq x < 6\},$$

$$\text{and } 9.95 \in \{x: 9 \leq x < 10\}.$$

[Pronounce '∈' as 'belongs to' or 'is an element of'.]

We say that the set of nonnegative real integers is a net which partitions the set of nonnegative real numbers into the half-open intervals

$$\{x: 0 \leq x < 1\}, \quad \{x: 1 \leq x < 2\}, \quad \{x: 2 \leq x < 3\}, \quad \dots$$

The approximation to a given nonnegative real number which is correct to the units place is the left end point of the half-open interval to which the given number belongs. That is, it is the greatest integer not greater than the given number. For example, 1 is the approximation to 1.7 correct to the units place, 3 is the approximation to  $\pi$  correct to the units place, 5 is the approximation to 5 correct to the units place, and 9 is the approximation to 9.95 correct to the units place.

Consider, next, the subset of the set of nonnegative real numbers which consists of just the quotients of the nonnegative real integers by 10. These are the numbers 0, 0.1, 0.2, ..., 34.8, ... . Let's call these nonnegative tenth-integers. These numbers form a net which partitions the set of nonnegative real numbers into the half-open intervals

$$\{x: 0 \leq x < 0.1\}, \quad \{x: 0.1 \leq x < 0.2\}, \quad \dots, \quad \{x: 34.8 \leq x < 34.9\}, \quad \dots$$

[3-112]

DEGREES

J  
ab'

3/130

The approximation to a given nonnegative real number correct to one decimal place is the left end point of that one of these half-open intervals to which the given number belongs. That is, it is the greatest tenth-integer not greater than the given number. For example:

since  $1.7 \in \{x: 1.7 \leq x < 1.8\}$ ,  
the approximation to  $\overline{1.7}$  correct to one decimal place is 1.7;

since  $\pi \in \{x: 3.1 \leq x < 3.2\}$ ,  
the approximation to  $\overline{\pi}$  correct to one decimal place is 3.1;

since  $5 \in \{x: 5 \leq x < 5.1\}$ ,  
the approximation to  $\overline{5}$  correct to one decimal place is 5;

since  $9.95 \in \{x: 9.9 \leq x < 10\}$ ,  
the approximation to  $\overline{9.95}$  correct to one decimal place is 9.9.

\*

Now, let's look at statement (a) given on TC[3-112]a:

(a) 5.47 is the approximation to  $\sqrt{30}$  correct to two decimal places.

As indicated in the text, we found that

$$5.47 < \sqrt{30} < 5.48.$$

This tells us, in particular, that

$$\sqrt{30} \in \{x: 5.47 \leq x < 5.48\}$$

which tells us that 5.47 is the greatest hundredth-integer not greater than  $\sqrt{30}$ . So, by definition [in analogy with the above discussion],

the approximation to  $\sqrt{30}$  correct to two decimal places is 5.47.

Now, if a nonnegative real number is not an integer, there are two nonnegative integers which differ from it by less than 1. The smaller of these is its approximation correct to the units place; the other is the next larger integer. If the given real number is not the midpoint of the "integer-interval" to which it belongs then it is closer to one of the two integers which differ from it by less than 1. The closer of these integers is the approximation to the real number correct to the nearest unit. [If the real number is the midpoint of its integer-interval, the approximation correct to the nearest unit is the left end point of the next integer-interval. Some texts give a different rule in the case of midpoints.] To illustrate, since  $1.7 \in \{x: 1 \leq x < 2\}$  and  $1.7 > 1.5$ , its approximation correct to the nearest unit is 2. Since  $\pi \in \{x: 3 \leq x < 4\}$  and  $\pi < 3.5$ , its approximation correct to the

[3-112]

DEGREE

I  
ab'

3/131

nearest unit is 3. Also, 9.95's approximation to the nearest unit is 10. [If a nonnegative real number is an integer, the approximation correct to the nearest unit is the approximation correct to the units place. Thus, the approximation to 5 correct to the nearest unit is 5.]

The approximation to a nonnegative real number correct to the nearest 0.1 is the tenth-integer from which it differs least. [If the real number in question is the midpoint of its tenth-integer interval, its approximation correct to the nearest 0.1 is 0.1 more than its approximation correct to one decimal place.] So, since  $1.7 \in \{x: 1.7 \leq x < 1.8\}$  and  $1.7 < 1.75$ , the approximation to 1.7 correct to the nearest 0.1 is 1.7. Since  $\pi \in \{x: 3.1 \leq x < 3.2\}$  and  $\pi < 3.15$ , its approximation correct to the nearest 0.1 is 3.1. 5's approximation correct to the nearest 0.1 is 5; 9.95's is 10. [People sometime use a numeral such as '5.0' to show that they are referring to an approximation correct to the nearest 0.1. This usually occurs in a context where the degree of approximation is clear. For example, in a table of square roots which lists approximations correct to the nearest 0.0001, you will find the approximation to the square root of 144 listed as '12.0000'. Clearly, the numerals '12.0000' and '12' stand for the same number.]

\*

Statement (b), that 5.48 is the approximation to  $\sqrt{30}$  correct to the nearest 0.01, is derived from two considerations:

$$5.47 < \sqrt{30} < 5.48,$$

$$\text{and: } 30 > (5.475)^2.$$

The first of these tells us that

$$(i) \quad \sqrt{30} \in \{x: 5.47 \leq x < 5.48\},$$

and the second tells us that

$$(ii) \quad \sqrt{30} \geq 5.475.$$

Another way of deriving statement (b) is to note that

$$5.477 < \sqrt{30} < 5.478.$$

Both (i) and (ii) are consequences of this last double inequation.

\*

Statement (c), that 5.48 is a better [or: closer] approximation to  $\sqrt{30}$  than is 5.47, merely means that the distance between 5.48 and  $\sqrt{30}$  is less than the distance between 5.47 and  $\sqrt{30}$ .

[3-112]

DEGREE

at

3/132

The fact that 5.48 is the approximation to  $\sqrt{30}$  correct to the nearest 0.01 means that

$$5.475 \leq \sqrt{30} < 5.485.$$

Since  $5.475 \neq \sqrt{30}$ , we know that

$$5.475 < \sqrt{30} < 5.485.$$

So,  $|\sqrt{30} - 5.48| < 0.005$  and  $0.005 < |\sqrt{30} - 5.47|$ .

Therefore,

$$|\sqrt{30} - 5.48| < |\sqrt{30} - 5.47|.$$

Notice that the approximation to a given number correct to the nearest 0.01 is at least as close to the number [and usually closer than] the approximation correct to two decimal places. Similarly, the approximation correct to the nearest 0.001 is at least as close as [and usually closer than] the approximation correct to three decimal places. However, knowing that an approximation is correct to the nearest 0.001 always gives a better estimate of error than knowing that the approximation is correct to three decimal places. For example, as shown in the text, 5.477 is the approximation to  $\sqrt{30}$  correct to the nearest 0.001; it is also the approximation to  $\sqrt{30}$  correct to three decimal places. Knowing that it is correct to the nearest 0.001, you know that

$$|\sqrt{30} - 5.477| \leq 0.0005.$$

Knowing that 5.477 is correct to three decimal places, you know that

$$|\sqrt{30} - 5.477| < 0.001.$$

\*

In working with approximations to square roots, especially with tables, a student is often given an approximation together with an estimate of its error. And, from this, he is supposed to derive other approximations of greater estimated error but sufficiently accurate for his purpose. For example, he may be told that 6.2449979 is the approximation to  $\sqrt{39}$  correct to seven decimal places. This tells him that

$$(*) \quad 6.2449979 \leq \sqrt{39} < 6.2449980.$$

From this it follows that  $6.2449975 < \sqrt{39} < 6.2449985$ , and in particular that

$$6.2449975 \leq \sqrt{39} < 6.2449985,$$

[3-112]

DEGREE

at



3/133

that is, that

6.244998 is the approximation to  $\sqrt{39}$  correct to the nearest 0.000001. From (\*) it also follows that

$$6.2449 \leq \sqrt{39} < 6.2450,$$

that is, that

6.2449 is the approximation to  $\sqrt{39}$  correct to four decimal places. From (\*) it also follows that

$$6.15 \leq \sqrt{39} < 6.25,$$

that is, that

6.2 is the approximation to  $\sqrt{39}$  correct to the nearest 0.1.

In practice, if one wants the approximation to  $\sqrt{39}$  correct, say, to three decimal places, he merely cancels the digits in the fourth and later decimal places. If he wants the approximation to  $\sqrt{39}$  correct to the nearest 0.001, he examines the digit in the fourth decimal place. If this digit is '0', '1', '2', '3', or '4', the approximation correct to the nearest 0.001 is the same as the approximation correct to three decimal places. If the digit is '5', '6', '7', '8', or '9', the approximation correct to the nearest 0.001 is 0.001 plus the approximation correct to three decimal places.

\*

In finding approximations to a negative real number, one approximates the opposite, and takes the opposite of the approximation. So, for example,

-5.47 is the approximation to  $-\sqrt{30}$  correct to two decimal places,

-5.48 is the approximation to  $-\sqrt{30}$  correct to the nearest 0.01,

-5.48 is a better approximation to  $-\sqrt{30}$  than is -5.47.

[3-112]

DEGREE

1

at



DEGREE

3/135

at

0.6 is the approximation to  $2/3$  correct to 1 decimal place.

The approximation correct to 1 decimal place for  $\pi$  is 3.1; for 8.1 is 8.1; for 9 is 9.

\*

A hundredth-integer is a real number whose product by 100 is an integer [or whose product by 10 is a tenth-integer]. Examples are 3847.29, -8.1, 0.32, 0.02, and -9.

The set of thousandth-integers contains all integers, tenth-integers, and hundredth-integers, and all real numbers whose decimal names contain a nonzero-digit in the thousandths place and zero-digits [or no digits] in all places to the right of the thousandths place.

Examples of millionth-integers are 7.823096, -2.51, and 700000000.

For each positive number  $x$ , there is just one hundredth-integer  $y$  such that  $y \leq x < y + 0.01$ . This hundredth-integer  $y$  is the approximation to  $x$  correct to 2 decimal places.



at

Answers for questions in lines 8 and 9 of page 3-113.

12 is the approximation correct to the units place for  $12\frac{3}{4}$ ,  
because  $12\frac{3}{4}$  belongs to  $\{x: 12 \leq x < 13\}$ .

6 is the approximation correct to the units place for 6.01,  
because  $6.01 \in \{x: 6 \leq x < 7\}$ . [You may find it convenient to  
introduce your class to the symbol ' $\epsilon$ '.]

17 is the approximation to 17.999 correct to the units place.

0 is the approximation to  $3/4$  correct to the units place.

3 is the approximation to  $\pi$  correct to the units place,  
because  $\pi \in \{x: 3 \leq x < 4\}$ .

19 is the approximation correct to the units place for 19,  
because  $19 \in \{x: 19 \leq x < 20\}$ .

[A short cut for finding the approximation to a real number correct to the units place is to take the decimal name for the number and delete [the decimal point and] all the digits to the right of the units digit. This leaves you with a name for the approximation. Two classes of exceptions to this short cut are the irrational real numbers ( $\pi$ ,  $\sqrt{2}$ , etc.) and those rational real numbers which cannot be named by terminating decimals ( $1/3$ ,  $1/7$ , etc.). In such cases, we find decimal names for "sufficiently" accurate approximations, and apply the short cut procedures to these names.]

\*

Answers for questions in lines 5 and 6 from the bottom of page 3-113.

1.1 is the approximation correct to 1 decimal place for 1.19,  
because  $1.19 \in \{x: 1.1 \leq x < 1.2\}$ .

12.7 is the approximation correct to 1 decimal place for  $51/4$ ,  
because  $12.7 \leq 51/4 < 12.8$ .

1 is the approximation correct to 1 decimal place for 1.003,  
because  $1.003 \in \{x: 1 \leq x < 1.1\}$ . [Of course, the answer '1.0'  
is correct, but the '0' is superfluous.]

0.3 is the approximation to  $1/3$  correct to 1 decimal place,  
because  $0.3 \leq 1/3 < 0.4$ . That is,  $1/3 \in \{x: 0.3 \leq x < 0.4\}$ .

An easy way to think of this is to picture  $0, 1$  as follows.

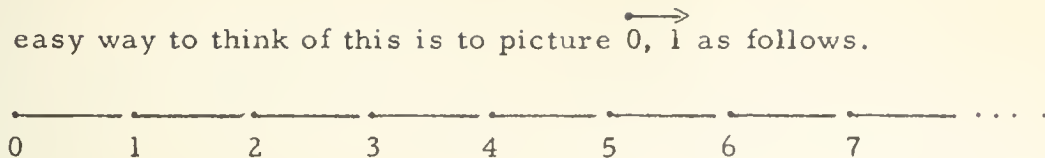

Each positive real number belongs to just one of these half-open intervals, that is, to just one of the sets

$$\{x: 0 \leq x < 1\}, \quad \{x: 1 \leq x < 2\}, \quad \{x: 2 \leq x < 3\}, \quad \dots$$

And, the approximation to a positive number correct to the units place is the left end point of that set to which it belongs. What is the approximation correct to the units place for  $12\frac{3}{4}$ ? For 6.01? 17.999?  $3/4$ ?  $\pi$ ? 19?

In order to say what we mean by 'correct to 1 decimal place' [or: 'correct to the tenths place'], it is convenient to introduce the term 'tenth-integer'. A tenth-integer is a real number whose product by 10 is an integer. For example, 3.1, -2.4, and +6 are tenth-integers. Now, picture  $0, 1$  as follows.

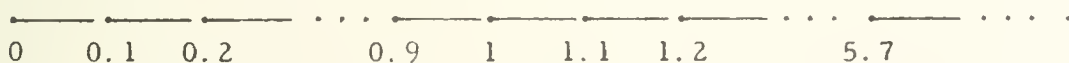

Each positive real number belongs to just one of the sets

$$\{x: 0 \leq x < 0.1\}, \quad \{x: 0.1 \leq x < 0.2\}, \quad \dots, \quad \{x: 8.9 \leq x < 9\}, \quad \dots$$

And, the approximation to a positive number correct to 1 decimal place is that tenth-integer which is the left end point of the set to which the positive number belongs. So, for each positive number  $x$ ,

the approximation to  $x$  correct to 1 decimal place  
is the tenth-integer  $y$  such that

$$y \leq x < y + 0.1.$$

What is the approximation correct to 1 decimal place for 1.19?

For  $51/4$ ? 1.003?  $1/3$ ?  $2/3$ ?  $\pi$ ? 8.1? 9?

What is a hundredth-integer? A thousandth-integer? A millionth-integer? Tell what is meant by 'the approximation to a positive number correct to 2 decimal places'. Now, answer the questions at the top of the next page.

- (1) What is the approximation to 78.9381 correct to 3 decimal places? Correct to 2 decimal places? Correct to the units place? Correct to 4 decimal places? Correct to 5 decimal places?
- (2) What is the approximation to  $\frac{1}{8}$  correct to 1 decimal place? 2 decimal places? 3 decimal places? 10 decimal places?
- (3) Suppose a number is between 0.2 and 0.3. What is the approximation to this number correct to 1 decimal place? Can you tell the approximation to this number correct to 2 decimal places?
- (4) 6.7 is the approximation to 6.73 correct to 1 decimal place. It is also the approximation to 6.7598 correct to 1 decimal place. Describe the set of positive numbers for each of which 6.7 is the approximation correct to 1 decimal place.
- (5) Describe the set of positive numbers for each of which 6.7 is the approximation correct to 2 decimal places.
- (6) On page 3-109 you discovered that

$$5.4772 < \sqrt{30} < 5.4773.$$

From this tell the approximation to  $\sqrt{30}$  which is correct to the units place. Correct to 1 decimal place. To 2 decimal places. To 3 decimal places. Can you tell from this the approximation to  $\sqrt{30}$  correct to 4 decimal places? To 5 decimal places?

You have seen, for example, that because

$$3 \leq 3\frac{2}{3} < 4,$$

the approximation to  $3\frac{2}{3}$  correct to the units place is the integer 3. But, there is another integer which is closer to  $3\frac{2}{3}$  than 3 is. This is the integer 4. We say that 4 is the approximation to  $3\frac{2}{3}$  correct to the nearest unit.

Let us now make precise the notions expressed by 'correct to the nearest unit', 'correct to the nearest 0.1', 'correct to the nearest 0.0001', etc.



3/136

Answers for questions on page 3-114.

- (1) 78.938 [Since  $78.9381 \in \{x: 78.938 < x < 78.939\}$  [or, equivalently, since  $78.938 < 78.9381 < 78.939$ ], it follows that 78.938 is the approximation to 78.9381 correct to 3 decimal places.]  
 78.93; 78; 78.9381  
 78.9381 [Since  $78.9381 < 78.9381 < 78.93811$ , the approximation to 78.9381 correct to 5 decimal places is 78.9381.]
- (2) 0.1; 0.12; 0.125; 0.125 [Recall that  $1/8 = 0.125$ .]
- (3) 0.2 [If the number is between 0.2 and 0.3, it belongs to the half-open interval  $\{x: 0.2 \leq x < 0.3\}$ . Hence, its approximation correct to 1 decimal place is 0.2.]  
 No. [To find the approximation correct to 2 decimal places, you would have to know the hundredth-integer-interval to which the number belongs. All we can tell is that the approximation correct to 2 decimal places is one of the ten numbers 0.2, 0.21, 0.22, 0.23, 0.24, 0.25, 0.26, 0.27, 0.28, and 0.29.]
- (4) It is the tenth-integer-interval whose left end point is 6.7. That is, it is  $\{x: 6.7 < x < 6.8\}$ . [Some of the numbers in this set are 6.7, 6.73, 6.737, 6.779, and 6.7999.]
- (5) It is the hundredth-integer-interval whose left end point is 6.7. That is, it is  $\{x: 6.7 \leq x < 6.71\}$ . [Some of the numbers in this set are 6.7, 6.701, 6.709, and 6.709999.]
- (6) 5 because  $5 \leq \sqrt{30} < 6$   
 5.4 because  $5.4 \leq \sqrt{30} < 5.5$   
 5.47 because  $5.47 \leq \sqrt{30} < 5.48$   
 5.477 because  $5.477 \leq \sqrt{30} < 5.478$   
 Yes. It is 5.4772 because  $5.4772 \leq \sqrt{30} < 5.4773$ .  
 No. All we can tell is that the approximation correct to 5 decimal places is one of the ten numbers 5.4772, 5.47721, 5.47722, ..., 5.47728, and 5.47729.

[3-114]

(1)

...

(1)

3/137

Answers for questions in lines 16 and 17 on page 3-115.

- 6 is the approximation to 6.3 correct to the nearest unit, because  $5.5 < 6.3 < 6.5$ . The approximation for 2.73 is 3; for 5.5 is 6; for 17 is 17.
- 0 is the approximation to  $1/7$  correct to the nearest unit, because  $1/7 = 0.142857 \dots$ , and so,  $1/7 \in \{x: 0 \leq x < 0.5\}$ .
- 1 is the approximation to  $4/7$  correct to the nearest unit, because  $4/7 = 0.571428 \dots$ , and so,  $4/7 \in \{x: 0.5 \leq x < 1.5\}$ .
- 3 is the approximation to  $\pi$  correct to the nearest unit, because  $\pi \in \{x: 2.5 \leq x < 3.5\}$ .

[The short cut procedure is the familiar one about "rounding to the nearest unit". Round down if the digit in the tenths place is '0', '1', '2', '3', or '4'. Round up in the other cases.]

\*

Answers for questions in the last three lines on page 3-115.

2.8; 2.9; 2.9

- 3 [The approximation to 2.97 correct to the nearest 0.1 is 3, because  $2.95 \leq 2.97 < 3.05$ .]

3.1; 17; 0.1; 0.9; 8.7

Picture  $0, 1$  as follows.

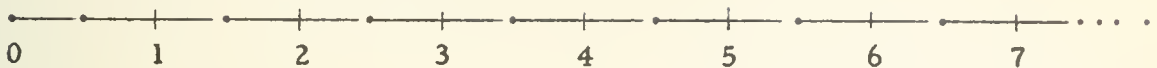

Each positive number belongs to just one of the sets

$$\{x: 0 \leq x < 0.5\}, \{x: 0.5 \leq x < 1.5\}, \{x: 1.5 \leq x < 2.5\}, \dots$$

The approximation to a positive number correct to the nearest unit is the integer which belongs to that set to which the positive number belongs. [In fact, except for numbers in  $0, 0.5$ , the approximation correct to the nearest unit is the midpoint of the set.] So, for each positive number  $x$ ,

the approximation to  $x$  correct to the nearest unit is the integer  $y$  such that

$$y - 0.5 \leq x < y + 0.5.$$

Thus, for example, since

$$4 - 0.5 \leq 3\frac{2}{3} < 4 + 0.5,$$

we say that 4 is the approximation to  $3\frac{2}{3}$  correct to the nearest unit. What is the approximation correct to the nearest unit for 6.3? For 2.73? 5.5? 17?  $1/7$ ?  $4/7$ ?  $\pi$ ?

Now, picture  $0, 1$  as follows.

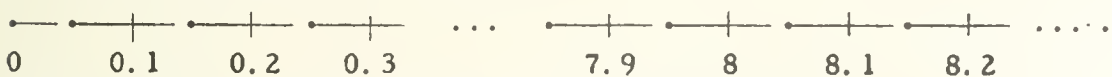

Each positive number belongs to just one of the sets

$$\{x: 0 \leq x < 0.05\}, \{x: 0.05 \leq x < 0.15\}, \dots, \{x: 12.95 \leq x < 13.05\}, \dots$$

For each positive number  $x$ , the approximation to  $x$  correct to the nearest 0.1 is the tenth-integer  $y$  such that

$$y - 0.05 \leq x < y + 0.05.$$

We know that  $3\frac{2}{3}$  is between 3.66 and 3.67. From this it follows that

$$3.7 - 0.05 \leq 3\frac{2}{3} < 3.7 + 0.05.$$

So, 3.7 is the approximation to  $3\frac{2}{3}$  correct to the nearest 0.1. What is the approximation correct to the nearest 0.1 for 2.81? For 2.87? 2.85? 2.97?  $\pi$ ? 17?  $1/7$ ?  $6/7$ ? 8.6543?

Tell what is meant by 'the approximation to a positive number correct to the nearest 0.01'. By 'the approximation to a positive number correct to the nearest 0.001'.

- (1) What is the approximation to 78.9381 correct to the nearest 0.001? Correct to the nearest 0.01? Correct to the nearest unit? Correct to the nearest 0.0001?
- (2) What is the approximation to  $\frac{1}{8}$  correct to the nearest 0.1? To the nearest 0.01? To the nearest 0.001? To the nearest 0.0001? To the nearest 0.000001?
- (3) Suppose a number is between 0.15 and 0.25. What is the approximation to this number correct to the nearest 0.1? Can you tell the approximation to this number correct to the nearest 0.01? Correct to 1 decimal place?
- (4) 6.7 is the approximation to 6.73 correct to the nearest 0.1. It is also the approximation to 6.6839 correct to the nearest 0.1. Describe the set of positive numbers for each of which 6.7 is the approximation correct to the nearest 0.1. Describe the set of positive numbers for each of which 6.7 is both the approximation correct to the nearest 0.1 and the approximation correct to 1 decimal place.
- (5) Describe the set of positive integers for each of which 6.7 is the approximation correct to the nearest 0.01.
- (6) On page 3-109 you discovered that

$$5.4772 < \sqrt{30} < 5.4773.$$

From this tell the approximation to  $\sqrt{30}$  which is correct to the nearest unit. Correct to the nearest 0.1. To the nearest 0.01. To the nearest 0.001. Can you tell from this the approximation to  $\sqrt{30}$  correct to the nearest 0.0001?

3/138

Answers for questions on page 3-116.

For each positive number  $x$ , the approximation to  $x$  correct to the nearest 0.01 is the hundredth-integer  $y$  such that  $y - 0.005 \leq x < y + 0.005$ .

For each positive number  $x$ , the approximation to  $x$  correct to the nearest 0.001 is the thousandth-integer  $y$  such that  $y - 0.0005 \leq x < y + 0.0005$ .

(1) 78.938; 78.94; 79; 79.9381

(2) 0.1; 0.13; 0.125; 0.125; 0.125

(3) 0.2 is the approximation correct to the nearest 0.1 to each number between 0.15 and 0.25, because each such number is in 0.15, 0.25, and 0.2 is the midpoint of 0.15, 0.25.

We can't find the approximation to this number correct to the nearest 0.01. But, we do know that it is one of the numbers 0.15, 0.16, 0.17, ..., 0.24, and 0.25.

The approximation correct to 1 decimal place is either 0.1 or 0.2, but we don't have enough information to tell which.

(4)  $\{x: 6.65 \leq x < 6.75\}$ ;  $\{x: 6.7 \leq x < 6.75\}$

(5)  $\{x: 6.695 \leq x < 6.705\}$

(6) 5; 5.5; 5.48; 5.477

No. It is either 5.4772 or 5.4773.

[3-116]

Tel

corr

nr



Let us summarize this discussion of degrees of approximation by considering various approximations to  $3\frac{2}{3}$ .

(a)

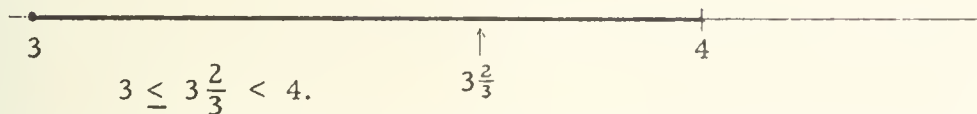

So, 3 is the approximation to  $3\frac{2}{3}$  correct to the units place.

(b)

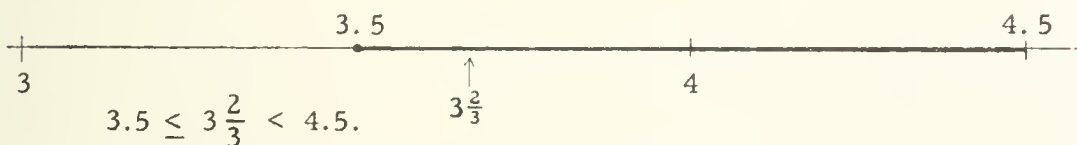

So, 4 is the approximation to  $3\frac{2}{3}$  correct to the nearest unit.

(c)

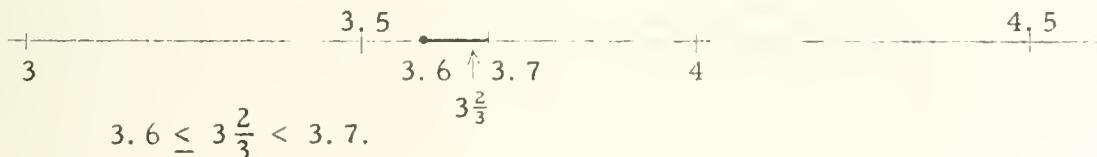

So, 3.6 is the approximation to  $3\frac{2}{3}$  correct to 1 decimal place.

(d)

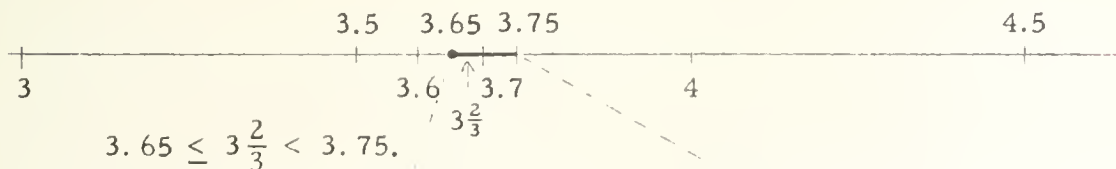

So, 3.7 is the approximation to  $3\frac{2}{3}$  correct to the nearest 0.1.

(e)

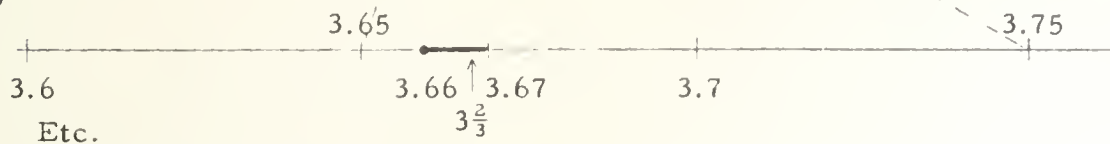

[Approximations to negative real numbers are found by obtaining approximations to their opposites, and taking their opposites. For example, the approximation to  $-3\frac{2}{3}$  correct to the nearest 0.1 is  $-3.7$ . Also, the approximation to  $-3\frac{2}{3}$  correct to 1 decimal place is  $-3.6$ .]

## ESTIMATES OF ERRORS

When you know that a number  $y$  is the approximation to a number  $x$  correct, say, to the nearest 0.01, you know that

$$y - \frac{0.01}{2} \leq x < y + \frac{0.01}{2} .$$

That is, you know that

$$-0.005 \leq x - y < 0.005.$$

So, for each  $x$  for which  $y$  is the approximation correct to the nearest 0.01,

$$|x - y| \leq 0.005.$$

We say that the approximation  $y$  is in error by at most 0.005. [If we know that  $x$  is not a hundredth-integer then the approximation to  $x$  which is correct to the nearest 0.01 is in error by less than 0.005.]

In general, the approximation to a positive number which is correct to the nearest unit, or 0.1, or 0.01, or 0.001, etc., is in error by at most  $\frac{1}{2}$ , or  $\frac{0.1}{2}$ , or  $\frac{0.01}{2}$ , or  $\frac{0.001}{2}$ , etc.

When you know that a number  $y$  is the approximation to a number  $x$  correct, say, to 2 decimal places, you know that  $y \leq x < y + 0.01$ . That is, you know that  $0 \leq x - y < 0.01$ . So, all you know about the size of the error is that  $|x - y| < 0.01$ . [Of course, you also know that an approximation which is correct to a certain number of decimal places is never greater than the number for which it is an approximation.]

In general, the approximation to a positive number which is correct to the units place, or to 1 decimal place, or to 2 decimal places, or to 3 decimal places, etc., is in error by less than 1, or 0.1, or 0.01, or 0.001, etc.

When you know either that a number is an approximation correct, say, to 2 decimal places or that it is an approximation correct to the nearest 0.01, in either case you know that the number being approximated is in a half-open interval of length 0.01. In the second case you know that the error is at most 0.005 while in the first case your only knowledge of the size of the error is that it is less than 0.01. But, this is compensated for by additional information about the direction of the error.



places, and:

$$\sqrt{112} = 10.5830+$$

means that 10.583 is the approximation to  $\sqrt{112}$  correct to four decimal places. According to this convention, the statement given at the beginning of Part B could be abbreviated to:

$$\sqrt{39} = 6.2449979+.$$

\*

3. The fact that 6.2449979 is the approximation to  $\sqrt{39}$  correct to seven decimal places tells us that  $\sqrt{39}$  belongs to

$$\{x: 6.2449979 \leq x < 6.244998\}.$$

Since this interval is of length 0.0000001, each number in the interval differs from  $\sqrt{39}$  by less than 0.0000001. One number which differs from  $\sqrt{39}$  by less than 0.0000001 is 6.2449979. Other such numbers are 6.24499791, 6.24499792, 6.2449979358215, etc. In fact, any number whose approximation correct to seven decimal places is 6.2449979 differs from  $\sqrt{39}$  by less than 0.0000001. [One such number is  $\sqrt{39}$ !] [Knowing, in addition, that  $(6.2449979)^2 \neq 39$  tells us that

$$\sqrt{39} \in \{x: 6.2449979 < x < 6.244998\}.$$

So, we also know that

$$|\sqrt{39} - 6.244998| < 0.0000001.]$$

\*

[We have not described all the numbers in the solution set of:

$$|\sqrt{39} - x| < 0.0000001.$$

Additional information about  $\sqrt{39}$ , for example that

$$6.24499799 < \sqrt{39} < 6.244998,$$

assures us that each of the numbers between 6.2449979 and 6.24499809 differs from  $\sqrt{39}$  by less than 0.0000001. Better approximations to  $\sqrt{39}$  would enable us to identify other members of the solution set of ' $|\sqrt{39} - x| < 0.0000001$ '.]



## Answers for Part B.

1. 6.2; 6.24; 6.244; 6.2449; 6.24499
2. 6.2; 6.24; 6.245; 6.245; 6.245; 6.244998

\*

Here is an opportunity to explain some of the usages which are found in discussions in other texts. We have seen that 6.245 is the approximation to  $\sqrt{39}$  correct to the nearest 0.001, correct to the nearest 0.0001, and correct to the nearest 0.00001. Some texts would indicate the first of these by writing:

$$\sqrt{39} = 6.245 \pm 0.0005,$$

the second by writing:

$$\sqrt{39} = 6.245 \pm 0.00005,$$

and the third by writing:

$$\sqrt{39} = 6.245 \pm 0.000005.$$

This is a colloquial use of '='. The first of these is meant to say that  $6.2445 \leq \sqrt{39} < 6.2455$ .

Another way of making the three assertions is:

$$\sqrt{39} \stackrel{a}{\approx} 6.245$$

$$\sqrt{39} \stackrel{a}{\approx} 6.2450$$

$$\sqrt{39} \stackrel{a}{\approx} 6.24500$$

where the convention is that the estimate of the error in the approximation is " $\frac{1}{2}$  unit in the last decimal place". A usage for indicating that an approximation is correct to a certain number of decimal places is to write a '+' at the right of the appropriate decimal name of the approximation. Thus, for example, one would write:

$$\sqrt{39} = 6.244+$$

to mean that 6.244 is the approximation to  $\sqrt{39}$  correct to three decimal



## Answers for Part A.



(a) tells us that  $\sqrt{112}$  belongs to 10.5, 10.6.

(b) tells us that  $\sqrt{112}$  belongs to 10.58, 10.59.



(e) tells us that  $\sqrt{112}$  belongs to 10.583, 10.58301.

(f) tells us that  $\sqrt{112}$  belongs to 10.583005, 10.583006.

[Number line pictures may help in all of the subsequent exercises.]

3. 10.58 [From (b) we know that  $10.58 \leq \sqrt{112} < 10.59$ . This amounts to saying that 10.58 is the approximation to  $\sqrt{112}$  which is correct to two decimal places.]

4. 11 [Use (a).]

5. 10.583 [Use (d).]

6. 10.583 [Use (e).]

7. 10.58 [Use (c).]

8. 10.583005 [Use (f).]

9. Either 10.583005 or 10.583006 [but not both!]. To determine which, square 10.5830055. Since  $(10.5830055)^2 = 112.00000541303025 > 112$ , 10.583005 is the approximation to  $\sqrt{112}$  correct to the nearest 0.000001.

10. (a) True [Use (c).]

(b) True [Use (d).]

(c) True [Use (c).]

(d) False [Use (d).]

11. (f)

\*



## EXERCISES

A. Here are several statements about  $\sqrt{112}$ .

- (a)  $10.5 < \sqrt{112} < 10.6$   
 (b)  $10.58 < \sqrt{112} < 10.59$   
 (c)  $10.583 < \sqrt{112} < 10.584$   
 (d)  $10.583 < \sqrt{112} < 10.5831$   
 (e)  $10.583 < \sqrt{112} < 10.58301$   
 (f)  $10.583005 < \sqrt{112} < 10.583006$
- Use one number line picture [page 3-117] to show (a) and (b).
  - Use one number line picture to illustrate both (e) and (f).
  - What is the approximation to  $\sqrt{112}$  correct to 2 decimal places?
  - What is [the approximation to]  $\sqrt{112}$  correct to the nearest unit?
  - What is  $\sqrt{112}$  correct to the nearest 0.001?
  - What is  $\sqrt{112}$  correct to the nearest 0.0001?
  - $\sqrt{112} = \underline{\hspace{2cm}}$ , correct to the nearest hundredth?
  - $\sqrt{112} = \underline{\hspace{2cm}}$ , correct to 6 decimal places?
  - $\sqrt{112} = \underline{\hspace{2cm}}$ , correct to the nearest 0.000001?
  - True or false?
 

(a) $ \sqrt{112} - 10.583  < 0.001$	(b) $ \sqrt{112} - 10.583  < 0.0005$
(c) $ \sqrt{112} - 10.584  < 0.001$	(d) $ \sqrt{112} - 10.584  < 0.0005$
  - Which of the six statements can be used to derive all the rest?

B. The approximation to  $\sqrt{39}$  correct to 7 decimal places is 6.2449979. That is,  $\sqrt{39} = 6.2449979$ , correct to 7 decimal places.

- What is the approximation to  $\sqrt{39}$  correct to one decimal place? Two decimal places? Three decimal places? Four decimal places? Five decimal places?
- What is  $\sqrt{39}$ , correct to the nearest 0.1? 0.01? 0.001? 0.0001? Hundred thousandth? 0.000001?
- Give one number which differs from  $\sqrt{39}$  by less than 0.0000001. Give another number which differs from  $\sqrt{39}$  by less than 0.0000001. Give still another number.

C. 1. Given only the information that

$$12.124 < \sqrt{147} < 12.131,$$

which of the following can you be sure of?

(a)  $\sqrt{147} = 12$ , correct to the nearest unit.

(b)  $\sqrt{147} = 12.1$ , correct to 1 decimal place.

(c)  $\sqrt{147} = 12.1$ , correct to the nearest 0.1.

(d)  $\sqrt{147} = 12.12$ , correct to 2 decimal places.

(e)  $\sqrt{147} = 12.12$ , correct to the nearest 0.01.

(f)  $|\sqrt{147} - 12.1| < 0.1$                       (g)  $|\sqrt{147} - 12.1| < 0.05$

(h)  $|\sqrt{147} - 12.1| < 0.01$                       (i)  $|\sqrt{147} - 12.1| < 0.005$

2. Given that  $9.4 < \sqrt{89} < 9.47$ . Use this information to justify as many statements like those in the preceding exercise as you can.
3. Repeat Exercise 2 using the facts that  $13.227 < \sqrt{175} < 13.23$ .
4. Repeat Exercise 2 using the facts that  $9.4339 < \sqrt{89} < 9.4341$ .
5. Each of the following sentences gives you information concerning the square root of some number. In each case where you have sufficient information give the approximation to the square root correct to 3 decimal places and the approximation correct to the nearest 0.01.
- (a)  $3.741 < \sqrt{14} < 3.742$ .
- (b)  $6.928202 \leq \sqrt{48} < 6.928206$
- (c)  $15.554 < \sqrt{242} < 15.565$
- (d)  $|\sqrt{26} - 5.099| < 0.0005$
- (e)  $17.143 < \sqrt{274} < 17.15$
- (f)  $|\sqrt{37} - 6.082763| < 0.0000005$
- (g)  $1.7724 < \sqrt{\pi} < 1.7725$
- (h)  $11.180 < \sqrt{125} < 11.185$

3/142

## Answers for Part C.

1. The given information tells you that  $\sqrt{147}$  belongs to  $\{x: 12.124 < x < 12.131\}$ .

(a) We can be sure of this because it follows from the given information that  $\sqrt{147}$  belongs to  $\{x: 11.5 \leq x < 12.5\}$ .  
[This is so because

$$\{x: 12.124 < x < 12.131\} \subseteq \{x: 11.5 \leq x < 12.5\}.$$

(b) We can be sure of this because it follows from the given information that  $\sqrt{147}$  belongs to  $\{x: 12.1 \leq x < 12.2\}$ .

(c) We can be sure of this because it follows from the given information that  $\sqrt{147}$  belongs to  $\{x: 12.05 \leq x < 12.15\}$ .

(d) We can not be sure of this because

$$\{x: 12.124 < x < 12.131\} \not\subseteq \{x: 12.12 \leq x < 12.13\}.$$

As far as we can tell from the given information, it might be the case that  $12.13 \leq \sqrt{147} < 12.131$ .

(e) We can not be sure of this because

$$\{x: 12.124 < x < 12.131\} \not\subseteq \{x: 12.115 \leq x < 12.125\}.$$

(f) We can be sure of this because the given statement is equivalent to:

$$12 < \sqrt{147} < 12.2,$$

[which is another way of saying that  $\sqrt{147}$  belongs to  $\{x: 12 < x < 12.2\}$ ], and because

$$\{x: 12.124 < x < 12.131\} \subseteq \{x: 12 < x < 12.2\}.$$

(g) We can be sure of this because

$$\{x: 12.124 < x < 12.131\} \subseteq \{x: 12.05 < x < 12.15\}.$$

(h) We can be sure that this is not the case because the given statement is equivalent to ' $12.09 < \sqrt{147} < 12.11$ '. This statement is false because  $\sqrt{147} \in \{x: 12.124 < x < 12.131\}$  and so,  $\sqrt{147} \notin \{x: 12.09 < x < 12.11\}$ .

[3-120]

C. 1.

3/143

a

- (i) We can be sure that this is not the case because the given statement is equivalent to ' $\sqrt{12.095} < \sqrt{147} < 12.105$ '. This statement is false because  $\sqrt{147} \in \{x: 12.124 < x < 12.131\}$  and so,  $\sqrt{147} \notin \{x: 12.095 < x < 12.105\}$ .
2. (a)  $\sqrt{89} = 9$ , correct to the units place.  
 (b)  $\sqrt{89} = 9$ , correct to the nearest unit.  
 (c)  $\sqrt{89} = 9.4$ , correct to 1 decimal place.  
 (d)  $|\sqrt{89} - 9| < 1$  (e)  $|\sqrt{89} - 9| < 0.5$   
 (f)  $|\sqrt{89} - 9.4| < 0.1$
3. (a)  $\sqrt{175} = 13$ , correct to the units place.  
 (b)  $\sqrt{175} = 13$ , correct to the nearest unit.  
 (c)  $\sqrt{175} = 13.2$ , correct to 1 decimal place.  
 (d)  $\sqrt{175} = 13.2$ , correct to the nearest 0.1.  
 (e)  $\sqrt{175} = 13.22$ , correct to 2 decimal places.  
 (f)  $\sqrt{175} = 13.23$ , correct to the nearest 0.01.  
 (g)  $|\sqrt{175} - 13| < 1$  (h)  $|\sqrt{175} - 13| < 0.5$   
 (i)  $|\sqrt{175} - 13.2| < 0.1$  (j)  $|\sqrt{175} - 13.2| < 0.05$   
 (k)  $|\sqrt{175} - 13.22| < 0.01$  (l)  $|\sqrt{175} - 13.23| < 0.01$   
 (m)  $|\sqrt{175} - 13.23| < 0.005$
4. (a)  $\sqrt{89} = 9$ , correct to the units place.  
 (b)  $\sqrt{89} = 9$ , correct to the nearest unit.  
 (c)  $\sqrt{89} = 9.4$ , correct to 1 decimal place.  
 (d)  $\sqrt{89} = 9.4$ , correct to the nearest 0.1.  
 (e)  $\sqrt{89} = 9.43$ , correct to 2 decimal places.  
 (f)  $\sqrt{89} = 9.43$ , correct to the nearest 0.01.  
 (g)  $\sqrt{89} = 9.434$ , correct to the nearest 0.001.

[It doesn't follow from the given information that  $\sqrt{89} = 9.433$ , correct to 3 decimal places. The approximation correct to 3 decimal places is either 9.433 or 9.434. Also, either 9.4339 or 9.434 is the approximation correct to 4 decimal places, and either 9.4339, 9.434, or 9.4341 is the approximation correct to the nearest 0.0001.]

[3-120]

C. 1.

3/144

- (h)  $|\sqrt{89} - 9| < 1$                       (i)  $|\sqrt{89} - 9| < 0.5$   
 (j)  $|\sqrt{89} - 9.4| < 0.1$                       (k)  $|\sqrt{89} - 9.4| < 0.05$   
 (l)  $|\sqrt{89} - 9.43| < 0.01$                       (m)  $|\sqrt{89} - 9.43| < 0.005$   
 (n)  $|\sqrt{89} - 9.434| < 0.0005$                       (o)  $|\sqrt{89} - 9.434| < 0.0001$

[Notice that we can be sure of (o) even though we are not sure that 9.434 is the approximation correct to 4 decimal places.]

5. (a) 3.741; 3.74                      (b) 6.928; 6.93  
 (c) not enough information  
 (d) not enough information [The given sentence is equivalent to '5.0985 <  $\sqrt{26}$  < 5.0995'. From this we can conclude that 5.1 is the approximation correct to the nearest 0.01 (and even that 5.099 is correct to the nearest 0.001), but we can't tell which of 5.098 and 5.099 is the approximation correct to 3 decimal places.]  
 (e) not enough information                      (f) 6.082; 6.08  
 (g) 1.772; 1.77  
 (h) not enough information [But, we can tell that the approximation to  $\sqrt{125}$  which is correct to the nearest 0.01 is 11.18, and that the approximation correct to 2 decimal places is 11.18.]

\*

As an introduction to the work on pages 3-121ff., you might raise the question concerning how anyone could get the inequations given in Exercise 5.

[3-120]

C. 1.



[3-121]

f a

If 9 were the square root of 89, the quotient of 89 by 9 would be 9 because the quotient of a positive number by its principal square root is this root. This generalization was stated and proved on TC[3-110, 111]c.

\*

Students will probably grant that since  $89 \div 9 > 9$ ,  $9 < \sqrt{89} < 89 \div 9$ . However, they should be able to follow the proofs of the theorems which justify this assertion. What we need to know is, first, that if the divisor [9] is less than the quotient [ $89 \div 9$ ] then the divisor is less than the square root [ $\sqrt{89}$ ]. Secondly, if the divisor is less than the square root then the square root is less than the quotient. So, we want to prove the theorems:

$$(i) \quad \forall_{x \neq 0} \forall_y \text{ if } x > 0, y > 0, \text{ and } x < \frac{y^2}{x}, \text{ then } x < y.$$

and: (ii)  $\forall_{x \neq 0} \forall_y \text{ if } x > 0 \text{ and } x < y \text{ then } y < \frac{y^2}{x}.$

Proof of (i).

Since  $x < \frac{y^2}{x}$ ,  $\frac{y^2}{x} - x$  is positive. And, since  $x > 0$ ,  $x(\frac{y^2}{x} - x)$  is positive. That is,  $y^2 - x^2$  is positive.

Hence,  $y^2 > x^2$ . So [by the theorem proved on TC[3-108, 109]b],  $y > x$ .

Proof of (ii).

[We want to show that  $\frac{y^2}{x} - y$  is positive.]

$\frac{y^2}{x} - y = \frac{y^2 - xy}{x} = \frac{y(y - x)}{x}$ . Since  $x > 0$  and  $x < y$ ,

it follows that  $x$  is positive,  $y$  is positive, and  $y - x$

is positive. Hence,  $\frac{y(y - x)}{x}$  is positive.

\*

Be sure that students understand why  $89 \div 9 < 9.9$ . This is best accomplished by letting them carry out the division:

$$\begin{array}{r} 9.88 \\ 9 \overline{)89.00} \end{array}$$

## COMPUTING APPROXIMATIONS TO SQUARE ROOTS

One method of computing approximations to the square root of a number was illustrated earlier when we were searching for the positive number whose square is 30. By doing a great deal of squaring we found that

$$\begin{aligned} 5 &< \sqrt{30} < 6, \\ 5.4 &< \sqrt{30} < 5.5, \\ 5.47 &< \sqrt{30} < 5.48, \\ 5.477 &< \sqrt{30} < 5.478. \end{aligned}$$

Clearly, we could continue the squaring procedure and "close in" on  $\sqrt{30}$  as closely as we might want to.

There is another method of closing in which requires less work. Let's illustrate it. Suppose we want to find the approximation to  $\sqrt{89}$  which is correct to the nearest hundredth. The first thing we do is to make a guess. We guess, say, that  $\sqrt{89}$  is approximately 9. Then, we divide 89 by 9, and get approximately 9.9. If 9 were the square root of 89, the quotient would be 9 [Why?]. Since the quotient is larger than 9, we know that  $\sqrt{89}$  is between 9 and  $89 \div 9$ . Since  $89 \div 9 < 9.9$ ,  $\sqrt{89}$  is between 9 and 9.9. So, let's use a number between 9 and 9.9 as our next guess. One of the numbers between 9 and 9.9 is their average which is 9.4, correct to 1 decimal place.

Now, let's divide 89 by 9.4.

$$\begin{array}{r} 9.46 \\ 9.4 \overline{) 89.000} \\ \underline{846} \phantom{0} \\ 440 \phantom{0} \\ \underline{376} \phantom{0} \\ 640 \\ \underline{564} \phantom{0} \end{array}$$

The quotient of 89 by 9.4 is 9.46, correct to 2 decimal places. So,  $9.4 < \sqrt{89} < 9.47$ . [Do you see that this last statement tells us that  $\sqrt{89}$  is 9.4, correct to 1 decimal place?] Take the average of 9.4 and 9.47.

$$\frac{9.4 + 9.47}{2} = \frac{18.87}{2} = 9.43, \text{ correct to 2 decimal places.}$$

Use 9.43 as the next guess.

Divide 89 by 9.43

$$\begin{array}{r}
 9.43 \\
 9.43 \overline{)89.0000} \\
 \underline{8487} \phantom{0} \\
 4130 \\
 \underline{3772} \\
 3580 \\
 \underline{2829}
 \end{array}$$

We are now sure that  $9.43 < \sqrt{89} < 9.44$ . So, 9.43 is the approximation to  $\sqrt{89}$  correct to 2 decimal places. But, is it the approximation correct to the nearest 0.01? Might this approximation be 9.44? To decide, just square 9.435.  $(9.435)^2 = 89.019225 > 89$ . So, 9.43 is the approximation to  $\sqrt{89}$  correct to the nearest 0.01.

Let's try another example. Find the approximation to  $\sqrt{175}$  which is correct to the nearest 0.001. First, we make a guess [it can be a wild one]. Try 10. Now divide 175 by 10 to get 17.5, and average 17.5 with 10 to get approximately 13.7. 13.7 is the next guess. Divide 175 by 13.7.

$$\begin{array}{r}
 12.7 \\
 13.7 \overline{)175.00} \\
 \underline{137} \phantom{0} \\
 380 \\
 \underline{274} \\
 1060 \\
 \underline{959}
 \end{array}$$

Since  $12.7 < \sqrt{175} < 13.7$ , the average of 12.7 and 13.7 should be close to  $\sqrt{175}$ . This average is 13.2. Divide again.

$$\begin{array}{r}
 13.25 \\
 13.2 \overline{)175.000} \\
 \underline{132} \phantom{0} \\
 430 \\
 \underline{396} \\
 340 \\
 \underline{264} \\
 760 \\
 \underline{660}
 \end{array}$$

So,  $\sqrt{175}$  is between 13.2 and 13.26. [What is the approximation to  $\sqrt{175}$  correct to 1 decimal place?] Our next approximation is the average of 13.2 and 13.26, that is 13.23.



Divi

3/146

The second example in the text [finding an approximation to  $\sqrt{175}$ ] shows that when the dividing-and-averaging procedure is used as illustrated, considerable computation may be required to arrive at an approximation which has the desired accuracy. As shown on TC[3-124, 125, 126]a, a more subtle use of the procedure avoids much of the computation.

The approximation to  $\sqrt{175}$  correct to the nearest 0.001 is 13.229.

\*

Answers for Exercises.

- |                       |                     |                     |
|-----------------------|---------------------|---------------------|
| 1. 7.681; 7.68        | 2. -5.385; -5.39    | 3. 1.414; 1.41      |
| 4. 2.954; 2.95        | 5. 14.317; 14.32    | 6. 1.732; 1.73      |
| 7. 76.413; 76.41      | 8. 0.824; 0.82      | 9. 13.076; 13.08    |
| 10. 1.307; 1.31       | 11. 130.766; 130.77 |                     |
| 12. 1307.669; 1307.67 | 13. 41.352; 41.35   |                     |
| 14. 4.135; 4.14       | 15. 0.413; 0.41     | 16. 413.521; 413.52 |

[Students should discover that the answer for Exercise 9 can be used in finding the answers for Exercises 10-12, and that the answer for Exercise 13 can be used in finding the answers for Exercises 14-16.]

\*

Younger students can sometimes become enthusiastic about a class project on making a table of approximations correct to the nearest 0.1 [or nearest 0.01] for the square roots of positive integers between 0 and 100. Each student could contribute 3 or 4 of these approximations. Then, the list can be mimeographed and distributed to the class. [Naturally, you will want to check against a published table before you do this!] The list should also include the squares of these positive integers. With such a list available, a student would have a good start on Exercise 1 [he could use the approximation correct to the nearest 0.1 as his first divisor]. The column of squares would help him start on Exercise 5, especially if he did just a bit of interpolating. The tabled approximations for  $\sqrt{58}$  and  $\sqrt{59}$  plus the knowledge that

$$10\sqrt{58} < \sqrt{5839} < 10\sqrt{59}$$

would give him a fast start on Exercise 7.

$$\begin{array}{r}
 13.23 \overline{) 175.0000} \\
 \underline{1323} \phantom{00} \\
 4270 \phantom{00} \\
 \underline{3969} \phantom{00} \\
 3010 \phantom{00} \\
 \underline{2646} \phantom{00} \\
 3640 \phantom{00} \\
 \underline{2646} \phantom{00} \\
 9940 \phantom{00} \\
 \underline{9261} \phantom{00}
 \end{array}$$

This tells us that  $13.227 < \sqrt{175} < 13.23$ . So,  $\sqrt{175}$  is 13.22, correct to 2 decimal places, and  $\sqrt{175}$  is 13.23, correct to the nearest 0.01. Also, the approximation correct to the nearest 0.001 is either 13.227, 13.228, 13.229, or 13.23. We must average and divide again to get more information.  $\frac{13.227 + 13.23}{2} = 13.228$ , correct to 3 decimal places.

$$\begin{array}{r}
 13.228 \overline{) 175.000000} \\
 \underline{132295} \phantom{000} \\
 42705 \phantom{000} \\
 \underline{396900} \phantom{00} \\
 301500 \phantom{00} \\
 \underline{264600} \phantom{00} \\
 369000 \phantom{00} \\
 \underline{264600} \phantom{00} \\
 1044000 \phantom{00} \\
 \underline{1044000} \phantom{00} \\
 000000
 \end{array}$$

Now, we know that  $13.228 < \sqrt{175} < 13.2296$ . We still can't tell whether 13.228, 13.229, or 13.23 is the approximation to  $\sqrt{175}$  correct to the nearest 0.001. We could find out by squaring each and determining which square is closest to 175. Or, we can make our next guess by averaging 13.228 and 13.2296, and then dividing. Finish the problem.

### EXERCISES

For each exercise, find the approximation correct to 3 decimal places, and the approximation correct to the nearest 0.01.

- |                   |                    |                     |                      |
|-------------------|--------------------|---------------------|----------------------|
| 1. $\sqrt{59}$    | 2. $-\sqrt{29}$    | 3. $\sqrt{2}$       | 4. $\sqrt{8.73}$     |
| 5. $\sqrt{205}$   | 6. $\sqrt{3}$      | 7. $\sqrt{5839}$    | 8. $\sqrt{0.68}$     |
| 9. $\sqrt{171}$   | 10. $\sqrt{1.71}$  | 11. $\sqrt{17100}$  | 12. $\sqrt{1710000}$ |
| 13. $\sqrt{1710}$ | 14. $\sqrt{17.10}$ | 15. $\sqrt{0.1710}$ | 16. $\sqrt{171000}$  |

[More exercises are in Part O, Supplementary Exercises.]

### ☆ MORE ON DIVIDING-AND-AVERAGING

The dividing-and-averaging procedure can be used with just a slight modification as a very efficient method for finding extremely accurate approximations to square roots.

The first step consists in finding an approximation whose error is less than 0.1. After this, one finds successively better approximations by dividing-and-averaging, carrying out the divisions so as to obtain twice as many decimal places in the quotient numeral as there are in the divisor numeral, and carrying out the averagings so as to obtain the approximation to the average which is correct to this doubled number of decimal places. Let's try this in finding approximations to  $\sqrt{89}$ .

First, we need an approximation to  $\sqrt{89}$  which is in error by less than 0.1. We have already found that 9.4 is the approximation to  $\sqrt{89}$  correct to 1 decimal place. [We knew this because  $89 \div 9.4 = 9.4$ , correct to 1 decimal place.] So,  $|\sqrt{89} - 9.4| < 0.1$ . Now, we continue the division of 89 by 9.4, carrying out the division to obtain two decimal places in the quotient numeral.

$$\begin{array}{r} 9.46 \\ 9.4 \overline{) 89.00} \end{array}$$

Next, we average 9.4 and 9.46, keeping two decimal places in the numeral for the average.

$$\frac{9.4 + 9.46}{2} = 9.43, \text{ correct to 2 decimal places.}$$

This completes the second step, giving us 9.43 as the second approximation to  $\sqrt{89}$ .

Now, we divide-and-average again.

$$\begin{array}{r} 9.4379 \\ 9.43 \overline{) 89.0000} \end{array}$$

$$\frac{9.43 + 9.4379}{2} = 9.4339, \text{ correct to 4 decimal places.}$$

So, our third approximation to  $\sqrt{89}$  is 9.4339.

Divide-and-average again.

$$\begin{array}{r} 9.43406226 \\ 9.4339 \overline{) 89.00000000} \end{array}$$



3/i47

The advantages of the dividing-and-averaging method for finding square roots become apparent when one investigates how the accuracy of the approximations increases from step to step. The theorem required is:

$$\forall x > 0 \forall y > 0 \quad \sqrt{x} - \frac{y + \frac{x}{y}}{2} = -\frac{(\sqrt{x} - y)^2}{2y}.$$

[The proof requires only routine manipulations.]

It follows from this theorem that if  $y_1$  is an approximation to  $\sqrt{x}$  and

$$y_2 = \frac{y_1 + \frac{x}{y_1}}{2} \text{ then}$$

$$(*) \quad \sqrt{x} \leq y_2 \quad \text{and} \quad |\sqrt{x} - y_2| = \frac{|\sqrt{x} - y_1|^2}{2y_1}.$$

\*

For example, suppose in approximating  $\sqrt{175}$  [ $\sqrt{x}$ ], we take 13.2 as the first approximation [ $y_1$ ]. The second approximation [ $y_2$ ] is the average of 13.2 and  $175 \div 13.2$ . So, by (\*),

$$(1) \quad \sqrt{175} \leq \frac{13.2 + \frac{175}{13.2}}{2} \quad \text{and} \quad \left| \sqrt{175} - \frac{13.2 + \frac{175}{13.2}}{2} \right| = \frac{|\sqrt{175} - 13.2|^2}{2(13.2)}$$

By long division, we find that  $175 \div 13.2 < 13.26$ . So, when we average 13.2 and 13.26, we get a number [13.23] which is larger than the average of 13.2 and  $175 \div 13.2$ . We know that  $13.2 < \sqrt{175}$ , and by (\*), we know that  $\sqrt{175} < 13.23$ . So,  $13.2 < \sqrt{175} < 13.23$ . These facts give us an estimate of the error in the approximation 13.2:

$$|\sqrt{175} - 13.2| < 0.03.$$

$$\text{Since} \quad \frac{|\sqrt{175} - 13.2|^2}{2(13.2)} < \frac{(0.03)^2}{26.4} < 0.00004,$$

it follows from (1) that

[3-124]

☆ MORE ON

sl:

3/148

$$(2) \quad -0.00004 < \sqrt{175} - \frac{13.2 + \frac{175}{13.2}}{2} \leq 0.$$

By long division, we find that  $13.25757 < 175 \div 13.2 < 13.25758$ . So, (averaging each of these bounds with 13.2), we know that

$$(3) \quad 13.22878 < \frac{13.2 + \frac{175}{13.2}}{2} < 13.22879.$$

It follows from (2) and (3) [by adding] that

$$13.22874 < \sqrt{175} < 13.22879.$$

Hence, the approximation to  $\sqrt{175}$  which is correct to the nearest 0.001 is 13.229, and 13.2287 is correct to 4 decimal places.

The foregoing discussion illustrates how, by finding an estimate of the error in 13.2, one can use (\*) to tell how many places it is profitable to obtain in carrying out the long division of 175 by 13.2.

\*

Returning to (\*), we see that, in particular, if  $y_1 \geq \frac{1}{2}$  then  $|\sqrt{x} - y_2| \leq |\sqrt{x} - y_1|^2$ , and if (in addition)  $|\sqrt{x} - y_1| < 10^{-n}$  then  $|\sqrt{x} - y_2| < 10^{-2n}$ .

For example, since (as we have previously seen)  $|\sqrt{30} - 5.4772| < 10^{-4}$ ,

it follows that  $|\sqrt{30} - \frac{5.4772 + \frac{30}{5.4772}}{2}| < 10^{-8}$ . Colloquially, the accuracy of the second approximation is "at least double" the accuracy of the first. Actually, since  $2 \times 5.4772 > 10$ , we can claim even more:

[3-124]

☆ MORE ON

T

sl:



[3-124]

☆ MORE ON

T

sl:

3/150

In practice, starting with an approximation  $y_1$ , one [as has just been illustrated] never takes  $\frac{y_1 + \frac{x}{y_1}}{2}$  as the next approximation. Instead, one takes an approximation to this average. The approximation  $y_1$  is a  $10^{-n}$ -integer such that  $|\sqrt{x} - y_1| < 10^{-n}$ , and the next approximation, say,  $y_2'$ , will be the approximation to  $\frac{y_1 + \frac{x}{y_1}}{2}$  which is correct to  $2n$  [or, if  $y_1 \geq 5$ , to  $2n + 1$ ] places. So,

$$0 \leq \frac{y_1 + \frac{x}{y_1}}{2} - y_2' < 10^{-2n} .$$

By the theorem, since  $|\sqrt{x} - y_1| < 10^{-n}$ ,

$$-10^{-2n} < \sqrt{x} - \frac{y_1 + \frac{x}{y_1}}{2} \leq 0 .$$

Hence,

$$-10^{-2n} < \sqrt{x} - y_2' < 10^{-2n} ,$$

that is,

$$|\sqrt{x} - y_2'| < 10^{-2n} .$$

So, even with the error introduced by approximating to the approximation  $\frac{y_1 + \frac{x}{y_1}}{2}$  [ $y_2'$  instead of  $y_2$ ], the accuracy of the approximation doubles at each step.

[If  $y_1 \geq 5$ , we have, carrying the division one more place,

$$0 \leq \frac{y_1 + \frac{x}{y_1}}{2} - y_2' < 10^{-(2n+1)} ,$$

[3-124]

☆ MORE ON

T

sl:



3/151

and, by the theorem,

$$-10^{-(2n+1)} < \sqrt{x} - \frac{y_1 + \frac{x}{y_1}}{2} \leq 0.$$

So, if  $y_1 \geq 5$  then

$$|\sqrt{x} - y_2'| < 10^{-(2n+1)}. ]$$

The use of this automatic procedure for getting doubly good approximations depends, of course, on beginning with an approximation which is in error by less than  $10^{-1}$ . In most cases, this can be obtained by an initial dividing-and-averaging, starting with the approximation to the desired square root which is correct to the nearest unit. For, if  $y_1$  is this approximation then  $|\sqrt{x} - y_1| \leq \frac{1}{2}$ . So, according to the theorem proved earlier,  $|\sqrt{x} - y_2| \leq \frac{1}{8y_1}$ . Now,  $\frac{1}{8y_1} < \frac{1}{10}$  if  $y_1 > 1.25$ . Since  $y_1$  is an integer this means, effectively, that  $y_1 \geq 2$ . And, the approximation to  $\sqrt{x}$  which is correct to the nearest unit will be greater than or equal to 2 if  $\sqrt{x} \geq 1.5$ , that is, if  $x \geq 2.25$ . So, in finding approximations to the square root of a number greater than or equal to 2.25, if one begins with the approximation correct to the nearest unit and divides, the division should be carried out until one obtains an approximation to the quotient correct to one decimal place. Then average this approximation with the divisor. This average [correct to one decimal place] is an approximation which differs from the desired square root by less than  $10^{-1}$ . The next division should be carried out until you have an approximation to the quotient which is correct to two decimal places. [In case the divisor is  $\geq 5$ , you can carry the quotient numeral out to one more decimal place.] The average of quotient approximation and divisor will differ from the square root by less than  $10^{-2}$  [or, in case the divisor  $\geq 5$ , by less than  $10^{-3}$ ]. Continue, doubling the number of decimal places at each stage [or, if the divisor  $\geq 5$ , doubling and adding one more decimal place at each stage]. The error in each approximation is certain to be less than one unit in the last decimal place.

[For a brief discussion of "iterative processes", see the article "Feed It Back" by Francis Scheid in the April 1959 issue of The Mathematics Teacher.]

[3-124]

☆ MORE ON

T

sl:



Do you see that as far as we have checked them each approximation is "at least twice as accurate" as the preceding one? As a matter of fact, it can be proved that this always happens when your first approximation is in error by less than 0.1 and you "double the number of places" for the quotient numeral in each division. This being so, we can be certain that

$$|\sqrt{89} - 9.4339811310566038| < 0.0000000000000001 \quad [16 \text{ decimal places}]$$

Let's return to our third approximation, 9.4339, and the error estimate:

$$|\sqrt{89} - 9.4339| < 0.0001.$$

This estimate tells us that

$$9.4338 < \sqrt{89} < 9.434.$$

So, from it we can conclude that 9.434 is the approximation to  $\sqrt{89}$  correct to the nearest 0.001. [From the division  $89 \div 9.4339$  we see that  $9.4339 < \sqrt{89}$ . And, this tells us that 9.4339 is the approximation to  $\sqrt{89}$  correct to 4 decimal places.]

The error estimate for the fourth approximation, 9.43398113:

$$|\sqrt{89} - 9.43398113| < 0.00000001$$

tells us that

$$9.43398112 < \sqrt{89} < 9.43398114.$$

So, from it we can conclude that 9.4339811 is the approximation to  $\sqrt{89}$  correct to the nearest 0.0000001. [This also tells us that either 9.43398112 or 9.43398113 is the approximation to  $\sqrt{89}$  correct to 8 decimal places. How can you tell which?]

What is the approximation to  $\sqrt{89}$  correct to the nearest 0.0000000000000001? What can you say about the approximation to  $\sqrt{89}$  which is correct to 16 decimal places? How could you find out what this approximation is?

Use this procedure to find the approximation to  $\sqrt{175}$  correct to the nearest 0.0000001, and the approximation to  $\sqrt{175}$  correct to 8 decimal places.

3/152

The fourth division  $[89 \div 9.43398113]$  tells us that the divisor is smaller than  $\sqrt{89}$ ; so, it, rather than 9.43398112, is the approximation to  $\sqrt{89}$  correct to 8 decimal places.

\*

The error estimate for the fifth approximation tells us that the approximation to  $\sqrt{89}$  correct to the nearest 0.0000000000000001 is 9.433981131056604. It also tells us that either 9.4339811310566037 or 9.4339811310566038 is the approximation correct to 16 decimal places. You could decide which by dividing 89 by the larger of the two.

\*

Three divisions and averagings, and a fourth division,

$$175 \div 13.2 = 13.25+,$$

$$175 \div 13.22 = 13.2375+,$$

$$175 \div 13.2287 = 13.22881311+,$$

$$175 \div 13.22875655 = 13.22875656+,$$

show one that

$$|\sqrt{175} - 13.22875655| < 0.00000001$$

and that

$$13.22875655 < \sqrt{175}.$$

So,

$$13.22875655 < \sqrt{175} < 13.22875656.$$

Hence, the approximation to  $\sqrt{175}$  which is correct to the nearest 0.00000001 is 13.2287566, and the approximation which is correct to 8 decimal places is 13.22875655.

[3-126]

Do v  
matio  
ma'

## EXERCISES

A. Find the approximations correct to the nearest 0.01.

Sample 1.  $\sqrt{48}$

Solution. One way to do this is to use the divide-and-average method. Another method is to notice that  $48 = 16 \times 3$  and that 16 is the square of an integer. Thus,

$$\sqrt{48} = \sqrt{16 \times 3} = \sqrt{16} \times \sqrt{3} = 4\sqrt{3}.$$

So, we can find approximations to  $\sqrt{48}$  by multiplying 4 by approximations to  $\sqrt{3}$ . [But, the error in such an approximation to  $\sqrt{48}$  will be 4 times the error in the approximation used for  $\sqrt{3}$ .] Now, suppose you know that the approximation to  $\sqrt{3}$  correct to the nearest 0.000001 is 1.732051, that is,

$$1.7320505 \leq \sqrt{3} < 1.7320515.$$

From this we could get an estimate for  $\sqrt{48}$ :

$$4 \times 1.7320505 \leq 4 \times \sqrt{3} < 4 \times 1.7320515,$$

that is,

$$6.928202 \leq \sqrt{48} < 6.928206.$$

This tells us that 6.93 is the approximation to  $\sqrt{48}$  correct to the nearest 0.01. But, we didn't need to use so accurate an approximation to  $\sqrt{3}$  to find this out. Doing so caused us more computational labor than was necessary. [Of course, if you don't mind doing a bit of extra computing, this is a sure way of getting the answer. All you need do is multiply 1.732051 by 4, and round to the nearest 0.01.]

Another procedure is to notice that

$$1.732 < \sqrt{3} < 1.733.$$

So, multiplying by 4, gives us:

$$6.928 < \sqrt{48} < 6.932.$$

So, 6.93 is the approximation to  $\sqrt{48}$  correct to the nearest 0.01. [Would noticing that  $1.73 < \sqrt{3} < 1.74$  have helped?]

(continued on next page)

Suppose we wanted to find  $\sqrt{48}$  correct to the nearest 0.001. We would need to use at least the information that

$$1.7320 < \sqrt{3} < 1.7321.$$

Multiplying by 4, we find that:

$$6.9280 < \sqrt{48} < 6.9284.$$

So, 6.928 is the approximation to  $\sqrt{48}$  correct to the nearest 0.001, [and it is also the approximation to  $\sqrt{48}$  correct to 3 decimal places].

Sample 2. Find  $\sqrt{242}$ , correct to the nearest 0.01.

Solution. Since  $242 = 121 \times 2$  and  $121 = (11)^2$ , it follows that  $\sqrt{242} = 11\sqrt{2}$ . Hence, we can find an approximation to  $\sqrt{242}$  if we know an approximation to  $\sqrt{2}$ . [But, the error in such an approximation to  $\sqrt{242}$  will be 11 times the error in the approximation to  $\sqrt{2}$ .] Suppose we know that

$$\sqrt{2} = 1.41421356, \text{ correct to the nearest } 0.00000001.$$

This tells us, for example, that

$$1.414 < \sqrt{2} < 1.415.$$

So, multiplying by 11, we learn that

$$15.554 < \sqrt{242} < 15.565.$$

This tells only that either 15.55 or 15.56 is the approximation to  $\sqrt{242}$  correct to the nearest 0.01. We must use a more accurate estimate for  $\sqrt{2}$ .

$$1.4142 < \sqrt{2} < 1.4143$$

Multiplying by 11, we get:

$$15.5562 < \sqrt{242} < 15.5573.$$

And, from this we see that 15.56 is the approximation to  $\sqrt{242}$  correct to the nearest 0.01. [Also, we see that 15.55 is the approximation to  $\sqrt{242}$  correct to 2 decimal places.]







\*

[You will find it helpful to memorize the facts that

1. 4142 is the approximation to  $\sqrt{2}$  correct to the nearest 0.0001,
1. 7321 is the approximation to  $\sqrt{3}$  correct to the nearest 0.0001,
2. 2361 is the approximation to  $\sqrt{5}$  correct to the nearest 0.0001.]

\*

Find approximations correct to the nearest 0.01.

1.  $\sqrt{32}$
2.  $\sqrt{12}$
3.  $\sqrt{80}$
4.  $\sqrt{8}$
5.  $\sqrt{20}$
6.  $\sqrt{72}$

Sample 3.  $\sqrt{12} + \sqrt{75}$

Solution.  $\sqrt{12} + \sqrt{75} = 2\sqrt{3} + 5\sqrt{3} = 7\sqrt{3}$

Now, compute the approximation to  $\sqrt{12} + \sqrt{75}$  correct to the nearest 0.01 by using an appropriate approximation to  $\sqrt{3}$ .

7.  $\sqrt{8} + \sqrt{50}$
8.  $\sqrt{3} + \sqrt{27}$
9.  $3\sqrt{50} + \sqrt{72}$

Sample 4.  $\sqrt{6} \times \sqrt{12}$

Solution.  $\sqrt{6} \times \sqrt{12} = \sqrt{6} \times (\sqrt{6} \times \sqrt{2}) = 6\sqrt{2}$ . [Complete the problem.]

10.  $\sqrt{7} \times \sqrt{21}$
11.  $\sqrt{5} \times \sqrt{30}$
12.  $\sqrt{80} \div \sqrt{10}$

B. Simplify each of the following expressions.

Sample.  $\sqrt{75}$

Solution.  $\sqrt{75} = \sqrt{25 \times 3} = \sqrt{25} \times \sqrt{3} = 5\sqrt{3}$ .

The expression ' $5\sqrt{3}$ ' is considered simpler than ' $\sqrt{75}$ ' because if one wanted to find an approximation to  $\sqrt{75}$  and knew an approximation to  $\sqrt{3}$ , he could find the approximation to  $\sqrt{75}$  by easy multiplication.

1.  $\sqrt{50}$
2.  $\sqrt{98}$
3.  $\sqrt{147}$
4.  $\sqrt{200}$
5.  $\sqrt{300}$
6.  $\sqrt{.03}$
7.  $\sqrt{.02}$
8.  $\sqrt{.75}$
9.  $\sqrt{125}$
10.  $\sqrt{75} + \sqrt{48}$
11.  $\sqrt{45} - 2\sqrt{5} + 3\sqrt{20}$

(continued on next page)

12.  $\sqrt{7} \times \sqrt{14}$

13.  $7\sqrt{3} \times 2\sqrt{12} \times 3\sqrt{9}$

14.  $2\sqrt{48} - \sqrt{3}$

15.  $\frac{1}{2}\sqrt{32} + \frac{1}{3}\sqrt{18} - \frac{1}{5}\sqrt{50}$

16.  $\sqrt{200} \times \sqrt{\frac{1}{2}}$

17.  $\sqrt{242} + \sqrt{162} - \sqrt{72}$

18.  $\sqrt{57} \div \sqrt{19}$

19.  $5\sqrt{18} \times 6\sqrt{8} \times 3\sqrt{25}$

20.  $(\sqrt{50})^2 \times (3\sqrt{7})^2$

21.  $\sqrt{20} + 2\sqrt{75} + \sqrt{45} - \sqrt{300}$

[More exercises are in Part P, Supplementary Exercises.]

C. Solve these equations. Give the roots, and also give approximations which are correct to the nearest 0.01.

Sample.  $2x^2 - 5 = 0$

Solution.  $2x^2 - 5 = 0$

$$4x^2 - 10 = 0$$

$$(2x - \sqrt{10})(2x + \sqrt{10}) = 0$$

$$2x - \sqrt{10} = 0 \text{ or } 2x + \sqrt{10} = 0$$

$$2x = \sqrt{10} \text{ or } 2x = -\sqrt{10}$$

$$x = \frac{1}{2}\sqrt{10} \text{ or } x = -\frac{1}{2}\sqrt{10}$$

The "exact" roots are  $\frac{1}{2}\sqrt{10}$  and  $-\frac{1}{2}\sqrt{10}$ .

Approximations to the roots are obtained by using an approximation to  $\sqrt{10}$ . By the dividing-and-averaging process we find that

$$3.16 < \sqrt{10} < 3.17.$$

So,  $1.58 < \frac{1}{2}\sqrt{10} < 1.585$ , and 1.58 is the approximation to  $\sqrt{10}$  which is correct to the nearest 0.01 [as well as to 2 decimal places]. Hence, 1.58 and -1.58 are the approximations to the roots correct to the nearest 0.01.

Roots:  $\frac{1}{2}\sqrt{10}$  and  $-\frac{1}{2}\sqrt{10}$

Approximations: 1.58 and -1.58

1.  $x^2 - 48 = 0$

2.  $y^2 = 75$

3.  $x^2 - 98 = 0$

4.  $100y^2 = 8$

5.  $25x^2 - 2 = 0$

6.  $50x^2 - 81 = 0$

7.  $64 = z^2$

8.  $12 - k^2 = 0$

9.  $x^2 - \frac{3}{2} = 0$

10.  $5x - \sqrt{3} = 0$

11.  $x^2 - 5.83 = 0$

12.  $0.0082 = y^2$



By definition, the square root of 25 is 5, and the negative square root of 25 is  $-5$ . By definition, the square root of 73 is  $\sqrt{73}$ , and the negative square root of 73 is  $-\sqrt{73}$ . Each positive number has a positive square root [its principal square root] and a negative square root. There is only one real number whose square is 0, and this number is 0 itself [which is neither positive nor negative]. So, we say that the square root of 0 is 0.

Since the square of any real number is nonnegative, there is no real number whose square is  $-4$ . So, the real number  $-4$  does not have square roots. [Do not confuse this last statement with the statement that the complex number  $-4 + 0i$  has two square roots,  $0 + 2i$  and  $0 - 2i$ , which are complex numbers.]

The square of 3 is 9. Since 3 is the nonnegative number whose square is 9, 3 is the square root of 9. So, 3 is the square root of the square of 3. [The negative square root of the square of 3 is  $-3$ .]

The square of  $-3$  is 9. Since 3 is the nonnegative number whose square is 9, 3 is the square root of 9. So, 3 is the square root of the square of  $-3$ . [The negative square root of the square of  $-3$  is  $-3$ .]

There is a tendency to regard the radical sign ' $\sqrt{\quad}$ ' as something which cancels the exponent ' $^2$ '. That is, students may think that

$$\sqrt{(-3)^2} = -3.$$

This is contrary to the definition of ' $\sqrt{\quad}$ '. For, by definition,  $\sqrt{(-3)^2}$  is the nonnegative number whose square is  $(-3)^2$ , that is, whose square is 9. And, this number is 3, not  $-3$ . [Why? Because although  $(-3)^2$  is 9,  $-3$  is not nonnegative.]

By definition,  $\sqrt{(2-8)^2}$  is the nonnegative number whose square is  $(2-8)^2$ . So, as in (f),  $\sqrt{(2-8)^2}$  is  $-(2-8)$ . The square of  $-(2-8)$  is  $(2-8)^2$  and  $-(2-8)$  is nonnegative.

A convention to the effect that the radical sign cancels the exponent would involve great inconvenience since it would enable you to prove, for example, that  $+3 = -3$ . Since  $(+3)^2 = 9 = (-3)^2$ ,  $\sqrt{(+3)^2} = \sqrt{9}$ , and  $\sqrt{(-3)^2} = \sqrt{9}$ . But, if  $\sqrt{(+3)^2} = +3$  and  $\sqrt{(-3)^2} = -3$ , it follows that  $\sqrt{9} = +3$  and  $\sqrt{9} = -3$ . So,  $+3 = -3$ .

## PRINCIPAL SQUARE ROOT

What is the square root of 25? What is the negative square root of 25?

What is the square root of 73? What is the negative square root of 73?

Does the real number 0 have square roots? Does it have a positive square root? Does it have a negative square root?

Does the negative number, -4, have square roots? Does it have a positive square root? Does it have a negative square root?

Correct answers to these questions suggest the following generalizations.

(1) For each number  $x > 0$ ,

there is just one positive number,  $\sqrt{x}$ , whose square is  $x$ , and there is just one negative number,  $-\sqrt{x}$ , whose square is  $x$ .

(2) 0 has just one square root, 0.

(3) Negative real numbers do not have real number square roots.

The nonnegative square root of a nonnegative real number is called the principal square root, or, simply, the square root.

What is the square of 3? What is the square root of the square of 3? What is the negative square root of the square of 3?

What is the square of -3? What is the square root of the square of -3? What is the negative square root of the square of -3?

Study each of the following true sentences:

$$(a) \sqrt{(-3)^2} = \sqrt{(+3)^2} = +3$$

$$(b) \sqrt{(+5)^2} = \sqrt{(-5)^2} = +5$$

$$(c) -\sqrt{(-5)^2} = -\sqrt{(+5)^2} = -5$$

$$(d) \sqrt{(8 - 2)^2} = 8 - 2$$

$$(e) \sqrt{(2 - 8)^2} = 8 - 2$$

$$(f) \sqrt{(2 - 8)^2} = -(2 - 8)$$

The examples at the bottom of the preceding page suggest the following generalization:

For each  $x$ ,

$$\sqrt{x^2} = x \text{ if } x \geq 0, \text{ and } \sqrt{x^2} = -x \text{ if } x < 0.$$

Recalling our agreement to the effect that ' $|x|$ ' is ambiguous and can be used as an abbreviation for '+ $|x|$ ', we can say that

$$\text{for each } x, \sqrt{x^2} = |x|.$$

Instances of this generalization are:

$$\begin{aligned} \sqrt{7^2} &= |7| = 7, & \sqrt{(-3)^2} &= |-3| = 3, \\ \sqrt{(3-9)^2} &= |3-9| = 6, & \sqrt{0^2} &= |0| = 0. \end{aligned}$$

### EXERCISES

A. Simplify.

Sample 1.  $\sqrt{x^2 - 6x + 9}$

Solution. Since, for each  $x$ ,

$$x^2 - 6x + 9 = (x - 3)^2,$$

it follows that, for each  $x$ ,

$$\sqrt{x^2 - 6x + 9} = \sqrt{(x - 3)^2}.$$

And, by the generalization stated above,

$$\text{for each } x, \sqrt{(x - 3)^2} = |x - 3|.$$

Sample 2.  $\sqrt{4y^2}$

Solution.  $\sqrt{4y^2} = \sqrt{(2y)^2} = |2y|$

- |                             |                              |                              |                    |
|-----------------------------|------------------------------|------------------------------|--------------------|
| 1. $\sqrt{16x^2}$           | 2. $\sqrt{64z^2}$            | 3. $-\sqrt{81a^2}$           | 4. $-\sqrt{25b^2}$ |
| 5. $\sqrt{36a^2b^2}$        | 6. $-\sqrt{49x^2y^2}$        | 7. $-\sqrt{100(x+3)^2}$      |                    |
| 8. $\sqrt{k^2 + 10k + 25}$  | 9. $\sqrt{a^2 - 4a + 4}$     | 10. $\sqrt{x^2 - 18x + 81}$  |                    |
| 11. $\sqrt{81 - 18x + x^2}$ | 12. $\sqrt{a^2 - 2ab + b^2}$ | 13. $\sqrt{x^2 + 2xy + y^2}$ |                    |



3/155

With regard to Sample 1 of Part A, students may feel more comfortable with the generalization:

$$\forall_x \sqrt{x^2 - 6x + 9} = |x - 3|$$

if they make some substitutions.

$$\sqrt{4^2 - 6 \cdot 4 + 9} = \sqrt{16 - 24 + 9} = \sqrt{1} = 1 = |4 - 3|$$

$$\sqrt{2^2 - 6 \cdot 2 + 9} = \sqrt{4 - 12 + 9} = \sqrt{1} = 1 = |2 - 3|$$

An equally good generalization is:

$$\forall_x \sqrt{x^2 - 6x + 9} = |3 - x|.$$

\*

Answers for Part A [on pages 3-132 and 3-133].

1.  $|4x|$
2.  $|8z|$
3.  $-|9a|$
4.  $-|5b|$
5.  $|6ab|$
6.  $-|7xy|$
7.  $-|10(x + 3)|$
8.  $|k + 5|$
9.  $|a - 2|$
10.  $|x - 9|$
11.  $|x - 9|$
12.  $|a - b|$
13.  $|x + y|$
14.  $|3x - 2|$
15.  $|7x - 5y|$
16.  $|2p - 3q|$
17.  $|(x + 3)(x - 5)|$  [or:  $|x^2 - 2x - 15|$ ]
18.  $|\sqrt{10}x(x + 4)|$  [or:  $\sqrt{10} |x(x + 4)|$ ]
19. This expression cannot be simplified.

\*

Answers for Part B [on page 3-133].

1. 3, -7
2.  $\frac{5}{2}, -\frac{5}{3}$
3. -2, -9
4.  $\frac{2}{3}, -9$
5. -5, [not 9]
6. -1
7.  $\{x: -9 < x < 9\}$
8.  $\{x: x < -6 \text{ or } x > 5\}$
9. 21
10.  $\frac{1}{11}, 1$

[3-132]

The  
follow

14.  $\sqrt{9x^2 - 12x + 4}$

15.  $\sqrt{49x^2 - 70xy + 25y^2}$

16.  $\sqrt{4p^2 - 12pq + 9q^2}$

17.  $\sqrt{(x + 3)^2(x - 5)^2}$

18.  $\sqrt{10x^2(x^2 + 8x + 16)}$

19.  $\sqrt{x^2 + y^2}$

[More exercises are in Part Q, Supplementary Exercises.]

B. Solve these equations and inequations.

Sample.  $x = 9 - \frac{8}{x}$

Solution.  $x = 9 - \frac{8}{x}$

$$x^2 = x\left(9 - \frac{8}{x}\right), \quad [x \neq 0]$$

$$x^2 = 9x - 8$$

$$x^2 - 9x + 8 = 0$$

$$(x - 1)(x - 8) = 0$$

$$x - 1 = 0 \quad \text{or} \quad x - 8 = 0$$

$$x = 1 \quad \text{or} \quad x = 8$$

The roots are 1 and 8.

Check.

$$1 = 9 - \frac{8}{1} ?$$

$$1 \mid 9 - 8$$

$$1 = 1 \quad \checkmark$$

$$8 = 9 - \frac{8}{8} ?$$

$$8 \mid 9 - 1$$

$$8 = 8 \quad \checkmark$$

1.  $\frac{21}{x} - 4 = x$

2.  $5 + \frac{25}{y} = 6y$

3.  $1 + \frac{11}{x} + \frac{18}{x^2} = 0$

4.  $\frac{6}{y^2} = \frac{25}{3y} + 1$

5.  $x + \frac{x+3}{x-9} = \frac{12}{x-9} - 4$

6.  $1 + \frac{3}{y+2} = \frac{y+4}{y+2} - y$

7.  $(y+3)^2 < 6(y+15)$

8.  $x(x+4) > 3 + 3(9+x)$

9.  $\frac{2x+3}{3x-3} = \frac{x+9}{2x-2}$

10.  $\frac{5y+2}{3y+4} = \frac{6y-3}{8y-5}$

[More exercises are in Part R, Supplementary Exercises.]

C. Solve these problems.

Sample. A salesman travels 224 miles at a rate which is 4 miles per hour faster than his usual rate. This saves him 1 hour. How many hours does he usually take to travel this distance?

Solution. Suppose that he usually takes  $x$  hours to travel this distance. Then, his usual rate is  $\frac{224}{x}$  miles per hour. His faster rate is  $(\frac{224}{x} + 4)$  miles per hour. So, his faster time is  $\frac{224}{\frac{224}{x} + 4}$  hours.

Hence, we are looking for a number  $x$  such that

$$(*) \quad \frac{224}{\frac{224}{x} + 4} = x - 1.$$

We solve equation (\*).

$$\frac{224}{\frac{224 + 4x}{x}} = x - 1, \quad [x \neq 0, 224 + 4x \neq 0]$$

$$\frac{224x}{224 + 4x} = x - 1$$

$$(224 + 4x) \frac{224x}{224 + 4x} = (x - 1)(224 + 4x)$$

$$224x = (x - 1)(4x + 224)$$

$$224x = 4x^2 + 220x - 224$$

$$4x^2 - 4x - 224 = 0$$

$$\frac{1}{4}(4x^2 - 4x - 224) = 0 \cdot \frac{1}{4}$$

$$x^2 - x - 56 = 0$$

$$(x - 8)(x + 7) = 0$$

$$x = +8 \quad \text{or} \quad x = -7$$

Since we are looking for a number of arithmetic, we know that 8 is the only number of arithmetic which satisfies (\*).

So, the salesman's usual time of travel is 8 hours.



Answers for Part C [on pages 3-135 and 3-136].

1. 10 [x boys in the original group, each would have had to contribute  $120/x$  dollars,  $x + 2$  boys in the new group, each contributes  $120/(x + 2)$  dollars;  $(120/x) - 2 = 120/(x + 2)$ ; the roots are  $-12$  and  $10$ ]
2. Raymond, 6 hours; Robert, 4 hours [x hours...Raymond,  $x - 2$  hours...Robert;  $(1/x) + [1/(x - 2)] = 1/2.4$ ; the roots are 6 and 0.8]
3. 6 m.p.h. [x m.p.h. ... still water rate,  $x - 3$  m.p.h. ... upstream rate,  $9/(x - 3)$  hours...upstream trip,  $x + 3$  m.p.h....downstream rate,  $9/(x + 3)$  hours...downstream trip;  $[9/(x - 3)] + [9/(x + 3)] = 4$ ; the roots are  $-1.5$  and  $6$ ]
4. The data are insufficient.
5. 3.6 hours [x hours...time for inlet pipe to fill an empty tank,  $x + 1$  hours...time for outlet pipe to empty a full tank;  $(2/x) - [2/(x + 1)] = 0.10$ ; the roots are  $-5$  and  $4$ ; if it takes 4 hours for the inlet pipe to fill an empty tank, it takes 90% of 4, or 3.6 hours to fill 90% of the tank]
6. 1 inch by 5 inches

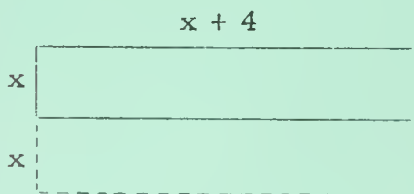

$$(2x)(x + 4) = 1.5[x(x + 4)] + 2.5$$

The roots are  $-5$  and  $1$ .

7. Bud, 20; Al, 25 [x...Bud's age now,  $x + 5$ ...Al's age now;  $2(x - 5)(x + 5 - 5) = x(x + 5) + 100$ ; the roots are 20 and  $-5$ ]
8. There are two such numbers. They are  $-1.5$  and  $-1$ .  
 $[x/(2x + 1) = (1/2)x + (3/2)]$
9. 500 [x ants in the colony,  $10/x$  ounces to be carried by each ant,  $(10/x) - (1/100)$  ounces to be carried by each ant if there were  $x + 500$  ants in the colony;  $[(10/x) - (1/100)](x + 500) = 10$ ; the roots are  $-1000$  and  $500$ ]

\*

Answers for Part D [on page 3-136].

1.  $x = 5n$  or  $x = 4n$
  2.  $x = -8r$  or  $x = 4$
  3.  $x = -a$
  4.  $x = 3b$
- TC[3-135, 136].

Check. The usual rate is  $\frac{224}{8}$  miles per hour, that is, 28 miles per hour. The faster rate is 32 miles per hour, and the time required at this faster rate is  $\frac{224}{32}$  hours, that is, 7 hours, which is 1 hour less than the usual time.

1. A group of boys decided to build a clubhouse, and share the cost equally. They estimated that the total cost would be \$120. Since this made their shares more than they could afford, they invited two other boys to join them. This reduced the cost per boy by \$2. How many boys were there in the original group?
2. Robert can mow a lawn in 2 hours less time than Raymond, and together they take 2.4 hours. How long does it take each one separately?
3. On a fishing trip a man can go 9 miles upstream and return in a total of 4 hours. If the current flows at the rate of 3 miles per hour, what is the speed of the boat in still water?
4. Bill bought several second-hand bicycles for \$180 during his summer vacation and tried to sell them to his friends, all at the same price. He sold all but two of them, and collected a total of \$250. How many bicycles did he buy?
5. A tank has an inlet pipe and an outlet pipe. The inlet pipe can fill the tank in 1 hour less time than the outlet pipe can empty it. The inlet pipe is turned on to fill the tank. After 2 hours, someone discovers that the outlet pipe is open. He turns off the outlet pipe. If only 10% of the tank has been filled, how long does it take the inlet pipe to finish filling the tank?

(continued on next page)

6. One side of a rectangle is 4 inches longer than another side. If the smaller side were doubled [and the longer side not changed], you would get a rectangle whose area was 2.5 square inches more than 1.5 times the original area. Find the dimensions of the original rectangle.
7. Al is 5 years older than Bud. Twice the product of their ages 5 years ago is 100 more than the product of their present ages. Find the present ages of Al and Bud.
8. Find the number which when divided by 1 more than twice itself gives a result which is  $\frac{3}{2}$  more than  $\frac{1}{2}$  the original number.
9. A colony of ants come upon 10 ounces of bread crumbs scattered around after a picnic. The ant leader decides that if there were 500 more ants, each would have to carry  $\frac{1}{100}$  of an ounce less. How many ants are there in the colony?

D. Solve for 'x'.

Sample.  $x^2 - ax - 20a^2 = 0$

Solution.  $x^2 - ax - 20a^2 = 0$

$$(x - 5a)(x + 4a) = 0$$

$$x - 5a = 0 \quad \text{or} \quad x + 4a = 0$$

$$x = 5a \quad \text{or} \quad x = -4a$$

[This solution shows that, for each a,

$$\{x: x^2 - ax - 20a^2 = 0\} = \{x: x = 5a \text{ or } x = -4a\}.$$

1.  $x^2 - 9nx + 20n^2 = 0$

2.  $x^2 + 7rx - 8r^2 = 0$

3.  $x^2 + 2ax + a^2 = 0$

4.  $x^2 - 6bx + 9b^2 = 0$





3/158

- |                        |                              |             |
|------------------------|------------------------------|-------------|
| 22. $32/5 = 32/5$      | 23. $-1 = -1$                | 24. $7 = 7$ |
| 25. $19/5 = 19/5$      | 26. $10/3 = 10/3$            | 27. $3 = 3$ |
| 28. $-1 = -1$          | 29. $-(2/9) = -(2/9)$        | 30. $2 = 2$ |
| 31. $4/13 = 4/13$      | 32. $-(1/4) = -(1/4)$        | 33. $0 = 0$ |
| 34. $0 = 0$            | 35. $7 = 7, -(3/2) = -(3/2)$ |             |
| 36. $91 = 91, 36 = 36$ | 37. ---                      | 38. ---     |
| 40. ---                | 41. ---                      | 42. ---     |

- B.
- |   |                             |                  |                 |
|---|-----------------------------|------------------|-----------------|
| 1. $15/8$   | 2. $8/7$                    | 3. $10/3$        | 4. $14/3$       |
| 5. $18/5$   | 6. $80/9$                   | 7. $12$          | 8. $7/3$        |
| 9. $12$   | 10. $35/3$                  | 11. $16/9$       | 12. $32/15$     |
| 13. $185/122$   | 14. $1102/17$               | 15. $1557/60200$ | 16. $16$        |
| 17. $15$  | 18. $9$                     | 19. $66/7$       | 20. $3/13$      |
| 21. $19/8$  | 22. $1481/485$              | 23. $1849/305$   | 24. $-1106/555$ |
| 25. $6, -6$   | 26. $12, -12$               | 27. $13, -13$    |                 |
| 28. $\sqrt{21}, -\sqrt{21}$   | 29. $\sqrt{12}, -\sqrt{12}$ | 30. $13, -5$     |                 |
| 31. $\frac{ac}{b}, [b \neq 0 \neq c]; \frac{bc}{a}, [abc \neq 0]; -\sqrt{ac} \text{ or } \sqrt{ac}, [ac > 0]$ |                             |                  |                 |



[Change Exercise 41 of Part A to ' $x^2 - 1 > 3[(x - 7) + 6]$ '.]

Answers for MISCELLANEOUS EXERCISES.

- A. 1. 9            2. 4            3. 11            4. 3  
 5.  $1/3$           6. 6            7. no roots      8. 0  
 9. -3            10. -8          11.  $14/5$         12. 3  
 13. 3            14.  $3/2$         15. no roots     16. 1  
 17. 0, 3        18. 0            19.  $\{r: r > 1\}$     20.  $\{m: m > -1\}$   
 21. 0            22.  $3/5$         23. 10            24. 12  
 25.  $-(3/5)$     26.  $10/3$        27. 9            28. -8  
 29. -15.5      30. 2.5        31.  $59/9$         32.  $-(2/11)$   
 33. -4, -5     34. 7, 10      35.  $3/2, -7$      36. -14, 8  
 37.  $\{x: x > -6\}$     38.  $\{x: x > 11/2\}$     39.  $\{x: x > 5/17\}$   
 40.  $\{x: x > -(16/33)\}$     41.  $\{x: x < 1 \text{ or } x > 2\}$   
 42.  $\{x: x = x\}$

\*

Check equations for Part A.

- |               |               |               |
|---------------|---------------|---------------|
| 1. $17 = 17$  | 2. $7 = 7$    | 3. $-6 = -6$  |
| 4. $10 = 10$  | 5. $9 = 9$    | 6. $-2 = -2$  |
| 7. ---        | 8. $0 = 0$    | 9. $3 = 3$    |
| 10. $5 = 5$   | 11. $18 = 18$ | 12. $15 = 15$ |
| 13. $5 = 5$   | 14. $0 = 0$   | 15. ---       |
| 16. $15 = 15$ | 17. $0 = 0$   | 18. $0 = 0$   |
| 19. ---       | 20. ---       | 21. $0 = 0$   |

## MISCELLANEOUS EXERCISES

A. Solve these equations and inequations.

1.  $x + 8 = 17$
2.  $3 + y = 7$
3.  $5 - z = -6$
4.  $2x + 4 = 10$
5.  $9 = 8 + 3y$
6.  $-2 = 4 - x$
7.  $6 + x = 7 + x$
8.  $6x = 7x$
9.  $-x = 3$
10.  $5 = -x - 3$
11.  $3a + 4 + 2a = 18$
12.  $7x - 3 - x = 15$
13.  $2y - (4 - y) = 5$
14.  $z - (3 - z) = 0$
15.  $8x + 2(3 - 4x) = 9$
16.  $5y + 2(7 - 2y) = 15$
17.  $x(x - 3) = x(3 - x)$
18.  $y(y + 1) + y(y - 3) = y(7 + 2y)$
19.  $5r - 2 > 7 - 4r$
20.  $6 - 5m < 7m + 18$
21.  $7t - t = 3t - 8t$
22.  $4(1 + x) = 7 - x$
23.  $\frac{a}{5} - 3 = \frac{a}{2} - 6$
24.  $\frac{x}{3} + \frac{x}{4} = 13 - \frac{x}{2}$
25.  $8 - (3 - 2x) = 7(x + 1) + 1$
26.  $4 - 2(x - 3) = 1 - (1 - x)$
27.  $\frac{x + 3}{2} - \frac{x}{3} = \frac{2x - 3}{5}$
28.  $\frac{3 - y}{11} + \frac{4 + y}{2} = 1 + \frac{y}{4}$
29.  $\frac{5}{x - 7} = \frac{3}{x + 2}$
30.  $\frac{5}{2z} + \frac{9}{4z - 1} = \frac{5}{z}$
31.  $\frac{x - 3}{x + 5} = \frac{x - 7}{x - 8}$
32.  $\frac{2y + 1}{3y - 2} = \frac{6y + 1}{9y + 2}$
33.  $x^2 + 9x + 20 = 0$
34.  $y^2 - 17y + 70 = 0$
35.  $x + \frac{11}{2} = \frac{21}{2x}$
36.  $\frac{1}{2}x(x + 1) = 56 - \frac{5x}{2}$
37.  $4x + 5 > 2x - 7$
38.  $5(x - 1) > 6x - 3(x - 2)$
39.  $\frac{5 - 3x}{7} < \frac{x + 5}{9}$
40.  $9 - 3(2x + 4) < \frac{x}{2} - \frac{3x + 1}{3}$
41.  $x^2 - 1 > 3[(x - 7) - 6]$
42.  $x^2 + 25 \geq 10x$

B. If both members of an equation are fractions, the equation is called a proportion. Here are examples of proportions:

$$\frac{3}{5} = \frac{6}{10}, \quad \frac{x}{7} = \frac{3}{14}, \quad \frac{5}{9} = \frac{3}{y}, \quad \frac{4}{3} = \frac{8}{17}.$$

Sample. Solve the proportion:

$$\frac{2}{x} = \frac{5}{7}.$$

Solution.

$$\frac{2}{x} = \frac{5}{7}$$

$$7x\left(\frac{2}{x}\right) = 7x\left(\frac{5}{7}\right), \quad [x \neq 0]$$

$$14 = 5x$$

The root is  $\frac{14}{5}$ .

Solve these proportions. [Be on the alert for short cuts.]

1.  $\frac{3}{x} = \frac{8}{5}$

2.  $\frac{7}{4} = \frac{2}{a}$

3.  $\frac{6}{5} = \frac{4}{y}$

4.  $\frac{2}{k} = \frac{3}{7}$

5.  $\frac{9}{x} = \frac{5}{2}$

6.  $\frac{8}{x} = \frac{9}{10}$

7.  $\frac{7}{7} = \frac{12}{x}$

8.  $\frac{y}{3} = \frac{7}{9}$

9.  $\frac{6}{11} = \frac{x}{22}$

10.  $\frac{3}{5} = \frac{7}{A}$

11.  $\frac{4}{B} = \frac{9}{4}$

12.  $\frac{8}{y} = \frac{15}{4}$

13.  $\frac{6.1}{3.7} = \frac{2.5}{x}$

14.  $\frac{38}{x} = \frac{17}{29}$

15.  $\frac{6.02}{0.03} = \frac{5.19}{x}$

16.  $\frac{3}{7} = \frac{6}{x-2}$

17.  $\frac{16}{x-3} = \frac{4}{3}$

18.  $\frac{6}{5} = \frac{x+9}{15}$

19.  $\frac{5}{y-8} = \frac{7}{2}$

20.  $\frac{2y+3}{5} = \frac{9}{13}$

21.  $\frac{5-x}{7} = \frac{3}{8}$

22.  $\frac{8.3}{x-1} = \frac{9.7}{2.4}$

23.  $\frac{5.8}{x+2.4} = \frac{6.1}{8.9}$

24.  $\frac{3.4+x}{7.1} = \frac{2.2}{11.1}$

25.  $\frac{3}{x} = \frac{x}{12}$

26.  $\frac{48}{k} = \frac{k}{3}$

27.  $\frac{x}{169} = \frac{1}{x}$

28.  $\frac{7}{y} = \frac{y}{3}$

29.  $\frac{3}{t} = \frac{t}{4}$

30.  $\frac{27}{x-4} = \frac{x-4}{3}$

31. Solve each for 'x':  $\frac{a}{b} = \frac{x}{c}$ ,  $\frac{a}{b} = \frac{c}{x}$ ,  $\frac{a}{x} = \frac{x}{c}$ .



B. If both  
a p

5.  $\forall_x \forall_y (xy)^2 = x^2 y^2$

$$\begin{aligned} & (xy)^2 \\ &= xyxy \quad \left. \vphantom{(xy)^2} \right\} \text{apm} \\ &= x(xy)y \quad \left. \vphantom{(xy)^2} \right\} \text{cpm} \\ &= x^2 yy \quad \left. \vphantom{(xy)^2} \right\} \text{apm} \\ &= x^2 y^2. \quad \left. \vphantom{(xy)^2} \right\} \text{apm} \end{aligned}$$

★ 6.  $\forall_{x \geq 0} \forall_{y \geq 0} \sqrt{x} \cdot \sqrt{y} = \sqrt{xy}$

Since  $\sqrt{xy}$  is the nonnegative number whose square is  $xy$ , we need only show that  $\sqrt{x}\sqrt{y}$  is nonnegative and  $(\sqrt{x}\sqrt{y})^2 = xy$ . Hence, since  $\sqrt{x}$  and  $\sqrt{y}$  are nonnegative, and since the product of two nonnegative numbers is nonnegative,  $\sqrt{x}\sqrt{y}$  is nonnegative. And,

$$\begin{aligned} & (\sqrt{x}\sqrt{y})^2 \\ &= (\sqrt{x})^2 (\sqrt{y})^2 \quad \left. \vphantom{(\sqrt{x}\sqrt{y})^2} \right\} \text{Exercise 5} \\ &= xy. \quad \left. \vphantom{(\sqrt{x}\sqrt{y})^2} \right\} \forall_{x \geq 0} \sqrt{x} \text{ is the } z \geq 0 \text{ such that } z^2 = x. \end{aligned}$$

★ 7.  $\forall_{x \geq 0} \forall_{y > 0} \frac{\sqrt{x}}{\sqrt{y}} = \sqrt{\frac{x}{y}}$

Since  $\sqrt{\frac{x}{y}}$  is the nonnegative number whose square is  $\frac{x}{y}$ , we need only show that  $\frac{\sqrt{x}}{\sqrt{y}}$  is nonnegative and  $\left(\frac{\sqrt{x}}{\sqrt{y}}\right)^2 = \frac{x}{y}$ . Hence, since  $\sqrt{x}$  is nonnegative and  $\sqrt{y}$  is positive, and since the quotient of a nonnegative number by a positive number is nonnegative,  $\frac{\sqrt{x}}{\sqrt{y}}$  is nonnegative. And,

$$\begin{aligned} & \left(\frac{\sqrt{x}}{\sqrt{y}}\right)^2 \\ &= \frac{\sqrt{x} \cdot \sqrt{x}}{\sqrt{y} \cdot \sqrt{y}} \quad \left. \vphantom{\left(\frac{\sqrt{x}}{\sqrt{y}}\right)^2} \right\} \forall_x \forall_y \neq 0 \forall_u \forall_v \neq 0 \frac{x}{y} \cdot \frac{u}{v} = \frac{xu}{yv}, [\sqrt{y} \neq 0] [\text{Th. 59}] \\ &= \frac{x}{y}. \quad \left. \vphantom{\left(\frac{\sqrt{x}}{\sqrt{y}}\right)^2} \right\} \forall_{x \geq 0} \sqrt{x} \text{ is the } z \geq 0 \text{ such that } z^2 = x. \end{aligned}$$





B. If both

a p

3/160

$$2. \quad \forall_x \forall_y (x + y)(x - y) = x^2 - y^2$$

$$\begin{aligned}
 & (x + y)(x - y) \\
 = & (x + y)x - (x + y)y \\
 = & [x^2 + yx] - [xy + y^2] \\
 = & [x^2 + xy] - [xy + y^2] \\
 = & [x^2 + xy] - [y^2 + xy] \\
 = & x^2 - y^2.
 \end{aligned}
 \left. \begin{array}{l} \\ \\ \\ \\ \\ \\ \\ \end{array} \right\} \begin{array}{l} \forall_x \forall_y \forall_z x(y - z) = xy - xz \text{ [Th. 38]} \\ \text{dpma} \\ \text{cpm} \\ \text{cpa} \\ \forall_x \forall_y \forall_z x + z - (y + z) = x - y \text{ [Th. 44]} \end{array}$$

$$3. \quad \forall_x \forall_y \forall_u \forall_v (x + y)(u + v) = xu + yu + xv + yv$$

$$\begin{aligned}
 & (x + y)(u + v) \\
 = & (x + y)u + (x + y)v \\
 = & [xu + yu] + [xv + yv] \\
 = & xu + yu + xv + yv.
 \end{aligned}
 \left. \begin{array}{l} \\ \\ \\ \end{array} \right\} \begin{array}{l} \text{ldpma} \\ \text{dpma} \\ \text{apa} \end{array}$$

$$4. \quad \forall_x \left(x + \frac{1}{2}\right)^2 = x(x + 1) + \frac{1}{4}$$

$$\begin{aligned}
 & \left(x + \frac{1}{2}\right)^2 \\
 = & x^2 + \frac{1}{4} + \left(x \cdot \frac{1}{2}\right) \cdot 2 \\
 = & x^2 + \frac{1}{4} + x\left(\frac{1}{2} \cdot 2\right) \\
 = & x^2 + \frac{1}{4} + x \cdot 1 \\
 = & x^2 + \left(\frac{1}{4} + x \cdot 1\right) \\
 = & x^2 + \left(x \cdot 1 + \frac{1}{4}\right) \\
 = & x^2 + x \cdot 1 + \frac{1}{4} \\
 = & x(x + 1) + \frac{1}{4}.
 \end{aligned}
 \left. \begin{array}{l} \\ \\ \\ \\ \\ \\ \\ \\ \end{array} \right\} \begin{array}{l} \text{Exercise 1; } \left(\frac{1}{2}\right)^2 = \frac{1}{4} \\ \text{apm} \\ \text{pq; } 2 \neq 0 \\ \text{apa} \\ \text{cpa} \\ \text{apa} \\ \text{ldpma} \end{array}$$





C. Solve these equations for the pronumeral indicated.

1.  $K = 2x - y$ ;  $x$

2.  $t = 7s - 3v$ ;  $v$

3.  $m = t\sqrt{s}$ ;  $s$

4.  $2r = s\sqrt{1 - k}$ ;  $k$

5.  $3x + 5y - 17 = 0$ ;  $y$

6.  $2(x - 3) + 7(y - 4) + 8 = 0$ ;  $x$

7.  $\frac{1}{x} - \frac{1}{y} = \frac{1}{z}$ ;  $y$

8.  $\frac{a + b}{ab} = c$ ;  $a$

D. State the generalization involved in each of the following descriptions and prove it.

1. The square of the sum of a first number and a second number is the sum of the square of the first number, the square of the second number, and twice the product of the first and second numbers.
2. The product of the sum of a first number and second number by the difference of the second number from the first number is the difference of the square of the second from the square of the first.
3. The product of the sum of a first number and a second number by the sum of a third number and a fourth number is the sum of the products of these four numbers taken two at a time, **one from each sum.**
4. The square of the sum of a number and  $\frac{1}{2}$  is  $\frac{1}{4}$  added to the product of the number by 1 more than the number.
5. The operation of squaring is distributed over multiplication.

\*

[In Exercises 6 and 7, use the fact that for each  $x \geq 0$ ,  $\sqrt{x}$  = the  $z \geq 0$  such that  $z^2 = x$ .]

- ☆6. The product of the square root of a first nonnegative number by the square root of a second nonnegative number is the square root of the product of the first number by the second number.
- ☆7. The quotient of the square root of a first nonnegative number by the square root of a second positive number is the square root of the quotient of the first number by the second number.

E. Evaluate each of the following pronumeral expressions using the given values of the pronumerals. [Answers which involve square roots should be given in exact form and as approximations correct to the nearest 0.01.]

1.  $\sqrt{b^2 + a^2}$  ; '7' for 'b', '24' for 'a'

2.  $\sqrt{c^2 - a^2}$  ; '9' for 'c', '3' for 'a'

3.  $4xy\sqrt{z - 5}$  ; '3' for 'x', '2' for 'y', '17' for 'z'

4.  $\sqrt{s(s - a)(s - b)(s - c)}$  ; '30' for 's', '10' for 'a', '24' for 'b',  
'26' for 'c'

5.  $4\pi r^2$  ;  $\frac{1}{2}\sqrt{3}$  for 'r'.

6.  $(\sqrt{x} - \sqrt{y})(\sqrt{x} + \sqrt{y})$  ; '6' for 'x', '5' for 'y',

7.  $\sqrt{\frac{3V}{\pi h}}$  ; '528 $\pi$ ' for 'V', '6' for 'h'

8.  $\sqrt{\frac{2A}{b_1 + b_2}}$  ; '252' for 'A', '18' for 'b<sub>1</sub>', '24' for 'b<sub>2</sub>'

9.  $\sqrt{2gh}$  ; '64' for 'g', '200' for 'h'

10.  $\frac{2\pi r}{T - 2\pi r^2}$  ; '168 $\pi$ ' for 'T', ' $\sqrt{2}$ ' for 'r'

11.  $\sqrt{\frac{4\pi^2 l}{g}}$  ; '16' for 'g', '4' for 'l'

12.  $\sqrt{l^2 + w^2 + h^2}$  ; '10' for 'l', '7' for 'w', '5' for 'h'

13.  $\sqrt{x^2 - 2xy + y^2}$  ; '-9873' for 'x', '127' for 'y'

F. Complete to make true sentences.

1. The sum of 7 and the number which is 2 less than 7 is \_\_\_\_\_.
2. The sum of 12 and the number which is 3 more than 12 is \_\_\_\_\_.
3. The number which is 25 more than 12 is \_\_\_\_\_.
4. The number which exceeds 18 by 5 is \_\_\_\_\_.
5. The number which exceeds 6 by 17 is \_\_\_\_\_.
6. The sum of three consecutive whole numbers, of which the largest is 13, is \_\_\_\_\_.
7. The difference of 39 from 46 is \_\_\_\_\_.
8. The difference of 46 from 39 is \_\_\_\_\_.
9. The difference of 58 from the number which is 5 more than 58 is \_\_\_\_\_.
10. The number by which 132 exceeds 123 is \_\_\_\_\_.
11. Mr. Hughes sold a house for \$23,350, and bought another for \_\_\_\_\_ which was \$1,475 less than he had received for the house he sold.
12. If Alice is 16 years old now, she was \_\_\_\_\_ years old 7 years ago.
13. If Ruthie was born 3 years ago and her brother was born  $5\frac{1}{2}$  years ago, Ruthie is \_\_\_\_\_ years older than her brother.
14. The product of 12 and the number which is 2 less than 12 is \_\_\_\_\_.
15. The number which is 20% of 40 is \_\_\_\_\_.
16. The product of 175 and  $\frac{1}{3}$  of 30 is \_\_\_\_\_.

(continued on next page)

17. The number which is 2 more than the quotient of 20 by 8 is \_\_\_\_\_.
18. If Debra is 10 years old, she was \_\_\_\_\_ years old 3 years ago.
19. 96 is \_\_\_\_\_ per cent of 80.
20. 80 is \_\_\_\_\_ per cent of 96.
21. The number which exceeds 50 by 15% [of 50] is \_\_\_\_\_.
22. The number which exceeds 80 by 15% is \_\_\_\_\_.
23. The number which is 40% less than 60 is \_\_\_\_\_.
24. The sum of 25% of 60 and 30% of 70 is \_\_\_\_\_.
25. Mike has 42 marbles; if Larry has 5 more than one third of this number of marbles then Larry has \_\_\_\_\_ marbles.
26. Mary added 15 bells to her bell collection; if this was one third as many as she already had, then altogether she has \_\_\_\_\_ bells.
27. If paper cups for cold liquids cost 18 cents per dozen, and paper cups for hot liquids cost one half cent more per cup than those for cold liquids, then the cost of 3 dozen cups for hot liquids is \_\_\_\_\_ cents.
28. If a school club bought sacks of salted peanuts at the rate of 3 sacks for 8 cents, and sold them at the ball game for 5 cents each, then their profit on 10 dozen sacks of peanuts was \_\_\_\_\_ cents.



29. If the cost price of an article is 38 dollars, and the margin is 25% of the cost price, the selling price is \_\_\_\_\_ dollars.
30. A man bought a horse for \$350 and sold it at public auction for 10% more than it cost, but he had to pay an auction fee of 10% of the selling price. So, he made \_\_\_\_\_ dollars.
31. The difference of 9 from the number which is 9 times as large as 4 is \_\_\_\_\_.
32. If Mel is now 16 years old and if Lew is 7 years less than one and one half times Mel's age, Lew is now \_\_\_\_\_ years old.
33. If red plums cost 6 cents more per pound than blue plums, 5 pounds of blue plums cost \_\_\_\_\_ cents less than the same number of pounds of red plums.
34. If the length of each side of a regular hexagon is 1 inch more than 3 times the length of each side of a square, and if the perimeter of the square is 10, then the perimeter of the hexagon is \_\_\_\_\_.
35. Pete has 5 quarters and 3 more half-dollars than quarters [and no other money]; hence, he has \_\_\_\_\_ cents.
36. If the number of quarters in a sack of quarters and dimes is 2 more than 3 times the number of dimes, and if the sack contains 11 dimes, then all the coins in the sack are worth \_\_\_\_\_ cents.
37. In a sum of money consisting of just quarters and half-dollars there are 7 quarters. If the sum amounts to \$3.00 then there are \_\_\_\_\_ half-dollars.

(continued on next page)

38. 3 pounds of apples at 12 cents per pound and 5 pounds of apples at 15 cents per pound will cost \_\_\_\_\_ cents.
39. If a nut mixture is made using 10 pounds of cashews at \$1.05 per pound and 5.4 pounds of pecans at 90 cents per pound then one pound of this mixture is worth \_\_\_\_\_ cents.
40. A grocer prepares 50 pounds of mixed hard candy to sell at 39 cents per pound by mixing 20 pounds of a 30 cents-a-pound kind with \_\_\_\_\_ pounds of a 45 cents-a-pound kind.
41. If a total of \$8000 is invested, with \$3000 at 5% and the rest at  $3\frac{1}{2}\%$ , the annual return on the total investment is \_\_\_\_\_ dollars.
42. There are \_\_\_\_\_ quarts in 2 gallons.
43. There are \_\_\_\_\_ gallons in 9 quarts.
44. Three quarts and three pints together make \_\_\_\_\_ cups.
45. Ann Parker has 9 half-pint jars, and 2 more than one third as many pint jars [as half-pints] which she wants to fill with strawberry jam; she will need \_\_\_\_\_ quarts of strawberry jam to do this.
46. There are \_\_\_\_\_ yards in 51 feet.
47. There are 51 yards in \_\_\_\_\_ feet.
48. If a girl can do a certain household task in 15 minutes, then she can do \_\_\_\_\_ of the job in 10 minutes.

49. If Mary can iron a certain number of sheets in 2 hours, and Gladys can iron the same number of sheets in  $2\frac{1}{2}$  hours, then in 1 hour Mary can iron \_\_\_\_\_ of the sheets and Gladys can iron \_\_\_\_\_ of the sheets; so, in one hour, if both girls iron sheets, they can iron \_\_\_\_\_ of them.
50. If Stan walks at an average rate of 5 miles an hour, he can walk \_\_\_\_\_ miles in  $2\frac{1}{2}$  hours.
51. If Mary walks at an average rate of 4 miles per hour, she can walk 6 miles in \_\_\_\_\_ hours.
52. Hitchcock walks 10 miles in 1 hour and 40 minutes. So, his average rate of walking is \_\_\_\_\_ miles per hour.
53. Gerald gets \$79.80 for a 42 hour work week. So, his wages are \_\_\_\_\_ cents per hour.
54. 45 pounds of a certain type of fertilizer contains 20 pounds of nitrogen and 25 pounds of phosphoric acid; 135 pounds of this same kind of fertilizer will contain \_\_\_\_\_ pounds of phosphoric acid.
55. If an alloy contains 80% copper and the rest tin, then 5600 pounds of this alloy will contain \_\_\_\_\_ pounds of tin.
56. If 6 quarts of water are added to 12 quarts of an acid solution that contains 15% acid, the new solution will contain \_\_\_\_\_ quarts of water.
57. If you add 2cc. of a 10% argyrol solution to 3cc. of a 5% argyrol solution, you get 5 cc. of solution containing \_\_\_\_\_ cc. of argyrol.

(continued on next page)

58. When 200 tickets had been sold for a school play, it was found that only 40% of them had been sold to adults; in order to have 60% of the total tickets sold be those sold to adults, it would be necessary to sell \_\_\_\_\_ more adult tickets.
59. Six gallons of a 10% salt solution are poured into eleven gallons of a 15% salt solution. The resulting solution contains \_\_\_\_\_ gallons of salt.
60. For each  $a$ , the product of 7 by the sum of  $a$  and 3 is \_\_\_\_\_.
61. For each  $b$ , the sum of  $b$  and the number which is  $^{-}2$  times  $b$  is \_\_\_\_\_.
62. For each  $c$ , the difference of  $c$  from a number 12 times as large as  $c$  is \_\_\_\_\_.
63. For each  $d$ , the number which is 12% of  $d$  is \_\_\_\_\_.
64. For each  $e$ , the number which is 125% [of  $e$ ] greater than  $e$  is \_\_\_\_\_.
65. For each  $f$ , the number which is 55% [of  $f$ ] less than  $f$  is \_\_\_\_\_.
66. For each  $g$ , for each  $h$ , the sum of 33% of  $g$  and 71% of  $h$  is \_\_\_\_\_.
67. For each  $i \neq 0$ , the quotient of 36 by the product of 9 and  $i$  is \_\_\_\_\_.
68. For each number  $j$  of arithmetic, if Jim is  $j$  years old now, he will be \_\_\_\_\_ years old 5 years from now.

3/162

- E.
- |                          |                       |                          |
|--------------------------|-----------------------|--------------------------|
| 1. 25                    | 2. $6\sqrt{2}$ ; 8.49 | 3. $48\sqrt{3}$ ; 83.14  |
| 4. 120                   | 5. $3\pi$             | 6. 1                     |
| 7. $2\sqrt{66}$ ; 16.25  | 8. $2\sqrt{3}$ ; 3.46 | 9. 160                   |
| 10. $\sqrt{2}/82$ ; 0.02 | 11. $\pi$             | 12. $\sqrt{174}$ ; 13.19 |
| 13. 10,000               |                       |                          |
- F.
- |                               |                    |                   |  |
|-------------------------------|--------------------|-------------------|--|
| 1. 12                         | 2. 21              | 3. 37             | 4. 23  |
| 5. 23                         | 6. 36              | 7. 7              | 8. -7  |
| 9. 5                          | 10. 9              | 11. \$21,875      | 12. 9  |
| 13. $-2\frac{1}{2}$           | 14. 120            | 15. 8             | 16. 1750                                     |
| 17. 4.5                       | 18. 7              | 19. 120           | 20. $83\frac{1}{3}$                          |
| 21. 57.5                      | 22. 92             | 23. 36            | 24. 36                                       |
| 25. 19                        | 26. 60             | 27. 72            | 28. 280                                      |
| 29. 47.50                     | 30. -3.50          | 31. 27            | 32. 17                                       |
| 33. 30                        | 34. 51             | 35. 525           | 36. 985                                      |
| 37. The data are inconsistent |                    | 38. 111           |  |
| 39. approximately 100 [99.8+] |                    | 40. 30            | 41. 325                                      |
| 42. 8                         | 43. $2\frac{1}{4}$ | 44. 18            | 45. $4\frac{3}{4}$                           |
| 46. 17                        | 47. 153            | 48. $\frac{2}{3}$ | 49. $\frac{1}{2}, \frac{2}{5}, \frac{9}{10}$ |
| 50. 12.5                      | 51. $1\frac{1}{2}$ | 52. 6             | 53. 190                                      |
| 54. 75                        | 55. 1120           | 56. 16.2          | 57. .35                                      |
| 58. at least 100              | 59. $2\frac{1}{4}$ | 60. $7a + 21$     | 61. -b                                       |
| 62. 11c                       | 63. .12d           | 64. 2.25e         | 65. .45f                                     |
| 66. $.33g + .71h$             | 67. $\frac{4}{i}$  | 68. $j + 5$       |  |

With regard to the negative answers for Exercises 13 and 30, see TC[3-58, 59, 60, 61].

[3-146]

58.

[3-147]

old

58.

3/163

- |     |                            |     |                      |      |                     |     |                |
|-----|----------------------------|-----|----------------------|------|---------------------|-----|----------------|
| 69. | $3k + 9$                   | 70. | $L$                  | 71.  | $4m$                | 72. | $\frac{n}{36}$ |
| 73. | $19P$                      | 74. | $25p + 50q$          | 75.  | $.82r$              |     |                |
| 76. | $3s + 4$                   | 77. | $5t + 6$             | 78.  | $\frac{u}{2u + 3}$  |     |                |
| 79. | $60v$                      | 80. | $5w$                 | 81.  | $xy$                |     |                |
| 82. | $\frac{z}{325}$            | 83. | $.045d$              | 84.  | $\pi b$             |     |                |
| 85. | $\frac{c}{2} + 6$          | 86. | $\frac{1}{d}$        | 87.  | $\frac{5}{6}e$      |     |                |
| 88. | $\frac{30}{f}$             | 89. | $63g + 252$          | 90.  | $19h - 20$          |     |                |
| 91. | The data are inconsistent. |     |                      | 92.  | $j - 2$             |     |                |
| 93. | $2k$                       | 94. | $.03L$               | 95.  | $.66\frac{2}{3}m$   |     |                |
| 96. | $n + 12.8$                 | 97. | $\frac{q + 30}{130}$ | 98.* | $\frac{8r}{20 + r}$ |     |                |
| 99. | $45 - \frac{30}{s}$        |     |                      |      |                     |     |                |

---

\*[See the footnote on TC[3-71, 72, 73, 74, 75].]



69. For each number  $k$  of arithmetic, if Karl is  $k$  years old now and Max is 3 times as old as Karl then Max will be \_\_\_\_\_ years old 9 years from now.
70. For each number  $L$  of arithmetic, if the difference of Helen's age from Laura's age is  $L$  years then the difference of Helen's age from Laura's age 3 years ago was \_\_\_\_\_ years.
71. For each number  $m$  of arithmetic, there are \_\_\_\_\_ half-pints in  $m$  quarts.
72. For each number  $n$  of arithmetic, there are \_\_\_\_\_ yards in  $n$  inches.
73. For each number  $P$  of arithmetic,  $P$  gallons, 3 times as many quarts, and 5 times as many pints (as gallons), together make \_\_\_\_\_ pints.
74. For each whole number  $p$  of arithmetic, for each number  $q$  of arithmetic, there are \_\_\_\_\_ cents in a total of  $p$  quarters and  $q$  half-dollars.
75. For each number  $r$  of arithmetic, if the selling price of an article is  $r$  dollars and the margin is 18% of the selling price, then the cost price is \_\_\_\_\_ dollars.
76. For each number  $s$  of arithmetic, if the length of a rectangle is  $s$  units and the width is 2 more than one half the length, then the perimeter is \_\_\_\_\_.
77. For each number  $t$  of arithmetic, if the base of an isosceles triangle is  $t$  units, and each of the two equal sides is 3 units more than twice the base, then the perimeter of this triangle is \_\_\_\_\_.

(continued on next page)

78. For each  $u \neq -\frac{3}{2}$ , the product of 3 by  $u$  divided by the sum of  $6u$  and 9 is \_\_\_\_\_.
79. For each number  $v$  of arithmetic, you can drive \_\_\_\_\_ miles in  $v$  hours at the average rate of 60 miles per hour.
80. For each number  $w$  of arithmetic, you can travel \_\_\_\_\_ miles in 5 hours at the average rate of  $w$  miles per hour.
81. For each number  $x$  of arithmetic, for each number  $y$  of arithmetic, you can travel \_\_\_\_\_ miles in  $x$  hours at the average rate of  $y$  miles an hour.
82. For each number of arithmetic  $z > 0$ , it takes \_\_\_\_\_ hours for an airplane to travel  $z$  miles if its cruising speed is 325 miles per hour.
83. For each number  $d$  of arithmetic, the annual income on  $d$  dollars invested at  $4\frac{1}{2}\%$  is \_\_\_\_\_ dollars.
84. For each number  $b$  of arithmetic, if the diameter of a circle measures  $b$ , the circumference is \_\_\_\_\_.
85. For each number  $c$  of arithmetic, if a regular hexagon has perimeter  $c$  then an equilateral triangle whose side is 2 units longer than a side of this hexagon will have perimeter \_\_\_\_\_.
86. For each number of arithmetic  $d > 0$ , if Bart can shovel the snow off the sidewalks at his home in  $d$  hours, he can clean \_\_\_\_\_ of the sidewalks in 1 hour.
87. For each number  $e$  of arithmetic, if Bart can clean the snow off the sidewalks in 2 hours, and Martin can do the same job in 3 hours, they can clean \_\_\_\_\_ of the sidewalks in  $e$  hours.

88. For each number of arithmetic  $f > 0$ , if Bill climbs  $\frac{2}{3}$  as fast as Dale, and if Dale climbs  $f$  feet per minute, then Bill requires \_\_\_\_\_ minutes to climb 20 feet.
89. For each whole number  $g$  of arithmetic, a pile of pennies, dimes, and half-dollars contains  $g$  dimes, 2 more than 3 times as many pennies, and 5 more half-dollars than dimes; the pile of coins is worth \_\_\_\_\_ cents.
90. For each whole number of arithmetic  $k > 1$ , if  $h$  three-cent stamps and 5 less than 4 times as many four-cent stamps are purchased, the entire purchase is worth \_\_\_\_\_ cents.
91. For each number  $i$  of arithmetic, if  $i$  pounds of potatoes at 13 cents a pound are mixed with 3 pounds of potatoes at 15 cents a pound, the resulting mixture contains \_\_\_\_\_ pounds worth 23 cents a pound.
92. For each  $j$ , if  $j$  is an even integer, \_\_\_\_\_ is the next smaller even integer.
93. For each  $k$ , if  $k$  is an integer, the sum of the next larger integer and the next smaller integer is \_\_\_\_\_.
94. For each number  $L$  of arithmetic,  $L$  gallons of milk containing 3% butterfat will contain \_\_\_\_\_ gallons of butterfat.
95. For each number  $m$  of arithmetic, if  $m$  gallons of a fruit juice and ginger ale mixture contains  $33\frac{1}{3}\%$  ginger ale, the mixture contains \_\_\_\_\_ gallons of fruit juice.

(continued on next page)

96. For each number  $n$  of arithmetic, if  $n$  ounces of black tea are added to 2 pounds of a blend which contains 40% black tea, the new blend contains \_\_\_\_\_ ounces of black tea.
97. For each number  $q$  of arithmetic, if 10 pounds of a flour mixture which contains  $q\%$  whole wheat flour [and the rest white flour] are combined with 3 pounds of whole wheat flour, the new mixture is \_\_\_\_\_ per cent whole wheat flour.
98. For each number of arithmetic  $r > 0$ , if it takes Ann  $r$  hours to fly an airplane 200 miles, and Marion flies 10 miles per hour faster than Ann, then it takes Marion \_\_\_\_\_ hours to fly  $\frac{2}{5}$  as far as Ann.
99. For each whole number of arithmetic  $s > 0$ , if  $s$  people share equally in the cost of a \$15 Christmas gift, a gift paid for by 2 less than 3 times this number of people should cost \_\_\_\_\_ dollars [if each person contributes the same amount as before].

G. Solve these problems.

1. The length of a rectangle is 7 feet more than its width, and its perimeter is 36. Find the dimensions of the rectangle.
2. Ben has 615 stamps in his collection. He has 5 times as many U.S. stamps as French stamps, 60 more British stamps than French stamps, and 75 more stamps of other nations [not including France and Britain] than of the U.S. How many stamps of each kind does he have?
3. A coin box contains quarters, dimes, and nickels which are together worth \$18.55. The number of dimes is 1 more than twice the number of quarters, and the number of nickels is 3 less than three times the number of quarters. How many coins of each kind are in the box?

3/164

G. 1.

x ... width

x + 7 ... length

$$2x + 2(x + 7) = 36$$

$$2x + 2x + 14 = 36$$

$$4x + 14 = 36$$

$$4x = 22$$

$$x = 5\frac{1}{2}$$

Dimensions of the rectangle are  $5\frac{1}{2}$  feet and  $12\frac{1}{2}$  feet.

2.

x ... French stamps

5x ... U.S. stamps

x + 60 ... British stamps

5x + 75 ... stamps of other nations

$$x + 5x + (x + 60) + (5x + 75) = 615$$

$$12x + 135 = 615$$

$$12x = 480$$

$$x = 40$$

Ben has 40 French stamps, 200 U.S. stamps, 100 British stamps, and 275 other stamps.

3.

x ... quarters

2x + 1 ... dimes

3x - 3 ... nickels

$$25x + 10(2x + 1) + 5(3x - 3) = 1855$$

$$25x + 20x + 10 + 15x - 15 = 1855$$

$$60x - 5 = 1855$$

$$60x = 1860$$

$$x = 31$$

The coin box contains 31 quarters, 63 dimes, and 90 nickels.

[3-150]

96.

[3-151]

96.

3/165

4. 13 inches; 23 inches; 26 inches

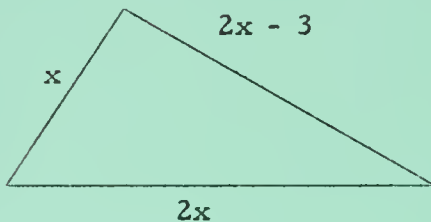

$$x + 2x + (2x - 3) = 62$$

5. 4%, \$5000; 5%, \$7000; 6%, \$10000
- $[0.04x + 0.06(2x) + 0.05[22000 - (x + 2x)] = 1150]$

6. 17
- $[(3x + 7)/2 = 29]$

7. John, 16; Joyce Ann, 20
- $[x \dots \text{John's age in years, } x + 4 \dots \text{Joyce Ann's age in years; } x - 8 = (2/3)[(x + 4) - 8]]$

8. 5 feet by 7 feet

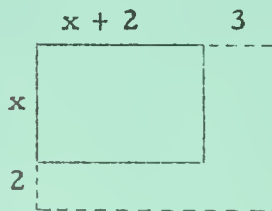

$$(x + 2)(x + 2 + 3) = 2[x(x + 2)]$$

The roots are 5 and  $-2$ .

9. \$7500; \$10000; \$12500
- $[3x + 4x + 5x = 30000]$

10. '7/15'
- $[x \dots \text{numerator-number, } x + 8 \dots \text{denominator-number; } (x + 9)/(x + 8 + 9) = 2/3]$

11. 5 m.p.h.
- $[x \dots \text{m.p.h. walking rate, } x + 7 \dots \text{m.p.h. bicycling rate; } 3x = (5/4)(x + 7)]$

12. extra large, 28; large, 32
- $[x \text{ dozen extra large eggs, } 60 - x \text{ dozen large eggs; } 55x + 46(60 - x) = 3012]$

13. 12; 25
- $[12x = 5(x + 13) + 19]$



4. The perimeter of a triangle is 62. The length of the longest side is double that of the shortest side, and the length of the third side is 3 inches less than that of the longest side. Find the length of each side.
5. Miss Mack had \$22000 to invest, and she bought bonds yielding 4% interest with part of it. She invested twice as much in stocks as she had in bonds, and the stocks yielded 6% interest. Finally, she loaned the remainder of the \$22000 on a mortgage which would pay 5% interest. The total annual interest received from these three investments was \$1150. How much money had she invested at each rate?
6. Rhoda said, "I am thinking of a number. If you triple it, add 7, and divide this sum by 2, the result is 29." What number was Rhoda thinking of?
7. Joyce Ann is 4 years older than her brother John. Eight years ago, John was  $\frac{2}{3}$  as old as Joyce Ann was then. How old is each now?
8. The length of a rectangle is 2 feet more than its width. If the measure of the width is increased by 2, and the measure of the length is increased by 3, the area of the new rectangle is twice the area of the original. What were the dimensions of the original rectangle?
9. An estate of \$30,000 was divided in the ratio of 3:4:5 and given to three charitable organizations. How much money did each of the three receive?

(continued on next page)

10. The number named by the denominator of a fraction is 8 more than the number named by the numerator of this fraction. If both the numerator number and the denominator number are increased by 9, the resulting fraction stands for  $\frac{2}{3}$ . What was the original fraction?
11. Dale can go into town from camp in one hour and fifteen minutes on his bicycle, but it takes him 3 hours for the trip if he walks. His rate of walking is 7 miles an hour less than his rate on the bicycle. Find Dale's rate of walking.
12. A farmer sold 60 dozen eggs to a market. For the extra large eggs he received 55 cents a dozen, and for the large ones, 46 cents a dozen. He received a check for \$30.12. How many dozen of each size did he sell?
13. One number is 13 more than another. Twelve times the smaller number is 19 more than 5 times the larger. What are the numbers?
14. The product of two consecutive integers is equal to the sum of 26 and 10 times the larger number. Find the two integers.
15. A building contractor sold a house for \$12,325, which was 15% less than it cost him. How much did it cost him?
16. Mrs. Reich paid \$8.35 for 100 Christmas cards. For some of them she paid 12 cents each; then she picked out some 10-cent cards, and took 3 more of them than she had of the 12-cent cards. The number of 5-cent cards bought was  $1\frac{2}{3}$  times the number of 12-cent cards, and the rest of the cards in the purchase were  $8\frac{1}{3}$  cents each. How many cards did she buy of each kind?

3/166

14. There are two such pairs of integers. They are 12 and 13, and -3 and -2.  $[x(x + 1) = 26 + 10(x + 1); \text{ the roots are 12 and -3}]$
15. \$14500  $[x - 0.15x = 12325]$
16. 12-cent cards, 15; 10-cent cards, 18; 5-cent cards, 25;  $8\frac{1}{3}$ -cent cards, 42  
 $[12x + 10(x + 3) + 5(1\frac{2}{3}x) + 8\frac{1}{3}\{100 - [x + (x + 3) + 1\frac{2}{3}x]\} = 835]$
17. There are two such pairs of numbers. They are 27 and 33, and -33 and -27.  $[x(x + 6) = 891; \text{ the roots are -33 and 27}]$
18. 35  $[x \text{ trees in a row, } x - 6 \text{ rows; } x(x - 6) = 1015; \text{ the roots are 35 and -29}]$
19. half-dollars, 12; quarters, 18; dimes, 36; nickels, 38  
 $[50x + 25(1.5x) + 10(3x) + 5(3x + 2) = 1600]$
20. 15 feet



21. (a)  $16/40$ , or 40%
- (b) 32; 32  $[x \text{ grams of 40\% solution in new mixture, } 40 - x \text{ grams of 30\% solution in new mixture; } 0.40x + 0.30(40 - x) = 0.32 \cdot 40; \text{ the root is 8}]$
22. \$1200, 4%; \$1300, 4.5%  $[1200x + 1300(x + 0.005) = 106.50]$
- ★23. Since the box does contain nickels, dimes, quarters, and half-dollars, it must contain at least 1 half-dollar. If it contains just 1 half-dollar, it must also contain 2 nickels, and 16 quarters, or \$4.60 worth of nickels, quarters, and half-dollars. [It can't contain 2 half-dollars.] So, it contains 17 dimes  $[6.30 - 4.60 = 1.70]$ .

[3-152]

10

17. One number is 6 more than another, and their product is 891. What are the numbers?
18. An apple orchard contains 1015 trees planted in rows, with each row containing the same number of trees. The number of rows is 6 less than the number of trees in each row. How many trees are there in each row?
19. The treasurer of the Zabbranchburg High Y-Teen Club needed to get money from the school bank to fill change boxes for a candy sale. She decided that she should get  $1\frac{1}{2}$  times as many quarters as half-dollars, three times as many dimes as half-dollars, and 2 more nickels than dimes. Altogether, she wanted to have \$16.00 worth of coins. How many coins of each kind should she get?
20. In an isosceles triangle, the length of the base is 6 feet less than the length of one of the two equal-length sides. If the perimeter is 57, find the length of the base.
21. Twenty-four grams of water are mixed with 16 grams of acetic acid. What per cent of the resulting solution is acetic acid? If a certain amount of this solution is poured out, and it is replaced by an equal amount of a 30% solution of acetic acid and water, the new solution will contain 32% acetic acid. How many grams of the original solution were poured out, and how many grams of the 30% solution were added, to get this 32% solution?
22. A man invests \$1200 at a certain yearly rate of interest, and he invests \$1300 at a rate one half per cent higher than that paid on his \$1200 investment. His total annual income from these two investments is \$106.50. What are the two rates of interest?

(continued on next page)

- ☆23. A money box contains nickels, dimes, quarters, and half-dollars, and nothing else. Altogether these coins are worth \$6.30. There are twice as many nickels as half-dollars, and 8 times as many quarters as nickels. How many dimes are there in the box?
- ☆24. A man leaves his home at 1:30 p.m. and drives to Zilchville, 72 miles away, to transact some business. It takes him one hour and ten minutes to conclude his business deal, and then he takes fifteen minutes to have a cup of coffee before starting home. On the return trip, traffic is heavier than before, so his average speed is 6 miles per hour less than it was as he drove to Zilchville. If he arrived home at 5:45 p.m., what was his average rate of speed on the trip to Zilchville?
- ☆25. Two inlet pipes can fill a certain tank in 24 minutes. The larger of the two pipes can fill the tank in 14 minutes less time than the smaller pipe. How long does it take each pipe to fill the tank?
- ☆26. One workman can do a certain job in 60 hours. With the help of another workman, the same job can be completed in 40 hours. How long would it take the second workman to do the whole job if he worked alone?
- ☆27. For assembly programs in the school gymnasium, a 672-member student body is seated in rows, with the same number of students in each row. If 2 more persons were seated in each row, it would take 6 fewer rows. How many students were seated in each row in the original arrangement?

3/167

- ☆24. The total time required for the trip was 4 hours and 15 minutes. If we subtract from this the time required to conclude the business deal and to have a cup of coffee, we find that the actual driving time was  $2\frac{5}{6}$  hours, or 170 minutes.

x...time in minutes to drive to Zilchville

170 - x...time in minutes to return

$$\frac{72}{x} = \frac{72}{170 - x} + \frac{1}{10}$$

The roots are 1530 and 80.

Since he obviously cannot take (170 - 1530) minutes to return, he takes 80 minutes to drive to Zilchville and 90 minutes to return.

His average rate of speed to Zilchville was  $\frac{72}{80}$  miles per minute or 54 miles per hour.

Here is an alternative solution.

x...rate on trip to Zilchville

x - 6...rate on trip home

$\frac{72}{x}$ ...time for trip to Zilchville

$\frac{72}{x - 6}$ ...time for trip home

$2\frac{5}{6}$ ...total driving time in hours

$$\frac{72}{x} + \frac{72}{x - 6} = \frac{17}{6}$$

The roots are 48/17 and 54.

Since it would make no sense to say that his rate was 48/17 [because his rate for the trip home would be (48/17) - 6], his average rate of speed on the trip to Zilchville must have been 54 miles per hour.

- ☆25. larger, 42 minutes; smaller, 56 minutes [x minutes for the larger pipe alone, x + 14 minutes for the smaller pipe alone;  $(1/x) + [1/(x + 14)] = 1/24$ ; the roots are 42 and -8]
- ☆26. 120 hours [(1/60) + (1/x) = 1/40]
- ☆27. 14 [x rows in original arrangement with 672/x students in each row;  $(x - 6)[(672/x) + 2] = 672$ ; the roots are 48 and -42]

[3-154]

☆23





- H.
- |     |                                     |     |                                     |
|-----|-------------------------------------|-----|-------------------------------------|
| 1.  | $b^2 + 2bc + c^2$                   | 2.  | $9d^2 - 49$                         |
| 3.  | $9d^2 - 30d + 25$                   | 4.  | $x^2 - 5x - 150$                    |
| 5.  | $12n^2 + 13n + 3$                   | 6.  | $a^2 - 7ab + 12b^2$                 |
| 7.  | $3ac + 5bc$                         | 8.  | $c^2e + 2ce - 24e$                  |
| 9.  | $25fg^2 - 10fg + f$                 | 10. | $64 - h^2$                          |
| 11. | $jk^2 - 12lj$                       | 12. | $15m^2 - 2m - 8$                    |
| 13. | $\frac{1}{9}n^2 - \frac{1}{16}p^2$  | 14. | $\frac{1}{4}a^2 + \frac{a}{2} - 12$ |
| 15. | $\frac{1}{4} - q + q^2$             | 16. | $r^2 + 9r + 14$                     |
| 17. | $s^2 + 4s + 3$                      | 18. | $28t^2 - 29t + 6$                   |
| 19. | $x^2 - 2xw + w^2$                   | 20. | $2u^2 + 5uv + 2v^2$                 |
| 21. | $8x^2 - 2x - 3$                     | 22. | $2\pi r^2 + 2\pi rh$                |
| 23. | $\frac{1}{2}hb_1 + \frac{1}{2}hb_2$ | 24. | $3x^2z - 5xz - 2z$                  |
| 25. | $15n^2 - 29an + 12a^2$              | 26. | $36c^2 - 60c + 25$                  |
| 27. | $100 - 60d + 9d^2$                  | 28. | $abc^2 + abcd + .25abd^2$           |
| 29. | $49e^2 + 56ef + 16f^2$              | 30. | $\frac{k^2}{6} + 3k - 60$           |
- I.
- |     |  |                    |                    |     |                             |
|-----|--|--------------------|--------------------|-----|-----------------------------|
| 1.  | $(n - 4)(n + 9)$                       | 2.                 | $(a + 7)(a - 9)$   | 3.  | $(c + 5)(c - 9)$            |
| 4.  | $(d - 5)(d + 8)$                       | 5.                 | $(a + 3)(a + 8)$   | 6.  | $(b + 2)(b - 12)$           |
| 7.  | $(c - 1)(c - 24)$                      | 8.                 | $(d + 2)(d + 12)$  | 9.  | $\frac{1}{6}(y + 2)(y - 3)$ |
| 10. | $(\frac{1}{3}x + 6)(\frac{1}{3}x + 6)$ | 11.                | $(e - 3)(e + 8)$   | 12. | $(g + 4)(g - 6)$            |
| 13. | $(h - 15)(h + 4)$                      | 14.                | $(j + 12)(j + 5)$  | 15. | $(2k + 24)(k + 4)$          |
| 16. | $(x + 3y)(x - 7y)$                     | 17.                | $a(b - 10)(b + 2)$ | 18. | $(2n + 5)(n - 7)$           |
|     | 19.                                    | $(2p - 3)(4p - 3)$ |                    | 20. | $(2q + 3)(4q + 7)$          |

H. Expand.

- |  |  |
|--|--|
| 1. $(b + c)^2$   | 2. $(3d - 7)(3d + 7)$  |
| 3. $(3d - 5)(3d - 5)$  | 4. $(x - 15)(x + 10)$  |
| 5. $(3n + 1)(4n + 3)$  | 6. $(a - 4b)(a - 3b)$  |
| 7. $c(3a + 5b)$  | 8. $e(c - 4)(c + 6)$   |
| 9. $f(5g - 1)^2$   | 10. $(8 - h)(8 + h)$   |
| 11. $j(k + 11)(k - 11)$  | 12. $(3m + 2)(5m - 4)$   |
| 13. $\left(\frac{1}{3}n - \frac{1}{4}p\right)\left(\frac{1}{3}n + \frac{1}{4}p\right)$ | 14. $\left(\frac{1}{2}a + 4\right)\left(\frac{1}{2}a - 3\right)$ |
| 15. $\left(\frac{1}{2} - q\right)^2$   | 16. $(r + 2)(r + 7)$   |
| 17. $(s + 3)(s + 1)$   | 18. $(4t - 3)(7t - 2)$   |
| 19. $(x - w)(x - w)$   | 20. $(2u + v)(u + 2v)$   |
| 21. $(4x - 3)(2x + 1)$   | 22. $2\pi r(r + h)$  |
| 23. $\frac{1}{2}h(b_1 + b_2)$  | 24. $z(3x + 1)(x - 2)$   |
| 25. $(5n - 3a)(3n - 4a)$   | 26. $(6c - 5)^2$   |
| 27. $(10 - 3d)^2$  | 28. $ab(c + .5d)^2$  |
| 29. $(7e + 4f)(7e + 4f)$   | 30. $\left(\frac{k}{2} - 6\right)\left(\frac{k}{3} + 10\right)$  |

I. Factor.

- |  |                                |
|--|--------------------------------|
| 1. $n^2 + 5n - 36$                     | 2. $a^2 - 2a - 63$             |
| 3. $c^2 - 4c - 45$                     | 4. $d^2 + 3d - 40$             |
| 5. $a^2 + 11a + 24$                    | 6. $b^2 - 10b - 24$            |
| 7. $c^2 - 25c + 24$                    | 8. $d^2 + 14d + 24$            |
| 9. $\frac{1}{6}y^2 - \frac{1}{6}y - 1$ | 10. $\frac{1}{9}x^2 + 4x + 36$ |
| 11. $e^2 + 5e - 24$                    | 12. $g^2 - 2g - 24$            |
| 13. $h^2 - 11h - 60$                   | 14. $j^2 + 17j + 60$           |
| 15. $2k^2 + 32k + 96$                  | 16. $x^2 - 4xy - 21y^2$        |
| 17. $ab^2 - 8ab - 20a$                 | 18. $2n^2 - 9n - 35$           |
| 19. $8p^2 - 18p + 9$                   | 20. $8q^2 + 26q + 21$          |

J. Simplify.

1.  $7x + 4x$
2.  $.8v + (-12v)$
3.  $12g - 9g + 5g$
4.  $8 \triangle - \square - 12 \triangle$
5.  $-4m + 9n - 11m - 15q$
6.  $2.5s + 7.5r + 9.4s - 11.6r$
7.  $6y - 5z - 5y + 6z$
8.  $3.2 + 16b - c + 4.7b - 2.3c$
9.  $\frac{1}{5}a + \frac{1}{4}a + \frac{3}{4}a$
10.  $\frac{1}{5}x - \frac{1}{4}y + \frac{4}{5}x - \frac{2}{7}y$
11.  $6y + 5y$
12.  $-3r + 4r$
13.  $11u - u + 2u$
14.  $7s + 12r - 4t - s$
15.  $\frac{1}{5}x + \frac{1}{10}x - 10x$
16.  $\frac{1}{3}m - \frac{2}{5}n + \frac{3}{4}m - \frac{1}{2}n$
17.  $6 \bigcirc + 4 \square + 5 \square - 3 \bigcirc$
18.  $9u - 2v + 12 - 19u - 12v$
19.  $2.6a + 5.4b + 3.7a - 4.5b$
20.  $4.8r - 9.6s - 5.4r + s$
21.  $3pq - 5p + 7pq$
22.  $9ac - 6a + 5a$
23.  $6.5xyz - 2.7yxz + 12.6xy$
24.  $\frac{5}{6} + 7m - 2n - \frac{2}{5} + 6m - 2n$
25.  $\frac{1}{5} + 9x - 3y + 7xy - \frac{1}{4} - 3x$
26.  $2.0rr - 6.8 + 5.5rr - 7.3rr$
27.  $8y^2 + 7y - 5y^2 - 4y - 5$
28.  $3ab - 4a^2 - 5ab + 3a^2 + 15b$
29.  $3.1uv - 2.9uv + 10.1v^2 - .2u^2$
30.  $5.5 - 7.0y^2 + 6.4y - 4.1y^2 + 8.6y$
31.  $7(x + 2y) - 4(x - y)$
32.  $4(c - d) + 2(d - c)$
33.  $6(2a - 4b) - 10a + 18b$
34.  $9r - 4r - 3(3r - 2p)$
35.  $7(-w + 3u) - 4(-w + u)$
36.  $6(a + b) - 14(-a + b)$

3/169

- J.
- |                                     |                                      |
|-------------------------------------|--------------------------------------|
| 1. $11x$                            | 2. $-11.2v$                          |
| 3. $8g$                             | 4. $-4\triangle - \square$           |
| 5. $-15m + 9n - 15q$                | 6. $11.9s - 4.1r$                    |
| 7. $y + z$                          | 8. $3.2 + 20.7b - 3.3c$              |
| 9. $\frac{6}{5}a$                   | 10. $x - \frac{15}{28}y$             |
| 11. $11y$                           | 12. $r$                              |
| 13. $12u$                           | 14. $6s + 12r - 4t$                  |
| 15. $-9\frac{7}{10}x$               | 16. $\frac{13}{12}m - \frac{9}{10}n$ |
| 17. $3\circ + 9\square$             | 18. $-10u - 14v + 12$                |
| 19. $6.3a + .9b$                    | 20. $-.6r - 8.6s$                    |
| 21. $10pq - 5p$                     | 22. $9ac - a$                        |
| 23. $3.8xyz + 12.6xy$               | 24. $\frac{13}{30} + 13m - 4n$       |
| 25. $-\frac{1}{20} + 6x - 3y + 7xy$ | 26. $0.2rr - 6.8$                    |
| 27. $3y^2 + 3y - 5$                 | 28. $-2ab - a^2 + 15b$               |
| 29. $0.2uv + 10.1v^2 - 0.2u^2$      | 30. $5.5 + 15y - 11.1y^2$            |
| 31. $3x + 18y$                      | 32. $2c - 2d$                        |
| 33. $2a - 6b$                       | 34. $-4r + 6p$                       |
| 35. $-3w + 17u$                     | 36. $20a - 8b$                       |

[3-156]

J. Sir

3-157]

(2r + 5s)

( + □)

37.  $46x^2y - 72xy - 24xy^2$                       38.  $6r^2s - 39rs^2$   
 39.  $-17 \square + 4 \triangle$                       40.  $24 \triangle - 25 \square$                       41.  $89.8p - 143.4q$   
 42.  $47.2c - 46.9d$                       43. 0                      44.  $3\frac{1}{2}w - 2v$   
 45.  $2a^2 + 17a + 7$                       46.  $-c^2 + 12c - 20$                       47.  $-2a^2 + 7a - 12$   
 48.  $2n^2 - 9n + 25$                       49.  $2d^2 - 5d - 21$                       50.  $r^2 + 33r - 31$

[In indicating restrictions on the set of values of the pronumerals, one may write, say, for Exercise 51:  $[bc \neq 0]$ , or:  $[b \neq 0, c \neq 0]$ , or:  $[b \neq 0 \neq c]$ . Each of these is correct.]

51. 2,  $[bc \neq 0]$                       52.  $-\frac{k}{4}$ ,  $[h \neq 0]$   
 53.  $-2y$ ,  $[xy \neq 0]$                       54.  $2t$ ,  $[gt \neq 0]$   
 55.  $\frac{2x}{y}$ ,  $[xyz \neq 0]$                       56.  $\frac{s}{3r}$ ,  $[rst \neq 0]$   
 57.  $c - d$ ,  $[b \neq 0]$                       58.  $R^2 - r^2$   
 59.  $k - 2$ ,  $[k \neq 0]$                       60.  $-3n - 2$ ,  $[n \neq 0]$   
 61.  $\frac{c}{ab}$ ,  $[ab \neq 0]$                       62.  $\frac{3xy}{2}$ ,  $[xy \neq 0]$   
 63.  $\frac{3ad}{2e}$ ,  $[ec \neq 0]$                       64.  $\frac{3x}{4yz}$ ,  $[xyz \neq 0]$   
 65.  $\frac{3n}{4r^2}$ ,  $[nrs \neq 0]$                       66.  $\frac{32xybc}{za}$ ,  $[abc \neq 0 \neq xyz]$   
 67.  $21n$                       68. 39,  $[y \neq 0]$                       69.  $17b - 33$   
 70.  $19d + 7$                       71.  $-9x + 85$                       72.  $36c - 6t + 60$   
 73.  $\frac{3d}{7e}$ ,  $[de \neq 0]$                       74.  $\frac{7a}{4np}$ ,  $[np \neq 0]$                       75.  $\frac{x^3}{a^2}$ ,  $[arxy \neq 0]$   
 76.  $\frac{am}{np}$ ,  $[abc \neq 0 \neq mnp]$                       77.  $\frac{a}{8}$                       78.  $-\frac{2}{3a}$ ,  $[a \neq 0]$   
 79.  $\frac{3n + 8}{4}$                       80.  $\frac{x + 1}{2}$                       81.  $\frac{x - 3}{8}$   
 82.  $\frac{5m - 3n}{20}$                       83.  $\frac{2}{2 - x}$ ,  $[x \neq 2]$                       84.  $\frac{17}{c - d}$ ,  $[c \neq d]$



37.  $2xy(5x - 36) - 4xy(6y - 9x)$       38.  $4rs(3r - 6s) - 3rs(2r + 5s)$   
 39.  $-2(\square + 3\triangle) + 5(2\triangle - 3\square)$       40.  $(4\triangle - 7\square)3 - 4(-3\triangle + \square)$   
 41.  $4(3.2p - 5.6q) + 10(7.7p - 12.1q)$   
 42.  $5(6.5c - 3.5d) + 7(2.1c - 4.2d)$   
 43.  $\frac{1}{5}(10m - 5n) + \frac{1}{3}(3n - 6m)$       44.  $\frac{1}{6}(3w - 6v) - \frac{1}{3}(3v - 9w)$

Sample 1.  $(x + 3)^2 + (x - 5)(x + 7)$

Solution.  $(x + 3)^2 + (x - 5)(x + 7)$   
 $= (x^2 + 6x + 9) + (x^2 + 2x - 35)$   
 $= 2x^2 + 8x - 26.$

45.  $(a + 5)^2 + (a - 2)(a + 9)$       46.  $4(c - 1) - (c - 4)^2$   
 47.  $(2a + 1)(a - 3) - (2a - 3)^2$       48.  $(n - 7)^2 + (n - 3)(n + 8)$   
 49.  $3(3 - 4d) + (2d - 5)(d + 6)$       50.  $(5r - 2)(r + 3) - (5 - 2r)^2$   
 51.  $\frac{-4bc}{-2bc}$       52.  $\frac{-3hk}{12h}$       53.  $\frac{-8xy^2}{4xy}$   
 54.  $\frac{4gt^2}{2gt}$       55.  $\frac{.6x^2yz}{3xy^2z}$       56.  $\frac{5rs^2t}{1.5r^2st}$   
 57.  $\frac{bc - bd}{b}$       58.  $\frac{\pi R^2 - \pi r^2}{\pi}$       59.  $\frac{2k^2 - 4k}{2k}$   
 60.  $\frac{9n^2 + 6n}{-3n}$       61.  $\frac{a}{b^2} \cdot \frac{bc}{a^2}$       62.  $\frac{x^2}{y} \cdot \frac{3y^2}{2x}$   
 63.  $\frac{3cd}{4e} \cdot \frac{4a}{2c}$       64.  $\frac{7x^2}{6yz} \cdot \frac{9}{14x}$       65.  $\frac{5n^2r}{7r^2s} \cdot \frac{2lrs}{20nr^2}$   
 66.  $\frac{128x^2y^2z}{31a^2bc} \cdot \frac{124ab^2c^2}{16xyz^2}$       67.  $56\left(\frac{n}{4} + \frac{n}{8}\right)$   
 68.  $6y\left(\frac{7}{2y} + \frac{3}{y}\right)$       69.  $72\left(\frac{2b + 1}{6} + \frac{b - 5}{8} - \frac{2b}{9}\right)$   
 70.  $40\left(\frac{d + 7}{8} - \frac{2d + 1}{5} + \frac{3d - 2}{4}\right)$

(continued on next page)

$$71. \quad 84 \left[ \frac{1}{7}(x+3) - \frac{1}{4}(x-2) + \frac{1}{12} \right] \quad 72. \quad 120 \left( \frac{3c-2}{10} + \frac{5t+6}{12} - \frac{7t-3}{15} \right)$$

$$73. \quad \frac{15cd}{21de^2} \div \frac{5c}{3de} \quad 74. \quad \frac{-14a^2n}{12np^2} \div \frac{2an}{-3p}$$

$$75. \quad \frac{x^2y^2}{ar^2} \div \frac{ay^2}{r^2x} \quad 76. \quad \frac{a^2b^2c}{mn^2p^2} \div \frac{ab^2c}{m^2np}$$

$$77. \quad \frac{3a}{8} - \frac{a}{4} \quad 78. \quad \frac{5}{6a} - \frac{3}{2a}$$

$$79. \quad \frac{n+5}{2} + \frac{n-2}{4} \quad 80. \quad \frac{x+7}{6} + \frac{x-2}{3}$$

$$81. \quad \frac{3x-1}{8} - \frac{x+1}{4} \quad 82. \quad \frac{m+n}{5} - \frac{7n-m}{20}$$

$$83. \quad \frac{5}{x-2} + \frac{7}{2-x} \quad 84. \quad \frac{12}{c-d} - \frac{5}{d-c}$$

Sample 2.  $\frac{5}{3x^2} - \frac{1}{2x} + 7$

Solution.  $\frac{5}{3x^2} - \frac{1}{2x} + 7$

$$= \frac{6x^2 \left( \frac{5}{3x^2} - \frac{1}{2x} + 7 \right)}{6x^2}$$

$$= \frac{10 - 3x + 42x^2}{6x^2}. \quad [x \neq 0]$$

Sample 3.  $\frac{12}{3y+1} - 9 + \frac{5}{2y-1}$

Solution.  $\frac{12}{3y+1} - 9 + \frac{5}{2y-1}$

$$= \frac{(3y+1)(2y-1) \left( \frac{12}{3y+1} - 9 + \frac{5}{2y-1} \right)}{(3y+1)(2y-1)}$$

$$= \frac{(2y-1)12 - (3y+1)(2y-1)9 + (3y+1)5}{(3y+1)(2y-1)}$$

$$= \frac{24y - 12 - (6y^2 - y - 1)9 + 15y + 5}{(3y+1)(2y-1)}$$

$$= \frac{24y - 12 - 54y^2 + 9y + 9 + 15y + 5}{(3y+1)(2y-1)}$$

$$= \frac{-54y^2 + 48y + 2}{(3y+1)(2y-1)}. \quad \left[ y \neq -\frac{1}{3}, y \neq \frac{1}{2} \right]$$



71.

3/171

85.  $\frac{7a + 6b}{a + b}$ ,  $[a \neq -b]$
86.  $\frac{10n - 9a}{a - n}$ ,  $[a \neq n]$
87.  $\frac{-4x^2 + 2xy + y}{2x^2}$ ,  $[x \neq 0]$
88.  $\frac{2r - 33s^2 + 3rs}{6s^2}$ ,  $[s \neq 0]$
89.  $-\frac{10d}{(d + 7)(d - 3)}$ ,  $[-7 \neq c \neq 3]$
90.  $\frac{4c^2 + 19c}{(5 - c)(8 + c)}$ ,  $[5 \neq c \neq -8]$
91.  $\frac{13n^2 - 2n - 135}{(n - 3)(n + 3)}$ ,  $[3 \neq n \neq -3]$
92.  $\frac{17k^2 + k - 22}{(k + 1)(k - 1)}$ ,  $[-1 \neq k \neq 1]$
93.  $\frac{3y^2 - 7y + 21}{3y(y - 3)}$ ,  $[0 \neq y \neq 3]$
94.  $\frac{3t - 3}{2t(t + 3)}$ ,  $[0 \neq t \neq -3]$
95.  $\frac{168k^2 + 7k - 12}{24k^2}$ ,  $[k \neq 0]$
96.  $\frac{105s^2 - 42s - 20}{70s^2}$ ,  $[s \neq 0]$
97.  $\frac{2b^2 - 8b - 40}{b(b - 8)}$ ,  $[0 \neq b \neq 8]$
98.  $\frac{-5d^2 - 5d + 6}{d(d + 2)}$ ,  $[0 \neq d \neq -2]$
99.  $-\frac{5t^2 + 39t + 70}{(t + 3)(2t + 5)}$ ,  $[-3 \neq t \neq -\frac{5}{2}]$
100.  $\frac{11u^2 - 10u - 4}{(u - 2)(3u - 4)}$ ,  $[2 \neq u \neq \frac{4}{3}]$
101.  $\frac{1}{n - 2}$ ,  $[-2 \neq n \neq 2, n \neq 0]$
102.  $\frac{5 - 3a}{7 + a^2}$ ,  $[a \neq 0]$
103.  $\frac{x + y}{y}$ ,  $[xy \neq 0, x \neq y]$
104.  $\frac{r^2(s - 1)}{r^2 - s^2}$ ,  $[rs \neq 0, r \neq s, r \neq -s]$
105.  $\frac{14(25k^2 - 3)}{3(21 - 20k^2)}$ ,  $[k \neq 0, k^2 \neq \frac{21}{20}]$
106.  $\frac{m}{n}$ ,  $[mn \neq 0, m \neq n]$

\*

Answers for TEST.

- I. 1. F      2. T      3. F      4. T      5. F  
     6. T      7. T      8. T      9. F      10. F
- II. 1. 19      2.  $7x - 5y$       3.  $4s - 12$   
     4.  $\frac{\bigcirc \triangle}{3 \square}$       5.  $\frac{y + x}{xy}$       6.  $60d - 125$

85.  $\frac{a}{a+b} + 6$

87.  $\frac{x+y}{x} + \frac{y}{2x^2} - 3$

89.  $\frac{d}{d+7} - \frac{d}{d-3}$

91.  $13 - \frac{4}{n-3} + \frac{2}{n+3}$

93.  $\frac{y}{y-3} - \frac{7}{3y}$

95.  $\frac{2}{3k} - \frac{1}{2k^2} + 7 - \frac{3}{8k}$

97.  $\frac{5}{b} + \frac{3}{b-8} + 2$

99.  $\frac{t+1}{t+3} - 5 + \frac{3t}{2t+5}$

86.  $\frac{n}{a-n} - 9$

88.  $\frac{r}{3s^2} - 5 + \frac{r-s}{2s}$

90.  $\frac{3c}{5-c} - \frac{c}{8+c}$

92.  $\frac{3}{k+1} - \frac{2}{k-1} + 17$

94.  $\frac{2}{t+3} - \frac{1}{2t}$

96.  $1 - \frac{2}{7s^2} + \frac{1}{2} - \frac{3}{5s}$

98.  $\frac{3}{d} - 4 - \frac{d}{d+2}$

100.  $\frac{u+8}{u-2} + 3 - \frac{u+2}{3u-4}$

Sample 4.  $\frac{\frac{5x}{2} - \frac{1}{3x}}{\frac{1}{2x} - \frac{5x}{6}}$

Solution.  $\frac{\frac{5x}{2} - \frac{1}{3x}}{\frac{1}{2x} - \frac{5x}{6}}$

$$= \frac{6x\left(\frac{5x}{2} - \frac{1}{3x}\right)}{6x\left(\frac{1}{2x} - \frac{5x}{6}\right)}$$

$$= \frac{15x^2 - 2}{3 - 5x^2}$$

$$[x^2 \neq \frac{3}{5}, x \neq 0]$$

101.  $\frac{1 + \frac{2}{n}}{n - \frac{4}{n}}$

102.  $\frac{\frac{5}{a} - 3}{\frac{7}{a} + a}$

103.  $\frac{\frac{x}{y} - \frac{y}{x}}{1 - \frac{y}{x}}$

104.  $\frac{r - \frac{r}{s}}{\frac{r}{s} - \frac{s}{r}}$

105.  $\frac{\frac{10k}{3} - \frac{2}{5k}}{\frac{3}{5k} - \frac{4k}{7}}$

106.  $\frac{1 - \frac{m}{n}}{\frac{n}{m} - 1}$

## TEST

I. In the blanks at the left, indicate with a 'T' or an 'F' whether each statement is true or false.

- \_\_\_\_\_ 1. For each a, for each b, if  $b \neq 0$ , then  $\frac{a}{b} \geq 0$ .
- \_\_\_\_\_ 2. For each r, for each s, if  $s \neq 0$ , then  $-\frac{r}{s} = -\frac{-r}{-s}$ .
- \_\_\_\_\_ 3. For each c, for each d,  $6(c + 3d) - 2(c - d) = 4c + 16d$ .
- \_\_\_\_\_ 4.  $\{9, -9\}$  is the solution set of the sentence ' $xx = 81$ '.
- \_\_\_\_\_ 5.  $\{a: a + 8 = 20\} = \{a: a = 28\}$ .
- \_\_\_\_\_ 6.  $\{n: n + 6 = n + 4\} = \{d: 0 > d > 2\}$ .
- \_\_\_\_\_ 7.  $\{5, 2, -3\} \subseteq \{-4, 0, 1, -3, 7, 2, 5\}$ .
- \_\_\_\_\_ 8.  $\{r: r^2 = 25\} \subseteq \{t: |t| = 5\}$ .
- \_\_\_\_\_ 9.  $\{x: 3x^2 = 15x\} \subseteq \{y: 65 - 5y = 8y\}$ .
- \_\_\_\_\_ 10.  $\forall_x \forall_y$  if  $x < 0$  and  $y < 0$ , then  $x + y = |x| + |y|$ .

II. Complete the following to make true sentences.

1. The midpoint of  $\overline{3, 35}$  is \_\_\_\_\_.
2.  $\forall_x \forall_y$  the midpoint of  $\overline{5x + 3y, 9x - 13y}$  is \_\_\_\_\_.
3. For each number of arithmetic  $s > 3$ , if the length of one side of a square is  $s - 3$  inches, the perimeter is \_\_\_\_\_.
4. For each number of arithmetic  $\square$ , for each number of arithmetic  $\triangle$ , for each number of arithmetic  $\circ$ , if  $\square$  dozen eggs cost  $4\triangle$  cents, then the cost of  $\circ$  eggs is \_\_\_\_\_ cents.
5.  $\forall_x \neq 0 \forall_y \neq 0$  the sum of the reciprocals of x and y is \_\_\_\_\_ . [Write a single fraction in the blank.]
6. For each whole number of arithmetic  $d > 3$ , the number of cents in d dimes and 5 less than twice that many quarters is \_\_\_\_\_ cents.

[3-161]

is

I.

3/172

$$7. A + 8 \quad 8. 0.085t + 150 \quad 9. \frac{m}{r + 5} \quad 10. \frac{33p + 35}{p + 1}$$

III. [We give two descriptions for each exercise; your students will doubtless write some others.]

$$\begin{aligned} 1. \{x: x \geq -1\}, \quad \{x: -2 \leq x - 1\} \\ 2. \{x: -2 < x < 3\}, \quad \{x: -3 < x - 1 < 2\} \\ 3. \{x: |x| = 10\}, \quad \{x: xx = 100\} \end{aligned}$$

IV. [We give one name for each exercise; your students may give others.]

$$\begin{array}{lll} \text{(a) } 1. \xrightarrow{2, 0} & 2. \bullet \xrightarrow{-4, 3} & 3. \{4, -6\} \\ 4. \xrightarrow{-2, -5} & 5. \xrightarrow{-3, 0} & 6. \emptyset \end{array}$$

$$\begin{array}{ll} \text{(b) } 7. \{x: -5 \leq x \leq 2\} & 8. \{x: x = 0\} \\ 9. \{n: n < 4\} & 10. \{a: -3 < a < 1\} \end{array}$$

$$\begin{array}{lllll} \text{V. } 1. -1 & 2. -4 & 3. -6 & 4. -\frac{1}{2} & 5. -3 \\ 6. \frac{19}{60} & 7. 19 & 8. \text{no roots} & 9. 9, 0 & 10. 3, -9 \\ 11. \{x: x < \frac{7}{18}\} & 12. \{x: x > \frac{38}{9}\} \end{array}$$

$$\begin{array}{ll} \text{VI. (a) } 1. b = \frac{A - 3a}{2} & 2. y = \frac{w - x}{7} \\ 3. w = \frac{V}{\ell h}, [\ell h \neq 0] & 4. b = \frac{N - a}{x - 1}, [x \neq 1] \\ 5. b = \frac{a}{10a - 1}, [\frac{1}{10} \neq a \neq 0 \neq b] & 6. a = -\frac{m}{3}, [a \neq m \neq -a] \\ \text{(b) } 7. 8\frac{1}{2} & 8. 24 & 9. 3.5 & 10. 1407.21 \end{array}$$

$$\begin{array}{lll} \text{VII. } 1. n^2 - 2n - 63 & 2. a^2 + 18a + 80 & 3. 2c^2 - 7c + 6 \\ 4. 25 - 16n^2 & 5. 9x_1^2 - 12x_1 + 4 & 6. 3xy^2 - xy - 14x \end{array}$$



7. For each number of arithmetic A, if Jim's age now is A years, his age in 8 years will be \_\_\_\_\_ years.
8. For each number of arithmetic t, if t dollars are invested at  $3\frac{1}{2}\%$  and \$3000 more than t dollars are invested at 5%, the number of dollars annual interest on the two investments is \_\_\_\_\_ dollars.
9. For each number of arithmetic m, for each number of arithmetic r, if Mr. Beecher drives at a rate of r + 5 miles per hour, it will take him \_\_\_\_\_ hours to drive m miles.
10. For each number of arithmetic p, if p pounds of hard candy selling at 29 cents per pound are mixed with 3 more than twice as many pounds of candy selling at 35 cents a pound, the resulting mixture is worth \_\_\_\_\_ cents a pound.

III. Each exercise contains a picture of the number line with a graph marked on it. For each exercise, give two descriptions of the set of numbers which are the coordinates of the points in the graph.

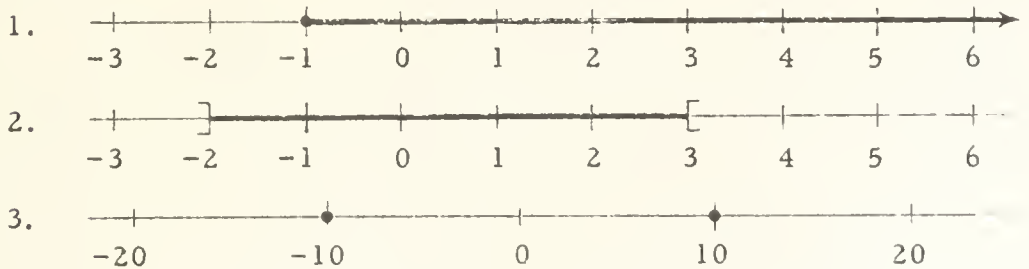

IV. (a) Use geometric language to name the loci of the following sentences.

Sample.  $x \geq 1$

Solution.  $\overrightarrow{1, 2}$

1.  $n < 2$
2.  $-4 \leq a \leq 3$
3.  $|x + 1| = 5$
4.  $-d \geq 2$
5.  $k > -3$  or  $k > 2$
6.  $-3 > b > 1$

(b) Use brace-notation [ $\{x: \dots\}$ ] to name the sets with these loci.

7.  $\overrightarrow{-5, 2}$
8.  $\{0\}$
9.  $\overrightarrow{4, -4}$
10.  $\overline{1, -3}$

V. Solve these equations and inequations.

1.  $3 + 2n = 7 + 6n$
2.  $-6a + 11 = 2a + 43$
3.  $\frac{2c}{3} + 1 = \frac{c}{2}$
4.  $\frac{2d + 5}{4} - \frac{10d + 13}{8} = 2d + 1$
5.  $\frac{1}{10}(7c + 1) - \frac{1}{4}(c - 9) = 1$
6.  $\frac{7}{2a} - 6 = 9 - \frac{5}{4a}$
7.  $\frac{2}{a + 5} = \frac{1}{a - 7}$
8.  $\frac{13}{a - 7} = \frac{13}{7 - a}$
9.  $x^2 = 9x$
10.  $x^2 + 6x = 27$
11.  $9 - 3x > 15x + 2$
12.  $6 + 4(2 - x) < \frac{1}{2}x - 5$

VI. (a) Solve each of the following equations for the pronumeral indicated.

1.  $A = 3a + 2b$ ;  $b$
2.  $x = -7y + w$ ;  $y$
3.  $V = \ell wh$ ;  $w$
4.  $N = a + (x - 1)b$ ;  $b$
5.  $\frac{1}{a} + \frac{1}{b} = 10$ ;  $b$
6.  $\frac{12}{m - a} = \frac{6}{m + a}$ ;  $a$

(b) Make the indicated substitutions and solve the resulting equations. [The solution for Exercise 10 should be given as an approximation correct to the nearest 0.01.]

7.  $A = \frac{h(a + b)}{2}$ , '136' for 'A', '15' for 'a', '17' for 'b'.
8.  $R = \frac{gs}{g + s}$ , '8' for 'R', '12' for 'g'.
9.  $\ell = a + (n - 1)d$ , '6' for 'a', '76' for 'ℓ', '21' for 'n'.
10.  $D = 89\sqrt{H}$ , '250' for 'H'.

VII. Expand.

1.  $(n + 7)(n - 9)$
2.  $(a + 10)(a + 8)$
3.  $(2c - 3)(c - 2)$
4.  $(5 - 4n)(5 + 4n)$
5.  $(3x_1 - 2)(3x_1 - 2)$
6.  $x(3y - 7)(y + 2)$

1)

- 5)

An alternative proof.

$$\begin{aligned}
 & a^2 - b^2 \\
 &= a^2 + -b^2 + 0 \\
 &= a^2 + -b^2 + [ab + -(ab)] \\
 &= a^2 + ba + [-(ab) + -b^2] \\
 &= a^2 + ba + (a \cdot -b + b \cdot -b) \\
 &= (a + b)a + (a + b) \cdot -b \\
 &= (a + b)(a + -b) \\
 &= (a + b)(a - b).
 \end{aligned}
 \left. \begin{array}{l} \\ \\ \\ \\ \\ \\ \\ \\ \\ \\ \\ \end{array} \right\} \begin{array}{l} \text{ps, pa0} \\ \text{po} \\ \text{apa, cpa, apa, apa, cpm} \\ \forall_x \forall_y -(xy) = x \cdot -y \text{ [Th. 20]} \\ \text{dpma} \\ \text{ldpma} \\ \text{ps} \end{array}$$

- IX. (a) 1.  $8\sqrt{2}$       2.  $\left|\frac{a}{2}\right|$       3. 8      4. 5  
 5.  $|r - 6s|$       6.  $|n^2 + 7n - 8|$       7. 22      8.  $6\sqrt{3} + 35$
- (b) 9. 11.31      10. 1.73

[3-163]

$\frac{1}{5}$ )

- 5)

3/173

7.  $25a - 30ac + 9ac^2$

8.  $6rs_1^2 - \frac{1}{6}r$

9.  $3a^2b - 15ab^2$

10.  $-4y + 24$

11.  $\forall_a \forall_b (a + b)^2 = a^2 + 2ab + b^2$

$$\begin{aligned}
 & (a + b)^2 \\
 &= (a + b)a + (a + b)b \quad \left. \begin{array}{l} \text{ldpma} \\ \text{dpma} \end{array} \right\} \\
 &= a^2 + ba + (ab + b^2) \quad \left. \begin{array}{l} \text{cpm, apa, apa} \\ \forall_x x + x = 2x; \text{ apm} \end{array} \right\} \\
 &= a^2 + (ab + ab) + b^2 \\
 &= a^2 + 2ab + b^2.
 \end{aligned}$$

VIII. 1.  $(c - 4)(c - 5)$

2.  $(d - 2)(d + 17)$

3.  $(k + 8)(k - 9)$

4.  $(2r - 5s)(2r - 5s)$

5.  $3(a - 3)(a + 4)$

6.  $n(a + 2)(a + 1)$

7.  $5(x - 6)(x + 6)$

8.  $x(y - 7)(y - 7)$

9.  $(b - \frac{1}{2})(b - \frac{1}{2})$

10.  $(\frac{n}{5} + \frac{d}{6})^2$

11.  $\forall_a \forall_b a^2 - b^2 = (a + b)(a - b)$

$$\begin{aligned}
 & (a + b)(a - b) \\
 &= a(a - b) + b(a - b) \quad \left. \begin{array}{l} \text{dpma} \\ \text{ldtms} \end{array} \right\} \\
 &= a^2 - ab + (ba - b^2) \quad \left. \begin{array}{l} \text{ps, apa, cpm} \\ \forall_x \forall_y x - y + y = x \text{ [Th. 32]} \end{array} \right\} \\
 &= a^2 - ab + ab - b^2 \\
 &= a^2 - b^2.
 \end{aligned}$$

[An alternative proof for Exercise 11 is on TC[3-163]b.]

7.  $a(5 - 3c)^2$

8.  $r(2s_1 - \frac{1}{3})(3s_1 + \frac{1}{2})$

9.  $3ab(a - 5b)$

10.  $(y - 3)(\frac{y + 5}{y - 3} + \frac{4}{y - 3} - 5)$

\*

11. Use the principles for real numbers to prove:

$$\forall_a \forall_b (a + b)^2 = a^2 + 2ab + b^2.$$

VIII. Factor.

1.  $c^2 - 9c + 20$

2.  $d^2 + 15d - 34$

3.  $k^2 - k - 72$

4.  $4r^2 - 20rs + 25s^2$

5.  $3a^2 + 3a - 36$

6.  $na^2 + 3an + 2n$

7.  $5x^2 - 180$

8.  $xy^2 - 14xy + 49x$

9.  $b^2 - b + \frac{1}{4}$

10.  $\frac{n^2}{25} + \frac{1}{15}nd + \frac{d^2}{36}$

\*

11. Use the principles for real numbers to prove:

$$\forall_a \forall_b a^2 - b^2 = (a + b)(a - b).$$

IX. (a) Simplify.

1.  $\sqrt{128}$  [128 = 64 × 2]

2.  $\sqrt{\frac{1}{4}a^2}$

3.  $\sqrt{32} \times \sqrt{2}$

4.  $\sqrt{150} \div \sqrt{6}$

5.  $\sqrt{r^2 - 12rs + 36s^2}$

6.  $\sqrt{(n + 8)^2(n - 1)^2}$

7.  $(2\sqrt{7} - \sqrt{6})(2\sqrt{7} + \sqrt{6})$

8.  $(\sqrt{3} + 5)^2 + (\sqrt{3} - 2)^2$

(b) Find the approximation correct to the nearest 0.01 by first transforming the expression into a simpler one which contains a ' $\sqrt{2}$ ' or a ' $\sqrt{3}$ '.

9.  $\sqrt{18} + \sqrt{50}$

10.  $\sqrt{108} - \sqrt{75}$

X. Solve these problems.

1. An 11-sided figure is made up of two parallelograms of exactly the same size, and one rectangle, placed as in this picture. The width of the rectangle is  $\frac{3}{4}$  its length; the shorter side of each parallelogram has the same measure as the measure of the width of the rectangle; the longer side of each parallelogram is twice the length of the rectangle; the three figures overlap in such a way that one half of one short side of each parallelogram is in the interior of the rectangle, and one half of one long side of the rectangle is in the interior of the parallelograms.

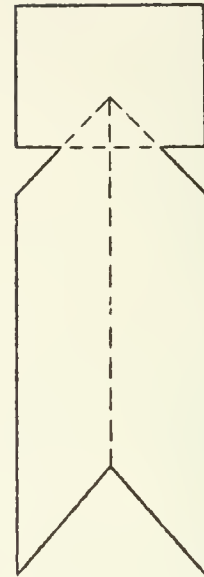

- (a) Find a formula for the perimeter of the 11-sided figure.
- (b) If the perimeter is 37, what is the measure of the length of the shorter side of one of the parallelograms?
2. The perimeter of a rectangle is 34; its area measure is 66. Find the measure of its length.
3. Mr. Abel invests a total of \$7000 in three enterprises. One enterprise returns 5% on the investment, another 4%, and a third 3.5%. He invests \$3000 more in the 4% enterprise than in the 5% one, and his total income from the three investments is \$280. How much does he invest in each of the three enterprises?



3/175

X. 1. (a) Using 'x' as a pronumeral whose values are measures of the lengths of rectangles, a formula for the perimeter of the figure described is ' $P = 9\frac{1}{4}x$ '.

(b) 3

2. One half the perimeter is 17.

w is the measure of the width of the rectangle

17 - w is the measure of the length of the rectangle

$$w(17 - w) = 66$$

$$17w - w^2 = 66$$

$$w^2 - 17w + 66 = 0$$

$$(w - 11)(w - 6) = 0$$

$$w = 11 \text{ or } w = 6$$

The measure of the length of the rectangle is 11.

3. n is amount invested at 5%

n + 3000 is amount invested at 4%

7000 - (2n + 3000) is amount invested at 3.5%

$$.05n + .04(n + 3000) + .035[7000 - (2n + 3000)] = 280$$

$$.05n + .04n + 120 + .035[4000 - 2n] = 280$$

$$.09n + 120 + 140 - .07n = 280$$

$$.02n = 20$$

$$n = 1000$$

Mr. Abel has \$1000 invested at 5%, \$4000 invested at 4%, and \$2000 invested at  $3\frac{1}{2}\%$ .

[3-164]

X.



X.

3/176

Answers for SUPPLEMENTARY EXERCISES.

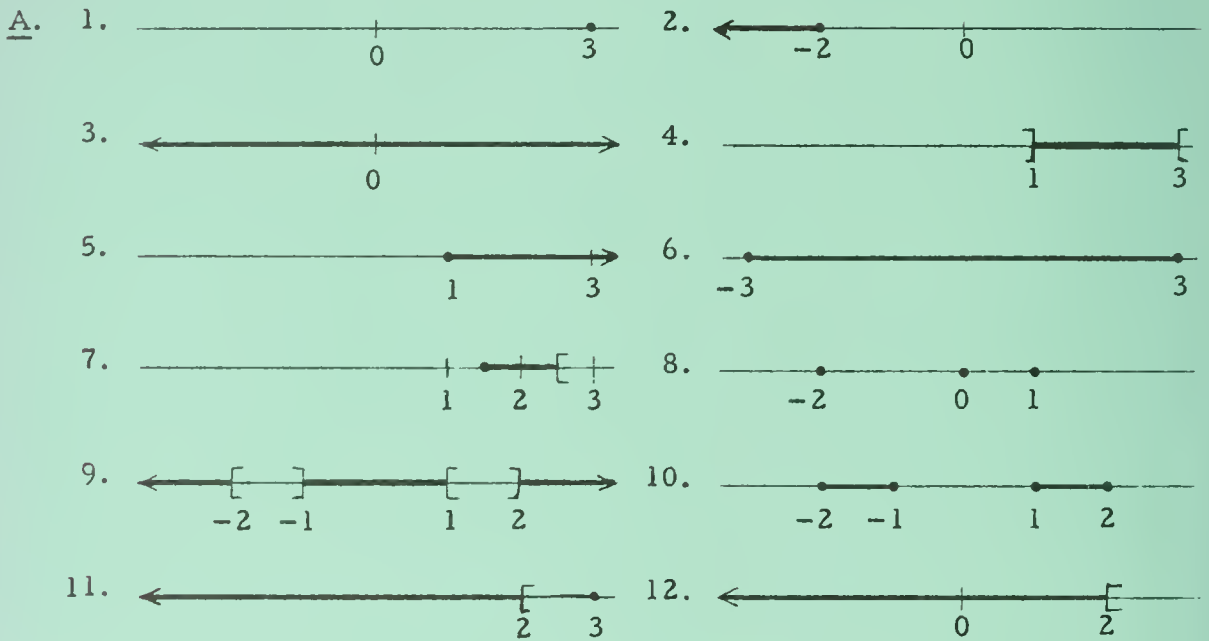

- |                |              |            |              |              |
|----------------|--------------|------------|--------------|--------------|
| <u>B.</u> 1. 3 | 2. 8         | 3. 2       | 4. 4         | 5. -7        |
| 6. 3           | 7. 4         | 8. -1      | 9. $-(1/3)$  | 10. 8        |
| 11. $2/3$      | 12. 0        | 13. 14     | 14. 14       | 15. $1/14$   |
| 16. 15         | 17. 15       | 18. $1/15$ | 19. 63       | 20. 6        |
| 21. -3         | 22. 3        | 23. $11/2$ | 24. -11      | 25. 7        |
| 26. 0          | 27. $3/4$    | 28. -1     | 29. $3/2$    | 30. $-(9/5)$ |
| 31. $1/2$      | 32. $-(1/2)$ | 33. $1/9$  | 34. 7        | 35. $7/2$    |
| 36. -7         | 37. $1/15$   | 38. 20     | 39. 0        | 40. 60       |
| 41. $-(19/2)$  | 42. 16       | 43. 25     | 44. -2       | 45. -6       |
| 46. 1          | 47. 1        | 48. $1/2$  | 49. 5        | 50. 1        |
| 51. 1, 5       | 52. -8       | 53. $4/3$  | 54. $-(2/5)$ | 55. 4        |
| 56. -1         | 57. -2       | 58. 4      | 59. -1       | 60. -2       |

## SUPPLEMENTARY EXERCISES

A. Sketch the graph of each of the following sentences.

1.  $3s + 7 = 16$

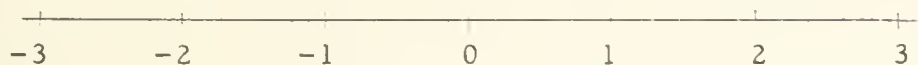

2.  $3x + 6 \leq 0$

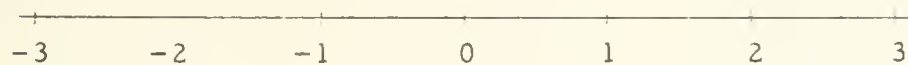

3.  $y \leq y + \frac{1}{5}$

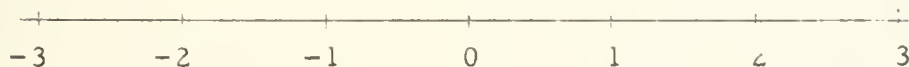

4.  $|x - 2| + 3 < 4$

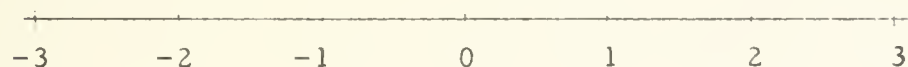

5.  $\frac{1}{3}(x + 5) \geq 2$

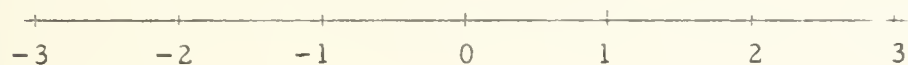

6.  $xx - 9 \leq 0$

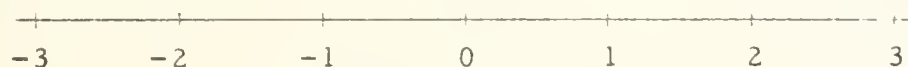

7.  $1.5 \leq x < 2.5$

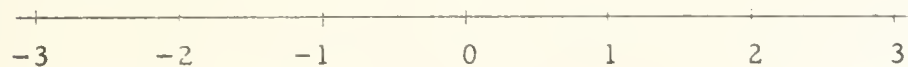

8.  $x = -2$  or  $x = 0$  or  $x = 1$

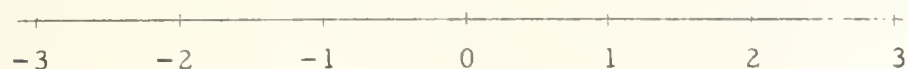

9.  $|x| < 1$  or  $|x| > 2$

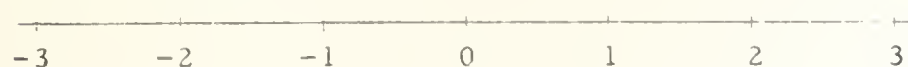

10.  $|x| \geq 1$  and  $|x| \leq 2$

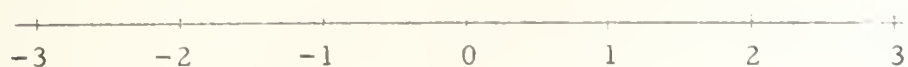

11.  $(x < 2$  and  $x < 6)$  or  $x = 3$

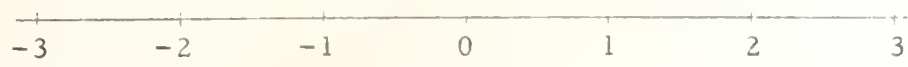

12.  $x < 2$  and  $(x < 6$  or  $x = 3)$



B. Find the roots of these equations.

- |                                     |                                    |   |
|-------------------------------------|------------------------------------|---|
| 1. $7a - 4 = 17$                    | 2. $3 + 2x = 19$                   | 3. $5 - 6y = -7$                        |
| 4. $-10 = -x - 6$                   | 5. $7y - 1 = -50$                  | 6. $28 = 8t + 4$                        |
| 7. $.5x + 9 = 11$                   | 8. $-6 = 3 + 9y$                   | 9. $3 - 9y = 6$                         |
| 10. $-6 = 2 - k$                    | 11. $6x - 2 = 2$                   | 12. $4 = 8y + 4$                        |
| 13. $\frac{5}{7}x = 10$             | 14. $\frac{5x}{7} = 10$            | 15. $\frac{5}{7x} = 10$                 |
| 16. $\frac{2}{5}y = 6$              | 17. $\frac{2y}{5} = 6$             | 18. $\frac{2}{5y} = 6$                  |
| 19. $\frac{1}{3}y - 17 = 4$         | 20. $3 - \frac{1}{2}x = 0$         | 21. $\frac{1}{2}y + 1 = -\frac{1}{2}$   |
| 22. $-6 + 6x = 12$                  | 23. $8 = 2y - 3$                   | 24. $-73 = 7k + 4$                      |
| 25. $-1 = -y + 6$                   | 26. $5 + 5y = 5$                   | 27. $5 = 8 - 4t$                        |
| 28. $9 = 7 - 2k$                    | 29. $-2m + 8 = 5$                  | 30. $9 + 5z = 0$                        |
| 31. $\frac{8}{z} = 16$              | 32. $\frac{8}{-z} = 16$            | 33. $\frac{8}{3z} = 24$                 |
| 34. $\frac{7}{x} = 1$               | 35. $\frac{7}{2x} = 1$             | 36. $\frac{7}{-x} = 1$                  |
| 37. $\frac{1}{3} = \frac{2}{5} - k$ | 38. $9 + \frac{k}{10} = 11$        | 39. $\frac{1}{2}(3 + 4x) = \frac{3}{2}$ |
| 40. $\frac{1}{3}(s + 6) = 22$       | 41. $5 = \frac{2}{5}(3 - x)$       | 42. $1 + \frac{3}{2}t = 25$             |
| 43. $\frac{5 + 3x}{4} = 20$         | 44. $\frac{8 - 3y}{7} = 2$         | 45. $1 = \frac{-2x - 7}{5}$             |
| 46. $\frac{9}{2y} = \frac{9}{2}$    | 47. $\frac{18}{7x} = \frac{18}{7}$ | 48. $\frac{19}{6y} = \frac{19}{3}$      |
| 49. $\frac{8}{x - 3} = 4$           | 50. $\frac{8}{3 - x} = 4$          | 51. $\frac{8}{ 3 - x } = 4$             |
| 52. $16 + 4f = -16$                 | 53. $5 = 1 + 3k$                   | 54. $2 - 5s = 4$                        |
| 55. $2x + 2 = 10$                   | 56. $6 - 3y = 9$                   | 57. $14 = 28 + 7x$                      |
| 58. $2(x + 1) = 10$                 | 59. $3(2 - y) = 9$                 | 60. $14 = 7(4 + x)$                     |

[3-167]

(4 + x)

3x + 6

.

B. Fi

3/178

Check equations for Part D [on page 3-168].

- |                       |                         |                         |
|-----------------------|-------------------------|-------------------------|
| 1. $12 = 12$          | 2. $-14 = -14$          | 3. $10 = 10$            |
| 4. $-10 = -10$        | 5. $5 = 5$              | 6. $-6 = -6$            |
| 7. $110 = 110$        | 8. $10 = 10$            | 9. $0 = 0$              |
| 10. $-12 = -12$       | 11. $0 = 0$             | 12. $20 = 20$           |
| 13. $4 = 4$           | 14. $110/3 = 110/3$     | 15. $0 = 0$             |
| 16. $-40 = -40$       | 17. $23 = 23$           | 18. $1790 = 1790$       |
| 19. $-95 = -95$       | 20. $11 = 11$           | 21. $0 = 0$             |
| 22. $-49 = -49$       | 23. $16 = 16$           | 24. $-101 = -101$       |
| 25. $36 = 36$         | 26. $1 = 1$             | 27. $105 = 105$         |
| 28. $350 = 350$       | 29. $132121 = 132121$   | 30. $2100 = 2100$       |
| 31. $4225 = 4225$     | 32. $3280 = 3280$       | 33. $4.5 = 4.5$         |
| 34. $14.5 = 14.5$     | 35. $14.5 = 14.5$       | 36. $3.5 = 3.5$         |
| 37. $13 = 13$         | 38. $- - -$             | 39. $-(25/3) = -(25/3)$ |
| 40. $-72.75 = -72.75$ | 41. $-(15/7) = -(15/7)$ | 42. $-(68/5) = -(68/5)$ |
| 43. $25/2 = 25/2$     | 44. $-18.2 = -18.2$     | 45. $34.6 = 34.6$       |
| 46. $-0.22 = -0.22$   | 47. $-.76 = -.76$       |                         |



[3-167]

(4 + x)

3x + 6

B. Fi

3/177

- |               |                                |              |              |
|---------------|--------------------------------|--------------|--------------|
| 61. $11/2$    | 62. $-4$                       | 63. $2$      | 64. no roots |
| 65. $6$       | 66. each real number is a root | 67. $8, -16$ |              |
| 68. $0, 5$    | 69. $-10, 6$                   | 70. $-3, 7$  | 71. no roots |
| 72. $-18, 24$ |                                |              |              |

- |                  |             |            |              |
|------------------|-------------|------------|--------------|
| <u>C.</u> 1. $2$ | 2. $0$      | 3. $-1/5$  | 4. $4$       |
| 5. $-6$          | 6. $-6$     | 7. $2$     | 8. $-3$      |
| 9. $3$           | 10. $3$     | 11. $-2$   | 12. $5$      |
| 13. $2$          | 14. $-4$    | 15. $-117$ | 16. no roots |
| 17. $1$          | 18. $2$     | 19. $-2$   | 20. $-13$    |
| 21. $3$          | 22. $9, -9$ | 23. $1/3$  | 24. $21$     |
| 25. $-80/29$     | 26. $1/2$   | 27. $-2$   | 28. $0$      |
| 29. $12.5$       | 30. $7$     |            |              |

- |                  |              |            |              |
|------------------|--------------|------------|--------------|
| <u>D.</u> 1. $4$ | 2. $-2$      | 3. $2$     | 4. $-2.5$    |
| 5. $-1$          | 6. $-2$      | 7. $-10$   | 8. $2$       |
| 9. $7/3$         | 10. $-12$    | 11. $0$    | 12. $1$      |
| 13. $2$          | 14. $37/6$   | 15. $2$    | 16. $-5$     |
| 17. $3$          | 18. $300$    | 19. $-5$   | 20. $4$      |
| 21. $6$          | 22. $-6$     | 23. $2$    | 24. $-12$    |
| 25. $10$         | 26. $1$      | 27. $9$    | 28. $298$    |
| 29. $24022$      | 30. $300$    | 31. $3925$ | 32. $4100$   |
| 33. $-1/2$       | 34. $9/2$    | 35. $5/2$  | 36. $3/4$    |
| 37. $3$          | 38. no roots | 39. $17/3$ | 40. $-12.75$ |
| 41. $4/7$        | 42. $-6/5$   | 43. $9/4$  | 44. $-12$    |
| 45. $20$         | 46. $-0.2$   | 47. $-2$   |              |

61.  $2(x + 1) = 13$

62.  $3(2 - y) = 18$

63.  $42 = 7(4 + x)$

64.  $3(x + 1) = 3x$

65.  $2(x - 5) = 2$

66.  $3(2 + x) = 3x + 6$

67.  $|4 + x| = 12$

68.  $|-2x + 5| = 5$

69.  $|8 + 4x| = 32$

70.  $3 + |a - 2| = 8$

71.  $8 - |3 - n| = 13$

72.  $|3 - d| - 8 = 13$

C. Solve.

1.  $3x - 5 + 8x - 12 = 5$

2.  $6m - 4 - 4m + 8 = 4$

3.  $7A - 6 + 13A + 18 = 8$

4.  $9b - 21 - 3b - 2 = 1$

5.  $3(n - 2) + 5 - 6n = 17$

6.  $9x + 7 - 2(x - 7) = -21$

7.  $2(6k - 3) + 4(5k - 4) = 42$

8.  $a - (6 - 2a) = -15$

9.  $y - (9 - y) - (8 - y) = -8$

10.  $2b - 2(3b - 7) = 2$

11.  $5(7r - 1) - 6(7r - 1) = 15$

12.  $7 + 8(x - 4) = 15$

13.  $13(s - 4) + 5(3s - 3) = -11$

14.  $12 - 3(s + 5) - 2(9s - 7) = 95$

15.  $7(x - 2) - 8x - 3 = 100$

16.  $3(x - 5) - 3x = 6$

17.  $t - (1 - t) + (t - 1) - 1 = 0$

18.  $6(2 - 9y) + 4(2y - 9) + y = -114$

19.  $18m - (m + 5) - 3(m - 2) + 4(m - 5) = -55$

20.  $9(x - 1) - 9(x + 1) + 2(x - 2) - 2(2 + 2x) = 0$

21.  $x(3 - 2x) - 5x(x - 3) + 7x(x + 2) - 18x = 42$

22.  $10(10 + yy) - 9(yy + 2) - 2(1 + yy) = -1$

23.  $2aa + 2(6a - 3) + 6(2a - 1) - a(2a + 3) = -5$

24.  $11(2 + s) + 2(11 - s) + 2 - 11s = 4$

25.  $5 + 4(5 - 2r) - 6r - 3(5r + 2) + 4 = 103$

26.  $(5n - 2) - 7 - (n - 2) + 7n - 5(2n - 5n) = 6$

27.  $7rr + 5r(r - 1) - 12r(5 + r) - 100 = 30$

28.  $2w + 2w(w - 2) + 2(2 - ww) + 4w = 4$

29.  $7x - 34(2x - 5) - 9(x - 7) - 64x = -1442$

30.  $m - 12m(m - 3) + 16m\left(\frac{3}{4}m - 11\right) + 175m = 252$

D. Solve.

1.  $3x = x + 8$
2.  $7k = k - 12$
3.  $5y = 18 - 4y$
4.  $4t = -6t - 25$
5.  $-5x = 6 + x$
6.  $3y = -12y - 30$
7.  $-11z = 50 - 6z$
8.  $5A = 9A - 8$
9.  $0 = 7 - 3b$
10.  $m = 12 + 2m$
11.  $10k = -7k$
12.  $20t = 19 + t$
13.  $2y = 20 - 8y$
14.  $4x + 12 = -2x + 49$
15.  $51x - 13x - 76 = 0$
16.  $7m - 5 = 3m - 25$
17.  $5y - 3y + 17 = 35 - 4y$
18.  $8t + 30 - 3t + 260 = 5 + 2t + 1185$
19.  $4x + 15x - x - 5 = x + 6 + 18x - 6$
20.  $9y - 25 = 4y - 5$
21.  $t - 6 = 18 - 3t$
22.  $11R - 7 - 4R = 5R - 19$
23.  $7V + 2 = 24 - 4V$
24.  $8x - 5 = 7 + 9x$
25.  $3.6y = 26 + y$
26.  $7 - 14x + 8 = x$
27.  $12a - 3 = 10a + 15$
28.  $x + 52 = 648 - x$
29.  $3r + 2.5r = 132121$
30.  $4t + 2t + t = 2100$
31.  $300 + d = 16000 - 3d$
32.  $g - 820 = .8g$
33.  $5K + 7 = 3K + 6$
34.  $3x + 1 = 5x - 8$
35.  $5y + 2 = 3y + 7$
36.  $7c + 2 - 5c = 8 - 9c + 3c$
37.  $2a - 8 + 5a = 2a + 7$
38.  $3x - 7 = x + 3 + 2x$
39.  $13 - 5c + 7 = 3 - 2c$
40.  $5c - 9 = 9c + 42$
41.  $5m - 5 = 12m - 9$
42.  $7k - 4 + k = 3k - 10$
43.  $6t - 1 = 2t + 8$
44.  $.6y - 11 = 1.6y + 1$
45.  $4.43a - 11 - 2.15a = 34.6$
46.  $4.1S + .60 = .75 - .08$
47.  $.80y + .84 = -.76$



D. Sc

3/179

- |                |                                |           |             |
|----------------|--------------------------------|-----------|-------------|
| <u>E.</u> 1. 2 | 2. 4                           | 3. 1      | 4. 2        |
| 5. 3           | 6. 10                          | 7. 4      | 8. 7        |
| 9. 3           | 10. 2                          | 11. 4     | 12. 10      |
| 13. 5          | 14. -28                        | 15. 216   | 16. 80      |
| 17. 8          | 18. 20                         | 19. 4.5   | 20. 12      |
| 21. 400        | 22. 6                          | 23. 100/3 | 24. 17      |
| 25. 36         | 26. each real number is a root |           | 27. 4       |
| 28. -17        | 29. 7                          | 30. -8    | 31. 72      |
| 32. 3/5        | 33. 7                          | 34. 2     | 35. 9       |
| 36. -15        | 37. 1                          | 38. 1     | 39. -(49/5) |
| 40. 5/3        | 41. 0                          |           |             |

Check equations for Part E.

- |                         |                   |                     |
|-------------------------|-------------------|---------------------|
| 1. $120 = 120$          | 2. $200 = 200$    | 3. $90 = 90$        |
| 4. $180 = 180$          | 5. $24 = 24$      | 6. $10 = 10$        |
| 7. $20 = 20$            | 8. $8 = 8$        | 9. $180 = 180$      |
| 10. $2 = 2$             | 11. $400 = 400$   | 12. $50 = 50$       |
| 13. $6 = 6$             | 14. $-140 = -140$ | 15. $21100 = 21100$ |
| 16. $1110 = 1110$       | 17. $32 = 32$     | 18. $6400 = 6400$   |
| 19. $495 = 495$         | 20. $60 = 60$     | 21. $5000 = 5000$   |
| 22. $101 = 101$         | 23. $3000 = 3000$ | 24. $385 = 385$     |
| 25. $84 = 84$           | 26. - - -         | 27. $2 = 2$         |
| 28. $-66 = -66$         | 29. $18 = 18$     | 30. $-22 = -22$     |
| 31. $792 = 792$         | 32. $8 = 8$       | 33. $15 = 15$       |
| 34. $14 = 14$           | 35. $81 = 81$     | 36. $-47 = -47$     |
| 37. $11 = 11$           | 38. $0 = 0$       | 39. $-690 = -690$   |
| 40. $-(68/3) = -(68/3)$ | 41. $0 = 0$       |                     |

E. Solve.

1.  $60x = 40(x + 1)$
2.  $50x = 40(x + 1)$
3.  $90x = 60(x + \frac{1}{2})$
4.  $90x = 60(x + 1)$
5.  $5x + 9 = 2(x + 9)$
6.  $20 - x = 2(15 - x)$
7.  $16 + x = 2(6 + x)$
8.  $2s - 6 = 8(s - 6)$
9.  $60t = 40(t + 1.5)$
10.  $x = 1 - (x - 3)$
11.  $100f = 80(9 - f)$
12.  $5y = 73 - (2y + 3)$
13.  $n + 1 = 5(6 - n) + 1$
14.  $5d = 6(5 + d) - 2$
15.  $25(628 - y) + 50y = 21100$
16.  $5(142 - t) + 10t = 1110$
17.  $5c + 2(4 - c) = 32$
18.  $80s + 60(100 - s) = 6400$
19.  $90(10 - b) = 110b$
20.  $5r = 4(27 - r)$
21.  $5n + 10(700 - n) = 5000$
22.  $a + 2a + 8a + 5(2a - 5) = 101$
23.  $50x + 80(50 - x) = 50 \cdot 60$
24.  $5n + 10(2n - 4) = 385$
25.  $6(50 - c) = 624 - 15c$
26.  $100(x + 4) + 10x + x = 111x + 400$
27.  $2(d - 3) = 8 - 3(d - 2)$
28.  $2(2x + 1) = 3(x - 5)$
29.  $3(x - 1) = 2(x + 2)$
30.  $x + 2(x + 1) = 2(x + 2) - 10$
31.  $9(160 - p) = 11p$
32.  $2t + 3(t + 2) - 1 = 8$
33.  $3(2x - 9) = 5(10 - x)$
34.  $3(5y - 2) - 5y = 8 - 2(y - 5)$
35.  $9a = 7 + 2(1 + 4a)$
36.  $4(3c + 7) - 7c = 2(c - 7) - 3$
37.  $8 + 3x = 2(5x - 3) + 7x$
38.  $4(y - 1) = 5y - 1 + 4(3y - 4)$
39.  $10(3a - 1) - 2(a - 3) = 15(2a + 3)$
40.  $4(2x - 3) - 24 = 5(x - 1) - 6(2x + 1)$
41.  $8(5 - a) - 5(8 - a) = 5(8 - a) + 8(a - 5)$

F. Solve.

1.  $\frac{x}{2} - \frac{x}{3} = \frac{x}{6}$
2.  $\frac{x}{2} + \frac{x}{3} = \frac{x}{6}$
3.  $1 = R - \frac{19}{4}$
4.  $x - \frac{1}{5} = \frac{1}{6}$
5.  $-\frac{x}{2} = 6$
6.  $-\frac{1}{3} = \frac{x}{4}$
7.  $\frac{s}{10} = \frac{13}{100}$
8.  $\frac{a}{0.3} = 1.2$
9.  $-2.1 = \frac{b}{-2.1}$
10.  $\frac{x}{4} - 3 = 2$
11.  $10C = \frac{1}{4}C - 39$
12.  $\frac{x+3}{4} = 2.5$
13.  $\frac{\frac{2}{3}x}{\frac{1}{3}} = \frac{5}{3}$
14.  $\frac{2-x}{\frac{3}{5}} = \frac{5}{3}$
15.  $\frac{\frac{1}{2}x}{\frac{1}{2}} = \frac{1}{2}$
16.  $\frac{s}{4} = -\frac{1}{2}$
17.  $\frac{2x}{9} = \frac{1}{5}$
18.  $\frac{x-1}{3} = \frac{1}{5}$
19.  $\frac{7}{4} = \frac{5}{4}x + \frac{1}{2}$
20.  $\frac{3}{2} - x = \frac{4}{3}$
21.  $\frac{y+3}{6} = \frac{3}{2}$
22.  $\frac{3K-2}{15} = \frac{2}{3}$
23.  $\frac{1}{5}(3y-12) = \frac{3}{5}$
24.  $3a = \frac{1}{2}a + 1$
25.  $\frac{1}{2}x - \frac{1}{3}x = \frac{1}{12}x$
26.  $\frac{4}{5}(t+2) = t$
27.  $\frac{1}{3}(3x + \frac{x}{2}) = x$
28.  $4(\frac{x}{3} + \frac{1}{2}) = \frac{x}{2} + 7$
29.  $\frac{\frac{1}{5}R - R}{2} = 2$
30.  $\frac{n+16}{6} = \frac{n+4}{3}$
31.  $2(s + \frac{s}{2}) = 300\% \text{ of } s$
32.  $\frac{n-10}{15} = 0$
33.  $\frac{s+2}{12} = \frac{s}{3} - \frac{s}{4}$
34.  $\frac{x+0.5x}{2} = x+1$
35.  $\frac{P+10\% \text{ of } P}{11} = P$
36.  $\frac{6-x}{2} = -7$
37.  $\frac{P+10\% \text{ of } P}{11} = 5$
38.  $\frac{x}{10} = \frac{x}{2} - \frac{x+1}{2}$
39.  $\frac{x}{2} - \frac{x}{5} = 5$
40.  $6(x-2x+3) = \frac{0}{2}$
41.  $40-x = \frac{3}{5}(50+x)$



3/180

- F.
- |                                |            |              |
|--------------------------------|------------|--------------|
| 1. each real number is a root  | 2. 0       | 3. $23/4$    |
| 4. $11/30$                     | 5. $-12$   | 6. $-(4/3)$  |
| 7. $1.3$                       | 8. $0.36$  | 9. $4.41$    |
| 10. $20$                       | 11. $-4$   | 12. $7$      |
| 13. $5/6$                      | 14. $1$    | 15. $1/2$    |
| 16. $-2$                       | 17. $9/10$ | 18. $8/5$    |
| 19. $1$                        | 20. $1/6$  | 21. $6$      |
| 22. $4$                        | 23. $5$    | 24. $2/5$    |
| 25. $0$                        | 26. $8$    | 27. $0$      |
| 28. $6$                        | 29. $-5$   | 30. $8$      |
| 31. each real number is a root | 32. $10$   | 33. no roots |
| 34. $-4$                       | 35. $0$    | 36. $20$     |
| 37. $50$                       | 38. $-5$   | 39. $50/3$   |
| 40. $3$                        | 41. $25/4$ |              |

Check equations for Exercises 1-41 of Part F.

- |                       |                       |                      |
|-----------------------|-----------------------|----------------------|
| 1. - - -              | 2. $0 = 0$            | 3. $1 = 1$           |
| 4. $1/6 = 1/6$        | 5. $6 = 6$            | 6. $-(1/3) = -(1/3)$ |
| 7. $13/100 = 13/100$  | 8. $1.2 = 1.2$        | 9. $-2.1 = -2.1$     |
| 10. $2 = 2$           | 11. $-40 = -40$       | 12. $2.5 = 2.5$      |
| 13. $5/3 = 5/3$       | 14. $5/3 = 5/3$       | 15. $1/2 = 1/2$      |
| 16. $-(1/2) = -(1/2)$ | 17. $1/5 = 1/5$       | 18. $1/5 = 1/5$      |
| 19. $7/4 = 7/4$       | 20. $4/3 = 4/3$       | 21. $3/2 = 3/2$      |
| 22. $2/3 = 2/3$       | 23. $3/5 = 3/5$       | 24. $6/5 = 6/5$      |
| 25. $0 = 0$           | 26. $8 = 8$           | 27. $0 = 0$          |
| 28. $10 = 10$         | 29. $2 = 2$           | 30. $4 = 4$          |
| 31. - - -             | 32. $0 = 0$           | 33. - - -            |
| 34. $-3 = -3$         | 35. $0 = 0$           | 36. $-7 = -7$        |
| 37. $5 = 5$           | 38. $-(1/2) = -(1/2)$ | 39. $5 = 5$          |
| 40. $0 = 0$           | 41. $135/4 = 135/4$   |                      |

[3-170]

F. Sc



F. Sc

3/181

42. -51	43. 12	44. 15	45. 90
46. 12	47. 200	48. 28	49. 7
50. 10/7	51. 1/4	52. 2	53. 10
54. 3	55. 11.25	56. 740	57. no roots

Check equations for Exercises 42-57 of Part F.

42. $-6 = -6$	43. $9 = 9$	44. $3 = 3$
45. $90 = 90$	46. $10 = 10$	47. $5 = 5$
48. $11 = 11$	49. $2.2 = 2.2$	50. $1 = 1$
51. $.10 = .10$	52. $1.70 = 1.70$	53. $1/2 = 1/2$
54. $5/2 = 5/2$	55. $.4125 = .4125$	56. $810 = 810$
57. - - -		

<u>G.</u> 1. 3.5	2. 1	3. 7	4. 40
5. 11	6. -8	7. 50	8. 77/25
9. 12/5	10. 50	11. 45	12. 20
13. 2	14. -9	15. 18	16. 9/4

Check equations for Exercises 1-16 of Part G.

1. $1 = 1$	2. $3 = 3$	3. $4/5 = 4/5$
4. $4 = 4$	5. $5 = 5$	6. $2/3 = 2/3$
7. $5/2 = 5/2$	8. $25/77 = 25/77$	9. $5/12 = 5/12$
10. $3/2 = 3/2$	11. $2 = 2$	12. $5/2 = 5/2$
13. $3 = 3$	14. $-(1/3) = -(1/3)$	15. $1/3 = 1/3$
16. $2/5 = 2/5$		

42.  $\frac{a-3}{9} = \frac{3+a}{8}$

43.  $\frac{3}{4}z = \frac{z+6}{2}$

44.  $\frac{a+6}{7} = \frac{a-9}{2}$

45.  $a = \frac{3}{4}(210 - a)$

46.  $\frac{5}{6}b = \frac{3}{4}b + 1$

47.  $\frac{m}{40} = \frac{m}{50} + 1$

48.  $\frac{r}{7} + \frac{r}{4} = 11$

49.  $\frac{w}{3.5} + \frac{w}{35} = 2.2$

50.  $\frac{h}{2} + \frac{h}{5} = 1$

51.  $.08(1+x) = .10$

52.  $[.7q - .7(1)] + 1 = .85q$

53.  $\frac{n+4}{4} - \frac{3n-9}{7} = \frac{1}{2}$

54.  $\frac{7n+4}{10} = \frac{n+11}{4} - 1$

55.  $.03x + .02(15-x) = .0275(15)$

56.  $x + 70 = 1.20[(x+5) - 70]$

57.  $2(y-6) = \frac{1}{2}(7+4y)$

G. Solve.

1.  $\frac{3.5}{r} = 1$

2.  $\frac{3(x+1)}{2} = 3$

3.  $\frac{5+a}{8+a} = \frac{4}{5}$

4.  $\frac{180}{n+5} = \frac{160}{n}$

5.  $\frac{b+4}{b-8} = 5$

6.  $\frac{2}{3} = \frac{m}{2m+4}$

7.  $\frac{500}{5m} + \frac{1}{2} = \frac{125}{m}$

8.  $\frac{1}{7} + \frac{1}{5\frac{1}{2}} = \frac{1}{x}$

9.  $\frac{1}{6} + \frac{1}{4} = \frac{1}{t}$

10.  $\frac{300}{4r} = \frac{300}{r} - 4\frac{1}{2}$

11.  $\frac{360}{4c} = \frac{360}{c} - 6$

12.  $\frac{150}{d} - 5 = \frac{150}{3d}$

13.  $\frac{3c}{2} + \frac{8-4c}{7} = 3$

14.  $\frac{4}{m-3} = \frac{3}{m}$

15.  $\frac{5}{b-3} = \frac{7}{b+3}$

16.  $\frac{3}{2x+3} = \frac{5}{6x-1}$

(continued on next page)

17.  $\frac{9}{d+2} = \frac{6}{d+5}$

18.  $\frac{12}{3k-7} = \frac{3}{7-k}$

19.  $\frac{182}{r+12} = \frac{182}{r+12}$

20.  $\frac{23}{t-7} = \frac{23}{7-t}$

21.  $\frac{1\frac{1}{3}}{r} + \frac{1\frac{1}{3}}{3} = 1$

22.  $\frac{u}{5} + \frac{2u}{5} = 18$

23.  $\frac{z}{4} - \frac{z}{3} = \frac{11}{12}$

24.  $\frac{d+1}{2} = \frac{d-5}{3}$

25.  $3e - \frac{4e}{5} = 22$

26.  $\frac{s-2}{4} - \frac{s-4}{6} = \frac{2}{3}$

27.  $\frac{6q-7}{5} = \frac{3q-1}{2}$

28.  $\frac{f+5}{f-3} + \frac{4}{f-3} = 5$

29.  $\frac{n+3}{2n} = 5$

30.  $\frac{-3}{r+10} = \frac{1}{r}$

31.  $\frac{n}{n+7} = \frac{2}{3}$

32.  $\frac{h}{200} + \frac{h}{160} = 9$

33.  $\frac{2+k}{7} + \frac{2+k}{13} + \frac{k}{7} = \frac{1}{13}$

34.  $\frac{2p+1}{2p} - \frac{3p-2}{3p} = \frac{7}{12}$

35.  $\frac{g+2.1}{g+3} = \frac{1.90}{2}$

36.  $\frac{3+j}{8+j} = \frac{2}{3}$

37.  $\frac{d+5}{4d+2} = \frac{1}{2}$

38.  $\frac{r+18}{4} - \frac{3r}{7} + \frac{r+2}{8} = 4$

39.  $\frac{120}{t} = \frac{120}{\frac{3}{4}t} - 1$

40.  $\frac{y-3}{4} = \frac{2y-5}{5} + 1$

41.  $\frac{2}{\frac{2}{3}r} + \frac{45}{r} = 8$

42.  $\frac{1}{3}(e+5) - 4 = \frac{e-8}{4} - \frac{1}{2}$

43.  $\frac{28.4}{9-n} = \frac{4n}{9-n} - \frac{18}{5}$

44.  $\frac{3}{4}\left(\frac{2}{1-a}\right) + \frac{1}{2} = \frac{24a-31}{4(1-a)}$

3/182

- |              |          |  |
|--------------|----------|--|
| 17. -11      | 18. 5    | 19. each real number<br>except -12 is a root |
| 20. no roots | 21. 12/5 |  |
| 22. 30       | 23. -11  | 24. -13                                      |
| 26. 6        | 27. -3   | 25. 10                                       |
| 30. $-(5/2)$ | 31. 14   | 28. 6  |
| 34. 2        | 35. 15   | 29. $1/3$                                    |
| 38. 14       | 39. 40   | 32. 800                                      |
| 42. -2       | 43. 8    | 33. -1                                       |
|              |          | 36. 7  |
|              |          | 37. 4  |
|              |          | 40. -5                                       |
|              |          | 41. 6  |
|              |          | 44. $3/2$                                    |

Check equations for Exercises 17-44 of Part G.

- |                       |                       |                   |
|-----------------------|-----------------------|-------------------|
| 17. $-1 = -1$         | 18. $3/2 = 3/2$       | 19. - - -         |
| 20. - - -             | 21. $1 = 1$           | 22. $18 = 18$     |
| 23. $11/12 = 11/12$   | 24. $-6 = -6$         | 25. $22 = 22$     |
| 26. $2/3 = 2/3$       | 27. $-5 = -5$         | 28. $5 = 5$       |
| 29. $5 = 5$           | 30. $-(2/5) = -(2/5)$ | 31. $2/3 = 2/3$   |
| 32. $9 = 9$           | 33. $1/13 = 1/13$     | 34. $7/12 = 7/12$ |
| 35. $.95 = .95$       | 36. $2/3 = 2/3$       | 37. $1/2 = 1/2$   |
| 38. $4 = 4$           | 39. $3 = 3$           | 40. $-2 = -2$     |
| 41. $8 = 8$           | 42. $-3 = -3$         | 43. $28.4 = 28.4$ |
| 44. $-(5/2) = -(5/2)$ |                       |                   |

[3-172]

1



[3-173]

licated.

H.

1. $s = \frac{P}{3}$	2. $n = \frac{P - b_1 - b_2}{2}$	3. $r = \frac{C}{2\pi}$
4. $b_1 = P - 2n - b_2$	5. $a = \frac{P - 5b}{4}$	6. $b = \frac{S - att}{t}, [t \neq 0]$
7. $x = \frac{y + b}{3}$	8. $y = 2x - b$	9. $a = mx - 6b$
10. $y = bx - d$	11. $y = \frac{N + z - 2x}{3}$	12. $s = 5r + 2t - N$
13. $a = 3c + 2d$	14. $b = \frac{4a - 3c - P}{4}$	15. $r = \frac{S}{2\pi h}, [h \neq 0]$
16. $h = \frac{S}{2\pi r}, [r \neq 0]$	17. $a = \frac{2S}{p}, [p \neq 0]$	18. $y = xz, [z \neq 0]$
19. $c = dI, [d \neq 0]$	20. $a = \frac{m}{c}, [a \neq 0 \neq c]$	
21. $S = \frac{rg - a}{r - 1}, [r \neq 1]$	22. $r = \frac{a - S}{g - S}, [g \neq S]$	
23. $h = \frac{6K}{\pi(a + b)}, [a \neq -b]$	24. $a = \frac{6K - \pi hb}{\pi h}, [h \neq 0]$	

I.

1. $y = x - 2$	2. $y = \frac{7 - 2a}{3}$	3. $y = n + 18$
4. $y = \frac{6 - 4z}{3}$	5. $y = \frac{m - 35}{5}$	6. $y = \frac{24 + 5r}{3}$
7. $y = \frac{9 - 11a}{3}$	8. $y = 6c - 7$	9. $y = \frac{7(10 - e)}{8}$
10. $y = \frac{4r - 3}{14}$	11. $y = \frac{8c}{9 - 8c}, [y \neq 0 \neq c \neq \frac{9}{8}]$	
12. $y = \frac{3}{5}d - 3$	13. $y = \frac{mn}{m + n}, [y \neq 0, m \neq 0 \neq n \neq -m]$	
14. $y = \frac{mn}{m - n}, [y \neq 0, m \neq 0 \neq n \neq m]$		
15. $y = \frac{c}{8c - 1}, [y \neq 0 \neq c \neq \frac{1}{8}]$	16. $y = \frac{14a}{15 - a}, [y \neq 0 \neq a \neq 15]$	
17. $y = \frac{c}{10 - c}, [0 \neq y \neq -1, c \neq 10]$		
18. $y = \frac{n}{25}, [n \neq y \neq -n]$		

H. Solve each of the following equations for the pronumeral indicated.

- |   |   |
|---|---|
| 1. $P = 3s$ ; $s$                       | 2. $P = 2n + b_1 + b_2$ ; $n$           |
| 3. $C = 2\pi r$ ; $r$                   | 4. $P = 2n + b_1 + b_2$ ; $b_1$         |
| 5. $P = 4a + 5b$ ; $a$                  | 6. $s = att + bt$ ; $b$                 |
| 7. $y = 3x - b$ ; $x$                   | 8. $2x = y + b$ ; $y$                   |
| 9. $mx - a = 6b$ ; $a$                  | 10. $bx - y = d$ ; $y$                  |
| 11. $N = 3y - z + 2x$ ; $y$             | 12. $N = 5r - s + 2t$ ; $s$             |
| 13. $d = 3(c + d) - a$ ; $a$            | 14. $P = 4(a - b) - 3c$ ; $b$           |
| 15. $S = 2\pi rh$ ; $r$                 | 16. $S = 2\pi rh$ ; $h$                 |
| 17. $S = \frac{1}{2}ap$ ; $a$           | 18. $x = \frac{y}{z}$ ; $y$             |
| 19. $I = \frac{c}{d}$ ; $c$             | 20. $\frac{m}{a} = c$ ; $a$             |
| 21. $rg = a + S(r - 1)$ ; $S$           | 22. $rg = a + S(r - 1)$ ; $r$           |
| 23. $K = \frac{1}{6}\pi h(a + b)$ ; $h$ | 24. $K = \frac{1}{6}\pi h(a + b)$ ; $a$ |

I. Solve each of these equations for 'y'.

- |   |   |
|---|---|
| 1. $x - y = 2$                                  | 2. $2a + 3y = 7$                                |
| 3. $n - y + 18 = 0$                             | 4. $4z + 3y = 6$                                |
| 5. $m - 5y = 35$                                | 6. $3y - 5r = 24$                               |
| 7. $7a + 3 - 2y = 12 - 5y - 4a$                 | 8. $9c + 10y - 6 = 12y - 3c + 8$                |
| 9. $7(e - 6) + 8(y - 2) = 12$                   | 10. $5(r + y - 3) + 9(y - r + 2) = 0$           |
| 11. $\frac{3}{2c} - \frac{4}{3y} = \frac{4}{3}$ | 12. $1 = \frac{d}{5} - \frac{y}{3}$             |
| 13. $\frac{1}{m} + \frac{1}{n} = \frac{1}{y}$   | 14. $\frac{1}{m} + \frac{1}{y} = \frac{1}{n}$   |
| 15. $\frac{1}{y} + \frac{1}{c} = 8$             | 16. $\frac{5}{2a} - \frac{7}{3y} = \frac{1}{6}$ |
| 17. $\frac{c}{y} = \frac{10}{1 + y}$            | 18. $\frac{12}{n - y} = \frac{13}{n + y}$       |

J. Complete with the simplest expressions you can to make true sentences.

1. For each  $k$ , the sum of the number 3 less than  $k$  and  $k$  is \_\_\_\_\_.
2. For each  $x$ , the sum of  $x$  and the number  $-5$  more than the quotient of 0 by  $x$  is \_\_\_\_\_.
3. For each  $e$ , the number which is 3.5 times larger than  $e$  is \_\_\_\_\_.
4. For each  $w$ , the difference of a number  $-3$  times as large as  $w$  from  $w$  is \_\_\_\_\_.
5. For each  $q$ , the number which exceeds  $q$  by 77 is \_\_\_\_\_.
6. For each  $a$ , the number which is 1% of  $a$  is \_\_\_\_\_.
7. For each  $s$ , the number which is 200% [of  $s$ ] larger than  $s$  is \_\_\_\_\_.
8. For each  $z$ , 50% of the number which exceeds  $z$  by  $-3$  is \_\_\_\_\_.
9. For each  $f$ , the number which is 35% less than  $f$  is \_\_\_\_\_.
10. For each  $c$ , for each  $d$ , the product of 100% of  $c$  and 40% of  $d$  is \_\_\_\_\_.
11. For each  $g$ , the product of  $-6g$  and  $\frac{1}{30}$  is \_\_\_\_\_.
12. For each  $j$ ,  $j$  less than  $-2$  is \_\_\_\_\_.
13. For each  $r$ , the difference of the quotient of  $-5r$  by 10 from the product of  $r$  and 3 is \_\_\_\_\_.
14. For each  $m \neq 0$ , the quotient of  $-45$  by the quotient of  $-25m$  by 5 is \_\_\_\_\_.

3/184

In Exercise 42 on page 3-177, change ' $y > \frac{4}{3}$ ' to ' $y > 2$ '.

- J.
- |                                |                           |                     |
|--------------------------------|---------------------------|---------------------|
| 1. $2k - 3$                    | 2. $x - 5$                | 3. $4.5e$           |
| 4. $4w$                        | 5. $q + 77$               | 6. $0.01a$          |
| 7. $3s$                        | 8. $(z - 3)/2$            | 9. $0.65f$          |
| 10. $0.4cd$                    | 11. $-(g/5)$              | 12. $-2 - j$        |
| 13. $3.5r$                     | 14. $9/m$                 | 15. $x - 7$         |
| 16. $3y + 9$                   | 17. $0.5z - 10$           | 18. $26$            |
| 19. $(7y - 30)/100$            | 20. $4n$                  | 21. $14p$           |
| 22. $s/36$                     | 23. $198f$                | 24. $10d$           |
| 25. $5(n + 5q)$                | 26. $r/20$                | 27. $5g$            |
| 28. $1.22c$                    | 29. $3g$                  | 30. $3a - 4$        |
| 31. $5t^2 + 35t$               | 32. $-(71y/8)$            | 33. $0.75N - 60$    |
| 34. $2r$                       | 35. $11m/2$               | 36. $sw$            |
| 37. $2m/91$                    | 38. $2p/13$               | 39. $.045y$ dollars |
| 40. $137.5 - .055r$            | 41. $100 + .015k$         | 42. $y - 2$ inches  |
| 43. $49b/\pi$                  | 44. $10 + (5v/4)$         | 45. $1/n$           |
| 46. $p/12$                     | 47. $11p/60$              | 48. $(w - 5)/(5w)$  |
| 49. $225/r$                    | 50. $100c + 150$          |                     |
| 51. The data are inconsistent. |                           | 52. $(w/3) - 32$    |
| 53. $4f/3$                     | 54. $(83p + 39)/(2p + 1)$ |                     |
| 55. The data are inconsistent. |                           | 56. $3230 - 8q$     |
| 57. $a + 2$                    | 58. $n - 2$               | 59. $2s + 6$        |
| 60. $g/5$                      | 61. $3g/5$                | 62. $1 + (d/4)$     |
| 63. $5(j + 6)/(j + 3)$         | 64. $(8 + b)/16$          | 65. $2r$            |
| 66. $(5n + 200)/7$             | 67.* $\frac{12d}{36 + d}$ | 68. $165 + (110/p)$ |
| 69. $100 + 0.02p$              |                           |                     |

---

\*[See the footnote on TC[3-71, 72, 73, 74, 75].]

[3-174]

J. Co

15. For each number of arithmetic  $x > 7$ , if George is  $x$  years old now, he was \_\_\_\_\_ years old 7 years ago.
16. For each number  $y$  of arithmetic, if Herb is  $y + 2$  years old now and Henry is three times as old as Herb, then Henry will be \_\_\_\_\_ years old 3 years from now.
17. For each number of arithmetic  $z > 20$ , if John's age is 10 years less than one half Dotty's age, and Dotty is  $z$  years old, then John is \_\_\_\_\_ years old.
18. For each number of arithmetic  $p < 26$ , if Ruth is 28 years old now and she was 2 years older than Nancy  $p$  years ago, then Nancy is now \_\_\_\_\_ years old.
19. For each number  $y$  of arithmetic, if a 45 r.p.m. record costs  $y$  cents, and a 78 r.p.m. record costs 10 cents less than a 45 r.p.m. record, then the cost of four 45 r.p.m. records and three 78 r.p.m. records will be \_\_\_\_\_ dollars.
20. For each number  $n$  of arithmetic, there are \_\_\_\_\_ quarts in  $n$  gallons.
21. For each number  $p$  of arithmetic,  $p$  pints and three times that many quarts together contain \_\_\_\_\_ cups. [Hint: there are 2 cups in one pint.]
22. For each number  $s$  of arithmetic, there are \_\_\_\_\_ yards in  $s$  inches.
23. For each number  $f$  of arithmetic,  $f$  feet, 5 times as many yards, and 6 times as many inches [as feet] together make \_\_\_\_\_ inches.
24. For each number  $d$  of arithmetic, there are \_\_\_\_\_ cents in  $d$  dimes.
25. For each whole number  $n$  of arithmetic, for each whole number  $q$  of arithmetic, there are \_\_\_\_\_ cents in a total of  $n$  nickels and  $q$  quarters.

(continued on next page)

26. For each whole number  $r$  of arithmetic, there are \_\_\_\_\_ dollars in  $r$  nickels.
27. For each whole number  $g$  of arithmetic, if Joe buys erasers at the rate of 3 erasers for 10 cents and sells them to his friends at the rate of 5¢ each, then his profit on the sale of  $3g$  erasers is \_\_\_\_\_ cents.
28. For each number  $c$  of arithmetic, if the cost price of an article is  $c$  dollars and the margin is 22% of the cost price, then the selling price is \_\_\_\_\_ dollars.
29. For each number  $g$  of arithmetic, if one of the shorter sides of a rectangle is  $g$  units long, and a side of an equilateral triangle has the same length as this shorter side of the rectangle, then the perimeter of the equilateral triangle is \_\_\_\_\_.
30. For each number of arithmetic  $a \geq 5$ , if a longer side of a rectangle is  $a$  units, and a shorter side of this rectangle is 2 units less than one half this longer side, then the perimeter of the rectangle is \_\_\_\_\_.
31. For each  $t$ , the sum of  $t$  and 7 multiplied by the product of 5 by  $t$  is \_\_\_\_\_.
32. For each  $y$ , the difference of the product of 9 by  $y$  from  $\frac{1}{8}$  of  $y$  is \_\_\_\_\_.
33. For each number of arithmetic  $N > 80$ , if Mr. Smith earns  $N$  dollars per year and Mr. Harris earns \$60 less than three fourths of what Mr. Smith earns, then Mr. Harris earns \_\_\_\_\_ dollars a year.
34. For each number  $r$  of arithmetic, you can walk \_\_\_\_\_ miles in  $r$  hours at the average rate of 2 miles per hour.
35. For each number  $m$  of arithmetic, you can travel \_\_\_\_\_ miles in  $5\frac{1}{2}$  hours at the average rate of  $m$  miles per hour.



36. For each number  $w$  of arithmetic, for each number  $s$  of arithmetic, you can travel \_\_\_\_\_ miles in  $w$  hours at the average rate of  $s$  miles per hour.
37. For each number  $m$  of arithmetic, it takes \_\_\_\_\_ hours for a freight train to travel  $m$  miles if its average rate is  $45\frac{1}{2}$  miles per hour.
38. For each number  $p$  of arithmetic, to travel  $p$  miles in  $6\frac{1}{2}$  hours, you must walk at an average rate of \_\_\_\_\_.
39. For each number  $y$  of arithmetic, if you invest  $y$  dollars at  $4\frac{1}{2}\%$ , the annual income on  $y$  dollars is \_\_\_\_\_.
40. For each number of arithmetic  $r \leq 2500$ , the annual income on  $(2500 - r)$  dollars invested at  $5.5\%$  is \_\_\_\_\_ dollars.
41. For each number of arithmetic  $k \leq 5000$ , the total annual income on \$5000,  $k$  dollars of which is invested at  $3\frac{1}{2}\%$ , and the rest at  $2\%$ , is \_\_\_\_\_ dollars.
42. For each number of arithmetic  $y > \frac{4}{3}$ , if the base of an isosceles triangle is  $y$  inches long and the perimeter is  $3y - 4$ , then the length of one of the two sides of equal length is \_\_\_\_\_.
43. For each number  $b$  of arithmetic, if the circumference of a circle is  $49b$ , a diameter measures \_\_\_\_\_.
44. For each number  $v$  of arithmetic, if a square has perimeter  $v$ , then a pentagon, each of whose sides is 2 units more than a side of the square, will have perimeter \_\_\_\_\_.
45. For each number of arithmetic  $n > 0$ , if Mary can clean the house in  $n$  hours, then she can clean \_\_\_\_\_ of the house in 1 hour.

(continued on next page)

46. For each number  $p$  of arithmetic, if Ned can paint a certain barn in 12 hours, then he can paint \_\_\_\_\_ of this barn in  $p$  hours.
47. For each number  $p$  of arithmetic, if Ned can paint a certain barn in 12 hours and Guy can paint this barn in 10 hours, then together they can paint \_\_\_\_\_ of this barn in  $p$  hours.
48. For each number of arithmetic  $w \geq 5$ , if an inlet pipe can fill a tank in 5 hours and an outlet pipe can empty this tank in  $w$  hours, then when both pipes are turned on [starting with an empty tank], \_\_\_\_\_ of the tank is filled at the end of 1 hours.
49. For each number of arithmetic  $r > 0$ , if Bruce runs  $\frac{2}{3}$  as fast as Cecil, and if Cecil runs  $r$  feet per second, then Bruce takes \_\_\_\_\_ seconds to run 150 feet.
50. For each whole number  $c$  of arithmetic, a pile of nickels, dimes, and quarters which contains  $c$  dimes, three times as many nickels, and 6 more quarters than nickels, is worth \_\_\_\_\_ cents.
51. For each number  $h$  of arithmetic, if the measure of the width of a rectangle is  $\frac{3}{4}$  the perimeter  $h$  then the length measures \_\_\_\_\_.
52. For each whole number of arithmetic  $w > 96$ , if 48 more than one half of the  $w$  students in a study hall are dismissed for lunch at 11:15, and one third of the remaining students are dismissed at 11:25, then there are \_\_\_\_\_ students left in the study hall.
53. For each number  $f$  of arithmetic, if a person can climb a smokestack in  $f$  minutes and descend 3 times as fast, the total time required for the trip up and down [no resting] is \_\_\_\_\_ minutes.

54. For each number  $p$  of arithmetic, if  $p$  pounds of peaches at 49 cents per pound are mixed with 2 more than 3 times as many pounds of smaller peaches at 39 cents per pound, then the resulting pile of peaches is worth \_\_\_\_\_ cents per pound.
55. For each number  $k$  of arithmetic, if  $k$  pounds of cookies worth 36 cents per pound are mixed with 10 pounds of cookies worth 30 cents per pound, the resulting mixture contains \_\_\_\_\_ pounds worth 40 cents per pound.
56. For each number of arithmetic  $q < 34$ , the total cost of  $q$  pounds of coffee at 87 cents per pound and  $(34 - q)$  pounds of coffee at 95 cents per pound is \_\_\_\_\_ cents.
57. For each  $a$ , if  $a$  is an integer, \_\_\_\_\_ is the second larger integer.
58. For each  $n$ , if  $n$  is an even integer, \_\_\_\_\_ is the largest even integer smaller than  $n$ .
59. For each  $s$ , if  $s$  is an odd integer, the sum of the next two consecutive odd integers is \_\_\_\_\_.
60. For each number  $g$  of arithmetic,  $g$  gallons of a salt and water solution is 20% salt, so the solution contains \_\_\_\_\_ gallons of salt.
61. For each number  $g$  of arithmetic,  $g$  gallons of a 40% salt solution contains \_\_\_\_\_ gallons of water.
62. For each number  $d$  of arithmetic, if 5 gallons of a 20% salt solution are added to  $d$  gallons of a 25% salt solution the new mixture contains \_\_\_\_\_ gallons of salt.

(continued on next page)

63. For each number  $j$  of arithmetic, if  $j$  liquid ounces of a 5% argyrol solution are added to 3 liquid ounces of a 10% argyrol solution, the new mixture is a \_\_\_\_\_ per cent argyrol solution.
64. For each number  $b$  of arithmetic, if  $b$  ounces of Brazil nuts are added to 2.5 pounds of a nut mixture which contains 20% Brazil nuts, the new mixture contains \_\_\_\_\_ pounds of Brazil nuts.
65. For each number  $r$  of arithmetic, if  $r$  quarts of a 50% antifreeze solution are mixed with twice as many quarts of a 75% antifreeze solution, the result is a mixture containing \_\_\_\_\_ quarts of antifreeze.
66. For each number  $n$  of arithmetic, if 5 quarts of an  $n\%$  alcohol solution are combined with 2 quarts of pure alcohol, the new mixture is \_\_\_\_\_ per cent alcohol.
67. For each number of arithmetic  $d > 0$ , if it takes Sandy  $d$  hours to ride her bicycle 12 miles and if Jody can ride her bicycle  $\frac{1}{3}$  mile per hour faster than Sandy, then it takes Jody \_\_\_\_\_ hours to ride  $\frac{1}{3}$  as far as Sandy.
68. For each whole number  $p$  of arithmetic, if  $p$  people share equally in the cost of a \$55 camping trip, a trip for 2 more than three times this number of people should cost \_\_\_\_\_ dollars.
69. For each number  $p$  of arithmetic, if 2000 pounds of milk containing 5% butterfat are added to  $p$  pounds of milk containing 2% butterfat, the new mixture will contain \_\_\_\_\_ pounds of butterfat.



63.

3/185

- K. 1. dimes, 24; quarters, 36 [x dimes, 60 - x quarters;  
 $10x + 25(60 - x) = 1140$ ]
2. 10¢ per lb., 24; 25¢ per lb., 36 [x pounds of 10¢ grade,  
 60 - x pounds of 25¢ grade;  $10x + 25(60 - x) = 1140$ ] [We hope  
 students will recognize that the equation for this problem is a  
 copy of the equation in Exercise 1, and thus be able to give  
 the answer to the question without solving the equation.]
3. 20 [(x ÷ 4 - 3)2 = 16]
4. The data are inconsistent. [x years...Walter's age 6 yrs.  
 ago, x - 12...Eddie's age 6 yrs. ago, x + 13...Walter's age  
 in 7 yrs., x + 13 - 12...Eddie's age in 7 yrs. So, we want  
 a number x of arithmetic such that
- $$x + 13 - 12 = (x + 13) \div 2.$$
- The only such number is 11. And, if Walter was 11 years  
 old 6 years ago, and he was 12 years older than Eddie, Eddie  
 would have been -1 year old. But this is ridiculous.]
5. 72 m.p.h. [Mr. King expected to arrive at the depot in 24  
 minutes; thus, his initial rate was 18/24 miles per minute.  
 At the time he reached the railroad crossing 6 miles from  
 home he had used up  $6 \div (18/24)$ , or 8 minutes. After the  
 11 minute delay he still had 10 minutes to catch the train.  
 To cover the remaining 12 miles in 10 minutes his average  
 speed was 12/10, or 6/5 miles per minute (72 m.p.h.).]
6. 2/9 of a gallon [x gallons of 18% ammonia solution; one gal-  
 lon of ammonia solution contains 0.22 gallons of ammonia;  
 $0.18x = 0.22$ ]
7. The data are insufficient.
8. 50 m.p.h. [Since in 24 minutes the truck could have gone 22  
 miles, its rate would have been 22/24 miles per minute, or  
 55 miles per hour. This rate was 5 miles per hour faster  
 than the rate during the actual trip. So, the truck was traveling  
 50 miles per hour.]

K. Solve these problems.

1. How many dimes and quarters are there in a collection of 60 of these coins if the collection is worth \$11.40?
2. How many pounds of cleaning compound worth 10¢ a pound should be mixed with cleaning compound worth 25¢ a pound to make a mixture of 60 pounds worth 19¢ a pound?
3. Jerry selected a number, divided it by 4, subtracted -3 from the result, multiplied the difference by 2. His final result was 16. What number did he select?
4. Six years ago Walter was 12 years older than Eddie. In 7 years Walter will be twice Eddie's age then. How old is each now?
5. Mr. King has 29 minutes to catch a train 18 miles from home. He starts out at a rate that will enable him to get to the depot 5 minutes early. However, he has an unexpected 11-minute delay at a railroad crossing 6 miles from home. For the remainder of the trip, he increases his speed, hoping to catch the train; however, he arrived at the depot just as the train pulled out. At what rate did he travel during the last part of the trip?
6. One gallon of an ammonia solution contains 22% ammonia, the rest water. How much water must be added to make the solution contain 18% ammonia?
7. Two trains are 480 miles apart at 6 p.m. and are traveling toward each other on parallel tracks. If one is traveling 20 miles an hour faster than the other, at what time will they meet?

(continued on next page)

8. A truck makes a trip at a uniform speed. Had the rate been 5 miles per hour faster, the trip would have taken 24 minutes less time, or the driver could have gone 22 miles farther. At what speed was the truck traveling?
9. How much candy worth 40¢ a pound should be mixed with candy worth 60¢ a pound to make 200 pounds of mixture worth 52¢ a pound?
10. Two planes are 30 miles apart and going in opposite directions. One travels 25 miles per hour faster than the other. At the end of 4 hours they are 1018 miles apart. If during this time each has maintained a steady rate what is the rate of each?
11. A painter could paint a certain house by himself in 16 hours. It would take his assistant about 24 hours to paint the same house. The painter begins at 8 a.m. At 10 a.m. his assistant joins him and they finish painting the house. How long did the assistant work?
12. A man invests a certain amount of money at 4%. He invests \$1000 more than twice that amount at 5%. If the total amount of interest he receives at the end of a year is \$840 how much did he invest at each rate?
13. It takes a man who rows 6 miles an hour in still water 14 hours longer to row a certain distance upstream than it does for him to row back the same distance. If the complete trip takes 24 hours, what is the rate of the current?
14. Water is flowing out of a tank through a single pipe. A second pipe is then opened so that the rate of outflow is increased by 25%. With both pipes open the amount of water which flows out in 24 minutes is 18 gallons. At what rate was the water flowing out of the first pipe?



3/186

9. 40¢ per lb., 80; 60¢ per lb., 120 [x lbs. of 40¢ per lb. candy, 200 - x lbs. of 60¢ per lb. candy;  $40x + 60(200 - x) = 52 \cdot 200$  ]
10. slower plane, 111 m.p.h.; faster plane, 136 m.p.h. [assuming that the planes do not pass each other]; slower plane, 118.5 m.p.h.; faster plane,  $143.\overline{5}$  m.p.h. [assuming that the planes do pass each other]

[The equation used under first assumption:  $4x + 30 + 4(x + 25) = 1018$ . The equation used under second assumption:  $4x - 30 + 4(x + 25) = 1018$ . See COMMENTARY for Exercise 8 on page 3-80 for diagrams which are analogous to those appropriate for this problem.]

11. 8.4 hours [In one hour the painter paints  $1/16$  of the house. His assistant paints  $1/24$  of the house in one hour. By 10:00 a.m.,  $1/8$  of the house was painted. x hours to finish painting the house;  $(x/16) + (x/24) = 7/8$ ]
12. 4%, \$3500; 5%, \$8000 [x dollars at 4%,  $2x + 1000$  dollars at 5%;  $0.04x + 0.05(2x + 1000) = 540$ ]

13. x ... time to row upstream  
 x - 10 ... time to row back  
 $x + (x - 10) = 24$

So, it takes him 17 hours to row upstream and 7 hours to row back. The distance is the same in each case.

y ... rate of current  
 6 - y ... rate upstream  
 6 + y ... rate downstream  
 $(6 - y)17 = (6 + y)7$

The rate of the current was 2.5 miles per hour.

14.  $37\frac{1}{2}$  gallons per hour [rate with both pipes open is 18 gallons in 24 minutes which is  $3/4$  gallon per minute, or 45 gallons per hour. x ... rate through first pipe,  $x + (x/5)$  ... rate of outflow with both pipes open;  $x + (x/5) = 45$ ]

[3-182]

8



An alternative solution. Since Dan had 15 cents left after Friday's expenses, and this was  $1/3$  of what he had left from Thursday, he must have had 45 cents left from Thursday [ $x/3 = 15$ ]. Now if he had  $y$  cents left after Tuesday's expenses, we want a number  $y$  of arithmetic such that  $y - [(1/2)y - 10] - 35 = 45$ . 140 is such a number; so, Dan had 140 cents left after Tuesday's expenses. If he had  $z$  cents left after Monday's expenses, we want a number  $z$  of arithmetic such that  $z - 30 - [(1/3)(z - 30) + 80] = 140$ . Such a number is 360. Hence, Dan had 360 cents left after Monday's expenses. If he had  $w$  cents in his weekly allowance, and he spent  $1/4$  of it on Monday, he had  $(3/4)w$  left. So, we want a number  $w$  of arithmetic such that  $(3/4)w = 360$ . Such a number is 480.

21. Gene's car, 11 yrs.; Ralph's car, 7 yrs.; Bob's car, 3 yrs.  
 [ $x$ ...age of Gene's car now,  $(1/2)x + (3/2)$ ...age of Ralph's car now,  $x - 1$ ...age of Gene's car last year,  $(1/2)x + (3/2) - 1$ ...age of Ralph's car last year;  $(1/2)x + (3/2) - 1 = (3/5)(x - 1)$ ]
22. 40 lbs. [The alloy now contains 39 pounds of copper and 21 pounds of zinc. This amount of zinc must be 21% of the new alloy. If  $x$  pounds is the total weight of new alloy, we want a number  $x$  of arithmetic such that  $0.21x = 21$ . Such a number is 100. Since there were 60 pounds of the original alloy, 40 pounds of copper must be added.]  
 [An alternative solution.  $x$ ...pounds of copper to be added,  $x + 39$ ...pounds of copper in new alloy,  $60 + x$ ...pounds of new alloy;  $0.79(60 + x) = x + 39$ ]
23. \$1.64 grade, 540; \$1.53 grade, 120 [ $x$ ...bushels of wheat @ \$1.64,  $660 - x$ ...bushels of wheat @ \$1.53;  
 $1.64x + 1.53(660 - x) + 99 = 660(1.77)$ ]
24. 27 [ $x$ ...pounds of first solution,  $0.18x$ ...pounds of water in first solution,  $0.58(16)$ ...pounds of water in 16 pounds of second solution,  $x + 16$ ...pounds of mixture,  $0.26(x + 16 - 4)$ ...pounds of water in mixture after evaporation;  
 $0.26(x + 12) = 0.18x + 0.58(16) - 4$ ]
25. 40 [First test:  $x$ ...students who failed,  $x + 32$ ...students who passed. Second test:  $x - 2$ ...students who failed,  $x + 34$ ...students who passed.  $2x + 32$ ...total students;  
 $0.95(2x + 32) = x + 34$ ]



15. The data are inconsistent. [Suppose there are  $x$  nickels. Then, there would be  $2x + 6$  dimes. The nickels would be worth  $5x$  cents, and the dimes would be worth  $10(2x + 6)$  cents. So, we want a number  $x$  of arithmetic such that  $5x + 10(2x + 6) = 290$ . The only such number is  $46/5$ . Since we cannot have  $46/5$  nickels, there is no solution to the problem.]

16. 20 minutes [Each minute each of the two inlet pipes fills  $1/15$  of the tank. Each minute the outlet pipe empties  $1/12$  of the tank. Thus, each minute  $2/15$  of the tank is filled, and  $1/12$  of the tank is emptied. So,  $(2/15) - (1/12)$ , or  $1/20$  of the tank is actually filled each minute.]

[An alternative solution.  $x$ ...time required to fill tank;  
 $(2/15) - (1/12) = 1/x$ ]

17.  $-3$  [ $x \div -(1/2) = 6$ ]

18. western edge, 10 yards; northern edge, 20 yards; southern edge, 25 yards; eastern edge, 35 yards [ $x$  yards (of fence) needed for western edge,  $2x$  yards needed for northern edge,  $2x + 5$  yards needed for southern edge,  $x + (2x + 5)$  yards needed for eastern edge;  $x + 2x + (2x + 5) + [x + (2x + 5)] = 90$ ]

19.  $3/4$  of a mile [ $x$ ...distance John has come,  $2x + (1/2)$ ...distance from home to school;  $2x + (1/2) = 2$ ]

20.  $x$ ...amount of weekly allowance (in cents)

$\frac{3}{4}x$ ...amount left after Monday's expenses

$\frac{3}{4}x - 30 - [\frac{1}{3}(\frac{3}{4}x - 30) + 80]$ , [or:  $\frac{1}{2}x - 100$ ]...amount left after Tuesday's expenses

$(\frac{1}{2}x - 100) - [\frac{1}{2}(\frac{1}{2}x - 100) - 10] - 35$ , [or:  $\frac{1}{4}x - 75$ ]...amount left after Thursday's expenses

$(\frac{1}{4}x - 75) - [\frac{2}{3}(\frac{1}{4}x - 75)]$ , [or:  $\frac{1}{12}x - 25$ ]...amount left after Friday's expenses

$$(x/12) - 25 = 15$$

So, Dan's weekly allowance was \$4.80.

[An alternative solution is on TC[3-183]b.]

15. John has some dimes and nickels; the number of dimes is 6 more than twice the number of nickels. These coins are worth \$2.90. How many of each denomination does he have?
16. A tank has 2 inlet pipes and one outlet pipe. Each of the 2 inlet pipes alone could fill the tank in 15 minutes. The outlet pipe could empty the tank in 12 minutes. If all three pipes are open, how long would it take to fill the tank?
17. If a number is divided by  $-\frac{1}{2}$ , the result is 6. What is the number?
18. A man needs 90 yards of fencing for his lot. He needs twice as much for the northern edge as he does for the western. He needs 5 more yards for the southern than he does for the northern edge. The eastern edge will take as much as the western and the southern together. How much does he need for each side?
19. John leaves home for school which is 2 miles away. At the end of 5 minutes he figures that the distance from home to school is  $\frac{1}{2}$  mile more than twice as far as he has already come. How far has he come?
20. On Monday, Dan spent  $\frac{1}{4}$  of his weekly allowance for a haircut and new shoelaces. On Tuesday, he bought a sundae for 30¢ and then paid 80¢ more than  $\frac{1}{3}$  of what remained for gas and one quart of oil. A movie Thursday evening lacked 10¢ of costing him  $\frac{1}{2}$  of what he had left. A hamburger and Coke afterward cost 35¢. Friday he had to pay  $\frac{2}{3}$  of what was left to have a flat fixed. This left him only 15¢. What was his weekly allowance?
21. Ralph's car is 2 years less than 3 times as old as Bob's and  $1\frac{1}{2}$  years more than one half as old as Gene's. Last year Ralph's car was  $\frac{3}{5}$  as old as Gene's was. How old is each car now?

(continued on next page)

22. An alloy of 60 pounds of zinc and copper is 65% copper. How much copper must be added to make an alloy which is 79% copper by weight?
23. A grain dealer mixed wheat costing \$1.64 a bushel with wheat costing \$1.53 a bushel, and sold the mixture for \$1.77 a bushel. He sells 660 bushels at this price and makes a profit of \$99. How many bushels of each did he use?
24. A solution which is 82% sodium dichromate salt, by weight, and the rest water is mixed with 16 pounds of a mixture containing 42% sodium dichromate salt and the rest water. In order to decrease the percentage of water in the final mixture to 26%, 4 pounds of water are evaporated. How many pounds of the first solution were used?
25. On an algebra test, 32 more pupils passed than failed. On the second test, one student who had passed the first test failed the second but 3 of those failing the first passed the second. Altogether, on the last test, 95% passed. How many students took the algebra tests?
26. A life insurance company offers its salesmen a commission of 55% of the first year's premium on each policy they sell, 10% of the second year's premium, and 5% of each succeeding year's premium for the next 8 years. If a holder of a certain policy pays the same yearly premium for 10 years, the salesman receives a total of \$420 in commission on this policy. What was the yearly premium on the policy?
27. The ratio of Jim's hourly wage to John's hourly wage is 4:5. If they could each work 8 hours, the total amount they would receive would be \$43.20. How much does Jim earn per hour?



3/189

26. \$400 [x...amount of yearly premium,  $0.55x$ ...amount received on first year's premium,  $0.10x$ ...amount received on second year's premium,  $8(0.05x)$ ...amount received on succeeding premiums for next 8 years;  $0.55x + 0.10x + 8(0.05x) = 420$ ]
27. \$2.40 [x...Jim's hourly wage in cents,  $(5/4)x$ ...John's hourly wage in cents;  $8x + 8[(5/4)x] = 4320$ ]
28. \$40000 [x...amount owed,  $0.25x$ ...amount to be paid to creditors,  $0.28x$ ...amount that could be paid [if an additional \$1200 were collected];  $0.25x + 1200 = 0.28x$ ]
29. 2.4 days [The dump cart fills  $1/8$  of the pit per day, and the motor truck fills  $1/6$  of the pit per day. x...days to fill pit with two dump carts and one truck working together;  $(1/8) + (1/8) + (1/6) = 1/x$ ]
30. 84 [8 qts. of original solution contains 6.56 qts. alcohol and 1.44 qts. water. If there are x qts. of the first new solution,  $0.08x$  qts. of it will be water. Since there are 1.44 qts. of water, there must be 18 qts. of this first new solution [ $0.08x = 1.44$ ], which means that 10 qts. of alcohol have been added.

The second new solution will contain a total of 30 qts., of which  $[10 + 6.56 + 0.72(12)]$  qts. are alcohol. If  $y\%$  of this second new solution is alcohol, we want a number y of arithmetic such that  $30(y/100) = 10 + 6.56 + 0.72(12)$ . Such a number is 84.]

- ☆31. 6.4 [Considering some unit (perhaps the shovelful!) of dirt, for each unit moved by the well digger, his partner moves  $3/5$  unit. So, in 1 hour, the partner will put into the truck  $3/5$  as many units of dirt as the well digger has tossed out of the well, and  $2/5$  as many units will remain on the ground.

h... hours well digger digs in well

8 - h... hours well digger helps shovel dirt into truck

We want a number h of arithmetic such that  $(2/5)h = (8/5)(8 - h)$ . Such a number is 6.4.]

[3-184]

27



A third solution.

When running in opposite directions, the boys together cover 1 block in 16 seconds. When running in the same direction, the faster boy must run completely around the block once in order to overtake the slower boy. In other words, when running in the same direction, for each 48 seconds, the distance covered by the faster boy minus the distance covered by the slower boy is 1 block.

Suppose that  $f$  is rate of faster boy in blocks per sec.,  
 and  $s$  is rate of slower boy in blocks per sec. [ $s < f$ ]  
 Then  $16f + 16s = 1$ ,  
 and  $48f - 48s = 1$ .  
 So,  $16(f + s) = 48(f - s)$   
 $f + s = 3(f - s)$   
 $f = 2s$ .

[Note that, from the third equation, we can derive:

$$\frac{f + s}{f - s} = \frac{48}{16}, [f - s \neq 0].$$

Hence, the rate of the faster boy is two times the rate of the slower boy. So, for any given amount of time, the faster boy will cover twice as much ground as the slower boy. Therefore, when running in opposite directions, if  $d$  is the distance in blocks covered by the slower boy, then  $2d$  is the distance in blocks covered by the faster boy, and  $d + 2d$  is the distance around the block [ $d + 2d = 1$ ]. So, the distance covered by the slower boy in 16 seconds is  $1/3$  block. Therefore, it will take him 48 seconds to run around the block.

[Alternatively, once we have determined from the given data that the faster boy's rate is twice that of the slower boy, we could have found the answer to the problem by considering the case in which the boys are running in the same direction. If  $d$  is the distance in blocks covered by the slower boy in 48 seconds, and  $2d$  is the distance covered by the faster boy in 48 seconds, then  $2d - 1 = d$ . So,  $d$  is 1. This means that the slower boy runs around the block once in 48 seconds.]



- ☆32. 48 seconds [assuming that the boys started running from the same point at the same time]

Running in opposite directions, the boys run a total distance of 1 block in 16 seconds. So, if the faster boy runs  $x$  blocks in 16 seconds [ $x < 1$ ], his rate is  $x/16$  blocks per second. Then, the slower boy's rate is  $(1 - x)/16$  blocks per second. Running in the same direction, it takes 48 seconds for the faster boy to overtake the slower. [In 48 seconds, the faster boy has traveled a distance of 1 block plus the distance traveled by the slower boy.] Hence, we are looking for a number  $x$  of arithmetic such that

$$48(x/16) = 1 + 48[(1 - x)/16].$$

$2/3$  is such a number. So, the faster boy runs  $2/3$  of the distance around the block in 16 seconds, and the slower boy runs  $1/3$  of the distance around the block in 16 seconds. Therefore, it would take the slower boy 48 seconds to run around the block.

A second solution.

Running in the same direction:

$x$ ...blocks covered by the faster boy in 48 seconds  
           [ $x > 1$ ]  
 $x - 1$ ...blocks covered by the slower boy in 48 seconds  
 $x/48$ ...rate in blocks per second of the faster boy  
 $(x - 1)/48$ ...rate in blocks per second of the slower boy

When running in opposite directions, the faster boy meets the slower boy in 16 seconds. So, the distance covered by the two boys in 16 seconds is that of one complete trip around the block. Hence,

$$16(x/48) + 16[(x - 1)/48] = 1.$$

The root of this equation is 2. So, the slower boy has covered 1 block in 48 seconds.

[Another solution is on TC[3-185]b.]

28. A company that has failed in business is able to pay its creditors at the rate of 25 cents on the dollar. If the company had been able to collect a certain debt of \$1200, it could have paid 28 cents on the dollar. How much did the company owe at the time of failure?
29. A dump cart can haul enough gravel to fill a pit in 8 days. A motor truck can do it in 6 days. How long would it take 2 dump carts and one truck working together to fill the pit?
30. A container is filled with a solution which is 82% alcohol and 18% water. All but 8 quarts are spilled. The container is then filled with pure alcohol making the new solution 92% alcohol. The solution is then mixed with 12 quarts of a solution of 72% alcohol. What is the per cent alcohol in this new solution?
- ☆31. A well digger can shovel as much dirt in 3 hours as his partner who stays above ground can shovel into a truck in 5 hours. Assume that they both work an eight-hour day. At the end of how many hours must the faster man stop digging to help the slower one shovel the dirt into the truck so that all of the dirt is in the truck at quitting time? [Assume that the faster man shovels dirt into the truck at the same rate as he shovels it out of the hole.]
- ☆32. Two boys run around the block in which their school gymnasium is situated; when they run in the same direction, the faster boy overtakes the slower boy every 48 seconds. When they run in opposite directions, they meet every 16 seconds. How long does it take the slower boy to run around the block?

L. Expand.

- |                           |                           |                           |
|---------------------------|---------------------------|---------------------------|
| 1. $(x + 5)(x + 7)$       | 2. $(n - 8)(n + 2)$       | 3. $(c + 12)(c - 5)$      |
| 4. $(y + 6)^2$            | 5. $(y + .6)^2$           | 6. $(y - 6)^2$            |
| 7. $(d - 11)(d + 1)$      | 8. $(r - 4)(r + 5)$       | 9. $(3a + 2)(4a - 3)$     |
| 10. $(k + 12)^2$          | 11. $(x - 13)^2$          | 12. $(z + 4)^2$           |
| 13. $(p - 2)^2$           | 14. $(r + 11)^2$          | 15. $(m + 8)^2$           |
| 16. $(t - \frac{1}{8})^2$ | 17. $(q - .3)^2$          | 18. $(b + \frac{1}{4})^2$ |
| 19. $(4x + 3)^2$          | 20. $(5y + 1)^2$          | 21. $(3z - 1)^2$          |
| 22. $(6n + 4)^2$          | 23. $(3m + 2)^2$          | 24. $(3y - 7)^2$          |
| 25. $(b - 2)(b + 1)$      | 26. $(x + 7)(x - 3)$      |                           |
| 27. $(y - 7)(y + 3)$      | 28. $(a - 10)(a + 10)$    |                           |
| 29. $(g - 14)(g + 4)$     | 30. $(y + 13)(y + 2)$     |                           |
| 31. $(x + \frac{3}{4})^2$ | 32. $(13r_1 + 2r_2)^2$    |                           |
| 33. $(p + q)^2$           | 34. $(p - q)^2$           |                           |
| 35. $(5 - s)^2$           | 36. $(q - p)^2$           |                           |
| 37. $(2x + 3)(x + 6)$     | 38. $(3n - 1)(6n + 7)$    |                           |
| 39. $(7e + 2)(2e - 6)$    | 40. $(9u - 5)(9u - 5)$    |                           |
| 41. $(10f + 3)(4f - 7)$   | 42. $(60x - 2)(2x + 1)$   |                           |
| 43. $(5 + 2p)^2$          | 44. $(9 - 4t)^2$          |                           |
| 45. $(11c + 3)^2$         | 46. $(3d - 8)^2$          |                           |
| 47. $(10W - v)^2$         | 48. $(2a_1 - 9a_2)^2$     |                           |
| 49. $r(16q + 6)(3q - 2)$  | 50. $(5b - 4)(6b - 7)$    |                           |
| 51. $(6 + 5y)(8 - 3y)$    | 52. $(-x + 3)(x + 11)$    |                           |
| 53. $(15 + r)^2$          | 54. $(3p + 2q)^2$         |                           |
| 55. $n(2r + 3)(r - 2)$    | 56. $c(2a + 5b)^2$        |                           |
| 57. $y(7x + 3)(1 + 5x)$   | 58. $(-4p - 2)(6p + 8)$   |                           |
| 59. $(-10x + 11)(-x - 3)$ | 60. $s(11r + 1)(11r - 1)$ |                           |



3/192

- L.
- |   |                                    |   |
|---|------------------------------------|---|
| 1. $x^2 + 12x + 35$                     | 2. $n^2 - 6n - 16$                 | 3. $c^2 + 7c - 60$                      |
| 4. $y^2 + 12y + 36$                     | 5. $y^2 + 1.2y + .36$              | 6. $y^2 - 12y + 36$                     |
| 7. $d^2 - 10d - 11$                     | 8. $r^2 + r - 20$                  | 9. $12a^2 - a - 6$                      |
| 10. $k^2 + 24k + 144$                   | 11. $x^2 - 26x + 169$              | 12. $z^2 + 8z + 16$                     |
| 13. $p^2 - 4p + 4$                      | 14. $r^2 + 22r + 121$              | 15. $m^2 + 16m + 64$                    |
| 16. $t^2 - \frac{1}{4}t + \frac{1}{64}$ | 17. $q^2 - .6q + .09$              | 18. $b^2 + \frac{1}{2}b + \frac{1}{16}$ |
| 19. $16x^2 + 24x + 9$                   | 20. $25y^2 + 10y + 1$              | 21. $9z^2 - 6z + 1$                     |
| 22. $36n^2 + 48n + 16$                  | 23. $9m^2 + 12m + 4$               | 24. $9y^2 - 42y + 49$                   |
| 25. $b^2 - b - 2$                       | 26. $x^2 + 4x - 21$                | 27. $y^2 - 4y - 21$                     |
| 28. $a^2 - 100$                         | 29. $g^2 - 10g - 56$               | 30. $y^2 + 15y + 26$                    |
| 31. $x^2 + \frac{3}{2}x + \frac{9}{16}$ | 32. $169r_1^2 + 52r_1r_2 + 4r_2^2$ |   |
| 33. $p^2 + 2pq + q^2$                   | 34. $p^2 - 2pq + q^2$              | 35. $25 - 10s + s^2$                    |
| 36. $q^2 - 2qp + p^2$                   | 37. $2x^2 + 15x + 18$              | 38. $18n^2 + 15n - 7$                   |
| 39. $14e^2 - 38e - 12$                  | 40. $81u^2 - 90u + 25$             | 41. $40f^2 - 58f - 21$                  |
| 42. $120x^2 + 56x - 2$                  | 43. $25 + 20p + 4p^2$              | 44. $81 - 72t + 16t^2$                  |
| 45. $121c^2 + 66c + 9$                  | 46. $9d^2 - 48d + 64$              |   |
| 47. $100W^2 - 20Wv + v^2$               | 48. $4a_1^2 - 36a_1a_2 + 81a_2^2$  |   |
| 49. $48rq^2 - 14rq - 12r$               | 50. $30b^2 - 59b + 28$             |   |
| 51. $48 + 22y - 15y^2$                  | 52. $-x^2 - 8x + 33$               |   |
| 53. $225 + 30r + r^2$                   | 54. $9p^2 + 12pq + 4q^2$           |   |
| 55. $2r^2n - rn - 6n$                   | 56. $4a^2c + 20abc + 25b^2c$       |   |
| 57. $35x^2y + 22xy + 3y$                | 58. $-24p^2 - 44p - 16$            |   |
| 59. $10x^2 + 19x - 33$                  | 60. $121r^2s - s$                  |   |

[3-186]

L. Ex



21.  $(k + 4)(k + 3)$

22.  $(y + 2)(y + 2)$

23.  $(x + 8)(x + 1)$

24.  $(p + 4)(p + 2)$

25.  $(b + 22)(b + 1)$

26.  $(a + 45)(a + 2)$

27.  $(q + 7)(q + 5)$

28.  $(r + 18)(r + 2)$

29.  $(x + 16)(x + 2)$

30.  $(c + 25)(c + 4)$

31.  $(g + 9)(g + 2)$

32.  $(e + 5)(e - 1)$

33. This expression has no binomial factors with integral coefficients.

34.  $(s + 12)(s + 12)$

35.  $(t + 4)(t + 36)$

[3-187]

61.  $9m^2 - \frac{1}{4}$       62.  $7k^2 + 12k - 4$       63.  $r^2s^2 - 49$   
 64.  $ac + bc + ad + bd$       65.  $\square\triangle + (\triangle + \square)a + a^2$   
 66.  $\triangle^2 + 2b\triangle + b^2$       67.  $\triangle^2 + 2\triangle\square y + \square^2y^2$   
 68.  $\bigcirc\bigcirc + \bigcirc\square c + \bigcirc\triangle c + \square\triangle c^2$

M. [We give three of the possible ways that Exercises 1-8 may be factored. Your students will doubtless suggest others.]

1.  $2 \cdot 12, 3 \cdot 8, 4 \cdot 6$       2.  $2 \cdot 18, 3 \cdot 12, 4 \cdot 9$   
 3.  $3 \cdot 131, 393 \cdot 1, 6 \cdot 65\frac{1}{2}$       4.  $2 \cdot 8, 4 \cdot 4, 2 \cdot 2^3$   
 5.  $6 \cdot 7x, 7 \cdot 6x, 2 \cdot 21x$       6.  $9a^2 \cdot 2b, 3 \cdot 6 \cdot a^2b, 6a^2 \cdot 3b$   
 7.  $10d \cdot 5, 10 \cdot 5d, 25 \cdot 2d$       8.  $3x \cdot 19y, 19x \cdot 3y, 3 \cdot 19 \cdot xy$

[We give two of the possible ways for factoring each of Exercises 9-20.]

9.  $3(x + 3), \frac{1}{9}(27x + 81)$       10.  $2(3y - 12), 6(y - 4)$   
 11.  $14(p + 3), 7(2p + 6)$       12.  $9(x + 9y), 3(3x + 27y)$   
 13.  $13(q - 5r), 2(6.5q - 32.5r)$   
 14.  $2(5s - t + 11u), 10(s - .2t + 2.2u)$   
 15.  $a(b - c), 2(\frac{1}{2}ab - \frac{1}{2}ac)$   
 16.  $4z(y - 5), 2z(2y - 10)$   
 17.  $p(15q - 18r - 6), 3p(5q - 6r - 2)$   
 18.  $b(9b - 21), 3b(3b - 7)$   
 19.  $11x(y - 4x), x(11y - 44x)$   
 20.  $-7mn^2(1 + 8o), mn^2(-7 - 56o)$

61.  $(3m - \frac{1}{2})(3m + \frac{1}{2})$

62.  $(7k - 2)(k + 2)$

63.  $(rs + 7)(rs - 7)$

64.  $(a + b)(c + d)$

65.  $(\square + a)(\triangle + a)$

66.  $(\triangle + b)^2$

67.  $(\triangle + \square y)^2$

68.  $(\hexagon + \square c)(\circ + \triangle c)$

M. Factor.

1. 24

2. 36

3. 393

4. 16

5.  $42x$

6.  $18a^2b$

7.  $50d$

8.  $57xy$

\*

9.  $3x + 9$

10.  $6y - 24$

11.  $14p + 42$

12.  $9x + 81y$

13.  $13q - 65r$

14.  $10s - 2t + 22u$

15.  $ab - ac$

16.  $4yz - 20z$

17.  $15pq - 18pr - 6p$

18.  $9b^2 - 21b$

19.  $11xy - 44x^2$

20.  $-7mn^2 - 56mn^2o$

\*

21.  $k^2 + 7k + 12$

22.  $y^2 + 4y + 4$

23.  $x^2 + 9x + 8$

24.  $p^2 + 6x + 8$

25.  $b^2 + 23b + 22$

26.  $a^2 + 47a + 90$

27.  $q^2 + 12q + 35$

28.  $r^2 + 20r + 36$

29.  $x^2 + 18x + 32$

30.  $c^2 + 29c + 100$

31.  $g^2 + 11g + 18$

32.  $e^2 + 4e - 5$

33.  $n^2 + 22n + 131$

34.  $s^2 + 24s + 144$

35.  $t^2 + 40t + 144$

\*

(continued on next page)

36.  $v^2 + 7v - 18$

38.  $w^2 + w - 12$

40.  $y^2 - 6y + 9$

42.  $q^2 + 14q + 33$

44.  $a^2 - 15a + 36$

46.  $f^2 - 4$

48.  $i^2 + 20i + 51$

50.  $d^2 - 3d + 28$

52.  $s^2 + 2s - 15$

54.  $55 - 16w + w^2$

56.  $x^2 + 27x + 72$

58.  $\triangle^2 - 16$

60.  $m^2 - m - 2$

37.  $k^2 - 7k - 18$

39.  $x^2 - 6x + 8$

41.  $p^2 - 49$

43.  $t^2 - 9t + 18$

45.  $c^2 + 9c - 36$

47.  $h^2 - h - 42$

49.  $b^2 - 15b + 50$

51.  $p^2 - 169$

53.  $27 + 12u + u^2$

55.  $40 - 3e - e^2$

57.  $14 - 5y - y^2$

59.  $x^2 - 2xy + y^2$

61.  $75 + 22n - n^2$

62.  $p^2 + 33p + 62$

\*

63.  $35t^2 + 46t + 15$

65.  $12x^2 + 41x + 24$

67.  $3r^2 + 10r + 3$

69.  $48m^2 + 86m + 35$

71.  $100t^2 - 9$

73.  $81m^2 - 1$

75.  $25k^2 + 10km + m^2$

77.  $56p^2 - 113p + 56$

79.  $3k^2 + 10kj + 3j^2$

64.  $16x^2 + 58x + 7$

66.  $25 + 70y + 49y^2$

68.  $12u^2 + 56u + 15$

70.  $100t^2 + 60t + 9$

72.  $35p^2 + 35p - 24$

74.  $121r^2 - 44r + 4$

76.  $9x^2 - 6xy + y^2$

78.  $1 - 64n^2$

80.  $6m_1^2 - 13m_1m_2 - 15m_2^2$



3/195

36.  $(v + 9)(v - 2)$       37.  $(k - 9)(k + 2)$       38.  $(w + 4)(w - 3)$
39.  $(x - 4)(x - 2)$       40.  $(y - 3)(y - 3)$       41.  $(p - 7)(p + 7)$
42.  $(q + 11)(q + 3)$       43.  $(t - 6)(t - 3)$       44.  $(a - 12)(a - 3)$
45.  $(c + 12)(c - 3)$       46.  $(f - 2)(f + 2)$       47.  $(h - 7)(h + 6)$
48.  $(i + 17)(i + 3)$       49.  $(b - 10)(b - 5)$
50. This expression has no binomial factors with integral coefficients.
51.  $(p - 13)(p + 13)$       52.  $(s + 5)(s - 3)$       53.  $(9 + u)(3 + u)$
54.  $(11 - w)(5 - w)$       55.  $(8 + e)(5 - e)$       56.  $(x + 24)(x + 3)$
57.  $(7 + y)(2 - y)$       58.  $(\Delta - 4)(\Delta + 4)$       59.  $(x - y)^2$
60.  $(m - 2)(m + 1)$       61.  $(25 - n)(3 + n)$       62.  $(p + 31)(p + 2)$
63.  $(7t + 5)(5t + 3)$       64.  $(8x + 1)(2x + 7)$       65.  $(4x + 3)(3x + 8)$
66.  $(5 + 7y)^2$       67.  $(3r + 1)(r + 3)$
68. This expression has no binomial factors with integral coefficients.
69.  $(8m + 5)(6m + 7)$       70.  $(10t + 3)^2$       71.  $(10t - 3)(10t + 3)$
72. This expression has no binomial factors with integral coefficients.
73.  $(9m - 1)(9m + 1)$       74.  $(11r - 2)(11r - 2)$       75.  $(5k + m)^2$
76.  $(3x - y)^2$       77.  $(7p - 8)(8p - 7)$       78.  $(1 - 8n)(1 + 8n)$
79.  $(3k + j)(k + 3j)$       80.  $(6m_1 + 5m_2)(m_1 - 3m_2)$

[3-188]

36



- N.
- |               |                      |          |               |
|---------------|----------------------|----------|---------------|
| 1. 8, -3      | 2. -12, -1           | 3. 0, 64 | 4. -7         |
| 5. $2/3$ , -7 | 6. $9/2$ , -1        | 7. -5, 4 | 8. $7/2$ , -2 |
| 9. $1/3$ , 5  | 10. $-(5/2)$ , $7/3$ |          |               |

- O.
- |                  |                  |                  |
|------------------|------------------|------------------|
| 1. 6.855; 6.86   | 2. -5.83; -5.83  | 3. 2.449; 2.45   |
| 4. 2.236; 2.24   | 5. 16.941; 16.94 | 6. 0.054; 0.05   |
| 7. 69.18; 69.18  | 8. 16.251; 16.25 | 9. 2.645; 2.65   |
| 10. -4.795; -4.8 | 11. 0.714; 0.71  | 12. 61.497; 61.5 |

- P.
- |                  |                  |                  |                  |
|------------------|------------------|------------------|------------------|
| 1. $3\sqrt{2}$   | 2. $3\sqrt{3}$   | 3. $8\sqrt{2}$   | 4. $11\sqrt{2}$  |
| 5. $3\sqrt{5}$   | 6. $6\sqrt{5}$   | 7. $2\sqrt{2}$   | 8. $2\sqrt{3}$   |
| 9. $12\sqrt{2}$  | 10. $10\sqrt{5}$ | 11. $11\sqrt{3}$ | 12. $6\sqrt{3}$  |
| 13. .7           | 14. $.7\sqrt{2}$ | 15. $8\sqrt{3}$  | 16. $.8\sqrt{3}$ |
| 17. $5\sqrt{2}$  | 18. $3\sqrt{5}$  | 19. $7\sqrt{3}$  | 20. 14           |
| 21. 12           | 22. 10           | 23. $\sqrt{3}$   | 24. 6            |
| 25. $13\sqrt{3}$ | 26. $3\sqrt{3}$  | 27. $2\sqrt{3}$  | 28. $8\sqrt{6}$  |
| 29. 2400         | 30. 28800        | 31. 1400         | 32. 1            |

- Q.
- |               |                    |                         |             |
|---------------|--------------------|-------------------------|-------------|
| 1. $ 5n $     | 2. $ 12b $         | 3. $- 3r $              | 4. $- 11t $ |
| 5. $ 13xy $   | 6. $- 15cd $       | 7. $-14 h+2 $           | 8. $ a+6 $  |
| 9. $ n-4 $    | 10. $ p-8 $        | 11. $ 7-r $             | 12. $ d-c $ |
| 13. $ p+q $   | 14. $ 4y-5 $       | 15. $ 3n-8a $           |             |
| 16. $ 3r-4s $ | 17. $ (a-7)(a+2) $ | 18. $\sqrt{5} b(b+10) $ |             |

Neither of the expressions given in Ex. 19, 20 can be simplified.

[Change Exercise 11 of Part R to ' $14(x^2 + 2) \geq 5(5.6 - x)$ '.]

- R.
- |  |                                   |  |                       |
|--|-----------------------------------|--|-----------------------|
| 1. 5, -3                                       | 2. $\frac{4}{5}$ , $-\frac{4}{3}$ | 3. 13, 2   | 4. $\frac{3}{4}$ , -8 |
| 5. -8, 4                                       | 6. -3, -1                         | 7. 5, -5   | 8. 8, -9              |
| 9. 5, $-\frac{1}{2}$                           | 10. -3, $-\frac{23}{19}$          | 11. $\{x: x \leq -\frac{5}{14} \text{ or } x \geq 0\}$ |                       |
| 12. $\{x: -3 < x < -2 \text{ or } 2 < x < 3\}$ |                                   |  |                       |

N. Solve these equations.

1.  $n^2 - 5n - 24 = 0$

2.  $12 + a^2 + 13a = 0$

3.  $r^2 = 64r$

4.  $b^2 + 49 + 14b = 0$

5.  $3s^2 = 14 - 19r$

6.  $2c^2 = 7c + 9$

7.  $x^2 + x = 20$

8.  $14 + 3d = 2d^2$

9.  $6x^2 - 32x + 10 = 0$

10.  $x(x + \frac{1}{6}) = \frac{35}{6}$

O. For each exercise, find the approximation correct to 3 decimal places, and the approximation correct to the nearest 0.01.

1.  $\sqrt{47}$

2.  $-\sqrt{34}$

3.  $\sqrt{6}$

4.  $\sqrt{5}$

5.  $\sqrt{287}$

6.  $\sqrt{0.003}$

7.  $\sqrt{4786}$

8.  $\sqrt{264.1}$

9.  $\sqrt{7}$

10.  $-\sqrt{23}$

11.  $\sqrt{0.51}$

12.  $\sqrt{3782}$

P. Simplify.

1.  $\sqrt{18}$

2.  $\sqrt{27}$

3.  $\sqrt{128}$

4.  $\sqrt{242}$

5.  $\sqrt{45}$

6.  $\sqrt{180}$

7.  $\sqrt{8}$

8.  $\sqrt{12}$

9.  $\sqrt{288}$

10.  $\sqrt{500}$

11.  $\sqrt{363}$

12.  $\sqrt{108}$

13.  $\sqrt{.49}$

14.  $\sqrt{.98}$

15.  $\sqrt{192}$

16.  $\sqrt{1.92}$

17.  $\sqrt{18} + \sqrt{8}$

18.  $\sqrt{5} + \sqrt{20}$

19.  $\sqrt{27} + 2\sqrt{12}$

20.  $\sqrt{28} \times \sqrt{7}$

21.  $\sqrt{6} \times \sqrt{24}$

22.  $\sqrt{\frac{1}{3}} \times \sqrt{300}$

23.  $\sqrt{72} \div \sqrt{24}$

24.  $\sqrt{180} \div \sqrt{5}$

25.  $\sqrt{300} + \sqrt{192} - \sqrt{75}$

26.  $\sqrt{108} - \sqrt{12} - \sqrt{3}$

27.  $\frac{1}{3}\sqrt{27} + \frac{1}{2}\sqrt{48} - \frac{1}{6}\sqrt{108}$

28.  $\sqrt{96} - 2\sqrt{6} + 3\sqrt{24}$

29.  $5\sqrt{2} \times 3\sqrt{50} \times 4\sqrt{16}$

30.  $4\sqrt{75} \times 5\sqrt{48} \times 4\sqrt{36}$

31.  $(\sqrt{70})^2 \times (2\sqrt{5})^2$

32.  $(\sqrt{6} - \sqrt{5})(\sqrt{6} + \sqrt{5})$

Q. Simplify.

- |                                  |                    |                                    |                     |
|----------------------------------|--------------------|------------------------------------|---------------------|
| 1. $\sqrt{25n^2}$                | 2. $\sqrt{144b^2}$ | 3. $-\sqrt{9r^2}$                  | 4. $-\sqrt{121t^2}$ |
| 5. $\sqrt{169x^2y^2}$            |                    | 6. $-\sqrt{225c^2d^2}$             |                     |
| 7. $-\sqrt{196(h+2)^2}$          |                    | 8. $\sqrt{a^2 + 12a + 36}$         |                     |
| 9. $\sqrt{n^2 - 8n + 16}$        |                    | 10. $\sqrt{p^2 - 16p + 64}$        |                     |
| 11. $\sqrt{49 - 14r + r^2}$      |                    | 12. $\sqrt{d^2 - 2dc + c^2}$       |                     |
| 13. $\sqrt{p^2 + 2pq + q^2}$     |                    | 14. $\sqrt{16y^2 - 40y + 25}$      |                     |
| 15. $\sqrt{9n^2 - 48na + 64a^2}$ |                    | 16. $\sqrt{9r^2 - 24rs + 16s^2}$   |                     |
| 17. $\sqrt{(a-7)^2(a+2)^2}$      |                    | 18. $\sqrt{5b^2(b^2 + 20b + 100)}$ |                     |
| 19. $\sqrt{a^2 + b^2}$           |                    | 20. $\sqrt{a^2 - b^2}$             |                     |

R. Solve these equations and inequations.

- |   |  |
|---|--|
| 1. $\frac{15}{a} + 2 = a$                     | 2. $-8 + \frac{16}{y} = 15y$                 |
| 3. $1 - \frac{15}{n} + \frac{26}{n^2} = 0$    | 4. $\frac{29}{4c} + 1 = \frac{6}{c^2}$       |
| 5. $\frac{18}{x-3} - 6 = x + \frac{x+4}{x-3}$ | 6. $1 + \frac{5}{d+4} = \frac{d+6}{d+4} - d$ |
| 7. $(s+6)^2 = 2(6s+30.5)$                     | 8. $r(r+7) = 6 + 6(11+r)$                    |
| 9. $\frac{2x-5}{2x+5} = \frac{x-1}{2x+2}$     | 10. $\frac{8x+9}{3x+4} = \frac{7x+3}{5x+9}$  |
| 11. $14(x^2+2) \geq 5(1-x)$                   | 12. $ x ^2 - 5 x  + 6 < 0$                   |













UNIVERSITY OF ILLINOIS-URBANA



3 0112 084223541